

# CONSOLE INSTALLATION IMPROVEMENTS

DECEMBER 7th

1929

15 CENTS

# RADIO

REG. U.S. PAT. OFF.

# WORLD

402nd Consecutive Issue—EIGHTH YEAR

## Three Cardinal Virtues of a Receiver

### Voltage Division

### Push-Pull Speakers

### How Current Flows Told for Schoolboys

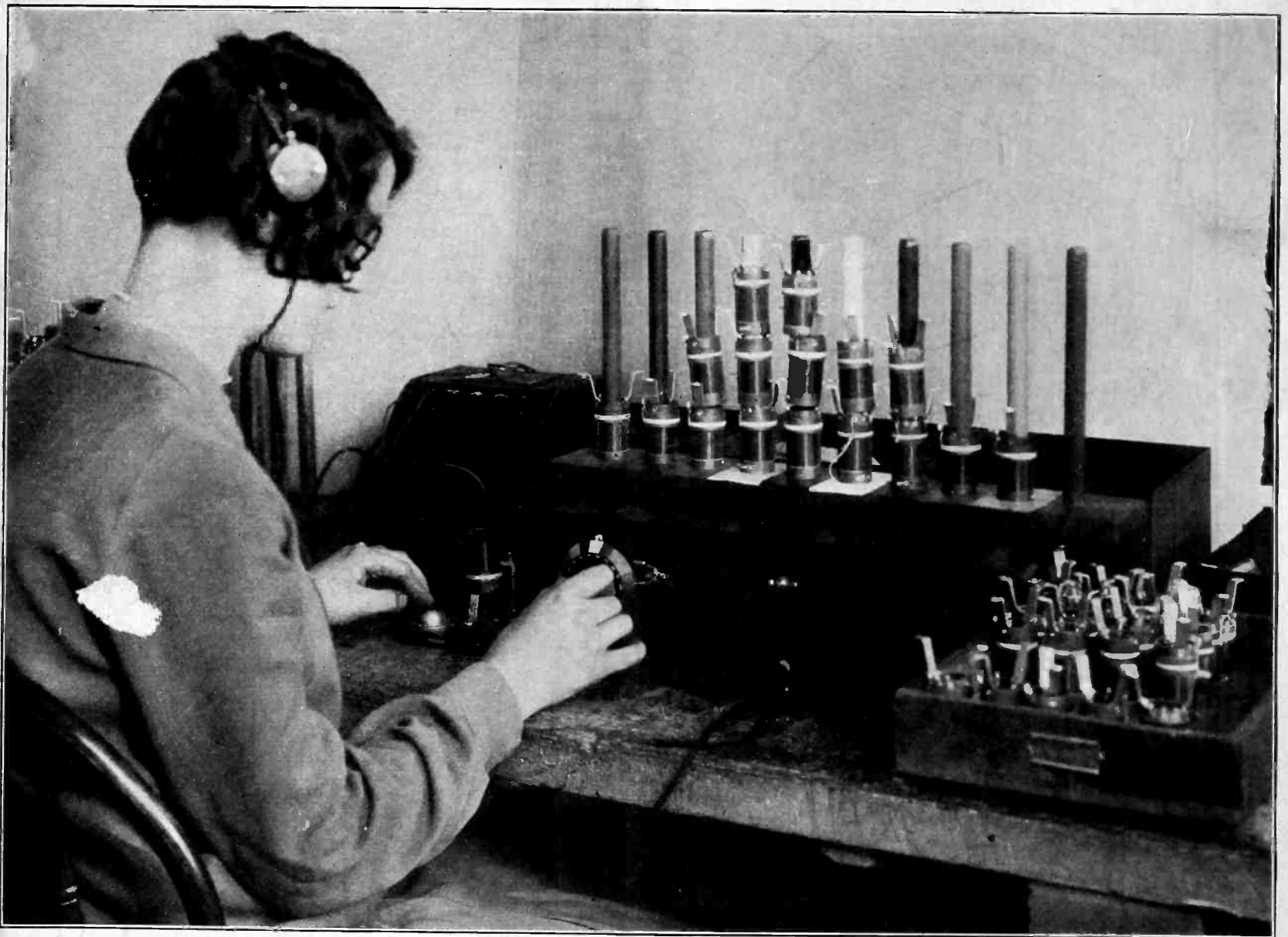

Coils are tested for identical inductance by means of an oscillator. When zero beat is established the coil under test is just the same inductance as the master model. See article on pages 5, 6 and 7.

# NEW J-245-X TROUBLE-SHOOTING JIFFY TESTER

*Illumination Continuity and Polarity Tester FREE with Each Outfit!*

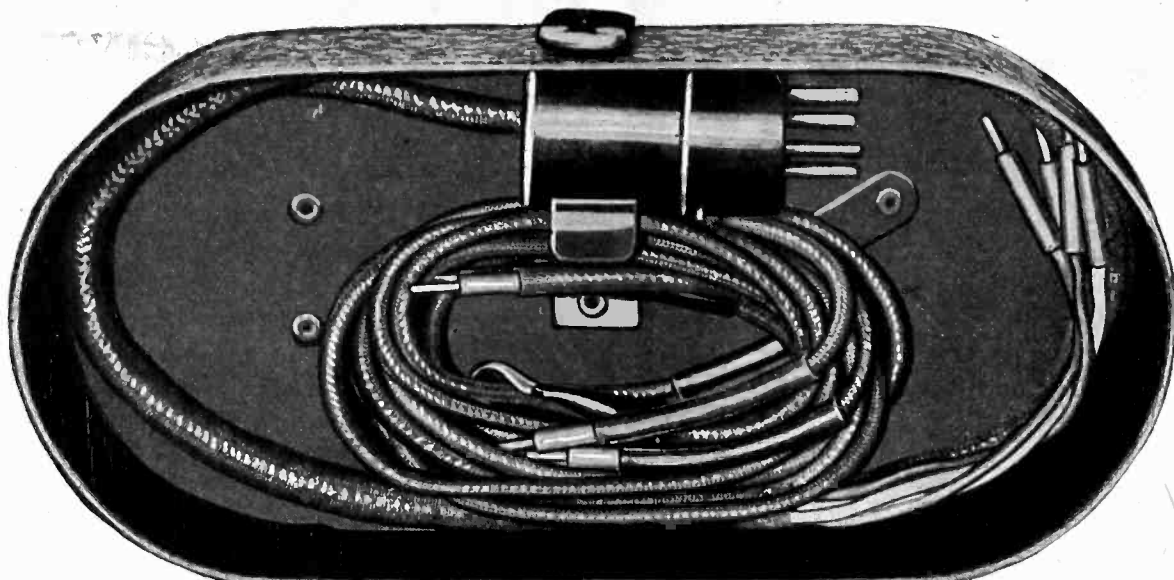

Your Price  
**\$15.82**

Complete

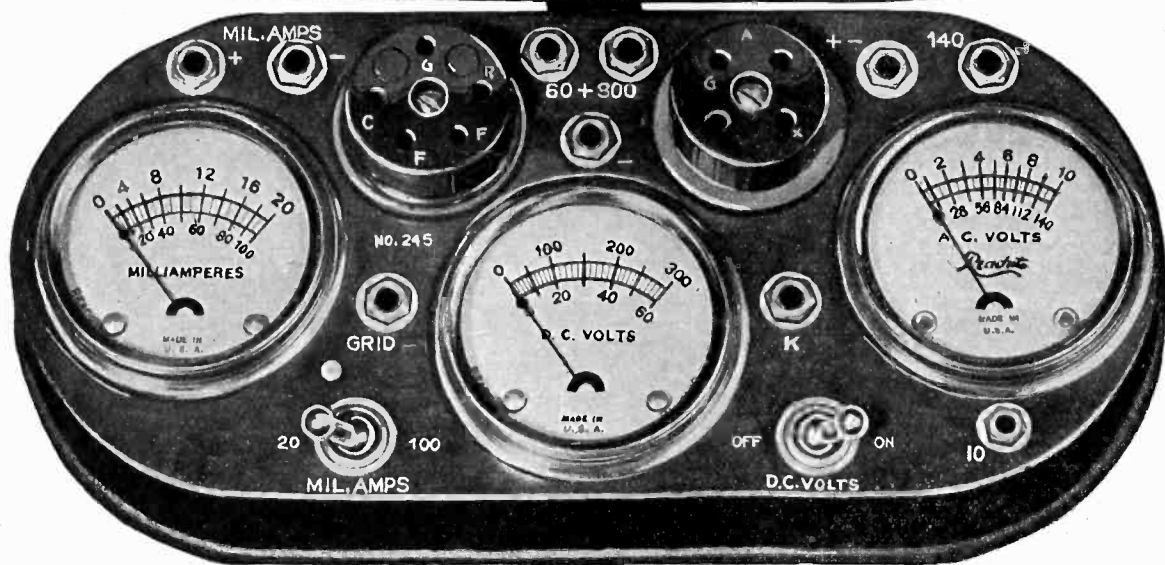

Illumination Tester, Vest Pocket Size, Shows Shorts and Opens Visually, also polarity of DC line. A Neon lamp is built in.



The three-meter assembly. In the crackle-brown finish carrying case, with slip-on cover and a cable plug. There are ten adapters. It is vital to have the complete outfit so you can meet any emergency.

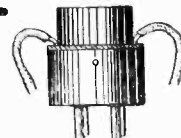

J-111 Multiplier, upper left, with tip; below it, J-106 Multiplier with tip; plugs, left to right, J-19, conforms UV socket to UX plug; J-20, conforms UX tester socket to UV199 tube; J-24, to test Kellogg and old style Arcturus tubes.

## Makes All Necessary Tests in a Jiffy and Simplifies Service Work!

**T**HE new Jiffy Tester, J-245-X, is a complete servicing outfit. It consists of a three-meter assembly in a metal case, with slip-on cover and a cable plug. There are ten adapters. It is vital to have the complete outfit so you can meet any emergency.

With this outfit you plug the cable into a vacated socket of a receiver, putting the removed tube in the tester, and using the receiver's power for making these tests: plate current, up to 100 milliamperes; plate voltage up to 300 volts; filament or heater voltage (AC or DC), up to 10 volts.

Each meter may be used independently. One of the adapters—a pair of test leads, one red, the other black, with tip jack terminals—serves this purpose. Multiplier J-106 extends the range of the DC voltmeter to 600 volts, but this reading must be obtained independently, as most readings on the 0-60 scale of the DC voltmeter. Independent reading of the AC voltmeter for line of voltage is necessary; also to use 0-140 scale while Multiplier J-111 extends the AC scale to 560 volts for reading power transformer secondaries.

The other adapters permit the testing of special receiver tubes, so that tests may be made, in all, of 22 different tubes: 201A, 200A, UX199, UV199, 120, 240, 171, 171A, 112, 112A, 245, 224, 222, 228, 280, 281, 227, 226, 210, 250, Kellogg tubes and old style Arcturus tubes.

**W**HEN servicing a radio set, power amplifier, speech amplifier or sound reproduction or recording equipment, the circuits and voltages are almost inaccessible, unless a plug-in tester is used.

The Jiffy 245-X plugs in and does everything you want done. It consists of:

- (1)—The enclosed three-meter assembly, with 4-prong (UX) and 5-prong (UY) sockets built in; changeover switch built in, from 0-20 to 0-100 ma.; ten vari-colored jacks, five of them to receive the vari-colored tipped ends of the plug cable; grid push-button, that when pushed in connects grid direct to the cathode for 224 and 227 tubes, to note change in plate current, and thus shorts the signal input.
- (2)—4-prong adapter for 5-prong plug of cable.
- (3)—Screen grid cable for testing screen grid tubes.
- (4)—Pair of Test Leads for individual use of meters.
- (5)—J-106 Multiplier, to make 0-300 DC read 0-600.
- (6)—J-111 Multiplier, to make 0-140 AC read 0-560.
- (7)—Two jack tips to facilitate connection of multipliers to jacks in tester.
- (8), (9), (10)—Three adapters so UV199 and Kellogg tubes may be tested.
- (11)—Illumination Tester.

The illumination tester will disclose continuities and opens and also the polarity of DC house mains. It is as handy as a pencil and fits in your vest pocket. It works on voltages from 100 to 400. There are two electrodes in a Neon lamp in the top of the instrument. On AC both electrodes light. On DC only one lights, and that one is negative of the line, the light being on the same side as the lead. Hence the illuminator shows whether tested source is AC or DC, and if DC, which side is negative.

Even the output of the speaker cord will show a light. Also, the device will test which fuses are blown in fused house lines, AC or DC. Besides it tests ignition of spark plugs of automobiles, boats and airplanes, also faulty or weak spark plugs.

Just flash on the illumination tester momentarily. It will last about 4,000 flashes.

**GUARANTY RADIO GOODS CO.**  
143 West 45th Street, Just East of Broadway,  
N. Y. City.

Please send me on 5-day money-back guaranty your J-245-X Jiffy Tester, complete, with all 10 adapters, and with Illuminated Tester FREE with each order. Also send instruction sheet, tube data sheet and rectifier tube testing information.

Enclosed please find \$15.82 remittance. Ship at your expense. [Canadian must be P.O. or Express M.O.]

Please ship C. O. D. @ \$15.82 plus cartage and P.O. fee.

NAME .....

ADDRESS .....

CITY ..... STATE .....

**5-DAY MONEY-BACK GUARANTY**

# O-600v, AC & DC

High Resistance Meter  
ACCURATE TO 1%!

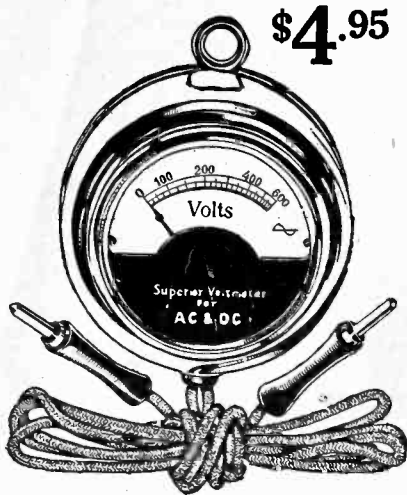

\$4.95

O-600 AC and DC Voltmeter—same meter reads both—with 32" long flexible cords built in, and equipped with hanger. Extreme diameter (less hanger) 2 3/4".

### MOST USEFUL!

Here is a meter that serves an abundance of uses, because it has a wide voltage range, 0 to 600 volts, and measures voltage of alternating current and direct current, and is accurate to 1%. In a meter it's accuracy that counts.

You can measure not only the DC voltages of B eliminators, power packs and B batteries, with easily legible readings of 20 volts per division of the scale, with wide divisions between 100 and 400 volts, so that you can easily see to within 5 volts, but you can also measure the AC voltage across high-voltage power transformer secondaries. If full-wave rectification is used, you measure each of the two sections of the transformer secondary and add the voltages. Thus up to 1,200 total volts across the secondary may be read. For half-wave rectification, a secondary up to 600 volts is read across the total winding. You find out at once whether this winding is open or shorted, since no reading then would be obtained, or find out whether the voltage is right, or too high or too low. In all instances the AC voltage across the secondary should read higher than the desired DC output, due to the voltage drop in the tube and to the current in the entire voltage divider and its sections. The normal deduction from the AC voltage, to obtain the DC voltage, is at least 10%.

### A REQUISITE FOR SERVICING!

Often service men, experimenters and students must know not only the transformer high voltage, but also whether the AC line voltage is the rated 110 volts or not. This meter tells you. Connect it across the 110-volt line. By reading this voltage and the voltage of the high-voltage secondary you can also determine the step-up ratio, by dividing the smaller reading into the larger.

Because this is a high-resistance meter you can rely on the accuracy of the readings.

Only a high-resistance meter can accurately measure the DC voltage of a B eliminator. Other meters draw so much current that the reading may be 50 volts less than what it should be, or still more inaccurate, and you could almost guess the voltage more accurately than a low-resistance meter would read.

### MONEY-BACK GUARANTY!

This meter is sold on a 5-day money-back guaranty. Buy one, try it, test it thoroughly, compare it with other meters in performance and appearance. If not fully satisfied, send it back and your money will be promptly refunded.

The meter is full nickel plated, highest possible polish, has green cords, with red (positive) and black (negative) moulded bakelite tip-holders, and sturdy tips. The positive and negative indications are for DC measurements. For AC the meter may be connected at random.

This meter, which is of the moving vane type, is made in Germany and represents finest workmanship.

Cat. M600 AC-DC .....\$4.95

### SEND NO MONEY!

GUARANTY RADIO GOODS COMPANY,  
143 West 45th Street, New York, N. Y.  
(Just East of Broadway).

Please ship at once C.O.D. one O-600 voltmeter, reading both AC and DC, on 5-day money-back guaranty. This meter must be exactly as advertised in Radio World. Cat. M600, price .....\$4.95

NAME .....  
ADDRESS .....  
City ..... State.....

5-DAY MONEY-BACK GUARANTY

New

# Farrand Inductor

Extremely Sensitive, Faithful Speaker at 50% off List Price!

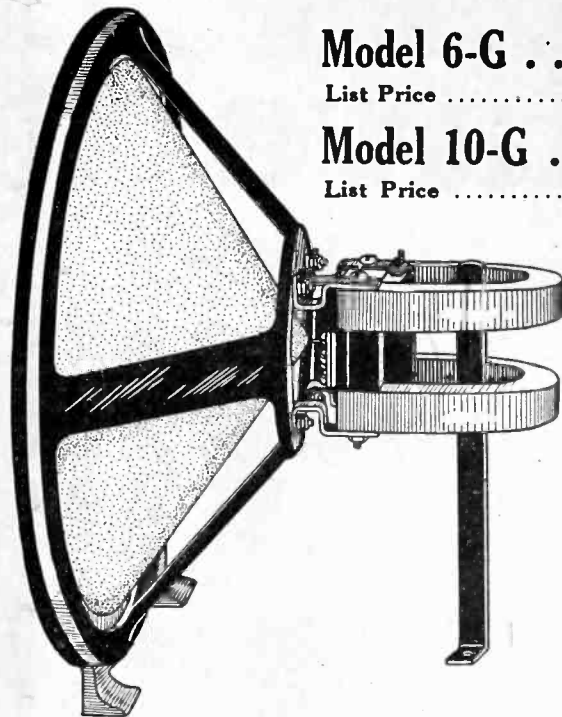

Model 6-G . . . \$10.00

List Price ..... \$20.00

Model 10-G . . \$11.00

List Price ..... \$22.00

The New Farrand Inductor Chassis, the inductor unit on a spider assembly, with cone and supporting brackets. Chassis comes completely assembled, with 10-ft. cord, ready to play.

## How the New Inductor Excels!

THE new Farrand Inductor Chassis is all the rage now because it affords extremely high sensitivity with faithful reproduction of all the notes of the audible scale. Here is a speaker that will support the good low-note reproduction of the most modern and most excellent audio amplifiers, without discriminating against middle or upper frequencies. If you do not have a speaker that will respond faithfully to the audible scale of frequencies, then the value of any good audio amplifier is largely lost.

An entirely new principle is involved in the Inductor Unit. The armature, instead of moving from side to side in the direction of the pole pieces, as happens in ordinary magnetic units, moves like a piston along the length of the air gap and maintains a steady distance from the pole pieces. As the sensitivity is extraordinarily high, the gap is made wide, and the armature will not strike the pole pieces.

The Inductor Chassis comes completely assembled, ready for operation. All you need do is connect the speaker cords to the output posts of your receiver or power amplifier. No energizing field is necessary.

Treat yourself to one of these exceptional chasses, and put it in a cabinet, or use some other form of baffle if you prefer. The chassis works well just as you get it, but works still better when aided by a cabinet or baffle.

These models, No. 6-G and No. 10-G, work exceptionally well with any of the following as single output tube: 171, 171A, 245 or 250. Also the same models are meant for *any* type of tubes in push-pull.

Model No. 6-G is 10" extreme outside diameter of cone, and Model 10-G is 12" extreme outside diameter of cone. The larger size, Model 10-G, gives a little better reproduction of low notes. Both types stand the same exceedingly high volume and output and use exactly the same unit.



Brookfield Cabinet  
Model 10 for 10-G inductor  
Model 6 for 6-G inductor  
Either cabinet ..... \$6.50

A highly suitable cabinet for the Farrand Inductor Chassis is the Brookfield, made in two models, one for each size Inductor cone. The finish is genuine ply walnut. The baffle effect is particularly fine. These cabinets are specially made for these speakers and are beautiful in appearance, as well as sturdy, because of extreme expertness and care in manufacture.

Acoustical Engineering Associates  
143 West 45th Street, New York City.  
(Just East of Broadway)

Gentlemen: Enclosed please find  money order  check for \$..... for which please send me at once  
 One Model 6-G Farrand Inductor Speaker Chassis, ..... \$10.00  
 One Model 10-G Farrand Inductor Speaker Chassis, ..... 11.00  
 One Model 10 Brookfield cabinet 6.50  
 One Model 6 Brookfield cabinet 6.50  
 For C. O. D. shipment put cross here

Name .....

Address .....

City ..... State.....

[Prepaid orders shipped same day as received. Canadian remittance must be by postal or express money order.]

# Have You Seen the NEW RADIO NEWS

*If it's  
radio news..  
it's in  
RADIO NEWS*

**O**CCASIONALLY a man gets so close to radio that he doesn't see the broader aspects of the industry. *Certainly* it is all right to know about the newest receivers, and how to build them. *Certainly* the newest discoveries in servicing and handling radio parts and sets should be told clearly and at length in the magazine he reads. The NEW RADIO NEWS brings you all this every month.

*But it brings you much more than this.* It provides you with the vital radio news of the whole world in a terse, business-like way that demands reading by every man whose interest lies in radio.

Beyond the fact that the NEW RADIO NEWS is actually new from cover to cover, you begin to realize that RADIO NEWS has *grown up*.

It sees with modern vision the trends and developments in the radio industry. If a new discovery in television occurs in Greece or even Patagonia, you'll find all you want to know about it in the NEW RADIO NEWS. If the Federal Radio Commission makes some new ruling, you can count on RADIO NEWS for the complete story of it. If an Austrian inventor designs a new improved radio tube, you'll be sure to find it all explained in RADIO NEWS.

That is why we say *with emphasis*—if it's radio news, it is in RADIO NEWS. And if you are the sort of man whose mind seeks an *executive viewpoint* of radio's rapid progress, you'll want the NEW RADIO NEWS delivered to you every month.

## A SPECIAL OFFER TO RADIO MEN

To introduce the NEW RADIO NEWS to those in the industry, we offer to send you *the next 9 Big Numbers for a single \$1!* On the newsstands you would have to pay \$2.25 for these same 9 issues, or \$2.50 a year by subscription. We make this exceedingly low offer, because we know that once you see the NEW RADIO NEWS, you will continue to read it in the years to come.

Simply fill out and mail the coupon at the left. It brings you the Big New RADIO NEWS at a jobber's discount.

The NEW RADIO NEWS,  
Dept. 3601,  
381 Fourth Avenue, New York, N. Y.



Gentlemen:

Please send me the next 9 Issues of the NEW RADIO NEWS at your special introductory offer of only \$1, which I enclose (regular newsstand price is \$2.25 for 9 issues, or \$2.50 a year by subscription). I understand that you will cheerfully return my dollar if I am not perfectly satisfied after reading the first issue.

Name .....

Street Address .....

City .....

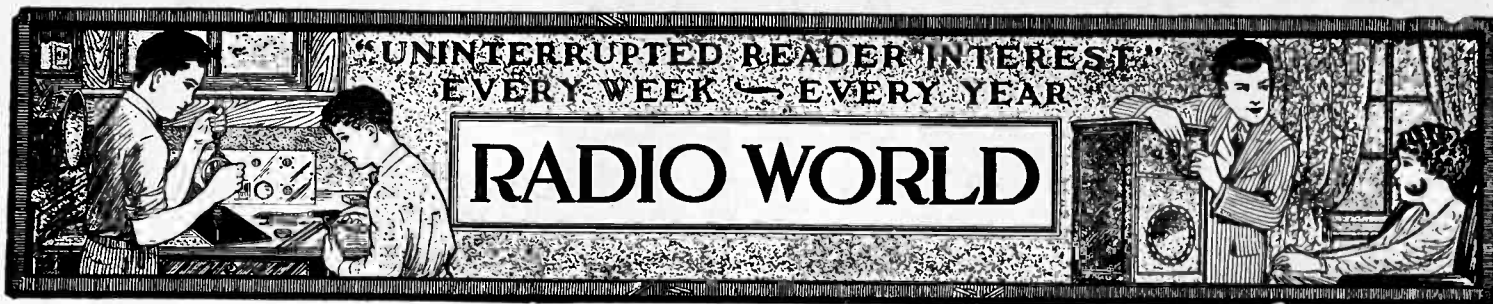

Vol. XVI, No. 12      Whole No. 402  
 December 7th, 1929  
 15c per Copy, \$6.00 per Year  
 [Entered as second-class matter, March, 1922, at the Post Office at New York, N. Y., under act of March, 1879.]

Technical Accuracy Second to None  
 Latest Circuits and News  
**EIGHTH YEAR**

A Weekly Paper published by Hennessy Radio Publications Corporation, from Publication Office, 145 West 45th Street, New York, N. Y.  
 (Just East of Broadway)  
 Telephone, BRyant 0558 and 0559

RADIO WORLD, owned and published by Hennessy Radio Publications Corporation, 145 West 45th Street, New York, N. Y. Roland Burke Hennessy, president and treasurer, 145 West 45th Street, New York, N. Y.; M. B. Hennessy, vice-president, 145 West 45th Street, New York, N. Y.; Herman Bernard, secretary, 145 West 45th Street, New York, N. Y. Roland Burke Hennessy, editor; Herman Bernard, business manager and managing editor; J. E. Anderson, technical editor.

# Console Installations

## How Some Common Troubles May Be Avoided

By H. B. Herman

**C**ONSOLE installations present some special problems, one of them being acoustical coupling, another box resonance. Also, occasionally the space problem arises, as apparently one has more apparatus than can be accommodated, and in seeking a way out he will run into stray coupling difficulties.

It has been noticed by nearly every experimenter who has been engaged on AC work that hum often arises as if from some inexplicable cause. This will happen almost invariably when the speaker is in the console, and the power amplifier is close to it. What is meant by "close" is hard to define exactly, as the degree of amplification in the audio amplifier has much to do with the consequent trouble.

If the amplification is high, the field about the audio apparatus is strong, hence the same separation that under other circumstances would be wide and hum-free becomes close and hum-bound. If hum arises the coupling is too close.

### TILT OFTEN SOLVES PROBLEM

Since the speaker is some form of electro-magnet, changing the relative position of the speaker in respect to the audio amplifier often will provide a ready remedy. If the console is so built that the speaker must be in a given position, as is nearly always the case, due to the baffle and cutout for the rim of a cone, then if relative alteration of position is to be introduced, that must be done by tilting the audio amplifier.

A slight tilt often will solve the problem.

Another simple remedy, where the power amplifier is independent of the tuner, is to turn the power amplifier around. Often the detector tube of the tuner is so positioned that it is too close to the output of the power amplifier. Of course coupling between tuner output and power amplifier input is intentional, the very means of delivering from one the voltage and current intended for the other. Stray coupling usually arises between the detector and the power amplifier output, or the speaker and detector.

By turning the power amplifier around, even at the sacrifice of putting binding posts out of ready reach, the separation between unintentionally united circuits may be increased, and a permanent cure effected.

### CAPACITY EFFECT ON HUM

Hum that is due to poor filtration requires better filtration. If the capacities are too low and the inductances of the choke coils in the filter section are too low, increase these. To increase capacity, connect extra capacity in parallel with existing capacity, but be sure that the condensers newly introduced have a sufficiently high voltage rating for the purpose. Do not use a 200 volt DC voltage rating condenser across a rectifier output, as these days the output voltage DC is more likely to be around 400 to 600 volts at that point.

Additional choke coils should be connected in series, preferably at the filter section output.

You can have too much capacity, as well as too little. This arises from the fact that the filter is, broadly speaking, a tuned circuit, tuned to trap out the objectionable frequencies introduced by the AC line itself through the power transformer. Therefore if you use too much capacity you may miss the region of desired exclusion, just as you may do by using too little. This point, important though it is, often is overlooked, and



FIG. 1

HOW A DYNAMIC SPEAKER IS PLACED IN A CONSOLE SO AS TO USE THE BOTTOM BOARD OF THE CONSOLE AS A BAFFLE. PARTICULARLY IN ROOMS THAT HAVE CARPETED FLOORS THIS METHOD WORKS OUT EXCELLENTLY.

seldom has been mentioned in print. The author never saw a published statement on the subject.

### POSITIONS OF SPEAKERS

In console installations hum accentuation may be due to box resonance, which is the characteristic of the box whereby frequencies of particular pitch are echoed and thus become additive in their radiation. This accounts largely for boominess and barrel-like reproduction. Hence the box resonance may be in the region of 120 cycles, the second harmonic of the common 60-cycle frequency of the AC line voltage. Also it may be around 60 cycles itself, but this is rather unlikely, because that is a low frequency indeed, and besides is not the predominating hum frequency. The second harmonic predominates.

Often in a console installation one is guided by someone's particular aesthetic choice. In general speakers are placed so that they radiate sound from above the tuner, in the direction of the ear of a person standing before the front panel, or

# Hum Eradication in U

## Acoustical Coupling and Poor

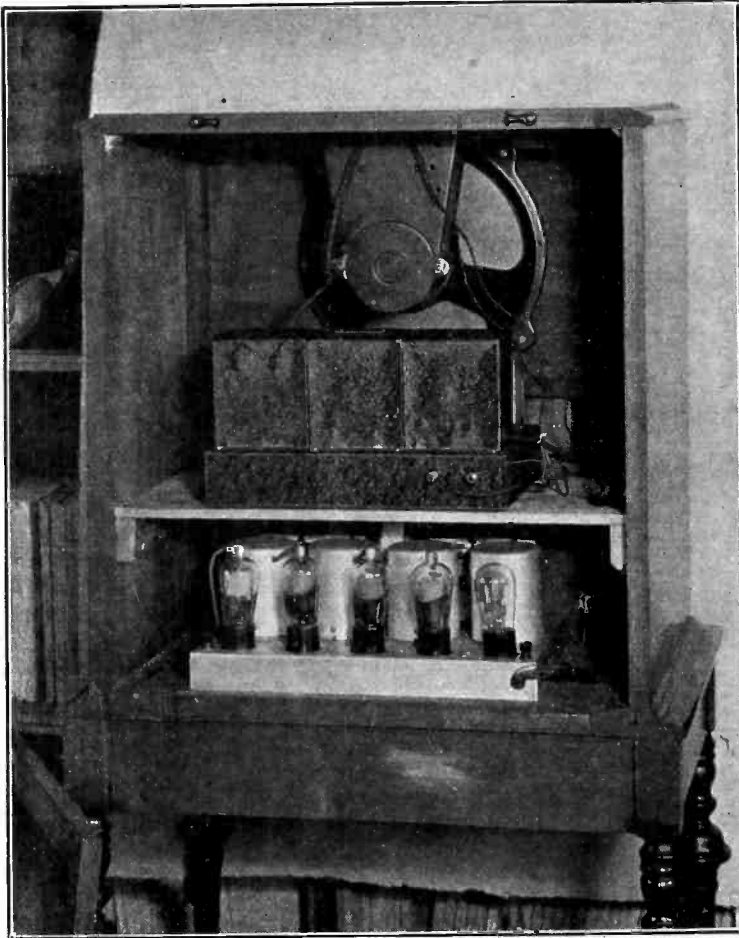

FIG. 2  
ANOTHER TYPE OF CONSOLE ASSEMBLY, WHERE THE SPEAKER IS ON TOP, BEHIND IT THE POWER AMPLIFIER AND BELOW THE TUNER.

from below the tuner, in the direction of the ear of a person sitting at the front panel.

In either instance the power amplifier, if a separate unit, likely will be in the remaining compartment, rather than on the same level with the speaker. But if the speaker and any part of the radil circuit proper are on the same level, separate them if hum is severe, by placing the other apparatus above or below the speaker. Where a front panel is a question, another piece of finished wood may be drilled to receive the tuning knob, volume control and switch, these extra pains being well worth while to cure the objectionable condition of seemingly ineradicable hum.

### AN EASY TEST

As a test of coupling, disconnect the console speaker and attach another speaker. Then carry the new speaker away from the console, and notice how the hum disappears. If you have no extra speaker you can contrive to detach the console speaker and carry this to perform the test. You will then confirm the existence of acoustical coupling, a magnetic union of two circuits that it is imperative to keep disunited.

Follow up this test by returning closer to the console, as close as you desire, and tilting the speaker. You will find that a certain angle will give minimum hum, and since the speaker in the console can not well be tilted, the power amplifier may be tilted to establish the angle.

### BOTTOM AS Baffle

Another method of establishing a workable condition is to have the cutout for the speaker at the bottom of the console, and while this usually will give right-angle relativity, hence small or non-existent coupling, it is beyond the contrivance of most service men and experimenters to drill out the necessary large hole to make the bottom of the console serve as the auxiliary sounding board or baffle. Yet, to cure a bad condition, it would be a good idea to get a replacement board for the bottom, even if you have to enlist the aid of a cabinet maker, and substitute this for the solid bottom, rearranging the radio apparatus accordingly, or remove the solid bottom and have a cabinet maker cut out the hole.

Fig. 1 shows a console installation with a dynamic speaker

using the bottom board of the console as a baffle, the sound radiation being in the direction of the floor. As the floor is supposedly carpeted, the rebounding effect of the sound waves is greatly reduced and excellent acoustical results prevail. Stray coupling is avoided by the disposition of the tuner and the power amplifier, so that the tuner is above and the power amplifier below. However, different apparatus might require different relative placement, but this can be arranged. First find the electrical solution—the eradication of the objectionability of hum—and the mechanical means necessary to attain that end must be enacted.

### WHEN RF GAIN IS HIGH

The tuner shown in Fig. 1 is the MB-29, and the power amplifier is the 245 push-pull Velvetone, both manufactured by National Company and both representing high standards of achievement. The MB-29 is a highly sensitive AC tuner, using an untuned screen grid input, three stages of tuned screen grid radio frequency amplification and a tuned input to the 227 tube used as a power detector. Thus four 224 tubes and one 227 tube are used.

With sensitivity of as high an order as resulting from an excellently designed RF channel, as in the MB-29, precautions have to be taken for hum avoidance, but it is an easy matter to do this, since the MB-29 is widely used, and those who have installed it according to directions have not reported any hum.

If hum does result it is usually due to misconnections or lack of connections in the power amplifier, where one other than the Velvetone is used. Of course the Velvetone, while specially suited for this circuit, need not necessarily be used, the objects of obtaining the proper coupling, amplification and voltages being attainable with installations that many users of the MB-29, present or prospective, now have.

### CHECK UP POWER AMPLIFIER

Every instance of connection to another power amplifier than Velvetone should be accompanied by a thorough check-up of the power amplifier used. For instance, an unconnected grid return in the first audio stage will result in hum of an astonishing magnitude, whereas establish the connection, provide the correct bias, and, lo, the hum disappears. This mistake actually was made by an executive who is not a radio expert, but does like to monkey around with radio. A service man had to travel eleven miles to cure the baffling nuisance, and it took just three minutes to find and remedy the defect. The executive had to pay \$8, but considered the money well spent.

The same pair—the MB-29 and the Velvetone—are shown in Fig. 2 in a different console with speaker on top, radiating in the direction of a person standing in front of the front panel, the power amplifier behind the speaker, and the tuner below. This arrangement also worked out well, due to the shield cases of the Velvetone.

In installing the MB-20 in a console, only four main front panel holes need be considered. The first is the circle for the window or screen of the new National modernistic dial. The second is the hole for the shaft that actuates the dial mechanism by means of a front panel knob. The layout inside the console will determine the height of centers of these holes, since both are on a perpendicular central line of the panel. The two dial holes may be taken right off the escutcheon and a couple of small extra holes drilled as required.

### DETAILS FOR TWO HOLES

But the location of the volume control shaft at left and AC switch at right require dimensional assistance. Fig. 3 shows the dimensions, the hole for the tuning shaft being used as the reference point. Notice that the distance is  $3\frac{1}{2}$ " to left and right and that a  $\frac{1}{2}$ " hole is provided in each instance for the volume control and the AC switch.

It is highly recommended that the MB-29 be tried by those desirous of using or placing a very sensitive tuner, because this circuit has not only stood up excellently, after six months of rigid tests under all operating conditions, but it has evoked enthusiasm from such hard-boiled radioists as owners of retail stores, who usually get enthusiastic over nothing except extra discounts, and from experimenters of many years' standing, who read of each "startling new development" with askance, but, though they may have doubted when they read, certainly were won over by personal experience with the MB-29.

If one does not feel he can wire the circuit successfully he may obtain a laboratory-wired receiver, expertly put together in the Jackson Laboratories, and tested for distance reception before shipment. Much distance is an assured fact with the

# Ultra-Sensitive Receivers

## Filtration Cause Annoyance

MB-29, also high selectivity without serious encroachment on sidebands.

### SOME POINTS CLEARED UP

Here are a few points that may be considered "installation-ary":

(1)—Detector voltage. The diagram of the MB-29 as printed herewith, Fig. 4, does not show any particular detector voltage. But a card that accompanies the parts for the MB-29 reveals that this voltage should be 135 volts. The B post of the input to the power amplifier therefore takes 135 volts, and while it is a fact that reception will be obtained even with lesser or greater voltage, it is inadvisable to use less, as then the detector is worked as a simple negative bias detector, instead of as a power detector (which means high plate voltage and high negative bias). Power detection affords a greater signed voltage handling capacity of the detector tube and should be used by all means. The bias is taken care of automatically, by resistors in the MB-29, but the amount of bias depends on the amount of plate and bleeder current. Do not use more than 135 volts here, as a resistor would heat up unduly.

(2)—The AC switch on the MB-29 subpanel or chassis is not intended for any direct use in connection with the tuner, for instance not for turning on and off the heater voltage on the 224 and 227 tubes, but is there merely for convenience, so that the AC line voltage may be turned on or off by this switch, hence the switch will control dynamic speaker, supply to and hence from the power amplifier, including heater voltage.

(3)—The tuning condensers have trimmers built in, and these trimmers are correctly set at the factory but may jar out of proper setting in transit. Do not assume they have gone wrong, as usually they remain intact. But if the amplification is not as you are led to suspect, at least that is a clue to the possibility of misadjustment. So tune in a low wavelength station, turn back the volume control until the signal comes in clearly, even though not loudly, and then adjust the trimmers, one at a time, starting with the first one at right. After you have adjusted for maximum volume, turn the dial knob slightly and see whether volume may be increased even a little. If so one or more of the trimmers are "out," so readjust at the new setting. The capacity condition, and not the coils, is a possible source of reduced sensitivity, as the coils are groove-wound, all precisely alike, and are tested for identity by an oscillator, as shown on the front cover.

When all is at it should be with the trimmers the DX stations will come pouring in—one station at a time, however. You will be surprised at the tremendous volume of the DX signals.

(4)—Poor tubes will make a failure out of any radio demonstration, so if you run into poor sensitivity trouble, first inspect the tubes and the voltages. Test the voltages first, as that costs nothing. If all voltages show up correctly, then try a new 224 tube in one of the four sockets, then the new tube in another socket until you have tried all four sockets. In one socket at least you should notice a marked improvement, and

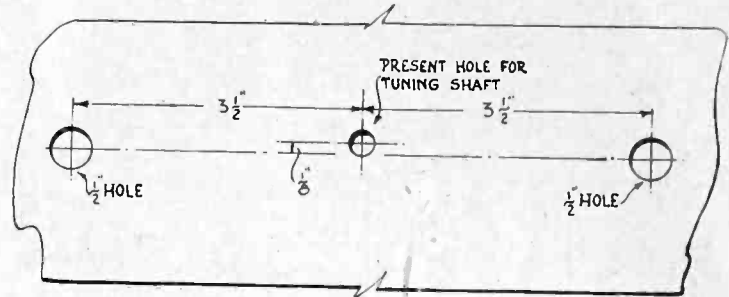

FIG. 3  
DETAIL FOR LOCATING THE VOLUME CONTROL HOLE AT LEFT AND THE AC SWITCH HOLE AT RIGHT FOR THE MB-29 TUNER.

the tube removed therefrom may be taken for granted to be defective.

### COILS MUST BE SHIELDED

The MB-29 is taken as an example because of its extreme sensitivity. However, there are other sensitive receivers, few of them of the commercial type, but nearly all of them specially engineered for discriminating users.

In dealing with any sensitive tuner it is imperative to select one that is carefully shielded, as to the coils, although the condensers and tubes do not have to be shielded. In the case of the tubes, however, if the amplification of the screen grid tube in particular is pressed too far, even at radio frequencies, microphonic effects will result, and it will be necessary to put some sort of mechanical damper on the tube itself, such as a howl arrester or a spring bracket that catches the bulge of the tube envelope and which bracket should be fastened to the sub-panel.

The fact of microphonism in audio amplifiers, where tubes of delicate geometrical structure, such as screen grid, are used at too high amplification, is well known. But that this condition may arise likewise at radio frequencies is now stated in print for what is believed to be the first time.

The detector tube itself may become microphonic in any receiver if pressed too far, in fact, microphonism has been associated with the detector tube and the output tube of an audio amplifier for years. A mechanical damper is usually a foregone solution.

Trouble from microphonism need not be expected with the MB-29, because of the circuiting of the detector tube to be able to stand a heavy signal voltage load without the tube's elements being subjected to mechanical jarring.

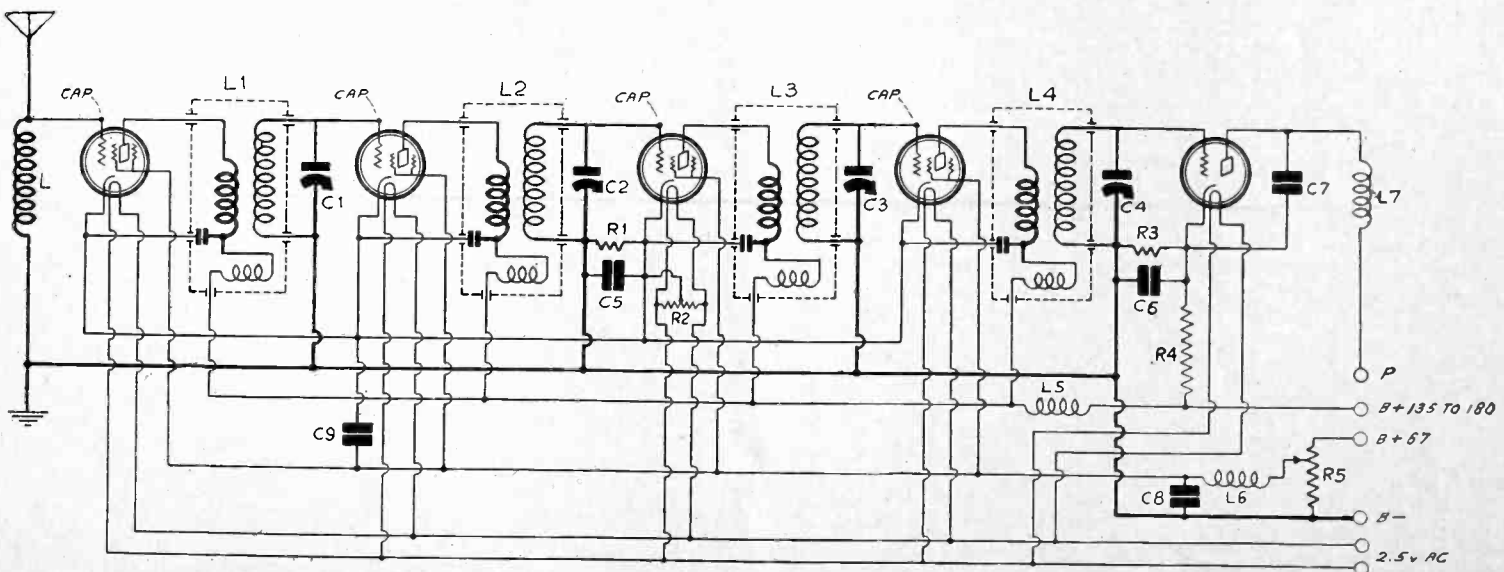

FIG. 4  
CIRCUIT DIAGRAM OF THE MB-29. P, EXTREME RIGHT, REPRESENTS A LEAD CARRIED FROM THE LEFT-HAND POST OF THE MB-29, OR DETECTOR OUTPUT, TO THE P POST OF THE PRIMARY OF THE FIRST AUDIO TRANSFORMER IN THE AMPLIFIER. THE B POST OF THE PRIMARY OF THE AUDIO TRANSFORMER SHOULD BE CONNECTED TO PLUS 135 VOLTS.

# Three Cardinal V

## Significance of Selectivity,

By James

Contributing

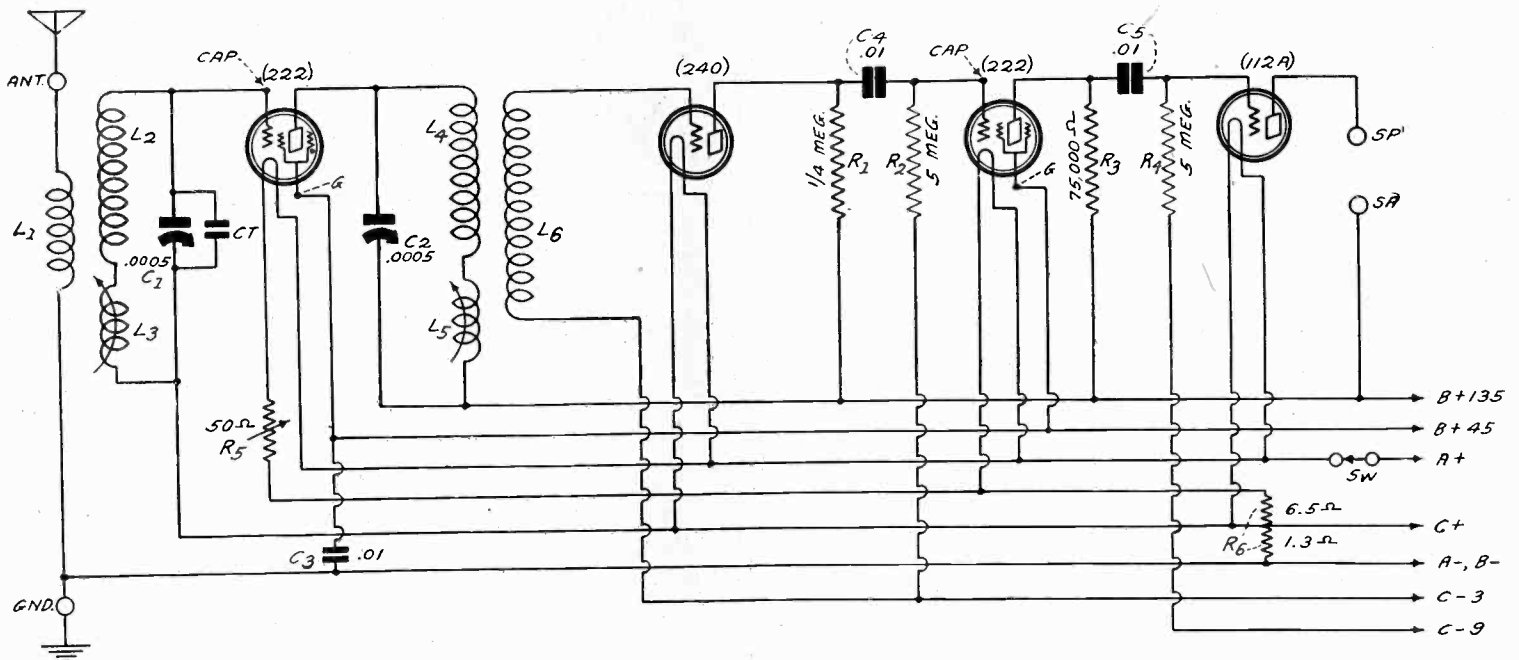

FIG. 1.

SENSITIVITY AND SELECTIVITY HAVE BEEN GIVEN APPROXIMATELY EQUAL CONSIDERATION IN THE DESIGN OF THIS CIRCUIT. THERE IS A MINIMUM OF SIDEBAND CUTTING, YET THE RECEIVER IS CAPABLE OF PICKING UP MODERATELY DISTANT STATIONS. THE QUALITY IS RETAINED BY USING RESISTANCE AND PUSH-PULL COUPLING IN THE AUDIO AMPLIFIER.

COMMERCIAL receivers vary greatly in the properties of sensitivity, selectivity, and fidelity, the three cardinal virtues of any receiver. All receivers, however, without exception are rated perfect on all three counts by the manufacturers. This does not mean, though, that the manufacturers are dishonest and deliberately place their own receivers on the pinnacle of perfection knowing that their claims are not true. Much depends on the point of view, or on the method of rating.

It is a simple matter for any manufacturer of radio receivers to devise a system of rating a receiver in such a manner that this receiver receives the highest possible percentage, or so that it rates higher than any other. This, however, as was stated above, does not signify any deliberate dishonesty. It simply means that the manufacturer has set a standard and then proceeded to design to fit that standard. Another receiver, possibly equally good, or even better, may on the same standard rate much lower because the designers of that receiver placed greater emphasis on other factors thought by them to be more important than the factors given first consideration by the designers of the first receiver.

### DEFINITION OF SENSITIVITY

The first consideration of a receiver is sensitivity. That is, it must be able to respond to extremely weak radio signals and amplify them so that a given output of sound results. Sensitivity can be defined in at least two ways but since both mean the same thing in effect we shall content ourselves with one of them. Suppose we fix a definite sound output level, say one watt delivered to the loudspeaker. What must the signal intensity be at the antenna binding posts to insure this output? If the answer to this question be given in microvolts per meter, that answer gives a numerical measure of the sensitivity. The smaller the number the greater the sensitivity. Thus one receiver may have a sensitivity of one microvolt per meter, another a sensitivity of 10 microvolts per meter, and still another a sensitivity of 100 microvolts per meter. The first of these three would be a very sensitive set and would be capable of getting many distant stations. The third receiver would be relatively insensitive and would only be able to receive some of the stronger local stations.

But sensitivity is not a constant quantity throughout the tuning range of the receiver. Usually it is greater at the upper frequency end of the range than at the lower. In the rating of a receiver this variation must be taken into account. Some

manufacturers may take the higher value of sensitivity while others may take the mean. Naturally if the higher value is taken the receiver will rate higher than if the average is used.

### THE BEST RECEIVER

Now the best receiver from the point of view of sensitivity is one which has a nearly constant value of sensitivity throughout the scale. This point is not covered in the rating either when the highest measured sensitivity is taken alone or when the average is taken. Receivers can be designed so that the sensitivity is substantially the same throughout the tuning range, but to achieve this end very careful and intelligent engineering work must go into the tuner.

Closely associated with sensitivity is the property of selectivity. Without sufficient selectivity an otherwise excellent receiver would be next to useless for it could not receive any station uniquely. It would receive many at the same time. On the other hand, with excessive selectivity an otherwise excellent receiver would be inferior because it would not be capable of good quality. The designer of the receiver must strike a happy medium in his choice of selectivity, and in doing so he must use good judgment. But what factors must be taken into account in making the choice? He may give too much consideration to selectivity and so sacrifice quality, or again, he may give quality too much consideration and so sacrifice necessary selectivity.

When this designer has set his standard—made his choice—he can easily design the receiver to meet it. But will this choice meet with the approval of other engineers equally well versed in the subject, and will it meet with the approval of the ultimate user? No matter what his choice may be it is certain that many will find fault with his particular compromise between selectivity and quality.

### SELECTIVITY VERSUS FREQUENCY

When the designer sets his standard of selectivity he must take into account the sensitivity of his receiver, which he had chosen previously, for the greater the sensitivity the higher the selectivity must be. The reason is obvious. The sensitive receiver may be required to receive a station 3,000 miles away while a local station, separated by only 10 kc., may be operated within a few miles. The untuned signal from the local station may be stronger than the tuned signals from the distant, unless the selectivity of the receiver is extremely high.



# virtues of a Receiver

## Sensitivity, and Fidelity

H. Carroll

Editor.

We found that the sensitivity of a receiver varied somewhat with frequency, unless it was carefully engineered to avoid this variation. Likewise the selectivity of a receiver varies with the frequency, and this variation is even greater, relatively. Moreover, it is well nigh impossible in a practical way to avoid this variation. The selectivity depends on the frequency ratio between the desired carrier and the closest interfering carrier and on the resistance in the tuned circuits. The more the frequency ratio differs from unity the more easily are the two stations separated. At the lower end of the broadcast band the frequency ratio may be 550/560, or .982, and at the other end it may be 1,490/1,500, or .993. Thus if the resistances in the two cases were the same, the receiver would be less selective at the upper frequency limit because the frequency ratio is closer to unity. But the resistances in the tuned circuits do not remain the same; they increase as the frequency increases. This effect operates in the same direction, that is, so as to make the receiver less selective at the upper frequency of the broadcast band.

Which selectivity is to be taken as that of the receiver, the one at 1,500 kc or the one at 550 kc? One manufacturer might take that at 550 and thus get a high rating for the receiver, and another might take the average and thus get a lower rating. The standard method is to show curves at both frequency extremes as well as one in the middle of the band in order to show completely the performance of the receiver in respect to selectivity. But such curves do not give a receiver a high rating number on an arbitrary scale, possibly chosen so as to show a particular receiver in a favorable light. But they do tell the complete story.

### POINTS OF QUALITY

We have already alluded to the fact that the quality of a receiver is intimately connected with the selectivity, but this is not the only thing that affects the quality. Indeed, there are so many things that influence the quality that it is practically impossible to mention all, much less discuss them at length.

There are two types of distortion. The first is variation in the output with frequency and the second is alteration of the wave form. If these two wave form distortion is the easier to discover by ear and the more difficult to measure with instruments. Yet with reasonable use of tubes and voltages, wave form distortion is negligible in comparison with frequency distortion or the variation of the output with frequency.

Frequency distortion first enters the signal in the tuner, assuming that no such distortion enters at the transmitting station. The selectivity of the tuner cuts out the higher audio notes. Then more of it enters in the detector and in the coupling devices between the audio tubes. The loudspeaker is usually a prolific source of this type of distortion. Another source, which is usually not fully recognized, is feedback through the B supply, whether that be a battery or a rectifier-filter combination.

It is customary to measure the total frequency distortion by comparing the signal impressed on the detector grid and the signal delivered to the loudspeaker. This measurement excludes the effect of the tuner because what is impressed on the detector grid is an audio signal. It also excludes some of the effect of the loudspeaker and its surroundings. However, if the measurement is made under dynamic conditions some of these effects are automatically taken into account.

When such a measurement on an audio amplifier and detector is made a certain result is obtained at 30 cycles per second, another result at 300 cycles, and still another at 3,000 cycles per second. In general there are probably not more than two frequencies at which the same result will be obtained. In the perfect amplifier the same result should be obtained at every frequency within the entire audio scale, which might be taken arbitrarily to be 30 to 10,000 cycles.

### FREQUENCY DISTORTION

In most practical receivers it will be found that the greatest response will be at about 500 cycles per second and that it will be less the farther the frequency of measurement is from this value. If the response falls off just a little between the limits 30 to 8,000 cycles per second it may be said that the amplifier is capable of very good quality. If the response falls off rapidly and to very low values at these arbitrary limits, the quality is poor. Only a few amplifiers can be rated good on this rigid

test. But if we place the limits at 60 and 5,000 cycles many receivers will rate highly.

What will be the difference in practical results between an amplifier which cuts off sharply at 5,000 cycles and another which holds up well to 8,000 cycles and above? In first there will be very little noise of the crackling, sparking variety. Many place a great deal of emphasis on this absence, rating the amplifier highly. But this amplifier will also be sadly lacking in clarity of speech and brilliancy of music. Speakers will mumble their words and understanding will largely be based on intelligent guesses as to what he or she is talking about. Many people don't rate this so highly; they prefer to understand without guessing. The second amplifier, having a cut-off at 8,000 cycles or above will do much better on speech but will bring a little more noise. But the difference in the amount of noise is not so great as to justify the sacrifice of clear speech and brilliant music. After all, the object of the radio receiver is to bring in signals, not to exclude incidentals. That is the writer's point of view, it is admitted, and it is not concurred in by all. Possibly the object of the receiver is to exclude the undesired. Certainly that is the object of the tuner.

### IMPORTANCE OF LOW NOTES

The amplifier which goes down to 30 cycles will predominate in the bass as compared with that which cuts off at 60 cycles. Some like the bass above all things. They think it a point of excellence in a receiver when the low notes are powerful enough to rattle the dishes in the cupboard and the bric-a-brac in the parlor. They think so much of the noises that these things make when they are shaken by the low notes from the speaker that they don't mind guessing at what speakers say on the radio. But then there are others who would rather have the primary noises over the radio set than the secondary. Perhaps they are those who are too lazy to enter a guessing contest every time the loudspeaker actually speaks. Or possibly they are those who abhor the voices of the announcer, of women, of political orators, and of all others who have a message.

Where is the line to be drawn between clearness of speech and absence of extraneous noises, between rattling of dishes and realistic low note reproduction? It is a matter of compromise. One engineer makes one compromise, for reasons best known to himself and the production department. Another engineer makes a different compromise. Each one can easily devise a rule for rating his receiver so that it rates 100 per cent, or so that it rates several points higher than his severest competitor.

The advertising copy writer is an expert in his line, which includes a thorough understanding of the psychology of the ultimate consumer, and he is able to convince almost any prospect that whatever the quality of the product he is momentarily interested in is superior to any other. And he may treat two different receivers the same day with equal skill. That is what makes some purchaser hesitate and ask somebody he knows who is supposed to have a knowledge of the real facts which receiver is really the better. And his answer in self defense is usually, stop, look and listen in any radio store. The one that the prospective purchaser likes the best out of all the receivers in the store is the best in that group. If the customer is really satisfied that he has got his money's worth, what does it matter whether the sound is down one or two decibels at 60 cycles, or if it is down the same amount at 30 cycles compared with the output at some other frequency. If the response of the receiver is really bad he knows enough not to be satisfied.

### WAVE FORM DISTORTION

The wave form distortion is the most serious form of distortion, but this is usually within the operator's control. If his receiver is not capable of great output all he has to do is to keep it within the limit. There is a sensitivity control incorporated in every set just for this purpose. No matter how faithful an amplifier is in respect to frequency distortion the output can be made horrible by turning up the sensitivity control too far.

It might be added that the demand for 10 kc selectivity is not consistent with the demand for faithful response. When fidelity is the paramount consideration sensitivity and selectivity should be sacrificed and the set should be tuned in on local stations whenever possible. From every point of view the reception from a local station will be superior to that from distant stations. There will be less interference picked up, less sideband cutting and hence greater realism.

# Variable Voltage Divider

## Accurate Settings Obtained

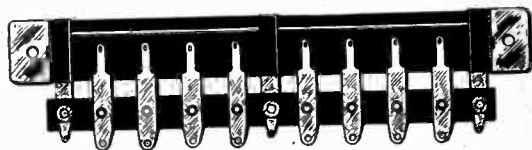

**T**HE desirability of having a voltage divider with movable taps so that any voltage may be obtained for any current distribution has always been recognized by circuit designers and resistance manufacturers, but there have been very few satisfactory units. The problem has always been to get taps which could be moved to any position on the voltage divider and so constructed that a large portion of the resistance would not be short-circuited by each tap. Various schemes have been tried and abandoned because of unsuitability of manufacture or because of unsatisfactory operation. Many have been abandoned because they are too clumsy.

However, there is one which has recently been devised which seems to meet all requirements and yet is very compact and convenient to use. The resistance wire, 10,000 ohms in all, is wound on a refractory tube, covered with enamel and baked. But before the baking process part of the enamel is wiped off so as to expose the bare wire without in any way short-circuiting any turns. After baking a strip across the turns of wire the length of the total resistor is clean and subject to pressure connection without any conductor desired.

The connectors are mounted on a bakelite strip running parallel with the coil and to it rigidly at the center and at both ends. The center support not only strengthens the bakelite strip, but it provides a fixed center tap. Between each end and the center tap are four movable contactors attached to the bakelite with eyelets in such manner that they can be turned through a considerable angle. When the contactors are set at right angles to the bakelite strip they divide the resistance into 10 approximately equal sections, that is, so that between any two adjacent contactors or between a contactor and the center tap, or between a contactor and the ends there is a resistance of 1,000 ohms.

### SWIVEL CONTACTORS

The contactors can swing so that any two adjacent ones can touch, either by turning one alone or by turning the two toward each other. This includes the two ends and the fixed center tap as well as the movable contactors. That is to say, the contactors nearest the ends can be turned to touch the ends of the resistance strip and the two near the center can be moved to touch the center. This insures maximum flexibility in adjusting the voltages.

The contactors are made so that any one will not touch more than two adjacent turns at one time, so that at most each contactor can short-circuit on one turn of wire. Moreover, they are constructed so that they slide over the wire easily without any cutting, yet with sufficient pressure to insure a positive, low resistance contact.

The opposite ends of the contactors are provided with soldering lugs, tinned to make soldered connections easy. The two ends of the wire and the center tap are accessible for connections through small machine screw binding posts.

The advantage of such construction of the voltage divider is readily appreciated by those who use circuits which require accurate voltage adjustments for a great variety of circuits. The sliding taps are especially advantageous for adjusting grid bias. For example, suppose that the circuit requires three different bias values, each to be adjusted accurately to a different value. The common cathode return is then made to the third contact from one end and set so that the highest required bias is correct when the grid return for the corresponding tube, or tubes, is made to the nearest end. There are then two sliding contactors between the end and the cathode connection and they can be set in different positions to provide the other two bias voltages required.

### VARIATION OF PLATE VOLTAGE

The plate voltage can likewise be adjusted by connecting the plate returns to the remaining contactors. All the plate voltages are measured from that contactor which is used for the cathode return. If two of the contactors are used for grid bias and one for the cathode, there remain five contactors, the center tap and the end for different plate voltages. These should be sufficient to accommodate almost any type of circuit.

It is true that 10,000 ohms may not be sufficient for some circuits, but in case a somewhat higher resistance is desired it is possible to connect a fixed resistor in series with the unit to make up the required total. This is usually done any-

way, especially when the total voltage available is of the order of 450 volts.

The question of determining just how to secure the proper voltages is sometimes not easy to solve. When a voltage divider of fixed taps is used it is only necessary to specify the total current that should flow and to give the number of the tap for a given grid return or plate return. But when the taps are adjustable this cannot be done. It is actually necessary to measure the voltages between any two taps, and, of course, there is no other way of getting an accurate adjustment.

The simplest way of adjusting the voltages is to connect a high resistance voltmeter across two taps, such as between the cathode return and one of the plate or grid voltage taps, and adjust the position of the slider until the meter reads the desired voltage. In order to be sure that the voltage thus obtained will be correct when the meter is removed, the voltmeter should have a resistance of 1,000 ohms per volt. A much better meter is a vacuum tube voltmeter, one which does not draw any current at all. Any voltage indicated by such a meter is the actual voltage existing across the taps both when the meter is connected and when it is not, since it takes no current that may alter the voltage and current distribution.

The suggestion to use a vacuum tube voltmeter is often appalling to radio fans, who are wont to believe that such a meter is too complex for them to build and to use. The fact about such a meter is that it is just as easy to build and to use as a one tube set, and with all the equipment necessary it costs less than a good 1,000 ohm per volt voltmeter—much less. Anybody who does a great deal of circuit testing and experimenting should rig up one of these meters. It pays because with it voltages can be measured that cannot be measured with any other kind of voltmeter regardless of its cost.

### CALIBRATION

Those having a 0-1 milliammeter can readily improvise a 1,000 ohm per volt voltmeter with which accurate measurements can be made. Suppose that it is necessary to measure grid voltages of the order of 84 volts. The range of the meter can be made 0-100 volts, which can be used not only to measure grid voltages, but also some of the plate and screen grid voltages. If a fixed resistance of 100,000 ohms is connected in series with the 0-1 milliammeter and then connected across the voltage taps the voltage will be 100 volts when the meter reads full scale. Other readings are in proportion to the deflection. That is to say, when the reading on the meter is 5 milliamperes the voltage across the terminals is 5 volts.

Now it will be quite difficult to get a resistance of exactly 100,000 ohms, for such resistances of sufficient accuracy are not obtainable in radio stores and can only be had at all at high cost. But it is not necessary to use accurate resistors provided the one used is calibrated. Select one rated at 100,000 ohms and connect it in series with the milliammeter. Then connect various voltages of known value, such as 22.5, 45, 67.5, and so on, using for the purpose a fresh B battery. Note the deflection on the milliammeter for each known voltage and plot a curve, voltage against deflection. The curve will be very nearly straight since the deflection is proportional to the voltage. The only deviation from true linearity will be because the resistance used does not remain constant but varies with the current in it.

Once the calibration curve of the resistance has been obtained any voltage within the range of the meter can be obtained just as accurately as if the meter had not been improvised. It is only necessary to connect the meter with the resistance in series across an unknown voltage and note the deflection. The curve gives the value of the unknown voltage whatever the deflection may be within the calibration range.

If it is necessary to measure higher voltages than 100 volts it is only necessary to use a resistance of higher value. For example, if it is necessary to measure up to 450 volts the resistance to be used should be 500,000 ohms. This, too, should be calibrated in the same way.

### USE AS VARIABLE RESISTANCE

One convenient and useful application of the voltage divider strip with the many contactors is as a variable resistance. By selecting suitable taps and by sliding one or both it is possible to get any resistance value between zero and 10,000 ohms.

Care should be exercised when it is used for this purpose in high voltage circuits, however, because the terminals are exposed and they have to be moved by hand. If one hand should touch one end of the resistor and the other a point of high potential, relatively, an unpleasant sensation might be experienced. Moreover, in some instances the resistance might be hot enough to burn the hand.

# Push-Pull Speakers

Magnet Winding Center-Tapped for Symmetrical Circuits

By Capt. Peter V. O'Rourke

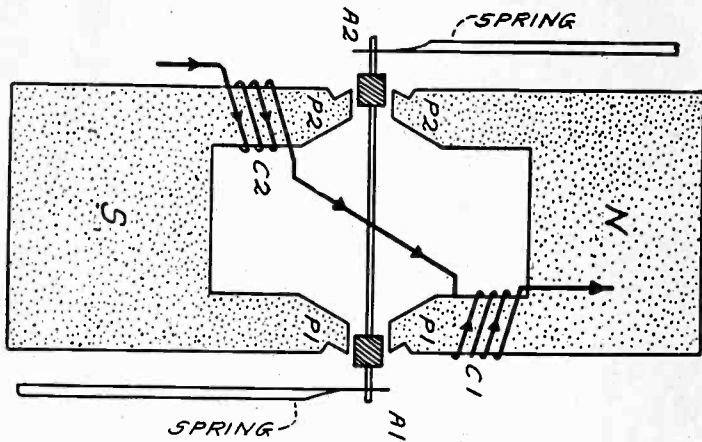

FIG. 1

A SKETCH SHOWING THE PRINCIPLE OF THE INDUCTOR DYNAMIC SPEAKER. THIS SPEAKER CAN BE CONNECTED DIRECTLY IN THE OUTPUT OF A PUSH-PULL AMPLIFIER BY CONNECTING THE EXTREME TERMINALS TO THE PLATES AND THE LEAD CONNECTING THE TWO COILS TO THE B SUPPLY.

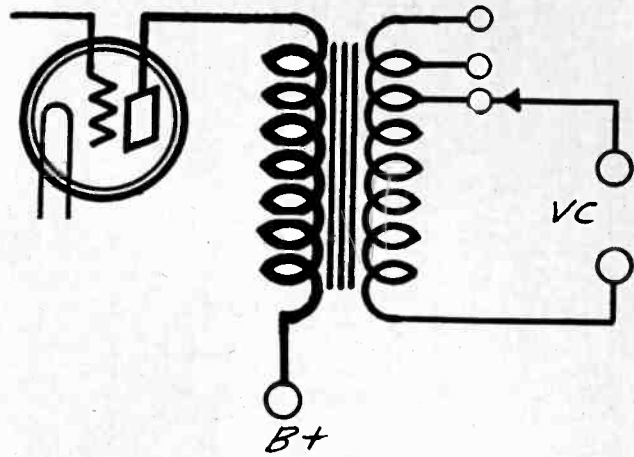

FIG. 2

A VARIABLE RATIO TRANSFORMER CAN BE CONNECTED BETWEEN THE POWER TUBE OF AN AMPLIFIER AND VOICE COIL OF A DYNAMIC SPEAKER WITH GOOD RESULTS PROVIDED THE RATIO OF TURNS IS CHANGED EXPERIMENTALLY UNTIL THE BEST POSSIBLE COMBINATION IS SECURED.

ONE of the advantages of the inductor dynamic loudspeaker is that it can be connected in push-pull without much trouble and thus make use of the superior quality which such amplification affords. There are two spools in the inductor, both of the same value, and connected by a lead which is readily accessible. To connect the speaker in push-pull it is only necessary to connect one of the extreme terminals to the plate of one tube and the other terminal to the plate of the other tube. Then a lead is connected to the junction between the two coils and run to the plate battery or the B supply unit. The speaker is then connected in the plate circuits of both tubes and coupled equally to both, and that without the use of the customary push-pull output transformer. Any distortion which the output transformer might introduce is thus eliminated from the receiver. The matching of the tubes to the speaker is good for most tubes because the impedance of each coil is such as to make the coupling efficient.

The principle of the inductor dynamic speaker is illustrated in the accompanying sketch, Fig. 1. The two equal coils are marked C1 and C2 and the lead joining them is run diagonally across the armature, in the picture, of course. It is this lead that should be tapped for making the B plus connection when the speaker is used directly in a push-pull circuit without the interposition of a transformer.

Some speakers of this type are provided with a lead for this purpose so that they can be used either in push-pull or in the ordinary fashion at will. When connecting such a speaker in push-pull without the use of a coupling transformer care should be taken that the plate current is not excessive. That means, of course, that the speaker should not be used directly in the plate circuit of a large power tube, such as the 250, unless it has been wound especially for such a large tube.

## COUPLING DYNAMIC SPEAKERS

Sometimes a considerable improvement in quality from dynamic speakers can be secured by the use of a special coupling transformer in which the ratio of turns can be varied. All speakers do not have the same impedance, neither do all tubes to which they may be connected have the same impedance. To match any speaker to any tube the ratio of turns of the special coupling transformer should be varied until best results are obtained. The transformer really matches the effective resistances of the tube and the speaker so as to get the maximum undistorted output from the tube into the speaker, or to get the maximum transfer of energy. As is well known, to get the maximum transfer of energy the impedance of the speaker should be equal to the impedance of the tube, and to get maximum undistorted output the impedance of the speaker should be twice that of the tube.

When the coupling transformer is regarded as part of the loudspeaker, the primary impedance of the transformer becomes the equivalent impedance of the speaker. By varying the ratio of turns the impedance of the primary, when the speaker is connected to the secondary and when it is working normally, can be made to equal the impedance of the tube or to be equal to twice this impedance.

## TAPPED OUTPUT DEVICE

There is a transformer of excellent design available which contains a number of taps in the primary. To vary the turns ratio of this transformer in practice it is only necessary to connect the voice coil of the dynamic speaker across different taps. Fig. 2 shows an output tube in which one of these variable ratio transformers is illustrated. The voice coil of the dynamic speaker is to be connected to the terminals marked VC. This does not mean that the two terminals of the dynamic speaker are to be connected here, because in most dynamics these leads run to a transformer of fixed ratio. This transformer should be disconnected and the variable ratio transformer substituted. Market improvement both in quality and volume have been secured by making this substitution. Of course, it is understood that the transformer substituted is equal to or better than the regular transformer in respect to quality capability.

## Dial Calibration by

## Wave or Frequency

To calibrate a tuning dial in kilocycles of meters some means must be taken to hold the input capacity or the capacity of the antenna circuit to a standard. In some instances this may be done by equalizing condensers, but after a dummy tube is used to make the succeeding tuned circuit independent of antenna capacity.

The recent development of pre-selector, band pass and band-filter units has simplified the use of a standard antenna capacity so there will be little or no variation when used on the antenna at home.

Whether the dial be calibrated in kilocycles or meters is a matter of taste, although the kilocycle readings usually are the more accurate. With a receiver having kilocycle readings, you can actually judge its selectivity characteristics. That is you can tell whether the receiver is capable of tuning in stations ten kilocycles apart. Calibration must be made for a particular receiver, or for identical patterns of this receiver.

# Sources of Receiver Power

## How Battery and AC Type Tubes

By J. E. Anderson and

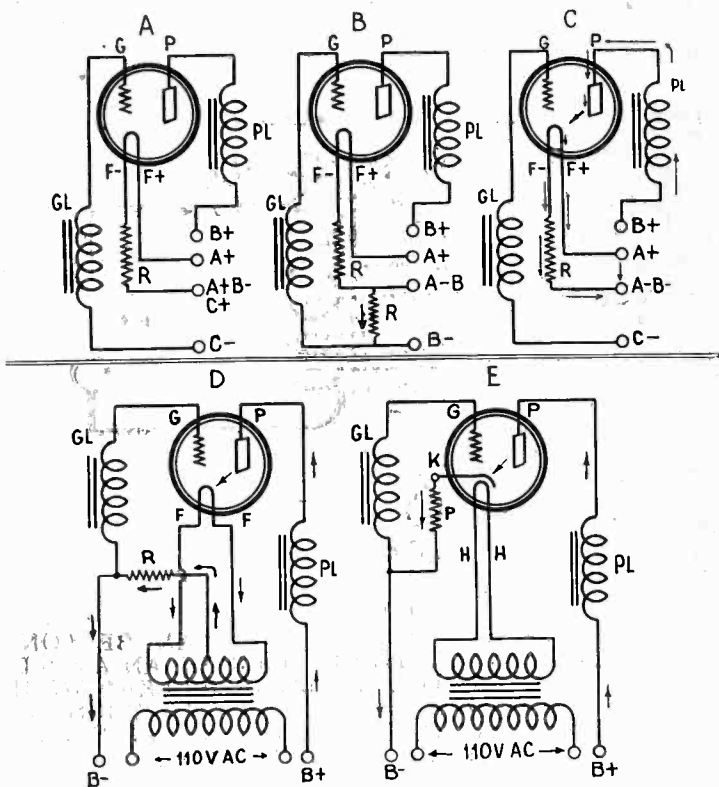

FIG. 26

- (A)—BATTERY HEATED FILAMENT TUBE, NEGATIVELY BIASED BY AC BATTERY.  
 (B)—A RESISTOR USED FOR BIASED.  
 (C)—DIRECTION OF PLATE CURRENT FLOW.  
 (D)—AN AC TUBE, DIRECTLY HEATED FILAMENT.  
 (E)—AN AC TUBE, INDIRECTLY HEATED CATHODE (K).

[The following article is one of a series entitled, "Radio for Schoolboys." Another instalment will be published next week, issue of November 30th.—Editor.]

**I**N THE operation of a receiver three sources of power are used: (1) the signal wave, introduced into the first tube; (2) the filament power and (3) the plate power.

The signal wave is power of alternating current and alternating voltages.

The filament power is either direct or alternating. If direct, the battery type tubes are used, such as 201A, 222, 199, 240, 112A, 171A. If alternating, special tubes for AC operation are used. These are of two types: the directly heated filament type and the indirectly heated cathode type. The directly heated AC type of tube is the 226, and in the case of the output stage of an audio amplifier, the 112A or 171A may be heated directly from 5 volts of AC. The indirectly heated type tube is represented by the 227, 224 and 228. An independent element heats up the heater, which communicates its heat by thermal radiation to the electron emitter, called the cathode.

The plate power is derived from B batteries or from a B

## Questions

(See answers on page 13)

- (1)—By virtue of what phenomenon does a crystal act as detector?
- (2)—In operating a regenerative receiver, should it be made to oscillate when you are tuning in or listening in?
- (3)—What are the source and effect of regeneration?
- (4)—Describe the action of capacity neutralization.
- (5)—State the six types of fundamental receiver circuits and describe their distinguishing characteristics.
- (6)—Is tuned radio frequency amplification advisable ahead of the modulator of a superheterodyne? If so, why?
- (7)—Is the oscillator selective in a superheterodyne?
- (8)—What type of receiver uses a supermediate frequency?
- (9)—May a weak interfering signal produce a strong effect in a superheterodyne? If so, why?
- (10)—Does a superheterodyne generate its own carrier? If so, why?

supply. The B supply is operated from the house lighting current, and may be of the DC type or AC type. If DC, then the output voltage is limited, always being less than the line voltage. There is no limit to the output voltage of an AC type B supply, except as imposed by the power transformer and other circuit constants.

The only other source of voltage is for grid biasing, but where C batteries are used, no current is drawn from the C batteries, so voltage alone is considered. To constitute power there must be voltage and current. In bias obtained from voltage drops in resistors, as in B supplies of the "electric" type, current flows through the resistor, but not in the grid load circuit itself.

### LOWER DETECTOR FILAMENT VOLTAGE

In Fig. 26A is shown the fundamental circuit of a battery-heated filament type tube. The grid load is GL and the plate load is PL. G, P, F minus and F plus represent the three elements of the tube and correspond to four posts on the socket. The filament, with its two socket posts, constitutes only one element. R is a resistor used to reduce the voltage of the battery to the required voltage for the filament. For a 201A tube used as here as an audio amplifier, with a 6-volt storage battery source of power, and a required filament voltage of 5 volts, R would be 4 ohms, because at 5 volts on the filament .25 ampere (a quarter of an ampere) flows, the resistance being equal to the voltage divided by the current. The voltage drop desired being 1 volt and the current .25 ampere, the quotient is 4. (1 divided by one-quarter.)

Where a tube is used as detector somewhat improved results often are obtained at a slightly lower than the rated filament voltage.

Negative grid bias is applied to the tube by connecting the positive of a C battery to negative of the A battery, and returning the grid of the tube, through the coil GL, to a negative post of the C battery. The actual bias is the battery voltage plus the voltage drop in R, because the negative filament is the reference point in computations. Hence minus A is 1 volt negative in respect to the negative filament. If the C battery voltage is 3 volts the effective negative bias is 4 volts.

If different biases are to be applied to different battery type tubes, the grid returns must be made to separate voltages.

If a resistor is interposed between negative A and negative B, as in Fig. 26B, the current flow will produce a voltage drop, and this drop may be used for biasing, so that negative bias results. But since negative A is common to all the battery-heated type tubes in a circuit, this method of eliminating the C battery is practical only when the same bias is to be applied to all tubes, which does not arise in practice.

### DIRECTION OF CURRENT FLOW

There is no direct current flowing in the grid circuit when the bias is negative. When it is positive grid current will flow, and this reduces selectivity in a radio frequency amplifier, and introduces some distortion in any circuit, amplifier or detector.

The direction of the flow of plate current, by the accepted method of considering direction of flow of electricity is revealed in Fig. 26C. This is an arbitrary method, and is not even correct, as the assumption of direction of current flow was made long before the electron theory became firmly established, hence before experimental proof of the direction of flow. Nevertheless, the whole technique of electricity was developed along the lines of this misconception of direction of current flow, and while the mistake is accepted even yet as the orthodox method of analysis, it is understood that an erroneous assumption is being followed. All meters are made on the basis of this assumption, and there is no resultant harm in continuing the acceptance of the error, so long as the facts themselves are understood.

The current flows from positive to negative under this theory, although subsequent research proved to the satisfaction of learned minds that the real direction was from negative to positive. So when we look at Fig. 26C we see the arrow leading from B plus, going up through the plate coil to the plate of the tube, past the grid to the filament and dividing to go down the two legs of the filament, uniting through the A battery to return to the starting point, common B minus and A minus.

Inside the battery, therefore, to get from minus B to plus B, the current must be assumed to be travelling from negative to positive. The direction is the same, but the point of view is different. Just as the direction of travel of the hands of a clock is always the same—clockwise—whereas at the upper semi-condensers and Ch1 and Ch2 are the chokes. The constants of the circuit are so chosen as to produce 300 volts between

# Power Told for Schoolboys

## Are Circuited—B Supply Analyzed

by Herman Bernard

circle the hands travel from left to right and at the lower semi-circle from right to left.

### DIRECTLY HEATED AC TUBES

Fig. 26D shows a directly heated AC tube. A power transformer, in this instance supplying only filament voltage and current and hence called a filament transformer, receive the 110 volt AC line voltage at the primary and steps it down to the required voltage for the filament of the tube. If a 226 tube is used, the filament voltage is 1.5 volts.

Here the plate current courses as in the case of the battery-heated type tube, but when it reaches the filament it goes down the two legs to the center-tap, and from the center tap to the grid return. The purpose of using a center tap is to establish a point of steady average voltage to reduce hum. Either the transformer secondary may be center-tapped or a center-tapped resistor may be placed across the secondary and the return made to the resistor's center.

In either instance it is usual to provide the negative bias by utilizing the voltage drop in a resistor. The plate current, to return to the B voltage source, has to be united with the electron-emitting circuit, here called the filament, so if a resistor is interposed between the filament's electrical center and B minus, a grid return made to B minus would constitute a negative bias equal to the voltage drop in the resistor.

Fig. 26 E shows the same type or circuit, only a heater type tube is used. The heater circuit is electrically independent of the elements of the tube and therefore the tube is still of the three-element variety. The heater communicates heat to the electron emitter. This method enables the use of this type tube as a detector without hum, whereas directly heated types of AC tubes can not be used as detectors without intolerable hum. The heater type tube, however, is not restricted to detector use, but is becoming more and more popular as an amplifier, too, for instance the 224 screen grid AC tube.

The bias for a heater type tube is obtained by using a resistor between cathode and B minus and connecting grid return to B minus.

### B SUPPLY ANALYZED

In any such instance of return to negative of the B supply, the question arises as to what to call this return. Should it be called C minus or B minus? If the return effects a C bias it should be called C minus for the particular tube or tubes thus biased, but if it effectuates no bias it should be called B minus. In either event it is correct to refer to it as negative of the B supply, which, while it means in a strict sense the same as B minus, nevertheless permits the use of two terms for distinction between a return made for bias purposes or without biasing.

The circuit arrangement of a B supply is shown in Fig. 27. The tube is represented by two plates and a filament. This is a rectifier tube of the full-wave type, e.g., the 280. The filament is heated by AC and is the positive of the B supply, taken from either filament post or from center tap. The two plates are represented by the G and P posts of a socket and may be connected either way.

The primary of the power transformer is connected to the house lighting and heating circuit, while there are two secondaries: the low-voltage filament secondary and the high voltage rectifier secondary. The negative of the B supply is taken from a center tap of the high voltage secondary.

To eliminate hum a filter circuit is introduced. This consists of condensers and choke coils. FC1, FC2 and FC3 are the filter of the circuit are so chosen as to produce 300 volts between negative and positive of the B supply. Intermediate voltages are provided by taps on a resistor connected across the output. This resistor is called a voltage divider. From each intermediate B voltage to ground a bypass condenser is connected, BP1, BP2 and BP3. The capacity should not be less than 1 mfd., and where the bypassing is across a section of the resistor carrying heavy current, as for biasing a power tube, the capacity should be considerably higher, at least 4 mfd.

### ALLOWANCE FOR VOLTAGE DROPS

The difference between the filter condensers and the bypass condensers, aside from capacity, is simply one of rating. The filter condensers must stand a heavy voltage, including surge voltages that rise to considerably beyond the steady value. The bypass condensers are of the low voltage type, e.g., 200 volts DC working voltage. For a supply of the type diagrammed, the filter condensers should have a rating of at least 500 volts AC working voltage. The AC working voltage rating is always

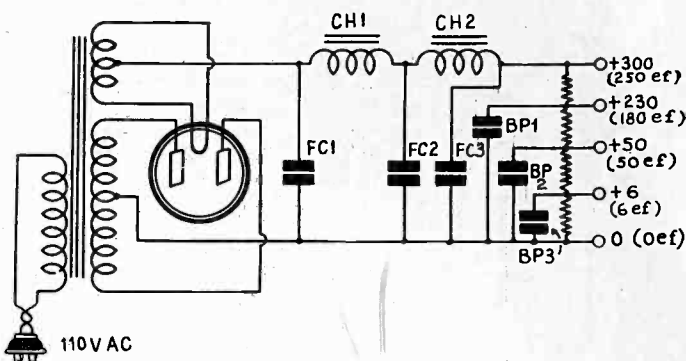

FIG. 27

CIRCUIT OF A B SUPPLY, OPERATED FROM 110 VOLTS AC.

lower than the DC working voltage rating of any condenser.

While 300 volts direct current appear across the extreme terminals, a greater voltage than this must be present in each half of the high voltage secondary, because the rectifier tube not only has resistance but its resistance changes according to the amount of current drawn, and also the choke coils have considerable direct current resistance. Therefore, in designing a power transformer for general use, an assumption must be made that a certain average amount of current will be drawn, which allows automatically for the resistance of the rectifier tube and takes into consideration likewise an average value of resistance of the choke coils, as well as the resistance of the voltage divider and to some extent the capacity of FC1. The less the resistance of the voltage divider, and also the greater the capacity of FC1, the higher the direct output voltage will be, particularly since the current drain through the resistor alone, known as bleeder current, is less.

## Answers

(Questions on page 12)

- (1)—A crystal detects by virtue of passing current in one direction only.
- (2)—A regenerative receiver should not be operated in an oscillating condition because it then acts as a radio frequency transmitter and sends out squeals that penetrate often for miles.
- (3)—The source of regeneration is an output voltage returned to a tube's input. The effect is to reduce the radio frequency resistance of the circuit, thus improving signal strength and selectivity.
- (4)—Capacity neutralization is effective because a feedback through tube-element capacity is negated by an external capacity adjusted to produce an equal but oppositely phased voltage, thus cancelling the feedback.
- (5)—The six fundamental receiver circuits are: crystal, regenerator, neutrodyne, tuned radio frequency, screen grid and superheterodyne. The crystal receiver uses a crystal as detector. The regenerator uses regeneration, controlled by a panel knob. The Neutrodyne employs tuned radio frequency amplification with external capacities to neutralize or cancel the feedback due to inter-electrode tube capacity. Tuned radio frequency is the same as the Neutrodyne with the neutralizing capacities omitted, but some other form of stabilization used. A screen grid receiver is one using screen grid tubes for radio frequency amplification. A Superheterodyne is a receiver that changes the desired incoming frequency, by a mixer, to save lower frequency for amplification at this fixed intermediate frequency prior to detection.
- (6)—Yes, because of interference reduction.
- (7)—The oscillator is not selective. It simply generates different oscillator frequencies. Its apparent selectivity is the selectivity of the intermediate amplifier.
- (8)—A receiver using a supermediate frequency is one that has a secondary radio frequency amplification level of higher frequency than broadcast frequencies, and uses the sum of the oscillator and modulator frequencies, instead of, as in the Superheterodyne, the difference.
- (9)—Yes, because the oscillator is strong, and the mixture is therefore strong.
- (10)—Yes, for intermediate frequency amplification.

# Resistance Coupled Aud

## High Power Push-Pull Also Used, Comb

By Knollys

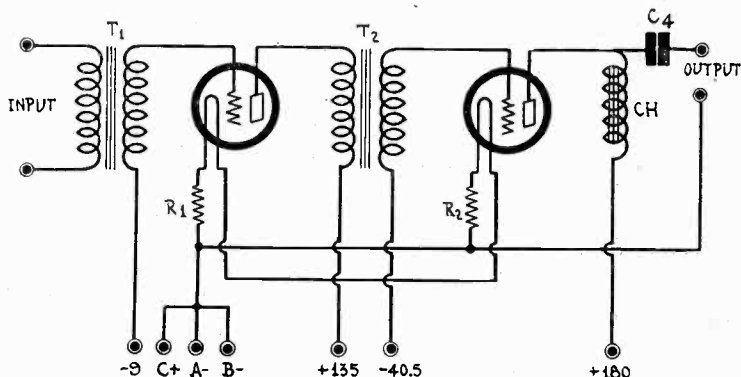

FIG. 40

TWO-STAGE, TRANSFORMER COUPLED AMPLIFIER FOR BATTERY OPERATION SUITABLE FOR USE WITH THE BATTERY OPERATED SUPERHETERODYNE DESCRIBED IN CIRCUIT OF FIG. 36, OR ANY OTHER BATTERY OPERATED RADIO FREQUENCY AMPLIFIER.

[This is an instalment of the series entitled "The Superheterodyne."—Editor.]

The normal plate current in the circuit in Fig. 40 is 28 milliamperes, and that in circuit in Fig. 41 is 38 milliamperes. These values assume that the tubes have average characteristics and that the voltages and grid bias resistors shown are used. In any particular instance the current, of course, may be either lower or higher by a few milliamperes.

The two circuits shown in Figs. 40 and 41 are the most popular where only a moderate undistorted output is required. The circuit in Fig. 40 is capable of a maximum undistorted output of 710 milliwatts and that in Fig. 41 an output of 1,600 milliwatts. Even the lower of these is more than sufficient for the average home when an efficient loudspeaker is used.

Those wishing the same undistorted output with greater economy of plate current and more uniform amplification over the audio scale can use the circuits given in Figs. 42 and 43. In either of these circuits the coupling resistors R3 and R5 should be not less than 100,000 ohms each, and values as high as 250,000 ohms can be used to good advantage. The grid leaks R4 and R5 may be two and one megohm, respectively. All these resistors should be either wire wound or metallized.

The stopping condensers C1 and C2 should preferably be .02 mfd. each, but .01 mfd. condensers will work satisfactorily. They should be of the mica dielectric type.

### OUTPUT FILTER

The output filter choke Ch should have as high inductance as practical, consistent with a low value of direct current resistance. Suggested values are 500 ohms, or less, for the resistance and 30 henries, or more, for the inductance.

The stopping condenser C3 in series with the speaker should be not less than 4 mfd., but a larger value than that is of

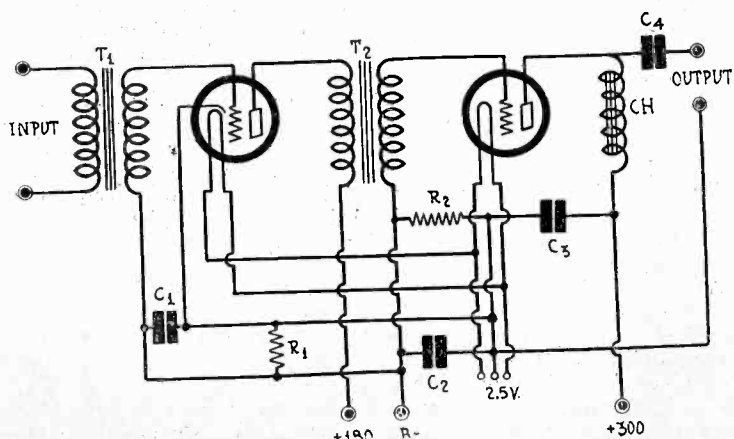

FIG. 41

A TWO-STAGE, TRANSFORMER COUPLED AMPLIFIER FOR AC OPERATION SUITABLE FOR USE WITH THE AC OPERATED SUPERHETERODYNE DESCRIBED IN FIG. 37, OR ANY OTHER AC OPERATED RADIO FREQUENCY AMPLIFIER.

doubtful advantage if the tube works into a high impedance speaker or a high impedance output transformer, such as are used in most instances. It is important that the speaker return to the filament just as is shown in the two drawings.

The potentiometer P in Fig. 43 should have a total resistance of 1,500 ohms and may be made up of a 1,000 ohm fixed resistor and a 500 ohm potentiometer, the fixed resistor being placed next to the center tap of the 2.5 volt winding.

The 500 ohm potentiometer placed next to the B minus allows for different grid bias values on the first tube in the circuit. If this tube is a 227 the bias should be 13.5 volts and the resistance between the slider and the B minus terminals should be 410 ohms. The only other tube that is suitable is the 228, which should have a bias between 3 and 4.5 volts. If the first of these is selected the resistance between B minus and the slider should be 93 ohms, and if the latter, it should be 140 ohms. Hence the 500 ohm potentiometer is adequate. The proper bias in any case can be found readily by trial. It is quite possible that the loudest signals will be obtained when the slider is set near B minus. This is not the proper setting if quality is to be the basis of adjustment. If there is any doubt include about one-fourth of the 500 ohm resistance between the slider and B minus.

### BYPASSING ESSENTIAL

In Fig. 43 are three by-pass condensers Co, C4 and C5. These are essential to good performance. The minimum values of these condensers should be 2 mfd. for Co and C5 and 4 mfd. for C4. It is particularly important that C4 be large, because if it is not the low notes will not be amplified well.

While there are no corresponding condensers in Fig. 42 it is understood that they are to be included in the B supply.

In Fig. 42 a dotted lead runs to a terminal marked F. If the same filament battery is used for both the audio amplifier and the radio frequency portion of the receiver, this lead should be omitted, since the connection is made automatically through the battery.

In Fig. 43 there is a similar dotted lead terminating at a point marked K or Grid return. The lead goes to the cathode of the detector if the grid condenser and leak method of detection is employed and to the grid return if grid bias or power detection is used.

The two circuits in Figs. 42 and 43 are very economical in plate current requirements. The currents taken by the detector, not shown, and the first audio amplifier are so small that they may be neglected in comparison with the current taken by last tube in each instance. The normal current taken by the 171A in Fig. 42 is 20 milliamperes and the total current is about 21 milliamperes. In the AC circuit the last tube, a 245, takes 32 milliamperes and the total current is about 33 milliamperes. In either case the current is so small that a B supply capable of delivering a total of 85 milliamperes can be used to supply not only the amplifier current, but also that for the radio amplifier and the voltage divider.

### REMEDIES FOR OSCILLATION

Both the circuits shown in Figs. 42 and 43 are inherently unstable on low audio frequencies when used on a B supply or high resistance B batteries due to the fact that they contain an odd number of plate circuits. However, they have been arranged so that this effect is minimized. Should oscillation occur notwithstanding this arrangement the simplest remedy is more and larger by-pass condensers across the voltage taps. It is not likely that any oscillation will occur at a frequency so low that condensers of reasonable size will not be effective. However, should the oscillation be so low in frequency that condensers are not effective, an audio frequency choke coil in series with the plate lead to the detector, or in series with R3, and a 2 mfd. condenser connected from the junction of this choke and R3 to B minus will aid materially. The circuit will not oscillate at any frequency if the B supply is properly designed.

# Power of Push

Undistorted Output May Be

# io for Superheterodynes

## ining Resistance and Transformer Units

Satterwhite

These two circuits are capable of the best quality of all practical audio amplifiers. Moreover they are not only the most economical in operation but also the least expensive to build.

In several popular commercial receivers the audio amplifier consists of one stage of resistance coupling and one stage of push-pull. Such an amplifier is not only capable of fine tone quality, but also of a high undistorted output. Indeed, the output is nearly four times as high, for the same tubes and voltages, as that for the corresponding single tube output circuit, and the quality depends on the grade of push-pull input and output transformers used.

Two such amplifiers are diagrammed in Figs. 44 and 45, the first for battery operation and the second for alternating current. The elements of these amplifiers have been discussed in the previous amplifiers and need not be discussed again except where differences occur.

### SAME VALUES USED

The coupling and grid leak resistors and the stopping condenser capacity have the same value as the corresponding values of the resistance coupled circuits in Figs. 42 and 43. R1 in Fig. 44 is a 4-ohm resistor and R2 a 2-ohm resistor, the first capable of carrying .25 ampere and the second .5 ampere.

The grid bias resistor P in Fig. 45 should have a value just half as much as the corresponding resistor in Fig. 43. In this circuit only a 227 tube is suitable ahead of the push-pull stage because transformer coupling follows. Since the bias on this tube should be 13.5 volts, and further, since the total current in the lower part of P is 70 milliamperes, the slider should be set at 193 ohms from B minus. Of the 70 milliamperes 6 are contributed by the 227 and 64 by the two 245 tubes. While the total value of P in this circuit should be 750 ohms it is all right to make it 800 ohms.

It may be impractical in some instances to use fixed resistors for P, since the required value is not standard. There is a commercial resistor of 1,000 ohms capable of carrying the current and having two sliders. One of these sliders can be used for adjusting the total resistance to the required value and the other for locating the cathode return at the proper place to give a bias of 13.5 volts on the first tube.

The current required by the circuit in Fig. 44 is about 47 milliamperes and that required by the circuit in Fig. 45 is 70, as was stated previously. This assumes that the first tube in Fig. 44 is a 112A, which is recommended. The plate current in either of these circuits is so high that a heavy duty B supply is necessary if the same unit is to supply the radio frequency portion. Of course it depends on how much current is taken by the radio frequency amplifier. But we have special reference to the Superheterodyne circuit described. For the AC circuit, particularly, it is recommended that two different B supply units be used, since this can usually be done more economically than using one which is substantial enough to handle the complete circuit adequately.

The low side of the input in both of these amplifiers is treated just as it was in Figs. 43 and 44.

### OUTPUT OF PUSH-PULL CIRCUITS

The maximum undistorted output of the circuit in Fig. 44 is about 2.5 watts, a conservative value, while that in the circuit in Fig. 45 is around 6 watts. That is, the output of a push-pull circuit may be as high as four times as great as that of a single tube of the same kind and with the same voltages. This is not to be interpreted to mean that for the same input voltage the output will be four times as great, but that the input can be increased until the output is about four times before the total harmonic distortion will be the same percentage of the total input.

If grid bias or power detection is used ahead of any one of the circuits shown in Figs. 40 to 45, inclusive, the output of the detector will be ample to load up the power stage to the highest permissible limit. Of course the amplification in the radio and intermediate frequency amplifiers must be high

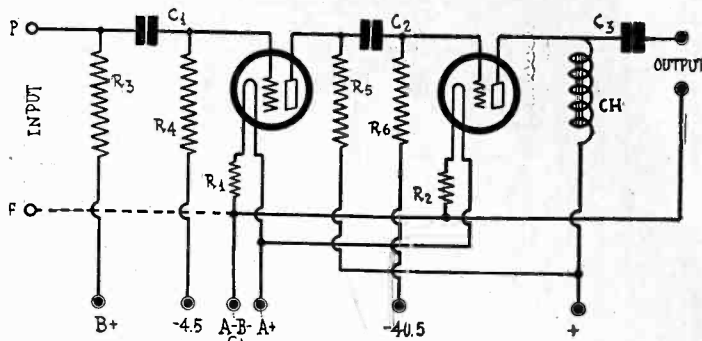

FIG. 42

A TWO-STAGE, RESISTANCE COUPLED AMPLIFIER FOR BATTERY OPERATION SUITABLE FOR USE WITH ANY RADIO FREQUENCY AMPLIFIER OPERATING ON DIRECT CURRENT. THIS AMPLIFIER IS CAPABLE OF EXCEPTIONALLY FINE QUALITY.

enough to supply the required signal voltage on the grid of the detector.

It would be desirable to use a single audio amplifier tube in a receiver, because the fewer tubes used the better the chance of retaining the quality of the output. The possibility of doing this, however, is contingent on using a power detector which is capable of delivering an undistorted signal large enough to load up the tube or tubes used as power amplifier. By using 180 volts on the plate of the detector and 25 volts bias on the grid it is possible by using a step-up transformer having a ratio of about 4-to-1 to get a signal of 38 volts on the power amplifier. This is sufficient, or nearly so, to load up a single tube of the 171A type.

It would not be sufficient, however, to load up a 245 or either two 171A or two 245 in push-pull. So when push-pull is used or a single 245, it is desirable to use at least one intermediate audio amplifier, and this might well be resistance coupled to the detector. It is not recommended that the plate voltage on the detector be increased much above 180 volts in order to get a higher possible output, the only alternative for another stage of audio amplification.

### RELATIVELY STABLE

The two amplifiers shown in Figs. 44 and 45 are relatively stable because if the final stage is well balanced there is only two plate circuits in which signal energy flows. However, if the power amplifier is unbalanced there may be considerable feedback which may cause instability. It is not possible to tell whether this feedback will result in a decrease in the amplification or in oscillation, because the action will depend on which tube is the stronger. If the circuit oscillates with the power tubes in one way, they should be reversed, which should stop the oscillation. Even if the circuit does not oscillate the tubes should be reversed and that combination used which gives the better quality.

If the B supply leads and the grid voltage battery or bias resistor are well by-passed, there should not be enough feedback one way or the other to produce any noticeable effect.

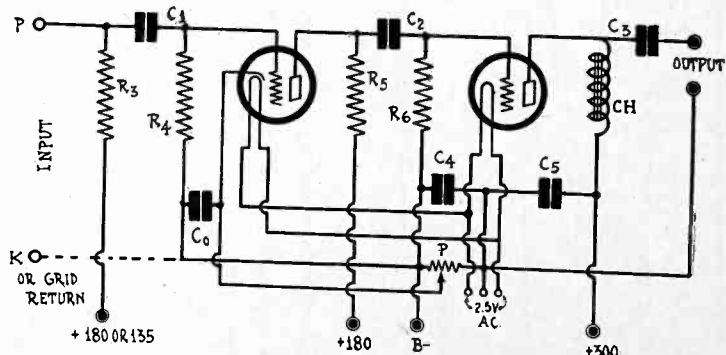

FIG. 43

THIS CIRCUIT IS ESSENTIALLY THE SAME AS THAT IN FIG. 42 EXCEPT THAT IT IS DESIGNED FOR AC OPERATION. EITHER A 227 GENERAL PURPOSE TUBE CAN BE USED IN THE FIRST STAGE, OR A 228 HIGH MU HEATER TYPE TUBE.

# -Pull Circuits

## Four Times Part of the Tube

# 171 A Push-Pull Output in Diamond

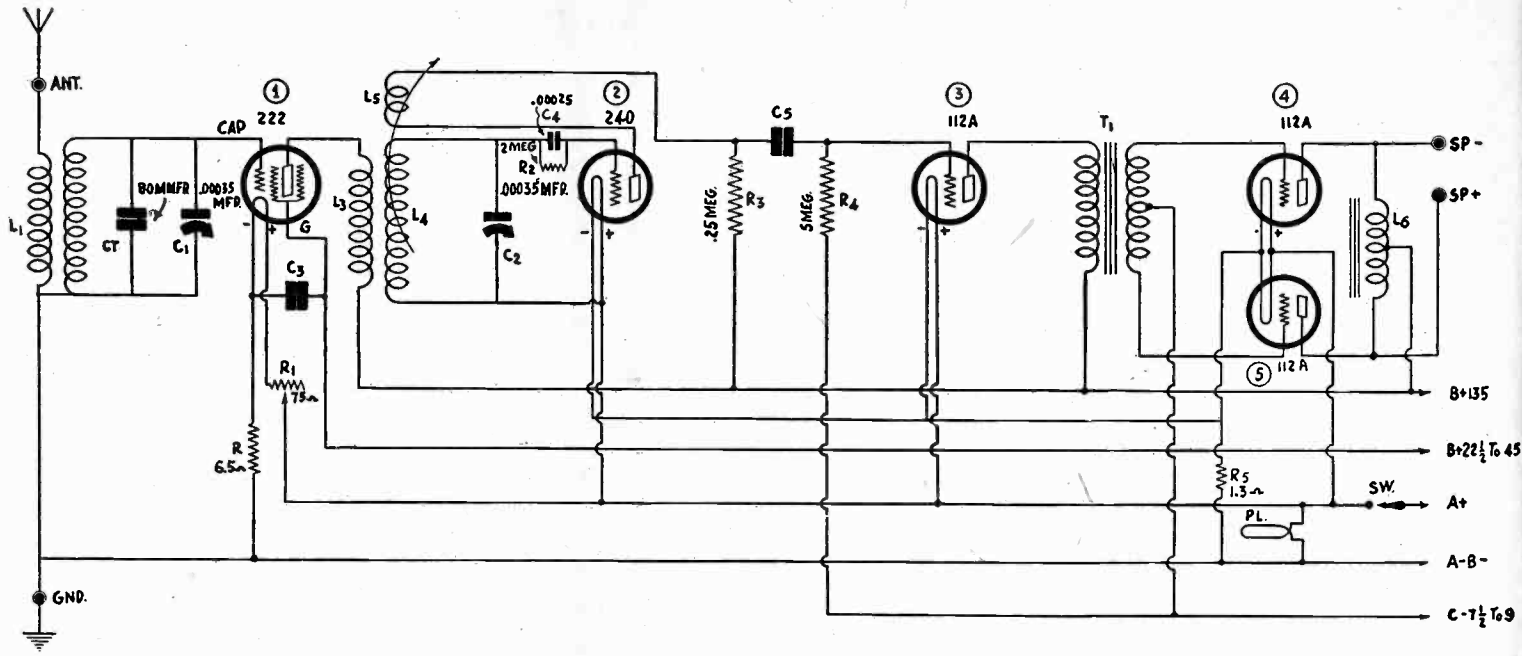

THE CIRCUIT DIAGRAM OF THE BATTERY MODEL PUSH-PULL, SCREEN GRID DIAMOND WHICH HAS BEEN BUILT BY A LARGE NUMBER WHO ARE DELIGHTED AT ITS PERFORMANCE. IT IS SELECTIVE, SENSITIVE AND CAPABLE OF A HIGH UNDISTORTED OUTPUT.

The audio amplifier of the battery model Push-Pull Screen Grid Diamond three 112A tubes are used as diagrammed. While this circuit is capable of sufficient undistorted output to satisfy most requirements in the home, some builders prefer to use 171A tubes in the output stage to insure a still greater undistorted output. When this change is made the tube ahead of the push-pull should be retained because its maximum undistorted output working into a transformer is more than sufficient to deliver the necessary signal to a 171A push-pull stage to load it up to the limit.

The main changes required in the circuit pertain to the voltages applied on the push-pull tubes, as shown in the circuit below. In the original circuit the output is taken across the center-tapped choke coil L6, but in the circuit below an output transformer is used.

Since a voltage of 180 volts is used on the power stage in the second circuit, this voltage is also used on the detector through the high resistance R3, which in the upper circuit is given as 25 megohm. This is satisfactory in either case. It must be realized that when the amplifier given below is used in connection with the Diamond the B voltage supply must be of the heavy duty type since the push-pull tubes in the lower circuit take considerably more current.

The coupling resistor R3 was given above as 250,000 ohms, which is a suitable value when the detector precedes. The grid leak R4 may well be 2 megohms and the coupling condenser C1 should be .02 mfd. Since the ballast resistors R1 and R2 are not represented directly in the complete circuit above, they should not be used when the amplifier is substituted in the receiver.

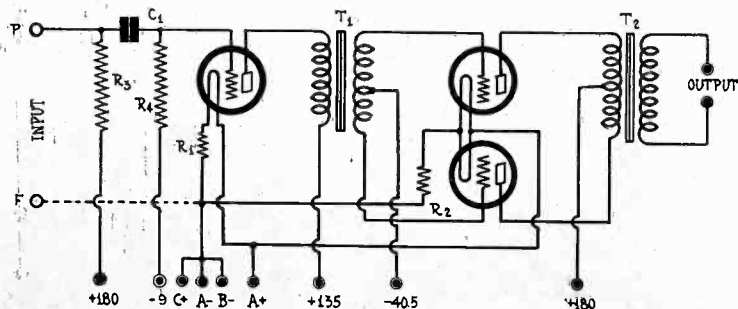

A BATTERY OPERATED AMPLIFIER USING RESISTANCE AND PUSH-PULL COUPLING AND 171A OUTPUT TUBES WHICH CAN BE SUBSTITUTED IN THE DIAMOND RECEIVER ABOVE WHEN GREATER OUTPUT IS DESIRED.

## Right o

(1)—Regeneration in a one tube set enhances both the sensitivity and the selectivity and the reason for this is that the energy fed back from the plate circuit to the grid circuit overcomes the radio frequency resistance in the circuit.

(2)—Neutralization in a radio frequency circuit is effected by feeding back energy from the plate to the grid in such phase and by such amount as to overcome the positive feedback through the plate to grid capacity.

(3)—If neutralization, so called, is overdone the circuit becomes insensitive.

(4)—There is no danger of oscillation in the intermediate frequency amplifier of a Superheterodyne because the frequency of operation is so low that the plate to grid capacity is not large enough to cause sufficient feedback.

(5)—It is the oscillator in a Superheterodyne which determines the selectivity of the receiver and this is readily proved by observing the accuracy with which the oscillator condensers must be adjusted to get maximum volume.

(6)—If a receiver is built exactly in accordance with the directions of the designer of the circuit there is no danger that the circuit will motorboat.

(7)—A receiver coupled with transformers throughout is immune from motorboating no matter what B supply is used, because such a circuit cannot amplify the low frequencies sufficiently to sustain the oscillation.

(8)—The plate current in a receiving tube is oscillating; that is, it flows first in one direction and then in the other.

(9)—The plate voltage on a tube is only pulsating. It does not oscillate.

(10)—Resistance coupled circuits are the most economical to operate because the plate current in them is lower than that in any other type, and therefore both the amplifier and rectifier tubes last longer.

### Answers

(1)—Right. Both the sensitivity and the selectivity of a receiver depends on the amount of effective resistance in the tuned circuits, both being less the higher the resistance. Where there is regeneration the energy loss in the resistance of the circuit is supplied by the feedback and hence the effective resistance is reduced.

(2)—Right. Neutralization proper is a balancing arrangement whereby a portion of the signal in the plate circuit is fed back to the grid in opposition to that fed back through the tube capacity. While there are many different variations of the method scheme they all work on essentially the same principle. The grid resistance method of so-called neutralization is not a neutralizing method at all but only a loss.



# Thorough Filtering in B Supply

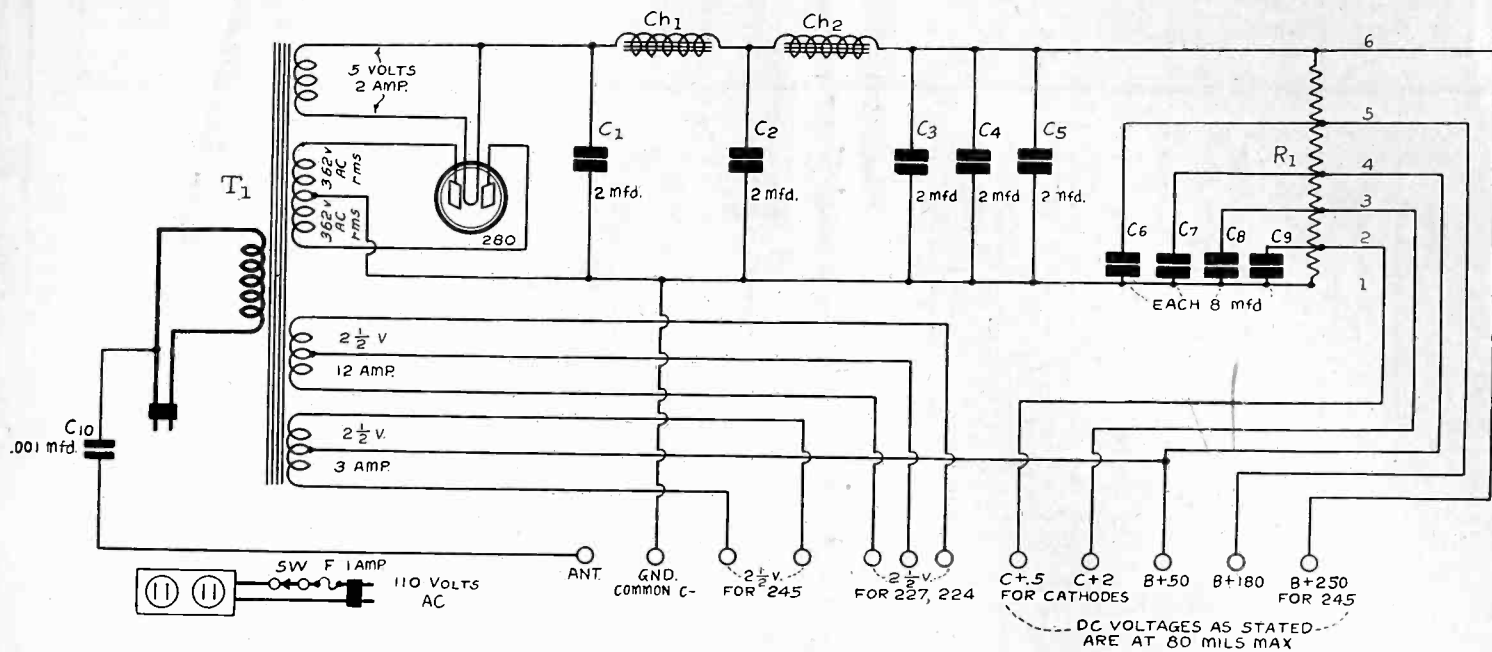

THOSE WHO ARE LOOKING FOR A GOOD B SUPPLY UNIT AND FILAMENT TRANSFORMER CAPABLE OF POWERING AN AC CIRCUIT OF FROM FIVE TO SEVEN TUBES WILL FIND THIS SUITABLE. THE POLO B BLOCK IS THE FOUNDATION.

## Wrong?

- (3)—Right. This is correct not only for the different type of true neutralizers but also for the lesser method of stabilizing a circuit.
- (4)—Wrong. The frequency cannot be too low, for even in audio frequency amplifiers it is possible to induce oscillation in the same way. It is true, though, that the higher the frequency the more easily the circuit oscillates by virtue of the feedback through the inter-electrode capacity.
- (5)—Wrong. The oscillator has nothing to do with the selectivity of the circuit, and all that the apparent sharpness of the oscillator shows is that the intermediate frequency filter is selective.
- (6)—Wrong. This statement presumes that the description given by the designer covers all possible conditions of operation. Obviously, no one can cover any subject so thoroughly, and particularly not such a complex subject as motorboating. Moreover, the term *exactly* is usually interpreted so loosely that any receiver whatsoever fits the case if the builder desires it to do so. Often an amateur builder will concoct his own receiver and call it by the same name given to a receiver by some designer and then blame him if the set does not work satisfactorily.
- (7)—Wrong. There is no receiver which is immune from motorboating, because the cause of this trouble is present in all and the frequency of oscillation is not limited. Some of the best transformers now available are so efficient at low and sub-audible frequencies that receivers coupled with them motorboat readily.
- (8)—Wrong. It is pulsating and unidirectional. It can only flow in one direction because the voltage source, battery or B battery eliminator, is always connected in the circuit in the same direction. It can drive current through the circuit in only one direction, but it can drive it through at different rates. Moreover, the tube only admits current in one direction.
- (9)—Right. This was stated in the preceding answer. It does not oscillate, but pulsates. However, the variation in the current behaves toward suitable coupling devices just as if it were oscillating.
- (10)—Right. If a tube is powered so that it can deliver a voltage of about 100 volts to the succeeding tube in a transformer coupled circuit, the plate current is about 10 milliamperes. If the tube is resistance coupled and powered so that it can deliver the same voltage it can easily be adjusted so that the current is no more than one milliamper, or even one-tenth milliamper. The less the current taken by the tube the longer will the amplifier and rectifier tubes last, because there is only a limited amount of life in any tube, and that life is measured in ampere-hours.

One of the special features of the B supply unit depicted above is the thorough filtering, that is, the use of many and large bypass condensers. This makes the circuit suitable for use with high quality audio amplifiers in which there is danger of motorboating when used with less thoroughly filtered B supply.

It will be observed that the capacities across the lower section of the voltage divider in the B supply above are 8 microfarad. This means that they are electrolytic for condensers of such large capacities cannot be obtained economically in any other type. It would be desirable also to make the condensers C3, C4 and C5 of this type for this would not only improve the filtering but would make the B supply more efficient on a high quality amplifier. The total capacity of these condensers if of the electrolytic type might well be 18 mfd.

It is especially suitable for a circuit in which the resistance and push-pull coupled amplifier below is incorporated. The B supply not only furnishes the plate voltages for this circuit but also the filament and heater current for the tubes. While the highest voltage in the B supply circuit is given as 250 volts and the highest called for in the amplifier below is 300 volts, the two really mean the same thing, for in either case the total DC voltage is 300 volts. In the circuit above the 50-volt bias required on the 245 tubes is not included in the computation while in the circuit below it is. The actual voltages are the same, however.

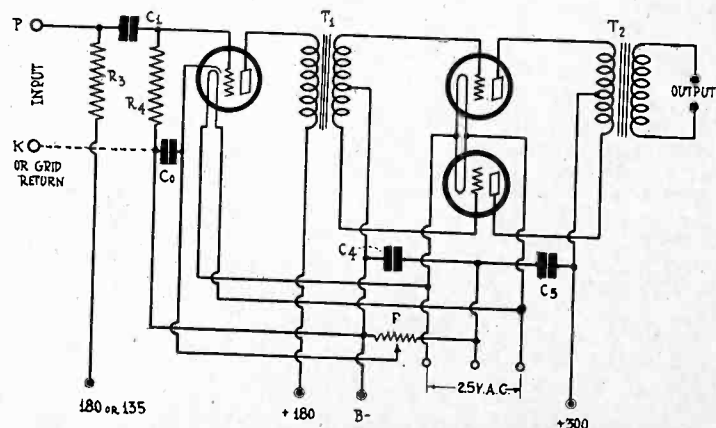

THE CIRCUIT OF A SPLENDID RESISTANCE AND PUSH-PULL COUPLED AC OPERATED AUDIO AMPLIFIER WHICH IS CAPABLE OF ABOUT 5 WATTS OF UNDISTORTED OUTPUT. IT CAN BE USED WITH THE B SUPPLY UNIT DEPICTED ABOVE.

# 171 A Push-Pull Output in Diamond

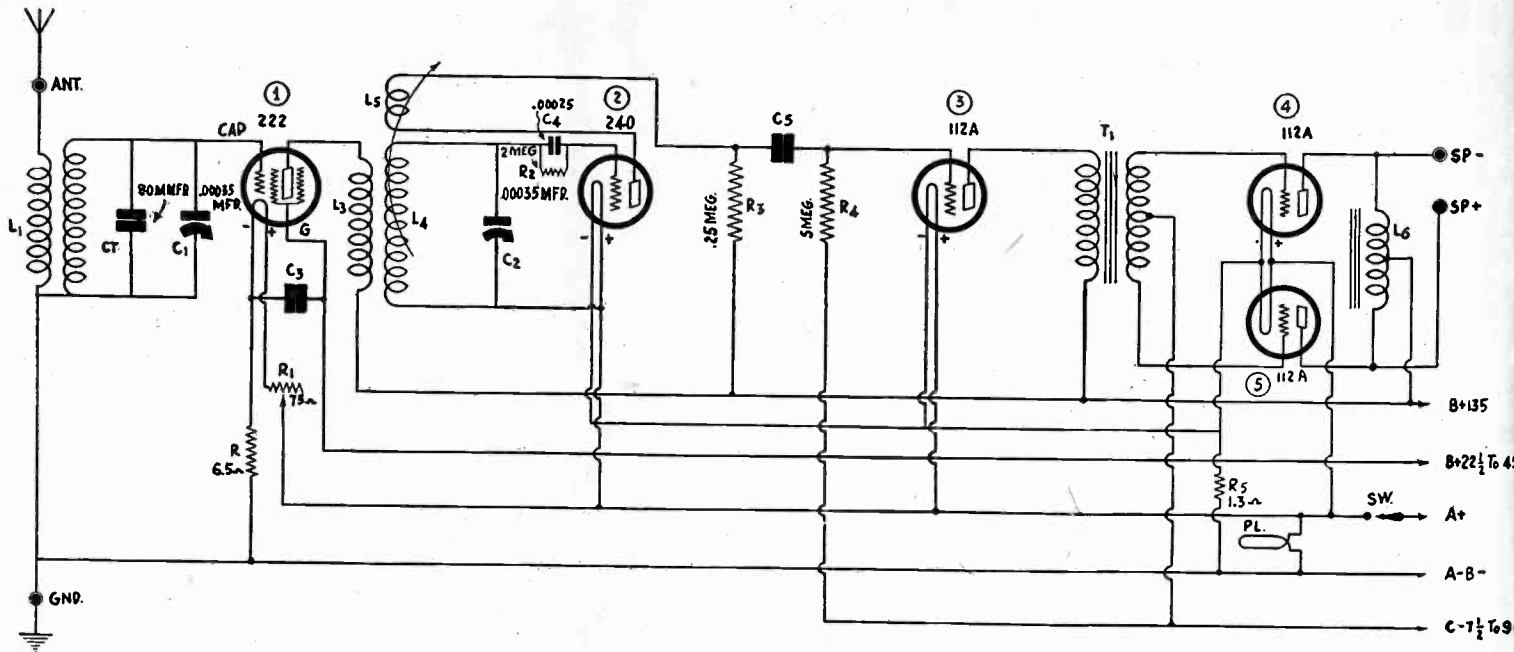

THE CIRCUIT DIAGRAM OF THE BATTERY MODEL PUSH-PULL, SCREEN GRID DIAMOND WHICH HAS BEEN BUILT BY A LARGE NUMBER WHO ARE DELIGHTED AT ITS PERFORMANCE. IT IS SELECTIVE, SENSITIVE AND CAPABLE OF A HIGH UNDISTORTED OUTPUT.

The audio amplifier of the battery model Push-Pull Screen Grid Diamond three 112A tubes are used as diagrammed. While this circuit is capable of sufficient undistorted output to satisfy most requirements in the home, some builders prefer to use 171A tubes in the output stage to insure a still greater undistorted output. When this change is made the tube ahead of the push-pull should be retained because its maximum undistorted output working into a transformer is more than sufficient to deliver the necessary signal to a 171A push-pull stage to load it up to the limit.

The main changes required in the circuit pertain to the voltages applied on the push-pull tubes, as shown in the circuit below. In the original circuit the output is taken across the center-tapped choke coil L6, but in the circuit below an output transformer is used.

Since a voltage of 180 volts is used on the power stage in the second circuit, this voltage is also used on the detector through the high resistance R3, which in the upper circuit is given as .25 megohm. This is satisfactory in either case. It must be realized that when the amplifier given below is used in connection with the Diamond the B voltage supply must be of the heavy duty type since the push-pull tubes in the lower circuit take considerably more current.

The coupling resistor R3 was given above as 250,000 ohms, which is a suitable value when the detector precedes. The grid leak R4 may well be 2 megohms and the coupling condenser C1 should be .02 mfd. Since the ballast resistors R1 and R2 are not represented directly in the complete circuit above, they should not be used when the amplifier is substituted in the receiver.

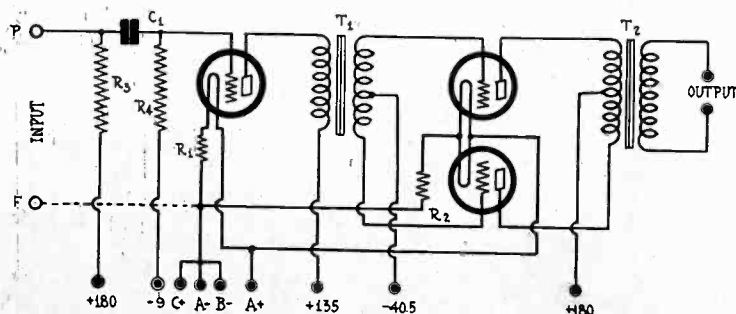

A BATTERY OPERATED AMPLIFIER USING RESISTANCE AND PUSH-PULL COUPLING AND 171A OUTPUT TUBES WHICH CAN BE SUBSTITUTED IN THE DIAMOND RECEIVER ABOVE WHEN GREATER OUTPUT IS DESIRED.

## Right o

(1)—Regeneration in a one tube set enhances both the sensitivity and the selectivity and the reason for this is that the energy fed back from the plate circuit to the grid circuit overcomes the radio frequency resistance in the circuit.

(2)—Neutralization in a radio frequency circuit is effected by feeding back energy from the plate to the grid in such phase and by such amount as to overcome the positive feedback through the plate to grid capacity.

(3)—If neutralization, so called, is overdone the circuit becomes insensitive.

(4)—There is no danger of oscillation in the intermediate frequency amplifier of a Superheterodyne because the frequency of operation is so low that the plate to grid capacity is not large enough to cause sufficient feedback.

(5)—It is the oscillator in a Superheterodyne which determines the selectivity of the receiver and this is readily proved by observing the accuracy with which the oscillator condensers must be adjusted to get maximum volume.

(6)—If a receiver is built exactly in accordance with the directions of the designer of the circuit there is no danger that the circuit will motorboat.

(7)—A receiver coupled with transformers throughout is immune from motorboating no matter what B supply is used, because such a circuit cannot amplify the low frequencies sufficiently to sustain the oscillation.

(8)—The plate current in a receiving tube is oscillating; that is, it flows first in one direction and then in the other.

(9)—The plate voltage on a tube is only pulsating. It does not oscillate.

(10)—Resistance coupled circuits are the most economical to operate because the plate current in them is lower than that in any other type, and therefore both the amplifier and rectifier tubes last longer.

### Answers

(1)—Right. Both the sensitivity and the selectivity of a receiver depends on the amount of effective resistance in the tuned circuits, both being less the higher the resistance. Where there is regeneration the energy loss in the resistance of the circuit is supplied by the feedback and hence the effective resistance is reduced.

(2)—Right. Neutralization proper is a balancing arrangement whereby a portion of the signal in the plate circuit is fed back to the grid in opposition to that fed back through the tube capacity. While there are many different variations of the method scheme they all work on essentially the same principle. The grid resistance method of so-called neutralization is not a neutralizing method at all but only a loss.

# Thorough Filtering in B Supply

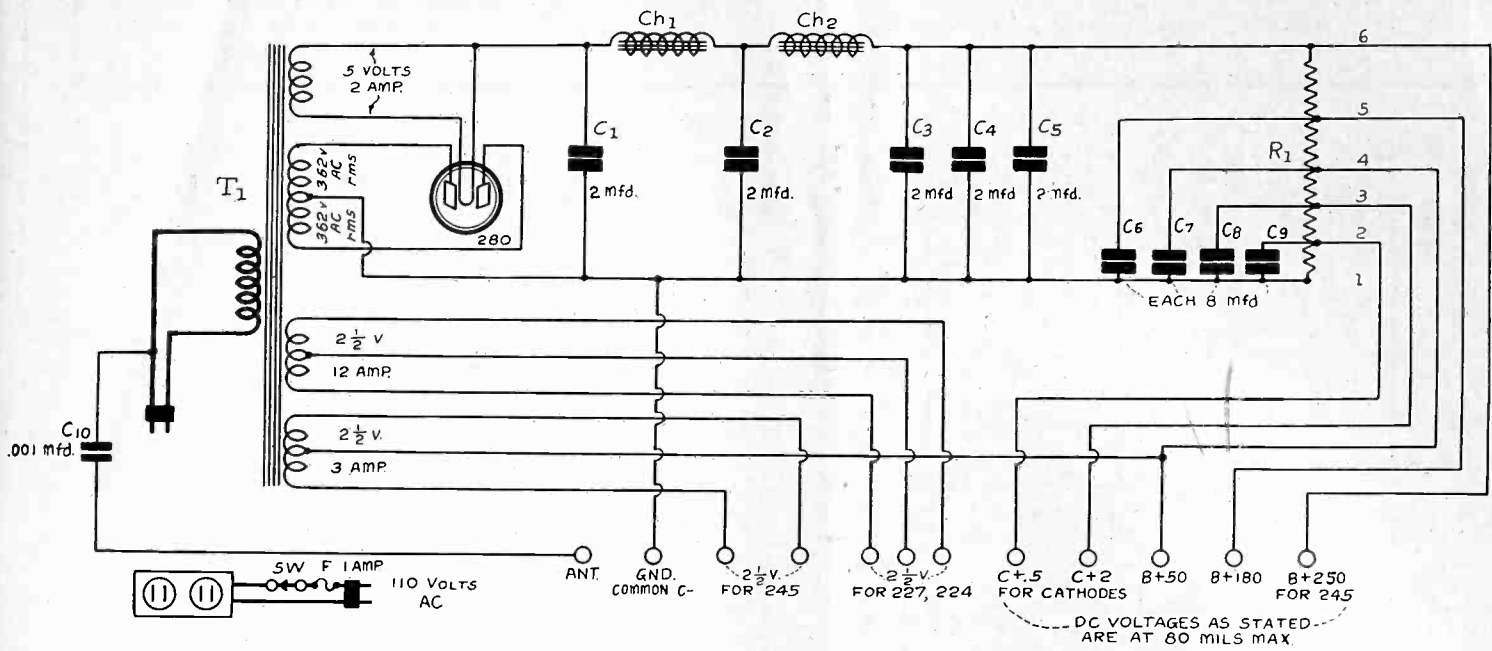

THOSE WHO ARE LOOKING FOR A GOOD B SUPPLY UNIT AND FILAMENT TRANSFORMER CAPABLE OF POWERING AN AC CIRCUIT OF FROM FIVE TO SEVEN TUBES WILL FIND THIS SUITABLE. THE POLO B BLOCK IS THE FOUNDATION.

One of the special features of the B supply unit depicted above is the thorough filtering, that is, the use of many and large bypass condensers. This makes the circuit suitable for use with high quality audio amplifiers in which there is danger of motorboating when used with less thoroughly filtered B supply.

It will be observed that the capacities across the lower section of the voltage divider in the B supply above are 8 microfarad. This means that they are electrolytic for condensers of such large capacities cannot be obtained economically in any other type. It would be desirable also to make the condensers C3, C4 and C5 of this type for this would not only improve the filtering but would make the B supply more efficient on a high quality amplifier. The total capacity of these condensers if of the electrolytic type might well be 18 mfd.

It is especially suitable for a circuit in which the resistance and push-pull coupled amplifier below is incorporated. The B supply not only furnishes the plate voltages for this circuit but also the filament and heater current for the tubes. While the highest voltage in the B supply circuit is given as 250 volts and the highest called for in the amplifier below is 300 volts, the two really mean the same thing, for in either case the total DC voltage is 300 volts. In the circuit above the 50-volt bias required on the 245 tubes is not included in the computation while in the circuit below it is. The actual voltages are the same, however.

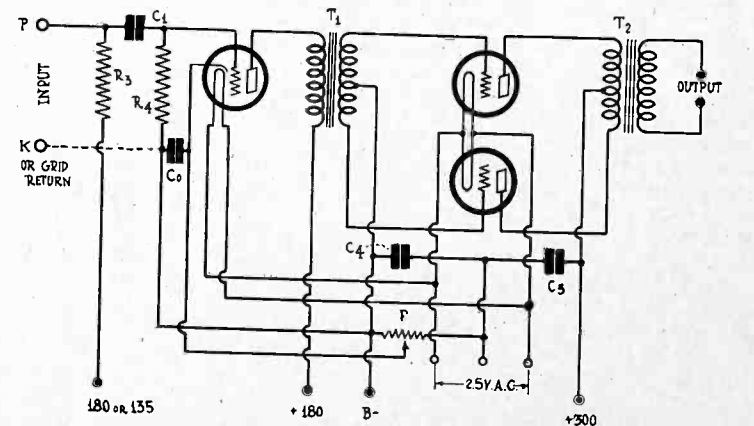

THE CIRCUIT OF A SPLENDID RESISTANCE AND PUSH-PULL COUPLED AC OPERATED AUDIO AMPLIFIER WHICH IS CAPABLE OF ABOUT 5 WATTS OF UNDISTORTED OUTPUT. IT CAN BE USED WITH THE B SUPPLY UNIT DEPICTED ABOVE.

## Wrong?

- (3)—Right. This is correct not only for the different type of true neutralizers but also for the lesser method of stabilizing a circuit.
- (4)—Wrong. The frequency cannot be too low, for even in audio frequency amplifiers it is possible to induce oscillation in the same way. It is true, though, that the higher the frequency the more easily the circuit oscillates by virtue of the feedback through the inter-electrode capacity.
- (5)—Wrong. The oscillator has nothing to do with the selectivity of the circuit, and all that the apparent sharpness of the oscillator shows is that the intermediate frequency filter is selective.
- (6)—Wrong. This statement presumes that the description given by the designer covers all possible conditions of operation. Obviously, no one can cover any subject so thoroughly, and particularly not such a complex subject as motorboating. Moreover, the term *exactly* is usually interpreted so loosely that any receiver whatsoever fits the case if the builder desires it to do so. Often an amateur builder will concoct his own receiver and call it by the same name given to a receiver by some designer and then blame him if the set does not work satisfactorily.
- (7)—Wrong. There is no receiver which is immune from motorboating, because the cause of this trouble is present in all and the frequency of oscillation is not limited. Some of the best transformers now available are so efficient at low and sub-audible frequencies that receivers coupled with them motorboat readily.
- (8)—Wrong. It is pulsating and unidirectional. It can only flow in one direction because the voltage source, battery or B battery eliminator, is always connected in the circuit in the same direction. It can drive current through the circuit in only one direction, but it can drive it through at different rates. Moreover, the tube only admits current in one direction.
- (9)—Right. This was stated in the preceding answer. It does not oscillate, but pulsates. However, the variation in the current behaves toward suitable coupling devices just as if it were oscillating.
- (10)—Right. If a tube is powered so that it can deliver a voltage of about 100 volts to the succeeding tube in a transformer coupled circuit, the plate current is about 10 milliamperes. If the tube is resistance coupled and powered so that it can deliver the same voltage it can easily be adjusted so that the current is no more than one milliampere, or even one-tenth milliampere. The less the current taken by the tube the longer will the amplifier and rectifier tubes last, because there is only a limited amount of life in any tube, and that life is measured in ampere-hours.

A Question and Answer Department conducted by Radio World's Technical Staff. Only Questions sent in by University Club Members are answered. Those not answered in these columns are answered by mail.

# RADIO UNIVERSITY

Annual subscriptions are accepted at \$6 for 52 numbers, with the privilege of obtaining answers to radio questions for the period of the subscription, but not if any other premium is obtained with the subscription.

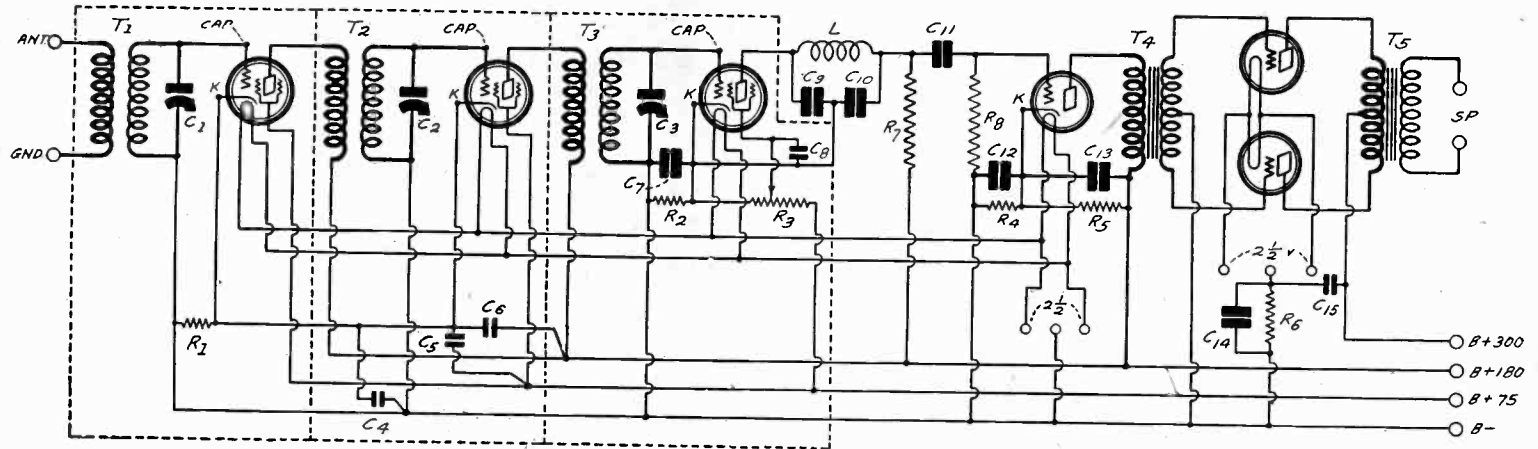

FIG. 810  
THE THREE CONDENSERS IN THE TUNER OF THIS CIRCUIT CAN BE GANGED SINCE THE ROTORS ARE ALL CONNECTED TO THE SAME POINT. THIS CIRCUIT IS CAPABLE OF HIGH SENSITIVITY AND GREAT UNDISTORTED VOLUME.

### A FADING PHENOMENON

HERE is a nut for you to crack. And if you do it you will earn my everlasting gratitude. My audio amplifier contains one resistance coupler and one push-pull input transformer. I also use a push-pull output transformer. The receiver is operated from a B battery eliminator. Here is the trouble. The signals fade in and out in a quite regular manner. The trouble must be in the circuit because I have another set and that does not act that way. What might be the trouble? Suggest the cause and a remedy.—E. W. A.

Your receiver, in the first place, is very efficient on the low notes and on frequencies below audibility. That is fortunate. Your B supply, in the second place, is not adequate for the job. That is not so good. It causes, in conjunction with your good amplifier, an oscillation at a very slow frequency. The remedy for this condition is not so simple as it would be if the oscillation were at a higher frequency. More condensers across the voltage taps in the eliminator are beneficial, and they will cure the trouble if they are large enough. Having used up all the condensers you have, or all that you can buy, the next thing is to reduce the value of the grid leak until the oscillation stops. If the resistance has to be reduced so much that the signals also are greatly reduced, change the stopping condenser in the resistance coupler for one of lower value.

### ESTIMATING PLATE CURRENT

CAN YOU suggest a good method for estimating the total current that a radio receiver will take when the plate and grid voltages and the number and type of tubes are given? I realize that if the current in any one tube is known under the specified conditions all the current can be obtained by addition. Hence give the method for obtaining the current in any tube.—E. A. Z.

There are tables and curves available for all the tubes in common use, and these should be consulted. There is no other way. Either take the values of current obtained by others or measure the current yourself. The most useful tables or curves are those which give the relationship between the plate voltage and the plate current for different values of grid bias. Such curves were given in several issues of RADIO WORLD last Fall and they are also given in Audio Power Amplifiers, by J. E. Anderson and Herman Bernard. In using curves select the bias desired and follow the line until the applied plate voltage line is reached, and read the corresponding current. Do the same for all the tubes in the set. If there are more than one tube of the same kind and operating under the same conditions simply multiply the current for one tube by the number of similar tubes.

### CALCULATING POWER REQUIRED

HOW can I determine the total power taken by an AC receiver without measuring the input to the transformer or transformers connected to the lighting circuit? Is there any way, without using meters?—H. A. F.

Some meters must be used to get a close estimation of the power required, but the measurement can be done with those

meters available to most set owners, that is, voltmeters and milliammeters. Many set owners now have circuit and tube testers which contain all the meters necessary. First figure out the power required by the filaments of all the tubes in the set, including the rectifier. This power can be estimated quite closely by taking the rated filament currents and the rated filament voltages. The power expended in any filament, or heater, is the product of the current and the terminal voltage. For example, if the rated filament voltage and current of a 250 are 7.5 volts and 1.25 amperes, the power required is 9.375 watts. The power for the others is obtained in the same way.

After the filament power has been obtained the plate power should be computed from the highest DC voltage in circuit and the total plate and bleeder currents. The product of the highest voltage and the total current is the plate power required. Add this to the filament power and increase the sum by about 20 per cent to allow for losses in the transformers. The results are close to the power taken from the AC line. If you have an AC ammeter, connect it in series with the primary of the power transformer to get the total AC current. Multiply this with the normal voltage of the line, say 110 or 115 volts, and the results is approximately equal to the power taken by the receiver. This value may be a few per cent high.

If you want to get the cost of the power it takes to operate the set, multiply the power by the cost per kilowatt hours and you get the cost per hour. For example, suppose that the computed or measured value of the power required is 60 watts and the price of electric energy is 7.5 cents, the cost per hour of operating the set is  $7.5 \times .06$  cents. That is, .45 cents per hour. Of course, this is a small part of the total cost of operation if the depreciation of the tubes and the receiver is taken into account, but even if this is counted in the cost will not be more than a few cents per hour.

### HE WANTS A COMPLEX CIRCUIT

WILL YOU kindly publish a circuit diagram of an AC receiver containing three screen grid tubes, including the detector, one 227 audio amplifier and two 245 tubes in push-pull? I would prefer one in which the tuners are shielded and in which the condensers can be ganged. I have followed very carefully your discussions on power amplifiers and I believe that I can fill in all the different values myself. At any rate I want to try my knowledge on the circuit and if I get stuck I'll impose on your good nature once more.—W. A. S.

Fig. 810 contains a circuit which seems to fill all the requirements. It is a straightforward circuit in every respect and complete with the exception of the B supply. Two features may need special attention, although you may have studied them in the series on power amplifiers. We refer to the method of getting proper bias voltages on the detector and the first audio amplifier. As a suggestion, R2 and R3 should have a total resistance value of 25,000 ohms and the sum of R4 and R5 may have the same value. However, there is no great need of using R5, since the plate current in this stage is considerable. If R5 is not used R4 should be determined on the basis that the plate current alone flows through R4.

**INTERESTED IN CRYSTALS**

I HAVE ALWAYS been partial to crystal rectifiers because of the excellent quality which can be obtained with them, and I should like to know on what principle they operate; that is, what makes them rectify. I would appreciate a full discussion of it.—M. O. G.

The superiority of crystal detection in respect to quality over tube rectifiers is a fiction pure and simple. It arose from the fact that at the beginning tube detectors were used in conjunction with very bad amplifiers and still worse loudspeakers, whereas crystal rectifiers were used directly on head sets. If you hook up the same amplifier to a crystal set and a tube detector you will get practically the same quality, but the crystal set will be much less selective. The difference in selectivity, however, is not so great as to account for any difference in the quality that may be thought to exist. Respecting the principle on which a crystal works, there is no agreement among those who have studied the crystal enough to have any opinion worth attention. Some say that the rectification occurs in the body of the crystal, others say that it takes place at the surface. In this respect probably both are right, for there are many different crystals. Some authorities think that the effect is thermal and others believe it is chemical. The chemical idea seems to have the upper hand, because the rectification seems to be similar to the rectification of dissimilar metals now used considerably in power supply devices. But the question is still open.

**MODULATION CAPABILITY**

RECENTLY I have seen the term "modulation capability." Is that an equivalent statement to per cent. modulation? There are now supposed to be stations the waves of which are modulated 100 per cent. Is such high modulation really possible?—D. J. W.

A transmitter radio frequency current is not modulated at the same percentage all the time, but depends on the intensity of the sound that is being transmitted. A very weak sound may not modulate the wave by more than one per cent. and a strong sound may modulate it 100 per cent., or it may even overmodulate it. The modulation capability is the highest percentage modulation of which the transmitter is capable without producing distortion. In modern transmitters the highest percentage is 100 per cent., or complete modulation. This does not mean that the wave is ever modulated to this extent, but that it may be during occasional bursts of sound. Such high degree of modulation is not desirable unless straight line rectification is used in the receiver. Since high degrees of modulation are desirable from the point of view of channel and power economy, there is no doubt that in the future all broadcast stations will have a 100 per cent. modulation capability and all receivers will have straight line detection. We are rapidly approaching that state of development.

**EMISSION TEST ON 112A TUBE**

KINDLY SUGGEST a method of making emission tests on the 112A tube, and give the current that can be expected. I have the information necessary for making such tests for all the other standard tubes but have not been able to find any directions for this tube.—J. C. D.

Emission tests should not be taken on this tube. Test it as an amplifier. What does an emission test indicate anyway? There are cases when emission tests will indicate the true condition of a tube, for example, if the plate current is very high and the tube still refuses to work, the tube is gassy and the emission will apparently be very large. The 112A tube will show a blue glow when it is gassy.

**PROPER CONNECTIONS OF RF COILS**

WHAT ARE the proper connections of a radio frequency transformer in which the primary and the secondary are wound on the same form? Does it really make much difference just so the primary is in the plate circuit and the secondary in the grid circuit?—D. A. M.

Assuming that the two windings are in the same direction, that is, such as would be the case if a single winding were cut at a suitable point to produce one terminal for the secondary and one for the primary, these two terminals should go to F minus and B plus, respectively. The outside terminal of the secondary should go to the grid and the outside terminal of the primary should go to the plate. This is the preferred way, but it really does not make much difference which way the terminals are connected, subject to your own proviso. However, if one particular method is selected for one transformer in a circuit, the same should be used for all. If the coil is to be used as an oscillator and both the extreme terminals are connected to the same tube, oscillations will not occur unless the above connection is used. There is one alternative connection for an oscillator, and that is to connect the inner terminals to the grid and plate and the outer terminals to F and B. But electrically this connection is essentially the same as the first.

**SUGGESTED EQUALIZATION**

I UNDERSTAND that the amplification in resistance coupled circuits is low on high frequencies due to inter-electrode capacities, and also if the load on the tube is inductive the amplification is high for the same reason. If that is so, would

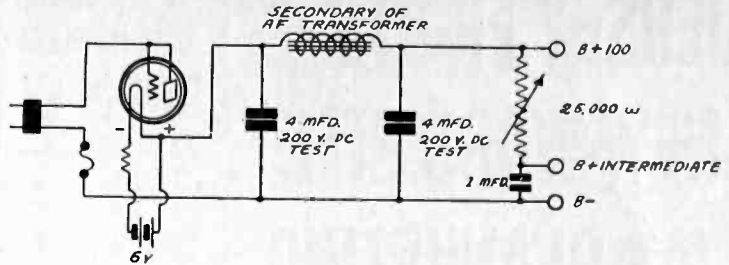

FIG. 811

A SIMPLE RECTIFIER CAN BE CONSTRUCTED WITH A RECEIVING TUBE AS RECTIFIER BUT IN MOST INSTANCES IT IS NECESSARY TO USE A TRANSFORMER BETWEEN THE LINE AND THE RECTIFIER EVEN WHEN A LOW VOLTAGE IS WANTED.

it not be possible to equalize the amplification by connecting a small inductance in series with the coupling resistor.—E. H. H.

It is so all right, for one of the defects of resistance coupling is that the amplification is low on the highest audio frequencies. It is also true that circuits having inductive loads oscillate at high frequencies, or at least amplify more than at low. It does seem possible to equalize the amplification just as you suggest. We cannot recall a circuit, however, in which it has been done, nor do we recall any experimental work on it. But the scheme is not worth while in an amplifier designed for broadcast reception or for use with any audio circuit, because the reduction in the amplification is not appreciable inside essential audio frequency band. For special circuits, such as television and picture receivers it might be worth while. There are other ways of getting full amplification up to as high as 30,000 cycles per second.

**A SIMPLE RECTIFIER**

IS IT POSSIBLE to use a small receiving tube heated with direct current as a rectifier in a low power Z supply unit without using any input transformer I can see no reason why this arrangement should not work. If there is any please point them out. A circuit diagram would be appreciated.—B. D.

Under certain conditions this is possible, but the tube used must be large enough to supply all the current that is required. The arrangement does not always work for ground on the line and the ground on the set may cause a partial or total short-circuit. If, however, an input transformer is used it works every time. Fig. 811 shows a circuit containing a six-volt tube as rectifier. The input plug should go to the secondary of a transformer the primary of which is in the line. Unless only a few milliamperes are wanted it is best to use a regular rectifier tube.

Join

Radio World's

**UNIVERSITY CLUB**

And Get Free Question and Answer Service for the Coming 52 Weeks. This Service for University Subscribers Only

Subscribe for RADIO WORLD for one year (52 numbers) Use the coupon below. Your name will be entered on our subscription and University Club lists by special number. When sending questions, put this number on the outside of the forwarding envelope (not the enclosed return envelope) and also put it at the head of your queries. If already a subscriber, send \$6 for renewal from close of present subscription and your name will be entered in Radio University.

**NO OTHER PREMIUM GIVEN WITH THIS OFFER**

[In sending in your queries to the University Department please paragraph and number them. Write on one side of sheet only. Always give your University Club Number.]

RADIO WORLD, 145 West 45th Street, New York City.

Enclosed find \$6.00 for RADIO WORLD for one year (52 nos.) and also enter my name on the list of members of RADIO WORLD'S UNIVERSITY CLUB, which gives me free answers to radio queries for 52 ensuing weeks, and send me my number indicating membership.

Name .....

Street .....

City and State.....

If renewing subscription, put cross here.

# JERSEY FIGHTS NEW WABC SITE AS BLANKETING

Washington

The State of New Jersey is making a determined fight to prevent the incursion of the Columbia Broadcasting Company into its territory. The System recently was granted a license by the Federal Radio Commission to build a 50,000 watt transmitter for its key station, WABC, at Columbia Bridge, near Morristown, N. J. The present transmitter is on the outskirts of New York City. The New Jersey Radio Commission was granted a hearing before the Commission at which every effort was made to have the permit rescinded.

The New Jersey Radio Commission issued a statement in which it is said that the new WABC high-power transmitter, if placed near Morristown, will effectively "blanket" that city, together with Montclair, the Oranges and Newark. Engineers of the Western Electric Company, designers and builders of the transmitter, say, however, that little fear need be felt on this score, tests having shown that interference of the "blanketing kind" is normally not found more than a mile from the transmitting antenna when modern receivers are used.

"This attitude on the part of the New Jersey Radio Commission does not reflect in any way on WABC or any other station," the radio board representative explained, nor on the quality of the programs broadcast by out-of-the-State radio facilities. It is merely that New Jersey thinks it should have a say in the question of whether any such broadcaster may set up a station on State soil without the people having a voice in the matter. It is understood that such transmitters ruin reception for listeners who reside nearby.

## Good News for Radio Dealers

Have you heard about it? Did you read the New York Times a few days ago to the effect that, notwithstanding the recent stock slump, R. H. Macy, B. Altman & Co., Arnold Constable & Co., John Wanamaker, Bloomingdale's and Gimbel's, the biggest department stores in New York—and maybe that means the world—announced that the recent jolt in the stock market had not affected their sales? As a matter of fact Macy said that the November sales of store was the biggest in the history of the firm. Every one of the stores has shown an increase in sales over last year.

Radio dealers, why not you?

## Silver Back on Job After Auto Accident

Chicago

McMurdo Silver, president of Silver-Marshall, Inc., was back at his desk after a month's absence due to injuries incurred in an automobile accident.

His health is completely recovered, and he has assumed all his former duties which were handled during his absence by a committee of three.

## Literature Wanted

THE names and addresses of readers of RADIO WORLD who desire literature on parts and sets from radio manufacturers, jobbers, dealers and mail order houses are published in RADIO WORLD on request of the reader. The blank at bottom may be used, or a post card or letter will do instead.

RADIO WORLD,  
145 West 45th St., N. Y. City.  
I desire to receive radio literature.

Name .....  
Address .....  
City or town .....  
State .....

- R. J. McCutcheon, c.o. Colorado Fuel & Iron Co., Pueblo, Colo.
- W. B. Bartholomew, Cleveland Ave., OBS. Sta., Pittsburgh, Pa.
- Harold L. Casto, 229 Chester Ave., N. S., Pittsburgh, Pa.
- W. W. Kroeger, Box 18, Sidney, Neb.
- Edward Taylor, 1394 E. Hewson St., Phila., Pa.
- A. Freedman, 1781 77th St., Brooklyn, N. Y.
- L. A. Weiss, R. F. D. 8, Parkview Ave., Kalamazoo, Mich.
- L. E. Dunston, Box 143, Athens, Ga.
- Don Drenner, 221 E. "D" St., Oklahoma City, Okla.
- Caswell Radio Repair Service, R. R. No. 1, Dayton, Ohio.
- O. L. Billingsley, P. O. Box 22, Brownwood, Texas.
- Earle W. Stahl, 499 Madison St., Milwaukee, Wis.
- M. C. Miller, Box 117, Centerville, Crawford Co., Pa.
- John A. Coy, 224 East Court St., Apt. 208, Flint, Mich.
- H. G. Knab, 238 13th St., Brooklyn, N. Y.
- Knelling's Radio Shop, 812 No. State St., Tacoma, Wash.
- Ed. Roberts, Fen'l. Del'y., Lubbock, Texas.
- Ray E. Krout, 1218 Topping, Kansas City, Mo.
- W. B. Lucas, R. F. D. No. 1, Pasco, Wash.
- Peter J. McEntee, 1210 Woodycrest Ave., New York City.
- Peter Bella, 218 Nimrod St., Brooklyn, N. Y.
- Ralph Quarles, 324 W. 53rd St., New York City.
- C. H. DeLander, 1839 N. Bryant, Minneapolis, Minn.
- J. W. Squires, co. Taft School, Watertown, Conn.

# Forum

### WE WON'T

I CAN NOT refrain from offering a word of congratulation on your excellent magazine. While others seem to be finding it difficult to maintain fan interest you show a constantly improving facility in that direction and RADIO WORLD has come with us here to be a sort of contemporaneous and up-to-the-minute text book. We wish you continued success, and don't let anybody tell you there ought to be more general news and fewer technical articles.

E. W. MATTHEWS,  
Augusta, Ga.

### SHOUTS FOR BIGGER SETS

I AM INTERESTED in the MB-29 because it is not the same old infernal four tuber. I know nothing of the coils or how to make them. This simply means that I have .0005 Hammarlund condensers and drum dials on hand and would not discard them. They are good. I also have sockets and condensers by the bunch. Now can a man be expected to buy a whole new outfit every time a new set comes out? That is why I am shouting for a six or seven tube set as a feature article in RADIO WORLD with full details. You can do it if you want to. Have some variety, please. I was listening to N. Y. at 3 P. M. this afternoon on a factory set. Will any of yours do that?

W. A. WEST,  
Halifax, N. S.

# DATE SLIP-UP BARS STATIONS ON RENEWALS

Washington

Two cases were dismissed by the Court of Appeals of the District of Columbia on like issues like those on appeal from decisions of the Federal Radio Commission. The By-Products Coal Company, of Bypro, Ky., and the J. P. Burton Coal Company, of Cleveland, Ohio, which had previously maintained between the two locations a limited point-to-point radiotelegraph service, lost their plea for renewal because they had not filed their appeal within the twenty-day period specified by law.

"The action of the court," the general counsel of the Commission, B. M. Webster Jr., said, "is significant in that the courts' action upholds a rule of the Commission that the date of the Commission's decision in a given case, unless otherwise specified by the Commission, is the effective date of that decision.

"The same issue arose in the case of the General Electric Company v. the Federal Radio Commission," Mr. Webster said, "the first case taken to the Court of Appeals under the radio act of 1927. The motions in that case were not passed upon by the court, although by proceeding to render a decision on the merits of the case, the court, in effect, denied the motions."

## RADIO WORLD AS A CHRISTMAS GIFT

Many persons have found that their friends appreciate subscription for RADIO WORLD as Christmas gifts. Why not send that friend of yours—especially the schoolboy who finds so much of real value in our columns—RADIO WORLD as a 52-weeks' gift? Send us \$6 with the name and the address of the person to whom you want the copies to go, and we shall see that your friend is advised to whom he is indebted for the yearly subscription.

Send now and the subscription will be sure to start during the holiday season. RADIO WORLD, 145 W. 45th St., N. Y. City.

## Board is Hard Up For Payroll Funds

Washington

The Federal Radio Commission had less than \$300 on hand to meet a \$15,000 payroll. A proposed transfer of \$25,000 from the Department of Commerce appropriation to the Federal Radio Commission has been disapproved by the Comptroller General of the United States, J. R. McCarl.

The appropriation of the Commission for the fiscal year was \$164,440 and there still remains of this fund \$45,000 for operating expenses, but under law this may not be used for payroll purposes.

### A THOUGHT FOR THE WEEK

More radio stores would stress service a little more and "unheard of prices" a little less, that ill-favored, interjectional appellation, "Gyp!" would be heard less frequently throughout the land.

# CRYSTAL TRUE TO 5 PARTS IN EVERY MILLION

Washington.

Great contributions to the advancement of radio as a science and as an art and to aviation have been made by the Bureau of Standards, as evidenced by the annual report of the Director, Dr. George K. Burgess.

Extracts from the department's summary of the report as appertaining to radio, follows:

"Among important developments listed in the report are the new type visual airplane radio beacon, improved methods of protecting electrical airplane equipment from radio interference, and better quartz oscillators for use in radio transmission.

### Accurate Quartz Oscillators

"A new type of visual airplane-radio beacon sending out any number of courses up to 12 was developed.

"Methods of shielding the electrical equipment of airplane engines have been devised to eliminate radio interference, and conferences have been held with manufacturers of engines and ignition systems.

"The type-testing of commercial engines has grown into one of the most important lines of test work at the Bureau and is a direct safeguard for every passenger on a commercial plane. As a result of experiments made in the Bureau the noise in an airplane cabin will be greatly reduced.

"The radio section has succeeded in improving the quartz oscillators used as fundamental standards of frequency, so that the error in constancy of these instruments does not exceed five parts per million.

### Sun Spot Theory Proved

"The precision of the methods used in testing oscillators for broadcasting stations has been increased tenfold. The study of the fundamentals of radio transmission has continued, and it has been found that daylight radio signal intensity varies directly and daylight static inversely as solar activity.

"In other words, the relationship between radio signal transmission and the sun-spot cycle seems established beyond doubt."

## Number of Stations Drops to Below 600

Washington

The Federal Radio Commission recently announced that for the first time since that body assumed control of the radio situation, more than three years ago, the number of broadcasting stations operating in the United States has dropped below 600.

When the Commission took over control, February 23rd, 1927, records show, there were 733 broadcasting stations on the air holding licenses from the Department of Commerce, the Commission's predecessor.

## Radio Signal Service Perfect for Planes

A new use for radio is a signal service for air lanes to cover every square mile of American territory where planes fly. This will be developed and put in use by the Aeronautics Bureau of the Department of Commerce, which is completing the greatest and most widespread weather information set-up ever established in any country.

Twenty-four stations located in various strategic parts of the country are already hooked-up for this service.

## Baird Television Ready for Proof

The Baird system of television, developed by John L. Baird, Scottish inventor, soon will be demonstrated in the heart of New York City, according to a statement issued by Captain O. G. Hutchinson, general manager of the Baird interests. The system is said to require only the width of wavelength used by American broadcasting stations.

"We are here to prove that television is an established fact. It can be made immediately acceptable in the home as an educational and entertainment feature through present radio broadcasting facilities," said Captain Hutchinson. "It is now possible, using the ordinary wave bands allotted for speech and music broadcasting, to transmit images and voices on the program wave lengths. Such broadcasting is being done through London, Berlin and many other stations, using the Baird system. British radio set owners are receiving television from ZLO daily and the German radio public from the station at Witzleben."

## CATHODE RAY REPLACES DISK

A new system of television in which the cathode ray tube is utilized in place of the former method of scanning the image by means of the conventional disk was demonstrated before the Institute of Radio Engineers Convention in Rochester, N. Y.

Dr. Vladimir Zworykin, research engineer of the Westinghouse Electric and Manufacturing Company, demonstrated the apparatus and pointed out that its use will make possible the transmission of motion picture and synchronized action without pre-empting numerous valuable wave channels now requisite for television purposes.

The cathode ray television receiver has no mechanical moving parts. It is quiet in operation and produces a picture with less flicker than systems using scanning disks.

The picture now possible with apparatus already developed is approximately four by five inches in size, but the inventor pointed out that additional experiments will undoubtedly lead to tubes which will produce larger pictures.

## Chain Stores Protest KWKH Talk as Slur

Statements alleged to be made over the air derogatory to chain stores, through the medium of KWKH, at Shreveport, La., by its owner, W. K. Henderson, have resulted in complaints to the Federal Radio Commission from trade associations and chain stores throughout the South.

Approximately forty telegrams, it was stated, were received on one day from chain stores within service range of the Shreveport station asking the Commission to take action. It is said that R. W. Lyons, of New York, executive secretary of the National Chain Stores Association, including in its membership such organizations as Sears-Roebuck and Montgomery-Ward and Company and other National chains, also wrote letters of protest to the Commission.

Next Week—Christmas Number  
of Radio World!

## BILL CONTINUES BOARD A YEAR AS EXECUTIVES

Washington

At the regular session of Congress, a joint resolution to be introduced by Senator Dill (Dem.), of Washington, and Representative White (Rep.) of Lewiston, Me., will propose indefinite continuation of the executive life of the Federal Radio Commission. These legislators have been co-authors from time to time of resolutions extending the life of the Commission and amending the radio law otherwise.

"We want the Radio Commission to live until a communications commission is created," said Mr. Dill, who is a member of the Interstate Commerce Committee, before which is now pending the bill (S. 6) of the chairman, Senator Couzens (Rep.), of Michigan, to create a commission on communications and power.

### Controversial Subjects Out

Regarding the resolution which will be drawn, Senator Dill said, "it will not contain any controversial amendments to the present law. It was at first planned to include an amendment to the act, repealing the Davis equalization amendment, and making some changes in procedure on appeals.

Senator Dill added, "that the resolution to continue the Commission might not be passed before the Christmas holidays, but that the regulating authority of the Commission would simply revert back to the Secretary of Commerce on the first of the year and continue under his authority."

### Must Continue, Says Davis

Representative Davis (Dem.), of Tullahoma, Tenn., in giving his views on the proposed resolution, said he favored not only inclusion of sufficient funds in a deficiency bill to meet the Radio Commission's pay roll discrepancy but also extension of the life of the Commission.

"I was the first in either House of Congress publicly to advocate a Federal commission on communications," he said. "I still believe in it and I believe it will ultimately be brought about. Meantime, everybody must realize that there is no alternative but to continue the Federal Radio Commission until such time as other Federal machinery for the purpose can be set up."

## Anti-Noise Body Gets Speaker Complaints

In New York City by the movement to abate unnecessary noises has caused some remarks about radio as a source of complaint. In response to questionnaires sent out by the Noise Abatement Commission, 1,500 answers list as noises most offensive and nerve-racking, shrill and far-reaching radio loudspeakers and amplifiers, rumbling trucks and screeching auto horns.

Many also complained against overloaded demonstration amplifiers used by dealers in front of their places of business.

### RADIO WORLD'S BOOK SERVICE

has been found of great value not only by radio fans, constructors, etc., but also by radio and other technical schools throughout the country. See the radio books advertisements in this issue.

# TERRELL LAUDS 17,000 "HAMS" ASKS SUPPORT

The difficult task of "policing the ether," performed by the radio division of the Department of Commerce, will be made easier when new equipment now on order is placed in service, according to the report of W. D. Terrell, chief of the division. Notable among the apparatus, said Mr. Terrell, will be the constant-frequency monitoring station, or "master radio traffic cop," now being installed in the geographical center of the country—at Grand Island, Nebr. This station, situated on a 50-acre tract, will cover the entire range of the spectrum, and from it transmitters the world over may be checked as to their frequency. The very latest in radio-checking apparatus is being installed, he said. The station will be complete within itself, generating its own energy and a 24-hour-a-day service will be insured throughout the year.

A fine tribute to the American amateurs, totaling approximately 17,000, was paid by Mr. Terrell, who said that while other countries are worrying over the problem of controlling, taxing and discouraging the few surviving amateurs they have, he said, "this country is constantly endeavoring to keep this large group of experimenters engaged in useful and interesting work."

# Crystal Standard Sought by Navy

Washington.

Invitations to a conference to be held by the Bureau of Engineering, Department of the Navy, have been issued to the Radio Corporation of America, General Electric Co., Westinghouse Electric & Manufacturing Company, General Radio Company and the American Optical Company, among others. The object is uniformity of production of quartz crystal controls employed in maintaining radio transmitters on specific frequencies, in the interest of reducing interference.

The crystal controls now made commercially are not uniform, it was stated, with the result that the product of one laboratory may not be interchanged with that of another, even if both are prescribed for the same frequency. Such conditions can be corrected if specifications are agreed upon. All departments of the Government interested in radio have also been invited to participate in the conference.

# BOARD FIGHTS KWY ATTEMPT TO CLINCH WAVE

Washington.

The suit brought by KYW, KFKX and KYWA, Westinghouse stations in the Chicago area, to compel the Federal Radio Commission to issue unrestricted licenses for operation on 1,020 kilocycles, is being fought by the Commission on the ground the renewal licenses were just like the former ones in effect. Also the board asks dismissal of the appeal on the ground the stations were late in filing it, and besides there is no provision of law under which the appeal can be taken.

The appeals claimed that the Commission had not renewed the licenses of the stations in exact accordance with the applications, but had inserted in the license a clause to the effect that the 1,020-kilocycle channel properly belongs to the Second or East-Central Zone under the reallocation order of the Commission and that it merely was loaned to the Fourth or Middlewestern Zones, in which KYW and KYWA are located.

The clause was inserted in the renewals for the 90-day period which began November 1st.

It was pointed out that KYW uses 10,000 watts power, 5,000 of which is issued experimentally, and that KYWA is used as a "booster" station, being automatically synchronized by wire with the main station.

The language inserted in the licenses for the current licensing period, specifying that the 1,020-kilocycle channel belonged to the Second Zone "was inserted pursuant to and in direct compliance with section 5 of the amendatory act of March 28th, 1928, commonly known as the Davis Amendment" the motion of the Commission for dismissal states. This section provides, it adds, "that if and when there is a lack of applications from any zone for the proportionate share of licenses, wavelengths, time or operation, or station power to which such zone is entitled, the licensing authority may issue licenses for the balance of the proportion not applied for from any zone, to applicants from other zones for a temporary period of 90 days each, and shall specifically designate that said apportionment is only for said temporary period."

Six stations in the Second Zone have filed applications for the 1,020-kilocycle channel, and hearings have been designated for early in 1930. The Westinghouse Company, the motion says, will have opportunity to defend its right to the frequency at these hearings, because its stations are "of exceptional quality."

# INCOME TAX IS LICENSE PLAN

A schedule of fees to be imposed on all radio broadcasting stations will be proposed in radio legislation to be sponsored soon by Senator C. C. Dill of the State of Washington. A fee of 20 cents per watt for broadcasting companies and a flat license charge for communication companies, together with a pro rata tax on net incomes has been suggested by members of the Commission in conference with the Washington Senator.

Ira E. Robinson, chairman of the Commission, in testimony before the Senate Interstate Commerce Commission, expressed himself as favoring such license fees.

# Short Wave Circuit

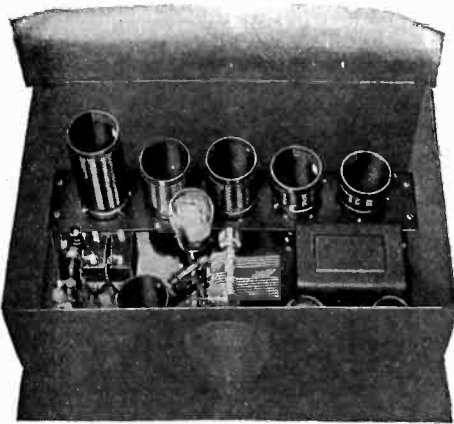

National Thrill Box, 4-tube short wave circuit, 15 to 535 meters, battery-operation of filaments; B supply, either batteries or eliminator.

Get a real kick out of listening to foreign stations on a real short-wave circuit, the National Thrill Box. Uses one 222 screen grid RF amplifier, one 200A detector, one 240 first audio and one 171A or 112A output. Single control. Buy the parts and build the circuit in two hours. Data sheet shows dial settings where foreign stations come in. Cat. SW4EF, all parts, including decorative brown steel cabinet, all six plug-in coils, list price \$51.90 (less tubes). Your price \$31.00.

## Guaranty Radio Goods Co.

143 West 45th Street New York City

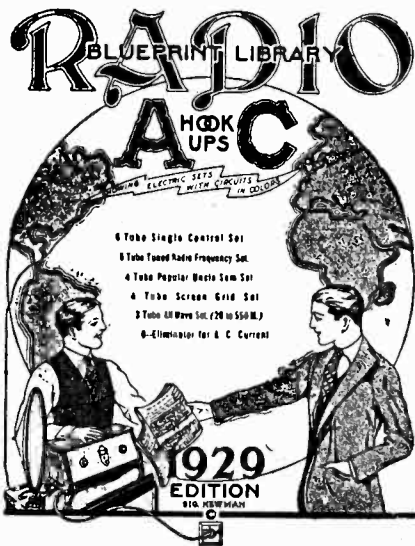

## Fourteen Circuits

Each Shown in Colored Picture Diagram, Colored Schematic Diagram and Front Panel Layout

Get This FREE Book!

Complete AC electric receivers, with B eliminators included, also AC receivers without B eliminators, also battery operated models, all easy-to-build circuits, using your own parts.

RADIO WORLD, 145 W. 45th St., N. Y. City. (Just East of Broadway)

Gentlemen: Enclosed please find \$1.00 for which please send me Radio World each week for eight weeks (regular price, \$1.20) and besides send me a FREE copy of the 1929 edition of The Radio Blueprint Library of AC and Battery Hookups.

Name .....  
Address .....  
City..... State.....

Note: Present mail subscribers may take advantage of this offer by putting a cross in this square.  Your subscription will be extended eight weeks.

[Canadian remittance must be by postal or express money order, due to high discount rate on cashing Canadian checks in New York.]

## Blueprint FREE!

Get a free blueprint of either circuit listed on the coupon below, by sending \$1.00 for eight weeks' subscription for RADIO WORLD, or send \$1.50 for 13 weeks' (quarter of a year) and get both blueprints free!

RADIO WORLD, 145 W. 45th St., N. Y. City

- Enclosed please find:
- \$1 for which send RADIO WORLD for 8 weeks and send free blueprint of the battery model 4-tube Screen Grid Diamond of the Air.
  - \$1 for which send RADIO WORLD for 8 weeks and send free blueprint of the 4-tube AC Screen Grid Diamond of the Air.
  - \$1.50 for which send RADIO WORLD for 13 weeks and send both blueprints free. (If renewing a subscription put cross here)

NAME .....  
ADDRESS .....  
CITY..... STATE.....



# ASKS AIR RULE BY COMMERCE DEPARTMENT

Washington.

A plan to have the Department of Commerce reassume regulation of radio was proposed by Representative Kelly (Rep.), of Pittsburgh, Pa.

Mr. Kelly, a majority member of the House Committee on Post Offices and Post Roads, has been studying both postal conditions and radio progress for a number of years. He believes there should be a reform in governmental procedure with respect to the handling of radio and is one of a group in Congress who have taken special interest in radio legislation. This group includes Senator Couzens (Rep.), of Michigan; Senator Dill (Dem.), of the State of Washington; Senator White (Rep.), of Lewiston, Me., and Representative Davis, (Dem.), of Tullahoma, Tenn., all of whom have been prominent in radio legislation.

### Favors Responsible Government

"My idea," Representative Kelly said, "is to leave the regulation of the radio to the Department of Commerce. I believe in responsible government. That means that wherever possible all these different independent Federal commissions should be placed under the appropriate departments instead of continuing as separate entities.

"The Department of Commerce is the logical agency for dealing with the problems of radio communication.

### Board May Be Continued

"It is, of course, quite likely that some extension of time may be necessary for the Commission in order to enable it to complete pending business that should be cleared up before it goes out of existence. But I believe that the ultimate power should be placed as soon as possible in the Department of Commerce, where it properly belongs today."

### REGULATION COSTS \$750,000

Radio regulation costs the Government \$750,000 annually, being disbursed between the Radio Commission and the radio division of the Department of Commerce. This expense is continually mounting, it is said, and it is not unlikely that in another year it will reach \$1,000,000. A large portion of this sum is expended in the technical and engineering department of radio, eventually benefiting the broadcaster and communication company.

# WGY Has Special Hours for Australia

A daily morning broadcast for the benefit of listeners in Australia and the far corners of the earth has been inaugurated by WGY and its associated short-wave transmitters, Schenectady, N. Y. The program, which includes news items, talks and music, is on the air between 6 and 7 a. m., Eastern Standard time, daily except Sunday. These broadcasts will be picked up in Eastern Australia at 9 p. m. the evening of the same day.

W2XAF, operating on the wave of 31.48 meters (9,530 kilocycles) will carry the program. This program is the result of numerous requests from listeners all through the Antipodes.

# AIR HAILED AS STUDY MEDIUM

In addition to its many other advantages in the cultural field, such as education in music and general entertainment of the masses, radio is also bringing a new educational opportunity to the American people, in the opinion of Charles W. Taylor, Superintendent of Public Instruction, State of Nebraska. Mr. Taylor said:

"They tell me that most of the 500 commercial stations are putting on talks of a more or less instructive sort—evidently because they believe that many of their listeners like something to think about now and then.

"We can see that radio may have quite surprising possibilities in many ways, for many people. College graduates who like to follow some of the subjects they had in college; high-school graduates who never had a chance for college; parents who have boys and girls away at school and like to follow what the youngsters are getting; people who are busy in store or office or shop all day but are ambitious to get ahead in their own line or in some other; blind and disabled and shut-in persons hungry for the interesting ideas they can't go out and get. These are some of the groups we can see would get a good deal from first-rate radio talks or courses.

"There is another interesting side to this question of broadcasting American education. The radio is coming into the schoolroom. This will never mean, I am told, that when the loudspeaker comes in the teacher goes out. It means only that the teacher can have, for a few minutes a day, the help of a specialist in some subject."

# EARL RECEIVER NAMED, DEBTS AT \$3,000,000,

On application recently made before him, Vice-Chancellor Church, in Newark, N. J., appointed Harry G. Hendricks and Oscar A. Klammer receivers for the Earl Radio Corporation of Clifton, N. J., and New York City, reputed to be one of the largest manufacturers of radio sets in the country.

The company had consented to the application for receivership and was instructed to show cause why the receivership should not be made permanent.

It is stated that 2,000 employees had been laid off and that the company had been running at 50 per cent. of its capacity and at a loss.

A petition filed by the Emeloid Company, of Kearny, N. J., stated that while the Earl company placed its assets at \$3,075,000 plus \$800,000 accounts receivable that a forced sale of the assets would not bring more than one-third.

This petition also set forth liabilities at more than \$3,000,000 to more than 200 creditors and states that the company has no ready cash and is insolvent.

Another petition filed by John A. Cozzone puts the assets at \$4,000,000, with liabilities of \$3,800,000. Among the larger creditors named are the Klammer Furniture Company, \$500,000; the Arc-turus Radio Corporation, tube manufacturers, \$250,000; the Westinghouse Electric & Manufacturing Company, \$56,000; the Scovill Manufacturing Company, \$150,000, and the Erickson Manufacturing Company, \$31,000. The Earl Radio Corporation's main offices are at 142 East 42d Street, New York City, and its factory at Clifton, N. J.

# Aristocrat Floor Speaker

With Mailed Wood Horn of 6 ft. 'see travel' (exponential type) with baffles and horn motor built in. Extraordinary bargain. **\$14.00**

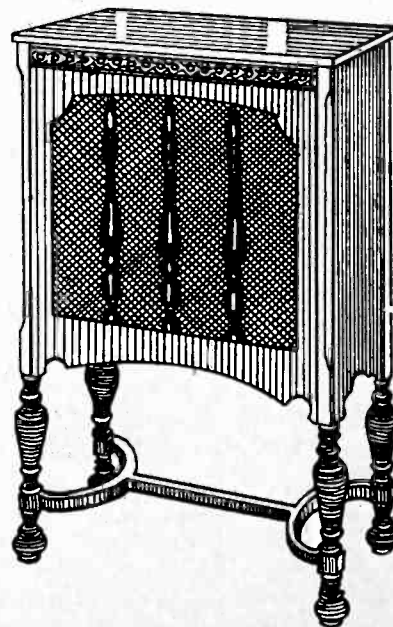

The speaker cabinet is walnut finish, 33" high, 24 1/2" wide, 17 1/2" deep, with carved legs. Golden cloth grille covers front opening. Built inside is No. 595 molded wood horn with baffle and No. 203 driving motor unit that stands 250 volts without filtration. Horn and motor removable. Table alone is worth price asked.

Shipped C.O.D. if desired.

Acoustical Engineering Associates  
143 WEST 45th STREET NEW YORK CITY

# SEPARATE TESTER COMBINATION

Consists of two-meter assembly in neat black metal case, with an external high resistance meter. The two meters in the case read (a) 0-20, 0-100 milliamperes; (b) 0-10 volts, AC or DC, same meter reads both. The external high resistance meter reads 0-600 volts, AC or DC (same meter reads both). Thus you can test any plate current up to 100 ma., any filament voltage, AC or DC, up to 10 V., and any plate voltage, or line voltage or other AC or DC voltage, up to 600 volts. Five-prong plug, screen grid cable, and 4-prong adapter included. Order Cat. ST-COMB @.....\$11.00 2-meter assembly, cable plugs, Cat. 215 @ \$7.00 0-600 AC-DC meter alone, Cat. M600 @ \$4.95



**\$11.00**  
As Illustrated

Guaranty Radio Goods Co., 143 West 45th St., N. Y. City



Your Choice of These Nine Meters FREE!

- 0-6 Voltmeter D.C. No. 329
- 0-50 Voltmeter D.C. No. 337
- 6-Volt Charge Tester D.C. No. 23
- 0-10 Amperes D.C. No. 336
- 0-25 Milliamperes D.C. No. 325
- 0-50 Milliamperes D.C. No. 350
- 0-100 Milliamperes D.C. No. 390
- 0-300 Milliamperes D.C. No. 399
- 0-400 Milliamperes D.C. No. 394

Equip Yourself Now With Necessary Meters!

To do your radio work properly you need meters. Here is your opportunity to get them at no extra cost. See the list of nine meters at left. Heretofore we have offered the choice of any one of these meters free with an 8-weeks subscription for RADIO WORLD, at \$1, the regular price for such subscription. Now we extend this offer. For the first time you are permitted to obtain any one or more or all of these meters free, by sending in \$1 for 8-week's subscription, entitling you to one meter; \$2 for 16 weeks, entitling you to two meters; \$3 for 26 weeks, entitling you to three meters; \$4 for 35 weeks, entitling you to four meters; \$5 for 44 weeks, entitling you to 5 meters; \$6 for 52 weeks, entitling you to six meters. Return this offer with remittance, and check off desired meters in squares at left.

RADIO WORLD will help you in your radio work, so you will be able to use the meters most valuably. Keep abreast of all the new circuits, intimate details on perfecting existing sets, and get inside track on sensitivity, distance reception, tonal quality, and news of radio, technical and non-technical. Enjoy the writings of Dr. Lee De Forest, McMurdo Silver, J. E. Anderson, Herman Bernard and a host of other radio engineers who contribute their knowledge to you through the medium of RADIO WORLD, the first and only illustrated national radio weekly. You can find no magazine that better caters to your needs than RADIO WORLD. Short waves? RADIO WORLD will tell you all about them. Extremely sensitive broadcast receivers? Their construction and operation are fully discussed with confident regularity. Power supplies—push-pull or otherwise? AC receivers? Screen grid tubes? Large receivers that give a super-abundance of performance—small, economical receivers that give performance out of all comparison to their size? Are you interested in these? Then you're interested in RADIO WORLD.

Present mail subscribers may renew their subscription under this remarkably generous offer. Put a cross in square.

RADIO WORLD

145 W. 45th St., N. Y. City—Published Weekly. All Newsstands. 15c per copy—\$3. six months—\$6 a year



GUARANTY RADIO GOODS CO. 143 West 45th Street, New York, N. Y.

One Tube? Two Tubes? Three Tubes? Four Tubes?

Circuits for Schoolboys—Easy to Build, Very, Very Inexpensive!

- A One Tube Receiver, parts costing \$4.28!
- A Two Tube Audio Amplifier, parts costing \$5.23!
- A Three Tube Speaker—Operating Circuit, parts costing \$11.10!
- A Four Tube Speaker—Operating Circuit, parts costing \$12.72!

The construction of these circuits, with a pictorial diagram as one of the illustrations, was described by Jack Tully, himself a schoolboy, in RADIO WORLD. See list below.

- Sept. 21st and 28th issues, One-Tube DX Set, by Jack Tully; two-part article.
- Oct. 5th, Three-Tube Single Dial Speaker Set, by Jack Tully.
- Oct. 12th, Two Stage Transformer, Coupled Audio Amplifier, by Jack Tully.
- Oct. 19th, Four-Tube DX Speaker Set, by Jack Tully. 15 cents a copy. Order at once while these copies are available.

RADIO WORLD, 145 W. 45th St., New York

Blueprint of the New One-Dial Push-Pull Battery Model SG DIAMOND

Full-sized picture diagram of the wiring, with list of parts. This 5-tube receiver is really superlative. It gives you screen grid radio frequency amplification and push-pull output, most economically.

Send \$1.00 today for this blueprint or order it shipped C. O. D.

RADIO WORLD

145 West 45th Street

Just East of Broadway New York City

EVERY WEEK in RADIO WORLD appears a feature article of intense interest to schoolboys. Parents and other relatives will bring great delight to youngsters by sending \$3 for a 6 months' subscription for RADIO WORLD (26 issues) in the youngster's name.—RADIO WORLD, 145 West 45th Street, New York City.

SUBSCRIBE NOW!

RADIO WORLD, 145 West 45th St., New York City. Enclosed please find my remittance for subscription for RADIO WORLD, one copy each week for specified period:

- \$6 for one year, 52 issues.
- \$3 for six months, 26 issues.
- \$1.50 for three months, 13 issues.
- This is a renewal of an existing mail subscription (Check off if true).

Your name .....

Address .....

City .....

LACAULT'S BOOK

GIVES YOU A FINE UNDERSTANDING OF the SUPER-HETERODYNE

R. E. LACAULT, E.E., I.R.E., who died recently, was one of the outstanding authorities on the Super-Heterodyne. He wrote a book, "Super-Heterodyne Construction and Operation," that explains in a non-technical manner the phenomena associated with a Super-Heterodyne. More, it gives a clear outline of the way such a receiver functions, and naturally gives the clues to solving virtually all the troubles that may arise in a Super.

So thoroughly did Lacault do his work that he covered associated topics, thus making his book a sidelight on radio in general, including advice on trouble-shooting.

Therefore the service man, the home experimenter, the custom set builder and the student will welcome this book.

It consists of 103 pages and includes 68 illustrations. It is bound in maroon buckram.

There are three valuable tables in the book, also. One classifies harmonics into groups, e.g., sound, radio, short waves, heat, light, chemical rays, X-rays and "unknown." Another is a trouble-shooting chart, classifying "trouble experienced" and "causes" and referring to the text for specific solutions. The third is a table for converting broadcast frequencies to wavelengths (accurate to .1 of a meter) or for converting the wavelength into frequency.

THE book begins with a comparison of alternating and direct current and proceeds to a discussion of the relation of wavelength to frequency. Then tuning is explained.

Condensers, coils, induction, vacuum tube operation and testing, earphones and speakers, rectification, oscillation, grid condenser action, modulation, grid bias detection, regeneration, beat notes, frequency changing, audio amplification, batteries, aerials, loops, wiring, sockets, and shielding are only some of the other important topics covered.

Besides, there is an entire chapter on the construction of a Super-Heterodyne receiver, with list of parts, front, top and rear views of set, front panel layout, shield dimensional drawings, schematic diagram of wiring and picture diagrams of the top and bottom views of the subpanel.

You Can Get This Book At Once!

You will want this book not only for present reading but also for future reference. It is authoritative and highly informative. Send for it now! It's free with each order for an eight weeks' subscription for RADIO WORLD. Present subscribers may renew under this offer. Their subscriptions will be extended eight weeks. Please use coupon.

RADIO WORLD, 145 W. 45th St., N. Y. City (Just East of Broadway)

Gentlemen: Enclosed find \$1.00. Please enter my subscription for RADIO WORLD for eight weeks at \$1.00 and send me at once one copy of R. E. Lacault's "Super-Heterodyne Construction and Operation," FREE!

I am a subscriber at present. (Check off if true.)

Name .....

Address .....

City..... State.....

5-DAY MONEY-BACK GUARANTEE

If C. O. D. desired, put cross here.

Component Parts

for

PUSH-PULL BATTERY DIAMOND

[Check off parts you want. Each part is sold separately.]

- L1L2—Antenna coil RF3 @ ..... \$ 0.80
- L3L4L5—3-circuit SG coil SGT3 @ ..... 1.30
- L6—Push-pull output transformer ..... 2.83
- T1—Push-pull input transformer ..... 3.41
- CT—80 mfd. equalizer ..... .35
- C1, C2—Two .00035 mfd. ext. shafts @ 98c ..... 1.96
- C3, C5—Two .01 mfd. mica condensers ..... .70
- R—One 6.5 ohm filament resistor ..... .25
- R1, Sw—One 75 ohm switched rheostat. .... .80
- R2, C4—2 meg. Lynch leak, grid clip condenser ..... .51
- R3—One .25 meg. .... .30
- R4—One 5.0 meg. .... .30
- R5—One 1.3 ohm filament resistor..... .20
- Ant., Gnd., Sp. (+) Sp. (-)—Four posts @ .10 ..... 1.40
- One drilled front panel 7x18" ..... 1.85
- One socketed, self-bracketing metal sub-panel, all holes drilled..... 3.50
- One National new modernistic drum dial with color wheel, pilot bracket, 6v. lamp, hardware, knob ..... 3.13
- Two matched knobs for rheo. and tickler @ .18 ..... .36
- Five vari-colored cable leads @ .07..... .35
- Flexible link and insulated shaft..... .55
- One screen grid clip..... .06
- All parts ..... \$23.91

GUARANTY RADIO GOODS CO., 143 W. 45th St., N.Y.C. (Just East of Broadway)

Enclosed please find \$..... for which please mail at once the parts for the Push-Pull Battery Model Diamond of the Air as checked off above.

If ordering C.O.D. put check mark here.

Name .....

Address .....

City..... State.....

TRIAL SUBSCRIPTION, 8 WEEKS, \$1.00. Send \$1 and we will send you Radio World for 8 weeks, postpaid. RADIO WORLD, 145 West 45th St., N. Y. City.

"AERIAL NAVIGATION and METEOROLOGY." By Capt. Yancey. \$4.00 postpaid. Radio World, 145 W. 45th St., N. Y. City.

# 0-60,0-300 HIGH RESISTANCE DC VOLTMETER

With three 28" tipped leads built in

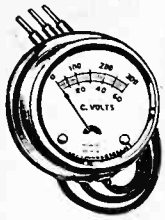

A portable type, high resistance meter, 2 3/4" outside diameter, for close reading of direct current voltages up to 60 volts, and for reading DC voltages up to 300 volts. Three vari-colored 28" insulated leads, with jack tips, are built in. Black is minus, yellow is 0 volts maximum and red is 300 volts maximum. These voltages are marked at the meter outlets. Cat. J-246. Net price, \$2.28.

J-246 Voltmeter, for measuring all direct current voltages, including B eliminators. 0-60, 0-300 (double range).

Multipplier, with jack terminals, to increase range 0-300 range to 0-600. Cat. J-108JT (with jack terminals), net price, \$1.18.

**GUARANTY RADIO GOODS CO.**  
143 West 45th St., N. Y. City

# MORECROFT

New second edition of "Principles of Radio Communication," by Prof. John H. Morecroft, of the Electrical Engineering Department of Columbia University and past president of the Institute of Electrical Engineers. This is an outstanding and authoritative book on the subject.

This large book on radio principles and practice is something that you must not be without. Every set builder, every designer, every engineer, every service man, simply must have this book. Ready reference to all intricate problems makes this volume invaluable. Set builders, experimenters, distributors, dealers, salesmen and teachers, students and operators, all find Morecroft their standby, and now the new second edition awaits you. 1,001 pages and 87 illustrations in this cloth-bound volume.

Price ..... \$7.50

**RADIO WORLD**  
145 West 45th Street  
New York City  
(Just East of Broadway)

RADIO WORLD'S BOOK SERVICE has been found of great value not only by radio fans, constructors, etc., but also by radio and other technical schools throughout the country. See the radio books advertisements in this issue.

All Parts for

## HB33-\$28.33

## HB44-\$46.44

THE HB33 is a three-stage screen grid radio frequency amplifier, with screen grid power detector, all shielded, 112A first audio and 112A push-pull output. Single dial control, seven-tube circuit. Price includes all parts and crackle brown finish drilled cabinet. Order Cat. HB33 at \$28.33 (less tubes).

THE HB44 is the same fundamental circuit as the HB33 but is for AC operation. Three stages of screen grid RF, with screen grid power detector, all shielded, 227 first audio and 245 push-pull output. Single dial control 7-tube circuit and 280 rectifier, 8 all told. Price includes all parts, including power equipment, socketed subpanel (8 sockets, including one for 280 rectifier) and crackle brown finish drilled cabinet. Order Cat. HB44 at \$46.44 (less tubes).

**GUARANTY RADIO GOODS CO.**  
143 West 45th Street  
New York, N. Y.

(Just East of Broadway)

- Remittance with order.
- Ship C. O. D.

**RADIO WORLD, 145 W. 45th St., N. Y. City.**  
(Just East of Broadway)

Enclosed please find \$3.00 for which please send one aluminum subpanel 10x20" for the new battery model 4-tube SG Diamond of the Air, with sockets built in, and with self-bracketing front and side and rear supports; also send hardware and insulating washers.

Enclosed please find \$2.35 for which please send 7x21" drilled Bakelite front panel for the new battery model Diamond.

Enclosed please find \$3.25 for the 10x20" aluminum subpanel, etc., for the new AC Screen Grid Diamond.

Enclosed please find \$2.35 for the 7x21" drilled Bakelite front panel for the new AC Screen Grid Diamond.

Enclosed please find \$5.00 for both the aluminum subpanel, etc., and the drilled Bakelite front panel of the battery model.

Enclosed please find \$5.25 for both the aluminum subpanel, etc., and the drilled Bakelite front panel of the AC model.

Name .....  
Address .....  
City ..... State .....

## For That Boy at Christmas Time

Why not have us send him RADIO WORLD for the coming year and keep him abreast of all that is going on in radio? Besides, every week RADIO WORLD will carry him a message that suggests your thoughtfulness.

Also, on receipt of your \$6, we shall take pleasure in sending him a special letter to the effect that you have requested us to put his name on our subscription list for 52 issues.

Subscription Dept., RADIO WORLD, 145 W. 45th St., N. Y. C.

### RECENT NUMBERS

for the current year are procurable at the rate of 15c a copy, or 8 copies for \$1.00. RADIO WORLD, 145 West 45th St., N. Y. City.

"AERIAL NAVIGATION and METEOROLOGY." By Capt. Yancey. \$4.00 postpaid. Radio World, 145 W. 45th St., N. Y. City.

## BROADWAY-HOLLYWOOD

World's most intriguing places. Where famous stage, screen, radio stars live their lives. Intimate stories of their stage and personal doings in

**NEW STAR** National Illustrated Amusement Weekly

Edited by Roland Burke Hennessy. Clever writers cover comedy, tragedy, fascination of professional life. Portraits and unusual pictures of favorites. 10c copy, \$5 year (52 issues). SPECIAL: 12 issues \$1 and experts answer your questions. FREE. STAR, 1562 Broadway, New York.

## PUBLISHERS CAN SUPPLY ALL 1929 SUMMER COPIES OF RADIO WORLD

If you have missed any copies of Radio World for the summer of 1929 and want to complete your file, let us know what issues you are short and we will mail them to you at 15c a copy, or any seven issues for \$1.00, mailed postpaid.

Circulation Dept., Radio World, 145 W. 45th St., N. Y. City.

## FILL OUT AND MAIL NOW SUBSCRIPTION BLANK RADIO WORLD

RADIO WORLD

145 West 45th Street, New York City

Please send me RADIO WORLD for ..... months, for which

### SUBSCRIPTION RATES:

- Single Copy.....\$ .15
- Three Months..... 1.50
- Six Months..... 3.00
- One Year, 52 Issues..... 6.00
- Add \$1.00 a Year for Foreign Postage; 50c for Canadian Postage.

please find enclosed

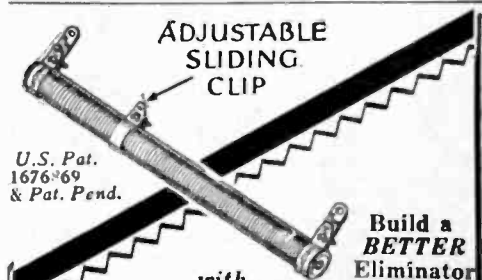

ADJUSTABLE  
SLIDING  
CLIP

U.S. Pat.  
1676'69  
& Pat. Pend.

Build a  
**BETTER**  
Eliminator

## TRUVOLTS

—the SAFE resistances for radio battery eliminators and power packs. Heavy nichrome wire uniquely wound for maximum air-cooling insures greater accuracy and durability. Fixed models have sliding clip for setting at exact value desired. All usual sizes.

TRUVOLT Variable has knob control and one-hole mounting. Lasts longer due to endwise travel of contact over wire. 22 sizes—\$2.50 each.



175 Varick St., New York, N.Y.

## ELECTRAD

Mail Coupon  
For Details

ELECTRAD, INC., Dept. RW-127, 175 Varick St., New York, N. Y. Please send TRU-  
Name .....  
Address .....

## New 228, High Gain Detector for AC Sets

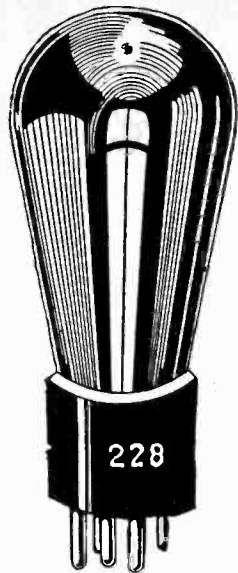

Kelly 228 Special Detector for AC circuits has a high mu. (Amplification factor) and increases sensitivity.

**I**NCREASE the sensitivity of modern AC-operated circuits by substituting the new Kelly 228 AC detector, a high mu tube (large amplification), for the 227 tube otherwise used. The result is immediately obvious in the greatly increased volume. Otherwise weak, distant stations come in stronger and tone quality is improved. Simply substitute the 228 for the 227. No wiring change of any kind is required.

If an AC receiver uses resistance-coupled or impedance-coupled first audio stage, where the resistor or coil is in the plate circuit of the first audio tube, the 228 may be used as audio amplifier, too. It is not suitable as a radio frequency amplifier.

### CHARACTERISTICS OF THE KELLY 228

Heater voltage 2.5 volts AC.  
Heater current 1.75 amperes.  
Amplification factor 45.  
Mutual conductance 1,000.  
Plate voltage 180 volts.

Grid bias, detector -6 volts.  
Grid bias, amplifier -2.5 volts.  
Load resistance, 0.1 to 0.5 meg.  
Internal plate resistance 45,000 ohms.

**\$2.50** NET PRICE

## Screen Grid Tubes

**T**HE Kelly screen grid tubes are of two types: the 222 for storage-battery operation of the filament, and the 224 for AC operation of the filament. The tubes are similar but not identical. Either type may be used as radio frequency amplifier, detector or, with resistor plate load, as audio amplifier.

The 222 has four prongs and fits into the regular UX socket. The 224 has five prongs and requires the special five-spring UY socket. The control grid is the cap of the tube.

The filament voltage of the 222 is 3.3 volts, the plate voltage 135, the screen grid voltage 45 volts or less. The heater voltage of the 224 is 2.5 volts AC, the plate voltage 180, the screen grid voltage 75 volts or less.

The net price of the 222 is \$3.50, while the net price of the 224 is \$3.00.

## Other Tubes

The line of Kelly tubes includes, besides the 228, 222 and 224, the following types: 245, 226, 227, 171A, 280, 240, 112A, 201A and UX199. The 240 is a high mu tube for battery operation of the filament. It is suitable as detector or audio amplifier where a resistor of .25 meg. or an impedance coil is in the plate circuit.

You run no risk whatever when you purchase Kelly tubes. Not only are they expertly made but they are sold on a 5-day money-back guarantee. This exclusive form of protection enables you to be the ultimate judge in your own laboratory or your own home, with no appeal from your decision on our part. If you are not delighted with the performance of Kelly tubes your money will be promptly refunded on the foregoing 5-day basis.

**GUARANTY RADIO GOODS CO., 143 West 45th St., N. Y. City.**  
Enclosed please find \$..... for which ship at once Kelly tubes marked below:

- |  |   |
|--|---|
| <input type="checkbox"/> 228 AC high mu. ....\$2.50          | <input type="checkbox"/> 171A power tube .....\$0.95                                |
| <input type="checkbox"/> 224 AC screen grid .....\$3.00      | <input type="checkbox"/> 201A battery tube .....\$0.65                              |
| <input type="checkbox"/> 245 AC power tube .....\$2.75       | <input type="checkbox"/> UX199 battery tube .....\$1.25                             |
| <input type="checkbox"/> 226 AC amplifier .....\$0.85        | <input type="checkbox"/> Matched pair of 245s for push-pull (for both) .....\$4.50  |
| <input type="checkbox"/> 227 AC det.-amp. ....\$1.50         | <input type="checkbox"/> Matched pair 171As for AC push-pull (for both) .....\$1.90 |
| <input type="checkbox"/> 280 AC rectifier .....\$1.75        | <input type="checkbox"/> Matched pair of 112As for push-pull (for both) .....\$1.90 |
| <input type="checkbox"/> 222 battery screen grid .....\$3.50 |   |
| <input type="checkbox"/> 240 battery high mu. ....\$1.25     |   |
| <input type="checkbox"/> 112A power tube .....\$0.95         |   |

**ALL PRICES QUOTED ARE SELLING PRICES AND ARE NET.**  
Name.....  
Address.....  
City..... State.....  
 Put cross here if C.O.D. shipment is desired.  
Canadian remittance must be by postal or express money order.

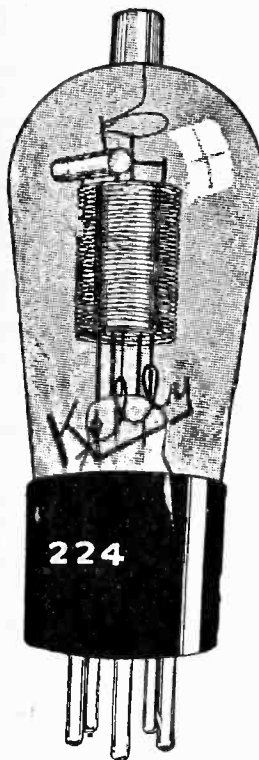

Kelly 224 Screen Grid Tube assures best tube performance in the most up-to-date AC circuits using screen grid tubes.

# MICROPHONE LIGHTERS

for cigars or cigarettes, with button switch at top. Press the switch and light up!

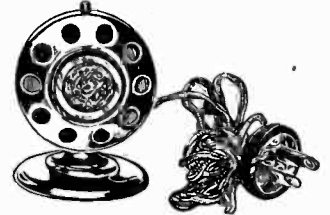

Model A lighter, microphone design, with 5-ft. AC cable and plug. Works on 110 volts, AC any frequency and on direct current. Price \$1.00



Model B lighter, microphone design, on tray, with 5-ft AC cable and plug. Works on 110 volt AC, any frequency, and on direct current. Exactly the same lighter as the other, only tray is added. Price.....\$1.50

This lighter is instantaneous. Hold button down only long enough to light a cigar or cigarette. The two models are furnished in attractive sprayed finish. Both are very compact! For instance, the tray is only 4 1/2" in diameter. Use these lighters in your home and for holiday gifts.

The heater element is renewable.

- RADIO WORLD, 145 West 45th St., N. Y. City**  
 Please send me Model A Microphone Lighter at \$1.00  
 Please send me Model B at \$1.50.  
 Enclosed is remittance [Canadian must be P.O. or express money order.]  
 Ship C. O. D.

Name.....  
Address.....  
City..... State.....

# New DRAKE'S ENCYCLOPEDIA

A reference work that has subjects classified in alphabetical order.

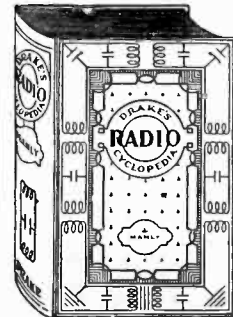

Each rule, fact, method, plan, layout and diagram is instantly picked out and separated from everything else by placing all subjects in alphabetical order with cross references for every imaginable name under which the information might be classed.

This alphabetical arrangement lets the experienced worker refer directly to the one thing in which he is interested at the moment without hunting through non-essentials. The needs of the beginner are cared for.

The important articles deal primarily with receivers and reception. They do not stop with the electrical end, but go also into the mechanics of construction.

- Every new thing in radio is covered in detail.  
1,680 Alphabetical Headings from A-battery to Zero Beat  
1,025 Illustrations, Diagrams, Layouts and Graphs  
920 Pages, Each 6 by 9 inches  
240 Combinations for Receiver Layouts

### OF THE PRINCIPAL ARTICLES

159 Concern service men, 129 help the set builder, 182 help the experimenter, 155 interest the student, 75 assist in sales work, 73 interest set owners.

**PRICE, \$6.00**

Remit with order and we pay cartage. Canadian remittance must be by postal or express money order  
Order C. O. D. and you pay cartage.

**RADIO WORLD, 145 W. 45th St., N. Y. City**

# SUBSCRIBERS!

Look at the Expiration Date on Your Wrapper

Please look at the subscription date stamped on your last wrapper, and if that date indicates that your subscription is about to expire, please send remittance to cover your renewal.

In this way you will get your copies without interruption and keep your file complete.

SUBSCRIPTION DEPARTMENT  
**RADIO WORLD**  
145 WEST 45TH ST., N. Y. CITY

# 4-GANG CONDENSER

With Trimmers Built in **\$3.95**

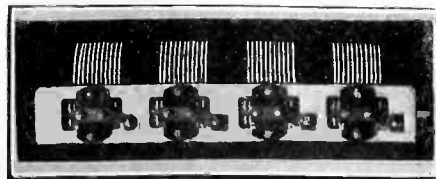

Capacity of each of the four sections is .00035 mfd. Overall length 1 1/2". Accurate capacity and precise alignment.

Guaranty Radio Goods Co.  
143 West 45th Street,  
New York City  
[Just East of Broadway.]

# RADIO WORLD BOOK SERVICE

AS the first and only national radio weekly, now in its eighth year, RADIO WORLD publishes the most timely, up-to-date news of radio circuits and events in the set-building and broadcasting fields. Technical accuracy second to none. Get a copy at your news-stand today, 15c. RADIO WORLD advises impartially on all radio topics, including what text books to buy, and helps you to read the books properly. Every book advertised on this page is essential to your radio library.

## Five New Volumes Offer Short-Cut to Knowledge!

### MORECROFT

#### "Elements of Radio Communication"

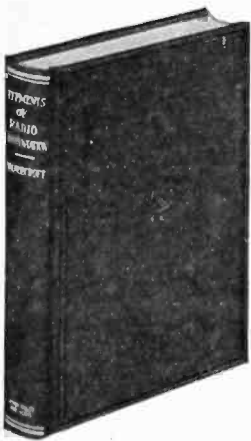

The latest book by Prof. John H. Morecroft, of the Engineering Department of Columbia University, and past president of the Institute of Radio Engineers, is his "Elements of Radio Communication," a book for the novice to enjoy. We regard this as the best elementary book to inform you authoritatively on the technical phases of radio in plain language, without requirement of mathematical knowledge. The book is a complete course on the elements of radio, containing much material never before published. It has 226 pages, 170 illustrations and a complete index. Just out, it is the book of the year in radio. Cloth bound. Order Cat. ME @ .....\$3.00

By the same author: "Principles of Radio Communication," second (new) edition. This book is for advanced students. It is the standard of excellence in its field. It covers much the same ground as the later book, only much more fully and more technically. Contains 1,001 pages, 831 illustrations. Cloth bound. Order Cat. MP @ .....\$7.50

### MOYER and WOSTREL

#### "Radio Receiving Tubes"

The need for an elementary book on radio tubes that answers all the important questions has been filled by James A. Moyer, Director of University Extension, Massachusetts Department of Education, and John F. Wostrel, Instructor in Radio Engineering, Division of University Extension, Massachusetts Department of Education.

This new book is a complete discussion of tube principles, functions and uses, thoroughly up-to-date. In this book the essential principles underlying the operation of vacuum tubes are explained in a non-technical manner as is consistent with accuracy. The book covers the construction, action, reactivation, testing and use of vacuum tubes as well as specifications for vacuum tubes and applications for distant control of industrial processes and precision measurements. 297 pages, cloth bound. Order Cat. MWT @ .....\$2.50

By the same authors: "Practical Radio," including the testing of radio receiving sets, 378 pages, 228 illustrations. Cloth bound. Order Cat. MWPR @ .....\$2.50  
"Practical Radio Construction and Repairing," 319 pages, a companion volume. Order Cat. MWPRC @ .....\$2.00  
[NOTE: The standard book on tubes for advanced students is "The Thermionic Vacuum Tube," by Hendrik Van der Bijl. Order Cat. VDB @ .....\$5.00]

### ANDERSON and BERNARD

#### "Power Amplifiers"

Here is the first book to be published on the subject of "Power Amplifiers." Now printing, it is certain to fill a void in radio literature. The whole subject is fully covered in a masterful theoretical discussion of audio amplifiers and power supplies, supplemented by constructional chapters, with complete wiring diagrams and specification of parts. Learn while you build! J. E. Anderson, M. A., technical editor of RADIO WORLD, and Herman Bernard, L. L. B., managing editor of RADIO WORLD, both of the Institute of Radio Engineers, have explained fully the phenomena of power amplifiers. Learn all about motorboating and its cures, push-pull theory and practice, grid bias methods and effects, vacuum tubes in audio circuits, AC and battery type AF amplifiers, phase relationships, common impedance, filter systems, by-pass condenser effects, necessities for tone quality, values of coupling constants, and a host of other topics associated with power amplification, including speech amplifiers and "talkie" installations.

More than 200 pages and more than 100 illustrations are devoted to an analysis of this outstanding radio subject. "Power Amplifiers" is authoritative, original and comprehensive. It is free from the traditional errors that have crept into this subject. The theoretical part of the book can be understood by most novices, while the constructional part, that capitalizes the previously imparted knowledge, is thoroughly understandable by anybody. There is virtually no mathematics in the book. Cloth bound. Order Cat. PAM @ .....\$3.50

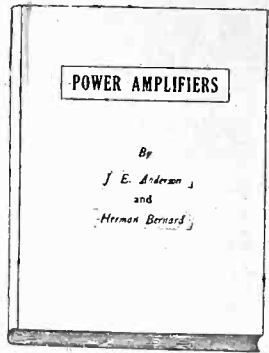

### RIDER

#### "Service Man's Manual"

Two new books by John F. Rider, R. E., Member, Institute of Radio Engineers, constitute the series grouped by him under the heading "Service Man's Manual." Part I is "Mathematics of Radio." Part II is "Trouble Shooter's Manual."

The value of one of these books is more than doubled by the possession of the other.

"The Mathematics of Radio," 128 pages, 8 1/2 x 11", 119 illustrations, bridges the gap between the novice and the college professor. It gives a theoretical background so necessary for a proper understanding of radio and audio circuits and their servicing. Flexible cover. Order Cat. MOR @ .....\$2.00

The first comprehensive volume devoted exclusively to the topic uppermost in every service man's mind is "Trouble Shooter's Manual," just published. It is not only a treatise for service men, telling them how to overcome their most serious problems, and fully diagramming the solutions, but it is a course in how to become a service man. It gives all the details of servicing as they have never been given before. Finding the right mode of attack, applying the remedy promptly and obtaining the actual factory-drawn diagrams of receivers always have been a big load on the service man's chest. But no more. Rider, expert on trouble shooting, has produced the outstanding volume on servicing, and has taken the load off the service man's chest!

This book is worth hundreds of dollars to any one who shoots trouble in receivers—whether they be factory-made, custom-built or home-made receivers. The home experimenter, the radio engineer, the custom set-builder, the teacher, the student—all will find this new book immensely informative and absolutely authoritative.

MORE THAN 100 WIRING DIAGRAMS OF RECEIVERS MADE BY MORE THAN FORTY DIFFERENT SET MANUFACTURERS ARE PUBLISHED IN THIS BOOK, INCLUDING OLD MODELS AND LATEST MODELS: RCA, ATWATER KENT, CROSLEY, MAJESTIC, ZENITH, STROMBERG CARLSON, KOLSTER, FEDERAL, FADA, Etc. 240 pages, size 8 1/2 x 11"; 200 illustrations. Imitation leather cover. Order Cat. TSM @ .....\$3.50

## FREE! Read Radio World Every Week



RADIO WORLD will help you in your radio work, so you will be able to use meters most valuably. Keep abreast of new circuits, intimate details on perfecting existing sets, get inside track on sensitivity, distance reception, tonal quality, and news of radio, technical and non-technical. Enjoy the writings of McMurdo Silver, J. E. Anderson, Herman Bernard, John F. Rider and a host of other radio engineers in RADIO WORLD. You can find no magazine that better caters to your needs than RADIO WORLD. Short waves? RADIO WORLD will tell you all about them. Extremely sensitive broadcast receivers? Their construction and operation are fully discussed with confident regularity. Power supplies—push-pull or otherwise? AC receivers? Screen grid tubes? Large receivers that give a super-abundance of performance—small, economical receivers that give performance out of all comparison to their size? Are you interested in these? Then you're interested in RADIO WORLD.

See the list of nine meters at left. Obtain one or more of these meters free, by sending in \$1 for 8-weeks' subscription, entitling you to one meter; \$2 for 16 weeks, entitling you to two meters; \$3 for 26 weeks, entitling you to three meters; \$4 for 35 weeks, entitling you to four meters; \$5 for 44 weeks, entitling you to 5 meters; \$6 for 52 weeks, entitling you to six meters.

Present RADIO WORLD mail subscribers may renew their subscription under this remarkably generous offer. Put a cross in square.

### RADIO WORLD

145 W. 45th St., N. Y. City—Published Weekly.  
All Newsstands, 15c per copy—\$3, six months—\$6 a year

Gentlemen: Enclosed find \$..... for which please send items checked on coupon. (R -10)

- 0-6 Voltmeter D.C. .... Cat. 326
- 0-50 Voltmeter D.C. .... Cat. 337
- 0-Volt Charge Tester D.C. .... Cat. 23
- 0-10 Amperes D.C. .... Cat. 339
- 0-25 Milliamperes D.C. .... Cat. 325
- 0-50 Milliamperes D.C. .... Cat. 350
- 0-100 Milliamperes D.C. .... Cat. 390
- 0-300 Milliamperes D.C. .... Cat. 399
- 0-400 Milliamperes D.C. .... Cat. 394

- CAT. ME @ .....\$3.00
- CAT. MP @ .....\$7.50
- CAT. PAM @ .....\$3.50
- CAT. MWT @ .....\$2.50
- CAT. MWPR @ .....\$2.50
- CAT. MWPRC @ .....\$2.00
- CAT. MOR @ .....\$2.00
- CAT. TSM @ .....\$3.50
- CAT. VDB @ .....\$5.00
- CAT. ....326 Name .....
- CAT. ....337
- CAT. ....23
- CAT. ....338
- CAT. ....325 Address .....
- CAT. ....350
- CAT. ....390
- CAT. ....399
- CAT. ....394 City..... State.....

PLEASE GIVE US TWO WEEKS for changing your address, showing new renewal expiration date, etc. Subscription orders are arriving in such large numbers that it takes two weeks to effectuate the change. RADIO WORLD, 145 West 45th St., N. Y. City.

TRIAL SUBSCRIPTION  
Send \$1 for trial subscription for 8 weeks, starting with current issue, or of any recent issue. Radio World, 145 W. 45th St., N. Y. City.

A GREAT ADVERTISING MEDIUM!  
That describes Radio World. Rates on application. Radio World, 145 W. 45th St., N. Y. City.

# Power Amplifier Equipment

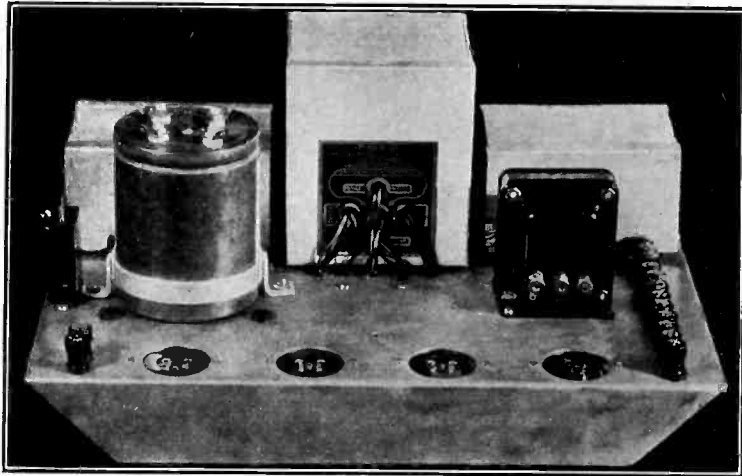

At left is illustrated a push-pull power amplifier, using a first stage of resistance coupled audio, 280 rectifier and two 245s in push-pull, as described in the November 2d issue of Radio World. Abounding volume and faithful tone reproduction are assured. The Polo Filament-Plate Supply, two Polo center-tapped audio chokes and a Multi-Tap Voltage Divider are used, with a Q 2-8, 2-18 Mershon condenser, an input push-pull audio transformer and auxiliary equipment. The total parts, including cadmium-plated steel sub-panel, come to \$43.57 net, the best power amplifier for that modest amount. Provision is made for phonograph pickup plug insertion. Thirteen output voltages are provided, including 300, 180, 75, 50 and an assortment of nine different voltages under 50 available for bias. All A, B and C voltages are provided for the power amplifier and for a tuner to be used with it employing 227, 224 or 228 tubes. Order Cat. PO-245-PA @ \$43.57 net, for 50-60 cycles, 110 volts. [For 25 cycles order PO-245-PA-25 @ \$48.57. For 40 cycles order PO-245-PA-40 @ \$46.07.]

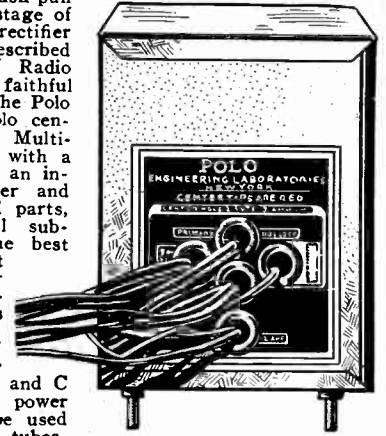

Polo 245 Filament Plate Supply (less chokes) has four windings, all save primary center-tapped (red), is 4 1/2" wide, 5" high, 4" front to back. Weight, 9 lbs. Filament windings, 2.5 v. at 12 amps., 2.5 v. at 3 amps. (for 245 filaments), 5 v. at 3 amps. for 280 rectifier, and 724 v. @ 100 m.a., center-tapped. Order Cat. PFFS @ \$7.50. [For 25 cycles order Cat. PFFS-25 @ \$12.00.] [For 40 cycles order Cat. PFFS-40 @ \$10.00.]

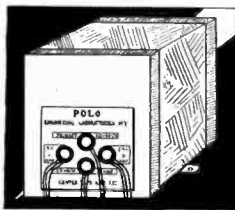

Polo Filament Transformer Only, four windings, consists of 50-60 cycles 110 v. winding, 2 1/2 v. at 12 amps., 2 1/2 v. at 3 amps., 5 v. at 2 amps. All windings, save primary, are center-tapped (red). Size, 4 1/2" high x 3 3/4" wide x 3" front to back. Weight, 6 lbs. Order Cat. PFT @ \$4.25. [For 25 cycles order PFT-25 @ \$7.00; for 40 cycles order PFT-40 @ \$6.25.]

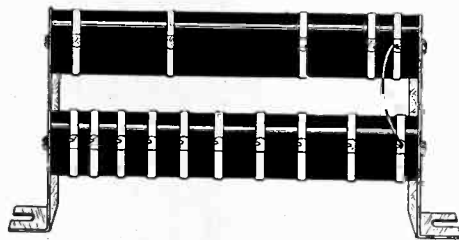

Two rugged, expertly engineered wire-wound, enamelled resistors, mounted in series, one atop the other, with fourteen useful lugs, providing all necessary choice of voltages without the uncertainty of adjustable variable resistance. The Multi-Tap Voltage Divider has a total resistance value of 13,850 ohms, in the following steps: 3,000, 4,500, 2,000, 800, 700, 600, 550, 500, 450, 400, 200, 100 and 50 ohms. With the zero voltage lug (at lower left) the total number of useful lugs is fourteen. The resistance stated are those between respective lugs and are to be added together to constitute 13,850 ohms total.

A conservative rating of the Multi-Tap Voltage Divider is 50 watts, continuous use. The unit is serviceable in all installations where the total current drain does not exceed 125 milliamperes.

Extreme care has been exercised in the manufacture of the Multi-Tap Voltage Divider. It is mounted on brackets insulated from the resistance wire that afford horizontal mounting of the unit on baseboards and subpanels.

There long has been a need for obtaining any necessary intermediate voltage, including all biasing voltages, from a Multi-Tap Voltage Divider, but each lug has to be put on individually by hand, and soldered, so that manufacturing difficulties have left the market barren of such a device until now.

The Multi-Tap Voltage Divider is useful in all circuits, including push-pull and single-sided ones, where the current rating of 125 milliamperes is not seriously exceeded and the maximum voltage is not more than 400 volts. If good ventilation is provided, this rating may be exceeded 15 per cent.

The expertness of design and construction will be appreciated by those whose knowledge teaches them to appreciate parts finely made.

When the Multi-Tap Voltage Divider is placed across the filtered output of a B supply which serves a receiver, the voltages are in proportion to the current flowing through the various resistances. If a B supply feeds a receiver with two-stage audio amplifier, the last stage a single-sided 245, then the voltages would be 250 maximum for the power tube, 180, 135, 75, 50, 40, 35, 30, 25, 16, 10, 6 and 3. By making suitable connection of grid returns the lower voltages may be used for negative bias or even for positive voltage on the plates.

If push-pull is used, the current in the biasing section is almost doubled, so the midtap of the power tubes' filament winding would go to a lug about half way down. Order Cat. MTVD at \$3.95.

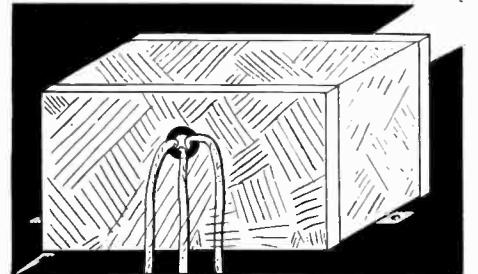

Center-tapped double choke, 125 m.a. rating, 30 henrys in each section. Used for filtering B supply or for a push-pull output impedance, where speaker cords go directly to plates of tubes. Center tap is red. Order Cat. PDC @ \$3.71.

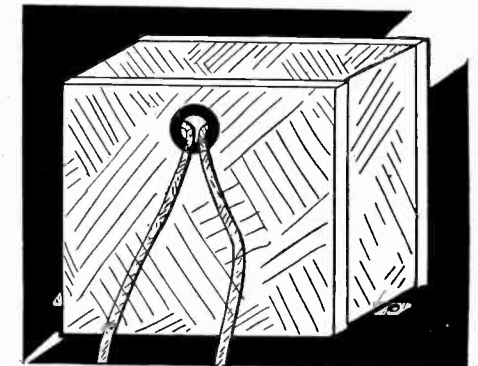

Single 30 henry 100 m.a. choke for filtered output (where condenser is used additionally) or for added filtration of a B supply. Order Cat. PSC @ \$2.50.

**By-pass Condensers**  
For by-passing B+ leads to ground or C minus from 200 v. post or less, where current is less than 10 m.a., 1 mfd. paper dielectric condensers are useful. Order LV-1 @ .....\$0.50 ea.

**Filter Condensers**  
For high voltage filtration next to the rectifier, use 1 or 2 mfd. The 2 mfd. makes the output voltage a little higher.  
Order Cat. HV-1 (1,000 v. DC, 550 v. AC) .....\$1.76  
Order Cat. HV-2 (1,000 v. DC, 550 v. AC) .....\$3.52

**Filament-Plate-Choke Block**  
Same as Filament-Plate Supply, except that two 50 henry chokes are built in. Six windings: primary, 110 v., 50-60 cycles; 2.5 v. at 12 amps.; 2.5 v. at 3 amps.; 5 v. at 2 amps.; 724 v. at 100 m.a.; choke. All AC windings center-tapped (red), except primary. Connect either end of a choke to one end of other choke for midsection. Order Cat. P-245-FPCH @ \$10.00 [For 40 cycles order P-245-FPCH-40 @ \$13.50.] [For 25 cycles order P-245-FPCH-25 @ \$14.50.]

**ACOUSTICAL ENGINEERING ASSOCIATES,**

143 West 45th St., N. Y. City.  
(Just East of Broadway.)

Please ship at once the following:

Quantity	Cat. No.	Product	Price
<input type="checkbox"/>	PO-245-PA	Power amp. parts, 50-60 c.	\$43.57
<input type="checkbox"/>	PO-245-PA-40	Same, 40 cycles	46.07
<input type="checkbox"/>	PO-245-PA-25	Same, 25 cycles	48.57
<input type="checkbox"/>	PFFS-40	Fil. plate supply, 50-60 c.	7.50
<input type="checkbox"/>	PFFS-25	Same, 40 cycles	10.00
<input type="checkbox"/>	PFT	Same, 25 cycles	12.00
<input type="checkbox"/>	PFT-40	Fil. trans., 50-60 c.	4.25
<input type="checkbox"/>	PFT-25	Same, 40 cycles	6.25
<input type="checkbox"/>	P-245-FPCH	Same, 25 cycles	7.00
<input type="checkbox"/>	P-245-FPCH-40	Power-filter block	10.00
<input type="checkbox"/>	P-245-FPCH-25	Same for 40 cycles	13.50
<input type="checkbox"/>	PDC	Same for 25 cycles	14.50
<input type="checkbox"/>	PSC	Double c.-t. choke	3.71
<input type="checkbox"/>	MTVD	Single choke	2.50
<input type="checkbox"/>	Q2-8, 2-18B	Multi-tap volt. div.	3.95
<input type="checkbox"/>	LV-1	Mershon with bracket	5.15
<input type="checkbox"/>	HV-1	200 v., 1 mfd. by-pass cond.	.50
<input type="checkbox"/>	HV-2	1,000 v., 1 mfd. filter cond.	1.76
<input type="checkbox"/>		1,000 v., 2 mfd. filter cond.	3.52

Enclosed please find check—money order—for the above. [Note: Canadian remittance must be by postal or express money order.]

Please ship C.O.D.

NAME.....

ADDRESS.....

CITY..... STATE.....

5-DAY MONEY-BACK GUARANTEE!

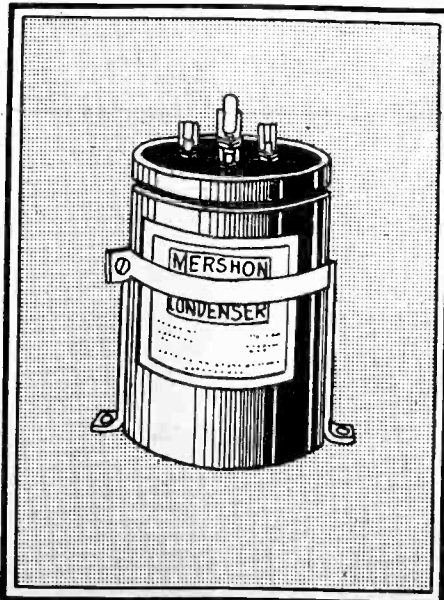

The Mershon electrolytic condenser, 415 volts DC, for filtering circuits of B supplies. Q 2-8, 2-18 has four capacities in one copper casing: two of 8 mfd. and two of 18 mfd. The copper case is negative. The smaller capacities are nearer the edge of the case. The vent cap should not be disturbed, and the electrolyte needs no refilling or replacement.

Mershon electrolytic condensers are instantly self-healing. Momentary voltages as high as 1,000 volts will cause no particular harm to the condenser unless the current is high enough to cause heating, or the high voltage is applied constantly over a long period.

High capacity is valuable especially for the last condenser of a filter section, and in by-passing, from intermediate B+ to ground or C+ to C-, for enabling a good audio amplifier to deliver true reproduction of low notes. Suitably large capacities also stop motor-boating.

Recent improvements in Mershons have reduced the leakage current to only 1.5 to 2 mils total per 10 mfd. at 300 volts, and less at lower voltages. This indicates a life of 20 years or more, barring heavy abuse.

In B supplies Mershons are always used "after" the rectifier tube or tubes, hence where the current is direct. They cannot be used on alternating current.

The Mershon comes supplied with special mounting bracket. Order **\$5.15** Q 2-8, 2-18 B @ .....

# What's Going to Happen Next Month?

IT'S easy enough to find out. If you are a radio dealer, jobber, service-man or radio salesman, we will tell you what to do in January and the months to follow. If you are not engaged in the business of radio merchandising, please do not communicate with us. Send us \$2.00, along with your business card or letterhead, proving that you are a radio business man, and we will send the next twelve issues of "RADIO" to you, starting with the great 126-page December number. Each month "RADIO" tells the radio merchant how to make more money SELLING RADIO. More than 35,000 radio dealers are now reading "RADIO." Subscriptions at the \$2.00 rate will be accepted during the month of December. Thereafter the rate is \$5.00 per year. Your money cheerfully refunded if you are not entirely convinced that "RADIO" is worth its weight in gold.

**Your Letter Head or Business Card Must Accompany  
Your Subscription. No Subscription Accepted  
From People Who Are Not in the Radio Business**

R.W.

**Publishers of "RADIO"**  
 415 Lexington Avenue New York, N. Y.  
 307 No. Michigan Avenue, Chicago, Ill.  
 428 Pacific Bldg., San Francisco, Cal.  
 86 St. Botolph Street, Boston, Mass.  
*(Send subscription to office nearest you.)*

**H**ERE is \$2.00 in full payment for a one year suscription to "RADIO" starting with the December issue. My business card or letterhead, proving that I am a radio merchant, is attached to this order.

Name .....

Street & No.....

City ..... State .....

I am a  Dealer     Jobber     Service Man     Salesman

(Please be sure to state which)

# Horn Unit \$2.25

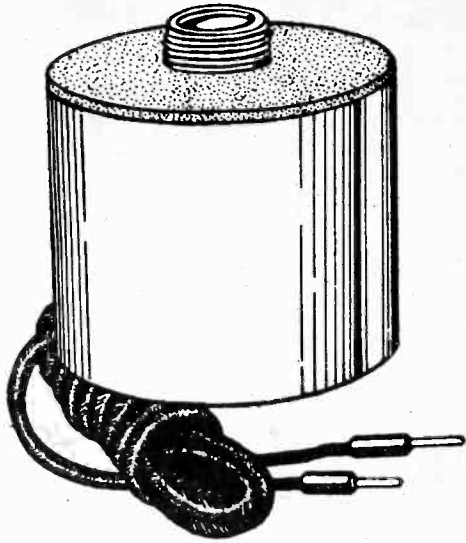

This unit is pre-eminent for horn-type speakers such as the exponential horns or other long tone travel horns. The faintest word from a "whispering tenor" or the tumultuous shout of the crowd or highest crescendo of the band is brought out clearly, distinctly. Stands up to 450 volts with out filtering. Works right out of your set's power tube, requiring no extra voltage source. Standard size nozzle and cap are die-cast aluminum, one piece, with milled platinum-like finish. The casing is full nickel, of highest possible polish. Works great from AC set, battery set or any other set, push-pull or otherwise.

### For Portable Use

This unit can be used in a portable without any horn attached and will give loud reproduction. Order Cat. 225, with 4 1/2 ft. cord attached . . . (Shipping weight, 2 lbs.) . . . \$2.25

### Air-Column Horn

8-ft. tone travel molded wood horn (less unit No. 225) is obtainable already mounted in a baffle box. Outside overall dimensions of baffle box, 21 1/4" high, 18" wide, 15" front to back. Shipping weight, 27 lbs. Order Cat. 596 @ \$8.00

Acoustical Engineering Associates, 145 W. 45th St., N. Y. City (Just E. of Bway). Please ship C. O. D.  Cat. No. 225 @ \$2.25  Cat. No. 596 @ \$8.00

Name .....  
Address .....  
City ..... State .....

FIVE-DAY MONEY-BACK GUARANTEE

# NATIONAL SCREEN GRID TUNER

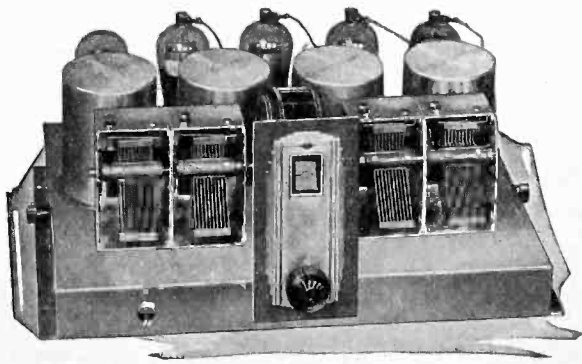

The most sensitive tuned radio frequency tuner so far developed, the MB-29 is long on distant reception, and penetrates seemingly unsurmountable barriers to reception. On the MB-29 the stations come in no matter where you are. The MB-29, designed by James Millen and Prof. Glen H. Browning, is the choice of the most discriminating. It is designed only for AC operation, uses four stages of screen grid RF and a power detector (227). Use 135 to 180 volts on the detector. Testimonials from radio's hardest-boiled experts prove this is the circuit of circuits. Buy the parts and find fullest radio delight. You will be sure nobody else has a tuner as good as yours, unless he too has an MB-29. Complete component parts for National Screen Grid Tuner MB-29, mounted on frosted aluminum chassis, including rainbow modernistic drum dial HC. Order catalog No. MB-29-K, list price, less tubes, \$69.50. Your price ..... **\$40.00**

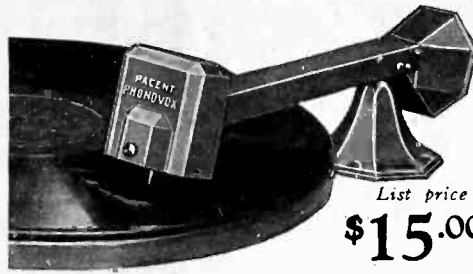

# PHONOGRAPH MUSIC

List price **\$15.00** is at its best

*Slightly higher west of the Rockies*

with the

# Super Phonovox

Plays records electrically through your radio with amazing tone realism and volume. New combination switch and volume control (with special adapter for screen grid tubes) switches instantly from radio to records without changing any connection. **English 36% Cobalt Magnets** provide extreme sensitivity. Hear it at your dealers. Two new low impedance models now available.

**PACENT ELECTRIC CO., INC., 91 SEVENTH AVE., N. Y.**

*Pioneers in Radio and Electric Reproduction for over 20 years*

*Manufacturing Licensee for Great Britain and Ireland: Igranic Electric Co., Ltd., Bedford, Eng. Licensee for Canada: White Radio Limited, Hamilton, Ont.*

# RADIO TONIC

When it comes to making sick radios well, or good radios better, just remember—

## CLAROSTAT

the name of a line of products dedicated to better radio results.

Clarostat Mfg. Co., 291 N. 6th St., B'klyn, N. Y.

# LYNCH

## TUBADAPTA

For Better TONE

List Price...\$2.50

Improves reception and prolongs life of expensive power tubes. Used in last audio stage. Write for descriptive circular and complete catalogue Lynch Guaranteed Radio Products. LYNCH MFG. CO., Inc., 1775 B'way, N. Y.



# SUBSCRIBERS! Look at the Expiration Date on Your Wrapper

Please look at the subscription date stamped on your last wrapper, and if that date indicates that your subscription is about to expire, please send remittance to cover your renewal. Please give our subscription department two weeks to make changes in expiration dates, street addresses, etc.

In this way you will get your copies without interruption, and keep your file complete.

SUBSCRIPTION DEPARTMENT  
RADIO WORLD, 145 West 45th St., N. Y. City

# MB-29

## Push-Pull Amplifier

The National Velvetone Push-Pull Power Amplifier (shown at right) consists of an AC-operated filament-plate supply, with two stage transformer audio amplifier and output transformer built in. Made only for 110-V., 50-60 cycles. Sold only in completely wired form, licensed under RCA patents.

The new Power Amplifier has been developed and built to get the very most out of the MB-29. It is a combination power supply and audio amplifier, using a 280 tube for a rectifier, one stage of transformer audio with a 227 tube and a stage of push pull amplification with two 245s. It furnishes all power for itself and for the MB-29, as well as the audio channel. Order catalog PPPA, list price, completely wired and equipped with phonograph jack, (less tubes) **\$55.00** \$97.50. Your price.

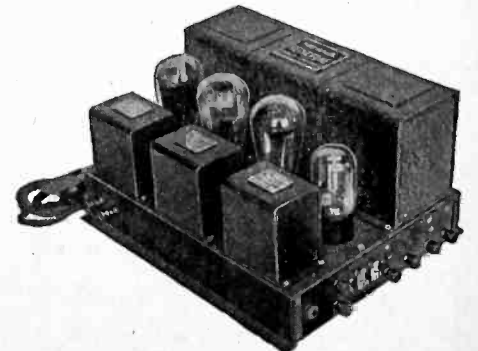

View of National Velvetone Push-Pull Power Amplifier, an expertly made A, B and C supply and audio amplifier, producing marvelous tone quality.

**GUARANTY RADIO GOODS CO.**

143 WEST 45TH STREET

NEW YORK CITY



# O-1 MA, \$5.95

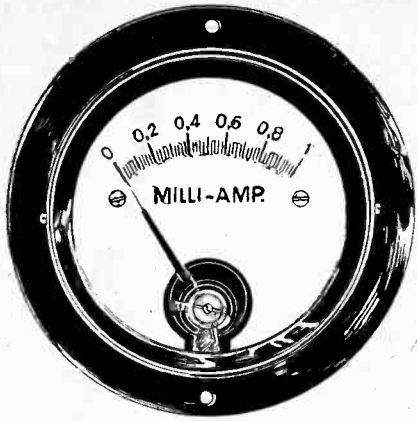

Here is a 0-1 milliammeter, accurate to plus or minus 1% clearly legible to two-one hundredths of a milliamperere at any reading (20 microamperes). This expertly made precision instrument is offered at the lowest price so far for a 0-1 ma. Order Cat. FO-1 at \$5.95. C. O. D. orders accepted.

**Guaranty Radio Goods Co.**  
143 West 45th Street,  
New York City

## AERIAL TUNER

Improves Your Reception

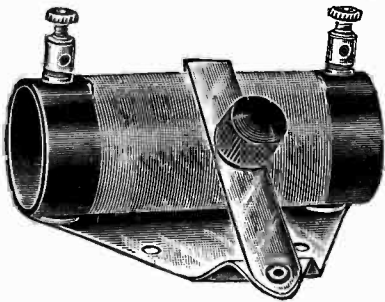

Remove aerial lead from set. Connect aerial instead to one of the binding posts of the Aerial Tuner. Connect the other binding post of the Aerial Tuner to antenna post of your set. Then move the lever of the Aerial Tuner until any weak station comes in loudest. The lever need not be moved for every different frequency tuned in. The Aerial Tuner acts as an antenna loading coil and puts the antenna's frequency at any frequency in the broadcast band that you desire to build up.

**GUARANTY RADIO GOODS CO.**  
143 West 45th Street  
New York City  
(Just East of Broadway)

# BRILLIANT, NEW NATIONAL

## MODERNISTIC PROJECTION DIAL WITH RAINBOW FEATURE

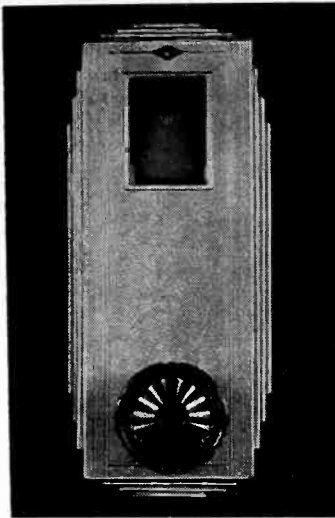

Modernize the appearance of your receiver by installing the brilliant new National dial, with color wheel built in, so that as you turn the dial knob one color after another floods the screen on which the dial numbers are read. On this screen the numbers are projected, so that you get the same dial reading from any position of the eye. This is just what DX hunters want—laboratory precision of dial reading.

The escutcheon is of modernistic design. The Velvet Vernier mechanism drives the drum superbly. Order today. Remit with order and we pay cartage. Shipments day following receipt of order.

### GUARANTY RADIO GOODS CO.

143 W. 45th St., N. Y. City (Just E. of B'way)

Enclosed please find \$3.13 for which please send me dial marked below:

- Cat. HC6, National modernistic drum dial, with color wheel built in, pilot bracket, 6-volt pilot lamp for storage battery or A eliminator sets; hardware; instructions ..... \$3.13
- Cat. HC2½, same as above, but with 2½-volt AC pilot lamp ..... \$1.13
- Order C.O.D. and I pay cartage.

NAME .....

ADDRESS .....

CITY ..... STATE .....

**RADIO WORLD'S BOOK SERVICE** has been found of great value not only by radio fans, constructors, etc., but also by radio and other technical schools throughout the country. See the radio books advertisements in this issue.

## LACAULT'S BOOK

"Super-Heterodyne Construction and Operation," giving the master's most masterful expounding of the theory, performance and construction of this fascinating type of circuit, is a necessity to every serious radio experimenter. More than 100 pages and more than 50 illustrations. Buckram cover. This book by B. E. Lacault, FREE if you send \$1.00 for an 8-weeks subscription for Radio World. Present subscribers may accept this offer. Subscription will be extended.

**RADIO WORLD** 145 W. 45th St., N. Y. City  
Just East of B'way

# NATIONAL

**Velvet B Eliminator \$16.13**  
180 Volts (230 Tube Free)



Latest Model National Velvet-B, Type 8680, in handsome crackle finish black metal casing, for use with sets up to and including six tubes. Input 105-120 volts AC, 50 to 60 cycles. Output, 180 volts maximum at 35 milliamperes. Three variable output intermediate voltages. (Det. RF, AF) Eliminator has excellent filter system to eliminate hum, including 30 henry choke and 18 mfd Mershon condenser. No motorboating! (Eliminator Licensed under patents of the Radio Corporation of America and associated companies.)

**Guaranty Radio Goods Co.**

143 W. 45TH STREET  
(Just East of Broadway)  
NEW YORK CITY

## New Junior Model

# POLO UNIT \$4

The famous twin magnet principle for double sensitivity, large magnets for great flux, permanently adjusted armature, all are in the new junior model Polo Unit. Weight, 2¾ lbs. Stands 150 volts unfiltered. Stands up to 250 push-pull filtered. Works any output tube, power or otherwise. Supplied with 10-ft. cord. Order unit now. Five-day money-back guarantee. Shipped C. O. D. if desired.

## Acoustical Engineering Associates

143 West 45th Street  
New York City  
(Just East of Broadway)

# RADIO WORLD and "RADIO NEWS"

BOTH FOR ONE YEAR @ **\$7.00**

You can obtain the two leading radio technical magazines that cater to experimenters, service men and students, the first and only national radio weekly and the leading monthly, for one year each, at a saving of \$1.50. The regular mail subscription rate for Radio World for one year, a new and fascinating copy each week for 52 weeks, is \$6.00. Send in \$1.00 extra, get "Radio News" also for a year—a new issue each month for twelve months. Total, 64 issues for \$7.00.

If renewing Radio World subscription, put cross square.  
**RADIO WORLD**, 145 West 45th Street, New York, N. Y.

# Quick Action Classified Ads

Radio World's Speedy Medium for Enterprise and Sales

10 cents a word — 10 words minimum — Cash with Order

**EDISON STORAGE BATTERIES**—100 volts \$6.50; ¼ Horsepower Alternating Motors \$7.00. Hoffmann Electrical Shops, 904 North Fifth, Philadelphia, Pa.

"**MATHEMATICS OF RADIO.**"—A great help to everybody interested in radio. \$2 postpaid. Radio World, 145 W. 45th St., N. Y. City.

**RECENT NUMBERS OF RADIO WORLD**, for 1929, 15c per copy. Any 7 copies for \$1. Radio World, 145 W. 45th St., N. Y. City.

**TELEVISION** and all about it in "A B C of Television," by Raymond Francis Yates. \$3 postpaid. Radio World, 145 W. 45th St., N. Y. City.

"**EVERYBODY'S AVIATION GUIDE.**" By Maj. Pagé. \$2 postpaid. Also "Modern Aircraft" by same author. \$5 postpaid. Radio World, 145 W. 45th St., N. Y. City.

**EXPERIENCED RETAIL SALESMEN** DAVEGA DIVISION AND CITY DIVISION OF THE ATLAS STORES CORPORATION IS NOW IN NEED OF SEVERAL HIGH-POWERED EXPERIENCED RETAIL RADIO SALESMEN WHO WOULD LIKE TO ASSOCIATE THEMSELVES WITH THE LIVEST RETAIL RADIO SALES ORGANIZATION IN THE UNITED STATES—A COMPANY THAT PERMITS ITS MEN TO EARN IN SALARIES AND COMMISSIONS UNUSUALLY LARGE WEEKLY INCOMES. PLUS UNLIMITED OPPORTUNITIES FOR PROMOTION. INTERVIEWS WILL BE TREATED IN CONFIDENCE. SEE ED. LEVY, SALES MANAGER FOR THE EASTERN DIVISION, DAVEGA, INC., 114 EAST 23 STREET, NEW YORK CITY.

"**A B C OF AVIATION.**" By Maj. Pagé. \$1.00 postpaid. Radio World, 145 W. 45th St., N. Y. City.

**EVERYTHING IN RADIO** At attractive Prices Sets or parts Orders shipped exactly as ordered. Prompt service. Write for prices. Inquiries invited. Send your address. **ALL RADIO CO.**, 417 North Clark St., Chicago

**BE SURE TO READ** the advertisement on another page of this issue about the HB Compact. Guaranty Radio Goods Co., 143 W. 45th St., N. Y. City.

**TWO FOR ONE.** Radio World for 52 weeks and Radio News twelve months at the combination rate of \$7. Radio World, 145 W. 45th St., N. Y.

"**MODERN AIRCRAFT.**" By Maj. Pagé. \$5. postpaid; and "Everybody's Aviation Guide," By Maj. Pagé, price \$2. postpaid. Latest and best up-to-date aviation books. Radio World, 145 W. 45th St., N. Y. City.

# THREE CHRISTMAS GIFT BOOKS FOR SERVICE MEN!

**"Trouble Shooter's Manual"** *The most popular and fastest-selling book in radio today. Wiring diagrams of commercial receivers are contained in this outstanding book.*

**"Mathematics of Radio"** *A sure route to a good grasp on radio technique. Radio theory outlined so that anybody can understand it.*

**"Testing Units for Service Men"** *Circuits and Methods of Testing Equipment, particularly use of individual meters and of meters united in combination testers.*

These Three Books by John F. Rider Constitute an Outstanding Asset to All Possessors!

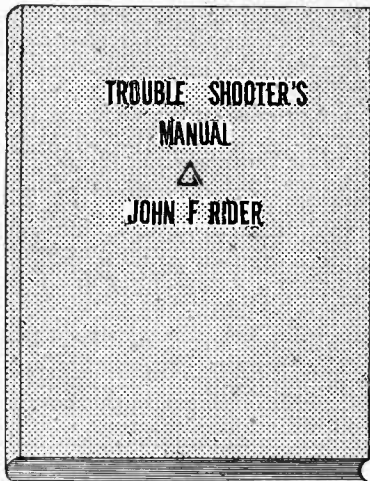

## "Trouble Shooter's Manual"

is the first comprehensive volume devoted exclusively to the topic. The 240 pages include 200 illustrations devoted to wiring diagrams of factory-made receivers, besides other illustrations. It is not only a treatise for service men, telling them how to overcome their most serious problems, and fully diagramming the solutions, but is a course in how to become a service man.

*This book is worth hundreds of dollars to any one who shoots trouble in receivers—whether they be factory-made, custom-built or home-made receivers.*

Besides 22 chapters covering thoroughly the field of trouble shooting, this volume contains the wiring diagrams of models, as obtained direct from the factory, a wealth of hitherto confidential wiring information released for the first time in the interest of producing better results from receivers. You will find these

diagrams alone well worth the price of the book. The wiring diagrams are of new and old models, of receivers and accessories and as to some of the set manufacturers, all the models they ever produced are shown in wiring diagrams! Here is the list of receivers, etc., diagrams of which are published in this important and valuable book:

- Wiring Diagrams of All These Receivers**
- |  |   |   |
|--|---|---|
| <p><b>R. C. A.</b><br/>60, 62, 20, 64, 30, 105, 51, 16, 32, 50, 25 A.C., 28 A.C., 41, Receptor S.P.U., 17, 18, 33.</p> <p><b>FEDERAL</b><br/>Type E series filament, Type E series filament, Type D series filament, Model K, Model H.</p> <p><b>ATWATER-KENT</b><br/>10B, 12, 20, 30, 35, 48, 32, 33, 40, 38, 36, 37, 40, 42, 52, 50, 44, 43, 41 power units for 37, 38, 44, 43, 41.</p> <p><b>CROSLEY</b><br/>XJ, Trirdyn 3R3, 601, 401, 401A, 608, 704, B and C supply for 704, 704A, 704B, 705, 706.</p> <p><b>STEWART-WARNER</b><br/>300, 305, 310, 315, 320, 325, 500, 520, 525, 700, 705, 710, 715, 720, 530, 535, 750, 801, 802, 806.</p> <p><b>GREBE</b><br/>MU1, MU2, synchrophase 5, synchrophase AC6, synchrophase AC7, Deluxe 428.</p> <p><b>PHILCO</b><br/>Philco-electric, 82, 86.</p> <p><b>KÖLSTER</b><br/>4-tube chassis used in 6 tube sets, tuning chassis for 7 tube sets, power amplifier, 7 tube power pack and amplifier, C tube power pack and amplifier, 6 tube power pack and amplifier, rectifier unit K-23.</p> | <p><b>ZENITH</b><br/>39, 39A, 392, 302A, 40A, 35PX, 35APX, 352X, 352APX, 37A, 35P, 35AP, 352P, 352AP, 34P, 342P, 33, 34, 35, 35A, 342, 352, 352A, 362, 31, 333, 353A, power supply ZE17, power supply ZE12.</p> <p><b>MAJESTIC</b><br/>70, 70B, 180, power pack 7BP3, 7P6, 7P3 (old wiring) 8P3, SP6, 7BP6.</p> <p><b>FRESHMAN</b><br/>Masterpiece, equaphase, G, G-60-S power supply, L and LS, Q15, Q, K60-S power supply.</p> <p><b>STROMBERG-CARLSON</b><br/>1A, 2B, 501, 502, 523, 524, 635, 638, 403AA power plant, 404 RA power plant.</p> <p><b>ALL-AMERICAN</b><br/>6 tube electric, 8 tube 80, 83, 84, 85, 86, 88, 6 tube 60, 61, 62, 65, 66, u and 8 tube A.C. power pack.</p> <p><b>DAY FAN</b><br/>OEM7, 4 tube, 5-5 tube 1925 model, Day Fan 8 A.C., power supply for 6 tube A.C., B power supply 5524 and 5525, motor generator and filter, 6 tube motor generator set, 6 tube 110 volt D.C. set, 6 tube 32 volt D.C. set.</p> | <p><b>FADA</b><br/>50/80A receivers, 460A, Fada 10, 11, 30, 31, 10Z, 11Z, 30Z, 31Z, 16, 17, 32, 16Z, 32Z, 18, 19, special, 192A-192S and 192BS units, R80A, 480A, and SF 50/80A receivers, 460A receiver and R60 unit, 7 A.C. receiver, 475 UA or CA and SP45-75 UA or CA, 50, 70, 71, 72, C electric unit for special and 7 A.C. receivers. ABC 6 volt tube supply, 86V and 82W, E180Z power plant and E 420 power plant.</p> <p><b>FREED EISEMANN</b><br/>NR5, P-18, NR-70, 470, NR57, 457, NR11, NR80 D.C.</p> <p><b>COLONIAL</b><br/>26, 31 A.C., 31 D.C.</p> <p><b>WORKRITE</b><br/>8 tube chassis, 6 tube chassis.</p> <p><b>AMRAD</b><br/>70, 7100, 7191 power unit.</p> <p><b>SPARTAN</b><br/>A.C. 89.</p> <p><b>MISCELLANEOUS</b><br/>DeForest F5, D10, D17, Super Zenith Magnavox dial, Thermodyne, Grimes 4DL inverse duplex, Garod EA, Ware 7 tube, Ware type T, Federal 102 special, Federal 59, Kennedy 220, Operadio portable, Sleeper RX1, Amrad inductrol.</p> |
|--|---|---|

## HERE ARE THE 22 CHAPTER HEADINGS

- |  |  |
|--|--|
| <p>Servive Procedure<br/>Practical Application of Analysis<br/>Vacuum Tubes<br/>Operating Systems<br/>Aerial Systems<br/>"A" Battery Eliminators<br/>Troubles in "A" Eliminators<br/>Trouble Shooting in "A" Eliminators<br/>"B" Battery Eliminators<br/>Troubles in "B" Battery Eliminators</p> | <p>Trouble Shooting in "B" Battery Eliminators<br/>Speakers and Types<br/>Audio Amplifiers<br/>Trouble Shooting in Audio Amplifiers<br/>Troubles in Detector Systems<br/>Radio Frequency Amplifiers<br/>Trouble Shooting in RF Amplifiers<br/>Series Filament Receivers<br/>Testing, and Testing Devices<br/>Troubles in DC Sets<br/>Troubles in AC Sets</p> |
|--|--|

## "Testing Units for Service Men."

A 43-page, liberally illustrated book on testing units and circuits. Tells what equipment a service man should have and how to use it most effectively and quickly. Rapidity of operation is one of the points stressed throughout this valuable book, as a service man's time is his chief stock in trade.

### CONTENTS

- Tube Reactivator and Voltages
- Calibrated Vacuum Tube Bridge
- General Utility Tube Tester
- AC-DC Receiver Tester
- Eliminator Testers
- Signal Generator for Receiver Testing
- Oscillators
- Cathode Ray Oscillograph
- Indicating Systems
- Tube Voltmeters
- Measurement of Inductance, Impedance, Capacity, DC Resistance
- Multi-Range Meters
- Service Station Test Bench

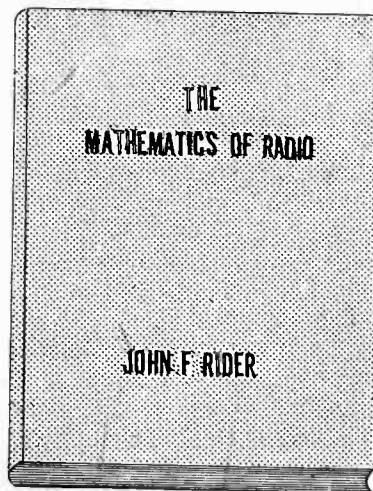
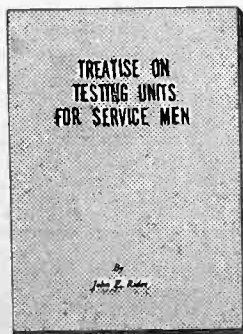

## "Mathematics of Radio"

### TABLE OF CONTENTS:

- OHM'S LAW.**
- RESISTANCES:** Basis for resistance variation, atomic structure, temperature coefficient, calculation of resistance variation, expression of ampere, volt and ohm fractions, application of voltage drop, plate circuits, filament circuits, filament resistances, grid bias resistances.
- DC FILAMENT CIRCUITS:** Calculation of resistances.
- AC FILAMENT CIRCUITS:** Transformers, wattage rating, distribution of output voltages, voltage reducing resistances, line voltage reduction.
- CAPACITIES:** Calculation of capacity, dielectric constant, condensers in parallel, condensers in series, voltage of condensers in parallel, in series, utility of parallel condensers, series condensers.
- VOLTAGE DIVIDER SYSTEMS FOR B ELIMINATORS:** Calculation of voltage divider resistances, types of voltage dividers, selection of resistances, wattage rating of resistances.
- INDUCTANCES:** Air core and iron core, types of air core inductances, unit of inductances, calculation of inductance.
- INDUCTANCE REQUIRED IN RADIO CIRCUITS:** Relation of wavelength and product of inductance and capacity, short wave coils, coils for broadcast band, coupling and mutual inductance, calculation of mutual inductance and coupling.
- REACTANCE AND IMPEDANCE:** Capacity reactance, inductance reactance, impedance.
- RESONANT CIRCUITS:** Series resonance, parallel resonance, coupled circuits, bandpass filters for radio frequency circuits.
- IRON CORE CHOKERS AND TRANSFORMERS:** Design of chokes, core, airgap, inductance, reactance, impedance, transformers, half wave, full wave windings.
- VACUUM TUBES:** Two element filament type, electronic emission, limitations, classifications of filaments, structure, two element, rectifying tubes, process of rectification, tungar bulb.
- THREE ELEMENT TUBES:** Structure of tube, detector, grid bias, grid leak and condenser, amplifiers, tube constants, voltage amplification, resistance coupling, reactance coupling, transformer coupling, variation of impedance of load with frequency, tuned plate circuit.
- POWER AMPLIFICATION:** Square law, effect of load, calculation of output power, undistorted output power, parallel tubes, push-pull systems, plate resistance.
- GRAPHS AND RESPONSE CURVES:** Types of paper, utility of curves, types of curves, significance of curves, voltage amplification, power amplification, power output, radio frequency amplification.
- MULTIPLE STAGE AMPLIFIERS:** Resistance coupling, reactance coupling, tuned double impedance amplification, underlying principles, transformer coupling, turns ratio, voltage ratio, types of cores, late current limitation, grid current limitation.
- ALTERNATING CURRENT TUBES:** Temperature variation hum, voltage variation hum, relation between grid and filament, filament circuit center tap, types of AC tubes.
- SCREEN GRID TUBE:** Structural design, application, amplification, associated tuned circuits, radio frequency amplification, audio frequency amplification.

RADIO WORLD, 145 West 45th St., New York, N. Y.  
(Just East of Broadway)

- Enclosed please find:
- \$3.50 for which please send me postpaid "Trouble Shooter's Manual" (Cat. TSM), by John F. Rider, 240 pages, 8 1/2 x 11", more than 200 illustrations, including wiring diagrams of commercial receivers as advertised; imitation leather cover, gold lettering.
  - \$2.00 for which please send me postpaid "Mathematics of Radio" (Cat. MOR), by John F. Rider, 128 pages, 8 1/2 x 11", 119 illustrations, flexible cover.
  - \$1.00 for which please send me postpaid "Treatise on Testing Units for Service Men" (Cat. TU), by John F. Rider, 43 pages, 6 1/4 x 9 1/4".
  - If ordering C.O.D., put cross in this square.

NAME.....  
ADDRESS.....  
CITY..... STATE.....  
(Canadian remittances must be made by postal or express money order.)