

MAY 26
1928

LATEST TELEVISION NEWS

15
CENTS

RADIO

REG. U.S. PAT. OFF.

WORLD

The First and Only National Radio Weekly
322nd Consecutive Issue—Seventh Year

SCREEN GRID ARTICLES

- (1) A Clever Shield
- (2) How to Use the Tubes
- (3) Single Control Solved

HOW PHONOGRAPH PICKUPS WORK

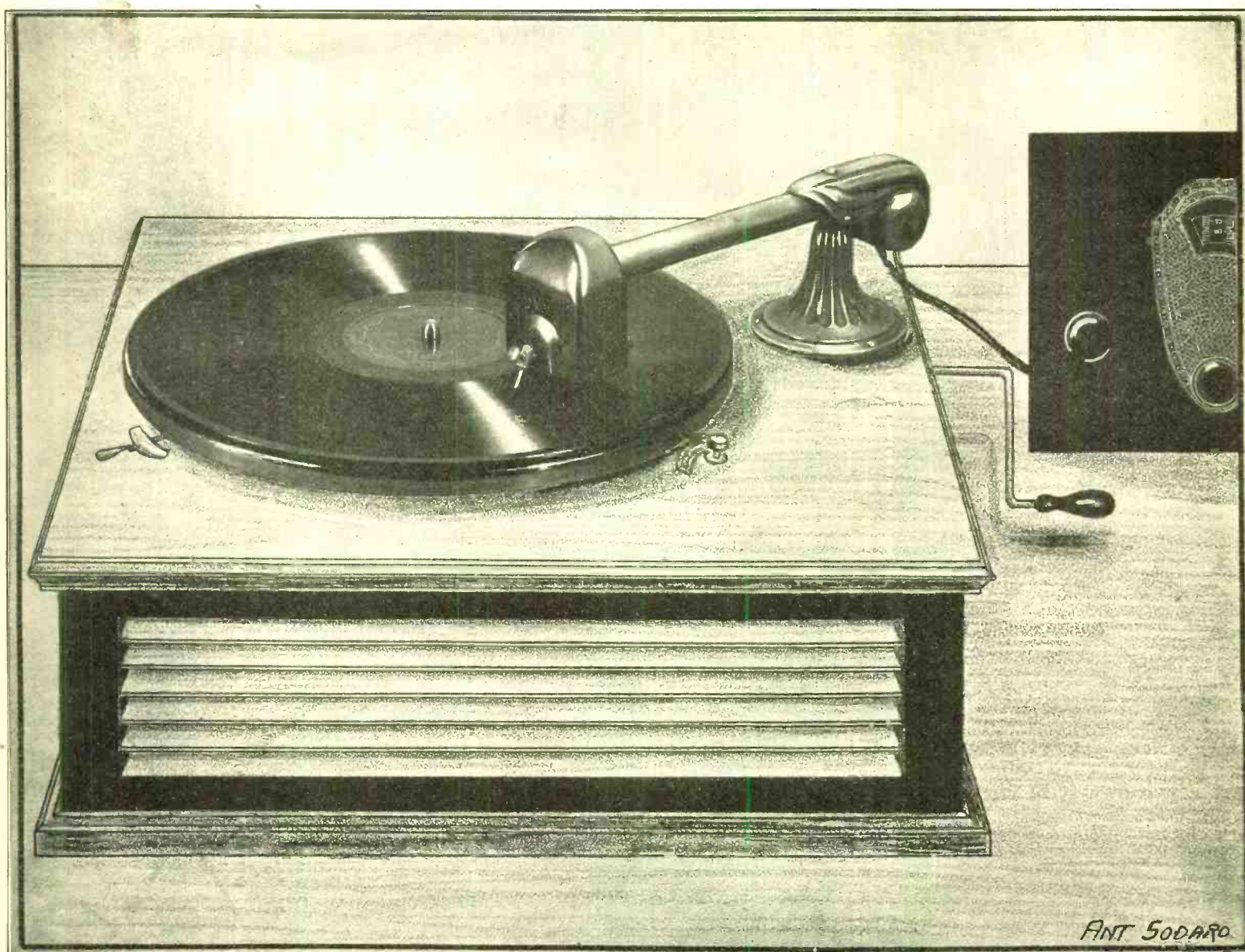

The pickup converts mechanical energy into electrical energy. The one shown is the new Phonovox.
See Page 3.

SIMPLE EXPLANATION OF PHASES

A Scientific Trouble-Shooting Test Set

Consisting of Tube Checker That Reads Filament Voltage and Plate Current; Extra Meter Reads Plate Voltage, including B Eliminator Voltages. **Only \$10.00**

The best inexpensive combination for trouble-shooting is a Double R Tube Checker, comprising a 0-10 D.C. milliammeter, a 0-6 D.C. voltmeter, a switch, a rheostat and a socket. Add a high resistance voltmeter (0-300 v.). With these it is advisable to use a plug, so that all you need do is remove a tube from a receiver that you're testing, put the plug in the empty socket and the removed tube in the socket of the tester. You can immediately find open any short circuits, broken or flimsy connections, reversed connections, etc. The Double R Cord and Plug, the Double R Tube Checker, and 0-300 high resistance voltmeter constitute the Scientific Trouble-Shooting Test Set.

The Biggest Value That \$10 Can Buy

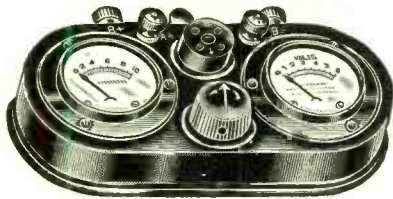

No. 210 Tube Checker consists of 0-6 volts D.C. Voltmeter, 0-10 D.C. Milliammeter, Grid Bias Switch, Rheostat, Socket, Blinding Posts (with instruction sheet) in handsome noire case....\$6.50



No. 346—High resistance voltmeter, for reading any and all DC voltages, including B eliminators, up to 300 volts. Portable type, full nickel finish, long connecting cords and tips\$4.50

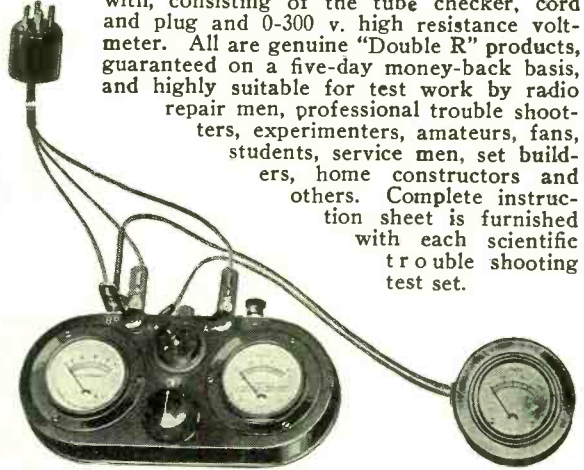

The complete combination is illustrated here-with, consisting of the tube checker, cord and plug and 0-300 v. high resistance voltmeter. All are genuine "Double R" products, guaranteed on a five-day money-back basis, and highly suitable for test work by radio repair men, professional trouble shooters, experimenters, amateurs, fans, students, service men, set builders, home constructors and others. Complete instruction sheet is furnished with each scientific trouble shooting test set.

The cord terminals of the plug leads correspond with the binding posts of the tube checker. Now connect the 6-300 volts high resistance voltmeter from A+ to B+ posts and you get all necessary readings. You can test plate voltage from B eliminators, or any other B supply, D.C. plate current and D.C. filament voltage, as well as the efficacy of the tube, by throwing the grid bias switch, for the plate current should change within given limits, depending on the type of tube.



No. 21—Cord and plug, with markers and lugs that fit tube checker binding posts..\$1.85

Service Men! Custom Set Builders! Experimenters! Students!

Equip your testing outfit with the indispensable combination that constitutes the Trouble Shooting Test Set and Time-Saver. You quickly locate trouble while others flounder about.

WHAT YOU GET

One No. 210 tube checker, with 0-6 voltmeter, 0-10 milliammeter, socket, rheostat, binding posts and bias switch, all built in; one No. 21 cord and plug, and one No. 346 high resistance 0-300 v. voltmeter.

FOR ONLY \$10

If You Want Complete Test Set, as Above, But With 0-500 High Resistance Voltmeter, price is \$11.

SEND NO MONEY!

Our Five-Day Money-Back Guaranty Fully Protects You!

Many professional and other radio technicians require a 0-500 high resistance voltmeter, as part of their scientific trouble-shooting test set, so that they can test ALL power pack B voltages. They do a great deal of work with high voltage power packs, especially where a -10 or -50 tube is used in the output of a receiver. For them the 0-500 v. high resistance voltmeter, No. 347, is just the thing to include in the test set, instead of the No. 346 high resistance 0-300 v. voltmeter. The combination may be obtained with the 0-500 v. voltmeter, instead of the 0-300 v. voltmeter, at only one dollar extra. The 0-500 v. meter is exactly the same as the 0-300 v. meter, except for difference in maximum voltage reading.

Guaranty Radio Goods Co.
145 West 45th Street, New York, N. Y.

GUARANTY RADIO GOODS CO.,
145 West 45th Street, New York City.

Please send me at once, on a five-day money-back guaranty, one complete scientific trouble-shooting test set, consisting of one No. 21, one No. 210 and one No. 346, for which I will pay the postman \$10, plus a few cents extra for postage.

If 0-500 v. high resistance voltmeter No. 347 is preferred, put cross in square and pay \$11, plus postage, instead of \$10, plus postage.

NAME

ADDRESS

CITYSTATE

ALL METERS SOLD ON FIVE-DAY MONEY-BACK GUARANTY

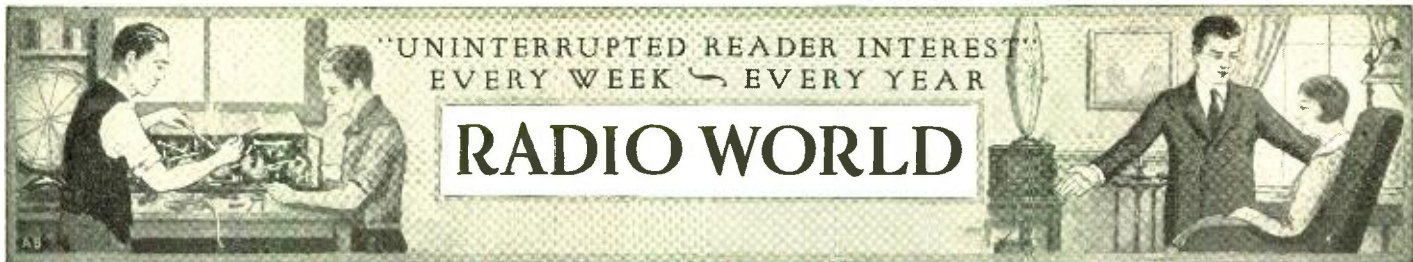

MAY 26, 1928.
 Vol. XIII. No. 10. Whole No. 322.
 15c per Copy.
 [Entered as second-class matter, March, 1922, at the post office at New York, N. Y., under Act of March, 1879.]

Technical Accuracy Second to None

A Weekly Paper published by Hennessy Radio Publications Corporation, from Publication Office, 145 West 45th Street, New York, N. Y. (Just East of Broadway)
 Phone: BRyant 0558 and 0559

Phonograph Pickups

What They Are, How They Work and Some Pointers on Design

By Sebastian de Groot

It is usually said that a phonograph pick-up unit of the magnetic type is an inverted loudspeaker. While that is true in a general sense it is more accurate to say that it is a magneto.

If it were an inverted loudspeaker unit it would transform sound energy into electrical energy. This it does not do.

It transforms mechanical energy into electrical, which is exactly what the magneto does. The comparison between the magneto and the pick-up unit assumes that the pickup unit has a permanent magnet for setting up the magnetic field.

There are several types of magnetic pickup units. The principle of one is illustrated in Fig. 1A. To a permanent magnet NS are attached two pole pieces PP, around which coils of wire are placed. An iron armature such as a diaphragm is mounted near the ends of the pole pieces. If this armature is made to move toward and away from the pole pieces the reluctance in the magnetic circuit is varied by the variation in the length of the two air gaps between the armature and the pole pieces.

As the reluctance in the circuit is varied, the magnetic flux is varied also. This variation of flux through the two coils wound around the pole pieces will induce an electro-motive force in the coils. This electro-motive force will vary in that same manner as the movement of the armature.

Record Controls Armature

The phonograph needle is attached to the armature and the unit is so mounted that when the needle follows the undulations in the record groove, the armature is moved away from and toward the pole pieces. Thus the electro-motive force in the coils becomes the electrical equivalent of the undulations in the record.

Another form of pick-up unit is shown in principle in Fig. 1B. One split pole piece is attached to each of the poles of the permanent magnet NS. Thus there are four pole extensions. An iron armature is mounted between the four pole extensions and pivoted at the center. It is mounted on a spring suspension which holds it half way between the pole pieces on both sides. A spool of wire is mounted between the split pole pieces so as to surround the armature.

When the armature is in the neutral position the flux passes directly across the ends of the armature from the north

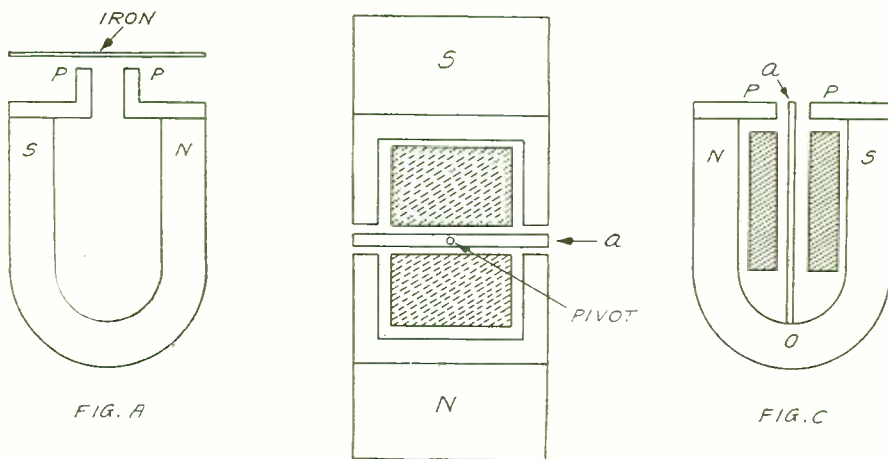

FIG. 1

THREE TYPES OF PHONOGRAPH PICK-UP UNITS (A) UNBALANCED TYPE, IN WHICH THE MOTION OF THE ARMATURE VARIES THE RELUCTANCE IN THE MAGNETIC CIRCUIT AND SO SETS UP AN ELECTRO-MOTIVE FORCE IN THE ARMATURE COIL. (B) BALANCED, PUSH-PULL TYPE IN WHICH THE MOTION OF THE ARMATURE CAUSES THE FLUX TO FLOW FIRST IN ONE DIRECTION AND THEN IN THE OTHER THROUGH THE ARMATURE COIL. (C) POLARIZED RELAY TYPE IN WHICH THE ACTION IS ESSENTIALLY THE SAME AS IN B.

pole to the south, and no flux passes through the armature lengthwise.

If the armature is displaced from its position of equilibrium about its pivot, one pair of air gaps will be shortened and the other pair will be lengthened. For example, if the armature is turned counter-clockwise the upper right and the lower left air gaps will be shortened and the other pair will be lengthened. Some magnetic flux will now pass through the armature lengthwise, and hence through the coil around it.

The flux will pass through the armature from the lower left to the upper right pole piece extensions. If the armature is displaced in the clockwise direction the flux will pass through the armature and coil in the opposite direction.

Alternating Flux

Thus if the armature is set into vibration about its pivot there will be an alternating flux set up in the armature and through the coil. This flux will vary in

the same way as the movement of the armature. The varying flux through the coil will induce an alternating electro-motive force in the coil, which will be the electrical equivalent of the mechanical vibration of the armature.

In Fig. 1C is another type of pick-up unit. It is of the polarized relay type. It differs from that in B only in the suspension of the armature. One end of it is free to move between the pole pieces and the other is attached to the neutral point on the permanent magnet, that is to the point half way between the north and south poles. As the armature is made to move back and forth between the pole pieces, the magnetic flux through it changes direction just as it did in the armature in B. This changing flux again induces an electro-motive force in the coil wound around the armature and it is the electrical equivalent of the movement of the armature.

In B and C as in A the phonograph
 (Continued on next page)

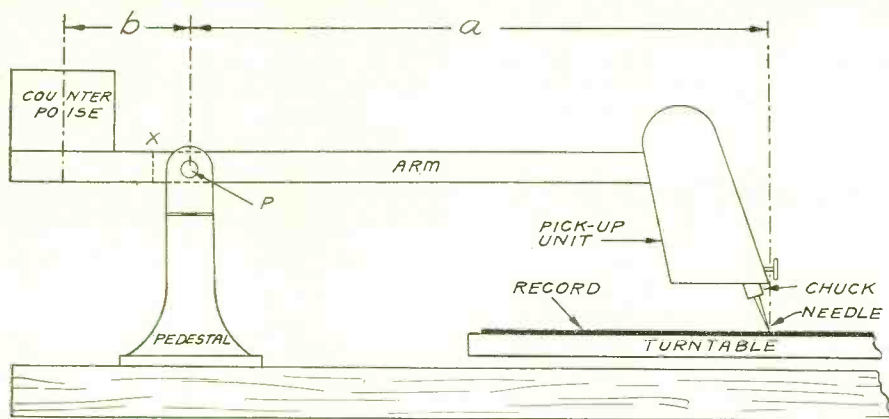

FIG. 2

THE CONSTRUCTION OF A PHONOGRAPH PICK-UP IN WHICH A COUNTER-POISE IS USED FOR TAKING THE WEIGHT OF THE UNIT OFF THE RECORD AND FOR STEADYING THE UNIT.

(Continued from preceding page)

needle is attached to the armature and the undulations in the phonograph record are made to move the armature. Thus in all these cases the electro-motive force induced in the armature coil is the electrical equivalent of the record.

Electro-motive Force Impressed

If the two terminals of the armature coil are connected to the grid circuit of an amplifier the electro-motive force induced in it by the movement of the armature becomes the signal voltage on the amplifier. From then on the amplifier handles it just as it handles the signal from a detector. Ultimately the undulations in the record are reproduced as sound by the loudspeaker.

If the two terminals of the armature coil are connected across the primary of a coupling transformer an alternating current is sent through the circuit formed by the armature coil and the primary. This current is maintained by the electro-motive force and it has the same wave form as the undulations in the record, except for such distortion as may enter during the process of pick-up.

Maintaining Fidelity

There are many details which must be properly adjusted if the electro-motive force induced in the armature coil is to be an exact electrical equivalent of the undulations in the record. These details are all based on simple physical principles.

One necessary condition for fidelity is that the unit as a whole shall not move with the armature. If it does, the relative motion between the armature and the pole pieces will not be so great as if the armature moved and the unit as a whole remained still. If the unit as a whole moves with the armature there is a loss in sensitivity of the pick-up unit. This would not be a cause of distortion if the reduction in sensitivity were the same for all frequencies. It is not.

On the high audio frequencies there is practically no motion of the unit as a whole, because the inertia of the unit keeps it in one place. But for the low frequencies the unit moves very much and there is only a small relative motion between the armature and the pole pieces. Hence the unit is less sensitive on the low frequencies than on the high.

Less Unit Motion

The heavier the unit is, the less will be its motion and the more sensitive it will be on the low frequencies as well as on the high. Hence one condition for faithful reproduction by a phonograph pick-up unit is that the unit be heavy, that is, that its mechanical inertia be high.

In some forms of construction the fidelity largely depends on the moment of inertia, that is, its rotational inertia. If the unit as a whole will turn easily the

low notes will not be reproduced as well as the high. The moment of inertia of the unit should be high. This can be expressed by saying that the fly wheel effect of the unit should be high, the point at which the armature is pivoted being taken as the center of rotation.

Complications Enter

Both the requirements that the inertia and the moment of inertia of the unit be high mean that the unit must be massive, or heavy.

But this introduces complications in the case.

If the unit is heavy the needle will engrave the record and will ruin it in a very few playings. For this reason units are made light. The faithfulness under such conditions is largely a matter of imagination. The light unit will move around as much as the armature, as can be determined by touching the unit lightly with a finger. On the low notes particularly the unit shakes very much.

So good design of pick-up units requires the best possible compromise between long record life and faithfulness of reproduction.

Counterpoise Used

A great improvement can be effected by the use of a counterpoise on the tone arm to take some of the weight off the record. This counterpoise can be adjusted so that any desired weight remains on the needle and the record. In that case there is no practical limit to the weight of the unit, and much more faithful reproduction is possible.

The counterpoise itself, although it is on the opposite end of the tone arm with respect to the pivot in the pedestal, adds to the inertia and thus prevents motion of the unit as a whole. If the counterpoise is used, the total weight can be made as great as the pedestal will support without causing much weight on the needle.

But in this case also complications set in. Suppose the record wobbles. The moment of inertia of the arm and counterpoise system will prevent the unit from following the record. Where the record recedes, the needle will leave the groove. Where the record approaches, the needle will dig in. Hence if the turntable wobbles ever so little and if the unit and counterpoise are heavy, the record will be ruined quickly. And there is not a turntable which does not wobble a little. Therefore it will not do to make the unit too heavy and then rely on a counterpoise to relieve the weight on the record.

Much can be gained with the counterpoise, nevertheless.

Fig. 2 illustrates a counterpoised pick-up unit. If the counterpoise were removed and the arm cut at X, the whole weight of the unit and most of the

weight of the arm would rest on the record.

Counterspring Used

In some cases a counterspring is used to relieve the record of the weight of the unit. The tension on this spring can be adjusted to any desired value so that the pressure of the needle on the record is just sufficient to hold the needle in the groove.

The spring method of relieving the weight takes the excess weight off the record and protects the record from the effects of wobbling of the turntable. It gives the needle a much better chance to follow the groove without causing it to engrave or to jump out. But it does not have the same steadying effect that a counterpoise has, and thus it will permit some motion of the unit as a whole and a reduction in the sensitivity on the low notes.

A combination of counterpoise and spring action could be used to good advantage. As far as the writer knows this has not been done. The unit could be made heavy and the weight of it taken off the record with a counterweight. Thus the sensitivity on the low notes as well as on the high would be safeguarded. Then the armature or the needle could be mounted on a spring which would allow the needle to follow the wobbling record without gravure or skipping.

This spring would have to be made so that it was pliant in the up and down direction but so that it would not give at all in the direction of vibration of the armature, that is, at right angles to the groove. If it were also pliant in this direction all the value of the counterpoise and the heavy unit would be lost.

Length of Arm

In many magnetic pick-up units as well as in many ordinary phonographs the arm from the needle to the vertical pivot is too short. The length of this arm has a great deal to do with the operation. In Fig. 2 the length of this arm is indicated by the letter *a*.

The effect of an arm that is too short is shown in Fig. 3. This is a top view of a record in which the circles *a*, *b* and *c* represent the outside, the middle, and the inside grooves, respectively, in the record. P is the vertical pivot around which the arm Pb swings in a horizontal plane.

Suppose that the position of P be adjusted so that the needle runs freely parallel with the middle groove *b*. Now if the arm Pb were infinitely long, as the arm swings the needle would follow the radius passing through *b*. The record would then play equally well in all the grooves from the inside to the outside. The needle would move freely parallel with the groove from one end of the record to the other.

But when the arm is of finite length the needle will follow the arc *abc*. When the needle is on the outside groove *a* it will drag against the inside wall and is likely to jump out and engrave a line across the record toward the center. When the needle is on the inside groove *c* it will drag against the outside wall and is likely to jump out and cause a scratch outward.

Armature Constrained

If the net weight of the unit is great enough there is little chance that the needle will jump out, but then it is heavy enough to engrave the record.

And that is not the only disadvantage of using an arm that is too short.

The pick-up unit is made so that the armature can move freely at right angles to the arm, or at least it should be so made. But when it is in the outside groove the record tries to make it move in another direction. Similarly when the needle is in the inside groove it tries to

(Continued on page 14)

The Solution of a Common Difficulty in Single Control Tuning

By Herbert E. Hayden

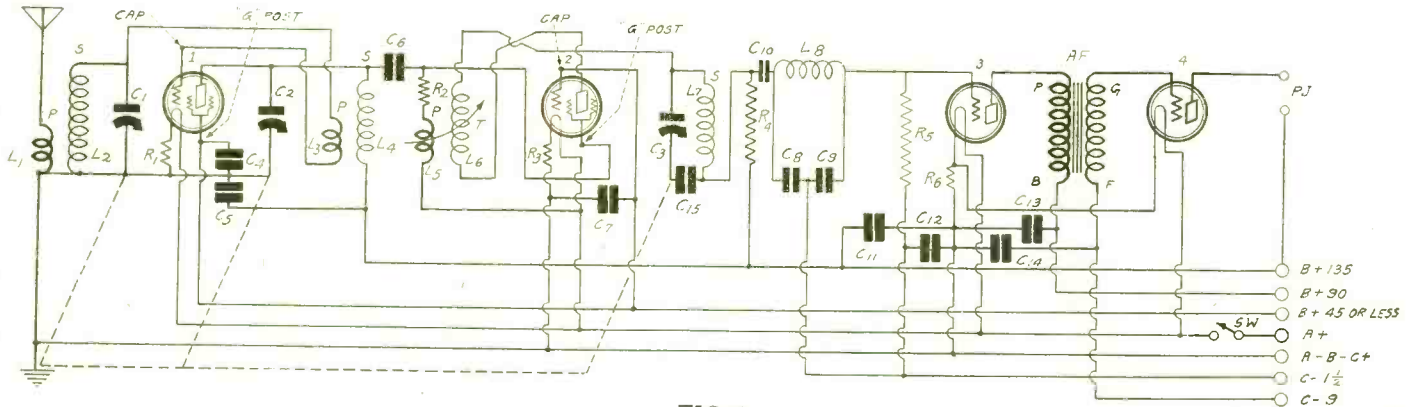

FIG. 1

THOSE who desire to use screen grid tubes, with tuned plate inductances to get very high gain, and who want strictly single control, encounter the problem of accommodating conflicting returns.

The first tube is tuned in the usual way, with condenser across the grid-to-A battery circuit. Now, if the multiple condenser has a common shaft, that is, rotor is common throughout the condenser, hence can be connected to only one point, how can the happy condition of successful single control be achieved, since one or more tuned coils must return to B plus?

The problem may be solved by using the principle suggested in Fig. 1. If one tuned circuit is from grid to negative A battery, and another is from plate to B plus, the stators, being insulated from each other, take care of the grid and plate connections, so by returning the common rotor to A minus, and putting a condenser of .006 mfd. or larger from B plus to A minus, single control is achieved.

The tuned circuit for the plate coil in Fig. 2 is completed through the bypass condenser. This must not be small, or synchronized tuning will be defeated, since the plate condenser and the bypass condenser are in series.

A large series condenser has virtually no effect on a tuning condenser in the broadcast frequency range, whereas a small one has a large effect, cutting down the actual capacity, principally at that part of the tuning condenser's scale where the capacity settings are as large as or larger than the capacity of the series condenser.

How the system is actually incorporated in a receiver is shown in Fig. 1. This contains several novelties well worthy of the attention of all radioists experimentally inclined.

The first novelty to strike the eye is the feedback coil L3. This is in series with the control grid lead of the first screen grid tube—the lead going to the cap on the tube. This small coil being in inductive relationship to the secondary L4, the tuned plate coil, small values of energy are fed back to the RF tube.

If it is desired to increase the amplification of this tube, the aiding method of back coupling may be used, which requires that the respective grid and plate terminals of L3 and L4 be in the same relative position, if the coils are wound in

the same direction, or in opposite relative position if wound one reverse to the other.

As this works out, if the windings are in the same direction, grid goes to the beginning of one coil, A minus to the end of that coil, plate to the beginning of the other coil and B plus to the end of the second coil. The grid and plate connections on the coil therefore are NOT side by side, nor are the B plus and A minus connections of the coils adjoining.

But if the windings are in opposite directions, then either of the two cited pairs of terminals should adjoin.

Whether the windings are in the same direction may be determined from an ocular examination. Also, the terminals relate to the actual terminals on the winding, and not to any points on the winding form to which these terminals may be brought out for lug or nut connection.

If the first tube amplifies too much, reversing the connections on either coil will make the feedback negative and aid stability.

Standard coils are used in the receiver, although screen grid tubes are employed on the RF side. The coils are used in such a way, however, that in each case, except in that of the antenna coil, the secondary is in the plate circuit.

Analyzing the use of the coils, we find

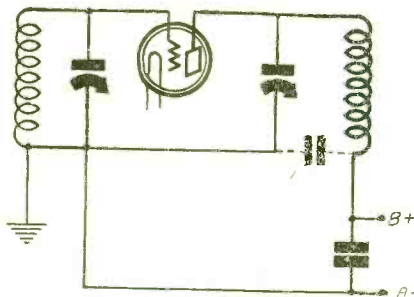

FIG. 2.

A MULTIPLE CONDENSER USED TO TUNE SIMULTANEOUSLY TWO CIRCUITS THAT RETURN TO DIFFERENT DIRECT CURRENT POTENTIALS. THE COMMON ROTOR CAN GO TO ONLY ONE POINT, SO THE GAP BETWEEN THE A MINUS AND P PLUS LEADS IS BRIDGED BY A FIXED CONDENSER (SOLID OR DOTTED SYMBOL.)

a standard hookup of the antenna coil. The next coupler is exactly the same in construction but its primary is used for interrupting the control grid lead of the first tube, while the secondary is in the plate circuit of that tube and is tuned.

The input to the detector tube is made mainly through the customary grid leak. No grid condenser need be added, since the action of C6, which is .00025 mfd., serves amply to insure good detection. The leak is connected to one side of the primary of a three circuit tuner, while the other side of that primary goes to the grid return, A plus. The coil referred to is L5.

Now, we have two remaining windings—the secondary (S) and the tickler (T). The secondary, as has been mentioned, is tuned and is in the plate circuit. It is in series with the tickler coil, which feeds back to the preceding input through the tickler's coupling to the small primary winding. As most three circuit tuners have the tickler at the opposite end of the form from the primary, the feedback will be gentle and easily controllable. It may be made reverse feedback by reversing the leads to the tickler coil—putting the plate to the other post and connecting the free post to the secondary coil. Try both ways to see which you like better. Both work.

For those desiring to experiment with this circuit the constants are given as follows: C1, C2, C2, one three-section condenser for .0005 mfd. tuning, this capacity being chosen because there are hardly any three circuit tuners now available for .00035 mfd.; L1L2, L3L4, two radio frequency transformers for .0005 mfd.; L5 L6L7, one three circuit tuner; R1R3, two No. 622 Amperites; R6, one No. 112 Amperite; C4, C6, C7, C8, C9, .00025 mfd. fixed condensers; C5, C15, .006 mfd. each, or larger; C10, C11, C12, C13, C14, .5 mfd. each; R4, 0.1 meg.; R5, 2 to 10 meg., preferably the higher values; AF, one audio frequency transformer; PJ, phone tip jacks; SW, one switch; tubes (1) and (2), screen grid, (3), 1A, (4), 112A.; one dial; one 7x24 inch front panel; one 8x22 inch subpanel; four standard sockets.

The coils may consist of 14-turn primaries and 55-turn secondaries on 2 1/2" diameters, using No. 24 double silk wire, with 1/4 inch between primary and secondary. The three-current tuner is the same, except for the tickler, which has 35 turns of No. 30 single silk covered wire on a 1 1/2 inch diameter.

Pendulums and Phases

By Capt. Peter V. O'Rourke

Contributing Editor

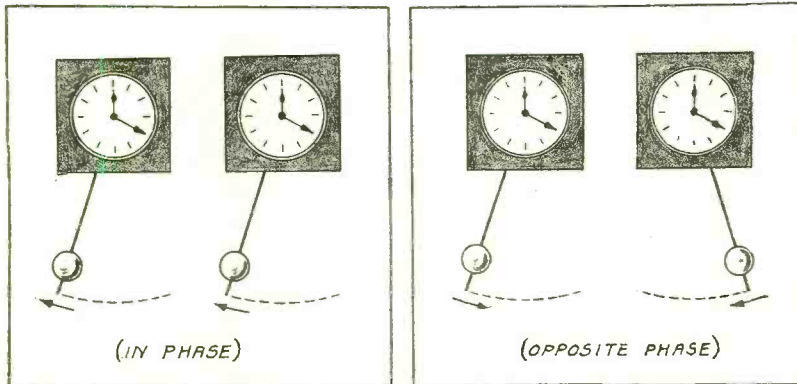

FIG. 1

FIG. 2

IN FIG. 1 TWO PENDULUMS SUSPENDED FROM A FLEXIBLE STRING ARE COUPLED. IF THE TWO HAVE THE SAME PERIOD OF VIBRATION AND ONE IS GIVEN A START THE SECOND WILL GRADUALLY TAKE UP THE MOTION AS THE FIRST DIES DOWN. AS SOON AS THE FIRST HAS STOPPED THE PROCESS IS REVERSED. THIS INTERCHANGE OF ENERGY WILL TAKE PLACE AS LONG AS THERE IS ANY ENERGY LEFT TO MAINTAIN THE SWING. IN FIG. 2 (LEFT) THE PENDULUMS OF THE TWO IDENTICAL CLOCKS MOVE IN PHASE. AT RIGHT THE PENDULUMS MOVE IN OPPOSITE PHASE.

THE term phase as applied to electric currents and voltages can be illustrated with the aid of two pendulums, such as those of clocks. Suppose that two equal clocks, adjusted to keep the same time, are suspended parallel to each other on the east wall. The two pendulums will swing in the north and south plane. If they move in the same direction at every instant they are in phase. They reach the farthest north at the same time, they turn at the same instant, pass through the lowest point together, and they make the southward trip together.

Suppose one pendulum moves north while the other moves south and that each reaches the farthest point at the same time, they are then in opposite phase. They also pass through the lowest point at the same instant, moving in opposite directions.

One pendulum may be a few degrees behind the other. One passes through the lowest point at a given instant moving in a certain direction. The other then will pass through the corresponding point a very short time later, but moving in the same direction. There is a phase difference between the two, one lagging behind the other. This lag may be any number of degrees between 0 and 360, or any fractional time of a total cycle.

If one clock is faster than the other the phase difference between the two will change continually, that is there will be a variable phase shift.

If two pendulums are swinging in phase a difference in phase can be introduced by stopping one for a fractional period and then letting it swing again.

Alternating electrical currents and voltages swing in a manner similar to two pendulums.

The behavior of coupled circuits can also be illustrated with the aid of pendulums. Suppose two equal pendulums be suspended from the same rigid support but so that each

swinging and the other left still, the moving pendulum will continue without starting the other.

Degree of Coupling

If the support of the two pendulums is not perfectly rigid but gives a little as a pendulum swings, the behavior of the pendulums is different. If one only is started swinging the other gradually will take up the motion. As the second pendulum picks up, the first dies down. When the second has reached its greatest swing the first is still. Then the process is reversed. This goes on as long as there is any energy left in the moving system.

If the two pendulums are suspended from a stretched string that gives very much as the pendulums swing the two exchange the energy very rapidly. That is the still pendulum gains speed quickly and the other loses it at the same rate.

The two pendulums always move in opposite directions under these conditions. That is they are in opposite phase.

When the support of the pendulums is rigid the coupling between them is zero. There is no means whereby the energy of the one can be transferred to the other.

Zero Coupling

When the support is nearly rigid the coupling between them is loose and the rate of transfer of energy from one to

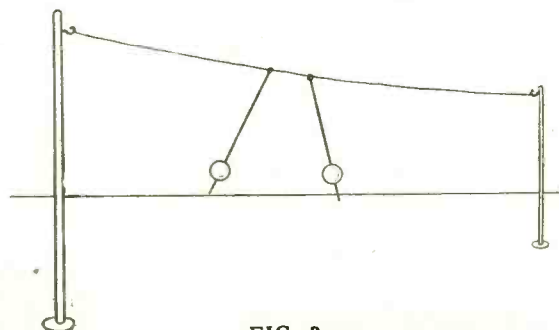

FIG. 3
TWO PENDULUMS ON THE SAME
AXIS, OUT OF PHASE

the other is very slow. When the two pendulums are suspended from a flexible support, like a stretched string, the coupling between them is very close and the rate of interchange of energy is rapid.

When two electrical circuits are placed close together and attuned to the same frequency they interact in the same manner as the two pendulums, provided that energy is not supplied to one of them continuously. If energy is supplied to the system by an alternating electromotive force there will be no back and forth interchange of energy but one circuit will drive the other, the currents in the two being in opposite phase.

Driven Pendulum

The same thing would take place if one pendulum is driven at a constant rate by a clock spring or by some other motive force. The second pendulum coupled to the first would be driven but in opposite phase.

It is well known that when two coils are placed at right angles the coupling between them is zero even when they are close together. There is a corresponding analogy in the pendulum system. Suppose two pendulums be suspended from the same flexible support, such as a tightly stretched string. If one pendulum is started swinging at right angles to the string and the other parallel to the string there will not be the same energy transfer. One will continue to swing a right angles and the other will swing parallel with the string.

It is true that the coupling between the two is not zero in this case as in the electrical. The crosswise motion of one pendulum will be transferred slowly to the other pendulum, which will begin to swing in a circle as a result of the two forces acting on it. Since only the crosswise force is sustained, this circle will degenerate into a line at right angles to the string.

Vacuum Tubes on a String

When an amplifier is connected so that all the plates derive their voltage from the same source all the plate circuits are coupled together. The case is somewhat analogous to suspending many pendulums on the same string. It is not difficult to see that if one of the pendulums is started all the others will be affected. They all will move in opposite phase to the first.

Now suppose the second pendulum be given an amplitude ten times as great as the first. It is clear that this will affect all the other pendulums, including the first. If each pendulum be given a start, the amplitude increasing in intensity from the first to the last with a ratio of ten. Every pendulum affects every other and the resulting motion will be very complex. But it is no more complex than the swinging of the plate signal current in an amplifier in which all the tubes are coupled by the impedance of the plate voltage supply.

When Distortion Arises

In the amplifier the signal current in the plate circuit of the last tube is supposed to be a greatly amplified copy of the signal current in the first, but when the coupling is close between the several circuits the copy is much distorted.

It will be like a cartoon, the characteristics exaggerated in some places and almost omitted in the other.

Parallel Plate Feed

By C. T. Burke

Engineering Department, General Radio Co.

THE use of a parallel feed, i. e., a separation of the direct current and alternating current paths in the plate circuit of a vacuum tube, certainly has no claim to novelty.

This system of connection has not, however, achieved the popularity to which its merit would seem to entitle it.

So far the set builder is familiar with the circuit only as associated with the loudspeaker, where the use of the so-called "speaker filter" has become general.

The parallel plate circuit applies the principle of the speaker filter to the audio amplifier. The circuit is illustrated in Fig. 1. L is an inductance of high value. It must be of such construction as to maintain its inductance at currents of several milliamperes. C is a condenser of sufficiently large capacity to offer a low impedance at low frequency.

Currents Separated

The direct plate current flows through the choke L, which has a low impedance to direct current, while the condenser offers an effectual bar to the flow of direct current through the primary of the transformer.

Alternating current is prevented from flowing through the choke L in appreciable amount by its high impedance, while the condenser and transformer primary offer a path of low impedance as compared with that offered by the choke.

In this way the two components of current existing in the plate circuit of the tube, i. e. the space current (constant and unidirectional) and the audio frequency signal current are directed into different circuits.

The separation of the direct and alternating components of the plate current of a vacuum tube is desirable for a number of reasons.

What Is Saturation?

Direct current flowing through the primary of a transformer sets up a field in the core which may cause magnetic saturation in the core. Saturation is a condition under which changes in magnetizing current do not produce corresponding changes in flux. Since the operation of the transformer is dependent on changes in flux, the instrument is naturally affected.

The better the transformer, the more likely is this to happen. If the transformer's core is of silicon steel, saturation is not likely to occur with tubes of the -01A or -99 type, but if a 112 or -27 tube is used, saturation may occur and is certain to occur if tubes of the -71 or -10 type are used to feed the transformer. Cores of nickel steel such as are coming to be used to an increasing extent are much more subject to this difficulty than are silicon cores.

Currents of more than a few milliamperes will seriously affect the behavior of the nickel steel transformer, and the instrument may easily be permanently injured by the application of too large a direct current magnetizing force.

Cuts Input Impedance

The effect of saturation of the iron is to reduce the input impedance of the instrument, resulting in a loss of amplification particularly marked at low frequency.

When using cores of some of the nickel alloys, the gain due to the special core material may be completely sacrificed as

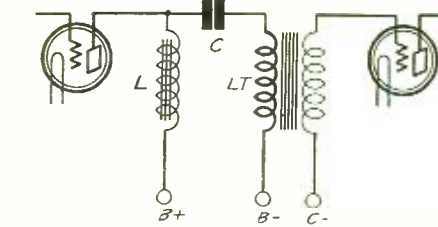

FIG. 1

A PARALLEL PLATE FEED IN AN AUDIO STAGE. L IS A HIGH INDUCTANCE CHOKE, C A LARGE ISOLATING CONDENSER AND LT AN AUDIO TRANSFORMER

a result of too much direct current in the primary.

The elimination of oscillation and motor boating in the amplifier is another advantage gained by the use of parallel feed.

It has been noted that the signal current does not flow through the direct current circuit, i. e., no signal or audio frequency current flows through the plate supply unit.

Permits Auto-Coupling

Since no signal current from any stage flows through the plate supply, no audio frequency voltages are set up, and no coupling between the stages results from the common impedance. The result is a great increase in the stability of the amplifier, and an elimination of regeneration and motor boating.

Another advantage of the parallel feed system is that it permits the use of auto-transformers for coupling. An auto-transformer is one having a continuous winding, with a tap for the primary, instead of two separate windings.

Since the primary of this type of transformer is common to a portion of the secondary, the auto-transformer cannot be used in the ordinary amplifier, where the primary of the transformer must

serve to transmit both alternating and direct current, because of the direct current potential which would be impressed on the grid of the following tube.

This type of transformer offers a considerable improvement in efficiency over the two winding type. A General Radio type 285 1:2.7 transformer will have a ratio of nearly 1:4 when connected as an auto transformer, and there is no loss in "quality."

Efficient Coupling Is Obtained

It is desirable to have the voltage across the transformer primary as high as possible, and this consideration determines the values of L and C. It will be noted from the diagram that the voltage across the transformer primary will be smaller than that across L by the amount of the drop through C. It is, therefore, important to have the drop through the condenser small. This is accomplished by making the impedance of the condenser small. When the transformer is followed by another vacuum tube, the following rule for the condenser capacity will be found satisfactory:

$f = \text{low frequency cut-off of the system (the point where the amplification curve drops sharply)}$

$L = \text{inductance of the transformer henrys}$
 $C = \text{Capacitance of the coupling condenser (farads)}$

Not Critical

The value of inductance is not critical, but it should be such as to have an impedance of several times the plate impedance of the tube or of the transformer (the latter impedances are nearly equal at the low frequency cut off of the system). A rough rule is

$$L = 4 \frac{R_p}{6.28f}$$

where L = inductance of the coupling coil, R_p plate impedance of the tube, and f low frequency cut off. About 100 henrys is the proper value of inductance for use with the usual interstage tubes. A suitable unit for this purpose is the General Radio type 369 coupling impedance.

CIRCUIT FOR "A" FILTER

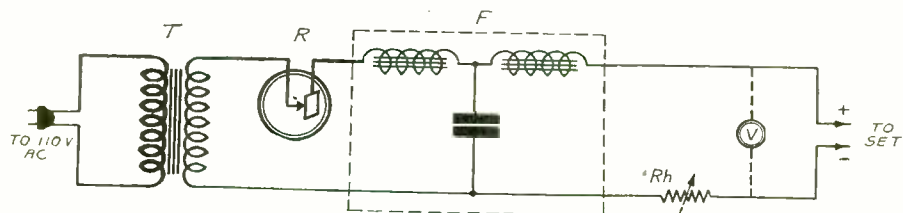

CIRCUIT DIAGRAM OF AN A BATTERY ELIMINATOR USING A TOBE A FILTER. T AND R ARE THE TRANSFORMER AND RECTIFIER OF ANY STANDARD 2 AMPERE CHARGER. F IS THE FILTER. RH IS A 20-OHM CLAROSTAT FOR ADJUSTING THE OUTPUT VOLTAGE TO 6 VOLTS, AS MEASURED BY THE VOLTMETER V.

The new Tobe A Filter, consisting of two heavy-duty chokes and a dry condenser of 7,600 mfd. capacity, connected across a 2-ampere charger, eliminates the A battery. The device is not in operation unless the set is.

If a B supply is used, then the receiver is a DC electric set, according to the official definition of the Radio Manufacturers Association. No batteries whatever are used, yet DC receiver tubes are employed, including screen grid tubes, if desired.

Too Many Screen Grid So Designer Uses

By H. G.

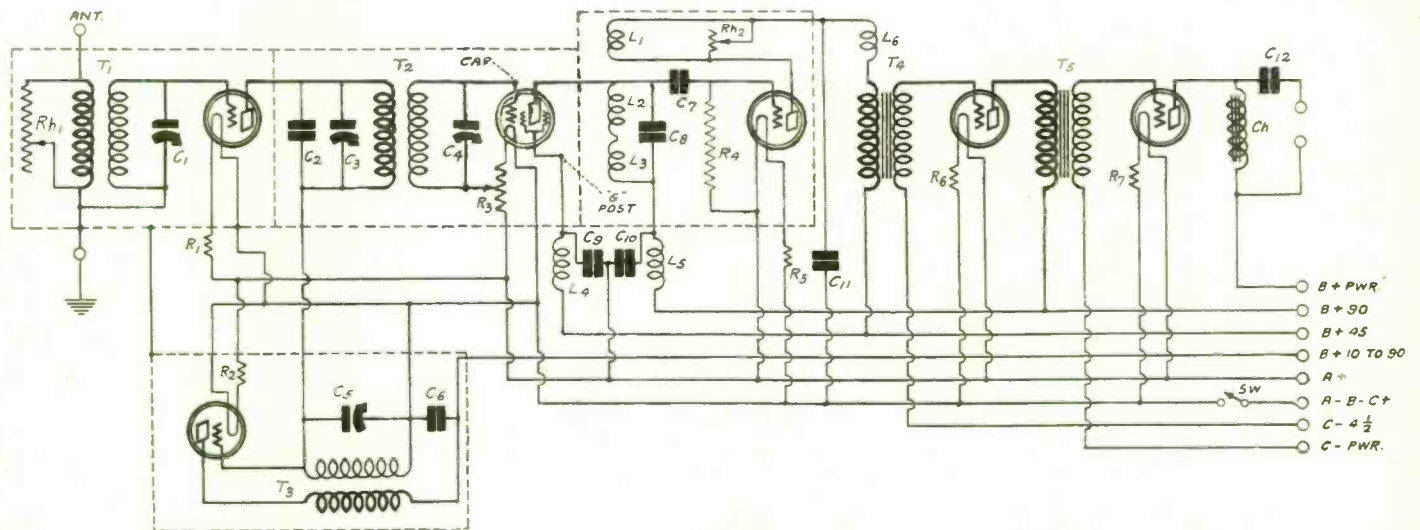

FIG. 1
THE SCHEMATIC DIAGRAM OF A SIX TUBE SUPER-HETERODYNE IN WHICH ONLY ONE INTERMEDIATE AMPLIFIER IS USED, AND THIS EMPLOYS A SCREEN GRID TUBE. SELECTIVITY IS OBTAINED BY TRIPLE TUNING AND BY REGENERATION.

THE high amplification obtainable with a screen grid tube has a strong appeal to those who want reception from remote stations. And this appeal has led many into serious error, which often has resulted in converting a sensitive receiver into a failure.

That error is the use of too many screen grid tubes in a receiver. It is a fallacy to argue that if one screen grid tube increases the reception range 50 times two screen grid tubes will increase the range 2,500 times, three of the tubes 125,000 times.

Perhaps if extreme precautions are taken with shielding the tubes, the coils and the leads in the set, and if the operator has complete control of the amplification at every stage in the circuit, such expansion of the reception range would be possible. But there are many limitations.

Purpose of Screen Grid Tube

In the first place, perfect shielding is not possible. If the amplification is high enough a point will be reached where the circuit will break into oscillation as a result of feedback through the imperfect shields and around the shields. In the second place, the voltage handling ability of the screen grid tubes is very limited. If there are several of these tubes in tandem and if any signal voltage at all is impressed on the first tube in the series, the last tube, or the next to the last, will be so overloaded that there will be no output. One or more tubes in the circuit will become paralyzed.

These conditions are not limited to the screen grid tube alone but apply to all tubes, and in many multi-tube circuits the failure to deliver the expected results is due to them. But general purpose tubes will not become overloaded nearly so quickly as the screen grid tubes.

The purpose of the screen grid tube is not so much to add sensitivity to a multi-tube receiver as to retain the sensitivity of a receiver when several tubes are

dropped from the circuit. The noise level in the atmosphere definitely limits the practical sensitivity in any receiver and it is idle to increase sensitivity beyond the point permitted by the noise level.

Proper use is made of a screen grid tube when it is operated so as to give the greatest amplification of a weak signal. Then it will do the work of two or three general purpose tubes.

Amplification of weak signals under proper conditions of operation is just what the screen grid tube is capable of doing. It will not amplify strong signals for it will overload and become paralyzed.

Screen Grid Tube in Super-Heterodyne

One place where the screen grid tube can be used to good advantage is in the first stage of intermediate amplification in a Super-Heterodyne. The signal level in this stage in a properly designed circuit is very low. Hence to make the receiver sensitive it is necessary to amplify the signal to a high degree before it is put on the second detector. This can be done by the use of two, and with very careful design, three, stages of general purpose tubes. It can be done also with a screen grid tube immediately following the first detector. If more amplification is required than one of these tubes will give, the second tube should be a general purpose tube. A screen grid tube in the second stage would become overloaded if the first were operated at full amplification efficiency. But the second stage should not be necessary.

One of the objects of the Super-Heterodyne is to increase the selectivity. The use of a screen grid tube usually reduces the sharpness of the circuit, and the elimination of one or two of the intermediate filter coils still further decreases it, unless special precautions are taken to retain the selectivity.

Even if the circuit does not have the same selectivity that multi-tube Super-Heterodynes have, nothing is lost and

much is gained in quality. Nearly all Supers are too selective for good reproduction. The higher audio frequencies are almost entirely suppressed by the ultra-selectivity. This can easily be varied by listening to a speaker. The voice is not clear cut and is not easily intelligible. The hissing sounds are missing and the speaker sounds as if he were mumbling his words. That is the price gained by super-selectivity, and it has to be paid. You get DX in return for it. The interference complained of in many Supers is there no matter how selective the circuit is in the intermediate amplifier. The cry for greater selectivity in a Super is based on a lack of understanding of what causes this interference.

Adequate Selectivity Retained

The selectivity of a Super using one screen grid tube and only two intermediate tuners can be made adequate without sacrificing distinctness in the articulation, and it can be obtained very simply.

One method of increasing the selectivity is to tune the plate circuit of the first detector. This can be done without inducing oscillation in the tube because the grid circuit is tuned to a broadcast frequency and the plate circuit is tuned to an intermediate frequency. Tuning the plate circuit has the additional advantage of increasing the detecting efficiency of the first detector, because the tuned circuit in the plate has a very low impedance to the broadcast frequency and an extremely high to the intermediate or detected frequency. This is a necessary condition for high detecting efficiency.

Additional intermediate frequency selectivity can be obtained by tuning the grid circuit of the screen grid tube which is coupled to the first detector. If the coupling between the primary and the secondary of the intermediate transformer is not too close, both windings can be tuned independently to the same frequency.

The most essential condition for getting

Tubes Spoil the Set One in a Super

Cisin

a high amplification out of a screen grid tube is to put a very high load impedance in its plate circuit and then making use of all the signal voltage developed across this impedance. There is no better way of getting a high impedance load than putting a parallel tuned circuit in the plate of the tube. This is not practical in a general purpose tube of the three electrode type because it would start oscillation. In the screen grid tube oscillation will not occur because of the low capacity between the plate and the control grid.

The tuned plate method of coupling a screen grid tube to another tube is admittedly not selective. In fact, it adds practically nothing at all to the selectivity of the intermediate filter. But there is a simple way of overcoming this difficulty, and in just the degree desired. That is by introducing a little regeneration into the stage which follows the screen grid tube.

Feedback is introduced into the parallel tuned circuit so that the effective resistance in the circuit is as low as desired. This not only increases the selectivity but it increases the amplification. This it does for two reasons. It makes the screen grid tube deliver much more of its possible amplification and it increases the amplification in the tube following.

If the regeneration is made adjustable, any desired amplification may be had, as well as any desired selectivity. And the selectivity increases in about the same ratio as the need for it increases, that is it increases with the sensitivity.

Shielding Improves Operation

The advantages of shielding the various radio and intermediate frequency stages from each other have been brought out forcefully in commercial receivers during the last two years. But home radio set builders are reluctant to take advantage of shielding because it entails considerable work. They would rather omit the shields and then ask questions why their receivers do not work as expected, why uncontrollable oscillations appear in the circuits, why the circuits are not selective.

At first thought it would seem that shielding would not help the selectivity, since every bit of shielding absorbs a certain amount of energy and thus introduces resistance in the tuned circuit. But it is not the selectivity of each circuit which determines the selectivity of a receiver. It is the combined effective selectivity of the entire receiver. And that is materially improved by proper shielding.

The reason becomes obvious after a little thought about what occurs in an unshielded receiver. All the wiring in the set and all the coils and condensers pick up some energy from space, particularly from local stations. Hence the unshielded circuit is not much more selective than the tuner preceding the detector. The tuners preceding do not aid in excluding the signals from the local stations for they do not necessarily pass through them.

If shielding is used around every stage the only place the signals can enter is by way of the antenna, and once entered they must pass through every tuner before they can get to the detector. Thus every tuner contributes to the exclusion

of unwanted signals, that is it contributes to the overall selectivity of the receiver.

If radio and intermediate frequency currents are permitted to wander outside the shielding the advantageous effects of it are partially lost. This is particularly true of the screen grid tube. The screening value of the screen grid tube is materially reduced if the screen grid voltage is permitted to vary as a result of signal frequency variations in the plate voltage. To reduce any possible variations of this type a choke coil suitable to the frequency should be inserted in series with the screen grid lead and then by-passed with a large condenser. This condenser should be connected directly to the screen grid terminal on the socket, or to a point on the lead as near it as possible. One side of this condenser should be connected to the filament of the screen grid tube. If practicable, the condenser should be placed inside the shield surrounding the screen grid tube. If not practical, it should be placed immediately outside with as short leads as possible.

A similar filter consisting of a choke coil and a condenser should be connected in the plate return lead of the tuned circuit in the plate circuit of the screen grid tube. This should not be in the same shielded compartment with the screen grid filter, because if both were together the fields of the two choke coils might interact and defeat the purpose of the filters.

The use of a similar filter in the plate circuit of the second detector is standard practice in nearly all receivers. The RF choke is put in series with the primary of the first audio transformer and the by-pass condenser is connected from the plate side of this choke to ground or to the filament. The condenser might be placed inside the metal shield surrounding the detector and associated tuner and the choke coil might be placed just outside the shield.

Schematic Exemplifies

Fig. 1 shows a schematic of a six-tube receiver which exemplifies the principles discussed. There are four heavy-walled aluminum box shields, one for each of the first detector, the oscillator, the screen grid intermediate amplifier and the second detector.

There is an unusual coupling arrangement between the first detector and the oscillator in this circuit. There is no positive plate voltage applied to the first detector or mixer tube. The plate return is connected to the grid of the oscillator tube. Thus the only voltage on the plate of the mixer is the alternating voltage set up on the grid of the oscillator by the oscillations. This voltage is negative half of the time and positive the other half. Plate current flows only when the voltage is positive. This current, which occurs in pulses, is modulated by the signal voltage applied to the grid of the mixer tube so that a beat current of intermediate frequency is set up in the plate circuit of the mixer. This beat is picked up by the first intermediate tuner and transmitted to the single intermediate amplifier, which is a screen grid tube.

The output of the screen grid tube is further selected by the regenerative

coupler between the screen grid tube and the second detector. The type of oscillator circuit and the audio amplifier follow standard practice.

The tuning condenser C1 is a .00035 mfd. The transformer T1 may be any radio frequency coil wound for .00035 mfd. condenser. A Silver-Marshall type 115-A is suitable. The oscillator condenser C5 is .0005 mfd. The oscillator coil T3 may be any two winding oscillator coil wound to this capacity. The Silver-Marshall type 110-A is suitable. The tuning condensers are Hammarlund Midline.

Condenser C2 is a fixed .0005 mfd. mica condenser and C3 is an XL type G-10 having a maximum capacity of .001 mfd. The coil across this may be wound on a 1 3/8 inch diameter with 300 turns of No. 36 enameled wire, the winding being about 2 inches long. The condenser C4 is an XL type G-5 which has a maximum capacity of .0005 mfd. The coil across this condenser may be wound on a 2 inch form with 450 turns of No. 26 double silk covered wire, the length of winding being about 2 inches. The tuned transformer T2 can also be obtained ready made if desired. A Silver-Marshall type 115-E is suitable.

The fixed condenser C8 across the winding L2L3 should be of .00035 mfd. capacity. The coil may be wound with 540 turns of No. 26 double silk covered wire on a form 2 inches in diameter, the length of winding being about 2 inches, or a little longer. The tickler coil L1 should consist of 80 turns of No. 26 double silk covered wire on a 1 inch diameter. It should be mounted inside L2L3 so that the amount of tickling can be varied. The coil system L1L2L3 may be a Silver-Marshall 110-E.

The Intermediate Frequency

The intermediate frequency of the receiver is determined by the natural frequency of the circuit L2L3C8. The doubly tuned transformer T2 should be tuned to the same frequency by adjusting the two XL condensers C3 and C4.

Each of the radio frequency choke coils L4, L5 and L6 may be a Hammarlund 250 millihenrys coil. Condensers C9 and C10 should have a capacity of not less than .1 mfd. while C11 may be a .001 mfd. condenser. C6 should also be a .1 mfd. condenser. C12 should be not less than .4 mfd. C7 should have a capacity of .00025 mfd.

Rh1 is a variable resistor of 200 ohms and may be a Yaxley potentiometer of that value, used as a rheostat. Rh2 may be a Electrad type "F" variable resistor.

R1, R2, R5, R6 and R7 are all ballast resistors suitable for .25 ampere tubes on 6 volts, such as Amperites 1A. R3 should be a tapped resistor of 15 ohms with the tap 10 ohms from the tube. A Carter 10-5 resistance for screen grid tubes is suitable. R4 should be a 2 megohm metallized grid leak.

Sw is a filament switch such as a Carter "Imp" lock switch.

Two high quality transformers, T4 and T5, should be used in the circuit, such as Silver-Marshall. The output choke Ch should have an inductance of 30 henrys.

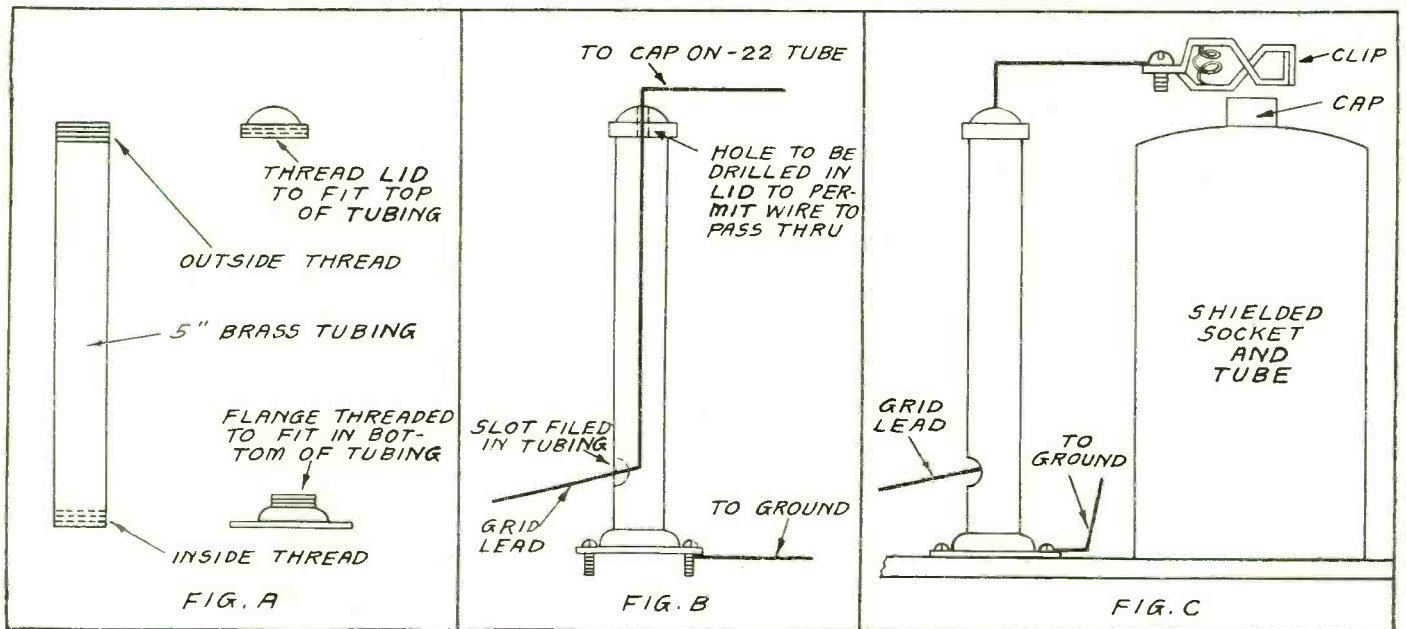

FIG. 1

THE REWARDS FOR THE INGENUITY AND PAINSTAKING WORK INDICATED IN THESE DRAWINGS WERE PERFECT STABILITY, GREATER SENSITIVITY AND IMPROVED SELECTIVITY IN THE SCREEN GRID AMPLIFIER BUILT BY M. U. WALLACH, OF NEW YORK CITY.

Unique Shield Aids Screen Grid Circuit

The importance of shielding tuning coils, leads, condensers and the tube in a screen grid tube radio frequency amplifier only can be realized fully when the performance of an unshielded circuit is compared with that of one which has been shielded very carefully. Thorough shielding not only stabilizes the circuit and eliminates oscillations but it increases both the sensitivity and the selectivity.

Shielding of the long flexible grid lead and the tube is particularly important. One way of doing this, which was devised and used with gratifying results by M. U. Wallach, Associate, Institute of Radio Engineers, is shown in the accompanying drawings. Fig. A shows a piece of brass tubing, threaded at both ends, and a threaded metal lid and pedestal intended for the shield of the grid lead. All these pieces were taken from standard electrical

fixtures, but if they are not available they can be made in any machine shop.

Fig. B shows the assembly of these pieces into the completed shield. The legends in the figure show clearly the necessary operations.

In Fig. C the grid lead shield and the screen grid tube shield are shown side by side in the relative positions which they should occupy in the receiver. All the shielding should be grounded to make it more effective.

The grid lead is terminated in a clip as usual for connection with the cap on the screen grid tube. The hole near the bottom of the grid lead shield should be made large enough to permit wrapping the wire with several layers of insulating tape to prevent a short circuit. The grid lead should be held in the center of the tube as near as possible.

A. J. Lyons in Charge of Tobe's N. Y. Office

Due to the great and healthy growth of the business of the Tobe Deutschmann Co., of Cambridge, Mass., it has become necessary to enlarge their Eastern headquarters. They have therefore removed to 117 Liberty Street, New York City, only a stone's throw from their former address. This office will be in charge of A. J. Lyons, who came direct from the factory. His aim is to render every aid to the trade and fan users of Tobe products.

In addition to the new A-Block, two types of Interference Filters are ready. Among the high-class line of technical apparatus manufactured by this concern are, by-pass condensers, Browning-Drake .1 mfd. condensers, filter condensers, 600 line power pack condensers, 1100 line condensers, Tinytobe condensers, Transmitting condensers, B blocks, vacuum Tipon leaks and Veritas resistors.

Radio Kit Company Gets Larger Quarters

Increased business has forced Radio Kit Company again to enlarge its quarters at 72 Cortlandt Street, New York City. It has moved from the fourth to the third floor.

In the new showroom new circuits that pass the tests of their engineers will be exhibited. Among the circuits now featured are all the Karas circuits; Browning-Drake; the Everyman 4, the Aero circuits, including the short wave receiver, and in the screen-grid division, the Harkness Screen-Grid; the National Screen-Grid Five, and the 4-tube Screen-Grid Diamond of the Air. All the Amertran Power Packs are on display. Full information on any of the above will be freely given by this concern if you mention RADIO WORLD.—J. H. C.

Equal Broadcasting Rights for Candidates

Washington.

The Federal Radio Commission issued a general order concerning the use of broadcasting stations by legally qualified candidates for public office which was prompted, it was stated orally at the Commission, by recent agitation on the subject. The order in full text follows:

"The Federal Radio Commission calls to the attention of all broadcasting stations Section 18 of the Radio Act of 1927, which reads as follows:

"If any licensee shall permit any person who is a legally qualified candidate that office in the use of such broadcasting station, he shall afford equal opportunities to all other such candidates for that office in the use of such broadcasting station, and the licensing authority shall make rules and regulations to carry this provision into effect:

"Provided, That such licensee shall

have no power of censorship over the material broadcast under the provisions of this paragraph. No obligation is hereby imposed upon any licensee to allow the use of its station by any such candidate."

"Any violation of this section of the act will be considered as sufficient ground for the revocation or denial of a radio broadcasting license."

Peerless to Broadcast

The United Radio Corporation, makers of Peerless speakers, will put on a "Peerless Period" over in the Fall over the National Broadcasting Company's Red network. The program will go out each Sunday, Arthur T. Haugh, vice-president, announced. Burton-Bigelow, Inc., Buffalo, N. Y. advertising agency, placed the contract for Peerless.

NEXT WEEK

A complete, illustrated article, 10,000 words, by D. E. Replagle, of the Raytheon Mfg. Co., on the fascinating history of rectifiers; also a playlet for broadcasting, by James H. Carroll.

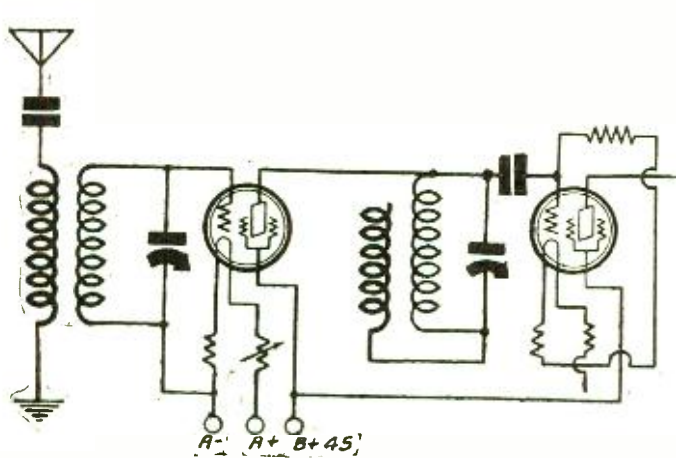

A RESISTOR IS PUT IN THE NEGATIVE FILAMENT LEAD FOR BIAS AND A RHEOSTAT IN THE POSITIVE FOR VOLUME CONTROL. THE COUPLING CONDENSER MAY HAVE A VALUE OF .0005 MFD.

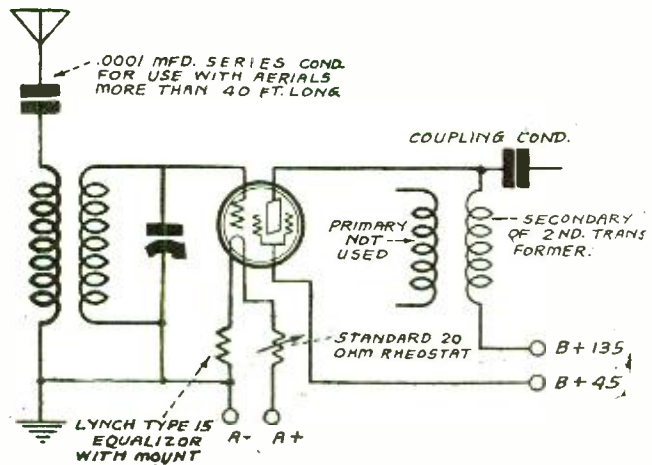

THE VOLTAGE ON THE SCREEN GRID SHOULD BE 45 VOLTS. THE PLATE OF THE TUBE SHOULD HAVE 135 VOLTS. CONNECT CIRCUIT SO THAT NO HIGH VOLTAGE IS APPLIED TO THE GRID OF THE DETECTOR TUBE

Virtues Aplenty in One Screen Grid Tube

By Arthur H. Lynch

The new screen grid tubes are becoming more and more popular because of their great sensitivity and the ease with which they may be applied to the new circuits. They may also be used to get a great deal more pep out of old receivers.

Some home constructors make the mistake of believing that because one of these tubes may be used to great advantage all they need to make a "world-beater" is a whole batch of them.

One of the best examples of an intelligent application of this new tube is found in "The National Screen Grid Five," described by James Millen in the April 14th 21st and 28th issues of RADIO WORLD. This receiver is simple to build and simple to operate and is of excellent design. It may be remembered by some of our readers that Mr. Millen was formerly on the editorial staff of "Radio Broadcast." His engineering writing is coming to be looked upon with more and more favor by those who know what it's all about.

Follow the Expert

Many of those who would find the screen grid tube to give satisfaction would do well to take a few pointers from Mr. Millen's excellent work.

For instance in this new receiver Mr. Millen has taken full advantage of the screen grid tube as a radio frequency amplifier. He has done this without resorting to any shielding or any so-called neutralizing devices and he has prevented the difficulties which arise if more than one screen grid tube is used.

Applied to TRF

In the filament circuit of the screen grid tube, Mr. Millen has used a standard 20 ohm rheostat and one of the new Lynch type 15 Equalizers. This, in itself is an ideal combination and may be used to advantage in any receiver. The Type 15 Equalizer in series with the rheostat provides the proper filament control as well as a very satisfactory volume control and the necessary grid bias for the new tube.

The same idea well may be applied to

any existing tuned radio frequency receiver by using a single screen grid tube in the first radio frequency stage.

In this connection it is advisable to use only one screen grid tube. There are several reasons for this. First of all, a single tube of this nature, properly employed will improve the sensitivity of the receiver greatly and because no more than one such tube is employed all complicated shielding and necessary changes in wiring are completely done away with.

Where receivers already are shielded and the constructor wishes to use more than one screen grid tube, this may be done by enclosing one screen grid tube and one tuner in each shielded compartment.

Tube Shields

It will be advisable in this sort of an assembly to use screen grid tube shields such as the Vac-Shield, and the filament circuits of all the RF tubes may be controlled by the new Lynch Screen Grid Filament and Bias Control, Type 22.

In all cases, the simplest method of using the RF coils already in the receiver is to cut out the use of the primaries in all but the antenna coupler. This procedure is shown in both Figs. 1 and 2.

For best results in connection with receivers of this type, it has been found advisable to use a CeCo Type F12A power tube for the detector. The reason for doing this is to prevent the detector overloading which is likely to occur on local signals if an ordinary detector tube is used because of the great amplification of the screen grid tube or tubes.

Short-Wave Protest

Made Against R. C. A.

Washington.

The Radio Protective Association has filed a protest with the Federal Radio Commission against the issuance or renewal of short wave licenses to either the Radio Corporation of America or any of its subsidiaries. The association contends that the corporation controls an interest in the radio patents owned by the American Telephone & Telegraph Co. in violation of Section 17, the anti-monopoly clause of the Radio Act of 1927.

This is the section the Radio Commission has asked the Attorney General to interpret.

Soon See By Radio Is Replogle's Idea

By C. D. Replogle

Only lately has the use of gaseous rectification been discovered and there is much reason to expect that many additional uses can be found for ionized gases, as an outgrowth from research.

Along with this development has been necessary the development of circuits in which the rectifier is the heart. This development has also been rather phenomenal and rapid, until today, with a minimum of materials, it is possible to supply all the power needed by a radio set with its associated power amplifier from that vast reservoir of power, the central power station.

It is my prediction that not only will we hear by radio, but we will soon also see by radio and in this new field of television gaseous conduction will very likely play a very distinct and useful part. If it does it will be because of the same sort of painstaking research and engineering that has been needed to produce the rectifiers of today.

NEXT WEEK—An important article by D. E. Replogle on the history of rectifiers, fully illustrated.

Jenkins Demonstrates Silhouettes in Action

Washington. Silhouette pictures of moving objects are being broadcast by C. Francis Jenkins and they may be received by simple receiving sets similar to ordinary broadcast receivers. In fact, any ordinary broadcast receiver may be used by attaching a suitable television to it.

The television receiving attachment is plugged into the loudspeaker jack, the set is tuned as for broadcast reception and the moving shadows of the distant scene appear on a mirror which forms the receiving screen.

A magnifying glass is used to enlarge the pictures received. The image on the mirror is apparently 6 inches square which is large enough to permit a group of persons to view the picture at the same time without crowding.

During the first demonstration, which was witnessed by government officials, a picture entitled "A Day With the Children" was first broadcast. The actors in the picture were the young daughters of

Lieut. and Mrs. Edward Rounds of the Navy. The second picture was a movie cartoon entitled "Old King Cole," drawn by J. Reginald Almand of Washington.

The transmission of the pictures was done on a frequency of 1,000 kilocycles, or 300 meters.

Speaking of the new system of silhouette transmission Mr. Jenkins said:

"This magic mirror reflects a pantomime picture story so realistic one's initial astonishment is lost in the fascination of the weirdly told tale."

Mr. Jenkins admits that the pictures thus far transmitted and received are not as perfect as the movies in a theatre, but he points out that the movies have been developed for thirty-five years, and that his demonstration is probably as good as the first movies projected in a theatre in 1893.

Mr. Jenkins predicts that the silhouette picture receivers will be ready for public distribution by Christmas.

Nakken to Broadcast Television from WRNY

Theodore H. Nakken, president of the Nakken Television Corporation of Brooklyn, a recently organized subsidiary of the Pilot Electric Manufacturing Company, announced a series of public television demonstrations on the 326 meter wave of station WRNY in New York City.

The television transmitter will be linked with the WRNY control apparatus in the Roosevelt Hotel and the electrical impulses corresponding to the object before the instrument will be sent by wire to the WRNY transmitter at Coytesville, N. J. From that point the radio waves will carry the picture back to the studio in the Hotel Roosevelt to operate the television receiving equipment.

Mr. Nakken said:

"My object is television which can be employed by every broadcasting station under present conditions, namely, the ten kilocycle variety of television, rather than television which requires a much wider channel. The wider or more perfect television might be better to look at, but there is no available radio band at present for its application because the channels are already crowded."

Mr. Nakken added that his instrument is to work on the principle of more perfect scanning but only ten repetitions of the image per second. The main disadvantage of this is that there will be a slight flicker as one image passes and the next begins. But this must be accepted

Television Is Broadcast Tri-Weekly from WGY

For the benefit of television experimenters, both professional and amateur, the General Electric Company of Schenectady is broadcasting pictures over station WGY. The broadcasting takes place on Tuesdays, Thursdays and Fridays between 1:30 and 2 P. M. Eastern Daylight

as long as the present crowding of the broadcasting exists and until a wider channel than 10 kc can be obtained.

New Symphony Group to be Heard in Series

The new Philharmonic-Symphony Orchestra, created by the merger of the oldest two musical organizations in New York, will be heard from the Lewisohn Stadium this summer through station WJZ, according to an announcement by Maurice Von Praag, Manager of the orchestra. Broadcasting will begin early in July over the blue network, which is expected to cover thoroughly the East and the Middle West.

There will be at least 110 players taking part in the open air concerts, the first of which will give the radio audience the first opportunity to hear the new organization.

The broadcasting will not be sponsored by any advertiser but will be rated as a sustaining program.

N. B. C. HAS CONCERT BUREAU

Formation of the National Broadcasting and Concert Bureau, and the appointment of George Engles, former manager of the New York Symphony, as its managing director, was announced by M. H. Aylesworth, president of the National Broadcasting Company.

Time, according to Martin P. Rice, manager of broadcasting.

Recently WGY broadcast television for a few minutes during the evening to acquaint listeners with the peculiar sounds which accompany television transmission. Few listeners caught on.

EXPERIMENTS

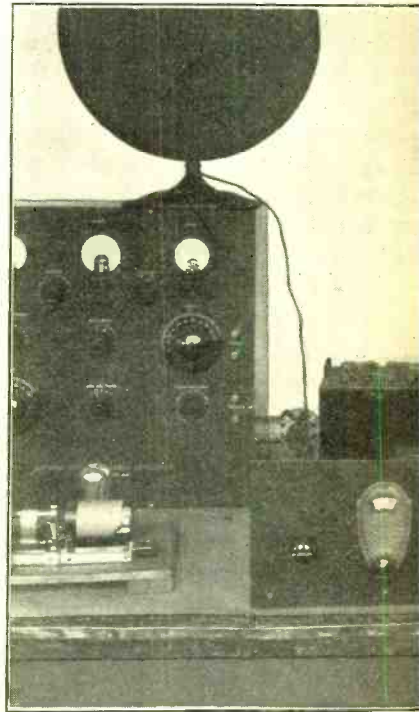

PART OF THE LABORATORY EQUIPMENT OF A RADIO ENGINEER. ON THE RIGHT IS THE SCANNING DEVICE AND ON THE LEFT IS A RADIO RECEIVER FOR PICKING UP THE SIGNALS.

NEW RUSSIAN

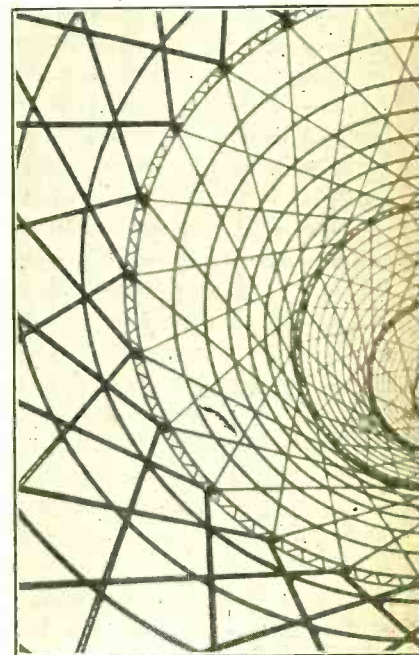

"THE NEW KOMINTERN" STATION IN MOSCOW. IT IS USED FOR BROADCASTING AND EXPERIMENTS. IT OPERATES ON 1,000 METERS. IT IS EUROPE'S MOST POWERFUL STATION. ORDINARY DETECTORS WITHIN A FEW MILES OF LENIN'S BROTHER-IN-LAW, AND STATION IN NINSCHNI-NOWGOROD. WAS TAKEN

COOLIDGE ON AIR MAY 30

Plans have been made for broadcasting President Coolidge's speech from Gettysburg battlefield on Memorial Day.

N ACTIVE VISION

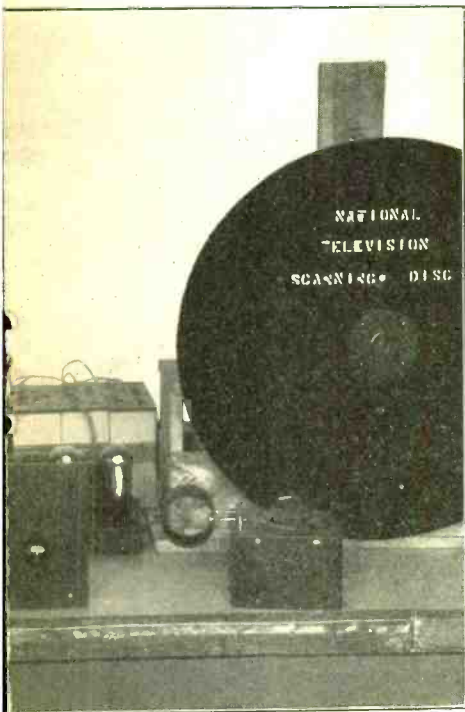

MENT USED BY JAMES MILLEN, CON-
EXPERIMENTS IN TELEVISION. AT
SC, BELOW A WAVEMETER, MIDDLE
THE TELEVISION SIGNALS, AND AT
QUENCY OSCILLATOR.

STATION LEADS

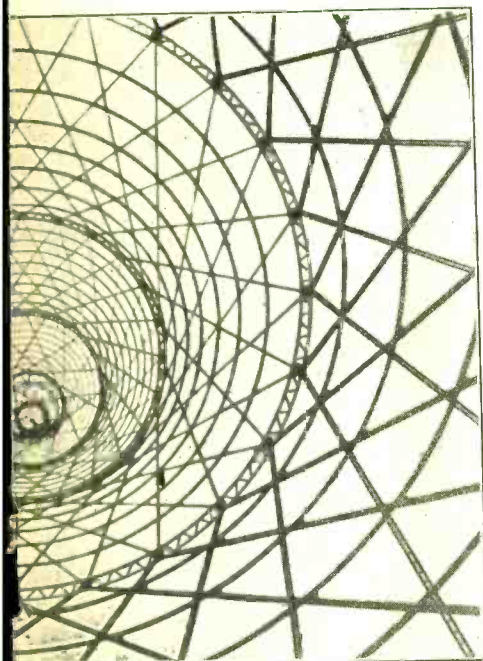

AS OPENED IN MOSCOW RECENTLY.
S WELL AS FOR TELEPHONE AND EX-
50 METERS, WITH 40 KILOWATTS, AND
TATION. THE TRANSMISSION IS FOR
A RADIUS OF 300 KILOMETERS. THE
OF PROF. BONTSCH-BRUJEWITSCH,
DIRECTOR OF THE RADIO LABORA-
THE VIEW OF THE ANTENNA TOWER
NEAR THE BASE.

BILLINGS DIRECTS WLW

H. Ford Billings, former manager of
WTIC, Hartford, Conn., is now director
of WLW, Cincinnati, O.

Travelling Authors Hear Books Reviewed

In his fifth year of broadcasting, Joseph Henry Jackson is a tremendous drawing card for KGO with his literary service that brings responses from Artic wilds and other remote regions.

Jackson pioneered in the field of radio book reviews when he started this feature at the General Electric station shortly after KGO went on the air.

During this time he has given 191 talks and reviewed 1,885 books, and he has prescribed weekly balanced reading rations for an audience that ranges from Bermuda to the great Columbia ice fields.

Dingle Tunes In

Jackson's free and easy style of talking before the microphone has won for him a host of friends, including many besides those who read books.

Public libraries in many cities have tried reviewing books over the air, but have failed. Jackson, in his friendly, chatty, conversational way, thoroughly interests his hearers while giving literary information and advice; and the responses from listeners show that he is exceedingly popular over a vast area and with all classes of people.

Captain Dingle, author of "Wide Waters," was cruising off the coast of the Bermudas one night when he tuned in on KGO and heard Jackson talking about his book. Captain Dingle was so delighted that he immediately sent Jackson an autographed copy of the work.

Freeman's Experience

Another author, living in San Diego, had just bought a radio set, and while DX-ing tuned in KGO and heard Jackson giving a talk about his books.

While Jackson was reviewing a travel book by Lewis R. Freeman, this author

was sitting in an ice-hut, half frozen, on top of the Arctic Divide. He heard every word Jackson uttered about him and when he came to San Francisco he dropped in on Jackson at "Sunset Magazine," of which Jackson is editor, and told about hearing him while sitting on the edge of a glacier.

Jackson always tries to have the authors appear with him when books are reviewed and he has already introduced fifty writers to the audience.

Youthful Chap

Probably on account of his wide literary knowledge, Jackson seems to be regarded by all his listeners as an elderly man of the traditional bookworm type. One enthusiastic feminine listener wrote to KGO: "I know that Mr. Jackson looks just like President Coolidge."

But there is no resemblance to any of the presidents. The reviewer is a youthful fellow who might get along very well in the movies, if he didn't prefer books.

Wooden Aerial Towers Reduce Absorption

Los Angeles.

KFI reports something new in the way of radio masts, the development coming out of Germany, where towers constructed of wood have been in use for several months now and are reported very successful.

Wood was resorted to because of the huge absorption of power by the steel towers and it is reported, says KFI, that the wooden masts absorb 62 per cent. less energy than the regulation steel.

Ice-Locked in Arctic, MacMillan Tunes in

News that the Bremen and her German-Irish crew of three had landed just around the corner was received by the members of the Rawson-MacMillan expedition while tuned to WGY, the Schenectady station.

Captain Donald MacMillan and brother scientists are now tightly confined by ice in northern Laborador, 59 degrees west longitude and 61 degrees north latitude near Nain. Greenely Island, the landing place of the fliers, is about 500 miles southeast of Nain.

On the day of the flight the expedition's radio operator heard reports of the progress of the fliers, and, like thousands of others, had begun to mourn their loss when late in the evening came news that the fliers were safe at Greenely.

Kept Well Posted

During the ensuing days the members of the expedition were kept closely posted as to the plans of the fliers and their rescuers. They heard of Floyd Bennett's flight from Detroit, his illness and death; they heard the description of the final departure of the fliers from Greenely and their reception in New York and Washington.

They felt even closer to the world of affairs, in spite of the icy fastnesses, when came news that Captain George H. Wilkins had penetrated the Arctic basin and had flown safely to Spitzbergen.

Raymond K. Strong, control room operator at WGY, and an amateur operator working under the call letters 2SF has been in frequent code contact with the operator of the Rawson-MacMillan expedition.

Reports on Reception

The expedition operator reports that in general if he cannot pick up WGY he tries for no other stations in the broadcast band, knowing that if conditions are so bad WGY will not get through, nothing else will. He reported that 2XAD, the 21.96 meter station of the General Electric Company, is generally very loud between noon and 6 p.m., but after 6 this station becomes erratic until 8 p.m., when WGY is generally better.

2XAF, the 31.4 meter station of the same company, is good from 6 p.m. to 9 p.m. and is audible many times when WGY is unheard.

"WGY certainly has a sock except on the very worst nights," is the operator's way of describing the signal of the Schenectady station.

Pickup Action Called the Most Interesting

By A. R. Wilson

Engineering Department, General Radio Company

The past year or two have seen remarkable strides in the design of audio amplifying equipment. Amplifiers and transformers have been developed to such a stage that it is difficult to see where an improvement in quality could be made.

With the introduction of the new —50 type power amplifier tube a far greater loudspeaker volume is possible than heretofore, since this tube is capable of delivering more than three times the undistorted power of the —10 type tube, long the favorite power tube for maximum volume and tone quality.

These developments in the quality of radio transmission and reception have reacted on the phonograph industry and it became necessary for the designers of phonographs to look around for some means whereby their previously unchallenged supremacy could be regained. Thus came the electric phonograph known under the various trade names as the Panatrope, the Electric Victrola, etc.

Pick-up Unit Most Interesting

These machines all use as their basis the modern high-grade audio amplifier instead of the old-fashioned sound box and

horn. The horn gave way to the cone type of reproducer and the sound box itself was replaced by the electro-magnetic pick-up.

This latter piece of apparatus, although the smallest in the make-up of the electrical phonograph, is probably the most interesting of all components. Its function is to translate into electrical energy the vibratory motion of a needle traveling over the surface of a phonograph record.

The vibration of the needle is utilized to generate current in an electric circuit. These changes in current represent the vibrations of the needle which in turn represent the sound originally impressed on the phonograph record.

Reversed Action

The action of the magnetic pickup is a reversal of the action of a loudspeaker.

The selection of a good magnetic pickup does not solve the problem of good reproduction, because the audio frequency amplifier must be carefully built and use must be made of both a power tube and a speaker of good design. There are now on the market several types of very good magnetic pick-ups.

Effect of the Arm on Pickup's Reproduction

(Continued from page 4)

make the armature move in still another direction. The armature does not move freely at any place except at *b*. A stress is set up at all other places which not only hurts the unit but also the record. The full undulations in the record are not transmitted to the armature and therefore the sensitivity of the pick-up unit varies with the position of the needle.

The shorter the arm is, the greater are these deleterious effects. It is obvious that the arm should be long so that the needle will travel across the record along a radius as nearly as is practical. To insure this length *a* in Fig. 2 or *Pb* in Fig 3 should be long.

In many cases the arm is adjusted so that the needle just touches the center of the record when it is swung in. As the needle moves out along an arc in this case it will not move freely parallel with the groove at any point in the record, and when the needle is in the outside groove the angle of departure is very large. It is about three times as great as it would be if the position of *P* were adjusted so that the needle moved freely parallel with the groove in the middle of the useful part of the record, that is at *b*.

The angle of departure from parallelism at any part of the record is least when the vertical pivot *P* is adjusted so that the needle moves freely parallel with the groove in the middle of the useful portion of the record.

On some units the armature is so mounted with the respect to the arm that the motion of the armature is not at right angles to the arm. In such cases it may not be possible to place the vertical pivot so that the armature can move at right angles to the groove at any point. Perfect reproduction under such conditions cannot be expected.

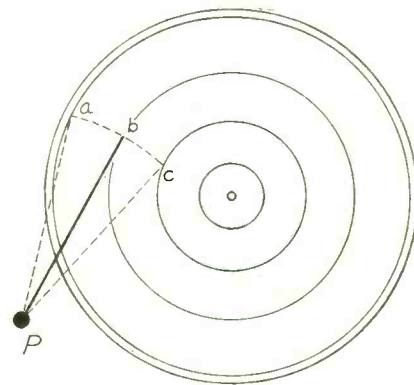

FIG 3

SCHEMATIC OF PHONOGRAPH TURNTABLE AND TONE ARM SHOWING THE IMPORTANCE OF HAVING A LONG ARM TO MINIMIZE THE ANGLE OF DEPARTURE BETWEEN THE GROOVE AND THE FREE MOTION OF THE NEEDLE.

It may be argued that the needle moves parallel with the groove at every point, since it moves in it. That of course is admitted. It is for that reason that the term "free parallel" was used. In the middle groove, when the unit is so adjusted, the needle moves in the groove without any constraints from the walls. At all other points the needle is constrained to move in the groove by a force either inward or outward depending on which side of the middle groove the needle moves. The less the constraint on the needle to keep it in the groove the more faithful is the pick-up and the less jarring of the armature.

Crosley Acquires WSAI; 50,000 Watts for WLW

Cincinnati.

WSAI has been taken over by the Crosley Radio Corporation, owner of WLW. Both are 5,000 watt stations. The United States Playing Card Company formerly owned WSAI. The Crosley Corporation is about to acquire a 50,000 watt transmitter for WLW. The Federal Radio Commission has been asked to authorize the increased power.

The Crosley Corporation would operate WLW with the 50,000 watt transmitter as an independent station. WSAI would be used to transmit programs from the Blue and the Red networks to listeners in the Ohio Valley. WSAI's power way will be reduced to that of a regional station.

WLW celebrated its seventh birthday in January with 62 hours of continuous broadcasting. The transmitter is located at Harrison, Ohio, 20 miles northwest of Cincinnati.

WSAI officially went on the air in June, 1923, with 500 watts of power. In January, 1925, the present 5,000 watt transmitter was installed at Mason, Ohio, about 20 miles northeast of Cincinnati.

Listeners Ask Law Against Interference

Spokane, Wash.

Asserting that 30,000 radio listeners in Spokane are affected, the Broadcast Listeners' Association of Spokane presented before the Spokane City Council an appeal for a city ordinance to control radio interference.

C. Hale Kimble, president of the association, presented a suggested ordinance.

It is stated that a close study of the situation in Spokane had led to the conclusion that the radio problems can be handled in Spokane only as it is handled in other cities. The petition declares that "30,000 listeners in Spokane have invested hundreds of thousands of dollars in radio receiving equipment, the use of which is becoming increasingly menaced with the alarming growth of unnecessary interference." It continues:

"The Broadcast Listeners' Association of Spokane has been making a study of local interference for the last four years and has determined that the situation can only be handled in Spokane as it is being handled in hundreds of other cities throughout the country, through fair and just local radio protective ordinance."

Two Branch Factories Acquired by Amrad

A. B. Ayers, general manager of the Amrad Corporation, Medford Hillside, Mass., announced the opening of two branch factories, one in Charlestown, Mass., and another in Chicago, to handle increased production. The main Amrad factory at Medford Hillside will be devoted to the manufacture of radio receiving set chassis, power packs and Mershon condensers. The branch factories in Charlestown and Chicago will be used for mounting the chassis in cabinets.

Geo. C. Beckwith Co. has been appointed exclusive Amrad distributor in the large area served from Minneapolis, and The Newark Electrical Supply Co. of Newark, N. J. has been appointed exclusive distributor in the Newark territory.

One-Tube Adapter for the Short Waves

By J. E. Anderson

Technical Editor

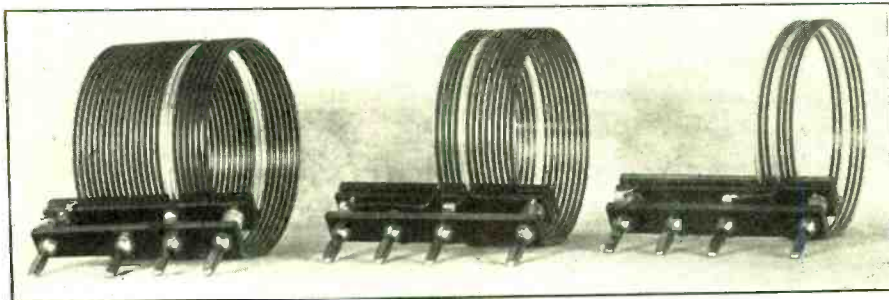

FIG. 5

THIS PHOTOGRAPH SHOWS THE SMALLEST THREE OF THE SHORT WAVE COILS IN THE HAMMARLUND SET. ANY ONE FITS INTO THE HAMMARLUND COIL RECEPTACLE, MAKING THE PROPER CONNECTIONS AUTOMATICALLY.

[Part I of this article was published last week. The final instalment follows.]

PART II

The tuning condenser C2 is a Hammarlund midline seven plate, .00014 mfd. The tickler condenser C3 is a similar variable condenser having eleven plates, .00025 mfd.

Note that the circuit is so arranged that the rotors of both condensers are grounded. This is done to minimize as much as possible the hand capacity effects. This is of vastly greater importance on short wave work than on broadcast reception. On short waves a very minute change in the capacity will throw the tuning off entirely.

The RF Choke

The RF choke Ch is a Hammarlund 85 millihenry coil. A larger coil should not be used, for it might have too much distributed capacity through which the radio frequency current could escape the tickler circuit.

The adapter is supposed to be used in conjunction with any standard broadcast audio frequency amplifier.

The detector tube in the receiver is taken out and inserted in the single socket of the short wave adapter. A plug connected to the adapter socket contains three cords with terminals marked A-, A+ and B+. This plug is inserted in the detector socket of the broadcast receiver. The tube in the adapter then takes its filament current and plate voltage from the broadcast receiver.

The filament rheostat in the detector circuit can then be used for the adapter. In case a ballast is used this will be just right for the adapter.

The plug for the adapter can be purchased ready made if desired. The Double R No. 21 plug with cord attached is suitable.

Making the Plug

The plug also can be made at home. The base of an old tube is removed from the glass tube. This can be done easily by heating the base gently over a gas flame until the sealing wax melts or softens. When this has been done, heat the four prongs until the solder melts. Then pull the base away from the glass tube. Heat the base uniformly all around and slowly, or the glass tube might burst. When the base has been pulled away from the glass, remove the remaining

solder from the holes in the prongs. Then insert a 3 foot flexible wire, such as Celatite, in each of the prongs except the grid prong. You can tell which are the plate A+ and A- leads by completing the circuit with a meter and small battery.

Make these wires of suitable length to reach from the adapter to the detector socket. These wires may be soldered permanently to the proper places in the adapter or they may be terminated in lugs for inserting in binding posts, as indicated in the circuit diagram.

The tickler on the 15-30 meter coil has three turns, the same number as on the tuned winding. The 27-59 meter coil has 7 turns on the secondary and 4 turns on the tickler. The 52-107 meter coil has 16 turns on the secondary and 6 turns on the tickler.

The 100-215 meter coil has 32 turns on the secondary and 14 turns on the tickler. This coil is wound with No. 20 wire and the turns are spaced 24 turns to the inch.

These data cover the specifications of the latest models of the Hammarlund short wave coils.

Tuning Ranges of Coils

The wavelength range of the smallest coil in the set is approximately 15 to 30 meters. That of the medium coil is from 27 to 59 meters, and that of the largest coil from 52 to 107 meters. A fourth coil may be obtained for the set, and this coil has a range of about 100 to 215 meters. These ranges are based on the use of a .00014 mfd. tuning condenser and a 112A tube for detector. This tube is used because it has a low capacity and at the same time a high detecting efficiency.

The wavelength ranges also depend on the setting of the antenna coil and on the length of the antenna. It is assumed that the coupling between the antenna and the tuning coils be set so that the sensitivity is the greatest. This is rather loose coupling. Fig. 4 showed approximately the optimum coupling for the 27-59 meter coil, the antenna coil being set at an angle of about 45 degrees. As the angle is decreased, that is as the coil is turned to the right in Fig. 4, the coupling is also decreased. For the smallest coil the coupling must be less, for the larger it may be closer.

Compact Set Possible

The tuning ranges are also affected to some extent by the setting of the tickler condenser. But this effect is small and it

LIST OF PARTS

L1—One Hammarlund plug-in coil receptacle with antenna coil.

L2, L3—One set of Hammarlund short wave plug-in coils.

Ch—One Hammarlund 85 millihenry RF choke coil.

C1—One XL adjustable grid condenser with resistor clips, type G (30 to 350 mmfd.)

C2—One Hammarlund .00014 mfd. Midline tuning condenser.

C3—One Hammarlund .00025 mfd. Midline condenser.

R1—One 3 megohm Lynch metallized grid leak.

One Silver-Marshall X type socket.

One Double R No. 21 cord and plug.

Two Karas Micrometric dials.

One 7x14-inch front panel.

One 7x11-inch baseboard.

One X-L Bakelite push post.

is assumed that as much regeneration as is practical is used in each case.

The adapter was built on a 7x14-inch panel and a 7x13-inch baseboard. But the panel may be reduced to 7x12 inches if desired, with a corresponding reduction in the length of the baseboard. No reduction should be made in the width of the baseboard for that would crowd the coil too close to the tube and the panel.

To operate the adapter disconnect the antenna leadin from the broadcast receiver and connect it instead to the antenna binding post of the adapter. The ground connection is not removed from the broadcast receiver, as it is assumed the filament circuit is connected to ground in the broadcast set. Remove the detector tube from the broadcast receiver, put the tube in the socket of the short wave adapter and insert the plug in the empty detector socket of the broadcast receiver. You are now ready to tune in.

[Any technical questions regarding short wave receivers should be addressed to J. E. Anderson, Technical Editor, RADIO WORLD, 145 West 45th Street, New York, N. Y.]

Thomas G. Nee Named Acme Wire President

Thomas G. Nee, engineer and executive with a record of brilliant achievement, has been elected president of the Acme Wire Company, leading manufacturers of wire for radio and other uses, and of the Acme Parvult condensers for filtration and by-passing. Mr. Nee already has made important progress at the company's plant at New Haven, Conn.

Mr. Nee is an engineering graduate of the University of Wisconsin, class of 1900. From 1905 to 1917 he was connected with the Mexican Telephone and Telegraph Company as vice-president and chief engineer in full charge of all of the company's operations in Mexico. From 1917 to 1927 he was connected with the Allied Machinery Company of New York, which was owned by the American International Corporation of that city, as president of its most important subsidiary, the Horne Company, Limited, in Japan. He made a notable success of this company, particularly during the trying years following the war.

Mr. Nee has had a long business training in lines that make him very familiar with the products of The Acme Wire Co. His long connection with the telephone and telegraph business familiarized him with coils, wire of all kinds, condensers and other electrical wire products. That he stepped from the position of chief engineer to executive leadership in both of the companies with which he has been connected is a compliment to his business sagacity and to his practical engineering training.

NEW WORD "GUSTY" IS IMPORTED

Pittsburgh.

From England has come a new word to be added to the vocabulary of the American radio fan. The word is "gusty" and it is used by the British listeners to indicate changes in volume. It is comparable to our word "fading."

"Gusty" as far as radio broadcasting is concerned, first appeared on our shores Thursday, April 19. It was contained in a cablegram received by Percy Scholes, music critic of the British Broadcasting Corporation, who was in Chicago, where he had attended, on the previous evening, a concert of the National High School Orchestras.

The concert was broadcast by the National Broadcasting Company, and Mr. Scholes, having been informed in advance that the program would be on the air, cabled his friend Arthur Mann, of Durrington, Sussex, England, to try to tune it in. Mr. Mann was successful in receiving the concert through KDKA and was so elated over the program and the ability of his set to "pick-up" such a distant broadcast that he sent a cablegram to Mr. Scholes.

The cablegram which brought "gusty" to the United States was as follows:

"Received concert through KDKA. Reception good but gusty. Wonderful orchestra. Fine rendering of symphony."

MAKES SHORT WAVE ADAPTER

The A-C Dayton Company, Dayton, O., announces it has acquired the sole right to manufacture the Flewelling Short Wave Adapter. E. T. Flewelling is now on the Dayton engineering staff.

Woman Got Germans' First News of Bremen

WGY, through its short wave transmitters, 2XAD and 2XAF, kept Germany posted on news of the Bremen, at least such news as was available during those hours when the plane was expected to complete her trans-Atlantic trip. It is apparent, from correspondence, that the German broadcasting stations finally became discouraged and shut down, but one station at Bayern maintained a listener and was able to announce the safety of the fliers five hours before the official bulletin was received. The correspondent's report follows:

"Everybody was eagerly awaiting news of the Bremen during the night of April 13 and 14, but at 1 a.m. all the stations closed down, having given up hope for that night.

"The Deutsche Stunde in Bayern, however, had a skilled operator on watch all night, on the chance of his receiving any news direct from America. As, however, he was unable to speak English, Frau Prof. Bassermann (nee Scarlett), of London, undertook the weary vigil. Shortly after 3 a.m. B. S. T., the operator was able to 'phone the good news, broadcast by Schenectady, on its short wave, that the Bremen had landed.

"Some officials of the Deutsche Stunde immediately motored to the transmitter, set it going, and at 3:57 a.m. B. S. T., Munich, the first European broadcasting station to do so, was able to tell Europe the glad tidings. The official bulletin arrived after 8 a.m. on the memorable morning."

Stiff Backing Stops Rustling of Papers

Los Angeles.

Perfection of reception of KFI broadcasts being of utmost importance to that station, Carl Haverlin has gone a step further in eliminating any possibility of little foreign sounds going out over the air.

With many programs of the incidental dialogue type being broadcast, it is sometimes necessary that the players have a script with which to follow the patter. Such papers rustle when being handled and the result is heard in the loud speaker as static noises.

Mr. Haverlin has issued a regulation requiring that all papers going into the broadcasting studio be pasted on stiff cardboard. This manner eliminates any noise caused by the bending or rustling of paper. With the sensitive new condenser microphones, every sound, no matter how slight, is picked up and magnified many times.

In some KFI broadcasts the crackling of paper has been found to give an excellent imitation of the crackling of fire, or when exceptionally loud, to be similar to a crack of thunder.

Paskman of WGBS Chronicles Minstrelsy

In a new book called "Gentlemen, Be Seated. A Parade of the Old-Time Minstrels," published by Doubleday-Doran & Co., Dailey Paskman, director of WGBS, Gimbel Bros.' station in New York City, collaborating with Sigmund Spaeth, gives a romantic and humorous history of minstrelsy from its earliest beginnings in the early 1840's up to the present time.

Mr. Paskman, the originator and organizer of the Dailey Paskman—WGBS Radio Minstrels, made an intensive study of the art of blackface, and his volume is the result of three years' of research and writing.

Songs in Fac-simile

It contains facsimiles of such famous songs of yester-year as "Old Dan Tucker," Billy Emerson's "Big Sun Flower," and "Dixie." The bill of sale for "Dixie," reproduced in the book, shows that its author, Dan Emmett, sold the song for \$300, a trifling amount as compared with the tremendous prices received for song hits written today.

The book is profusely illustrated with photographs of pioneer minstrel men, among those pictured being Honeyboy Evans, Backus, Birch & Wambold, Dan Bryant, Primrose & West, Lew Dockstader, Harrigan & Hart, and so offers "a parade of the old-time minstrels" from

The Big Four up to Eddie Cantor and Al-Jolson.

Minstrelsy Analyzed

In addition to its many fascinating pictures, this saga of the most romantic troupers in the whole history of the American state contains an analysis of minstrelsy, many minstrel jokes, a real minstrel show ready for production, the stories of famous teams, etc. It outlines the entire growth of minstrelsy from its first presentation, through its height of popularity, to its decline of a few years ago. Then, reborn at the microphone, blackface revived on the stage, and now is bringing fond memories to the old folks while it conjures up a new thrill for the younger generation.

The initials of the book's title, "Gentlemen, Be Seated," are GBS.

**40,000,000 Listeners;
12,000,000 Receivers**

A survey recently made by "Radio Re-tailing" showed the following:

Receiving sets in U. S.	12,000,000
Extent of audiences.	40,000,000

Crystal sets and one-tube sets were not included in the receiver tally.

The New Morecroft A Valuable Book

When a student of radio asks what book he should read to get a comprehensive understanding of radio the answer invariably is: Morecroft's "Principles of Radio Communication," published by John Wiley & Sons. (\$7.50). The second and revised edition is now published. It treats the subject concisely and clearly and covers as much of the principles and practice of radio communication as is possible in 1,000 pages without sacrificing lucidity. It is profusely illustrated with graphs of experimental results, many of which were obtained by the author himself and his associates in the Marcellus Hartley Research Laboratory of Columbia University. The book is authoritative and up-to-date.

The book includes the basic radio circuits with critical discussion of each. In this respect it is not intended to solve directly the problems for the service man and the set builder but to enable him to solve his own problems and instill self-reliance.

If any fault at all can be found with the book it is the brevity of the discussion on B battery eliminators and the problems associated with them. Much more space could have been devoted to this subject but only at the expense of more basic radio principle. The book contains more trustworthy information on radio than any other single volume, and it is given in plain language which everybody can understand.

WHAT GIVES RADIO PLAY ITS APPEAL

Broadcasting a Play Is Grotesque Sight

By Wilda Wilson Church

Director of KGO Players

In a radio drama each speaker must be brought into the picture and taken out of the picture by text. This becomes very trite if it is always done with "here comes" and "good-bye." Before a speaker has said more than two sentences he must be addressed by name, and in a long conversation this must be frequently repeated.

There must be no dead sentences in which the audience cannot tell who has spoken, or sentences which do not build into the story.

On the stage a group of people keep their place in the picture by each one entering with some reactionary sentence. Over radio this separates climax and story too greatly. In other words, the story dies if we wait for each person in the picture to say something.

Talkiness No Good

A person can be kept in the picture by little snatches of song, by playing on the piano, or other sound devices.

A talky play is not good over radio. Action is necessary and can be well understood. Speeches should not be long. English should be plain and modern. I like a playwright who says what he means and means what he says. Stopping for involved sentences or poetic effects becomes boring. The play's the thing over radio.

Mystery, sentiment, home life characterizations and problems are well accepted. Sincerity, naturalness and spontaneity are the keynotes. The actor who struts and frets his little hour upon the stage has no place in radio.

O. Henry Fits in Well

So far this year all of the plays given over KGO have been written especially for the General Electric station. Two were penned by Helen Norris, a cripple, with little literary experience. Although hundreds of miles from the station, Miss Norris received her understanding of radio play technique from KGO.

The KGO Players have passed through the period of revivals of old stage plays, most of which have proven overstuffed and overemphasized for radio. O. Henry stories lend themselves admirably to radio.

Radio playwrights should use short words and sentences. Time and space motives are unlimited. Scenes impossible on the stage or in the movies can be used in the radio drama.

Adelman to Sail for Europe Soon

Leon L. Adelman, chief engineer and sales manager of the A. M. Flechtheim & Co., Inc. of 136 Liberty St., New York City, manufacturers of Flechtheim condensers, plans to sail early in June to visit England, France and Germany for business and recreation.

Mr. Adelman has been commissioned by several firms to get information on a new system of radio television recently developed in secrecy on the other side. He expects also to get new types of condensers for the American market.

Imagine yourself in a theatre, listening to a play but blindfolded. You are unable to see the stage settings or observe any of the movements of the actors. Only the words of the speakers and other sounds reach you.

The situation seems improbable—yet for hundreds of thousands of persons a similar situation is created several times every week. This vast audience attends the production of a play but the play reaches it only through the ear and the imagination. Not blind, this audience—merely the huge group that does some of its playgoing as it attends its concerts, operas and as it gets education and amusement—by way of radio.

The radio play, when you listen to it at home, seems to be a simple affair yet the production is a complicated matter.

New Technique Employed

Only because of a new technique, developed to meet conditions imposed by radio, is it possible to "put over" the production.

The spoken words of the actors must point the scenery, must give the stage directions, must display the costumes and create the desired atmosphere for proper understanding of the drama.

It is done frequently and it is done successfully. The production department of the National Broadcasting company, under the direction of Gerald Stopp, produces four plays or more a week, among them Biblical dramas, Socony Sketches, Retold Tales and Great Moments in History.

The Dialogue's the Thing

How is it done?

Mr. Stopp, a veteran of the theatre, reads a large number of plays and stories each week.

Contrary to the usual method, he totally disregards the stage directions and reads only the dialogue. When he happens upon a play or story that may be understood through the dialogue alone, he knows he has something that meets the first requisite for radio production.

After he has made a selection, the "play" in its available form is turned over to Henry Fitz Carlton, a playwright who has developed an original technique in radio adaptation.

Mr. Fitz Carlton reads the manuscript and then substitutes dialogue for straight descriptive matter. Instead of the scenic artist taking care of the setting, the character is given speeches to describe or suggest the scenery. The physical appearance and the outstanding characteristics of the radio players are revealed in the dialogue.

How Cast Is Selected

The play, now nothing but dialogue, goes back to Mr. Stopp.

The production is ready for casting. Let us assume that the characters in the play include a leading man who is supposed to be tall, dark and handsome, the beautiful leading lady and an old woman.

Stopp runs through his list of available players. He selects a man whose voice fits in with the character. His leading lady has a voice that suggests everything sweet and beautiful. The old woman must be an actress with a voice that is capable of suggesting age. And so on. The voices must differ widely for the voices are the "actors."

Actors Read Their Parts

Then rehearsals. The players read their lines until they are thoroughly familiar with them. Mr. Stopp coaches them care-

fully on their voices until each voice harmonizes with the character.

More rehearsals are held before a microphone. The director listens to them at a reproducer in an adjoining room. He hears their voices as they will be heard by the radio audience and as he listens he makes necessary corrections.

Sounds, other than voices, are worked into the production. A newspaper is rustled by a character in order that the suggestion of reading may be given. A squeaky hinge is opened and closed—a character has entered the room.

Then the play is ready for the air.

In the studio there are music stands in front of the microphone to hold the parts the actors must play. Instead of memorizing, the actors read their parts.

Can't Shake Off "Acting"

As the dialogue pours into the microphone, Stopp is very much on the job. He analyzes whether every sound effect comes at the right time, and makes sure that the actors keep their voices at the right pitch and speed, and work at the proper distance from the microphone.

The actors—many of them well-known professionals—act as well as speak. Unable to shake off the technique of the stage, they use all the gestures, facial expressions and actions that they would use in front of a big audience. To the on-looker the scene is grotesque, but to the radio audience it is as it should be. By actually playing the part—living it out before the microphone—the actors make the speeches more real and convincing.

First Night Is Last Night

There is no applause to stimulate the players—yet they never slacken in their efforts.

The curtain comes when the microphone is switched off. The first night—and the closing night—of the play is over.

Tests to Be Held for Assistant Inspector

The United States Civil Service Commission announces an open competitive examination for assistant radio inspector. Applications must be on file with the Civil Service Commission at Washington, D. C., not later than June 26.

The duties of the assistant radio inspector will be primarily to assist the radio inspector in the enforcement of the Radio Act. The assistant radio inspector will be required to inspect radio equipment on vessels and at land stations, which involves the carrying of 30 or 40 pounds of testing and measuring instruments; to make high frequency and field intensity measurements; to assist in the examination of radio operators, and to perform such office work as is required. The performance of these duties will involve considerable traveling, for which necessary traveling expenses will be allowed. The entrance salary is \$2,400.

Full information may be obtained from the United States Civil Service Commission at Washington, D. C., or the secretary of the United States Civil Service Board of Examiners at the post office or custom house in any city.

NEXT WEEK

How to make an AC set out of the Lynch-Aero Five, by using a harness and AC tubes, described by Zeh Bouck.

A THOUGHT FOR THE WEEK

"MY wife warned me that if I came home with a set that had to use batteries she'd throw me out!" Thus hath many a husband spoken, and thus does one know how the popularity of the AC tube has arisen.

RADIO WORLD

The First and Only National Radio Weekly

Radio World's Slogan: "A radio set for every home."

TELEPHONES: BRYANT 0558, 0559

PUBLISHED EVERY WEDNESDAY

(Dated Saturday of same week)

FROM PUBLICATION OFFICE

HENNESSY RADIO PUBLICATIONS CORPORATION

145 WEST 45TH STREET, NEW YORK, N. Y.

(Just East of Broadway)

ROLAND BURKE HENNESSY, President

M. B. HENNESSY, Vice-President

HERMAN BERNARD, Secretary

Kansas City, Mo.: E. A. Samuelson, 300 Coca Cola Bldg.

Los Angeles: Lloyd Chappel, 611 S. Coronado St.

European Representatives: The International News Co.,

Breams Bldgs., Chancery Lane, London, Eng.

Paris, France: Brentano's, 8 Avenue de l'Opera.

EDITOR, Roland Burke Hennessy

MANAGING EDITOR, Herman Bernard

TECHNICAL EDITOR, J. E. Anderson

ART EDITOR, Anthony Sodaro

CONTRIBUTING EDITORS:

James H. Carroll and Capt. Peter V. O'Rourke

SUBSCRIPTION RATES

Fifteen cents a copy, \$6.00 a year, \$3.00 for six months, \$1.50 for three months. Add \$1.00 a year extra for foreign postage; Canada, 50 cents.

Receipt by new subscribers of the first copy of RADIO WORLD mailed to them after sending in their order is automatic acknowledgment of their subscription order. Changes of address should be received at this office two weeks before date of publication. Always give old address; also state whether subscription is new or a renewal.

ADVERTISING RATES

General Advertising

1 Page, 7 1/4" x 11"	462 lines	\$300.00
1/2 Page, 7 1/4" x 5 1/2"	231 lines	150.00
1/4 Page, 8 1/2" D. C.	231 lines	150.00
1/4 Page, 4 1/2" D. C.	115 lines	75.00
1/4 Page, 4 1/2" S. C.	57 lines	37.50
1 Column, 2 1/4" x 11"	154 lines	100.00
1 Inch		10.00
Per Agate Line		.75

Time Discount

52 consecutive issues	20%
26 times consecutively or E. O. W. one year	15%
13 times consecutively or E. O. W.	12 1/2%
4 consecutive issues	10%

WEEKLY, dated each Saturday, published Wednesday. Advertising forms close Tuesday, eleven days in advance of date of issue.

CLASSIFIED ADVERTISEMENTS

Ten cents per word. Minimum 10 words. Cash with order. Business Opportunities, 10 cents per word. \$1.00 minimum.

Entered as second-class matter March 23, 1922, at the Post Office at New York, N. Y., under the Act of March 3, 1879.

Portable Transmitter Licenses are Revoked

Washington.

The Federal Radio Commission issued an order concerning licenses of portable broadcasting stations, of which there are 13. The order in full text follows:

"It is hereby ordered by the Federal Radio Commission that no licenses or renewal or extension of existing licenses will be issued to portable broadcasting stations after July 1, 1928; and that on that date all portable broadcasting stations will cease operations."

How Near Is Television?

EVERY now and then news about some television development increases interest in this fascinating subject.

The less a person knows about television the more he expects at this time, so each succeeding news account raises questions as to when television for the home may be expected, and how one may obtain data from which to build a television receiver or televisor.

Just now television is a baby trying to learn how to walk, and impatience does not expedite the slow process of development.

Some results have been demonstrated, notably by the Bell Laboratories and the General Electric Company. These two deal with actual television, or the reception of moving pictures in photographic fashion. The General Electric demonstration was made by Dr. E. F. W. Alexanderson, at Schenectady, N. Y. The Bell Laboratories exhibited their device in New York City.

Besides, C. Francis Jenkins has demonstrated his system of sending and receiving silhouettes, which may be just black shadows moving on a gray background, or an animated cartoon, since simple black and grey constitute the sole two tones of which the system is capable.

In England the Baird system has created considerable interest, and some demonstrations have been given in New York State and aboard a liner in mid-ocean.

None of the demonstrations shows the development of television to such a point as to make the system worthy of offer to the general public at this time, although all show promise and invite the earnest attention of experimenters. However, skill in mechanics, as well as knowledge of physics and particularly the electrical subdivision thereof, are required if one is to experiment intelligently.

One hampering condition has been the absence of regular transmission of television, but this has been removed, now that WGY is sending out television-modulated carriers on schedule, three afternoons a week.

It is still a big problem for the experimenter to get a televisor working so that it will receive this transmission, even poorly. Most of those who have made the attempt have received nothing. Hence until a receiver is developed to such a point that construction can be encouraged by proven results it is idle to recommend the building of a televisor. A man should be able to say first: "See what I have done. Go thou and do likewise."

When broadcasting itself was in a comparatively embryonic state it was relatively simple and inexpensive to build a receiver, but the televisor calls for apparatus that will cost much more money, including in nearly every instance a Neon lamp, a motor, a scanning disc, a receiver and a lens system. The object of the lenses is to enlarge the tiny picture received.

Many laboratories throughout the country are hard at work on television receiving apparatus and are trying to get results that would warrant them to make a definite announcement. Among these, of course, are the laboratories of the radio magazines.

Meanwhile some are contenting themselves with encouraging the transmission and reception of still pictures, but the demand is for motion. Stereopticon views have long since lost public interest.

It behooves the radio experimenter to check any tendency toward impatience and to await the inevitable announcement that a television has been built that is well worthy of emulation.

That announcement should not be expected tomorrow, and even when it is made, the inevitable challenge should be: "Show me." Meanwhile do not "invest" in any television stock issues.

The Warm Touch

JOHN PHILIP SOUSA, "the march king," in his new book, "Marching Along," gives the following reason for refraining from broadcasting:

"At the moment radio is undoubtedly wielding a tremendous influence over the public. By this medium the masses are becoming acquainted as never before with the best of the world's music. It is pleasanter, moreover, at times to give one's self up to the charms of music with pipe and foot-stool at hand than in the crowded concert hall. I cannot tell whether this influence extends to the student of music in his practice.

"Radio fulfills its purpose as the movies do, but its scope is limited. The rapport between performer and audience is invaluable and can be fully attained only through actual vision. I have refrained from broadcasting for this very reason; I am reluctant to lose the warm personal touch with my audience. Still, the radio is excellent for our busy people."

A heated microphone might suit Mr. Sousa.

Insight Into Personality

RADIO has done a lot to let the world know about the personalities of noted men and women.

We say so-and-so has a fine, or a charming or a winning or an unpleasant personality. This opinion is, usually, based on personal contact. A man might be a brilliant orator, or poet or novelist, or even a surpassingly great composer, but what do you know about his personality through the medium of the printed word or note?

Put that man in front of a microphone and it won't take his audience long to know what kind of a human being he is.

A man may hide his thoughts, but it's mighty hard for him to disguise his voice, which, besides its intonations, expression, vibratory and general qualities, also has illuminating qualities that soon make him liked or disliked by his hearers, whose ears must also function for the eyes which do not see him but which somehow take him in as he is.

Interest in Short Waves

SHORT waves recently have won a new measure of attention from radio experimenters. Enough musical programs are on the air on short waves to interest listeners who do not understand code. Of course most of the reception is code, and if an experimenter wants to know at least the location of the code station he is receiving, he should learn the code. This can be done in short order.

"IN TUNE WITH THE INFINITE"

When a tuned circuit is resonant with a certain frequency the impedance of the circuit is said to be infinite at that frequency (assuming no losses or damping). If there were no losses there'd be no reception, because the finite modulation current would be lost compared with the current of the carrier.

BRITON CONFERS WITH BOARD

Washington.

Lieut. Col. A. S. Angwin of the British General Post Office, who recently came to this country to confer with officials of the American Telephone & Telegraph Company on the trans-Atlantic telephone service, conferred briefly with the members of the Federal Radio Commission.

WOLFE MADE CREDIT MANAGER

John G. Wolfe has been appointed credit manager of North American Radio Corp., 1845 Broadway, N. Y. City.

Move to End Muddle Over "Electric" Sets

To improve advertising and merchandising of radio receiving sets, and to aid the public in its purchases by official definitions of "electric," "socket powered," and other receiving sets, the Radio Manufacturers' Association, in cooperation with other radio trades associations, is presenting a radio receiver nomenclature.

Intended As Guide

The definitions of different types of receiving sets are intended as a guide not only to the 300 principal radio manufacturers belonging to RMA, but also to advertising and business interests, as well as the public.

The receiving set definitions were developed by the RMA Engineering Division, of which H. B. Richmond, of the General Radio Co., Cambridge, Mass., is director, with the assistance of technical committees of other organizations.

The new and official radio merchandising definitions follow:

1. Battery Operated Set.

A radio receiver designed to operate from primary and/or storage batteries, shall be known as a "Battery Operated Set."

2. Socket-Powered Set.

A radio receiver of the "Battery Operated" type, when connected to a power unit operating from the electric light line, supplying both filament and plate potentials to the tubes of the receiver, shall be known as a "Socket Powered Set."

3. Electric Set.

A radio receiver operating from the electric light line, without using batteries, shall be known as an "Electric Set."

4. A C Tube Electric Set.

A radio receiver employing tubes which obtain their filament or heater currents from an alternating current electric light line without the use of rectifying devices, and with a built-in tube rectifier for the plate and grid biasing potentials, shall be known as an "A C Tube Electric Set."

5. D C Tube Electric Set.

A radio receiver employing tubes which obtain their filament or heater currents from a direct current electric light line without the use of rectifying devices, and with a built-in power plant for the plate and grid biasing potentials, shall be known as a "D C Tube Electric Set."

Literature Wanted

- D. C. Kinzie, 112 West 2nd St., Davenport, Ia.
- F. H. Gifford, 39 62nd Street, Milwaukee, Wis.
- W. J. Patrick, 309 Bay St., Hattiesburg, Miss.
- J. M. Downing, 2946 Ogden St., Philadelphia, Pa.
- Auburadio Co., Salvatore DiRusso, 438 Lexington St., Auburndale, Mass.
- M. E. Morse, Box 355, McCook, Nebraska.
- W. H. McInturff, 110 E. Oak Ave., Knoxville, Tenn.
- J. R. Drummond, Timken Roller Brg. Co., Columbus, Ohio.
- A. U. Clenard, 5500 Monterey Rd., Los Angeles, Calif.
- Square Deal Electric Shop, Morris, Illinois.
- R. A. Kelly, Prospector Club, Rollo, Mo.
- Geo. B. Goheen, Penna Furnace, Pa.
- A. R. Kosby, 1414½ Encinal Ave., Alameda, Calif.
- Harry Slackway, Jr., 2304 Sepviva St., Philadelphia, Pa.
- R. W. Geary, 140 Elmwood Place, Utica, N. Y.
- Geo. McKnoate, 4874 Annunciation St., New Orleans, La.
- Fulton Theogmorton, 509 N. Brewer St., Paris, Tennessee.
- Earl Baird, 1121 Obispo Avenue, Long Beach, California.
- J. H. Reinhart, 326 E. Ellis Avenue, Inglewood, California.
- B. P. Hays, 890 Campus Way, San Bernardino, California.
- Bob M. Simmons, Milan, Missouri.
- Elmer Clark, Springdale Elm Grove Ohio Co., Wheeling, W. Virginia.
- E. Robinson, 334 South 21st Street, Irvington, New Jersey.
- J. A. Hiener, c/o Hiener Hardware Co., 1301 Market St., Wheeling, W. Va.
- J. L. Pence, Lock Box 322, Evans City, Butler Co., Pennsylvania.
- C. Emil Koch, 43 East 84th Street, New York City.
- C. H. Tiemann, 930 East 141 Street, Cleveland, Ohio.
- Edwin Leroy, 1206 S. Central Park Ave., Chicago, Ill.
- R. B. Lawton, 5 Chester Street, Glens Falls, New York.
- John Valaskovic, 4617 So. Crawford, Chicago, Illinois.
- Ervin James, 4486 Tennyson Street, Denver, Colo.
- M. P. McBride, 1236 E. Broadway, East St. Louis, Missouri.
- G. M. Arthur, 105 Inglis Street, Halifax, N. S., Canada.
- Lee A. Myers, 65 13th Ave., Columbus, Ohio.
- J. B. Evans, 4000 Brown Street, Philadelphia, Pa.
- H. J. Lehfeldt, 1102 West Flagler Street, Miami, Florida.
- Patsy Franco, 77 Allen Place, Hartford, Connecticut.

NEW INCORPORATIONS

Federated Purchasing Service Corp., radio sets
-Atty., M. W. Vogle, 2 Lafayette, New York, N. Y.

Booklet Tells How to Cut Interference

Further effort to aid the radio public in reducing its interference troubles to a minimum is to be made by the Radio Manufacturers Association. A new, revised and improved booklet advising the public how to reduce static troubles by simple home-made remedies is to be issued soon. The Interference Manual of the R. M. A., "Better Radio Reception," is now having a wide sale, over 60,000 copies having been distributed. Many thousand additional copies are being made available, upon application to the R. M. A. offices, 32 West Randolph Street, Chicago, at 25 cents each, the cost of production.

Other radio associations are cooperating with the R. M. A. in the development of the Interference Manual, which tells in detail how simple and easily applied remedies may eradicate man-made static. The R. M. A. Engineering Division, headed by H. B. Richmond, of the General Radio Co., Cambridge, Mass., after a national survey of causes of and remedies for static, prepared the Interference Manual, and in the revised edition the R. M. A. had the advice of other radio associations.

New S-G AC Tube

A new AC shielded grid tube has just been added to the Arcturus line of radio tubes. The new tube is said to have the following characteristics:

Amplification constant	400
Mutual conductance	445 micromhos
Plate to control grid capacity	0.04 mmfd.
Filament voltage	15 volts
Heater current	35 ampere
Plate voltage	135 volts
Shield voltage	30 volts
Control grid bias	1.0 volt
Plate impedance	900,000 ohms

This tube is said to be particularly effective in resistance coupled audio amplifiers and in short wave radio frequency amplifiers.

Take Your Choice of 6 Other Publications

For NEW RADIO WORLD Subscribers Ordering NOW

Radio World has made arrangements

-To offer a year's subscription for any one of the following publications with one year's subscription for RADIO WORLD-

RADIO NEWS or POPULAR RADIO or SCIENCE AND INVENTION or BOYS' LIFE or RADIO DEALER or RADIO (San Francisco).

This is the way to get two publications

- for the price of one:
- Send \$6.00 today for RADIO WORLD
- for one year (regular price)
- for 52 numbers)
- and select any one of the other
- six publications for twelve months.
- Add \$1.00 a year extra for
- Canadian or Foreign Postage
- Present RADIO WORLD subscribers
- can take advantage of this offer by
- extending subscriptions one year
- if they send renewals NOW?

Radio World's Special Two-for-Price-of-One Subscription Blank

RADIO WORLD, 145 West 45th Street, New York City.

Enclosed find \$6.00 for which send me RADIO WORLD for twelve months (52 numbers), beginning _____ and also without additional cost, Popular Radio, or Radio News, or Science and Invention, or Radio Dealer, or Radio (San Francisco), or Boys' Life (or \$10.00 for a two-year subscription to one address), thereby getting RADIO WORLD and the other selected magazine, BOTH for two years. No other premium with this offer.

Indicate if renewal. Name

Offer Good Until Street Address

June 30, 1928. City and State

NO OTHER PREMIUM OF ANY KIND WITH THIS OFFER!

36" GIANT CONE \$6.00 KIT



(Pedestal FREE with all orders received before June 15.)

Kit consists of one Powertone Unit, one designed front sheet of Phonotex, one plain Phonotex back sheet, two metal rings, one metal bracket, one apex, thumbscrew and chuck; one tube of cement; hardware; instruction sheet. Tri-foot pedestal. FREE if you order NOW!

SEND NO MONEY! We Ship C. O. D.

GUARANTY RADIO GOODS CO.
145 West 45th Street New York, N. Y.
FIVE-DAY MONEY-BACK GUARANTY!

"DOUBLE R" METERS

Our Complete Catalogue of Meters is Contained in This Advertisement

POCKET AMMETER

No. 1—For testing dry cells, 0-40 ampere DC scale pocket meter\$1.50

POCKET AND PORTABLE VOLTMETERS

- No. 8—For testing A batteries, dry or storage, 0-8 volts DC scale.....\$1.65
- No. 10—For testing A batteries, dry or storage, 0-10 volts DC scale..... 1.65
- No. 13—For testing A batteries, dry or storage, 0-16 volts DC scale..... 1.65
- No. 50—For testing B batteries, dry or storage, but not for B eliminators, 0-50 volts DC scale 1.65
- No. 39—For testing B batteries, dry or storage, but not for B eliminators, 0-100 volts DC scale 1.85
- No. 40—For testing A and B batteries, dry or storage, but not for B eliminators; double reading, 0-8 volts and 0-100 volts DC scale.. 2.25
- No. 42—For testing B batteries, dry or storage, but not for B eliminators; 0-150 volts DC scale 2.00
- No. 346—For testing B voltages, including eliminators. High resistance water 0-300 volts DC scale 4.50
- No. 347—Same as No. 346, except that scale is 0-500 volts 5.50
- No. 348—For testing AC current supply line, portable, 0-150 volts 4.50

VOLTAMMETERS

- No. 18—For testing amperage of dry cell A batteries and voltage of dry or storage A batteries, double reading, 0-8 volts, and 0-40 amperes DC.....\$1.85
- No. 35—For testing amperage of dry cell A batteries and voltage of B batteries (not B eliminators); double reading, 0-50 volts, 0-40 amperes DC 2.00

PANEL VOLTMETERS

- No. 335—For reading DC voltages, 0-8 volts..\$1.65
- No. 310—For reading DC voltages, 0-10 volts.. 1.65
- No. 316—For reading DC voltages, 0-16 volts.. 1.65
- No. 326—For reading DC voltages, 0-6 volts.. 1.65
- No. 337—For reading DC voltages, 0-50 volts.. 1.65
- No. 339—For reading DC voltages, 0-100 volts.. 1.75
- No. 342—For reading DC voltages, 0-150 volts.. 1.75
- No. 340—For reading DC voltages, double reading, 0-8 volts, 0-100 volts..... 2.25

(Panel meters take 2-5/64" hole)

PANEL AC VOLTMETERS

- No. 351—For reading 0-15 volts AC.....\$2.25
- No. 352—For reading 0-10 volts AC..... 2.25
- No. 353—For reading 0-6 volts AC..... 2.25

(See No. 348 under "Pocket and Portable Voltmeters.")

PANEL MILLIAMMETERS

- No. 311—For reading 0-10 milliamperes DC..\$1.95
- No. 325—For reading 0-25 milliamperes DC.. 1.85
- No. 350—For reading 0-50 milliamperes DC.. 1.65
- No. 390—For reading 0-100 milliamperes DC.. 1.65
- No. 399—For reading 0-300 milliamperes DC.. 1.65
- No. 394—For reading 0-400 milliamperes DC.. 1.65

DC PIN JACK VOLTMETERS

- No. 306—For Radiolas No. 25 and 28, 0-6 volts DC\$2.50
- No. 308—For No. 20 Radiola, 0-6 volts DC.. 2.50
- No. 307—Desk type voltmeter with cord, 0-6 volts DC 2.50

6-VOLT A BATTERY CHARGE TESTER

No. 23—For showing when 6-volt A battery needs charging and when to stop charging; shows condition of battery at all times....\$1.85

PANEL AMMETER

No. 338—For reading amperage, 0-10 amperes DC\$1.65

SEND NO MONEY!

GUARANTY RADIO GOODS CO.,
145 W. 45th St., N. Y. City.

Please send at once your meters, catalogue numbers:

for which I will pay postman advertised price plus few cents postage.

Name

Address

City..... State.....RW-B28

ALL METERS SOLD ON FIVE-DAY MONEY-BACK GUARANTY

Child Artists Learn to Win the Audience

By WALTER C. STONE

Ever since there was a stage, and actors to act upon it, there has been a tradition of stage families. Some of the greatest

artists before the footlights today come from families who have been actors and actresses for several generations.

Even the movies, a comparatively young medium of artistic expression, already are beginning to build up a group of artists imbued from childhood with the traditions of the screen.

Radio, too, is following along the same path as the elder arts. In a small, but none the less significant, manner it is beginning to train its musicians and artists from an early age, so that when they and their talents reach maturity they will have a thorough knowledge of this specialized medium of transmitting entertainment.

A Broadcasting School

The National Broadcasting Company's Children's Hour, heard each Sunday morning through WJZ, New York, was re-instituted not long ago because of the demands of children and their parents in a dozen states.

However, the program department of the National Broadcasting Company soon discovered that, quite unwittingly, it was conducting what amounted to a school for teaching young artists the fundamentals of broadcasting technique.

In the group heard Sunday morning, according to Miss Madge Tucker, who arranges the programs and is in charge of the youngsters, the ages run from four to fourteen, and the older ones already know more about what can be presented successfully through the microphone than their elders knew a few years ago, when broadcasting was something of a mystery, even to those engaged in it.

Tricks Learned

The matter of leaning away from the microphone on crescendos and creeping up on it in diminuendos is already known to all the older children, and some of them according to Miss Tucker and Milton J. Cross, announcer, have learned a great

(Continued on next page)

POWER CLAROSTAT

Interested in Shielded Grid Tube?

Critical thing. Wonderful, however, if properly operated. One big point is to have just the correct plate and shield grid voltages—not too high or too low. Simple with

CLAROSTAT
PAT. OFF. REG. U. S.

WAVE TRAP, \$1.50



Genuine Moulded Bakelite Casing, panel or sub-panel mounting option, or placement atop of cabinet, mark this new model wave trap that cuts out interference. Send check, P. O. money order, or postage stamps.

Five-day money-back guaranty

Guaranty Radio Goods Co.

145 West 45th St., N. Y. City

BLUEPRINT and Instruction Sheet

for the Silver-Marshall Shielded Grid Six

The New Receiver Utilizing the New Shielded Grid Tubes with Their Powerful Kick.

25 Cents

Guaranty Radio Goods Co.

145 WEST 45TH STREET
NEW YORK CITY

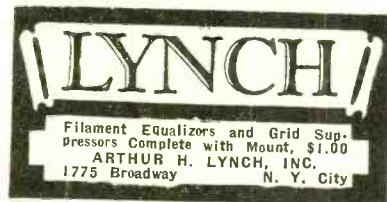

FILL OUT AND MAIL NOW

SUBSCRIPTION BLANK

RADIO WORLD

RADIO WORLD

145 West 45th Street, New York City
(Just East of Broadway)

Please send me RADIO WORLD for months, for which please find enclosed

SUBSCRIPTION RATES:
Single Copy\$.15
Three Months 1.50
Six Months 3.00
One Year, 52 Issues..... 6.00
Add \$1.00 a Year for Foreign Postage; 50c for Canadian Postage.

(Continued from preceding page)
deal about what will go well over the air and what won't.

Just as there are certain effects which are especially adapted for presentation by motion pictures, which appeal to the eye, so there are others which best can be presented by means of the radio.

This helps most in the development of radio as an art, which these young musicians and actors are learning in their work in the Children's Hour.

For some of the younger children the radio work is hardly more than a matter of "speaking a piece" or "playing a tune," yet others are finding in broadcasting something much different from what they could find in another medium.

No Girl Violinist Yet

At even so tender an age as seven, Winifred Toomey, one of the stars of the Children's Hour, has learned the difference, generally speaking, between what is good material for broadcasting and what is not.

Winifred, for example, already knows that a poem which depends upon pantomime for its success cannot be given before the microphone. She also is learning some of the fundamentals of portraying character by voice alone.

Most of the youngsters who are given hearings for engagements to appear in the Children's Hour are pianists, and most of these are girls.

Good singers of both sexes are hard to find, but they are not nearly so rare as usable violinists. Almost all of the young hopefuls of the bow are inclined to scrape and rasp in a fashion that would affront the ears of listeners.

Girls, by the way, seldom take to the violin, and no girl violinist has come within the ken of Miss Tucker and Mr. Cross.

Donle Has New Tube

A new six volt special amplifying tube is now on the market ready for fan and trade. This tube, the Donle-Bristol DA-2, is the latest production of Harold P. Donle, inventor of the Sodian detector tube. No changes in wiring, values or capacities in the set are needed. The tube can be used in the radio or audio stages of any standard DC set.

It has a new type of oxide-coated fila-



SIMPLIFIED A SUPPLY

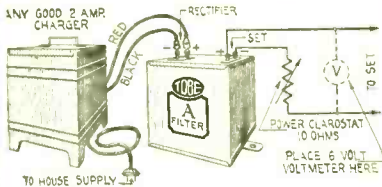

An A FILTER consisting of a new and different DRY condenser of 7,600 mfd. with two especially designed choke coils of proper size combined in one unit to supply HUMLESS A CURRENT to any radio set.

This new filter can be attached to any good two ampere charger as shown, for completely eliminating the A Battery.

Without a charger, only a rectifier and step down transformer are needed to assemble this eliminator in a few moments, as the principal wiring is done inside of the TOBE A FILTER.

TOBE A CONDENSER is also sold separately. Write for pamphlet on this new A FILTER and A CONDENSER. For sale by all the better dealers.

TOBE DEUTSCHMANN CO.
Cambridge, Mass.

New York Office: 117 Liberty St., in charge of Arthur J. Lyons. Telephone: CORtlant 3446

ment producing a high emission. The filament is platinum base. Complete characteristics and details may be had on application to the manufacturers, the Donle-Bristol Corporation, Meriden, Connecticut by mentioning RADIO WORLD.—J. H. C.

**Use Only
X-L PRODUCTS**

as specified in this issue of Radio World for
Hammarlund Short Wave Adapter and Cisin Super

X-L Vario-Densers and X-L Bakelite Insulated Push Posts in every high grade Receiver and Circuit today.

FREE Book of Wiring Diagrams, write—

X-L Radio Laboratories
Dept. L
1224 Belmont Ave. Chicago

How about Line Voltage?

It fluctuates. Low during day. Medium in early evening. High late at night. Yet your set calls for steady voltage. That's easy—with the



**CORD AND PLUG
for
Hammarlund
Short Wave Adapter**

as specified by
J. E. ANDERSON

Catalogue No. 21
Cord and Plug.....\$1.85

Guaranty Radio Goods Co.

145 West 45th Street
New York, N. Y.

The Perfected PLUG-IN COIL

Set of Three Coils, with Plug-In Base, complete... \$10.00
Plug-In Coils, Each..... 2.50
Base only..... 3.00

It's the Hammarlund!

NOW the famous Hammarlund low-loss, space-wound coils may be had in convenient plug-in form. A set of three coils covers the low-wave band—20, 40 and 80 meters. Special coils for higher wave lengths.

Contacts are perfect. The double silk-covered wire is space-wound and firmly anchored in a film of high-test dielectric material. Losses are low. Short circuits are impossible.

The variable primary coil has phosphor-bronze flexible connections and is integral with the Bakelite base. Friction holds it at any desired coupling.

These coils, together with Hammarlund Low-wave Condensers and R.F. Chokes, are used in the Hammarlund Short-Wave Adapter, Low-wave Receiver, featured by RADIO WORLD.

WRITE FOR SPECIAL FOLDER

HAMMARLUND MFG. CO.
424-438 West 33rd St. New York



VICTOREEN Super Coils

Send for Folder
Geo. W. Walker Co.
2825 Chester Avenue
Dept. B Cleveland, O.

Parts for Airplane Cloth Speakers

FRAME

The wooden frame, with coping of decorative moulding, may be purchased in standard sizes and used as such, or may be cut down from a larger standard size to a smaller special size, and cloth cut by purchaser accordingly. The frames come complete with moulding and hardware, in factory sealed carton.

- 13x16 3/4" Cat. No. 1103A. \$2.00
- 18x24" Cat. No. 1103.... 5.00
- 18x36" Cat. No. 1104.... 5.25
- 24x36" Cat. No. 1105.... 5.35
- 36x36" Cat. No. 1106.... 5.50

CLOTH

Genuine airplane cloth, same as used for best airplanes; great tensile strength, light weight. Govt. specifications. 13x16 3/4" (with 7x7 for baffle).
Cat. No. 1099A..... \$1.00
18x24" (with 7x7 for baffle).
Cat. No. 1099..... \$1.50
18x36" (enough extra to cut own baffle with shears).
Cat. No. 1100..... \$1.80
24x36" (enough extra to cut own baffle with shears).
Cat. No. 1101..... \$2.00
36x36" (enough extra to cut own baffle with shears).
Cat. No. 1102..... \$2.50

APEX

The Apex is of the double type, so that one metal shield is placed outside the diaphragm and the other inside, but the same apex may be used on any type of cone speaker. Each apex is equipped with threaded sleeve and thumbnut for fastening unit drive. Highest quality and durability of metal used. Outside diameter of apex, 1 1/4". Guaranteed to be enduring and serviceable. Firm grip assured.

Cat. No. 1107..... 25c

60" Connecting Cord. Cat. No. 1107B..... 30c

SPECIAL: 13x16 3/4" Speaker, with Diamond Unit, Airplane Cloth, Cord, Frame, Moulding (complete kit). Cat. No. 1107C..... Only \$5.00

13x16 3/4" Made-up Speaker. Cat. No. 1107D (\$1.00 extra)..... \$6.00

GUARANTY RADIO GOODS CO.
145 WEST 45TH STREET NEW YORK CITY

Calcutta Hears Briton Talk with New York

Blueprint of Screen Grid Diamond 4-Tube Model Using Space Charge Detection

As Designed by H. B. HERMAN

\$1.25

This circuit uses TWO screen grid tubes. One is the RF amplifier, the other the detector. The RF tube is used in regular screen grid fashion. The detector operates on the space charge method, as explained in February 18th issue. Audio consists of one resistance coupled and one transformer coupled stage. Copy of this issue, 15 cents extra.

RADIO WORLD
145 West 45th Street
NEW YORK CITY
(Just East of Broadway)
Telephones: Bryant 6558, 6559

RADIO WORLD, 145 W. 45th St., N. Y. City.

Please send me following at once:

- One blueprint, 27 x 27 inches, clearly showing every connection for the 4-tube SG Diamond using space charge detector. \$1.25 enclosed.
- One copy of February 18th issue of RADIO WORLD, 15 cents extra.

NAME

ADDRESS

CITY STATE

Radio telephone conversations carried over 2XAD of Schenectady and 5SW of Chelmsford, England, were heard in Calcutta, India, by Arthur MacArthur, an employe of the International General Electric Company in the Indian city.

In a recent letter to Schenectady, Mr. MacArthur reported that on Tuesday evening, February 28, at bedtime in Calcutta, he heard C. P. Edwards of Canada inform E. P. Edwards, manager of the radio department of the General Electric Company at Schenectady, that it was tea-time in England. Mr. E. P. Edwards responded that it was lunch time for him. C. P. Edwards is in charge of the communications branch of the department of marine and fisheries in the Canadian government.

It was apparent that Mr. MacArthur was hearing both sides of the conversa-

THE DIAMOND OF THE AIR

Using General Purpose Tubes

4 Tubes

Set uses three type A tubes and one 112 type; has TRF stage; regenerative detector and two stages of transformer coupled audio. (This is not Shielded Grid Diamond.)

5 Tubes

Same RF and detector as the other, but has one transformer and two resistance coupled audio. Especially suitable for B battery operation. (Not Shielded Grid Diamond.)

Guaranty Radio Goods Co.,
145 West 45th Street, New York City.

Please send me one newly printed official blueprint of the—

- 5-tube Diamond of the Air
- 4-tube Diamond of the Air

(Check off one you want.)

and the textual data giving full directions for construction.

Enclosed please find 25 cents to defray all expense.

NAME

ADDRESS

CITY STATE

(These are not Shielded Grid Diamonds.)

tion from 5SW as at that station the output of the loudspeaker reproducing the signal of 2XAD was feeding into the microphones in which C. P. Edwards was speaking. The only other way in which both voices could be heard was the use of two receivers, one tuned to Schenectady station operating on 21.96 meters and the other tuned to the 24 meter wave of the English station.

\$3,122,874.05 Surplus

of R. C. A. for Quarter

C. J. Ross, Comptroller of the Radio Corporation of America and subsidiary companies, issued the following statement of operations for the quarter ending March 31, 1928:

Gross Income from Sales, Communications, Real Estate Operations and Other Income	\$16,792,547.63
General Operating and Administrative Expenses, Depreciation, Cost of Sales, Patent Amortization, Estimated Federal Income Tax and Accrued Reserve for Year End Adjustments	13,669,673.58

Surplus Profits for Quarter Ended March 31, 1928.....\$ 3,122,874.05

MORE BUILDERS ENLIST

Additional set builders who enlisted in the custom set club movement of "Wally" McCord include:

- Fred R. Owen, 212 6th St., N., Great Falls, Mont.
- Andrew L. Bolz, 830 W. 179th St., New York, N. Y.
- L. B. Sims, Princeton, Ky.
- P. H. Beckman, Redfield, S. Dakota.
- Israel Wolkin, 2607 Germantown Ave., Philadel-

Make any Good Receiver BETTER



NOTICE!

For best results use genuine patented non-magnetic

"VAC-SHIELD"

on your Shield Grid Tubes. Beware of imitations and infringements. Look for name and patent No. 1,564,694 on each shield.

At your Dealer's or by mail, \$1.00.

ORANGE RESEARCH LABORATORIES
247 McKinley Avenue East Orange, N. J.

RADIO WORLD FOR SEVEN WEEKS, \$1.00

4-TUBE SHIELD GRID DIAMOND OF THE AIR BLUEPRINT FREE WITH EACH SUCH SUBSCRIPTION!

At 15c per copy, each week for seven weeks, Radio World costs you \$1.05, but if you subscribe for seven weeks at \$1.00 you will also get the official blueprint of this circuit FREE! The blueprint was designed by H. B. Herman from the original laboratory receiver. Size of blueprint, 27 x 27 inches. All connections, leads, parts, etc., shown actual size. Very simple to follow.

Home constructors of radio receivers, and custom set builders, by following the blueprint, and lol a new world of radio achievement is before you! Distant stations that four-tube sets otherwise miss come in, and come in strong. No tuning difficulty is occasioned by the introduction of this new, extra powerful, startling tube, but, in fact, the tuning is simplified, because the signal strength is so much greater.

The circuit consists of one shield grid stage, detector and two transformer audio stages, with 112A in the last stage.

When you work from the official wiring diagram you find everything so delightfully simple that you marvel at the speed at which you get the entire receiver masterfully finished. And then when you tune in—more marvels! 'Way, 'way up, somewhere around the clouds, instead of only roof high, will you find the amplification!

RADIO WORLD, 145 West 45th St., N. Y. City.

Enclosed please find:
 \$1.00, for which enter my name on your list of mail subscribers for seven weeks and send me FREE at once one official blueprint of the Four-Tube Shielded Grid Diamond of the Air, as designed by H. B. Herman, and described by him in the February 4th, 11th and 18th issues of Radio World. No other premium this offer. 45c extra for Feb. 4th, 11th and 18th issues.
Renewal Present subscribers may renew for seven weeks under this offer. Put a cross next to word "Renewal."

NAME

ADDRESS

CITY STATE

following the blue print, can build a distance-getting and voluminous set, the parts for which list remarkably low.

The new shielded grid tube is used as the radio frequency amplifier. That is why the amplification finally is boosted forty times over and above what it would be if an -01A tube were used instead.

Such simplicity of construction marks the receiver that it can be completely wired, skillfully and painstakingly, in two and a half hours.

Great stability! No neutralization required! No shielding necessary!

You'll be overjoyed. But you should place every part in exactly the right position. Stick to the constants given, and, above all, wire according to the blueprint!

When you work from this blueprint you find that every part is shown in correct position and every wire is shown going to its correct destination by the ACTUAL ROUTE taken in the practical wiring itself. Mr. Herman's personal set was used as the model. This is a matter-of-fact blueprint, with solid black lines showing wiring that is above the subpanel, and dotted lines that show how some of the wiring is done underneath.

Everything is actual size.

EVEN A NOVICE CAN BUILD THIS CIRCUIT SUCCESSFULLY!

Not only is the actual size of the panel holes and instruments given, but the dimensions are given numerically. Besides, it is one of those delightful blueprints that novice and professional admire so much—one of those oh-so-clear and can't-go-wrong blueprints.

Be one of the first to send for this new blueprint, by all means, and build yourself this outstanding four-tube receiver, with its easy control, fine volume, tone quality, selectivity and utter economy. It gives more than you ever expected you could get on four tubes—and the parts are well within the range of anybody's purse.

Complete official list of parts given on each blueprint; also the schematic wiring diagram (besides the picture diagram of the wiring.)

SEND YOUR ORDER TODAY!

Put Pick-up in Grid Circuit

The phonograph pick-up unit is nothing but an inverted loudspeaker unit. It transforms mechanical energy into electrical. It does this by mechanically varying the reluctance in the magnetic circuit. As the reluctance is varied according to the record in the groove, the flux in the magnetic circuit is varied. The variation in the flux induces an electro-motive force in the coil wound around the armature.

If the coil around the armature is connected directly into the grid circuit of a tube the entire electro-motive force in-

duced in the coil will be impressed on the grid.

If the coil is connected in series with the primary of a transformer the electro-motive force will drive a current through the thus completed circuit. Part of the electro-motive force will be expended in the armature coil and part in the primary of the transformer.

Only that expended in the primary is useful in producing a signal on the tube following the transformer. It is therefore better to connect the pick-up unit across the grid circuit.

A Strong, Rugged Loud Unit

That Drives Any Cone Speaker and Reproduces Fine Tone at Great Volume!

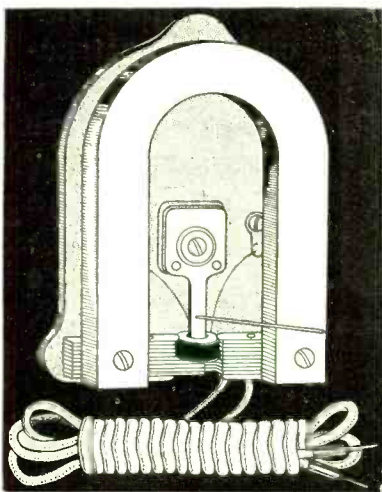

This unit has a full floating armature, which means that armature is mounted so that it acts like a plunger between two sets of magnets or pole pieces. As the magnetization of the armature changes under the influence of the signal it plunges first toward one pair of pole pieces and then toward the other.

The large field magnet used insures a strong and permanent polarizing flux, which protects against loss of sensitivity from self-demagnetization to which some loudspeaker units are subject.

The cone driving pin is directly coupled to the full floating armature at that point on the armature where the force is greatest. This insures against loss of power through complicated levers.

The sturdy construction and heavy weight of the assembled unit prevent motion of the unit itself and insure that all the power is transformed into sound.

The armature is adjustable from an exposed knob in the back.

Apex, chuck and thumbscrew supplied with each unit!

This unit stands 150 volts unfiltered. With filtered output the unit has stood up to 550 plate volts continuously without damage.

Each unit is supplied with an apex, consisting of two metal plates, so that any type of airplane cloth or cone speaker may be built; also with each apex are supplied a threaded chuck and thumbnut for engaging the pin. The screw firmly grips the pin. Besides, a 60-inch cord with tips, is also supplied with each unit.

The Powertune Giant Unit, complete with apex, chuck, screw and 60" cord; total weight, 3 lbs. (Cat. No. 1098).....\$3.75

SEND NO MONEY!

GUARANTY RADIO GOODS CO.,
145 West 45th St., New York City.

Please send me one cone speaker unit (Cat. 1098), as advertised, with apex. I will pay postman \$3.75, plus few cents extra for postage. Your 5-day money-back guaranty is accepted.

Name

Address

CityState

5-DAY MONEY-BACK GUARANTEE!

THE

AEROVOX

"Research Worker"

is a free monthly folder which will keep you abreast of the latest developments in Radio. Your name will be placed on the mailing list on request. Aerovox Filter Condenser Blocks and Resistors are built better and will endure.

AEROVOX WIRELESS CORP.

72 Washington Street

Brooklyn, N. Y.

THE SCREEN GRID EQUAMATIC...

and be sure to use genuine
KARAS PARTS

Write for Literature to
Karas Electric Co.
4039-ED N. Rockwell St.
CHICAGO

Build One of these FAMOUS CIRCUITS

The 3 TUBE SHORT WAVE KIT

Subscribers: Look at the Expiration Date on Your Wrapper

We do not like to take your name from our subscription list without specific instruction to do so because many of our readers wish to keep a complete file of the paper.

Please, therefore, look at the subscription date stamped on your last wrapper, and if that date is earlier than the issue contained in the wrapper, please send check to cover your renewal.

In this way you will get your copies without interruption.

Subscription Dept., RADIO WORLD,
145 West 45th Street, New York City.

THE NATIONAL SCREEN GRID 5, described by James Millen in April 14th, 21st and 28th issues. Fully illustrated, including picture diagrams of wiring. Uses screen grid tube for the single RF stage, four other tubes standard. Send 45c for these three copies and get blueprints free. RADIO WORLD, 145 West 45th St., New York City.

Quick Action Classified Ads

Radio World's Speedy Medium for Enterprise and Sales

10 cents a word — 10 words minimum — Cash with Order

MAKE MONEY IN SPARE TIME. 25c for sample and details. R. Dodge, 877 E. 4th St., So. Boston, Mass.

THE A C KARAS EQUAMATIC—Full description, analytical article, in Feb. 11th and 18th issues. Send 30c for these issues and get free blueprint. Radio World, 145 West 45th St., N. Y. City.

KARAS SHORT WAVE SET, three tubes, 13 to 750 meters, described in the March 31, April 7, 14, 21 and 28 issues. Send 60 cents for these five issues and get blueprint free. RADIO WORLD, 145 W. 45th St., N. Y. City.

MEN—Big pay working romantic, wealthy South America. Fare. Expenses paid. South American Service, 14,600 Alma, Detroit, Mich.

WHY NOT EARN a new automobile in your spare time? You can do so easily. Let us tell you how. Pequod Nurseries, Yalesville, Ct.

GUARANTEED Safety Razor, with strop, in neat, strong carrying case, 25 cents. First-class, new. Send coin, M. O. or stamps.—P. Cohen, 236 Varet Street, Brooklyn, N. Y.

NEW SHIELDED GRID TUBES for Diamond, S-M Six or Laboratory Super, Tyrman 70. Price \$5 each. Philip Cohen, 236 Varet St., Brooklyn, N. Y.

RECENT ISSUES of Radio World, 15c each. Be sure to give date of issue when writing. Radio World, 145 West 45th Street, New York City.

RADIO—Fastest growing business in the world. Are you sharing the profits? Let us show you how. No selling. Free booklet. Co-Operative Radio Doctors Dept. W, 131 Essex St., Salem Mass.

RADIO CARTOONS, CUTS, \$1.50. Particulars Free. RAD-GPO, Box 471, New York City.

RECEIVING PARTS. Bargains. Write for list. A. W. Clement, Bay City, Texas.

THE NATIONAL SCREEN GRID 5, described by James Millen in April 14th, 21st and 28th issues. Fully illustrated, including picture diagrams of wiring. Uses screen grid tube for the single RF stage, four other tubes standard. Send 45c for these three copies and get blueprints free. RADIO WORLD, 145 West 45th St., New York City.

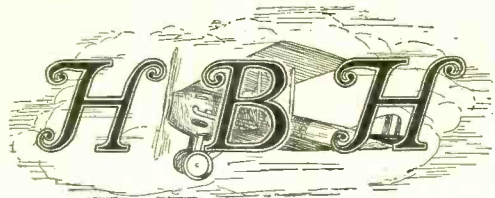

\$7.00

Airplane Cloth Speaker Kit

Special size 16½" x 22½", (Cat. 1086) Price, Including Unit.

Kit Consists of airplane cloth, frame, moulding, unit, stiffening fluid, apex, crossarm, bracket, long cord, apex, hardware and instruction sheet.

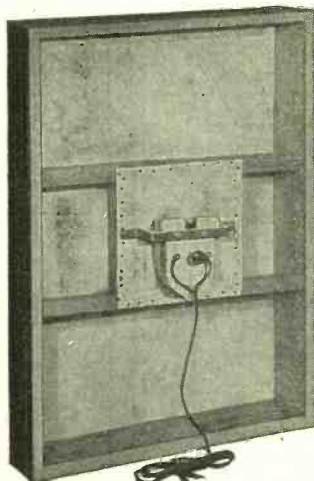

Rear View of the HBH Airplane Cloth Speaker
Size, 16½x22½ Inches

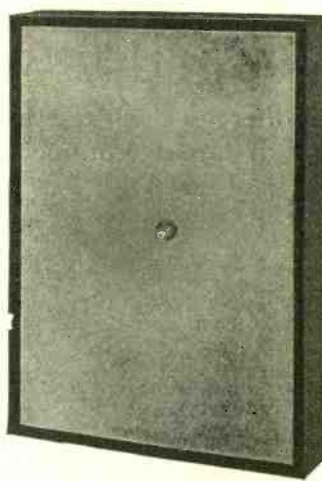

Front View of the HBH Airplane Cloth Speaker
Size, 16½x22½ Inches

An Opportunity is presented to you to obtain a kit of this special but attractive size, 16½x22½", because a manufacturer accumulated an extraordinarily large stock of them.

For \$1 Extra We Build It for You!

If you do not want to build the speaker yourself, at \$1 extra cost you can quickly receive the factory-built speaker in your home, all ready to play. Size 16½x22½" (Cat. 1086B)....

\$8.00

Buy a Kit and Build Speaker Yourself at These Prices

Complete Kit, 18x24", Cat. No. 1109.....	\$10
Complete Kit, 24x36", Cat. No. 1110.....	\$12
Complete Kit, 36x36", Cat. No. 1111.....	\$14

Buy a Factory - Made Speaker, Ready to Play, at These Prices

18x24", Cat. No. 1088.....	\$11
24x36", Cat. No. 1090.....	\$14
36x36", Cat. No. 1091.....	\$16

CHOOSE WHAT YOU WANT, BUT SEND NO MONEY!

GUARANTY RADIO GOODS CO.,

145 West 45th Street, New York City

Ship me the following items as advertised in Radio World:

Cat. No..... Cat. No..... Cat. No.....

Cat. No..... Cat. No..... Cat. No.....

for which I will pay postman advertised price plus few cents extra for postage.

Name

Address

City State

Five-Day Money-Back Guaranty

LOUD UNIT

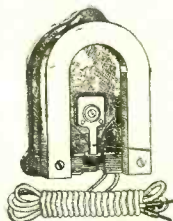

Powerful unit, excellent for any cone or similar type speaker, standard for HBH speaker; very loud. Cat. No. 1098, with apex, \$3.75.

The unit is the Power-tone model, which provides high degree of volume and is very sensitive. Stands great strain. Used successfully in all radio receivers, including power pack installations up to 550 volts on the plate. Up to 135 volts DC may be passed through coils of unit without damage. For higher voltages filtered output is recommended, but unit has long stood up to 180 v. unfiltered.

Unit mounting bracket, Cat. No. 1113..... 35c. Apex. Cat. No. 1107, 25c.

GENUINE "DOPE"



Genuine HBH Stiffening Fluid, secret compound, with superlative effect on tone quality. Large sized can, enough for three coats. Cat. No. 1097, \$1.50.