

April 7

1928

315

SCREEN GRID SECRETS!

15
CENTS

RADIO

REG. U.S. PAT. OFF.

WORLD

The First and Only National Radio Weekly

TUNING
KARAS
SHORT WAVE
RECEIVER

EQUAL
FRANCHISE
LAW WINS
IN CONGRESS

SHOOTING
TROUBLE IN
SCOTT'S
SUPER

CUSTOM
SET BUILDERS
ANSWER
QUESTIONS

Vol-13 No-3 315

FINE EYE APPEAL IN ALUMINUM SUBPANEL

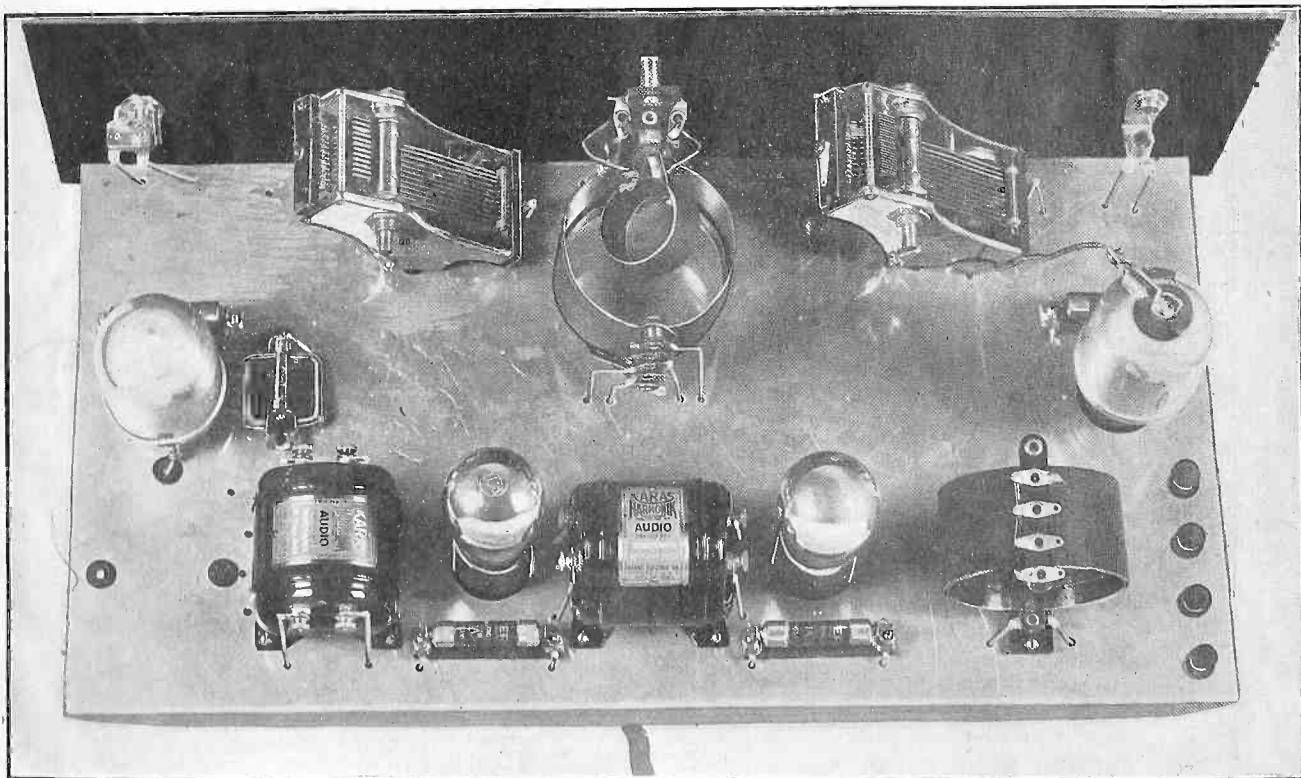

A New Opportunity for Attractive Construction is Afforded by a Self-Bracketing Aluminum Drilled Subpanel, with Affixed Sockets. See Page 3.

HOW
ELECTRIC
BRAIN
WORKS

A NOVEL
AND EFFECTIVE
MIXER
CIRCUIT

A SUPER
THAT FITS
IN YOUR
AUTO

DOUBLE
MODULATION
TESTS FOR
HOME

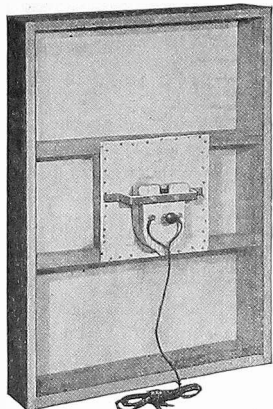

Rear View of the HBH Airplane Cloth Speaker
Size, 18x24 Inches

All Ready to Play with
Amazing Fidelity

H.B.H.

AIRPLANE CLOTH SPEAKER

"The Speaker That Speaks for Itself"

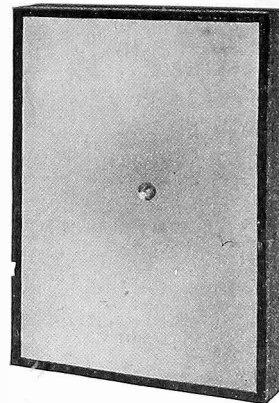

Front View of the HBH Airplane Cloth Speaker
Size 18x24 Inches

Size 18x24 inches, factory-constructed. **\$11.00**
All ready to play. Cat. No. 1088.

OTHER SIZES OF FACTORY-MADE MODELS

18x36" Cat. No. 1089... \$13 24x36" Cat. No. 1090... \$14 36x36" Cat. No. 1091... \$16

Any factory-made HBH Speaker, or complete kit, less unit, deduct \$3.75.

COMPLETE KITS AND SEPARATE PARTS FOR HBH AIRPLANE CLOTH SPEAKER



Genuine HBH Stiffening Fluid, secret compound, with superlative effect on tone quality. Large sized can, enough for three coats. Cat. No. 1097.....\$1.50

The HBH Airplane Cloth Speaker may be purchased completely made up, in factory-sealed cartons, at the prices listed above, but if you prefer to build the speaker yourself you may do so at a saving of from \$1 to \$2, depending on the size of the speaker.

The complete kit consists in each case of airplane cloth, frame, moulding, unit, stiffening fluid, apex, crossarm, brackets, long cord, apex, hardware and instruction sheet.

We sell separately every component of the kit. See announcements below.

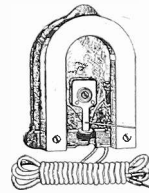

Powerful unit, excellent for any cone or similar type speaker, standard for HBH speaker; very loud. Cat. No. 1088.....\$3.75

"DOPE"

HBH Stiffening Fluid may be used on any cloth type speaker to great advantage. It is of special manufacture, secret formula, and noted for superior effects on tone quality. Two coats will suffice. Three are slightly better. Large size can, enough for three coats. When the first coat dries, in 15 minutes, a special speed feature, apply the second coat. When that dries put on the third and last coat. Cat. No. 1097.....\$1.50

CLOTH

Genuine airplane cloth same as used for best airplanes: great tensile strength, light weight, Gort. specifications. 18x24" (with 7x7 for baffle). Cat. No. 1099.....\$1.50 18x36" (enough extra to cut own baffle with shears). Cat. No. 1100.....\$1.80 24x36" (enough extra to cut own baffle with shears). Cat. No. 1101.....\$2.00 36x36" (enough extra to cut own baffle with shears). Cat. No. 1102.....\$2.50

FRAME

The wooden frame, with coping of decorative moulding, may be purchased in standard sizes and used as such, or may be cut down from a larger standard size to a smaller special size, and cloth cut by purchaser accordingly. The frames come complete with moulding and hardware, in factory sealed carton. 18x24" Cat. No. 1103.....\$5.00 18x36" Cat. No. 1104.....\$5.25 24x36" Cat. No. 1105.....\$5.35 36x36" Cat. No. 1106.....\$5.50

APEX

The apex is of the double type, so that one metal shield is placed outside the diaphragm and the other inside, but the same apex may be used on any type of cone speaker. Each apex is equipped with threaded sleeve and thumbnut for fastening unit drive. Highest quality and durability of metal used. Outside diameter of apex, 1 3/4". Guaranteed to be enduring and serviceable. Cat. No. 1107..... 25c

UNIT

The unit is the Powertone model, which provides high degree of volume and yet is sensitive. Stands great strain. Used successfully in all radio receivers, including power pack installations up to 550 volts on the plate. Up to 135 volts DC may be passed through coils of unit without damage. For higher voltages filtered output is recommended, but unit has long stood up to 180 v. unfiltered. Cat. No. 1108.....\$3.75

Complete Kit, 18x24", Cat. No. 1109.....\$10.

Complete Kit, 24x36", Cat. No. 1110.....\$12

Complete Kit, 36x36", Cat. No. 1111.....\$14

Everybody wants a first-class speaker, because no set or power pack is any better than the speaker it feeds. Now the general public is enabled to obtain the famous HBH Airplane Cloth Speaker, both in factory-assembled form and in kit form, as well as each individual component of the kit separately, and thus can obtain a wonderfully clear-toned and faithful reproducer at the lowest cost at which such fine results are generally obtainable.

Those who have special cabinets, consoles, phonographs, etc., into which they want to build a fine speaker, have every opportunity now to build a speaker that will create a sensation. It is very simple to make the famous HBH Airplane Cloth Speaker any size you want. Determine the size desired, and multiply the dimensions in inches, thus obtaining the number of square inches. Multiply this by three cents to obtain price. Then send cash, check or money order with your order, as odd size kits are not C.O.D. items. All else are. Or you may order the next larger standard size C.O.D. and cut it down yourself. In either case you get complete kit.

The story of the excellence of the HBH Airplane Cloth Speaker is best told by the speaker itself. As all goods are sold on a five-day money-back guaranty, you run no risk. Also you SEND NO MONEY. Have one of these speakers in your home and let your friends, too, compliment you on the fine tone quality and volume. And, besides, think of all the real enjoyment you get yourself from the best speaker in the low-price range.

GUARANTY RADIO GOODS CO.,
145 West 45th Street, New York City

Ship me the following items as advertised in Radio World:

Cat. No. Cat. No. Cat. No.
Cat. No. Cat. No. Cat. No.
for which I will pay postman advertised price plus few cents' extra for postage.

Name

Address

City State

Five-Day Money-Back Guaranty

REPLACEMENT COILS

You may have a unit in which there is nothing wrong except that the small coil built into it, or one of the two coils, or both, are burnt out. Replace these coils and you have the same old fine unit. These coils are hard to get, but we have plenty of them in three different sizes. When ordering, state the dimensions of the bobbin, or, preferably, send your old coil and we will send the correct replacement coil. Cat. No. 1112, each, 75c.

UNIT MOUNTING BRACKET. Cat. 1113.....35c

GUARANTY RADIO GOODS CO.

145 West 45th Street

New York City



Vol. XIII, No. 3 Whole No. 315
 APRIL 7, 1928
 15c per Copy. \$6.00 per Year
 [Entered as second-class matter, March, 1922, at the post office at New York, N. Y., under Act of March 1879]

Technical Accuracy Second to None

A Weekly Paper Published by Hennessy Radio Publications Corporation, from Publication Office, 145 West 45th Street, New York, N. Y.

Phone: BRyant 0358 and 0359.

Design Analysis of the Shield Grid Diamond

By H. B. Herman

THE use of the new screen grid tube as the radio frequency amplifier in the popular four tube circuits, using a regenerative detector, as for instance the Screen Grid Diamond of the Air, carries with it definite advantages. Provided that an ample-sized primary is used in the three circuit coil, the amplification is increased tremendously, when one considers that the gain in the first tube is squared by the detector and the total multiplied at audio frequencies.

The amplification in that first or RF tube may be made even higher if the plate voltage is increased or the number of primary turns is made larger, or if both magnification opportunities are seized.

This all-important primary, the smaller fixed winding on the three circuit tuner, if too large, will cause the RF tube to oscillate, and will reduce selectivity at normal operation. Therefore the chosen coil, a Hammarlund HR 23 three circuit tuner, represents a good compromise, since it has a rather generous primary when the entire winding is used.

Twice Ordinary Primary

The coil was originally designed for the Hammarlund-Roberts circuit, hence the HR, and has a midtap on the primary, for connection of a neutralizing condenser. Therefore the total winding was twice as large as on the other types then prevalent. By disregarding the neutralization tap, since the screen grid tube requires no neutralization, and by connecting plate of the screen grid tube to one terminal of the primary, and B plus to the other, a suitable degree of amplification is achieved and the usual losses incidental to neutralization are avoided.

Those who desire a still larger primary, either on such a coil or some other, may obtain a tubing that will fit inside of the secondary of the coil, without interfering with motion of the tickler, and put on 35 turns of any kind of insulated wire from No. 30 to No. 24. This new primary may be secured to the subpanel by two diametrically opposite right-angle brackets, which of course are affixed to the new coil for support. At any event a skinny primary on the three circuit coil must not be used.

The plate voltage on the screen grid tube may be high, and should be 135 at least. Up to 150 volts are permissible under the automatic system of negative

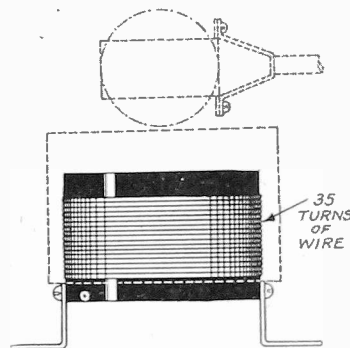

SIDE VIEW OF A SPECIAL PRIMARY WHEN INSERTED IN A THREE CIRCUIT COIL (DOTTED LINES) FOR THE USE OF A SCREEN GRID TUBE. THE EXISTING PRIMARY ON THE THREE CIRCUIT COIL WOULD BE IGNORED IN SUCH AN INSTANCE.

grid bias used in the Screen Grid Diamond, whereby the voltage drop in the No. 622 Amperite is capitalized.

Improves Selectivity

As the voltage source is 6 volts, and the filament voltage is 3.3, the negative grid bias, obtained by connecting the grid return to minus A, is the difference, or 2.7 volts. The grid is thus made 2.7 volts negative in respect to the negative filament.

This is a little more than the bias recommended on the slips enclosed in the tube cartons, but is highly satisfactory, nevertheless, because the extra negative bias proportionately increases the input impedance, and improves selectivity. Since it is very easy to use a screen grid tube in circuits that provide tremendous amplification at the expense of selectivity, the extra bias is a step in the right direction. Also, it enables the application of the 150 volts.

The standard hookup is shown herewith for the first time in pictorial diagrammatic form. Those who desire to build the circuit, recognizing that it possesses outstanding virtues in distance-getting, selec-

tivity and tone values with a maximum volume that reaches almost incredible levels, and all at small outlay, of course will follow the life-sized point-to-point picture diagram published in the official blueprint, where the schematic diagram also is given.

An Innocent Question

One man, who introduced himself as one who didn't know the first thing about radio, proceeded to prove it by saying: "With all these six, seven, eight, nine and ten tube circuits on the market, how come that it is possible to get satisfactory results with a four tube set? Aren't eight tubes twice as effective as four? Don't they get stations twice as far off, or the same stations with twice as much volume?"

Well, that depends on a variety of factors, as was explained to the innocent inquirer. One nine eight-tube circuit, for instance, has an amplification factor twenty times as great as that of the Screen Grid Diamond, whereas faulty design and incorrect choice of parts easily could make an eleven tube circuit inferior to a four one.

Efficiency Sacrificed for Convenience

As for the run of five, six and seven tube factory-made receivers, it is a recognized fact that the public that buys such sets is a convenience-loving aggregation, hence single dial control, even without trimming facilities to compensate for inequalities in tuning that science can not well avoid, are produced.

This usually means that one or two tubes are used simply to make up for the loss due to dissonance produced by single dial operation. The chain of RF tubes causes self-oscillation even at a low broadcast frequency (high wavelength), so "lossers" are introduced, and before we've finished we find that three stages of TRF ahead of a plain detector tube may not perform as well as one decent RF stage, i.e., a four tube set may surpass in performance a six tube set.

On the question of cost, the four tube receiver requires fewer sockets, coils, tuning condensers, neutralizers, tubes, less A and B current and no ganging. For a given amount of space the parts may be spread out more effectively, with a distinct amplification and stability gain, due on the one hand to absence of eddy current losses and on the other to absence

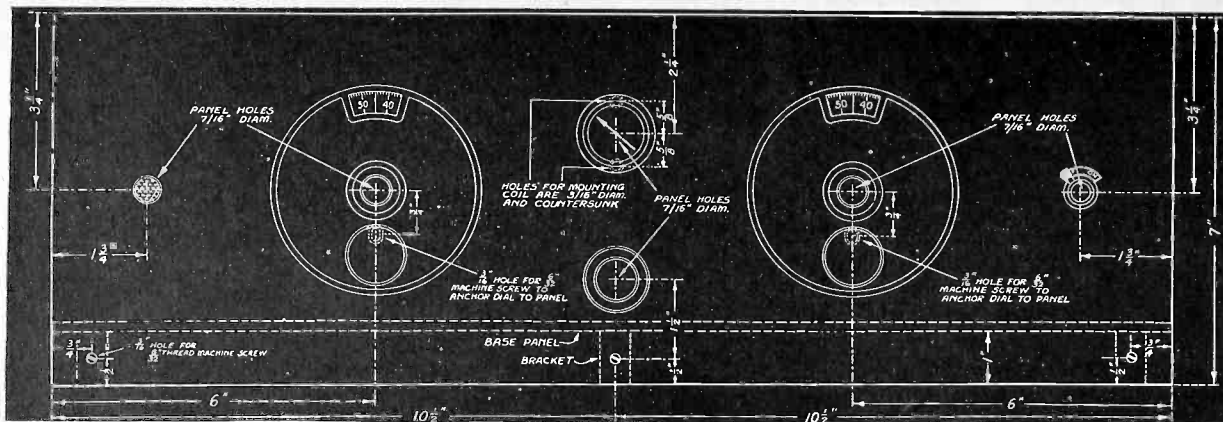

PLAN OF THE FRONT PANEL OF THE FOUR TUBE SCREENGRID DIAMOND OF THE AIR. THE ELLIPTICAL HOLES SHOWN IN DOTTED LINES BELOW THE DIAL CENTER-CAPS ARE FOR THE ANCHORAGE OF THE MARCO DIALS.

of squealing that requires still further "lossers" to keep the set quiet in operation, or make it operable at all.

Regeneration's Effect

As if this were not enough, a four tube set of proper design, as compared with a multi-tube factory-made set that serves convenience first, may have the detector tube regenerative, which enables an increase in the amplification at radio frequencies even to a thousand-fold, or more, so that weak signals are strengthened, greater distance traversed, and at the same time selectivity sharpened, say, 200 per cent.

Thousands of persons have built the Diamond of the Air in the three and a half years this circuit has been featured in RADIO WORLD. Incidentally, no other publication has featured one circuit so long, and so successfully. Now 19,000 blueprints have been sold. The circuit has been essentially the same all the time. This year the Screen Grid Model was brought out, which changes only two connections.

The value of substituting the screen grid tube for the 01A tube has been conclusively demonstrated. Delighted users of the Screen Grid Model attest to the supremacy of the circuit.

Sonorous Audio

The radio frequency level is well balanced and effective, in the present reigning success, and is followed by a highly efficient and sonorous audio channel, consisting of two Karas Harmonik audio transformers, which have a tone unexcelled by any other transformer in the same price class.

Hence, to sum up the circuit, we have a TRF stage that attains a degree of amplification not dreamed of last year and a regenerative detector, with each of these two circuits separately and individually tuned. (If two condensers were used on the same shaft or otherwise actuated by the same main dial, a trimming condenser or inductance would have to be used, and this, too, would constitute each of the two circuits separately tuned.) The audio channel is two stages of transformer coupling, because the highest degree of volume per tube is thus obtainable, consistent with stability, while quality remains excellent. Other forms of audio might provide better quality, but always with lower efficient efficiency per tube—three tubes might be needed where two are used now.

Fine Appearance Made Easy

There is one comparative point not yet even hinted at—the appearance of the home-constructed receiver. It is admitted that many who build sets for their

own use and enjoyment are not the most skillful compositors of radio parts into a finished receiver.

Placement of parts may be done poorly, and that is the main short-coming, but this is overcome by following a blueprint that is an exact duplicate of the wiring, at every point and angle, as laid out by the designer of the circuit himself. The official blueprint of the Screen Grid Model Diamond is an exact copy of my own receiver.

Then there is the important subject of the subpanel. If a baseboard is used, anything approaching fine appearance is next to impossible. The day of the baseboard is gone forever from the sphere of the custom built or home-built set, just

LIST OF PARTS Vital Kit

One Hammarlund HR 23, coil kit, consisting of one antenna, coupler and one three-circuit coil, both for .0005 mfd. tuning.

Two Karas .0005 mfd. SFL condensers, type 23.

Two Karas Harmonik audio frequency transformers.

One No. 622 Amperite with mounting.

Three No. 1A Amperites with three mountings.

One Lynch 5 meg. grid leak.

One Volume Control Clarostat.

Three Aerovox .006 mfd. fixed mica condensers.

One Aerovox .00025 mfd. mica grid condenser, with clips.

One .001 mfd. Aerovox mica fixed condenser.

One Yaxley No. 10 battery switch.

One Yaxley No. 310 pilot light bracket (lamp extra).

Two Ely binding posts (Speaker +, Speaker -).

Two Eby binding posts (Ant., Gnd.).

One 7 x 21 inch Bakelite front panel (already drilled).

One 10 x 20 inch aluminum self-bracketing subpanel with four built-in sockets (subpanel already drilled for all holes).

Two Mar-co dials.

One Pee-wee clip (No. 45 Universal clip).

ACCESSORIES

One Vac-shield for shielded grid tube.

One shielded grid tube, CeCo RF 22.

One CeCo type H, special detector tube.

One CeCo type A.

One CeCo type F (112)

One roll flexible Acme Celatsite.

One 7-lead battery cable.

One set of cable markers.

Two dozen lugs.

One HBH Airplane Cloth Speaker.

A, B and C supplies.

as surely as it is gone from the field of factory-made receivers.

Aluminum Subpanel

A man wants to build for himself or for others professionally, a receiver that, tube for tube, outperforms the others, yet at least equals them in eye appeal.

Hence why not turn to the same source that supplies the set manufacturer, and use a genuine aluminum subpanel, of the self-bracketing type, with built-in sockets, to which one may affix a Bakelite front panel, already drilled for the Yaxley pilot light and switch, two Karas variable condensers, Hammarlund tickler coil and Volume Control Clarostat—holes of standard size, by the way, so that no inconvenient situations arise.

This opportunity is here, for a self-bracketing aluminum subpanel and a drilled front panel for the Four Tube Screen Grid Model Diamond of the Air are now commercially produced. All holes are drilled for all specified parts and all leads, and insulators are seconded where necessary. If you are interested in such construction of the receiver, further information will be gladly furnished if you will address me: H. B. Herman, c/o RADIO WORLD, 145 West 45th street, New York City, as I am now collating full information.

Lynch Resistors Used

Another form of the Four Tube Diamond comprises two screen grid tubes, the second one being the detector, and in that instance the first audio stage should be resistance coupled, using .1 or .05 meg. Lynch metallized resistor for the plate circuit, 2 meg. for the grid circuit, and a .01 Aerovox stopping condenser. The grid leak remains a Lynch 5 meg. metallized product. The holes on the aluminum subpanel are so drilled as to take care of these parts if the space charge (screen grid) detector circuit is preferred. The second audio stage remains transformer coupled.

A different blueprint is published for the Diamond using two screen grid tubes, and is known as the Space Charge Detector Diamond of the Air blueprint.

In either event, if the constructor prefers to drill his own subpanel, he may do so from the information contained in either blueprint, or if he desires to drill his own front panel, he may follow the data contained in the front panel diagram published herewith.

In both types of circuits the front panel is the same.

A 222 Vac-Shield should be placed over the screen grid tube, whereas it is a good plan to use a 201 A Vac-Shield over the detector tube, too.

Tune in the Short Waves

J. E. Anderson

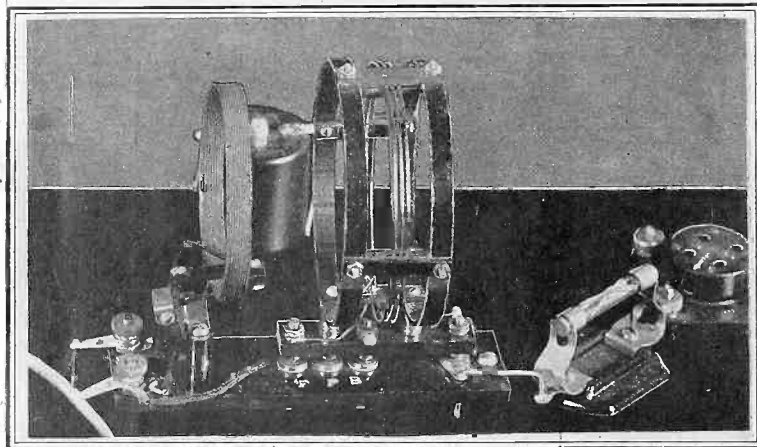
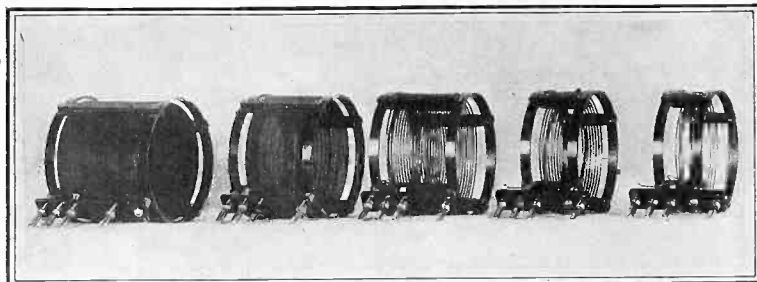

FIGS. 5 AND 6

ON TOP IS A VIEW OF THE AERO COILS THAT AFFORD A RANGE OF 13 TO 725 METERS WHEN USED WITH A KARAS SHORT WAVE CONDENSER. THE PRIMARY OF THE INDUCTANCE SYSTEM IS ADJUSTABLE (LOWER VIEW), WHICH ASSURES HIGHEST EFFICIENCY FOR THE RANGE ONE IS WORKING ON. WITHIN THAT RANGE—ANY GIVEN SECONDARY DEPICTED ABOVE—FURTHER ADJUSTMENT IS NOT ABSOLUTELY NECESSARY.

THE fact that a single tuning condenser is used in the Karas short wave receiver described in the March 31 issue of RADIO WORLD makes the circuit extremely easy to tune. There is no intricate dial setting combination to solve. Just one sweep of the single dial from zero to maximum covers the entire range of the coil in use. No station within oper-

ating range of the receiver escapes, provided that the condenser is not turned too rapidly.

Turning of the condenser too rapidly is not likely with the Micrometric, for that dial is truly a slow motion tuning aid. By that is not meant that it has one of those ridiculously high gear ratios which require an hour for turning the conden-

ser from one extreme to the other, but that it has a practical ratio. It turns the condenser slowly enough to insure that all stations be heard, yet not so slowly as to incite the impatience of the operator.

The ease of tuning is greatly increased by the special cut of the condenser plates. They are cut to straight line frequency capacity variation. This is a feature of utmost importance in a short wave receiver in which the stations may be crowded closely together. The condenser spreads these stations out in direct proportion to the frequency. The advantage of this cannot be fully appreciated except when tuning in the short waves:

In constructing the receiver it is important that the rotor plates of the condenser be put on the grounded side of the circuit and that the stator be connected to the grid side. This eliminates body capacity and greatly facilitates the separation of short wave stations as well as keeping the "tune." Also it is vital to use a dial with no metal part exposed, and the micrometric is just that.

Just as it is important to ground the rotor plates of the tuning condenser, so it is important to ground the rotor plates of the tickler condenser C2. The stator of this condenser should be connected to the tickler coil L3. The advantage of this connection is great when a weak station is being coaxed in and when the circuit is brought up to critical regeneration. Be not misled by the circuit diagram in this respect, but follow the wiring diagram Fig. 4 in the first part of this article.

Inductance Changes

The apparent inductance of the tuning coil L2 changes as the regeneration is advanced. As the capacity of the tickler condenser is turned up the apparent inductance of coil L2 increases, and it is necessary to decrease the capacity of C1 to keep the circuit in exact resonance with the signal frequency.

A good practice in tuning is to set the tuning condenser a little below the point where the signal is maximum before advancing the regeneration. Then as the tickling is increased the apparent increase in L2 offsets the lack of capacity in C1. The optimum combination of tuning and tickling is thus arrived at much more quickly than when the circuit is returned every time the tickling has been changed. Of course the two condensers can be man-

High Frequency Phenomena Give a

A few years ago short waves were called freakish because sometimes signals were received from tiny transmitters thousands of miles away with simple receivers. The waves seemed to violate all the laws governing radio waves, or thought to govern radio waves. They did not at all behave like the longer and more familiar waves.

Long waves, such as were used in broadcasting and commercial radio telegraphy, did not travel so well in the daytime as at night. Some of the shorter waves on the other hand seemed to travel much better in daylight than in the dark. Where long waves attenuated at a fairly definite rate with distance, short waves seemed to increase or decrease in strength in a perfectly haphazard manner. Theory predicted that short waves should attenuate much more rapidly with distance than

long waves, but actual results partially disproved the theory.

They Skip Around

And then it was discovered that the short waves advanced over the surface of the earth in kangaroo fashion. They made one gigantic leap and came down to earth hundreds of miles away, or even thousands of miles. In the space between the transmitter and the receiver located where the waves came down after a long leap they could not be received with even highly sensitive equipment. Where they came down a very simple receiver sufficed.

When this apparently erratic behavior of the short waves was studied the skip distance theory was advanced to explain the action. The more data collected on the behavior of the short waves the better does the skip distance theory explain the

action, the more order is seen in the apparently haphazard travel of the waves.

The Heaviside Layer

The skip distance theory assumes that the so-called Heaviside ionized layer in the upper atmosphere is a fact. This layer acts as a mirror which sends the waves down to earth after striking it, or as a refractor which bends the waves so as to follow the curvature of the earth. Abundant data have shown that this theory is in agreement with observed facts.

The distance up to the Heaviside layer has actually been measured. And it has been found that the layer rises and falls according to the amount of sunlight. It may descend to a region 200 miles above the surface of the earth, or even lower, and it may ascend to 400 miles or above.

Karas S-W

Without Missing a Station

Technical Editor

LIST OF PARTS

- C1—One Karas .00014 mfd. variable condenser.
- C2—One Karas .00025 mfd. variable condenser.
- C3—One Sangamo .0002 mfd. fixed condenser with clips.
- C4—One Sangamo .001 mfd. condenser (across sec. of T2).
- T1, T2—Two Karas Harmonik audio frequency transformers.
- R1—One 4 megohm Durham grid leak.
- R2—One No. 112 Amperite unit.
- Rh1—One Yaxley 20 ohm rheostat.
- S—One Yaxley No. 10 filament switch.
- L1, L2, L3—One set of Aero short wave coils (see text).
- L4—One Aero radio frequency No. 60 choke coil.
- Two Yaxley phone tip jacks.
- Two Karas Micrometric dials.
- Two Karas sub-panel brackets.
- Three Benjamin sockets.
- Eight X-L binding posts.
- One Bakelite 7x18x3/16 inch panel.
- One Bakelite 8x17x3/16 inch sub-panel.

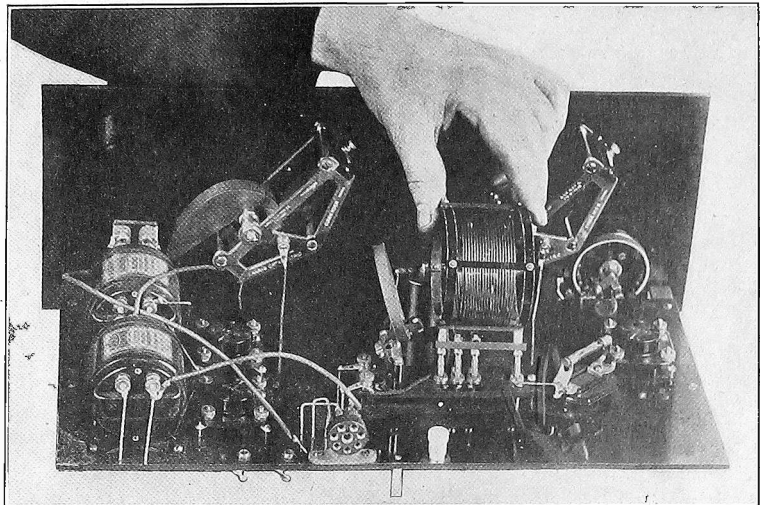

FIG. 7

THE SECONDARY COIL DETERMINES THE WAVELENGTH RANGE, SINCE THE SAME TUNING CAPACITIES ARE USED FOR ALL COILS. IT IS ONLY A MOMENT'S WORK TO PUT IN ANOTHER COIL.

ipulated simultaneously, in opposite directions, to arrive at the optimum combination still more rapidly. With a little experience it is possible to keep the two condensers in exactly the proper relation all the time.

Choice of Battery Termination

Some builders prefer to bring all battery terminations to a strip of binding posts while others prefer to bring them to a cable connector terminal. This receiver has been assembled to satisfy both of these classes of fans. Of course it makes no difference in the operation of the circuit. It is simply a matter of convenience. Fig. 4, which is a tracing of the official blue print, shows the arrangement of the binding posts when that method is selected.

If a cable terminal connector is selected all the battery terminals are brought to this connector. In this connector all the terminals are marked and colored according to RMA standards.

The set of coils used to cover the range from 13 to 725 meters is shown in Fig. 5. The largest coil at the left covers the range 235 to 550 meters. By connecting a 100 mmfd. condenser in parallel with this

coil the range is extended to 725 meters. The smallest coil at the right covers the range from 13 to 29.4 meters. The secondary of this coil contains only three turns of wire. In Fig. 6 this coil is shown mounted in its receptacle. It is coupled closely to the antenna coil, which can be seen at the left. To loosen the coupling the antenna coil should be inclined at an angle to the three turn coil.

Changing Coils

Fig. 7 shows the rear view of the completed set and indicates how the coils are inserted into the receptacle. Note that this receiver has been built with a cable terminal connector instead of binding posts.

Receiver Layout

The arrangement of the parts on the panel is indicated on the panel view Fig. 2 and on the wiring diagram Fig. 4. All the necessary dimensions for layout of the panel are given on the upper half of Fig. 4, and all the necessary dimensions laying out the sub-panel are given on the lower half. Every lead and connection

is also distinctly shown in Fig. 4 so that there is no chance of going astray in wiring the circuit.

Whereas only 5 coils are shown in Fig. 5 there are actually six in the complete set. If No. INT-0 is used the range is from 13 to 29.4 meters and if No. INT-1 is used the range is from 15 to 33.5 meters. The next coil No. INT-2 covers the range from 31.5 to 68 meters. The smallest coil is used mainly to increase the range from 15 to 13 meters. The complete set of aero coils follows:

No. INT-0.....	13 to 29.4 meters
No. INT-1.....	15 to 33.5 meters
No. INT-2.....	31.5 to 68 meters
No. INT-3.....	57 to 133 meters
No. INT-4.....	125 to 250 meters
No. INT-5.....	235 to 550 meters

[The first presentation of the Karas Short Wave circuit was published last week. Any reader who desires a blueprint of the circuit may obtain a complimentary copy by addressing J. E. Anderson, Technical Editor, RADIO WORLD, 145 W. 45th Street, N. Y. City.]

Mystic Appeal to Reception

The propagation of all radio waves is affected by the layer in a manner depending on the altitude of that layer. But short waves are particularly affected. For example a short wave may strike the layer when it is 200 miles up, rebound and come down to earth 400 miles, from the starting point. It may again leave the earth only to be thrown back by the layer and come down another 400 miles away.

The Rise and Fall

When the layer rises to a higher altitude the skipped distances on the earth may be much greater. In fact there may be only one rebound. Since the region of reception of the short waves is that where they come down it is apparent that the distance of reception depends on the altitude of the Heaviside layer, and since that in turn depends on the sunlight it

is apparent why reception varies with the time of the day.

Waves of all lengths do not behave in the same manner. Hence a 20 meter wave may be the best for communicating between two given distant points at one time of the day and a 40 meter wave at another.

The vagaries of the short waves have been carefully studied and it is now well known what wave length is best between two given points at any time of the day. Commercial companies may have one wave for the night operation and another for day time operation. The transmitters are arranged so that the operators can change quickly from one wave to the other and thus avoid any interruption in the service.

Fading is closely associated with the Heaviside layer and the reflection of

waves. If the altitude of the layer changes the strength of the received signal in any reception region will change also. If the layer rises and falls the signals will wax and wane. This explains slow fading.

The explanation of rapid fading may be found in the fact that at any given point signals will reach a receiver both by the sky route and the earth route. The two components of the waves may arrive at the receiver so as to strengthen the total signal effect or so as to weaken it. If there is any change in the effective distances of travel, either by the sky route or the earth route, the degree by which the two components will strengthen or weaken each other varies, and this variation is fading. The variation may be slow or rapid. Fast fading may cause a squeal in the speaker.

Screen Grid Coil Design

By Hemstreet Hilles

CONTRARY to the prevalent impression among radio experimenters, it is not essential to employ a tuned plate impedance in connection with the new screen grid tube when this tube is used as a radio frequency amplifier. That is simply one method of coupling the tube to take advantage of the properties of the tube. But the tuned impedance method is subject to certain disadvantages which may be avoided by selecting another type of coupling. One of these disadvantages is the lack of selectivity and another the tendency toward instability of the current.

A necessary condition for getting a high amplification out of the screen grid tube is that the useful load impedance in the plate circuit be high. This condition can be satisfied with a radio frequency transformer having a large number of turns on the primary and then tuning the secondary in the usual manner.

The method of coupling retains the selectivity of the circuit and is more stable than the impedance method. Shielding and neutralization may be dispensed with entirely.

When the screen grid tube is coupled with one radio frequency transformer of this design and followed by a regenerative detector the circuit is so sensitive that it

becomes impractical to use an ordinary antenna. The signals brought in would be entirely too intense. So a very small antenna may be used, even one of four or five feet of wire. For example, a piano hinge would be entirely adequate.

The use of such a small antenna greatly increases the selectivity of the circuit and makes it possible to tune in distant stations while the locals are operating. For example, with a National Shield Grid Five receiver constructed in this manner and operating in Boston, WJZ was brought in from Bound Brook, N. J. while WNYC in Boston was going. The frequency separation of these two stations is only 10 kc.

The satisfactory operation of this receiver in a large measure is due to the high impedance slot-wound primary on the coupler between the screen grid tube and the detector. The high impedance of the winding extracts from the screen grid tube a large proportion of the total signal voltage in the plate circuit of the tube. If a tuning coil is closely coupled to this high impedance primary the high voltage is transferred to the secondary, and thence to the grid of the detector tube.

The special construction of the National

coils insures close inductive coupling between the primary and the secondary and at the same time keeps the capacity coupling down to extremely small values. These factors are consistent with high selectivity and extreme sensitivity, and they largely account for the popularity and performance of these circuits.

The regenerative feature in the detector builds up the selectivity to a point comparable to that obtained in circuit that have miniature primaries and small amplification. Thus with a screen grid tube, a high impedance primary and with a regenerative detector it is possible to attain almost unbelievable amplification without in the least sacrificing selectivity. Thus a circuit like the Browning-Drake is greatly improved.

Proper location of coils is assured by employing the National kit, in which the coils, condensers and the dial are mounted on a frame as a unit. The coils are at the extreme ends of this assembly so that capacity coupling is negligible. The coils are also placed at right angles so that the inductive coupling between them is nil.

One Control

The two condensers are control by the same drum dial, making the circuit single control. To compensate for the difference between the input capacities of the screen grid tube and the -01A tube a .0001 mfd. condenser is connected in parallel with the condenser which tunes the first tuned circuit. Thus the two circuits are made practically identical.

For compensating for the effect of the antenna on the first tuned circuit an inductive trimmer is used. This is a small rotor in inductive relation with the first tuning coil, with which it is connected in series. Thus no loss of selectivity results from the use of a common tuning control.

Since a screen grid tube has only a negligible capacity between the plate and the control grid frequency amplifier will not oscillate when the regeneration in the detector is turned up. In fact the regeneration in the detector makes the RF amplifier work a greater efficiency as regards voltage amplification, but this is regular amplification and not regenerative.

Set Does Not Radiate

When tuning in distant stations it is permissible to use the squeal method for the circuit will not radiate. The screen grid tube prevents the oscillation from reaching the antenna, where they would be radiated. The small size of the three circuit tuner and its vertical placement still further limit radiation from the circuit while oscillating.

The circuit is very simple to build due to the fact that the essential kit is already assembled in one unit and no neutralizing or shielding is necessary. There is not much to do but mount the sockets and the audio amplifier.

The audio amplifier in the receiver is designed for high quality reproduction and stability. Three different National Impedance transformers are used, each specially designed for the position it is to occupy. The first is designed to take the output of a -71A detector efficiently, the second to work between a -40 type tube and a -71A. Careful attention has been given to contributory causes of motorboating when the circuit is operated with a B battery eliminator in designing these audio couplers.

[James Millen will describe the construction of the National Shield Grid Five in next week's issue, April 14.]

Layout of Parts for Breadboard Unipac

A simple way of building the Silver-Marshall AC audio amplifier and power supply (either 881-250 or 882-250) is to put all the parts on a wooden baseboard. This also affords a free ventilation of the parts. Everything is out in the open where the heat generated can escape as fast as it is liberated. This is an important feature in power amplification where considerable heat is liberated by tubes, transformers, resistor strips and even some by condensers.

If heat is not removed from these parts the temperature rises to a dangerous point. The wax in the condensers softens and melts, insulation on wires becomes damaged and the circuit as a whole loses efficiency.

A suitable layout of the breadboard type is shown in the accompanying diagram. At the left are the S-M328 power transformer and the S-M filament transformer. In the middle are the various by-pass condensers and the resistors, and at the right are the audio frequency transformers, the S-M 331 Unichoke and all the tubes.

The two large tubes at the extreme right are the two -81 half wave rectifiers. The remaining large tube is the -50 type power tube. One of the small tubes is a -26 type tube used as an audio frequency amplifier ahead of the -50 power tube.

The other small tube is a -27 heater type tube which is used as an audio frequency amplifier between the phonograph pick-up unit and the audio frequency amplifier.

A large baseboard should be used so that there is plenty of room for all the parts. Crowding is not consistent with thorough ventilation and cool operation. There is also room for the voltage regulation tube, in case one is used, as is advised.

An important feature of this unit is the manner in which the phonograph pick-up is coupled to the audio amplifier. The ordinary method is to connect the pick-up unit in series with the primary of the first transformer. The result of this coupling is mediocre at best. But in this circuit the pick-up unit is coupled through the medium of a -27 type tube. That is the pick-up is connected to the grid circuit of the tube and then the first audio transformer is connected to the plate circuit of the tube in usual manner. The advantages are greater volume and better quality. The pick-up works more effectively into the grid circuit of the tube than into the primary of a transformer, and the primary of the transformer is more effective both as to quality and volume when it is connected to the plate circuit of the tube than when it is connected to the pick-up.

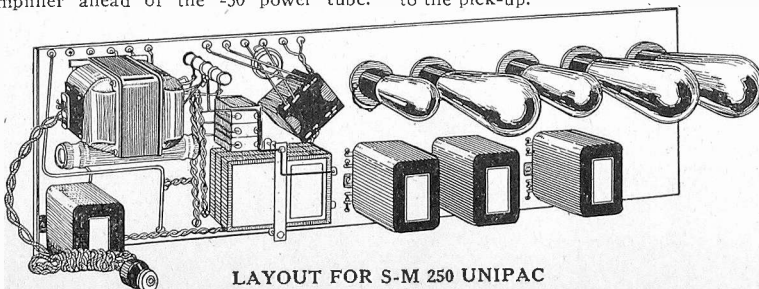

LAYOUT FOR S-M 250 UNIPAC

Electric Brain a Success

Machine Transforms Speech to Gibberish Then Translates It—Permits Secrecy in Transmission—Works on Distortion Principle—Artificial Larynx, Another Invention, Permits Some of Dumb to Talk Again—Deaf Aided.

STRANGE languages synthetically manufactured, and spoken by no human beings, issued from the horns of the loudspeakers in the United States Engineering Auditorium, 29 West 39th Street, New York City, during the talk and demonstrations of Sergius P. Grace, general commercial engineer of Bell Telephone Laboratories, who was telling the members of the New York Electrical Society about a few of the marvelous scientific accomplishments of the Laboratories.

Mr. Grace explained that in connection with radio transmission systems designed to make radio conversations secret, there had been developed methods of inverting and distorting the natural speech frequencies, or tones, so as to make the transmitted speech unintelligible to the ordinary radio listener.

Mr. Grace had with him phonographic records of such inverted speech in which the natural high frequencies had been transformed into low frequencies and vice versa.

Manufacturers Gibberish

When a record of this kind was played by Mr. Grace on a Victrola there issued from the horn a form of synthetic speech which was absolutely unintelligible to the audience, but in which there were retained, nevertheless, all the original frequencies, or tones, in the voice of the person making the record, but with these frequencies reversed.

The resulting language was something like an imaginary mixture of English, French, Chinese, Siamese and a few other languages thrown in for good measure. If we had been accustomed from childhood to such a language, we would understand it, Mr. Grace said. Then Mr. Grace startled his audience when he told them he had brought with him from the Laboratories a machine with "electrical ears" and an "electrical brain," which could understand this unintelligible gibberish and retransform it into its original language.

The audience of 1,000 members of the New York Electrical Society and guests waited in suspense while he proceeded to demonstrate this modern "Babel" translator.

Electrical Brain at Work

While the unintelligible speech was issuing from the Victrola, Mr. Grace held in front of the horn an electrical pick-up transmitter similar to the transmitters used in radio broadcasting studios. The electrical current from this transmitter was carried into the "electrical translating brain," then amplified and connected with the loudspeakers of the public address system which had been installed in the auditorium.

Immediately, these loudspeaking horns burst forth at a volume several times louder than the phonograph, with the original speech in English and clearly understandable by all the audience. Whenever

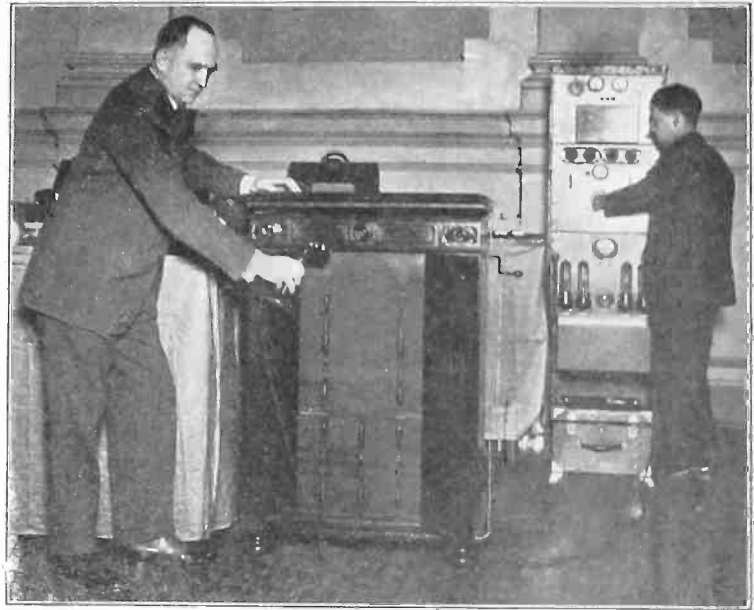

SERGIUS P. GRACE, GENERAL COMMERCIAL ENGINEER, BELL TELEPHONE LABORATORIES, DEMONSTRATING THE ELECTRICAL EQUIPMENT DEVELOPED BY THE LABORATORIES, WHICH TURNS SPEECH INTO GIBBERISH AND BACK AGAIN, AT THE MEETING OF THE NEW YORK ELECTRICAL SOCIETY, ENGINEERING AUDITORIUM, 29 WEST 39TH STREET, NEW YORK CITY.

Mr. Grace would move the pick-up transmitter, or "electrical ear," away from the phonograph, the sound from the loudspeakers would cease and the audience would again hear the unintelligible gibberish issuing from the phonograph.

Curiously enough, although at all times the synthetic speech was being transmitted into the room, whenever the loudspeakers connected with the electrical translation system were in operation, the translated speech sounds over-rode entirely the phonograph gibberish. Thus we have added to the marvels of science an electrical machine that can understand a language unintelligible to ordinary human beings.

Chance for Secret Language

To demonstrate his ability to speak some of this new synthetic language, Mr. Grace himself spoke into the transmitter the cryptic words "Play-a-fine Crink-a-nope" which, after translation by the machine, came out of the loudspeakers as "Telephone Company." In this way, Mr. Grace pointed out, it would be possible to build up a new language from an old one, with the individual words inverted so as normally to be not understandable.

Mr. Grace during his talk about other products, he described the functions of the loading coil and telephone repeater, and gave brief descriptions of television and radio trans-Atlantic telephony, both recent accomplishments of the Laboratories' staff.

Mr. Grace also pointed out that much as the research work of the Laboratories had proved of value from purely a humanitarian point of view. In particular, he described and demonstrated the Artificial Larynx, a product of the Laboratories which enables people who have lost their larynges through surgical operations to talk again.

Deaf Are Aided

Another most interesting contribution to humanity is the new telephone receiver de-

veloped by the Laboratories for teaching the deaf. This device has five miniature individual receivers with contact pins upon which the deaf person places his thumb and fingers. The incoming electrical current from the transmitter of the teaching instructor is electrically filtered into five frequency bands suited to each receiver and thus, whenever a particular word is spoken, there is a definite rhythm or sequence of the vibrations in the five receivers in contact with the fingers of the hand.

The deaf person soon learns the "pattern," so to speak, of each individual word and in some cases is able to acquire a very considerable vocabulary in a short time. This method of instruction was conceived and is being used by Dr. Robert H. Gault in Washington under the auspices of the National Research Council, the apparatus being built for him by the Bell Telephone Laboratories.

Penn Manufactures Brielle Balanced Unit

The Brielle Balanced Armature Motor, a new driving unit for any type cone, cloth or wood diagram speaker, is now on the market and is finding favor. This is a sturdy unit, well designed and possessing unusual mechanical features. The parts, while well protected, are readily accessible. Among the improvements unique in this motor are direct magnetic path, broad pole face and armature of large effective surface assure maximum action on armature, it handles output of modern power packs direct through coils no output transformer being required.

This motor is put out by the G. R. Penn Manufacturing Co., 34 West 3rd Street, New York City. Full information may be had from them by mentioning RADIO WORLD.—J.H.C.

A Good Mixer in the

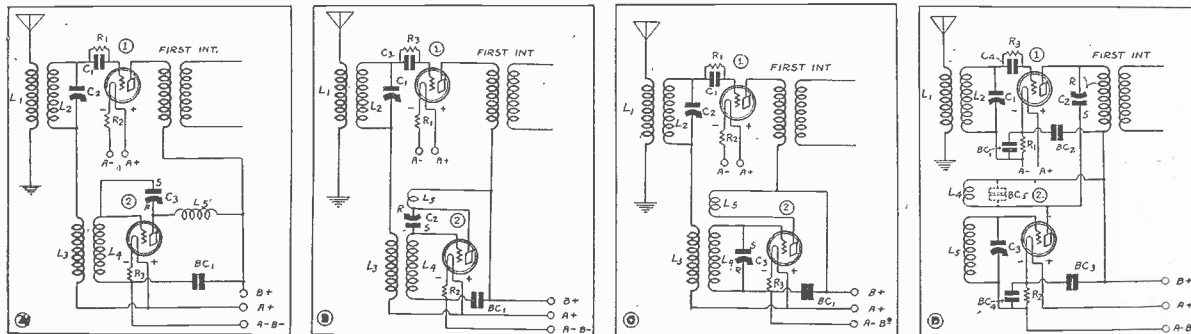

FIG. 1

IN A AND B THE SAME OSCILLATOR HOOKUP IS SHOWN, THE PLATE COIL IN B BEING PROPERLY DIAGRAMMED IN INDUCTIVE RELATIONSHIP TO THE GRID COIL. A DIFFERENT TYPE OF OSCILLATOR, WITH THE GRID TUNED, IS SHOWN IN C. AN UNUSUAL METHOD OF COUPLING THE OSCILLATOR TO THE MODULATOR IS SHOWN IN D, WHERE THE CONDENSER RS IS ALSO USED AS A SELECTIVE VOLUME CONTROL.

MANY interesting possibilities present themselves when one seeks the construction of a suitable mixer for a Super-Heterodyne.

Nearly all of the methods used in standard Super-Heterodyne kits are good. Some are better in one respect than in another, but the designers simply choose the hookup that gives them what they deem the most desirable compromise.

At every point in radio design compromise enters. Your engineering knowledge is no better than your ability to compromise, whether that compromise be between selectivity and quality, sensitivity and stability, volume and undistorted power output, simplicity and efficiency or between economy and performance.

In the Super-Heterodyne mixer itself

the selectivity factor enters only at a preventive of secondary interference. This is the greatest source of audible beat notes, whistles, gurgles and squeals, and is due largely to the inability of the tuner or first detector to discriminate in favor of the desired frequency against all others. Hence as a palliative one may include regeneration in the first detector, or may precede a straight detector with a stage of tuned radio frequency amplification, a method which makes tuning easier than by the regenerative method.

The Unusual Detection

In Fig. 1A is shown a familiar mixer, consisting of the tuner or first detector (1) and the oscillator (2). The first detector does not detect for the usual pur-

pose, that is, to produce audible signals, but detects by receiving a higher radio frequency and, through modulation, delivering a lower, but still radio, frequency, still inaudible. That lower frequency is known as the intermediate frequency and is produced by the mixing of the station frequency with the oscillator frequency. The mixing place is tube (1) and is known technically as modulation.

The tuning condenser connected between plate and grid of the oscillator, with stator S to grid, in conjunction with the secondary L4, governs the oscillator frequency. Note that L5 is shown to the right, as is usual in such diagrams, although in fact this plate coil is always in inductive relationship to the primary L3 (the pickup coil) and particularly the secondary L4, hence the diagram in Fig. 1B shows the real situation accurately in respect to L5.

Instead of placing the oscillator tuning condenser from grid to plate, thus tuning both those circuits at once, one may tune only the secondary. This requires more turns on the plate coil L5 (Fig. 1C), because the coupling is exclusively inductive, save for some tiny capacity coupling due to the distributed capacity of the coil windings and to a possible radio frequency potential difference between the physically adjoining terminals of the plate coil and the grid coil.

Body Capacity

The method shown in C is a good one. The oscillation is no better than in the other instance, indeed, due to insufficient plate coil inductance, some coils might be used in this fashion without producing any signals in the loudspeaker, or whereby failing to produce them at the lower broadcast frequencies (higher wavelengths) at which the plate coil might fail to produce oscillation.

On the other hand granting oscillation, one has a greater latitude in choice of types of tuning condensers, since one side of the tuned circuit is at ground potential, and the rotor is connected to this point. The condenser stator S goes to grid.

Absence of body capacity is more easily attained by this method, because in Fig. 1A and Fig. 1B both the high radio frequency potentials of two coils in one oscillating circuit go to the tuning condenser. By proper design, excellent choice of condensers and wise location of parts, body capacity may be greatly re-

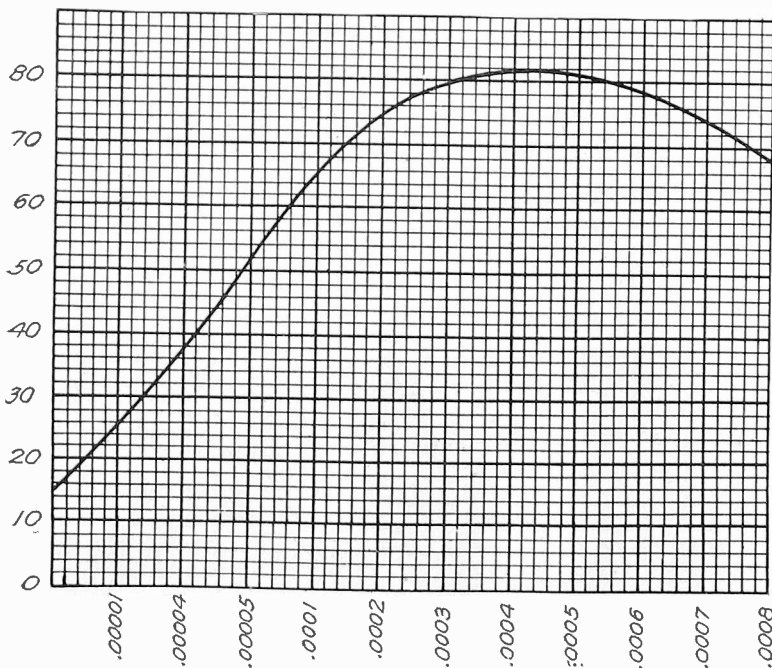

FIG. 2

CURVE SHOWING HOW THE COUPLING CONDENSER CAPACITY AFFECTS VOLUME. INCIDENTALLY, AS THE VOLUME IS DECREASED THE SELECTIVITY IS INCREASED AUTOMATICALLY.

Aristocracy of Circuits

duced or prevented, even when the grid-to-plate method, or Hartley oscillator, is used, but with the other design it is far easier to avoid body capacity.

If the reactance of the plate coil is not high enough at a low broadcast frequency to induce oscillation, a fixed condenser across it may help (Fig. 1D, dotted lines). However, in any event a rotary tickler coil, as in conventional three circuit tuners, will produce oscillation over the entire wave band when the plate coil is tightly coupled to the grid coil. The tickler is set once and left thus, hence need not be panel mounted.

Rare Method

Whereas a pickup coil of few turns was used in the previously cited instances, in Fig. 1D another and rare method of coupling is shown. The object of any form is to link the oscillator and the first detector circuits. In the coil method the grid system of modulation was used, that is, the oscillator's generation was induced in the grid circuit of the first detector by mutually inductive coupling.

In Fig. 1D the capacity method of coupling is used, and number of windings in the oscillator system is two, instead of three. There is no pickup winding. The condenser RS couples the circuits selectively.

It will be seen, therefore, that two radio frequency transformers or antenna coils of the same characteristics might be used, provided the primaries are large; or, if small, the primary on the coil to be used in the oscillator circuit would be enlarged and the other primary left as it is. About 35 turns on a 3 inch diameter, using No. 24 single silk covered wire, would be sufficient winding for L₄, whereas the other windings might be 50-turn secondaries and a 10-turn primary (L₁).

At Same RF Potential

Body capacity effects will not be noticed in the condenser method of coupling, because there is no essential potential difference between the two points of connection, the plates of the two tubes, nor is either in a very critical state, anyway.

Any selective method of coupling is one where the coupling is adjustable from a very low limit to as high a degree as is practical or desirable.

In this connection the capacity of the coupling condenser is important. It was found that with coils wound of No. 24 single silk wire on the three inch diameters that and with -01A tubes for oscillator and modulator, terminals of the coils being connected in the same relative order to avoid phase shifting, beyond .0005 mfd. an increase in capacity had a throttling effect, diminishing volume, where as from minimum capacity setting of the coupling condenser up to .00035 the variation was not only smooth but from faintest reception, just enough for earphone use, to powerful sound sufficient to be heard two blocks away.

This was a range with a vengeance, hence the coupling condenser was selective of degrees of volume, and accomplished this work very nicely while increasing the actual selectivity when volume was lowered.

By-pass Condensers

This is exactly as it should be, since the loudest stations we receive have a greater dial spread than the weaker ones, and the selective method of coupling reduces the dial spread about proportionally to the

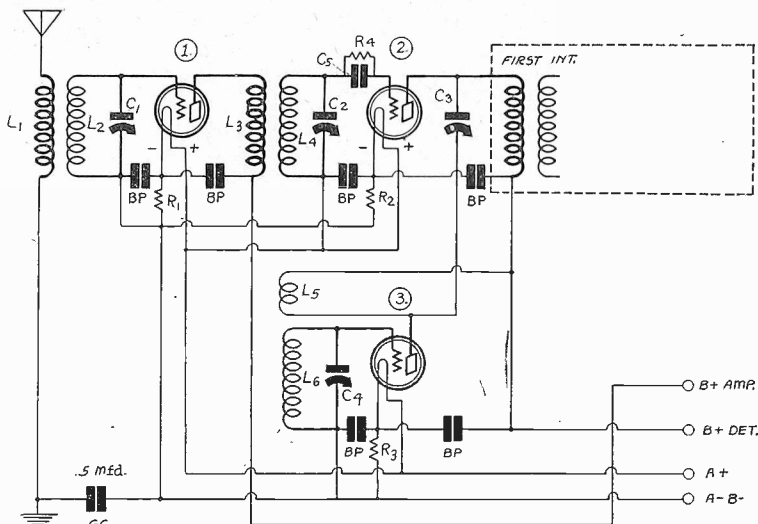

FIG. 3

A STAGE OF TUNED RADIO FREQUENCY AMPLIFICATION AHEAD OF THE FIRST DETECTOR, PLUS A VARIABLE CAPACITY COUPLING BETWEEN OSCILLATOR AND MODULATOR, FOR SELECTIVE VOLUME CONTROL. IF THE TRF AND FIRST DETECTOR TUNING CONDENSERS ARE GANGED, AND HAVEN'T TOALLY INSULATED ROTORS AS WELL AS TOTALLY INSULATED STATORS, THEN THE LEFT-HAND CONNECTION OF THE GRID LEAK SHOULD BE MADE TO A PLUS DIRECT, INSTEAD OF TO THE GRID COIL. THIS REQUIRES A SEPARATE LEAK MOUNTING.

decrease in volume. This is not always true of other forms of volume control, for these often leave selectivity where they find it, and merely reduce volume.

As we are progressing toward a tuner and oscillator of certain design it is well to note another point of difference in Fig. 1D. A lone bypass condenser BC, say about 1 mfd., between A minus and B plus, was all we discovered previously, but now appear three more, two of them across the Amperites, and the third from filament minus of the modulator to B plus. Note, too, that the common point is made the negative filament in each tube. This is supported by the general use of negative filament in determining grid bias and indeed in making all static reckonings in respect to vacuum tubes. Also it is the most likely place to be put at ground potential, since it marks the end of the desired radio circuit for that tube.

Bypass Reason

The reason for bypassing the resistor is to render the circuit as stable as can be, and to negative so far as possible the

effect of the plate current passing through the filament. While a bypass condenser across any filament resistor does not affect the direct plate current, it does detour the AC component or radio frequency current in the plate circuit and minimize the common coupling introduced by the unison of filament and plate current in this resistor, which otherwise produces small values of feedback.

The fact that the direct plate current flows partly through the filament resistor is often overlooked, but the plate current from the B supply is delivered to the plate, is conducted past the grid to the tube filament through the space path inside the tube, and divides unequally in both legs of the filament, one of which wears as a protective legging the filament resistor.

Constructors will say that, testing such a circuit with the filament resistor bypass condensers in and out, they do not notice any difference. Neither do they notice any difference in time between a thousand-dollar watch and a dollar watch, when they simply look at both for a

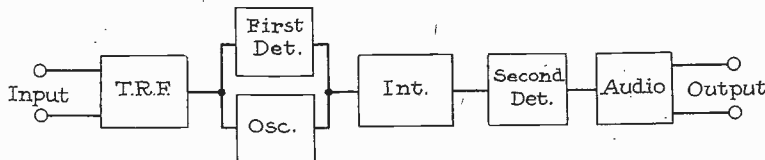
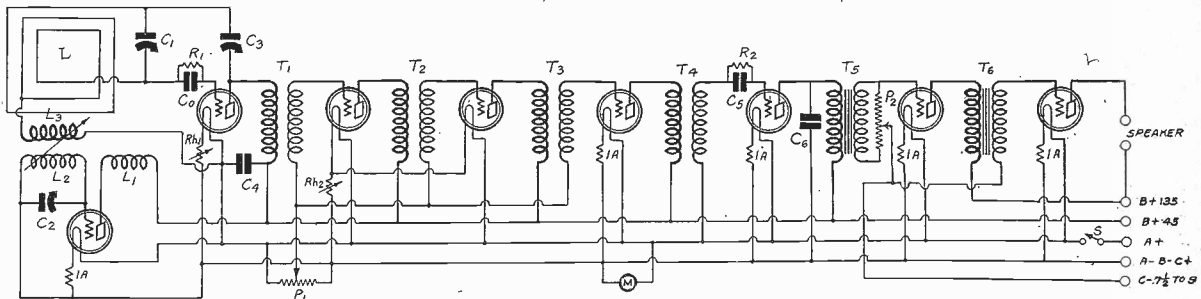

FIG. 4

THE ELECTRICAL ORDER OF THE CIRCUITS SHOWN IN FIG. 3. THE TRF STAGE FEEDS INTO THE FIRST DETECTOR, TO WHICH THE OSCILLATOR IS COUPLED. THE COMBINED RESULT IS DELIVERED TO THE INTERMEDIATE AMPLIFIER, WHICH IMPRESSES THE GREATLY AMPLIFIED INTERMEDIATE CARRIER UPON THE SECOND DETECTOR, AFTER WHICH THE AUDIO CHANNEL DOES THE REST.

A Super for

By Bramhall



THE CIRCUIT DIAGRAM OF A SUPER-HETERODYNE SUITABLE FOR A TRANSPORTABLE RECEIVER LIKE THAT MADE BY SEYMOUR SAGER. REGENERATION IS USED IN THE FIRST DETECTOR.

HERE is a transportable receiver rather than a portable one, excellent for installation in an automobile. It is too heavy to be carried suit-case fashion but is of a size that permits mounting on the instrument board of the car.

The automobile receiver, like the portable, must be sensitive enough to pick up signals wherever the automobile may be, and that often is in places where ultra-sensitivity is required. The receiver therefore is naturally of the Super-Heterodyne type.

It contains eight tubes, which in a correctly designed receiver of this type will give sufficient sensitivity for all reasonable requirements.

Ruggedness a Requisite

A receiver designed for constant use in an automobile must have certain characteristics not required of small portable receivers or of home receivers.

The first is that of unusual ruggedness. It must be built to withstand all the jolts and vibrations to which it will be subjected in an automobile which may travel fast over rough roads.

The structure of the set must be sturdy and well braced so that there will be a minimum of play between the parts.

All nuts used for holding parts together must be locked either with lock washers or in some other positive manner.

Special attention must be given the mounting of the tubes. Ordinarily the ordinary sockets, either the push or the bayonet types, are not dependable, as the tubes are likely to be shaken out of either type in time. Of the two types, perhaps the bayonet type is the more reliable, particularly when used for tubes mounted upside down, as many of the tubes are in this "automobile" set.

Many methods of locking the tubes in place will suggest themselves to the builder of such a set. For example, rubber bands can be used to hold the tubes in place, or twine may be used for the same purpose. For more or less permanent tubes plastic wood or a suitable cement can be used for fastening them in their sockets.

If the tubes are not mounted securely they will fall out of their sockets, and as this will happen when the car is in motion, the probability of breakage of tubes then would be high.

Individual Design

It would not be practical to give the exact details of the receiver built for a particular car, for the design that fits that car may not necessarily fit any other car. A mere suggestion to the ingenious radio fan and automobilist will suffice.

The photographs of the set built and designed by Seymour Sager, 92 Carrick Ave. South, Hamilton, Ontario, Can., show that his eight-tube Super-Heterodyne is a type of double-decker. It has only one deck but parts are mounted both above and below it. Thus some of the tubes and transformers are mounted right side up and others are mounted upside down.

The panel of the receiver is a square 11 inches on a side. The sub-panel partition is made of wood thick enough to allow mounting of parts on both sides with wood screws without mutual interference. The arrangement of the parts on the panel can be seen on the photograph of the automobile instrument board.

A filament circuit voltmeter of diminutive size is mounted in the center near the upper edge. Below are the two tuning controls, which are General Radio vernier type condensers. The various volume controls are distributed on the lower two-thirds of the panel.

Placements of Parts

The radio frequency portions of the circuit are placed on top of the baseboard while the intermediate and audio frequency parts are mounted under it. A good idea of how this is done is gained from the upper left and right photographs.

The loudspeaker, consisting of the driving unit and a large horn, is placed under the hood of the car beside the engine. The manner of placement is shown in the lower left photograph. By comparing this photograph and that of the instrument board it is apparent that the loud speaker is placed directly behind the receiver viewed from the drivers seat.

The filament power is derived from the automobile battery, while the B power is derived from a set of dry cell batteries and the C voltage from a small dry cell battery mounted in the upper compartment in the receiver.

Loop Operated

The receiver is loop operated, as befits a Super-Heterodyne and a transportable set. The loop is placed in the car over the driver, and is so mounted that it can be raised or lowered as suits the purpose of the operator.

Mr. Sager, the designer and builder of the set, took 11 months to iron out all the kinks from the set, and to get it working properly while the car was running at high speed. His greatest difficulty was in holding the tubes in place. No less than 4 dozen tubes were lost before this trouble was overcome. Note that the sockets used are of the bayonet type.

Sockets of this type are used for electric lights in all trains, cars and boats because they hold the lamps.

Sensitivity of Set

When the car is motionless and the engine not running stations within a 1,500 mile radius come in regularly with loud speaker volume, and often more distant stations come in with similar volume. While traveling at a speed of from 30 to 40 miles an hour stations within a radio of 500 miles can be heard distinctly. Thus while trav-

LIST OF PARTS

L—One loop to tune with a .0005 mfd. condenser.

L1, L2, L3—Oscillator coupler to tune with a .0005 mfd. condenser.

T1, T2, T3, T4—Four Silver-Marshall No. 210 intermediate frequency transformers.

T5, T6—Two Thordarson R-200 audio transformers.

C0, C5—Two Carter .00025 mfd. grid condensers with grid leak clips.

C1, C2—Two General Radio vernier type .0005 condensers.

C3—One General Radio 100 mmfd. midget condenser.

C4—One Carter 1 mfd. by-pass condenser.

C6—One Carter .001 mfd. by-pass condenser.

1A—Five No. 1A Amperites.

Rh1—One Frost 20 ohm rheostat.

Rh2S—One Frost 10 ohm rheostat with filament switch attached.

R1, R2—Two Durham 2 megohm grid leak.

P1—One Frost 400 ohm potentiometer.

P2—One Centralab 500,000 ohm modulator.

Eight bayonet type (old) sockets, spring suspension.

One 0-6 volt panel mounting "Double R" voltmeter.

Two General Radio Bakelite type vernier dials.

Two Carter Imp jacks.

Seven Eby binding posts.

One 11 x 11 inch Cortlandt panel.

One wooden sub-panel.

Seven O1A tubes and one 112A tube.

Three 45 volt B batteries.

One 7½ volt grid battery.

One loudspeaker.

One automobile.

Your Auto

Torrence

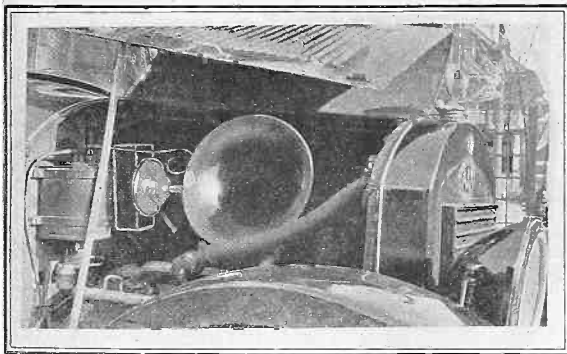
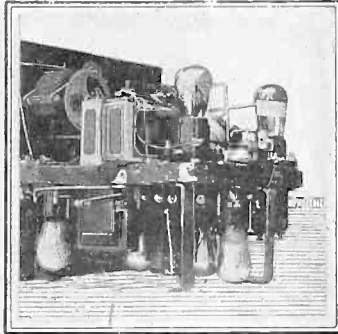
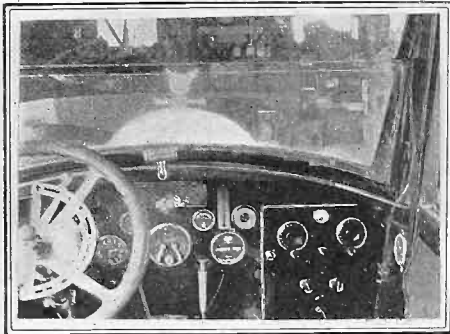
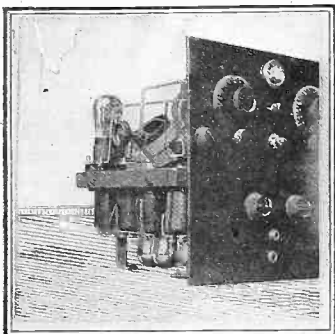

UPPER LEFT—LEFT VIEW OF THE 8-TUBE SUPER-HETERODYNE OF SEYMOUR SAGER, SHOWING THE OSCILLATOR AND THE INTERMEDIATE TRANSFORMERS. TOP CENTER—INTERIOR OF THE AUTOMOBILE SHOWING HOW THE RECEIVER IS INSTALLED ON THE INSTRUMENT BOARD. UPPER RIGHT—REAR VIEW OF THE RECEIVER WHICH SHOWS THE DOUBLE DECK CONSTRUCTION. LOWER LEFT—THE LOUD SPEAKER IS INSTALLED UNDER THE HOOD OF THE CAR AS SHOWN HERE. LOWER RIGHT—MR. SAGER HIMSELF AND HIS RADIO-EQUIPPED CAR.

eling at that rate at a distance of 500 miles from New York it is easy to follow a speaker from the New York stations.

Mr. Sager, whose home is in Hamilton, Ontario, listened in to the Tunney-Dempsey fight direct from station WLS while he was seated in his car near New York.

The difference between the stand-still and the running sensitivity is due to interference from the engine. The sparking can be heard and becomes objectionable when the sensitivity is turned up toward its maximum. But it speaks well for both the car and the receiver that the interference is not any more troublesome than it is.

Selectivity

The selectivity is enough for the range of the set. No interference from stations nearby is experienced when listening to the farthest receivable stations even when the frequency separation is small.

A suitable circuit diagram for a receiver of this kind is shown in Fig. 2. This shows that regeneration is employed in the loop. This is a very useful feature in any portable set where sensitivity is required, as well as for suppressing certain squeals which may at times be present unless the radio frequency selectivity is high as well as that of the intermediate frequency.

The regeneration is controlled by means of a 100 mfd. midget condenser C3. This is the first volume control aside from the tuning controls.

Volume Controls

There are four additional controls of the volume. One is the 20 ohm rheostat Rh1 in the negative lead to the modulator tube. The next is the 10 ohm rheostat Rh2 in the negative filament lead to the first two intermediate tubes. The fourth is the 400 ohm potentiometer P1 across the filament circuit to which the grid returns of the three intermediate amplifiers are connected. These two controls, that is, Rh2 and P1, control the amplification and the oscillation in the intermediate amplifier.

The fifth volume control is the half meg-ohm potentiometer P2 across the secondary of the first audio transformer.

The oscillator is of the tuned grid type, which is used because of the absence of body capacity.

The filament current in all those tubes which are not controlled by rheostats is limited by means of Amperites. One of these is used for each tube. Since all the tubes in the circuit are either of the 01A or the 112A type all the Amperites are No. 1A. Only the last tube is a 112A.

Detection and Modulation

The modulation is accomplished by means of the grid and condenser method. The grid condenser C0 is of .00025 mfd. capacity and the grid leak across it is 2 megohms. A condenser as small as .0001 mfd may be used here if desired.

The detection is done by the same method.

The capacity of condenser C5 is .00025 mfd. and the resistance R2 across is also 2 megohms. Of course the grid returns of both the modulator and the detector go to the positive end of the filament.

Both of the tuning condensers C1 and C2 are General Radio .0005 mfd. vernier type condensers. The loop must be designed to this size condenser and it should be tapped at the center turn. The oscillator coupler also should be wound for the .0005 mfd condenser. The pick-up coil L3 may well be mounted so that its coupling with L2 can be varied. But it is not desirable to have a knob for this variable on the panel, for it affects the.

M is the filament voltmeter. S is the filament switch, which should be incorporated in one of the volume control rheostats, Rh2 for example.

T1, T2, T3 and T4 are intermediate frequency transformers while T5 and T6 are audio frequency transformers.

The oscillator coil and pickup can be made easily by the constructor. On a 3-in. diameter the secondary 12 should consist of 43 turns of No. 24 magnet wire. The plate winding L1 may consist of 30 turns of the same wire, or finer wire if available. The pick-up coil L2 may have from ten to fifteen turns. The larger number gives slightly greater sensitivity but correspondingly lower selectivity. If an old three circuit tuner is re-wound for the job the pick-up coil should be put on the rotor so that the pickup can be varied as desired.

Double Modulation

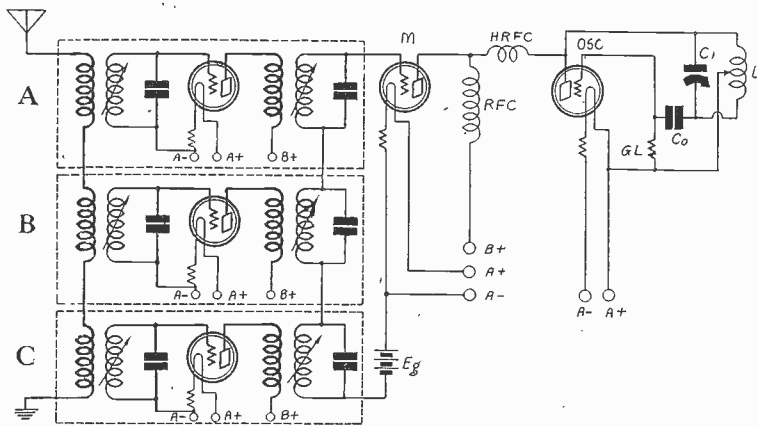

THE CIRCUIT DIAGRAM OF AN EXPERIMENTAL HOOK-UP FOR DOUBLE MODULATION. THE MODULATED CARRIERS FROM THREE DIFFERENT BROADCASTING STATIONS ARE IMPRESSED ON THE MODULATOR OF A HIGH FREQUENCY TRANSMITTER.

By Brunsten Brunn

THE new plan involving double modulation and transmission on high frequencies outlined by J. E. Anderson, Technical Editor, in RADIO WORLD March 17 has attracted considerable attention both in technical and lay circles, due to the promise which the system holds out to those who would like to broadcast and cannot find room in the present broadcast band and to those listeners who would like a greater practical latitude in their choice of broadcast entertainment.

Let us review the theory. As a first step consider what occurs when a broadcasting station transmits a given musical note. Let us further confine our attention to a broadcast frequency of 1,000 kc or 300 meters, and to a pure tone or musical frequency of 1,000 cycles per second. This frequency is a little lower than the C two octaves above middle C.

Modulation or Mixing

When the 1,000 cycle note is sounded before the microphone in the studio an electric current of 1,000 cycles per second is produced in the modulator circuit. This current is amplified and ultimately

mixed with the 1,000 kc radio frequency of the transmitting oscillator.

The mixing or modulation is not a simple process and the result of it is no simpler. But for practical purposes we can say that the product of the modulation consists of four different components. One is the 1,000 kc radio frequency current of the oscillator, which is known as the carrier. The second is a radio frequency current the frequency of which is the sum of the oscillator frequency and of the 1,000 cycle note impressed on the carrier. In this case this frequency is 1,001 kc.

The third component is a radio frequency current the frequency of which is the difference between the oscillator frequency and the 1,000 cycle note impressed on the carrier. In this case this frequency has a value of 999 kc.

The fourth component in the modulated wave is a current the frequency of which is that of the 1,000 cycle note impressed on the carrier.

Although the purpose of the entire transmission is to convey the 1,000 cycle musical note to listeners at the receivers

tuned in on the transmitting station, we are not at all interested in the current of 1,000 cycle frequency. It is not transmitted.

Transmitted Trio

But we are very much interested in the three other components? All these are radio frequency currents and have the frequencies 999, 1,000 and 1,001 kc. The middle is the carrier and the others are the lower and upper side frequencies, respectively. The transmitting antenna radiates all of these in the form of electro-magnetic waves.

And every receiver tuned in on the station receives all of these. Although every receiver is tuned nominally to the carrier frequency only, it also receives the side frequencies. This is possible because no tuner is perfectly selective. If it were, telephone reception would be impossible.

The three radio frequencies picked up are amplified and finally impressed on the detector or demodulator.

Demodulation or Detection

The product of the detector or demodulator is a highly complex electric current. It contains one component in which we are much interested, and that is a current having the same frequency as the musical note that was sounded before the microphone. The transmitter rejected this, but in the receiver that is the only one that is finally desired. It is carefully nurtured and amplified in a regular receiving set until it has the desired magnitude, when it is turned into the loudspeaker. The energy contained in this current comes out of the loudspeaker as a musical note, a close reproduction of the note that was sounded before the microphone.

Thus the musical note we selected, namely 1,000 cycles, has been carried by radio waves across the space between the transmitter and the receiver and finally reproduced as sound.

Other musical frequencies are carried and reproduced in the same way. And many different musical frequencies and other sounds can be carried and reproduced simultaneously.

The frequency of the carrier of all of these is the same, namely 1,000 kc. But the side frequencies differ. For a tone of 100 cycles the three frequencies are 999.9, 1,000 and 1000.1 kc. For a 10,000 cycle sound they are 990, 1,000 and 1010 kc.

Frequencies Not Limited

In broadcasting even the highest audio frequency impressed on the radio frequency carrier is very low as compared to the carrier frequency. But there is no frequency limit to two frequencies that may be mixed. The two may be equal, in which case one side frequency is zero and the other is twice that of either, i.e., the sum of the two. As one of the intermodulating frequencies is varied and the two are brought to equality the lower side frequency approaches zero through the entire audio scale. That is the heterodyne squeal which can be heard in all oscillating sets.

The frequency impressed on a carrier frequency can thus have any value, at least from zero up to the value of the carrier frequency. And the carrier can have any frequency we choose.

High Frequency Chosen

Let us therefore choose a carrier frequency of 20,000 kc, twenty times as high as the radio frequency carrier we con-

New R.C.A. Eliminator Is Dry and Tubeless

A B eliminator which marks a departure in socket power devices was announced by the Radio Corporation of America. The new device, according to its sponsors, is designed to meet the demand for a reliable and efficient B or plate supply requiring minimum attention and maintenance expense.

The new eliminator, which will be known as Model AP-1080, is of rugged construction, and employs no acids or liquids to be replenished; it has no mechanical parts or tubes to be replaced. The secret operating mechanism is enclosed and sealed in permanent steel containers. It is extremely compact, measuring 7¼ by 10¾ by 6½ inches high and will readily fit into the usual radio

cabinet. When the new eliminator is connected to the lighting socket and radio set, it requires no further care or attention.

The operating cost is low. The device draws 22 watts under average load. The power output is ample for any type of receiver up to the eight-tube circuit with power tube. The maximum voltage has been limited to 135, since for all practical purposes in the average home the loudspeaker volume of a -71 or -71A, when used with a plate voltage of 135, will give the same satisfactory results as when the maximum allowable potential of 180 is applied. Furthermore, at the lower plate voltage the life of the power tube is materially prolonged.

Producible in Home

sidered before. We can modulate this high carrier with any frequency we choose. Then we can modulate it with a radio frequency of 1,000 kc. The main products of the modulation will be the four frequencies 19,000, 20,000, 21,000 and 1,000 kc. Just as we rejected the 1,000 cycle frequency in broadcasting so we now reject the 1,000 kc frequency in this case. The two side frequencies and the 20,000 kc carrier are radiated.

Shortwave Receiver Used

Now a short-wave receiver can bring in the 20,000 kc carrier and the two side frequencies, 19,000 and 21,000 kc. The tuner should not be too sharp or the side frequencies will be suppressed too much.

If these three frequencies are received and impressed on a detector or a modulator the 1,000 kc frequency previously rejected will be reproduced. Beyond the detector this is the only frequency we are interested in for the moment, and we tune for it. We tune for it just as we would for a broadcast frequency of 1,000 kc and we can use the broadcast receiver.

Thus the 1,000 kc radio frequency has been carried through the space intervening between the transmitter and the receiver on a radio frequency of 20,000 kc, and it has been reproduced at the receiving end.

Double Modulation

Of course the 1,000 kc frequency cannot be heard in the receiver because it carries nothing. But there is no reason why it should not carry a musical program or some other intelligence. It could have been modulated before it was impressed on the 20,000 kc carrier. And it could have been modulated with the same equipment that is now used to modulate a broadcast frequency.

If it had been, the detector in the broadcast receiver would have converted it to a current of audible frequency and the loudspeaker would have converted that to sound.

Many Frequencies Ride Through

Just as many audio frequencies ride from the studio to the receiver on the back of the radio frequency carrier, so many radio frequencies can ride from the short wave transmitter to the short wave receiver on the short wave, or high frequency, carrier. Each one of these carried radio frequencies in turn can carry all the audio frequencies, and any one of them can be picked out of the plate circuit of the short wave detector by the ordinary radio receiver.

So all that is necessary to provide another broadcast band within tuning range of the ordinary receiver is to modulate the broadcast frequencies as is now done, impress all these modulated radio frequencies on a single high frequency carrier, and then to prefix a short wave receiver to the ordinary broadcast receiver.

A Problem

How to impress these modulated broadcast frequencies on the high frequency carrier is a problem for the radio engineers to solve. It does not seem insuperable, particularly if the radio frequencies are spaced 50 kc apart. More difficult problems have been solved and are being solved as a matter of routine in the large development laboratories here and abroad.

The experimentally inclined radio fan can readily test the theory by setting up a small high frequency oscillator in his home and modulate its output by the

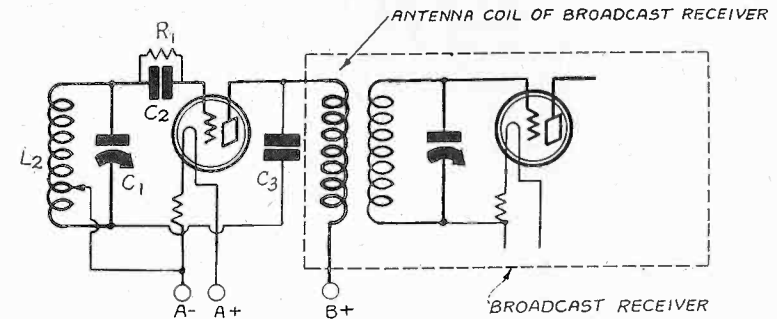

A CIRCUIT DIAGRAM SHOWING HOW TO RECEIVE DOUBLY IN MODULATED HIGH FREQUENCY WAVES ON THE ORDINARY BROADCAST RECEIVER BY PREFIXING A SHORT WAVE TUNER AND DETECTOR.

modulated radio carriers from a few broadcast stations. Then he can receive the high frequency by setting up a suitable receiver in another part of his home. The transmitting oscillator should not be a power tube for then it might create a disturbance which might bring the wrath of the radio supervisor on him. A -01A tube or even a -99 could well be used. For receiving the local broadcasting stations a tuner and RF amplifier are required for each station, but no detector. The tuners in this case need not necessarily involve tuning condensers, for fixed condensers can be used and each circuit can be adjusted to one station by varying the inductance coil.

Circuits Suggested

The modulator and transmitting oscillator may take the form shown in Fig. 1. There are three broadcast RF amplifiers A, B and C, each tuned to a separate frequency about 50 kc apart, or more. These amplifiers may be connected to separate antennas if desired.

All these amplifiers feed into the grid circuit of the same modulator tube M. Each of these amplifiers then "talks into" the modulator grid circuit, but each talks at a frequency which is the carrier of the broadcast receiver tuned in.

In the modulator plate circuit is a radio frequency choke coil RFC. It should have sufficient inductance to look like a very high impedance to the input frequencies. But it should not offer much impedance to audio frequencies. It might be a 1/4 henry RF choke coil.

The plate currents for both the oscillator and the modulator flow through this choke, and the plates of the two tubes are connected together, except that a high frequency choke HRFC is put in the plate circuit of the oscillator Osc. This coil serves to prevent the ultra-high frequency of the oscillator to pass through the distributed capacity of RFC and of the plate circuit of the modulator tube. Its value would depend on what frequency is selected for transmission. For ten million cycles a 150 microhenry

coil should suffice.

Those familiar with circuits will recognize that this is Heising's method of modulation.

Heising Modulator

Condenser Co should be a midget 100 mmfd. or smaller and the grid leak GL may have a value from 10,000 or 50,000 ohms.

The oscillating coil L1 of course depends on the frequency desired. It may, for example, consist of 3 turns of No. 14 bare wire wound to a diameter of 5 inches. Whether or not condenser C1 is necessary depends on the frequency desired and on the stray capacities. The circuit will probably oscillate at a high frequency without it, and the actual value of the frequency for a test set is of no importance. The frequency will be higher without the condenser than with it. At any rate C1 should only be a midget if used.

The grid return should be connected to some point near the middle of the three turn coil. The lead should terminate in a clip so that the position can be adjusted for best results.

The oscillating coil L1 will serve for the radiating antenna.

While the frequency of this oscillator may not be as high as 20,000 cycles it will be high enough to serve the test.

The Receiver

The receiver of this system is much simpler. The wave collector may be a loop just like L1 with a midget condenser across it. The two loops should be pointing in the same direction. Fig. 2 shows a possible hook-up.

The grid leak R1 may be of 5 megohms, the grid condenser C2 of 100 mmfd. or less. C1 is a midget variable condenser and L2 is a coil of the same specifications as L1 in Fig. 1. C3 can also be a small condenser of 100 mfd.

The regeneration can be varied by sliding the clip at the end of the grid return on the three turn coil. The receiver should not oscillate.

Inversion of Speech Matter of Sidebands

Inversion of speech so that the high audio frequencies come through as low frequencies and so that the low come through as high is a problem in modulation and the selection of the lower side band. If the speech frequencies range

from 0 to 10,000 cycles the lower side band will range from 10,000 to 0, or the lower side band will be the speech band inverted. It is only necessary to insert appropriate filters in the circuit to select the lower side band.

Literature Wanted

THE names and addresses of readers of RADIO WORLD who desire literature on parts and sets from radio manufacturers, jobbers, dealers and mail order houses are published in RADIO WORLD on request of the reader. The blank below may be used, or a post card or letter will do instead.

RADIO WORLD,
145 West 45th St., N. Y. City.

I desire to receive radio literature.

Name

Address

City or town

State

E. C. Stansfield, 686 E. Sec. St., Highfire, Pa.
C. G. Schville, Tannersville, N. Y.
J. H. Walker, 12 Front St., New London, Conn.
Carl Alverson, Danville, N. Y.
Joe Nathan, P. O. Box 242, Beacon, New York.
Chas. Van Cleve, 8012 89th Ave., Woodhaven, N. Y.
Livingston Lansing, Box 54, Salisbury, Conn.
Al Johnson, 1409 Shelby St., Sandusky, Ohio.
Ascorta Hnos, P. O. Box 2334, Lima, Peru
F. A. Coyen, 1 Morin Ave., Danielson, Conn.
M. P. Fox, 1280 Marcy St., Akron, Ohio.
Joseph D. Andrew, Route 3, Box 233, Salisbury, North Carolina.
Alfred Q. Carroll, 3220 17th St. N.W., Washington, D. C.
Lon J. Gray, 4970a Delmar Ave., St. Louis, Mo.
O. H. Stephens, 1806 Fairmont Ave., Philadelphia, Pa.
C. B. McCarty, 9 Barbara St., Jamaica Plains, Mass.
E. A. Chimner, 2539 Chevrolet Ave., Flint, Mich.

F. W. Suseny, 1600 Jackson St., San Francisco, Calif.
Leonard B. Wormald, 116 Quebec St., Lowell, Mass.

W. A. Spangler, Wyoming, Ohio.
Robert S. Lytle, Harlingen, Texas.
C. R. Gray, Box 625, Nevada City, Calif.
H. Arnold Jackson, Box 625, Nevada City, Calif.
L. S. Ross, 1288 Second Ave., San Francisco, Calif.

Barney Coleman, 1162 N. Sierra Bonita St., Pasadena, Calif.
C. F. Welsh, Box 21, Pleasant Hill, Mo.
Geo. J. Night, 23 Water Blvd., Auburn, N. Y.
Louis Warren, 1318a No. 21st St., St. Louis, Mo.
Henry H. Koch, Jr., 48 West 120th St., New York, N. Y.
Harold Schooley, Allenwood, Penna.
Stanley M. Craven, 302 Runnymede Ave., Jenkintown, Pa.

V. E. Crosby, Hinckley, Minn.
Louis Acin, 1335 Boynton Ave., New York, N. Y.
Lawson Jones, R2 Box 222, Danville, Ill.
James Millen, 28 Wedgemere Road, Malden, Mass.
C. H. Wagner, 127½ Oak St., Binghamton, N. Y.
O. R. Allen, 322 Dundas East, Toronto, Ont., Canada.
Willice E. Groves, 15th Service Co., Fort Monmouth, N. J.

Martin Fahey, 1935 Harlan St., Philadelphia, Pa.
Dan McKinnon, 157 Roxbury St., Roxbury, Mass.
R. H. Van Dooser, 13 Remoleno St., Buffalo, N. Y.
Owen Cunningham, R. R. A., Kingfisher, Okla.
Joseph A. Krulfeifer, 399 Bleecker St., Brooklyn, N. Y.

S. Marini, 102 Intervale St., Quincy, Mass.
Joseph Marshall, 525 Devitt Ave., Campbell, Ohio
K. A. Newell, 146 Harding Place, Syracuse, N. Y.
A. W. Burgess, 1019 E. 49th St., Cleveland, Ohio
Harry A. Drew, 424 14th St., West New York, N. J.
John Mathews, 765 St. Johns Place, Brooklyn, N. Y.

Chas. Yerigan, Box 384 Alexandria, Minn.
W. H. Williams, 606 So. 17th Ave., Humboldt, Tenn.
G. Wise, 115 Margaret St., Sarnia, Ont.
Arthur J. LeMay, 94 Ford St., Lynn, Mass.
Myron F. Church, 901 S. Harvard Blvd., Los Angeles, Calif.

David E. Ratcliffe, Box 846, 312 Cutler St., Cleo Balanzar, 29-C Guy Place, San Francisco, Calif.
Roy A. Anderson, 703 Puget Ave., Sedro Woolley, Wash.
Forrest M. Beeson, 246 East Ave. 39, Los Angeles, Calif.
Carl P. Sorensen, 3843 N. Ridgeway Ave., Chicago, Ill.

John Reardon, 400 West 52nd St., New York City
Arthur H. Ellis, 43 East Ave., Middletown, N. Y.
Robert B. Riester, 15 Benton St., Stafford Springs, Conn.

The Radio Trade

Coolidge Prohibits Bakelite Bootlegging

Washington.

The Department of the Treasury has made public the text of its circular to customs officers carrying out the embargo order placed by the President against importations of laminated insulation products sold in the United States as bakelite, and used extensively for radio panels. Complaints had been made to the Tariff Commission that importers were bringing into this country products which simulate the bakelite material and it was claimed these were infringing on the American patents covering the manufacture of bakelite.

The President directed, therefore, refusal of entry of such products in the case of any shipment as to which doubt existed as to the infringement, and in carrying out this order, the Treasury advised Collectors of Customs to make a full report of consignments of this character immediately upon presentation at the customs houses.

Full Text of Announcement

Following is the full text of the announcement:

"The Department has been advised by the President that Formica Insulation Company, Continental Fibre Company, Fibroc Insulation Company, National Vulcanized Fibre Company, Spaulding Fibre Company, Inc., and the Bakelite Corporation, engaged in the manufacture and sale in the United States of laminated products composed of paper or other materials and an insoluble and infusible condensation product of phenols and formaldehyde, have made complaint asking relief under section 316, Title III, of the

Tariff Act of 1922, from unfair methods of competition and unfair acts in the importation or sale of such laminated products.

"The President has also advised that upon the facts submitted to him by the reason to believe that laminated products are offered or sought to be offered for entry into the United States in violation of said section 316, and that the continuance of such apparent violation of section 316 pending completion of final findings by the United States Tariff Commission, will work substantial injury to the industry of the complainants.

Refusal Ordered

"The President has, therefore, by authority of subdivision (f) of section 316 of the Tariff Act, directed that entry be forbidden into the United States of laminated products in the manufacture of which synthetic phenolic resin varnish covered by United States letters patent Nos. 1018385 and 1037719 was used, provided that the presence in the laminated products of an insoluble and infusible condensation product of phenols and formaldehyde shall be satisfactory evidence that said synthetic phenolic resin varnish was used in their manufacture, unless the contrary shall be established.

"In the event any such merchandise is offered for entry in your district, which, in your opinion, constitutes an infringement of the President's order, the entry thereof should be refused and in the case of any shipment as to which any doubt of such infringement exists, you should submit a report thereof to the Department for instructions, together with a sample."

C. Arthur Liacos, West Groton, Mass.
E. B. Polk, Cheriton, Va.
Thomas L. Marshall, 196 Woodside Ave., Buffalo, N. Y.
O. R. Allen, 322 Dundas East, Toronto, Ontario, Canada
Arthur C. Ocasin, 58 E. 106th St., New York City
Chauncey B. McGill, 221 Manhattan Ave., Jersey City, N. J.
F. H. Parks, 1915 Garrard St., Covington, Ky.
L. E. Mattler, 9137 A. South Broadway, St. Louis, Mo.
Sidney Nordgren, 42 McGovern Ave., Ashtabula, Ohio
Archie Miller, 19 Nashua St., Manchester, N. H.
John A. Dutca, 29 Pearl St., Town Hall, Provincetown, Mass.
W. A. Ellis, 424 Drakert St., Hammond, Ind.
W. M. Blaney, 500 S. Smallwood St., Baltimore, Md.
Anton Dyczus, 579 Sumner St., W. Lynn, Mass.
C. C. Wilson, 155 N. Mechanic St., Cumberland, Md.
W. C. Thomas, 139 Chestnut, Holyoke, Mass.
Wm. Hamsell, 116 E. Main St., Ottumwa, Ia.
Wm. L. Morrissey, 337 No. 41st St., Camden, N. J.
Vernon V. Vaupel, 2106 Lunt Ave., Chicago, Ill.
P. Cohen, 635 E. 21st St., Brooklyn, N. Y.
H. B. Robeson, 554 Myers St., Toledo, Ohio.
James G. Parsons, 1821, Duquesne St., McKeesport, Pa.
Holstein Kerr, 5 Castle Ave., Upland, Pa.
C. W. Studivant, 1007 West 5th St., Austin, Texas.
S. C. Irvin, 2959 California St., Denver, Colo.
Chas. Rich, 119 Post Ave., New York, N. Y.
Charles L. Banker, 130 South Ave., Poughkeepsie, N. Y.
S. Watkinson, New Lebanon, N. Y.
R. W. Phelps, 5127 Centre Ave., Pittsburgh, Pa.
Ernest R. Eybel, 605 Winchester Ave., New Haven, Conn.
Leo H. Ware, 2338 E. 85th St., Cleveland, Ohio.
E. C. Taylor, 1738 5th St., S.E., Canton, Ohio.

F. W. Rohrs, Phila. Rd. and Hamilton Ave., Rosedale, Md.
Stanley Carpenter, 516 Locust St., Kalamazoo, Mich.
W. H. Gemmell, Homer City, R.D. No. 2, Penna.
Samuel C. Hyer, 79 Fairview Ave., Port Washington, N. Y.
Bayard E. Bryan, 596 Eshelman St., Highspire, Penna.
L. C. Leach, 444 Fifty-first St., Brooklyn, N.Y.
Wrightman Radio Shop, 132 N. 5th St., Middletown, Ind.
Hyman Sobel, 2047 73rd St., Brooklyn, N. Y.
James Millen, 28 Wedgemere Road, Malden, Mass.
Peter E. Greene, 21 Briggs St., West Warwick, R. I.
F. M. Cornwell, Webster, S. D.
E. J. Umphrey, 82 Vine St., Dayton, Ohio.
H. G. Turner, Box 473, Hopewell, Va.
S. R. Beaver, 763 Woodlawn Ave., Jackson, Mich.
P. P. Wells, 756 East 11th St., Pittsburgh, Pa.
A. A. Valentine, 427 W. 154th St., New York, N. Y.
Frank J. Seib, 64 Lincoln Road, Brooklyn, N.Y.
R. Twombly, 1389 N. Sierra Bonita Ave., Pasadena, Calif.
M & D Radio Co., 1411 East 35th St., Kansas City, Mo.
R. S. Lytle, Harlingen, Texas.
James S. M. Neves, 218 W. Main St., Alhambra, Calif.
Elton Kelley, 3327 College Ave., Kansas City, Mo.
Herman R. Wallin, 693 Watkins St., Brooklyn, N. Y.
Dr. Earl R. Hoskins, 17 N. State St., Chicago, Ill.
J. Polnik, 9117 W. Lafayette Ave., Detroit, Mich.
Lewis G. Dale, 302 East 95th St., New York City
L. Ralph Lloyd, Lloyd In. Studio, 20 West 22nd St., New York City
Henry Roese, 797 Quincy St., Brooklyn, N. Y.
William Mitzel, 1310 E. Price St., Philadelphia, Pa.
Stanley M. Craven, 302 Runnymede Ave., Jenkintown, Pa.

Expert Efficiency Data

on the World's Record Super 10

By E. H. Scott

THE construction of Scott's World's Record Super 10 was described in the March 24th and 31st issues. Trouble-shooting is discussed herewith.

IN SHOOTING trouble in any set it is always well to use a tube checker or tube tester. This usually consists of two or three meters in a handy case, with socket attached, so that a tube may be removed from the receiver and placed in the tester's socket, a plug being inserted in the vacant receiver socket. Two meters usually consist of milliammeter and low-reading voltmeter, to test plate current and filament voltage. It is well to have a third meter to test B voltages, preferably a 0-500 high resistance voltmeter.

If you have no tube tester, the next best thing to do is to remove your tubes from your set, take them to a friend who has a set operating using the same type of tubes, and place them in his receiver one at a time, noting if the receiver functions properly as each tube is inserted.

If you find that the receiver does not operate when one particular tube is inserted, it shows that the tube is defective.

Have Extra Tubes Handy

Remember, just one bad tube will upset the operation of your whole receiver. It is a good idea to have one or two new tubes on hand at all times, and if you are in doubt as to the condition of your tubes, take one of the new ones and insert it in turn in each socket. If your signal strength increases, it shows that the tube you have replaced is not working efficiently.

We have recently found that the -40 tube (high mu) makes the most efficient first detector. This is the tube located third from the end. Use a -01A for the second detector. Under certain conditions, the 112A also makes a good second detector, but never use a -40, or a -00A as a second detector.

If you find that the receiver has a tendency to start howling when you turn up your potentiometer to get any degree of volume, and especially if this occurs when you have the speaker and set together in a console cabinet, or when speaker is near the receiver, you probably have a microphonic tube.

Keep Speaker Away from Set

It is always a good idea to keep the speaker away from set five or six feet.

Generally, the tube in the second detector socket is the one that will cause the trouble. To test for this, hold the second detector tube firmly with your hand, noting if the hum or howl stops. If it does, then you know positively that the tube is microphonic. Try the other tubes in set in second detector socket, and you will probably find one that is not microphonic.

How to Balance Condenser

The results that you obtain particularly with regard to selectivity, tone quality and distance, depend on the careful balancing up of the three gang condenser. This gang condenser has three small trimmers between the plates, and before you can get proper selectivity and sensitivity, these trimmers must be adjusted so that the two RR stages are correctly balanced. The best way to adjust this condenser is

as follows: Tune in a station between 300 and 370 meters. Then with a wooden screwdriver loosen the small screw on the trimmer next to the drum dial. Now loosen the screw on the trimmer in the center until it is about half way out. Next see that the plates on the small midget condenser on the front panel are half out. You are now ready to start adjusting.

First, retune the station between 300 and 370 meters until you have the best volume. Second, adjust the trimmer at the end of condenser until you get the mer near the drum dial. While adjusting screw on the center trimmer in or out, until you get the loudest signal.

Finally, adjust the screw on the trimmer near the drum dial. While adjusting the trimmers, tune station by moving the knob on the gang condenser slightly one way or the other, noticing that the station snaps in and out. Make sure that you do not get the station at two points on the dial a few degrees apart; that is, get the station in a one point on the dial, then as you turn dial further get a silent space and bring in the station again. If this occurs, it proves that the gang is not balanced correctly.

Oscillation Begins

You may notice while adjusting that the radio frequency tubes will go into oscillation. This will show that you are approaching the proper point. When this occurs, lower the filament voltage a trifle on the two RF tubes. (controlled by the rheo stat below voltmeter), and continue adjusting.

If you find that in balancing the first and center trimmer, it has very little effect on the increase in volume of the station, it is a sign that there is either a shorted stage or an open stage.

First, check up your wiring on the two RF tubes, and see that everything is wired according to the blueprints. Make sure that you have inserted the transformers correctly. Sometimes constructors get them reversed or get the 530 or 520 in wrong places.

Next unsolder the connections on your three gang condensers; then take the voltmeter and small C battery, or a pair of headphones and C battery, and test across the terminals of each individual condenser. If headphones are used, there should be no click heard, and if a voltmeter, there should be no reading. If there is a reading, it is a sign that that particular condenser is shorted, and it should be returned for adjustment to the Remler Co. The same check should be made on the small midget condenser on the front panel.

First unsolder the leads running to it. There should be no click or reading when testing across the two terminals, nor should there be a click in the phones or a reading when the plates are rotated.

If, after testing the condensers you can find nothing wrong, remove the B530, and the two B520s, test from S to F post and from P to B post. There should be a click or reading between each of these. If there is no reading or click between these points, it is a sign of an open transformer and should be returned to factory for replacement.

Next test between the S to P posts, then

between F and B posts. There should be no reading on your voltmeter. If there is a reading, it shows a shorted transformer and should be returned to factory for replacement.

First, note that your voltmeter shows between 4½ and 5 volts. Generally, you will find that you get best reception at about 4½ volts. However, after the receiver has been turned on for about five minutes, the battery will have settled; then by means of the master rheostat on the subpanel, readjust voltage so that it reads about 4½ volts. Turn on the rheostat controlling the RF tubes about three-quarters. Turn potentiometer up about half way. Tune in a station by rotating both dials together.

You will note that on stations about 400 meters, the dials read very close together. However, on the very low wavelengths, the oscillator dial will read from 30 to 40 points higher than the gang condenser or wavelength dial. On the higher wavelengths, the oscillator will read a little lower than the gang condenser dial.

Tips on Tuning

It is impossible, at the frequency at which the transformers for the World's Record Super Ten are peaked, to make both dials run together using the .00035 condenser. However, this does not affect the operation of the receiver or its efficiency, for it is a simple matter to tune in a station and make a note of the dial readings. Once the station is logged, you can go to the numbers shown for the station and it will come in.

You will find it necessary, to stop tubes from oscillating, to keep the rheostat controlling the RF tubes turned down more on the lower wave lengths than on the higher wavelengths. When you have a station tuned in, you can turn this rheostat on until the receiver begins to squeal, then turn back until the squeal disappears. You will then have your rheostat stages operating at maximum efficiency.

Now tune in the station, using both dials, until you get the maximum volume and best tone quality, and control the volume by means of the potentiometer. This will enable you to regulate the volume from a whisper to maximum volume. The midget condenser on the lefthand side of panel is used to bring in distant stations with maximum volume and also to kill off interference.

The best antenna to use with the World's Record Super Ten is one about 50 feet long, including the lead-in. You will find that you will get better results with the antenna facing in one particular direction. In Chicago, on the North Side, stations on both coasts come in best with the aerial facing East and West. However, if you are near a very powerful broadcasting station, a little experimenting with the direction of your aerial will enable you to eliminate this station easier.

The best ground to use is a copper plate with your ground wire soldered to it and buried five or six feet in damp earth. The next best ground is a ground clamp with wire or a cold water pipe. The next best a ground clamp and wire on a radiator or radiator pipe.

A good ground is absolutely necessary if you wish to obtain maximum results from your receiver.

A THOUGHT FOR THE WEEK

WHEN, during recent years, a well-known player disappeared from Broadway and the speaking stage, in all likelihood he could be found in one of the motion picture studios. Now the broadcasting studio also gives work and shelter to many a player who, not so long ago, before our native legitimate stage became a thing of rags and tatters, strutted his brief hour before the footlights and bowed to the plaudits of his admirers. Cold silence is his reward now—silence and a more or less plethoric envelope on pay day. 'Tis a merry world, my masters! Merry—but so still and cold. But—there's the envelope!

SEVENTH YEAR

RADIO WORLD

The First and Only National Radio Weekly

Radio World's Slogan: "A radio set for every home."

TELEPHONES: BRYANT 0558, 0559

PUBLISHED EVERY WEDNESDAY

(Dated Saturday of same week)

FROM PUBLICATION OFFICE

HENNESSY RADIO PUBLICATIONS CORPORATION

145 WEST 45TH STREET, NEW YORK, N. Y.

(Just east of Broadway)

ROLAND BURKE HENNESSY, President

M. B. HENNESSY, Vice-President

HERMAN BERNARD, Secretary

Chicago: 55 West Jackson Blvd.

Kansas City, Mo.: B. A. Samuelson, 309 Coca Cola Bldg.

Los Angeles: Lloyd Chappel, 611 S. Coronado St.

European Representatives: The International News Co.

Breams Bldgs., Chancery Lane, London, Eng.

Paris, France: Brentano's, 8 Avenue de l'Opera

EDITOR, Roland Burke Hennessy

MANAGING EDITOR, Herman Bernard

TECHNICAL EDITOR, J. E. Andersen

ART EDITOR, Anthony Sadara

CONTRIBUTING EDITORS:

James H. Carroll, John Murray Barron and

Capt. Peter V. O'Rourke

SUBSCRIPTION RATES

Seven cents a copy. \$6.00 a year. \$3.00 for six months. \$1.50 for three months. Add \$1.00 a year extra for foreign postage. Canada, 50 cents.

Receipt by new subscribers of the first copy of RADIO WORLD mailed to them after sending in their order, is automatic acknowledgment of their subscription order. Changes of address should be received at this office two weeks before date of publication. Always give old address; also state whether subscription is new or a renewal.

ADVERTISING RATES

General Advertising

1 Page, 7 1/2" x 11"	462 lines.....	\$300.00
1/2 Page, 7 1/2" x 5 1/2"	231 lines.....	150.00
1/4 Page, 8 1/2" x 5 1/2"	231 lines.....	150.00
1/4 Page, 4 1/2" D. C.	115 lines.....	75.00
1/4 Page, 4 1/2" S. C.	57 lines.....	37.50
1 Column, 2 3/4" x 11"	154 lines.....	100.00
1 Inch	10.00
Per Agate Line.....	75

Time Discount

52 consecutive issues.....	20%
26 times consecutively or E. O. W. one year.....	15%
13 times consecutively or E. O. W.	12 1/2%
4 consecutive issues.....	10%

WEEKLY, dated each Saturday, published Wednesday. Advertising forms close Tuesday, eleven days in advance of date of issue.

CLASSIFIED ADVERTISEMENTS

Ten cents per word. Minimum 10 words. Cash with order. Business Opportunities, ten cents per word. \$1.00 minimum.

Entered as second-class matter March 23, 1922, at the Post Office at New York, N. Y., under the Act of March 3, 1879.

Eveready Reduces Price; Adds New Layerbilt

The National Carbon Company, makers of Eveready radio batteries, announced a new smaller size Eveready Layerbilt B battery, No. 485, as an item additional to its large size Eveready Layerbilt B battery, No. 486.

A price reduction on the two leading Eveready round-cell B batteries, the Nos. 770 and 772, also was announced.

Equal Franchise Wins; Board Life Preserved

Washington.

The radio bill, continuing the Commission for another year and including a modified "equal franchise" provision, was adopted by the House and the Senate and sent to President Coolidge.

The President carefully considered the bill and then signed it.

The equal franchise provision directs that the total power for each of the five zones be the same, except that where applications are lacking in one zone, temporary grant of such spare power may be made to another zone. This exception was a Senate amendment to the original absolute House provision. The amendment, originally and as adopted, was designed to grant greater power principally to the South.

Provisions of Bill

Section 5 of the bill deals with equal franchise as follows:

"It is hereby declared that the people of all the zones established by Section 2 of this act are entitled to equality of radio broadcasting service, both of transmission and of reception, and in order to provide said equality the licensing authority shall as nearly as possible make and maintain an equal allocation of broadcasting licenses, of bands of frequency or wavelengths, of periods of time for operation and of station power, to each of said zones when and in so far as there are applications therefor; and shall make a fair and equitable allocation of licenses, wavelengths, time for operation and station power to each of the States, the District of Columbia, the Territories and possessions of the United States within each zone, according to population.

"The licensing authority shall carry into effect the equality of broadcasting service hereinbefore directed, whenever necessary or proper, by granting or refusing licenses or renewals of licenses, by changing or reassigning wavelengths, by changing periods of time for operation and by increasing or decreasing station power when applications are made for licenses or renewals of licenses.

The Modification

"Provided, that if and when there is a lack of applications from any zone for the proportionate share of licenses, wavelengths, time of operation or station power to which such zone is entitled, the licensing authority may issue licenses for the balance of the proportion not applied for from any zone to applicants from

other zones for a temporary period of ninety days each, and shall specifically designate that said apportionment is only for said temporary period. Allocations shall be charged to the State, district, territory or possession where the studio of the station is located and not where the transmitter is located."

Senator McKellar, (Dem.), of Tennessee, sought to have the measure re-committed with a substitute for the redistribution clause under which the Federal Radio Commission is directed to make a reallocation of stations, wavelengths and power for each of the five radio zones of the country. Senator McKellar said he wanted to correct the ambiguity in the redistribution clause. His motion was ruled out, of order by Vice-President Dawes.

Shorter Licenses

The bill, in providing that the terms of the present members of the Federal Radio Commission shall expire at the end of one more year, also continues the Commission's authority for a year.

Broadcasting station licenses, under the bill, are to be issued for no longer than three months, and all other licenses for no more than one year.

Senator Dill (Dem.), of Washington, criticized Commissioner O. H. Caldwell, of New York, for stating that the redistribution clause of the radio bill was unworkable.

The Washington Senator declared that stations affiliated with the Radio Corporation of America had obtained the "lion's share" of the station power and hence, the equalization plan was needed.

Victor Deal Discussed

Negotiations under way for a merger of the Victor Talking Machine Company with the Radio Corporation were brought into the debate on the bill. Senator King (Dem.), Utah, charged the Radio Corporation with being part of a "trust" seeking to control the radio field, asserting that the acquisition of the Victor Company was for the purpose of assuring the other broadcasting stations the use of Victor artists hitherto denied.

Indications are that the new law will curtail the number of licenses and the power of such centres as New York and Chicago. It is the understanding that under one tentative plan the number of stations throughout the country would be reduced from 685 to 550. This again raises the Constitutionality question.

Separate B Supply Advocated for Audio

A device announced by the Wholesale Radio Service Company, 6 Church Street, New York City, is the Ra-pam Audio Unit, for use with practically all makes and models of radio receivers and also for phonograph reproduction.

The Ra-pam is a completely self-contained, light-stock operated two-stage amplifier. A heater-type AC tube is used in the first-stage and two 210 type power tubes in the second stage. A 281 type rectifier tube is used to supply the B current through the power transformer and filter system, which is self-contained in a metal case approximately 15 x 11 x 7". The

Ra-pam will fit nicely into most consoles. The Ra-pam does not supply the B current for the tubes in the set that remain in use after the Ra-pam is connected.

The sponsors said:

"Six months hence the trade will acknowledge the step taken in the design of the Ra-pam as a great advance over past practice. The idea of supplying all the tubes in a radio receiver from the same B eliminator filter system is the cause of much trouble that has been experienced in the form of motorboating and audio distortion. A separate B supply is better."

Help Name the Baby!

Set Builders Rush to Fill Questionnaire

- American Association Radio Builders.....
- American Federation of Raditricians.....
- American Radio Set Builders Association.....
- American Radio Set Builders of America.....
- American Radio Technicians Association.....
- American Radiotricians.....
- American Radiotricians Association.....
- American Radiotricians, Inc.....
- American Society of Master Set Builders.....
- American Society of Set Builders.....
- Association Custom Radio Set Constructors.....
- Association of Radio Technicians.....
- Association of Radio Technicians of America.....
- Custom Builders Association.....
- Custom-Built Radio, Inc.....
- Custom-Built Radio Set Guild.....
- Custom Radio Builders Association.....
- Custom Radio Builders Club.....
- Custom Radio Builders Guild.....
- Custom Radio Builders, Inc.....
- Custom Radio Builders of America.....
- Custom Radio Builders Service Club.....
- Custom Radio Guild.....
- Custom Set Builders Association.....
- Custom Set Builders Club.....
- Custom Set Builders Club of America.....
- Custom Set Builders Guild.....
- Custom Set Builders, Inc.....
- Custom Set Builders of America.....
- Custom Set Builders of U. S. & Canada.....
- Custom Set Builders of the World.....
- Custom Set Guild.....
- Custom Radio Constructors Club.....
- DX Finders Club.....
- Guild of Master Radiotricians.....
- Home Radio Builders Club.....
- Institute of Master Radio Receiver Constructors.....
- Institute of Radio Set Builders.....
- Institute of Radiotricians.....
- International Custom Set Builders Guild.....
- Master Builders of Custom Made Sets.....
- Master Custom Radio Receiver Constructors.....
- Master Custom Radio Receiver Constructors Guild.....
- Master Radiotricians' Club of America.....
- Master Radiotricians' Guild.....
- Master Radiotricians of America, Inc.....
- Mutual Association of Radiotricians.....
- Nacuset Builders' Association.....
- Naraset Builders' Association.....
- National Association Custom Radiotricians.....
- National Association of Custom Set Builders.....
- National Association of Radio Builders.....
- National Association of Radio Set Builders.....
- National Association of Radiotricians.....
- National Custom Set Builders Club.....
- National Custom Set Builders Club of America.....
- National Custom Set Builders, Inc.....
- National Custom Set Builders & Radiotricians Association.....
- National Radio Builders' Association.....
- National Radio Builders League.....
- National Radio Club.....
- National Radio Custom Builders Association.....
- National Radio Set Builders.....
- National Radio Technicians.....
- National Radiotricians Association of America.....
- National Radiotricians Corporation.....
- Organized Institute of Custom Set Builders.....
- Pioneer Custom Set Builders Club of America.....
- Pioneer Radio Builders Society.....
- Professional Radio Set Builders.....
- Professional Radio Set Builders of America.....
- Professional Set Builders Club.....
- Professional Set Builders Club of America.....
- Professional Set Builders Union.....
- Radio Assemblers & Designers International Organization.....
- Radio Builders Association.....
- Radio Builders Club.....
- Radio Constructors Association.....
- Radio Craft Club.....
- Radio Craftsman.....
- Radio Craftsman Club of America.....
- Radio Doctors & Set Builders of America.....
- Radio Engineers Club of America.....
- Radio Path Finders Club.....
- Radio Receiver Builders of America.....
- Radio Repair & Service Club.....
- Radio Repair & Service Union.....
- Radio Set Builders Association.....
- Radio Set Builders Association of America.....
- Radio Set Builders, Inc.....
- Radio Technical Association of America.....
- Radio Technical Society of America.....
- Radio Technique Club of America.....
- Radiotricians, Inc.....
- Set-U-Need Builders.....
- Society of America Technicians.....
- Society of Master Custom Radio Set Builders.....
- Society of Radiotricians.....
- United Custom Set Builders.....

The custom set builders proved conclusively their real interest in forming an organization of their own by quickly filling out and sending in the questionnaire published last week and reprinted herewith. If you have not filed your answers, please do so now, as the organization will get under way speedily, and it should have every rightful prospect aboard the band wagon.

Next week the general trend of the answers will be divulged.

Herewith is a questionnaire which all prospective members of the custom set builders club should fill out and mail to RADIO WORLD, 145 West 45th Street, New York City, attention Mr. McCord. If you have already filled out and sent in one of the coupons previously published, it is nevertheless necessary to fill out and mail to RADIO WORLD the accompanying questionnaire.

Only from the list of those who send in the questionnaire will those be chosen to whom membership application blanks will be sent.

Please answer all questions frankly. If more room is needed, write on a separate sheet of paper.

Do not hesitate to answer any question. Do not fail to send in questionnaire just because you prefer not to answer some question or questions. All replies will be treated in strict confidence. Not even names of those sending in questionnaires will be published. No obligation attaches to mailing in a questionnaire. If you want blanks for others or a duplicate for yourself, write to RADIO WORLD, enclosing 2c stamp.

- | | |
|---|---|
| <p>(1) Your name</p> <p>Address</p> <p>City State</p> <p>(2) How old are you?.....</p> <p>(3) Are you a citizen of the United States?.....</p> <p>(4) If not, of what country?.....</p> <p>(5) Do you make custom radio sets as your exclusive means of livelihood?.....</p> <p>(6) If not, do you make custom radio sets for hire as a side line?.....</p> <p>(7) How long have you been making custom radio sets?.....</p> <p>(8) How many have you made?.....</p> <p>(9) If you do not make them for pay, do you make them for others without charge for labor?.....</p> <p>(10) Do you make radio sets exclusively for your own use and enjoyment?.....</p> <p>(11) From whom do you buy your parts?.....</p> <p>(12) Are you an annual mail subscriber for any radio magazines?.....</p> <p>(13) If so, state which.....</p> <p>(14) If not, do you regularly buy radio magazines at news-stands?.....</p> <p>(15) If so, state which.....</p> <p>(16) How did you obtain your radio knowledge?.....</p> <p>(17) How much did you spend last year (1927) on parts?.....</p> <p>(18) Are you a beginner interested in attaining radio knowledge so you may become a custom set builder?.....</p> <p>(19) Are you neither a custom set builder nor a prospective one, but interested in purchasing a custom made set?.....</p> <p>(20) From what institutions of learning were you graduated? Include public school, high school, college, with addresses.....</p> <p>(21) Do you favor incorporation of the prospective custom set builders club?.....</p> <p>(22) Do you favor co-operative buying by the club for its members?.....</p> | <p>(23) Do you favor local branches of such a club, in addition to the central organization?.....</p> <p>(24) What dues, if any, do you think should be charged?.....</p> <p>(25) Do you favor the club maintaining a central laboratory for the benefit of its members?.....</p> <p>(26) And sending out confidential circuits, tube and other data, including blueprints?.....</p> <p>(27) What circuits, if any, have you specialized in?.....</p> <p>(28) How many customers have you?.....</p> <p>(29) Do you sell factory-made sets?.....</p> <p>(30) If so, state which.....</p> <p>(31) Do you service sets other than those of your manufacture?.....</p> <p>(32) Do you accept time payments for sets you make?.....</p> <p>(33) If so, does anybody discount this paper for you?.....</p> <p>(34) What is your gross income per year from custom set building?.....</p> <p>(35) Net income from same?.....</p> <p>(36) Give two references as to your character.</p> <p>Name of reference.....</p> <p>Address</p> <p>Name of reference.....</p> <p>Address</p> <p>(37) Is your set building business in your home?.....or have you a separate place of business?.....</p> <p>(38) Give name and address of two whom you recommend for membership.</p> <p>Name</p> <p>Address</p> <p>Name</p> <p>Address</p> <p>Name</p> <p>Address</p> <p>(Be sure to choose the name you want the club to bear. See next column.)</p> |
|---|---|

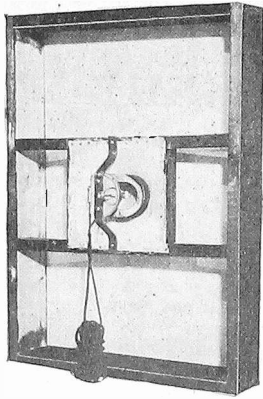

ANOTHER FENCO HIT!

Thousands of Fenco 3 foot Cones have been sold to discriminating radio fans. Again Fenco engineers have produced a triumph. Quantity production—enormous buying power enables us to offer at the lowest price, a high quality complete kit, with full directions for building the famous

FENCO AIRPLANE CLOTH SPEAKER

Kit consists of wood frame, first quality Airplane Cloth, Genuine Fenco Master Unit, 10 feet phone cord, U. S. specification Airplane dope and unit support, nails. Nothing else to buy.....

\$7.50

\$2.00 Deposit on C.O.D.

Absolutely Guaranteed. Dealers Write

FENCO CONE CO.

57 MURRAY STREET NEW YORK CITY



VICTOREEN

Super Coils

Send for Folder

Geo. W. Walker Co.
2825 Chester Avenue
Dept. B Cleveland, O.

Subscribers: Look at the Expiration Date on Your Wrapper

We do not like to take your name from our subscription list without specific instruction to do so because many of our readers wish to keep a complete file of the paper.

Please, therefore, look at the subscription date stamped on your last wrapper, and if that date is earlier than the issue contained in the wrapper, please send check to cover your renewal.

In this way you will get your copies without interruption.

Subscription Dept., RADIO WORLD,
145 West 45th Street, New York City.

RECENT ISSUES of Radio World, 15c each. Be sure to give date of issue when writing. Radio World, 145 West 45th Street, New York City.

BLUEPRINTS

for

Diamond of the Air

Using Standard Tubes
(not shield grid tubes)

4-Tube Model25c

5-Tube Model25c

Send stamps, coin, M. O. or check.

RADIO WORLD

145 West 45th St. N. Y. City

Take Your Choice of 7 Other Publications

For NEW RADIO WORLD Subscribers Ordering NOW

Radio World has made arrangements

—To offer a year's subscription for any one of the following publications with one year's subscription for RADIO WORLD—

RADIO NEWS or POULAR RADIO or SCIENCE AND INVENTION or BOYS' LIFE or RADIO DEALER or RADIO (San Francisco) or RADIO AGE.

This is the way to get two publications

- for the price of one;
 - Send \$8.00 today for RADIO WORLD
 - for one year (regular price
 - for 52 numbers)
 - and select any one of the other
 - nine publications for twelve months.
- Add \$1.00 a year extra for
 - Canadian or Foreign Postage
 - Present RADIO WORLD subscribers
 - can take advantage of this offer by
 - extending subscriptions one year
 - if they send renewals NOW!

Radio World's Special Two-for-Price-of-One Subscription Blank

RADIO WORLD, 145 West 45th Street, New York City.
Enclosed find \$8.00 for which send me RADIO WORLD for twelve months (52 numbers), beginning and also without additional cost, Popular Radio, or Radio News, or Science and Invention, or Radio Dealer, or Radio (San Francisco), or Radio Age, or Boys' Life (or \$10.00 for a two-year subscription to one address). No other premium with this offer.

Indicate if renewal. Name

Offer Good Until Street Address

May 15, 1928 City and State

Radio University

WHEN I TUNE in WOR on my receiver I hear a steady flute-like squeal not unlike that produced by the steam whistle on a peanut stand. I have tried everything to eliminate it but have not succeeded. Sometimes it disappears of itself. Can you explain what causes it and how it can be remedied?

JOSEPH J. CALLAHAN,
Brooklyn, N. Y.

The cause of the whistle you hear is another station which is operating on the second harmonic of the frequency of WOR. The carrier frequency from that station modulates with the second harmonic of WOR. This second harmonic is generated in your own set. There is no complete cure for the condition except to stop one of the stations. But it can be reduced by carefully excluding the signal from the interfering station by tuning and shielding.

The interference is caused by one of the stations which operate on 1420 kilocycles. WCDA and WRST operate on this frequency.

* * *

I AM TROUBLED a great deal by heterodyning when I tune in distant stations. It seems like I cannot get any distant stations, either west or east, without interference. Is there any way of tuning out one of the stations when the other is desired when the two are operating on the same frequency?

FRANCIS STOESEL,
Milwaukee, Wis.

(1)—Yes, there is one way. If you arrange the receiver so that it operates on a loop and an antenna at the same time and adjust the pick-up of the two so that they are equal you can entirely eliminate one of the stations provided that they are not in a straight line and on the same side of you. This is the same method used in direction finding at sea for eliminating the 180 degree uncertainty.

SCOTT WORLD'S RECORD

Build the 9,400-mile receiver. **SUPER 10** Listen in on all the world. Easy and economical to construct. Results guaranteed. Write today for free circuit diagram, parts list and copies of long distance reception verifications.

SCOTT TRANSFORMER CO.

7626 Eastlake Terr. Dept. E Chicago

FOUR WORLD'S RECORDS

★ SCOTT'S SUPER TEN ★

Official Service Station
Also for NEW Screen Grid **DIAMOND** of the AIR
Sets Built of Tested, Guaranteed Parts. Shipped Anywhere. Satisfaction Absolutely Guaranteed.
H. & F. RADIO LABORATORIES, Inc.
168 Washington Street New York City

BIG REWARDS!

Big rewards await you in Radio if you want to make more money quickly. Millions being made by others. Get your share NOW. Get complete facts. Send for FREE complete booklet and guide of money-making opportunities. Be first to get this. BARAWIK CO., Dept. 884, Chicago, U. S. A.

BLUEPRINT

and Instruction Sheet

for the Silver-Marshall

Shielded Grid Six

The New Receiver Utilizing the New Shielded Grid Tubes with Their Powerful Kick. **25 Cents**

Guaranty Radio Goods Co.
145 WEST 45TH STREET
NEW YORK CITY

Radio's Biggest Season Forecast by Polymet

Due to enormous business, the Polymet Mfg. Corp., manufacturers of filter and block condensers, bakelite moulded condensers, wire-wound resistances, etc., has been compelled to take over another floor at 599 Broadway, New York City.

This additional space will enable Polymet to increase manufacturing facilities and maintain service to the increasing number of radio receiver and power unit manufacturers who are adopting Polymet essentials as standard equipment.

This was the first public announcement made by Otto Paschkes, president, and Nat. C. Greene, vice-president, upon their return from abroad, where they surveyed radio conditions in England and on the continent.

The company issued a statement saying: "This optimistic announcement by one of radio's leading parts manufacturers is highly significant in the face of rumors of unsatisfactory conditions at the present time.

"It is no doubt true that many small manufacturers are plowing a hard row and will be unable to survive, but the announcement of expansion by the Polymet Mfg. Corp. proves that the industry is daily becoming more stabilized and that there is an ever-increasing demand for the products of dependable and financially strong manufacturers."

In commenting on the Polymet expansion program Mr. Greene said:

"Our growth has not been of the mushroom variety. Polymet is one of the pioneers in radio, but its growth has been steady and sure and built on that firmest of all foundations, the determination to produce and sell quality and service.

"The orders we now have on hand from these manufacturers convinces us that the radio business has only begun to grow and that next season will be one of the biggest in the history of the industry."

Accurate Panel Compilation

For those fans who wish to know which standard circuit panels may be procured from stock, all drilled and engraved and ready for use, Cortlandt Panel Engraving Co., 165 Greenwich Street, New York City, has carefully compiled a list containing this information. Every popular circuit is covered and exact dimensions are given.

It also contains a price list on all size

THE VERY UNIT FOR EXPONENTIAL HORNS

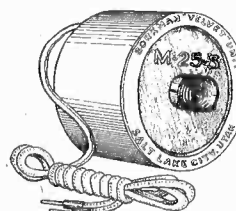

This purchase direct from the manufacturer permits us to offer this well known excellent unit at the special price of \$3.00. Satisfaction guaranteed. Money refunded if requested after a 5-day trial. Take advantage of this offer, send in your \$3.00 and receive a good unit for \$3.00. Little money.

Borkman Unit, Salt Lake City, Utah
Double Magnet Moving Armature
List Price, \$9.00

Suitable for the Exponential or the usual cabinet horn

Tested and Approved by Radio World Laboratories
N. Y. C. RADIO SALES CO.
2230 OCEAN AVENUE, BROOKLYN, N. Y.

THE A. C. KARAS EQUAMATIC—Full description, analytical article, in Feb. 11th and 18th issues. Send 30c for these issues and get free blueprint. Radio World, 145 West 45th St., N. Y. City.

EVERY FRIDAY at 5.40 P. M. (Eastern Standard Time) Herman Bernard, managing editor of Radio World, broadcasts from WGBS, the Gimbel Bros. station in New York, discussing radio topics.

plain panels of bakelite and hard rubber. A list of this kind is invaluable to fans and custom set builders and should be in the hands of everyone. It is also unique, insofar as we know, being the only one of its kind. It may be had for the asking by addressing the above concern and mentioning RADIO WORLD.—J. H. C.



POWER and QUALITY

With the introduction of the new UX250 and CX350 tubes, Silver-Marshall are ready with the new 681-250 and 682-250 Power Amplifiers. The 681-250 is a one stage power amplifier and may be added to any existing first stage audio system. The 682-250 is a complete AC operated two stage amplifier and may be connected directly to the detector output. Either model may be had completely wired or in kit form, ready to assemble. Model 681-250 kit, \$78.25; Model 682-250 kit, \$93.25. Wired models are \$15.00 additional.

SILVER-MARSHALL, Inc.
878 W. Jackson Blvd. Chicago, Ill.

POWERFUL UNIT

Drives Any Cone Speaker and Produces Delightful Tone at Great Volume

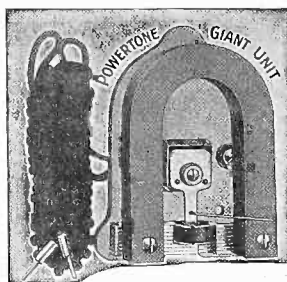

Try It for Five Days!

If not delighted with it, return it and your money will be refunded.

A Superb Creation
At a Price That
Fits All Purses **\$3.75**

QUARANTY RADIO GOODS CO.,
145 West 45th St., New York City.

Please send me one cone speaker unit as advertised. I will pay postman \$3.75, plus few cents extra for postage. Your 5-day money-back guaranty is accepted.

Name.....
Address.....
City..... State.....

CARTER

**Rheostats
Fixed Condensers
Jacks**

Used in the majority of popular circuits. Experienced designers realize nothing can successfully be used in place of Carter parts.



RECENT ISSUES of Radio World, 15c each. Be sure to give date of issue when writing. Radio World, 145 West 45th Street, New York City.

BRETWOOD

Variable Grid Leak
De Luxe Model

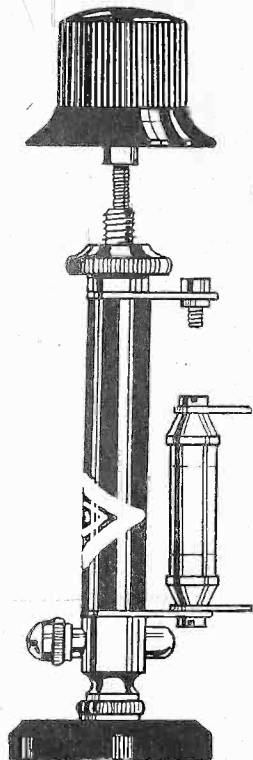

BETTER BY FAR, than any fixed leak in the detector circuit is the Bretwood Variable Grid Leak.

DON'T SEND A SOLITARY CENT!

The Bretwood Leak may be baseboard or panel mounted. Works the same in any position. No fluid used.

Guaranty Radio Goods Co.,
145 West 45th Street, N. Y. City

Please mail me at once one New and Improved 1928 Model De Luxe Bretwood Variable Grid Leak with one Bretwood Bullet Condenser attached, for which I will pay the postman \$2.25 on receipt. Both must be the genuine Bretwood articles, imported from England.

Name.....
Street Address.....
City..... State.....

FORTY TIMES as Much Amplification!

The New Shielded Grid 4 - TUBE DIAMOND OF THE AIR

Designed by H. B. HERMAN and described by him in the February 4, 11 and 18 issues of RADIO WORLD.

The favorite four-tube design, simple as can be, takes a great step forward, so that home constructors of radio receivers, and custom set builders, can build a distance-getting and voluminous set, the parts for which list remarkably low.

The new shielded grid tube is used as the radio frequency amplifier. That is why the amplification is boosted forty times over and above what it would be if an —0A tube were used instead.

Such simplicity of construction marks the receiver that it can be completely wired, skillfully and painstakingly, in two and a half hours.

All you have to do is to follow the official blueprint, and lo! a new world of radio achievement is before you! Distant stations that four-tube sets otherwise miss come in, and come in strong. No tuning difficulty is occasioned by the introduction of this new, extra powerful, startling tube, but, in fact, the tuning is simplified, because the signal strength is so much greater.

When you work from the official wiring diagram you find everything so delightfully simple that you marvel at the speed at which you get the entire receiver masterfully finished. And, then when you tune in—more marvels! 'Way, 'way up, somewhere around the clouds, instead of only roof high, will you find the amplification!

You'll be overjoyed. But you should place every part in exactly the right position. Stick to the constants given, and, above all, wire according to the blueprint!

Front Panel, Subpanel and Wiring Clearly Shown

When you work from this blueprint you find that every part is shown in correct position and every wire is shown going to its correct destination by the ACTUAL ROUTE taken in the practical wiring itself. Mr. Herman's personal set was used as the model. This is a matter-of-fact blueprint, with solid black lines showing wiring that is above the subpanel, and dotted lines that show how some of the wiring is done underneath.

Everything is actual size.

Not only is the actual size of the panel holes and instruments given, but the dimensions are given numerically. Besides, it is one of those delightful blueprints that novice and professional admire so much—one of those oh-so-clear and can't-go-wrong blueprints.

Be one of the first to send for this new blueprint, by all means, and build yourself this outstanding four-tube receiver, with its easy control, fine volume, tone quality, selectivity and utter economy. It gives more than you ever expected you could get on four tubes—and the parts are well within the range of anybody's purse.

The circuit consists of a stage of tuned RF shielded grid tube amplification, a regenerative detector, and two transformer coupled audio stages.

What a receiver!

\$1.00 for 27" x 27" Blueprint,

Send your order today!

RADIO WORLD,
145 West 45th St., N. Y. City.

Enclosed please find:

\$1.00, for which send me at once one official blueprint of the Shielded Grid Diamond of the Air, as designed by H. B. Herman, and described by him in the February 4, 11 and 18 issues of Radio World.
45 cents extra for Feb. 4th, 11th, 18th issues.

NAME
ADDRESS
CITY STATE

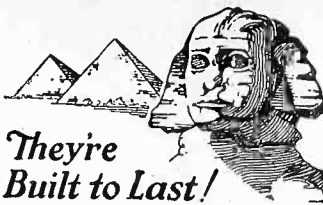

*They're
Built to Last!*

Don't throw away your CeCo Tubes because you've had them for a long time. They LAST for a long time--- they're built that way.

You get your full money's worth of service in every CeCo Tube and there's a type for every radio need.

Ask your dealer to help you choose the right types for your set.

C. E. Mfg. Co., Inc.
Providence, R. I., U.S.A.



Allow us to introduce to you the--

POWER CLAROSTAT

The big brother of the Clarostat family, intended for the heaviest jobs in radio layouts, in place of cumbersome and costly wire-wound resistors. Provides exact resistance value required for best results, rather than a crude approximation. Available in three ranges—0-10 ohms for filament and line-voltage control; 25-500 ohms for line-voltage control and certain voltage control; 200-100,000 ohms for voltage control in power units and electrified receivers. Resistance range covered in several turns of knob providing micrometric resistance. Noiseless operation. Slays put. Rated at 40 watts for handling heat work. Sold for \$3.50.

See the Power Clarostat at your dealer, as well as the other types of Clarostat. But be sure you are offered genuine Clarostats, in familiar green box and with name stamped on metal shell. And ask the dealer for literature, or write us direct.

American Mechanical Laboratories, Inc.
MEMBER RMA 285 North Sixth St.
Brooklyn, N. Y.

Acme Wire Company Announces New Line

The Acme Wire Company of New Haven, Connecticut, makers of the well-known Celatsite Wire and Parvot Condensers, announces a complete line of wound by-pass and filter condensers to meet every requirement of modern radio practice, including complete groupings of Filter condensers in handsome metal housings with lead-in-terminals designed for the more important AC and DC power supply units such as Samson, Thordarson, Hi-Q, Victoreen, Silver-Marshall and Amertran.

V. M. Tyler, president of the Acme Wire Company, says that this company has been studying the developments in electrified radio for several years and has spent a great deal of money in designing the special complete groups of housed amplification service.

Acme Parvot by-pass condensers are now available in all standard capacities and voltage ratings, while the Parvot Filter types are made in standard capacities and in ratings of 200, 400, 600 and 800, 1000 and 1500 volts. All are tested for sustained duty and not only meet the standards of the R. M. A. but have an added factor of safety self-imposed by Acme to overcome any possibility of breakdown from the sudden voltage surges expected in electrified radio.

For Best Results
With the
**SCREEN GRID
DIAMOND**
and other
Featured Circuits
Use only the
**HAMMARLUND
PARTS**
Specified by the Author
**For Better Radio
Hammarlund
PRECISION
PRODUCTS**

FILL OUT AND MAIL NOW
SUBSCRIPTION BLANK

RADIO WORLD

RADIO WORLD

145 West 45th Street, New York City
(Just East of Broadway)

Please send me RADIO WORLD for months, for which please find enclosed

SUBSCRIPTION RATES:
Single Copy \$.15
Three Months 1.50
Six Months 3.00
One Year, 52 Issues 6.00
Add \$1.00 a Year for Foreign Postage; 50c for Canadian Postage.

Hammer Moves Into Large, New Quarters

The growth of the Hammer Radio Co., formerly at 303 Atkins Avenue, Brooklyn, necessitated enlarged quarters and they are now located at 142 Liberty Street, New York City. A complete stock of standard parts in stock at all times, and all the popular kits are carried. They are distributors for Magnafomers, Scott Selectone Transformers for the Scott Super, Silver-Marshall and Sampson Power Blocks. Sets built from these well-known parts are on demonstration. Under the able leadership of S. Hammer, this house is prepared to render an even better and greater service to all branches of the trade. An enlarged mail order division is prepared to make prompt delivery on all orders.—J. H. C.

Super Oscillator

I WISH TO WIND an oscillator coil for a Super-Heterodyne to tune with a .0005 mfd. condenser. I have a Bakelite form 2 3/8 inch in diameter. What size of wire should I use and how many turns on each winding? I want to connect the condenser across only one winding.

RASMUS SORENSEN,
Duluth, Minn.

(1)—Use No. 28 DSC wire and wind 53 turns for the secondary, 40 for the tickler and 15 for the pick-up coil.

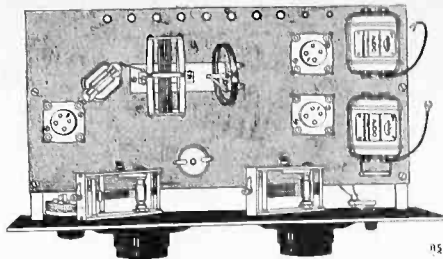

—It Reached Half Way 'Round the World!

THE KARAS 3-TUBE SHORT WAVE KIT

A short wave kit using the famous Karas parts—your guarantee of satisfaction! The Karas Micrometric dials are the only practical dials for short wave receivers—smooth, even tuning—free from backlash—made of Bakelite! Instantly applied; requires no drilling; only one set screw; two knobs—rough tuning and vernier. Also Karas Orthometric Variable Condensers, built of the finest materials under precision standards. Greater separation—broader tuning range! Build this new set! Get the complete kit at your dealer's or write to

—Includes These Famous Karas Parts:

- Karas Micrometric Dials, 0-100
- Karas .00025 Mfd. Variable Condenser, Orthometric
- Karas .00014 Mfd. Variable Condenser, Orthometric
- Karas Subpanel Brackets
- Karas Harmonik Transformers
- and all other parts by famous manufacturers!

Cost of Complete Kit:

\$58.95

KARAS ELECTRIC COMPANY

4039DA North Rockwell Street

CHICAGO

SMOOTHER POWER!

For "The Diamond of the Air" and other A.C. Sets, Aerovox Non-Inductive Condensers last longer and filter better.



AEROVOX
"BUILT BETTER"
70 Washington St., B'klyn, N. Y.

LYNCH
Resistors for every requirement of the fan builder and engineer.
ARTHUR H. LYNCH, Inc.
1775 Broadway N. Y. C.

You Need
"Vac-Shield"
for the New 222 Shield Grid Tube to Stabilize Your Set

THE invention of these non-magnetic shields for Type 201-A or the new Type 222 Tubes prevents inter-static coupling and electro-static effects, overcoming stray capacities that make tuning of distant stations so difficult. Just the thing to stabilize short-wave set, too. Attached in a minute. Order today by mail, C. O. D., \$1.00

ORANGE RESEARCH LABORATORIES
247-249 McKinley Avenue
East Orange, N. J.

Big 30 inch Cone Speaker
—Build it yourself and Make Money!

Here it is at last! A real 30-inch power cone for only \$6.50. The new Excelcone is unlike other impractical knocked-down cones on the market. Easy to build. Everything furnished and cut to exact dimensions. Simple illustrated instructions furnished impossible to go wrong. Beautiful clear and natural tone. Gets all the notes from highest piccolo note (frequency 4,096 per second) to the lowest bass tuba note (frequency 36 per second) without squeal, rattle, rumble or distortion. Cone handsomely lithographed in old rose and black harmonizing colors; base in beautiful brown frostene lacquer. Has sold in stores for \$32.50 assembled. Build it yourself and sell it to your friends.

Thousands of satisfied users. Send no money. Shipped C.O.D., plus express company charge. Indicate size and model desired.

30" Cone, Pedestal Type.....	\$7.50
30" Cone, Wall Type.....	6.50
22" Cone, Pedestal Type.....	7.25
22" Cone, Wall Type.....	6.00

MONMOUTH PRODUCTS COMPANY
887 E. 72nd St. Cleveland, Ohio

Quick Action Classified Ads

Radio World's Speedy Medium for Enterprise and Sales

10 cents a word — 10 words minimum — Cash with Order

SETS BUILT TO ORDER, modernized, repaired. Save money on kits and radio supplies. Write: Geibel, 1243 North 30th Street, Philadelphia, Pa.

FOR SALE

Madison-Moore "One Spot" 8 tube Superheterodyne in beautiful Fritz walnut cabinet. Flat loop. Matched Cunningham tubes. Guaranteed perfect. \$115.00. C. Sherwood, 225 Delaware St., Saginaw, Mich.

GUARANTEED Safety Razor, with strop, in neat, strong carrying case, 25 cents. First-class, new. Send coin, M. O. or stamps.—P. Cohen, 236 Varet Street, Brooklyn, N. Y.

NEW SHIELDED GRID TUBES for Diamond, S-M Six or Laboratory Super, Tyrman 70. Price \$5 each. Philip Cohen, 236 Varet St., Brooklyn, N. Y.

MAGNAVOX M7 cone speaker, List \$15, A1 condition, used two weeks. Fine tone. Price, including baffle, \$9. Send M. O. on 5-day money back guarantee. L. Andersen, 118 Goodrich St., Astoria, N. Y. City.

BE THE LICENSED RADIO DOCTOR in your community. \$7-\$10 spare time evenings. Our cooperative plan secures all the work you want. Secure franchised territory now. Write for booklet. Co-operative Radio Doctors, Dept. W, 131 Essex St., Salem, Mass.

RADIO BARGAIN BULLETIN. Sets and accessories less than wholesale. Unusual offering of standard new sets with factory guarantee. Get listing and save at least half. Columbia Sales, Box 362, Winona, Minn.

RADIO SETS built to order. Sets repaired. Superhets a specialty. Sweeney Radio Shop, Dept. RW, Pearsall, Texas.

LARGE MANUFACTURER of popular priced Radio Cabinets wants representatives selling radio dealers. Models listing at \$13 and up. Well made in large modern plant. Quantity sellers. Straight commission basis. For full details, address Drawer RW 10, Boonville, N. Y.

AIRPLANE SPEAKER OFFER—One piece airplane cloth 24x18, one piece 10x10, one can dope and apex, all sent for \$2.25 postpaid. Jefferson Mail Service, Box 184, Maplewood, N. J.

"RADIO THEORY AND OPERATING" by Mary Texanna Loomis, member Institute of Radio Engineers, Lecturer on radio, Loomis Radio College. Thorough text and reference book; 886 pages, 700 illustrations. Price \$3.50, postage paid. Used by Radio Schools, Technical Colleges, Universities, Dept. of Commerce, Gov't Schools and Engineers. At bookdealers, or sent on receipt check or money order. Loomis Publishing Company, Dept. RW, 405 9th St., Washington, D. C.

GUARANTEED Safety Razor, with strop, in neat, strong carrying case, 25 cents. First-class, new. Send coin, M. O. or stamps.—P. Cohen, 236 Varet Street, Brooklyn, N. Y.

"RADIOPHONE RECEIVING" by nine specialists, 75c postpaid. Halldorson copper-shielded transformers 3 1/2 to 1 ratio, \$1.25 postpaid. Wm. Wagner, 819 DeKalb Ave., Brooklyn, N. Y. C.

SEND NO MONEY

"Double R" Meters Improve Your Set

Use Them to Maintain Accurate Voltages and Currents So That Maximum Reception Efficiency is Assured

Pin Jack 0-6 Voltmeter for A Battery Measurement

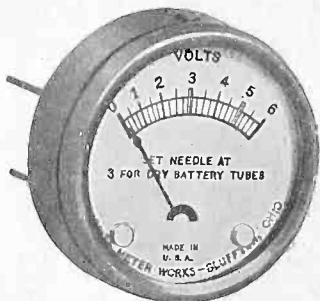

This 0-6 voltmeter, No. 306, is especially useful for the No. 25 and No. 28 Radiolas, because it is equipped with pin jacks which fit into the plugs with which those sets are provided. The meters may be used in any home-constructed set, too, where the builder desires to place tip jacks on the front panel, so the meter can be plugged in for obtaining reading. The meter may be kept permanently in circuit, if desired.

No. 306, 0-6 volts DC..... **\$2.50**

MULTI-TUBE SET MILLIAMMETER

Panel model. Recommended for sets having six tubes or more, particularly if a -71, -10 or -50 tube is used as the output. May be kept permanently in circuit. For DC measurements 0-100 milliamperes.

No. 396..... **\$1.65**

POCKET AMMETER

No. 1 For testing dry cells, 0-40 ampere DC scale pocket meter, \$1.50

POCKET AND PORTABLE VOLTMETERS

- No. 8 For testing A batteries, dry or storage, 0-8 volts DC scale.....\$1.65
- No. 10 For testing A batteries, dry or storage, 0-10 volts DC scale..... 1.65
- No. 13 For testing A batteries, dry or storage, 0-16 volts DC scale..... 1.65
- No. 50 For testing B batteries, dry or storage, but not for B eliminators, 0-50 volts DC scale..... 1.65
- No. 39 For testing B batteries, dry or storage, but not for B eliminators, 0-100 volts DC scale..... 1.85
- No. 40 For testing A and B batteries, dry or storage, but not for B eliminators; double reading, 0-8 volts and 0-100 volts DC scale..... 2.25
- No. 42 For testing B batteries, dry or storage, but not for B eliminators; 0-150 volts DC scale..... 2.00
- No. 348 For testing AC current supply line, portable, 0-150 volts..... 4.50

VOLTMETERS

- No. 18 For testing amperage of dry cell A batteries and voltage of dry or storage A batteries, double reading, 0-8 volts, and 0-40 amperes DC..\$1.85
- No. 35 For testing amperage of dry cell A batteries and voltage of B batteries (not B eliminators); double reading, 0-50 volts, 0-40 amperes DC.. 2.00

Also Track Down Trouble in a Jiffy and Permanently Cure It with the Aid of These Fine Meters

It is absolutely necessary to use a high resistance voltmeter in measuring the voltage of B eliminators, either across the total output or at any intermediate voltage. A low resistance meter at least partly short-circuits the eliminator and causes the voltage reading to be away off. Sometimes the reading is as little as 25 per cent of the total actual voltage.

All "Double R" meters are accurate to 2 1/2 per cent, plus or minus, and all, except the ammeters Nos. 1 and 338, may be kept permanently in circuit.

Panel meters take 2 5/64-inch hole.

Our Complete Meter Catalogue is contained in this advertisement.

TROUBLE-SHOOTING TEST SET

The best inexpensive combination for trouble-shooting is a "Double R" Tube Checker, comprising a 0-10 milliammeter, a 0-6 voltmeter, a switch, a rheostat and a socket. Add a high resistance voltmeter (0-300 or 0-500 v.). With these it is advisable to use a plug, so that all you need do is remove a tube from a receiver that you're testing, put the plug in the empty socket and the removed tube in the socket of the tester. You can immediately find any open or short circuits, broken or flimsy connections, reversed connections, etc.

The "Double R" Cord and Plug, and the "Double R" Tube Checker are shown with high resistance meter.

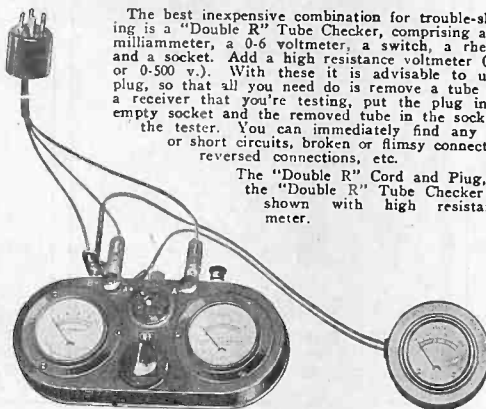

SERVICE MEN!

- No. 210 Tube Checker, consists of 0-6 volts DC Voltmeter, 0-10 DC Milliammeter, Grid Bias Switch, Rheostat, Socket, Binding Posts (with instruction sheet)..... \$6.60
- No. 21, cord and plug. For connecting meters in A and B leads of a receiver without any disconnections. Terminals correspond with posts on No. 210 tube checker..... \$1.85
- No. 346 DC Voltmeter (high resistance)..... \$4.50
- No. 347 DC Voltmeter (high resistance)..... \$5.50

The cord terminals of the plug leads correspond with the binding posts of the tube checker.

Now connect the 0-300 or 0-500 volts high resistance voltmeter from A-4 to B-4 posts and you get all necessary readings. You can test plate voltage from B eliminators, or any other B supply, DC plate current and DC filament voltage, as well as the efficiency of the tube, by throwing the grid bias switch, for the plate current should change within given limits, depending on the type of tube.

Equip your testing outfit with the indispensable combination that constitutes the Trouble Shooting Test Set and Time-Saver. You quickly locate trouble while others fumble about.

- Complete Combination Nos. 21 and 210 (with 0-300 Voltmeter, No. 346)..... \$12.00
- Complete Combination Nos. 21 and 210 (with 0-500 Voltmeter, No. 347)..... \$13.00

PANEL VOLTMETERS

- No. 335 For reading DC voltages, 0-8 volts..... \$1.65
- No. 310 For reading DC voltages, 0-10 volts..... 1.65
- No. 316 For reading DC voltages, 0-16 volts..... 1.65
- No. 337 For reading DC voltages, 0-50 volts..... 1.65
- No. 339 For reading DC voltages, 0-100 volts..... 1.75
- No. 342 For reading DC voltages, 0-150 volts..... 1.75
- No. 340 For reading DC voltages, double reading, 0-8 volts, 0-100 volts..... 2.25

High Resistance Meters for B Eliminators

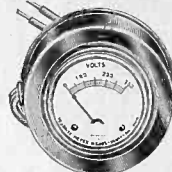

Here is the meter you've been wishing for! A 0-300 DC voltmeter with a very high resistance. Specially made that way so it will test the output voltages, from maximum to any intermediate voltage, of any B eliminator or grid biasing resistor. It also makes all the measurements of any other meter of its voltage range, hence will give correct readings of B batteries, C batteries, cells, or any other DC voltage source not exceeding 300 volts. Full nickel finish. Portable type (fits in sack coat pocket easily). Accurate to 2 1/2 per cent, plus or minus. Fully guaranteed. Requires 35 different dyes to make. Furnished with long connecting cords and convenient tips. May be kept permanently in circuit.

No. 346..... **\$4.50**
 [Note: 0-500 volts, instead of 0-300 volts, is No. 347. Tests ALL power packs—Price \$5.50.]

PANEL VOLTMETER FOR A BATTERIES

One of the most popular meters, the 0-6 panel voltmeter, DC. May be kept permanently in circuit. Panel model.



No. 326..... **\$1.65**

PANEL AC VOLTMETERS

- No. 351 For reading 0-15 volts AC..... \$2.25
 - No. 352 For reading 0-10 volts AC..... 2.25
 - No. 353 For reading 0-6 volts AC..... 2.25
- (See No. 348 under "Pocket and Portable Voltmeters.")

PANEL MILLIAMMETERS

- No. 311 For reading 0-10 milliamperes DC..... \$1.95
- No. 325 For reading 0-25 milliamperes DC..... 1.85
- No. 350 For reading 0-50 milliamperes DC..... 1.65
- No. 399 For reading 0-300 milliamperes DC..... 1.65
- No. 394 For reading 0-400 milliamperes DC..... 1.65

DC PIN JACK VOLTMETERS

- No. 308 For No. 20 Radiola, 0-6 volts DC..... \$2.50
- No. 307 Desk type voltmeter with cord, 0-6 volts DC..... 2.50

6-VOLT A BATTERY CHARGE TESTER

- No. 23 For showing when 6-volt A battery needs charging and when to stop charging; shows condition of battery at all times..... \$1.85

PANEL AMMETER

- No. 338 For reading amperage, 0-10 amperes DC..... \$1.65

GUARANTY RADIO GOODS CO., 145 W. 45th St., N. Y. City.
 Please send at once your meters, catalogue numbers:

for which I will pay postman advertised price plus few cents postage.

Name.....

Address.....

City..... State..... RW-28

ALL METERS SOLD ON FIVE-DAY MONEY-BACK GUARANTY.

SEND NO MONEY

"Double R" Meters Improve Your Set

Use Them to Maintain Accurate Voltages and Currents So That Maximum Reception Efficiency is Assured

Pin Jack 0-6 Voltmeter for A Battery Measurement

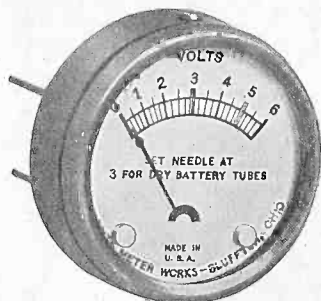

This 0-6 voltmeter, No. 306, is especially useful for the No. 25 and No. 28 Radiolas, because it is equipped with pin jacks which fit into the plugs with which those sets are provided. The meters may be used in any home-constructed set, too, where the builder desires to place tip jacks on the front panel, so the meter can be plugged in for obtaining reading. The meter may be kept permanently in circuit, if desired.

\$2.50

MULTI-TUBE SET MILLIAMMETER

Panel model. Recommended for sets having six tubes or more, particularly if a -71, -10 or -50 tube is used as the output. May be kept permanently in circuit. For DC measurements 0-100 milliamperes.

No. 390

\$1.65

POCKET AMMETER
No. 1 For testing dry cells, 0-40 ampere DC scale pocket meter. \$1.50

POCKET AND PORTABLE VOLTMETERS
No. 8 For testing A batteries, dry or storage, 0-8 volts DC scale \$1.65
No. 10 For testing A batteries, dry or storage, 0-10 volts DC scale 1.65
No. 13 For testing A batteries, dry or storage, 0-16 volts DC scale 1.65
No. 50 For testing B batteries, dry or storage, but not for B eliminators, 0-50 volts DC scale 1.65
No. 39 For testing B batteries, dry or storage, but not for B eliminators, 0-100 volts DC scale 1.85
No. 40 For testing A and B batteries, dry or storage, but not for B eliminators; double reading, 0-8 volts and 0-100 volts DC scale 2.25
No. 42 For testing B batteries, dry or storage, but not for B eliminators; 0-150 volts DC scale 2.00
No. 348 For testing AC current supply line, portable, 0-150 volts 4.50

VOLTMETERS
No. 18 For testing amperage of dry cell A batteries and voltage of dry or storage A batteries, double reading, 0-8 volts, and 0-40 amperes DC. \$1.85
No. 35 For testing amperage of dry cell A batteries and voltage of B batteries (not B eliminators); double reading, 0-50 volts, 0-40 amperes DC. 2.00

Also Track Down Trouble in a Jiffy and Permanently Cure It with the Aid of These Fine Meters

It is absolutely necessary to use a high resistance voltmeter in measuring the voltage of B eliminators, either across the total output or at any intermediate voltage. A low resistance meter at least partly short-circuits the eliminator and causes the voltage reading to be away off. Sometimes the reading is as little as 25 per cent of the total actual voltage.

All "Double R" meters are accurate to 2 1/2 per cent, plus or minus, and all, except the ammeters Nos. 1 and 338, may be kept permanently in circuit.

Panel meters take 2 5/64-inch hole.

Our Complete Meter Catalogue is contained in this advertisement.

High Resistance Meters for B Eliminators

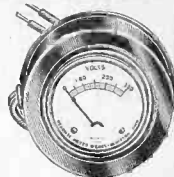

Here is the meter you've been wishing for! A 0-300 DC voltmeter with a very high resistance. Specially made that way so it will test the output voltages, from maximum to any intermediate voltage, of any B eliminator or grid biasing resistor. It also makes all the measurements of any other meter of its voltage range, hence will give correct readings of B batteries, C batteries, cells, or any other DC voltage source not exceeding 300 volts. Full nickel finish. Portable type (fits in sack coat pocket easily). Accurate to 2 1/2 per cent, plus or minus. Fully guaranteed. Requires 35 different dyes to make. Furnished with long connecting cords and convenient tips. May be kept permanently in circuit.

\$4.50

[Note: 0-500 volts, instead of 0-300 volts, is No. 347. Tests ALL power packs—Price \$5.50.]

PANEL VOLTMETER FOR A BATTERIES

One of the most popular meters, the 0-6 panel voltmeter DC. May be kept permanently in circuit. Panel model.



\$1.65

No. 326

PANEL AC VOLTMETERS
No. 351 For reading 0-15 volts AC \$2.25
No. 352 For reading 0-10 volts AC 2.25
No. 353 For reading 0-6 volts AC 2.25
(See No. 348 under "Pocket and Portable Voltmeters.")

PANEL MILLIAMMETERS
No. 311 For reading 0-10 milliamperes DC \$1.95
No. 325 For reading 0-25 milliamperes DC 1.85
No. 350 For reading 0-50 milliamperes DC 1.65
No. 399 For reading 0-300 milliamperes DC 1.65
No. 394 For reading 0-400 milliamperes DC 1.65

DC PIN JACK VOLTMETERS
No. 308 For No. 20 Radiola, 0-6 volts DC \$2.50
No. 307 Desk type voltmeter with cord, 0-6 volts DC 2.50

6-VOLT A BATTERY CHARGE TESTER
No. 23 For showing when 6-volt A battery needs charging and when to stop charging; shows condition of battery at all times \$1.85

PANEL AMMETER
No. 338 For reading amperage, 0-10 amperes DC \$1.65

TROUBLE-SHOOTING TEST SET

The best inexpensive combination for trouble-shooting is a "Double R" Tube Checker, comprising a 0-10 milliammeter, a 0-6 voltmeter, a switch, a rheostat and a socket. Add a high resistance voltmeter (0-300 or 0-500 v.). With these it is advisable to use a plug, so that all you need do is remove a tube from a receiver that you're testing, put the plug in the empty socket and the removed tube in the socket of the tester. You can immediately find any open or short circuits, broken or flimsy connections, reversed connections, etc.

The "Double R" Cord and Plug, and the "Double R" Tube Checker are shown with high resistance meter.

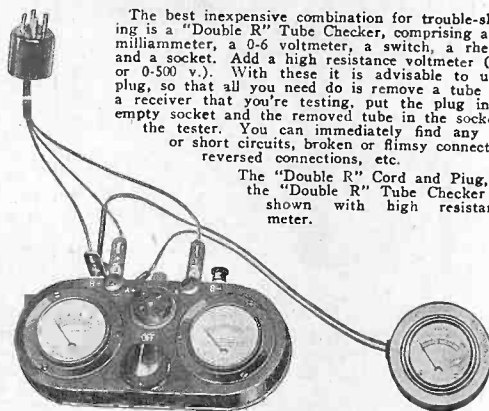

SERVICE MEN!

No. 210 Tube Checker, consists of 0-6 volts DC Voltmeter, 0-10 DC Milliammeter, Grid Bias Switch, Rheostat, Socket, Binding Posts (with instruction sheet) \$8.50
No. 21, cord and plug. For connecting meters in A and B leads of a receiver without any disconnections. Terminals correspond with posts on No. 210 tube checker. \$1.85
No. 346 DC Voltmeter (high resistance) \$4.50
No. 347 DC Voltmeter (high resistance) \$5.50
The cord terminals of the plug leads correspond with the binding posts of the tube checker.

Now connect the 0-800 or 0-500 volts high resistance voltmeter from A+ to B+ posts and you get all necessary readings. You can test plate voltage from B eliminators, or any other B supply, DC plate current and DC filament voltage, as well as the efficiency of the tube, by throwing the grid bias switch, for the plate current should change within given limits, depending on the type of tube. Equip your testing outfit with the indispensable combination that constitutes the Trouble Shooting Test Set and Time-Saver. You quickly locate trouble while others flounder about.

Complete Combination Nos. 21 and 210 (with 0-300 Voltmeter, No. 346) \$12.00
Complete Combination Nos. 21 and 210 (with 0-500 Voltmeter, No. 347) \$13.00

PANEL VOLTMETERS
No. 335 For reading DC voltages, 0-8 volts \$1.65
No. 310 For reading DC voltages, 0-10 volts 1.65
No. 316 For reading DC voltages, 0-16 volts 1.65
No. 337 For reading DC voltages, 0-50 volts 1.65
No. 339 For reading DC voltages, 0-100 volts 1.75
No. 342 For reading DC voltages, 0-150 volts 1.75
No. 340 For reading DC voltages, double reading, 0-8 volts, 0-100 volts 2.25

GUARANTY RADIO GOODS CO., 145 W. 45th St., N. Y. City.

Please send at once your meters, catalogue numbers:

for which I will pay postman advertised price plus few cents postage.

Name

Address

City State RW-28

ALL METERS SOLD ON FIVE-DAY MONEY-BACK GUARANTY.