

RADIO WORLD

REG. U.S. PAT. OFF.

*Holiday Gifts
Number*

15¢

December 10



*The
Caroler*



MAGNAVOX

Speaker Quality

Plus

for the Electric Set and Electric Phonograph Builder

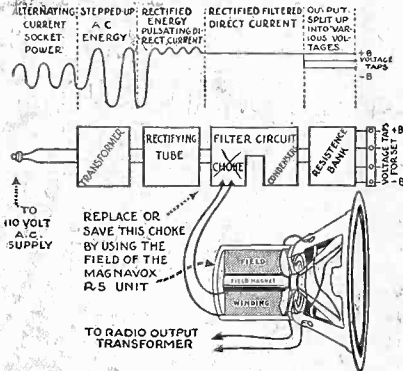

The field of the Magnavox type R-5 Electro-dynamic speaker unit provides the highest class high resistance choke for A. C. rectifier and filter units. The current passed energizes the field for its function as a speaker.

Only the electro-dynamic type speaker can give the wonderful quality of radio reception possible with modern sets and broadcasting.



Magnavox R-5 Electro-dynamic Speaker-Unit Price \$55.00

Easily installed in radio or phonograph cabinets.

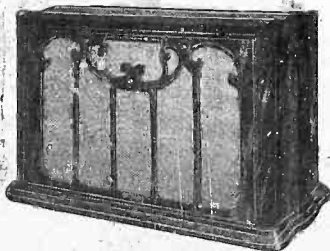

Beverly Model

Table type cabinet, mahogany finish, curved top, equipped with R-5 Unit \$80. Aristocrat model, floor type, butt burl walnut panels, two tone mahogany legs and corners, equipped with R-5 unit \$90.

Write for full description of this and other units and complete electro-dynamic type speakers.

THE MAGNAVOX CO.
Oakland California
1315 So. Michigan Ave. Chicago

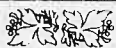

The GENERAL RADIO

TYPE 441

Push-Pull Amplifier

In search for an amplifier combination which would give the maximum in quality and volume, the push-pull method has proved particularly satisfactory.

While push-pull transformer coupling does not increase the amplification per stage, the maximum undistorted power output is greatly increased. The reason for this is that distortion due to tube overloading cancels out, permitting a greater output from each tube than would be possible if the tubes were used as in other methods of coupling. A further advantage of push-pull amplification when using an A.C. filament supply is that hum voltages also cancel out, rendering the amplifier very quiet.

The type 441 unit with two type 171 power tubes having a plate voltage of 180 will give more volume and better quality than a single transformer coupled stage using the type 310 power tube with 400 volts on the plate.

The General Radio Type 441 unit is completely wired and mounted (as illustrated) on a brass base-board with conveniently located binding posts so that the unit may be built into a receiver or connected with an existing set as a separate unit.

The type 441 may be used with either the UX-226, UX-326, or UX-171, CX-371 tubes.

Type 441 Push-Pull Amplifier\$20.00

The type 441 unit is licensed by the Radio Corporation of America for radio amateur, experimental, and broadcast reception, and under the terms of the R. C. A. license the unit may be sold only with tubes.

Type UX-226 or CX-326 Amplifier Tube\$3.00

Type UX-171 or CX-371 Amplifier Tube\$4.50

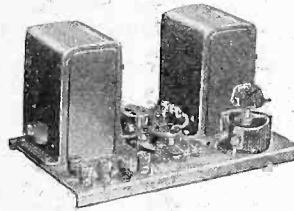

GENERAL RADIO COMPANY

CAMBRIDGE, MASS.

\$12.50
Complete

The Pacent PHONOVOX gives new enjoyment to your favorite records

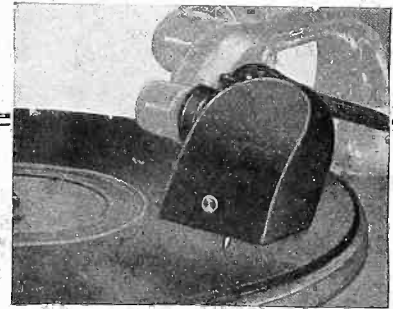

ATTACH the Pacent Phonovox, the better phonograph pick-up device, to your radio and phonograph! Play one of your favorite records! The wonderful tone quality of reproduction will amaze and delight you, giving you, at a small cost of \$12.50, the equivalent in reproduction of

the costly electric phonograph. Your dealer will gladly demonstrate the Phonovox and show you how easily and quickly it is attached without tools or changes in wiring. All good radio and phonograph dealers handle the Phonovox. Ask for it by name and accept no substitute.

Sold and demonstrated by dealers everywhere

PACENT RADIO CORPORATION

156 West 16th Street

New York

Makers of the famous Pacent Balanced Cone

Guaranteed "A" Power Unit—\$13.75

No better "A" Socket Power Unit can be obtained even at twice this amazingly low price. No hum or noise. Operates on 50 or 60 cycles at 110 volts A. C. Approved by rigid laboratory tests of Radio News and Popular Radio. Fully guaranteed. Shipped complete, subject to inspection, on receipt of price—or C.O.D. if you wish. 5% discount if cash in full is sent with order. Send order NOW! WORLD BATTERY CO., 1219 South Wabash Ave., Dept. 64, Chicago, Ill.

RADIO MAILING LISTS AND SALES COPY

We furnish all classification of lists—and write copy for Sales Letters, Folders, Catalogues, Ads for the Radio and Auto Industries. Outline your proposition for FREE suggestions.

FAULTLESS ADVERTISING SERVICE.

430 Quincy Bldg., Chicago, Ill.

RADIO WORLD

REG. U.S. PAT. OFF.

A Weekly Paper Published by Hennessy Radio Publications Corporation, from Publication Office, 145 West 45th Street, New York, N. Y.
Phone: BRyant 0558 and 0559

[Entered as second-class matter, March, 1922, at the post office at New York, N. Y., under Act of March, 1879]

My Three Months With the Magnaformer 9-8

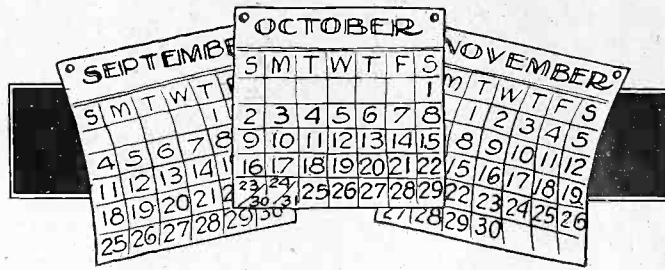

By *J. E. Anderson*

Technical Editor

IT humbles that implacable enemy, "Distance." It disciplines stations by the rule of "One at a time." It silences one bragging set owner after another. It is the circuit I played with, worked against, tested, tried, used and abused for three solid months—the Magnaformer 9-8, and it is outstanding in performance, almost beyond belief.

The receiver is long on distance, short on interference, keen on selectivity, fine on fidelity, and great on volume. It covers the ground from 600 to 200 meters with a gentle stride and a slightly twisting motion. It tells the broadcast stations as it goes, thus: KSD, WHO, KYW, WCAE, WIP, WBAP, WFAF, and so on down to WRAH. To be sure, it brings them in with differing volume, but with a simple touch of a knob the volume of any one can be changed from the softest pianissimo to the most roaring fortissimo. The receiver is completely at the disposal of the operator and ready to deliver any signal at any volume any home may demand.

It is satisfying to know that one's receiver is capable of annihilating distance,

that through it far-away stations will pop in just like locals, that friends and neighbors come to listen to it even though they all have receivers of their own. It is still more satisfying to know that it has been designed correctly, that it is ahead of the times, and that it is surpassing because it was designed and built to win.

It Does All You Ask

It is satisfying to know that with it you have space at your mercy, that you have the power to command it to shrink, to put the remotest broadcast station in your back yard, and to banish the station across the street to a place across the continent.

I built the receiver, but not until I had heard it, seen it, studied it, worked it. I did not build it until the set had impressed itself favorably by actual performance. And the building was easy, pleasant pastime, that consisted of assembling into a unified whole beautiful parts that fitted exactly both physically and electrically. It was like play, so devoid of the usual difficulties of marking, punching, drilling,

and countersinking. With little effort there loomed a receiver beautiful to see, entrancing to hear, and a worthy object of pride.

The double detection system of radio reception, as used in the Magnaformer 9-8, has always appealed to my sense of the logical as the optimum, the non plus ultra, in radio. It has always given promise of the maximum of desirable qualities and of the minimum of radio ills. It has offered the greatest sensitivity, the keenest selectivity, the firmest reliability, the most realistic quality and the least interference.

Magnaformer's DX Breaks Records

Yes, the system, and particularly the Magnaformer—the receiver pictured on the front cover—has justified itself eloquently and forcefully. K. G. Ormiston, of Los Angeles, with a party of friends, pulled in Tokio, Japan, and Sydney and Melbourne, Australia, on the loudspeaker, using only eight of the nine tubes. This was on Sept. 11, 1927, while Summer conditions still prevailed. R. C. Anderson, a

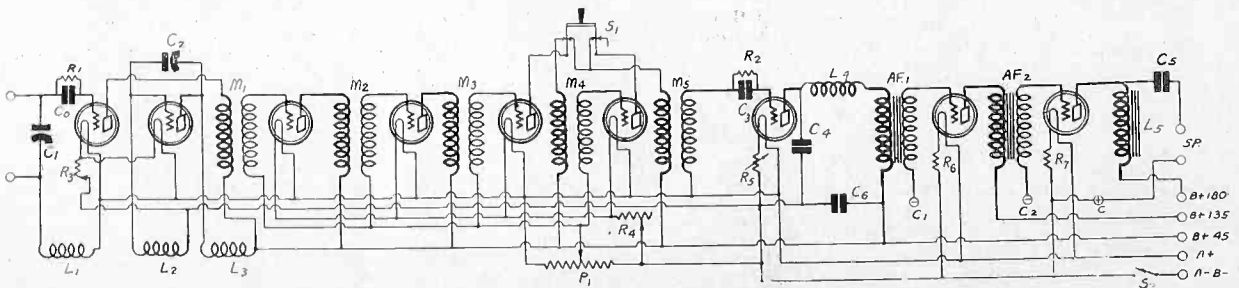

THE CIRCUIT DIAGRAM OF THE MAGNAFORMER 9-8 RECEIVER

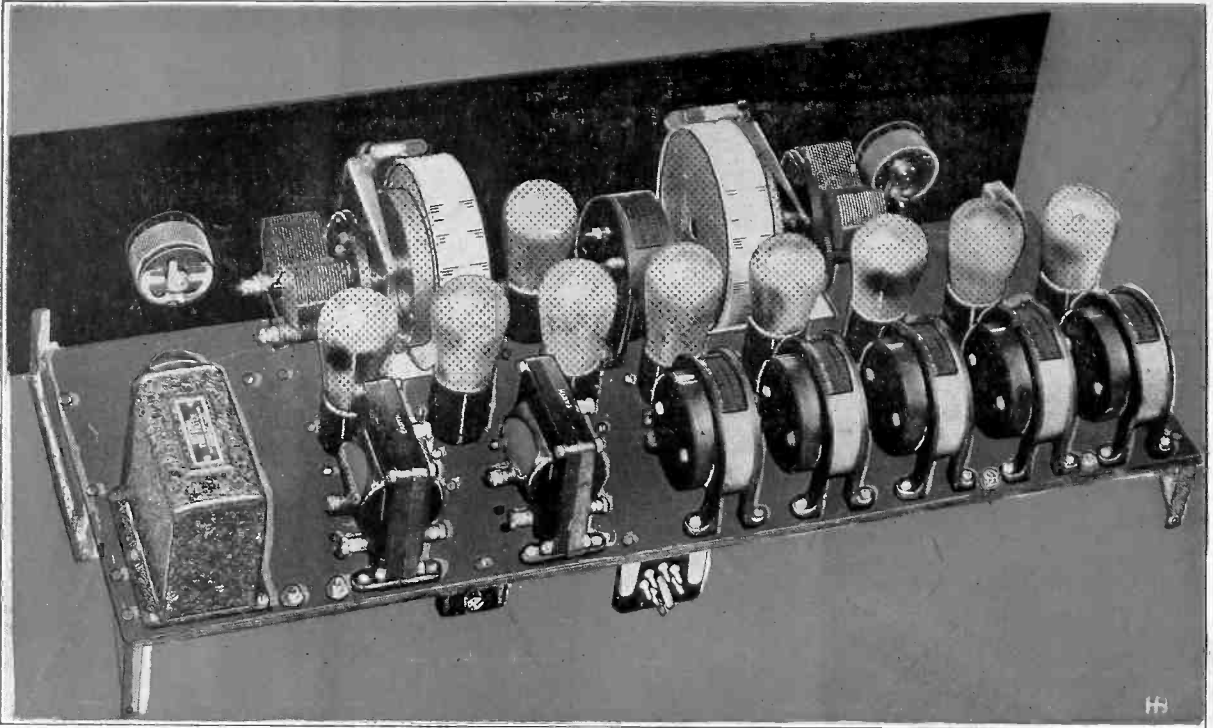

DRAWN UP IN PERFECT ALIGNMENT BEFORE THE OSCILLATOR ARE THESE TWO SQUADS OF SPACE-FIGHTING AMPLIFIERS. THEY GET THEIR STATION EVERY TIME NO MATTER WHERE IT MAY BE LOCATED, AND THEY GET IT IN VOLUME APLENTY. THE QUALITY OF THE SIGNAL THEY BRING IN IS AS SPIC AND SPAN AS THE MEMBERS OF THE COMPANY ITSELF. AN ACTUAL VIEW OF THE MAGNAFORMER AS IT APPEARS FROM THE REAR BEFORE THE TUBES HAVE BEEN INSERTED.

Long Beach jeweler, on Nov. 5, 1927, with a home-built Magnaformer 9-8, pulled in with loudspeaker volume stations from 6,000 to 9,000 miles away, some of which were 1YA, Auckland, New Zealand; 2BL, Sydney, Australia; 5CL, Adelaide, Australia; JOAK, Tokio, Japan; Jock, Nagoya, Japan; and 61 long distance stations in the western hemisphere scattered from the Atlantic to the Pacific.

One evening in Chicago, when all the powerful local stations were going full blast, J. M. Douglas, with a home-built Magnaformer 9-8, pulled in 32 out-of-town stations without the slightest interference from the locals.

So many have had such remarkable results with the Magnaformer 9-8 receiver that these cases are typical rather than outstanding examples. And it makes no difference where the receiver is set up—on the West Coast, on the Atlantic seaboard, in the mountain regions, on the great plains, in the city or in the country—the performance is consistently record-breaking.

What is remarkable about this power of overcoming distance is that the programs pulled in from remote points are enjoyable. On the cover of this issue is depicted a man and his wife enjoying a radio program as brought in with the Magnaformer 9-8, and the program might have originated in Buenos Ayres or Tokio!

Has this system of reception justified its appeal and its promises by actual performances? It has in every way. The superiority of the system is not confined to mathematical abstractions but ascends to the plane of reality. The system has been proved unbeatable by thousands of intelligent observers; it has been fortified by imposing facts and by evidence of all-surpassing superiority.

What It Is

What is this double detection system of reception that stands out above all others? It is that system of reception

which employs a selector and amplifier at radio frequency, which embodies a local oscillator and a first detector to change the frequency, which employs an intermediate frequency amplifier, and which finally rectifies the signal and amplifies it at audio frequency.

Do all receivers that employ the double detection method of operation fulfill the promises which the system makes? Far from it! There are some examples of application of the principle of double detection which fall far short of the promises. Some lack selectivity, others have too much of it; some lack sensitivity, others pick up more noise than signals when the sensitivity is high; some lack volume and quality, others are difficult to tune and to control.

But circuits employing this method of detection and amplification which do not perform according to the promises of the system have not been properly engineered. They have been tossed together in a haphazard and unintelligent manner. Some people have lost confidence in the system because of their experiences with receivers of this kind, though their own intelligence tells them that there is nothing superior to it.

How Success Is Won

But there are some circuits of the type which have been designed in strict observance of scientific principles and laboratory facts—circuits which have been engineered intelligently and painstakingly. These receivers fulfill all the promises of the system; and they do it in direct proportion to the degree in which the engineers and designers understood their problem, to the closeness with which their specifications conformed with the requirements of the correct solution to the problem, to the correct co-ordination of all the component parts, and to the scrupulousness with which they kept faith with the public.

The most satisfying example of this system of reception came to my attention

about three months ago. It was a receiver of exceptionally distinguished appearance. I thought to myself that it would be a travesty on the radio art if that receiver was not as outstanding in performance as it was in appearance. But I was skeptical, for I had had previous experience with radio incongruities. Claims of record-smashing performance made for it, seemingly extravagant, were smile-provocative. But I worked the set. Skepticism gave way, not to utter credulity, but to set-building interest. I would build it, analyze it, measure its properties, pit it against other sets.

Finishing Touch by Physician

When all the components had been mounted and the wiring was ready for the finishing touches, a friend of mine, a physician of national repute, came around.

"What's new in radio?" was his first query after the usual friendly greetings.

"Oh, I don't know, nothing much," I stilled, knowing full well that in a moment he would spot the magnificent receiver I was building.

"What's that, another Super-Heterodyne?" he demanded as soon as he spotted the receiver in the making.

"Oh, that is the Great Recreator, a receiver for which I have high hopes," said I, permitting a bit of my enthusiasm to leak out.

In response to this he made a few comments which showed that his radio enthusiasm ran high. He demanded peremptorily to hear the new set work, but when he learned that the set was not completely wired, he insisted on finishing that part himself. Reluctantly I acceded. No sooner had I said "Go ahead" than he had the soldering iron in the socket and all the requisites on the work bench.

"Like an X-Ray," Says Doctor

He finished the wiring. I merely watched him. He followed the part-to-part wiring diagram line for line and did not miss a lead or a joint.



A BEAUTIFUL RADIO CABINET AND THE MAGNAFORMER RECEIVER GO WELL TOGETHER, AS THIS PHOTOGRAPH CLEARLY SHOWS. MANY PREFER THIS TYPE OF INSTALLATION, PARTICULARLY WHEN THEY ALREADY HAVE A SUITABLE TABLE ON WHICH TO PUT THE RECEIVER.

"Like an X-ray," he commented as he pointed to the diagram.

He checked off the part of the wiring that he did. Then he examined the set for any neglected terminals. There was none.

"Well," he exclaimed when he was satisfied that all had been done, "I think she is ready to go."

And she was.

A few moments later we had the batteries, the loop and the loudspeaker connected.

We literally cut the broadcast spectrum to shreds with the selectivity of that set, we brought in stations with the score with the sensitivity of it, we "raised the roof" with the volume of it, and we shamed the quality of the best receiver in the neighborhood with it. My medical friend paid the circuit a great compliment when he said, somewhat dejectedly:

"I thought I had a great set." Some hours later, on leaving, he remarked: "I'm going to have the duplicate of that set in my office in a few days!"

And now after three months of experience with the Great Recreator, what is the final report?

What?

Well, exactly what was said in the beginning.

Advice on Construction

The official X-Ray diagram in colors, 24 inches by 36 inches, may be obtained complimentary by addressing me at Radio World, 145 West 45th St., N. Y. City, or by sending direct to Radiart Laboratories, 19 South LaSalle St., Chicago, Ill. On a smaller scale it is reproduced in black and white herewith.

It is strongly urged that the specified parts and none other be used.

Study the layout and instruction sheet. Not much study is necessary, for the layout is extremely simple and orderly, and every part fits in its own place and nowhere else. The main thing to watch out for is that transformers and sockets are not mounted backwards, or on the wrong side of the sub-panel. If they are so mounted no harm will have been done, but it is very annoying to have to do the work over again in penalty for a slight oversight.

There are many reasons why no substitutions of parts should be made. In the first place the panel and the sub-panel have been drilled, and the various dimensions have been gauged for the parts specified, and if others are used the layout

has to be altered. Then again, the parts used have been chosen for their electrical characteristics, which dovetail so that the overall characteristic of the circuit is as nearly perfect as scientific design and laboratory methods can produce.

The substitution of any other part for one specified would upset the balance and could only result in inferior results.

Work Made Pleasant, Easy

Those who derive pleasure out of the sweat of their brows may buy their panel

and sub-panel in the rough and do their own laying out and drilling. Thereby they can save a few cents and gain a little exercise, but they will lose one or two evenings of enjoyable broadcast reception with the set. The wiser and more experienced fans will get the Formica panel and sub-panel ready drilled and engraved. They will get a better looking receiver when the pleasant work is done, and they will most likely get a more efficient receiver on account of the greater accuracy of the layout.



THE MAGNAFORMER, THE GREAT RECREATOR, INSTALLED IN A HANDSOME CONSOLE IS AN ORNAMENT IN THE HOME AS WELL AS A CONSTANT SOURCE OF ENTERTAINMENT AND PLEASURE. THE DIGNIFIED SIMPLICITY OF THE PANEL LAYOUT ENHANCES THE ATTRACTIVENESS OF THIS RADIO CONSOLE.

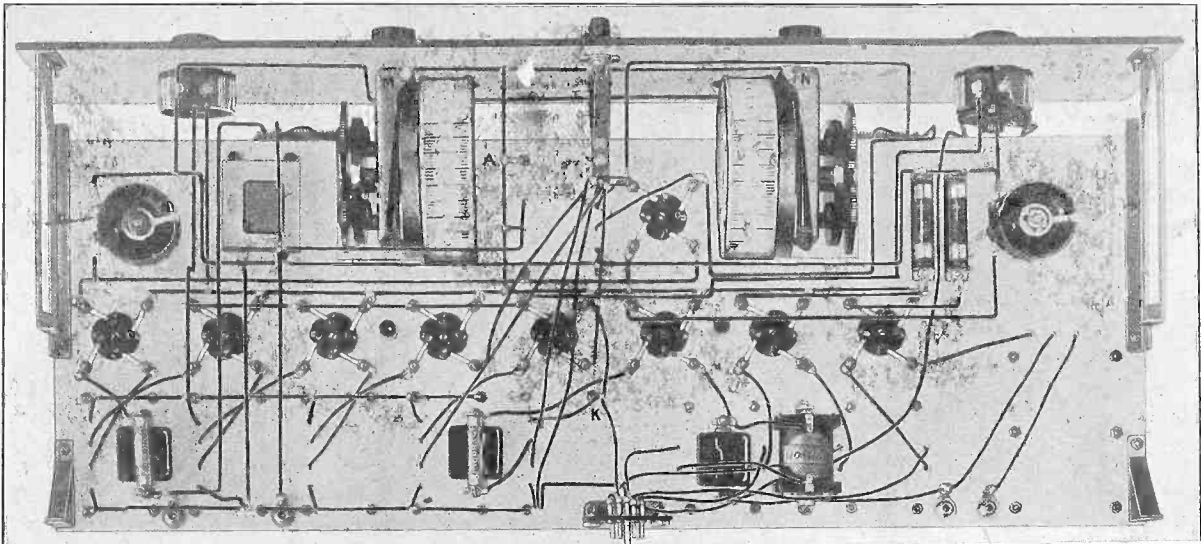

THE SUBPANEL VIEW OF THE COMPLETED MAGNAFORMER, INCLUDING FULL WIRING.

The mounting of the parts on the drilled panel and sub-panel is just one bolt and nut after another. The proper length, size and number of screws are furnished with every part, as well as a nut or two for every screw. To mount all the parts with neatness a socket wrench for holding the nut and a screwdriver for turning the screw should be provided.

Make sure that all the parts that go on the sub-panel are in place before running any of the wires. It may be necessary to remove one part to get another more easily in place. This is easier before any wiring has been done than after. However, if the builder scrupulously follows the printed directions this possibility will not occur, because the directions give the exact order in which to mount the parts.

Which Side Is Which

Here is a precaution which may prevent mounting the sockets and the transformers on the wrong side of the sub-panel. Before anything has been mounted it is

not easy to tell which side should be to the left and which to the right.

The only obvious thing is that the square indentures should be toward the front, since they are cut out for the tuning condensers.

But there are two ways in which the sub-panel may be turned with these in front. Only one is right. Perhaps the easiest way to tell which is right is to remember that the National output unit should be at the extreme right end at the rear. There are six holes for mounting this unit and these holes cannot be mistaken. Don't mount the output unit first but merely use it as a preliminary guide. It is best to mount it only after most of the other parts are in place.

Make sure at the start that everything is on the right side. A wrong start may not be noticed until most of the parts have been mounted, and the sooner the error is discovered the less will have to be taken apart and done over.

We leave the sub-panel for a while and

direct our attention to the Remler tuning condensers and drums. Unpack and handle these with care.

The Remler Parts

The tuning condensers have been so designed that they can be mounted on the panel, if desired, and there are three mounting screws provided for mounting.

But in this receiver they are not to be mounted directly on the panel. They are to be mounted so that the axes or shafts of the condensers are parallel with the panel.

A sturdy right angle brass fixture is provided for each condenser for this more modern method of mounting. This fixture is mounted on the panel in place of the condenser and then the condenser is mounted on the fixture. There are several holes in this fixture which fit the condenser, and these holes provide a varied choice as to the method of mounting the condenser. Any one of these is as good

(Continued on page 8)

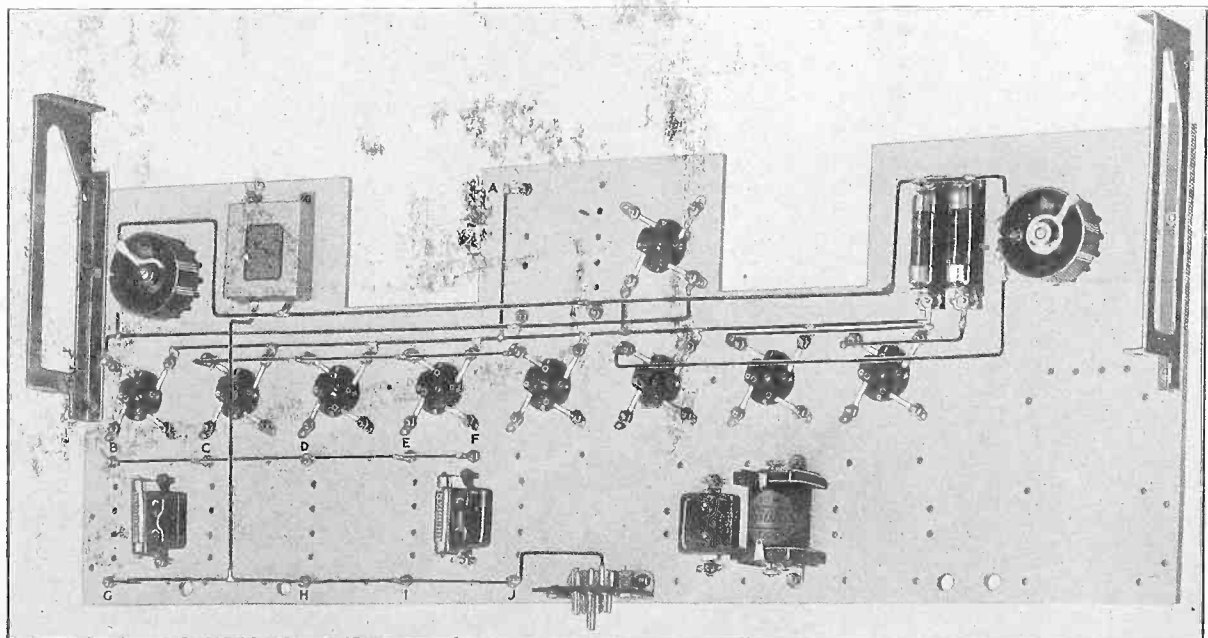

THE FILAMENT WIRING UNDER THE SUBPANEL OF THE MAGNAFORMER, TOGETHER WITH OTHER MINOR PARTS IN PLACE.

The X-Ray Picture of the Magnaformer 9-8

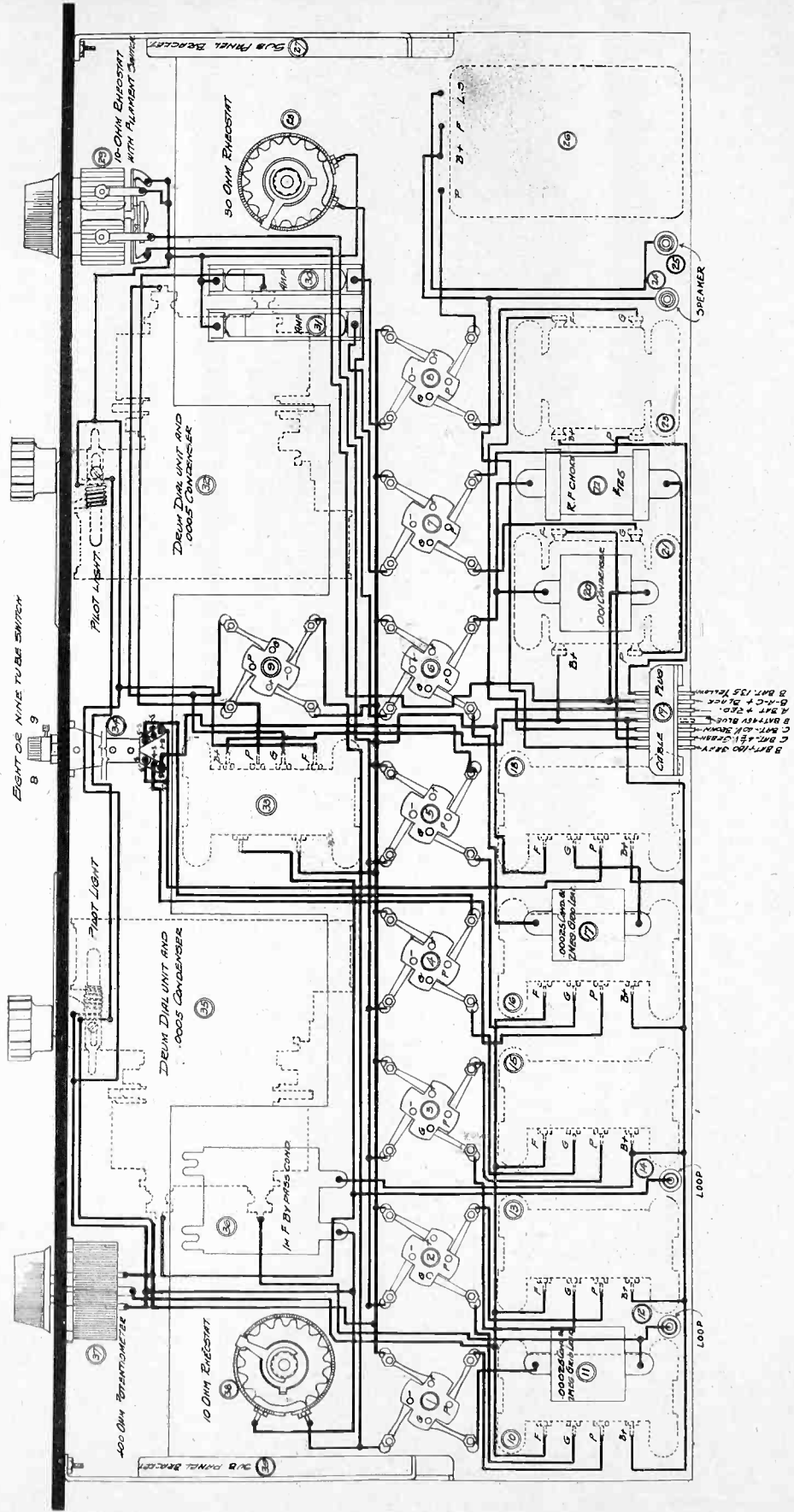

THE X-RAY WIRING DIAGRAM OF THE MAGNAFORMER 9-8 RECEIVER. THIS IS THE FIRST TIME IN RADIO THAT A TRANSPARENT VIEW OF A RECEIVER HAS BEEN USED TO INDICATE THE PROPER WIRING CONNECTION. LIKE THE RECEIVER ITSELF IT MARKS AN OUTSTANDING ADVANCE IN RADIO TECHNIQUE. THE WIRING IS SHOWN IN FULL HEAVY LINE, THE PARTS UNDER THE PANEL IN FINE CONTINUOUS LINES, AND THE PARTS ON TOP OF THE SUBPANEL IN DOTTED LINES.

(Continued from page 6)

as the rest and therefore there is no room for a mistake here.

The drum fits over the shaft of the condenser which protrudes out of the brass fixture. It is locked in place with a set screw in the usual manner.

The condenser mounted in place is turned with a small knob on the front panel. This knob is attached to a special coupling shaft which terminates in a small worm pinion. This pinion engages a large gear on the drum. Fine teeth are used on the gear and pinion to make the motion smooth and easy and to prevent lost motion.

The Reverse Mounting

The condensers come for mounting so that the condenser is to the left of the drum. But symmetry of the layout of this receiver demands that one of the condensers be mounted in the reverse position, that is, with the drum to the left of the condenser. This change is provided for in the Remler drum. The right angled brass fixture is reversible. However, it is necessary to shift the pinion shaft from its position to another similar position on the opposite side of the brass fixture, and it is also necessary to remove the pinion and substitute another which works in the reverse direction. Every drum is provided with two of these pinions, one for right hand motion and the other for left hand motion. The adaptation from one to the other type of motion takes only a few minutes.

When the two condensers are mounted they will turn in opposite directions. At least two scales are furnished with the drums. On one the numerals run in one direction, on the other scale in the opposite direction. At the same time that one dial is changed to run in the opposite direction the proper scale is inserted. Hence both dials read the same for the same condenser setting.

The Frost intermediate frequency rheostat and filament switch combination is mounted on the panel at the right. The Frost volume control potentiometer is mounted on the panel at the left, symmetrically with the rheostat. The two other auxiliary controls are mounted back of the front panel on the sub-panel. They are set in position for best results and are not thereafter touched.

The sockets for the scale illuminating lights are mounted on the brass fixtures after the dials are in place. They should be at the top.

A Point About Pins

Some difficulty may be experienced mounting the escutcheons. Small holes are in the Formica panel to take the escutcheon pins. It may be that these are too small. In that case do not try to hammer in the pins. There is a good chance of ruining the pins, escutcheons and the panel. The copper pins will give before the Formica will. If the pins will not go in with light tapping, enlarge the hole with a drill one size larger than the one originally used for drilling the hole, or file the pin down. Drilling is the easier. Make sure that the drill is not too large. The pin must fit close enough to hold the escutcheon plate.

When everything has been mounted the panel contains two knobs for volume control, two knobs for tuning, and the 9-8 switch for throwing in and out one intermediate stage, and two illuminated dial windows.

When all the parts are mounted on both the sub-panel and the front panel, the two should be combined through the medium of the Benjamin brackets. Attach them first to the panel. Two flat head, nickel plated 6-32 machine screws with nuts to match are furnished for each bracket. And the holes are countersunk just the right amount. Then attach the brackets

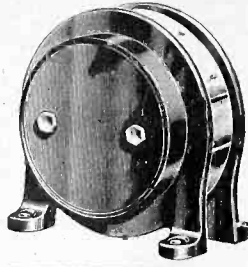

External Appearance of the Magnaformer Intermediate Frequency Transformer.

LIST OF PARTS

One Formica Front Panel 7x26x3/16"	\$ 6.50
One Formica Sub-Panel 9x25x3/16"	6.50
Five Magnaformer Intermediate Transformers, Unit R.F. No. 61 @ \$8.50	42.50
One Unicoupler, Unit C.U. No. 71	6.50
Two Remler Universal Drum Type Dials with Controls, No. 110 @ \$4.50	9.00
Two Remler .0005 mfd. Variable Condensers No. 639 @ \$5.00	10.00
Nine Benjamin Sockets No. 9044 @ 50c	4.50
Two Benjamin Sub-Panel Brackets 2" high, No. 8629	.70
Two Ferranti Audio Transformers, A.F. No. 4 or A.F. No. 3—A.F. No. 4 @ \$8.50	17.00
One National Tone Filter	8.00
One Samson Radio Frequency Choke Coil No. 125	2.25
Two Aerovox .00025 Grid Con- densers, Type 1475, with Mount- ings @ 40c	.80
One Aerovox .001 Fixed Condenser, Type 1450	.40
One Aerovox 1 mfd. By-Pass Con- denser, Type 200 Short	.90
Two Durham 2 megohm Grid Leaks @ 50c	1.00
One Frost DeLuxe 400 ohm Potentiometer, gold arrow knob No. 1824	1.25
One Frost DeLuxe 10 ohm No. S1810 or 6 ohm No. S1806 Combination Rheostat and Battery Switch with gold arrow knob (6 ohm preferable)	1.35
One Frost DeLuxe 10 ohm Rheostat, No. 1810	1.00
One Frost DeLuxe 30 ohm Rheostat, No. 1830	1.00
Four Frost Tip Jacks, No. 253, @ 30c pair	.60
Two No. 112 Amperites, with Hold- ers @ \$1.10	2.20
One Yaxley Cable Connector Plug No. 660	3.00
One Yaxley Radio Jack Switch No. 60, Gold Plated	1.25
Twelve Feet Acme Bus Bar Wire No. 14 round tinned @ 2c foot	.24
Twenty-five Feet Acme Flexible Spaghetti covered wire	.95
Two 2" right angle supports for supporting rear of sub-panel @ 5c	.10
Screws, Lugs, Nuts, Bolts, Solder	.50
Two 3/8x3/8x2" wood blocks for sub- panel center supports	
	\$129.99

Unless you have them on hand you will also require the following:

One Quali-Tone Loop, one Cone Type Speaker, one 7x26x12" Cabinet, seven UX 201A, one UX 112 power tube, one UX 171 power tube—RCA Radiotrons, one 6-V. A Battery, one 180-V. B Battery, one 45-V. C Battery, one 4 1/2-V. C Battery.

to the sub-panel. Two round head, nickel plated 6-32 machine screws with nuts to match are provided for each bracket. The sub-panel is set back from the panel considerably, but the right amount is determined by the holes which are drilled in the sub-panel.

Bracing Properly Provided

With the panel and sub-panel joined together with the brackets the set will not be stable enough. It will be back heavy, due to brevity of the brackets and the weight concentrated in the back row of the sub-panel. The sub-panel will also sag in the middle.

Additional supports are necessary. At each back corner of the sub-panel a right angled bracket is mounted. Both of these brackets together with their mounting screws and nuts are furnished. Even the holes are provided so that there can be no error in placement. The sagging in the middle is prevented by two 2-inch wood props cut out of 3/8 inch birch doweling. The holes and the wood screws for these are provided.

Before starting out on the job of assembling the receiver it is well to study a picture of the receiver to see how well the designer did the job. Such a picture gives the appearance of the set as viewed from the rear. This is an exceptionally lucid view.

Parts You See

Let us mention some of the parts seen. Under the sub-panel in the middle is the Yaxley terminal compact in which all the battery leads are terminated. To the right of this is seen a corner of the Samson 125 mh. RF choke coil, which is connected in series with the primary of the first audio transformer. The two corner brackets and one of the main supporting brackets are also seen. By-pass and grid condensers, grid leaks, amperites and the wooden props mounted under the sub-panel are not visible.

On top of the sub-panel, reading from left to right in the first row, we have the National Tone Filter, the two Ferranti AF-4 audio frequency transformers, and the five Magnaformers. In the second row, again reading from left to right, we have the —71 power tube, the 112 semi-power tube, the second detector, the four intermediate frequency amplifier tubes and finally the first detector or modulator.

On the panel the first to the left is the Frost switch and rheostat, then the Remler oscillator condenser with its drum dial and pilot light, then the loop tuning condenser with its drum dial and light, and finally the Frost volume control potentiometer. The oscillator tube and the oscillator coil or Uni-coupler are on the sub-panel between the two drum dials.

Review of Purposes

Let us review the purposes and the characteristics of the separate units that go into the Magnaformer 9-8 receiver. The Remler tuning condensers and drums have already been discussed in detail, so let us pass to the tuning coils.

The oscillating coil is a part of the Uni-coupler and consists of two parts, L2 and L3, the plate circuit winding and the grid circuit winding.

These are connected by the oscillator condenser C2 on one side and by the batteries and the by-pass C6 on the other. The windings are so proportioned as to give a uniform oscillation over the whole tuning range.

The third winding in the Uni-coupler is the pick-up L1. This is so proportioned as to give the optimum coupling between the oscillator and the first detector. This means maximum signal strength consistent with independence between the two tuned circuits and with selectivity in the radio frequency level. The three windings —L1, L2 and L3—are all inclosed in a

Bakelite moulded case similar to that of the intermediate frequency transformers.

Loop, Choke and AF Coils

The first tuning coil in the circuit is the Duro Metal Products Qualitone loop, a coil antenna of exceptionally high pick up and low radio frequency resistance. It is provided with three long leads for making connections to the receiver, one of which is a mid tap for use when regeneration is employed. This loop is designed to cover the broadcast band with a .0005 mfd. condenser.

L4 is a Samson 125 millihenry radio frequency choke coil. Its purpose is to prevent currents of radio and intermediate frequencies from entering the audio frequency amplifier. The Aerovox .001 mfd. condenser C4 aids in this action.

Note that the two audio frequency transformers AF1 and AF2 are Ferrantys, Type AF4. Why did the designers choose these transformers when the makers have another model which has a slightly flatter response curve? Because all the components of the receiver were chosen so as to make the final result the best possible. Each part was chosen because it fitted most perfectly into the quality-producing team. No other transformer fitted in with the desired object as well as this.

Tone Filter and Volume Controls

L5C5 is a National tone filter. Its object is to separate the AC from the DC component of the plate current in the power tube. It was selected because it had a choke coil of high inductance and low DC resistance, and because its condenser C5 was of large capacity. This tone filter protects the loudspeaker and it insures that the low notes get as fair distribution as the high.

R1 and R2 are Durham 2 megohm metalized grid leaks. These were chosen for their constancy of resistance and for their quietness in operation.

R6 and R7 are two Amperites used for controlling automatically, the filament current in the last two tubes.

R3 is a Frost 10 ohm rheostat used for controlling the filament current in the oscillator and the first detector. R4 is a Frost 6 ohm rheostat, and this is used to control the filament current in the intermediate tubes, and also to control the volume. It carries the filament switch S2, which is the master switch. R5 is a 30 ohm Frost rheostat which controls the filament current in the second detector. P1 is a 400 ohm Frost potentiometer employed for adjusting the grid bias on the intermediate frequency amplifiers. It is the main volume control in the receiver. P1 and R4 are put on the front panel; all the other rheostats and resistors are placed on the sub-panel.

Switch, Sockets, Panel

The two grid condensers C0 and C3 are of Aerovox make and each has a capacity of .00025 mfd. Each is provided with resistor clips. The 1 mfd. by-pass condenser C6 is of the same make as the preceding.

The switch S1 has been referred to as the 9-8 switch. It is a Yaxley double pole, double throw jack switch used for cutting in or out a stage in the intermediate amplifier. It is mounted on the panel. The battery terminals are brought to a Yaxley cable connector plug.

The sockets in the set are Benjamin. These were selected for their positive contact and resilient, non-microphonic suspension. Benjamin sub-panel brackets are also used.

Formica panel and sub-panel are used because of the mechanical and electrical excellence of this material.

The amazing selectivity and sensitivity

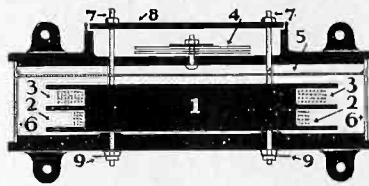

DETAIL OF MAGNAFORMER
INTERMEDIATE FREQUENCY
TRANSFORMER

of this receiver depend on the intermediate amplifier and filter.

In this receiver each of the five radio frequency stages is in EXACT resonance with every one of the other four stages. The Magnaformer Intermediate Transformers insure this condition without special matching of the tubes.

With all RF stages in perfect resonance, the incoming signal passes through all stages easily with no interference whatever, therefore with ALL of its vital, quality producing, harmonic carrying side bands intact.

With all stages in absolute resonance with each other, the receiver is in a super-sensitive condition and is operating at its very highest efficiency. In this ideal condition it delivers perfect tone quality—maximum volume—is at its point of greatest sensitivity and greatest selectivity. And only by having every radio frequency stage in perfect resonance can the utmost in these vital factors be secured. And only by the use of precisely and permanently peaked Intermediates can perfect resonance be gained.

Magnaformer RF Transformers

Perfect resonance in the Magnaformer 9-8 is secured by reason of the absolute precision of the Magnaformer Intermediate Coils. There is no mystery about Magnaformer Coils. But they are new, different and of the very highest efficiency. Being EXACTLY and precisely peaked at 69.73 kilocycles (4,300 meters) perfect resonance in all RF stages IS insured. More than two years of exhaustive laboratory tests proved that 4,300 meters is the ideal wave length at which to peak intermediate transformers for greatest efficiency.

Number 1 (in the center) is the Bakelite spool upon which the primary and secondary coils are wound. After being wound with the proper number of turns to give the exact inductance required, these spools are boiled in wax, all moisture and air is driven out. The coils are thoroughly impregnated with the wax, making it impossible for them thereafter to be affected by moisture, humidity or change of climate or temperature. The lower coil 2 is the primary, the upper coil 3 is the secondary.

Can't Change Wavelength

Number 4 (in the upper space entirely separated by Bakelite insulation) shows the several plates of the small variable fixed condenser by which the secondary coil is tuned in the laboratory to exactly 69.73 kilocycles (4,300 meters). After the tuning is done, the condenser is sealed so that the wavelength to which the coil is tuned cannot be changed.

Oscillation Control

Number 5 is a wide metal strip placed across the field of the secondary coil between the secondary coil and the Bakelite insulation separating it from the variable fixed condenser. The condenser is there-

fore entirely outside the field of the secondary coil. The electrostatic field of the condenser cannot affect the coil; nor can the electro-magnetic field of the coil affect the condenser. This factor is very important.

Number 6 is a metal shield that entirely surrounds the circumference of both the primary and secondary coils. This shield is soldered to the metal strip 5. The shield and metal strip are permanently located at very exact positions with relation to the fields of the coils. This shield and strip, in combination with other factors of the coil, change the character of the field and prevent the tube with which it is connected from spilling into violent oscillation. The favorable result of this combination of factors is directly responsible for the double amplification per stage developed by Magnaformer Coils. Regarding the oscillation tendencies of the tube to EXACTLY the proper degree causes it to develop its maximum amplification.

Unchangeably Constructed

The two Numbers 7 are bolts which extend entirely through the frame structure and hold it solidly together so that it is impossible to change the electrical characteristics of the transformer by jars or jolts of any kind. The lower ends of these bolts are not shown in the drawing as they are countersunk in the lower Bakelite portion.

The manufacturer sets forth: "Each coil is peaked in the laboratory to exactly 69.73 kilocycles (4,300 meters), and checked against elaborate precision instruments. Each coil is then aged for three days and tested. If O.K. it is aged for ten days more and again tested. If O.K. it is packed for shipment. No coil is shipped until it has gone through this aging process and has proved to remain peaked absolutely and exactly at 4,300 meters. This precise matching provides perfect resonance for ALL radio frequency stages."

Now, Number 8 (at the top of the drawing) is a Bakelite disc which seals and shields the small variable fixed condenser. After the coil is given its final test, the nuts and ends of the bolts (Number 7) are soldered together to prevent tampering. The two Numbers 9 (at the bottom of the drawing) represent two soldering lugs attached to two of the four terminals of the two coils. The two other terminals are not shown.

Join Now!

Those radio enthusiasts who demand the best quality the art affords at this stage of radio development, those who must have the greatest sensitivity and distance getting ability, those who insist on getting their radio signals thoroughly distilled of all disturbing influences and foreign noises, those who must have the most reliable receiver, those who would have the most outstanding receiver yet developed, they will have none other than the Magnaformer 9-8 receiver.

That is the claim of the designers of the circuit, the affirmation of all technicians who have tested and studied it, and the enthusiastic praise of all proud owners of this remarkable receiver.

Jubilant Magnaformer owners have made Magnaformer fans out of persons who heretofore had regarded any radio set as a diabolical device and positively refused to have one in the house.

If all these classes of radio men are unanimous in their enthusiasm for this receiver, its superlative qualities must be real, and the fans who have patiently waited for the ultimate, the non-plus-ultra in receivers, need not wait any longer. If they do, they will probably wait a long time and in the end have nothing but regrets for not having joined that large and delighted crowd of radio enthusiasts that now proudly say:

"I own a Magnaformer, and still see no reason why I should have any other."

The Object of a Power Amplifier

With Special Emphasis on the Functions and Operation of a Push-Pull Stage

C. T. Burke, brilliant engineer, in his article, published herewith, sets forth some rules:

- (1) A power amplifier can not be applied successfully directly after the detector; one or more stages of voltage amplification must precede it.
- (2) The audio amplifier should not be depended on for distant reception; that is the function of the radio frequency system.
- (3) The only proper place for a volume control is in front of the detector.
- (4) The maximum undistorted output from the push-pull amplifier, using two tubes, is not twice but five to seven times that of a single tube.

By C. T. Burke

Engineering Department, General
Radio Co.

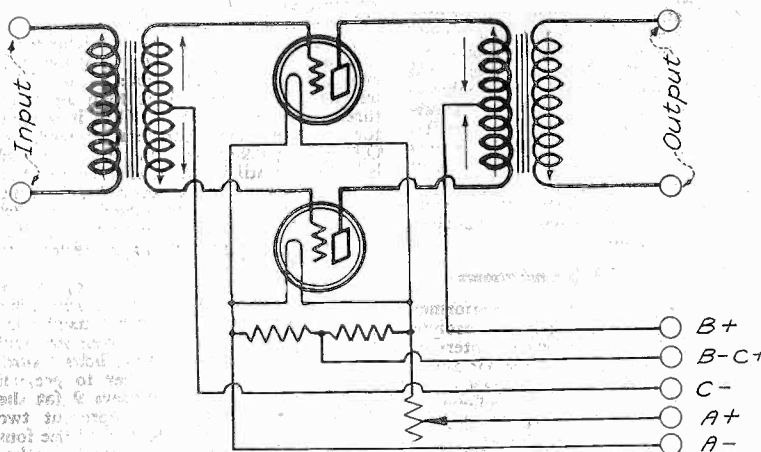

ONE STAGE OF TRANSFORMER COUPLED PUSH-PULL AMPLIFICATION WHICH CAN BE USED WITH EITHER AC OR DC ON THE FILAMENTS. THE LONG ARROWS INDICATE THE DIRECTION OF THE SIGNAL CURRENT OR VOLTAGE. THE SHORT ARROWS INDICATE THE DIRECTION OF THE EVEN HARMONICS OF THE SIGNAL CURRENT OR VOLTAGE.

UNLIKE the grid circuit of a vacuum tube, a loudspeaker consumes a considerable amount of power. The action of the last stage in the audio amplifier is therefore different from that of any preceding stage.

In order to understand clearly the difference in the action of the last amplifier stage, it is necessary to consider load impedances in the several stages and the current delivered to them.

When amplification per stage is spoken of, voltage amplification is usually meant. It is customary to speak of the vacuum tube amplifier as a purely voltage device. This is not strictly true in any stage and is far from the truth in the power stage.

Where Difference Lies

While the grid of the tube operates on voltage alone, the plate must deliver power. The objection to the specification of voltage amplification alone is evident when an amplifier feeding a load of 100,000 ohms is compared with one feeding a

load of 2,500 ohms. It is proper to refer to voltage amplification alone, only when the load impedances are equal; otherwise the load impedances should be specified or a correction applied. When an output transformer is used, the voltage across the primary of the transformer rather than across the speaker should be considered as the output voltage in considering voltage amplification.

The power consumed in the stages of the amplifier prior to the last is not generally appreciable. While the current delivered by the secondary is negligible, exciting current and transformer losses must be supplied by the plate circuit of the preceding tube.

Speaker Needs Much Power

The power requirements of the speaker, however, are large. Some of the power delivered is lost in the speaker windings, but most of it is transformed into sound waves and radiated.

Current is required to actuate the

speaker, and modern speakers are comparatively low impedance devices.

This requires an impedance adjusting transformer in the plate circuit of the last tube, which involves a considerable step-down in voltage.

The last stage of the amplifier must be capable of delivering an amount of power to the speaker commensurate with the volume of sound desired without overloading the tube if quality is to be preserved. In order to meet this requirement, a power stage should precede the speaker.

Not Just after Detector

It is perhaps necessary to distinguish between a power amplifier and a powerful amplifier. A power amplifier cannot be applied successfully directly after the detector; one or more stages of voltage amplification must precede it. The greater the power rating of the amplifier, the more the voltage amplifications required to precede it, as a general rule.

Receiving set power amplifier tubes range all the way from the -20 type with an undistorted output of about 100 milliwatts to the -10 type with an undistorted output of about 1,500 milliwatts. As each of these tubes differs as to input requirements, the choice of the power amplifier will depend on the rest of the amplifier.

If sufficient signal voltage is not available to operate the power amplifier satisfactorily, nothing is gained by adding it. It is, therefore, necessary to consider the first part of the amplifier in designing the power stage.

Too great voltage amplification in the audio amplifier should not be attempted, as undue noise and an unstable amplifier are likely to result.

The audio amplifier should not be depended on for distant reception; that is the function of the radio frequency system.

Rely on RF Gain in DX

For satisfactory amplification the detector output should be one-tenth to five-tenths volts (across the primary of the first coupling unit).

Signal strengths of less than the lower value should be increased by radio frequency amplification, those greater than one-half volt should be cut down by means of a volume control, otherwise the detector is overloaded.

Obviously, the only proper place for the

volume control is in front of the detector. Volume controls across the audio transformer secondaries, or the speaker, are poorly placed.

Assuming a signal of 0.2 volt, and a voltage amplification of 20 (one stage low-ratio transformer and tube) there is available for operating the power stage 4 volts.

Assuming a 2 to 1 step-up for the input transformer to the power tube, 8 volts are available at the grid of the power tube. Tube data tables show the output under these conditions with various tubes to be as follows. Power is in milliwatts in each case.

Concrete Examples

As the plate voltage available is generally limited, the plate voltage required is also given. If lower plate voltages are used the input must be reduced to avoid overloading, and, as will be observed, this is an important factor in choosing the amplifier tube. These data are calculated from vacuum tube data tables and represent approximate average values.

Signal Voltage 8

Tube	Output Power	Voltage Plate
201A	50	135
120	15	68
112	120	135
171	28	67
210	65	135

Obviously the 112 is the proper tube to use. Suppose, however, that the input voltage and amplification ratio had been such as to give 25 volts at the power tube grid.

What It Leads To

As neither the -01A nor 112 tube can be used on this voltage the choice reduces to:

Signal Voltage 25

Tube	Output Power	Voltage Plate
120	110	135
171	350	135
210	950	350

In comparing the -71 and -10 tubes it should be noted that under these conditions the -10 requires a plate voltage of 350 as compared to 135 for the -71. To operate with 135 volts on the plate of the -10, the input voltage would have to be cut to 9 volts with the volume control, when the output would become but 65 milliwatts.

Only Two Left

Increasing the input still further to 35 volts, only the -71 and -10 tubes may be used, the -71 giving 530 milliwatts output with 170 volts plate, and the -10 giving 1500 milliwatts with 425 volts plate. Again comparing the outputs for equal plate voltage, we find that the output of the -10 is only 140 milliwatts at 170 volts plate.

The -71 tube will take a maximum input of 40 volts with 180 volts plate, giving a 700 milliwatt output.

So far, only single power tubes have been considered. Where considerable power output is required, the push-pull connection, using two tubes in a single stage, offers many advantages even where the output desired is no greater than could be obtained with a single tube.

For Several Watts

In the push-pull stage, two tubes are so connected that their power outputs add. Any type of tube may be used, the choice of tube depending on the same consideration outlined as applying to the single tube type.

Thus the push-pull connection might be used with 112 type tubes when the input voltage is too low for operating a tube of the -71 type satisfactorily, but when greater power is required than is obtained from a single 112 type, -71 tubes might

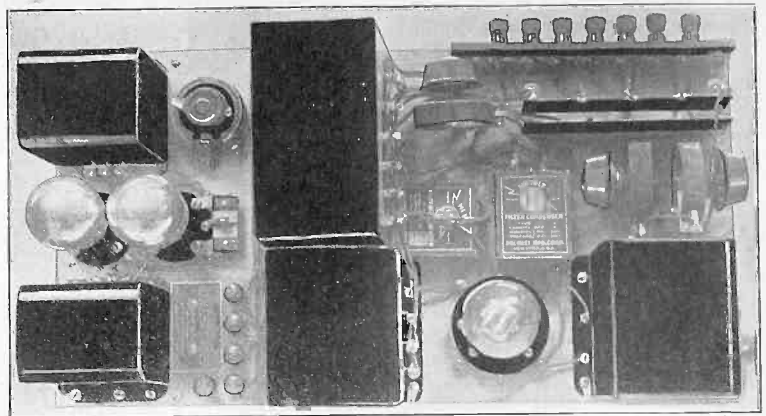

LAYOUT FOR A PUSH-PULL AMPLIFIER AND POWER SUPPLY, USING THE GENERAL RADIO PUSH-PULL AND POWER TRANSFORMERS AND CHOKES. CENTRALAB VARIABLE RESISTORS AS WELL AS POLYMET BYPASS AND HIGH VOLTAGE CONDENSERS ARE USED IN BOTH THE AMPLIFIER AND POWER SUPPLY. THE TWO AMPLIFIER TUBES CAN BE SEEN TO THE LEFT BETWEEN THE PUSH PULL TRANSFORMERS, WHILE TO THE RIGHT, IN BETWEEN THE POWER TRANSFORMERS, IS THE RECTIFIER TUBE.

be used in order to obtain a greater power output than is possible with a single -10, without the high plate voltage needed for that type of tube, or -10 tubes might be used where a power output of several watts was required.

Explanation of Arrows

Referring to the diagram the large arrows show how voltages impressed across the input are added in phase in the output. The smaller arrows show the course of voltages which are in phase in the grid circuits. These voltages cancel out and do not appear in the output. This fact is of great importance in the operation of the amplifier as it permits a greatly increased power output. Tube overloading, so long as grid current does not flow, is due to the amplifier working over a curved portion of its characteristics, introducing harmonics of the original frequency.

As these harmonics are in phase, they cancel out and do not appear in the output.

The working range of a tube is not limited to the straight portion of the characteristic when used in a push-pull amplifier

Five to Seven Times as Much

So greatly is the power output increased by this fact, that the maximum undistorted output from the push-pull amplifier is not twice but five to seven times that of a single tube. This feature is of particular importance when working into the low impedance load presented by most of the modern high quality loudspeakers, since the effect of a low impedance in the plate circuit is to increase the curvature of the tube characteristic, and lessen its capacity for undistorted power output.

If alternating current filament supply is used a further advantage of the push-pull connection appears, because hum voltages in the two tubes are in phase and therefore their fundamentals and odd harmonics cancel in the output. The result is a much quieter amplifier than is possible using a single tube.

Use of -26 Tubes

For use with the Type 441 Push-Pull Amplifier, illustrated, the General Radio Company recommends the type -26 tubes. The maximum undistorted power output of the amplifier with these tubes is greater than a single type -71 tube, and the unit possesses the further advantage of quiet operation on alternating current supply, and a greater gain than is possible with a -71.

Due to the latter fact the unit requires considerably less signal voltage on the tube grids to obtain maximum output.

This in turn requires less gain between the detector and the power stage.

If, however, the voltage amplifier has sufficient gain to deliver fifteen to twenty volts at the primary of the input transformer -71 type tubes can be used in the push-pull amplifier with excellent results.

Impedance Considerations

As is usual when using a power stage, the gain in voltage is comparatively small, about 6 from the primary of the input transformer to the speaker terminals. The gain from the primary of the input transformer to the primary of the output transformer is about 20. It should be remembered, however, that very little power is delivered to the input transformer, while several hundred milliwatts are delivered to the speaker.

The input impedance of the type 441 unit is 30 henries. The turns ratio of the primary of the input transformer to the entire secondary is 1 to 4.5. There is a step down of about 3.5 to one in voltage in the output transformer to adapt the tubes to the speaker impedance.

This gives the proper impedance ratio for -26 type tubes.

When using the -71 type better results will be obtained if the speaker is connected between one plate terminal and the center of the primary of the output transformer. The resistance of the output transformer primary is so low that little direct current flows in the speaker under these conditions, and no stopping condenser is required.

UNDERSTOOD, THOUGH OVERLOOKED

Writing to the Radio Manufacturers Association in praise of its booklet, "Better Radio Reception," written by Robert J. Casey, and listing many common interferences with radio reception, N. D. Parham, of Washington, D. C. observes that the Manual lists practically all potential trouble makers, except the house cat.

"As I remember it," continued Mr. Parham "there is much electricity generated in the fur on the arched back of this member of the feline family, as well as plenty of static when she parades her stuff on the backyard fence, so it may be that Mr. Casey may have overlooked a good bet."

The Floating Armature Coil Reproducer

The Design That Features the Magnavox R-4, R-5 and R-500

By H. B. Herman

Acoustical Expert

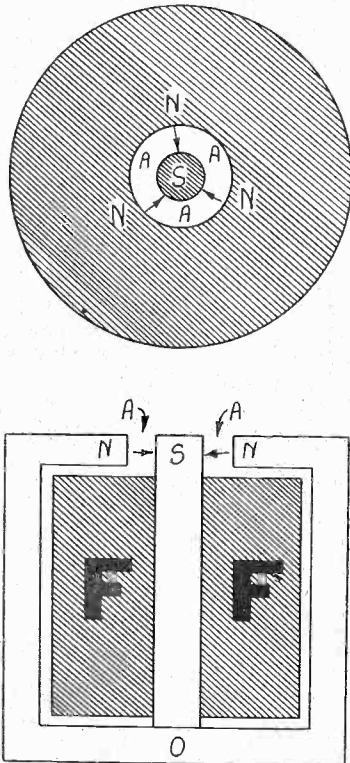

FIG. 1

THIS SHOWS THE PLAN AND THE CROSS SECTION OF MAGNETIC CIRCUIT OF THE ELECTRO-DYNAMIC SPEAKER UNIT.

If an electric current is sent through a wire which is placed in a strong magnetic field the wire moves, if it is free to do so. The distance it moves is proportional to the intensity of the current flowing in the wire and to the strength of the magnetic field, and it is inversely proportional to any restraining force which may act on it. The direction of motion depends on the direction of the current through the wire and the direction of the magnetic field. The motion is at right angles to both.

If a coil of wire is placed in a magnetic field and a current sent through the winding a mechanical force acts on the coil and causes it to move. The direction of motion is such that wires move at right angles to the magnetic field, just as in the case of a single wire.

A Specialized Electric Motor

This principle is made use of in electric motors, electric instruments, and in the electro-dynamic type of loudspeaker.

The electro-dynamic speaker unit is in

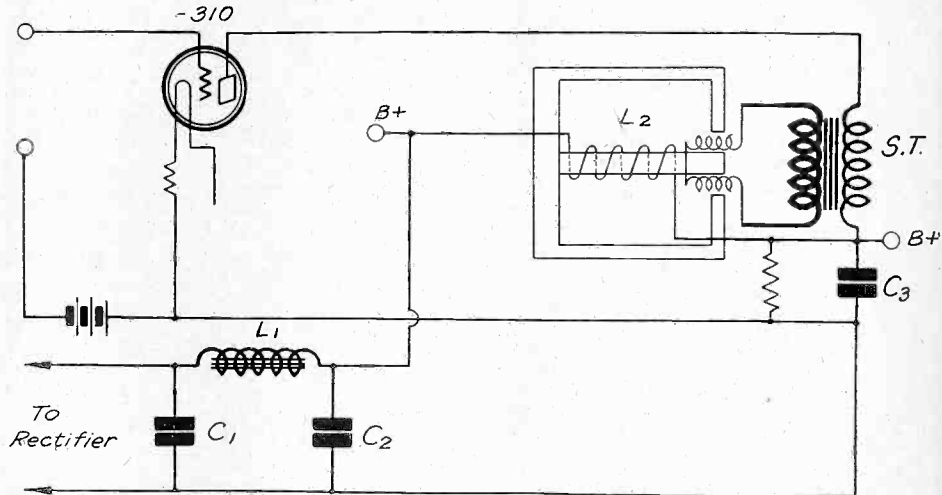

FIG. 2

THIS SHOWS HOW THE FIELD COIL IN AN ELECTRO-DYNAMIC SPEAKER UNIT CAN BE USED AS PART OF THE FILTER IN A B BATTERY ELIMINATOR. L1 IS THE FIRST CHOKE COIL AND L2, THE FIELD COIL, IS THE SECOND CHOKE IN THE FILTER. THE FILTER CONDENSERS C1, C2, AND C3 ARE CONNECTED IN THE USUAL MANNER. THE SECONDARY OF THE STEP-DOWN TRANSFORMER ST IS CONNECTED IN SERIES WITH THE MOVING COIL.

fact only a specialized form of electric motor. It has a strong magnetic field established by a powerful electromagnet, and it has a small coil mounted in the magnetic field in such a manner that it can move when acted on by the force existing between the field and the current flowing in the coil. The construction of one such speaker unit is shown in Fig. 1. The core, which is made of soft iron or high permeability alloy, is built in the form of a cylindrical cup with a round core in the center.

The magnetic circuit contains an annular air gap AA in which the magnetic field is intense and uniform. When the central core is the south pole and the top of the cup the north pole, the direction of the field is from the periphery toward the center core, as shown by arrows. The construction can be visualized better with the aid of the plan drawing shown above the section.

A large field coil FF is wound around the central core; and when a steady electric current is sent through this coil the iron core becomes a magnet, establishing the field across the annular air gap.

Needs Strong Field

The intensity of the field established depends on the area of the iron core, on the distance across the annular air gap, on the number of turns of wire in the magnetizing coil F, and on the strength of current sent through the winding. The

stronger the field is the more sensitive will be the loud speaker. Hence it is desirable to make the distance across the annular gap as short as practical, to make the area of the cross section of the core as large as design limitations permit, to

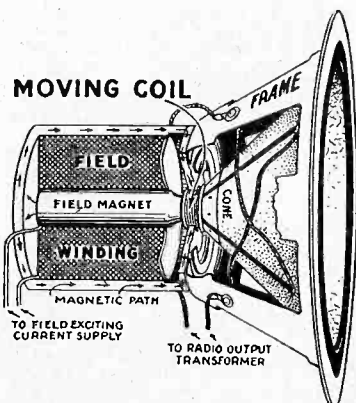

A SECTION OF A MAGNVOX ELECTRO-DYNAMIC REPRODUCER, SHOWING THE FIELD WINDING, THE FIELD MAGNET, THE MOVING COIL ATTACHED TO THE CONE, AND THE FRAME HOLDING THE UNIT AND THE CONE TOGETHER.

How to Mount and House An Electro-Dynamic Speaker

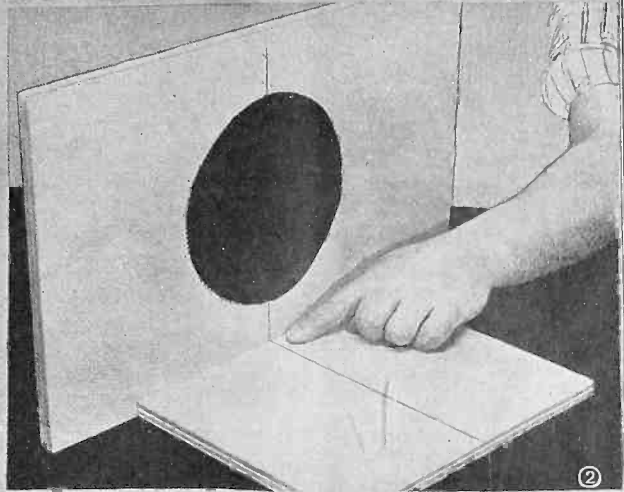
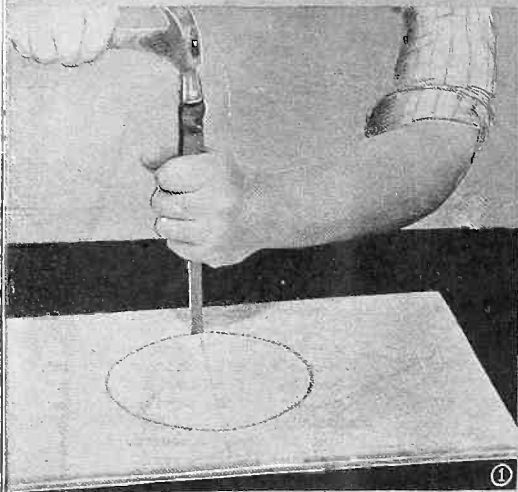

(1) To mount an electro-dynamic speaker get a 5-ply piece of wood, drill many small holes along a carefully measured and centered circle, and knock out the center with a chisel. (2) Then mount the remainder, or baffle board, in an upright position on a small base board, centering the two carefully.

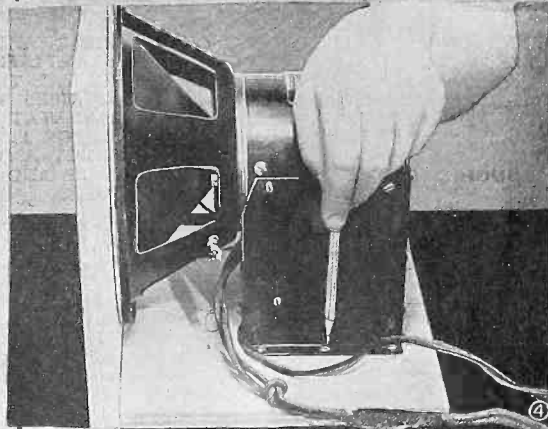
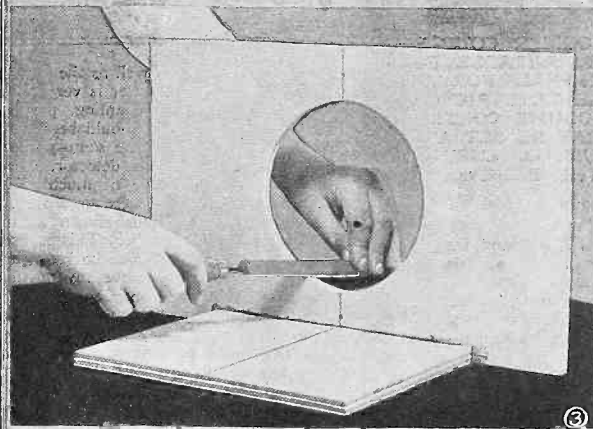

(3) Remove the rough edges on the circular hole with a course half round file. Do this carefully, to prevent chipping on the front side. (4) Then mount the speaker in this manner, screwing it to both the baffle board and the baseboard.

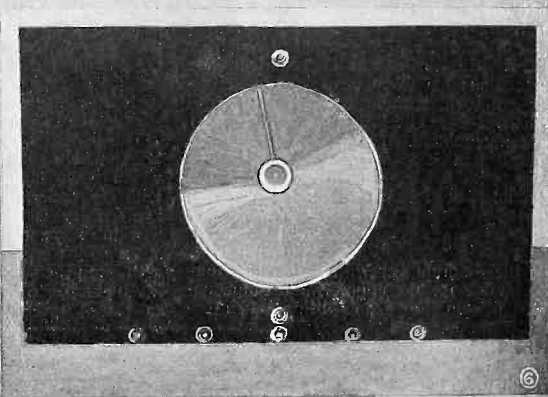
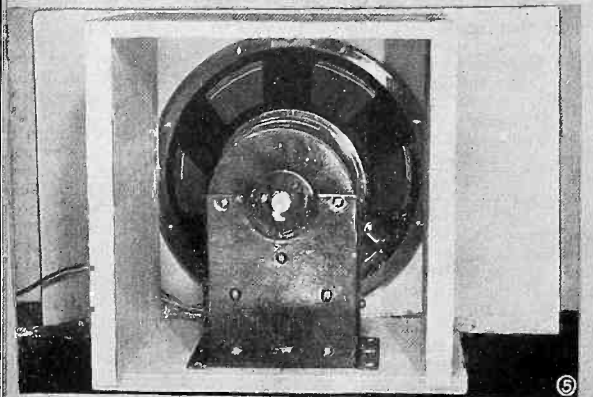

(5) A wooden housing, open at the back, should be put around the exterior of the mechanism to improve the operation. (6) The front of the baffle board is given a suitable coat of paint and the job is done.

(Hayden)

make the number of turns large, and to use a large magnetizing current. The current in the coil is limited by the size of wire used, but the strength of the field in which the small coil moves may be made almost as great as is desired.

The alternating current which constitutes the signal is sent through the small coil. The force acting on the coil then is

proportional to the signal current, and it alternates in direction as the current alternates. Since the coil is free to move it follows accurately the fluctuations of the current, and since the coil is attached to the sounding board or cone, this also vibrates with the current fluctuations.

The impedance of the moving coil is small, because a comparatively small num-

ber of turns is used in it. For this reason it is necessary to employ a step-down transformer between the power tube and the speaker. This transformer is wound to take the greatest amount of undistorted power from the tube at high voltage and low current, and to deliver to the speaker coil nearly the same amount of power at

(Concluded on page 29)

A Battery-Powered 2-Tube Phonograph Amplifier

By James H. Carroll

Contributing Editor, Associate, Institute of Radio Engineers

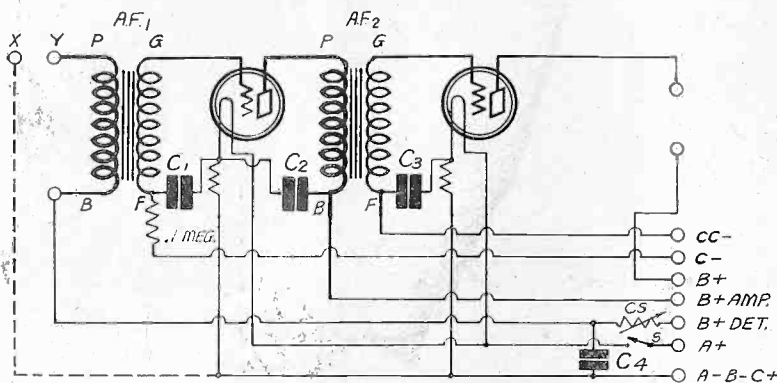

THE CIRCUIT DIAGRAM OF A TWO STAGE TRANSFORMER COUPLED BATTERY POWERED AUDIO FREQUENCY AMPLIFIER SUITABLE FOR PHONOGRAPH PICK-UP USE. X AND Y ARE THE TERMINALS FOR THE PICK-UP UNIT. THE DOTTED LINE COMPLETES THE ELECTRIC CIRCUIT WITH THE B BATTERY, CS IS A CLAROSTAT VOLUME CONTROL. IT MAY BE USED AS A VOLUME CONTROL, OR IT MAY BE SET AT A GIVEN VALUE WHICH ADMITS THE CORRECT AMOUNT OF CURRENT THROUGH THE WINDINGS OF THE PICK-UP AND THE PRIMARY OF THE TRANSFORMER

NEARLY all phonograph audio frequency amplifiers described are for use with a B battery eliminator and an alternating current source. This leads some to believe that it is not practical to use batteries with a phonograph pick-up, a most ridiculous misconception. If the voltages used in the two cases are approximately the same, the results will be better with battery operation, as long as there is ample life left in the batteries.

When good batteries are used to supply the power to an amplifier there are not nearly so many complications militating against the quality of the output as when battery substitutes are used. When good coupling transformers and the proper tubes and voltages are used the battery-supplied amplifier will give the quality one expects from the combination; but when some battery substitutes are used, without taking certain precautions, the unexcelled quality is largely in the imagination. This is not to be taken to mean that it is impossible to get good quality with battery substitutes. It is not impossible, but more care is required to bring it out.

Suitable Circuit

In the diagram herewith is shown a circuit suitable for the amplification of phonograph pick-up, the supply being taken entirely from batteries.

The circuit is designed so quality of the music will not be impaired when passing through it. That is, it is a high quality amplifier. Why is it a high quality amplifier? Because the parts have been chosen so as to introduce no distortion; because tubes have been chosen which will handle all the volume required without introducing any harmonics; because the voltages employed are high enough to prevent overloading of either of the tubes; because batteries are used to supply the power required; because nothing has been inserted into the circuit which will introduce any noise or any distortion.

Let us consider the several parts.

There are two good audio frequency transformers, AF1 and AF2, meaning that they amplify down to the lowest audible notes without appreciable suppression, and maintain uniform amplification over the entire audio scale up to about 5,000 cycles per second. Thus the output lacks neither in the low nor the high sounds, provided that they are in the record.

Need Ample Cores

The cores of the transformers should be made of a special steel giving them high permeability and low core losses, and the cross section of the cores should be ample to prevent core saturation. This point is of utmost importance when the transformers are used in connection with a power tube like the 112 or 112 A. The inductance of the primaries is high, making the amplification high over the entire audio scale and preventing the introduction of harmonics.

The filaments of the two tubes, 112A and 171A, take a total of only one half ampere, which is so low that it could be supplied with No. 6 dry cells when no six volt storage battery is available. Note that these new tubes are fully as efficient as the older tubes which required just twice the amount of filament current.

An amperite is used in each filament to take up the extra volt in the supply voltage. In view of the fact that each tube takes only .25 ampere, the amperites should be of the 1A type.

The two sockets used in the amplifier should be of the non-microphonic type, such as the Benjamin cushion sockets, in order that noises due to mechanical jars be reduced to a minimum.

Losses Minimized

The two by-pass condensers C1 and C3 are used to minimize noises which may be picked up in the grid batteries and leads as well as to reduce injurious couplings through this means. Each of these condensers should be 1 or 2 mfd. Condenser C2 is connected across the plate supply at

LIST OF PARTS

AF1, AF2—Two Pacent Super Audio-formers.
C1, C2, C3, C4—Four Polymet by-pass condensers, 1 mfd. or larger.
S—One switch.
AA—Two No. 1A Amperites.
CS—One volume control Clarostat.
Two Pacent sockets.
One Lynch .1 megohm resistor and mounting clips.
One 7x10 inch baseboard.
One Pacent Phonovox.

ACCESSORIES

One CeCo Type F tube.
One CeCo-J71 tube.
One tapped 45 volt C battery.
Four heavy duty, Eveready No. 486 45 volt dry B batteries.

points where the leads as well as the battery are by-passed. This condenser is very effective in minimizing back coupling, particularly when it is large. It should be 1 mfd. or larger. C4 is serving the same purpose in the plate circuit of the detector, or in the pick-up circuit. To be of much effect it should have a capacity of over 1 mfd.

•A .1 megohm resistor is shown in the grid circuit of the first tube. This is used to minimize the tendency to audio frequency feed-back and hence to remove any possible amplification peaks which may be due to the connections rather than to the parts. The by-pass condensers greatly aid the resistor in this distortion prevention. When the batteries are absolutely fresh both the resistor and the batteries are unnecessary, but the need for them increases continually as the batteries are used up. The resistor and the condensers greatly lengthen the useful life of the B batteries and prevent noise in the amplifier toward the latter stages of the batteries.

The Volume Control

CS is a volume control. It is in series with the primary of the first transformer, with the pick-up unit and with the 45-volt section of the B battery. It should have ample range, like the Clarostat. When the amplifier is used for phonograph purposes only, the pick-up unit is connected between the points marked X and Y and the broken line is closed. When the amplifier is to be used for a radio receiver as well, Y represents the plate binding post on the detector socket and X represents the minus filament binding post. To connect the Phonovox pick-up, the detector tube is removed from the socket and the pick-up terminal plug is inserted in its place.

The plate voltage on the last tube should be 180 volts and the grid bias, applied at CC-, should be 40 1-2 volts. The plate voltage on the first audio tube should be 157 volts and the grid bias, applied at C-, should be 10 1-2. The voltages are based on the use of a 112A in the first stage and a 171A in the last stage.

The loud speaker cannot be connected to the 171 tube without the use of a filter to separate the DC from the AC components of the plate current. This filter is not shown in the drawing. It may consist of either an output transformer or a choke coil and a condenser.

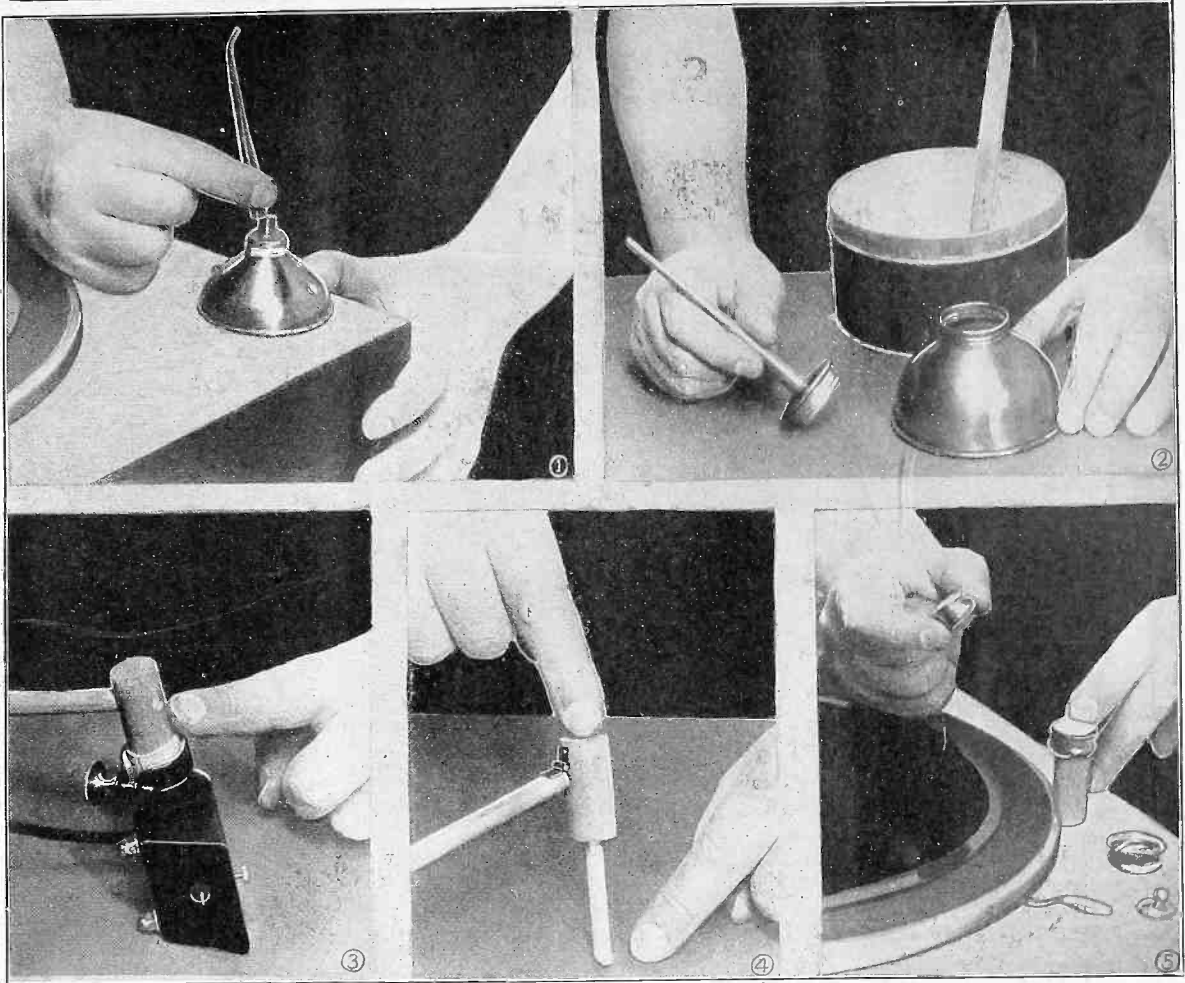

(Hayden)

(1) A pedestal for a phonograph pick-up can be made of an oil can. Remove the long neck. (2) To make the base heavy enough, fill it full of plaster of paris. (3) The arm from the pedestal to the phonograph pick-up is made of a wood dowel a quarter of an inch in diameter. A 1 inch dowel

is mounted at right angles to the $\frac{1}{4}$ inch dowel in this manner, and the phonograph pick-up unit is clamped over the larger dowel. (4) The arm is hinged as shown. (5) is a rest for the Phonovox, when machine is not worked. Complete installation below.



(6)

Criss-Cross Silences Gong Secret Pe

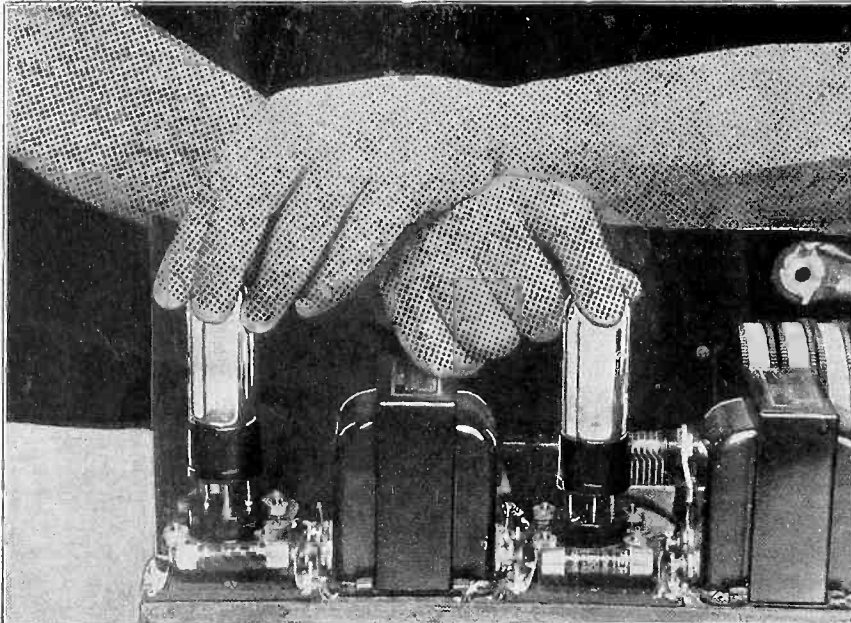

Some tubes, more than others, cause ringing sounds when jarred. The smaller tubes are particularly subject to this trouble. Interchanging tubes often cures the trouble.

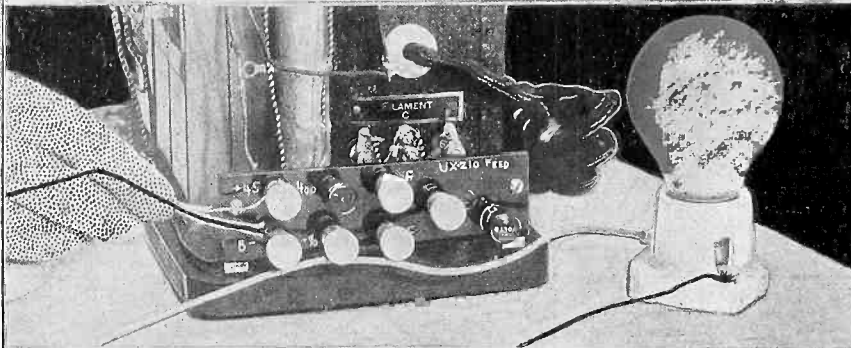

A 25-watt electric light can be used for testing the output of a B battery eliminator to determine if current is flowing and which posts are higher voltage. The degree of light tells this.

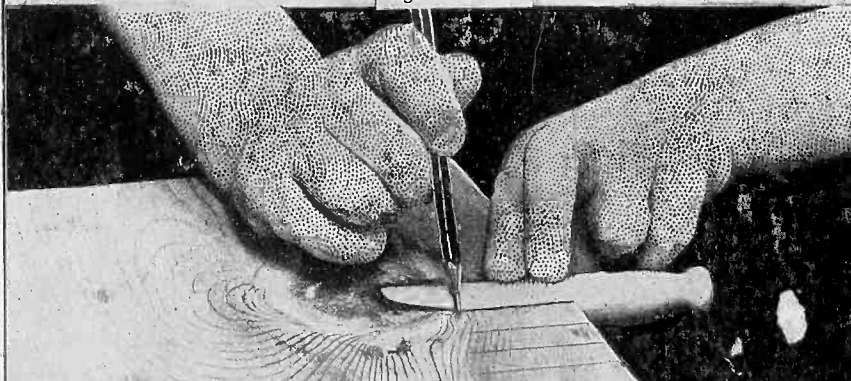

A simple T-square can be made by cutting off one-half of a clothes-pin. It is useful in laying out radio panels and sub-panels.



We are not supposed to know Christmas morning, but see what on his secret picture transmiss baby! And Ma and Pa will find

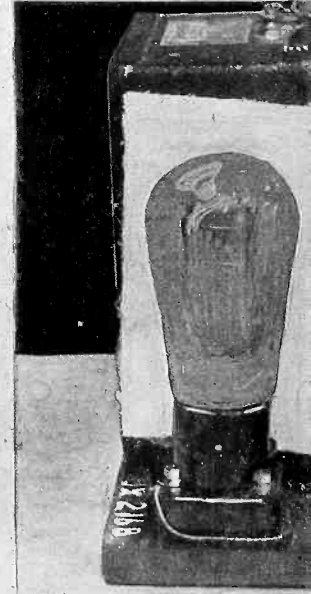

Rectifier tubes in operation glow with a sheet of

retrated

Brushing Up Is Needed



at Santa Claus intends to do
 e got by accidentally tuning in
 vave. He sure is generous to
 loudspeaker on the tree, too.



t. Protect closely adjacent parts
 bestos between.

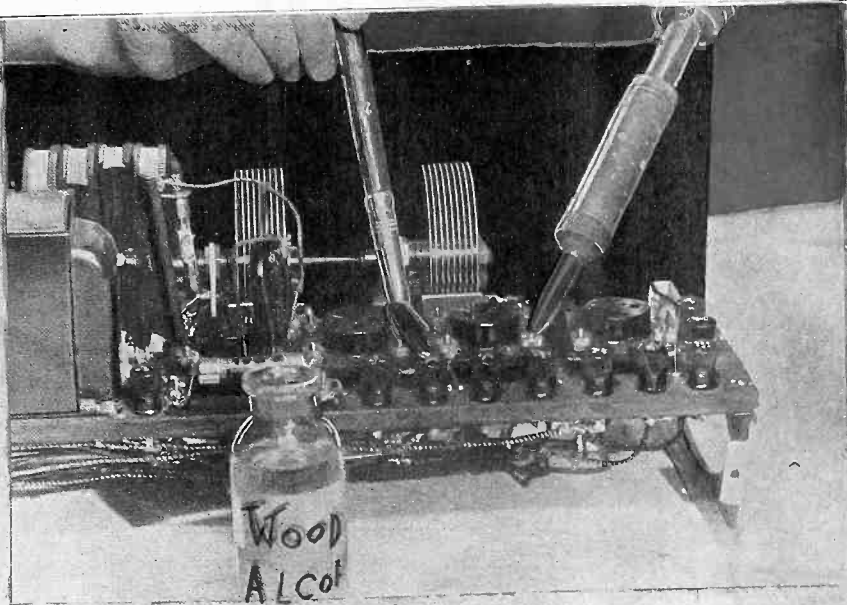

Rosin core solder is best for radio, because non-corrosive. The superfluous rosin can be removed from the joint with a brush and wood alcohol.

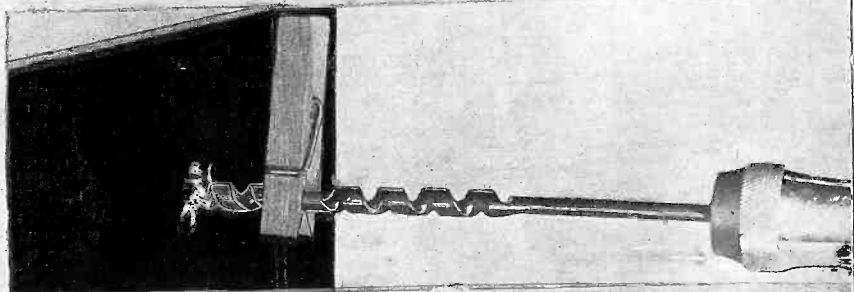

A clothes-pin of this type can be used as a drill stop. The depth of the hole is first determined and the pin clipped to the drill. Turn until contact is made.



A grid bias battery should be tested with a voltmeter in this manner, never with an ammeter. Only a high resistance voltmeter should be used.

(Photographs by Herbert K. Havden)

Giving the Crackles the

By Tim Turkey

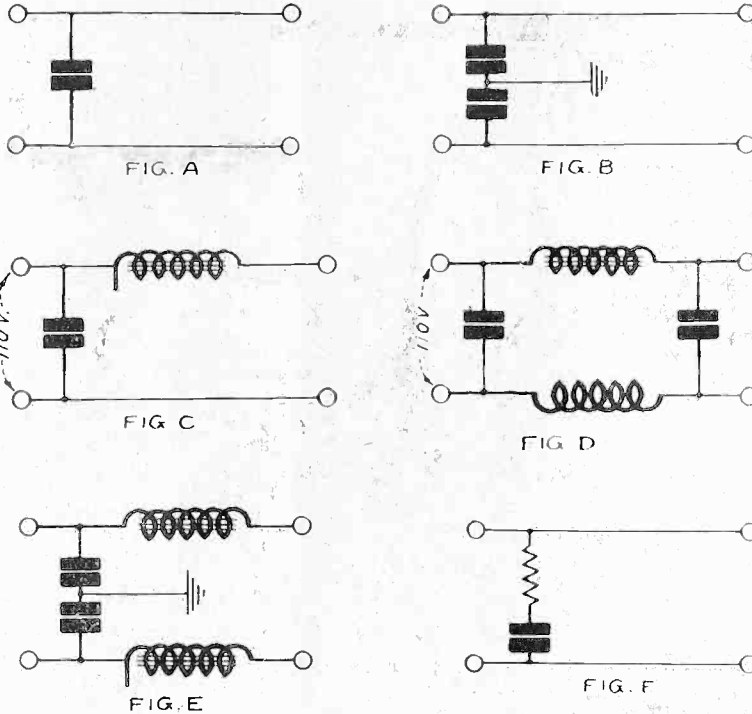

FIG. 1
SIX DIFFERENT FILTERS WHICH CAN BE USED TO SUBDUE RADIO INTERFERENCE FROM SPARKS MADE BY BREAKING CIRCUITS. F SHOWS A SPARK PREVENTER.

AN overwhelming proportion of all the crackles, hisses, crashes and pops frequently heard in radio receivers is man-made and can be prevented. Even in the Summer, when true static and atmospherics add to the general din, the man-made strays account for the greatest amount of the noise. In Winter, it is safe to say more than 99 per cent. of all the noise is caused by various electrical appliances used in the home and factory.



Tim Turkey

In practically every case of noise in a receiver the cause is the passage of electricity through air—an electric spark or a bolt of lightning.

There is nothing that can be done to stop lightning, and very little can be done to stop the effects of it on a radio set. But since this only accounts for a negligible proportion of the total noise in the receiver, this need not worry anyone. Let's look at some of the home-made noise and see what can be done about it.

Travels a Long Way

Whenever an electric circuit is broken there is a spark or passage of electricity through air, and that spark can be heard for blocks or miles around, depending on the sensitivity of the receiver. The severity of any spark depends on the intensity of the current that is broken and on the amount of inductance there is in the line that is opened. If there were no inductance in the line there would be no spark when the line is opened.

Inductance is electric inertia which

tends to keep the current flowing after the normal path for it has been interrupted. It flows through the air space between the two contact points at the switch for an instant after the line has been broken.

A spark also takes place when a charged condenser is closed, or when a charged condenser breaks down under the electric stress. Lightning is a case of condenser breakdown.

Sparks from the closing of charged condensers are of more frequent occurrence than is usually thought. To have a charged condenser it is not necessary to put the terminals of that condenser across a battery or a generator. Charges sometimes accumulate on all well insulated conductors, and when an uncharged or oppositely charged conductor comes in contact with one of these self-charged conductors there is a spark.

It is a tiny one in most cases, to be sure, but it is usually strong enough to cause a click in a receiver in the same room where the spark occurs, or perhaps in all receivers within a quarter of a mile. It depends on the capacity of the self-charged conductor and on the potential to which it has become charged, as well as on the sensitivity of the various receivers around it.

An Interesting Example

A wire suspended from an insulated support is a sample of a conductor which may become charged. If that wire should swing due to wind, and occasionally touch ground or a grounded conductor, it may become a constant source of interference with radio reception. Every time the wire touches a grounded object there is a small spark, causing a disturbance which is radiated by the wire as an antenna.

Other cases of self-charged conductors

can be found right in the radio set or in the home. The metal case of a headset is one. Sometimes the cores and casings of transformers become charged, as do metal shields, plates, nails, screws and similar objects. These objects are particularly excitable when the radio set is oscillating.

No harm is done if these insulated metal objects become charged as long as they remain insulated. It is when they come in contact with another conductor of different charge, or no charge, that they become nuisances.

The cure for troubles from the condenser effect of insulated metal objects is either to ground them or to protect them from possible contact with any other conductor. In the case of the suspended wire the remedy is to cut the wire down.

Intensity No Distance Measure

The sparking which occurs on breaking inductive circuits is by far the most severe source of trouble. Even when the line is supposed not to have any inductance there is enough electric inertia in the straight wires to cause sparks when heavy currents are broken. Turn out an electric light in your own home while the radio set is going. There is a click or a pop in the loudspeaker.

When your neighbor turns out one of his lights there is another click, just like the one you yourself made. And during an evening there may be hundreds of the clicks, all caused by the same thing—the breaking of an electric circuit. These clicks may come from a considerable distance, due to the antenna effect of the power lines.

The intensity of a click is not necessarily a measure of the distance to the origin, but rather of the amperage carried by the line which was broken. In AC lines the severity of a click also depends on the instant the break occurs relative to the current cycle. If it occurs at an instant when the current is zero there will be no click. But there is small chance that the break will occur at such an instant.

Like a Cataract

Electric motors, large and small, are very prolific sources of sparks, particularly when the contacts are dirty and pitted. They set up a continuous racket in the radio sets around them. The larger the motor the more severe the trouble is likely to be.

An elevator motor which is in bad condition is a very annoying source of trouble of this kind.

Induction coils such as are used in X-ray machines cause the greatest racket of all, but fortunately they are not as common as motors and they are not operated often when the radio receiver is of most interest.

When they are going radio reception is impossible, for blocks around them.

The noise an induction coil makes when in operation is not a crackle, but a series of rapid fire crackles which in the aggregate sounds like the roar of a mighty cataract.

Thermostats are a source of continuous disturbance wherever they are employed, and they are used for keeping constant the temperature in rooms, incubators, refrigerators, furnaces and ovens. They operate on the make-and-break principle.

When the temperature of the space controlled rises to a certain value, a circuit is broken which allows the tempera-

Gate

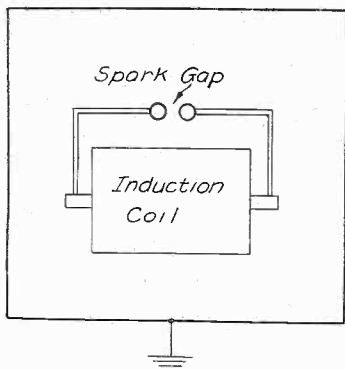
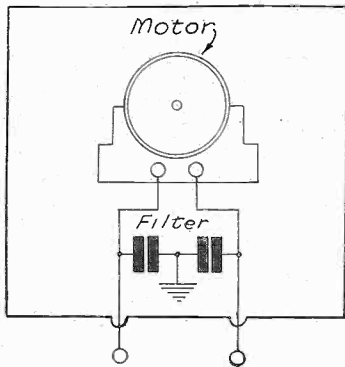

TWO NOISE MAKERS

When a motor gives a considerable amount of trouble from sparking brushes, it should be enclosed in a metal case and the feed line should be by-passed, as shown at top. The disturbance from an induction coil, used for X-ray machines, violet ray machines and similar applications, can be silenced by putting the coil inside a substantial, grounded metal case. When the disturbance is very serious the feed line should be by-passed with one of the filters shown in Fig. 1.

ture to fall. It falls to a predetermined value and then the circuit is closed again, causing the temperature to rise. In some cases the breaking and closing give rise to a continuous chatter, and the electric disturbance is not unlike that radiated from an induction coil.

Bells and Buzzers

Electric bells and buzzers also operate on the principle of make-and-break. Hence they are sources of disturbance whenever they are operated. Sign flashers also operate on the make-and-break system, and since some of these requires a very heavy current, they are often causes of serious trouble to radio receivers.

There are too many types of electrical appliances in which the current is broken to be possible to enumerate all. In some cases the make-and-break is the normal operation. In other cases it is due to defective contacts. It can be stated as a rule that any joint or contact which is not welded or soldered is a potential source of electrical disturbance. Sputtering across a dirty or corroded joint gives rise to a hiss which is due to miniature sparks.

How can disturbances from sparks be minimized or eliminated? There are at least two ways. One of these is to localize the disturbance and the other is to prevent the sparking.

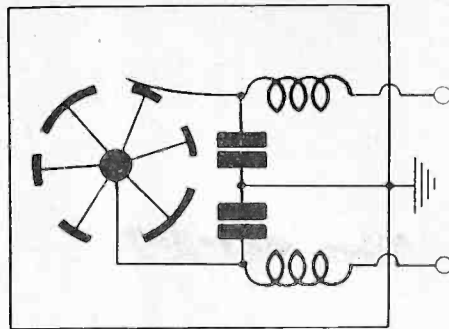
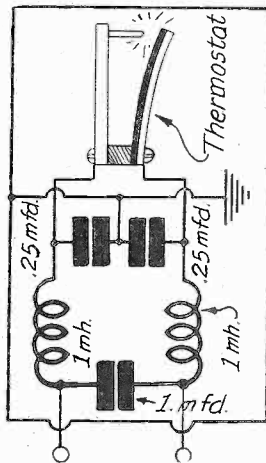
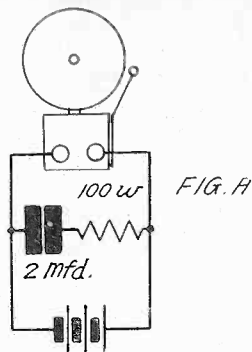

FIG. B

FIG. C

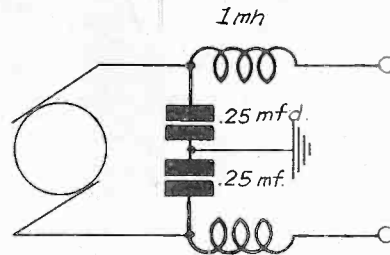

FIG. D

(A), AN ELECTRIC BELL WITH A SPARK ELIMINATOR ACROSS ITS TERMINALS. (B), A SIGN FLASHER CONTACTOR DRUM WITH A SPARK FILTER CONNECTED ACROSS THE MAKE-AND-BREAK POINT. THE WHOLE IS ENCLOSED IN A GROUNDED METAL CASE. (C), A THERMOSTAT SILENCED BY A FILTER ACROSS THE SPARK GAP AND BY THE GROUNDED METAL CASE SURROUNDING THE WHOLE. (D), THE SPARKING AT THE BRUSHES OF A MOTOR CAN BE LOCALIZED IN THIS MANNER

Localization of the disturbance can be done either by shielding the point of origin or by filtering. The prevention of sparking can be done by suitably shunting the spark gaps or by keeping the contacts firm and clean.

Shield Helps Greatly

A metal shield, preferably of iron, placed around the spark gap or sparking appliance will help greatly to localize any disturbance which may be a source of annoyance when unhampered. The shield should be grounded to the best ground that is available.

But shielding alone will not confine the disturbance to the point of origin if wires lead to and from it. The wires will act as radiating antennas which may broadcast the disturbance over a wide area. To prevent the wires from acting as carriers and broadcasters suitable filters can be connected across the line.

These filters constitute the second method of localizing the disturbance.

A number of such filters is shown in Fig. 1. The leads to the filters should always be as short as possible and the filters should be connected as close as possible to the point of sparking. If a metallic shield is placed around the source of disturbance, the filter should be placed preferably inside the shield, or else very close to the shield on the outside.

The prevention of sparking is done with a condenser and a resistance in series connected across the spark gap. The values of the capacity and the resistance depend somewhat on the constants

of the circuit in which the sparking occurs. A condenser of 2 mfd. and a resistance of 100 ohms usually make a very effective spark preventer. In Fig. 1F such a combination is shown. A spark preventer not only helps to make a clean break in the circuit, but it also protects the contacts from burning and corroding, which in turn helps to prolong the life of the contacts.

All Hands Pitch In!

It may be too much to hope for complete elimination of all noises from radio receivers, particularly the more sensitive sets, but it is quite possible to reduce the amount to such a point that a noise foreign to the desired signal is as rare as thunder storms in mid-Winter. If the work is to be done thoroughly it is necessary that everybody take a hand in it and realize his own responsibility to the public. If you hear a noise in your own receiver make sure that it does not originate in your own home.

That is easily established by a process of elimination of possible causes.

When your own house has been set in order it is time to suspect your neighbor. If there is a physician or a dentist nearby don't blame his X-ray outfit until your own violet ray machine has been silenced.

If you are certain that all your own electrical appliances are innocent of disturbing the radio peace, try to locate the source of trouble with the aid of a loop. When you have located the source suggest to the owner of the disturbing appliance that he correct it.

The Everyman 4

By E. Bunting Moore

The Radio Kit Co.

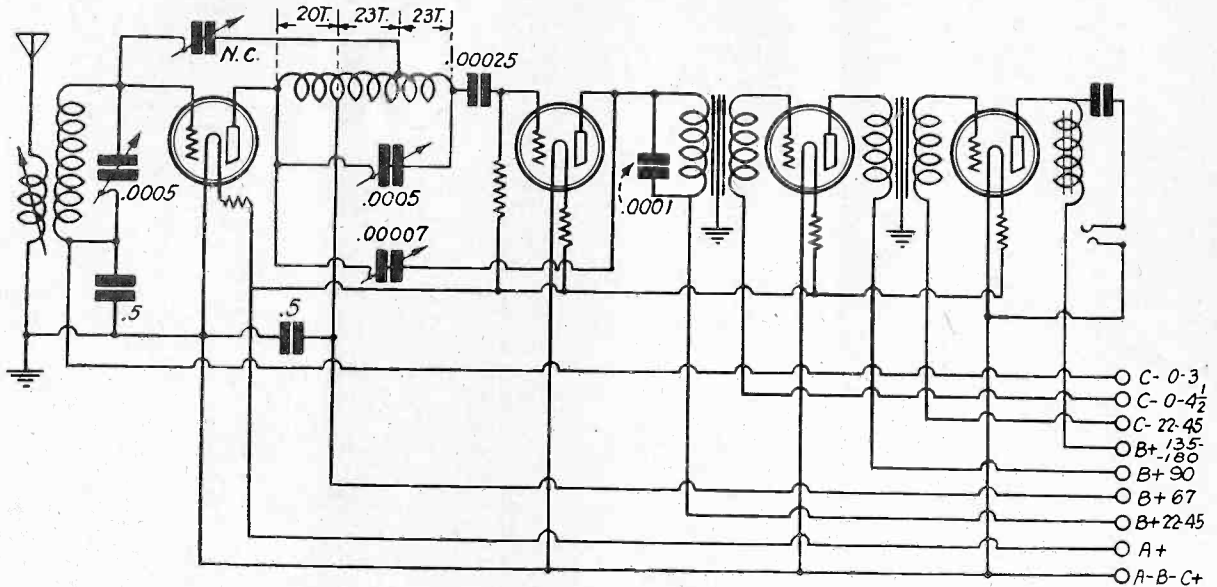

THE WIRING DIAGRAM OF THE EVERYMAN 4, THE CIRCUIT DEVELOPED BY FRED EHLERT.

(Last week, December 4 issue, analytical and constructional data on this excellent receiver were given. Herewith is the concluding instalment, in which important information on the operation of the set is given.)

NOW connect the B cable wires to the B and C batteries, as follows:

RF stage CeCo -A tube 67 volts B battery plus; 4½ volts C battery minus; detector, Q. R. S. super-detector, 45 volts B battery plus; no C battery; first stage audio CeCo -A 90 volts B battery plus; 4½ volts C battery minus; first stage audio CeCoF, 90 to 135 volts B battery plus; 4½ to 9 volts C battery minus; second stage CeCoJ71, 135 to 180 volts B battery plus; 27 to 40½ volts C battery minus.

B minus and C plus must be connected to the A battery negative.

CeCoA is the same type as UX201A and CX301A. CeCo F is the 112 type and J71 is the 171 or 371 type. The detector tube is some what like the 200 A and 300A.

Assuming all connections are now properly made, connect the speaker, but disconnect the cable plug first, or you will probably find out just what 135 or 180 volts of B feels like! Then plug in the cable and turn on the switch. Turn regeneration condenser to O or with plates out of mesh, variable coil primary close to the secondary coil, dial at 100. Rotate the dials together until a station is heard. If the set tends to oscillate, it may be checked by adjusting the neutralizing condenser on the baseboard. This is best accomplished by screwing down until the squeal stops.

How to Neutralize

Take a local station around 325 meters as a guide, or the nearest one on a higher wavelength, for neutralizing. Tune in the station at its maximum strength, without regeneration, and with close coupled primary. Lift out the RF

tubestat and adjust the neutralizer to inaudibility or to faintest signal. This should be the proper and final setting for the RF tube. Replace tubestat.

If difficulty is still met, reduce the 67

LIST OF PARTS

- One Drilled and engraved bakelite panel 7x21, by Twin Coupler Co. \$ 3.75
- One Set Everyman Twin Coupler Coils and rod 5.00
- Two Cardwell No. 192-E variable condensers @ \$5.00 10.00
- One Cardwell No. 613-A variable condensers, regeneration 1.50
- One Muter first stage audio transformer 7.00
- One Muter second stage audio transformer 7.00
- One Muter Clarifier (output) ... 5.00
- One Muter RF choke coil 1.50
- One Muter No. 1900 Variall neutralizing condenser75
- Two Muter .5 by-pass condensers @ .75 1.50
- Three Muter .25 amp. Tubestats @ .50 1.50
- One Muter 5 amp. Tubestat50
- One Muter .00025 fixed grid condenser40
- One Muter 3 meg. heavy duty grid leak and mounting65

NECESSARY ADDITIONAL PARTS

- Four Na-Ald UX sockets @ .65 2.60
- Two Vernier dials National or Marco 100-0 @ \$2.50 5.00
- One Yaxley battery cable with connector plug 3.00
- One small knob for regeneration condenser20
- One baseboard painted 10x20 inches 1.00
- Wire and necessary hardware .. 1.00

Total cost of the kit \$58.85

volts to 45, or try another tube in their RF socket and reneutralize. Regeneration may be used without fear of radiating energy that will annoy the neighbors.

For distance reception the regeneration is increased as both variable tuning condensers are increased. The dials should read nearly alike, but increasing the selectivity, especially on the lower wavelengths, by separating the primary from the secondary coil, causes a slight comparative increase in the left-hand tuning dial, unless volume is too much. It is better to tune the set without regeneration, and increase volume after the station has been tuned in.

The only complaints I have heard were found, upon examination, to be due to inexperienced substitution of parts by the dealer or by the buyer. As with other kits, substitution is possible only if the electrical characteristics and workmanship of the parts substituted are the same as those parts specified.

A Promise

You have now a new set capable of great things, providing the directions have been carefully followed, and its performance will improve, depending upon your learning the intimate characteristics quickly, as well as your development of skill in handling its dials and controls. Just as a new or strange automobile cannot be most efficiently operated or controlled at the first attempt, neither should you expect to achieve the utmost with this new radio set at once, but only after patient study of its "personalities."

As for tubes, these may be as set forth previously. The new Q. R. S. 200-A superdetector tube will prove a knockout! It will get the remaining few miles and bring phone volume to loudspeaker reception.

A 112 type tube can be used in the first audio stage, but changing the tubestat from .25 amp. to .5 amp. This

(Concluded on page 28)

The Analysis of the Concertrola

By Leo Fenway

Associate, Institute of Radio Engineers

(Copyright 1927)

FOR the benefit of those readers to whom this analysis is their first introduction to the Fenway Concertrola, it might be well to reiterate my theory of a



Eder
LEO FENWAY

1928 all-electric receiver, as I set it forth in the November 5 issue of RADIO WORLD. It is simply this: The next great fortune in the radio business will be made by the man who produces the cheapest and best *new-type* of all-electric set. But it must be a *new-type* instrument. Not merely a "half-portion" replica of an

existing model, supplied by wet or dry trickle chargers. It should be *different*. Simplicity will be the keynote throughout. A few tubes—four should be ample. Two dial control; one volume control; one quality control, and one switch for operating the whole outfit. This new-type instrument must be capable of reproducing phonograph records with a fidelity of tone. And by the same token, it should reproduce radio programs with a realism that leaves not the slightest trace of the mechanical.

A New Start

Naturally, to design an instrument of this kind it is necessary, first of all, literally to turn one's back upon previous years' radio architecture and start anew.

The Fenway Concertrola, as described in RADIO WORLD November 5, 12, 19 and 26, and December 1, should prove particularly interesting to the set builder because it illustrates to a marked degree the idea behind this "new-era" in all-electric radio receivers.

Before digressing further, let us examine the data in the November 5 issue.

We find on page 4 that the set builder can select good AC tubes. Everybody knows that the difference between an all-electric set and an electrified set lies in the tubes. Without proper AC tubes it would be impossible to produce a first-rate electric instrument.

The second paragraph on page 4 shows that the writer has been experimenting with AC tubes since 1925. It further shows that the McCullough or Kellogg tube is a very satisfactory unit. The next paragraph tells us that the Thordarson 171 power compact will supply the proper B current; we also learn from this paragraph that this Thordarson compact is very easy to construct.

The Ferranti Transformers

Another point of interest on page 4 is the fact that Ferranti AF-3 audio transformers will produce the tone quality and volume which we are seeking. Few set builders realize that transformers like these, when used with a 171 tube, will produce better tone quality than inferior transformers when used, with a 210 tube, and 475 volts of B current. Nothing is said on page 4 about the writer selling Ferranti transformers. As a matter of fact he does not sell these transformers. He simply chose them because they were absolutely

needed in his scheme of things, and not because Ferranti or anybody else manufactured them. By harking back to the November 5 issue, we get the idea that only the best instruments available were specified for the Concertrola.

Two important things are brought out in the November 12 issue. First, the circuit diagram, and secondly, constructional data for making the Concertrola coils. Let's examine that diagram.

The first tube, we notice, is a stage of tuned radio frequency with regeneration. The regeneration is produced by means of the variable coupling in the No. 368-B coil. What happens when you add regeneration to a radio frequency stage? (First of all, it can be added to a single stage of TRF without bad effects, and with many good ones.)

Double Regeneration

It makes the first tube "go after" the signal; this is immediately apparent because there are seldom such things as weak signals, where it is used. The strong signal it creates is passed on to the detector tubes. It improves the selectivity of the first tuning stage; thereby making the set much more selective than it would be otherwise, without regeneration in the TRF stage. Consequently, there is little cause for complaint because of interfering stations.

The next thing in the diagram that stands out is the fact that regeneration is on the detector tube, in addition to the radio frequency stage. *Double regeneration!* Exactly. That is why the Concertrola produces such tremendous volume.

Notice that this is the first public appearance of a net with *controllable* super regeneration. Notice also on the diagram that the detector tube employs the grid condenser-gridleak method in addition to the C battery method of detection. This is new. The Yaxley No. 64 switch, and the method of connecting it into the electrical circuit is also new.

Some Expert Tips

The double resistances in the filament of the detector tube, and the potentiometer placed near the first tube are things you have doubtless never before read about. Why are these things so? Because the detector tube is the cause of *all trouble* in an electric set—except "hum," which is sometimes caused by the first radio frequency tube. The 75 or 100 ohm Carter potentiometer connected close to the first tube does away with ALL hum.

The Concertrola is one set that is properly connected with the house wiring circuit. Examine the Yaxley switch and notice that BOTH LEGS of the AC line are broken, when the switch is in the "off" position. After you have perused hundreds of other circuits you will agree that this feature is new with the Concertrola.

Perhaps you wonder if it is necessary to break both legs of the AC line? Well, if you ever do have a small fire in your electric receiver the chances are a hundred to one that it will be caused by the line short-circuiting in the set—through the aerial or ground side and the "live" leg of the line, which the single switching method does not cut-out.

This fire will doubtless be centered around the aerial coil.

Switch Explained

It can be caused by having your neighbor's aerial touch your aerial, upon the roof; it can also happen through a defective lighting arrester. Don't you see, the single switch on one side of the line only, merely cuts out or disconnects that side of the line. The other side of the line is alive and coming into your set through the B eliminator—not through the ground where you, foxily, have inserted a fixed condenser! But all this is avoided in the Concertrola because *both legs* of the house current are turned off with a single throw of the switch.

Further data in the November 12 issue explain how to mount the various parts before wiring. Now turn to the 19th issue. RADIO WORLD says that the Fenway is the 4-tube for you! On page 6 we learn that the entire set has less than fifty connections; we learn how to make the connectors for the AC tubes; and we are shown that it pays to build your own set. On page 7 we come face to face with the diagram of the battery model. "Always the same outstanding circuit," says Radio World, "only a difference in tubes and sockets."

The Battery Model

All the features that have been brought out in the all-electric Concertrola are apparent in the battery model. A set built up from the diagram on this page should be a great DX getter. Even with ordinary tubes, and fair batteries, the volume should be tremendous.

You hear much talk about this set and that set being capable of getting DX stations. Did you ever hear of a set that couldn't get distance? Neither did I! There's talk going around about a set being capable of separating two or more stations. Does anyone believe that in designing a set these days a man can possibly sign his name to an outfit that is not selective?

Hardly.
1928 is not 1922. It is not even 1926. Radio conditions in this country have so greatly changed in the last few months that practically all sets today, that is, those designed for 1928 reception, are selective, have good quality and plenty of volume. The difference lies in the instruments used, in the ability of the one who uses them, and in the simplicity of the circuit.

Three "radioteers" put over the idea that given a proper chance, either the battery model or the all-electric is capable of bringing in the broadcast programs with a quality that is beyond criticism. Speech is clear, distinct, and natural; the upper, middle, and lower notes of musical transmissions are properly brought out; there is no trace of reediness, harshness, or "wooliness."

And so, my radio audience, I've told you all there is to tell. There isn't any more. Herman Bernard, managing editor of RADIO WORLD says: "If you don't build the Concertrola, then the loss is distinctly yours."

And with that, I rest my case.

Hoover Summarizes Conference Results

The International Radiotelegraphic Convention, which the International Radiotelegraph Conference had been formulating for seven weeks in Washington, was un-

animously adopted and signed by the representatives of the 80 governments. Secretary Hoover was chairman of the entire conference.

By *Herbert Hoover*

Secretary of Commerce; Chairman, International Radio-Telegraphic Conference

It is a great honor to be able to congratulate the delegations and in fact the peoples of their countries on the successful issue of this Conference. That the representatives of 80 different governments, the largest international conference in history, have been able to sit together for a period of 7 weeks and, without any important disagreement, to reach a unanimous conclusion upon so highly a technical and so difficult a problem, is in itself not only a sign of progressive capacity of the world to solve international problems, but it is a fine tribute to the character and spirit of the delegations from all these nations.

The subject with which we have to deal is one of such scientific character and complex technology that we can expect the world at large to have little understanding or appreciation of the difficulties which it presents or the importance to each human being of its results.

Even to understand the content of these 60 different provisions in the treaty, and the 26,000 words required to give expression to it, founded as it is upon over 150 different committee reports, involves a technical knowledge of electrical physics which is naturally outside of the profession of all but specialists.

Worse Than Street Problem

I would be glad if I could even imperfectly translate this accomplishment into terms of general understanding in order that the work and success of the conference might be fully appreciated. For those outside these sessions I may repeat that the necessity for this conference rests upon the fact that there are a limited number of channels through the ether in which radio communication may be conducted.

More than one message at the same time upon a particular wavelength, or too near to it, destroy each other over a wide area of the earth. The growing crowds of messages along these channels require traffic regulation just as do the crowds upon our streets. And it is infinitely more complex than street traffic.

Communications must be carried on not only between these eighty peoples. A considerable part of all messages are transmitted from the multitudes of stations used for internal purposes whose radiation yet spreads vagrantly over national frontiers to interfere with the domestic business of other nations. Without orderly national control and direction the whole industry would dissolve instantly into complete chaos and entire defeat of this, one of the greatest gifts of science to the welfare of man.

More Than Programs at Stake

Our general public appreciates the difficulties of the limited number of channels available, through their experiences in domestic broadcasting. But broadcasting is only one of the major applications of radio. While enormous values in education and recreation have come from this application, yet the saving of thousands of lives and hundreds of millions of dollars of property at sea every year and the vast commercial use of these means of communication over land and sea are equally important.

And most of the radio service would, without the convention which we have agreed upon, be lost to the world.

In realization of the limited number of channels or wavelengths for communication, you will all recollect that at one time it was proposed that the use of these channels through the ether should be divided among the different countries of the world. That would have been equal to an assignment of different lanes across the seas upon which the vessels of a particular nationality should travel exclusively.

It soon became apparent that this solution would lead only to greater confusion, to international jealousies and to injustice.

A Basic Solution

This conference has found a basic solution by dividing the channels into groups, each group being used for a particular variety in communication. To pursue the analogy further, the solution which all have happily agreed upon is that lanes are established across the sea which are devoted to specific types of service, all nations being free to engage in that special form of traffic upon these particular lanes.

I may say parenthetically, owing to the lack of precision of the term "wavelength," the conference has adopted as a major designation the "kilocycle."

And in these terms the channels from 10 to 100 kilocycles have been set apart chiefly for long distance transoceanic service; the channels from 100 to 500 kilocycles have been set aside primarily for ship to shore and aircraft service; the channels from 500 to 1,500 kilocycles have been set aside for broadcasting; the very great number of channels from 1,500 to 5,000 kilocycles have been apportioned into 40 different bands and divided between 4 or 5 varieties of service, including the amateurs.

Stronger Covenants

The conference has established regulations for each of the different bands assigned to specific purposes. In the mobile service band—mostly ship communications—it has greatly clarified and strengthened the regulations in such fashion as will result in greater safety of life and property at sea. These regulations set forth detailed and stringent rules of practice for communication between ships to shore. They facilitate the making of contacts between ships. They give full place to that great invention, the radio compass. They place distress communications in priority over the world's other communications.

The broadcasting band has been clarified and defined for the whole world in such a fashion that there will be less conflict and interference—a direct contribution to every owner of a receiving set.

The point to point radio-telegraph services, mostly land stations, have been likewise clarified and defined in such a fashion as to permit constantly extended use in the commercial world.

The area of higher kilocycles—that is the shorter wavelengths—is the field in which we all feel the largest development

of the art will take place, and this region has been so divided as to give stimulation to the many applications which are now tentatively before the world.

Of course, in a large sense many of the problems of the conference could be expressed as a reduction of interference. Aside from the broad provisions for the orderly arrangement of traffic, detailed regulations to this end have been developed through the requirements as to technical operation of stations, which shall result in lessening the amount of present interference, and above all, assure development of the art itself.

It will be of interest to the general public to know of the provisions of the Convention as to spark sets, whose interference is so fatal to the broadcast listener. It provides that 12 months after adoption, no more spark sets are to be installed in the world, and that existing sets, within a definite period of years, shall be replaced by continuous wave sets or other more modern equipment, and thereby interference will be greatly minimized.

The Amateur Recognized

At this point I should mention that this conference, for the first time, has recognized the amateur as an important element in radio communication and has conferred upon him, by international treaty, certain definite wavelengths. The effect of these arrangements for the amateurs has been agreed by their representatives as increasing and assuring their opportunities to make contact with their companions overseas.

To have given the boys of the world a status of international life by treaty is a fine recognition not only of the rights of all boys, but a tribute to their service in developing the art.

The conference throughout its work has had before it the complete necessity that its conclusions should be of such elastic order that its provisions should not interfere with the development of its art. Many of us believe that we are only at the threshold of further development and discovery, and the development of its further vast usefulness to man.

And the conclusions of the conference I am certain occupy a safe middle ground between avoidance of restriction and the maintenance of orderly traffic. Entire freedom has been left for national determination of all questions which do not cause international interference. It has been determined that a conference is to be held at Madrid five years hence, where this agreement may be revised to meet the needs called forth by the further development of the art.

Provision for Arbitration

Numerous incidental problems have been worked out in the conference. Among them are the provisions by which messages from the sea shall be transmitted through ships of other nationalities and through land service to their destinations.

The agreement has been developed in such a manner that in those countries whose radio communications are conducted by private enterprise they permit these agencies themselves to establish their rules on all those questions which are naturally their own province.

Provisions are made for the exchange of regular information between nations as to the establishment and operation of radio stations. Further provisions assure the secrecy of radio messages.

Progress has been made by the special section of the Conference devoted to the development of a uniform International Code of Signals. Provision has been made for arbitration of all questions which arise from the Convention. Many other problems are dealt with which I shall not detain you to rehearse. They will be appreciated by all those engaged in this great world service.

DIZZY TASK

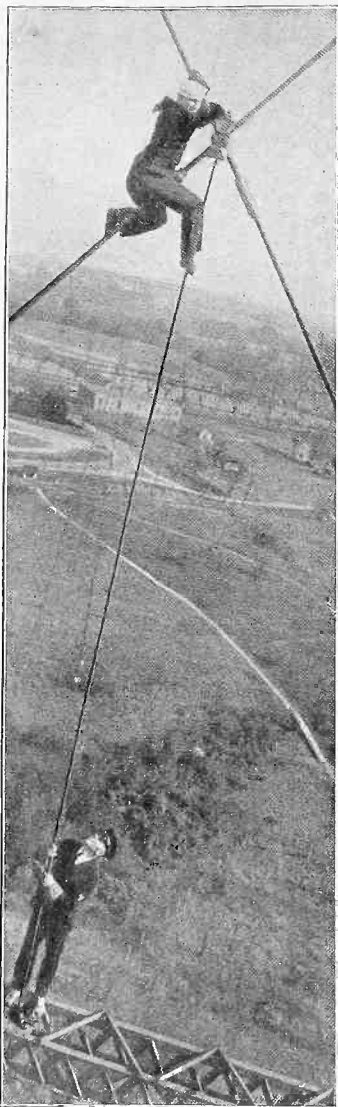

(Underwood & Underwood)
GOBS, SEEN FROM AIRPLANE, EXAMINING THE TOWERS OF THE ARLINGTON RADIO STATION. MEN WORK IN THEIR STOCKING FEET TO MAKE CLIMBING EASIER AND SAFER.

THE SPIRIT OF LOVE RETURNETH

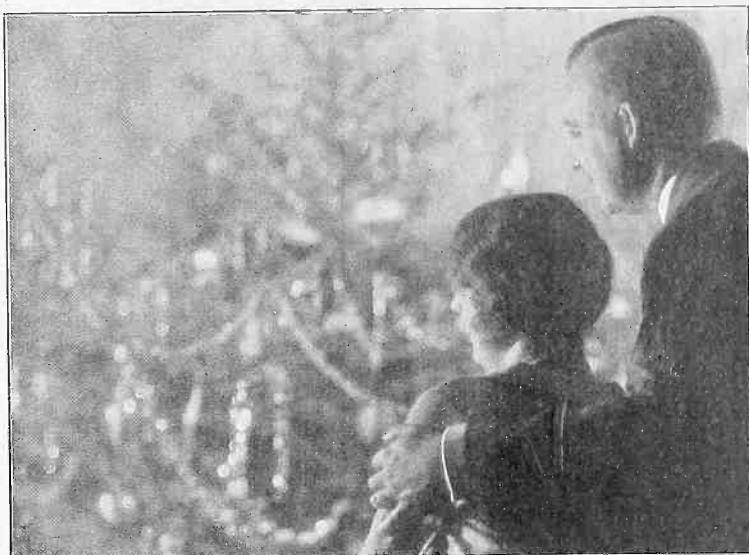

(Underwood & Underwood)

WON'T BABY BE SURPRISED AND DELIGHTED WHEN SHE WAKES UP IN THE MORNING! MA AND PA HAVE JUST DECORATED THE CHRISTMAS TREE AND SANTA CLAUS ALREADY HAS FILLED THE STOCKINGS.



BUILDS SETS TO PAY DOCTOR

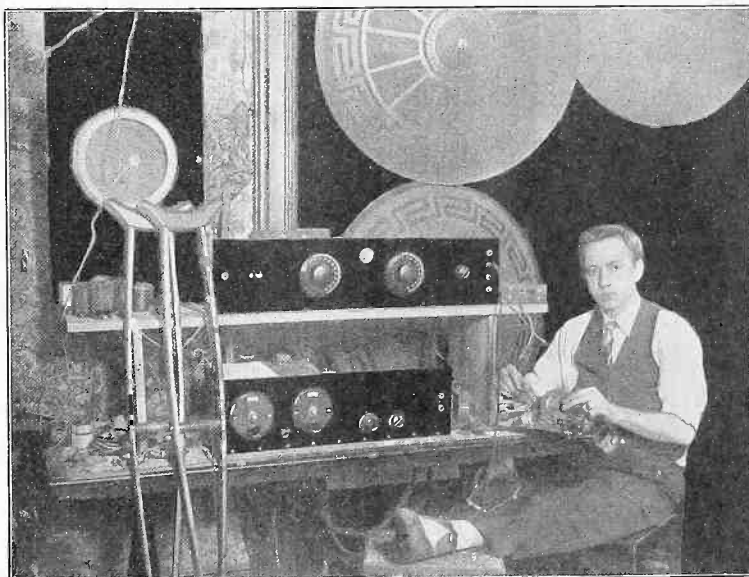

(Herbert Photos, Inc.)
RICHARD E. WEITZLER, OF NEW YORK, BUILDS RADIO SETS AND SPEAKERS IN HIS HOME TO MEET THE EXPENSES OF MEDICAL TREATMENT. OVER A YEAR AGO HE WAS OPERATED ON FOR A LEG AFFLICTION AND TOOK UP THE BUILDING OF RADIO SETS WHILE HE WAS STILL LYING IN BED.



MRS. WILLIAM MARCONI SEATED BESIDE A RECEIVER WHICH HER NOTED HUSBAND DESIGNED. THERE IS ONLY ONE OTHER SET LIKE THIS, AND IT IS OWNED BY THE PRINCE OF WALES.

The Christmas spirit is not confined to the well and strong; neither is it an individual affair.

The convalescent man in the lower photo builds radio sets which are to be used for Christmas presents to brighten the homes of others. He in turn receives remuneration which enables him

to alleviate his own sufferings and to buy presents for his own beloved.

There is a wealth of comfort and joy in the Christmas-tide for the favored as well as the hurt, for the poor no less than for the rich.

Christmas, love, radio—they go hand in hand.

SIXTH YEAR
RADIO WORLD
 The First and Only National Radio Weekly

Radio World's Slogan: "A radio set for every home."

TELEPHONES: BRYANT 0558, 0559
 PUBLISHED EVERY WEDNESDAY
 (Dated Saturday of same week)
 FROM PUBLICATION OFFICE
HENNESSY RADIO PUBLICATIONS CORPORATION
 148 WEST 45th STREET, NEW YORK, N. Y.
 (Just East of Broadway)

ROLAND BURKE HENNESSY, President
M. E. HENNESSY, Vice-President
HERMAN BERNARD, Secretary

Chicago: 55 West Jackson Blvd.
 Kansas City, Mo.: E. A. Samuelson, 360 Coea Cola Bldg.
 Los Angeles: Lord Chapin, 611 S. Coronado St.
 European Representatives: The International News Co.
 Brooks Bldg., Chancery Lane, London, Eng.
 Paris, France: Brentano's, 8 Avenue de l'Opera

EDITOR, Roland Burke Hennessy
 MANAGING EDITOR, Herman Bernard
 ASSISTANT EDITOR, Lewis Winner
 TECHNICAL EDITOR, J. E. Anderson
 ART EDITOR, Anthony Sadoro

CONTRIBUTING EDITORS:
 James H. Carroll, John Murray Barron and
 Capt. Peter V. O'Rourke

SUBSCRIPTION RATES
 Fifteen cents a copy, \$6.00 a year, \$2.00 for six months, \$1.50 for three months. Add \$1.00 a year extra for foreign postage. Canada, 50 cents.

Receipt by new subscribers of the first copy of RADIO WORLD mailed to them after sending in their order is automatic acknowledgment of their subscription order. Changes of address should be received at this office two weeks before date of publication. Always give old address; also state whether subscription is new or a renewal.

ADVERTISING RATES
 General Advertising

1 Page, 1 1/4" x 11"	462 lines	\$300.00
1/2 Page, 7/8" x 11"	231 lines	150.00
1/4 Page, 3/4" x 11"	115 lines	75.00
1 Column, 3 1/4" x 11"	57 lines	37.50
1 Inch	154 lines	100.00
Per Agate Line		10.00

Time Discount

52 consecutive issues	20%
26 times consecutively or E. O. W. one year	15%
13 times consecutively or E. O. W. one year	10%
4 consecutive issues	5%

WEEKLY, dated each Saturday, published Wednesday. Advertising forms close Tuesday, eleven days in advance of date of issue.

CLASSIFIED ADVERTISEMENTS
 Ten cents per word. Minimum 10 words. Cash with order. Business Opportunities ten cents per word. \$1.00 minimum.

Entered as second-class matter March 23, 1922, at the Post Office at New York, N. Y., under the Act of March 5, 1879.



TOBE
 Trade Mark Registered U. S. Patent Office

CONDENSERS
 are exclusively specified by Leo Fenway for the Fenway Electric Concerts.

It is the constant report from leading laboratories as well as radio editors and authors that Tobe condensers are superior to all others tested.

For the Fenway performance by using Tobe condensers. Your dealer has them in stock.

"It's got to be Tobe"
 Send for Price Catalogue

TOBE DEUTSCHMANN CO.
 Engineers and Manufacturers of Technical Apparatus
 CAMBRIDGE, MASS.

Scientists Easily Freeze Resistance Out of Metals

By Moe Hare Cogswell

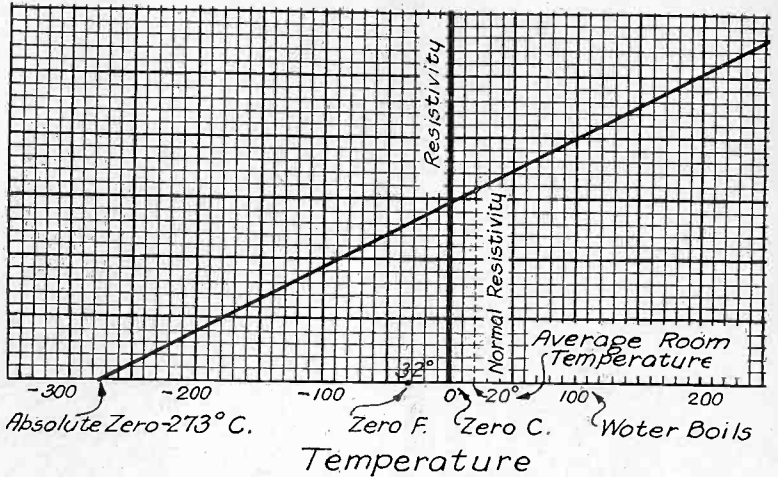

A STRAIGHT LINE SHOWING THE RELATIONSHIP BETWEEN THE RESISTIVITY OF PURE METALS AND THE ABSOLUTE TEMPERATURE. THE RESISTIVITY BECOMES ZERO AT THE ABSOLUTE ZERO IN TEMPERATURE, WHICH IS MINUS 273 DEGREES CENTIGRADE. NORMAL RESISTIVITY CORRESPONDS TO THAT AT ROOM TEMPERATURE.

It is a property of most pure metals that their electrical resistivity decreases as their temperature decreases. The rate of decrease at ordinary temperatures is such that at absolute zero temperature the resistivity would be zero if the rate of decrease remained constant all the way down.

If the rate of decrease remains constant as the temperature descends to the absolute bottom, the resistance of such metals as silver, copper and aluminum would be absolutely zero, and a small voltage would send an infinite current through them. Then there would be no IR drop in a wire of the material, there would be no heat dissipated in the conductor, and there would be no energy loss.

A tuned circuit formed of a coil and a condenser, subjected to this base temperature, or rather lack of temperature, would in fact be a no-loss circuit and its selectivity would be perfect.

Onnes Confirms Theory

There is much more than speculation in these statements. Some years ago Dr. Kammerlingh Onnes, a physicist in the University of Leyden, Holland, tested the theory and confirmed it as far down the temperature scale as he could at the time. He actually came within less than 2 degrees Centigrade of the absolute zero. He measured the resistivity of metals at this low temperature and found that it was in accord with the theory, that is, that it was practically zero.

And now comes a report from a physical laboratory in Berlin stating that the tests have been repeated and that the theory has been confirmed again. The results were similar to those found by the Dutch physicist.

Tests have been conducted on the resistivity of metals at temperatures of 452 degrees Fahrenheit below zero, which is only 8 degrees above absolute zero on the same scale. As the absolute limit is approached the resistivity of metals becomes of the order of one billionth of the value at ordinary temperatures.

The absolute zero means that all molecular activity has ceased. It occurs at approximately 273 below zero on the Centigrade scale, or 460 degrees below zero on the Fahrenheit scale. Brrrr, that's cold!

How Lowest Are Obtained

The lowest temperatures are attained in the laboratory by boiling liquid hydrogen or helium. These gases are first liquefied by successive stages of cooling and by subjecting them to pressures of 3,000 pounds to the square inch. The general process is based on the same principles as underlie the making of artificial ice or refrigeration. A gas is compressed. In doing so it heats up. It is cooled as much as possible while it is in the compressed state. Then it is permitted to expand as much as possible. Its temperature drops, and it does so for the same reason that it heated up when it was compressed.



NATIONAL TONE FILTER
 officially specified for the
MAGNAFORMER 9-8

The output tube of the Magnaformer, as recommended by the designer, is a 371 or 171 tube. The makers of the tubes recommend passing the output to the loud speaker through a Tone Filter. The NATIONAL Tone Filter is designed for this purpose. It contains an impedance of the proper value through which the plate of the power tube is supplied, and which will carry as high as 45 milliamperes continuously without heating or saturation. Also used in the Tone Filter is a 2 mfd. Tobe filter condenser, through which the AC component of the power tube passes to the loud speaker.

List Price: Without Cord... \$6.50
 With Cord..... \$7.00

NATIONAL COMPANY, INC.
 Engineers and Manufacturers
 W. A. READY, Pres. Malden, Mass.

The Circuit They All Rave About —and Why!



HELLO JAPAN!

THE easy supremacy of the Intermediate Frequency System of Reception has long been recognized by technical experts because of the intensely greater amplification, sensitivity and selectivity possible. But the achievement of remarkable results in tone quality, great distance-getting ability and maximum power has, until now, been hampered by criticalness of tuning and instability of operation. The problem that long awaited solution, therefore, was the problem of design and perfection of coils of such superior electrical characteristics and mechanical strength that they could be accurately and permanently tuned, all to the same identical long wave length—coils that would stubbornly hold to that identical adjustment despite hard knocks, changes of temperature, climatic conditions, moisture or all other circumstances that operate to change the frequency characteristics of ordinary coils. When the Magnaformer Intermediates were eventually perfected, after two years of intensive laboratory research and experiment, the supreme circuit of circuits finally had its supreme coil of coils.

So REAL is this superiority of Magnaformer Intermediate Coils that such famous technical authorities as Gerald M. Best, Technical Editor of "Radio"; Laurence M. Cockaday, Technical Editor of "Popular Radio"; J. E. Anderson, Technical Editor of "Radio World"; Kenneth G. Ormiston, Technical Editor of "Radio Doings"; and the Technical Editors of the "Citizens Radio Call Book", constituting the highest judges of the SECOND HIGHEST RADIO COURT, after thoroughly testing Magnaformer Intermediates, looked into the standard circuit in their several Laboratories—some of them for three months—unanimously decided on Magnaformer Intermediates in presenting the circuit of circuits. Throughout the present radio season they have expounded the circuit and coils for the benefit of their great followings in their personal articles in all of the recent numbers of the publications of which they are the Technical Editors.

And as for the HIGHEST RADIO COURT—the set-building public itself—the verdict of these world-famous technicians has been unanimously and enthusiastically affirmed. Knowing that no ordinary coil could awaken such endorsement from this array of technical talent, professional custom set builders and home constructors generally have taken the advice of these foremost fathers of the art and are building the receiver that they now know from personal experience is the very best that can be built.

Magnaformer 9-8 Commander-in-Chief of the Air

SO not only do Best, Cockaday, Anderson, Ormiston and many others rave about the Magnaformer Intermediates, but the public that follows their sound advice and counsel and builds the circuit, does likewise. Doctors, no less, the most particular class of set constructors, proudly demonstrate their Magnaformers, with that quiet pride attaching to the possession of the best there is! Anybody who really is entitled to the fine things in life ultimately gets them. You, as a radiolast, surely want your friends to look up to you as the possessor of the last word in receivers. You run no risk when you decide on the Magnaformer 9-8. Eight tubes bring in stations a thousand to two thousand miles away. Nine tubes stretch out infinitely farther. Ormiston, for instance, reports loud speaker reception of Tokio, Japan; Auckland, New Zealand; Sydney, Australia, and Melbourne, Australia, on his home-built Magnaformer 9-8, spanning 6,000 to 9,000 miles of space, and using only 8 tubes.

But not in distance alone does the Magnaformer 9-8 excel. Tone quality is so pure that the name Magnaformer—from two Latin words meaning "The Great Creator"—has a real and definite meaning. And no circuit could accomplish such outstanding distance reception unless it were outstanding in selectivity also.

Magnaformer 9-8 Commander-in-Chief of the Air Spans the Seas

THE unique RADIO thrill of receiving Tokio, Japan, and Sydney and Melbourne, Australia, on the loud speaker, using only 8 tubes, was first experienced on the night of September 11, 1927, by K. G. Ormiston and party of witnesses using a home-built Magnaformer 9-8 Receiver. On the night of November 5, 1927, R. C. Anderson, Long Beach jeweler, with a home-built Magnaformer 9-8 Receiver pulled in five 6,000 to 9,000 mile distant Eastern Hemisphere stations—1YA, Auckland, New Zealand; 2BL, Sydney, Australia; 5CL, Adelaide, Australia; JOAK, Tokio, Japan; JOCK, Nagoya, Japan, and 61 long distance Western Hemisphere stations from the Atlantic to the Pacific as follows, in the order in which he received them.

WBMM; KDYL; KFEL; KYW; WIO; WOV; WBAP; KSL; KFXF; KFEB; WSE; WRR; WJZ; WLW; WHT; WCCO; KOIN; KIQ; WLS; KSOO; KJR; WEW; WSN; KSOB; KSEI; KOA; KOIN; WGN; KMMJ; KDKA; WBAK; WLIW; KLDJ; KOMO; WJJD; WGY; WBT; WAU; KMOX; WENR; WJAZ; KEX; KFOA; WSMB; PWX (Havana, Cuba); KZ; KWKH; KOB; KSJR; KSBV; CFNC; KGW; WSA; WPA; KHQ; WEBH; WSMK; KOW; KMO; KSYR.

During one evening when the numerous powerful local stations were going full blast, J. M. Douglas, of Chicago, on a home-built Magnaformer 9-8, cut cleanly through this blanketing barrage and pulled in 32 out-of-town stations without interference.

On the night of Nov. 12, 1927, H. Dallas Johnson tuned in 1 New Zealand, 2 Australian, 3 Japanese and 49 long distance Western Hemisphere stations on his home-built Magnaformer 9-8—all on the loud speaker, using only 8 tubes, as follows:

CJQR; CHCY; CKWX; CNRV; CFCT; CFNC; CYE; WGV; WABC; KDKA; WTAM; WGN; WLBI; WLS; WCFL; WEBH; KYW; WBBM; WFIW; WDAG; WENR; WSM; KFYP; WJAG; WCCO; KFAB; KRLD; WIO; KMOX; WBAP; KOB; KVOO; KOIN; KIE; KILZ; KSL; KOA; WJAZ; KWKH; KGW; KEX; KMO; KFOA; KHQ; KGA; KMA; KMOX; WOAI; JOAK; JOBR; JOCK; 2BL; 5CL.

Only a "Commander-in-Chief of the Air" can deliver such performance to you. It brings them in not only from Coast to Coast, but also from Continent to Continent.

THE circuit that Best, Cockaday, Anderson, Ormiston and thousands of others have built can be built by you, without the slightest difficulty. Full details are contained in the official Wiring Diagram and Instruction Sheet, 28"x34" in size, printed on both sides, each side just crammed with helpful information, diagrams, progressive wiring photographs, etc., etc. This, the most complete, thorough, plain and comprehensive instruction sheet ever issued for any circuit ever published, sells for 50c and is easily worth \$2.00. But one will be mailed FREE OF CHARGE to every reader of this Special Magnaformer 9-8 issue of Radio World who sends in the coupon. Be sure to get your complimentary copy. Mail the coupon today, TODAY.

Nobody need feel that any task confronts him in building the Magnaformer 9-8, for drilled and engraved front and sub-panels are available everywhere, dispensing with tedious drilling. The part-to-part and point-to-point connections are so clearly shown in diagrams and photographs that nobody, not even the veriest novice, would miss up.

Everybody who ever hears a Magnaformer 9-8 is consumed with an immediate and overpowering desire to own one. But even if you have not heard one, you can take the word of the best experts that it is all THEY say it is.

Let the best be none too good for you—make your holiday choice a Magnaformer 9-8!

Mail This FREE Coupon Today!



RADIART LABORATORIES CO., Dept. 69
19 So. La Salle St., Chicago, Ill.

Please mail without charge, complimentary copy of the 50c. full size, 28"x34" Magnaformer 9-8 official wiring diagram and instruction sheet printed both sides and fully illustrated; also long distance (8,000 to 9,000 miles) record breaking loud speaker reception records using only 8 tubes.

NAME ADDRESS
CITY STATE

RADIART LABORATORIES CO., Dept. 69
19 South La Salle Street
Chicago, Ill.

Exclusively Specified for the Magnaformer 9-8 Commander-in-Chief of the Air

FROST-RADIO

EXCLUSIVELY SPECIFIED
FOR THE

Magnaformer

9-8



The powerful Magnaformer, one of the season's most popular circuits, specifies Frost-Radio De Luxe Parts exclusively. Demand these quality parts from your dealer by name, ordering from the list below, so that you can build this great receiver right away.

**FROST-RADIO PARTS
FOR THE MAGNAFORMER**

- 1 No. S-1810 De Luxe 10-ohm Bakelite Combination Rheostat and Battery Switch, engraved pointer knob.
- 1 No. 1824 De Luxe 400-ohm Bakelite Potentiometer, engraved pointer knob.
- 1 No. 1810 De Luxe 10-ohm Bakelite Rheostat, engraved pointer knob.
- 1 No. 1830 De Luxe 30-ohm Bakelite Rheostat, engraved pointer knob.
- 4 No. 253 Frost Cord Tip Jacks.



**Write Today for
Valuable Booklet**

Our new booklet, "What Set Shall I Build?" will be mailed you free on request. This booklet tells you all about the popular circuits, gives much interesting and instructive data regarding them, and will prove of tremendous value to the set builder. Write for your copy today.

HERBERT H. FROST, Inc.
Main Offices and Factory
New York Elkhart, Ind. Chicago

YAXLEY

APPROVED RADIO PRODUCTS

Specified for
Magnaformer
9-8

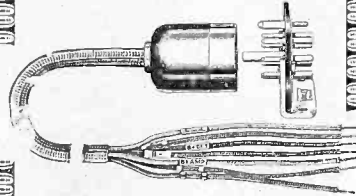

**Cable
Connector Plug**

A most ingenious and useful radio convenience for the set builder. Facilitates easy connection and disconnection of set from battery and eliminator leads.

No. 660 - - - - \$3.00

**Double Pole, Double
Throw Jack Switch**

Brass frame, with Bakelite insulation. Meets the most exacting requirements.

No. 60 - - - - \$1.25

At Radio Dealers
and Jobbers.

Yaxley Mfg. Co.
Dept. J, 9 So. Clinton Street
CHICAGO, ILL.

AMPERITE

REG. U.S. PAT. OFF.

Is Exclusively Specified
for the
MAGNAFORMER 9-8
Commander-in-Chief of the Air

Improves-
tone fidelity, clarity, sensitivity - by automatically keeping tube filament voltage constant, despite "A" battery variations.

AMPERITE

REG. U.S. PAT. OFF.

The "SELF-ADJUSTING" Rheostat
eliminates hand rheostats. Simplifies wiring, tuning, panel design. Particularly essential with Battery Eliminators. Accept only Amperite. \$1.10 mounted (U.S.A.)

FREE - "Amperite Book" of interest circuits and construction data.
Write Dept. R W 25,
RADIALL CO.
56 Franklin St., New York



BENJAMIN

TRADE MARK

Cle-Ra-Tone Sockets



Spring Supported
Shock Absorbing

Specified for
Magnaformer 9-8

The choice for practically every prominent circuit for several years. Stop tube noises. Tube holding element "floats" on five finely tempered springs.

At All Radio Dealers and Jobbers

BENJAMIN ELEC. MFG. CO.
New York Chicago San Francisco

REMLER

Drum Dial

and
**Twin-Rotor
Condenser**

Exclusively Specified
for the
Magnaformer
9-8 CIRCUIT

as described in this issue
By **J. E. ANDERSON**
Technical Editor



Remler Drum Dial, No. 110
List Price - - \$4.50

Remler Twin-Rotor Condenser,
.0005 mfd. maximum capacity.
No. 639 - S.L. Wavelength
No. 649 - S.L. Frequency
List Price - - \$5.00

The Remler Drum Dial gives a full 15 inches of dial space, divided into 200 divisions - 2 for each broadcast channel. Calibration strips are rigidly mounted. Socket and 6-volt lamp furnished for illumination. Easily mounted; round drilled hole required for panel plate. The Remler Drum Dial will drive all standard makes of condensers either single or in gangs of one, two, or three condensers.

REMLER DIVISION
Gray & Danielson

New York Chicago

260 First St., San Francisco

Specified Again!



Aerovox Condensers are
Exclusively Used in the

Magnaformer

9-8 CIRCUIT

AEROVOX

"Built Better"

70 Washington St., Brooklyn, N. Y.

BULLARD DIES SOON AFTER HIS AIDE, DILLON

For the second time within two months a member of the Federal Radio Commission died. Rear Admiral William H. G. Bullard, chairman of the commission, passed away suddenly at his home in Washington Thanksgiving morning.

Admiral Bullard was born in Media, Pa., December 5, 1866. He was graduated from the Naval Academy in 1880. It was he who in 1907 organized the Department of Electrical Engineering at the Naval Academy. Admiral Bullard had a notable career in

radio being connected with it ever since radio became the chief means of communication in the Navy. He was the first person to be assigned as Chief of Naval Communication. He served in this capacity from 1912 to 1916.

President Coolidge's selection of Admiral Bullard as the chairman of the commission in March met with general approval.

Admiral Bullard was a member of the Institute of Radio Engineers, the Veterans of Foreign Wars of the United States and Naval and Military Order, the Army and Navy Club, the Officers' Club of Annapolis, and the New York Yacht Club.

HARTZELL TO HANDLE PARATONE

Hartzell Sales Co., 50 Church Street, New York City, have added to their lines, and will nationally handle, the new Paratone Cone Unit, manufactured by the Paratone Mfg. Co., Inc., 45 Lispenard Street, New York City. This is an excellent product, made of the best materials by experts.

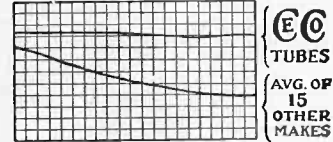

Steadier Performance -Longer Life!

A nationally known set maker tested CeCo Tubes, and 15 other kinds.

The results are shown by the graph printed above. After 1000 hours (the average life of most 201A Type Tubes) CeCo Tubes proved to be as efficient as at the beginning of the test. (See upper line of graph). The average decline in efficiency of the other 15 makes is shown by the lower line.

There's a CeCo Tube for every radio need to make a good receiver better!

ASK YOUR RADIO DEALER

C. E. MFG. CO., Inc., PROVIDENCE, R. I.



QUALI-TONE LOOPS

(Collapsible-Adjustable)

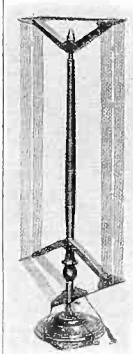

Specified Exclusively for the **Magnaformer**

As Described in This Issue Also recommended for use with the 9 World's Record Super's Popular Mechanics Economy 9, Melo Heald and many other popular receivers.

Holds Two World Records for DX Reception

Improve the performance of your set with a Quali-Tone Loop. Ask your Jobber or Dealer.

The De Luxe \$12.50
The Quali-Tone 10.00

Duro Metal Products Co.
2643 N. Kildare Ave. Chicago, Ill.



Exclusively Specified for MAGNAFORMER 9-8

WHEN foremost radio engineers—when leading set manufacturers—when successful professional builders—and when informed radio fans ALL endorse, adopt and use Durham Metallized Resistors and Powerohms, SUCH LEADERSHIP MUST BE DESERVED!

Various Sizes for All Uses
INTERNATIONAL RESISTANCE CO.
Dept. 4, 2 1/2 So. 20th Street, Phila.

DURHAM

METALLIZED
RESISTORS
& POWER OHMS

There's a Difference!

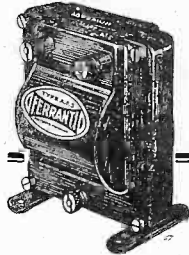

Ferranti Transformers give you different sound tones—different because they are true reproductions. Every note clear, loud and undistorted. A difference in musical reception which is easily recognized by the untrained as well as trained ear.



Audio Frequency Transformers

A. F. 4 Exclusively Specified for the **MAGNAFORMER** Circuit

FERRANTI, Inc.

130 West 42nd Street, New York, N. Y.
FERRANTI, Ltd., Hollinwood, England
FERRANTI ELECTRIC, Ltd., Toronto, Ontario, Canada

End Radio Bothers

DO YOU KNOW what's wrong when your radio set isn't working right? Ten to one, you don't. Twenty to one, you would if you had a copy of

Hoff's Radio Trouble Finder



Ever hear of M. M. Hoff, radiotrician, of Philadelphia? He was one of the very first "radio bugs" and has been building and studying sets ever since. And now, out of his broad experience, this man has written a book to tell radio owners how to keep their sets working right.

He tells in plain words and illustrations how a set is made, what the parts are called, what are the few usual troubles and how to fix them. Then he lists 103 troubles that sometimes happen and tells how to detect and fix each one.

The book is a regular cyclopedia of radio information—only it's in a language anyone can understand. Read it five minutes and you'll know more about radio than you ever dreamed of.

It will save you many a repair man. It will save you hours of guessing and fussing and fuming. It will help you to keep the tone of your set always sweet and strong. It will keep you from losing many programs. And, best of all—

IT WILL MAKE YOU STOP SWEARING—MUCH TO THE SURPRISE OF YOUR FAMILY—because radio repairs are expensive. Why hire them done when you can easily learn how to keep your set from needing them?

All It Costs Is \$1

Send cash with your order and you get also a Dictionary of Radio Terms and the latest list of Radio Broadcasting Stations with call letters and the new Federal Radio Commission wave lengths. Send your dollar today while the copies last.

CHICAGO BARGAIN HOUSE

426 QUINCY BUILDING

CHICAGO, ILLINOIS

Building Everyman 4 Described in Detail

(Concluded from page 20)
would possibly give better quality when using the powerful Q. R. S. detector tube.

Some Important DONT'S

Don't mount coils closer than one inch to transformers or condensers.

Don't neglect in grounding the transformers. Solder lug to nickle eyelet.

Don't use other values of by-pass condensers.

Don't use longer leads than necessary from the tube P terminals to the regeneration condenser.

Don't leave those pretty little coils at either end of the coil windings. Short leads are best.

Don't mount RF tube socket in same position as the rest. G and P terminals face the rear of set.

Don't use shunt type of grid leak and condenser for the detector tube.

Don't connect neutralizing condenser to the twentieth turn tap.

Don't expect a tube to perform cor-

rectly in a stage it is not designed to work best in.

Don't change tubes around in set, or take out socket, without turning off the switch. It shortens the life of the tube.

Don't expect quality from low B batteries, or 90 volts on the last stage.

Don't expect the best performance from this set until you have mastered its workings.

Don't forget to bunch the battery leads along the rear edge of the baseboard on their way to the cable socket connection.

Don't use any other capacity neutralizing condenser. That has caused more downfalls than all the rest put together.

Don't make "cold soldered" joints.

Don't use any wire for coils, other than No. 24 silk covered cotton covered.

Pointer on Diagram

In the diagram of the Everyman 4, on page 9 of the Dec. 3 issue, reverse the two center taps of the tapped coil, i. e.,

the 20 turn tap goes to the .5 mfd. fixed condenser and to the 67 B plus post. The 23 turn tap goes to the neutralizing condenser.

Praise for Set

This remarkable receiver has already been built by thousands of fans who have only the highest words of praise for it. The following results letter shows what Sidney Greenstein of 828 Dawson Street, N. Y. City, thinks of the receiver.

"I have built hundreds of receivers, of all types. That is, from a 1 tuber to a 8 tuber and never yet I have been so pleased as with the results obtained with Everyman 4. It is simple to tune, voluminous and a bear for distance. The quality is just flawless. Really it seems to good to be true. Why, it is as simple to tune in KOA, the General Electric station at Denver, as a local."

"It happened to be my hard luck, that when I installed this set, some one had cut down my antenna. It was necessary for me to use a makeshift indoor antenna. I expected just moderate results. But, what a surprise I received! WGY rolled in like a local. Well, why go on. The set is just a peach, and that's all there is to it."



All Specified Parts in Stock—

OFFICIAL STATION

We Supply Only Tested Parts—No Substitution

RADIO KIT CO., TEL: CORT 1849 72 Cortlandt St., New York City

SET ON DEMONSTRATION

Mail Orders on Kits,
or Sets Wired to Your
Order. Shipped Anywhere

Cardwell

Type 192-E, \$5.00

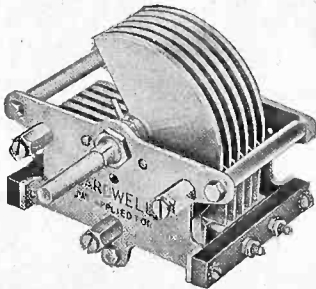

Q·R·S

AUDIO—RECTIFIER TUBES

Super Detector

200A, \$4.00

201A, \$1.75

NA-ALD

V. T. SOCKETS, 65c

CE-Co

A Tube for Every Need

TWIN COUPLER COIL CO., Inc.

Everyman COILS

MICARTA PANEL

DRILLED and ENGRAVED

"Everyman 4"

Its Possibilities Will Never Be Exhausted

FOR BEST RESULTS USE ONLY MUTER AND OTHER SPECIFIED PARTS

Muter Supreme Audio Transformer, First Stage.....	\$7.00
Muter Supreme Audio Transformer, Second Stage.....	7.00
Muter Clarifier and Tone Filter.....	5.00
Muter Radio Frequency Choke.....	1.50
Muter Neutralizing Condenser.....	.75
Muter Push-Pull Panel Switch.....	.35
Muter Moulded Fixed Condenser.....	.40
Muter Heavy Duty Grid Leak.....	.50
Muter Grid Leak Holder.....	.15
Muter 5 mfd. Bypass Condenser.....	.75
Muter Tubestat.....	.50

The number of owners of the Everyman 4 circuit is running into thousands. Selectivity, volume, distance, tone quality, ease of tuning, simplicity of construction, extreme low cost.

LESLIE F. MUTER CO.

76TH AND GREENWOOD AVENUE

CHICAGO, ILL.

New York Representative: EDWARD J. BECKLEY, 154 Nassau St., N. Y. C.

Distortion Eliminated

(Concluded from page 13)

low voltage and high, alternating current. An example of the six volt field winding is that of the Magnavox Type R-4 unit, which has a resistance of 12 ohms

SM 87%
at 30
Cycles



That's why more S-M audio transformers have been sold last year than any other similar type—simply because they give real bass note amplification.

And the 5000 cycle cut-off they introduced means less interference—fewer heterodyne squeals.

Type 220 is unconditionally guaranteed the finest of audio transformers—or your money back. It's priced at \$8.00, and its companion 221 output, priced at \$7.50, boosts speaker bass performance.

Silver-Marshall, Inc.

846 W. Jackson Blvd. Chicago, U. S. A.

and takes a direct current of one half ampere, or the same as the filament of a 112 tube. The R-4 is the one illustrated in the baffle board installation on page 13. Speaker field coils are also wound to be connected directly across an 110 to 115 volt DC line. An example of this is the Magnavox R-5 unit. This has a resistance of 2,500 ohms and requires an excitation current of from 40 to 80 milliamperes. The power consumption in the winding is about 5 watts. This unit can also be connected to a battery eliminator having an output voltage of from 100 to 120. The R-500 incorporates the unit and a power amplifier. This coil can be used in place of a

choke coil in a filter when used with certain circuits. It has an inductance of 40 henrys.

The Ideal Gift!
Everyman's Guide to Radio
The Latest and Best Radio Book on the Market at \$2.00
Endorsed by Radio Institute of America, and Used by Radio Schools, Y. M. C. A., Radio Corp. of America
A Thorough Treatise of the Fundamentals and Mechanics of Radio.
4 Volumes in 1 de luxe binding. Over 800 illustrations and diagrams. Contributing authors include Langmuir, Fessenden, Steinmetz, Marconi and 12 others.
Limited quantity in Publishers' Hands. Remit with Order.
Inquiries solicited from the Trade
HEISTEN & ROBERTS
116 WEST 39TH ST. NEW YORK CITY

FREE! With Regular \$27.50 Eliminator for Only \$15.00
\$4.50 Tube • **GUARANTEED FOR 1 YEAR**

For slightly more than the cost of "B" batteries you can now enjoy the advantages of a high quality, tested and guaranteed SERPA "B" ELIMINATOR—furnishing smooth, unflinching power of 160 volts. This offer of a high quality product at such a bargain price, together with a FREE \$4.50 tube, is possible only because we sell DIRECT FROM FACTORY TO YOU. YOU GET THE BENEFIT.

Don't pay exorbitant prices for batteries—the SERPA "B" ELIMINATOR costs no more and lasts for years—and delivers the correct amount of current at all times—without trouble—for best results. May be used on any type of set using up to 6 tubes. No noise, hum or vibration when operating.

Read our guarantee and offer of FREE TEST—then insure yourself of some real pleasure with your radio set by getting our "B" eliminator.

Try It for Ten Days

On your own set, in your own home, and make every test to convince yourself of the exceptional performance and amazing value of this wonderful eliminator—then, if you are not completely satisfied, in every way, with its operation and performance and that it offers the greatest eliminator value on the market today at the price—just return it to us and your money will be refunded.

MAIL THIS COUPON NOW

Gentlemen:
Here is my dollar and I want you to send immediately your tested and guaranteed SERPA "B" ELIMINATOR with FREE TUBE, and I will pay the expressman the balance of \$14.00, plus small express charges. It is understood I can return same at the end of ten days' trial if I am not satisfied, and my money will be refunded.
NAME
ADDRESS
TOWN..... STATE.....

Guaranteed for One Year
Your purchase of the SERPA "B" ELIMINATOR is fully protected and guaranteed for one full year against any mechanical, material or labor defects. Certificate of guarantee given with each eliminator. Full responsibility of any defects appearing within one year will be assumed and corrected by us.

Send for Your Eliminator Today

Don't fail to take advantage of getting our real quality eliminator at the rock-bottom price of \$15.00. YOU TAKE NO RISK. Approval of radio experts and engineers plus, our money-back and one-year-guarantee, is your protection.

Only \$1.00 with coupon brings a tested, guaranteed eliminator with a FREE TUBE direct from the factory to your home for the ten-day trial. The expressman will collect the balance of \$14.00, plus the small express charges, upon delivery. Send the coupon with a \$1.00 bill now and we will send your eliminator immediately.

Serpa Manufacturing Co.

Dayton and Weed St., Dept.
CHICAGO, ILL.

Total Shielding
for **Leading Kits**
The Vee Dee
No. 250 Cabinet

LIST PRICE \$18.00

Including Panel

F.O.B. Factory. Packed in STRONG CARTON.
Dimensions: 23½x12x7 or 8 in.
Special Chassis, Size: 20x11x1½ in., \$2.10

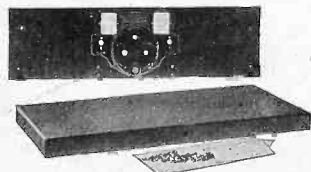

Metal Panel and Chassis for SILVER-MARSHALL 1927 Improved Laboratory Model

Complete assembly, fully drilled, beautiful wood finish with special two-color decoration, all fibre bushings and washers included, also screws, bolts and hardware accessories.

THE VAN DOORN COMPANY
160 North La Salle Street Chicago, Ill.
Factories, Quincy, Ill.

**THE LATEST IMPROVED
"DIAMOND OF THE AIR"**

**Herman Bernard's Great Set
Still the Best Circuit**

Complete Authorized Kit
of Parts for 5 Tube Set,
as specified in this issue,
ready to build.....

\$39.00

4 TUBE DIAMOND KIT, \$35.00
Get our money-saving prices on following kits!
Karas Equamatic, Karas Knickerbocker 4, Silver-
Marshall Shielded Six, New Hammarlund-Roberts
Hi-G, Everman 4, Aero-7, Powertone, 4-Tube
Diamond of the Air, Lynch Five and all New Kits.
IF IT'S A KIT, WE HAVE IT
Send for New Free Catalog, Just Out
B.C.L. RADIO SERVICE CO., Inc.
220 Fulton Street New York City

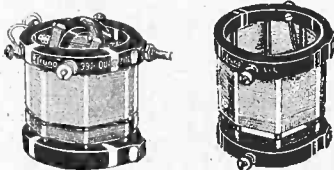

**BRUNO QUARTZITE TUNING
COILS** and other radio parts illus-
trated in an article in this issue on the
4 and 5 tube Diamond have been repeat-
edly specified in new circuits for their high
degree of efficiency, selectivity, and sensi-
tiveness.

The No. 99 Jr. Tuning Coil has been designed to
be used with a .0005 mfd. condenser across the
secondary winding. When used with the No. 99
TRF Coil, if the condensers have the same capac-
ity, the two readings should be alike. Absorp-
tion losses are completely eliminated. Wavelength
200 to 575 meters. List price.....\$5.50

The No. 99 Jr. TRF Coil when used in conjunc-
tion with a .0005 mfd. condenser will cover the
entire wavelength band from 200 to 575 meters.
Furthermore, it is suitable for any circuit em-
ploying tuned radio frequency. List price.....\$3.00

Both Coils are perfectly made and wound
with green and orange silk-covered wire
on Quartzite—a special glass containing no
metallic base.

Your Dealer has the SPECIFIED BRUNO
parts. If not, then send direct to us.

BRUNO RADIO CORPORATION
Long Island City New York

FOR COMPLETE DATA on the Winner, a
4-tube set of excellence, see the Oct. 1, 8, 15, 22
and 29 issues of RADIO WORLD.

Tips on 4 and 5-Tube Diamonds

(Constructional data on the ever-popular
four and five-tube models of the Diamond
were published in the December 4 issue of
RADIO WORLD. Herewith is some more in-
teresting information on these remarkable
receivers.)

KARAS PARTS Specified for the DIAMOND OF THE AIR

IN the Dia-
mond of
the Air de-
scribed in
this issue
of Radio
World Karas
Harmonik Au-
dio Frequency
Amplifying
Transformers
and the NEW
Karas S. F. L.
Removable
Shaft Variable
Condensers are
specified. Be
sure to order
these parts for
your Diamond
of the Air when
you build this
receiver.



The Karas Harmonik Transformer, price \$5, gives the
maximum of distortionless audio frequency amplifica-
tion, producing tremendous, volume and superb tone.

Two Karas S. F. L. .0005 Variable Con-
densers, price, each
\$5.50, are used in the
Diamond of the
Air. These new
Karas Conden-
sers have been
found superior to
scores of even
higher priced
condensers be-
cause of their
low losses, abso-
lutely straight
line tun-
ing, and
the fact that
they may be
used with
either 100-0
or 0100 type
Dials.

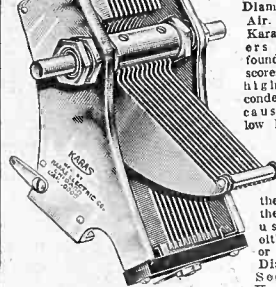

Secure these
Karas parts for
your Diamond of the Air from your dealer today.

KARAS ELECTRIC CO.
4039-L North Rockwell St., Chicago

THERE is only one way to elicit the
best results from the four and five-
tube models of the Diamond of the Air.
That is to follow step by step, carefully
and exactly, the circuit diagram, the parts
layout and the list of parts.

Each and every part was chosen be-
cause it was found to give not alone satis-
factory results, but exceptional results.

The connecting up of the coils can be
made to be a very intricate proposition,
if the diagram and textual data are not
followed, even though the entire operation
should be a very simple one.

Before placing any of the parts onto
the subpanel, test each and every part for
continuity. It is just possible that a lead
between the winding and the terminal post
on a coil has been broken. Nobody's fault,
yet your loss of temper, perhaps; so dis-
cover the fault and remedy it with your
iron.

The transformers in the four-tube model
can be placed either on top of the sub-
panel or underneath, but top position is
preferable. When placing them on top,
the second transformer is mounted right
over the fourth socket from left, on the
socket strip.

LIST OF PARTS

(For Five-Tube Model)

- L0L1—One Bruno No. 99 Jr. TRF coil.
- L2L3L4—One Bruno No. 99 Jr. tuning coil.
- C1C3—Two Karas SFL .0005 mfd. variable condensers.
- C2—One Polymet .00025 mfd. grid condenser.
- R, R1—Two No. 1A Amperites.
- R2, R7—Two 112 Amperites.
- AF1—One Karas Harmonik audio transformer.
- R3, R5—Two Polymet .25 megohm resistors with mountings.
- R4, R6—Two Polymet 1 megohm resistors with mountings.
- R0—One Bretwood Variable Grid Leak.
- C4, C5—Two Flechtheim .1 mfd. fixed condensers.
- J1, J2—Two double circuit jacks.
- J3—One single circuit jack.
- S—Two 2 inch pieces bus bar.
- S1—One Bruno light switch.
- S2—One push switch for socket strip.
- WXYZ—Four binding posts.
- Two binding posts. (Ant., Gnd.)
- One Bruno pilot light.
- One 7x24 inch panel.
- One pair of Bruno brackets.
- Two Marco 4 inch dials.
- One Marco 2 inch dial for tickler.
- One CeCo type K tube for socket 1.
- One CeCo type H tube for socket 2.
- Two CeCo type G tubes in sockets 3 and 4.
- One CeCo type F tube for socket 4.
- One battery cable.
- N. B.—For the four-tube Diamond use two Karas Harmonik transformers and omit R3, R4, R5, R6, R7, C4, C5 and one socket.

Improved, Positive Voltage Control for "B" Eliminators

HEAVY DUTY Centralab Potentiometer

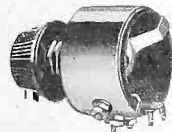

The new Centralab Heavy Duty Potentiometer is all wire wound and will carry the entire output of any "B" power device with an unusually high margin of safety. Resistance remains constant at any knob setting so that panel or knob can be marked in volts. A single turn of the knob will give full variation.

Has sufficient current capacity to permit shunting a low resistance value across the "B" power unit to obtain constant voltage regulation. A sufficient current load is maintained through the resistances to reduce the rectifier voltage to workable pressure even though set is not connected—an insurance against filter condenser breakdown.

Resistances 2,000, 3,000, 5,000, 8,000, 10,000, 15,000, 20,000, 50,000, price \$2.00; at your dealer's or C.O.D.

CENTRAL RADIO LABORATORIES
13 Keefe Avenue Milwaukee, Wis.

Write for folder
giving details of
this circuit.



25 Cents

Brings ALL THIS!

- One Official Blueprint of the Five-Tube Diamond of the Air
 - One official booklet describing in detail how to build this famous set, wind coils, etc.
- Act Now! Send That Quarter to
RADIO WORLD**
145 West 45th Street, New York City

ARTHUR H. LYNCH, INC.,
1775 Broadway, New York City.
GENTLEMEN:
Please send me a copy of your booklet, "Resistance
the 'Control Valve' of Radio." I am enclosing
25 cents.
NAME
STREET
CITY STATE R. W.



LYNCH

**Resistance in Radio
What It Is**

This compact hand-book, "Resistance the 'Control Valve' of Radio," tells you all about the uses and importance of resistance in radio. Contains a wealth of interesting, dependable information on resistors, equalizers, grid leaks, and other important radio devices.
A copy costs only 25 cents. Return the coupon with your quarter today or see your nearest dealer.

ARTHUR H. LYNCH, Inc.
General Motors Building
1775 Broadway, at 57th Street, New York
SALES OFFICES IN MOST LARGE CITIES

**BUILD Your Last Set
FIRST!**
If you haven't yet filled
out and sent in this
coupon do so now—

Leo FENWAY for DX! INC.,
249 W. 53rd St., New York, N. Y.
Gentlemen: Tell me more about how I
can purchase a complete kit of Concertrola
parts and pay for it on the deferred pay-
ment plan. No obligation, of course.
Quote your lowest cash price for the
same kit.
NAME
ADDRESS
(R. W.)

FOR XMAS - A HOMEKASTER!

The wonderful new HOMEKASTER is a gift that delights any radio set owner. It enables you to furnish your own radio entertainments. With HOMEKASTER, anyone can announce, sing, etc., before the transmitter in any room and the sounds will be greatly amplified, coming out of the loud speaker, just as if the performer were at the broadcasting studio. Mystical, entertains, delights children and everyone. Hear your own voice "over the air!"
Reverse the process, and the HOMEKASTER becomes the most sensitive detective device—really marvellous. HOMEKASTER is complete, ready to use. Guaranteed fully. Orders filled in rotation. Send check, money order, or pay postman \$5.00 upon delivery.
Approved by RADIO WORLD Laboratories
APLIN RADIO LABORATORIES
30 Church St., Suite 429, New York City

VICTOREEN
Super Coils
Send for Folder
Geo. W. Walker Co.
2825 Chester Avenue
Dept. B Cleveland, O.

C · R · A ·
The REAL RECTIFIER TUBE
Guaranteed for a Full Year
PRICE, \$4.50
CHARLES R. ABLETT CO.
Lamp Specialists for Twenty Years
22-24-26 READE ST. NEW YORK

**For Best Results
with the
"FENWAY ELECTRIC
CONCERTROLA"
RECEIVER**
Featured in
RADIO WORLD
Use Only the
**HAMMARLUND
CONDENSERS AND CHOKE**
Specified by the Designer
HAMMARLUND MFG. CO.
424-438 West 33d Street, New York
**For Better Radio
Hammarlund
PRECISION
PRODUCTS**

COMPLETE DETAILS on the Laboratory-Super appeared in the Nov. 19, 26 and Dec. 3 issues of RADIO WORLD. Send 45c for these issues.

**Accurate
Constant!**

**Polymet
Bakelite Mica
Condensers**

Every Polymet Mica Condenser is individually tested for accuracy and high voltage break down. They are not affected by heat, cold, moisture or atmospheric changes. Polymet Mica Condensers are standard equipment with a majority of the nationally known set manufacturers and are specified in the leading popular circuits. Follow the leaders. Use the best—POLYMET.
At All Dealers
Write for complete information regarding Polymet parts and all Polymet radio essentials.
POLYMET MANUFACTURING CORP.
597 Broadway, New York City

POLYMET

**New! The Braxton-King
SHIELDED PLUG-IN
Intermediate
Transformers**

The last word for intermediate stages. Fully shielded, therefore very stable. Plug into any UX socket. Ideal for compact construction. Only 2 1/2" high, 1 1/2" wide. Air-core, sharply peaked and laboratory-matched in sets. No filter necessary.
SET OF 4, \$18.00
Order direct if dealers can't supply. Jobbers and dealers, write for catalogue sheets, samples, and discounts.
Mississippi Valley Radio Company
914 Pine Street St. Louis, Mo.

**RADIO ACCESSORIES
at WHOLESALE**

Radio Sets, "B" Eliminators, Chargers, Tubes, Kits, Parts—everything new in Radio at lowest wholesale prices. Thousands of nationally advertised bargains. All listed and illustrated in my Big New Catalog and FREE Gift Book. 132 Pages of valuable Radio information—trouble finding, set building—Radio knowledge of all kinds. Write today. HARRY SCHWARTZBERG, Prop. AMERICAN AUTO & RADIO MFG. CO. Dept. 194 American Radio Bldg. Kansas City, Missouri

SEND \$1 for 8 weeks' subscription to RADIO WORLD, 145 W. 45th St., N. Y. C.

Radio World's CLASSIFIED ADS for Quick Action
10 Cents a Word—10 Words Minimum—Cash With Order

THOROPHONE LOUDSPEAKER, perfect condition, cost \$45. Will sacrifice. No reasonable offer refused. H. D. McChesney, Crandon, Wis.

MEN—SOUTH AMERICAN WORK—Oil, fruit, rubber companies. Expenses paid. South American Service Bureau, 14,600 Alma, Detroit, Mich.

THE WINNER, a superb 4-tube receiver, was full described in the October 1, 8, 15, 22 and 29 issues of RADIO WORLD. Send 75c for the complete series or begin your subscription with any of the issues. RADIO WORLD, 145 West 45th Street, New York City.

DIRECT FACTORY SALE—Wholesale prices. Tremendous Savings. Selling direct to you. Here are some of our many items: 30 Henry Choke, 100 M.A., \$2.19; 10 Henry Choke, 400 M.A., \$5.48. Power Transformers for all kinds of Eliminators and for all types of A.C. Tubes, at Special Low Prices. **EVERY ITEM FULLY GUARANTEED.** Promptly shipped, upon receipt of order. Send for free illustrated catalog today. Todd Electric Co., Inc. (Manufacturers) 36 West 20th Street, Dept. D, New York City.

EDISON "A" BATTERIES—Three-cell, 20-ampere-hour; in neat metal cases. Price, \$2.50 each; ten or more, \$3.00 each. Cash with order. Department "B," 25 East South Street, Indianapolis, Indiana.

HOW TO BUILD RADIO WORLD'S Four-Tube Universal Receiver fully described by Herman Bernard in the March 12, 19 and 26 issues of RADIO WORLD. Send 45c and get these three numbers or start your subscription with the first of these numbers. RADIO WORLD, 145 West 45th Street, New York City.

Perfecting the gift of radio

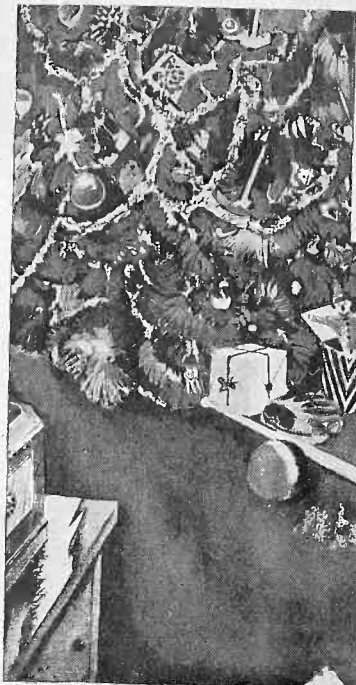

Eveready's greatest provider of Battery Power—the Eveready Layerbilt "B" Battery No. 486.



Radio is better

WHEN you give the great gift of a radio set, remember that you are giving not merely a handsome, intricate and sensitive instrument, but you are also giving radio reception, radio enjoyment, radio itself. So give a receiver that can use the best source of radio power—batteries, for batteries perfect the performance of a radio receiver. The power they provide is pure D. C., Direct Current, which is entirely silent. Battery Power will insure the enjoyment of the listener, for battery-run sets produce exactly the tone their designers built into them.

All Eveready "B" Batteries will give you the vital qualities of Battery Power. Behind Eveready Radio Batteries are 33 years of dry battery manufacture, of pioneering, invention, discovery, continual leadership. Buy Eveready Radio Batteries and ahead of you are hours, days, weeks and months of daily use, of solid

with Battery Power

enjoyment of radio at its best. For modern receivers, choose the Eveready Layerbilt "B" Battery No. 486, built according to a radically new design that gives it ample and even excess capacity to meet the demands of powerful sets. This battery is the longest lasting of all Evereadys. Its unique, patented construction packs the maximum possible quantity of active materials within a given space, and also makes those materials more efficient producers of current.

NATIONAL CARBON CO., INC.
New York  San Francisco
Unit of Union Carbide and Carbon Corporation

Tuesday night is Eveready Hour Night
—9 P. M., Eastern Standard Time

- | | |
|------------------|--------------------|
| WEAF—New York | WOC—Davenport |
| WJAR—Providence | WCCO—(Minneapolis) |
| WEEL—Boston | St. Paul |
| WFI—Philadelphia | KSD—St. Louis |
| WGR—Buffalo | WDAF—Kansas City |
| WCAE—Pittsburgh | WRC—Washington |
| WSAI—Cincinnati | WCY—Schenectady |
| WTAM—Cleveland | WHAS—Louisville |
| WWJ—Detroit | WSB—Atlanta |
| WGN—Chicago | WSM—Nashville |
| | WMC—Memphis |

Pacific Coast Stations—
9 P. M., Pacific Standard Time

- | |
|-----------------------|
| KPO—KGO—San Francisco |
| KFOA—KOMO—Seattle |
| KFI—Los Angeles |
| KCW—Portland |

EVEREADY

Radio Batteries

—they last longer

The air is full of things you shouldn't miss