

MARCH, 1953

MAR 20 1953

# Radio-Television SERVICEMAN DEALER

ALEXANDER PLAKADIS  
1111 BRADY ST.  
CLEVELAND, OHIO 44102-49



The Professional Radio-TVman's Magazine

**IN THIS ISSUE:**

Modern AGC Systems  
(TV Symposium Series No. 3)  
Fringe Area Installations  
Booster Standards Defined  
Auto Radio Noise Elimination  
Sound Systems in TV, Part 2  
Vertical Roll Troubles  
Video Speed Servicing Systems

**AM-FM-TV-SOUND**

# why install 2 when 1 will do?

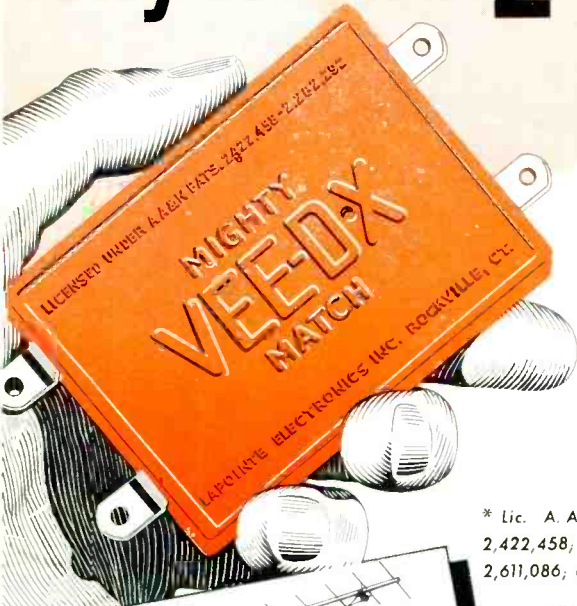

## THE VEE-D-X Mighty Match\*

IS MIGHTY IMPORTANT  
FOR EVERY VHF-UHF INSTALLATION

\* Lic. A. A. K. Pats.  
2,422,458; 2,282,292;  
2,611,086; others pending.

**1**

With the Mighty Match you can connect separate UHF and VHF antennas to a single transmission line.

**2**

With the Mighty Match you can quickly and easily terminate a single transmission line at the converter or TV set equipped with two sets of terminals — one for VHF and one for UHF.

**3**

With the Mighty Match you can use a single transmission line between separate high and low channel VHF antennas.

### Available 6 ways



Plain MM-30 (red) for UHF-VHF

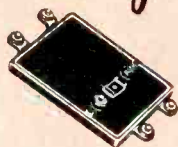

Plain MM-20 (green) for VHF only



SO-MM-30 (red) for VHF-UHF with standoff for mounting on mast



SO-MM-20 (green) for VHF only with standoff for mounting on mast



AB-MM-30 supplied with Universal Mounting Bracket for attaching UHF antenna to present VHF mast

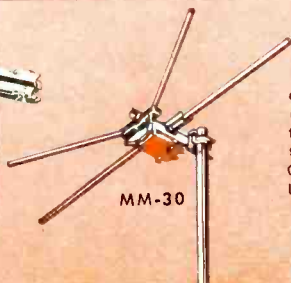

MM-30

MM-30 built into certain VEE-D-X antennas, such as the UHF "V" antenna, the Ultra Q-Tee and the Ultra Q-Tee S.

No television set owner wants two transmission lines when one will do. No installation man wants to waste time installing two when one will do. Mighty Match takes care of both situations the fastest, easiest, most profitable way for you. The patented\* VEE-D-X Mighty Match is the only practical device yet perfected to make single transmission line VHF-UHF possible. Mighty Match has a double-barreled application — at the antenna — at the terminals on TV set or converter. The Mighty Match is extremely compact (only 3¼" x 2¼" x ¼"), thanks to its newly developed printed circuits that separate all channels (2-83) automatically. Is it any wonder that Mighty Match is the magic name for all UHF-VHF installations? **WARNING** — Accept no substitute for Mighty Match. It is completely protected under A.A.K. Pats. 2,422,458; 2,282,292; 2,611,086.

**LaPointe ELECTRONICS INC.**  
ROCKVILLE, CONNECTICUT  
Formerly The LaPointe-Plascomold Corporation

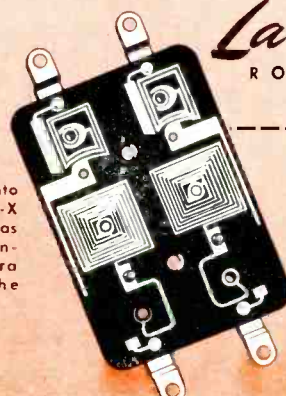

LaPOINTE ELECTRONICS INC.  
Rockville, Connecticut

Gentlemen:

Send complete literature on Mighty Match.

Name .....

Street .....

City ..... Zone ..... State .....

# INCREASED SERVICE BUSINESS 123%!



Miami TV-radio  
service dealer  
L. T. Sample  
proves that  
promotion  
pays off!

"Because of our summer promotion, June service sales were 194 per cent of May; July sales 223 per cent. August service will equal or exceed July. Newspaper ads, mailing cards, television spots, radio announcements—we used them all successfully."

LAURENCE T. SAMPLE  
Electronic Television of Florida, Inc.  
1003 S. W. 27th Avenue, Miami, Fla.

Follow L. T. Sample's lead . . . use G-E promotion aids  
to get more service business!

**B**EGINNING the first day you use them, these 1953 promotion helps work hard to bring you more service business—bigger profits! See your General Electric tube distributor for your copy of G. E.'s new catalog! Or write direct to *General Electric Company, Tube Department, Schenectady 5, New York.*



## Now you can do it!

. . . with the sure-fire promotion aids described in General Electric's brand-new catalog for 1953—

- Identification aids, such as decals, clock, signs, and tube display cartons.
- Advertising aids, such as mailing pieces, newspaper ad mats, doorhangers, and streamers.
- Business aids, such as job tickets, calling cards, letterheads, and tube-test stickers.
- Service aids, such as tube puller, jumper cord, drop cloth, and shop garments.
- Technical manuals and publications.

*You can put your confidence in—*

**GENERAL**  **ELECTRIC**



161-1A1

# CBS-HYTRON TRANSISTORS

## CBS-HYTRON PT-2A



ACTUAL SIZE



## CBS-HYTRON PT-2S

- Moisture-resistant
- Plug-in or solder-in
- Sturdy triangular basing
- Polarized base connections
- Auto-electronically formed
- Thoroughly stabilized
- Operate up to 55° C

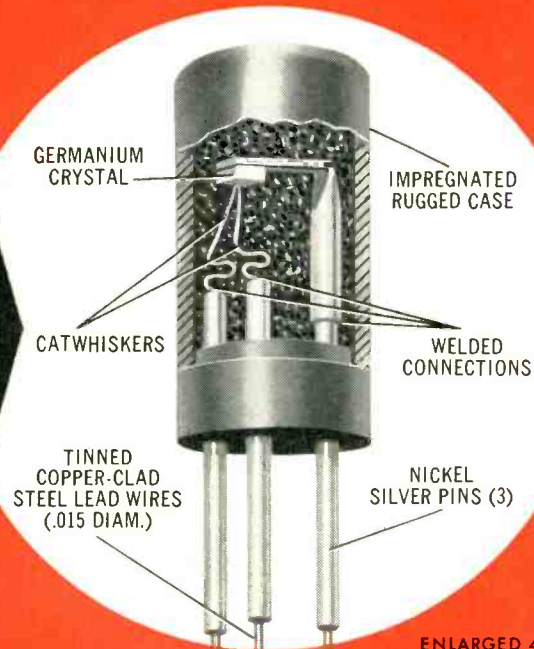

ENLARGED 4 TIMES

### MECHANICAL FEATURES

1. Single-ended construction gives maximum mechanical stability.
2. Rugged triangular basing design resists shock and vibration.
3. Dual-purpose connections permit use of flexible leads or stiff plug-in base pins.
4. Direct soldering of germanium wafer to base support guarantees positive contact, avoids flaking.
5. Glass-filled plastic case and high-temperature impregnating wax assure moisture-resistant, trouble-free operation.

### BASING AND SOCKET



Note similarity of pin layout to that of transistor symbol. CBS-Hytron type T-2 transistor socket features groove to guide pins into socket. Also anti-burn-out design to insure that base connection of transistor will always be made first.

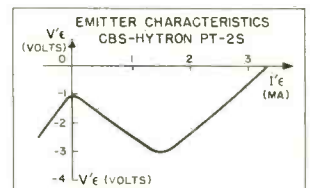
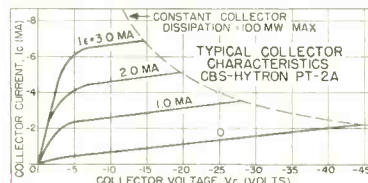
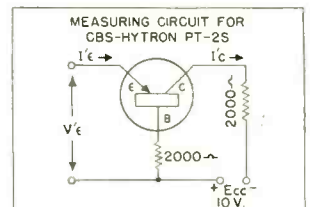

## AND YOU CAN BUY THEM NOW!

Already a major producer of germanium diodes, CBS-Hytron now offers you prompt delivery of transistors: Point-contact CBS-Hytron PT-2A (for amplifying) and PT-2S (for switching). Both have stable characteristics and are guaranteed moisture-resistant. Note flexible leads welded to base pins. You may solder flexible leads into circuit. Or snip them to use stiff base pins in CBS-Hytron type T-2 socket.

Triangular arrangement of base pins is stronger . . . avoids bent pins. Easy-to-remember basing layout simulates basing symbol (see diagram). Polarization makes socket connections foolproof. You are assured of uniformly optimum characteristics by electronic control of pulse forming. Thorough aging achieves maximum stability. You may operate these transistors up to 55° C. And you can order both CBS-Hytron PT-2A and PT-2S for immediate delivery.

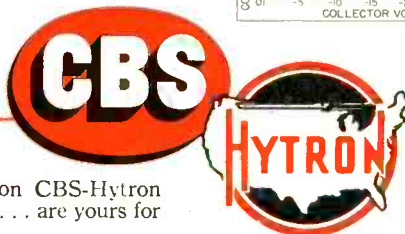

MANUFACTURERS OF RECEIVING TUBES SINCE 1921  
**HYTRON RADIO AND ELECTRONICS CO.**

A Division of Columbia Broadcasting System, Inc.  
Main Office: Danvers, Massachusetts

WRITE FOR DATA. Complete free data on CBS-Hytron PT-2A and PT-2S . . . and the T-2 socket . . . are yours for the asking.

RECEIVING . . . TRANSMITTING . . . SPECIAL-PURPOSE AND TV PICTURE TUBES • GERMANIUM DIODES AND TRANSISTORS

# EDITORIAL

by S. R. COWAN

## The Elements and TV

Weather conditions in all parts of the country during January and February affected TV with great impact. Winds of gale force and exceptionally heavy sleet-snow storms wreaked havoc. Countless thousands of antennas went down blanking out reception, so Service Dealers were swamped with emergency calls. Man-power shortages and the unexpected demand for replacement antennas added to the problem so that unconscionable delays in restoring service prevailed. Moral: Keep a sufficient supply of antennas on hand, and let weather bureau reports act as your guide towards preparedness when storms are predicted. Being prepared for emergencies and the consequent ability to render prompt service when an emergency arises are marks of a good businessman.

## Trends & New Products

The rumors that an acceptable method of color TV will "soon be marketed" are nothing more than so much scuttlebutt. Some of the big TV manufacturers have perfected compatible color TV equipments and systems which meet all the requirements of all parties concerned (the FCC, telecasters, manufacturers and marketers), but the truth of the matter is simply this: no color TV will be launched for several years to come while the demand for black and white TV is so great that the demand cannot be supplied. Opening of new *vhf* and *uhf* stations is the objective of TVset and TVcast equipment manufacturers. Then, later on, when a reasonable degree of saturation is attained thought will be given to the introduction of color TV. Logical, eh!

## Transceivers and the Serviceman

Soon a leading manufacturer will announce a new type of handie-talkie (transceiver). The units will be smaller and lighter than any similar type of equipment, and because of the relatively low price, should enjoy immediate consumer acceptance. In fact, at this writing, the applications for the transceivers are so numerous it can't even be guessed as to who will buy how many for what purpose. A 1-year factory service warranty is to be issued with the initial production to eliminate the possibility of having incompetents or untrained technicians do the wrong things when service is required. Transceiver circuitry is new to most radio-TV technicians but the use of such equipment will soon become so wide-spread that we deem it our duty to publish material on the subject. Look for it in a few months.



**Sanford R. Cowan**  
EDITOR & PUBLISHER

**SAMUEL L. MARSHALL**  
MANAGING EDITOR

**ADOLPH SUCHY**  
**LEONARD LIEBERMAN**  
Contributing Editors

**COWAN PUBLISHING CORP.**  
67 WEST 44TH ST.  
NEW YORK 36, N. Y.



Vol. 14, No. 3

MARCH, 1953

Editorial .....	3
Trade Flashes .....	4
Trade Literature .....	20
Modern AGC Systems, <i>by Matthew Mandl</i> (TV Symposium Series No 3) .....	23
Latest type of keyed agc circuits described, bringing serviceman up-to-date on these systems.	
Fringe Area Installations, <i>by Rudolf F. Graf</i> .....	28
Useful information on fringe area installations. A how-to-do-it article.	
Booster Standards Defined, <i>by Harold Harris and H. E. Sudders</i> .....	34
A classic discussion on Booster Standards. A "Must" for all persons interested in this device.	
Auto Radio Noise Elimination, <i>by Jack Davr</i> .....	38
Down-to-earth methods of curing auto radio interference.	
Sound Systems In TV, Part 2, <i>by Leonard Lieberman</i> .....	41
Concluding article. Simple alignment procedure discussed.	
Vertical Roll Troubles, <i>by Harry Mileaf</i> .....	42
Puzzling vertical roll troubles and cures.	
Video Speed Servicing Systems Data Sheets (VSSS) .....	44
Information this month covers the Admiral 20A1, 20B1, 21A1 chassis series; the Sentinel Models 412, 413, 415; the Stromberg-Carlson 119 chassis series; and the Sylvania C12, C13, B12, B13 chassis series.	
Circuit Court .....	53
Conrac Model 61-Multi-purpose tube circuitry; G.E. Model 21T4-Noise reduction.	
Association News .....	54
Personnel Notes .....	55
New Products .....	56

SANFORD L. CAHN, Advertising Director    HARRY N. REIZES, Advertising Manager  
DAVID SALTMAN, Production Manager    NATHAN BOYCE, Circulation Mgr.

TED E. SCHELL, 2700 West 3rd St., Los Angeles 5, Calif., Dunkirk 2-4889  
HAROLD F. MANN, Mid-West Sales, 333 No. Michigan Ave., Chicago. Franklin 2-7100  
RADIO-TELEVISION SERVICE DEALER is published Monthly by Cowan Pub. Corp., 67 West 44th St., New York 36, N. Y. Subscription price: \$2 per year in the United States, U.S. Poss. & Canada: elsewhere \$3. Single Copies 25c. Reentered as second class matter Sept. 25, 1950 at the Post Office at New York, N. Y. under the Act of Mar. 3, 1879. Copyright 1953, Cowan Pub. Corp.

get out ahead in

uhf

THIS NEW BOOK GIVES YOU THE "KNOW-HOW"

"UHF Converters"



describes their design... shows you how they work  
44 pages  
8 1/2 x 11

Covers 21 Converters and Tuners

Cash in on the terrific expansion of TV through new UHF transmission. Be among the first to understand the design, installation and operation of the new UHF converters and tuners. This book describes all the popular converter designs and tells how they work with present VHF sets. Gives you the timely UHF information you want. Covers 21 converters in the following makes:

Arvin	Motorola	Standard Coil
Crosley	RCA	Stromberg
Dumont	Raytheon	Sutco
G. E.	Regency	Sylvania
Mallory	Sarkes-Tarjian	

To stay ahead in TV... to get in on the ground floor as a UHF expert—you'll want this essential, profit-building book. Get a copy today!

ORDER UC-1. \$1.00  
"UHF CONVERTERS," Only.....

HOWARD W. SAMS & CO., INC.

Order from your Parts Jobber, or write direct to Howard W. Sams & Co., Inc. 2209 E. 46th St., Indianapolis 5, Ind.

ORDER TODAY

Send.....copy(ies) of "UHF CONVERTERS" \$1.00 per copy.

(check) (money order) for \$.....enclosed

Name.....

Address.....

City.....State.....

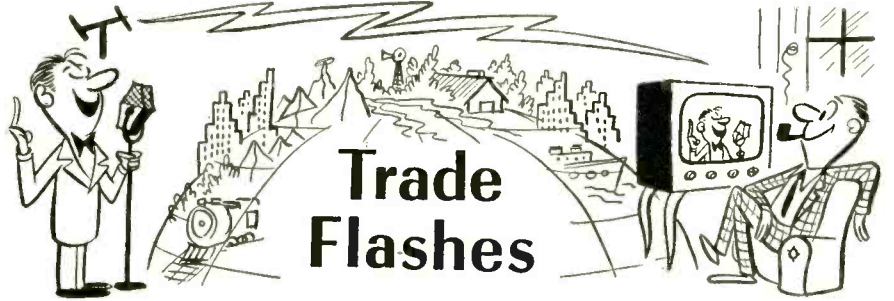

RTMA Reports On Tube & Set Sales

Over 7.6 million cathode ray tubes and 368.5 million receiving-type tubes were sold by manufacturers in 1952, the Radio-Television Manufacturers Association announced recently. Cathode ray tube sales totaled 7,635,666 units valued at \$170,652,078.72 while 368,519,243 receiving-type tubes valued at \$259,116,089.21 were sold by manufacturers.

Over six million television sets and 6.8 million radio receivers were sold to the public in 1952. Total retail sales were estimated at 6,144,990 TV receivers and 6,878,547 radios, excluding auto sets.

TV Repairs Attains Collegiate Status

Iowa State College is offering television repairmen in Iowa special training at the collegiate level, the better to prepare themselves for effective service to viewers in their areas. This is being done through a series of technical clinics and short courses especially designed to give the TV serviceman a working knowledge of the electrical and electronic characteristics of the elements and components which comprise a TV receiver, rather than to teach him the mechanical technique of "shooting trouble." This objective and training procedure represents a radical departure from the usual serviceman's training course.

TV "Protection" Plan Ends

In Bankruptcy

Early in 1952 a new organization offered its services to "harassed" television set owners. In large advertisements headed, for example, "Open Letter to Every Television Owner Who Has Ever Been Cheated On Television Service and Repairs," the organization, Televideo Affiliates of America (also designated as TAA), described various methods through which the public was purportedly being cheated by unscrupulous servicemen and promised "complete" protection against television service chicanery. The TV set owner was asked to mail a \$15 "subscription fee," and an additional \$1.50 was to be paid to

a TAA "franchised" service contractor to inspect the set. If the set passed inspection, the contractor presented the set owner with a price list, other instructive literature, and a contract which provided among other things, that no matter how many service calls were made during the year, the total payment for service and parts would not exceed a previously determined maximum.

On November 25th, 1952 the Televideo Affiliates of America filed a petition in bankruptcy, with no schedule. Creditors' meetings are currently being held.

BBB Monthly Memo

Radioactivity Methods Used For Transistor Manufacture

The use of radioactivity methods has greatly accelerated research in semiconductor materials used in transistors, according to Dr. George H. Morrison of the Central Engineering Laboratories staff of Sylvania Electric Products Inc., Bayside, New York. He said that it is possible to measure impurities of one part in 100 million by radioactivity methods in germanium a semiconductor metal used in transistors. Conventional chemical methods of measurements are ineffective at these extremely low concentrations, according to Morrison.

NEDA Convention Committee

Program

Arrangements for a full-scale Educational Program with financing of expanding distributor operations, and Ultra-High Frequency as the keynotes are now underway for the Fourth Annual Convention and Manufacturers' Conference sponsored by the National Electronic Distributors Association to be held September 14 to 16 in St. Louis, Mo.

It was unanimously agreed by the Industry Committee that NEDA once again, as in the 1952 Convention held in Atlantic City, N. J., last September, give prominence to Ultra-High Frequency—how it affects the parts distributor, what opportunities uhf

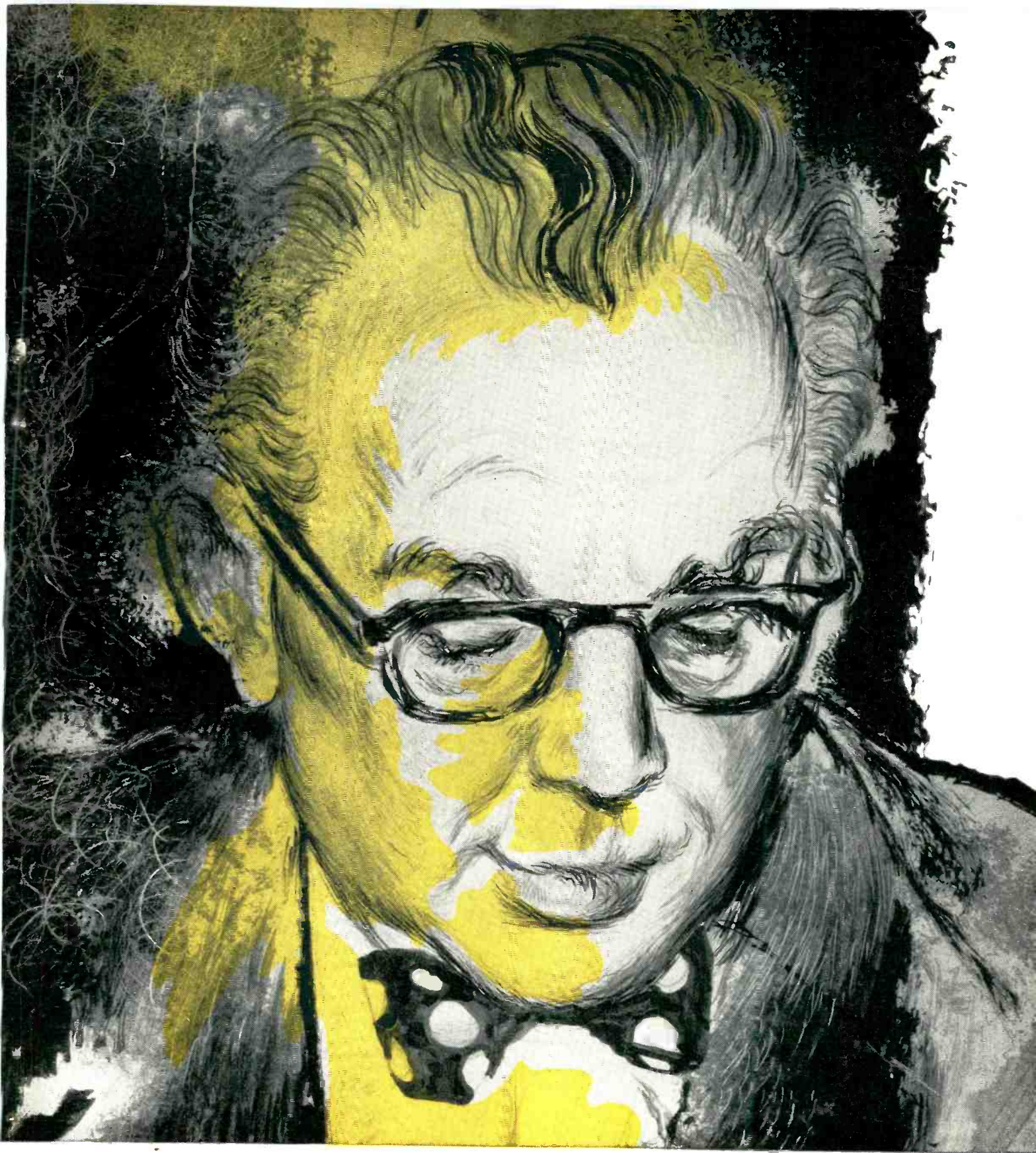

Thomas A. White

president: Jensen Manufacturing Company, Chicago, Illinois

says: "In every field there's one leader  
.... in boosters it's **Regency**"

the largest selling booster at any price

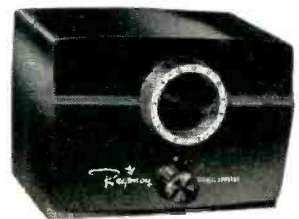

# You can win 3 ways in Olin's Great \$10,000

## EXTRA Store Traffic

More opportunities to sell portable radio batteries and everything else you handle.

## EXTRA "Bonus" Deals

To step up your profits.

## PARTICIPATING PRIZES

for dealers whose names are on top winning entries.

Order one of these 3 Bonus Deals

This is your contest. Everybody who enters must get an entry blank from an Olin Radio Battery Dealer. There's no other way.

It's the hottest traffic and sales building promotion ever offered in the radio battery business.

Get in on it now—

	Regular Display Kit	Contest Display Kit	Floor Display Stand	Number of 1710 Batteries at No Charge	Dealer's Extra Profit	Per Cent Extra Profit
With order of \$50 you get:	1	1		1	\$2.50	5%
With order of \$100 you get:	1	1	1	3	\$7.50	7.5%
With order of \$200 you get:	1	1	1	7	\$17.50	8.75%

MAKE UP YOUR OWN ASSORTMENT from the Olin line of Portable Radio Batteries—51 batteries for every need, including these popular stand-bys:



1710



6210



614



# Radio Battery Contest

## FIRST PRIZE

**FREE TRIP to HAWAII**  
**VIA PAN AMERICAN CLIPPER (or \$1500)**  
**Plus 167 OTHER EXCITING PRIZES!**

This is the kind of contest that really pulls in the entries!

And remember, every contestant must get an entry blank from an Olin Radio Battery Dealer.

Make them come to you—with these tie-in displays—as part of your "bonus" order!

ENTER OLIN PORTABLE RADIO BATTERY \$10,000 "GREAT DISCOVERERS" CONTEST!

**Win a Free Trip to HAWAII** VIA LUXURIOUS PAN AMERICAN CLIPPER!

ALL EXPENSES PAID FOR 2 PERSONS FOR 10 GLORIOUS DAYS! or **\$1500 CASH**

SUN! SWIM! LOAF! in beautiful Waikiki Beach in Honolulu

167 ADDITIONAL PRIZES

SECOND PRIZE	\$1000
THIRD PRIZE	\$500
FOURTH PRIZE	\$500
FIFTH PRIZE	\$500
SIXTH PRIZE	\$500
SEVENTH PRIZE	\$500
EIGHTH PRIZE	\$500
NINTH PRIZE	\$500
TENTH PRIZE	\$500
ELEVENTH PRIZE	\$500
TWELFTH PRIZE	\$500
THIRTEENTH PRIZE	\$500
FOURTEENTH PRIZE	\$500
FIFTEENTH PRIZE	\$500
SIXTEENTH PRIZE	\$500
SEVENTEENTH PRIZE	\$500
EIGHTEENTH PRIZE	\$500
NINETEENTH PRIZE	\$500
TWENTIETH PRIZE	\$500
ONE HUNDRED AND SIXTY SEVEN PRIZES	\$500 EACH

FAMOUS HALLICRAFTERS PORTABLE RADIOS

Get One Sheet and Entry Blank from your Olin Portable Radio Battery Dealer

There's an OLIN PORTABLE RADIO BATTERY for every radio need!

**OLIN's Great Discovery "CRYTOLITE!"**

OLIN INDUSTRIES, INC. • ELECTRICAL DIVISION • NEW HAVEN 4, CONN.

## CONTEST WINDOW DISPLAY

Big, colorful eye catcher, around which to build a display of Olin Radio Batteries. (We supply dummy cartons.)

## COLORFUL WINDOW POSTER

A stopper that makes your store "contest headquarters"—brings 'em in for entry blanks, makes new friends for you.

WIN A FREE ALL-EXPENSE TRIP TO HAWAII via Luxurious Pan American Clipper

65 CASH PRIZES Plus 103 HALLICRAFTERS PORTABLE RADIOS

OLIN'S \$10,000 Great Explorers Contest

Get Your CLUE SHEET and ENTRY BLANK INSIDE waiting to buy



## CONSUMER ENTRY BLANKS

Every contestant needs one. You get a liberal supply, with space to stamp your name. Remember, if one of your entrants wins a top prize, you get a prize too!

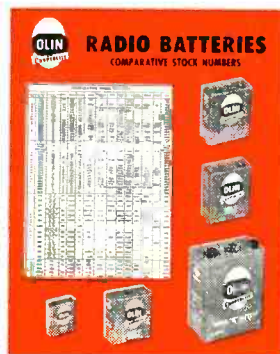

## JUMBO WALL CHART

An additional contest reminder and a practical selling aid for the right Olin Battery for any portable.



## FLOOR DISPLAY STAND

You get this with order of \$100 or more. A whiz of a salesman that never shows up on your payroll!

Get your order in to your wholesaler NOW—Contest begins at the start of your peak selling season!

OLIN INDUSTRIES, INC. • ELECTRICAL DIVISION • NEW HAVEN 4, CONN.

Makers of Olin Flashlights • Lanterns • and Olin Batteries for Flashlights • Lanterns • Hearing Aids • Farm and Industrial Uses.

# ATR

Makes it easy to  
**DEMONSTRATE and TEST**  
D.C. apparatus from A. C. lines  
with "A" **BATTERY**  
**ELIMINATORS**



for  
**Demonstrating**  
**and Testing**  
**Auto**  
**Radios**

New Models . . . Designed for testing  
D.C. Electrical Apparatus on Regular A.C. Lines.  
Equipped with Full-Wave Dry Disc Type Rectifier,  
Assuring Noise-less, Interference-Free Oper-  
ation and Extreme Long Life and Reliability.

See your jobber  
or write factory

- ✓ NEW MODELS
  - ✓ NEW DESIGNS
  - ✓ NEW LITERATURE
- "A" Battery Eliminators, DC-AC  
Inverters, Auto Radio Vibrators

# ATR

**AMERICAN TELEVISION & RADIO Co.**  
*Quality Products Since 1931*  
SAINT PAUL 1, MINNESOTA—U. S. A.

offers him and his service dealer, etc. Demonstrations, lectures and panel discussions will feature technical experts representing all phases of uhf and Financing so that final, up-to-the-minute reports and discussions are offered the convention guests. Other vital subjects are being planned as part of the Educational Program, announces Mr. Lippman, convention chairman.

### Raytheon Ships Transistors

The recent announcement of commercial availability of Raytheon types CK721 and CK722 Germanium Junction Transistors has created tremendous interest in the electronics industry. Shipments are now going forward to all Raytheon distributors to take care of the widespread demand among their customers for Junction Transistors.

### Educational TV Committee Formed

The appointment of a three-man committee to pass on all applications made by educational institutions for the Emerson \$100,000 educational television grant was announced by Benjamin Abrams, President of Emerson Radio & Phonograph Corporation.

The committee will consist of Dr. James G. McDonald, former Ambassador to Israel; Dr. Leonard Carmichael, Secretary of the Smithsonian Institution; and Dr. Orestes H. Caldwell, former FCC Commissioner and Editorial Director of Caldwell-Clements, Inc.

### RTMA Names Chief Instructor To Direct TV Servicemen's Course

As another step in its program to advance the technical ability of the television serviceman, the RTMA Service Committee has named Paul B Zbar to be chief instructor for the industry's training course at the New York Trade School. Mr. Zbar's assistant is yet to be selected by the Service Committee, under the chairmanship of R. J. Yeranko, The Magnavox Co.

The course, which is being underwritten in both money and equipment by RTMA members, is slated to get underway about the end of February. At present Mr. Zbar is formulating the preliminary plans for the course of instruction and installing on each of the 15 work benches test equipment donated by member-companies of the RTMA Instrument and Test Equipment Section, under the chairmanship of Roland M. Bixler, J-B-T Instruments Inc.

The course, the first of its kind under RTMA sponsorship, is designed

# PHILCO TESTERS

Now Yours on

## NEW SPECIAL PAYMENT PLAN

*Finest, Most Up-to-Date Testing Instruments Ever Produced!*

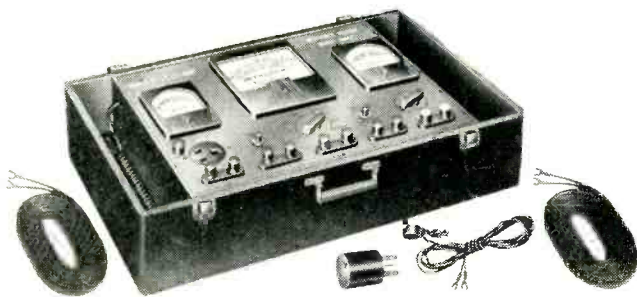

**APPLIANCE TESTER • MODEL 5007**

This new Philco Appliance Tester Model 5007 permits complete analysis of over-all performance of refrigerators, air conditioners, ranges and household appliances. It provides accurate temperature measurements in degrees Fahrenheit from  $-30^{\circ}$  to  $600^{\circ}$  on a large 6" meter. Ascertain power requirements of appliances up to 6 kilowatts, and includes an AC voltmeter for measuring voltages up to 260 volts. Gives positive check for shorts or open circuits on appliances. Equipped with all necessary "pick-up" elements for temperature determination.

Size: 12" W. x 8" H. x 6" D.

Weight: 9 lbs.



### MUTUAL CONDUCTANCE DYNAMIC TUBE CHECKER

**MODEL 7052.** A companion piece to Philco Model 7051 Emission Type Tube Checker. This model 7052 checks all tubes from sub-miniature to low power transmitting tubes. Checks shorts and leakages between elements of tubes. Determines noise characteristics. Ascertain gas content. Gives mutual Conductance readings directly in microhms. Permits forecasting remaining tube life. A portable or counter type tester with a beautiful blue leatherette finish. Operating Voltage: 105-130 Volts AC.

Size: 17" W. x 15" L. x 12" D. Weight: 22 lbs. (Shipping Wt. 34 lbs.)



### VISUAL ALIGNMENT GENERATOR • MODEL 7008

**FEATURES:** AM Generator (and Marker): 3.2-250 mc. • FM Generator: 4-120 mc., and 145-260 mc. • Sweep-frequency width to 15 mc. (Flat to within .2db/mc.) • Audio Generator: 400 cycles • Only one input and output connection • Special oscilloscope circuits • Vertical-deflection Sensitivity: 25 millivolts/inch (with amplifier) • Swiveled cathode-ray-tube housing for compact carrying size • Telescoping light shield • High-frequency probe for signal tracing • Crystal calibrator to provide check points for marker generator.



**FILL OUT AND MAIL THIS  
COUPON . . . OR SEE YOUR  
PHILCO DISTRIBUTOR TODAY!**

PHILCO CORPORATION, Accessory Division  
Allegheny & "A" Sts., Philadelphia, Pa.

I am interested in the Philco Test Equipment shown here. Please send me details of your SPECIAL PURCHASE PLAN for obtaining these units.

Please send FREE copy of your new booklet on Philco Test Equipment.



NAME .....

ADDRESS .....

CITY ..... STATE .....

Like  
money  
in the  
Bank...

**WALSCO UHF-VHF**



- A. CORNER REFLECTOR**  
For fringe and ghost area reception
- B. REFLECTO-FAN**  
For local reception
- C. TROMBONE**  
For combination UHF-VHF reception

**AVAILABLE NOW**

YOU are completely protected when you buy, sell or install WALSCO. Every model is now a "proven performer" . . . thoroughly tested and endorsed in all the new UHF-VHF areas. Designed for all present and future channels. The best high gain, all channel performance and a model to fit every installation

Protect your profit . . . eliminate costly call-backs. Install WALSCO, America's most dependable TV antennas. It's like money in the bank!

**WALSCO**

Walter L. Schott Co.  
3225 Exposition Place  
Los Angeles 18, Calif.

Overseas Representative:  
Ad Aurien, Inc., 89 Broad St.,  
New York 4, N.Y.

WRITE FOR COMPLETE PRICE  
AND CATALOG INFORMATION—Dept. P-53

to up-grade the present television serviceman and increase his technical proficiency. From the experience gained at the New York Trade School, a privately endowed school, a syllabus of the course will be prepared for use by vocational training schools throughout the country.

Mr. Zbar has had wide experience in both the education and radio-television fields. He has been the director of a national group of television training schools and holds a master's degree in education. Mr. Zbar also is a member of the Institute of Radio Engineers.

**Powerful UHF Station in Pa.**

WHUM-TV, Channel 61, received the first production model 12,000-watt UHF transmitter built by General Electric, and a new type antenna. Together they will provide 260,000 watts of effective power from an antenna height 1783 feet above the average eastern Pennsylvania terrain.

The station's primary service area is expected to extend over a 62-mile radius of the transmitter site, serving about 800,000 families in Eastern Pennsylvania, and parts of Delaware, New Jersey and Maryland.

**Mallory Expands Tuner Division**

Overwhelming demand for Mallory UHF Converters has caused P. R. Mallory & Co. Inc., Indianapolis, to embark on an extensive expansion program in its TV Tuner division.

Upon completion of its new program in April, the firm expects to have increased its production of *uhf* Converters, *vhf* Tuners and *rf* Assemblies to five times the rate maintained in the last quarter of 1952. Back orders for converters will be filled shortly, after which future demand can be met as it occurs.

**Precision 1953 Television Servicing Lectures Begin**

Precision Apparatus Co., Inc. Elmhurst, N. Y., manufacturers of radio and television test equipment, opened its 1953 "Precision" Lecture Series on Television Circuitry and Servicing, Tuesday night, January 6, at the Engineering Societies Building, New York City. The session, conducted by R. G. (Bob) Middleton, senior field engineer of the company, dealt with *uhf* and *vhf* Television Receiver Circuitry and Trouble-Shooting. In attendance at the meeting were radio and television service technicians from metropolitan New York. Several electronic parts distributors co-sponsored the meeting.

**New ICS Radio-TV Courses**

Two new courses in radio and television servicing—one for the person

**RAYTHEON BONDED  
ELECTRONIC TECHNICIANS**

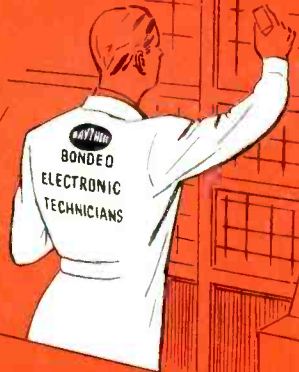

***Bonded!***

**... sign of Service Dealers  
who are *Building for Tomorrow***

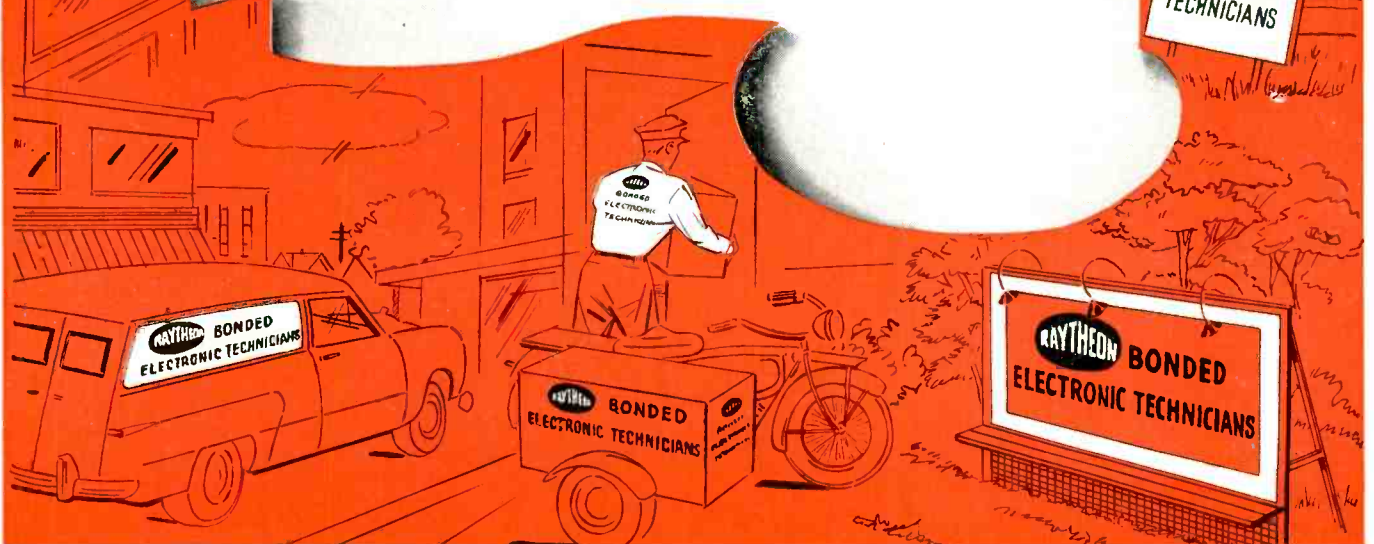

**RIGHT... FOR SOUND AND SIGHT!**

WHEREVER you see Service Dealers who are featuring the Raytheon Bonded Electronic Technician Program, you're looking at good businessmen who are as interested in tomorrow as in today. True, the cash-protection of the Raytheon Bond (backed by Continental Casualty Company) and the Raytheon "Code of Ethics" create initial customer confidence and thus stimulate sales right now.

But, more important, the sound, sensible way Raytheon Bonded Electronic Technicians do business insures future profits from an ever-increasing backlog of satisfied customers.

Your Raytheon Tube Distributor will be happy to give you the whole story on the Raytheon Bonded Program, and tell you whether or not you can qualify for this double-barreled asset. Call him today.

**RAYTHEON MANUFACTURING COMPANY**

Receiving Tube Division  
Newton, Mass., Chicago, Ill., Atlanta, Ga., Los Angeles, Calif.

RAYTHEON MAKES ALL THESE:

RECEIVING AND PICTURE TUBES • RELIABLE SUBMINIATURE AND MINIATURE TUBES • GERMANIUM DIODES AND TRANSISTORS • NUCLEONIC TUBES • MICROWAVE TUBES



*Excellence in Electronics*

## ULTRA FAN series — Complete VHF-UHF coverage

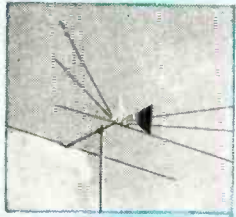

single bay — model no. 413

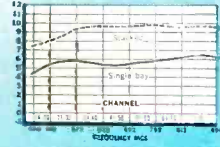

Today's most sensitive All-VU\* antennas! The Ultra Fans actually operate on *three* separate electronic principles — automatically:

1. Low Band VHF (Channels 2-6) . . . Conical antenna with parasitic reflector
2. High Band VHF (Channels 7-13) . . . Large diameter V antenna
3. UHF (Channels 14-83) . . . Triangular dipole with sheet reflector

One set of All-VU\* stacking rods provides highest VHF and

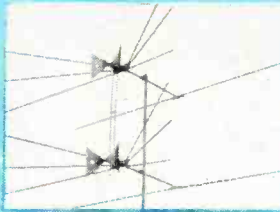

stacked — model no. 4132

UHF gain. Each Ultra Fan has its own 2-stage inter-action filter, so that only one transmission line to the set is required.

\*All VHF, all UHF

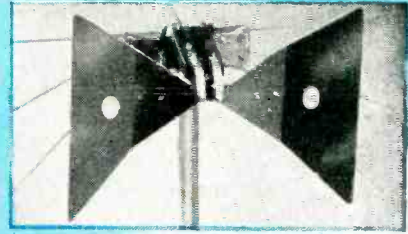

**ULTRA DAPTER**  
model no. 414

Instantly converts all Channel Master Super Fans into high gain, all-channel, VHF-UHF antennas. Features a built-in inter-action filter.

# Your best bet for UHF!

## CHANNEL MASTER Ultra-Tennas

*America's most complete — most effective — UHF antenna line.*

Channel Master's advanced engineering pays off again! While rain caused hundreds of UHF antennas to FAIL recently in Portland, not one Channel Master antenna dimmed or shorted out a picture! The facts speak for themselves: Rain or shine, Channel Master antennas out-perform all others.

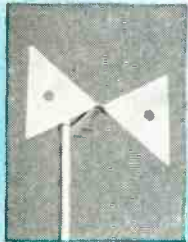

**ULTRA BOW**  
model no. 401

The basic UHF antenna for primary signal areas, and the outstanding member of the bow-type antenna family.

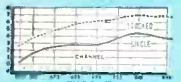

Only Channel Master Antennas are designed to eliminate the "TWIN TERRORS" OF UHF RECEPTION:

- Vibration, which causes picture flicker.

Eliminated by Channel Master's Ultra-Rigid construction and advanced mechanical design.

The accumulation of dirt or moisture around the antenna terminals, which dims and eventually shorts out the TV picture.

Eliminated by Channel Master's sensational "free-space" terminals which prevent the accumulation of foreign deposits at the feed points.

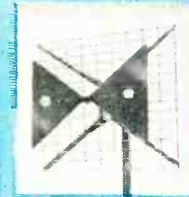
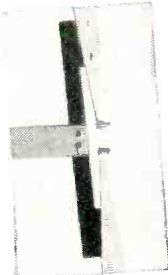

**ULTRA BOW**  
with SCREEN REFLECTOR  
model no. 403

Can be stacked in 1, 2, and 4 bays. High, all-channel UHF gain, excellent front-to-back ratio.

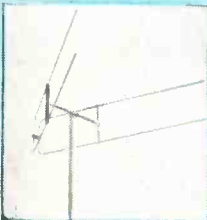
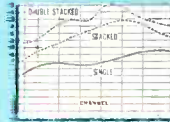

**ULTRA VEE**  
model no. 404

- Good UHF gain
- Low VHF gain
- The most rigid UHF antenna of its type and size.

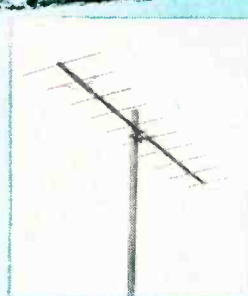
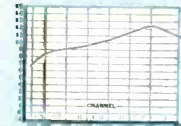

Gain: 11 DB, single  
14 DB, stacked

### DELTA WELD

Wide Band 10 Element UHF Yagi

Custom-designed for full coverage of your specific areal Brilliant high gain performance across as many as 23 different channels.

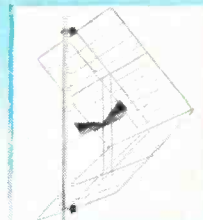

**CORNER REFLECTOR**  
model no. 405

The outstanding all-channel UHF FRINGE antenna.

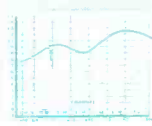

Sold through the nation's leading distributors

**CHANNEL MASTER CORP.**  
ELLENVILLE, N. Y.

Write for complete technical literature



**ULTRA-TIE** model no. 9034  
Electronic Inter-Action Filter

**JOINS** separate antennas into a single VHF-UHF antenna system, for use with a single transmission line.

**SEPARATES** VHF and UHF signals at the set or converter where separate inputs are provided.

The only filter with "free-space" terminals.

**New!** another Channel Master development!

beats 'em all on **UHF!**

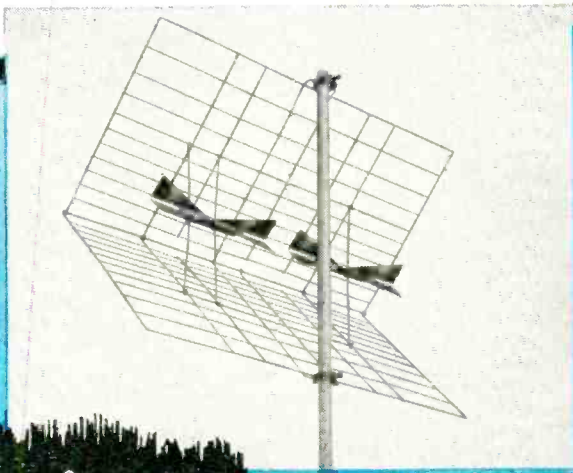

**CHANNEL MASTER'S**  
**TWIN CORNER REFLECTOR**

Model No. 406

Gives the brilliant performance of **2** antennas!

up to **16** db gain

**THE MOST SENSITIVE UHF ANTENNA EVER DEVELOPED!**

Extremely narrow forward lobe with no side lobes and negligible rear lobe

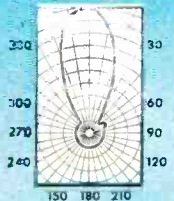

Twice the gain of the BEST standard UHF Corner Reflector

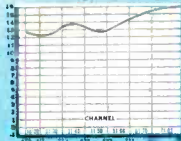

Excellent 300 ohm impedance match over the entire UHF range, provided by built-in, pre-cut matching harness

because Channel Master's Twin Corner Reflector really is 2 antennas . . . .

stacked side by side into one simple structure

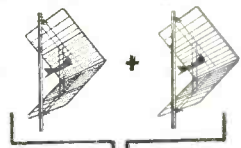

exclusive **DUBL-DIPOLE** design

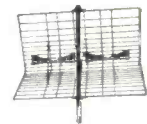

- 2 antennas, electrically
- 1 antenna, mechanically
- One simple structure . . . . one simple installation . . . . highest gain, all-channel UHF coverage!

In any area you pick, the Twin Corner Reflector will out-perform any other antenna available today!

**Ties together all 3 TV reception bands!**

"Free space" terminals. Impossible for dirt or rainwater to accumulate between the terminals, which can short out the picture. Assures you of brilliant, steady reception in ANY KIND OF WEATHER!

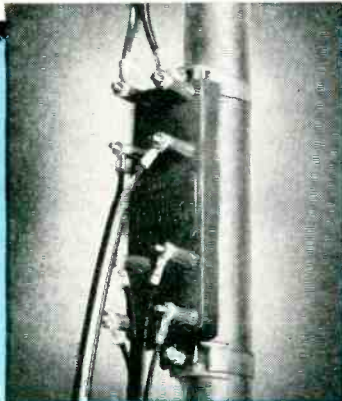

**CHANNEL MASTER'S New!**

**TRIPLE-TIE** model no. 9035

electronic inter-action filter

Combines up to 3 antennas with only 1 lead to the set.

1. Low Band VHF
2. High Band VHF
3. All UHF (Broad Band or Yagi)

Eliminates Inter-action between all 3 antennas.

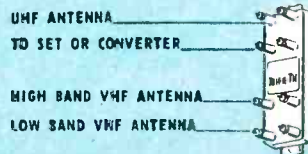

Designed to adapt all HI-LO VHF installations to UHF — quickly and economically

**SINGLE LEAD • NO SWITCHING**  
**ELIMINATES INTER-ACTION • NO SIGNAL LOSS ON VHF OR UHF**

# NEW!

**NICHOLS**  
**NEVER-STAIN**  
TRADE MARK

## Aluminum TV AND RADIO GROUND WIRE

**RUST  
PROOF**



- ★ High Electrical Conductivity
- ★ Inconspicuous — Low Reflectivity
- ★ Pliable — Specially Tempered
- ★ Etched finish — clean
- ★ STD. No. 8 B & S Ga. (.128" dia.)

## Aluminum TV ANTENNA GUY CABLE

**RUST  
PROOF**



- ★ Seven — 18 Ga. Stranded Wires
- ★ Flexible — Specially Tempered
- ★ High Strength Aluminum Alloy for all Types of Antennas.
- ★ Approx. break strength — 500 lbs.



\*Packed 2-500 ft. continuous coils per carton marked every 100 ft. with bright red tape.



PACKAGING DATA		
ITEM	PKG. NO.	DESCRIPTION
TV Grd. Wire	8	100 ft. coil per box. 10 boxes per ctn.
TV Grd. Wire	9*	2 - 500 ft. continuous coils.
TV Cable	50	100 ft. coil per box. 10 boxes per ctn.
TV Cable	60*	2 - 500 ft. continuous coils.

Order from your jobber or write us direct. Address Dept. TV1.

**NICHOLS**  
WIRE & ALUMINUM CO.  
DAVENPORT, IOWA  
World's Largest Manufacturer of Aluminum Nails

with some practical knowledge of radio and the second for the beginner — have just been announced by John C. Villaume, dean of the faculty of the International Correspondence Schools of Scranton, Pa.

The first course, Radio and Television Servicing, is designed for the amateur, the experimenter, the apprentice service technician who wants more training and wants it faster than experience provides.

The second course, Radio and Television Servicing with Training Equipment, is basically the same except for additional features which make it more suitable for the beginner.

### DuMont Plans Increased Pix Tube Facilities

Production of television picture tubes by the cathode-ray tube division, Allen B. Du Mont Laboratories, Inc., established new records during January, it was announced by F. P. Rice, division manager.

Plans for further expansion of production facilities are already underway. A substantial investment has been made in new tube fabricating equipment which is scheduled for delivery shortly, Rice said.

Discussing picture tube sizes, Rice declared that the 24-inch rectangular tube would play a prominent part in Du Mont's 1953 production plans, with pressure already extremely heavy from the remainder of the industry for production in that size. He opined that 10-15% of the total industry picture tube production during the last half of 1953 would be in the 24-inch rectangular category.

Rice reported that 27-inch tubes would be produced by Du Mont; as required by the industry. He pointed out that Du Mont's vast experience in pioneering development and production of big picture tubes, would place them in a vantage point when large scale 27-inch production was required by the industry.

### RCA Provides Lecture Series On Transistors

A comprehensive lecture series on the transistor, one of the most significant electronic developments in recent years, and its application in various electronic circuits was started during the week of Jan. 31 for 350 engineers employed at the Camden plant of the RCA Victor Division, Radio Corporation of America. The enrollment is the largest for a single course in the history of the company's training program.

The ten lectures in the series will be conducted by Dr. A. W. Lo, of the

## BETTER BUSINESS CONTROL OVER YOUR TV SERVICE

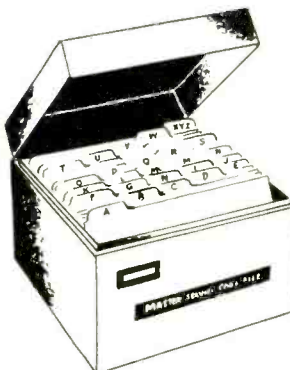

**WITH  
THE**

### No. 700 MASTER SERVICE CARD FILE

The wide awake TV-Radio Service Dealer is recognizing the fact that his TV Service customers are his greatest asset. He is no longer judging a customer's worth on a job basis but as an account who will use his service repeatedly over a long period of time.

It is absolutely essential that the customers be treated intelligently, expertly and courteously to retain good will permanently.

That is why every TV Service Dealer needs a control system over service that will supply him with complete service details, customer information, expiration dates on warranties, service contracts, etc., so that he knows and can give accurate intelligent data at a moment's notice.

A control system provides important statistics over a period of time such as number of jobs performed, customers serviced, jobs per customer, pix tubes sold, sets sold, shop jobs, home calls, etc., to give the dealer important facts about his business.

For instance, it is important for a dealer to know what percentage of his customers have used his service more than once during a year, to determine whether or not he is satisfying his customers and to what degree.

The "MASTER SERVICE CARD FILE" serves as the best possible mailing list and will provide the data required if the dealer will spend a few minutes a day entering the previous day's work.

The #700 "MASTER SERVICE CARD FILE" consists of a metal file box, 500 5"x8" Master Service cards and one set of index cards and is priced at \$14.95.

#701 Master Service cards are available at \$2.00 per hundred. Sample #701 card, data sheet and name of your nearest distributor on request.

### OTHER LOW COST BUSINESS AIDS AT YOUR RADIO-TV PARTS DISTRIBUTOR

100—Radio-TV Cash Sales Book.....	\$1.00
101—Radio-TV Service Pricer.....	\$1.00
102—Collection Aider .....	\$1.00
103—Trouble Tracing AC-DC Radios .....	\$1.00
104—Television Service Call Book .....	.75
105—TV Service Plan (Contracts) .....	\$2.25
106—Television Service Reports.....	\$3.95
107—Television Job Ticket.....	\$1.60
108—Radio Service Record.....	\$1.50
109—Radio Work Sheet.....	.60
110—TV Service Chart.....	.60
114—TV Service Call Router.....	\$2.00

Complete line catalog on request.

**OELRICH PUBLICATIONS**  
4135 NORTH LAWLER AVE.  
CHICAGO 41, ILL.



Depend on Mallory  
for  
Approved Precision Quality



## Get More Jobs Done In A Day

There's no profit in sets waiting to be repaired. Profits depend on turning out more jobs . . . and cutting down on time wasting call-backs.

Midgetrols<sup>®</sup> are designed for fast, easy installation in any set, TV or radio.

*Round tubular shafts can be cut accurately and quickly . . . fit split-knurl or flatted-type knobs.*

*AC switches can be attached instantly without disassembling the control.*

*Their unique design simplifies inventory problems . . . always available from your Mallory Distributor.*

Midgetrols are engineered to duplicate the precise characteristics of original equipment. They will give equal . . . and often better performance and life than the original control.

Save time . . . find extra minutes to turn out more finished jobs . . . be sure of dependable, precision quality for all your TV and radio repairs . . . ask for Mallory Midgetrols the next time you call your distributor.

*Another time saver.* Get your copy of the Mallory Control Guide. It is a complete cross reference between set manufacturers' part numbers and the equivalent Mallory control.

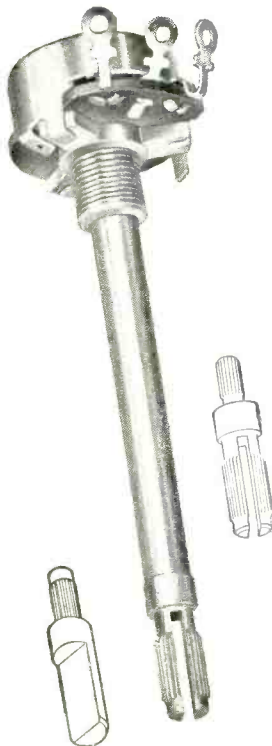

P. R. MALLORY & CO. Inc.  
**MALLORY**

CAPACITORS • CONTROLS • VIBRATORS • SWITCHES • RESISTORS  
• RECTIFIERS • VIBRAPACK\* POWER SUPPLIES • FILTERS

\*Reg. U. S. Pat. Off.

**APPROVED PRECISION PRODUCTS**

**P. R. MALLORY & CO. Inc., INDIANAPOLIS 6, INDIANA**

**SAVE Up to \$1.00 each.**

**Form a Group,**

**Subscribe to "RTSD"—**



"The Professional Radio-Television man's Magazine"—published monthly. All articles are exclusive and timely. Practically every issue is worth what an entire 1 year subscription costs.

The more in a group the bigger the savings. 6 men in a group save \$1.00 each; 4 men groups save 80c per man. Present "RTSD" subscribers may participate in or form a group with co-workers, or even competitors. Still active subscriptions are automatically extended 2 years. Start a Group today! The timely and exclusive technical data appearing in future issues of "RTSD" will make this the best investment you ever made. The special Group Rate offer may be withdrawn at any time—so hurry.

**Use This Coupon For Convenience**

(The coupon below can be used for from 1 to 6 subscription orders. Use it today!)

**TEAR OUT — MAIL TODAY**

**RADIO-TELEVISION SERVICE DEALER**  
67 West 44th Street, New York 36, N. Y.

Please enter 2 years subscription orders for the names given below. Our remittance is enclosed.

NOTE: If you do not wish to tear this order blank out, just print or type the information on a single sheet of paper, following the style given. Each subscriber's occupation must be clearly described.

<input type="checkbox"/>	One 2-year subscription	In U.S.A. <b>\$3.00</b>
<input type="checkbox"/>	Two 2-year subscriptions each	<b>2.50</b>
<input type="checkbox"/>	Three 2-year subscriptions, "	<b>2.30</b>
<input type="checkbox"/>	Four 2-year subscriptions, "	<b>2.20</b>
<input type="checkbox"/>	Five 2-year subscriptions, "	<b>2.10</b>
<input type="checkbox"/>	Six 2-year subscriptions, "	<b>2.00</b>

Name .....

Address .....

City ..... Zone ..... State .....

Describe Title or Position and Type of Business .....

State whether a New Subscriber  or Renewal Order

Name .....

Address .....

City ..... Zone ..... State .....

Describe Title or Position and Type of Business .....

State whether a New Subscriber  or Renewal Order

Name .....

Address .....

City ..... Zone ..... State .....

Describe Title or Position and Type of Business .....

State whether a New Subscriber  or Renewal Order

Name .....

Address .....

City ..... Zone ..... State .....

Describe Title or Position and Type of Business .....

State whether a New Subscriber  or Renewal Order

Name .....

Address .....

City ..... Zone ..... State .....

Describe Title or Position and Type of Business .....

State whether a New Subscriber  or Renewal Order

Name .....

Address .....

City ..... Zone ..... State .....

Describe Title or Position and Type of Business .....

State whether a New Subscriber  or Renewal Order

David Sarnoff Research Center, and by personnel of the optics, sound, and special engineering section of the RCA Engineering Products Department, Camden. M. C. Batsel, chief engineer of the Engineering Products Department, opened the first lecture with a talk on the background of transistor research and development.

As a part of the intensive development work going on in this field, the new lecture series was inaugurated to give engineers in the company's Engineering Products and Home Instrument Departments and its Parts Engineering Section the opportunity to acquire a thorough grounding in transistor theory and application, and in the relative merits of transistors and tubes in various circuits.

#### Marsh Service Clinics Continue

The seventh service and dealer clinic sponsored by Earl Marsh of Marsh Radio Co., Milwaukee, was held Thursday evening, January 15, in the company's newly acquired building. About twenty-five persons were present to hear Bob Mueller, Centralab Distributor Sales Manager speak and show stereo slides on Printed Electronic Circuits and related service products.

#### Crosley Promotes Merchandising Program

The largest sustained parts and accessories merchandising program ever attempted in the appliance and electronics industry opened recently with more than \$50,000 in merchandise prizes being offered, according to R. H. Schneberger, general service manager for the Crosley Division, Avco Manufacturing Corporation. Commenting on the program, he said:

"Crosley's objectives in this program are threefold: (1) to urge dealers to stock sufficient parts to be able to offer top-flight appliance and electronics service to the public (2) to emphasize to our dealers that service leads to sales through satisfied customers; (3) to assist new Crosley dealers in TV areas just opening-up in establishing their service operations on a sound basis so that they serve as an aid in selling other appliances as well as electronics products."

#### Unique Duotone Display

"Stop Record Ruin" is featured on the new Duotone point-of-sales Counter Display which will spark a new push for needle sales. Featured in the display is a microscope with which customers can examine their old needles and see for themselves the damage being done to their records. There is a button next to the microscope which

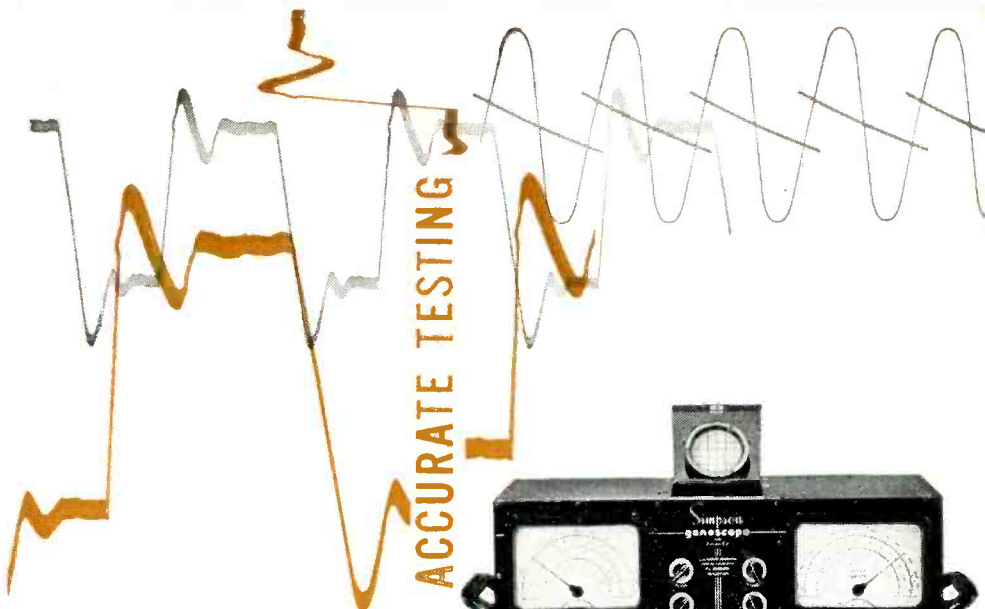

approved by  
service managers of:

*admiral*

*zenith*

*motorola*

*emerson*

*hoffman*

*hallicrafters*

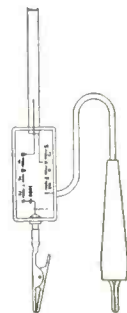

**SIMPSON MODEL 480 GENESCOPE FOR ACCURATE TESTING**

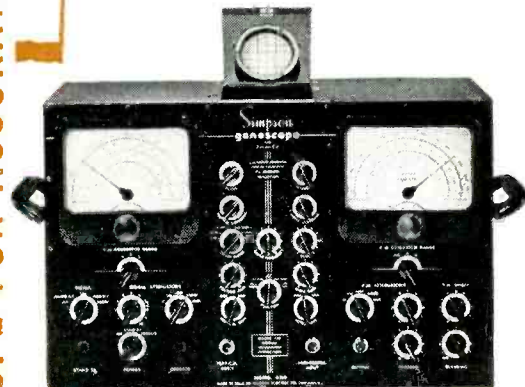

- All the necessary signal sources for alignment of FM and TV receivers • Includes the Simpson High Sensitivity Oscilloscope and high frequency crystal probe for signal tracing • Independent, continuously variable attenuators and step attenuators for both AM and FM units offer complete control of output at all times • 0.15 megacycle sweep is provided by a noiseless specially designed sweep motor based on D'Arsonval meter movement principles • The exclusive Simpson output cable (illustrated) includes a variable termination network, quickly adapted to provide open, 75 or 300 ohm terminations — the addition of a pad provides attenuation and isolation • Use of appropriate resistors across certain terminals will provide any other termination required. A .002 MFD blocking condenser can be added on any termination for use on circuits containing a DC component • The FM generator output voltage is constant within .2 DB per MC of sweep.

**dealer's net \$395.00**

SIMPSON ELECTRIC COMPANY

5200 W. Kinzie St., Chicago 44, Illinois • Phone: COlumbus 1-1221 • In Canada: Bach-Simpson, Ltd., London, Ont.

lights up the needle point for close inspection and an instruction card explains how to use the microscope.

#### Aerovox Expands Westward

Keeping pace with the phenomenal growth of the electronics industry, Aerovox Corporation of New Bedford, Massachusetts, announced recently through its President, W. Myron Owen, the construction of a modern completely equipped plant in Monrovia, Los Angeles County, California. This up-to-date facility is being made available to West Coast manufacturers and distributors as a source of elec-

tronic components. Thus, Aerovox becomes the first large eastern capacitor manufacturer to establish West Coast manufacturing facilities. Construction of this new plant is expected to get underway very shortly and it is estimated that the facility will be in operation early this summer.

#### UCP Improves Pricing Service

At the birthday cake celebration in honor of the third year of the Pricing Service—which provides up-to-date resale prices for distributors of Radio-TV-Electronic Parts and Equipment—Sam Roth, President of United Cat-

alog Publishers, 110 Lafayette Street, New York, announced plans to further increase the speed and efficiency of this service. Specially designed colating machinery is now being installed in new and larger quarters. Servicemen and amateurs will be assured of the latest authoritative on-the-spot, on-the-phone quotations from their distributors.

#### La Pointe Plascomold Changes Name

The company name of The LaPointe Plascomold Corporation has now been changed to La Pointe Electronics

Inc., it was announced by company president, Jerome E. Respass, after authorization by the stockholders of the company at the annual meeting held on Monday, January 26. This name change was desirable, Mr. Respass stated, because the major products of the company today are in the electronics field. It was felt that the proposed name accords with business trends toward simplification of corporate titles. The name change, Mr. Respass continued, in no way will affect the corporate structure of the company and Vee D-X will continue

to be the trademark of all television antennas and accessory equipment.

#### TVI Reduction Demonstration

On February 20, 1953, the Hamfeters Radio Club and Newark Electric Company of Chicago jointly sponsored a special conference of Television Service Men and Dealers, Radio Amateurs and Radio and Television Manufacturers in the Main Ballroom of the Midwest Hotel, 3800 West Madison Street, Chicago. The purpose of this meeting was to discuss and demonstrate how to combat TVI (Television Interference).

#### Ungar Electric Expands

Ungar Electric Tools, Inc., expanding West Coast manufacturer of industrial soldering handles with the innovation of interchangeable tips, moved from its Los Angeles location to a new \$200,000 establishment in the nearby Venice (California) Industrial Tract in February.

The new structures, nearing completion on a spacious three-acre site, will more than double present facilities of the rapidly growing company at 615 Ducommun Street, Los Angeles.

#### Wolin Announces Ad Agency

Sylvan A. Wolin, closely associated with the electronic parts field for twenty years, has just announced the establishment of his own advertising agency. The new corporation, Sylvan A. Wolin & Associates, has its offices at 15 West Palisade Avenue, Englewood, New Jersey.

#### Poitras Joins Astron

Astron Corporation, 255 Grant Avenue, E. Newark, N.J., manufacturer of fixed capacitors and radio interference suppression filters, announced the appointment of Mr. Joseph Poitras, to be in charge of Astron's recently expanded New Products' Design & Development Division.

#### Admiral Promotes Dye

Paul Dye has been named to the newly created position of general sales manager of Admiral Corporation according to Wallace C. Johnson, vice president—sales. Dye has been manager of distribution for Admiral since 1948. He joined the company in 1946 as midwest regional manager.

#### Stromberg-Carlson Promotes Granger

F. Leo Granger has been appointed distributor manager of Stromberg-Carlson Company's radio-television division, following ten years as national service manager for the company. He takes over the responsibilities of company relationship with its radio-television distributors and deal-

[Continued on page 62]

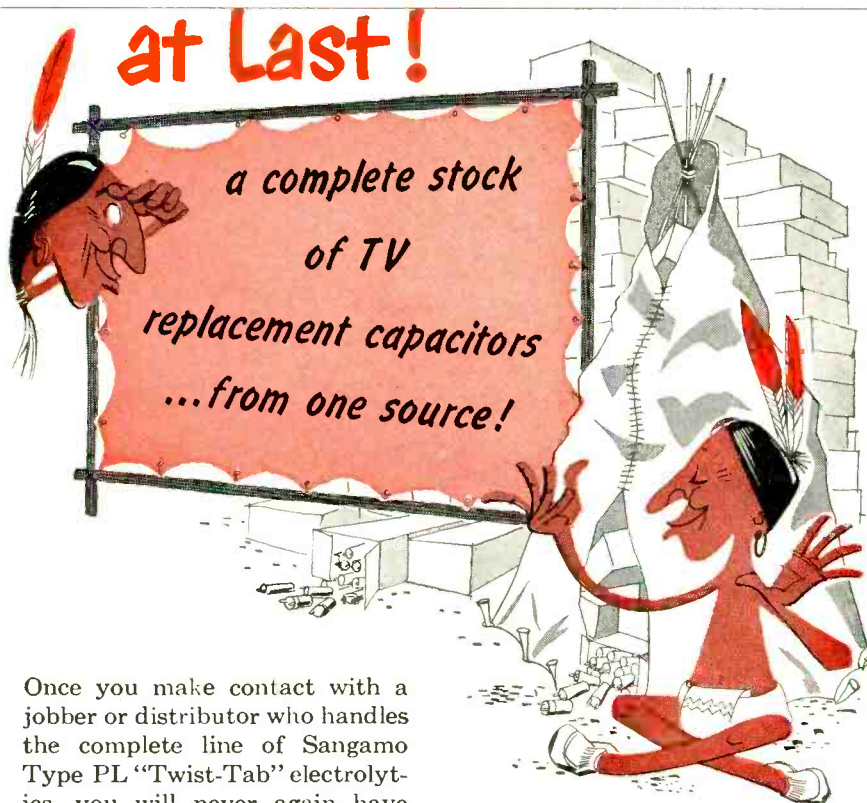

Once you make contact with a jobber or distributor who handles the complete line of Sangamo Type PL "Twist-Tab" electrolytics, you will never again have to "shop around" for odd sizes or capacities. Why? ... because the Sangamo line is the most complete in the industry.

Used by all leading manufacturers of TV sets, Sangamo Type PL "Twist-Tab" electrolytics are exact replacements. They assure long life and dependable performance at 85° C and under conditions of high surge voltages and extreme ripple currents often found in TV applications.

Ask your distributor for a copy of the Sangamo TV Replacement Catalog. It's easy to use and helps you choose the *right* replacement every time.

Deal with your Sangamo "Head-quarters."

*Those who know ... choose Sangamo*



**SANGAMO ELECTRIC CO.** MARION ILLINOIS

# FAR BETTER RECEPTION

# IN EVERY LOCATION

with Sensational New

# TRIO ZIG-ZAG

Patent Pending

## TV ANTENNAS

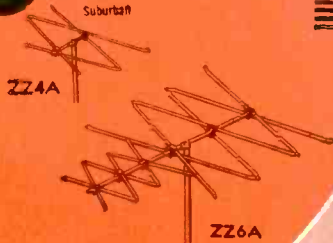

### SUBURBAN MODELS

Models ZZ4A and ZZ6A give you all-channel (2 thru 13) reception in ONE SINGLE BAY ANTENNA. The Model ZZ4A has excellent gain and is designed for suburban areas. Model ZZ6A has even greater gain and provides excellent all-channel reception in near fringe areas.

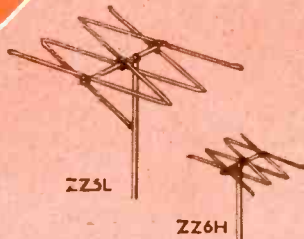

### NEAR FRINGE MODELS

For near fringe area reception, the Models ZZ6L and ZZ6H are recommended. Model ZZ6L covers Channels 2 thru 6, Model ZZ6H is for Channels 7 thru 13. Each antenna offers high gain with patterns and front-to-back ratios similar to cut-to-channel yagis.

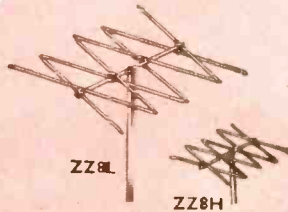

### FRINGE MODELS

Models ZZ8L and ZZ8H were designed for normal fringe area reception and provide clear, snow-free pictures. Forward lobe patterns and front-to-back ratios are similar to a good single channel, multi-element yagi.

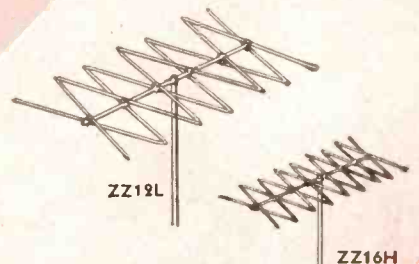

### ULTRA FRINGE MODELS

The extremely high gains of the ZZ12L and the ZZ16H models provide unequalled reception in ultra-fringe areas. Model ZZ12L covers Channels 2 thru 6 and Model ZZ16H, Channels 7 thru 13. These two models when stacked, are fed with only one 300 ohm line and provide ALL VHF CHANNEL RECEPTION. Line match is excellent and front-to-back ratios are unusually high.

ZZ12L and ZZ16H are stacked for all VHF Channel Reception

\* To provide even greater strength, TRIO Antennas now have stamped steel element clamps.

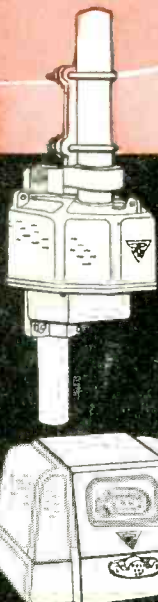

### TRIO ROTATOR AND DIRECTION INDICATOR

The TRIO Rotator is America's most dependable — has two powerful 24 volt motors — one for each direction of rotation. Absolutely weather-proof, permanently lubricated. All motors, shafts and gears mounted on a rugged, one-piece casting for true alignment, strength and longer life. Every TRIO Rotator fully guaranteed for two years! Beautiful Direction Indicator has "finger tip" control — no need to hold knob for rotation. A touch of the finger starts it — a touch stops it!



# TRIO

TRIO MANUFACTURING COMPANY

GRIGGSVILLE, ILLINOIS

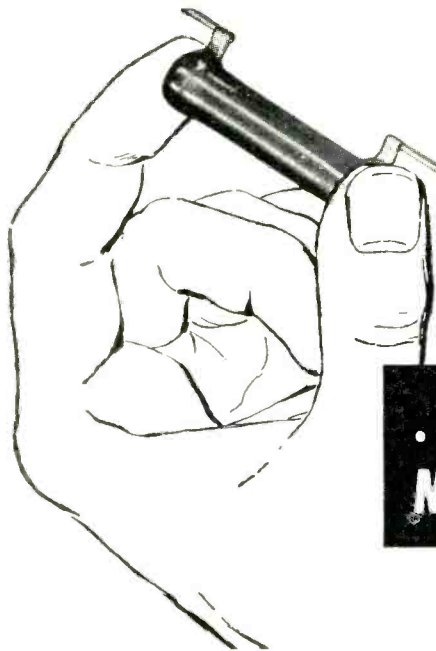

# OHMITE *resistors*

**... for that EXTRA  
MARGIN OF SAFETY!**

Customers judge your service by the results they get. If a radio or TV repair job fails to stand up, they blame *you*, not the parts you used.

Don't jeopardize your business reputation with "just-as-good" replacement parts. OHMITE resistors provide an extra margin of safety. You can depend on these quality resistors—wire-wound or composition—to give years of trouble-free service.



**OHMITE MANUFACTURING COMPANY**  
4846 Flourney Street, Chicago 44, Illinois

*Send for stock catalog*

*Be Right  
with...*

# OHMITE®

**DEPENDABLE RESISTANCE UNITS**

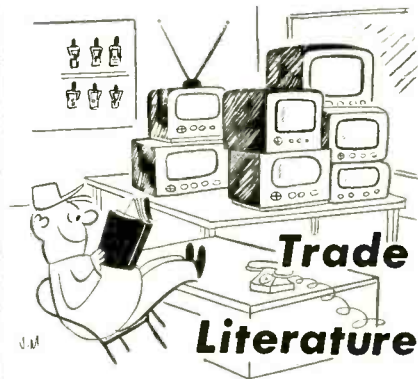
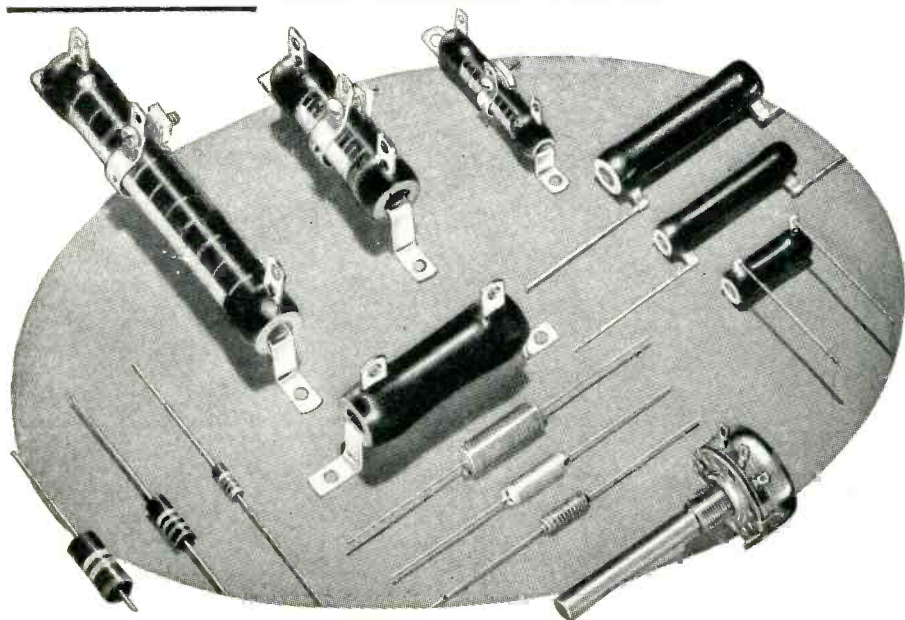

*TV Tenna Tips*, prepared by Ed Noll, Mathew Mandl, & Edgar Dailey of Snyder Mfg. Co.

This booklet has been prepared for the television technician as a reference for the principles of antenna systems and their characteristics. It is hoped this information will prove of material aid in the solution of the many problems which may be encountered in the field.

While it is impossible to cover all phases of antenna theory within the confines of such a small publication, sufficient basic information has been included on fundamental antenna types so that a good working knowledge of performance is readily available for reference purposes.

Other pertinent data include various hints which will enable the technician to secure greater antenna performance because of a superior installation, while at the same time adding to customer satisfaction—the technician's best advertisement.

Because of the unprecedented demand for the first edition of this booklet, the present issue has been expanded to encompass new antenna types as well as discussions of antenna factors involving reception at the ultra-high frequencies. Much of the information is the result of exhaustive field tests in widely scattered areas with portable laboratory equipment.

\* \* \*

*Annual Report 1952*, of La Pointe Electronics Inc., is a revealing source of information on the activities and status of this enterprising organization. An excellent TV coverage map is included in the center spread; and its pages are replete with interesting illustrations of its operations.

\* \* \*

The Allied Radio Corporation, Chicago, has released the first issue of the *Allied High-Fidelity Auditor*, an attractive 4-page quarterly publication containing information about new audio products and developments, especially in the field of high-fidelity.

An interesting feature is a column called "Hi-Fi Clinic," with questions and answers about typical problems encountered with hi-fi equipment.

The *Allied High-Fidelity Auditor* will be sent without charge to audio technicians, hi-fi installers, experimenters and hobbyists. To be placed on the mailing list, readers of Radio-TV Service Dealer should write to *High-Fidelity Auditor*, Allied Radio Corporation, 833 W. Jackson Blvd., Chicago 7, Illinois.

\* \* \*

Three booklets, "*Let's Hold Better Meetings*," "*Let's Be Better Salesmen*," and "*Let's Make Better Presentations*," have been written by R. H. Schneberger, General Service Manager of Crosley Division, AVCO Mfg. Corp.

They are excellent capsules of sales ammunition which every salesman or service dealer should be acquainted with.

*Let's Hold Better Meetings* discusses the Do's and Don'ts of successful sales and service meetings. *Let's Be Better Salesmen* points out in basic manner what makes for more effective sales. *Let's make Better Presentations* concerns itself with more effective preparation and delivery of talks, lectures, etc. before a group.

Single copies of these booklets are available at 15c each, orders of 25 or more copies at 10c each postpaid. Send your Money Order to, Tri-State Offset Co., 817 Main Street, Cincinnati 2, Ohio.

\* \* \*

John F. Rider Publisher, Inc., 480 Canal St., New York 13, N. Y., announces that two new books for the TV servicing industry will be available in March.

TV Manufacturers' Receiver Trouble Cures, Volume 2, is the second volume in this series of practical servicing books that gives exact directions for correcting TV receiver performance "bugs." Each remedy is developed by the receiver's own manufacturer. Specific troubles in specific TV models are pin-pointed by brand and model or chassis number. The book shows how to correct some of the most difficult TV receiver faults—picture jitter, hum, instability, buzz, tearing, etc. In all cases exact instructions are given as to how to make the repair. All trouble cures are listed in the complete index for instant accessibility of information.

Volume 2, contains over 110 pages in a paper binding. It is abundantly illustrated. The price is \$1.80. Other

## single test — double check



new

MODEL 485

### synchronized crosshatch pattern generator

You control your own broadcast test pattern for initial installations and linearity adjustment calls with the Simpson Model 485. Newly developed Model 485 provides a synchronized signal, modulated on the carrier frequencies of channels 2 through 6, which can be tuned and sent through the receiver under test — anywhere, at any time! The vertical and horizontal sync pulses provide means by which the pattern is locked in on the TV receiver. Since this is a transmitted TV signal, it is not necessary to check against a broadcast pattern. Linearity is double checked with a single test — no call back to cut service profits.

Dealer's net price, including special output cable for 75 and 300 ohm terminations, only \$147.50. Ask your jobber for full information or write —

**SIMPSON ELECTRIC COMPANY**

5200 West Kinzie Street, Chicago 44, Illinois  
CO 1-1221

BURTON BROWN ADVERTISING

Another reason why Simpson is world's largest manufacturer of test equipment

volumes in the series are now in preparation.

*TV Sweep Alignment Techniques*, by Art Liebscher, is the publisher's second book scheduled for March publication.

The author, formerly with RCA as a test equipment specialist, includes in the book exclusive information used by set manufacturers' assembly lines and test equipment manufacturers' laboratories. These techniques may now be used by TV service technicians in their every day operations. Of the many sweep alignment methods used

by receiver and test equipment manufacturers, one of the most unique, which is introduced here to the service technician for the first time, is the supermark method.

Contains over 100 5¼" x 8¼" pages in a paper binding. It is priced at \$2.10.

\* \* \*

In line with their policy of providing free technical information on high-fidelity equipment, Jensen Manufacturing Company, Chicago, has

[Continued on page 62]

**Snyder**  
PHILADELPHIA

**UHF  
BROADBAND  
YAGI**

**PINPOINT  
TO  
PROFIT**

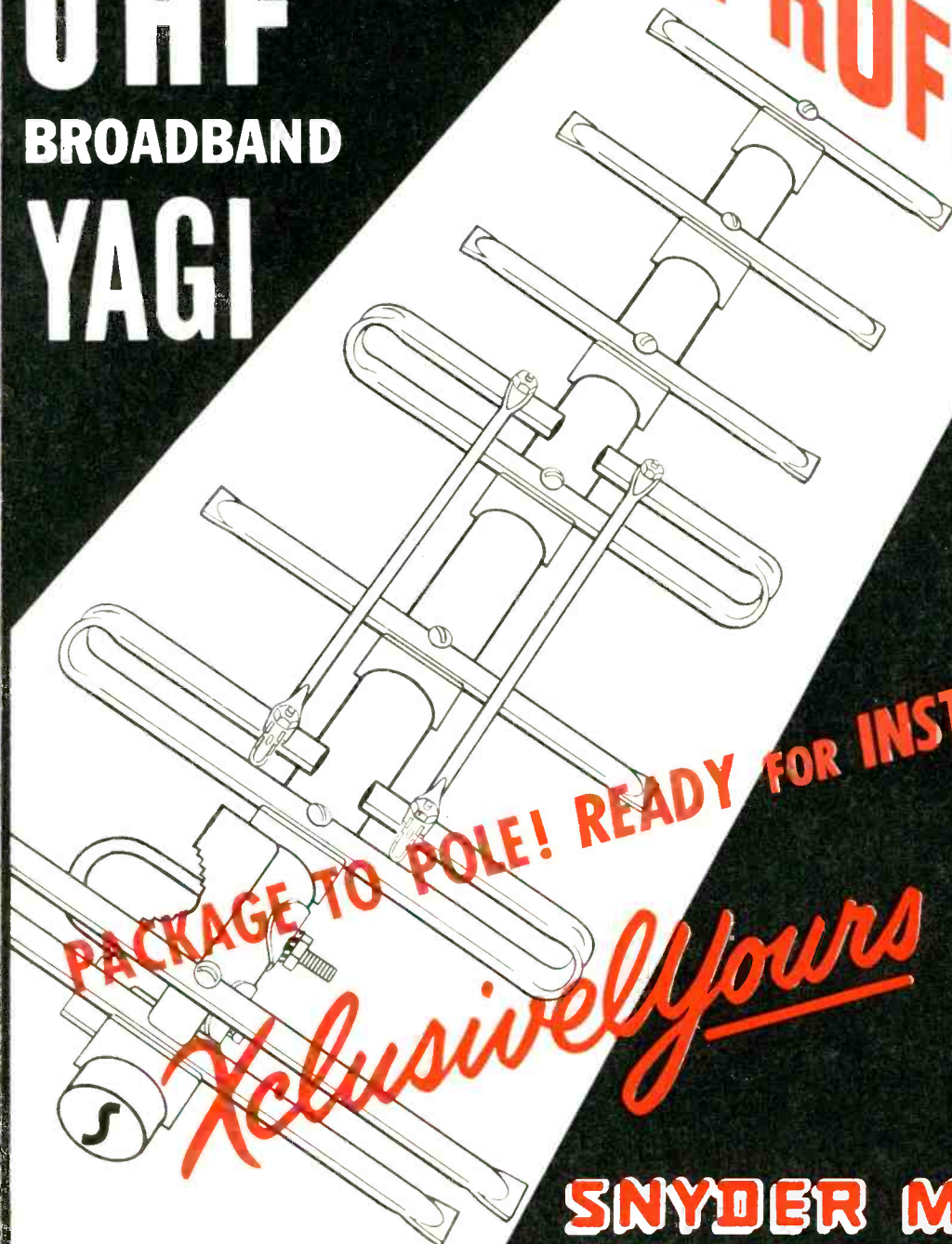

**PACKAGE TO POLE! READY FOR INSTALLATION**

*Exclusively Yours*



**Model A - CHANNELS 14 to 48**  
**Model B - CHANNELS 27 to 62**  
**Model C - CHANNELS 47 to 83**

**SNYDER MFG. CO.**  
ANTENNA ENGINEERS®  
PHILADELPHIA

WORLD EXPORT: ROBURN AGENCIES, INC., 39 WARREN ST., N.Y. 7, N.Y.  
CANADIAN DISTRIBUTOR: VAN DER HOUT ASSOC., LTD., NEW TORONTO



# TV SYMPOSIUM SERIES— No. 2

**A discussion of latest keyed agc systems with the idea of bringing the serviceman up to date on these systems. A theoretical and a practical approach to a subject that can increase your potential profits by decreasing the time necessary in servicing the complex functions of agc.**

## MODERN AGC SYSTEMS

by **MATTHEW MANDL**

**M**ODERN *agc* systems in television receivers have been improved to a considerable extent over older versions. They have good noise immunity and are of the keyed or gated type to reduce airplane flutter. Many are adjustable so that the *agc* action can be set for best function in either strong signal areas, fringe areas or by establishing a compromise for both.

Considerable circuit variations exist, however, among the various manufacturers because of the particular gain and design characteristics encountered in different receivers. In some instances provisions are made to control the bias on the *rf* stage in different proportion than that applied to the video *if* stages. To accomplish this, engineers have used unusual and ingenious methods. Occasionally, a separate amplifier is required for the *agc* circuit. Thus, an understanding of the function of modern *agc* systems will prove of benefit to the servicing technician. The more clear circuit function becomes, the more readily may such systems be serviced.

Before analyzing the more complex methods used in representative receivers, it would be well to review briefly the basic function of the keyed or gated *agc* circuit. This is helpful because all versions, no matter how intricate, are based on the single triode keying process.

*Figure 1* is a typical keyed *agc* circuit. Plus B voltage is applied to the top of the cathode resistor (*R2*). Since both the grid and plate circuits are returned to ground (*R1* and *R3*) the positive polarity at the cathode would make both grid and plate circuits minus with respect to the cathode. Thus, the tube will not conduct until *both* the minus potentials are overcome. A positive spike is applied to the plate from the horizontal output circuit. This has sufficient amplitude to overcome the negative polarity of the plate and permit conduction, *providing* the grid bias is also reduced.

The video signal (or sync from the sync separator circuits) is applied to the grid. Bias is sufficiently high so

that only the sync tips have adequate amplitude to overcome enough bias to permit tube conduction. Thus, neither the grid signal alone nor the pulse on the plate can cause conduction. When *both* are present, however, tube conduction occurs. Thus, we key the tube into conduction once every 15,750th of a second (the horizontal sweep rate). Conduction is short because sync pulse width is only slightly more than five microseconds. The sync pulse (plus the positive spike at the plate) thus opens the gate for current flow—hence the term “gated *agc*.”

When the tube conducts, current flows from cathode to plate and *down* the plate resistor *R3* (*Fig. 1*) in the direction shown by the arrow. This makes the top of the resistor minus and this is the voltage used for bias purposes on the *rf* and *if* amplifiers. The filter network capacitors charge during conduction and hold this charge during tube non-conduction. This produces a steady *dc* voltage, for the *agc* tube acts as a rectifier

with the filter network smoothing out the ripple. The latter is at 15,750 and, as compared with the old *agc* systems, the 60 cycle need not be filtered out because the gating principle does not permit them to appear in the output. Thus, a shorter RC constant can be employed. The short time constant minimizes rapid changes of signal such as would be caused by airplanes flying overhead. Besides this, noise pulses which occur for the remainder of the video signal (between sync pulses) cannot open the gate because the horizontal pulses are not at the plate between sync pulses.

Sync pulse amplitude depends on the strength of the signal received. With a strong signal, sync pulse voltage at the grid is higher permitting greater conduction. This develops a higher bias for the *rf* and *if* tubes and reduces their gain proportionately—thus preventing overloading. The latter would cause picture pulling, excessive contrast, a negative picture, or complete blanking out of the video signal.

When signal strength is low for a particular channel, sync pulse amplitude at the grid declines unless conduction occurs. The negative voltage at the filter network drops and this reduces the bias on the amplifier tube—thus decreasing gain.

#### Typical Commercial Circuits

A typical commercial circuit which utilizes the basic principle detailed in the foregoing analysis of Fig. 1 is shown in Fig. 2. This is the *agc* system used in many Admiral receivers, including those with chassis 24D1, 24E1, 24F1, 24G1, etc. In this instance a pentode 6AU6 is utilized instead of a triode, though the basic function is essentially the same. The

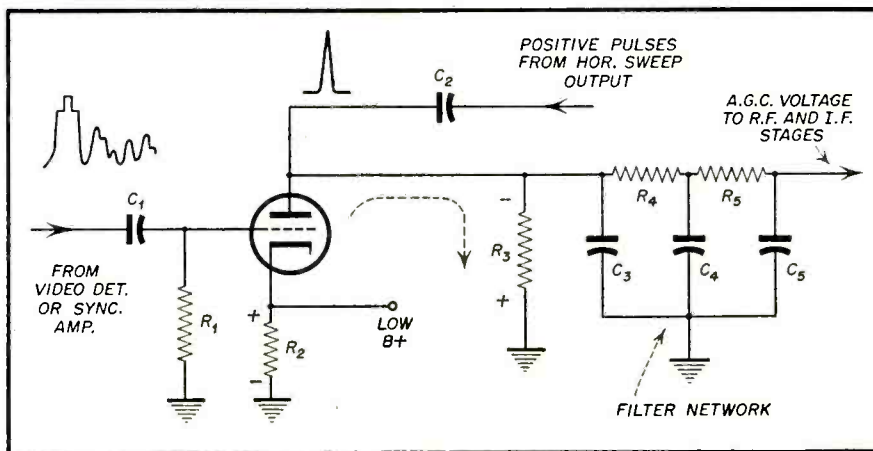

Fig. 1—Basic keyed *agc* circuit with waveform analysis and filter network.

positive voltage for the plate of the *agc* tube is procured from the width coil as shown. A .001 capacitor is used to couple this positive-going sync pulse to the plate of the 6AU6. The grid signal is supplied from the video amplifier tube. This means that the composite video signal appears at the grid of the 6AU6 *agc* tube, but as previously mentioned, only the sync pulses (highest amplitude of signal) are effective in opening the gate for tube conduction. The primary *agc* filter network consists of two 47,000 ohm resistors and two capacitors, one .005  $\mu$ f and the other .5  $\mu$ f. The 22,000 ohm resistor in series with the .1  $\mu$ f capacitor to ground is for the purpose of filtering out any 60 cycle "bump" which might appear in the *agc* voltage because of uneven response characteristics caused by improper antenna orientation, slight misalignment, or tuner tracking. This filter network will remove any such ripple component which might be present and this would eliminate the tendency for audio buzz to be produced.

In this circuit the *agc* voltage is applied across a bleeder network of 27,000 ohms in series with a 100,000 ohm resistor to ground. This acts as a voltage divider for the *agc* voltage and permits two voltages of different polarities to be procured. Inasmuch as current flow is from plate to ground, as shown by the arrow, negative polarities are provided for both the *rf* amplifier and the video *if* amplifiers. Thus, the proportion of bias voltages to these stages can be allocated for proper circuit function.

#### Bias Clamp

The typical *agc* circuit shown in Fig. 3 is that used in a number of RCA receivers, including those using the KCS66 chassis. Here, a 6CB6 pentode tube is used as an *agc* tube in similar fashion to that shown in Fig. 2. A low plus B is again applied to the cathode circuit, while positive pulses are again derived from the width coil for the plate of the *agc* tube. The signal for the grid, however, is somewhat different than that previously described. In Fig. 3, a voltage is derived from across the cathode resistor of the sync separator circuit. This is an average *dc* bias voltage but this will change according to the sync level in the sync separator circuit. Thus, as the sync level increases at the separator, more current will flow through the cathode resistor and a more plus voltage will be applied to the grid of the 6CB6 tube. While this is a somewhat different method for securing the voltage for the grid of the *agc* circuit, the function is essentially the same as occurs in circuits previously discussed. Tube conduction still cannot occur except during the presence of the positive pulses at the plate of the *agc* rectifier. Thus, the amount of negative *agc* bias voltage developed across two 150 ohm

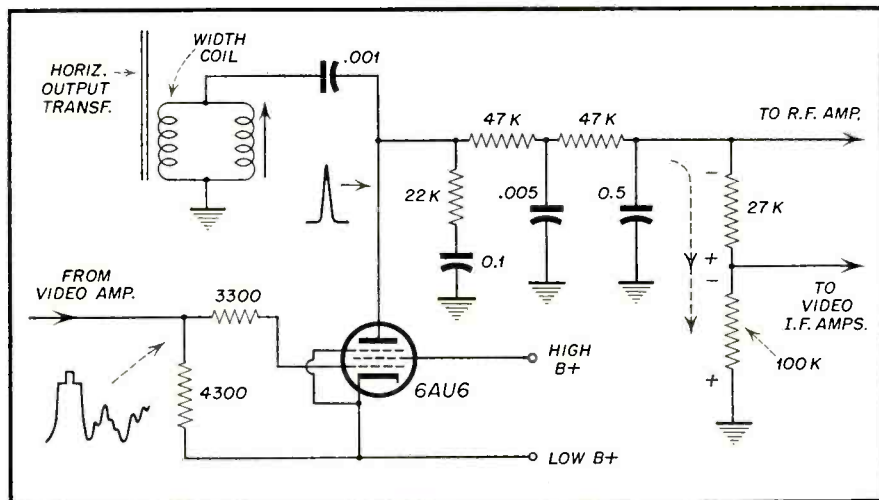

Fig. 2—AGC used in Admiral Chassis 24D1, 24E1, etc. series receivers.

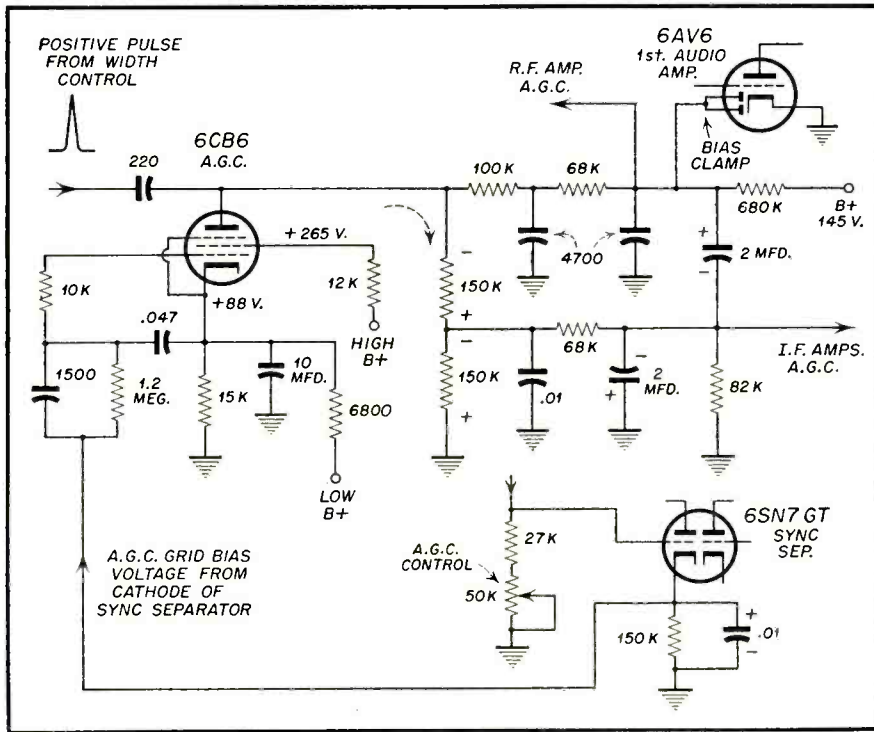

Fig. 3—Keyed AGC circuit used by RCA in Chassis No. KCS66. Bias clamp circuit is featured.

resistors is still proportionate to the amplitude of the sync signal.

As with the Admiral receiver previously discussed, a bleeder system is used to derive two separate voltages. One *agc* voltage is for the *rf* amplifier tube and the other for the *if* amplifier tubes. The voltage applied to the *rf* amplifier is less than that to the video *if* amplifiers. This is done so that the *rf* stage will have greater sensitivity for reception of weak signals.

Besides the voltage division for the *rf* and *if* tubes, a circuit known as a "bias clamp" is also utilized. This consists of applying the circuit which contains the *agc* bias for the *rf* tube to a diode circuit. In most instances a dual diode-triode tube is used such as a 6AV6 or a 6AT6. The triode section is commonly employed as the first audio amplifier with the diode sections functioning independently of the triode section. The purpose for this circuit is to regulate the *agc* bias on the *rf* tube with respect to the reception of strong and weak signals. It is so designed that the sensitivity of the *rf* amplifier is greatly improved during the reception of weak signals as opposed to strong signals.

When a weak signal is received the bias voltage developed for the *rf* amplifier is decreased. When this occurs, the plus B voltage (145) applied to the 680,000 ohm resistor will cause the bias clamp diode to conduct. This

prevents the *rf* amplifier grid from going positive and permits a minimum bias to be applied to the grid for maximum gain during weak signal reception. When signal strength is of average value, a greater negative bias voltage will be developed for the *rf* amplifier and this will overcome the plus potential. The negative polarity at plates of the bias clamp diodes will prevent their conduction. Thus, the bias clamp acts as an independent

gating circuit which is opened to permit conduction on weak signals and closed during reception of normal or strong signals. The bias clamp has no effect on the *agc* voltages applied to the *if* amplifiers.

A manual control is provided for adjusting the *agc* for the average signal strength present in any given locality. The control consists of a 50,000 ohm resistor which is part of the grid leak of the sync separator tube. By varying the potentiometer the bias relationships between grid and cathode are altered. This changes tube conduction and permits regulation of the amount of voltage derived from the cathode voltage. Since this is applied to the grid of the 6CB6 *agc* tube, it will regulate the amount of conduction therein and thus, the developed *agc* bias for the *rf* and *if* tubes. When such controls are provided, they should be adjusted below the point of picture bending for the strongest signal which is received in the area.

#### AGC Sync Amplifier

In some instances an amplifier stage precedes the *agc* tube in order to procure sufficient sync pulse amplitude for the grid of the latter. One such instance is the *agc* system used in the new Capehart receivers (CX-36 chassis). This is shown in Fig. 4, and a 6BA6 sync amplifier is utilized for the express purpose of building up sufficient signal amplitude for application to the grid of the 6AV6 *agc* tube. The 6BA6 sync amplifier circuit has no other function, since a

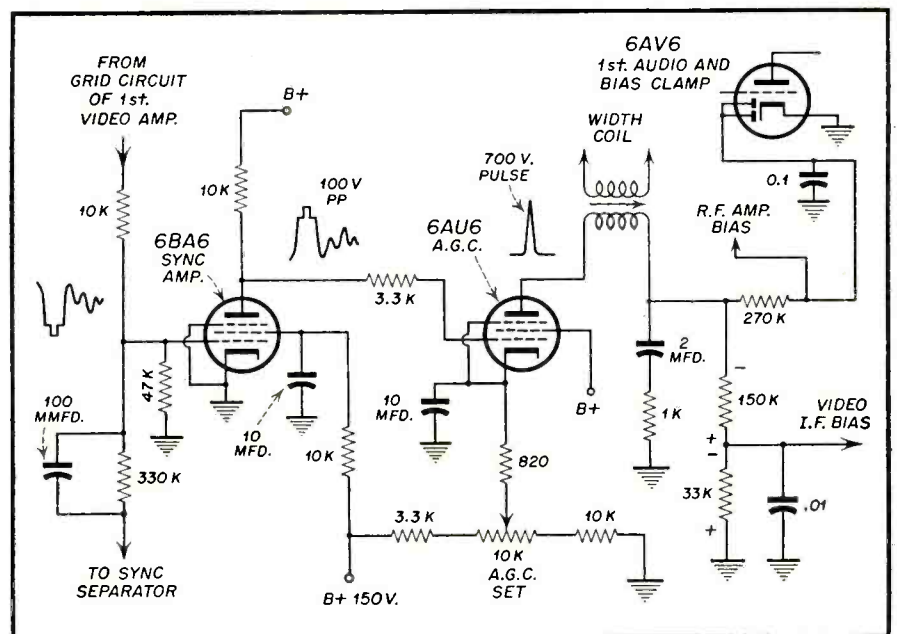

Fig. 4—AGC using a sync amplifier. This is an extract of Capehart CX-36 circuit.

conventional sync separator is used for vertical and horizontal sweep without the use of an amplifier prior to separation. The sync amplifier tube actually amplifies the complete composite video signal and produces the amplified version of this in its plate circuit. The plate circuit is directly coupled to the grid of the *agc* tube via a 3,300 ohm isolating resistor. The *agc* circuit is similar to that previously described. Positive pulses having an amplitude of 700 volts are derived from the width coil section of the horizontal output transformer. A filter network is included for buzz control (the 2  $\mu$ fd. capacitor in series with the 1,000 ohm resistor to ground). An *agc* voltage divider network is formed with a 150,000 ohm resistor in series with a 33,000 ohm to ground. This divides the *agc* voltage across this bleeder network for application to the *rf* amplifier as well as the first two video *if* amplifiers. The usual clamp circuit is utilized with the diode sections of the first audio amplifier employed for this purpose.

An *agc* setting control is provided. This permits adjustment of the *agc* bias developed so that the signal output from the plate of the 6BA6 sync amplifier can be adjusted for 100 volts peak-to-peak. This control consists of a 10,000 ohm potentiometer which is preset at the factory and normally needs no readjustment unless the characteristics of the circuit change because of tube or parts values changing. The control has a recessed screw-driver slotted shaft to prevent accidental maladjustment during the time the other controls are being set. When necessary to adjust the *agc* control it is recommended that an oscilloscope be used which is calibrated for peak-to-peak voltage readings. By observing the waveform at the output of the sync amplifier, the peak-to-peak voltage of 100 can be set with the *agc* potentiometer.

**Double Delayed Gated AGC**

A most unusual *agc* system is employed in the new 1953 model Zenith receivers using chassis 19K20, 19K22, 19K23, and 21K20. This is referred to by the company as "double delayed gated *agc*."

As discussed for the previous *agc* systems, a clamping circuit is often employed to delay the application of bias to the *rf* tube and during weak signal reception. Zenith's method for doing this is quite off the beaten path. To illustrate the principle involved it is necessary to show the design of some sections of the first three video *if* stages. For this reason, a partial

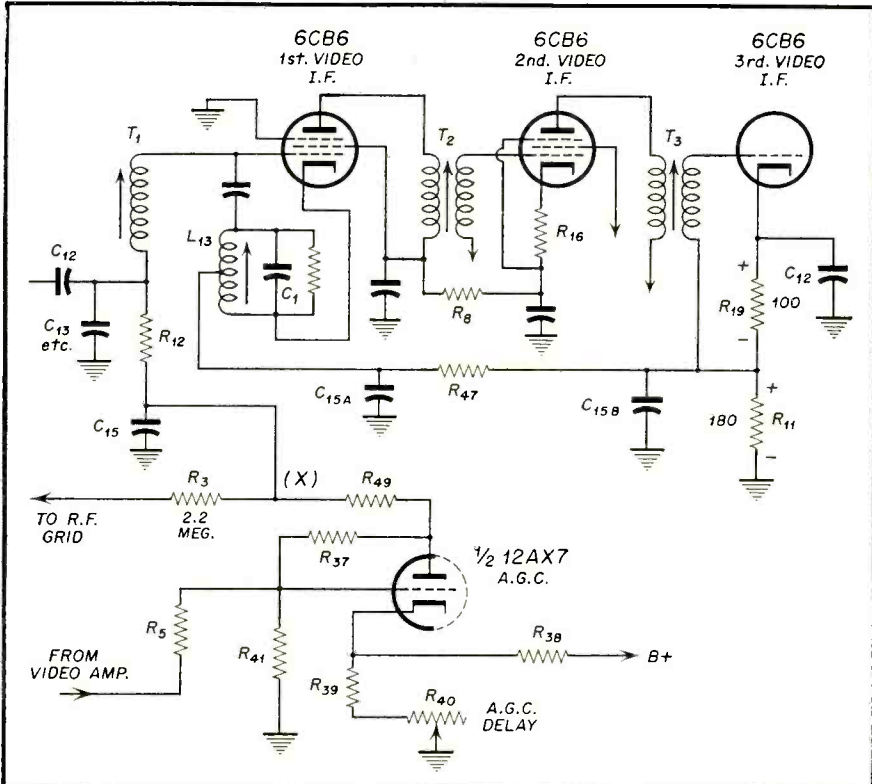

Fig. 5—AGC system used in 1953 Zenith receivers. (Chassis No. 19K20 and 21K20 series).

schematic of them plus the *agc* circuit is shown in Fig. 5.

The *agc* tube is wired in a conventional manner. An *agc* delay potentiometer is provided so that the amount of delay introduced can be regulated for the strength of the signal received in any particular locality. A composite video signal is applied to the grid of the *agc* tube from the video amplifier.

For the best performance in the weak signal areas, Zenith has designed the system so that the application of *agc* bias to the *rf* tube is withheld until the signal level from the antenna reaches about 500 microvolts. This gives the best signal to noise ratio figure for the tuner system. The manner in which this is done utilizes an unusual design feature in the *if* stages. The cathode of the first video *if* amplifier ((6CB6) is approximately 8 volts positive because of the tie-in to the cathode resistor of the third *if* amplifier. The connection is from the cathode trap composed of L13 and C1 via R47 to the junction of R19 and R11. The 8 volts secured from across R11 plus the current flow through the tube causes the grid of the first video amplifier to be 9.3 volts negative with respect to the cathode. The third video *if* amplifier procures its bias from R19, the 100 ohm resistor, inasmuch as the grid circuit is tapped

right below R19. The potential at the junction of R19 and R11 varies from 4 volts for strong signals to approximately 8 volts with zero signal.

It will be noted that the plate circuit of the first video *if* stage is returned to the cathode of the second *if* amplifier. Thus, the two stages are in series and any changes in plate current for the first tube will also affect the second tube. This causes the second *if* amplifier to be controlled indirectly by the *agc* applied.

When a weak signal arrives at the tuner the sync amplitude at the grid of the *agc* tube will be decreased. The output of the tube at "X" will be approximately 8 volts positive. This positive potential is not applied to the *rf* tube, however, because of the series 2.2 megohm resistor. Actually, the *rf* amplifier grid is slightly negative because of the contact potential which is developed because of the high value of series resistance. The aforementioned 8 volts, however, is applied to the cathode of the first *if* amplifier. Inasmuch as the latter is 9.3 volts negative with respect to the cathode, only 1.3 volts of negative potential will be present at the grid with respect to the cathode. Thus, a minimum of *agc* voltage is applied during weak signal conditions.

When strong signals are received,  
[Continued on page 70]



# HERE'S WHY ALLIANCE TENNA·ROTOR IS THE ANSWER TO UHF RECEPTION!

TURN THE ANTENNA  
TO ANY STATION...  
*avoid costly changes!*

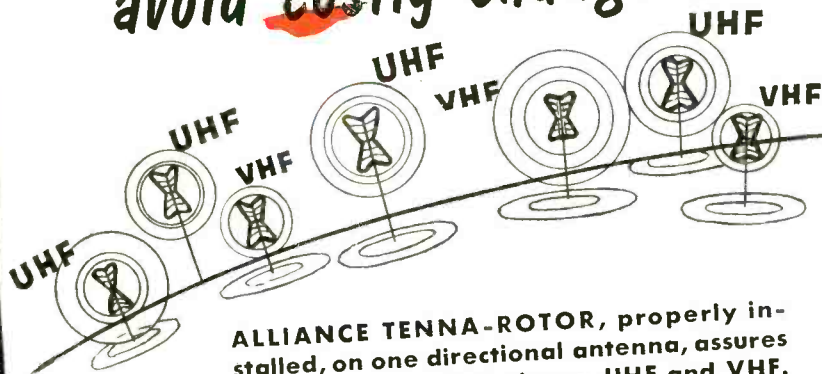

ALLIANCE TENNA-ROTOR, properly installed, on one directional antenna, assures top gain from all stations—UHF and VHF.

- **UHF is more critical—highly directional!**  
Tenna-Rotor is accurate—pin-points the antenna—puts it right on the beam!
- **Many channels are changing!\***  
Tenna-Rotor gives directional all-channel reception—stays costly antenna alterations and re-alignments.
- **Make ONE antenna installation the final installation!**
- **Hundreds of thousands of Alliance Tenna-Rotors are in use!**

*It pays to insist on Alliance Tenna-Rotor!*

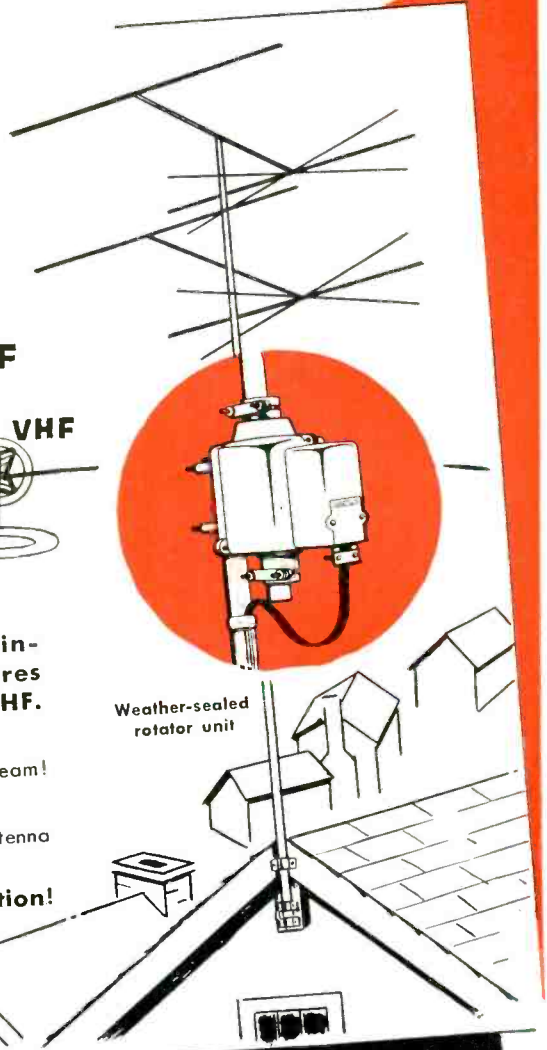

Weather-sealed rotator unit

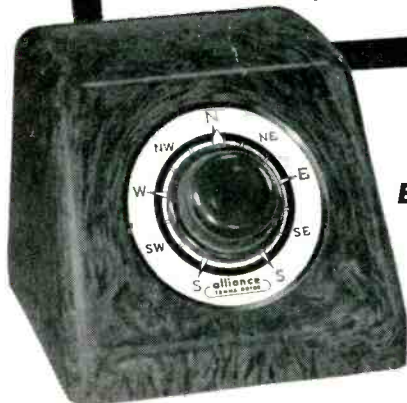

Automatic HIR with direction indicator control. Price \$44.95

**Sold by  
TV Dealers  
Everywhere**

*For nearly 4 years—Eye-compelling Alliance TV spots continue to increase the number of viewers—extend the fringe around every major TV area.*

## IMPORTANT NOTICE!

\*Changes in television demand changes in present antennas! New UHF and VHF stations mean more channels! Current FCC rulings have assigned channel changes to nearly one-third of all VHF stations. This makes single-channel antennas and other fixed position antennas obsolete! Prepare now. Meet the coming changes in television with ALLIANCE TENNA-ROTOR.

**alliance  
TENNA·ROTOR**

(TV ANTENNA ROTATOR)

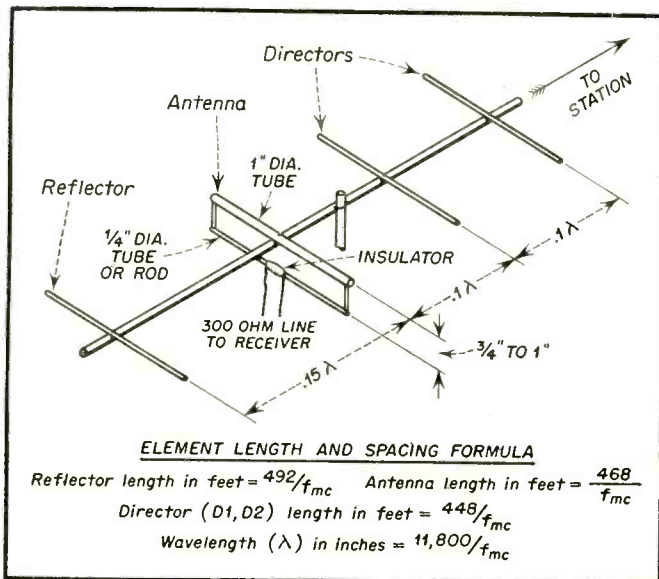

Fig. 1—Dimensional and constructional data for a 4-element high gain Yagi Antenna matching a 300 ohm line.

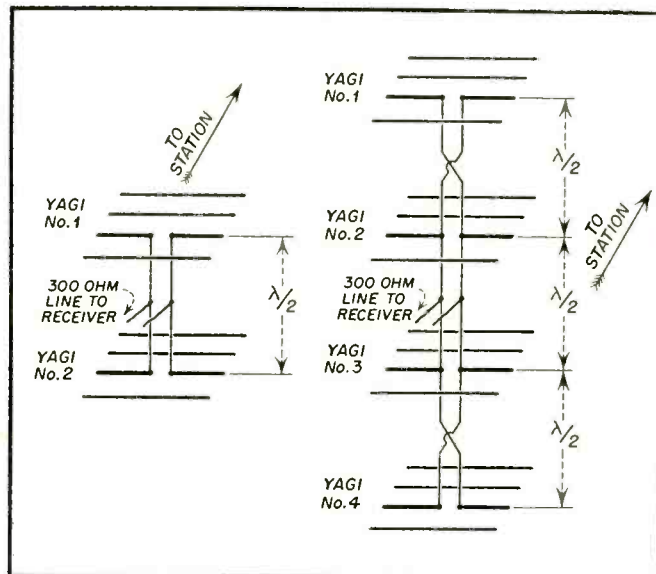

Fig. 2—Satisfactory method of stacking Yagi antennas to obtain increased gain. Note dimensions between antennas.

# FRINGE AREA INSTALLATIONS

by **RUDOLF F. GRAF**

*Director of Engineering & Sales of Electronic Equipment, Camburn, Inc.*

**A practical, how-to-do-it, article which will give the reader some useful information for all fringe area installations. Methods of "souping-up" receivers is featured along with antenna problems.**

**A**LTHOUGH television receivers upon leaving the factory are properly aligned and adjusted to give satisfactory reception on all TV channels, it is still the serviceman who, with the proper technique of installation, makes it possible to get pleasing and dependable reception at the final location of the TV receiver. The installation of sets in areas more than approximately 40 miles from the transmitter or in the so-called fringe areas, presents a number of problems. These difficulties, though at times they may tax the ingenuity and patience of the television servicemen can, with the proper information and skill, be solved to the satisfaction of all concerned.

The following factors are involved in the proper operation of the receiver; The stability of the sync circuits, the signal-to-noise ratio, sufficient picture detail, undesired interference and associated sound. The elements involved in obtaining peak performance in fringe area installations are:

1. The antenna
2. The transmission line
3. The booster amplifier
4. The receiver itself.

We shall treat these subjects in detail and indicate the methods employed to obtain peak performance from each.

Let us first of all determine what can be expected in the way of signal

strength in a fringe area location. The present allocation plan as set up by the FCC specifies a field strength of 5,000 microvolts per meter for a primary service area and 500 microvolts per meter for a secondary service area. The primary service area is generally found within a radius of ten miles from the transmitter, and the secondary service area within a radius of 10 to about 30 miles. Within these confines most all commercial receivers will yield a satisfactory picture with the usual antenna installation. We shall concern ourselves here with the problems encountered when the field strength drops to a value of less than 50 microvolts as would be the case in locations beyond the secondary service area.

Field strength is the intensity of a signal at a given distance from the transmitting antenna. This field intensity is a measure of the number of microvolts of the signal from any one particular station, that would be intercepted by an antenna exactly one meter (3.281 ft.) long. Thus we have the term microvolts per meter. Usable pictures have been produced on the screens of television receivers in areas where the signal strength was as low as 3 microvolts per meter.

Now let's start with the antenna and work our way to the receiver proper in the sequence outlined above.

## The Receiving Antenna

The first and most important link of any fringe area installation is the receiving antenna. It must have as high a gain as possible and, if interference from other stations is a problem, be sufficiently directive to "pick out" only the desired signal. There are

# THE Webcor® "HF" DISKCHANGER

*belongs in every High-Fidelity installation*



Model 126 HF

**PUSH-OFF CHANGING**—universally acclaimed as the most gentle method known. Makes records last longer.

**HIGHLY FINISHED SPINDLE**—special design of "step" and satin-smooth shank save wear on record center hole.

**ELECTROSTATIC FLOCKING**—exclusive Webcor process forms thick, resilient record cushion—prevents record slip.

**TONE ARM REST**—prevents injury to Balanced Tone Arm when in "rest" position. Spring latch immobilizes tone arm when transporting unit.

**BALANCED TONE ARM**—provides feather-light needle ride and optimum tracking. Available equipped with crystal or G.E. Triple Play Cartridge—or for plug in of magnetic cartridges.

**SPEED SELECTOR**—conveniently located. Immediate, positive speed selection. In "off" position, the drive wheel is retracted to prevent flat spot causing "wow."

**EXTRA-HEAVY TURNTABLE**—mounted on ball bearings. Extra weight and precise balancing allow it to act as fly-wheel for motor. Makes for constant, accurate speeds.

**TWO-TIER MAINPLATE**—made of 18-gauge steel. Will not warp or throw parts out of alignment. Spring mounted to absorb unwanted vibrations.

**4 POLE—SHADED POLE MOTOR**—for smooth power. Eliminates "hum," "wow" and "rumble"—delivers accurate, constant speeds.

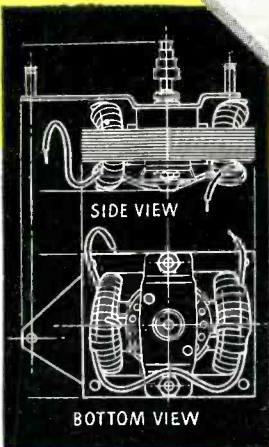

**STEP-DRIVE COUPLING**—for accurate transfer of speeds from motor to turntable. Has fewer working parts.

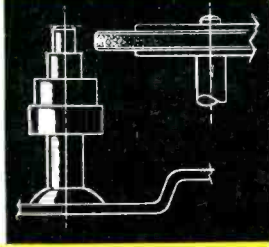

**VELOCITY TRIP**—eliminates damaging lateral needle pressure in record grooves. Tone arm moved by record—not by mechanical drives.

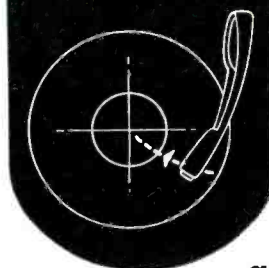

Webcor's mechanical excellence and design superiority make it the ultimate in automatic record changing for custom, high-fidelity installations. The powerful 4 pole—shaded pole motor is statically and dynamically balanced for positive, accurate speeds—and to eliminate "hum," "wow" and "rumble." The ball-bearing mounted, extra-heavy turntable changes speeds smoothly and accurately by means of the new "step-drive" coupling.

This Webcor precision means the utmost in convenient listening pleasure—up to four hours of uninterrupted music—then, automatic shut-off. It means your precious records will sound better and last longer on a Webcor "HF" Diskchanger.\*

\*Available mounted on beautiful base pan for plug into phono-jack of radio, television, or amplifier.

*all music sounds better on a*

# Webcor®



8103

© W/C-1952

WEBCOR PRODUCTS ARE MANUFACTURED BY WEBSTER-CHICAGO, CHICAGO 39, ILLINOIS

RADIO-TELEVISION SERVICE DEALER • MARCH, 1953

29

a great number of good antennas on the market which may, if necessary, be stacked for highest gain. We shall not delve into all of the available types, but shall restrict ourselves to three antennas which are particularly suitable for fringe area work. These antennas are most efficient for only the one channel for which they are designed and individual antennas are generally required for each channel in fringe area installations.

### Yagi Antenna

The yagi is the most popular fringe area type of antenna. Because of its flatness and simplicity it can be most easily erected and, if necessary, stacked for higher gain. Its high front-to-back ration makes it ideal for rejection of co-channel interference. If desired, several Yagis can be mounted one on top of the other on the same mast, with each of them cut and oriented for a different channel. Several different types of Yagi antennas are on the market today. They differ mainly in the number of director elements they employ. Including one reflector, the antenna proper and then adding the directors, there are 3 element (1 director) 4 element, 5 element, 8 element, 10 element and even 12 element (10 directors) Yagi antennas available.

It is a well known engineering fact that as we increase the number of elements in a Yagi array, the gain also increases, though not exactly in direct proportion to the number of elements employed. However, as we add more elements, the antenna bandwidth decreases rapidly and so does the impedance. Thus even though we get sufficient gain, we are faced with the problem of increasing the bandwidth of the antenna to 6 mc and raising the impedance to obtain a good match to a 300 ohm line. This can be realized by proper design of element length and exact inter-element spacing.

One of the nuisances in the installation of Yagis is the time consuming tightening of wingnuts, screws, bolts, etc. In a low channel 10 element Yagi there may be as many as 40 joints to be tightened by means of nuts and screws. A recently introduced line of Yagi antennas utilizes an ingeniously designed spring arrangement which is a great time saver. The elements snap securely and permanently into place in a few seconds and make installation much simpler.

The dimensions for a high gain 300 ohm yagi are given in Fig. 1. For best fringe area results the antenna should be cut at or near the picture carrier.

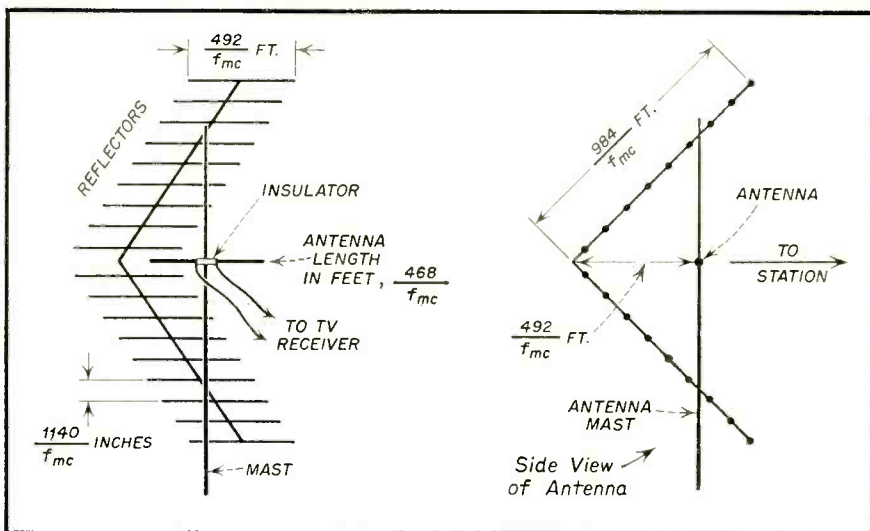

Fig. 3—Dimensional data for a high gain corner reflector antenna. This type of antenna is very successful especially in areas where ghosts are troublesome.

If the sound comes in too weak, the front director *D1* may be shortened by about 5% to improve it. In a future article we shall give complete dimensions and element spacing for multi-element Yagi antennas covering all existing *uhf* and *vbf* channels. Fig. 2 shows how Yagis may be stacked for higher gain.

### Corner Reflector

The corner reflector has an excellent front-to-back ratio (100:1), a narrow beam angle, and a gain of approximately 10 db over a simple dipole. The dimensions for this antenna are given in Fig. 3. The driven element is mounted a half wavelength or slightly less from the vertex of the reflector and the reflector elements are spaced one-tenth wavelength apart. The reflector elements may be made of 1/4" tubing or rod. The two groups of reflector elements are mounted at an angle of 90 degrees and may be connected together electrically though that is not necessary.

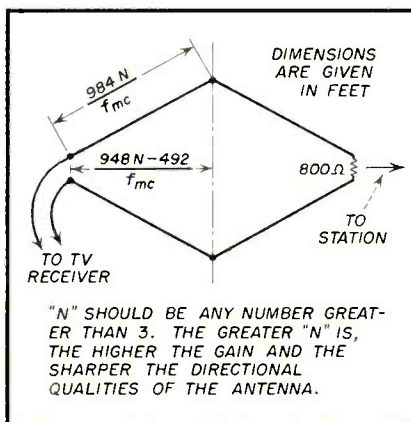

Fig. 4—Data on the Rhombic antenna. Most successful for very long hauls.

The transmission line should be run out at the rear of the reflector as shown so as to keep the whole system as symmetrical as possible. The antenna should be used with a 300 ohm line and is generally satisfactory for reception only on one *vbf* channel though it may cover more than one *uhf* channel.

### Rhombic Antenna

If there is sufficient space available for its erection the rhombic antenna is ideally suited for all fringe areas and bad ghost areas. The antenna is characterized by a high gain over a relatively broad frequency range and can be made sharply directional by terminating the far end (the end pointed to the station) with an 800 ohm non-inductive resistor. If the front-to-back ratio is of importance try different values of resistors for best results. The rhombic can also be designed to be bidirectional. This can be done by simply omitting the terminating resistance. The characteristic impedance of the rhombic antenna is 800 ohms but for short distances a 300 ohm line is satisfactory. Otherwise use either an open line with the wires spaced approximately 2 inches apart with a quarter wave matching section at the antenna or a 300 ohm line tapered outward for about 1/2 ft. and connect the widely spaced end to the antenna. The dimensions for a rhombic antenna are given in Fig. 4. If the transmission line must be run through an area of high ambient noise, and it is necessary to use a 75 ohm coaxial line, a balanced-to-unbalanced transformer as shown in Fig. 5 must be used.

Not only is it necessary to use a high gain antenna, but it is also im-





**GOOD NEWS AGAIN!**... for "Eveready" Portable Radio Battery Dealers.

Last year's "Bonus-in-Batteries" sales plan was a big success. This year's extra-profit program is even better!

See your "Eveready" radio-battery supplier *today* for full details of the 1953 plan. Don't miss this chance to *add* profit dollars to your fast-turnover, portable-radio battery business.

**ORDER NOW** ... Make "Eveready" brand *your* battery brand this year ... *all* year!

*The terms "Eveready", "Mini-Max", "Nine Lives" and the Cat Symbol are trade-marks of Union Carbide and Carbon Corporation*

**NATIONAL CARBON COMPANY**  
A Division of Union Carbide and Carbon Corporation

30 East 42nd Street, New York 17, N. Y.

District Sales Offices: Atlanta, Chicago, Dallas, Kansas City, New York, Pittsburgh, San Francisco

IN CANADA: National Carbon Limited, Montreal, Toronto, Winnipeg

**BIG**  
**Bonus**  
**Offer**  
with your  
**Best**  
**Battery**  
**Brand!**

**Also ...**

**COLORFUL DISPLAY KIT**  
**INCLUDED IN**  
**1953 "EVEREADY"**  
**BATTERY PROMOTION**

Jumbo No. 467 battery, nearly 30" high, and many other sales helps. Get this big kit ...

**USE IT NOW!**



portant that the antenna be located in a space loop. A space loop is an area of maximum signal strength. Such a space loop can be located by using a simple test antenna in the following manner.

Construct a simple test antenna such as a folded dipole half a wavelength long, cut to the frequency of the desired station. Mount the test antenna on a light mast the same height as that used for the final antenna installation. Locate the test antenna at the desired antenna site and orient it toward the station. Now move the antenna toward or away from the station until you find a space loop. This can be noticed in one of two ways. One is on the TV receiver by a marked increase in picture con-

trast or a rise in *agc* voltage. The second method requires the use of a field strength meter. A space loop is found when we have maximum meter reading.

If it is desired to get the best location for more than one station, repeat the same procedure and if possible find a spot which is a space loop for both of the desired stations. If a simple dipole does not pick up a sufficient amount of signal a more elaborate antenna such as the Yagi antenna shown in *Fig. 1* is indicated for this test.

A simple check to make sure that the antenna is properly located can be made if a twin lead transmission line is used. Reverse the leads at the receiver or at the antenna and observe

the effect on the picture. If there is no change in picture quality the antenna is oriented properly. If, however, there is a change in the picture, the antenna should be reoriented. This test cannot be employed if an unbalanced coaxial line is used.

#### The Transmission Line

It would be useless to erect an elaborate and efficient antenna and then use a low quality and improper transmission line and lose the so very carefully obtained signal on the way to the receiver. If maximum signal is to be delivered, it is important that the line is matched to the antenna as well as to the receiver. The line may be matched by using either a "Q" section or a quarterwave matching stub.

Be sure to choose a line which has a low capacity, lowest loss and a good quality dielectric. This is particularly important if the line must be run over a substantial distance from the antenna to the receiver. If the location is one where the line is subject to noise pickup, a shielded coaxial line

**Don't Gamble....**  
**ON ULTRA HIGH FREQUENCY**

**"RECEPTION"**



**..you can count on the....**  
**MI-TEE RAY**

**UHF ANTENNA**



- designed and engineered exclusively for UHF
- all aluminum sturdy construction
- minimum space requirements
- matchless reception
- nationally advertised

PATENTS PENDING

channel 14

channel 83

**Fretco** INCORPORATED  
 Pittsburgh 19, Pennsylvania

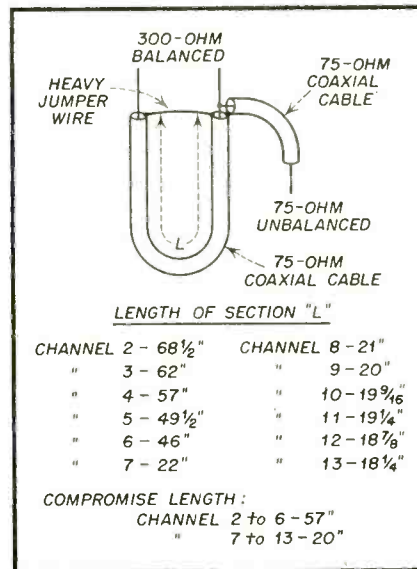
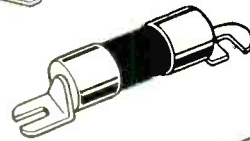
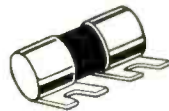
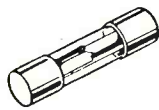

Fig. 5—"Balun" or balanced to unbalanced transformer to couple from a 75 ohm unbalanced to a 300 ohm balanced line.

or a shielded parallel line is necessary. Here are a few helpful suggestions concerning unshielded transmission lines:

1. Use high quality line. A few pennies saved may cost many dollars later.
2. Keep the line away from all pipes, radiators, gutters and other metallic objects.
3. If possible use one piece of line, do not splice.

[Continued on page 66]



You'll Find the  
Right Protection  
Every Time When  
You Look to

# BUSS FOR FUSES

A COMPLETE LINE FOR TELEVISION • RADIO • RADAR •  
INSTRUMENTS • CONTROLS • AVIONICS

For almost four decades, BUSS has specialized in the production of fuses that are unexcelled for dependability and quality. Today, this experience and forward-looking BUSS research combine to give you the most complete line of fuses for modern needs.

Your added assurance of BUSS dependability is the rigid testing every fuse must undergo. Sensitive electronic testing devices check BUSS fuses for proper construction, correct calibration and accurate physical dimensions.

BUSS fuses help you build sales and service. When you install BUSS fuses, you can forget about troublesome "callbacks" caused by unnecessary blowing... and yet you can be certain of positive protection. In addition, your customers have confidence in the BUSS name... famous in home, farm and industry for 39 years. They'll know you've used the best.

and A COMPLETE LINE OF FUSE CLIPS,  
BLOCKS AND HOLDERS



BUSSMANN Mfg. Co. (Division of McGraw Electric Co.) 8D-353  
University at Jefferson, St. Louis 7, Mo.

Please send me bulletin SFB containing facts on  
BUSS small dimension fuses and fuse holders.

Name \_\_\_\_\_

Title \_\_\_\_\_

Company \_\_\_\_\_

Address \_\_\_\_\_

City & Zone \_\_\_\_\_ State \_\_\_\_\_ 353

BUSSMANN Mfg. CO., Division McGraw Electric Company  
University at Jefferson, St. Louis 7, Missouri

# BOOSTER STANDARDS DEFINED

by

**HAROLD HARRIS, Vice-Pres., & H. E. SUDDERS, Chief Engineer**

*Channel Master Corp.*

**I**N fringe areas where signal strength is too low to provide a satisfactory picture, the device most frequently used to surmount this shortcoming is the booster. Oddly enough, although the booster frequently means the difference between picture and no picture, very little technical information for the technician is available on it. Practically no factual data has been presented on booster measurements, and no attempt has been made to define performance standards. Consequently, most installation men have no choice but to employ trial-and-error procedures in choosing and installing boosters.

It is different with antennas. The antenna industry has done an outstanding job in making available full data concerning performance. By now, practically all installation men know that antenna performance depends on gain, directivity, and impedance. And they know that gain is measured in *db* relative to a tuned dipole, that directivity is presented in a horizontal polar diagram, and that impedance matching is a prime consideration as well. The average installation man knows how this information is presented, how to interpret it, and how the data affects his choice of antennas.

It is the purpose of this article to acquaint the dealer-serviceman, in simple terms, with the theory and the measurement of boosters. The dealer-serviceman should know what the standard of booster performance are, and how to evaluate boosters in terms of gain, Noise Figure, Voltage Stand-

**Here is an article that will enable the serviceman to take advantage of the strong points of boosters and choose the correct booster to insure maximum satisfaction on each installation. A complete discussion of the subject by experts in this field and one that has application.**

ing Wave Ratio, and balance-to-unbalance ratio. And perhaps, most of all, he should know that, when attached, a booster is literally part of the set and, therefore, can either improve or diminish picture quality depending on the characteristics of the set, as well as the booster.

## Standards of Booster Performance—Gain

The first and most simple of booster measurements is gain. This is a measure of its ability to amplify a signal. If a 100 microvolt signal is fed into a booster and its output is 1000 microvolts, the booster has a

voltage gain of 10. This is usually written as 10X or 10 times. However, on occasion, the gain is expressed in *db*, and represents the ratio between the input and output voltages. Below is a simple graph (*Fig. 1*), showing voltage gains expressed in *db*. Either way, gain in boosters is a measure of a booster's ability to amplify a signal fed into it.

## Automatic Gain Control (AGC)

Unfortunately, it is not all so simple. Other factors complicate the situation. If this were not the case, we could put a booster having a voltage gain of 10X in front of a set and expect to get a 10 times signal increase at the cathode ray tube. The two limiting factors are automatic gain control (*agc*) in the set, and noise. We will first concern ourselves with *agc*.

The *agc* circuit in the set compensates automatically for changes in signal input level and in amplifier gain. A *dc* voltage proportional to the peak synchronizing level is fed back to the control grid of the *rf* amplifier and two or more *if* stages. If the signal level increases, a greater negative voltage is fed back. This decreases the gain of the set. If the signal decreases, a smaller negative bias is fed back to the control grids so that the set gain increases. In this way, the signal level

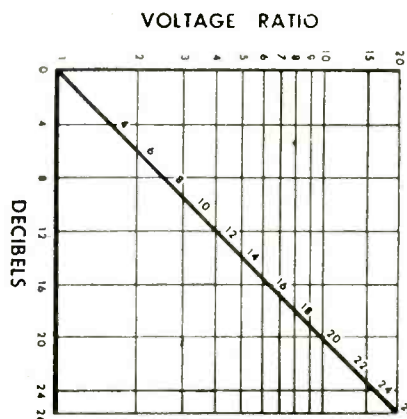

Fig. 1—Relationship of voltage gain to *db* in booster calculations.

at the picture tube is kept constant over wide variations in signal strength (Fig 2). In most cases, this system is so effective that a variation of input signal at the antenna terminals of 100 to 1 is established to about 2 to 1 at the picture tube.

There are many different types of *agc* circuits which produce these remarkable results, but it will be seen that, under ordinary circumstances, these circuits tend to minimize booster gain. For instance, if by means of a booster, we increased the signal input to the set 10X or 1000%, the *agc* circuit would minimize this increase so that the net gain at the picture tube would be only 20%.

However, there is a signal level, called the threshold level, below which the *agc* circuit is not actuated. Since sets in weak-signal areas are generally operating below this threshold level, gain contributed by the booster, under these conditions, becomes significant. If the *agc* is not actuated, the same booster, having a voltage gain of 10X will increase the signal at the picture tube 10X, a gain of 1000%.

#### Booster Standards-Noise

All of the foregoing omits what is probably the most important of all booster considerations—noise. This consideration is what determines picture quality, because it is the presence of noise in the system which limits the weakest signal that can be usefully amplified by the set.

Noise, which appears on the screen as snow, is composed of a multitude of narrow pulses of voltage of various amplitudes occurring at random frequencies. Before exploring the sources of noise, it is important to realize that the amount of noise voltage present, compared to the amount of signal voltage, is an important relationship. This is called the signal-to-noise ratio.

For instance, if the magnitude of signal at the picture tube is 10,000 microvolts, and that of noise is 1,000 microvolts, the signal to noise ratio is 10 to 1. If we put our booster with a gain of 10 times in front of the set, assuming we are below the *agc* threshold, we will get 100,000 microvolts of signal, and 10,000 microvolts of noise at the picture tube. Our signal to noise ratio is still the same and, therefore, our picture quality is not improved. It has been determined that a signal to noise ratio of 100 to 1 is required to produce a snow-free picture at normal viewing distances.

#### The Four Sources Of "Snow"

Obviously, the presence of noise is a major consideration in picture quality. There are four types of noise

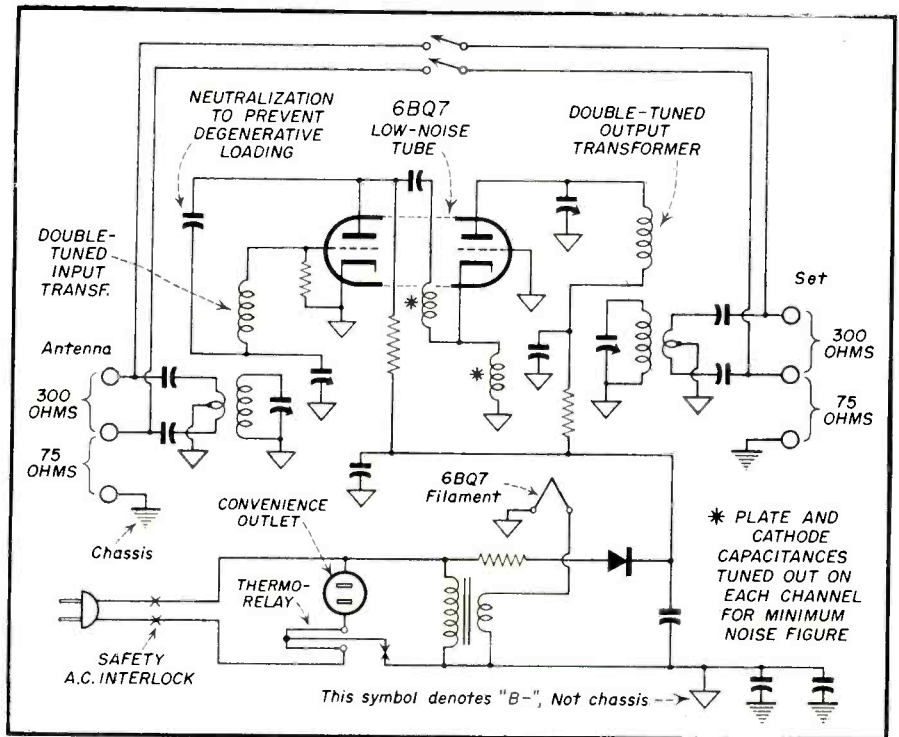

Circuit diagram of typical booster showing the necessity of tuning out plate and cathode capacities for each channel.

present in any receiver system.

1. Static, cosmic hiss, and man-made interference which are picked up by the antenna and transmission line. These variables are not at the discretion of the booster design engineer.

2. Noise generated in carbon resistors due to fluctuation in contact resistance between adjacent granules. Noise here is proportional to current alone.

3. Tube noise voltages (shot effect) caused by (a) random variation in electron emission from the cathode, (b) random variation in current division between the plate and other positive electrodes, (c) variation in grid current due to positive ion current. Reason (b) explains why noise energy from a pentode is about 3 times greater than that from a triode having equivalent amplification.

4. Thermal Agitation Noise (Johnson noise) is caused by random mo-

tion of free electrons in a conductor. This random motion causes small potential differences to be developed across the conductor terminals. This voltage is proportional to a factor called KTB: i.e., Boltzmann's constant (K), Temperature (T), and Band width (B). It is this KTB which is the most important concept in noise consideration and as we shall see, it is KTB which is the standard to which all Noise Figures refer.

#### "Noise Figure"

The noise introduced by the antenna and transmission line is small compared to the other 3 sources. Most noise or snow is caused by the set itself. The amount of noise a set produces determines its sensitivity, and therefore, limits the magnitude of the weakest signal that the set can amplify. It is measured as Noise Figure. This Noise Figure, which is expressed in *db*, is the most important single characteristic of a television set or booster. As always, the *db* represents a ratio and, in this case, it is the ratio between an ideal or perfect receiver and the receiver in question. More specifically, it compares the signal-to-noise ratio of a theoretically perfect receiver with the signal-to-noise ratio of an actual receiver.

#### KTB—The Theoretical Idea

A theoretically perfect or ideal receiver has no tube noise and no carbon noise. The only noise present in our ideal receiver is Johnson noise, generated in an imaginary resistor whose

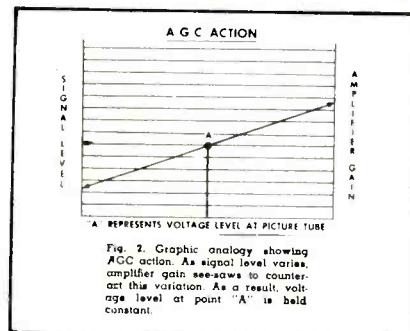
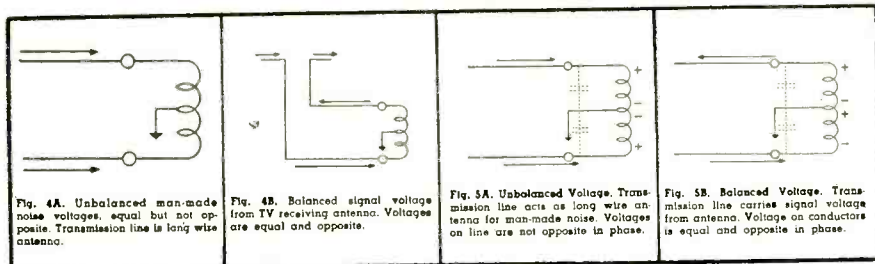

Fig. 2—Graphic analogy showing AGC action.



Figs. 4 and 5—Balance to unbalance ratio conditions in antenna system. For best results a high ratio is desired. This provides the greatest rejection of man-made static.

magnitude is equal to the radiation resistance of the antenna. This Johnson noise is present in both our ideal receiver and in our actual receiver.

The amount of Johnson noise in the ideal receiver is at a level determined by KTB. This tiny magnitude of voltage is the theoretical minimum and depends on Boltzmann's constant, Temperature in ° Kelvin, and band width in megacycles. An actual booster or receiver which generates tube and resistor noises can never achieve this low level of KTB and, therefore, its noise figure is always so many *db* above KTB. (At Channel Master, KTB is desirable but unapproachable, and for this reason we feel that these are feminine characteristics. Therefore, our engineers call this unattainable standard "Katy-B".)

#### How Temperature And Band Width Affect Noise

Since K is a constant, it is T and B which affect Noise Figure. For instance, if we had a booster with a given Noise Figure at a temperature of 32° F. (273.1° Kelvin, at 100° F. (310.9° Kelvin) its Kelvin temperature rise is 11%. This 11% rise represents 1 *db* and, therefore, the Noise Figure is 1 *db* higher or worse at the higher temperature.

Since noise energy is directly proportional to band width (B), broad band untuned boosters cannot possibly achieve the low-noise performance of single channel boosters. In a typical case, a broadly tuned booster designed to cover the entire low band (34 megacycles) has a band width ratio of approximately 6:1 compared to a single channel booster. Under optimum conditions, the best performance of this broad band booster, on any channel, would be approximately 9 *db* worse than the equivalent single channel booster.

This can be explained by the fact that in order to broaden the band of a tuned circuit, such as the antenna coupling transformer at the input to the booster, the operating Q must be lowered. This operating Q is a measure of gain and, in practical terms, it

means that the signal to the grid is reduced  $\sqrt{6}$  times if we increase the band width 6 times. However, the noise in the tube remains constant and, therefore, the signal-to-noise ratio deteriorates seriously.

#### Good Pictures Depend On More Than Just Gain

This Noise Figure in DB above KTB (or Katy-B is more than just theoretically interesting. It is this figure which determines the amount of voltage gain that is actually usable! To illustrate this, let us assume that we have a set, with a Noise Figure of 10 *db*, operating below its *agc* threshold. Let us assume further, that at the picture tube we measure 1,400,000 microvolts of signal and 140,000 microvolts of noise. Its signal-to-noise ratio is, therefore, 10 to 1 (Fig. 3A).

Let us connect booster 1 to this set. This booster has a gain of 10X and its Noise Figure is 10 *db*, the same as the set. Since the two noise figures are the same, the signal-to-noise ratio remains the same—10:1—although we have amplified both by a factor of 10. The signal is now 14,000,000 and the noise 1,400,000 but the picture quality is the same. There is no reduction in the ratio of snow to picture (Fig. 3B).

Now, let us connect booster 2, which has the same gain, 10X, but a Noise Figure of 16 *db*. This increase of 6 *db* means that the booster is producing

twice as much noise as the set, and this double amount of noise is amplified through the entire system along with the signal. The signal is amplified 10X so that it is again 14,000,000 microvolts. But since we started with twice as much noise in the booster, the noise now is 2,800,000 microvolts. The signal-to-noise ratio is now 14,000,000 to 2,800,000, or 5:1. Our picture quality has been deteriorated even though we have amplified the signal (Fig. 3C).

Booster 3 has the same gain, 10X, but has a Noise Figure of only 4 *db*. This decrease of 6 *db* means that half as much noise is generated in this booster as in the set and, therefore, this smaller amount of noise is amplified through the system along with the signal. The signal, amplified 10X, is again 14,000,000 microvolts, but the noise is only half as great, 700,000. The signal-to-noise ratio is 14,000,000 to 700,000, a ratio of 20:1. This is a significant improvement in picture quality (Fig. 3D).

Now, let us connect booster 4 which has a gain of 12X, and a 16 *db* Noise Figure. Our signal is now increased 12X to 16,800,000 microvolts. Our noise, which was 140,000 microvolts in Fig. 3A, is now doubled since our booster has 6 *db* more noise. This 280,000 microvolts of noise is now amplified 12X to 3,360,000. Our signal-to-noise ratio is 14,800,000 to 3,360,000, or 5 to 1. It is interesting to note that booster 4 has higher gain than booster 3 but that the signal-to-noise ratio is four times as bad (Fig. 3E).

In the final example (Fig. 3F), booster 5 has a gain of 12X and a Noise Figure of 4 *db*. We increased the signal 12X to 16,800,000 microvolts. Our noise which is reduced 6 *db*, or halved, is then amplified 12 times to 840,000. The signal-to-noise ratio is 16,800,000 to 840,000 or 20:1.

The above magnitudes of voltage are chosen merely to illustrate the principles involved and have no actual relation to specific sets or boosters.

#### Voltage Standing Wave Ratio (VSWR)

The third of the important booster measurements is Voltage Standing Wave Ratio (VSWR). This is the measure of impedance mismatch between the transmission line and the booster. If the transmission line has an impedance of 300 ohms and the booster has an impedance of 150 ohms (without reactance), a mismatch of 2 to 1 is present. Under these conditions, we will have a voltage standing wave ratio of 2 to 1. If the im-

Fig. 3A		$\frac{14,000,000 \text{ uv (signal)}}{140,000 \text{ uv (noise)}}$	10:1
Fig. 3B	10X gain 10 DB N.F.	$\frac{14,000,000 \text{ uv (signal)}}{1,400,000 \text{ uv (noise)}}$	10:1
Fig. 3C	10X gain 16 DB N.F.	$\frac{14,000,000 \text{ uv (signal)}}{2,800,000 \text{ uv (noise)}}$	5:1
Fig. 3D	10X gain 4 DB N.F.	$\frac{14,000,000 \text{ uv (signal)}}{700,000 \text{ uv (noise)}}$	20:1
Fig. 3E	12X gain 16 DB N.F.	$\frac{16,800,000 \text{ uv (signal)}}{3,360,000 \text{ uv (noise)}}$	5:1
Fig. 3F	12X gain 4 DB N.F.	$\frac{16,800,000 \text{ uv (signal)}}{840,000 \text{ uv (noise)}}$	20:1

Fig. 3—Chart showing signal-to-noise ratios and relative picture quality.

[Continued on page 64]

For accurate  
flexible and  
quick tube  
testing at  
low cost...  
model 3413-A

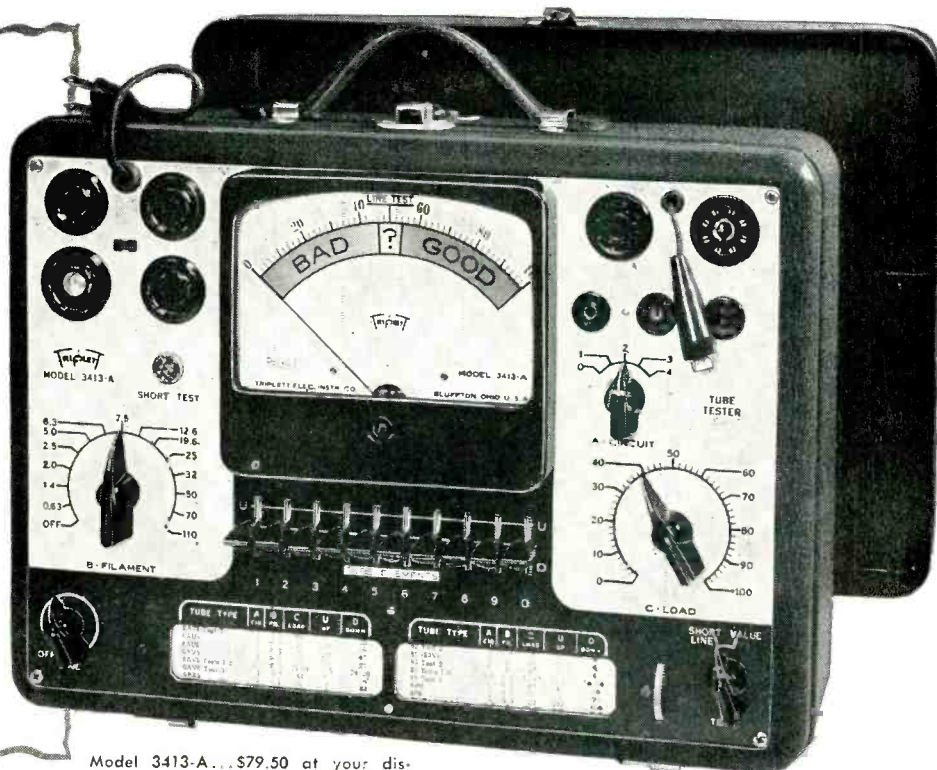

Model 3413-A...\$79.50 at your distributor. (Price subject to change.) BV Adapter, \$7.90 Add'l.

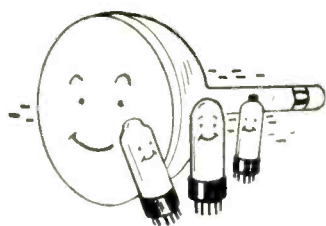

1. YOU CAN TEST MORE TYPES of tubes, also appliances for shorts and open circuits.

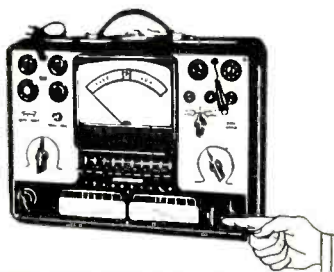

2. JUST SPIN THE KNOB—for correct, last-minute data, on the speed roll chart. Lists 700 tubes.

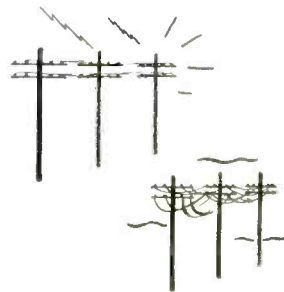

3. YOU CAN COMPENSATE for line voltage—just throw snap-action switch.

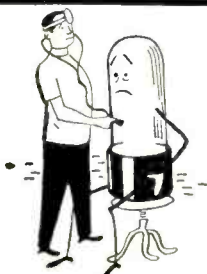

4. YOU CAN TEST EACH ELEMENT in each tube—by a simple flip of the switch.



5. YOU CAN TEST THE NEW TUBES—including those with low cathode current.



6. YOU GET NEW TUBE DATA—immediately, while it is still news. No waiting.

*Nearly Half a Century of Service to the Service Man*



TESTS PICTURE TUBES, TOO! With this BV Adapter, Model 3413-A tests every tube in a TV receiver, including the Picture Tube—without even removing tube from receiver or carton! Saves time!

FOR THE MAN WHO TAKES PRIDE IN HIS WORK

**Triplet**

TRIPLET ELECTRICAL INSTRUMENT CO., BLUFFTON, OHIO, U. S. A.

# AUTO RADIO NOISE ELIMINATION

by JACK DARR

**This article discusses methods, parts and techniques used to locate and remove causes of auto radio interference encountered in the field.**

**T**HE prime requisite of a satisfactory auto-radio installation is the complete elimination of all electrical noise: spark-plug noise, generator noise, and the many random noises originating on other electrical units and the car's chassis. Until these have been either eliminated or minimized so that they are not noticeable in normal operation, the job cannot be considered complete. It is the purpose of this paper to discuss methods, parts and techniques used to locate and remove these causes of interference.

## Installation

Before any noise elimination is attempted, the installation should be checked. The set, control unit and speaker must be perfectly grounded, and the shield of the antenna leadin must be perfectly grounded, both at the set and at the point where it goes through the car body. Imperfect grounding at any of these points will result in noise pickup, especially on the antenna leadin cable, and any attempts to remove the noise by applying correction elsewhere will prove useless. Check for this by operating the set with the antenna lead pulled

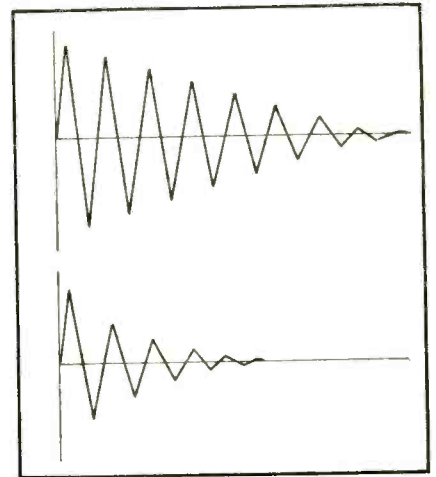

Fig. 1—(Top) Undamped waveform approximately, from one firing of spark plug, without suppressor. (Bottom) Damping of wave resulting from insertion of resistor in series with ignition coil high-tension lead.

out of its socket, and the volume full up. If any noise is heard, it is the so-called 'Chassis pickup.' This is entering the set through the 'A' lead or other cabling, and must be eliminated before any further work is done. A bypass condenser across the switch or ammeter, where the hot lead is connected, will generally remove this type of noise. The set should be perfectly noiseless, so far as interference is concerned, when operated at full volume, with the antenna out, and the engine idling.

With the antenna connected, and the antenna trimmer properly peaked, the engine noise is then checked. There will be a very few installations which will show no appreciable noise, even without any form of noise suppression equipment. Unfortunately, however, the largest percentage of cars will require some form of noise suppression.

## Further Points to be Checked

Standard equipment is the suppressor in the distributor lead, and the condenser across the armature of the generator. This will clear up the noise in about 70% of the cars. The remainder will require more drastic treatment.

There are three basic remedies for noise: bypassing, usually accomplished with special auto-radio type condensers, .5  $\mu$ f, at 200 WV, in metal cases with a mounting lug, or paper types with two heavy flexible leads terminating in spade lugs. These are known as 'generator' condensers and 'ammeter' condensers, respectively. Suppression, for the high-tension ignition system, which is done by placing resistors in

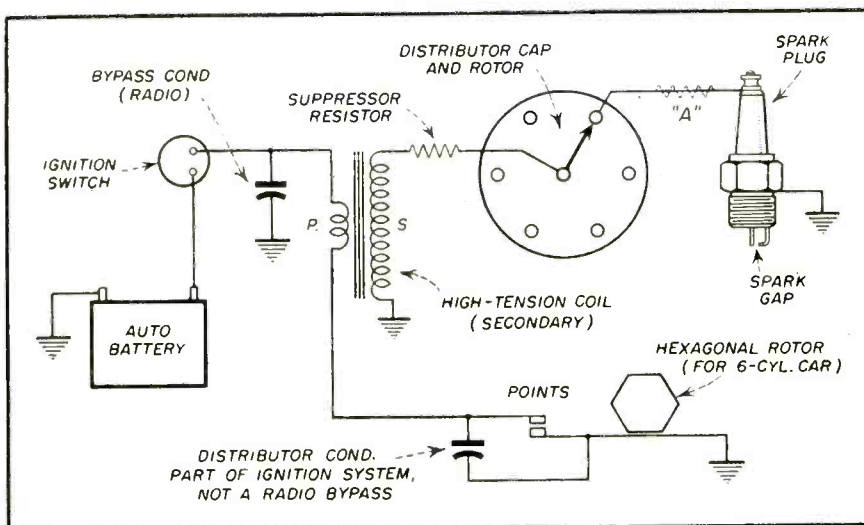

Fig. 2—Basic diagram of ignition system of average car. Battery voltage is connected to primary of coil when ignition switch is turned on. Circuit is completed to ground when points close, sending pulse of current through coil, generating high-voltage pulse in secondary. This is fed to proper spark plug through distributor cap and upper rotor. Only one plug shown. Suppressor resistance is connected in series with high-voltage lead from cap to coil. Individual suppressors for each spark plug may be connected at "A". Radio bypass condensers must be connected on switch side of coil, never on distributor side. Condensers never used in high-tension leads.



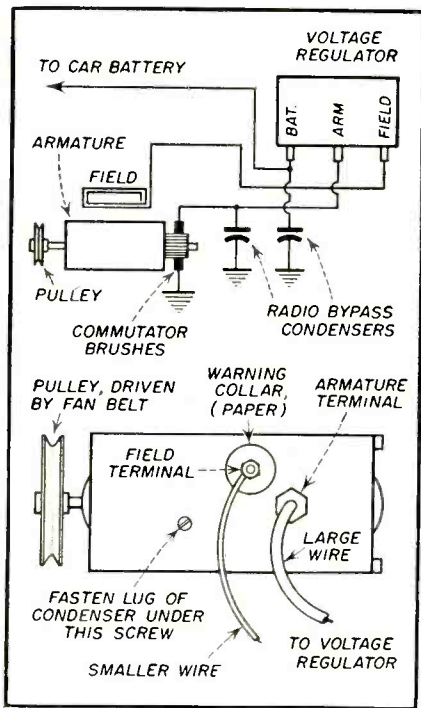

Fig. 3—Typical auto generator. Bypasses shown are connected to "Armature" terminal of generator itself, and to "BAT" post of voltage regulator but never to "FIELD" terminal of generator or regulator. To do so would upset the action of the regulator.

series with the leads, and last, bonding. This is the process of connecting the various units of the car body together with heavy flexible braid, so as to insure the whole body of the car being at the same electrical potential, to avoid building up and intermittent discharge of static potentials, which will cause noise in the receiver.

#### Plug Noise

The most common noise encountered is 'plug-noise.' This is a sharp popping noise, heard each time a spark-plug fires, and changing in frequency as the engine speed is increased or decreased. The basic cause of this is the pulse of extremely high voltage generated by the ignition coil, distributor and high-tension system, and applied to the plugs through the wiring harness. Each pulse is a sharply peaked burst of energy, rising rapidly to a peak, and decaying at a uniform rate. See Fig. 1. A great reduction in the intensity of this noise is accomplished by connecting a 10,000 ohm resistor in series with the output lead of the ignition coil usually between the coil and the distributor cap. This resistance damps the pulse, preventing the formation of excessive peaks, and inducing a rapid decay of the waveform.

Despite the many arguments to the contrary, the insertion of suppressors

in the ignition system does not reduce the efficiency of the system, and may even improve it. The Army conducted a series of tests on cold weather starting, using an Army truck, both with and without the suppressors, and reported that the extremely cold weather starting characteristics of the engine were improved by the use of ignition suppressors!

Although the resistance-type suppressors are the most common, inductive wirewound suppressors can be used instead. Several major spark plug manufacturers are building 'resistor-type' spark plugs, which incorporate a 10,000 ohm resistor, built into the body of the plug. The writer has used a set of these in a Ford V-8 for the last three years, with excellent results. A short-wave receiver was used in the car during this time, and most excellent results were obtained, with broadcasts being received from such points as London, Radio Australia, Brazzaville, FWA, Radio Moscow, and many others, on 9, 10 and 11 mc. No plug noise was picked up from the engine, although we could hear other cars approaching for as far as a half-mile away!

#### Bonding

Front-wheel noise and other chassis noises originate in the automobile's chassis and running gear itself, due to the accumulation of static charges through an intermittent ground. Noise originating in the body can be eliminated by bonding the noisy parts with heavy flexible braid. The front wheels will build up a static charge when rolling on a dry pavement, due to intermittent insulation of the wheel by the grease in the hubcaps. This manifests itself as a sharp 'scratching' noise, periodic in character, which is heard only when the car is in motion, and can be definitely identified by running the car up to about 25 mph on a dry pavement, until the noise appears, then cutting the ignition switch, and allowing the car to coast to a stop. If the noise slows down with the speed of the car, and can be stopped at any time by applying the brakes, it is front-wheel noise. Application of the brakes ground the wheels through the brake shoes.

This noise can be taken out by installing special springs made for the purpose. These fit into the 'grease-caps' of the front wheels. Remove the greasecaps, and insert the coil of the spring, with the center pointing out. See Fig. 2. Replace so that the tip of the spring goes into the lathe-center of the front spindle. The grease need not be removed for this. They furnish

a perfect ground for the front wheels at all times.

#### Special Cases

In addition to the more 'conventional' noises, as technicians like to call them, a few cars will be found with noise originating elsewhere in the electrical system. Fortunately, these are in the minority.

A few instances are the older Ford cars, of the vintage 1937, 1938, etc. These had a noise similar to front-wheel noise, a 'scratching' noise, noted when the car was in motion. However, this stopped when the ignition was turned off. This can be checked by turning the ignition switch and radio on, and jarring the car body with the foot, or jarring the rear bumper. The noise originates in the tank unit of the fuel gauge, and can only be eliminated by installing a condenser at the tank. Take up the floor mat in the trunk, exposing a small metal access-plate, held by one screw. Removal of this exposes the top of the gas-tank and the unit. Loosen one of the screws holding the unit, and slide the lug of the generator-type condenser under it. Connect the wire lead to the screw in the center, on the insulator.

Fuel-gauge noise is also found in some Chrysler cars, but this time it originates in the indicator unit, on the instrument panel. This may be identified by turning the ignition switch on and jarring the panel with the heel of the hand. To eliminate this noise, a special fuel-gauge filter unit is required, available at most Chrysler agencies. The unit is

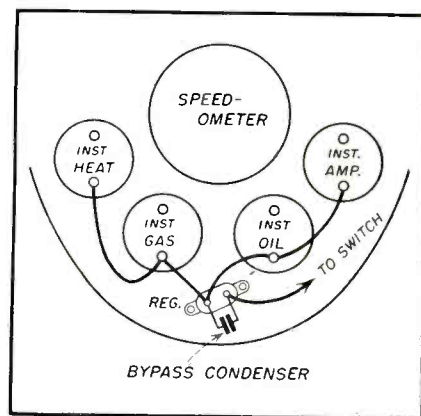

Fig. 4—Sketch of "Instrument Cluster" on Kaiser-Frazer cars, shown upside-down, as it appears when let down for service. Bottom of figure is actually top of cluster. "Reg" is instrument voltage regulator; bypass condenser must be connected across it, as shown, to eliminate noise. Use "ammeter" condenser, at least .5  $\mu$ f and dress carefully to avoid damage when replacing instrument cluster in panel.

a bypass condenser and a small *rf* choke, mounted on a fiberboard panel, with brass eyelets for the connections. Remove the nuts and wiring from the gauge, install the filter, and replace the wiring. Watch out for short circuits, as this unit will come out with very little clearance on the radio chassis itself.

The 1951 Kaiser Frazers presented a very unusual problem in this category. Severe noises were finally traced to a small unit labelled 'Instrument Voltage Regulator,' inside of the 'instrument cluster.' To gain access to the device, remove the four Phillips screws, two on top and two underneath. It is advisable to wrap several thicknesses of cloth around the steering column, to avoid scratching it when the instrument cluster is lowered. The speedometer cable must also be disconnected. The voltage regulator is located at the upper right side of the group of instruments, as you face the front, and resembles a small bathtub condenser, with two terminals on top. It is a thermal-break type of regulator, with a bimetal strip, and the contact is broken by the passage of current through it, several times per second. This had a most peculiar symptom, in that the conventional connection of a bypass, from the terminals to ground *increased* the noise. It was finally remedied by using an ammeter-type condenser, connected *across* the unit, from one terminal to the other! Place this condenser above the regulator, tucking it under the wiring, so as to allow clearance when the instrument cluster is pushed back into place.

Another unusual noise was found in a pickup truck. This was a slowly increasing, whistling screech, beginning at a speed of about 35 mph. As the car's speed increased, so did the volume and the pitch of the noise. After much work bonding body joints, mufflers, etc., it was finally discovered that the small plastic 'corona-ball' atop the antenna was missing. Replacing this stopped the noise! Evidently a heavy corona was building up on this particular vehicle, due to tire characteristics, etc. Although this was not tried, blowing the Anti-Static powder into the tires might also have helped in this case.

#### Hood Radiation

Some cars will be found which seem to have more plug noise than others. This is sometimes due to faulty assembly procedures paint between joints, etc, and sometimes due to other causes, such as burned points, leaky wiring, etc. The ignition system

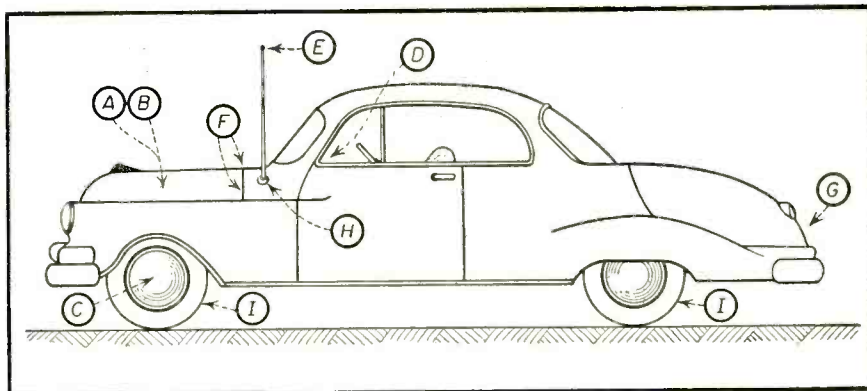

Fig. 5—Automobile, showing points of noise-origination, and cures.

- A—Distributor and high-tension system. Apply suppression, first in distribution center lead, then to individual plugs.
- B—Generator noise. Condensers, on Generator Armature terminal, and on "BAT" terminal of voltage regulator.
- C—Front Wheels. Install grounding springs.
- D—Instruments. Install bypass condenser at Ign. switch and on fuel gauges, regulators, etc. See text.
- E—Antenna. Corona ball on tip. May cause whistling or screeching noises if missing.
- F—Hood and front fenders: will let noise escape unless well grounded. Apply grounding springs at back of hood or bond with pieces of heavy flexible braid to rest of body. Front fenders: same treatment.
- G—Fuel-gauge noise: Fords only. Apply bypass condenser at tank-unit.
- H—Antenna mounting. Check for loose grounds, leakage from moisture absorption. No electrical leakage at all permissible. Characteristic resistance of leadin wire itself, measured from pin of plug to antenna rod, 3-5 ohms. This is due to very fine wire used as leading conductor.
- I—Tire-static. Install "static-powder" (graphite) by blowing in through valve, with applicator.

must be in first class shape before any noise elimination is attempted. If one of these difficult jobs is encountered, the following procedures are recommended, in order, until the noise is removed:

1. Install distributor suppressor and generator condenser.
2. Install bypass condenser on switch side of coil. Note: Never connect this condenser to the lead which goes from the coil to the distributor. Always connect to the terminal which goes to the switch, sometimes marked 'Batt.'
3. Install full set of suppressors, or change to resistor plugs. These measures should eliminate or materially reduce the amount of noise. If noise still is present, check the bonding of the hood, front fenders, and the firewall. If the hood or front fenders are not perfectly grounded, they will pick up *rf* energy from the ignition system and re-radiate it into the antenna rod itself. Obviously, this cannot be filtered out, so the only alternative is to prevent it from reaching the rod. The installation of small brass springs under the rear hood-lacing, or the actual connection of the hood to the body, using a heavy flexible braid, will

ground the hood, causing it to act as a shield, confining the interference. The fenders and firewall form part of this shielding compartment, hence they must be bonded as well.

A good test for hood-radiation is to ground the antenna-rod, just above the insulators, with a screwdriver. If this stops the noise, it is being picked up by the antenna itself. If there is no perceptible change in the noise, it is probably being picked up by the leadin. Remove the leadin from the antenna end, and see if the noise is still present. If not, ground the cable well, and clean and tighten all connections in the antenna itself.

This trouble is quite common on older installations, particularly on the cheaper types of antennas. The insulators used on some were highly hygroscopic, and in consequence developed a leakage, in damp weather. Strange as it seems, this leakage, although in shunt across the antenna terminals, does not seem to cut down the volume of the receivers, but instead introduces engine noise into it! One case showed around 5,000 ohms leakage to ground, with a severe noise, and plenty of volume. Replacement of the an-

[Continued on page 71]

# SOUND SYSTEMS IN TV

**PART 2** By Leonard Lieberman

**This concludes the article started in the February issue on the Theory of Intercarrier Sound in the modern TV receiver. Alignment procedure is included in this part.**

## Quadrature Detection

The third method used in commercial sets is not as common as the two previously discussed. In this method, a tube is used whose physical construction is such that the 90° phase shift present in the other systems tuned circuits is produced by tube geometry.

This tube, the 6BN6, is shown schematically in Fig. 9. While the tube is conventionally drawn as a pentode, the tube elements shown do not correspond to the usual tube elements. The cathode and the plate are the only two which are the same as in the usual pentode. Around the cathode there is an electrode which has no external connections. This electrode acts to focus the electron stream coming off the cathode and is called the focusing electrode. Past the focusing electrode is a grid. After the grid is another electrode which in conjunction with the focus electrode tends to make the cathode current inde-

pendent of the voltage on the first grid. Thus once past a predetermined threshold level by the grid to cathode bias, any increase in grid voltage has no effect on the cathode current. We, thus, have the basis of a limiter. The first grid is called the limiter grid. The third grid is not a suppressor as is shown but is actually another control grid. The structure of the third grid plus the tuned circuit across it causes the voltage at this grid to lag the voltage on the limiter grid by 90°.

Since this quadrature grid is also a control grid, it can be seen that the tube will only conduct when both control or gating grids are open. Further, the tube geometry is such that any variation from the frequency of the quadrature grid tuned circuit will cause a change in the phase relationship of the limiter and quadrature grid. This variation in phase with frequency will determine the length of time both gates are open and therefore, how much plate current will flow. The output is a voltage which vary as the input frequency. Since this tube is grid controlled, there is an amplification through the tube. We have here in a single tube, a limiter, detector and audio amplifier.

Now that basic principles have been analysed, let us evaluate the various service problems which arise in the sound system. As any serviceman who has been servicing for more than 2 or 3 years will remember the number of defects in intercarrier sets were numerous and to a great extent insoluble. Some of these problems were, the notorious intercarrier buzz, sound "holes" caused by ignition noise, poor picture quality, sound bars in the picture and many others.

## Intercarrier Defects

Why did these defects occur and what has or can be done to correct them? As for intercarrier buzz, it

was found to be most frequently caused by the 60 cycle vertical sync pulse. The root of this trouble lay in the manufacturing economy mentioned earlier. Since it was found that the .5 mcs signal could be amplified in the video amplifier stage, it was possible to eliminate the sound i.f. stages. The 4.5 mcs signal could be taken off the plate of the last video amplifier and fed directly into the limiter or as was often tried directly into the ration detector. The drawback to this is that the video amplifiers are designed to clip the tops of the sync pulse as a noise immunity measure. This led to the tube being cut off during this time and as a result, the sound would also be cut off. During the horizontal pulse this occurred at the 15.75 kcs rate and was of short duration and was not, therefore, audible. The vertical pulses, however, occurred at an audible 60 cycle rate and were of a long enough duration to be heard.

The "holes" in the sound resulted from the use of large electrolytic condensers across the ratio detector to reduce the need for a limiter tube. These condensers could not discharge quickly enough when heavy ignition pulses rode through and would cause the detector to block.

The poor definition in the picture resulted from the fact that in order to keep the 4.5 mcs signal from the picture the video amplifier response was cut down as shown in Fig. 10. This video amplifier response led to the reduction of both the bandwidth and number of stages in the i.f. since at a reduced bandwidth the same amount of amplification could be achieved with less tubes. This deg-

[Continued on page 62]

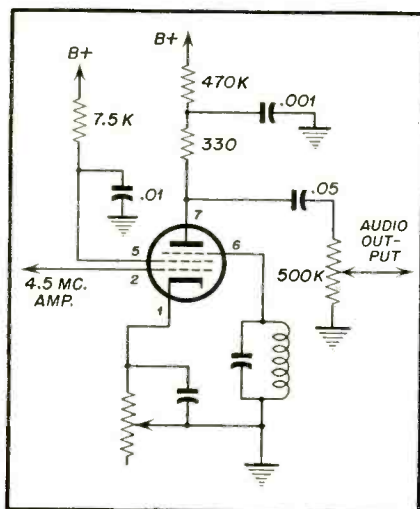

Fig. 9—Typical circuitry using the 6BN6 gated beam tube.

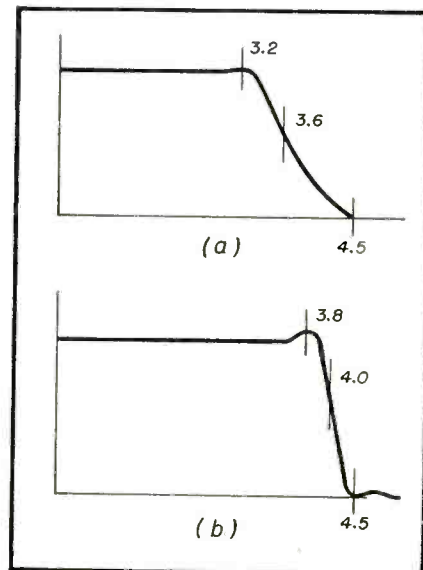

Fig. 10—Effect of reduction of bandwidth of video IF on picture quality.

# VERTICAL ROLL TROUBLES

by

HARRY MILEAF

**Have you been puzzled by vertical roll? Here is an article that answers many vertical roll questions. It discusses the theory of different types of vertical deflection circuits and gives you a practical approach to the solution of the problems which develop in the field.**

**T**HIS article deals mainly with the more difficult vertical sync problems, such as the trouble that develops after the receiver is in operation a while, or the composite signal. But the vertical sync problem.

Vertical sync is controlled by the vertical sync pulses that are part of the composite signal. But, the vertical sync pulses that are transmitted by the transmitter are very different from the horizontal sync pulses. One complete vertical sync pulse cannot be transmitted due to the fact that there would be, in proportion, a long period of time where there would be no horizontal pulses present to control the horizontal *afc*. Because of this the vertical sync pulse is broken up into eighteen separate pulses. Six short duration pulses, six long duration pulses, and six more short duration

advancement in engineering design since television first started its spectacular climb. As a matter of fact, in many of the newer 1953 models on the market manufacturers have reverted back to an off-shoot of a multivibrator type of oscillator-amplifier circuit. In this type of circuit a portion of the output is taken from the plate of the output (vertical) tube and is fed back to the grid of the oscillator tube of sufficient proportion to maintain oscillation. In this type of circuitry both the vertical size and the vertical linearity controls affect the vertical frequency of oscillation. Because of this inherent factor variations of the characteristics of the components in the oscillator section as well as defective components in the output section might result in vertical

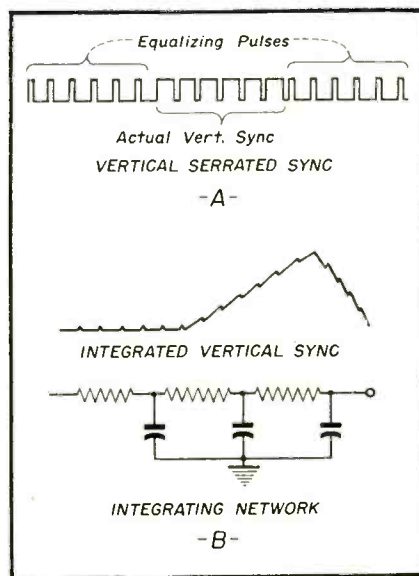

Fig. 1—Vertical pulse before (A) and after (B) integration.

pulses. See Fig. 1a. This is shown as a serrated sync pulse. Each individual pulse of the vertical serrated pulse acts also as a horizontal sync pulse. After passing through the integrating network the serrated pulse becomes one pulse, as shown in Fig. 1b. Vertical roll troubles can develop not only in the vertical sync section, but as far back as the tuner.

### Vertical Roll In Multivibrator Oscillators

The vertical oscillator, sweep amplifier section and its sync control is probably the only circuitry of present day television that has seen no great

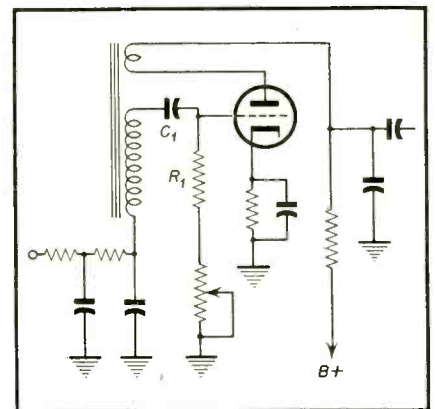

Fig. 3—Typical vertical blocking oscillator.

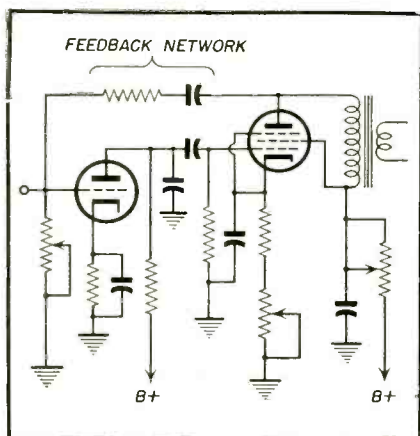

Fig. 2—Multivibrator type of vertical oscillator. Note feedback network.

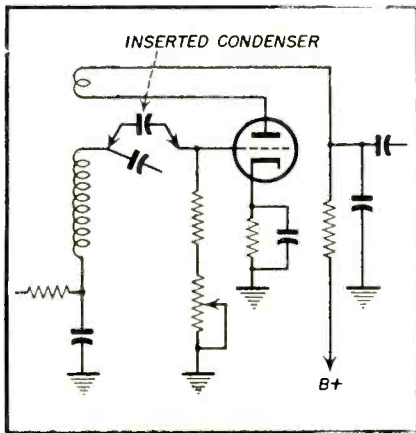

Fig. 4—Method of inserting and shunting components for test purposes.

"drift." Any change in value of the components of the vertical amplifier section will change the amount of regenerative feedback voltage to the oscillator, therefore changing its frequency of oscillation. See Fig. 2. This means that a defective vertical output tube or component, becomes a source of troublesome vertical drift. Probably the first thing to do is to observe whether or not the vertical size has changed when vertical drift occurs.

#### Blocking Oscillators

More than likely the most popular type of vertical oscillator employed by the various TV manufacturers is the blocking oscillator. See Fig. 3. In this circuit any of the components involved could change value and so cause the vertical frequency to drift. Probably the biggest offenders in this circuit are *C1* and *R1*. The best way to check components in this circuit is to set up the receiver on the bench and adjust the vertical hold properly. Then, leave the receiver on a hot run till the picture starts running vertically. This condition may take a few hours to develop. When the picture develops a roll, disconnect each com-

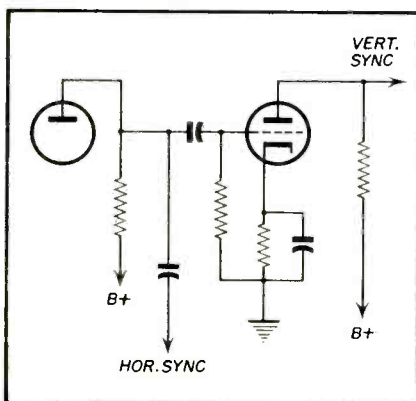

Fig. 5—Vertical sync amplifier stage employed in some receivers.

ponent one at a time and insert in its place a component of the same value. See Fig. 4.

This is a time consuming operation and patience is required. Many servicemen change all of the condensers at the beginning and then run the set to see if the drift is cured. If not, they then change all the resistors, and so on. Using this method, more components are changed than are necessary, and the serviceman does not have the satisfaction of knowing which part caused the trouble.

#### Complete Loss of Sync

The previous portion of this article dealt mainly with the problem of drift causing mainly the problem of drift causing vertical roll. Another problem encountered is the complete loss of vertical sync. Some receivers employ a vertical sync amplifier stage. See Fig. 5. This stage is treated just like an ordinary amplifier stage with or-

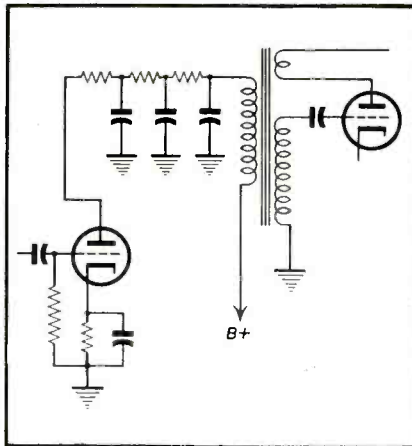

Fig. 8—Position of video coupling condenser—frequent cause of trouble

inary troubles except for the novel Dumont sync feed circuit as seen in Fig. 6. In this circuit the most common trouble encountered is the breaking down of the sync winding of the blocking transformer, although the integrating condensers have a tendency to break down rather often.

Vertical sync troubles also develop from a condition known as clipped sync, or overloaded sync. If the sync is clipped rather severely it would also have a tendency to affect the horizontal sync as well. But in the majority of cases the horizontal *afc* circuits function so well that the horizontal sync may not be affected at all or only occasionally. Many times, the *if* or video amplifiers will develop a grid to cathode leakage that will cut down the bias applied to this particular stage, and the composite video signal will have a tendency to send the tube into partial saturation. See Fig. 7. Because of this the sync pulses are clipped. The result of this is very little

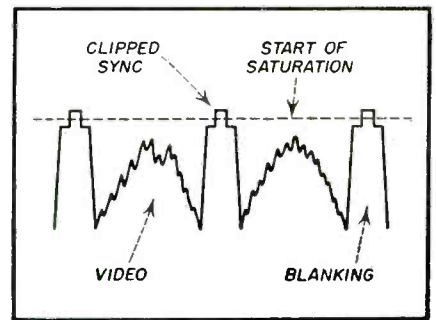

Fig. 6—Sync feed circuit employed by Du Mont.

range in the setting of the vertical hold control and a tendency of the picture to hop or lock in off frame. Another common cause of this complaint is the video *if* coupling condenser. See Fig. 8. This condenser on occasions, may develop a very high resistance leakage that will alter the bias considerably so as to cause the clipping of the sync pulses. On the other hand, this condenser has been known to cause vertical sync trouble in another way. This condenser can change its capacity to a lower rating and so reduce the low frequency response of the video stage sufficiently to limit the effect of the vertical sync pulse. The hold control would have very little effect and the picture would have a tendency to roll quite often. There have been some cases where this condition has caused complete loss of vertical sync, although, usually, in a case such as this there is a noticeable effect on the video such as smear, etc.

In accordance with this trend of thought, the alignment of the video *if* can have the same effect on the vertical sync. If the *if* is misaligned or drifts out of alignment so that the bandpass prevents sufficient gain of the sync frequencies, there can also be poor vertical synchronization. Usually just a minor touch up to the video *if* will cure this condition.

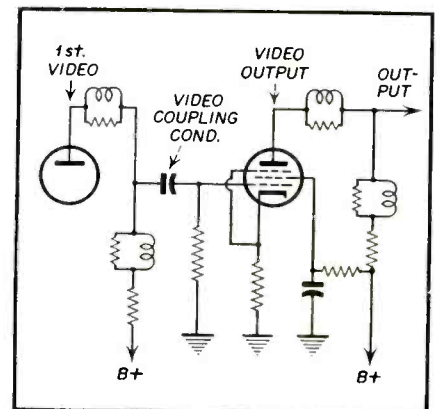

Fig. 7—Saturation caused by grid to cathode leakage in IF tubes.

# VIDEO SPEED SERVICING SYSTEMS 6th INSTALLMENT

FOR JAN. FEB. & MAR.

<i>Mfr.</i>	<i>Model</i>	<i>Section Affected</i>	<i>Page</i>	<i>Card No.</i>
Admiral	20A-1	Pix	Jan. 31	20-1
Admiral	20A-1	Sound	Jan. 31	20-2
Admiral	20A-1	Sync	Jan. 31	20-3
Admiral	20A-1	Sound	Jan. 32	20-4
Admiral	20A-1	Raster	Jan. 32	20-5
Admiral	20A-1	Raster	Jan. 32	20-6
Admiral	20A1 (chassis)	Pix and Sound	Mar. 45	A20-7
Admiral	20A1 (chassis)	Pix and Sound	Mar. 45	A20-8
Admiral	20A1 (chassis)	Pix	Mar. 45	A20-9
Admiral	20A1 (chassis)	Pix	Mar. 46	A20-10
Admiral	20A1 (chassis)	Pix	Mar. 46	A20-11
Admiral	20A1 (chassis)	Sound	Mar. 46	A20-12
Capehart	CX-33	Sound and Pix	Feb. 43	C-1
Capehart	CX-33	Pix	Feb. 43	C-2
Capehart	CX-33	Pix	Feb. 43	C-3
Capehart	CX-33	Raster	Feb. 44	C-4
Capehart	CX-33	Raster	Feb. 44	C-5
Capehart	CX-33	Pix	Feb. 44	C-6
CBS	700-10	Raster	Jan. 33	A-1
CBS	700-10	Pix	Jan. 33	A-2
CBS	700-10	Pix	Jan. 33	A-3
CBS	700-10	Pix	Jan. 34	A-4
CBS	700-10	Pix	Jan. 34	A-5
CBS	700-10	Sync	Jan. 34	A-6
Emerson	120118	Pix	Jan. 35	E-1
Emerson	120118	Pix	Jan. 35	E-2
Emerson	120118	Pix	Jan. 35	E-3
Emerson	120118	Pix	Jan. 36	E-4
Emerson	120118	Pix	Jan. 36	E-5
Emerson	120118	Pix	Jan. 36	E-6
Olympic	TA	Sound	Feb. 45	C-1
Olympic	TA	Raster	Feb. 45	C-2
Olympic	TA	Pix and Raster	Feb. 45	C-3
Olympic	TA	Pix	Feb. 46	C-4
Olympic	TA	Pix	Feb. 46	C-5
Olympic	TA	Pix	Feb. 46	C-6
Philco	49-1040	Sound	Feb. 47	49-B-1
Philco	1240	Pix and Sound	Feb. 47	49-B-2
Philco	49-1040	Pix	Feb. 47	49-B-3
Philco	49-1040	Sync	Feb. 48	49-B-4
Philco	49-1040	Pix	Feb. 48	49-B-5
Philco	49-1040	Sound	Feb. 48	49-B-6
Sentinel	412-1	Raster	Jan. 37	412-1
Sentinel	412-1	Raster and Pix	Jan. 37	412-2
Sentinel	412-1	Raster	Jan. 37	412-3
Sentinel	412-1	Pix	Jan. 38	412-4
Sentinel	412-1	Raster	Jan. 38	412-5
Sentinel	412-1	Raster	Jan. 38	412-6
Sentinel	412, 413, 415	Raster	Feb. 49	412-7
Sentinel	412, 413, 415	Raster	Feb. 49	412-8
Sentinel	412, 413, 415	Raster	Feb. 49	412-9
Sentinel	412, 413, 415	Raster	Feb. 50	412-10
Sentinel	412, 413, 415	Raster	Feb. 50	412-11
Sentinel	412, 413, 415	Raster	Feb. 50	412-12
Sentinel	412, 413, 415	Raster	Mar. 47	SE412-13
Sentinel	412, 413, 415	Raster	Mar. 47	SE412-14
Sentinel	412, 413, 415	Pix and Sound	Mar. 47	SE412-15
Sentinel	412, 413, 415	Pix and Sound	Mar. 48	SE412-16
Sentinel	412, 413, 415	Sync	Mar. 48	SE412-17
Sentinel	412, 413, 415	Sync	Mar. 48	SE412-18
Stromberg-Carlson	119 Series	Pix	Mar. 49	SC119-1
Stromberg-Carlson	119 Series	Pix	Mar. 49	SC119-2
Stromberg-Carlson	119 Series	Pix	Mar. 49	SC119-3
Stromberg-Carlson	119 Series	Pix	Mar. 50	SC119-4
Stromberg-Carlson	119 Series	Pix	Mar. 50	SC119-5
Stromberg-Carlson	119 Series	Pix	Mar. 50	SC119-6
Sylvania	1-186 (chassis)	Pix	Mar. 51	S186-1
Sylvania	1-186 (chassis)	Pix	Mar. 51	S186-2
Sylvania	1-186 (chassis)	Pix	Mar. 51	S186-3
Sylvania	1-186 (chassis)	Pix	Mar. 52	S186-4
Sylvania	1-186 (chassis)	Pix	Mar. 52	S186-5
Sylvania	1-186 (chassis)	Sync	Mar. 52	S186-6

# CIRCUIT COURT



## Conrac Model No. 61—Multi-Purpose Tube Circuitry

The Conrac Model #61 (Fig. 1) is another in the increasing number of sets which are appearing on the market with complex multi-purpose tube circuitry. V7-( $\frac{1}{2}$  12AU7) serves as the video detector, *agc* rectifier and amplifier, and as a point of sound take-off. V10-6BE6 operates as a sync stripper, amplifier and sync separator.

### Detection

Let us examine the operation of these circuits in detail. In the cathode of V7, we find the last *if* transformer coil. It is coupled to the plate of the last *if* amplifier through C39. The grid of V7 goes to ground through R71, R72 and L15. The plate goes to ground through R70. If a negative bias is applied to the plate, plate current flows if the cathode goes sufficiently negative. When plate current flows, it goes to ground through R70 establishing a negative voltage at the top of R70 with respect to ground. With sufficient filtering, this voltage can be applied as *agc*. Initially the plate current starts flowing some time after the negative half of the *if* envelope appears across L12. The RC network in the plate charges up. This charge trickles off at a low enough rate to maintain bias on the plate, therefore, the plate current flows only during the peaks of the sync pulse. Amplification arises from the fact that grid to cathode bias variations can occur in either element, a negative going signal at the cathode having the same effect as a positive going signal at the grid. Therefore, the grid *dc* level is kept constant, the signal appearing at the cathode can be amplified as a result of the grid voltage still controlling large plate current.

The changes in grid to cathode voltages also appear across R72 and L15, due to grid current flow. This flow arises from the fact that when the cathode goes negative with respect to the grid it is the equivalent of the grid being positive. Since the grid draws current only during the negative half of the *if* envelope and the *if* component is bypassed to ground through C40, the resulting rectified in-

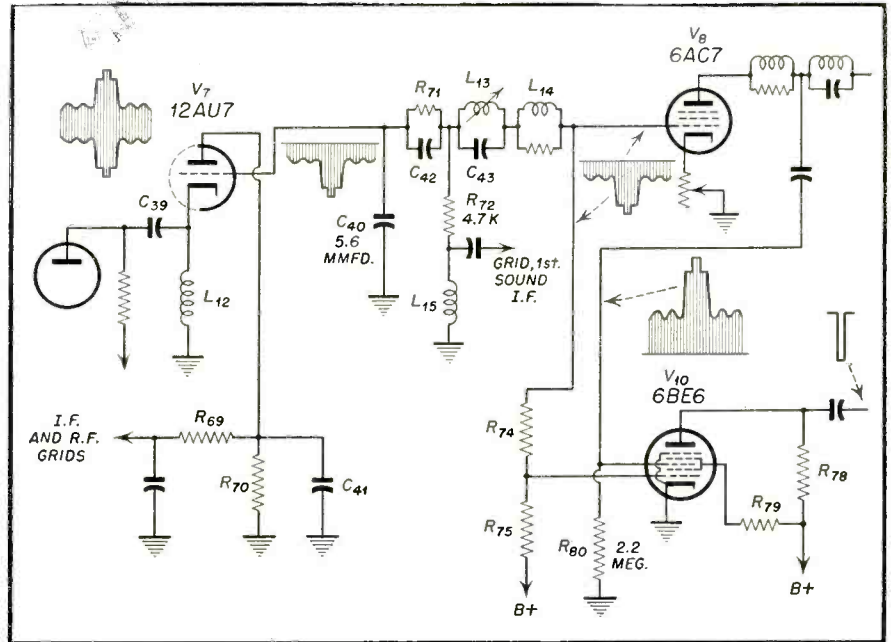

Fig. 1—Partial schematic Conrac Model 61

formation can and is fed to the grid of the 6AC7 video amplifier.

L15 in this circuit acts as a high impedance to the 4.5 mc FM beat. The sound is taken off through C47 and fed to the grid of the first sound *if* amplifier. L13 and C43 act as a tuned parallel circuit offering a very high impedance to that portion of the 4.5 mc which appears across R72.

### Sync

The 6BE6 sync stripper and amplifier operates in the following manner. The plate goes to B plus through R78. Grids #2 and #4 also return to B plus through R79. The cathode is grounded. Grid #3 is bias by R80 and grid #1 is bias by the grid of the video amplifier. In this type of multi-element tube, the grid, closest to the cathode has the greatest effect when the tube

is near cutoff but once any sizable plate current starts flowing it loses this control and the third grid has the greatest control over the plate current. Therefore, once the plate current starts flowing it acts as a limiter. Also, since both grids must simultaneously have the correct bias for current flow, the tube acts as a gating device.

The composite video signal is fed to grid #1 sync phase negative and to grid #3 sync phase positive. The bias on the two grids is such that only the sync pulse on grid #3 is of sufficient amplitude to bring the tube into conduction. As a result of the tubes gating action therefore, only the sync pulse appears at the tube plate circuit. Due to the clipping by cutoff and the limiting in the plate as previously explained only a clean sync pulse is present in the plate output.

## TECHNICAL ARTICLES WANTED on

TV, AM RADIO, FM RADIO, PHONO MECHANISMS, HI-FI AUDIO, AUTO RADIO, TEST EQUIPMENT, ANTENNAS

pertaining to their

Theory, Installation, Application, Service & Maintenance

submit manuscripts to Managing Editor

**RADIO-TELEVISION SERVICE DEALER**

67 West 44th Street

New York 36, N. Y.

# ASSOCIATION NEWS



## **National Association of TV & Electronics Service Ass'n (NATESA)**

On April 11-12, 1953, NATESA (National Association of Television and Electronics Service Association) holds their Annual Convention in Kansas City, Missouri.

Several of the advertisers in trade publications have offered their assistance in publicizing this event. Such cooperation indicates to readers the adviser's interest in promoting the welfare of the service industry.

The Convention invites all members of the Radio and Television Service industry and allied fields.

## **Joint Electronic & Radio Committee on Service**

"How to Interpret What You See in UHF" is the subject of the third program in the current series of educational service meetings for television technicians to be held here. Open to all TV servicemen, the meeting took place Thursday, February 26th at 8:00 p.m. at the Franklin Institute, 18th Street and the Parkway, under the sponsorship of the Joint Electronics & Radio Committee on Service, in cooperation with the Philadelphia Radio Servicemen's Association and the Television Contractors' Association.

The two hour meeting covered demonstration and explanation of UHF methods and equipment used by 70 manufacturers. Films will be shown of actual installations and equipment used in UHF areas, covering also, antennas and feed lines in use.

Servicing of complete UHF receivers, from antenna to picture tube using the fastest and best methods of isolation and signal tracing, will be presented via two large projector screens—one showing the picture tube condition and the other, the circuit involved.

Lecturer for the program was Bill Ashby, Raytheon Television Sales Engineer. Mr. Ashby has been actively

Mr. Sanford R. Cowan, Editor  
Radio-TV Service Dealer Mag.  
New York 36, N.Y.

Dear Sir:

I have a couple of suggestions that would be beneficial to the servicing industry, that could be compiled and published in your magazine if you see fit:

(1) A list made of every service association thru-out the country, their names and addresses. In this way, a service man in any locality could ascertain the nearest organization, in order to become a member, and benefit thereby, and thereby lend his support to the association. Further, this might create interest to the extent of organizing associations in localities where there is none.

(2) A list of average or standard charges which prevail in various sections of the country. Such as Eastern, Midwest, Mountain, and West Coast, and perhaps North and South.

Respectfully,  
John Hancock  
Hancock Radio-TV  
Keokuk, Iowa

TO OUR READERS . . .

RTSD is willing to print this list. Will all associations please help us compile this list by mailing their names and addresses to us.

engaged in the industry for the past eight years as a station owner, TV service manager, TV dealer and pioneer UHF amateur.

This program was the third in a year long series of meetings planned as a part of a progressive educational program for TV servicemen by the Joint Electronics & Radio Committee on Service. The remaining lectures in this series will be held March 19, April 7 and 23, and May 28. Speakers and subject matter to be announced.

The Joint Electronics & Radio Committee on Service was organized a year ago to promote intra-industry harmony and to promulgate educational programs for both TV servicemen and the consumer. Officers include Albert D. Steinberg, Chairman; Albert M. Haas of T.C.A.; Morris Green of N.E.D.A.; Samuel Brenner of P.R.S.M.A.; Thomas F. Joyce and Harry Ehle, Vice-Chairman; Albert N. Kass and Richard Barnett, Treasurers, and Gene Castroville, Chairman of the Technical Educational Advisory Panel.

## **Federation Radio Servicemen's Ass'n of Pa.**

On Sunday, January 18th, the Federation of Radio Servicemen's Associations of Penna. met in Harrisburg with other 65 delegates representing 20 Technicians and Service Dealers Associations from surrounding states to honor the General Electric Company at a presentation luncheon.

The annual Federation award was awarded to General Electric Co. "for their initiative in providing a public relations program in behalf of the independent Television technician." The award was received by Mr. John T. Thompson, Sales Manager of General Electric Replacement Tube Department, on behalf of the General Electric Co. Mr. Thompson, in his acceptance speech, outlined the results of the General Electric 1952 public relations program and then proceeded to outline the 1953 program and many of its fine features that will help the entire servicing industry in both their public acceptance and in merchandising of their commodity—Service.

Mr. Gordon E. Burns, Field Sales Manager, presented on behalf of Mr. J. M. Lang, an outline to the future in electronic servicing, calling the attention to the progress being made in

[Continued on page 58]



# PERSONNEL NOTES

Meet the key men responsible for the manufacture and distribution of servicemen's products.

Robert C. Sprague, left, Founder of the Sprague Electric Company, is congratulating his brother, Julian K. Sprague, right, just after the announcement was made before a group meeting of executive personnel and department heads in this city wherein the Board of Directors named Mr. Julian K. Sprague as President of the Sprague Electric Company.



Wallace E. Carroll, President Simpson Electric Company, Chicago, announces the appointment of Jim Summers as Advertising Manager of Simpson and associated Chicago Companies, Walsh Press & Die Company and Size Control Company. Mr. Summers was formerly Advertising Manager of Ampro Corporation, Chicago manufacturers of cameras, projectors and tape recorders.

Ray Robinson, a leader in the post-war development of the television industry and former eastern regional sales engineer for the Philco Corporation, has been named General Manager of Jerrold Electronics Corporation of Philadelphia. Jerrold president Milton J. Shapp, in announcing the appointment, said that Mr. Robinson will take charge of the expansion and general development of the company.



The appointment of Harold P. Gilpin as general sales manager of the Radio Tube and Television Picture Tube Divisions of Sylvania Electric Products Inc., was announced by H. Ward Zimmer, executive vice president. Mr. Gilpin will report to Arthur L. Chapman, vice president in charge of electronic operations.



Mr. Sheldon F. Myers recently named advertising and sales promotion manager of the Television-Radio Division, Westinghouse Electric Corporation by J. F. Walsh, sales manager. He will direct all advertising and sales promotion activities at the division.

Mr. Monte Cohen, veteran of 37 years standing in the radio-electronics field, has been elected President of General Instrument Corporation, manufacturers of radio, television and electronic components. It was announced by Abraham Blumenkrantz, Chairman of the Board.



Bernard O. Holsinger, General Sales Manager of the Radio and Television Division, Sylvania Electric Products Inc., announced the appointment of Mr. Walter Lefebvre as Director of New Television Market Development for the Division. His principal duties will consist of directing and coordinating sales and relative activities in cooperation with Sylvania TV distributors in new television markets.



Charles F. Stromeyer, vice president in charge of manufacturing and engineering of Hytron Radio & Electronics Co., a Division of Columbia Broadcasting System, Inc., announced the appointment of Dr. Russell R. Law as his assistant. Dr. Law, in this capacity, will advise Mr. Stromeyer on special technological problems.



The appointment of John G. Weaver as manager of advertising and sales promotion for television and radio of the Crosley Division of Aveco Manufacturing Corporation was announced by E. W. Gaughan, general sales manager for Crosley electronics. Mr. Weaver comes to Crosley from Swift and Company, Chicago.

Mr. J. K. McDonough, General Manager of the Radio and Television Division, Sylvania Electric Products Inc., announced the appointment of Mr. Eugene Vigneron as Controller of the Division. Mr. Vigneron succeeds Mr. Leon C. Guest, Jr., who has been transferred to the Sylvania General Offices in New York City.



Fred R. Ellinger, president of Waldom Electronics, Inc., 911 N. Larrabee, Chicago, manufacturers of replacement cones and electronic components parts, announced the appointment of Jay J. Greengard as general manager of the firm. Greengard formerly was sales and advertising manager of Talk-A-Phone Co., Chicago.



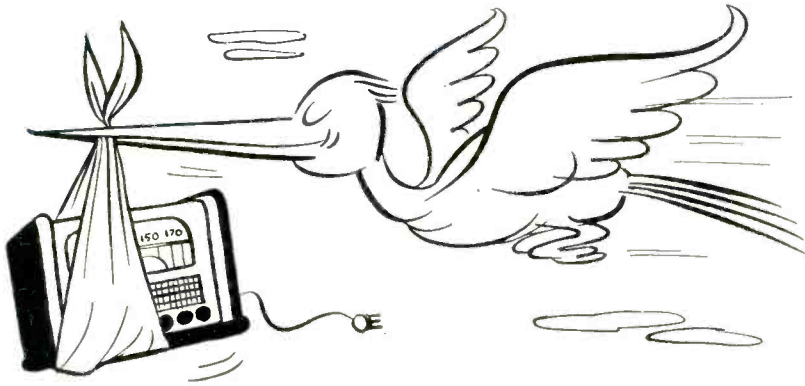

# New Products

## BROAD BAND UHF YAGI TV AERIAL

Introduction of its new broad band UHF Yagi television aerial has been made by Snyder Manufacturing Company of Philadelphia.

The Snyder UHF Yagi TV aerial comes in 3 models coded UHF-3A, UHF-3B and UHF-3C, which cover channels 14 to 48, 27 to 62 and 47-83 respectively.

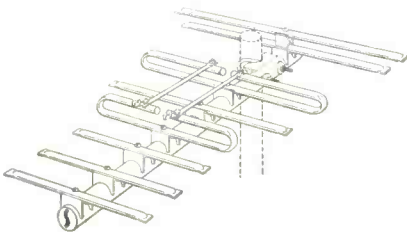

Completely factory preassembled and ready for roof installation, "from package to pole," the Snyder UHF Yagi features eight  $\frac{3}{8}$  inch aluminum elements and has a universal mast clamp. Catalogs on the aerial may be obtained by writing to Dick Morris at Snyder Manufacturing Company, Philadelphia 40, Pennsylvania.

## TV COUPLER

Vidaire Electronic Manufacturing Co., N. Y. City, announces that deliveries have begun on their "Tele-Coupler," a new device which permits use of one antenna with two television receivers. The special Vidaire design transfers a maximum signal from a single antenna lead to the sets without interaction from one set

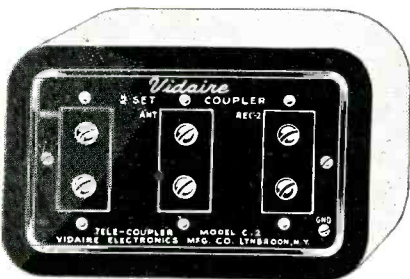

to another. It also reduces effects of local oscillator radiation from one receiver to another, and its filter action cuts interference at  $\frac{1}{2}$  frequencies. Engineered for most TV receivers with either 72 or 300 ohm input the Vidaire "Tele-Coupler" also reduces reflections as a result of excellent matching.

## CORONA FREE TRANSFORMER

The picture below illustrates an advertising theme "Taking the Kick out of TV" used by



Merit Coil & Transformer Corp., Chicago, in the introduction of their new corona free HVO-X7 Flyback Transformer. Bill Barron, Merit Sales Manager, poses with the donkey used in the campaign which has caused widespread comment. The sequence of ads—a teaser and an explanatory ad—present the new HVO-X7 Flyback Transformer which is a development long needed by servicemen.

The new transformer has a hard, non-hygroscopic, new insulation which encloses the high voltage winding, is impervious to moisture and high humidity and forms a water-tight seal for the high voltage lead. This tough coating is physically and electrically unaffected by high humidity or cycles of heat and cold, withstanding operating temperatures 50% above normal without change.

## PORTABLE VOLTMETER

Television servicemen pressed for time will profit from a new, low cost, high voltage measuring device called the TV Voltprobe, and developed by the American Research Corporation, 1504 11th St., Santa Monica, California. The Voltprobe is easily carried in pocket or tool kit. Saves time on the job or in the shop. Enables servicemen to measure the accelerating D. C. voltages on a TV tube from 4000 to 25,000 volts quickly, easily, and accurately on location in the home, as well as in the shop.

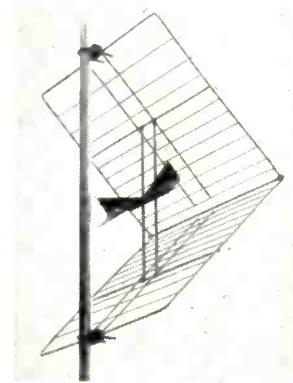
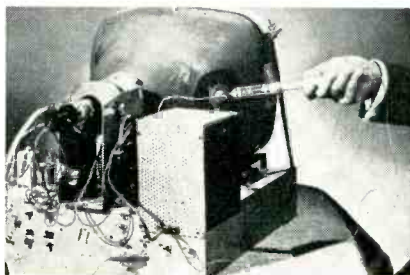

## BROAD BAND UHF ANTENNA

Channel Master Corp., Ellenville, New York, has announced the introduction of a new broad band UHF fringe antenna—the Corner Reflector, Model No. 405.

This antenna features a unique construction idea which gives the most rigid reflecting screen ever built in an antenna of this type.

The antenna is mounted behind the mast and the reflecting screen is held absolutely rigid by two separate U-bolt assemblies which are welded to the extreme ends of the screen.

The "double-truss" construction of Model 405 prevents the screen from vibrating, and prevents any variation in the angle. This assures maximum signal strength and continuous peak performance, with no picture flicker.

Model No. 405 is completely preassembled, and its reflecting screens simply swing open like a book. The dipole assembly is instantly snapped into place, and automatically fixes the screen at its optimum reception angle. This critical angle is then permanently held by the two U-bolt assemblies.

## TV-FM-AM TESTER

Radio City Products Co., Inc., announces its latest addition to the famous "RCP SERVICE SHOP" series, Model 8873 is really a complete service shop for TV-Radio-FM and

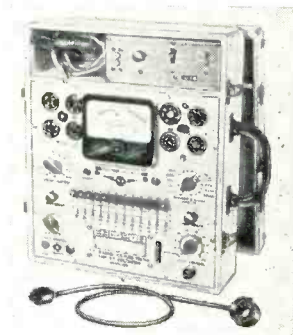

practically sets a service man up in business. It combines the TV-Radio-CR Tube Tester Model #730, with all necessary leads in a smart looking hand-rubbed oak carrying case.

The "Dynoptimum" free point tester uses a burn-out protected  $4\frac{1}{2}$  inch meter and has spare switches and socket blanks to test and reactivate all present and projected tubes and CR tubes.

## INSULATED TEST CLIPS

An entirely new concept in insulated test clips is announced by Industrial Devices, Inc., Edgewater, N. J. The new test clips are designated as Model #1410A.

New convenience and safety is realized through the use of 100% insulation on the new test clips. The plastic insulation covers the entire clip, including the nose, without the bulkiness of rubber boots or insulating tape.

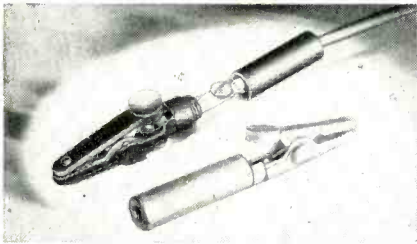

The Model #1410A can be used in pairs as a source of power for equipment under test without the danger of a short circuit due to the clips touching each other or other components. In use on test equipment leads, the clips may be changed from one connection to another without cutting off the power in the equipment.

### BROAD BAND UHF ANTENNA

Telrex, Inc., Asbury Park, N. J., announces the introduction of a new super high gain screen reflector array Model 800-2X employing their patented "Conical-V-Beam" dipoles for full fidelity and uniformly high response at all channels in the uhf-tv band.

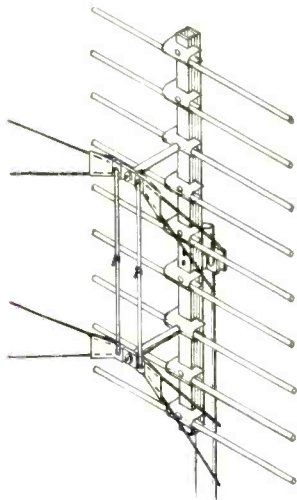

The "Ultra High" Conical-V-Beam, Model 800-2X, utilizes two, full-wave, stacked conical dipoles and reactance compensated transformer bars to develop gain up to 18 db at an average front to back ratio of 20 db. Another unique feature of Model 800-2X is the provision for converting to a parabolic array, to increase gain and vertical directivity, by the addition of two pre-assembled screens which are available as an accessory and may be quickly secured to the antenna mast.

### OLD COMPENSATOR FOR GE RECORDS

A lost world of priceless entertainment has been opened to exploration by General Electric audio engineers. The immortal performances of Enrico Caruso, Amelita Galli-Curci, of

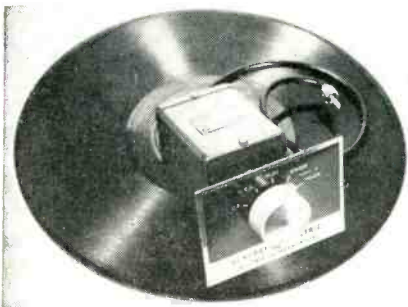

John Phillip Sousa and Harry Lauder, of all the great artists whose legacies have been buried under the scratched and worn surfaces of thousands of old phonograph records, have been freed by a newly developed record compensator announced recently.

The compensator, designated Model A1-900 is now available to the retail trade at a list price of about \$15.00. According to E. A. Malling, manager of parts sales in the receiver department, the compensator is the first item in a complete General Electric high fidelity system now being developed.

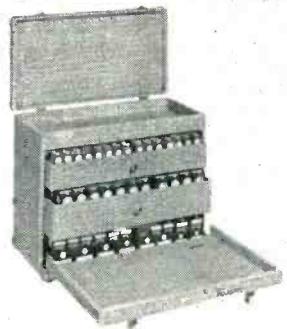

### TUBE CADDY

A new De Luxe Tube Caddy with convenient tool tray for TV servicemen has been announced by Argos Products Company, Genoa, Illinois. Other new features include heavier draw type clasps, a standup support for the cover, and smart black-and-white pebble-grain leatheroid covering. First shipments to parts jobbers were scheduled for February, with resale price \$14.95 net to service dealer.

Effective February 1, the resale price of Argos Products Tube Caddy, Jr. will change from \$8.95 to \$7.75. Argos will henceforth offer three Tube Caddies as follows: De Luxe 18 x 14 1/2 x 9 1/4 in., \$14.95; Regular 20 x 13 1/2 x 9 in., \$13.50; Junior 15 1/2 x 13 x 8 in., \$7.75.

### UHF TRANSMISSION LINE SPLICER

A new solderless transmission line splicer designed to provide a constant impedance splice of tubular types 300 ohm line to flat types

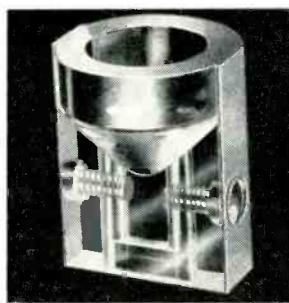

has been announced recently by Carl E. Mosley, President of Mosley Electronics, Inc. The new splicer, Catalog No. 29-S, is intended for use with any of the now available tubular or oval types of line in popular use for uhf television installations.

The new Mosley Splicers are now available at Radio and Television Parts Jobbers, coast-to-coast. For complete information, write Mosley Electronics, Inc., 2125 Lackland Road, Overland 14, Missouri.

### UHF CONVERTER

Roland D. Payne, Sales Manager of CBS-Columbia Inc., set manufacturing subsidiary of Columbia Broadcasting System Inc., announced the availability for immediate de-

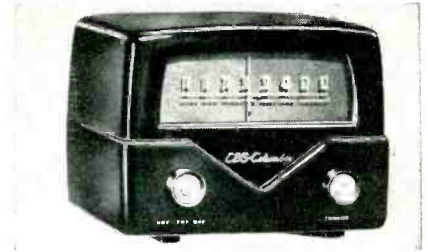

livery of a new CBS-Columbia UHF Converter

The converter known as "Model 2001" enables CBS-Columbia and other makes of television receivers to receive the entire band width of UHF channels.

### BROAD BAND VHF YAGI

The JFD Manufacturing Company, Inc. announces the production, availability and sale of a new Yagi for VHF. The JFD Broad Band Cascode Yagis will be available in a number of models.

With the exclusive JFD Balanced Line-Matching Transformer System, impedance matching to 300 ohm line is guaranteed in stacking. Whenever stacked arrays are ordered, Baline Matching Transformers are supplied free by JFD.

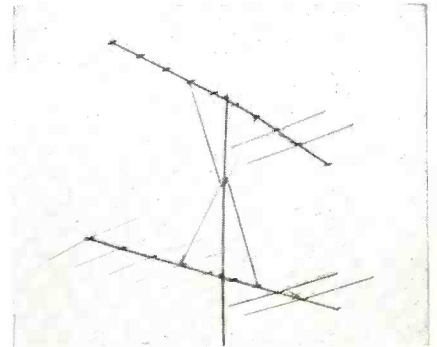

Complete information on this and all other JFD Broad Band Yagis is available now. Simply write to the JFD Manufacturing Company, Inc., 6101 16th Avenue, Brooklyn 4, New York.

### DISC CERAMICON CAPACITORS

Erie Resistor Corporation announces a line of high voltage disc ceramicon capacitors. The advantages claimed for the new Ceramicons are space saving and production economy. The company states that the Erie line provides the smallest capacitor available for a given voltage and capacitance.

Exhaustive tests for life and other qualities of the high voltage disc Ceramicons have been carried on over a period of years to establish required dielectric thickness for safe ratings.

The standard sizes in the new line are 3/8" 19/32" and 3/4" maximum diameter. They have phenolic dipped, vacuum wax impregnated case insulation. Leads are #22 tinned copper wire. Standard D.C. working voltage ratings are 1000, 1500, 2000, 3000, 5000, and 6000, with a dielectric strength test of twice the rated working voltage.

Write to Erie for samples and full information.

### INDOOR TV ANTENNA

Neva Tip, the newest idea in indoor antenna design, has just been introduced in a tastefully styled unit so effectively balanced that it cannot be tipped over by the weight of its own elements. Tipping and consequent damage to the antenna or to the furniture surface is overcome by Radio Merchandise Sales, Inc., manufacturers of the new antenna, by making

use of an effective counter-balancing principle in the design of the Neva Tip base.

Manufactured by Radio Merchandise Sales, Inc., 2016 Bronxdale Ave., New York 60, N. Y. Available at radio and television service dealers. Retail price \$7.50.

### SELENIUM-RECTIFIER-CIRCUIT ELECTROLYTICS

For the filtering function in selenium-rectifier circuits, several twist-prong base electrolytic capacitors, designated as Type AFHS, are announced by Aerovox Corporation, New Bedford, Mass., and made available to and through distributors.

While these selenium-rectifier electrolytics look exactly like the usual AFH twist-prong electrolytics, there are important departures in internal construction. Usual electrolytics

are not always suitable in selenium-rectifier circuits, due to high ripple currents. However, Aerovox engineers have studied the operating conditions as well as the Howard Sams' recommendations in listing numbers used as initial equipment by leading TV set manufacturers and for replacement purposes. The selection does not duplicate any of the numbers that can be used from the usual AFH series.

### TV CONTROLS

International Resistance Company announces the addition of three new TV Controls to its Distributors. Type 4WK, a husky, universal 4-watt wire-wound control especially designed for TV replacement service, comes equipped with IRC Knob Master Shaft . . . knurled, flatted and grooved to fit most knob requirements without modification except for cutting to required length. Diameter 1 1/4",

depth behind panel 11/16", Bushing, 1/4", shaft length 3". Type 4WS is identical to Type 4WK in construction and size except equipped with short, knurled and slotted shaft—5/8" long. This type designed for replacement of TV controls mounted at chassis rear or under front panel concealment without shaft alteration Type HV, a two-watt carbon element high voltage control for use in television receivers using picture tubes requiring electrostatic focus, also comes equipped with Knob Master Shaft. Diameter 2 11/64", depth behind panel 25/32", bushing 1/4" shaft length 3". For further information on new TV controls, write for Form S-081. International Resistance Company, 401 North Broad Street, Philadelphia 8, Pa., Walnut 2-2166.

### VIBRATOR

After months of laboratory research and a year of actual field testing, P. R. Mallory & Co. Inc., Indianapolis, announces the availability of the Mallory 4548 vibrator, the first of a new 4500 series, specifically designed for two-way communications equipment.

Field tests were made by full-time service engineers of taxi, municipal and state police, and utility mobile communications facilities, located in widely separated geographic areas. Their enthusiastic response to these tests indicate the 4500 series vibrators are the answer to the specialized requirements of communication service.

Designed for use in 6 volt application only, the new 4548 vibrator will replace the presently recommended 248 in servicing various models of Federal Television & Radio, Motorola, and RCA sets. For more complete servicing information, servicemen are referred to the listings and installation notes for the 248 vibrator in the latest Mallory Vibrator Guide.

## ASSOCIATIONS

[from page 54]

UHF and Color TV and transistors. The facts as outlined by Mr. Lang, showed the greater need for continuous studies on behalf of the TV Servicing technician and also the need for such training program as the industry can provide.

Mr. Bert Brogenzer, head delegate of the Pittsburgh Radio Servicemen's Association to the Federation, made the presentation.

Dave Krantz, President of the Federation, thanked General Electric for their progressive leadership in providing the service dealer this public relations program and its merchandising aids.

*Dave Krantz*

### Television Servicing Dealers Association (Pa.)

On Thursday, January 22nd, the Television Servicing Dealers Association inaugurated its first public relations program with a half hour broadcast on station WIP. The program was arranged with the cooperation of Mr. Arnold, Program Director for station WIP. Mr. Louis J. Smith, Vice-President of the Television Servicing Dealers Association, with the assistance of Miss Mary Biddle, staff

# PRICE REDUCTIONS

## ON STANCOR YOKES and FLYBACKS

It's our way of saying, "Thanks for your confidence." Yes, thanks to you, the sale of these Stancor TV components has increased tremendously . . . our costs are lower . . . and we are passing these savings on to you.

These components are the same high quality, triple-tested units you have always received and come to expect from Stancor. At these new, low prices they are even better values than before.

### DEFLECTION YOKES

PART NO.	OLD LIST PRICE	NEW LIST PRICE
DY-8	10.75	9.80
DY-8A	11.00	10.00
DY-9	10.75	9.80
DY-9A	11.00	10.00
DY-10	10.75	9.80
DY-10A	11.00	10.00
DY-11A	*	10.00
DY-12A	*	10.00

### FLYBACKS

PART NO.	OLD LIST PRICE	NEW LIST PRICE
A-8128	10.50	10.00
A-8129	11.00	10.50
A-8130	11.00	10.00
A-8131	7.00	6.50
A-8132	*	10.50
A-8133	11.00	10.50
A-8134	11.00	10.50

\*New items: DY-11A is used in 172 models of 15 manufacturers. DY-12 is used in 160 models of 8 manufacturers. A-8132 is an exact replacement for Muntz TO-0031, used in over 300,000 sets. Ask your Stancor distributor for Bulletin No. 461 listing applications of these units, or write Stancor direct for your free copy.

## STANDARD TRANSFORMER CORPORATION

3380 ELSTON AVENUE  
CHICAGO 18, ILLINOIS



Stancor Transformers are listed in Photofact Folders, Tek-Files and Counterfacts.

Export Sales: Roburn Agencies, 39 Warren Street, New York 7, N. Y.

*truly  
outstanding*

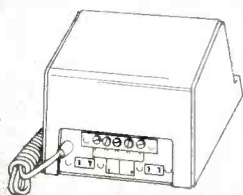

**the perfect partner  
to the C·D·R ROTOR**

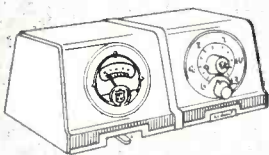

SUBSIDIARY OF



## the **RADIART TV BOOSTER**

*has all the outstanding features*

- ★ Stand-By Position . . . eliminating "Warm-up" time for Booster.
- ★ 110 Volt Outlet to plug in TV Set—Power Control through the Booster.
- ★ Extra 110 Volt Convenience Outlet . . . plug in Rotor or any Appliance.
- ★ High Signal-To-Noise Ratio.
- ★ Wide Band Amplification.
- ★ Complete Neutralization for Stable Operation
- ★ Handsome Mahogany Finish.

Any way you look at it . . . the RADIART BOOSTER is truly outstanding! Its many features make it superior in performance . . . its handsome design sets it off in a class by itself . . . and it is so flexible . . . with its extra outlet!

**THE RADIART CORPORATION CLEVELAND 13, OHIO**

VIBRATORS • AUTO AERIALS • TV ANTENNAS • ROTORS • POWER SUPPLIES

# Why not repair TV the easy way?

Rider TV MANUALS. These are the large, bound volumes that come out about 3 times a year. Each volume covers the current production of every receiver brand from A to Z. There are now 10 TV volumes that cover a total of more than 4,650 different models. Each volume has 2,000 or more 8 1/2 x 11" pages of official, factory-authorized information and all contents are clearly indexed for fast and easy use. With a Rider TV Manual, you'll know all about the different production runs and changes, circuits, voltages, trouble cures . . . everything the manufacturer has to tell for easy service.

Rider's TV 11 out in April

We don't mean by saying a few magic words over the set. Before you can do that they'll build a set that just won't break down . . . and we'll all be out of business. We mean that once you know the make and model of the tv receiver, think how easy it would make your job if you knew as much about the set as the company that made it. Impossible? No. Rider servicing information tells you all you need to know to do a permanent repair job. One that really makes the customer happy. This complete and easy-to-use data comes two ways . . .

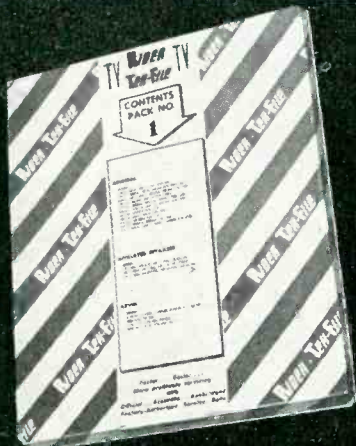

TEK-FILE. Here is the same complete, official factory-authorized Rider information in packaged form. TEK-FILE information is just like the Manuals . . . organized, indexed, easy-to-use. Buy TEK-FILE when you need information for just certain receivers and models. There are now 77 TEK-FILE packs that cover over 2,800 tv models. You can find out what packs are available from the free TEK-FILE indexes at your jobbers, or by writing to us.

Beginning with TV Manual 10 and TEK-FILE Pack 57, you'll find this new feature: a listing — by brand names — of dependable replacement parts. All parts' specifications are checked and rated against original parts. If you can't get TEK-FILE information, let us know. We'll tell you where to buy it . . . or sell you direct. Find out for yourself how easy tv servicing can really be. Try a TEK-FILE Pack — if you're not completely satisfied—return it to us within 7 days and we'll return your money!

Rider's TV 11 out in April

**NOTE TO ALL TV 10 OWNERS! Do yourself and us a favor by filling in and sending to us the registration coupon on the first page of TV 10. This will help us send you additional exclusive information. Thank you.**

• For Easier Radio Servicing . . . Use Rider's 22 AM-FM Manuals!

## JOHN F. RIDER

PUBLISHER, INC.

480 Canal Street, New York 13, N. Y.

West Coast Office:

4216-20 W. Jefferson Blvd. Los Angeles, California

announcer for the station, presented a question and answer forum concerning daily questions and problems that the consumer public continuously confront the servicing dealer with. Among the questions answered were the following:

Are the stories we hear and read about the television service racket true?

Why is there a service charge?

Why is there a variation in price for service charges?

Can most television sets be repaired in the home?

What is a guarantee on repairs and its coverage?

Why must I pay again when I make a recall within the 90 day guarantee?

Many other pertinent questions in regard to the members of the association were discussed.

The organization has now made additional arrangements for the continuance of such programs both on Radio and Television.

Dave Krantz

### Philadelphia Radio Servicemen's Association (PR SMA)

Our last open meeting was held January 13, 1953, at the Franklin Institute instead of on our regular meeting night of January 6, 1953, due to the speakers not being able to be in Philadelphia at that time.

This meeting was co-sponsored by the P.R.S.M.A., TCA, JERCES and the Radio Electric Service Co. who presented Richard Marsh, Sales Engineer for the P. R. Mallory Co. who touched briefly on the development research that has gone into the Mallory UHF Converter. Then Mr. Marsh discussed the circuit employed in the unit, its uses and applications, alignment, servicing and the many measures taken to safeguard the quality of the converter. This included explanation of the air check run made on each Mallory Converter before it passes inspection standards. The reasons why Mallory chose to make an all-channel converter was also discussed prior to the question and answer period.

One of the highlights of this meeting was the showing of Channel Master's new film, "The Antenna Is The Payoff." This film was a full length motion picture in sound and color, and it featured Ed Thorgersen, the nationally known sports commentator.

The following is a list of future meetings to be held in the following months: February 26, 1953, will be Raytheon Television and Radio Corporation; March 19th, Sprague Products Company will have a guest speaker;

# This name spells Quality and Profits



**U**NBEATABLE quality is built into every Sylvania product. Even beyond that, Sylvania quality goes back to its essential metals, chemicals, and materials.

### Sylvania quality is fundamental

Sylvania grinds and formulates its own phosphors, and applies them by improved methods which assure maximum uniformity and fine picture-tube performance. Sylvania draws its own high-quality tungsten filaments and winds and tests its own coils.

Naturally, this far-reaching quality control results in an enviable nation-wide reputation. Today 7 of the top 10 television set makers use Sylvania Picture Tubes and Receiving Tubes. Naturally, too, Sylvania quality pays off in fewer call-backs, more satisfied customers . . . and *more profits for you.*

You'll find your friendly Sylvania Distributor a mighty high quality man to do business with, too. Call him today!



Be sure to install Sylvania Picture Tubes and Receiving Tubes in all the sets you service. Your customers know about Sylvania's fine quality and they'll appreciate your selection of Sylvania products for their sets.



RADIO TUBES; TELEVISION PICTURE TUBES; ELECTRONIC PRODUCTS; ELECTRONIC TEST EQUIPMENT; FLUORESCENT LAMPS, FIXTURES, SIGN TUBING, WIRING DEVICES; LIGHT BULBS; PHOTOLAMPS; TELEVISION SETS

April 23rd will be DuMont Laboratories; and May 28, 1953, the Hickok Electrical Instruments Company will be here.

## TRADE FLASHES

[from page 18]

ers, the post formerly held by T. R. Mathews who recently resigned. Mr. Granger first joined Stronberg-Carlson in 1924, and left in 1932 to operate his own retail radio business for nine years.

### Westinghouse Ups Doyle and Brown

Appointment of two Westinghouse Electronic Tube Division sales executives to newly-created sales posts was announced today by Harold G. Cheney, division sales manager.

Effective immediately, John J. Doyle, a 25-year-man with Westinghouse, assumes the new post of manager of renewal tube sales, and James L. Brown, a veteran of 16 years electronic tube sales experience, becomes manager of equipment tube sales.

### Rosen Leaves JFD

Mr. Daniel M. Rosen, personnel director of the JFD Manufacturing

Company, Inc. for the past two and one half years, has left that position to rejoin the federal administration in the New York offices of the Postmaster General.

Replacing him as the new JFD personnel director is Mr. Sheldon Williams. Mr. Williams is a graduate of New York University's Industrial Relations school. His past service includes work with the Associated Transport Corporation, as personnel assistant and with the Gotham Carpet Company as personnel executive.

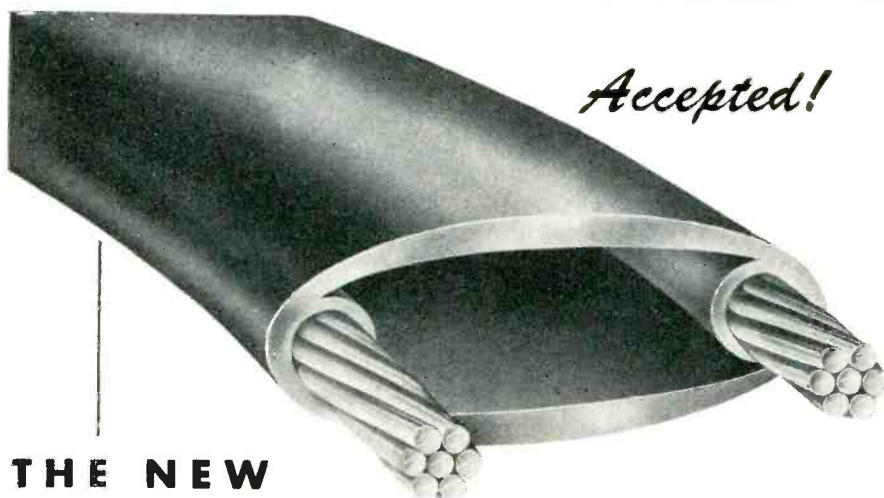

THE NEW

# Synkote® "OVALTUBE"

*Low-loss tubular twin-lead  
for better reception on VHF and UHF*

Here is a unique, *practical* down-lead that minimizes the effects of dirt, salt air and moisture on TV picture quality. Smooth, rounded exterior — no place for dirt to accumulate. Fits the same hardware and handles as easily as ordinary twin-lead, but gives excellent, trouble-free reception under *all* weather conditions!



#### SEAL THE ENDS IN 60 SECONDS

Simply heat with match or cigarette lighter, then squeeze ends together with pliers or knife blade.

#### USE YOUR REGULAR HARDWARE

Synkote OVALTUBE fits into the usual slotted stand-off insulator quickly and easily. No special threading, no special hardware required.

Write for **FREE**  
Sample Length!

**PLASTOID**  
Corporation

plant: HAMBURG, N. J. • offices: 42-61 24th St., Long Island City, N.Y.

## TRADE LIT.

[from page 21]

issued *Technical Bulletin No. 4*. The bulletin describes the unusual four channel ultra-fidelity system which was demonstrated at the two 1952 Audio Fairs and at the February 1953 Audia Fair in Los Angeles.

It gives constructional information for the unique Transflex Bass Reflex Transmission Line Unit and associated 45 cycle crossover network for the frequency range adjacent to the lower limits of audibility. This unit is a unique arrangement quite compact in terms of the wavelengths involved and is one of the outstanding features of the "Reproducer of the Future." The bulletin has been issued in response to many inquiries requesting details.

## TV SOUND

[from page 41]

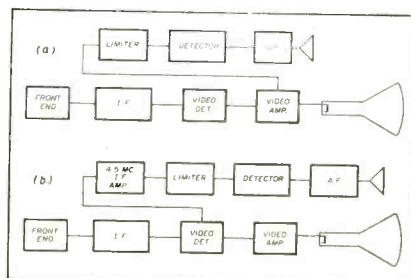

Fig. 11—(a) Early intercarrier sets. (b) Present-day intercarrier sets.

gradation of the I-F bandpass led directly to another intercarrier defect. This arose because with the reduced bandwidth the sound carrier rode higher on the I-F curve than the minimum 36 db that good operation required. The outcome of this state of affairs was that in the video detector



# TUBULAR TWIN TRANSMISSION LINE for UHF

## Saves the picture when it RAINS



Now available from your Admiral distributor

TRANSMISSION LINE COMPARISONS

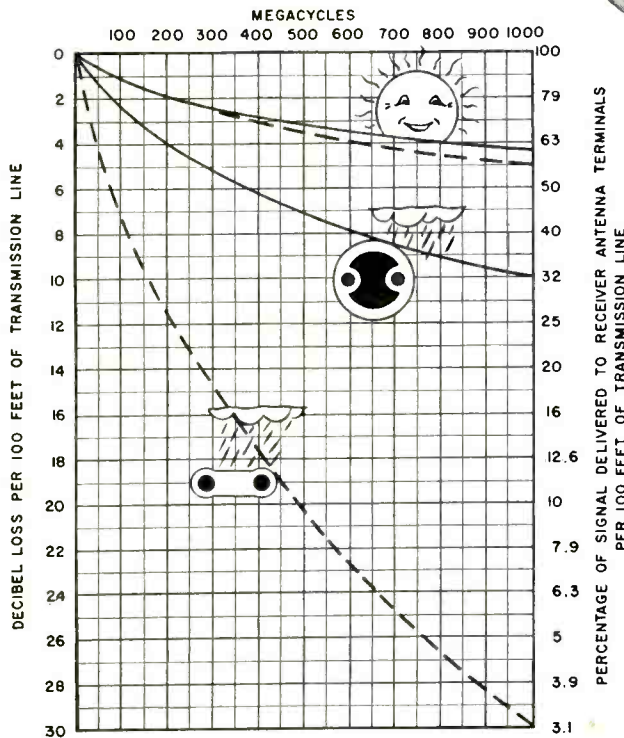

**DRY**  
Transmission Line,  
Tubular or Flat



**WET**  
Transmission Line,  
Tubular

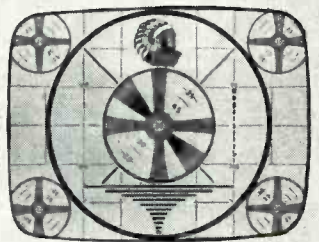

**WET**  
Transmission Line,  
Flat



Many dealers are in doubt about the type of transmission line to use in the new UHF areas. The graph and test patterns tell the story. When rain, fog, dew, etc., accumulate on flat transmission line, the electrical field is short-circuited, causing loss of signal strength. The higher the frequency, the greater the loss. Only a tubular line provides a weather-free air space for constant impedance.

Admiral tubular transmission line is made of virgin

polyethylene, free from impurities that reduce impedance. Aluminum oxide is added to reflect light and prevent deterioration due to sunshine. It is kink-proof and long-lasting . . . impervious to rain, sleet, snow, wind or salt spray. Furnished in 600 ft. spools. Order from your Admiral distributor by part number—95A22-32.

**Admiral Corporation**

Accessories and Equipment Division • Chicago 47, Illinois

### A COMPLETE LINE OF ADMIRAL TV ANTENNAS . . . NOW AVAILABLE FROM YOUR ADMIRAL DISTRIBUTOR

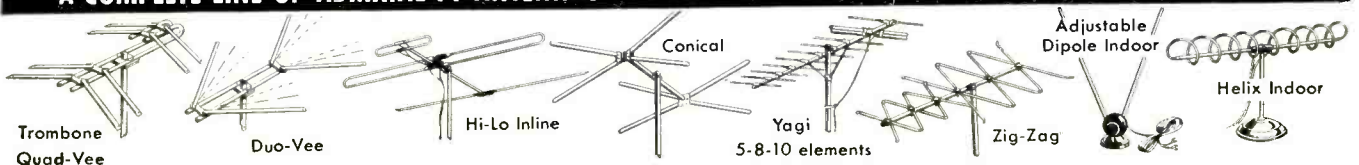

the sound signal was strong enough to cause slope detection. The detected signal appeared on the screen as bars.

After a short while it became apparent that good design was being sacrificed to economy. It was realized that this economy was penny-wise and pound-foolish and could wreck the industry. As a result, the 14 and 15 tube "gutless wonders" quickly vanished from the market. Most current intercarrier sets now have a 4.5 mcs amplifier and a limiter stage. Most of them take the sound carrier off at the video detector and those sets which take it off the video amplifier have very high Q traps after the take-off

point so that their video amplifier response can be sharpened. The I-F bandpass has been widened and the two tube i-f stage is past history.

#### Alignment of Intercarrier Sets

One of the major benefits accruing to the serviceman from the intercarrier design is the ease with which the sound I-F can now be aligned. Assuming that the composite I-F is properly aligned, all the equipment needed to align an intercarrier sound system is a fairly strong station and a good v.t.v.m. Turn the set on to a good station and you have a ready made 4.5 signal generator.

To align the 4.5 mcs system, turn

the set to a good station, connect the v.t.v.m. so that the positive lead goes to ground, and insert a 220K resistor in the other lead probe. Set the meter on the 5 volt scale, put the 220K resistor on the grid of the limiter stage and align the sound take-off and i-f coils for maximum meter reading. After this is done, connect the probe to the negative end of the detector electrolytic and tune the transformer primary for a maximum reading. Next connect the probe to the junction of the output condenser and the detector load resistor and tune the secondary for a zero meter reading. Repeat the last two steps till there is no variation of one when the other is correctly aligned.

## BOOSTER STANDARDS

[from page 36]

pedance of the line and the booster is the same, all of the energy from the line is fed into the booster. But when the impedance of the booster is different, some of the signal is reflected back up the line and this reflected signal represents energy that is not usefully employed. These standing waves on the line can also cause ghosts to appear on the screen. In practice, voltage standing wave ratios under 1.5:1 are considered excellent.

In the case of broad band boosters, the VSWR creates further problems. Since the inductance of the primary of the antenna coupling transformer varies with frequency, its impedance will also vary. This causes different VSWR's at the different frequencies. This variation in impedance can be overcome somewhat by loading the primary with a resistor. However, this reduces the voltage step-up in the transformer. Since the noise in the tube remains constant and the voltage has been reduced, the Noise Figure is impaired.

#### Standards of Booster Performance—Balance-To-Unbalance Ratio

The final major booster measurement is balance-to-unbalance ratio. In this case (unlike VSWR), we look for a high ratio because balance-to-unbalance ratio is the measure of the ability of a booster to reject man-made interference.

Impulse noise, ignition noise, diathermy, Ham interference, oscillator radiation, etc, are unbalanced voltages generally picked up in the transmission line. To these unbalanced voltages the transmission line functions as a long wire antenna (Fig. 4A). Signal picked up by the receiving an-

# Exclusive!

## External Control Method Satisfies All R-C Network Variations



**THE FIFTH LEAD DOES THE TRICK!**

HALLDORSON DF601 & DF602

### NO MORE DIGGING INTO THE YOKE TO SOLVE YOUR NETWORK PROBLEMS...

Whether inductive or autoformer horizontal output coupling is encountered, the "anti-ringing" capacitor in the yoke may be properly positioned to satisfy the circuit requirements. This Halldorson external switching feature is provided in the most used deflection yokes (8.5 to 14 mh.). Here is another "First" by Halldorson—actually priced lower than competitive units not having the plus features of DF601 & DF602. Bulletin No. 110 gives complete details.

HALLDORSON TRANSFORMER COMPANY  
4500 N. Ravenswood Avenue  
Chicago 40, Illinois

HORIZONTAL COILS      VERTICAL COILS

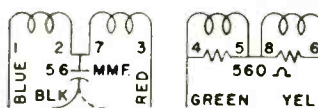

Fifth lead places capacitor across either half of horizontal windings by merely joining the black lead to either the blue or red lead.

#### Direct-Drive Yokes



Halldorson DF603 & DF604 heavily insulated at 6,000 volts! See Bulletin No. 109



# Halldorson

QUALITY Transformers SINCE 1913

EXPORT: Intex Co., Inc., 136 Liberty St., New York 36, N.Y. Cable Address: Intexcom, N.Y.

# Order Yours Now!

## VIDEO speed SERVICE SYSTEMS

**\$4.95**

(post paid)

Distributors—order your supply now!

Delivery will be made on or about May 1st. See VSSS at our Display Room 628A at the Chicago Trade Show in May.

Contains over 600 Service Items representing over 500 of the most-serviced Television models now in use. Over 25 different manufacturers' lines are covered.

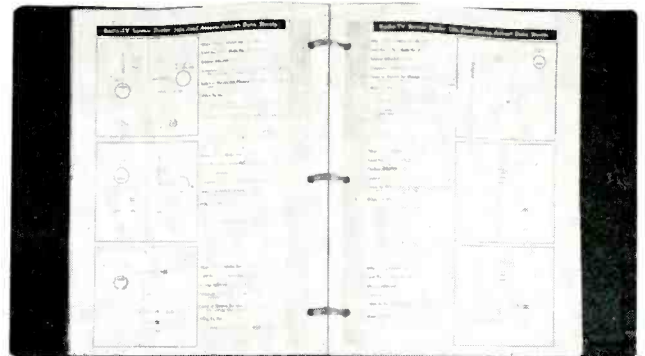

The expansion type ring binder (of finest quality) is 9 x 12 inches, holds all 224 pages of VSSS Vol. I, and has room for another year's supply of VSSS Data Sheets. Opens flat for bench use. TVset models and chassis are cross indexed for speedy reference.

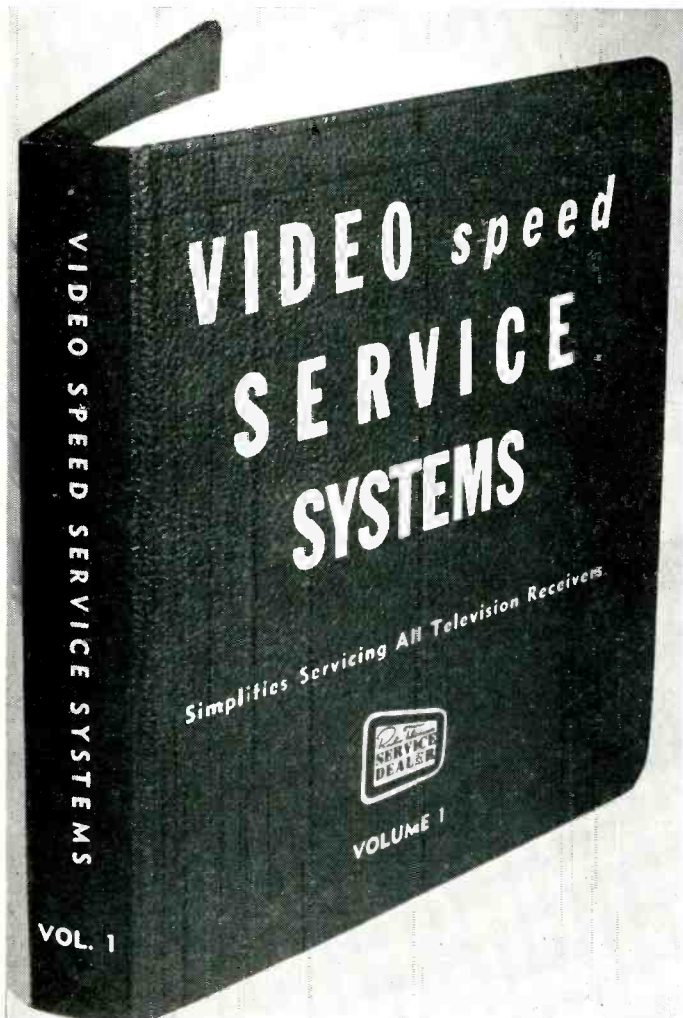

Video Speed Service Systems IS GUARANTEED To Simplify Servicing All TVsets

**TEAR OFF AND MAIL NOW**

RADIO-TELEVISION SERVICE DEALER  
67 West 44th Street, New York 36, N. Y.

S-33

Please send me post-paid VIDEO SPEED SERVICE SYSTEMS Volume 1 as soon as available. Enclosed herewith is

my  check  money order for \$\_\_\_\_\_ for \_\_\_\_\_ copies at \$4.95 each.

Name .....

Address .....

City ..... Zone ..... State .....

tenna appears as balanced voltages (Fig. 4B).

In actual practice, balance-to-unbalance is a measure of the ratio of distributed capacity in the antenna coupling transformer. As can be seen in Fig. 5A, if these distributed capacities are equal, the unbalanced voltages are cancelled out and no man-made noise voltage is coupled to the secondary. If one capacity is smaller, then the voltage across it will be greater. The difference will be passed as noise. In the case of balanced signal voltage, the voltages are added and the total is passed.

If one capacity has a value of 5  $\mu\text{f}$  and the other a value of 6  $\mu\text{f}$ , we say that the latter is 20% greater. This 20% difference compared to a base of 100% represents a balance-to-unbalance ratio of 5:1. Or, if one capacitance is 10  $\mu\text{f}$  and the other 11  $\mu\text{f}$ , the latter is 10% greater. This difference, compared to the base of 100% gives a balance-to-unbalance ratio of 10:1. Fig. 6 is a table showing several capacitance ratios converted to balance-to-unbalance ratios:

From the above, it will be seen that the closer to each other the capacitances are, the higher the balance-to-unbalance ratio will be.

Capacitance ratio	Balance-to-unbalance ratio
20:21	20:1
10:11	10:1
5:6	5:1
2:3	2:1
1:2	1:1

Fig. 6—Conversion ratios.

#### Noise Figure Is Most Important

Summarizing the above, booster performance can be evaluated by four characteristics.

1. Gain: Expressed either as the number of times a given signal is amplified, or as the ratio in db between the input and output signal. In either case, the higher the number, the better the performance.
2. Noise Figure: Expressed in db above KTB, the theoretical noise level of an ideal circuit. In the case of Noise Figure, the lower the number, the better the performance.
3. Voltage Standing Wave Ratio: Expressed as a numerical ratio indicating the degree of mismatch between booster and transmission line. The lower the ratio, the better the performance.
4. Balance-to-unbalance ratio: Ex-

pressed as a numerical ratio indicating the ability of the booster to reject man-made interference. The higher the ratio, the better the performance.

In the final analysis, it is the Noise Figure which will chiefly determine picture quality. And it is KTB, the level of the theoretically perfect booster, that we strive to achieve. KTB in our ideal booster remains highly desirable, not quite attainable, and virtually noiseless.

## FRINGE AREA

[from page 32]

4. Do not cover the line with any shield or covering for any appreciable length.
5. Do not paint the line to "make it look better." It will only make the picture "look worse."

One of the ever existing hazards of installation is that of lightning striking any part thereof. Ordinary lightning arresters that are used with radio receiving antennas are not suitable for television work. A number of arresters are on the market and one must be used with every installation. Not only must the transmission line be

# THIS IS IT! THE RELAY

WITH *Interchangeable Coil*  
FOR A WIDE RANGE OF RADIO APPLICATIONS

## GUARDIAN Series 200

Interchangeable  
**COIL and CONTACT**  
Switch Assembly



Two basic parts—a coil assembly and a contact switch assembly—comprise this simple, yet versatile relay. The coil assembly consists of the coil and field piece. The contact assembly consists of switch blades, armature, return spring and mounting bracket. The new Guardian Midget Contact Assembly which is interchangeable with the Standard Series 200 coil assembly, is also available in either single pole, double throw, or double pole, double throw.

### CONTACT SWITCH ASSEMBLIES

CAT. NO.	TYPE	COMBINATION	
		Single Pole	Double Pole
200-1	Standard	Single Pole	Double Throw
200-2	Standard	Double Pole	Double Throw
200-3	Contact Switch Parts Kit		
200-4	Standard	Double Pole	Double Throw
200-M1	Midget	Single Pole	Double Throw
200-M2	Midget	Double Pole	Double Throw
200-M3	Midget Contact Switch Parts Kit		

### 13 COIL ASSEMBLIES

A.C. COILS*		D.C. COILS	
CAT. NO.	VOLTS	CAT. NO.	VOLTS
200-6A	6 A.C.	200-6D	6 D.C.
200-12A	12 A.C.	200-12D	12 D.C.
200-24A	24 A.C.	200-24D	24 D.C.
200-115A	115 A.C.	200-32D	32 D.C.
		200-110D	110 D.C.

\*All A.C. coils available in 25 and 60 cycles

**GUARDIAN**  **ELECTRIC**  
1606-C W. WALNUT STREET CHICAGO 12, ILLINOIS  
A COMPLETE LINE OF RELAYS SERVING RADIO AMATEURS

## ASK YOUR JOBBER for the GREAT NEW CARLCO KITS



**GUARANTEED PERFECT STANDARD BRANDS**  
RESISTORS  
CAPACITORS  
MICA, etc.  
(BRAND NEW)

Only  
**\$1.98**

each kit

Dealer Net Price

Carlco RESISTOR KIT, contains 100 assorted values (1/2 Watt; 1 Watt; 2 Watt). Standard brands. Guaranteed perfect.  
Carlco MICA KIT, contains 50 assorted values (5MMf. to .001). Guaranteed perfect; standard brands. Values stamped on each unit for easy selection.  
Carlco MOLDED TUBULAR CAPACITOR KIT, contains 25 assorted capacitors; easy reference color code on back of kit package. Standard brands; guaranteed perfect.  
Carlco CERAMIC CAPACITOR KIT, contains 35 assorted capacitors; easy reference color code on package. Standard brands. Guaranteed perfect.

Try a CARLCO KIT—there is no greater value!

**JOBBERS: Ask for our GUARANTEED SALE policy. CARL CORDOVER & CO.**

100 Warren St., New York 7

WOrrh 4-0272-3

protected with an arrester, but the tower or mast as well must be connected to a good ground. Each conductor of a twin lead must have an arrester connection. However, if a coaxial transmission line is used, and the outer conductor is connected to a good ground an arrester is not required. (See the National Electric Code Article 810 section 8141 and revisions in the 1949 supplement.) The arrester may be mounted on the mast, providing that the mast itself is properly grounded.

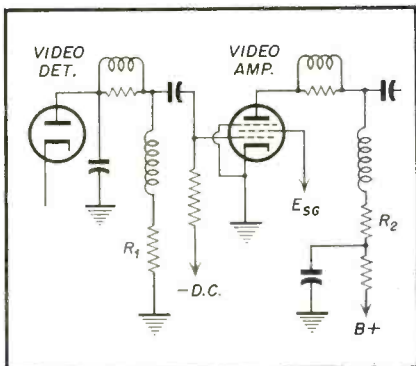

Fig. 6—Video detector and amplifier circuit. Increasing the values of  $R_1$  and  $R_2$  will increase low freq. gain.

#### The Booster Amplifier

In order to achieve proper operation of a TV receiver in a fringe area a well designed booster or pre-amplifier is almost a must. The booster must not only amplify, but it must also have a very little inherent noise otherwise the signal-to-noise ratio will become worse than when no booster is used. It is sometimes advisable to use two sharply tuned boosters in series, with one tuned for best picture and the other for sound. Even though this is not necessarily the best way to use boosters, it may sometimes be the only way left. If the transmission line has to run for any appreciable distance, it will usually help if the booster is mounted right next to the antenna in order to amplify the already weak signal before it picks up any additional noise along the line.

As mentioned above, one of the important factors in the proper functioning of the complete installation is a correct match between the booster, the antenna and the receiver. If standing waves appear either between the booster and the set or on the transmission line coming from the antenna, reception will be impaired. An improvement can be made in either one of two ways.

If a coaxial line is used connect a small variable condenser (either air or ceramic) of about  $15 \mu\text{f}$  maximum

# KESTER

Since the most important single step in Radio-Television Servicing is soldering . . . it's just plain good sense to use the best — KESTER SOLDER . . . Key Name in Solder for More Than 50 Years.

**KESTER SOLDER COMPANY**  
4239 Wrightwood Avenue • Chicago 39, Illinois  
Newark 5, New Jersey • Brantford, Canada

# SOLDER

## A HOT Little BOOSTER for HOT Front Ends



**\$24.95**  
LIST

**VIDEON JR.** won't oscillate with the hot front ends of new sets!

**PERFORMANCEWISE**—It's tops

**PRICEWISE**—It's right . . . and as for customer satisfaction, you cut costly call backs when you install a VIDEON JR.

Write For Descriptive Folder And Name Of Your Distributor



Watch for it—  
The new VIDEON  
OHF Converter

**ELECTRONIC CORPORATION**

222 East Ohio Street • Indianapolis, Indiana

Your One Complete Speaker Source

## UTAH REPLACEMENT SPEAKERS

Export Dept. Rocke International Corporation, N. Y. C.

*Utah*

**RADIO PRODUCTS CO., INC.**  
HUNTINGTON, INDIANA

A WHOLLY OWNED SUBSIDIARY OF NEWPORT STEEL CORPORATION

### MOSLEY 3-WAY TV ANTENNA SWITCH

For Multiple

#### UHF and VHF ANTENNA INSTALLATIONS

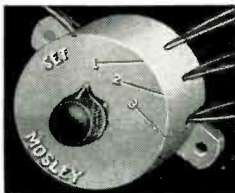

Cat. No. F-20  
MOSLEY 3-Way  
TV Antenna Switch  
List Price .....\$3.75

- Install anywhere. Extension rod supplied for back of set mounting.
- Constant impedance—Low loss—Solderless.
- Sturdy rotary switch making silver-to-silver contact.
- In brown or ivory polystyrene case.
- Also available in Flush Wall Plate style.

At Radio Parts Jobbers

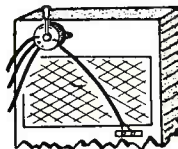

**MOSLEY Electronics** 2125 Lackland Rd.  
Overland, Missouri

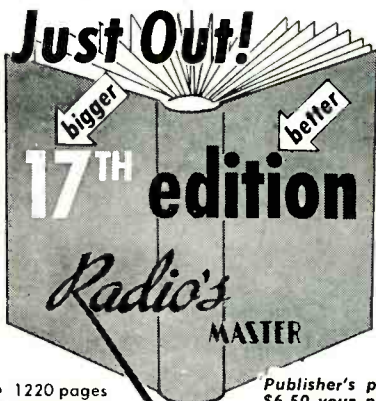

- 1220 pages
- 80,000 items
- 8,000 illustrations
- 8" x 11" — 5 lb.

Publisher's price  
\$6.50—your price  
through your  
regular parts  
distributor. **\$1.95**

#### The right part when you need it for service

This permanent, hard cover Official Buying Guide of the electronic-TV parts and equipment industry with its comprehensive detailed index, eliminates the need for maintaining files of small catalogs and manufacturers' literature. *Radio's Master* catalogs 90% of TV and electronic equipment. Not merely part number listings — complete descriptions, specifications and illustrations written and compiled by each manufacturer. Enables you to make comparisons or substitutions right now!



UNITED CATALOG PUBLISHERS, INC.  
110 Lafayette St., New York 13

### MOVING?

When you change your address, please notify our circulation department as soon as possible. This is to your advantage, since it takes approximately 5 weeks to have your stencil changed and duplicate copies cannot be sent. Be sure to give your old as well as your new address.

#### RADIO-TELEVISION SERVICE DEALER

67 West 44th St.  
New York 36 N. Y.

capacity across the line at either the set or the booster. Adjust the condenser for best picture. For twin lead the best thing to use is a small piece of aluminum foil wrapped around the transmission line. This sleeve should now be moved along the line starting at the antenna and going back. Try for best results and finally hold it in place with a small piece of Scotch tape. An unshielded transmission line can be checked for standing waves by holding the line and moving the hand along it. If there is a marked improvement in the picture at any one point along the line, there are standing waves present and they should be tuned out by the method outlined above.

#### The Receiver

Let us now turn our attention to the receiver itself. If it is possible for the serviceman to recommend the purchase of any one particular receiver, it would certainly be very advantageous to suggest a set with four high gain *if* stages, a good front end, and a full overall bandwidth of at least four megacycles. There are, however, a number of simple modifications that may be made on even such a receiver, which will materially improve its operation in fringe areas.

A simple modification in the *rf* stage would be to remove the *rf* amplifier grid return from the *avc* line and ground it. This will prevent the *avc* voltage from cutting down the vitally necessary gain of the *rf* stage. This change should not be made if strong stations are also received on the same set since they would overload the receiver. If either a 6AG5, a 6AU6, a 6BC5 or a 6CB6 is used, a slight increase in B plus voltage to no more than 200 volts will increase the gain.

Now let us see what we can do with the video *if* stages. One very simple way of attaining a very marked improvement in gain is to replace the tubes in this stage with high-limit tubes of the same type or with some of the "hotter" new tubes. Since television receivers are manufactured for reception in normal signal strength areas, the tubes for the *if* stages are not especially selected by the manufacturer, but good average tubes are used. A tube quite frequently employed in video *if* stages is the 6AG5. This tube may be replaced with the new and "hotter" type 6BC5. The 6BC5 is an exact replacement as far as type and base-connection is concerned, but it will give an appreciable increase in gain. (Transconductance of the 6AG5 is 5,000  $\mu$ mhos and

that of the 6BC5 is 5,700  $\mu$ mhos.

Another very good substitution for the 6AG5 is a 6CB6. The transconductance of this tube is 6,200 micro-mhos which is more than 20% higher than the transconductance of the 6AG5. If three or four tubes are substituted in the *if* stages, the increase in overall gain is quite substantial. Pins #2 and #7 must, however, be tied together if the tube is used in place of a 6AG5, since the 6CB6 has separate pins for the cathode and the suppressor. The set may have to be realigned a little, since the inter-electrode capacitance of the 6CB6 is slightly different.

Another thing that may be done is to select from your present stock of tubes those which are used in video *if* stages. Pick out the ones which give the highest reading on a *transconductance* tube tester and save them for just such an occasion. You may very likely find that the tubes of one particular manufacturer have a higher transconductance than the same type made by another manufacturer. Make sure that you have a few of those "hot" tubes put aside from the rest for sets that need a little "souping up." The tubes in the *if* stages which are being replaced are still perfectly good and may be used in a different receiver, or perhaps in the sound section of the same set. If you don't have any spare tubes on hand it may sometimes pay to substitute tubes from the sound *if* section into the video *if* stages providing they are of the same type. A convenient way of observing whether or not there is any improvement, is to measure the *agc* voltage while trying different tubes. Be sure that a constant strength signal is being received while these measures are made.

Proper realignment will generally also improve the operation of any TV set. Since television receivers are aligned on a production line basis, they are made to meet only certain minimum specifications set up by the manufacturer. It is generally possible to "squeeze" out just a little more gain with a slight amount of touch up here and there. Be sure, however, that the alignment is carried out under the same conditions under which the set will operate, namely with a weak signal. That is very important! If the receiver is checked in the shop with a signal from the shop antenna, insert an attenuator in the line which will give about the same signal strength as that available at the final location of the receiver.

If the video *if* amplifier is stagger

## NO WONDER THE TREND'S TO CERAMICONS®

### Compare ERIE size with other types of capacitors

**Size . . .** Ceramicons are small enough that they fit in any space. This compactness makes replacement of any type easier with the correct Ceramicon.

**Stability . . .** The rugged construction makes Ceramicons impervious to moisture and even the most severe climatic conditions.

**Price . . .** Ceramicons are equal or lower in price than corresponding values of paper or mica capacitors.



ERIE components are stocked by leading electronic distributors everywhere.

**ERIE**  
RESISTOR CORP.

ERIE RESISTOR CORPORATION ELECTRONICS DIVISION

Main Offices: ERIE, PA.

Sales Offices: Cliffside, N. J. • Philadelphia, Pa. • Buffalo, N. Y. • Chicago, Ill.  
Detroit, Mich. • Cincinnati, Ohio • Los Angeles, Calif.

Factories: ERIE, PA. • LONDON, ENGLAND • TORONTO, CANADA

## ONLY Copperweld RADIO and TV PRODUCTS

Offer the EXCLUSIVE ADVANTAGES of Copperweld's Molten-Welded Construction



also HOOK-UP WIRE, TWIN-LEAD AND COAXIAL CABLES, AND MANY OTHER ELECTRONIC WIRE PRODUCTS

# The Leader

Model A

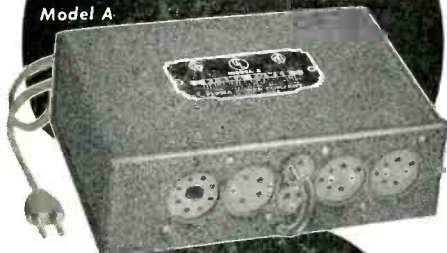

## Perma-Power Battery Eliminator for 1½, 2 and 6 Volt Radios

mfd. by

**Perma-Power** COMPANY

Chicago 25, Illinois

Manufacturers of Electronic Equipment Since 1928

## South River ★★ NEWS ★★

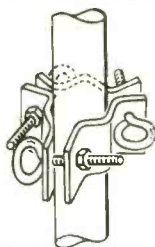

### GUY WIRE CLAMP

Model GC-3

Clamps on mast with a sure grip . . . accommodates masts to 2" O.D. Features 3 eyebolts for guy wire attachment. Model GC-1 . . . 12 holes for guy wire attachment. Accommodates masts to 1½" O.D. Model GC-2 . . . Similar to Model GC-1 with 2 eyebolts for guy wire attachment. South River Antenna Mounting Accessories are carried by every leading TV Parts Jobber from coast to coast.

Write for your copy of our new 1953 catalog.

**SOUTH RIVER METAL  
PRODUCTS CO., INC.**  
SOUTH RIVER, N. J.

PIONEER AND OUTSTANDING PRODUCER  
OF FINEST LINE OF ANTENNA MOUNTS

tuned, it is possible to increase the gain materially by aligning the individual stages to give a greater overall gain with an accompanying decrease in bandwidth. This modification will greatly increase the contrast, however, it will reduce the detail in the picture. Nevertheless, a reduction of bandwidth to 3 or 3.5 megacycles will not materially reduce the quality of the picture. As mentioned before, this alignment should be carried out with a very low signal so as to develop an *agc* voltage corresponding to that developed under actual operating conditions. Remember that the shape of the response curve is affected by the *agc* voltage.

If all of the aforementioned techniques do not produce satisfactory results, there are still some circuit changes possible which will yield a usable though not perfect picture. These steps should, however, be taken only as a last resort.

One of the things that can be done is to increase the size of the loading resistor across the *if* stage which is tuned to the high frequency end of the response curve. This will increase the gain at that end of the curve where the picture carrier is located. Try various sizes for best results, but be sure to stop at a value low enough to keep the *if* stage from oscillating. Now realign the set for best picture. The definition will be lowered, but the marked increase in signal-to-noise ratio may mean the difference between a usable picture and none at all.

Another modification which will increase the gain at the low end of the video frequencies is to increase the value of the video detector load resistor or to increase the load resistor in the video amplifier. These resistors are usually range from 3,000 to 5,000 ohms and should not be increased to more than 10,000 ohms.

The author hopes that all of the above suggestions and techniques will prove helpful to the TV technician concerned with the problems of fringe area installations.

## MODERN AGC SYSTEMS

[from page 26]

the composite video signal applied to the grid of the *agc* tube increases. Thus, the output of the *agc* tube will be a negative potential of approximately 4 to 5 volts at "X". This negative voltage will be applied to the *rf* tube via the 2.2 megohm resistor *R3*. Thus, both the *rf* and *if*

stages will then be under direct control of the developed *agc* bias.

### Service Factors

With keyed *agc* systems the positive pulses applied to the plate must have sufficient amplitude so that the control voltage on the grid can develop the necessary bias. For this reason a decline in amplitude of the positive pulse at the plate of the *agc* tube can seriously affect performance. Thus, any defects in the horizontal sweep system which would decrease the potentials at the secondary of the high voltage transformer will also influence the behavior of the *agc* system. The absence of a positive pulse or an abnormal decline will make the *agc* system inoperative. When this occurs, no *agc* control voltage will be applied to the *rf* and *if* tubes, and in consequence the gain will be excessive for strong signals. When this occurs, the picture (as well as sound in intercarrier receivers) may be obliterated entirely. In other instances the picture may be excessively contrasty with resultant bending and pulling.

The oscilloscope is useful for determining the presence and amplitude of the pulse at the plate of the *agc* tube. An oscilloscope which is calibrated with peak-to-peak voltage should be utilized. The amount of *agc* voltage can also be ascertained by using a *VTVM* on the *agc* bus. With the voltmeter connected to the *agc* line a negative potential should be secured. When stations of different signal strength are tuned in with the station selector the *agc* bus should vary. Lack of variation for different stations would indicate a defective *agc* system.

The composite video signal or sync pulses applied to the grid of the *agc* tube can also be checked for peak-to-peak readings by a calibrated oscilloscope or a peak voltage reading *VTVM*. The *VTVM* is also useful for checking the low plus B voltage applied to the cathode as well as the other potentials. In all instances, comparisons should be made with the recommended voltages given in the service notes for the particular receiver. Defective or shorted capacitors in the *agc* bus can contribute to *agc* failure by grounding out the bias voltage developed. A change of resistor value in the *agc* line is also a contributing cause to *agc* difficulties. The same holds true for coupling capacitors which provide the composite video signal for the grid of the *agc* tube as well as the positive pulse for the plate.



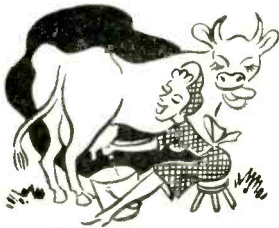

You can milk that C.R.T. with a Gemco Super Ellenbogen Re-fractor



**GREAT EASTERN MANUFACTURING CO.**  
BROOKLYN 12, NEW YORK

### MAGNESIUM LADDERS

World's Lightest Structural Metal  
33% Lighter Than Aluminum  
5 Times Lighter Than Wood  
Stronger, Tougher than Aluminum or Steel, pound for pound

Free Folder and Prices

Magnesium or Aluminum Step, Extension and Straight Ladders

INDUSTRIAL MAIL ORDER CO.  
131 West 53rd St., N.Y. 25, N.Y.  
Telephone: JUDson 6-0116, 0117  
mechanics & Homeowners. Visit Our Showrooms

### \$1.00 to \$5.00 PAID "for SHOP NOTES"

Write up any "kinks" or "tricks-of-the-trade" in radio servicing that you have discovered. We will pay from \$1 to \$5 for such previously unpublished "SHOP NOTES" found acceptable. Send your data to "Shop Notes Editor," RADIO-TELEVISION SERVICE DEALER, 67 West 44 St., New York 36, N. Y. Unused manuscripts cannot be returned unless accompanied by stamped and addressed return envelope.

PLEASE,  
GIVE NOW



March 5 • April 5

National Society for Crippled Children & Adults, Inc., 11 S. LaSalle St., Chicago 3, Illinois.

## AUTO RADIO

[from page 40]

tenna cleared up the noise, and did improve the volume somewhat. In all cases, replacement of the antenna with a more modern type using the polyethylene insulation, etc., will improve reception and cut down on the noise pickup.

Although it's quite unlikely that any more of this type will be encountered, this was found in a case of noise-trouble some years ago: A running-board antenna, using two 'U'-shaped dipoles, one beneath each running-board, was found to be solidly shorted to ground, at the end farthest from the set. The set still played well; the only bad result was a severe noise-pickup. Clearing the short removed the noise. This is mentioned merely as a curiosity, as this type of antenna fortunately left us, along with runningboards!

### Generator Noise

Generator noise is easily identified, as it has the characteristic whine of an electric motor, and will vary in pitch with engine speed. This noise originates in the brushes, at the commutator, and can usually be eliminated by installing a bypass condenser at the armature terminal. This condenser should be mounted directly on the case of the generator, and the lead connected to the armature terminal. If any brush noise remains, check the armature and brushes for excessive sparking. If this is too severe, and will not respond to cleaning and sand-papering, it may be necessary to have the generator serviced. With the voltage-regulated generator found on practically all of today's cars, two terminals will be found on the generator housing; the field and armature. The field terminal is generally identified by a small red paper collar around the bolt, warning against connecting radio bypass condensers there: to do so would upset the action of the voltage regulator. If this collar is missing, the two terminals may easily be distinguished, however: the armature terminal always carries the largest wire, and is usually at the rear of the housing.

### Voltage-Regulator Noise

Voltage-regulators contribute their full share to the noise picture, too. Voltage-regulator noise can be distinguished by its popping, intermittent sound, almost like plug noise, but not as regular. It is only heard when the engine is speeded up enough to cause the regulator to cut in. This noise can be removed by connecting



536K Multimeter Kit \$12.90  
Wired \$14.90  
1000 ohms/volt

425K 5" Scope  
Kit \$44.95  
Wired \$79.95

YOU BUILD

**EICO**

KITS  
IN ONE  
EVENING-

but they  
last a lifetime...  
and you save  
**50%!**

21 Kits and 25 Instruments —  
the industry's most complete  
line of **MATCHED  
TEST INSTRUMENTS!**

Over 1/4-million EICO Instruments are now in use the world over! That's the proof of EICO's leadership in **Value to the Serviceman!**

For latest precision engineering, finest components, smart professional appearance, lifetime performance and rock-bottom economy — see and **compare** the EICO line at your jobber's today **before you buy any higher priced equipment!** You'll agree with over 100,000 others that only EICO Kits and Instruments — no other — give you the industry's greatest values at lowest cost.

Write NOW for  
**FREE latest Catalog  
D-3**



525K Tube Tester  
Kit \$34.95  
Wired \$49.95

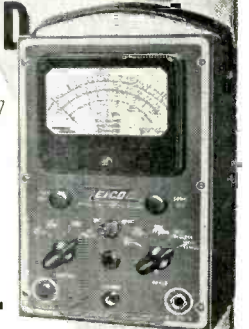

221K WTY/M Kit \$25.95  
Wired \$49.95



565K Multimeter Kit \$24.95  
Wired \$29.95  
20,000 ohms/volt

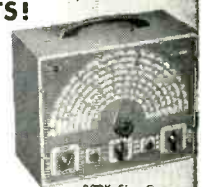

320K Sig. Gen.  
Kit \$19.95. Wired \$29.95



360K Sweep Gen.  
Kit \$34.95. Wired \$49.95



1320K Battery Eff.  
Kit \$25.95. Wired \$34.95

Laboratory  
Precision  
at Lowest Cost

Prices 5% higher on West Coast.

**EICO**

©1952 **INSTRUMENTS & KITS**  
**ELECTRONIC INSTRUMENT CO., Inc.**  
84 Withers Street, Brooklyn 11, N. Y.

**FASTER  
STURDIER**  
Lower Installed Cost

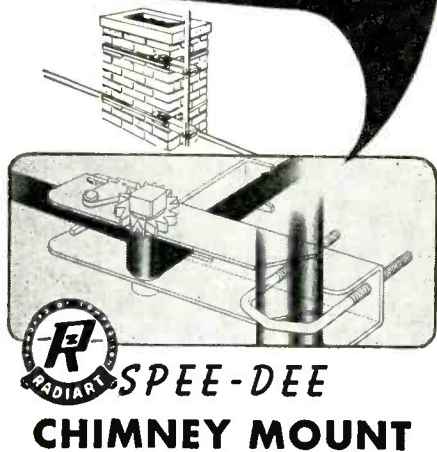

**Model AK 85** The fastest-installed chimney mount ever devised for TV antennas! Rugged in design—simple to install. Simply thread strapping through ratchet, around chimney and back through ratchet—wind up ratchet tight—and the job's done! Heavy gauge, zinc-plated steel with large "U" bolt for up to 1 3/4" O.D. mast and full length galvanized steel strapping.

**THE RADIART CORPORATION**  
CLEVELAND 13, OHIO



You can brighten that picture with a Gemco Ellenbogen Re-fractor



**GREAT EASTERN MANUFACTURING CO.**  
BROOKLYN 12, NEW YORK

## TECHNICAL ARTICLES WANTED

on  
TV, AM RADIO, FM RADIO, PHONO MECHANISMS, HI-FI AUDIO, AUTO RADIO, TEST EQUIPMENT, ANTENNAS

pertaining to their

**Theory, Installation, Application, Service & Maintenance**

submit manuscripts to  
Managing Editor

**Radio-Television Service Dealer**

67 West 44 Street New York 36, N. Y.

a bypass condenser across the 'BAT' terminal, at the regulator itself. The noise originates in the contacts of the 'voltage-coil' of the regulator, which open and close rapidly, as the regulator operates, to prevent the voltage across the battery from rising too high.

Some sets produced in the past few years have been of the two or three-piece type, with a chassis, speaker, and a separate control head containing the dial and volume control itself, connected to the chassis by a shielded cable. These will occasionally give trouble due to imperfect grounding. This can be detected by an apparent 'vibrator-buzz,' which increases in volume as the volume control is turned down. In some cases, this will also give rise to engine noise pickup. It can be stopped by grounding the units together with a heavy braid, cleaning the paint well from under the screws. The primary cause of the buzz is the fact that some of the supply current for the set is returning through the audio-cable shield, setting up eddy currents therein which are picked up by the volume control wiring.

Noise is sometimes fed into the car body through leads to electric oil gauges, temperature gauges, choke rods, throttle rods, etc. Try connecting bypass condensers across the suspected units. On some cars, it will be necessary to bond the choke rods, emergency-brake cable, hood-latch release cables, etc. Connect a piece of small shielding-braid under a convenient bolt, cleaning the paint well, then wrap at least two or three turns around each shaft or cable, then ground it again on the other side.

If the noise refuses to respond to treatment, and especially so if the set is not a standard make, remove the chassis, and check the amount of 'A' lead filtering included in the design, especially into the *rf* and oscillator filament circuits. The addition of an *rf* choke and a .5  $\mu$ f bypass condenser will often help to remove chassis pickup. If no 'spark-plate' condenser is used on the 'A' lead, one may be added. Moisture, causing electrical leakage in these, will sometimes cause noise pickup. Disassemble and replace the insulating material, which is usually electrician's 'fish-paper' or the equivalent.

In conclusion, a careful analysis of each job will save much time in making a correct diagnosis and effecting a cure. Whenever some new type of noise is encountered, make a careful note of the symptoms, and the method job, and a well-satisfied customer, and lead to much repeat business.

## AD INDEX

Admiral Corporation	63
Alliance Manufacturing Co.	27
American Television & Radio Co.	8
Bussmann Manufacturing Co.	33
Channel Master Corp.	12, 13
Clarostat Mfg. Co., Inc.	Cover 3
Copperweld Steel Co.	69
Cordover, Carl & Co.	66
Electronic Instrument Co., Inc. (EICO)	71
Erie Resistor Corp.	69
Fretco	32
General Electric Company	1
Great Eastern Mfg. Co.	71, 72
Guardian Elec. Mfg. Co.	66
Halldorson Co., The	64
Hytron Radio & Electronics Co.	2
Industrial Mail Order Co.	71
Kester Solder Company	67
LaPointe-Plascomold Corp.	Cover 2
Mallory, P. R. & Co., Inc.	15
Mosley Electronics	68
National Carbon Co.	31
Nichols Wire & Aluminum Co.	14
Oelrich Publications	14
Ohmite Manufacturing Co.	20
Olin Industries, Inc.	6, 7
Perma-Power Company	70
Philco Corporation	9
Plastoid Corporation	62
Radiart Corporation	59, 72
Raytheon Manufacturing Co.	11
RCA Tube Dept.	Cover 4
Regency	5
Rider, John F. Publisher, Inc.	60
Sams, Howard W. & Co., Inc.	4
Sangamo Electric Company	18
Schott, Walter L. Co.	10
Simpson Electric Company	17, 21
Snyder Manufacturing Co.	22
South River Metal Prods. Co.	70
Standard Transformer Corp.	58
Sylvania Electric Products, Inc.	61
Trio Manufacturing Co.	19
Triplett Electrical Instrument Co.	37
United Catalog Publishers	68
Utah Radio Products Co., Inc.	68
Videon Electronic Corporation	67
Webster-Chicago Corp.	29

# COMPLETE

information

products

Brand new *Clarostat TV Manual*  
Over 275 pages of TV control  
replacement listings — by  
brand names, model, chassis;  
with manufacturer's part number,  
catalog number, function,  
description, list price, etc.,  
etc. Simply indispensable!  
Ask your Clarostat distributor  
for a copy.

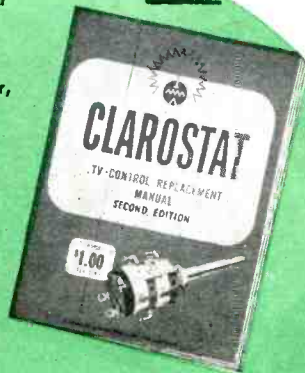

Then, to keep your Clarostat TV Manual up-to-date, there are the TV Supplementary Sheets published in each issue of *PF Index and Successful Servicing*. Just tear out the pages and place them in your Manual. You're always up-to-date with Clarostat!



Many TV controls not available from other manufacturers, are stock items in the RTV line. Clarostat has the largest choice of exact-duplicate replacements that match the initial-equipment controls. Don't improvise—RTV-ize! Catalog on request.

Where standard controls can do, Clarostat has a wide selection of carbon 15/16" and 1-1/8" dia. controls; and in wire-wound 2, 3 and 4 watt controls. "Pick-A-Shaft" provides a choice of 12 field-attached shafts. "Ad-A-Switch" provides field-attached switches.

CLAROSTAT  
CAN FILL YOUR  
AND ONLY  
TV CONTROL  
NEEDS

STAND PAT WITH

## CLAROSTAT Controls & Resistors

CLAROSTAT MFG. CO., INC., DOVER, NEW HAMPSHIRE  
In Canada: Canadian Marconi Co., Ltd., Toronto, Ontario

**Portrait of a serviceman**

*...building a reputation*

*This could be you . . . making a name for yourself in your own community . . .*

To you, fixing a television set is a routine job . . . but to your customer, it's an important event . . . and she expects to get her money's worth.

Once she's seen the familiar RCA trademark on those tube cartons, you have her complete confidence. She's sure now that her set is in good hands.

And it is . . . because you've learned from experience, that the superior quality of RCA Tubes and Kinescopes is your best measure of protection against the costliness and inconvenience of premature tube failures. It's good to know you can fix a receiver and forget about call-backs.

Helping you to safeguard your reputation is a vital, everyday service of RCA Tubes. And that protection is yours at no extra cost.



**DYNAMIC NEW PROMOTION PLAN TO HELP YOU BUILD YOUR BUSINESS**

Ask your RCA Tube Distributor for your copy of the colorful, 16-page booklet "A Magic Pass-Key to Customer Confidence."

**FREE**

A brand-new campaign is outlined, illustrated, and described in full detail. Be sure to get your copy. It's free!



**RADIO CORPORATION OF AMERICA**  
ELECTRON TUBES

HARRISON, N. J.