

APRIL, 1950

Radio
**SERVICE
DEALER**



The Professional Radio-TVman's Magazine

IN THIS ISSUE:

- Servicing Sync Separators
- First Aid To Cabinets, Part I
- The Television Waveform and its Components, Part 4
- Understanding Push-Pull
- What Have We To Gain—Or Lose—In Television

AM-FM-TV-SOUND

Paid Circulation Of This Issue: Over 22,000
Total Distribution Of This Issue: Over 24,000

This Little Fellow Is Some Performer!

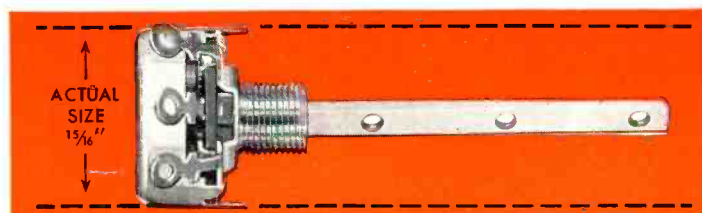

The Mallory Midgetrol

Here's the answer to your control problems . . . a $\frac{15}{16}$ " diameter precision control with electrical characteristics superior to $1\frac{1}{8}$ " controls, while physical size meets requirements of auto and personal sets. Now you can standardize on *one* control for all of your replacements . . . profit by the versatility of the Mallory Midgetrol!

And that's not all! Exclusive precision equipment and scientific inspection assure smooth, uniform tapers. Electrical noise is eliminated, because there is no metal-to-metal contact on moving parts except where conductivity is required. The moisture-proof base prevents warping and provides greater stability.

The Mallory Midgetrol has been designed to meet *your* problems. Your Mallory distributor is ready to serve you.

WIDER APPLICATION

The small size allows you to service portables, auto radios and small AC-DC receivers requiring $\frac{15}{16}$ " controls.

LESS INVENTORY

Electrical characteristics allow you to use the Mallory Midgetrol to replace $1\frac{1}{8}$ " as well as $\frac{15}{16}$ " controls. Since no special shafts are required, you carry fewer controls in stock.

SIMPLER INSTALLATION

The new and unique flat shaft design of the Mallory Midgetrol saves installation time with all types of knobs.

See your Mallory distributor for this new standard in carbon controls!

P. R. MALLORY & CO., Inc.
MALLORY

CAPACITORS . . . CONTROLS . . . VIBRATORS . . .
SWITCHES . . . RESISTORS . . . RECTIFIERS . . .
VIBRAPACK* POWER SUPPLIES . . . FILTERS

*Reg. U. S. Pat. Off.

APPROVED PRECISION PRODUCTS

P. R. MALLORY & CO., Inc., INDIANAPOLIS 6, INDIANA

EDITORIAL

by S. R. COWAN

Progress Report

"RSD", now in its 11th year, has recently attained a position about which we are prone to boast: our paid circulation has passed the 22,000 mark. Over 80% of our subscribers either own or manage the establishment with which they are associated. No other publication purporting to cater to radio-TV technicians even closely approaches our dominant coverage of the servicing field. Even more important is the fact that the radio-TV servicing field has become a basic part of the over-all electronics industry and now accounts for the use of over \$200 million in replacement parts, tubes, test equipment and accessories annually.

Line of Demarcation

Jobbers in all cities where telecasts are received report that radio retailers, especially department, furniture, music and specialty stores, are giving up the operation of their own service departments preferring to "farm out" such service work to independents and specialty TV service firms. By the same token independent servicemen and service firms are obtaining in ever-increasing volume TV service contract work from TV set buyers who having bought a set without a "service policy" subsequently found it advantageous to obtain same from a reputable and technically competent firm. Hundreds of thousands of TV case histories to date prove that every TV set owner should have a year-round maintenance policy—and this is especially true now because the current TV sets aren't standing up as well in use as did the first models to get into distribution. Reduced prices resulting from inferior components used are reflecting in increased demands for servicing. Hurrah for TV!

Bright Prospects

Over 88 million home and auto radios and over 5 million TV sets are now in use. RMA reports its members expect to produce over 5 million TV sets and 10 million radios during the coming year so by mid 1951 this country will have in use for the first time over 100 million radio and TV receivers. Wow! If past history is any criterion the servicing field can anticipate handling over \$250 million worth of replacements in the year ahead; upwards of \$100 million in wages will have been earned and jobs for approximately 100 thousand men are assured.

To service firm operators we offer this advice: clean house from a business management point of view. Take on no jobs unless assured of a reasonable profit. Keep your inventories moderate. When buying replacement parts, etc., use standard nationally advertised brands because they are more dependable and cost less in the long run. And, don't overlook the fact that all service firms can make profits by handling such sideline items as the sale of a TV mast, a booster or wave trap, long-playing phono needles, or replacement 3-way record players.

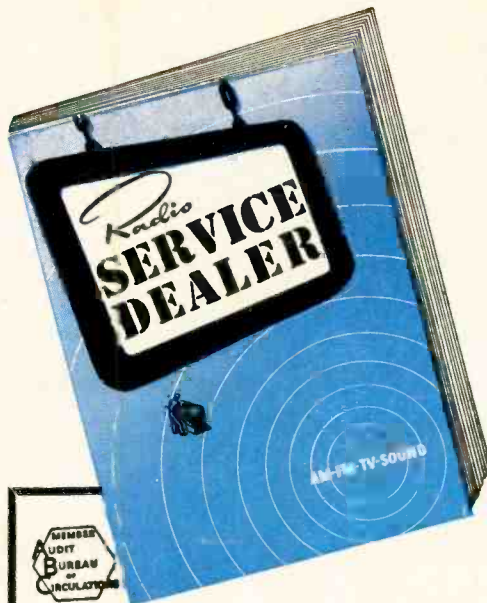

Sanford R. Cowan
EDITOR & PUBLISHER

Samuel L. Marshall
MANAGING EDITOR

COWAN PUBLISHING Corp.
342 MADISON AVENUE
NEW YORK 17, N. Y.

Vol. II. No. 4

APRIL, 1950

Editorial	1
I Told You So, by San D'Arcy	4
Trade Flashes	6
Servicing Sync Separators, by Matthew Mandl	11
An analysis of sync separator circuits, and methods of servicing.	
First Aid To Cabinets, Part I, by William R. Wellman	13
Learn how to make those necessary cabinet repairs that spell the difference between a finished and an unfinished job.	
The Television Waveform and its Components, Part 4, by Samuel L. Marshall	15
Final installment in this section which deals with TV bandwidth requirements and how they are met.	
Understanding Push-Pull, by Allan Lytel	17
A clear explanation of the operation of this popular circuit.	
Shop Notes	18
What Have We To Gain— Or To Lose— In Television? by Charles Golenpaul	19
A down-to-earth discussion of the significance of TV to the serviceman, and how he can make the best of this golden opportunity.	
Circuit Court	21
New Products	22

SANFORD L. CAHN
National Advertising Sales Manager

HARRY N. REIZES
Advertising Manager

NATHAN BOYCE, Circulation Manager

BRANCH: J. C. GALLOWAY 816 W. 5th St., Los Angeles 13, Calif., Mutual 8335

RADIO SERVICE DEALER is published monthly by Cowan Publishing Corp., 342 Madison Ave., N. Y. 17, N. Y. Subscription price: \$2 per year in the United States, U.S. Possessions & Canada: elsewhere \$3. Single copies: 25c. Entered as second class matter Dec. 13, 1948 at the Post Office at New York, N. Y. under the Act of Mar. 3, 1879. Copyright 1950 by Cowan Pub. Corp.

Attention:

...DEALERS
...SERVICEMEN
...JOBBER
...DISTRIBUTORS

Telrex

**initiative and
originality is
your short-cut to
greater profits**

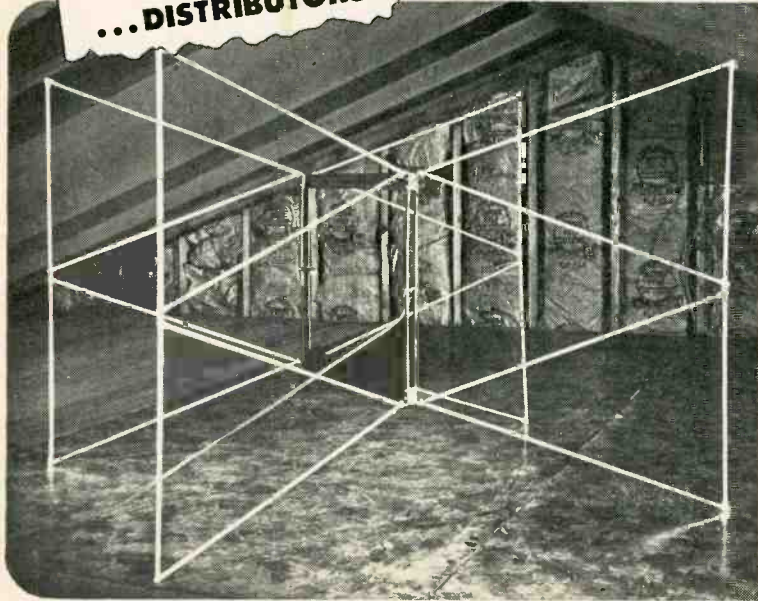

REVOLUTIONARY **INDOOR ANTENNA**

**— outperforms
most outdoor
installations**

the new Telrex **ATTIC-V-BEAM***



**LOOKS BETTER—
AND IS BETTER!**

Homeowners and landlords everywhere are enthused about this antenna. Best of all, once installed you don't worry about call backs because of damage from snow, sleet or wind. No gradual loss of efficiency because of chemical and soot deposits. No more steeplejacking either!

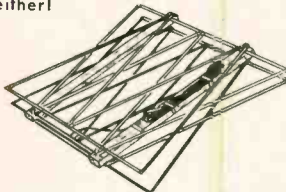

**NOT A KIT OF PARTS —
COMPLETELY ASSEMBLED!**

That's right, it's complete with TL already attached. Comes folded into compact package. To install, just unfold and place in position. That means quick, easy installation in any weather — winter or summer. Order today.

SOLVES TV INSTALLATION PROBLEMS IN ALL PRIMARY AND MANY SECONDARY AREAS — Makes outdoor installations unnecessary in most locations within a radius of 30 miles from transmitters without sacrificing pic or sound quality on any channel. (Reports of good reception at 80 miles have been received.)

SAME WELL-KNOWN TELREX SUPERIORITY IN SENSITIVITY, DIRECTIVITY BAND PASS AND CONSTRUCTION — Famous Telrex Conical-V-Beam design eliminates spurious lobes to increase forward gain and insure full band pass on all TV channels. It's a Telrex from start to finish, mechanically too.

OVERCOMES LANDLORD AND HOME OWNER OPPOSITION TO ROOF ANTENNAS FOR TV OR FM INSTALLATIONS — The first really practical indoor antenna. Ideally suited wherever space permits, in attic, garage, air spaces, or even utility rooms. Compact design, light in weight. Self-supporting on floor, beams, rafters or can be suspended.

EVERY SET OWNER — OLD OR NEW — IS A SALES PROSPECT FOR THIS ANTENNA — Every TV set owner would be happy to discard his roof antenna. That means that right now he's your prospect for this antenna. Why not stock up today and start selling this market. Wherever you see a rooftop antenna and an attic, you have a live prospect. Don't delay.

OTHER MODELS FOR RECEPTION CLOSER TO THE TRANSMITTER

Patents Pending
Copyright 1950

Be sure it's a "CONICAL-V-BEAM"
—Look for the TELREX* Trademark

* REGISTERED TRADE MARK

Telrex INC.

CONICAL-V-BEAMS*

AMERICA'S
STANDARD OF
COMPARISON

Asbury Park 5, N. J.

Unit switch construction houses precision resistors in insulated recesses.

Easy-to-change standard batteries. Double spiral springs give permanent connection.

Direct connections—no harness cabling—no shorts.

Molded selector switch fully enclosed. Spiral spring index control—over 150,000 cycles without breaking.

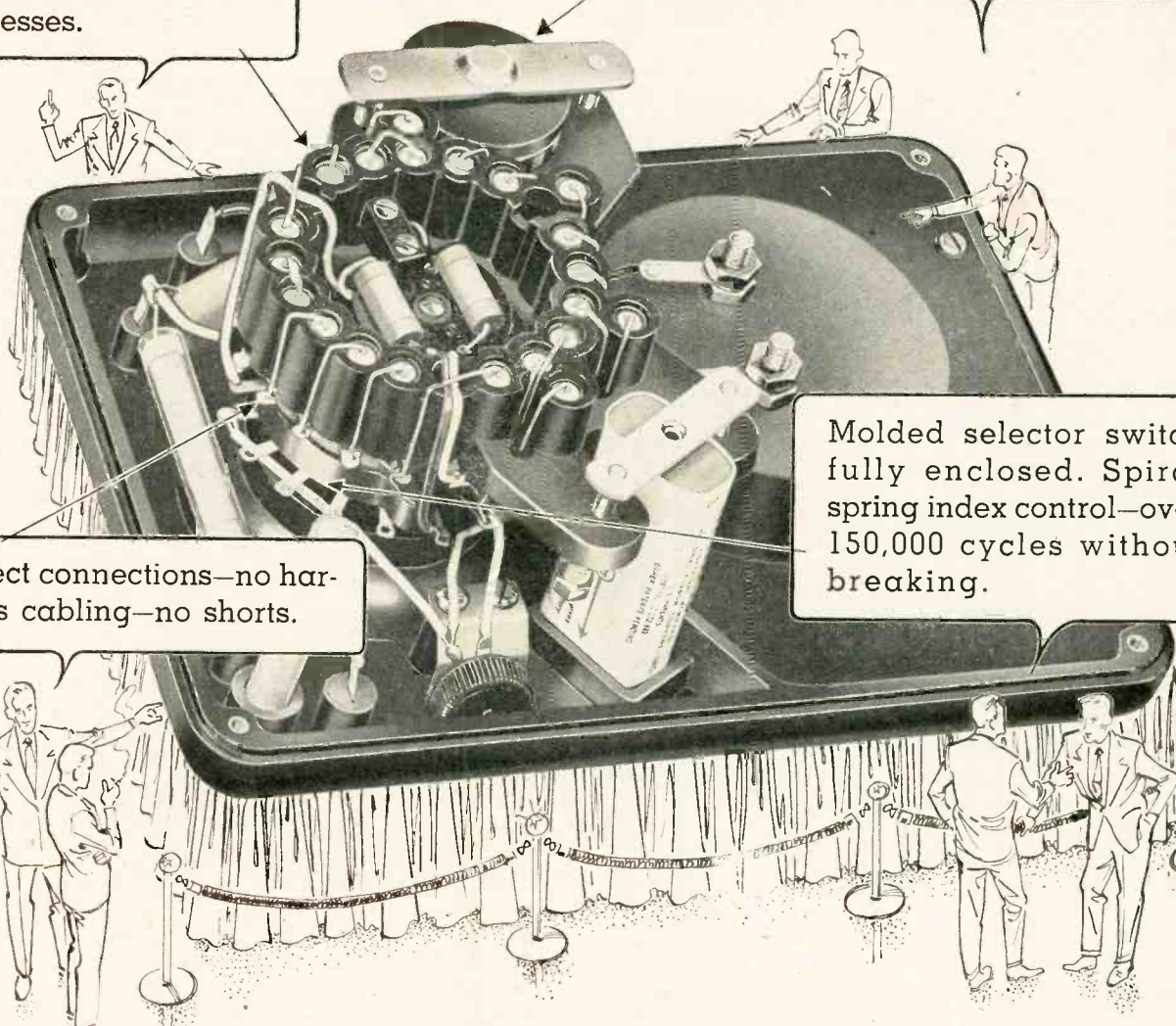

Here's why top engineers and technicians use Model 630

Features like those shown above are what make this popular V.O.M. so outstandingly dependable in the field. The enclosed switch, for instance, keeps the silvered contacts *permanently clean*. That's rugged construction that means stronger performance, longer life. And tests show that the spiral spring index control, after more than 150,000 cycles of switch rotation, has no disruption or appreciable wear! Investigate this history-making Volt-Ohm-Mil-Ammeter today: 33 ranges, large 5½" meter.



ONLY
\$37.50
AT YOUR DISTRIBUTOR

FOR THE MAN WHO TAKES PRIDE IN HIS WORK
Triplett
TRIPLETT ELECTRICAL INSTRUMENT COMPANY • BLUFFTON, OHIO, U.S.A.

I TOLD YOU SO

by San D'Arcy

Color TV. RCA engineers have given the press a demonstration of their color TV transmitter and a color TV set, electronically controlled, which is compatible with black and white telecasts. It was claimed that the new system would not make present TV sets obsolete. Their owners would continue to see telecasts in black and white while those people who purchased a color TV set would see the same program in color. Also said to be in the developmental stage is a single multicolor picture tube and set which will operate it. This picture tube would provide full color pictures without the aid of filters or other mechanical aids, and thus would permit the manufacture of a video set having "normal" dimensions. There is only one "catch" to the whole thing. Before a home TV receiver can pick up color pictures the transmitter must send such color pictures. Transmitters capable of doing this require an awful lot of time to make, are not yet perfected, and cost much more than conventional black and white Telecast equipment. If all the TV transmitter manufacturers in the world started to make all the color TV transmitters their facilities and manpower would permit, no more than 20 to 30 such units could be made in a year. Thus, it would take from 3 to 5 years just to make enough color TV transmitters to substitute for those that are now in use in the 100 TV stations now on the air. So, it is easy to see why color TV is still a long way off. Also, it is now understandable why FCC is moving so cautiously.

Get Me Down! *The other day a New Jersey TV installer went up onto the roof of a house to install an antenna. It started to snow. The sloping slate roof got so slippery, the fellow couldn't get down without help from the fire department. Moral, get a ladder long enough to meet any requirements for up or down travel, but more important—appreciate that installing TV antennas on roofs is a hazardous occupation.*

Radioactive Ores. *We apologize to the hundreds of RSD who ordered samples of uranium and radioactive ores from the Atomic Energy Commission as a result of reading John Parker's article on repairing Geiger Counters in our February issue. AEC advises that such samples were taken off the free list as of January 17th. However, for a nominal sum, radioactive materials can now be obtained from the U. S. Bureau of Standards, Washington; Wards Natural Science Estab., Box 24, Beachwood Sta., Rochester, N. Y. and A. D. Machay, 198 Broadway, N. Y. C. The AEC will sell for Lab. use radioactive ores the contents of which are accurately predetermined.*

We Told You So. We predicted editorially, months ago that RCA would introduce a line of 33 $\frac{1}{3}$ rpm records to be sold along with their 45 rpm type. Our forecast was scoffed at then. But now RCA's 33 $\frac{1}{3}$ rpm records are being advertised, sales are phenomenal, and we have the last laugh. Now we predict that eventually 78 rpm records will become passé.

RADIO SERVICE DEALER • APRIL, 1950

"Pardner, this Amphenol
INLINE* Antenna is up to
stay! Our boss knows his
business, because these
people will get the best
possible pictures and we
won't have any call-back
time here."

AMERICAN PHENOLIC CORPORATION
1830 SO. 54TH AVENUE • CHICAGO 50, ILLINOIS
* U. S. PATENT NO. 2,474,450

AMPHENOL

BULLSEYE!



the Sangamo Chieftain scores with Repairmen everywhere!



Types MT, MTD and MTH electrolytic capacitors, the Sangamo Chieftains, are ideal replacement electrolytics. Tiny, but durable, they fit anywhere! Their small physical size makes them a "natural" for application in tight spots beneath a chassis, and the bare tinned-copper wire leads make them easy to mount.

Sangamo Chieftains are manufactured under carefully controlled conditions to protect against

source contamination and assure corrosion-free elements. Types MT, MTD and MTH have heavy insulating sleeves that are wax impregnated—not dipped. Polarity is clearly indicated. Positive electrodes are formed of rugged, etched foil aluminum plate to insure longer life, greater dependability, and better electrical characteristics. See your Jobber—if he can't supply you—write us direct.

BIG CHIEF SANGAMO SAYS:

LITTLE CHIEFTAINS YOUR GOOD FRIENDS!
MAKE REPAIR WORK EASY... FIT IN
TIGHT SPOTS... LAST LONG TIME.



Your own trial-use will convince you that new standards of dependability and longevity have been built into Sangamo Electrolytics. Full information is given in Sangamo Capacitor Catalog No. 800, which is yours for the asking, and without obligation.

Micas, Papers, Electrolytics, Buttons, Molded Tubulars



SANGAMO ELECTRIC COMPANY
SPRINGFIELD, ILLINOIS

In Canada: Sangamo Electric Company Limited, Leaside, Ont.

RADIO SERVICE DEALER • APRIL, 1950



5C39-8

ONLY

SPRAGUE

TELECAP[®]
MOLDED PHENOLIC
TUBULARS

GIVE YOU

**PREMIUM
QUALITY**

AT

NO EXTRA COST

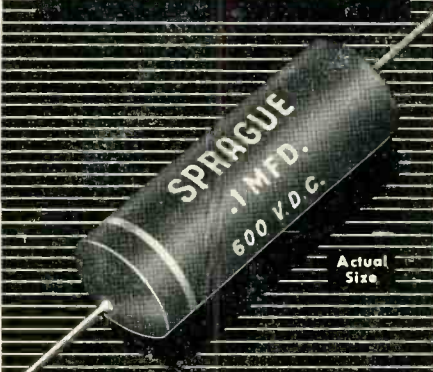

Sprague Telecaps are the only paper tubular capacitors oil-impregnated and solder-sealed AFTER dry assembly molding in genuine non-flammable Bakelite phenolic. Unaffected by continuous operation at 185° F. (85° C.), these "Black Beauties" provide unusually high insulation resistance . . . give you top capacitance stability. Write for Bulletin today!

SPRAGUE PRODUCTS CO.

71 Marshall Street
NORTH ADAMS • MASS.

TRADE FLASHES

A "press-time" digest of production,
distribution & merchandising activities

RMA Fights Excise Tax

A ten percent excise tax on television receivers, as proposed by Secretary of the Treasury Snyder, would seriously hamper the growth of the television industry and the expansion of television broadcasting by inevitably increasing the price to the public, the House Ways and Means Committee was told by representative manufacturers, broadcasters, distributors and dealers.

Under sponsorship of the Radio Manufacturers Association, spokesmen for all segments of the television industry testified that the tax is discriminatory, would endanger the industry's high employment, and, as Secretary Snyder has stated of all excise taxes, would be "most burdensome on the lower income groups."

The House Ways and Means Committee was also told that it is important to keep the television manufacturing industry in a healthy condition because of its great importance to national defense as the supplier of electronic equipment and components used in ultra-modern weapons of war.

Industrial Color TV

A color television system designed specifically for industry was introduced here by Allen B. Du Mont Laboratories, Inc., at the opening session of the Institute of Radio Engineers' national convention. The new system is directly fitted to the needs of the medical world, varied branches of industry and the multiple fields of merchandising.

Dr. Du Mont emphasized that his organization had "developed a high color fidelity, high resolution, wide-band television system, specifically for non-broadcast, closed circuit industrial applications. Television broadcasting's problem of narrow bandwidth and compatibility which has restricted picture resolution and color fidelity in other color systems was ignored in the design of this new industrial system."

New Name For PRSMA

This will be the New Name for the oldest and most progressive Service

Technicians Association in America. (Phila. Radio Service Mens Association), Electronic Technician Guild.

At the last closed business meeting, the Guild Committee Chairman, Mr. Karl Vogelsang, presented an 18 page typewritten report on the formation and operation of PRSMA as a Guild with the advantages clearly shown. The New Guild will consist of Radio-TV Dealers, Distributors and their Sales Personnel, Independent Radio & TV Service Shop operators and their employees. Shops will be classified and wage rates set, working conditions will be regulated, committees will examine and grade all members and grievances between employers and employees, or management and employees will be arbitrated. Attendance at Meetings and Technical School or lectures will be compulsory, until a Master Grade is reached and then attendance is required at Meetings, so that the operating procedures will remain strictly democratic.

Antenaplex Brochure Available

A non-technical brochure (Form 2R6301) describing RCA's television Antenaplex system for apartment houses, hotels, department stores, institutions, and other multiple-unit structures has just been published and is available on request from the Sound Products Section of the RCA Engineering Products Department, Camden, N. J.

The four-page, illustrated brochure provides a quick understanding of the fundamentals of the new television equipment, and of the advantages of multiple-receiver operation from a single antenna system. It also describes the nationwide installation and service facilities offered architects, builders, owners, management, and operating personnel.

A. C. Lescarboursa Honored

For technical assistance rendered over many years and more recently to industrial missions sent here in conjunction with the rehabilitation of postwar France, Austin C. Lescarboursa of Croton-on-Hudson, N. Y., well-

HERE IS THE LONG SOUGHT ANSWER IN TELEVISION TRAINING FOR THE MAN ALREADY IN RADIO! TRAIN AT HOME—FULL PROGRAM—4 TO 8 WEEKS!

Low Cost—Monthly Payments. Everything You Need to Learn...

TELEVISION

I Send You NOT JUST an Ordinary TV Kit—But a Complete Training System Including TV Test Equipment

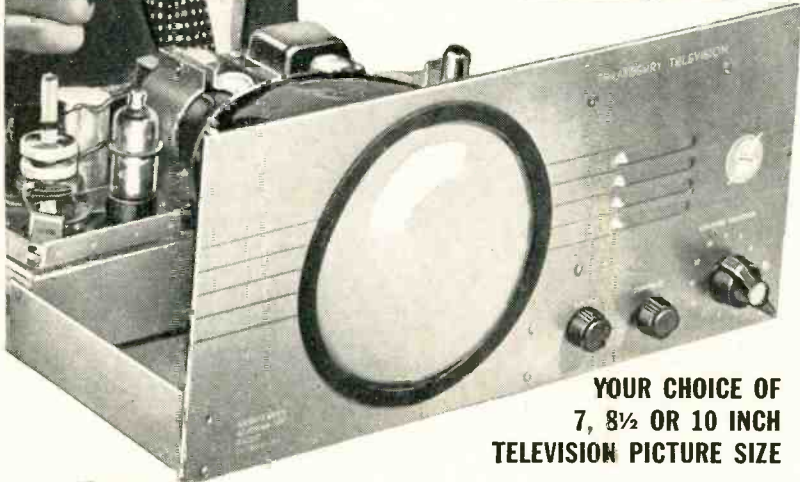

YOUR CHOICE OF 7, 8½ OR 10 INCH TELEVISION PICTURE SIZE

Here is the NEW Combination Sprayberry Television Training System

Out of my laboratory has come an entirely new Television Training...cutting months off the time required in old methods. I give all the knowledge and experience you need in weeks instead of months. I start where your present radio experience ends. The same day you enroll with me, I rush the first of many big Television kits that I will send during your training. From the first hour you are experimenting and testing practical TV circuits...and you keep right on from one fascinating experiment to another. You build the remarkable new Television Receiver-Tester illustrated at the left and useful TV Test Equipment. I give you theory, too, but it's 100% practical stuff that will make money for you in Television.

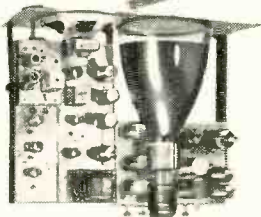

Exclusive THREE-UNIT Construction

You build my Television Receiver-Tester in three separate units—one unit at a time...each complete and self contained within itself. With each unit you perform dozens of important experiments—and each unit may be used in actual Television receiver servicing. In this way my training may save you many dollars by eliminating the need for costly TV Test Equipment. With these three units you can locate most TV Receiver troubles quickly and easily.

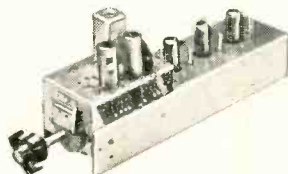

TV Tuner—I.F. Unit

Contains the RF amplified local oscillator, mixer and three stages of broad band IF amplification and the video second detector. The output constitutes the video signal and audio IF signal. For training, it is used to build and test video second detector, and stagger tuned IF amplifier obtaining 4.5 mc band pass. For TV servicing, it becomes a TV calibrator for IF alignment, substitute tuner, IF signal injector and second detector.

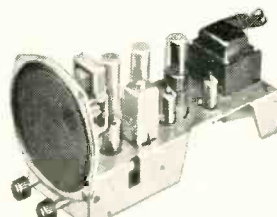

Video-Audio Amplifier Unit

Provides 4.5 mc IF ratio detector, low voltage power supply. For TV, it becomes the audio output, including speaker, video output and low voltage power supply for RF and IF stages. For training, it is used to build and test transformer type power supplies, audio, video, IF amplification and FM detection. For TV servicing, it is an audio signal tracer, IF signal tracer, video signal tracer and low voltage power supply.

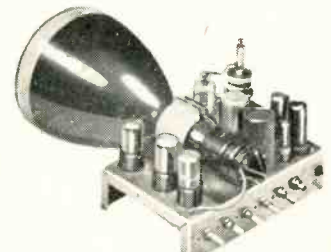

Video Tube "Scope" Unit

Scope unit contains low and high voltage (6000 V.) power supply for independent operation. For television, it becomes the sync, vertical and horizontal sweep circuits and their power supplies. For training, it is used to build and test most TV power supply, deflection, sweep, oscillator, and sync circuits. For TV servicing, it is a video signal tracer and sweep signal analyzer as well as substitute high and low voltage power supplies.

BE READY FOR TOP PAYING TELEVISION JOBS

If you are a radio-serviceman, experimenter, amateur or advanced student... YOUR FUTURE IS IN TELEVISION. Depending upon where you live, Television is either in your town now... or will be there shortly. This is a vast new industry that needs qualified trained men by the thousand to install and service TV sets. There's really big money in Television, but you MUST know what you are doing to "cash-in" on it. I will train you in a few short weeks if you have had previous radio training or experience.

IMPORTANT—FOR MEN JUST STARTING OUT IN RADIO-TELEVISION

If you have no previous experience in Radio work, be sure to mark that fact on the coupon below. I will send you complete information about my Radio-Television training that starts with basic fundamentals and carries you right through my new Radio and Television Training. I will send you my two big Radio-Television books, including an actual lesson selected from my course. I want you to know exactly what this great industry has in store for you. There is no obligation, of course, and NO SALESMAN WILL CALL.

VETERANS—Radio portion of training available under G. I. Bill

FILL OUT AND MAIL COUPON
Get these Valuable Books FREE!



Every Radio Serviceman today realizes his future is in Television. He knows he MUST have training—the right kind of practical training such as I am now offering—to protect his job, his business for the future. This is equally important for the man just starting out. And so I urge you to get the facts I offer you FREE and without obligation. Learn how quickly and easily you can get into Television. Fill out and mail the coupon TODAY.

SPRAYBERRY ACADEMY OF RADIO, Dept. 8-H
111 North Canal St., Chicago 6, Ill.

Please rush to me all information on your Radio-Television Training plan. I understand this does not obligate me and that no salesman will call upon me.

Name..... Age.....

Address.....

City..... State.....

Please Check Below About Your Experience

Are You Experienced? No Experience

SPRAYBERRY ACADEMY OF RADIO, 111 N. Canal, Dept. 8-H Chicago 6, Ill.

RADIO SERVICE DEALER • APRIL, 1950

You're Right 3-Ways With **BURGESS**



1st The RIGHT Line!

BURGESS is America's Best-Known Line of radio batteries. America's best-sellers, too! Cash in with sales on the tradition of quality that has made Burgess Batteries famous throughout the world. And remember BURGESS is the complete dry battery line—the line that helps you sell all portable radio battery customers!

2nd The RIGHT Promotion

FREE SALES-BUILDING KIT—Includes a sturdy floor display merchandiser that puts your minimum stock battery assortment out front where they sell themselves; a big, bold 9"x22" window streamer; a lively new counter-window card; new enclosures; ready-to-run ad mats; dummy display cartons; and the big, new 1950 Burgess Replacement Guide that answers all your replacement questions.

3rd The RIGHT Advertising

BURGESS is advertised in leading national magazines with a heavy concentration of male readers—your best battery customers. Eye-catching, colorful advertising all during the portable radio season will pre-sell millions of portable radio battery users—will pre-sell your customers on Burgess quality and long life.

Get This Minimum
Stock Assortment
that Serves Over

63%

of All
Portable Radios

- 6 No. XX45 67½ v. "B"
- 6 No. M30 45 v. "B"
- 6 No. G3 4½ v. "A"
- 6 No. 4F 1½ v. "A"
- 48 No. 2R 1½ v. "A"
- 3 No. F6A60 7½,
9 and 90 v. "A&B"
- 3 No. T6Z60 7½,
9 and 90 v. "A&B"

*Ask Your
Distributor*

about this
Burgess Portable
Battery Promotion and how
to get your **FREE** Sales-
Builder Kit of Promotional
Material.

BURGESS BATTERIES

America's Best-Known Line of Portable Radio Batteries

known journalist and industrial advertising consultant, has been awarded the French Legion of Honor.

This is the third French decoration to be awarded this native-born New Yorker of French ancestry. In 1919 Lescarboursa received the Officier d'Académie decoration, followed by his promotion to Officier de l'Instruction Publique in 1947.

Servicemen Honor Sylvania

Robert H. Bishop (left), Vice-president in charge of sales for Sylvania Electric Products Inc., and Terry P. Cunningham, Director of Advertising (right), examine the plaque awarded their company by the Federation of Radio Servicemen's Associations of Pennsylvania.



The award is presented annually by the Federation for outstanding consistency in promotion and advertising to the public in an effort to promote public confidence, and for assistance to the radio-television technician.

Looking on are Robert Penfield, Editor of Sylvania News, Richard G. Devaney, radio service engineer of Philadelphia, and Mr. Krantz.

Simpson Employees Congratulate Prexy

The 260,000th Simpson Model 260 VOM to roll off the production line at the main factory of the Simpson plant at 5200 W. Kinzie St., Chicago, was gold plated recently for a surprise presentation to Ray Simpson, Chairman of the Board. Attached to the top of the instrument was a plaque expressing the congratulations of the factory and office employees of the Simpson plant. Pictured from left to right are: Ray Simpson, Pres., Herb Bernreuter, V.-P., and Mel Buehring, Sales Mgr.

Centralab Acquires New Plant

The acquisition of a new plant in Denville, New Jersey, for the exclusive production of a full line of ceramic capacitors from the raw material to the finished product has been announced by Centralab Division of Globe-Union Inc., Milwaukee, Wis.

The plant, which is expected to employ some 300 persons, will cover 46,000

[Continued on page 24]

FREE

with purchase of
100 Sylvania Receiving Tubes...
or 3 Sylvania TV Picture Tubes

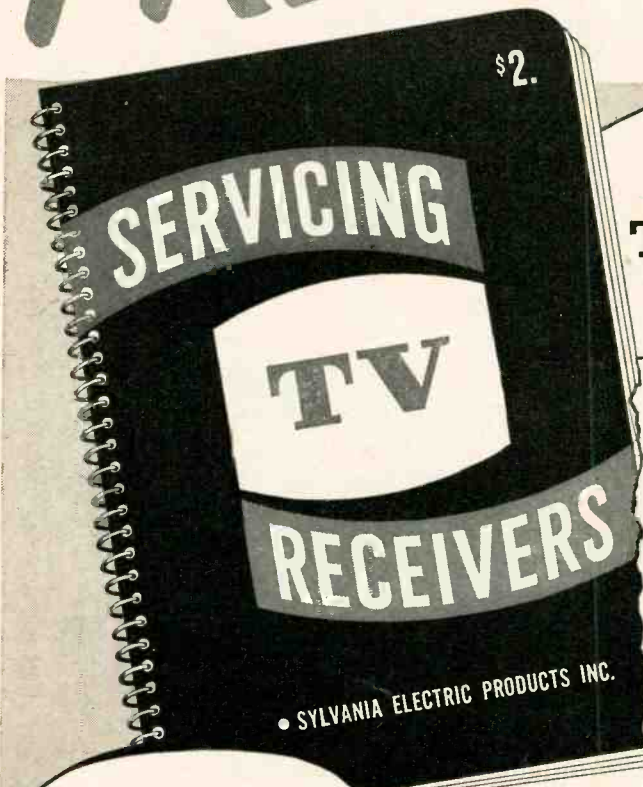

The clearest
 and most complete
Television Servicing Book
 ever printed

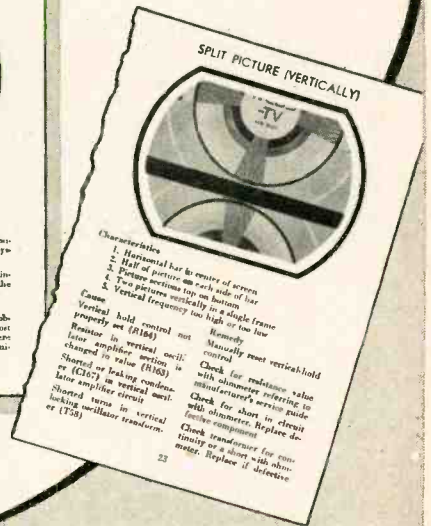
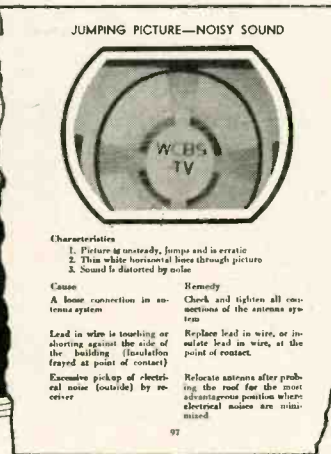

FREE

during April, May, June, July and August

Here are 2 sample pages from "Servicing Television Receivers." Note the easy-to-read type arrangement and the simplified photographic instructions.

HERE at last is a guidebook to help simplify TV set service for you. You'll be amazed how it will enable you to quickly identify trouble . . . solve tricky problems.

Contains more than 100 pages with scores of actual photographs and easy-to-read diagrams, to help you increase and improve your TV set repair business.

Not for sale . . . it's FREE!

This valuable book is yours absolutely free, from your regular Sylvania distributor, with your order of 100 Sylvania receiving tubes . . . or just 3 TV Sylvania picture tubes. Spirally bound with a sturdy board cover to stay open and lie flat on your bench.

NOTE: This important booklet offer is open for a limited time only. So don't delay. Send your order for the tubes you need today to your Sylvania distributor and he'll mail this free, helpful guidebook to you immediately.

**Quickly answers
 scores of questions**

- Shows more than 80 actual photos of screen test patterns. Shows how to identify trouble by pattern behavior.
- Gives simple, concise instructions for making repairs, proper adjustments.
- Contains complete circuit diagrams of typical television receiver.
- Explains latest television developments such as "Intercarrier sound."
- Tells about television test equipment and what each instrument will do.
- Provides a practical dictionary of television set trouble.

SYLVANIA ELECTRIC

RADIO TUBES; CATHODE RAY TUBES; ELECTRONIC DEVICES; FLUORESCENT LAMPS, FIXTURES, WIRING DEVICES, SIGN TUBING; LIGHT BULBS; PHOTOLAMPS

RADIO SERVICE DEALER • APRIL, 1950

Wins 30% more business with SYLVANIA DEALER CAMPAIGN

"Last summer we obtained your coordinated campaign and mailed the postal cards to just certain sections. Then we kept track of service business, and found we received 30% more from the sections which got the cards.

"We're convinced . . . your campaign is the best insurance against a summer slump in service business.

"This year, May, June, July, and August are going to be our big profit months."



Albert Gale

Gale Radio and Television Lab., New Rochelle, N. Y.

- 1—Displays
- 2—Window Streamers
- 3—Post Cards
- 4—Ad Mats
- 5—Radio Spots

You, too, will cash in **BIG** with this powerful, new summer campaign

Right now is the time to send for the new, complete advertising campaign that's bound to bring you extra business . . . all through May, June, July, and August.

Look at all the colorful, sales-making material you get! Everything from large 3-dimensional window- and counter-displays, to complete newspaper ad mats and postal cards. Even radio spot announcements to be broadcast over your local station. It's all yours . . . and it's all FREE . . . you pay only the postage on the postal cards, 1¢ for each card.

Written and designed to tie in with Sylvania's big national magazine advertising which your customers will see in the Saturday Evening Post, Collier's, Look, Life and other publications.

So, don't delay! Mail the coupon for full details **TODAY!**

S
 RADIO TUBES; CATHODE RAY TUBES; ELECTRONIC DEVICES; FLUORESCENT LAMPS; FIXTURES, WIRING DEVICES, SIGN TUBING; LIGHT BULBS; PHOTOLAMPS

SYLVANIA ELECTRIC

Sylvania Electric Products Inc.
 Advertising Dept. R-1604A, Emporium, Pa.
 Please send me full information about the May-June-July-August Service Dealer Campaign.

Name _____
 Company _____
 Street _____
 City _____ Zone _____ State _____

Servicing SYNC SEPARATORS

by **MATTHEW MANDL**

Technical Institute, Temple Univ.

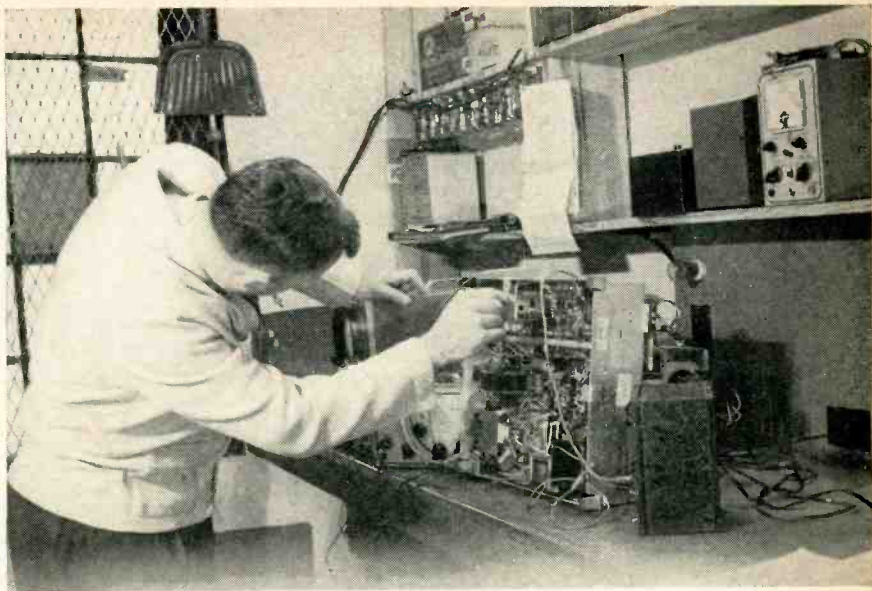

WHEN vertical and horizontal sync troubles occur simultaneously in a television receiver, the trouble will usually be found in the sync separator circuit or its associated amplifiers. The reason lies in the fact that it is in these circuits that the vertical and horizontal sync pulses are separated from the composite video signal for eventual channeling to their respective sweep circuits. Thus, any circuit deficiency in the sync separator or amplifier will show up in both vertical and horizontal instability, and the troubles may range from a jittery picture to complete loss of synchronization. Typical indications of sync separator faults include the following:

1. Picture "jitters" and is generally unstable.
2. Both vertical and horizontal hold controls require constant and critical adjustment.
3. Intermittent instability of both vertical and horizontal sweep.
4. Horizontal sections of picture sway slightly.
5. Slight noise or ignition pulses are sufficient to cause vertical or horizontal sync loss.

An exceptionally clear explanation of sync circuit action. Also discussed are the effects produced by defective sync circuits and components, their possible causes, and methods of testing this section of the TV receiver.

6. Complete loss of vertical and horizontal sync with both "hold controls" ineffective.

For a better understanding of the service problems which are encountered with such circuits, a brief summary of circuit function will be found worthwhile.

Sync Circuit Theory

Sync separators are essentially clipper circuits which remove the sync pulse from the video signal so that such pulses may be properly shaped to trigger the sweep circuits. The clipping action is so arranged that the portion of the sync pulse above the blanking level is separated.

The circuit itself is fairly simple and usually consists of a pentode in which the signal contributes to the bias of the tube. Diodes and triodes can also be used, but the preference in modern television receivers is for

the pentode because it gives a fairly constant output despite an appreciable variation in the amplitude of the input signal. Essentially, however, all types work on the same basic principles—that is, the signal furnishes bias, the input capacitor and grid leak combination have a long time constant, and the tube characteristics are chosen to have a fairly sharp cut-off.

Figure 1 will help in showing sync separation function. The composite video signal (picture signal with blanking levels, vertical and horizontal sync pulses, etc.) are taken from either the video detector or video amplifier and applied to the input of the sync separator as shown in "A." The manner in which this signal appears on the grid of the tube is indicated in "B" of the same figure. The sync tip causes grid current to flow which charges *C1* to peak value—the latter established by the amplitude of the sync tips. The capacitor *C1* charges rapidly because the grid is conducting and the tube input thus has low resistance. When the sync pulse leaves the input the relatively high voltage is removed and the capacitor, being charged to peak value, takes over. This capacitor now discharges across *R1* and thus establishes a bias on the grid of the tube which will depend on the amount of charge it procured.

Inasmuch as the sync levels from a particular station are set at the same amplitude during transmission, an average bias will be established across *R1* which does not allow the tube to conduct until signals appear which

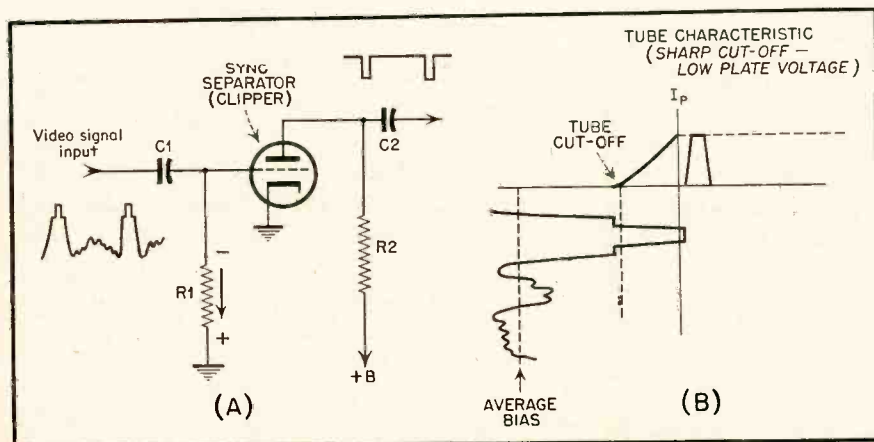

Fig. 1. Circuit used to separate sync pulse from signal.

are above the blanking level. Since only the sync pulses appear above the blanking level, these are the only ones which appear on the plate side of the separator. A point to watch when making oscilloscope tests is the polarity of the signal. It will be noted that the signal input in "A" of Fig. 1 has a positive polarity, but the output signal at the plate is of negative polarity due to the inverting properties of vacuum tubes. Grid voltage and plate current are in phase—that is, a more positive voltage on the grid will cause a greater current flow through the tube. An increase in current through the load resistor (R_2) will produce a greater voltage drop across this resistor, decreasing signal voltage across plate and cathode as shown. Thus, the signal voltage on the plate side of the tube has opposite polarity to the signal voltage applied to the grid.

The time constant ($R \times C$) of the grid condenser-resistor combination is made sufficiently long to hold the charge between sync tips. When switching to another station which has a different sync tip level, the bias which results will again average itself so that tube conduction only occurs above the blanking level of the input signal to the separator.

In many cases some external bias is applied to the tube besides the bias developed when the grid runs positive during the sync tip. This is done to assure that the clipping will occur at the blanking level and to minimize the possibility that the tube will remain at cut-off for some portion of the sync pulse.

While the input signal to the separator can be secured from the output of the video detector, the modern trend is to take it from the output of the last video amplifier. This means a higher amplitude is available and much of the noise which might be higher in strength than the sync pulse will have been reduced by the video amplifier stages.

When the signal is taken from the video amplifier stage there is also less need for additional amplification of the sync before or after separation, thus eliminating extra circuits. The

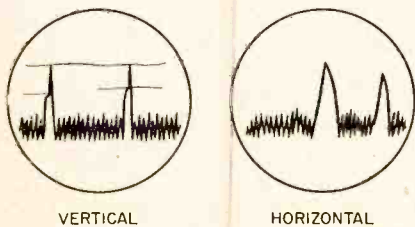

Fig. 3. Waveforms of signals at grid of first amplifier.

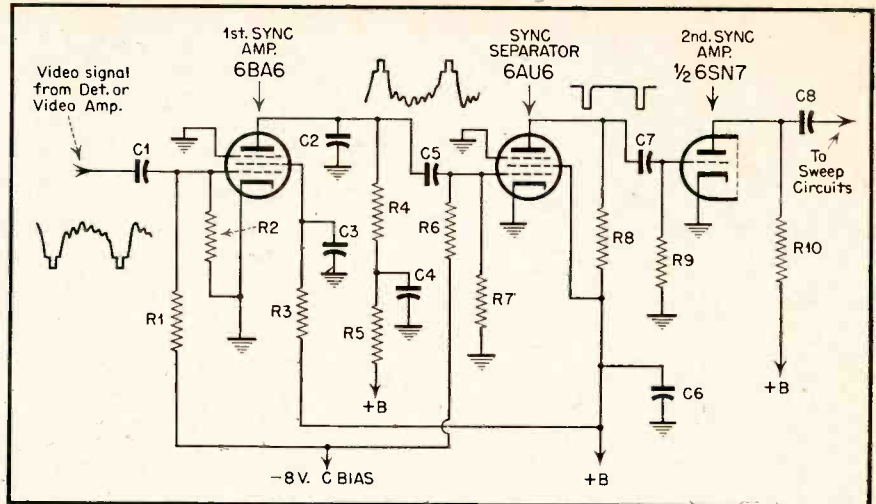

Fig. 2. Typical sync separator and amplifier circuit.

technician will, therefore, encounter sync separators with only one stage of amplification preceding it, or he may find sync separator stages with an amplifier before and after sync clipping. Occasionally only a sync separator circuit may be used without any special amplification of the sync before clipping. All these stages, whether single or combined, function in a similar fashion and have com-

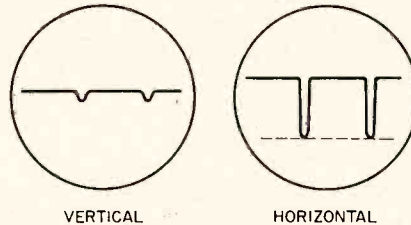

Fig. 4. Waveforms of signals at output of sync separator.

mon troubles. For this reason a three-stage affair will be analyzed in terms of function and typical service problems which may be encountered.

Typical Circuit Troubles

Figure 2 shows the type of sync separator and amplifier circuits commonly found in various receivers. While tubes and part values may differ, the circuits are essentially similar in various model sets. The first sync amplifier may use a 6BA6 pentode as shown, or may consist of a 6SK7. Sometimes a triode tube may be used, such as the 6AB4 type. Some receivers also use a dual purpose tube such as the 7N7 or 12AT7 as a combined 1st amplifier and sync separator, thus saving space. In such cases, however, both circuits are still individual ones and function separately just as those of Fig. 2.

The function of the first sync amplifier besides increasing the ampli-

tude of the sync before separation, is to further decrease any noise which might be riding over the sync pulses. As can be seen in Fig. 2, the polarity of the input signal is negative and any noise pulses above the sync level are compressed in this circuit. Too low a bias value will upset such noise suppression characteristics and the value of bias given by the manufacturer in his service notes should be checked when servicing this stage. Capacitor C_2 also aids in cutting down high frequency noise pulses as well as any video signal which gets through this stage. R_5 and C_4 serve as a low frequency boost as well as an isolation network for any feedback of signal from subsequent stages.

If an oscilloscope check shows the presence of abnormal noise pulses in this circuit the previously mentioned components should be checked, for improper bias or open capacitors will materially alter proper performance of this circuit. The screen capacitor, C_3 , is usually made large in value and may run from 10 to well over 40 microfarads in some receivers. A short, or excessive leakage of this capacitor will overheat R_3 and this resistor may open. Trouble in the screen circuit will decrease the gain of this stage to a considerable extent.

The sync separator uses a 6AU6 sharp cut-off pentode tube with low plate voltage, which in combination with the high bias effectively clips the video portions of the input signal below the blanking level. Other typical tubes for such a circuit are: 6SH7, 6BN6 and the dual-purpose tubes previously mentioned. Since this circuit functions in a semi-automatic fashion with respect to the average bias developed, the values of C_5 and R_7 should be checked if any trouble develops in this stage. The additional

[Continued on page 31]

FIRST-AID TO CABINETS

by WILLIAM R. WELLMAN

PART I

Almost every Service Dealer has attempted to perform cabinet repairs with varying degrees of success. In this article the author attempts to point out the correct steps to be taken in effecting cabinet repairs of various types.

MODERN cabinets are constructed almost entirely of plywood; exceptions to this are the frame, corner posts and many curved or rounded parts. The plywood portions of the cabinet have an outer layer of mahogany, walnut, maple or other variety of veneer; this face veneer is usually 1/28 inch thick. The reason for mentioning this is to point out the thinness of the veneer and to emphasize the care to be used in transporting and handling cabinets to avoid damage. Any solid portions of a cabinet are either made of the same variety of wood as the face veneer or are stained to resemble it. The various members of the cabinet are glued together; screws are used only in corner reinforcing blocks; nails never.

Before attempting to describe repair techniques which may involve refinishing part of a surface, it is well to understand how a finish is built up. The wood is first sanded smooth and then stained to the desired tone. Wood filler is then applied to fill in the pores which are present in all woods. The actual finish consists of a number of coats of shellac, varnish or lacquer, each coat being rubbed to smoothness with some kind of abrasive such as steel wool, abrasive paper, powdered pumice stone or powdered rotten stone.

Those repairs which are within the scope of the worker who is not a trained cabinet finisher will be taken up in order of difficulty, beginning with the simplest type and proceeding to the more complex. In such order we find the repair jobs arranged about as follows: (a) dulled or dirty finish; (b) shallow scratches which penetrate one or more layers of finish but which do not penetrate through the veneer; (c) deep scratches, dents or bruises which go through finish and veneer to the under layers of raw wood; (d)

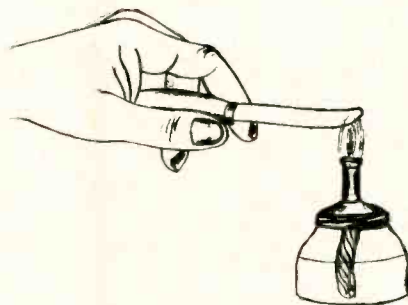

Fig. 1. Method of heating knife with alcohol lamp.

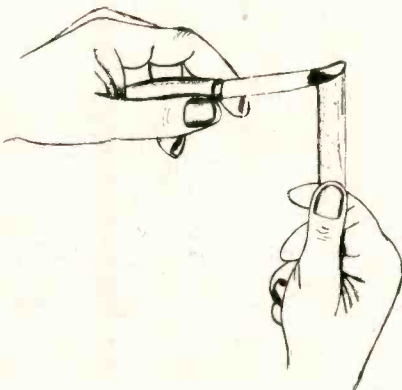

Fig. 2. Applying stick-shellac to hot blade of knife.

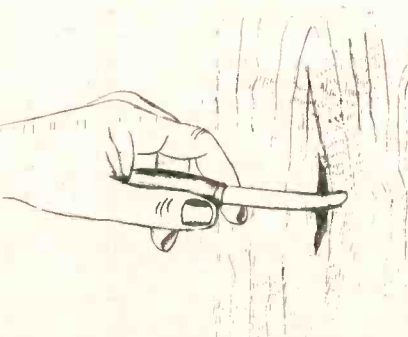

Fig. 3. Transferring shellac from stick to surface being repaired.

cracked, broken or loose veneer; (e) loose or separated joints, and (f) broken cabinet members.

Dulled or Dirty Finish

In the course of time the surface of any cabinet will become dull and under certain conditions will acquire a layer of dust, dirt or even grease. The latter condition arises when the unit is located in or near a kitchen. Finger marks are all too common, especially on the front panel around the controls. Very often a new cabinet will arrive

The operations shown at the left illustrate the manner in which stick-shellac repairing is done.

with its surface marked up due to contact with the riders or carton inserts.

The simplest, and probably the best method of cleaning the finish is to use soap and water. In view of the fact that dampness and moisture are considered enemies of finished woodwork, this may seem to be a dangerous procedure, but it is perfectly safe provided that two rules are observed: use water sparingly and do not allow it to remain in contact with the surface any longer than is absolutely necessary. Dip a piece of cloth in water, wring it out almost dry and then rub it over a cake of good quality soap. Sponge the cabinet surface as vigorously as may be necessary to remove all dirt or finger marks, then dry immediately. You will find that this treatment is remarkably effective on all except the most persistent incrustations of dirt or grease. For such stubborn cases use a piece of cloth barely dampened with benzine, but be very careful in using this fluid. First of all it is highly inflammable and second, unless the cabinet has a lacquer finish, benzine allowed to remain on the surface too long may affect the finish. It is best to have the

benzine cloth in one hand and a dry cloth in the other; as you clean a small area, wipe the benzine off immediately. Before leaving this topic, mention should be made of the fact that paste cleaners designed for automobile finishes have been used successfully on cabinets and furniture. While such cleaners are very effective, again you are advised to use them cautiously, for most contain an abrasive. Over-energetic rubbing might result in cutting through the layers of finish and cause damage that will be difficult to repair.

With the surface of the cabinet cleaned, you are ready to begin applying a polish to restore it to its original lustre. Polishing agents are of four general types: liquid wax, paste wax, oil and cream polishes. Each type has some particular advantage to recommend it, and selection usually depends upon individual preference. Liquid wax and some of the newer cream polishes are easiest to apply; paste wax and polishing oils require more work. Many experienced cabinet finishers prefer to use crude oil for polishing; some say that applying crude oil regularly keeps the finish flexible and less liable to crack under temperature and climatic changes. It is true that crude oil does have some kind of preservative action, and the writer has seen many pianos and radio cabinets with perfect finishes after many years of use; in each of the cases observed crude oil was the only polishing agent used. If you wish to try it, you will need about a pint of crude oil-benzine mixture which your local paint dealer can prepare for you at trifling cost. The correct proportion is three parts of oil to one of benzine. You will also need a half-inch-thick polishing felt four or five inches square. Several layers of felt taken from an old hat and wrapped around a wood block of convenient size will serve equally well. Dip the felt in the oil and apply to the surface, rubbing in the direction of the grain. Rub well, covering the entire surface and saturating the felt with oil as often as necessary. The idea is to apply as much oil as the surface can absorb. Now, for a real good job, allow the oil to remain on the finish overnight; wipe off the excess next day with a clean cloth, then rub to bring up the gloss.

Shallow Scratches

This is probably the most common type of damage, and if not too serious is relatively easy to conceal, especially if the defect is likely to be viewed under subdued light or will be in shadow. To avoid too many classifications, we shall also consider under this heading the matter of cracks or "checks" in the finish. This type of

defect is not the result of injury but is caused by extremes of temperature, climatic changes and aging. Apparently the finish cracks because of expansion and contraction. This defect should not be confused with cracking or checking of the veneer itself.

Many superficial scratches may be concealed by applying stain, and for this purpose prepared oil stain is easiest to use. Apply the stain with a small artist's brush or a piece of cloth, making as many applications as necessary to color the damaged finish and conceal the scratch. The finish at the edges of the scratch will be lighter in color than the surrounding surface, and it is this difference which must be concealed. Sometimes an oil stain will not be too effective in doing this and you might have to resort to the use of colored shellac. To prepare colored shellac for this purpose, dilute white shellac with alcohol until it is very thin; ordinarily, about two parts of shellac to one of alcohol will be correct. The shellac is now colored by stirring in it a spirit-soluble powder; this can

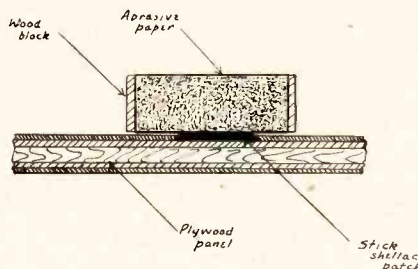

Fig. 4. Smoothing down surface with abrasive paper and oil.

be bought at most well-stocked paint stores in a variety of colors such as walnut, mahogany, maple, etc. Add the powder slowly, stirring meanwhile until the mixture has a shade corresponding to that of the cabinet finish. Apply with an artist's brush, being careful to touch up the blemish only and to avoid getting any of the shellac on the surrounding area. If this does happen, it may be removed later by rubbing very lightly with very fine steel wool. Several applications are usually needed to conceal the average scratch. Remember that by following this method you have only concealed the damage; the scratched finish has been colored to resemble the rest of the cabinet and nothing has been done to fill up the indentation which was a result of the injury. If the damage is still visible after staining, it will have to be filled in as described in the section following.

A cracked or checked finish may often be restored by using a paste rubbing compound. Such compounds consist of fine abrasive grains in a solu-

tion such as benzine. They are applied with a cloth or a felt pad, using a fairly liberal quantity and rubbing with the grain. Rubbing must be done judiciously, and it is well to pause after a few strokes, wipe away the compound with a cloth and note the progress of the work. Too much and too vigorous rubbing can result in wearing through the entire finish and down to the veneer. Paste cleaners intended for removing film from automobile finishes are also suitable for this work.

Deep Scratches, Dents and Bruises

When a cabinet is so damaged that a deep scratch, dent or bruise which penetrates to the veneer or beyond results, or when a small piece or sliver has been gouged out of the surface, the repair job becomes a little more difficult. Under such conditions, the crevice must first be filled with a plastic material which matches the tone of the surrounding finish, and this patch must then be rubbed down so that it is smooth and level. The recommended procedure is the use of the stick shellac repair process. It is possible to make such a repair by using one of the available forms of wood putty, but the results will be definitely inferior. First of all, such compounds, when they have hardened, are not easy to sand to smoothness. Furthermore, they do not stain well, and matching the color of the original finish is very difficult.

Before trying stick shellac repairing, you should realize that although some skill is required this skill can be acquired through practice. On the other hand, even though your first few attempts turn out to be amateurish, the results will still probably look better than an unsightly scratch or other blemish.

Gather all of the materials that will be needed before starting the job. These materials are: an alcohol lamp; a wood finisher's "burning in" knife or spatula; stick shellac in the shades to match the cabinet finish; a supply of clean cloth; some 6/0 garnet paper; rubbing oil, and a block of wood large enough to cover the damaged area. An alcohol lamp is preferred to any other source of heat because an alcohol flame burns with a clean flame and the melted shellac is not likely to be discolored by soot. Stick shellac is sold in pieces from four to six inches long and roughly about a half inch square; in appearance it resembles sealing wax, and like sealing wax it becomes plastic, or even liquid when heated. If you are unable to obtain a professional burning in knife, small kitchen knives make good substitutes. A small paring

[Continued on page 29]

The Television WAVEFORM and its COMPONENTS

by SAMUEL L. MARSHALL

(From a forthcoming book, "Television Service Techniques")

Part 4

In this installment the author explains the manner in which the bandwidth requirements for TV are accommodated in the transmitted signal. This completes the portion of the series dealing with the transmitted signal. In subsequent installments the various signal components with relation to the receiver will be discussed. Comment from readers on the manner in which this subject is treated is welcome; merely address your letters to the Editor.

TV Bandwidth Requirements

Present channel allocations and their respective bandwidths are shown in *Table 1-1*. Notice that one characteristic in common with all channels is the bandwidth, which is 6 mc wide. Recalling that in AM a 5 kc audio modulating frequency results in a bandwidth of 10 kc, 5 kc above and 5 kc below the carrier, we might wonder how it is possible to compress the video bandwidth which is 9 mc (4.5 mc above and 4.5 mc below the video carrier) into an allotted 6 mc. So far we have not even considered the sound signal which requires a 50 kc bandwidth of its own, 25 kc above, and 25 kc below the sound carrier.

The answer lies in the use of single-sideband transmission in TV. In double-sideband transmission, which is used in AM, an audio frequency modulates an r-f carrier, producing sum and difference frequencies. The sum is the upper sideband and the difference is the lower sideband. Thus, in the case of a 5 kc audio signal modulating a 1 mc carrier, the upper sideband is 1,005 kc and the lower sideband 995 kc. Both upper and lower sidebands can be considered as separate signals, and both contain the same information. For 100% sine wave modulation the total radiated power is increased by only 50%. The carrier power does not change, and $\frac{1}{2}$ of this 50% power increase goes into each sideband. In

Channel Number	Channel Frequency (mc.)	Video Carrier Frequency (mc.)	Audio Carrier Frequency (mc.)
1	not used	-	-
2	54 - 60	55.25	59.75
3	60 - 66	61.25	65.75
4	66 - 72	67.25	71.75
5	76 - 82	77.25	81.75
6	82 - 88	83.25	87.75
7	174 - 180	175.25	179.75
8	180 - 186	181.25	185.75
9	186 - 192	187.25	191.75
10	192 - 198	193.25	197.75
11	198 - 204	199.25	203.75
12	204 - 210	205.25	209.75
13	210 - 216	211.25	215.75

Table 1-1: Channel numbers, channel frequency limits, and carrier frequencies (video and audio) of channels assigned in present day TV services.

FM or PM of course, this situation is vastly different.

It is customary for a receiver to be able to tune in both sidebands so that the energy received is that contained in both the upper and lower sidebands. However, if a receiver is slightly detuned it is possible to receive only one complete sideband and part of the other with more or less loss in quality of reception due only to the fact that there is more energy in one sideband than in the other. If the total energy in one complete sideband were removed and the reception obtained was that due to the entire remaining sideband

no loss in quality would occur. Reference to *Fig. 1-24* will reveal that in the case shown the energy of the low audio frequency sidebands is twice that of the higher audio frequencies.

If the receiver is detuned beyond the carrier as shown in *Fig. 1-25* all the low frequencies will be lost and only one sideband of the highs will be received. In this case the tone becomes harsh and raspy due to the complete loss of low frequencies.

Single-Sideband Transmission in TV

In TV, if double-sideband transmission were used, the required band-

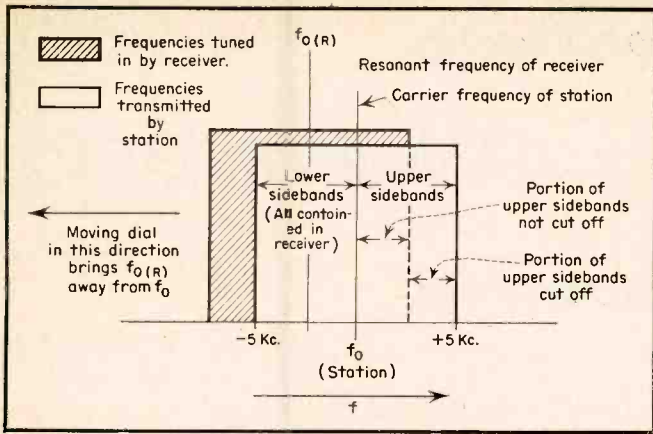

Fig. 1-24: Illustrating how a slight mistuning of the receiver cuts off only part of the upper sidebands.

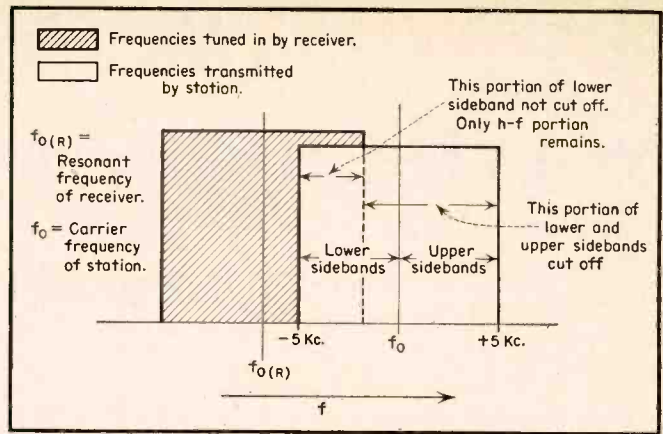

Fig. 1-25: How greater mistuning cuts off all of the upper sidebands and the h-f portions of the lower sidebands.

width would be about 10 mc. By making use of the principle of single-sideband transmission only the upper sideband of the video signal is broadcast. The lower video signal sideband is attenuated at the transmitter by means of suitable filters placed between the final stage of the transmitter and the antenna.

However, it is impossible to cut the lower sidebands off right at the carrier frequency. One must allow for a certain amount of overlapping on the lower sideband side in order to keep the center carrier frequency voltage at its required level as shown in Fig. 1-26. Therefore the sideband filters at the transmitter are adjusted so that the lower sideband signal is reduced to practically zero at a point $1\frac{1}{4}$ mc below the video carrier. Notice that the upper limit of the video signal is located about 4.25 mc above the carrier.

Single-Sideband Energy Relations

A close study of Fig. 1-26 will reveal that the signal broadcast contains both lower and upper sidebands up to

1.25 mc, and only single-sidebands energy above 1.25 mc. This is shown with greater effect in Fig. 1-27. For this reason the received signal contains twice as much low-frequency video energy as it does high frequency reproduction on the picture tube, or over-emphasis of the blacks. However, as will be explained in a later section, this inequality is compensated for in the receiver alignment.

The Audio Signal

The audio FM carrier is located 4.5 mc above the picture signal carrier. The actual audio bandwidth is 50 kc, 25 kc above and 25 kc below the audio carrier.

The end of the band is located 250 kc above the audio carrier, thus making the total bandwidth.

$$1.25 + 4.5 + .25 = 6.0 \text{ mc}$$

The distance between the upper limit of the band and the upper edge of the audio spectrum is 225 kc and carries no signal. This is called the "guard band". Its only purpose is to prevent sound energy from entering the upper adjacent channel.

Summary

To summarize the preceding paragraphs on bandwidth we observe that double-sideband transmission as used in AM cannot be used in TV because of bandwidth restrictions. As a result, single-sideband transmission is used. However, a vestige (1.25 mc) of the lower sideband is included in the transmitted signal so that the system is not strictly single-sideband. Because of this characteristic this system is often referred to as "vestigial" or "sesqui" sideband transmission.

Having discussed the television waveform and its components with regard to frequency and amplitude characteristics, we are now ready to analyze the manner in which these components are utilized in the TV receiver. Which brings us into the actual operation of the various sections of the receiver. We shall see that these sections are primarily designed and concerned with acting on those signal components previously discussed so that both sight and sound are reproduced satisfactorily.

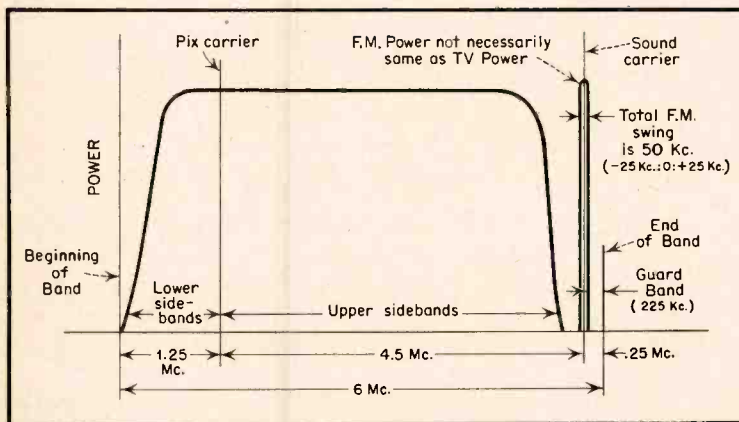

Fig. 1-26: Picture and sound frequency distribution of TV channel. Observe that the pic carrier is located 1.25 mc above the lower end of the band, and that the sound carrier is located 0.25 mc below the upper end of the band.

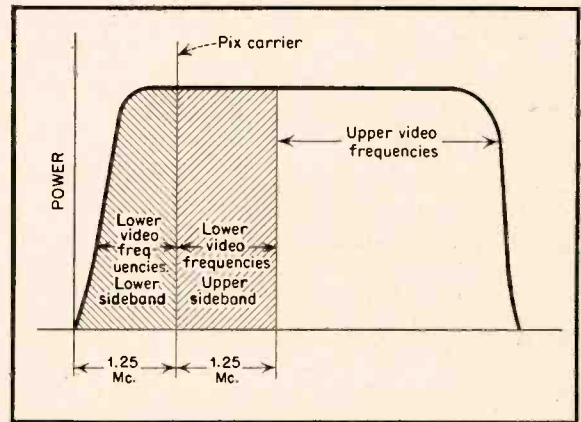

Fig. 1-27: The above illustration indicates how the lower video frequency sideband energy which is broadcast is approximately equal to twice the energy contained in the upper video frequency sidebands.

Understanding

PUSH-PULL

by Allan Lytell

Author of TV Projection and Enlargement

THE use of two amplifier tubes working in a balanced or push-pull circuit offers many advantages over the single-ended amplifier. More than twice the power output may be obtained through proper circuit designs; a push-pull amplifier also eliminates the second harmonic distortion which occurs in an ordinary amplifier. The use of this circuit arrangement is necessary to produce high quality audio amplification for finest reproduction.

Figure 1 illustrates the use of two triodes in a push-pull circuit; there is an input transformer with a split secondary (T_1) and an output transformer with a split primary (T_2). Voltage applied to the two grids is out of phase and while one grid is going positive, the other grid is going negative. The two ends of the input transformer at A and B are always 180 degrees out of phase with each other. Assume that the current flow in the primary has produced a current flow in the secondary going from A to B . Since the center tap is at ground potential, the current flow will be from A up to ground and from ground up to B . This produces a complete phase difference between points A and B which is applied to the two grids. Figure 2 shows how a center tap on the input transformer second-

To those who have wondered why "push-pull" is employed, this article will be welcome, explaining, as it does in easy-to-grasp language the theory of this popular circuit.

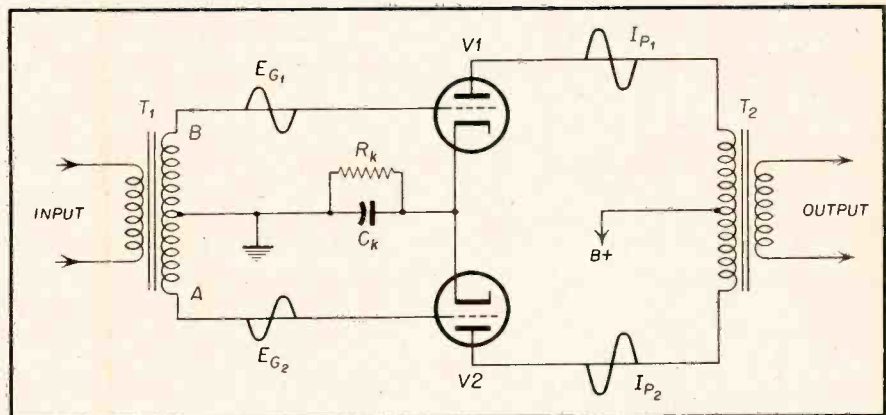

Fig. 1. Typical push-pull circuit using triodes.

ary will produce the 180 degree phase reversal necessary to drive push-pull. Assume that the magnetic coupling from primary to secondary produces 20 volts a.c. from point A to point B . Point A may be grounded and there will then be 20 volts of signal available at point B . If point H or the center tap is grounded instead, there will still be 20 volts between A and B but point H will be halfway between A and B . Since the ground voltage is reference for all the other applied potential, point B will now be 10 volts above ground and point A will now be 10 volts below ground. Another viewpoint is to say that the signal current, at a given moment, is going from A to ground and from ground to B . Thus, the grounding of the center tap of the input transformer in no way affects the magnitude of the secondary voltage but it does provide a reference point.

Plate voltage is applied through the primary of the output transformer to the plates of both tubes. As is well

known, there is a complete phase reversal from grid to plate in any amplifier vacuum tube. This phase reversal through both vacuum tubes provides two signal plate currents of opposite phase. Since the grid voltage of tube 1 was going in a positive direction, the plate current of tube 1 will increase, therefore there will be an increasing current through the top half of the output transformer primary. The grid voltage of tube 2 is going in an opposite direction hence the plate current of tube 2 will be decreasing. Signal plate currents in the primary of the output transformer are going in opposite directions and since the plate current of tube 1 is increasing and the plate current of tube 2 is decreasing, they both will provide the same magnetic field which induces a voltage into the secondary winding. One of the plate currents is pushing and the other of the plate currents is pulling which gives this circuit its name "push-pull."

[Continued on page 27]

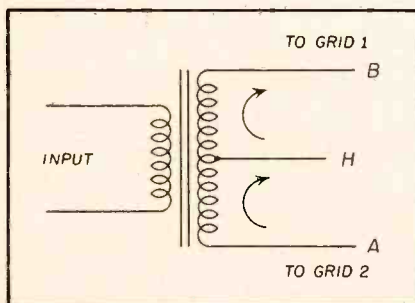

Fig. 2. Grid 1 is 180° out of phase with respect to Grid 2.

SHOP NOTES

Write up any "tricks-of-the-trade" in radio servicing that you have discovered. We pay from \$1 to \$5 for such previously unpublished "SHOP NOTES" found acceptable. Send your data to "Shop Notes Editor".

Horizontal Sweep Sing—Models

10-401, 10-404, 10-412,
10-418

Horizontal sweep sing can be caused by vibration of the mounting bracket on the horizontal output transformer, T 107. This mounting bracket occasionally vibrates at a sub-harmonic of the 15,750 CPS horizontal sweep frequency. On later production sets this condition has been corrected by

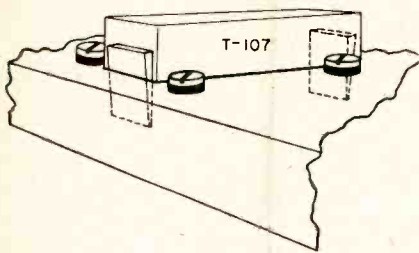

Fig. 1. How to insert wedge.

dipping the core and mounting bracket in a high melting point wax.

Receivers in the field that do not have this wax treatment can be corrected by inserting small wedges between each end of the transformer and the chassis as shown in the sketch below.

It is not necessary to remove the chassis from the cabinet to make this correction.

Crosley Service Dep't.

Replacing Bias Cells

For those who have encountered two bias cells in one spring holder and have sweated and fumed trying to get both cells in at once here's a hint. Wrap scotch or other tape around the cells to hold them together and see how easy it is to insert them in the holder.

*Submitted by
Wayne E. Lemons
Buffalo, Mo.*

Zenith 28T925R Repair

Customer brought this 10" TV table model receiver in with complaint that picture had fallen down to thick horizontal line. Sound was okay.

This of course was a vertical circuit problem, limited down to a maximum of two stages—vertical oscillator, and

vertical amplifier stages. We plugged in set after customer was gone and the picture was fine.

Three hours later it did drop down to a one inch horizontal line. When we turned it over to measure vertical voltages the moment the prod touched the tube socket pin the picture jumped back. An *intermittent!*

As a routine check we removed the vertical output transformer. Primary and secondary resistances checked perfectly with Sams Photofacts. Then absently, I touched the ohmmeter prods between primary and secondary—1600 ohms! Your guess is as good as mine what broke down. A new transformer fixed it ok.

*Submitted by
David Gnessin
Columbus, Ohio*

G. E. Models 800 Series—Horizontal Sync adjustment

On the above production receivers, a tuned circuit was added to the horizontal blocking oscillator circuit to stabilize the sync. The method described below uses instruments for adjustment of the circuit which will give better performance than the method described in ER-S-805 and ER-S-817 service notes.

VALUE OF "R"	TYPE OF OSCILLOSCOPE
18,000 ohms	General Electric CRO-3A*
150,000 ohms	General Electric CRO-5A
82,000 ohms	General Electric CRO-5S
82,800 ohms	Dumont Type 208

*Note: Vertical attenuator set at mid-range.

Fig. 2. Values of "R" for various types of scopes.

Adjustment. Connect a low input oscilloscope (General Electric Type ST-2A or equivalent) to the junction of L316, and the Horizontal blocking oscillator transformer L313 through a .05 mfd. capacitor. Connect the ground side of the oscilloscope to B- of the horizontal sweep circuit. Other oscilloscopes, while their input capacities are high, may be used if the special probe shown below is incorpo-

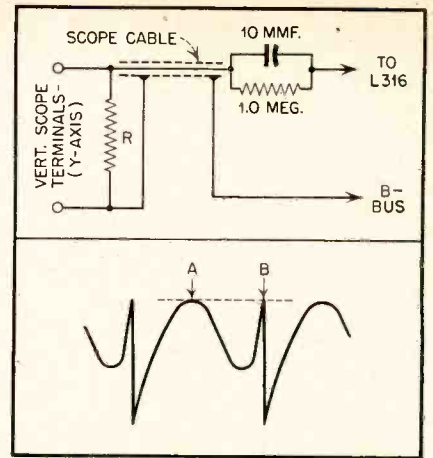

Fig. 3. Probe details (above). Wave form obtained (below).

rated in the test set-up. The value of "R" for a given type oscilloscope is shown in the table given in Fig. 2.

The television receiver must first be tuned for normal picture, the usual adjustments of either or both, front panel or rear of chassis, Horizontal Hold Controls being made to obtain horizontal sync. The flywheel coil, L316, is adjusted for equal amplitude of its positive peaks, A and B, as shown in Fig. 3. Keep the picture in sync during adjustment of the flywheel coil by adjusting either or both of the Horizontal Hold Controls.

After properly setting L316, the rear of chassis Horizontal Hold Control should be readjusted as described in the paragraph for "Horizontal Hold."

G. E. Service Dep't.

Aligning AC-DC Table Models

Much time can be saved in aligning small AC-DC sets if a piece of wire is tacked zig-zag beneath the top of the test bench and connected to the output of the signal generator. This saves making a direct connection to the set as most small sets will pick up enough IF or RF signal for alignment purposes. This trick is not meant to be used on large sets or on FM, only on small sets where work must be done rapidly.

*Submitted by
Spears Radio Service
Clearwater, Fla.*

Heavy Soldering

On occasion, in most radio shops, it is found necessary to solder large lugs to heavy cables. This can be done quickly by removing the tip from a Weller soldering gun and holding the lug between the posts with the switch on. The excess current drain does not seem to harm the soldering gun (at least not so far).

*Submitted by
George Miller
Perth Amboy, N.J.*

What Have We To Gain— OR LOSE-IN TV?

by **CHARLES GOLENPAUL**

Jobber Sales Manager Aerovox Corporation

We are now in Radio's second boom. Read what an oldtimer, who lived through the first boom, has to admonish with regard to making the best of the opportunities presenting themselves.

THERE'S one advantage in growing old, as I see it. That's the growing fund of experience from which you can draw more considered and, I hope, *wiser* decisions. Some one has said that "History repeats itself." I've lived long enough to know that history *does repeat itself* over and over and over again.

Right now radio history is repeating itself just as we old-timers have seen it done before. Television is bringing us another boom—a bigger, better, more spectacular and definitely more profitable boom than that which ushered in radio broadcasting almost three decades ago. Yes, television is the biggest thing we radio men have ever experienced. And that's why I'd like to say a few words to you to outline what you have to gain in television or what you can easily lose in television—and why.

TV Parallels Radio

First of all, let's see how television parallels the early days of radio broadcasting. I estimate that television is now at a point in its development, both technically and commercially, attained by radio broadcasting by 1924. It was in 1924 that broadcasting got its early networks under way, linking together a number of scattered stations with the great program-producing center of New York. It was in 1924 that homemade radio sets gave way to the mass-produced radio sets . . . that headphones gave way to the trumpet loudspeakers . . . that "ham" performers (who had performed for fame and glory rather than for hard cash) gave way to the professional entertainers. All in all, 1924 marked the real commercialization of radio broadcasting, and the end of a noble experiment and a grand hobby. From there on it was simply entertainment for the entire family, at the twist of a knob.



As we enter 1950, television is also at the commercialized stage. While some folks will build their own television set either from the several excellent kits now on the market or, the vast majority of TV sets will be factory-built, fully standardized, and certainly tried-tested-proven products.

Also, television now has some mighty fine programs. Shortly after the war the pioneer stations went from the experimental to the commercial license basis, which pinned them down to a stated number of hours per day minimum, which hours of operation called for telecasts of true entertainment value. A bit later came the first of the television sponsorships. Now television has just as much sponsorship for its programs as radio broadcasting.

Just as radio had to shed its earphones in favor of the loudspeaker

for the entertainment of the entire household, so television has progressed to larger screen sizes, either by using larger cathode-ray tubes for direct-vision performance, or again by using ingenious optical systems for projected images. John Q. Public wants to see the show in comfort, rather than through a mere knothole.

The television networks, brought about by film-recorded programs, or by ultra-high-frequency radio relays, or again by coaxial cables, are joining together more and still more scattered television transmitters so that really excellent programs can be justified by a large and growing audience. Already we have networks joining together the stations from Boston to New York to Washington to Pittsburgh, Cleveland, Detroit, Chicago and St. Louis—and all the intermediate cities. A transcontinental television network is already in course of construction. Just as rapidly as there are television transmitters set up in different parts of the country, the networks will come right along to provide the top-flight programs originating in the big centers of the entertainment world.

Definitely, *but very definitely*, television is here to stay. It is paralleling the development of radio broadcasting with this one big difference: where radio broadcasting dealt with nickels and dimes, this television proposition deals in dollars. It's a far brighter boom than that which hit this radio industry of ours back in the early 'twenties. And if you fail to make the most of this amazing opportunity, you'll have only yourself to blame.

Proper TV Installations

Now let's get down to business:

From the servicing standpoint, television is certainly a "natural". By that I mean it's *complicated*—so *complicated*, indeed, as to be beyond the

reach of the handyman. And that's where you servicemen come into the picture in a big way.

To begin with, the television set has to be properly installed. Unlike the modern radio with its built-in loop antenna, or even the earlier radios which required no more installation than a bit of wire strung out to any length between any handy supports, the television set requires a special antenna placed in just the right spot and aimed just so, if satisfactory results are to be realized. I'm not saying that it will always be that way, for sooner or later some bright chap will come along with a really fine all-channel indoor television antenna. And, of course, ultimately television transmitters will be "upped" in power, so the receiving antenna can be reduced to the simplest proportions, corresponding to the stepping up of radio broadcasting stations from 500 watts, which was considered a terrific sock in the early days, to the 50 kilowatts of today.

But be that as it may, the fact is that today in most localities the television receiving antenna is a critical proposition. The best television set can perform like the worst, and the worst can out-perform the very best, depending entirely on the antenna. That's why most television sets are sold only in conjunction with a proper installation by the retailer or his service organization. While John Q. Public may howl at the extra \$50 to \$100 "installation fee" he can be mighty grateful when he realizes that proper installation is absolutely vital and that the \$50 or \$100 expended for installation and a year's service is really a worthwhile investment.

I'm strongly in favor of the installation fee, BUT, I believe that fee should be fully earned. Too many gyp jobs have been done. I see simple dipoles being installed in spots where double-decked dipoles and reflectors should be used for adequate reception. Also, I see the usual simple low-frequency dipoles being installed in areas where the higher-frequency TV channels are or soon will be available, and therefore high-frequency dipoles or adapters should be part of the original installation.

Especially is this shabby sort of business deplorable in localities far removed from television transmitters. I can speak from first-hand experience. My home is in New Bedford, about 50 miles from the two television stations in Boston. Soon we shall have television stations in Providence, some 30 miles distant. But at the moment the New Bedford folks must turn to

distant Boston for their two television program sources.

Yet many of the television antennas in New Bedford are not adequate for the relatively weak signals we get from the Boston transmitters. Of course I appreciate that the dealer who is out to sell a television set, hesitates to tell the buyer that a super-duper antenna will be required, and that the cost may be one-quarter to one-half that of the receiver itself. The installation may require a pretty tall mast and a stacked array of dipoles. That may arouse considerable sales resistance. I'll admit all that, BUT—and this is the big issue—it's *wrong to sell a television receiver unless that receiver can be installed so it will perform satisfactorily.*



In my own home our television receiver is still pretty much of a novelty. Because of the remoteness of New Bedford in present television coverage, there are still relatively few sets around. Consequently, anyone who has a television receiver must figure on a healthy budget for beer and cheese, soft drinks and crackers, or wine and cake, several evenings a week. That's the price of pioneering home television. We take that sort of thing in our stride, provided the television set behaves itself before our company. However, performance failure is where the sour note comes in. While I enjoy fairly good reception from one Boston station and rather poor reception from the other, there are evenings when the signal strength is so weak that I get very poor pictures with plenty of "snow". And those evenings are usually the ones when we have a houseful of company interested in buying a television set. Right then and there, the local television retailers are piling up a lot of sales resistance for themselves. They are providing ammunition for those folks who keep on saying: "I'll wait

until television is perfected," or "I'll buy when the sets are cheaper," or "I'll wait for color television."

What I'm driving at is that the New Bedford dealers—and the dealers everywhere else—should make each television installation *just as efficient* as they know how. And their servicemen should be instructed and even admonished to work hard to get the most out of each individual installation. This may mean trying the antenna at this spot or that on the roof; it may mean spending an hour or two orientating the antenna for the best possible signals from all stations within range; it may mean trying an additional high frequency antenna to get the available 7-13 channel signals. Regardless, the installation should be tops in every case; for one bum installation, mind you, can kill a lot of other sales.

TV Requires Best Installation

I can't make it too strong when I say that TV has brought us a boom. Yes, TV spells dollars whereas regular radio deals in nickels and dimes. In every locality where television opens up, the dealers and the servicemen should handle this boom with due care. Don't kill it by overselling! Don't kill it by sloppy installations! Don't kill it with badly performing sets! You've got to provide *the very best* when you're selling a television proposition running well up in the hundreds of dollars. It just ain't peanuts.

If the locality has some poor television spots, it's up to dealers and servicemen to spot those spots. It's just no use trying to push television receivers in spots where reception will be unsatisfactory. Unless an exceptional antenna job can work the receiver properly in a poor spot, it's far better for present and especially future business to lay off that sale entirely. It's not losing money, mind you. It's safeguarding future sales.

Some dealers and servicemen are equipped to appraise television reception throughout their territory. I've seen some pretty nice test and survey rigs for the purpose. Some are in the form of trucks equipped with telescopic or collapsible masts and dipole assemblies, operating the television receiver. It's a simple matter with such equipment to test out reception in any neighborhood. There are also portable receivers and antennas in use, whereby to check the reception not only in a given neighborhood but even as to the precise spot on the roof and the best orientation of the antenna.

[Continued on page 24]

CIRCUIT COURT

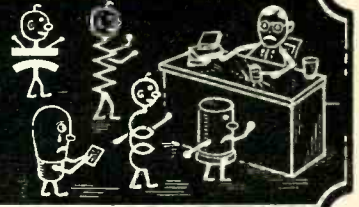

National NC-TV7

The problem of generating high voltage for the picture tube in TV receivers brings forth an interesting variety of circuits. In the case of the 7" tubes such as the 7JP4 where the requirement is for potentials in the vicinity of 4500 there are many possibilities. A unique arrangement appears in this 22 tube instrument.

The portion of the schematic dealing with the subject problem is shown. Basically, the circuit consists of a free-running oscillator employing a 12AU7 tube. The elements of the two triode sections are parallel connected. The output of the oscillator lights the 1B3GT rectifier and develops high voltage for the transformer to act upon.

The transformer has four windings. One is tuned by a 510 μmf fixed capacitor and a small trimmer. This con-

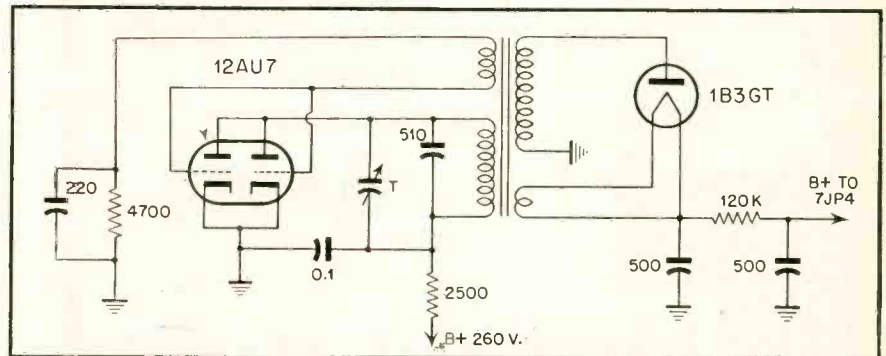

High voltage circuit of National NC-TV7

ord changer. The chassis makes use of a super-heterodyne circuit designed around miniature tubes.

A partial schematic is shown, indicating the details of the audio amplifier circuits. An unusal ar-

pass capacitors have been omitted. The 12AT6 and 50C5 have cathode resistors to ground of 100 and 150 ohms respectively.

Between the cathodes is a network consisting of two 1500 ohm resistors with a .1 μf capacitor from their junction to ground.

The features claimed for this circuit are reduction in low-frequency phase shift and improved stability. The resistors between the cathodes actually act as neutralizing elements.

Airline Model 64BR-7300A

Among the methods used to reduce the generation of hum voltages in the input stages of high gain amplifiers is that of operating the heaters or filaments of the tubes from a d-c source. There are several possible sources of this d-c potential. In some of the earlier instruments rectifier-filter supplies were provided. A simpler scheme is to make use of some of the d-c developed

[Continued on page 24]

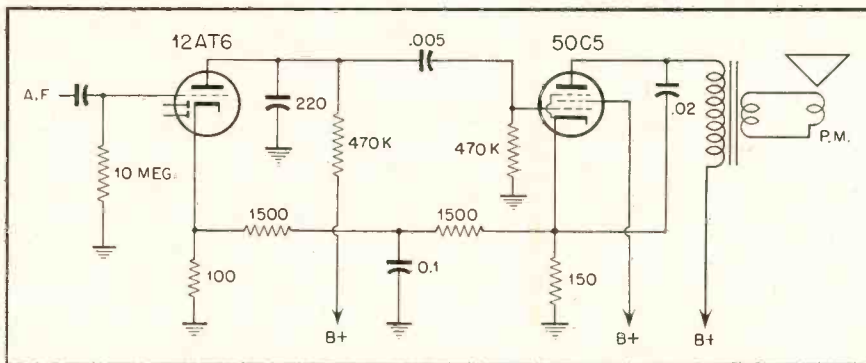

Amplifier details of Motorola Model 59F11

stitutes the plate coil and frequency determining circuit. Feedback is provided by a grid coil, untuned. A filament winding provides 1.25 volts for the 1B3GT tube. The fourth coil develops the high voltage.

High voltage d.c., at very small current, is taken from the filament of the rectifier and filtered by a 120K resistor and two 500 μmf capacitors. This amount of filter is adequate for a high frequency source feeding a high impedance load. The d-c source for the oscillator is 260 volts. 42 volts ohm grid leak so the rating of the tube is adequate for the service.

Motorola Model 59F11

This phono-radio combination is one of the portable instruments built around the new compact 45 RPM rec-

angement of components is used to provide a unique sort of feedback.

Note that the customary cathode by-

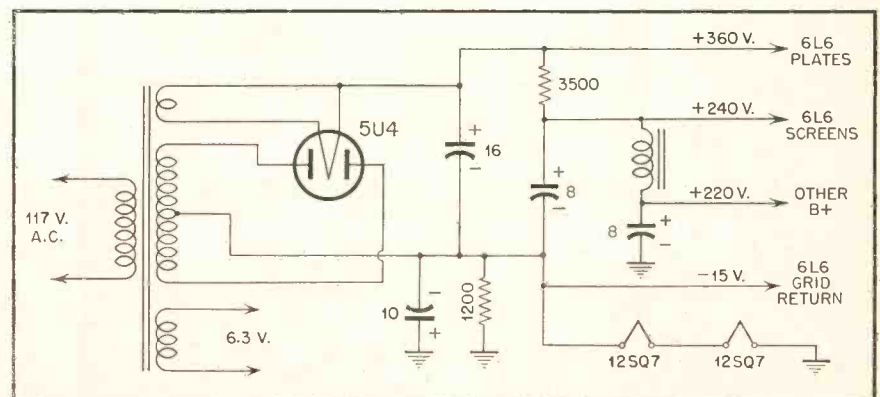

Obtaining d-c for heaters of 125Q7s in Airline 64BR-7300A

NEW PRODUCTS

LOW DRAIN PORTABLE TUBES

A new line of miniature radio tubes for portable radio receivers which it is claimed will triple useful battery life and provide performance comparable to similar tube types has been announced by the Radio Tube Division of Sylvania Electric Products Inc., according to C. W. Shaw, general sales manager.

The new Sylvania low-drain battery tubes include type 1U6, a heptode converter with

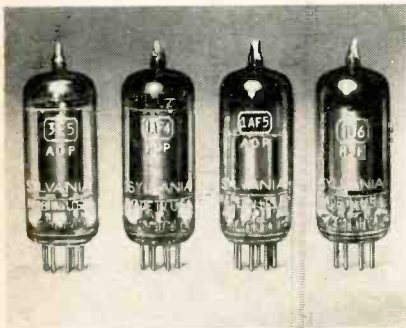

oscillator anode as a separate element; type 1AF5, a diode pentode; type 1AF4, a sharp cutoff r-f pentode; and type 3E5, a beam power output tube. All tubes have 25 milli-ampere filaments and are supplied with 7-pin miniature button bases.

Power required for a complement of the new tubes in a typical battery-operated super-heterodyne is only 2.1 watts or one half the average required for other available types. The new tubes will also operate satisfactorily over a range of 1.4 volts to 1.1 volts, or about ten percent greater than the rating of comparable types.

NEW PICTURE TUBES

General Electric is in production on two new dark face TV picture tubes, a 16-inch glass rectangular (16KP4) and a 19-inch (19AP4A) metal-coned round-face tube at the company's new picture tube factory here at Electronics Park.

"The 16KP4 provides sufficient space on the neck of the tube to readily mount the ion trap, focus coil and deflection yoke", according to K. C. DeWalt, Manager of the Cathode

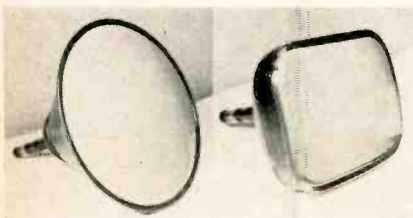

Ray Tube Division. "The air gap in the focus coil can be located just ahead of the limiting aperture in the gun structure of the tube which is necessary for best focusing," he said.

An offset gun structure is used in the 16KP4 which permits the use of a single field ion trap. The tube has a useful picture area of approximately 140 square inches.

Maximum ratings of the 16KP4 are: anode voltage, 16,000 volts; grid no. 2 voltage, 410 volts; and negative bias value, 125 volts. A conventional heater supply voltage of 6.3 volts is necessary for the tube operation.

The 19-inch (19AP4A) has a useful picture area of about 250 square inches. Its maximum

ratings are: anode voltage, 19,000 volts; grid no. 2 voltage, 410 volts; and negative bias value, 125 volts. A conventional heater supply voltage of 6.3 volts is necessary for tube operation.

Further information on these two new tubes may be obtained from the Tube Division of the General Electric Company, Schenectady, N. Y.

NEW INDOOR ANTENNA

Telrex, Inc. announces the introduction of a new television receiving antenna expressly designed for indoor installation. The new antenna, is known as the Attic "V" Beam.

The Attic "V" Beam is easily and quickly installed, requires no masts, towers, guy wires etc., and is free of all hazards. It is ingeniously designed and folds into a compact

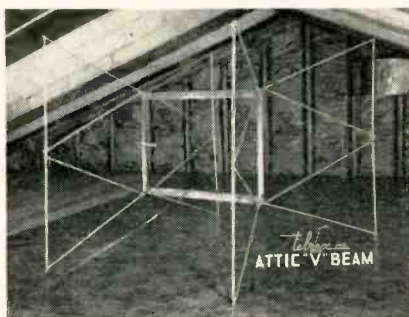

package for easy handling and placement, and opens up completely assembled, into a full two bay Conical "V" Beam array, complete with transmission line. The array is extremely light and entirely self supporting. It may be suspended or rested on flooring, beams, rafters.

BLAST FILTER FOR MIKES

A practical way to stop wind and breath blasts and prevent "pop" in dynamic microphones has been produced by Electro-Voice research-engineers, to meet the particular need of broadcast engineers and high quality public address specialists.

The new E-V Model 335 Blast Filter effectively stops breath blasts even when the speaker works extremely close to the microphone. In outdoor pick-up, it completely eliminates any interference from wind rumble—reproduction is clear and clean. Especially



helpful when reproducing untrained voices on audience participation and man-in-the-street programs.

For full details, write for Bulletin No. 86 to Electro-Voice, Inc., Buchanan, Michigan.

TAPPED ISOLATION TRANSFORMER

This unique test instrument, known as the RCA Television Isotap Transformer, has just been announced by the RCA Tube Department for the testing and servicing of TV receivers,



radios, and other electronic and electrical equipment. Designed to bring a new degree of safety and efficiency to these operations, the single compact unit embraces an auto-transformer and an isolation transformer.

TV ANTENNA ACCESSORIES

Amphenol announces two new products related to TV installation. The first is a matching transformer employing the Amphenol four-conductor Twin Lead specially connected to provide a transformation in impedance from 300 ohms down to 75 ohms. It is particularly useful in matching 300 ohm lines to 72 ohm or 75 ohm circuits.

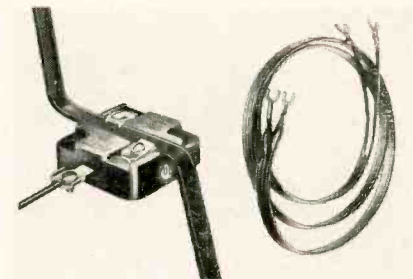

The second product is a new arrester which bears the Underwriters' Laboratories stamp of approval, and is a combination of gap type and shunt-resistance type of arrester. It is easily installed under eaves, on a window sill or on the wall; it can be used with all types of transmission lines but is primarily designed for use with 300 ohm flat twin-lead. No stripping is necessary as toothed clamps on the arrester penetrate the insulation to make contact.

INTERCOM ANNUNCIATOR

F. & H. Electronics Co., Maywood, California announces its lamp signal annunciator which

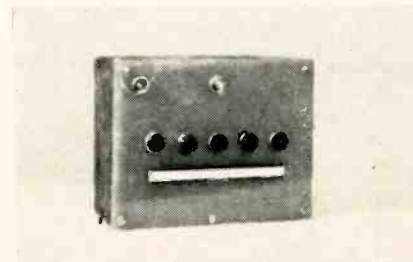

eliminates code signaling from substations to master. Features include: Straight A. C. 115 Volts, Self-Contained, no Transformer or Bat-

teries to Add. Uses Standard 6-Volts Dial Lamps. Desk or Wall Mounting. Release button can be located some distance from annunciator. Quiet operating, A. C. Locking Relays with silver contacts, trouble free, Audible Buzzer where desired or Silent Visual Signal only. Switch Buzzer On or Off as desired. Furnished also for Flush Mounting for Conduit Jobs. Five Lamp standard size but can be had in any number of lamps on special order. Also furnished with special coils for parallel operation.

ANTENNA SWITCH

The La Pointe-Plascomold Corp. recently recently started production on a new three-way antenna switch.

Where multiple antennas are used, and a separate transmission line for each antenna is used, the VEE-D-X Antenna Switch makes it no longer necessary to attach a separate transmission line every time a different antenna is to be used. By just turning the



knob the viewer can change over instantaneously from one antenna to another. The antenna switch is also very useful for TV dealers when demonstrating more than one receiver from a single antenna.

Featured in this unit is a specially designed low loss switch that prevents leakage. Also, the antenna switch is furnished in a very attractive ivory plastic case with a satin finished aluminum face. A terminal strip is located at the rear and will accommodate three separate lead-ins as well as the output line to the receiver.

NEW LOUDSPEAKER

Completely weather-proof and vibration proof the Racon MN-15B features a built-in watertight cast aluminum transformer housing. This feature represents a 75% savings when compared with costly external waterproof transformers. The husky "U"-bracket facilitates installations which require horizontal or vertical positioning. Three bosses make provision for flush rear mounting as well.

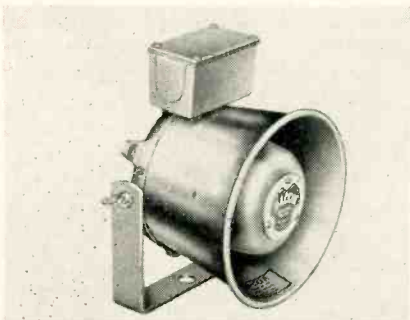

Additional Specifications: 20 watts continuous capacity; 35 watts peak capacity; frequency range 450-6000 cycles; available in 8, 15 or 45 ohms; tropicalized driver unit; 18-month guarantee.

For your free copy of the new Racon Catalog describing this speaker and the complete Racon line, write directly to Racon Electric Co., Inc., 52 East 19th Street, New York 3, N. Y.

TV LIGHTNING ARRESTER

The JFD Manufacturing Co., Inc. of Brooklyn, New York, announces the manufacture of their new AT103 Lightning Arrester especially designed for the latest types of heavy and tubular twin lead.

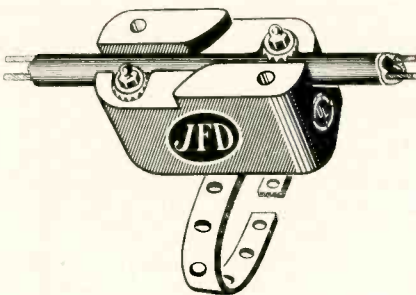

Approved by Underwriters' Laboratories for outdoor-indoor use, the AT103 follows the highly successful AT102 regular twin lead lightning arrester developed by JFD six months ago.

Completely preassembled, the AT103 can be installed in seconds on masts, walls, or cold water pipes without any preparation or the use of special tools. No splicing or cutting of the lead is necessary. The lead-in is simply slipped into the slot and tightened in place.

HIGH VOLTAGE TESTER

The amazing new model 102 miniature TV High Voltage tester checks all high voltages in any direct-view or projection TV set. It features a precision 10,000 ohm/volt move-

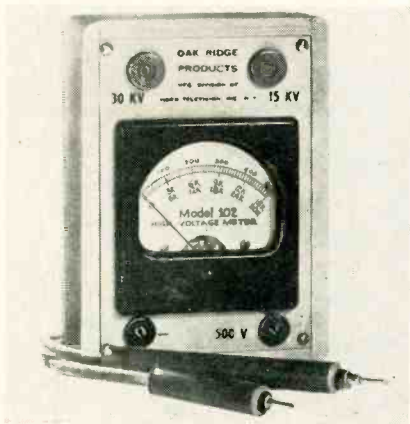

ment and three scales: 0-500V, 0-15KV, and 0-30KV, and comes complete with special high voltage test lead. Pocket size (5 3/4 x 4 x 2 1/4"),

For further details on these new miniatures, write directly to Oak Ridge Products, 239 East 127th Street, New York 35, N. Y.

SOLDERING GUN

Caliri Manufacturing Co. Inc., 45 Washington St., East Orange, N. J. announces their



new high speed soldering gun, the "Cal 88". The gun is designed for ruggedness, dependability and high heat.

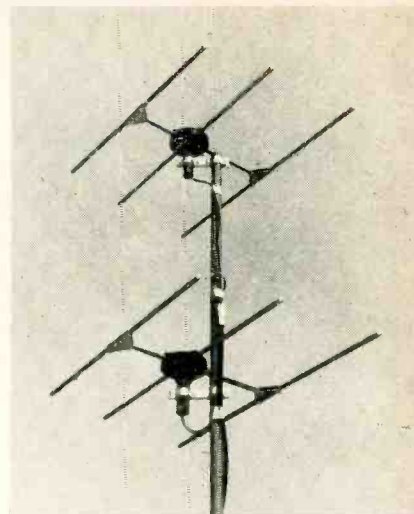

TV ANTENNA

The above photograph shows the rugged construction of the new Workshop super high gain single channel 6-element array. Specifications of this highly successful antenna are shown on Page 6 of the new WORKSHOP catalog. Workshop Associates, 66 Needham St., Newton Highlands 61, Mass.

CHIMNEY MOUNT

T-V Products Company stresses economical quality—in the newly designed CM-200. A simple one piece stamping of hi-grade, heavily plated steel, the CM-200 maintains all the rigidity and strength of more cumbersome and complicated designs, but at a lower cost. The

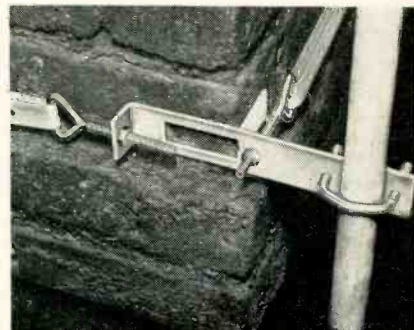

CM-200 features a re-inforcing rib in the right-angle extension to prevent any change of angle, regardless of stress or strain. In addition, a specially designed notched U bolt is provided to prevent any mast slippage.

The CM-200 comes complete with two brackets and all necessary hardware including 24 feet of plated, perforated strapping.

AUDIO UNITS

The Pickering Co. of Oceanside, L. I. announces the Model 130H Preamplifier designed



to equalize low frequencies and provide necessary gain for magnetic pickups. It is self-powered, operates with any high quality, high input impedance amplifier and installs by plugging in.

TRADE FLASHES

[from page 8]

square feet, according to an announcement by W. S. Parsons, vice-president in charge of sales of Centralab.

West Coast Exhibit Planned for Sept.

The 6th annual Pacific Electronic Exhibit in 1950 will be staged Sept. 13, 14 and 15 at the municipal auditorium in Long Beach, Cal.

The event rotates annually between northern and southern California.

Heckert Parker is general exhibit manager and L. W. Howard chairman of the show committee of the West Coast Electronic Manufacturers association, sponsors of the event.

The annual coast IRE convention will also be held during the same dates in the beach city with Loyd Sigmon as IRE liaison chairman with WCEMA.

Chicago Show News

With nearly three-quarters of its allotment of hotel rooms already assigned, the Housing Committee of the 1950 Parts Distributors Conference & Show this week urged distributors who

planned to attend the Show the week of May 22nd, to get their reservations in as soon as possible to avoid last minute disappointments in securing accommodations. Kenneth C. Prince, show manager, said that while the Hotel Stevens has been most generous in the number of rooms it has made available for guests attending the Parts Distributors Conference & Show, the record breaking advance registration on the part of distributors already has accounted for three out of every four rooms set aside for persons attending the Conference & Show.

Erratum

The name of the second manufacturer of Picture Tubes on page 21 of the March issue of RSD should be:

Sheldon Electric Company, Division of Allied Electric Products Inc.

NEW! DIRECTION INDICATOR



TV ANTENNA ROTATOR



DELUXE MODEL
DIR

● This deluxe model Alliance Tenna-Rotor is in use and on sale in every TV market! Priced only slightly higher than the standard ATR, it provides a direction indicator which quickly shows where the antenna is pointed!

Here's why it pays to sell Tenna-Rotor!

- The only rotator proved by thousands of users in major TV markets from coast to coast!
- Tenna-Rotor is demonstrated in over a million TV homes each week! Millions see the Alliance films now scheduled on 52 TV stations!
- Tenna-Rotor has Underwriters' Laboratories' approval!
- Tests conducted by Electrical Testing Laboratories Inc. prove Tenna-Rotor works in sub-zero—rainy, snowy and icy weather!

The only rotator featuring the Alliance 4-conductor cable with "Zip" feature which makes for faster, easier installations!

Guaranteed for one year!

Write for your copy of "Fastest profit maker in Television today."

Alliance Manufacturing Company • Alliance, Ohio

Export Department: 401 Broadway, New York, N. Y., U. S. A.

CIRCUIT COURT

[from page 21]

to apply to the high voltage circuits in the amplifier.

In this case, as can be seen in the accompanying partial schematic, all the tubes are supplied through a common resistor in the negative side of the high voltage supply. The drop across this resistor actually performs three functions.

A certain amount of filtering action takes place as a result of the resistor being in this place. Further filtering will be noted in the 3500 ohm resistor in the positive supply side, as well as in the filter choke following. Only the voltages for the 6L6 output stage are taken off ahead of the choke.

The drop across the 1200 ohm resistor in the negative lead is used to develop fixed bias for the 6L6 stage, the grid return going to the negative side. Also across the 1200 ohm unit are connected the heaters of the two 121 SQ7 input amplifiers. The series connection of the heaters across the 15 volt source may appear to be inadequate to supply two 12 volt heaters, but in such a position only a fraction of the total possible emission of the cathodes is required for normal operation. Lower voltage on the heaters improves tube life and reduces generation of both hum and noise.

GAIN OR LOSE IN TV

[from page 20]

Profits in TV Installations

Now believe me, it's no punishment for you to put up television antennas as a business proposition, because there are two chances to make a nice profit: First, there's the good markup

on the antenna kit itself, or the difference between your own cost and the list price, and certainly you should charge *the full list*; second, there's the item of labor. The wide variety of antenna installations ranging from the simplest single dipole to the more elaborate stacked arrays and reflectors, and again from a direct mounting on the roof peak, to a lofty mast supported by a chimney mount, means that you can meet just about every purse and purpose. Where price is the main consideration, you can keep the antenna installation as simple as is practical. Where results are the main consideration, you can sell the works.

I know many service organizations that are doing very well on television antenna installations. Their men have become fine mechanics in this field. They can size up a situation, figure out the best spot for the antenna, work on the logical mounting means, and then do the job with skill and dispatch. Such organizations have the right ladders, and other equipment to handle the work efficiently and safely. They are making money, because they have worked out the right routine. And mind you, they carry the right sort of compensation insurance, or accident insurance in the case of self-employed, to be protected against any possible hazards.

Even after the installation has been made, these service organizations are in for still more business. When additional television stations come on the air in their territory, these wide-awake servicemen go after their previous installations and suggest improvements whereby to bring in the new programs, such as supplementary antennas, realignment of existing antennas, the use of boosters, and so on. Amazing as it may seem, there seems to be no limit to what the television enthusiast will spend to enjoy the best in television.

TV Guarantees

In many cases the installation cost is generally part and parcel of the year's guarantee policy. For one year the dealer or serviceman will service the television receiver, regardless. Some propositions are handled by the set manufacturer's own service setup, but most of them are now being delegated to the local radio serviceman or TV service organization.

As a component manufacturer's man, I'm happy to report that the service calls on those one-year guarantees have been well within reason. And the reason is not hard to seek: Most receiver manufacturers have gone in for conservatively-rated com-

ponents. That is why we seldom hear of a major component failure, such as a capacitor, resistor, transformer, control and so on. We do hear of some tube failures, and that's to be expected since the television receiver represents four to six times as many tubes as does the usual broadcast receiver.

The one-year guarantee proposition has proved profitable to all concerned. Of course there have been irritating calls, such as the readjustment of the horizontal or vertical holds, the blowing of the protective fuse, and other such trivials. But so far as actual repairs and replacements are con-

cerned, the servicing of new television receivers has been very light indeed.

However, now we are entering our third year of home television. And that's another matter. Whether the second-year service policy can be handled for the same price as the first, is something manufacturers and servicemen are still trying to figure out. To be sure, there are more tube failures the second year. The one factor that stands out clearly is the tremendous amount of use—and often abuse—to which the average television receiver is subjected. Recently program

BACK NUMBERS of "RSD" Order them now - the supply is low.

FEBRUARY 1948

High Speed Servicing
Visual Alignment
Income Tax Deductions

MAY 1948

FM Set Alignment Procedure
Video Detectors
How Vectors Simplify Servicing
Significance of Power Factor and Q

JULY 1948

Television's Service Outlook
Video Amplifiers
Bad Acoustics Cured Electrically

SEPTEMBER 1948

De-emphasis In FM Set Circuits
Video Amplifiers, D-C Restorers
Simple Wattmeter

OCTOBER 1948

Projection TV
Distributed Capacitance
TV Picture Tubes
High Voltage Test Probes

NOVEMBER 1948

Sweep Generators
TV Picture Tubes
155 Loudspeakers, Voltage-Fed
Making Good TV Installations
FM-TV Antenna Mast Support

DECEMBER 1948

Checking Video & Synch Waveforms by CRO.

Magnetic Recording
Projection Television, Part 2

FEBRUARY 1949

Test Equip. Symposium Issue:
CROs - VTVMs - Sq. Wave Generators -
Markers - Multimeters - Kilovolts -
High Voltage Probes, etc.

JUNE 1949

Direct View Enlarging Lens
Modern Tape Recorders, Part 2
Custom Building High Fidelity Circuits,
Part 2

JULY 1949

Picture Tube High Voltage Systems
High Quality Tuner Analysis
Amateur TV Interference

SEPTEMBER 1949

Legality of TV "Policies" Clarified
A Klystron TV Sweep Generator
High Quality Analysis Series, Part 1
"Aspen" — Philco's Built-In TV Antenna

OCTOBER 1949

P.A. Techniques For The Coming Elections
The Kay Megaliner
TV Quiz No. 5
Servicing Photo-Electric Equipment, Part 1
Sixteen Inch TV Conversion Kit

NOVEMBER 1949

The 'Scope as a Modern Service Tool,
Part 1
A Wide-Range Impedance Bridge
Tone Controls
A New Aid to Rapid Servicing
High Quality Analysis Series, Part 2
Ladders — Their Use & Care

DECEMBER 1949

Servicing Sound I-F Stages in TV & FM Sets
Modern Electronic VOM
Servicing Photo-Electric Equipment, Part 2
TV Truck Solves Installation Problems

RADIO SERVICE DEALER MAGAZINE
342 MADISON AVE., NEW YORK 17, N.Y.

Please send me the
back numbers checked
here . . .

The price is 35c. for
each copy unless 10 or
more are ordered. If 10
or more are ordered the
price is 25c. each copy.

Feb. 1948
 May 1948
 July 1948
 Sept. 1948
 Oct. 1948

Nov. 1948
 Dec. 1948
 Feb. 1949
 June 1949
 July 1949

Sept. 1949
 Oct. 1949
 Nov. 1949
 Dec. 1949

I remit herewith \$..... for thecopies ordered atc. each.

NAME

ADDRESS

CITY ZONE STATE

times have been extended in some areas, so that one or more stations are now on the air from morning until late night.

All of which adds up to many hours of wear and tear on the television receiver, and that means hastening the eventual replacement of tubes and even certain components which do not last forever. The second and third years will also see the replacement of the cathode-ray tube, because the fluorescent screen darkens or discolors after many hundreds of hours of use. Such a replacement is a considerable cost item, and in most "after the first year" service policies will not be included as part of the bargain.

At any rate, many home television receivers are entering their second year of continuing usage. Regardless of whether they be covered by service policies or not, there's going to be a lot of service work for those properly trained and equipped to do such work. Even more so when the third year rolls around. I can see a tremendous amount of service work piling up.

Unlike regular radio servicing, however, television servicing is going to be limited to those who've got the real "know-how" and also the right test equipment. This is no job for

just any serviceman. Television circuits are mighty intricate. A lot of time can be lost tracking down some defect, unless the serviceman is a television specialist and knows what to look for with any given symptom.

There's another peculiar angle to this television service proposition. Usually there's just the one television set in the home. When it breaks down, the household is simply lost for want of its regular television entertainment. Even at this early date, the up-and-coming dealers and service outfits are ready to replace the defective set with a "loan", so that the customer will not miss his favorite programs. Such "loans" cost a lot of money, but they do bring in the television service business.

Meanwhile, the service shop should carry an adequate stock of replacement parts, because, I repeat, television customers want fast action. If the serviceman does not have a "loan" to tide over the repair time, then his next best bet is to have the necessary replacement parts right at hand for the quickest possible job. Speed is of the very essence of TV service.

The intricacy of the television set, the impatience of the usual set owner, the need for utmost speed—all these

factors are more than warranted by the nice profits which television servicing can offer. But I cannot repeat too often that *relatively few radio servicemen* are going to qualify for television servicing. Only those who have acquired the required technical skill and knowledge, and who can afford the elaborate test equipment needed for television circuits and adjustments, are going to make the grade.

That the television service business will be tremendous in a year or two, must be obvious to you all. Each time a cathode-ray tube will be replaced, a nice profit will be chalked up. And think of it—new TV stations are going on the air—from coast to coast—every month. Soon TV will be where you are, if you haven't got it now.

Get on the Band Wagon

So there you are, fellows. Television is the second boom in a radio lifetime. Right now television is "hot"—the "hottest" proposition that ever came along. Day-by-day we see more and more television antennas appearing on roof tops. The fact that the public may hesitate to buy a good radio set for \$50, yet will not hesitate to pay \$500 for a television set, is one of the *miracles* of this Television Age. And again, while the public may hem and haw when it comes to spending \$10 to repair the old radio, yet will pay \$50 or more for the television antenna installation, again is one of the *miracles* of this Television Age.

We've had this television boom dropped right in our laps. It's up to us to make the most of it. Some servicemen are going to cash in this time, because they will have the training and experience, the equipment and the facilities, and the kind of prompt and considerate attention which the television addicts expect when their sets go bad. But the major portion of the service fraternity is not going to be in the running when television servicing starts piling up in a year or less from now. Too many just won't be prepared for this sort of rich fare.

It's entirely up to you. Whether you cash in or don't cash in on television, is for you to decide. Being an old-timer . . . having seen this radio show from the earliest broadcast days . . . and now being able to say, "Well, this is where I came in before, and I know the story from here on! . . . the television profits will go to a mere handful of servicemen who have the necessary getup-and-go to exploit a boom to the utmost.

So this is it—the boom—and probably the last boom you'll see in your lifetime. Why not make the most of it?

Heathkit

TEST EQUIPMENT



Heathkit
AUDIO GEN.
KIT \$34.50

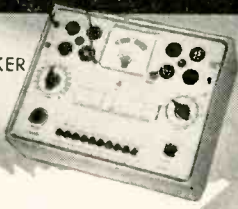

Heathkit
TUBE CHECKER
KIT \$29.50

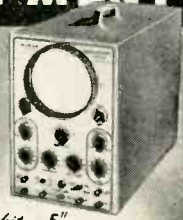

Heathkit 5"
OSCILLOSCOPE KIT \$39.50

Heathkits are beautiful factory engineered quality service instruments supplied unassembled. The builder not only saves the assembly labor cost but learns a great deal about the construction and features of the instrument. This knowledge aids materially in the use and maintenance of the equipment. Heathkits are ideal for and used by leading universities and schools throughout the United States. Each kit is complete with cabinet, 110V 60 cycle transformer (except Handi-Tester), all tubes, coils assembled and calibrated, panel already printed, chassis all punched, formed and plated; every part supplied. Each kit is provided with detailed instruction manual for assembly and use. Heathkits provide the perfect solution to the problem of affording complete service equipment on a limited budget. Write for complete catalog.



Heathkit
TELEVISION
GENERATOR
KIT \$39.50



Heathkit
SIGNAL
TRACER KIT \$19.50



Heathkit
BATTERY
ELIMINATOR
KIT \$22.50



Heathkit
CONDENSER
CHECKER KIT \$19.50



Heathkit
ELECTRONIC
SWITCH KIT \$34.50



Heathkit
R.F. SIGNAL
GEN. KIT \$19.50



NEW
Heathkit
IMPEDANCE
BRIDGE SET \$69.50



Heathkit
VACUUM TUBE
VOLTMETER KIT \$24.50



NEW **Heathkit**
HANDI-TESTER
KIT \$13.50

HEATH COMPANY

BENTON HARBOR, 12
MICHIGAN

EXPORT DEPARTMENT
13 EAST 40th STREET
NEW YORK 16, N.Y.
CABLE - ARLAB - N.Y.

PUSH-PULL

[from page 17]

The normal plate current which flows when there is no applied signal goes in opposite directions through this primary of the output transform-

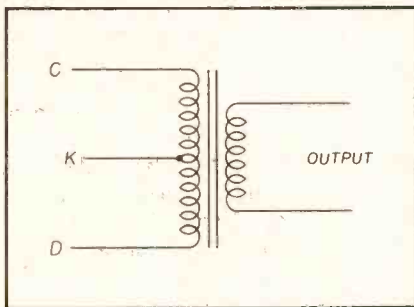

Fig. 3. Output transformer

\$1.00 to \$5.00 PAID for "SHOP NOTES"

Write up any "kinks" or "tricks-of-the-trade" in radio servicing that you have discovered. We will pay from \$1 to \$5 for such previously unpublished "SHOP NOTES" found acceptable. Send your data to "Shop Notes Editor," RADIO SERVICE DEALER, 342 Madison Ave., New York 17, N. Y. Unused manuscripts cannot be returned unless accompanied by stamped and addressed return envelope.

**TECHNICAL WRITERS
WANTED**
for articles on
AM - FM - TV - SOUND
Radio Service Dealer Magazine
342 Madison Avenue
New York 17, N. Y.



BUY BONDS TODAY!

er to the *B plus* of the power supply. These plate currents produce an equal and opposite effect of magnetization in the core of the output transformer which prevents saturation due to the magnetization by the steady state plate currents.

A cathode resistor is used which is half the normal value for a single tube since there is twice the current flow through this resistor. Simple calculation shows that a double current flow requires half the resistance if the voltage, or IR drop, is to remain constant. This bias resistor need not be by-passed if the two tubes are exactly balanced. Signal currents flowing through the cathode resistor are always equal and opposite (in a completely balanced circuit). Thus the effect of a cathode by-pass or filter capacitor is present but in many uses of the push-pull amplifier circuit, a cathode capacitor is used because of the possibility of unbalance between the tubes or other circuit components.

Since the plate currents through the primary of the output transformer are equal and opposite they will add together to produce a single magnetic field. Figure 3 illustrates the output transformer which has steady state or average plate current flowing from *C* to *K* and *D* to *K*. It is these currents which cancel out the d-c magnetization of the iron core. Signal currents, however, flow equally and oppositely through the split primary and thus aid each other.

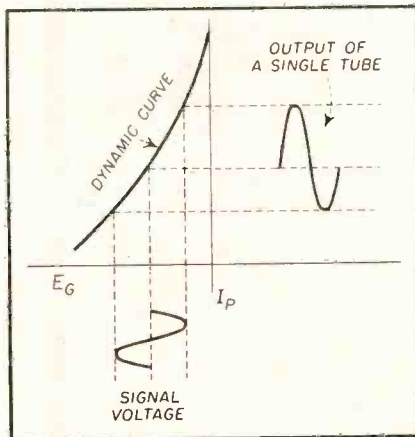
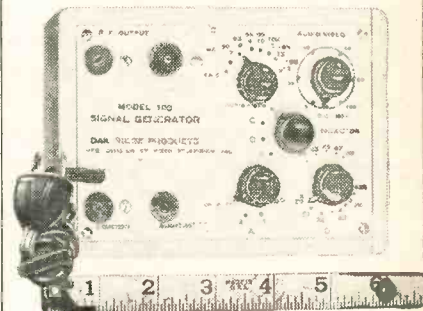

Fig. 4. Typical E_g/I_p characteristic curve.

The dynamic characteristics of a single tube should ideally produce a straight line relation between grid voltage and plate current. In any tube however, the dynamic characteristic is somewhat curved producing the distortion shown in Figure 4 which is due to a second harmonic

NEW! FOR FIELD OR BENCH WORK...
OAK RIDGE miniatures
work like **GIANTS** for You!
EASIER, FASTER, MORE PROFITABLE
TV-FM SERVICING... at lowest cost!



OAK RIDGE 10-in-1 MINIATURE TV-FM SIGNAL GENERATOR

Pinpoints any signal failure from antenna to CRT or speaker in 2 minutes flat! Incorporates 3 separate tuning bands and modulation output and attenuator for TV & FM. Generates a signal to perform as complete

- RF, OSC, and Mixer (1st Det.) Tester • Video IF Tester • Audio IF Tester • Video & Audio 2nd Detector Tester • Video & Audio Amplifier Tester • Sound Trap Aligner or Tester • Adjacent Picture Trap Aligner or Tester • Marker Generator • Antenna Orientation Tester • Antenna Sensitivity Tester.

You get ALL TEN IN ONE with this extremely adaptable, precision-made Model 100! Size: 5 3/4 x 4 x 2 1/4". Dealer's Net \$22.95.

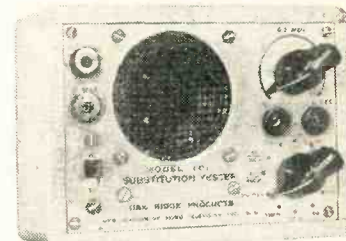

OAK RIDGE 7-in-1 MINIATURE TV-FM-AM SUBSTITUTION TESTER

Which of these Servicing Aids do You Need Most?

- Test Speaker Without Transformer • Test Speaker With Transformer • Paper Condenser Substitutor • Electrolytic Condenser Substitutor • Fixed Resistor Substitutor • Variable Potentiometer Substitutor • Audio Signal Tracer for Video, Audio & Sweep Circuits in TV, FM, AM, Audio Amplifiers, etc.

You get ALL SEVEN IN ONE with the versatile, precision-made Model 101! Size: 5 3/4 x 4 x 2 1/4". Dealer's Net \$16.25.

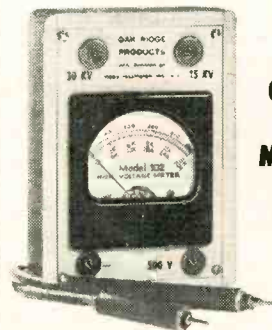

OAK RIDGE 3-in-1 MINIATURE TV HIGH VOLTAGE TESTER

Accurately checks all high voltages in any direct-view or projection TV set. Has precision 10,000 ohm/volt movement, three scales: 0-500V, 0-15KV, 0-30KV. Complete with special high voltage test lead. Size: 5 3/4 x 4 x 2 1/4". Dealer's Net \$14.95.

Boost your efficiency and earnings! Ask your parts jobber for these amazing new MINIATURES today! Write for free Catalog T-D.

OAK RIDGE PRODUCTS
239 EAST 127th STREET NEW YORK 35, N. Y.
Manufacturing Division of VIDEO TELEVISION, INC.
Makers of the famous OAK RIDGE Patented
SNAP-LOCK TV-FM Antennas and Accessories.

TINY TINIER Electrolytics TINIEST!

● It's Aerovox, of course, for "space miser" electrolytics. And logically so because Aerovox pioneered the dry electrolytic and has maintained its superior "know-how".

The Aerovox "Bantam" is the ultimate in space-saving electrolytics. Shown is a 150 v. 10 mfd. unit—smaller than a cigarette! Ideal in tight spots. Favorite in hearing aids, personal radios, etc. Type SRE is available in low-voltage values—3 to 150 v., 5 to 500 mfd.



Higher voltage electrolytics in slightly larger sizes.

See Your Jobber...

Ask for these latest Aerovox "space miser" electrolytics and our latest catalog.

component in the output. If the amplified output signal could be viewed on a cathode ray oscilloscope the distortion would appear as a flattening of one alternation as shown.

Since the two output signals are of opposite polarity they will add together and cancel out this second harmonic distortion. Because of the phase relationship between the two tubes, the second harmonic distortion is cancelled in the output transformer where the two tubes add their outputs, as shown in Fig. 5. While the second harmonics cancel each other, the fundamental frequencies are added together producing a greater output. In Fig. 5 this addition is illustrated and while the two amplifier tubes produce

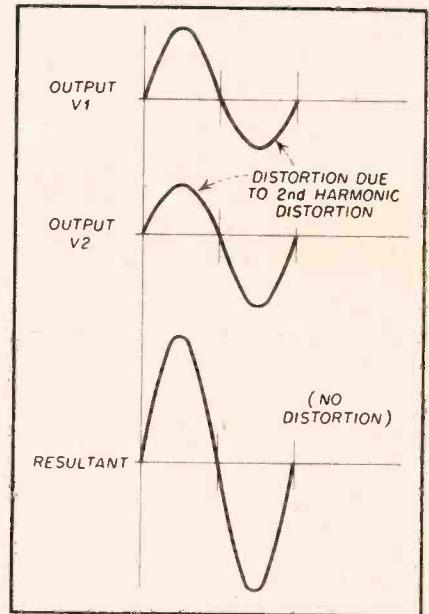

Fig. 5. Cancellation of 2nd harmonic components and addition of fundamentals.

out of phase currents they are shown as adding because of the magnetic fields produced. More than twice the output of a single tube may be obtained due to the harmonic cancellation which allows a higher value of load impedance to be used. The ac hum from the power supply will also be balanced out by this same method.

Push-pull provides a means of increasing the output of an amplifier using a given value of plate voltage. This increased output will contain virtually no second harmonic distortion and will have a greatly reduced hum level. Triodes are usually used for push-pull because they have a high second harmonic content. Pentodes may be used in push-pull but since their third harmonic distortion is higher than for a triode there is little advantage to this method. While all of the even harmonic distortion is reduced to a very low level in push-



FOR RADIO-ELECTRONIC AND INDUSTRIAL APPLICATIONS

AEROVOX CORPORATION, NEW BEDFORD, MASS., U. S. A.

SALES OFFICES IN ALL PRINCIPAL CITIES • Export: 13 E. 40th ST., NEW YORK 16, N. Y.

Cable: 'ARLAB' • In Canada: AEROVOX CANADA LTD., HAMILTON, ONT.



See Us
at the
**MAY
SHOW**

CONNEAUT, O.

and we'll explain how to
make TV SIGNALS strong
enough to do MOST ANYTHING

IN ADDITION to our leading role in the production of microphones, pickups, pickup cartridges and related equipment—making weak TV signals strong has become a big business with us. You've heard of the Astatic Model AT-1 Television Booster, of course—the one with such unequalled quality that it holds top sales despite top price. Well, we want to give you the whole story on the AT-1 at the Show, plus a good look inside a real SURPRISE PACKAGE! We will have a brand new model booster to show you... not a modified version of our present booster but one that's entirely different, from the inside out!

The newest Astatic cartridges and pickups will be there for your inspection. Never before have we had so much that's new to warrant your interest and enthusiasm!

We're anxious to tell you all you want to know about Astatic products... and we're anxious to see you and shake your hand. You'll be more than welcome.



pull, the odd harmonic distortion remains unchanged.

Because of its many advantages push-pull enjoys wide popularity in audio output stages. An increase in fidelity can be expected from any circuit of this type which is reasonably well balanced. The advantages of push-pull may only be fully realized when a complete and true balance is obtained. For this reason component parts and tubes should be matched as closely as possible. Under proper conditions, the signal voltage difference between the two plates should be zero at any given instant.

FIRST AID TO CABINETS

[from page 14]

knife with a square end and a curved grapefruit knife serve very well.

The process of burning in or stick shellac patching consists of heating the knife or spatula in the alcohol flame, pressing the hot knife against the stick of shellac and then transferring the melted shellac to the surface to be patched where it is pressed into the crack or scratch. The knife (and the melted shellac) must be somewhere near the correct temperature, the damaged area must be filled level with the surrounding surface, and the shellac used must match the finish closely. See Figs. 1, 2, and 3.

There are two general types of stick shellac: transparent and opaque. If you are going to fill in a superficial scratch which penetrates only the finish and if the wood beneath has not been damaged, the original color will have been preserved; in such cases transparent shellac should be used. If the defect is so deep that raw unstained wood is exposed, an opaque shellac is required.

With all of the materials ready, light the lamp and select a stick of shellac of the right type and the desired shade. The shade may be determined by comparing the sticks with the cabinet finish. Close inspection will show that most standard cabinet finishes show definite light and dark tones, and generally speaking it is better to try to match the lighter background rather than the darker areas. For instance, the average walnut cabinet has deep chocolate-colored streaks or markings against a tan background. Of course, the matching will also depend upon the particular area being patched; if it is predominantly dark a darker shade will have to be used.

Place the end of the knife in the flame and hold it there until it is hot enough to melt the shellac and cause it to flow freely when it is pressed

**A
Better
Model
at an even
Better
PRICE**

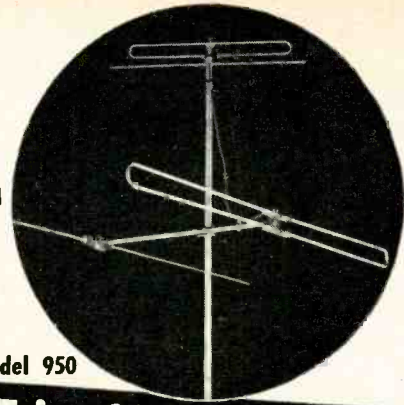

Model 950

The New "Tricraft Duo-Band"

HIGH AND LOW BAND arrays orient individually . . . can be assembled in matter of seconds . . . here is the new outdoor antenna that is unexcelled for quality, construction and price value . . . matching connecting harness is designed to correctly match high band elements with low band elements. Factory assembled with sturdy weatherproof construction for fast installation.

ALWAYS QUALITY-NOW LOW PRICE!

Tricraft Antennas are accepted for their unsurpassed quality. We have increased our production facilities in order to offer our complete line at greatly reduced prices . . . but our quality will still "lead the field."

"TRICRAFT ANTENNAS" • Jobbers: send for our are sold through jobbers • new low price list!



Tricraft Products Co.

1535 North Ashland Ave., Chicago 22, Ill.

Manufacturers of complete line of Television, FM and AM antennas and accessories.

RIDER MANUALS mean SUCCESSFUL SERVICING

RIDER MANUALS mean SUCCESSFUL SERVICING

RIDER MANUALS mean SUCCESSFUL SERVICING



A GOLD MINE

(in catalog form)

A big, fact-filled volume. Every word important. No extraneous matter. Fully describing the RIDER Manuals and Books you must have if you are to compete in this highly specialized electronic field. PLUS a GOLD MINE of HELPFUL DATA . . . including Charts, Diagrams, Symbols and other material that you can put to GOOD USE in your DAILY work. Write today!

SEND ME THE GOLD MINE!

John F. Rider Publisher, Inc.
480 Canal Street, New York 13, N. Y.
Please send me my FREE Copy of the RIDER Catalog,
as soon as it is off the press.

Name.....

Address..... Zone..... State.....

City.....

I'm A..... (Engineer, Service Technician, Dealer, Radio Amateur, Student. State which.) RSD-4

RIDER MANUALS

Watch for the NEW Sensational WORKSHOP TV ANTENNA All Channel Low Price

"TELEVISION CLARIFIER"

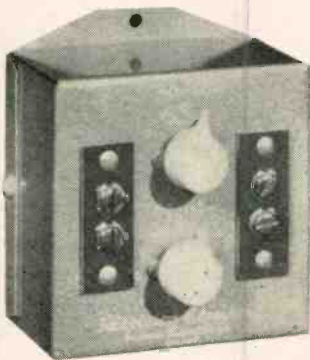

LIST
\$7.50
YOUR
NET
\$4.50
at your
Jobber's.

*an efficient TV
interference eliminator*

• These small, dependable wave traps eliminate or reduce TV picture interference caused by appliances, diathermy, S.W., adjacent channel or other sources. They are a "MUST" for ALL TV Service Contractors as they stop call-backs due to tearing pictures, ghosts, snow, etc. caused by interference.

• Simple to install and adjust in either AC line or antenna lead. A profitable item, too, to sell to any TV set owner having interference problems. Get details from your jobber or write to:

PRECISION ELECTRONICS, INC.

639 Milwaukee Ave. Chicago 22, Ill.

against the stick. The temperature can be tested by trial. If the knife is too hot the shellac will be burned and there is a possibility of scorching the finish; on the other hand, too low a temperature will result in shellac that is gummy and difficult to work into the crevice. Pick up some of the shellac from the stick, transfer it to the surface under repair, and by reversing the knife blade, press the plastic material into place. Try to confine the shellac to the actual damage and avoid spreading it over the neighboring area if possible. Unless the defect is very small, one application of shellac will probably not be sufficient. Before making a second application, reheat the knife, wipe off with a cloth and then burnish with sandpaper. The purpose of this is to remove all used shellac. When the knife has been cleaned, heat it again and apply more shellac. Continue the process until the shellac patch is very slightly higher than the adjoining surface. Now take up the straight knife, heat it and smooth the patch by passing the blade lightly over it. When concealing very small holes or cracks, you may find that the shellac bubbles out of the opening as soon as it is applied. This is due to entrapped air, and it can be overcome by pressing the still soft shellac into place with your finger. The repair is now completed, except for sanding and polishing.

The patch must now be sanded smooth, using 6/0 garnet paper, with oil as a lubricant. You may use the regular rubbing oil sold for this purpose but lemon oil or a mixture of SAE 10 motor oil and kerosene (equal parts) make acceptable substitutes. Wrap a small square of garnet paper around the wood rubbing block and dip the abrasive paper in the lubricant; spread some of the oil on the patch as well. Place the block on the repair as shown in Fig. 4 and rub with strokes that are parallel with the direction of the grain. Be sure to hold the block level and do not rub beyond the patched area; failure to observe these rules might result in damage to the finish. After a few strokes, wipe the oil from the surface and inspect the work. If it is not yet level, apply more oil and proceed with the rubbing. Continue until a smooth, level, unbroken surface is seen. If a good color match has been made and if the defect has been completely filled the patch will now be almost undetectable. All that remains is to give the repair a gloss, nothing further need be done, but if the piece has a relatively dull finish the patch must be dulled accordingly. This may be done by rubbing it lightly with 3/0 steel wool. Before concluding

QUICK, EASY WAY TO READ TUBULAR CAPACITOR CODING



Having trouble deciphering the color coding on tubular molded capacitors in new TV and Radio sets? There's no need to consult complicated wall charts or tables!

The Sprague Capacitor Indicator gives you the needed data in a jiffy. Just flick the dials to the color bands and read the capacitance, tolerance, and voltage directly.

This slick plastic service help fits your pocket. Always on hand, it saves time and avoids mistakes... and it's only 15c. Ask for one at your Sprague distributor today!

SPRAGUE PRODUCTS COMPANY

Distributors' Division of the Sprague Electric Co.
NORTH ADAMS, MASS.

C.T.I. TRAINED MEN ARE AVAILABLE!

Each month C.T.I. graduates ambitious young men who have completed an intensive course in Radio and Television maintenance and repairing. Their training has been practical. They've learned by working on modern equipment under personal, expert supervision. If you need a trained technician, we invite you to write for an outline of our course, and for a prospectus of the graduate. (No fees, of course).

Address:

Placement Manager, Dept. P105-4
COMMERCIAL TRADES INSTITUTE
1400 GREENLEAF CHICAGO 26

ODEGAARD ORIGINAL NAIL



for Ribbon or
Coaxial Cable

Saves more labor, time and money than any other standoff! No drilling—just quick, easy hammer strokes. Easily drives into wood, mortar, iron, aluminum, etc. Excellent most-coupler. "Step"-locked, permanent installation. Cadmium-plated hardened high-carbon steel nail. Specially punched lo-loss polyethylene.

SERVICEMEN: For free sample and nearest distributor's name, write today to Dept. D.

PARTS DISTRIBUTORS: Choice protected territories still open. For full details, write today to Dept. D.

COPYRIGHT 1950,
JOHN ODEGAARD,
BROOKLYN, N. Y.

ODEGAARD MFG. CO.
5416 EIGHTH AVE., BROOKLYN 20, N. Y.

TECHNICIANS AVAILABLE

Carefully selected group of trained men, graduates of reliable and well established trade school now available to fill positions in the Radio or Refrigeration field. Willing to travel anywhere. Why not fill that vacancy with an efficient and reliable man. Write Eastern Technical School, 888 Purchase Street, New Bedford, Mass.

ing the discussion of burning in, mention should be made of a technique that may help you. To avoid burning the finish when the hot shellac is applied, some workers mask the area with cellulose tape. The tape is applied along the edges of the area under repair so that the hot knife cannot touch the finished surface.

[To Be Continued]

SYNC SEPARATORS

[from page 12]

fixed bias developed via R6 should also be checked for correct value.

Improper fixed bias or incorrect values of C5 and R7 may result in improper clipping. If some of the video signal rides through the separator stage it will tend to affect stable synchronization. This condition, while not resulting in complete sync loss, will sometimes cause sections of the picture to sway or move slightly along a horizontal plane. An open C5 will result in complete loss of both vertical and horizontal sync because it removes the necessary sync pulses from the input to the sync separator and thus from subsequent sweep circuits. The same condition will occur if C6 shorts or R8 opens. Thus, complete loss of sync calls for a check of tubes, all coupling capacitors, as well as plate and screen voltages in these three stages.

Checking Circuits with Scope

Figure 3 gives typical scope patterns which are obtained at the grid of the sync separator tube. The vertical patterns and the horizontal are both observed at this point, the different ones being obtained by setting the horizontal sweep frequency of the scope for either the vertical (60 cps) or the horizontal (15,750 cps) pulses present at the grid. For observation of such patterns apply the vertical input of the scope across the grid and cathode of the sync separator and set the coarse frequency control until a single-line pattern is obtained on the scope. Tune the fine frequency control and use the sync control for stabilizing the trace on the oscilloscope screen.

It must be pointed out here that the technician should not expect to observe the exact patterns as reproduced in Fig. 3, or as shown photographically in the service manuals for the sets under repair. Scope patterns will always vary due to slightly different settings of the controls, the particular characteristics of the scope in the use and the type of signal being picked up by the receiver. The video

BUILD 15 RADIOS . . Only \$14.75

- ABSOLUTELY NO KNOWLEDGE OF RADIO NECESSARY
- NO ADDITIONAL PARTS NEEDED
- EXCELLENT BACKGROUND FOR TELEVISION

The PROGRESSIVE RADIO EDU-KIT will help you, if you want an EDUCATIONAL AND INTERESTING HOBBY, or if you want to get into a WELL-PAYING BUSINESS, or if you want to INCREASE YOUR KNOWLEDGE OF RADIO.

Absolutely no knowledge of radio is necessary. The PROGRESSIVE RADIO EDU-KIT is the product of many years of teaching and engineering experience. The detailed instructions and quizzes, are clearly written and illustrated, so that they can be understood by anyone between the ages of 12 and 80.

The PROGRESSIVE RADIO EDU-KIT is not merely a collection of radio parts accompanied by a radio diagram. IT IS PRACTICALLY A RADIO COURSE, offered at a mere fraction of its real value. You will be taught to build radios in a progressive manner. First, you will build a very simple 1-tube receiver. The next set is a little more advanced. Gradually you will find yourself constructing elaborate radio sets, and doing work like a professional radio technician. Every part is illustrated. EVERY STEP INVOLVED IN BUILDING THESE SETS HAS BEEN CAREFULLY PLANNED. YOU CANNOT MAKE A MISTAKE.

Each of the 15 radios you will build operates on 110-120 volts, AC or DC. These sets have been designed to teach you the PRINCIPLES OF RADIO. Therefore, you will build a variety of circuits. The PROGRESSIVE RADIO EDU-KIT is EXCELLENT FOR LEARNING THE PRINCIPLES OF RECEIVER, TRANSMITTER, AND AMPLIFIER DESIGN. It is used in many Radio Schools and Colleges in U.S.A. and abroad. It is used by the Veterans Administration for veteran training.

Quizzes are provided as part of the PROGRESSIVE RADIO EDU-KIT. They will be corrected by our staff at no extra cost.



FREE 1950 EXTRAS: ELECTRICAL AND RADIO TESTER SCREWDRIVER BOOK ON TELEVISION GENEROUS HANK OF WJRE

ELECTRIC SOLDERING IRON ALIGNMENT TOOL SPOOL OF ROSIN CORE SOLDER MEMBERSHIP IN RADIO-TV CLUB

ORDER YOUR PROGRESSIVE RADIO KIT TODAY, OR SEND FOR FREE "KIT-KATALOG" POSTAGE PREPAID ON CASH ORDERS. C.O.D. ORDERS ACCEPTED IN U.S.A.

PROGRESSIVE ELECTRONICS CO.

497 UNION AVE., Dept. D-1
BROOKLYN 11, NEW YORK

DEALERSHIPS AVAILABLE

Insure BETTER Television Service to Your Customers! . . . Exclusively Designed

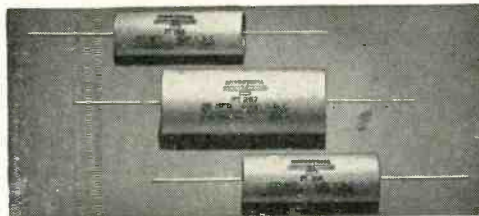

HIGH VOLTAGE AND ELECTROLYTIC TUBULAR

TELEVISION CAPACITORS

Especially Engineered for Television Circuits by INDUSTRIAL CONDENSER CORP.

The economical quality line for replacement. Industrial Condenser Corp. manufacturers of Capacitors exclusively brings you highest quality for the particular requirements of Television at exceptionally attractive prices! Special Capacitors are Pyrotec impregnated for low power factor, high insulation resistance, high operating temperatures. Oil, Pyrotec, Wax and Electrolytic Capacitors. Finest materials throughout.

Ask Your Jobber for our Attractive Prices Today!

Or write for Bulletin 1095. Industrial makes quality Capacitors for Televisions, Radio, every electronic and industrial application—all types.

Send for Complete Catalog

INDUSTRIAL CONDENSER CORP.

1215 CALIFORNIA AVENUE CHICAGO 18, ILLINOIS
Sales offices in all principal cities



Modern plant built by Industrial Condenser Corp. for manufacture of capacitors only



MODEL 620

HICKOK

Linearity Pattern TELEVISION GENERATOR

SOLVES THE NUISANCE CALL and . . . MAKES IT PROFITABLE

Furnishes accurate, stable pattern on the screen of any TV receivers; independent of station operation.

THE HICKOK ELECTRICAL INSTRUMENT CO.
10533 DUPONT AVE. • CLEVELAND 8, OHIO

SEE YOUR JOBBER OR WRITE FOR COMPLETE INFORMATION TODAY

SHOOTS TROUBLE FASTER!

MAKES MORE MONEY
FOR YOU ON JOB OR
AT SERVICE BENCH!



PRICE
\$9.95 at
Distribu-
tor or
postpaid,
direct
No COD's
please.
Ohioan's
add 3%
State
Sales Tax

Signalette

MULTI-FREQUENCY GENERATOR

In radio service work, time means money. Locate trouble faster, handle a much greater volume of work with the SIGNALETTE. As a trouble shooting tool, SIGNALETTE has no equal. Merely plug in any 110 V. AC-DC line, start at speaker end of circuit and trace back, stage by stage, listening in set's speaker. Generates RF, IF and AUDIO Frequencies, 2500 cycles to 20 Megacycles. Also used for checks on Sensitivity, Gain, Peaking, Shielding, Tube testing. Wt. 13 oz. Fits pocket or tool kit. Satisfaction, or money back! See at your dist. or order direct.

CLIPPARD INSTRUMENT LABORATORY, INC.

Dept. F, 1125 Bank Street
Cincinnati 14, Ohio

Qualified Jobbers write, wire for details.

DRAKE *insta-heat* SOLDERING GUN

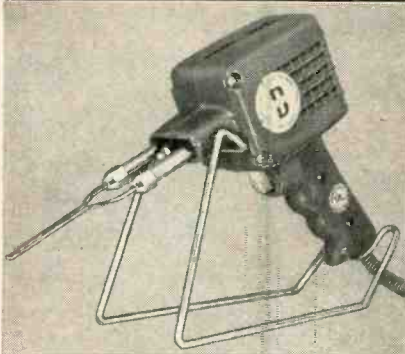

with the *New*

READY STAND

Designed and engineered for you, the perfectly balanced Drake "insta-heat" Soldering Gun features a full 135 watts, easy-removable tip and the ideally located *visa-lite*. Now with the new ready stand—to keep the Drake *insta-heat* Soldering Gun at hand for instant use — it's the gun with all the features you've wanted. See your distributor today.

DRAKE ELECTRIC WORKS, INC.
3656 LINCOLN AVENUE CHICAGO 13

signal will always be a blurred and indistinct section along the horizontal plane, because every horizontal line of video signal differs from the preceding one, even when a stationary test pattern is under observation. It is for this reason that the technician must become familiar with his particular scope and with the general appearance of the patterns he secures.

The use of the scope in the circuits of Fig. 2 will show, however, the absence or presence of the signals and will give indications of the efficiency of the clipping action, and this is all that is required for trouble-shooting this section. Once the lack of signal has been indicated in a certain stage, the trouble will have been localized and can then be corrected in a relatively short time.

An observation of the pattern at the grid for the 1st sync amplifier will result in the same time signals as shown in Fig. 3, except that they will be opposite in phase—that is, negative in polarity. Since this is an earlier stage, the amplitude will also be less. The clipping action of the sync separator may be checked by placing the vertical input probe of the scope across the output of the separator tube and the type of patterns which will be visible are shown in Fig. 4. Here, again, the polarity of the signal is reversed from Fig. 4, while at the same time the video signal has been removed, leaving a fairly clean trace as shown.

Checking Circuits with VTVM

The vacuum-tube voltmeter is also a valuable instrument for trouble-shooting these stages, for it gives us a means of voltage checks and also ohmic checks of the component parts. The "R x 1 meg" scale of the ohmmeter section of the VTVM will also prove useful for checking the leakage of fixed capacitors. The suspected capacitor should be disconnected from the circuit (one side will be sufficient) and a reading of leakage resistance taken with the VTVM. All paper, mica and ceramic capacitors should read well over 500 megohms for low loss and efficient service.

For voltage readings the service notes for the set under repair should be consulted. It will be found that the values of voltages which are given are based on actual VTVM readings with the permissible percentage off value designated. If no off-value percentages are given, voltages should hold within plus or minus 15% with an accurate VTVM. Any voltage or resistance values which are off by a greater percentage indicate further checks are necessary and corrections are in order.

AD INDEX

Aerovox Corporation	28
Alliance Manufacturing Co.	24
American Phenolic Corp.	4
Astatic Corporation, The	28
Burgess Battery Company	8
Clippard Instrument Laboratory	32
Commercial Trades Institute	30
Drake Electric Works, Inc.	32
Eastern Technical School	30
G-E Co., KenRad Tube Div.	Cover 3
Heath Company, The	26
Hickock Elec'l Instrument Co.	31
Industrial Condenser Company	31
KenRad Tube Div. of G-E Co.	Cover 3
Mallory & Co., Inc., P. R.	Cover 2
Oak Ridge Antennas	27
Odegaard Manufacturing Co.	30
Precision Electronics, Inc.	30
Progressive Electronics Co.	31
RCA (Electron Tubes)	Cover 4
Rider Publisher, Inc., John F.	29
Sangamo Electric Company	5
Sprague Products Company	6, 30
Sprayberry Academy of Radio	7
Strand Hotel	32
Sylvania Elec. Products Inc.	9, 10
Telrex, Inc.	2
Tricraft Products Co.	29
Triplett Elec'l Instru. Co.	3
Workshop Associates	30



HOTEL STRAND

ATLANTIC CITY'S IDEAL CONVENTION HOTEL

Exceptional Convention Facilities adaptable to small, medium or large groups. Ample Meeting, Banquet and Exhibition Rooms. Wonderful location Boardwalk opposite Steel Pier. Write Convention Manager TODAY.

The Strand features Spacious Colorful Lounges—Open and Inclosed Solaria—Salt Water Bath in rooms—Garage on premises. Courteous Personnel.

When in Atlantic City visit

Famous Fiesta Lounge

Food for Epicures

Exclusive Penna. Avenue and Boardwalk.

IF IT'S NEW...

KEN-RAD DEALERS HAVE IT!

IN RAPID radio-TV progress, your neighborhood reflects a national trend. Receivers of brand-new design, with new circuits—*new tubes*—are being installed daily. Here is potential service business you want! With Ken-Rad tubes, you can get it—by having the new types ahead of time, in order to meet new socket requirements as they arise . . . 6CB6 is one of many Ken-Rad tubes geared to 1950 servicing needs. You'll come on this 7-pin pentode soon in both the video-i-f and r-f-amplifier stages of TV receivers. Have the 6CB6 and other new tubes *available when you need them* . . . by stocking the Ken-Rad brand! Widen your market—*increase your income*—by drawing profitably on the big fund of research and engineering which General Electric offers you in the form of up-to-the-minute Ken-Rad types, TV-picture, metal, glass, and miniature! Your Ken-Rad distributor will be glad to help. Phone or write him today!



A sharp-cutoff r-f-amplifier miniature pentode, Type 6CB6 differs from the 6AG5 (among existing similar tubes) by having the suppressor brought out to a separate pin connection, instead of connected internally to the cathode. This improves performance—particularly in the new 40-mc i-f applications—by enabling the TV designer to reduce inter-action effects between input and output circuits. Transconductance of the 6CB6 is higher than the 6AG5 by approximately 1,100 micromhos. Grid-plate capacitance is lower—an especially desirable feature in h-f work.

102-JA3

KEN-RAD *Radio Tubes*

PRODUCT OF GENERAL ELECTRIC COMPANY

Schenectady 5, New York



HOT THIS MONTH!

New Ken-Rad tube display and storage cabinet jumps up sales, speeds selection of tubes . . . saves space! You'll want this jimdandy accessory once you set eyes on its stunning dark blue crinkle finish, test its heavy 24-gage welded steel construction, glimpse the good-looking Ken-Rad electric sign at the top. Cabinet is 28" high, 21" wide, 8" deep. The six shelves hold over 150 tubes. Additional shelf units can be added, if desired, for still greater storage. Here's a real sales winner that comes in first every time! It's ready now! Ask your Ken-Rad tube distributor how you can get one.

THE QUALITY OF RCA TUBES IS UNQUESTIONED

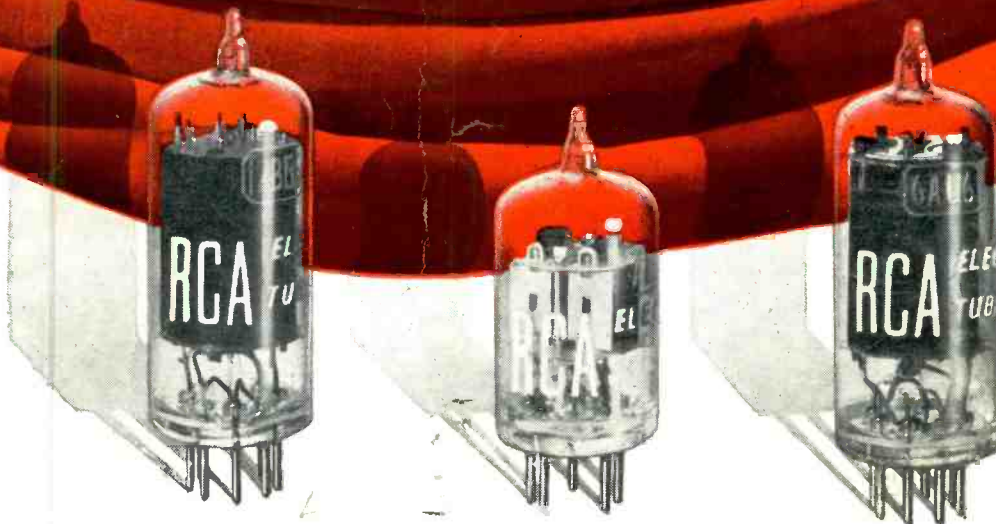

Higher Quality Standards

for TV, FM and AM

THE *QUALITY LEVEL* of RCA miniatures has been continually advanced in step with circuit progress. Improved design . . . more rigid control over manufacture and inspection . . . and more exacting tests, including rigid re-test before shipment, are the reasons why RCA miniatures have unusually uniform characteristics, so important to tubes for television receivers in particular, and also for FM and AM receivers. Their dependability in criti-

cal circuits cuts down costly service call-backs.

And now . . . this *extra* quality of RCA miniatures is "packed in so it can't be shaken out." A new type "snug-fit" carton protects tubes against damage by holding them securely in place during transit.

RCA's engineering leadership adds *value beyond price* to the RCA tubes you sell. Your customers know about this advantage too.

Always keep in touch with your RCA Tube Distributor



RADIO CORPORATION of AMERICA
ELECTRON TUBES

HARRISON, N. J.