

ELECTRONIC SERVICING

JUNE
1957
50¢

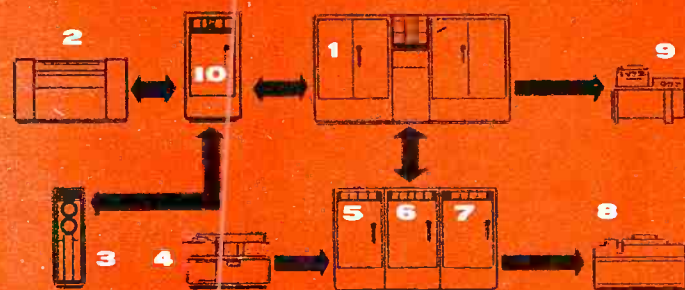
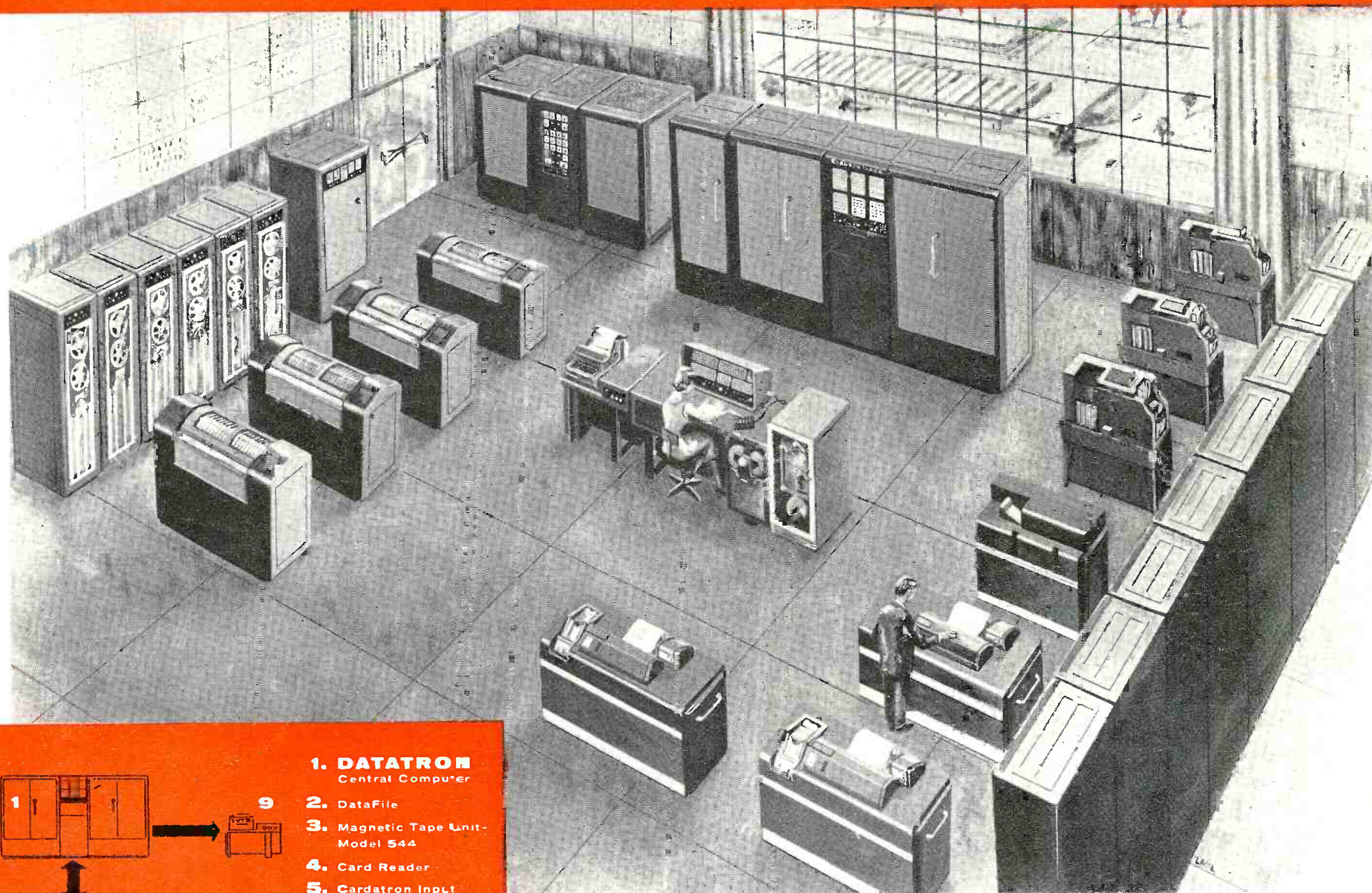

1. DATATRON
Central Computer
2. DataFile
3. Magnetic Tape Unit-
Model 544
4. Card Reader
5. Cardatron Input
6. Cardatron Control
7. Cardatron Output
8. Printer
9. Flexewriter
10. Tape Control Unit

Power Amplifiers in Hi Fi
Marine Radio Direction Finders
Transistor Theory
Vertical Retrace Blanking
Taxicab Communications Systems

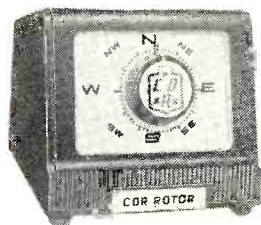

AR-22

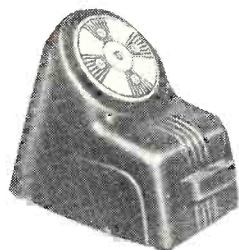

TR-2

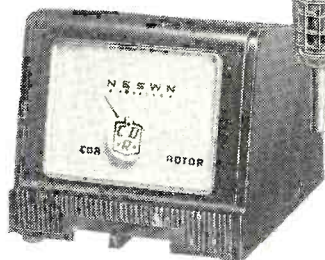

TR-4

5-star feature...

1 the best color TV picture

the growth of color TV means an even greater demand for CDR Rotors for pin-point accuracy of antenna direction.

2 a better picture on more stations

CDR Rotors add to the pleasure of TV viewing because they line up the antenna perfectly with the transmitted TV signal giving a BETTER picture . . . and making it possible to bring in MORE stations.



CDR ROTORS

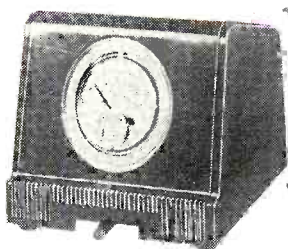

TR 11 and 12

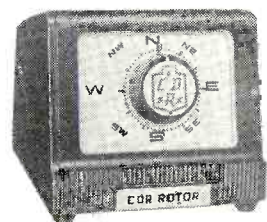

AR 1 and 2

3 tested and proven dependable

thousands and thousands of CDR Rotors have proven their dependability over years of unflinching performance in installations everywhere in the nation. Quality and engineering you know you can count on.

4 pre-sold to your customers

the greatest coverage and concentration of full minute spot announcements on leading TV stations is working for YOU . . . pre-selling your customers.

5 the complete line

a model for every need . . . for every application. CDR Rotors make it possible for you to give your customer exactly what is needed . . . the right CDR Rotor for the right job.



CORNELL-DUBILIER
SOUTH PLAINFIELD, N. J.



THE RADIART CORP.
CLEVELAND 13, OHIO

EDITORIAL STAFF

Sanford R. Cowan	Publisher
Samuel L. Marshall	Editor
Oscar Fisch	Associate Editor
Robert T. Dargan	Technical Editor
David Fish	Editorial Assistant
Irving Tepper	Editorial Assistant
Charles W. Gardner, Jr.	Production Manager
San D'Arcy	Contributing Editor
Paul Goldberg	Contributing Editor
Elbert Robberson	Marine Communications Editor
Lawrence Fielding	Hi-Fi & PA Editor

BUSINESS STAFF

Advertising Sales

New York and East	Richard A. Cowan Jack N. Schneider 300 West 43rd Street New York 36, N. Y. JUdson 2-4460
--------------------------	--

Chicago and Midwest	Jim Summers Suite 55 C Pure Oil Building 35 E. Wacker Drive Chicago 1, Ill. ANdover 3-1154
----------------------------	---

West Coast	Ted E. Schell 2700 West 3rd Street Los Angeles 57, Calif. DUUnkirk 2-4889
-------------------	--

	Charles W. Hoefler 1664 Emerson Street Palo Alto, Calif. DAvenport 4-2661
--	--

David Saltman	Business Mgr.
---------------	---------------

CIRCULATION

Harold Weisner	Circulation Manager
Carol J. Binderman	Ass't Circulation Mgr.
Madeleine Sturmer	Circulation Processing

ELECTRONIC SERVICING (formerly Radio-TV Service Dealer) is published monthly by Cowan Publishing Corp., 300 West 43rd Street, New York 36, New York, JUdson 2-4460. Subscription Price: \$3.00 one year, \$5.00 two years in the United States, U. S. Possessions, Canada and Mexico. Elsewhere \$1.00 per year additional. Single copies 50c. Second Class Mail privileges authorized at New York, N. Y.

POSTMASTER: SEND FORM 3579 TO ELECTRONIC SERVICING, 300 WEST 43rd STREET, NEW YORK 36, N. Y.

ELECTRONIC SERVICING

VOL. 18, NO. 6

Member

JUNE, 1957



FEATURE ARTICLES

- Introduction To Transistor Theory**, by George Browne 2
Description of semiconductor action simplified
- Radio Direction Finders In Marine Electronics, Part 2**, by Elbert Robberson 4
Preliminary precautions to be observed when installing direction finders.
- Vertical Retrace Blanking**, by Irving Tepper 6
Techniques for adding and servicing vertical retrace circuits.
- Radio Performance and Noise Suppression in Taxicab Communication Systems**, by George A. Svitek 8
Valuable techniques to ensure satisfactory system operation.
- TV Cooking Bench**, by Harry J. Miller 12
An ounce of prevention is worth a lot of callbacks.
- Power Amplifiers In Hi Fi**, by Lawrence Fielding 16
Calculation of power requirements for various room sizes.

CIRCUIT AND SERVICE FORUM

- Complete Manufacturer's Schematics—TV** 17-32
Admiral 19Z4RS, 19Z4PRS RCA KCS 101 Ch.
G.E. ST line Zenith Ch. 1530
- Video Speed Servicing Systems** 33-36
Emerson Ch. 120292 P, V
Muntz Ch. 49A4
- Workbench** 37
- Answerman** 42

DEPARTMENTS

- Trade Flashes** 16 **Trade Literature** 40
- Association News** 38 **Rider Speaks** 41
- Advertisers' Index** Cover III

THIS MONTH'S FRONT COVER

Artist's rendering of Datatron system featuring ideal placement of component parts. Electronic automation of office operations offers tremendous opportunities for the enterprising electronic serviceman. ElectroData, Pasadena, California.

Entire Contents, Copyright 1957, Cowan Publishing Corp.

COWAN PUBLISHING CORP., 300 West 43rd Street, New York 36, N.Y.

AMPHENOL

TWIN LEAD HANKS

*...make your
Job Easier!*

AMPHENOL job-size hanks make your selling job, your installing job easier! Pre-assembled with lugs on one end, attractively packaged in convenient 25, 50, 75 and 100 foot lengths, AMPHENOL hanks are easy to use for new and replacement installations, easy to sell to the "do it yourself" market. No bulky spools to handle, just job size hanks for every twin lead application!

Lighten up your work load, boost your sales with AMPHENOL Twin Lead hanks!

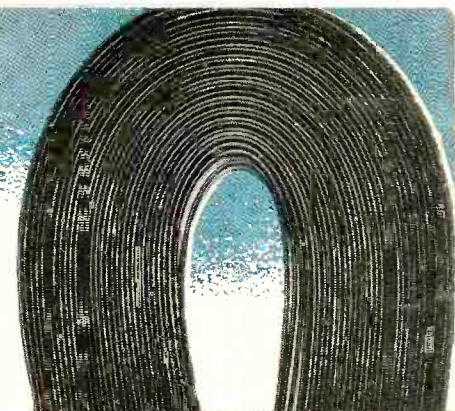

50 FEET
GENUINE

AMPHENOL

no. 214-056
FLAT
TWIN LEAD

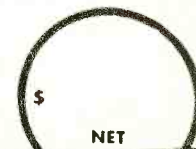

NET
PREASSEMBLED!
WITH LUGS ON ONE END!

AMPHENOL ELECTRONICS CORPORATION
CHICAGO 50, ILLINOIS

Part No.	Description	Available in Hanks of			
		25 ft.	50 ft.	75 ft.	100 ft.
214-318	Indoor—60 mil. 7 28 pure copper cond.	✓	✓	✓	✓
214-056	Standard—60 mil. 7 28 pure copper cond.	✓	✓	✓	✓
214-559	Steelcore—72 mil. 7 28 copperweld cond.	✓	✓	✓	✓
214-298	Rotator—4 conductor—7 28 pure copper cond.	✓	✓	✓	✓
214-100	Century—100 mil. 7 28 pure copper cond.	✓	✓	✓	✓
Now Available in Coils					
214-271	Air-Core—U.S. Pat. 2543696 7 28 pure copper cond.	✓	✓	✓	✓

Remember
for finest quality, virgin
polyethylene is used in all
AMPHENOL Twin Leads.

PRE-ASSEMBLED
with lugs on one end!



AMPHENOL ELECTRONICS CORPORATION
chicago 50, illinois

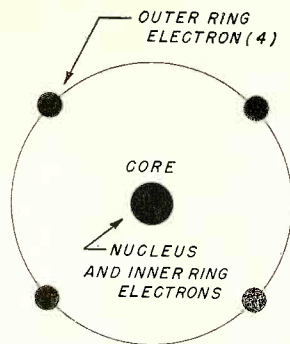

Fig. 1—Simplified germanium atom.

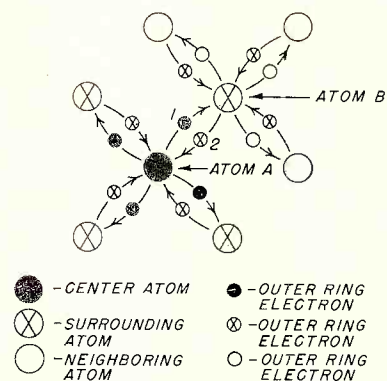

Fig. 2—How atoms share valence bonds.

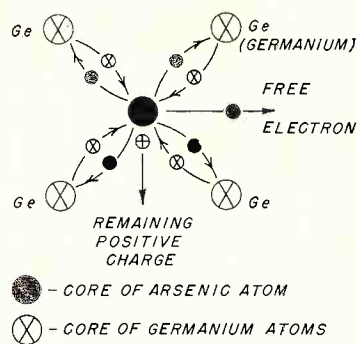

Fig. 3—Production of free electrons.

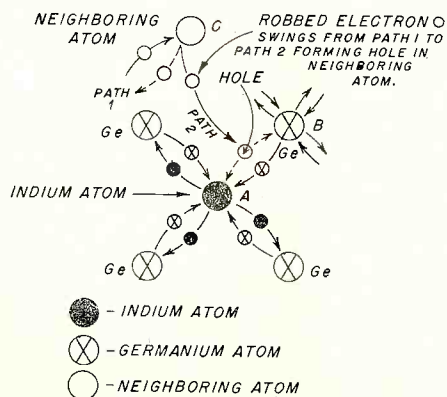

Fig. 4—Production of holes.

Introduction to Transistor Theory

by George Browne

A down-to-earth presentation of the essentials of transistor theory for the serviceman with an eye to the immediate present and the imminent future.

UNDERSTANDING transistors requires an understanding of semiconductors and their characteristics. A semiconductor is a material with a conductivity less than that of a conductor and greater than that of an insulator.

The degree of conduction in any material depends largely on the number of free electrons present. In a conductor this number is large. In a semiconductor it is insignificant.

The number of free electrons present in a semiconductor depends on such factors as: heat, light, the application of external magnetic and electric fields, and the presence of impurities within the semiconductor.

Of particular importance in transistors is the manner in which such impurities produce free negative, or equivalent positive, charges within the semiconductor. To understand this action it becomes necessary to understand the structure of the atom itself.

To this end we direct our attention to Fig. 1 which illustrates a simplified diagram of an atom of germanium which is the most commonly used metal employed in transistors. In this simplification we show a core which contains the inner ring electrons as well as the neutrons and protons that make up the nucleus of the atom. We also show an outer ring of electrons, the lat-

ter being four in number. These electrons, called valence electrons, may be torn away from the atom by the application of suitable forces. As such they become free electrons.

In Fig. 2 we observe how the many atoms contained in a sample of germanium may be pictured as being connected to one another. Here we see a core of atom "A" (black) surrounded by its four (black) valence electrons. Also surrounding the core are four adjacent atoms, each marked with an X. Although only atom B of this group is shown with its four valence electrons (these being identified by small X's) all of the other atoms are also surrounded by four valence electrons as explained in the previous paragraph.

Focusing our attention on a single pair of these electrons such as 1 and 2, 1 being associated with the core of atom A, and 2 with that of atom B we arrive at certain conclusions with regard to the mutual forces being exerted. First, atom B exerts a force of attraction on electron 1, while atom A exerts an equal force of attraction on electron 2. Thus, electrons 1 and 2 act as the connecting links that serve to keep atom A bound to atom B as shown in the figure. It must be understood that core A also exerts a force of attraction on electron 1, so that electron 1 is actually shared by atom A and atom B. A similar condition obtains for electron 2. This same arrangement extends to other atoms one of which is shown in the upper right. Electrons 1 and 2 and

their counter-parts throughout the crystal structure form what are commonly referred to as "electron bonds," the latter being in effect types of dynamic linkages between atoms which tend to maintain the entire structure intact. This structure is called a lattice.

Electron Shells

Studies in chemistry and physics reveal that atoms are stable when the outer or valence ring contains eight electrons. In fact, there is a strong tendency for atoms whose outer rings contain less than eight electrons, to acquire a sufficient number of electrons, from whatever source may be available, so as to enable these outer rings to contain eight electrons. As a matter of fact the tendency to complete such a ring may be so great that in many cases it overcomes the attractive force of a neighboring core on one of its own outer electrons, and "steals" this electron.

Of particular interest is the case previously discussed, and illustrated in Fig. 2, where electrons of adjacent atoms are "shared" rather than stolen. Thus electrons 1 and 2 in the figure are shared by atoms A and B.

"N" Type Germanium

If an impurity atom of some other material such as arsenic is added to germanium, which has a lattice structure corresponding to Fig. 2, it will actually displace one of the germanium

atoms, becoming part of the structure in the manner shown in Fig. 3. Arsenic, having five outer ring electrons, forms a stable structure of four valence bonds with the germanium electrons as shown, resulting in one superfluous electron. The end result is the production of a free electron and a single unbalanced positive charge in the arsenic nucleus. This is a stable condition, because by sharing electrons the outer ring of each atom contains eight electrons.

Impurity atoms, such as arsenic which result in the production of free electrons (negative charges) in a semiconductor material such as germanium are called "donors." Germanium, to which arsenic (or any other suitable pentavalent material) is added in controlled amounts is referred to as N-type germanium. It must be kept in mind that the actual ratio of impurity atoms to germanium atoms in a typical prepared sample is very small, approximately 1 in 10 million. Some other impurity elements which may be used to produce N type germanium are antimony and phosphorus.

The addition of an impurity atom containing three electrons (trivalent) such as indium, gallium, boron, or aluminum, produces different results. Now, as shown in Fig. 4, the three valence electrons of indium enter into valence bonds with three of the four germanium valence electrons. Notice that the germanium atoms B, (see Fig. 2.) previously linked to the displaced atom A, is left with one of its valence electrons unshared. A vacancy therefore occurs in the outer ring, which now contains only seven electrons. The space which lacks an electron to complete the final valence bond is called a "hole."

The tendency to establish an 8-electron ring shell in this case is stronger than the energy binding one of the valence electrons to a neighboring germanium atom such as C. As a result this electron is robbed from the outer ring of atom C. The 8-electron shell structure between the indium atom and its four surrounding germanium atoms is now complete.

Inasmuch as the process involves *attraction* or gaining an outside electron,

[Continued on page 44]

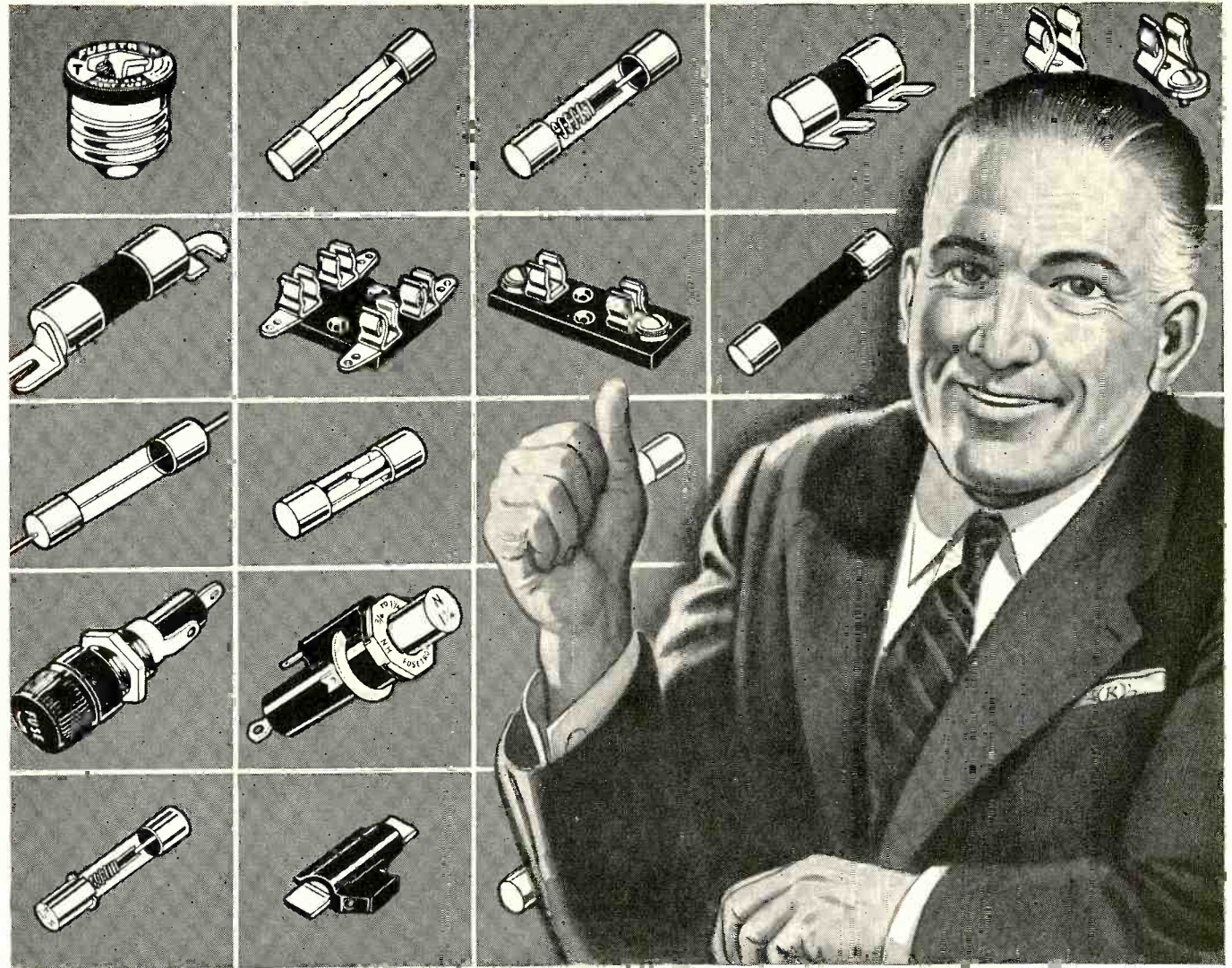

Dependable Electrical Protection

BUSS FUSES OPERATE PROPERLY

Under all Service Conditions . . .

HERE'S WHY . . . To assure un failing dependability, BUSS fuses are electronically tested. A sensitive device automatically rejects any fuse not correctly calibrated, properly constructed and right in all physical dimensions.

Because of this careful testing, you can rely on BUSS fuses to provide maximum protection against damage due to electrical faults. And just as important, BUSS fuses eliminate useless, irritating shutdowns due to faulty fuses blowing needlessly.

As a result, BUSS fuses help protect your reputation for quality and service and . . . BUSS fuses also help servicemen avoid costly,

unnecessary call-backs.

With a complete line of fuses available in all types and sizes, it is just good business to standardize on BUSS fuses.

BUSS FUSES HAVE READY CUSTOMER ACCEPTANCE . . .

Over the past 42 years, millions upon millions of BUSS fuses for home, industrial and automotive use have firmly established BUSS as the Known brand. Sales are easier to make and with never a 'come-back'.

For more information on BUSS and FUSE-TRON Small Dimension fuses and fuseholders . . . Write for bulletin SFB. Busmann Mfg. Co. (Div. of McGraw-Edison Co.), University at Jefferson, St. Louis 7, Mo.

BUSS fuses are made to protect—not to blow, needlessly



Makers of a complete line of fuses for home, farm, commercial, electronic, automotive and industrial use.

Direction Finders In Marine Electronics

Part 2

Part 2 of this 3-part article deals with the precautions to be observed in the preliminary stages of installing marine direction finders.

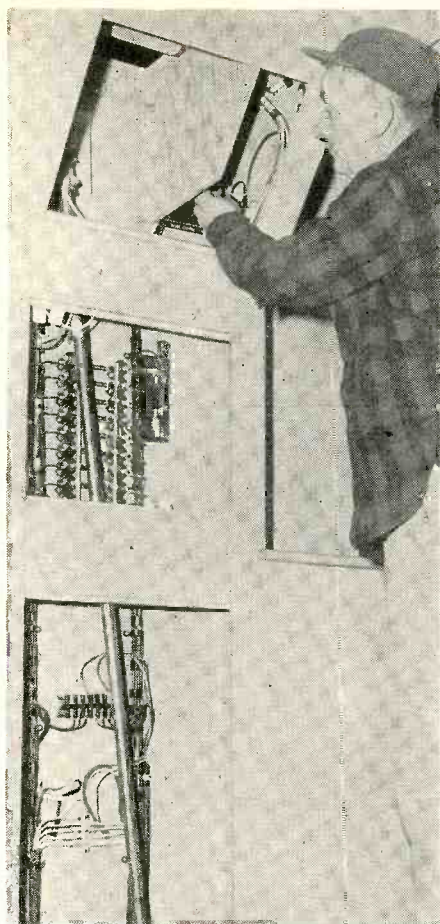

Interconnecting wiring must be routed away from disturbing elements.

THE previous installment discussed the directional characteristics of various types of antennas which are used in radio direction finding. This installment deals with practical loop design, and discusses the problems involved in installing the equipment aboard ship.

Commercial vs. Small Craft Installations

The first radio-direction-finder installation I worked on was a commercial job. It took a couple of men several trips to carry the equipment aboard, and a couple of days work to get it in place, connected up, and operating. After that the direction finder was calibrated, a project involving three technicians, a special transmitter in a rented powerboat, and taking the ship out to a clear spot in the harbor.

This procedure was by no means unique. Professional installers of equipment on commercial vessels still consider a radio-direction-finder installation

an extensive project, requiring close work between electricians, ship fitters, engineers, and the navigating personnel of the ship.

But things are much different in the small-boat field. Today, the purchaser of many a marine direction finder tucks it under his arm, carries it aboard, places it on a table somewhere, and considers himself "in business." True enough, the equipment will pick up the various beacons and broadcast stations, and nulls are obtainable. Mere possession of a radio direction finder, however, does not wrap an electronic coat around the vessel to protect it from the chill of fog. The fact is that the commercial installers do not go to all of the trouble they do simply to pad the bill. Careful installation of a radio direction finder is absolutely required for any degree of reliability, and in many cases, calibration of the equipment is essential if bearings are to be trustworthy.

Although vendors of the modern small radio direction finders do not stress the point, this equipment is as vulnerable to bearing inaccuracy, because of the rigging and top hamper of the vessel in which they are installed, as are the large steamship types of equipment. Bearing accuracy with either kind of equipment may slide many degrees off in one sector or another, and the inaccuracy may change from frequency to frequency. For this reason, a radio-direction-finder installation should not be considered as completed until the installer has checked the operation of

the equipment and furnished a calibration curve or chart as necessary, or else instructed the skipper of the boat on how he may perform this important task himself.

Location of the Direction Finder

But to get back to the installation, the choice of a proper location for a radio direction finder is very important. It is not enough to find clear space on a shelf or table, and then simply screw the cabinet in place. For accurate and satisfactory direction finding, the location for the equipment must be chosen very carefully. This is not the place for cursory inspections and snap decisions. Before choosing the location, the entire environment of the spot should be studied. Things to avoid are metallic masses, electrical conductors, rigging wires, stove pipes, etc., close to the field of the loop. Sources of possible radio noise, and large moving objects are also to be avoided. Many boats have metal window screening which may have an undesirable effect on a loop receiver placed immediately alongside.

Another thing to watch for is the presence of metal conduit, wiring, or piping, concealed inside wooden members of the cabin or wheel house in which the equipment is being installed. Without checking the top and bottom of such a wooden member, the installer might place the equipment in a position where the direction-finder loop was directly alongside a mahogany post that

actually concealed a copper ventilating duct for the engine room. It is necessary to check the structure and wiring plan of the area in which the direction finder will be installed, and then to place the equipment as far as possible from the disturbing elements.

Using the Ship's Power Supply

Many modern radio direction finders are of the portable type with self-contained batteries. However, the larger and more professional type of equipment is powered by a vibrator power supply, or dynamotor, from the ship's main or auxiliary batteries. Direction-finder power consumption is comparatively small, running in the neighborhood of from three to six amperes at 6 volts, to one or two amperes at 32 volts. Nevertheless, the equipment ordinarily should not be tapped into any other existing power line. Although an existing line may have sufficiently large conductors to carry the current, its routing through the vessel and the connections which are made to it, may be disadvantageous to best direction-finder operation because of the possible pick-up of extraneous noise and signals.

Well engineered vessels will probably have extra terminals on their switchboards for such equipment as the radio direction finder. In this event, connection is made to the board. Otherwise, an extra fused terminal should be added to the switchboard.

To reduce unwanted noise and signal



by Elbert Robberson

pickup in the power line, it is best to install direction-finder wiring in grounded metallic conduit or else to employ shielded cable. Although power circuit by-passing is employed in direction-finder receivers, it is still a good idea to keep such "back-door" noise and signal levels to as low a value as possible. To help this power line filtering, it is also desirable to ground the equipment cabinet to the radio ground by a short and direct lead.

Some equipment has a power supply external to the cabinet. If at all possible, this should be placed some distance below the receiver-and-loop assembly in order that noise pickup from the vibrator or dynamotor be minimized. Another caution is to always make certain that the ground polarity of the equipment power supply is the same as that of the boat's battery system. I have more than once, received a jolt — mental as well as physical — from several hot-and-healthy volt's difference of potential between equipment power supplies and nearby grounded objects. The negative side of a circuit is normally grounded. In marine battery systems, however, the positive side is very often grounded, so watch out for this peculiarity and check the ground polarity of the battery system before turning power on the equipment you install. Equipment may be made to conform to the boat-battery ground polarity by reversing the vibrator, or changing the connection of a couple of internal leads supplied for this purpose. ■ ■

Get all this extra value . . .

When you buy **RAYTHEON** ALUMINIZED PICTURE TUBES for your replacement work

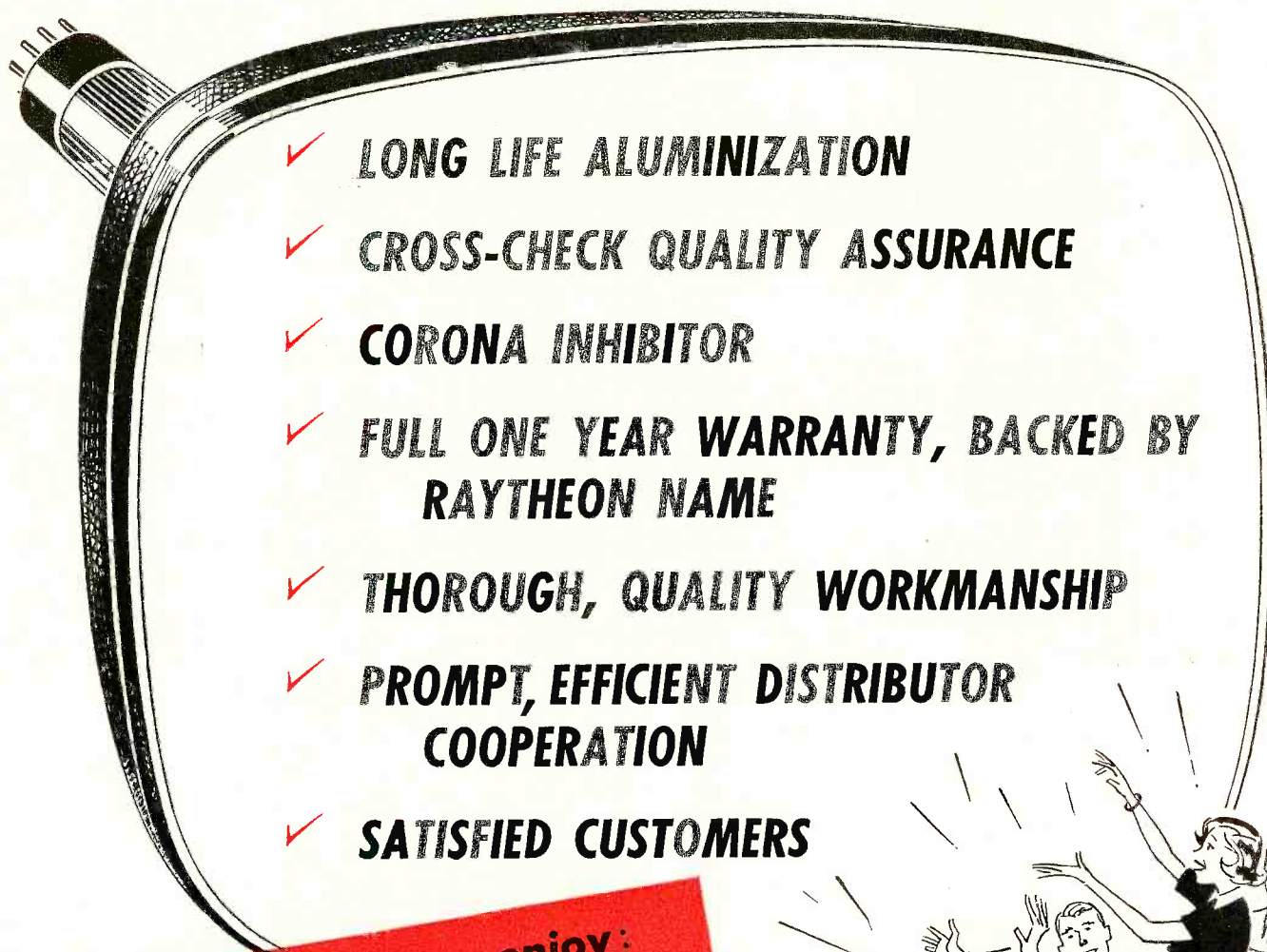

- ✓ LONG LIFE ALUMINIZATION
- ✓ CROSS-CHECK QUALITY ASSURANCE
- ✓ CORONA INHIBITOR
- ✓ FULL ONE YEAR WARRANTY, BACKED BY RAYTHEON NAME
- ✓ THOROUGH, QUALITY WORKMANSHIP
- ✓ PROMPT, EFFICIENT DISTRIBUTOR COOPERATION
- ✓ SATISFIED CUSTOMERS

because they enjoy:
WHITER WHITES
BLACKER BLACKS
CRISPER PICTURES
SHARPER CONTRAST
LONGER LIFE



RAYTHEON MANUFACTURING COMPANY
Receiving and Cathode Ray Tube Operations
Newton, Mass. • Chicago, Ill. • Atlanta, Ga. • Los Angeles, Calif.

Raytheon makes all these { Receiving and Picture Tubes, Reliable Subminiature, J. Miniature Tubes, Semiconductor Diodes, Power Rectifiers and Transistors, Nucleonic Tubes, Microwave Tubes

RAYTHEON
Excellence in Electronics

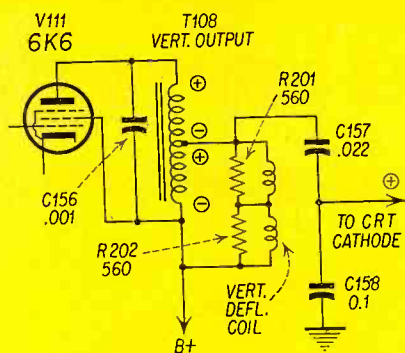

Fig. 1—Pulse applied to cathode of CRT via capacitive divider.

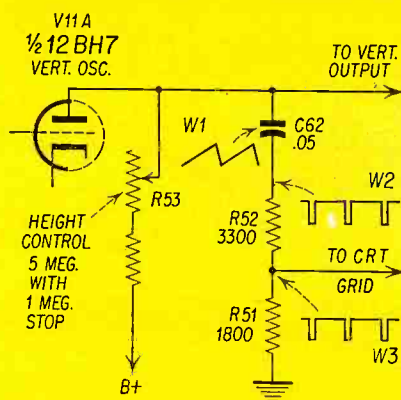
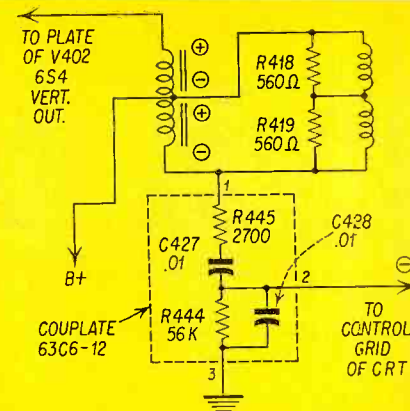
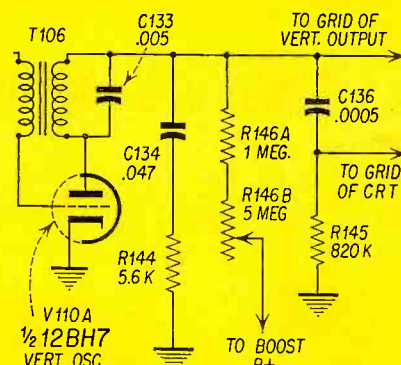

Fig. 2A,B,C—Methods used to obtain blanking pulses for the CRT grid. At A, (left) the pulse is obtained from the peaking resistor in the trapezoidal forming circuit; at B and C, (center and right), the trapezoid is differentiated.



Vertical Retrace Blanking

The addition of vertical retrace blanking circuits and the problems encountered in the servicing of these circuits are treated in this article.

by Irving Tepper

VERY often a serviceman encounters a receiver that has a bad case of "retrace lines." The lines cannot be eliminated without loss of good picture brightness. To overcome this defect, many modern television sets incorporate sweep blanking circuits. The serviceman's outlook is two-fold. He may have to service these blanking circuits or he may find it necessary to add a blanking circuit to a receiver not already having one.

Need For Blanking Circuits.

It might be asked why a blanking circuit is necessary if blanking pulses are transmitted as a part of the composite video signal. The need for additional blanking may be better understood from the following discussion.

The appearance of vertical retrace lines is caused by insufficient blanking voltage at the driven element of the CRT during the retrace period. This condition may be a result of any one of several causes, the simplest being a misadjusted brightness control. Correc-

tion of the CRT bias with the brightness control will restore normal operation. There are situations however where the brightness control does not compensate properly. These may be:

1. A weak CRT
2. Extreme program material
3. Poor circuit design
4. Loss of gain in the video strip

With a weak picture tube, it becomes necessary to lower the bias in order to achieve acceptable brightness. This shift of the operating point towards zero prevents the blanking pulse from extending into the cut-off region, thus making the retrace lines visible.

Extreme program material may also be a factor since very dark scenes frequently show retrace lines. The dc restorer should develop a correcting bias but it is often unable to produce sufficient restoring voltage for very dark scenes.

Sets using direct coupling between the last video amplifier and the CRT exhibit a marked tendency to show retrace lines. If the picture tube emission drops the situation worsens considerably.

Retrace Blanking Circuits.

The simplest corrective measure is a modification of the set to accept a vertical blanking circuit. This circuit will perform the blanking duty during the vertical retrace period. The amplitude of the blanking pulse is so great, from 40 v to 70 v peak to peak, that no retrace lines can possibly show. Even between channels with no video signal present and maximum brightness, retrace lines will not appear. The simplicity of the blanking circuit is such that a majority of manufacturers now include it as standard circuitry.

The circuit operation is extremely simple. A pulse is taken from the vertical circuit, shaped, attenuated and applied to an element of the CRT which can control the beam intensity.

When the video signal is applied to the control grid of the CRT, the blanking pulse is fed to the cathode. In Fig. 1 the blanking pulse is taken from the high side of the vertical deflection coil, attenuated by the action of capacitors C157 and C158. It is then applied as a positive pulse to the cathode of the

CRT, driving the pix tube into cut-off during retrace. A variation of this circuit is shown in Fig. 6B.

Since many receivers apply the video signal to the cathode of the CRT, the blanking pulse is fed to control grid. This requires that the blanking pulse be negative. Three such circuits are shown in Fig. 2. In Fig. 2A the source of the blanking pulse is the trapezoid forming circuit in the output of the vertical oscillator. Resistors R51 and R52 develop negative pulses, W2 and W3 in the figure, which are added to the sawtooth developed across capacitor by C62 to form a trapezoidal wave, W4. The pulse across R51 is negative, and occurs during retrace time. Thus it is suitable for application to the control grid of the CRT. The circuit of Fig. 2B also applies a negative pulse to the control grid by differentiating the trapezoidal output of V110B through capacitor C136 and resistor R145. In Fig. 2C the trapezoid is taken from the lower side of the vertical deflection coil, differentiated, and applied to the control grid of the CRT. Compare this circuit to that shown in Fig. 1 and note

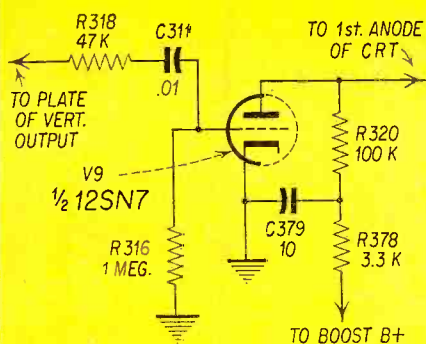

Fig. 3—1st anode blanking used in some General Electric models.

that in order to change the polarity of the pulse, it was necessary to reverse the B plus feed and the pulse take off point. The circled polarities in Figs. 1 and 2C are the instantaneous polarities during retrace time.

First Anode Blanking.

Blanking may also be accomplished at the first anode of the CRT as is done in some GE receivers. The circuit, shown in Fig. 3 is not used frequently since it requires the use of a triode (V9) exclusively for blanking. V9 is grid leak biased and is in cut off during the vertical trace. Since no plate current flows in V9 the voltage drop across resistors R320 and R378 is due to the first anode current. When vertical retrace occurs, a positive pulse is applied to the control grid of V9 through C311 and R318. This pulse drives the grid positive, brings V9 out of cut off, and recharges C311. The heavy conduction of V9 creates a large voltage drop across resistors R320 and R378 and lowers the first anode voltage to a point where the CRT is cut off.

Service Problems.

Due to the simplicity of most blanking circuits few service problems arise. Those that do, usually affect the raster so that we have maximum brightness with no control or no raster at all. The circuit shown in Fig. 1 can develop either difficulty. Should C157 short, the

[Continued on page 46]

Mr. Service Dealer...



PHILCO 7100A—Newest Philco Universal Color and Dot Bar Generator

BUILT-IN QUALITY FEATURES

- 4 crystals for maximum accuracy.
- Crystal controlled sound carrier, picture carrier, sync circuitry and color display.
- Visual marker signal to identify color bars.
- Regulated power supply.
- Separate R.F. and video attenuators.
- Positive and negative video signals for localizing trouble.
- Complete with R.F. and video cables.
- Tube complement of 14 tubes: 7-12AT7, 1-12AU7, 2-6CS7, 1-6CL6, 1-513, 2-OD3.

PHILCO is the Best Buy in Color Servicing

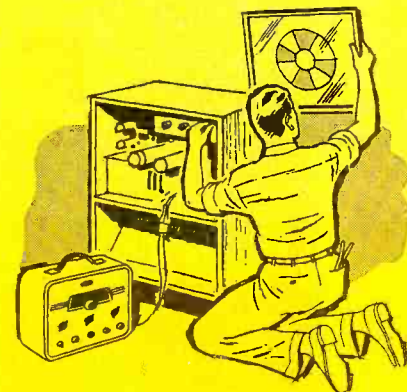

The new Philco Universal Color and Dot Bar Generator, like all Philco Test Equipment, was designed by expert engineers who know service work best. Built by trained technicians to rigid and high quality standards for more dependable, more accurate, faster work on the job.

For Sure Success in Color Servicing

Philco Test Equipment is designed to help your profits grow by being faster and more accurate in solving every service problem. This latest Philco Universal Color Bar and Dot Bar Generator combining both services in one compact, lightweight case eliminates the nuisance of using separate instruments. Improved convergence signals are provided and a "white-raster" display is included to speed up accurate "color-purity" adjustments.

Now, it's no longer necessary to disable the set by removing a tube or changing circuit to obtain the "quiet", snow-free raster required. Halves the work time and eliminates old-fashioned methods requiring you to handle hot tubes. Front panel of etched aluminum with black knobs and easy-to-read etched markings. 18 lbs. light. Dimensions: 13 $\frac{3}{8}$ " wide, 11 $\frac{1}{8}$ " high, 9 $\frac{3}{4}$ " deep.

Get the full story on how the Philco Universal Color Bar and Dot Bar Generator can streamline color servicing.

PHILCO CORPORATION
Accessory Division • Phila. 34, Penna.

PHILCO CORPORATION ACCESSORY DIVISION
"A" Street and Allegheny Avenue
Philadelphia 34, Pa.

Please send me information on Philco Universal Color Bar and Dot Bar Generator with superior accuracy and speed.

Name _____

Address _____

City _____ Zone _____ State _____



Electro
ADVANCED DESIGN
DC POWER SUPPLIES

MODEL D-612T
Electro

Specially designed . . . not a conversion
IMPROVED D-612T
now better than ever . . .
at same low cost!

\$44.95 net

LESS THAN $\frac{1}{2}$ % RIPPLE
(up to 5 Amperes)

DC POWER FOR . . .

TRANSISTOR Portables
TRANSISTOR Auto Radios
TUBE Auto Sets

- Dual Range—0-8 and 0-16 V., continuously variable.
- 10 Amperes continuous duty up to 12 V.
- 20 Amperes intermittent service.

NEW DUAL RANGE EFB . . .

. . . for laboratory and design work on transistor circuits and electronic equipment.

1/10% ripple 0-16 or 0-32 V.
Carbon brush-type variable transformer for smooth voltage control.

SEND TODAY FOR NEW BULLETINS



**ELECTRO
PRODUCTS
LABORATORIES**
4501-D North Ravenswood Ave.
Chicago 40, Illinois

CANADA: Atlas Radio Ltd., Toronto

7456

Radio Performance and in TAXICAB

Reproduction permission granted by G.E. Original article appeared in TAXICAB INDUSTRY, April, 1957.

A MODERN FM set is an intricate and precise tool. Under favorable conditions it can detect and translate into fully audible information a signal only half of one millionth of a volt. Think of it! By comparison, normal *ac* line voltages found in a home are over two hundred million times stronger.

The FM receiver is designed to accept all electrical signals which fall within its frequency band. It has no way of determining whether the electrical signal is a *desired* or an *undesired* signal. Therefore, the receiver will do what it was designed to do: It will detect any intelligence on signals falling within its pass band, regardless of the origin of those signals.

By way of analogy, most taxi companies are familiar, we believe, with channel-sharing which becomes necessary due to the large number of radio users in a small frequency spectrum. When one transmitter is on the air, the others must stand by and wait until the message is concluded. As a means of explaining electrical interference, let us think of noise sources on a cab as small transmitters, some powerful and some weak, sending out signals on the receiver frequency and trying to hog the channel. Since these small transmitters are on continuously, the only hope of getting effective channel utilization is to silence or weaken as many of these sources as possible.

Noise Sources—What Are They?

In taxis, the most prominent noise source is the *ignition system*. There are at least five points within the ignition system which can generate noise, and

which merit consideration. The most obvious source is the *spark plug* itself. The *distributor* gap is another source of noise. The *breaker points* located in the distributor are a third source. *Loose connections* within the ignition wiring are a fourth possible source, and the *coil* is the fifth.

In addition to the ignition system, the *generator* is very often a source of noise signals. Rapidly reversing current within the armature winding, as well as sparking at the brushes caused by a dirty commutator, are definite factors. The *voltage regulator* contains two sets of points, and under normal circumstances one of these sets is intermittently, but at high speed, interrupting the field current in the generator with resultant arcs and noise. Usually instruments or gauges are a minor source of noise, but on some installations they can prove to be a major cause. Another major offender is *static electricity*. This can be generated by a fan belt which has not sufficient lubrication, or can be generated by wheels rolling on the pavement. The static electricity phenomenon is more acute in a vehicle which does not have good solid *dc* continuity from part to part.

There is a subordinate problem on any cab which can create additional noise sources. This comes about due to the many resonant lengths of rods, fluid tubes, and wires within a car. If noise is either conducted or radiated to these wires, they will re-radiate the particular frequency which corresponds to their resonant lengths very effectively. It will be necessary in suppression to pay some attention to this problem.

Noise Suppression COMMUNICATION SYSTEMS

by George A. Svitek,

National Service Manager, Mobile Radio,
General Electric Communications Products

Basic Suppression Requirements

While the suppression problem appears to be enormous and the solution most difficult, it has been found that generally speaking the two main sources of noise are the ignition system and the generator. Other sources may or may not be an important factor in a particular taxi, but in many cases suppression of ignition noise and of the generator noise will usually suffice to achieve a satisfactory noise level. When this is true (and it will be in a large number of cases) it is only necessary to insert resistor plugs into the ignition system, a resistor in the distributor, and a coaxial by-pass capacitor on the generator armature. In many high band (144-172 mc) systems, even the coaxial capacitor on the generator armature occasionally proves unnecessary. It is only after these basic techniques have failed to solve the ignition noise problem that it is necessary to go into the minor noise sources. If it becomes necessary to track down and eliminate noise from these other sources, then a systematic procedure must be used along with proper techniques to solve the problem as quickly and as completely as possible.

Identifying Noise Sources

Much time can be saved if the source of the noise can be rapidly pinpointed. Since many of the noise sources are active only when the taxi is in motion, this is not always easy. Considerable exploration is usually possible with the car standing still, however, and certain sources of noise can either be verified or

eliminated. In searching for noise it is desirable to feed a weak signal into the receiver to just open the squelch. A weak signal is more desirable than a strong one because it will not necessarily eliminate the amplitude effects of the noise signal and these can therefore be heard in the speaker.

Ignition noise can be easily identified because of its nature. It produces a popping crackling sound in the speaker and the rate of these pops is tied to the engine speed. Speeding up or slowing down the engine will cause corresponding changes in the ignition noise. From this standpoint we might say that ignition noise is a relatively uniform type. It is not, however, as uniform as the generator noise. *Generator* noise is characterized by a high pitched whine which is a function of the speed of the generator. Separating the ignition noise from the generator noise is easy, for it can be accomplished by turning off the ignition switch. This will immediately kill the ignition noise, but since the generator is still turning, the noise from the generator will still be present. It is entirely possible that noise from the *voltage regulator* is still also present. This noise, however, does not have the characteristic whine of the generator and produces sharp crackling popping sounds in the speaker. These sounds occur not at a uniform, but rather at a random rate, and as such can be distinguished from ignition noise. Further identification of our noise source is now possible from certain logical considerations. If resistor plugs have already been added to the ignition system, and the ignition noise persists, then in all likelihood noise is

... another
MALLORY
service-engineered
product



Servicemen's favorites in wire-wound controls

You're sure of giving your customers the best when you use Mallory wire-wound controls. The choice of servicemen and manufacturers everywhere, they have set the standards of the industry for value and performance.

They're conservatively rated—to assure you of cool operation without need for using over-sized units.

They're compact—fit readily into crowded chassis locations.

They're long lasting—give years of stable, dependable service.

They're uniform—made to strict specifications to meet or exceed original equipment requirements.

Mallory 2-watt and 4-watt controls are available in resistance values and tapers to match every replacement need. Your local Mallory distributor has a complete stock—see him today!

P. R. MALLORY & CO. Inc.
MALLORY

P. R. MALLORY & CO. Inc., INDIANAPOLIS 6, INDIANA

- Capacitors
- Controls
- Vibrators
- Switches
- Resistors
- Rectifiers
- Power Supplies
- Filters
- Mercury Batteries

being conducted back into the cab's wiring. A systematic search can be made to see if this is so.

Chase the Trouble Away

Various "Noise Chaser" schemes have been tried with different degrees of success. One such scheme employs a long piece of RG8 transmission line. One end is plugged into the receiver and the other has the external shield removed exposing a $\frac{1}{8}$ inch length of the center conductor. A current meter with equally long leads is plugged into the first limiter jack of the receiver under consideration, and carried around with the RG8 probe. When the probe is placed near any wire or area which is radiating considerable interfering signal, the limiter current will increase. If for some reason the limiters become saturated, then the pick-up of the probe can be decreased by looping over the center conductor and soldering it to the braid.

A variation of this noise chaser uses an AM detector and audio amplifier as the indicating source in preference to the limiter current. Such a device will produce an audible signal similar to those encountered on AM radios, a technique with which many radio technicians may already be familiar. The radio set itself can be used as an AM detector by removing the 6AL5 in the squelch circuit, detecting the incoming signal at the limiter grid, and feeding it into the audio amplifier. The method using the portable AM detector is more easily applied, however, because of the speaker's being carried with the probe. In this manner various parts of the vehicle can be jarred to see if noise is being produced in audio output. This affords a good means for finding loose or intermittent connections. It is also quite effective for finding noise generated by the elements of the various gauges in a car.

Noise due to static electricity is usually generated with the auto in motion. This makes a detecting job more difficult. Two sources, however, can easily be identified. The first is wheel static, and the second tire static. Wheel static can be detected by putting on the brakes while the car is in motion. If wheel static is present, it will disappear while the brakes are on. Leaving the pave-

ment and pulling the car onto the shoulder will eliminate tire static if it is present.

Detection of fan belt static is a little more difficult. Perhaps here the cure is easier than the searching job, for proper lubrication of the belt will minimize the electricity generating capability. Static discharges which occur while the car is in motion which can neither be pinned down to fan belt nor tire or wheel noise, can usually be cured by bonding. Unfortunately, there is no simple way of detecting these noises and the method for suppressing them is usually "cut and try." The most promising areas to try bonding are fairly well known, however, which simplifies this test somewhat.

Suppression Pitfalls

The main weapons in attempting noise suppression are by-passing or filtering, and bonding. Both techniques must be properly understood and applied, however, if proper results are to be achieved. To understand this problem we must answer the questions, "When is a by-pass not a by-pass?" and "When is a bond not a bond?" For effective by-passing, either coaxial capacitors or very high quality paper or mica capacitors must be used. This is because poor quality capacitors have considerable internal inductance. Thus, the capacitor can be represented by an R L and C in series. The larger the inductance the less effective is the capacitor when used as a by-pass. A typical condenser used for by-passing in the AM broadcast band has a peak by-passing efficiency in the area of one and one-half to two megacycles. Attenuation drops off very rapidly, however, at a frequency of two and a half to three megacycles. This is because such a capacitor contains considerable internal inductance. To be an effective *rf* by-pass a capacitor must show a very low impedance to ground. This it cannot do if it contains considerable internal inductance or has long leads connecting either to ground or to the line being by-passed. The longer a lead is the more inductance it contains. An element with high inductance does not present low impedance to ground but high impedance. For this reason it is absolutely

necessary to use high quality capacitors as well as very short leads. Coaxial capacitors are specially designed to have low internal inductance, and are very good by-passes up to the area of 1000 *mc* when used with very short leads.

In order for a bond to be effective, it must meet two requirements. First, it must present a low *dc* resistance between the two members being bonded, and second it must present a low *rf* impedance as well. It is a fact that any two members being bonded together will have a certain amount of distributed capacity between them. This can be easily seen in the case of a hood and fire wall. At the back the hood is insulated from the body by a cloth strip. It can be seen that considerable capacity can exist between these two members. This capacity is in parallel with any bond which is connected between them. If the bonding strap is long and has considerable inductance, we then have effectively a parallel tuned resonant circuit. Thus, instead of presenting a low *rf* impedance between the two members we may present a very high *rf* impedance between them at the resonant frequency of the trap. If we are unfortunate enough to have this frequency fall near our receiver frequency, the bond will be totally ineffective. It can be readily seen from the two above examples that false indications can be obtained by improperly applied techniques.

The third most important fundamental technique is to always by-pass sources of noise close to the source. For instance, it does little good to by-pass the temperature gauge at the dash of an automobile when the noise is actually being generated within the heat-sensing element of the motor block. In many cases, this noise has to travel a long length of wire before it reaches the dashboard. It will radiate over the whole length of this wire and possibly into the receiver. In order to be truly effective gauges must be by-passed as near to where the actual element is as possible. This same consideration applies to armature or regulator by-passes or to by-passes on the ignition coil.

Suppressing the Ignition System

It has already been mentioned that the primary source of noise in the igni-

tion system is the spark plug. The situation can be almost cured by using resistor plugs. Considerable bias exists against the use of resistor plugs in certain areas. When properly applied, however, these plugs are highly satisfactory, and the benefits to be achieved by their use from the noise standpoint certainly outweighs any small disadvantages which might result from their use.

Proper application of resistor plugs requires first of all to use the correct plugs. It has been recorded for instance that certain types of plugs give excellent life and performance on cars of one manufacturer, whereas other spark plugs have given excellent service in vehicles made by other companies. Resistor plugs can be identified by the plug number. If a set of non-resistor plugs is replaced by a set of resistor plugs, it is also highly desirable to check the time of the engine. Failure to do this may result in sub-par engine performance which is in no way the fault of the plugs.

Suppression of noise generated in the distributor is usually accomplished in the same manner. Many distributors have resistors built in, and if this is not the case, a center tower resistor can be used. These techniques are effective on the noise generated by the arcing from distributor rotor to stator. There is, however, another point to be considered in connection with distributors. An old distributor with perhaps forty to fifty thousand miles of operation will have many tiny particles of metal imbedded in the bakelite. These have been torn from the rotor and stator by the arcing, and they contribute to an overall noisy situation. Under these conditions the distributor cap should be replaced, since engine performance will also be improved.

Resistance type ignition cable has come into common use during the past few years and is very effective. Such leads have been known to age and become brittle after a period of years though, with a resultant breakdown in their conductivity. Under such circumstances the leads must also be replaced. A potential problem exists in the use of the steel stranded ignition cable. Electrical connection to the end ferrules is made by crimping, and where this crimp is not effective, we have a possible source

of arcing. This can be cured by correcting the crimp or by replacing with ignition cable which can be soldered and soldering all the ferrules.

The breaker points in the ignition system are also a source of potential noise. Arcs in this part of the circuit are usually quenched very quickly by the capacitor. If the point setting is incorrect or if the capacitor is old or of improper value, arcing will be more severe than necessary, with resultant increase in ignition noise.

The coil itself is not usually a source of ignition noise. It can, however, pick up ignition noise from the ignition wiring and re-radiate it, particularly if the body of the coil is not properly grounded to the vehicle frame. In many cases it will happen that the metal body of the coil has been painted and placed in a strap which is grounded to the frame. There is no DC contact between the body and the bracket and the coil will radiate noise. This can be cured by removing the coil and scraping the body of the coil clean along with the inside of the bracket and then replacing. With a plastic-cased coil, it is sometimes necessary to completely enclose the coil with a metal shield.

To keep the ignition noise penned up under the hood, it is desirable to place a coaxial by-pass capacitor in the battery lead to the coil primary located as close to the coil as possible. Such a capacitor will prevent ignition noise from being conducted out on the car wiring where it can find many lengths of wire suitable for radiating to the antenna.

Generator Suppression

In general the only suppression that will be required on the generator is the coaxial capacitor, from the generator armature to ground. This capacitor must be mounted as close to the generator armature terminal as possible, preferably on the generator body. These capacitors come in fifty and one hundred amp sizes and a value of about one half microfarad usually works very well. If such a capacitor proves ineffective, it is a good idea to check the generator. In all likelihood the generator has not received any maintenance for a considerable period of time and cleaning up the

[Continued on page 43]

INSTALL 'EM...



FORGET 'EM!

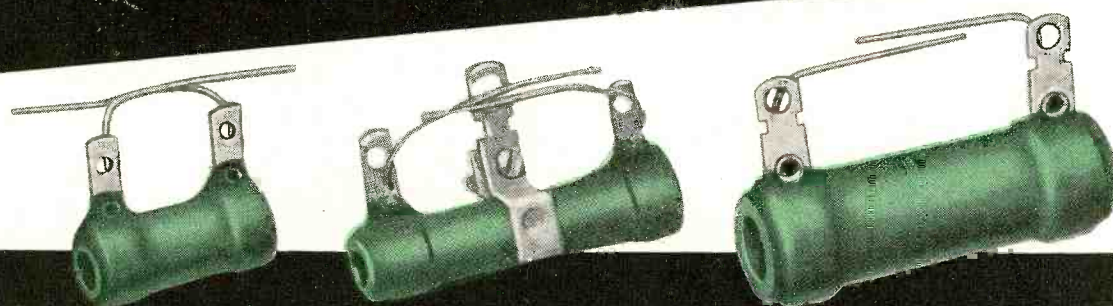

Greenohm^{*}

WIRE-WOUND POWER RESISTORS

You can count on Clarostat "Greenohm" power resistors — they won't let you down. "Greenohm" power resistors are used in the most expensive, critical electronic equipment where dependability is the prime requisite. You can have this same dependability, by insisting on "Greenohm" power resistors.



LOOK — Overload a "Greenohm" power resistor. Get it so hot you can light a cigarette from it...



THEN . . . plunge the over-heated "Greenohm" power resistor in cold water. No blisters, no cracks, in fact, it will work good as new.



* Reg. U.S. Pat. Off.

Ask your Clarostat Distributor for Greenohm Resistors

CONTROLS AND RESISTORS

CLAROSTAT MFG. CO., INC., DOVER, NEW HAMPSHIRE

In Canada: CANADIAN MARCONI CO., LTD., TORONTO 17, ONT.

The Case of The Serviceman WHO KEPT IT CLEAN!



The fringe area Jones family wanted TV entertainment but got "snow". When Junior's favorite show was ruined once too often, the serviceman was called in.



He pointed out that even with a good antenna weak signals are affected by line loss and noise, making good reception impossible . . . recommended a Jerrold DE-SNOWER.

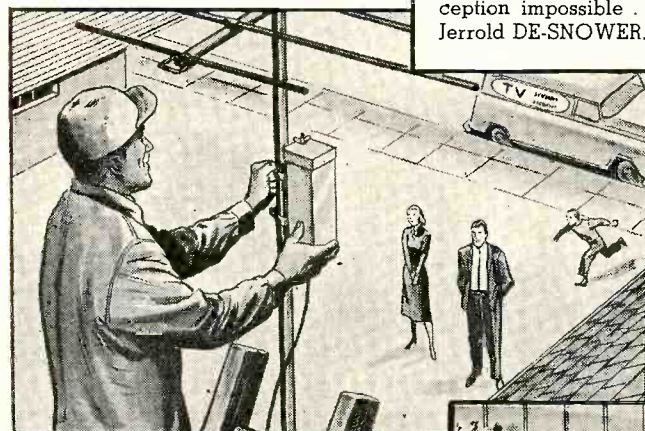

Antenna mounted, the DE-SNOWER captures the signal before loss and noise affect it, delivers it to the set over shielded coax . . . providing snow-free pictures.

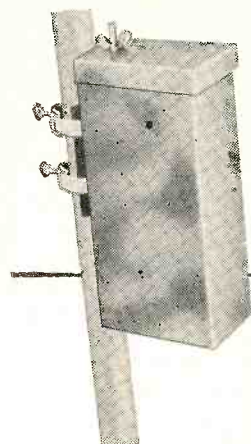

Thanks to the serviceman and Jerrold the Joneses get high fidelity color and black and white pictures every time!

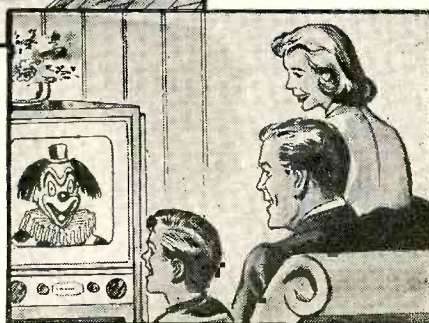

THE JERROLD DE-SNOWER

A high profit pre-amplifier accepted everywhere! Combines 25 db gain with low noise input—only 6 db. No AC outlet or separate wiring on mast.

Available in 3 models—Single Channel; Broadband Chs. 2-6, Broadband Chs. 2-13. Packed complete with remote 24 volt power supply.

See the DE-SNOWER line at leading distributors or write direct for illustrated brochure to: Dept. P. D. #8

JERROLD

ELECTRONICS CORPORATION

Philadelphia 3, Pa.

Jerrold Electronic, Inc.
Toronto 10, Canada

Export Representatives
C B S International
New York 22, New York

LOOK TO JERROLD FOR AIDS TO BETTER TELEVIEWING

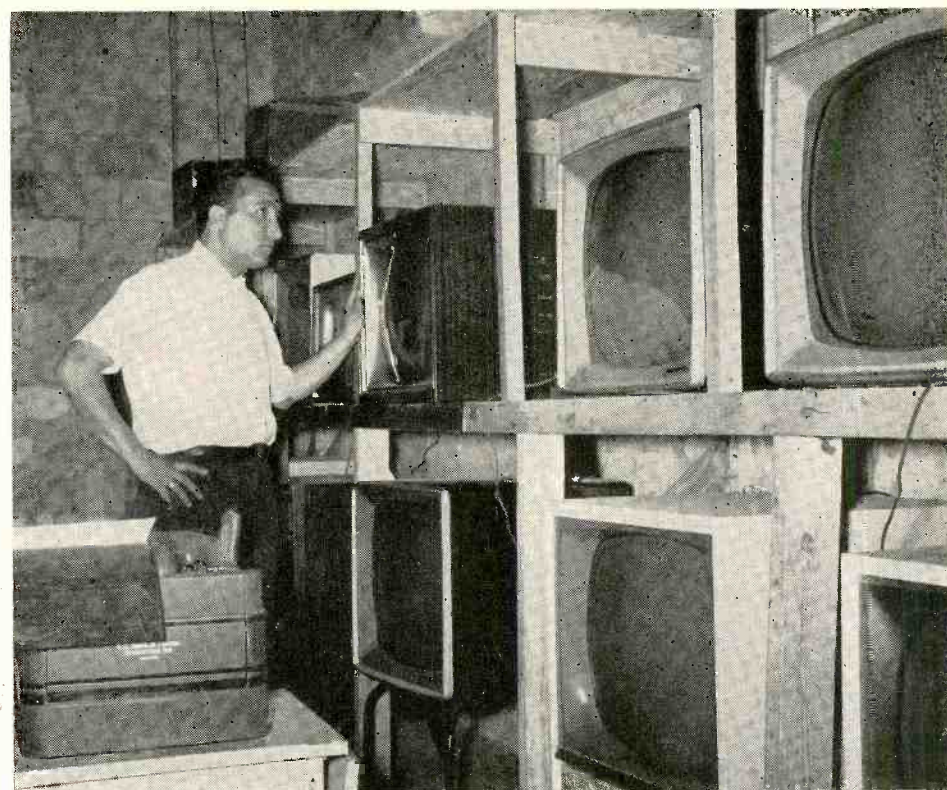

TV Cooking Bench Insures Satisfaction

by Harry J. Miller

Good will is created and needless call backs avoided by the pre-testing procedure described in this article

"HELL hath no fury like a woman scorned!" aptly describes the state of mind of a customer who has waited years to buy a television set, then has trouble with it right after delivery," says James H. Yergey, who manages the TV and Appliance department at Webb's City, largest store in St. Petersburg.

To prevent this catastrophe, the Florida manager never permits a video set to get out on the showroom floor, or to be delivered to a customer, until it has been parked on a "Cooking Bench."

The bench is a series of compartments

into which new sets are moved directly from their packing cases and hooked up across the line. "For 48 to 72 hours," said Yergey, "we let these sets fry. Sometimes a tube is missing or a part requires adjustment or some fault has developed during shipping. In any case, we line them up and turn them on."

From time to time during this pre-test, the service foreman will examine the operating set to see if anything has developed to warrant pulling the chassis. This can be done on the spot, thus avoiding the embarrassment of having to yank a chassis a few days after de-

WIN A WEEKEND AT THE WALDORF FOR 2

IN THE PYRAMID TWIST-MOUNT CAPACITOR CONTEST

TOTAL—147 WONDERFUL PRIZES—PLUS A PRIZE TO EVERY ENTRANT SERVICEMEN, ENTER NOW! YOU CAN'T LOSE!

IT'S EASY TO WIN ANY ONE OF THESE WONDERFUL PRIZES:

GRAND PRIZE: Weekend at New York's fabulous Waldorf Astoria Hotel for 2, guest of Pyramid. Air transportation from your home to New York and return. Weekend of entertainment including a visit to the famous Gaslight Club, dinner at the Waldorf's Starlight Roof, and breakfast at the Waldorf. Air transportation by CAPITAL Airlines Viscount.

1st PRIZE: One 4-drawer steel file cabinet plus your choice of 50 sets of PHOTOFAC folders. Value: \$120.45.

FIVE 2nd PRIZES: 5 CR-30 PRECISION Cathode Ray Tube Testers. dlr. net \$109 ea.

TEN 3rd PRIZES: 10 CRA-2 PYRAMID Capacitor-Resistor Analyzers. dlr. net \$92.50 ea.

TWO 4th PRIZES: 2 SW-54 NATIONAL Short Wave Receivers. dlr. net \$59.95 ea.

TEN 5th PRIZES: 10 JENSEN professional speaker units consisting of a D-30 lifetime driver unit and RT-20 rectangular horn. dlr. net \$44.40 per set.

FIFTEEN 6th PRIZES: 15 TW CHANNEL MASTER 7 element "traveling wave" TV antennas, Model 350. dlr. net \$33 ea.

EIGHTEEN 7th PRIZES: 18 PYRAMID Pyra-Pak kits consisting of \$69.95 in Pyramid capacitors, metal tool box and tool kit. dlr. net \$29.95.

THIRTY-FIVE 8th PRIZES: 35 PYRAMID gift certificates entitling you to \$10. (dlr. net) of Pyramid capacitors at your distributor.

9th PRIZE: WALCO twin-point diamond phono needle. dlr. net \$30. For G.E. Var. Rel. Cartridge.

FIFTY 10th PRIZES: 50 WALCO needles for G.E. twin-point sapphires. \$3.50 dlr. net.

AND to all entrants a kit of 5 bypass and coupling capacitors featuring the Pyramid type IMP.

It's easy to win any one of 147 big prizes—just follow these simple rules: Identify the unnamed Pyramid T-M capacitor in the TV set schematic appearing on this page. Give the Pyramid stock number, name and model number of TV set. Then mail your entry to Pyramid. Use coupon on this page or obtain additional blanks from your distributor. A different schematic will appear in these servicemen's magazines for 4 months. Prizes will be awarded on a points-earned basis as follows: 5 points for Contest No. 1; 10 points for Contest No. 2; 15 points for Contest No. 3; 20 points for Contest No. 4; and 10 points each contest for neatness. Possible perfect score: 90 points. However it is not necessary to achieve a perfect score to be declared a prize winner.

So act quickly...send in your entries early each month...you can't lose.

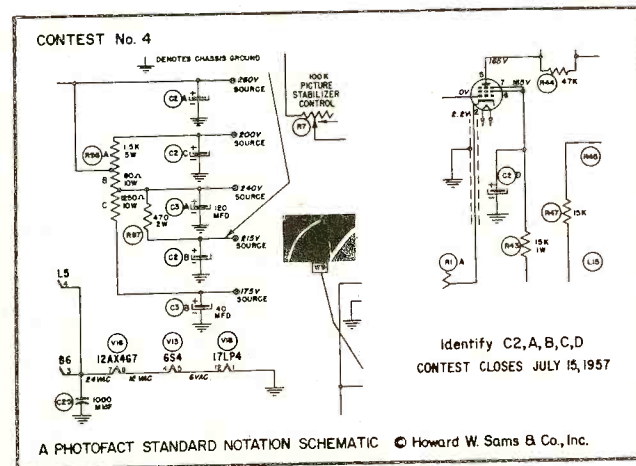

livery. Result—fewer comebacks, fewer service calls, and a more satisfied customer.

"If we're having a sale on a particular number," said Yergey, "we line up the models of that number and turn them on to find out how well they're working. Should a set be delivered to a customer, and the serviceman sent to answer a complaint find a major repair is necessary, we send out a new chassis the very next day, and yank the faulty one for repairs in our shop. Nothing makes a new customer happier than this action, and nothing makes him unhappier than to have a number of repairs on his set right after he's bought it. In this way, we've eliminated at least 25% of needless service calls.

"Another thing we do that keeps our customers satisfied, is to give each buyer a warranty that begins the day the set is installed, not the purchase date. Very often, this few days' difference in time may result in a set conking out just out of warranty, and this isn't fair to the customer.

"Within 30 days after a new set has been installed, we send a man out on a "courtesy call," regardless of whether or not we've heard from the customer. On this occasion, the serviceman checks the set's performance and the ability of the customer to set the controls.

"We've found that old people especially—and they comprise many of our customers—don't get the hang of tuning properly, nor can they adequately follow the information in the set's instruction book. Our technician reviews with them the set's operation."

The TV setup in this giant Florida store is broken down into three units; an antenna crew which does nothing else; a 'make-ready' crew which checks all incoming sets and operates the cooking bench; and finally, there is a repair department of top technicians. Should the 'make-ready' department find any minor defects in a new set, they do the repairing. If the job is a major one or elusive, it goes to the experts in the repair department.

St. Petersburg is a town of retired people, and these oldsters chat for hours together on the town's benches or at their trailer camps. "Word of our service soon spreads," said Yergey.

JUDGES: M. Harvey Gernsbeck, editorial director, Radio-Electronics
Oliver Read, D.Sc., publisher, Radio & Television News
Howard W. Sams, chmn. board, Howard W. Sams & Co., Inc.



HELPFUL HINTS

The unidentified capacitor in each entry will be a Pyramid Twist-Mount. All schematics are of TV sets made in the U. S. by a known manufacturer within the past 2 years.

Schematics for reference may be those published by the TV set manufacturers, Howard Sam's Photofacts, or by any other accepted publisher. You may enter as often as you like but be sure to include a box top (showing stock number) of any Pyramid Twist-Mount Capacitor, with your letterhead or business card with each entry.

WHO MAY ENTER

Any Radio-TV serviceman or employee of a Radio-TV service company may enter. Officers, employees, (members of their families) of Pyramid Electric Co. or its advertising agency are not eligible to enter the contest. All entries are limited to residents of the continental U. S. over 21 years of age.

All entries become the property of Pyramid Electric Co., none will be returned and the decisions of the judges are final. In case of ties, duplicate prizes will be awarded. This contest is subject to all federal, state and local laws and regulations.



MAIL THIS ENTRY BLANK NOW!

Pyramid Twist-Mount Contest, Dept J
Pyramid Electric Co.
P.O. Box 655, Tyler Park Station, North Bergen, New Jersey

Entry No. (1) (2) (3) (4)—(check one)—is: Pyramid stock No. _____
Twist-Mount values _____

Set manufacturer's name _____ TV set model No. _____
I enclose a box top (indicating stock number) of any Pyramid Twist-Mount Capacitor together with my business card or letterhead or my employer's.

Contestant's name _____ Position _____

Contestant's address _____

City _____ Zone _____ State _____

Employer's Firm name _____

Employer's address _____

City _____ Zone _____ State _____

My jobber's name and address _____

ENTER AS OFTEN AS YOU LIKE FOR ADDITIONAL ENTRY BLANKS
SEE YOUR JOBBER.

Capacitors, Selenium Rectifiers—for original equipment, for replacement
PYRAMID ELECTRIC COMPANY North Bergen, New Jersey

HAVING investigated the means by which minute audio signals are amplified, equalized, altered and selected in high fidelity preamplifiers and control chassis, we are now ready to examine the "powerhouse" of the hi fi chain—the basic power amplifier. Strictly speaking, the power amplifier of any audio system consists of a single, a pair, or more power output tubes, coupled to a transformer designed to match the plate impedance of the output stage to the voice coil of a loudspeaker. Standardization of terminology in the hi fi industry enlarges quite a bit on this definition, however. In hi fi, the power amplifier (or basic amplifier) is a unit having no compensation or tone controls (other than perhaps a pre-set input level control), several voltage amplifying stages, a power supply section and finally the actual output stage which does the "power amplifying." There are several reasons for this rather arbitrary break-down. Really large power amplifiers are very bulky affairs and are meant to be "heard but not seen." That means that a physical as well as an electrical separation between preamplifier (which houses the customer controls) and amplifier is desirable. It would be neither practical nor desirable to transmit the large driving voltages across long lengths of cable from one to the other. On the other hand, there is a practical limit to the "low signal" side below which the signal to hum ratio problem would become important. As a rule, the voltage necessary to drive these basic amplifiers to full output falls anywhere between about .75 to 3.0 volts. This range of voltage amplitude is great enough to be beyond the hum problem, yet small enough to be handled by inexpensive shielded audio or microphone cable. Thus, preamplifier control chassis equipped with cathode followers (see February issue of SD) may be separated by distances of several hundred feet from the basic amplifier. It should be noted at this point that not all amplifiers are so divorced from their associated preamplifiers. In recent years the two units have been recombined on one chassis with great success. Generally, however, these units will have much lower power ratings than their separated counterparts, because of space limitations in design. Regardless of the

format used, we shall consider the amplifier portion of a system to be those stages following all tonal compensation and equalization whose sole function is amplification and final presentation to the terminals of a loudspeaker system for reproduction.

Selling Power Output

Long experience in this field has shown that a hi fi customer is like no other consumer in the world. You, as a hi fi service dealer, will be sought after not only for repair work but for earnest consultation and advice. One of the most serious questions you will be asked is: "How much power do I need in a power amplifier for good reproduction?" There is, of course, no single answer to this question, so at this point let us consider the problem in some detail. One watt of *acoustic* power would be enough to fill an auditorium having 1,000,000 cubic feet with sound equal to that of a symphony orchestra playing at average volume. Why, then, do we see amplifiers on the market having ratings of 25, 50 or even 100 watts of audio power and being eagerly bought by the public? Well, in the first place, we said that one watt of *acoustic* power would fill an auditorium, but *acoustic* power is not electrical audio power. There's a loudspeaker in between, and by far the most inefficient unit in the

entire hi fi chain is the loudspeaker. Efficiencies of the order of 10% for this component are considered high and some popular speakers are designed with efficiencies as low as 1/2 of 1%. It can be readily seen that a speaker of the latter type, when fed with 10 watts will only produce .05 watts of *acoustic* energy, enough to fill a 13,000 cubic foot volume of space. Still more than most living rooms, but we're not finished. We spoke of an orchestra playing at average loudness. We must add another 20 db or so for

Power Amplifiers in Hi Fi

by Lawrence Fielding

The procedure used in determining the required power output of an amplifier is discussed in this installment. The measurement of power response and sensitivity are also treated.

cymbal crashes, drum beats and other crescendos. 20 db represents a change of power of 100 to one. Putting it another way, this maximum energy of .05 watts would now take care of absolute peaks in a room having a volume considerably less than 1000 cubic feet and a one thousand cubic foot living room is one that measures, say about 10' x 10' x 10', so we're in trouble with a ten watt amplifier *using a low efficiency speaker*. There is a practical way to calculate power requirements, by which you can intelligently advise prospective customers in the choice of a power amplifier.

Calculating Power Amplifier Ratings

Referring to Table I you will note that acoustic power requirements are listed for various sound levels and for various cubic enclosures. It should be noted that 80 db corresponds to average concert hall volume. Not everyone will want to play music that loud in the home (and even if they do, the neighbors wouldn't permit it). Explain this to the customer and get his opinions in the matter. Suppose he decides that 70 db is all he will ever want in the living room. Add 20 db for peaks in the music and possible differences in furnishings (draperies, sound absorbing rugs, etc.) between his living room and the "average" for which this table was derived. This makes a total of 90 db.

TABLE I

Volume or Intensity Level	CUBIC FEET				Acoustic Power Requirement in Watts
	1000	2000	3000	4000	
55db	.0000051	.0000098	.000014	.000019	
60db	.000016	.000031	.000045	.000059	
65db	.000051	.000098	.00014	.00019	
70db	.00016	.00031	.00045	.00059	
75db	.00051	.00098	.0014	.0019	
80db	.0016	.0031	.0045	.0059	
90db	.016	.031	.045	.059	
100db	.16	.31	.45	.59	
110db	1.6	3.1	4.5	5.9	

Calculate the cubic volume of the listening area (to the next largest 1000 cubic feet, as shown in the table). Suppose it is about 3000 cubic feet. Consultation of Table I shows that 0.45 watts of actual acoustic power will be required to meet these conditions. Next, determine the efficiency of the loudspeaker system the customer proposes to use. (This specification is beginning to appear with increasing regularity in the "spec" sheets put out by loudspeaker manufacturers.) Suppose the efficiency is 1%. Then divide .045 by .01 (efficiency expressed as a decimal) and we come up with the answer of 4.5 electrical watts of audio power. Even a full safety margin of 2 to 1 would still mean that a ten watt package will fill the bill with power to spare. To advise such a customer to get a high-powered job would be doing him an injustice. There are, of course, exceptions even to this scientific approach. Find out whether the customer plans to add different speakers in other rooms at a future date, all to be operated from the same system (and very likely, all operating at once under certain circumstances). If such proves to be the case the whole power picture changes accordingly.

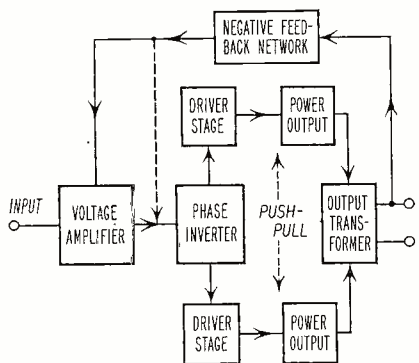

Fig. 1—Block diagram of stages in a typical power amplifier.

Circuit Elements

The various circuits which comprise a power amplifier are illustrated in block diagram form in Fig. 1. Each of these elements will be treated in greater detail in future articles. For the time being, there are several overall measurements which you will be required to make in connection with the proper servicing of amplifier and these will

[Continued on page 48]

Electro-Voice® POWER-POINT

HELP YOURSELF TO PROFITS BY HELPING YOUR CUSTOMERS!

HERE'S YOUR PROFITABLE OPPORTUNITY

to do your customers—and yourself—a favor! Stock and sell E-V POWER-POINT, the unique phonograph cartridge-and-needle combination that ends service and inventory headaches, insures customer satisfaction, assures repeat business!

ONE SERVICE CALL DOES THE JOB!

You install the mount and cartridge—there's a type for almost any phonograph. From there on it's repeat, repeat business for you! Because . . . come replacement time, your customer slips out the old, returns it to you for replacement, slips in the new faster than you can read this sentence!

POWER-POINT

is a nylon-encased FRESH ceramic cartridge PLUS two Jeweled (Superior synthetic sapphire or natural diamond) playing tips—ALL IN A SINGLE UNIT! There's a POWER-POINT for every record speed. List prices, \$3.95 (for two sapphire tips) to \$21.50 (for two diamond tips).

Plenty of sales-stimulating merchandising aids are available, backed up by national ads. Millions of POWER-POINTS are in use as original equipment, guaranteeing volume replacement sales.

3 MOUNTING MECHANISMS

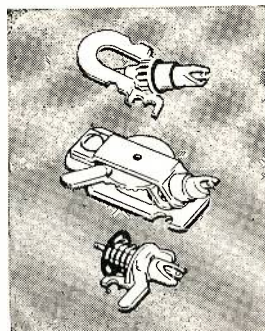

Model PFT-1, fixed mount, 50¢ List.

Model PT-1, turnover mount, \$1 List.

Model PT-2, turnunder mount, \$1 List.

HERE'S
POWER-POINT
ACTUAL SIZE



E-V POWER-POINTS

Model 51-1 (red) Two 1-mil sapphire tips List	\$ 3.95	Model 56DS (orange) One 1-mil diamond, one 3-mil sapphire tip List	\$21.50
Model 52-2 (green) Two 2-mil sapphire tips List	3.95	Model 76S (white) One 1-mil, one 3-mil sapphire tip. . . List	4.25
Model 53-3 (black) Two 3-mil sapphire tips List	3.95	Model 76DS (pink) One 1-mil diamond, one 3-mil sapphire tip. List	21.50
Model 56 (blue) One 1-mil, one 3-mil sapphire tip. . . List	3.95		



write FOR COMPLETE POWER-POINT
INFORMATION AND SPECIFICATION
SHEET SD-76

Electro-Voice®

ELECTRO-VOICE, INC. • BUCHANAN, MICHIGAN

Export: 13 East 40th Street, New York 16, U.S.A.
Cables: ARLAB

trade flashes

A medical milestone was marked recently with the introduction, at St. Luke's Hospital in Chicago, of a "surgeon's eye" technique that brings medical students as close to an incision as the doctor's own elbow. Manufactured by Dage Television, Division Thompson Products, Incorporated, Michigan City, Indiana, full-color, closed-circuit television is the device that makes this possible, transmitting to students many floors away the life-and-death immediacy of the surgical routine. The doctor's commentary, simultaneously transmitted, informs them as well of the special problems attendant upon each individual case.

Cumulative television figures compiled during the first quarter of this year amounted to 1,474,729 receivers compared with 1,844,632 made during the first quarter of 1956. Television sales totaled 534,115 in March compared with 525,437 sold in February and 544,411 sold in March 1956. Cumulative television sales totaled 1,682,911 this year as against the 1,689,178 sold in the corresponding quarter of 1956.

The transistor industry is now 2.7 times greater than it was at this same time last year. Factory sales of transistors in March totaled 1,904,000 units with a dollar value of \$5,321,000 compared with 1,785,300 sold in February with a dollar value of \$5,172,000. Cumulative sales of the semi-conductor device during the first quarter of this year amounted to 5,125,300 units with a dollar value of \$14,612,000 compared with the sale of 1,898,000 units with a dollar value of \$5,688,000 during the corresponding quarter of 1956.

Figures show 3,959,367 radios were produced this year compared with 3,532,243 at this time last year. Sales totaled 730,584 in March, excluding auto sets, compared with 525,029 sold in February and 527,649 sold through retail outlets in March 1956. Cumulative radio sales increased to 1,818,976 over the 1-513,722 sold during the first three months of last year. Since the bulk of car radios produced are sold direct to automobile manufacturers for installation in new cars, RETMA does not include such radios in its count of retail radio sales.

125,041,000 receiving tubes worth \$104,808,000 during the first quarter of this year shows a substantial increase over the 120,420,000 tubes worth \$96,919,000 sold in the corresponding 1956 quarter. Television picture tube sales in March totaled 833,088 units valued at \$14,847,798 compared with 728,363 such tubes sold in February with a dollar value of \$13,134,778. Cumulative TV picture tube sales during the first quarter of this year totaled 2,322,306 with a dollar value of \$41,577,018 compared with 2,638,503 tubes with a value of \$49,867,451 sold during the corresponding quarter of last year.

Robert F. Halligan, vice president in charge of operations at the Hallicrafters Company announced two new appointments. Cletus A. Wiot has been promoted to director of personnel and Anthony R. Dambrauskas to national service manager. Both promotions, Halligan said, were made to strengthen the operations of the personnel and service departments in line with Hallicrafters expansion program.

The Blonder-Tongue Labs. Inc., has moved to larger quarters. The new building is located at 9-25 Alling Street, Newark 2, N. J.

According to Leonard Ashback, who spoke at a recent NARTB meeting, FM is enjoying a revival because of the poor quality programs on AM radio and television. If the present trend continues, FM sets will outsell AM sets within ten years. Ashback said, "We are getting the radio back into the living room and the TV sets are going to the bedrooms and dens.

"Because 960 out of every 1,000 portable television sets sold have 14 inch screen sizes with 96 sq. in. viewable area and larger, Hotpoint will concentrate in 1958 on larger portables, namely, 14- and 17-inch sets with more than 96 sq. in. viewable area." This statement from Howard W. Hibshman, marketing manager, television receiver dept., Hotpoint Co., was made as the company prepared introduction plans for its new 1958 portable television line.

Ram Electronics has expanded its engineering and production facilities and has moved to new and larger quarters at 600 Industrial Avenue, Paramus, New Jersey.

The General Electric Company announced a reorganization of its high-fidelity sound components operations, to result in "increased concentration on technical development and sales efforts" for the products. Responsibility for engineering, manufacturing, and marketing of the hi-fi products is being transferred from the company's TV Receiver Dept., Syracuse, to its Specialty Electronic Components Dept., in Auburn, N.Y.

Paul Jackson, President of Jackson Electrical Instrument Company of Dayton died in that City on Saturday, April 27th. Mr. Jackson was a pioneer in the manufacture of test equipment for the radio and television servicing industry. The business which bears his name was incorporated in 1933 to manufacture tube testers, and other equipment.

Scientists at Raytheon Manufacturing Company's Food Laboratory are using radar's electronic energy to preserve fresh and cooked foods so they can be stored on a kitchen or grocer's shelf at room temperature indefinitely without refrigeration. Still in the laboratory stage, the new process is expected to make available normally perishable meats, fish, fruits and vegetables in unfrozen form the year round without loss of flavor, texture or nutrient value.

Flying by means of "electronic road maps," helicopters can now operate completely on instruments in cities, the open country or in remote areas according to flight demonstrations by Bell Helicopter Corporation and the Pacific division of Bendix Aviation Corporation. Military and civilian aviation experts recently witnessed three days of blind-flight demonstrations at the Bell Helicopter plant here that "dramatically prove the helicopter can now make full use of its unique flying abilities regardless of weather and visibility." The new flight aids made it possible for the helicopter, which can hover in the air of weather and visibility."

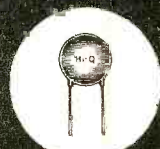

DISKS



TUBULARS

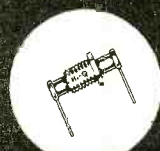

FEED-THRU

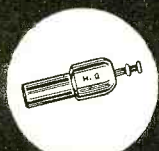

STAND-OFFS

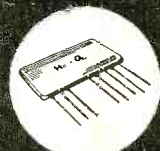
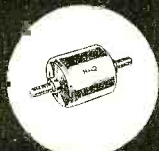

PLATE ASSEMBLIES



HIGH-VOLTAGE CARTWHEELS

You can do a **BETTER**
job **FASTER**
when you use...

AEROVOX CERAMIC CAPACITORS

You can be sure that Aerovox Ceramic Capacitors are exactly right for your service applications because of the extra-care taken in the manufacturing of these capacitors to provide you with trouble-free, exact-duplicate replacements. This extra-care assures your customers of stay-put installations saving you time and money on costly call-backs.

The Aerovox line of ceramic capacitors is the most complete on the market. A type for every application is available to you for prompt delivery from the complete stock selection carried by your local Aerovox Distributor.



AEROVOX CORPORATION

DISTRIBUTOR DIVISION
NEW BEDFORD, MASS.

In Canada: AEROVOX CANADA LTD., Hamilton, Ont.
Export: Ad Auriemo, Inc., 89 Broad St., New York, N. Y.
Cable: Auriemo, N. Y.

Mfr: Emerson Chassis No. 120292 P, V

Card No: EM 120292-1

Section Affected: Horizontal and/or Vertical Sweep.

Symptoms: Intermittent operation of horizontal hold, Vertical Sweep, or both.

Cause: Intermittent contact between etched circuit sweep board and chassis.

What To Do:

Tighten screws which secure etched board to the chassis. (Each screw grounds a separate circuit.) If this doesn't work, make an electrical connection which will be soldered from the component C-43, to chassis ground.

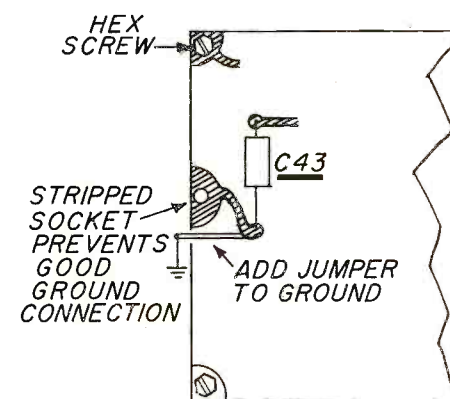

Mfr: Emerson Chassis No. 120292 P, V

Card No: EM 120292-2

Section Affected: Horizontal Sweep.

Symptoms: No brightness.

Cause: Defective condenser in grid circuit of the Horizontal oscillator.

What To Do:

Change: C-44 (330uf-500V).

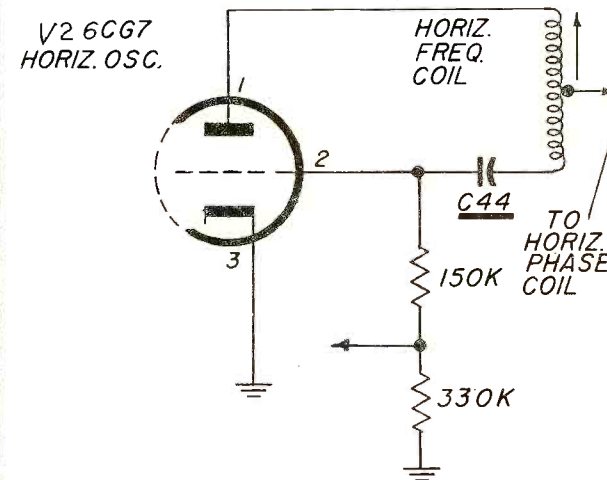

Mfr: Emerson Chassis No. 120292 P, V

Card No: EM 120292-3

Section Affected: Video

Symptoms: Streaking or tunable R F interference on channel #6 when using a built in antenna.

Reason For Change: To eliminate interference on channel #6.

What To Do:

Change: R-97 from 1000 ohms to 4700 ohms. Add: a 22 mmf condenser between pins #6 and #7 of the 3rd video if tube (3CB6).

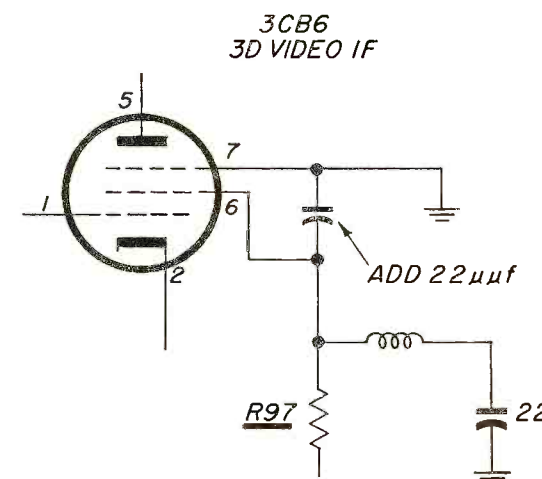

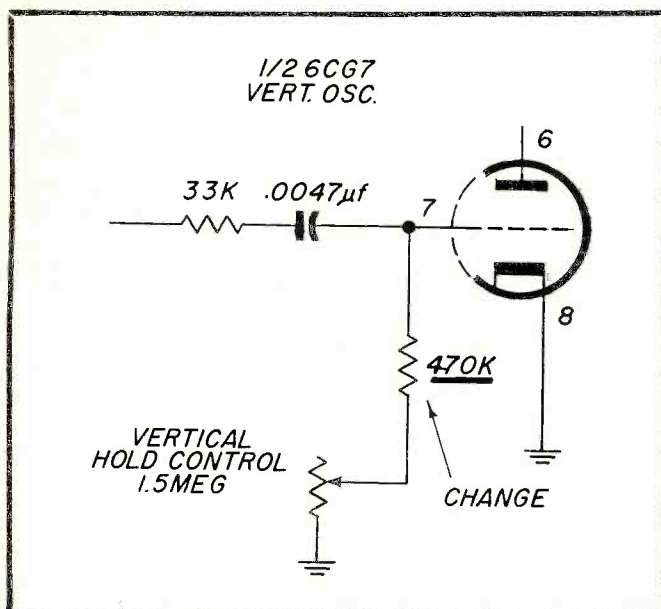

Mfr: Emerson Chassis No. 120292 P, V

Card No: EM 120292-4

Section Affected: Vertical Sync. Circuit.

Symptoms: Vertical control holds at one end only. Possible vertical jitter and/or poor vertical sync.

Cause: Aging components.

What To Do:
Change value of resistor in series with vertical hold control from 470K to 680K or 1 meg to produce a point of hold in the center of control rotation.

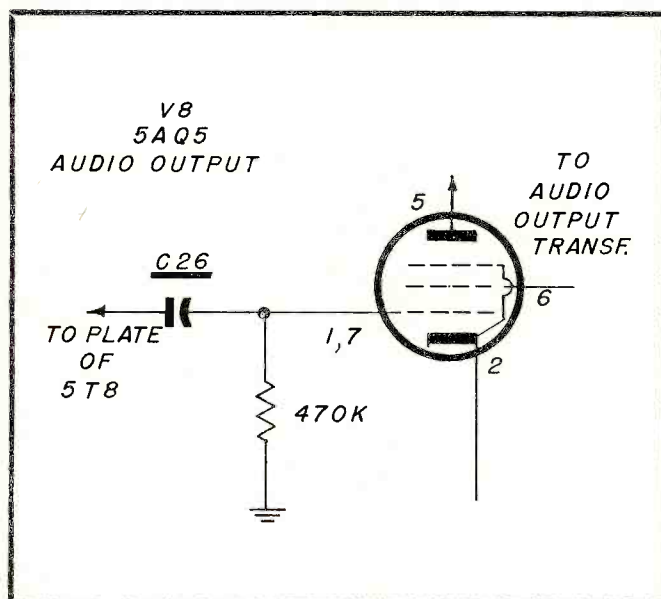

Mfr: Emerson Chassis No. 120292 P, V

Card No: EM 120292-5

Section Affected: Picture

Symptoms: Picture bounce at high audio output levels.

Cause: Leakage of audio coupling condenser allows audio output tube to draw grid current on peaks of loud passages which causes a change in picture size.

What To Do:
Change C-26 (.047 uf).

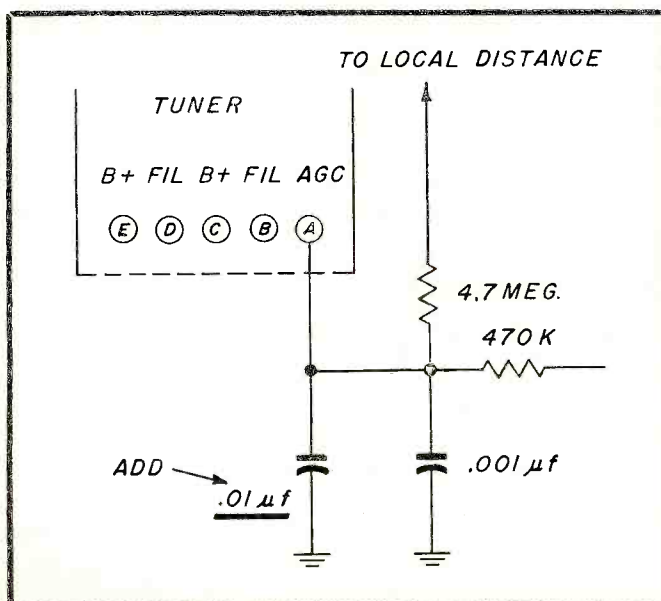

Mfr: Emerson Chassis No. 120292 P, V

Card No: EM 120292-6

Section Affected: Video

Symptoms: Hum bars in picture on weak signals. Not apparent on blank raster.

Cause: Hum is entering the rf thru agc line.

What To Do:
Add a .01 uf condenser from the agc tuner feed, (terminal A) to chassis ground.

ATR SHAV-PAK
NEW, LOW PRICE!

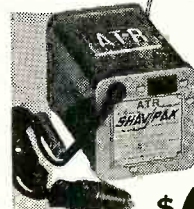
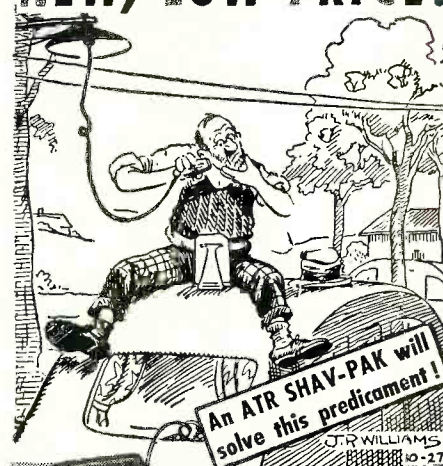

SHAVE IN THE COMFORT OF YOUR CAR, Boat or Plane!

Specially Designed for Operating Standard A.C. Electric Shavers in Automobiles, Buses, Trucks, Boats, and Planes.

\$6.63
Plugs into Cigarette Lighter Receptacle on Dash
DEALER PRICE
LIST PRICE \$9.95

TYPE	INPUT D.C. VOLTS	A.C. OUTPUT 60 CYCLES	OUTPUT WATTAGE	DEALER PRICE
6-SPB	6	115 volts	15	6.63
12-SPB	12	115	15	6.63

Introducing
ATR MIGHTY MIDGET
portable INVERTER
WITH GREATER OUTPUT

dictate reports ACCURATELY-PROMPTLY!

make your car, boat or plane a "rolling office"

with ATR INVERTERS

for changing your storage battery current to A. C.

Household ELECTRICITY

Anywhere in your own car!

Plugs into Cigarette Lighter Receptacle on Dash

\$13.30 DEALER PRICE AND UP

LIST PRICE \$19.95

ATR INVERTERS . . .

especially designed for operating standard 110 volt A. C. . . .

• DICTATING MACHINES • TAPE RECORDER

• ELECTRIC RAZORS • WIRE RECORDERS

• DICTATING MACHINES • TAPE RECORDER

• ELECTRIC RAZORS • WIRE RECORDERS

TYPE	INPUT D.C. VOLTS	A.C. OUTPUT 60 CYCLES	OUTPUT WATTAGE	DEALER PRICE
12-DME	12	115	40-50	13.30
12U-RHG	12	115	150-175	59.97

Inverters available for 6, 12, 28, 32, 110 & 220 D.C. Input Operation

See your jobber or write factory today for complete information

ATR AMERICAN TELEVISION & RADIO CO.
Quality Products Since 1931
SAINT PAUL 1, MINNESOTA - U. S. A.

This is the house
that Jack built.



This is the clatter
that came from the house
that Jack built.



For all was the matter
with the musical clatter,
that came from the house
that Jack built.



This was the platter?
Which made all the matter
with the musical clatter,
that came from the house
that Jack built.



Reviewing the data
'twas not the platter
which made all the matter
with the musical clatter,
that came from the house
that Jack built.

*The difficulty was traced and
was found to arise from the
loudspeaker. It was promptly
replaced with a Norelco FRS
Speaker. And now...*

This is the house
with the Norelco horn
and the maiden who's
no longer forlorn.



Her mate's lust for data
discovered the platter
was not ere the matter
that made musical clatter,
that came from the house
that Jack built.



*Norelco*FRS Speakers are available
in 5", 8" or 12" sizes in standard imped-
ances. Priced from \$6.75 to \$59.98.*

ADD TO ... and improve any sound system
with **Norelco® *FULL RESPONSE SPEAKERS**

Write today to Dept. E6 for brochure
and prices of these unique speakers.

NORTH AMERICAN PHILIPS CO., INC.
High Fidelity Products Division
230 Duffy Ave. Hicksville, L. I., N. Y.



Mfr: Muntz

Chassis No. 49A4

Card No: MU 49A4-1

Section Affected: Sync.

Symptoms: Unstable vertical lock.

Reason For Change: To improve vertical hold.

What To Do:

Rewire 25 volt filaments so that they are in
the order shown in diagram.

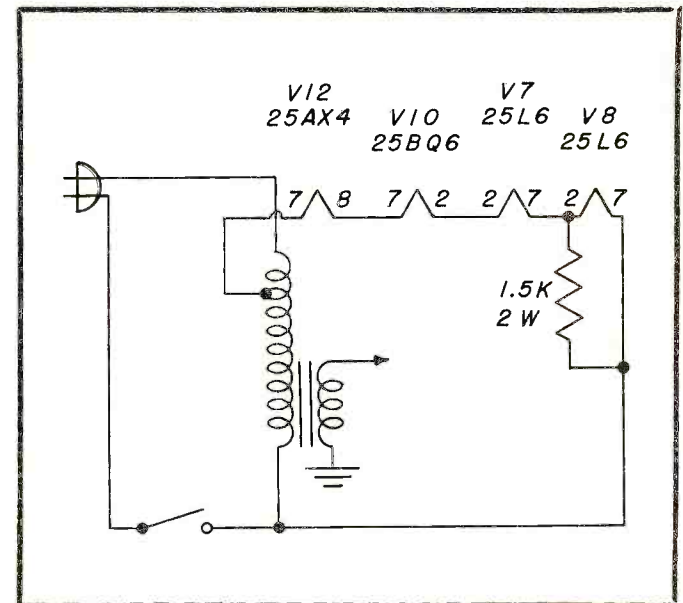

Mfr: Muntz

Chassis No. 49A4

Card No: MU 49A4-2

Section Affected: Raster

Symptoms: Blooming.

Reason For Change: Circuit improvement—
Increase 1X2 filament voltage.

What To Do:

Remove R68 (2.2 ohms).

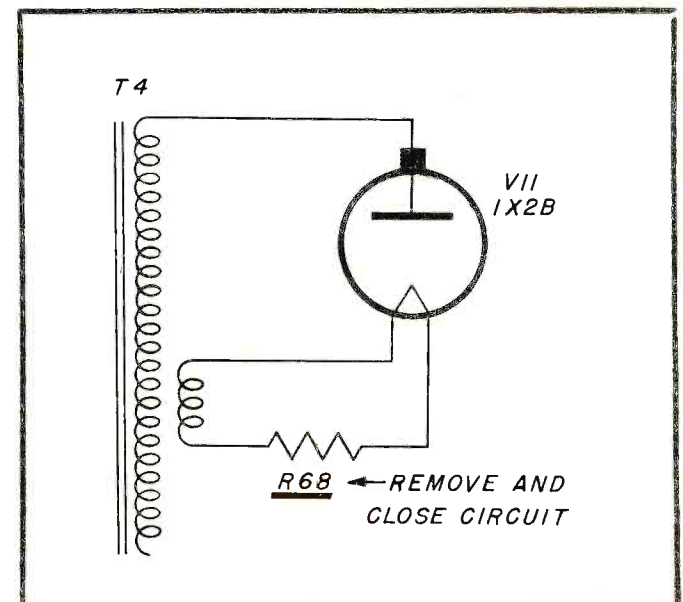

Mfr: Muntz

Chassis No. 49A4

Card No: MU 49A4-3

Section Affected: Raster

Symptoms: Unstable horizontal sweep.

Reason For Change: Circuit improvement.

What To Do:

Change: R74 (12K) to 10K.
Also: C68 (.01) to .1uf.

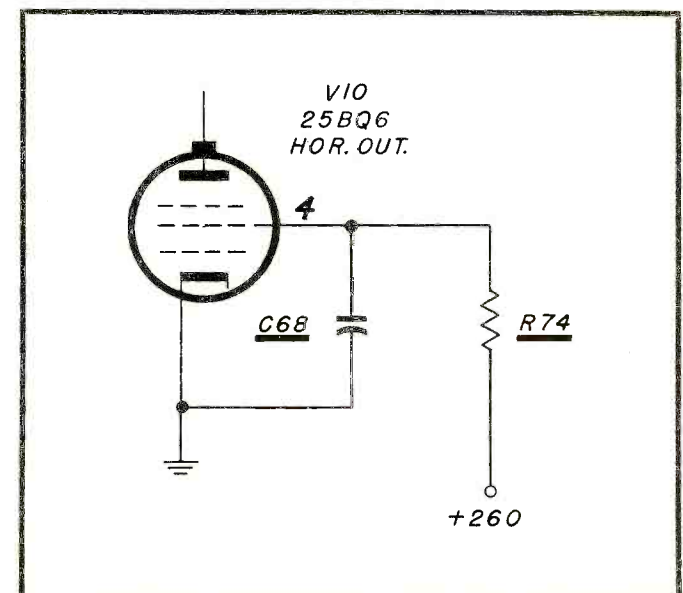

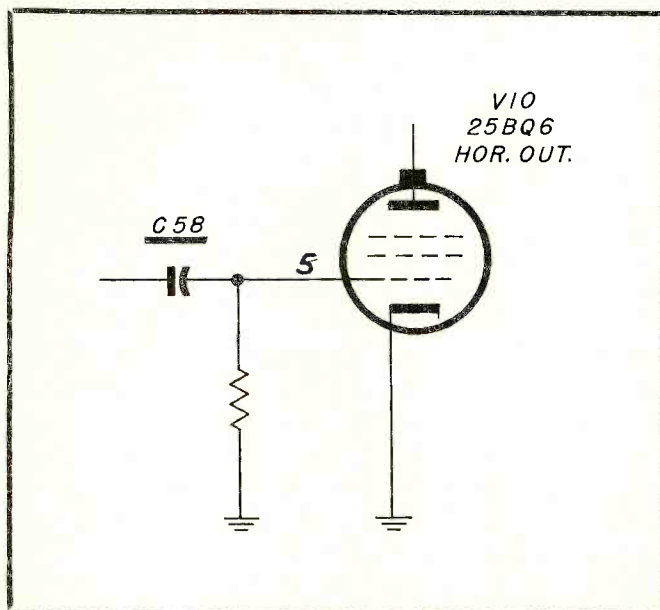

Mfr: Muntz

Chassis No. 49A4

Card No: MU 49A4-4

Section Affected: Raster

Symptoms: Drive lines present with certain 25BQ6 output tubes.

Reason For Change: Circuit improvement.

What To Do:

Change: C58 (.005-500V) to .001uf 500V.

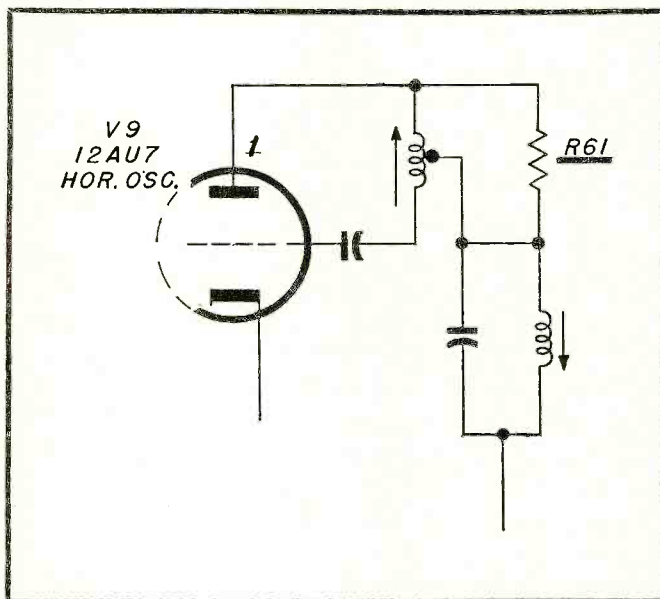

Mfr: Muntz

Chassis No. 49A4

Card No: MU 49A4-5

Section Affected: Sync.

Symptoms: Poor hold range with changes of V9, 12AU7.

Reason For Change: Circuit improvement.

What To Do:

Change: R61 (10k) to 18k.

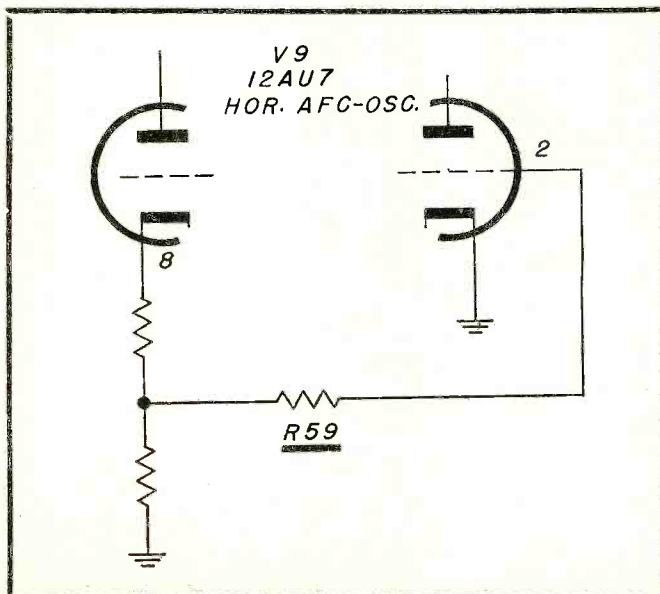

Mfr: Muntz

Chassis No. 49A4

Card No: MU 49A4-6

Section Affected: Sync.

Symptoms: Difficulty in adjusting horizontal hold.

Reason For Change: Circuit improvement.

What To Do:

Change: R59 (220K) to 180K.

USE LOW COST



IMPEDANCE MATCH ACCESSORIES

with **coax cable**

improve reception
as much as 6db

Eliminate Signal Losses, Smear,
Ghosts and Other Picture-De-
grading Conditions Resulting
From Antenna-to-Line or Line-to-
Set Mismatch.

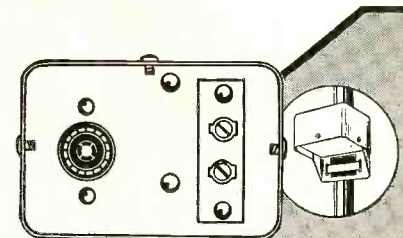

B-T BALUN
model MB

\$9⁰⁰
list

Mounts on antenna mast or strut.
Provides exact impedance match
between 75-ohm unbalanced line
and 300-ohm balanced line or
antenna. Has 75-ohm coax fitting
and 300-ohm screw terminals.
Built into weather protecting
cowling housing.

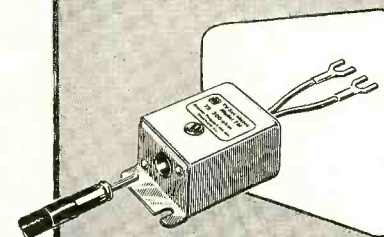

B-T TV SET MATCH
model TM

\$3⁵⁰
list

Used at TV receiver to match 75-
ohm cable to 300-ohm TV set in-
put. Cable plug and jack permit
quick, easy disconnect. Has
heavy duty, 300-ohm output
leads.

At electronic parts distributors.
For complete accessory catalog,
write to Dept. SD-6.

BLONDER-TONGUE LABS., INC.
9-25 ALLING STREET, NEWARK 2, N. J.

THE WORK BENCH

Unusual Service Problems And Their Solutions

by PAUL GOLDBERG
Service Manager

WHEN servicing printed wiring panels, carefulness is of utmost importance. There are many excellent kits containing specialized tools, special solder, lacquer and lacquer solvents in order to accomplish a perfect repair job. The most important thing to remember however, is to work slowly and carefully.

Philco TV-440

The receiver was turned on and it was noted that there was neither video and nor sound. The customer had complained previously of intermittent video and sound. The 1st and 2nd video *if* tubes, 6DE6's were replaced individually but had no effect. As the 6AM8, the 3rd video *if* and 2nd detector was about to be removed from its socket for checking purposes, the video and sound popped in. Upon pressing lightly on the 6AM8 the video and sound again disappeared. This receiver utilizes a separate printed *if* panel for the 1st, 2nd, and 3rd *if* stages, the second de-

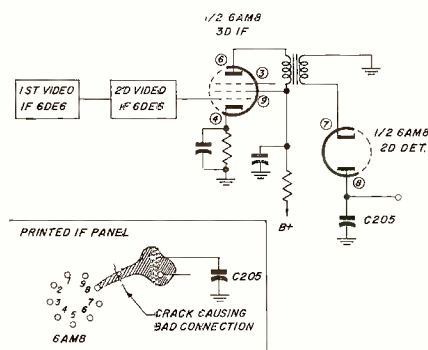

Fig. 1—Crack in printed wiring caused intermittent in Philco.

rector, and their respective circuits. Pressing lightly on the 6AM8 a few times, we deduced that the printed wiring was opening intermittently. We next removed the screws and the four connections from the *if* panel and observed the connections on the underside of the bakelite panel. While holding the *if* panel and pressing on the 6AM8, we noted a slight crack in the bakelite which swept across one printed connection. (See Fig. 1). It was the printed connection from pin 8 of the 6AM8 to capacitor C205 that had a tiny crack across it. Thus any vibration would cause this connection to open. Using a low wattage soldering gun and working slowly and carefully, the break was soldered over. Now pressing on the 6AM8 or the 6DE6's did not cause the printed wiring to open. The printed panel was re-installed and the receiver functioned properly.

Admiral Chassis 17Z3D

The receiver was turned on and it was observed that there was no raster, but the sound was normal. The high

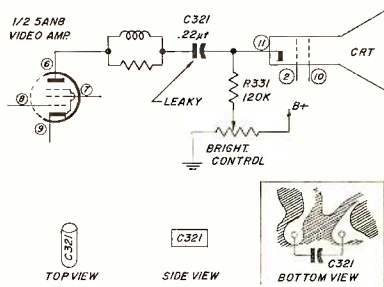

Fig. 2—Leaky C321 caused loss of raster in Admiral 17Z3D.

voltage arc from the 1B3 filament seemed to be sufficient. The diagram (Fig. 2) was consulted and it was seen that the video signal and brightness control voltage were fed to the cathode of the CRT. The voltage at the cathode of the CRT was then measured as the brightness control was varied. The voltage readings measured too high. However, when the voltage was measured at the center arm of the brightness control the voltage was closer to being correct. This could not be a cathode to heater short, since the cathode voltage measured high. We then eliminated the possibility of any other inter-element short by installing a series picture tube rejuvenator in its place. When the voltages remained the same we deduced that capacitor C321, .22 mf, was leaking. C321 was mounted vertically on a printed circuit wiring board. It was unsoldered and then resistance checked for leakage. It was found to be leaking about 500K. We obtained the exact replacement and installed it, working slowly and carefully to avoid solder drippings. The receiver was then turned on and functioned properly.

Crosley Chassis 386

The receiver was turned on and it was observed that the picture was tearing horizontally and skipping vertically. Because this was a composite sync problem V109, 6SN7, the sync clipper in Fig. 3 was replaced but had no effect.

The diagram was next studied. It was noted that a portion of the composite video signal is taken from the plate side

of the video amplifier (6AH6) plate load resistor R121 and fed to the grid pin #1 of the 6SN7, 1st Sync clipper section of V109 through R124, C122, R125, C123.

The signal that appears at the grid is positive in polarity and drives the grid pin #1 of the first sync clipper very positive, the grid current charging C123 negatively. This tube's bias is obtained by grid rectification of the video signal. The voltage drop across R126 biases the tube so that plate conduction occurs only on the peaks of the video signal. Since the maximum amplitude of the video signal is actually the sync pulses, only the sync pulses appear at the plate pin #2 of the 1st sync clipper. The negative going signal is applied through C125 to the 2nd sync clipper. The 2nd sync clipper is biased so that any noise pulses that would appear at the negative portion of the pulses would drive the tube beyond cutoff. Thus it limits the amplitude of the sync pulses and clips the peaks caused by noise pulses.

Knowing these facts the scope was set up and a waveform was measured at pin #1 of V109 to ground. The scope showed a much smaller (1/10) waveform than the diagram called for. (Refer to diagram). A waveform was next measured at the junction of C122 and C123. Here the waveform was correct. C123 was next checked and was found to be OK. C124 was next resistance checked and was found to have a leakage of about 200K. C124 was replaced with a new 22 μ f condenser and the receiver functional properly. ■ ■

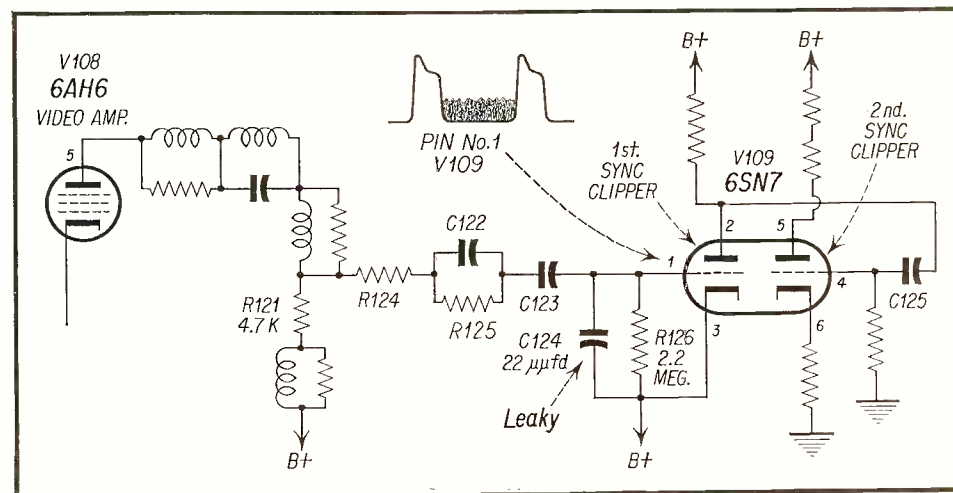
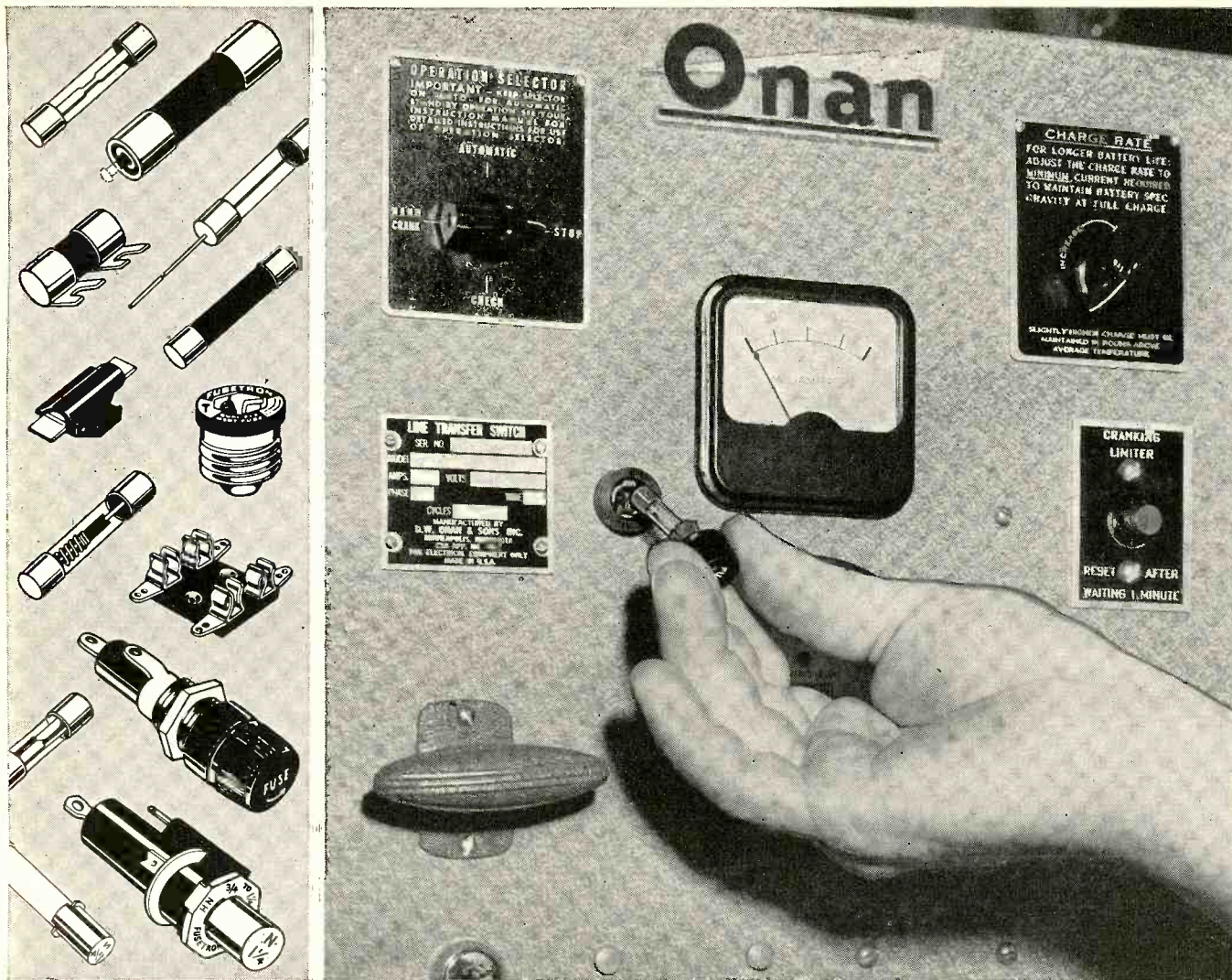

Fig. 3—Leaky by-pass condenser caused loss of horizontal and vertical sync in the Crosley 386 chassis. A partial sync circuit schematic is shown.



"We find BUSS Fuses provide the dependable electrical protection we must have for our equipment" . . .

George Thole, CHIEF CONTROL DESIGN ENGINEER
D. W. ONAN & SONS INC., MINNEAPOLIS, MINNESOTA

"Our automatic line transfer units are used to transfer the electrical load from the normal commercial service to the Onan Standby Generating Set should a power failure occur.

"It is essential that our units operate properly in this emergency otherwise there would be a plant shut-down and the possibility of damaged equipment and property. In some cases human lives would be in danger.

"You can see why all the components used in our equipment must meet the very highest standards for dependability.

"Fuses are an integral part of the battery charging circuit which is incorporated into our line transfer controls.

"In fuses, we have found by experience that BUSS Fuses

can be depended upon to meet the standards of reliability that are required by our stand-by power units."

In sales and service, you too, can profit by standardizing on BUSS fuses.

The unfailing dependability of BUSS fuses protects you against 'kicks' and complaints. Whereas faulty fuses might cause needless burnouts or useless shutdowns, — BUSS fuses can be relied on to operate properly under all service conditions.

Complete Line: There is a BUSS Fusetron fuse to meet your needs,—plus a companion line of fuse clips, blocks and holders.

For more information on BUSS and FUSETRON Small Dimension fuses and fuseholders . . . Write for bulletin SFB. Bussmann Mfg. Co. (Division of McGraw-Edison Co.) University at Jefferson, St. Louis 7, Mo.

BUSS fuses are made to protect — not to blow, needlessly

597



Makers of a complete line of fuses for home, farm, commercial, electronic, automotive and industrial use.

ASSOCIATION

National Alliance of Television and Electronic Service Associations (NATESA)

The NATESA Board of Directors meeting at New Orleans was a huge success. Present were over 100 Directors, Alternates and guests from points as widely separated as San Mateo, California, Buffalo, New York and Miami, Florida. The one day session was held in conjunction with a regional open series of seminars on technical and business subjects conducted for all area service people by the host Affiliate, RETA of New Orleans. A special committee on licensing was set-up to prepare a brochure on licensing. It will be a "do's and don'ts" publication.

Empire State Federation of Electronic Technicians Associations (ESFETA)

ESFETA held its election of officers. Gordon Vrooman of the Syracuse TV Technicians was reelected President. Robert Larsen of the Valley Stream Radio TV Guild was elected Vice President. Pat Pratt of the TV Electronic Service Association was reelected Treasurer.

California State Electronics Association

CSEA'S drive to license service dealers in California ran into a delay last month when a hearing on the bill was rescheduled. Committee members voted to consider the measure at another date because four members of the group were absent. Anthony J. Anatsi, CSEA legal counsel who is guiding the measure, said that although five votes could send the measure out to the Senote, it was decided to reschedule the bill and hope for full committee attendance at the session.

Long Island Guild

A bill licensing TV repairmen has gone into effect in the city of Long Beach on Long Island. The Radio and

NEWS

by Samuel L. Marshall

TV Guild of L.I. won a major point in the bill by having provisions written in to protect the ethical serviceman from dishonest customers. The Guild feels that the existing law is fair and protects both the serviceman and customer.

Radio TV Technicians Association, Pasadena, Calif. (RTA)

A regular technical meeting of R.T.A.-Pasadena heard and saw a demonstration and lecture on "Horizontal Sweep Systems." Irving Tjomsland, technical speaker from Triad Transformer company, reviewed basic sweep circuits, using a special "live" demonstration board. He covered a step-by-step method for determining all horizontal sweep system (horizontal output & high voltage) troubles. The meeting was then opened for a question and answer session. Coffee and doughnuts were served before and after the meeting.

United Electronic Service Council

Meeting for the first time since the joint industry conference, service leaders from the northeastern states gathered at the Hotel Roosevelt in New York City to lay plans for future activity. The meeting was directed by Frank E. Silverman who, in addition to being president of the Television Service Associations, Inc., of Connecticut, is also chairman of the United Electronic Service Council. The latter group is responsible for the initiation of talks with officials of the National Electronic Distributors Association which give much promise of cooperative activity between distributors and service dealers. First order of business was the consideration of a 20-point industry program which had been submitted by the Council of NEDA officials for their approval. It had been set aside at the request of NEDA until such time as dubious legal aspects of some points had been cleared by legal counsel.

IN AMERICA'S GREAT SOUTHWEST...

RCA provides new opportunities

for electronic instructors!

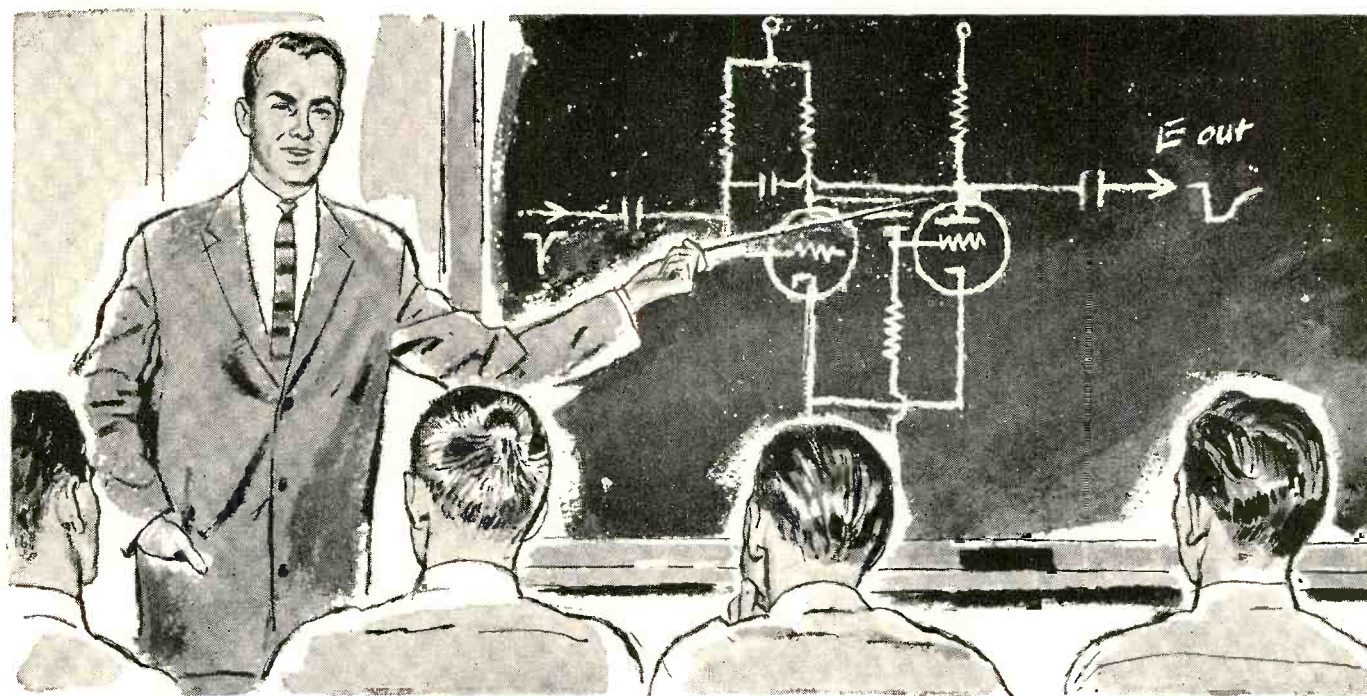

This is it . . . your moment to make the big shift to the road that leads ahead . . . as a career electronic instructor with RCA! You'll teach basic electronic theory—including radar circuitry—to military personnel at Fort Bliss, Texas. You'll need a good knowledge of basic electronics, plus teaching experience. Military electronics maintenance experience is desirable. Enjoy RCA extras . . . like tuition refunds for advanced study, complete company-paid benefit program, salary increase and promotion based upon merit.

For convenient confidential interview, send resume to:

Mr. James Bell
Employment Manager, Dept. Y-13F
RCA Service Company, Inc.
Cherry Hill, Delaware Township
Camden 8, New Jersey



RCA SERVICE COMPANY, INC.

Government Service Department

"Practical Radio and Electronics Course," prepared under the direction of M. N. Beitman. This is a completely new and revised edition of the famous home - study training, incorporating three early volumes into a single large manual. There are now 35 lessons in all. As in previous editions, explanatory notes and teacher comments are printed in the narrow column alongside the text. An answer booklet to the problems is available for 25 cents. The "course" is priced at \$3.95 postpaid.

A new brochure that describes the three vital functions of General Electric's magnetic engineering laboratory, was released recently by the Magnetic Materials Section of the Metallurgical Products Department, Erdmore, Mich.

A new catalog supplement sheet cross-referencing exact yoke, flyback, transformer and coil replacements for Bendix TV receivers has been released by Rogers Electronics Corp., 49 Bleecker St., New York 12, N. Y.

TRADE LITERATURE

The book, "Radio-Electronics Made Simple" by Martin Schwartz, explains the subject of radio theory in a simple, non-technical manner. No previous radio background is required. The more difficult concepts of radio and electronics are explained in everyday language. The book is complete in its coverage of radio theory. It starts with basic electricity and covers all phases of radio right up through transmitters and receivers. By going through the book the reader gains an excellent background for further study of television and other specialized subjects. Published by the American Electronics Co., 1203 Bryant Ave., N.Y.C. Price \$1.95.

John F. Rider Publisher, Inc., has released a new 56 page T.V. *Tube Location & Trouble Guide*. This book shows the tube locations for all RCA television receivers produced between 1947 and 1956. It lists the tube complement, key voltages and common troubles correlated with the tubes that may be responsible for them. It also includes a complete chassis and model index. The price is \$1.25.

"Repairing Television Receivers," by Cyrus Glickstein, is a modern, and completely practical book on TV trouble shooting and repair techniques. It presents step-by-step, the procedure on how to diagnose and troubleshoot a faulty TV receiver. It explains how to localize the defective section, then the defective stage and finally, the defective component. A down to earth approach to successful TV servicing, covering the use of test equipment, both simple and complex, with numerous practical illustrations showing troubleshooting test setups. Published by John F. Rider. Price \$4.40.

"How to Install and Service Inter-communication Systems" by Jack Darr, covers the entire field of "intercom" systems in sufficient detail to enable the reader to do installation and maintenance work on this type of electronic equipment. It discusses the basic amplifiers, special speakers, switching arrangements, a-c and a-c/d-c systems, wireless systems, cabling networks, all call systems, paging systems, remote and master systems, one and two way intercom systems, installations for the home and for industrial use, outdoor wiring, and system requirements for particular applications. Published by John F. Rider. Price \$3.00.

"Audiofile," a catalog service for high fidelity dealers, completely catalogues the products of more than 228 manufacturers of high fidelity and sound equipment.

A new and enlarged Semiconductor Products Booklet was announced recently to all Raytheon Industrial Tube Distributors. This new booklet contains complete and up-to-date information on *Raytheon Transistor and Diode characteristics*.

John F. Rider Publisher, Inc., 116 W. 14th Street, N.Y.C., has released a clear, practical, easy to understand book called "Resonant Circuits" by Dr. Alex Schure. This 72 page book is the 16th volume in the Electronic Technology Series by this publisher. It concerns itself with resistors, capacitors and inductors which are found in various combinations of series and/or series parallel resonant circuits. Analyses are made for the elements comprising each circuit and then the circuit itself is analyzed. This book sells for \$1.25.

ATTENTION: People who service 2-way Communications

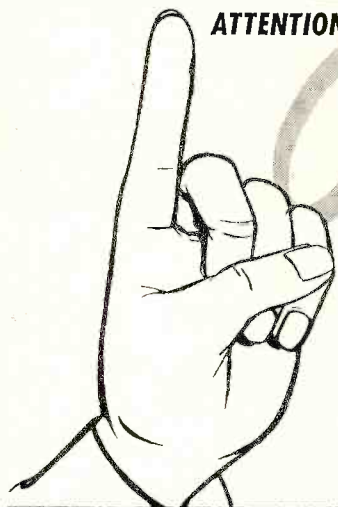

One day! PROCESSING

F6 Series Crystals

for STANDARD 2-WAY Equipment in Commercial Use

Wire mounted plated crystals for use in commercial equipment where close tolerances must be observed. All units are calibrated for the specific load presented by equipment. HOLDERS: Metal, hermetically sealed. CALIBRATION TOLERANCE:

±.0025% of nominal at 30° C.
TOLERANCE OVER TEMP. RANGE:
±.002% from -30° + 60° C.

CIRCUIT: As specified by customer. Crystals available for all major 2-way equipment. (In most cases the necessary correlation data is on file).

DRIVE LEVEL: Maximum— 10 milliwatts for fundamental,
5 milliwatts for overtone.

F-605	F-609	F-612
Pin dia. .050	Pin dia. .095	Pin dia. .125
Pin length .238	Pin length .445	Pin length .620

HOW TO ORDER:

Specify • Channel Frequency • Holder Type* • Circuit Data (32 mmf load, series resonance, etc.) • End Use (Equipment type and manufacturer, development, etc.)

*Adaptors can be supplied for 3/4" pin spacing.

Orders of 5 Units or Less Air Mailed Within One Working Day!

FREE!

1957 CATALOG

Send for YOUR Copy Now!
Specify Catalog SD-57!

International

CRYSTAL MFG. CO., Inc.

18 N. LEE OKLAHOMA CITY, OKLA.

RIDER SPEAKS



JOHN F. RIDER

WE recently made a trip to the middle west and it was really gratifying to note that many service organizations believe there is merit in our suggestion that the service industry should diversify.

We had occasion to talk to several men, strangely enough the largest operators among those to whom we spoke, and each one of them has diversified his service efforts. Yes, they do TV installation and service, but in addition to that they install and service auto radio receivers. They buy the receivers from the manufacturer set distributor and do the installation work. They service whatever hi-fi equipment becomes available. The territory is not yet too hot for hi-fi, but even so, they see this field as a source of income, and every dollar of income counts.

In addition, tape recorders are serviced, as are record players and room air conditioners. The latter type of effort has special significance because it helps take up the summer slack, as far as TV is concerned. The midwest is a good air conditioning area because it sure can get hot in the summertime! Their eyes are also set on whatever industrial electronic business can be developed.

All of this in the face of the fact that there is still television service work to be done.

We had occasion to speak to another group which is embarking upon an apprentice training program which is trying to work out with one of the local schools. This training program, while starting with TV, will not necessarily be limited to TV. They are mindful of the fact that men must be trained if there is going to be a supply of per-

sonnel for the servicing field in the face of whatever attractions are being offered to pull men out of the servicing field.

Another interesting item, at least to us, was that many people in the servicing industry are not too brand conscious. Somehow or other, servicemen (we don't know how many, but we do know that there are some) seem to feel that the brand means very little when they make their selection of replacement parts. Of course, they are interested in procuring parts which fit a need without any "gimmicking," but whether they buy one brand or another seems to make no difference. It's simply a case of what the jobber has to sell. If he has brand A they'll buy brand A, and if he has brand B they'll buy brand B. Whether or not this situation prevails all over the nation we don't know, but maybe some parts manufacturers are faced with the problem of selling brands more emphatically than in the past. Admittedly, some manufacturers have been doing this, but the impression is that the program of selling a brand could be strengthened to advantage.

One other item which wants more attention than it seems to be getting is the self-serviced tube checker. There are some who feel that this tube selling plan is going to die. It does in some stores, then rears its head somewhere else. We can't quarrel with the right of people to sell tubes in this manner, but we do believe that those facets of the industry concerned with the sale of tubes to the public via service channels and the service industry itself might well afford more serious consideration of this problem. There are places in the

[Continued on page 47]

look what **\$24⁵⁰** buys
in test equipment!

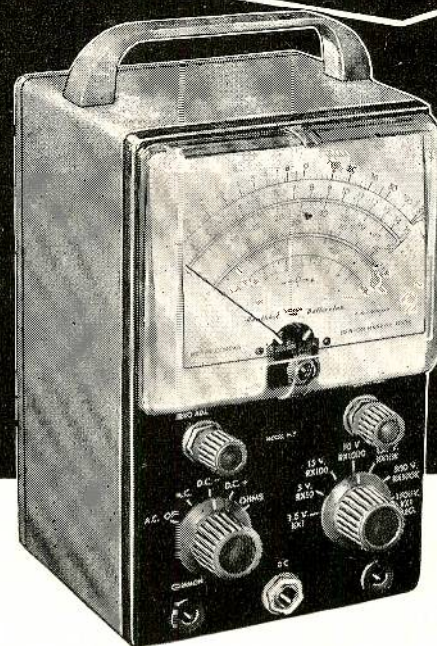

**HEATHKITS
GIVE YOU
TWICE AS MUCH
equipment for
every dollar
invested**

The famous model V-7A Vacuum-Tube-Voltmeter is a perfect example of the high-quality instruments available from Heath at 1/2 the price you would expect to pay! Complete, only **\$24⁵⁰**

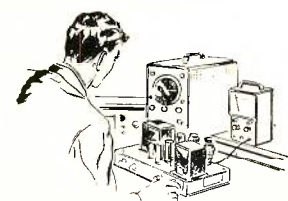

Get the most out of your test equipment budget by utilizing HEATHKIT instruments in your laboratory or on your production line. Get high quality equipment, without paying the usual premium price, by dealing directly with the manufacturer, and by letting engineers or technicians assemble Heathkits between rush periods. Comprehensive instructions insure minimum construction time. You'll get more equipment for the same investment, and be able to fill your needs by choosing from the more than 100 different electronic kits by Heath. These are the most popular "do-it-yourself" kits in the world, so why not investigate their possibilities in your particular area of activity! Write for the free Heathkit catalog now!



Contains detailed descriptions of Heathkit models available, including VTVM's, scopes, generators, testers, bridges, power supplies, etc.



Also describes Heathkit ham gear and hi-fi equipment in kit form. 100 interesting and profitable "do-it-yourself" projects!

FREE catalog

Mail coupon below for your copy—Now!

HEATH COMPANY
A SUBSIDIARY OF DAYSTROM, INC.,
BENTON HARBOR 29, MICHIGAN

Name _____

Address _____

City & Zone _____

State _____

Your **ERIE** Distributor Has
"PAC" Replacement Modules

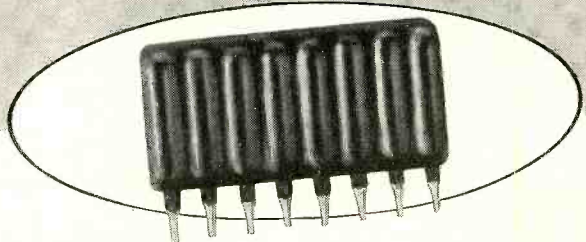

for Servicing 1957 Auto Radios

PAC is a group of interconnected capacitors and resistors, combined in a single-insertion unit. Several popular 1957 model automobile and truck radios employ this new concept in component packaging. When servicing these auto radios, a complete PAC (Pre Assembled Circuit) module can be quickly and easily replaced.

Your ERIE Distributor has PAC Replacement Modules in stock. See him for complete information and prices.



a full calendar of fun

Brilliant festivals and glittering events . . . cocktail hours . . . delicious dinners and breakfasts . . . sports, all sorts . . . 6 acres of fabulous tropic gardens . . . olympic pool and 3 blocks of private beach.

TV in every room
 100% Air Conditioned
 Ample Parking

Write for:
FREE COLOR BROCHURE
 and RATES or
 See your travel agent

RONEY PLAZA
 (7 Acres on the Ocean) COLLINS AVE. AT 23rd ST. MIAMI BEACH

THE ANSWERMAN

Inquiries Sent To The Answerman Will Be Acknowledged Only If Accompanied By Radio-TV Service Firm Letterheads.

by **ELECTRONIC SERVICING** Technical Staff

Dear Mr. Answerman:

I have a Magnavox receiver in which the picture is quite snowy. The RF amplifier tube has been checked and the antenna is good. I tried another TV receiver on the antenna and the substitution receiver worked fine. Also, in my shop the receiver exhibits the same condition of a snowy picture. The voltages seem to be about normal and all other tubes that might contribute to this condition have been substituted. Now, I don't know what to do. What can you suggest?

H. P.
 Mineola, N. Y.

When the *agc* resistor feeding the positive delay voltage to the tuner *agc* line increases in value the symptoms produced are just as you have found, a snowy picture. It is suspected that R225, the 9.1 megohm resistor shown in Fig. 1 has become higher in resistance and is thus the cause of this difficulty. Resistors which feed positive delay voltages in such circuits often increase in value and cause this type of trouble.

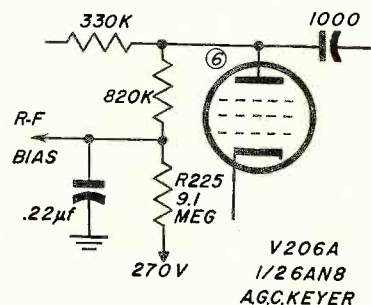

Fig. 1—An increase in the value of R225 may cause excessive snow.

It is suggested that you replace the 9.1 megohm resistor with one that has a 5% tolerance. Magnavox supplies the resistor under part number 230094-254.

Mr. Answerman:

I have a Dumont RA-170 that is giving me trouble. There is insufficient width, the picture being short 1½ inches on each side. I have checked all the components in the horizontal circuit

J. C. D.
 Cheyenne, Wyo.

There are few components that can cause lack of width without a serious changing in any of the *dc* voltages. Several possibilities are immediately apparent. If C276, the cathode by-pass condenser opens, degeneration will occur and reduce the input signal thus reducing the width. Shorted turns in the horizontal size coil L214 will cause a narrow picture because of the absorption of large amounts of energy. This

[Continued on page 44]

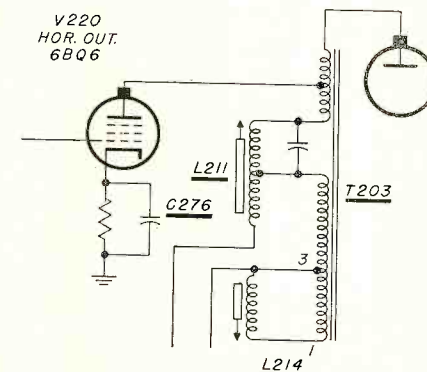

Fig. 2—Elements which may be responsible for the loss of sweep.

TAXICAB COMMUNICATIONS

[from page 11]

generator commutator will prove to be satisfactory. Should such a capacitor prove ineffective, a generator filter can be used which has more attenuation. These are available from many manufacturers.

If the armature commutator is dirty, then there will be more than average arcing at the brushes. If the generator receives irregular maintenance, it might be wise to by-pass the brushes with a pair of high quality capacitors.

Regulator Suppression

Regulator suppression can be done on a "cut-and-try" basis. Generally speaking coaxial capacitors will be required on either the battery or the armature or both. If these capacitors prove ineffective, however, they should be removed. The field terminal of the regulator cannot be directly by-passed. To do so would quickly burn up the points in the regulator. In addition an accidental short in the capacitor would remove all resistance from the generator field and perhaps cause very serious damage to the generator. On a cut-and-try basis again, however, a small resistor of about four ohms in series with a .002 capacitor can be tried. This should be mounted inside the regulator body if possible. If it proves ineffective, it should be removed. If all the above techniques fail, some thought might be given to the use of shielded wires between the armature and regulator.

Bonding

In general bonding material should be as non-inductive as possible. This dictates the use of solid materials for connections where possible. Where flexibility is a definite consideration braid will have to be used, although this has more inductance than solid material might have. Generally speaking, it is necessary to have a good bond between the fire wall, frame, and the engine. In many cases bonds from the hood to the fire wall on both sides of the car prove quite effective. A definite source of noise on many cars is the insulated tailpipe. Some sort of bond

on this tailpipe to the frame should be considered. There have also been reported cases where bonding the steering column to the frame produced excellent results, and in at least one case a floating bumper was proving to be quite a noise source until bonded to the frame.

Static Noises

The static charge built up in tires, brake shoes, front wheels, fan belt, etc. require individual attention. Tires can be treated with anti-static powder. Brake shoes can be grounded to the back-up lights. Another consideration for bonding the exhaust pipe is heavily graphited penetrating oil. The oil evaporates or burns off and leaves a conductive bond between the parts. This has been found to be more effective than grounding straps in some cases as the straps lose their effectiveness as oxidation continues. The graphite does not oxidize but stops oxidation at the points of contact. In bonding to eliminate static discharges between parts of a car, it is a good idea to make a generous use of heavy star washers on both ends of bolts to provide good contact.

Other Possibilities

In searching for noise it might be a good idea to inspect the engine while it is running in a dark garage. Sparks can be clearly seen under such conditions and sources of arcing which generate noise in the receiver can be eliminated. Some care should also be given to the proximity of wires, fluid tubes, and rods to the ignition wiring, and if so indicated, such rods, tubes or wiring should be separated from the ignition harness by a greater distance. It has even been found that wet heater hoses running close to the ignition harness will pick up ignition noise and radiate it into the antenna. Another technique which has been reported to show good results is the use of a series tuned trap run through the bundle of ignition wires where they come together. The resonant trap is grounded to the motor block at both ends and consists of an LC circuit resonant in the neighborhood of six or

seven megacycles. This trap is tuneable, and is tuned for minimum noise response.

It is sometimes a good idea to wait for one or two thousand miles before suppressing or attempting to suppress a brand new vehicle. It is generally found that a car will prove to be less noisy after a two thousand mile break-in run because the body continuity has been somewhat improved by the constant vibration along city streets. Thus the suppression job is often simplified.

In most cases it will be unnecessary

to go through *all* the suppression techniques just described. Generally speaking, it will be enough to add resistor plugs, a distributor resistor, and a coax capacitor on the generator armature. With perhaps the addition of a coaxial capacitor to the battery side of the ignition coil, the average car will be brought to a satisfactory noise level. Where this is *not* true, then the foregoing suggestions may prove helpful. Each has proved to be the answer to a stubborn noise problem that resists the simplified treatment. ■ ■

Why Waste Time and Energy? Save With This
Complete "Starter" Assortment
Plus A Bonus For You!

**NEW
STACKPOLE
CARBON
RESISTOR
KIT**

YOU GET 30 BOXES OF THE MOST USED 1/2, 1, 2 WATT RESISTORS...

No more fumbling around the bench or tool kit . . . or running down to the jobber for a single resistor! Here's a kit that has the 30 most used values, scientifically packaged to prevent damage . . . famous Stackpole Resistors used by all leading TV set makers. And to "sweeten the deal," here's a big

G-C 60 LINE CARBON RESISTORS

PLUS—THIS HANDSOME ALL-METAL RACK FREE For your bench or wall!

BUY THE RESISTORS... GET RACK FREE!

World's Finest Carbon Resistors—Color-Coded and Labeled—In Hinged Cover Plastic Boxes

FREE YOUR G-C CATALOG
... send postcard today.

ASK YOUR ELECTRONICS DISTRIBUTOR ABOUT THIS KIT—No. 5245—IF HE DOESN'T HAVE IT, TELL HIM TO GET ONE FOR YOU. COSTS YOU JUST \$18.00 . . .

G-C ELECTRONICS MFG. CO.
Division of General Cement - Textron Inc.
400 South Wyman Street • Rockford, Illinois

FREE

by subscribing to **ELECTRONIC SERVICING**
now on this special order form you will get **FREE!** **FREE**

96 PAGE TV SCHEMATIC PACKET

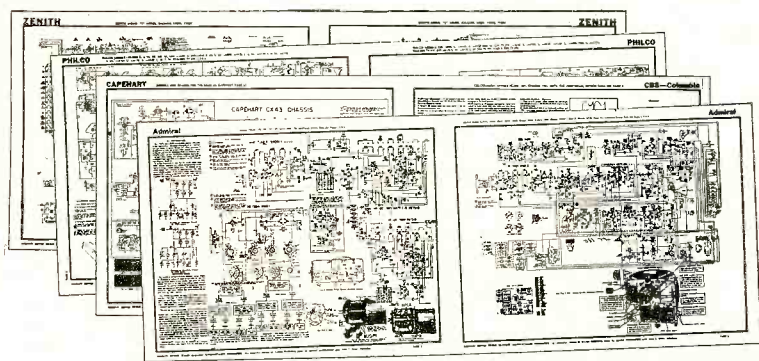

You get 16 more pages of new schematics in every issue

Every issue of **ELECTRONIC SERVICING** now carries 16 pages of new TV schematics. Many of these will not be available from any other source for months. Each schematic is crystal clear and accurate — (prepared by John F. Rider) — ready for immediate use and easy filing for future reference. The schematics include Alignment Data, Waveforms, Operating Voltages, Tube Location Guide, Essential Parts Numbers, etc.

In addition you'll get 4 more new pages of
VIDEO SPEED SERVICING SYSTEMS Data Sheets in each issue

**HURRY . . . HURRY . . . This Special Offer Good Only
While The Present Supply of Schematic Packets Last**

---TEAR OFF --- MAIL TODAY --- GET YOUR FREE 96-PAGE TV SCHEMATIC PACKET FREE---

ELECTRONIC SERVICING, 300 W. 43rd St., New York 36, N. Y.

I accept your FREE OFFER . . . a complete 96 PAGE TV SCHEMATIC PACKET together with a 2-year subscription to **Electronic Servicing**. Here is my \$5.00

CHECK YOUR CLASSIFICATION

- | | |
|--|---------------------------------------|
| <input type="checkbox"/> Independent Radio-TV Serviceman | <input type="checkbox"/> Owner |
| <input type="checkbox"/> Radio-TV Service Organization | <input type="checkbox"/> Employee |
| <input type="checkbox"/> Retail Store having Service Department | <input type="checkbox"/> Service Mgr. |
| <input type="checkbox"/> Industrial Electronic Service Firm | <input type="checkbox"/> Student |
| <input type="checkbox"/> Firm having electronic equipment which I service and maintain | |

If some other type of company describe: _____

- Check if New Subscriber
 Check if this is to renew or extend your present subscription when it expires

(Please Print)

Name _____

Address _____

City _____ Zone _____ State _____

Name of firm _____

Firm's business address _____

City _____ Zone _____ State _____

ANSWERMEN

[from page 42]

may be tested by removal of one lead of the width coil from terminal one of the fly back transformer. A similar condition may exist in the horizontal linearity coil *L211* and fly back transformer *T203*. Shorted windings in these components would reduce width and not affect the *dc* voltages radically. Unfortunately the latter two components are best checked by substitution since a short of several turns will not alter the resistance reading materially.

Dear Sir:

I have run into a real problem I have in my shop a Truetone 2D3770A portable. After two minutes of operation the bottom of the pix folds over and the top of the pix stretches out. The picture also starts to roll.

H. J. E.
Waco, Texas.

From your description, the trouble appears to be in the vertical output stage. The 12L6 is saturating and producing foldover. This is borne out by your cathode current reading of the 12L6, V106, which is caused by a lowered grid bias. There are two reasons

that the grid bias may be lowered. These are, a leaky coupling condenser, or a gassy output tube, or both. Many service problems that lead up to a blank wall are caused by the combination of problems that may alone be very simple. There exists the possibility of your not having tried both components simultaneously; that is the coupling condenser and the output tube. A further possibility is that occasionally new tubes are defective. Try several output tubes, to be sure.

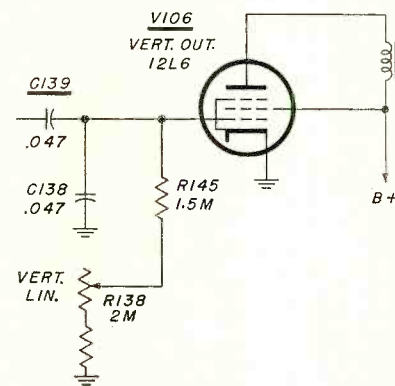

Fig. 3—Schematic shows the elements which will cause vertical fold-over.

TRANSISTOR THEORY

[from page 3]

the effect is the same as if a positive charge were present. Actually, the robbed electron is said to fall into the hole created by the substitution of the indium atom for a germanium atom. Thus, holes behave as if they were positive charges.

Since the neighboring germanium atom is robbed of an electron it can also be pictured as being left with a hole. To fill this hole it robs another neighboring atom of one of its valence electrons, thereby creating another hole. This process is repeated throughout the sample of germanium and sets up a chain of events whereby holes are pictured as moving outwardly from the source of the disturbance. Since holes are equivalent to positive charges, germanium to which indium is added is said to be "P" type germanium, P standing for positive. In this case indium is referred to as an "acceptor" type

material.

Comparing the processes involved in creating N and P type germanium, we may summarize by stating that:

1—In N type germanium the donor is a pentavalent substance, such as arsenic, and leaves a number of free negative charges available for conduction.

2—In P type germanium the acceptor is a trivalent substance, such as indium, and leaves a number of holes or equivalent positive charges available for conduction. It should be kept in mind that conduction here is still a flow of electrons. However, conduction in semiconductors is more readily understood if we adopt the concept of a hole being equivalent to a charge equal in mass, and opposite in polarity, to that of an electron. N and P type semiconductors are the foundation units in the manufacture of rectifiers and transistors.

[To be continued]

SELL SERVICE WITH EFFECTIVE ADVERTISING

PART 2

By M. E. WIRT

NEWSPAPER advertising is probably the best all-round medium available to the average service agency or department, both from the number of people reached and the cost of advertising per person. By far the best advertisement we have ever used (and are still using), is a "column," which at present appears once a week on Friday—a "fight" night—next to the station listings, which in our local paper is next to the sports pages. It is entitled "TELEVISION TIPS," and in it is discussed almost anything pertaining to the servicing of television receivers, strictly from the non-technical point of view. It makes an honest effort to save the customer money by giving "tips" as to minor adjustments the customer can make himself, how to clean the safety glass, how to identify certain types of interference sporadically seen on the screen, the advantages of an outside antenna, etc.

There is, of course, a limit to what the customer can do for himself, so these "tips" are rewritten and repeated at irregular intervals, on the theory that there will have been many who have not read the original, have forgotten, or have recently moved into the area and subscribed to the newspaper. In between, subjects of general interest are covered, but these "general interest" columns still are linked with television service.

Newspaper advertising, good as it is, should be supplemented by other forms—and don't sell radio short! "Spot" announcements, for example, are surprisingly low in cost, price being governed by the number you use and the length of the "spot." Many manufacturers of television receivers furnish, free of charge, spot announcements already written and timed, and if you sell as well as service, use them. Some high-priced "brains" have turned out the copy and you can depend upon it—it's good. If yours is a service set-up only, and you can't write your own copy, the radio station will do it for you if you let them know in a general way what it is

you wish to stress. Have them "pitch" your advertisement toward the feminine listener; it can and will result in more service calls.

Direct mail can be a most effective advertising medium, yielding a return of 2% to 10% in replies. If used correctly and followed faithfully, it can do a very good job. However, in service we normally have nothing to sell until the set breaks down. Then, and only then, do we come into our own, and at that time the customer is not too interested in what we have to use in order to repair the set—just so that it is repaired. In service, therefore, we must be doubly careful in making up our mailing list, to whom we will mail our cards, circulars, etc., and how frequently it will be done. Otherwise cost can exceed benefits. Keep an accurate record of returns on your direct mailing returns; people *do* move, die, or disappear. The Post Office can help you keep your mailing list current as to addresses at a very small cost to you.

Tube manufacturers offer a wide variety of post cards, posters, signs, window streamers, and door-knob hangers for your use. Their cost is low—for instance, post cards, imprinted with your name, will cost you only the postage of two cents, and they carry a hard-hitting, cartoon-illustrated message.

Closely associated with direct mail advertising using post cards or form letters is the circular, or "throwaway," and that is exactly what the average recipient will do with it—unread. Envelope stuffers suffer the same fate. They have their place in an all-out advertising campaign to sell appliances, dresses, or flower seeds, but their value in selling service is debatable. After all, it is not the parts and tubes we will use in repairing the set which we are anxious to push, it is the service itself. So all our advertising should be done with one thought only—to implant your name and your company's name so firmly in the customer's mind that when his set *does* require service, his first reaction will be to think of you.

And after you have repaired his set, think of you he will, one way or the other, good thoughts or bad. If you have done a *good* job, then you are in line for the best of all possible forms of advertising, the hardest-hitting, lowest cost type imaginable—*word-of-mouth* advertising. It is so good it is priceless. You can't buy it. But if you have repaired the set properly, and made the right impression in doing it, you have hired an untiring salesman for your service that won't cost you a dime. A customer whom you have pleased by returning his set to operating condition in a very short time, at a nominal charge, will tell his neighbor—and you've got another customer. Since your original customer has "no axe to

grind," his advice is accepted with thanks, and when it is necessary for the neighbor to call for service, it's *you* they will call. That type of advertising can't be beat, and it's worth a little extra effort to earn. Don't be too rushed to spend the few extra minutes necessary to clean the safety glass, make minor adjustments, touch up a scratch on the cabinet, or oil a squeaking caster. The small, thoughtful things are what the women remember!

Advertising *service* is like anything else—you will benefit in direct proportion to what you put into it. It is an axiom that you must *spend* money in order to *make* money—and one of the best ways to spend it for tangible returns is in advertising. ■ ■

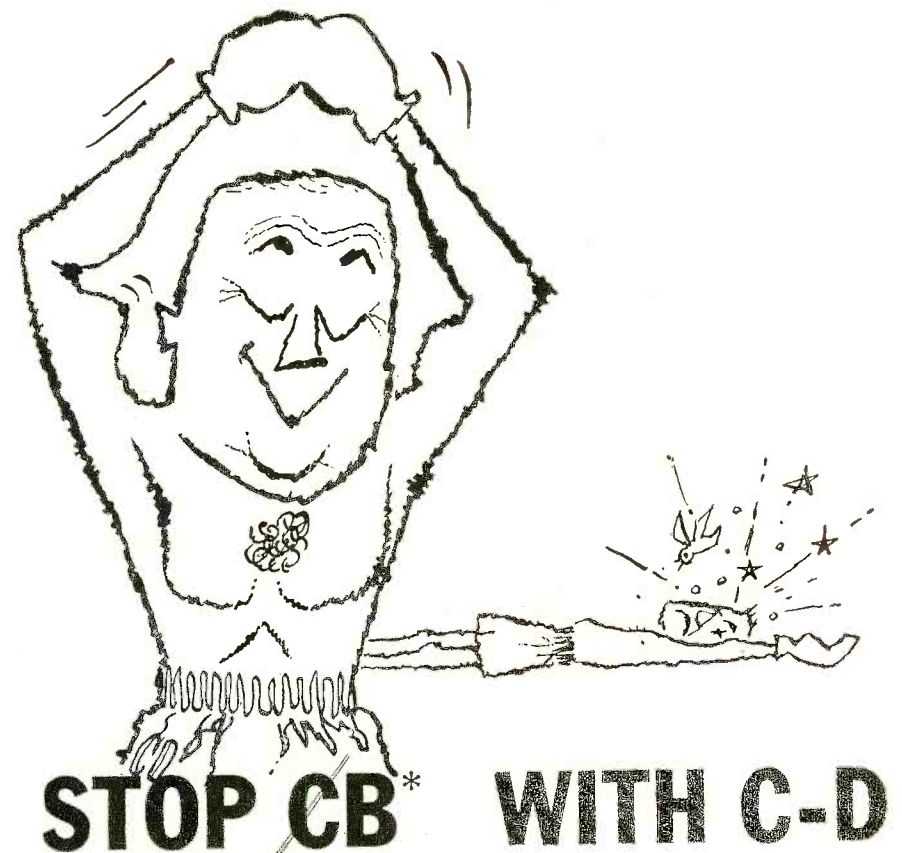

STOP CB* WITH C-D

*STOP CALL BACKS by always using C-D "CUBS"®—the tubular that has proven itself the champ in the service field. They out-perform any other replacement because they're the only molded tubular with built-in extras that insure call-back-free servicing. C-D "CUBS" are made exclusively for the service trade.

SPECIAL! "CUB SERVICE KIT" in all-plastic dispenser. You pay only for the capacitors. Ask your distributor salesman to show you the new C-D "CUB SERVICE KIT" or write for details Cornell-Dubilier Electric Corporation, South Plainfield, N. J.

stop callbacks...insist on

CORNELL-DUBILIER CAPACITORS

SOUTH PLAINFIELD, N. J.; NEW BEDFORD, WORCESTER & CAMBRIDGE, MASS.; PROVIDENCE & HOPE VALLEY, R. I.; INDIANAPOLIS, IND.; SANFORD, FUQUAY SPRINGS & VARINA, N. C.; VENICE, CALIF.; & SUB.: THE RADIART CORP., CLEVELAND, O.; CORNELL-DUBILIER ELECTRIC INTERNATIONAL, N. Y.

There
is a
faster
way

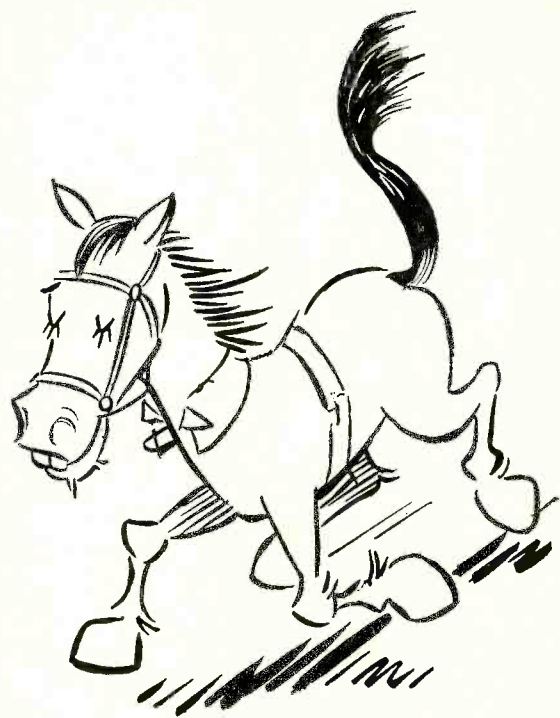

to **SPEED SERVICING!**



Time is money to servicemen. Thousands of servicemen who have bought Vol. 1 VSSS report that it is a time-saver which helps them pinpoint their trouble-shooting so they can service sets more efficiently.

A compilation of specific receiver service repairs, "bugs," chronic troubles, field circuit changes, manufacturers' production revisions, etc. The compilation enables the service technician to pinpoint what is wrong with any given TV set and to correct the fault in the shortest possible time.

Video Speed Service Systems is guaranteed to simplify servicing all TV sets. Contains over 600 service items representing over 2500 of the most serviced TV models now in use. Over 25 different manufacturers' lines are covered.

CUT OUT AND MAIL

COWAN PUBLISHING CORP., 300 WEST 43rd STREET, NEW YORK 36, N. Y.

Please send me postpaid Video Speed Servicing Systems

Vol. 1 in Paper Bound Edition for \$2.95
Vol. 1 in Hard Cover Ring-Binder Edition for \$4.95
Vol. 2 in Paper Bound Edition for \$2.95

My Check for \$..... is enclosed.

Name.....

Address.....

City..... Zone..... State.....

VERTICAL RETRACE BLANKING [from page 7]

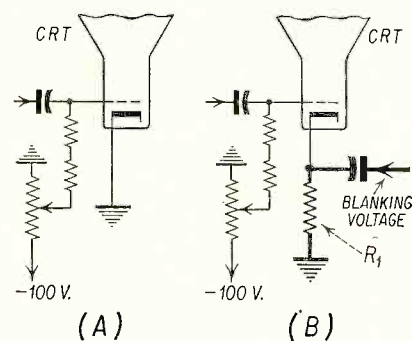

Fig. 4—Modification for blanking.

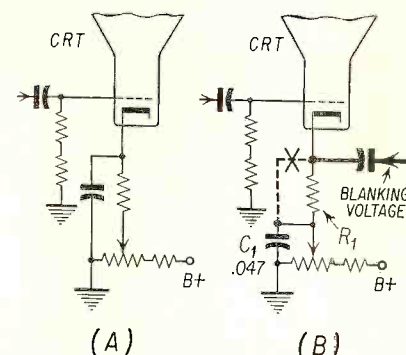

Fig. 5—A different modification.

full B plus would be applied to the cathode driving it so positive that the CRT would be cut off. If $C158$ shorts, removing all bias, thus giving full brightness with the brightness control being ineffective.

The General Electric circuit of Fig. 3 may cut the CRT off if capacitor $C311$ shorts or becomes leaky. The positive voltage on the grid of V9 causes heavy plate current thus producing a large voltage drop across $R320$, the plate load resistor. This lowers the first anode voltage to about 10 volts so that the CRT is cut off.

If any of the coupling condensers open, the results will vary. Returning again to Fig. 1, if $C157$ opens, the blanking pulses would not reach the cathode and retrace lines would appear on the screen. Should $C158$ open, the

voltage divider action will fail and the full pulse will be applied to the cathode through $C157$. The excessive blanking voltage may tend to shade the upper portion of the picture if the CRT comes out of cut off during the early portion of the vertical scan. This effect will also occur as a result of a lengthened time constant in the wave shaping network.

Set Modification.

When modifying a set to accept a vertical blanking circuit, there are three factors to be considered. These are:

1. Modification of the CRT circuit to accept the blanking pulse.
2. Selection of an appropriate shaping network.
3. Selection of a pulse take off point in the vertical circuit.

In order to modify the CRT circuit we must observe which element is driven by the video signal. If the grid is the driven element the blanking pulse should be applied to the cathode circuit. Figs. 4A and 5A show two basic cathode circuits and Figs. 4B and 5B show the corresponding modifications.

The shaping networks used vary

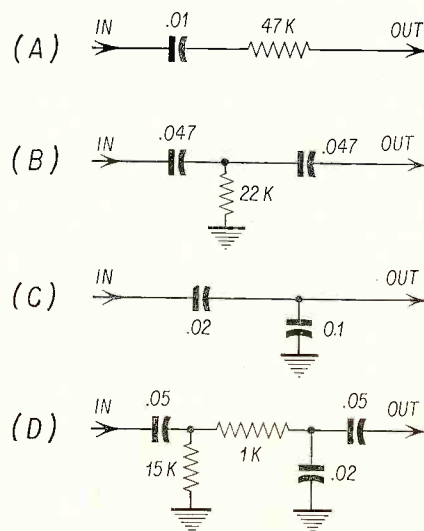

Fig. 6—Typical wave shaping circuits to obtain blanking pulses.

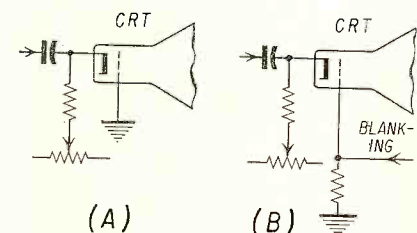
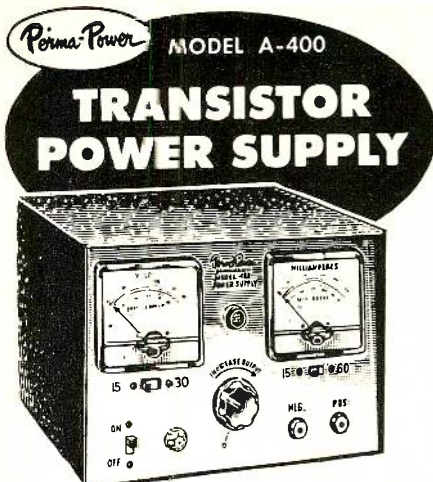

Fig. 7—Modification to allow injection of pulse into grid circuit.



Especially designed to operate, service and test transistor portable radios and low power transistor circuits. Features: • Continuously adjustable output using variable autotransformer control • Two output voltage ranges (0-15 volts and 0-30 volts) for accurate setting of all transistor battery voltages • Two output current ranges (0-15 MA and 0-60 MA) monitor current for single transistor or entire set • Extremely low ripple (less than 500 μ V — .002% at full load) for testing lowest level transistor circuits • Very low internal impedance (less than 20 ohms DC to R.F.; including 7 ohm removable meter fuse) providing excellent regulation • 2% Precision D'Arsonval meters provide laboratory accuracy • Milliammeter protected by front panel fuse; additional internal line fuse • Output isolated from line and case • Attractive Slope — Front, Maroon Hammerloid Cabinet — Rubber feet.

\$64.50
NET

From Electronic Parts Distributors only

Perma-Power COMPANY

3100 N. ELSTON AVE. • CHICAGO 18, ILLINOIS
There's Always Something NEW Being Developed by Perma-Power

50
Free



Perfect door opener — ideal maker of that extra sale — advertised in Life — Esquire — costs you nothing — the OFF® Home Needle Tester Card. Lets you test needle in cartridge. Lets you sell needle each time. Write:

• Duo-tone — Jelly Focus

Duo-tone Company, Inc.
KEYPORT, NEW JERSEY

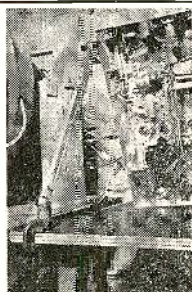

**ADJUST-
ABLE
3rd ARM**

FOR HOLDING
CHASSIS IN
POSITION ON
WORK BENCH

\$5.50
each

SUPPORTS VERTICAL CHASSIS.
PREVENTS BREAKAGE OF
PRINTED CIRCUITS AND
OTHER COMPONENTS

Send checks or money orders only
TELE-SCOPIC PRODUCTS, INC.
262 Sullivan Pl., • Bklyn 25, N. Y.

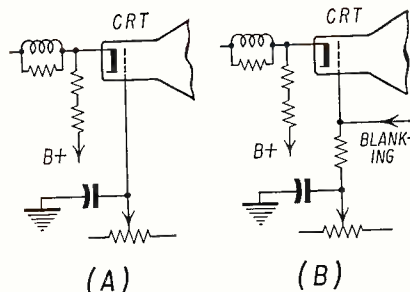

Fig. 8—Modification when brightness control is in grid circuit.

from a two component circuit to complex arrangements. For purposes of modification, the simpler the wave shaping circuit is, the easier the task becomes. Fig. 6 presents four typical wave shaping circuits. Of the four, Fig. 6A has generally been found satisfactory for most sets. Use may be made of the printed circuit employed in the Admiral 19T1 shown in Fig. 2C. The Admiral part number is 63CG-5.

If the grid circuit is to receive the blanking pulse, it is the one which must be modified. When the grid is grounded it may be changed as shown in Figs. 7A and 7B and if it is used as the brightness control circuit it may be modified as shown in Figs. 8A and 8B.

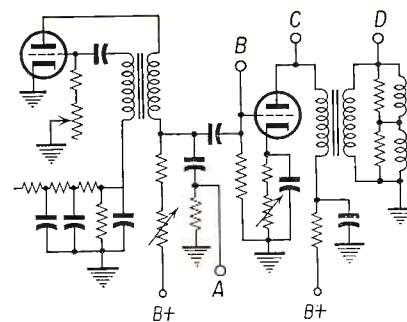

Fig. 9 — Take-off points for securing blanking pulses.

Pulse Take-Off Points

The pulse to be shaped and applied to the CRT may be taken from several points in the vertical circuit. A typical vertical circuit is shown in Fig. 9. The take-off points are lettered from A to D. Points A and B may be used for control grid blanking. When using the pulse from point A it is not necessary to use a shaping network since we already have the desired negative pulse.

In circuits using auto transformer outputs such as those of Figs. 1 and 2C, the pulse polarity may be reversed by relocation of the B plus feed thus giving us three possible take off points; the plate or high side of the transformer, the bottom or the center point. ■ ■

RIDER SPEAKS

[from page 41]

nation where the method has taken a beating, but there are many places in the nation where it is still very much alive. Just what will be done to overcome its selling features on Saturday night and Sunday, the times when service shops are closed, we don't know. Maybe nothing can be done to overcome the availability of self-service at these times, but certainly, every effort to acquaint the public with the availability of self-service in service shops during the other six days a week is warranted. The supermarket may not be as big a problem as the drugstore because the supermarket is closed Sundays. Nevertheless, we have learned of chains of 100 or 150 stores which have contracted for self-service tube checkers. Supermarket operators are not foolish people. By and large their marketing practices are the result of investigation. They are not going to waste any space. They are handling a greater variety of products than ever before, and they can, without

too much difficulty, persuade the housewife to bring in a bag full of tubes for testing. The whole thing is too big to be sloughed off.

In connection with self-service tube checking in service shops we would like to express one word of caution. The public should be given the opportunity to check tubes in a service shop without any aid on the part of the service technician. The shop owner or his people should stay as far away as possible from John Q. Citizen while he is checking his own tubes. The atmosphere of the tube checking in service shop by the public should be exactly the same as in the drugstore or supermarket. Make it a "Do-It-Yourself" deal throughout. This may not be possible with the conventional types of tube checkers which most service shops have, in which event fire must be fought with fire; the service shop owner is faced with the problem of getting the self-service type of tube checker for use by the public. ■ ■

FOR SOUND
SATISFACTION



... use

**RCA
GOLD LABEL
SPEAKERS!**

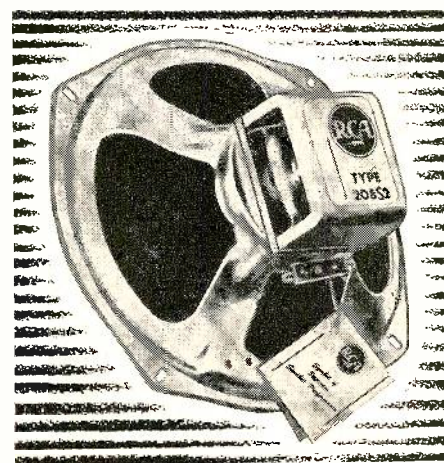

Replace dead speakers with live RCA Gold Label Speakers. They're short on installation time . . . long on customer satisfaction. All types built to RETMA size standards REC 148 . . . mounting hardware is included on most smaller sizes . . . For all your speaker requirements . . . play it smart and safe! Be sure you ask for RCA Gold Label Speakers . . . at your local distributor.



**RADIO CORPORATION
of AMERICA**

COMPONENTS DIVISION

CAMDEN, N. J.

SENCORE
Another Sencore Time-Saver
Handy "36"
R-C
Substitution Unit



"36"
Most Often Needed Components At YOUR Fingertips!

3 pole, 12 position switch individually selects one of the "36" components for direct substitution.

Contains:

- ★ 12-1 watt 10% resistor from 10 ohms to 5600 ohms
- ★ 12-1/2 watt 10% resistors from 10K ohms to 5.6 megohms
- ★ 10-600 volt capacitors from 100-mmfd. to .5mfd.
- ★ 1-10mfd., 450V Electrolytic
- ★ 1-40mfd., 450V Electrolytic

Completely isolated

★ For Shop, Lab, or outside service AVAILABLE AT ALL PARTS DISTRIBUTORS!

POPULAR SENCORE PRODUCTS

- Transistor Tester
- Leakage Checker
- Filament Tester
- Voltage Regulator
- Bias Supply

ONLY \$1275 DEALER NET

SENCORE SERVICE
INSTRUMENTS CORP.
171 OFFICIAL RD., ADDISON, ILL.
Cut out this ad now for further information.

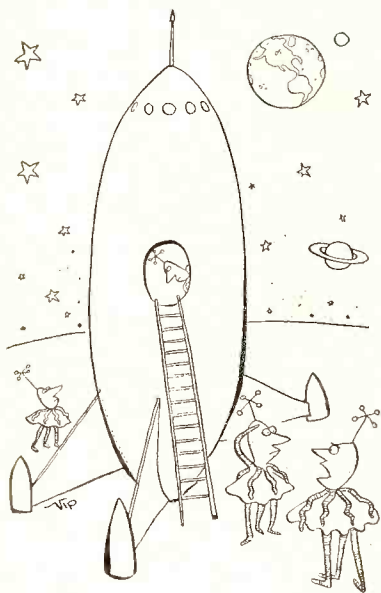

"Your mission is to bring back JENSEN NEEDLES no matter what."

POWER AMPLIFIERS IN HI-FI

[from page 15]

now be discussed, together with an explanation of what the measurements are designed to show.

Test Equipment Required for Servicing

The essential equipment you will require for servicing includes:

1. A good audio generator having a low impedance output, flat frequency response from at least 20 cycles to 20 kc and harmonic distortion of less than 1% at all frequencies. The generator should also be equipped with a variable attenuator, but this need not be calibrated accurately.
2. An oscilloscope having a vertical sensitivity of at least 0.05 volts per inch and good frequency response within the audio range.
3. An *ac* VTVM with the lowest full scale range of .03 volts or less and good frequency response within the audio range.
4. Calibrated wirewound resistors (of at least 50 watt rating) of 4, 8 and 16 ohms. Variable tap resistors can be used, if you have an accurate ohmmeter with which to set the taps.
5. Your regular VTVM.

In addition to the above, a completely equipped audio service center should include the following:

6. An audio wattmeter, calibrated directly in watts and having its own load resistors.
7. A distortion analyzer, either harmonic or intermodulation type. (The latter is by far easier to use and is preferred.)

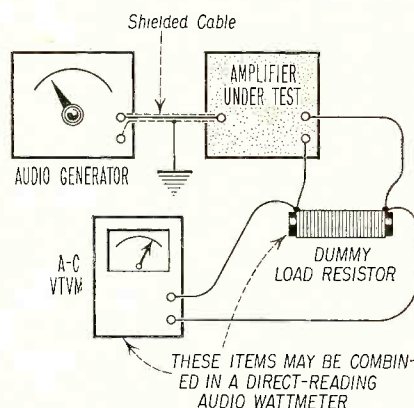

Fig. 2 — Setup to measure the sensitivity of an amplifier.

8. A square wave generator (used only on rare occasions).

Measuring Amplifier Sensitivity

The sensitivity of an amplifier is defined as the voltage input necessary to drive that amplifier to full output. It has nothing whatever to do with the power rating of an amplifier. Thus, a 10 watt and a 50 watt amplifier may each have sensitivities of 1 volt. That is, one volt input will drive *either* amplifier to its full rated output. This specification is easily checked by applying the signal voltage required at the input (with all level controls fully clockwise) and measuring the wattage output with your audio wattmeter. (In the absence of this instrument, an *ac* VTVM and a proper load resistor may be used, together with the formula $W = E^2/R$, where W is in watts, E is in *ac* volts and R is the load resistance.) The setup is shown in Fig. 2.

Power Response

Power response, the ability of an amplifier to produce uniform output at all frequencies, can be measured with the same set-up as that used to measure sensitivity. Set the audio input voltage at 1000 cycles to provide maximum power (the actual power rating of the amplifier). Vary the frequency of signal throughout the audio range—from 20 to 20,000 cycles and note any deviation from the initial reading. The statement that an amplifier has uniform power response from 20 to 20,000 cycles *within 1 db* means that at no time should the meter reading depart from the initial reading by more than 1 *db* either positive or negative. It should be noted that in power considerations, a change of three decibels corresponds to a change of two to one in power. Thus, a ten watt amplifier which is "down only three *db*" at 30 cycles is one which can produce only 5 watts at thirty cycles. This is usually somewhat of a surprise to the unsuspecting customer, who has been led to believe by optimistic specifications that "3 decibels" is practically inaudible.

[To be continued]

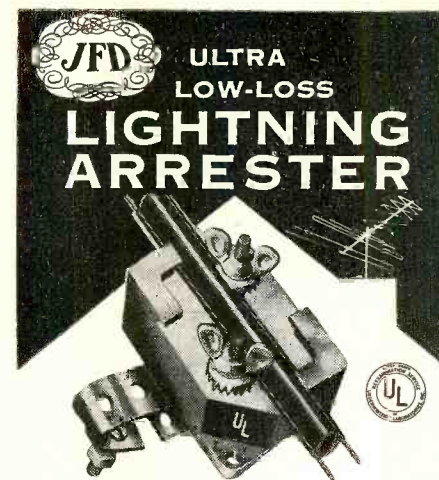

Ultra low-loss performance on VHF-UHF frequencies.

Patented strain-relief retaining lips prevent tearing or ripping of wire.

Universal design takes all transmission lines.

NO.	LIST
AT110	\$1.50
(wall mounting)	
AT110S	1.75
(stainless steel strap)	

"World's largest manufacturer of TV Lightning Arresters"

JFD MANUFACTURING CO., Inc.
BROOKLYN 4, NEW YORK
OUR 26TH YEAR

SPRAY it or DROP it



the NEW
QUIETROLE
Spray-Pack

or the
QUIETROLE
Bottle with the
Eye Dropper Cap



Now QUIETROLE offers you both types of containers. Either way assures you of the same unflinching results that QUIETROLE is known for.

Make your next purchase QUIETROLE, get both and learn the difference between quality and poor substitutes. QUIETROLE is the original product of its kind, it is a FIRST of the industry and you can depend on it to end your noisy control and switch troubles.

manufactured by
QUIETROLE
COMPANY
Spartanburg, South Carolina

Advertisers' Index

Aerovox Corporation	33
American TV & Radio Co.	34
Amphenol Electronics Corp.	1
Belden Manufacturing Co.	Cover 3
Blonder Tongue Laboratories	36
Bussmann Manufacturing Co.	3, 38
Clarostat Manufacturing Co. Inc.	11
Cornell-Dubilier Elec. Corp.	45, Cover 2
Duotone Company, Inc.	47
Electro Products Labs, Inc.	8
Electro-Voice, Inc.	15
Erie Resistor Corp.	42
General Cement Mfg. Co.	43
Heath Company	41
International Crystal Mfg. Co.	40
JFD Manufacturing Co., Inc.	48
Jensen Industries, Inc.	48
Jerrold Electronics Corp.	12
Mallory, P. R. & Co. Inc.	9
North American Philips Co., Inc.	35
Perma-Power Company	47
Philco Corporation	7
Pyramid Electric Company	13
Quietrole Company	48
RCA Batteries	Cover 4
RCA Service Company	39
RCA Speakers	47
Radiart Corporation	Cover 2
Raytheon Mfg. Co.	5
Roney Plaza	42
Service Instruments Corp.	48

If it's worth
engineers'
time...

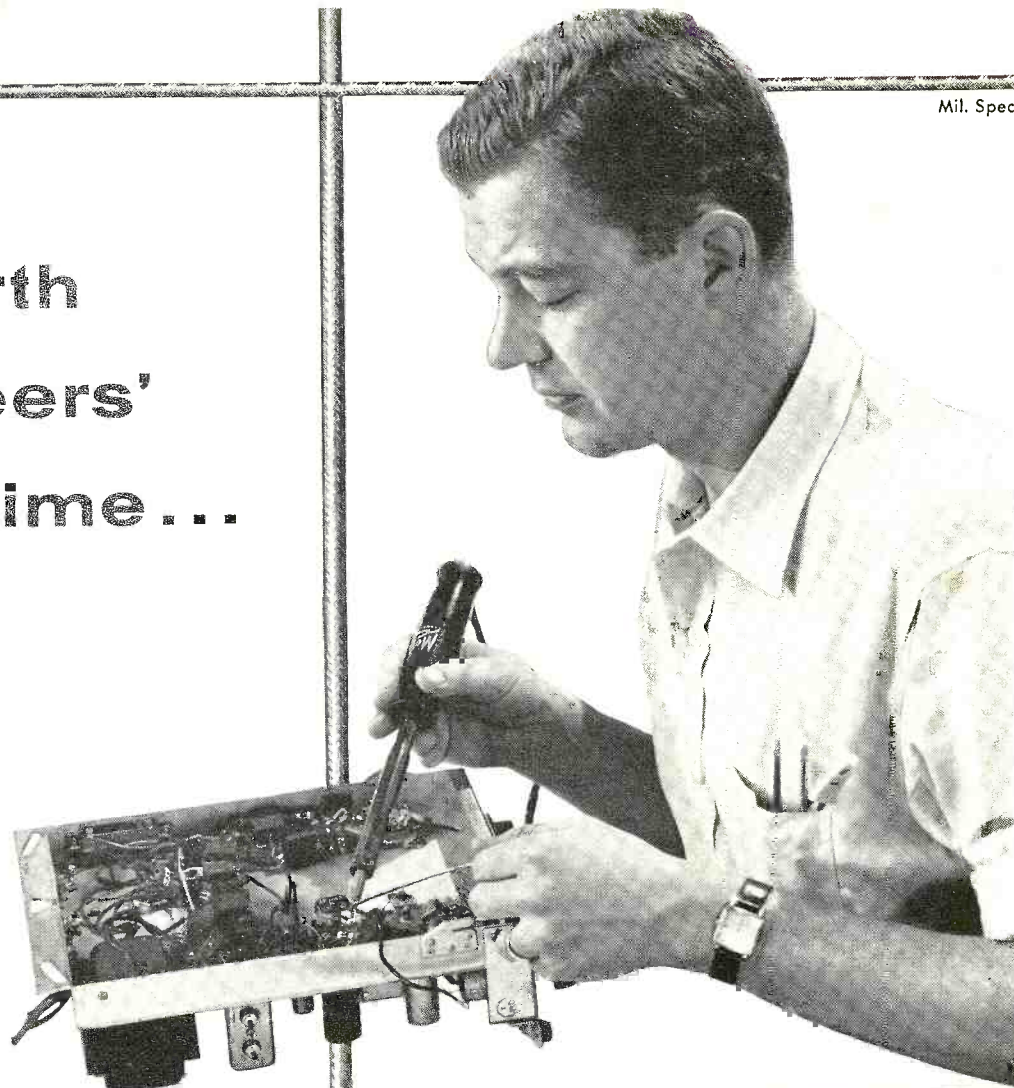

Mil. Spec.

Mil. Spec.



...it's worth
engineered
electronic wire



6-8

Magnet Wire • Lead and Fixture Wire • Power Supply Cords, Cord Sets and Portable Cord • Aircraft Wires
Welding Cable • Electrical Household Cords • Electronic Wires • Automotive Wire and Cable



He does...



He doesn't...



... stock and sell RCA Batteries!

Successful dealers look ahead and move fast—with *fast-moving* RCA Batteries.

With portable radio sales as big as all outdoors these days, RCA Batteries will be prime movers to bigger sales and more profits... all summer long!

Order your stock of RCA Batteries NOW!



RADIO CORPORATION of AMERICA
COMPONENTS DIVISION

CAMDEN, N. J.

RCA Batteries... the brand that commands public demand!

COWAN PUBLISHING CORP., 300 West 43rd Street, New York 36, N. Y.

**ELECTRONIC
SERVICING**

APR 6E 1718 16 SEP 57A
M J HINKO
15927 TRAFALGAR
CLEVELAND 10 OHIO