

1940  
August

*Radio*  
**SERVICE  
DEALER**

SOUNDMAN \* JOBBER



*Price*  
**20¢**

**COMPLETE  
COVERAGE  
For Your  
Condenser  
Requirements**

P. R. MALLORY & CO., Inc.  
**MALLORY**

**Replacement  
Condensers**



Here's the answer to replacements on millions of condensers now in use . . . and the only adequate answer to the problem of replacements on inexpensive compact receivers.

On every point, the Mallory line of Tubular Condensers assures you of faster, more efficient replacement . . . at a better profit. The line is complete. You never have to compromise on replacement needs. And each individual unit reduces mounting problems to the simplest possible form.

Remember . . . Mallory Tubular Condensers have been developed around an exhaustive study of *all* original equipment types. You can be sure of the exact replacement you need every time.

**Over 50 Ratings to choose from**

Mallory Tubular Condensers include, wherever sizes permit, multiple separate section units. The complete line is furnished in attractive, neat, permanently marked tubes . . . definitely sealed against humidity and moisture. All condensers are provided with 6-inch flexible leads for installation convenience.

See Your  
Mallory Distributor  
for Complete  
Information Today!

**\*FP (Fabricated Plate) Tubular Condensers (Type BB)**

TRADE MARK REG. U. S. PAT. OFF.

made by **MALLORY**

Every advantage of FP construction is afforded in these small, metal enclosed tubulars. Made with one piece drawn aluminum can and insulated with an attractive cardboard cover clearly marked for rating identification. Strong internal construction eliminates troublesome open circuits.

**P. R. MALLORY & CO., Inc.**  
INDIANAPOLIS INDIANA  
Cable Address—PELMALLO



*\*Not etched construction*

Use

P. R. MALLORY & CO. Inc.  
**MALLORY**  
APPROVED  
PRECISION PRODUCTS

*Include*

VIBRATORS • VIBRAPACKS • CONDENSERS • VOLUME  
CONTROLS • ROTARY SWITCHES • SINGLE AND  
MULTIPLE PUSH BUTTON SWITCHES • RESISTORS  
RADIO HARDWARE

*Radio*

# SERVICE-DEALER

**SOUNDMAN AND JOBBER**

Reg. U. S. Pat. Off.

## Ad Index

<b>Centralab</b> . . . . .	<b>4th Cover</b>
Volume Controls	
<b>Clarostat Mfg. Co., Inc.</b> . . . . .	<b>26</b>
P-A Output Attenuators	
<b>Jackson Elec. Inst. Co., The</b>	<b>3rd Cover</b>
Dynamic Tube Tester	
<b>Mallory &amp; Co., P. R.</b> . . . . .	<b>2nd Cover</b>
Replacement Condensers	
<b>Racon Electric Co.</b> . . . . .	<b>2</b>
Horn & Cone Speakers	
<b>Raytheon Production Corp.</b> . . . . .	<b>15</b>
Tubes for Precision Equipment	
<b>Radio Servicemen of America</b>	<b>28</b>
Membership	
<b>Selectar Mfg. Corp.</b> . . . . .	<b>27</b>
Universal Connector Kit	
<b>Supreme Instruments Corp.</b> . . . . .	<b>25</b>
Model 547 and 543 Multimeters	
<b>Triplett Elec. Inst. Co., The</b> . . . . .	<b>26</b>
Model 1213 Tube Tester	

## Contents

<b>Transients (Editorial)</b> . . . . .	<b>3</b>
<b>Sound Facts For Sound Men</b> . . . . .	<b>4</b>
By J. P. Kennedy	
<b>Set of the Month</b> . . . . .	<b>6</b>
RCA Victor BP-10 Personal	
<b>Cutting P-A Corners</b> . . . . .	<b>7</b>
<b>Sound For Movie Makers</b> . . . . .	<b>8</b>
By H. M. Guthman	
<b>Technical Service Portfolio</b> . . . . .	<b>9</b>
Section IV—V-T Voltmeters	
<b>Serviceman's Diary</b> . . . . .	<b>13</b>
By J. P. Hollister	
<b>Horace (Cartoon Strip)</b> . . . . .	<b>13</b>
<b>Puppets Are Sound Sales Prospects</b> . . . . .	<b>14</b>
<b>Circuit Court</b> . . . . .	<b>17</b>
Penny Savers	
Stromberg Degenerative Tone Control	
Majestic Degenerative Tone Control	
G. E. Oscillator Drift Correction	
<b>Motorola B2RC, B3RC, B4RC Record Changers</b> . . . . .	<b>18</b>
<b>Shop Notes</b> . . . . .	<b>20</b>
Electrolytic Symbols	
Emerson EC, EM, DB, DL, DW Dial Cord Replacement	
G. E. HM-80A, 85A, 136A Osc. Drift Correction	
Miniature Tubes; Removal Precaution	
Philco 41-90 Squeals	
Philco 37-38 Intermittent	
RCA R-103-S Victrola Attachment Tone Compensation	
RCA 117N7-GT, VR75/30 Tubes	
Zenith 1940 Advance Line Service Notes	
<b>Chrysler Skyway Antenna Installation</b>	<b>21</b>
<b>New Products</b> . . . . .	<b>22-24</b>
<b>Book Reviews</b> . . . . .	<b>27</b>
<b>Appointments</b> . . . . .	<b>28</b>

## Cover Photo



★ Forerunner of a popular trend in portable design, the RCA Victor BP-10 "Persona" miniature receiver employing peanut tubes. Low loss provides high gain. Receiver range—50 miles plus. (And isn't she a honey?) See article on page 6.

Published Monthly by

**COWAN PUBLISHING CORP.**

11 WEST 42nd ST., NEW YORK, N. Y.

Telephone: CHickering 4-3278-9

**M. L. MUHLEMAN, EDITOR**

**S. R. COWAN, ADV. MANAGER**

Subscription rate, \$2.00 a year in U. S. and Canada; single copies, 20 cents. In foreign countries, \$4.00 a year. Editorial and advertising offices, 11 West 42nd St., New York, N. Y.

VOL. 1 No. 5 ★ AUGUST, 1940

**DON'T SEND A BOY  
ON A MAN'S  
ERRAND!..**



Soundmen can't make such an error when they use RACON Horns, Speakers and Speaker units. RACON Speakers deliver the maximum output and response obtainable for the size of speaker used. There is a RACON reproducer for every purpose, it is the only complete line made. True, lots of imitators make horns and units that look something like RACONS—but looks don't count, performance does! And profits depend upon results as every successful soundman knows. That's why those leaders specify, insist upon and use RACON products exclusively.

*Illustrated here are several RACON PRODUCTS. Complete data and literature sent on request.*

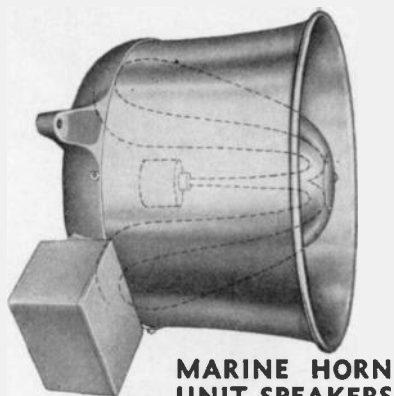

**MARINE HORN  
UNIT SPEAKERS**

Re-entrant type speakers using horn type units for marine and general P-A applications—may be used as loudspeaker or as a microphone. Miniature and regular sizes approved by the Bureau of Marine Inspection and Navigation, Department of Commerce, for marine work. In all sizes, miniature, midjet, regular and bull, handling from 5 to 50 watts.

**Super Giant P. M. Horn Unit**

Operating capacity 12-15 watts, peak 25 watts. Other P.M. Units available, from "baby unit" of 5 watts to "bull unit" with an operating capacity of 50 watts. Efficiencies of the highest order obtainable with the finest magnetic material and steel utilized.



**RE-ENTRANT  
TRUMPETS**

A compact trumpet of the double re-entrant type. Occupies but a small space, nevertheless has a long air column enabling it to deliver highly concentrated sound of the greatest efficiency over long distances. Base and inside cone arm made of aluminum castings, outside bell of heavy gauge aluminum spinning, center section of RACON ACOUSTIC material to prevent resonant effects. Available in 6', 4½', 3½', and 3' air column units.



**PAGING HORN**

A small, extremely efficient 2-foot trumpet speaker, for use where highly concentrated sound is required to override high noise levels, such as in factories, outdoors, etc. Uses a small, very efficient Permanent Magnet unit.

**RACON  
ELECTRIC CO.**

52 East 19th St.

New York, N. Y.

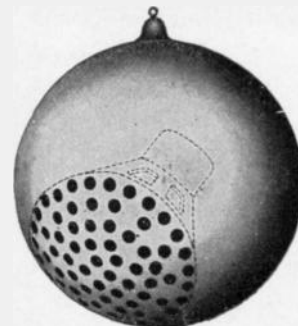

**BALL TYPE CONE SPEAKER**

A new type of ball speaker to be used where directional sound is required and where the standard type of cone projectors clash with the surrounding furnishings or architecture. Made of steel finished in silver with a hanging lamp fixture. Acts as an unlimited baffle giving low response down to 60 cycles and high response up to 10,000 cycles. Made in sizes to take 6", 8"-10" cone speakers.

# Transients

**PERSONAL . . .** Another instance where Radio has invaded the territory of the Newspaper has come to our attention. A friend of ours bought one of these RCA Victor Personal Radios, and claims that it is perfectly swell to take to the bathroom. He rests it on his lap.

The day may come when a newspaper will no longer be one's companion during a philosophical interlude in the Inner Sanctum.

★

**RECORD BLANKS . . .** Why shouldn't servicemen handle instantaneous blanks for amateur recordists? And cutting styli? If a serviceman handles tubes, replacement batteries for portables, phono needles and so on, why not record blanks?

Why not stock a batch and see what you can do along these lines as a test? It's nice business if you can get it.

★

**FATHER OF RADIO . . .** Saturday, September 7th, has been officially set as De Forest Day at the Golden Gate International Exposition being held on Treasure Island in San Francisco Bay. The Day will honor Dr. Lee de Forest, recently acclaimed by the U. S. Patent Office as one of the nineteen greatest American inventors of all times.

The Day will be held under the direct auspices of the Veteran Wireless Operators Association, of which Dr. de Forest is the Honorary President.

The program during the Day calls for several coast-to-coast broadcasts and one to South America.

★

**EXPERT SERVICE . . .** Honest, we wouldn't deprive any serviceman of a job, but you know how relatives are . . .

This cousin buys a loop to stick on his midget howler, which has a trailing wire that gets wound around his ankles every time he lugs the set from the living room to the porch. Naturally, he can't make the change (which he knew when he bought the loop) so he starts referring to us again as an engineer.

We did the job at home, then put the set "on test" for a period of days. Our wife used it exclusively, because she thought it was cute.

It was evident from the start that the thing had an intermittent, if not

two. The pilot would flicker and the speaker would clack, and distortion would manage to creep in before the day was done.

The first trouble we put down to a loose pilot light or a bum ballast resistor; the second fault, as we explained to the wife, was unquestionably a case of an intermittent bias failure in the circuit of the power tube—to which she agreed, knowing nothing about it.

Pressed by more important considerations, we let the troubles ride. But on arriving home the second day, the wife

doing. You know George. I'll replace it, but kick me if I ever so much as touch a radio again."

So I pulled the tubes, took them down to Rider's lab and tested each one with the greatest of care. They were all perfect.

"Well, honey," I said that night, "the tubes and pilot light are okay. There's nothing left but the ballast resistor. It's gone west and I'll have to get a replacement."

"How much will that cost?" the wife wanted to know.

"Never mind the cost," I said. "It's the principle of the thing."

"Principle?" she said. "What principle?"

"Suppose," I said, "we just let the matter rest. After all, the resistor may not be open at all; it may be entirely a matter of a poor connection. I'll put the tubes back and get around to the ballast tomorrow night."

When I arrived home the next evening, the set was going full blast.

"What in the name of heaven," I said.

"It plays," my wife yelled from the kitchen.

"I'll bet George fixed it," I yelled back.

"No," she shouted, "I did."

I went to the kitchen. "Listen," I said, "you can't fix radios. Who fixed it? Did you get in a serviceman? Haven't you any confidence in me at all?"

"No," she said. "I fixed it. I just jiggled the plug and all of a sudden the set lit up, and after a while it played—"

"It operated," I corrected.

"And it's played ever since," she went on. "I was talking to Grace on the phone and she said George tried to take the set out onto the porch without taking the plug out of the socket, and we think maybe he bent something. Grace said he dropped it on the floor, and she said it always sounded awful anyway, so you don't have to fix the distortion if you don't want to. George doesn't know the difference, Grace says."

"Honey," I said, "do you want to buy yourself a pair of nylon stockings? I like you in nylon stockings. I practically love you. But, honey, a radio doesn't play. As the wife of a radio engineer, you shouldn't say that."

"Okay," she said. "And I'll take the nylons."

The moral of the yarn—if it has a moral—is: Look before you leap, or, don't let the horse out of the barn until you're sure he is there.

M. L. M.

## Dr. Lee de Forest

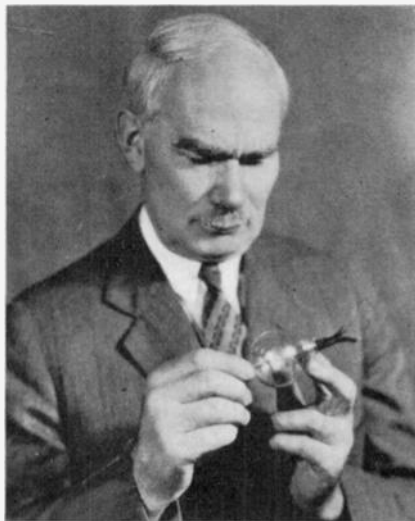

Will have his day at Golden Gate

informed us that "the little set won't play any more."

"Listen," I said, "Radios don't play—they either operate or they don't operate, but they never play."

"Well," she said, "whatever it is that a radio does, this little dingus isn't doing it any more."

"Did it light up?" I asked.

"I don't know whether it did or not—I didn't notice. It just didn't play."

I flipped the switch, and the tubes remained as dark as my thoughts.

"Hell," I said, "that means we're out a tube. Those tubes are wired in series so that if one blows, they all go out, just like our Christmas Tree Bulbs. You know Christmas Tree Bulbs?"

"Why," said the wife, "can't George replace the tube? It isn't your fault it blew out. Probably George was doing something to it, anyway. I can buy a pair of nylon stockings for the price of a tube."

"And he ribbed?" I said. "Nothing

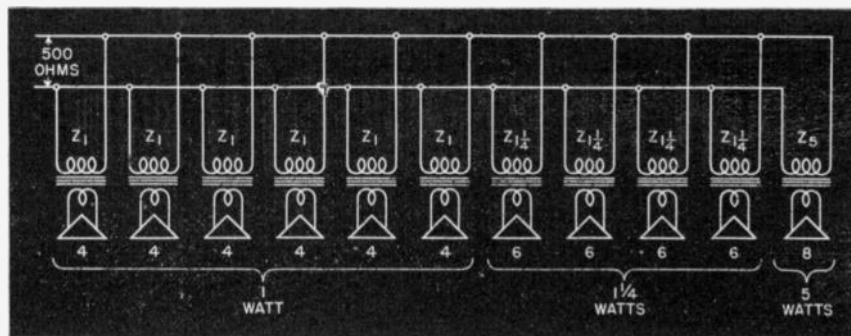

FIG. 1. SPEAKER DISTRIBUTION ON 500-OHM LINE. SEE TEXT.

# SOUND FACTS FOR SOUND MEN

Dealing With The Problems of Multi-Speaker Installations in P-A Work

By J. P. KENNEDY

**M**ULTI-SPEAKER installations on public-address systems present several interesting problems, the solution of which has not previously been published in simplified form. The increasing tendency of speaker manufacturers to standardize voice-coil impedances in the vicinity of 8 ohms further simplifies the presentation of circuit data for these speakers. While circuits are given on the opposite page for permanent-magnet dynamic speakers with 8-ohm voice coils, electro-dynamic speakers may be employed with suitable field current supplies.

## USE OF PADS

Feedback to a microphone is generally the limiting factor in advancing the volume control of an amplifier. Reducing the gain to permit operation of speakers close to the microphone also reduces the power of more distant speakers and impairs the overall response. By the use of attenuation pads of either the variable or fixed type on those speakers which are close to a microphone, full power is still available for the more distant speakers. This may also be accomplished by selection of suitable transformers by which the power distribution in several speakers may be predetermined; however, the use of fixed or variable attenuation pads presents a simpler and more flexible solution

TABLE I

Speaker Circuit	Max Length No. 18 Pair	Max. Power Handling Capacity
2 ohms	15.35 ft.	15 watts
4 ohms	30.7 ft.	36 watts
8 ohms	61.4 ft.	72 watts
16 ohms	122.8 ft.	144 watts
166 ohms	1275.0 ft.	.....
250 ohms	1925.0 ft.	.....
500 ohms	3840.0 ft.	.....

TABLE II

Voice Coil Impedance	Number of speakers on 500-ohm line									
	1	2	3	4	5	6	7	8	9	10
4	11	16	19	22	25	28	30	33	34	36
6	9	13	16	18	20	22	24	26	28	29
8	8	11	14	16	18	19	21	22	24	25
10	7	10	12	14	16	17	19	20	21	22
12	6	9	11	13	15	16	17	18	19	20

of this problem. Resistance values of suitable pads are included in the accompanying circuit data.

The use of No. 18 rip-cord for wiring speaker circuits has become standard practice among sound engineers. Regulations of the National Board of Fire Underwriters limit current-carrying capacity of No. 18 rubber-covered wire to 3 amperes. Good engineering practice limits the resistance of wire in speaker circuits to 10 percent of the load impedance. In reference to this, Table I is a handy guide.

## TRANSFORMER DATA

Determination of primary impedance and ratio of transformers to match several speakers to a 500-ohm line, and to secure a predetermined distribution of power to each speaker, may be reached through use of the following formula. A hypothetical circuit is shown in Fig. 1.

### Known factors:

1. Power output of amplifier in watts. (W)
2. Voice-coil impedance of each speaker (z)
3. Power distribution to each speaker (W<sub>s</sub>)
4.  $W = EI = E^2/R$ .  $E^2 = WR$ . Primary impedance Z of each speaker transformer having W<sub>s</sub> watts out-

put =  $E^2/W_s$ . Ratio of transformer

$$= \sqrt{\frac{Z}{z}}$$

R = Line impedance

### Example:

1. Amplifier, 16 watts output
2. One speaker, 8 ohms, 5 watts; four speakers, 6 ohms, 1/4 watts; six speakers, 4 ohms, 1 watt, each.
3. Line impedance, 500 ohms.

### Solution:

$$W = 16, R = 500, E^2 = 500 \times 16 = 8000$$

$$Z_5 = 800/5 = 1600 \text{ ohms, pri. imp. of 5-watt speaker.}$$

$$Z_{1/4} = 8000/1:25 = 6400 \text{ ohms, pri. imp. of 1/4-watt speaker.}$$

$$Z_1 = 800/1 = 8000 \text{ ohms, pri. imp. of 1-watt speaker.}$$

Ratios of transformer windings;

$$Z_5 = \sqrt{1600/8} = 14.16$$

$$Z_{1/4} = \sqrt{6400/6} = 32.6$$

$$Z_1 = \sqrt{8000/4} = 44.7$$

Transformer ratios for matching speakers of various voice-coil impedances to a standard 500-ohm line with equal power distribution are given in Table II.

**Opposite Page:** The most common 8-ohm speaker circuits encountered in p-a work. Use of fixed and variable pads is shown. Output transformers may be matched to line by series or parallel connections.

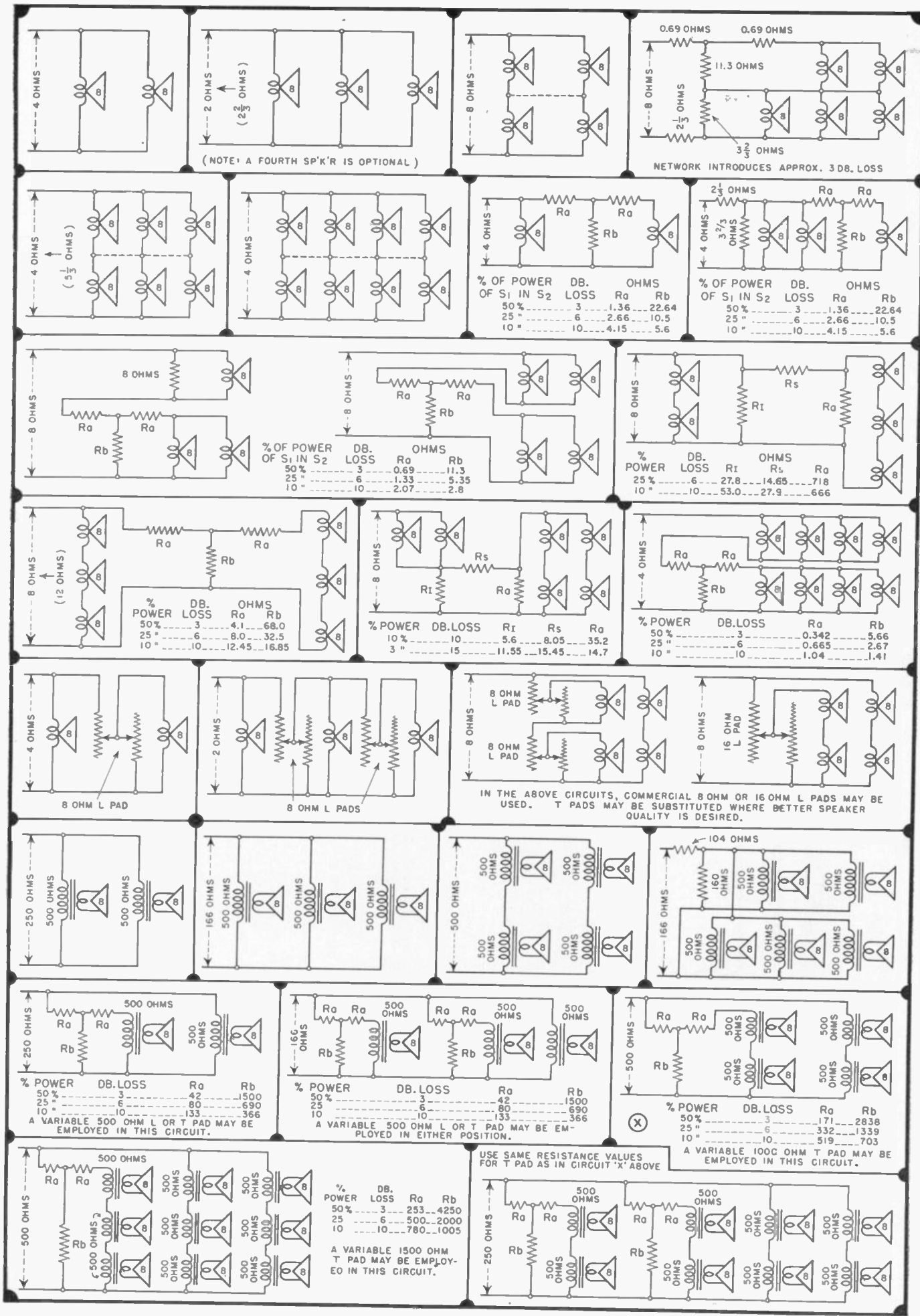

# Set of the Month—

## RCA VICTOR'S BP-10 PERSONAL

**T**HIS handful of high gain is the sweet job that set New York on its ear and caused jams where it was placed on sale. It is now being introduced in other sections of the country.

It is a superhet operating at an i.f. of 455 kc and having a tuning range of 540 to 1600 kc. The undistorted power output is .05 watt; maximum, .12 watt. The 3-inch p-m speaker has a voice-coil impedance of 3 ohms at 400 cycles. The four miniature tubes draw 0.25 ampere of filament current from a single 1.5-volt Eveready No. 950 flashlight cell or its equivalent, and 8.5 ma plate current from one of the new Eveready No. 467 baby Minimax 67.5-volt B batteries. The approximate life of the A cell is from 3 to 5 hours, intermittent duty, and from 25 to 40 hours for the B battery. The batteries are reached by removing the bottom of the metal case. Their location is shown in Fig. 1.

High Q is obtained in the loop and coils through the use of litz wire and high-grade insulation. The loop is moulded into the lid of the receiver. Raising the lid places the loop in operat-

ing position and closes the A and B circuits to the tubes.

The schematic is shown in Fig. 2. The oscillator is of the tickler-feedback type, with the tickler in the screen circuit of the 1R5. This arrangement provides high conversion gain. Bias for the 1S4 output tube is obtained by using a part of the B-supply voltage, and is derived from the voltage drop across resistor R9 which is in series with the negative B-battery lead.

### THE TUBES

Both the 1R5 converter and 1T4 i-f amplifier have a remote cut-off characteristic which enables them to handle a

wide range of signal strengths without modulation distortion. As a result, a receiver using these tubes can have a better avc characteristic than a receiver using sharp cut-off types. This statement is illustrated by Fig. 3 which shows avc curves for a typical battery-operated receiver before and after conversion to the miniature tubes. The curve for the sharp cut-off tubes bends upward at an antenna input of about 30,000 microvolts. At this value of input, the avc bias on the converter and i-f tubes is a large percentage of their cut-off bias. As a result, there is some clipping of negative signal peaks on the i-f amplifier grid. This clipping produces an increase in the percentage modulation of the i-f amplifier output, and thus causes the upward bend in the curve for measured audio output. In other words, the upward bend in the curve indicates the signal strength at which modulation distortion starts. The curves show that the range of signal strengths amplified without appreciable modulation distortion is about five times larger for the miniature tubes than for the sharp cut-off types.

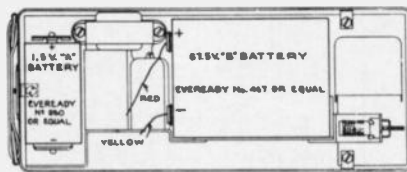
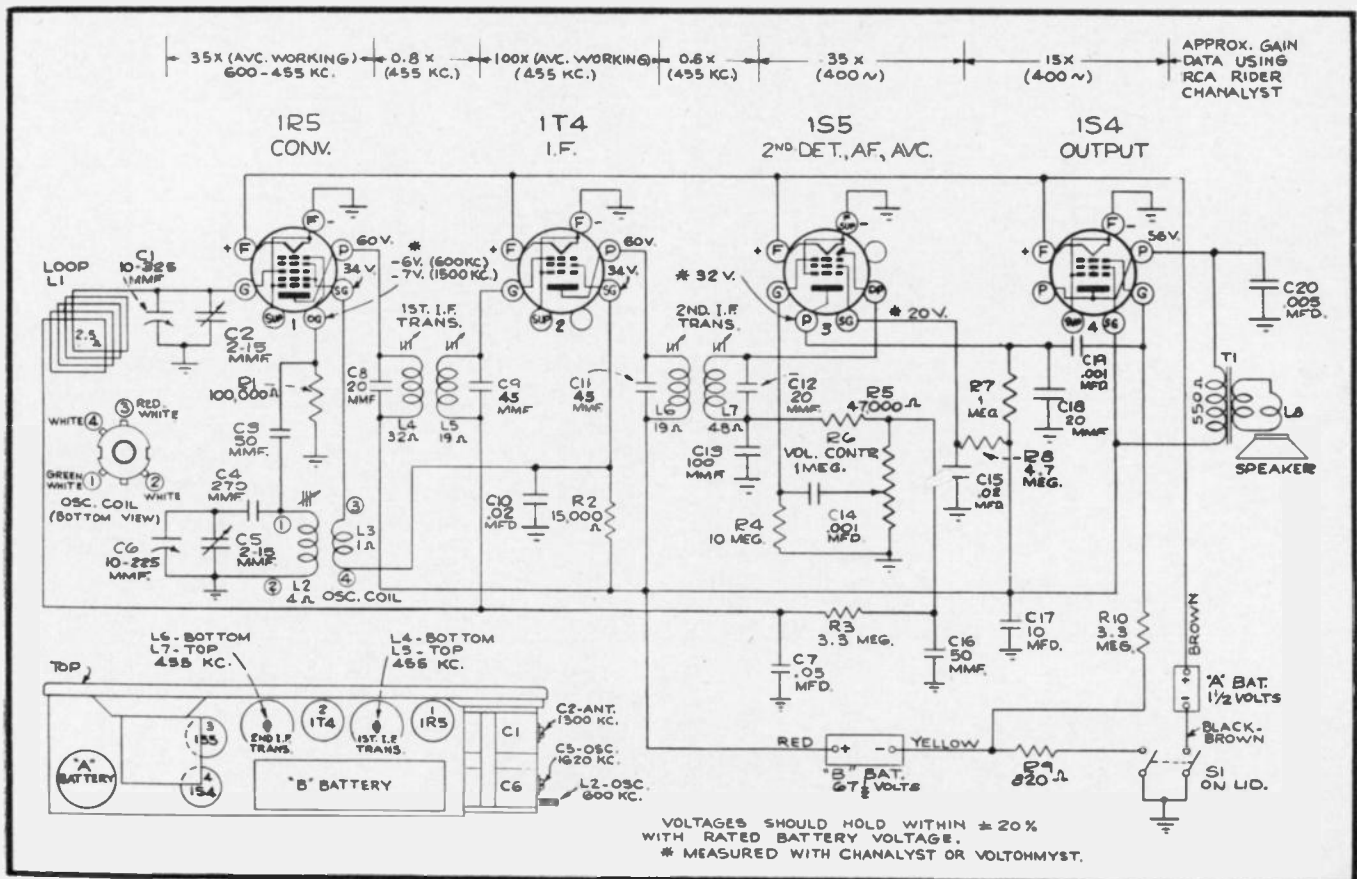

Fig. 1. Above: Sketch of BP-10 with bottom cover removed, showing location of batteries. Fig. 2. Below: Schematic and chassis layout of BP-10.





The 1S5 diode-detector and a-f amplifier tube has a pentode amplifier section which can provide an audio gain of 30 when the B-supply is 45 volts, and adequate signal output when the B-battery is at the end of its life.

When removing any of these miniature tubes, do not rock them. See note on this in the Shop Notes section of this issue.

#### ALIGNMENT

If output meter is used for alignment observations, connect meter across the voice coil, and turn the receiver volume control to maximum. For all alignment operations, keep the output of the test oscillator as low as possible to avoid AVC action. Location of trimmers is shown in Fig. 2.

Adhere to the following procedure in the order given:

**Step 1:** Connect high side of test oscillator to antenna condenser stator through a .01-mfd capacity. Tune test oscillator to 455 kc. Turn receiver tuning dial to quiet point at 1600-kc end. Adjust the i-f transformer trimmers L7, L6, L5 and L4 for maximum output.

**Step 2:** Provide radiated signal from

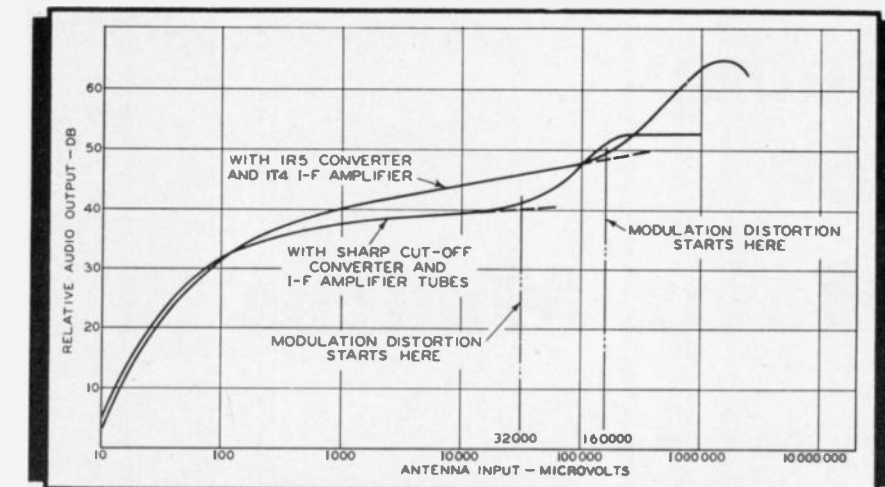

Fig. 3. Two AVC curves illustrating the advantages of the 1R5 and IT4 over sharp cut-off converter and i-f tubes insofar as modulation distortion is concerned.

test oscillator at 1620 kc, turn tuning dial so that gang condenser is out of mesh, and adjust the oscillator trimmer C5 for maximum output.

**Step 3:** Provide radiated signal from test oscillator at 1300 kc, set receiver dial at same frequency and adjust antenna trimmer C2 for maximum output.

**Step 4:** Provide radiated signal from

test oscillator at 600 kc, set receiver dial at same frequency, and adjust iron core of oscillator coil, L2, for maximum output.

**Step 5:** Repeat Steps 2, 3 and 4.

The schematic diagram, Fig. 2, includes tube voltage measurements and also approximate gain measurements from stage to stage.

## CUTTING P-A CORNERS

**C**UTTING corners in public-address work is fine business if only the corners are cut, and not the quality or the service. Still, hurry-up jobs, prodigious installations of a temporary nature, special speaker extensions, etc., are the rule rather than the exception, and often call for makeshift arrangements, cable splices and what not.

Neatest trick of the month comes from the Selectar Mfg. Corp., in the form of a series of standard and baby connectors, interconnectors and extension units, both male and female, which permit just about any circuit arrangement one would ever run into in p-a work.

If you've got a speaker cable terminating in a standard connector, male or female, and your problem is to con-

nect it to a baby connector—male or female—on the amplifier chassis, there's an interconnecting unit that will make the junction possible. If you've got two cables with dissimilar connectors, and you wish to form a junction, there's an interconnector that will do the job—even though one may be a baby female and the other a standard female, or males, or whatever crazy combination you can think of.

Do you want to terminate in a phone plug for some reason? There's a phone plug adapter for that purpose, and an interconnector in the event that the cable connector and phone plug adapter don't jibe.

#### ADDING SPEAKERS

The biggest boon are the male and

female standard and baby three-way connectors with which two speakers (or more if additional connectors are added) can be hung on to a single output connector on an amplifier chassis. Speakers can be hung on and taken off as rapidly as one can screw the connectors together.

Practically any combination one desires or is faced with, can be obtained with but ten such connectors, which can be kept on hand for temporary or permanent installations.

Three connectors which serve to illustrate the ease with which one type of connector can be converted into another, and suggestive of the number of combinations that are possible, are shown in the accompanying sketch.

The three-way connector at the left is a female unit of the standard type. It can be metamorphosed by means of the interconnector shown at the upper center (three being required for complete conversion). A similar interconnector—not shown—is standard male at one end and baby male at the other end, and by its use, any one of the standard female connectors on the three-way unit can be converted to baby male.

The three-way connector at the right is a male unit of the baby type. It can be converted to a female unit by use of three interconnectors of the type shown at the lower center.

The baby connectors are equipped with 1/2-inch-27 thread to prevent accidental mixing of cables with microphone input.

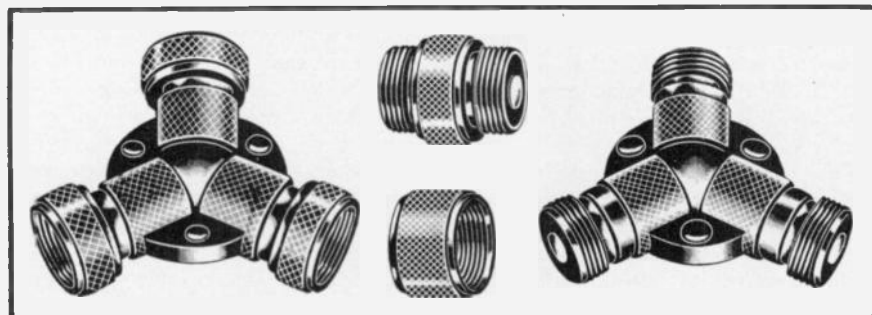

Four of the ten connectors by which various tie-in combinations are made possible.

# SOUND FOR MOVIE MAKERS

By H. M. GUTHMAN



View of the dual-turnstile, triple-pickup record player for movie work or continuous musical reproduction.

BEING an amateur movie maker, and wishing to put on the best show possible for friends, it became necessary to have some means of playing records scored for each film, and to have full control over the operation at all times. Starting with a single turntable and pickup in a portable case and used in conjunction with a 5-watt amplifier, the equipment has grown to the two units pictured. As a 200-foot reel runs approximately 15 minutes, it is important to have two turntables so that music may be played without a break, and so that special sound effects may be blended with the score.

The unit is very simple to construct and should provide a source of revenue to servicemen, who can build them to order for home movie fans and record enthusiasts. The only special item is the carrying case, which can be built to order at a reasonable price.

## DETAILS OF UNIT

Three Astatic SB8 crystal pickups are used, and placed in such a position that the center pickup, which is *P2* in Fig. 1, can be used on either turntable. There

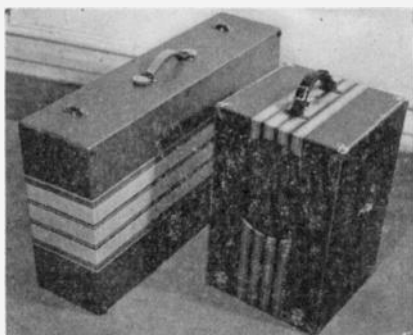

The record player and dual speakers in their individual cases.

are three volume controls so connected that fading or mixing any or all pickups is possible. With *P1* in use, the upper half of *R1* controls the volume, while the lower half permits fading into *P3*.

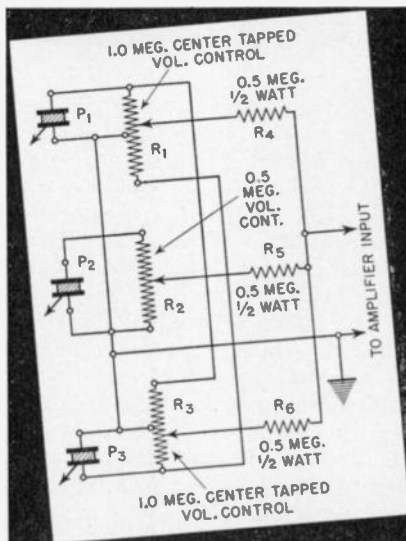

Fig. 1. Schematic of record player.

Again, with pickup *P1* in use—the upper half of *R1* controlling—*P3* may be used, with the lower half of *R3* controlling the volume, thus providing a mix. Moreover, pickup *P2* may be used with its individual control, *R2*, in such manner that this pickup will also fade or mix with either pickup *P1*, *P2* or both.

The motors are General Industries single-speed units, with rubber mountings and individual switch control. The cover of the case has a work light mounted at the top center with a clip set directly below the light to hold the score sheets of the film being shown.

The records are stacked in order of use and set in the cover, as shown. They are transferred from one side to the other as they are used. There are two "anti-record rollers" fastened to the cover to prevent the records rolling from side to side. There are also two dowlings which fit on top of the turntable pins to prevent the turntables from coming off when carrying the unit. The dimensions of the case are 30 $\frac{3}{4}$ " by 17" by 7 $\frac{1}{2}$ ".

There are two receptacles on the side of the case, one male for the a-c line connection and the other female to take the amplifier a-c plug. The pickups feed into a single shielded line terminating in a jack on the turntable motor board. All wiring is completely shielded.

The amplifier used is a 14-watt Stan-cor job with 6L6's in push-pull Class A. Two Utah No. 10P p-m speakers are used, and these are mounted in the portable case shown in one of the accompanying pictures. Where a running commentary is called for a mike is used in conjunction with the amplifier—usually with a musical background from the record player.

## CONTINUOUS REPRODUCTION

If the center pickup, *P2*, and the associated volume control *R2* and resistor *R5* are dispensed with, the unit described is just the thing for record fans who take their music seriously. With such dual equipment, recorded symphonies, etc., can be run through without a break if the album sets are pressed for automatic sequence. Few people realize that this can be accomplished, and would welcome such a unit. As far as the writer knows, no such job is available on the open market, aside from the very expensive professional equipment.

# TECHNICAL SERVICE PORTFOLIO

## SECTION IV — V-T VOLTMETERS

**I**N testing radio receiver circuits, it is frequently necessary to measure signal and other alternating voltages in high-impedance circuits. For such applications the vacuum-tube voltmeter is indispensable, since it consumes negligible current in operation and therefore does not appreciably load the circuit under test.

In Section I of the Portfolio, the applications of the tuned v-t voltmeter, employed in some channels in signal-tracing instruments, were considered. In the present discussion, we concern ourselves with v-t voltmeters of the untuned type which are calibrated to read alternating voltages.

Any tube which will serve as a detector or rectifier will function as a vacuum-tube voltmeter. Diodes, triodes, tetrodes and pentodes have been employed for this purpose. In some instances, a diode direct-coupled to a triode is used and such a device will be described later. In general, if a single-tube v-t voltmeter is to be employed, there is no particular advantage in using a multi-element tube unless it is connected as a triode. The more tube elements which must receive voltages, the more difficult it becomes to keep these operating voltages constant and consequently for the v-t voltmeter to hold its calibration.

In general, vacuum-tube voltmeters may be divided into two broad classes; those which give readings proportional to the peak value of the a-c wave and those which are designed to read rms values. Usually the calibration on the meter is in terms of rms values regardless of the mode of operation of the v-t voltmeter.

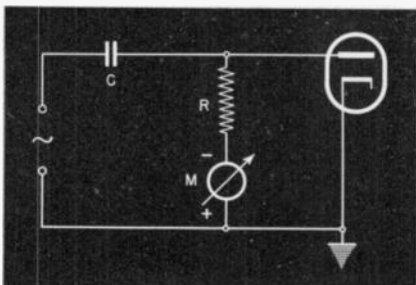

Fig. 1. Simplest type of peak v-t voltmeter.

### PEAK VOLTMETERS

The simplest type of peak v-t voltmeter is shown in Fig. 1. When an a-c voltage is applied to the input terminals, the diode draws current over the positive half cycle of the applied signal wave. This causes the condenser  $C$  to charge, and if the resistance  $R$  is high enough, this charge will not leak off before the next positive half-cycle occurs. Thus, an increasing potential is built up across  $C$  which approaches the peak value of the applied alternating voltage. When the diode draws current, this rectified current must flow through the resistance  $R$  which is in series with the milliammeter

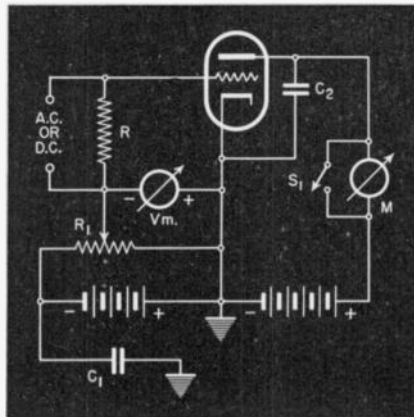

Fig. 2. A more practical peak v-t voltmeter, with milliammeter in plate circuit of a triode.

$M$ . The current flowing in the circuit is thus registered on the meter.

The fundamental circuit as shown in Fig. 1 serves to illustrate the principle, but is impractical to apply. For, if  $R$  is made very high in resistance—which is essential in most applications—then but little current can flow. For instance, if  $R$  were 10 megs, then, when the average voltage across  $R$  were 10 volts, the current indicated by the meter would be but 1 microampere. Hence, an extremely sensitive meter would be required.

The circuit shown in Fig. 2 is also a peak voltmeter but the milliammeter is connected in the plate circuit of a triode. In operation, the potentiometer  $R$  is adjusted until the grid bias is such that the plate milliammeter gives a very low read-

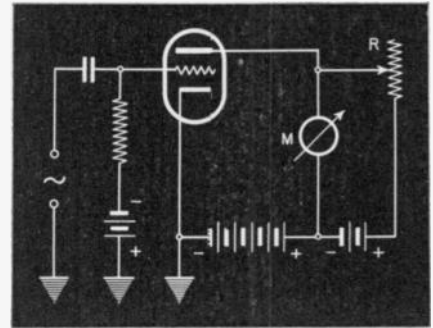

Fig. 3. Fundamental circuit of rms v-t voltmeter.

ing, say 0.1 ma. The bias voltage is noted and the voltage to be measured is applied to the input terminals. The plate meter reading will increase. The potentiometer  $R$  is then readjusted until the original plate meter reading of 0.1 ma is restored. This will necessitate an increase in the grid bias and will accordingly cause an increase in the grid voltmeter reading. The amount by which the bias must be increased to restore the original plate current reading is a measure of the peak a-c voltage applied to the tube voltmeter. For a sine wave, the rms value will be 0.7 of this reading.

This voltmeter may also be used to measure d-c voltages, either positive or negative. The voltage is measured in the same way as above. A positive voltage will necessitate an increase in the negative bias applied to the tube while a negative voltage will require a proportionate decrease in the bias.

It is obvious that such a voltmeter requires careful handling to avoid damaging the plate milliammeter, due to accidental overload. It is customary to employ shunts when making preliminary adjustments, to prevent overload.

### RMS VOLTMETERS

The fundamental circuit of rms tube voltmeters is shown in Fig. 3. In such instruments, the meter is directly calibrated in terms of rms voltages. Such instruments are of two types, half-wave square law and full-wave square law. This simply means that the tube is so biased, in the first condition shown in Fig. 4A, that the meter reading increases

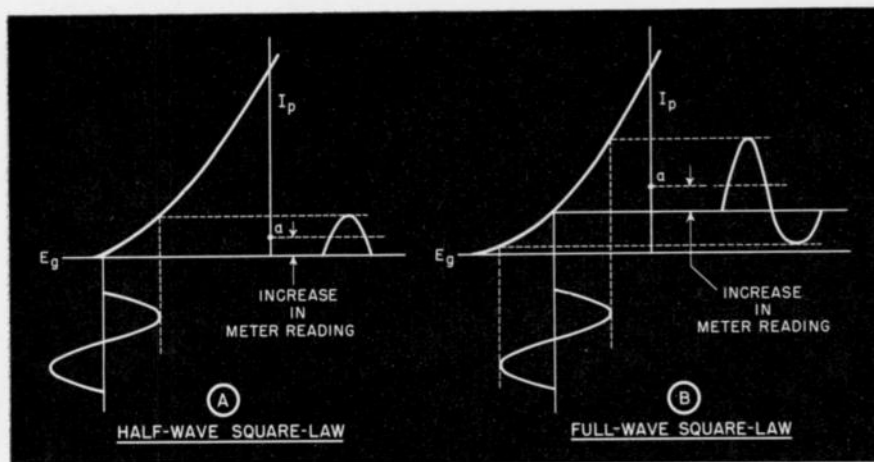

Fig. 4: A: Tube biased to near cut-off. B: Plate current flows over entire cycle.

by an amount which is proportional to the peak a-c voltage over one-half its cycle in the half-wave type, and the increase in the reading of the d-c meter in the plate circuit is proportional to the square of the input signal voltage. Note that, in Fig. 4A, the tube is biased approximately at cutoff, so that little or no plate current is present when no signal is applied.

The operating characteristic of the full-wave square law type of v-t voltmeter is illustrated in Fig. 4B. Note that plate current flows over the entire cycle. The normal bias for this type of operation is such that appreciable plate current flows, but operation is still on the curved portion of the tube characteristic, so rectification takes place. To balance out the steady plate current, and thereby increase the meter range, the resistor  $R$  in Fig. 3 is adjusted to apply a bucking voltage until the meter reads zero with no applied signal. It is then possible to use a more sensitive meter, or to switch to a more sensitive range, and thus increases the sensitivity of the instrument. This is the most accurate type of v-t voltmeter insofar as waveform error is concerned, but all instruments of the square-law type necessarily have dial scales of limited range, since doubling the input voltage will cause the current reading of the meter to increase about four times. Multi-range instruments of this type are favored for laboratory work. However, this type of instrument will give accurate readings for a-c voltages only.

**PEAK MEASUREMENTS**

A method of adapting the principle of the peak v-t voltmeter shown in Fig. 1 so that it is practical for measuring purposes in high-impedance circuits, is shown in Fig. 5A. In operation, the rectified d-c voltage developed across  $R_1$  is filtered by  $R_2$ - $C_1$  and applied to the input circuit of an electronic voltmeter, such as the

one shown in Fig. 5B. Since the latter has an extremely high input resistance, the circuit loading is low and a highly sensitive and practical instrument results. This arrangement is practically advantageous to owners of signal-tracing instruments, since it enables the adaptation of the electronic voltmeter channel to

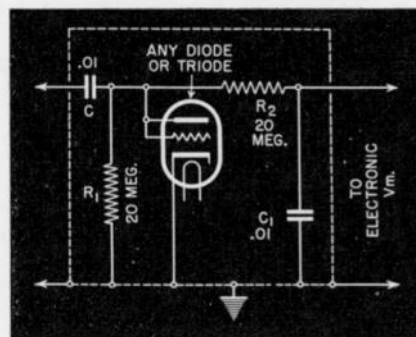

Fig. 5A. Used in conjunction with 5B for measuring peak voltages in high-impedance circuits.

alternating voltage measurements. The resulting combination is similar in principle to the high-grade laboratory v-t voltmeter manufactured by the General Radio Company.

In operation, when an alternating voltage is applied to the input circuit in Fig. 5A, the tube draws current over the positive half-cycle of the wave, charging the condenser  $C$ . This charge cannot leak off before the next positive half-cycle adds an additional charge. Thus,

the potential of the diode remains at a constant value equal to the voltage drop across  $R_1$ . Since the voltage developed across  $R_1$  is negative with respect to ground, this negative voltage will be applied to the grid of the electronic voltmeter tube, Fig. 5B. As a result, the plate current reading will decrease. If the voltage so applied is excessive, the grid will become so highly negative that the plate current will become zero. Thus, the only result of applying an excessive voltage is to drive the tube to cutoff and the meter cannot be damaged by overload. This is an invaluable feature of this type of instrument.

The effective input resistance of this type of tube voltmeter is slightly less than one-half the value of  $R_1$ , therefore about 10 megohms. This is lower than many of the triode-type voltmeters, but is not so low as to interfere with the instrument's serviceability. Multi-range operation is obtained by using the range switch on the electronic voltmeter. Operation above 100 volts should not be attempted unless a high-voltage rectifier tube is used as the diode.

The diode is preferably built in a small shielded box so that it may be placed close to the circuit under test, thus avoiding long leads. Since the output circuit is filtered and isolated from the input circuit, the heater and other leads may be cabled for connection to the electronic voltmeter and power source.

The tube voltmeter may be calibrated at 60 cycles. This calibration will be maintained over radio-frequency ranges up to several megacycles. Scale readings will be substantially linear except for very low voltages. It will cover a range from approximately 0.2 volt to 100 volts.

**APPLICATIONS**

Now let us take up some of the applications of the v-t voltmeter in receiver testing. In Fig. 6, we see how the gain of an antenna coil is checked. Occasionally antenna coils become defective, due to internal shorts between turns which do not show up on ohmmeter checks, but which cause a severe drop in gain in the transformer. This defect causes a high noise level and decrease in sensitivity of the receiver.

Fig. 5B. Schematic of typical electronic voltmeter such as used in signal tracing

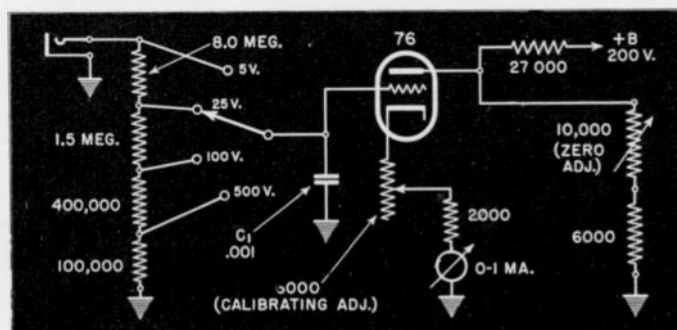

To check antenna coil gain, the receiver need not be operating. Feed a strong r-f signal to the antenna coil, as shown, and connect the v-t voltmeter to the secondary. Keep the "high" lead as short as possible in all r-f measurements in tuned circuits to minimize detuning. Tune the transformer secondary to resonance by varying the gang condenser setting until the v-t voltmeter shows a maximum reading. Let us assume the v-t voltmeter reads 3 volts when connected to point 1. Then transfer the v-t voltmeter lead from point 1 to point 2. Let us assume the reading at this point is 0.3 volt. The antenna coil gain is then 3/0.3 or 10. The average gain which we should expect varies from 2 to 10 in home receivers, and from 20 to 100 in auto receivers. In the latter type of receiver, be sure to use the dummy antenna value specified by the manufacturer or the full gain will not be realized. High antenna coil gain is particularly important in auto receivers if the noise level is to be low and the sensitivity high.

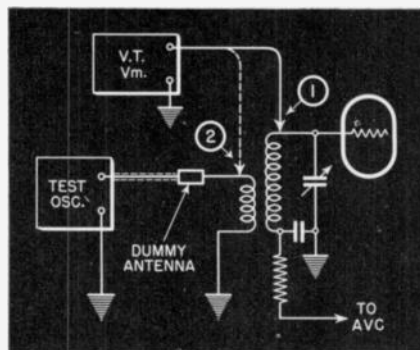

Fig. 6. Manner of checking gain of antenna coil with v-t voltmeter and test oscillator.

**R-F, I-F STAGE GAIN**

To measure stage gain in r-f circuits, the receiver should be operating and the signal should be applied to the receiver input terminals as described above. The actual gain will be influenced by avc action, so a true measurement of stage gain can be made only when the avc is inoperative. In superheterodyne receivers, when checking r-f circuits, this is best done by shorting the oscillator gang condenser. In i-f circuits, the avc may be rendered inoperative by removing the avc tube or by grounding the avc bus. Make certain, in checking i-f circuits, that the signal level is not so high that the tube grid is overloaded. Also, unless the range of the v-t voltmeter is at least 150 to 1—which means an instrument with many ranges—it will not be possible to measure such high gains.

The stage gain in the circuit, Fig. 7, is the ratio of the signal level at point 1 to that at point 3 and is measured in the same way as antenna transformer gain.

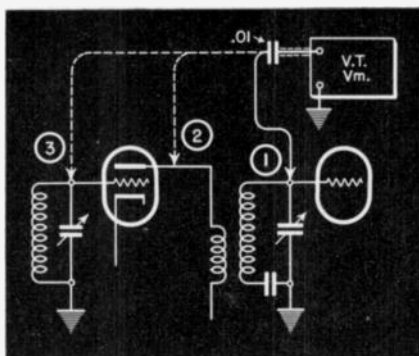

Fig. 7. Measuring stage gain with v.t.v.m.

The average stage gain is shown in Table I of Average Gain-Per-Stage Values, appearing in Sections I and II of the Portfolio. Usually there is no gain in the r-f coupling transformer from primary to secondary, but a severe loss at point 1 indicates a defective transformer.

Measuring gain in i-f stages is done in the same manner as for r-f stages. The signal level at the receiver input should be reduced to avoid overload when checking in the output i-f stage.

**CHECKING SUPERHET OSCILLATORS**

Superheterodyne oscillator circuit operation can be checked quite simply by shunting the v-t voltmeter across the oscillator tuning condenser and varying the gang over its tuning range. The connecting leads must be kept very short; for short-wave bands, it is better to use a small coupling coil connected to the tube voltmeter and placed not too close to the oscillator coil. Failure to pick up the oscillator voltage indicates a dead oscillator. Dead spots over the tuning range are also readily detected by this method. Note that this test may also be made by measuring the rectified d-c voltage across the oscillator grid leak, as described in Section I of the Portfolio.

**CHECKING PENTODE DETECTORS**

A grid-leak pentode detector circuit of the type shown in Fig. 8 is often employed in small midsets. Poor sensitivity can often be traced to unsatisfactory operation of the detector, yet direct tests of the circuit are difficult by ordinary methods.

In operation, a modulated r-f signal will be applied to the detector and an amplified replica of the modulation voltage should appear at point 2. The gain of the detector will be represented by the ratio of the audio voltage at point 1 to the audio component of the modulated r-f voltage at point 1. Thus, if a one-volt 30-percent modulated signal is applied to point 2, the audio component will be

0.3 volt. If the output audio voltage at point 1 is 3 volts, the gain of the detector is 10. Actually, gains of the order of 50 may be expected in such circuits when performing efficiently.

When the percentage modulation of the r-f signal is known, measuring the gain is relatively simple. All one has to do is to determine the signal voltage at point 1 and compare it with the calculated audio voltage at point 2. There will be some error in reading the modulated voltage, as compared with an unmodulated voltage at point 2 when a peak-type voltmeter is employed, in that the modulated voltage will give a higher reading. So the modulation should be switched off when making the reading at point 1. The audio voltage can be determined on the basis of the known percentage modulation as explained above.

Another method, which checks detector efficiency, is to inject an audio voltage in series with the grid return circuit at point X in Fig. 8. Then the gain of the detector as an audio amplifier can be measured. The ratio of the gain as a detector to that as an a-f amplifier is a measure of the detection efficiency.

**CHECKING AUDIO CIRCUITS**

Testing of some a-f circuits by means of a tube voltmeter was discussed in Section II. Many other tests are possible. In Fig. 9, for instance, we may measure the audio gain by applying an a-f signal to point 3 and, comparing the amplified signal voltage measured with the tube voltmeter at point 1 with the audio voltage at point 3, the stage gain is determined. Thus, if the signal level at point 1 is 10 volts and the audio voltage at point 3 is 0.3 volt, the gain is 10/0.3 or 33. Care should be taken to keep the signal level at point 1 low enough so that the input circuit is not overloaded. Overload will occur when the peak alternating voltage applied to the grid exceeds the cathode or grid bias

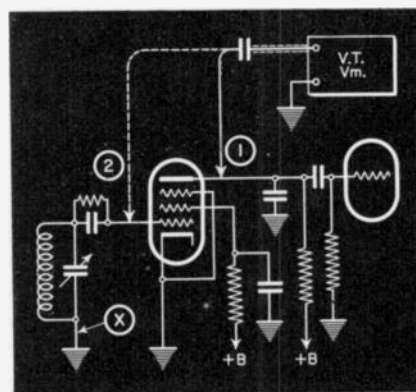

Fig. 8. Manner in which pentode detectors may be checked.

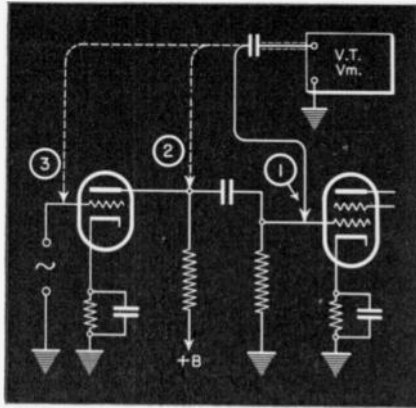

Fig. 9. Using v-t voltmeter for checking audio circuits.

voltage. Thus, if the measured voltage at point 3 is 10 volts rms (most tube voltmeters are calibrated in rms values regardless of their mode of operation) the peak voltage for a sine wave will be 14.1 volts. Since the usual bias for an output pentode is in the neighborhood of this value, a 10-volt signal at the grid of an output pentode is about as high as one dare go.

Often, due to gas, or leakage in the coupling condenser, the cathode bias of an output tube is not the same as the actual grid bias. This is because the presence of gas often causes a positive ion current in the grid circuit which bucks the grid bias. Such tubes will easily overload and distort, though reception seems normal at low signal levels. A check of the actual signal voltage at point 1 and comparison with the operating bias of the tube, will indicate whether the circuit is performing properly.

An open coupling condenser in an audio stage will be revealed by noting the signal voltage at the amplifier tube plate, point 2, and comparing it with that at the output tube grid. If the coupling condenser is open, little or no signal voltage will be passed by the coupling condenser.

**CHECKING POWER-SUPPLIES**

Hum and other alternating voltages in power-supply circuits may be measured with the vacuum-tube voltmeter. In Fig. 10, a single-section power supply filter circuit is shown. The maximum hum voltage will be present at point 1, since this is the input of the filter circuit. If C1 is partly or completely open, the hum voltage will be excessive. In any case, the hum level should be lower at point 2. If C2 is defective the filter section will be ineffective and the hum voltage will not be greatly reduced at point 2. A hum voltage of the order of one or two volts is normal at the output of such a filter network; this value will vary greatly in

power supplies of different design.

Many receivers employ no bleeder to limit the peak voltages when the set is first switched on. When the rectifier reaches full emission before the other tubes in the receiver commence to draw appreciable current, excessive voltages may appear across the filter condensers, thus shortening their life. This peak voltage may be measured with a slide-back tube voltmeter, similar to that shown in Fig. 2, but omitting the blocking condenser. A cathode-ray oscilloscope may also serve as a peak voltmeter if the screen is calibrated against sine wave voltages. Such high voltages as are found in power-supply systems are best checked by connecting the cathode-ray tube vertical plate directly to the point of high voltage. Peak voltages of unusually high values are frequently found in cheap power transformers which have poor regulation. When the receiver is warming up, the power transformer output voltage becomes excessive, dropping to normal only under full load. Watch for this

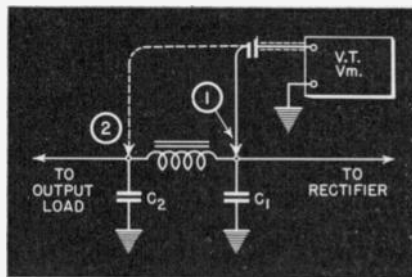

Fig. 10. Checking hum in filter circuit.

trouble when making replacements; sometimes this is the cause of filter condensers blowing mysteriously after a power transformer replacement when an unknown substitute is employed.

**CHECKING COMPONENTS**

A simple setup for checking r-f and i-f transformers, oscillator coils, etc., is shown in Fig. 11. Often, especially in damp weather, such coils and transformers are affected by humidity, corrosion and other influences, with the result that their Q is reduced and consequently their impedance. This causes a drop in gain in the stage in which such a unit is employed. By means of this setup it is possible to determine the relative Q of two similar coils, to match and pre-align transformers before installing replacements, and to detect, under actual operating conditions, troubles which might ordinarily be overlooked. Often, too, a trimmer condenser will become affected by weather conditions when the coil which it shunts is OK. This can be discovered conveniently by a simple substitution with a setup of this type.

As shown in Fig. 11, the setup consists of a simple amplifier stage employing a 6K7 or similar tube. Normal operating voltages may be applied in any manner desired. A test oscillator signal is fed to the input grid and the coil under test is connected in the plate circuit of the tube. The tube voltmeter shunts the coil under test.

In checking an i-f transformer, for instance, the primary is connected in the plate circuit of the test setup, as shown. A signal of the frequency at which the i-f transformer is designed to operate is fed to the input grid and the transformer primary trimmer adjusted until a maximum voltage reading is secured on the tube voltmeter, which indicates a condition of resonance. The higher the Q of the coil, the higher will be the voltage reading secured on the tube voltmeter. Thus, if the coil under test gives an appreciably lower reading than a standard i-f coil using a similar shunt capacity, its Q is proportionately lower. When the coil is very bad, the resonant voltage output will also be low. Thus, the relative merits of similar coils may be checked.

Obviously, when making this check, we are also pre-aligning the coil before installing in the receiver, if it is to act as a replacement. This saves time.

All r-f and oscillator coils may be similarly checked, by comparison with other coils. The test oscillator frequency may be varied to fall within the tuning range of the coil under test.

Audio transformers may also be tested by this method, using an audio oscillator as a signal source. It will be preferable, however, to use a triode or triode-connected pentode for such tests, of a type similar to that with which the transformer is designed to be employed.

Many other tests along these lines will suggest themselves, all of which may be made if a v-t voltmeter of some sort is available. The latter test can also, of course, be made with the channel tuned v-t voltmeters in signal-tracing instruments. J. H. P.

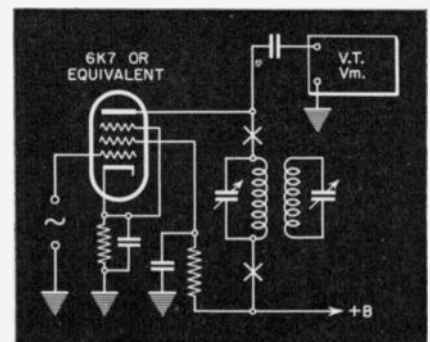

Fig. 11. Checking and pre-alignment of r-f and i-f transformers with oscillator and v-t voltmeter.

# Serviceman's Diary

By J. P. HOLLISTER

**F**RIDAY—You'd have thought Jerry would have got sore, but he didn't. Especially since he doesn't think dumb dames are really dumb, but only pretend to be. Take this one, for instance (you would if you saw her). All done up in blue slacks, a bright blue handkerchief knotted around her blonde head, she came skipping into the store and planked her International Kadette right smack on Jerry's desk before he realized she was there. Then she sat on the desk, clasped her hands around one knee and turned on a million candle power smile—all for his benefit.

"Please, mister, will you fix my radio?"

Jerry snapped out of it fast.

"Certainly, certainly," he gushed. I never saw him look so happy before. He started to pick up the set, then noticed the knobs were missing.

"Pardon me, but do you happen to have the knobs for your receiver?" He sure got polite all of a sudden. Usually he'd have told the customer right off the bat that the International had special thin knobs in brown bakelite which he'd have to get on order since we didn't stock parts for such old models. But not this time.

"Here they are!" she fished them out of a pocket. "You know, it shouldn't take long to fix my radio. My brother got it all ready for you. He took it all apart and pulled off some of the wires so you could examine it easier. He knows all about radios. Whenever the little portable which he carries around stops playing, he puts in new batteries and makes it play, all by himself. He would have fixed this one, only he wasn't quite sure which part went bad. He thinks it's the condenser, though. He says one side of it looks a little dirty and smudgy."

I could see Jerry was thinking hard. His smile looked a little frozen now. It disappeared altogether when he slid the chassis out of the bakelite cabinet and saw a tangled mass of disconnected wires and the electrolytics dangling from the chassis.

"Your brother is perfectly right about the condenser," he said. "Why, it is positively filthy! But don't worry, it won't take a moment to replace it."

I wondered what had got into Jerry. He had never pulled anything like this before. And he knew perfectly well that, regardless of what was wrong with the midget, it would take all day to trace out and resolder the leads on the set. But he wasn't through. He took out a magnifying glass and started to look over the resistors.

"Excuse me just a moment, please," he smiled to the girl. "I just want to examine the set for other possible faults. Hard to see with the naked eye, you know, and your brother may have overlooked something."

"Yes," she replied. "You know I told you that he wasn't quite sure that the condenser was the only trouble."

"Ha!" cried Jerry. "He was right again! Just look at that green spot." He held the magnifying glass over the one-meg plate load resistor, coded, of course, with a green dot on the brown body.

She had to come close to him to look through the magnifying glass, the way he held it.

"See," said Jerry triumphantly. "I have saved you the expense of a new condenser."

"How so?" she inquired. "I thought you said the condenser was so dirty."

"Yes, but that wasn't all. That green spot means sporadic heterodynes. Even if we replace the condenser, the set won't

work right. We could work for days on the set, but unless it is completely rebuilt, as your brother will tell you, the sporadic heterodynes are likely to pop out at any moment." He shoved the chassis back in the cabinet and handed the set back.

"So what's to be done?" She didn't look so happy now.

"I leave that to your brother's judgment," Jerry told her. "He may come to the conclusion that it might be better to trade in the set on a nice new model; you know, they make them in all colors now—and they really aren't very expensive. After all, you know this set is nearly five years old." (He knew perfectly well it was eight years old, but no customer ever does).

"So I'll have to carry it all the way back home," she said plaintively.

"I'll be glad to drive you home in my car," Jerry offered. She looked at him a little doubtfully.

"Maybe," she had a bright idea, "you could talk to my brother over the phone and tell him what you found. He could tell you exactly what to do."

It looked to me as if Jerry had let himself in for something. Suppose the brother was not quite so dumb, after all. I was aching to get hold of Jerry and give him a good talking to. But I realized, too, that they couldn't take the set in that condition any place in town and get it fixed right for any price they would be willing to pay.

But Jerry had the brother on the phone. "Yes," he was saying, "a microscopic investigation of the anterior anode potential gradient supply mechanism revealed the presence of a well-developed area of sporadic heterodyne adjacent to the demodulator anode control grid power amplifier capacitor coupler,

(Turn to page 27)

## HORACE—

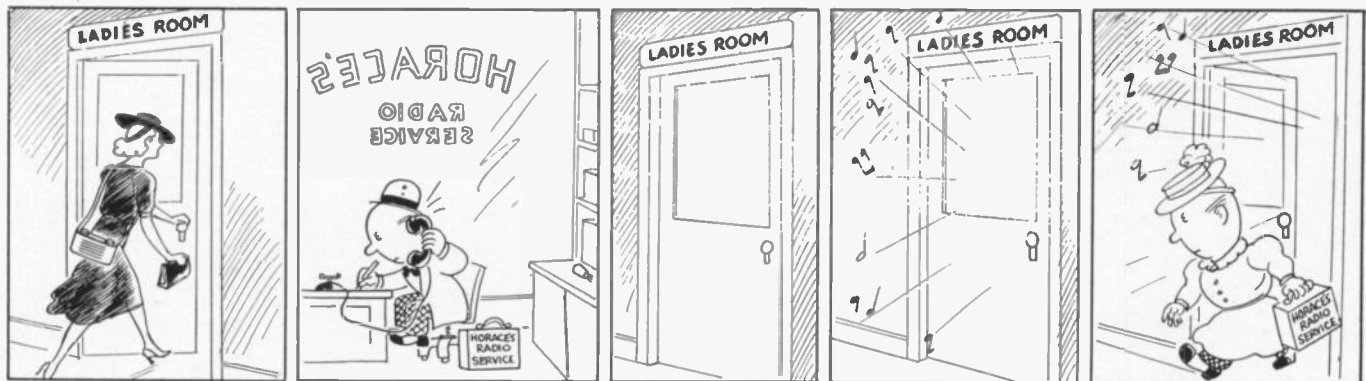

# PUPPETS ARE SOUND SALES PROSPECTS

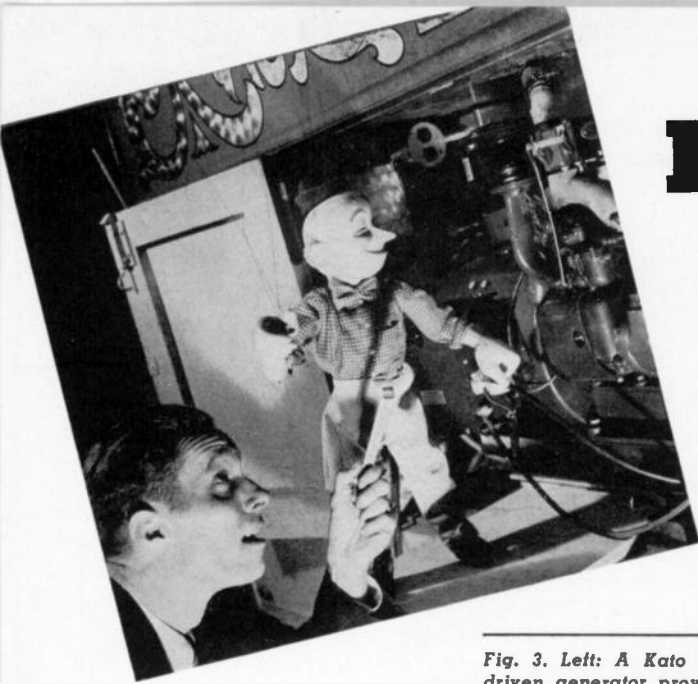

Fig. 3. Left: A Kato gas-driven generator provides 110-volt a.c. for the sound system and night lighting.

THE sound specialist or dealer is not likely to think of the operators of marionette shows as prospects for sound equipment, yet sound systems add materially to the effectiveness of such shows and are practically essential to any commercial showing of marionettes.

An example of a "professional" show of this type, used for advertising purposes, is Bill Baird's presentation in the Shell Oil Company's "Courtesy Crusade" to promote safe driving. This crusade utilizes two truck-mounted marionette shows, touring different sections of the country and each showing in a different town each day. The accompanying photos show inside and outside views of one of these.

Fig. 2 shows the inside arrangement as seen from the rear end. At the right is the "stage" with the tiny car and driver in the right foreground awaiting his entrance cue. In the center is the backdrop and behind it the platform on which the operators work, a part of the roof being raised to give them headroom. At the left is a group of puppets being prepared for the next act. Beyond these is Bill Baird at the amplifier equipment.



Fig. 2. At the far end is the Lafayette 6/110-volt universal amplifier and record player. One of the two 12-inch speakers is shown at the right.

The script for this show, which depicts the antics of different types of road pests, including "screw-drivers," "screw-jays" (jay walkers) and the like, was written just as for any other type of show. The dialogue was then recorded by professionals and is reproduced through the built-in sound system.

The sound system consists of a standard Lafayette 30-watt, 6-110 volt amplifier with a 33-1/3 rpm turntable mounted on its cover, a microphone, and a pair of 12" Utah speakers mounted in the wall of the truck. The microphone is not used as a part of the show but only for occasional addresses by the local police chief, or to warn against crowding too close to the truck, etc.

The power for the amplifier and for night illumination is provided by a Kato 20-ampere, 110-volt a.c. gas generator which is mounted in a compartment in one side of the truck. This compartment is of metal and is insulated with rock-wool to deaden the noise and prevent heat radiation to the interior of the truck. It is accessible from the outside of the truck, as shown in Fig. 3 (with one of the "screw-driver" puppets giving it the once-over).

The amplifier equipment normally operates from this 110-volt source but can be operated directly from the gas generator's 6-volt starting battery or the truck's battery when occasion demands.

Applications such as this represent just one of the growing markets for sound equipment being opened up by improved roads and the growing tendency to utilize trucks and trailers for advertising, political campaigning, propaganda and educational purposes. In the marionette show field the application is by no means limited to mobile shows. There are numerous amateur and professional producers of these shows, and many of them are prospects for sound equipment, recording service, etc. Even those who go in for these shows as a hobby are not beyond the realm of possible sound sales or rentals because many of them on occasion present their productions before sizable crowds at local entertainments and really need suitable sound equipment.



Fig. 1. The puppet show in action from the special truck. Note speaker openings at left and right of stage.





Among the world's most scientific, highly developed precision instruments are the TAG Celecstray Pyrometers for indicating, recording and controlling temperatures.

So accurate and sensitive in operation are these instruments that some of them sell for as much as \$600. In comparison with this price, the cost of the single tube used is trivial. Yet this one tube is vital to the accurate performance of the instrument. It must be as soundly engineered and as dependable in its function as the instrument itself. It must be rugged enough to stand up under 24-hour service, day in and day out. With these factors essential, it is not surprising that Celecstray engineers should specify RAYTHEONS.

It is another example where nothing but the best will do. It is a RAYTHEON because RAYTHEONS are scientifically designed and constructed by engineers who specialize on tubes alone . . . engineers who are constantly

looking ahead, anticipating, developing! When a tube need occurs, new or old, there's always a RAYTHEON ready for it.

That is why thousands of servicemen who are real money makers depend on RAYTHEONS for all their tube requirements. They have found that the big service contracts are landed by men who use only the best of materials . . . and RAYTHEONS *cost no more!*

*Your RAYTHEON Distributor has an unusual tube deal for you. See him without delay.*



NEWTON, MASS. • NEW YORK • CHICAGO • SAN FRANCISCO  
**WORLD'S LARGEST EXCLUSIVE RADIO TUBE MANUFACTURERS**  
 ATLANTA

SEPTEMBER 1940						
S	M	T	W	T	F	S
1	2	3	4	5	6	7
8	9	10	11	12	13	14
15	16	17	18	19	20	21
22	23	24	25	26	27	28
29	30	---	---	---	---	---

MONDAY  
**2**  
SEPTEMBER

OCTOBER 1940						
M	T	W	T	F	S	S
---	1	2	3	4	5	6
7	8	9	10	11	12	13
14	15	16	17	18	19	20
21	22	23	24	25	26	27
28	29	30	31	---	---	---

a big day for the 20,000  
"key" radio service dealers—  
the readers of RADIO SERVICE-  
DEALER magazine.  
It ends their slack sea-  
son... back to work they  
go, accounting for 90% of  
the country's annual radio  
service and sound work...  
buying vast quantities of  
replacement parts, tubes, etc.

Labor Day, Mon. Sept. 2

SERVICE-DEALERS ...  
remember Sept. 2  
ADVERTISERS ...  
remember Sept. 5

The next few months will be the busiest and best ever for radio parts jobbers, service-dealers and soundmen. Elections—War News—FM—Television and sporting events galore will make this a memorable Fall for everyone in the radio industry. Manufacturers of radio replacement parts, sound equipment and instruments should not forget September 5th either, for on that date the big September issue of RADIO SERVICE-DEALER goes to press. Advertising in the September and Fall issues of RSD will pay big dividends. Make your space reservation at once! RADIO SERVICE-DEALER reaches more independent, "key" servicemen, soundmen and jobbers than any other trade paper in the field . . . and actually at the lowest advertising rates.

★ Advertising Department, Cowan Publishing Corp., 11 West 42nd Street, New York, N. Y. ★

# Circuit Court

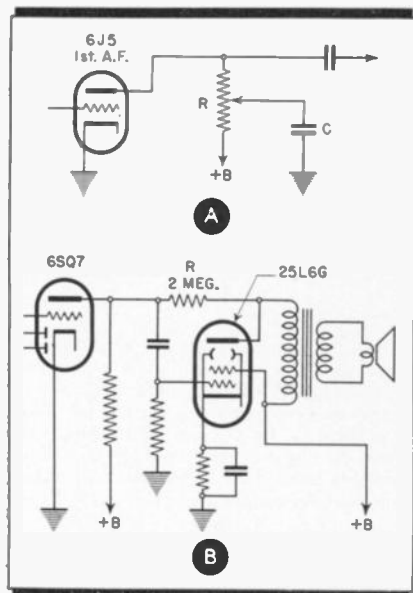

Fig. 1. Cheap tone control and degeneration.

## PENNY SAVERS

ENGINEERING PRACTICE plays an important role in reducing the manufacturing cost of receivers. Where price is a prime factor, shortcuts in design often permit a reduction in the list without sacrificing overall quality.

Outstanding examples are: the use of resistance-capacity filters in power supplies, utilization of contact-potential bias, open-ended coils to replace grid condensers, etc.

In A of Fig. 1 is shown a tone-control scheme, employed in the *Fairbanks-Morse* Model 12B, which eliminates one resistor. The potentiometer R functions

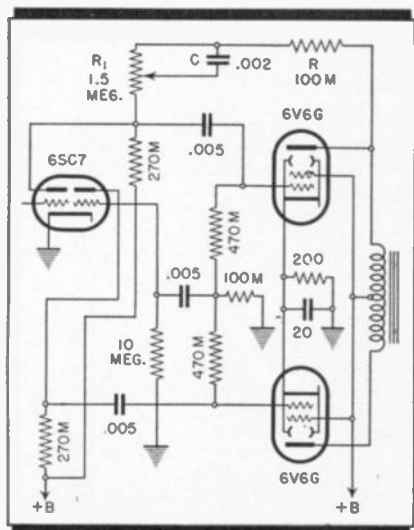

Fig. 2. The tone control is in the inverse feedback circuit, from plate of upper 6V6G to 6SC7 plate.

both as the plate load resistor and as the tone control. The degree of high-frequency attenuation is dependent upon the position of the potentiometer arm, to which is tied the grounded condenser C. The nearer the arm is to the plate end of R, the greater the degree of bypassing through C.

An inexpensive manner of obtaining inverse feedback over one stage is shown in B of Fig. 1. This arrangement is used in the *Fada* Models 27, 68, L96A and L67T & C, and in some of the *Stromberg-Carlson* 400 Series receivers.

Inverse feedback is provided by the 2-meg resistor R, connected from the plate of the 25L6G to the plate of the 6SQ7 triode. No other additional components are required.

## DEGENERATED TONE

THE TITLE SOUNDS bad, but the tone control in the *Stromberg-Carlson* Model

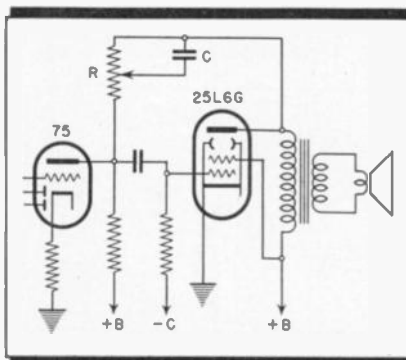

Fig. 3. More inverse feedback tone control.

455 receiver forms a part of a degenerative or inverse feedback loop from the plate of one 6V6G to one plate of the 6SC7, as shown in Fig. 2.

The negative feedback circuit consists of the resistor R, the potentiometer R1, and the condenser C. If C is ignored, the percentage of feedback from plate to grid of the 6V6G tube is determined by the values of R and R1. The feedback at any given frequency is dependent upon the value of the plate-to-grid coupling condenser which, in this case, is .005 mfd.

The condenser C makes the feedback loop selective. Its effect is to increase or decrease the degree of negative feedback at the higher frequencies, the extent of the feedback naturally being dependent upon the position of the potentiometer arm. At one extreme condenser C is shorted, and is therefore ineffective; at the other extreme it completely shunts or bypasses R1 and its

effect is maximum. In the latter position of the potentiometer arm, feedback at the higher audio frequencies is at a maximum; hence the gain at these frequencies is reduced. Response at the higher audio frequencies is therefore attenuated.

It should be noted that the feedback voltage also appears across the 100,000-ohm resistor connected between ground and the midpoint of the 470,000-ohm 6V6G grid resistors. Therefore it also appears on the grid of the inverter section of the 6SC7 which feeds the lower 6V6G.

## MORE INVERSE TONE

A SINGLE-ENDED version of the negative feedback tone control is shown in Fig. 3. This arrangement is employed in the *Majestic* 1D59. It consists of the condenser C and the potentiometer R. It operates in the same manner as the arrangement shown in Fig. 2.

## DRIFT CORRECTION

THE LATEST *General Electric* frequency-modulation receivers employ an oscillator drift correction network. The arrangement used in receiver Models HM-80A and HM-85A is shown in Fig. 4.

The network consists of the 5-mmfd compensating condenser, C39, and the 47-ohm resistor R28 which physically parallels C39.

Ordinarily, the compensating condenser C39 would correct or balance out oscillator drift, but only after the receiver had reached temperature stability. In the meantime, the receiver might drift off the station to which it

(Turn to page 26)

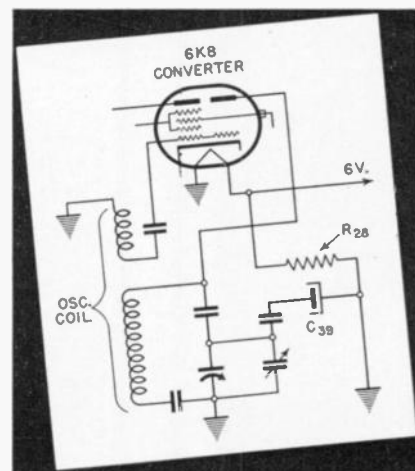

Fig. 4. Oscillator drift correction network (R28, C39) in 1-m set.

# MOTOROLA

## B2RC, B3RC, B4RC

# RECORD CHANGERS

**A**LL service adjustments on Motorola Models B2RC, B3RC and B4RC Automatic Record Changers should be made with the instrument in a normal operating position.

Therefore, the instrument should be supported in such a fashion that parts underneath are accessible. A jig consisting of four corner support posts would be helpful. A mirror would also permit the serviceman to make observations and adjustments without getting into awkward positions.

### CHECK RECORDS

Before attempting to service or adjust, check the records first to make sure they are not causing the trouble. The instrument will handle most of the 10- or 12-inch records now available on the market, but it may not handle them all. Records must be in good mechanical condition, and should not be chipped, particularly around the center hole. Do not try to play automatically, records that are too thick, too thin, or that are oversized or undersized, as regards diameter of record or center hole. Do not mix 10- and 12-inch records on the changer.

Old records made before the days of automatic record changers may not change automatically, due to the differences in thickness, or to lack of a proper eccentric groove at the finish. Most of the old records, however, may be played one at a time.

### THEORY OF OPERATION

As in most modern phonograph turntables, power is derived from an electric motor. This power is transmitted to the

turntable through a geared-down rim drive of the friction type.

The turntable is keyed to a small drive pulley, which in turn drives a large (3 inch) pulley, through a spring belt, both of these units being located on top of the base plate (See Fig. 1.) The 3-inch pul-

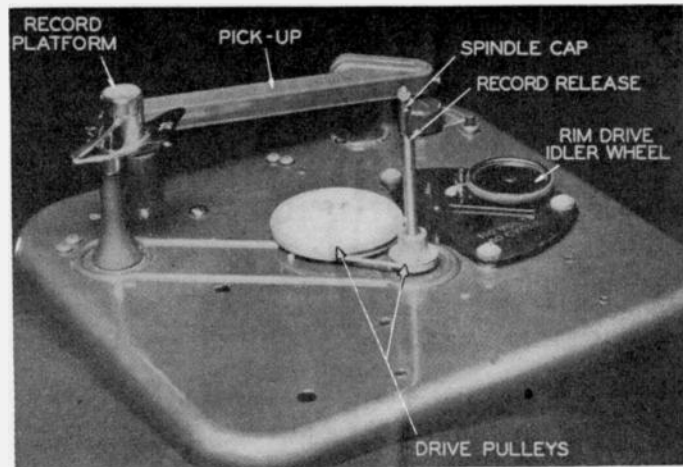

Fig. 1. TOP OF CHANGER.

plate.

When the turntable revolves, all of these pulleys and wheels mentioned above, also revolve, regardless of whether or not the Changer is going through a cycle of changing a record. By means of this series of pulleys, a high ratio is obtained between the motor and the changing mechanism, which assures ample power.

### CHANGING CYCLE

By referring to the various photographs and figures, you can readily follow through the changing cycle from the continuity given hereafter.

1. The needle in the pickup finishes a record and enters the eccentric groove.
2. As the pickup has slowly approached the eccentric groove, a phosphor-bronze spring clip has gripped a fin of the automatic change switch.
3. When the needle enters the eccentric groove on the record, the pickup oscillates slightly, which in turn causes the automatic change switch to make contact.
4. The first momentary contact of the automatic change switch is all that is necessary to start the changing cycle. When the switch closes, a small electromagnet is energized. The electromagnet pulls an armature back out of the way, permitting a drive pawl which is mounted on the cam wheel to fall down and engage in one of the notches which are provided on the upper surface of the main drive wheel. (See Fig. 2.)

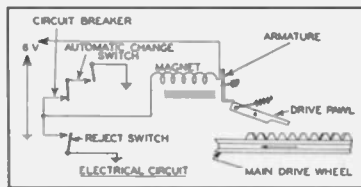

Fig. 2. Automatic change switch.

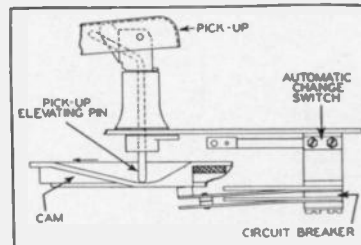

Fig. 3. Circuit-breaker switch.

ley transmits power by direct drive to another small pulley located under the mounting plate. This second small pulley in turn drives the large (4 inch) main drive wheel, also located under the mounting

5. Since the main drive wheel is already revolving, the engagement of the pawl now causes the cam wheel to revolve with it.
6. When the cam starts to revolve, it causes several things to occur. In the first few degrees of revolution, it opens a circuit breaker switch (Fig. 3) which automatically opens the magnet circuit, thereby de-energizing it, to prevent "chattering."
7. The next few degrees of rotation causes the pickup elevating pin to ride up on an inclined section of the cam, thereby elevating the pickup and lifting the needle from the record which has just been played. (See Fig. 3.)

8. A few more degrees of revolution cause the pickup guide groove on top of the cam wheel to come into play. This part of the mechanism is not visible, since the cam wheel is mounted too close to the mounting plate, but Fig. 4 shows a drawing of the upper surface of the cam wheel. As the wheel revolves with the pin in the groove, it causes the pickup to swing out beyond the edge of the record so it will be out of the way when the next record falls on the turntable.

9. The cam wheel continues its revolution, and at another point on its circumfer-

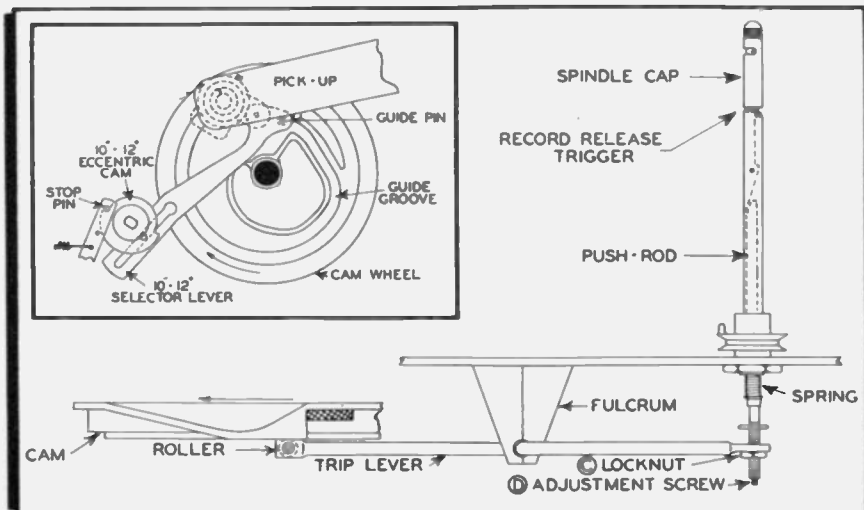

Fig. 4. (Inset) Details of cam governing movement of pickup. Fig. 5. Details of roller and trip lever.

ence a roller on the end of the trip-lever rides up an inclined section on the cam. This trip-lever is the copper-plated rod which is hinged approximately in the center by running through a die cast fulcrum block. As the roller on one end of the trip-lever rolls up the incline on the cam, the other end of the trip-lever bears against the push rod which operates the record release, which is located near the top of the spindle, causing it to push the next record off its support, thereby dropping it on the turntable. (See Fig. 5.)

10. The cam continues to revolve, the groove in the top bringing the pickup back over the edge of the record to the proper position where the needle will fall near the first groove when it comes down.

11. A few more degrees of revolution, and the pickup elevating pin rides down another incline, permitting the needle to settle gently on the first groove of the record. (Fig. 3.)

12. At this point, the cam has completed one full revolution of 360 degrees. At the same time the needle touches the record, the drive pawl hits the magnet armature, which forces it up, thereby disengaging it from the notch in the drive wheel. The cam wheel therefore stops, the turntable continues to revolve, and the record is played.

13. During the last few degrees of revolution, the circuit breaker switch has again been closed, as its fibre stud rides up an incline on the lower surface of the cam. (Fig. 3.) This switch must be closed at all times except when the instrument is going through a changing cycle, otherwise, it would be impossible to start a new changing cycle automatically.

#### RECORD SETTING

The record support platform is adjustable for either 10- or 12-inch records, depending upon which "lip" is turned toward the center of the turntable. The platform may be swung in an arc of 180 degrees, so that either the 10- or 12-inch lip may point to-

words, it adjusts the pickup for playing automatically either 10- or 12-inch records, depending upon the position to which the record support platform is turned. The eccentric cam and the selector lever are shown in Figs. 4 and 6.

#### START-REJECT SWITCH

The push switch mounted near one corner of the mounting plate is connected in

wiring diagram showing switches and magnet can be seen in Fig. 2.

#### TO ADJUST RECORD RELEASE

1. Place a stack of 10-inch records on the changer, after turning the record support platform to the "10-inch" position.
2. Start the turntable revolving.
3. Press the "Start-Reject" button.
4. If the first record does not drop to

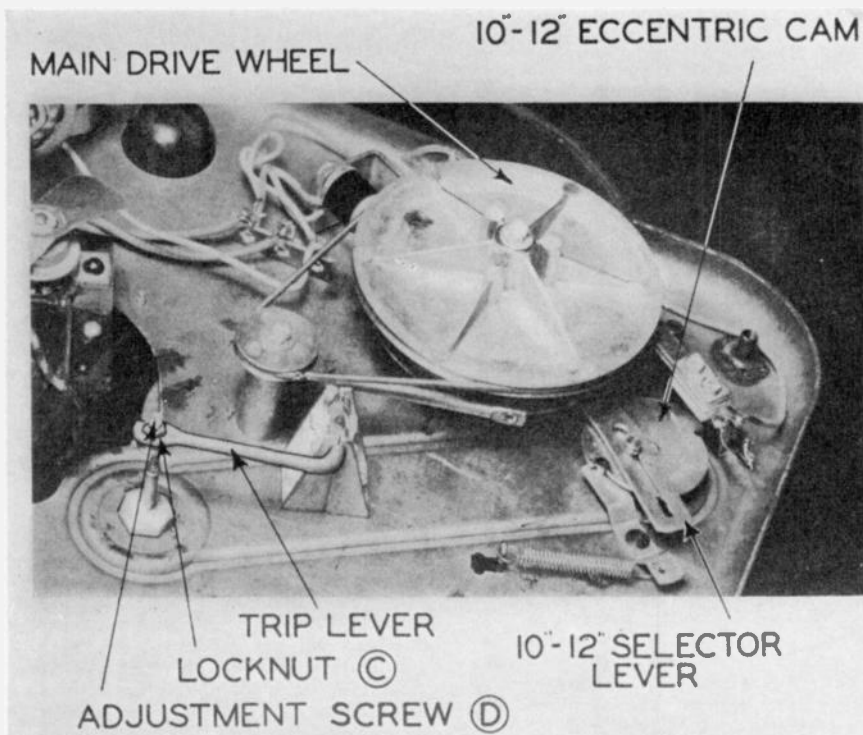
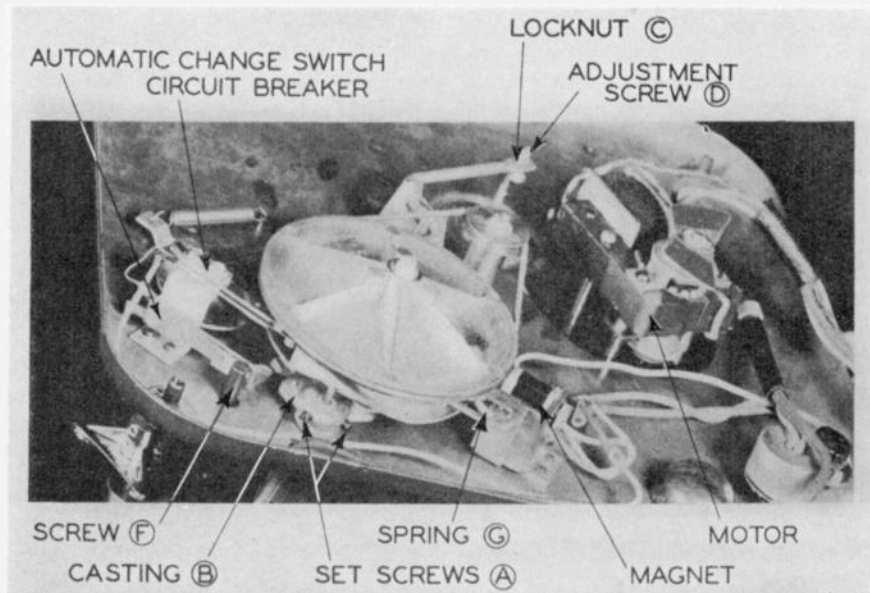

Fig. 6. Above: Parts controlling the essential mechanical movements.

Fig. 7. Below: View same as above from a different angle.



ward the spindle.

Underneath the mounting plate, and mounted rigidly to the record platform support shaft is an eccentric mechanism which moves the 10"-12" selector lever when the platform is moved. The position of this selector lever determines the point where the needle will come down on the record at the end of a changing cycle. In other

parallel with the automatic change switch previously discussed. When this switch is closed, it energizes the electromagnet exactly in the same fashion as does the automatic change switch, thereby making it possible to start the changing cycle at any time, regardless of whether or not the record has been completely played. By this means a record can be "rejected." The

the turntable, double check the record to make sure that it is not too thick, or that the diameter of the center hole is not undersized, causing it to bind.

5. If the record proves to be normal, and is not causing the failure, loosen lock nut (C) which locks adjustment screw (D), as shown in Figs. 5, 6, or 7.

6. With a slab-head wrench, turn screw (D) a fraction of a turn clockwise, and press the "Start-Reject" button again, checking to see if record is released.

7. If the record fails to drop, tighten screw (D) a trifle at a time, testing after each adjustment, until setting is reached, which releases record.

8. Tighten lock nut (C), after which a few more records should be changed, to make sure that this did not alter adjustment of screw (D).

Note: If the Changer stalls during the adjustment procedure, it may be an indication that screw (D) is too tight, in which case it should be turned back (counterclockwise).

#### TO ADJUST PICKUP POSITION

This adjustment is made to cause the needle to drop in the first groove of the record, as the Changer completes a changing cycle.

1. Turn the record support to the 10-inch position. (See Fig. 1.)
  2. Place a standard 10-inch record on the turntable and start it revolving.
  3. Press the "Start-Reject" button. The Changer will now start a changing cycle.
  4. Do not let the Changer complete the cycle, but stop it at the point where the pickup starts to drop downward towards the outer rim of the record. If the cycle is stopped at the right point, the pick-
- (Turn to page 25)

# Shop Notes

## ELECTROLYTIC SYMBOLS

### Used In Schematics

Recent schematics from RCA, Stromberg and others include the square, triangular and semi-circular designations which appear adjacent to the lugs on multi-section electrolytics. An example is given in the accompanying diagram.

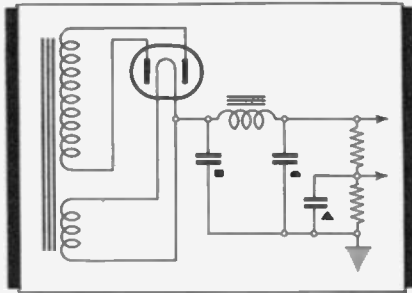

The identification on the electrolytics is generally accomplished by small cut-outs in the insulating base, or raised outlines where the insulating base is moulded. Usually one positive lug is not marked and consequently is not marked in the schematic. The capacitance and voltage ratings of the various sections, along with the identifying symbols, are usually stamped on the case of the electrolytic, so one can't go wrong in testing the sections or in making the proper connections where a replacement is called for.

## EMERSON 1941 CHASSIS EC, EM, DB, DL, DW

### Dial Cord Replacement

For chassis using the narrow "V" shaped notch in the drive pulley, use a half turn of cord, part number 6RZ-870. For chassis using the drive pulley with a broad "U" shaped groove, use a turn and a half of cord, part number 7BZ-867A. Draw the cord snugly around the condenser pulley and knot it, with no slack, near the notch in the pulley, after which the spring may be hooked to the cord and pulley. The dial face should bear against the fibre washer when finally assembled.

## G. E. HM-80A, 85A, 136A F-M SETS

### Oscillator Drift Correction

These f-m receivers employ an oscillator drift correction network (see diagram in Circuit Court of this issue). The placement of the parts comprising this network materially affects the amount of oscillator drift correction.

For maximum performance in Models HM-80A and HM-85A, the positions of the 47-ohm, 1-watt resistor  $R_{28}$  and the 5-mmfd compensating condenser  $C_{39}$  should be adjusted until they are parallel and separated by exactly 1/16 inch. In Model HM-136A, the 15,000-ohm, 2-watt resistors  $R_{34}$  and the 5-mmfd compensating condenser  $C_{81}$  should be parallel and separated exactly 3/64 inch.

## MINIATURE TUBES

### Removal Precaution

When a miniature tube is removed from its socket, the tube should be pulled straight away from the socket without rocking motion. Rocking the tube in its socket produces a transverse pressure on the base pins which may crack the glass base. Keep this in mind when you're working on one of these coat-pocket jobs.

## PHILCO 41-90

### Squeals

No remedy has been found for this difficulty except the replacement of the volume control.

## PHILCO 37-38

### Intermittent

This is usually due to failure of the audio input transformer, which must be replaced.

## RCA R-103-S VICTROLA ATTACHMENT

### Tone Compensation

Because of the widely varying frequency characteristics of various types of audio amplifiers with which this Victrola Attachment may be used, it may be desirable in some cases to alter the pickup circuit to compensate for the characteristics of the amplifier. The accompanying circuits show means of making such refinements.

In circuit A, the resistor  $R_1$  controls the low-frequency response; larger values of  $R_1$  give increased lows. For maximum low-frequency response, remove  $R_1$ . Resistor  $R_2$  controls pickup output, smaller values of  $R_2$  giving increased output. Condenser  $C_1$  controls high-frequency response; to increase highs, increase the value of  $C_1$ .

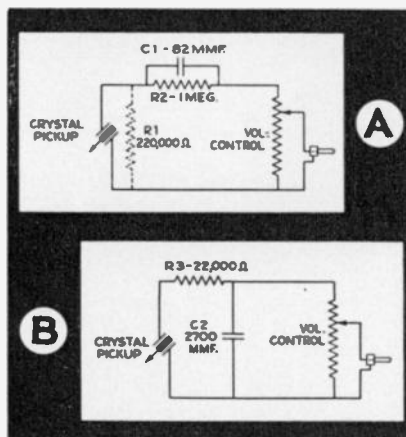

Where a decrease in high-frequency response may be desired (to reduce needle scratch, for instance) circuit B is applicable. In this circuit,  $C_2$  acts as a load on the pickup and is also a controlling factor on the high-frequency response. Smaller values of  $C_2$  give more pickup output and also more highs. Resistor  $R_3$  gives a sharper high-frequency reduction; increasing  $R_3$  decreases highs.

The suggested values shown in circuits

A and B should serve as a basis from which slight alterations may be made to suit individual cases.

## RCA 117N7-GT, VR75/30 TUBES

The 117N7-GT is a multi-unit tube containing a half-wave rectifier and a beam-power amplifier in the same (T-9) envelope. It is intended primarily for use in portable 3-way receivers. The power amplifier delivers 1.2 watts with 100 volts on plate and screen. The heater is designed for operation directly across a 117-volt line.

The VR75/30 voltage regulator tube is of the cold-cathode, glow-discharge type. It has an operating voltage of approximately 75 volts and a maximum operating current of 30 ma.

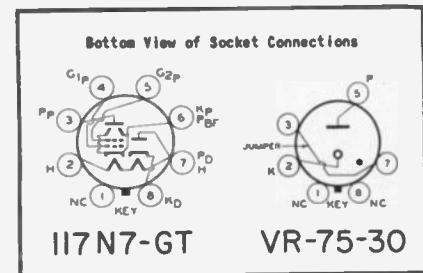

Socket connections for both tubes are given in the accompanying sketch.

## ZENITH 1940 ADVANCE LINE

### (Chassis 5419 to 5721 Inclusive)

In many cases a ground lead may be eliminated by connecting the ground terminal on the wave-magnet to the chassis base.

The operation of the bass radiorgan button in chassis 5719-5721 can often be improved by connecting a 1-megohm resistor from the high side of the volume control to the tap on same.

Noisy operation of the automatic tuning may be caused by the leads to the automatic assembly or coil leads laying against the metal frame of the assembly.

Excessive oscillation in Model 4K401 will be caused by the 1A7 tube which should be replaced.

Motorboating in Model 4K401 will be due to a poor ground connection on the electrolytic condenser at the rivet which fastens it to the chassis.

Care should be taken that the leads from the tone control condenser and switch in all six tube bakelite models be kept away from the 6Q7 tube; otherwise the tone will be affected.

Excessive hum in ac-dc or voltage-doubler chassis can be corrected by reversing the power plug in the light socket.

Cutting out in the portable receivers will usually be due to poor connections at the battery pack plug. Slight bending of the prongs will correct this condition.

Excessive regeneration in 5659 chassis may be corrected in most cases by moving the 12A8G grid lead away from the oscillator section of the gang condenser.

FIG. 1.

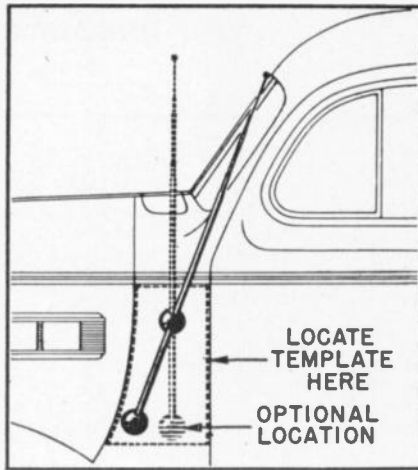

FIG. 5.

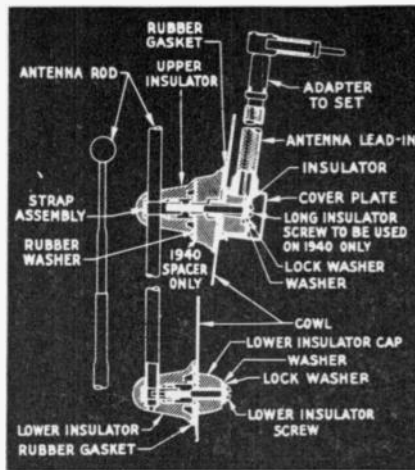
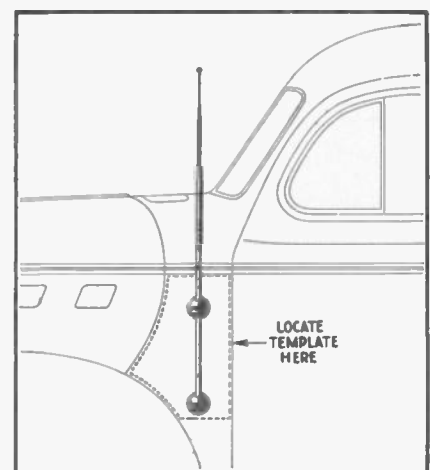

FIG. 2.



# Chrysler Skyway Antenna Installation

**F**OLLOWING are the details of the Chrysler three-section Skyway Antenna designed for installation on any 1937, 1938, 1939 or 1940 Chrysler, DeSoto, Dodge or Plymouth cars.

The antenna rod is telescopic and can easily be extended from its compact position to its full length, or adjusted to an intermediate length.

In its compact position, adequate pickup is provided for local broadcasts and, in locations where trolley line and other electrical interference is experienced, it will give quieter reception. In areas distant from broadcast stations, the rod sections should be extended to their full length.

Fig. 1 shows where antenna should be

located on 1939 cars, with either vertical or slant mounting. Fig. 2 shows where antenna should be located on 1940 cars.

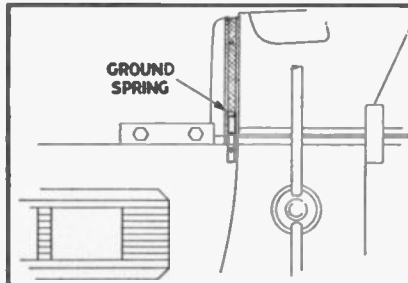

Fig. 3. Above: Ground spring installation.

Fig. 4. Below: Drilling templates. These can be enlarged to proper size by tracing on paper ruled off in half-inch squares.

## HOOD GROUNDING

Install hood grounding clip spring, as shown in Fig. 3. Loosen the hood side panel bolts on the left hand side and pry out the lower hood lacing screw. Apply the clip with a self-threading screw using the hole from which the lacing screw was removed, then drill the other hole and apply screw. Use a No. 29 drill. This operation grounds the top and side of the hood to the cowl.

## INSTALLATION

Remove the left cowl trim-pad.

Select the correct template for the car (see Fig. 4). Align the template with the belt moulding on the outside of the cowl

(Turn to page 26)

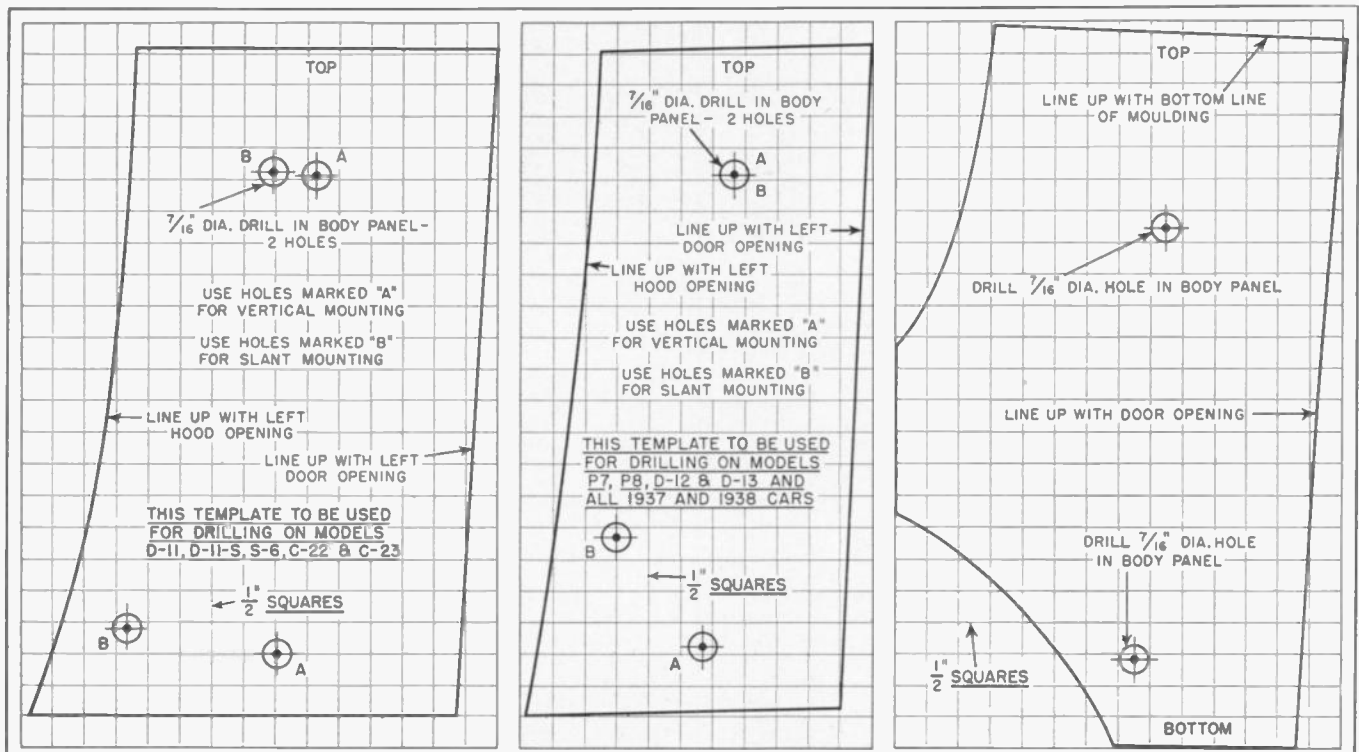

# Presenting—

## NEW PRODUCTS

### TRIPLETT

**A-C Ammeter**—Model 670, one of a new series of matched instruments, has a self-contained current transformer permitting measurements on the following ranges: 0-1/2.5/5/10/25 a-c amperes. For use on 60 cycles.

Incorporates three-inch Triplet instrument with long scale. Has Red • Dot life time guarantee. Red molded case, 3-1/16" x 5-7/8" x 2-1/8". Panel, ivory with red markings and trim.

Also available in single-unit matched instruments are: A-C and D-C Milliammeters, A-C and D-C Ammeters, A-C and D-C Voltmeters, D-C Microammeters,

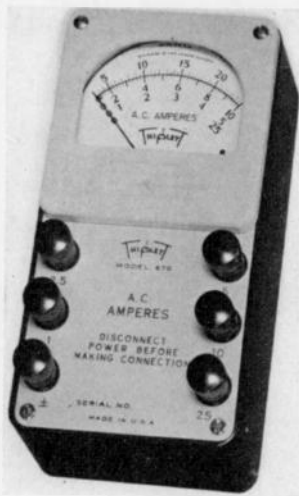

Ohmmeters, Volt-Ohm-Milliammeters and Battery Testers. By The Triplet Electrical Instrument Co., Bluffton, Ohio. RADIO SERVICE-DEALER.

### OHMITE

**Direction Indicator**—Model DR-125 Direction-Indicator Rheostat with 360° continuous winding, designed for use on d.c. up to 24 volts.

May be connected to moving part of rotary beam antenna, direction-finding loop, wind vane, etc., in order to transmit an indication of position to a remote point.

Consists of glazed ceramic housing 1 7/8" diameter and 13/16" deep behind panel. Mounted by a 3/8"-32 bushing and nut on

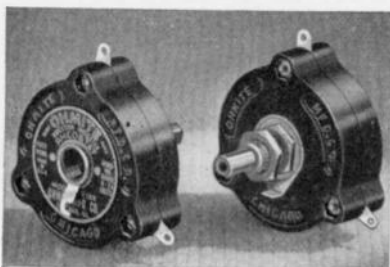

any panel up to 1/4" maximum. Equipped with non-turn washer. Shaft 1/4". By Ohmite Mfg. Co., 4835 Flournoy St., Chicago, Ill. RADIO SERVICE-DEALER.

### MALLORY

**Noise Filters**—A complete line of Mallory Noise Filters, scientifically constructed to

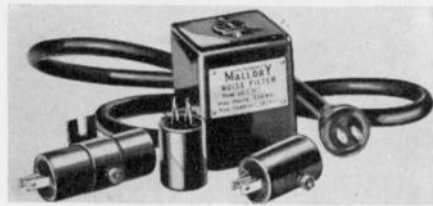

combat the particular type of man-made interference for which each is recommended, has just been introduced.

Heavy duty filters in standard cut-out boxes, for use with equipment that is permanently connected to the power line or which draws a minimum of 10 amperes or more, are included.

Type ZA1 is a capacity and inductance combination using house wiring as an antenna. Field-tested recommendations in technical data folder NF-100 tell the correct type and size of Mallory Filter to install in order to overcome a given character and intensity of interference. By P. R. Mallory & Co., Inc., Indianapolis, Ind. RADIO SERVICE-DEALER.

### MECK

**6-110 v. Amplifier**—Audiograph Model AMR-250 mobile amplifier for operation



from 6-volt storage battery or 110 volts a.c. For phono or microphone operation. Output is 25 watts.

Has built-in switch to conserve plate current between announcements. Heaters remain on for instant operation. By John Meck Industries, Randolph & Elizabeth St., Chicago, Ill. RADIO SERVICE-DEALER.

### HALLICRAFTERS

**3-in-1 Portable**—Model S-29 "Sky Traveler" combines universal convenience of 3-in-1 portable with those of a communications receiver.

Housed in crackle-finished aluminum case, it weighs 18 pounds with self-contained batteries. Battery life is prolonged by built-in charging circuit.

Nine tubes provide one r-f and two i-f stages, mixer, detector & avc, two audio stages, beat oscillator, automatic noise limiter, and line rectifier. Continuous tuning range from 542 kc to 30.5 mc in four steps, with electrical bandspread. Sensitivity better than 2 microvolts in all ranges.

Has built-in speaker and headphone jack, and a collapsible rod antenna socket on case, plus external antenna connections for



doublet and L antennas. By The Hallcrafters, Inc., Chicago, Ill. RADIO SERVICE-DEALER.

### WEBSTER CO.

**"Uni-Vel" Mike**—Incorporates such features as true cardioid characteristics—wide-angle pickup in front, dead in back—full-range frequency response, operates 30 percent closer to speakers, and unidirectional characteristics which permit favorable pickup under reverberatory conditions without background noise or feedback.

Housed in streamline black and chrome case. By The Webster Co., 5622 Bloomington Ave., Chicago, Ill. RADIO SERVICE-DEALER.

(Turn to page 24)







# HEADACHES RELIEVED

Rx

All radio servicemen, dealers and soundmen suffer from headaches on occasion, generally from business troubles. But the top notch service-dealers who read RSD every month suffer less as they obtain exclusive information that keeps them ahead of competition

(TEAR OUT AND MAIL TODAY)

**WORTH \$1.00—MAIL NOW!**

Regular \$2.00 ANNUAL SUBSCRIPTION TO RSD COSTS BUT \$1.00 with this coupon.

RADIO SERVICE-DEALER, SOUNDMAN & JOBBER  
11 West 42nd Street, New York, N. Y.

Sirs: Enclosed herewith is my  check (or  money order) for \$.....  
Please enter my annual subscription order (12 issues) at \$1.00 for 1 year or \$2.00 for 2 years, (24 issues)—1/2 the regular price. Foreign subscriptions are \$2.00 yearly. I believe the information given below is accurate. **IF MY SUBSCRIPTION IS REJECTED I EXPECT TO RECEIVE IMMEDIATELY A REFUND IN FULL FOR THE AMOUNT ENCLOSED HEREWITH.**

NAME (print carefully) .....

ADDRESS .....

CITY ..... STATE .....

FIRM NAME ..... Est. 19.....

YOUR POSITION .....

Please check whether firm is

- An independent servicing organization
- An independent service-dealer (engaged primarily in service work)
- A service-dealer (does servicing, but is primarily interested in retailing)
- Selling, renting or servicing Sound Equipment
- Jobber                       Any other classification
- Manufacturer                      (State it) .....

I belong to a serviceman's organization.... Yes  .... No

We stock the following checked items:

- TUBES
- PARTS
- RECEIVERS
- BATTERIES, etc.
- SOUND EQUIP.
- ELEC. APP'L'S

We own the following Instruments:

- V-T Voltmeter
- Tube Checker
- Analyzer
- Oscillator
- Signal Generator
- Volt-Ohm Meter
- Others
- MANUALS

RSD's editorial staff, like a physician, is constantly examining current happenings in the field to ascertain what business and technical problems confront those 20,000 key service-dealers who account for 90% of the nation's annual radio servicing and replacement parts and sound equipment business.

Since its inception 5 months ago RSD has been constantly "scooping" the field—publishing more technical data on radio's newest developments (FM, home recording devices and the use of test equipment) than all other radio publications combined. Dozens of our subscribers say that the authoritative data published in one issue alone is worth the year's subscription price.

You service-dealers are in this business to make real money. Our job is to help you do just that. Follow this suggestion—subscribe to RSD now while the introductory 1/2 price rates are still in effect and the \$1.00 you pay for the next 12 issues of RSD will prove to be one of the soundest investments you've ever made.

Foreign subscriptions \$2.00 annually. Subscriptions from students in accredited Radio Training Schools \$2.00 each for 12 issues.

## New Products

### HICKOK

**Electronic Bridge**—Model 575, which may be used as a conventional bridge, as a percentage bridge or as a synchrometer. It permits electrical triangulation.



The shielded circuit features a cosine galvanometer, has built-in standards and provision for external standards. Galvanometer cannot be damaged by extreme unbalance of bridge. Though it operates from a.c., it has null balance the same as standard d-c bridges.

Measurements which may be made include capacity, resistance, inductance, impedance, power factor and frequency. Can detect change in capacity as low as 1 mmfd. and make capacity measurements beyond 1000 mfd. Measurements to 500 megohms are by true bridge balance. By The Hickok Electrical Instrument Co., 10514 Dupont Ave., Cleveland, Ohio. RADIO SERVICE-DEALER.

### UNIVERSAL

**Crystal Mike**—Model KO, high-output unit with slightly rising frequency characteristics together with well-rounded bass response. Weighs a trifle over one pound packed.

The output level is 48 db below one volt per bar, and the frequency range is 50 to 6000. Stand coupling is  $\frac{5}{8}$ " 27 thread with mike diameter of  $2\frac{3}{4}$ " and depth of  $2\frac{3}{8}$ ". Assembly includes 10 feet of low-capacity, rubber-covered cable in color to match mike, which is finished in satin statuary bronze, with polished chrome face and



grille for contrast. By Universal Microphone Co., Inglewood, Calif. RADIO SERVICE-DEALER.

### UNITED TRANSFORMER

**Varitrans**—New design changes have been made in the UTC Varitrans units. In addition to glass-insulated wire throughout all sizes, multiple contact units now employ ballast coils to insure uniform contact loading.

The Varitrans units are available for 115- or 230-volt service with respective output voltages of 0-130 and 0-260 volts. Non-interrupted control is effected in all sizes from the 2-amp Model V-O to the 44-amp



Model V-7. By United Transformer Corp., 150 Varick St., New York, N. Y. RADIO SERVICE-DEALER.

### BURTON-ROGERS

**Roof Aerial**—Model 357 replacement roof aerial for Ford and Buick cars. In four pieces, and fitting standard base already



on car, it has an extended length of 57 inches and will telescope to 17 inches. Furnished with set screw and wrench for easy installation.

Provides better reception, particularly in mountainous sections. By The Burton-Rogers Co., 857 Boylston St., Boston, Mass. RADIO SERVICE-DEALER.

### UNIVERSITY LABS

**Booster Loudspeaker**—The Model CR is a compact loudspeaker of extremely high acoustic output for use in intercommunication systems, etc., where there is a high background noise level. Its very high

voice range efficiency gives the "booster" effect.

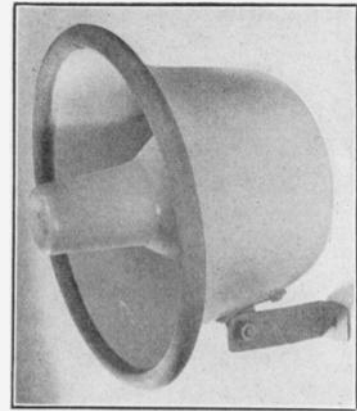

It requires no additional amplification and boosts "talk-back" pickup enormously.

It is 100% waterproof and non-resonant. Bell opening is 11", depth 8". By University Laboratories, 195 Chrystie St., New York, N. Y. RADIO SERVICE-DEALER.

### SUN

**Portable Amplifier**—New line of Mercury Amplifiers, including a 14-watt portable amplifier system in a single carrying case.

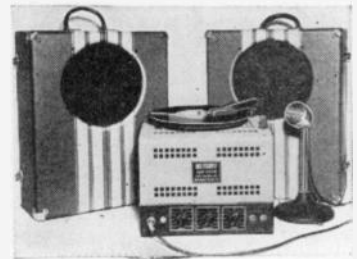

Consists of high-gain amplifier with built-in record player, two 10" dynamic speakers, 50-foot cable and desk mount crystal mike and cable. Also available with two walnut speaker baffles in lieu of portable case.

Satisfactory for indoor audience of 1500. Outdoor coverage over 4000 square feet. By Sun Radio Co., 212 Fulton St., New York, N. Y. RADIO SERVICE-DEALER.

### CORNELL-DUBILIER

**Hi-Capacity Electrolytics**—Type BRH tubular dry electrolytics available in capacities ranging up to 500 mfd at 25 v., 1000 mfd at 15 v., and 2000 mfd at 6v. Particularly applicable to special cathode bypass and resistance-capacity filter circuits.

Enclosed in vented aluminum container protected by varnished cardboard tube. Pigtail or lug terminals. By Cornell-Du-

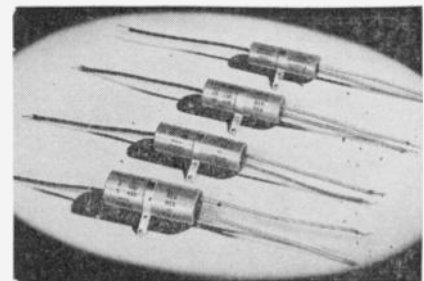

bilier Electric Corp., South Plainfield, N. J. RADIO SERVICE-DEALER.

## MOTOROLA CHANGERS

(From page 19)

up will still be "in cycle" and will not be free to swing back and forth. Check this gently. Do not exert too much sidewise pressure on the pickup.

5. Now loosen the two hex-head set screws (A) in the bell crank casting (B), shown in Fig. 7.

6. With the set screws loose, the pickup arm can now be moved back and forth. Move it to the point where the needle rests directly over the first groove in the record. (The correct dimension for proper adjustment is 4-25/32" from the needle point to the center of the spindle.)

7. Tighten one set screw securely so that the shaft does not move while checking proper position of the pickup arm. After proper position has been located tighten both set screws securely.

8. Now place a 12-inch record on the turntable; turn the record support to the 12-inch position.

9. Press the "Start-Reject" button and let the Changer go through another cycle, watching carefully to make sure the needle comes down on the record at the proper point. If necessary, make minor readjustment.

### ALIGNING RECORD PLATFORM

It is important that all points on the "lip" of the record support platform be equidistant from the center point of the spindle. This will assure that all points of the record will leave the platform at the same time. If the record support is too far out of alignment, the record would actually hang on the point nearest the spindle and fail to drop properly.

1. To check this alignment, turn the spindle-cap so it is in alignment with the rest of the spindle, which is the correct position for removing records. (See Fig. 8.)

2. Turn the record support platform to the "10-inch record" position, making sure it is turned all the way to the stop.

3. Slip a standard 10-inch record over the spindle and check to make sure it clears the lip of the platform at all points. (See Fig. 9.)

4. If one point on the lip extends farther than the other, the position of the record support may be adjusted after loosening the two Bristol set screws (E), located directly under the numeral "12" on the record support. (See Fig. 9.)

**Caution:** Make sure the eccentric selector cam, which is located under the base, is turned all the way to its stop. (See Fig. 4.)

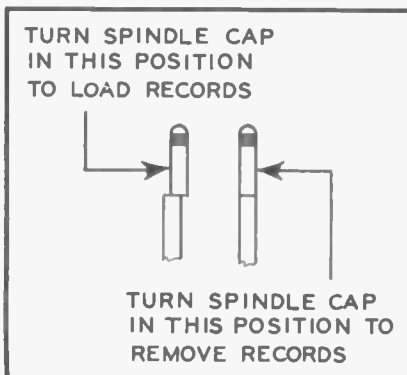

Fig. 8. Details of spindle cap on which records are loaded.

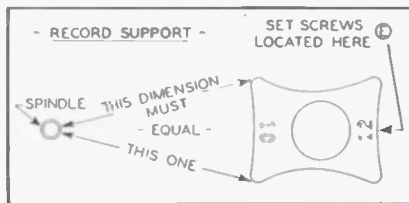

Fig. 9. Correct platform alignment.

**Test:** After tightening the set screws, test the adjustment by running a 10-inch record through a complete cycle and check the point where the needle falls. If the needle misses the record by one inch, the record platform is 180 degrees out of line with the eccentric cam, and should be

turned one-half turn without turning the cam.

### AUTOMATIC CHANGE SWITCH

The Automatic Switch (See Fig. 7) starts the changing cycle after a record has been completely played. The switch is actuated by the oscillating of the tone arm in the eccentric groove of the record, through the spring clip which grips the movable switch blade.

If the switch fails to operate positively, it may be readily adjusted by means of the adjustment screw (F). (See Fig. 7.)

To make the adjustment, place a record on the turntable, start it revolving, and move the pickup over to the end of the record. Adjust screw (F) until switch

# THE ILLUMINATED GIANT

## Push Button Operated

FOR ONLY

\$33<sup>95</sup>



**Dealer Net Cash Price**  
S.I.C. Time Payment Plan  
**\$4.00 cash and 8 monthly payments of \$4.17.**  
In Metal Case

## SUPREME MODEL 547 MULTIMETER

SUPREME'S Speed Button System has proved to be the simplest, fastest and most convenient of all types of multimeter range and circuit selections. All that is necessary to obtain any range is to press one button on the left hand row and one button on the right hand row. Thus, at your finger tips you have instant control of 36 ranges as follows:

- 0.1 TO 3000 O.C. VOLTS**—covered by six overlapping ranges of 0/6/30/150/300/600/3000, 1000 ohms per volt standard sensitivity. Accuracy  $\pm 2\%$  on all ranges except 3000 volt which is  $\pm 3\%$ .
- 0.1 VOLT TO 3000 A.C. VOLTS**—covered by six overlapping ranges of 0/6/30/150/300/600/3000. Accuracy  $\pm 3\%$ . This guaranteed circuit is fully compensated for temperature variations so you are assured that you can use it in winter or summer with equal accuracy.
- 0.1 VOLT TO 3000 OUTPUT VOLTS**—covered by six overlapping ranges of 0/6/30/150/300/600/3000. No external condenser necessary. May be used with any signal generator for receiver alignment.
- 0.1 TO 600 MILLIAMPERES**—covered by five overlapping ranges of 0/6/30/150/300/600. Uses wire wound shunts calibrated to  $\pm 2\%$ .
- 1 OHM TO 20 MEGOHMS**—covered by five carefully selected ranges of 0/2000/20,000/200,000 ohms and 0/2 meg. /20 meg. Low range has center scale resistance of 25 ohms.
- 10 TO +44 D.B.**—covered by ranges of -10/+3/+18/+32/+38/+44 calibrated to read D.B. directly on any 500 ohm line. Simple conversion chart is supplied so that readings may be taken on any line of known impedance.
- 0.005 TO 20 MICROFARADS**—covered by three ranges of 0/2/20/200 mfd. Capacity values read directly on meter scale.

Model 547 incorporates a large 7" illuminated meter which allows accurate reading with minimum eye strain. Call at your parts jobbers and it will take you only a minute to see the difference between the Model 547 and other types of multimeters.

The Model 547 is also available in a beautiful Oak carrying case, as illustrated. \$38.50 cash or \$4.00 cash and 9 monthly payments of \$4.02.



### MODEL 543 MULTIMETER

The Model 543 Pocket Multimeter uses a beautiful bakelite case measuring only 3" x 5 3/8" x 2". Attractive two-color panel—full size 3" one mill meter. A single rotary selector switch provides functions and ranges of: Resistance—0/2000/200,000 ohms; Direct Current—0/6/60/600 M.A.; A.C.—0/15/150/600/3000 volts; D.C.—0/15/150/600/3000 volts. Batteries furnished and contained within case. Ranges at 1,000 ohms per volt standard sensitivity.

**DEALER NET PRICE, \$11.95**

## SUPREME

SUPREME INSTRUMENTS CORP.  
GREENWOOD, MISSISSIPPI, U. S. A.

SEND FOR NEW CATALOG

—just off the press. Large, two color illustrations, complete descriptions of 22 new 1941 model SUPREME quality testing instruments. Write today!

# P-A

## Output Attenuators

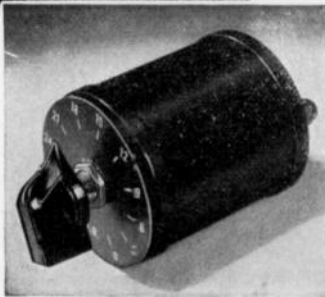

★ If you take particular pride in those P-A or sound systems you build or service, don't overlook these Clarostat Constant-Impedance Output Attenuators for controlling individual speaker volume without distortion or unbalance.

★ Series C1B (above) dissipates 10 watts at any setting. Insertion loss zero. DB range in 3 DB steps up to 24, then 6 DB, and final step to infinity. Stock ohmages: 8, 15, 50, 200, 250 and 500. Compact. Neat. One-hole mounting. Only \$6.50 dealer's net.

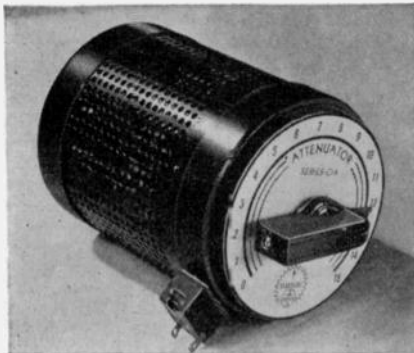

★ Series C1A can be used if your wattage requirements run higher. 25-watt dissipation at any setting. Linear up to 45 DB in 3 DB steps. Minimum insertion loss, 1.3 DB. Stock ohmages: 8, 15, 50, 200, 250 and 500. One-hole mounting. Handsome etched silver-and-black dial. With power switch, \$16.00 dealer's net; without switch, \$15.00.

### Ask Your Jobber . . .

★ He can show you these constant-impedance output attenuators. Also constant-impedance T-pads, L-pads, faders and other controls for sound systems and radio receivers. Ask for data—or write direct.

**CLAROSTAT MFG. CO., Inc.**  
Dept. S1, 285 N. 6th St. Brooklyn, N. Y.



The boys who make the wheels go 'round—the Sales and Credit Managers of this here radio field, and their guests, at the Annual Golf Tournament (and crap game) at Green Meadows Country Club, Westchester, N. Y., July 25th.

closes the magnet circuit and starts the change cycle. Check points visually to make sure they do not remain closed after cycle is completed.

If the Changer immediately starts another cycle, it is an indication that the points are remaining closed or that the clutch release spring (G) (Fig. 7) does not have enough tension. This tension may be increased by taking it up another notch.

### CIRCUIT COURT

(From page 17)

was first tuned when turned on.

By the addition of the 47-ohm resistor *R28* in close proximity to *C39*, and heating it electrically, the temperature of *C39* is brought to maximum in short order, and is made independent of receiver temperature. In this manner, the heating time of *C39* is made approximately equal to the heating time of the oscillator tube.

Resistor *R28* is connected directly across the tube heater supply circuit, as shown. Hence, the resistor heats up as soon as the receiver is turned on.

### CHRYSLER SKYWAYS

(From page 21)

panel at the door and the hood, as shown in Figs. 1 and 2. Carefully mark hole center locations with a center punch and then drill two holes. Remove the insulating material from around the holes on the inside of the cowl.

Make sure the rubber gaskets are over the base of the antenna insulators.

### MOUNTING

For 1937, 1938 and 1939 cars, place the strap assemblies in the insulators and loosely assemble the insulators on the antenna rod, as shown in Fig 5. Hold the insulators against the cowl over the holes just drilled. Place the lower insulator cap in the hole from the inside and

fasten securely, using a washer, lock washer and the pointed mounting screw. Place the other mounting screw (the short one) with a washer and lock washer through the eyelet terminal of the lead-in cable, then through the bakelite terminal placed on the grounding plate of the lead-in and fasten securely.

Place the cover cap over the grounding plate and snap into place. The special adaptor must be used to plug the end of the lead-in cable into the set. Complete mounting by replacing the trim-pad.

### Conclusive Testing



**\$22.00** Dealer Net

**TRIPLET**

Model 1213

- Exclusive Handy Hinged Postcard Reference Tube Chart
  - Filament Voltages from 1.1 to 110
  - RED DOT Lifetime Guaranteed Instrument
  - Neon Shorts Test
- Model 1213 contains all sockets to test all present day tubes including Pilot Lamps and Gaseous Rectifiers. Ballast Tube Continuity Test . . . Has separate line voltage control meter . . . Housed in snappy appearing metal case with brown suede baked enamel finish. Three-tone panel is brown, tan and red with silver markings. Dealer Net Price . . . \$22.00  
Write for catalog—Section 478 Harmon Drive

**THE TRIPLET ELECTRICAL INSTRUMENT CO.**  
Bluffton, Ohio

For 1940 cars, follow the same procedure with the exception that the large angle insulator must be used with its two rubber gaskets on the upper stanchion to fit the car contour. Also the long mounting screw must be used to fasten this stanchion, as in Fig. 5.

The left hand template in Fig. 4 is for 1939 Dodge, DeSoto and Chrysler cars. The center template can also be used on 1937 and 1938 Plymouth, Dodge, DeSoto and Chrysler cars. The right hand template is for use on the 1940 models.

## SERVICEMAN'S DIARY

(From page 13)

dehumidified electrolytic capacitors, excessively decoupled connecting leads to many components which, in view of the senility of the instrument, in my opinion, makes a decision to discard the apparatus obligatory."

She was listening in open-mouthed wonder. So was I.

Jerry listened to the reply, then called me over.

"This fellow says he'd like to talk to someone else," he muttered.

I picked up the phone and said hello.

"Say," an angry voice shouted, "what in hell was that nut trying to tell me?"

"Why," I told him, "he just said he didn't think your sister's set was worth fixing."

"Oh," he answered. "That's what I told her, too."

## BOOK REVIEWS

*PERPETUAL TROUBLE SHOOTER'S MANUAL, VOL. XI*, by John F. Rider. Stiff cover, special looseleaf binder mechanism, 9" by 11½", 1625 pages, illustrated. Separate Index and Vest Pocket Manual. Published by John F. Rider Publisher, Inc., 404 Fourth Ave., New York, N. Y. Price \$10.00.

Rider's new Manual, containing the servicing data released up to about May 15, 1940, plus a batch of last-minute material inserted in the front of the book, has approximately the same number of pages as Volume X, but possibly more actual data, due to further efforts made to reduce to a minimum the duplication of alignment procedure, etc., applying to more than one receiver model.

A study of Volume XI—a veritable encyclopedia of receiver design—serves to emphasize the progress made not only in the manner of presenting servicing data, but also in the amount of information provided. The advent of loop receivers has brought on special servicing considerations which are adequately covered; automatic tuning systems require special treatment; f-m receivers

have introduced a completely different alignment technique for the serviceman to digest; the trend toward tuned and untuned electronic voltmeters in servicing work has led many receiver manufacturers to provide gain data in their service notes and precise voltage values on their schematics at points where such values cannot be ordinarily read. The value of such data should not be underestimated, for it is by means of such measurements that a serviceman is enabled to duplicate in all respects the original performance of a given receiver.

The Complete Index for Volume XI is not cumulative, as were the previous indexes. It is handier to use for this reason. Where a certain job is associated with data printed in preceding volumes, the listing in the Volume XI Index bears an asterisk related to a footnote giving the previous reference.

The 17-page "How It Works" section in the Index deals with the latest engineering advancements in receiver design. Consideration is given loop circuits, oscillator voltage bias control, resistance-capacity power-supply filter systems, negative feedback, untuned r-f circuits, modern phase inverters, remote control, etc.

The Vest Pocket Manual—a supplement to Volume XI—is something new.

This little book has 44 pages of useful information for the serviceman, such as color codings, a socket connection chart, etc. Of special interest is the Table of Push Button Frequency Ranges, which will be particularly handy when the FCC commences the rearrangement of broadcast station channels.

M. L. M.

♦  
*AUTOMATIC TUNING*, by Engineering Staff, P. R. Mallory & Co., Inc., Indianapolis, Ind. Punched for binder, 8½" by 11", 27 pages, illustrated. Supplement No. 8 to the 3rd Edition of *Mallory-Yaxley Radio Service Encyclopedia*.

The data presented supplements the instructions previously published in the 2nd Edition of the M-Y Radio Service Encyclopedia, bringing the subject up to date.

Supplement No. 8 contains a handy reference table, with alphabetical listings, giving receiver model number, number of push-buttons, type of automatic tuning employed, the system to which it is similar in a representative group of receiver models, and reference page number.

Section I of the Supplement covers rocker bar mechanisms, Section II the cam and lever type. Other sections

FOR GREATER  
*flexibility...*

# BRUNO connectors by Selector

Introducing  
**"CONNECTAR"**  
*A Universal Connector Kit\**

*Assembled for Servicing Convenience*

List

**\$5.50**

Think of the time and money to be saved with this kit that makes possible all sorts of wiring combinations! You can connect Standard to Baby sizes, males to males, females to females... make splices, extensions, phone plug connections. Experienced Service Men will welcome "CONNECTAR" with a whoop of joy!

*\*All parts may be purchased separately*

**KIT CONSISTS OF**

Two ACI, one AB1 Adaptor Ring. One F2M 3-way Connector, one each CX, BX Cable Extension. One BCX Cable Extension Reducer (from 5/8" to 1/2"-27 thread). One PA Plug and a Cable Extension 1½ feet long, terminated with one F and one BF Connector.

**SOLD THROUGH JOBBERS**  
Write for Complete Literature

**SELECTAR MFG. CORP.**  
30 West 15th Street, New York, N. Y.

**Mr. Radio Serviceman:**

# RSA MEANS BUSINESS!

New business promotion plans and new member-helps spell increased profits for RSA members at the start of the new season. Watch for the RSA Replacement Parts Guide—New Broadcast Promotions—New Member Helps! Don't be the last man in your neighborhood to join RSA. Send the coupon Today!

**MAIL THIS COUPON NOW!**

**RADIO SERVICEMEN OF AMERICA, INC.**

304 S. Dearborn St.,  
Chicago, Illinois

I am interested in RSA Membership. Tell me about it.

Name .....

Address .....

City ..... State .....

RS-740

Let's Grow Together  
in 1940!



**RADIO SERVICEMEN  
OF AMERICA, Inc.**

*Reliable Service Assured*  
**JOE MARTY, JR., EXECUTIVE SECRETARY**  
304 S. DEARBORN STREET, CHICAGO, U.S.A.

cover permeability tuning, individual solenoid tuners, motor-operated devices, and the flash tuning system. Setting-up instructions are given for each type.

*FREQUENCY MODULATION, Supplement No. 9 to the 3rd Edition of M-Y Radio Service Encyclopedia, by Engineering Staff, P. R. Mallory & Co., Inc., Indianapolis, Ind. Punched for binding, 8½" by 11", illustrated, 22 pages.*

An excellent, concise summary of the fundamentals of frequency modulation, covering the points of particular importance to the radio serviceman.

An introductory section emphasizes the differences between amplitude modulation and frequency modulation, numerous sketches serving to illustrate these differences. A brief section on transmitters explains the manner in which a frequency-modulated wave is produced.

The section on f-m receivers deals with the main units separately; first the r-f amplifier and converter, then the i-f amplifier and limiter, and finally the discriminator. Data is also provided on audio amplifiers and special antennas for f-m reception. The complete schematic diagrams of seven representative commercial f-m receivers are included.

## APPOINTMENTS

**RCA-Allen**—W. H. "Win" Allen, RCA territorial representative in the New York area specializing in tubes and parts, has been transferred to RCA's Camden headquarters to head up a new activity aiding RCA Parts Distributors in developing still further their activities and services.

**Sprague-Trinkle**—Wilmer S. Trinkle who has represented the Sprague Products Company on condenser sales in the Philadelphia area, has been appointed to handle the industrial representation on Sprague Koolohm Resistors in that territory.

**Brach-Hansen**—L. S. Brach Mfg. Corp., Newark, and the Rapid Electro Plating Process, Inc., Chicago, have appointed William Hansen & Associates, Niles, Michigan, as manufacturer's representative to cover the states of Michigan and Indiana.

**Emerson-Geartner**—Emerson Radio & Phonograph Corp., New York, have appointed Jack Geartner, former sales manager of Arcturus, as manager of their newly instituted Radio Tube Division.

**Clarostat-Murphy**—Clarostat Mfg. Co., Inc., Brooklyn, have appointed Frank Murphy as their sales engineer in the Chicago area. He will work together with L. G. Cushing, long with Clarostat, whose office is maintained at 540 North Michigan Blvd., Chicago.

**Clarion**—Transformer Corp. of America

have announced the following appointments:

The Michigan area will be handled by Art Adams of the R. A. Adams Company, in Detroit.

Pennsylvania, Metropolitan New York, New Jersey, Delaware, Maryland and Washington, D. C., will be covered by Harold Weiler.

Mr. Hugh Snyder has taken over the Clarion line in Virginia, West Virginia, the Carolinas, and Florida.

**Worner-Campbell**—Worner Products Corp., 1019 W. Lake St., Chicago, manufacturers of photoelectric equipment, have announced the appointment of Robert H. Campbell as General Sales Manager.

**Du Mont-Hudson**—The appointment of G. W. Hudson, 338 East Broad St., Richmond, Va., as factory representative in Eastern Tennessee, Virginia and the Carolinas, is announced by the Allen B. Du Mont Laboratories, Inc., Passaic, N. J.

**N.U.-Philco**—A substantial interest in National Union Radio Corp. has been purchased by Philco Corporation as the first step in a program to expand the scope and activities of National Union in the radio field.

National Union will continue as a separate company to manufacture its products and distribute them nationally under its own trade-mark, as in the past. There will be no change in N.U. sales policies.

Plans call for modernization of and additions to the company's plants.

# See why you get MORE

# in a **JACKSON** Tube Tester

## Learn how *Dynamic* method doubles accuracy, boosts profits

### JACKSON INSTRUMENTS ARE THE FIRST CHOICE OF EXPERT RADIO ENGINEERS

In the most exacting branches of Radio Communication, where reliable testing methods are absolutely necessary to protect human life and valuable property, experts select Jackson instruments.

#### AIRWAYS COMMUNICATIONS

To safeguard passengers and maintain flight schedules, service engineers select Jackson Dynamic Test Equipment to keep airways radio systems in perfect working order.



#### POLICE COMMUNICATIONS

To prevent failures in the vast Police Radio Communications Systems, skilled maintenance engineers select Jackson Test Equipment.



#### BROADCASTING SYSTEMS

Only the very finest equipment is selected by Radio Engineers in charge of Broadcast Stations. WBNS, Columbus, Ohio—one of the best equipped stations in the nation—selected Jackson test instruments.



Are you putting up with expensive "call backs" and customer complaints? Or are you losing tube sale profits that should be yours? Are you trying to "get by" with obsolete equipment? Solve these problems by using a Jackson Dynamic Tube Tester. Jackson is more accurate because it tests every element of a tube **SIMULTANEOUSLY**—just as it would operate in a radio receiver. BOTH mutual conductance and emission must be satisfactory to produce a "good" reading. Often a Jackson finds "poor" tubes which might pass for "good" in ordinary testers. Jackson Tube Testers have full range filament selection marked directly in volts, high voltage power supply, sockets for latest tubes and additional "spares." **FREE** new tube data for one year. You'll be proud to own a Jackson. Order from your Distributor now.

### SIGNAL ANALYZERS

Signal testing with a Jackson Signal Analyzer is direct, positive and easy. Analyzer is actually simple to use. Measures the signal itself, tracing its path through the receiver to the exact point of trouble. It shows ALL results instantly on direct reading meters. A money-maker for any shop!



**"SERVICE LAB" UNIT** Remember, a well equipped modern shop attracts customers. Investigate Jackson "Service Labs." The Service Lab earns extra profits—helps obtain better prices—speeds up shop work. Each unit in the assembly is a standard Jackson Instrument.

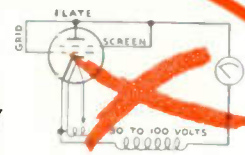

### ORDINARY TESTERS

Will pass many BAD tubes as OK because tube elements are "tied together" for the test.

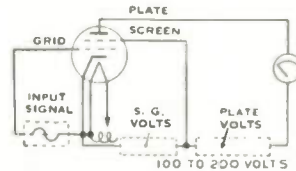

### JACKSON DYNAMIC TESTERS

Detects ANY fault because tube elements are properly connected to separate circuits. The complete method—all yet all in one simple reading.

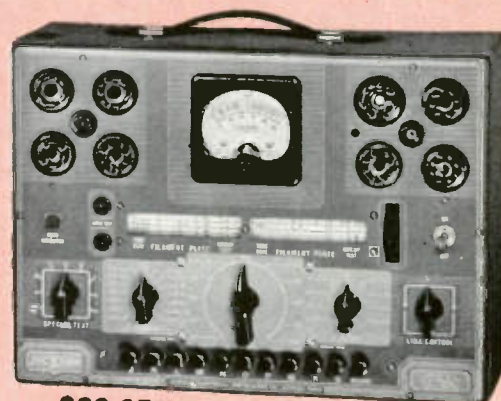

**\$29.95 net**

Bench style Tube Tester No. 636-B. Built-in roll chart. Weight 10 lbs. \$29.95 net.

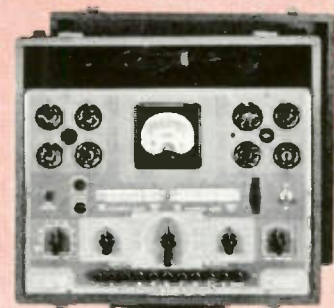

Portable Style Tube Tester No. 636. Strong leatherette case. Roll chart. \$34.95

Model 666 Signal Analyzer. Simple to use. Makes all signal tests. \$79.50

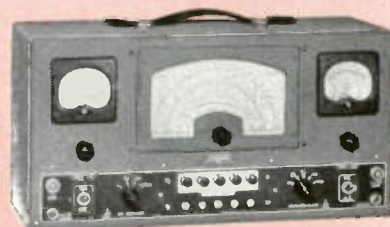

**FREE!**

"Learn The Truth about Dynamic Tube Testers" is an informative booklet that you'll want. Write for it today.



Leading Distributors Sell Jackson Instruments

**THE JACKSON ELECTRICAL INSTRUMENT CO., Dayton, Ohio**

# The CENTRALAB Family

## of VOLUME CONTROLS

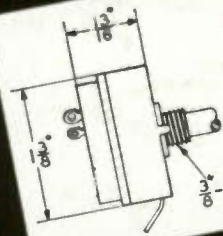

### STANDARD

Long famous for the reliability of Centralab's non-rubbing contact and long wall type resistor. Available plain, or with one, two, or three taps, and with SPST, DPST, or SPDT Underwriters Approved switches.

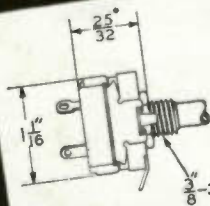

### MIDGET

Small in size, but large control efficiency due to the long straight path of the wall type resistor. Fits well in crowded chassis as solder lugs do not project far beyond the control radius of 17/32". Available single, dual, or triple, plain, or tapped, with SPST, SPDT, DPST, and a special dial lite push switch for battery sets.

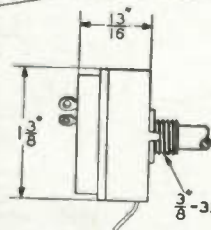

### WIRE WOUND RADIOHM

Identical in size and appearance with the Standard Radiohm except has brown colored base. Resistances range from 2 ohms to 10,000 ohms. Rating 3 watts. Furnished plain or with SPST, SPDT, or DPST Underwriters Approved switches.

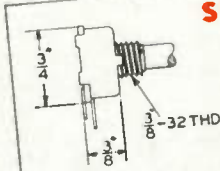

### SUB-MIDGET

The smallest diameter reliable control. Long wall type resistor gives low noise level. Rapid Transfer of heat from resistor to metal shell gives maximum load rating of 1 1/2 watts. No switch or taps. Available as grounded or insulated rheostat or potentiometer with solid or tubular shaft.

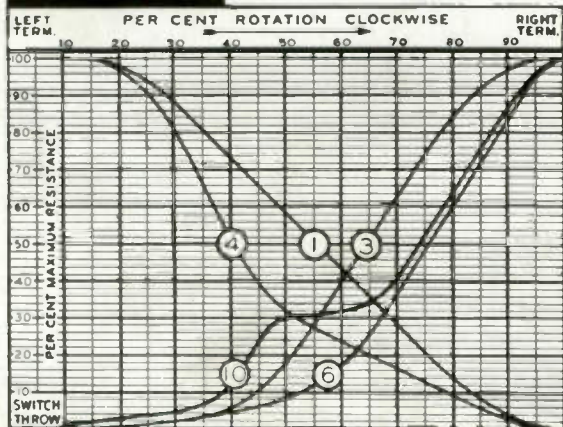

The resistor curve of a volume control is more important than its overall resistance... that is why Centralab controls are furnished with the variety of curves shown here. Curve six is most widely used for high resistance radio grid and diode controls. Curve 1, or 4, are best for C bias, and Curve 3 for antenna C bias. Curve 10 is used on tapped controls.

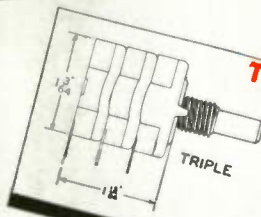

### TWIN AND TRIPLE CONTROLS

Two or three sections assembled in tandem for special purposes. Each section fully shielded and has independent connections. All variable contacts attached to a single shaft. Twin controls also available with concentric shafts; one inside the other. Supplied with or without Underwriters Approval snap switches.

# Centralab

CENTRALAB • 900 E. KEEFE AVE • MILWAUKEE, WISCONSIN  
A Division of GLOBE-UNION INC. Cable Address: Centralab Milwaukee





