

*Radio*  
**SERVICE  
DEALER**

DECEMBER, 1949



**IN THIS ISSUE:**

Servicing Sound I-F Stages in TV and FM Receivers

Modern Electronic VOM

TV Truck Solves Installation Problems

Servicing Photo-Electric Equipment, Part 2

**AM-FM-TV-SOUND**

*The Professional Radioman's Magazine*

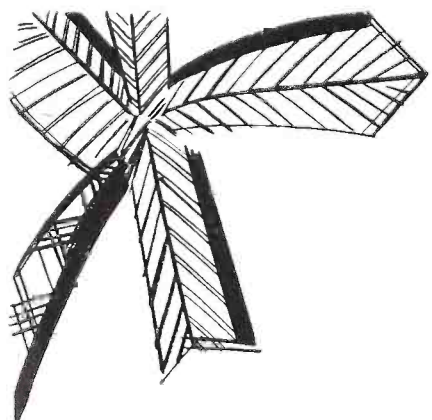

Discover a New  
and Richer Market  
with...

## The Mallory Midgetrol

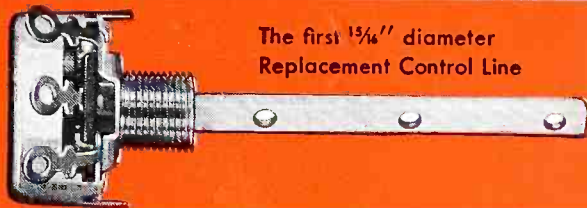

The first  $\frac{15}{16}$ " diameter  
Replacement Control Line

How much business did you let slip through your fingers last year? Good business! Big business! All because you couldn't get controls small enough to service personals, portables and auto radios!

This year, discover how profitable these jobs can be. Stock up on the  $\frac{15}{16}$ " Mallory Midgetrol and discover more business with a lower inventory!

**WIDER APPLICATION**—The small size lets you service portables, auto radios and small AC-DC receivers requiring  $\frac{15}{16}$ " controls.

**SIMPLER INSTALLATION**—The new and unique flat shaft design of the Mallory Midgetrol saves installation time with *all* types of knobs.

**LESS INVENTORY**—Electrical characteristics allow you to use the Mallory Midgetrol to replace  $1\frac{1}{8}$ " as well as  $\frac{15}{16}$ " controls. Since no special shafts are required, you carry fewer controls in stock.

### NEW FEATURES—NEW FEATURES!

NEW SIZE	NEW SHAFT	NEW SWITCH	NEW CONTACT
NEW DESIGN	NEW EXTENSION	NEW ELEMENT	NEW TERMINAL
	NEW TWO-POINT SUSPENSION		

*Don't Miss the Mallory Television Service Encyclopedia.  
Get Your Copy From Your Mallory Distributor . . . Only 35c!*

**P. R. MALLORY & CO., Inc.**  
**MALLORY**

CAPACITORS . . . CONTROLS . . . VIBRATORS . . .  
SWITCHES . . . RESISTORS . . . RECTIFIERS  
VIBRAPACK\* POWER SUPPLIES . . . FILTERS

\*Reg. U. S. Pat. Off.

**APPROVED PRECISION PRODUCTS**

**P. R. MALLORY & CO., Inc., INDIANAPOLIS 6, INDIANA**

# Television Arithmetic

*\$200 Television Set + \$5 Antenna = \$5 Picture*

*\$200 Television Set + \$25 Antenna = \$225 Picture*

Yes...it's as simple and basic as that. Just like 2 plus 2 equals 4. Let all of us square up our thinking and recognize OPENLY that in a great, great majority of cases, the television buyer can get the full value from his set ONLY with a good outdoor antenna properly installed.

Certainly, there is great value for the indoor antenna. We make them ourselves, and good ones, too, BUT...

We'll be the first to admit that the best indoor antenna cannot compare with even the poorest outdoor antenna for picture quality. In certain "ideal" conditions, an indoor antenna will perform satisfactorily, BUT...

Let us not abuse this "condition" by recommending indoor or "built-in" antennas where they will not give the customer his full dollar's worth. It is up to the Television Industry to see that the American Public gets its money's worth in television and that means simply... A GOOD OUTDOOR ANTENNA SHOULD BE INSTALLED WHEREVER POSSIBLE.

The indoor antenna is a good short cut to quick consumer sales, BUT DOES NOT GIVE THE CUSTOMER THE PICTURE HE IS PAYING FOR! This is the truth about television antennas... as related to picture quality. Tell it to your customers, let them decide for themselves.

**THE MAKERS OF THE COMPLETE LINE OF GOOD TELEVISION ANTENNAS  
THAT MAKE GOOD TV SETS EVEN BETTER!**



**THE RADIART CORPORATION • CLEVELAND 2, OHIO**

*Reprints of this advertisement  
available upon request.*

# TWO STANDOUTS from the OUTSTANDING LINE

## CHANNEL MASTER'S FAN-FLECTOR

This sensational new preassembled antenna, the Fan-Flector, a development of Channel Master's research laboratories, is the most sensitive all-channel antenna developed to date.

No high band attachments.  
No multiple lead in wires.  
No wasted assembly time.  
Dealer after dealer has made his most difficult fringe installations stick with the Fan-Flector, America's fastest selling antenna.

**OVER 100,000  
SOLD IN 3 MONTHS**

		List
BM312	Fan-Flector	13.75
BM312X2	Stacked Fan-Flector	29.30
BM312X4	Double Stacked Fan-Flector	63.25

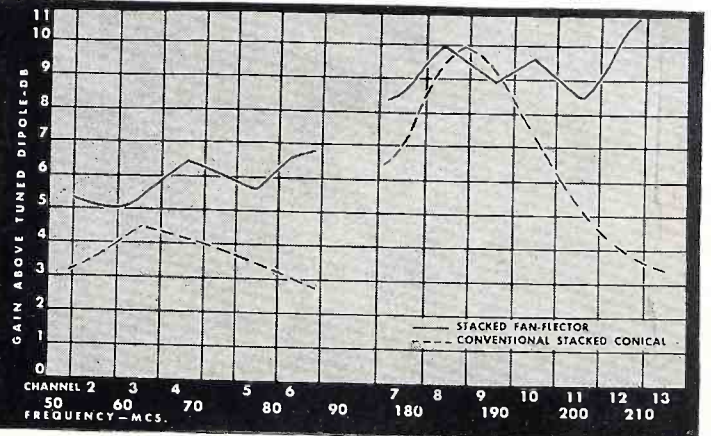
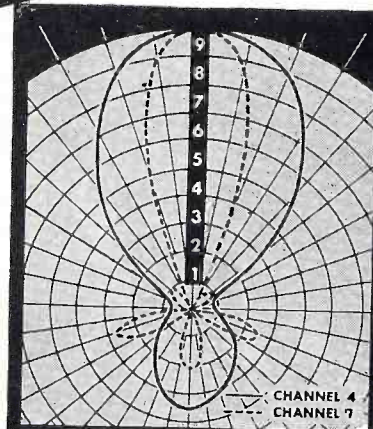

### HORIZONTAL POLAR DIAGRAMS

Low band front-to-back ratios between 3 and 4 to 1. Lobe width decreases on high band for ghost-free reception. Vee-Beam engineering minimizes side lobes.

### GAIN CURVES

"Most popular" conventional stacked conical antenna (broken lines) compared to the stacked Fan-Flector (solid lines).

TO: CHANNEL MASTER CORP., ELLENVILLE, N. Y.

DEPT. D-12

Please send me:

- Name of nearest Channel Master Distributor
- Technical data and literature

YOUR NAME.....  
COMPANY NAME.....  
ADDRESS.....  
CITY..... STATE.....

# CHANNEL MASTER'S H I D E A W A Y

*Combines*  
**THE DISAPPEARANCE  
OF A BUILT-IN ANTENNA**  
*with*  
**THE PERFORMANCE OF  
AN OUT-DOOR ANTENNA**

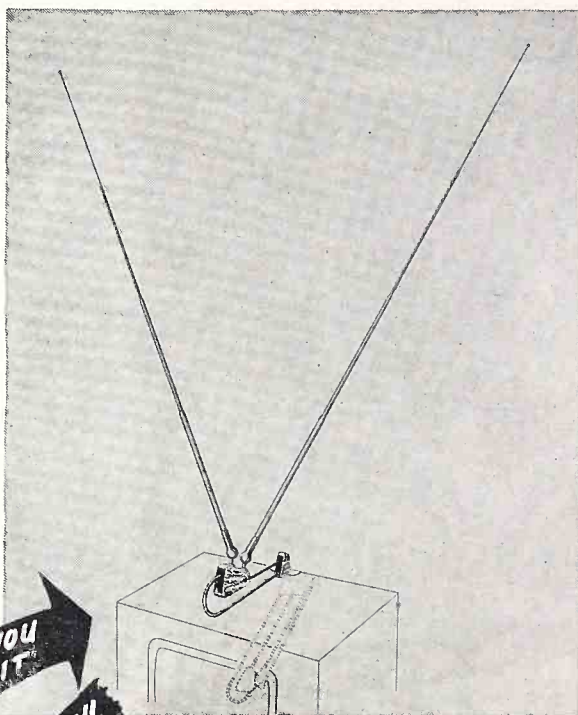

**NOW YOU  
SEE IT**

**NOW YOU  
DON'T**

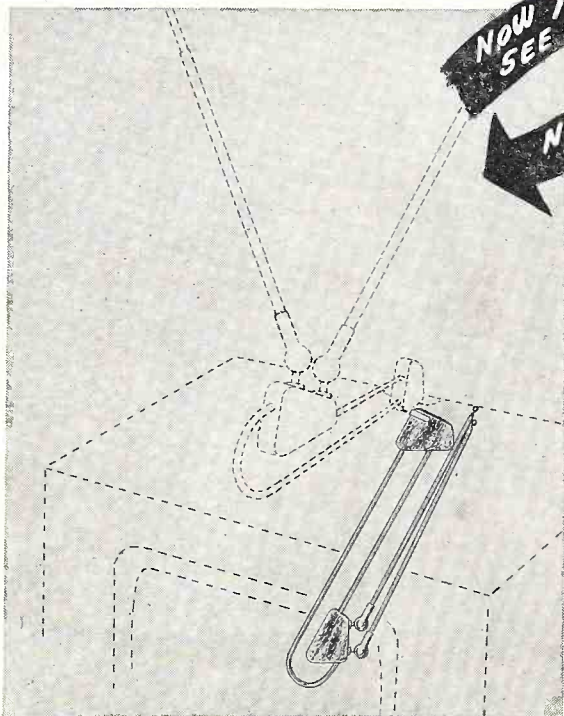

Channel Master's exclusive Multiflex Action\* enables this antenna to be hidden away behind the set when not in use. The elements can be arranged to form a horizontal Vee for any channel in any direction thus increasing the gain.

The hand rubbed hardwood surfaces, nickel plated metal components and smart design makes the Hideaway the most attractive indoor antenna on the market today.

**LIST 975**

available in blond,  
mahogany and  
walnut

\*Pat. Pend.



**F I R S T I N P R E A S S E M B L E D A N T E N N A S**

# EDITORIAL

by S. R. COWAN

## Beware of Bargains

The December issue of McCall's *Redbook* has an article "How Cheap Can It Get" that teaches a worthwhile lesson. Too many of us try to buy things because a friend can "get it wholesale" or we patronize "discount" houses that seem to offer better values than regular supply channels.

Genuine bargains are seldom, if ever, offered by discount houses. There's a big difference between what seems to be a bargain and a genuine one. Take radio tubes and parts for example. Common-sense should forewarn us that the so-called "bargains" being offered through advertising in the newstand type radio magazines cannot be, in most cases, all that is claimed for them. There never was a truer adage than that oldy "Cheap is Cheap." If you want to play safe (and good businessmen always try to do so), stick to standard, nationally advertised brands obtained from your regular legitimate supply house. All standard merchandise whether it be tubes, replacement parts, accessories or test equipment, has manufacturer's warranty, conformity to specifications and dependability. Experience will prove standard merchandise to be better buys than "bargains."

## Business Trends

Business conditions and earnings in the radio-TV field are, according to latest indices, holding steadily on a slightly upward plane. Dumping has dropped to almost zero; price-cutting amongst retailers is less rampant; service-fees are quickly stabilizing at profitable levels. The confusion caused by different speed phono record makers has passed further into the background and now people are buying or are having repaired in ever-increasing quantities radios and record players and player attachments. It appears as though 1950 will be a good year, better than 1948 or 1949, and both were pretty good, don't you agree? And now, before I forget, "Happy Holiday and a Prosperous New Year" to you all.

## Looking Ahead

The Federal Communications Committee hearings on UHF and color TV are still in progress. The general consensus of those who are "in the know" is that because the subject is so complex FCC will hold to a conservative status quo position for many months.

Full details regarding New York and Pennsylvania's two-state Preventive Radio Maintenance Month Campaign, held in October, are still too meager to warrant reporting, other than that radio servicing business and earnings in the two states were well ahead of normal. In fact, the campaign was successful enough to justify immediate planning for another on a national basis for 1950. To get the ball rolling in this regard it seems advisable for all independent service firms to arrange immediately for closer tie-ups with servicemen's associations. Stated another way, if you are not already a member of some radioman's association, join one pronto.



Sanford R. Cowan  
EDITOR & PUBLISHER

Samuel L. Marshall  
MANAGING EDITOR

COWAN PUBLISHING Corp.  
342 MADISON AVENUE  
NEW YORK 17, N. Y.

Vol. 10, No. 12

DECEMBER, 1949

Editorial .....	4
Trade Flashes .....	6
Servicing Sound I-F Stages in TV and F-M Receivers, by Matthew Mandl .....	11
A description of various types of sound i-f stages and servicing techniques.	
Modern Electronic VOM, by Allan Lytel .....	13
A popular electronic vom is explained together with its applications.	
Servicing Photo-Electric Equipment, Part 2, by William R. Wellman .....	15
Concluding installment of this article. Servicing information and adjustments are presented.	
TV Truck Solves Installation Problems, by I. Shyke .....	17
An interesting example of how a dealer exploited a good idea with an attractive truck.	
Circuit Court .....	18
Philco Model 49-1606, Masco Model MA 25HF	
Shop Notes .....	19
Cleaning condensers. Westinghouse Model H-217- ground connection to Aquadag. Repair loosened radio tubes. Utility heater. Bendix a-c/d-c chassis tube failures. Admiral 49C8-2 tuners—frequency drift. Motorola VT 71 repair. G. E.—exchanging stylus. Admiral Model 30—interference. Tube-base connectors. Delco a-c/d-c portables—hum.	
New Products .....	20
Association News .....	22

SANFORD L. CAHN  
National Advertising Sales Manager

HARRY N. REIZES  
Advertising Manager

JEAN M. WHEELER, Circulation Manager      DAVID SALTMAN, Production Manager  
BRANCH: J. C. GALLOWAY 816 W. 5th St., Los Angeles 13, Calif., Mutual 8335

RADIO SERVICE DEALER is published monthly by Cowan Publishing Corp., 342 Madison Ave., N. Y. 17, N. Y. Subscription price: \$2 per year in the United States, U.S. Possessions & Canada; elsewhere \$3. Single copies: 25c. Entered as second class matter Dec. 18, 1948 at the Post Office at New York, N. Y. under the Act of Mar. 3, 1879. Copyright 1949 by Cowan Pub. Corp.

# "NO BETTER TUBES SOLD THAN KEN-RAD TUBES —SALES PROVE IT!"

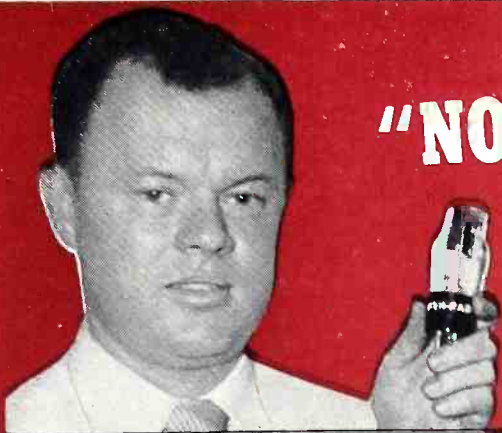

O. B. CONLEY and H. T. CONLEY, Conley Radio and Electrical Shop, Corinth, Miss., like thousands of servicemen, have increased turnover, boosted profit by pushing high-quality Ken-Rad Tubes.



"Ken-Rad Tubes have been a steady seller for us ever since we started in business.

"Now, I don't pretend to be a merchandising expert—but when an item satisfies customers and brings them back for more, year after year, the reason is simple.

"It's quality. Quality and value that stand out.

"Ken-Rad Tubes sell fast, stay sold because you can't beat them on either count."

# "NO BETTER TUBES MADE THAN KEN-RAD TUBES —TESTS PROVE IT!"



ROBERT E. MOE, Division Engineer, Ken-Rad plants, is one of many experts who help direct the testing of Ken-Rad Tubes. Besides noise and microphonics, these quality tubes are checked for static characteristics, life, shorts, appearance, gas, air and hum.

"I help make Ken-Rad Tubes. And I know—there are no better tubes made!

"Ken-Rad Tubes have to prove their quality over and over again at every stage of production.

"On the right, a Ken-Rad Tube is receiving the microphonic and noise check, with the aid of an amplifier having a known response and a specified gain. The tube is tapped by a motor-driven tapper, and the resulting audio output is checked on a standard VU meter.

"This is only one of the numerous quality tests Ken-Rad Tubes must pass before being shipped to you.

"Good? They've got to be good!"



## KEN-RAD *Radio Tubes*

PRODUCT OF GENERAL ELECTRIC COMPANY

Schenectady 5, New York

THE SERVICEMAN'S TUBE  
... backed by profit-making sales aids which your Ken-Rad distributor will be glad to show you. Phone or write him today!



# For YOU! from SPRAGUE

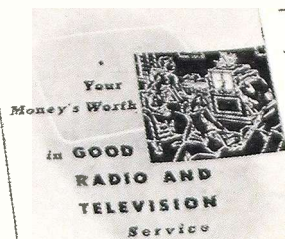

**New Booklet to  
BUILD BETTER  
SERVICE BUSINESS**

- Gives customers a new appreciation of your service facilities
- Helps you avoid "cut-throat" price competition

"Your Money's Worth in Good Radio and Television Service" is the title of this new 16-page booklet now made available by the makers of Sprague Capacitors and Koolohm Resistors for distribution to your service customers and prospects *under your own name!*

Profusely illustrated, finely lithographed in two colors, the booklet will help you win customers, justify fair service prices and meet "cut throat" competition that is springing up on all sides. It tells set owners about the complexities of today's radio and television equipment and about the extensive service facilities needed to keep receivers in first class working order.

In short, it is a book designed to win confidence for you by showing customers how complicated the work really is and by proving to them exactly how and why good service work commands a fair price.

**Write for  
FREE  
SAMPLE**

Dept. RSD-129, Sprague Products Co.  
North Adams, Mass.

Please rush free sample of the new booklet "Your Money's Worth in Good Radio and Television Service" and tell me how I can obtain additional copies for distribution to my service customers.

Name \_\_\_\_\_

Address \_\_\_\_\_

City, Zone, State \_\_\_\_\_

# TRADE FLASHES

A "press-time" digest of production, distribution & merchandising activities

## TV Shipments

Washington, Nov. 25—RMA member-companies reported shipments of 503,352 television receivers to 49 cities and a few unspecified areas during the third quarter of 1949, the Radio Manufacturers Association reported recently. At the beginning of October 2,209,724 television receivers had been shipped to these same areas.

## Sylvania Promotes Servicemen— Public Goodwill

Sylvania Electric Products, Inc., radio division, will continue to promote radio and television servicemen during 1950 in a new series of national ads in the Saturday Evening Post, Life, Look, Collier's, and Radio & Television Best, scheduled to start in January.

Sylvania will supplement the ads with a cooperative campaign kit for servicemen and dealers which includes four-color window posters based on the monthly ad, two-color streamers, three-color postal cards, free mats for local newspaper advertising, and radio spot announcements.

## RCA Multiple Outlet TV Antenna System

RCA announced recently the signing of three separate contracts for the installation of multiple outlet TV antenna systems in three large New York apartment projects, with an aggregate of 1,000 apartment units. The contracts for the RCA Television Antenaplex Systems were placed with the Commercial Radio Sound Corp., RCA's sound products representative in the New York Area.

## New Needle Package

Duotone Company, Inc., 799 B'way, N. Y. 3, N. Y., announces the availability of replacement needles for most of the popular cartridges. Introduction of this new addition to the Duotone Line is being made through a special Service-Aid-Kit which contains on each of fourteen (14) different types of needles enclosed in a metal storage case.

## Rider Receives Educational Award

John F. Rider, president of the publishing company bearing his name, was the recipient of an award tendered by the Empire State Federation of Electronic Technicians Associations. Samuel L. Marshall, Education Direc-

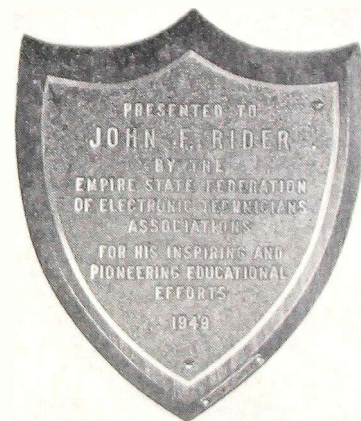

tor and Managing Editor of Radio Service Dealer, made the presentation on November 12, 1949, at the Radio Technicians' Guild of Rochester, N.Y., banquet held at Locust Lawn, Ionia, New York.

## Aerovox Acquires Elec. Reactance Co.

The purchase of the entire outstanding stock of Electrical Reactance Company by Aerovox Corporation of New Bedford, Mass., is announced by W. Myron Owen, Aerovox president.

## Town Meetings Progress

Progress in education of radio and television technicians has been advanced five year by "Town Meetings" of Radio Technicians, R. C. Sprague, chairman of the Radio Manufacturers Association's "Town Meetings" Committee, told a Washington "Town Meeting" recently in the U. S. Chamber of Commerce.

The Washington "Town Meeting," the seventh to be held in two years, was sponsored jointly by RMA and the Washington Electric Institute with the cooperation of local set and



**5000 SERVICEMEN  
HAVE PROFITED FROM  
SYLVANIA'S DEALER  
ADVERTISING CAMPAIGNS**

# ... and YOU can do the same by ACTING NOW!

Another of Sylvania's famous profit-building campaigns is getting under way! The campaign runs through the months of January, February, March and April—with half-page ads like this in LIFE, THE SATURDAY EVENING POST, LOOK, COLLIER'S, and RADIO AND TELEVISION BEST. The ads tell your customers and prospects to come to you for radio and television service.

But that's just the start! THEN . . . you tie in with this national advertising by using Sylvania's complete kit of display and direct mail material—all built around the ads—designed for you—and ready for you now!

Sylvania's previous campaigns paid off in a big way for thousands of dealers and servicemen. Be ready to cash in on this latest big push!

## HERE'S WHAT YOU GET IN THE SYLVANIA KIT:



LOOK FOR THIS  
SIGN OF DEPENDABLE  
RADIO SERVICE

Does your radio give out with squeals and grunts? Then call the serviceman who displays the Sylvania sign. Because your radio needs expert care, the kind this fellow is trained to give. He has Sylvania test equipment to root out trouble spots . . . high-quality Sylvania radio tubes to bring you the crystal-clear reception you want. Hear your old set perform as it did the day you bought it. Get it fixed at the Sylvania sign of dependable service.

**SYLVANIA  
RADIO TUBES**  
PRODUCT OF SYLVANIA ELECTRIC PRODUCTS INC.



**DECALS.** You get as many Decals as you need—in 8 or 12 inch diameter. Your choice of wording—RADIO SERVICE or RADIO TELEVISION SERVICE. Sylvania's ads make these Decals nationally known—cash in on their familiarity!



**1 POST CARDS.** You get 4 sets of Postal Card Mailings—one for each month in the campaign. They're in 3 colors—imprinted with your name and address! You pay *only* the government postage on each card—that's *all* you pay for the entire kit! **EVERYTHING ELSE IS FREE.**



**3 AD MATS.** You get 4 Newspaper Ad Mats—two sizes for each 2-month period. Sizes are one and two columns wide, 7 inches deep. Easy way to tie your local newspaper advertising in with Sylvania's national ads!



**5 RADIO SPOT ANNOUNCEMENTS.** You get 4 booklets of Radio Spot Announcements—one for each of the 4 months in the campaign. When you've planned your schedule, just hand the spots to your local radio station—they're all ready to use!



**2 WINDOW DISPLAYS.** You get 2 Window Displays—featuring the same illustrations as the Sylvania national ads. 3-dimensional—4 colors—2 by 3 feet. 2 **COUNTER CARDS**, too, 12 by 18 inches.



**4 STREAMERS.** You get 2 Window Streamers—in 2 colors—11 by 26 inches. Like the other items in the campaign, Streamers feature *both* radio *and* television service.

Mail coupon today for full details on the complete campaign!

Sylvania Electric Products Inc.  
Advertising Dept. R-1812, Emporium, Pa.

Please send full details of your new 1950 January, February, March and April Service Dealer Campaigns.

NAME .....

COMPANY .....

ADDRESS .....

CITY ..... ZONE ..... STATE .....

# SYLVANIA ELECTRIC

RADIO TUBES; CATHODE RAY TUBES; ELECTRONIC DEVICES; FLUORESCENT LAMPS, FIXTURES, WIRING DEVICES, SIGN TUBING; LIGHT BULBS; PHOTOLAMPS  
RADIO SERVICE DEALER • DECEMBER, 1949

**RCA 195-A  
STANDARD VOLTOHMYST\***

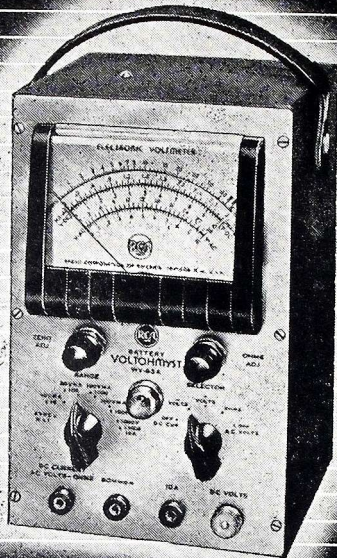
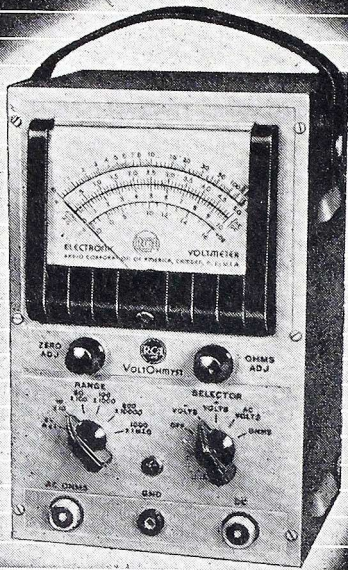

**RCA WV-65A  
BATTERY VOLTOHMYST\***

*One for the shop... One for the field...*  
**means more business for you**

**RCA 195-A STANDARD VOLTOHMYST\***

*AC-Powered for the Shop*

TV, FM, AM, and PA service require the modern features designed into the RCA 195-A Standard VoltOhmyst.

The 195-A measures dc and RMS ac voltages up to 1000 volts, resistance values from 0.1 ohm to 1000 megohms, and decibel values (db, vu, or dbm) from -20 to +52.

Its dc input resistance is 10 megohms on all ranges. Zero-center indication is available for FM work. The ac input resistance is 200,000 ohms.

An isolating resistor in the dc probe permits dc voltages to be measured without disturbance of high-impedance high-frequency ac circuits.

When the 195-A is used with the accessory RCA Crystal Probe WG-263, rf voltages can be measured up to 100 Mc. With accessory RCA High-Voltage Probe WG-288, dc voltage can be measured up to 30,000 volts.

An electronic bridge circuit protects the meter movement against burnout.

See your RCA distributor for further details about these famous electronic meters, or write RCA, Commercial Engineering, Section 55LX, Harrison, N. J.

**See Your RCA Distributor For Test Equipment You Can Trust**



**RADIO CORPORATION of AMERICA**

TEST AND MEASURING EQUIPMENT

HARRISON, N. J.

**RCA WV-65A BATTERY VOLTOHMYST\***

*Self-Powered for the Field*

Here is a portable electronic meter which measures dc and RMS ac voltages up to 1000 volts, dc current from 0.3 ma to 10 amps, and resistance values from 0.1 ohm to 1000 megohms.

The self-contained battery power supply lasts up to 10 months in normal service.

The WV-65A is supplied with an isolating resistor in the dc probe, and can be used with accessory RCA Crystal Probe WG-263, or with accessory RCA High-Voltage Probe WG-284.

The dc input resistance is 11 megohms on all ranges. This instrument will measure avc voltages, detect leaky coupling capacitors, and can be used to trace sync and deflection voltages in TV receivers.

At the sensational price of \$59.50, the RCA WV-65A is your best buy for service of two-way car radios, farm sets, marine, airplane, railway, bus, and theatre sound equipment.

\*Trade Mark "VoltOhmyst" Reg. U. S. Pat. Office

parts distributors. Each of the three night sessions—Tuesday through Thursday—was attended by 800 or more service technicians—the largest such assembly ever held in the nation's capital.

**Astatic Reaches Public Direct**

Another company might have known what to expect, but Astatic was taken completely by surprise when letters started recently to pour in from the public, from all sections of the country. Reason for the sudden friendly attitude from "just plain folks" is Astatic's introduction of its Channel Chief, Model AT-1 Television Booster—a product that not only marks Astatic's first entry in the Television field, but the first Astatic product of general application to hit the market with the company name in plain sight, visible to the user at all times.

**Oxford Appoints Jobbers**

Oxford Electric Corporation, 3911 So. Michigan Avenue, Chicago, Ill., manufacturers of the well known Oxford Speakers, have announced their entry into the jobber speaker replacement field. A complete packaged line of P.M. and E.M. speakers will be available to the Jobber Trade on or about January 1, 1950.

**RCA Pict-o-Guide No. 2**

A second volume of the RCA Television Pict-O-Guide, containing trouble-shooting photographs which enable the serviceman to locate television-receiver troubles by the "picture analysis" method, has been announced by the RCA Tube Department.

**G. E. Shows Lab Equipment**

General Electric's full line of laboratory equipment, including power supplies, oscilloscopes, sweep and marker generators and tube analyzers was displayed and demonstrated recently at Sun Radio and Electronics, Inc., or New York City, for a full week.

**Philco TV Jigs**

Consistent reliable alignment of TV sets requires the use of alignment jigs. A group of alignment jigs has been designed for Philco television receivers, to be used with practically any make of test equipment, which permit the serviceman to do a much better and faster job, thus reducing call-backs which usually result in considerable customer dissatisfaction and a loss of profit to the serviceman.

**Rider TV 3 Available**

John F. Rider Publisher, Inc., 480 Canal Street, New York 13, N. Y., announces the availability of the new TV Manual Volume 3 at all Rider distributors. Also announced as available for Jan. 1950, is Manual No. 20.

# Service Dealers

## Form A Group,

## Subscribe to "RSD"—

## SAVE Up to \$1.00 each.

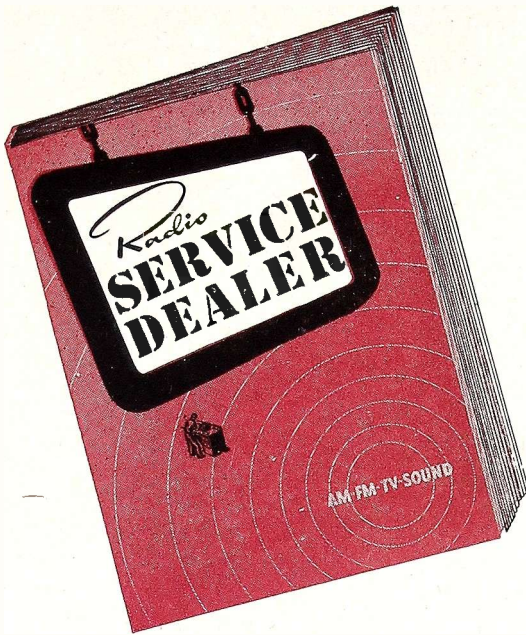

"The Professional Radioman's Magazine"—published monthly. All articles are exclusive and timely. Practically every issue is worth what an entire 1 year subscription costs.

★ The more in a group the bigger the savings. 6 men in a group save \$1.00 each; 4 men groups save \$ .75 per man. Present "RSD" subscribers may participate in or form a group with co-workers, or even competitors. Still active subscriptions are automatically extended 1 year. Start a Group today! The timely and exclusive technical data appearing in future issues of "RSD" will make this the best investment you ever made. The special Group Rate offer may be withdrawn at any time—so hurry.

### Use This Coupon For Convenience

(The coupon below can be used for from 1 to 6 subscription orders. Use it today!)



**TEAR OUT — MAIL TODAY!**

RADIO SERVICE-DEALER MAGAZINE  
342 Madison Ave., New York 17, N. Y.

Please enter 1 year subscription orders for the names given below. Our remittance is enclosed.

NOTE: If you do not wish to tear this order blank out, just print or type the information on a single sheet of paper, following the style given. Each subscriber's occupation must be clearly described.

Name.....  
Address.....

Describe Title or Position and Type of Business.....

State whether a New Subscriber  or Renewal Order

Name.....  
Address.....

Describe Title or Position and Type of Business.....

State whether a New Subscriber  or Renewal Order

Name.....  
Address.....

Describe Title or Position and Type of Business.....

State whether a New Subscriber  or Renewal Order

	In U.S.A. & Canada	Foreign Rates
<input type="checkbox"/> One 1-year subscription	\$2.00	\$3.00
<input type="checkbox"/> Two 1-year subscriptions, each	1.75	2.75
<input type="checkbox"/> Three 1-year subscriptions, "	1.50	2.50
<input type="checkbox"/> Four 1-year subscriptions, "	1.25	2.25
<input type="checkbox"/> Five 1-year subscriptions, "	1.10	2.00
<input type="checkbox"/> Six 1-year subscriptions, "	1.00	1.50

Name.....  
Address.....

Describe Title or Position and Type of Business.....

State whether a New Subscriber  or Renewal Order

Name.....  
Address.....

Describe Title or Position and Type of Business.....

State whether a New Subscriber  or Renewal Order

Name.....  
Address.....

Describe Title or Position and Type of Business.....

State whether a New Subscriber  or Renewal Order

**"TV+FM+AM... We're making sure that we get all of this business..."**

**"We don't propose to let even one customer walk out of our place. If it's a TV, AM or FM set that needs servicing, we're making sure that we can handle the job satisfactorily. And one way of making sure is by constantly using our reference library of Rider Manuals."**

**—Says Mr. I. Zwickel  
Signal Radio Hospital  
Brooklyn, New York**



**For Greater Efficiency... For More Information... For More Value For Your Money**  
Place Your Order Now for the **NEW RIDER TV MANUAL vol. 3**  
**Larger Page Size! 12" x 15"! All Pages in Place! Easier to Use!**

**Order Now From Your Jobber**  
**New RIDER MANUAL**  
**vol. XX**

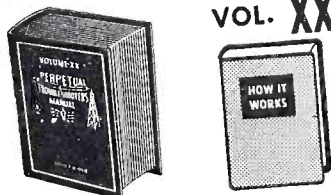

**New Material! More Material!**  
**New Profit-Possibilities!**

Reliable, authentic, factory-authorized servicing information covering the latest AM, FM radio, Auto Receivers, Record Changers, etc. . . . Complete in every respect, but with the added advantage of text and double spreads assembled in position.

**FREE! Eye-Stoppers For Service Shop Windows**

A very clever Rider Display Idea, 14 x 17 inches, captioned "Which One Is The Phony?". It shows two greatly enlarged photos of postage stamps, one genuine, one a known counterfeit, with identifying characteristics and means of recognizing the forgery. This Display is a real traffic-stopper, and will help build more business for you. 2 Displays are issued each month, and you can get them **FREE OF CHARGE** from your Jobber.

**NOTE: Are you receiving your copy of "Successful Servicing"? It's Rider's own publication of interest to every Serviceman. Write for it... It's FREE!**

Here is accurate, authentic, reliable servicing information direct from 74 TV receiver manufacturers. New, enlarged page size, 12 x 15 inches, with all pages filed in position. Giant pages have been retained...but now have only one fold for greater convenience and durability. There's more ease in using, too, because there are fewer pages to turn and because diagrams and related text are more closely positioned. Order now from your jobber.

Equivalent of Approximately 2032 Pages (8½ x 11"), Plus Cumulative Index Volumes 1, 2 and 3, Plus the Famous "How It Works" Book

**\$21<sup>00</sup>**  
Complete

**RIDER MANUALS**

- Television Manual Volume 3 (Plus "How It Works" Book and Index).....\$21.00
- Television Manual Volume 2 (Plus "How It Works" Book and Index).....\$18.00
- Television Manual Volume 1 (Plus "How It Works" Book and Index).....\$18.00
- Volume XIX.....\$19.80
- Volume XVIII.....\$19.80
- Volume XVII.....\$18.50
- Volume XVI.....\$ 8.40
- Volume XV.....\$19.80
- Volume XIV to VII (each volume).....\$16.50
- Volume VI.....\$12.50
- Abridged Manuals I to V (one volume).....\$19.80
- Record Changers and Recorders.....\$ 9.00
- Master Index, Covering Manuals, Vols. I to XV.....\$ 1.50
- PA Equipment Manual, Vol. I.....\$18.00

**FM TRANSMISSION and RECEPTION**

by John F. Rider and Seymour D. Usian

A "must" book for the radio serviceman who looks to FM and television as an important part of his future earnings. Covers all types of frequency modulation systems employed in TV, radio, amateur radio, railroad, aviation, marine, police, point-to-point and mobile receivers. 416 pages, profusely illustrated. **\$3<sup>60</sup>**

**TV PICTURE PROJECTION and ENLARGEMENT**

by Allan Lytel

Timely... Complete... Authoritative and well-organized explanation of the fundamentals of light, optics and optical systems as employed in home television receivers, with emphasis on projection types and front lens enlargements. 192 pages; 119 illustrations, **\$3<sup>30</sup>**

**BUSINESS HELPER**

by Leslie C. Rucker (Rucker Radio Wholesalers)

Written by a successful business man who started from scratch and worked his way up to a chain of 3 stores. Any one of his many worthwhile ideas can mean fifty times the cost of this book in your pocket. 144 pages; 22 chapters. **\$2<sup>00</sup>**

JOHN F. RIDER PUBLISHER, Inc., 480 Canal Street, New York 13, N. Y. • Export Agent: Rocke International Corp., 13 E. 40th St., N.Y.C., Cable, ARLAB.

**RIDER MANUALS mean SUCCESSFUL SERVICING**

NOTE: The Mallory TV Service Encyclopedia, 1st TV Edition, makes reference to only one source of TV receiver schematics—Rider TV Manuals.

NOTE: The Mallory Radio Service Encyclopedia, 6th Edition, makes reference to only one source of radio receiver schematics—Rider Manuals.

NOTE: The C-D Capacitor Manual for Radio Servicing, 1948 Edition No. 4, makes reference to only one source of receiver schematics—Rider Manuals.

# Servicing SOUND I-F STAGES in TV and FM Receivers

by **MATTHEW MANDL**

*Technical Institute, Temple University*

**I**f great importance in the servicing of television and frequency modulation i-f stages is consideration of loss factors. Failure to observe certain precautions will invariably result in a weak signal—particularly in the higher frequency range of the receiver. This, of course, applies to the r-f, mixer and oscillator stages as well as the i-f stages, for in all high frequency circuits the manufacturer takes numerous precautions to keep losses down. Such losses vary, and include those due to stray capacitance to ground, lead inductance, inter-electrode capacity, insulation losses and skin effect. Coils and capacitors are mounted on forms which are known to have low loss for high frequencies, and such materials include Isolantite, Polyethelene, Lucite, Plexiglass and other high frequency insulators.

Tubes are chosen which have low inter-electrode capacity so that the shunting effect of such capacity will be small. Wiring is kept away from ground and adjacent leads so that the capacity formed between two such sections will not provide a low reactance path for the signal energy. Hook-up wire between parts is kept as short as possible so that it will not act as an inductance for the very high frequencies and thus behave as a choke instead of a conductor. Skin effect, the tendency of high frequency currents to flow on the outside (skin) of the wire, is minimized by using large diameter wire in coils and other conductors of signal energy.

The technician must take the same precautions detailed above when servicing TV and FM receivers so that he will not unknowingly undo the manufacturer's high frequency design construction. When any capacitor, resistor or coil is found defective care must be taken that the leads on such

**Servicing high frequency i-f stages requires an understanding of the behavior of high frequency components and construction. In this article the author deals with practical service problems relating to h-f sound i-f circuits.**

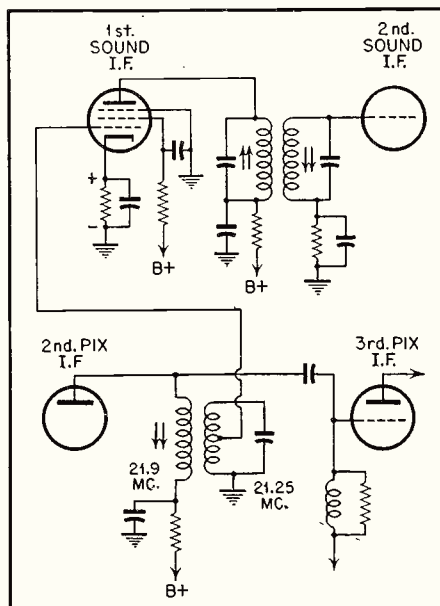

Fig. 1. Sound pick-off in R. C. A. 8T241-8T242 TV receivers.

new units are as short as the ones which were on the original components. Lead dress must also be observed carefully, for bunching wire too closely together during servicing, or running them along the chassis, will contribute seriously to losses and will decrease the receiver gain far below than what it should be.

## I-F Input Methods

In regular FM receivers, the coupling between mixer and i-f stage is conventional, but in the FM (sound) section of television receivers, various

methods will be encountered. One popular method is that shown in *Fig. 1*, used by RCA in their 8T241-8T242, etc. series of receivers. Here, the sound is picked off a transformer arrangement between the 2nd pix i-f stage and the 3rd pix i-f. The circuit is a transformer for the sound only, because the picture i.f. is coupled to the 3rd i-f stage through a series coupling capacitor. The primary of this transformer is resonant to one of several frequencies used for the stagger-tuned picture i-f system. The secondary has two functions—one is to trap the sound out of the picture i-f stages so that it will not put sound bars on the picture tube face—and the other function is to act as a pick-up coil for the sound i-f. (21.25) which is then applied to the grid of the 1st sound i-f stage.

Other receivers, including Emerson, Admiral, DeWald, etc. use a similar system though some take the sound after the 1st picture i.f. instead of the second. When the inter-carrier system is used, sound i-f is procured from the 2nd video detector, and sometimes from the output of the 1st video amplifier. The two signals, video and sound, are mixed in the detector to produce 4.5 mc for the i.f. of the sound stages.

Other variations of input to the sound i.f. will, of course, be encountered, and the receiver schematic should be consulted when in doubt during trouble-shooting. Some use series traps instead of the type trap shown in *Fig. 1*. *Figure 2* indicates

the method employed in Zenith television receivers.

The sound i.f. frequency as produced in the output of the mixer is 21.3 mc for the Zenith models using Chassis 28F20. This signal is coupled to the 1st sound i.f. by utilizing a series tuned trap. As with all series tuned circuits, the impedance is low at the resonant frequency and maximum current flows. This means, of course, that this series circuit will pass a maximum signal current for the frequency to which it is tuned—21.3 mc in this case.

Inasmuch as a series circuit presents a high impedance to frequencies above or below resonance, this series circuit in the Zenith thus traps out the picture frequencies. The small inductance shown in *Fig. 2* between points marked 2 and 5 of *T2* provides common coupling between the *L15* series resonant trap and the sound input coil at the grid.

#### FM I-F Stages

The intermediate frequency stages of an FM receiver or the sound portion of a television set, must have wide band characteristics in order to pass the necessary carrier and side-band components present during modulation. In standard FM each station is allocated a 200 kc bandwidth, of which 75 kc each side of the carrier represents maximum carrier swing. An ideal response curve in the i-f amplifiers would be as pictured at *A* in *Fig. 3*. Here the response curve would have steep, vertical sides, and have a uniform flat top. Such an ideal, however, is virtually impossible to achieve in our receivers and compromise measures must be resorted to. An ordinary response curve, such as at *B* gives good gain, but has too sharp a peak to be generally useful. The curve shown at *C* more nearly approaches the type generally found in typical receivers and this is the compromise referred to.

Over-coupling will broaden the response of an amplifier stage, but will, of course, also reduce gain since the

Q of the circuit if affected. Loading down a tuned circuit with resistance will also lower the Q and increase band-width. The curve shown at *C*, while not flat over the entire 200 kc range, does, nevertheless, give improved gain and better adjacent channel selectivity and represents the band-pass usually encountered.

In the television sound i-f stages, wide bands are again employed, and in this instance a band-pass as large as that in standard FM is used so that the sound i.f. does not drift out of range when the local oscillator drifts. A 50 kc band-pass would normally be adequate, and would bring in all the sound information necessary. Since, however, present-day oscillators of television receivers are prone to drift, the sound i.f. bandpass is made 200

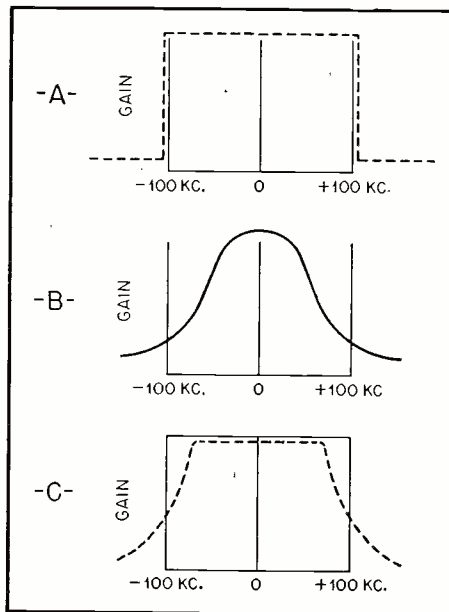

Fig. 3. Ideal, ordinary and preferred i-f response curves.

or more kc wide, so that the 50 kc spread of the FM signal would have sufficient room to drift without loss of sound. Picture drift is not as critical because of the 4 mc band-pass in the picture i.f. stages. A 50 kc drift in the sound would be serious,

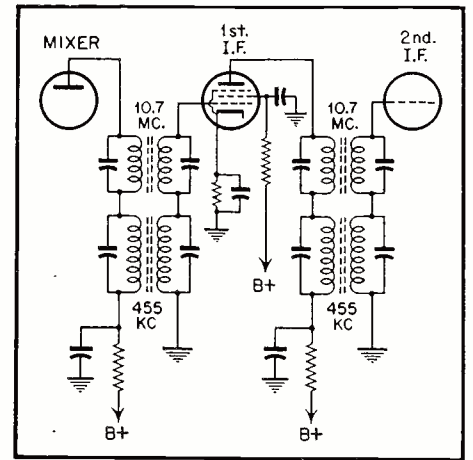

Fig. 4. A typical combination AF and FM i-f arrangement.

while a 50 kc drift in a 4 mc band-pass (4,000 kc) would be relatively small.

#### Double-Tuned I-F Stages

When standard FM (88-108 mc) is used in radio receivers which also incorporate AM, the arrangement as shown in *Fig. 4* is often used. Both the FM coils (10.7 mc) and the AM coils (455 kc) are enclosed in the same i-f shield. Powdered metal core slugs are utilized to tune individually the various transformer primaries and secondaries. Separate coil forms may be used for the FM and AM, or both may be wound on the same form. In either case, the FM coils are so arranged that the leads from them go into the tube terminals first.

When the set is turned on the FM band, and a 10.7 mc i.f. appears in these circuits, it will find a resonant frequency in the top coils shown in the figure. A parallel resonant circuit is present which offers a high impedance and thus develops a large signal voltage for the desired frequency (10.7 mc).

During this time the coils which are tuned to 455 kc are not at resonance, and for this reason present a low impedance to the 10.7 mc frequency present in these circuits. Thus, they appear as a short circuit to the 10.7 mc signal.

During the time the receiver is set for AM, and a 455 kc signal appears in the amplifier circuits, the lower coils are at parallel resonance and present a high impedance to the 455 kc signal. This means, then, that there will appear a large signal voltage across these coils. The 10.7 mc coils, not encountering a resonant frequency, will offer a low impedance and will act as a short circuit to the 455 kc signals. In this fashion each coil is

[Continued on page 30]

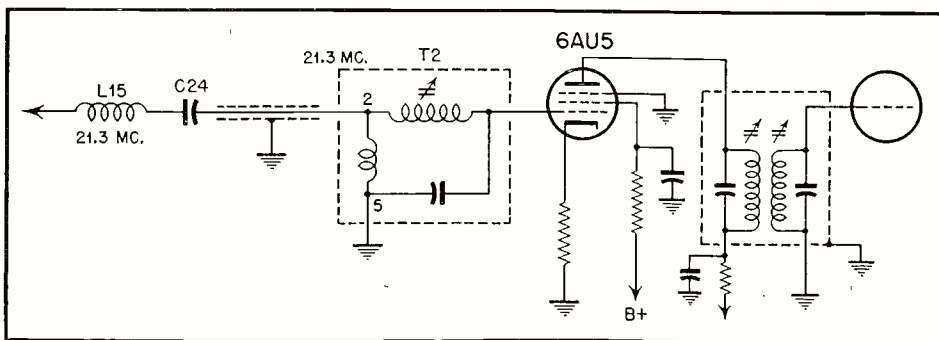

Fig. 2. Sound pick-off in Zenith 28F20 TV receivers.

# MODERN ELECTRONIC VOM

by **ALLAN LYTEL**

*Author of TV Projection and Enlargement*

## Describing the design, operation, and applications of a modern electronic VOM

**V**OLTAGE and resistance measurements play an important part in the servicing technique of any well equipped radio and television repair shop. As far as voltage is concerned, there are many points in television and radio circuits where electronic vacuum tube voltmeters alone can provide reliable readings. One of these points of special interest is the grid leak of an oscillator. The voltage reading measured on the d-c scale obtained across the grid leak resistor is an important indication of the operating condition of an oscillator. However, voltmeters with insufficient input resistance on the voltage scale, can cause a severe enough loading effect to make the oscillator inoperative. Furthermore, it is essential that the measuring instrument place no load, resistive or capacitive, upon the circuit to be measured, otherwise the normal operation of the circuit will be impeded by the measuring device, and an inaccurate reading will be obtained.

The testing of an audio coupling capacitor is an example of where the electronic meter is needed for its extremely high resistance scale. Because the grid resistor used in an audio amplifier stage is usually of a high value, severe distortion will be produced by a leaky coupling capacitor having a shunt resistance of many megohms. Only a high resistance ohmmeter can be used to measure the shunt resistance of this coupling capacitor with any degree of accuracy.

These electronic meters do not always have their full capabilities realized by the servicemen. The model illustrated (RCA WV75-A Volt-ohm-ist) is an example of modern up-to-

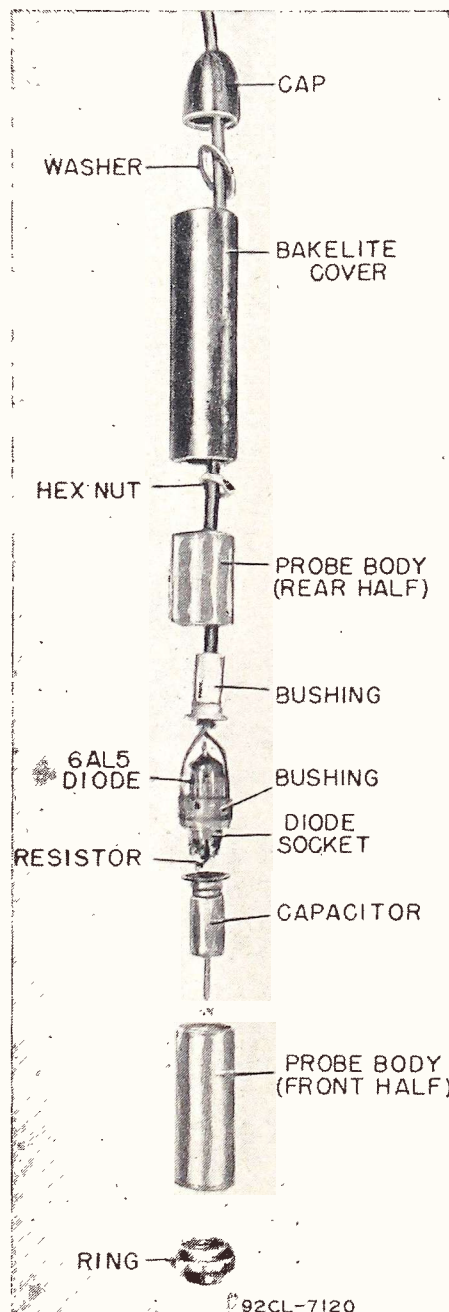

date design in a meter. Among its features, is a Zero-Center Reading scale which is useful in aligning discriminators whose output may be either plus or minus, depending upon the frequency input during alignment.

### R.M.S. vs. Peak-To-Peak Values

This meter will measure d-c voltages from 0.3 to 1000, a-c voltages from 0.3 r.m.s. to 1000 r.m.s. and resistance measurements from 0.1 ohms to 1000 megohms. The r-m-s. (Root Mean Square) values are given for sine wave voltages which is an indication of 0.345 of the actual peak-to-peak value on which the reading is based. Complex waves or pulses may also be measured in terms of

Exploded view of special diode probe which is used in conjunction with electronic VOM to measure r-f and a-f voltages.

peak-to-peak values, where r-m-s readings do not convey useful information. In order to convert from r-m-s voltages to peak-to-peak voltages the chart shown in *Fig. 1* is quite helpful. By means of this conversion chart, the scale reading which is in r.m.s. volts may be changed into peak-to-peak readings without any calculations. Using this chart, the actual peak-to-peak value of pulses may be found directly. *Figure 2* illustrate the relationship between the r-m-s and peak-to-peak value of a sine wave, as well as a comparison of other waveforms that may be encountered. This represents one of the ramifications of the use of a vacuum tube voltmeter. This

the method employed in Zenith television receivers.

The sound i.f. frequency as produced in the output of the mixer is 21.3 mc for the Zenith models using Chassis 28F20. This signal is coupled to the 1st sound i.f. by utilizing a series tuned trap. As with all series tuned circuits, the impedance is low at the resonant frequency and maximum current flows. This means, of course, that this series circuit will pass a maximum signal current for the frequency to which it is tuned—21.3 mc in this case.

Inasmuch as a series circuit presents a high impedance to frequencies above or below resonance, this series circuit in the Zenith thus traps out the picture frequencies. The small inductance shown in Fig. 2 between points marked 2 and 5 of T2 provides common coupling between the L15 series resonant trap and the sound input coil at the grid.

### FM I-F Stages

The intermediate frequency stages of an FM receiver or the sound portion of a television set, must have wide band characteristics in order to pass the necessary carrier and side-band components present during modulation. In standard FM each station is allocated a 200 kc bandwidth, of which 75 kc each side of the carrier represents maximum carrier swing. An ideal response curve in the i-f amplifiers would be as pictured at A in Fig. 3. Here the response curve would have steep, vertical sides, and have a uniform flat top. Such an ideal, however, is virtually impossible to achieve in our receivers and compromise measures must be resorted to. An ordinary response curve, such as at B gives good gain, but has too sharp a peak to be generally useful. The curve shown at C more nearly approaches the type generally found in typical receivers and this is the compromise referred to.

Over-coupling will broaden the response of an amplifier stage, but will, of course, also reduce gain since the

Q of the circuit if affected. Loading down a tuned circuit with resistance will also lower the Q and increase band-width. The curve shown at C, while not flat over the entire 200 kc range, does, nevertheless, give improved gain and better adjacent channel selectivity and represents the band-pass usually encountered.

In the television sound i-f stages, wide bands are again employed, and in this instance a band-pass as large as that in standard FM is used so that the sound i.f. does not drift out of range when the local oscillator drifts. A 50 kc band-pass would normally be adequate, and would bring in all the sound information necessary. Since, however, present-day oscillators of television receivers are prone to drift, the sound i.f. bandpass is made 200

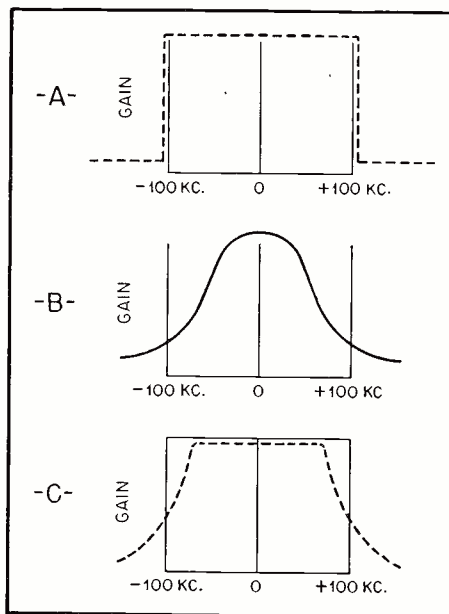

Fig. 3. Ideal, ordinary and preferred i-f response curves.

or more kc wide, so that the 50 kc spread of the FM signal would have sufficient room to drift without loss of sound. Picture drift is not as critical because of the 4 mc band-pass in the picture i.f. stages. A 50 kc drift in the sound would be serious,

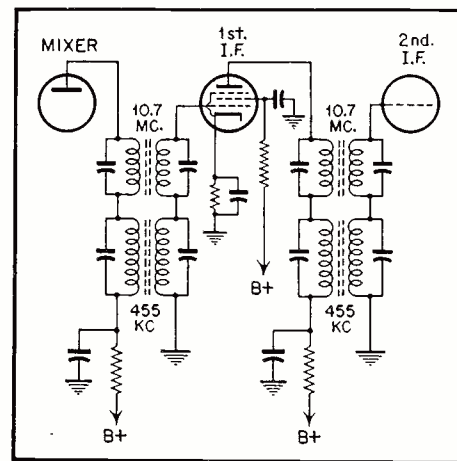

Fig. 4. A typical combination AF and FM i-f arrangement.

while a 50 kc drift in a 4 mc band-pass (4,000 kc) would be relatively small.

### Double-Tuned I-F Stages

When standard FM (88-108 mc) is used in radio receivers which also incorporate AM, the arrangement as shown in Fig. 4 is often used. Both the FM coils (10.7 mc) and the AM coils (455 kc) are enclosed in the same i-f shield. Powdered metal core slugs are utilized to tune individually the various transformer primaries and secondaries. Separate coil forms may be used for the FM and AM, or both may be wound on the same form. In either case, the FM coils are so arranged that the leads from them go into the tube terminals first.

When the set is turned on the FM band, and a 10.7 mc i.f. appears in these circuits, it will find a resonant frequency in the top coils shown in the figure. A parallel resonant circuit is present which offers a high impedance and thus develops a large signal voltage for the desired frequency (10.7 mc).

During this time the coils which are tuned to 455 kc are not at resonance, and for this reason present a low impedance to the 10.7 mc frequency present in these circuits. Thus, they appear as a short circuit to the 10.7 mc signal.

During the time the receiver is set for AM, and a 455 kc signal appears in the amplifier circuits, the lower coils are at parallel resonance and present a high impedance to the 455 kc signal. This means, then, that there will appear a large signal voltage across these coils. The 10.7 mc coils, not encountering a resonant frequency, will offer a low impedance and will act as a short circuit to the 455 kc signals. In this fashion each coil is

[Continued on page 30]

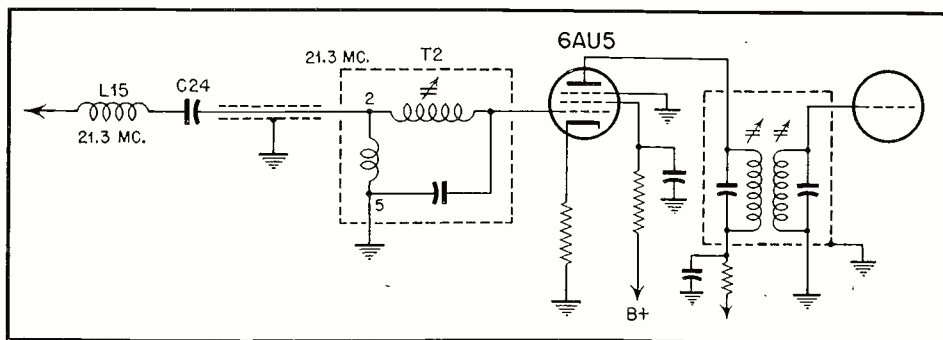

Fig. 2. Sound pick-off in Zenith 28F20 TV receivers.



# MODERN ELECTRONIC VOM

by **ALLAN LYTEL**

*Author of TV Projection and Enlargement*

## Describing the design, operation, and applications of a modern electronic VOM

**V**OLTAGE and resistance measurements play an important part in the servicing technique of any well equipped radio and television repair shop. As far as voltage is concerned, there are many points in television and radio circuits where electronic vacuum tube voltmeters alone can provide reliable readings. One of these points of special interest is the grid leak of an oscillator. The voltage reading measured on the d-c scale obtained across the grid leak resistor is an important indication of the operating condition of an oscillator. However, voltmeters with insufficient input resistance on the voltage scale, can cause a severe enough loading effect to make the oscillator inoperative. Furthermore, it is essential that the measuring instrument place no load, resistive or capacitive, upon the circuit to be measured, otherwise the normal operation of the circuit will be impeded by the measuring device, and an inaccurate reading will be obtained.

The testing of an audio coupling capacitor is an example of where the electronic meter is needed for its extremely high resistance scale. Because the grid resistor used in an audio amplifier stage is usually of a high value, severe distortion will be produced by a leaky coupling capacitor having a shunt resistance of many megohms. Only a high resistance ohmmeter can be used to measure the shunt resistance of this coupling capacitor with any degree of accuracy.

These electronic meters do not always have their full capabilities realized by the servicemen. The model illustrated (RCA WV75-A Volt-ohm-ist) is an example of modern up-to-

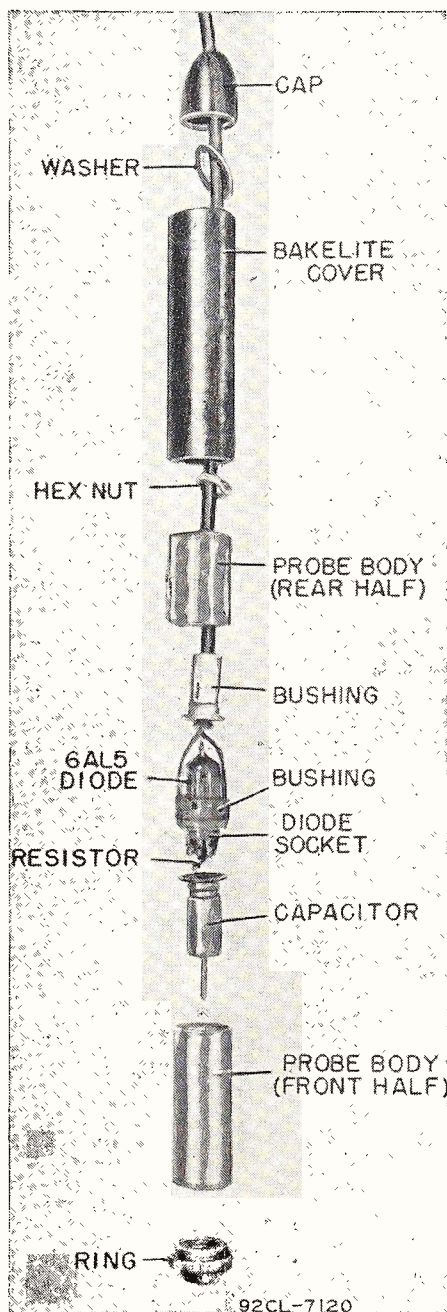

date design in a meter. Among its features, is a Zero-Center Reading scale which is useful in aligning discriminators whose output may be either plus or minus, depending upon the frequency input during alignment.

### R.M.S. vs. Peak-To-Peak Values

This meter will measure d-c voltages from 0.3 to 1000, a-c voltages from 0.3 r.m.s. to 1000 r.m.s. and resistance measurements from 0.1 ohms to 1000 megohms. The r-m-s. (Root Mean Square) values are given for sine wave voltages which is an indication of 0.345 of the actual peak-to-peak value on which the reading is based. Complex waves or pulses may also be measured in terms of

Exploded view of special diode probe which is used in conjunction with electronic VOM to measure r-f and a-f voltages.

peak-to-peak values, where r-m-s readings do not convey useful information. In order to convert from r-m-s voltages to peak-to-peak voltages the chart shown in *Fig. 1* is quite helpful. By means of this conversion chart, the scale reading which is in r.m.s. volts may be changed into peak-to-peak readings without any calculations. Using this chart, the actual peak-to-peak value of pulses may be found directly. *Figure 2* illustrate the relationship between the r-m-s and peak-to-peak value of a sine wave, as well as a comparison of other waveforms that may be encountered. This represents one of the ramifications of the use of a vacuum tube voltmeter. This

technique is becoming increasingly important in television servicing and repair.

### Circuit Operation

The measuring circuit (see Fig. 3) of this electronic voltmeter uses 2 6K6 GT tubes in a balanced bridge circuit providing a very high degree of stability and input impedance. As seen in the schematic, resistor R-29 (39K) is a cathode resistor which is common to the two circuits. Depending upon the function the control grid of one tube is at a fixed potential while the voltage to be measured is placed upon the grid of the other tube. The varying potential applied to the first grid will cause a change of the plate current of the first tube; since the grid of the other tube is at a fixed potential, the plate current of the first tube will cause an opposite effect on the grid of the second tube. Thus, there will be an unbalance between the plate circuits of the two tubes. A changing plate voltage in V-1 will cause the opposite change in plate voltage in V-2 because of the common cathode resistor. This unbalance is read on the 200 microampere meter movement and the scale is calibrated to read either volts or ohms.

A 6AL5 tube is used as a full-wave rectifier in the diode probe and the contact potential of this tube is balanced out against a similar 6AL5 tube located in the meter case. In this manner the zero scale setting is unchanged when the range switch is changed from one position to another.

As a d-c voltmeter, there are ranges 1,000. The input resistance is 11 meg-

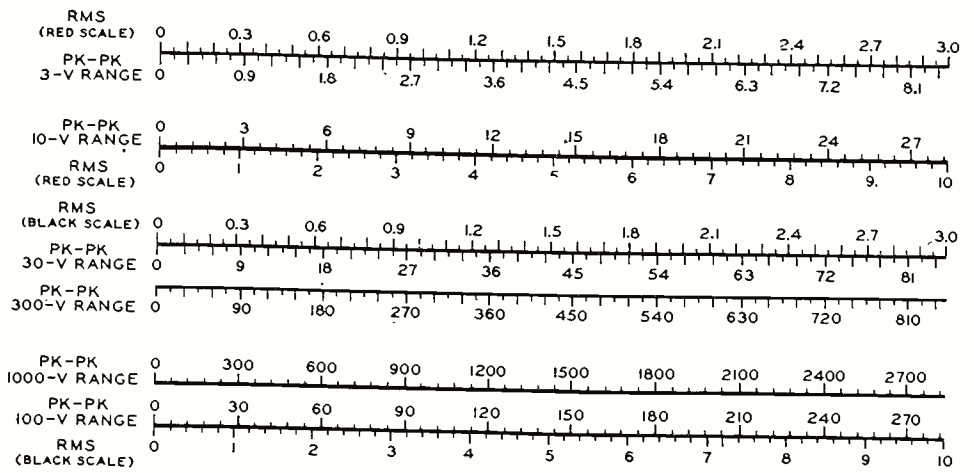

Fig. 1. Conversion chart for r-m-s to peak-to-peak voltages.

ohms on all ranges, which amounts to 3.7 megohms per volt on the 3 volt range. As an a-c voltmeter, there are ranges from 0 to 3, 10, 30, and 100, r.m.s. volts directly to the diode probe.

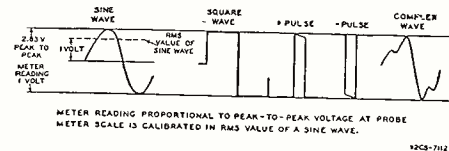

Fig. 2. Relationship between r-m-s value and peak-to-peak values of a sine wave. Note values of other waves.

An audio frequency multiplier is available which has an attenuation ratio of 10 to 1. This provides 2 scales, 0 to 300 and 0 to 1000 r.m.s. volts up to a frequency of 15 kc.

The frequency response when the diode probe is used directly is from

30 cps to 250 mc. When the diode probe is used with the leads supplied, the frequency response drops to 30 cps to 30 mc and with the diode probe and audio frequency multiplier, the frequency response is 30 cps to 15 kc. See Fig. 4 for values of effective input resistance and capacitance of diode probe versus frequency.

### Operation

The electronic voltmeter is set in operation by plugging in the power cord and using the Zero Adjustment to bring the pointer to zero. The selector Switch is thrown to plus volts and the zero adjust is rotated to obtain zero reading. Selector Switch is then thrown to Ohms and Ohms Adjust is used to bring the meter to the last line on the ohm scale. When measuring d-c volts, the meter is used as with any voltmeter except for the fact that there are two positions on the selector switch which may be used; one is for positive volts and the other for negative volts. This allows the test leads to stay in position even if the polarity of the voltage changes. The ground lead should be kept at chassis potential whenever possible. If the selector switch is thrown to Zero Center position the needle will move to the center of the scale. This is convenient for special applications such as discriminator voltage alignment for FM and TV receivers. As may be seen from the scale of the meter, the zero center position will not give true scale indication unless it is used with care. As an example on a 10 volt range, zero center is located at 5 volts. A reading of 8 volts is an indication of 3 volts positive while a reading of 2 volts is an indication of 3 volts negative.

The special diode probe is used to measure a.c. which may be either  
[Continued on page 29]

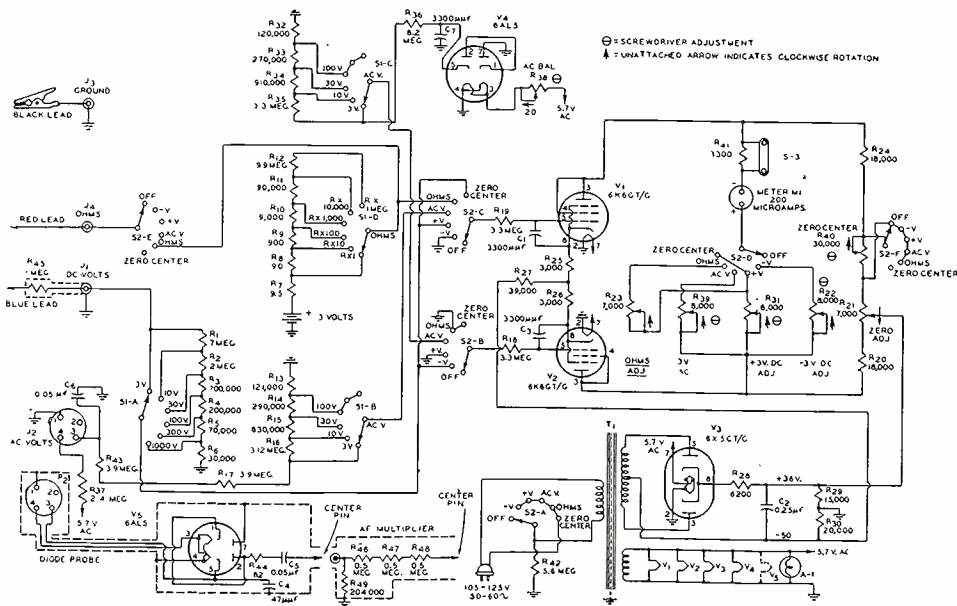

Fig. 3. Circuit diagram of R.C.A. WV75-A VoltOhmyst.

# Servicing

# PHOTO-ELECTRIC

# Equipment

by WILLIAM R. WELLMAN

## PART 2

**Final installment of this article began in the October R.S.D. Further servicing techniques, special types discussed.**

One or two comments seem appropriate before leaving the subject of adjustment. While we are likely to regard the type of equipment under discussion as an "on-off" device, this is not strictly true. The opening or closing of the relay contacts depends not merely on the absence or presence of light at the phototube, but rather on the change in the total amount of light reaching it. Extraneous light must, therefore, be taken into account, and very often adjustments must be made with a considerable amount of light reaching the tube from a source other than that of the actuating lamp. Under such conditions some trial and error adjustment must be made before the desired operation is obtained. Another important factor is the current required to close the relay contacts compared with that necessary to hold it in operation once it is energized. As an illustration, suppose we assume that a given relay takes 15 milliamperes for full closure of its contacts, but once closed they will remain closed with only 10 milliamperes flowing through the coil. If we were now to adjust the sensitivity control so that the amplifier plate current at full illumination and at zero illumination varied between 12 and 20 milliamperes, we would find that we will not obtain correct operation; the 20 milliamperes current at full illumination of the phototube is ample to energize the relay, but when the light is cut off the plate current drops to 12 milliamperes (more than enough to hold the relay in operation once energized) and the relay will not drop out properly.

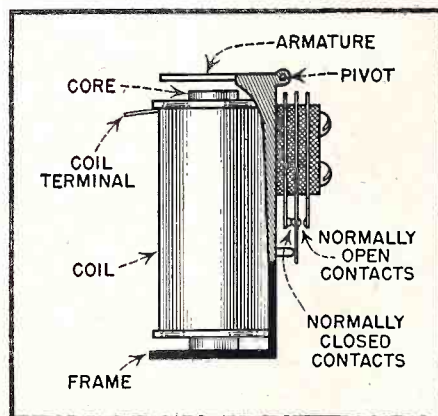

Fig. 4. Typical relay used in photoelectric apparatus.

### Conditions Causing Lack of Sensitivity

By lack of sensitivity we mean a condition in which the relay will not operate properly with normal illumination and darkening of the phototube, and in which no setting of the control accomplishes the desired results. It is one of the more common complaints associated with this type of apparatus, and may arise from a variety of causes. If you encounter trouble of this nature, it is suggested that you go over the material contained in the preceding section.

A listing of some of the causes of poor sensitivity would include the following: defective phototube or amplifier tube, defective lamp or improper focusing, damaged or improperly adjusted relay, serious changes in

plate or screen voltages, and possibly a change in the value of the grid resistor, although this is not too likely.

Suppose we take up the possible defects listed above. Many units use a standard automobile lamp as a light source. The filament of such a lamp affords a concentrated spot or strip of light. It is important that when replacement is made the correct type of lamp be installed. It has been noted that in some types the maker's trademark or monogram on the bulb has a tendency to interfere with correct focusing at the distances commonly used in photoelectric work. Of course, it is understood that both the lamp and the lens must be clean; this can best be done with an alcohol swab, followed by polishing with lens tissue. Incidentally, the new silicone-impregnated tissues are excellent for this purpose. Proper focusing has already been taken up as well as the matter of the distance between the lamp and the phototube.

The majority of commercially built units are so designed that the tubes are operated at very conservative voltages and therefore their life is lengthened, but failure is a distinct possibility and cannot be overlooked. Replacement of amplifier tubes is a routine matter since in most cases they are standard radio types. Of course, the number of phototube types made is far smaller than in the case of general purpose tubes, yet it is a good idea to keep at hand a copy of the RCA bulletin describing

such tubes; Westinghouse and General Electric publish similar material. Concerning the electrode voltages applied to the tubes, it should be noted that it is common practice to use no higher than 90 to 100 volts on the plate of a gas type phototube, and not more than 250 on the plate of a high vacuum type. Remember that in measuring the electrode voltages of tubes used in a-c operated equipment an a-c voltmeter range must be used.

Since relays are not used to any great extent in ordinary radio equipment, a few words concerning the operation and adjustment of these components may be appropriate. *Figure 4* shows a relay of the type common to photoelectric apparatus. Except in cases where a thyatron tube is used, the coil resistance of such relays is likely to be somewhere between 2,000 and 10,000 ohms. Contact arrangements vary between a simple pair of normally open contacts (meaning that the contacts are open when the relay is not energized) and four, six or even more contacts, depending upon the work that the device is expected to do. Very often there is a combination of normally open and normally closed contacts. As can be seen from the illustration, the tension or force which holds the armature in a normal position is supplied by the contacts themselves. Damage to the contacts due to rough handling or other cause might possibly change the amount of current needed to make or break the contacts. Adjustment should never be attempted unless it is definitely known that the relay is out of order, and then only with the greatest of care. A piece of steel about 1/8 inch wide and having a slot in the end which is slightly wider than the thickness of the contact

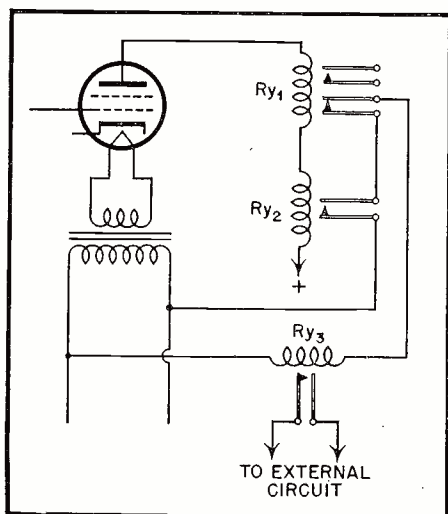

Fig. 5. System of safeguarding work against machine failure using three separate relays.

spring is the best type of tool to use, although adjustments might be made with a pair of long nose pliers. You will notice that the armature carries a projecting tongue or lever which bears against the movable contact. Bending the moving contact toward the armature lever will increase the tension and thus more current will be needed to fully close the contacts. On the other hand, bending the contact in the opposite direction will have the effect of making the relay more sensitive. All bending should be done at the upper end of the spring; that is, at the end opposite the contact. Adjusting contact springs is a rather delicate operation. At no time should the bending be sufficient to produce a kink or visible bend in the spring. Relay adjustment should be attempted only in emergencies, for unless data is available concerning the operating current of the relay, and unless means is at hand for measuring and controlling the current while adjustments are made, it is likely to be largely guess work.

#### Causes of Non-operation of Unit

Very often the complete failure of a unit may be traced to causes which are the same as those listed above. It is quite obvious that a defective phototube or amplifier tube, an improperly adjusted relay, reduced electrode voltages or a complete lack of voltages, a light source which is too far away or not properly focused on the phototube, are each capable of preventing the unit from functioning. Then, there are the usual power supply failures common to all electronic equipment, such as a defective transformer, rectifier tube or filter condenser. Shorting of the condenser *C* connected across the relay coil or an open winding will, of course, prevent the relay from operating. Many failures may be traced to tarnished, pitted or burned relay contacts; the latter two causes are especially likely in cases where the contacts open and close circuits carrying considerable current. Cleaning contacts is best done with crocus cloth. It should be noted that readjustment is sometimes necessary after cleaning.

In line with modern methods of trouble isolation and diagnosis, a very simple procedure for localizing trouble may be used. This is the measurement of the voltage change across the grid resistor, *R*. Of course, since the resistor is usually very high, the use of a high resistance voltmeter (a vacuum tube voltmeter, preferably)

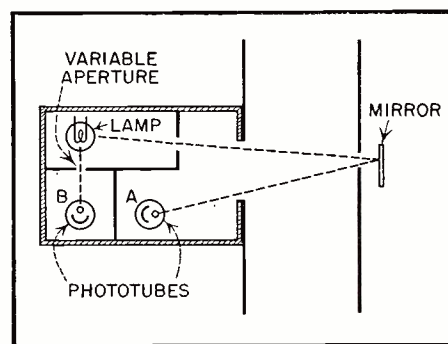

Fig. 6. Typical smoke detector.

is mandatory. Connect the meter across the resistor and note the voltage with the lamp turned on; then turn the lamp off or cover the phototube and observe the new reading. The difference between the two is a measure of the current developed by the phototube. If the voltage change is great enough to vary the amplifier plate current over wide enough limits to result in opening and closing of the relay contacts under normal circumstances, the trouble then lies in the amplifier or the relay. On the other hand, if the voltage change seems too small, the light source, the phototube or possibly the resistor itself is at fault.

Before leaving the subject of trouble location, mention should be made of a common defect which does not fit into either of the classifications just discussed. This is chattering or buzzing of the relay; and is most likely to occur in equipment using an a-c the relay coil, and will be found to be caused by opening of the condenser *C* connected in parallel with the coil.

#### Special Types of Photoelectric Equipment

Many types of phototube apparatus differ materially from those already described. First of all, there are some types in which the amplifier does not terminate in a relay. In equipment used for measurement and comparison purposes, some type of current measuring instrument is used instead, and this instrument will be calibrated in appropriate units. One such device is used for matching and comparing the colors of such materials as textiles, paints, paper, dyes, etc. In use, a calibrated potentiometer is adjusted until the light reflected from the standard sample gives a predetermined reading on the meter scale. The sample to be compared is then inserted and the potentiometer readjusted un-

[Continued on page 28]

# TV TRUCK

## Solves Installation Problems

by I. SHYKE

**T**HE problems were how to save time, money and labor in television servicing. The firm concerned with the solutions is the L & S Radio Sales Company, 132-134 North Street, Middletown, New York. Merchandising was actually being retarded because customers and potential buyers could not be given the right amount of attention at regular convenient periods for themselves and for L & S.

Mr. Earl Lounsbury and Mr. Dave Shohet, the two partners of the company, began to think that television selling was going to become somewhat of a burden. They had twelve years radio experience behind them. Today they can look back at two years of television business. With demands coming to them steadily they saw, not long ago, that some improvement in servicing was necessary at once.

### Solution of Problem

"What we wanted was accurate engineered television installation," Mr. Lounsbury explained. "It seems simple now but before we hit upon the right answer we spent many anxious months trying to figure out what was then a very tough problem. The solution came with a special one half ton panel Ford truck. It is rigged with two ladders. One is aluminum. The other is wood. They are both double sectioned. When jointed the aluminum ladder reaches a height of 80 feet. The wooden ladder goes as high as 60 feet. The truck is fully equipped with testing apparatus. We are now able to give our customers not only complete satisfaction but constant rapid service."

The result is an increase in television business volume of twenty-five percent. Time and labor saving is estimated at fifty percent.

The L. L. Peters Company of Allentown, Pennsylvania, supplied the towers. This cost was \$450.00. The truck was bought for \$2,200.00. It has paid for itself many times over,

**How a Radio Service Dealer solved his problems of locating the most effective heights and locations of TV antennas in fringe area installations, where these factors are critical.**



This attractive truck, and the adjustable extension ladder shown mounted on the roof of the truck, has resulted in increased business, as well as quicker and better installations.

Mr. Lounsbury said. The Ford is about seventeen feet long and about seven feet wide. It is around seven and one half feet high. The ladders rest on frames on either side or middle of the top of the truck. It has an all white enamel body with black lettering with the company's name, address and telephone number. The Fada emblem is on the door of the machine. Thus far it is the only truck of this type and used for television in the area. The L & S firm was so enthusiastic about the portable towers that it accepted agency sales for them. So far L & S has sold them in Poughkeepsie, Kingston, Newburgh, Monroe, Port Jervis, Milford and other near-by cities and towns.

Test panel RCA equipment in the truck consists of a vacuum tube volt

meter, sweep generator, scope, calibrator, tube tester and a regular signal FM and AM generator.

"By having this new truck we are busy daily with it," Mr. Lounsbury went on to say. "We continually are revising new installations. Before this we had to throw up jobs haphazardly. It was all guess-work as to height. Now we can go to the various heights until we get the right picture."

The only local competition that L & S could get with the new portable tower is from the Middletown Fire Department's new hook and ladder which can attain a height of seventy feet. Until the L & S tower the Fire Department was the only one that could go that high. Of course usage of the hook and ladder as a television

[Continued on page 27]

# CIRCUIT COURT



## Philco Model 49-1606

The development of dry-disc type rectifiers in a number of current ratings and small size have made possible the design of instruments with space and weight saving qualities which must be very pleasing to the cabinet design groups. In addition, it is likely that cost factors may profit from the move. While most compact instruments use the line voltage applied directly to a single bank of rectifier plates, ending up with some value of d.c. below 100 volts, it is possible to achieve more nearly normal operating voltages for the tubes. Increased performance from all angles can then be obtained, in fact the comparison with transformer operated instruments becomes favorable.

The instrument under discussion is a good example of the present trend in such design. A console radio-phono combination, it has seven tubes, of which three are multi-purpose, and operates on both AM and FM broadcast bands. A schematic of the power circuits is shown and details of its function may be of interest. Keep in mind that one side of the power line is common to the returns of all circuits within the set. This point is the negative end of the d-c supply circuit.

Beginning at the power plug, we find both r-f and a-f by-pass capacitors. The pilot light operates from the full line voltage, as does the phono motor. Then comes a protective resistor of 50 ohms to limit the charging current of the large filters. The first filter condenser, a 40  $\mu$ f unit, is connected so that it charges up on each half cycle when the top plate of the first rectifier stack is positive. A positive voltage is thus developed at point A. An additional protective resistor is connected in the negative side of the rectifier.

The surges of voltage are also rectified in the second rectifier and add their potential to that developed at point A. The result is that at point B we find a potential equal to something like twice the line voltage. This

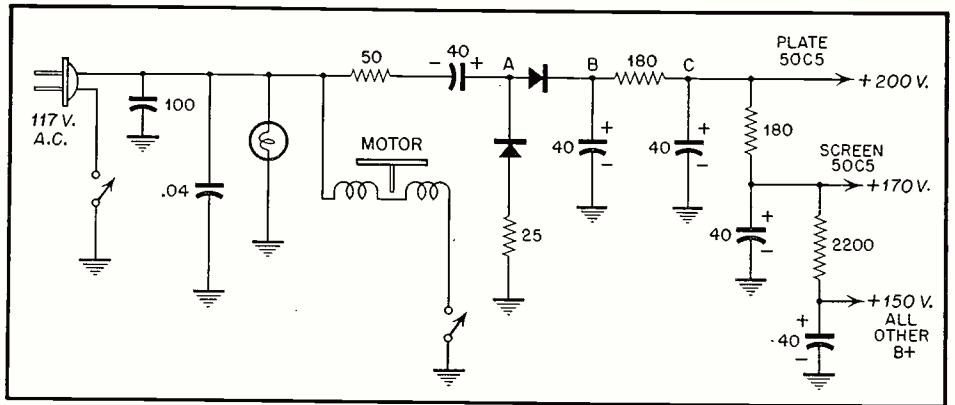

Partial schematic of Philco Model 49-1606

voltage is stored in the second 40  $\mu$ f capacitor. Filtering begins at this point and the first section has 180 ohms and another 40  $\mu$ f. Potential for the plate of the 50C6 output tube is taken off at this point. The value is 200 volts.

Another section of 180 ohms and 40  $\mu$ f drops the voltage to 170 for the output tube screen and further reduces hum. The remainder of the tubes are supplied after a final section of filter with 2200 ohms and 10  $\mu$ f. The potential here is 150 volts.

The tube heaters are, of course, series connected across the line.

ing variations on the usual PA system. The advent of the low impedance, moving coil and variable reluctance phono pick-up devices has made high-gain hum-free input stages mandatory. Improved speakers and interest in wide-range sound has called forth improved circuitry and layout.

The amplifier under discussion incorporates many recent developments. Two have to do with the reduction of hum, particularly in the high-gain input stages, of which there are two. One stage, using a 12SJ7 pentode, accepts high impedance devices. The other, utilizing a 12SC7

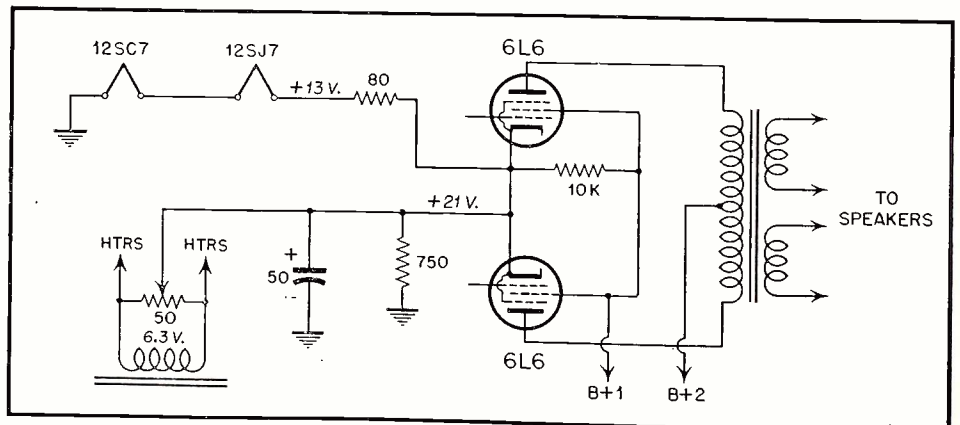

Partial schematic of Masco Model MA-25HF

## Masco Model MA-25HF

The current interest in high fidelity reproduction of sound, particularly recorded music, has brought to the market amplifiers containing interest-

ing dual triode, has a switch which permits connection of either high or low impedance sources.

[Continued on page 26]

# SHOP NOTES

Write up any "tricks-of-the-trade" in radio servicing that you have discovered. We pay from \$1 to \$5 for such previously unpublished "SHOP NOTES" found acceptable. Send your data to "Shop Notes Editor".

## Cleaning Condensers

We often have occasion to clean out dust lodged in variable condensers where ordinary pipe cleaners cannot be inserted. For this use we have devised the resonant high voltage, low current unit shown in *Fig. 1*, which not only burns out every particle of dust but also locates minute shorts or tendencies in that direction.

Submitted by:  
Jack D. Garkim  
Horicon, Wisconsin

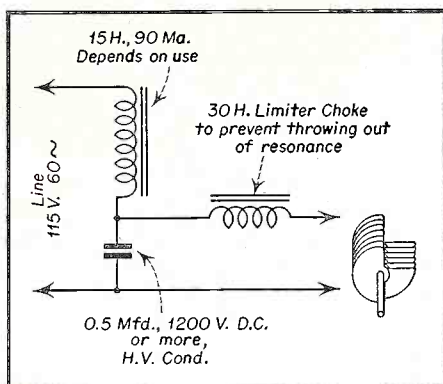

Fig. 1. Circuit of condenser cleaner

## Westinghouse Model H-217—Ground Connection to Aquadag

Wear or vibration may sometimes develop a poor connection between the outside coating of the cathode ray tube and its grounding springs. The attendant arcing at that point can result in tearing of the picture and insufficient picture width.

To insure a permanent ground contact, a piece of aluminum foil is inserted between the aquadag and the grounding springs on later production models. This foil, one side of which is coated with adhesive, is first cut to a size of 1" x 1½". One edge is then folded ¼" over the adhesive side of the foil. Finally, the foil is placed between the aquadag and the grounding spring in such a manner that adhesive holds the foil to the aquadag, the spring bears against the uncoated side of the foil, and the uncoated side of the ¼" fold bears tightly against the aquadag.

The foil is stocked in rolls of 20 feet and can be ordered by part number V-6237-2.

## Repair Loosened Radio Tubes

A sure way to repair glass radio tubes which have loosened from their bases is shown in the accompanying drawing. Tie a piece of dial cord (or ordinary string) *tightly* around the base of the bulb where it enters the base see *Fig. 2*. Then paint the cord thoroughly with coil dope, speaker dope, or collodion, allowing the dope to run a sixteenth of an inch or so each side of the cord onto the bulb and base.

This makes such a tight seal that the bulb subsequently may be twisted without breaking its adherence to the base.

This method may be applied with equal success to GT tubes, as well as to older style glass tubes. It works satisfactorily with bakeilte, ceramic, and the other materials used for tube bases.

Submitted by:  
Rufus P. Turner,  
919 East 116th Pl.  
Los Angeles 2, Calif.

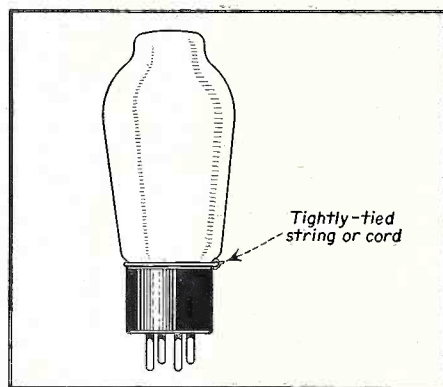

Fig. 2. Repairing glass tubes

## Utility Heater

In order to heat plastic for bending, and for drying parts that may have become water soaked or damp; as well as for other quick drying jobs around the shop the item shown in *Fig. 3* works very well. It consists of a 10 qt. pail with the handle legs cut off, and an infra red bulb mounted as shown.

Submitted by  
Marion L. Rhodes  
Knightstown, Ind.

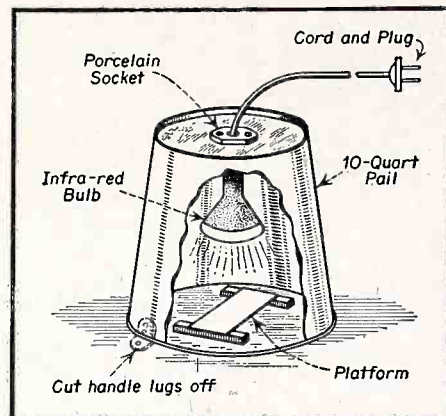

Fig. 3. Utility heater details

## Bendix, A-C D-C Chassis tube failures

Some reports have been received concerning tube failure in Bendix a-c/d-c 5 and 6 tube receivers. These reports come mainly from areas served by the REA or other power sources unable to maintain a reasonable stable line voltage. Since the tube filaments of a-c/d-c receivers are connected in series directly across the 110 volt line, any great increase in line voltage may increase the voltage across the individual filament beyond the rated maximum. This may either burn out one or more tubes immediately, or, at least, seriously shorten the life of all the tubes.

To reduce this hazard a 75 ohm, 3 to 5 watt resistor may be inserted in series with the filament string. A convenient location in the Bendix five tube chassis for this resistor is between pin 7 of the 12SA7 and pin 7 of the 12SQ7. On the six tube chassis, this resistor may be inserted between the 14A7 and the 14Q7 by removing the filament lead from pin 8 of the r-f, 14A7, tube and mounting the 75 ohm resistor directly on the tube socket lug.

## Admiral 49C8-2 Tuners—Frequency Drift

High ambient temperatures encountered under certain operating conditions may result in excessive oscillator frequency drift in some 94C8-2 tuners. Under such conditions, frequent readjustment of the sharp tuning control will be necessary. In some cases, oscillator drift may even go beyond the normal tuning range of the sharp tuning control.

This condition is most probable in 30D1 (16") chassis due to higher operating temperatures in this model.

When excessive oscillator frequency drift is encountered in a 94C8-2

[Continued on page 24]

# NEW PRODUCTS

## NEW FM-TV TUBE

A new miniature tube (6BC5) designed primarily for use as a radio-frequency and intermediate frequency amplifier in television and FM receivers is now in production at the Owensboro, Ky. plant of the General Electric Company.

According to J. M. Lang, Manager of the Tube Divisions here, the 6BC5 represents an

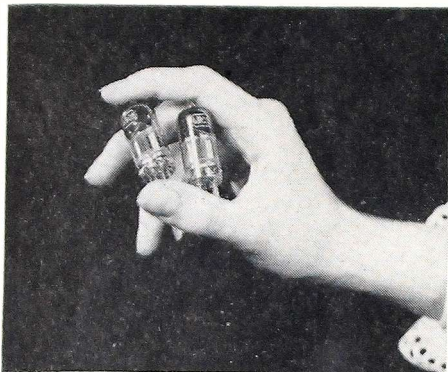

improved version of General Electric's 6AG5 and is interchangeable with that tube. The chief difference is an increased transconductance.

## CONICAL ANTENNA

Tricraft Products Company, manufacturers of television antennas, has just announced their new "300" Hi-Lo Conical Type X Antenna series. These newly designed antennas are

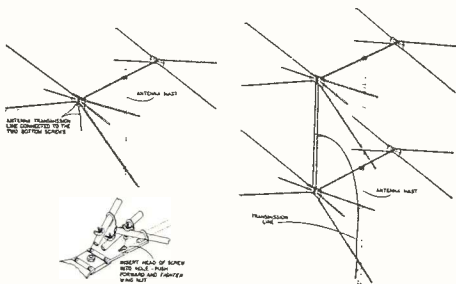

pre-assembled at the factory, ready to install (no loose parts). They match 72, 150 and 300 ohm impedance; are all-wave, high gain on all channels; and are durably constructed of the finest aluminum (will not rust).

## CONTROLS MAY NOW BE GANGED

The technician can now assemble his own ganged controls in a matter of moments. The reason is a completely new development in control units, pioneered by International Resistance Company. Known as Multisections,

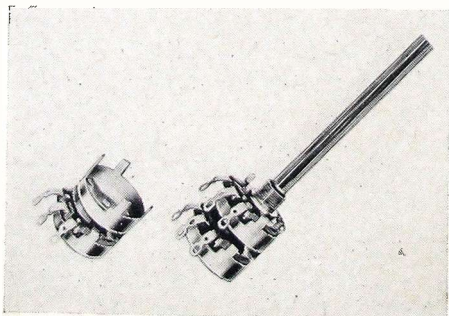

these new IRC units are complete control sections that can be added to any of the recently announced IRC miniature Q, PQ or RQ Volume Controls, just as switches are attached.

## NEW TV COMPONENTS

Seven new picture i-f components giving improved sensitivity, selectivity, and response have been announced by the Tube Department, Radio Corp. of America, Harrison, N. J.

These new components are as follows: Converter Transformer, Type 202K5; 1st Picture IF Transformer, Type 202K6; 2nd Picture IF

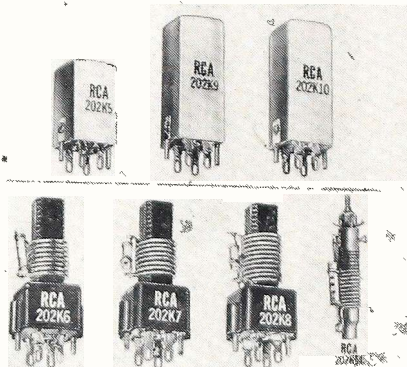

Transformer, Type 202K7; 3rd Picture IF Transformer, Type 202K8; 4th Picture IF Transformer, Type 202K9; 5th Picture IF Transformer, Type 202K10; and cathode-circuit trap, Type 202K11.

## NEW SYLVANIA TUBES

Three new receiving tube types including an audio frequency amplifier; an r-f amplifier for television; and a horizontal deflection amplifier for television have been announced by Sylvania Electric Products Inc., according to C. W. Shaw, general sales manager, Radio Tube Division.

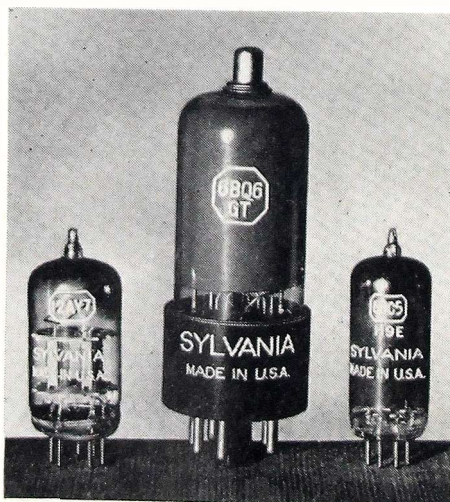

The audio amplifier, type 12AY7, is a T6½ miniature, medium-mu diode particularly suitable for use in the first stage of a-f amplifiers where absence of noise and microphonism is desirable. The tube is supplied with a center-tap heater for use with 6.3 volt or 12.6 volt source.

The r-f amplifier, type 6BC5, is a T5½ mutual conductance, designed for r-f and i-f

amplifier applications in television receivers. The tube is listed as an equivalent of type 6AG5 but it provides higher gain.

The horizontal deflection amplifier for television receivers, type 6BQ6GT, has been designed and processed for transformer operated sets where high peak interelectrode voltages are encountered.

## RECTANGULAR 16-INCH TUBE

Hytron Radio & Electronics Corp. announces their new Hytron type 16RP4, a directly-viewed, 16-inch picture tube with a rectangular



screen. Hytron claims it to be the shortest 16-inch picture tube on the market. The picture, with standard 3 to 4 aspect ratio, has a usable screen area of 138.7 square inches. No high-voltage isolation of the tube is required. Magnetic focus and deflection are employed. Complete technical data are available from Hytron Radio & Electronics Corp., Salem, Massachusetts.

## YAGI ANTENNA

A new Yagi, an highly efficient double folded dipole television antenna has just been announced by the Trio Manufacturing Company of Griggsville, Illinois.

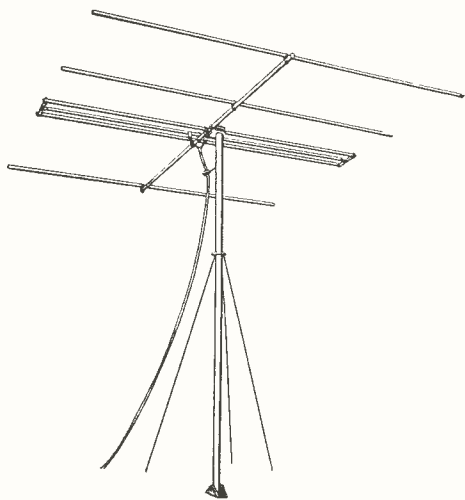

Its flexibility permits mounting of more than one bay on mast with independent orientation of each. The new yagi is available on channels 2 to 6 with mast and mounting hardware, and for the high bands, less mast. Descriptive folder is available from the manufacturer.



**CAPACITORS**

The growing demand for a tubular capacitor approaching the performance of a plastic-molded type yet available at a price closer to that of conventional paper tubulars, is met by the Type '87 capacitor just announced by

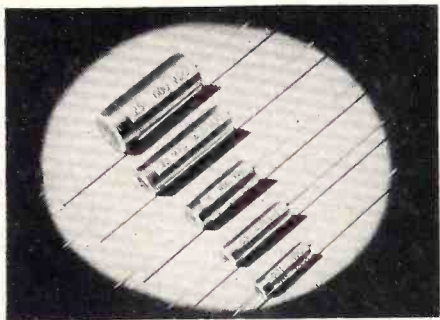

Aerovox Corporation of New Bedford, Mass. This modified paper tubular features Aerolene and Duranite new impregnating and sealing materials developed by Aerovox research engineers and already the basis of the Duranite molded tubulars in general use.

**ROLLER BEARING GUY RING**

Crown Controls Company, Inc., New Bremen, Ohio announces the new Crown Roller Bearing Guy Ring. This unit has been designed so that the masts of antenna can be rotated without loosening the guy wires.

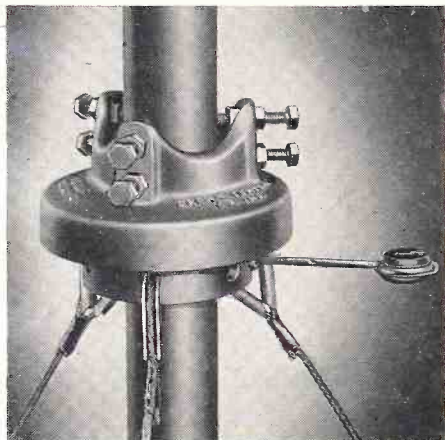

**TWIN-DRIVEN YAGI**

A new antenna design is realized in the new Twin-Driven Yagi introduced by Tech-

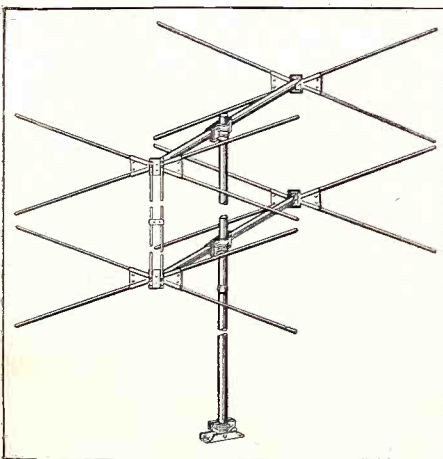

nical Appliance Corporation, Sherburne, N. Y. Tests have proved the gain of this antenna to be greater than any other antenna tested

**FASTEST SELLING**

**ANTENNA**

**line we ever stocked!**

Jobbers everywhere find demand for Telrex Antennas growing by leaps and bounds. Telrex—the conical “V” beam—is the one antenna that guarantees your customers better, brighter pictures, longer service and *no* service call-backs due to antenna failure. You can sell more antennas and your customers will sell more TV receivers if you stock, sell and recommend Telrex, *exclusively!*



*it's*



*and*



- *for bigger profits*
- *finest performance*
- *longer service life*

**THE ONE ANTENNA LINE WE CAN RELY ON TO SOLVE EVERY INSTALLATION PROBLEM**

That's the typical comment on Telrex Conical “V” Beams from dealer and service man, alike. Special Series or Deluxe, every genuine Telrex Conical Antenna is engineered and field-tested for better reception and durability in all TV areas.

ALL TELREX ELEMENTS ARE MADE OF HI-STRENGTH DURAL

PATENTS PENDING  
COPYRIGHT 1949



Telephone—ASBURY PARK 2-7252



AMERICA'S  
OUTSTANDING  
TELEVISION  
BEAM

ASBURY PARK 5, N. J.

at the Taco field and laboratory testing grounds.

Taco claims to have designed and developed this new type low-band antenna to overcome the detrimental effects of parasitic elements that are used in all Yagi type antennas. In the usual type Yagi the mutual impedance of the parasitic elements reduce the impedance of the array to a very low value.

### CAPACITOR INDICATOR

A new capacitor code indicator just introduced by the Sprague Products Company, 71 Marshall St., North Adams, Mass. makes it easy to decipher molded paper tubular capacitor color codings. The Sprague Capacitor Indicator consists of a pocket-size plastic device

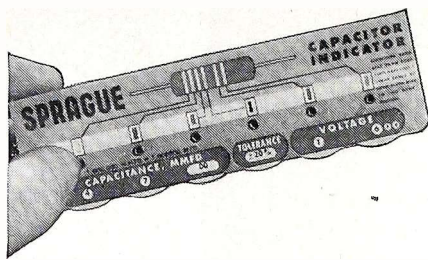

with rotating dials printed in full and accurate colors. When flicked to the proper color bands, the dials instantly indicate capacitance, tolerance, and rated working voltage.

# TELEVISION SELLS Alliance Tenna-Rotor Right in the Home!

"Son, there's the answer! clearer pictures... more stations ALLIANCE TENNA-ROTOR!"



**4,500,000 Viewers**  
**Around 40 TV Stations**  
**See TENNA-ROTOR in Action—Each week!**

Every TV set owner wants more distance—less interference—clearer pictures! Alliance Tenna-Rotor means faster antenna installations—fewer call-backs—happier customers! *Guaranteed for one year!*

**ALLIANCE MANUFACTURING COMPANY • Alliance, Ohio**  
 Export Department: 401 Broadway, New York, N. Y., U. S. A.

## ASSOCIATION NEWS

*Radio Technicians Guild of New England*  
*Whaling City Chapter,*  
*New Bedford, Mass.*

The following is a copy of a newspaper clipping:

"Regulations governing the installation of television antennae in New Bedford were drafted yesterday afternoon by the special committee on building codes.

"Believed to be the first attempt of a city to list specific requirements for

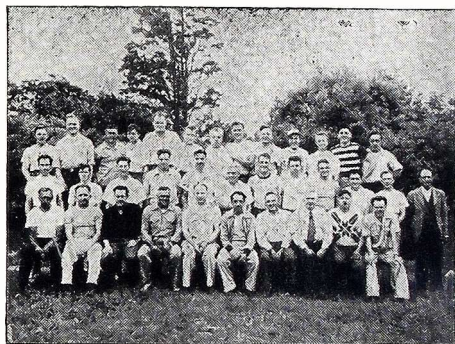

Group photograph of Whaling City Chapter members.

such installations in Massachusetts, the regulations were prepared by the committee, meeting with representatives of the Radio Technicians Guild of New Bedford."

Our thought in attending this meeting to propose TV Antenna Code was that it would be better to take part in drawing it up, rather than complain about it after it was in force.

*Dallas Radio Sales & Service Ass'n., Inc.*  
*Dallas, Texas*

Dallas reports preparations for a TV Antenna Installation Clinic. This includes a round table forum concerning problems encountered in this area. TV set distributor reps have been invited to reveal how their particular receivers operate with different kinds of aerials. This is a good stunt and should be emulated by other groups.

*Lackawanna Radio Technicians Ass'n.*  
*Carbondale, Pa.*

Michael Csigi was installed as president of the Lackawanna Radio Technicians Association at a meeting recently in the Chamber of Commerce Building. Leon J. Helk, past president, was in charge.

Other officers inducted were: August Cianchetti, first vice-president; Mer-

rill Greene, second vice-president; James Jerome, treasurer; Howard E. Greene, secretary; Homer Kinback, assisting secretary; Louis Perna, Stephen Csigi and John Riegel, trustees.

Robert A. Stang, executive of the Jackson Instrument Co., New York, spoke on "Television Test Equipment and Application."

*Associated Radio-TV Servicemen of New York*

The sixth lecture of the TV series, the title of which is, "Detector and Video Amplifiers," was delivered in the New York City Area by John Meagher of R.C.A., on Nov. 16, 1949.

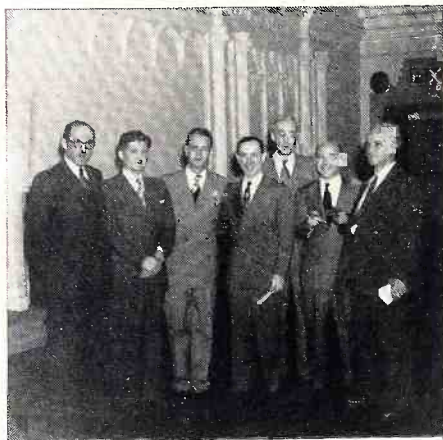

RCA, Radio Service Dealer, and ARSNY group at lecture.

As usual, whenever Johnny speaks, the boys were enthusiastic in their praise of his efforts.

Shown in the photo are (left to right): Arthur Silverberg, Sec.; Gerard Nierenberg, Att'y; Hal Bersche, R.C.A.; Max Leibowitz, Pres.; John Meagher, R.C.A.; Sam Marshall, Radio Service Dealer Magazine; and Noel Payne, Corr. Sec.

*New Organizations Formed*

Radio Technicians' Assn.

Station A, Box 1096

Fort Smith, Arkansas.

Mr. LeRoy Ragsdale

Connecticut Television Technicians' Association

29 Grenhart Road

Stamford, Conn.

Mr. Joe Di Preta

*Federation of Radio Servicemen's Associations of Pennsylvania*

The Federation of Radio Servicemen's Association of Pa. is setting up their Speakers Schedule for the entire year of 1950. Leading manufacturers will be contacted, requesting them to provide a speaker on some subject allied to their product. Any manu-

facturer desiring to have representation by providing a speaker should write to:

Paul Smith, Program Chairman,  
306 Chestnut St., Harrisburg, Pa.  
*Dallas Radio Sales & Service Ass'n, Inc. Dallas 1, Texas*

The third TV station for the Dallas-Fort Worth area will make its debut on Dec. 3, 1949.

Our brethren from the heart of Texas claim that their prey, E. Pflughaupt, is an old spook—his birthday is on Halloween.

They also claim that June 7th, 1929, was the date of the first successful

TV telecasts in color, being done by old Ma Bell. Explain yourselves, pod-ners.

*Longview Radio Sales & Service Ass'n, Longview, Texas*

All of the service shops in Longview, Texas, came together and agreed that it was now time for them to have their own local organization. They therefore extended an invitation to the Sec'y-Treasurer of the Dallas Radio Sales & Service Ass'n., Inc., to come to Longview and set up an organization for them. An organiza-

## GENERAL INDUSTRIES *leads the Parade*

**33 1/2  
RPM**

**78  
RPM**

**45  
RPM**

**MODEL TS—45-78-33 1/2 R. P. M.** General Industries' newest rim-drive phonomotor, designed to accommodate *all* types of records now on the market.

### ... with this low cost **THREE-SPEED PHONOMOTOR!**

It's GI's Model TS . . . the *one* motor designed and engineered to meet *all* requirements for true record reproduction at 33 1/2, 45 and 78 R.P.M. Already time-proved in actual service, this latest addition to the famous GI phonomotor line today is being used in a wide range of portables, table models and console radio-phonographs.

Outstanding features: standard narrow-flange turntable for easy, compact installation . . . simple, yet positive speed shift mechanism with external control lever . . . dependable, quiet *Smooth Power* motor for long, trouble-free service.

*For full details—blueprints, performance specifications and quotations—write, wire or phone today.*

**The GENERAL INDUSTRIES Co.**  
DEPARTMENT K • ELYRIA, OHIO

## TECHNICIANS AVAILABLE

Carefully selected group of trained men, graduates of reliable and well established trade school now available to fill positions in the Radio or Refrigeration field. Willing to travel anywhere. Why not fill that vacancy with an efficient and reliable man. Write Eastern Technical School, 888 Purchase Street, New Bedford, Mass.

tion meeting was held on the evening of Sept. 22, 1949 at the Hilton Hotel in their community. All shops were represented and a splendid spirit of cooperation was evident. The organization structure of the Dallas Ass'n was fully explained and its many ac-

complishments were recounted. Following this the Longview Radio Sales & Service Association was organized with Mr. James Henry as President and Mr. W. L. Beasley as Sec'y-Treas. They are already planning to extend invitations to several nearby towns to become a part of their organization. It might be interesting to note that they voted to use the Code of Ethics of the Dallas Ass'n in full. We certainly congratulate them on their organization and wish for them the very best of luck.

## NEW Tricraft "3000" Series "X" ANTENNAS (Hi-Lo Conical Type)

- PRE-ASSEMBLED AT FACTORY, READY TO INSTALL (no loose parts)
- Matches 72, 150 and 300 ohm impedance
- All-wave, high gain on all channels
- Durable construction of finest aluminum (will not rust)
- Quality at the right price
- Excellent all-around performance eliminates constant servicing and maintenance

Tricraft "X" ANTENNAS are furnished in single, double or quad element assembly, with or without masts.

Available at leading jobbers.

Write for technical information, literature and prices.



**Tricraft Products Co.**

1535 North Ashland Ave., Chicago 22, Ill.

Manufacturers of complete line of Television, FM and AM antennas and accessories

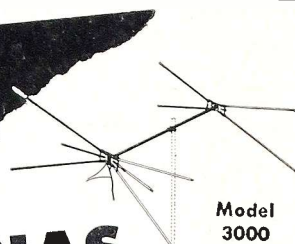

Model 3000

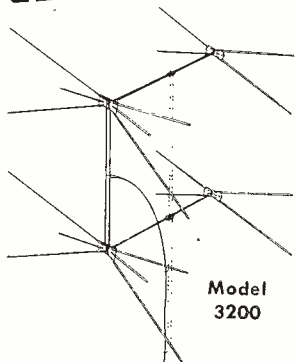

Model 3200

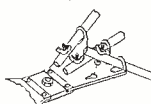

Unique clamp simplifies installation—just push in and tighten.

## SHOP NOTES

[from page 19]

tuner, the following part change will correct this condition:

Replace old part: C109, part #98A45-28 (10 mmfd., -300 temp. coef., ceramic capacitor).

With new part: C109, part #65B6-33 (10 mmfd., -750 temp. coef., ceramic capacitor).

Capacitor C109 is accessible by removing the cover plate located on the side of the chassis pan, next to the tuner. Capacitor C109 is connected between the second turret contact block terminal (from front of chassis) and ground.

After replacement of C109, the oscillator must be realigned by means of trimmer C110. Realignment should be made either with a TV signal on the highest available channel in your area or on channel 13 with a signal generator whichever is more convenient.

### Motorola VT 71 Repair

Customer brought in this new 7" electrostatic ac/dc model, complaining that after a week of excellent operation, suddenly, during a program, the picture went out. Sound continued normal. This eliminated the low-voltage rectifier, sound and common r-f circuits. A quick check of the voltages on the other circuits showed them to be normal. Yet there was no picture.

That started me to thinking. As a routine check I had already touched the rectifier cap with an insulated screwdriver and drawn a nice blue spark. *But, that, I realized, was nothing more than an r-f spark.* How could I find out if there was d-c high-voltage? The voltage chart said "DO NOT MEASURE" under the 1B3GT. The 1B3GT couldn't be checked in the tube tester because there was the feedback gimmick around it. (See drawing of H.V. Feedback Coil Fig. 4. Once I had the

## Insure BETTER Television Service to Your Customers! . . . Exclusively Designed

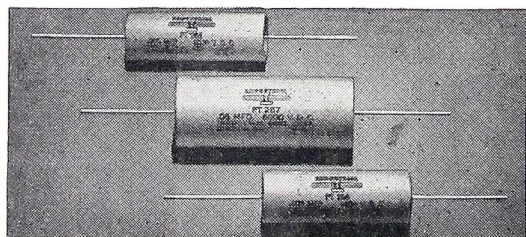

### HIGH VOLTAGE AND ELECTROLYTIC TUBULAR

## TELEVISION CAPACITORS

### Especially Engineered for Television Circuits by INDUSTRIAL CONDENSER CORP.

The economical quality line for replacement. Industrial Condenser Corp., manufacturers of Capacitors exclusively brings you highest quality for the particular requirements of Television at exceptionally attractive prices! Special Capacitors are Pyroteen impregnated for low power factor, high insulation resistance, high operating temperatures. Oil, Pyroteen, Wax and Electrolytic Capacitors. Finest materials throughout.

Ask Your Jobber for our Attractive Prices Today!

Or write for Bulletin 1095. Industrial makes quality Capacitors for Television, Radio, every electronic and industrial application—all types.

Send for Complete Catalog

### INDUSTRIAL CONDENSER CORP.

3243 N. CALIFORNIA AVENUE CHICAGO 18, ILLINOIS  
Sales offices in all principal cities

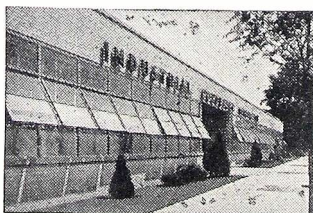

Modern plant built by Industrial Condenser Corp., for manufacture of Capacitors only.

drawing carefully made I removed the coil and checked the rectifier tube. The filament was open!

It was just a few minutes' work to hook up a new 1B3GT, following the drawing and the instruction data on location of the coil. That fixed it. If

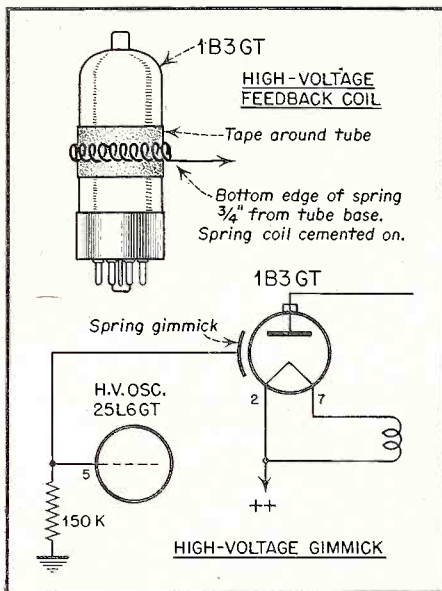

Fig. 4. Motorola VT71 high voltage circuit.

you're interested in just how the *gimmick* works, see the schematic drawn for only the feedback section High Voltage Gimmick above.

*Submitted by:*  
David Gnessin  
Columbus, Ohio

#### G. E.-Exchanging Stylus

These are the two main steps necessary to exchange the stylus of the General Electric replaceable stylus variable reluctance phonograph cartridge. The upper picture shows how the stylus can be pushed out with a

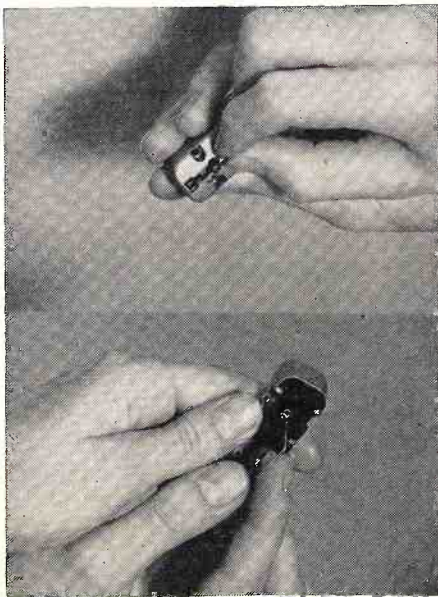

Fig. 5. Exchanging stylus in G.E. cartridge.

paper clip, and the lower one shows how a new one can be pushed into place with only the fingers. Several different size styli are available in sapphire and diamond for use with all types of recordings, including the long-playing records. Cartridges and styli are being made at G.E.'s Electronics Park at Syracuse, N. Y.

#### Admiral "30" - Interference

Bulletin TV-37 describes a remedy for an interference pattern caused on Channel 5 from the sound carrier of Channel 7.

In weak signal areas, there may be rotating black bars on Channel 5

where Channel 7 does not operate. This is caused by feedback from the last video IF stage to the RF tuner input. The last video IF stage generates a strong third harmonic of the video IF frequency of 25.75 mc. This harmonic is 77.25 mc which falls right in the Channel 5 frequency band. The feedback is caused by the piece of transmission line in the set between the antenna terminals and the tuner input, being close to the last video IF stage.

The remedy for this difficulty is to remove the piece of transmission line from the set, and run it down from the front of the chassis through the

## DEPENDABLE SERVICING STARTS HERE

### Advanced type BT resistors

You have never seen the equal to the way these new IRC resistors perform! Advanced BT's are so superior to conventional resistors of this type, they have established new standards of performance throughout the industry.

Advanced Type BT Resistors have extremely low operating temperature, and are especially suited to television servicing. They are supplied in RMA ranges in 5 small sizes: BTR  $\frac{1}{3}$  watt, BTS  $\frac{1}{2}$  watt, BTA 1 watt, BTB new miniature 2 watt, and BT-2 2 watt.

Full details are given in new catalog DC8—write for your free copy. International Resistance Co., 401 N. Broad St., Phila. 8, Pa., In Canada: International Resistance Co., Ltd., Toronto, Licensee.

INTERNATIONAL RESISTANCE CO.

Wherever the Circuit Says  $\sim\sim\sim$



#### ADVANCED BT's

are tiny, light-weight and fully insulated.



NEW METAL RESIST-O-KIT  
pocket-size, furnished at no extra charge with inexpensive  $\frac{1}{2}$  and 1 watt assortments.



#### ALL-METAL RESIST-O-CABINET

with 28 compartments in a choice of 3 assortments. Nothing extra for cabinet.



#### ALL-METAL BASIC KIT

meets daily resistor requirements of average service shop. No extra charge for cabinet.



hole in the cabinet which is used for the audio load. It can then be spliced to the antenna leadin somewhere down near the bottom of the cabinet.

We suggest that this remedy be used wherever this type of interference is present on Channel 5. The method outlined in TV-37 should be user in those cases where the interference is coming from Channel 7. In some cases, both types of interference may be present so that both remedies will be needed.

#### Tube Base Connectors

The serviceman who has to go through a TV alignment often finds

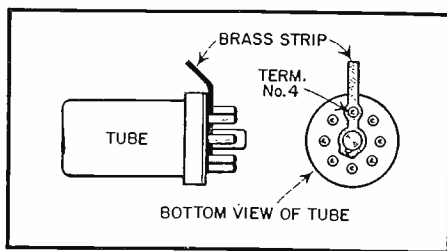

Fig. 6. Tube-base connector.

it easier to do his aligning from the top side of the chassis. For this reason he should provide himself with a number of tube base adapters of the type illustrated in Fig. 6. The illustra-

tion shown refers to an octal tube. However, connectors may easily be made for any tube.

#### Delco A-C D-C Portables—Hum

A kink on the Delco a-c/d-c portables is as follows: Complaint is continuous a-c hum even after the set is turned off. Tracing the circuit I found that B— is above chassis. The set uses a PM speaker with one side of the voice cell going to chassis and to the secondary of the output transformer. To correct this condition remove these leads from chassis and connect direct to a common terminal point insulated from chassis.

Submitted by;

Al Pratesi

White Plains, N. Y.

## SELL APPEAL WITH A "S" CAPITAL

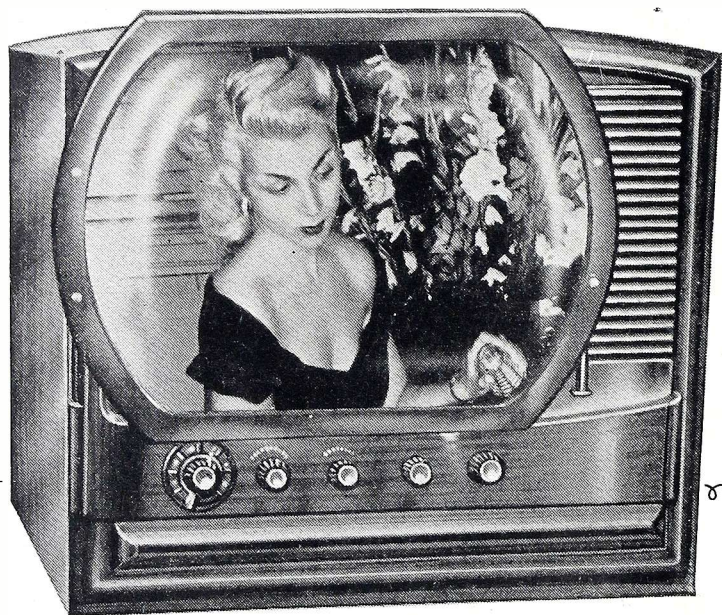

### DUOTONE'S DAYLIGHT TELEVISION ENLARGING LENS!

#### A SMASH HIT WITH YOUR CUSTOMERS

because . . .

- ★ It's easy to attach to any television set.
- ★ Fits console or table models.
- ★ Makes image **FOUR TIMES BIGGER.**
- ★ No eyestrain! No glare! No distortion!
- ★ More contrast! Sharper outlines!
- ★ Wide angle view! 3-dimensional impression!

#### BIGGER PROFITS FOR YOU

because . . .

- ★ Duotone Daylight lens is available in all sizes.
- ★ Lens available tinted or clear.
- ★ Generous dealer discounts are our policy!

**LENS PRICES** start as low as \$12.95

#### Also Available . . . . FILTERS

- ★ Duotone Daylight Television Filters scientifically tinted for maximum clarity, heightened contrast, elimination of eyestrain. 7" \$2.00, 10" \$3.50, 12" \$5.00, 15" or 16" \$7.50.

CONTACT YOUR DISTRIBUTOR OR DUOTONE DIRECT

THE **DUOTONE** COMPANY, INC.

799 Broadway New York 3, N. Y.

MAKERS OF THE FAMOUS DUOTONE NEEDLES

### CIRCUIT COURT

[from page 18]

Whatever steps are taken to reduce hum later in the circuit, it is always a big problem to limit the generation of hum in the first stage. One of the sources which plagues designers is the a-c voltage appearing across the heater, and between the heater and cathode, of the input stage. One method of holding this source of trouble to a low value is to use d.c. on the heaters or filament.

In the amplifier at hand, as shown in the partial schematic, a d-c source is used for the two input stage heaters. They are in series and across a 750 ohm resistor from the cathodes of the 6L6 output tubes to ground. Paralleled with them is a 50  $\mu$ f electrolytic condenser to maintain a very low impedance path for audio frequencies.

Another feature of the circuit which will permit some variation in components and tubes, and still make low hum possible, is the variable resistor across the heaters. The arm of this control is connected to the cathodes of the 6L6 stage, thus placing all the heaters to limit the total voltage potential above ground. This scheme is frequently helpful in removing an otherwise obstinate source of hum.

It should be noted that there is a resistor in series with the input tube heaters to limit the total voltage across them to 13 volts. The full emission of the tubes is not needed in the application at hand and tube life is increased many times by such a reduction.

Although not shown, voltage feedback is used around the last two stages to give improved response and further reduce hum.

## TV TRUCK

[from page 17]

installation medium is strictly prohibited.

### Service Methods

L & S service is given in the following way. Customers select the cabinet style at the store. Before there is any payment Mr. Hullet Shipman, the firm's TV technician, goes to the place of installation. Mr. Shipman has had extensive United States Navy training in radio, television and radar. Also arriving at the home or office or store where the television is to be placed is the Ford truck. This is taken care of by Mr. Ralph Riggs and Mr. Tony Santos.

Within a half hour to forty-five minutes Mr. Shipman knows the right height. He directs the two men in the Ford at the task of raising the portable tower. One moves the tower up while the other watches picture reception. A correct installation can be made in three hours. This is a saving of eight hours by former and more antiquated methods.

In the event that there is no picture up to 70 feet the location is classified as a "dead spot." No charge is made for the test unless it is outside of a twenty-five mile radius of Middletown. Then a small service cost is collected.

In the erection of about 175 sets only 3 "dead spots" have been encountered. In only a few instances have people objected to paying the cost of a tower that would have to be as high as 70 feet.

Middletown receives seven New York City stations on channels 2,4,5,7,9,11 and 13. Reception is called good on the average. The summer drought, with lack of humidity, weakened signals to a slight extent. Foliage has not cut down reception to the point where pictures could not be looked at.

Before the Ford truck and portable tower were employed it was necessary to have three installation crews. The new system finds L & S attending to one job in a half hour test with accuracy instead of the previous method of taking four hours, or longer, for a rough guess. Immediately after the half hour findings are made the Ford goes to another task. It can thus make a number of calls in a single day.

The L & S store is located on one of the main business streets of the

COMPARE RESULTS  
NOT CLAIMS —  
FOR RESULTS  
IT'S THE NEW —

# TACO TWIN-DRIVEN YAGI

BOOSTS SIGNAL!  
LOWERS COSTS!  
PINPOINT DIRECTION!

• WRITE FOR FREE BULLETIN ON TACO YAGIS.

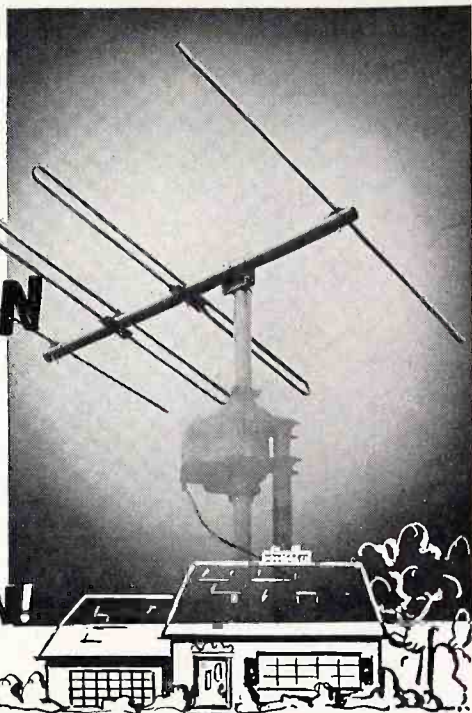

# TACO

RADIO & ELECTRONIC  
EQUIPMENT  
TECHNICAL APPLIANCE CORP.  
SHERBURNE, N. Y.

IN CANADA: STROMBERG-CARLSON CO., LTD., TORONTO 4, ONT.

## for superb HIGH-FIDELITY reproduction MASCO high frequency tweeter unit HFT-100

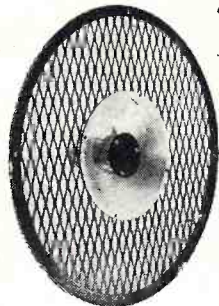

HFT-100  
with  
mounting  
screen

HFT-100  
mounted  
within  
cone  
speaker

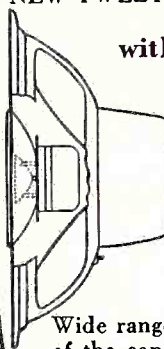

EXCLUSIVE NEW TWEETER THAT GIVES *living presence*

with **NO** distortion  
**NO** cumbersome horns  
**NO** crossover network  
necessary  
**NO** additional space required  
**NO** narrow dispersion angles  
**NO** need for separating  
sound sources

Wide range reproduction from the lowest response of the cone speaker to better than 15,000 cycles is obtained by using the HFT-100 Tweeter.

The tweeter is mounted within the cone speaker and connected in series with it.

No filter network is necessary. The HFT-100 has a built-in mechanical filter.

HFT-100 with attached mounting screen for 12" cone speaker. . . . \$24.50 List Price

HFT-100 with attached mounting screen for 15" cone speaker. . . . \$26.50 List Price

Write to factory for Catalog RD-12

HFT-100 Specifications	
Frequency range . . .	900 to beyond 15,000 cycles
Impedance	5 ohms
Power Handling	8 watts
Capacity	8 watts
Dispersion, horizontal and vertical	70 degrees
Width, less screen	5 1/4 in.
Height, less screen	5 1/4 in.
Depth	2 3/8 in.

# MASCO

MARK SIMPSON MANUFACTURING CO., Inc.  
32-28 49th Street, Long Island City 3, N. Y.

**SOUND SYSTEMS and ACCESSORIES**

RAvenswood 8-5810-1-2-3-4

# 3 GREAT NEW TITONES

meet changing pickup needs!

NOW a full line of Titone's amazing ceramic pick ups—made by famous Sonotone! All with these great basic features: Full frequency (response from 50 to 10,000 cycles.) Bell-like supertone makes new or old players thrilling. Climate-proof, moisture-proof, fungus-proof! Lightest pressure saves needle wear, revives worn records. NO needle talk! NO crystals, magnets, filaments to fail. NO pre-amplifiers. Performs perfectly for years!

## 3 NEWEST! TITONE MICROGROOVE PICKUP

For all 45 and 33 1/3 rpm players. Highest compliance and 5 to 6 grams needle pressure give minimum wear on record and needle! Aluminum case—1-mil permanent sapphire needle.

Order #W 7530 . . . . . \$7.95 list

## 2 NEWER! TITONE 3-MIL PICKUP

New superlight aluminum pickup complements famous original Titone pickup below. 15 grams needle pressure gives unparalleled reproduction, lowest wear!

Order #W 7540 . . . . . \$7.95 list

## 1 NEW! ORIGINAL CERAMIC TITONE

Within a few scant months in widest use from coast to coast! Plays at 20 grams needle pressure. Used instead of the newer aluminum Titone above for changers requiring over 15 grams pressure to "flip" records.

Order #7500 . . . . . \$7.50 list

NO TONE LIKE TITONE



Call your Jobber or write to SONOTONE, Box 5, Elmsford, N. Y.

city. Television sales have been progressive in the community which has a population of around 22,000 people. Middletown is situated about 70 miles north of New York City. In Orange County of the Mid Hudson Valley Middletown is the hub of the well known fruit belt and milk shed region. Middletown is often spoken of as the typical small city of the Empire State. By the end of 1949 the retail sales volume is being estimated at approximately \$30,000,000 compared to \$25,000,000 in 1948. Television is definitely helping with this above average little city business.

## PHOTO-ELECTRIC

[from page 16]

til the same meter reading is obtained. The two samples are then compared by noting the difference in the settings of the potentiometer. In this case, as in some others, color filters are used so that light of only one color reaches the tube.

Sometimes it is necessary that failure of the unit be guarded against. An example of this is seen in a device used to protect workers against injury in the operation of machines such as power shears, saws, etc. A beam of light thrown across the danger area of the machine is broken when any part of the operator's body is in this area, and prevents the machine from operating. Failure of some part of the photoelectric safeguard might leave the worker unprotected, probably without warning that he is not protected. Just how such an occurrence can be prevented will be seen in the illustration of Fig. 5. Three relays are used in this arrangement,  $Ry_3$  being the one which causes the device to fail on the safe side if a failure does occur. The circuit for  $Ry_3$  is completed through the contacts of  $Ry_1$  and  $Ry_2$ . One of these is the usual relay which is energized whenever the light beam is broken, the other is a type which will drop out if the amplifier plate current is reduced or is interrupted. Notice that failure of the light source, phototube, amplifier tube or power supply is guarded against.

A smoke detector is shown in Fig. 6. We have here an example of equipment in which a change in light intensity due to line voltage variations is compensated for. Two phototubes are used and are connected so that the current produced by one cancels that developed by the second. Since the unit is intended to



# THE REDSKINS ARE COMING!

NEW Radiodyne TV ANTENNA ACCESSORIES

## LOW PRICED MAST

- Tubular Steel
- 46 Ft. High
- Weighs Only 46 lbs.
- Baked Enamel Finish

ONLY \$43.50 LIST

For easier selling, feature Radiodyne's newly designed tubular steel masts. They're fully weather-treated . . . support antennas up to 25 lbs. . . and are priced to attract all customers who cannot afford towers. Special roof brackets furnished with each mast. Easily stocked and installed.

## All Steel GUY RINGS



Proper orientation of arrays WITHOUT STRUGGLING WITH GUY WIRES is a cinch with Radiodyne guy rings. Fit any mast from 0 to 2 1/16 O.D. Also available in heavy-duty cast aluminum.

Write for full information.

WESTERN COIL & ELEC. CO.

DEPT. RS 12

Racine, Wisconsin

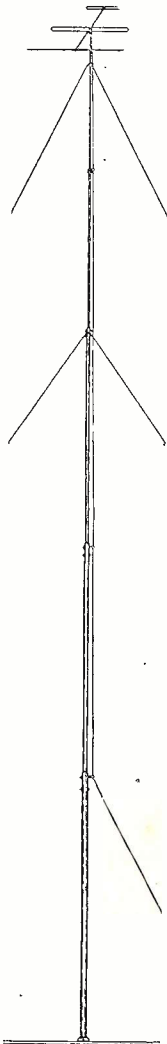



# YOU'LL WANT BOTH OHMITE

RESISTOR  
ASSORTMENTS

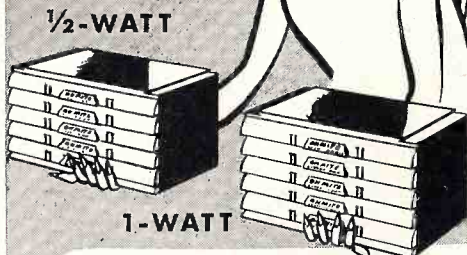

PACKED IN **RUGGED**

ALL-PLASTIC CABINETS

1/2-Watt Little Devil Assortment, Tolerance  $\pm 10\%$ . Stock No. CAB-1, \$12.50  
1-Watt Little Devil Assortment, Tolerance  $\pm 10\%$ . Stock No. CAB-2, \$18.75

NO CHARGE FOR CABINETS

It's easy to find the *right* resistor . . . *fast* . . . in these handy, handsome, all-plastic OHMITE cabinets. Compact—only 9" x 5 1/4" x 4 3/4"—each one has 40 compartments factory packed with a carefully selected serviceman's assortment of 125 individually marked "Little Devil" resistors, either 1/2 watt or 1 watt, in the 40 values from 10 ohms to 10 megohms most frequently used. And, you pay only the regular price of the resistors . . . *nothing extra* for cabinets.



See Your Distributor

**BROWN DEVIL**

Vitreous Enameled Resistors



A favorite with servicemen. Easily mounted by its tinned wire leads. In sizes 5, 10, and 20 watts. Tol.  $\pm 10\%$ .

**DIVIDOHM**

Adjustable Resistors

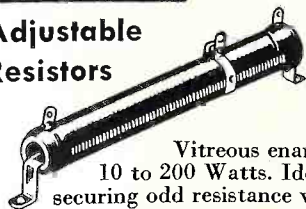

Vitreous enameled. 10 to 200 Watts. Ideal for securing odd resistance values.

**OHMITE MANUFACTURING CO.**

4846 Flournoy Street • Chicago 44, Ill.

Be Right with  
**OHMITE**

Reg. U. S. Pat. Off.

RHEOSTATS • RESISTORS • TAP SWITCHES

detect the presence of smoke in a ventilating shaft or duct, such a provision is quite important, otherwise line voltage variations might result in reduced lamp brilliance and so set off an alarm. Light from the lamp is focused on the mirror at the other side of the duct, whence it is reflected back to *phototube A*. At the same time, light reaches *phototube B* by way of the variable aperture in the lamp housing. The size of this aperture is adjusted until the light reaching both tubes is the same. The phototube currents are then balanced, and only a reduction in the amount of light reaching *A* (which would be caused by smoke in the duct) will cause the unit to function.

## ELECTRONIC VOM

[from page 14]

audio frequency or radio frequency. The multiplier is necessary when measuring an a-f voltage between 100 and 1000 r.m.s. volts. The a-c voltages below 10 r.m.s. are read on either of the two lower scales—the 3 or the 10 volt scale. Voltages between 10 and 100 r.m.s. are read on the scale marked "ac above 10". The audio frequency voltages between 100 and 1000—which

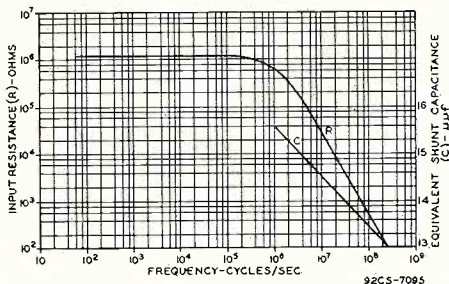

Fig. 4. Effective input resistance and capacitance of diode probe versus frequency.

require the use of the multiplier, are also read on this scale.

### Applications

An electronic voltmeter of this type has many specialized applications which ordinary measuring instruments cannot adequately measure. Oscillator grid bias may be measured by virtue of the high input impedance of this meter and it is a well-known radio fact that the amplitude of the oscillation output is proportional to the oscillator grid bias. Automatic volume control (a-v-c) voltage may also be measured because the high input impedance of the instrument does not affect the circuit. As an output meter, the WV-75 A may be connected across the load resistor of the

Everybody agrees  
**ATR VIBRATORS**  
are TOPS!

**ATR**

**AUTO RADIO VIBRATORS**

have Ceramic Stack Spacers



A COMPLETE LINE OF VIBRATORS...

Designed for Use in Standard Vibrator-Operated Auto Radio Receivers. Built with Precision Construction, featuring Ceramic Stack Spacers for Longer Lasting Life.

Backed by more than 17 years of experience in Vibrator Design, Development, and Manufacturing.

ATR PIONEERED IN THE VIBRATOR FIELD.

NEW VIBRATOR GUIDE  
FREE



**ATR**

"A" BATTERY  
ELIMINATORS

for DEMONSTRATING AND  
TESTING AUTO RADIOS

New Models . . . Designed for testing D. C. Electrical Apparatus on Regular A. C. Lines. Equipped with Full-Wave Dry Disc Type Rectifier, Assuring Noiseless, Interference-Free Operation and Extreme Long Life and Reliability.

NEW MODELS ✓ NEW DESIGNS  
NEW LITERATURE ✓  
ATR "A" Battery Eliminator, DC-AC Inverters,  
Auto Radio Vibrators  
See your jobber or write factory

**AMERICAN TELEVISION & RADIO Co.**

Quality Products Since 1931

SAINI PAUL 1, MINNESOTA-U.S.A.



A Radically Improved New Type of  
**TELEVISION BOOSTER**  
 Offering Great New  
**ADVANTAGES IN  
 RECEPTION AND TUNING**

LIST PRICE  
**\$49<sup>50</sup>**

**ADDITIONAL  
 FEATURES**

- 1 Self-contained power supply operating from 115 volt, 60 cycle AC power line.
- 2 On-off switch allows booster to be switched in or out of the circuit at will.
- 3 Recessed pilot light indicates when booster is on.
- 4 Beautiful, furniture-finish mahogany cabinet (8-1/2" wide x 6-1/2" high x 7-3/8" deep) to complement fine home furnishings.
- 5 Simple to install and operate—complete instructions with each unit.

**THE ASTATIC**  
*Channel Chief*

**T**HE NEW ASTATIC CHANNEL CHIEF, Model AT-1 Television Booster, eliminates the common failing of many boosters—showing a "peak" on some channels and "fall-off" on others. The Channel Chief provides extremely high gain, uniform on all 12 television channels. Its dual controls allow separate tuning of picture and sound, with no sacrifice of one for the other. A variable gain control permits reduction of signal strength to prevent picture distortion when the signal input is greater than that required for good definition. Altogether, the results are the considerable extension of fringe areas, good reception in areas previously rated as unsatisfactory, easier tuning and added selectivity on any receiver, elimination of the need for expensive outdoor antennas within service areas. The increased selectivity serves to reduce drastically, or eliminate, interference. No other booster can do so much . . . for you or for your customers. Write for added details.

Leading Manufacturers of Microphones, Phonograph Pickups, Cartridges and Related Equipment.



**SOUND I-F**

[from page 12]

electronically and automatically eliminated from the circuit when its use is not needed.

**Coupling Methods**

Coupling methods in both standard FM receivers and TV-FM sections consists primarily of transformer coupling between the stages. Typical ones are shown in *Figs. 1 and 2*. The capacitors which make up the resonant circuit are usually fixed, and tuning—when necessary during alignment—is done by adjusting the slugs.

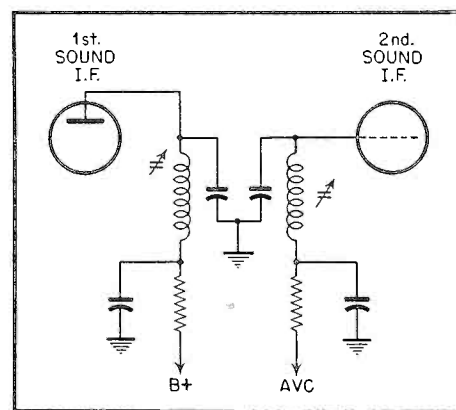

Fig. 5. Capacity coupling in DuMont RA-105

The small arrows indicate that the coils are tuned by means of slugs within the coil instead of capacitors. *Figure 1* shows the small arrows pointing either up or down. Many manufacturers use this method to indicate whether the coil is tuned from above the chassis or from underneath.

Some manufacturers (Such as DuMont in the RA-105 TV receivers) use capacitor instead of transformer coupling. *Figure 5* indicates this method. The plate coil and the grid

*Heathkit*  
**TEST EQUIPMENT**

Build YOUR OWN

**Heathkit AUDIO GEN. KIT** \$34<sup>50</sup>

**Heathkit TELEVISION GENERATOR KIT** \$39<sup>50</sup>

**Heathkit CONDENSER CHECKER KIT** \$19<sup>50</sup>

**NEW Heathkit IMPEDANCE BRIDGE SET** \$69<sup>50</sup>

**NEW Heathkit HANDITESTER KIT** \$13.50

**Heathkit TUBE CHECKER KIT** \$29<sup>50</sup>

**Heathkit 5" OSCILLOSCOPE KIT** \$39<sup>50</sup>

**Heathkit BATTERY ELIMINATOR KIT** \$22<sup>50</sup>

**Heathkit ELECTRONIC SWITCH KIT** \$34<sup>50</sup>

**Heathkit R.F. SIGNAL GEN. KIT** \$19<sup>50</sup>

**Heathkit VACUUM TUBE VOLTMETER KIT** \$24<sup>50</sup>

**Heathkit SIGNAL TRACER KIT** \$19<sup>50</sup>

Heathkits are beautiful factory engineered quality service instruments supplied unassembled. The builder not only saves the assembly labor cost but learns a great deal about the construction and features of the instrument. This knowledge aids materially in the use and maintenance of the equipment. Heathkits are ideal for and used by leading universities and schools throughout the United States. Each kit is complete with cabinet, 110V 60 cycle transformer (except Handi-Tester), all tubes, coils assembled and calibrated, panel already printed, chassis all punched, formed and plated, every part supplied. Each kit is provided with detailed instruction manual for assembly and use. Heathkits provide the perfect solution to the problem of affording complete service equipment on a limited budget. Write for complete catalog.

**HEATH COMPANY**  
 BENTON HARBOR, 12 MICHIGAN

EXPORT DEPARTMENT  
 13 EAST 40th STREET  
 NEW YORK 16, N.Y.  
 CABLE—ARLAB—N.Y.

# THE REDSKINS ARE COMING!



# DRAKE

*insta-heat*  
SOLDERING GUN

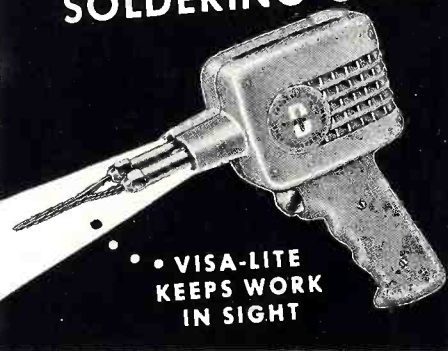

VISA-LITE  
KEEPS WORK  
IN SIGHT

Perfectly balanced, functional in design, the DRAKE "insta-heat" Soldering Gun gives you all the features you've wanted: A full 135 watts, this gun has the perfectly located VISA-LITE, that keeps work always in full view—even in dark difficult corners. The soldering tip is easily - instantly - removable, using only a screwdriver. See your distributor.

**DRAKE ELECTRIC WORKS, INC.**  
3656 LINCOLN AVENUE CHICAGO 13

coil are tunable by adjusting the metal slug, while the two capacitors, with a center common ground, give the desired coupling. This method assured over-coupling for wide-band response.

In the plate side of all the circuits shown, a decoupling network is inserted below the plate resonant circuit. This resistor and capacitor effectively isolates the stages from others, and thus prevents signal energy feedback which would set these amplifiers into oscillation. This is common practice with all i-f amplifiers as well as high gain audio stages.

### Common I-F Troubles

As with most amplifiers, common troubles fall into several categories. In the absence of sound, the tubes should be checked first. Once the tube factor has been eliminated, voltage and resistance measurements should be undertaken, and signal tracing resorted to if necessary. Severe misalignment would, of course, also prevent the signal from getting through. Unless, however, the receiver has been tampered with, alignment should not be necessary because the percentage drift of i-f stages in broad band work is negligible. If the set had been playing well and suddenly stopped, the trouble would not be with alignment.

A common trouble in i-f stages is a defective screen by-pass capacitor. Take, for instance, the capacitor at the screen of the 1st sound i.f. of Fig. 1. If this capacitor opens, the 1st sound i-f stage will go into oscillation. In a wide band stage oscillation virtually kills all signal, because while in the oscillatory state the circuit Q rises. The high selectivity, and the sustained oscillations, will usually give zero sound output. Occasionally a partially defective capacitor will not reduce the sound to total zero, but will bring it to such a low level that the sound is heard only faintly with the volume control turned on full.

When this stage oscillates in a television receiver, it will feed back this r-f oscillation into the picture i-f stages. The result then appears on the screen as a pronounced herringbone pattern with a reduction of picture contrast. If this capacitor should short instead of open, it would cause excessive heating of the screen dropping resistor, for the shorted capacitor will raise to a high level the current flowing through the resistor. An over-heated or burned out screen resistor should result in an immediate check of the screen by-pass capacitor.

Another capacitor which gives trouble is the decoupler capacitor previously mentioned. When this capacitor shorts, the series resistor through which plate current normally flows

*Nation-wide*  
**ACCEPTANCE**  
on Proven Superiority



**ANCHOR**  
**TV PRE-AMPLIFIER**  
Here's Proof of Distributor Acceptance

SOUTH BEND, IND.—"We have found Anchor TV Pre-Amplifier to be superior in performance to anything else on the market. It has been a profitable item on which we have built up dealer good will."

COMMERCIAL SOUND & RADIO CO.—A. E. Kester, Pres.

PHILADELPHIA, PA.—"Anchor Booster's consistency, its high gain and its performance in outer fringe areas have built for it a reputation which cannot be beat in our area. The excellency of this product has opened up many television areas and many additional sales in Television Receivers, their component parts and accessories."

RADIO ELECTRIC SERVICE COMPANY OF PENNSYLVANIA  
Albert N. Kass, Sales Manager

**ANCHOR** has established  
general acceptance and good will  
for all good boosters through its own  
top-notch performance!

Unanimous proven verdict of users. Anchor's engineering is not approached—nor will it ever be.

The ANCHOR BOOSTER is built to help you make the best TV installations possible for your customers.

Why then be satisfied with the ordinary? Anchor builds demand for reliable boosters—making more sales—adding good will. Tie Anchor Booster into every television sale.

Here is dependability with instant sales appeal—2½ times average gain (Voltage Ratio), guaranteed coverage of low and high band—precision with beauty—pride in having the best!

Get in touch with your jobber—  
or write ANCHOR

"ANCHOR ENGINEERING ALWAYS A YEAR AHEAD"



**NEED HELP?**

**TRAINED MEN AVAILABLE**

Solve your trained manpower shortage by employing C.T.I. graduates. These men have completed a rigid course of training. What they've learned has been PRACTICAL, because most of their training period was spent IN THE SHOP. We probably have graduates from your area. Write for prospectus on Available men. (No employment fees).

**COMMERCIAL TRADES INSTITUTE**  
1400 Greenleaf Dept. P 105-12 Chicago 26



ANOTHER **HYTRON FIRST** YOU'LL BE BUYING SOON

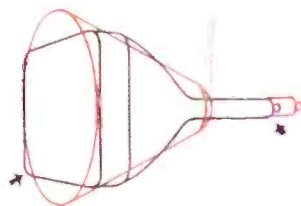

# NEW HYTRON RECTANGULAR all-glass 16RP4

Meet Hytron's space and money saver. The new Hytron 16RP4. Revolutionary 16-inch rectangular picture tube. Takes approximately same cabinet space as 12LP4. Automatically sets the pace for more compact and economical TV set design. You'll be seeing it . . . buying it . . . soon.

The new 16RP4 is latest in a long series of Hytron firsts. Including: The GT tube. Over 50 GT types. The subminiature. Many new miniatures. Special low-cost TV deflection-circuit tubes: 1X2, 6BQ6GT, 6U4GT, 25BQ6GT. Check the 16RP4's many features. Watch for it. Buy the best by the leader. Buy Hytron!



With old-style round tube, you lose the corners.



With Hytron 16RP4, you see the picture just as transmitted.

## Features of HYTRON 16RP4

- 1 Rectangular shape permits smaller, less costly cabinets.
- 2 Also just as short as 12LP4
- 3 Weight is approximately two-thirds that of 16-inch, all-glass round tube.
- 4 Easy to mount. Can't roll or twist.
- 5 No high-voltage isolation of tube required.
- 6 Neutral gray face . . . increases contrast ratio.
- 7 Large viewing screen. You get the entire transmitted picture; no lost corners. Gives picture (with standard 3 by 4 aspect ratio) 10 $\frac{1}{4}$  inches by 13 $\frac{1}{2}$  inches.

Write for Bulletin E-147 giving complete data.

OLDEST MANUFACTURER OF RECEIVING TUBES  
**HYTRON**  
RADIO AND ELECTRONICS CORP.



MAIN OFFICE, SALEM, MASSACHUSETTS



*A Merry Christmas and  
a Prosperous New Year*

Good cheer, good health, good profits  
... these are our wishes to you for  
Christmas and the New Year.



**RADIO CORPORATION of AMERICA**  
HARRISON, N. J.