

RADIO
Retailing

SERVICE ENGINEER

Radio, Television and Audio Servicing

Pardner, This Deal is All Aces!



Play your first ace—tell the customer the replacement tube is Mullard 'Radiant Screen'.
 You know from practical experience these picture tubes are the world's finest. The customer is already sold on them through Mullard's national advertising!
 Play an ace with the service engineer—he prefers the quality and reliability of Mullard 'Radiant Screen' replacement tubes!
 Ring up the next ace on your till—'Radiant Screen' tubes minimise call backs, maximise profits!
 And the fourth ace? That's the little Gold Book and the lasting good will you win from the customer!

Mullard *Radiant screen*

THE FINEST
PICTURE TUBE
IN THE WORLD.



MULLARD LIMITED • MULLARD HOUSE • DRINGTON PLACE • LONDON • W.15.



GOOD NEWS FOR SERVICE ENGINEERS!



TELEVET

TYPE 259

The ONLY complete Television Tester providing every facility needed for completely checking, repairing, overhauling and aligning TV sets. Covers Bands I and III, crystal calibration. Can be used with AC and AC/DC type sets. Completely portable. H.P. terms available.

Incorporates:

- Wobbulator
- AM or CW Signal Generator
- Pattern Generator
- Audio Oscillator
- AC and DC (including EHT) voltage measuring facilities
- Line transformer test

66 GNS NET TRADE
IMMEDIATE DELIVERY



RADIVET

TYPE 211

The ONLY complete Broadcast Receiver Tester, providing every facility for completely checking, repairing and aligning any Radio Receiver. Particularly useful for VHF testing. Covers Long, Medium and Short Waves, and Band II, crystal calibration, linear tuning scale, pre-emphasised signal available, usable with both AC and AC/DC Type Receivers. Fully Portable. H.P. terms available.

66 GNS NET TRADE

IMMEDIATE DELIVERY

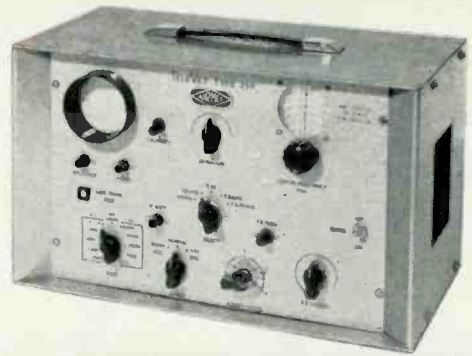

**THIS AIRMEC DOUBLE
WILL HALVE YOUR WORK**



Send for fully descriptive literature.

Airmec

AIRMEC LIMITED · HIGH WYCOMBE · BUCKS
TELEPHONE: HIGH WYCOMBE 2501-7

SERVICE ENGINEER

Vol 4. No. 1 May, 1961

Edited by W. Norman Stevens

Issued as a special supplement with "Radio Retailing"

In this issue:

	Page
Trade Notes	1
Service Viewpoint	2
New Books	2
Modern Tape Recorder, Part 2, by B. R. Good	3
Technical Gen for Servicing Men	7
Service Data Sheet Listing	8
Handy Solder Dispenser, by V. D. Capel	14
Trade Topics (Letters to the Editor)	14
RTEB Annual Report	15
Service with a Grin, by H. W. Hellyer	16

SERVICE DATA SHEETS

SI6: Kolster-Brandes RT20 tape recorder
TV177: Ultra 1780/1782 series TV receivers
RR Annual Index, Vol. XV, May 1960—April 1961

Type 2A Aerosol Applicator for Electrolube

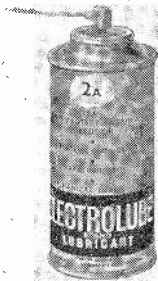

A new "aerosol" dispenser for *Electrolube* is now available from wholesalers at the price of 22s. 0d., net trade. This 6-ounce dispenser has been developed in response to requests from users and will convey the lubricant in a fine spray directly on to working contacts, switches, etc.

The type 2A aerosol applicator combines the actions of *Electrolube* No. 1 and No. 2 in loosening tarnish, lubricating and spark inhibiting. A five-inch snorkel extension is also provided for directing the spray into inaccessible places. A 20-page illustrated technical booklet on the applications of *Electrolube* is available, free, from Electrolube Ltd., 16 Berkeley Street, London, W.1. (Tel.: HYDe Park 0501).

MAY, 1961

ADDITION TO GRUNDIG INSTRUMENT RANGE TYPE 701

One of the Grundig instruments recently introduced into this country (sole distributors: Wolsey Electronics Ltd., Cray Avenue, St. Mary Cray, Orpington, Kent) is the Type 701 grid dip meter, which may also be used as an a.m. test oscillator and as a simple receiver.

The circuit consists basically of an r.f. oscillator, the frequency of which is determined by interchangeable coils and by setting of a tuning capacitor. A meter indicates the oscillator grid current. A four-position switch changes the function of the instrument as follows:

Receiver: The h.t. is disconnected from the oscillator, the valve becomes a rectifier and the rectified current is switched to the phone sockets. The instrument thus becomes a receiver supplying an a.f. signal to a pair of headphones.

Absorption Meter: In this position, h.t. is disconnected from the valve which then behaves as a rectifier. Maximum meter reading is obtained when in resonance with a radiating source.

Grid Dip Meter: In this position, resonance with a circuit coupled to the coil is indicated by a dip in the grid current reading.

Modulated Oscillator: The oscillator is modulated by the mains supply

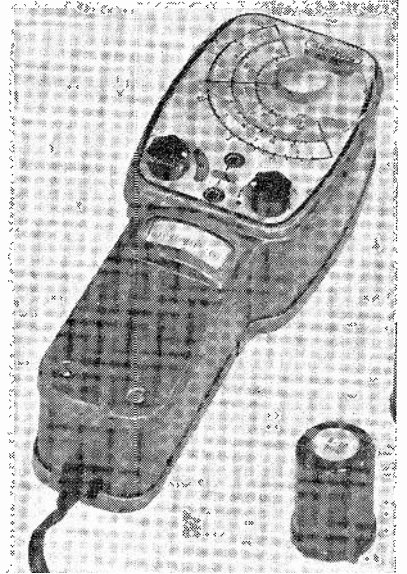

frequency to become a radiating source of known frequency.

The Type 701 covers from 1.7 Mc/s to 250 Mc/s in six ranges. The frequency is by direct reading from the tuning scale and is held within a tolerance of $\pm 1.5\%$. It weighs 2½ lb. and measures 8 × 3 × 2½ in. The unit sells at £21 nett.

EKCO-PYE SCOTTISH SERVICE

R & TS have moved from Waterloo Street, Glasgow, into the Ekco Depot at 17 Cadogan Street, which now becomes the main RTS Scottish Depot. Mr. E. Forbes, previously Ekco Depot manager continues as manager, with former RTS manager, Mr. R. Mackie, as his deputy. Mr. R. T. Frost continues as RTS area manager. This pooling of resources aims to provide second-to-none servicing facilities in Scotland.

Steadfast Introduce New Sheet Saw

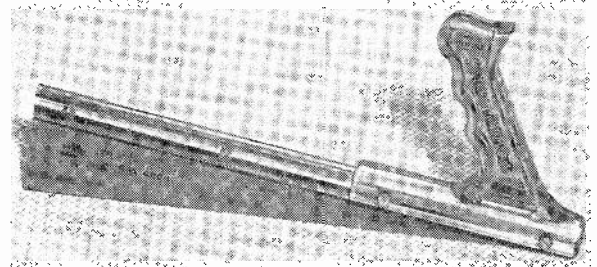

An interesting new sheet saw has been introduced by J. Stead & Co., Manor Works, Cricket Inn Road, Sheffield, 2. A 12-inch triangulated blade of "Cobaltcrom" special abrasion resisting steel is held in a polished alloy spine to which is fitted a shatterproof amber plastic handle.

Two blades, of 14 and 24 teeth-per-inch, are supplied and are available separately as replacements. The tool is intended to cut asbestos, plastics, wood, steel, and other metals and materials in a variety of forms, including corruga-

tions, sheet, laminates, tubes, blocks, boards, etc.

A sample saw was found to be strong and rigid in use, giving accurate cuts. It cut cleanly and easily on a variety of materials and the finger-grip handle was found to be comfortable in use, easing fatigue. It would find many applications in the average workshop.

The price of the new saw is 16s. 0d., including two blades of different pitch. Spare blades are available at 3s. 3d. each. The tool is obtainable from most hardware and tool dealers.

YOU think you are having trouble with service? Take heart, things could not be so bad as they are behind the Iron Curtain, where, according to a letter in *Electronics Weekly*, "People are jamming the doors of television workshops . . . in Moscow . . . 20 thousand television sets are not working."

The letter quotes from the Soviet magazine *Ogonyok*—Russian equivalent of *Time*. There, an article stated that the editorial board had received many letters confirming that the television set has permanently entered into the life of towns and villages and workers' settlements.

"It is therefore all the more irritating," the *Ogonyok* editor goes on, "to learn of the poor service given to many viewers".

The Trust responsible for servicing is hampered by a lack of components,

Red Dogs

including tubes, valves and line transformers. This shortage is blamed on the failure of factories to meet their quotas. And the sales network is even worse: "Many managers of radio shops have already forgotten the day when they had these goods for sale".

Quoting excerpts from readers' letters, the writer states that there is annoyance because people are not even given dates for repairs, which have frequently not been carried out "after periods in excess of six months".

It seems strange in a well-ordered society that such conditions exist. Or can it be that, in an effort to be foremost, Russian TV production plumped more for quantity than quality?

The letter-writer, N. G. Anderson, a member of the British-Soviet Friendship Society, suggests that British manufacturers might try siphoning off their surplus sets to Russia: "It would give our flagging television industry a much-needed outlet".

We would add that such a situation justifies the export of a few of our underworked service engineers. Nominations will not be accepted unless accompanied by a stamped addressed copy of *Das Kapital*. Disgruntled readers who feel they could acquire a taste for vodka and master the mystery of the samovar could do worse than follow in the footsteps of Fuchs.

Yet, we'll warrant that Ivan and Boris and Mrs. Grumbleovski will prove to be just the same as their British counterparts—except that they seem to have more to niggel about.

New Books

★ SERVICE ENGINEER REVIEWS OF THE LATEST TECHNICAL LITERATURE

Fun With Electricity, by Tom Kennedy, Jr. Published by Gernsback Library Inc., 154 West 14th Street, New York 11. (U.K. Agents: Modern Book Company, 19 Praed Street, London, W.2.) 128 pages. Size 8½ × 5½ in. Price 21s.

RADIO engineers who want to interest their proteges in things electrical will often be stuck for presents, sometimes puzzled as to which is the best type of book to leave casually lying around.

Here is their answer—a quite unpretentious little volume that begins with a brief introduction to electricity and magnetism, quickly progresses to "nucleonic forces", then, after stumbling over a section devoted to the care of tools (presumably so that Junior can get his breath back), slips into a young do-it-yourselfer's paradise.

Exact and simple details are given for making a galvanometer, simple d.c. motor, a.c. generators, solenoids, spark coils, magnetic engines and finally meters.

By the time Junior has worked his way through the ten chapters, Dad had better watch out, for there is quite a lot of educational matter squeezed in these pages, despite the "Fun" in the title. Books on fundamentals are usually deep and digressive, off-putting to the young, or cartoon-style monodies, an insult to the inquiring intelligence. Mr. Kennedy's book falls neatly between these extremes, and is worth Dad's consideration.—H.W.H.

★

The Story of Stereo: 1881, by John Sunier. Published by Gernsback Library Inc., 154 West 14th Street, New York 11. (U.K. Agents: Modern Book Company, 19 Praed Street, London, W.2.) 160 pages. Size 8½ × 5½ in. Price 23s.

THERE is nothing new under the sun. That would seem to be the slogan under which this interesting book will sell.

It will surprise many readers to find that stereophony was practised, and indeed patented, sixty years ago. The now historic 1881 Paris Exposition used a system drawn up by Parisian engineer Clement Ader to "broadcast" presentations from the Paris Opera. This was direct telephony, with the microphones grouped at each side of the stage and the subscriber listening to the individual sounds from each transmitter group.

From these beginnings, hardly more than a novelty, the history of stereo has been largely a matter of technical argument. Not the "why" but the

"wherefore". There have been the vehement exponents of the "broad front", the "selective channel", the binaural and stereophonic systems as we know them today.

With a wealth of intriguing fact and numerous references for the student who would delve deeper, Mr. Sunier has traced the history of stereo from those beginnings to the present day.

But he has done more. In tracing his historical path, Mr. Sunier has not omitted to wander off into the little-trod byways. We learn all sorts of curious facts about sound applications.

We can also learn quite a lot about the principles of stereo. The first chapter treats the theories, argues the advantages and discusses definitions. Chapter two is largely an historical groundwork; the next four deal with special applications of stereo to film, tape, disc and broadcasting; and a final chapter describes stereo techniques—domestic, industrial and medical.

This is a book full of fascination for an audiophile, guaranteed to wake enthusiasm in the lukewarm, even to tickle the fancy of those who, seeing its futuristic cover and terse title "Stereo: 1881" on the bookstall, purchase it in mistake for science-fiction.

This is science-fact, and well-written fact at that, illustrated in the thorough, occasionally humorous way we have come to associate with Gernsback publications. Mr. Sunier, and Gernsback, are to be congratulated.—D.C.

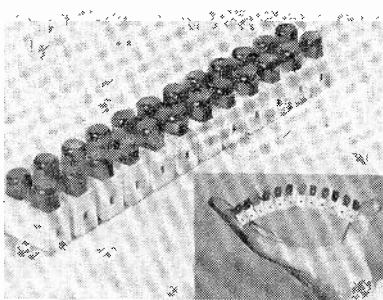

Hellermann have added a new flexible terminal block in PVC to their range of *Suprafix* spring-loaded terminal blocks. The new block, shown in the photograph above, rated at 10A and working up to 500V, is designed for use with standard Hellermann terminal which obviate the use of solder or pinch screws.

Servicing the MODERN TAPE RECORDER

PART TWO OF A NEW SERIES BY **B. R. GOOD**

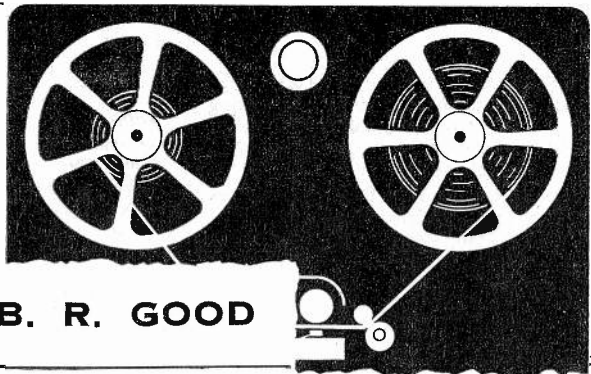

BY FAR the greater part of the tape recorder market is taken up by "popular" or "family" models. Of these, although there are a number of different manufacturers, the majority use the BSR *Monardeck*, The Collaro *Studio Deck*, and the Garrard *Magazine Deck*.

This is not to ignore such stalwarts as Walter, Philips, Grundig, and Truvox, whose products will engage our attention a little later. At present we are concerned with the majority—and here the BSR *Monardeck* surely leads the field.

BSR MONARDECK

At the last Radio Show I remember enquiring how many machines used the TD2 as the basis of construction. The exact number on show was not discovered, but we found later that twenty distinct companies used this popular deck in their current range of tape recorders.

Its great attraction is simplicity—and this does not mean a skimping of design.

Obviously, much care has been taken to streamline the mechanics without sacrificing efficiency, and with no detriment to style.

The TD2 has a single speed of $3\frac{3}{4}$ i.p.s., one way only, recording the upper track from left to right, which is the now accepted standard. Spool size is limited to $5\frac{1}{2}$ inches, which gives a playing time of about 45 minutes per track on standard tape. Rewind time is about three minutes for a full spool.

Servicing

There is no difficulty in getting at the *Monardeck* to service it. After pulling off the control knobs and removing three screws, the top cover lifts away, revealing a two-level chassis. The spools, motor, flywheel, idler pulley and coupling rods are mounted

on the lower main chassis and the top plate carries the heads, capstan, pinch wheel, pressure arms and pivots, operating levers, and brake assemblies.

A good feature of this deck is the simplicity with which the capstan and drive belts can be removed at this stage of operations. The capstan (A), with its alloy flywheel, three inches in diameter and $\frac{3}{8}$ inch thick, is mounted in a bearing which takes the form of a sleeve and base cup over 2 inches in length. This is driven from the motor pulley (B) by an elastic belt (C), giving remarkably smooth performance. Another elastic belt (D) is looped from the capstan spindle to the take-up spool (E) (record/playback).

Rewind

In the Rewind positions, a more direct drive is given to the turntables by a swivel lever (F) which engages the rim of the appropriate turntable with either a bush on the motor spindle (rewind) or an idler wheel (G) (fast forward). This action is initiated by the slotted lever (H) directly beneath the control knob. Moving the control sideways causes this lever to move, but the rod of the control (J) is free to slide forward in the slot for "Record" or "Playback".

This action is quite positive, but is assisted by the small coiled spring (K) on the right, which has been known to break on occasion, leading to erratic operation.

If any quantity of these decks are to be serviced it would be advisable to stock a few of these springs as replacement.

Brake Springs

Another spring which can give rise to some peculiar symptoms is that which holds the two brake levers in tension (L) and is connected between the inner angles of the levers. Braking is automatic between function switching, and essentially simple, pads on the levers (M) being applied to both spool rims.

(Continued overleaf)

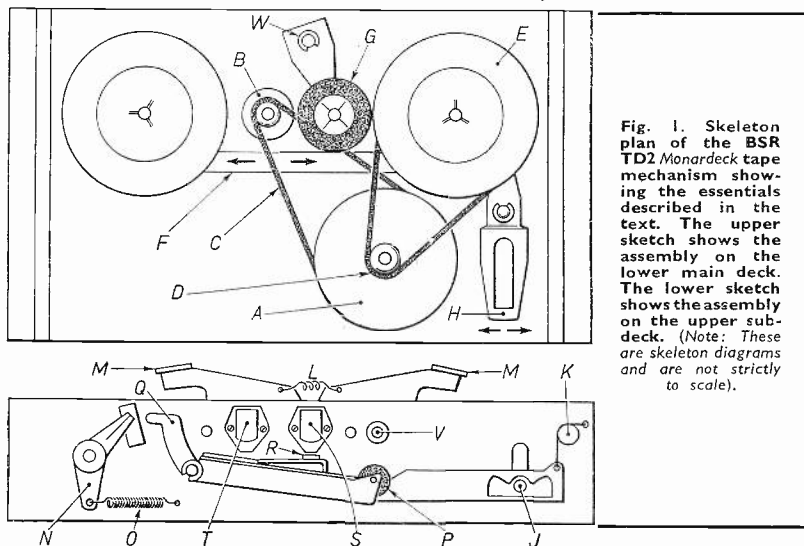

Fig. 1. Skeleton plan of the BSR TD2 *Monardeck* tape mechanism showing the essentials described in the text. The upper sketch shows the assembly on the lower main deck. The lower sketch shows the assembly on the upper sub-deck. (Note: These are skeleton diagrams and are not strictly to scale).

MODERN TAPE RECORDER

—continued

As the control lever must pass through "Neutral" between functions, braking is straightforward, and apart from checking the friction pads, should require little attention.

The safety switch for "Record" is now a general feature of most tape recorders. On this deck, however, it presents little complication. The Record/Playback knob is mounted on an angle arm (N) which is spring-loaded (O) toward the "Playback" position. When held in the "Record" position, it can only be locked by the main function control being pushed forward, that is to its "Record or Playback" setting.

This latter action engages the pinch wheel (P) and allows a protruding end of the carrying bracket (Q) to lock the inner part of the swivel arm.

Any movement of the function control toward neutral releases this catch, allowing the swivel arm to spring to "Playback". The swivel arm actuates a simple switch beneath the deck plate.

Pinch Wheel

Pinch wheel operation is normal, but there is only one pressure pad (R), holding the tape against the Record/Playback head (S). This stands back well in the neutral or rewind positions, allowing plenty of clearance for tape-loading or inspection of head faces.

The tape is held in intimate contact with the erase head (I) by the positioning of the guides and capstan (V). Despite a certain scepticism when this deck first came on the market, there have been very few complaints of inadequate erasure, and most of those turned out to be due to either a film of foreign matter or incorrect head setting.

Azimuth Setting

The azimuth angle setting can be difficult on some machines, requiring great care and numerous trial and error alterations. Here we have the simple "two-screw" technique. The heads are mounted to "rock" on their plates, held by two screws. One screw is spring-loaded—*do not alter it*—adjust the screw *without* the spring washer for maximum playback of a test tone. 8 kc/s is recommended for this adjustment.

Both high and medium impedance Record/Playback heads have been used. For the former, bias current is about three-quarters of a milliamp, and signal current 50 microamps. The medium impedance head requires twice this current. Bias is at 50 kc/s (approx. 20 volts r.m.s.), and erase head current (low impedance), should be between 75 and 100mA.

The plastic spools are on simple disc clutches, and there should be no trouble with clutch action—that bugbear of so many models.

The right-hand spool tends to rotate faster than required until drive is applied to the spool by the capstan. Then the clutch slips, allowing just enough pressure for take-up.

The left-hand spool rests on a direct bearing and is free to rotate in the Record/Playback or Fast Forward settings, but receives clockwise impetus on Fast Rewind from the motor spindle.

Lubrication

The manufacturers recommend that medium grease is used at the following points: connecting link slot, jockey pulley pivot (W), rubbing surface of pressure lever adjacent to control knob, shouldered pin on connecting link, pivot of control lever, and support arms.

Light oil only should be used at: jockey-pulley spindle, spool bearings, and pressure roller bearings.

The usual strictures apply to lubrication. Avoid grease or oil on rubber and plastic

surfaces. Lubricate sparingly and only when strictly necessary.

Performance

This deck is deservedly popular. It is not always done justice by manufacturers who incorporate it in models that defeat the aims of the BSR designers to achieve the utmost simplicity without sacrificing technical excellence.

For example, the head gaps are 0.0002 in. and 0.09 in. With correct equalisation, at the set speed of $3\frac{1}{2}$ i.p.s., it should be possible to hold the response to ± 3 dB from 30 c/s to 10 kc/s.

Not every tape recorder that incorporates the BSR Monardeck is capable of this response. Luckily, changing the head, with its mumetal shroud, is a simple matter, and a falling off in response can soon be proved, and the deck exonerated.

Mechanically, the deck is as good as any other in a similar price range, and better than many. Wow and flutter should be better than 0.04 per cent r.m.s. Anything more than this should lead one to check drive belts, pressure wheel and a slipping R.H. clutch.

COLLARO "STUDIO" DECK

This is another example of development that has led to simplification, yet entailed no sacrifice of efficiency. The *Studio* has achieved wide popularity, both with manufacturers and the retail trade.

It is confidently predicted that it will also prove attractive to the home constructor, being both elegant and easy to incorporate in "the furniture". Only four connections are required to the amplifiers, plus the mains lead.

More elaborate than the deck previously discussed, the *Studio* is a three-motor job, push-key controlled, three-speed, with a very fast rewind.

Head Cover

Other features that will enhance its reputation are the streamlined head cover, enabling a 7 inch reel to be fitted, overlapping the deck, if required. (a $5\frac{1}{2}$ inch sits within the confines of the top-plate), the digital revolution counter, and the auxiliary hole for an additional control beneath the nameplate at front left of the deck. There is also provision for an additional head, for monitoring, or stereo replay.

One drawback is the lack of a safety interlock to prevent accidental erasure. This is the price of simplicity, for its inclusion would have meant a re-planning of the lever system to allow separate Record and Playback positions.

At present, the deck is in a basic "operative" condition, that is with the tape passing across both head faces from left to right at the selected speed. Function switching is entirely electrical, and done at the amplifier. There is a strong school of thought favouring this approach.

Top of Deck

A glance at the top of the deck with the push-fit head covers removed (Fig. 2) shows a clean layout with a minimum of moving parts. Spring tension on the pinch roller (A) and pressure pads (B) is such that they tend to remain engaged until the stop button (C) is depressed. For this reason it is advisable to check that the deck is mechanically as well as electrically switched off by the customer after use.

Continued pressure without movement will cause distortion of the pinch wheel, hardening of the pressure pads and damage to the tape at the point of tension.

Spool Carriers

The spool carriers (D) and (E) are driven by their own induction motors (Dd), (Ee) which are fully energised in the rewind operation, when keys (F) for Rewind and (G) for Fast Forward are depressed. During Record or

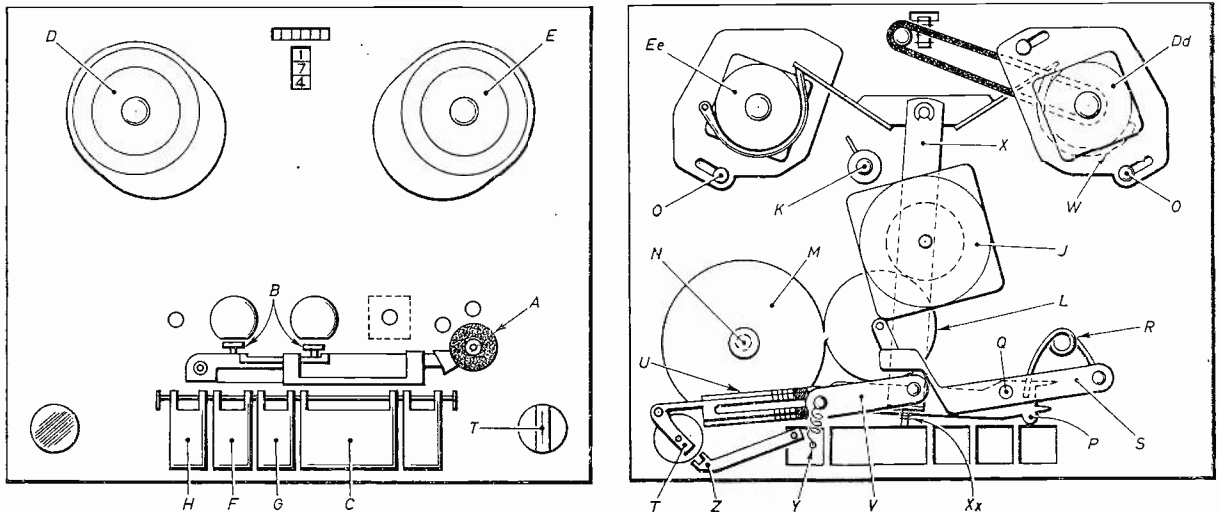

Fig. 2. Skeleton plans of the Collaro Studio tape deck showing the essential components as described in the text. The left-hand sketch is a top view and the right-hand sketch an underside view. (Note: these sketches are not to scale.)

Replay, when the Start button (H) is depressed, the capstan motor (J) is fully energised and the spool motors are switched to a series-parallel arrangement in conjunction with resistor (K).

This allows a small outward pull, keeping the tape in tension while it is driven via idler (L) and flywheel (M) on which capstan (N) is mounted.

Underside

A view of the underside reveals that the Start operation is positive and simple. When key (H) is pressed, a lug on lever (P) is pushed rearwards, allowing the lever to move on its pivot (Q), assisted by the snap action of spring (R). Attached to lever (P) is lever (S), at a point near the inner side of the lug.

This lever is pivoted near its outer end, and its movement engages the idler wheel with the drive motor and flywheel. Stop action forces lever (P) in the opposite direction by pressure at its other end, i.e., away from the pivot.

Interlock

A refinement is the speed change safety interlock, also released by the Stop action. This is a simple fork lug (Z) operated by the reverse motion of lever (P) when the Start key is pressed. The fork prevents rotation of the speed control while the idler wheel is engaged.

Some earlier models did not have this refinement and a jammed mechanism can result from incorrect operation.

The procedure for speed changing is conventional. When the control (T) is turned a stepped bar (U) slides past the pivot of swivel link (V) to which the idler wheel is attached. This raises

or lowers the idler wheel to engage with the appropriate step of the drive pulley on the spindle of the motor.

Faults that may be found here are incorrect setting of the levels, due to loosening of the pulley. Take care, when adjusting, to allow for the small end-play of the rotor; after re-setting always test with the deck in its correct, operating position.

Also, when re-fitting this deck, ensure that it is not screwed down too tightly. The Studio is mounted on four rubber spacers.

Braking

When correctly adjusted, the braking action of the Studio deck is very effective. The principle is the popular "wrap-around" technique, with acetate strips (W) in a semi-circular loop around the brake pulleys of the spool motor shafts. The brake lever (X) is pushed forward by the Stop button, applying tension to the strips.

Adjustment is by a screw (Xx) at the end of (X) attached to the stop button assembly. With the Start Key depressed (or any other), this screw is pulled forward, releasing the brakes. Turn the screw to such a position that brakes just clear when the start key is pressed, to give positive braking on "Stop".

Performance

Some of the claims made for this deck may seem rather ambitious, but on test it proved capable of all the makers claimed.

The attainable frequency response, with CCIR equalisation, is 12 kc/s ± 3 dB, at the top speed, 7½ i.p.s. At the middle speed of 3½ i.p.s., wow and flutter was no greater than 0.15 per

cent. Fast winding time is really fast, taking only a little over a minute for a full 7 inch reel of 1,200 feet.

Servicing

There may be a tendency to loose spooling as the speed works up, and a little vibration is sometimes noticeable—a small fault that could be reduced by the fitting of a hub-cap.

The recording head has an impedance of 30kΩ at 10 kc/s, and a gap of 0.00025 in. Azimuth adjustment is similar to that described for the previous deck.

The erase head is a low impedance type, 200–300 ohms at bias frequency of 45 to 60 kc/s. Except 25 volts at a head current of 120mA.

There are one or two small points to be watched in servicing these decks. As ever, spring links are possible offenders when erratic action is reported. Check the snap spring (R) and spring (Y) from the idler wheel link lever to the upper plate of the switch bank.

Also the spring tension that hold the brake lever in the "On" position until the operational keys are depressed and that which tends to return the motor switching plate of the switch bank to a neutral position.

Spooling

The spool positioning arrangement is such that the spool motors are adjustable, (O), allowing the spool carriers to take up a more central position for mounting 5½ inch spools without overlap of the deckplate. See that the locking spools are tight, the hubs correctly placed, and the spool carries at the right level.

(Continued on page 13)



If anything on earth is sure, it is that the sun will rise tomorrow. As the sunrise represents certainty, so the symbol of the BVA is your assurance of certain and dependable quality.

you know where you are with the



The members of the BVA contribute in no small way to the prosperity of the radio and television trade as a whole. Their constant policy of research and development, and their advanced manufacturing techniques, are an assurance that every product is of the highest technical standard and as dependable as the most modern production techniques can ensure.

By always fitting valves and tubes supplied by members of the Association and marked 'BVA', you are sure of satisfying your customers and safeguarding your reputation.

BRIMAR
COSSOR
EDISWAN MAZDA
EMISCOPE
EMITRON
EVER READY
FERRANTI
G.E.C.
MARCONI
MULLARD
PHILIPS

BRITISH RADIO VALVE MANUFACTURERS ASSOCIATION
Mappin House, 156-162 Oxford Street, London W1



TECHNICAL GEN for SERVICING MEN

RADIO, TELEVISION and AUDIO FAULT FINDING

PRESENTING DETAILS OF FAULTS ENCOUNTERED, DIAGNOSED AND CURED BY SERVICE ENGINEERS ON RADIO, TELEVISION AND AUDIO EQUIPMENT, TOGETHER WITH HINTS AND TIPS OF USE TO OTHER SERVICEMEN IN DEALING WITH DAY-TO-DAY SERVICE WORK.

Invicta 30

Weak and Distorted Complaint on this transistor portable was weak signals and distortion.

Batteries were checked as an "obvious" and were replaced. Two days later the set was back with us, the customer complaining of exactly the same thing and demanding replacement batteries.

On test, the batteries were found to be O.K., however, and further tests became necessary. Voltages appeared to be in order and so the signal generator was brought into action. It was found that a healthy output could be obtained from the base of the audio amplifier but no signal could be obtained from the base of the second i.f. amplifier.

The voltage on the i.f. transformer were normal and we then tried substituting the detector. This cured the trouble. Since then we have had three more of these sets in with exactly the same trouble—but which caused us a lot less time wasting.—T.G., Seaford (945).

Cossor 951

Vision, Sound Cut-out It was most disturbing to receive the report that sound and vision had cut out on a brand new set on three successive evenings for periods of up to half an hour.

Even more annoying was the (usual) fact that the set refused to go wrong when we called. We arranged for the customer to telephone and report.

When he telephoned we cross-questioned him. There was no sound—not even background noise; no picture, not even a light on the screen with the brilliance control advanced, but all the valves appeared to be lighting up. As a final blow, ruling out the "No h.t." theory, he mentioned that the line whistle was still there, and it did not change as the picture and sound faded.

Thoroughly baffled, we went over and sat by the now functioning receiver, waiting for it to go wrong. Eventually it did, and we were quick to note that only the tube heater and the PCL82 sound output valve heater went out—all the rest glowed healthily.

A glance at the circuit showed that

the heater chain has C.R.T. at the earthy end, then the sound o/p valve and then the ECC82 frame oscillator. This last was the culprit, going intermittently heater/cathode short-circuit.—B.R.G., Gilfach (967).

Stenorette Models

Some Recent Faults On one Stenorette Type T the symptoms were instability on playback which varied with the gain control. This was traced to contact K1 on the record relay being dirty. Thorough cleaning of the contact cured the fault.

On another Type T the trouble was distorted recording and distorted playback; this was proved by making a recording on another machine known to be in good working order. A check on the recording bias indicated that this was about half its normal operating current. Measured across a 100Ω resistor, a reading of 160mV should be indicated.

On a Type S machine, symptoms were high background noise, weak volume and distorted playback. Here the fault was traced to the 0.005μF coupling capacitor C9 between the EBF80 and the ECC82, which was leaking.—E.T.E., Fleet (963).

Items for publication

in this feature are welcome; particularly in regard to the more unusual type of faults. All contributions used will be paid for at our usual rates.

When sending in items for Technical Gen, please write (or type) on one side of paper only, adding rough sketches (where considered necessary) on a separate sheet of paper. Correspondence should be addressed to — RR Service Engineer, 46 Chancery Lane, London, W.C.2.

Philco 1019

Sound Goes Weak The outside engineer informed us that the fault was intermittent weak sound. He had made two visits to try and cure the trouble but it had not appeared. We soak tested the set in the workshop for a day with no results. On the second day, however, the sound went weak.

The valves were tapped and the components on the printed circuit board were probed. The sound returned to normal when pushing the panel near to the 140pF capacitor C35.

Having previously made a sound sensitivity check during the faulty condition, we cut the capacitor out and rechecked sensitivity. The culprit was indeed C35 and it was going open-circuit. We thought ourselves lucky to have found it so easily.—J.H.P.-J., Bristol (932).

G.E.C. BT2448

Vision, Sound Fades A rather unusual fault was observed on one of these receivers recently. Sound and picture when first switched on were normal but after about ten minutes the picture and sound both faded gradually away until only a blank raster remained.

An i.f. signal injected from a generator revealed that the trouble was in the common i.f. stage and as we were out of stock of Z77 valves at the time, V3 was swapped with V9, the a.p.c. amplifier. Picture and sound returned and remained, with the a.p.c. working as normal. The valves were then swapped back to their original positions and the fault returned.

Apparently, although the valve did not like working at 36 Mc/s it was quite happy to work at line frequency in the a.p.c. circuit.—N.C., Seaford (942).

Pye FenMan I

Random Tunable Whistles This receiver worked on all wavebands but on the long-wave and medium-wave bands instability in the form of tunable whistles was encountered. The points on the tuning range at which this occurred varied.

(Continued on page 9)

The Editor does not necessarily endorse the views expressed by contributors to this feature

SERVICE DATA SHEETS

THE DATA SHEETS LISTED BELOW
ARE STILL AVAILABLE FROM STOCK
TO SUBSCRIBERS, POST FREE, AT
THE PRICES QUOTED. A COMPLETE
INDEX TO ALL DATA SHEETS PUB-
LISHED UP TO DECEMBER 1960 IS
AVAILABLE AT 9d.

(Please send cash with order)

DATA SHEET BINDERS are available from
★ for trouble-free filling of your own Data ★
sheets. Simple spring-clip action. Small size,
10s. 6d. post free. Large size, 12s. 6d. post free.

Price 1s. each

Price 9d. each

Ace "Astra" Mk. II Model 553 (TV52, May, 54).
Alba T655 TV (TV130, Dec., 58).
B.S.R. UAR autochanger (S7, March, 57).
Bush T36 series TV receivers (TV83, Apr., 56).
Bush TV22 series TV receivers (TV67, Jan., 55).
Bush TV53 series TV receivers (TV101, Feb., 57).
Cossor 930 series TV receivers (TV62, Feb., 55).
Cossor 937, 938 and 939 (TV90, July, 56).
Cossor 943 TV (TV127, Oct., 58).
Cossor 945 (TV112, Nov., 57).
Cossor 946 TV (TV104, May, 57).
Cossor 947 TV receiver (TV114, Jan., 58).
Decca DM35/45/55 (TV155, May, 60).
Ekeo T330/331 series (TV154, April, 60).
Ekeo T342/344/348 (TV157, June, 60).
Ekeo T345 series (TV165, Oct., 60).
Ekeo T368/T371 series (TV176, April, 61).
Ferranti T1002 series (TV154), April, 60.
Ferranti T1021, 1023, 1027 (TV157, June, 60).
Ferranti T1024 series (TV165, Oct., 60).
Ferranti T1046/T1049 series (TV176, April, 61).
Ferguson 204T series TV receivers (TV87, June, 56).
Ferguson 306T/308T TV receivers (TV97, Nov., 56).
Ferguson 506T, 508T, 546T (TV171, Jan., 61).
Ferguson 516T series (TV173, Feb., 61).
G.E.C. BT1252 series TV receivers (TV96, Oct., 56).
G.E.C. BT1746 series TV (TV81, Mar., 56).
Grundig 500L and 700L/C (S3, Dec., 53).
H.M.V. 1840 series TV receivers (TV109, Sept., 57).
H.M.V. 1890 and 1892 (TV171, Jan., 61).
H.M.V. 1892, 1892C (TV173, Feb., 61).
Invicta 538 series (TV168, Dec., 60).
Kolster-Brandes HF40 series TV (TV70, Aug., 55).
Kolster-Brandes MV30 and MV50 (TV91, Aug., 56).
Kolster-Brandes NV40 series (TV115, Feb., 58).
Kolster-Brandes OV30 series (TV148, Jan., 60).
Marconiphone VC/VT59DA (TV100, Jan., 57).
Marconiphone VC60DA (TV61, Jan., 55).
Marconiphone VT68DA/VT69DA (TV84, May, 56).
Marconiphone VT163 (TV173, Feb., 61).
Marconiphone VT164 (TV171, Jan., 61).
McMichael 55 series TV receivers (TV79, Feb., 56).
Murphy V214/V216 TV receivers (TV78, Jan., 56).
Murphy V230 portable TV (TV103, April, 57).
Murphy V270/V270C TV (TV120, May, 58).
Murphy V270A TV receiver (TV140, July, 59).
Murphy V280A 300C TV (TV124, Aug., 58).
Murphy V280A series (TV134, March, 59).
Murphy V310 TV receiver (TV145, Dec., 59).
Murphy, V320 series (TV159, July, 60).
Murphy V330 series (TV167, Nov., 60).
Murphy V350 series (TV175, March, 61).
Pam 500 TV receiver (TV108, Aug., 57).
Pam 600S, 606S, 690 (TV144, Nov., 59).
Pam 800 series (TV168, Dec., 60).
Peto Scott TV 1411 series (TV65, Apr., 55).
Philo BT1412 and BT1551 (TV71, Sept., 55).
Philo 1000 *Slender Seventeen* (TV139, June, 59).
Philo A1960/1, A2060/1 (TV137, May, 59).
Philo A1962M/A1967M (TV142, Oct., 59).
Philips 1458U series (TV129, Nov., 58).
Philips 1756U series TV (TV111, Oct., 57).
Philips 1768U/2168U (TV117, March, 58).
Philips 1796U/2196U (TV152, Mar., 60).
Pilot PT450 series (TV161, Aug., 60).
Pilot TV84/87 television series (TV59, Nov., 54).
Pye PTV portable TV (TV113, Dec., 57).
Pye CW17 series TV (TV122, June, 58).
Pye CTL58VS series (TV150, Feb., 60).
Pye CTM17S series (TV131, Feb., 59).
Pye V200/V400 series (TV163, Sept., 60).
Pye V210 series (TV168, Dec., 60).
Regentone "Big 15/5", T and C (TV48, Feb., 54).
R.G.D. 1455 and 1456 TV receivers (TV99 Dec., 56).
Ultra V84 and Y84 TV receivers (TV47, Jan., 54).
Ultra 81 series TV receivers (TV74, Nov., 55).
Ultra 915 and 917 TV receivers (TV93, Sept., 56).
Ultra 50 series TV (TV123, July, 58).
Ultra 52 series TV (TV135, April, 59).
Ultra 60 series TV (TV126, Sept., 58).
Ultra 62 series TV receivers (TV141, Sept., 59).
Ultra V1770 series (TV161, Aug., 60).
Vidor CN4217/8 TV receivers (TV57, Oct., 54).

Alba T717 and T721 (TV143, Nov., 59).
Alba T744FM TV series (TV121, June, 58).
Alba T766 TV receiver (TV166, Nov., 60).
Ambassador-Baird TV 19-20 (TV119, May, 58).
Argosy Model T2 TV receiver (TV53, June, 54).
Beethoven B94, 95, 98 and 99 (TV92, Aug., 56).
Bush BE15 battery radio (R51, Mar., 54).
Bush RC94 AC radiogram (R34, Nov., 52).
Bush VHF54/VHF55 receivers (R94, Jan., 57).
Bush VHF61 a.m.-f.m. radio (R134, Oct., 59).
Bush VHF64/RG66 radios (R116, July, 58).
Collaro RC54 record changer (S6, Oct., 55).
Cossor 500 series series radios (R95, Feb., 57).
Cossor 522/523 a.m.-f.m. radio (R72, May, 55).
Cossor 524 *Melody Maker* (R85, Mar., 56).
Decca SG177/SG188 Stereograms (S12, Oct., 58).
Decca *Double Decca* Model 51 (R65 Dec., 54).
Deccalian radiograms 91 and 92 (R23, Dec., 51).
Deccalian Model 90, radiogram (R21, Nov., 51).
Dyna-Ton TV38 series (TV151, Mar., 60).
Etronic EC52231 projection TV (TV46, Dec., 53).
Etronic ETA632 radio receiver (R43, Aug., 53).
Ever Ready *Sky Monarch* (R104, July, 57).
Ever Ready *Sky King, Queen, Prince* (R106, Sept., 57).
Ever Ready *Sky Personal, Sky Leader and Sky Baron* (T150, April, 61).
Ferguson TV tuner units (TV85, May, 56).
Ferguson 300RG autogram (R78, Aug., 55).
Ferguson 382U series (R124, Jan., 59).
Ferguson 341BU portable radio (R67, Jan., 55).
Ferranti 105, 105 and 405 (R36, Jan., 53).
Ferranti 147 series radio receivers (R81, Nov., 55).
Ferranti 255, 355, 455, radios (R107, Oct., 57).
Ferranti 1325/1825 TV receivers (TV95, Oct., 56).
G.E.C. BT302-5 (TV160, Aug., 60).
G.C.E. BT1449/BT2448 (TV107, March, 57).
G.C.E. BT2155/8149 (TV156, June, 60).
Kolster-Brandes HG30 radiogram (R53, April, 60).
Kolster-Brandes QV20/I series (TV162, Sept., 60).
Marconiphone T/C10A radio (R41, June, 53).
Marconiphone VT64/65DA (TV76, June, 55).
Masteradio D154 "Ripopt" series (R84, Feb., 56).
Masteradio TD4T and TD7C (TV58, Nov., 54).
Masteradio TE series (TV128, Nov., 58).
McMichael *Clubman* Model 535 (R62, Oct., 54).
McMichael FM55 a.m.-f.m. radio (R82, Dec., 55).
McMichael MP20 (TV174, March, 61).
Murphy A146CM baffle radio (R75, June, 55).
Murphy V200 TV receiver (TV72, Sept., 55).
Pam 701, 702, 714, radios (R100, May, 57).
Peto Scott 16 series TV receivers (TV86, June, 56).
Peto Scott 19 series TV (TV116, March, 58).
Peto Scott 1222/1273 (TV149, Feb., 60).
Peto Scott 1730 and 2128 (TV158, July, 60).
Peto Scott 1731/2131 (TV164, Oct., 60).
Peto Scott 732 series (TV172, Feb., 61).
Philips 141U portable radio (R56, June, 54).
Philips 643 series a.m.-f.m. radio (R87, July, 56).
Philips G62A series (R131, July, 59).
Pilot TV94 series TV receivers (TV107, Aug., 57).
Pilot VS9 console TV receiver (CV34, Nov., 52).
Pilot PT451, PT651 (TV171, Jan., 61).
Pye P23CR and P24CR (R48, Jan., 54).
Pye P29UBQ (R37, Feb., 53).
Pye *Fen Man I* and *IRG* (R109, Nov., 57).
Pye *Fen Man II* and *IIRG* (R112, Jan., 58).
Raymond F46 radio receiver (R69, Feb., 55).
Regentone ARG81 series (R127, March, 59).
Regentone RT50 tape recorder (S14, Sept., 59).
R.G.D. T14 transportable VT (TV138, June, 59).
Sobell TS17 and T346 TV (TV94, Sept., 56).
Sobell 626 Series a.m.-f.m. radios (R102, June, 57).
Sobell TPS710, T192, T293 (TV174, March, 61).
Sound A20 tape recorder (S9, Feb., 58).
Stella ST151A radio (R66, Jan., 55).
Stella ST8314U TV receiver (TV55, Aug., 54).
StradModel 510 table receiver (R35, Dec., 52).
Taylor testmeter Type 171A (TV16, Aug., 54).
Ultra ARG891 "Ultra-gram" (R83, Jan., 56).
Ultra "Troubadour" U696 (R4, Aug., 53).
Ultra "Twin" portable radio (R5, June, 54).
Ultra U930/U940 *Ministrals* (R119, Aug., 58).
Ultra V1763 TV receiver (TV147, Jan., 60).
Ultra VP14/1753 series (TV153, April, 60).
Ultra 1771 series (TV170, Jan., 61).

Vidor CN4228/9 TV receivers (TV136, May, 59).
Vidor CN4230/1 TV receivers (TV125, Sept., 58).
Waveforms *Radar* 405D (T.I.7, Apr., 56).

Price 6d. each

Alba 69 series radiograms (R120, Sept., 58).
Alba 3211 series (R126, Feb., 59).
Baird baffle radio receiver (R61, Oct., 54).
Bush TC184 television tuner (TV75, Nov., 55).
Cossor Model 466 car radio (R71, Apr., 55).
Cossor radio Model 494U (R38, Mar., 53).
Cossor *Melody Portable* 543 (R92, Dec., 56).
Cossor 546 transistor portable (R115, May, 58).
Cossor 551/552 portables (R117, July, 58).
Cossor 575/579 (R142, June, 60).
Cossor 580 stereo player (S13, April, 59).
Cossor 581 and 569 portables (R137, Nov., 59).
Cossor CR1500A stereo radiogram (R147, Nov., 60).
Decca *Deccalian* 88 player (S10, March, 58).
Decca RG200 radiogram (R125, Jan., 59).
Deccalian Model 81 (R29, Apr., 52).
Defiant M953 AC radio (R40, May, 53).
Defiant RSGH89 AC radio (R70, Mar., 55).
Dyna-Ton TP11/TP12 (R127, May, 60).
Ekeo BPT333 transistor portable (R145, July, 60).
Ekeo BPT351 transistor portable (R145, Sept., 60).
English Electric *Rotomatic* TV tuner (TV82, Mar., 56).
Etronic EPZ4213 portable radio (R52, Mar., 54).
Etronic radio Model ETU5329 (R39, Apr., 53).
Ever Ready Model "C" radio (R50, Feb., 54).
Ever Ready *Sky Baby, Sky Princess* (R99, May, 57).
Ferguson 348BT transistor portable (R151, April, 61).
Ferranti 13-channel TV tuner (TV73, Oct., 55).
Ferranti 525 radio receiver (R58, Aug., 54).
Ferranti Model 546 radio (R45, Sept., 53).
Ferranti U1003/RP1008 (R123, Dec., 58).
Ferranti PT1010 transistor portable (R143, July, 60).
Ferranti PT1030 transistor portable (R145, Sept., 60).
G.E.C. BC501/BC502 portables (R146, Oct., 60).
G.E.C. BT306, BT308 (TV169, Jan., 61).
H.M.V. radio Model 1122 (R54, May, 54).
H.M.V. radio Model 1356 (R42, July, 53).
H.M.V. 1252 f.m. adaptor (R111, Jan., 58).
H.M.V. 1417 transistor portable (R151, April, 61).
Invicta 26 "Vicki" portable (R93, Jan., 57).
Invicta 33 series radio receivers (R89, Sept., 56).
Invicta Models 37 and 59RG (R86, May, 56).
Invicta Model 55 portable (R46, Oct., 53).
Kolster-Brandes TV converter (TV77, Jan., 56).
Kolster-Brandes FB10 portable (R32, Sept., 52).
Kolster-Brandes MP151/2, PE251 (R135 Oct., 59).
Kolster-Brandes NG20/NR30 (R113, Feb., 58).
Kolster-Brandes OP1 (R122, Nov., 58).
Kolster-Brandes PP11, PP21, PP31 (R130, June, 59).
Marconiphone P17B portable (R49, Jan., 56).
Marconiphone T2211 converter (TV30, Feb., 56).
Marconiphone T24DAB (R77, Aug., 55).
Marconiphone T82B transistor portable (R151, April, 61).
McMichael 153 table radio (R75, July, 55).
McMichael 493 portable radio (R47, Nov., 53).
McMichael 554 radiogram (R96, Feb., 57).
McMichael 855 table radio (R91, Nov., 56).
McMichael MT102 portable (R149, Feb., 61).
Masteradio D155 series (R108, Nov., 57).
Murphy V310 modifications (TV146, Jan., 60).
Pam 111 transistor portable (R140, April, 60).
Pam 706 *Pixie* portable (R97, March, 57).
Pam 710 portable (R90, Oct., 56).
Pam 955 series radios (R103, July, 57).
Pam TB59 (R138, Feb., 60).
Peto Scott MR60 *Faufare* tape recorder (S15, March, 61).
Portogram "Junior 8" reproducer (S4, July, 54).
Portogram "Preil 20" amplifier (S5, May, 54).
Philco A 536 W/M radio receivers (R68, Feb., 55).
Philips television tuners (TV88, June, 56).
Philips G77B, G81U, G83B (R137, Dec., 59).
Philips 301T and 395T (R148, Dec., 60).
Pilot television tuners (TV89, July, 56).
Pilot PR251 transistor portable (R144, Aug., 60).
Pye HF25/25A hi-fi amplifiers (S11, June, 58).
Pye P131MBQ portable (R121, Oct., 58).
Pye P43 radio receiver (R63, Nov., 54).
Pye 13-channel tuner unit (TV66, May, 55).
Pye *Pipers* P115U/P116U (R110, Dec., 57).
Pye *Black Box* record reproducers (S8, Sept., 57).
Pye 84113 series TV tuners (TV110, Oct., 57).
Raymond F55 table radio (R74, June, 55).
Regentone PRG1 and Five-18 (R139, Mar., 60).
R.G.D. B56 portable radio (R132, July, 59).
Roberts CR portable radio (R80, Oct., 55).
Roberts "Junior" portable (R26, Feb., 52).
Roberts P5A portable radio (R73, May, 55).
Roberts R66 portable radio (R88, Aug., 56).
Roberts R77 portable (R105, Aug., 57).
Roberts RT1 transistor portable (R118, Aug., 58).
Sobell FMG57/FMG708 radios (R114, April, 58).
Sobell ST301 portable (R149, Feb., 61).
Taylor Model 20B (T.I.5, Sept., 52).
Ultra 101 transistor portable (R144, Aug., 60).
Ultra FM950 f.m. radio (R129, May, 59).
Ultra TR100 portable (R128, March, 59).
Ultra U960 portable radio (R133, Sept., 59).
Vidor Model CN414 portable (R28, Apr., 52).
Vidor CN420A portable radio (R64, Dec., 54).
Vidor CN421 portable radio (R79, Sept., 55).

TECHNICAL GEN

continued

It was noticed that moving the speaker leads around also varied the whistles.

After exhausting tests, checking almost every component in the set (it being impossible to pin down a particular stage) we decided to try a new output transformer.

We did this not because anything really pointed this out as being suspect (the d.c. resistance was correct) but because it was the only thing left that we had not checked by substitution.

The new transformer effected a complete cure with no instability at all even when the speaker leads were moved.—G.H., Harrogate (972).

Cossor 948F

Double Line Speed This looked like a flywheel sync fault at first. The line oscillator frequency would intermittently flip to double frequency. Although it was then possible to approach lock with the switch S1 on the hold control depressed (flywheel inoperative), as soon as the knob was released the line would double and the raster shrink.

To make matters worse, the fault seldom stayed long enough for us to prove a cure. We tried the ECC82 multivibrator, the PCF80 sync separator, the PL36 line output valve, and even the W7 and W8 combined discriminator diode.

But still the fault came back and we decided it had to be the extra winding on the line output transformer breaking down. We changed the transformer.

This gave us the clue. On fitting the new transformer the earthing pigtail

to the main chassis was left disconnected—quite by accident—and the "fault" became permanent. Inspection of the earth tag on the original transformer revealed a corrosive film.

Thorough cleaning and a good solid earth was the cure for this one—and we shall not be caught again!—H.W.H., Bargoed (964).

Philips EL3541

Tape Deck Fault This tape recorder would cease to function after two hours on playback. After several hours of fruitless investigation, owing to the fact that the slightest movement of the chassis would clear the fault, the culprit was traced to an intermittent s/c of the polythene insulated screened lead from the volume control to the EF86 and ECC83 board.

There was a fair amount of slack in the lead passing over the output valve and when the lead was warmed by the valve it went s/c and cleared immediately when it was disturbed. This lead is one of a pair of screened leads running in a twin piped plastic.—W.S., Warminster (935).

Steelman 2-7111

Faulty Mercury Cells One of these portable tape recorders had been inspected by an apprentice for the faults of a slow running motor and poor reproduction. Unable to find the cause, the job had been passed to myself.

I was told that the battery supply was down by approximately 1V for the motor and 1V for the amplifier, six mercury type cells being the amplifier's supply and seven mercury cells for the motor supply.

This slightly reduced voltage had been dismissed as negligible. However, I decided to find the low cell and to replace it before proceeding further.

No Frame Scan: Common causes of this condition are (a) C118 s/c, (b) frame oscillator anode decoupling capacitor C68 leaking, usually about 15kΩ.

Low H.T.: In this series, this condition has been overcome on several occasions by fitting two 250V 300mA silicon rectifiers in parallel with a 20Ω or 30Ω surge resistor in series with each as shown in the accompanying diagram.—R.R., Mansfield (959).

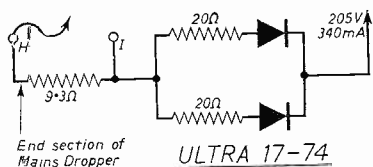

End section of Mains Dropper

ULTRA 17-74

Brainless Bertie

The neon glows where e'er it goes,
But Bertie fails to see
It indicates, in series sets,
The neutral line's o/c.

Feste

Two cells were found to be faulty. One, believe it or not, had reverse polarity on and off load, the other being reverse polarity on load but showing on the voltmeter off load only half a volt. Replacements cured both faults.—C.H., Harrogate (969).

Bush VHF70

Cord Drive Trouble A new tuning gang had just been fitted and although the set worked satisfactorily, the v.h.f. calibration was at the wrong end of the scale.

As the v.h.f. cord drive between the f.m. unit and the drum had been removed for the gang fitting, it was thought that it had been fitted the wrong way round, but this was not so. The medium-wave calibration was correct.

Appearing simple, it became rather perplexing. After some thought, the end of the cord that is attached to the slug in the v.h.f. unit was investigated and here was the cause of the trouble.

The cord in here passed round a pulley and the cord was off the pulley, so allowing the iron-dust slug to tune at the wrong end of the coil. This lengthened the external cord, putting the pointer in the wrong position. Simple, but not immediately obvious.—G.H., Harrogate (968).

Invicta 738 and 638

Elusive Line Fault The trouble on one of these sets (also applicable to Pye PV110, V110, 310F) was no e.h.t., very little r.f. pulse current at the EY86 anode. Replacement of line oscillator, line output, boost and e.h.t. rectifier valves provided no improvement.

The PL81, screen resistor was O.K., as was the PL81 grid pulse waveform and there was sufficient amplitude. Scan coils and series capacitor C94 were O.K. The tube was checked for excessive beam current, but this was normal, as were bias conditions. Disconnected e.h.t. lead and accelerator anode connection removed in case of leakage but still no e.h.t.

(Continued on page 11)

RECEIVER

SPOT

CHECKS

No. 69: ULTRA 1774 SERIES

Here are details of the symptoms and causes of some common faults in this series of receivers:

Weak and Distorted Sound: Suspect the sound noise limiter coupling capacitor C96 for leakage.

Bent Verticals: If accompanied with intermittent line and frame slip, check the sync separator coupling capacitor C50 for leakage.

No Frame Hold: If accompanied with slight flaring, check the video amplifier cathode decoupling capacitor C46 for o/c.

TEST CARD 'C' all day - every day

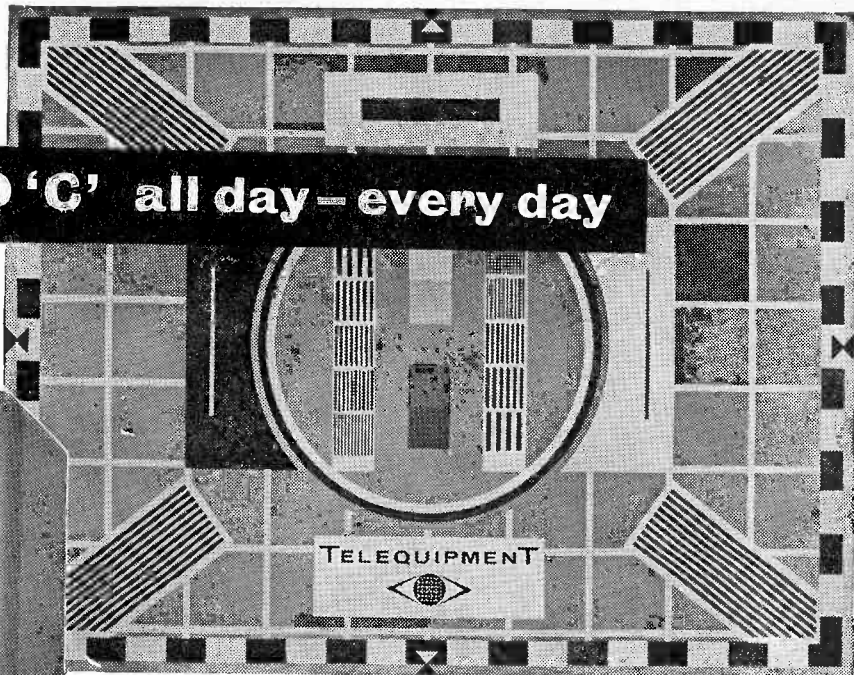
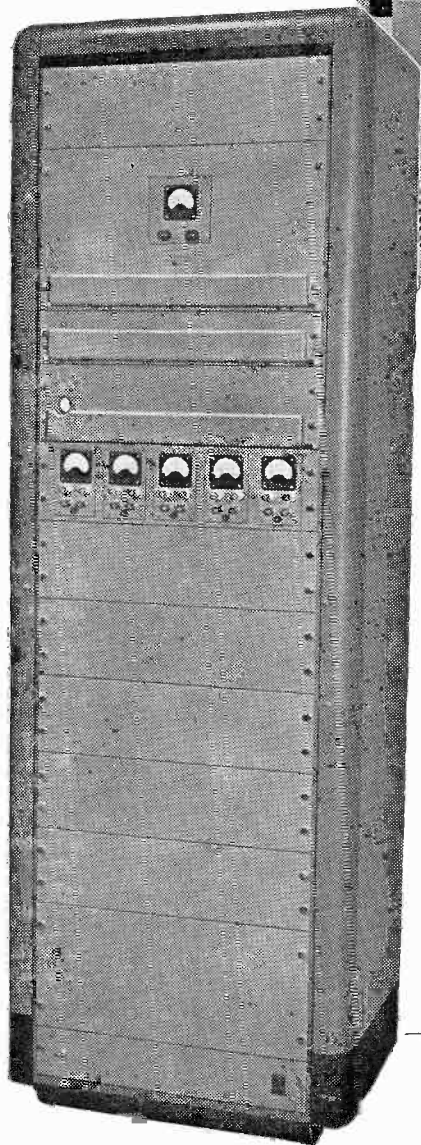

For efficient full scale servicing—the Telequipment Monoscope test card generator.

- ★ C.C.I.R. standard.
- ★ Video response to 6 Mc/s.
- ★ Crystal controlled transmitters.
- ★ Rated for continuous operation.
- ★ Prices from £570.

TELEQUIPMENT



**R.E.C.M.F. Exhibition,
Olympia,
May 30th—June 2nd.
Stand No. 497, Grand Hall Gallery**

For the smaller user—
Telequipment WG44
portable waveform
generator at £62.

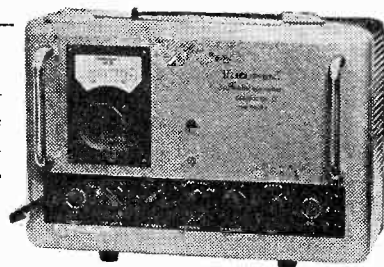

Telequipment Limited, 313 Chase Road, Southgate, London, N.14. Telephone: Fox Lane 1166

TECHNICAL GEN

continued

All capacitors and resistor in line output, boost and sawtooth reference waveform circuit were replaced from line output transformer to discriminator diodes, and the diodes were replaced as well—still no clues. Then the output transformer was replaced, again with no luck.

The fault could not have been in the oscillator stage because there was sufficient drive to the PL81, yet everything had been checked. What had been overlooked? There was a small choke (L16) which injects h.t. to the line transformer but a resistance check showed normal, a voltage check at either end showed normal voltages and there was h.t. at various points on the line transformer.

As an experiment, the choke was shorted out. The line output stage sprang to life and the raster appeared. When short was removed, raster and e.h.t. disappeared again. The choke was replaced and the fault cleared. But another resistance check showed nothing wrong and it was in new condition with no dry joints at the tags.—S.W., Buckingham (957).

Ekco TUI69

Bad Frame Bounce This receiver had the familiar complaint of frame bounce, very similar to the trouble associated with 6K25's used in earlier models. After frame valves had been replaced without success, various other components in the oscillator and output stages were checked and all were found to be satisfactory.

The h.t. smoothing then fell under suspicion and here the trouble was found not (as one might have expected) in the main 250 μ F capacitor across the h.t. rail but in the 60 μ F reservoir capacitor. This was found to have dropped in value to about 50 μ F.

Replacing the electrolytic cured the trouble, but although the problem was solved it needs a little explanation.—K.C., Enfield (960).

Bush TV75

Heater Chain Fault Symptoms were heaters glowing but no heater volts. This sounded a most peculiar situation, on testing heater volts the report was confirmed although the heater chain seemed to be O.K. After trying another meter and switching it to d.c., an apparently correct reading was obtained, but, of course, d.c.

The answer to this problem was that the outside engineer had called and

found the fuse blown and on replacing it the set had worked normally but took rather too long to warm up.

The dropper had gone o/c and the

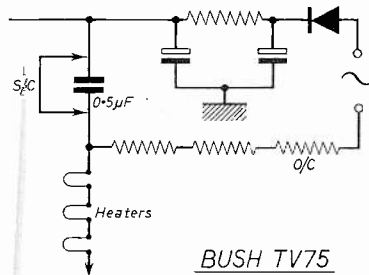

0.5 μ F 250V a.c. hum cancelling capacitor had gone s/c, thereby allowing the d.c. from the h.t. line to be applied to the heater chain as shown in the diagram. Replacing the dropper, fuse and capacitor cured the trouble.—E.D., Sale (951).

SERVICE BRIEFS

Alba T766: Trouble was buzz on Band III. No circuit was available at the time so the tuner was checked by substitution but this did not clear the fault. Band III has its own sensitivity control, decoupled by a 0.1 μ F capacitor. This was found to be o/c and a new one cleared the trouble.—A.H., Barnsley (886).

Ferranti T1.24: Within a few days we had in two of these sets, in addition to a Cossor 950, all suffering from exactly the same trouble of weak and poorly contrasted picture and all due to exactly the same trouble—a short circuited crystal diode video detector, in the Ferranti models, Type CG12E. This must have been "video detector week"; during the preceding week we repaired five sets of different makes all the scan coil failure!—G.C., Boroughbridge (867).

Murphy V25A: Although there was vision modulation, the line and frame timebases would not lock and there appeared to be a 50 c/s hum on either side of the raster. The anode voltage of the sync cathode follower and flywheel phase splitter V15A (a 20L1) was down from 175V to a mere 5V. It was found that the lead from R142 (4.7k Ω) to the anode was shorting through its insulation to pin 1 (carrying valve heater current). Removing this s/c took the unwanted a.c. from the anode and restored the correct d.c. voltage and normal operation.—D.McL., Lochgilphead (846).

G.E.C. 203 Series: We have experienced negative overloaded picture and poor sync with several of these receivers. The video amplifier overheats and the control grid can be seen to be red-hot. If the control grid voltage is checked with a high resistance meter, a positive voltage of 5–10V is present on the grid. The trouble is an o/c decoupling capacitor C60 on the printed circuit panel. This ceramic capacitor decouples the first video i.f. valve V5 screen grid.—G.C., Boroughbridge (860).

Ultra VT9-17: Trouble was sound instability, the symptoms being similar to those of i.f. instability; i.e., faint motor-boating which became louder as the volume control was advanced towards the half-way position and fainter as the control reached maximum. Feeling that this was rather uncharacteristic of i.f. instability we checked the output stage first and found the 10P13 output valve had a grid-screen leak.—G.C., Boroughbridge (861).

Murphy V250AD: This flywheel sync receiver was brought in with intermittent line slip. After unsuccessful changing of relevant valves it was decided to check the metrosil feeding the triode buffer stage, because of past experience, and it was found to be faulty (increased in value). Replacement cured the slip but the top of the picture tended to pull out; this was due to feed capacitor C103 which had gone o/c.—D.E., Pocklington (893).

Ferranti T1046: Trouble was striations and jagged verticals. Previously a faulty U26 e.h.t. rectifier has caused this trouble, but in this case it was not the culprit. The fault was caused by a dry joint on the U26 base, between pins 3, 4, and the centre spigot, which is used as a socket for the e.h.t. lead. This was not an immediately obvious fault as the base is covered by an anti-corona screen.—G.C., Boroughbridge (868)..

MULLARD SERVICE

The Mullard Birmingham Service Depot has moved to brand new premises at 2219 Coventry Road, and is equipped for handling and testing valves and tubes, with an improved high speed valve tester service section. A spacious car park is available for the convenience of dealers. The trade counter is situated in a reception room with informative displays of products.

AEI COURSES

A school for training engineers in the use of electronic equipment has been established by A.E.I. Ltd, at New Parks, Leicester, HQ of the Electronic Apparatus Division. Trainees include customers' engineers as well as members of the AEI construction department. There are two courses—advanced, lasting about five weeks, and elementary, lasting five days.

CUT YOUR SERVICING TIME

MODEL 77a MULTIRANGE METER 20,000 o.p.v.



Essential Features:

- ★ HIGH SENSITIVITY ★ INEXPENSIVE
- ★ SIMPLE SELECTION OF RANGES
- ★ WIDE OPEN SCALE

Sensitivity: 20,000 ohms per Volt D.C. 5,000 ohms per Volt A.C.

Ranges: D.C. Volts: 0-7.5-30-75-300-750-3,000

(30 Kv D.C. with adaptor Model 477)

A.C. Volts: 0-7.5-30-75-300-750

D.C. Current: 0-15-1.5-15-150-1,500 M.A., 15 Amps.

Accuracy: D.C. Ranges 2%, A.C. Ranges 4%.

Overload Protection.

Resistance: 10 ohms to 50 megohms in three ranges, self contained.

Buzzer: For Continuity Tests.

TRADE PRICE **£14.17.6**

or 9 monthly instalments of £1.16.2 each

Taylor

Write for fully illustrated literature to:

TAYLOR ELECTRICAL INSTRUMENTS LIMITED
Montrose Avenue • Slough • Bucks. Tel: SLOUGH 21381 Cables: TAYLINS, SLOUGH

METAL INDUSTRIES GROUP



MODERN TAPE RECORDER

—continued

The digital rev. counter is fed by a rubber band from the reservoir motor spindle. Erratic action may be due to perished band or slight greasiness—always check this before suspecting the counter.

GARRARD MAGAZINE DECK

In pursuit of simplicity, Garrard have carried the operational side of tape recording to its logical conclusion. The success of the magazine loading technique is shown by the number of makers who favour the Garrard deck in their complete machines.

To achieve this simplicity, several interesting features of construction

Among the operational faults that have been reported on this deck are those caused by mishandling. It is wise to instruct the customers to make a positive action when pressing the keys, to use the "Stop" button between each function, and to operate the speed change control only with the idler wheel disengaged—that is, with the Stop key depressed.

magazine being turned over in a matter of seconds at the end of a spool

A Record Safety Button is incorporated in this machine and function operation is by lever. There are only two controls. No provision is made for "Pause", this being considered unnecessary because of the extremely efficient braking of the magazine.

step position of switch (R), allowing the take-up motor (S) to operate on half-power to maintain tape tension.

On this same lever (P) is mounted a rod (T), which protrudes above the deckplate, and, moving forward, releases the brake (U) of the magazine. This also locks the magazine in place, preventing its removal while the spools are free to turn in any functional position.

A further advantage of this brake system is that the spools are firmly locked in the magazine even when the plastic cassette is opened—a great boon to the fumbler!

Fast Wind

Fast wind is an extension of this latter operation, link lever (P) again moving forward as lever (V) swings on its pivot in response to forward movement of the Fast Wind lever (Vv). This takes (Q) to the second position

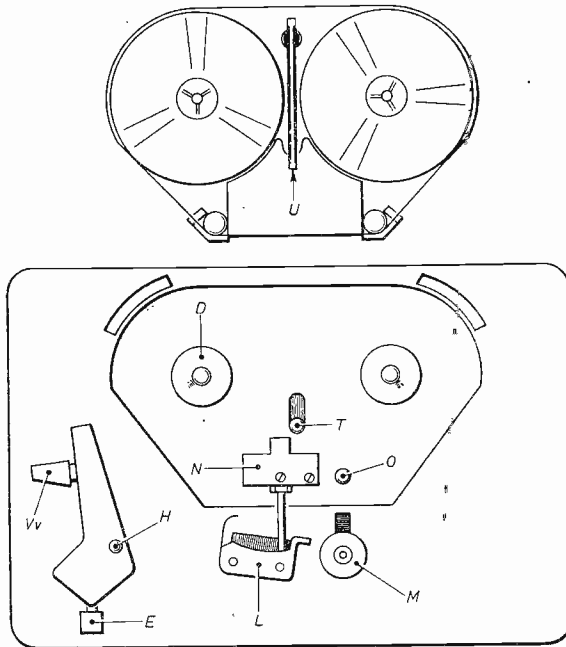

Fig. 3. Skeleton plans of the Garrard Magazine tape deck—left, top of deck; right, underside of deck. (Note: These sketches are not to scale.)

have been employed (Fig. 3). The idler pulley (A) is permanently sprung against the flywheel (B) from main drive motor (C), which runs continuously. There is no conventional braking system, merely a friction disc on the spindle of the reservoir spool (D) to avoid overspill. (Braking, which is done on the magazine itself, will be described later.)

Instant Stop

Other features are instant stop at any place on the tape and instant start from that place, with no fiddling for marks, or inching, Fast Wind in the one direction only and two-gap heads, the

Record/Replay

Movement of the Record/Play lever (E) has an identical result beneath the deck, owing to the shape of cam (F) on the spindle (G). This spindle has a long shaft for the fitting of extra wafer switches. The safety button (H) prevents movement of the lever (E) to the right until (H) is pressed.

Cam (F) rocks lever (J) about its pivot (K). To the inner end of (J) is attached the tape guide assembly (L) and the pressure roller (M), which takes the tape in contact with the dual head assembly (N) and capstan (O).

At the same time, lever (J) actuates lever (P), moving lever (Q) to the first

of the take-up motor switch, connecting full-power to (S). This movement can only be effected when the Record/Play lever is at neutral.

Very few operational adjustments are necessary on this deck. The heads should not require alignment, as they are combined with the tape guide system. A small adjustment of the pressure roller is provided, this being a set screw altering the tension of a spring (W) attached to lever (E). This should be adjusted to allow slip at the end of the tape, to prevent breakage.

Other points to look for are springs on idler pulley and switch lever (Q), splines on the magazine spool centres that may bind, preventing good seating, and distortion of the end piece of the pressure pad assembly.

Electrically, there are connections for either high or low impedance heads, both having gaps of 0.0002 in. For high impedance, bias currents should be 0.5–1.4mA. at 56 volts, and the signal current in the range of 30–100µA.

(Continued on page 15)

A Handy Solder Dispenser

by
V. D. CAPEL

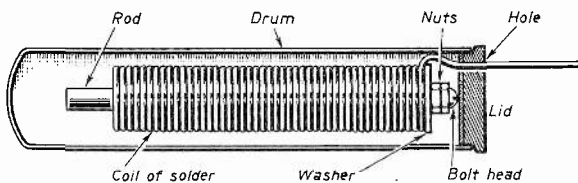

AN EASY-TO-MAKE ACCESSORY FOR THE WORKSHOP

ONE of the minor difficulties of the service engineer is the application of solder to the joint. An odd length broken off from the reel is soon used down and becomes too short to be conveniently applied, especially if the joint is "deep" in the chassis. Furthermore the odd few inch-remnants are more often than not wasted.

A small hand reel can be used but is often found to be a bit cumbersome, especially when soldering in awkward places. It is not possible to bring the reel near enough to the joint, and the resulting long end of the solder is insufficiently stiff to guide it accurately to where it is required.

To overcome some of these snags, a solder dispenser was made up from one of the "Little John" drums which are used to pack the silicon rectifiers supplied by Messrs. Radiospares. This is a long cylindrical drum as shown in the illustration.

A length of metal rod similar to volume control shafting was cut about an inch short of the length of the drum. A hole was drilled in one end and tapped out to take a 6BA bolt. A bolt of

suitable length was found and first fitted with a couple of nuts to act as distance pieces. Next a large washer was fitted small enough to allow plenty of clearance inside the drum, and the bolt then screwed home into the rod.

Next, a hole was drilled in the plastic lid of the drum. It is important that this hole is not in the centre of the lid, but well over to the side, otherwise the solder will be trapped by the bolt head when it is pulled out.

All that was now left to do was to wind some solder on the rod, several layers deep. It is better to wind on as evenly as possible. A washer can be fitted at the other end of the rod if desired but is not really necessary providing the solder is not wound right up to that end.

Inserting the rod in the drum with the washer at the open end, threading the solder through the lid and fitting same to the drum, and the dispenser was ready for use.

In practice, it has been found easy to use, the solder being readily pulled out to the desired length, and the complete unit fitting snugly in the hand. Another minor difficulty solved!

values beside the component? It only needs the legend k and M for resistors and μF for capacitors, those without suffix being either ohms or puffs. If necessary, the value could be on the left and above and the list number on the right and below. Some manufacturers can do it without making their diagrams look cluttered. Why not all?—J. Brown, Plymouth.

Tailored Car Radios

CONGRATULATIONS are due to R. N. Reeder (and to *Radio Retailing*) for the excellent article on Hybrid Car Radios in the March issue.

This is a field that is often neglected, and one that can give the serviceman a lot of trouble. But it should not be overlooked that the modern trend is toward "tailored" car radios. The range of sets made to fit particular cars is extremely wide, and fitting nowadays has been greatly simplified.

For this reason we may anticipate much more of this class of repair business in the future. Articles such as this are a great help. Thank you.—T. Styles, Watford.

Tools and Boxes

I WAS pleased to see a responsible publication such as yours giving some thought to the subject of tools, and I hope the promised review of soldering irons will not be long in coming.

To pick up a couple of points raised in letters in your April number, the valve remover illustrated will no doubt be familiar to many ex-servicemen, but I doubt if it would be suitable on domestic equipment. This type of extractor requires a straight pull of about five inches, and it happens that the very valve which needs such assistance will be in a confined space.

Actually, I find the easiest aid is the corrugated cardboard of the packing in the replacement valve box. Much neater than Mr. Mapleton's rag, and always ready to hand.

There are small rubber "pullers" on the market. These are in the form of a suction cup, with a round handle containing a plastic pin straightener.

In the same collection of Letters to the Editor, was a description of a personal toolbox by Reader W. Smith of Warminster (whose name will be familiar to readers of Technical Gen., no doubt.) His personal choice would not suit me. I like to carry a small meter and a few "popular" valves with me into the house.

It is notable that Mr. Smith's box lacks a small soldering iron, yet contains "3-inch sidecutters with 8 inch handles welded on". How often does he need those, I wonder?—T. Featherstone, Durham.

TRADE TOPICS Letters to the Editor

The Editor welcomes letters on subjects of technical or trade interest, but does not necessarily endorse the views or opinions expressed by correspondents.

Money is the Root . . .

I WAS surprised to see *Service Viewpoint* (March) joining the "Line Standard" battle. It should be obvious to us all that the ultimate decision will be that which satisfies the faction holding the heaviest purse.

There can be no doubt that a 625-line system would be an improvement, and would pave the way to colour TV. But just so long as the innovation would upset the plans of certain influential people, any change will be delayed.

It is time we got rid of the Ostrich

Mentality, as your editorial suggests, and converted our standards to what is best for the future of television—not just what is most expedient for a few financial jugglers.—P. L. Taylor, Ashton-under-Lyne.

Modern Failing?

IT WAS interesting to note, in a Book Review on page 175 of March *Service Engineer*, a criticism of what has become a modern failing.

I refer to the method of numbering components on service diagrams. It may seem very neat and tidy to list all components in a table, but the service engineer when studying a circuit, makes his judgments and diagnoses by taking into account the values of components, and may overlook the fact that a particular resistor (for example) is of an unusual ohmic value, or higher wattage than may be expected.

Surely the best method is to insert

Extracts from the

RTEB ANNUAL REPORT

NEW SYLLABUS

ELECTRONICS EXAMINATIONS

BETTER SELECTION

HIGHER STANDARDS—LOWER ABILITY

ENTRY QUALIFICATIONS

A NEW syllabus for 1961, the first electronic servicing examinations and the possibility of limiting the entry for the radio TV and electronic courses to provide a minimum entrance standard are some of the points raised in the annual report of the Council of Management of the Radio Trades Examination Board.

1961 SYLLABUS

The new syllabus in radio and TV servicing will be introduced this year, superceding the present syllabuses which have been almost unchanged since 1944 (radio) and 1950 (television).

The whole scheme has been revised, combining the two syllabuses and introducing the principles of TV at a much earlier stage. At the end of the first three years of the part-time course, candidates will now take an Intermediate radio and TV servicing certificate examination and at the end of the fifth year a Final examination.

The syllabus and scheme for the first electronic servicing examinations have now been published and the first Intermediate will be held this year.

The scheme of examination allows for a common first two years for radio, TV and electronic servicing, and a separation after that point into radio/TV or electronics.

STANDARDS

Since the war there has been an increase in the standard required to pass examinations, including those of RTEB. *The Council considers, however, that the general standard of ability of technicians and mechanics is not keeping pace with new industrial requirements. This, they say, reflects on selection and possibly on methods of training.*

The Board's purpose in setting the examinations is to provide a standard of qualification fitted for the most senior servicing mechanics and technicians and many certificate holders have found their way into industry, not only in servicing but in development and production appointments.

Since the new electronic servicing examinations will mean more successful candidates being employed in industry, an even higher standard will be required. The limitation is the entry standard rather than restricting the standard of the courses.

SELECTION

It is considered that very little selection has been carried out by

technical colleges, candidates being accepted for a particular course without question. After a few months the candidate may be advised to transfer to another course if his performance is very bad but, in general, particularly in the lower courses there is very little in the way of another course that can be offered to him.

Thus, a large number of candidates are brought through to the examination, inflating the failure rates, and at the same time preventing any real progress in the syllabus as a whole.

The Board is now very much concerned with the introduction of some specific standard of entrance to the course.

QUALIFICATION

Qualification to enter the RTEB examinations could be based on academic record while at school (problem: most applicants do not reach G.C.E. level and have passed no form of examination which is comparable). Or some form of vocational testing could be introduced at the college, intended to determine latent ability to cope with the course and find the type of mind which lends itself to logical fault finding procedure.

If employers co-operated with technical colleges with a view to holding such interviews prior to employment, this would reduce the risk of employers having apprentices unsuitable for training but who are required by their indentures to attend part-time courses.

Some form of national examination, like the G.C.E. but at a lower standard, is recommended to assess the candidate's ability from his school record. But there are difficulties here and it would probably be a long time before any such examination could be introduced. It is suggested that such tests could be organised by such bodies as the Royal Society of Arts, the College of Preceptors and the Educational Unions.

REGIONAL SCHEMES

The RTEB believe it could be advantageous to bring the regional

educational unions into the scheme of examinations, together with the City and Guilds of London Institute, to participate in the Board's work. If this idea develops, the local Educational Unions may be prepared to collaborate in introducing to their regional schemes to test the suitability of students for entry into the vocational courses.

Meanwhile, the RTEB is considering limiting entry to the radio, television, and electronic servicing courses to those candidates who have had full time education up to sixteen years, or who have completed a preliminary course.

Once this selection has been carried out and introduced, it will enable a rather higher standard of examination and a more intensive training.

MODERN TAPE RECORDER

—continued

Low impedance reading will be 1-2.8mA at 28 volts and signal current of 60-200 μ A.

The erase head has an impedance (at the bias frequency of 50 cycles) of 250-300 Ω , and a power of half a watt. Current will be 75 to 100mA, approximately 20 volts r.m.s.

There is only one tape speed, 3 $\frac{1}{2}$ i.p.s., and rewind time for the four-inch spool of double-play tape, about 650 feet, plus six foot leaders, is only 40 seconds.

Performance

Although the manufacturers expect a response of 20-10,000 cycles \pm 3dB, with correct equalisation, much depends on the associated equipment and this quality may be difficult to attain.

But a wow and flutter figure both better than 0.1 per cent was noted on the test model. The manufacturers state 0.2 per cent maximum wow, which is a modest claim for what is an excellent and very foolproof deck.

From the 2 $\frac{1}{2}$ -pound brass flywheel to the quality rubber of the idler wheel—which, contrary to expectation—shows no sign of developing a flat!—the engineering of this deck is in the best Garrard tradition.

To be Continued

Getting us Typed

WHAT else do you read? If you are like me, you will savour all and any printed matter, from the dusty tomes in other people's libraries to the back of your own wireless licence. You *do* have a licence, I hope.

In the course of this catholic perusal it is interesting to note the regularity with which some topics recur. Round about now, in the women's magazines, there is a spate of articles on entertaining the wedding guests, or making a trousseau from a set of old bleached curtains. The subject ties in with the season. Like the "cuckoo letters" in *The Times*.

In the radio trade we find the trend toward "Qualifications"—this being examination time. In the correspondence columns of the radio magazines we will probably see heated controversies about the status of the service engineer.

That title, according to some of the protagonists, is in itself a misnomer. They would have us call ourselves "Technicians" until we have qualified for the crossed soldering irons and bar in an approved seminary.

According to these well-lettered gents, the "engineer" is the chap who is engaged on research and development only. Repairs are routine.

Their idea of progress is for we technicians to study the theory while indulging in the practice, taking exams like steps up a ladder until we can pull ourselves out of the common rut and become "engineers".

Many of us already do this—or try. We find that the Servicing Certificates, Guild Examinations, Institute Diplomas, etc., help us to understand more fully the job we're attempting to do. Sometimes they also help us to land a better job. This, I'm told, is progress.

But the paradox is that the higher up the ladder we climb the more

restricted our view. Conversely, to widen our horizons we find it necessary to narrow our aim. If the ad-boys wanted an appropriate slogan they couldn't do better than: "If you want to rise—specialise." I shall be happy to sell the copyright to any correspondence college.

My point is that, in this trade, or any other technical pursuit, the lack of diplomas does not necessarily indicate a lack of knowhow. It may only indicate a lack of time to study. We are so darn busy doing the job that we haven't the time to explain it! Except occasionally to the customer



Taking exams like steps up a ladder until we can pull ourselves out of the common rut . . .

who demands chapter and verse on why his set went wrong.

All this means that as a trade we rank about level with the chap who comes to read the meter. We have no status beyond that which we individually earn.

Things are different elsewhere. In some parts of the States it is impossible to earn a living as a serviceman unless one is properly licensed. That means passing certain trade tests and accepting standardised conditions and pay.

Whether or not you admit that's a good thing depends—be honest—whether or not you are the studious type. If we desire a "Status" here, we must accept the need to qualify. It may mean giving up the weekly darts match and attending the "Poly" instead.

Did you know that National Plumbing Week occurs at the end of this month? Mr. James Haig, A.M.I.W., A.M.I.P., R.P., is hoping to convert the country to a realisation that the



Go and get your red flag, Joe!

cap and muffler days are past, that tools are not always forgotten. He claims that the plumber is worthy of semi-professional status. Fit to wear the foreman's bowler hat, in fact.

And if the plumbers can do it, why not us, Joe? We have already the rudiments of a profession, qualifying examinations, a protective guild, the judgement seat of the R.I.R.A, the tentative respect of the public. Let's get the public relations boys cracking and organise a "Serviceman's Week", hire the Albert Hall for a get-together during Radio Show time. Then we can put stickers on our vans, even on our toolboxes.

Unfortunately, some of our employers do not share the wish for us to improve our status. A young friend of mine, a real enthusiast, had to turn down a job the other day because his prospective employer was not willing for him to continue with his "one day a week" course at the local technical college. This despite an offer to work equivalent time in lieu.

Others eschew the junior, regarding learners as a burden on the firm's economy. The apprentice schemes throughout the country are nothing like so widespread as they should be. At about the time that colour comes in we older hands will all be retiring. And if the office wallahs imagine that sets will by then be foolproof they are heading for disillusion: and eventually dissolution when the right sort of service engineer cannot be found.

Yes, *engineer*. Only a designer's dreamchild can believe that service is a day-to-day routine. Not a few of us are also enthusiastic amateurs, burning the midnight oil over impossible hookups, building rigs that occasionally work, and learning all the time. We wouldn't be in the job unless we liked it—and isn't that, alone, worth some sort of status?

When the pressure of work irks I'm with Max Beerbohm, who said that he reminded himself "when the stress of my labours tells on me, that I am lucky not to be a porter on the Underground Railway."

Go and get your red flag, Joe.

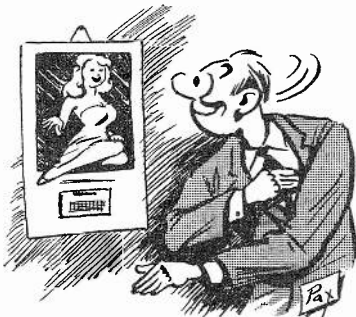

You will savour all and any printed matter.



The kit-sets which give you the Best Possible Servicing Equipment at Absolutely Minimum Cost!

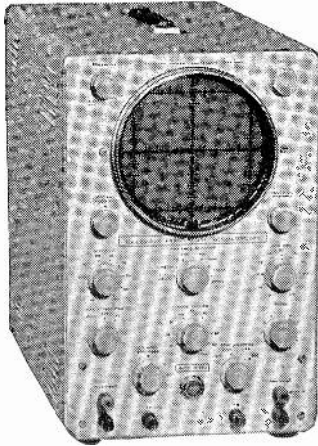

Heathkit 'Scope

PORTABLE 2½" SERVICE 'SCOPE, Model OS-1

The OS-1 uses a 2½" cathode ray tube and is a compact portable oscilloscope ideal for servicing and general laboratory work. Y amplifier sensitivity 10mV/cm; response ±3dB 10 c/s-2.5 Mc/s. Time base 15 c/s-150 Kc/s. Features include Int. Ext. and 50 c/s sync; Sine sweep; time base output for wobulator; X amplifier socket; 1, 10 and 50 volt-calibrator. Uses printed circuit board for consistency and ease of assembly. Case 7⅞" × 4⅞" × 12½" long. Weight only 10½ lbs. **£19. 10. 0.**

5" FLAT-SCREEN OSCILLOSCOPE, Model O-12U

Laboratory instrument at utility 'scope price. Exceptionally wide-range time-base (10 c/s to 500 Kc/s) "Y" frequency range 3 c/s to over 5 Mc/s, sensitivity 10mV RMS/cm. Electronically stabilised. Output for Wobulator. Voltage Calibrator (1 volt pk. to pk. source). Instantaneous shift, drift free. Automatic lock-in synch. Rise time 0.08µ secs or less. "Z" modn. facilities. 2-gold-plated printed-circuit boards and pre-cut cable wiring harness greatly facilitate assembly. **£36. 10. 0.**

Besides this test equipment, we have a full range of "HAM" and HI-FI equipment including AMPLIFIERS, SPEAKER SYSTEMS and CABINETS.

VALVE VOLTMETER, Model V-7A

Because of the accuracy, reliability and sheer value of the Model V-7A it is outselling all other VVM's. The precision and quality of its first-class components cannot be duplicated elsewhere at this price. Indication is by a large 4½" 200µA meter clearly calibrated for all ranges. The voltage divider networks use 1% precision resistors. A gold-plated printed-circuit board simplifies the assembly, saves time and eliminates the possibility of wiring errors. It also ensures duplication of laboratory performance.

This multi-function VVM measures A.C. Volts (RMS and pk. to pk.), D.C. Volts and Resistance. The 7, A.C. (RMS) and D.C. ranges are 1-5, 5, 15, 50, 150, 500 and 1500. The 7, A.C. pk. to pk. Voltage ranges are 4, 14, 40, 140, 400, 1400 and 4000. D.C. input impedance is 11MΩ. Seven Ohm-meter ranges have multiplying factors of X1, X10, X100, X1000, X10K, X100K and X1MΩ. Centre-scale resistance readings are 10, 100, 1000, 10K Ohms, 1MΩ and 10MΩ. A centre-zero dB scale is provided also for measuring audio amplifier performance. Test leads, prods and battery are included in the kit.... **£13. 0. 0.**

PROBES: R.F. £1. 9. 6., H.V. (30kV d.c.) £2. 15. 6.

Other Models Include :

OSCILLOSCOPE TRACE DOUBLER, Model S-3U. Will extend application of single beam oscilloscope by enabling it to give simultaneous traces of two separate and independent signals. **£10. 15. 6.**

RESISTANCE/CAPACITANCE BRIDGE Model C-3U. Measures Capacitance 10pf (0.00001µF) to 1000µF; Power Factor; Resistance, 100 Ohms to 5 Megohms, and indicates leakage. **£8. 6. 6.**

AUDIO SIGNAL GENERATOR. Model AG-9U. 10 c/s to 100 Kc/s Sine-wave output, 10 volts down to 3 mV f.s.d. Less than 0.1% distn. Decade frequency selection, dB ranges, -60+22. **£19. 19. 6.**

Multimeter, MM-1U. Measures wide range of voltage, current, resistance and dB in over 20 ranges. Sensitivity 20,000 ohms/volt D.C. and 5000 ohms/volt A.C. 0-1.5, 1500 volts A.C. and D.C. 0-150 µA, 15 A D.C. Resistance 0.2 ohms to 20 megohms. 4.5 in. meter, 50 µA f.s.d. **£11. 18. 6.**

WIDE-BAND AUDIO WATTMETER. Model AW-1U. Ideal for audio power measurements. 10 c/s to 250 Kc/s, 25WV, continuous 50W intermittent. Switch-selected non-inductive int. or ext. load. 1% multipliers. 200µA meter calibrated in Watts and Decibels. **£14. 14. 0.**

WIDE BAND AUDIO VALVE-MILLIVOLTMETER. Model AV-3U. This sensitive and highly stable VVM quickly measures A.C. mains, ripple and heater voltages, audio input/output, gain in volts and dB's. Range 10mV to 300V full scale deflection **£13. 18. 6.**

DIRECT READING CAPACITANCE METER. Model CM-1U. 0-100pF to 0-0.1mFd. 4 ranges. 1% external standards provided for each of the four ranges. **£4. 15. 0.**

POWER SUPPLY UNIT. Model MPG-1. Provides 3 D.C. outlets 250-300 volts up to 90 mA., 170-220v. up to 30 mA, 150-200v. up to 10mA and 6-3v at 2.5 A A.C. **£4. 16. 6.**

DECADE CAPACITANCE BOX. Model DC-1. Precision 1 per cent silver mica capacitors are used and switches are of the ceramic wafer type to ensure minimum loss. Three decade switches are used and cover a range of 100 pF to 0.111 µF in increments of 100 pF. **£6. 5. 6.**

R.F. SIGNAL GENERATOR. Model RF-1U. Provides extended frequency coverage in six bands from 100 Kc/s to 100 Mc/s on fundamentals and up to 200 Mc/s on calibrated harmonics. Up to 100mV output on all bands. Ideal for alignment. **£11. 18. 0.**

GRIP DIP METER. Model GD-1U. A Grip Dip Meter giving continuous coverage between 1-8 and 250 Mc/s. Self contained, including mains power supply for 200-250 volts A.C. operation. Box of 5 plug-in coils supplied. The instrument can be used to measure resonant frequency, inductance, capacitance and Q factor together with locating the source of parasitic oscillation, etc. **£10. 9. 6.**

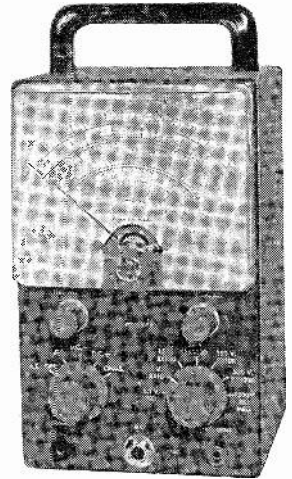

V-7A

Please send for **CATALOGUE** of whole range and terms to Trade

DAYSTROM LTD. DEPT. R5, GLOUCESTER, ENGLAND.

A Member of the Daystrom Group, manufacturers of

THE FINEST AND LARGEST-SELLING ELECTRONIC KITS IN THE WORLD

Every Service Department

ESSENTIAL SERVICING DATA

VOL. 1

Television Receivers

saves time with

E. S. D.

the radio and television
engineer's first reference

Compiled by GORDON J. KING

ESSENTIAL SERVICING DATA

VOL. 2

Radio Receivers
and Radiograms

Volume One has 142 pages of information on TV receivers, of immediate practical value to the television service engineer, both in the workshop and in the field. Details are given of valve complement, c.r.t., i.f.'s, controls, electrolytics, metal rectifiers and diodes, thermistors, surge limiters and mains droppers, mains input, fuses, e.h.t., aerial inputs, together with servicing notes or special remarks. A special section deals in detail with Band III converters and conversion.

Valves: 1 ECH35; 1 EF30; 1 EB34; 1 6X7.

Inter. Freq.: 460kc/s.
Pilot Bulb: 6.5V 0.3A M.E.S.

SPECIAL REMARKS: The radio section has its own power pack, but uses the a.f. amplifier of the TV sound channel.

T141 (12in. table model), TC138 (12in. console model), TRC139 (12in. console with pre-set radio)

Valves: 5 6F1; 2 6D2; 4 SP61; 1 6P28; 1 U24; 1 PY31; 1 6P25; 1 6K25; 1 PZ30.

C.R.T.: Mazda CRM121B.
Inter. Freq.: Sound 19.7 Mc/s; Vision 16.2 Mc/s.

Channels: All in Band I—lower sideband.

Band III Tuner: Type TT234.
Controls: Contrast 5k w/w; Brightness 100k DP switch; Volume 20k w/w.

Electrolytics: 100+50µF 350V kwg. common negative.

Aerial: 70-80 ohms unbalanced.
Mains: 200-250V a.c. only live chassis.

Fuses: Two 1.5 amp.
E.H.T.: 7kV (line flyback).

SPECIAL REMARKS: For fringe areas a single-valve pre-amplifier is available, and a slot is provided to hold it on the back of the cabinet. The amplifier is powered from a socket on the back of the chassis. SP41s may be found in place of the SP61s; and one of F1 may be replaced by a 6C9.

—osc. high.
Channels: All five
Band III Tuner
TT258.

Controls: Bright
Volume 25k
w/w.

Electrolytics: 12
common negat
Aerial: 70-80 oh
Mains: AC only
d.c.).

Fuses: Two 1.5
E.H.T.: 8kV (in

SPECIAL REMARKS: a sound i.f. of 19.7 Mc/s.

SERVICING NOTE: adjustment occurs check the 2.7-meg between the cent blocking oscillator in valve.

T217 (17in. table, also later version and T206)

Valves: 1 6F1
2 10A13; 1 2C
1 6P28; 1 U
(not-wobble)

C.R.T.: Mazda
Inter. Freq.: Sound
16 Mc/s.

Channels: All five
Band III Tuner:
Controls: Volume

Volume Two has 190 pages of information on radio receivers and radiograms of equal value to the field engineer and the man at the bench. Details are given of valve complement, mains input, i.f.'s, electrolytics, pilot lamps, controls, mains droppers, waveband coverage, speaker fuses, and in the case of radiograms or record player unit, pick-up.

Notes on aerial inputs, and provision of extension speaker and pick-up sockets are also given.

There are also sections on tuners and notes on transistors and printed circuits.

Extract from Vol. 1 showing typical entry.

Volume 1 covers the basic circuit specifications of the vast majority of post-war TV receivers and includes a section on Band III converters. Volume 2 deals similarly with radio receivers and radiograms and includes a section on tuners. Both volumes are packed with data, invaluable in the service workshop, essential to the outside engineer.

Vol. 1—(Television Receivers) 10/6 post paid

Vol. 2—(Radio Receivers and Radiograms) 13/6 post paid

from

Radio Retailing, 46 Chancery Lane, London, W.C.2