

FEBRUARY 1976 • 75 CENTS



A HARCOURT BRACE JOVANOVICH PUBLICATION

ELECTRONIC TECHNICIAN/DEALER

WORLD'S LARGEST TV-RADIO SERVICE & SALES CIRCULATION

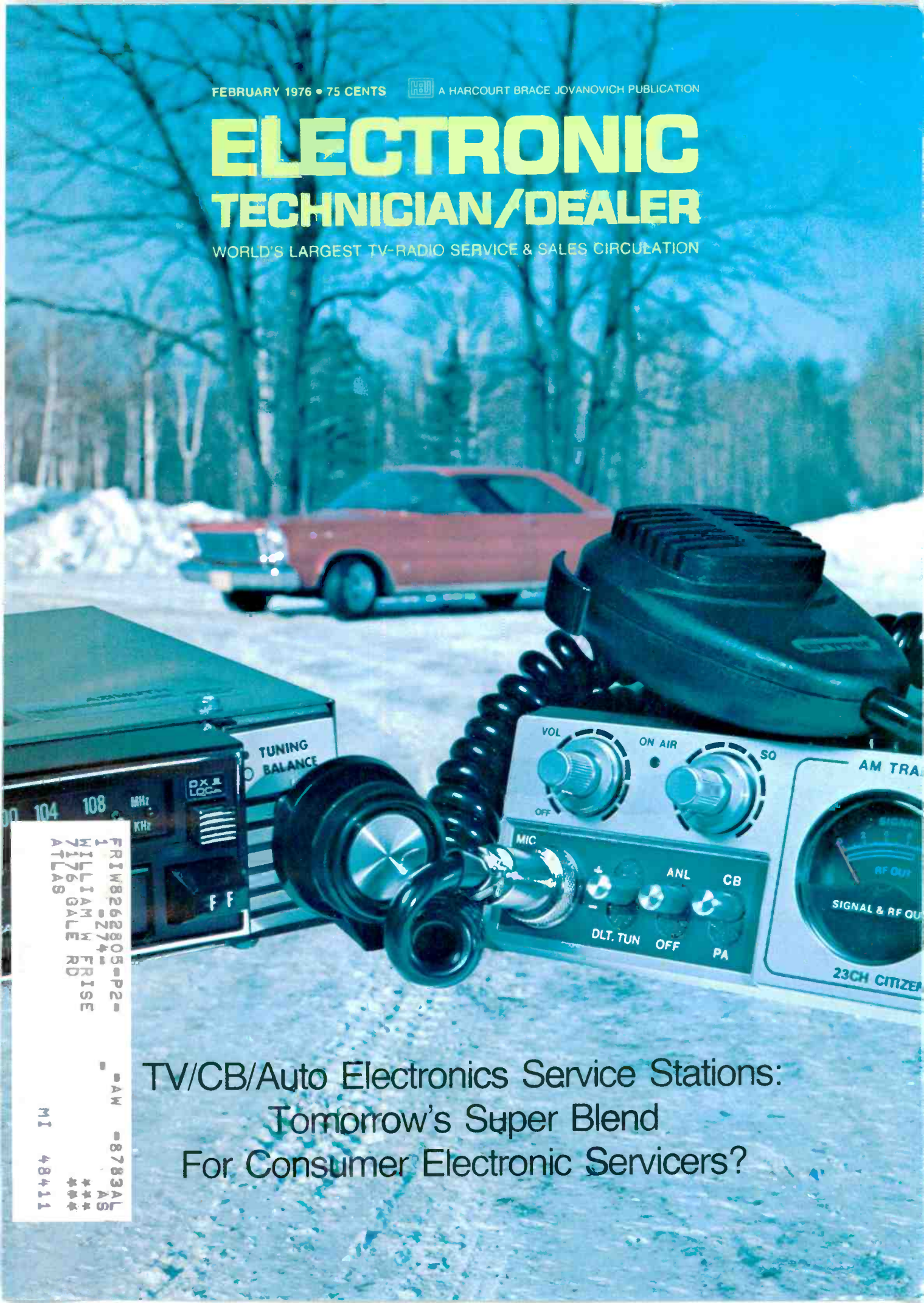

FR1W8262805-P2-
 1 WILLIAM W FRISE
 7176 GALE RD
 ATLAS
 MI 48411

TV/CB/Auto Electronics Service Stations:
 Tomorrow's Super Blend
 For Consumer Electronic Servicers?

You've Got Us Where You Want Us



Even though we're the world's largest tuner repair service, recommended by more TV manufacturers than any other company, we think small. Really! We could put the whole thing under one roof. Instead, we have 35 small service centers across the country, staffed by more than 200 professional technicians. Why? Service for one thing . . . same-day

service. Bring us a tuner . . . any tuner . . . at 8 a.m. and it's repaired and tested by 4 p.m. Then there's quality . . . original parts, and once repaired, it's good as new. Oh sure, being the world's largest is something we're proud of. But we also like the fact that with 35 service locations, we can be small enough to give every tuner repair job a personal as well as a professional touch.



ELECTRONICS, INC.

PRECISION TUNER SERVICE

Consult the white pages of your telephone directory for the address and telephone number of the PTS center nearest you.

...for more details circle 102 on Reader Service Card

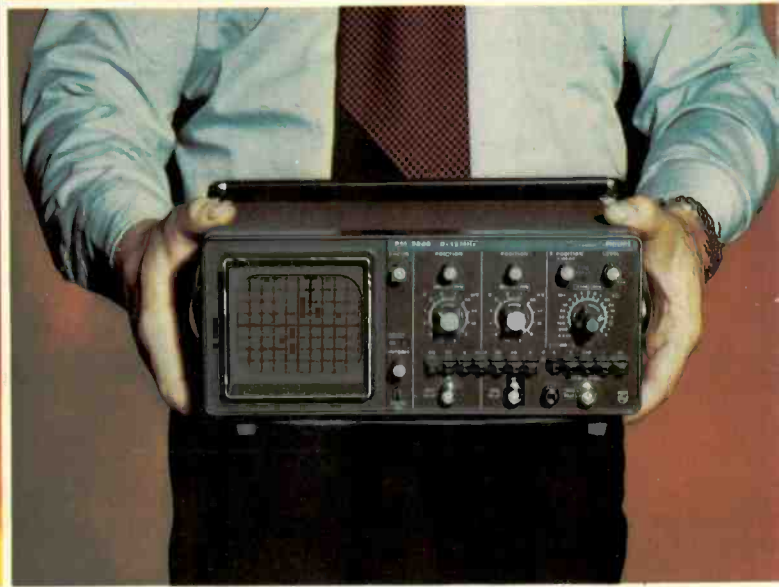
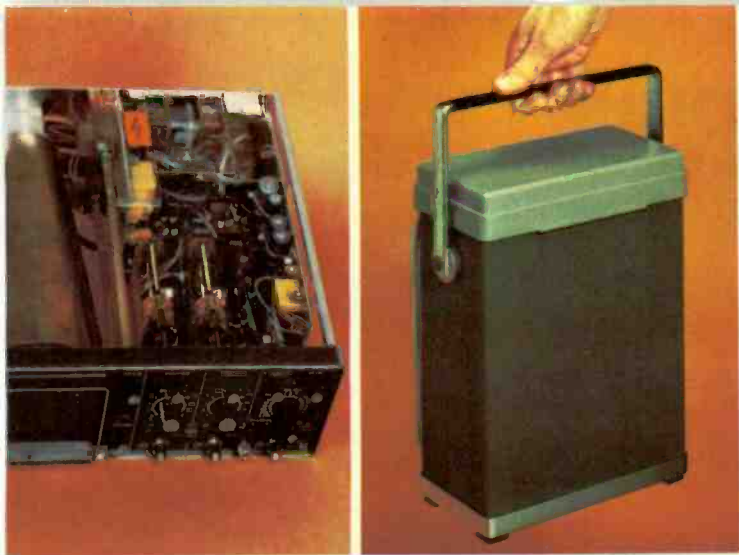

THEY'RE BEAUTIES ALRIGHT... in more ways than one

- Real portability: Single trace model PM3225 is only 8 pounds, 2 ounces. Dual trace model PM3226 is only 9 pounds, 10 ounces
- Convenient compactness: PM3225: 5.4" H x 10.1" W x 12.4" D and PM3226: 5.4" H x 11.9" W x 12.4" D
- Sensitivity: 2mV/div at 15 MHz bandwidth • 8 x 10 division screen
- Complete triggering facilities: Auto, line, External, TV line or frame
- Automatic DC balancing and drift control
- Logical layout of operating controls for quick error free setup
- A most logical and convenient internal layout for optimum servicing
- Prices that put genuine professional scopes easily within your budgets.

**NOW AVAILABLE FROM
MAGNAVOX PARTS CENTERS**

From Magnavox and Philips . . .
The experience gained by manufacturing the products you sell is applied to the design of the service instruments you need.

Available at your Magnavox Parts Centers. Or, call our toll free HOT LINE number for complete price, delivery, and technical information. Dial 800 645-3043. New York residents, call (516) 921-8880 collect.

Philips Test & Measuring Instruments, Inc.
 400 Crossways Park Drive
 Woodbury, New York 11797
 (516) 921-8880



PHILIPS

. . . for more information circle No. 126
 . . . for demonstration circle No. 127

ELECTRONIC TECHNICIAN/DEALER

February 1976 • VOLUME 98 NUMBER 2

J.W. PHIPPS

Editor
1 East First Street
Duluth, Minn. 55802
(218) 727-8511

ALFRED A. MENEGUS

Publisher
757 Third Avenue
New York, N.Y. 10017
(212) 754-4382

TOM GRENEY

Publishing Director

DONALD W. MASON

Managing Editor

DEBI HARMER

Production Manager

BERNICE GEISERT

Production Supervisor

JOHN PASZAK

Graphic Design

LILLIE PEARSON

Circulation Fulfillment

GENE BAILEY

Manager, Reader Services

ROZ MARKHOUSE

Classified Advertising Manager

CONTRIBUTING EDITORS

JOSEPH J. CARR

DAVID NORMAN

DISTRICT MANAGERS

DAVE HAGELIN

43 East Ohio Street
Chicago, Ill. 60611
(312) 467-0670

CHUCK CUMMINGS

Ad Space South/West
613 North O'Connor
Irving, Texas 75060
(214) 253-8678

ROBERT UPTON

Tokyo, Japan
C.P.O., Box 1717

THE COVER: CB and auto entertainment equipment—two categories of consumer electronics which should become increasingly more appealing and compatible to TV servicers as an increasingly larger percentage of their total volume shifts from in-home to carry-in business.

COMMUNICATIONS ELECTRONICS

8 Troubleshooting CB Transceiver Audio

Typical causes of audio and/or modulation problems in CB transceivers and how to quickly localize them—often before removing the cover. By David F. Norman, ET/D Communications Editor.

12 Comm Chat

Communications Editor Dave Norman passes along some tips about how and how not to deal with communications clubs.

VEHICULAR ELECTRONICS

14 Carr Talk

Vehicular Electronics Editor Joe Carr lists the tools and provides some procedural tips which have improved his own proficiency at auto electronics removal and reinstallation.

20 Common Car Tape Faults

Causes of the most frequently encountered trouble symptoms displayed by car eight-track and cassette tape players and how to cure them. By Joseph J. Carr, ET/D Vehicular Electronics Editor.

BUSINESS MANAGEMENT/SHOP OPERATIONS

25 TV/CB/Auto Electronics Service Stations: Tomorrow's Super Blend For Consumer Electronic Servicers?

ET/D Editor J. Phipps discusses how the nature of TV servicing probably will be changed significantly by the shift to more carry-in business and why TV servicers and servicing dealers should begin placing increased emphasis on the servicing of other electronics products such as CB and auto entertainment equipment.

29 Controlling Your Business Cash

How to help insure that you will have enough when you need it and not too much when you don't need it. By D.S. Campbell.

HOME ENTERTAINMENT ELECTRONICS

32 Color TV Module Guide

A cross-reference listing of modules. This month: GTE Sylvia.

34 Magnavox Color TV 1976

A detailed examination of the most revolutionary circuits and features of Magnavox's two newest chassis, the T991 and the T995. By Joseph Zauhar.

DEPARTMENTS

- | | |
|---------------------------|----------------------|
| 4 TECHNICAL LITERATURE | 48 CLASSIFIED ADS |
| 6 NEWS OF THE INDUSTRY | 50 ADVERTISERS INDEX |
| 38 TECH DIGEST | 51 READER SERVICE |
| 40 TEST INSTRUMENT REPORT | 53 TEKFAK |
| 41 NEW PRODUCTS | |



A HARCOURT BRACE JOVANOVIICH PUBLICATION



HARCOURT BRACE JOVANOVIICH PUBLICATIONS: James Milholland, Jr., Chairman, Robert L. Edgell, President, Lars Fladmark, Senior Vice President, Richard Moeller, Treasurer, John G. Reynolds, Vice President, Thomas Greney, Vice President, Ezra Pincus, Vice President, Bruce B. Howat, Vice President, James Gherna, Vice President, Lois Sanders, Vice President.

ELECTRONIC TECHNICIAN/DEALER is published monthly by Harcourt Brace Jovanovich Publications. Corporate offices: 757 Third Avenue, New York, New York 10017. Advertising offices: 43 East Ohio Street, Chicago, Illinois 60611 and 757 Third Avenue, New York, New York 10017. Editorial, Accounting, Advertising Production and Circulation offices: 1 East First Street, Duluth, Minnesota 55802. Subscription rate: one year, \$7; two years, \$12; three years, \$16 in the United States and Canada. Other countries: one year, \$15; two years, \$24; three years, \$30. Single copies: 75¢ in the U.S. and Canada; all other countries, \$2. Second Class postage paid at Duluth, Minnesota 55806 and at additional mailing offices. Copyright © 1976 by Harcourt Brace Jovanovich, Inc. All rights reserved. No part of this publication may be reproduced or transmitted in any form or by any means, electronic or mechanical, including photocopy, recording, or any information storage and retrieval system, without permission in writing from the publisher.

POSTMASTER: Send Form 3579 to ELECTRONIC TECHNICIAN/DEALER, P.O. Box 6016, Duluth, Minnesota 55806.

The death of a solid-state device needn't complicate your life.

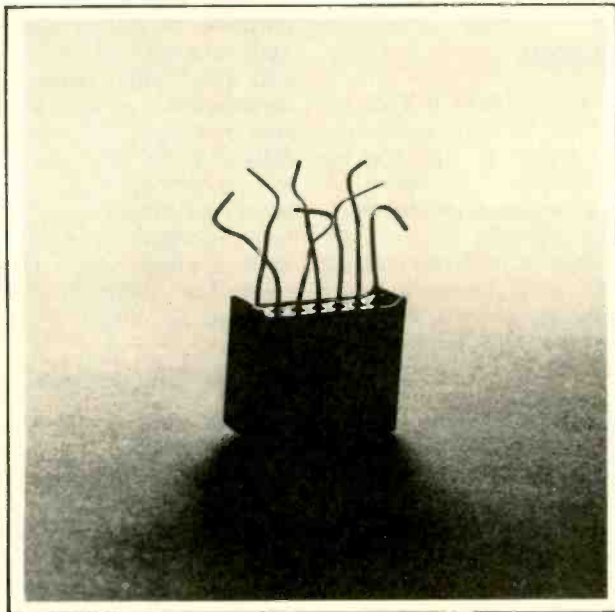

Repair over 126
domestic and imported
brands with
Sylvania modules and IC's.

You take a look at the job and the brand name's Bigston or Kobekiito or Teaberry or Pace.

No problem!

Sylvania replacement modules and IC's fit these brands like a glove. They also fit over 122 other brands, including RCA, Panasonic, Sony—and, of course, Sylvania.

For the vast majority of domestic and imported electronic equipment, all you need is a basic stock of Sylvania ECG™ Semiconductors. And our new Replacement Guide to show you which ones go where.

For a copy, see your Sylvania distributor.

We're helping you make it.

GTE SYLVANIA

ARROW AUTOMATIC STAPLE GUNS

CUT WIRE & CABLE INSTALLATION COSTS

... without cutting into insulation!

SAFE! Grooved Guide positions wire for proper staple envelopment! Grooved Driving Blade stops staple at right depth of penetration to prevent cutting into wire or cable insulation!



No. T-18—Fits wires up to 3/16" in diameter.

BELL, TELEPHONE, THERMOSTAT, INTERCOM, BURGLAR ALARM and other low voltage wiring.

Uses T-18 staples with 3/16" round crown in 3/8" and 7/16" leg lengths.

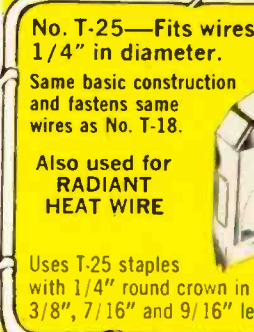

No. T-25—Fits wires up to 1/4" in diameter.

Same basic construction and fastens same wires as No. T-18.

Also used for RADIANT HEAT WIRE

Uses T-25 staples with 1/4" round crown in 9/32", 3/8", 7/16" and 9/16" leg lengths



NEW! Intermediate

No. T-37—Fits wires and cables up to 5/16" in diameter.

Same basic construction as Nos. T-18 & T-25.

Also used for CATV and DRIVE RINGS in stringing wires.

Uses T-37 staples with 5/16" round crown in 3/8", 1/2" and 9/16" leg lengths

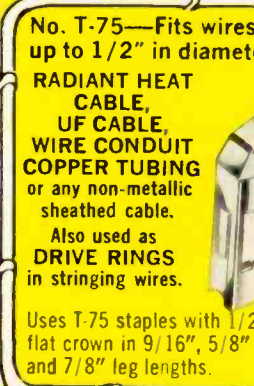

No. T-75—Fits wires and cables up to 1/2" in diameter.

RADIANT HEAT CABLE, UF CABLE, WIRE CONDUIT COPPER TUBING or any non-metallic sheathed cable.

Also used as DRIVE RINGS in stringing wires.

Uses T-75 staples with 1/2" flat crown in 9/16", 5/8" and 7/8" leg lengths.

ARROW FASTENER COMPANY INC

271 Mayhill Street, Saddle Brook, N. J. 07663

...for more details circle 109 on Reader Service Card

TECHNICAL LITERATURE

TELE-COMMUNICATIONS TOOLS

A new 1975 catalog covering everything needed in small tools for the communications, telephone and electronic industries is now available. It makes available to the user photographs of all tools along with sizes and descriptive information in classification order along with stock numbers for easy ordering. Such items covered are Cable and Wire Tools, Spring Tension Gauges, Thickness Gauges, Contact Burnishers, Wrenches, Test Connecting Tools and Brushes, and various kits for Numbering and Lettering right through to the unique Cable Tool Kits. *P.K. Neuses, Inc.*, P.O. Box 100, Arlington Heights, IL. 60006.

TEST INSTRUMENTS

A new 32-page, 1975/76 Test Instrument catalog is now available, featuring a complete quality line for industry, education and service. Listed are oscilloscopes/vectorscopes, color bar and pattern generators, DVM's, multimeters, millivolt meters, signal generators, sweep/marker generators and accessories. For convenience and easy product identification, the instruments are listed under four principle application categories—instruments for service and industry; for audio and quality control; for video—CATV, MATV, CCTV, VTR; and for technical training. *Leader Instruments Corp.*, 151 Dupont Street, Plainview, NY. 11803.

SEMICONDUCTOR CROSS-REFERENCE GUIDE

A 196-page semiconductor cross-reference product guide has been published by *Mallory Distributor Products Co.* The book lists information about replacement semiconductors, transistors, complementary pair transistors, zener diodes, diodes, high voltage components, color crystals, integrated circuits and field effect transistors. The guide also has an alpha-numeric index, semiconductor installation tips, drawings and diagrams. The guide is available only through electronic parts distributors.

COLOR-BRITENER SELECTOR GUIDE

A new *Perma Power* Color-Britener Selector Guide is now available. The guide contains a complete listing of all color tube numbers, color-coded to simplify proper britener selection. With the tube numbers printed in

color, the service technician has only to look for a britener packaged in a box of the same color. The guide also calls attention to a number of unusual picture tube styles with special sockets, which cannot be brightened with a plug-in britener, but can be brightened with a wired-in *Perma Power Tech-Brite*, packaged in a brown box. *Chamberlain Manufacturing Corp., Perma Power Division*, 5740 North Tripp Avenue, Chicago IL. 60646.

AUDIO CONNECTORS

A new Product Bulletin No. 292, describing a new audio coupler, Model 395P1, is available. It provides ready connections between two different size audio phone plugs—standard commercial 3/4-inch diameter finger, 2-conductor phone plug to miniature commercial 9/64-inch diameter finger, 2-conductor phone plug. The coupler is suitable for standard and miniature audio plugs used widely on hi-fi, stereo and quad audio equipment, test instrumentation, telephone and intercom, radio and TV sets. It features a fully shielded body and nickel plating for attractive appearance. Internal nickel silver springs provide stable, low resistance connections between mating plugs. Sales Dept., *Switchcraft, Inc.*, 5555 No. Elston Ave., Chicago, IL. 60630.

PICTURE TUBE PROMO MATERIAL

A full color folder designed as an envelope stuffer to help dealers save old TV sets by promoting picture tube replacement is offered. The folder, which fits into small bill-sized envelopes, features the theme, "You can save your set from an early grave". It includes a four point check list advising set-owners how to tell when their color tubes may be ready for replacement, and a graph indicating year-to-year color loss as a CRT grows older. The folder also describes the benefits of Channel Master's Opti-Vue Plus consumer protection warranty plan, as an alternative to scrapping the set. CRT Division, *Channel Master*, Ellenville, NY. 12428.

WWW/WWVH USER'S GUIDE

"The Use of NBS High Frequency Broadcasts for Time and Frequency Calibrations" is a new guide, NBS Technical Note 668, which permits users to get the maximum benefits from the National Bureau of Standards' service. Although newer dissemination techniques are being developed to give even greater stability, accuracy and reliability, shortwave broadcasts still provide a convenient and economical means of distributing

time and frequency information to thousands of users in dozens of different occupations and endeavors. NBS began transmitting standard radio frequencies on a regular schedule from its station WWV (originally in Washington, D.C., now in Fort Collins, Colorado) in 1923, and station WWVG (in Kekaha, Kauai, Hawaii) started operations in 1948. Together the two stations now broadcast accurate time and frequency signals to broad areas of the western hemisphere. Dimensions and construction details for several types of antennas are given, as are instructions for measuring or computing receiver and propagation delays, great circle distances and incident wave angles. An adjustable time delay generator can be built by the reader from instructions and circuit diagrams provided in the guide. Price is \$1.05. Superintendent of Documents, U.S. Government Printing Office, Washington, D.C. 20402.

SOLID STATE LAMPS

A 4-page folder showing the nearest-equivalent cross references for eleven leading manufacturers of discrete solid state lamps (LEDs) is published. The folder matches all widely used LEDs primarily on the basis of size, shape, input and output characteristics. Actual part numbers are listed on side-by-side charts to show which LEDs are interchangeable with CM products, and an alphabetical coding is used to indicate specific differences in cross-referenced pairs, such as 25 percent or more difference in typical intensity, lack of minimum intensity specs, differences in lead shape or other minor mechanical differences. *Chicago Miniature Lamp*, 4433 N. Ravenswood Ave., Chicago, IL 60640.

ANTENNA SYSTEM PRODUCTS

A 51-page catalog, Broadband MATV/CATV and Antenna Installer Products, Reference No. 75-72A and a 20-page catalog, MATV/CATV and Antenna Installer Products, Reference No. 75-82 are now available. The catalogs have been specially prepared for finding solutions to TV reception and design problems. Some of the products listed include antennas, test equipment, coaxial cable, cable connectors, taps, matching transformers, amplifiers, antenna rotators, modular CATV headend processors, TV channel modulators, traps, and channel converters. The special technical data section includes a signal-to-noise ratio chart and television channel data. *Blonder-Tongue Laboratories Inc.*, One Jake Road, Old Bridge, NJ 08857. ■



WE'RE HELPING CB GROW

Two-stepping CB Antennas through local Distributors, to CB Service-Dealers who service the equipment they sell.



FREE

Window streamer available only from your local distributor

A BARGAIN ISN'T A BARGAIN UNLESS YOU GET MORE THAN YOU PAID FOR

We service the CB equipment we sell



russell industries inc.

96 Station Plaza, Lynbrook, NY 11563 • (516) 887-9000

...for more details circle 131 on Reader Service Card

NEWS OF THE INDUSTRY

"Madman" Muntz Announces Self-Contained, Giant-Screen Home TV

Earl W. "Madman" Muntz, the California used car dealer who turned to TV manufacturing in the 1950s and later, in 1962, began producing and marketing car stereos, recently introduced what he says is the first fully self-contained, giant-screen TV set for home and commercial use.



Called the Muntz Home Theater Television, the unit has a 50-inch (diagonal) screen which provides 1200 square inches of viewing area. A special lens system, developed by Muntz, reflects the TV picture onto the 40-inch wide by 30-inch high viewing screen.

The complete unit is 68 inches high and 49- $\frac{3}{4}$ inches wide and weighs 300 lbs. Equipped with remote control of channel selection, on/off and volume, the Muntz Home Theater Television has a suggested retail price of \$1595.

CB License Applications Running At Over 300,000 A Month And Growing

The number of citizens band license applications received each month by the Federal Communication Commission's (FCC) Gettysburg, Pennsylvania, license processing facility is now over the 300,000 mark and is expected to eventually reach a million a month.

As of December, the Gettysburg facility had a backlog of about 150,000 unprocessed CB license applications but finally had reached what one FCC spokesman called a "catch-up phase."

Sanyo Reportedly Negotiating Purchase of Warwick

According to two recent reports in *Television Digest*, Sanyo, a major Japanese electronics manufacturing firm, has opened discussions with Whirlpool to purchase Warwick, the private-label TV manufacturing firm which is owned by Whirlpool (57 percent interest) and Sears (25 percent interest).

NATESA 1976 Convention Set For August 19-22

The National Alliance of Television & Electronic Service Associations (NATESA) has announced that its 1976 annual convention will be held August 19-22 at the Pheasant Run Inn in St. Charles, Illinois, the site of its 1975 annual convention.

CB Sales In 1976 To Reach \$1.3 Billion Says Dynascan Chief Executive

The retail value of citizen band equipment sales in 1976 should reach \$1.3 billion, an increase of 30 percent over 1975 sales, and private automobile owners will be the biggest purchasers of such equipment.

These, according to a recent report in *Radio & Television Weekly*, are the predictions of Carl Korn, president of the Dynascan Corporation, manufacturer of Cobra citizens band transceivers.

Korn's belief that private automobile owners will be the major purchasers of CB equipment in 1976 instead of truckers is based on the fact that at the end of 1975 only about 3 percent of all private cars were equipped with CB radios, while 75 percent of over-the-road truckers already had such equipment.

The *Radio & Television Weekly* report also stated that dealer margins on CB radios now are between 30 and 35 percent and are substantially ahead of dealer margins on TV.

JFD Receives Sear's "Symbol of Excellence" Award For 10th Consecutive Year

JFD Electronics Corporation, manufacturer of TV and auto radio antennas and accessories, recently was presented with Sears, Roebuck & Company's 1975 "Symbol of Excellence" award, the tenth consecutive year that the company has received the award.

JFD is one of about 14 companies, selected from among the more than 12,000 merchandise sources used by Sears, which have received the award on such a consistent basis.

Television Digest Survey of Consumer Electronics Manufacturers Indicates That 1976 Will be Year Of "Some Improvement"

In a summary of the findings of its annual "what's ahead" survey of consumer electronics manufacturers, *Television Digest* says that the industry sees a comeback in 1976,

with some improvement in sales and profits, but nevertheless "a year which wouldn't look good in any comparison except with 1975."

The results of its survey of manufacturers, says *Television Digest*, indicate that most expect retail sales of color TV to be around 7.7 million units, with prices nudging up about 2 to 5 percent, and about 38 percent of 1976 color TV sales will be replacements for existing color sets, while about 22.5 percent will be additional sets for homes which already have color TV. Manufacturers expect the console-portable mix to change only slightly, but again in favor of portables, with only about 31 percent of total color TV sales being consoles.

According to the *Television Digest* survey report, of the manufacturers who ventured a guesstimate about videodisc players, 6 out of 7 said it will be 1979 or 1980 before annual sales of such products reach 250,000. Of the two predominate types of videodisc systems, the capacitance pickup type seemed to be winning increased favor over the optical pickup type, although large numbers of respondents abstained from committing themselves to either type.

In their own "out on a limb" forecast of the consumer electronics industry in 1976, the editors of *Television Digest* seem to agree in general with the manufacturer's predictions. Says *Television Digest*, "Things will be better in election-year 1976—but just a little better. Recovery will be slower than many have anticipated, and by midyear the government finally will take action which, on the surface at least, will appear to be heading the economy in the right direction. For consumer electronics, the degree of recovery will vary by product—CB will be running stronger than ever, audio will be picking up sharply, TV will be improved but sluggish."

The editors of *Television Digest* see no startling new consumer electronic technology for 1976, but do feel that "the changeover to 1977 models could come a little early as industry holds down inventories of '76s". Says *Television Digest*, "TV technology will be aimed largely at taking costs out of sets without cutting quality, and there could be some major progress here, keyed to new ICs."

The CB boom will continue, says *Television Digest* editors, but the creation of Class E service won't take place until 1977 or later. ■

Three ways you can put test bench performance in your pocket with Hickok.



Model 215
A fully automatic in-circuit semiconductor analyzer.
\$138



Model 239
A rock-solid MOS LSI color bar generator.
\$115

Model 350
A true auto polarity 10 megohm FET multimeter
\$119



Now you can take the equipment you need wherever you need it with these versatile pocket performers from Hickok.

Our Model 215 Pocket semiconductor analyzer checks transistors, FETs, diodes and SCRs for conductance and gross leakage and identifies base or gate leads both in and out of circuit. And it does it all with a self-sequencing good/bad test and LED display.

The Model 350 Pocket FET multimeter features foolproof overload protection, true auto polarity, a polarity indicator and 10 megohm input impedance. It measures 9 dc voltage ranges, 9 ac voltage ranges, 7 hi/low resistance ranges and decibels. And it displays its findings on a long 2.4" mirrored arc.

Hickok-developed MOS LSI ICs give our Model 239 Pocket Color Bar Generator exceptional reliability, extremely low battery drain, rugged industrial performance and crystal stability. Simple matrix switches select any of its nine patterns, including a gated rainbow. And you can put its output on channels 2, 3 or 4.

But don't just take our word for the way these midget marvels perform. Ask your Hickok distributor for a demonstration. He may even offer a 10 day trial. Then we've got you for sure.

HICKOK

the value innovator
INSTRUMENTATION & CONTROLS DIVISION
THE HICKOK ELECTRICAL INSTRUMENT CO.
10514 Dupont Avenue • Cleveland, Ohio 44108
(216) 541-8060 • TWX: 810-421-8286

Troubleshooting CB Transceiver Audio

By David F. Norman, ET/D Communications Editor

A sequence of checks for quickly localizing the source of audio and/or modulation problems

■ Because some circuits in the audio section of a CB transceiver affect operation in *both* the receive and the transmit modes while others affect only *one* of these two modes, the source of many audio-related troubles often can be localized, if not isolated, even before the unit is removed from the case.

A simplified functional diagram of a CB audio section, which is representative of but not necessarily exactly like the various designs employed in contemporary CB transceivers, is presented in Fig. 1.

To determine whether or not the audio circuits themselves are functioning correctly, either inject a strong, modulated carrier at the IF input or apply an on-channel signal at the RF input. Then measure the RMS voltage across the speaker coil. Use the formula $E^2 / R = P$ to determine the actual output delivered to the speaker. For example, if an 8-ohm speaker is used, 5 volts RMS across the speaker indicates that a little over 3 watts audio is being produced (5 times 5 divided by 8 equals 3.125 watts).

If the preceding test indicates insufficient voltage across the speaker, try subbing a speaker known to be good; a shorted speaker voice coil might be the cause of the reduced volume. A shorted voice coil won't be encountered nearly as often as an open coil, but it does happen. If a unit is

operated with insufficient output impedance (the condition established by a shorted or partially shorted voice coil), damage to the output transistors or transformer usually occurs in minutes.

A damaged speaker usually produces severe distortion. Consequently, any time that distortion is evident, a substitute speaker should be tried before proceeding further.

If audio output is low and a modulation check shows that modulation is also substandard, especially if accompanied by distortion, you should suspect either the output transistors, the output transformer, or both. As a rule, failure of any of the single-ended driver amplifiers or their coupling circuitry will cause complete loss of audio output. This is true because of the relatively high level of power needed to drive the output transistors. An exception to this rule might be a failure of one of the emitter bypass caps. More on that later.

If the audio output at the speaker is normal but modulation of the transmitter is weak, suspect the mike cartridge. Dynamic mikes seldom fail; they are much more likely to have only a broken wire somewhere in the mike cord. Ceramic or crystal cartridges, on the other hand, are frequently damaged by dropping, moisture, or heat. One of my favorite tests is to cup the ceramic mike in both hands and shout into it. If modula-

tion increases considerably during this test, replace the mike element.

If the radio being tested is an E.F. Johnson unit and exhibits low or missing modulation (assuming normal receive audio), the problem is almost surely either the mike element itself (Johnson calls them "cup resonators"), or the mike cord. While on the subject of Johnson units, I'll cover a few other mike problems that seem to be peculiar to Johnson's *Messenger* series of CBs.

Under certain conditions of moisture, the ceramic elements used by Johnson have a tendency to become "tinny" sounding or even break into full oscillation. Under these conditions the modulation level, as shown on a meter, might still appear normal. So if you get signal reports of poor quality modulation, try replacing the element.

Another odd complaint is noise in the speaker when the mike is handled or spoken into while the transceiver is in the *receive* mode. This complaint is most likely to occur if the unit is used on a boat. What has happened is not as strange as it sounds. In the Johnson units, both sides of the mike are above ground. When moisture (usually salt spray) invades the mike case, a low resistance path to ground is created. This leakage may be either from the cartridge directly to the mike wires, to the switch, or to both. In some cases, removing the element and rinsing the rest of the mike assembly with fresh water and thoroughly drying it will solve the problem. Of course, under these conditions the element is usually defective and should be replaced. In other cases, the only solution is replacement of the entire mike assembly, including the cord. Personally, I prefer to replace the whole assembly even if the problem is only a broken mike cord. Replacement of the cord requires working on both ends of the cord and, consequently, also requires more time. Either the customer has to pay for this extra time or you have to absorb it yourself. This is an area where your conscience must be your guide. Most

customers understand if you tell them that the cost will be about the same to buy and install new parts as it will be to repair the unit, which involves extra labor. For some reason, most customers do not mind parts cost as much as they do labor.

Please don't get me wrong. I am not down on the Johnson units. On the contrary, we sell many of them every month. I am just pointing out problems that we have encountered often enough to warrant checking them first.

Another recurring "problem", which usually is associated with several of the imported makes, is not really a *service* problem at all, but, instead, involves incorrect insertion of the four-pin mike plug in the keyed jack. For some reason, such units are often brought in for service or repair without the mikes. Usually it's no big deal because most servicemen can substitute a mike, if necessary. The problem arises when the customer gets the unit home and plugs the mike into the unit. I have seen them come back in a few minutes hopping mad, loudly asking, "what kind of place are we running". When their unit is once again placed on the bench (this time the customer usually is too mad to remember to remove the mike), the trouble is spotted instantly: If you try hard enough, these four-pin mikes can be plugged in 90 or 180 degrees removed from the correct position. Naturally, the radio doesn't work properly. One word of caution: Unless you really feel that the customer's future business is something that you can do without, avoid the temptation to embarrass him as he did you. He already knows what a jerk he was, and so does anyone else that was watching or listening. Just tell him that you are glad that he brought the unit back before other damage could occur (in fact, it seldom hurts anything). He'll get the idea.

The last check that you should make before putting the unit on the bench and opening it up, is the good old "hammer" test. While you watch or listen for audio output to return, try jarring the unit in several positions, then key the mike

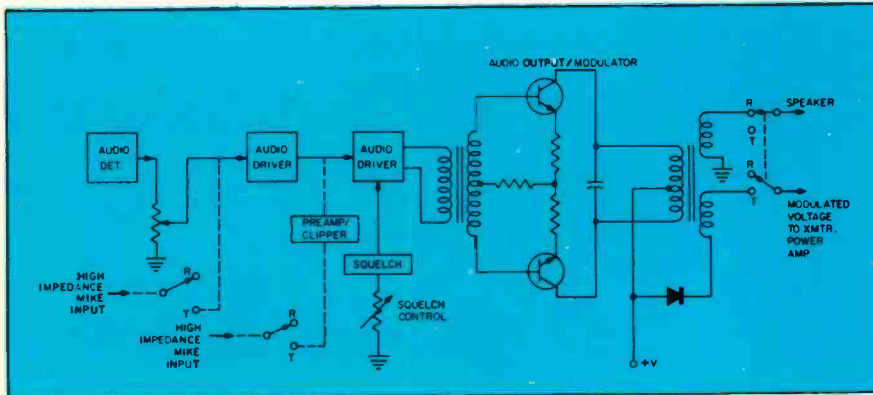

Fig. 1—Simplified functional diagram representative of the audio section and related functions in a contemporary CB transceiver.

several times in rapid succession. If output or modulation return (or disappear) during this "test", you have reason to believe that either a connection is loose or a relay contact is not closing or opening properly. (I am assuming that you have already done your thing on the mike cord.)

Alright, let's make a short review of what you can learn before actually opening up the unit:

1) You can ascertain whether the problem is common to both receive and transmit or whether it is only evident in one mode and, if so, which one.

2) You can usually connect a substitute speaker to the "external speaker" jack and thereby eliminate the speaker as the source of the problem(s).

3) You can check the mike cord and sometimes the element itself to see if all is in order there.

4) The "hammer" test will show up most loose connections or intermittent relay operation.

5) While making the other tests, you can monitor input current to the unit. A symptom of either too low or too high current can help pinpoint the problem.

Now, study the schematic of the unit for a few minutes to relate your observations to the most probable source(s) of the trouble. For example, the combination of normal receive audio but no transmit RF plus low current (transmit mode) point to loss of modulated B+. Study of the schematic will show you where the modulated B+ could be lost. A minute or two with a VOM probe should reveal where the trouble is.

If no audio (neither receive nor

transmit) is present, and the speaker is okay and you have normal RF output, the problem could be at any point *shared* by both modes. Try injecting an audio signal at the first point common to both modes (probably the arm of the relay which controls low-level audio switching). If output is restored, check the relay and the solder connections to it. If no output is noted, go from one stage to the next (input-output, input-output, etc.) until you get a positive response.

If the problem is apparently in the audio push-pull circuitry, give this area a close visual examination. Unless a short still exists, you can usually see some evidence of where one has been. Bias resistors usually act as a slow-blow fuse and they are usually burned completely through when an output transistor shorts. If you have decided that the problem is in the push-pull section, go back and inject an audio signal at the "common" point and look for the signal to appear at the output of the driver (last stage before the outputs). If it does, your suspicions are confirmed.

Although this procedure seems more complicated than simple stage-by-stage troubleshooting, it actually only takes minutes—during which you have pinned down the problem to one stage, and confirmed it.

Actually, all of the above tests can be performed in less time than it takes to read about it. Thereafter, continuity and voltage checks will tell you which component is defective in the output stage.

continued on page 11

GE 19" diagonal MODULAR Solid State Set gets 91.7% serviceability rating from panel of NESDA members.



MODEL WYC7608WD

This high rating is another example of our continuing commitment to make your business easier.

It's based on a comprehensive checklist of items considered by NESDA (National Electronic Servicing Dealer Association) to be key factors in allowing service technicians to quickly and easily diagnose and repair a TV set.

According to Dick Glass, Executive Vice-President of NESDA, the panel found the overall serviceability of GE's 19" diagonal model WYC7608WD was "excellent".

The YC chassis is modular in design . . . Seven module subassemblies contain approximately 85% of all set components. But, like all General Electric modular chassis, it's designed to be serviced with or without modules. Its swing-away design provides easy access to module components and each module has abundant, clear markings.

We're making it our business to make your business easier.

 **performance**
TELEVISION

GENERAL  ELECTRIC

...for more details circle 119 on Reader Service Card

(Caution: Always replace push-pull transistors in pairs; small differences in brands of transistors can lead to early repeat failures.

Problems which cause loss of only receive audio are usually traceable to three areas: low-level input; speaker problems; or output transformer troubles. Occasionally, the problem will be as simple as a faulty external speaker jack or a dirty relay. These are easy to check. (In fact, always check the easy places first. This is how reputations for fast service are made.)

When the problem is proven to be in one of the single-ended audio driver amps, check two things first: 1) Try subbing the emitter bypass caps, and if no improvement is noted, 2) check the transistor voltages. Coupling caps seldom fail, because of the relatively low power levels at which they operate. Never assume, however, that any component is immune to failure.

Squelch problems normally cause trouble only in the *receive* mode. Listening for a small "pop" in the speaker as the squelch is opened or closed is a "quick and dirty" way to check for proper squelch operation.

Because the audio output circuits are designed to handle fair amounts of power, they should be suspected any time that a unit is blowing fuses. Many "power supply" problems can be traced to audio outputs. Consequently, after repairs have been made in the power supply section, voltage should be reapplied with caution. It can be pretty embarrassing to have to make the same repairs over again before the unit even leaves the bench.

Shorted RF output transistors also can quickly damage audio output transistors and transformers. Any time that power handling components are replaced, all connecting circuitry should be checked for hidden damage.

One last warning: Sometimes one of the transistors in a push-pull setup will *open* and the other will still operate. The symptoms of this are slightly reduced audio, with or without distortion, and heating of one output transistor more than another. The remedy is to replace both transistors, and it's a good idea to check bias components closely. ■

Electronics

CHROMA-POWER

from **ACA**

Solid State Home Systems
Designed for Quality
 • Economy • Simplicity

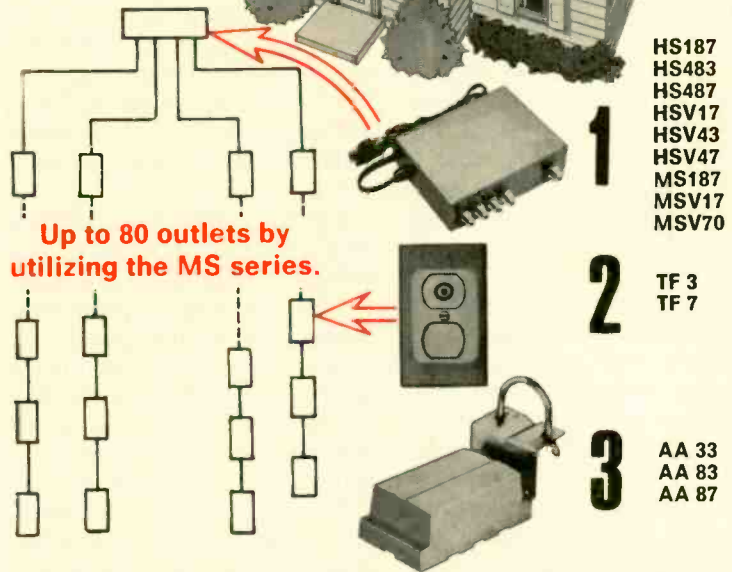
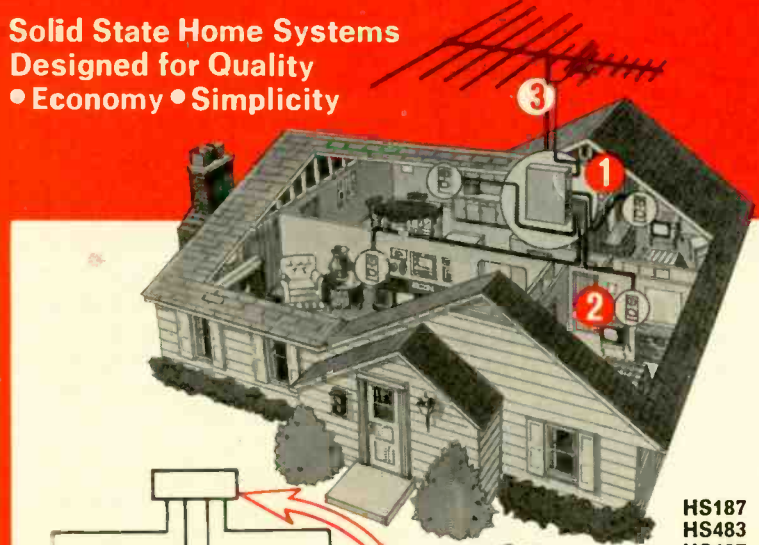

plus a complete line of Electronic Products including Amplifiers, Couplers, Band Separators, Transformers, Coaxial Cable.



Ask about our Cable-Master
write or call 319-753-1625



Box 865, Burlington, Iowa 52601

...for more details circle 108 on Reader Service Card

COMM CHAT



With David Norman, ET/D Communications Editor

SUPPORT OF COMM CLUBS GOOD PR, BUT BE CAREFUL

■ Every communications shop is sooner or later asked to donate or loan equipment to one communications club or another. This is especially true if the shop sells amateur or CB equipment. There are several reasons why such loans and donations are good business, but a certain amount of caution is a healthy thing.

Most of us in business like to feel that we are community-minded, and we want to help worthy organizations. Fine, but we don't want to get hurt in the process either. Here are a few suggestions whose worth I have learned the hard way (seemingly the only way that I ever learn anything).

If a local club is holding a "jamboree" and booths are available for dealers, I suggest that you rent space and attend. Often you can make new "contacts," and believe it or not, many people bring *money* to such jamborees. I have seen dealers do several hundred dollars worth of sales in only a few hours. Take a good representative stock—bottom of the line and top of the line as well.

Usually, the person selling space for the event also will ask if you would like to donate something as a door prize. If you are

going to do business with these people in the future, there is no graceful way that you can decline. However, you can spread it around a little bit. Instead of donating one large prize, (for example, a new transceiver), donate several small items.

Also, instead of giving the items at the jamboree, give gift certificates to be redeemed at the store. Don't feel that this is a mercenary approach to donations—it's no more mercenary than giving the prizes on the spot. It also offers two important advantages for everyone involved; 1) The space required for a handful of gift certificates is much smaller than the space required for the prizes they represent; consequently, you have less to take to the event with you, and the officials have less to keep up with and provide security for. 2) There is the chance that the winner will bring a friend with him and you will do a little extra business.

If a winner is unable to redeem a prize from your store or shop because he is visiting from out of town, you can either make a substitution out of what you have with you or arrange to mail his prize.

Let the jamboree officials know well in advance what prizes you will be donating, so that they can advise the other merchants and thereby avoid duplication.

Hold back a few small prizes for spur-of-the-moment gifts. At all of these events, the PA system is manned almost continuously. Just tell the MC that "ABC Electronics will donate a super-doooper whatzis to the first person that can show an Alaskan drivers license." Get the idea?

You often will be asked to join or support this CB club or that Amateur group. Personally, I recommend supporting all of them but *joining none*. Members of competing clubs have a way of avoiding those businesses that they consider aligned with the "other" club. Your support of all groups in an impartial manner is good for business; your membership in the wrong club can kill you.

Your support can be in the form of donations for official events or they can be outright gifts of equipment needed for the club's

public service activities. Another form of support needed by all clubs is the loan of equipment for special events. These loans are good PR, but there is a drawback: Too many times, equipment is returned in much worse condition than when it was loaned. As far as collecting for damages—forget it.

The best way that I have found for getting equipment returned in good condition is to make one person responsible for its care. You don't have to request a deposit; just let the borrower know that you are loaning the equipment to *him*. When this is made clear, the person responsible usually will protect the equipment from loss or damage. Or, at least, he will keep careless hands off of it.

Another way that you can support local groups is by donating your (or your employees') time when someone is needed to install an antenna or to man a radio as a dispatcher.

Besides just plain making you "feel good," the practices we have covered are *good business*. When the club votes to buy a new piece of gear, your name is sure to come up in the discussion. Most people know the value of buying from a local concern; they know that they might need another donation from you.

HOW TO AVOID TAKING A SOAKING FROM WET EQUIPMENT

Just because a piece of electronic gear has been soaked by rain or flooding, it is not necessarily beyond restoration. As long as the water was *fresh*, and the equipment was not under power when it got wet, you might be able to repair it.

Speakers, microphones, and other items that are water-soluble will have to be replaced.

Before you try to operate the equipment, place it in a warm (250 degree F) oven for a couple of hours. (If the unit is equipped with "soft" plastic materials, you might need to use a lower temperature.) Be sure you do not place the equipment too near the oven's heating elements.

If any water runs out of IF cans or pots after the drying period, dry it some more. After the equipment has been dried thoroughly, if pos-

continued on page 47

"Breaker . . . Breaker . . ."

Break-through with BREAKER!

The New Freedom Line of CB Mobile and Base Antennas and Accessories made in the U.S.A. for communications between people.

A wide selection of "revolutionary" new CB High Efficiency communications antennas of superior strength, electronically and physically, for all the talk power your CB rig will deliver—coming and going in the 27 Megahertz frequency band.

Mobile Breaker antennas for cars, trucks, trailers, sports cars, station wagons, motorcycles, boats. Breaker base station antennas to communicate with mobiles and hand helds . . . all designed specifically for the outstanding transmission and reception of CB signals.

The high quality and materials of the Breaker CB antennas and accessories assure you the maximum in performance for many years and at reasonable cost. Performance-tested Breaker CB antennas offer you these advantages plus more:

- ★ Easily adjust for lowest VSWR
- ★ Long-life stainless steel and fiberglass whips
- ★ Highest quality coaxial cable with solderless connections
- ★ Innovative engineering designs
- ★ Packaged for quick, easy installation to get you on the air fast, complete with cables and hardware

All Breaker antennas are American made in Arlington, Texas. In keeping with the tradition of the Bi-Centennial they are proudly named after our revolutionary heroes and places. Red, white and blue are also the colors of Breaker. Chosen because we too are very proud of our heritage and contribution to making exciting products for use by people communicating with people. See and buy the Freedom line of Breaker antennas and accessories at your nearest electronic distributor. Look for the red, white and blue packaging.

WRITE FOR FREE CATALOG.

GEORGE WASHINGTON

West Coast Mirror Mount
Dual Truck, RV Antennas
Model 10-200

Weather resistant dual 57" stainless steel whip antennas with static arrestor tips. Secure horizontal or vertical mounting to West Coast side view truck type mirrors. Twin antennas co-phased for more directional power and easily adjustable for fine tuning. Hermetically sealed, white oversized ABS center load. Dual 18' low-loss coaxial phasing harnesses with solderless connectors and quick disconnect PL-259 plugs. Complete with corrosion resistant mounting hardware.

INDEPENDENCE

Gutter Mount Antenna
Model 10-245

Low-profile 21" stainless steel whip antenna with static arrestor and flex-ratic shock spring. Fits practically any vehicle rain gutter. No interference with door opening or passenger exit. Heavy-duty molded clamp bracket insulates and supports antenna. Center loaded ABS load coil for excellent transmission and reception. 14' coaxial cable with solderless connector and quick-disconnect PL-259 plug. Complete with corrosion resistant mounting hardware.

PAUL REVERE

Roof Mount Antenna
Model 10-215

Special "power-plus" 42" base-loaded roof mount with long-life stainless steel whip, rugged stainless steel shock spring and high-quality 16-ft. shielded coax cable and solderless connections for fast "on-the-air" installation. Named after the famed communicator and hero of revolutionary era.

THE PATRIOT

Omni-directional
¼-Wave Base Antenna
Model 11-101

High in quality, performance and efficiency, low in cost. Has three 108" quarter wave tubular aluminum radials plus a quarter-wave radiator (vertical element). Heavy-duty U-clamp fits mast up to 1½" diameter. Built-in lightning protector. SO-239 style connector mount. Mates with PL-259 plug Shunt loaded coil. Heavy duty insulated moldec clamp bracket. Easy to assemble and dis-assemble. Fixed construction.

THE MINUTEMAN

Trunk Mount Antenna Model 10-230

Sturdy, durable, no-hole required in trunk of vehicle. Super 44" stainless steel whip, base loaded low-profile antenna with stainless shock absorbing spring, chrome plated brass bell housing, 18-foot shielded coaxial cable and solderless connections.

"Just say it with Breaker!"

...for more details circle 136 on Reader Service Card

BREAKER
CORPORATION

1101 Great Southwest Parkway
Arlington, Texas 76011

■ Since the start of this column last September, I've received numerous requests for the following list of the tools I recommend for proficient removal and reinstallation (RNR) of car radios, car tape players and related equipment.

IN THE RNR TOOL BOX

The Toolbox

It is advisable to keep a special tool box handy for RNR use only. This improves efficiency by eliminating the time that otherwise would be wasted by working between an inside bench where the tools are and the curbside or garage areas where they are needed.

The tool box should be only large enough to hold the tools. If it is too large it will become unwieldy inside the car. A box which is about the same size as a medium fishing tackle box is usually best.

Screwdrivers

The number of straight-blade screw drivers needed is rather modest. A stubby 5/16-inch blade will be useful, as will a small, assorted collection of 1/8-inch screwdrivers. The latter are needed for adjusting antenna trimmers.

Because of Murphy's Law, antenna trimmers are often located in the area of least accessibility. Consequently, it will be helpful to take one of the 1/8-inch screwdrivers (preferably one already ruined or worn out) and cut it off so that the overall length, including the handle and 3/8 to 1/2 inch of blade, is a little over an inch. Then grind a new tip on the end of the blade.

Phillips screwdrivers needed are a No. 1 and a No. 2, type; in both regular and "stubby" lengths. Buy the tungsten or carbide-tipped types; they last longer.

Nutdrivers

An assortment of nutdrivers in sizes 8, 10, 11, 12, 14, 16, 18 and 20 are essential. The sizes from 8 to 14 should include both regular and stubby lengths, and *all* of the nutdrivers should be the *hollow-shank* type.

Wrenches And Socket Sets

A set of box-end/open-end

CARR TALK

With Joseph J. Carr,
ET/D Vehicular Electronics Editor

Tools And Procedures Recommended For Auto Electronics RNR

wrenches is needed and should include 1/4-, 1/2-, 5/16-, 5/8- 3/4- and 7/8-inch sizes. An adjustable wrench with a 6-inch handle also is handy. (To avoid a lot of busted knuckles and attendant cursing, buy a high-quality adjustable wrench.)

Also useful is a 1/4-inch drive ratchet and socket set and, if your budget permits, a 7/16-inch ratchet-type wrench.

Pliers, Cutters and Strippers

At least one pair of side cutters (small) and a pair of heavy long-nose pliers are needed. Also useful is a pair of slip-joint pipe pliers (also called "gas pliers"). Your RNR man also will need a set of wire strippers. After he bungs up his knuckles by using a pair of side cutters for wire stripping, you can be sure he will begin lobbying for regular strippers.

ON THE RNR BENCH

Needed as back-up tools, but not necessarily required in the tool kit all the time, are a collection of heavy hand tools and some power tools.

Have available a set of heavy locking, duckbill pliers.

For soldering, use a soldering gun, *not* an iron, of about 200 watts dissipation. The reason for discriminating against irons is that they are always on and therefore can easily damage expensive upholstery or carpeting.

You might want to install on a work bench a fairly heavy vise and a bench grinder. Other power tools which are useful are an electric drill and a set of bits. When buying bits, keep in mind that auto metal is hard and that the drilling often must be done in cramped and uncomfortable circumstances. Some RNR men keep both the regular type of electric drill and a right-angle type for getting up under dashboards.

In addition to the set of drill bits, also obtain a heavy duty hole saw. However, beware of the low-cost types which are really only suited for wood or thin aluminum. If they break while in use they can throw off bits of metal shrapnel that can cause injury.

GENERAL RNR TIPS

Many car radio problems are not actually inside the radio. Diagnose the problem as far as possible before removing the chassis from the car—it saves a lot of work and embarrassment. Keep a known-good speaker and an "eight ball" antenna handy for car radio preliminary checkout. The test antenna comes self-contained, but the test speaker will require at least a set of alligator clips leads. If you do a lot of repairs of one make of radio, it also might be wise to make up an adapter cable for this manufacturer's type of speaker connector. Some RNR men also keep a pair of straight pins attached to the speaker magnet. These can be used to pierce the insulation of wires if no easy test points are available. (In actual practice you will find that you can often hear the output transformer laminations rattling in step with the audio when the speaker is open.)

Use an inexpensive VOM or a homemade 12-volt test lamp for checking power to the radio. Because many gas stations have ruined car radios by installing a new battery backwards, it is preferable that your "tester" be able to distinguish reverse from normal polarity. Placing a lamp rectifier diode in series with the test lamp will permit this capability.

Teach your RNR man to always be suspicious of a blown fuse. Don't allow him to send customers out with a new fuse unless some effort is made to determine why the old fuse blew. I remember Nelson Moodie, one of the first full-time car radio men in the U.S., who used to drill into the heads of apprentices that a "fuse doesn't *cause* trouble, it *indicates* trouble." That was good advice two decades ago and it remains good advice today.

Besides internal shorts and sloppy wiring, there also are some less obvious causes of fuse blowing

continued on page 47

"We've Got Our Act Together"



MOTOROLA HEP
SEMICONDUCTORS



**—WHERE THE
CUSTOMER
IS #1**

- **All Devices Manufactured By Motorola
NO REBRANDS**
- **Finest Reliability & Quality in the Industry**
- **A Complete Line to Serve Your Every Need —
From CB, Radio, TV to
Hobbyist Applications**

MOTOROLA

P.O. Box 20902 Phoenix, Az. 85036



...for more details circle 123 on Reader Service Card

FEBRUARY 1976, ELECTRONIC TECHNICIAN/DEALER / 15

An Extraordinary Offer

to introduce you to the benefits of Membership in

ELECTRONICS BOOK CLUB

for a limited time only you can obtain

**THIS
NEW**

**602-page
\$10.95 Book-**

2nd Class FCC Encyclopedia

for only

99¢

WITH
TRIAL
MEMBER-
SHIP

May we send you this helpful new book, described on the facing page as part of an unusual offer of a Trial Membership in Electronics Book Club?

This is a quality hardbound volume, especially designed to help you increase your know-how, earning power, and enjoyment of electronics.

This handsome, hardbound book is indicative of the many other fine offerings made to Members . . . important books to read and keep . . . volumes with *your* specialized interests in mind.

Whatever your interest in electronics—radio and TV servicing, audio and hi-fi, industrial electronics, communications, engineering—you will find Electronics Book Club will help you.

With the Club providing you with top quality books, you may broaden your knowledge and skills to build your income and increase your understanding of electronics, too.

How You Profit from Club Membership

This special offer is just a sample of the help and generous savings the Club offers you. For here is a Club devoted exclusively to seeking out only those titles of direct interest to you. Membership in the Club offers you several advantages.

1. **Charter Bonus:** Take "2nd CLASS FCC ENCYCLOPEDIA" . . . publisher's list price \$10.95 . . . for only 99¢ with your Trial Membership.

2. **Guaranteed Savings:** The Club guarantees to save you 15% to 75% on all books offered. All books are offered at low Member prices (plus a small shipping charge).

3. **Continuing Bonus:** If you continue after this trial Membership, you will earn a Dividend Certificate for every book you purchase. Three Certificates, plus payment of the nominal sum of \$1.99, will entitle you to a valuable Book Dividend which you may choose from a special list provided members.

4. **Wide Selection:** Members are annually offered over 50 authoritative, new books on all phases of electronics.

5. **Bonus Books:** If you continue in the Club after fulfilling your Trial Membership, you will receive a Bonus Dividend Certificate with each additional Club Selection you purchase. For the small charge of only \$1.99, plus three (3) Certificates, you may select a book of your choice from a special list of quality books periodically sent to Members.

6. **Prevents You from Missing New Books:** The Club's FREE *News* gives you advance notice of important new books . . . books vital to your continued advancement.

This extraordinary offer is intended to prove to you, through your own experience, that these very real advantages can be yours . . . that it is possible to keep up with the literature published in your areas of interest . . . and to save substantially while so doing.

How the Club Works

Forthcoming selections are described in the FREE *Club News*, published thirteen times a year. Thus, you are among the first to know about, and to own if you desire, significant new books. You choose only the main or alternate selection you want (or advise if you wish no book at all) by means of a handy form and return envelope enclosed with the *News*. As part of your Trial Membership, you need purchase as few as four books during the coming 12 months. You would probably buy at least this many anyway . . . without the substantial savings offered through Club Membership.

Limited Time Offer!

Here, then, is an interesting opportunity to enroll on a trial basis . . . to prove to yourself, in a short time, the advantages of belonging to Electronics Book Club. We urge you, if this unique offer is appealing, to act promptly, for we've reserved only a limited number of books for new Members.

To start your Membership on these attractive terms, simply fill out and

mail the postage-paid airmail card today. You will receive "2nd CLASS FCC ENCYCLOPEDIA" for 10-day inspection.

SEND NO MONEY! If you are not delighted, return it within 10 days and your Trial Membership will be cancelled without cost or obligation. Electronics Book Club, Blue Ridge Summit, Pa. 17214.

Typical Savings Offered Club Members on Recent Selections

Master Handbk. of 1001 Pract. Elec. Cir.	List Price \$12.95; Club Price \$7.95
Central Heating/Air Cond. Repair Guide	List Price \$9.95; Club Price \$5.95
Aviation Electronics Handbook	List Price \$11.95; Club Price \$7.95
Small-Screen TV Servicing Manual	List Price \$9.95; Club Price \$5.95
Step-by-Step Guide: Carburetor Tuneup and Overhaul	List Price \$7.95; Club Price \$3.95
Electronic Music Circuit Guidebook	List Price \$9.95; Club Price \$5.95
Pract. CB Radio Troubleshooting & Repair	List Price \$8.95; Club Price \$5.95
Electronic Conversions, Symbols & Formulas	List Price \$8.95; Club Price \$4.95
Color TV Case Histories Illustrated	List Price \$8.95; Club Price \$5.95
The Complete Auto Electric Handbook	List Price \$8.95; Club Price \$5.95
Computer Programming Handbook	List Price \$12.95; Club Price \$8.95
Transistor Theory for Tech. & Engineers	List Price \$8.95; Club Price \$5.95
Adv. Applications for Pocket Calculators	List Price \$8.95; Club Price \$5.95
Integrated Circuits Guidebook	List Price \$8.95; Club Price \$5.95
Auto Electronics Simplified	List Price \$8.95; Club Price \$5.95
The Complete FM 2-Way Radio Handbook	List Price \$9.95; Club Price \$6.95
RCA Color TV Service Manual—Vol. 3 & 4	List Price \$17.90; Club Price \$8.95
Introduction to Medical Electronics	List Price \$9.95; Club Price \$6.95
Basic Digital Electronics	List Price \$7.95; Club Price \$4.95
Auto Stereo Service & Installation	List Price \$8.95; Club Price \$5.95
Effic. Troubleshooting with EVM & Scope	List Price \$8.95; Club Price \$5.95
Modern Communications Switching Sys.	List Price \$17.95; Club Price \$13.95
Pract. Circuit Design for the Experimenter	List Price \$8.95; Club Price \$4.95
Installing TV & FM Antennas	List Price \$7.95; Club Price \$3.95
Microprocessor/Microprogramming Hdbk.	List Price \$9.95; Club Price \$6.95

SEND NO MONEY! Simply fill in and mail postage-paid Airmail card today!

An Unprecedented Offer!

Accept This NEW
602-page 2nd Class FCC
Encyclopedia

for only **99¢**

with Trial Membership in the Club

Your Membership
in the Electronics Book Club brings you
the most important, authoritative books
on electronics . . . at substantial savings.
Read the details of this unique offer!

**MAIL THIS MEMBERSHIP CARD TODAY!
NO STAMP NEEDED - SEND NO MONEY**



ELECTRONICS BOOK CLUB Blue Ridge Summit, Pa. 17214

Please open my Trial Membership in the Electronics Book Club and send me my own personal, hardbound copy of "2nd CLASS FCC ENCYCLOPEDIA" (billing me only 99¢ plus a small shipping charge). If not delighted, I may return the book within 10 days and owe nothing. Every four weeks you will send me the Club News, describing current offerings. If I want the selection, I do nothing; it will be sent to me automatically. If I do not wish to receive the selection, or if I want to order one of the many alternates offered, I simply give instructions on the reply form provided, and return it to you by the date specified. This date allows me at least 10 days in which to return the form. If, because of late mail delivery of the Club News, I do not have 10 days to make a decision, and so receive an unwanted selection, I may return it at your expense. Otherwise, to complete my Trial Membership, I agree to purchase at least four additional selections or alternates during the next 12 months. I have the right to cancel my membership anytime after purchasing these four books.

Name _____ Phone No. _____

Address _____ (NOTE: check if Home or Business address)

City _____ State _____ Zip _____

Company _____ Title _____ T-26
(The Club assumes postage on all prepaid orders. Foreign and Canadian prices 10% higher.)

Club Membership Advantages

Charter Bonus: Take 2nd CLASS FCC ENCYCLOPEDIA . . . publisher's list price \$10.95 . . . for only 99¢ with your Trial Membership.

Continuing Savings: The Club guarantees to save you at least 25% to 75% on the books you need. All books are offered at low Member prices (plus a small shipping charge).

Wide Selection: Members are annually offered over 50 of the new and authoritative books on all phases of electronic servicing.

Editorial Advisory Service: The Club's Editorial Advisory Board selects only the important books of direct interest to you.

Bonus Books: If you continue in the Club after fulfilling your Trial Membership, you will receive a Bonus Dividend Certificate with each additional Club Selection you purchase. For the small charge of only \$1.99, plus three (3) Certificates, you may select a book of your choice from a special list of quality books periodically sent to Members.

Prevents You From Missing New Books: The Club's FREE "News" provides advance notice of new books vital to your continued professional advancement.

BUSINESS REPLY MAIL

No Postage Stamp Necessary if Mailed in the United States

POSTAGE WILL BE PAID BY

ELECTRONICS BOOK CLUB

P. O. Box 10

Blue Ridge Summit, Pennsylvania 17214

FIRST CLASS
Permit No. 9
Blue Ridge Summit, Pa.

VIA AIR MAIL

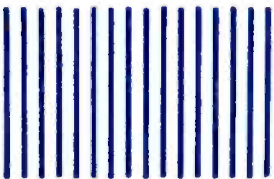

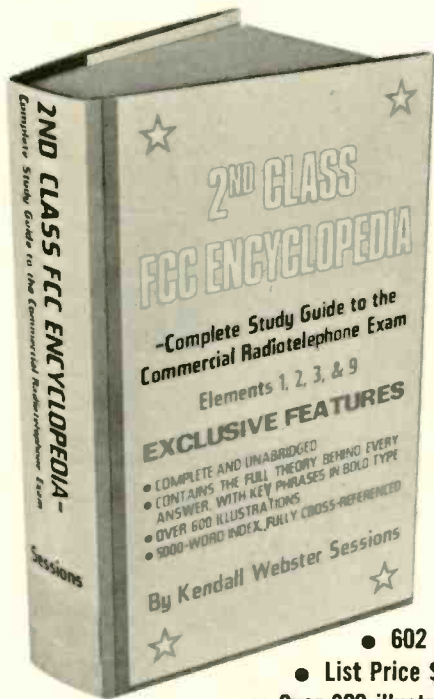

2nd Class FCC Encyclopedia

By Kendall Webster Sessions

- 602 pages
- List Price \$10.95
- Over 600 illustrations
- Handsome, hardbound volume

Truly a one-volume electronics library all by itself . . . a supercourse in electronics that belongs on the bookshelf of everyone in electronics!

Partial List of Contents

BASIC LICENSE INFORMATION: FCC Examination; Basic Requirements of Applicant; verification of License Holding; Renewals, Duplicates, and Replacements; Operator Privileges; Employment — BASIC LAW AND OPERATING PRACTICES (ELEMENTS 1 & 2): Element 1: Basic Law; Element 2: Operating Practice—BROADCAST ENDORSEMENT FOR THIRD CLASS OPERATOR LICENSE (ELEMENT 9): Rule Changes; License Required; Equipment Adjustments; Normal Operating Position; Operating Power; Modulation; Operating Log Entries; Station Identification; Broadcast of Recorded Material; Rebroadcast; Antenna Tower Lighting; Emergency Broadcasting System (EBC); Posting Operator Permits; Study Questions—BASIC RADIOTELEPHONE THEORY (ELEMENT 3): R&R Part 2 Sec. 13, 74; R&R Part 2 Sec. 10, 105; R&R Part 2 Sec. 10, 108—SUPPLEMENT TO ELEMENT 3: Alternating & Direct Current; Electron Tubes; Indicating Instruments; Oscillators; Audio Amplifiers; Radio-Frequency Amplifiers; Transmitters; Amplitude Modulation; Transmission Lines; Frequency Measurements; Batteries; Motors and Generators; Microwave Equipment—TROUBLE-SHOOTING: Step 1; Symptom Recognition; Step 2; Symptom Elaboration; Step 3; Listing of Probable Faulty Functions; Step 4; Localizing the Faulty Function; Step 5; Localizing Trouble to the Circuit; Step 6; Failure Analysis; Sample FCC Functions—APPENDIX A: Extended Radio Operator Examination Program—INDEX.

This mammoth 602-page volume is as sweeping and all-encompassing as the FCC exam itself, and is undoubtedly the most thoroughly detailed, elaborately illustrated and easiest-to-read handbook on the 2nd and 3rd Class FCC license. It's a "quick-guide" to learning the answers to the FCC exams, as well as an intensive, no-nonsense course in radio theory specifically designed to help you obtain your license . . . and to provide you with the knowledge you need for a successful career in the burgeoning fields of CB, business, and 2-way radio. The result is a study guide that is not just a course, but a whole series of courses that can make you the master of any field in radio communication.

A special feature of this unique new guide is the short-form/long-form answer format to hundreds of FCC-posed questions. Whenever possible, the answer to a question is divided into the shortest answer needed to satisfy the FCC requirements: a longer answer then shows how any similar question may be answered, and is included for reference or more complete understanding. Questions appear in italicized type. A boldface type section in most answers enables you to immediately extract from the detailed discussion that portion which directly answers the specific question. These "theory packets" amount to an extremely comprehensive educational

approach to the FCC exam, and are just one of the many ways in which "2nd Class FCC Encyclopedia" is the easiest-to-use of all radio courses and the most comprehensive and truly helpful.

The first Section covers basic exam info: how and where to apply; how and where to take the test; the fees; what the license can do for you; and what you have to know to pass. All material was double-checked at press time for late rule changes, etc. The next Section contains questions and answers for the Third Class radiotelephone operator permit (FCC elements 1 and 2). Then, there's a Section on Element 9, for the broadcast endorsement. Another Section answers the basic electronics theory questions for the Second Class license, and still another covers the advanced questions. An entire Section is devoted to the troubleshooting questions asked on the exam. These carefully programmed step-by-step techniques are designed to enable you to obtain your license as easily as possible.

An extremely complete 5000-word index, fully cross-referenced, provides instant access to any rule, formula, circuit diagram, or technical explanation. "2nd Class FCC Encyclopedia" is truly a digest of today's radio and electronics technology, with authoritative data on everything technical, always available for your immediate reference and use.

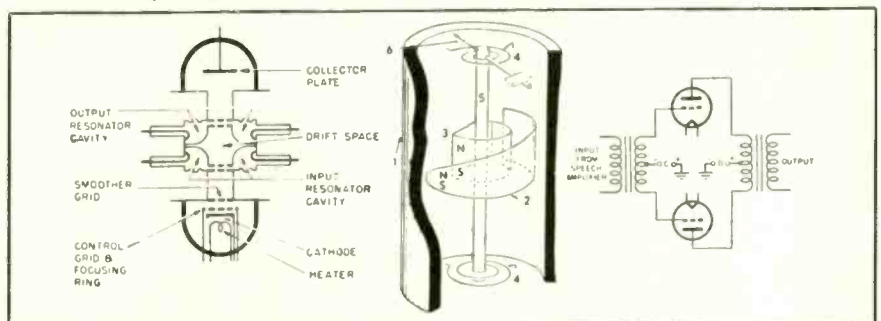

Over 600 drawings, schematics, block diagrams and photos make each of the hundreds of subjects in "2nd Class FCC Encyclopedia—Complete Study Guide to the Commercial Radiotelephone Exam" of immediate, practical benefit to you.

AN EXTRAORDINARY OFFER...

...for more details circle 117 on Reader Service Card

Common Car Tape Faults

By Joseph J. Carr, ET/D Vehicular Electronics Editor

A cause-and-cure discussion of the most frequently encountered troubles in car eight-track and cassette tape players.

EIGHT-TRACK PLAYERS

■ The basic design of the drive mechanism employed in car eight-track tape players has changed very little since the debut of such "closed-loop" tape players in the early 1960's.

Figs. 1 and 2 are side and front views, respectively, of a typical eight-track drive mechanism.

When the eight-track cartridge (Fig. 1) is inserted into the machine, the cartridge pushes against and closes the turn-on switch (Fig. 2) which, in turn, applies power to the drive motor (Fig. 1). The drive motor turns a flywheel (Fig. 1) via a rubber or plastic drive belt. The flywheel shaft, called the *capstan* (Figs. 1 and 2), then rotates. The tape of the cartridge is pressed against the capstan by a rubber or plastic pinch roller (which is an integral part of the eight-track cartridge itself), and as the capstan rotates, it pulls the tape across the playback head (Fig. 2).

The flywheel/capstan assembly (Fig. 1) usually is supported by two bronze sleeve bearings, which are an integral part of the capstan housing, and one or two end bearings, which in some

machines are made of nylon.

Speed Problems

The trouble which seems to occur most frequently in eight-track tape players is incorrect speed, which usually is exhibited in one of three ways: 1) constant but too slow, 2) constant but too fast, 3) intermittent variation of speed (if at a *low* rate, it is called *wow*, and if it is at a *high* rate, it is called *flutter*).

Constant-but-slow and/or intermittent slowdown symptoms usually are caused by slippage in the drive mechanism. Such slippage frequently is the result of contamination of the drive mechanism by the magnetic oxide and adhesive binder coatings on the tape. This material sloughs off the tape onto the capstan, causing slippage between the capstan and tape or, in some cases, actually clogs up the capstan assembly. The second most common cause of slow-speed problems is a worn drive belt.

Because of the frequency of the preceding causes of constant-but-slow and intermittent slowdown trouble symptoms, in my opinion it is

Illustrations in this article are from a Howard W. Sams book titled *Automotive Electronics Servicing Guide*, Courtesy of Howard W. Sams & Co.

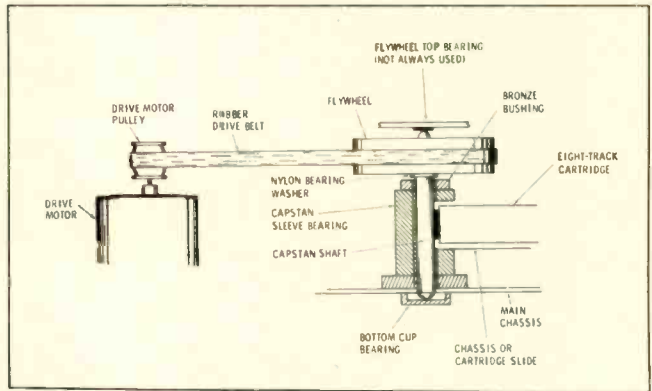

Fig. 1—Side view of a typical eight-track drive mechanism.

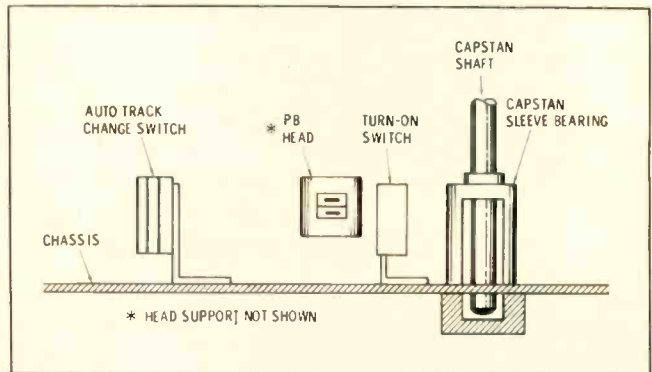

Fig. 2—Front view of the tape transport system of a typical car eight-track player.

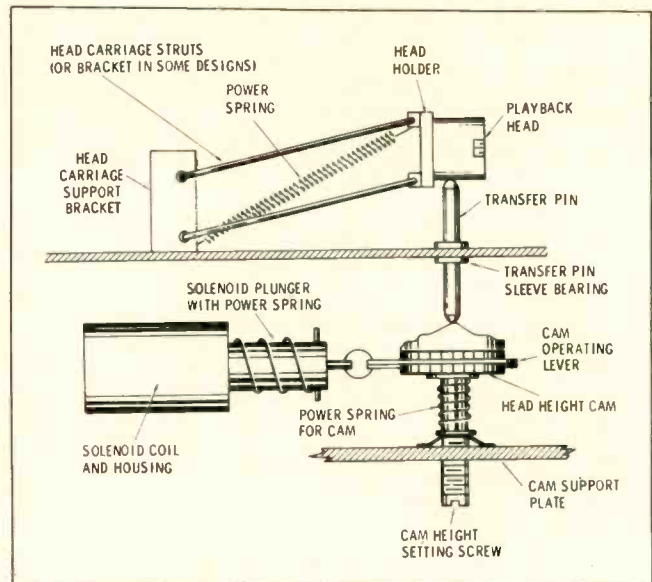

Fig. 3—Motorola track-change mechanism.

good practice to change the drive belt and thoroughly clean the drive mechanism of every tape player you service—unless, of course, the unit is new and has not been operated long enough to cause excessive belt wear and/or oxide contamination.

Thorough cleaning of the drive mechanism of most eight-track players

requires removal of the flywheel/capstan assembly. After removal, thoroughly clean all associated parts with either a liquid or aerosol "degreaser" solvent. (Avoid the use of solvents which leave residue on parts.) If no other solvent is available, you can try isopropyl alcohol as a substitute. Grain alcohol works better than iso-

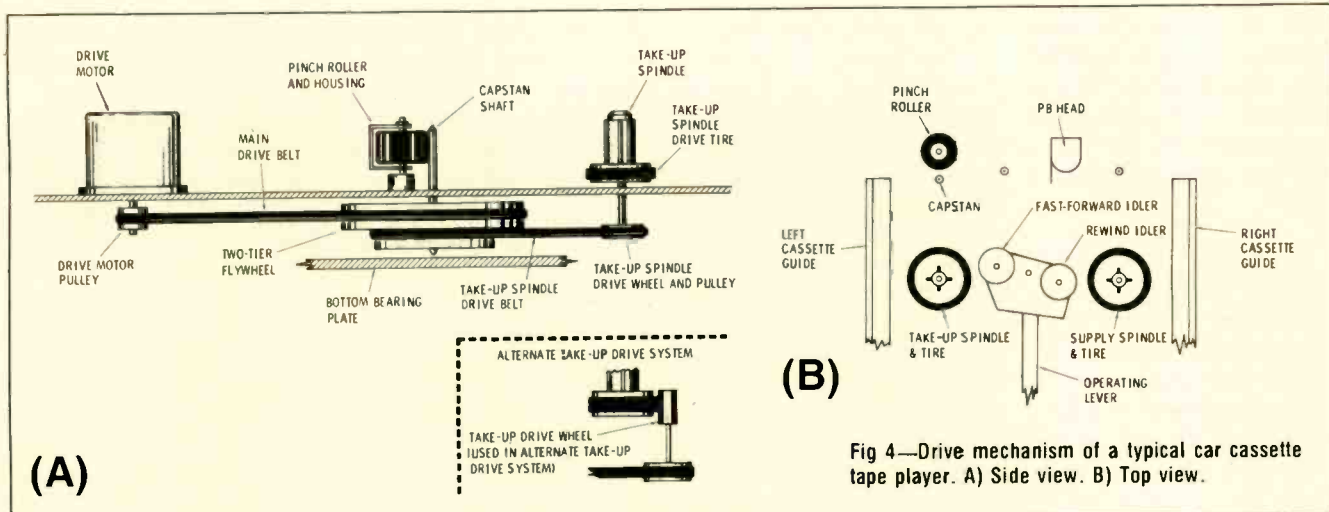

Fig 4—Drive mechanism of a typical car cassette tape player. A) Side view. B) Top view.

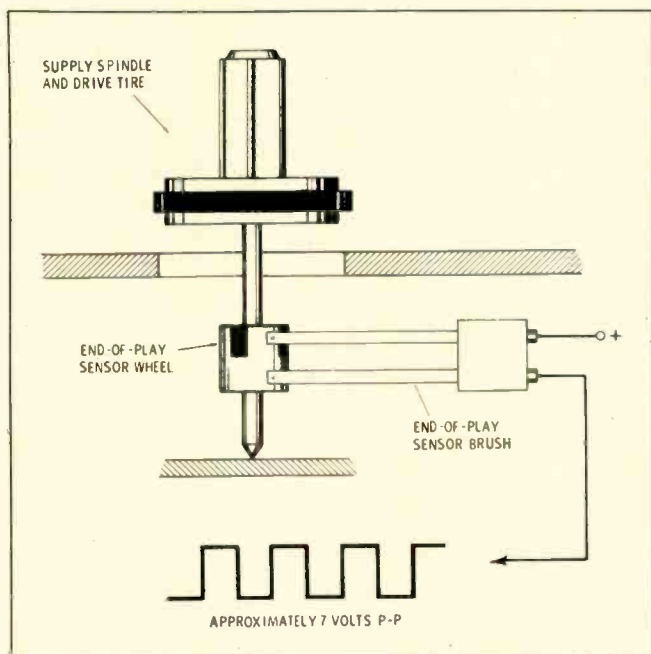

Fig. 5—End-of-play sensor mechanism representative of the type employed in some car cassette tape players.

propyl, but has the drawback of being consumable by humans. (For example, a relative of mine, who is a foreman in an electronic service facility which employs a few hundred avionics technicians, reports that they use about three gallons of grain alcohol throughout the year to clean about 2000 special RF switches. On Christmas Eve, however, he reports that, by his calculations, the technicians clean approximately 4,250,000 of the special switches—all in less than three short hours.)

The capstan shaft can be cleaned with a lint-

free rag or paper towel dipped in solvent, and the bearings and capstan housing can be cleaned with solvent-soaked Q-Tips.

Whether or not you should lubricate certain points of the drive mechanism after cleaning, is open for debate. The "official" rules indicate that you should apply "one thin dab" of white or silicon grease (or petroleum jelly) on the top and bottom end bearings and "maybe one drop" of lightweight oil on the *bottom* sleeve bearing. (Do not apply oil to the top sleeve bearing, because it will drip onto

the surface of the tape.) My present practice is to use no oil, and grease only if there is positive evidence that the manufacturer did so when the unit was originally assembled.

Two other common causes of intermittent speed variations in eight-track players are worn end bearings (particularly those that are nylon) and a worn capstan housing. In either case, replacement is the only cure.

Constant but excessive speed usually is attributable to one of two causes. First, check for tape wrapped around the capstan shaft. (When a tape breaks, some of it might wrap around the capstan shaft, increasing the shaft's diameter and, therefore, the speed at which it moves tape across the playback head. Your unknowing customer removes the broken tape cartridge, inserts a new one, and is suddenly confronted with an excessive speed problem. In most such cases, the customer forgets to tell you about the cartridge with the broken tape.)

If there is no tape around the capstan, next suspect a stuck or broken centrifugal regulator in the motor.

CAUTION: Do not

overlook the possibility that the speed problem is caused by a defect in the customer's tape cartridge. If the tape inside the customer's cartridge is wound too tightly or too loosely, or if the pinch roller is out of round or otherwise defective, speed problems will result. To preclude such problems, when troubleshooting any tape player, always use your own tape cartridge—one that you are sure has no "built-in" defects.

If a speed problem persists after you have cleaned the drive mechanism, changed the drive belt, checked out the capstan shaft. (When a tape breaks, some of it might wrap around the capstan shaft, increasing the shaft's diameter and, therefore, the speed at which it moves tape across the playback head. Your unknowing customer removes the broken tape cartridge, inserts a new one, and is suddenly confronted with an excessive speed problem. In most such cases, the customer forgets to tell you about the cartridge with the broken tape.)

If there is no tape around the capstan, next suspect a stuck or broken centrifugal regulator in the motor.

will not press the tape firmly enough against the capstan to insure smooth, uninterrupted transport of the tape across the playback head.

Track-Change And Crosstalk Problems

Variations of the basic design of the Motorola track-changing mechanism illustrated in Fig. 3 are found in almost all car eight-track players. Very few are more complex, and most are simpler.

In the Motorola design, the playback head rests on a moveable pin (called the transfer pin in Fig. 3) which is raised and lowered by the head-height cam to any one of four levels, each of which aligns the playback head with one of the four different pairs of tracks recorded on the eight-track tape. (Two tracks are required to produce each of the four stereo channels.) Horizontal rotation of the serrated edge of the head-height cam is accomplished by the plunger of the solenoid. The solenoid is activated either manually by the track-change switch or automatically by the foil at the end of each track on the tape. (The foil closes a set of contacts which energize the solenoid.) When the solenoid is activated, the plunger and cam operating lever rotate the head-height cam, lowering the playback head one position. As the head-height cam is rotated, the power spring connected to the head-height cam is compressed. At the end of channel 4 (or sooner if the cycle is manually interrupted), the head-height cam is released by the cam operating lever and the fully compressed power spring rotates the head-height cam back to

the channel 1 position.

The "cam height setting screw" in Fig. 3 (usually called "head height adjustment") permits slight readjustment of the playback head position, to eliminate crosstalk between channels. For accuracy and fewer callbacks, crosstalk adjustments should be performed only while monitoring the output produced by a "genuine" test tape cartridge. Most conventional music tapes and "homemade" test tapes have neither the quality content nor accuracy required for such adjustment.

Installation Defects

If a tape player functions correctly on the bench but does not when reinstalled in the car, check out the associated wiring in the car. One frequently encountered cause of this type of problem is inadequate grounding of the player to the car body, which serves as the DC return path. In many such cases, the DC power applied to the player effectively flows through a speaker to ground, and the resultant reduction in operating voltage causes the player to slow down or operate erratically.

CASSETTE PLAYERS

Side and top views of the drive mechanism of a relatively simple design of car cassette tape player are shown in Figs. 4A and B, respectively. This is a two-tiered arrangement, with one tier of the flywheel connected to the motor pulley via the "main" drive belt and the second tier of the flywheel connected to the take-up reel via a second drive belt.

Speed Problems

As in eight-track

players, speed problems are the most frequently encountered trouble symptom in cassette players, and most are caused by the same sort of drive mechanism problems that occur in eight-track systems.

One common cause of low or intermittently low speed in cassette players is worn tires on the take-up supply spindles. In some designs these tires can be removed and replaced with relative ease, while in other designs it is necessary to replace the complete spindle/platform/tire assembly.

The pinch roller assembly is another common cause of speed problems. In addition to excessive wear of various parts of the assembly, including the pinch roller itself, another cause of inadequate pinch roller tension is a weak or misadjusted pinch roller spring. (This spring is usually the only source of the tension needed to insure that adequate pressure exists between the pinch roller and capstan.)

As with eight-track players, the drive mechanism of cassette units should be used, except that the pinch roller and all tire surfaces should be cleaned with a solvent which does not deteriorate rubber.

In a relatively few cases, speed problems in cassette players are caused by such less-obvious defects as bent levers and worn surfaces in the mechanical linkages associated with the idler and operating lever assemblies.

End-of Play Problems

An end-of-play sensor system like that in Fig. 5 is employed in some car cassette players. The purpose of this sensor is

to initiate turn off and ejection of the cartridge at the end of the tape.

The sensor wheel, which is rotated by the supply spindle shaft, consists of a lower section and an upper section. The lower section is all metal, while the upper section consists of alternate metal and strips of insulating material. A pair of wipers, which feed the inputs of a differentiator circuit, ride on the sensor wheel. (The differentiator produces an output only when the input is varying; with constant or zero inputs, the differentiator produces no output.)

When the supply spindle is rotating, the segmented upper section of the sensor wheel produces a square wave, which is applied to one input of the differentiator. With a varying input, the differentiator produces an output, which, in turn, is applied to a control circuit. As long as the control circuit senses an output from the differentiator, it does not initiate turn-off.

When the supply spindle stops rotating at the end of the tape, the sensor no longer produces a square-wave output, and in turn, with a constant input applied to it, the differentiator no longer produces an output. The control circuit then initiates player turn-off and ejection of the cassette cartridge.

The most common problem associated with such end-of-play sensor systems is oxidation of the sensor wheel surface, which causes erratic or premature turn-off and ejection. In such cases, clean the surface of the sensor wheel with an eraser and lightly burnish the wiper contacts with emory cloth or a burnishing tool. ■

When you install a B-T Booster outside, you get a lot of new boosters inside.

The service technician's job is a tough one. Customers are always grumbling about the high cost of TV service calls. And they complain about poor reception—even when it's almost impossible to get a good signal.

But now and then a TV service technician wins one. And one of the products that can make him a winner, and create customer goodwill, is a Blonder-Tongue outdoor booster.

B-T Boosters can produce a dramatic improvement in picture quality, particularly on color and especially in difficult reception areas. After 25 years of making outdoor boosters, B-T is number one in sales, and enjoys the finest reputation for making

products of highest performance and reliability. B-T Boosters do cost a bit more than competition, but they perform and last longer. And that's what makes satisfied customers.

The VAULTER, for example, is the number one outdoor booster today in the B-T line...and in the entire industry. This ultra-high performance, all-channel amplifier offers the ideal combination of lowest possible noise figure (4.6dB, VHF; 7.0dB, UHF) and high gain (15dB). While it can't make unusable, snowy pictures perfect, it can reduce fading, loss of color, overcome cable loss and reduce lead-in cable noise. It can even feed more than one TV set from the same antenna in fringe reception areas. It

has separate U/V inputs and a coax output. Finally, it's specially designed for lightning prone areas.

The B-T line consists of 5 all-channel models (including the popular VOYAGER); 5 VHF models and 4 UHF boosters (the ABLE-U2b is a favorite).

See your B-T distributor for details. And see why you can count on boosters inside, when you install B-T Boosters outside. Blonder-Tongue Laboratories, Inc., One Jake Brown Road, Old Bridge, N.J. 08857.



BLONDER-TONGUE



...for more details circle 111 on Reader Service Card

"I wouldn't trade my Tradesman for all the wood in Woodstock." And here are 5 good reasons why:



1. Dodge Tradesman: Best gas mileage.

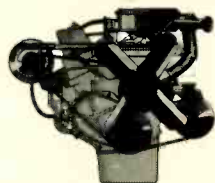

Trade my Tradesman? No way. Not when it got the best gas mileage of any van on the road. In the latest EPA tests, Tradesman—powered by a 225/6 with a manual transmission—turned in an estimated mileage of 26 miles per gallon on the highway. And 18 in the city. Of course, the mileage you get will depend on your own driving habits, road conditions and your van's equipment. See your Dodge Dealer for California estimates.

2. Dodge Tradesman: Carries more.

Dodge Tradesman weighs less and can carry more than any other van. On comparable models, it weighs 524 pounds less than Ford. And 140 pounds less than Chevy. A lot less weight that can add up to a lot more cargo. And the more cargo you carry in one trip, the less trips you have to make.

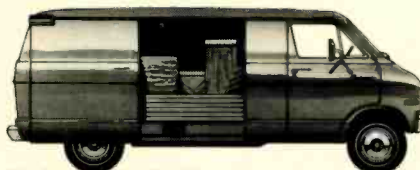

3. Dodge Tradesman: Better maneuverability.

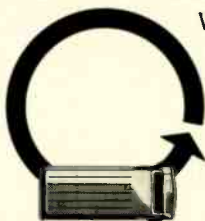

When you've got a narrow loading dock staring you in the face, you'll be darn glad you've got a Dodge. Curb to curb, Tradesman's turning circle is shorter than either Ford's or Chevy's. So even in the tightest spots, it's a cinch to do your business a good turn.

4. Dodge Maxivan: Biggest van there is.

For extra-big jobs, Dodge Maxivan gives you 18 extra inches of load length to work with. And that makes it the biggest van in the business. Got a big bundle of 12-foot two-by-fours? Maxivan can swallow 'em whole.

5. Dodge Tradesman: Single rear door.

Looking for a van with a view? Tradesman's new optional single rear door has a single rear window that's wide enough to take in the world. Plus a door opening that's wide enough to take on a load of cargo. And only Dodge has it. As for getting in and out on the side, you can go with our swing-out doors. Or opt for one that slides.

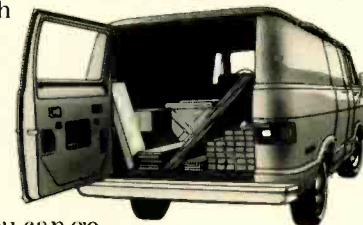

Dodge Tradesman: A whole lot more.

Dodge has made Tradesman even more untradable with other great features like: Small 6 and V8 engines (225/6 and 318 V8). A standard gas tank that's 22 gallons big. Large side-door opening for easier side loading. Short 109-inch wheelbase on B 300 model. In-cab hood release. Automatic speed control. Proven electronic ignition. Glove box. Auxiliary rear heater. Lower overall vehicle height and shorter length for garageability. And a standard two-stage front door check.

Fleet Purchase Allowance.

If you own as few as ten vehicles (cars or trucks), you can qualify for an allowance direct from Chrysler Corporation. It'll be well worth your time to find out about this program. For complete information on how you can qualify for our Fleet Purchase Program, see your Dodge Dealer.



DODGE
TRADESMAN
VAN

...for more details circle 113 on Reader Service Card

■ It's February 1977. Although the economy has improved a little, John D. Consumer has still got many problems. Among them are a three-year-old portable color TV that produces only black-and-white pictures, a car radio that won't pick up anything but two stations on the left side of the dial, a car tape player that refuses to change channels by itself, and a CB transceiver that hasn't worked right since he purchased it from a mass merchandiser and installed it himself two years ago.

John has been intending to get his "electronics marvels" fixed, but he just hasn't had the time. And besides, despite some improvement in the economy, John's pocketbook still hasn't fully recovered from the effects of 1974-75's stagflation.

However, on his way to work this morning, John saw what seems to be the answer to at least his "electronics" problems. At the corner of 8th and Washington Streets, in what used to be a big cut-rate gas station before the so-called gas shortage of '74, John saw, for the first time, one of those new drive-in electronics service stations that his co-worker Sam told him about a couple of months ago.

According to Sam, anytime he has a problem with his car radio, car tape player, CB transceiver or any of the other electronic parts of his car, including the electronic ignition and new fuel control system, all he has to do is call the electronic service station a day or two in advance and then, on the appointed day, he drops off his car on the way to work and picks it up on his way home. (A co-worker meets him at the electronics service station in the morning and drops him off there after work, or he can catch the bus.)

If the problem requires removal of his radio, tape unit or CB transceiver, the service station pulls it out and Sam then picks up his car on his way home that night. When the unit is repaired and ready for reinstallation, the service station calls him and tells him what day he again can drop off the car and pick it up in the evening.



With J.W. Phipps, Editor, ETD

TV/CB/Auto Electronics Service Stations: Tomorrow's Super Blend For Consumer Electronic Servicers?

TV service is even easier. All Sam has to do is pull in on his way to work, drop off the set (which only takes a minute or so) and when it's fixed (which usually only takes a couple of days), the station calls him and he picks it up on his way home from the office—with no extra travel and no home service charge.

And, according to Sam, not only do the new drive-in electronic service stations save you time, travel and money on servicing, but most of them also sell CB and auto electronics products, which they install in the same time-, travel- and money-saving manner in which they offer servicing. As Sam so aptly put it: "Now that these new drive-in electronics service centers have eliminated the cost, inconvenience and worry involved in finding someone else to install and service a new piece of electronics gear, you have to be a fool to buy a CB, car tape player or car radio from a mass merchandiser, 'discount' store or other non-servicing and non-installing source."

At this point in his reflection of Sam's comments, John D. Consumer decides that there is no longer any excuse for putting off the repairs needed on his "electronics marvels." He reaches for the Yellow Pages in his desk drawer and looks up the phone number of the drive-in electronics

service station he passed this morning.

If you believe that the need for electronic service stations, as depicted in the preceding scenario, is a bit farfetched, consider the following factors:

- *The need for relocation of electronic service businesses to high-traffic, easily accessible sites or, at least, the need for establishment of "satellites" in such locations.*

What appears to be a well-established and permanent trend toward more carry-in and less in-home TV servicing was discussed in last month's *Profitably Speaking* article. The basis of this trend is the increasing dominance of table and portable models among TV sets in use, as indicated by the Electronic Industries Association's sales-to-dealers statistics for the period 1965-1974.

Because it is anticipated that most carry-in service customers will tend to choose a service center principally on the basis of how close it is to either their home, a shopping center they regularly patronize or the route they travel to and from work, shop location will have a more significant impact on service volume than it had in the past. The reason for this is that, while a servicer's potential market for *in-home* TV servicing is limited principally by how far he is willing to travel to make a house call, his potential market for *carry-in* business will be limited by how far the *customer* is willing and able to travel for TV service.

Consequently, to prevent a reduction in business volume as a result of what appears to be an inevitable shift to carry-in business as the principal source of TV service income, servicers will have to either relocate their present facility to a site more convenient to carry-in customers or else establish an annex, or "satellite", operation at such a site.

- *The need for more diversification beyond TV servicing*

The demand for TV service is dependent principally on two factors: 1) the *number* of sets in use, and 2) the *reliability* of sets in use.

Although the number of TV receivers in use has been steadily

25 Invitations to great reception.

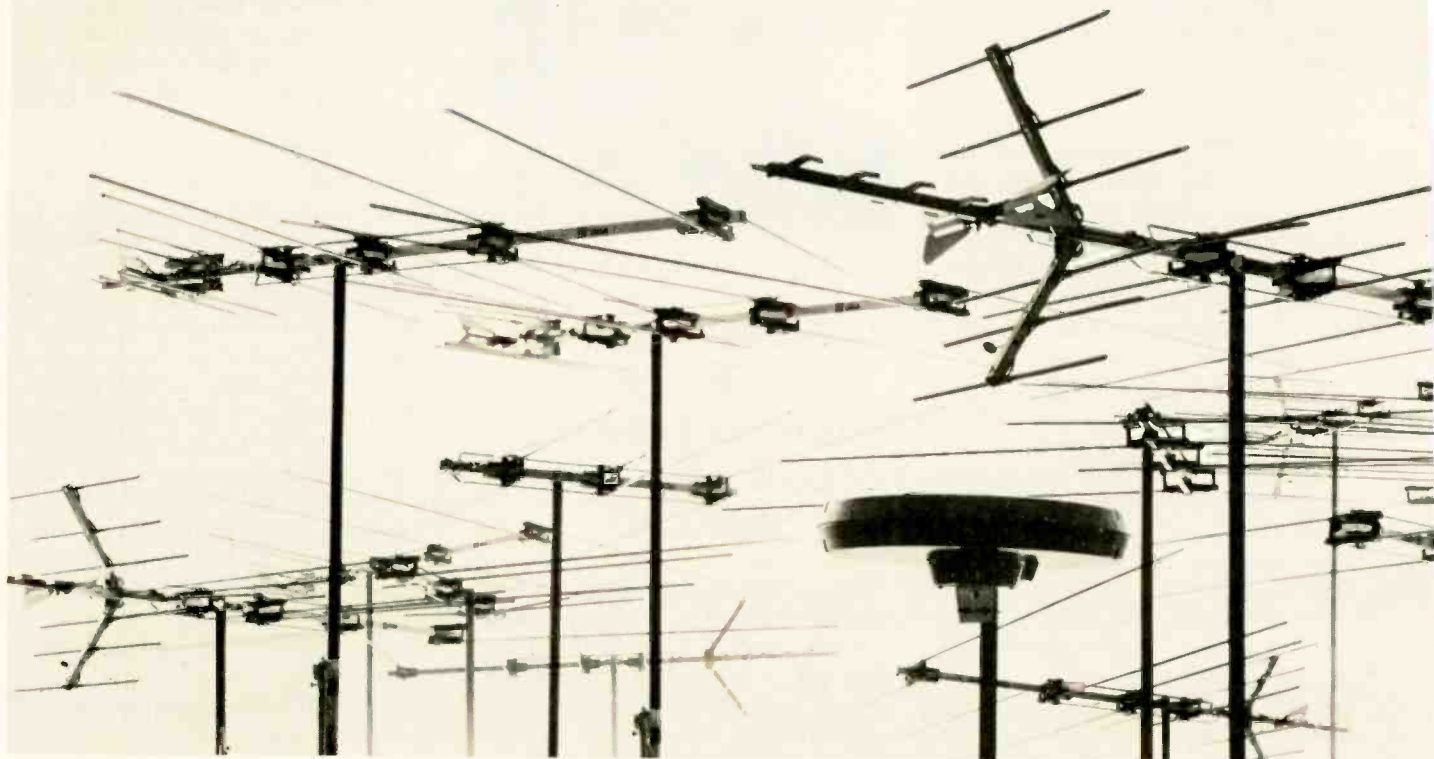

increasing, the rate of increase undoubtedly will slow in the near future as the TV market approaches saturation and the rate of growth of the U.S. population continues to slow down. According to data published by the Marketing Services Department of the Electronic Industries Association, over 96 percent of the nation's homes already have one or more TV receivers and, based on U.S. Census data and NBC research estimates, over 65 percent of the nation's homes already have one or more color TV receivers.

The reliability of TV receivers, on the other hand, seemingly is improving and should continue to improve as a result of the combined effects of solid-state technology, design advancements and better quality control. Consequently, the incidence of need for service per television receiver should be steadily declining and should continue to do so. Evidence of this trend is documented in a recent study conducted by the Center For Policy Alternatives, Massachusetts Institute of Technology (MIT). Says a report of

the findings of MIT's study: "The 1965 color TV set required, on the average, two service calls per year; in 1972 only one." (A synopsis of the findings of the MIT study will be presented in next month's *Profitably Speaking* article.)

Based on the preceding factors, and assuming that the sizes and number of existing TV service businesses remain relatively stable, it seems inevitable that at some point in the next one to three years the downward curve representing the rate of increase of sets in use and the upward curve representing the increase in set reliability will cross and, as a result, the curve representing the incidence of need for TV service per existing service shop will begin a slowly steepening downward movement. At that point, the revenues and profits of TV service businesses will begin declining at an ever increasing rate unless the reduction in TV service revenue is offset by increased revenue from servicing other types of consumer electronic products.

• *The two most obvious and viable markets into which TV servicers*

can easily diversify: CB and auto electronics

Consumer electronic sales and service businesses which today receive all or most of their income from television should now begin diversifying into or placing more emphasis on other categories of consumer electronic products—preferably those which 1) presently exist in large numbers, 2) are in a growth pattern, and 3) whose servicing is compatible to the changes that service businesses will have to make to successfully meet the needs of a predominantly carry-in TV trade.

The two categories of consumer electronic products which seem to meet these prerequisites better than any others are CB and auto electronics.

According to data compiled and published by the Marketing Services Department of the Electronic Industries Association, the U.S. Department of Commerce and the Federal Communications Commission, there were an estimated 100 million car radios in use in this country as of 1974, and during the period 1969-1974, over

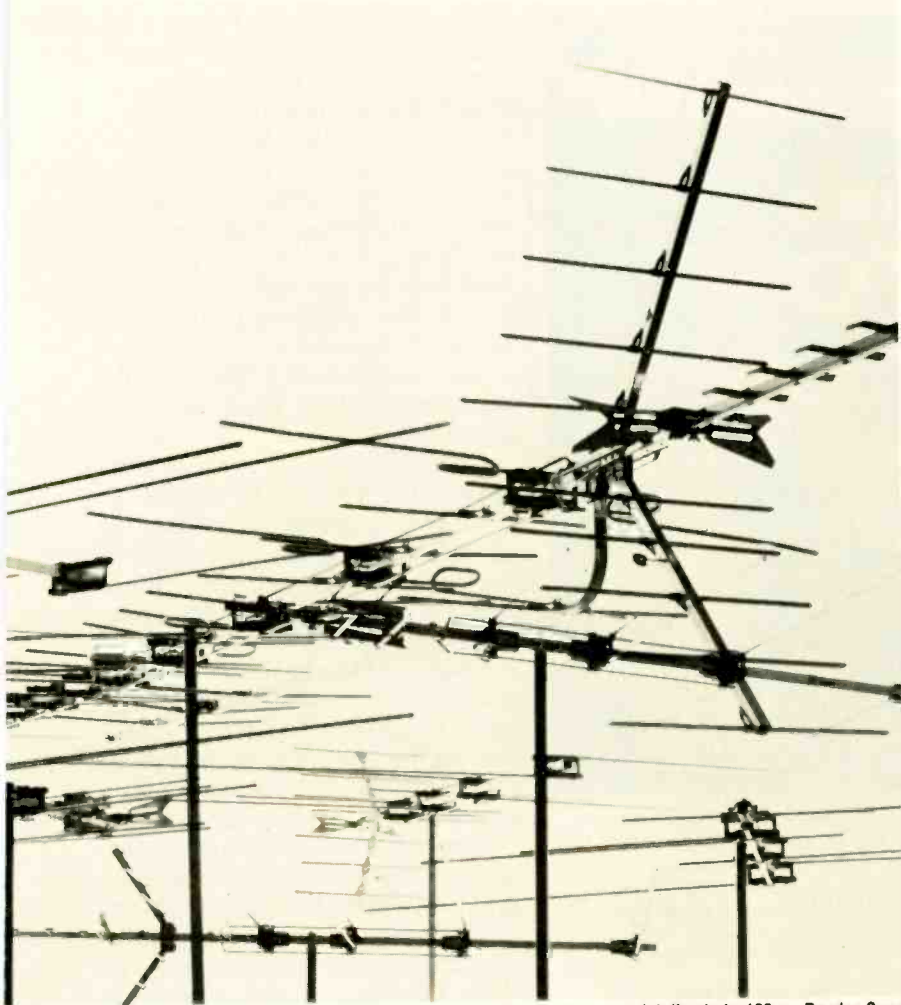

...for more details circle 129 on Reader Service Card

Outdoor antennas, for sure. For UHF, VHF and FM — and almost any combination. Plus Mini-State — RCA's newest and most advanced miniature rotating antenna for the best possible reception in apartments, homes, boats, trailers and RVs.

We don't stop there, either. Our line of great rotators for outdoor antennas, our reception aid amplifiers, splitters, transformers, and our easy-as-pie mounting hardware, give you the most complete line of invitations for great reception anywhere.

RSVP. For all the details, see your RCA Distributor — or contact RCA Distributor and Special Products Division, Cherry Hill, N.J. 08101. Phone: 609-779-5763.

RCA Permacolor
Outdoor Antennas

21.3 million car tape players were imported into and sold in the U.S. In addition, as of March 1975, there were more than 6,250,000 CB transceivers in use, with installations in 1 out of every 33 vehicles on the road, and CB license applications during the past year have increased almost 200 percent over those of the preceding year.

Yet, despite the phenomenal growth of mobile CB transceivers, car radios and car tape players in use, a nationwide survey conducted recently by ET/D indicates that only 45 percent of consumer electronic servicers now repair car radios and/or tape players and only 15 percent now service CB equipment.

Based on a comparison of these and other related statistics, it seems that a disproportionately high percentage of consumer electronic servicers and servicing dealers are passing up a large growing market for their services—a market which, by virtue of its *drive-in* nature, should be highly compatible to the requirements of a predominantly carry-in TV service business.

Of the various reasons given by servicers for shunning CB and auto electronics servicing, the three most frequently cited are: 1) that CB servicing requires a 2nd or 1st Class FCC license; 2) that such servicing requires the removal and reinstallation (RNR) of equipment within the confined, cluttered and difficult-to-reach environment of vehicle dashboards—a function which most electronic technicians do not want any part of and which, because of the many variations in dashboard layout and methods of installation, cannot be accurately priced in a manner that assures profit; and 3) that such servicing requires a heated (and/or air conditioned) garage-like facility capable of accommodating one or more vehicles.

The first of these three "obstacles" to CB and auto electronics servicing can be overcome merely by hiring one technician who possesses a 2nd or 1st Class FCC license. Because most of the actual troubleshooting and repair involved in CB servicing can legally be accomplished by technicians

who do *not* possess an FCC license, so long as any servicing that affects the frequency and power output of the transmitter is checked by an FCC licensed technician, most shops probably will need only one FCC licensed technician.

Undeniably, RNR of mobile CB transceivers, car radios and car tape players is significantly different than most other functions involved in consumer electronic servicing. Equally undeniable is the fact that a good "RNR man" must possess the finger dexterity of a safecracker, the agility of a one-legged gymnast, the patience of a monk, the arm strength of the six-million-dollar man and the tenacity of flypaper.

Despite the relatively extreme physical and emotional demands of RNR work, believe it or not there are individuals who have the previously described attributes and like the physical and mental challenges RNR work offers. So if you've shied away from auto electronics and CB servicing merely because you feel that *you* personally do not have the body and mind for RNR work, shy no

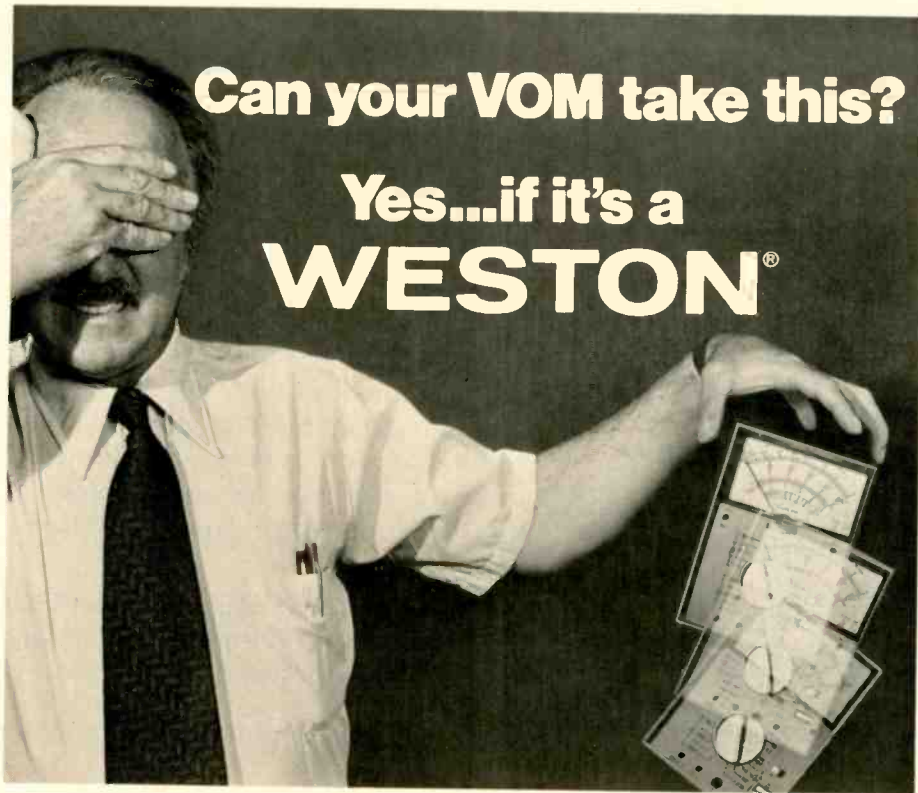

Can your VOM take this?

Yes...if it's a
WESTON®

That's right! WESTON makes its entire 660 VOM series "Drop-Proofed". Dropped from any height up to five feet, they will still work—and accurately, too. They're engineered that way. In fact, every one of them comes with a written warranty.

All meters in the WESTON 660 series are 7"H x 5"W x 2 1/4"D. Weight is less than 2 lbs. including furnished batteries. Models 660, 661, 662, and 663 have a sensitivity of 20,000 ohms/volt DC, 5,000 ohms/volt AC. The 660 and 662 are accurate to 2% DC (1.5% on 50 ua range) and 3% AC. The others, both of which have overload relays, are accurate to 1% DC, 2% AC.

Model 666, the top of the line, has an accuracy of 2% DC volts, 3% AC volts, 3% DC current and 4% AC current. Sensitivity: 10 Megohm DC, 10 Megohm (100 pfd) AC, and a current circuit drop of 100 millivolts. Measurement capability: DC millivolts (2 ranges) 0-300, DC volts (7) 0-1000, AC millivolts (2) 0-300, AC volts (7), 0-1000, DC microamps (3) 0-100, AC milliamperes (3) 0-30, ohms (7 normal and 7 low power ranges) w/lt Rx1 to Rx1 Meg, and 9 dB scales —40 to +62.

The single range switch, jacks, and meter face are recessed flush with the high-impact type plastic case for protection. The ruggedized meter movement is diode-protected. Recalibration and fuse replacement can be done externally.

The WESTON "Drop-Proofed" 660 VOM series is easy to use...hard to hurt...and easy to get, either from your local WESTON distributor, or by mail. Use the coupon below with your Master Charge, BankAmericard, check or money order. Even if you have someone else's voltohmmeter, you still need a WESTON VOM...in case you drop the other one.

more. Just place a classified ad in your local paper for "a young, athletic man who is mechanically inclined, has a basic understanding of electronics, likes to work in and around cars, and would like to learn a challenging, well-paying trade." (Forget such requirements as "must like to lay on with feet in air and head under automobile dashboard" or "is capable of assuming a variety of unique positions in a mobile working environment that can take him places.")

Although it is true that the time required to perform RNR of a car radio or tape player depends principally on the make and model of the vehicle involved and, therefore, can vary over a wide range, such work nevertheless can be profitable. All you have to do is charge for it on a straight hourly basis, at an hourly rate that is sufficient to recover your labor, materials and overhead costs plus a reasonable markup for profit.

The requirement of a drive-in, garage-like facility for mobile CB and auto electronics likewise should pose no insurmountable obstacle to servicers, particularly those TV servicers who, as a result of the changes dictated by the shift to predominantly carry-in TV servicing, will have to relocate their businesses to sites more convenient to carry-in customers.

One example of the type of facility needed for both CB/auto electronics and carry-in TV servicing is the many former filling stations left vacant by the recent demise of large numbers of independent gasoline dealers. These facilities typically are situated at the cross-road of main traffic arteries and have easy-in and easy-out features plus ample inside room for RNR work.

There undoubtedly are other product categories into which TV servicers can successfully diversify. I have discussed the potential and requirements of CB and auto electronics servicing only because they seem to be the most compatible with what appears to be the coming nature of TV servicing.

Regardless of how individual TV servicers choose to cope with the demands and changes necessitated by the increasing predominance of carry-in servicing, they should be analyzing, choosing and executing their options now. ■

Please send me the WESTON 660 VOM "Drop-Proofed" champ

Name _____

Address _____

City _____ State _____ Zip Code _____

Model	660	661	662	663	666
Price	\$79.00	\$91.00	\$122.50	\$135.00	\$164.00

Quantity () () () () ()

Add \$2.00 for handling charge. (New Jersey residents add 5% sales tax to cost of unit.)

Total amount of purchase \$ _____

PLEASE CHECK ONE MASTER CHARGE BANK AMERICARD

[] [] [] [] [] [] [] [] [] [] [] []											
INTERBANK NO.								EXP. DATE		MONTH	YEAR

Payment by check Payment by money order Offer effective through Mar., 1976.

Signature _____

WESTON INSTRUMENTS, INC.

614 FRELINGHUYSEN AVENUE, NEWARK, N. J. 07114



...for more details circle 135 on Reader Service Card

Controlling Your Business Cash

By D. S. Campbell

How to maintain that delicate balance between too little and too much

■ Maintaining an adequate, realistic level of cash is a problem for many electronic servicers and retailers. Service dealer "A" says, "I never seem to have enough cash. Often I have to slight one creditor to pay another." On the other hand, service dealer "B" says, "At times, I have more cash than my business needs."

THE RIGHT AMOUNT

The secret of controlling cash can be stated in one word: *Balance*. A firm should aim to have just the *right amount* of cash on hand—never too little for its needs and never too much.

When a business has a permanent year-around pressure on cash, as does service dealer "A", the firm may be undercapitalized. Such a chronic shortage of cash can lead to disaster because the owner can't pay the firm's bills when they are due. Or the firm may go broke because its owner lacks the financial resources to meet the sudden demands of new cut-throat competition. Service dealer "A" needs to get more capital into his firm because his present investment does not generate enough cash to keep the business financially healthy.

On the other hand, an excess amount of cash, as in the case of service dealer "B", often indicates that the small marketer is not using his liquid assets properly. Service dealer "B" could use his

**The author is the financial vice president of J. J. Newberry Company, New York. (This article is part of a financial management series produced by the Small Business Administration for small retail and service firms.)*

excess cash, for example, to stock new, profitable lines which would help his business grow. Or he might invest his excess cash in short term securities which could be redeemed when his firm needed funds. And if he should accumulate fairly large amounts of excess cash on a regular basis, his best investment probably would be that of plowing the money into modernizing his firm—into remodeling which will help attract a greater number of customers, or into new equipment that will improve his shop's productivity.

Control of cash involves two paths of action. The first is having the right amount on hand to pay your bills. The second is using any excess of that amount wisely.

Book control—your day-to-day and month-by-month accounting—governs your journey on both paths. It tells you how much money you have available, how much you need to pay your bills, and whether there is a deficit to be made up or a surplus to be invested. In the latter case, you may sometimes have to take prudent risks—as do all successful business owners—in order to make your cash balances produce income.

One approach to sound cash management involves four steps: (1) making sure that your book control works properly, (2) determining the cash flow pattern for your business, (3) estimating future cash balances, and (4) using excess cash to produce income.

CHECK YOUR BOOK CONTROL

Some owners of small retail and service firms find the going rough because they try to operate without adequate book control.

In thinking about your control over cash, start by checking your present way of keeping books. Are your records on cash adequate? Do they tell you what you need to know about the cash which goes out of your business? Do they alert you to cash deficits? To cash surpluses?

Keep in mind that such records do not have to be elaborate. However, they should account for every penny of cash coming into your firm and for every penny of cash going out. Even a one-man business—with no employees—should keep accurate books on all

Now you can stock only 300 semiconductors instead of 112,000.

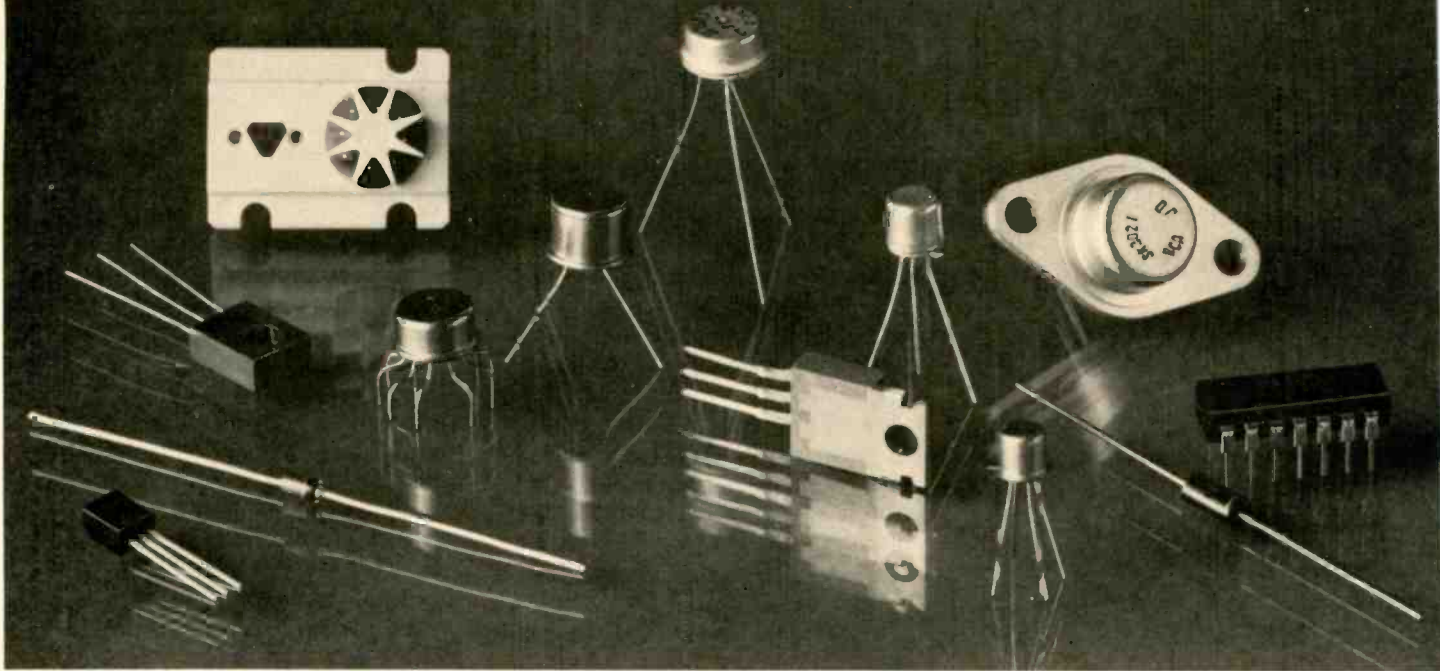

receipts and disbursements.

Input And Output

In checking the kinds of records you use to control cash, it may be helpful to keep in mind the following facts about cash.

Cash usually comes from four sources: (1) daily cash sales, (2) payments which customers make on their accounts, (3) loans which you arrange to meet short-term needs, and (4) additional capital which you borrow on a long-term basis.

On the out-going side, cash is used for at least six things: (1) to pay for inventory, (2) to pay personnel, including the owner/manager's salary and his profit (return on investment), (3) to reduce accounts payable—to pay for things, other than inventory, which you bought on credit, (4) to liquidate loans, (5) to pay rent, and (6) to pay for utilities and other overhead expenses.

Good control over stock is important in controlling cash. Your aim should be to have adequate stock for serving customers without tying up money in unnecessary inventory.

Control Procedures

Keeping track of the cash that comes into your business requires two things: (1) procedures and records which will help you to safeguard the funds (2) attention to the details necessary to keep those procedures working. The following suggestions should be helpful as you establish book control of your cash:

- Guide your activities by the rule that "handling business cash as though it belonged to someone else" is vital to a firm's success—especially when your firm's cash is limited.
- Keep personal cash separate from cash generated by your business. One way to do it is by paying yourself a weekly or monthly salary.
- Keep a record of all incoming cash. It should be a simple one which will show you: (1) the amount of cash, (2) the date received, and (3) the source.
- Use a bank account for your business funds.
- Deposit *all* cash receipts in your firm's bank account.
- Never make a disbursement out

of your daily cash receipts.

- Deposit each day's cash receipts intact on a daily basis.
- Pay all bills, if possible, with checks. They provide a record and serve as a control. Checks also help you to keep disbursements in coin and currency to a minimum.
- Use a petty cash fund if you do have to pay some small bills in coin and currency. This fund should be a fixed amount and balanced regularly. Get a properly signed receipt when making a payment from the petty cash fund. Reimburse your petty cash fund with a check which notes, for example, "to cover cash used in paying receipts numbered 21, 22, and 23."
- Make disbursements only if you have (1) a supplier's invoice or (2) a receipted paid-out voucher which is dated and fully signed by the person to whom you give the check (or money if it's a small petty cash expense).
- Keep your records simple. In a busy schedule, you will be more apt to refer to your records if they are easy to use.
- Periodically have your procedures and controls checked by

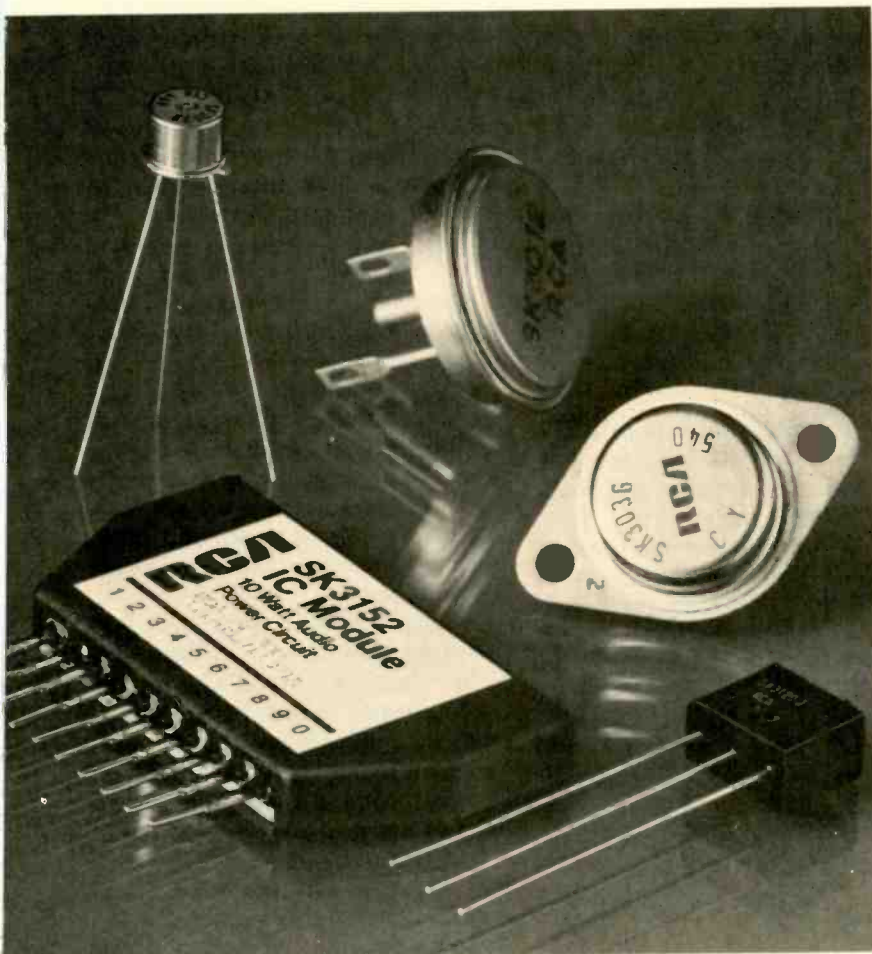

...for more details circle 130 on Reader Service Card

With RCA's SK Series you need stock fewer different semiconductors than you'd have to with any other major brand. Because our 300 devices can replace 112,000. And they're all immediately available.

OEM Quality. You don't have to be concerned about quality with RCA SK's. They measure up to strict AQL Standards to protect you from time-wasting callbacks. Lets you make more calls. And more profits.

See your RCA Distributor for a copy of the new RCA SK Replacement Guide. Or send \$1.00 to RCA Distributor and Special Products Division, P.O. Box 85, Runnemede, N.J. 08078. Phone: (609) 779-5735.

RCA SK Replacement Semiconductors

your accountant or a key employee to see that they are working effectively.

DETERMINING YOUR CASH FLOW PATTERN

Book control gives you information which you need on the second path of cash management. On this path, your concern is keeping your business healthy by: (1) providing funds when there are deficits in cash and (2) using surpluses wisely. Here you are working with dynamic situations—ones that change from month to month.

Before a service dealer can achieve efficient use of his cash balances, he has to know his firm's cash flow pattern. You need answers to the following questions:

How much cash comes into your business each month? How much goes out? Is any left at the end of the month? If so, how much?

You can get your answers by looking at the records which give you book control of cash. See what they tell you about your past cash flow pattern.

You'll need to use a budgeting technique and look at your records

for the past. You may want to ask your accountant or bookkeeper to work out the details for you.

One simple budget technique involves: (1) adding to the cash balance at the beginning of the month your estimates of income expected during the next month and (2) subtracting estimates of expenses for the next month. When this is done for 12 months, you have your expected cash balances for each of the 12 months.

However, at this point, you are not interested in the future. You need to find out what *has happened* to your cash. This information will be a guide when you start thinking about the future. So look at your cash records for last year and see on a monthly basis: (1) where your cash came from, (2) where it went, and (3) how much was left at the end of each month.

Suppose, for example, that your fiscal year starts with January. The first fact you need is the cash balance you had on hand on December 31. Suppose further that this balance was \$1560. Then from your last January records add the following income items to the \$1560:

(1) All payments from customers both against accounts receivables and as cash sales; (2) Any money received as a loan from a bank or other source; (3) Additional capital invested in the business; and (4) All payments received from sale of fixed assets.

To carry the example through, suppose further that the January income items accounted to a total of \$3000. Thus total available cash in January was \$4560 (\$1560 plus \$3000).

The next step is subtracting the January expense items from the \$4,560. Subtract the following expense items:

- (1) All payments you made against accounts payable;
- (2) All expenses paid (not merely accrued);
- (3) All cash withdrawals by the owner;
- (4) All repayment of loans; and
- (5) All payments for fixed assets.

Suppose further that these expenses totaled \$2,800. Thus your cash balance at the end of last January was \$1,760 (\$4,560 minus \$2,800).

This \$1,760 was your cash on

hand at the start of last February. Repeat the process of adding cash income for February and subtracting cash paid out in order to get your cash balance at the end of February. Do the same for each of the 12 months in that year.

As a final step, you may want to: (1) underestimate cash receipts by 5 percent and (2) overestimate cash payments by 5 percent. Allowing such margins gives you a 10 percent (5 + 5) leeway which helps provide for unforeseen expenses and overestimated cash receipts.

Check For Trouble Spots

The exercise of working up last year's cash balances by months should give you an exact idea of what the cash flow pattern of your business was for that year. However, before trying to predict your cash balances for each month of next year, look again at your records.

This check is for trouble spots. Were there any in last year's operation? For example, were there months when:

(1) Expenses were greater than the gross profit you made from sales.

(2) Cash was inadequate at the start of the month.

(3) There was over expansion of the business without new capital being made available.

(4) There were excessively high accounts receivable which were not discounted at the bank. (You may want to offer a cash discount for prompt payments.)

(5) Cash was reduced below an adequate balance because you had to buy fixed assets—such as new test equipment—that are recoverable only through depreciation.

Some of these trouble spots can be caused by seasonal fluctuations. One way to avoid them is by short-term borrowing.

Many owners of small retail and service firms borrow at various times during the year to tide their businesses over months when there are cash deficits. They know that they can pay the costs (interest) of borrowing and repay the loan, and still make a profit on the money they borrowed. Thus they are able to get by with less cash of their own in the business. Such bank loans, for example, enable them to take advantage of the dating on their suppliers' invoices.

List Your Long-Range Needs

Before you start to plot out how you will improve your control of future cash, take time to list the long-range needs of your firm. List items such as:

(1) Equipment, tools, and other fixed or depreciating assets which will need replacing.

(2) Additional equipment or other fixed assets which you may need in order to hold your own with competition.

(3) Remodeling or expansion of your facilities which may be needed to increase sales and boost your net profit dollars.

You need to have an idea of these long-range requirements so that you can provide for them without crippling your cash. Some service dealers fail, for example, to depreciate their fixed assets and set up financial reserves for their replacement. Thus, they have to dip into their cash balances—into funds for paying the firms day-to-day bills—to pay for the replacement of worn out equipment.

Such a situation can be avoided by planning—that is, by trying to chart the course of your business for the next 1 to 5 years. In addition to budgeting for the short-range needs, as will be discussed in the next section, you should at least make a tentative plan for handling your long-range needs.

ESTIMATE YOUR CASH BALANCES

At this point, you should be ready to estimate your cash balances for the next 12 months. These estimates are made by working out a budget. As was previously discussed, budgeting is a means of forecasting the income and expenses of your business during the next month, during the next 6 months, and up to the next 12 months.

The knowledge which you gained about your last year's cash flow pattern can be the basis for your estimates of future cash balances.

In looking ahead, keep your peak seasons in mind. Then you can have the cash on hand, or arrange for a loan, to take care of the increased inventory and increased accounts receivable which are part of a peak season.

A good rule is to keep your forecasting as simple as possible. Tailor it to your business so it will

help you to know the amounts of cash you can expect to have on hand at various times during the next year. It is also a good idea to provide for growth by setting up a reserve fund in accordance with your estimated future sales.

USE BALANCES TO PRODUCE INCOME

Knowing what your cash balances will be—provided things go as you expect them to—helps you to achieve dynamic control of your cash. This sort of control is similar to driving your automobile in a safe manner on a highway. You not only have it under control but are also using it to accomplish a purpose. Cash control helps you in three ways:

First, it guards your cash balances so that they will be available when you need them. For example, resist the temptation to use your cash for new fixtures, or for other fixed assets, which should be paid for out of other funds.

Second, cash control will warn you of the month, or months, when the cash balance is less than expected expenses. Meet this problem head-on by arranging for a short-term bank loan to tide your business over the gap and to its next peak.

Third, knowing your cash balances can help you to determine your rate of growth. It is your roadmap in using cash surpluses. In the month, or months, when your cash inflow is greater than your business needs, be prepared to put that excess cash into something which will earn income.

As we suggested earlier, you may want to invest such excess cash in: (1) new lines which can increase sales and profit, or (2) in short-term securities. The important thing when you are just starting is to keep such investments fairly liquid so you can turn them into cash should the need arise. Put the excess cash where you can get it when your business needs it.

If your firm grows to the extent that larger amounts of excess cash are accumulated, you'll probably want to think about putting some of it into investments such as Government securities, savings and loan shares, bank savings, or stocks or bonds recommended by your banker or a reliable investment expert who is familiar with your investment objectives. ■

COLOR TV MODULE GUIDE

GTE Sylvania Color TV Chassis

CHASSIS NUMBER	IF MODULES				CHROMA MODULE		DEF. MODULE			BAND SW MODULE			MAIN MODULE					RMT. RCVR.			PRE-AMP		
	02-37500-2,3	02-37502-3	02-37502-4	02-39220-14	02-37501-2	02-39198-1	02-37503-2	02-37503-3	02-39212-1	02-37556-4 XX	02-39276-1 XXX	02-39276-2 XXX	02-37907-1	02-37907-2	02-37907-3	02-37907-4	02-37907-5	02-37559-2	02-37559-3	02-39634-1	02-37560-2	02-37560-3	
E03-1	X				X		X																
E04-1		X			X		X											X					
E04-2			X		X		X		X									X					
E05-1	X				X		X																
E05-13	X				X		X																
E09-1	X					X																	
E09-13,14	X					X																	
E10-1	X					X																	
E10-2	X					X																	
E11-1				X		X																	
E11-3				X		X																	
E11-4				X		X																	
E12-1				X		X																	
E12-2				X		X																	
E06-1																							
E06-2																							
E08-1																							
E08-2																							
E08-3																							

X-3 & -4 USE INTERCHANGEABLY - SEE INSTRUCTIONS PACKED IN BOX.
 XX E04-2 REMOTE MUST HAVE SC1214 & SC1216, THOUGH WHEN USED IN NON-REMOTE, THEY ARE INACTIVE.
 XXX-2 SAME AS -1

E11-1 CHASSIS 30 K V DETENT TUNER
 E11-3 CHASSIS 30 K V VARACTOR
 E11-4 CHASSIS 30 K V VARACTOR - REMOTE

HOME ENTERTAINMENT ELECTRONICS

Magnavox Color TV 1976

By Joseph Zauhar

All-solid-state chassis and an expanded range of models offering all-electronic channel selection highlight Magnavox's color TV line.

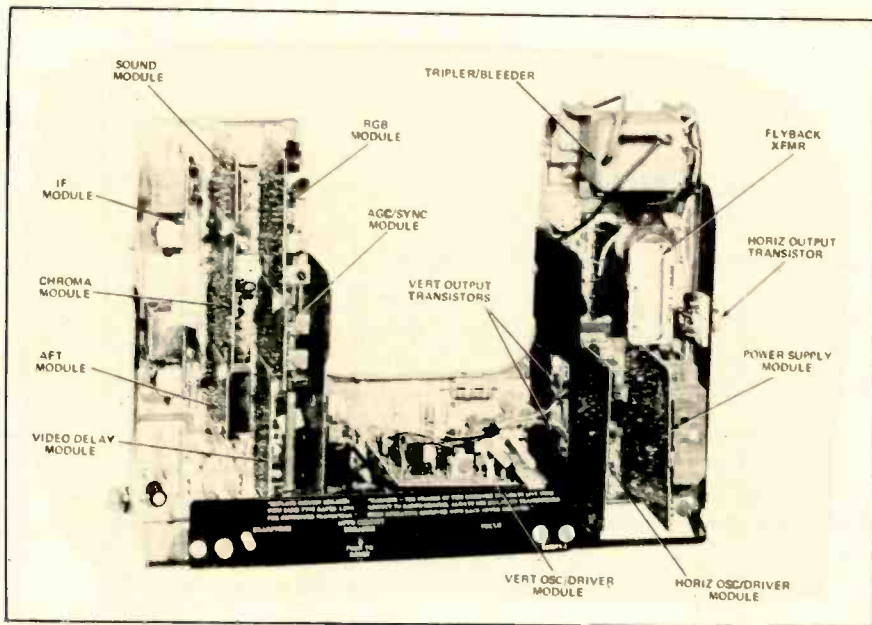

Fig. 1—Magnavox modularized solid-state color TV chassis T991.

■ Magnavox's 1976 color TV line features totally solid-state, plug-in, modular chassis for lower power consumption and simpler servicing.

Many of the models feature redesigned control panels with up-front access to secondary adjustment controls, larger speakers and improved audio circuitry.

The all-electronic "STAR" remote control tuning system which permits instant selection of any one of the 82 VHF or UHF channels at random, is now available on lower priced 25-inch models and for the first time on the 19-inch (diagonal) color TV sets.

Magnavox's color TV line consists of 63 models featuring modular chassis and offers screen sizes

ranging from 13- to 25-inch (diagonal).

The models include: four 13-inch (diagonal) portables employing the T985 chassis, two 15-inch (diagonal) portables with the T986 chassis, four 19-inch (diagonal) portables employing the carry-over T982 chassis, four 19-inch decorator portables with the T987 chassis, five 19-inch decorator portables employing the new T991 color TV chassis.

Two 19-inch (diagonal) consoles will employ the new T991 chassis and 29, 25-inch (diagonal) console model TV sets will employ the T995 chassis.

COLOR TV CHASSIS T991

The new T991 color TV chassis, Fig. 1, is a vertical, fully solid-state chassis designed for 19-

inch (diagonal) portable, table and console model TV receivers for 1976.

The "U-shaped" chassis is mounted vertically and consists of ten plug-in modules and two circuit board assemblies. All of the modules are mounted on the exposed side of the main chassis for easy accessibility. The signal processing modules are located along the left side of the chassis. The deflection and power supply modules are found along the bottom and right side of the chassis. The flyback transformer is designed to be plugged-in, except for the one high-potential lead soldered to the tripler. The tripler is a new type with a built-in bleeder resistor to provide focus voltage; it also discharges the CRT each time the set is

turned off.

The two circuit boards employed are the CRT Socket Board (Fig. 2) and the Control Board. The CRT Socket Board assembly mounts directly onto the base of the picture tube. The Control Board assembly is mounted to the front panel and contains the customer controls and the preset controls. No transistors are used on either of the two boards.

To make servicing of the chassis less complicated, eight of the eleven modules are identical with those found in smaller Magnavox portables and larger screen consoles and stereo theaters.

This chassis drives, a Precision In-Line, Negative-matrix CRT, which has vertical color strips instead of dots, and the

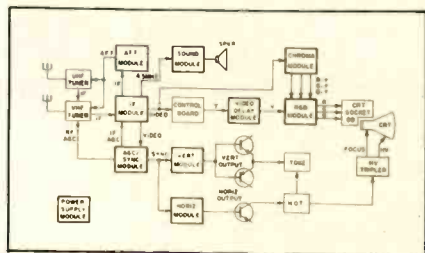

Fig. 2—Simplified block diagram of Magnavox's T991 color TV chassis.

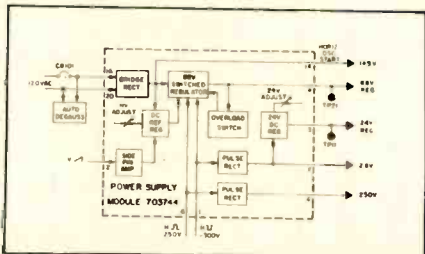

Fig. 3—Block diagram of the power supply employed in the T991 color TV chassis.

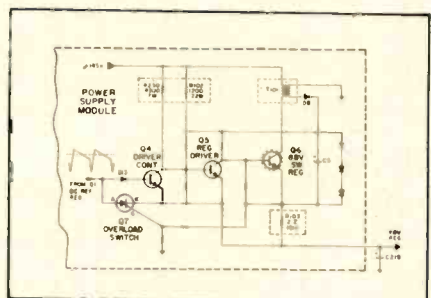

Fig. 4—The Switched Regulator circuit supplies the 88-volt DC voltage for the horizontal output circuitry in the T991 chassis.

Photos and schematics supplied through the courtesy of Magnavox.

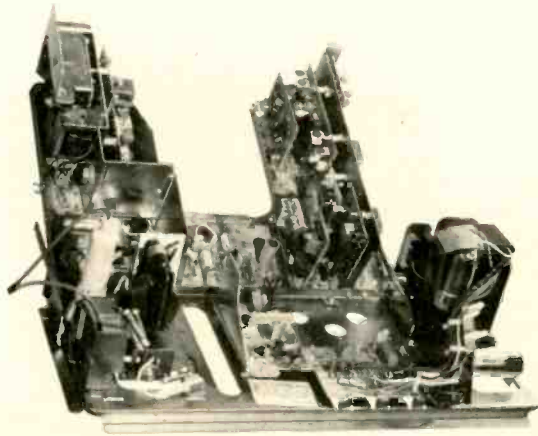

Fig. 5—Magnavox's color TV chassis T995 is all-solid-state and is employed in all 25-inch (diagonal) screen size TV sets.

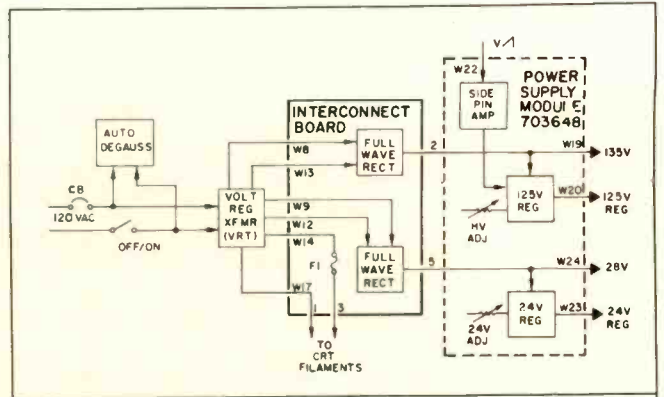

Fig. 6—Block diagram of the low voltage power supply employed in the T995 color TV chassis.

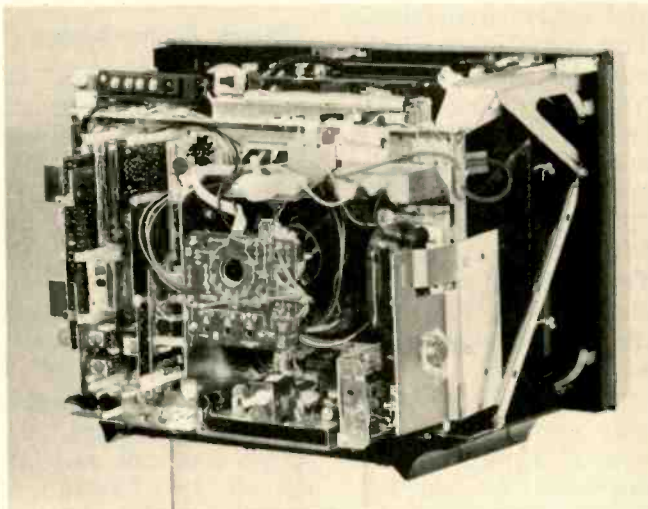

Fig. 7—Magnavox's color TV chassis T986.

red, green and blue electron guns are arranged in a single horizontal plane rather than in the delta configuration found in conventional tubes. The in-line gun arrangement, combined with a permanently positioned deflection yoke, eliminates the convergence adjustments required on other conventional picture tubes.

The IF, AGC/Sync., AFT, and Sound module can be used in the T985/986 chassis and the T995 chassis. The RGB and Vertical Oscillator/Driver modules can also be used in the T985/986 chassis. Four new modules have been designed for the T991 chassis that are unique: 1) The Power Supply module is completely new in design. Almost all components

in the supply circuit, including rectifiers, are located on this module. A new design of the regulating circuits results in more efficient operation. 2) A new beam killer circuit is contained on the Video Delay module to prevent phosphor burns to the CRT when the horizontal sweep is interrupted. 3) All the chroma processing and demodulation circuitry is now found on the Chroma module, which performs the functions of two or three modules in other chassis. 4) The Horizontal Oscillator/Driver module now employs an integrated circuit for the oscillator and includes a high voltage limiter circuit.

Low Voltage Power Supply

The power supply (Fig. 3) employed in the T991

color TV chassis is quite different from previous Magnavox power supplies.

A "switched regulator" (Fig. 4) supplies the 88 volt DC for the horizontal output circuitry. This unusual regulator provides regulation for line voltage variations as well as load current variations, and it accomplishes it with higher efficiency than conventional type regulators. The Switched Regulator uses pulses received from the flyback for its operation and will automatically shut off if the output current should become excessive.

Practically the complete power supply is contained on the Power Supply module. The AC line voltage is coupled through the circuit breaker into the bridge rectifier network. The 145 volt bridge output supply is used to start the horizontal oscillator immediately so that the horizontal pulses will be present to operate the 88 volt Switched Regulator stage.

The DC Reference Regulator is used to control the 88 volt Switched Regulator. The *high voltage adjust* sets the output of the DC Reference Regulator and the Switched Regulator, thus setting the high voltage level. The DC

Reference Regulator also supplies a side pincushion correction signal to the 88 volt Switched Regulator. The pincushion signal is obtained from a vertical rate sawtooth which is processed by the Side Pin Amplifier. The Overload Switch monitors the current from the 88 volt supply and turns off the regulator in the event of excessive current flow.

The 250 volt and 300 volt flyback pulses not only operate the Switched Regulator, but they are rectified by two pulse rectifiers, resulting in a 28 volt and a 250 volt supply. The 28 volt supply is applied to the 24-volt DC Regulator which furnishes a 24 volt source. The *24 volt adjust* is used to set the 24 volt supply. The CRT filament source is obtained from the flyback transformer, not the Power Supply module.

COLOR TV CHASSIS T995

The T995 color TV chassis (Fig. 5) is all-solid-state and employed in all 25-inch (diagonal) screen size TV sets.

There are 14 Solid-state modules used in the chassis. The vertical frame chassis, into which the solid-state modules are plugged into simplifies servicing by tilting out, completely clear of the cabinet, making all

components easily accessible. A choice of two tilt-out positions is available—one at 45 degrees and a second at 20 degrees from the horizontal position.

Low Voltage Power Supply

The T995 color TV chassis low voltage power supply consists of a special voltage regulating transformer to compensate for line voltage fluctuations, two full wave rectifier circuits, plus two DC voltage regulators to compensate for changing load current requirements. The DC operating voltage remains very stable over a wide range of line voltage and load current changes.

A block diagram of the T995 color TV chassis power supply is shown in Fig. 6.

The outputs of the Voltage Regulating Transformer (VRT) drive two full wave rectifier circuits on the interconnect board. One rectified circuit provides 135 volts DC and another rectified circuit provides 28 volts DC. The VRT also has a CRT filament winding which supplies a regulated filament voltage to the picture tube filament through a fuse on the interconnect board.

The 135-volt and 28-volt sources are coupled into the Power Supply module. The plug-in Power Supply module contains two DC voltage regulators. One provides a regulated 24 volts which is used for most of the signal processing circuitry in the chassis. The circuit provides a regulated 125 volt supply used in the horizontal output sections. A vertical sawtooth voltage is applied to the 125 volt regulator through a Side Pin Amplifier. This pulse is used to provide pin-

cushion correction to the sides of the raster.

The Power Supply module actually supplies four DC voltages—135 volt, 125 volt regulated, 28 volt and 24 volt regulated. In addition to these supplies, the chassis produces three more DC supplies by rectifying pulses from the flyback transformer. These three supplies are 250 volts for the video amplifiers, 1000 volts for the screen controls and 30 volts for the vertical deflection circuitry.

1st and 2nd Video IF Stages

The active devices used in the 1st and 2nd Video IF stages are depletion type, N-channel, dual insulated gate, field effect transistors (dual gate MOSFET's). One gate (G1) is employed for the signal input while the other gate (G2) is used for gain control. They operate very much like vacuum tubes. The use of MOSFET's has many advantages over conventional transistors, among these advantages are: 1) Lower feedback capacity (no neutralization required) 2) Superior cross-modulation performance. 3) Negligible AGC power consumption. 4) Greatly improved thermal stability. 5) Higher gain. 6) Lower Current requirements.

COLOR TV CHASSIS T985/986

The carry-over chassis T985 is used with 13-inch (diagonal) screen size TV sets and the T986 is used with 15-inch (diagonal) screen size TV sets.

These chassis are modularized, solid-state types that are used in portable color TV receivers and drive in-line color picture tubes with permanent deflection yokes.

The only essential dif-

ference between the chassis is the horizontal output transformer and the size of the picture tube employed.

Constructed in a vertical format, the T985/986 chassis employs 13 modules. Molex connectors are used on the modules to mate with the main chassis member.

The chassis is hinged on the right side and swings outward slightly to allow access to the 120 volt regulator module and other components. The remainder of the modules are accessible from the back of the chassis. The IF, AFT, and AGC/Sync modules employed in the T985/986 chassis are identical with those used in the T995, 25-inch solid-state chassis. The T985 and the T986 both employ the same modules.

Shown in Fig. 7 is the rear view of the T986 color TV chassis. Both of the chassis include Magnavox's Videomatic system, which automatically adjusts the picture's brightness, contrast and color levels to compensate for changes in ambient room lighting. The *Videomatic* button is located on the front of the TV set, which actuates this light sensing circuitry and switches in the preset controls. The customer controls now have a limited range of adjustment. The *brightness, color and tint preset controls* are accessible from the back of the TV set.

COLOR TV CHASSIS T982/987

The carry-over T982 chassis is used in the 19-inch (diagonal) portable color TV sets, and the carry-over T987 is used in 19-inch decorator models. With minor exceptions, the chassis are identical.

The "U" shaped chassis consists of two main circuit boards and 14 plug-in modules.

This chassis drives the in-line picture tube system, with the deflection yoke and neck components preadjusted and permanently attached.

The sound, high voltage, vertical scan, video output, and parts of the horizontal scan circuits are basically the same as those used in the T989 or earlier chassis.

Remote Control System

The "Star System," is an all-electronic remote control tuning system that allows the selection of any one of the 82 VHF and UHF channels in any sequence.

The system was first introduced on selected 25-inch (diagonal) color TV models at the end of 1975, and is now available on 19-inch (diagonal) screen size sets, as well as on an expanded number of 25-inch console and stereo theaters.

These TV sets come equipped with a hand-held remote control unit. To select channels the user presses two buttons,—6 plus 2 for channel 62, 0 plus 9 for channel 9, etc. The computer circuitry automatically tunes in the selected station and causes the selected channel number to appear on the screen in a five inch high display, then disappears in a few seconds. The remote control is also used to turn the set on and off, control volume, temporarily shut the sound off, then bring it back without changing the volume setting, and to recall the channel display.

All remote control model TV sets employ a keyboard control duplicating the one found on the hand-held remote control. ■

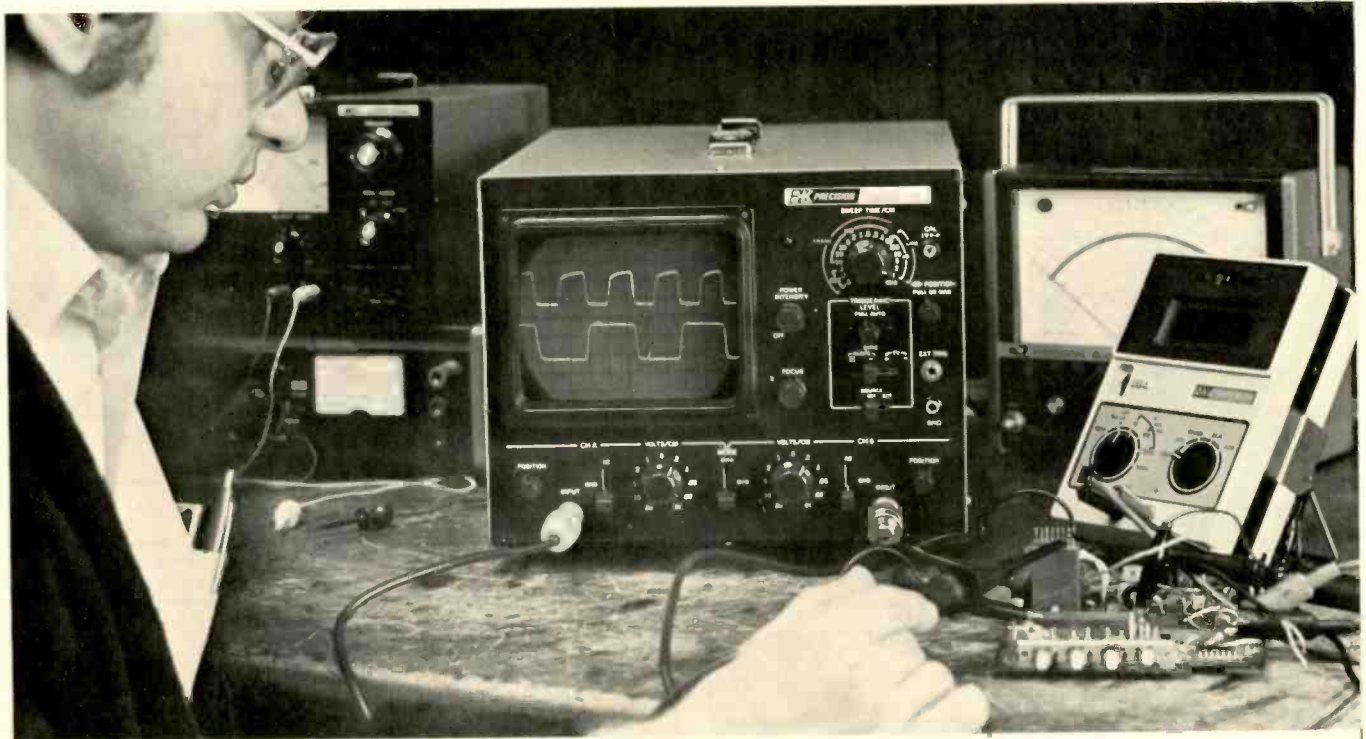

Remember when a good dual trace scope cost less than \$500? It does again.

Model 1471 Dual Trace Oscilloscope \$495

As the B&K-Precision Model 1471 rolls back the economic calendar, it significantly advances performance capabilities of 10MHz oscilloscopes. Model 1471 shares many of the performance and convenience features of our higher priced scopes, benefiting from Dynascan's position as a leading supplier of medium bandpass scopes.

Deflection factor is 0.01V/cm to 20V/cm in 11 ranges. Model 1471 has 18 calibrated sweeps— $1\mu\text{SEC}/\text{cm}$ to $.5\text{SEC}/\text{cm}$ and sweep to 200nSEC/cm with 5x magnification. Regulation maintains calibration accuracy from 105 to 130VAC. Rise time is 35nSEC. Automatic triggering is obtained on waveforms with as little as 1cm deflection. Dual trace display mode automatically shifts between CHOP and ALTERNATE as sweep time is changed, speeding set-up.

Front panel X-Y operation uses matched vertical amplifiers, preserving full calibration accuracy for both amplitude and phase. The intensity modulation input (Z axis) is compatible with TTL, permitting use in character display systems, and for time or frequency markers. Bright blue P31 phosphor makes any waveform easy to see. Circuit board with plug connectors permit easy user maintenance. BNC connectors. Operates on 117/230-VAC 50/60Hz.

- 10 MHz Bandwidth—useable to 15 MHz
- Mode automatically shifts between CHOP and ALTERNATE as you change sweep time
- Bright blue P31 phosphor
- 18 calibrated sweeps— $1\mu\text{SEC}/\text{cm}$ to $.5\text{SEC}/\text{cm}$
- Sweep to 200nSEC/cm with 5X magnification
- Maintains calibration accuracy over 105-130VAC range
- Front panel X-Y operation using matched vertical amps
- Input grounding switches
- TV sync separators
- Check most digital logic circuitry including CMOS
- Character display applications using TTL Z-axis intensity modulation
- BNC connectors

In-Stock Free Trial

Model 1471, or any B&K-Precision oscilloscope, can be obtained from your local distributor—or call Dynascan. You'll find the scope you need in stock today. Write for detailed specifications.

B&K PRECISION

PRODUCTS OF DYNASCAN

1801 W. Belle Plaine • Chicago, Illinois 60613

TECHNICAL DIGEST

The material used in this section is selected from information supplied through the cooperation of the respective manufacturers or their agencies.

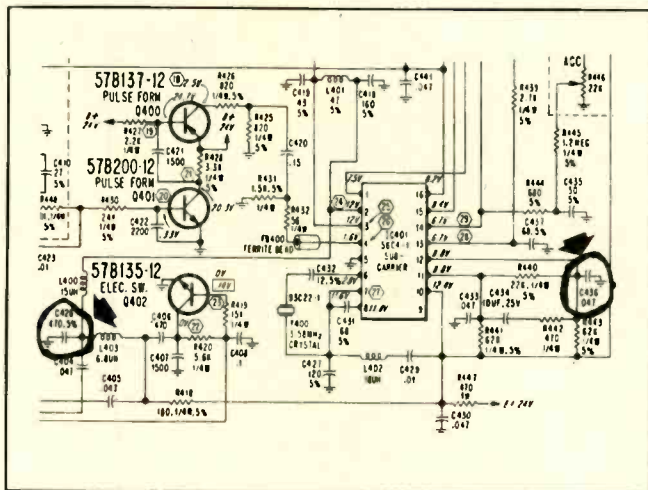

ADMIRAL Color TV Chassis M10—No Or Poor Color Sync

A symptom of no or poor color sync can be caused by a defective capacitor C426 or C436. Also, try substituting IC400 and/or IC401.

When servicing this chassis for color or color sync problems, check the 24-volt regulated supply. This supply is a

The Money Generator

GENERATES MONEY FOR YOU!

It's a DOG FIGHTER, TOO!

The Model ATC-10 is much more than a color bar pattern generator. It should be called a portable multi-purpose TV diagnostic and servicing aid, but that's too much of a mouthful. We would have nicknamed it the Dog Fighter (instead of the Money Generator), but that might be misinterpreted to mean that it's only useful in the shop. The versatile ATC-10, a portable, moderately-priced instrument, combines the most essential features of a color bar pattern generator, a TV "analyzer," and a substitute tuner plus several brand new "dog fighting" and timesaving innovations. With all this extra versatility, however, the ATC-10 is human engineered with only four simple-to-master controls.

Two illustrated brochures describe the ATC-10. The first brochure describes the many unique and unusual features which make the ATC-10 a "dog fighter" and a time-saver. The second brochure compares the money-making potential of the ATC-10 with 18 competitive models. It includes a comprehensive chart which compares the features of 19 makes and models, lists the estimated timesaving potential of these 33 respective performance features, and then calculates the money making potential of the various models. We think you are in for some surprises, such as the potential of the ATC-10 for returning its \$299.95 purchase price in as little as three or four months.

These brochures are yours for the asking — write direct for immediate reply. **AMERICAN TECHNOLOGY CORPORATION**
225 Main, Dept. 2B, Canon City, CO 81212

...for more details circle 107 on Reader Service Card

scan-derived B+ voltage developed by D1001 and regulated by IC1000 (found on the Pincushion module). If this voltage is low, substitute the Pincushion module. Other likely causes of reduced voltage would be a leaky capacitor or other component on the 24-volt regulated line.

Color TV Chassis M24, M25, M30—Service Hint

A symptom of no high voltage, or horizontal frequency problems related to the M800 horizontal oscillator module can be caused by a defective component in the M800 board (A8924-1).

The components most often found defective are: Capacitor C810 (10 mfd, 25 volts)—replace with 10 mfd at 50 volts, Part No. 67A200-100-7.

Resistor R819 (820 ohms, 3 watt)—replace with 820 ohms at 5 watts, Part No. 61A105-821.

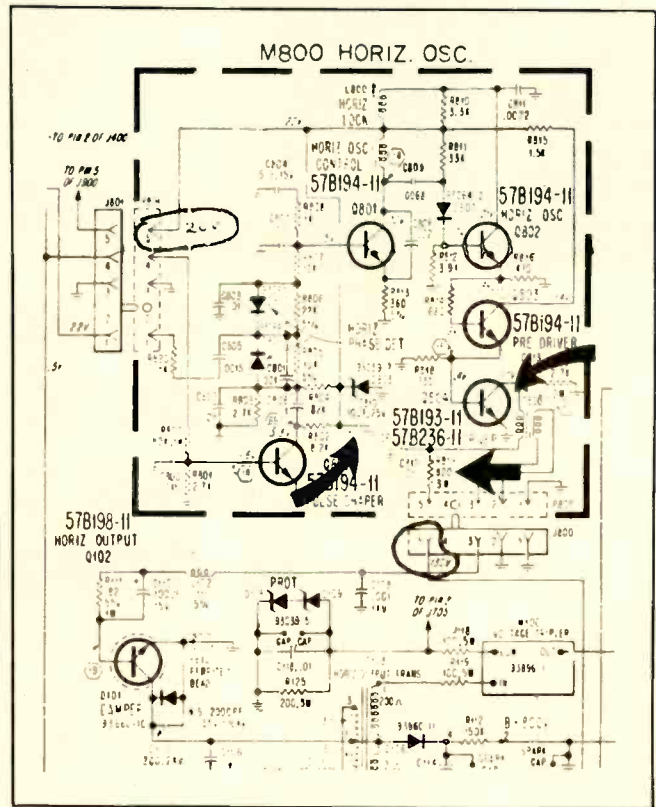

Horizontal Driver Transistor Q804,—replace with Part No. 57A193-11.

To speed servicing, check for presence of 20 volts of B+ at pin 5 of P801 and for 130 volts at pin 5 of P800. Both voltages must be applied to the horizontal module to produce horizontal drive.

The 20 volt B+ source is the power supply module. The regulated 130 volts B+ is also taken from the power supply module. This supply is fused and connected to pin 5 or P800 through an interlock on the windings of the output transformer.

GENERAL ELECTRIC Color TV Chassis 190B—HVT Pulse Coil Overheats

If the HVT Pulse Coil (EP36X96) overheats, most likely the grey lead is shorted to chassis ground. This lead has a 100 v p-p pulse voltage on it, and may not measure shorted with an ohmmeter. But there may be a solder splash, strand of wire, lead dress short, etc. which will arc and cause the coil to overheat when the set is turned on.

The best repair procedure is to make a good visual inspection of the grey lead and its connections on the circuit board. The lead from the coil connects to the 12 pin connector near C404. From the connector, it goes to the circuit

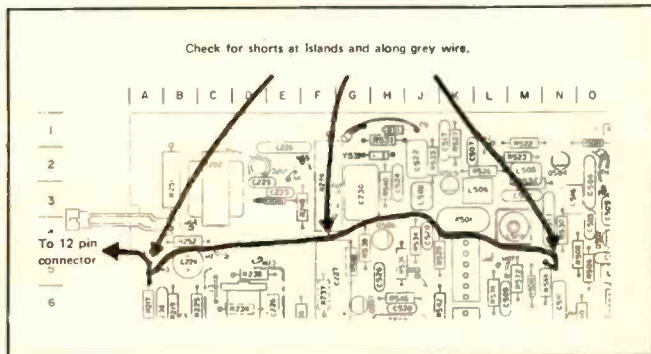

board near resistor R217, and then another lead connects it to R566. Be sure to inspect the leads and both sides of the circuit board for foreign material, or dress shorts. The diagram shows the location of the leads on the circuit board.

Color TV Chassis MC—No Raster

A symptom of no raster—sound normal, and resistor R1103, which is found the Buffer Module, is overheated or open, can be caused by the following problems: 1) Remove HV assembly mounting screw and turn the assembly to view the back side. Check for a broken wire to C1702B (can type electrolytic). In early production the wire was stretched tight and may break in shipping. 2) Replace or redress the wire to provide slack, and resolder to capacitor C1702B. 3) Replace resistor R1103 (EP14X63) if overheated or open. 4) If raster is not restored, check Q1702. If the set was left on, it may have failed.

Color TV Chassis 19QB—Vertical Retrace Lines

A symptom of vertical retrace lines at all brightness levels can be caused by resistor R646 increasing in value. In late production receivers, R646 consists of two 200 K resistors in series. Check the value of both resistors.

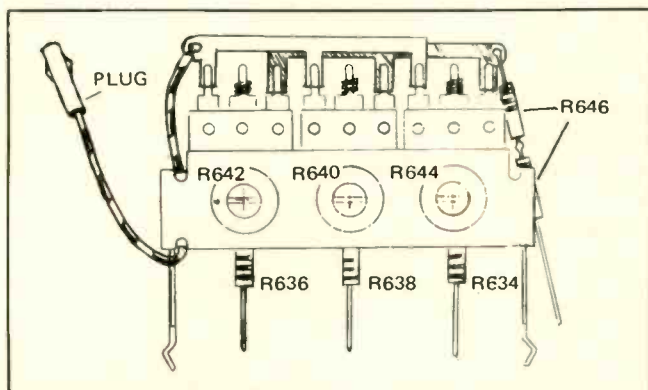

MAGNAVOX

Star Remote Control—No Channel Readout On Screen

This symptom can be caused by a defective Vertical module on the T995 chassis, although the chassis will operate normally and no apparent symptoms may be evident. If the Vertical Blanker (Q9) on the Vertical module is defective, no vertical pulse is supplied to the STAR Tuning Assembly. The result is no character generation. Also, no vertical blanking will be applied to the CRT, but this fact may not be evident unless the brightness is turned up. The solution is to replace the T995 Vertical Module.

Color TV Chassis T995—HV Adjust Has No Effect

Apparent normal operation may result when the 125 volt regulator transistor, Q4, shorts C-E on the Power Supply module. However, the HV will be in the vicinity of 33 kv and the HV Adjust will have no effect. Replace the Power Supply module. ■

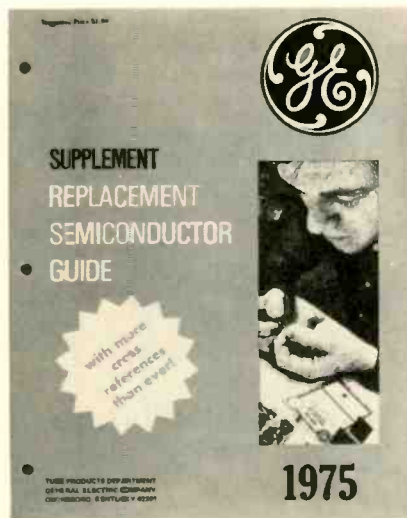

SUPPLEMENT AVAILABLE ONLY AT YOUR AUTHORIZED DISTRIBUTOR

The General Electric line of replacement semiconductors and accessories has grown so fast that you need this special GE REPLACEMENT SEMICONDUCTOR GUIDE up-to-date.

You've told GE you need hybrid modules, focus rectifier assemblies, IC's for foreign-made equipment, and Japanese transistors. You've asked for even more accurate cross references. Now you have it all from General Electric at your authorized distributor.

(And, more is on the way throughout 1976).

TUBE PRODUCTS DEPARTMENT
GENERAL ELECTRIC COMPANY
OWENSBORO, KENTUCKY 42301

GENERAL  ELECTRIC



Tektronix Dual-Trace Oscilloscope Model T922. For more information about this instrument, circle 106 on the Reader Service Card.

■ Each year the electronic equipment that we must service becomes more sophisticated and the demands for a higher quality oscilloscope increase.

Also, we find greater demands for dual-trace scopes, because waveform comparisons are often as important as waveform measurements. Possibly, the best way to judge the similarities and differences between two waveforms is to place them next to each other.

By carefully considering the functions, performance, and characteristics most needed for the intended application, a high quality oscilloscope can be designed at a moderate cost.

We recently received Tektronix's Model T922, 12 MHz, modular, dual-trace oscilloscope for review.

The first, most noticeable feature which caught our eye, was its compact size and light weight. The instrument measures 7 inches by 10 inches by 19 inches, and weighs 15 lbs. Its impact-resistant case is molded from durable Cyclopedia KHP plastic with a finish which is quite mar resistant.

Although the unit is light and small in size, it offers a large (8 x 10 cm) display area. A 12 kv accelerating voltage is used with the post-accelerator CRT. The oscilloscope produces an extremely bright trace enabling viewing waveforms at low rep-rates and fast sweep speeds. The display area employs an internal graticule to help eliminate paral-

TEST INSTRUMENT REPORT

Tektronix Oscilloscope Model T922

ax errors in critical measurements.

Switching between alternate and chopped sweep modes and TV line or frame triggering is performed automatically for optimum display presentation. A delay line in the vertical system allows you to view the leading edge of fast-rise time signals.

To help insure the 3 percent accuracy in amplitude and timing measurements, the *power on* pilot light flashes if the line voltage exceeds the power supply regulation limits.

Even if you haven't previously used an oscilloscope, its features will shorten familiarization time and help make day-to-day measurements easier and more accurate. The functionally related controls are color coded for easy identification and grouped together for convenience. The green colored controls are the *triggering controls*, blue for *mode selection* and the red for *variable* (uncalibrated) controls.

The *deflection factor* switch has a wide range (2 mv to 10 volt/cm in 12 steps) and accommodates the most commonly encountered signal amplitudes. Clear windows on the switch skirt yield two readings—one for the X1 probe, the other for the X10 probe. This feature eliminates the distracting mental arithmetic conversions. The *compensated step attenuator* offers constant input impedance across the entire bandwidth.

The dual-trace mode provides automatic selection of alternate or chopped-sweep display for the best viewing depending on the selected sweep rate.

The *sweep rate selector* provides sweep rates from 200 ns to 0.5 s/div in 18 steps. The clear window on the switch skirt clearly iden-

tifies sweep time/cm.

The *sweep expander* control is variable from X1 to X10 and is calibrated in the X10 detent position for 5 percent accuracy. It expands the center one centimeter of the display by the factor of ten (max.), providing a maximum equivalent sweep rate of 20 ns/div.

If you prefer detailed displays of selected waveforms, just position the trace to the center of the screen and turn the sweep expander to the desired magnification level.

A convenient push-button *beam-finder* quickly reveals the presence or absence of input signal and locates the trace position.

The automatic trigger mode provides free-running internal trigger in absence of input signal for quick location of the sweep trace. The TV trigger mode automatically provides line or frame-triggered displays for the viewing of the composite TV signal.

If the oscilloscope should require service and you prefer servicing it yourself, the task is simplified by its internal construction. The modules can be quickly removed because of the edgeboard and harmonica connectors employed, eliminating most wiring and soldered joints. No switches, potentiometers or other hardware components are mounted on the rear face of the front panel, but are mounted on the circuit boards. When a component requires replacing, most of them can be purchased at a local electronic supply distributor.

The accessories also contribute to ease-of use and include x 10 probes as standard equipment. Optional accessories include scope stand, camera, protective front-panel cover and rain/dust jacket. Price is \$850.■

NEW PRODUCTS

Descriptions and specifications of the products included in this department are provided by the manufacturers. For additional information, circle the corresponding numbers on the Reader Service Card in this issue.

DIGITAL MULTIMETER 138

The Model 3026A Digital Multimeter, a 3½ digit portable instrument is introduced by *Ballantine Laboratories*. It features a large readout using seven-segment 0.43 inch high LEDs which are bright orange in color. The instrument measures AC/DC voltages from 100 µV to 1200 volts in five ranges; AC/DC current from 100 nA to



2A in five ranges; and resistance from 0.1 ohm to 20 Megohms in six ranges. The metal case provides excellent shielding against RFI and protection against damaging environments. Other features are MOS-LSI reliability, auto-zeroing, high normal and common mode rejection; complete overload protection and automatic polarity indication. Price is \$299.

STAPLE TACKER 139

The Model ET-20 Electro-Matic Staple Tacker, a hand gun tacker from *Electro-Matic Staplers, Inc.*, can drive up to 300 staples per minute. The electric tacker operates without shock impact and recoil of conventional tackers. The tool uses four interchangeable staple sizes, has unbreakable

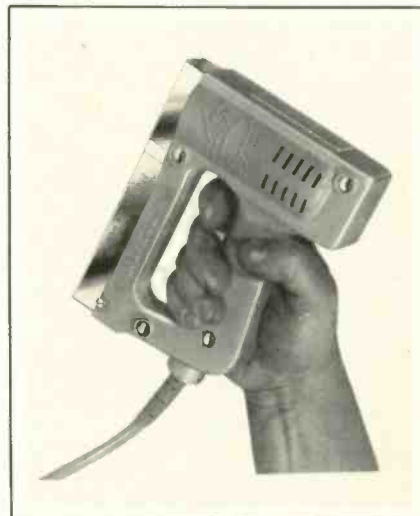

plastic housing, flush front for getting into corners and feathertouch trigger.

FM TWO-WAY MOBILE RADIO 140

General Electric's new "Custom MVP" line of solid state two-way FM mobile radios has a modular design permitting a mobile unit to become a desktop base station with the addition of an attachable power supply. The radios are offered in two basic versions: one is single channel and the other can go up to four channels. This



enables the single channel user to buy only what he needs. For low band (30-50 MHz) and high band (138-174 MHz), the power is 20 watts. In UHF (406-420 and 450-512 MHz), it is 20 and 17 watts. The microphone is transistorized and plug-in/detachable. The speaker is mounted separately for better positioning as preferred, either close to the driver or away. Selectivity is -95 dB in low band and -90 dB in high band. In UHF it is -85 dB. Spurious and image rejection for the three bands is -100 dB. Intermodulation protection is -80 dB - 85 dB in all three bands. Sensitivity is .25 microvolts in low band. Used with a pre-amplifier in high band, it is .175 microvolts and in UHF it is .20 microvolts.

SOLDERING STATION 141

Designed for soldering heat, voltage and current sensitive components, the *Weller* MP low voltage station features the "closed loop" system with grounded tip and automatic control of maximum tip temperature. The unit is complete with choice of 650- or 750-degree F. lightweight pencil-type iron



There is only
one
2-WAY
RADIO
HOME
STUDY
COURSE

exclusively devoted
to professional FM radio equipment

We don't know how many
TV repairman or
other people there are
in electronics
who would like to move up to
professional FM two-way radio.

Nor do we know how many
servicemen and installers
there are
already in the field
who want to expand
and upgrade their knowledge.

But we do know how many
home study schools
cater exclusively
to both these groups.

ONE!

Please send me more information.

Name _____

Address _____

Code _____

- I am a former MTI student.
 I am presently in the military.
 I am a veteran.

P

9

MTI

Formerly

MOTOROLA
TRAINING INSTITUTE

Summerdale, PA 17093

(717) 732-3636

...for more details circle 125 on Reader Service Card

with a new "freeze-proof" tip assembly, a quick connect/disconnect receptacle for attaching either iron, on/off switch and red indicator light, receptacle and sponge, non-heat sinking pencil holder, and three-wire non-burning cord. The power unit operates from line voltage with a step-down transformer. A 3/8-inch chisel tip is provided, and seven other types and sizes are available.

TOOL ORGANIZER 142

A pallet constructed of tough urethane, which is ideal for holding a large selection of small tools is intro-

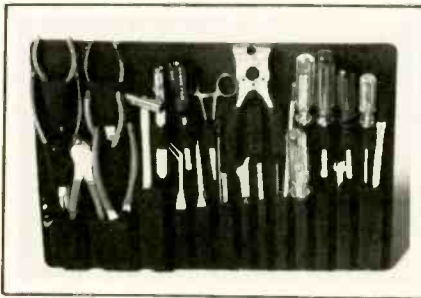

duced by *Platt Luggage, Inc.* The tool organizer can be used next to the workbench to keep the tools out of the grit and grime. The pockets are molded without any seams, stitches or

rivets to form a one-piece unit. It has an unconditional five year guarantee. Price is \$12.75.

PICTURE TUBE BRITENER 143

A new low-cost autoformer-type picture tube britener, the Perma Power Tech-Brite, Model C-611 is now available from Chamberlain Manufactur-



ing Corp., *Perma Power Division*. The unique new britener may be used to brighten any color TV picture tube, either round or rectangular, if the tube has the prevalent 60 Hz heater. Installing the britener involves a small amount of wire cutting and stripping, and three simple wire connections, with tab connectors supplied. This connection method eliminates the single purpose socket of plug-in briteners, and creates a unit that is more nearly universal and can be used for close to 90 percent of all color brightening applications. It does not provide isolation characteristics, but can substitute for all boost models, including Perma Power's Model C-501 and C-511. The price is \$3.50.

AUDIO SQUELCH 144

A self-compensating signal-to-noise squelch that operates directly on the audio signal, is announced by *Kahn Communications, Inc.* This "Sound Off" unit can be placed anywhere in the audio line and will effectively squelch the signal whenever speech or other information is removed. Ideal for SSB, the unit contains its own AC power supply and can be used in a wide range of applications since it requires only audio signal connections and will match all of the common line imped-

THE COMPLETE PORTABLE DVM



\$198

Low batteries and optional AC adaptor

PATENT PENDING

IT'S PORTABLE FOR BENCH OR FIELD...

COMPACT & LIGHTWEIGHT, (Only 2 1/2 lbs with batteries.) Fits in any tool box or tube caddy.

DROP-PROOF with tough Cyclocac® case that will stand up to any field use.

BURN-OUT-PROOF up to 2000V DC. Saves you from costly downtime.

VERSATILE 3-WAY POWER: Standard "C" cells, rechargeable "C" cell Nicads or line operation. (No special built-in, recharger pack. Standard "C" cells for the DVM32 for true portability.) And you'll get up to 10 times the battery life with the DVM32, using the patent pending *auto-off* that turns off the bright L.E.D. displays between measurements. The DVM32 is truly portable.

IT'S COMPLETE FOR ANY JOB...

Most portable DVM's sacrifice functions, features, or accuracy. Not the DVM32.

HIGH ACCURACY Accurate with full 3 1/2 digit readout, .5% of reading accuracy and 15MegΩ input impedance.

COMPLETE FUNCTIONS AND RANGES: From 1mV to 1999V DC, 1mV to 1000V AC rms, .1 ohm to 19.99 MegΩ and 1uA to 1.999A, AC, and DC, plus Hi and Lo power ohms. The DVM32 is a complete and versatile measuring capabilities in a truly portable meter.

IN STOCK NOW AT YOUR LOCAL SENCORE FULL LINE DISTRIBUTOR

DVM32 backed by SENCORE'S 100% MADE RIGHT LIFETIME GUARANTEE
SENCORE 3200 Sencore Drive, Sioux Falls, S.D. 57107 Phone: 1 605-339-0100 TWX: 910 660-0300

...for more details circle 132 on Reader Service Card

The 5 SECOND TUNER RESTORER



CLEANS! LUBRICATES! POLISHES!

Spray TUN-O-POWER on tuner contacts, rotate the tuner and *within 5 seconds* you get beautiful color pictures on all channels. It's a minor miracle!

TUN-O-POWER is the most powerful polisher and lubricant ever developed. It works so well, you use a lot less. You can spray twice as many tuners with TUN-O-POWER as you can with an ordinary cleaner/lubricant.

What's more, TUN-O-POWER lubricant lasts for months longer than ordinary sprays. Detent action stays smooth as silk so you never have to worry about callbacks.

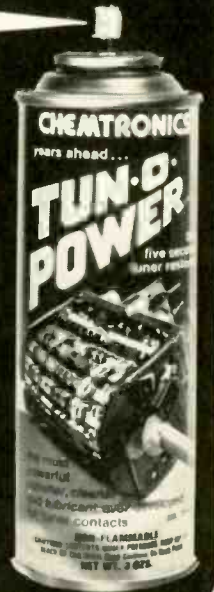

CHEMTRONICS INCORPORATED
45 HOFFMAN AVE. HAUPPAUGE, N.Y. 11787 • (516) 582-3322

Our business is improving yours!

...for more details circle 112 on Reader Service Card

ances. The all solid state unit automatically compensates for changes in atmospheric noise and is insensitive to false triggering by impulse or other noise. The heart of the unit is a patented miniature signal analysis device which constantly monitors the content of the channel and determines if information or noise is present. Applications include; VHF communications, SSB communications, telephone circuit systems, and voice operated tape recording devices.



SCANNING MONITOR DISPLAY 145

A display which has been designed to act as a self-functioning dealer demonstrator of scanning monitors is announced by *RCA*. The display's basic feature which shows RCA



Monitors in operation, unattended and on a continuing basis, not only helps reflect the versatility of the instruments but also frees the dealer from the need to spend his time on personal demonstrations. It was devised to demonstrate a choice of scanning monitor receivers and is equipped with interchangeable panels, each featuring a different model. A dramatic two-color back-lighted picture background depicts the various types of public service broadcasts which can be received by the monitors. The display is 20 inches high by 10 inches deep and 18 inches wide and is fabricated with a laminated wood tone base and a lithographed board back.

OSCILLOSCOPE 146

A new dual-trace 10 MHz triggered sweep scope is announced by *B & K Precision*. Designated Model 1471, the scope has 18 calibrated ranges from 1 μ sec/cm to 0.5 sec/cm and it sweeps to 200 nsec will display characters directly from TTL drives. The deflection factor is 0.01 volt/cm to 20 volts/cm + 5



percent in eleven ranges. Calibration accuracy is maintained from 105 volts AC to 130 volts AC. Rise time is rated at 35 nsec. Automatic triggering is obtained on waveforms with as little as 1 cm deflection at 10 MHz. Dual trace mode shifts automatically between CHOP and ALTERNATE as the sweep time is changed, saving substantial setup time. TTL-compatible

intensity modulation Z-axis input enables the scope to be used in character display systems, and for time and frequency markers. Specifications include built-in calibration voltage, frequency square wave 1 volt p-p; Z-axis intensity modulation, 5 volt p-p nominal; 470 K nominal input impedance. The instrument weighs 19.6 lbs and measures 9 $\frac{1}{8}$ inches wide by 16 $\frac{1}{8}$ inches deep by 7 $\frac{1}{8}$ inches high. Price is \$495.

SWEEP/MARKER GENERATOR 147

The Model LSW-333, an all-channel sweep(marker generator for checking and aligning all tuned circuits in TV/VHF/UHF and FM receivers is introduced by *Leader Instruments Corp.* The sweep section covers TV channels 2 to 13 and 14 to 83, while video sweep modulation is available for VIF and chroma circuit checking.

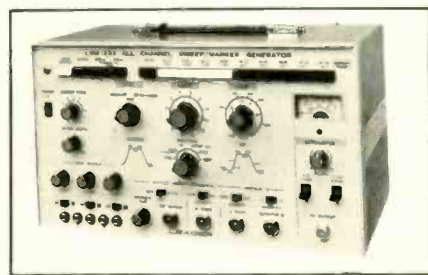

ISO TIP® QUICK CHARGE

Recharges in 1/3rd the time of any other cordless iron.

Complete line of accessories available:

- | | | |
|---------------------------------|------------------------------------|--|
| No. 7566
Micro Soldering Tip | No. 7577
Chisel Tip | |
| No. 7535
Regular Tip | No. 7574
Concave Tip | |
| No. 7546
Heavy Duty Tip | No. 7569
"V" Tip | |
| No. 7596
Knife Tip | No. 7573
Tinning Tip | |
| No. 7545
Fine Tip | No. 7572
Blunt Tip | |
| | No. 7556
Tuner
Extension Tip | |

WAHL CLIPPER CORPORATION
 ORIGINATORS OF PRACTICAL CORDLESS SOLDERING
 Sterling, Illinois 61081 (815) 625-6525
 "Manufacturing Excellence Since 1919"

...for more details circle 134 on Reader Service Card

FM and IF sweeps are also provided. The marker section is said to feature an unusually high level of accuracy through the use of crystal controlled signals and permits the use of 100 KHz and 1 KHz side markers on all signals. Trap adjustments and IF alignments are simplified by employing ten VIF markers with horizontal and vertical tilt. There is also a 1 KHz AM modulation signal. Polarity reversal switches for inverting both the vertical and horizontal traces as well as three supplies are provided. Other features include: a vertical gain with X5 magnification to compensate for scope sensitivity; an output meter with calibrated attenuator and 15.75 MHz filter to suppress TV horizontal receiver sweep; sweep output voltage of over 100 mV/rms into 75 ohms. It is supplied with an output cable; one input cable with detector; two scope connection cables; an external marker input cable; and three bias supply output leads. It is priced at \$649.95.



tems. The Levelite can be connected quickly to virtually any TV signal source. Complete with three standard adapters, it instantly connects to any F fitting, G fitting, autoplug type fitting or 300-ohm terminal screws. Signals fed into the indicator are amplified, detected and fed to a light emitting diode (LED) through an IC circuit. It incorporates two LED's. The red LED indicates battery power and the green LED indicates the presence of signal. The threshold for illuminating the green LED is selected by a two-position range switch. In the "distant" position, the green LED lights when the signal is -6 dB mv (500 μ v) or greater. In the "local" position the green LED lights when the signal is +6 dB mv (2000 μ v) or greater. It provides reliable results over a tempera-

TV SIGNAL INDICATOR 148

An innovative new instant TV signal presence indicator called "Levelite" is developed by *Jerrold Electronics*, which can be used to make rapid go, no-go tests on home TV antenna installations and MATV sys-

ture range from 20 degrees F to 100 degrees F. It works from composite signals in the high VHF-TV band (Channels 7 through 13) only. Use of the 174 to 216 MHz range prevents the possibility of false indications because of the presence of strong FM signals (88 to 108 MHz). Price is \$47.50.

MOBILE TWO-WAY RADIO 149

Motorola's new front or trunk mount MICOM HF-SSB Mobile two-way radio is available in 125 or 60 watts P.E.P. and operates in the 2-18 MHz range. The MICOM High Frequency Single Sideband Mobile two-



way radios will meet all communications requirements. The two-way radios are available with *Motorola's* QUIK-CALLS Selective Signaling option, either front or trunk mount versions for ease of vehicular installation, constant Sinad squelch, direct 12 volt dc operation (no power supply), and offer 100 percent solid-state operation.

COAXIAL RELAY 150

When used with a companion coupler, *Inline Instrument's* Type 101 SPDT Coaxial Relay derives its control power through the signal cable. It can be installed on a tower or pole to

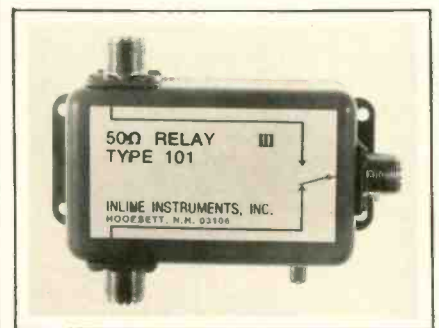

switch two antennas, enhancing communications coverage. Features include multi-octave bandwidth, SWR < 1.1, insertion loss > .1 dB and weatherproof construction. Selectable control polarity permits multiple relays on a single coaxial line to change

BOOST your TV service profits with the NEW Heathkit CRT Tester/Rejuvenator

The NEW IT-5230 CRT tester/rejuvenator adds versatility to your service bench. You can check, "clean" and rejuvenate virtually every TV picture tube available including NEW IN-LINE GUN CRT's without adaptors! It's portable, practical and priced right...you NEED it on your bench!

Kit IT-5230, Shpg. wt. 10 lbs. 89.95
Assembled ST-5230 140.00

Write for FREE Catalog

Heath Company, Dept. 24-14
Benton Harbor, Michigan, 49022



TE-333



...for more details circle 120 on Reader Service Card

antenna patterns or RF loads. Frequency coverage is available from medium frequency through UHF. It will handle minus DBM levels to 150 W. Price is \$24.50.

VOLT-OHM-MILLIAMMETERS 151

A.W. Sperry Instruments Inc., announces the introduction of three Multi-Testers, Models SP-60, SP-70 and SP-80. The meters offer features and capabilities usually associated

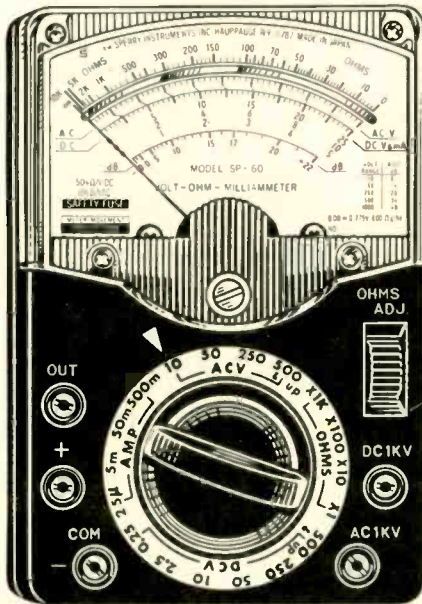

with larger, more expensive meters. The higher sensitivities from 20 K ohms/volt to 50 K ohms/volt, expand the resistance and DC MA capabilities. It comes with mirrored scale, three percent DC FS and four percent AC FC accuracies, Safety fused and diode overload protected, 20 ranges, and furnished with test leads, batteries, fuse and operating instructions. The unit measures 5½ inches high by 3¾ inches wide by 1½ inches tall and weighs 1 lb.

COLOR-PATTERN GENERATOR 152

A compact, all solid-state generator for faster, easier color TV servicing called the Chroma-Line Model 432 is available from *Simpson Electric Co.* It provides 16 "touch command" patterns through the use of a 4 by 4 pushbutton selector matrix, located on the front panel. The generator incorporates the latest digital large scale integration (LSI) technology for maximized color-pattern stability and reliability. It provides a total of five channel outputs: three VHF channels and two UHF channels. Channels 3 and 4 are fully crystal controlled, offering good stability. Channel 7 and the UHF channels 23 and 52 are stabilized L-C controlled. Two additional crystal-controlled outputs are:

ISN'T IT TIME YOU DID SOMETHING TO SHOW YOUR CUSTOMERS THAT YOU'RE QUALIFIED?

There's a way you can
... without joining an association
... without attending meetings
... without paying dues.

All you have to do is bone up on your theory a bit and take the test to become a Certified Electronic Technician. Then, instead of just saying "John Doe" on your business card, it will say "John Doe, CET". Just as the MD after a doctor's name identifies the doctor as being trained and competent, so does the CET identify you as being competent in your profession.

And we'll help you do it. First, we'll supply the study guide. We've purchased 5,000 copies of H. W. Sams' "The Study Guide for CET Examinations", by Wilson and Glass which sells for \$5.95. We'll send a copy free, to the first 5,000 technicians that write asking for one. The only qualification is that you are presently working as a TV technician. Just write me on your company letterhead, or if you don't have one, enclose your business card. Be sure to include your mailing address and zip code.

Second, we'll reimburse you for half the cost of the test, which is twenty dollars. Well, actually, we'll send you ten dollars worth of our products, free, when you send us a copy of your certificate. Fair enough?

There's just one catch — you must request the Study Guide by March 31st, 1976 and must take the test by November 1st, 1976.

Why are we doing this? Simply because the heart of our business is with the professional technician. Whatever is good for his profession is good for us at Tech Spray. Besides, the TV industry has been good to me and I owe it one.

Now, we've put up our end —
How about putting up yours?

**TECH
SPRAY**

Dick Pavek, President

P. O. Box 949, Amarillo, Texas 79105

makers of *BLUE STUFF*, *BLUE SHOWER*, Rx, minus 62 and many other products for the Professional Technician.

...for more details circle 133 on Reader Service Card

45.75 MHz picture IF and 4.5 MHz sound IF. The sound IF is available both as an unmodulated carrier and as a modulated carrier with a 1000 Hz audio signal. Additional features include a composite video output vertical and horizontal sync outputs, a built-in cable storage compartment, 75-ohm coax and 300-ohm impedance matching transformer (balun) outputs, and red, blue and green gun killers. The generator is supplied complete with cable assemblies for 75-ohm coax and 300-ohm (with balun) inputs and an operator's manual. Priced at \$179.

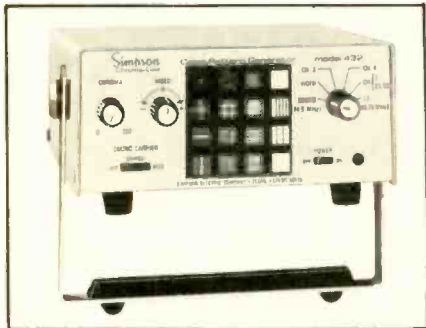

CRT TESTER ADAPTER 153

A new Sony Trinitron Adapter developed by *Coletronics Service Inc.*, can be used with any color CRT tester

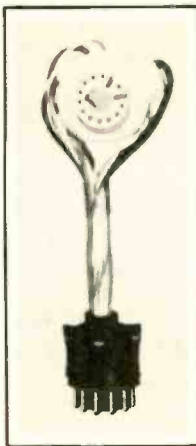

or receiving tube tester that uses a color CRT adapter. This adapter converts the 8-pin Sony Trinitron basing to a standard 70-degree, 14-pin color basing. After connecting the adapter you simply test as you would a standard 21AXP22 picture tube. Price is \$6.95.

MATV/CATV BROADBAND DRIVER AMPLIFIER 154

The general purpose Model DA-0550 Broadband Driver Amplifier introduced by *Q-Bit Corp.* has high output drive characteristics. Applications include distribution amplifier, line ex-



Electronics, offers a dynamic frequency range from 0.002 Hz to 2 MHz with sine, square, triangle, and variable time symmetry of all waveforms



for ramp and pulse operation. An internal ramp generator is provided to sweep the main generator over an adjustable sweep width from zero to 1000:1. The ramp (sweep) generator rate is continuously adjustable from 1 msec to 10 seconds. The HI output delivers 20 volt p-p open circuit, 10 volt p-p into 50 ohms. The LO output delivers 632 mv p-p open circuit, 316 mv p-p into 50 ohms. The amplitude control provides a 30 dB attenuator for both the HI and LO output which are available simultaneously. An invert switch allows the pulse and ramp output to be reversed in polarity. + 10 volts of DC offset is provided and an input for controlling the frequency with a remote voltage (VCF). The ramp (sweep)

**sh-h-h-h
silence
is
golden**



Put the hush on scratchy, raspy, whiney controls with Quietrole electronic cleaners and lubricants. You'll have happy customers that you'll see again next time their equipment needs servicing. Quietrole aerosol and eye-dropper lubricants are easy to use, extremely effective. Harmless to plastics and metals. Non-conductive, non-inflammable, non-corrosive. With zero effects on capacity and resistance. Quietrole lubricants — for tuners, switches, controls, relays, slides, etc. Carried by leading jobbers and distributors everywhere.

Product of
QUIETROLE
COMPANY
Spartanburg, South Carolina

...for more details circle 137 on Reader Service Card

tender, or for a general purpose shop amplifier. It features low intermod distortion, flat gain response from 10 to 220 MHz, and good input/output impedance match. This amplifier can drive over 100 TV outlets when using directional taps and hybrid splitters. Because of its flat gain response, it can be used in the shop to achieve higher drive from RF sweep generators, measuring marginal signals, etc. The unit measures 3-1/16 inches high by 4-1/4 inches deep by 6-5/8 inches wide.

SWEEP/FUNCTION GENERATOR 155

The Model 121 Sweep/Function Generator introduced by *Dana Exact*

FREE ALARM CATALOG
Huge selection of burglar & fire systems, supplies. Motion detectors, infrared beams; controls, door switches, bells, sirens. 500 items, 99 pp. packed with technical details, notes.
(Outside U.S., send \$1.00.)
mountain west alarm
4215 n. 16th st., phoenix, az. 85016
...for more details circle 124 on Reader Service Card

FREE CATALOG
HARD-TO-FIND PRECISION TOOLS
Lists more than 2500 items—pliers, tweezers, wire strippers, vacuum systems, relay tools, optical equipment, tool kits and cases. Also includes ten pages of useful "Tool Tips" to aid in tool selection.
JENSEN TOOLS
4117 N. 44th Street, Phoenix, Ariz. 85018
...for more details circle 122 on Reader Service Card

CORNELL ELECTRONICS COMPANY
4213 N. UNIVERSITY AVE. SAN DIEGO CALIF. 92105

THE ORIGINAL HOME OF

36¢ PER TUBE
UNLESS OTHERWISE PRICED
100 TUBES OR MORE
33¢ PER TUBE

Same Low Price East or West Coast!

★ Bargain Tools
★ Transistor Tester
★ Technician's Library

SEND FOR FREE NEW 48 PAGE COLOR CATALOG

★ Dumont Picture Tubes
★ Diodes—Transistors—Kits
★ Tube Cartons

ONE YEAR GUARANTEE
INDIVIDUALLY BOXED
5 DAY MONEY BACK OFFER
LAB TESTED USED

SPECIAL OFFER
ON ALL ORDERS OVER \$10.00
25¢
PER TUBE (NO LIMITS)
FROM THIS LIST
6AG5 6CB6
6AU6 6J6
6AX4 6SN7

Your Order FREE if Not Shipped in 24 Hours

waveform is available through a connector on the rear panel. Price is \$275.

Please do not send money for items for which there is a fee. The Reader Service Card indicates your interest in an item. The company or organization will bill you directly.

COMM CHAT

continued from page 12

sible apply power through a variable voltage supply, starting with only a volt or two and increasing voltage as you monitor the current drain.

One note of caution: Advise the customer before you begin work that you cannot guarantee repair of the unit nor that the repair will last. Explain that you have no way of knowing what damage has occurred inside IF cans, capacitors, pots, or switches. If the customer is unwilling to let you do the work under these conditions, *pass*. (In some cases, you might want to get a reasonable deposit *before* you attempt repairs.)

If the unit has been soaked by salt water (as when a boat sinks), don't even think about repairing it. The chances of the unit not having hidden damage that will show up in a few days or weeks is nil. You will *not* be doing the customer a favor by working on his "salted" electronics, and you probably will be doing yourself and your shop a disservice. Your reputation is bound to suffer. If you tried it once and got away with it, count yourself lucky and quit while you are ahead. ■

CARR TALK

continued from page 14

unique to the auto electronics trade. For example, in a doubtful attempt at economy, most auto makers use the same fuse for several functions. One comical application of this is the make of car in which the fuse for the backup lamps also is used to protect the radio. Of course, the customer cannot see the backup lamps but he is intimately aware of the radio. When the fuse blows and the radio quits playing, he goes to a radio shop, where the fuse is re-

placed. When he puts the car in reverse to back out of the shop, the fuse blows, the radio goes dead and the smile on his face disappears.

Remember, there is no such thing as "only a fuse" problem.

I wish I could give you specific procedures or even generally applicable guide lines for actual removal and reinstallation of car radios. Unfortunately, there are too many variations. In most cases, the method will become obvious on inspection. The radio either will come out through the back of the dash, through the front

of the dash, or out the top. In a few cases, though, you'll probably think you need a blowtorch or demolitions expert.

In some cases, the RNR instructions will be published in the care dealer's shop manual. In others, the local car dealer's RNR man can give you advice; however, be careful of protocol. Call the dealership service manager and ask his permission before you take up his man's time. Besides, the service boss at a car dealership is a very valuable contact for more repair business. ■

**Pay \$9⁹⁵ for the PANTS.
Get a \$6⁶⁵ Shirt lettered
to advertise your business
FREE as a BONUS!**

**OFFER LIMITED:
One to a customer
and to new customers
only.**

WE WANT YOU to be our customer. And we'll do anything to make it happen! Why? Because once you've experienced the quality, value and long wear of our vast array of work garments and accessories—the business-building impact of our lettered garments—you'll do business with us for a long time. And that's the whole idea.

So, we'll give you a 65% Dacron/35% Cotton Permanent Press \$6.65 shirt free . . . lettered free . . . when you buy a pair of our Permanent Press Dacron/Cotton pants at regular price. One day's wear will convince you that we should be your work uniform source from now on!

PICK COLORS & SIZES HERE

PANTS COLORS: Navy blue, grey, green, blue or brown.

PANTS SIZES: Waist 28" thru 34";
Even 36" thru 50";
Inseams: 28" thru 35".

SHIRT COLORS: White, light grey, blue, green or tan.

NECK SIZES: Small, Med., Lg., Xlg., XXlg.
(Short sleeves only with this offer).

Just check exactly what you want on coupon below. Clip and mail with \$9.95. We ship postpaid. Satisfaction guaranteed.

ELIN MANUFACTURING CO.

Dept. 21, Rochester, Indiana 46975

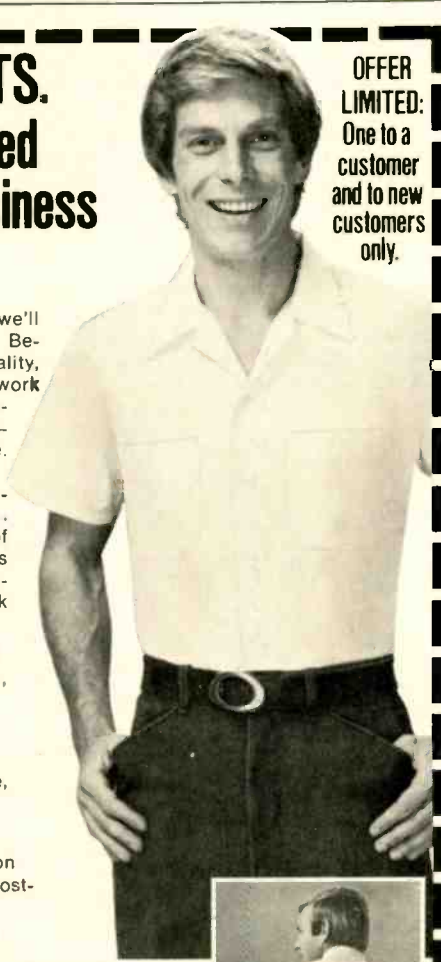

SHIP TO: _____

ADDRESS _____

CITY & STATE _____

Zip _____

Permanent
Press
PANTS:

Permanent
Press
SHIRT:

Color _____

Color _____

Waist _____

Size _____

Inseam _____

Short Slv. only

I enclose \$9.95 full payment.
Ship postpaid.

Mail entire ad and \$9.95 to

ELIN MANUFACTURING COMPANY

Dept. 21, Rochester, Ind. 46975.

Print lettering for shirt here:

Lettering color. Check one.

Red Blue Gold Green

...for more details circle 116 on Reader Service Card

CLASSIFIED

RATES: 40¢ per word; 50¢ per word Bold Face Type. Add \$3.00 if you wish Box Number. Minimum \$10.00 charge. Classified Display Rate billed \$43.00 per inch, 1 inch minimum. Remittance must accompany order. Mail ad copy to: Roz Markhouse, ET/D, 757 3rd Ave., N.Y. 10017.

Business Opportunities

EXPERT TV Technician needed to repair and update master antenna systems with new patented method. No previous experience as I will train you the "right way" the first time. No competition, as you will be one of a select number directly under my technical assistance tied together with a WATS telephone. Earning potential? Over \$200.00 per day. Send complete resume and credit references: Melvin Cohen, Television Broadcast Engineer, May Company Building, 3651 Prospect Avenue, Riviera Beach, Fla. 33404. Be patient for my reply. Enclose 13¢ addressed envelope. 2/76

Profitable TV service business and home for sale. One half mile apart in Eastern Nassua Co. Well established and respected. Contact P. Reindorf, 6 Milford Place, Farmingdale, NY 11735. 2/76

TV SHOPS needed to repair and update master antenna systems with new patented method. I will train you. No competition. You will be one of a select number directly under my technical assistance by WATS telephone. Send resume and credit references: Melvin Cohen, Television Broadcast Engineer, May Company Building, 3651 Prospect Avenue, Riviera Beach, Fla. 33404. Enclose 13¢ addressed envelope. Be patient for my reply. 3/76

ELECTRONICS/AVIONICS EMPLOYMENT OPPORTUNITIES. Report on jobs now open. Details FREE. Aviation Employment Information Service. Box 240 Y, Northport, New York 11768. 3/76

TV TECHNICIANS: Broadcast engineers fix equipment quickly. So will you if you qualify for my "Tough Dog" TV repair (and "hard to get" parts) WATS telephone assistance program. Send resume and credit references to Melvin Cohen, Television Broadcast Engineer, May Company Building, 3651 Prospect Avenue, Riviera Beach, Fla. 33404. Enclose 13¢ addressed envelope. 2/76

For Lease in Sunny Arizona, T.V. Sales & Service Business. Established in 1964—Fast Growing Area—Great Opportunity—Zenith & Sylvania Authorized. Write E. R. Curl, 9901 E. Apache Trail, Mesa, Arizona 85208. 3/76

Catalogs

TV & RADIO TUBES .36¢ EA!! Send for free color parts catalog Your order free if not shipped in 24 hours. Cornell Electronics 4215-17 University San Diego California 92105

CANADIANS SAVE BIG MONEY! SURPLUS, CLEAROUTS AND BANKRUPTCY INVENTORIES. HI-FI AND PARTS. CATALOGS \$1.00. ETCO-D ELECTRONICS. Box 741, MONTREAL H3C 2V2.

NEW CANADIAN MAGAZINE. "ELECTRONICS WORKSHOP" \$5.00 YEARLY. SAMPLE \$1.00. ETCO-C, Box 741 MONTREAL H3C2V2.

Construction Plans

Convert any transistorized T.V. tuner to a tuner substituter. Plans \$2.00. New accelerated Radio & T.V. course, RADIO TELEVISION TRAINING, Box 279, ET-115, Syracuse, N.Y. 13206.

send a message...
...write here.

1. Number of insertions: (circle) 1 2 3 6 12
2. Start with (month) _____ issue (Copy must be in by 1st of month preceding)
3. Amount enclosed: \$ _____

PAYMENT MUST ACCOMPANY ORDER WE'LL BILL RATED FIRMS NO AGENCY COMMISSION

NAME _____ COMPANY _____

STREET _____

CITY _____ STATE _____ ZIP _____

MAIL COPY FOR AD(S) TO: ROZ MARKHOUSE, Electronic Technician/Dealer, 757 Third Ave., New York, N.Y. 10017

RATES: 40¢ per word; 50¢ per word Bold Face Type. Add \$3.00 if you wish Box Number. Minimum \$10.00 charge. Classified Display Rate billed \$43.00 per inch, 1 inch minimum.

**ELECTRONIC
TECHNICIAN/DEALER CLASSIFIED**

SURPRISE! SURPRISE! Digital Piano Tuning Device tunes **ALL** musical instruments **Accurately! Perfectly! Inexpensively!** Construction-Instruction Plans Complete \$12.95 Airmailed Postpaid! Moonlighting quickly repays \$40 electronics investment! **GREEN BANK SCIENTIFIC**, Box 100Y, Green Bank, WV 24944. 2/76

CONVERT YOUR B & K 465 OR 466 REJUVENATOR TO A POWERFUL C.R.T. RESTORER SYSTEM. Step by step detailed plans with pictures, parts-list and operating instructions \$25.00. James Chancellor, 1708 Edgerly Ave., Albany, Georgia 31707. 4/76.

REPAIR TV TUNERS-High earnings, Complete Course Details, 12 Repair Tricks, Many Plans, Two Lessons, all for \$2. Refundable. Frank Bocek, Box 3236, Ent., Redding, CA 96001. TF

For Sale

JAPANESE TRANSISTORS -All Transistors Original Factory Made. Free Catalog. West Pacific Electronics, Box 25837, W. Los Angeles, CA 90025. 12/76

DEALER INQUIRIES invited. Add color telephones and accessories to your sales. Send for additional information on business letterhead. Telectra Sales, Box 9218-ET, Richmond, VA 23227. 4/76

COLOR TELEPHONES New American made with one year warranty. Free information or send \$1.00 for color digest and prices. Telectra Sales, Box 9218-ET, Richmond, VA 23227. 4/76



TELEVISION PICTURE TUBES

STOP...

Don't junk that television set. ASE manufactures the world's most complete line of television picture tubes. No other company offers:

- Over 1700 types of television picture tubes.
- Most types immediate delivery.
- Transportation in the Midwest—paid; 1/2 transportation paid in other states.
- Tubes for Old or New Models.
- Complete line of both black & white and color.
- Full 2-year factory warranty.
- Lowest prices anywhere.
- Finest quality.

Write today for more information.

Allied Sales & Engineering, Inc.
Dept. 21, Plimento, Ind. 47866
Telephone 812-495-6555

PRESSURE sensitive miniature cable for burglar alarm systems. Place under carpet in any contour for intrusion detection or secret switching. \$4.95 for twenty feet. Cable Switch Corp. Box 72-ET. West Long Beach, N.J. 07764. TF

DYNACO-A-R-TRANSISTORS, REPAIR BOARDS & UNITS, SPEAKER SERVICE. SEND FOR PRICES AND DETAILS: BEAR ELECTRONICS—177-E-HILL-CREST ROAD, MT. VERNON, N.Y. 10552.

ELECTRONIC TEST EQUIPMENT FOR SALE. Reconditioned or repairable, from Aerospace Industry and DOD. \$0.50 for catalog. James Walter Test Equipment, 2697 Nickel Street, San Pablo, CA 94806. 8/76

DIALING UNIT MODEL 672

This Dialing Unit is for use with a simple tape recorder to automatically make telephone calls for emergency or other use.

\$29.95. Free literature.

SIGHT & SOUND SYSTEMS

5619 St. John Avenue (DEPT. 51) Kansas City, Mo. 64123

NEW RF WATTMETES FOR SALE. Dielectric Communications model 1000-\$125.00, Elements-\$35.00. Direct replacement for Bird 43, accepts all 43 type wattmeter elements. Call **TUCKER ELECTRONICS CO.** TOLL-FREE 800-527-4642. In Texas (214) 348-8800. 2-76

ELECTRONIC TECHNICIAN DEALER

is not responsible for any of the items, plans, courses or quality of products offered through our classified section.

Ad
Council

A Public Service of
This Magazine &
The Advertising Council

How would you like to sign the work you do?

Maybe it's a shame that most of us will never get to sign our work. Because as good as we are, it might make us better. And we can afford to be. No matter what kind of work we do, we'd have

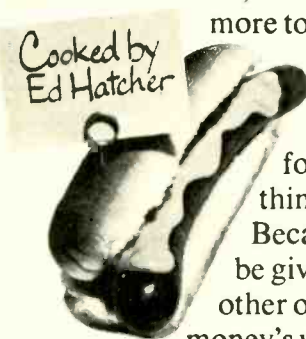

more to show for it. More money, for one thing. Because we'd be giving each other our money's worth for

the products, the services and even the government we pay for.

For another thing, we'll be giving America better ammunition to slug it out with our foreign competitors. That should help bring the lopsided balance of payments back onto our side. And help make your dollars worth more.

Best of all, as we hit our stride we'll be protecting our jobs here at home. And we'll get more satisfaction out of the jobs we've got.

You don't have to sign your work to see all these things happen. And more.

Just do the kind of work you'd be proud to have carry your name.

America. It only works as well as we do.



The National Commission on Productivity, Washington, D.C.

This ad is the work of Orrie Frutkin and Gavino Sanna.

**Some stores
sell test
equipment
at discount
prices.**

**At Fordham
we discount
their discount
prices.**

B&K, EICO, RCA, SENCORE
FLUKE, HICKOK, LEADER
and SIMPSON

Complete line of tubes,
tools and electronic supplies

**FREE CATALOG
FORDHAM**

RADIO SUPPLY CO., INC.

558 Morris Ave., Bronx, N.Y. 10451
Tel: (212) 585-0330

...for more details circle 118 on Reader Service Card

need belts?

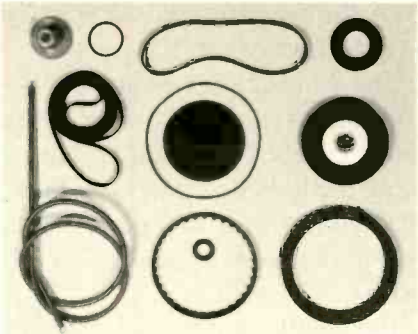

Standard and special belts and tires ready for immediate shipment — fit over 3,000 new and obsolete makes of tape recorders, projectors, dictating machines, video recorders, and turntables. Simplified cross reference system makes ordering easy with **one day service** on most items. Drive tires, wheels, phono idlers also listed. Call or write for **free catalog**.
DEALER INQUIRIES INVITED.

**PROJECTOR-RECORDER
BELT CORP.**

319 Whitewater St., Whitewater,
WI 53190 — (414) 473-2151

...for more details circle 128 on Reader Service Card

READER SERVICE INDEX

ADVERTISER'S INDEX

107 American Technology Corp.	38
108 Antenna Corp. of America	11
109 Arrow Fastener Co., Inc.	4
110 B & K Division, Dynascan	37
111 Blonder-Tongue Laboratories, Inc.	23
136 Breaker Corp.	13
112 Chemtronics, Inc.	42
113 Chrysler Corp.	24
114 Cornell Electronics	46
115 EICO Electronic Instruments Co.	50
117 Electronic Book Club	16-19
116 Elin Mfg. Co.	47
103 Fluke Mfg., John	Cover 3
118 Fordham Radio Supply Co., Inc.	50
GTE Sylvania Consumer Renewal	3
119 General Electric Co., Television Product Services	10
General Electric Co., Tube Division	39
120 Heath Company, The	44
121 Hickok Electrical Inst. Co.	7
122 Jensen Tools & Alloys	46
125 MTI	41
123 Motorola Semiconductor Prods., Inc.	15
124 Mountain West Alarm Supply Co.	46
102 PTS Electronics, Inc.	Cover 2
126 Philips Test & Measuring Inst., for further information	1
127 Philips Test & Measuring Inst., for demonstration	1
128 Projector-Recorder Belt Corp.	50
137 Quietrole Co.	46
RCA Distributor and Special Products	
129 Outdoor Antennas	26, 27
130 Solid-State SK Series	30, 31
131 Russell Industries	5
132 Sencore, Inc.	42
133 Tech Spray	45
104 Triplett Corp.	Cover 4
134 Wahl Clipper Corp.	43
135 Weston Instruments	28

FREE EICO CATALOG

346 Ways To Save On Instruments!

EICO's Test Instruments line is the industry's most comprehensive because each instrument serves a specific group of professional needs. You name the requirement—from a resistance box to a VTVM, from a signal tracer to a scope, from a tube tester to a color TV generator, etc., you can depend on EICO to give you the best professional value. Compare our latest solid state instruments at your local EICO Electronics Distributor, he knows your needs best—and serves your requirements with the best values!

**"Build-it-Yourself" and save
up to 50% with our famous
electronic kits.**

For latest EICO Catalog on Test Instruments, Automotive and Hobby Electronics, Eicocraft Project Kits, Burglar-Fire Alarm Systems and name of nearest EICO Distributor, check reader service card or send 50¢ for fast first class mail service.

**EICO—283 Malta Street,
Brooklyn, N.Y. 11207**

*30 years of service to the Professional
Serviceman.*



...for more details circle 115 on Reader Service Card

GROUP
282

SCHEMATIC NO.

SCHEMATIC NO.

ADMIRAL1627
TV Chassis T5R3-1A/2A

RCA1629
Color TV Chassis CTC74 Series

AIRLINE1628
Color TV Models GAI-12936A/46A

SYLVANIA1630
TV Chassis A12-7-8-9

SYMBOL	DESCRIPTION	ADMIRAL PART NO.
R501	— 28 ohm, 5%, 7w	61A20-114
R502	— 5 ohm, 10%, 72	61A20-117
C302	— 1mf, 200v, poly	64A41-74
C320	— 1mf, 200v, poly	64A41-74

C432	— 68pf, 4Kv, 10%, cer disc	64A53-52
	chassis support frame	33A1363-3
F301	— fuse, 2a	84A7-8
	pc board with parts	A8852-9
	pc board less parts	714A463-3

MODEL CHART

MODEL	FINISH	CRT	VHF	UHF	CHASSIS
12P641	Brown	12VAEP4	94A363-2	94A465-2	T5R3-1A
12P641M	Brown	12VAEP4	94A438-2	94A461-2	T5R3-2A

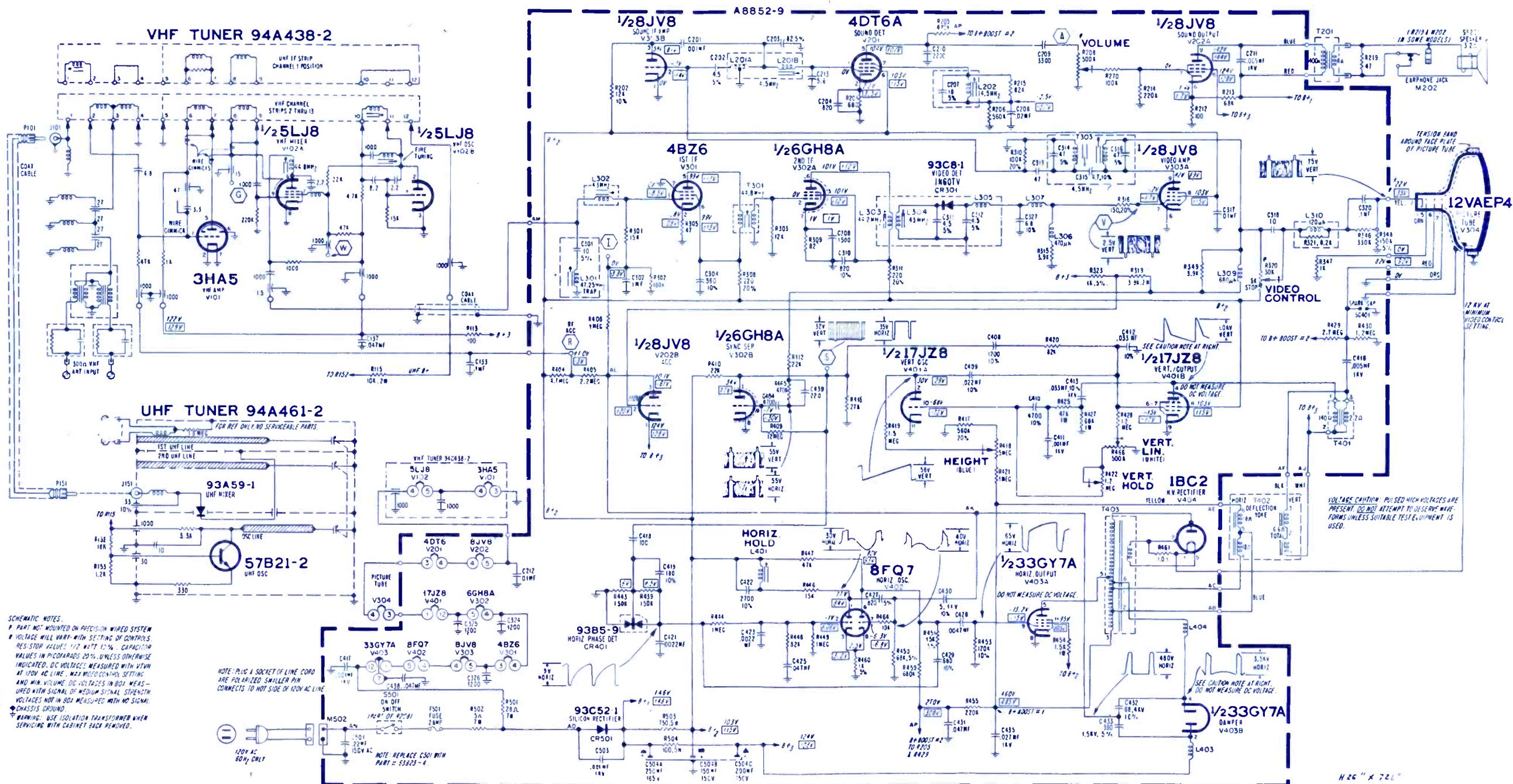

SCHEMATIC NOTES:
* PART NOT MOUNTED ON PRECISION WIRED SYSTEM
VOLTAGE WILL VARY WITH SETTING OF CONTROLS
RESISTOR VALUES: 1/2 WATT 10% CAPACITOR
VALUES IN PICOFARADS 20% UNLESS OTHERWISE
INDICATED. DC VOLTAGES MEASURED WITH VTVM
AT 100V AC LINE. MAXIMUM CONTROL SETTING
AND MIN. VOLUME. DC VOLTAGES IN BOX MEAS-
URED WITH SIGNAL OF MEDIUM SIGNAL STRENGTH.
VOLTAGES NOT IN BOX MEASURED WITH NO SIGNAL.
CHASSIS GROUND.
WARNING: USE ISOLATION TRANSFORMER WHEN
SERVICING WITH CABINET BACK REMOVED.

NOTE: PLUG A SOCKET OF LINE CORD
ARE POLARIZED SMALLER PIN
CONNECTS TO HOT SIDE OF 120V AC LINE

NOTE: REPLACE C501 WITH
PART # 53823-4

H 26" X 7.1"

SYMBOL	DESCRIPTION	AIRLINE PART NO.
R306	2.2K, AGC	75A199-1
R319	10K, AGC delay	75A199-2
R401	22K, tilt	75A199-3
R410	100K, color kill	75A199-4
R438	22K, APC	75A199-3
R446	22K, ACC	75A199-3
L206	coil, 41.25MHz trap	72A316-12
L404	coil, chroma take-off	73A135-3

L500	coil, sound quad	72A329-4
T200	xformer, 4.5MHz trap	72A216-8
T400	xformer, chroma bandpass	73A137-1
T500	xformer, 4.5MHz sound take-off	72A318-6
R741	20K, brite limit	75A101-47
T800	xformer, horiz osc adj	94A351-3
T801	xformer, horiz drive	79A167-2
R901	22K, B+ 120v, adj	75A199-3
F900	fuse, 1.5a	36201-5
R630	200K, vert size	75A101-28
R631	60K, vert hold	75A191-2

OSCILLOSCOPE WAVEFORM INFORMATION

Oscilloscope waveform patterns shown have been taken at important observation points throughout the television chassis. Voltages given for each waveform observation point is in peak-to-peak voltage.

All waveforms were taken with a wideband scope using a low capacity probe to prevent loading.

Waveforms taken with a standard color bar generator with the Color control set to 100% or normal.

Receiver was adjusted with the AGC control for a 1 volt peak-to-peak waveform at TP201 using the standard color bar generator as the signal source. This corresponds to a 2 volt peak-to-peak

video waveform from an off-the-air station signal. The difference in signal amplitude is due to the lack of luminance information in the color bar signal when switched to the color bar pattern. All receiver controls set for normal picture.

Oscilloscope sweep was set at 50 Hertz or V position for vertical waveforms, and 7.875 Hertz or H position for horizontal and chroma waveforms.

Shape of waveforms should resemble those given, depending upon bandwidth of oscilloscope used. Peak-to-peak voltages may vary, depending on calibration of test equipment, chassis parts tolerances and control settings.

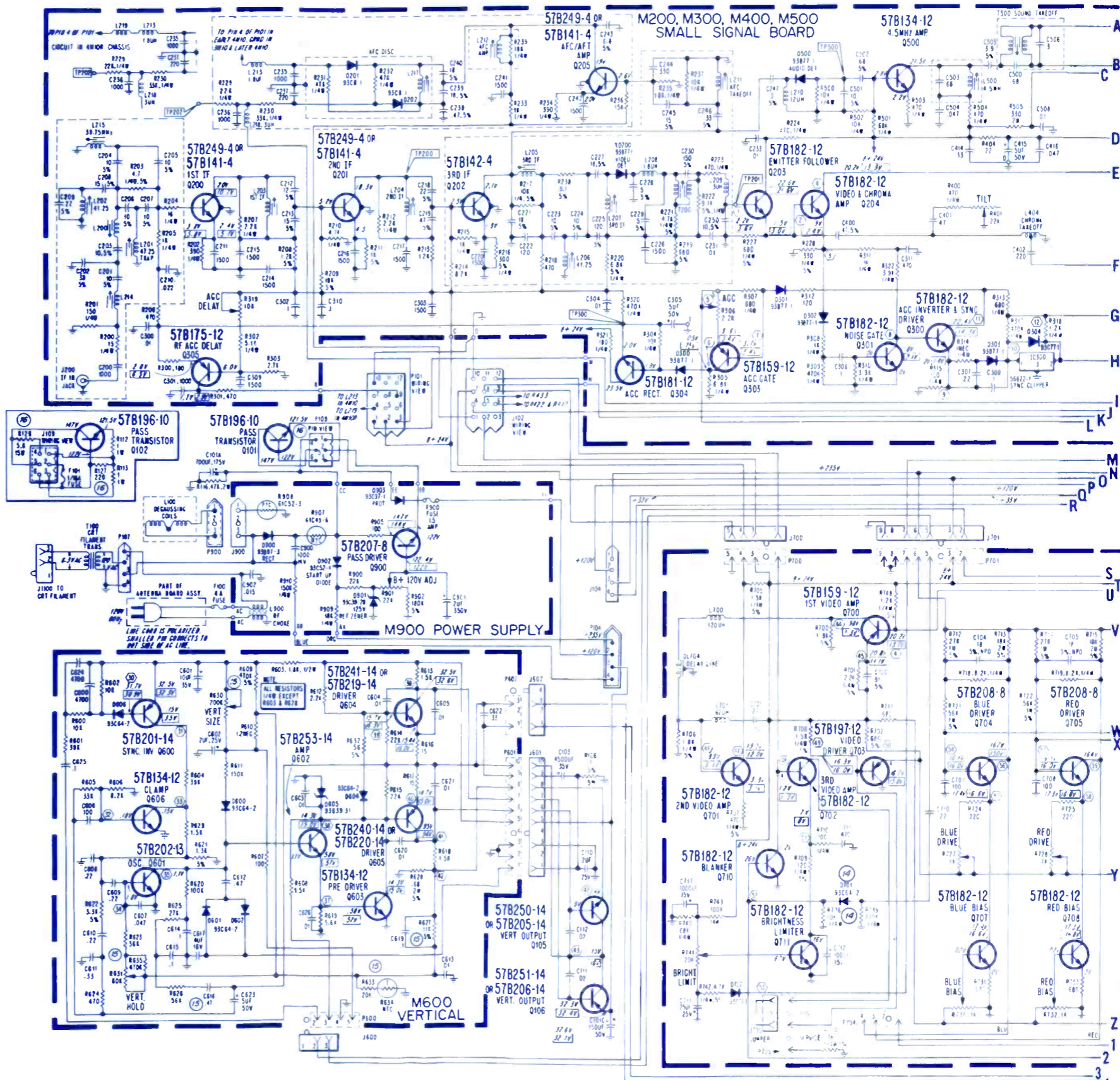
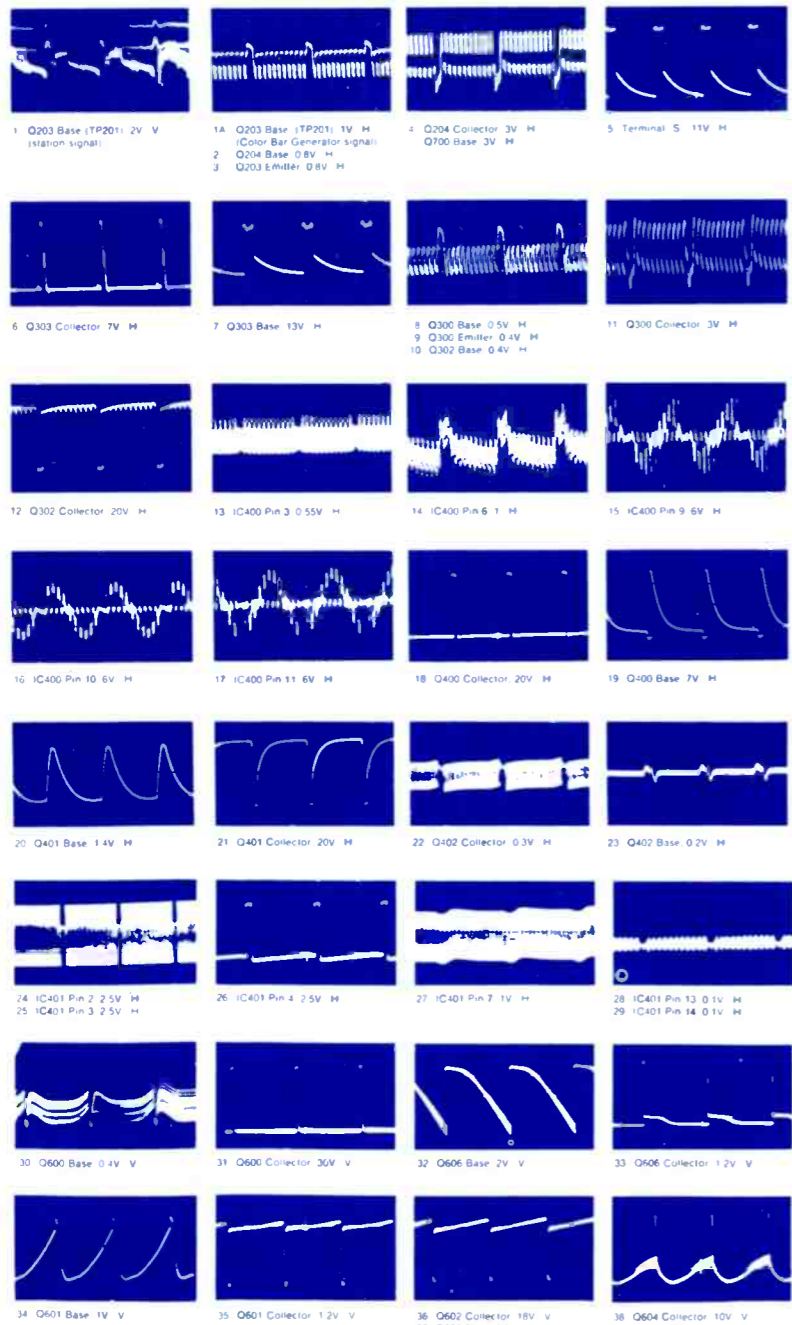

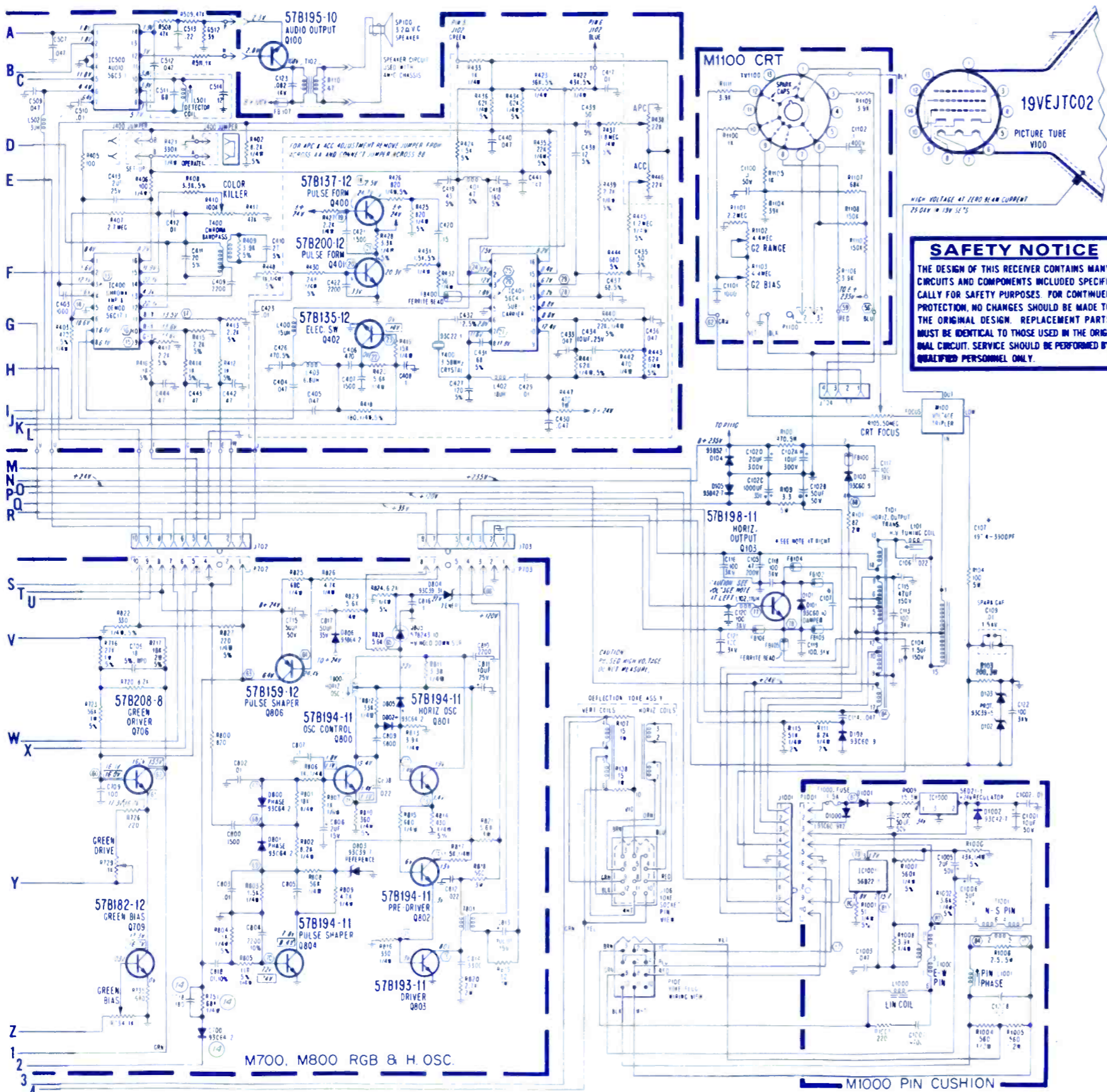

39 Q64 Base 18V V	40 Q65 Emitter 18V V	41 60S Collector 3.6V V	42 Q105 Emitter 1.4V V
43 Q105 & Q106 Collectors 16V V	44 Q700 Collector 3.4V H	45 Q700 Emitter 3.8V H	46 Q701 Base 1.5V H
47 Q701 Collector 3.5V H	48 Q702 Base 1.5V H	49 Q702 Collector 9V H	50 Q703 Emitter 7V H
51 Q702 Emitter 1V H	52 Q710 Base 0.7V H	53 D702 Cathode 6.5V H	54 Q704 Base 5V H
55 Q704 Emitter 7V H	56 Q704 Collector 132V H	57 Q705 Base 4V H	58 Q705 Emitter 7V H
59 Q705 Collector 120V H	60 Q706 Base 2V H	61 Q706 Emitter 6V H	62 Q706 Collector 80V H
63 Q806 Collector 0.5V H	64 Q806 Base 2V H	65 Q805 Anode 11V V	66 D804 Cathode 24V H
67 D800 Anode 1.5V H	68 D800 & D801 Cathode 15V H	69 D801 Anode 8V H	70 Q804 Base 2V H
71 Q800 Emitter 2.2V H	72 Q801 Base 4V H	73 Q801 Emitter 3.8V H	74 Q802 Collector 17V H
75 Q803 Base 0.7V H	76 Q803 Collector 20V H	77 Q103 Base 30V H	78 Q103 Emitter 32V H
79 IC1001 Pin 3 2.3V V	80 IC1001 Pin 1 1.1V V	81 IC1001 Pin 2 2.5V V	82 T1000 Pin 4 33V H
83 P1000 Pin 4 0.8V H	84 T1001 Pin 2 20V H	85 T1001 Pin 5 13V H	86 T1001 Terminal 17 28V H
87 D1001 Anode 250V H	88 T101 Terminal 4 120V H		

SYMBOL	DESCRIPTION	RCA PART NO.	RF401 — resis, fusible	141411
F1101	— fuse	141486	STM401 — tripler	141254
Q1101	— triac—778-2	137876	T401 — xformer, high volt	141252
T1101	— xformer	141416	T402 — xformer	141253
CPR201	— circuit encapsulated	109956	R4201 — control, vol	141311
CPR202	— circuit encapsulated	109956	R4203 — control, color	141313
F202	— fuse	111819	R4207 — control, contrast	141314
F203	— fuse	111819	R4205 — control, horiz hold	141356
RT201	— therm	141238	R4206 — control, vert hold	141357
RT202	— therm	141239	R4209 — control sharp	141357
F301	— fuse	98105	R4310 — control screen	141359
R412	— control, focus	138749	R4311 — control, vert height	141360
			S4301 — switch, LDR defeat	136246

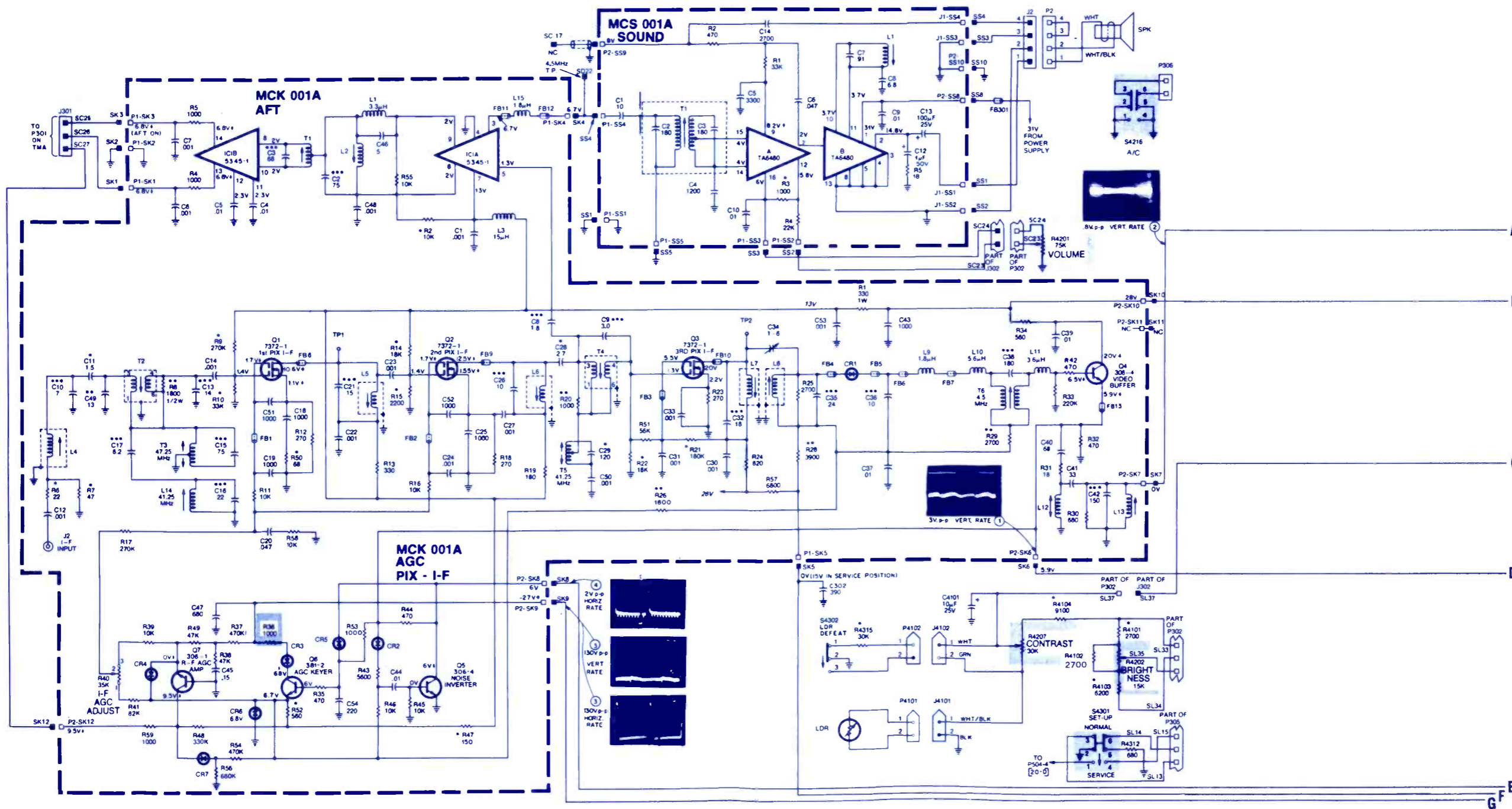

CHASSIS LAYOUT

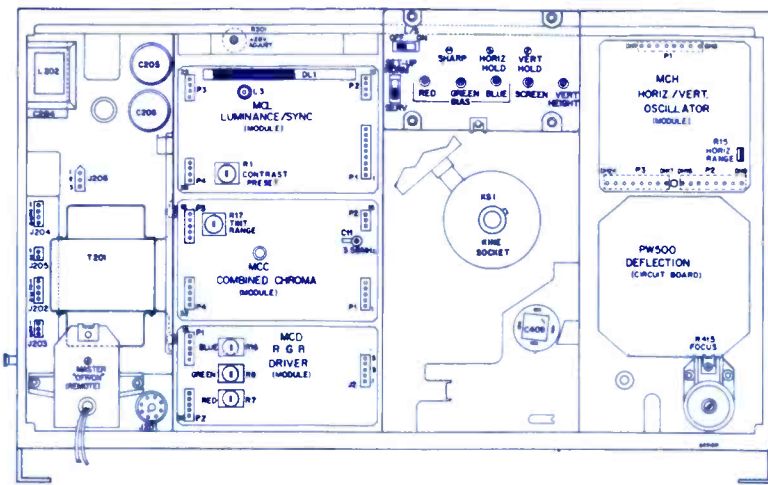

Rear View

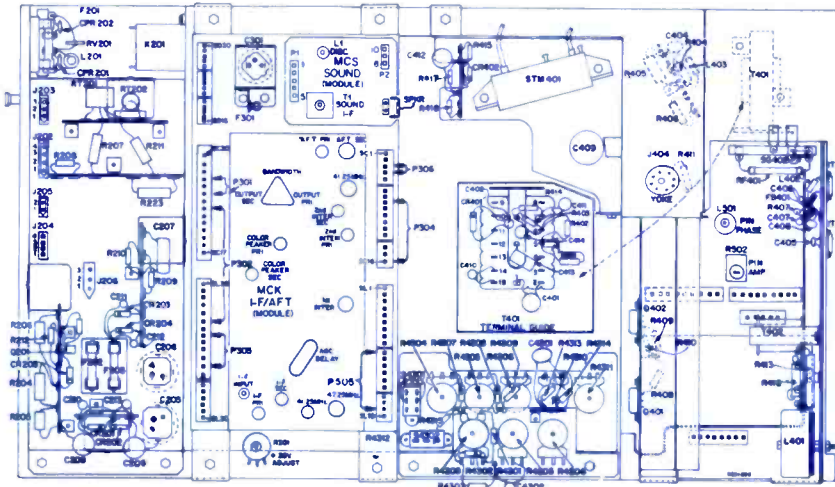

Top View
(Service Position)

RCA
Color TV Chassis
CTC74 Series

RCA CONTINUED
NEXT PAGE

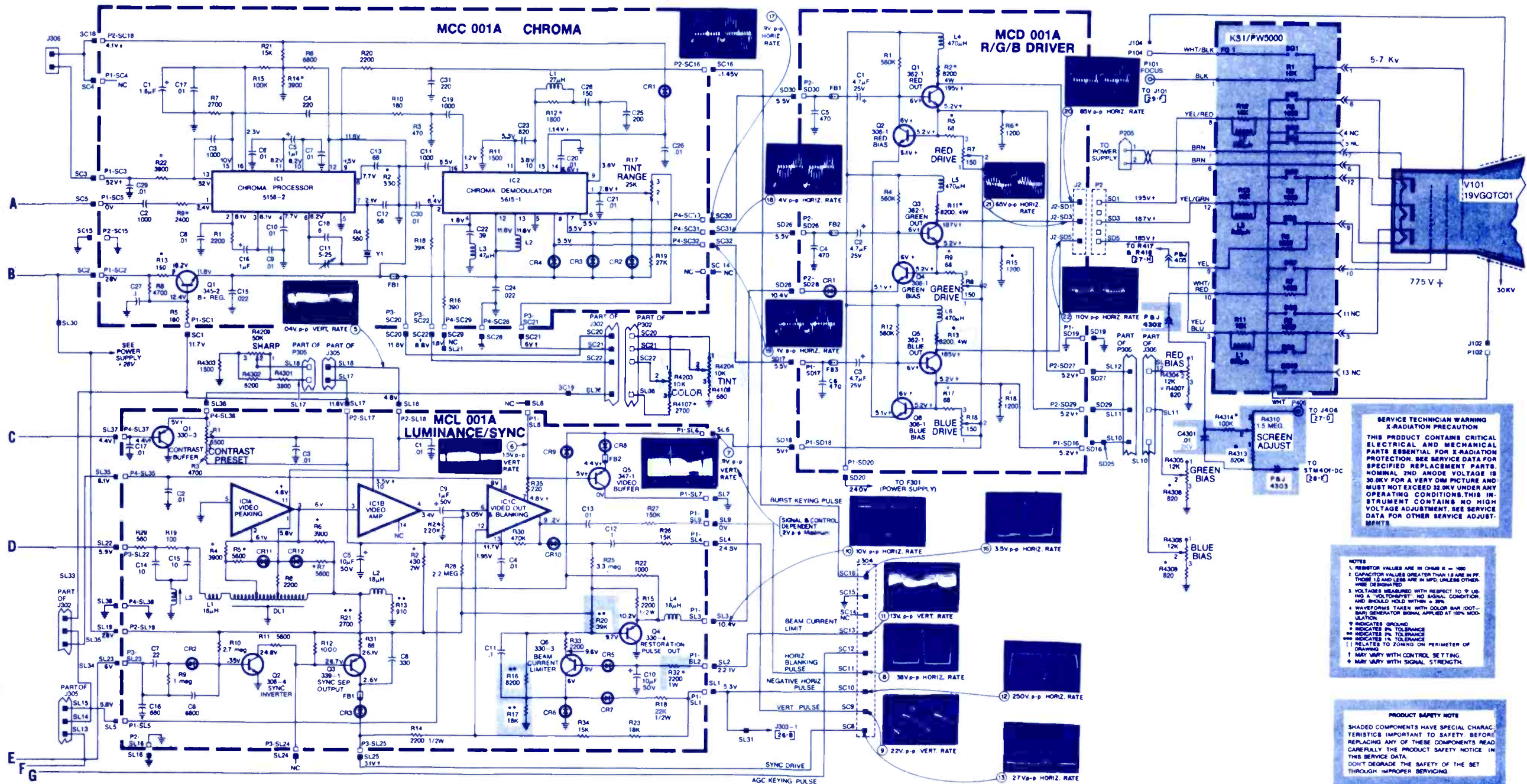

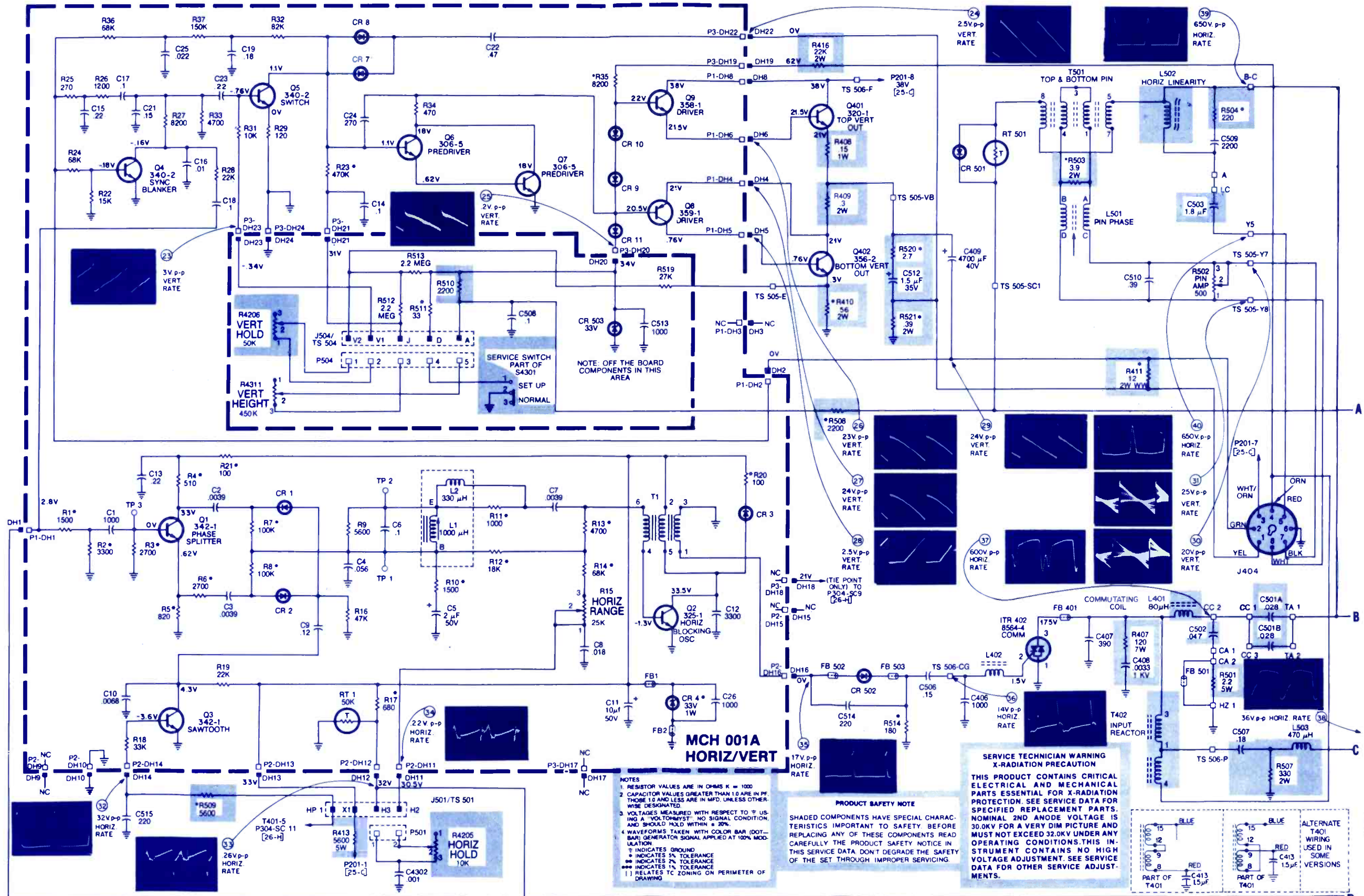

SYMBOL	DESCRIPTION	SYLVANIA PART NO.
C504	4 section electro	41-37861-1
A	500-175v	
B	300-150v	
C	20-150v	
D	30-175v	
L100	coil, quad detect	50-33195-2
L102	coil, sound input	50-35989-1
L201	coil, 39.75MHz trap	57-23832-1
L202	coil, 47.25 MHz trap	50-37714-4
L212	coil, 4.5MHz trap	50-37714-3
L400	coil, horiz hold	50-39870-2

T100	xformer, audio output	56-37872-1
T400	xformer, horiz drive	56-37922-1
T402	xformer, horiz output	50-39871-1
SC100		
SC102	+150 protect zener, -9 ch	13-33187-10
SC410	damp	13-33172-1
R105	100K, vol	37-35105-10
R240	500 ohm, contrast	37-39237-10
R258	200K, brite	37-27242-57
R272	4.7K, AGC	37-23063-10
R314	500K, vert hold	37-33036-14
F500	fuse, 1.5a. slo-blo	29-37730-3
1C100	integ. sound IF/det	15-35059-1

*IC100 VOLTAGE CHART

PIN NO	1	2	3	4	5	6	7	8	9	10	11	12	13	14
IC CHIP INSERTED	+2V	+2V	OV	OV	+12V	OV	+6.8V	+6.2V	+4.2V	+4.2V	N.C.	+3.4V	N.C.	+1.8V
IC CHIP REMOVED	OV	OV	OV	OV	+27V	OV	OV	OV	OV	OV	N.C.	OV	N.C.	OV

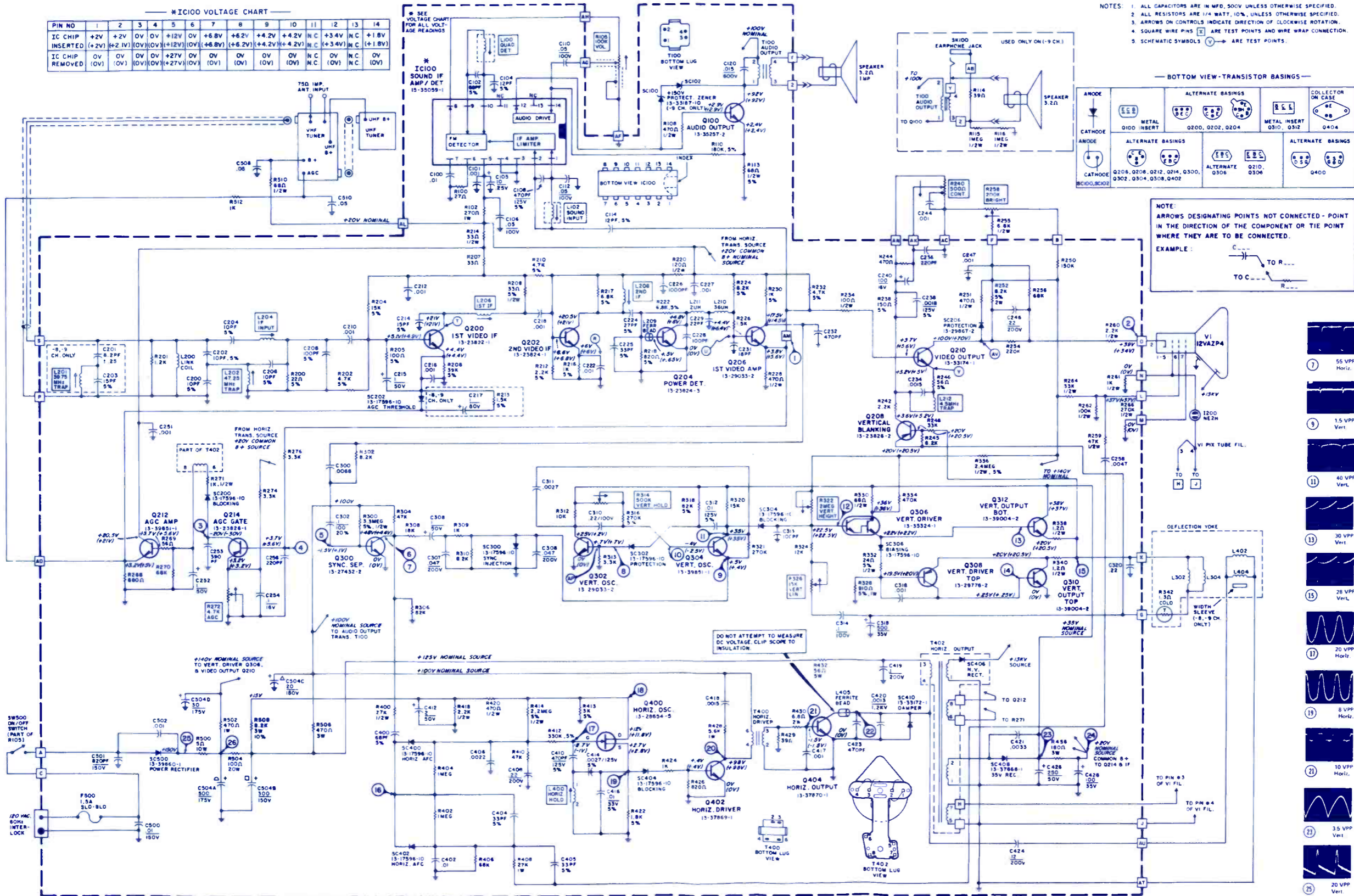

Your VTVM is obsolete!

This may sound like a harsh claim, but it's true. Thousands of TV technicians are using instruments designed in the 1950's to troubleshoot circuits designed in the 1970's.

And now, most color TV's have solid state circuits. So use of out-of-date test equipment just compounds the problem.

The generation gap has grown too big.

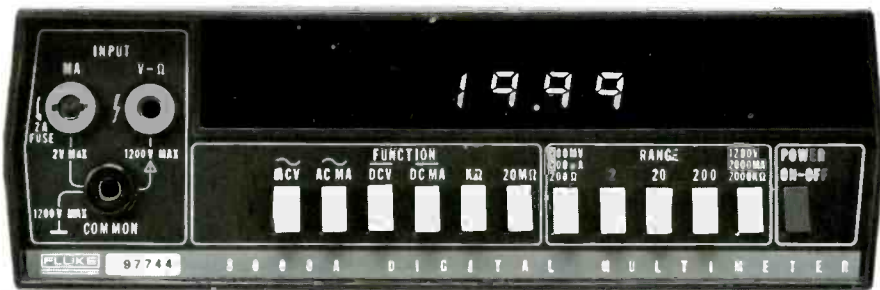

Resolution is 100 microvolts, 100 nanoamps and 100 milliohms

You get the sensitivity you need for low level dc measurements. The 200 millivolt range with 100 microvolt resolution tells you *exactly* what your values are.

The 8000A has an AC frequency response from 45 Hz to 20 KHz and, with accessory probes, to 500 megahertz. Resistance measuring capability ranges from 100 milliohms to 20 megohms. It offers a 15°C to 35°C accuracy temperature span. And a 1-year accuracy time span, meaning it seldom needs calibration.

Unlike other DMM's the 8000A has fast response time—3 readings a second. And the bright, digital readout means that no interpolation is necessary.

The 8000A measures high voltages, too.

Our 8000A is designed to answer *all* the needs of an electronic service technician.

One very important (and talked about!) safety requirement is that the picture tube anode voltage must not exceed the maximum specified by the manufacturer. Our 8000A has an optional high voltage probe that gives you guaranteed accuracy of 1% at 25,000 volts. The probe also extends the capability of the 8000A to 40,000 volts to measure the high voltage in the new 32,000 volt chassis.



High voltage probe accessory gives you 1% accuracy at 25,000 volts

There's new high voltage protection on all ac/dc voltage ranges. The instrument will take transients up to 6 KV, 10 μ seconds wide over a duty cycle of 60 per second.

Get the most up-to-date instrument available.

Don't be caught in the typical trap. Many electronic service shops don't really update their equipment when they decide to update. Switching to a TVM or a FET voltmeter doesn't really give you the accuracy and resolution you need today, or for that matter, tomorrow.

But with the 8000A on hand, you know you have a *true* solid state testing device.



Carry it anywhere. Use it on line or with optional rechargeable battery power (\$50 extra). Note the conveniently mounted specs on the bottom decal.

It costs just \$299 (\$40 more with HV probe).* And it is far and away the largest selling, most rugged and reliable 3 1/2 digit multimeter in the world.

*Domestic only.



The Fluke 8000A 3 1/2 digit multimeter

Solid state calls for new performance standards.

Your "old fashioned" test equipment simply doesn't measure up to today's requirements. For example, the typical VTVM gives you 5% accuracy and 2% resolution. In the old days, that was good enough. Not so today.

Now you need an instrument to look at the voltages at each pin of an IC with sufficient accuracy and resolution to determine proper IC operation.

For example, a reading of "around 2.8 volts" is no longer sufficient. You must be able to distinguish between 2.80 and 2.82 volts.

You need a test instrument that gives you 0.1 ohm resolution so you can reliably measure resistance of switch contacts, circuit breakers, and low value resistors.

To do all this and more, you need the superior capabilities of the Fluke 8000A 3 1/2 digit multimeter.

An instrument designed specifically for testing solid state equipment.

The 8000A gives you up to 50 times the accuracy and 20 times the resolution of a VTVM, so you can measure the various voltage levels in a solid state chassis with absolute confidence.

For data out today, dial our toll-free hotline, 800-426-0361

John Fluke Mfg. Co., Inc.
P. O. Box 43210, Mountlake Terrace, WA 98043
...for more details circle 103 on Reader Service Card

FLUKE
®

The easy-to-read 630 makes learning easy.

The Model 630 V-O-M is priced at a thrifty \$78.

The rugged, general purpose Triplett Model 630 is the kind of dependable V-O-M that both teachers and students appreciate. And for the same reasons the electronic and electrical maintenance professionals do. Uncompromising accuracy. Sturdy lightweight (only 3 lbs. with batteries). Simplified single switch operation holds errors to a minimum, and diode overload protection for the meter suspension movement reduces the chance of tester damage when mistakes do occur.

With long, clean scales covering 27 ranges in only four arcs, the Triplett Model 630 is remarkably easy-to-read.

It's packed with major features:

1. Diode overload-protected suspension movement V-O-M; single range switch minimizes error.
2. 4 Ohmmeter range with 4.4 ohms center scale.
3. Simplified scale—only 4 arcs for all 27 ranges.

Sensitivity is 20,000 Ohms per Volt DC, 5000 Ohms per Volt AC.

Accuracy is an excellent 2% on DC, and 3% on AC. Measures resistance to 100 megohms, with 6,000 Volt AC and DC capability.

Handles DC microamperes 0-60, and DC milliamperes 0-120, both at 250 mV, and can read DC amperes 0-12.

Rugged black molded plastic case with removable black leather carrying strap. All this for just \$78.

Get the same convenience and operating advantages plus 1½% DC accuracy and mirrored scale with the Triplett Model 630-A, priced at only \$90.

See them for yourself. Just ask a Triplett distributor or sales represen-

tative to give you a free demonstration of the tester that fits your needs. You'll be glad you did. So, do it today. Triplett Corporation, Bluffton, Ohio 45817.



TRIPLETT
ALL YOU'LL EVER NEED IN V-O-M's.

Triplett. The easy readers.

...for more details circle 104 on Reader Service Card