

AUGUST 1970  A HARCOURT BRACE JOVANOVIICH PUBLICATION

ELECTRONIC TECHNICIAN / DEALER

WORLD'S LARGEST TV-RADIO SERVICE & SALES CIRCULATION

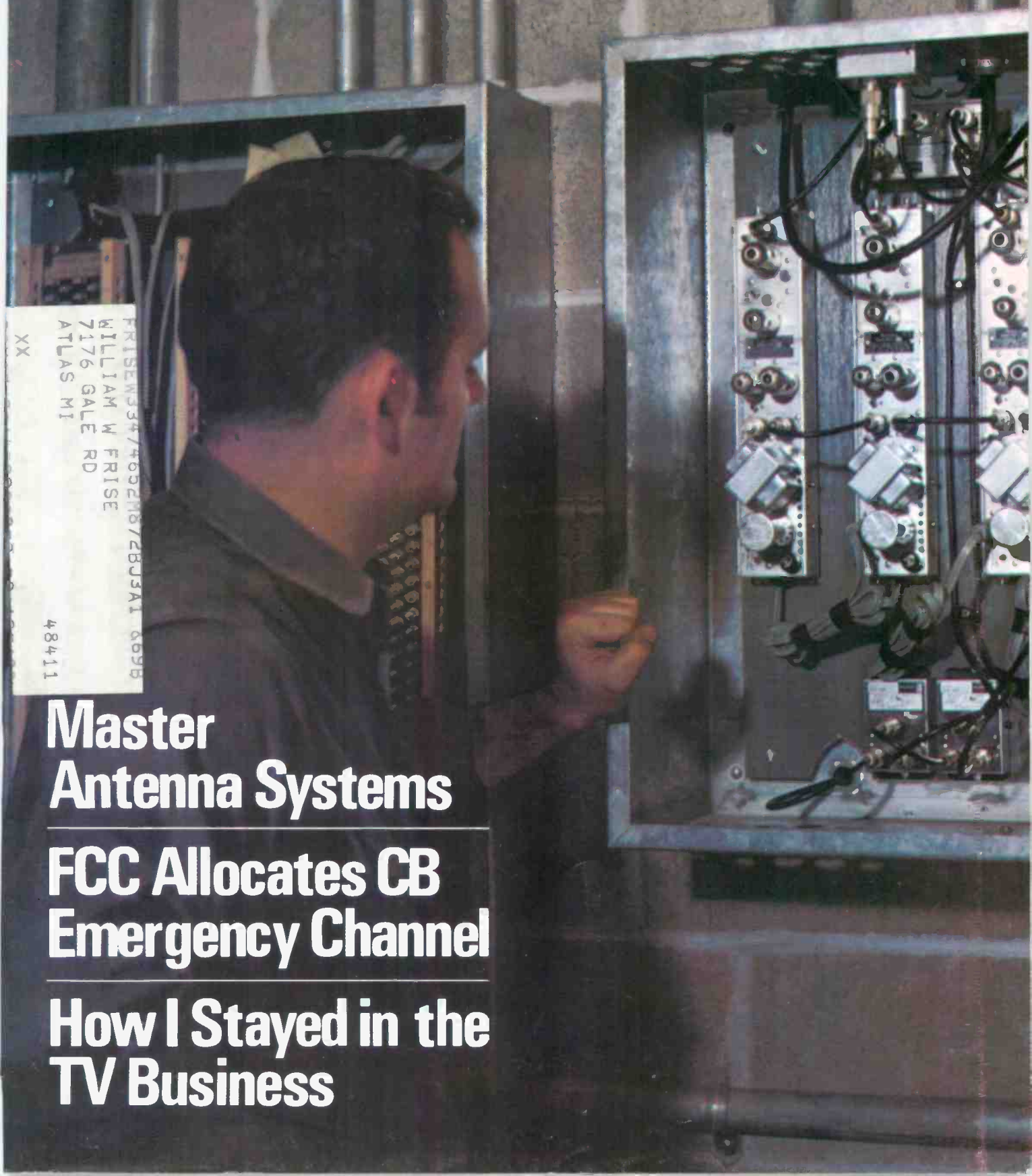

FRISEN334/4692M8/2B3JA1 009B
WILLIAM W FRISE
7176 GALE RD
ATLAS MI
48411
XX

**Master
Antenna Systems**

**FCC Allocates CB
Emergency Channel**

**How I Stayed in the
TV Business**

The first and only solid-state test equipment guaranteed for 5 years.

Now EICO, because of its emphasis on reliability in engineering and manufacture, offers the industry this breakthrough.

EICO's new line of solid-state test equipment comes with an unprecedented 5-year guarantee of performance and workmanship. (Send

for full details of this EICO 5-year GUARANTEE on factory-assembled instruments.)

Additional advanced features include: new functional design, new color-coordinated esthetics, new PC construction, new easier-to-build kit designs.

New EICO Solid-State Test Equipment



EICO 240 Solid-State FET-VOM \$59.95 kit, \$79.95 wired.

One all-purpose DC/AC OHMS Uniprobe®. Reads 0.01V to 1 KV (to 30 KV with optional HVP probe). 7 non-skip ranges, in 10 dB steps. AC or battery operated. RMS & DCV: 0-1, 3, 10, 30, 100, 300, 1000V P-P ACV: 0-2.8, 8.5, 28, 85, 280, 850, 2800V. Input Z: DC, 11 M; AC, 1 MΩ. Response 25 Hz to 2 MHz (to 250 MHz with optional RF probe). Ohmmeter reads 0.2 to 1 MΩ in 7 ranges. 4½" 200 μA movement. HWD: 8½", 5¾", 5", 6 lbs.

EICO 242 Solid-State FET-TVOM \$69.95 kit, \$94.50 wired.

All the versatility of the EICO 240 plus: AC/DC Milliammeter, 1 ma to 1000 ma in 7 non-skip ranges; single all-purpose DC/AC-Ohms — MA Uniprobe®; and large 6½" 200 μA meter movement.

EICO 150 Solid-State Signal Tracer \$49.95 kit, \$69.95 wired.

Multi-purpose troubleshooter for TV/FM/AM & Audio Equipment. Independent RF Audio inputs. Speaker and meter output indicators. 400 mW continuous power output. Substitution amplifier, output transformer, speaker. Input for rated output: 1 mV RF, 63 mV audio.

Hum 60 dB below 400 mW, 105-132 VAC, 50/60 Hz, 5VA. HWD: 7½", 8½", 5", 6 lbs.

EICO 330 Solid-State RF Signal Generator. \$59.95 kit, \$84.50 wired.

5 fundamental bands 100 kHz to 54 MHz. Vernier control 0-100%. Output 300,000 μV into 50-Ohm load. External signal modulation or internal 400 Hz, 0 to 100%. 105-132 VAC, 50/60 Hz, 1.7 VA. HWD: 7½", 8½", 5", 5 lbs.

EICO 379 Solid-State Sine/Square Wave Generator. \$69.95 kit, \$94.50 wired.

5 sine wave and 4 square wave bands. Low distortion Sultzer feedback FET circuit. Sine: 20 Hz to 2 MHz; 0-7.5V rms into hi-Z, 0-6.5V into 600 ohms Max. distortion 0.25%. Square: 20 Hz to 200 kHz; 0-10V p-p into hi-Z, pos. direction, zero ground. Rise time at 20 kHz less than 0.1 μ sec. 105-132 VAC, 50/60 Hz, 10VA. HWD: 7½", 8½", 8½", 9 lbs.

New EICO High Performance Instruments



EICO 385 — Solid-State Portable Color Generator \$79.95 Kit, \$109.95 Wired.
EICO 465 — Wideband Vectorscope/Oscilloscope \$179.95 Kit, \$249.95 Wired.
EICO 1025 — Solid-State Power Supply \$34.95 Kit, \$49.95 Wired.
EICO 443 — Semiconductor Curve Tracer \$79.95 Kit, \$119.95 Wired.
EICO 633 — CRT Tester & Rejuvenator \$79.95 Kit, \$119.95 Wired.
EICO 635 — Portable Tube Tester \$44.95 Kit, \$69.95 Wired.

New EICO Probes for the Pros

Hi-Voltage Probe HVP-5, Wired \$19.95.

Convenient built-in voltmeter. Barrier sections isolate HV tip from handle and meter. Measures up to 30 KV. Lightweight, compact.

Solid-State Signal Injector Probe PSI-1, Kit \$5.95, Wired \$9.95.

Pen-size, 1-ounce, self-powered signal generator. Frequency range from 1kHz to 30MHz, with harmonics. Clip it to your pocket — Ideal for signal tracing in the field.

Solid-State Signal Tracer Probe PST-2, Kit \$19.95, Wired \$29.95.

Flashlight-size, 2.2oz, self-powered. Hi-gain amplifier, 50Hz to 200MHz with demod tip. Input Z: 3500Ω, 35KΩ, 350KΩ; Output: 0.3 p-p volts. Noise —45dB. Distortion <5%. Complete with earphone, all probe tips, AA battery, pocket clip.



SEND FREE 1970 CATALOG

Name _____
Address _____
City _____ State _____ Zip _____



EICO Electronic Instrument Co., Inc.
283 Malta Street, Brooklyn, N.Y. 11207
EICO Canada Ltd.
20 Millwick Drive, Weston, Ontario

COMPLETE MANUFACTURER'S CIRCUIT DIAGRAMS
AND TECHNICAL INFORMATION FOR 5 NEW SETS

GROUP
216

SCHEMATIC NO.	SCHEMATIC NO.
AIRLINE1312 Color TV Model GEN-12440C	RCA VICTOR1314 Color TV Chassis CTC41 Series
EMERSON1313 Color TV Chassis 120976, 977, 980, 981, 982, 983, 984	RCA VICTOR1315 TV Chassis KCS184A
MAGNAVOX1311 TV Chassis T928 Series	

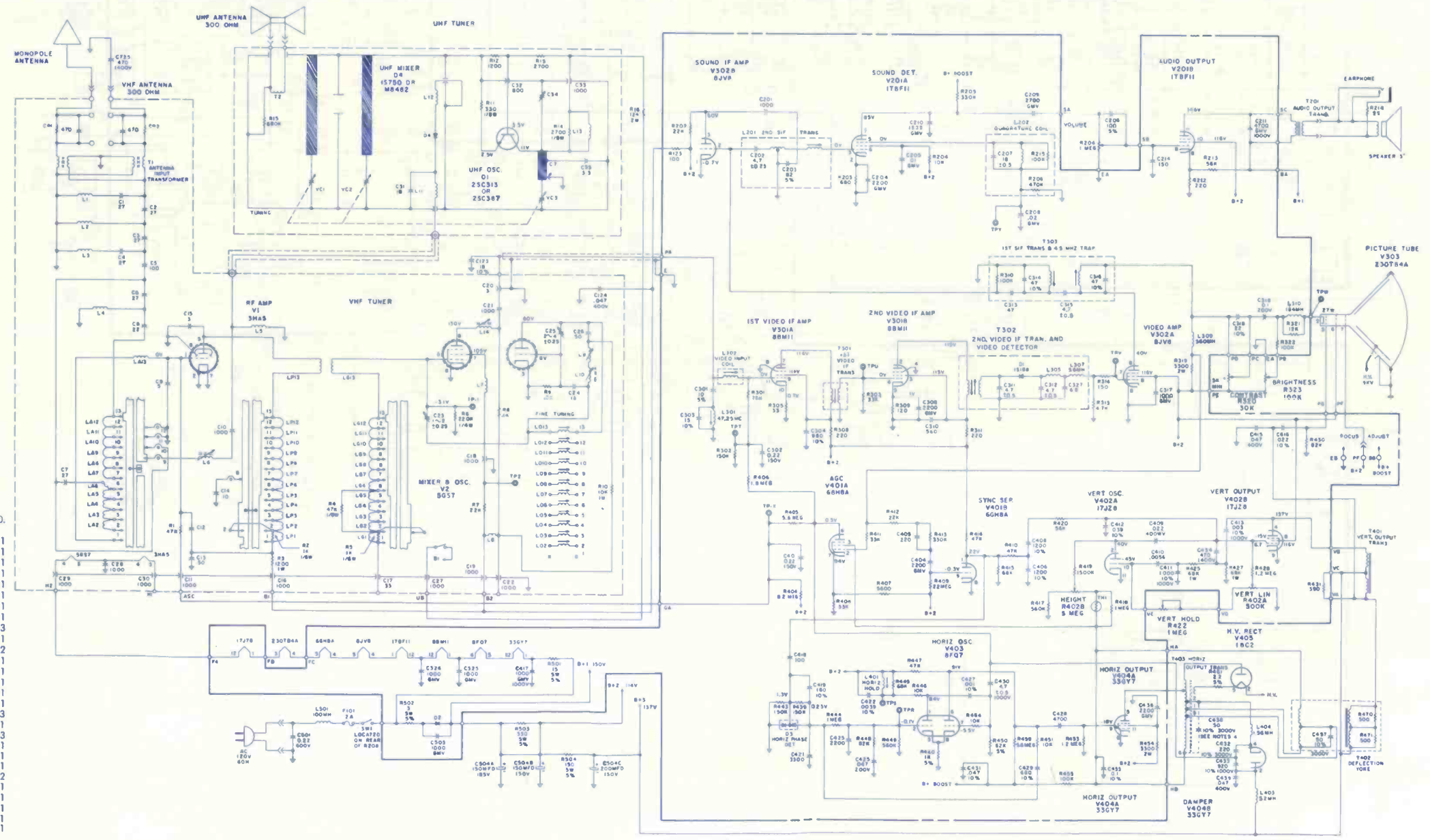
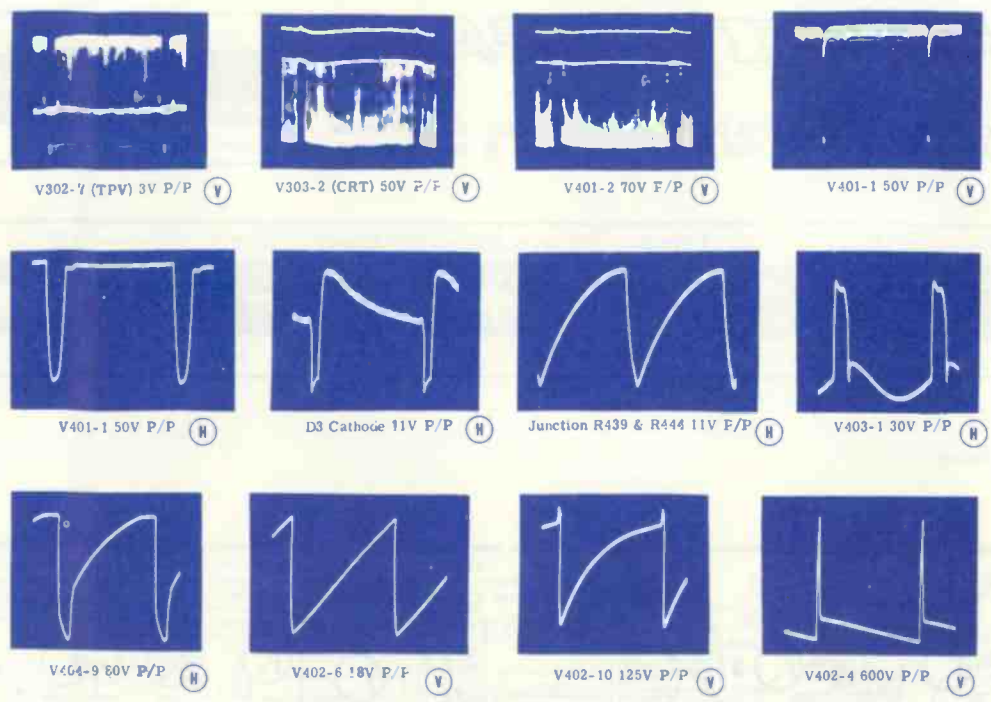

SYMBOL	DESCRIPTION	MAGNAVOX PART NO.
T201	audio output transformer	32B009-1
T303	1st sound IF transformer & 4.5MHz Trap	36B036-1
T401	vert output transformer	32B010-1
T402	deflection yoke	36B041-1
T403	horiz output transformer	36B029-1
L201	2nd sound IF coil	36B030-1
L202	quad coil	36B031-1
L301	47.25MHz trap	36B032-1
L307	5.6µh peaking coil	36B035-3
L309	560µh peaking coil	36B040-1
L310	184µh peaking coil	36B040-2
L401	horiz hold coil	36B039-1
L404	horiz w coil	36B038-1
L501	100µh ac line filter	32B008-1
C504A,B,C	elect, 150/150/200µf; 165/150/150v	27B032-1
R503	330Ω, 5%, 5w(WW)	240080-161
R504	150Ω, 5%, 5w(WW)	240080-153
R208	1M, off-on vol	22B014-1
R320	30K, contrast (5K minimum)	22B015-3
R323	100K, bright	22B015-1
R402A	500K, vert lin	22B013-1
R402B	5M, vert height	22B013-1
R422	1M, vert hold	22B015-2
	fuse, 2a, 125v	18B018-1
D3	horiz AFC dual diode	53B007-1
TH1	therm, 1M	23B003-1
	VHF tuner	34B002-1
	UHF tuner	34B003-1

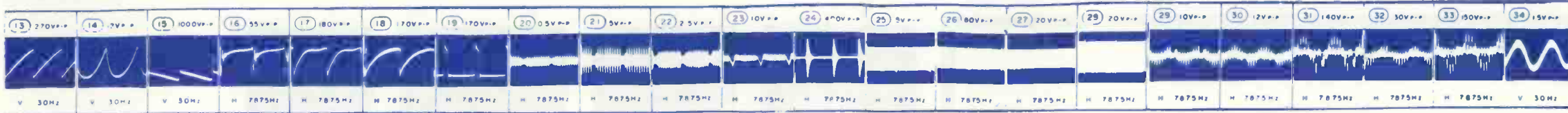
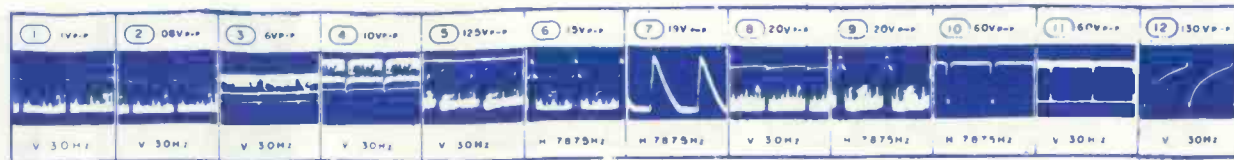

⊗ Components which affect X-Radiation

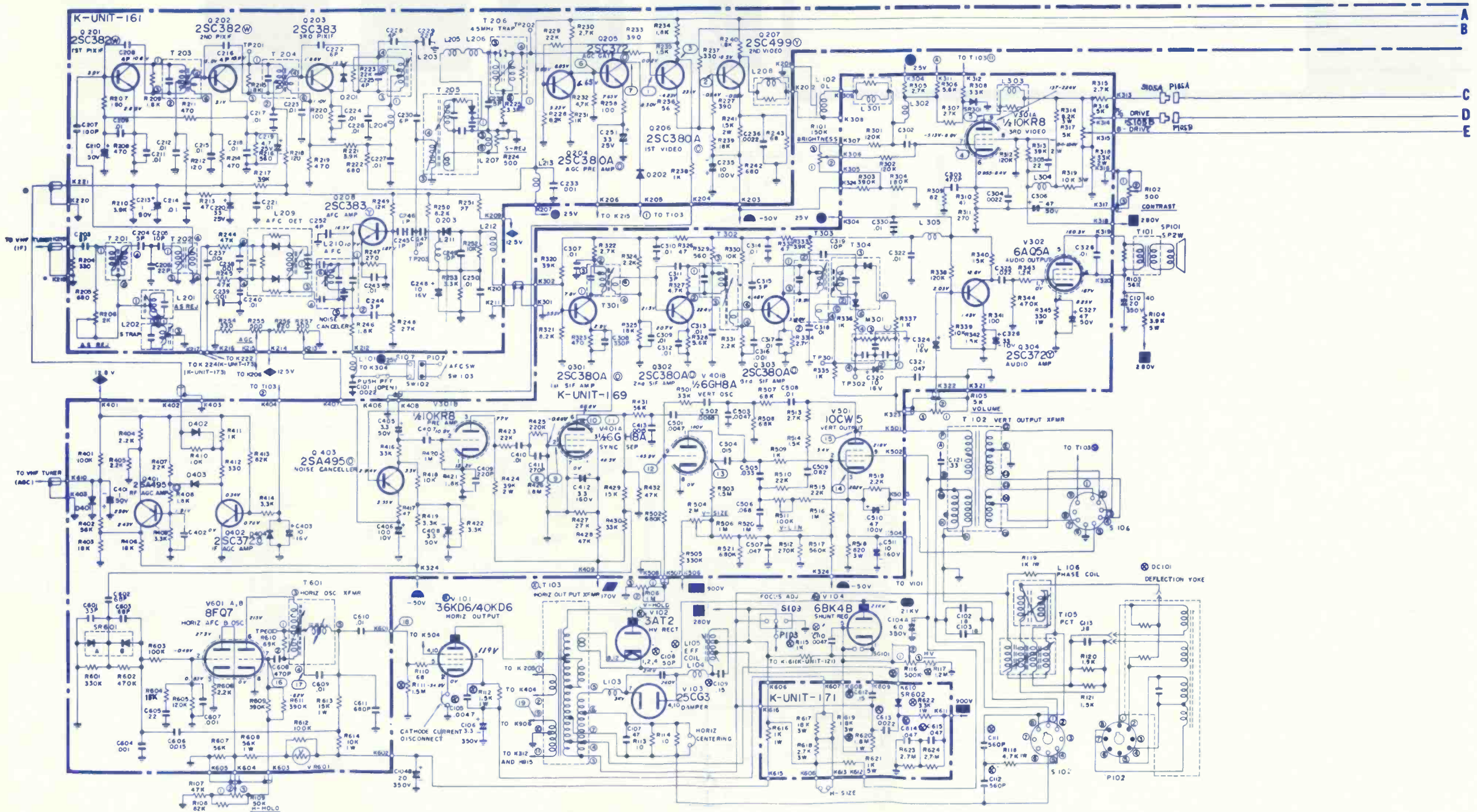

AIRLINE
Color TV Model GEN-12440C

SYMBOL	DESCRIPTION	AIRLINE PART NO.
C104A,B,C,D	60µf/20µf/20µf/20µf @ 350v, elect.	TV 32452
C117A,B	150µf/150µf @ 350v, elect.	TV 32451
R101	150K pot, bright (9V-171)	TV 25264
R102	500Ω pot, contrast (9V-331)	TV 25354
R105	5K pot, vol	TV 25342
SW101	w/on-off switch (9V-229)	TV 25342
R106	1M pot, vert hold (8V-172)	TV 25268
R109	50K pot, horiz hold (9V-311)	TV 25363
R126	500Ω pot, color (9V-245)	TV 25345
R127	5K pot, tint (9V-223)	TV 25346
R129	1M pot, red screen (9V-205)	TV 25343
R206	2K pot, adjacent sound reject (9V-235)	TV 25347
R224	500Ω pot, sound reject (9V-217)	TV 25348
R316	5K pot, green red drive (9V-241)	TV 25349
R317	5K pot, blue drive (9V-241)	TV 25349
R504	2M pot, vert size (9V-241)	TV 25349
R511	100K pot, vert lin (9V-241)	TV 25349
R255	500Ω pot, AGC (9V-239)	TV 25350
R257	500Ω pot, noise canceller (9V-239)	TV 25350
R923	500Ω pot, color killer (9V-239)	TV 25350
R952	500K pot, G1 drive (9V-239)	TV 25350
L102	coil, delay line (2TL-111)	TV 61672
L105	coil, horiz efficiency (2TL-91)	TV 61673

L107	coil, degaussing (2TL-161)	TV 61680
L202	coil, sound trap (91F-565)	TV 61658
T101	x-former, audio output (7T-193)	TV 11239
T102	x-former, vert output (8T-209)	TV 11297
T103	x-former, horiz output (8FT-666)	TV 11278
T106	x-former, power (5T-203)	TV 11275
T201	x-former, 1st pix IF (91F-569)	TV 62464
T206	x-former, 4.5MHz trap (91F-571A)	TV 62513
T301	x-former, sound take off (TIF-575A)	TV 62471
T304	x-former, sound det (TIF-573)	TV 62474
T601	x-former, horiz osc (2TL-980)	TV 62334
T701	x-former, ac line filter (2TL-69)	TV 62476
T901	x-former, burst (2TL-71)	TV 62480
T903	x-former, chroma take off (TIF-577A)	TV 62516
T904	x-former, 1st band pass (2TL-67A)	TV 62514
T905	x-former, 2nd band pass (2TL-101A)	TV 62515
M101	cap (PRC-366)	TV 3465
M301	cap (PRC-382)	RV 34107
VR601	varistor, AOC (TS-217)	TV 24238
Y901	crystal, 3.58MHz (Crystal-802)	TV 24279
CB101	circuit breaker	TV 12204
	tuner, UHF (UT7-3U2P with/dial cord drum & gear installed)	TV 35194
	tuner, VHF (RTH-7U2A)	TV 35206
DC101	yoke, deflection	TV 60218

DIPOLE ANT



TO VHF TUNER INPUT

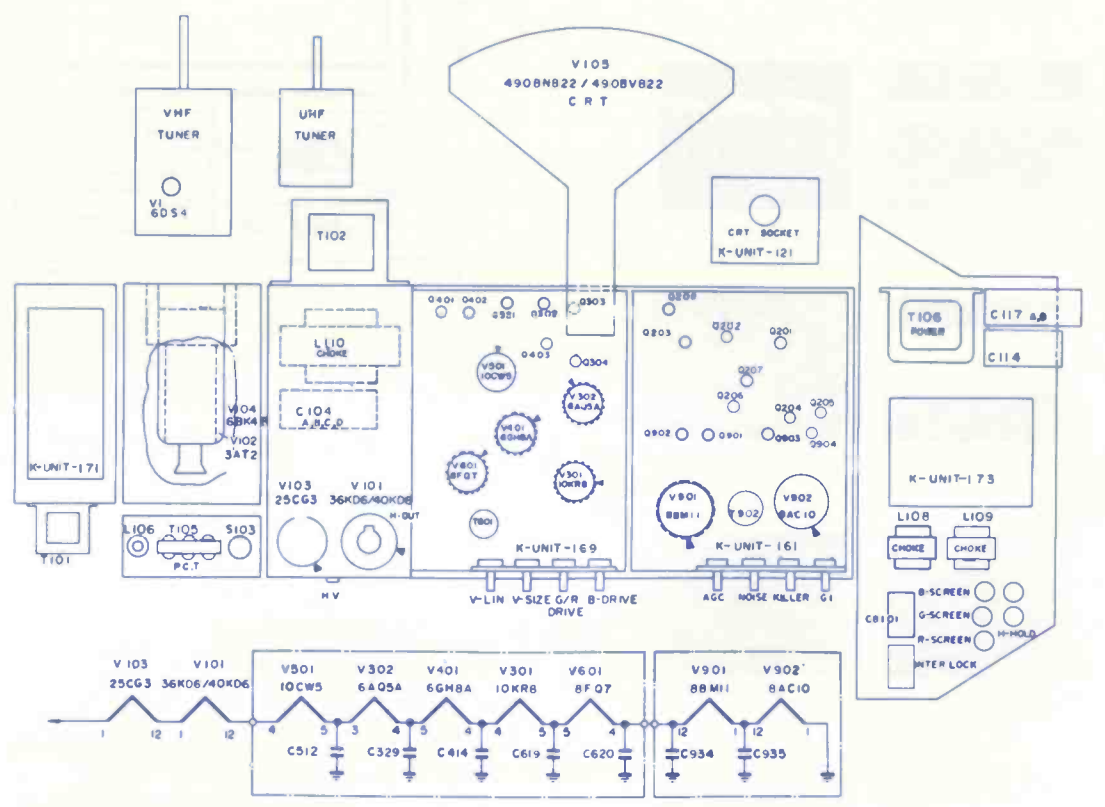
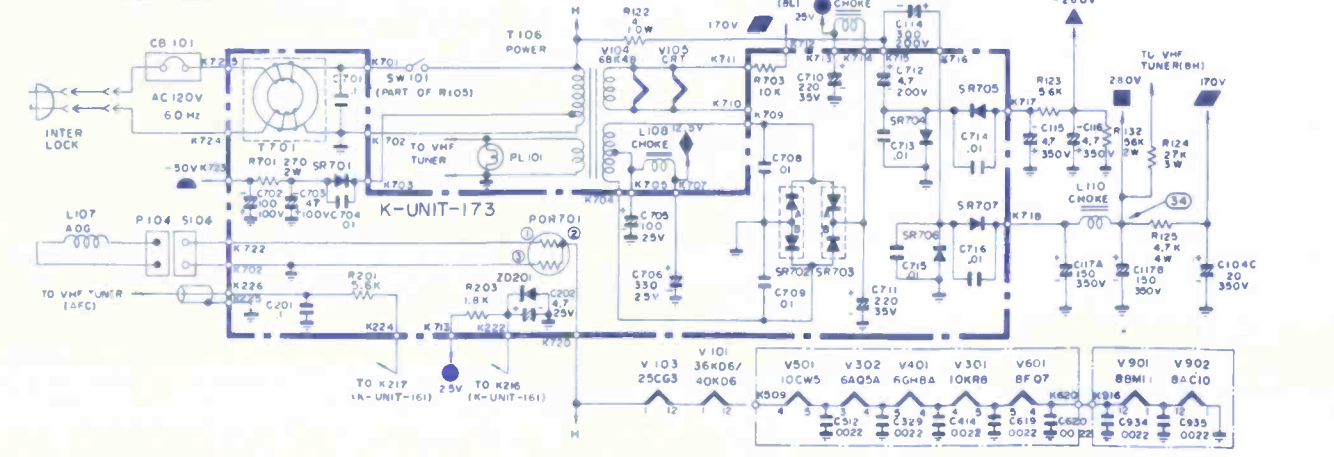
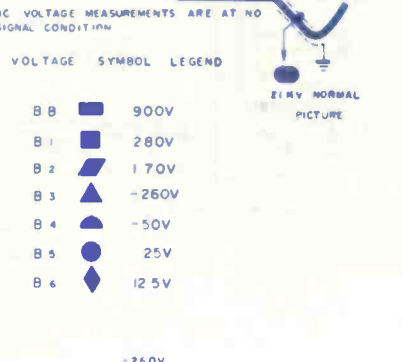
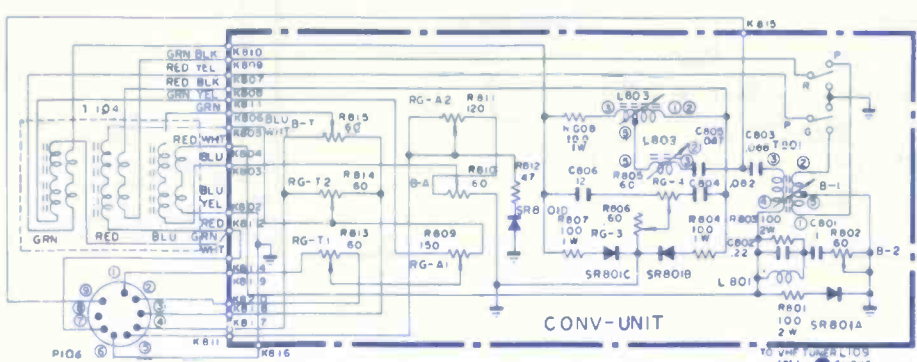
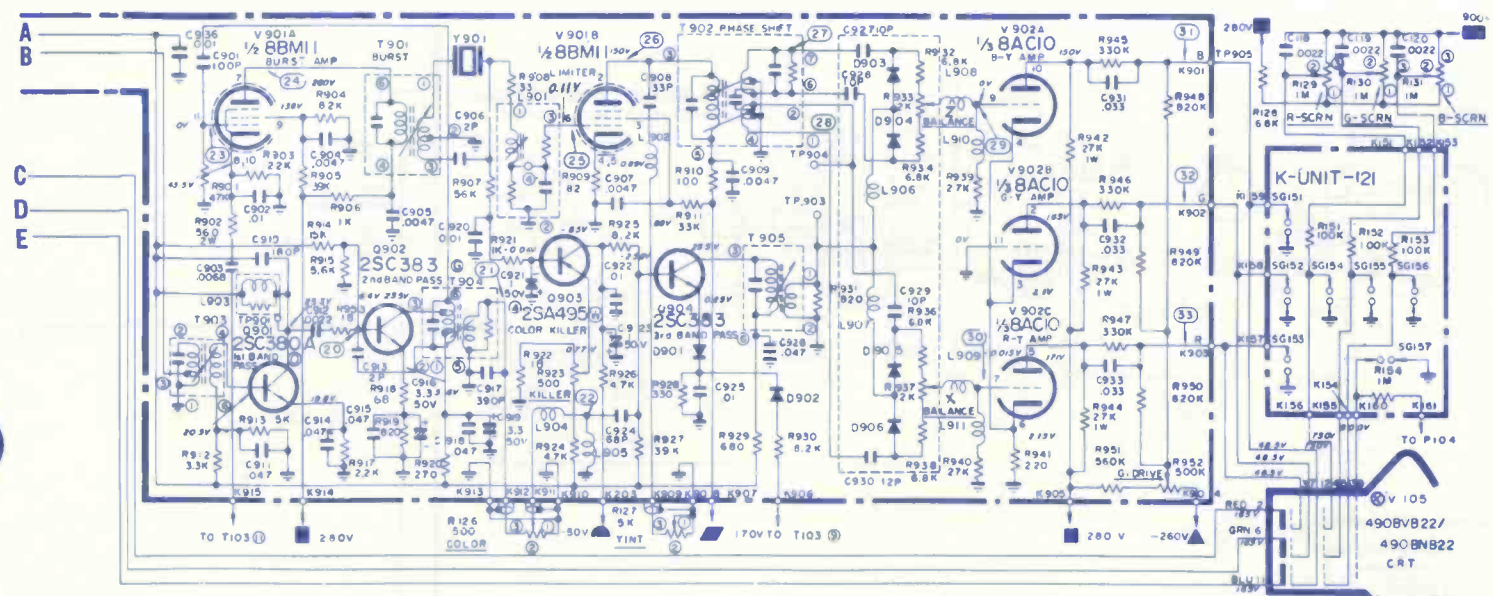
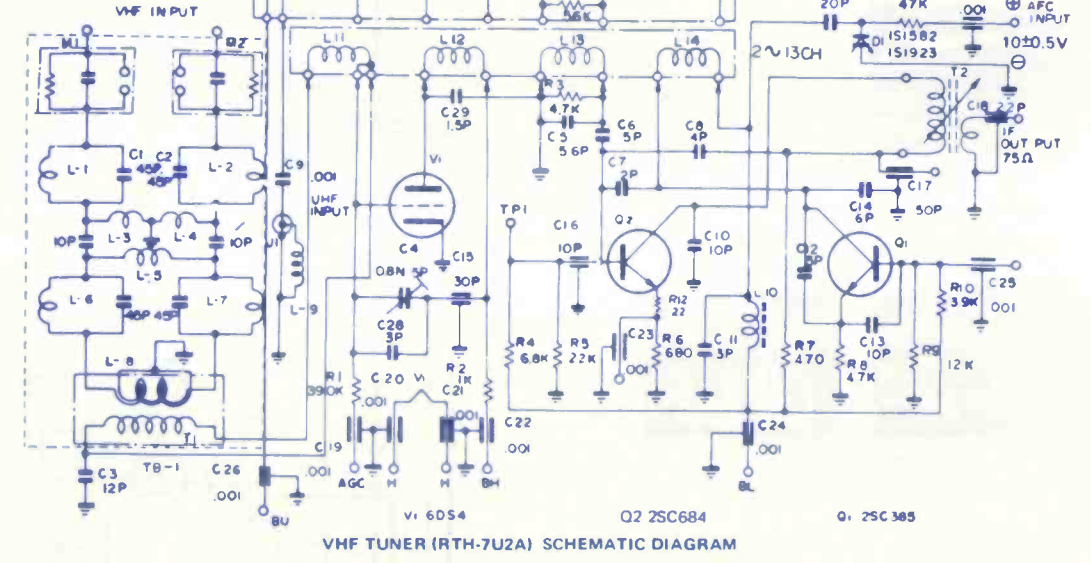



15. PIN 6, V305 180V P-P
22. PINS 1, 8 V101 150V P-P



16. PIN 7, V305 60V P-P

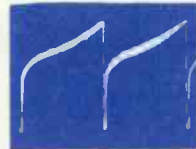

17. PIN 1, V301 85V P-P
19. PIN 2, V308 80V P-P



18. PIN 9, V301 200V P-P

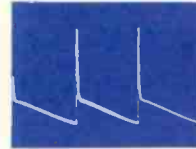

20. PIN 7, V308 110V P-P

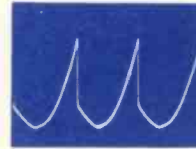

21. PIN 3, V308 10V P-P

WAVESHAPES 1, 2, 3
VERTICAL RATE



1. PIN 9, V-207 4.5V P-P
2. PIN 8, V-207 4.0V P-P
3. PIN 2, V-207 2.0V P-P

WAVESHAPES 4, 5, 6
VERTICAL RATE



4. PIN 6, V-207 100V P-P
5. PIN 2, V-208 60V P-P
6. PIN 9, V-208 40V P-P

HORIZONTAL RATE



WAVESHAPES 7
HORIZONTAL RATE

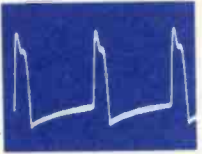

7. PIN 6, V-208 650V P-P



8. PIN 1, V-208 70V P-P



9. PIN 6, V304 70V P-P

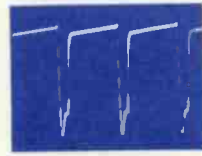

10. PIN 1, V304 10V P-P

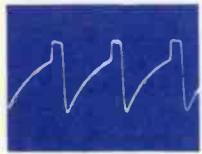

11. PIN 9, V304 240V P-P

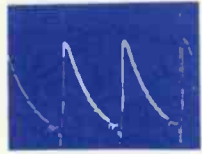

12. JUNCTION X306 60V P-P

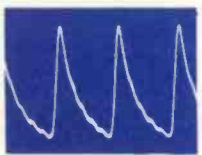

13. JUNCTION X307 50V P-P



14. PIN 2, V305 110V P-P

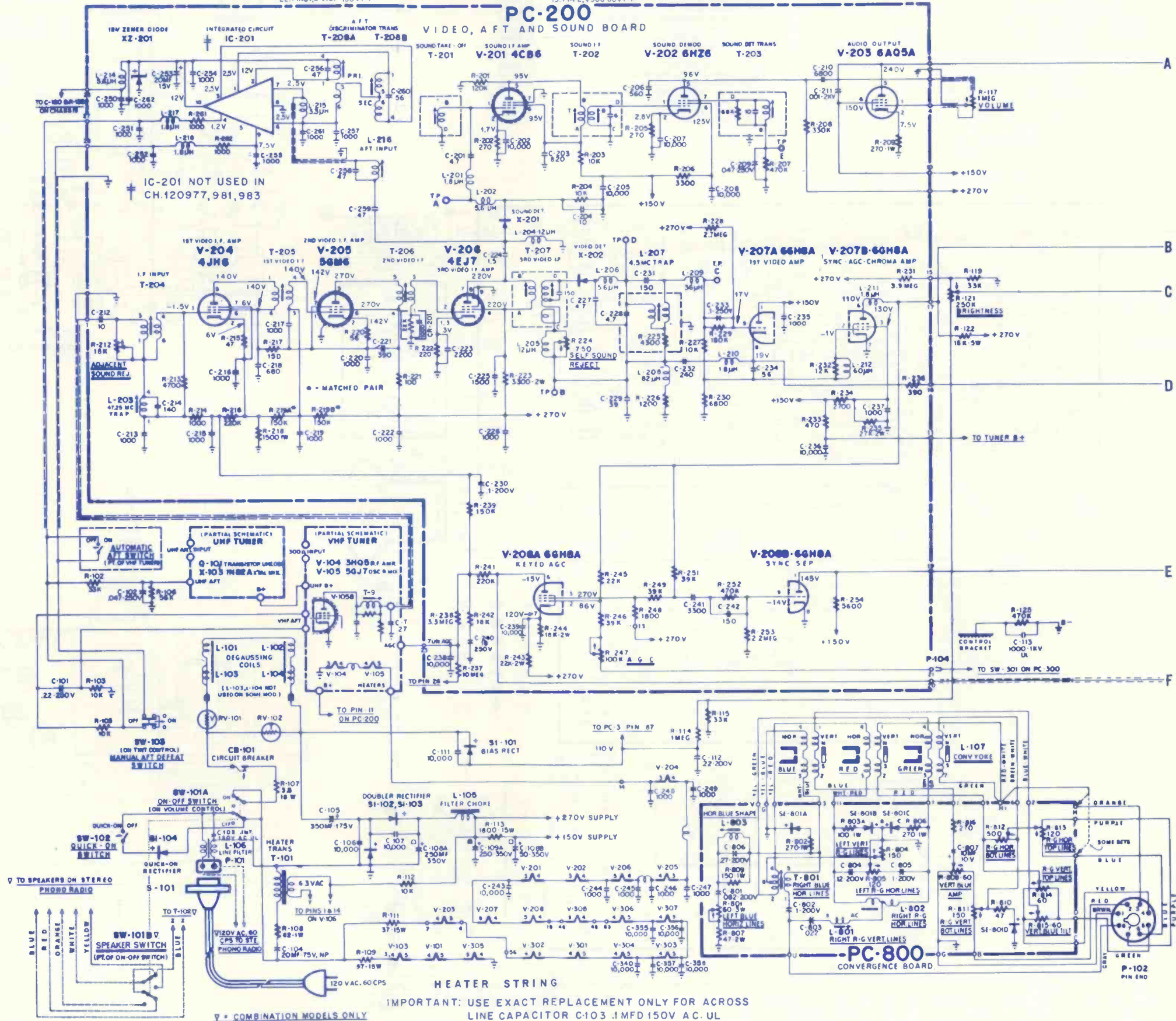

EMERSON
Color TV Chassis 120976, 977,
980, 981, 982, 983, 984



23. PIN 2, V302 44V P-P
24. PIN 6, V302 250V P-P
25. PIN 2, V301 2V P-P
35. PIN 9, V302 3V P-P
26. PIN 3, V303 18V P-P
36. PIN 1, V302 40V P-P
27. PIN 2, V303
PIN 2, V307 7V P-P
28. PIN 9, V303 9V P-P
29. PIN 9, V307 14V P-P
30. PC-300, TERM 79, TO
PIN 3, CRT 140V P-P
31. PC-300, TERM 80, TO
PIN 7, CRT 112V P-P

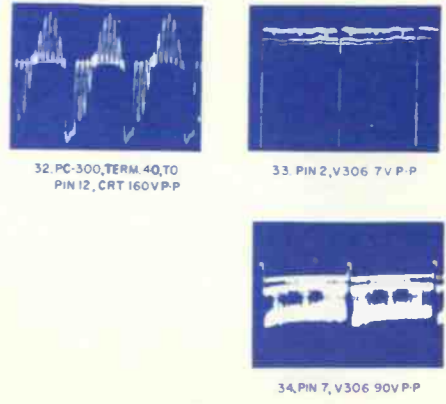
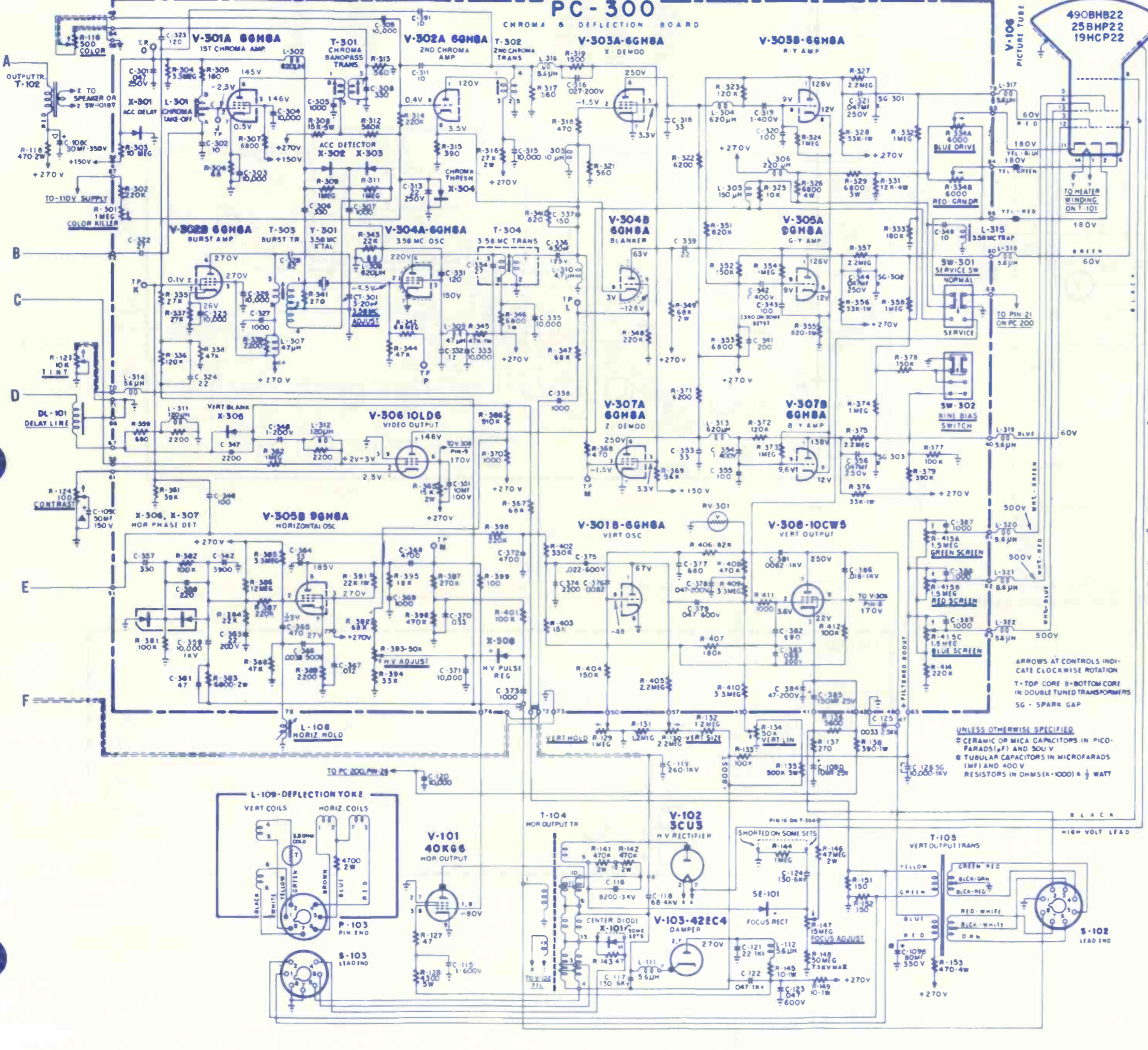

32. PC-300, TERM 40, TO
PIN 12, CRT 160V P-P
33. PIN 2, V306 7V P-P
34. PIN 7, V306 90V P-P

RESISTANCE READINGS

SYM. NO.	TUBE TYPE	PIN 1	PIN 2	PIN 3	PIN 4	PIN 5	PIN 6	PIN 7	PIN 8	PIN 9	PIN 10	PIN 11	PIN 12	PIN 13	PIN 14
V-101	40K66	640K	640K	NC	Filament	4.3K†	0	NC	0	NC	0	NC	0	NC	0
V-102	3CU3	-	Fil.	-	-	-	-	-	-	-	-	-	-	-	-
V-103	42EC4	NC	NC	NC	Filament	NC	20	NC	NC	NC	NC	NC	NC	NC	NC
V-106	CRT	Fil.	7.4K†	730K	(3)	(4)	(1)†	730K	NC	NC	NC	NC	NC	NC	NC
V-201	4CB6	3.6	270	Filament	10K†	10K†	0	0	0	0	0	0	0	0	0
V-202	6H7Z	4.4	270	Filament	330K	5K†	470K	0	0	0	0	0	0	0	0
V-203	6A05A (7)	2.70	Filament	1K†	1.6K†	1.6K†	(7)	0	0	0	0	0	0	0	0
V-204	4JH6	210K	1.6K	Filament	INF.	INF.	1.5K	0	0	0	0	0	0	0	0
V-205	5GM6	80K	INF.	Filament	100	100	INF.	0	0	0	0	0	0	0	0
V-206	4EJ7	220	22K	220	Filament	0	3.3K†	3.3K†	0	0	0	0	0	0	0
V-207	6GH8A	1.6K†	4.6K	4K†	1.6K†	1.6K†	13K†	0	1.1K	180K	0	0	0	0	0
V-208	6GH8A	7K†	36K†	1.6K†	Filament	600K	11K	0	2.2M	180K	0	0	0	0	0
V-301	6GH8A	3.2M	330K	9K†	Filament	15K†	68	0	260K	600K	0	0	0	0	0
V-302	6GH8A	27K†	25K	0†	Filament	10†	27K	390	600K	0	0	0	0	0	0
V-303	6GH8A	27K†	25K	0†	Filament	10†	27K	390	600K	0	0	0	0	0	0
V-304	6GH8A	26K†	480	1.6K	Filament	6.8K†	0	800	220K	0	0	0	0	0	0
V-305	9GH8A	26K†	44K	47K†	Filament	6.8K†	0	390	220K	0	0	0	0	0	0
V-306	10LD6	100	400K	0†	Filament	22K†	2.2K	800	800	1M	0	0	0	0	0
V-307	6GH8A	26K†	470	1.6K	Filament	4K†	0	800	800	1M	0	0	0	0	0
V-308	10CW5	3.4M	3.4M	5.2K	Filament	NC	4K†	0	800	1M	0	0	0	0	0
V-309	10CW5	3.4M	3.4M	5.2K	Filament	NC	4K†	0	800	1M	0	0	0	0	0

TUNER SCHEMATIC DIAGRAM

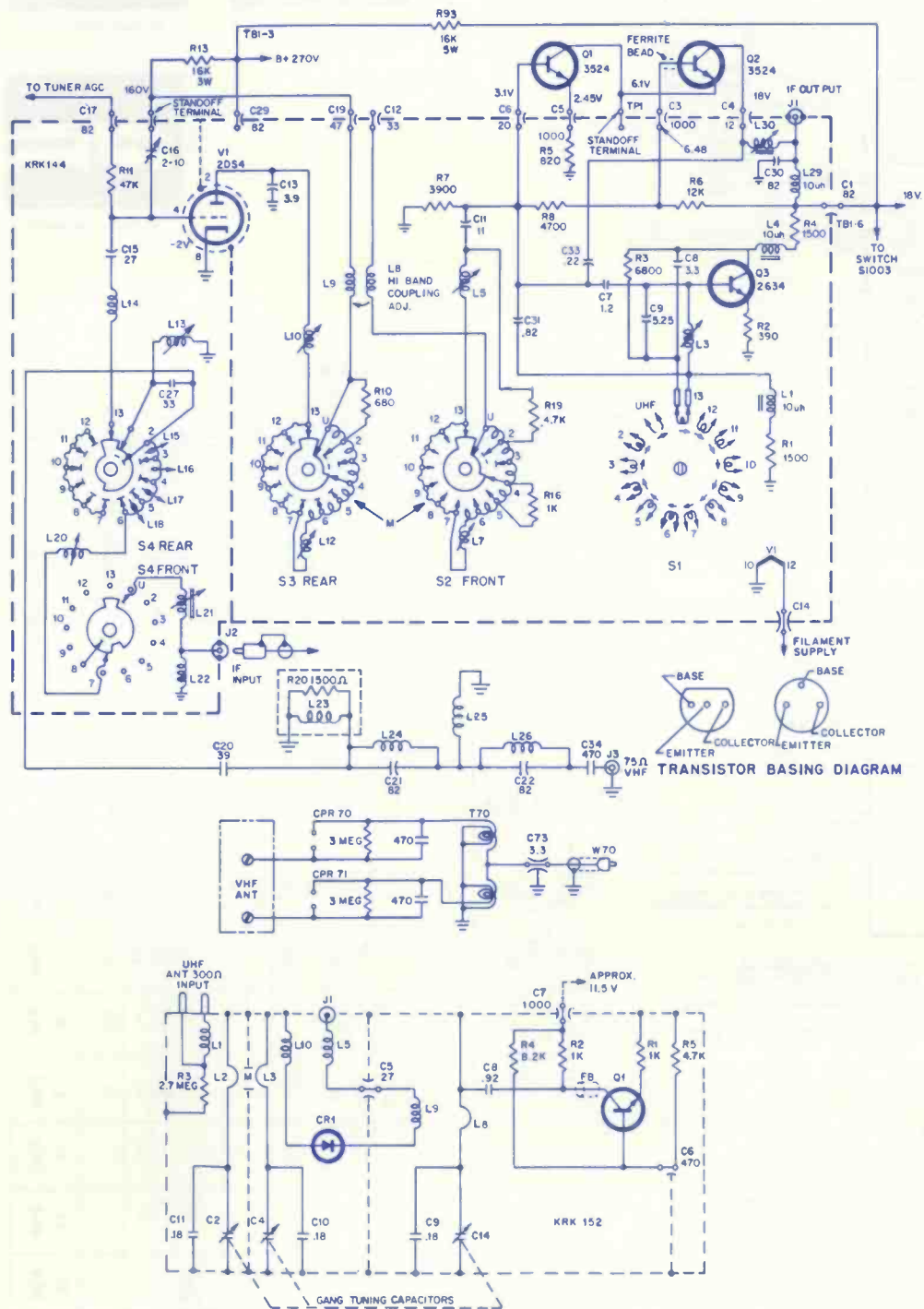

NOTES:
 ALL RESISTANCE VALUES ARE IN OHMS K=1000
 ALL CAPACITANCE VALUES ARE IN PF
 FRONT AND REAR SECTION OF ROTARY SWITCHES ARE VIEWED FROM FRONT, SHAFT IN CH 13 POSITION.
 ○ DENOTES CONTACT CONNECTED TO CONTACT ON OPPOSITE SIDE OF SWITCH.
 ⊕ DENOTES CONTACT INSULATED FROM CONTACT ON OPPOSITE SIDE OF SWITCH.

SYMBOL	DESCRIPTION	RCA PART NO.
C105	4 sec elect.	130821
C105A	200μf, 200v	130821
C105B	175μf, 175v	130821
C105C	40μf, 300v	130821
C105D	200μf, 10v	130821
C106A	200μf, 350v	126340
C106B	150μf, 350v	126340
C8101	brkr cir	130077
CR401	dumper	120818
CR402	video bias	119596
DL701	Delay-line	130109
F101	Fuse-7a	120785
L109	choke	112829
L113	choke, 1.8μh	109248
L201	41.25MHz	121564
L202	47.25MHz	124803
L299	discriminator	130121

L401	horiz eff	129453
L501	horiz	109947
L703	6.8μh	130105
L706	620μh	109257
L709	reg mutual	115427
Q201	AGC	124753
Q202	1st pix IF	124757
Q203	2nd pix IF	124757
Q204	3rd pix IF	124754
Q205	1st video	130139
Q206	chroma pre-amp	130139
Q207	2nd video	130139
Q501	AGC keyer	126713
Q502	sync amp	130139
Q503	sync sep	129899
Q504	noise gate	130139
Q701	killer	124755
Q702	ACC	123941
R110	control, tint/bright/color CTC 41A	130621

R110	control, tint, bright, color CTC 41XP	130622
R420	control, contrast/vert hold/horiz hold	130108
R421	control, bright limiter	125076
R701	control, killer/vert height/vert lin	130107
RT102	thermistor-250Ω cold	127227
RT103	thermistor-16Ω cold	131164
RT201	thermistor-4300Ω cold	128413
RV401	varistor-hold down	124811
RV401	varistor-degauss	126424
T102	horiz output	130093
T103	audio output	130091
T104	vert output	130092
T105	filament	130090
T299	input	130120
T701	burst	130104
T702	1st chroma	130100
T703	oscillator	121559
RT101	thermistor-temp. comp., 3.8Ω	115942
yoke	deflection	131786

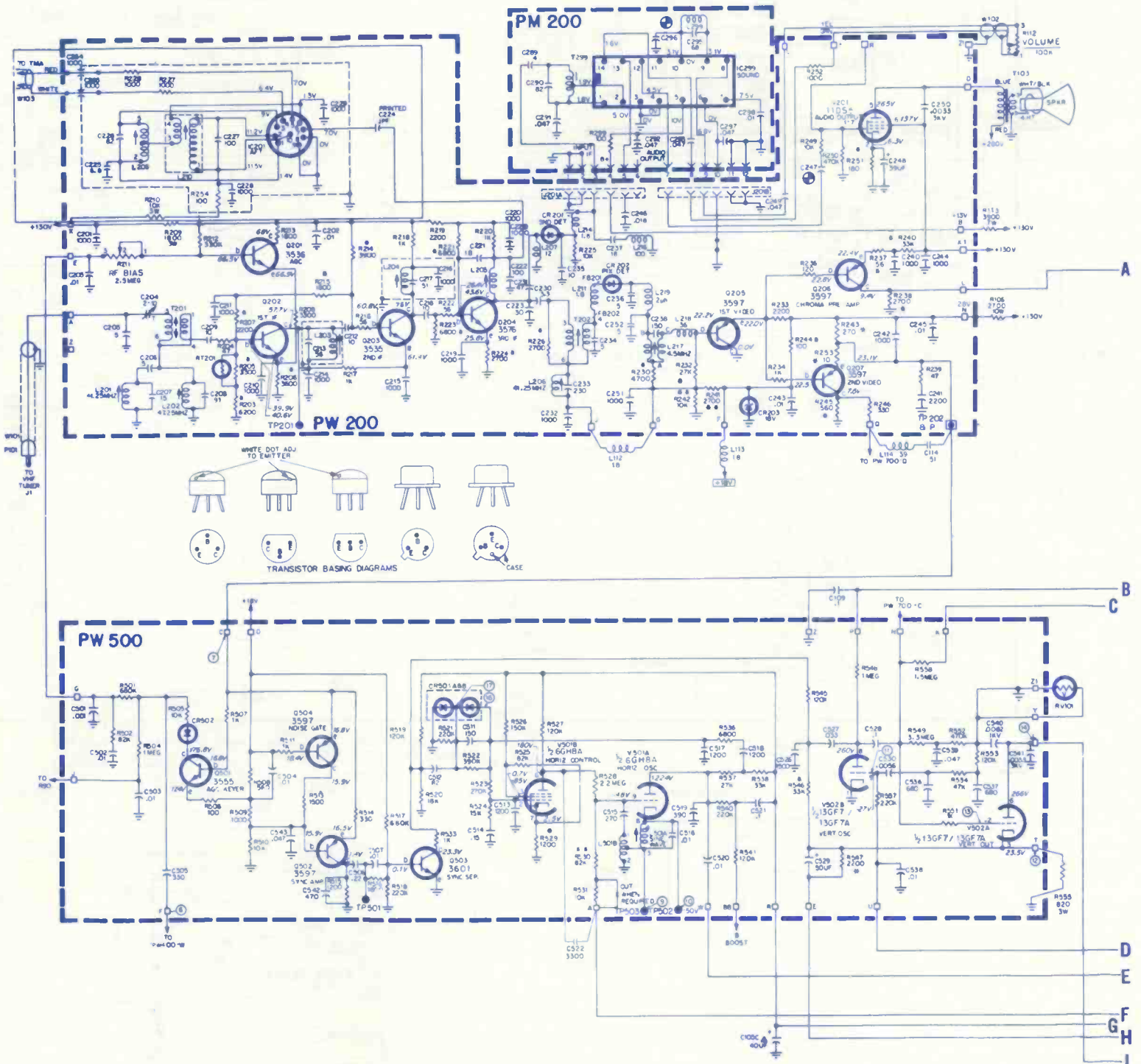

RCA VICTOR
Color TV Chassis CTC41 Series

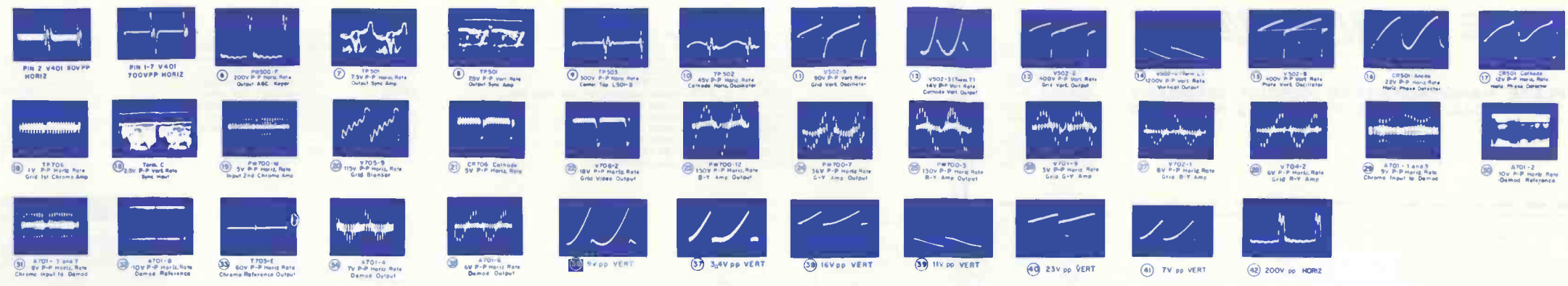

- NOTES:**
1. RESISTANCE VALUE IN OHMS, 10000
 2. RESISTORS ARE 1/2 WATT EXCEPT AS NOTED.
 3. 8 INDICATES 5% TOLERANCE-REPLACE ONLY WITH APPROVED PART.
 4. 8 8 INDICATES 2% TOLERANCE.
 5. CAPACITANCE VALUES 1.0 AND ABOVE ARE IN PF, THOSE BELOW ARE IN UF, EXCEPT AS INDICATED.
 6. INDUCTOR VALUES IN MH EXCEPT AS INDICATED.
 7. VOLTAGES ARE MEASURED TO CHASSIS GROUND WITH A VOLTMETER (RMS SIGNAL) AND SHOULD HOLD WITHIN 20% AT RATED SUPPLY VOLTAGE, TUNER TO LOW POSITION.
 8. ALL TUNER SWITCHES ARE SHOWN IN CHANNEL 13 POSITION.

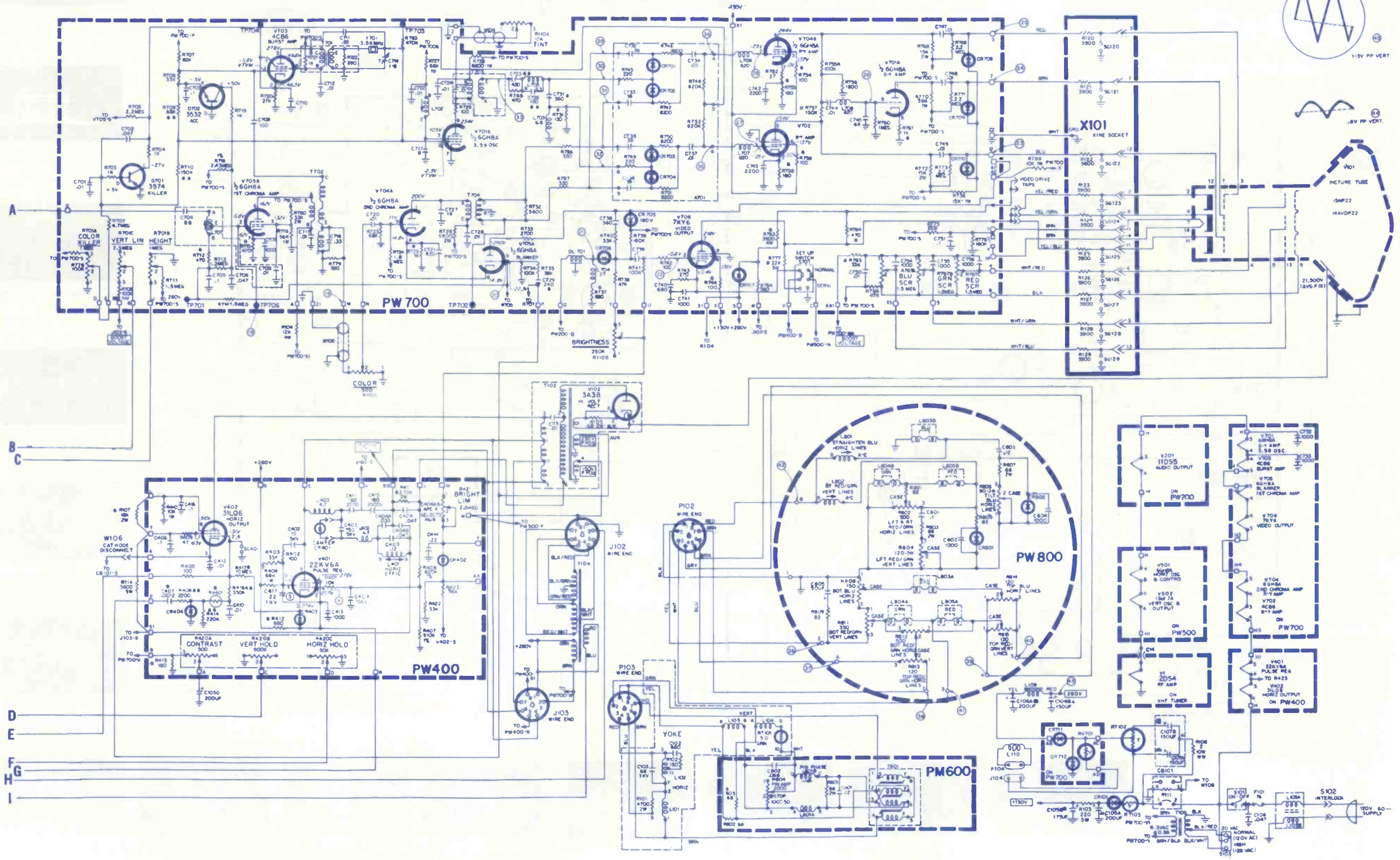

SYMBOL	DESCRIPTION	RCA VICTOR PART NO.
C101	capacitor—4 section elect.	129099
C101A	—250µf, 200v	129099
C101B	—650µf, 175v	129099
C101C	—50µf, 175v	129099
C101D	—10µf, 150v	129099
F101	—fuse—5a	118969
IC301	—circuit—integrated, sound	129871
L101	—choke—line	114293
L103	—choke—RF, 8.2µh	107385
L201	—coil—40MHz	125129
L402	—coil—47.25 trap	131655
L404	—coil—RF choke, 2.7µh	129703

L501	—coils—IF, 4.5 trap	128457
PW300	—circuit—sound module	129702
PW400	—circuit—video IF module	131952
PW500	—circuit—video module	131951
R102	—27Ω 10%, 3w, film	129693
R115	—control, contrast, vert hold, horiz hold	131795
R208	—control video bias	131466
R234	—control vert lin	121223
R240	—control vert size	121223
R429	—control AGC	126347
R514	—6.8K 10%, 3w, film	105662
RF201	—fuse—resistor	121086

RL401	—coil—RF choke	131791
RT401	—therm—4300Ω cold	124813
RV201	—varistor—48v, 1ma	118506
RV202	—varistor—80v, 1ma	131652
T102	—xformer—horiz output	131956
T103	—xformer—vert output	131633
T104	—xformer—audio output	129715
T301	—xformer—deductor	126738
T302	—xformer—discriminator, snd take off	129707
T401	—coil—IF	131465
T403	—xformer—IF	131656
RT101	—yoke—deflection	124245

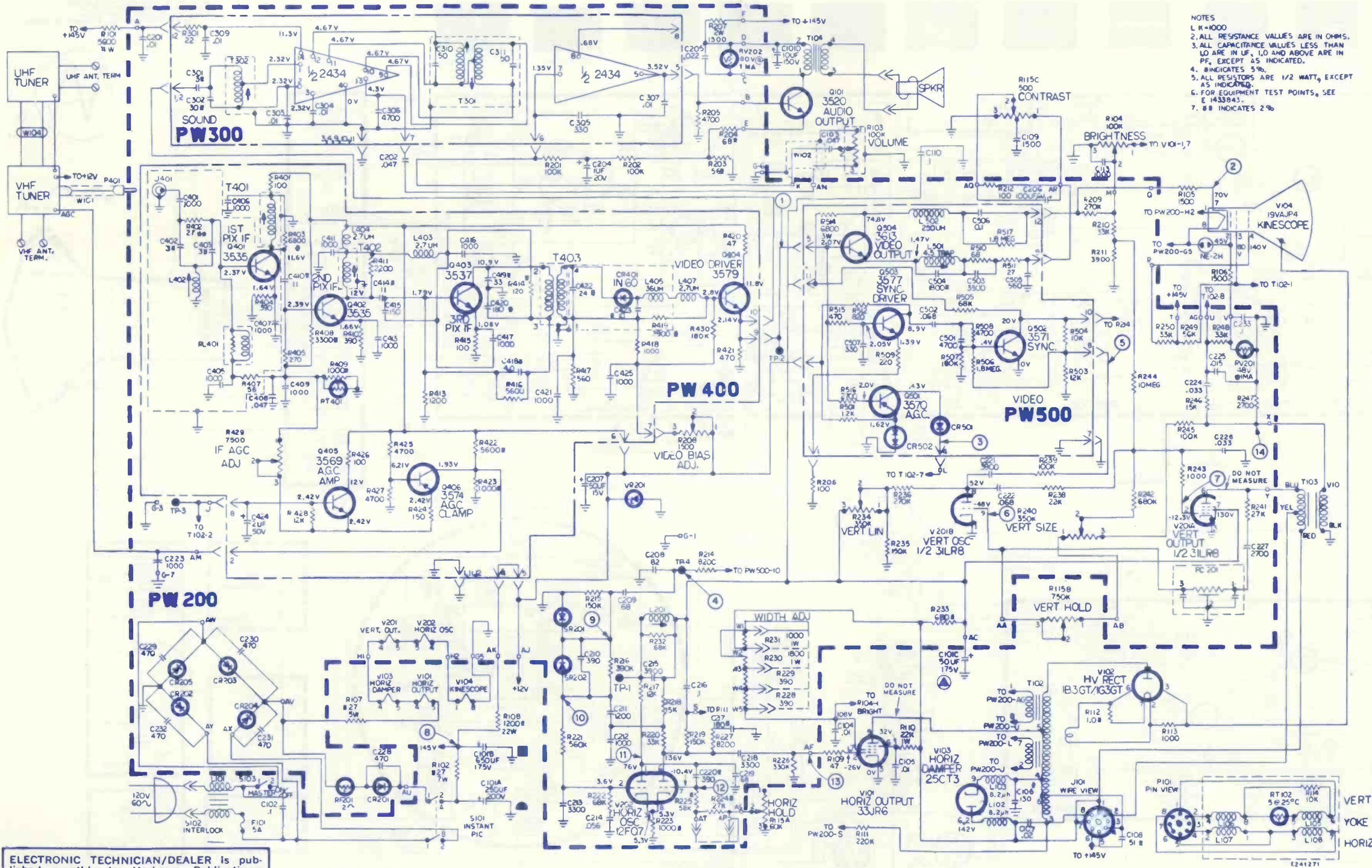

NOTES
 1. L = 1000
 2. ALL RESISTANCE VALUES ARE IN OHMS.
 3. ALL CAPACITANCE VALUES LESS THAN 10 ARE IN UF, 10 AND ABOVE ARE IN PF, EXCEPT AS INDICATED.
 4. # INDICATES 5%.
 5. ALL RESISTORS ARE 1/2 WATT, EXCEPT AS INDICATED.
 6. FOR EQUIPMENT TEST POINTS, SEE E 143343.
 7. # INDICATES 2%.



1 1.5V P-P VERTICAL RATE



2 50V P-P VERTICAL RATE



3 23V P-P HORIZONTAL RATE



4 27V P-P HORIZONTAL RATE

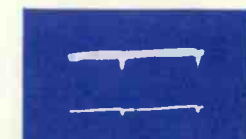

5 18V P-P VERTICAL RATE

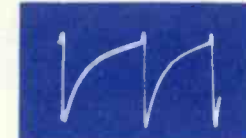

6 160V P-P VERTICAL RATE



14 300V P-P VERTICAL RATE

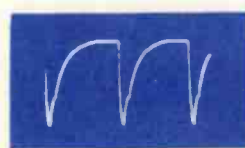

13 110V P-P HORIZONTAL RATE



12 35V P-P HORIZONTAL RATE



11 45V P-P HORIZONTAL RATE

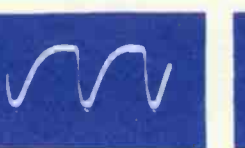

10 13V P-P HORIZONTAL RATE

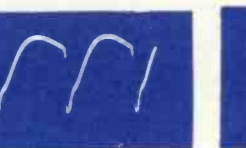

9 10V P-P HORIZONTAL RATE



8 10V P-P VERTICAL RATE



7 25V P-P VERTICAL RATE

ELECTRONIC TECHNICIAN/DEALER is published monthly by Harbrace Publications, Inc., Harbrace Building, Duluth, Minnesota 55802, a subsidiary of Harcourt, Brace & World, Inc. Subscription rates: One year \$5, two years \$8, three years \$10, in the United States and Canada. Other countries: One year \$9, two years \$14, three years \$18. Single copies 60¢. Second class postage paid at Dansville, New York and at additional mailing offices. Copyright 1970 by Harbrace Publications, Inc.
 POSTMASTER: Send Form 3579 to ELECTRONIC TECHNICIAN/DEALER, Harbrace Building, Duluth, Minnesota 55802.

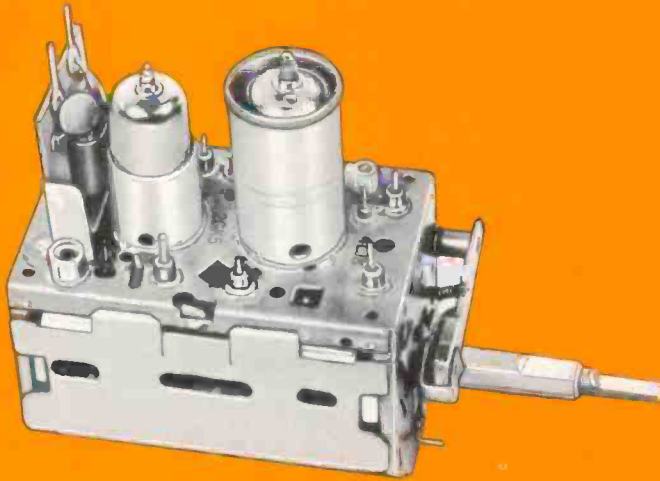

\$975

TUNER SERVICE CORPORATION

PROVIDES YOU WITH A COMPLETE SERVICE FOR ALL YOUR TELEVISION TUNER REQUIREMENTS AT ONE PRICE.

TUNER REPAIR

VHF Or UHF Any Type \$9.75.
UHF/VHF Combo \$15.00.

In this price all parts are included. Tubes, transistors, diodes, and nuvistors are charged at cost.

Fast efficient service at our four conveniently located service centers.

1 year guarantee backed up by the largest tuner manufacturer in the U.S.—SARKES TARZIAN, INC.

All tuners are cleaned inside and out, repaired, realigned and air tested.

TUNER REPLACEMENT

Replacement Tuner \$9.75.

This price buys you a complete new tuner built specifically by SARKES TARZIAN INC. for this purpose.

The price is the same for every type of universal replacement tuner.

Specify heater type

Parallel 6.3V
Series 450 mA
Series 600 mA

All shafts have the same length of 12".

Characteristics are:

Memory Fine Tuning
UHF Plug In
Universal Mounting
Hi-Gain Lo-Noise

If you prefer we'll customize this tuner for you. The price will be \$18.25. Send in original tuner for comparison purposes to our office in INDIANAPOLIS, INDIANA.



TUNER SERVICE CORPORATION

FACTORY-SUPERVISED TUNER SERVICE

MIDWEST	817 N. PENNSYLVANIA ST., Indianapolis, Indiana	TEL: 317-632-3493
EAST	547-49 TONNELE AVE., Jersey City, New Jersey	TEL: 201-792-3730
SOUTH-EAST	938 GORDON ST., S. W., Atlanta, Georgia	TEL: 404-758-2232
WEST	SARKES TARZIAN, Inc. TUNER SERVICE DIVISION 10654 MAGNOLIA BLVD., North Hollywood, California	TEL: 213-769-2720

. . . for more details circle 131 on Reader Service Card

Why get caught with your pants down because of false shorts? The new B & K Model 607 Dyna-Jet is the first reasonably priced tube tester to give you nothing but positive short indications in every tube you'll ever test.

Why? Because 10 lockout buttons let you create any combination of live pin connections you want. How? By locking out the pin connections you *don't* want.

It's so easy to use too. A shape-coded chart does practically all the thinking for you. And the B & K multiple socket design means you need only 3 or 4 settings to complete a quality check.

Consider all the advantages:

- Exclusive multiple-pin lockout switches mean *all* tubes now can be tested for shorts. You never get false short indications regardless of pin connections. Reset button clears all lockouts.

- Tube testing speed doubled by (1) exclusive shape-coded symbols that match controls to chart, and (2) minimum number of settings—maximum of 4, and sometimes only 3.
- Checks tubes the accurate way—under simulated load conditions.
- Exclusive grid leakage and gas tests.
- Simplified heater voltage setting.
- Power 'ON' indicator.
- Superior load and plate voltage capability.
- Attractive, attache-type case for professional appearance.

Ask your distributor about the new solid state Model 607 Dyna-Jet from B & K. It's the most modern portable tube tester yet. And you'll never be left in the cold with false shorts. And that's the naked truth!

Put an end to false shorts that leave you naked

...with the new 607 portable tube tester from B&K

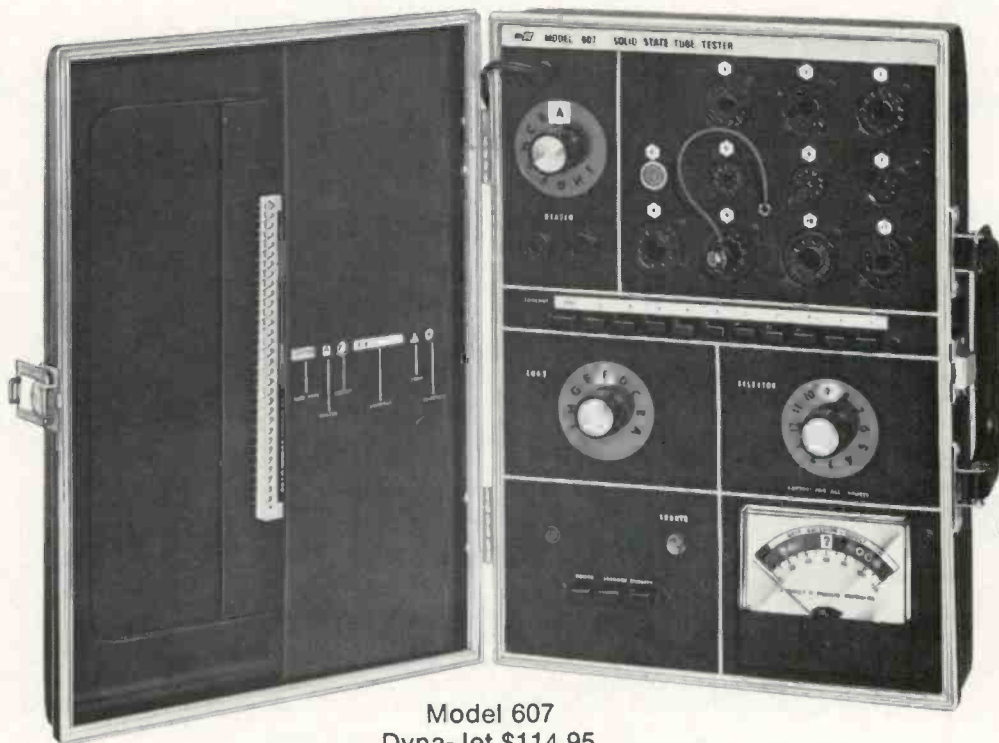

Model 607
Dyna-Jet \$114.95

... for more details circle 101 on Reader Service Card



Product of
DYNASCAN CORPORATION
1801 W. Belle Plaine
Chicago, Illinois 60613

**The professional
test equipment.**

HUGH "SCOTTY" WALLACE

Publisher
Chicago:
(312) 467-0670

PHILLIP DAHLEN

Editor
Duluth:
(218) 727-8511

JOSEPH ZAUHAR

Managing Editor

EMILY WILSON

Associate Editor

DEBBIE GOLDBERG

Production Editor

BOB ANDRESEN

Graphic Design

LILLIE PEARSON

Circulation Fulfillment

JOHN KESSLER

Manager, Reader Services

BERNICE GEISERT

Advertising Production

OFFICES

757 Third Avenue
New York, N.Y. 10017
Phone: (212) 572-5000
Telex: 01-26286
43 East Ohio St.
Chicago, Ill. 60611
Phone: (312) 467-0670
Telex: 02-53549
1901 West 8th St.
Los Angeles, Calif. 90057
Phone: (213) 483-8530
1 East First Street
Duluth, Minn. 55802
Phone: (218) 727-8511
Telex: 02-94417

MANAGERS**HUGH "SCOTTY" WALLACE**

Chicago: (312) 467-0670

DEAN GREENER

Chicago: (312) 467-0670

ALFRED A. MENEGUS

New York: (212) 572-4829

DONALD D. HOUSTON

Los Angeles: (213) 483-8530

ROBERT UPTON

Tokyo, Japan
I.P.O., Box 5056

**CHARLES S. HARRISON,
CY JOBSON**

San Francisco:
(415) 392-6794

HARCOURT BRACE JOVANOVICH PUBLICATIONS

JOHN B. GELLATLY
President

RICHARD MOELLER
Treasurer

LARS FLADMARK
Senior Vice-President

HARRY RAMALEY
Vice-President

TOM GRENEY
Vice-President

JAMES GHERNA
Art Director

EDWARD CROWELL
Director of Marketing Services

ELECTRONIC TECHNICIAN / DEALER

WORLD'S LARGEST TV-RADIO SERVICE & SALES CIRCULATION

AUGUST 1970 • VOLUME 92 NUMBER 2

37 INTRODUCING EMERSON'S MODEL 26C56 COLOR TV SET

Part II—A review of this set's color circuits, plus a listing of production changes and simplified color control adjustments for faster troubleshooting techniques.

40 MASTER ANTENNA SYSTEMS

The basic principles of designing a satisfactory MATV system are described in detail in this staff written article.

48 FCC ALLOCATES CB EMERGENCY CHANNEL

Increase sales and service by taking advantage of a field rapidly developing with growing public demand for emergency communications.

51 SERVICING SOLID-STATE STEREO

Part III—This month's article deals with circuits designed to offer protection against line-voltage fluctuations.

53 HOW I STAYED IN THE TV BUSINESS

Retired electronic technician maintains adequate income by rebuilding cathode ray tubes.

54 TESTLAB REPORT

Our firsthand evaluation of Sencore's BE156 dc bias supply and its 39G26 link detector—with statistical data compiled from actual units.

22 EDITOR'S MEMO

24 LETTERS TO THE EDITOR

30 TECHNICAL DIGEST

32 COLORFAX

59 DEALER SHOWCASE

64 NEWS OF THE INDUSTRY

70 NEW PRODUCTS

75 CATALOGS AND BULLETINS

76 READER SERVICE INDEX

COVER

Elizabeth Hawkes Hall, located on the Superior campus of Wisconsin State University, contains an unusual MATV amplification-distribution system. The Blonder-Tongue system not only provides individual channel amplification for all receivers in this dormitory, but also carries combined signals through a cable to Frank A. Ross Hall, the men's dormitory, for additional amplification and distribution.

TEKFAX • 16 PAGES OF THE LATEST SCHEMATICS • Group 216

AIRLINE: Color TV Model GEN-12440C

EMERSON: Color TV Chassis 120976, 977, 980, 981, 982, 983, 984

MAGNAVOX: TV Chassis T928 Series

RCA VICTOR: Color TV Chassis CTC41 Series

RCA VICTOR: TV Chassis KCS184A



A HARCOURT BRACE JOVANOVICH PUBLICATION



ELECTRONIC TECHNICIAN/DEALER is published monthly by Harbrace Publications, Inc., a subsidiary of Harcourt Brace Jovanovich Publications, Inc. Corporate Offices: 757 Third Avenue, New York, New York 10017. Advertising Offices: 43 East Ohio Street, Chicago, Illinois 60611 and 757 Third Avenue, New York, New York 10017. Editorial, Accounting and Circulation Offices: 1 East First Street, Duluth, Minnesota 55802. Subscription rates: One year \$5, two years \$8, three years \$10, in the United States and Canada. Other countries: one year \$9, two years \$14, three years \$18. Single copies: 75¢ in the U.S. and Canada; all other countries \$2. Second class postage paid at Dansville, New York 14437 and at additional mailing offices. Copyright 1970 by Harbrace Publications, Inc. POSTMASTER: Send form 3579 to ELECTRONIC TECHNICIAN/DEALER, 1 East First Street, Duluth, Minnesota 55802.

SIX PACK OF BLUE STUFF

GET YOUR CUSTOMER'S SETS READY
FOR THE WORLD SERIES



Bring in any old empty six pack carton from beer, soft drinks, soap or any old carton that holds six cans and our distributor will fill it with six cans of BLUE STUFF and only charge you for four cans.

NOTHING NEW TO TRY...

JUST AN OLD FASHIONED SPECIAL IN TIME FOR A WORLD SERIES TUNE UP.

Offer expires September 15, 1970.

TECH
SPRAY better chemical tools for technicians

P. O. Box 949 Amarillo, Texas • Canada: Wm. Cohen, Montreal • Export: Empire Exporters, N.Y.C.

. . . for more details circle 130 on Reader Service Card

ET/D

EDITOR'S MEMO

The Consumer Electronics Show

I appreciate having had the opportunity to visit with many of you last month at the Consumers Electronics Show in New York City, and am certain that all of you who were able to attend were as impressed as I was with the many new products being offered for 1971. This fall, special issues of ELECTRONIC TECHNICIAN/DEALER will describe many of these products.

For the benefit of those unable to attend, I thought it might be interesting to mention just a few electronic developments shown that might give you a better idea of products you will be encountering in the near future.

Several manufacturers demonstrated four-channel sound Hi-Fi systems requiring the placement of a speaker system in each corner of the room. The music in each demonstration area was very impressive for you could easily tell whether the music was coming from the left front, right front, left rear or right rear. The music just seemed to dance around you.

When looking inside many of the pieces of electronic equipment—whether TV sets or audio equipment—I was impressed with the fact that more and more electronic equipment contain only solid-state circuits, and that the trend is definitely going toward plug-in modular circuits.

There seems to be an increased emphasis on reducing cabinet sizes—even in large-tube color TV sets. And one manufacturer even showed how small TV sets can be made by demonstrating a prototype 4½-in. color TV set about the size of a pop-up toaster. I would certainly hate to have to dig into a complex circuit reduced to those dimensions.

Also demonstrated was a color TV set with a cassette system for recording and playing back TV programs in color, or playing back rented cassette movies.



This show further demonstrates the fact that our technology is changing at an extremely rapid rate, requiring constant training in order to keep abreast of new servicing requirements.

Phillip Dahlen

ELECTRONIC TECHNICIAN/DEALER

The hunt is on!

(Beware of the Grope.)

How to keep the Grope from bagging your prospects without them lifting a finger.

The Grope preys on people who don't know where to find what they're hunting for . . . turning their search for you into a jungle hunt.

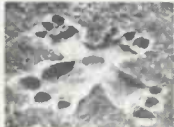

The Grope footprint goes in all directions, like you without the Yellow Pages.

But you can put one over on the Grope, if you don't spread yourself thin. Cover your territories . . . all of them, by listing yourself in the surrounding area Yellow Pages.

You see, a lot of your prospects that are nearby, use a nearby Yellow Pages. And when they lift a finger, if you're not there . . . they miss out on you and you on them.

So play it smart and list yourself in the surrounding area Yellow Pages. After all, why try for some of the customers some of the time, when you can try for all of the customers all of the time!



The Yellow Pages



Now it costs less to own the best Sweep/Marker Generator you need.



The new RCA WR-514A TV Sweep Chanalyst

The best you need is the new RCA WR-514A TV Sweep Chanalyst.

Some statistics:

- Fundamental sweep output on all VHF TV channels
- Video and IF sweep output for IF amplifiers, video, and chroma circuits
- New ChromAlign chroma sweep signal
- Seven crystal IF markers for checking IF, sound, video, and color bandpass stages
- Built-in, solid-state marker-adder for clean distortion-free displays
- High, flat sweep-output voltage. 10 MHz or more sweep width on all VHF channels
- On-off blanking control
- Balanced, 300-ohm RF output from low-leakage piston attenuator
- Sweep output in the FM range, from 88 to 108 MHz
- BNC connectors used throughout
- Optional distributor resale price... only \$375.
(Includes 1 RF output cable, 3 direct shielded cables, 2 direct cable adapters, one 75 ohm cable adapter, and 1 connector adapter)

Some statistics! For complete details, contact your local RCA Distributor.

RCA/Electronic Components/Harrison, N. J. 07029

... for more details circle 122 on Reader Service Card

RCA

*Inexpensive Quality

ET/D

**LETTERS
TO THE EDITOR**

Comments

After reading the June Letters to the Editor, I felt I must comment on the letter sent in by T. David Thomson referring to the article entitled "Selling CCTV" (March).

After doing recording in the high school here over the past four years with video recorders, I was very upset by the cleaning techniques Thomson specified. If you read any of the operator's manuals put out by any major manufacturer, they will tell you to use only quality head cleaner—no alcohol. The major reason for this is that most commercially available alcohol contains 30% water which could cause rust if the VTR were to sit idle during the summer, such as in our program. I at one time used alcohol and found that I could run the recorder for only thirty minutes during playback without picture loss. I also found that if the recorder sat idle during the vacation it would not play back when we tried to use it again.

I also disagree with Thomson's use of linen. I use cotton swabs mainly because they are softer and easy to store. We also at one time used linen until we got a thread caught on a video head and chipped it. I do agree with Thomson on the points of degaussing and sideways motion.

I found that the rest of the article was helpful to people starting out in the business. I wish to thank you for printing it.

JAY GOLDEN

For Sale

I am retiring after more than 30 years in the servicing business. I have nearly 700 Howard Sams' which I will sell all at once or in lots of 25 for \$1.00 each. I have thousands of obsolete but unused tubes. Name your own price. I also have many parts.

I have enjoyed and used your magazine for many years and will continue reading it in the future.

BUD & FRANK'S RADIO-TV SERVICE
91 Burlington Ave.
Paterson, New Jersey

Readers' Aid

I am in need of a copy of the operating manual and schematic for a Solar Model CCB capacitor analyzer (Solar Manufacturing Company—no longer in business). I will pay all costs for the loan of same or photostats,

the set choice is yours...

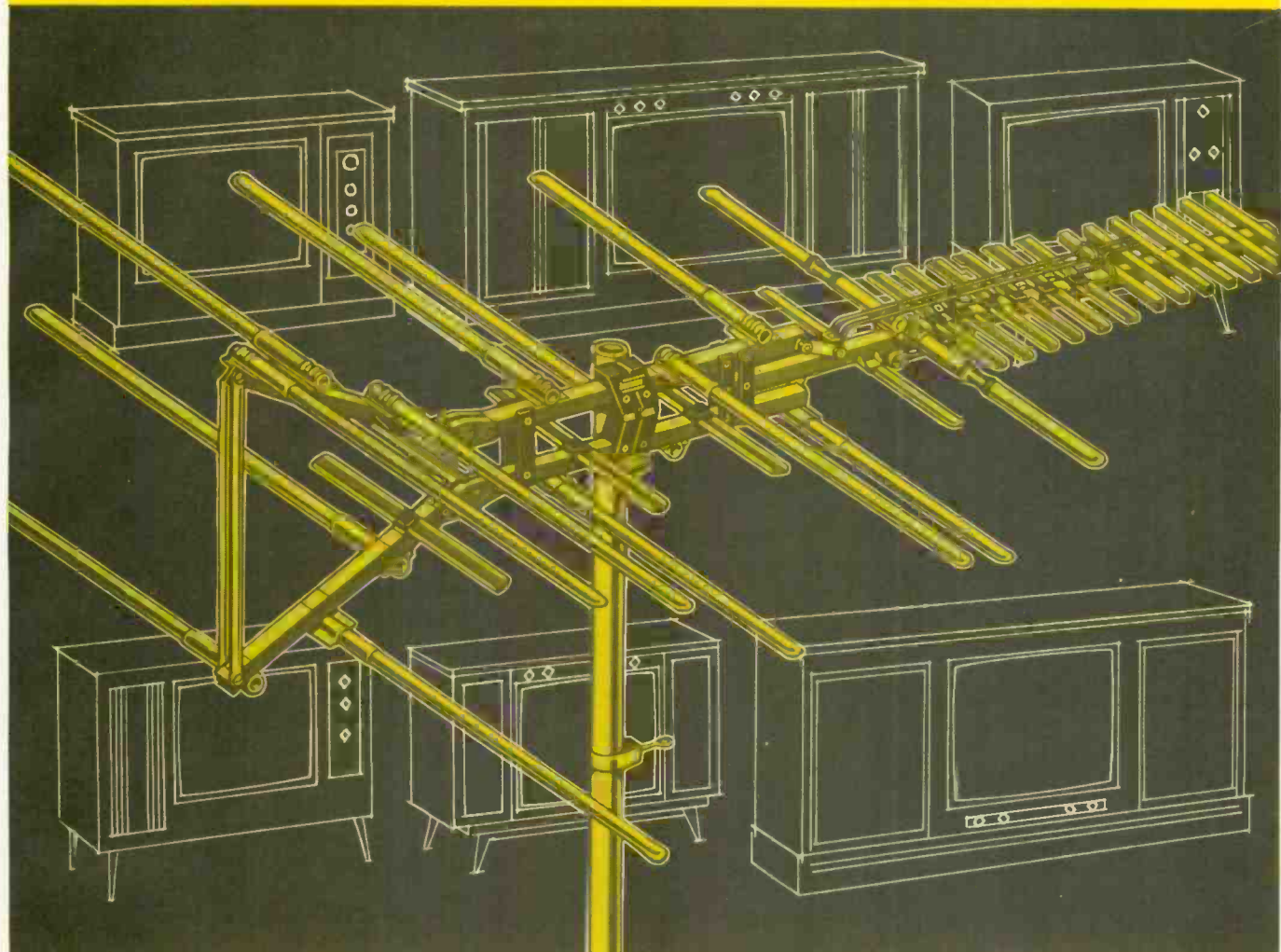

the antenna choice is...

FINCO®

NEW '70 SERIES COLOR SPECTRUM TV ANTENNAS

Send for free Catalog 20-556

NAME _____

ADDRESS _____

CITY _____ STATE _____ ZIP _____



THE FINNEY COMPANY

34 WEST INTERSTATE STREET
DEPT. 110-8
BEDFORD, OHIO 44146

popular paks



- GE-504A
- GE-509
- 6GC1
- GEGR-1

rectifiers and diodes for the replacement market

GE-504A—1-amp, 600-volt PIV universal silicon rectifier with a 60-amp surge current rating.

GE-509—1-amp, 1000-volt PIV universal silicon rectifier with a 60-amp surge current rating.

6GC1—VAC-U-SEL® dual diode primarily used as a discriminator or phase detector in TV receivers.

GEGR-1—Focus rectifier designed as a heavy-duty replacement for the focus diode in color television.

ask for
General Electric
Popular Paks at
your GE distributor

TUBE DEPARTMENT
OWENSBORO, KENTUCKY

GENERAL  ELECTRIC

... for more details circle 110 on Reader Service Card

ET/D

LETTERS TO THE EDITOR

whichever is more convenient.

I would also like to purchase another of this model, so long as it is in fair to good condition, with or without operating data.

Your magazine is read by us all in our shop, and everyone agrees its content and value are immeasurable. True, you always get a few bellyachers who complain about anything and everything, who rave madly about technicians who desire to repair and maintain older electronic test instruments and old time radios, etc. We have in our shop an old Triumph 3 scope, a DuMont 224A scope and a Reiner Electronics VTVM, all of which are in perfect mint condition. We have a thorough monthly preventive maintenance program which applies to both the older and the up-to-date test equipment. All of the equipment mentioned is over 25 years old and still serving a functional purpose. Only DuMont is still extant amidst the three manufacturers.

Just as a good carpenter maintains and cares for his tools, every technician should learn to repair and maintain his test instruments to the best of his ability without its having to be returned to the manufacturer. It is part of his bread and butter and it aids immensely in his servicing. It also helps him to satisfy his customers who are the real salary payers. No customers and poor service to them mean no business and no salary.

Most of the complainers are made up of the lazy, "don't give a damn" technicians who louse up the whole electronic repair business by their shoddy work and "Broadway prices" to match their corrupt and dishonest practices.

RAYMOND DUNN

I would like some information in trying to locate Century Electronic, Inc. I have a Century fast check Model FC2 and I have misplaced the roll chart that goes with it. I would like to find out how I can replace it. If someone could give me the address of Century Electronic, I would be very grateful.

ROBERT LAMBERT

2736 Bechelli Lane
Redding, Calif. 96001

I am a subscriber of ELECTRONIC TECHNICIAN/DEALER and have been for many years. I thoroughly enjoy

reading everything in it.

I need some information, and I thought maybe you might be able to help me. I am repairing an "Ultrasonic Cleaner" Model No. C4001P, Serial No. 9389. I need a power transformer for it.

I wrote to Ultrasonic Industries at 141 Albertson Ave., New York, N.Y., but the letter came back stamped "Moved, Left No Address."

There is no number of any kind stamped on the transformer. The secondary winding is shorted. It uses an 826 tube. I have no schematic on the thing, so I have no idea what the voltages should be. If you could send me some information on a replacement transformer, I certainly would appreciate it.

JESSE PARKER

4084 34th Ave.
Meridian, Miss. 39301

I need information and a schematic on Eltron, Inc.'s radio noise locator, Model No. 117, Serial N. 500. If any of your readers could furnish a copy of the information, we would duplicate and return.

Your magazine is of great benefit to all of us.

WILLIAM F. FORD

Audiovision Service Co.
P.O. Box 259
Elmer City, Wash. 99124

I have been a subscriber for many years, and I want to get some information, if possible, through your magazine.

I have a Pentron Tape Recorder for which I need a schematic and the mechanical brochure. I would like to find out the name of the company that repairs their equipment and provides replacement parts, schematics and brochures on Pentron tape recorders.

I am hoping that you can find out this information for me.

ANTHONY BOCHICHIO

45 Andrews St.
Staten Island, N.Y. 10305

Sometimes I think TV Engineering Design personnel should be compelled to go out into the field and service some of the sets they've designed.

I've been in electronic servicing for 30 years, and lately I've seen such a gamut of obvious design errors that I marvel at the \$20,000 annual salaries these people draw.

Admittedly, I work in Florida where humidity and salt severely test any electronic apparatus. But other areas of the U.S. are just as humid.

I have listed some of the servicing

ELECTRONIC TECHNICIAN/DEALER

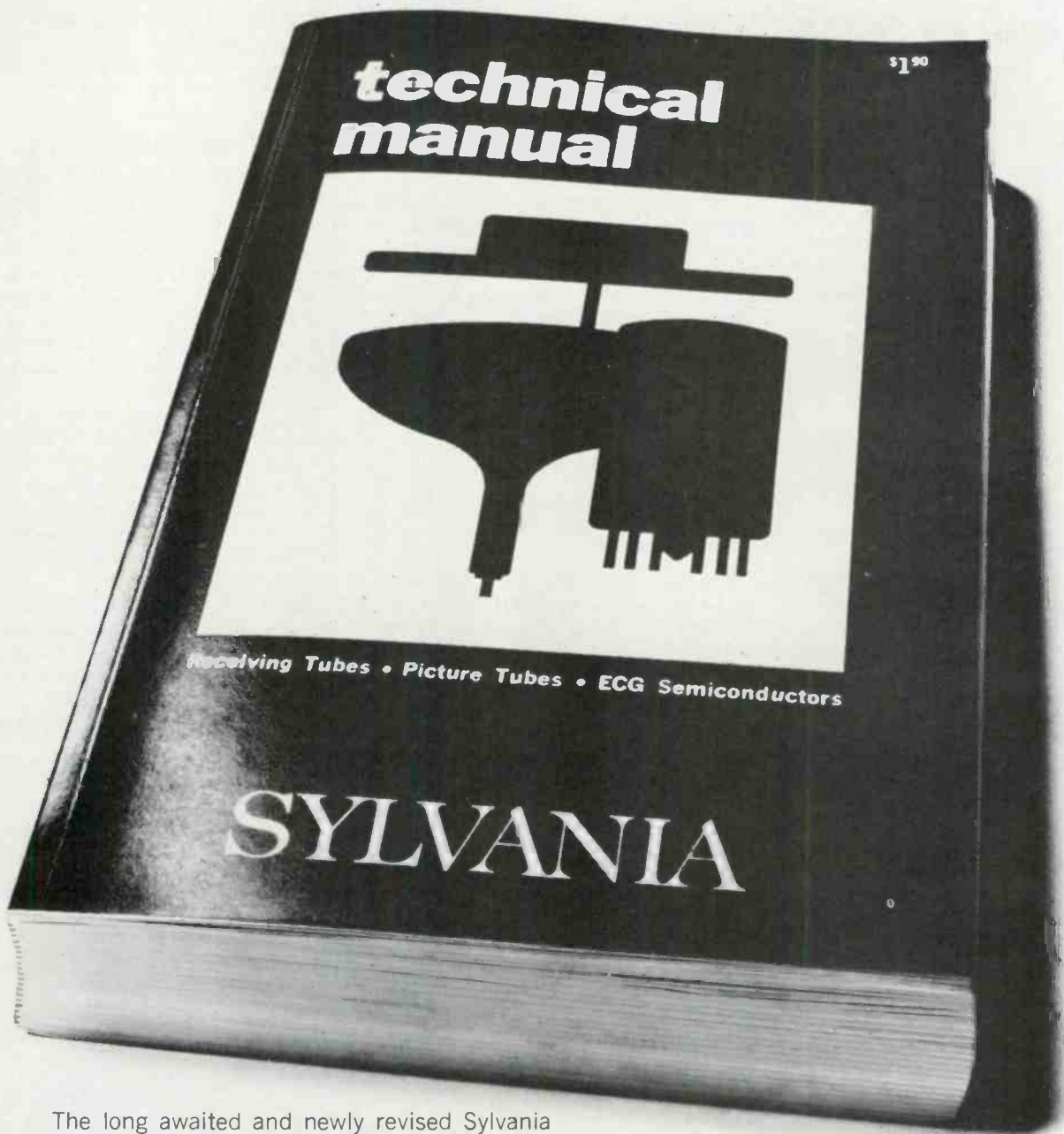

The long awaited and newly revised Sylvania Technical Manual is out. Complete and unexpurgated. The fantasy of every Independent Service Technician. Written anonymously by an agile team of Sylvania engineers. 32,000 components described in breathtaking detail. Including thousands of unretouched diagrams and illustrations. Discover the unspeakable thrill of new color TV Tubes, listed as never before. The ecstasy of 28,000 ECG Semiconductors.

From exotic Deflection Oscillators to a lurid account of Transistors and Rectifiers.

This book has what you want. Components for the man who knows what to do with them.

The 14th Edition of the Sylvania Technical Manual is not available in any bookstore. Your Sylvania Distributor is discreet. Speak to him.

SYLVANIA
GENERAL TELEPHONE & ELECTRONICS

“Electrifying”

nightmares I've recently encountered in color sets:

- Sharp bent wire-type anode connectors—corona radiation eats up the rubber insulation in six months.
- Purity rings which literally rust together in less than a year and require disassembly to pry them apart.
- Unyielding adhesives applied to yoke and picture tube surfaces which require (shudder) pressure on the picture tube bell to pry them loose.
- Printed boards where high vertical output pulses are isolated from ground by a scant 1/4 in. of questionable insulation.
- Backs of sets which require three separate tools to remove.
- Powdered iron slugs which freeze so tightly in the coils that adjustment without damage is impossible. One hotel here bought 10 color sets and, early in the second year, had 100% flyback failure.

Set manufacturers—is anyone listening?

ROBERT M. SICKELS

I am in desperate need of a book on the Analab 1100R dual trace scope. If nothing else is available, just the schematics will do.

FRANK PANKOMIN

22487 Bertie
Edgemont, Calif. 92518

After 10 years of TV service, I am expanding into mobile radio service.

Could you supply me with a list of sources for service literature and schematics similar to Howard W. Sams' publications for TV.

I read your magazine regularly and find it very informative and educational.

AHREND'S ELECTRONICS

21 Poplar St.
Bloomington, N.J. 07403

Error in Article

On page 60 of the May 1970 issue of ELECTRONIC TECHNICIAN/DEALER, it states "50 times .000208 or .0104 sec (104 msec)."

I believe that it should read 10.4 msec.

In view of the large number of articles on math for technicians, it is obvious that accuracy is a must. Tech-

nicians must be sticklers for details if they expect to master the complex monsters that they are supposed to service properly.

ARTHUR A. GAGE

Thanks Given for Help

I would like to thank you for your return letter to my letter of May 19, 1970. (We provided him with the name of a manufacturer of a product he remembered seeing sometime back in ELECTRONIC TECHNICIAN/DEALER.) I'm sure the problem which I posed was not an easy one for you to solve. I'm sure it took a lot of time and trouble on your part.

I'm sure I can well understand the pride taken in their work by the people who are employed by ELECTRONIC TECHNICIAN/DEALER when one such as you takes so much time and trouble to assist a subscriber, especially under the circumstances that were involved in this request.

Again, thank you and, if you will, submit this letter of appreciation to your superior to let him know of the excellent job you are doing for ELECTRONIC TECHNICIAN/DEALER.

Thanking you again for your cooperation in this matter.

JOHN WILLIAM WEIDOWKE

ANOTHER REVOLUTIONARY **1st** from *South River*

SOUTH RIVER
GOLD VINYL COATED STEEL ANTENNA MOUNTS
WITH 100% STAINLESS STEEL BANDING & HARDWARE



■ Heavy duty steel riveted. ■ Will not peel, chip or crack due to bad weather or exposure to the rays of the sun. ■ Will not corrode; eliminates rust streaks.

THE FIRST VINYL COATED TV ANTENNA MOUNTS
GUARANTEED NOT TO RUST FOR 25 YEARS
OR WE WILL REPLACE THEM FREE OF CHARGE
SEND FOR DATA SHEET

SELL & INSTALL SOUTH RIVER GOLD VINYL COATED MOUNTS FOR THE FINEST INSTALLATIONS

SOUTH RIVER METAL PRODUCTS CO., INC.
SOUTH RIVER, NEW JERSEY 08882 / (201) 254-5252

... for more details circle 129 on Reader Service Card

"U" BOLT MAST SOCKET



TWO TO A SET

GOLD VINYL COATED CHIMNEY MOUNT

MODEL V-DM-ST — 12 ft. S.S. STRAPS
MODEL V-DM-ST-XL — 18 ft. S.S. STRAPS
ALSO AVAILABLE IN SNAP-IN CHIMNEY MOUNT MODELS

ALL HARDWARE 100% STAINLESS STEEL

GOLD VINYL COATED 6" SNAP-IN TYPE WALL BRACKET STAINLESS STEEL SCREWS SUPPLIED



TWO TO A SET

MODEL V-SN-6

ALSO AVAILABLE IN 4" SNAP-IN & 6" "V" TYPE WALL BRACKET MODELS

NEW COAX LINE SPLITTER

For UHF/VHF
Color/B&W TV

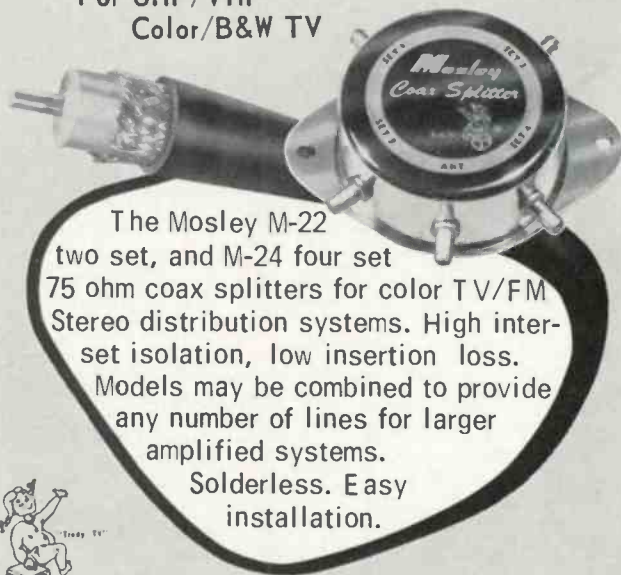

The Mosley M-22 two set, and M-24 four set 75 ohm coax splitters for color TV/FM Stereo distribution systems. High inter-set isolation, low insertion loss. Models may be combined to provide any number of lines for larger amplified systems. Solderless. Easy installation.



Write Dept. 159A for FREE detailed brochure.

Mosley Electronics Inc. 4610 N. Lindbergh Blvd.,
Bridgeton Missouri 63042

... for more details circle 118 on Reader Service Card

Now a Heathkit®

Solid State **Vectorscope/Color Generator**

Only \$124.95*



Accurately Performs All Of These Adjustments:

- Raster
- Static & Dynamic Convergence
- Purity
- Gray Scale

- 3.58 MHz Oscillator
- Reactance Coil
- Phase Detector Transformer
- Demodulator Angle Check
- Chroma Bandpass Touch-Up

Kit IO-101, 12 lbs. \$124.95*

Fast switch selection of standard 9 x 9 display . . . or exclusive Heath "3 x 3" display

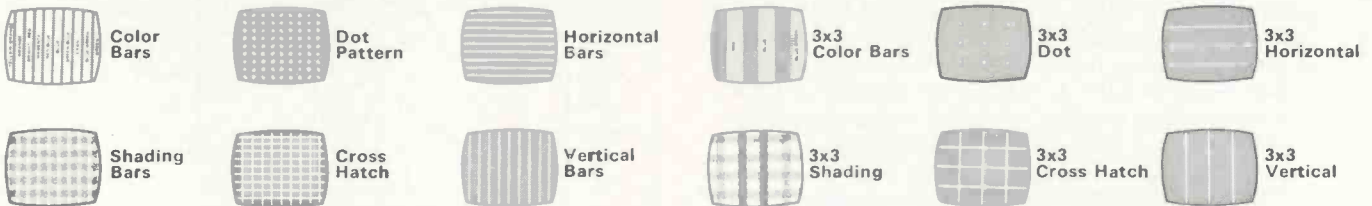

IO-101 SPECIFICATIONS — PATTERNS — **Purity:** Produces a snow-free raster for purity adjustments. **Dots:** 9 x 9 produces a display of 110 small dots. 3 x 3 produces a display of nine dots for convergence adjustments. **Crosshatch:** 9 x 9 produces a display of 11 vertical and 10 horizontal lines. 3 x 3 produces a display of three vertical and three horizontal lines for convergence and linearity adjustments. **Horizontal Lines:** 9 x 9 produces a display of 10 horizontal lines. 3 x 3 produces a display of three horizontal lines for vertical linearity and pin-cushion adjustments. **Vertical Lines:** 9 x 9 produces 11 vertical lines. 3 x 3 produces a display of 3 vertical lines for horizontal linearity and convergence adjustments. **Color Bars:** 9 x 9 produces a display of ten standard color bars. 3 x 3 produces a display of three standard color bars. A visual fingerprint (voltage pattern) of all ten color bars in the form of a petal pattern is displayed for color circuit servicing. **Gray Scale:** Provides a wide bar crosshatch pattern with six shades of brightness for color gun level adjustments. **OUTPUT SIGNALS** — **Video:** Greater than ±1 volt peak-to-peak composite signal for composite signal injection beyond the video detector. **RF:** Variable to approximately 25,000 μV output, channels 2 through 6, for composite signal injection into the TV receiver antenna input terminals. **Sync:** Greater than 3.5 volts peak-to-peak signal for servicing sync circuits without video, or sets having separate video and sync demodulator phase adjustments. **GENERAL** — **Power Requirements:** 105-125 or 210-250 VAC, 50/60 Hz, 20 Watts. **Cabinet Dimensions:** 6¾" W x 9¼" H x 14½" D. **Net Weight:** 9½ lbs.

*The number of dots, lines, and bars indicated for a 9 x 9 display is the number displayed if the receiver under test has no overscan.

HEATH COMPANY, Dept. 24-8

Benton Harbor, Michigan 49022



- Please send FREE Heathkit Catalog
- Please send IO-101 Specification Sheet

Enclosed is \$ _____ plus shipping.
Please send Model IO-101

Name _____

Address _____

City _____ State _____ Zip _____

Prices and specifications subject to change without notice.
*Mail Order Prices; F.O.B. Factory

TE-222

The material used in this section is selected from information supplied through the cooperation of the respective manufacturers or their agencies.

EMERSON

Remote Control Receiver Chassis 471917—Addition of Thermal Fuse

The Model 19P86 receiver uses remote control receiver chassis 471917, which hereafter will include the addition of a thermal fuse—Emerson Part No. 808028. The purpose of this fuse is to provide protection for the stepping relay. It is wired in series with the relay coil and is dressed snugly against the coil body so as to react to any extreme temperature rise of the coil.

Whenever servicing a Model 19P86 receiver, it is recommended that this simple modification be made in the remote receiver. Fix-kit Part No. 966529, consisting of the fuse, a 1-pt. dummy lug, nut and screw, is available from the factory at no charge.

The sketches show top and side views of the relay end of the remote chassis. Install the dummy lug as shown. Remove the two wires from Terminal A of the relay coil and

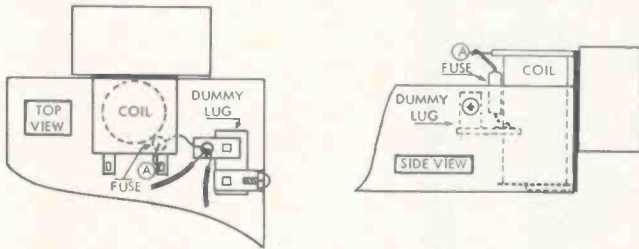

connect them to the dummy lug. Then connect the fuse from the dummy lug to Terminal A. Dress the fuse against the body of the coil to provide maximum sensitivity to coil temperature.

OLYMPIC

TV Model 9P56/9P65—Horizontal Oscillator Drift

Symptom: Horizontal oscillator drift during warm up.

Correction:

- Locate C261, a 471pf capacitor adjacent to the V10 tube socket. This component should be tilted outward to position it away from the hot tube envelope.
- Locate R258, usually a 1M ½w or possibly a 100K ½w resistor also adjacent to the V10 tube socket. Replace this resistor with a value of 470K ½w.
- Perform the following alignment tests with the chassis secured in its original cabinet mounted position. (Important: due to interactive coupling existing between deflection yoke fields and the stabilizer coil L208, chassis must be cabinet mounted.)

1. With the set warmed up and tuned to a station, attach a jumper from the junction of C256 and R258 to ground and also add a second jumper across the leads of C260 to effectively short it out. The picture may now be out of sync.
2. Adjust the hold control VR201C to bring picture into sync, although it may drift sideways due to the jumper at the sync input.
3. If the hold control must be set at or near the end of its range to achieve the condition of zero beat,

as described in previous step, check and/or replace C259, C261, R264 and R262 to obtain a zero beat at control near center position.

4. Now remove jumper across C260 and adjust L208 to bring picture back to sync. Some of these coils have waxed cores which may require a few drops of cement thinner or tuner spray to dissolve wax before the slug can be moved.
5. Remove jumper at sync input C256 and R258, and picture should now lock in.

RCA SALES CORPORATION

Checking SCR's with an Ohmmeter

The SCR sweep system has proved to be quite reliable. However, when failures do occur there seems to be some indecision as to how to check silicon controlled rectifiers. Several elaborate methods of testing SCR's have been devised. However, the following is adequate for TV servicing.

If the sweep circuit troubleshooting procedure indicates the possibility of a defective SCR, substitution with a known good device is the best test method. If a known good SCR is not available, an ohmmeter check will give a reasonable evaluation of the device. This is true since, generally speaking, an SCR in the OFF state will either:

- block current (good device, high-resistance reading anode-to-cathode, either direction) or
- not block current (shorted device, low-resistance reading anode-to-cathode, either direction).

Gating problems, as far as the device itself is concerned, are practically nil in this type SCR.

Outlined are the normal expected ohmmeter readings between the various elements of known good trace or retrace SCR's.

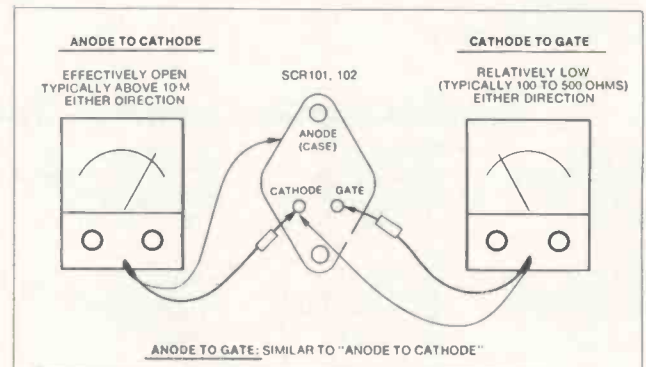

GENERAL ELECTRIC

TV Chassis P2/S2—Intermittent High Voltage

To correct this high voltage problem, the high voltage rectifier tube quite often is replaced. However, the real source of trouble may be a poor solder connection at the high voltage rectifier socket. Always check the solder connections before replacing the high voltage rectifier tube. The connections should have rounded edges.

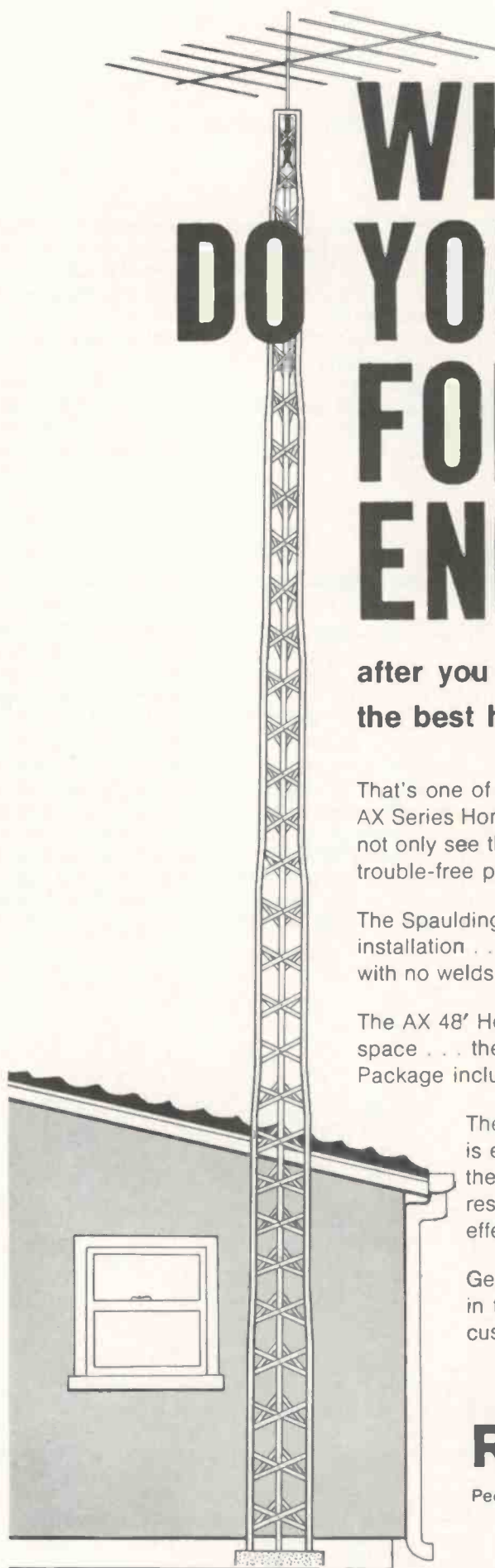

WHAT DO YOU DO FOR AN ENCORE . . . ?

**after you have sold your customers
the best home TV towers.**

That's one of the big advantages when you stock and sell Spaulding AX Series Home TV Towers. You're offering a tower in which they'll not only see the quality, which is apparent, but they'll also see the trouble-free performance they are looking for.

The Spaulding AX Home TV Tower is designed for quick economical installation . . . and is all-steel, galvanized and all riveted construction with no welds to rust.

The AX 48' Home TV Tower package only requires 2 sq. ft. of floor space . . . the AX series packages are available in heights up to 64'. Package includes base stubs, hardware, mast and mast kit.

The Spaulding AX Series Tower is a self-supporting tower and is extremely rigid under most erection situations. The higher the tower goes, the greater the strength at the base. The wind resistance at the top decreases with height. The "tapering" effect adds to the attractiveness of the tower.

Get specifications on this complete tower package, and profit in two ways—bigger sales and greater goodwill from your customers.

ROHN®-SPAULDING, INC.

Peoria, Illinois • Birmingham, Alabama • Frankfort, Indiana

. . . for more details circle 124 on Reader Service Card



COLORFAX

by JOSEPH ZAUHAR

The material used in this section is selected from information supplied through the cooperation of the respective manufacturers or their agencies.

ADMIRAL

Color TV Receivers—Deflection Yoke Adapter

The adapter illustrated will enable you to use a bench test jig incorporating a seven lead yoke to test current color-TV chassis with four lead yokes. Plug P1 fits chassis 3H10 and higher plus 11H12 and higher. Socket J1 fits yokes 94A-304-1, -2, -3, -4; 94A275-1 and 94A306-1.

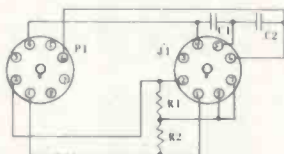

Parts List

C1,2	65A10-212	100pf, 4kv
R1,2	60A14-271	270Ω 10% 1w
P1	88A23-6	Plug
J1	87A84-2	Socket

To connect the "round CRT" chassis to the "rectangular CRT" yoke, make an adapter using a BP193 adapter cable and the circuit illustrated.

Parts List

C1	64A32-33	0.47μf, 200v
C2,3	65A10-372	470pf, N1500, 2.5kv
R1,2	60A8-391	390Ω, 10%, 1/2w
P1-4	BP193	Extension Cable
J1	87A84-2	Socket

These cables will save you time and dollars! You will work more efficiently because you can see what you are doing and do it more comfortably and precisely. Most important, the color picture tube, all neck components and convergence adjustments are left undisturbed.

MAGNAVOX

Color TV Chassis T940—Color and Volume Control Drive Motor Variations

A number of T940 chassis, used with the 704054 8-Function Remote Control units, were built using 48vac motors instead of the 120vac motors listed in the T940 service manual. To make this substitution the following circuit changes were made:

- R405 was changed to 1.2K, 10w.
- A 2μf, 50v capacitor (non-polarized) was added between the blue and green motor leads of each motor.

The originally specified 120v motor, however, can be used as a field replacement in these chassis provided that the 2μf capacitor is first removed.

The units equipped with these 48v motors are all identified by a label attached to the rear plate of the VHF tuner motor assembly which reads as follows: When replacing the Volume or Color control motor in this instrument, eliminate the 2μf, 50v capacitor wired between the blue and green leads of the original motor.

These 48v motors are identified by an X following the group number. For instance, a 48v color drive motor used in a T940-02-AA chassis would be identified as 500225-3X. However, should the motor fail, you should order a replace-

ment 500225-3 (120vac motor) as specified in the service manual. The only circuit change required to replace the 48v motor with the 120v motor is that the 2μf capacitor on the control unit must be removed; it is not necessary to change resistor R405.

NOTE: R405 was added as a 5.6K resistor on early remote versions to reduce the torque of the motor since some problems had been experienced with shaft breakage on the capacitor type tint control. The value was later changed to 2.7K and this value is not critical when the 120v motors are used.

ZENITH

Color TV Chassis 12A13C52—Improved Brightness Stability

An additional circuit enhancing brightness stability is incorporated in the 12A13C52 chassis. Otherwise the 12A-13C52 is the same as the 12A12C52 chassis. Since part of the circuitry includes an additional transistor, the chassis number has been changed from 12A12C52 to 12A13C52.

As shown, the brightness limiter circuit includes a Brightness Limiter transistor and a Brightness Limit control which is adjusted to provide maximum brightness without picture blooming. Essentially, any change in the average picture tube current is "sensed" as a change in current through the limit control. An increase in the average beam current causes an increase in the charge on the 50μf capacitor at the base of the Brightness Limiter transistor. In turn, the Brightness Limiter transistor increases in conduction,

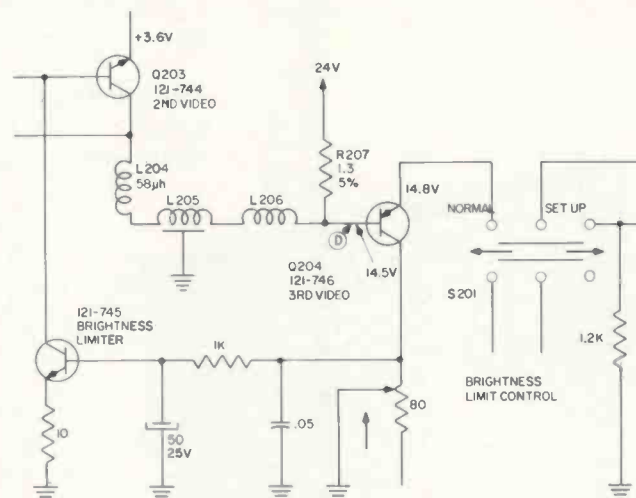

which results in a decrease of collector-to-emitter resistance. The base of the second video amplifier is lowered in potential, reducing base bias and therefore the gain of the stage. The result is a reduction in average picture tube beam current.

In making adjustments:

- Tune in a B/W program (or temporarily set Chroma Level control to minimum if only color programs are available). Then set the Color Commander, Brightness

and Brightness Limit controls to maximum.

- Adjust the Brightness Range control for a vertical overscan (bloom) of approximately 1 in.
- Adjust the Brightness Limit control to reduce overscan (bloom) by 3/4 in.
- The 1/4-in. bloom remaining can be checked by slightly reducing the Brightness control.

OLYMPIC

Color TV Model CT400—Color Sync Problem

Symptom: Intermittent color sync, or no color sync.

Correction: Check capacitor C621 (0.33 μ f, 400v) located near 8JV8 (center of board); it may have opened. Also check capacitor C633 (.01 μ f, 400v) located near L605 (top front corner of board), as it may cause reactance control drift.

Color TV Model CT400—No Color

Symptom: Intermittent color, or no color. Screen may appear predominantly green. Correction: Check 6GH8 tube, the 3.58MHz subcarrier and replace, if defective. Also check capacitor C635 (.01 μ f, 400v) located near the top center of the board and replace it if necessary to correct intermittent or no color condition.

RCA SALES CORPORATION

Color TV Model 14F, 14G, 14H Employing CTC15 Chassis—Power On/Off Switch

The color television receivers referenced have a pull-on, push-off type switch assembly that may experience premature failure. Original switch assemblies should be removed and approved replacements installed as outlined: (1) Remove rear cover and identify the type switch in the receiver. If the switch is the same type as the approved replacement, replace rear cover and restore operation. No further action is necessary. (2) If the original type switch is identified, it should be removed and the approved replacement (RCA Stock No. 128976) installed. (3) The switch should be replaced in the home as follows: Loosen the tuner mounting assembly, unsolder ac leads and remove original switch from the control by bending the three

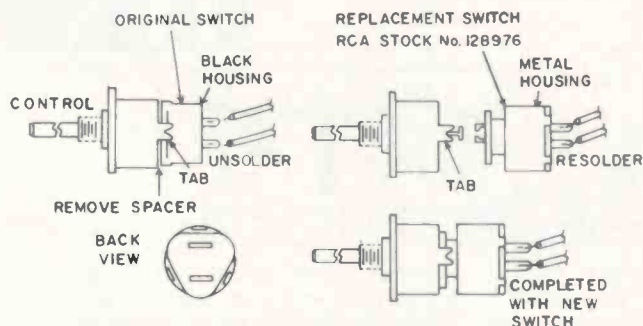

retaining tabs outward. Remove spacer, pull the actuating shaft of the replacement switch to its extended position and slip over the end of the control shaft. Now, secure the switch by bending tabs inward over the switch shoulder. Resolder leads, install TMA and check switch action. Replace rear cover and restore receiver operation with no further action necessary.

The RCA Stock Number of the approved switch is 128976. It is recommended that all service technicians carry this approved type when making in-home service calls on referenced receivers.

AT LAST solid state triggered sweep, wide-band at a price you can afford!

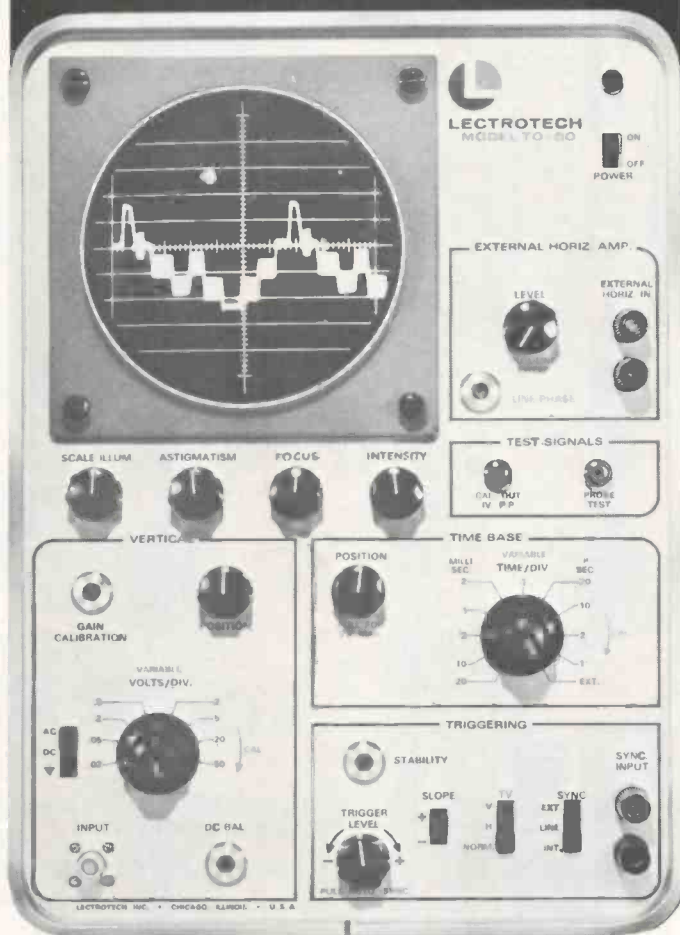

Made in U.S.A.

5" oscilloscope / vectorscope

Triggered Sweep: Easy to use. Positive sync results in absolute stability of patterns.

Solid State: For reliability and performance.

Wide Band: 10 MHz—for increased use in all servicing, industrial and educational applications.

D.C. Amplifiers: Eliminates pattern bounce. Permits viewing A.C. signals and D.C. level simultaneously. Use as a sensitive D.C. voltmeter.

plus . . . Calibrated vertical attenuator. • Calibrated horizontal time base. • Automatic sync mode. • TV sync selector. • Vectorscope input for color TV servicing. • External horizontal amplifier. • 60 cycle horizontal sweep (sine wave) with phasing control. Compatible with all sweep generators. • Edge lit calibrated scale. • All solid state (tube protected input).

ONE YEAR WARRANTY

T0-50—oscilloscope / vectorscope Net 33950

See your distributor or write Dept. ET-8



LECTROTECH, INC.

4529 North Kedzie Avenue • Chicago, Illinois 60625

. . . for more details circle 116 on Reader Service Card

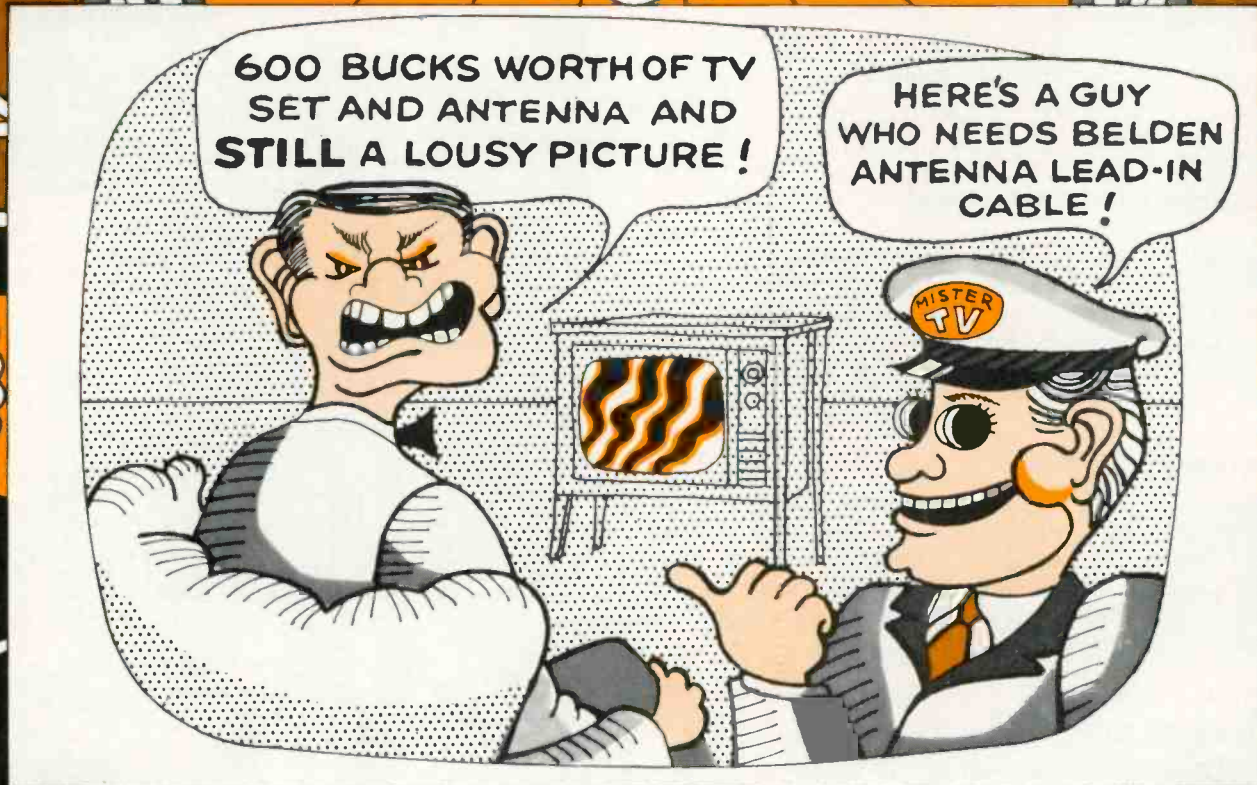

Color or UHF set perfect? Antenna perfect? Then obviously there's a missing link. Check that antenna lead-in cable. Old, worn-out, weather-beaten cable, or the ordinary flat ribbon kind designed for black and white VHF, causes more fuzzy, distorted pictures than you can count. It's your opportunity to upgrade these customers to a cable matched to their particular signal reception situations. One of Belden's Big Four—the link to perfect reception.

FOR CONGESTED AREAS...

8290 SHIELDED PERMOHM®



In congested, in-city areas, stray electrical interference and noise are at their worst. For perfect, all-82 channel reception—color or B/W—replace old cable with Belden's 8290 Shielded PermoHM. Its aluminum Beldfoil® shielding prevents pickup of ghost signals and electrical noise by the lead-in. Weather-proof and water-proof. You can tape it right to the mast. Or install it underground, in conduits—even in rain gutters.



AWG & (Stranding)	Color	Nom. O. D. (inch)	Nom. Velocity of Propagation	Nom. Capacitance (mmf/ft.)	Nom. Attenuation per 100'		Standard Package Lengths in ft.
					mc	db	
22 (7 x 30)	Brown	.305	69.8%	7.8	57	1.7	50', 75', 100' coils have terminals attached.
		x .515			85	2.1	
					177	3.2	
					213	3.5	
					473	5.4	
					671	6.6	
	887	7.7	Available in counter dispenser.				
Copperweld, 2 conductors, orange polyethylene insulation and web between conductors, cellular polyethylene oval insulation, Beldfoil shield, stranded tinned drain wire, polyethylene jacket.							
250', 500' spool.							

BELDEN 8285 - PERMOHM

FOR FRINGE AREAS...

8285 PERMOHM®

Antenna cable in uncongested or fringe areas picks up little electrical interference. But does get a lot of weathering, which degrades an already weak signal. These customers need encapsulated cable. Belden 8285 Permohm. Its special polyethylene jacket protects the energy field, regardless of weather conditions. It delivers the strongest signal of any unshielded twin lead under adverse conditions. Requires no matching transformers and connectors. For all 82 channels, color or B/W.



AWG & (Stranding)	Color	Nom. O. D. (inch)	Nom. Velocity of Propagation	Nom. Capacitance (mmf/ft.)	Nom. Attenuation per 100'		Standard Package Lengths in ft.
					mc	db	
22 (7 x 30)	Brown	.255 x .468	73.3%	5.3	100	1.4	50', 75', 100' coils have terminals attached. Available in counter dispenser. 250', 500' coils and 1000' spool.
					300	2.8	
					500	3.8	
					700	4.8	
					900	5.6	

Copperweld, 2 conductors parallel, orange polyethylene insulation and web between conductors, cellular polyethylene oval jacket.

FOR LOCAL BLACK AND WHITE...

8275 CELLULINE®



Cracked, corroded, weathered cable, full of dirt and moisture, loses signal strength; prevents any TV set from delivering a quality picture. Upgrade B/W VHF and local UHF customers to Belden 8275 Celluline. Performance is improved because all possible moisture between conductors has been eliminated. Abrasion-resistant and weather-resistant for a long, long service life. And, it requires no end sealing.

AWG & (Stranding)	Color	Nom. O. D. (inch)	Nom. Velocity of Propagation	Nom. Capacitance (mmf/ft.)	Nom. Attenuation per 100'		Standard Package Lengths in ft.
					mc	db	
20 (7 x 28)	Brown	.300 x .400	80%	4.6	100	1.05	50', 75', 100' coils in counter dispenser. 250', 500', 1000' spools.
					200	1.64	
					300	2.12	
					400	2.5	
					500	2.98	
					700	3.62	
					900	4.3	

Bare copperweld; 2 conductors parallel, polyethylene jacket with inert gas filled unicellular polyethylene core.

FOR MATV AND CATV...

8228 DUOFOIL® COAX

EN DUOFOIL



Got an apartment or townhouse complex in your area? Motels or hotels? Or is CATV coming? Use Belden's new 75 ohm coaxial cable—8228 Duofoil. Shielding is 100%—sweep tested 100%. Spiral wrapped drain wires provide long flex life. Small diameter saves space in conduit installations. Use Duofoil for all coaxial color and B/W VHF, UHF and CATV applications.



AWG & (Stranding)	Color	Nom. O. D. (inch)	Nom. Velocity of Propagation	Nom. Capacitance (mmf/ft.)	Nom. Attenuation per 100'		Standard Package Lengths in ft.
					mc	db	
18 Solid, Bare	Black	.242	78%	17.3	50	1.5	100', 500', 1000' spools.
					100	2.1	
					200	3.1	
					300	3.8	
					400	4.5	
					500	5.0	
					600	5.5	
					700	6.0	
					800	6.5	
					900	6.9	

Don't forget to ask them what else needs fixing.

See your local Belden distributor for full details or to order. For a free copy of the recent reprint article, "Electronic Cable," write: Belden Corporation, P.O. Box 5070-A, Chicago, Illinois 60680.



B-G-84

... for more details circle 102 on Reader Service Card



Shortstop.

Our exclusive posted-filament design stops shorts in high-voltage rectifiers.

And you know what shorts cause . . . catastrophic failure, or weakened tubes and components.

The result: unprofitable callbacks.

Our 3CU3A, 3BM2A, 3BL2A, and 3DC3 high-voltage rectifiers all use the fail-safe posted-filament design.

Put our shortstops on your team. You'll find that callbacks won't even get to first base.

Sylvania Electronic Components, Electronic Tube Division, West Third St., Emporium, Pa. 15834.

SYLVANIA
GENERAL TELEPHONE & ELECTRONICS

ET/D **TEKLAB REPORT**

The killer threshold control is now placed in the plate circuit of the color killer stage and the tint control now adjusts the phase of the 3.58MHz oscillator in a manner opposite that of previous chassis

Emerson Model 26C56 Color TV - Part II

by JOSEPH ZAUHAR

■ Last month we covered the customer features (simplified adjustments) employed on this chassis and the Automatic Fine Tuning (AFT)

circuit with a time-saving procedure for troubleshooting the IC.

We will now review the color circuits employed, along with color

The on/off switch is a multiple section slide switch mounted on the control panel with the tuner, AFT switch, tint and volume control.

MULTIPLE SELECTION
ON/OFF SWITCH
VOLUME CONTROL

AFT SWITCH
TINT CONTROL

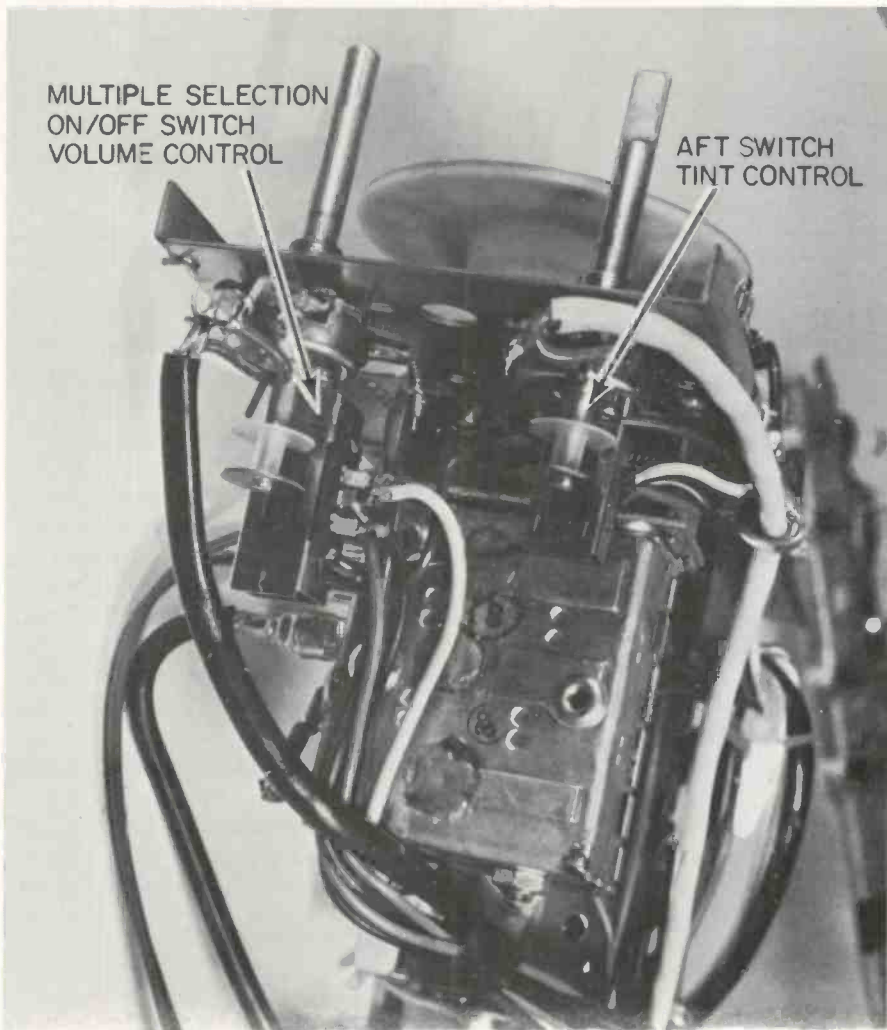

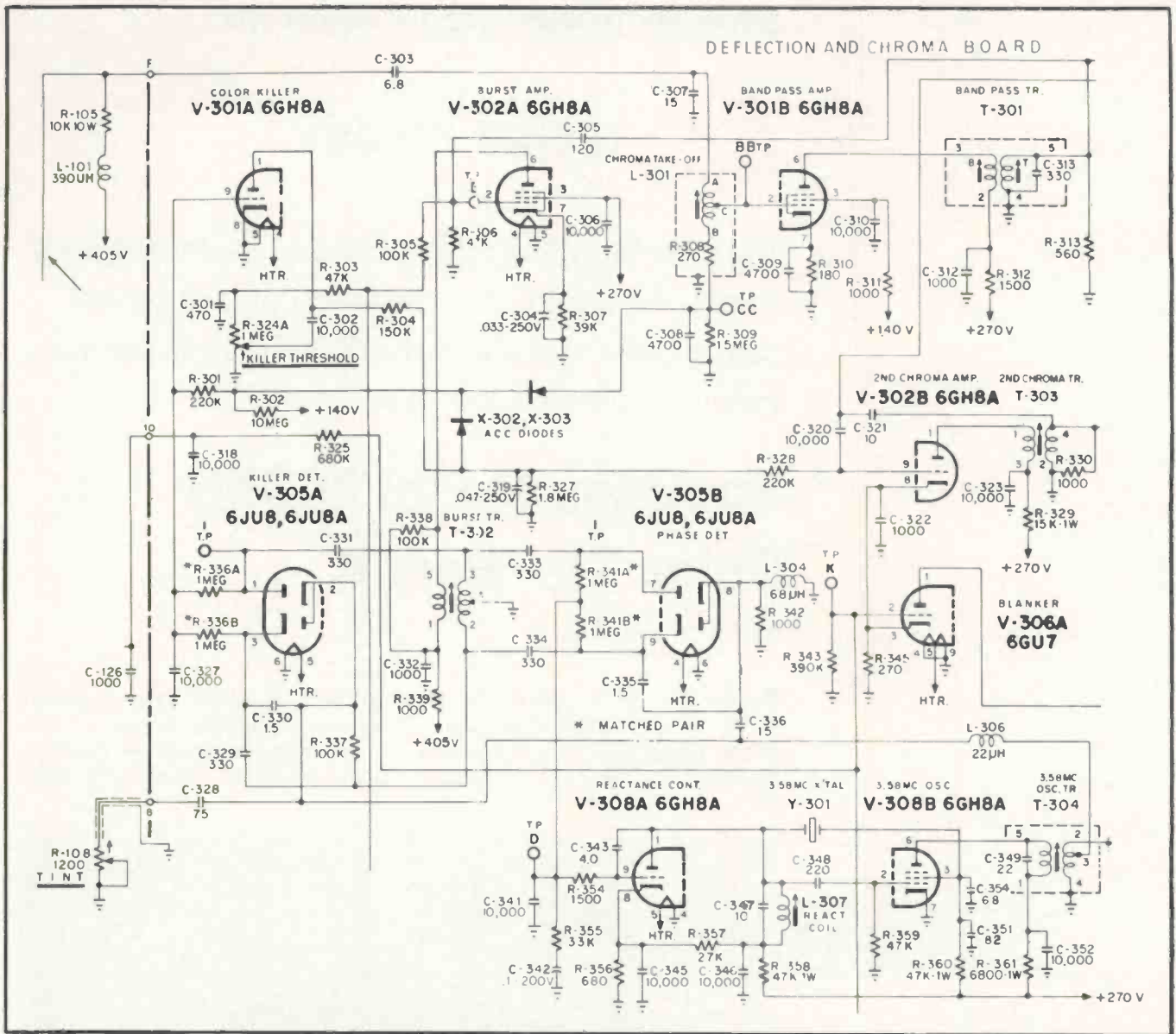

Fig. 2—The Automatic Color Control circuit (ACC) in this chassis has a Color Killer control in the plate circuit of the color killer stage.

control adjustments pertaining to this new chassis.

AUTOMATIC COLOR CONTROL CIRCUIT (ACC)

An improved ACC circuit is employed in these models. As shown in Fig. 2, the chroma and burst signals are obtained from the plate of the first video amplifier stage. These signals are applied through an RF choke coil and capacitor C303 to the chroma takeoff coil, L301. Chroma and burst signals are amplified in the bandpass amplifier, V301B, and are then applied to the bandpass transformer, T301, the burst amplifier and the color con-

rol. The burst signal is amplified by the bandpass amplifier before it is applied to the burst amplifier.

The output of the burst amplifier consists only of the burst signal, which is fed to the burst transformer, T302. This signal is then applied to the phase detector, V305B, which compares the phase of the burst signal with that of the crystal-controlled 3.58MHz oscillator. When the phase of burst differs from that of the 3.58MHz oscillator, an error control voltage is developed across resistors R341A and R341B, which is applied to the reactance control tube. The reactance of a control tube is designed to correct the phase

of the 3.58MHz oscillator.

The burst signal applied to the burst transformer, T302, is also applied to the killer detector, V305A. The output of the killer detector develops a negative voltage across resistor R336A and R336B when burst signals are present. Since the burst signal is always present during color programs, the killer detector output is a negative voltage, which biases the color killer grid, V301A, to cutoff. At the same time the negative voltage developed by the killer detector is applied to the bandpass amplifier grid, V301B, and the second chroma amplifier grid, V302B, through ACC diodes X302 and

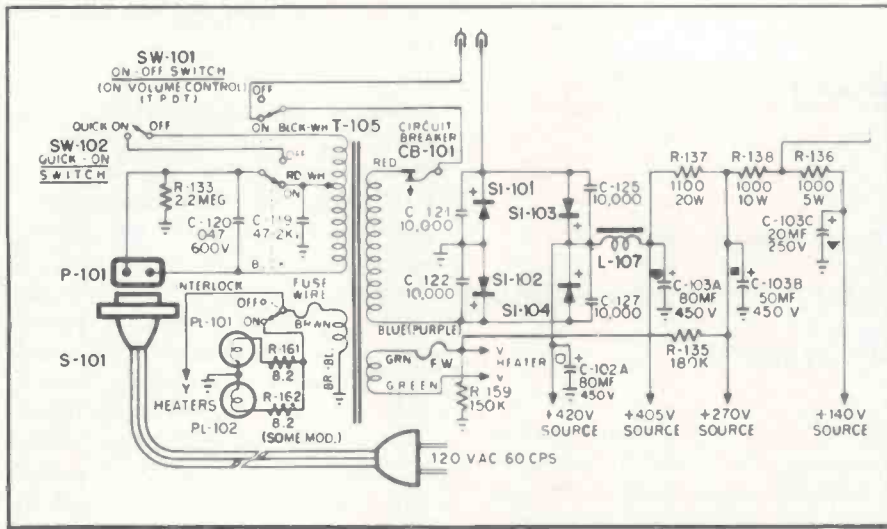

Fig. 3—Schematic of the low-voltage supply with a multiple section on/off switch.

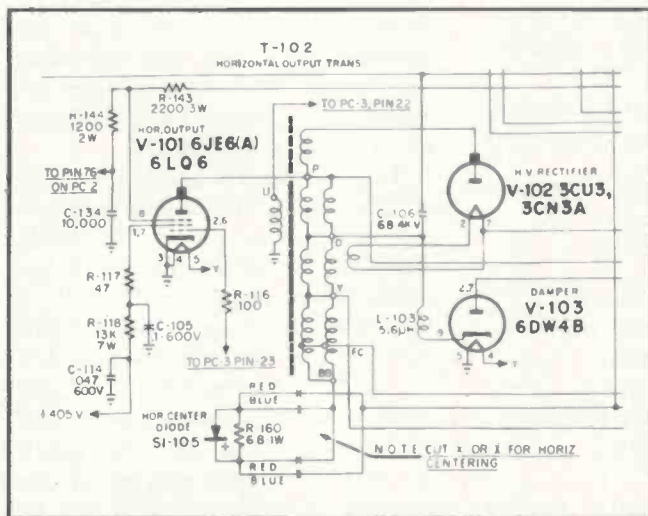

Fig. 4—Schematic of the HV circuit and horizontal centering diodes.

X303. When the color signal increases, the amplitude of the burst signal also increases, resulting in a greater negative output voltage from the killer detector. When the color signal decreases in amplitude, the burst signal also decreases, resulting in a decrease in the negative voltage at the killer detector output. This variation in negative voltage biases the bandpass amplifier grids and the second chroma amplifier to either increase or decrease the gain of these stages.

During B/W transmissions, the burst signal is not present and the negative output of the killer detector drops, permitting the color killer stage to be biased into operation. The color killer develops negative voltage at its plate, which is applied to the second chroma amplifier grid

circuit, the bandpass amplifier is always operating and the color circuits are shut off when the second chroma amplifier is biased to cut-off.

In this chassis the killer threshold control is in the plate circuit of the color killer stage. This control changes the amplitude of the horizontal pulse applied to the plate of the color killer, which in turn effects the amount of negative voltage developed.

QUICK-ON CIRCUIT

The circuit diagram in Fig. 3 shows that the on-off switch, SW-101, is a multiple section switch. In addition, a quick-on switch, SW102, is provided to increase the inductance of the primary winding when this switch is placed in its ON position. With switch SW101 in its

OFF position, the number of turns in the primary winding of the power transformer is increased, thus reducing the filament winding voltage to approximately 4.5v. One section of the switch, SW101, disconnects the secondary winding from the bridge diode rectifiers to prevent any B+ voltage from being applied to the receiver circuitry. At the same time, the third section of switch SW101 disconnects the pilot lights from their filament winding.

A new 3CU3 or 3CN3 HV rectifier tube is employed in this chassis. These tubes have a quick heating filament and are needed for proper operation of the quick-on feature. When making a replacement, do not use the slower heating 3A3 as a substitute.

COLOR CONTROL ADJUSTMENTS

The color killer threshold control should be adjusted during B/W reception. Adjust the set for optimum B/W reception, turn up the color control, and adjust the killer threshold control in a clockwise direction to eliminate false colors. Then check the AFT circuit during color programs to make certain that the adjustment of the killer threshold control is not affecting color when the TV set is operating in the AFT position. Do not advance the color killer threshold control in a clockwise direction any more than is necessary for proper ACC circuit operation.

The color tint control, R108B, shown in Fig. 2 is connected in the 3.58MHz circuit to change the phase of the oscillator output signal for proper color reproduction.

The tint control is now adjusting the phase of the 3.58MHz oscillator in a manner opposite that experienced on other chassis. Greenish flesh tones will now appear when the control is rotated in a clockwise direction.

DIODES FOR HORIZONTAL CENTERING

A horizontal centering diode, SI-105, is employed on this chassis. As shown in Fig. 4, a pair of red and blue leads are connected to the diode from the horizontal deflection

continued on page 56

Master Antenna Systems

by PHILLIP DAHLEN

Some basic principles of TV signal losses and channel separation must be understood before installing the larger, more profitable MATV systems

■ Large apartment buildings, schools and even some office buildings offer a lucrative market for the TV technician. Technicians looking for additional business can sell apartment owners on the fact that such systems, in this age of color-TV watching, will help make it easier to rent apartments at higher rates. With greater emphasis on educational TV, school systems are becoming more conscious of MATV systems—particularly if they choose to make use of special TV channels not available to the general public. Even office buildings require such systems if executives are to keep abreast of outside current events.

MATV systems used in these applications can be divided into three basic parts: Antennas for receiving the desired channels; electronic equipment for amplifying and modifying such signals, as necessary, for distribution to the receivers; and the system for carrying the signals to the various TV sets that are to receive them.

Since the system must be designed to supply each TV set with the required signal, distribution system signal requirements should be calculated first in order to determine the signal strength required from the other components in the system.

DISTRIBUTION SYSTEMS

The accurate design of a distribution system requires that signal losses in each portion of the system be accounted for in order to be certain that once the system is constructed, it will supply an adequate signal to each TV set—without using unnecessarily expensive components to supply greater than required signals.

These signal levels and losses are most frequently measured in decibel

units. If losses were instead given in percentages, it would be necessary to multiply signal strength by each rate of loss encountered in order to determine the final signal present at the receiver. However, by instead using a logarithmic system of measure, total signal loss can be determined by subtraction, thus simplifying calculations.

For MATV systems, the decibel (dB) is defined as being equal to 20

$\log_{10} \frac{E}{1000\mu v}$ when the voltage in question is present across a 75Ω coaxial cable, or $20\log_{10} \frac{E}{2000\mu v}$ when

the voltage is present across a 300Ω twin lead. The term E represents the voltage present, while 1000μv represents the standard signal voltage that should be supplied a TV set.

Fortunately, the use of decibel units does not require an understanding of the theories of logarithms, and conversion between decibels and voltages can be made simply with the use of tables, such as Table 1. [Example: If you have a 1778μv signal (5dB) and a 1dB signal loss through a cable, the remaining signal is 1585μv (4dB), 5dB — 1dB = 4dB. *Exact decibel-to-voltage conversions are possible since they are merely set by definition. However the voltages used in this article merely represent these conversions and are to a much higher degree of accuracy than measurements would require, or even generally permit.*]

The most significant cause of undesired signal loss is the coaxial cable or twin lead used to carry the TV signal from the central system to each receiver. The signal characteristics of such wire is described in

the article, "The Long and Short of MATV Cables," on page 53 of the May issue. Based on the information in that article, we can conclude that 75Ω coaxial cable is preferred for MATV use. Since the UHF and VHF antenna terminals at the back of most TV sets require signals from 300Ω twin lead, a matching transformer should be secured to the back of each set to provide 300Ω impedance UHF and VHF signals, as required, from a 75Ω coaxial cable. A wall outlet (tap off) should also be provided near each set, from which a coaxial cable can supply the TV signal to the matching transformer (Fig. 1).

Each tap off will result in some signal distortion and generally a distribution cable should be limited to no more than 15 tap offs. Thus the number of TV sets will determine the number of distribution lines required (two typical cable arrangements as shown in Fig. 2).

The general layout for a portion of a typical MATV distribution system is shown in Fig. 3. The cable shown in this illustration has a per hundred foot signal loss of 3.0dB at VHF channel 13 and 8.0dB at UHF channel 83. The first 30-ft section of cable, therefore, has a 0.9dB VHF signal loss and a 2.4dB UHF signal loss (3.0dB × .30, 8.0dB × .30). The signal loss for the remaining segments of cable can be calculated in the same manner.

The four-way splitter used in this example has a 7.0dB VHF signal loss and a 7.7dB UHF signal loss.

If our example distribution system were long enough to contain 15 taps on a single cable, the signal at the first tap would overload the TV set, while the signal at the end of the cable would be too weak for the TV set to handle it. To compensate for this problem, the taps are designed to provide some isolation between the TV sets and the distribution cable—the greatest isolation being provided for the first sets, and the least for the last ones. These taps also result in some signal loss in the balance of the cable. Typical isolation losses and through-line losses are listed in Table II.

For convenience, the 75Ω coaxial cable between the tap offs and the isolation transformers have the same

signal loss characteristics as the distribution cable. This need not be the case in all MATV installations since cost, protective coverings, flexibility and appearance are also factors in cable selection.

The matching transformers used in this example have a 0.6dB signal loss at VHF channel 13 and an 8.0 dB signal loss at UHF channel 83.

Assuming that 40dB UHF and VHF signals are supplied to the distribution system, the signal supplied each TV set can be determined by subtracting signal losses. The calculations for determining the strength of signals remaining for the last TV set are shown in Table III. Similar calculations can be made to determine the signal strength at the other TV sets.

Although the 300Ω UHF signal present at the last TV set is less than the recommended 2000μv, it differs by less than 7 percent from the recommended voltage. TV sets can adequately handle much weaker signals, and the recommended 0dB signal strength merely provides a good safety factor for future TV set and MATV system deterioration.

Fig. 4 also indicates a 24.3dB VHF signal and a 10.0dB UHF signal remaining on the stub of coaxial cable extending from the last tap. Should this stub be left without some connection at the end of its leads, the signal will reflect from the end of the cable and return toward the signal source, producing a "ghost" image that can be observed most noticeably on TV sets near the end of the cable. This signal can be absorbed, rather than reflected, by

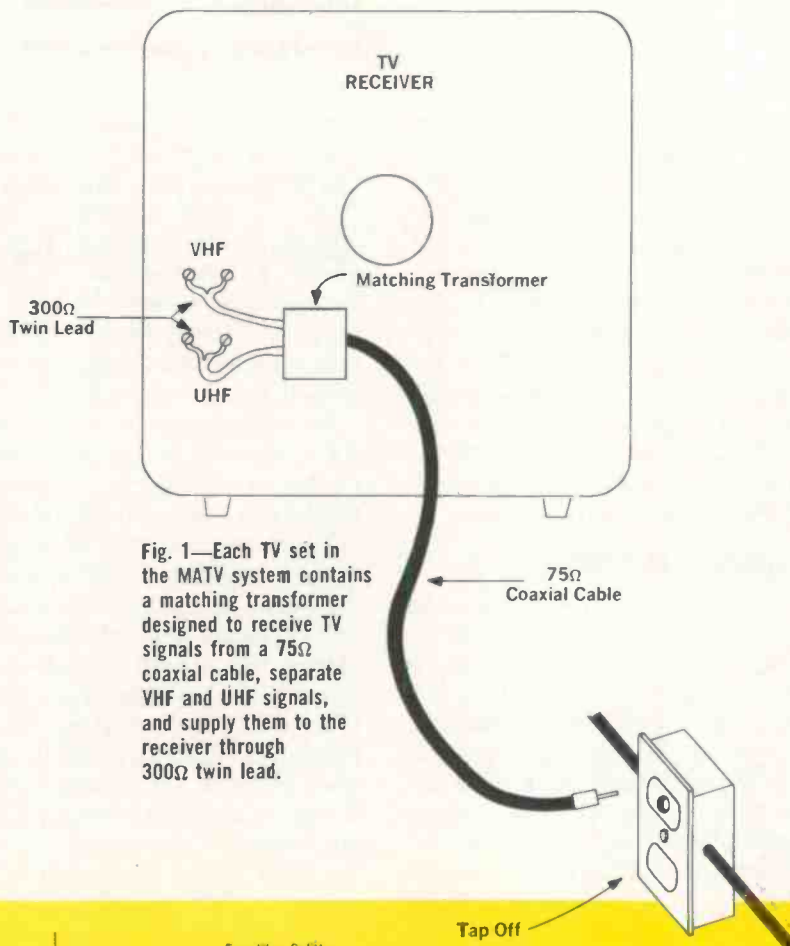

Fig. 1—Each TV set in the MATV system contains a matching transformer designed to receive TV signals from a 75Ω coaxial cable, separate VHF and UHF signals, and supply them to the receiver through 300Ω twin lead.

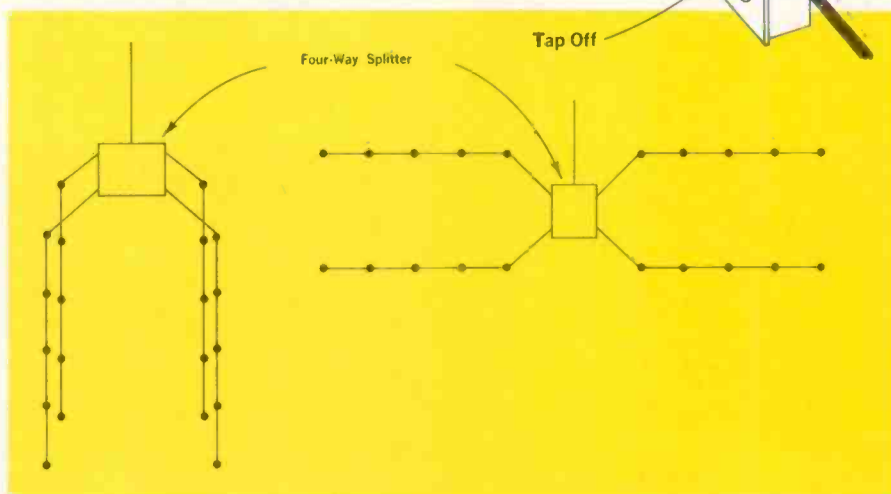

Fig. 2—Two typical coaxial cable arrangements for an MATV distribution system.

Table I—Decibel to Microvolt Conversions for 75Ω Coaxial Cable

-20 dB	100.0μv	0 dB	1000μv	20 dB	10,000μv	6.020 dB	2000μv
-15 dB	177.8μv	1 dB	1122μv	25 dB	17,783μv	9.542 dB	3000μv
-10 dB	316.2μv	2 dB	1259μv	30 dB	31,621μv	12.042 dB	4000μv
-5 dB	562.4μv	3 dB	1413μv	35 dB	56,238μv	13.980 dB	5000μv
-4 dB	631.0μv	4 dB	1585μv	40 dB	100,000μv or 0.1v	15.564 dB	6000μv
-3 dB	708.0μv	5 dB	1778μv	50 dB	.3162v	16.902 dB	7000μv
-2 dB	794.3μv	10 dB	3162μv	60 dB	1.0v	18.062 dB	8000μv
-1 dB	891.4μv	15 dB	5624μv	80 dB	10.0v	19.084 dB	9000μv

By definition, 0 dB = 1000μv across a 75Ω coaxial cable or 2000μv across a 300Ω twin lead.

connecting a 75Ω resistance to the end of the distribution cable.

In the same manner, if the coaxial cable leading to a TV set is unplugged from its tap, TV signals present at the "open" tap connection will reflect back along the distribution cable, causing "ghost" signals in adjacent TV sets. These reflected signals are virtually eliminated with the use of outlets that automatically connect a 75Ω resistor across the tap outlet when unplugging the TV set's coaxial cable.

ANTENNA SYSTEMS

The location of TV stations, their channel assignment and reflected TV signals all determine the type of antenna system that should be selected for an MATV installation. Like the signal distribution system, the antennas should be selected before selecting equipment for amplifying and modifying TV signals.

When all the TV signals to be received by an MATV installation originate from one general location, a single all-channel VHF-UHF an-

tenna is generally adequate for the system. If the MATV installation is located many miles from these stations, a larger antenna having greater gain is required. When reflected TV signals are a problem, the antenna selected should have greater front-to-back sensitivity, thus reducing the percentage of undesired signals received.

In some instances, a few of the TV stations to be received may be located in a direction different than that of the other stations or located at a radically different distance, requiring greater or reduced sensitivity. Since single-channel antennas are less expensive than all-channel antennas, they should be used for receiving these exceptional TV signals. (Using an antenna rotor for this purpose is, of course, entirely unsatisfactory since TV reception on one TV set would then be dependent on the channels selected for another TV set.) These single-channel antennas are also available in a wide assortment of gains and front-to-back sensitivities.

Using maps and similar aids in calculating antenna needs will only result in rough estimates. The simplest method involves climbing up on the roof with one or more antennas and a portable TV set, and seeing the results before ordering equipment. This permits the discovery of any unexpected "ghost" conditions or the presence of any unexpectedly weak or strong TV signals. TV sets in some parts of town may readily receive signals from stations over a hundred miles away with a relatively small antenna, while in other parts of town they may not be able to receive less distant stations with even the largest antennas.

OTHER SYSTEM COMPONENTS

Electronic equipment is available for matching the impedance of the antenna to 75Ω coaxial cable, amplifying TV signals right at the antenna to eliminate the effect of any noise developed by the lead-in wire, transferring TV signals from the channel received to a more convenient channel, transferring FM-

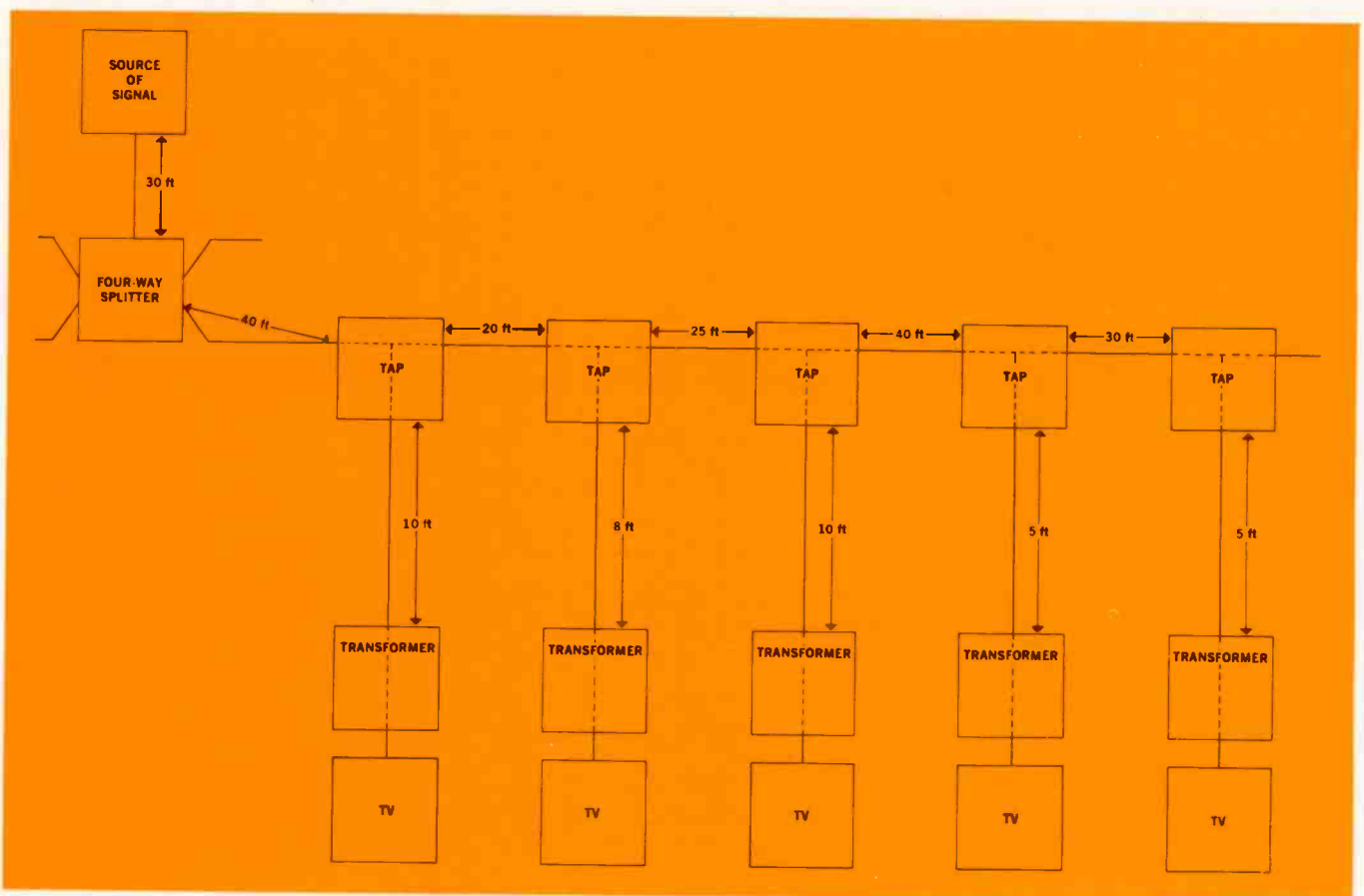
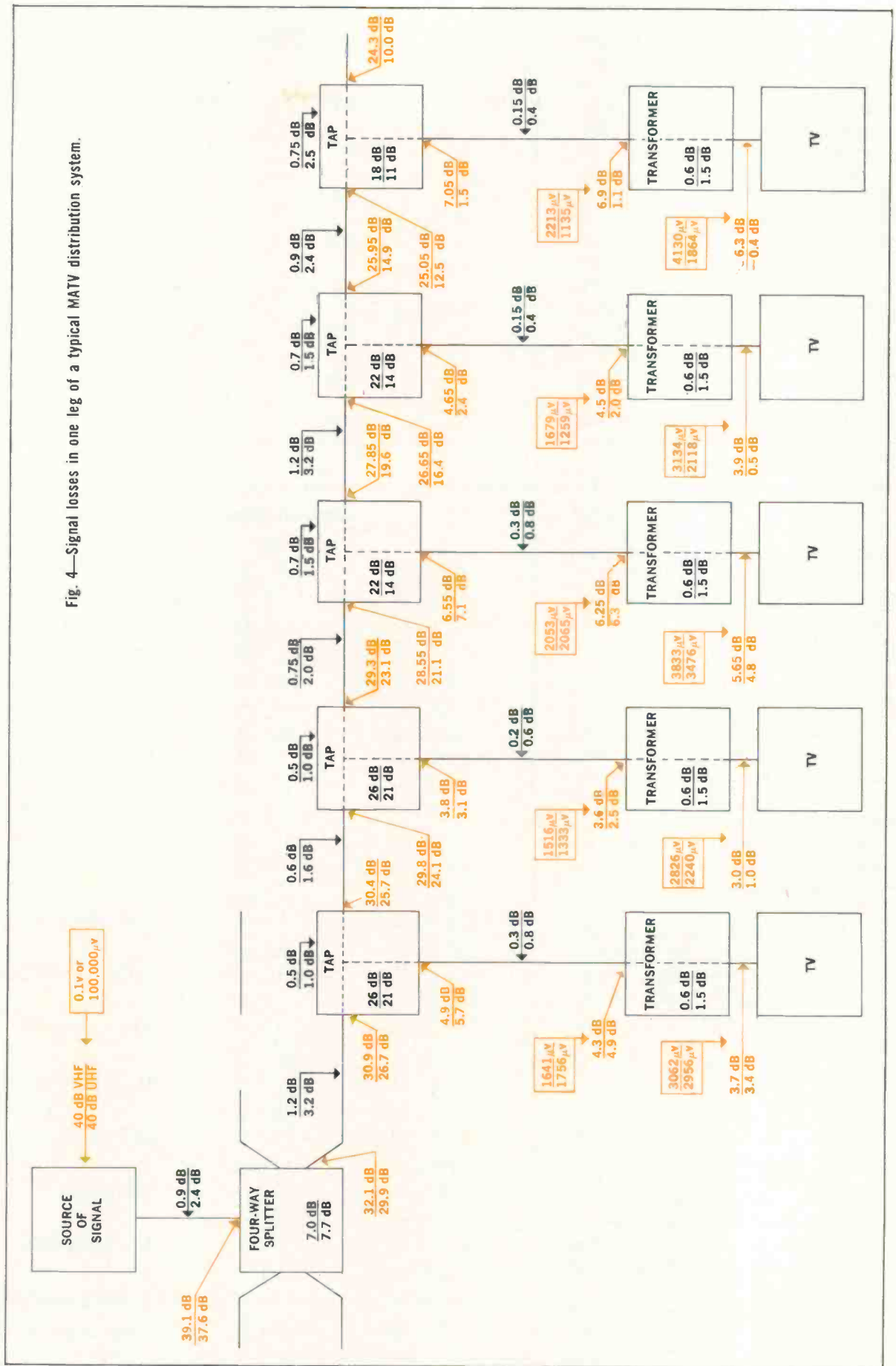

Fig. 3—The components and lengths of coaxial cable used in one leg of a typical MATV distribution system.

Fig. 4—Signal losses in one leg of a typical MATV distribution system.



band signals from their frequency to a TV channel, adding closed-circuit TV to an antenna system, eliminating FM-signal interference and eliminating adjacent-channel interference. Despite all of these noteworthy applications, there is no equipment commercially available for improving the antenna signals—it can strengthen them but not improve them. An antenna signal, containing “ghosts” and noise in the desired TV channel, will contain the same annoyances no matter what commercially available electronic equipment is used. This equipment is merely capable of performing the functions just described.

The distribution system that was described (Fig. 4) requires 40dB VHF and UHF signals in order to provide adequate signals to the TV sets in the system. This is more power than can normally be provided by an antenna—unless the antenna is unreasonably large or located adjacent to the TV transmitters. The signal present at the antenna must be amplified to be of sufficient strength to adequately serve an MATV system.

Most TV antennas are designed to be connected to 300Ω twin-lead wire. This wire may extend from the antenna into the building where the amplifier is located (Fig. 5)—the amplifier having a 300Ω input to match the impedance of the twin lead and a 75Ω output to match the coaxial-cable impedance of the distribution system.

The 300Ω twin lead, like the antenna, may pick up TV signals as it runs to the amplifier. These “ghost” producing signals can be eliminated by shielding the twin lead, but another solution more frequently used is the substitution of 75Ω coaxial cable. Such cable is already shielded and can be connected to the antenna with a balun (also called a matching transformer).

Even during the winter, heat from the outside air can cause the metal molecules in the twin lead or coaxial cable to vibrate, thus generating noise. This noise is of very weak signal strength and will not be a problem unless the TV signal transmitted through the wire is not much stronger than the “snow” producing noise.

Table II—Typical Losses in One Set of Taps

		Isolation	Through-Line Loss
Type 1	VHF	29.0 dB	0.75 dB
	UHF	34.0 dB	0.25 dB
Type 2	VHF	21.0 dB	1.0 dB
	UHF	26.5 dB	0.5 dB
Type 3	VHF	14.0 dB	1.5 dB
	UHF	22.0 dB	0.7 dB
Type 4	VHF	11.0 dB	2.5 dB
	UHF	18.0 dB	0.75 dB

Table III—Signal Loss to Last TV Set

VHF	UHF	
40 dB	40 dB	signal supplied
— 0.9 dB	— 2.4 dB	30-ft coaxial cable
39.1 dB	37.6 dB	
— 7.0 dB	— 7.7 dB	four-way splitter
32.1 dB	29.9 dB	
— 1.2 dB	— 3.2 dB	40-ft coaxial cable
30.9 dB	26.7 dB	
— 0.5 dB	— 1.0 dB	tap through-line loss
30.4 dB	25.7 dB	
— 0.6 dB	— 1.6 dB	20-ft coaxial cable
29.8 dB	24.1 dB	
— 0.5 dB	— 1.0 dB	tap through-line loss
29.3 dB	23.1 dB	
— 0.75 dB	— 2.0 dB	25-ft coaxial cable
28.55 dB	21.1 dB	
— 0.7 dB	— 1.5 dB	tap through-line loss
27.85 dB	19.6 dB	
— 1.2 dB	— 3.2 dB	40-ft coaxial cable
26.65 dB	16.4 dB	
— 0.7 dB	— 1.5 dB	tap through-line loss
25.95 dB	14.9 dB	
— 0.9 dB	— 2.4 dB	30-ft coaxial cable
25.05 dB	12.5 dB	
— 18.0 dB	— 11.0 dB	tap isolation
7.05 dB	1.5 dB	
— 0.15 dB	— 0.4 dB	5-ft coaxial cable
6.9 dB	1.1 dB	
— 0.6 dB	— 1.5 dB	matching transformer
6.3 dB	— 0.4 dB	signal present at last TV set

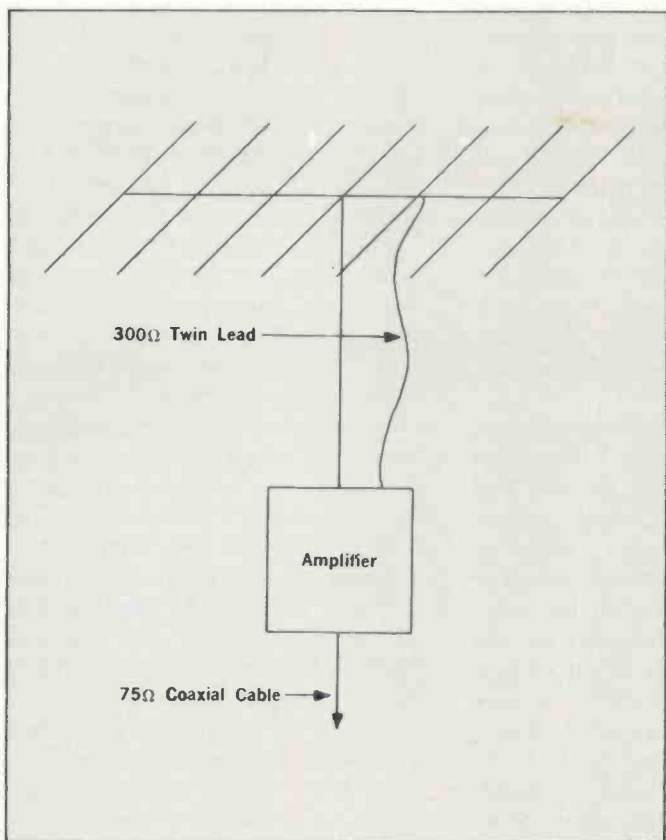

Fig. 5—In some MATV systems a 300Ω twin lead transmits signals from the antenna to an amplifier inside the building.

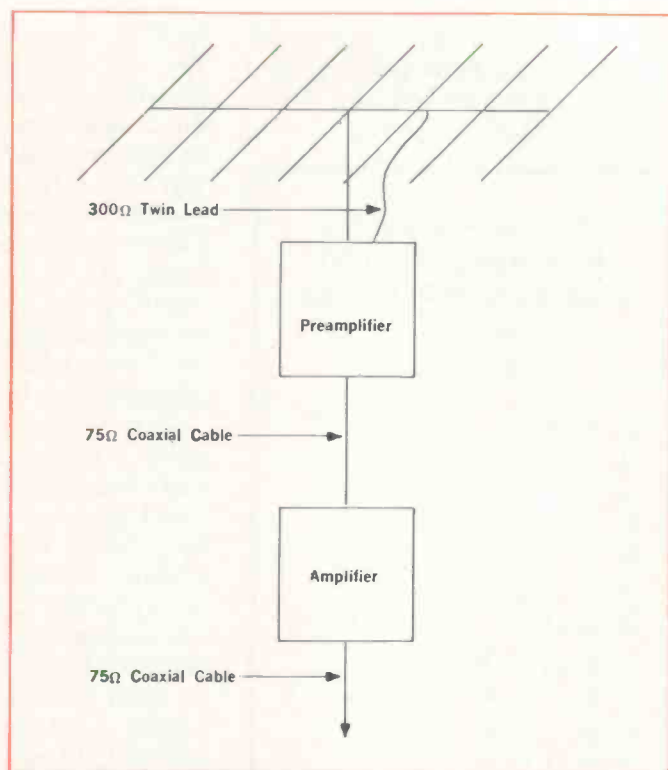

Fig. 6—Stray signals can be reduced by substituting a 75Ω coaxial cable for unshielded 300Ω twin lead (their impedances being matched with a balun or matching transformer), while noise can be reduced by using a preamplifier to increase the antenna signal before it is transmitted through the coaxial cable.

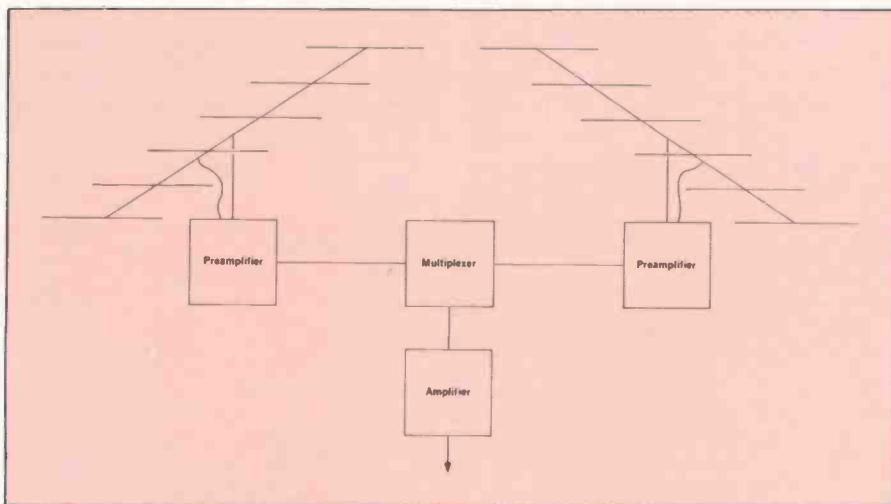

Fig. 7—TV signals from two antenna systems can be combined with a multiplexer for further amplification through a common amplifier.

A preamplifier attached directly to the antenna (Fig. 6) can be used to amplify antenna signals before they pass through the lead in. In this manner, these TV signals can be made significantly stronger than the noise. The noise, then being weaker in comparison to the signal, is no longer noticed. (A 34dB signal-to-

noise ratio (S/N ratio) is defined as a "fine" picture, while a 44dB ratio is defined as an "excellent" picture.)

When some TV channels are received from one direction with one antenna and others are received from another direction with a second antenna, the output signals from both may be combined with a

multiplexer (Fig. 7) for further amplification through a common amplifier. Such a circuit should function properly, provided the two antenna systems are not receiving the same TV channels or some adjacent TV channels.

Proper handling of adjacent TV channel problems requires an understanding of FCC channel allocations. Each TV channel is assigned a 6MHz bandwidth with the picture carrier, color subcarrier and sound subcarrier assigned certain frequencies within that channel (Fig. 8).

TV sets must have broadly tuned circuits in order to receive the entire 6MHz bandwidth of a TV channel. However, such circuits are unable to eliminate signals from adjacent TV channels, and for this reason the FCC has had a policy of not assigning adjacent channels to two stations in the same geographical area. Channels 4 and 5, plus 6 and 7, are the only exceptions since there is a 4MHz separation between Channels 4 and 5 (Fig. 9) and even a larger separation between the other pair of

channels. (Even with a 4MHz separation, many TV sets in portions of such cities as Minneapolis are unable to adequately separate these two channels.)

Table IV—Forbidden Conversions from UHF Channels to VHF Channels (Because of Harmonic Distortions)

14, 15, 16	to 5
18, 19, 20, 21, 22	to 6
23, 24, 25, 51, 52	
53, 54, 55, 81, 82	
83	to 7
25, 26, 27, 28, 55	
56, 57, 58, 59	to 8
14, 28, 29, 30, 31	
59, 60, 61, 62, 63	to 9
16, 17, 31, 32, 33	
34, 63, 64, 65, 66	
67	to 10
19, 34, 35, 36, 37	
67, 68, 69, 70, 71	to 11
21, 22, 37, 38, 39	
40, 71, 72, 73, 74	
75	to 12
29, 40, 41, 42, 43	
75, 76, 77, 78, 79	to 13

Although most electronic equipment for improving channel separation and otherwise modifying TV signals are designed along the same basic principles and have impedances that match 75Ω coaxial cable, there is little uniformity in component terminology. Some manufacturers show two or more components used in a signal modification requiring but one component built by another manufacturer. However, the basic principles involved are shown in Fig. 10.

Assume that the left antenna receives Channels 3 and 5 from one city while the right one receives FM plus Channels 2 and 7 from another city. Since the audio portion of Channel 2 would normally interfere with Channel 3, the Channel 2 signal is isolated and the audio portion attenuated (reduced) so that it is 6 to 10dB below its associated picture carrier—thus adequately reducing adjacent channel interference.

The FM and Channel 7 signals present in the right preamplifier alone do not interfere, but interference may result in Channel 7 when these signals are combined with Channel 5. When a 77MHz signal from Channel 5 is combined with a strong 100MHz FM signal, they can produce a 177MHz harmonic signal corresponding to signals in Channel

7. Virtually all VHF tuners used in today's TV sets contain FM traps to prevent such interference on Channel 7 and other channels. However, if the undesired harmonic signal has already been produced in the MATV system, it will pass through the tuner's FM traps as Channel 7 signals. To eliminate such interference, the splitter separates the FM frequencies as well as Channels 2 and 7.

A TV camera has been included in this system to display information concerning local weather conditions, alternately scanning a clock and an assortment of weather instruments. Its video output is modulated by the camera to appear on Channel 10.

Music to accompany this weather data can be obtained from an FM station. Some units are available that can be tuned to the desired FM station and then convert the resulting IF signal directly to the desired TV sound frequency in Channel 10. Converting the IF signal directly eliminates a number of unnecessary circuits—the IF detector, audio amplifier, audio FM modulator, etc.

Other units are available for converting UHF channels to VHF channels. But if there are a number of local VHF stations included in the MATV system, this may not be very convenient since harmonic dis-

Fig. 8—Each TV channel is assigned a 6MHz bandwidth with the picture carrier, color subcarrier and sound subcarrier assigned certain frequencies within that channel.

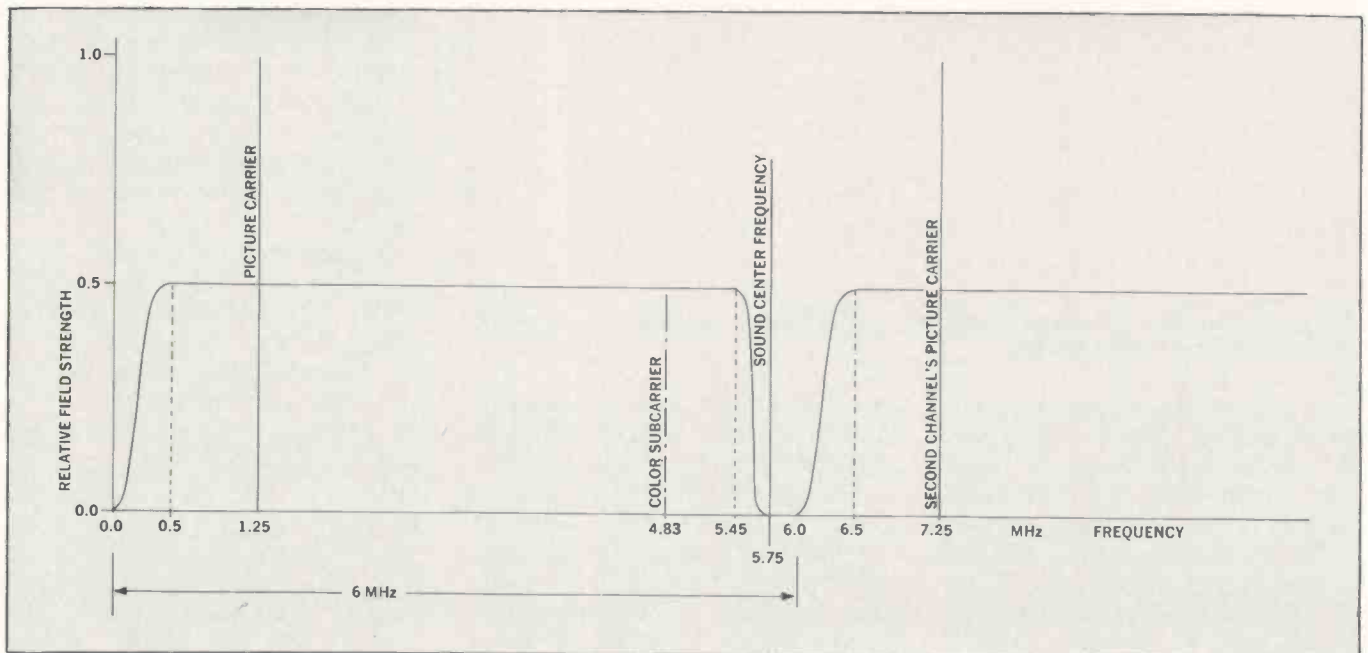

tortion prohibits certain UHF-to-VHF channel conversions (note the list of forbidden conversions given in Table IV). Now that all new TV sets are required to have UHF tuners, and there are more UHF stations on the air every year, most MATV systems are now being designed to handle UHF signals at the frequencies received.

Still other units are available for converting VHF signals from one channel to another. This may be desirable should the antenna system be capable of receiving the same assigned channels from two stations in

different geographical areas. It would then, of course, be necessary to convert the signals from one station to another channel.

Some MATV systems are designed to receive TV channels that cannot be received by standard TV sets. These would include the subchannels and channels 7A and 13A. Stations transmitting on such channels provide non-public programs, such as possibly educational programs for use in schools.

All of these TV channels are then combined in a multiplexer (Fig. 10) for additional amplification through

a common amplifier. (More sophisticated MATV systems use a single amplifier for each channel received. This offers more flexibility in filtering, less harmonic distortion, the control of individual channel gain and the use of AGC circuits not possible with broadband amplifiers, but it also costs significantly more.)

The video signal level of each channel at the input of the broadband distribution amplifier should be approximately equal (within 6 to 10dB) in order to provide equal quality reception on each channel. Separate channel attenuation or preamplification may in some instances be required to equalize these signals.

Gain and output capacity are two basic factors that must be considered when selecting the distribution amplifier. If the amplified input signals exceed the amplifier's output capacity, sync clipping and cross-modulation may occur—resulting in interference between channels, jittery pictures and/or horizontal tearing.

The amplifier must have sufficient gain to meet the signal needs of the distribution system. The amount of gain required for the desired output can be easily calculated once the strength of the input signal is known. If there is an input of -12 dB ($251\mu\text{v}$) and the distribution system requires 40dB (0.10v), the amplifier must provide about 52dB of gain [$40\text{dB} - (-12\text{dB}) = 52\text{dB}$]. On the other hand, if there is an input of $+2\text{dB}$ ($1259\mu\text{v}$), the amplifier must provide about 38dB of gain ($40\text{dB} - 2\text{dB} = 38\text{dB}$). Problems will result if a 50dB amplifier ($1000\mu\text{v}$) input signal, since it would attempt to produce a 70dB (3.16v) output ($50\text{dB} + 20\text{dB}$) while the amplifier is not rated for handling output signals greater than 50dB (0.32v).

CONCLUSION

There is a great assortment of components to choose from when designing an MATV system. The selection of components too sophisticated for the job will make a bid for installing such a system unrealistically high and will probably not result in a sale—or a financial loss if

continued on page 75

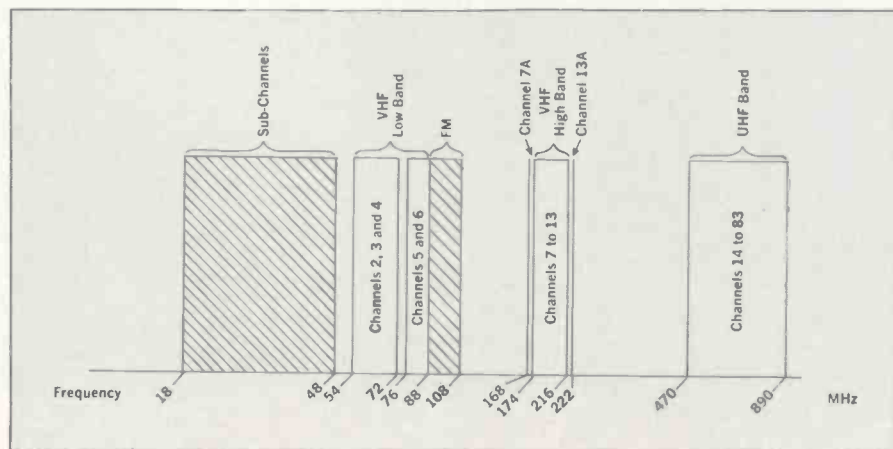
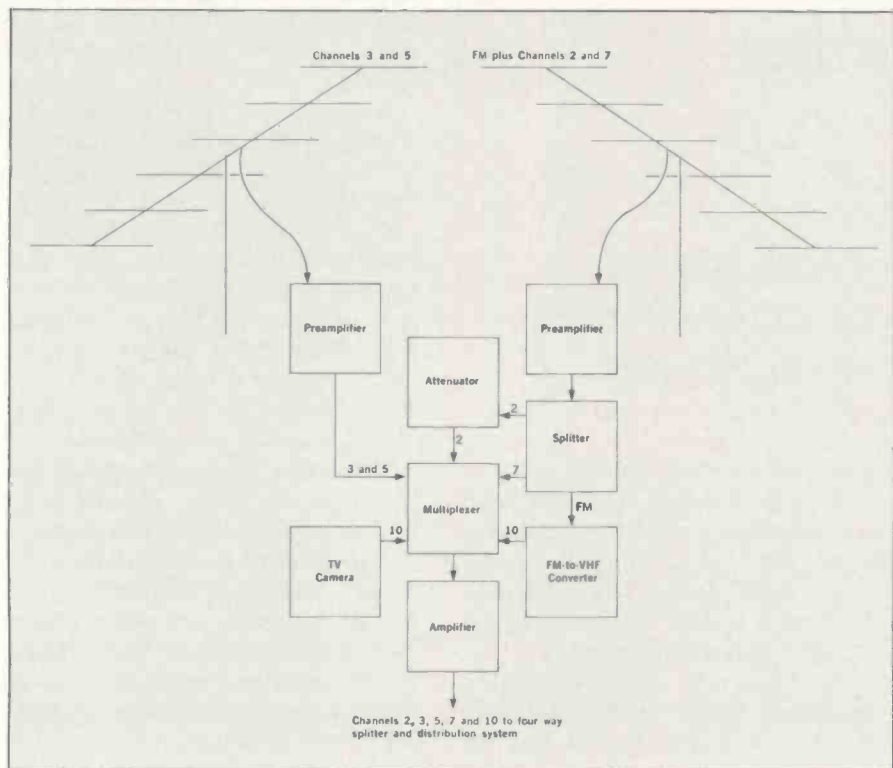

Fig. 9—Frequencies that the FCC has assigned the various TV channels.

Fig. 10—MATV components used to generate, modify and amplify signals for distribution to TV receivers.





This woman needn't worry about being out on the highway alone when experiencing an engine breakdown for she is able to radio for help. *Courtesy of EIA.*

FCC Allocates CB Emergency Channel

by PHILLIP DAHLEN

Be prepared to service a more rapidly growing market as the general public seeks the protection of an emergency mobile communications system

■ Last month we described the installation of a powerful transceiver capable of providing communications with amateur radio operators in all parts of the world. Such units have provided critically needed information during natural disasters. They, or at least two-way radios of similar design, form the basis for some rather complex communications systems. These are generally

considered the "big money" jobs.

There is, however, another class of two-way equipment, which, though not as sophisticated, represents a much larger sales and service market—Class D Citizens Band communications equipment.

The Electronic Industries Assn. reports that the use of this band has experienced a phenomenal growth (note Table I). Moreover, recent

changes in FCC regulations have opened the door for an even greater rate of expansion. So now is the time to prepare for a "piece of the action."

Effective July 24, the FCC has reserved CB Channel 9 exclusively for emergency communication use. This means that any U.S. citizen, age 18 or over, however lacking in electronics background, can purchase a two-way radio for the purpose of protecting him or his family (plus many other uses of course) should trouble develop on the highway or anywhere else where a telephone is not readily available.

The FCC has established priorities when allocating Channel 9 for this use, recognizing that a situation that may not be considered an emergency under some circumstances will be an emergency under others. First priority is given to communications dealing with an existing situation dangerous to life or property, then communications dealing with a potentially hazardous situa-



Fortunately the first one to arrive at the scene of this accident was equipped with CB Channel 9 emergency communications equipment. *Courtesy of EIA.*

tion, then road assistance for a disabled vehicle on a street or highway, and finally to street directions.

The FCC was very specific in specifying that this channel will be restricted exclusively for this use. After emergency communications have been established on that channel, it may be continued on the same channel if absolutely necessary. But whenever possible, both parties should switch to another channel once contact has been made in order to free the channel for other emergency contacts.

As indicated in the EIA Fact Sheet, there are now more than 2000 volunteer organizations, plus many fire departments and police stations, monitoring Channel 9 and ready to accept emergency calls any time of the day. However, the FCC makes it clear that none of these groups can consider Channel 9 exclusively theirs for emergency use. It is available to everyone with a licensed CB transceiver.

In some states two-way communi-

cations are not legal while hunting, the authorities feeling that this leads to unsportsmanlike practices. However, this does not mean that a CB transceiver should not be brought along just in case an emergency requires calling for help—a hunter becoming ill, injured or lost.

CB transceivers can also be used on boats for emergency communications (in addition to more casual communications, of course). There is, however, both a plus and a minus factor concerning the use of this band for such communications. There is a Marine Band available for use on boats, and this band is monitored by the Coast Guard for providing emergency assistance. The Coast Guard is too busy monitoring this band to install CB equipment and attempt to monitor that band as well—so they will not be there to respond directly to your CB call for help. On the other hand, the Marine Band is already overcrowded and at times more jammed than the non-emergency portion of the CB band.

For this reason, it is quite possible that a distress call received by a CB operator will be forwarded to the Coast Guard by telephone before it is possible to make direct contact on the Marine Band.

Car owners will be the first to respond to the added protection resulting from a CB installation, and auto installations will constitute the bulk of future CB transceiver sales and maintenance. These CB units can do much more than help assure the driver that communication is available when there is an accident or breakdown. As a personal example: There have been a number of times when I have driven my car across country accompanied by someone driving another vehicle. From personal experience I can say that it can become rather frightening when you are driving the second car, following some distance behind on a super highway and then remember that your car has a smaller gas tank than that of the other driver. It is also no fun when driving through

a strange city and having to wait for a red light, as the car ahead continues on, making a turn some distance down the road. If nothing else, you can at least use the CB transceiver to yell "stop" to the other driver.

It is hoped that this month's article has made you aware of a "golden opportunity" that has resulted from the recent change in FCC regulations. Let's take advantage of this situation by selling, installing and maintaining CB equipment.

We plan on providing additional information in future articles, but in the meantime please feel free to contact us if we can be of any additional help. ■

Station attendant receiving Channel 9 road service request. Courtesy of EIA.

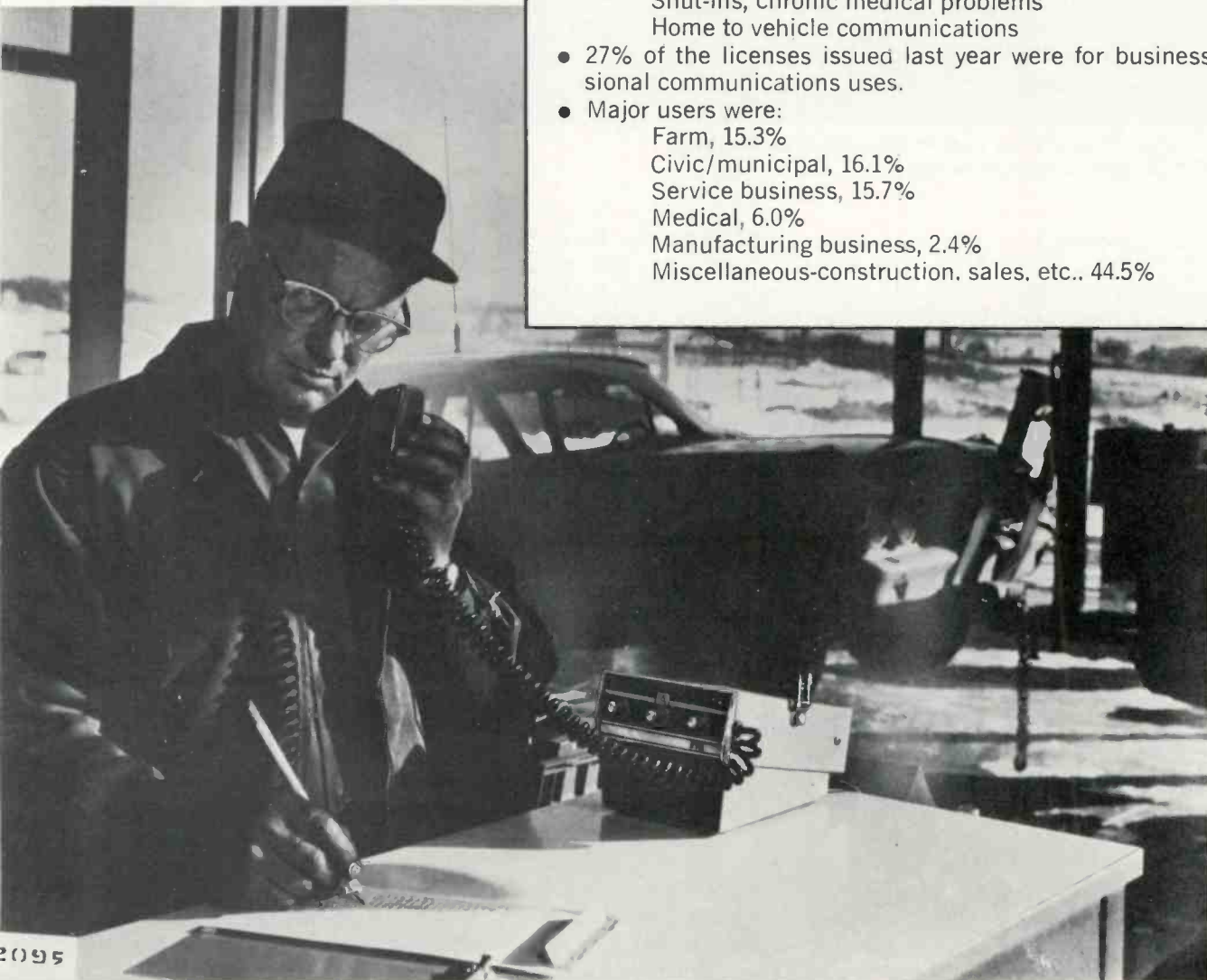

Table I—Citizens Two-Way Radio EIA Fact Sheet

- More than 3,500,000 5-w CB two-way radios have been purchased by Americans for business and personal use.
- 1,359,355 CB licenses have been granted by the FCC.
- 1 out of every 60 cars on the road today already is equipped with a CB radio.
- An estimated 1,800,000 emergencies were reported last year via CB radio.
- An estimated 72% of the emergencies handled involved automotive accidents or other automotive emergencies.
- Over 2000 volunteer organizations provide 24-hour-a-day monitoring to accept emergency calls on Channel 9.
- An estimated 500 police and fire departments now monitor CB radio for emergencies.
- 73% of the licenses issued last year were for personal communications uses.
- Typical personal communications uses include:
 - Marine pleasure craft
 - Hunting, fishing, camping
 - Personal safety, vehicles
 - Volunteers, civil defense and fire
 - Shut-ins, chronic medical problems
 - Home to vehicle communications
- 27% of the licenses issued last year were for business-professional communications uses.
- Major users were:
 - Farm, 15.3%
 - Civic/municipal, 16.1%
 - Service business, 15.7%
 - Medical, 6.0%
 - Manufacturing business, 2.4%
 - Miscellaneous-construction, sales, etc., 44.5%

Servicing Solid-State Stereo

by NORMAN H. CROWHURST

Part III—Varying line voltages and defective power supply components must also be considered when servicing this equipment.

■ Problems appearing in the output circuit of many solid-state amplifiers may actually result from improper bias voltages. These voltages may vary as a result of changes in the line voltage or, if the amplifier uses a regulated power supply, a defect in one of its components.

SUPPLY VOLTAGE FLUCTUATION

The working voltage of the large electrolytic capacitors in rectified supply circuits must include a tolerance above the normal working voltage or they would leak and overheat if the equipment happened to be operated in a location where the line voltage was abnormally high. However, it is not always economically feasible to construct the unit with electrolytic capacitors rated for voltages much in excess of the legal limit for line voltage variation—they are physically larger and more costly. Such a choice would also allow the dc supply voltage to rise and probably endanger other components in the unit.

In some parts of the country the legal range of line voltage fluctuations is ± 6 percent, which means that a nominal supply voltage of 117v could vary from 110v to 124v. But in other areas a larger voltage swing is possible, often as great as 10 percent, which makes it possible for a nominal 117v to vary between 105v and 129v. And variations between 100v and 135v are not by any means impossible.

In old tube circuits such variations had their greatest effect on available output power. Changes in the supply voltage usually caused a variation in output power that was about three times the variation in supply voltage. Thus an amplifier

rated at 50w from a 117v power line could vary from 35w to 65w when the line voltage varied from 105v to 129v.

The output of transistorized equipment usually changes with the square root of the supply voltage—the same change in line voltage causing a 100w amplifier to vary its output from 80w to 120w. (This is a much smaller variation than that experienced with the tube circuits.) And the use of current-limiting circuits can reduce the variation in output to between 90w and 110w from a 100w amplifier.

This is not the only effect of varying line voltage. Running at a low voltage will limit the output power, but it will usually also ensure that everything is running cool. Running at a high voltage can result in exceeding the voltage rating of some components, destroying them.

The power supplied amplifier output circuits usually has little or no voltage regulation. Any filtering usually comes from a very large capacitor connected across the rectifier output. On the other hand, the power supplied earlier stages of amplification is regulated and filtered

to remove ripple—usually with at least a series resistor and shunt capacitors in an R-C circuit.

If excess line voltage is suspected as the cause of component failure, the balance of the circuit should be checked thoroughly for defective components—particularly those that may not prevent the circuit from functioning but normally provide some protection to other components.

REGULATED POWER SUPPLIES

Some of the problems in high-quality stereo-amplifier systems can result from unwanted coupling through the power-supply circuits. The voltage supplied to earlier stages of amplification will vary according to the output-signal level.

The simplest circuit for reducing such problems is an adaption of the basic R-C filter network, using a transistor (Q1) to multiply the effective time constant (Fig. 1). This proves satisfactory for many systems, but feedback coupling may still occur when a low-frequency response must be achieved in high-quality systems.

This is due to the fact that this circuit is still basically an R-C circuit with an equivalent time constant of about 3.75 sec, due to the 7.5K resistor in series with the 500mfd capacitor. Even this slow change in voltage supplied the earlier stages can cause problems wherever critical potentials are required. (Note that the regulated voltage supplied the earlier stages changes slower than that supplied the output circuit.)

This time constant can be reduced by including a zener diode (D3) in

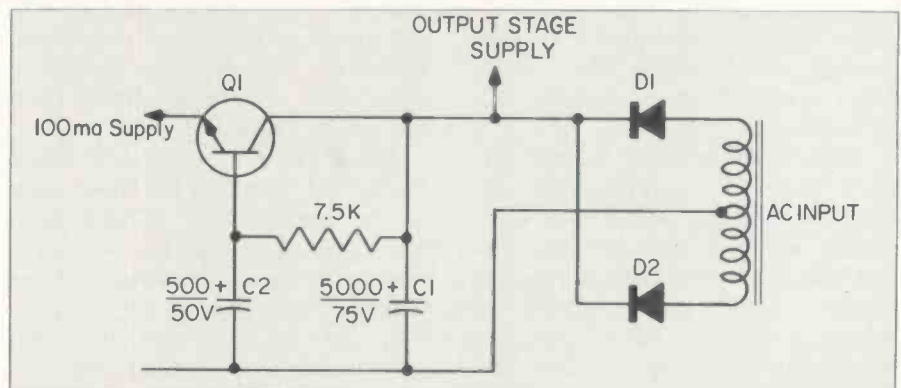

Fig. 1—Some of the simpler power supplies provide regulated voltage only to the earlier amplifier stages, supplying the output stage with only capacitor filtered voltage direct from the diode rectifiers.

the transistor's base-bias circuit (Fig. 2). There is, however, still a small time constant remaining due to the 47Ω resistor and 100mfd capacitor used in biasing the transistor's base.

These output voltage fluctuations can be even further reduced with a circuit (Fig. 3) incorporating dc amplification. In this circuit, the current for biasing the zener diode is kept more constant since it is obtained from the regulated portion of the power supply. This differs from the other power supply circuit where the current for biasing the zener diode is obtained from an unregulated source where the applied voltage is subject to wide variations, even without output load current changes.

Comparison between the zener voltage and the "potted-down" output voltage controls the collector current in transistor Q2, which in turn controls the bias of the base of transistor Q1.

The dc voltage from diodes D1 and D2 is filtered with a 5000mfd capacitor, while additional filtering is provided by an R-C circuit for the current biasing the collector of transistor Q2 and the base of transistor Q1.

This circuit achieves precise control of the regulated voltage, which does not vary with average output load current. And it can be adjusted to any desired voltage (within a limited range) by means of the potentiometer.

POWER SUPPLY FAILURE

Failure of the transistor in Fig. 1 will not directly disable the output circuit, but it may indirectly cause more damage by causing the earlier amplifier stages to operate with either too high a voltage, or with no voltage at all—while the output stage continues to receive its normal supply.

What happens under these conditions depends somewhat on the mode of coupling used between the earlier amplifier stage and the output stage. Some modern circuits are direct coupled; and supplying the earlier stages with full voltage, because the regulating transistor has become short circuited, may apply a higher voltage across one output transistor, with a lower voltage de-

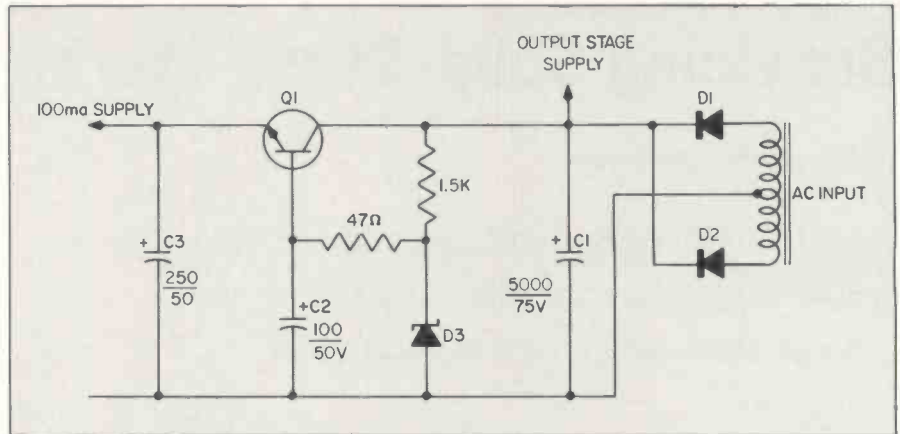

Fig. 2—A zener diode may be added to the circuit to reduce any voltage changes as the output load current varies with program content.

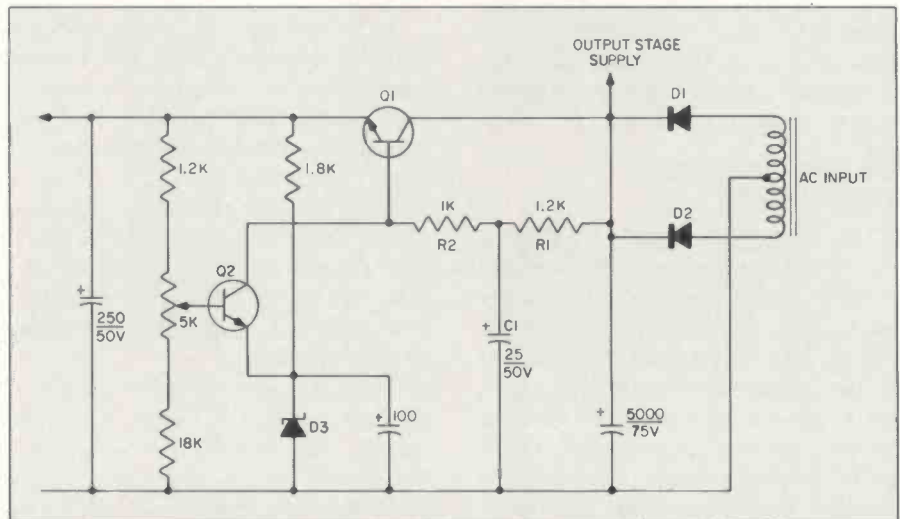

Fig. 3—In a more sophisticated regulator circuit the current supplied the zener diode is regulated, improving zener voltage tolerances.

veloping across the other. This could breakdown and destroy the transistor receiving the excess voltage.

On the other hand, if the regulating transistor "blows," developing an open circuit, the earlier amplifier stages will receive no supply voltage, while the full voltage may appear across one of the output transistors. However, this may not damage it since there will be no signal from the earlier stages.

Many circuits still use a transformer for coupling the drive stage to the output stage. Under these conditions, a change in the voltage applied to the earlier stage will not jeopardize the output stage in any way. Only the stages that may themselves be over-run by the higher supply voltage are in danger.

The circuit shown in Fig. 2 will behave in a manner similar to that

of the circuit shown in Fig. 1. However, if the transistor becomes short circuited, its base may conduct enough current to destroy the zener diode. Replacing the transistor without replacing the zener diode (D3) will result in a higher supply output voltage, and no voltage control. The circuit will then behave as a modified version of the circuit shown in Fig. 1. For this reason, the zener diode (D3) should be checked as well as the transistor.

The circuit shown in Fig. 3 offers much better protection. The only component in this circuit that is apt to be damaged from excess input voltage is the main regulator transistor (Q1). Whether it becomes open- or short-circuited, nothing else should be seriously endangered in the regulator circuit. Of course,

continued on page 56

How I Stayed in the TV Business

by R. L. WARNER

Retired TV repairman remains active in the industry by rebuilding picture tubes

■ Having reached the age of 71, I am just a little too old to make TV house calls any more. I had wanted to retire, but my Social Security benefits were not adequate to meet my needs. I just had to seek some other form of work to supplement my income.

An ad in *ELECTRONIC TECHNICIAN/DEALER* told of the money that could be made rebuilding picture tubes, so I wrote the company for more details. The brochure that I received described in detail the equipment used for rebuilding picture tubes, and I also received an invitation to Chicago for a complete and thorough demonstration.

I was so impressed with the equipment that I saw and the results that it could produce that I immediately purchased a rebuilding unit and stayed on in Chicago for training.



Warner displaying his tube rebuilding equipment.

Once a unit was delivered to my shop, I tinkered with it for a week or two to refresh my memory—then I started into business. I must admit that I was really scared, but I made my way through okay. And how surprised I was with the amount of business that I was soon handling!

Since then I have been successfully rebuilding both black-and-white and color picture tubes, wholesaling my tubes to the TV repairmen in my area. They all say that they are very pleased with my work.

With this unit I am even able to rebuild the 20mm Japanese tubes as well as radar and scope picture tubes. I find black-and-white tubes simple to rebuild and color tubes just as easy.

My small shop, about the size of a garage, is located in the rear of my home. By operating there I have no additional overhead.

When first deciding to go into this business, I figured that if I were to rebuild and sell only six picture tubes a week, I would have a nice income of about \$150.00 weekly. And with this, plus my Social Security, I would get along quite well financially. Well, things have gone much better than that and the demand for my picture tubes is quite heavy.

I have a young friend who would very much like to join me in my venture. I have decided to bring him here to Sacramento and have him work with me. This will take quite a load off my hands—for as I had stated previously, I am retired.

Once I have trained my new helper, I will then be our good-will man, contacting the various shops in our

area and talking with them about our excellent rebuilt tubes. I plan to call on TV shops and introduce myself—telling them that I am a picture-tube rebuilder, and that if they will give me a dud I will rebuild it free of charge to demonstrate my work. I will then take the dud to my shop and rebuild it (it only costs me about \$1.50 to rebuild a black-and-white tube or about \$5.50 to rebuild a color tube). Then I will bring the tube back to the prospective customer, while at the same time offering him one of my tube price sheets.

When the prospective customer has seen the quality and performance of my finished product and then compares my price sheet with those of other wholesalers, he will eventually decide to buy his picture tubes from me—no matter how stubborn he may be.

Recently I ran into a little problem and called the manufacturer. Although I was told on the phone how to solve the problem, to my amazement a company representative flew out to offer his personal assistance, arriving at our airport 11:55 one Sunday morning. When we reached my place, the representative said, "Let's go to work." Well, we worked from 1:00 in the afternoon to 2:00 the following morning.

During this time the company representative showed me how to overcome my problem and, while he was doing this, he rebuilt three more picture tubes for me! This is the reason I have written of my experiences. I felt it something that I must do to show my appreciation.

R. L. Warner
9430 Mary Ellen Wy.
Elk Grove, Calif. 95624 ■

Sencore's BE156 DC Bias Supply and its 39G26 Link Detector

by PHILLIP DAHLEN

Two test instrument accessories have been designed to assist in making TV set tuner-IF alignments

■ Sencore has developed a three-output bias supply and an IF link detector which can be of considerable value for tuner and first IF stage alignment.

BIAS SUPPLY

Many of today's TV tuners require a constant voltage for biasing the AGC (automatic gain control) and AFC (automatic frequency control) circuits before they or the first IF can be aligned with maximum accuracy.

Generally there is no need to know exactly the bias voltage supplied, since it generally is varied over a given range by associated circuitry; and the amount of current at the applied voltage is too low to be of any consequence.

It would be economically unreasonable to build a high-power bias supply when only a negligible amount of current is required. Likewise, there is no need to pay extra

to obtain voltages with precision accuracy when slightly different (though stable) voltages will have no apparent effect when aligning the tuner and first IF.

After examining the unit, it was felt that it adequately performs the job required of it. Remember, it is a bias supply and not a power supply. Even at the $-75v$ setting, it will be unable to supply enough power to operate many transistor radios—in our attempt the maximum voltage available dropping to a mere $5v$. From Table I it can be seen that the voltages indicated by the knobs do not exactly correspond to voltages obtained from the bias supply. But again, they are obtained with the degree of accuracy required for the job—and that should be the reason for purchasing the unit in the first place. Its three outputs can be varied continuously between $-25v$ and $+25v$ with respect to a common ground, while one of the three

Sencore's Model BE156 dc bias supply. For more details circle 900 on Reader Service Card.

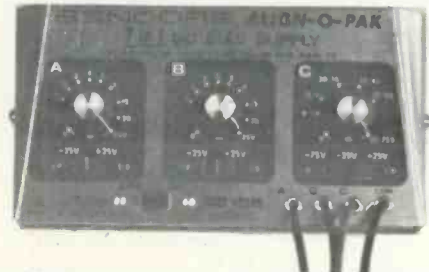

Sencore's Model 39G26 link detector. For more details circle 901 on Reader Service Card.

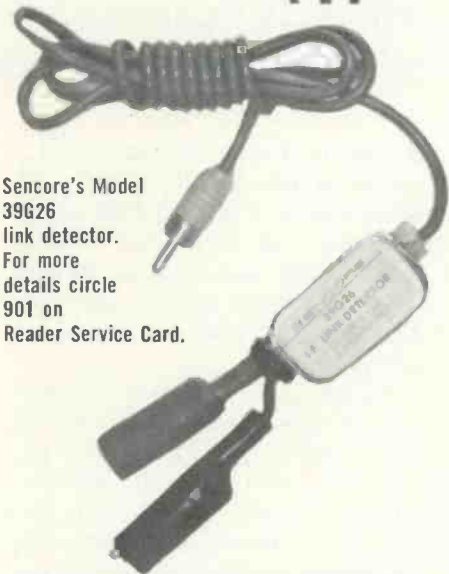

can also be varied between $0v$ and $-75v$ —an unusual degree of flexibility.

Three outputs are obtained from the circuit shown in Fig. 1. There the transformer's secondary voltage is rectified by a diode (CR1) and then filtered by an R-C type circuit (R1, R2, C1 and C2). The resulting $100vdc$ is supplied to a resistance voltage divider (R3, R4 and R5) where voltages can be measured at $+25v$, $0v$, $-25v$ and $-75v$ with respect to the common-output lead.

Table I—Bias Supply Output Voltage
(115vac applied)

Lead A -25v position		Lead A +25v position		Lead B -25v position		Lead B +25v position		Lead C -75v position		Lead C -25v position		Lead C +25v position	
Setting	Reading	Setting	Reading	Setting	Reading	Setting	Reading	Setting	Reading	Setting	Reading	Setting	Reading
0	0.0	0	0.0	0	0.0	0	0.0	0	0.0	0	0.0	0	0.0
1	1.6	1	2.0	1	1.0	1	1.0	6	6.1	2	2.3	2	1.9
2	2.4	2	3.0	2	1.8	2	1.8	15	15.8	5	5.6	5	4.3
3	3.3	3	4.3	3	2.8	3	2.8	30	32.3	10	11.6	10	9.1
4	4.7	4	6.0	4	3.8	4	3.8	45	49.5	15	17.9	15	13.9
5	6.5	5	8.4	5	5.2	5	5.1	60	64.8	20	23.4	20	18.3
8	9.6	8	12.3	8	7.8	8	7.6	75	78.4	25	28.2	25	22.1
15	14.0	15	18.0	15	13.2	15	13.4						
20	17.8	20	22.8	20	19.3	20	19.3						
25	21.0	25	26.8	25	23.6	25	23.8						

Switch S2 determines whether the maximum voltage at output A is +25v or -25v; switch S3 determines whether the maximum voltage at output B is +25v or -25v; and switch S4 determines whether the maximum voltage at output C is +25v, -25v or -75v. Three potentiometers (R6, R7 and R8) also function as voltage dividers to vary the output voltage between 0v and the maximum voltage selected. These potentiometers are calibrated to indicate the approximate output voltage resulting from each knob setting.

We found the circuit well designed to prevent damage from overload; and no harm was done when we overloaded it in an attempt to power a portable radio or when we left it on all night.

IF LINK DETECTOR

The link section, for which the Sencore detector probe is intended, consists of the TV set mixer coil, the cable connecting the output of the tuner to the input of the IF strip, the first IF transformer, and the traps associated with the input circuit of the first IF stage.

The link section of the TV set must have a broader frequency response than the following stages of the IF section, since anything not passing through the link section cannot be amplified by the remaining IF section. For this reason it is best to align the link section first in order to obtain the best possible response from the TV set.

Unfortunately some scopes do not have adequate sensitivity for observing signals present at the first IF—particularly those in TV sets incorporating low-impedance semiconductors. In order to overcome this problem, Sencore incorporated a voltage multiplier circuit (Fig. 2) in this probe. Circuits of this type were described in detail some time back in the "Semiconductors From A to Z" series of articles; but in simplified terms we might say that each diode-capacitor pair functions as a sort of "electronic pump," each pair increasing the rectified voltage developed as a result of the applied high-frequency ac-signal voltage.

Designed to eliminate the need

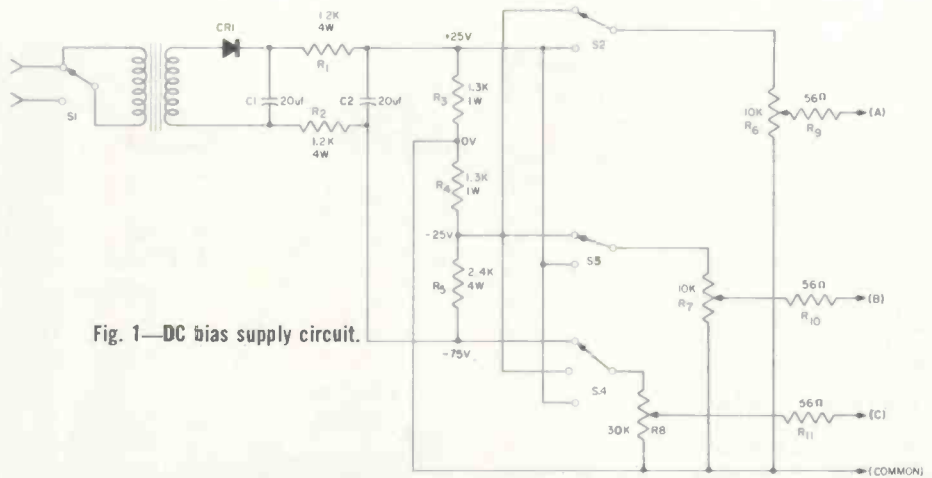

Fig. 1—DC bias supply circuit.

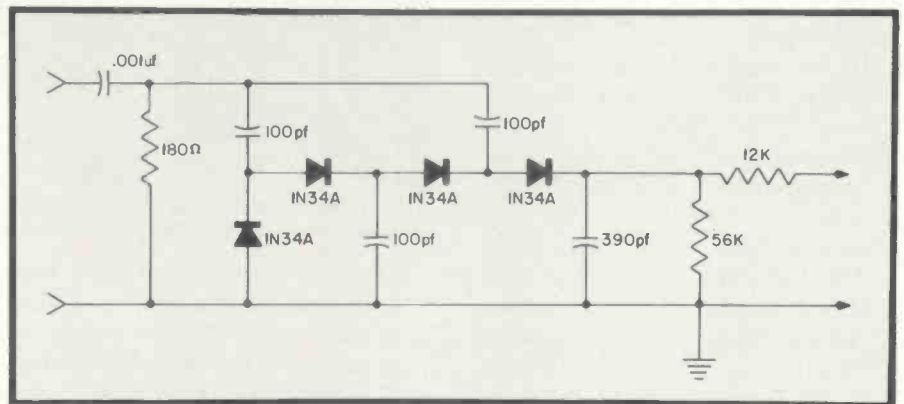

Fig. 2—Link detector circuit.

Components inside the dc. bias supply.



for any home built detector probes, loading assemblies or amplified detector probes, the voltage-quadrupler detection system is reportedly unable to introduce distortion as would an amplifier-type probe.

The voltage gain that does result (with a corresponding loss in scope signal current) can bring the IF signal up to a sufficient level for viewing on a scope that might otherwise lack adequate sensitivity. Since

there is virtually no scope signal-input current drain, the loss of any available input current is of no consequence.

The earlier semiconductor article showed how the output voltage from a voltage-multiplier circuit is dependent on the frequency of the applied ac voltage. This is probably one of the reasons Sencore advises on the side of the detector to "use for IF link alignment only." ■

EMERSON 26C56...

continued from page 39

circuitry. Horizontal positioning can be obtained in either direction by cutting the red or blue leads. These leads will be found at the rear of the chassis adjacent to the horizontal output tube.

To position the picture to the right (as viewed from the front), cut the blue leads; for left positioning, cut the red leads.

PRODUCTION CHANGES

- In the brightness control circuit, R330 has been changed from 150K to 120K for increased brightness.
- In the second chroma amplifier circuit, R330 has been changed from 1K to 390R.
- To provide additional protection against internal tube shorts, fuse links have been added to the filament circuits on PC2 and PC3. The links are of No. 28 solid tinned copper wire with fiber-glass sleeving. On PC2, the filament supply is applied to Pin 6 of V204, then through the fuse wire to the other heaters on PC2.

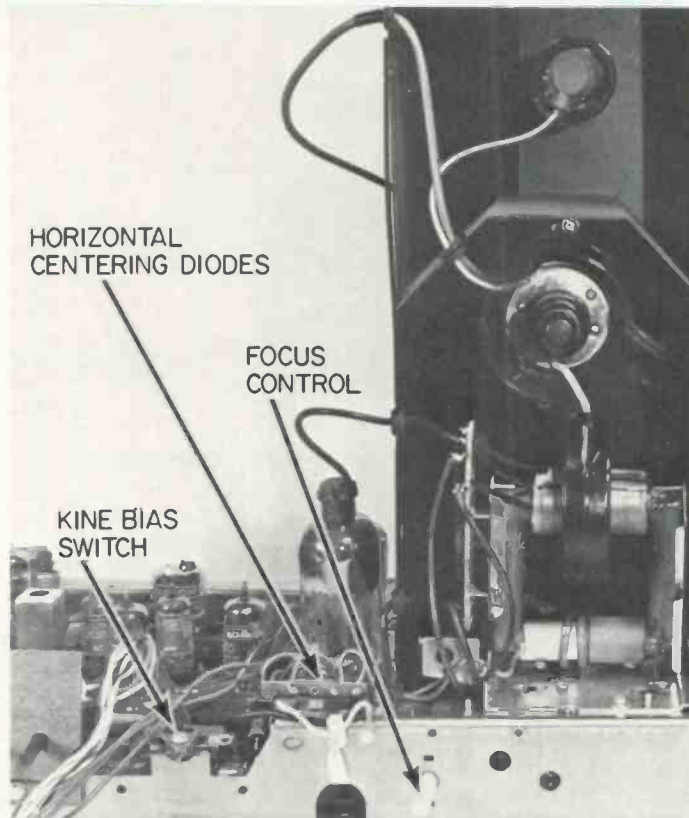

Partial chassis view showing horizontal centering diode and cover removed on HV cage exposing the shielded flyback, shunt regulator and HV rectifier tube.

On PC3, the filament supply has been moved from Pin 5 of V310 to Pin 3 of V307. From there it is applied to the other heaters on PC3 through the fuse wire.

- The power source is now shown

as 125vac to conform to the new standard line voltage. A new power transformer, 730169, is used in place of the 730157 transformer used with 120vac line voltage. ■

SOLID STATE...

continued from page 52

the circuits supplied by the regulated voltage are subject to the same dangers as those supplied by the power-supply circuits shown in Fig. 1 and 2.

UNUSUAL VOLTAGE SURGES

So much for faults that occur during the "normal" operation of a solid-state amplifier system. Another factor to consider is the possibility of abnormally high supply voltages resulting from power-line surges of relatively short duration.

In any circuit using a zener diode as a voltage reference, the regulator circuit will attempt to hold the voltage constant, which means that the

series regulator transistor will be seriously over-run with excess bias voltages, and thus much more likely to be damaged.

Protecting against such a possibility poses certain difficulties. If there is any likelihood of its repeated occurrence, a necessary increase in cost would be justified. But many solid-state-amplifier systems will never be exposed to such line voltage surges. Possibly the most economical protection is the use of electrolytic capacitors rated for only slightly more than the normal voltage — reducing voltage surges through leakage. These capacitors must be inserted at the dc voltage output of the rectifying diodes (Fig. 4) before any series resistors.

The momentary surge current into the electrolytic capacitors may

amount to several amperes—possibly more than the normal working load of the power supply. The rectifier diodes may not have a high enough power rating to handle this excess current in combination with the surge voltage. However, it would be less costly for the diodes to be destroyed by such a surge than other components exposed to excess dc voltage.

A simple, low-cost component for protecting the diode is the old-fashioned fuse. By making the electrolytic capacitors leak enough current to blow the fuse before the rectifier diodes are destroyed, all that needs replacing is an inexpensive fuse.

However, before replacing the fuse it is a sound practice to attempt to determine why the fuse blew. Even though it only blew to provide protection against over voltage from the power line, it is best to check and make certain that some other component, such as a zener diode or transistor, was not damaged at the same time. ■

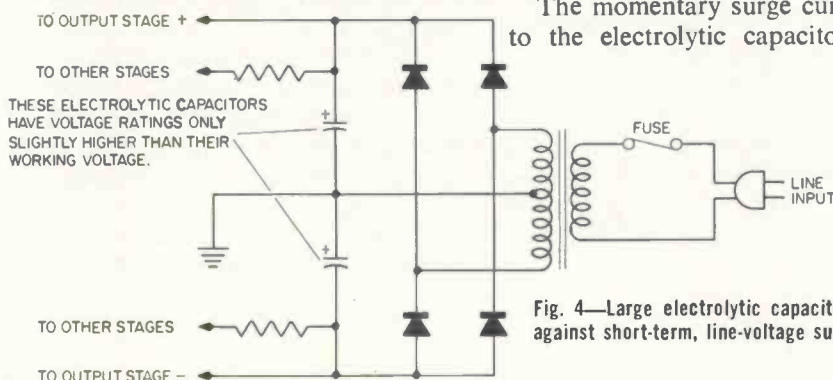

Fig. 4—Large electrolytic capacitors and fuses may be used for protecting power supply circuits against short-term, line-voltage surges that might otherwise cause serious component damage.

The replacement picture tube no other color tube can replace!



Simulated TV picture

ZENITH
CHROMACOLOR

Now you can install the revolutionary Chromacolor picture tube in almost any brand of 23" (diag.) color TV. And let your customer see the difference: a new, sharper Chromacolor picture with greater brilliance, contrast and color definition.

Zenith pioneered, developed and patented (U.S. Patent No. 3146368) the Chromacolor picture tube. And only Zenith has Chromacolor.

Chromacolor is an easy sale because people already know of Chromacolor's superiority. (Last year, after the revolutionary new Chromacolor system was

introduced, Zenith giant-screen color TV sets became the No. 1 best-seller!)

Full two-year warranty.

Here's your sales clincher: Chromacolor replacement color tubes are warranted for two full years. Exactly double the warranty period for most other replacement color picture tubes.

Give your customers the best — Chromacolor replacement color tubes. Only your Zenith Distributor has them.

TWO-YEAR WARRANTY

Zenith Radio Corporation warrants the replacement CHROMACOLOR picture tube to be free from defects in material arising from normal usage for two years from date of original consumer purchase. Warranty covers replacement or repair of picture tube, through any authorized Zenith dealer; transportation, labor and service charges are the obligation of the owner.



Zenith Chromacolor picture tube pinpoints the color dots on a jet black background and for the first time fully illuminates every dot.

ZENITH

The quality goes in
before the name goes on

No woman should be allowed
to drive alone at night...

...without citizens
two-way radio

Sure as fate it's going to happen—the inevitable inconvenience on the highway that *could* turn into a nightmare for someone close to you.

Unless, of course, her car is equipped with citizens two-way radio to close the gap between auto and help *instantly* when trouble occurs.

To more than a million American families, citizens two-way radio already has become not only a marvelous everyday convenience but a vital and irreplaceable communications link. It can bring a squad car, travel information, a friendly voice or a loaf of bread with equal facility. And for less than the cost of a new set of tires.



Can you think of a better way to promote family togetherness or peace of mind?

ELECTRONIC INDUSTRIES ASSOCIATION

2001 Eye Street, N. W. Washington, D. C. 20006 Citizens Radio Service Section



For additional information on products described in this section, circle the numbers on Reader Service Card. Requests will be handled promptly.

INTERCOM SYSTEM 700

Electronic switching can handle 100 stations

The M100, a decentralized intercom system with all-electronic switching, can reportedly handle 100 stations and expand to an unlimited number



of master stations by using the common 8-pair single interconnecting cable. The decentralized design of the unit divides functions between the station and the separate control pack. All active circuits, such as digit selection, registration and connecting for the speech signal, are reportedly located in the stations. Functions such as engaged/vacant registration, checking of individual communication lines and the power supply, are said to be located in the control pack. Specifications indicate that apart from the manually operated contacts in the stations, there are no electro-mechanical components such as relays or cross bar switches. Stations are said to be voice-controlled for hands-free operation, and the units can handle multiple conversations. Norelco.

STEREO RECEIVER 701

100w power output at a moderate price

The Model 202 "Fuçura Series" stereo receiver is rated 100w power output and reportedly features muting, tape monitoring facilities, and mono/stereo modes of operation. Specifications indicate that the unit incorporates FET and IC components,

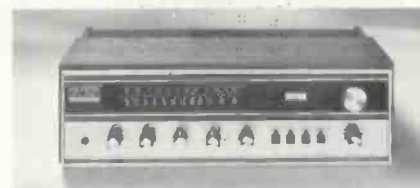

illuminated program selector and dial pointer, Baxandall feedback circuit for bass and treble to assure well-balanced sound at all volume levels, and a four-way speaker selector. The main unit is said to measure 23 $\frac{3}{8}$ in. wide by 8 in. high by 16 in. deep, and it weighs 32 $\frac{1}{2}$ lb. Under \$250. Fisher Radio.

AM/FM RADIO AND TAPE RECORDER 702

AC/DC powered, with push button control

The Silverton, Model RQ-236, an AM/FM radio with a built-in cassette tape recorder, is said to be adaptable for playing in a car or a boat. The ac or dc powered unit has a push-button operation for recording and playback. An automatic stop switch is designed



to prevent damage to tape and equipment by automatically stopping the tape when it runs out. A VU battery level meter reportedly indicates recording levels, while the three-position "Easy-Matic" recording level control insures against overloading and permits recording without adjusting the recording level. Specifications indicate that other features include speaker monitoring while recording, capstan drive to allow the tap to run at a continuous speed for distortion-free sound, and a safety-lock cord button that guards against accidental erasing and recording. Retail price \$99.95. Panasonic.

MICROPHONE 703

Front-to-back rejection ratio of 25dB

The Ultra-Cardioid Dynamic Microphone features a 25dB front-to-back rejection ratio that reportedly



minimizes reverberation and microphone placement problems. Specifications indicate that it has a sintered phosphor bronze acoustic filter. The effects of "pop," "blast," and wind are said to be reduced by a grille assembly of stainless steel mesh that encloses a foam filter and a fine magnetic screen which prevents dust and magnetic particles from reaching the diaphragm. The microphone is said to have a uni-directional polar pattern and a frequency response of 40 to 15,000Hz. The adjustment of a connection per-

Now! Prepare Co-Ax Cable in 5 Seconds!

R-SERIES CO-AX CABLE STRIPPER*

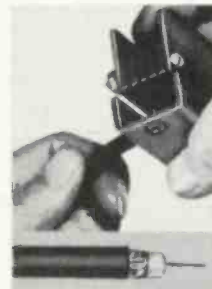

Accurate cuts are easy:

(A) Open tool, place CO-AX cable in groove and while closing -

(B) Rotate tool ground cable, cutting jacket, shield and dielectric.

(C) Special Shield Dressing Fitting prepares braid for easy cable insertion in tap-off or connector.

*Pat. Pending

Here's the only tool made that offers you simultaneous cutting of jacket, shield and dielectric! It's fast, precise, time-saving, trouble-free and versatile! Uses inexpensive razor blades.

Model R-100 —Prepares RG59 cable for "F" and "C" fittings, tap-offs, splitters, couplers, PL259, etc.

Model R8/11 —Prepares RG8, RG11 cable for PL259 fittings, cable splices, etc.

Model R58 —Prepares RG58, RG58AU cable for PL259, phono plugs, etc.

Model R6/CAC—Prepares .275" all-channel cable for "F" fittings, tap-offs, splitters, couplers, etc.

Only \$5.95 guaranteed.

See it at your Distributor/Dealer or write
UNITED TEL-TRONICS COMPANY

Allison Park, Pa. 15101

412/443-6200

... for more details circle 132 on Reader Service card

Who Needs a Tuner Wash?

Use

QUIETROLE Mark II Spray Pack

The product that cleans and lubricates better than any product you can buy and has been used for more years than any product of its kind.

The Choice of "Better Servicemen" Everywhere



... for more details circle 120 on Reader Service Card

ET/D DEALER SHOWCASE

mits the selection of either high impedance (E1A 40,000Ω) or low impedance (E1A 150Ω). Sensitivity at high impedance is rated at -50dB re: 1V/microbar. At low impedance, the sensitivity is rated at -54dB re: 1mw/10 microbars. Special shielding is designed to reduce hum to a negligible level in environments where electrostatic or magnetic pick-up may be a problem. Hum pick-up is reportedly attenuated to -121dBm re: .001 Gauss, 60Hz. The microphone reportedly has a shock mounted diaphragm virtually unaffected by moisture, temperature extremes (-80° to +300° F), most acids, alkalies, and solvents. It is said to have a chrome finish that is non-reflecting and a scratch- and mark-resistant black chrome trim. Astatic.

STEREO RECEIVER 704

Speaker range
of 18 to 26,000Hz

The RS 17 stereo receiver is designed for the listener who prefers to

assemble his own components. The all-transistor unit is rated at 65w for each channel and is equipped for use with the RL 17 speaker enclosures (rated at 18 to 26,000Hz). Input jacks are said to be provided for the use of headphones and popular model turntables, record changers or tape

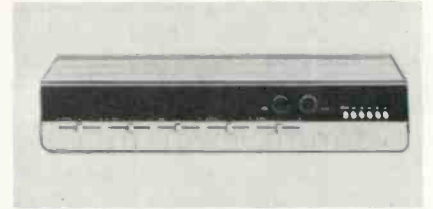

recorders. The radio section of the receiver reportedly includes five wavebands, AFC control and electronic FM tuning. The cabinet is said to feature sliding dials set against a black background, with wood veneer or white ground lacquer finish. Price \$410 without speakers. Siemens.

ELECTRONIC CROSSOVER 705

Complete control to
match Hi-Fi components

A stereo electronic crossover, the SF-700, is designed to supply complete Hi-Fi control through its ability to match amplifiers, speaker systems and room acoustics. Four knobs on its front panel reportedly control the cut-off characteristics near each crossover frequency. Specifications indicate that they supply an attenuation of 6dB/octave, 12dB/octave, or 18dB/octave at four positions: low, mid-low, mid-

THE GREAT PUT-ON

Put it on printed circuits, components . . . anything that has to be encapsulated, sealed, isolated, protected.

It's our spray-can-hand polyurethane coating that's fast-drying, tough, flexible. It's waterproof. Resists cleaning solvents, chemicals, marring and abrasion. Even today's atmosphere.

Use it as a potting or metal primer . . . finishes stick right on. It's always ready to go. So no mixing too much or not enough. No shelf- or pot-life worries either. Want to brush it on, dip it, use your own spray gear? OK. We'll send it over in bulk . . . gallons or drums. Or a tank car.

Use Urethane Seal Coat . . . it'll cover your problems.

CRC URETHANE SEAL COAT



CRC Chemicals
Division of C. J. Webb, Inc.
Dresher, Pa. 19025

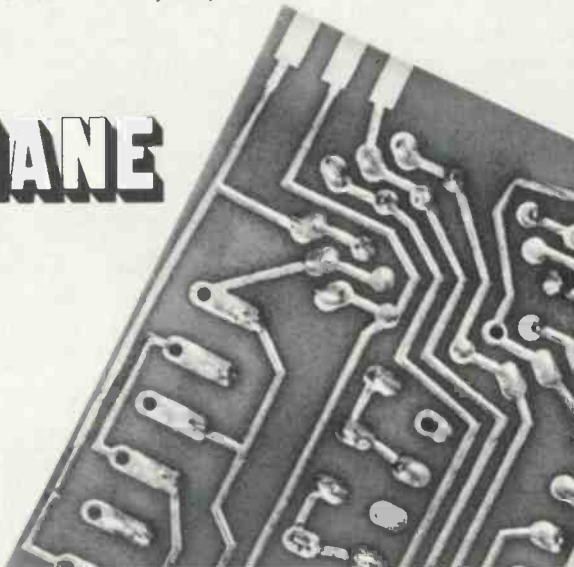

... for more details circle 107 on Reader Service Card

NOW A ONE STOP SHOPPING CENTER FOR YOUR AUTO RADIO AND 8 TRACK STEREO PARTS. AT FACTORY DISCOUNTS

WE ARE AUTHORIZED PARTS
DISTRIBUTORS FOR:

DELCO	PANASONIC
BENDIX	PHILIPS
MOTOROLA	BELLE WOOD
LEAR JET	WARD
TENNA	QUICKMOUNT
METRA	DEWEKO
AUTOMATIC	AC SPEEDO
ON GUARD	KING SEELEY
CRAIG	STEWART WARNER

STEREO LOCK MOUNTS

SEND YOUR ORDERS WITH
PART NUMBERS TO

Laran Electronics, Inc.

3768 BOSTON ROAD
DEPT. 100 BRONX, N.Y. 10469

OR SEND MODEL, MAKE AND
DESCRIPTION OF PART WANTED.

... for more details circle 115 on Reader Service Card

high, and high. Through these controls the user can shade tonal quality of sound reproduction. There are also two knobs for range selection of crossover frequencies. The low-mid knob reportedly provides a choice of 125Hz, 250Hz, 500Hz, 700Hz, or 1kHz and off; while the mid-high



knob reportedly provides a choice of 1kHz, 2kHz, 4kHz, 6kHz, or 8kHz and off. The input impedance is rated at 100K at 1kHz, and the output impedance is less than 200Ω at 1kHz. Price \$179.95. Pioneer.

STEREO SYSTEM 706

Entire system packed in a single carton

The Model RTS-40 stereo system is said to feature an R-40 50w AM/FM/MPX receiver. Reportedly coupled with the receiver is a Model 310/X Total Turntable, and a pair of SS-2 acoustic suspension speaker systems. Specifications indicate that the stereo system is factory packed in a single "Tote-All" carton which contains the entire system and all the necessary cables. BSR (USA).

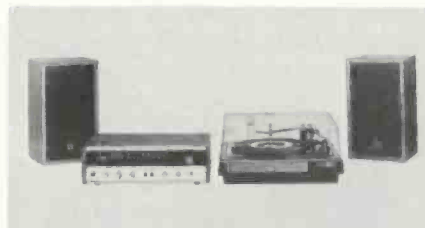

SPEAKER SYSTEM 707

Frequency response from 40Hz to 20kHz

The Model A-2000 acoustical suspension speakers will reportedly fit into any high quality stereo component system. With the controls set ap-

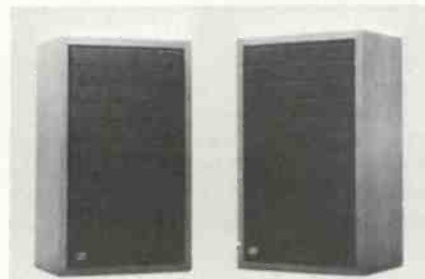

propriately, the woofer output is said to be flat to within ± 1 dB from 55 to 1300Hz. Specifications indicate that the woofer high frequency roll-off is very rapid due to the incorporation of damped radial decouplers in the cone design, which minimize interference effects between the woofer and the tweeter. The dome tweeter is designed to be free of mechanical breakup resonances below 18kHz. It is coupled to the air with the aid of a diffraction loaded plate designed to help eliminate purely acoustical wave length phenomena. The speaker system reportedly measures 13½ in. by 10¼ in. by 23 in. and is housed in a walnut cabinet with a grill. List price \$159.95 each. 3M Co.

TELEPHONE ANSWERING MACHINE 708

Delivers message to caller and records incoming calls

The Phone-Mate 100, an automatic telephone answering instrument, is de-



signed to automatically deliver a pre-recorded message to each caller and record an incoming message when plugged into an ordinary cassette or reel-to-reel tape recorder. The user can reportedly override the unit to talk to the caller if he wishes. An external cassette or reel-to-reel tape recorder to record callers' incoming messages can be placed on top or next to the instrument. Specifications indicate that the instrument plugs into an ordinary four-prong telephone extension jack, which is supplied with the unit, and reportedly works with any type of telephone instrument or system. Price \$149.95. Tron-Tech.

PA AMPLIFIERS 709

With notch filter calibration from 35 to 100Hz

Two lines of solid-state PA amplifiers, the Flex-Pak series NT and the Custom-Flex series NXT, are said to have all-silicon circuitry and power ratings of 30, 60 and 120w. Specifications indicate that the standard microphone input capability of the ampli-

NEW TV/radio/Hi Fi

fix-it tools



make tricky jobs easy

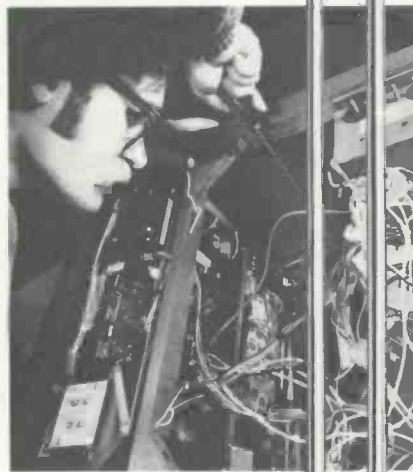

SUPER LONG NUTDRIVERS

Over 20" long with 1/4" and 5/6" hex openings, color-coded plastic (UL) handles, full length hollow shafts.

Eliminate skinned knuckles and the frustration of trying to reach tuners, bezels, other up-front components from the back of a TV set with ordinary tools.

Extra length means more convenience, greater driving power for many other "fix-it" jobs.

INVERTED PALNUT DRIVER SHANKS

Fit all Xcelite "99" handles, including Tee and ratchet types. Popular 7/16" and 1/2" external hex sizes, hollow shanks.

Save time, prevent damage to fastener or equipment when removing Palnuts on balance controls, on-off switches, volume control shafts of most TV sets, record players, portable radios.

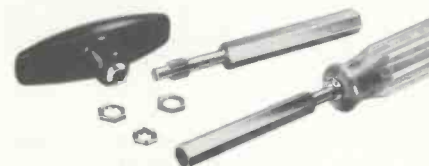

nationwide availability through local distributors

REQUEST BULLETIN N470

XCELITE

XCELITE INC., 14 BANK ST., ORCHARD PARK, N. Y.
In Canada contact Charles W. Pointon, Ltd.

... for more details circle 135 on Reader Service Card

Model No. W01

SOLID STATE
ONE GUN BOOSTER
FOR COLOR TV

EXTENDS COLOR GUN LIFE

RESTORES RED, BLUE OR GREEN BRILLIANCE

EASY TO INSTALL
(INSTRUCTIONS ON BACK)

WORKMAN Electronic PRODUCTS, INC.
SARASOTA, FLORIDA

BEFORE WEAK SERVICE LINE

AFTER BOOSTED SERVICE LINE

installation of
ONE GUN BOOSTER
Boosts the one weak color needed for a **BALANCED** color picture.

MANUFACTURED BY
WORKMAN Electronic PRODUCTS, INC.
SARASOTA, FLORIDA

... for more details circle 133 on Reader Service Card

REBUILD YOUR OWN PICTURE TUBES?

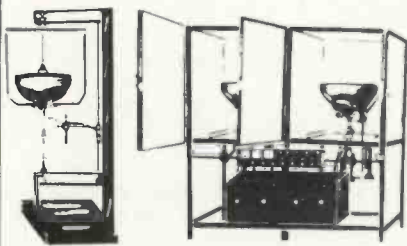

With Lakeside Industries precision equipment, you can rebuild any picture tube!

EASY TO OPERATE!

Requires only 4 x 8 ft. of space.

Your cost to rebuild black and white—\$1.50.

Your cost to rebuild Color—\$5.80.

For complete details, mail coupon.

LAKESIDE INDUSTRIES

5234 N. Clark St.
Chicago, Ill. 60640
Phone: 312-271-3399

- Free demonstration appointment
 Send me more information

Name
Address
City State

... for more details circle 114 on Reader Service Card

ET/D DEALER SHOWCASE

fiers is three high-impedance inputs for the NT line, and five high-impedance inputs for the NXT models, with two inputs from either the NT or NXT models easily converted for use with a magnetic phono cartridge. An input facility for two additional microphones can reportedly be incorporated

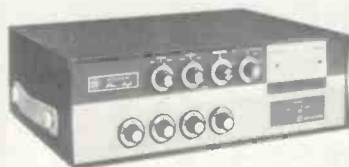

into any of the amplifiers by mounting an accessory module on the NT or NXT chassis. This gives the NT models five microphone inputs and the NXT units seven microphone inputs. On the front panel of each amplifier, a special notch filter is said to be calibrated from 35 to 100Hz to suppress undesirable low-frequency signals, such as hum and rumble. There is also an independent speech filter which is said to improve clarity of speech and to eliminate undesirable bass frequencies. Both lines of amplifiers are equipped with a protective circuitry designed to shut down power immediately in case of overload from speaker mismatch or short circuit. Bogen.

STEREO TAPE PLAYER 710

Response of 50 to 10,000Hz and 5w output power

An eight-track stereo home tape player, Model WHP-100, can reportedly be used as a self-contained sound system or adapted as a tape deck with other amplifiers and tuners. The tape player is said to be equipped with output jacks for conversion to a tape deck. Specifications indicate that it also has two satellite speakers and an illuminated indicator light which gives the exact location of each channel. The low-noise, ten-transistor stereo tape player has a reported frequency



response of 50 to 10,000Hz and an output power of 5w. Tape speed on the 4-channel system is rated at 9.5 cms, with wow and flutter at less than 0.3% RMS. Price \$99.95. Weltron.

BASE TRANSCEIVERS 711

Slide rule channel selection and digital clock

Two CB transceivers are said to feature integrated circuitry and full 23-channel operation utilizing slide rule selection. Model SFT-500 is reportedly equipped with two speakers and a digital clock that can be programmed to turn on the transceiver automatically and give an audible alarm, while Model SFT-400 is reportedly equipped with one speaker and has no clock. Specifications indicate that both solid-state models offer a built-in PA system with volume control, an auxiliary speaker/phone jack and 100% modulation to assure full talk power. Fanon.

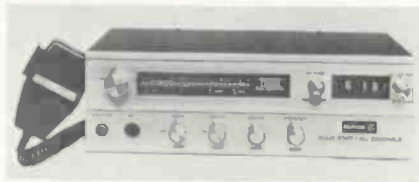

PORTABLE CASSETTE RECORDERS 712

AC/DC operation with automatic record level

Four additions to a line of portable ac/dc cassette recorders reportedly have automatic record level circuitry,



and two have built-in AM/FM radio. Deluxe Models 4500 (without radio) and 4510 (with radio) are said to accept rechargeable nickel cadmium batteries. Model 4500 priced at \$79.95, and Model 4510, \$99.95. Models 4400 and 4410, which have single function knob controls, list at \$49.95 and \$79.95, respectively. Storage space for the microphone and power cord is in the back of the units. Wollensak.

GREATEST TV Schematic Bargain EVER Offered

NOW-Complete TV Schematics for less than 5¢ each

COLOR TV
Covers ALL
Color Sets
1960 - 1968

BLACK & WHITE
Coverage for
23 U.S. Brands
1965 - 1968

TV TECH/MATICS - 8 Giant Volumes

Cover 99% of Color TV-4 Years B&W!

Here are FABULOUS savings on nationally-known TV schematic and service data. Here is everything you need to fill your vital service data needs for TV model years 1965 through 1968 . . . plus COLOR TV coverage from 1960 through 1968! What it amounts to is a low, low cost of less than \$7.50 per year for your TV service data . . . with an extra 5 years of Color TV coverage thrown in for good measure!

SERVICE DATA FOR MORE THAN 20 BRANDS

TV TECH/MATICS is the ideal Service Data package for today's modern technician. It includes complete schematic diagrams and vital servicing data for every TV receiver produced by more than 20 leading American Manufacturers for 1965, 1966, 1967, and 1968. All diagrams and servicing details are completely authentic, based on information provided by the original equipment manufacturers. Each year's coverage is permanently bound into two convenient-to-use volumes which open flat to 11" x 29½", ready to provide you with instant service data at your workbench. Some of the diagrams are as large as 58" x 22".

EASY TO USE

TV TECH/MATICS is easy to use. Brand names are arranged alphabetically by model year. No more hunting through several file drawers to find the schematic you need! And at the special low price, think of the savings you will enjoy on your schematic needs . . . think of the time you'll save by having the schematics you need right at your fingertips in handy, permanently-bound form!

TV TECH/MATICS is the ideal way to cut down your schematic expenses, and to enjoy the convenience of having all your data needs right at your fingertips.

HERE'S WHAT YOU GET

You receive 8 BIG volumes in all, two for each year from 1965

8 BIG Volumes
Regular Price **\$79.60**
...NOW YOURS
for only **\$29.95**

through 1968. Included is a clearly detailed and annotated TV schematic diagram for each specific model. You also get complete replacement parts lists, alignment instructions, tube and component location diagrams, plus key waveforms and voltage readings . . . all the information you need to service over 90% of the TV receivers you'll encounter!

Compare that with the over \$100 a year you may now be paying for comparable information.

STREAMLINED AND CONVENIENT

All the information for a given model is contained on two facing sheets. The special bound-leaf format allows pages to lie flat when open. Each volume is organized alphabetically by manufacturer, then numerically by model number. In addition, a handy Chassis/Model Finder is bound into each volume. Regular list price for each year's coverage — 2 BIG volumes — is \$19.90. All 8 volumes normally sell for \$79.60. Your price is ONLY \$29.95 . . . a savings of nearly \$59.00!

MONEY-BACK GUARANTEE

You MUST be satisfied that TV TECH/MATICS is the greatest bargain in TV Schematics ever offered. Order at our risk for FREE 10-day examination. Prove to yourself they are worth many times the price. You can return them in 10 days for full refund or cancellation of invoice. No need to send money. But, the supply is limited, so fill-in and mail the NO-RISK coupon today to obtain these time-saving, money-making manuals.

-CONTENTS-

CONTENTS 1965 MODELS

Covers all 1965 models for: Admiral, Airline, Andrea, Coronado, Curtis Mathes, Dumont, Electrohme, Emerson, Firestone, General Electric, Magnavox, Motorola, Muntz, Olympic, Packard-Bell, Philco, RCA Victor, Sears-Silvertone, Setchell-Carlson, Sylvania, Truetone, Westinghouse, and Zenith . . . plus all color sets 1960-1965, at no extra cost!

PUBLISHER'S LIST PRICE \$19.90

CONTENTS 1966 MODELS

Covers all 1966 color and B & W models of: Admiral, Airline, Andrea, Coronado, Curtis Mathes, Dumont, Emerson, General Electric, Hoffman, Magnavox, Motorola, Olympic, Packard-Bell, Philco, RCA Victor, Sears-Silvertone, Setchell-Carlson, Sonora, Sylvania, Truetone, Westinghouse, and Zenith.

PUBLISHER'S LIST PRICE \$19.90

CONTENTS 1967 MODELS

Covers all 1967 color and B & W models of: Admiral, Airline, Andrea, Coronado, Curtis Mathes, Dumont, Emerson, General Electric, Hoffman, Magnavox, Motorola, Olympic, Packard-Bell, Philco-Ford, RCA Victor, Sears-Silvertone, Setchell-Carlson, Truetone, Westinghouse, and Zenith.

PUBLISHER'S LIST PRICE \$19.90

CONTENTS 1968 MODELS

Covers all 1968 color and B & W models for: Admiral, Airline, Andrea, Coronado, Curtis Mathes, Dumont, Emerson, General Electric, Hoffman, Magnavox, Motorola, Olympic, Packard-Bell, Philco-Ford, RCA Victor, Sears-Silvertone, Setchell-Carlson, Sonora, Sylvania, Truetone, Westinghouse, and Zenith.

PUBLISHER'S LIST PRICE \$19.90



LARGE PAGES contain complete circuit schematics, replacement parts lists, alignment instructions critical part locations, important waveforms and voltage readings.

NO RISK COUPON—MAIL TODAY

TAB Books, Blue Ridge Summit, Pa. 17214

- I enclose \$29.95 for which please send me your complete 8-Volume Tech/Matics Schematic offer postage prepaid.
 Please invoice me for \$29.95 plus postage. Same return privileges.

Name

Company

Address

City

State

Zip

(Paid orders shipped prepaid. Pa. resident add 6% Sales Tax. Outside USA 10% extra.)

ET87



Electronic Industry Show Corp. Elects New Directors

Exhibitors at the highly successful NEW Show climaxed their activities by electing a new slate to the Board of Directors of Electronic Industry Show Corp. The election was the first under a new set of by-laws calling for the exhibitors to elect directors rather than the sponsoring trade associations to appoint members of the Board. Of the thirteen directors elected, nine are incumbents, three have previously served on the board, and one—Vincent Hook—is a newcomer.

Hook, executive vice-president and general manager of C & G Electronics Company, Tacoma, Wash., is a past president and director of the Northwest Chapter of the National Electronic Distributors Assn., and has served as president and director of Electronic Distributors Research Institute.

Returning to the Show Board are James L. Nichols, president of Mallory Distributor Products; Edward M. Rothenstein, executive vice-president of Philmore Manufacturing; and Arthur I. Rabb, president, United Technical Publications.

Incumbents reelected to the Board include James S. Silverman, Electronic Expeditors; Robert C. Trinkle, Trinkle Sales, Inc.; John N. Leedom, Wholesale Electronics Supply; James C. Neustadt, Burstein-Applebee; Glenn E. Ronk, Sola Electric; Clyde J. Schultz, Switchcraft; Philip E. Gustafson, Hughes-Peters; Robert B. Morris, Specialty Distributing, and Roy Vetzner, Vaco Products.

Hereafter all directors will be elected for three-year terms, with one-third retiring each year. The new Board of Directors will meet in August in California to make plans for the 1971 NEW Show, scheduled to be held the week of June 1 in Bal Harbour, Fla.

Consumer Protection Plan for Zenith Color TV Purchasers

Zenith Radio Corp. announced a new "consumer protection plan" for purchasers of the company's color TV sets, starting with the 1971 line of models. The major objective of the plan is to assure that in-warranty service is performed at no cost to the consumer for parts or labor during the first 90 days of set ownership. The plan, including its warranty provisions, offers:

- Service labor required during the 90-day warranty period will be performed without charge to the set owner, and replacement of any parts required during the warranty period will be performed without charge to the set owner.
- Replacement of a color TV picture tube that becomes defective within two years of the color set's original consumer purchase will be made without charge for the tube.
- Replacement or repair of any other parts that become defective within one year of the set's initial installation will be made without charge for the components.

Under the plan, 90-day in-home service is provided at no charge for consoles and large screen table models, 20-in diagonal and larger. Portable and Compact Table Model receivers (14- through 19-in. diagonal screen sizes) brought into the dealer or his servicing contractor by the

owner will be serviced at no cost during the first 90 days of set ownership.

An integral part of Zenith's plan is the provision for in-warranty service through the local Zenith dealer, where the set was purchased, or his independent servicing contractor.

"Strengthening the dealer's after-sale responsibility for the product is the key element which can make the most important single contribution to efficient and responsible service in any warranty program," said W. C. Fisher, president of the Zenith Sales Co. division.

U.S. Consumer Electronic Sales Figures for First Quarter of 1970

Total U.S. sales of consumer electronic products, including imports, have been released by the Electronic Industries Assn.'s Marketing Services Dept. The EIA report reflects the size of the U.S. market in units for monochrome and color TV sets, radios, tape recorders and players for the first three months of 1970, along with comparisons for the same period in 1969.

Total TV sales in the first quarter reached 2,652,479 sets in 1970 vs. 3,363,678 sets in 1969, down 21.1%. Color TV's share reached 1,160,419 sets. Some 1.8 million sets of first-quarter sales were produced in this country. U.S. manufacturers also imported some 429,000 sets for merchandising under their own labels; foreign-label TV sets amounted to some 421,424 units, or about 15% of the total TV market.

The total home radio market in the first quarter (excluding TV and photograph combinations and auto radios) amounted to 7.6 million units compared to 8.3 million units in the same period in 1969. U.S. manufacturers produced 0.6 million units and imported 1.3 million units for sale under their own labels. Foreign labels, with 5.7 million radios imported, accounted for 75% of the sales vs. 67% in the first quarter of 1969.

Total U.S. sales of auto radios in the first quarter at 2.8 million units matched the 3.3 million units sold in the same 1969 period.

The FM share of radio sales continued to increase. Some 5.0 million radios were sold in the first quarter as compared to 4.1 million in the same period in 1969. Home radio sales share (excluding radio-TV-phonograph combinations) jumped to some 60% compared to about 44% in the same period in 1969 and only 40% in the first quarter of 1968.

Total U.S. phonograph sales in the first quarter totaled 1.1 million units compared to 1.5 million in the same period in 1969.

Magnetic tape continued to be the fastest growing consumer electronic product in the first quarter. Tape recorders, including reel-to-reel and cassette equipment, totaled 1.6 million units compared to 1.2 million in the same 1969 period. Tape player imports totaled 1.4 million units compared to only 801,000 units in the 1969 first quarter. U.S. product figures in this category are not available.

Magnavox Introduces Home Study Color TV Service Course

Magnavox has announced a home-study color TV service course. Entitled "Color TV . . . An Introduction to Servicing," the 16-lesson course is designed to provide the basic training for persons considering TV service as a vocation.

Magnavox National Service Manager Ray Yeranko explains that this training program is unique because students must be sponsored by a servicing dealer or service

contractor and be given access to shop facilities, equipment and Magnavox products in order to carry out specific lesson assignments. In this way, each student is given the opportunity to become familiar with Magnavox Color TV service procedures as he studies his lesson materials.

Lesson quizzes must be completed and sent to Magnavox for grading by its Service Training Department. After the student completes the course at a pace he has established, he is presented with a certificate qualifying him for advanced studies at any one of the seven Magnavox Service Training Centers.

It is expected that dealers who have been hard pressed for more qualified service technicians will include in their recruitment plans the hiring of young men from their local high schools as part-time employees. Such men taking the Magnavox home study course could, after a reasonable time, relieve the employer's more experienced technicians of less complex servicing assignments. Further information can be obtained from the Service Training Dept., 1700 Magnavox Way, Fort Wayne, Indiana 46804.

ICS Announces New FCC License Course

International Correspondence Schools (ICS), a division of INTEXT, Scranton, Pa., has announced the release of a new FCC license course: The Commercial Radiotelephone License Course. Students can enroll either in one or more divisions of the course or in the whole course.

Division 1 is relatively short and covers preparation for the Third Class Radiotelephone License, with or without Broadcast Endorsement (FCC Elements 1, 2, and 9). An optional section of Division 1 is preparation for the Radio Amateur Novice License.

Division 2 covers FCC Element 3, for the FCC Second Class Radiotelephone License examination.

Division 3 covers preparation for the FCC First Class Radiotelephone License (Element 4). A separate text also covers study for the Radar endorsement. The course is covered by the ICS Double Warranty.

All three divisions include self-check review exams which permit the student or trainee to test his own knowledge with FCC-style questions—answers are provided separately as a guide to technical or specialized areas.

Study material and texts have been written by such well known experts in the communications-broadcasting field as Dr. Charles R. Ammerman, Thomas R. Haskett, Charles T. Morgan, Edward M. Noll, William Ornstein, and Leo G. Sands. Further information can be obtained by contacting Joseph Risse, ICS, Scranton, Pa. 18515.

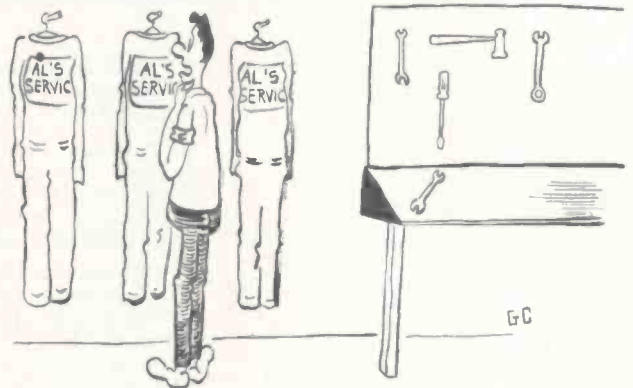

"What should I wear today?"

no other heat gun... offers all these attachments!

Attachments to speed your job... attachments that tailor Master heat gun airflow precisely to your needs... attachments that fit any existing Master flameless heat gun. No other line offers so many choices... including the exclusive patented cone for 1/4" concentrated heat, optional adjustable base, convenient carrying case, and the only U.L. listed gun available. Send for free 12 page catalog.



for shrinking thermoplastic tubing and film, curing, forming, melting, drying, soldering.

MASTER HEAT GUNS

Racine, WI 53403

... for more details circle 117 on Reader Service Card

An Extraordinary Offer

to introduce you to the benefits of Membership in

ELECTRONICS BOOK CLUB

for a limited time only you can obtain

ANY 3 OF THESE UNIQUE BOOKS ... yours for only **99¢** each
(Combined List Price \$23.85) Club Membership ... with Trial

May we send you your choice of any three books on the facing page as part of an unusual offer of a Trial Membership in Electronics Book Club?

Here are quality hardbound volumes, each especially designed to help you increase your know-how, earning power, and enjoyment of electronics.

These handsome, hardbound books are indicative of the many other fine offerings made to Members... important books to read and keep... volumes with your specialized interests in mind.

Whatever your interest in electronics—radio and TV servicing, audio and hi-fi, industrial electronics, communications, engineering—you will find that Electronics Book Club will help you.

With the Club providing you with top quality books, you may broaden your knowledge and skills to build your income and increase your understanding of electronics, too.

How You Profit From Club Membership

This special offer is just a sample of the help and generous savings the Club offers you. For here is a Club devoted exclusively to seeking out only those titles of direct interest to you. Membership in the Club offers you several advantages.

1. Charter Bonus: Take any three of the books shown (combined values up to \$23.85) for only 99¢ each with your Trial Membership.

2. Guaranteed Savings: The Club guarantees to save you 15% to 75% on all books offered.

3. Continuing Bonus: If you continue after this trial Membership, you will earn a Dividend Certificate for every book you purchase. Three Certificates, plus payment of the nominal sum of \$1.99, will entitle you to a valuable Book Dividend which you may choose from a special list provided members.

4. Wide Selection: Members are annually offered over 50 authoritative books on all phases of electronics.

5. Prevents You From Missing New Books: The Club's FREE monthly *News* gives you advance notice of important new books... books vital to your continued advancement.

This extraordinary offer is intended to prove to you, through your own experience, that these very real advantages can be yours... that it is possible to keep up with the literature published in your areas of interest... and to save substantially while so doing.

How the Club Works

Forthcoming selections are described in the FREE monthly *Club News*. Thus, you are among the first to know about, and to own if you desire, significant new books. You choose only the main or alternate selection you want (or advise if you wish no book at all) by means of a handy form and return envelope enclosed with the *News*. As part of your Trial Membership, you need purchase as few as four books during the coming 12 months. You would probably buy at least this many anyway... without the substantial savings offered through Club Membership.

Limited Time Offer!

Here, then, is an interesting opportunity to enroll on a trial basis... to prove to yourself, in a short time, the advantages of belonging to Electronics Book Club. We urge you, if this unique offer is appealing, to act promptly, for we've reserved only a limited number of books for new Members.

To start your Membership on these attractive terms, simply fill out and mail the postage-paid airmail card today. You will receive the three books of your choice for 10-day inspection. SEND NO MONEY! If you are not delighted, return them within 10 days

and your Trial Membership will be cancelled without cost or obligation. Electronics Book Club, Blue Ridge Summit, Pa. 17214.

Typical Savings Offered Club Members on Recent Selections

How to Repair Home & Auto Air Conditioners	List Price \$7.95; Club Price \$4.95
How to Repair Solid-State Imports	List Price \$7.95; Club Price \$3.95
Handbook of Magnetic Recording	List Price \$7.95; Club Price \$4.95
Magnavox Color TV Service Manual	List Price \$7.95; Club Price \$4.95
Amateur Radio Advanced Class Study Guide	List Price \$6.95; Club Price \$3.95
Servicing Modern Hi-Fi/Stereo Systems	List Price \$7.95; Club Price \$4.95
Electronic Circuits	List Price \$11.95; Club Price \$8.95
Dictionary of Electronics	List Price \$6.95; Club Price \$5.50
CATV System Engineering	List Price \$12.95; Club Price \$7.95
Solid State Circuit Design & Operation	List Price \$9.95; Club Price \$5.95
How to Build a Working Digital Computer	List Price \$7.95; Club Price \$3.95
Zenith Color TV Service Manual	List Price \$7.95; Club Price \$4.95
Servicing Electronic Organs	List Price \$7.95; Club Price \$4.95
Digital Computer Analysis	List Price \$10.95; Club Price \$7.95
How to Test Almost Everything Electronic	List Price \$5.65; Club Price \$3.95
How to Use Your VOM, VTVM & Scope	List Price \$6.95; Club Price \$4.95
Radio Operator's Q & A Manual	List Price \$8.95; Club Price \$7.50
Tape Recording For Fun & Profit	List Price \$7.95; Club Price \$4.95
Elements of Tape Recorder Circuits	List Price \$7.95; Club Price \$3.95
Industrial Electronics Made Easy	List Price \$8.95; Club Price \$5.95
Electronic Test & Measurement Handbook	List Price \$7.95; Club Price \$4.95
Easy Way To Service Radios	List Price \$6.95; Club Price \$3.95
Practical Color TV Servicing Techniques	List Price \$8.95; Club Price \$5.95
Mathematics for Electronics	List Price \$10.95; Club Price \$7.95
Transistor Projects	List Price \$5.95; Club Price \$2.95
Electronic Musical Instruments	List Price \$10.00; Club Price \$7.95

AN EXTRAORDINARY OFFER...

101 TV Troubles: From Symptom to Repair

101 TV TROUBLES



An invaluable "cause and cure" guide to the practical, easy solution for virtually any TV trouble—color or B&W. All you do is analyze what you see and hear, look up the symptoms in the book, and follow the clear and simple steps to a speedy trouble cure. To show how and why certain troubles occur in specific types of circuits, schematics and other illustrations are included for every major manufacturer—Admiral to Zenith. TV troubles are broken down into five basic categories: Brightness, Contrast, Sweep, Color, and Sound. Each category lists specific troubles relating to that symptom. For example, under "Contrast" are 22 causes of actual picture problems. With the categorized trouble list and index, you can quickly and easily find the exact symptom—and the trouble cure—for virtually any TV circuit defect you might encounter. 224 pps. Hardbound.

List Price \$7.95

Order No. 507

Philco Color TV Service Manual



An all-in-one service guide for Philco color sets, with 12 complete schematic diagrams for chassis 15M90/91 to 20QT88. Here in one manual is complete service data for all the color models produced by Philco and Philco Ford (thru 1970), from the all-tube to the latest hybrid solid-state chassis, including the small-screen portable

Model T5062WA. The unique 36-page foldout section contains 12 complete schematic diagrams, representing all the chassis covered. The profusely illustrated text delves into each section (video, chroma, vertical, horizontal, etc.), and points out specific problems based on the author's extensive experience. Included are complete alignment and setup instructions, detailed in step-by-step form. 160 pps., plus 36-page schematic foldout section. Long-life vinyl cover.

List Price \$7.95

Order No. 522

How to Use Test Instruments in Electronics Servicing



A long-needed, practical handbook on test equipment applications—ranging from the use of audio gear to tube and transistor checkers. Just what you need to put your test equipment to work. Not a "how-it-works" treatment, but a "how-to" manual describing specific tests and troubleshooting techniques for the electronic technician. You'll discover new ways to use your scope and several new "tricks" you can perform with multimeters. You'll learn signal-injection troubleshooting, how to measure inductance and capacitance with the help of your signal generator, pointers and pitfalls for using markers, sweeps and pattern generators, shortcuts and special techniques for color TV troubleshooting, how to test audio circuits and FM stereo equipment, and much more. 256 pps., over 200 illus. Hardbound.

List Price \$7.95

Order No. 485

Working with Semiconductors

Working With SEMICONDUCTORS



A BRAND-NEW working guidebook to semiconductor circuit operation of value to technicians and others who work with solid-state equipment. The wonderful aspect of this book is that you can really develop a thorough understanding of semiconductors—and actually enjoy doing it! In striking contrast to the usual textbook

approach, this up-to-the-minute volume avoids dry, theoretical mathematical explanation—it tells you simply how and why things work... backed up by large, clear expository illustrations. More advanced circuits covered are: transistor oscillators, multivibrators, Eccles-Jordan and Schmitt trigger circuits, crystal-controlled generators, counters, power supplies, high-frequency circuits, field-effect transistors, unijunction transistors, tunnel diodes, SCRs, etc. 224 pps., over 185 illus., 15 Chapters.

List Price \$7.95

Order No. 501

1970 Popular Tube/Transistor Substitution Guide

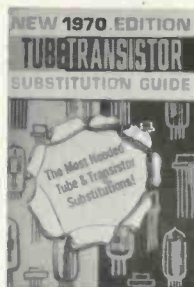

Now, a brand-new updated edition of this famous guide, containing 40% more material, including the newest popular tube and transistor types. Lists 99% of the tubes and transistors you'll ever need to replace. Moreover, only readily-available and comparably-priced substitutes are listed—no need for you to search through lists of tubes and transistors you'll rarely see in use to find a substitute. Contains 8 BIG sections: Popular Receiving Tubes, Industrial and Commercial Tubes, American Substitutes for Foreign Tubes, Tube Circuit and Base Diagrams, Popular Transistor Substitutes, American/Foreign Transistor Cross-Reference, General Purpose Transistor Substitutes, Transistor Base Diagrams and Manufacturer Abbreviations. 224 pps. Long-life vinyl cover.

List Price \$4.95

Order No. 525

Installing & Servicing Home Audio Systems



At last, a long-needed UP-TO-DATE guidebook on home audio systems—your "passport" to the lucrative field of audio equipment servicing, including sales and installation. Included in the comprehensive content are technical descriptions of the latest audio and hi-fi equipment, accompanied in each case by servicing data. The author describes all the various types of units, illustrates the typical circuits used, then tells how to look for troubles. You'll receive scores of practical "tips," plus troubleshooting shortcuts. After an introduction to audio, and a discussion of test instruments needed, the author gets into AM and FM tuners (including stereo-multiplex), preamps and amplifiers, tape recorders and players, mobile radios and tape players, and automatic record players. 256 pps., over 150 illus., 12 Chapters. Hardbound.

List Price \$7.95

Order No. 505

Small Appliance Repair Guide

SMALL APPLIANCE REPAIR GUIDE

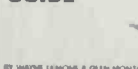

Learn to repair dozens of small household appliances with the use of this authoritative, low-cost handbook. Profusely illustrated, the text tells how to find the cause of trouble in minutes, and how to go about making the required repairs. You'll also pick up helpful hints on disassembly and assembly, one of the real "tricky" aspects of many appliance repair jobs. General troubleshooting procedures are explained to familiarize you with the techniques of appliance repair. Succeeding chapters deal with thermostats, skillets, sauce pans, irons, toasters, coffee makers, blankets, mixers, knives, deep fryers, hair dryers, electric shavers, and small motors found in countless appliances. You'll learn, in detail, how each appliance operates, and how to make practical tests and actual repairs. 11 Chapters, 224 pps. Over 150 illus. Appendix and Index.

List Price \$7.95

Order No. 515

Electronic Hobbyists' Handbook

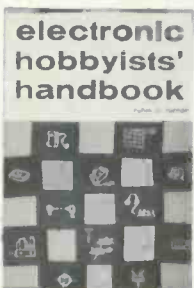

Nearly 100 tested and debugged circuits for technicians, engineers, experimenters, and hobbyists. If you are an avid project builder, or like to dabble around developing circuits to perform special functions, this book is for you. As a matter of fact, it is THE time-honored classic on the subject, having served many thousands of

readers through its many printings. Some 100 different practical circuits are included, all tried-and-proven by the author. Projects range from amplifiers and oscillators for scores of applications (signal tracers, hearing aids, PA amps, grid-dip and code-practice oscillators, etc.) to transmitters, receivers, photo-electric devices, Geiger counters, metal locators, and field strength meters. 160 pps., 118 illus. 9 chapters. Hardbound.

List Price \$6.95

Order No. 69

Transistor Circuit Guidebook



Regardless of your niche in the world of electronics, you'll find this collection of transistor and solid-state circuits of value. Section titles read like an electronic circuit "Who's Who": tuners and receivers—amplifiers—test devices—power—controlling—light—controlling—transmitter—audio—special receiver—auto-

motive—computer—TV circuits, and many, many others. Within each section is a wide variety of circuits touching virtually every point of interest. Each circuit is accompanied by a description of how it works, pointing out unusual features and applications. Technicians who acquire a familiarity with these circuits will be far better equipped to cope with present and future equipment troubles. 13 big sections, 104 circuits in all, 224 pps. Hardbound.

List Price \$7.95

Order No. 470

SEND NO MONEY! Simply fill in and mail postage-paid Airmail card today!

For additional information on products described in this section, circle the numbers on Reader Service Card. Requests will be handled promptly.

FREQUENCY COUNTER 713

Frequency range extended without price increase

The "B" version of the 1192 counter has reportedly increased to 50MHz, the frequency range of the low-priced universal counter. The five-digit mod-



el is said to offer dc to 50MHz range, an internal room-temperature crystal oscillator, and overall stability better than 2×10^{-6} per month. Sensitivity is rated at 10mv up to 20MHz, 20mv

to 35MHz, and 30mv to 50MHz. Measurement parameters include frequency, single and multiple period, frequency ratio, time interval and count. Six- or seven-digit resolution can reportedly be obtained in the 1192-B at a cost of \$100 per additional digit. A BCD output option is also offered for \$50. Measurements up to 500MHz are said to be possible by adding the optional 1157-B Scaler to the 1192-B. The basic 1192 counter has been type-accepted by the FCC for AM frequency monitoring; the 1192-Z has received similar approval for FM use (including VHF TV). Price \$575 in the U.S. General Radio.

PANEL METER 714

With dc sensitivity from 100 μ a up to 5a

A 1½-in. square panel meter, Model 2018, is said to be completely shielded and reportedly will not interact with other meters or be affected by stray magnetic fields. The meter is rated in sensitivity from 100 μ a up to 5a, and, as a self-contained dc voltmeter, up to 300v dc. The meter can be used behind the panel with a die cast metal bezel (2018/B) or with painted fronts. Hoyt.



CAPACITOR CHIP KIT 715

Contains 300 ceramic capacitor chips for hybrid circuits

An NPO ceramic capacitor chip kit has been developed for use in the hybrid, high voltage, and RFI/EMI filter hybrid circuits. Containing 300 ceramic capacitor chips, there are 10 chips, each of all standard RETMA values from 3.9pf to 1000pf in $\pm 10\%$ tolerances at 50vdcw. The NPO chip kit



is packaged in a 7- by 10-in. hard-cover holder with individual see-through pockets of all standard RETMA values for reference and selection. Price \$99.50. Monolithic Di-electrics.

TUNER SPRAY 716

Cleans, lubricates and polishes tuner contacts

A new type of tuner spray reportedly not only cleans and lubricates tuner contacts, but polishes them as well. Called TUN-O-BRITE, the aerosol spray is said to include hollow, non-abrasive polishing agents. In addition, the spray reportedly uses a heavy-duty, permanent type lubricant and a proprietary blend of organic and inorganic materials. The tuner spray reportedly causes less than 0.5MHz drift, even at the time it is sprayed. The tuner spray comes in an 8 oz. can for \$2.39, dealer net. Chemtronics.

VIDEO TAPE RECORDER SYSTEM 717

Selection of ten speeds and manual control

A variable-speed time-lapse video tape recorder, Model VTL 310, has been developed for use in traffic control, time and motion study, and scientific observation. The tape recorder reportedly offers the choice of selecting speeds of 1:1, 2:1, 3:1, 5:1, 7:1, 9:1, 11:1, 15:1, 29:1 and 61:1. A manual control for single frame recording is designed to advance frames

A NEW AND IMPORTANT DEVELOPMENT FOR TV SERVICING

12 MODELS

SANS-A-FUSE®

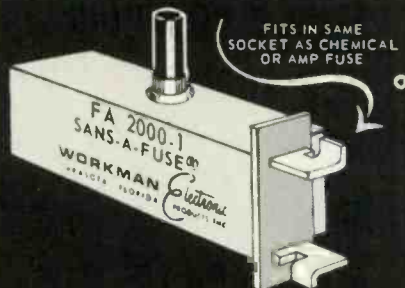

FITS IN SAME SOCKET AS CHEMICAL OR AMP FUSE

COLOR CODED CIRCUIT BREAKER REPLACEMENT FOR CHEMICAL OR AMP FUSE

SAVES TIME AND FUSES WHEN LOCATING SHORTS IN TELEVISION CIRCUITS

DEVELOPED AND MANUFACTURED BY

WORKMAN

BOX 3828 SARASOTA, FLA. 33578
TELEPHONE: Area Code 813

Electronic
PRODUCTS, INC.
955 - 4242

one at a time during playback. Individual frames may reportedly be "held" for either closer analysis or for photography. The VTL 310 is said to operate on a 12v dc battery through



use of an HK-MP-14 inverter. Recording or playback may be made from an automobile battery, or from any mobile power source. Other features are said to include: twin rotary heads made of a hot pressed ferrite for longer recording life, wide frequency range of over 3MHz to deliver more than 300 lines in horis resolution, and guaranteed tape compatibility from one VTL 310 to another. Specifications indicate that the unit also offers a 42dB signal-to-noise ratio, measures 22 7/16 in. by 10 5/8 in. by 1 3/4 in. and weighs 72 lb. Price less than \$4000. Odetics.

CASSETTE CARTRIDGE 718

Produced for
8-track use

A new 8-track cartridge has been developed. The cartridge, which is said to be highly reliable, features an extremely low rejection rate. Cassette.

TERMINAL INSTALLING TOOL 719

A multipurpose tool available
in a variety of package offers

The Model WT1000 is a multipur-

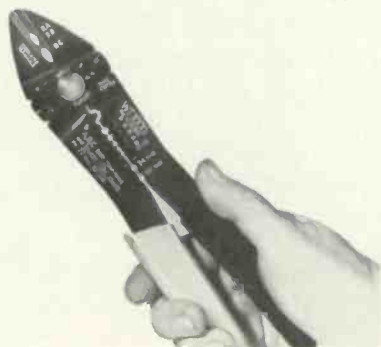

pose terminal installing tool which can reportedly be used for crimping solderless terminals, cutting wire and bolts, stripping wire and chasing bolt threads. The tool features a nose cutter for cutting solid or stranded wire from No. 22 to 10, and a new side cutter for cutting solid wires up to No. 8 AWG with .230 maximum insulation. Four bolt cutters provide for cutting No. 4, 5, 6, 8 and 10 bolts. There are six marked stripping holes for No. 22 through 10 wire. For cleaning, or chasing threads on bolts, place the bolt in the properly indicated position, apply pressure and screw the bolt out of the chaser. Price of the tool is only \$6.95. Thomas & Betts.

CONTROLS 720

Ranges from 6Ω through
15K in assorted mountings

A new line of 3/4 in. dia 3w and 1 1/2 w WW controls is being produced for AGC, convergence, hum balance and general purpose applications. These controls come in resistance ranges from 6Ω through 15K and in configurations for bushing mounting, printed circuit board mounting, flange mounting and twist-tab mounting. Price from \$1.10 to \$1.55. Centralab.

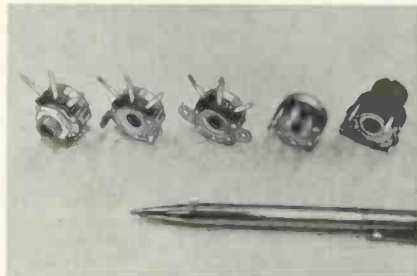

TV CAMERA 721

Selects output frequencies, channels 2
through 6 with screwdriver adjustment

The TVC-500 TV camera develops monochrome pictures in video or in RF signal at a switch-selected output. Video is viewed on a monitor, but, when the camera is switched to RF output, the pictures are displayed on a standard TV receiver. With a screwdriver adjustment, the operator can reportedly select the output frequency, covering channels 2 through 6. Complete within itself, the camera is said to contain synchronizing circuits and an RF modulator. Specifications indicate that the output level on a composite signal is 1.4v P-P, while the video level output is 1v P-P. RF output is said to be greater than 29.5dBmv (30mv) with a 75Ω output impedance. Horizontal resolution



When you're
putting up an
antenna,
RCA supports it.
With a complete
line of hardware.

Chimney, wall, and roof mounts. Masting. Guy wires, fittings . . . and standoffs, too. Whatever your requirements . . . RCA meets them with a complete line of Antenna Installation Hardware.

Every item in the line has been given that special attention to design and quality that you've come to expect from RCA.

Ask your RCA Distributor about the RCA antenna hardware line, and about his special deal on a hardware merchandiser for profitable "do-it-yourself" sales. Sell the hardware line with built-in consumer acceptance—RCA.

Parts and Accessories,
Deptford, N.J. 08096

RCA
Antenna
Installation Hardware

... for more details circle 121 on Reader Service Card

ET/D NEW PRODUCTS

of center is rated at 550 lines on video output and 300 lines on RF output. Each camera weighs 6 lb and is supplied with a 25mm F/1.8 lens. Wide angle and telephoto lenses are reportedly also available. Dealer net price \$3.25. Jerrold.



722 WIRELESS SPEAKER ADAPTER

Automatic volume control prevents distortion from over-modulation

A device called the Wireless Speaker Adapter can reportedly be hooked

up to the speaker, or speaker terminals, of any equipment using a speaker (stereo, TV, tape recorder, CB, record player, etc.) and broadcast the sound to any regular or portable radio within 100 ft. An electronic automatic volume control circuit is said to prevent distortion from over-modulation as well as to eliminate the need for critical adjustment of volume on the equipment to which the adapter is attached. The unit is said to need no other connections except the two wires that clip to the equipment speaker, speaker terminals or the earphone jack. The sound is broadcast to the receiving radio now used as an extension speaker. Specifications indicate that the adapter measures 4 in. by 3 in. by 1½ in. and comes in two models: Model 65—output tunes from 640 to 660kHz; and Model 76—output tunes from 750 to 770kHz. Price

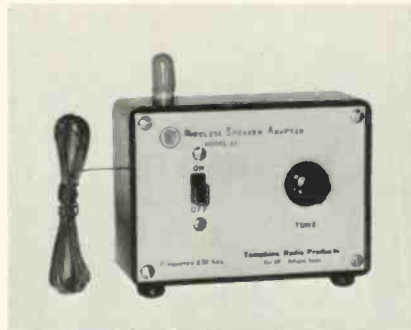

\$19.95, including 9v transistor battery; \$23.50 with dc power supply. Herbert Salch.

SPEAKER ENCLOSURES 723

Walnut bookshelf enclosures manufactured in two sizes

Genuine walnut wood bookshelf enclosures for 8 in. Hi-Fi speakers are being produced in two sizes. Model WS-8 measures 7½ in. wide by 16½ in. by 10½ in. high. With an 8-in., 8Ω Hi-Fi speaker, the enclosure is Model WS-8S. Model WS-85 is 4¾ in. wide by 16½ in. by 10½ in. high. The enclosure is also produced with an 8-in., 8Ω Hi-Fi speaker as is Model WS-85S. The walnut wood enclosures are said to have a hand rubbed oil walnut finish. With provision for mounting a 4-in. tweeter, each enclosure is reportedly made of heavy-duty construction with thick composition hard-board back. RMS Electronics.

PANEL METERS 724

Shallow design for panel space limitations

A series of shallow barrel panel meters with molded plastic backs is being produced for applications having back-of-the-panel space limitations. The special shallow barrel is designed for 1½, 2½, 3½ and 4½-in. G-Series panel meters. Voltmeter, millivoltmeter, ammeter, millimeter



DECISION MAKER

The Sencore CRT Champion. Judge and jury when it comes to color CRT analyzing. Reaches a verdict in seconds — tells you if the tube has adequate emission, and if it will track in the TV set.

Automatic color tracking according to industry standards with exclusive 3 Gun G2 Control.

One-step controlled rejuvenation with automatic RC timer. A Sencore exclusive.

Lots more, too. So try the decision maker — the Sencore CRT Champion — at your distributor today. You'll reach the right verdict. CR-143 \$119.50



SENCORE

NO. 1 MANUFACTURER OF ELECTRONIC MAINTENANCE EQUIPMENT

426 SOUTH WESTGATE DRIVE, ADDISON, ILLINOIS 60101

... for more details circle 125 on Reader Service Card

WHOLESALE TO ALL

Breadboard Kits—"RF" Kits—"PC" Kits—Perf. Phenolic Board—Copper Clad Board—Cowl Type Electronic Cabinets—Heat Sinks—Solid State Hobby Kits—Solderless Connectors—Hardware Kits—Transistor Sockets and many more items. (Products approved by the Defense Supply Agency—Federal Supply Code number furnished upon request.) Send for free catalog from:

H. M. C. SALES

P.O. Box 276

Santa Susana, Calif. 93063

... for more details circle 113 on Reader Service Card

and microammeter versions with front panel or bezel mounting are reportedly being manufactured. Also, a wide assortment of scale ranges, scale divisions, ohm/volt capability, resistance and special features are provided. All GS panel meters are said to utilize self-shielded Bar-Ring magnets in all dc meters. Specifications indicate that

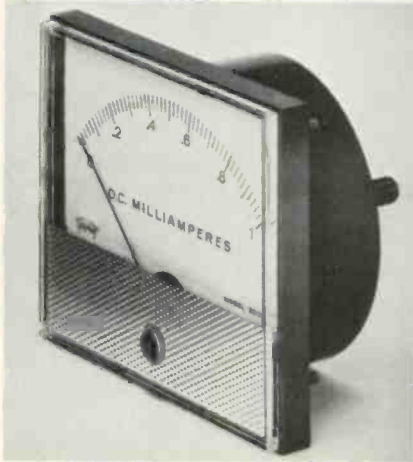

the 120-GS shallow barrel panel meter has a behind-the-panel dimension of 0.940 in. and a barrel diameter of 1.5 in.; the 220-GS measures 1.113 in. behind the panel and 2.2 in. in diameter; the 320-GS and the 420-GS measure 1.113 in. behind the panel and have a barrel diameter of 2.75 in. Triplet.

HI-LO MULTIMETER 725

Low voltage of 0.08v
for solid-state devices

The Model FE21 multimeter has been designed as a general purpose meter offering all of the advantages of instant-on use with an FET, high-input impedance and the ability to read resistors in circuit without disconnecting them. The ohmmeter section is said to be powered by 1.5v or a lower voltage of only 0.08v so that resistors can be measured while in



solid-state circuits. The lower voltage reportedly does not cause conduction of the semi-conductor, which would result in a misreading of the resistance value. The 1.5v higher voltage is necessary in cases that require semiconductor. Specifications also indicate 10 dc voltage ranges from 0.1v to 3000v, 10 dc zero-center-scale ranges with full calibration from .05v to 1500v, 7 resistance ranges from 1K to 1000M, 9 dc current ranges from 100 μ a to 1a and fused multiplier resistors which prevent damage to the instrument in case of improper use. Price \$99.50. Sencore.

SCANNING FM RECEIVER 726

Eight-channel automatic scanning
plus selective listening

An automatic scanning FM monitor receiver, designed for 8 channels, features switches for selective listening. The unit is reportedly also equipped with a front-mounted speaker. Specifications indicate that the receiver has a programming switch and indicator lamp for each channel to provide lock-in or lock-out, with a flashing indication of scanning and a steady indication of an active channel. There are three models: Model BCH for high-

NEW DYNAMIC UHF/ VHF PERFORMANCE...

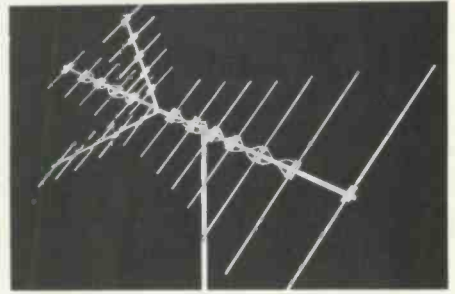

#CB-22

the RMS COLOR-BOOSTER COLOR ANTENNAS WITH SINGLE DOWN-LEAD

#CB-22: 22 elements, #CB-28, 28 elements, #CB-34: 34 elements. All designed to add mileage to UHF and VHF TV reception. Each antenna is actually two antennas in one—the front section for UHF—the rear section for VHF—plus a corner array reflector to amplify desired signals from the front and to screen out all undesired signals from the rear. Brings in clearest reception on Channels 2 to 83 free of co-channel interference and ghosts. Model SP-332 UHF/VHF quality Splitter is included with each antenna to facilitate simple single-line installation. The CB series antennas feature Reynolds Aluminum weather-proof COLORWELD Gold finish! Write for complete specs—

RMS ELECTRONICS, INC.

50 Antin Place, Bronx, N.Y. 10462

• Tel. (212) 892-6700

... for more details circle 123 on Reader Service Card



Get in line for
your all new
solid state
instant-on

MIGHTY MITE VI

- Now faster than ever. Instant-on action with all solid state FET circuitry—no waiting for warm-up.
- New push-button operation speeds up every test—saves you valuable time.
- New 13th socket checks still more tubes—now over 3000 including foreign.
- New hi-style case—vinyl-clad and brushed steel. A professional instrument designed for professionals.

At your distributor now, TC-154 only \$99.50



SENCORE

NO. 1 MANUFACTURER OF ELECTRONIC MAINTENANCE EQUIPMENT

426 SOUTH WESTGATE DRIVE, ADDISON, ILLINOIS 60101

... for more details circle 126 on Reader Service Card

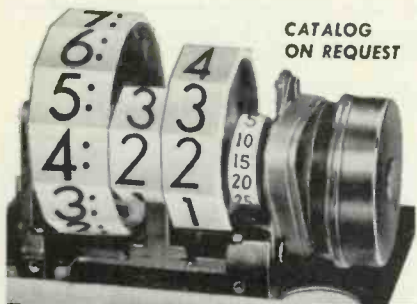

CATALOG
ON REQUEST



CLOCK MOVEMENTS

DIGITS RESETTABLE INDIVIDUALLY

Available in 50, 60 cy., all voltages, AC. UL approved motor, cord. One Year Guarantee.

#130...12-HOUR #131...24-HOUR

Made in U.S.A.

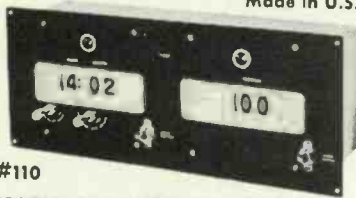

#110

SECOND BY SECOND 12 and 24 Hour
READ OUT DIGITAL CLOCK

Complete Line: Delay, Interval
and Cycle Timers, Digital Computers

PENNWOOD NUMECHRON CO.
TYMETER ELECTRONICS

7249 FRANKSTOWN AVE., PITTSBURGH, PA. 15208

... for more details circle 119 on Reader Service Card

ET/D NEW PRODUCTS

band (150-174MHz), Model BCL for low-band (30-50MHz), and Model BCU for UHF (450-470MHz). Prices: BCH and BCL each \$139.95, BCU \$149.95. Plug-in crystals \$5 each. Electra.



MAGNETIC SCREWDRIVER 727

Tips held in place
by an integral magnet

The VACO-Matic Magnetic Screwdriver features four interchangeable bits—two conventional and two Phillips—which meet the majority of screwdriving requirements and are held in place by an integral magnet in



a lightweight aluminum shaft. The four screwdriver bits are stored in the screw-cap container located in the "confordome" handle. Vaco.

INSTRUMENT ENCLOSURES 728

Constructed of aluminum wrap-around and molded ABS end panels

A line of instrument enclosures has been constructed of aluminum wrap-around and molded ABS end panels. The Professional Series is finished in instrument grey with black vinyl panel inserts, and the Decorator Series in eggshell white with wood grain top and side panels. Specifications indicate that the two basic sizes are: 2½ in. high by 5¾ in. deep by 4 through 10 in. wide, and 4¼ in. high by 6¼ in. deep by 5 through 12 in. wide. Special finishes and punched holes and matching chassis are reportedly available on order. Ten-Tec.

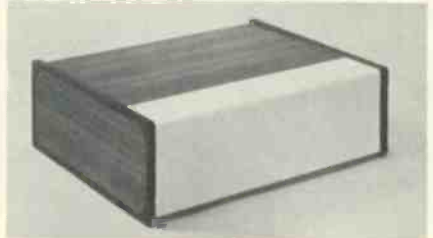

EDITING KIT 729

Splices can be made with less than 0.001 in. between tape ends

The KA-2 Editing Kit has been developed to aid in editing 2-in. audio tape. Splicing can reportedly be accomplished with less than 0.001 in. space between tape ends. Joel Tall.

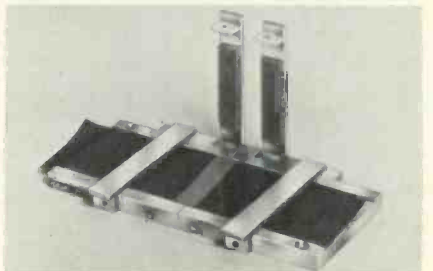

SENCORE SM152—ONLY COMPLETE SWEEP AND MARKER GENERATOR

• Sweeps all VHF channels • Sweeps all UHF channels • Sweeps chroma through IF or Direct • Sweeps FM IF and complete band of RF • Covers 20Mhz older sets and new import sets • All crystal controlled markers • Self generator base line for zero reference (as shown in all alignment instructions)

Sure—it's a little more than others—but who else has UHF for example? And all new tuners must have UHF on them. **\$450.00**

IN STOCK AT YOUR LOCAL
PARTS DISTRIBUTOR.



SENCORE

NO. 1 MANUFACTURER OF ELECTRONIC MAINTENANCE EQUIPMENT

3200 Sencore Drive, Sioux Falls, South Dakota 57100

... for more details circle 127 on Reader Service Card

Microwave Tubes 400

A new 48-page condensed catalog is being published which describes the manufacturer's line of microwave tubes. The catalog gives specifications on more than 200 magnetrons, klystrons, crossed field amplifiers, traveling wave tubes, and backward wave oscillators operating at various frequency bands and power levels. Many of the tubes are illustrated. In addition to the usual table of contents, the catalog also contains an index to aid in locating specific tube type numbers. Within the various product sections, tubes are conveniently listed by operating band. Raytheon.

Microphones 401

A 24-page illustrated catalog has been published which describes the manufacturer's complete line of microphones and accessory equipment. The catalog contains specifications and prices of professional, recording, broadcast and PA cardioid dynamic microphones; standard and transistorized mobile communications and base station communications microphones; tape recording and general purpose mikes; paging and PA microphones; and stands, cartridges and accessories. A section on "how to choose a microphone" is also contained in the catalog. Turner.

Product Guide 402

A 70-page, full color, 1970-71 "Cross Reference and Product Guide" contains a comprehensive listing of the manufacturer's replacement products, including transistors, capacitors, heat exchangers, silicon controlled rectifiers and diodes. The catalog also includes a complete cross reference guide. Products are listed in tabular form by product category. Illustrations of the various case styles are presented on each page for reference. Following this is an alpha-numeric index of all products listed. The complete cross reference is divided into major device categories. Transistor, rectifier, capacitor and heat exchanger types used in professional service jobs are listed in numerical sequence and cross referenced for replacement. International Rectifier.

Ad Guide 403

A booklet that will be helpful to retail dealers in their local advertising efforts is entitled "Retail Advertising

Guide for Dealers." The 10-page guide offers pointers on the selection of ad media, including newspapers, radio, TV, direct mail and transit ads. It tells how to prepare ads for each medium. The guide gives hints on creating ads which contain the underlying theme of selling product benefits. In addition, the guide lists a number of sample promotion ideas from which a retailer might generate his own ideas. Jerrold.

Microphones 404

A free booklet is offered on the fundamentals of microphones, including characteristics of each type. The text includes information on microphone placement, feedback, limiting factors, impedances, techniques and applications. Stanford International.

Electronic Chemical Catalog 405

The 1970 edition of "Chemical Products Exclusively for the Electronic Industry" is an eight-page catalog devoted to aerosol and bottled chemicals used to speed electronic servicing. Included are a variety of lubricants and cleaners for tuners, contacts, tape decks, record players, relays, tube sockets and other contact devices and moving parts used in electronic equip-

ment. The catalog also features circuit component coolers, insulating sprays, glues, rubber drive restorers, record cleaners, and TV and radio cement. Chemtronics.

MATV

continued from page 47
not included in the estimate. The selection of other less expensive components, designed for stronger or different signal areas, may result in the installation of a nicely priced system that works so poorly that the technician's reputation is ruined for future installations—if payment is even made for the work performed.

Most MATV equipment manufacturers will gladly assist in the design of an MATV system that uses their equipment. Such assistance will include the selection of equipment most appropriate for the job, providing supplemental technical information as required and reliable cost estimates. ■

**DOUBLE FEATURE****PS148A OSCILLOSCOPE • VECTROSCOPE**

With NEW "Triggered Action" sync.

Guaranteed to lock in composite video waveforms faster than a triggered scope or your money returned.

- High sensitivity wide band oscilloscope.
- Professional 5-inch vectroscope. Converts at the flick of a switch in the rear.
- Equips you for every servicing job—complete for color servicing.
- Outstanding flexibility—ideal for field engineering and production line testing.

A Sencore Top Performer, only \$269.50 All Domestic Made

IN STOCK AT YOUR LOCAL
PARTS DISTRIBUTOR.

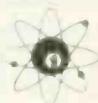

SENCORE

NO. 1 MANUFACTURER OF ELECTRONIC MAINTENANCE EQUIPMENT
3200 Sencore Drive, Sioux Falls, South Dakota 57100

... for more details circle 128 on Reader Service Card

If you're not using these tools of the trade, YOU'RE LOSING MONEY!

That's right. The combination of TUN-O-WASH and TUN-O-BRITE for tuners increases customer satisfaction and eliminates costly callbacks. Super Frost Aid is far superior to other circuit coolers in tracking down thermal intermittents. Without these professional chemical tools of the trade, you're wasting hours of labor and a lot of referral business from satisfied customers.

TUN-O-WASH

GETS TUNERS
REALLY CLEAN!



NO. 2400

TUN-O-WASH is completely unlike any other tuner spray on the market. TUN-O-WASH contains no lubricants. All of the power of its high pressure spray is designed to do just one job superlatively well—to melt away grease, oil, dust, dirt, corrosion and any other foreign material that may be on the tuner contacts. No other spray can even approach TUN-O-WASH in pure cleaning power. TUN-O-WASH restores the tuner to its original condition, leaving parts and contacts like new. Especially good for removing old, encrusted tuner sprays.

SUPER FROST AID

TAMES THERMAL
INTERMITTENTS FAST!
LEAVES NO LIQUID RESIDUE



NO. 1550

Just let the chassis "cook" for an hour or so and then spray each component in the suspected circuit until you see a dramatic change on the TV screen or hear it on the speaker. The last component you have sprayed is usually the defective one.

Some component coolers don't work fast enough to enable you to be sure, but with Super Frost Aid, the reaction is fast and definite—as though you had clicked a switch.

TUN-O-BRITE

THE HEAVY DUTY TUNER
SPRAY WITH BUILT-IN
CONTACT BRIGHTENERS!

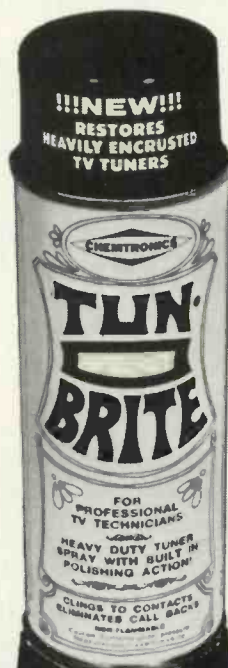

NO. BT-8

Polishes tuner contacts, removing all dirt and corrosion. Can't damage precious metal platings because polishing particles are hollow—disintegrate after initial wiping action. Leaves film of thick, protective lubricant with more body and staying power than any other aerosol lubricant on the market.

READERS SERVICE INDEX

ADVERTISER'S INDEX

American Telephone & Telegraph Co.	23
B & K Division, Dynascan Corp.	20
Belden Corporation	34 & 35
Book Club—Tab Books	66-69
Book Club—Techmatics	63
Chemtronics, Inc.	76
Cornell-Dubilier	3rd Cover
C R C Chemicals	60
EICO Electronic Instruments Co., Inc.	2nd Cover
Finney Co., The	25
General Electric Co.	26
Grantham School of Engineering	76
Heath Co., The	29
Houle Mfg. Co.	72
Lakeside Industries	62
Laran-Electronics, Inc.	60
Lectrotech, Inc.	33
Master Appliance Corp.	65
Mosley Electronics, Inc.	28
Pennwood Numechron Co.	74
Quietrole Co.	60
RCA Parts & Accessories	71
RCA Picture Tubes	4th Cover
RCA Test Equipment	24
RMS Electronics, Inc.	73
Rohn Mfg. Co.	31
Sencore, Inc.	72
Sencore, Inc.	73
Sencore, Inc.	74
Sencore, Inc.	75
South River Metal Products Co.	28
Sylvania Electric Products	27
Sylvania Electric Products	36
Tech Spray	22
Tuner Service Corp.	19
United Tel-Tronics Co.	59
Workman Electronic Products, Inc.	62
Workman Electronic Products, Inc.	70
Xcelite, Inc.	61
Zenith Radio Corp.	57

NEW PRODUCTS

700 Intercom System	59
701 Stereo Receiver	59
702 AM/FM Radio and Tape Recorder	59
703 Microphone	59
704 Stereo Receiver	60
705 Electronic Crossover	60
706 Stereo System	61
707 Speaker System	61
708 Telephone Answering Machine	61
709 PA Amplifiers	61
710 Stereo Tape Player	62
711 Base Transceivers	62
712 Portable Cassette Recorders	62
713 Frequency Counter	70
714 Panel Meter	70
715 Capacitor Chip Kit	70
716 Tuner Spray	70
717 Video Tape Recorder System	70
718 Cassette Cartridge	71
719 Terminal Installing Tool	71
720 Controls	71
721 TV Camera	71
722 Wireless Speaker Adapter	72
723 Speaker Enclosures	72
724 Panel Meters	72
725 Hi-Lo Multimeter	73
726 Scanning FM Receiver	73
727 Magnetic Screwdriver	74
728 Instrument Enclosures	74
729 Editing Kit	74

CATALOGS AND BULLETINS

400 Microwave Tubes	75
401 Microphones	75
402 Product Guide	75
403 Ad Guide	75
404 Microphones	75
405 Electronic Chemical Catalog	75

TEST INSTRUMENTS

900 Sencore's Model BE156	54
901 Sencore's Model 39G26	54

Technicians, Earn Your Associate DEGREE

mostly by correspondence

Accredited by the Accred. Comm. of National Home Study Council. G.I. Bill Approved. Free catalog. Write: Dept. T

Grantham School of Engineering
1505 N. Western, Hollywood, Calif. 90027

... for more details circle 111 on Reader Service Card

ELECTRONIC TECHNICIAN/DEALER

CHEMTRONICS

CHEMTRONICS 1260 RALPH AVENUE
BROOKLYN, N. Y. 11236

... for more details circle 105 on Reader Service Card

**GET
MORE
FACTS**
NO POSTAGE
NECESSARY

Circle
the
Reader
Service
numbers
of those
items of
interest
to you.

OK

FOR MORE INFORMATION fill out and mail today!

Please send more information on items circled.

ADVERTISED PRODUCTS

101	102	103	104	105	106	107	108	109
110	111	112	113	114	115	116	117	118
119	120	121	122	123	124	125	126	127
128	129	130	131	132	133	134	135	136
137	138	139	140	141	142	143	144	145
146	147	148	149	150	151	152	153	154

TEST INSTRUMENTS

900	901	902	903	904	905	906	907	908
-----	-----	-----	-----	-----	-----	-----	-----	-----

NEW PRODUCTS

700	701	702	703	704	705	706	707	708
709	710	711	712	713	714	715	716	717
718	719	720	721	722	723	724	725	726
727	728	729	730	731	732	733	734	735

CATALOGS & BULLETINS

400	401	402	403	404	405	406	407	408
409	410	411	412	413	414	415	416	417

Note: Inquiries serviced until November 6, 1970.

(Please type or print)

8/70

Name

Position

Company

Street

City

State Zip Code

Please describe your type of business.
.....

FOR MORE INFORMATION fill out and mail today!

Please send more information on items circled.

ADVERTISED PRODUCTS

101	102	103	104	105	106	107	108	109
110	111	112	113	114	115	116	117	118
119	120	121	122	123	124	125	126	127
128	129	130	131	132	133	134	135	136
137	138	139	140	141	142	143	144	145
146	147	148	149	150	151	152	153	154

TEST INSTRUMENTS

900	901	902	903	904	905	906	907	908
-----	-----	-----	-----	-----	-----	-----	-----	-----

NEW PRODUCTS

700	701	702	703	704	705	706	707	708
709	710	711	712	713	714	715	716	717
718	719	720	721	722	723	724	725	726
727	728	729	730	731	732	733	734	735

CATALOGS & BULLETINS

400	401	402	403	404	405	406	407	408
409	410	411	412	413	414	415	416	417

Note: Inquiries serviced until November 6, 1970.

(Please type or print)

8/70

Name

Position

Company

Street

City

State Zip Code

Please describe your type of business.
.....

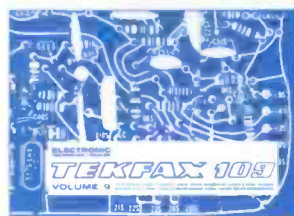

GET THIS FREE BONUS WITH YOUR PERSONAL SUBSCRIPTION TO ELECTRONIC TECHNICIAN/DEALER!

Enter your subscription for a two- or three-year term and we'll send you the new TEKFAX 109 Book of Schematics—FREE!

- \$10 for 3 Years \$8 for 2 Years \$5 for 1 Year
 Payment Enclosed Bill Me Later

Name

Title

Firm

Street

City

State Zip

PLEASE CHECK BELOW:

1. In the TV, Radio and other consumer products fields, is your firm **PRIMARILY a:** (check most descriptive item)
- Retailer with service department
 - Service/repair firm with some retail
 - Industrial electronics service firm
 - Manufacturer
 - Other (please describe)
2. Title: (please check one)
- Owner, manager, buyer, other executive
 - Service manager
 - Service repairman or other employee

If you are renewing your subscription, check here and attach your address label. If you renew your subscription for 2 to 3 years, you are still eligible to receive the TEKFAX 109 as your free bonus.

BUSINESS REPLY MAIL

NO POSTAGE STAMP NECESSARY IF MAILED IN THE UNITED STATES

POSTAGE WILL BE PAID BY

Reader Service Department

**ELECTRONIC
TECHNICIAN / DEALER**

HARBRACE BUILDING, DULUTH, MINNESOTA 55802

FIRST CLASS

PERMIT NO. 665

DULUTH, MINNESOTA

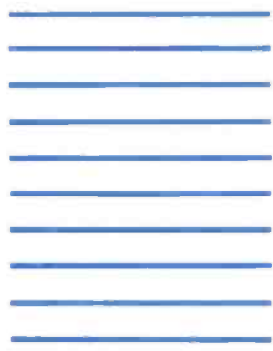

**GET
MORE
FACTS**

NO POSTAGE
NECESSARY

BUSINESS REPLY MAIL

NO POSTAGE STAMP NECESSARY IF MAILED IN THE UNITED STATES

POSTAGE WILL BE PAID BY

Reader Service Department

**ELECTRONIC
TECHNICIAN / DEALER**

HARBRACE BUILDING, DULUTH, MINNESOTA 55802

FIRST CLASS

PERMIT NO. 665

DULUTH, MINNESOTA

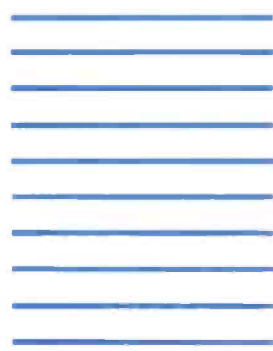

**GET
MORE
FACTS**

NO POSTAGE
NECESSARY

BUSINESS REPLY MAIL

NO POSTAGE STAMP NECESSARY IF MAILED IN THE UNITED STATES

POSTAGE WILL BE PAID BY

Circulation Department

**ELECTRONIC
TECHNICIAN / DEALER**

HARBRACE BUILDING, DULUTH, MINNESOTA 55802

FIRST CLASS

PERMIT NO. 665

DULUTH, MINNESOTA



**FOR
ONLY
PENNIES
PER
MONTH—
YOUR
OWN
PERSONAL
COPIES**



Put your parts in order.

All it takes is **genius** to arrive at simplicity. This new display stand is deceiving. It's more than a display stand. It's set up to operate like a store within your store for instant servicing.

Here, within this unit, is a complete stock of all the wide range twist prongs you'll need plus micas, miniature electrolytics, ceramics, wide range tubulars and dipped paper Mylar.* The selection was based on an extensive study of all capacitors used in the replacement market. Now, with the Re-Place, you're in the capacitor

replacement business. The Re-Place only takes 2' x 5' in space and you have all your parts in order.

Interested? Write for our new catalog on The Re-Place™ capacitor line. 'The Replacers' — the most complete line of replacement capacitors in the smallest possible package.



10 million reasons why it pays to promote matrix, the brightest, sharpest color picture tube in RCA history!

Reasons 1 to 10,000,000. Large-screen MATRIX can upgrade the performance of at least 10 million color TV sets now in use. The RCA 25BCP22 is a direct replacement for the 25XP22, 25AP22A, 25BGP22, 25BAP22 (Chromacolor), and 20 other industry types! Giant-screen sales potential for the RCA MATRIX—practically unlimited!

More RCA Color Picture Tubes are stocked and sold by

distributors than any other color picture tubes in the industry. So, MATRIX is more readily available to you no matter where you are, to give your customers faster service and ring up more profitable sales.

MATRIX is the brightest and sharpest color picture tube in RCA history!

Here's why:

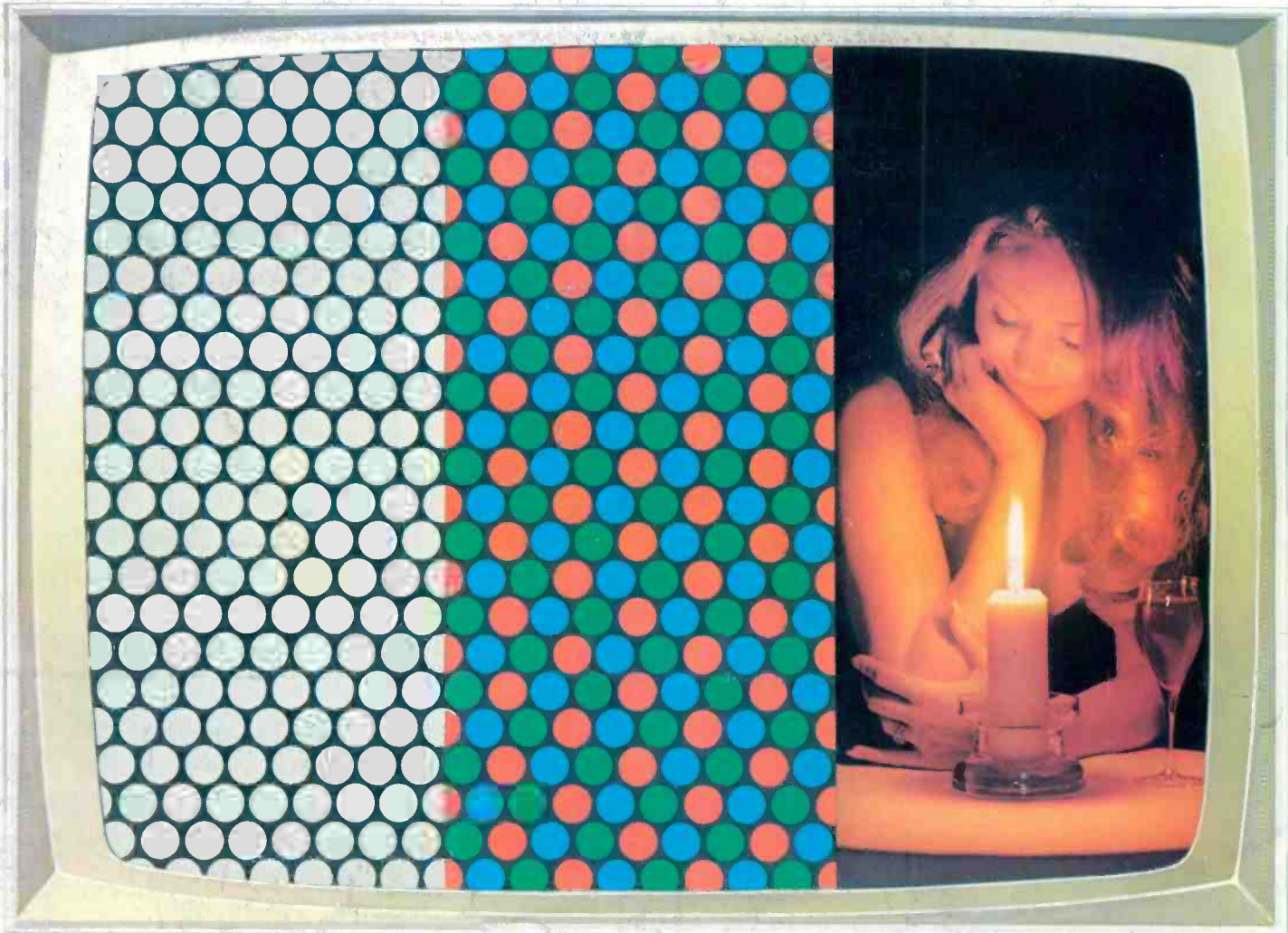

The RCA jet-black matrix

It soaks up room-light normally reflected back at the viewer from the face of the tube. Result: brighter pictures because now there's no need to "filter out" brightness to maintain contrast under strong room-light conditions.

The RCA MATRIX phosphor-dot process*

First, we developed brilliant new phosphors and a unique screening process incorporating a jet-black matrix. Then we deposited the 1,200,000 red, green, and blue high-intensity phosphor dots precisely within the black matrix. Result: brightness doubled with dramatic improvement in contrast and clarity.

The RCA MATRIX picture.**

Spectacular! In operation, a new, unique high-resolution gun "shoots" the phosphors with more energy than any other gun previously available. Result: black matrix + phosphors + high-resolution gun = maximum sharpness over the entire brightness range, truer colors under all viewing conditions.



New 4-color consumer flyer on MATRIX is available from your RCA Distributor.
RCA | Electronic Components | Harrison, N. J. 07029

*Magnified drawing **Simulated