

# ELECTRONIC TECHNICIAN

WORLD'S LARGEST ELECTRONIC TRADE CIRCULATION

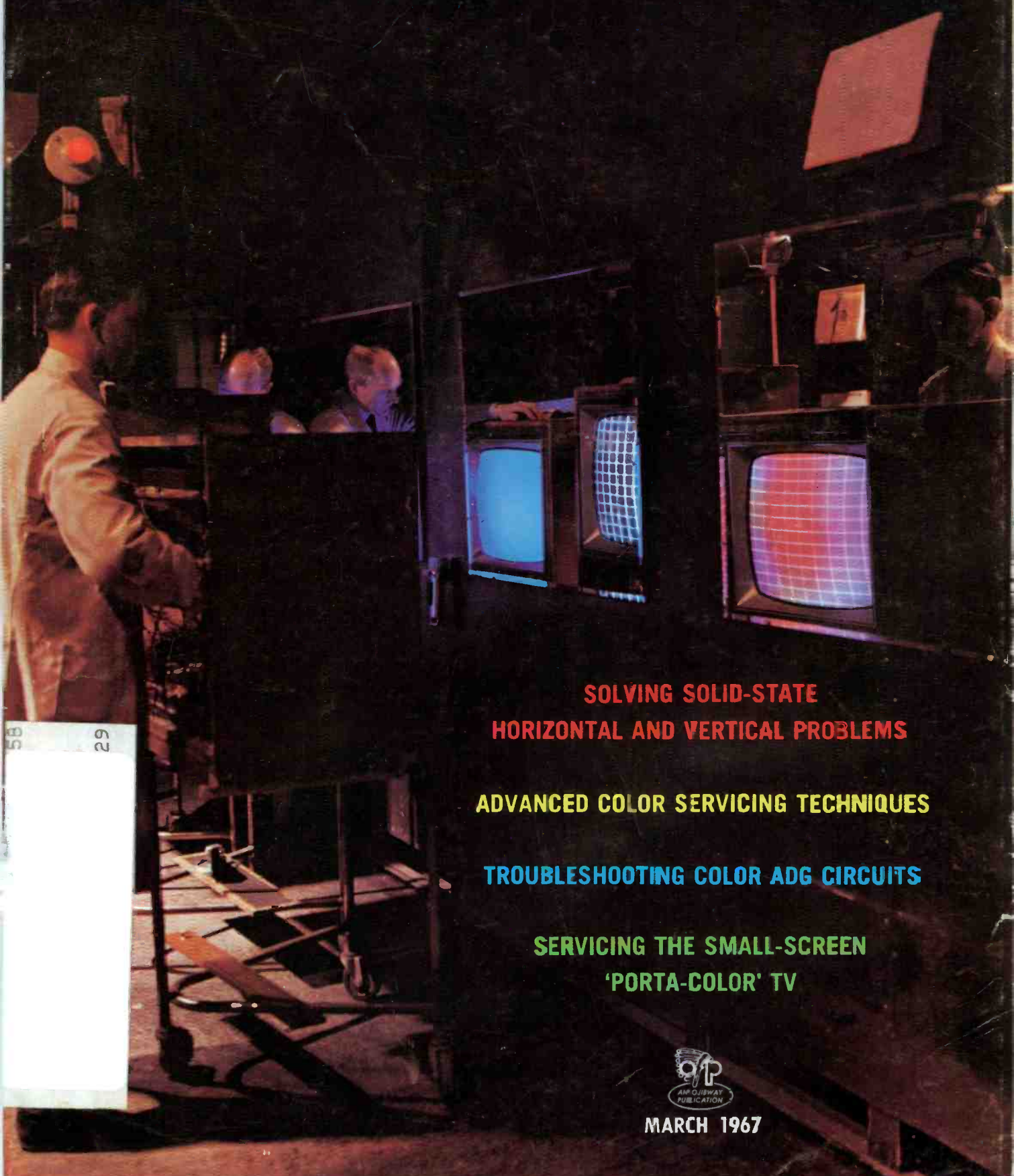

**SOLVING SOLID-STATE  
HORIZONTAL AND VERTICAL PROBLEMS**

**ADVANCED COLOR SERVICING TECHNIQUES**

**TROUBLESHOOTING COLOR ADG CIRCUITS**

**SERVICING THE SMALL-SCREEN  
'PORTA-COLOR' TV**



MARCH 1967

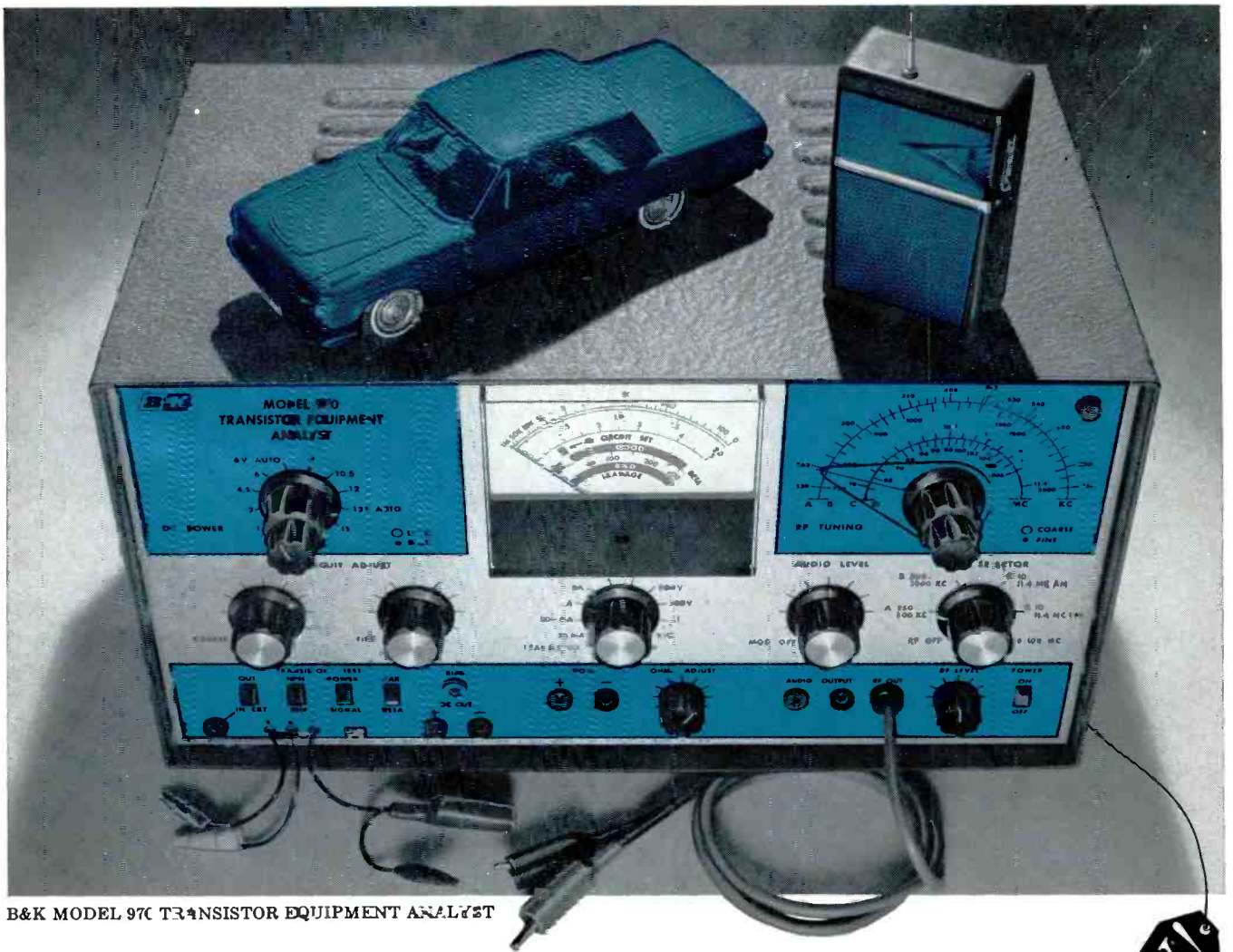

B&K MODEL 970 TRANSISTOR EQUIPMENT ANALYST

# SERVICE AM & FM AUTO & TRANSISTOR EQUIPMENT AT A PROFIT!

**NEW!**

Jobs that used to be unprofitable now go so quickly that you can make good money handling them! There are millions of auto radios and transistor radios in the field—portables, auto and table models, plus hi-fi and communications equipment. Instead of turning them away, you can turn them into money-makers with the B&K Model 970 Radio Analyst.

The 970 is effective because it's *accurate* and *complete*. Using the famous B&K signal injection technique, this all-in-one instrument provides the required dc power, lets you test power and signal transistors in and out of circuit; generates RF and audio signals, and includes a rugged, accurate VOM. Four functions in one compact package—with solid state reliability, B&K professional quality.

## LOW INVESTMENT—QUICK RETURN

See your B&K Distributor or write for Catalog AP22-R

Net \$199<sup>95</sup>

## FEATURES:

### BUILT-IN POWER SUPPLY

**Auto Radios**—High current, low-ripple, for transistor, hybrid, and vibrator types.

**Transistor Portables**—1½ to 12 volts for battery substitution—plus separately variable voltage tap for bias.

### QUICK AND ACCURATE TESTING OF POWER AND SIGNAL TRANSISTORS

**In-Circuit**—stage by stage DC signal injection and sensitive metering of power supply current.

**Out-of-Circuit**—Direct Beta and Leakage meter scale readings. Easy balancing or matching.

### VERSATILE SIGNAL GENERATORS

**RF Generators**—provide broadcast and IF frequencies for both AM and FM bands.

**Audio Generator**—for AM or FM modulation of the RF signals, and for troubleshooting audio circuits.

### RUGGED VOM

**Volt-OHM-Milliammeter**—with rugged, taut band meter—provides correct ranges for easy, fast servicing of all home and auto radios, as well as transistor portables.

... for more details circle 101 on postcard



**B & K DIVISION OF DYNASCAN**

1801 W. BELLE PLAINE AVE. • CHICAGO, ILL. 60613

Canada: Atlas Radio Corp., 50 Wingold, Toronto 19, Ont.  
Export: Empire Exporters, 123 Grand St., New York 13, U.S.A.

# Complete TUNER REPAIR for only

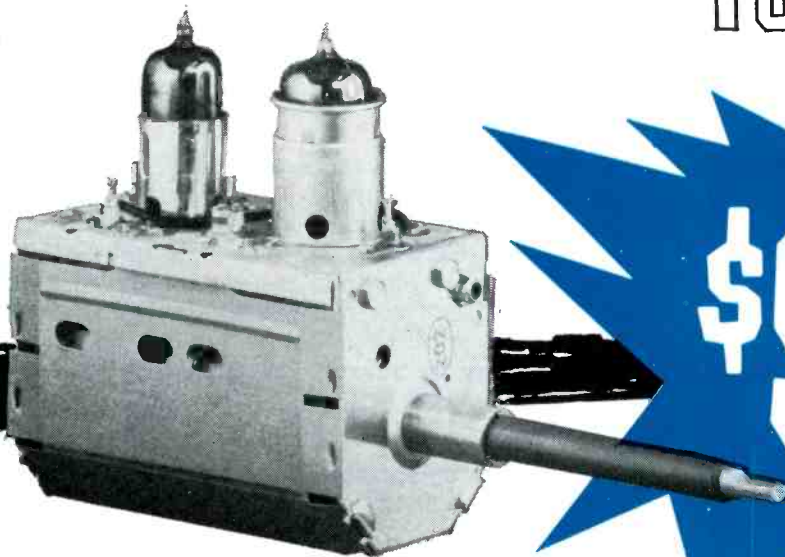

**\$9.50**

Sarkes Tarzian, Inc., largest manufacturer of TV and FM tuners, offers unexcelled tuner overhaul and factory-supervised repair service. Completely-equipped and conveniently-located Service Centers offer fast, dependable and factory-supervised repair service on all makes and models. Centers are staffed by well-trained technicians, assisted by engineering personnel.

Most Tarzian-made tuners received one day will be repaired and shipped out the next. More time may be required on other makes. Every channel—not just the channels existing in any given area—is checked and re-aligned per orig-

inal specifications. Exclusive cleaning method makes the tuner look—as well as operate—like new.

Cost, including ALL labor and parts (except tubes) is only \$9.50 and \$15 for UV combinations. No additional charge. No hidden costs. Too, you get a full, 12-month warranty against defective workmanship and parts failure due to normal usage.

Always send TV make, chassis and Model number with faulty tuner. Check with your local distributor for Sarkes Tarzian replacement tuners, parts or repair service. Or, use the address nearest you for fast, factory-supervised repair service.



## TUNER SERVICE CORPORATION

*(Factory-supervised tuner service authorized by Sarkes Tarzian)*

MIDWEST — 817 N. Pennsylvania St.  
Indianapolis, Ind., Box 1642  
Tel: 317-632-3493

EAST — 547-49 Tonnele Ave., Jersey City, N. J.  
Tel: 201-792-3730

SOUTH-EAST — 938 Gordon St., S. W.  
Atlanta, Georgia  
Tel: 404-758-2232

WEST—

**SARKES TARZIAN, Inc.**  
Tuner Service Division

10654 Magnolia Blvd.,  
N. Hollywood, Calif.  
Tel: 213-769-2720



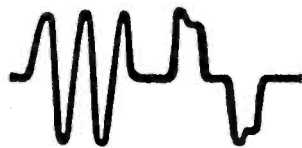

## Which miniature electrolytics for transistorized AM-FM radios ?

**COMPARATIVE SIZES  
OF CAPACITORS ALL RATED  
10 MFD., @ 25 WVDC  
(shown actual size)**



**TT aluminum electrolytic**



**MTA aluminum electrolytic**



**TAS solid tantalum**



**TAP wet slug tantalum**



**TLS wet slug tantalum**



**MTP wet slug tantalum**

The new portable AM-FM radios are so compact you wonder how they get all those components into that little box. You wonder even more when you have to replace some of the parts.

Electrolytic capacitors, for example. The original electrolytic usually turns out to be a tiny thing jammed in among a dozen other midget gadgets. Getting it out is a trick in itself. Getting a suitable replacement is even tougher! And unfortunately, you're apt to need replacements, because many of these tiny capacitors just aren't much good. They don't meet the quality specs of good domestic capacitor makers. But high quality domestic capacitors are often just a bit too big to fit in the space available.

What's the answer? Search the town for another "little-bitty" original capacitor? Tell your customer you can't finish the job?

Don't give up. We have a few suggestions.

First, try a Mallory TT aluminum electrolytic. This is a real quality capacitor, rated 85°C, and it's pretty doggone small. Or a Mallory MTA, a revolutionary molded case aluminum electrolytic with excellent quality at low price.

If neither of these will fit, try a Mallory tantalum capacitor. The TAS solid tantalum is about the same size as the TT, but it's rated 125°C. Need still smaller size? Take a look at the Mallory "wet slug" tantalum types TAP and TLS—and the super-miniature MTP, which gives you the most microfarads in the smallest size of anything on the market. The pictures at the left show you comparative sizes, all for a 10 mfd, 25 WVDC rating.

Sure, you'll pay a little more for the tantalum capacitor. But not as much as you might think. The TAP only costs 42c more than the TT, in the rating shown. And you get the utmost in reliability.

We certainly don't expect you to use a tantalum capacitor to replace every aluminum electrolytic. But they come in mighty handy sometimes. And you can get them when you need them from your Mallory Distributor. Ask him for our latest catalog, or write to Mallory Distributor Products Company, a division of P. R. Mallory & Co. Inc., Indianapolis, Indiana 46206.

**DON'T FORGET TO ASK 'EM** — *What else needs fixing?*

... for more details circle 125 on postcard  
ELECTRONIC TECHNICIAN

MARCH 1967  
VOL. 85, NO. 3

# ELECTRONIC TECHNICIAN

WORLD'S LARGEST ELECTRONIC TRADE CIRCULATION

RON KIPP Publisher  
JACK HOBBS Managing Editor  
JOSEPH ZAUHAR Technical Editor  
PHILLIP DAHLEN Associate Editor  
DONALD GRANT Assistant Editor  
RICHARD CLAYTON Field Editor  
JUDITH BERINI Editorial Production  
KEN McSHANE Artist  
MAGGIE KANE Advertising Production  
RUTH GELINEAU Circulation Fulfillment

## OJIBWAY PRESS, Inc.

Ojibway Building, Duluth, Minn. 55802  
AREA CODE 218 727-8511

### PUBLICATIONS DIVISION:

ROBERT EDGELL President  
ANGUS STONE Marketing Manager  
BEN MARSH Editorial Director  
HARRY RAMALEY Production Director  
JIM GHERNA Art Director  
LARS FLADMARK Circulation Director  
WARREN BODIN Ad Production Supervisor

### Sales Offices:

NEW YORK: Ron Kipp, 25 W. 45 St.  
New York: N.Y. 10036  
AREA CODE 212 581-4200

CHICAGO: Jack Daniels, 43 E. Ohio St.  
Chicago, Ill. 60601  
AREA CODE 312 467-0670



Copyright 1967 by Ojibway Press, Inc., Duluth, Minn. 55802. Reproduction and reprinting prohibited except by written authorization of the publication. Subscription price: \$5 for 1 year, \$8 for 2 years, \$10 for 3 years. Pan American and Foreign, \$9 for 1 year, \$14 for 2 years, and \$18 for 3 years.

If you have a change of address or a question about your subscription, write: ELECTRONIC TECHNICIAN, Circulation Department, Ojibway Building, Duluth, Minnesota 55802. BE SURE TO SEND ALONG THE ADDRESS LABEL FROM YOUR MOST RECENT ISSUE. Second class postage at Waseca, Minnesota and at additional mailing offices.

POSTMASTER: Send notification form 3579 to ELECTRONIC TECHNICIAN, Ojibway Building, Duluth, Minnesota 55802.

MARCH 1967

## Cover

Our photographers recently wandered into the lab section of a TV manufacturer. Chassis were being taken from the assembly line and checked out with elaborate test instruments. Production changes, circuit revisions and new circuitry were being made and developed. We are reminded once again that we live in an era of rapid technological change and that every service-dealer and technician must exert the utmost effort to keep pace with it—or fall by the wayside.

## FEATURES

- A Thinking Technician's' Approach to Chroma Circuit Problems** ..... 43  
*Here's an article that brings you up to date on modern color servicing techniques*
- Troubleshooting Color ADG Circuits** ..... 46  
*The information contained in this one article alone will save you many hours of time when servicing color sets*
- Solving Horizontal and Vertical Problems in Solid-State TV's** ..... 50  
*Tells you how to get your scope going and those transistorized portables moving off the bench*
- A Technician Looks at G-E's 'Porta-Color' TV Receiver** ..... 55  
*This TEKLAB report will show you what to do with this unusual color set when it hits your work bench*
- Semiconductors from A to Z** ..... 59  
*Part 8 of a continuing series on solid-state components. This article is now receiving wide-spread, favorable comment throughout the industry. The most important articles in the series are yet to come*
- Using Audio Test and Alignment Instruments** ..... 64  
*Part 1 of a series which many of you have asked for*

## DEPARTMENTS

- |                       |    |                      |    |
|-----------------------|----|----------------------|----|
| Letters to the Editor | 22 | Catalogs & Bulletins | 84 |
| Editor's Memo         | 26 | Book Reviews         | 86 |
| Technical Digest      | 28 | News of the Industry | 88 |
| Colorfax              | 70 | Advertisers Index    | 92 |
| New Products          | 72 | Reader Service       | 93 |

## TEKFAX — 16 PAGES OF THE LATEST SCHEMATICS

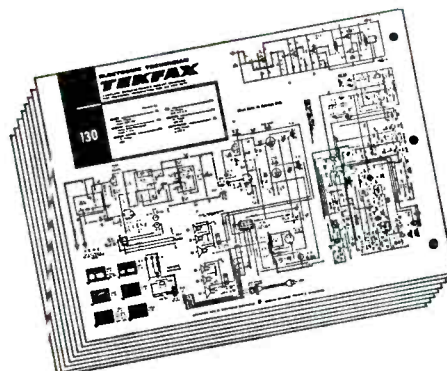

- Group 175 March • 1967
- ADMIRAL: Color TV Chassis H10  
AIRLINE: TV Models GMW 1447A,57A  
CORONADO: TV Model TV2-9454A  
DUMONT: TV Chassis 120804A,B 805A,B 806B 807A,B  
MAGNAVOX: Color TV Chassis T922 Series  
TRUETONE: TV Model 2DC3712

# LETTERS TO THE EDITOR

## "Dishonest" Technicians

From one end of the country to the other there is great concern about the shortage of qualified technicians. This is especially true in the home entertainment equipment area. Let me tell you one of the great causes for this situation.

About a month ago I watched a

TV show on channel 12, regarding "dishonest" TV-radio service dealers. They did a good job of exposing the few crooks in our midst — but they didn't seem to recognize the harm they were doing to the overwhelming majority which are honest.

There are dishonest people in every trade but no one seems to make an issue of other trades, like they do with TV technicians. This has been a problem to thousands of honest TV-service dealers and technicians for years.

I was one of those for 15 years. I gave up servicing 4 years ago. I just

couldn't take it—being distrusted. I am doing very well as a technician for a CATV and antenna manufacturing company.

TOM TONER

Jerrold Electronics Corp.  
Philadelphia, Pa.

## NATESA Fights Back

Herewith, copy of a letter sent to all TV-radio networks, both commercial and educational.

"In recent weeks several highly questionable programs, covering alleged shortcomings of TV-radio service-dealers, have been aired. NATESA, recognized as a prime voice of independent service and listed thus in various industry and government publications, was not consulted prior to the airing. We firmly believe that fair play and responsibility to the public and the industry, should have dictated the wisdom of 'getting the other side' before doing great and irreparable harm.

"Perhaps the view is that the castigation is aimed at 'little Joe down the street' who is of no consequence to the broadcaster and who can't fight back and tell the real facts. If this is so, it would be extremely shortsighted. Heavy evidence, derived from direct and regular contact with millions of TV and radio set owners, proves each such 'expose' of TV-radio service-dealers hurt all stations gravely. How? It's simple. Every time a set owner is given reason to believe that he is almost certainly going to be 'robbed' for 'questionable' service, he thinks many times before he calls even a previously trusted service-dealer of long standing and so many sets stand idle or perform at a level far below that which would encourage extensive use. There goes your audience, regardless of what your 'use surveys' show!

"Obviously then, you would be true to yourself and your advertisers if you demanded both views before putting such material on the air.

"Independent service-dealers have served broadcast stations and the public well since the early 1920s. How else would you explain the public's reliance on independent service-dealers for 47 years as the main source of maintenance? Obviously we have earned appreciation and fair play. And it doesn't take an economist to prove that the fees collected by the average service-dealer for services rendered are far from lucrative."

FRANK MOCH

Executive Director  
National Alliance of TV  
& Electronics Service  
Associations

Chicago, Ill.

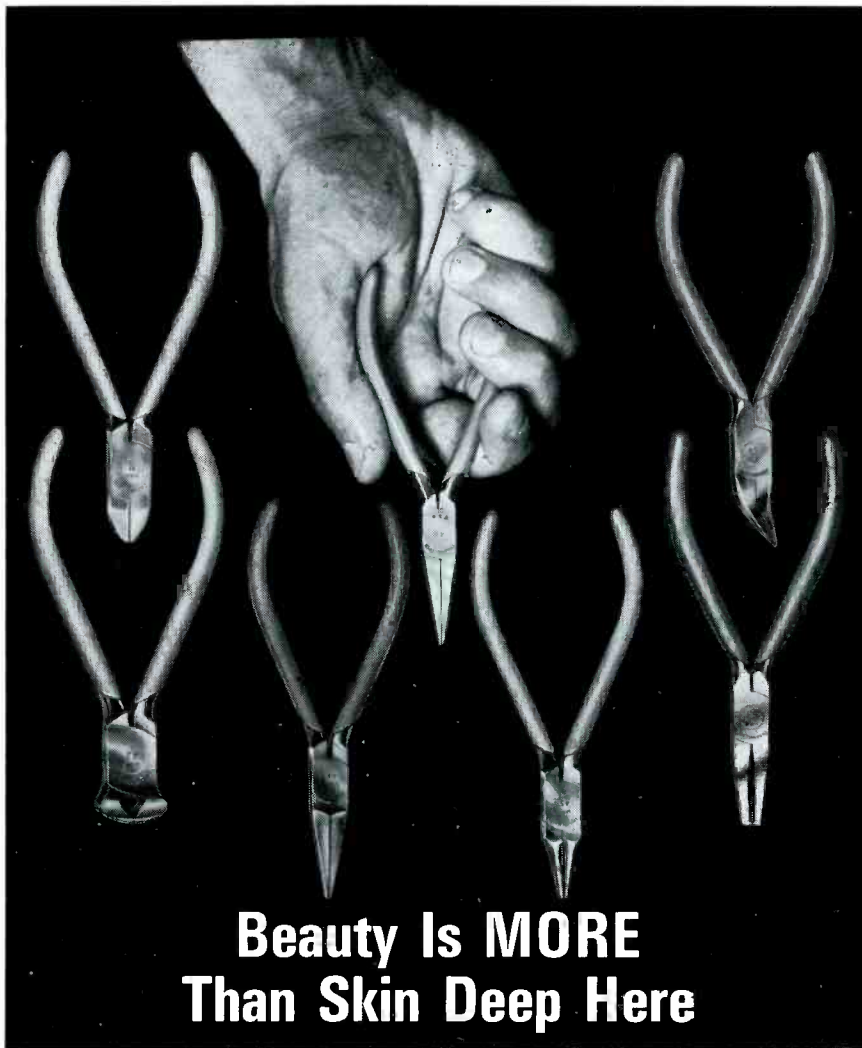

So beautifully finished they could occupy a position of pride in a jeweler's window. But, for all their eye appeal, these Channellock Little Champ pliers aren't decorator pieces. They're down-to-earth worksavers on hundreds of delicate jobs that need firm treatment . . . in short, the finest precision pliers you can buy.

We don't ask that you take our word for it. We merely suggest you tell your dealer you want to see and try Channellock Little Champ pliers. We'll wager it will be a case of love at first sight. You can get the whole pedigree on Little Champs—and their equally fine big cousins—in our catalog. Let us send you a copy, no charge.

TOOLS BY  
**CHAN NEL LOCK**  
MEADVILLE, PA.

... for more details circle 112 on postcard



# 2,365 reasons why Sprague Twist-Lok<sup>®</sup> Capacitors help you to protect your reputation

When you fool around with makeshift or "fits-all" capacitor replacements by substituting sizes and ratings, you leave yourself wide open for criticism of your work, you risk your reputation, and you stand to lose customers. With so much at stake, it just doesn't pay to use makeshifts when it's so easy to get exact replacement capacitors from your Sprague distributor.

With 2,365 different Sprague Twist-Lok Capacitors as standard catalog items, and more being added regularly, Sprague gives you the world's most complete selection of exact replacements.

We don't have to tell you that it's easier to service with exact replacements. And we don't have to tell you that it's better, too. When sets are designed, specific capacitance values are used for peak operation, so it takes exact replacements to restore original set performance.

And who better than Sprague knows which values and sizes are needed in the replacement market? Sprague, the world's largest component manufacturer, has the most complete specification file on original set requirements. That's why you're always right when you work with Sprague Twist-Lok exact replacements!

GET YOUR COPY of Sprague's comprehensive Electrolytic Capacitor Replacement Manual K-108 from your Sprague Distributor.



## HAVE YOU TRIED KWIKETTE<sup>™</sup> CONNECTORS?

Not just another wire spring connector! Copperweld wire inner core, a layer of flux, and an outer coating of solder . . . all you supply is heat! They're now being packed with Sprague Capacitors at no extra cost to you! See your distributor!

★TRADEMARK



65-5106R3 WORLD'S LARGEST MANUFACTURER OF CAPACITORS

Sprague Products Co., 65 Marshall St., North Adams, Mass. 01248  
 . . . for more details circle 136 on postcard

# LETTERS TO THE EDITOR

## Helpful and Interesting

I find every feature article and department in **ELECTRONIC TECHNICIAN** most helpful and interesting. I also feel that the "Editor's Memo" gives us not only an outlook in the future but ways to improve ourselves and the field in which we work . . . Please let me know if any reader would like to part with **TEKFAX 1** to 169 and 172. Answer via **ET** please.

LE ROY SCHULZE

Finland, Minn.

## Needs Schematic

Perhaps an **ET** reader can help me with this problem. I need a schematic for a Tamar transceiver. Apparently the manufacturer is out of business but I have two of them in use and cannot service them properly without a schematic. The model I am interested in uses a 6AS8 and a 12AZ7 in the receiver and a 12BH7 plus vibrator in the transmitter. Reply via **ET**.

CALVIN O. LETENDRE

Northford, Conn.

## Approved Electronics

For those who need the address of **Approved Electronics**, they are now located at 75 Leonard St., New York City.

JIM BRADY

New York City, N.Y.

## Zenith Schematic

Tell Robert Spachmann, Souderton, Pa., that the Zenith model 6S152 schematic is located in volume 7 of John F. Rider's **Perpetual Trouble Shooter's Manual**, pages 7-9 to 7-17, which we have in our shop.

E. W. FRENCH

Jackson, Miss.

•Thank you very much but we have already located one and forwarded it to him.—Ed.

## Letters Informative

I think your "Letters to the Editor" columns is a wonderful source of information. I need an operators manual and schematic for a Sico Model No. 79 Super Meter made by Superior Instruments Co. Can any reader help me? Write via **ET**.

ARNOLD AMERSON

Pittsburg, Calif.



**SCORE**  
with **Jif**  
the **WINNER** among  
**CONTACT & CONTROL CLEANERS**



SPECIFIED  
BY  
GOVERNMENT  
INDUSTRY  
TECHNICIANS

**JIF** Contact and Control Cleaner - cleans and lubricates plus providing contacts and controls with the longest possible protection. Won't harm plastics - contains no harsh solvents - formulated with silicone. Try **JIF** on your team of service aids. It's great

**FREE GIFT COUPONS**  
on **GC Aerosol Chemicals**



**GC ELECTRONICS**  
Div. of Hydrometals, Inc.  
400 S. Wyman St.  
Rockford, Ill., U.S.A.

... for more details circle 119 on postcard

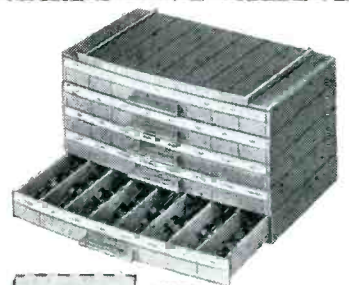

Little Devil® Composition Resistors

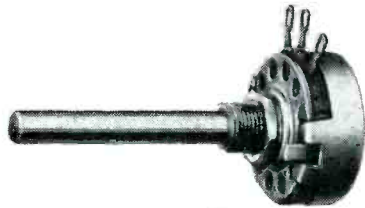

Type AB 2-Watt Molded Pots

five ways to  
stop customer  
"static"

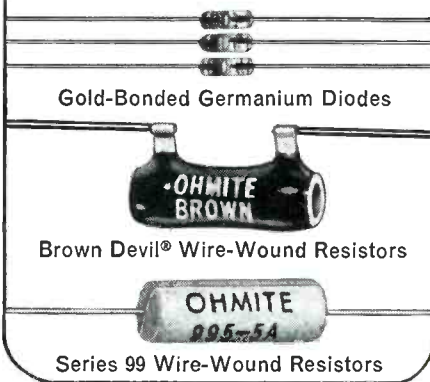

Customer "static" is hard on the ears . . . hard on profit. But you're always safe with **Ohmite** quality replacements in your repair jobs. Order **Little Devils** in handy cabinet assortments or on **Tally-Tape**; all popular sizes and values. Select **AB Pots** from 50 ohms to 5 megohms in several shaft lengths. Choose from ninety **1N** types of diodes. Get **Brown Devils** from 3 to 20 watts in 0.5-ohm to 100K-ohm values. Order **Series 99** resistors in 1½, 2¼, 3¼, 5, 11 watt sizes from 1 to 51,000 ohms. Ask your distributor for the latest edition of **Ohmite's Stock Catalog 30**.

Be right with



**OHMITE**  
RHEOSTATS • RESISTORS • VARIABLE TRANSFORMERS • TAP SWITCHES  
TANTALUM CAPACITORS • RELAYS  
R.F. CHOKES • SEMICONDUCTOR DIODES

3087 Howard Street, Skokie, Ill.

... for more details circle 128 on postcard

**ELECTRONIC TECHNICIAN**



# RCA ANNOUNCES NEW ANTENNA ACCESSORIES ENGINEERED FOR COLOR TV

New catalog tells the full-line story.  
Get it from your RCA Distributor.

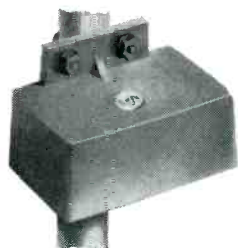

## 5

### RCA Deluxe Transistorized Antenna Amplifiers

... a full line of dual purpose units with the most advanced silicon transistors in high-gain, low-noise circuits. They are masterfully designed to bring in the sharpest picture on color or black and white TV. Or they can drive multiple receivers from a single antenna using RCA multi-set couplers as a small distribution system. Five types include: 300 ohm UHF type 10P223; 300 ohm VHF/FM type 10P213; 75 ohm coaxial VHF/UHF type 10P215 and 10P235; and 300 ohm VHF/UHF type 10P233—all with remote, A.C. operated power supplies.



## 4

### RCA Deluxe Multi-Set Couplers

... UHF/VHF/FM 300 ohms, couple two or four sets to one antenna or amplifier. Channels 2 to 83, types 10P302 and 10P304. Also VHF/FM 75 ohm coaxial types 10P752 2-set coupler; 10P754 4-set coupler.



## 3

### RCA Deluxe Band Splitters

... Separate UHF, VHF and FM signals from a single transmission line or combine separate antennas. 300 ohms. Three types include: 10P311 couples VHF/UHF signals to one line; 10A135 separates UHF and VHF at set; 10P312 separates UHF, VHF and FM.



## 3

### RCA Deluxe Coaxial-to-twin lead Transformers

... streamlined for fast installation. Coax plugs in using solderless connector. Terminals for twin lead connections. Models: 10P723 and 10P753 for indoor use and 10P375 for outdoor use.



## 2

### RCA Deluxe Lightning Arrestors

... Positive contact with all varieties of twin-lead (flat, round, and oval). Eliminate lead stripping, insert line in slot, screw on cap for fast installation. Low insertion loss, does not increase VSWR of a good antenna even at critical UHF frequencies. Screw mount type 10A118; and strap-mount type 10A119.

When you buy antenna accessories bearing the  
RCA Mark of Quality, you know they're reliable.

RCA PARTS AND ACCESSORIES, DEPTFORD, N.J.



The Most Trusted Name in Electronics

# EDITOR'S MEMO

## Educating ETV

For more than a decade Educational Television has been trying to get off the ground. It has made slow progress—but it has made progress—aided primarily by the government, a hand-full of outstanding educators, some philanthropic individuals and organizations like the Rockefeller Foundation, for example, who have long recognized the vast potential of Educational TV.

Recently, however, ETV has stuck both of its feet in its mouth and both fists in its eyes by telecasting an expose-type unmentionable about alleged unethical practices of TV-radio service-dealers. This is not the first time the industry has come in for this type of "smearism." And it won't be the last—until the service-dealer organizations of the nation spend considerably more time and money informing the public of the facts of home-entertainment-equipment service life. This happens to be one of the most important and urgent needs facing the industry today and it ranks in importance with the technician shortage.

The ETV people responsible for dishing up this cup of hemlock should have known better. But, as in many other areas, not all educators are educated.

There are brain-warping experts and expert brain-warpers in many areas—but ETV is the last place we would expect to find them. Or is it? Is ETV becoming like some newspapers of the past (but no longer with us), a medium heavily devoted to molding public opinion? We hope this is not true.

Perhaps those who have been entrusted with steering ETV's ship have forgotten the difficulties that generations of their predecessors had in selling the basic ideas of modern education—especially during Mid-Victorian days. Perhaps they can be induced to remember—before the educational television ship ends up like the Titanic.

The national, state and local-area TV-radio service-dealer associations should take great pride in the efforts they have already expended in exposing this pot of brain-washing tripe to the public. And they should redouble their efforts and spend a little more time and money educating the uneducated who appear to be in control of the nation's Educational Television system.

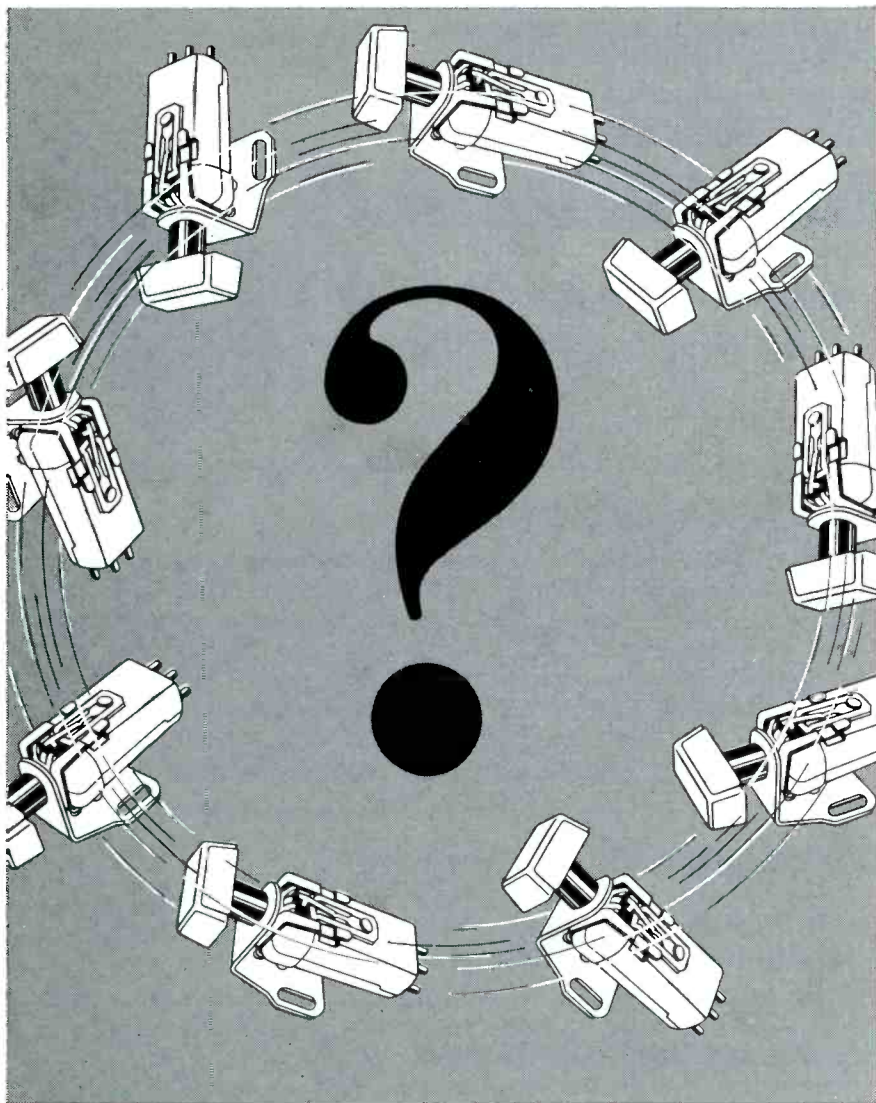

## In the Replacement Cartridge Business **LOOK-ALIKES ARE NOT ENOUGH!**

Only **PERFORM-ALIKES** and **FIT-ALIKES** will do!  
Everyone gets skinned when the resemblance is only skin deep!

Astatic has stayed **FIRST BY FAR** in the cartridge field for more than three decades by supplying **EVERY TYPE OF CARTRIDGE** needed, **WHEN** needed, and with **EXACT DUPLICATE FIT** and **SUPERIOR PERFORMANCE**.

It's the No. 1 formula for cartridge business success offered **ONLY** by the No. 1 cartridge manufacturer—Astatic.



**THE ASTATIC CORPORATION**

Conneaut, Ohio 44030 U. S. A.

In Canada: Canadian Astatic Ltd., Toronto, Ontario • Export Sales: Roburnt Agencies, Inc., 431 Greenwich Street, New York, New York 10013, U. S. A.

**THE PIONEERS AND THE PACESETTERS OF QUALITY SOUND REPRODUCTION**

... for more details circle 107 on postcard

# Compare Color Generators

look at the rest... and you'll buy the best, new **B&K model 1245**

The all solid-state B&K Model 1245 Color Generator duplicates the waveforms transmitted by a color TV station.

Adherence to these waveforms makes it easy to converge the color tube, check sync and make other raster adjustments . . . and the color generator with station quality signal will be able to sync next year's sets. Generators with compromise waveforms do not give you this obsolescence protection.

Here are oscilloscope photographs from the outputs of two typical competitive color generators, one transistorized and one tube type, and the B&K Model 1245. The detailed analysis with each photograph shows a few of the reasons why you'll save time and effort with B&K.

## COLOR

## CROSSHATCH

### STANDARD STATION SIGNAL

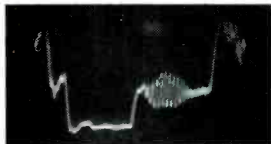

One horizontal sync pulse with its color burst.

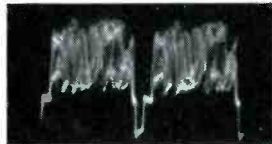

Two lines showing horizontal sync pulse with black and white tv signal, and horizontal sync pulse with color burst.

### TRANSISTORIZED B&K MODEL 1245

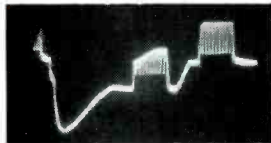

Good duplication of station signal including back porch. If the set won't sync, the set is defective.

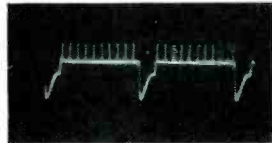

Well defined back porch on horizontal sync pulse permits accurately setting color killer and almost eliminates need to adjust brightness and contrast.

### TRANSISTORIZED GENERATOR A

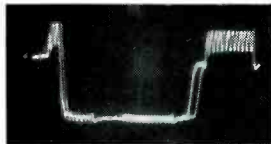

No back porch causes unstable color sync. Burst amplitude compression may permit sync on wrong color bar.

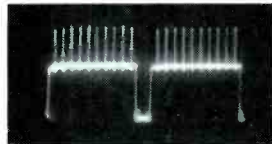

Square wave horizontal sync pulse with no back porch and poor dc coupling forces adjustments of brightness, contrast & fine tuning to obtain usable pattern.

### GENERATOR B

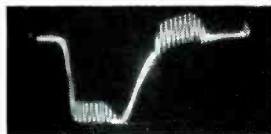

No back porch; color information on top of sync-pulse makes sync difficult on some sets.

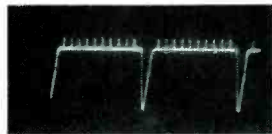

Complete absence of any back porch necessitates readjustment of brightness, contrast and fine tuning to obtain a usable pattern.

See your B&K Distributor for a demonstration or write for Catalog AP22.

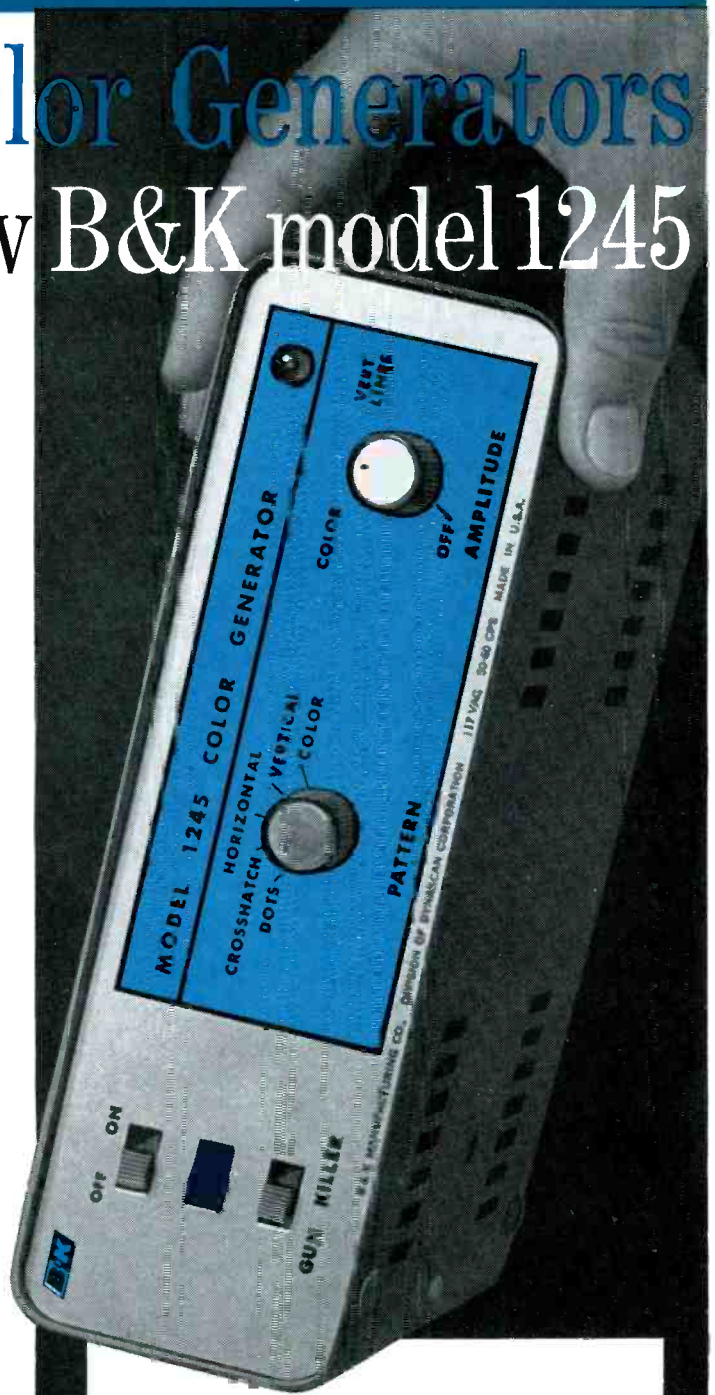

For the first time with the no-compromise waveforms from the B&K Model 1245, it is possible to accurately set the color killer threshold control with a color generator.

The miniature size and convenience of the Model 1245 match its performance. It provides crystal-controlled keyed rainbow color bar display, and dot, crosshatch horizontal line and vertical line patterns as well as gun killer controls that will work with any picture tube. Size only 2 7/8 x 8 1/2 x 3 7/8". Net \$134<sup>95</sup>.



## B & K MANUFACTURING CO.

DIVISION OF DYNASCAN CORPORATION  
1801 W. BELLE PLAINE AVE. • CHICAGO, ILL. 60613

Canada: Atlas Radio Corp., 50 Wingold, Toronto 19, Ont.  
Export: Empire Exporters, 123 Grand St., New York 13, U.S.A.

... for more details circle 109 on postcard

# TECHNICAL DIGEST

## RCA VICTOR

VHP70 Series Radio/Record Changer, RC1227C Chassis—Stereo Multiplex Circuit Description

The stereo multiplex portion of the RC1227 receiver is composed of six transistors and six diodes. Two transistors are used as 19kHz pilot amplifiers that supply signals for two doubler diodes that drive the 38kHz amplifier transistor. Four diodes are used in the stereo demodulator. The left and right signals are further processed in the two transistor differential amplifier stage and passed on to the function switch.

The mono FM and composite stereo pass through a 72kHz trap to the first 19kHz amplifier that acts as an emitter follower to all frequencies except 19kHz. By virtue of the high input impedance offered by the 19kHz amplifier the stage does not load the ratio detector. The mono FM from the collector of the 1st 19kHz amplifier passes through a de-emphasis network that restores the normal frequency responses to the signal and on to the selector switch.

The FM stereo signal consists of three components,

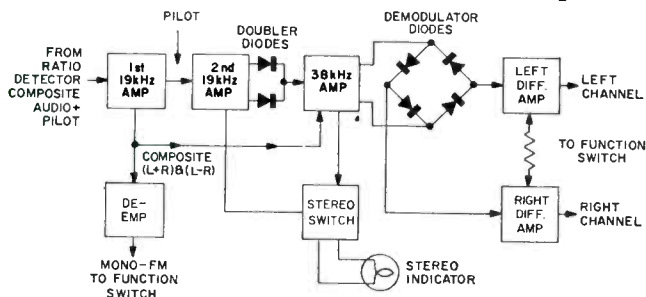

$L+R$ , the sum of the left and right channels that can be received on a monophonic FM receiver. The  $L-R$  difference signal composed of the side bands of the suppressed 38kHz carrier frequency and a 19kHz 10 percent amplitude pilot frequency is used in the receiver to recreate the phase locked 38kHz carrier required to demodulate the side band  $L-R$  information.

The stereo information splits at the first 19kHz amplifier; the 19kHz pilot appears at the collector and is coupled through a tuned 19kHz transformer to the 2nd 19kHz amplifier. The  $L+R$  sum and the  $L-R$  difference signals appear at the first 19kHz amplifier's emitter where they are passed on to the synchronous detector stage. The 2nd 19kHz amplifier further increases the amplitude of the pilot frequency to a level high enough to bias and drive the 38kHz amplifier. A dc bias voltage is applied to the emitter of the stage through the stereo switch circuit. The bias reduces the gain of the 2nd 19kHz amplifier to prevent spurious signals from activating the stereo circuits. The output of the 2nd 19kHz transformer is fullwave rectified by the two diodes. The output of the diodes is a dc voltage with a strong 38kHz ripple component. The dc voltage provides bias to the base of the 38kHz amplifier transistor. The ripple component acts as a 38kHz drive signal that, because it was derived from the 19kHz pilot signal is synchronized with the station sub carrier. The high level 38kHz is coupled by a tuned 38kHz transformer to the demodulator diodes. The diodes function as switches

and sample the  $+(L+R)$  and  $-(L-R)$  sidebands as well as the  $L+R$  signal at a 38kHz rate. The composite signal that entered the diode demodulator circuit at the 38kHz transformer center tap is removed as two signals predominantly left and right. The signals after de-emphasis are applied to the differential amplifier circuit for further processing. The differential amplifier, in addition to signal amplification, removes the undesirable components from each channel leaving a pure left and right channel output signal.

The stereo switch circuit has three functions: it provides a visual indication (light) of a stereo signal, it removes the hold off bias on the 2nd 19kHz amplifier and the dc bias that allows monophonic FM to pass through the demodulator bridge. A 19kHz pilot of 6 percent or greater amplitude will provide sufficient drive to the 38kHz amplifier and activate the stereo switch circuit. A fixed threshold bias is applied to the 2nd 19kHz amplifier and no adjustment is required.

## SENCORE CR133 Tube Checker

Set-up Specifications

Until new set-up booklets are available covering the latest CRTs or until an up-to-date CRT tube manual covering the 23EGP22 and 25AP22 color tubes can be obtained, the following specifications are being supplied.

	23EGP22	25AP22
G2, maximum peak voltage, including video signal voltage	650v max.	1kv max.
G1, maximum value negative bias	400v max.	400v max.
G1, maximum negative operating cutoff value	175v max.	200 max.
G1, maximum positive bias value	0v	0v
G1, maximum positive peak value	2v	2v
$E_r$ , Filament voltage	6.3v	6.3v

23EGP22 with G2 of 380v, change in G1 for min. +max. spot cutoff -60 to -120. With G1 of -75v, change in G2 for min. +max. spot cutoff 240 to 470.

25AP22 with G2 of 400v, change in G1 for min. +max. spot cutoff -95 to -190. With G1 of -150v, change in G2 for min. +max. spot cutoff 285v to 685.

The CR133 will operate directly from these specifications with only three (3) figures needed: filament voltage, control grid cutoff range and G2 voltage. With the above figures, a set-up booklet is not necessary.

## MOTOROLA

Vibrasonic Microphone KM202R—"Bongo" From Vibration

If a KM202R vibrasonic develops a susceptibility to "bongo" on minor road shocks after the unit has been in use, a possible cause is an uncurling of the tape on the transducer coil. If the uncurled tape edge touches or is too close to the transducer the slightest vibration can cause "bongo." The cure is to cut away the uncurled portion of the tape or to reglue the tape in position on the coil. If wires are dressed against the transducer springs the same "bongo" condition can result.

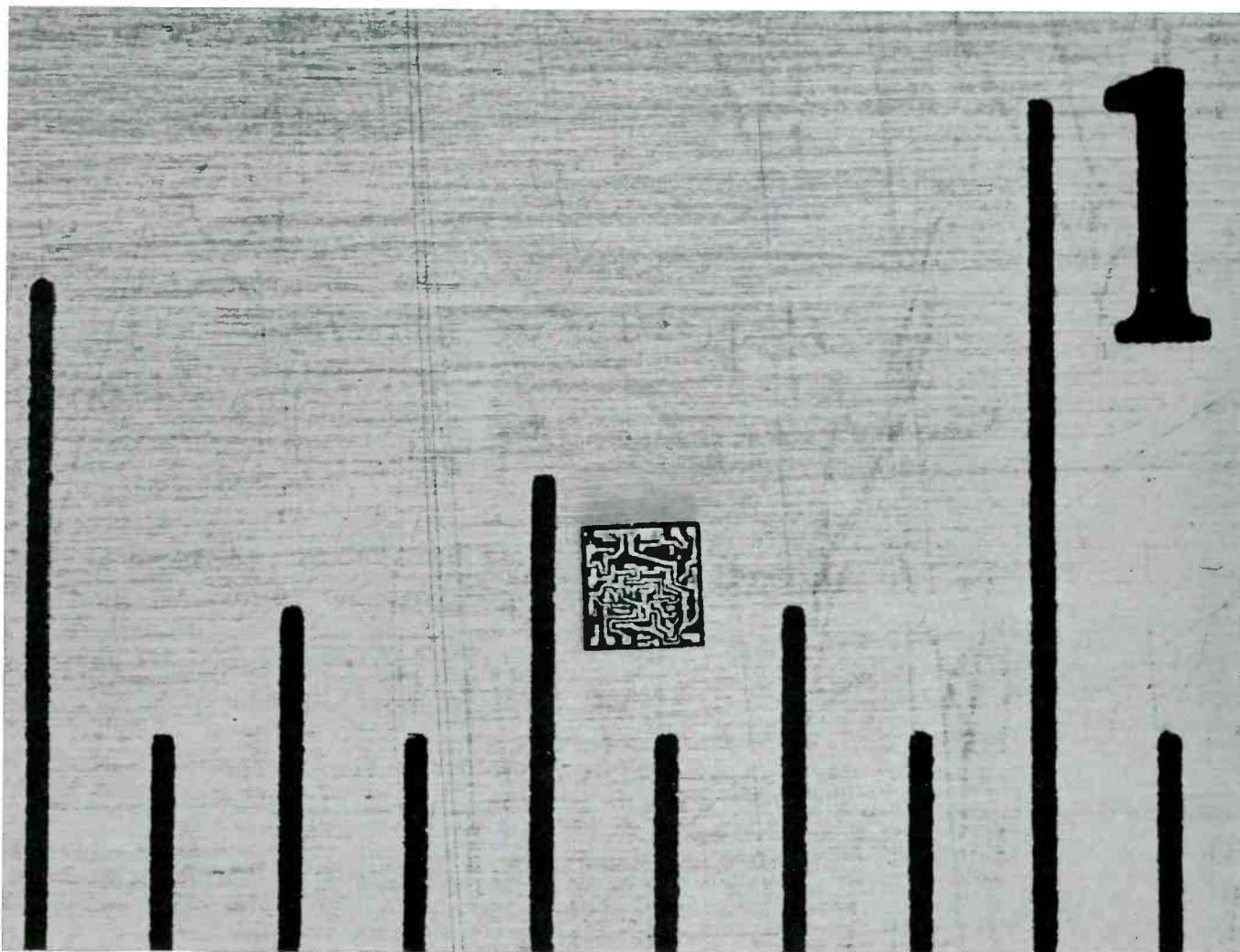

**At 1/20<sup>th</sup> of an  
inch square it's  
the biggest thing  
in electronics**

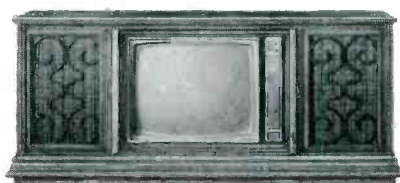

(And RCA Victor is using it now)

RCA Victor was first to use integrated circuits in home entertainment products. Why? Because the integrated circuit is the most reliable circuit ever made for a consumer product. It's made in a room continuously cleansed of microscopic particles • Computer-controlled tests assure that it functions properly • Each is firmly mounted and connected to leads by ultrasonic bonding to enhance reliability (and that's what helps you sell). See your RCA Victor distributor today.



The Most Trusted Name  
in Electronics

## MAGNAVOX

Remote Control Receiver 704028—Sensitivity

Some comments have been received indicating that the sensitivity of the receiver may be such that extraneous signals will trigger the relays. In some cases the 28kHz relay (Channel Change) was being triggered by the second har-

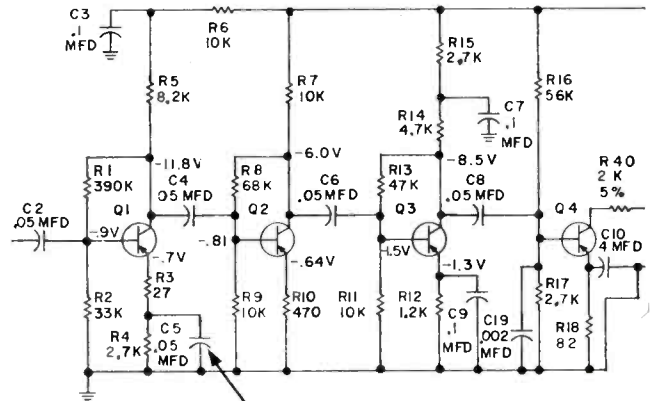

Change To .01

monic of the horizontal oscillator as this stage warms up during initial turn on of the receiver. In these cases the receiver sensitivity can be reduced, without materially effecting the normal operating range of the hand transmitter, by changing the emitter bypass capacitor in the 1st stage of the receiver from .05μf to .01μf.

## ADMIRAL

Battery Operated Phono YH1421—Turntable Speed Reduction During Cycle

Reduction in turntable speed during the change cycle when playing records automatically, either on battery or ac, especially at 33RPM, is a normal condition.

The 12vdc phono motor was designed to require a minimum of power to achieve maximum battery life. As a result, the motor speed will decrease to about 1/2 playing speed during the change cycle.

## CANADIAN GENERAL ELECTRIC

TV Chassis M657 Code "Z"—Substitution of CRTs and Schematic Corrections

In the plate circuit of the horizontal oscillator, V7B, resistor R257 should read 150k.

The schematic shows 180k and only 150k resistors have been used in production.

When removing and connecting sockets to the base of 12BMP4 and 16CFP4 CRTs, to minimize glass breakage, the tubes have been substituted by a 12CDP4 and 16CQP4.

Electrically, these two types are identical to their predecessor. Physically, a moulded base has been added to the 12CDP4 and 16CQP4. The socket used for connecting the 12BMP4 and the 16CFP4 will not fit the new tubes. This means that the two types are not interchangeable with the original types.

The tube department will continue to make the 12BMP4 and 16CFP4 available for replacement purposes.

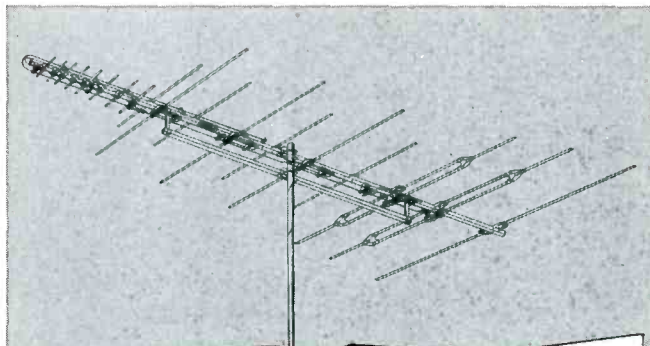

**3-Way Combination**  
**FREE SPACE STANDING WAVE**  
**MAGNETIC ANTENNA**

**ZEROS IN YOUR SIGNAL—**

**Discriminates Between**  
**Desired Signal and**  
**Unwanted Noise!**

Here is an antenna with the unique ability to discriminate between the desired signal and unwanted noise! A complete absence of minor lobes and an extremely high front to back ratio are characteristics of these antennas. This is made possible by the development of the Free Space Standing Wave Magnetic Drive Antenna system (F.S.M.). The outstanding electrical qualities, combined with the simplified mechanical construction of this system yields a total performance package unparalleled in today's market. 4 models, 60-inch to 180-inch boom, all modestly priced.

**UNEXCELLED!**

**UHF — VHF — FM — COLOR**

**INVESTIGATE NOW!**

**S&A Electronics Inc.**

Manufacturers of the TARGET ANTENNA

West Florence Street  
 Toledo, Ohio 43605

... for more details circle 134 on postcard

# This little part plays a big role in radio.

This box gives you top revues.



The transistor is no bit player when it comes to radio performance. That's why Delco transistors are manufactured under controlled conditions that assure extremely high reliability.

And why they're thoroughly tested before being placed in the familiar blue and black box.

Delco Radio engineers are leaders in auto radio design and transistor technology.

One reason why Delco radios are original equipment on over half of the cars on the road today.

That United Delco box is your guarantee of genuine OEM

quality replacement parts.

Doesn't it make good sense to stock the best for your customers?

Remember these facts when you re-order. And remember, too, that your United Delco supplier handles the most widely advertised, merchandised and recognized name in the parts business.

Next time you think little, think big. Think Delco.

DELCO RADIO, Div. of General Motors, Kokomo, Ind.



MARK OF EXCELLENCE



# Color them green



## Channel Master's Crossfire Antenna Series has

**...More dealers prefer Channel Master to any other brand (2 to 1 by survey of leading trade magazine).**

**...More have been sold (and are still being sold) than any other antenna in the history of television. And dealer acceptance is still growing.**

**...More dealers bought Crossfire antennas in January and February than in any previous first two month period.**

No wonder other antenna manufacturers try so hard to re-work their own designs along the famous Channel Master

Crossfire lines.

But it just can't be done.

Legally, the Crossfire series is protected by five U.S. patents or patents pending.

And, in terms of mechanical and electronic design, the Crossfire series maintains a standard that has never been equalled.

Take mechanical design, for instance. Crossfire antennas have weathered six tough winters, verifying structural superiority originally proven in wind tunnel tests at the University of Miami hurricane test labs. Channel Master dealers ...who have just recorded the biggest

first-two-months Crossfire sales in history...can tell you many of those antennas went up to replace less rugged makes that couldn't take the winter storms.

Most, of course, were teamed up with new set sales to meet the critical demands of color reception. Because, when it comes to electronics, Channel Master Crossfire Series antennas set the industry pace for clean, crisp color as well as outstanding black and white and FM Stereo.

In seven VHF models of Color Crossfires, electronic leadership takes the form of Proportional Energy Absorption



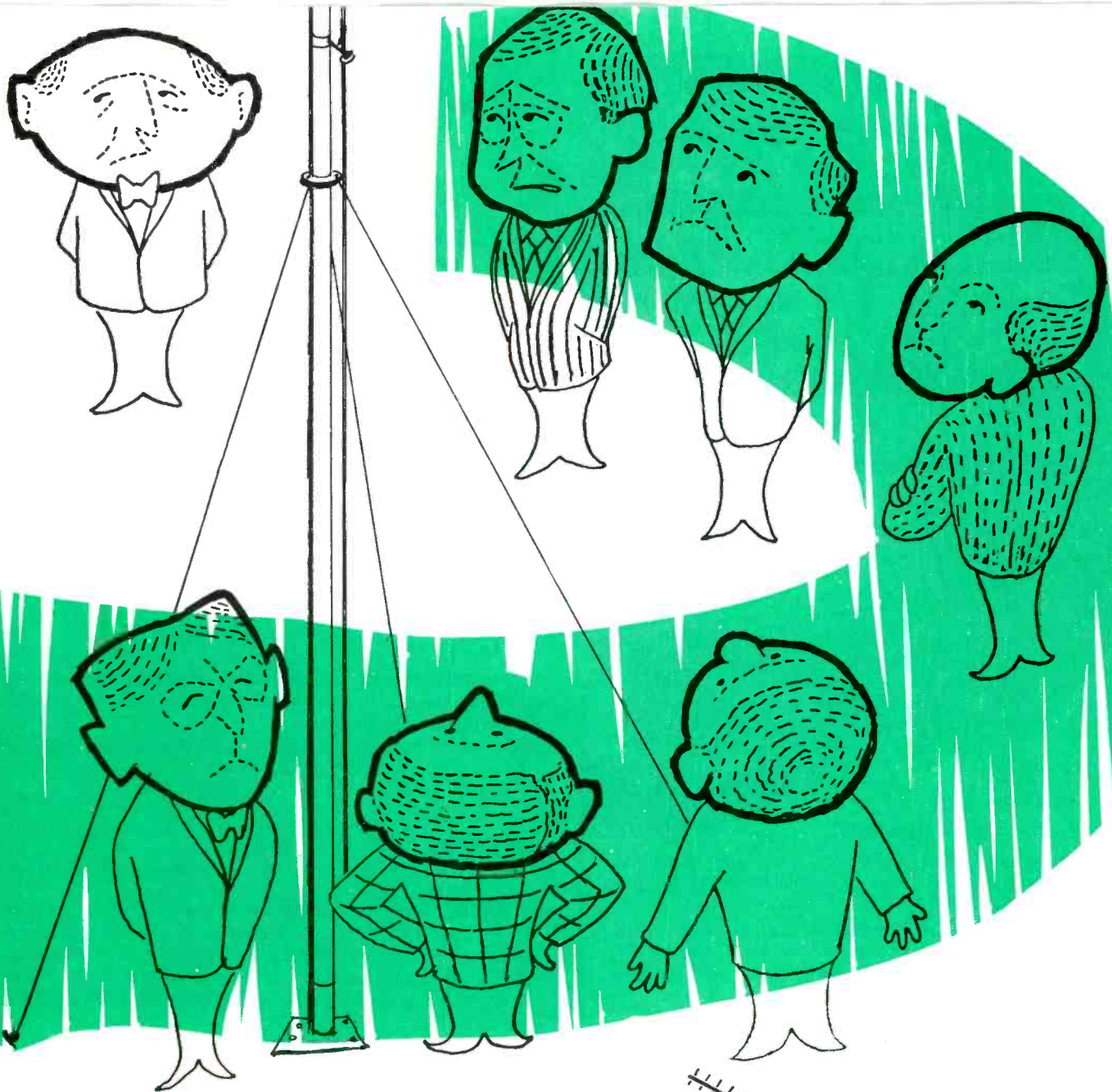

## our competition green with envy.

and gain-boosting Tri-Band Directors. Then there are the 82-channel Ultradyne Crossfires...6 of them...with the most advanced, self-coupling, UHF section ever developed, plus all the Color Crossfire features. Finally, the Coloray group provides television's first electronic ghost-killing service in an 82-channel model and two VHF/FM models. All are finished with Channel Master's famous golden E.P.C...the coating that has been adopted by the military

because of its weather protection.

Channel Master dealers know green is the color of envious competition. But they also know green is the color that lines their cash drawers when they meet the critical demands of Color head on with Channel Master Crossfire Antennas. Only Channel Master gives dealers full profit...then protects that profit from mail order and discounter inroads.

Color your cash drawer green. Call your Channel Master Distributor.

Ultradyne Crossfire  
Model 3634-G

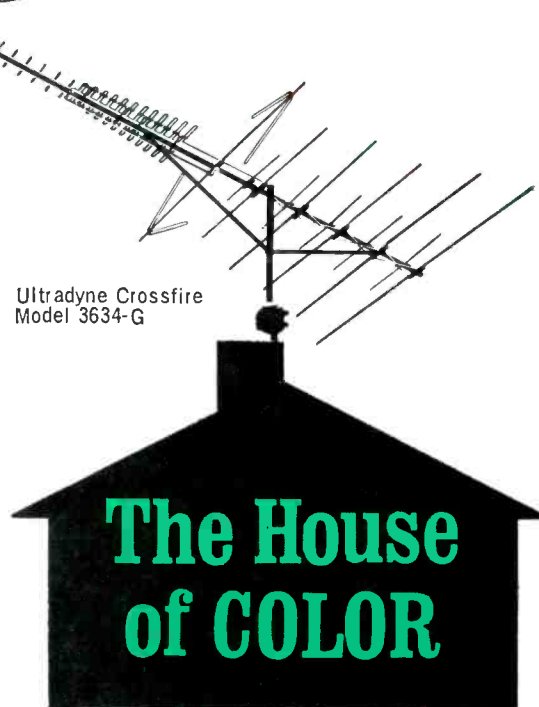

# CHANNEL MASTER®

ELLENVILLE, N.Y.

© 1967 Channel Master Corp.

... for more details circle 113 on postcard

# PEARCE-SIMPSON'S "DIRECTOR"

NOW COMES EQUIPPED

with "S" METER

and TONE CONTROL

at NO EXTRA COST



**DIRECTOR**  
23 Channel CB  
... For Mobile Operation

The *all solid state* DIRECTOR is the finest mobile rig in the industry. It takes less current to operate than your car's dashboard clock.

Features exclusive HetroSync® circuitry, and a dual conversion Superhet receiver. Utilizes a zener diode for stability. Special high-gain audio power amplifier for superior modulation.

**\$269.90** (Complete with crystals for 23 channels.)



**GUARDIAN 23 • 23 Channel CB • \$269.90**  
... The Standard of Base Station Quality!

- Dual conversion superhet receiver with low noise Nuvistor front end
- RF gain control, tone control and noise limiter switch
- Illuminated "S" meter
- Transistorized universal (AC/DC) power supply.

PEARCE-SIMPSON, INC. 4701 N. W. 77th Ave. Miami, Fla. 33166  
P. O. Box 800—Biscayne Annex, Miami, Florida 33152

Please send me FREE dealer kit and profit-making details on the complete Pearce-Simpson 1967 Marine Electronics Leadership Line.

ET-367



Name.....  
Company.....  
Address.....  
City..... State..... Zip.....



**PEARCE-SIMPSON, INC.**  
MIAMI, FLORIDA

... for more details circle 130 on postcard

## TECHNICAL DIGEST

### PHILCO-FORD

TV Chassis 17LT43, 17JT41, 17NT45—Vertical Lines on Left of Screen

If one or more vertical lines are noticed on left of center screen, this condition may be caused by parasitic oscillation in the horizontal output tube. If this condition is en-

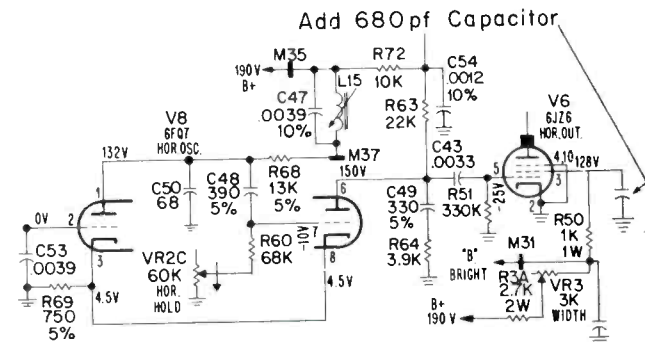

countered, the addition of a 680pf capacitor from screen grid pin 3 of the horizontal output tube (6JZ6) to ground will eliminate the oscillation.

Later production of the above chassis will incorporate the addition of the 680pf capacitor.

### OLYMPIC

Portable Phonograph Models MA100 and SA400—Insufficient Volume

When the tone control is turned counter-clockwise for minimum treble, the phonograph is unable to produce sufficient volume. To correct this difficulty, it is necessary to lift the entire assembly from the bottom of the case after removing four Phillips-head screws from the changer board.

On the Model MA100 phonograph only, connect a 470K ½w resistor across the tone control terminals on

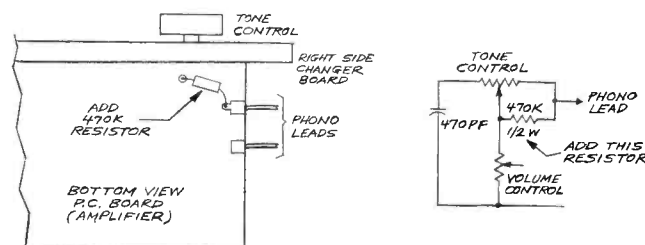

the bottom of the amplifier printed circuit board, as shown in the sketch.

On the Model SA400 phonograph, connect two 470K ½w resistors, one each from the center lug to the high side of the tone control in each of the stereo channels. The high side of the tone control is easily identified by a brown lead connecting it to the phonograph pickup.

Once the change has been made in the wiring, the changer board can be reassembled into the case and the phonograph can be tested.

**Use Your Zip Code**

# LOOK!

## A New Electronics Slide Rule with Instruction Course

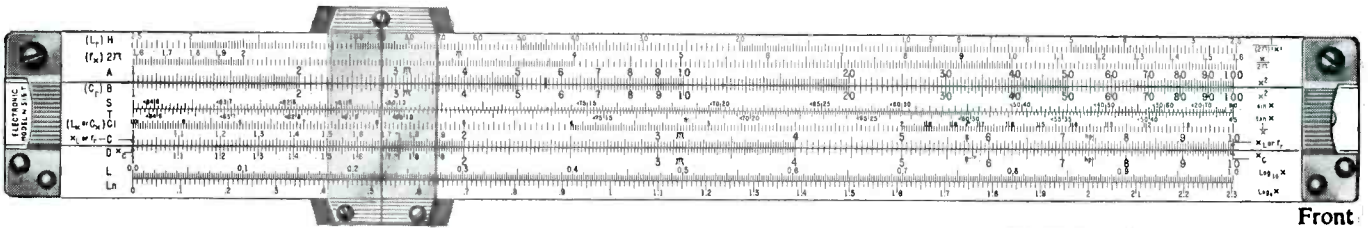

Front

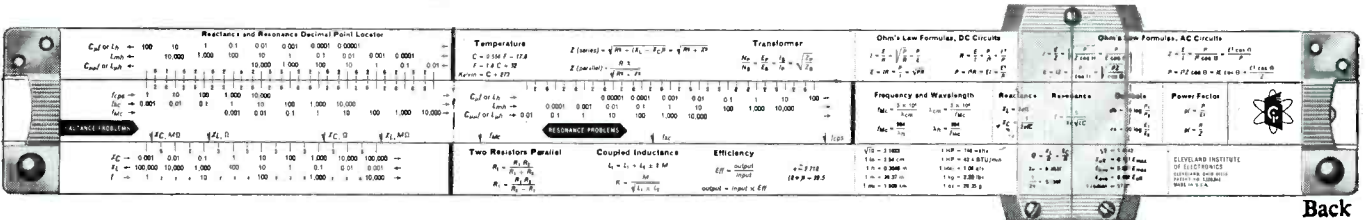

Back

This amazing new "computer in a case" will save you time the very first day. CIE's patented, all-metal 10" electronics slide rule was designed *specifically* for electronic engineers, technicians, students, radio-TV servicemen and hobbyists. It features special scales for solving reactance, resonance, inductance and AC-DC circuitry problems . . . an exclusive "fast-finder" decimal point locator . . . widely-used formulas and conversion factors for instant reference. And there's all the standard scales you need to do multiplication, division, square roots, logs, etc.

Best of all, the CIE Slide Rule comes complete with an Instruction Course of four **AUTO-PROGRAMMED\*** lessons. It includes hundreds of illustrations, diagrams and practice problems. You'll learn ingenious short cuts . . . whip through exacting electronics problems quickly and accurately. This course alone is worth far more than the price of the entire package!

Electronics Slide Rule, Instruction Course, *and* handsome, top-grain leather carrying case . . . a \$50 value for less than \$25. Send coupon for **FREE** illustrated booklet and **FREE** heavy vinyl Pocket Electronics Data Guide. Cleveland Institute of Electronics, 1776 E. 17th St., Dept. ET-116, Cleveland, Ohio 44114.

\*TRADEMARK

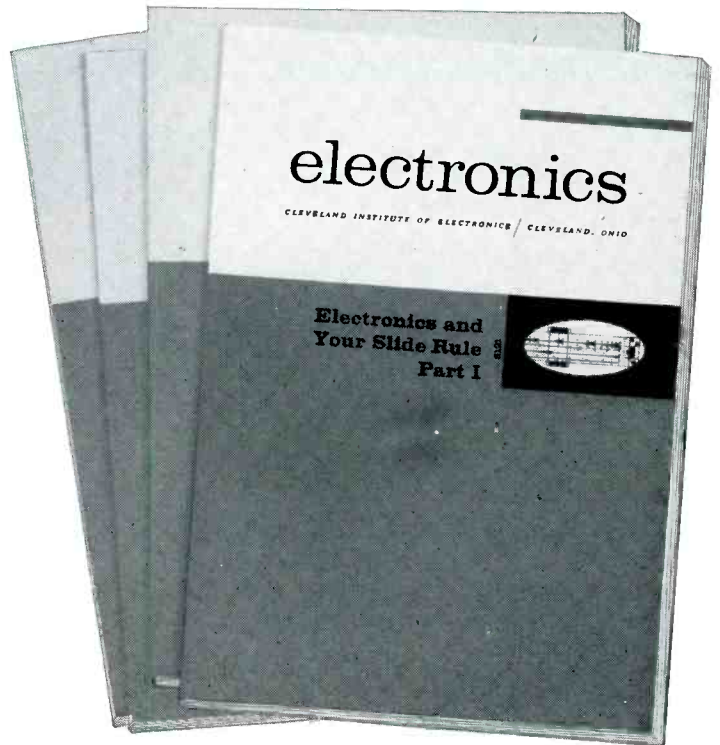

**GET BOTH FREE!**

**ELECTRONICS SLIDE RULE**

**Send coupon today →**



**Cleveland Institute of Electronics**

1776 E. 17th St., Dept. ET-116, Cleveland, Ohio 44114

Please send **FREE** Illustrated Booklet describing your Electronics Slide Rule and Instruction Course.

**SPECIAL BONUS!** Mail coupon promptly . . . get **FREE** Pocket Electronics Data Guide too!

Name \_\_\_\_\_ (PLEASE PRINT)

Address \_\_\_\_\_ County \_\_\_\_\_

City \_\_\_\_\_ State \_\_\_\_\_ Zip \_\_\_\_\_

A leader in Electronics Training . . . since 1934.

... for more details circle 114 on postcard

# From picture-on ... Locked-in Color Purity

*Perma-Chrome* a unique feature available only in RCA color TV picture tubes, provides temperature compensation which eliminates the beam register problem due to shadow mask expansion.

*No more set-up time lag... No more "guess-timated" yoke positions... within minutes you can set an optimum color picture on a rectangular Hi-Lite tube and be sure of customer satisfaction whether his set operates for half an hour or half a day!*



REGISTER WITHOUT PERMA-CHROME

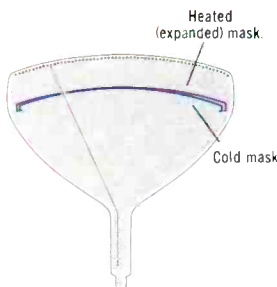

Brand "X" tube without *Perma-Chrome*. Exaggerated drawing of cross-section of rectangular Brand "X" tube shows the expansion of the shadow mask and the change in beam-landing register.

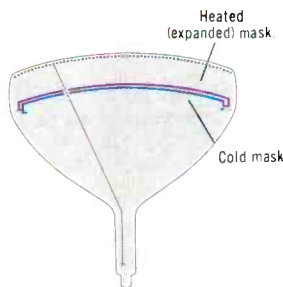

RCA Hi-Lite tube with *Perma-Chrome*. Exaggerated drawing shows locked-in register of beam with phosphor dot as shadow mask is heated. NOTE: Mask moves toward face of tube as it expands. Apertures in shadow mask move along paths of electron beam as mask expands or contracts with rise and fall of tube temperature.

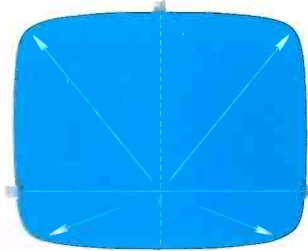

Non-uniform temperature expansion of the shadow mask is caused by the design limitations of 3-position non-symmetrical mounting in Brand "X" rectangular picture tubes. Shadow mask expansion thereby develops from a point other than the geometric center of the mask.

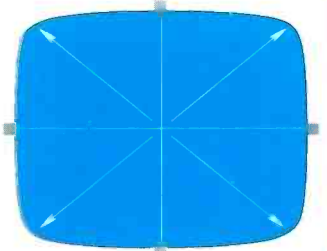

RCA's 4-position mounting makes possible the successful achievement of a temperature-compensated shadow mask assembly. RCA Hi-Lite rectangular tubes with PERMA-CHROME, lock the apertures of the mask "on target" with their respective phosphor-dot trios.



REGISTER WITH PERMA-CHROME

*Perma-Chrome* lets you quickly, positively, and accurately adjust Hi-Lite rectangular color TV picture tubes to the full potential of their rare-earth phosphor screen...from picture-on throughout normal operation at temperature equilibrium. Easier for you... much more satisfactory for your customer. Tube set-up errors due to shadow mask expansion are a thing of the past...and your customer gets the full benefits from the set's "auto-degauss" feature. You owe it to yourself to check with your authorized RCA Distributor about the full advantages of this exclusive innovation from the acknowledged leader in color television. Call him today and ask about *Perma-Chrome*...available in 19-inch and 25-inch tube types!

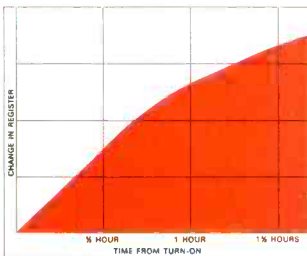

Change in register of electron beam and phosphor dot versus time for rectangular Brand "X" tube using three-position shadow-mask mounting.

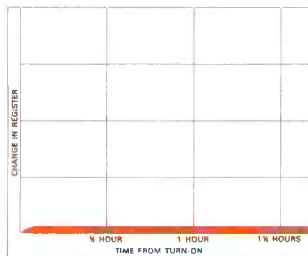

Change in register of electron beam and phosphor dot versus time for RCA Hi-Lite rectangular color picture tube with PERMA-CHROME.

RCA Electronic Components & Devices,  
Harrison, N.J.



The Most Trusted Name in Electronics

## Nowhere Else Can You Get All Of These Features For Less Than \$875



The New Heath IO-14... a 5" DC to 8 MHz Scope with continuous duty ratings, triggered sweep, 0.25 u sec coaxial vertical input and time base... factory assembled & tested for \$399.00... kit only \$299.00

The Heath IO-14 Features The Engineering And Quality Components You Expect Only In Higher Priced Oscilloscopes. For example, switches are ball-detent type; all major control potentiometers are precision high-quality sealed components; all critical resistors are 1% precision; and vertical signal delay is provided through high-linearity coaxial delay lines. Here is the ultra-stable, low-noise performance demanded from a truly professional industrial, academic, electronic engineering laboratory oscilloscope. Check the prices and specifications yourself, and you'll agree the Heath IO-14 gives a new meaning to 'scope value.

**Kit IO-14** (with standard P-2 phosphor), 53 lbs..... \$299.00  
**Assembled IO-14** (P-2 phosphor), 47 lbs..... \$399.00  
**Assembled IO-14S** (with long persistence P-7 phosphor for bio-medical or industrial use), 47 lbs..... \$410.00  
**Kit PK-1**, Low-Capacitance Probe, 1 lb..... \$4.95

**IO-14 SPECIFICATIONS** — (Vertical) Sensitivity: 0.05 v/cm AC or DC. Frequency response: DC to 5 MHz, —1 db or less; DC to 8 MHz, —3 db or less. Rise time: 40 nsec (0.04 microseconds) or less. Input impedance: 1 megohm shunted by 15 uuf. Signal delay: 0.25 microsecond. Attenuator: 9-position, compensated, calibrated in 1, 2, 5 sequence from 0.05 v/cm. Accuracy: ±3% on each step with continuously variable control (uncalibrated) between each step. Maximum input voltage: 600 volts peak-to-peak; 120 volts provides full 6 cm pattern in least sensitive position. (Horizontal) Time base: Triggered with 18 calibrated rates in 1, 2, 5 sequence from 0.5 sec/cm to 1 microsecond/cm with ±3% accuracy or continuously variable control position (uncalibrated). Sweep magnifier: X5, so that fastest sweep rate becomes 0.2 microseconds/cm with magnifier on. (Overall time base accuracy ±5% when magnifier is on.) Triggering capability: Internal, external, or line signals may be switch selected. Switch selection of + or — slope. Variable control on slope level. Either AC or DC coupling. "Auto" position. Triggering requirements: Internal; ½ cm to 6 cm display. External: 0.5 volts to 120 volts peak-to-peak. Horizontal input: 1.0 v/cm sensitivity (uncalibrated) continuous gain control. Bandwidth: DC to 200 kHz ±3 db. General: 5ADP81 or 5ADP2 Flat Face C.R.T., interchangeable with any 5AD or 5AB series tube for different phosphor characteristics. 4250 V. accelerating potential. 6 x 10 cm edge lighted graticule with 1 cm major divisions & 2 mm minor divisions. Power supply: All voltages electronically regulated over range of 105-125 VAC or 210-250 VAC 50/60 cycle input. (Z Axis) Input provided. DC coupled CRT unblanking for complete retrace suppression. Power requirements: 285 watts, 115 or 230 VAC 50-60 Hz. Cabinet dimensions: 15" H x 10½" W x 22" D includes clearance for handle and knobs. Net weight: 40 lbs.



**FREE 1967 Heathkit Catalog**  
Use this coupon for your free copy.

**Heath Company, Dept. 24-3**  
Benton Harbor, Michigan 49022

Please send FREE Heathkit Catalog & Information describing the New Heathkit IO-14 Oscilloscope

Enclosed is \$\_\_\_\_\_, plus shipping. Please send model \_\_\_\_\_

Name \_\_\_\_\_

Address \_\_\_\_\_

City \_\_\_\_\_ State \_\_\_\_\_ Zip \_\_\_\_\_

Prices & specifications subject to change without notice.

TE-155

... for more details circle 121 on postcard



A 6ft console controls audio for the 800-seat Circus Maximus supper club in Las Vegas.

## Giant Audio System Installed

■ One of the nation's most advanced audio reinforcement systems has been installed behind the scenes at the new 800-seat Caesars Palace in Las Vegas, by Studio Electronics Corp. for a cost exceeding \$100,000.

The major element of the new system is a 6ft console that controls all the audio from the 65ft wide Circus Maximus stage. Up to 30 microphones can be connected to the console (up to 18 of which can be "live" at any one time), plus six magnetic-tape tracks and six tape-cartridge units.

Color-coded switches and level controls on the console allow all the various inputs to be blended into three "point source" outputs that go to three loudspeaker clusters above left, right and center stage. Two switches on the console can be depressed to convert the three outputs into a single output to all three clusters.

Each input can be individually equalized at low and high frequencies and each of the three outputs is provided with its own echo chamber (constructed in the hotel sub-basement) and echo-volume controls. Selected inputs, (such as special effects from tape cartridges) may be directed to "surround" speakers mounted around the room. Controls on the console allow thunder, for example, to roll across the audience or for a gunshot to sound at the rear of the auditorium an instant before an actor falls on the stage.

A special feature of the console is the capability of controlling and presetting the position of five drop microphones and three pop-up microphones with markings on the controls to determine the final height of each microphone. The operator sets the control to the desired setting and at the proper time in the program depresses the switch that raises or lowers the unit.

The Caesars Palace installation also includes three wireless microphone systems. A permanent antennae system above the stage picks up the transmitted signal and directs it by coaxial cable to the console. ■

... for more details circle 142 on postcard →

Winegard introduces  
the world's first  
**TOTAL DESIGN ANTENNAS**  
Total Electronic Design!  
Total Construction Design!  
Total Performance!

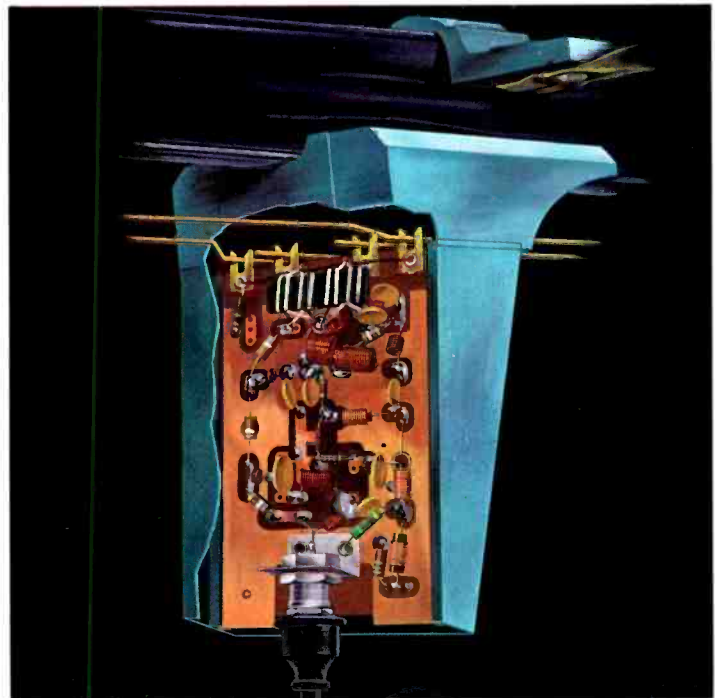
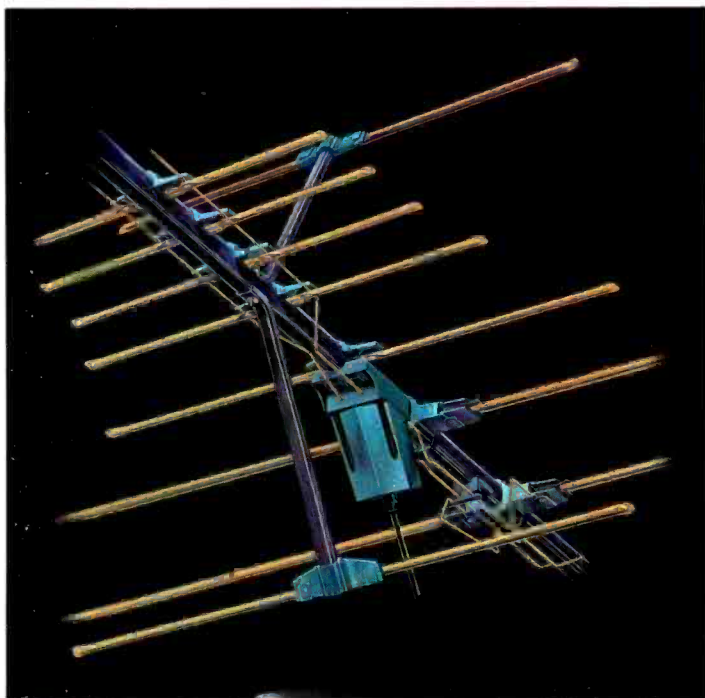
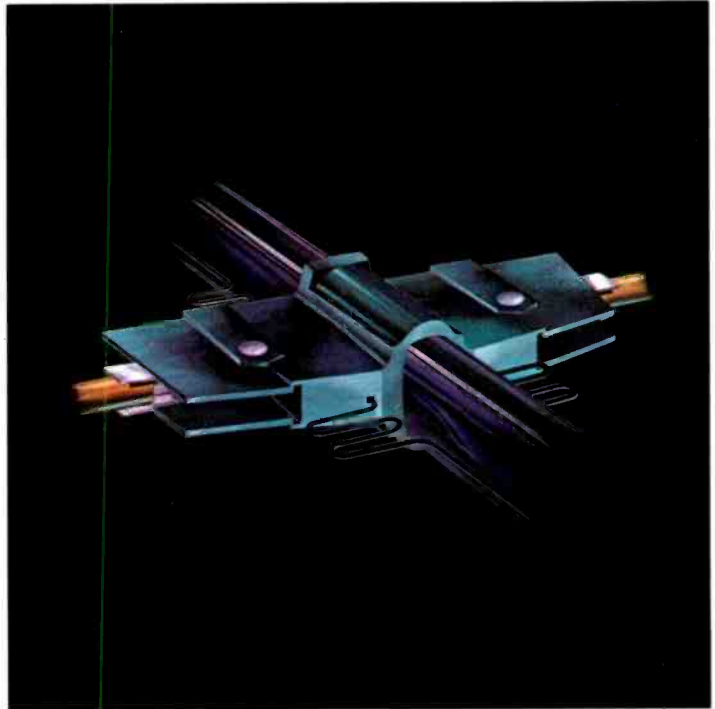
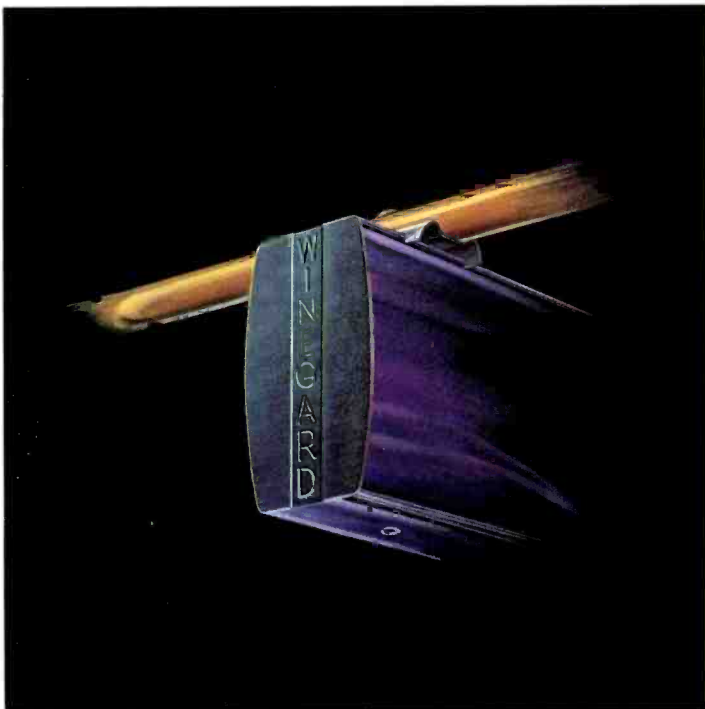

# Winegard Introduces Super Compact Total Design Electronic SUPER COLORTRONS

Five 82-Channel Models  
Four VHF/FM Models  
Three UHF Models

...so revolutionary in design and concept,  
they have 7 patents and patents pending

82-Channel Super Colortron  
Model SC-82; \$54.95

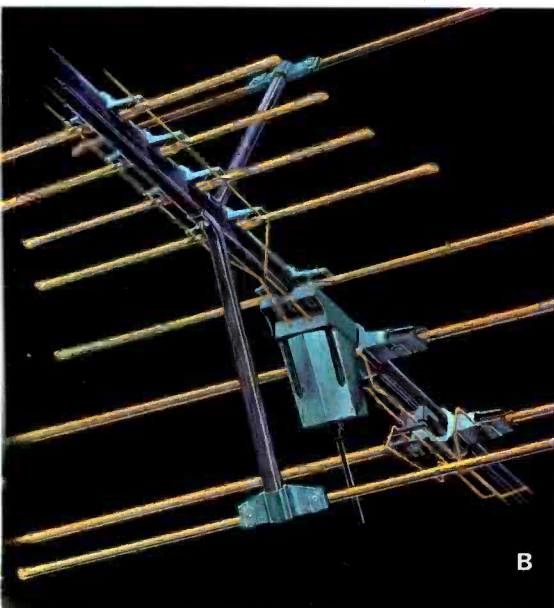
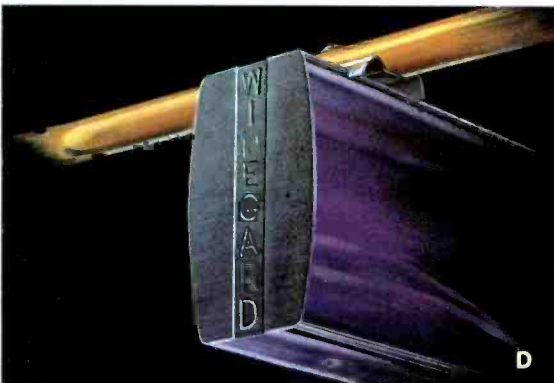

## The World's First Total Design Antennas

New antennas come and go. But there's never been an antenna like the amazing Winegard Super Colortron. 12 models in all—totally designed with more exclusive electronic, construction and performance features than all other antennas combined. It's taken us a while to create and develop and perfect the Super Colortron. But it was worth the time. See for yourself. Read about the Super Colortron's exclusive features. Then call your Winegard distributor. Or write for full color, 8-page brochure.

### (A) Total Design

#### Cartridge Pre-Amps:

Exclusive solid state, instant-loading cartridge pre-amps drop into totally enclosed, weatherproof cartridge housing at point of signal interception. Models for 82-channel (VHF-UHF) antennas, VHF only, UHF only—plus a color spectrum filter. Custom-match the Super Colortron to any reception requirements.

#### Total Design

#### Impedance Correlators:

Exclusive impedance correlators (2 patents pending) automatically increase 75 ohm driven elements to 300 ohms to provide 100% signal transfer from antenna to set. Enables antenna to be 20% more compact!

### (B) Total Design

#### Vertical Resonant Reflectors:

Exclusive UHF vertical resonant reflectors achieve highest realizable gain on channels 14-83 because of exceptionally large vertical capture area. More UHF gain than any other 82-channel antenna design.

#### Total Design

#### Electro-Lens Director System:

Exclusive patented Electro-Lens system (U.S. Patent 2,700,105; Canada 511,984) absorbs entire signal and focuses it directly onto the driven elements to give Super Colortrons pinpoint directivity.



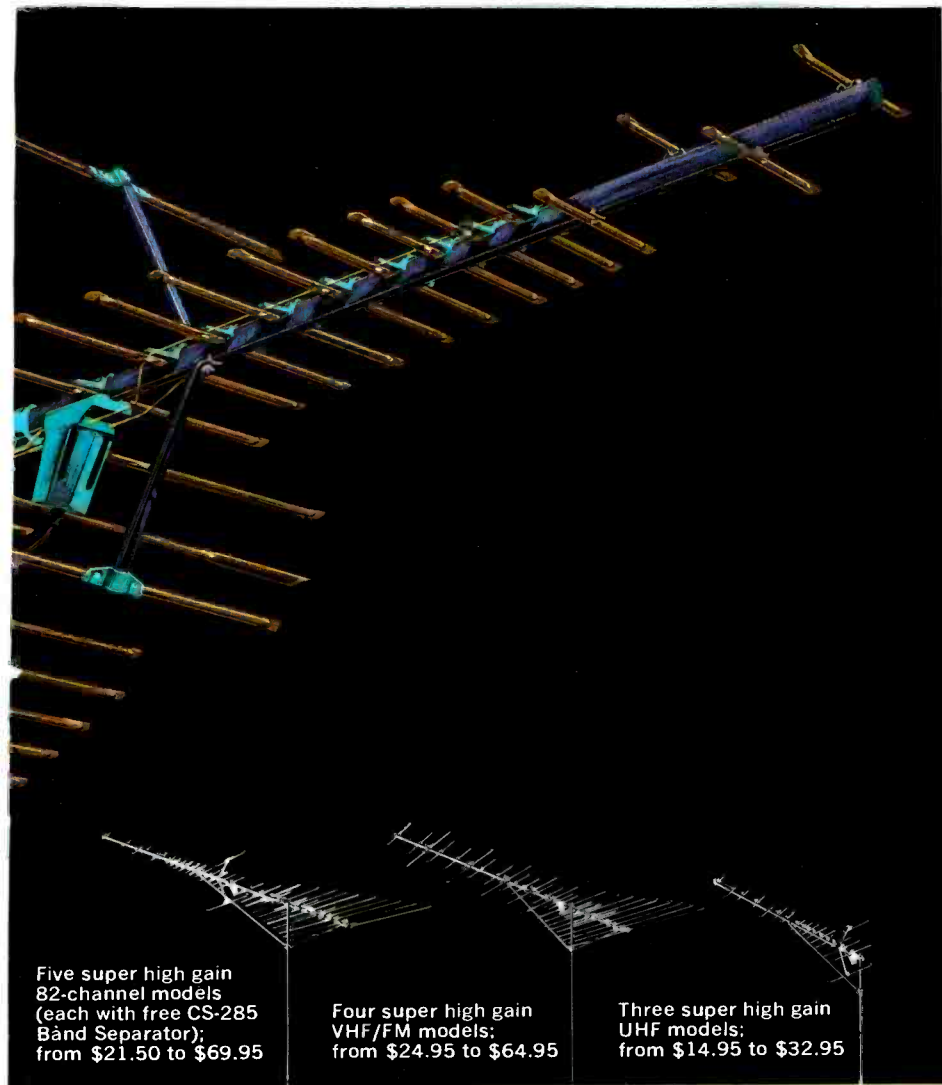

Five super high gain  
82-channel models  
(each with free CS-285  
Band Separator);  
from \$21.50 to \$69.95

Four super high gain  
VHF/FM models;  
from \$24.95 to \$64.95

Three super high gain  
UHF models;  
from \$14.95 to \$32.95

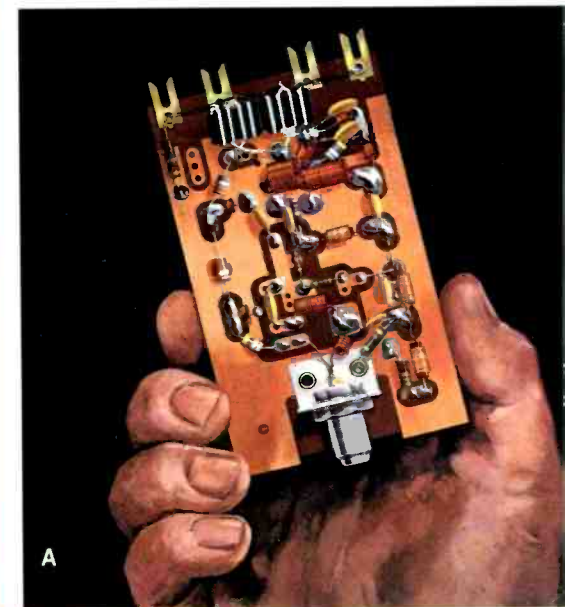
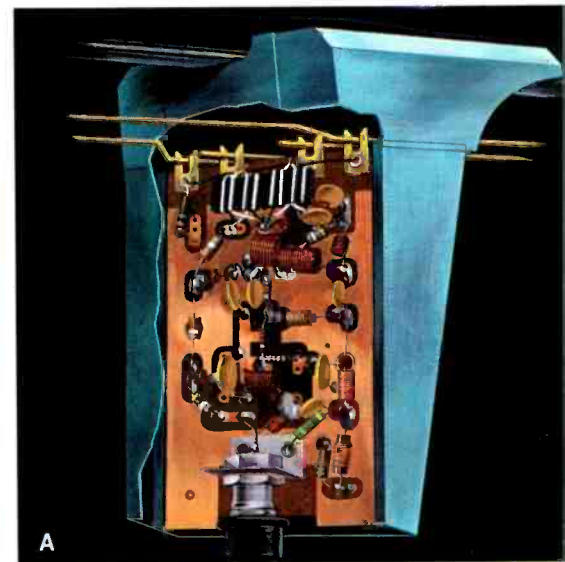
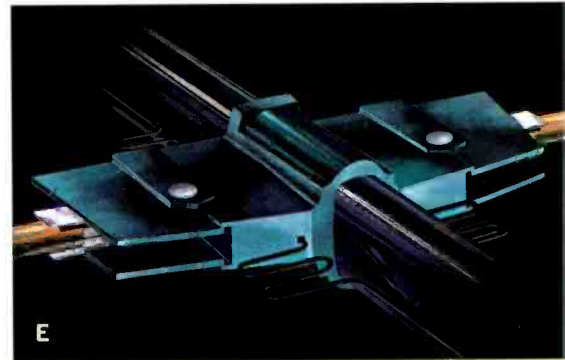
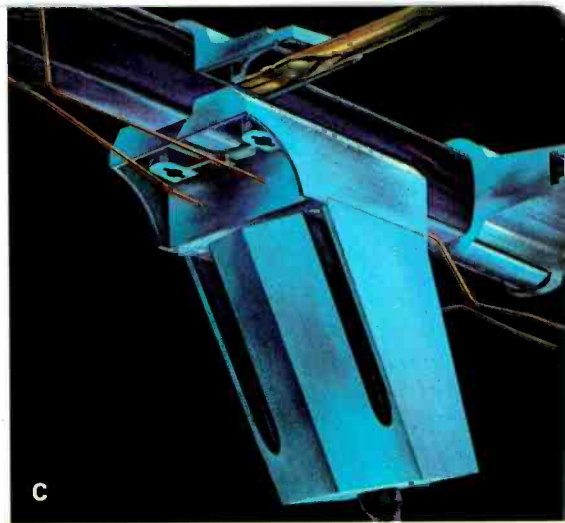

**Total Design FM Control Element:**

Exclusive FM element provides high gain on FM bands—and enables you to attenuate FM bands in areas where strong FM signals interfere with TV reception.

**(C) Total Design Cartridge Housing:**

Exclusive housing is an integral part of Super Colortron—built-in and permanent. Completely weatherproofed to protect solid state cartridge pre-amps and connections.

**(D) Total Design Ellipsoidal Boom:**

Exclusive boom is the first aluminum tubing shape engineered especially for antenna use. Proved far stronger than any other existing boom design.

**(E) Total Design Wrap-Around Insulators:**

Exclusive low loss dielectric insulators completely encapsulate and weatherproof elements and correlators at point of electrical contact. Hi-impact polystyrene. Provide perfect alignment of elements and eliminate sagging and loosening.

**Total Design High Tensile Aluminum Elements:**

Exclusive aluminum alloy has PSI rating of 38,000 as compared to 27,000 PSI for alloys used in other antennas. More than 49% stronger—and 29% more resistant to bend and wind distortion.

**Total Design Wrap-Around Mast Clamp:**

Exclusive mast clamp has 4 pair of locking jaws (not just 2) to automatically align antenna on mast and for greater strength and durability. Requires only one U bolt.

**Total Design Gold Anodizing:** Exclusive Gold Anodizing is the only permanent gold finish used on any antenna—the only positive protection against corrosion and fading.

**Total Design Assembly:** Exclusive construction makes the Super Colortron truly easy-to-install—unfolds in seconds—completely factory pre-assembled.



**Winegard**  
ANTENNA SYSTEMS

WINEGARD COMPANY, 3000 KIRKWOOD STREET, BURLINGTON, IOWA 52601

# Be a Bright Guy. Get your name into TV Guide up to 4 times this year.

Your Sylvania Distributor will put your name, your town and your phone number in TV Guide for your area as many as four times this year. And to make the most of it, we'll tie you into our big in-store display program. If you're a bright TV serviceman, you carry the most advanced replacement parts: Sylvania's famous *color bright 85*<sup>®</sup> color picture tube and receiving tubes.

Because you're an Independent, we're telling TV Guide readers you're in the best position to make an honest, unbiased recommendation on color set repairs. We list your name right on the facing page.

That's what our double-page, full-color ads in TV Guide, and the display program, are all about. Business for you. If you like the bright idea, see your Sylvania distributor and ask him to include you in.

Sylvania Electronic Tube Division, Electronic Components Group, Seneca Falls, New York 13148.

**SYLVANIA**  
SUBSIDIARY OF  
GENERAL TELEPHONE & ELECTRONICS **GTE**



# A 'THINKING TECHNICIAN'S' APPROACH TO CHROMA CIRCUIT PROBLEMS

Raise your color 'intelligence quotient' and repair those sets faster



Fig. 1—Color phase problem. Note the faces are blue. Correct facial tint could not be obtained.

## ■ The pressure is on!

There's a shortage of experienced color-TV technicians.

Color set sales doubled during the past year and all available working technicians are being called upon to service more sets in less time.

And you can speed the servicing process, eliminate much wasted time and "floundering around," if you learn how to match wits with modern color TV circuits—develop a "thinking technician's" approach to color circuit problems.

New advances in color CRT technology have made it more difficult to use the CRT screen as a trouble-symptom analyzer. Not much evidence appears on the screen, for instance, when one of the color guns is incorrectly adjusted or precise purity has not been obtained. The B/W picture usually

looks good and we cannot always use the screen symptoms as a "tip off" regarding improper performance of the color CRT and associated circuits. Some problems, of course, do show up on the screen.

But let's look at some everyday cases that require logical approaches.

### Reversed Color

You may bump into this color phase problem sometimes. But make a quick visual check before it grows into a large time-consuming "dog." Suspect this trouble on new color sets or on sets that may have been tampered with. This case was a new set just unpacked. On its first color program, the faces were blue (see Fig. 1) and with the color bar pattern on the CRT screen, they appeared as shown in Fig. 2. The B/W picture was normal. After checking further and observing more carefully, the red and blue colors seemed reversed. Now what could cause that?

Many color sets today have the CRT cathode and control grid leads plugged into pin-receptacles on the chassis—and you guessed it: the blue and red control grid leads to the CRT were reversed. After changing these plugs around (most sets have them marked, or color coded) and touching up gray-scale tracking, the color bar pattern appeared normal again (see Fig. 3). Once again, don't let little things waste your time.

### Dig Those Crazy Patterns

The isolation resistor located under the HV rectifier socket in some color chassis can really be a trouble maker—if you allow them to. When the HV rectifier shorts, like a 3ATZ, for example, this resistor will sometimes overheat and deteriorate. When this happens, all kinds of oscillations and RF radiations may occur. A visual inspection of this resistor may not tell the story because it frequently burns internally.

This defective resistor has been known to create all kinds of vertical, horizontal and diagonal lines, plus elaborate "rainbow" effects. It can occasionally cause loss of color and RF interference is not always evident on the screen.

One set like this came into the shop for repair and it "broadcast" RF radiation so strong that a similar pattern was picked up by all the other sets in the shop which were "cooking" on the test bench. This set would no doubt have been frowned on by the FCC.

The permanent cure for this defect is to eliminate the resistor completely.

We have modified over 200 color sets having this problem and have observed no side effects. If the HV rectifier shorts, no damage will result and only the tube will have to be replaced. One trouble this resistor can cause is shown in Fig. 4. The same trouble as it appears on a blank screen is shown in Fig. 5.

### When They Won't Track

If you encounter gray-scale tracking problems in the new 90deg color CRTs and the color does not appear normal, check the CRT emission. Make sure the emission is the same for each of the three guns. This is a must if you expect to obtain proper B/W and color

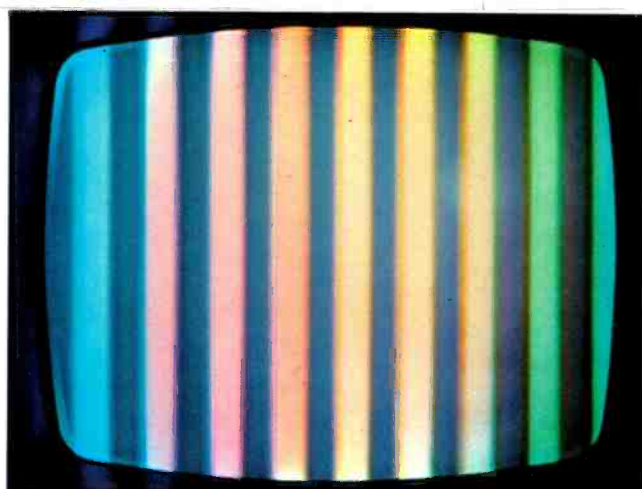

Fig. 2—The red and blue bars were reversed on the color bar/dot generator pattern.

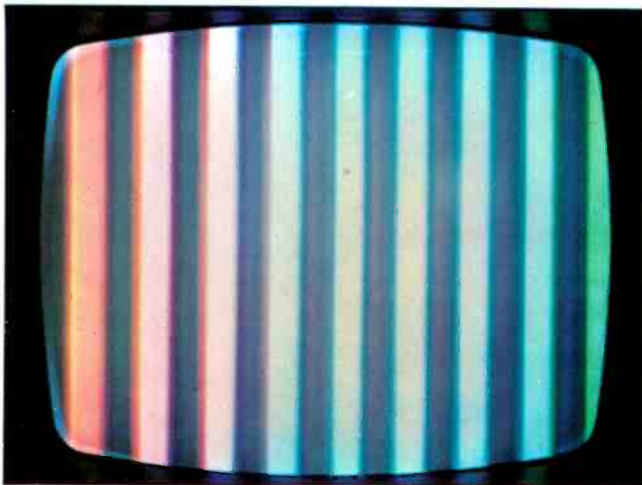

Fig. 3—Normal color bar pattern after control grid wires are in proper place.

redundancy. It would seem logical to invest in a top-quality color CRT tester designed for this purpose.

Shifting and movement of 90deg deflection yokes used on rectangular color tubes also seems to be quite common. This can cause improper purity.

The yoke should be adjusted for proper purity after the set has warmed up for 30 minutes or more. Heat seems to cause the yoke's shape to change slightly. Tighten the yoke band snug. If the yoke still seems to shift, try cementing a strip of sandpaper inside the yoke mounting ring and this should secure the yoke.

### A 'Who Did It'

A house call was made on a new 19in. color receiver. The B/W picture was excellent—but the color picture appeared to be missing the red component. After a fast visual check, we decided that trouble existed in the R-Y demodulator or the CRT had a weak red gun. The set's back was removed. Then we hesitated.

On *second thought*—logical thought based primarily on past experiences—we decided to perform a complete gray-scale tracking job and purity adjustment. During this process, the red screen control was found turned down slightly. When the gray-scale tracking was set correctly and the CRT was degaussed, good color was obtained.

At this point the owner came in and commented on the good color picture. He also mentioned something



Fig. 4—Burned or carbonized HV isolation resistor can cause out-of-focus picture and lines on screen.

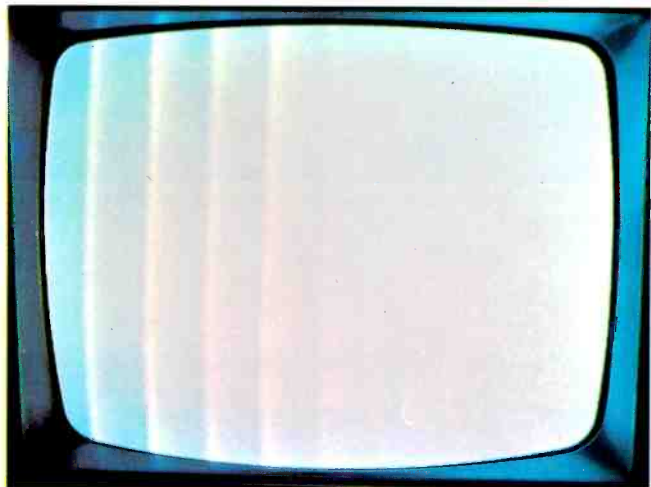

Fig. 5—Same problem as shown in Fig. 4 but as viewed on a blank screen.

about "trying to adjust those little red and green controls on the back of the set for a better color picture."

The moral is, don't jump to conclusions and take the set apart. Use your head. Put first checks first and follow through in logical order.

#### Then We Saw Too Much Red

While checking a Zenith 25in. color set which had 6JH8 tubes as color demodulators, the CRT screen indicated too much red and adjustment of the red screen control had no effect. Substituting 6JH8 tubes did not help. The CRT was checked and it was OK.

The chassis of this set was pulled and taken to the shop for further checks. All voltages in the demodulator and CRT circuits checked OK except on tube terminal 8—the R-Y demodulator plate. This should have been 185v but it metered out at 310v—indicating the tube was not conducting. All resistors, solder joints and connections were checked but nothing unusual turned up.

Before the set left the owner's home, we had noted that the heater of the R-Y 6JH8 tube was lit and the tube was hot to the touch. A closer look confirmed this. But we hesitated and said, *so what?*

The R-Y demod tube was removed and a test socket inserted in its place and the tube was inserted in the test socket. It lit up "brightly" but a VOM check showed only 3v across the heater terminals. Further investigation showed that the ground connection of socket ter-

minal 4 had a cold solder joint. When the joint was resoldered solidly to ground, the set operated normal. Don't use your eyes and fingers to measure voltages.

#### Intermittent Color

When a color TV has complete color, fades for a few minutes and then is normal for 5 or 10 minutes, it can create a tough service problem if you don't use your head. This condition may occur 8 or 10 times during an evening of viewing and then correct itself for the next two or three days.

On this set, the 3.58MHz subcarrier oscillator is checked first and adjusted for zero beat. Then the color killer must be properly set. But after routine checking, substituting tubes involved, checking for defective solder joints and short circuits and the trouble still persists, what's the next move?

Well, let's think for a moment. Most later model color sets are designed so that the color killer goes into action and disables the chroma amplifier section whenever the 3.58MHz oscillator goes off frequency. Because of this, you do not know whether you have a loss of color burst, color subcarrier oscillator drift or a malfunction of the bandpass color amplifier section. Now we're up a creek, but good. But wait! Let's use a little more logical thought, and locate the trouble.

We'll turn the color killer control up or disable the color killer. In sets so equipped, we'll also disable the automatic chroma control section (ACC).

Using a color bar/dot generator or a color telecast, we can now see if the 3.58MHz oscillator is operating and if it is on frequency. If the colors run through the picture, then we'll check the sync and AFC phase detector for good color lock. If the color can be locked in, then we'll air-test the set for an hour or two and watch for the possibility of oscillator drift.

If you get no color when the color killer is disabled, use a scope or VTVM and check for 3.58MHz oscillation. If the oscillator checks OK, then the defect is in the color amplifier or the demodulator section. You will frequently find that a 3.58MHz crystal can cause erratic and intermittent color.

#### Watch That Burst

Here's a rare problem that may crop up occasionally and it depends on the TV station transmitting color. The set does not appear to have enough color gain even with the color control set at maximum. But when the set is switched to a different channel, the color comes in good and strong. This occurs in color sets that have automatic color control or level provisions. If the color burst is too high, from the telecasting station, the ACC section will bias off the bandpass amplifier stage and very weak color will result. It would be advisable to check the burst level with a scope to confirm if this is too high. Check with the set manufacturer's service data and a modification can usually be made to eliminate this problem. But you may also contact the chief engineer of the TV station.

The "old pro" hopes these few tips will help elevate your color IQ and that the color you see in most abundance is "cabbage green." ■

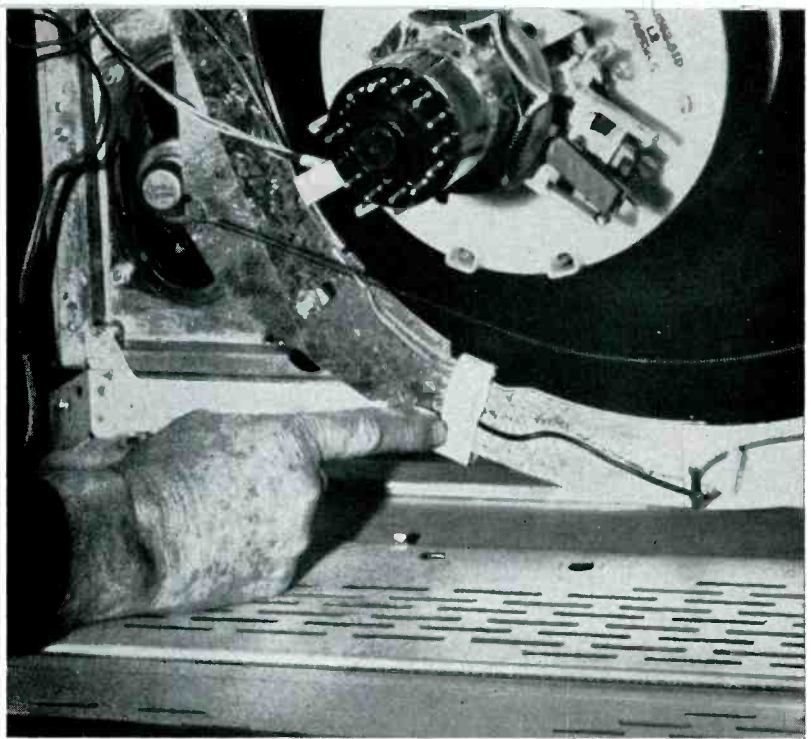

Fig. 2—Degaussing coils in RCA color receiver are mounted top and bottom on a metal frame that serves as a transformer.

# Troubleshooting

'Simon simple' —  
but you can't  
fix them unless  
you know how  
they work

■ The voltage dependent resistor (VDR) and thermistor automatic degaussing circuit is being used in the latest color receivers. In 1964/'65 color sets, there were several ADG circuits used to degauss the front screen of color CRTs. Several circuits employed a spring-loaded switch, thermal switch and even a "rolling-magnet" system. The thermal switch is still used, but most

manufacturers are now employing the VDR/thermistor system.

ADG circuits were designed to remove impurities that appear on the color screen. These various colors, or combinations of colors, appear in both the B/W and color picture. This is caused by magnetization of the metal shadowmask at the front of the CRT. Thus, ADG was designed to provide good purity from a color CRT at all times.

Before ADG circuits were designed, service technicians had to degauss color CRTs with a regular degaussing coil after the receiver had been moved, before adjusting convergence and on many service calls.

Color CRTs can be magnetized by the earth's magnetic field or by electrical or electronic equipment used in the home. An electric clock or radio placed on top of a color receiver cabinet, for example, often created a degaussing job. When various other types of equipment, including vacuum cleaners, are operated near the color set, they may cause the screen to become magne-

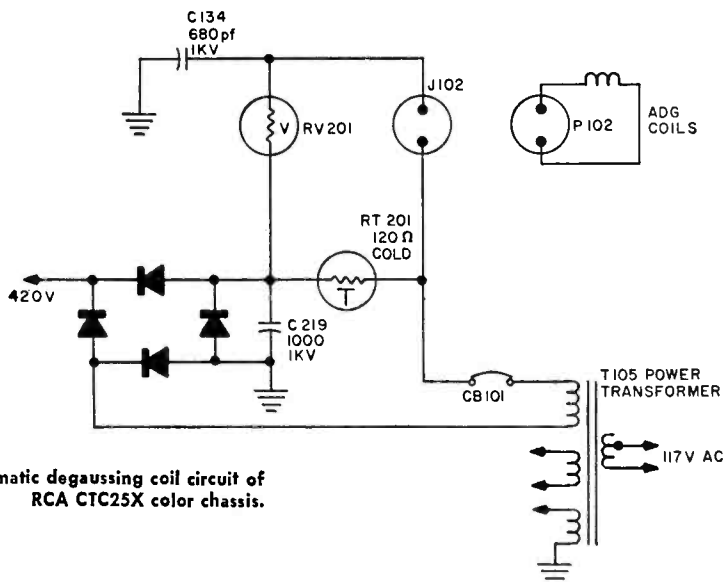

Fig. 1—Automatic degaussing coil circuit of RCA CTC25X color chassis.

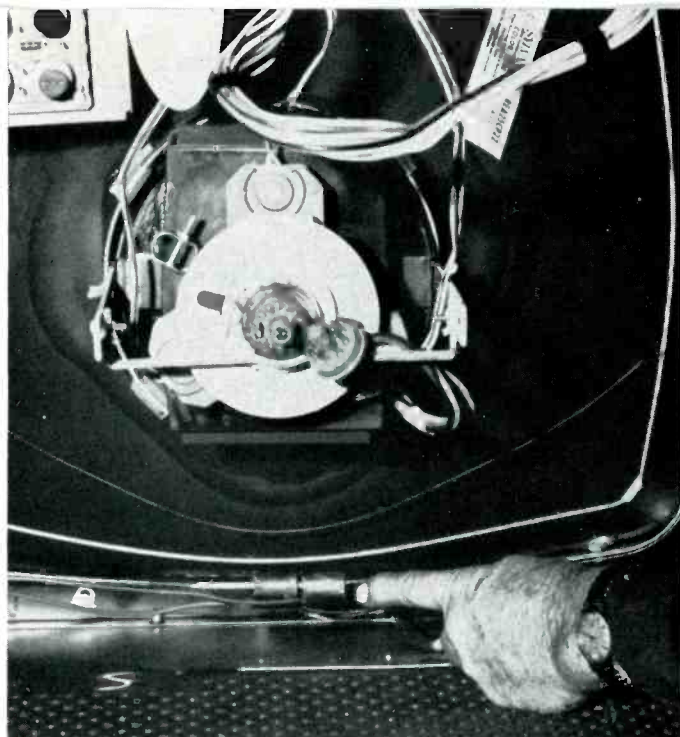

Fig. 3—A technician points to two degaussing coils located at the bottom of a CRT in a Sylvania color receiver. Two coils are also mounted on the metal flange at the top of the CRT.

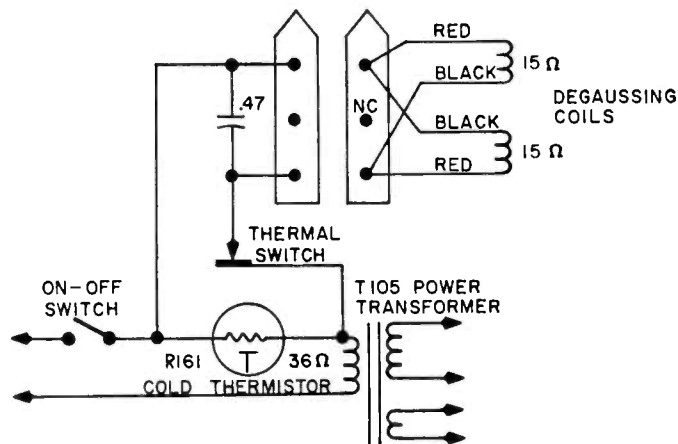

Fig. 4—Automatic degaussing coil circuit in Admiral D11 chassis.

# Color ADG Circuits

tized. If "Mrs. Jones" wanted to move the color set from the living room to the den, a service technician had to be called to degauss the CRT. Even shifting the set from one corner of a room to another frequently caused a degaussing job. Hence, the advantages of ADG not only allow the set to be moved around, but it keeps the CRT magnetically "clean" at all times. It also eliminates the necessity for many callbacks and nuisance trips.

Although ADG circuits are used in all new color receivers today, wise TV technicians still carry a degaussing coil on service calls. It is always best to degauss the color CRT before a new receiver is delivered or after working on it. This is especially true after installing a new color CRT which shows impurities at the corners and sides.

## VDR/Thermistor Systems

When a color receiver is first switched on, the ADG circuit automatically begins to degauss the CRT—before the picture appears on the screen. A sudden current

passes through the degaussing coils, is shut off and then passes into the secondary circuit of the power transformer (see Fig. 1). Let's briefly observe how this takes place.

A thermistor, when cold, offers high resistance to the sudden current surge—allowing the degaussing coils to become operative. This current sets up a magnetic field around the coils—providing a demagnetizing circuit. When the thermistor begins to warm up, its resistance begins to decrease—allowing current to flow through the thermistor to the low voltage silicon rectifiers.

Likewise, the VDR's resistance is extremely low when no voltage is applied to it. When the color receiver ON/OFF switch is first closed, current in the secondary of the power transformer is routed through the degaussing coils and the VDR. As the thermistor heats, closing off the current through the coils to the VDR, the VDR's resistance increases. With the VDR's resistance increasing and the thermistor's resistance decreasing, all ac current is routed through the power supply

and the degaussing action is completed.

Each time the ON/OFF switch is placed in the ON position, the circuit is degaussing the color CRT—if the set is allowed to first remain off for a few minutes. Normally, the degaussing action is completed by the time the picture comes on the TV screen.

In the earlier Admiral models, however, where a thermal-type switch is used, the B/W picture will sometimes come on before degaussing is completed—displaying a colorful array caused by magnetic lines of force.

## Coil Mounting

Most degaussing coils used in VDR/thermistor circuits are mounted on a metal flange around the color CRT. This metal flange offers a greater magnetic field at the front of the CRT. The RCA degaussing system has two coils at the top and bottom on the metal flange of the CRT (see Fig. 2). The degaussing coils in a Sylvania color cabinet are shown in Fig. 3.

## Troubleshooting . . .

Many circuit variations exist for VDR/thermistor circuits. In the Admiral D11 chassis, the thermistor and degaussing coils are in the primary winding of the power transformer (see Fig. 4).

Practically all VDR/thermistor components are wired in the power transformer secondary circuit. For example, the G-E CB23 and CB25, Zenith 25NC37, Curtis-Mathes CMC20 and the RCA CTC25X chassis have the thermistor circuit in the top leg of the secondary winding. The Philco 16M91, Muntz AS9021 and Westinghouse V2650 chassis incorporate the VDR/thermistor circuit in the bottom leg of the secondary winding. The Philco 16M91 and 16M91A degaussing circuit is shown in Fig. 5.

### Thermal Switch/Thermistor Circuit

The thermal cutout circuit is primarily used in the Admiral color receiver. When the ac switch is in the ON position, the thermistor resistor has a high resistance and the ac current goes through the degaussing coils. As the color receiver draws more current, the thermistor becomes warm and more current begins to flow through it—cutting out the degaussing coils with the thermal switch.

Generally, only two large coils are used in this circuit. They rest on each side of the color CRT close to the front of the tube face. If the HV socket is located in the side of

Fig. 5—Automatic degaussing coil circuit in Philco-Ford 16M91 and 16M91A chassis.

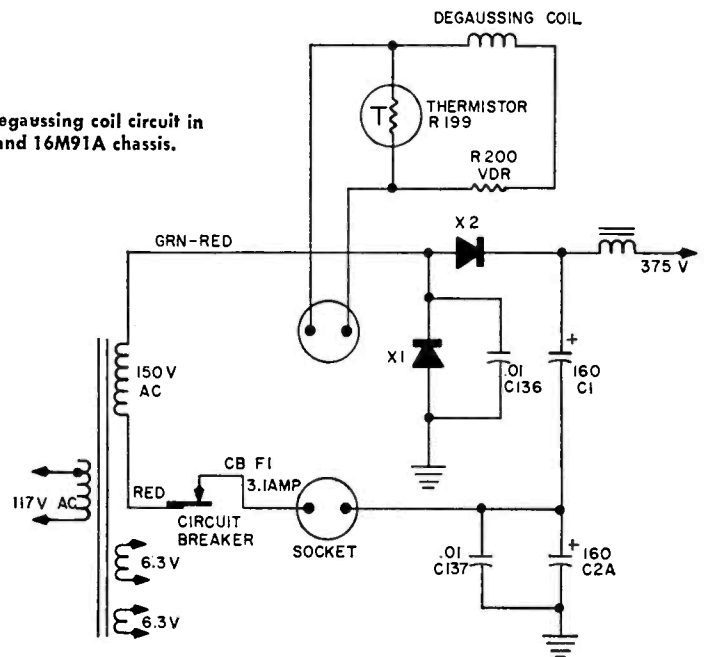

the CRT, these two coils are mounted at top and bottom.

Degaussing coils may be connected in series, parallel or in series/parallel. The Sylvania DO2 chassis has four degaussing coils connected in series/parallel having a total resistance of  $2\frac{1}{2}\Omega$ . RCA degaussing coils are wired in series and have a resistance of 10 to 12 $\Omega$ . The two large Admiral degaussing coils in the D11 chassis are in parallel and have a resistance of 15 $\Omega$  for each coil.

When a defective degaussing coil or a color CRT is replaced, make sure the degaussing coils are placed in the exact position of the original coils. They cannot be turned over or turned around as they will be working against one another. Mark the back outside edge with a white arrow pointed upward.

### Chasing Trouble

A defective degaussing system is indicated when color blotches or impurities appear in B/W pictures. You may degauss the screen one day and be called back within a week to do it over again. Another symptom is a "lag," or the degaussing coil is working late—after the picture comes on the screen.

You may get no degaussing action if a VDR or thermistor becomes defective. Open degaussing coils or poor socket connections will give similar results. A sluggish switch in a thermal-switch circuit will cause

a delay and the picture will come on ahead of shut-off time. Burned or dirty thermal switch points may cause intermittent operation or prevent degaussing action altogether.

If the degaussing coils remain energized, a whirly-color pattern remains on the screen. An open or poor board connection to the thermistor that's shown in Fig. 1 can cause intermittent reception or no reception. If one of the coils mounted on the metal flange shorts to the metal holder, the circuit-breaker will kick out.

A high resistance thermistor will cause the degaussing coils to remain on for a long time or they may not be turned off at all. Likewise, a high resistance VDR will weaken or cancel degaussing action.

Several methods may be used to check ADG circuits. One method is to short out the thermistor resistor with a clip lead. Now plug in the cheater cord and obtain a picture on the screen. First notice if impurities appear on the color screen. Remove the clip lead and watch the degaussing action. This sudden surge of ac current is only momentary and must be observed carefully.

Another easy method is to use the regular service degaussing coil and place it against the front of the TV screen (see Fig. 6). With the color receiver operating, plug the degaussing coil into the ac line. Leave it there a minute or two and then





Fig. 6—Using service degaussing coil to isolate a defective ADG system.

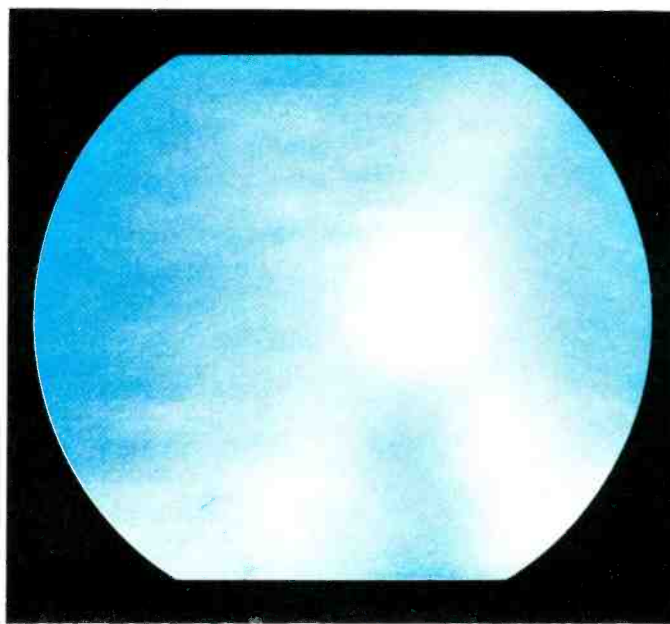

Fig. 7—Photo shows impurities on B/W screen caused by defective ADG circuit.

quickly pull the degaussing coil plug from the ac outlet. You will observe several blotched color areas. Now switch the color receiver off and let it cool for five minutes. Switch it back on and check for purity. If the screen is not pure (see Fig. 7), the ADG system is not functioning as it should. In the event that several impurity areas show on the screen, check for shorted turns in the ADG coils. Also substitute a new VDR unit for the one in the circuit.

When checking degaussing coil resistance, compare the resistance with that indicated on manufacturers' circuit diagrams. Some degaussing circuits, like the Philco-Ford 16M91 chassis, for example, have the VDR, thermistor and degaussing coils isolated from the TV chassis. Be sure and measure only the resistance of the coils.

This method of checking degaussing coil circuits is much easier than clipping a wire across the thermistor resistor. In most color receivers, the VDR and thermistor are located under the chassis. On the RCA color chassis they are mounted on top, but it's a little difficult to clip a lead onto them because of short component leads.

You can actually see the sudden charge of current by placing a 100K resistor in series with a NE2 neon lamp. A neon test lamp, the type with the two insulated leads, will give the same results. Remove the

degaussing coil plug from the chassis. Plug the neon lamp indicator into the receptacle holes. Now plug in the cheater cord and notice the sudden charge of current. If the neon lamp stays lit or takes a long time to come on, replace the thermistor.

#### Intermittent ADG

After an RCA CTC24 Chassis was in the owner's home for two months, the customer complained of color appearing on B/W pictures. A few preliminary degaussing checks were made and the receiver seemed to work perfectly. The service degaussing coil cleaned the screen as usual. Within another month the screen was impure once again. At first, we suspected the lady of the house was switching-off the vacuum cleaner in front of the receiver. But with the receiver operating, the service degaussing coil was placed near the screen and quickly switched off. Then the screen appeared perfect. Since the VDR and thermistor are mounted on top of the chassis, each component was "pushed around" a bit and the next time we went through the procedure, the screen was impure. The trouble proved to be a badly soldered joint on one leg of the VDR.

Another case, in an Admiral G12 series chassis, was similar. The degaussing system on this set worked perfectly sometimes and at other times, the degaussing action was

dead. After cleaning the thermal switch points, the set worked perfectly. In still another Admiral chassis which used a thermal switch circuit, the entire thermal-switching assembly had to be replaced because the degaussing coils were still energized after the picture came on.

#### Faulty Purity

In an Admiral 1965 chassis the owner complained of an impure picture when the set was one month old. After two unsuccessful repair trips, the set was brought to the shop. It was degaussed with the service coil, but within two days it was fouled up again.

The service degaussing coil was placed against the CRT screen, with the receiver operating, then the coil was switched off. The receiver was left to cool for a few minutes. When the set was switched on, impurities were obvious. Replacing the thermistor-switch assembly did not remedy the situation but further checks revealed an open silicon rectifier in the power supply. The output voltage was almost normal but one diode in the bridge circuit was open.

You can save a lot of time by removing one lead from each silicon diode and checking each one separately. Be sure and double-check all four silicon diodes. And remember—a defective color CRT can show the same impurity symptoms as those caused by a defective ADG system. ■

# Solving Horizontal and Vertical Problems in Solid-State TVs

Use your scope to speed troubleshooting in these areas

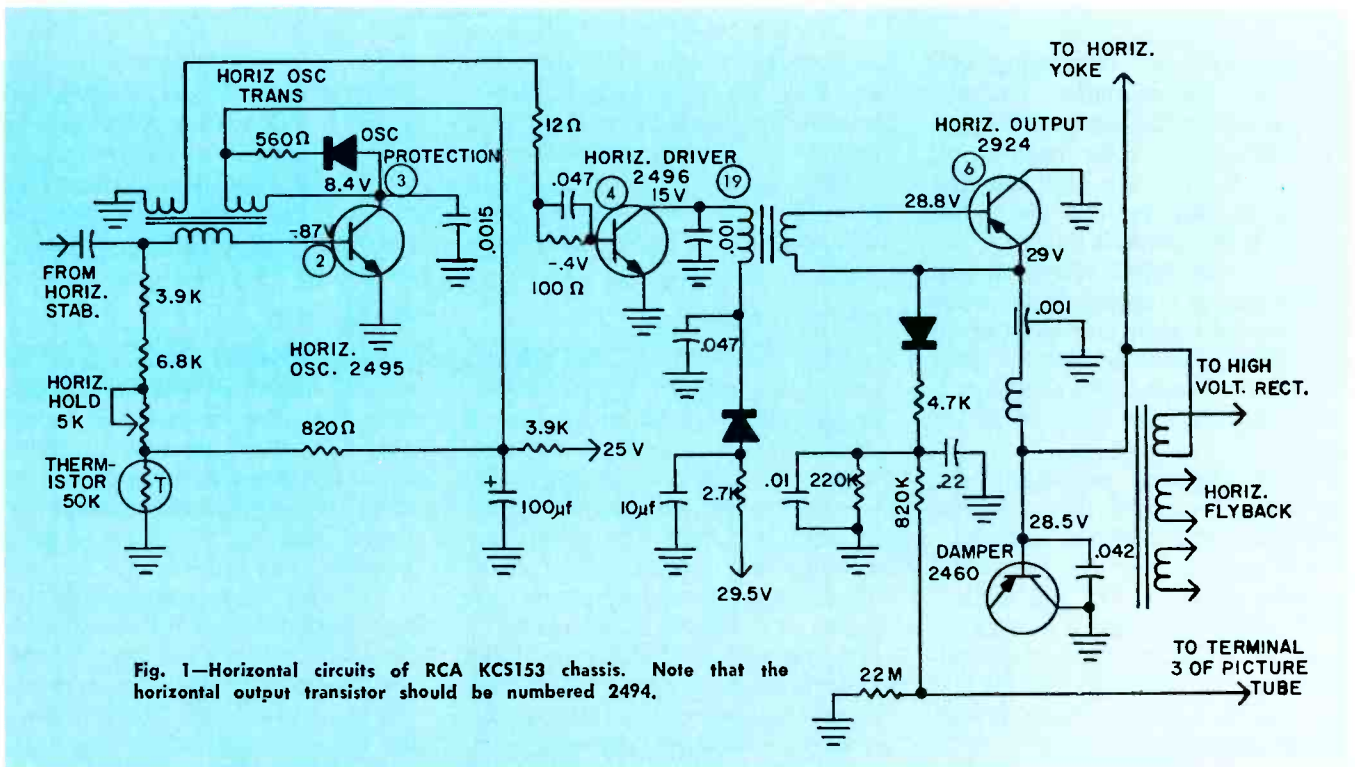

Fig. 1—Horizontal circuits of RCA KC5153 chassis. Note that the horizontal output transistor should be numbered 2494.

■ Your scope can eliminate many frustrating hours from your solid-state TV receiver servicing. Since time is your greatest asset, you have to telescope as many jobs as possible into an hour. If you know how to use your scope effectively, how to observe and compare manufacturers' waveforms and apply a little knowledge of theory to solid-state TV receiver circuits, then you "have it made." This is especially important in horizontal and vertical sections

of solid-state receivers. In fact, we believe these sections pose more difficult problems than all the other sections put together.

## Scoping the Horizontal Section

Generally, the circuit-breaker will kick out when trouble arises in the horizontal section of a solid-state TV receiver. This condition is caused by poor or no drive voltage on the horizontal output transistor. The horizontal output transistor

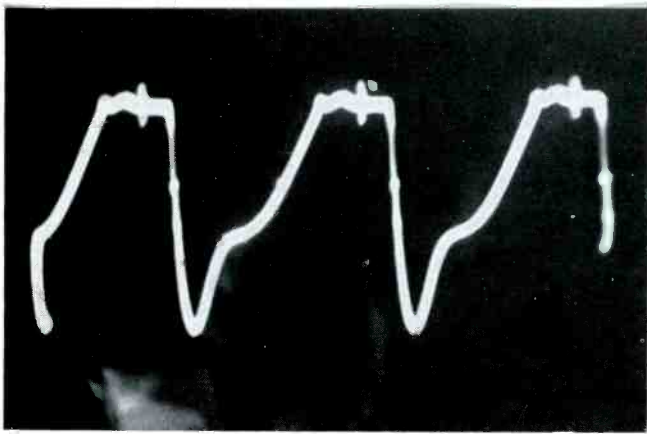

Fig. 2—Waveform at base of horizontal oscillator, 2495, test-point number 2 in Fig. 1.

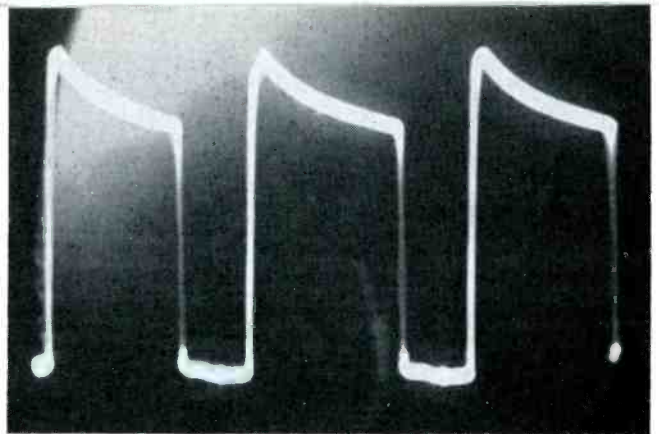

Fig. 3—Waveform at collector terminal of the horizontal oscillator, test-point number 3.

draws heavy current, kicking out the circuit-breaker. But if the circuit-breaker goes out as soon as the reset button is pressed, the trouble could easily be in the low voltage solid-state power supply. In the event the raster remains or the circuit breaker stays put for a few seconds and then kicks out, the trouble is generally in the horizontal or vertical circuits. Also, don't overlook the possibility of a defective circuit-breaker.

Of course, it is difficult to make checks and use the scope in a receiver when the circuit-breaker won't hold. An overloading condition exists under these conditions and the circuits should be disconnected one by one to isolate the exact circuit causing the overload. Unsoldering or unplugging connections may be necessary. Don't short out or bypass the circuit-breaker. You may seriously damage one or more horizontal power transistors. Let's take a look at the horizontal circuit of an RCA KCS153 solid-state chassis, as shown in Fig. 1.

Where do we begin when the circuit breaker won't hold? First, remove the chassis from the cabinet but leave all cables and connecting wires intact. There's enough room to see what goes on between chassis and the small 12-in. CRT.

Check and determine if the low voltage power supply is functioning properly. Unplug the yoke lead from the chassis but leave the speaker lead connected. Now reset the circuit-breaker and apply power to the TV receiver. If a rushing noise comes from the speaker, we generally assume that the low voltage power supply is OK. A quick check at the power supply will definitely

bear this out if a 40v reading is obtained on the VTVM.

Now, when the yoke is reinserted and the circuit-breaker kicks out, you know the trouble exists in either the horizontal or vertical section. The horizontal circuits give more trouble than the vertical circuits and it is very wise to suspect the horizontal section first. Trouble in the horizontal section may also show up in the flyback and HV circuits. Go directly to the horizontal output transistor (2924) and remove the mounting screws. Remove the horizontal output transistor from its socket.

Reset the circuit-breaker and see if it will hold. If it does, we know the trouble is definitely in the horizontal circuits. Use a direct scope probe and begin at the horizontal oscillator transistor base. Does the waveform look like that shown in Fig. 2? If so, proceed to the collector terminal of the transistor. Check the waveform you get on the scope with that shown in Fig. 3.

A voltage gain or increase in height of the sawtooth which you get at the base of the horizontal drive transistor (2496) should be like that shown in Fig. 4.

Now go to the collector terminal of the same transistor and check the voltage gain and waveform.

The voltage gain at the base of the horizontal output transistor is seven times that on the base of the horizontal drive transistor. Tremendous voltage gain is obtained in the horizontal driver circuit. With the horizontal output transistor out of the circuit, the waveform appears like that shown in Fig. 5. When the horizontal output transistor is in the circuit and functioning properly, the

waveform appears as shown in Fig. 6, taken at the emitter.

### Scope Practice

When you have sufficient practical experience with the scope on solid-state receivers, you can quickly spot the defective stage. If a waveform does not appear as shown here or those shown in manufacturers' service data, we have located the trouble. At this point, use the VTVM and milliammeter section of the VOM to pinpoint the defective component.

For instance, if all the horizontal output transistor waveforms check out, substitute a new transistor and see if the circuit-breaker holds. Always remember to keep a pulsed waveform on the base of the horizontal output transistor or the transistor may be immediately damaged. Now check the damper transistor for possible leakage or damage.

Remove the damper transistor and quickly measure the resistance between base and collector. A good damper transistor will measure around  $3\Omega$  one way and with the meter leads reversed, measure more than 20K. If the resistance is low both ways, you have located the trouble. Also, a good transistor tester will show up a defective transistor. In case the resistance checks good, put the damper back in its socket and go to the current limiter transistor. But if the resistance measures 10K or lower, replace the damper with a new transistor.

If a damper is substituted and the circuit-breaker still kicks out, proceed to the current limiter transistor. When this transistor is substituted and the circuit-breaker kicks out, the trouble is in the flyback circuit.

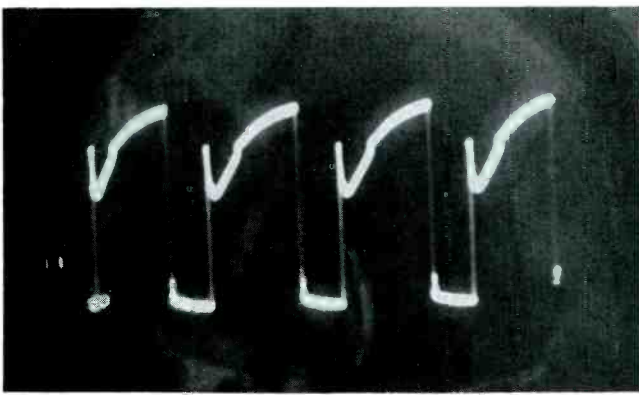

Fig. 4—Waveform taken at the base (test-point 4) of the driver transistor, 2496.

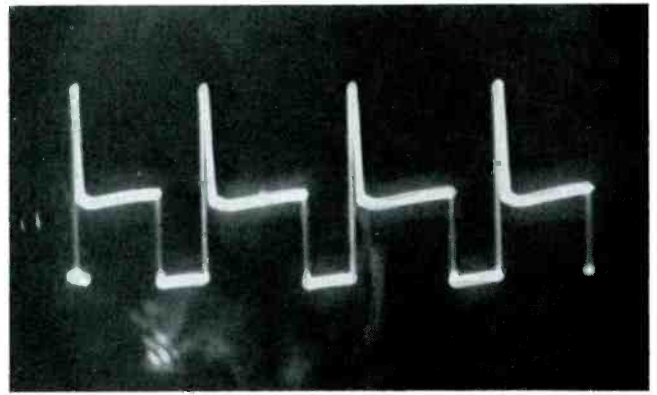

Fig. 5—Waveform at the base of the horizontal output transistor (test-point 6) when the transistor is removed from the circuit.

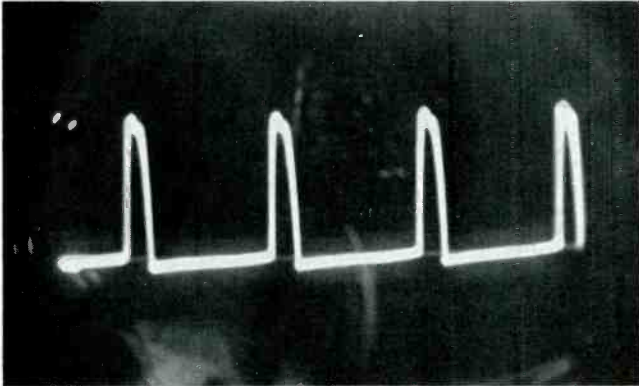

Fig. 6—Correct waveform at the emitter of the horizontal output transistor when it is in its socket and working properly.

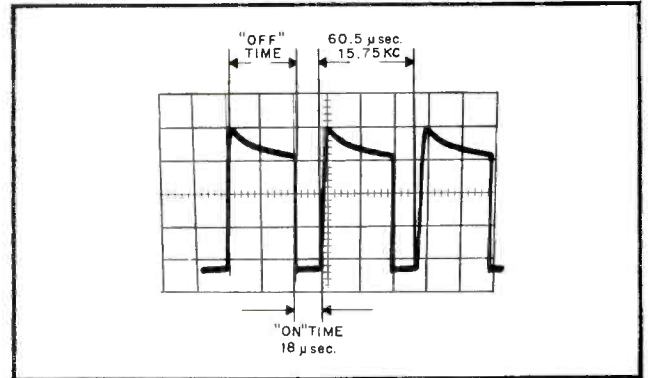

Fig. 7—Horizontal sweep adjustment waveform for the KCS153.

If the current limiter transistor is left out of the socket for a minute or two, the protective resistor will become hot and begin to smoke. Just remove the current-limiter transistor long enough to check the holding of the circuit-breaker.

In replacing power transistors, it is best to check the mica insulator and alignment of the transistor socket. Place silicone grease on both sides of the insulator for good heat dissipation. If a power transistor socket does not line up properly, it is sometimes easy for the transistor terminals to short against the chassis.

#### Adjusting Horizontal Sweep In KCS153 Chassis

If the horizontal stabilizer coil slug in the horizontal sweep circuit of this chassis is not properly adjusted, serious damage can be caused to the horizontal output circuits. First, be sure the receiver is switched off. Then connect a clip-lead from the collector terminal of the sync separator, 2475, to ground.

Connect the scope's vertical input probe to the collector terminal

of the horizontal oscillator (2495) and the scope's low side to ground. Place a clip-lead across coil terminals 2 and 3 of the horizontal stabilizer coils. Switch the TV receiver on and adjust the horizontal hold control for minimum side-drift of the picture. Adjust the horizontal stabilizer coil slug (top of coil), for a pulse width of  $18\mu\text{sec}$  (see Fig. 7).

Switch the receiver off and disconnect the scope leads. Remove the clip-lead shorting terminals 2 and 3 of the horizontal stabilizer coil. Adjust the bottom slug of the horizontal stabilizer coil so the picture will just drift sideways. Now check the horizontal hold control on a regular TV picture. In setting the horizontal hold coil of a solid-state receiver, follow the manufacturers' servicing procedures closely.

#### Checking the Vertical Section

The waveforms in the vertical section are more difficult to measure than in the horizontal section. These waveforms seem to be quite unstable unless you have a well designed scope. Most troubles ob-

served on the TV screen are poor height, poor vertical linearity, insufficient vertical amplification and simply a white horizontal line across the screen—indicating no vertical sweep. A scope check of transistors will locate the defect.

Begin at the vertical oscillator and go from base-to-collector of each stage. Notice the gain or loss in each stage and also the waveform. Most solid-state vertical amplifiers are directly coupled from collector-to-base or from emitter-to-base of the preceding transistor. From three to five transistors may be used in the vertical section. The vertical sweep circuit schematic of an RCA KCS153 is shown in Fig. 8.

The sawtooth waveform at the vertical oscillator base should approximate that shown in Fig. 9. The waveform at the vertical oscillator collector and base of the vertical amplifier (2501) is shown in Fig. 10. You'll note that the waveform at the vertical-amplifier base (2501) has about the same amplitude as the waveform at the vertical driver emitter (not shown). In checking vertical waveforms, use a direct-

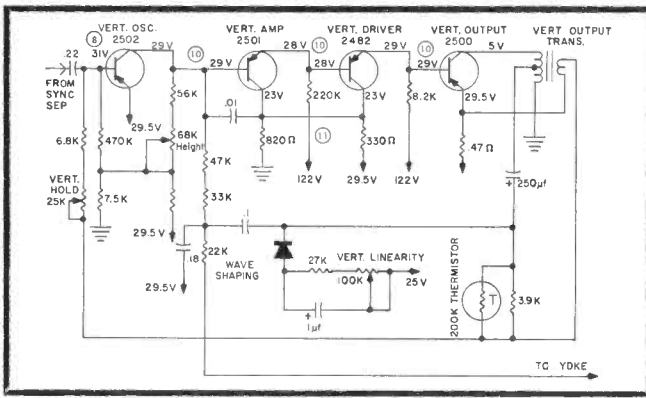

Fig. 8—Vertical circuit schematic of RCA KCS153.

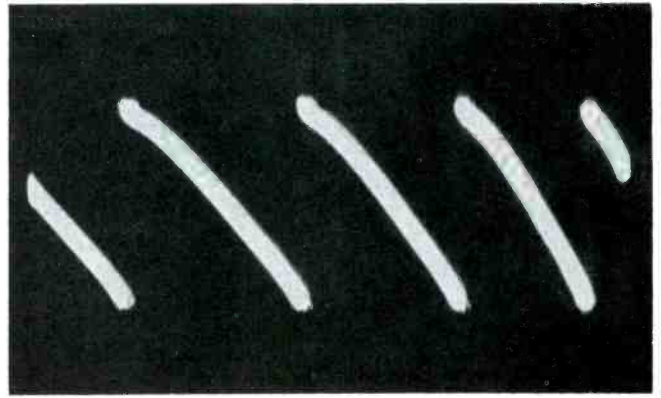

Fig. 9—Waveform at the base of the vertical oscillator transistor, 2502.

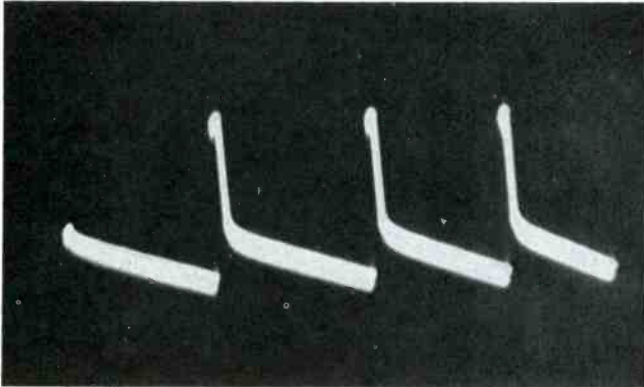

Fig. 10—Waveform at the collector of the oscillator and the base of the vertical amplifier.

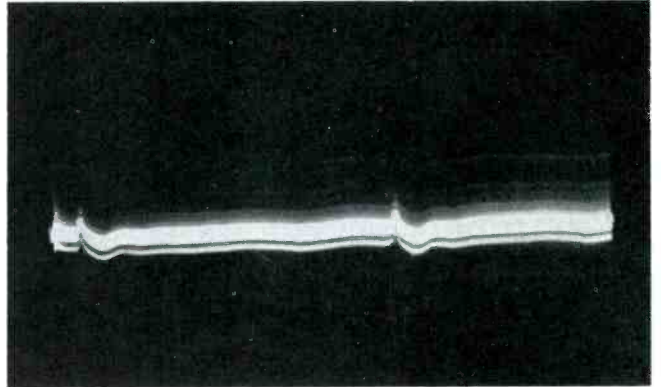

Fig. 11—Waveform at the emitter of Q304, vertical driver stage of Sylvania AO1 chassis. A great loss in gain is indicated.

coupled probe. Set the scope frequency to 50 or 60Hz.

The greatest voltage gain is noted in the vertical output transistor. Here the gain is about 10 to 1 in the KCS153 chassis, while in a Sylvania AO2 chassis, the ratio is about 5 to 1. A quick check of the gain of any vertical or horizontal waveform should be made against the manufacturers' schematic. Most manufacturers place these waveforms on the diagram or elsewhere in their service manuals. (When the manufacturer furnishes them, ET prints these waveforms on TEKFAK schematics.)

It may prove difficult at times to locate a point on the circuit board to place the scope probe tip. One or more transistors may be tightly located between chassis and CRT. Extreme care should be exercised to prevent shorting transistor elements with the probe tip. But, if you follow the schematic carefully, you'll find test points or test terminals numbered on the diagram.

For example, the vertical output transistor in the RCA KCS153 chassis, is mounted under a sub-chassis. The transistor terminal connections

are between CRT and main TV chassis. Sometimes it is rough to get a probe down to this vertical transistor. But, if you'll look at a tie-point on the etched board, a letter "U" is in plain view. The vertical output transistor waveform can be checked from this tie-point.

When a signal loss or a weak waveform of a given stage shows on the scope, you may have located the trouble. And it is wise to have your scope screen accurately calibrated. If your scope is fairly old, it should be re-calibrated often. This is important in servicing both vertical and horizontal sections of solid-state sets because of the small gain produced by some stages. There may be only a P-P voltage change of 0.3v at a given stage. The principal idea of using the scope in solid-state TV servicing is to quickly locate the defective stage. You can then follow through with a VTVM to pinpoint the ailing component. The scope probe will not load the circuit you are checking and this becomes a great help when troubleshooting intermittent circuits. Now, let's get down to some everyday cases.

### Getting Down To Cases

A Sylvania AO1 chassis came to the shop having a fine white horizontal line across the screen. No vertical amplification was apparent so we went directly to the vertical section. Beginning at the vertical oscillator, Q302, the scope was set at 50Hz and both input and output waveforms appeared normal. The waveform at the emitter of the driver transistor, Q304, showed a waveform like that shown in Fig. 11. Since the stage acts like a cathode follower, there is some loss here—but obviously not this much.

A new vertical driver transistor was substituted at this point and we obtained a full raster immediately. When the vertical driver transistor was checked, a leakage showed between collector and emitter. The correct waveform is shown in Fig. 12.

Another AO1 Sylvania chassis had a "long-necked" running picture. The picture was stretched out into wide lines and we couldn't stop it from "flipping." When the vertical hold control was rotated, the bottom

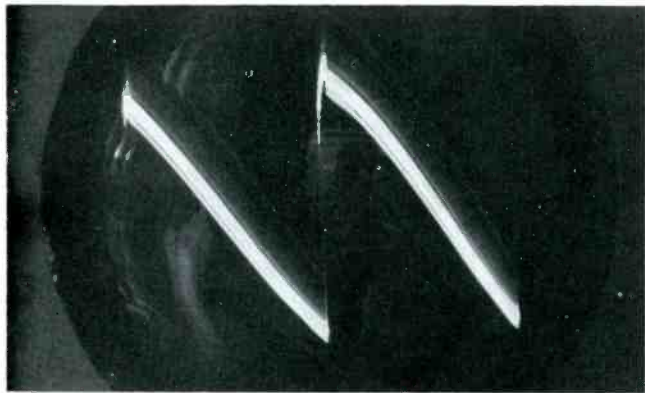

Fig. 12—Correct waveform after the defective vertical driver transistor, Q304, was replaced.

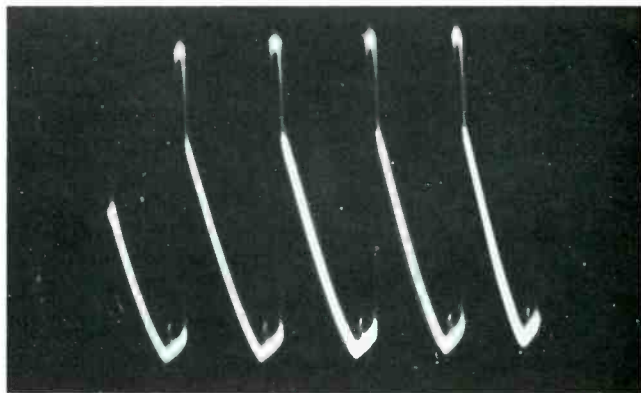

Fig. 13—Waveform at the base of the vertical driver transistor, Q304.

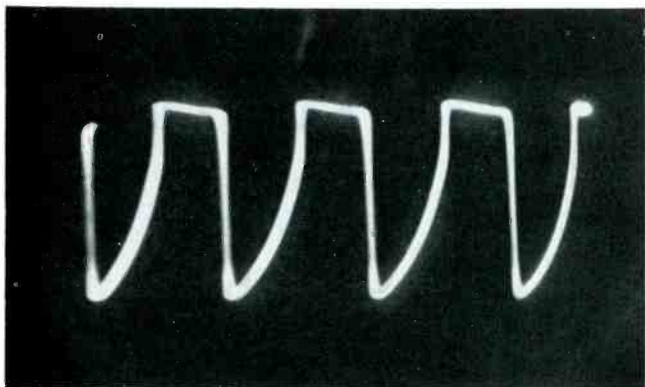

Fig. 14—Defective waveform taken from the collector terminal which was caused by a decreased emitter resistor in Q402.

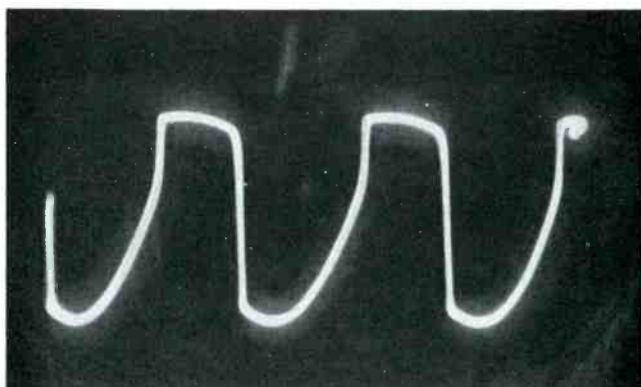

Fig. 15—Correct waveform at the collector terminal of Q402 after the emitter resistor was replaced.

of the raster pulled up two or three inches.

Beginning at the vertical oscillator transistor with a scope, we ended up at the same vertical driver transistor, Q304. The waveform at the base of this transistor was like that shown in Fig. 13. The height and linearity controls were adjusted but did not help.

Since we've had trouble with this same transistor before, we automatically substituted it and the picture became normal. Further checks showed leakage between base and emitter of the vertical driver transistor.

#### Intermittent Chassis

The overload circuit-breaker on another KCS153 chassis would kick-out as soon as the set was switched on. At other times the small TV would run for several hours without trouble. At first, we tried to isolate the section where the intermittent component was located. Once, when the circuit-breaker would not hold, the yoke assembly was disconnected. When this was done, the circuit-breaker stayed put and noise came

from the speaker. We knew the audio and low voltage power supply was good. We next removed the horizontal output transistor and the circuit-breaker was reset again. A quick scope check on the base terminal of the horizontal output transistor indicated the horizontal circuit was good. The horizontal output transistor was substituted and the circuit-breaker kicked out again.

We removed the current-limiter transistor from the chassis momentarily. The circuit breaker stayed on. We were chasing the trouble "into a corner." A check of the 100 $\mu$ f filter capacitor and silicon limiter protection tied it down. The small silicon transistor was intermittently bad and a new one in its place solved the problem.

#### Narrow Picture

A portable AO1 Sylvania came into the shop having two inches of black on each side of the screen. In a tube TV receiver we usually think of this problem in terms of a weak horizontal output tube, a weak damper or possibly a weak low voltage rectifier tube. Why think

any differently about a solid-state TV receiver? Actually, the trouble could be caused by any one of the horizontal transistors but before you remove one from the circuit, check the waveforms with a scope.

We began with the first transistor, Q400, in the horizontal oscillator and proceeded toward the horizontal output transistor. At the base of the horizontal driver transistor the waveform was a little weak. Going back to the base and collector of Q402, the second transistor in the horizontal oscillator, a voltage loss showed up. The trouble had to be in transistor Q402 or related circuit components. But substituting the transistor didn't solve the problem.

The waveform on Q402's collector terminal was narrow and had about a 1v amplitude loss (see Fig. 14).

The emitter bias resistor was checked with an ohmmeter and it measured 320 $\Omega$  instead of 510 $\Omega$ . You may jump to the conclusion that this 190 $\Omega$  difference would cause little trouble. But in a transistor circuit an out-of-tolerance of only a few ohms can frequently

*continued on page 87*

# TEKLAB REPORT

## A Technician Looks At G-E's 'Porta-Color' TV Receiver

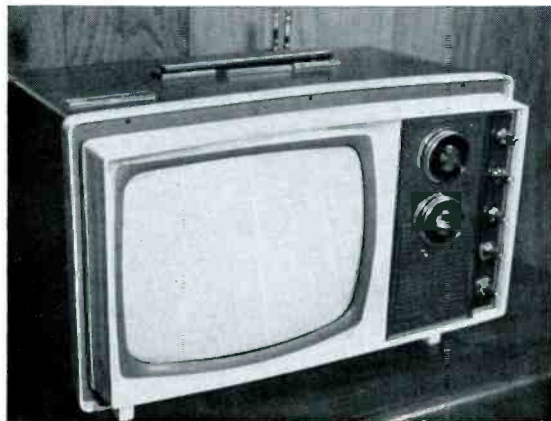

Fig. 1—Photo of G-E's 'Porta-Color' receiver showing three front cabinet screws loosened at top of set front.

### Part 1 of a series

You'll probably be seeing more of these sets in the future and servicing problems are different

■ When you first “heft” G-E's small-screen, model M213CWD color TV receiver with one hand, you will probably jump to the conclusion that it is fully semiconductor. But, aside from the CRT, the set contains 13 tubes (a majority are compactrons), 13 diodes and one transistor.

Because the 60-sq in. viewing-area 11SP22 color CRT is unconventional in design, the set has a number of unconventional circuit innovations and adjustments.

#### General Description

Although the set's cabinet appears to be made of simulated wood-grained metal, it is actually made of high-impact plastic. It has a carrying handle, a two-element retractable VHF “rabbit-ear” antenna, illuminated channel indicator and a built-in spring-loaded activating-switch degaussing circuit.

It is easy to get to the “guts” of the set by removing three screws from the cabinet front (See Fig. 1) and three from the back. The major covering section then slips off easily and exposes the components which are all top-board mounted.

The etched circuit board is re-

tained at the front by “slots” and the left side by a channel molded into the bottom shelf of the cabinet front. Five screws are used to secure the circuit board in position on the cabinet shelf. Mounted on a small sub-chassis and fastened to the high voltage compartment are various components of the power supply — filter capacitors, choke, power rectifiers, fuse, etc.

Control assemblies, which consist of the VHF/UHF tuner cluster and secondary control assembly, are mounted to the cabinet front by hex-head screws. The speaker is also mounted and retained to the front cabinet directly below the tuner assembly. Nothing is mounted to the cover except the antenna. On the first try, a TEKLAB technician removed the six screws, disconnected the antenna from the tuner input and removed the cover in exactly 58 seconds.

#### The CRT and Its Deflection System

The most unconventional part of the set is its CRT and its circuits for beam deflection. The CRT is a three-gun shadow-mask type, but its three electron guns are placed in line on a horizontal plane and

the guns scan in-line dot rows of colored phosphor dots—red, green and blue—instead of the conventional three colored dot triad groups.

The beams of the electron guns are deflected simultaneously by a deflection-yoke system which directs each beam to the desired group of color dots (see Fig. 2). With each of the beams properly

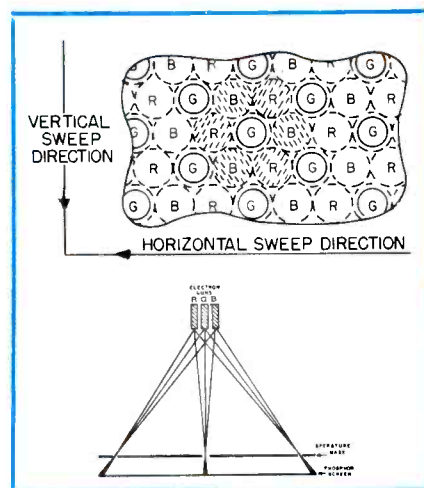

Fig. 2 (Top)—Red, green and blue light-emitting dots are arranged in a horizontal line with the dot of each successive line staggered in respect to previous line. (Bottom)—Beam landing with respect to phosphor dots and aperture mask.

# Porta-Color . . .

registered on its group of color dots, three separate rasters result. These rasters are superimposed, one on top of the other, resulting in a single raster which can produce either a B/W or color picture under proper conditions.

This deflection arrangement, together with over-all system considerations, leads to an unconventional convergence arrangement. In fact, the convergence system is simple—compared to that on the conventional color receiver.

As indicated previously, the red, green and blue light-emitting dots, 19 mils in dia, are arranged in a horizontal line with the dot of each successive line staggered with respect to the previous line as shown in Fig. 2. Located behind the dot pattern is a metal aperture mask which contains one third the number of 12-mil dia holes as there are phosphor dots on the screen (see Fig. 2). The mask is positioned and shaped so the holes line up behind the green phosphor dot as shown. The distance of beam travel from the aperture hole to the phosphor dots allows approximately 14 mils of dot bombardment by the electron beam. The approximate attitude of the three electron beams, with respect to the phosphor dots and aperture mask is also illustrated.

Each of the three electron guns is similar to a monochrome electrostatic focus CRT gun. Although the aperture mask holes are behind the green dots, beams of the red and blue guns do not strike the green dots because of the approach angle of the beams. The beam angle and the distance of the aperture mask from the tube screen is such that the beams strike only the proper phosphor dot.

It should be understood at this point that "purity" achieves illumination of each of the three color phosphor dots by the proper elec-

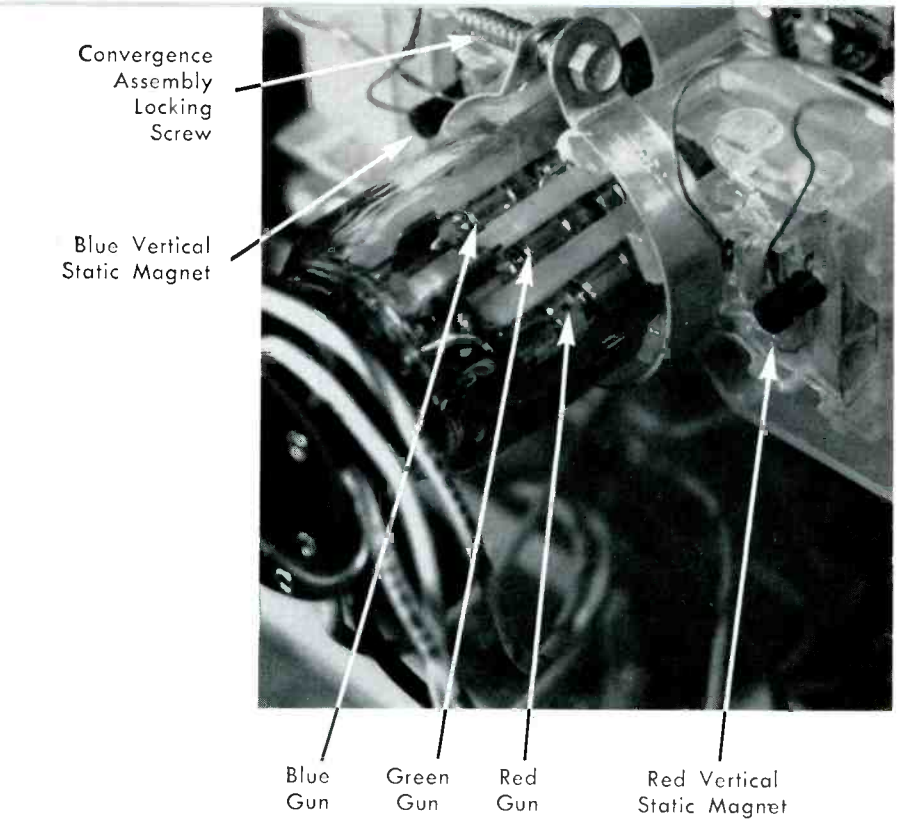

Fig. 4—The two vertical and horizontal magnet assemblies mounted on an elongated piece of clear plastic 1.5in. from socket end of CRT.

tron gun—and this does not necessarily mean that three beams are "converged."

For the 11SP22 CRT, the green gun may be viewed as a reference for convergence because the gun is in the center of the gun cluster.

A cylindrical metal shield is provided on the end of the green gun structure to reduce the effects of the magnetic field applied to each of the outside guns by the convergence assembly.

As illustrated in the drawing shown in Fig. 3 and the photo in Fig. 4, the convergence assembly is made up of two vertical and two horizontal magnet assemblies

mounted on an elongated piece of clear plastic. This complete assembly is mounted on the neck of the CRT 1.5in. from the socket end of the tube as shown. This places the vertical correction magnets over the "C" shaped pole pieces on the red and blue guns and the horizontal magnets of the "L" shaped pole pieces at the very front of the structure (viewed from the set's rear).

Each vertical magnet assembly has several turns of wire on the inside leg of an "E" shaped core and with the coil connected in series with the vertical deflection coils, a magnetic field is produced in this arm of the core. The field produced is coupled from this arm of the core through a movable permanent magnet to the "U" shaped portion of the core where the direction of the field disperses to both ends of the core.

From here the field is coupled through the glass envelope of the CRT to the pole pieces of the red or blue gun, resulting in a vertical deflection of the beam as shown in Fig. 2. Since the permanent magnet is energized, the beam can be moved by rotating the magnet for static adjustment. The field produced by the vertical yoke current flowing through the coil on the

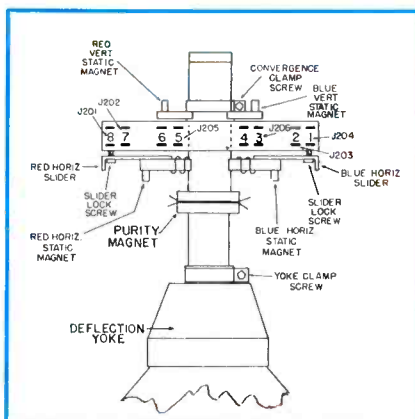

Fig. 3—Complete convergence assembly showing, horizontal and vertical static adjustments and correct positioning of convergence assembly and purity ring.



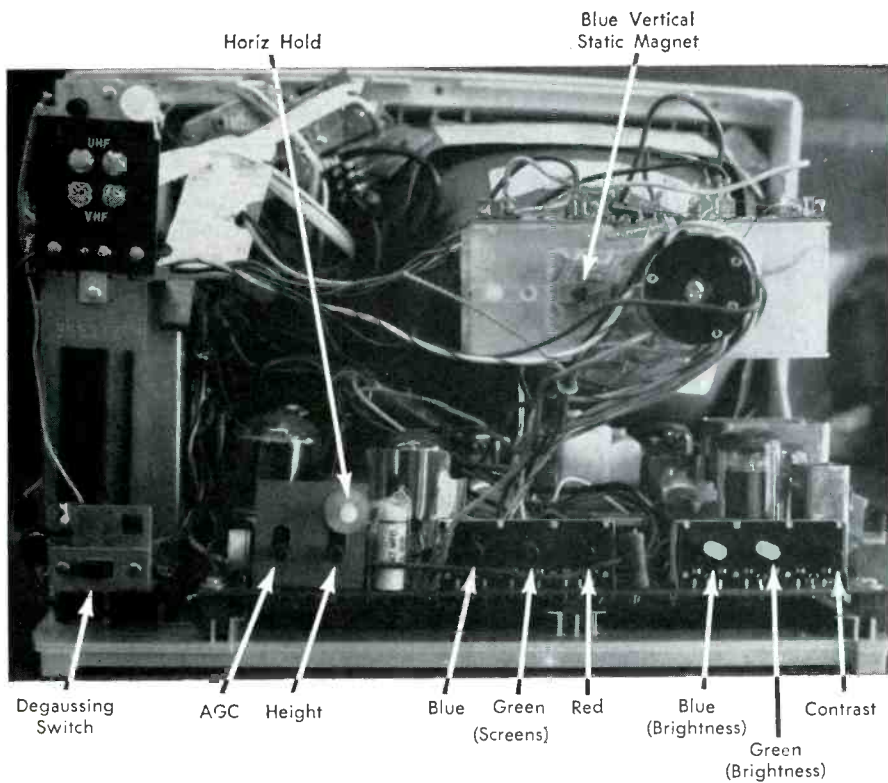

Fig. 5—Rear view of chassis showing the three CRT screen controls and the blue and green color brightness controls.

core follows the same path as the permanent magnet field. It then moves the associated beam vertically at a vertical rate. In addition, the coil polarity may be changed or completely removed from the circuit by interchanging the wiring on the terminal strip at the top of the plastic convergence assembly.

### Getting Down to Business

Now let's get to the business of making gray-scale (color temperature), purity and convergence checks and, when necessary, adjustments.

With the receiver completely assembled and in the cabinet, switch the set on and let it warm for 10 minutes. Tune the receiver to an active B/W channel, adjust the contrast and front-mounted controls for a normal B/W picture. Demagnetize the CRT screen with a service-type degaussing coil and make necessary height, vertical linearity and hold control adjustments. At this point, check the gray-scale (color temperature tracking). This is done as follows:

1. Turn the three CRT SCREEN controls located on the back of the set (see Fig. 5) fully clockwise (CW).

2. Short the antenna terminals and switch the VHF channel selector to an unused channel. Turn

the CONTRAST control fully counter-clockwise (CCW).

3. Turn the master BRIGHTNESS control (on the receiver front) CW to a point just short of defocusing the raster.

4. Adjust either or both of the two BRIGHTNESS controls (BLUE and GREEN controls in the set's rear as shown in Fig. 5) to eliminate color shading of the white raster. And if you cannot get a pure white screen with these adjustments, don't worry about it. Continue with the gray-scale procedure.

5. Turn the master BRIGHTNESS control (front of set) CCW until the raster is almost dark.

6. Adjust the appropriate color SCREEN control to reduce color shading of the dark-gray raster to a minimum.

7. Check the raster through highlights to lowlights—adjusting the controls as necessary to maintain gradations from dark gray to white throughout the brightness range. Repeat steps 3 through 6 if necessary to maintain gray-scale tracking.

8. Check the three SCREEN controls to make certain that at least one is set at maximum CW.

Now, if the CRT screen is not as pure white as it should be, proceed with purity and convergence checks as follows.

With the set warmed up, connect a bar/dot generator to the receiver's antenna terminals (making sure the terminals have been unshorted). If only minor adjustments are required, a slight touch-up of the static convergence magnets will usually do the job. Study the raster closely to determine the color and direction of misconvergence. We had no trouble making these adjustments in ET's TEKLAB—it took about 5 minutes. Make only slight adjustment to the appropriate horizontal or vertical convergence controls directly associated with the misregistered color. Keep in mind that the green gun is between the red and blue guns and it does not require adjustments. Register both the blue and red rasters on the green raster. The red and blue rasters move both horizontally and vertically to coincide with the green.

The static convergence magnets are cemented in position at the factory. To turn the magnet, exert a slight pressure to break the cement bond. A drop of acetone can also be used to soften the cement. When turning the magnets, maintain a slight inward pressure to keep the magnets fully seated in the cores. After adjustments have been completed, lock the magnets with a drop or two of Glyptal cement.

If for any reason it is necessary to move the purity magnet or the static convergence magnets excessively, for example, after changing a CRT, perform the complete purity and convergence procedure.

### Purity and Convergence Procedure

1. Check for correct positioning of the convergence assembly and purity ring on the CRT neck as shown in Fig. 3 and Fig. 6.

2. Loosen the screws on the horizontal convergence sliders and move each slider to place the core end  $\frac{1}{8}$  in. from the CRT neck.

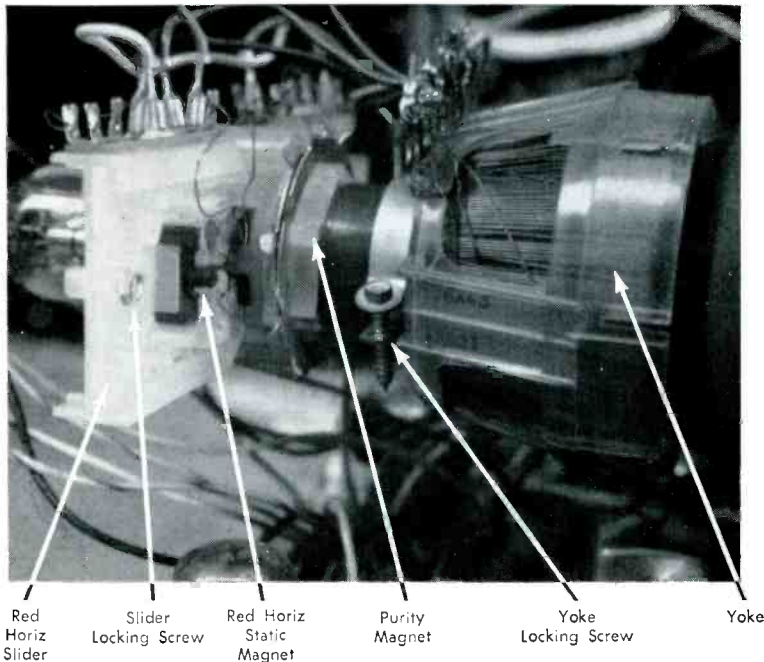

Fig. 6—Location of yoke, yoke locking screw, purity magnet, red horizontal static magnet, slider locking screw and red horizontal slider.

3. Position the purity rings for zero field by adjusting the rings so that the square tab on each ring is 180 deg from the other and then position the assembly on the tube so that the square tabs are on a vertical plane.

4. Position the four static convergence magnets for zero field. For the vertical convergence magnets this is achieved when the line marked on the end of the magnet is in a vertical plane, and for the horizontal magnets, the line is positioned on a horizontal plane.

5. Adjust the master BRIGHTNESS control (on the front of the receiver) approximately  $\frac{1}{4}$  to  $\frac{3}{8}$  turn CW from the maximum "off" position and turn the CONTRAST control "off" (CCW).

6. Turn the CRT SCREEN controls (R546, R547 and R548) fully clockwise then adjust the green and blue color BRIGHTNESS controls (R539 and R545) for proper gray scale.

7. Using either a dot pattern or a crosshatch pattern, adjust the static convergence magnets to produce center convergence.

8. Turn the color BRIGHTNESS controls (R539 and R545) "off" and loosen the yoke clamp screw (Fig. 6). Slide the yoke back as far as possible. Tighten screw so

yoke will just slide and turn.

9. Adjust purity ring as follows:

Rotate assembly around the tube neck or spread tabs for uniform pure red field in center of raster.

10. Check center convergence as follows:

A. Turn the GREEN color BRIGHTNESS control "on" (CW) to obtain

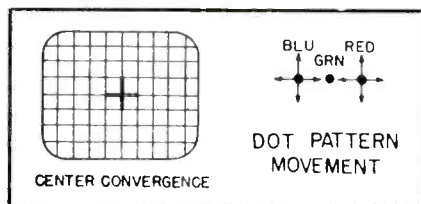

Fig. 7—Red and blue dot pattern movement for center convergence.

a red and green pattern in the center of the raster and center converge the red on the green (see Fig. 7).

B. Turn the BLUE color BRIGHTNESS control "on" and center converge the blue on the yellow.

11. Make preliminary purity check as follows:

Turn the GREEN and BLUE color BRIGHTNESS controls "off" then slide the yoke forward for best over-all pure red raster and proper leveling of the picture.

12. Repeat steps 8 through 11 as necessary to obtain best center convergence consistent with best purity.

13. Make horizontal slider adjustments as follows:

(A) Turn the GREEN color BRIGHTNESS control "on" (CW) and check the relationship between the red and green vertical lines at both sides of the raster.

(a) Move slider close to tube if red appears inside of green (closer to raster center).

(b) Move slider away from tube if red appears outside of green (closer to raster edge).

(B) Rotate red horizontal static convergence magnet to converge the red and green vertical lines at the center horizontal line.

(C) Turn the BLUE color BRIGHTNESS control "on" (CW) and in the same manner as previously described at "A" and "B" and adjust the BLUE horizontal slider along the BLUE static horizontal magnet to achieve blue convergence.

(D) Repeat steps "A" through "C" as necessary to obtain best center and edge convergence at the center horizontal line. Lock sliders in place by tightening the screws.

14. Repeat steps 8 through 11 as necessary to obtain best "over-all" convergence consistent with best "over-all" purity.

15. Check convergence of the horizontal lines at the center vertical line. If additional adjustment is necessary, the connections to each vertical dynamic convergence coil may be changed to either reverse its polarity or remove it completely from the circuit. Clips and lugs are provided on the top of the assembly for ease of altering these connections.

16. Check final over-all purity as follows:

Turn the GREEN and BLUE color BRIGHTNESS controls "off" and position the yoke on the neck of the picture tube for pure over-all red raster and for proper leveling of the picture. Tighten the yoke clamp screw while supporting the yoke weight with one hand. Check each color field and check over-all convergence, then lock the convergence magnets in position with a drop of Glyptal cement.

A forthcoming article will explore other circuits and servicing procedures for this unusual color receiver. ■

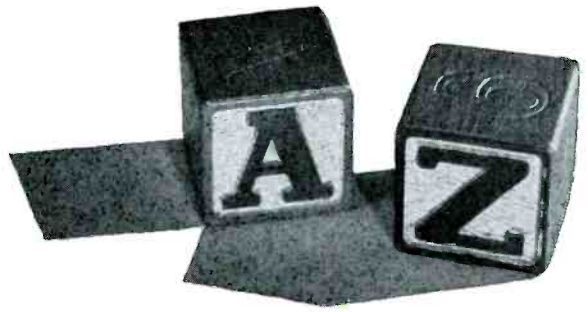

# Semiconductors from A to Z

Understand how tunnel diode circuits operate and you can troubleshoot them faster

■ Many tunnel diode characteristics were discussed in the February issue of *ELECTRONIC TECHNICIAN*. Since these characteristics are important in the proper function of tunnel-diode circuits, the previous article should be referred to when studying these circuits.

The importance of having an output or load resistor ( $R_2$ ) of proper

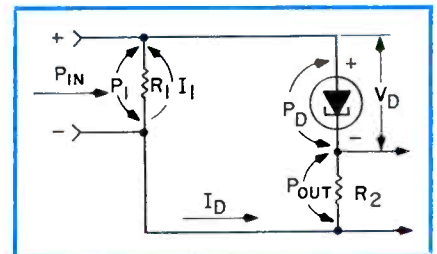

Fig. 1—Power losses in a tunnel diode amplifier.

taking a different look at the circuit (Fig. 1). The power supplied to the circuit ( $P_{in}$ ) must equal the power consumed by the tunnel diode ( $P_D$ ), plus that consumed by the input resistor ( $P_1$ ) and the output resistor ( $P_{out}$ ).

$$(P_{in} = P_D + P_1 + P_{out})$$

The power consumed by the tunnel diode can be calculated by multiplying its voltage by its current ( $P_D = V_D I_D = 50\text{mv} \times 1.3\text{ma} = 50 \times 10^{-3}\text{v} \times 1.3 \times 10^{-3}\text{a} = 65 \times 10^{-6}\text{w} = 0.065 \times 10^{-3}\text{w} = 0.065\text{mw}$ ).

The power consumed by the input resistor ( $R_1$ ) equals the square of the current passing through it times the value of the resistor

$$[P_1 = I_1^2 R_1 = (2.82\text{ma})^2 \times 60\Omega = 2.82 \times 10^{-3}\text{a} \times 2.82 \times 10^{-3}\text{a} \times 60\Omega = 477.1440 \times 10^{-6}\text{w} \approx 477 \times 10^{-6}\text{w} = 0.477 \times 10^{-3}\text{w} = 0.477\text{mw}]$$

The power consumed by the output resistor ( $R_2$ ), like that consumed by the input resistor ( $R_1$ ), is equal to the square of the current passing through it times the value of the resistor. Since the resistor is connected in series with the diode, the same current ( $I_D$ ) passes through both the output resistor and the diode. The power consumed by this resistor has already been calculated for Table II

$$(P_{out} = I_D^2 R_2 = 0.155\text{mw})$$

$V_D$ (mv)	$I_D$ (ma)	$P_D = V_D I_D$ (mw)	$I_1$ (ma)	$P_1 = I_1^2 R_1$ (mw)	$P_{out}$ (mw)	$P_{in} = P_{out} + P_D + P_1$ (mw)
50	1.3	0.065	2.82	0.477	0.155	0.697
75	1.2	0.090	3.09	0.573	0.132	0.795
90	1.1	0.099	3.19	0.611	0.111	0.821
105	1.0	0.105	3.28	0.646	0.092	0.843
117	0.9	0.105	3.33	0.665	0.075	0.845
129	0.8	0.103	3.38	0.686	0.059	0.848
142	0.7	0.099	3.44	0.710	0.045	0.854
157	0.6	0.094	3.54	0.752	0.033	0.879
178	0.5	0.089	3.73	0.835	0.023	0.947
200	0.4	0.080	3.95	0.936	0.015	1.031
227	0.3	0.068	4.24	1.079	0.008	1.155
295	0.2	0.059	5.22	1.635	0.004	1.698

Table I: The power consumed by the various components in a tunnel-diode amplifier.

value in a tunnel-diode amplifier circuit (Refer to Fig. 3 in the Feb. issue) was discussed, and we found that too small an output resistance reduced the circuit's voltage gain while too large a resistance resulted in voltage instability.

### The Amplifier's Input Resistance

The value of the input resistor ( $R_1$ ) is also important for the stability of the tunnel diode circuit. This can be seen more effectively if we study the power consumed by

## Semiconductors from A to Z

in the Feb. article. We can add this data to again determine the total power consumed by the circuit

$$(P_{in} = P_{out} + P_D + P_1 = 0.065\text{mw} + 0.477\text{mw} + 0.155\text{mw} = 0.697\text{mw}).$$

(Note: the slight discrepancy between this total power calculated for Table I of this article and that calculated for Table II of the previous article results from rounding off numbers.) In the same manner the total power consumed can be calculated for other voltages across the tunnel diode, as shown in Table I.

With the use of curves (Fig. 2), we can more effectively see the relationships of the power consumed by the various components in the circuit (Fig. 1). As in the case of

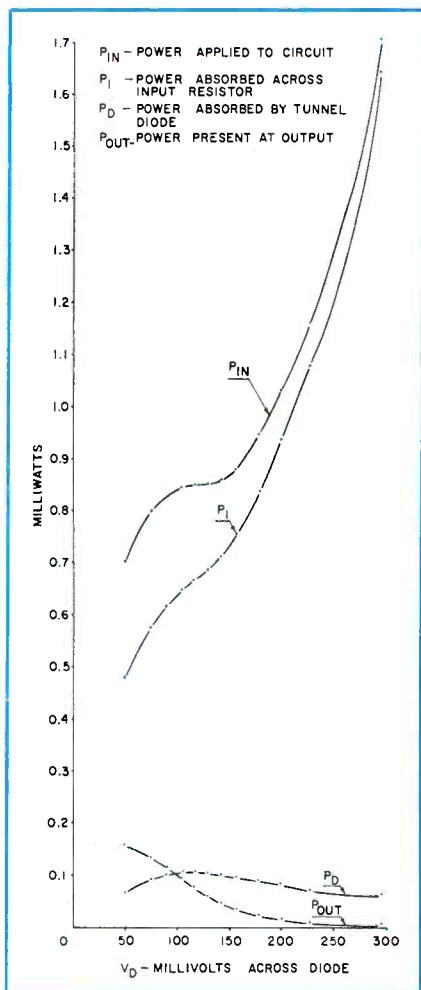

Fig. 2—Comparing the power consumption of components in a stable amplifier circuit.

the voltage curves (Fig. 4 of the previous article) where the input voltage was equal to the sum of the voltages applied to the various components, the applied power curve (Fig. 2) is equal to the sum of the powers consumed by the components.

From the curves we note that as the voltage across the tunnel diode ( $V_D$ ) increases, the power consumed at the output ( $P_{out}$ ) continuously decreases; and above approximately 111mv ( $V_D$ ), the power consumed by the tunnel diode ( $P_D$ ) also decreases. The total power consumed by these two components (the height of the  $P_D$  curve added to the height of the  $P_{out}$  curve) decreases with an increase in diode voltage ( $V_D$ ).

Unlike these curves, the curve representing the power consumed by the input resistor ( $P_1$ ) increases as the diode voltage ( $V_D$ ) increases.

As had been indicated earlier in this article, the power applied to the circuit is equal to the sum of the powers consumed by the components.

$$(P_{in} = P_{out} + P_D + P_1).$$

Since the total power consumed by the output resistor ( $P_{out}$ ) and the diode ( $P_D$ ) is decreasing as the power consumed by the input resistor ( $P_1$ ) increases, there is a very small resulting increase in the total power consumed by the circuit ( $P_{in}$ ), as the diode voltage increases from 105 mv to 129 mv. Over this range of values, a 0.005mw increase in the power applied to the circuit results in a 0.033mw decrease in the power consumed by the output. The power gain curve (Fig. 11 of the previous article) shows that the circuit's power gain is greatest over this range of diode voltages. When the input resistor is of its present value, the power applied to the circuit is able to control the amount of power present in the output.

By increasing the value of the input resistor, we can decrease the amount of power consumed at the input resistor when a given voltage is applied to that resistor. This can be shown by means of some basic electrical equations with which the reader is probably familiar. The power consumed by a resistor is

equal to the voltage applied to the resistor times the current passing through it ( $P = VI$ ). The current passing through the resistor is equal to the voltage applied to the resistor divided by the value of the resistor

$$(I = \frac{V}{R}).$$

These two equations can be combined to show the relationship between the value of the input resistor ( $R_1$ ) and the power ( $P_1$ ) that it consumes

$$\left[ P_1 = V_1 I_1 = V_1 \left( \frac{V_1}{R_1} \right) = \frac{V_1^2}{R_1} \right]$$

If the value of the input resistor ( $R_1$ ) is halved, the power that it consumes ( $P_1$ ) is doubled; while if the value of the input resistor is doubled, the power that it consumes is halved.

By decreasing the value of the input resistor ( $R_1$ ), the power consumed by the resistor increases, increasing the power consumed by the circuit. When the value of the input resistor is reduced, the curve representing the power that it consumes becomes higher and steeper. This in turn increases the height and steepness of the curve representing the power applied to the circuit. A larger increase in input power will, therefore, be required to produce the same amount of change in output power as before, and the circuit's power gain has been reduced.

When the value of the input resistor is increased, the power consumed by the resistor is reduced. The resulting curve showing the power consumed ( $P_1$ ) by this resistor will be lower and less steep. Under these conditions, the decrease in total power consumed by the output resistor and diode ( $P_{out} + P_D$ ) may be greater than the increase in power consumed by the input resistor ( $P_1$ ) over a certain range of values. As a result of this situation, a portion of the total power consumed ( $P_{in}$ ) curve will drop over a certain range of diode voltages ( $V_D$ ). As a result of this situation, we have an unstable power input curve similar to the unstable voltage input curve (Fig. 5 of previous article) discussed before. Just as several output voltages could result from a single input voltage, several amounts of power consumed

at the output can result from a single amount of input power.

We have seen that when the value of the output resistor ( $R_2$ ) is too small, the circuit's voltage gain is reduced; and when the value of the resistor is too large, the circuit loses its stability. We have also seen that when the value of the input resistor ( $R_1$ ) is too small, the circuit's power gain is reduced; and when the value of the resistor is too large, the circuit loses its stability.

Experiments have shown that a tunnel diode circuit is stable when the sum of the positive resistances in the circuit is smaller than the tunnel diode's maximum negative resistance. The total positive resistance calculated for the circuit must include the positive resistance ( $r_s$ ) present in parts of the tunnel diode that are in series with its negative resistance ( $-r_d$ ), as well as the other positive resistances present in the circuit. (Circuit stable when

$$R_1 + R_2 + r_s < -r_d.)$$

The tunnel diode's negative resistance is frequently expressed in terms of its negative conductance

$$\frac{1}{-r_d} = -g_d. (g_d = \frac{\Delta_i}{\Delta_v}.)$$

For the sake of simplicity, we have considered only the positive dc resistances present in the input, output and tunnel diode. At higher frequencies, the impedance of each of these portions of the circuit must be included in their total resistance.

Experiments have also shown that the tunnel diode generally experiences better gain when the value of the output resistor ( $R_2$ ) is greater than that of the input resistor ( $R_1$ ). (Normally  $R_2 > R_1$ .)

### More Common Amplifier Circuits

The tunnel diode circuits that have been shown (Fig. 3 and 10 of the previous article and Fig. 1 of this article) are identical and were illustrated only for the purpose of discussing different aspects of the circuit. The same circuit can be shown in still a different prospective (Fig. 3). Although this circuit has many practical applications in its present form, occasionally the bias supply must be separated from the input signal. This can be done with the use of coils (Fig. 4).

As many readers know, the amount of current that can pass through a coil is dependent on the resistance of the coil, its impedance and the frequency of the voltage across it. When a dc voltage is applied to a coil, the current is dependent solely on the coil's resistance ( $I = \frac{V}{R}$ ).

A coil's ability to conduct current decreases as the frequency of the voltage increases. This reduction in

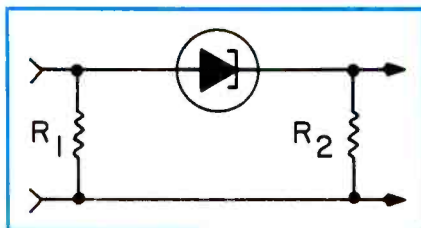

Fig. 3—A more common view of the simplified amplifier circuit.

current flow is due to the reactance ( $X_L$ ) of the coil ( $I \approx \frac{V}{X_L}$ ).

There is a definite relationship be-

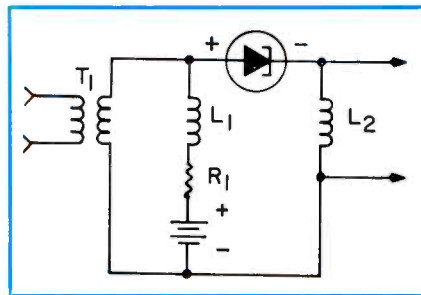

Fig. 4—A more complicated tunnel-diode amplifier circuit.

tween the impedance of the coil ( $L$ ), the frequency of the voltage ( $f$ ) and the reactance ( $X_L$ ). ( $X_L = 2\pi fL$ .) If the impedance of a coil is  $15\mu h$ , and the frequency is  $100MHz$ , we can calculate the reactance ( $X_L = 2\pi fL \approx 2 \times 3.14159 \times 10^6 Hz \times 15 \times 10^{-6} L \approx 9,424.8 \approx 9K$ ).

A resistor ( $R_1$ ) is placed in the circuit (Fig. 4) to reduce the current passing through the tunnel diode and secondary winding of the transformer ( $T_1$ ). If the transformer has a  $60\Omega$  secondary winding and the output coil ( $L_2$ ) has a  $92\Omega$  resistance, the resulting voltage drops would be the same as those shown

in Table II of the previous article, and a current of  $4.23ma$  would have to pass through the resistor ( $R_1$ ) before  $200mv$  could be developed across the transformer's secondary winding. When the power is supplied by a  $3v$  battery, the total dc resistance of the coil ( $L_1$ ) and resistor ( $R_1$ ) must be sufficient to develop a  $2800mv$  ( $2.8v$ ) drop in voltage ( $3000mv - 200mv = 2800mv$ ). We can calculate the total resistance required for these conditions

$$(R = \frac{V}{I} = \frac{2800mv}{4.23ma} \approx 662\Omega).$$

If the coil has a dc resistance of  $5\Omega$ , the resistor ( $R_1$ ) must have a value of  $657\Omega$ .

Since the transformer cannot transfer dc currents from one winding to another, the primary winding is free of dc current and the resulting bias. An unbiased input signal can pass through the transformer's primary winding and develop a signal on the biased secondary winding. Due to the high impedance of the coil ( $L_1$ ) in the battery circuit, virtually all of the ac signal current is applied to the tunnel diode portion of the circuit. The signal, imposed on the bias voltage present at the transformer's secondary winding, changes the diode's voltage and the output voltage in the same manner discussed earlier. From Table I of the previous article we see that if a  $2.8mv$  signal is present on the  $200mv$  bias of the transformer's secondary winding, a  $9.2mv$  signal is developed across the output coil ( $L_2$ ).

### Tunnel Diode Oscillators

With a slight modification, the amplifier circuit (Fig. 4) can be changed into a Hartley-oscillator circuit (Fig. 5). This can be done by substituting a coil ( $L_3$ ) for the secondary winding of the transformer ( $T_1$ ). By properly aligning the input coil ( $L_3$ ) with the output coil ( $L_2$ ), any signal present across the output coil is induced in an inverted form across the input coil. This signal is then amplified and inverted by the tunnel diode, increasing the amplitude of the signal originally present across the output coil ( $L_2$ ). The circuit oscillates as

Part one of a

# TEKLAB REPORT

test instrument series

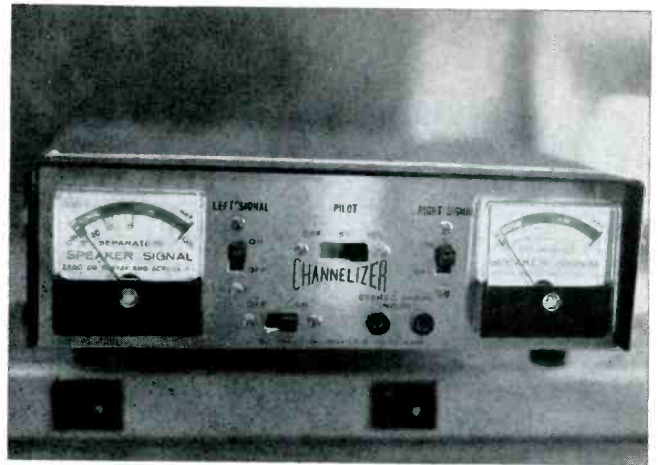

Sencore's MX 11 solid-state multiplex stereo generator.

## Using Audio Test and

■ More FM broadcasting stations are going over to FM/stereo every year. The public is buying more and more FM/stereo receiving equipment. And alert service-dealers and technicians have already up-dated their test instruments and have "beefed-up" their technical "repertoires." But many service-dealers and technicians have not done this. They cannot continue in the same old rut and operate in this area successfully. There are good reasons why this cannot be done.

The FM/stereo reception standards laid down by the FCC, for example, cannot be met without employing specialized test instruments. And because the public becomes increasingly discriminating and demanding, we already know that signals from FM stations are not accurate enough to align an FM/stereo multiplex receiver. You can't use your ears to determine if the program material from right and left channels is being properly reproduced.

Major test instruments needed for applying fast and accurate troubleshooting techniques to FM/stereo equipment include a good scope—either a dual-trace, dual amplifier type—or one having an adequate accessory electronic switch (flip-flop), a good squarewave generator and a multiplex generator for checking out and aligning FM/stereo

equipment. The latter instrument will be considered first in this article series.

It may prove helpful at this point, however, to briefly review FM/stereo principles by way of refreshing our memories.

### FM/Stereo Principles

To transmit FM/stereo over present FM channels—without having to increase the number of channels—the present multiplexing system was developed. It involves a "time-sharing" process whereby the left and right channel signals are "mixed" together to form two new signals—

sert the 38kHz carrier in the receiver. This is the complete FM/stereo signal as transmitted.

To demodulate and "decode" the signal into left and right, a multiplex section is used in the FM receiver (see Fig. 2). The composite FM signal is detected in the regular way and fed into the multiplex section. Here the 19kHz is picked off and amplified. It is then doubled to 38kHz or used to control a 38kHz oscillator. The signal from the 38kHz oscillator is fed to the diode demodulator. The L-R and L+R signals are fed to the center tap of the transformer secondary at the

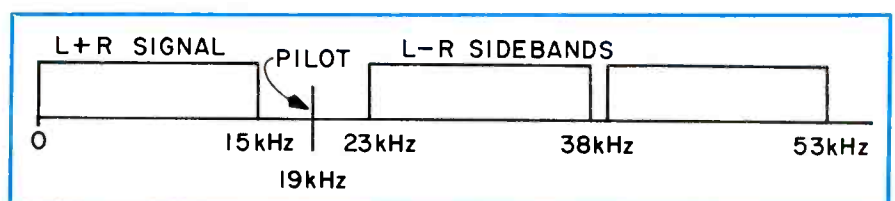

Fig. 1—The complete FM/stereo signal as transmitted.

L+R and L-R (see Fig. 1). The L+R signal is used to frequency-modulate the standard carrier. This gives listeners with a regular FM receiver the full broadcast.

The L-R signal is used to modulate a 38kHz subcarrier and produces L-R sidebands. The 38kHz subcarrier is suppressed at the transmitter and a 19kHz signal, one half of 38kHz, is transmitted to rein-

output of the demodulator. These are mixed with the 38kHz signal and the two are "beat" together again to form the left and right signals.

If the phase of the 38kHz signal in the receiver is not the same as that of the transmitter, then some of the left signal will appear in the right channel and some of the right signal will appear in the left channel.

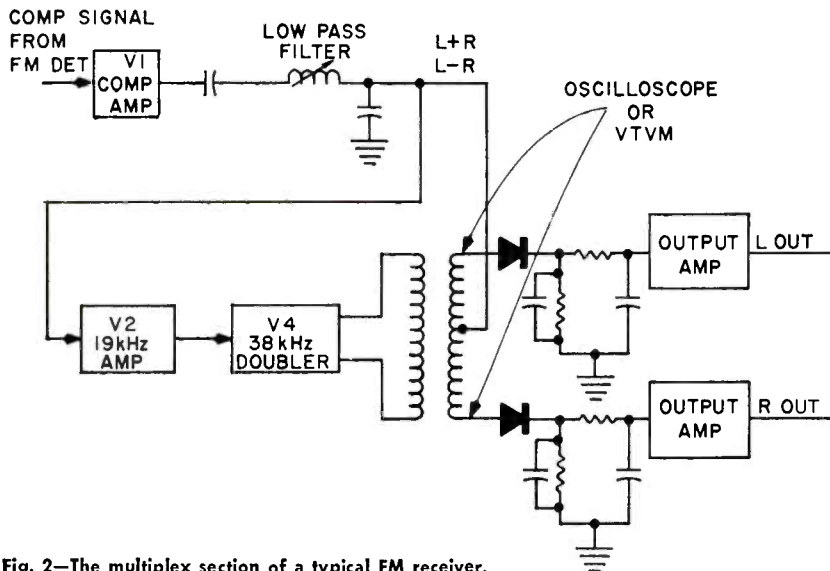

Fig. 2—The multiplex section of a typical FM receiver.

# Alignment Instruments

This would result in poor separation—poor stereo reception. Thus, the 19kHz must be peaked to provide good lock-in and the 38kHz must be phased to give good stereo reception. Here is where we need a stereo multiplex generator.

## A Typical Multiplex Generator

The schematic of a typical solid-state stereo multiplex generator is shown in Fig. 3. Important specifications which most technicians are interested in are listed in Table I.

This generator produces a composite multiplex signal similar to that transmitted by an FM stereo station. The generator provides left and right channel signals and a 19-kHz pilot signal. Composite signals can be used to modulate an FM carrier from a jack on the front panel.

This particular generator uses transistor TR1 and the 76kHz crystal in the Pierce-type oscillator to control multiplexing (see Fig. 3). The output of the 76kHz oscillator is coupled through C3 to the shaping stage, TR2. Here, the signal is shaped into pulses, then coupled through diodes D1 and D2 to the 38kHz bistable multivibrator, TR3 and TR4.

The 38kHz bistable multivibrator divides the input 76kHz frequency signal by one half or 38kHz. The 38kHz output signals are sym-

metrically square waves 180deg out of phase with each other, used to control the left and right signal switches, TR9 and TR10.

A phase shift oscillator, TR6, operates at 1kHz producing the audio note for the generator. The output is directly coupled to an emitter follower, TR7. The output of TR7 is coupled through the left and right panel switches, S2 and S3, to emitter followers, TR8 and TR11. When S2 and S3 are off, supply voltage is removed from TR6 and TR7 to prevent interference from the 1kHz signal.

TR8 couples the right signal into the right signal switch, TR10. Here, signal switches turn the left and right signals off/on at the 38kHz rate and produces the multiplex signal. The multiplex signal is taken from the center arm of the balance control, R27, and direct coupled to a balanced emitter follower, TR12. The output of TR12 is coupled through a filter consisting of L2, L3 and C16 (see Fig. 3). This filter removes the 3rd harmonic of the 38kHz signal (114kHz) which causes interference if left in the signal. Linearity control, R34, compensates for any phase shift in the filter. The output of the filter is coupled through R33 to the base of the modulator, TR13.

This particular generator employs a Colpits oscillator, TR5, used for

the 19kHz pilot oscillator, controlled by a pulse from one side of the 38kHz bistable multivibrator. The phase is adjustable by the slug of L1 to provide correct phase between the 19 and 38kHz signals. The 19kHz output is coupled through the pilot switch, 54, to the modulator. The pilot switch has three positions, OFF, 5 percent, and 10 percent. In the off position, supply voltage is removed from the 19kHz oscillator to insure no interference when not using the 19kHz signal. In the 5 percent position, the signal passes through R17 and in the 10 percent position through R16 providing the proper amount of pilot signal to the composite signal.

Multiplex signal from the filter and the pilot are fed to the base of the modulator TR13. The modulator output is coupled to the stereo signal jack through C17 (0.1μf 400v) reduced, in divider R36, R37 and coupled to the base of the RF oscillator, TR14, through C18.

The RF oscillator is adjustable by L4 from 90 to 105MHz. The composite signal, from the modulator frequency modulates the RF oscillator. The RF output is taken from the emitter of TR14 and coupled through C24 to the RF cable. The RF cable is coupled through C24 to the RF cable. The RF cable is terminated with a resistor pad, R47, R48, R49, to match the 300 input of the FM receiver.

The generator has a self-contained power supply making it portable, consisting of 8 "C" cells forming two supplies, plus 6v and negative 6v with the same common. When the potential drops below 5v, on either the plus or minus supply, the batteries should be replaced.

In case the receiver outputs are not at ground, the left and right meters, M1 and M2, are separate from other circuitry in the generator and do not tie to a common ground. The meters are simple ac volt meters. In case the speakers are removed, 2 8Ω5w resistors are used as loads, R43 and R44. The ac signals impressed across resistors R43 and R44, are rectified by diodes D3 and D4 which supply dc current to deflect the 1ma meters. R45 and R46 are selected so that 3v RMS will deflect the meter full scale.

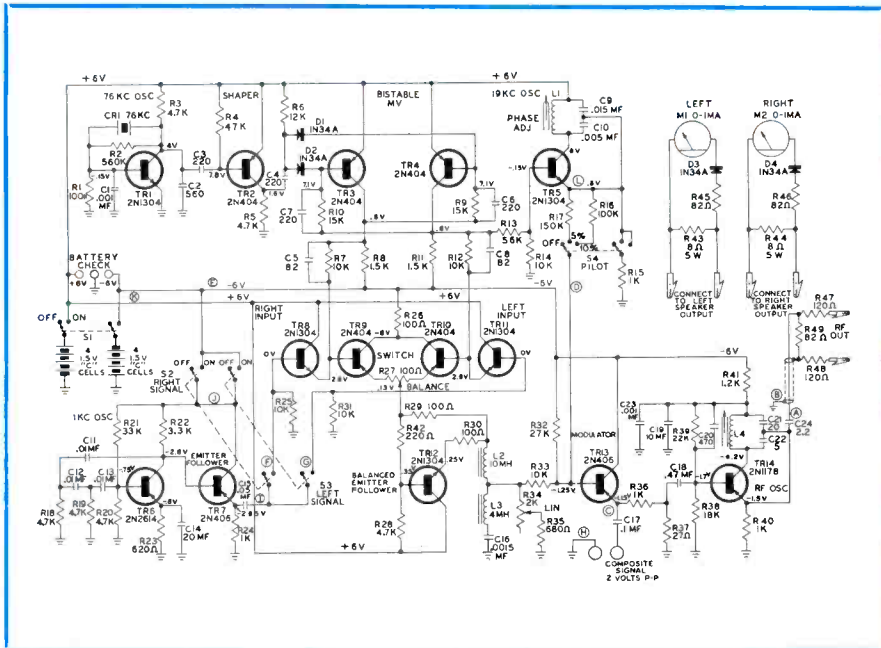

Fig 3—Schematic of Sencore's Solid-state MXII stereo generator.

### Using the Generator

To use the generator:

1. Connect the RF cable of the generator to the antenna terminals of the receiver under test. The RF signal produced by the generator is basically the same as that transmitted by a stereo FM station.

2. Turn both left and right signal switches on. Tune the receiver to 100MHz but if a local station is operating near this frequency it may cause interference, the generator can be adusted from 90 to 105MHz.

3. Connect the left speaker from the generator to the left speaker output terminals on the receiver, and the right speaker leads to the right speaker output terminals. If the 1kHz tone is not desired you may disconnect the leads to the speakers. The generator has built in load resistors to provide a load.

4. Switch the generator and the receiver on. Adjust the receiver volume and balance controls until both meters on the generator read on the REF line (full scale). Now the generator is hooked up to the receiver and a monophonic signal will be coming through.

### Checking Separation

Check separation by turning the left signal switch off and turn the pilot to 10 percent. The left meter

indication should drop from the REF line while the right meter indication will remain at the REF line or will change only slightly. Read the channel separation on the left meter. It can be read as LOW, GOOD or HIGH from the meter or in actual db. If the meter falls into the green area the separation is 10 to 20db or better. The low area indicates that it is less than 10db. If the receiver shows low separation, it is a good idea to check the multiplex section of the receiver for proper alignment.

If we turn the right signal switch off and leave the left signal switch on, the right meter indication should drop and the left meter indication should remain about the same. Separation will show on the right meter.

### Checking A Multiplex Receiver

A tube or component failure will narrow the bandpass of the RF or IF section of a receiver and will affect the stereo signal and the separation. To isolate the problem to the RF, IF or multiplex section, a signal is injected directly.

1. Speaker leads from the generator are connected to the speaker outputs on the receiver.

2. Connect a lead from the black STEREO SIGNAL jack to the chassis or common of the receiver, and a lead from the red STEREO SIGNAL jack to the input.

TABLE I

#### RF Output

1. Factory tuned to 100MHz (adjust from 90 to 105MHz)
2. Output, 3K
3. Impedance at cable, 300Ω

#### Composite Multiplex Signal:

1. Output at jacks, 2v P-P
2. Output impedance, 1KΩ

#### 10kHz Pilot:

1. Output at signal jacks, .2v P-P at 10% setting
2. Frequency, crystal controlled 19kHz ± .01%

#### Semiconductor Complement:

- |           |          |
|-----------|----------|
| 5—2N13404 | 1—2N1178 |
| 5—2N404   | 1—2N2614 |
| 2—2N406   | 4—1N34A  |

#### Power Consumption:

- 12ma from —6v Supply
- 12ma from —6v Supply

#### Size:

8x10x3

#### Weight:

5½ Lb.

Important specifications of Sencore's MXII generator.

3. Turn the LEFT and RIGHT signal switches to ON. Adjust the receiver volume and balance controls until both speaker meters read at the REF line.

4. Turn the PILOT to 10 percent and turn the LEFT signal switch to OFF. The LEFT speaker meter indication will drop off while the RIGHT will remain at the REF line.

5. Read the channel separation from the LEFT meter. If the separation is the same as when the signal was placed through the RF cable into the antenna terminals, then the multiplex section is at fault. Proceed with the alignment of the multiplex section. If the separation is better than that obtained when the signal was placed through the RF cable into the antenna terminals, then there is a problem in the RF or IF sections.

The generator can also be used to check lock-in ability of a stereo receiver. The receiver may give separation on a strong signal but may give no separation on a weak signal. Generally the 19 and 38kHz are out of alignment in this case and a weak signal can be simulated.

Alignment of the multiplex section can also be performed accurately with the generator.

A forthcoming article will cover other test instruments and their uses in servicing audio equipment. ■



This **Remington** PREMIER PORTABLE TYPEWRITER

**FREE**



**WHEN YOU BUY THIS RCA WR-64B  
COLOR BAR / DOT / CROSSHATCH  
GENERATOR...THE ESSENTIAL  
COLOR TV TEST INSTRUMENT**

Here's a deal you can't afford to miss! A FREE Remington portable typewriter—yours when you purchase the most essential color-TV test instrument—the RCA WR-64B!

Just imagine how handy your new typewriter will be—in the shop or at home. You'll use it almost as much as you use the RCA WR-64B—standard of the color TV servicing industry.

Here's how to get your FREE Remington Typewriter. Mail in the warranty card plus the gold label from the shipping carton of your new RCA color bar generator to RCA Test Equipment Headquarters, Bldg. 17-2, Harrison, N.J. We will ship your new Remington portable typewriter to you direct, freight prepaid. But remember—this offer covers only equipment purchased between February 1, 1967 and May 15th, 1967. To allow for postal delay, we will honor cards postmarked up to May 31st.

Plan NOW to take advantage of this BIG offer—a FREE Remington portable typewriter with your purchase of an RCA WR-64B color bar/dot/crosshatch generator.



The standard of the Color-TV Servicing Industry. Generates all necessary test patterns—color bars, crosshatch, dots plus sound-carrier. **Only \$189.50\***

\*Optional Distributor resale price. All prices subject to change without notice. Price may be slightly higher in Alaska, Hawaii, and the West.

Ask to see it at Your Authorized  
RCA Test Equipment Distributor

RCA Electronic Components and Devices, Harrison, N.J.



The Most Trusted Name in Electronics



# RCA FIELD SERVICE GUIDE

RCA  
COLOR TV  
RECEIVERS  
1955-1966

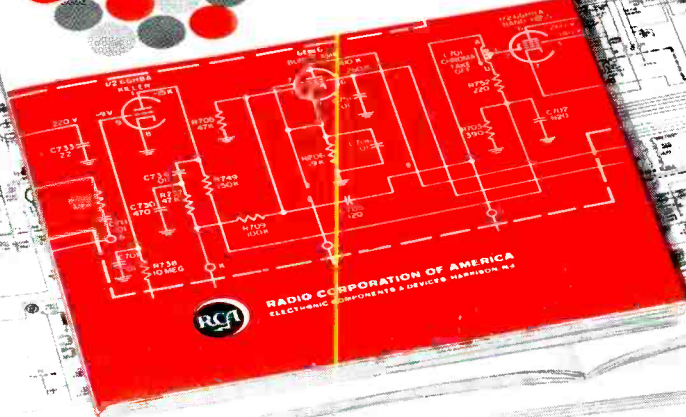
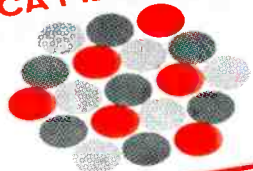

RCA  
RADIO CORPORATION OF AMERICA  
ELECTRONIC COMPONENTS & DEVICES, HARRISON, N.J.

CTC-19A, C, D, U, P Series



# Get RCA's new field service guide FREE with your purchase of RCA's receiving tube Color Pack '67!



When you buy the RCA Color Pack '67 from your local participating RCA Tube Distributor, you get 21 popular RCA receiving tubes for color TV *plus* the new RCA Field Service Guide for the price of the tubes alone.

The RCA Field Service Guide helps you perform *all adjustments on an RCA color set that can be performed in the home with the aid of a color bar generator, including step by step procedure for replacing a color picture tube.*

**WHAT THE GUIDE CONTAINS:**

- Schematics on all RCA color sets for the last ten years
- Field service adjustments
- Parts lists
- Wave forms for majority of chassis
- Top and rear chassis views
- Photos of typical receivers
- Index of models from CTC2 through CTC20
- Convergence, purity and black and white setup adjustments
- Separate section on tuner schematics

Three part index lets you look up the set you are working on by model number, name or chassis number. The RCA Field Service

Guide will be your constant companion on house calls for RCA color sets.

**Each Color Pack '67 contains one each of these tube types:**

1V2	6BK4B	6EA8	6GH8A
3A3A/3B2	6CB6A	6EM7	6CU7
6AQ5A	6CG8A	6EW6	6JU8A
6AU4GTA	6DQ5	6FQ7/6CG7	6U8A
6AW8A	6DW4B	6GF7A	12BH7A
			12BY7A

See your participating RCA Tube Distributor now. Order the RCA Color Pack '67 and get your copy of the Field Service Guide FREE!

RCA Electronic Components and Devices, Harrison, N. J.



THE MOST TRUSTED NAME IN ELECTRONICS

# NEW PRODUCTS

For additional information on any products in this section, circle the numbers on Reader Service Card. Requests will be handled promptly

## CB Transceiver 700

A solid state 23-channel frequency-synthesized citizen band transceiver is announced. It delivers 5w with 100%

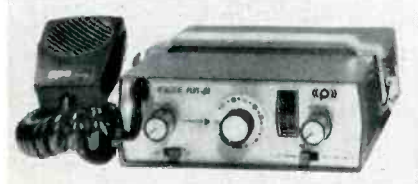

modulation. The receiver section incorporates a field-effect transistor in a double conversion design. The signal strength meter indicates strength of incoming signal in "S" units. A total of 22 silicon transistors are installed on glass-fiber circuit boards. Other features include a noise-clipping switch for extended range or high noise areas and an external public address jack with front-panel control. Dimensions, 6-3/4 x 2-3/8 x 8 3/8 in. Power, 12vdc or 115vac. Price \$199.00. Pace.

## Audio Generator 701

An audio sine and squarewave generator is announced, which reportedly produces a 7v signal across a 1M load. Specifications indicate that the sinewave frequency range is



60Hz to 30kHz. The output impedance is reportedly adjustable from 0 to 5K. The instrument measures 7 1/2 x 10 1/2 x 5 3/8 in. Price \$35.95. Olson Electronics.

## Adhesive Cable Duct 702

Introduced is an adhesive backed cable duct which is designed to accommodate coaxial cable or bundles of wire up to to 3/8 in. diameter on desks, tables, counters, cabinet chassis or as a raceway along corridors



and across ceilings. The duct reportedly requires no tools to install and eliminates the need for drilling holes. It is mounted with the aid of an adhesive foam backing; a paper backing protects the adhesive until ready for use. After the cable is laid in the duct, the top is pressed into place, where it locks shut. 3M Co.

## Universal Test Clamp 703

Announced is a test clamp that consists of a fine retractable spring

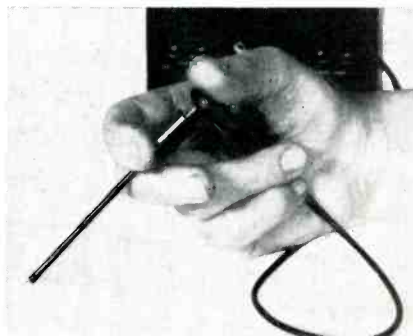

clamp, which is activated by a light pressure on the head of the handle. According to the manufacturer, the clamp will grip the finest wire and then retract into the insulating sleeve thus permitting its use in high-density circuitry without any danger of short circuits. The head contains a standard banana plug jack which allows flexibility in rapid interconnection. Price \$1.50. Hunter Associates.

## Amplifier/Modulator 704

An assembled amplifier/modulator is available, having a circuit con-

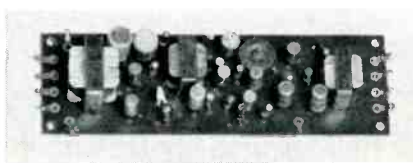

taining 5 transistors and a thermistor. The 5 1/2 x 1 3/4 in. circuit board contains a shielded input transformer with 50Ω and high impedance primary windings and an output transformer with 8Ω and 500Ω secondary windings. Powered by any 9vdc source, the amplifier reportedly has a 200mw push-pull output and an 80db gain. Round Hill.

## Portable Generator 705

A portable electric generator incorporates a permanent magnet outer



space design. Specifications indicate that it provides up to 2kw of 60Hz, 115v or 230v electric power. The voltage as shown on the voltmeter can be adjusted from the throttle of the 5hp engine. It is fused and weighs 76 lb. McCulloch.

## CB Signal Generator 706

A CB signal generator, designed for checking and servicing citizens' band

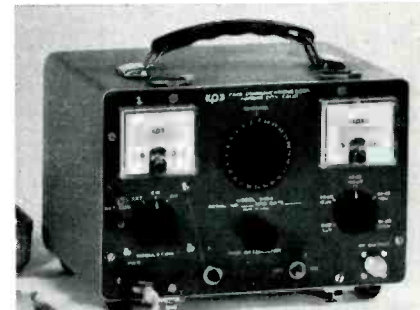

radio equipment, is announced. The solid state unit provides 24 crystal-controlled channels (23 discrete CB frequencies plus one spare). Modulation is adjustable. Pace.

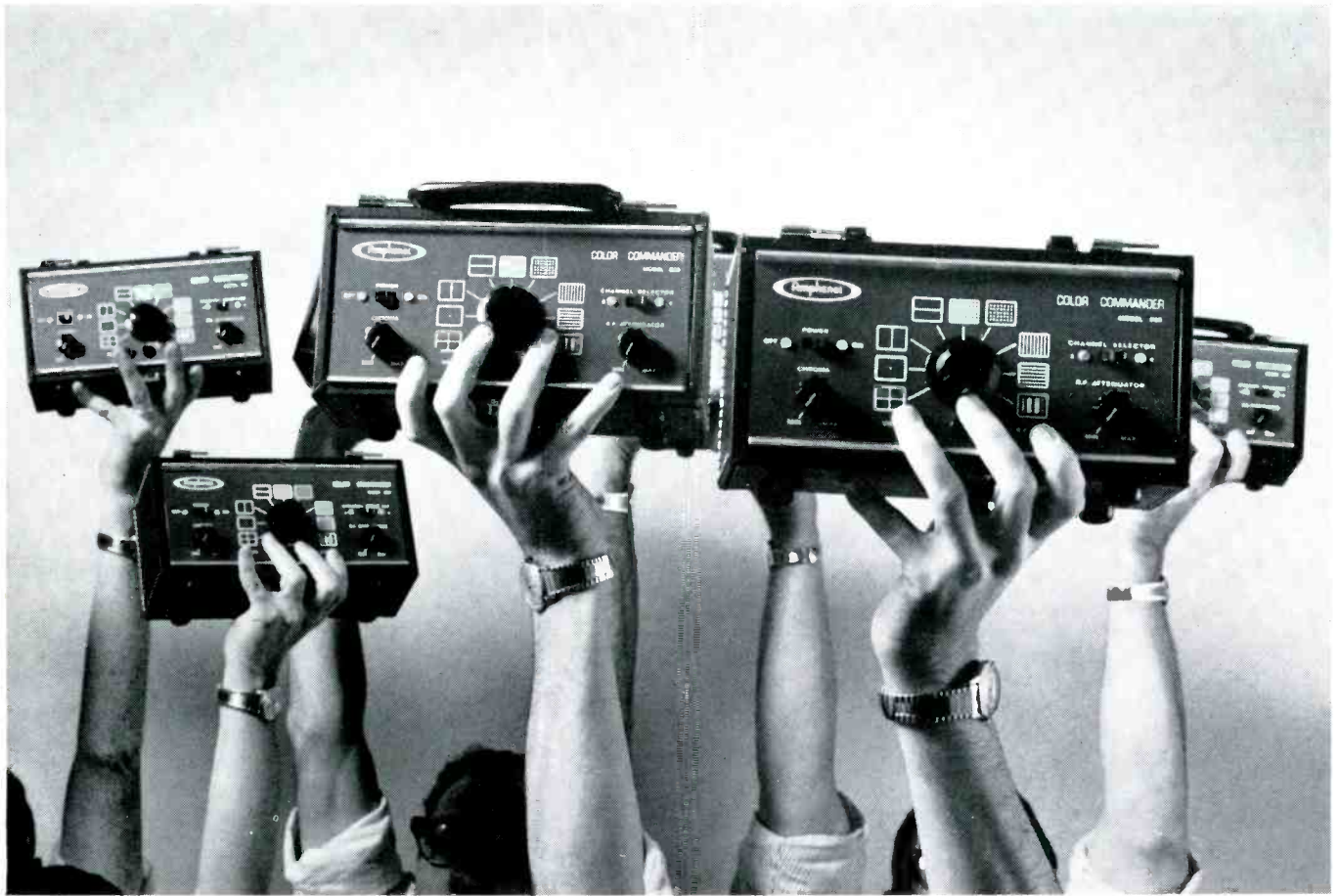

## Suddenly, everyone's a Watch Watcher

We hate to say we told you so. But never-the-less, we told you so.

Service dealers everywhere have been watching their watches. And they've found we were right when we said the Color Commander could save enough time for two or three extra calls a day.

### The reasons are simple.

The *single cross bar* gives fast, accurate reference for both vertical and horizontal raster centering, constant monitor of yoke leveling, and center reference for center purity adjustment.

For static convergence, the *single dot* pattern alone can save about fifteen minutes on your next call. Because it's an excellent quieting pattern, there's no need to pull an IF tube for purity check.

### Everything about the Color Commander is simplified.

For instance, there's a *single vertical line*, for dynamic convergence at top center and bottom center, and a *single horizontal line*, for dynamic convergence left center and right center.

### This simplicity adds up to easier, faster operation.

We could go on and on about the three color bar that's so much faster to work with than the old 10 bar patterns, the three to four aspect ratio cross-hatch for making height, width, and linearity adjustments, and all the rest.

### But you're probably watching the time.

So just ask your Amphenol distributor salesman for a demonstration of this *super stable* generator. He'll be watching for your call.



TM

# AMPHENOL

... for more details circle 104 on postcard

## NEW PRODUCTS

### CB Transceiver Kit 707

A 5w, 23-channel, CB transceiver of solid-state design, is announced.



Specifications indicate the receiver has an IF selectivity of  $\pm 4\text{Hz}$  at 6db down and over 30db of channel rejection on 5 tuned circuits. They indicate the transmitter has  $\pm 80$  percent minimum modulation with 3w of output power. Powered by 12vdc (negative ground). Price \$84.50. AC power supply \$19.95 extra. Battery pack \$19.95 extra. Allied Radio.

### Resin Cable Sealer 708

A two-part resin, designed for capping and sealing communications cables and for capping dropwire stubs

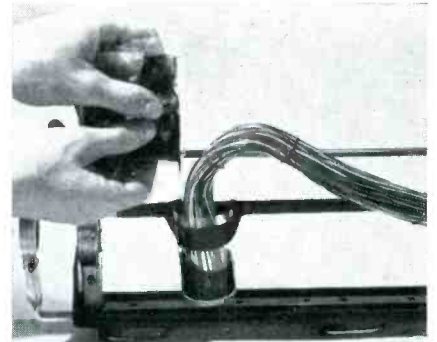

in direct burial splices, is introduced. It is reportedly a fast curing, flexible polyurethane material especially designed for telephone companies and in other communications applications where low-voltage systems are used. The manufacturer indicates that it cures within 2 to 5 minutes at 75°F, a low cure temperature which will not harm sensitive plastic wire insulation. 3M Co.

### CB Transceiver 709

Announced is a solid-state CB transceiver designed for 2w input and a minimum of 1w output. Specifications indicate that the receiver has a sensitivity of  $1\mu\text{v}$  and a selectivity of  $\pm 3.5\text{-kHz}$  -6db. The transceiver is designed



for two-channel use and reportedly comes with one pair of crystals. The manufacturer indicates that jacks are included for an earphone plus external antenna, microphone and stabilized 12v power source. Price \$159.95. Shoulder strap with accessory antenna, speaker and microphone, \$39.95. Sonar.

### AM/FM Radio 710

Announced is a solid-state AM/FM radio. The manufacturer indicates that



this radio has a 3½-in. speaker and slide-rule vernier tuning. Price \$34.95. G-E.

## SHARP NEW BRITENER PROMOTION!

Free

## SCISSORS

with your next pack of  
Vu-Brites or Tu-Brites

This useful premium item is a cut above most "free gifts," just as Perma-Power Vu-Brites and Tu-Brites are a cut above most briteners. These 8-inch and 8-inch straight trimming scissors, nickel-plated, with magnetized blade tips, and they're included with both of these specially priced Britener Packs... available now from your distributor.

SHARP  
SERVICEMEN  
RELY ON  
PERMA-POWER  
TO GIVE  
EXTRA LIFE  
TO FAOING  
PICTURE  
TUBES!

◀ **TU-BRITES**—If the base is right, the boost is right! 4 assorted Tu-Brites—only \$8.95—including the scissors!

▶ **VU-BRITES**—The world's best-selling Britener! 12 Series, or 12 Parallel Vu-Brites—only \$9.95—including the scissors!



**PERMA-POWER COMPANY** 5740 North Tripp Avenue Chicago, Illinois 60646  
Phone: (312) 539-7171

... for more details circle 131 on postcard

Finally somebody is helping...  
helping you prepare for

# The growing crisis in service

Motorola takes the bull by the horns . . . introduces  
“on-the-job” technical training  
for your men—with a greatly expanded  
staff of technical personnel.

Home entertainment products are changing—fast. There’s more transistorization . . . and of course more color every year. This means great opportunity for service organizations that keep abreast. Well-informed technicians will be in even greater demand than they are now.

Motorola can help your service department be well prepared.

We have recently increased our staff of field technical personnel. It is their job to help provide you with Technical information for your men and to give some of the training your men will need to cope with this rapidly changing industry.



Each of our technicians has had extensive, practical consumer experience. They know their business—from your side of the fence. The training will be done *right in your place of business*. It will provide a valuable adjunct to the large-scale training meetings held by Motorola Regional Managers & Distributors.

Two hours will be spent in formal training. The remainder of the day will be spent working with your men *on your work* to give information—and to help find ways to make more profitable and productive use of service time. Get full information on availability of this training for your shop. Just call your Motorola Distributor.



**MOTOROLA®**

... for more details circle 126 on postcard

# NEW PRODUCTS

## Tape Channel Selector 711

Introduced is a home stereo system designed to store a full day and night's worth of taped stereo music, for selection by dial. The system is designed to record, store and play back more than 27 hours of continuous tape programming. Styled as a long, low console, it has 81 tape channels and 162 tracks for recording and playback. Each of the channels reportedly plays for 22 minutes. The console also contains a record turntable, FM/AM/FM-stereo tuner and two dynamic microphones, all of which can be used for stereo tape programming. Retail Price \$1300. G-E.



sole, it has 81 tape channels and 162 tracks for recording and playback. Each of the channels reportedly plays for 22 minutes. The console also contains a record turntable, FM/AM/FM-stereo tuner and two dynamic microphones, all of which can be used for stereo tape programming. Retail Price \$1300. G-E.

communication systems has an internal nickel-cadmium battery supply to take over in the event of an ac power failure. The volume control, located at the front of the set, may be used to turn the volume down, but cannot turn the set off. The ON-OFF switch is located at the back of the set to prevent accidental turn-off. Decoder options may be mounted internally for signaling or alarm. This permits individual receivers or groups to be called selectively and allows for the activation of buzzers, lights and bells. Communication Products.

### Save Time on PC Board Repairs!

MODEL 100A

Melted solder disappears up hollow tip into tube

## The ENDECO Desoldering Iron Removes Soldered Components in seconds... without damage!

Endeco melts solder, then removes it by vacuum • Leaves terminals and mounting holes clean • Resolders too • One-hand operation • Temperature controlled for continuous use • Ideal for use with shrinkable tubing • 4 tip sizes • Quickly pays for itself in time saved • Only \$18.75 net.

SMALLER SIZE AVAILABLE. SEE YOUR DISTRIBUTOR OR WRITE:



ENTERPRISE DEVELOPMENT CORPORATION

5123 E. 65th • INDIANAPOLIS, IND. 46220  
IN CANADA: A. C. Simmonds & Sons, Ltd.  
100 Merton St., Toronto 7

... for more details circle 116 on postcard

## Stereo Amplifier 712

A silicon solid-state amplifier is announced, which reportedly has a 50w IHF power output across an 8Ω load.



Specifications indicate that the amplifier has a frequency response of 20Hz to 20kHz  $\pm 1$ db with less than 1 percent distortion. Kit price, less cabinet, \$99.95. Allied.

## FM Monitor 713

A solid-state, FM monitor receiver for 25 to 50MHz and 132 to 174MHz



## WORLD'S FINEST 5-CORE SOLDER

### ERSIN MULTICORE

### NEW EASY DISPENSER PAK ONLY 69¢

BUY IT AT RADIO-TV PARTS STORES  
MULTICORE SALES CORP., WESTBURY, N.Y. 11591  
... for more details circle 127 on postcard

ORIGINATORS and DESIGNERS of the WORLD FAMOUS CROSS PHASE CIRCUIT  
Now Used By Most Modern-Day Antennas

# KAY-TOWNES

## UHF-VHF-FM antennas

KAY-TOWNES Antenna Co. 1511 Dean Ave., Rome, Ga. 30162

FULL COLOR AND BLACK AND WHITE RECEPTION

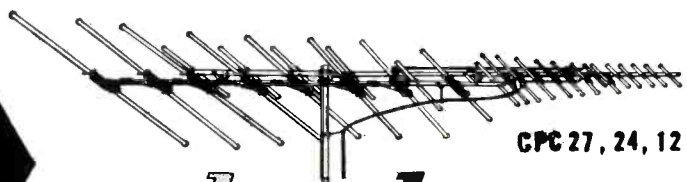

CPC 27, 24, 12

# colorphase

COMBINATION ANTENNA

GETS ALL 82 CHANNELS + FM!

1511 Dean Ave., Rome, Ga. 30162

... for more details circle 124 on postcard

ELECTRONIC TECHNICIAN



**STEP UP  
TO THE  
NEW**



**CONTINENTAL**  
AMERICA'S FINEST,  
MOST RELIABLE  
TUBE  
ANALYZER

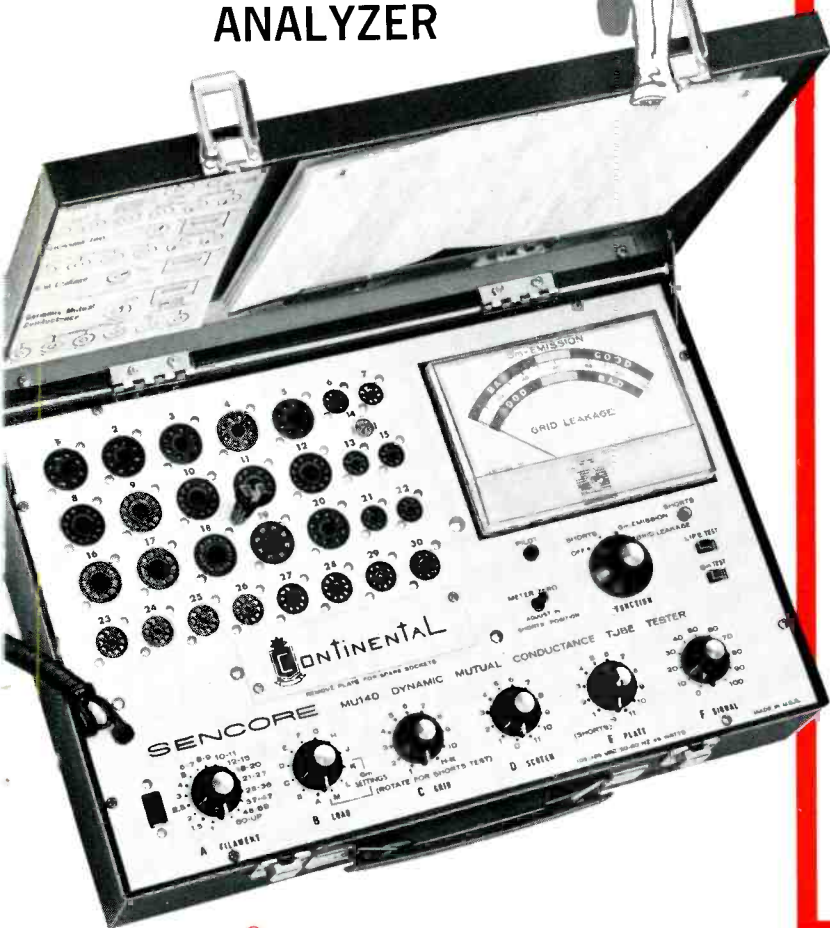

**A "MUST" FOR MODERN SERVICING  
... PRODUCTION LINE TESTING ...  
QUALITY CONTROL ... LABORATORY.**

**A True Gm Tester**

- 5000 Cycle Gm Test
- Full Cathode Emission Check
- 100 Megohm Grid Leakage Test  
and Still the Speediest Tester in Town

In a nut shell . . . here is how Sencore does it. Using only the first three controls, the MU140 becomes a speedy "Mighty Mite" cathode emission tester with grid leakage sensitivity checks up to 100 megohm . . . for fast on the spot service. Flip the last three switches into operation from the set-up data and the MU140 becomes a true mutual conductance tube tester using 5000 cycle square wave to completely analyze any tube. You can't go wrong. No more need to mess around with time-consuming old fashioned tube testers with up to fourteen knobs and a rough 60 cycle sine wave test. The Continental tests them all including foreign tubes . . . over 3000 in all. And, it's guaranteed against obsolescence too with replaceable "new socket" panel and controls so standard that the switch numbers correspond to the pin numbers shown in any tube manual. You can actually set up the Continental without the set-up data in the cover if the need should arise. Here is everything that you could want. Its famous four way independent tests make you a master of the art of tube testing . . . internal shorts test; full cathode emission test; 100 megohm grid leakage test; and to back you up on critical tubes . . . a superb mutual conductance test. The beautiful Continental is housed in a vinyl-clad solid-steel attache case with lustrous all-chrome front panel. Yet at a price below all competition.

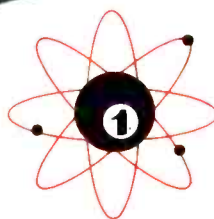

**SENCORE**

*NO. 1 MANUFACTURER OF ELECTRONIC MAINTENANCE EQUIPMENT*

426 SOUTH WESTGATE DRIVE, ADDISON, ILLINOIS 60101

**\$179<sup>50</sup>**

. . . for more details circle 135 on postcard

# look to Xcelite for the best in pliers & snips, too

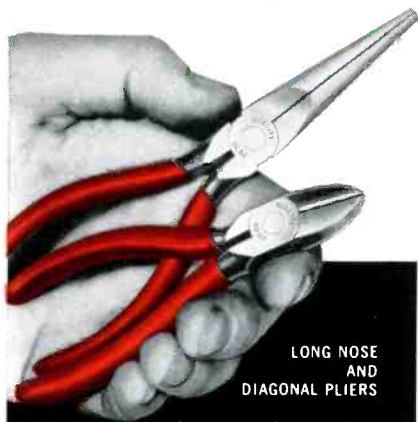

LONG NOSE  
AND  
DIAGONAL PLIERS

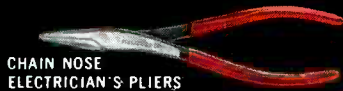

CHAIN NOSE  
ELECTRICIAN'S PLIERS



COMBINATION  
SLIP JOINT PLIERS

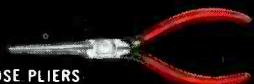

NEEDLE NOSE PLIERS



RADIO AND TV PLIERS



SIDE CUTTING PLIERS



TRANSVERSE CUTTING PLIERS



UTILITY PLIERS

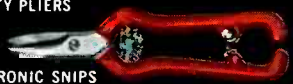

ELECTRONIC SNIPS

Same professional quality as famous Xcelite screwdrivers and nutdrivers. Forged alloy steel construction. Precision machined. Scientifically proportioned. Variety of sizes. All available with permanent, plastic coated Cushion Grip handles for extra working comfort (except slip joint models).

WRITE FOR CATALOG SHEET N664

# XCELITE®

XCELITE, INC., 14 BANK ST., ORCHARD PARK, N. Y.  
Canada: Charles W. Pointon, Ltd., Toronto, Ontario

... for more details circle 143 on postcard

## NEW PRODUCTS

### SW Receiver

714

Announced is a four-tube shortwave superheterodyne receiver designed for continuous tuning from 550kHz to 30MHz with bandspread. Two silicon diode rectifiers are included in the cir-



cuit. Specifications indicate that the variable BFO can be used for the reception of CW and SSB. A Q-multiplier input jack is also included. Kit price \$49.49. Assembled price \$69.95. EICO.

### Solid-State Scope

715

A 6-lb, portable, solid-state, 3-in. oscilloscope is available. The entire



unit measures 3½x7½x12in. Specifications indicate a maximum sensitivity of 10mv P-P per division with a frequency response of 0 to 100kHz for dc or 10Hz to 100kHz for ac. Vertical and horizontal attenuation is adjustable in three ranges of approximately 20db each. The input impedance is reportedly 0.5M shunted by 100pf for both vertical and horizontal amplifiers. Power requirements are 115/230vac, 50-400Hz, 15w. Schaevitz-MCD.

For more information on these

NEW PRODUCTS

See pages 93 & 94

READERS SERVICE

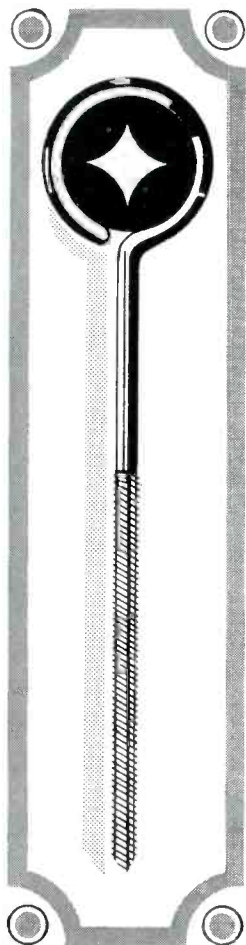

## SEE THE ANTIQUE!



Columbia Wire Products Company's new shielded ultra-low loss Permafoam transmission cable has made standoff insulators a thing of the past. Hookup to the antenna (with terminals already fitted to the cable for your convenience), then run the cable to the set by the easiest route. **Easily terminated at TV set.** You can tape new shielded Permafoam cable to the antenna mast . . . run it down gutters . . . anywhere! Yet, there is no pickup interference. It gets the job done faster . . . to make you more of a good, old-fashioned profit.

You can get full specifications on new shielded Permafoam from your distributor.



*Columbia*   
**WIRE PRODUCTS COMPANY**  
2850 Irving Park Rd., Chicago, Ill. 60618

Available in 50', 75' and 100' coils - 500' spools and 1000' reels.

... for more details circle 115 on postcard

ELECTRONIC TECHNICIAN

As a sample of the important savings and significant books available from **Electronic Technician's Book Club**,

accept this helpful new book for only **99¢**

... with Trial Membership in the Club

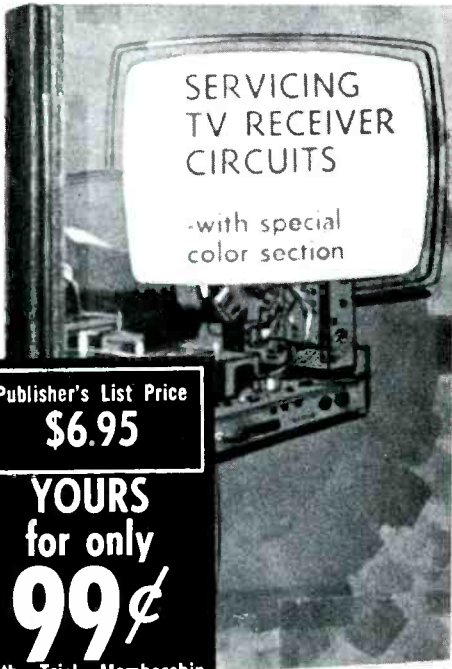

Publisher's List Price

**\$6.95**

**YOURS for only 99¢**

with Trial Membership in Electronic Technician's Book Club.

SERVICING TV RECEIVER CIRCUITS

with special color section

- 224 pages
- Special Color Section
- 34 FACT-FILLED Chapters
- Permanent, Hardbound Volume

### PARTIAL LIST OF CONTENTS

**SERVICING TV RECEIVER CIRCUITS** — with Special Color Section, contains 224 pages — 34 BIG Chapters of the type of practical servicing data every TV service technician should have . . . expert troubleshooting techniques and solutions to the most complex circuit problems. Contains step-by-step approaches to locating and correcting defects in every section of the receiver — from tuner to picture tube, from power supply to audio output. Contains complete analyses of TV circuit troubles and solutions for sweep and sync problems, AGC malfunctions, RF and IF faults, sound and audio trouble, power supply defects, etc.

Using Logic to Diagnose Troubles  
 Developing a Methodical Approach  
 Troubleshooting Sync Circuits  
 Vertical Sweep Servicing Tips  
 Troubleshooting Noise Circuits  
 Troubleshooting AFC Circuits  
 Troubleshooting Synchronizing Circuits  
 Troubleshooting Multivibrators  
 Troubleshooting Horizontal Sweep  
 Selecting Yoke Replacements  
 Solving HV Flyback Problems  
 Troubleshooting B+ Circuits  
 Servicing Sound and Audio Circuits  
 Eliminating Unwanted Oscillations  
 Understanding Transistor Circuits I  
 Understanding Transistor Circuits II  
 Servicing Transistor TV Circuits

Color Television Basics  
 Basic Color TV Circuitry  
 Understanding Chroma Circuitry  
 Details of Color Sync Circuitry  
 Details of Color Demodulation  
 Blanking and Gating in Color Sets  
 Color TV High-Voltage Circuits  
 Color TV Servicing Equipment  
 Chroma Circuit Servicing I  
 Chroma Circuit Servicing II  
 Color Sync and Demodulator Servicing  
 Obtaining Proper Scope Waveforms  
 Automatic Degaussing Circuitry  
 General Color Servicing Tips  
 Servicing the Horizontal Section  
 Servicing the Vertical Section  
 Adjusting Color Convergence

May we send you this unique time-saver as part of an unusual offer of a Trial Membership in Electronic Technician's Book Club?

#### A Massive, Authoritative Compilation

Now you can have at your fingertips, this carefully-planned, comprehensive handbook which contains the TV service data most needed for troubleshooting both monochrome and color receivers.

Selected by the Editorial Staff of "Electronic Technician," this brand-new volume contains just the kind of practical, down-to-earth information you can use in your everyday service work . . . in home or at the service bench.

While no one book is a cure-all for TV troubles, *Servicing TV Receiver Circuits* comes about as close as you can get. Every chapter follows the time-proven method of experienced troubleshooters—analyzing circuit performance and applying logical and efficient test procedures. Numerous example troubles are cited to help you solve "tough-dog" problems.

More than half the content is devoted to color, and includes the practical background theory needed to troubleshoot and repair today's complex color TV receivers. A full 10 chapters are devoted to step-by-step color TV servicing techniques, complete with test procedures, waveform photos, and trouble-correction techniques. While experience is the best teacher, an occasional re-reading of a chapter or two when you're faced with a "tough-dog" set will make this book invaluable to you in servicing TV receivers.

#### How You Profit From Club Membership

This is just a sample of the help and generous savings the Club offers you.

For here is a Club devoted exclusively to seeking out only those titles of interest to you as an electronic technician. Membership in the Club offers you several advantages:

1. **Charter Bonus:** *Servicing TV Receiver Circuits* carries a retail price of \$6.95. But it can be yours for only 99¢ with your Trial Membership.
2. **Continuous Savings:** The Club saves you 15% to 75% on needed books.
3. **Editorial Advisory Services:** The Club's Editorial Advisory Board selects only the books of interest to you.
4. **Wide Selection:** Members are annually offered over 50 books on all phases of electronic servicing by means of the Club's FREE monthly *News*.

This extraordinary offer is intended to prove to you, through your own experience, that these very real advantages

can be yours . . . that it is possible to keep up with professional literature . . . and to save substantially while so doing.

#### Limited Time Offer!

Here, then, is an interesting opportunity to enroll on a trial basis . . . to prove to yourself, in a short time, the advantages of belonging to the only Book Club devoted *exclusively* to electronic servicing. We urge you, if this unique offer is appealing, to act promptly, for we've reserved only a limited number of Handbooks for new Members.

To start your Membership on these attractive terms, simply fill out and mail the Trial Membership coupon today. You will receive *Servicing TV Receiver Circuits* for 10-day inspection. **SEND NO MONEY!**

Send No Money! Simply fill in and mail Trial Membership Coupon Today!

ELECTRONIC TECHNICIAN'S BOOK CLUB, Thurmont, Maryland 21788

Please open my Trial Membership in the Electronic Technician's Book Club and send me a copy of your 224-page *Servicing TV Receiver Circuits* billing me for only 99¢ plus a few cents postage and mailing expense. If not delighted, I may return the book within 10 days and owe nothing. Otherwise, to complete my Trial Membership, I agree to purchase at least 4 additional monthly selections or alternates during the next 12 months. I have the right to cancel my membership anytime after purchasing these four books.

Name \_\_\_\_\_ Phone No. \_\_\_\_\_

Address \_\_\_\_\_

(NOTE: check if  home or  business address)

City \_\_\_\_\_ State \_\_\_\_\_ Zip \_\_\_\_\_

Company \_\_\_\_\_ Title \_\_\_\_\_

(The Club assumes postage on all prepaid orders. Foreign and Canadian prices 10% higher.)

T27

... for more details circle 146 on postcard

# Now an Atlas Sound speaker that can do more than any one speaker could do before...



**SERIES AP-30**  
U. S. DESIGN PATENT #205,663.  
OTHER PATENTS PENDING.

... and all you need is a screwdriver to mount, connect and adjust it.

New Series AP-30 install easier, faster and better with built-in transformers, screw-to-line terminals and watts/impedance switch. Very high efficiency is thrifty with amplifier power for low level reinforcement. The speakers are 30 watts rugged for penetration over distance and noise.

From solderless installation to quality performance on the job, four weather-sealed AP-30 models cover your requirements for most single and multiple installations.

**From \$23.70 net.**

For the complete Professional Series AP-30 story, ask for catalog ETH-13



**ATLAS SOUND**, Division of  
American Trading and Production Corporation  
10 Pomeroy Road, Parsippany, N.J. 07054  
Canada: Atlas Radio Corporation, Toronto  
THIRTY YEARS OF LEADERSHIP IN COMMERCIAL SOUND

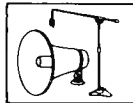

... for more details circle 108 on postcard

## DON'T BOTHER TO READ THIS AD UNLESS...

you're interested in a company that will:



- ★ design your MATV system free of charge
- ★ manufacture all the cable and electronic components
- ★ provide fast delivery—anywhere
- ★ arrange easy credit terms

*This is what we call "Nutshell" service.*

Need equipment or replacement? Interested in Viking's "Nutshell" service? Want to know more? Write or call collect (of course) Viking TODAY!

Remember...for the very best...specify Viking. We give you more...because we can!!!

**viking**

400 Ninth Street, Hoboken, New Jersey 07030  
N.Y. (212) 943-5793 • N.J. (201) 656-2020

... for more details circle 141 on postcard

## NEW PRODUCTS

### CB Walkie-Talkie 716

A 2w walkie-talkie, measuring 8x 3 $\frac{3}{8}$ x1 $\frac{1}{2}$  in. and weighing 2 $\frac{1}{2}$  lb, is now available. Powered by a rechargeable nickel cadmium battery,



it reportedly has an operating range of up to 6 miles when used with similar units, and up to 10 miles when operated with a 5w CB base station. Assembled and tested, it is priced at \$99.95. Heath Co.

### VHF/FM Radiophone 717

Announced is a narrow-band FM, two-way radiotelephone designed to

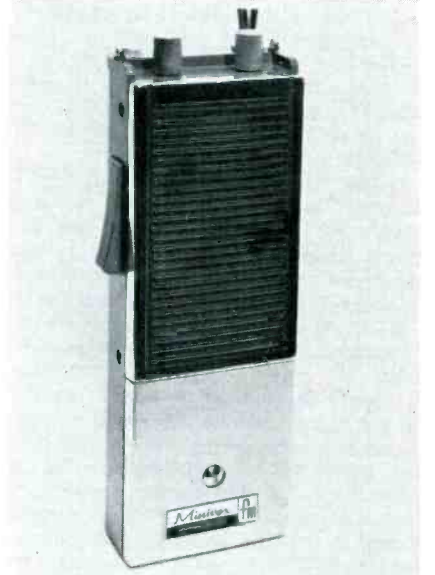

operate on any frequency between 147 and 174MHz. The manufacturer indicates that it contains a 28 transistor, 12 diode circuitry designed to operate from self-contained batteries. According to specifications, it has an RF power rating of more than 1w. Uni-metrics.

# Getting a hernia and not getting paid for it?

Let Arcolytic® capacitors lift the load off your mind. Or anywhere else it happens to be.

These aluminum electrolytics are built to last: wound with computer-grade 99.99% pure aluminum foil so they'll keep operating in your customers' sets even at continuous temperatures of 85°C.

You'll find they take the worry right out of premature failure, lost customer confidence and costly call-backs.

There's no premium cost, either. Arcolytics are priced along with other home entertainment capacitors.

Ask your Authorized Arco Distributor for Arcolytic electrolytic capacitors in single-section tubular, multiple-section tubular, or twist-mount designs. It may be the best break you get this year.

## Arco Electronics

A DIVISION OF LORAL CORPORATION  
Community Drive, Great Neck, N.Y./  
Dallas, Texas/Pasadena, Menlo Park,  
California/Write for our free catalog.



... for more details circle 105 on postcard



ONE GREAT SOURCE

FOR ALL YOUR

# rear seat AUTO SPEAKER KIT needs!



Simplify your inventory problems . . . elevate your quality image with one simple action. Standardize on the complete Oxford line of rear seat auto speaker kits. The Oxford line embraces three separate price and value ranges . . . the Custom line . . . the Deluxe line . . . and the Standard line. In all, there are 11 different speaker kits to choose from in these three ranges.



All are engineered to peak performance and value standards. Alnico V magnets and oversize gap clearances compatible to original automotive equipment are features of all three lines. Easy to install; solderless connectors used on all speakers. Top quality switches and faders featured throughout. Wire harnesses are completely assembled, and heavy gauge plastic coated wire are additional top quality hallmarks of the Oxford line. Both switches and controls are fungus and moisture resistant. All necessary hardware included.



Write for catalog A-105 today and learn how Oxford can make and save extra money for you!

**OXFORD TRANSDUCER COMPANY**

A Division of Oxford Electric Corporation

Visit display room 509-A June 19th through 21st Conrad Hilton Hotel, Chicago.

3911 S. Michigan Ave. Chicago, Ill. 60653

## NEW PRODUCTS

### 9-Pin Test Socket 718

Announced is a new test socket tube adapter designed to simplify servicing TV sets equipped with 9-pin Magnival tubes. When installed between a



tube and its socket, the adapter reportedly permits technicians to make voltage, resistance, audio, and video measurements at the tube base — instead of tracing circuitry to test points underneath the chassis. Price \$2.75. Pomona.

### Tape Recorder 719

A four-track, three-motor, three-speed, solid-state stereo tape recorder is announced. It features straight-line



tape loading with a swing-away pinch roller. Specifications indicate that the frequency response is 50Hz to 15kHz at 7½ ips, 50Hz to 10kHz at 3¾ ips, and 60 Hz to 5kHz at 1½ ips. List price, \$249. Viking of Minneapolis.

### Sideband Crystal Filter 720

A single-sideband, crystal filter, developed for use in amplitude modulated communications equipment, is announced. The filter features carrier and adjacent sideband suppression.

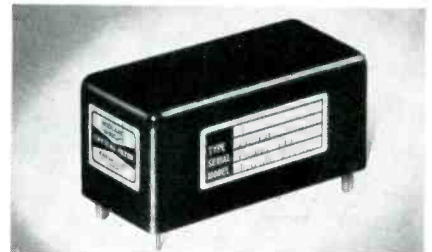

The manufacturer has rated the carrier attenuation at 50db minimum with the unwanted sideband at 65db minimum from -200Hz to -75kHz. The specifications indicate a 1.65 MHz carrier frequency with a 3db bandpass from +300Hz to +3kHz, a ripple of ±0.5db and a nominal impedance of 12K. Unit price \$75. Midland.

### MOVING?

Be sure to include your Zip Code number when sending a change of address notice.

# NEW POWER FROM FINCO

### Model 65-3 VHF-TV ANTENNA AMPLIFIER

improves reception of WEAK VHF-TV signals in FRINGE AREAS even where strong local TV or FM signals are present. AMPLIFIES UP TO 7 TIMES for Better Color and B/W

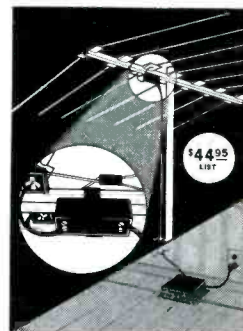

Model 65-3 VHF-TV ANTENNA AMPLIFIER

A two-transistor-amplifier. Engineered to provide the lowest noise and highest amplification with the most desirable overload characteristics.

Amplifier used in conjunction with dual outlet power supply for one, two, or multiple set installations. 117 V 60 cycle input. AC power up to amplifier: 24 volts-60 cycle.

Let Finco solve your Color and B & W reception problems. Write for complete information, schematics and specifications. Form #20-357.

### THE FINNEY COMPANY

34 West Interstate St., Dept 110, Bedford, Ohio

. . . for more details circle 129 on postcard

. . . for more details circle 117 on postcard



RCA  
Transistors  
Rectifiers  
Integrated  
Circuits  
  
For  
**EXPERIMENTERS**  
**HOBBYISTS**  
**HAMS**  
and  
**TECHNICIANS**

LOOK FOR THIS  
DISPLAY AT YOUR  
RCA DISTRIBUTOR

Here displayed on the RCA Solid-State Center is the RCA SK-Series Transistors, Rectifiers, and Integrated Circuits; the new RCA 3N128 MOS Field-Effect Transistor; RCA's 40214 Silicon Stud Rectifier; and three RCA Experimenter's Kits. This new Solid-State Center, in addition to its host of devices, also includes technical literature to support the devices right on the rack. It's the "one-stop" answer to the solid-state needs of experimenter, hobbyist, ham, or the replacement requirements of the service technician.

All devices and kits are packaged in easily identifiable see-through packs for your convenience. Included with each device is broad performance data or specific ratings and characteristics where applicable.

RCA Solid-State Center Includes:

- RCA Experimenter's Kits. Three kits enable you to build a light dimmer or any one of 14 different circuits for dozens of applications around the house.
- RCA SK-Series "Top-of-the-Line" Devices: 17 Transistors, 2 Rectifiers, and 2 Integrated Circuits, for exper-

imenter or replacement use.

- RCA Technical Manuals. Four manuals include: RCA Experimenter's Manual, RCA Transistor Manual, RCA Linear Integrated Circuits Fundamentals Manual, and RCA Tunnel Diode Manual.
- RCA Solid-State Replacement Guide. Lists all RCA SK-Series "Top-of-the-Line" Transistors, Rectifiers, and Integrated Circuits and the more than 7,300 types which they replace.

Keep RCA Experimenter's Kits and the RCA SK-Series in mind when you're shopping for solid-state devices. Look for the RCA Solid-State Center. Now at your RCA Distributor. Do it today!

RCA Electronic Components and Devices, Harrison, N.J.



The Most Trusted Name in Electronics

... for more details circle 133 on postcard

... for more details circle 123 on postcard

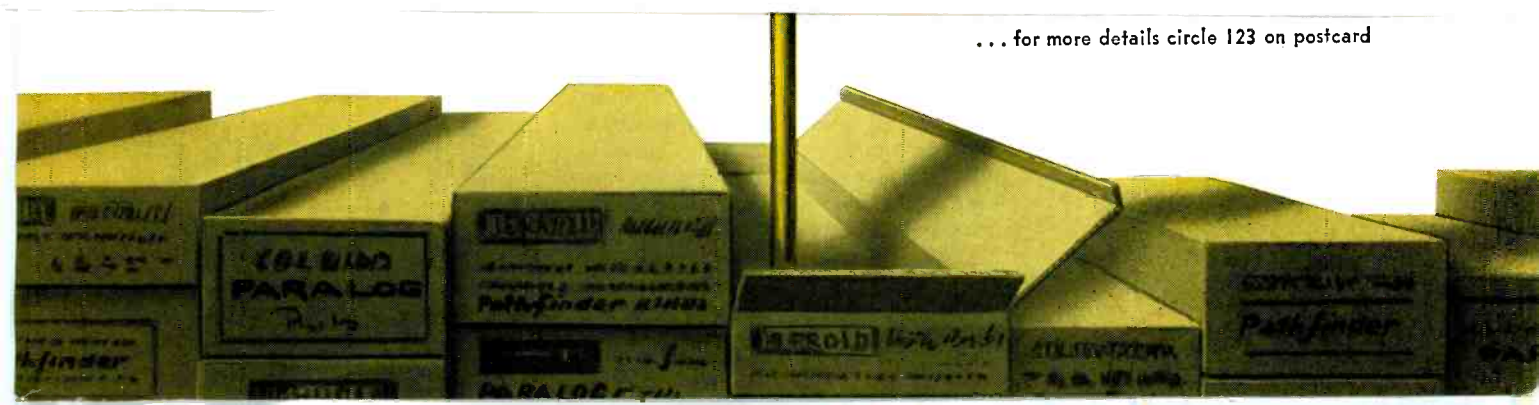

# How Would YOU Like To Have An EXCLUSIVE

FRANCHISE

*Eliminate*  
**confusion  
duplication  
waste**



**STOCK AEROVOX COLOR  
CERTIFIED ELECTROLYTICS  
and be ready for every  
TV set you run across!**

Your customers will like the idea of a high quality "COLOR CERTIFIED" Aerovox Electrolytic replacement going into his set... and you will like the ease and convenience afforded by the New Aerovox Color TV Color Certified Electrolytic Capacitor Replacement Guide.

Get one of these guides FREE the next time you visit your Authorized Aerovox Distributor—and while you're at it, put in a supply of Aerovox COLOR CERTIFIED electrolytics to take care of your service needs... you just can't go wrong.

**AEROVOX**  
Hi-Q  
**AEROVOX**  
CORPORATION

DISTRIBUTOR DIVISION, New Bedford, Mass. 02741  
See us at Aerovox IEEE booths 3J-13-15  
... for more details circle 103 on postcard

## CATALOGS AND BULLETINS

- Power Transistor** 400  
A data sheet describes the characteristics and appropriate circuits for a transistor reportedly capable of delivering 25w at 100°C. Bendix.
- Color Generator** 401

## BOOK REVIEWS

**HANDBOOK OF ELECTRONIC CIRCUITS.** Edited by R. Feinberg. Published by Barnes & Noble, Inc., 196 pages, hard cover. \$9.

A wide assortment of circuits, ranging from dc power supplies to frequency modulators and error predicting circuits, are presented in this book, along with a brief description of their characteristics. Although the book may not tell the reader how to make a finished product as such, it does present basic circuits that can be combined for many applications. The electron tubes for most tube circuits described are generally marketed in this country, while transistor codes for solid-state circuits will seem strange to the average reader and may present a problem for those constructing circuits outside of Great Britain. Under these restrictions, the book should be of interest to anyone who has a basic knowledge in electronics and wishes to construct some electronic circuits.

**101 WAYS TO USE YOUR COLOR-TV TEST EQUIPMENT.** By Robert G. Middleton. Published by Howard W. Sams and Co., 160 pages, soft cover. \$2.95.

A brief discussion of the cost of test instruments in factory assembled and kit form, is followed by techniques for checking the instruments. The book then describes the procedures that should be used for chroma signal tracing, and the tests for color sync, chroma demodulation, matrix, bandpass selection, regeneration, sequential chroma and convergence. Other miscellaneous checks are also included. This information is supplemented with diagrams of circuits checked, plus drawings and photographs of related waveforms. This book should be helpful to technicians who are familiar with B/W TV circuits, and who need to know the fundamentals of color TV repair.

**TRANSISTOR BANDPASS AMPLIFIERS.** By W. Th. Hetterscheid. Published by Philips Technical Library, 338 pages, hard cover.

With the aid of martex algebra, analytical geometry and calculus, the author describes transistor bandpass circuits as four-terminal networks. Such factors as neutralization, double-tuned bandpass filters, staggered tuning and non-ideal transformers are discussed. Since the book was printed in The Netherlands, a three page list

program, bi-stable, time delay and telephone relays — as well as timers and dc contactors. Cornell-Dubilier.

**Base Stations** 409  
Facts about a base station for two-way radio systems are told in a six-page brochure now available. Motorola.

**Miniature Tweezers** 410  
A catalog describes a line of

## Listen!



Service Dealers  
... Eliminate the  
"Time Killer"!

It's not that we have anything against catalogs or those who must refer to them umpteen times a day. It's just that we're in complete sympathy with the time-conscious dealer who'd rather turn a profit than a page.

That's one reason why Jensen has every loud-speaker in the book... so you won't need a book. Simply tell your Jensen distributor the type speaker you need and he'll take it right off the shelf. Easy as that!

When you need a speaker—any speaker—call your local Jensen distributor.

... insist on Jensen.

# jensen

Jensen Manufacturing Division, The Muter Company,  
6601 South Laramie Avenue, Chicago, Illinois 60638.

... for more details circle 122 on postcard  
ELECTRONIC TECHNICIAN



of symbols is important reading for anyone planning to study the book. This book may be of some value to electronic specialists who have studied tube bandpass amplifiers while taking graduate work in electrical engineering.

**COMMUNICATION SYSTEMS AND TECHNIQUES.** By *Mischa Schwartz, William R. Bennett and Seymour Stein.* Published by McGraw-Hill, 618 pages, hard cover. \$16.50.

The material in the first portion of this book was prepared as the text for a one-semester graduate course in statistical communications, while the second was prepared for a course in probability and random processes and the third for a graduate communications sequence. The authors have assumed that the reader has a graduate school background in the theory of linear systems and random processes plus a senior level understanding of communications systems. Beginning with the fundamental aspects of digital and continuous-wave communications in the presence of noise, the theories of these types of communications are developed with the aid of waveform curves and calculus.

## SOLVING . . .

*continued from page 54*

cause a lot of trouble. The resistor was replaced, the new transistor left in the circuit, and the horizontal width was restored to normal. The broader and higher-amplitude waveform at Q402's collector terminal is shown in Fig. 15.

Many technicians, especially apprentices, entertain many confused ideas regarding *theory* and *practice*. Don't confuse basic theory—proven scientific processes—with hypothetical road maps. Electron tubes were designed, operate and check out according to the electron theory. And solid-state circuits follow the theories used to design them and the theories by which they function. And your service techniques must conform.

If you follow theory and fail to get immediate results, don't suspect the theory. Find out where you made a mistake and departed from the beaten path. You'll then be troubleshooting twice as many sets in a day than you did previously. ■

## "TORQUE WRENCH" MANUAL

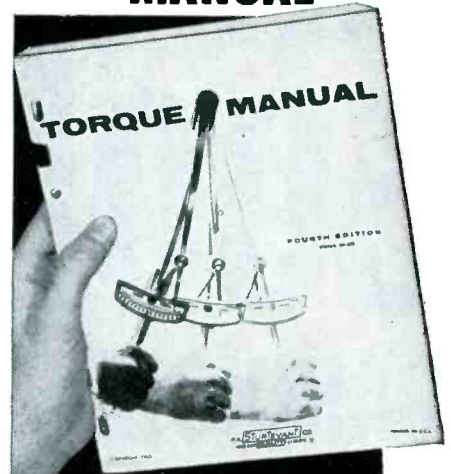

SENT UPON REQUEST  
**Formulas**  
**Applications**  
**Engineering Data**  
**Screw Torque Data**  
**Adapter Problems**  
**General Principles**

P.A. **STURTEVANT CO.**  
 ADDISON QUALITY ILLINOIS

Manufacturers of over 85% of the torque wrenches used in industry

... for more details circle 137 on postcard

# FAMOUS ZENITH QUALITY TUBES for greater reliability, longer life



### TV Picture Tubes

A complete line of more than 200 top-quality tubes. For color, black-and-white, or special purposes.

Zenith black & white replacement picture tubes are made only from new parts and materials except for the glass envelope in some tubes which, prior to reuse, is inspected and tested to the same high standards as a new envelope. In Color tubes the screen, aperture mask assembly and envelope are inspected and tested to meet Zenith's high quality standards prior to reuse. All electron guns are new.

BUILT TO THE QUALITY STANDARDS OF ZENITH ORIGINAL PARTS



### "Royal Crest" Circuit Tubes

A full line of more than 875 tubes . . . the same quality tubes as original Zenith equipment. Your assurance of the world's finest performance.

Order all genuine Zenith replacement parts and accessories from your Zenith distributor.



The quality goes in before the name goes on®

# RECOMMEND THE TURNER 500 CARDIOID

In your business, your reputation depends on your recommendation. Don't risk either — always recommend the high-performing, trouble-free Turner 500 Cardioid. Most problems in PA or sound applications — extraneous noises, poor acoustics, etc. — can be successfully solved by incorporating Turner 500's into the system. So before you make your next installation, check the Reader Service card for the complete Turner catalog. Get details on the Model 500 — list price \$84.00 — and the rest of the Turner line, including:

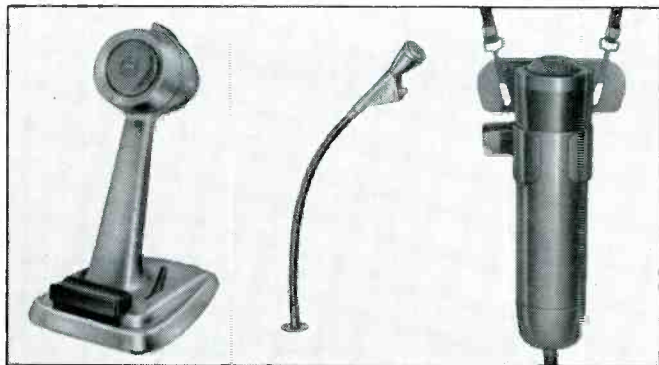
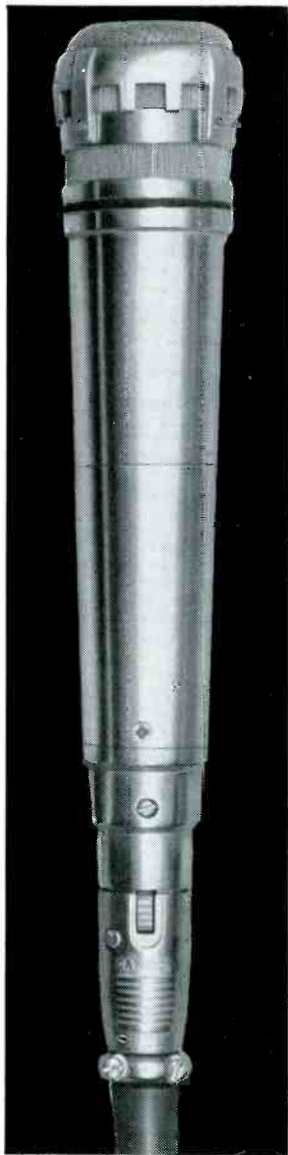

**MODEL 251**

Low cost, high performance paging microphone with Turner's unique lift-to-talk feature. List price \$49.50.

**MODEL SR585D**

Fixed mounted microphone conveniently mounted on a flexible 16" gooseneck. List price \$40.

**MODEL 58**

A natural for any application requiring freedom and mobility ... does double-duty on desk stand. List price \$57.

**THE TURNER MICROPHONE COMPANY**  
918 17th Street N.E.  
Cedar Rapids, Iowa

In Canada: Tri-Tel Associates, Ltd.  
Export: Ad Auriema Inc., 85 Broad Street, New York, N.Y. 10004

... for more details circle 139 on postcard

## NEWS OF THE INDUSTRY

### Merger of ITT with ABC Still Delayed

International Telephone and Telegraph Corp. has issued a statement concerning the action of the Dept. of Justice in attempting to delay the merger of ITT with American Broadcasting Co.'s. The statement said "International Telephone and Telegraph Corp. will vigorously oppose the attempt of the Dept. of Justice to reopen the Federal Communications Commissions proceeding.

"The intention to merge was announced by both companies more than a year ago. Voluminous information about both companies was supplied both voluntarily and on specific request to the FCC which has conducted a continuing investigation during all that time.

"The commission held public hearings which were publicized in advance along with invitations to all interested parties to attend.

"Despite this opportunity, no significant opposition to the merger was raised. The Dept. of Justice neither asked for a delay of these hearings nor appeared at them.

"It is quite clear from the commission's opinion that all facts and considerations raised by the Dept. of Justice were the subject of careful consideration by the commission in approving the merger.

"We are advised by legal counsel that the proposed merger will not be in violation of the antitrust laws. Instead, as the commission has found in its opinion, the merger

### COLOR TV & UHF GHOSTS BEWARE of the

*Brach*

LATEST  
"GHOST ENEMY"



- Outstanding in Value!
- Unequaled in Performance
- Ultimate in Design!

"GHOST ENEMY"  
Model #6702  
Gold Finish

SEND FOR our latest catalog with our complete line of antennas

Dept. Stores, Distributors & Television Manufacturers—Let us quote you on your PRIVATE BRAND requirements.

### UHF/VHF TV ANTENNAS for Black/White & Color

Pinpoint tuning of UHF Loop with separate knob control.

BRACH MFG. CORP. Div. of General Bronze Corp.

899 Main Street, Sayreville, N.J. 08872

... for more details circle 110 on postcard

ELECTRONIC TECHNICIAN

promises unquestionable public benefits' and will 'enhance rather than lessen competition in the field of communications.'

"Therefore, on the basis of the record we will request the commission to reject the Dept. of Justice's petition," the statement said.

### G-E Increases Line of Portable Radios

Six new portable radios have been added to G-E's 1967 line. They include two miniature, eight-transistor models; two miniature, 10-transistor models, with vernier tuning; a multi-band radio for operation in the 4 to 12MHz SW bands and 540 to 1600kHz; plus a marine band portable operating on 1.8 to 5.1MHz, in addition to the standard AM frequency band. Prices of these radios range from \$9.25 to \$24.95.

### Reports on 1966 Sales

While the consumer electronics industry turns its attention more and more to the new year, details of the excellent sales performance of 1966 continue to accumulate.

Color TV and FM radios were the star performers. Year-to-year figures indicate that 4,070,949 color TV sets were sold in 1966, 70 percent more than the 2,394,017 sold in 1965. Predictions for color TV sales in 1967 exceed 7 million sets.

Year-to-year figures show that 1966 FM radio sales were 28.3 percent over the 1965 figures. In 1966, 3,324,707 FM radios were sold as compared to 2,590,387 in 1965. The growth in FM has paralleled the increase in FM stations from 530 in 1965 to over 1500 in 1966.

# INSTANT GRIP



**HOLD . . . START . . . DRIVE** that screw with the wonderful VACO Screw Launcher, the screw-holding driver that turns a job into a jcy. Grasp the large Comfordome® handle and test the superb screw-holding power of the patented double action blade. You'll discover a new world of driving pleasure. 8 sizes and lengths to choose from. Unconditionally guaranteed.

#### SIMPLE TO OPERATE

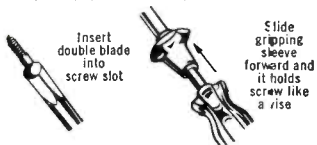

# VACO®

The most powerful name in hand tools . . . terminals  
**VACO PRODUCTS COMPANY**  
 510 N. Dearborn, Chicago, Ill. 60610

... for more details circle 140 on postcard

# Don't let Money-Making Technical Advances Pass You By!

RCA Institutes offers these four comprehensive home study courses especially designed to help build your income immediately:

### COLOR TV

Take advantage of the growing profit potential in this area. Add color TV to your skills with this home training course, newly revised to include information on the latest techniques, receiver circuitry and equipment. Train under the direction of RCA Institutes... experts in Color TV home study training.

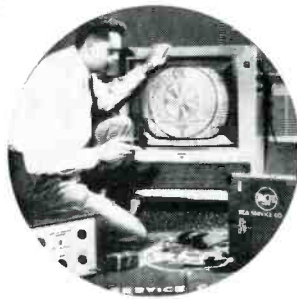

### SOLID STATE ELECTRONICS

You get the necessary background for semiconductor technology including characteristics of tunnel diodes, rectifiers and other solid state devices. Transistor trainer also available.



### AUTOMATION & INDUSTRIAL ELECTRONICS

Trains you for the many applications of automation electronics in industry and government including Photo-electronics, Digital Techniques, Synchros and Servomechanisms, Automatic Control Systems, Nuclear Instrumentation and many more!

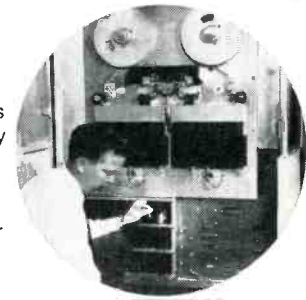

### COMMUNICATIONS

Trains you to service and maintain 2-way radio communications on land, sea and air! Gives you the technical foundation for space communications.

You have no long-term obligations with RCA Institutes Liberal Tuition Plan. You only pay for lessons you order. Licensed by New York State Education Department. Approved for veterans.

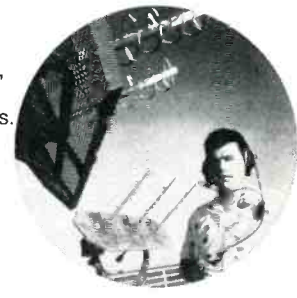

Send this coupon now for complete free information



### RCA INSTITUTES, INC.

Home Study School, Dept.  
 350 West Fourth Street, N.Y., N.Y. 10014

Without obligation rush me free information on the following RCA Home Training Course:  COLOR TV  SOLID STATE  COMMUNICATIONS  AUTOMATION & INDUSTRIAL ELECTRONICS

Name

Address

City  State

IN CANADA - The RCA Victor Company, Ltd.

**MOST  
VERSATILE**

**TRIPLET**

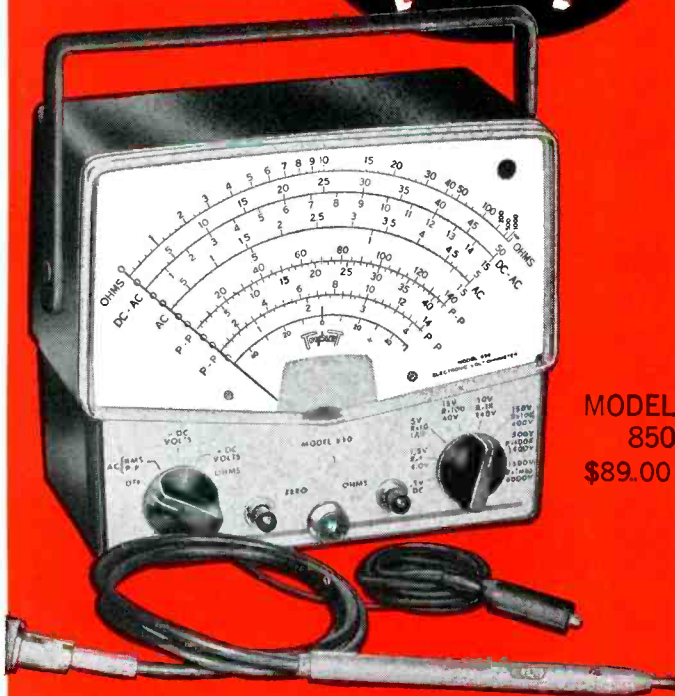

**MODEL  
850  
\$89.00**

## **MODEL 850 ELECTRONIC VOLT-OHMMETER IS BEST FOR YOU**

### **FACTS MAKE FEATURES:**

- 1** Long 7" easy-to-read scale.
- 2** .5 D.C. volt range for transistor circuits.
- 3** HIGH STABILITY. Meter connected in cathode circuit of 12AU7.

High Input Impedance (11 MEGOHMS) and wide Frequency Ranges give this extremely versatile Electronic Volt-Ohmmeter considerable advantage in the measurement of DC voltages, AC RMS and Peak-to-Peak voltages. It measures directly the Peak-to-Peak values of high-frequency complex wave forms and RMS values of sine waves on separate scales.

**ADDED PROTECTION.** Meter is shorted out in OFF position for greater damping, meter safety during transit, electrically protected against accidental overload. ZERO CENTER mark for FM discriminator alignment, plus other galvanometer measurements.

New pencil thin test probe used for all functions: DC, AC, and ohms. No need to change cables. Beautifully styled case for professional appearance and functional utility, 7 $\frac{1}{8}$ " x 6 $\frac{7}{16}$ " x 3 $\frac{3}{4}$ ".

Carrying handle can be used as a tester stand to place the tester at 25° angle for ease in reading.

Frequencies to 250 MC may be measured with auxiliary Diode Probe, \$8.50 extra. DC voltages to 50 KV may be measured with auxiliary High Voltage Probe. \$24.00 extra.

**TRIPLET ELECTRICAL INSTRUMENT COMPANY, BLUFFTON, OHIO**

... for more details circle 138 on postcard

### **Admiral Introduces 180-sq-in. Color TV Set for Commercial Use**

The Commercial Products Div. of Admiral Corp. has introduced a color TV receiver especially designed for hotels, motels or hospitals. Edward J. Troutt, sales manager of the division, said the new color table model features a transformer powered 26,000v chassis, a built-in volume limiter and a 72 $\Omega$  tuner to match a central antenna system. The model also has a switch for blanking out the CRT when music or radio is being received.

### **Electronic Parts Distributor Installs Computer for Stock Control**

Radio Specialties Co. of Detroit has installed an IBM System/360 Model 20 computer to provide up-to-date stock control and better serve their customers in south-eastern Michigan. The computer receives information on current inventory levels — new items received from suppliers and shipments of items to customers. With this data, the master records are updated with the latest information and stock below critical supply levels is listed for purchasing. The computer is also used for billing and sales analysis.

### **3M Develops New Lubricated Magnetic Tape**

The market for lubricated magnetic tapes was once limited to background music and broadcast cartridges. D.T. Windahl, professional accounts sales manager at 3M, indicates that the situation has suddenly changed with the development of automobile tape systems. Mr. Windahl said, "This is especially true when you consider that up to eight separate information tracks as small in width as 0.51mm are now recorded on a single length of 1/4-in. wide tape." Sliding affects tape alignment and a good quality oxide is essential for the slow-speed recording and playback techniques employed in popular cartridge systems. Because of this new demand, 3M indicates they are now producing a lubricated tape containing new lubricants designed to increase performance under the temperature and humidity extremes peculiar to the automobile stereo tape cartridge market.

### **G-E Introduces New Tubes**

G-E's tube department is introducing a new pair of color TV HV rectifier diodes — the 3BN2 and the 3CN3. The 3NB2 reportedly has a four-second cathode warm up time and was designed to provide rectified voltage to the CRT anode in transistor color TV receivers. This tube is generally interchangeable with the 3AT2, which takes nine seconds for warm-up.

The 3CN3 is a heater-cathode type diode that reportedly has a special cathode coating to minimize arcing. Specifications indicate that it has a higher current-handling capability and is also designed to provide the rectifier voltage to the CRT anode in a color TV receiver.

G-E indicates that the 6LC6 it is also introducing is an octal version of the 6EF4 introduced last year. The design-maximum ratings of the two tubes are reportedly identical and include a maximum dc plate rating of 27,000v and a corresponding current rating of 1.6ma.

### Polytronics Cuts Price of CB Walkie-Talkie

Jack Spink, general manager of Polytronics Laboratories, Inc. has announced that the price of the Duo-Comm 120 CB walkie-talkie has been reduced from \$129.50 to \$109.50 as part of an effort to capture a larger share of the CB radio market. The transceiver reportedly contains 11 transistors, a dual-conversion super-heterodyne receiver circuit and a nickel-cadmium battery.

### Mass Production Reduces Integrated Circuit Costs

RCA announces that prices of integrated circuits can be reduced as a result of new levels of production. The price of the CA3005 to equipment manufacturers has been reduced from \$3 to \$1.75, in quantities of 1000 and up.

This integrated circuit is packaged in a transistor-type case no larger than a common aspirin tablet.

### Predictions Made For Future TV Receivers

Laser beams for large screen color TV and other special-purpose displays were discussed at the 100th

conference of the Society of Motion Picture and Television Engineers in Los Angeles. Henry R. Senf, head of the applied quantum electronics section of Hughes Aircraft Co.'s research laboratories, indicated that laser beams can be modulated in intensity and deflected in a manner similar to the way electron beams are acted upon in cathode ray tubes by using electro optic techniques.

Mr. Senf indicated that laser beams are sufficiently bright to permit projection of displayed information to a large screen. Since various types of lasers produce intense light beams in different colors, several different lasers could be integrated into a multi-color laser display.

In New York, still other predictions were made for the future of TV. A progress report on the state-of-the-art indicated that, "Pictures in three dimensions will soon become a normal and necessary part of the art of visual presentation just as color and audio have become so essential today." This prediction was made by Alvin M. Marks, president of Marks Polarized Corp., during the opening session of the International Film & TV Festival.

Mr. Marks discussed various approaches to the achievement of 3-

dimensional TV viewing including: especially prepared screens; solid images produced in space by an electrically responsive medium; 3-D image holography using laser beams and the Cinetron system using multiple planes of polarized light.

## TECHNICIANS FIELD ENGINEERS

Our Medical X-Ray division needs qualified technicians at various locations to install, service and repair sophisticated Medical X-Ray/CCTV systems.

Requirements include electronic schooling, experience in installing and maintaining electronic apparatus plus a knowledge of medical x-ray equipment or a willingness to be trained.

- LIBERAL SALARIES
- MANY COMPANY BENEFITS
- A GROWTH INDUSTRY
- MAJOR METROPOLITAN LOCATIONS

Write indicating current salary to:

MARTIN G. WOLFERT

NORTH AMERICAN PHILIPS CO., Inc.  
100 E. 42 St., New York, N.Y. 10017

# Norelco®

An Equal Opportunity Employer

... for more details circle 147 on postcard

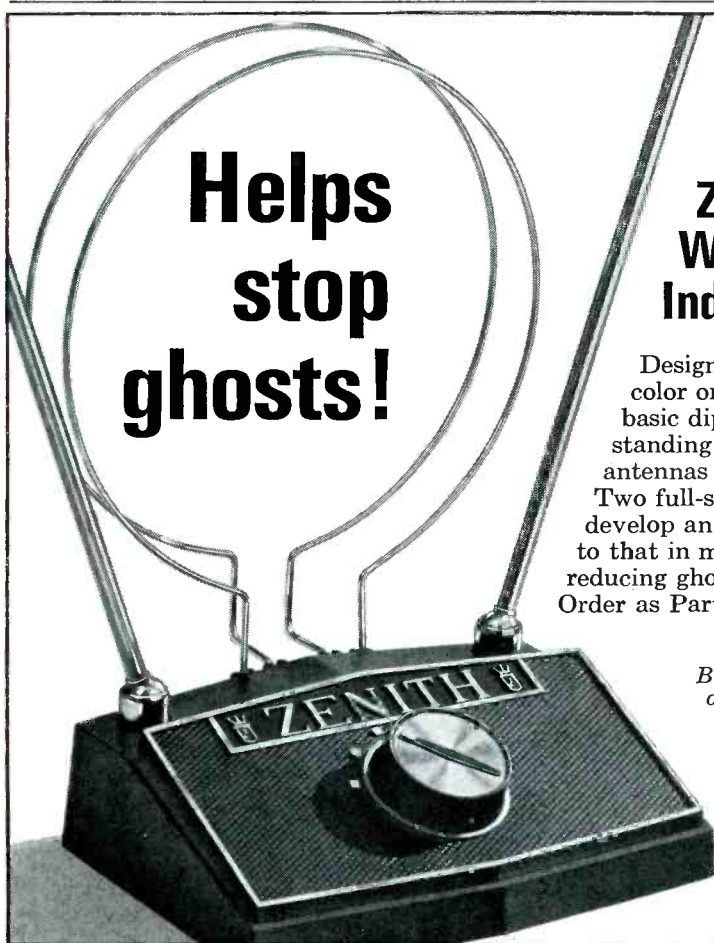

# Helps stop ghosts!

## Zenith Quality Wavemagnet® Indoor TV Antenna

Designed for finest all-channel (2 to 83) reception in color or B&W. Special network provides stepped-up basic dipole impedance, resulting in lower voltage standing wave ratio than ordinary VHF indoor antennas . . . cuts down snow, reflections and ghosts. Two full-size UHF loops, one behind the other, develop an unusually high front-to-back ratio (equal to that in many outdoor antennas), remarkably reducing ghosts and man-made interference. Order as Part Number 973-56 from your Zenith distributor!

Built to the quality standards  
of Zenith original parts

# ZENITH®

The quality goes in before the name goes on

... for more details circle 145 on postcard

**COMPLETE TUNER OVERHAUL**

**995**

**ALL LABOR AND PARTS**  
(EXCEPT TUBES & TRANSISTORS)\*



**COLOR TUNERS**

GUARANTEED ALIGNMENT  
ADDITIONAL COLOR NO CHARGE

Simply send us the defective tuner complete; include tubes, shield cover and any damaged parts with model number and complaint. Your tuner will be expertly overhauled and returned promptly, performance restored, aligned to original standards and warranted for 90 days. UV combination tuner must be single chassis type; dismantle tandem UHF and VHF tuners and send in the defective unit only. Exact Replacements are available for tuners unfit for overhaul. As low as \$12.95 exchange. (Replacements are new or rebuilt.) And remember—for over a decade Castle has been the leader in this specialized field . . . your assurance of the best in TV tuner overhauling.

**CASTLE**  
TV TUNER SERVICE, INC.

5713 N. Western Ave., Chicago 45, Illinois  
41-92 Vernon Blvd., Long Island City 1, N. Y.

For service in Canada write to Chicago or use reader service card in this magazine.  
\*Major parts are charged extra in Canada.

. . . for more details circle 111 on postcard

**FINCO**  
"has 'em both!"



Model #65-1  
\$2995 list

Model #65-2  
\$3995 list

**BOOSTER COUPLERS FOR 300 OR 75 OHM**  
For Deluxe Home or Commercial Use

Now available for either 75 OHM CO-AX or 300 OHM operation . . . you can't beat the price, quality and performance of Finco's famous 2-tube, 4-set VHF or FM Distribution Amplifiers. Finco challenges 'em all! Equip either model with Finco low loss splitters (#3001 or #3003) and you can drive up to 16 sets in a master antenna system!

All Finco Products Are Engineered for Color!



Dept. 110

**THE FINNEY COMPANY**  
34 West Interstate Street, Bedford, Ohio

. . . for more details circle 118 on postcard

**ADVERTISERS' INDEX**

Aerovox Corp. ....	86
Amphenol Distributor Div. ....	73
Arco Electronics ....	81
Arrow Fastener Co. ....	92
Astatic Corp. ....	26
Atlas Sound ....	80
B & K Mfg. Div., Dynascan Corp. ....	2nd Cover, 27
Brach Mfg. Corp. ....	88
Castle TV Tuner Service ....	92
Channellock, Inc. ....	22
Channel Master Corp. ....	32-33
Cleveland Institute of Electronics ....	35
Columbia Wire Products Co. ....	78
Cornell-Dubilier ....	3rd Cover
Delco Radio Div. ....	31
ELECTRONIC TECHNICIAN Book Club ....	79
Enterprise Development Corp. ....	76
Finney Co., The ....	82, 92
GC Electronics ....	24, 92
Heath Co. ....	38
Jensen Mfg. Div., The Muter Co. ....	86
Jerrold Electronics ....	85
Kay-Townes Antenna Co. ....	76
Mallory Distributor Products Co. ....	20
Motorola Consumer Products, Inc. ....	75
Multicore Sales Corp. ....	76
North American Philips Co. ....	91
Ohmite Mfg. Co. ....	24
Oxford Transducer Co. ....	82
Pearce-Simpson, Inc. ....	34
Perma-Power Co. ....	74
Polytronics Laboratories, Inc. ....	84
Radio Corp. of America RCA Electronic Components & Devices ....	4th Cover, 36-37, 69, 71, 83
RCA Institutes, Inc. ....	89
RCA Parts & Accessories ....	25
RCA Sales Corp. ....	29
S & A Electronics, Inc. ....	30
Sarkes Tarzian Tuner Service Corp. ....	19
Sencore, Inc. ....	77
Sprague Products Co. ....	23
Sturtevant Co., P. A. ....	87
Sylvania Electric Products, Inc. ....	42
Triplett Electrical Instrument Co. ....	90
Turner Co., The ....	88
Vaco Products Co. ....	89
Viking Electronics ....	80
Winegard Co. ....	39, 40-41
Xcelite, Inc. ....	78
Zenith Sales Corp. ....	87, 91

**ARROW**

**EFFICIENT!  
SAFE!  
FAST!**

**AUTOMATIC STAPLE GUNS**

For Fastening Any  
Inside or Outside  
Wire Up to 1/2" in Diameter

- |  |                                |   |
|--|--------------------------------|---|
|  | UP TO 3/16"<br><b>No. T-18</b> | • Telephone wire<br>• Intercom wire<br>• Bell wire<br>• Thermostat wire                                 |
|  | UP TO 1/4"<br><b>No. T-25</b>  | • Radiant heating wire<br>• Hi-Fi, Radio & TV wires<br>• Tapered striking edge gets into close corners! |
|  | UP TO 1/2"<br><b>No. T-75</b>  | Available in:<br>Brown, Ivory, Beige, Monel, Bronze, Natural  |

**ARROW FASTENER COMPANY, INC.**  
1 JUNIUS STREET • BROOKLYN 12, N. Y.  
. . . for more details circle 106 on postcard

**GC ELECTRONICS**

**PROVIDES THE LARGEST COMPLETE STOCK OF EXACT REPLACEMENT TV KNOBS**

**IN THE INDUSTRY!**

**NOW AVAILABLE AT YOUR NEAREST STOCKING DISTRIBUTOR**

**TV KNOBS FOR ALL POPULAR SETS - ADMIRAL - MOTOROLA GE - MAGNAVOX - RCA - ZENITH WESTINGHOUSE & MANY OTHERS**

If GC Knobs are not available locally, send for your copy of Cross Reference Guide and name of nearest distributor.

**FREE! TV Knob Cross Reference Guide.**

Send Cross Reference  
 Send name of nearest distributor

**WRITE TO: Dept. RD**  
**GC ELECTRONICS**  
400 S. Wyman Street Rockford, Ill. 61101

. . . for more details circle 120 on postcard  
ELECTRONIC TECHNICIAN

# Never ask a lightweight rotor to do a heavyweight's job.

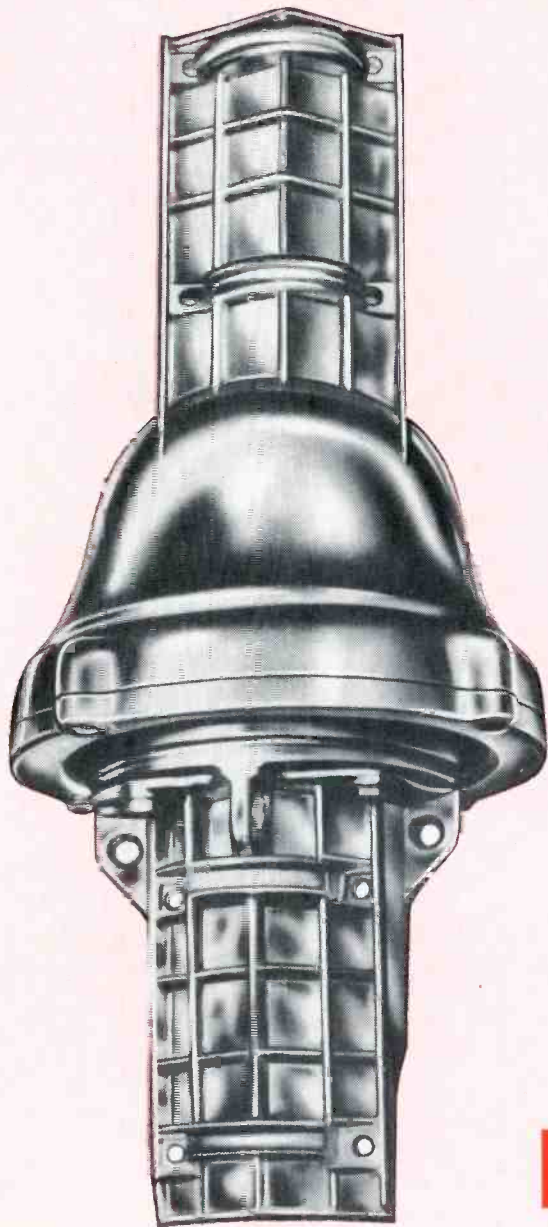

Selling your customer a lightweight rotor when he has a large antenna array just doesn't make sense. Especially since you can offer him an alternative: the heavy-duty "Bell Series" rotor, from CDE.

Available in both automatic and manual forms, this rotor is designed specifically for large, heavy antenna arrays... designed specifically for unmatched fringe-area reception... designed to give your customers the finest color TV reception possible. In fact, this is the *only* heavy-duty rotor available.

We call it the Bell Series because of its completely weatherproof, die-cast aluminum housing. You'll call it rugged because it has 4 to 5 times the stalling and braking torque of any other rotor! This means *any* antenna will turn, even under the most adverse weather conditions... and that your customers will get terrific color or black and white reception despite high winds or heavy icing. Great FM reception too!

The Bell Series rotor: one-of-a-kind built for one-of-a-kind performance!

**CDE** **CORNELL-  
DUBILIER**

Your local participating  
RCA Tube Distributor invites you to

# Step into the winner's circle

with 1967's greatest collection of  
technical, service and promotional aids  
to make your servicing jobs easier and  
help you promote more business.



Get RCA's new Field Service Guide Free in the RCA Color Pack '67... This tremendously helpful book holds the schematics and field service adjustments of all color TV sets manufactured by RCA Victor from 1955 to 1966. With it you can do all adjustments possible with a color bar generator, including replacing a color TV tube... in the home. You get it FREE when you buy the RCA COLOR PACK '67 assortment of 21 popular RCA receiving tubes for color TV from your participating RCA Tube Distributor.

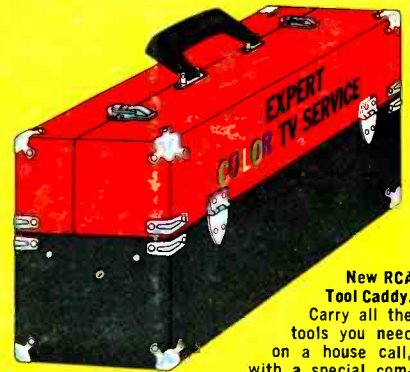

**New RCA Tool Caddy.** Carry all the tools you need on a house call, with a special compartment for your model WV-38 VOM. Sturdy metal trays for different size tools fold out easily, fall back readily. Covered in strong SUPERWELD fabric with metal guards protecting the corners, it will take a lot of abuse. Note color TV service message on the side. 1A1630

**48" Power Control Multiple Outlet Box.** Centralize your power for 8 different operations. Maneuver your test equipment with greater efficiency. Has pilot light and switch and circuit breaker. 1A1619

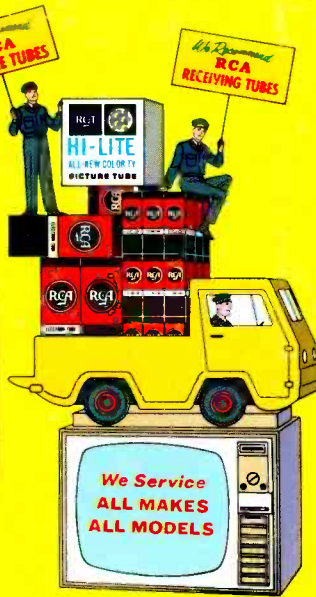
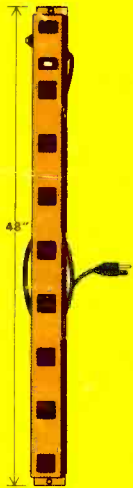

**Mylar Decal for truck or window.** Bright, bold colors on all-weather mylar send your color TV service message all over town on your truck. Put one in your store window, too. 1A1620



**Set of RCA Monogram Decals.** In three sizes... a perfect way to dress up any surface that calls for product identification. 1A1624



**The Agfa Isoflash Camera Kit...** Is also available with your purchase of RCA Receiving Tubes. You'll be a winner when you bring home this easy loading beauty complete with film, battery, bulb, flash cube adapter, carrying case and shoulder strap. 1A1629

**TV Cleaning Cloth Set.** A set of two to take with you on house calls... one for the cabinet and one for the faceplate of the picture tube. 1A1627



**Motion Display on RCA Receiving Tubes and Picture Tubes for Window or Counter.** Ingenious, striking! Service truck moves back and forth atop a simulated color set. Draw attention to your window or counter with this novel display which promotes all of your services—color TV, black and white TV, radio and hi-fi. Electrically powered, it combines your receiving tube and picture tube story in one visually compelling unit. Put one in your window and watch the reaction! Two auxiliary serviceman pieces carrying additional service messages, can be used in conjunction with the center display or as separate units. 1A1621

**Swingline Corrugated Carton Staple Extractor.** One squeeze opens staples on corrugated cartons... easily, neatly and safely. 1A1626

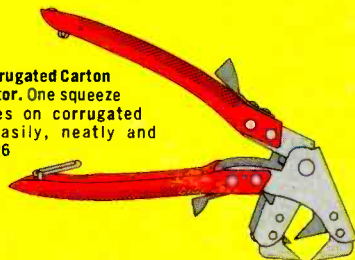

Many other attractive and valuable items are available through THE WINNER'S CIRCLE program, including ad mats, RCA's Color TV Fastcheck series of helpful hints, the famous RCA Receiving Tube Manual, post-cards and new business cards, and a bottle opener premium. Check with your local RCA tube distributor. He can supply you with the finest in receiving tubes for color and black-and-white TV, radio and hi-fi. And he can tell you how to STEP INTO THE WINNER'S CIRCLE.

RCA Electronic Components and Devices, Harrison, N.J.



**The Most Trusted Name in Electronics**