

ELECTRONIC TECHNICIAN

WORLD'S LARGEST ELECTRONIC TRADE CIRCULATION

Test Instrument Probes For Color
Methodical Troubleshooting
Servicing Solid-State TVs



58
29



JUNE 1966

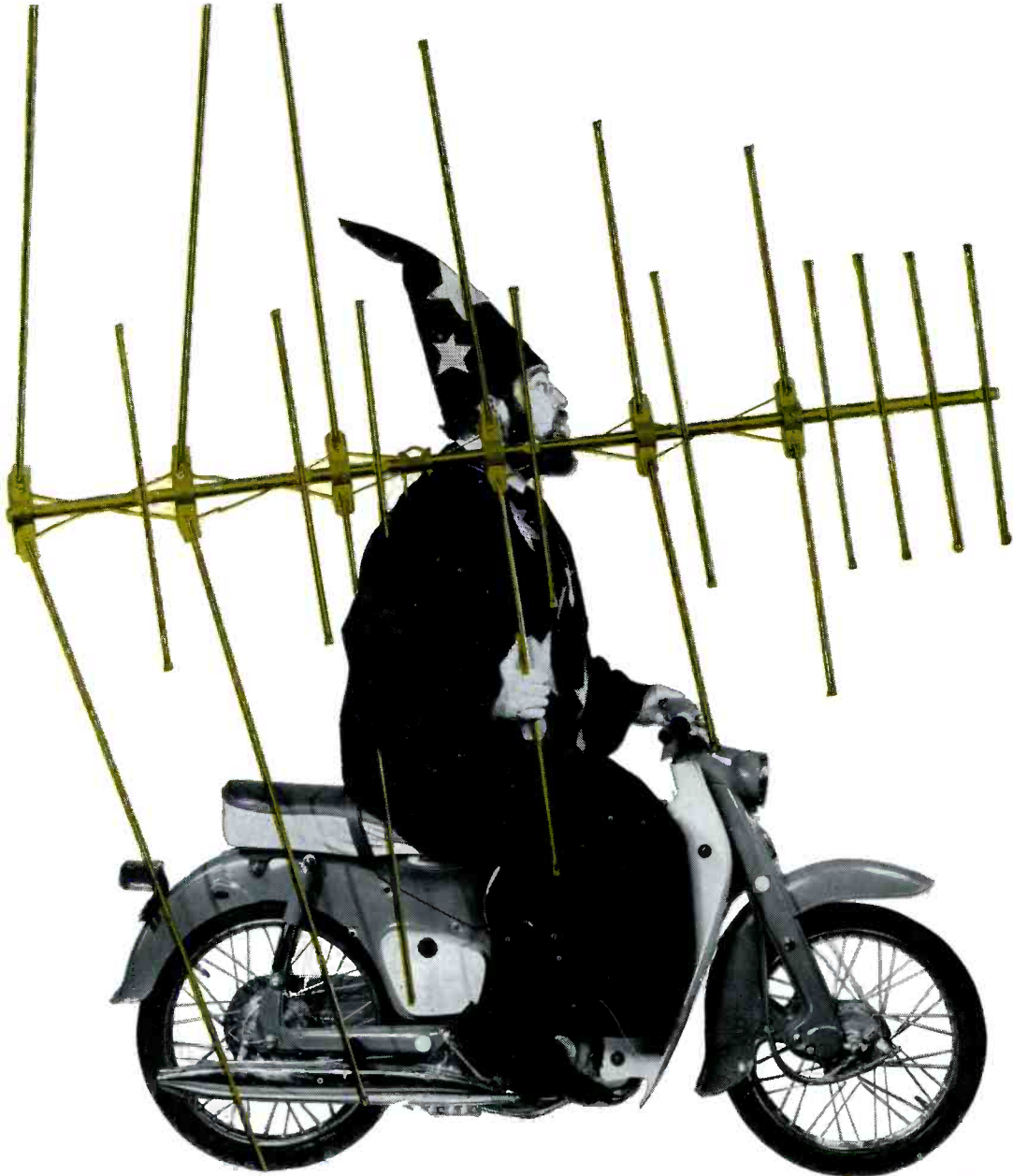

CHARGE INTO COLOR WITH GAVIN GOLD CREST

Concerned about color? Now Gavin conquers it. Captures it. With Color Antennas so new . . . so ahead of the rest . . . each bears a new, bold Gold Crest. Only Gavin tests and certifies each antenna for perfect color! For greatest gain. For best match. For lighter weight . . . with *five times* the strength. Charge into color with confidence. With the best. With new Gavin . . . Gold Crest.

| | | | | |
|---------------------------------------------------|---------------------------------|---------------------------------------|------------------------------------|-------------------------------------|
| | | | | |
| <p>TESTED AND CERTIFIED FOR PERFECT COLOR</p> | <p>UHF CR-5 Fringe Area</p> | <p>UHF/VHF/FM 1113 Mid Fringe</p> | <p>VHF/FM 1015H Mid Fringe</p> | <p>VHF/FM 1023H Deep Fringe</p> |

PUT A RAINBOW ON ANY ROOF...ANYWHERE

DISTRIBUTORS: Write for franchise information



GAVIN INSTRUMENTS, INC. SOMERVILLE, N. J.
... for more details circle 113 on postcard

Complete TUNER REPAIR for only

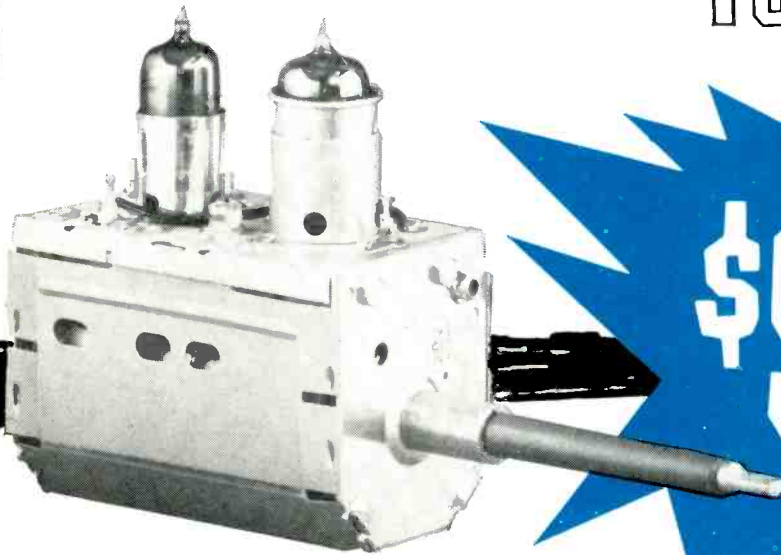

\$9.50

Sarkes Tarzian, Inc., largest manufacturer of TV and FM tuners, offers unexcelled tuner overhaul and factory-supervised repair service. Completely-equipped and conveniently-located Service Centers offer fast, dependable and factory-supervised repair service on all makes and models. Centers are staffed by well-trained technicians, assisted by engineering personnel.

Tarzian-made tuners received one day will be repaired and shipped out the next. More time may be required on other makes. Every channel—not just the channels existing in any given area—is checked and re-aligned per orig-

inal specifications. Exclusive cleaning method makes the tuner look—as well as operate—like new.

Cost, including ALL labor and parts (except tubes) is only \$9.50 and \$15 for UV combinations. No additional charge. No hidden costs. Too, you get a full, 12-month warranty against defective workmanship and parts failure due to normal usage.

Always send TV make, chassis and Model number with faulty tuner. Check with your local distributor for Sarkes Tarzian replacement tuners, parts or repair service. Or, use the address nearest you for fast, factory-supervised repair service.

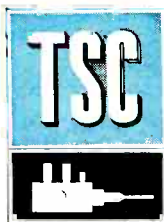

TUNER SERVICE CORPORATION

(Factory-supervised tuner service authorized by Sarkes Tarzian)

MIDWEST—817 N. Pennsylvania St.,
Indianapolis, Ind. Box 1642
Tel: 317-632-3493

EAST — 547-49 Tonnele Ave., Jersey City, N. J.
Tel: 201-792-3730

WEST—

SARKES TARZIAN, Inc.
Tuner Service Division

10654 Magnolia Blvd.,
N. Hollywood, Calif.
Tel: 213-769-2720



MANUFACTURERS OF TUNERS, SEMICONDUCTORS, AIR TRIMMERS, FM RADIOS, AM-FM RADIOS, AUDIO TAPE and BROADCAST EQUIPMENT

WOULD YOU BELIEVE YOU'LL GET A FORD MUSTANG IF YOU BUY PHILCO TUBES?

HOW ABOUT A TOY MUSTANG FOR YOUR KIDS?

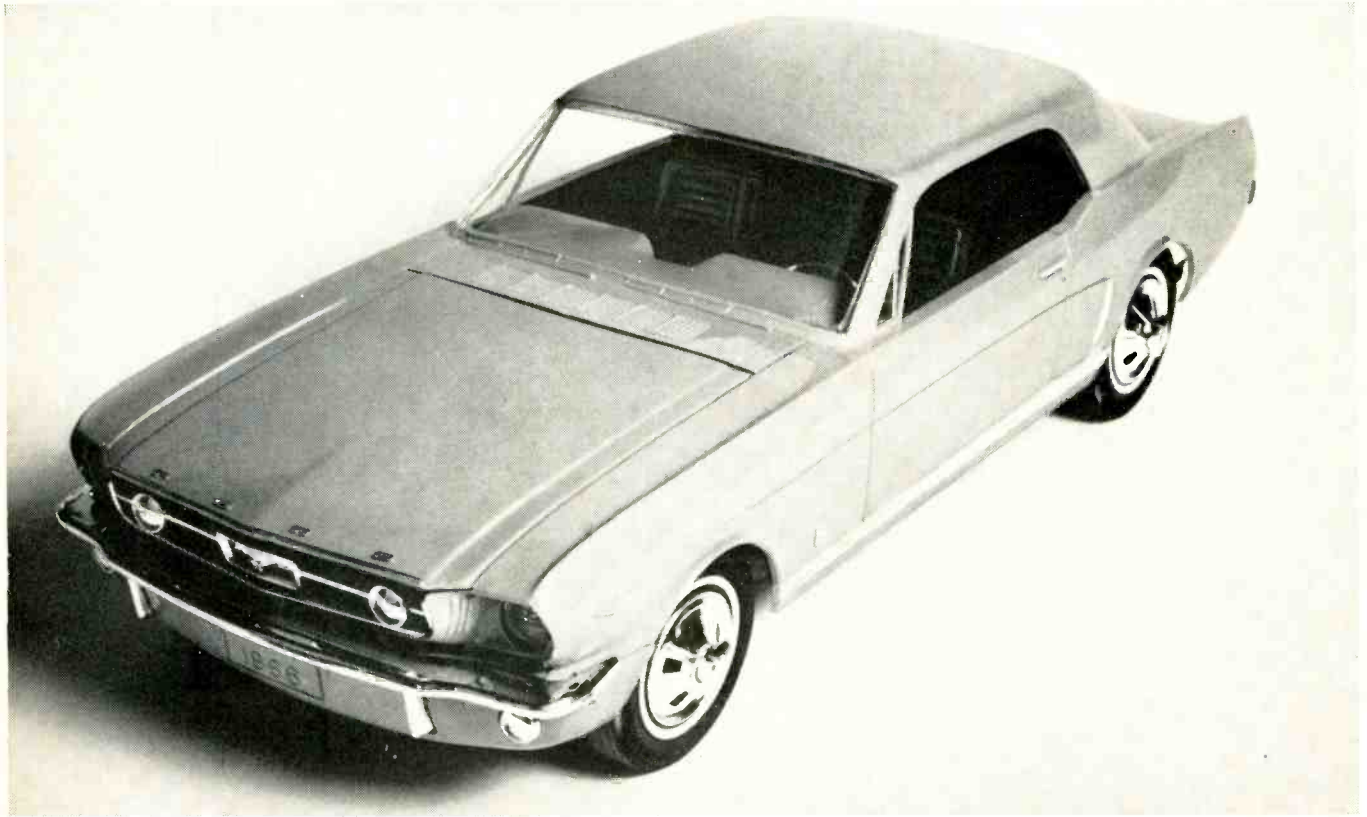

You'd better believe the one about the model Ford Mustang.

To get one free, all you have to do is buy 4 Philco Star Bright Picture tubes or 100 Philco Star Light Receiving tubes. Or any other combination, since one picture tube is worth 25 receiving tubes.

The Mustang is a 16-inch scale model of the real McCoy.

Complete with battery-operated motor and lots of sporty extras. Your kids will put it through the paces. And you might, too.

And the Mustang will be a breeze to get, because you know

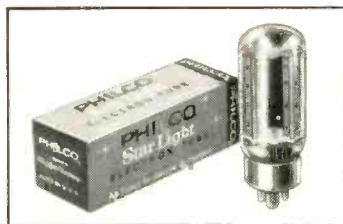

that Philco tubes stand for the finest quality. Philco Star Bright 20/20 Picture tubes and Star Light Receiving tubes are built to the most demanding specifications. So they assure you of complete customer satisfaction.

And, speaking of satisfaction, you can really make your kids happy. So be the first dad on the block to get them this sleek model Mustang. And why not give your Philco distributor a call while you're at it?

Would you believe he has as many as 65 other premiums that you can get?

PHILCO
A SUBSIDIARY OF *Ford Motor Company*

... for more details circle 122 on postcard
ELECTRONIC TECHNICIAN

JUNE 1966

VOL. 83 NO. 6

ELECTRONIC TECHNICIAN

WORLD'S LARGEST ELECTRONIC TRADE CIRCULATION

RON KIPP Publisher
JACK HOBBS Managing Editor
QUINTO BOCCHI Technical Editor
DOUGLAS HEDIN Industrial Editor
RICHARD CLAYTON Field Editor
DONALD GRANT Assistant Editor
JUDITH BERINI Editorial Production
MAGGIE KANE Advertising Production
GEORGE LIPPISCH Artist
RUTH GELINEAU Circulation Fulfillment



AN OJIBWAY PUBLICATION

OJIBWAY PRESS, Inc.

Ojibway Building, Duluth, Minn. 55802
AREA CODE 218 727-8511

PUBLICATIONS DIVISION:

ROBERT EDGELL President
ANGUS STONE Marketing Manager
BEN MARSH Editorial Director
HARRY RAMALEY Production Director
JIM GHERNA Art Director
JOE WOLKING Circulation Director
WARREN BODIN Ad Production Supervisor

Sales Offices:

NEW YORK: Ron Kipp, 25 W. 45 St.
New York, N.Y. 10036
AREA CODE 212 581-4200

CHICAGO: Jack Daniels, 43 E. Ohio St.
Chicago, Ill. 60611
AREA CODE 312 467-0670



Copyright 1966 by Ojibway Press, Inc., Duluth, Minn. 55802. Reproduction and reprinting prohibited except by written authorization of the publication. Subscription price: \$5 for 1 year, \$8 for 2 years, \$10 for 3 years. Pan American and Foreign, \$9 for 1 year, \$14 for 2 years, and \$18 for 3 years.

If you have a change of address or a question about your subscription, write: ELECTRONIC TECHNICIAN, Circulation Department, Ojibway Building, Duluth, Minnesota 55802. BE SURE TO SEND ALONG THE ADDRESS LABEL FROM YOUR MOST RECENT ISSUE. Second class postage paid at Waseca, Minnesota and at additional mailing offices.

POSTMASTER: Send notification form 3579 to ELECTRONIC TECHNICIAN, Ojibway Building, Duluth, Minnesota 55802.

JUNE 1966

Cover

Recently our photographers barged into ET's TEKLAB with special lights, camera, a tricky lens and tall stepladder. This three-quarter birds-eye view of a color bar/dot generator, color TV and scope was the result of their ceiling-to-bench-top endeavors.

FEATURES

| | |
|-----------------------------------------------------------------------------------------------------------------------------------------------------|-----------|
| Methodical Troubleshooting | 39 |
| <i>Tells how you can organize servicing and repair procedures that result in getting more done in a day</i> | |
| Homer Davidson Pushes Color TV | 42 |
| <i>The well-known technical writer and long-time TV-radio service-dealer tells how he has survived and progressed in the business for 18 years.</i> | |
| Volume Limiting in PA and Background Music Systems | 44 |
| <i>The concluding part of an article series covering sophisticated audio amplifier equipment</i> | |
| The New Look in Citizens Band Radio | 47 |
| <i>Concluding part of an article series which brings you up to date on citizens band developments</i> | |
| 'Door To Door' | 50 |
| <i>Another 'real life' Bob and 'Scoot' story that reveals a few in-home servicing tricks</i> | |
| Servicing Transistorized TVs | 53 |
| <i>Understanding solid-state circuits now being designed into many current TV sets</i> | |
| You and Color TV | 56 |
| <i>Another TEKLAB report that zeros in on increasing your scope's diagnostic efficiency by using the proper probes</i> | |
| Spray It—Cement It—Fix It! | 59 |
| <i>A review of chemical cleaners, lubricants and repair cements</i> | |

DEPARTMENTS

| | | | |
|-----------------------------|----|---------------------------|----|
| Editor's Memo | 22 | Colorfax | 62 |
| Letters to the Editor | 26 | New Products | 66 |
| Sync on Business | 28 | Advertisers Index | 82 |
| Technical Digest | 32 | Reader Service Card | 83 |

TEKFAX ____ 16 PAGES OF THE LATEST SCHEMATICS

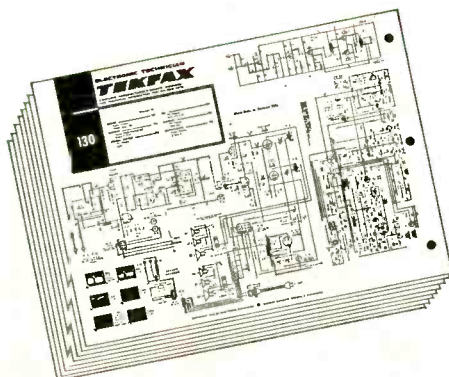

- Group 166 June • 1966
- CORONADO: TV Model TV2-9368A
 - GENERAL ELECTRIC: Color TV Chassis HB
 - MAGNAVOX: Color TV Chassis T919 Series
 - OLYMPIC: TV Chassis NDP
 - WESTINGHOUSE: TV Chassis V-2490 Series
 - ZENITH: TV Chassis 14N28

Winegard's New CS-283; the only UHF-VHF Signal Splitter with a printed circuit!

EDITOR'S MEMO

Filing Your TEKFAQ

Some ELECTRONIC TECHNICIAN readers want to know the best way to file their 16-page monthly group of TEKFAQ schematics. Many readers have devised their own methods. But one method seems to be more popular than all others. Here's how it works:

(1) Tear the entire 16-page TEKFAQ section from ET — the sheets are perforated to make this job easy.

(2) Punch holes as marked at the left of the TEKFAQ sheets.

(3) Obtain an ordinary three-ring binder, available at five-and-ten or school supply stores. These binders will hold one year's TEKFAQ sheets.

(4) Separate the individual pages from each other, fold each double page and file numerically — according to schematic numbers. Keep the sheets folded until ready to use. Ignore the group number and contents table. Place the year in large numerals on the "spine" section of each binder.

Note the small duplicate schematic numbers (beginning with the January 1966 TEKFAQ) located to the left of the word "copyright" at the bottom of each schematic. This was added to help locate schematics.

ET is publishing a semi-annual TEKFAQ index beginning with the present (June 1966) issue. It appears on page 24. A cumulative index, covering schematics published during the past 10 years, will appear in the regular TEKFAQ of December, 1966.

The semi-annual index in the present issue should be carefully removed and placed on top of your January 1966 TEKFAQ sheets. Use this index for locating schematics from January through June 1966. Use the table of contents of each TEKFAQ group to locate schematics in each following issue.

When the December 1966 index is published, you can then use it exclusively for locating any schematic you have filed through that date.

The index planned for December 1966 will contain *chassis numbers* of all TV sets which have this number stamped on the chassis. Most manufacturers do this. But some do not. In the latter case, sets will be listed by *model numbers*.

To locate a schematic on file: Look at the manufacturer's name in the index, the chassis or model number, note the schematic number and year. Remove the proper year's binder from the shelf and refer to the schematic number. It's that easy.

How do you improve on a product that out-performs and outsells all competition? It isn't easy. But Winegard has done it with the new CS-283 UHF-VHF Signal Splitter! True, the CS-283 still attaches easily (with only a screwdriver) to the terminals on the back of any TV set or UHF converter. And it still separates the UHF and VHF signals coming from an all-band antenna.

But that's where the resemblance ends. The new CS-283 has a printed circuit—the only one on the market!

The result? The most efficient performance possible with lower VSWR; near perfect 300-ohm impedance match; 15db minimum isolation between UHF and VHF; and the total elimination of capacitance between coils.

That's the new (and better) CS-283 UHF-VHF Signal Splitter. Still only \$3.00 list. And still available free of charge with any Winegard Chroma-Tel antenna.

What do your customers need for the best possible UHF-VHF-FM reception—in color and black & white? Matching Transformers? Splitters? Hi-Lo Couplers? You name it and Winegard makes it. And makes it better. And, chances are, Winegard created and perfected it! Call your Winegard distributor or write for complete information today.

Winegard antenna systems

WINEGARD CO. ■ 3000 KIRKWOOD ■ BURLINGTON, IOWA 52602



... for more details circle 132 on postcard

*the instrument with
endless uses...the all new
improved completely solid state
SENCORE FS134 FIELD STRENGTH METER*

HERE ARE JUST A FEW OF THE MANY USES...



A. Distribution Systems



B. Antenna Installations

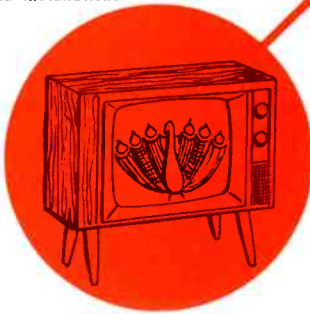

C. Color Insurance

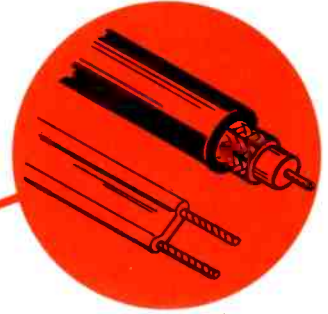

D. Transmission Lines

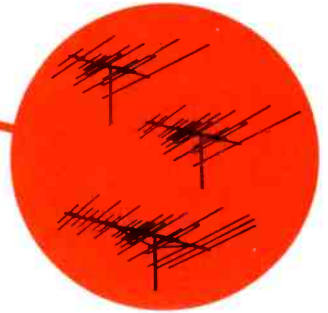

E. Antenna Comparisons



F. Checking Generators

only
199.50
lowest price going

A. INSTALLING AND CHECKING OUT DISTRIBUTION SYSTEMS

Qualify for this multimillion dollar business in hotel, motel, and hospital installations.

B. INSTALLING UHF, VHF, AND FM ANTENNAS

Cut down installation time and pay for the FS134 in a short time on critical UHF as well as VHF and FM antennas.

C. COLOR INSURANCE

Be sure the signal is adequate on each channel for proper color TV operation.

D. CHECK TRANSMISSION LINES

For the first time read actual db loss in either 75 or 300 ohm transmission lines.

E. COMPARE ANTENNAS

For actual db gain; see which is best for each location, both VHF and UHF. Also excellent for

orienting "dishpans" for translator use at the high end of UHF band.

F. CHECK ANY GENERATOR OUTPUT

For correct frequency and output all the way up to a tenth of a volt RMS. What a time saver when you want to know if your generator is putting out.

PLUS: LOCALIZE NOISE AND INTERFERENCE

Find noise source fast; pick quiet locations for antenna installations or orient antenna away from noise when possible.

These are only a few uses of this UHF-FM-VHF accurately microvolt calibrated field strength meter. You can start paying for the FS134 tomorrow in the time saved today — if you see your Sencore distributor now. Why not pick up the phone and ask him to show you the new FS134?

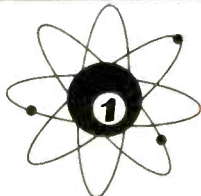

SENCORE

NO. 1 MANUFACTURER OF ELECTRONIC MAINTENANCE EQUIPMENT

426 SOUTH WESTGATE DRIVE, ADDISON, ILLINOIS 60101

... for more details circle 125 on postcard

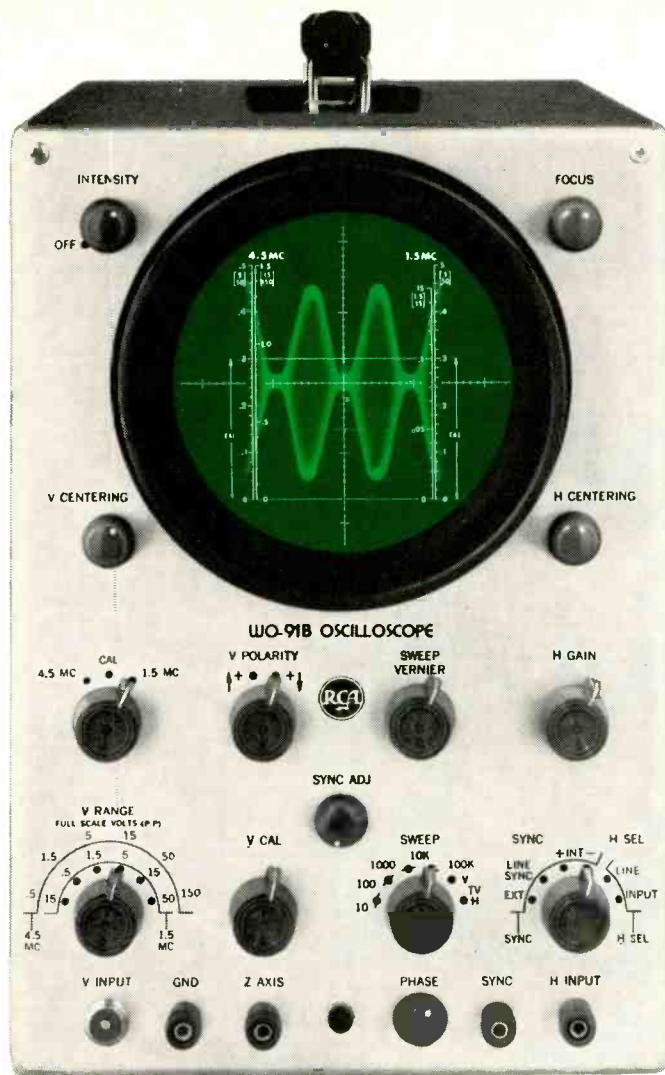

The famous RCA 5-inch scope
NOW WITH MORE FEATURES
TO SIMPLIFY YOUR JOB

Here's the latest model of the famous RCA 5-inch scope: the NEW WO-91B

- Provision for connecting signals directly to the vertical deflection plates of the CRT. Permits observation of high frequency RF waveforms, such as trapezoidal and wave-envelope modulation patterns.
- Two-stage sync separator simplifies checking of TV horizontal and vertical sweep synchronization... provides exceptionally solid lock-in action on composite TV signals.
- Choice of wide-band or high-sensitivity, narrow-band display.
- Complete with RCA WG-300B Direct/Low Cap. Probe and Cable.

- Optional at slight extra cost: RCA WG-354A slip-on capacitance-type voltage-divider probe that extends the range of the scope to permit observation of signal pulse amplitudes up to 5000 volts. RCA WG-302A slip-on RF/IF/VF signal tracing probe for RF applications from 100 Kc to 250 Mc.

- WO-91B Scope: **\$249.50***
- WG-354A Probe: **\$ 7.50***
- WG-302A Probe: **\$ 8.50***

Ask to see it at your Authorized
RCA Test Equipment Distributor.

*Optional distributor resale price. All prices subject to change without notice. Prices may be slightly higher in Alaska, Hawaii and the West.

RCA Electronic Components and Devices, Harrison, N. J.



The Most Trusted Name in Electronics

TEKFAX INDEX Jan.-Jun. '66

| | |
|----------------|---------------|
| ADMIRAL | |
| Chassis: | Schematic No. |
| G2 | 991 |
| G7 | 976 |
| G13 | 997 |

| | |
|------------------------|------|
| AIRLINE | |
| Model: GEN-1866A | 1003 |
| Model: GHJ-1466A | 978 |
| Model: GHJ-1566A | 978 |
| Model: GHJ-1786A | 978 |
| Model: GHJ-4516A | 978 |
| Model: GHJ-4546A | 978 |
| Model: GHJ-4556A | 978 |

| | |
|------------------------|------|
| CORONADO | |
| Model: TV2-9368A | 1015 |
| Model: TV2-9369A | 1015 |
| Model: TV2-9370A | 1015 |
| Model: TV2-9371A | 1015 |

| | |
|-------------------|------|
| EMERSON | |
| Model: 9P50 | 1005 |

| | |
|-------------------------|------|
| GENERAL ELECTRIC | |
| Chassis: | |
| DC | 990 |
| HB | 1011 |
| TB | 1004 |
| VB | 979 |

| | |
|-------------------|------|
| MAGNAVOX | |
| Chassis: | |
| T907 Series | 981 |
| T908 Series | 993 |
| T910 Series | 985 |
| T918 Series | 1012 |
| T919 Series | 1012 |
| T920 Series | 1012 |

| | |
|-------------------|------|
| OLYMPIC | |
| Chassis: | |
| NDP | 1013 |
| Model: 6P28 | 992 |
| Model: 6P29 | 992 |
| Model: 6P30 | 992 |

| | |
|---------------|------|
| PHILCO | |
| Chassis: | |
| 15J25 | 1007 |
| 16J27 | 980 |

| | |
|-------------------|------|
| RCA VICTOR | |
| Chassis: | |
| CTC19 | 984 |
| KCS136M | 1008 |
| KCS142XA | 982 |
| KCS144E | 998 |

| | |
|-------------------------|------|
| SEARS-SILVERTONE | |
| Model: 5100 | 988 |
| Model: 6122 | 1009 |
| Model: 6123 | 1009 |
| Model: 6150 | 995 |
| Model: 6151 | 995 |
| Model: 6152 | 995 |
| Model: 6154 | 995 |
| Model: 6155 | 995 |
| Model: 6156 | 995 |
| Model: 6157 | 995 |
| Model: 6164 | 1000 |

| | |
|-----------------------|-----|
| SONORA | |
| Model: S64K236M | 989 |

| | |
|------------------|-----|
| SYLVANIA | |
| Chassis: | |
| A02 Series | 999 |
| D03 Series | 987 |

| | |
|----------------------|-----|
| TRUETONE | |
| Model: 2DC1605 | 983 |

| | |
|---------------------|------|
| WESTINGHOUSE | |
| Chassis: | |
| V2486 Series | 996 |
| V2487 Series | 1002 |
| V2490 Series | 1014 |

| | |
|---------------|------|
| ZENITH | |
| Chassis: | |
| 1M30T20 | 977 |
| 1N29T20 | 977 |
| 14N22 | 1001 |
| 14N28 | 1010 |
| 14N31 | 986 |
| 16N24 | 1006 |
| 24NC31 | 994 |

WHY

risk your reputation with "just-as-good" capacitors?

When you pay little or no attention to quality in tubular replacement capacitors, you leave yourself wide open for criticism of your work . . . you risk your reputation . . . you stand to lose customers. It just doesn't pay to take a chance on capacitors with unknown or debatable performance records when it's so easy to get guaranteed dependable tubulars from your Sprague distributor!

There's no "maybe" with these 2 great SPRAGUE DIFILM® TUBULARS!

The ultimate in tubular capacitor construction. Dual dielectric . . . polyester film and special capacitor tissue . . . combines the best features of both. Impregnated with HCX®, an exclusive Sprague synthetic hydrocarbon material which fills every void in the paper, every pinhole in the plastic film *before it solidifies*, resulting in a rock-hard capacitor section . . . there's no oil to leak, no wax to drip. Designed for 105°C (220°F) operation without voltage derating.



DIFILM® BLACK BEAUTY®
Molded Tubular Capacitors

The world's most humidity-resistant molded capacitors. Tough, protective outer case of non-flammable molded phenolic . . . cannot be damaged in handling or installation. Black Beauty Capacitors will withstand the hottest temperatures to be found in any TV or radio set, even in the most humid climates.



DIFILM® ORANGE DROP®
Dipped Tubular Capacitors

A "must" for applications where only radial-lead capacitors will fit . . . the perfect replacement for dipped capacitors now used in many leading TV sets. Double-dipped in rugged epoxy resin for positive protection against extreme heat and humidity. No other dipped tubular capacitor can match Sprague Orange Drops!

For complete listings, get your copy of Catalog C-616 from your Sprague distributor, or write to Sprague Products Company, 65 Marshall Street, North Adams, Massachusetts 01247

WORLD'S LARGEST MANUFACTURER OF CAPACITORS



LETTERS TO THE EDITOR

Blowtorches Tube

I'm not usually an experimenter—have no time. But I received a small radio that had microphonics that refused to be cured after changing 1U5 tubes several times. An idea came to me to experiment along rather unusual lines. I put the 1U5 on a cement floor, placed a screwdriver

blade across it at about the middle point of the glass shell and turned the blowtorch on it. As the glass heated the weight of the screwdriver caused it to bend inward slightly toward the plate. The dented tube worked fine and the microphonics completely disappeared.

OSCAR SCHECTAR

Pittsburgh, Pa.

Silvertone Color TV

This may help some ET reader. A Silvertone, model 528-61111, had an

intermittent raster. It would come on for about 3 to 5 minutes and then would slowly go out of focus and fade. The sound remained normal. The circuit breaker did not cut out. The 3A3 and 6BK4 were both overheating. High voltage at the CRT was 16kv. In a situation like this we quickly learned that a capacitor, located under the chassis and shunted across pin 1 (cathode) and pin 5 of the 6BK4 should be replaced in the home before pulling a set to the shop. This is a disc type, value 0.0033 μ f, rated at 660vdc. We also suggest that it be replaced with an epoxy type if an exact-type replacement ceramic cannot readily be obtained. The 1V2 should also be changed since it is frequently damaged when the capacitor develops low resistance leakage or a short.

HOWARD KEILHOLTZ

Ellicott City, Md.

Harmon Morse CB

Can any reader tell me the name and address of the manufacturer of a Harmon Morse model CB15 transistorized citizens band transceiver? I need a schematic.

B. W. DORTCH

Granite City, Ill.

• We cannot find a clue to the manufacturer in our directories. Can any reader help?—Ed.

They Need Info

Can any ET reader provide information or a schematic for an Accurate Instruments Co., model AT162, Dwell-Tachometer? Can't get the info from the manufacturer. Write via ET.

JOHN HOLLOWMAN

Kensington, Md.

... Can anyone supply me with a schematic for a Rider Chanalyst Model 11 made by Service Instruments, N.Y.? Via ET please.

GAY'S

West Oneonta, N.Y.

... Have a Shell amplifier that needs a power transformer . . . Does anyone know who made the original xformer? Amplifier model number is 2020P. It was made by Shell Electronic Mfg., Corp., Westbury, N.Y. Via ET please.

E. BROTMAN

Chicago, Ill.

... Can any one help me with a schematic, data or parts list, etc., for a Hickok model 540 tube tester? Glendale, N.Y. Write via ET.

BOB ULSCHMID

NEW B & K MODEL 606 DYNA-JET

**TESTS
LATEST
TUBES
QUICKLY
AND
ACCURATELY**

This new B&K Tube Tester provides the sockets and the features you need to test the latest color and compactron receiving tubes, as well as older types.

You can test for all shorts, grid emission, leakage and gas; and check cathode emission the accurate way—under simulated load conditions! Each section of a multiple section tube is checked. With the Model 606, you won't reject the good tubes, and you'll quickly find the bad ones, reducing call backs, selling more tubes, and increasing service profit.

You'll find "tough dogs" and weak tubes with the exclusive adjustable grid emission test, which has a sensitivity of over 100 megohms. Tube sockets have phosphor bronze contacts for long, trouble-free life. Complete tube listings are provided in a handy reference index.

This efficient instrument, in a small, handsome, leatherette covered carry case, will perform professionally on house calls or the service bench. Its low price will soon be paid for with increased profit.

Net \$79.95

PORTABLE/LOW COST/PROFESSIONAL

For additional information write for Catalog AP-22.



B & K MANUFACTURING CO.
DIVISION OF DYNASCAN CORPORATION
1801 W. BELLE PLAINE AVE. • CHICAGO, ILL. 60613

Export: Empire Exporters, 123 Grand St., New York 13, U.S.A.

... for more details circle 106 on postcard

Odds are 285-1



Sylvania makes the cathode ray tube you need.

You can hardly lose. Your Independent Sylvania Distributor carries up to 285 Sylvania cathode ray tubes. And in the unlikely case he doesn't have what you need, he'll probably be able to get it.

Sylvania can make just about anything.

We developed a low-heater power tube that consumes 94% less power for battery-powered portable oscilloscopes. A high-speed static charge printing tube for address label printing and computer readout. Console and rear window tubes for computer readout or radar navigation. Also high-resolution assemblies for photographic recording. Fiber optic CRTs. Multiple gun tubes.

And our tubes are customized to give optimum performance throughout life. You can get virtually any combination: high brightness, high resolution, double deflection, high visibility, high deflective sensitivity.

Sylvania gives you these benefits, times 285. Sylvania Electronic Tube Division, Electronic Components Group, Seneca Falls, New York 13148.

SYLVANIA
SUBSIDIARY OF
GENERAL TELEPHONE & ELECTRONICS **GTE**

Gain to spare at the toughest location

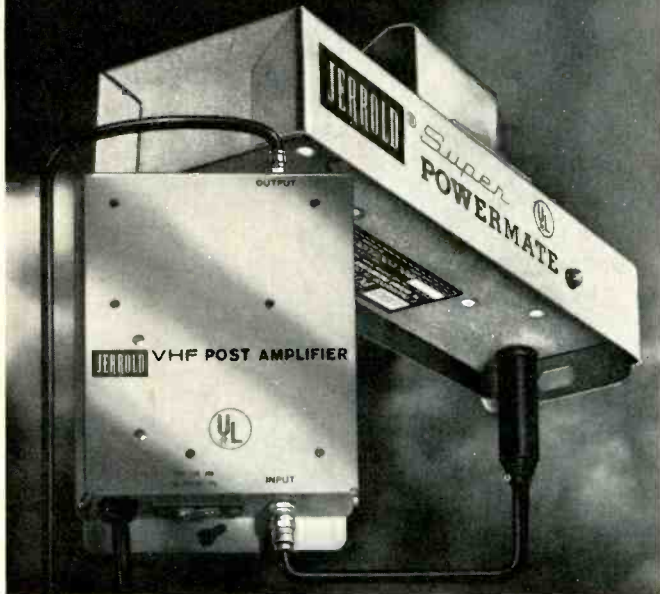

JERROLD SOLID-STATE "DE-SNOWER" AMPLIFIERS MODELS SPC-132, SPC-103

The famous Jerrold 5-transistor Powermate "De-Snowder," Model SPC-132, shown above, and its 2-transistor companion model, SPC-103, give you a choice of antenna-mounting coaxial VHF amplifiers that can't be equalled for bringing bright, snow-free pictures to master-antenna systems.

Their high gain (SPC-132 up to 29 db, SPC-103 up to 16 db) and extremely low noise figure make these preamps ideal for the really tough system installation from custom home to motel or apartment house. Coaxial download is a *must* for good color reception, and belongs in any quality system for longtime interference-free reception.

Examine the "De-Snowder" at your Jerrold distributor's, or write for complete information. *Jerrold Electronics, Distributor Sales Division, 4th & Walnut Sts., Philadelphia, Pa. 19105.*

JERROLD

... the most experienced name
in TV signal distribution



... for more details circle 117 on postcard

SYNC ON BUSINESS

A steel equipment reference manual which gives specifications on steel shelving, racks, drawers, lockers, work benches, cabinets, other storage, store, office, warehouse and shop equipment, is available free from Equipto, Aurora, Ill.

• • •

Electronic experimenter's kits are being sold by the millions to school children and hobbyists. And some technicians are using the kits to learn more about solid-state circuit operations. See your RCA jobber.

• • •

A highway emergency safety kit consisting of an "extra spare" tire repair cannister, a flashing red light, a fire extinguisher, sterilized first aid kit and a "nite-glo" SOS flag, is being given free to all service - dealers who purchase an established grouping of capacitors for \$22.95. The kit contains 25



bypass tubular capacitors, six twist-prong capacitors and eight tubular electrolytics. List price for the total package is said to be over \$50. See your Aerovox distributor.

• • •

Packaged Electronic Circuit Guide No. 8 is a very useful directory of "PECs" and lists replacements for home entertainment, auto radio, industrial sound and CB radio equipment. It is a must for your repair bench. At your distributor or write direct to: Distributor Products, Centralab, P.O. Box 591, Milwaukee, Wis. 53201.

• • •

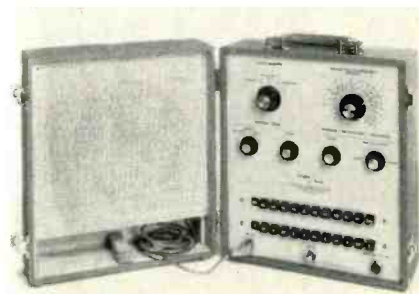

Electronics continues to write new tunes in the world of music.

Now a portable electronic unit combines a tuning device and metronome. The unit is manufactured by Electronic Research Products, Palo Alto, Calif., and is now being distributed by H. & A. Selmer, Inc., Elkhart, Ind. 46514. The elaborate "Magna-Tuner" has 156 different fixed tones and 144 intervals, all selected by pushbutton. It has the ability to sound any interval from a minor second to an octave at the touch of a button. A less elaborate unit, the "Tempo-Tuner," comes in three models: for band, orchestra and guitar.

Why are RCA solid
copper circuits made with
computer precision?

To give them

Space Age dependability.

RCA SOLID COPPER CIRCUITS

They won't come loose.
Won't short circuit.
Won't go haywire.
That's why they're
the circuits of
the Space Age.



The Most Trusted Name in Electronics

TM&©

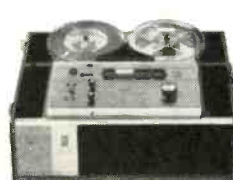
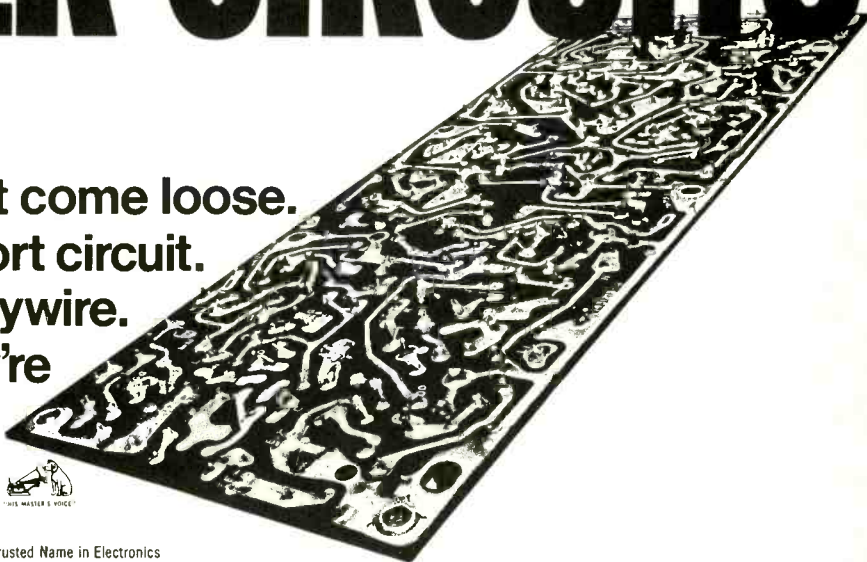



**FINEST
OF ITS KIND**

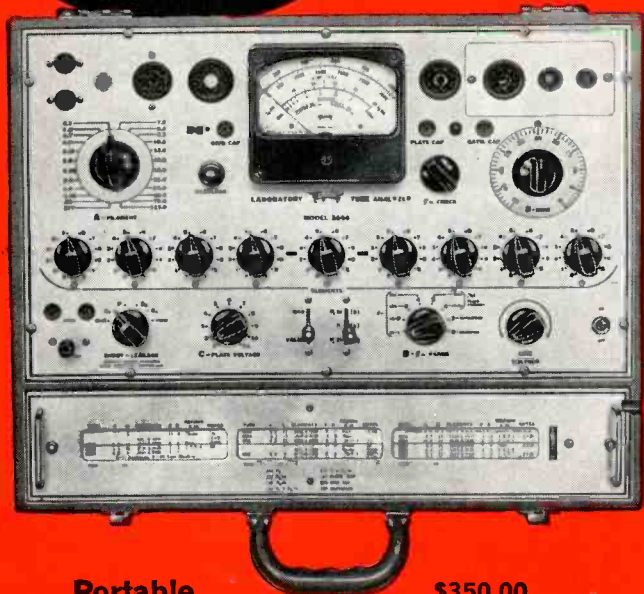

Portable

\$350.00

True Dynamic Mutual Conductance

MODEL 3444 TUBE ANALYZER

FACTS MAKE FEATURES:

- 1** The only tube tester under \$1,000 that is simple and fast to operate, and will measure tube characteristics at known readable potentials.
- 2** The only tube tester under \$1,000 that is simple and fast to operate, and provides readings to:
 - (a) Plot tube characteristic curves.
 - (b) Measure grid current at known potentials.
 - (c) Compare cutoff characteristics of dual tubes.
- 3** The only tube tester under \$1,000 that is simple and fast to operate, and reads directly in micromhos with a self checking Gm circuit.

This superb unit speedily and accurately solves the most perplexing tube analysis problems. Measures true Gm without any compensating factors; using proper value DC electrode potentials. Checks PLATE current cutoff. Checks GAS under actual operating conditions. Checks RECTIFIERS under load. Checks THYRATRON firing voltage and grid currents. Checks DUAL section tubes with only one lever movement. Provides SHORTS and leakage measurements from 0-10 megohms using a filtered DC supply of 85 volts. Case: Wood, gray leatherette covered, 15³/₁₆" x 18¹/₁₆" x 7³/₄".

TRIPLET ELECTRICAL INSTRUMENT COMPANY, BLUFFTON, OHIO

THE WORLD'S MOST COMPLETE LINE OF V-O-M'S.
AVAILABLE FROM YOUR TRIPLET DISTRIBUTOR'S STOCK.



The precision "lab-line" group of measuring instruments by Simpson is now being sold on a direct, factory representative-to-user basis through the firm's own representatives. This move will enable the company to provide on-the-spot engineering counsel to customers and prompt shipment of orders. A catalog giving full specifications and application data on the Lab-Line is available from: Lab-Line Marketing Dept., Simpson Electric Co., 5200 W. Kinzie St., Chicago, Ill. 60644.

The National Society of Professional Engineers (NSPE) reports that industry acceptance of its certification program for engineering technicians continues to grow. It said that 3M Company of St. Paul, Minn. supports and encourages the certification of its draftsmen. Certification is recognized as the equivalent of the academic requirements necessary for promotion to the position of Senior Design Draftsman. Another company pays the annual dues for its engineering technician employees. For information on the Institute for the Certification of Engineering Technicians, write directly to National Society of Professional Engineers, 2029 K. Street, N.W., Washington, D.C. 20006

The rush for the solid-state "gold mines" is on. Motorola has staked claims to a portion of the consumer semiconductor market with its "HEP" (hobby, experimenter, professional) program. Both retail and wholesale outlets are being established throughout the country. If you're interested, write on your letterhead to Motorola Semiconductor Products Inc., P.O. Box 955, Phoenix Ariz., 85001.



New tube tester set-up booklets are available from the Sencore Service Dept. You can get this information as it is printed, usually twice a year, by signing the "Authorization to Invoice" portion of your instrument warranty card. You will automatically receive and be invoiced for the data. CRT set-up data for any CRT tube tester is \$1 per copy; same for the "Mighty Mite" tube testers, \$2 per copy; for the bench tube tester the data is \$2.75 per copy. Replacement operating instruction booklets can be ordered also. Since the number of pages in the booklets are not the same for each unit, the following prices prevail: cost of 8¹/₂ x 5¹/₂ in. operating instruction booklets under 8 pages — no charge; 9 to 12 pages — .75¢; 13 to 16 pages — \$1 and 17 to 24 pages — \$1.25. Send requests and payment to SENCORE Service Dept., 426 Westgate Dr., Addison, Ill.

← ... for more details circle 129 on postcard

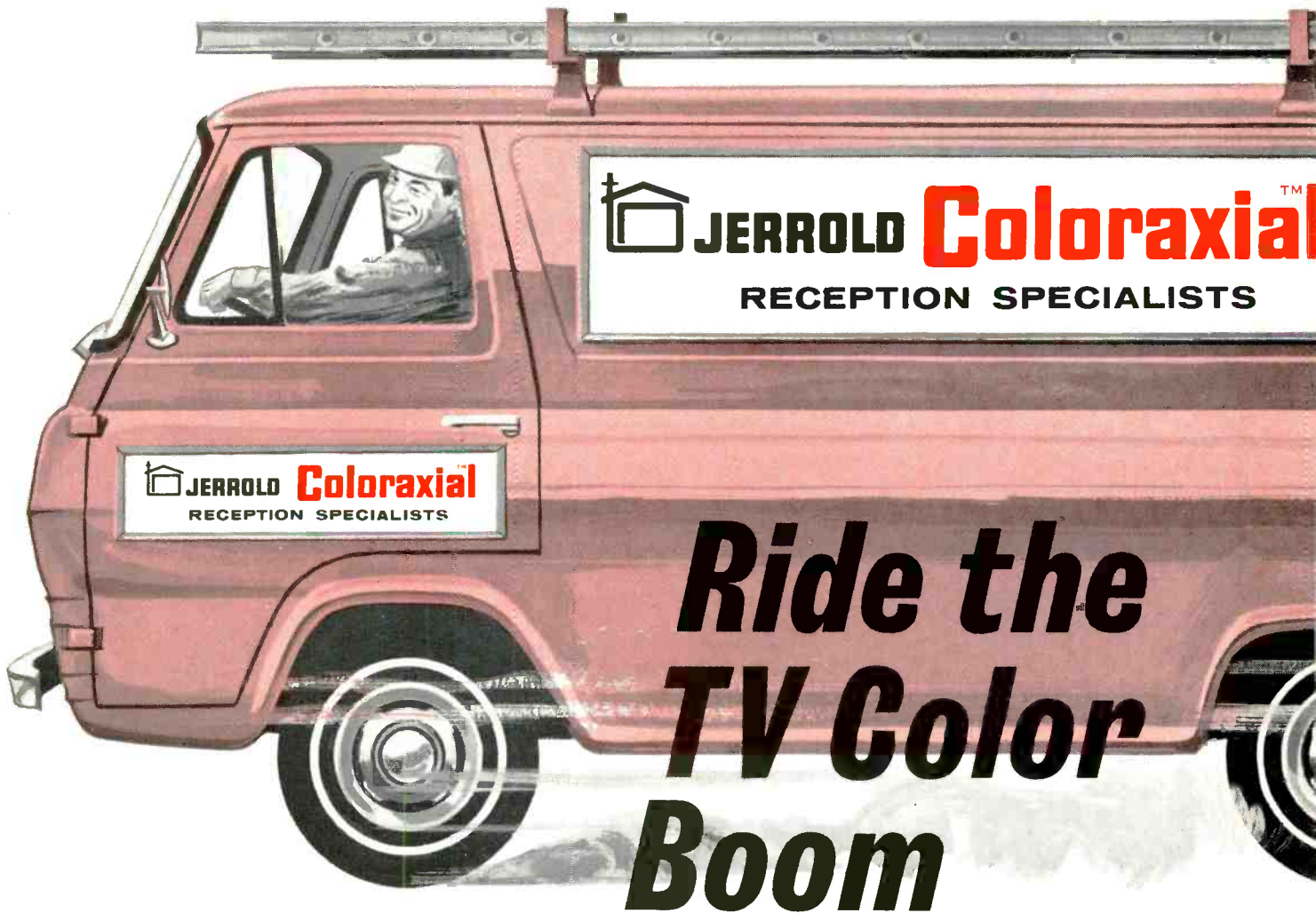

JERROLD Coloraxial™

RECEPTION SPECIALISTS



JERROLD Coloraxial
RECEPTION SPECIALISTS

Ride the TV Color Boom

ALL THE WAY TO THE BANK

with Jerrold's New Show 'n Sell Program

'65 was a banner year for antenna sales. In '66 you'll double and triple antenna profits—when you tie in with Jerrold's money-making Show 'n Sell program!

PROMOTION POWER! Jerrold furnishes everything you need to mass merchandise antenna systems. Eye-catching window and floor displays, antenna danglers and mast wrap arounds, knob danglers for TV sets, bulletin board displays, colorful banners, plus hard-selling door hangers to give you leads . . . arm patches and truck signs; window banners to identify you as an "Accredited Reception Specialist"—issued by the American Institute for Better Television Reception.

ADVERTISING! Jerrold's automatic co-op ad program means business. Sales-building ads are easily adapted to give you an individualized ad program that tells everyone to see you for expert antenna services.

HOW TO! Jerrold and your distributor will invite you to dramatic meetings to show you how to take advantage of the booming color TV, second set, UHF and FM stereo antenna markets. You ring up the profits.

SALES! Jerrold packages consumer-accepted antenna systems and reception aids that are right for the specific needs of your area. Consumer acceptance means high sales volume.

PROFITS! You'll profit as never before with Jerrold's Show 'n Sell program. Talk to your Jerrold Distributor fast—he'll show you how to set new profit records this spring.

JERROLD ELECTRONICS CORPORATION
Distributor Sales Division
401 Walnut St., Philadelphia, Pa. 19106



. . . for more details circle 118 on postcard

TECHNICAL DIGEST

CHEVROLET

Radio Model 986545—Antenna Trimmer Short

When a solder lug (green wire attached) on the antenna trimmer touches the escutcheon and shorts out the antenna coil primary, the radio has normal background noise but is dead otherwise. If you connect an ohmmeter

SHORTS HERE

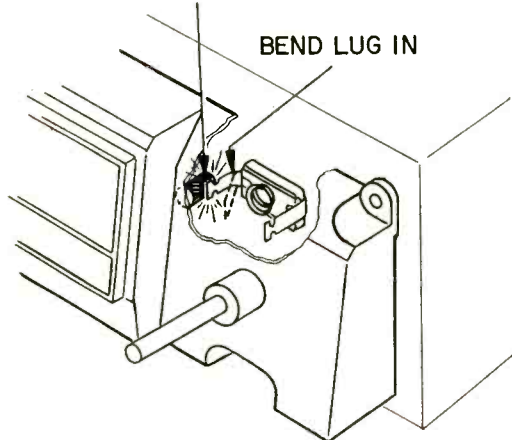

from antenna socket to ground you will find a shorted indication of from 0.4 to 1Ω. The normal indication is 6.4 to 10Ω. To correct the fault, remove the escutcheon and bend the lug with the green wire attached toward the adjusting screw.

GENERAL ELECTRIC

Record Changers—Repair to Bent Velocity Trip Lever

When servicing the General Electric record changer for a center trip condition, it may be found that the velocity trip lever trip item #125 is bent for no obvious reason. Careful examination of the tip of the velocity trip arm assembly item #144 may reveal burrs on the right edge of the arrow head tip.

During a normal cycling sequence the velocity trip lever does not contact the tip of the velocity trip arm after center trip has been accomplished because a stud on the underside of the main gear contacts and resets the velocity trip arm assembly before the velocity trip lever cycles to such a position, but if the Reject ON-OFF knob is held

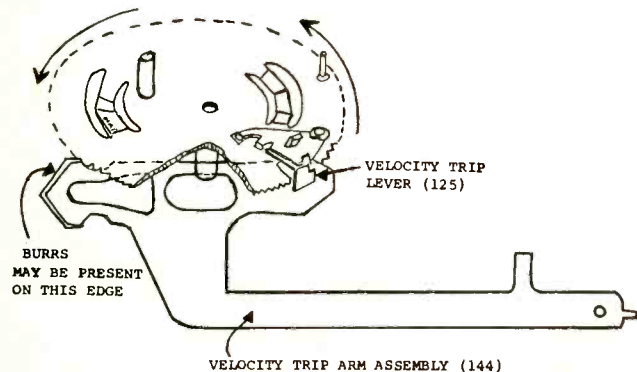

in either the manual off or reject position during cycling after this stud has passed by the arrowhead tip of the velocity trip arm assembly, the velocity trip arm assembly is pushed into such a position that the velocity trip lever must contact and reset the arrowhead tip of the velocity trip arm assembly. The velocity trip lever may catch and be damaged on this burred edge during this cycling sequence.

To properly repair such a defect the velocity trip arm assembly should be removed from the bottom of the mechanism assembly and the right hand edge of the arrow tip of the velocity trip arm assembly should be dressed down with emery paper to remove all burrs or rough edges.

MAGNAVOX

TV Chassis T908 Horizontal Sweep Circuits—Circuit Description

The horizontal oscillator uses the blocking oscillator configuration. The initial forward bias to start oscillation is provided by R608 through the feedback winding of the transformer. As the transistor conducts, the increasing collector current through the primary winding induces a voltage into the feedback winding which applies a positive voltage to the base of the NPN transistor. The rise in forward bias is very fast and the transistor becomes a closed switch almost instantly. The negative side of the feedback winding pulses the 15.750Hz resonant circuit formed by L601, C606, and a diode, D602 which acts as a variable capacitor.

When collector current ceases to change, the field in the transformer collapses and reverses the polarity across

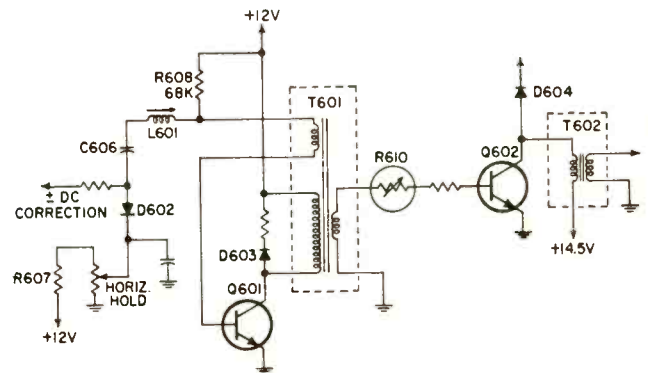

the feedback winding which immediately cuts off the transistor. The transistor remains cut off until the sinewave voltage produced by the resonant circuit goes into its positive half cycle of oscillation. At this time the base-emitter junction becomes forward biased and the cycle is repeated. D603 and its series resistor damp the high positive voltage spike which occurs when the transistor is switched off.

The frequency of the oscillator is controlled by the pulse or minus dc correction voltage from the AFC circuit. This correction voltage is applied to diode D602. D602 serves as a variable capacitor in series with the other frequency determining components. To act as a

Getting a hernia and not getting paid for it?

Let Arcolytic® capacitors lift the load off your mind.
Or anywhere else it happens to be.

These aluminum electrolytics are built to last: wound with computer-grade 99.99% pure aluminum foil so they'll keep operating in your customers' sets even at continuous temperatures of 85°C.

You'll find they take the worry right out of premature failure, lost customer confidence and costly call-backs.

There's no premium cost, either. Arcolytics are priced along with other home entertainment capacitors.

Ask your Authorized Arco Distributor for Arcolytic electrolytic capacitors in single-section tubular, multiple-section tubular, or twist-mount designs. It may be the best break you get this year.

Arco Electronics

A DIVISION OF LORAL CORPORATION
Community Drive, Great Neck, N. Y./
Dallas, Texas/Pasadena, Menlo Park,
California/Write for our free catalog.



... for more details circle 102 on postcard

at last...
instant color patterns
at your finger tips...
zero warm-up time



THE ALL NEW SENCORE CG135 DELUXE TRANSISTORIZED COLOR GENERATOR

The big push is on in Color TV. Equip yourself now with the new, solid state Sencore CG135 and cash in on the zooming volume of new service business as Color-TV booms! Instant, service-ready RCA standard color bars, cross-hatch, white dots and individual vertical and horizontal bars enable you to set up or trouble-shoot more Color TV sets per day; earn top money in this fast growing service field. It's an analyzer too: Color gun interruptors, unmodulated video for chroma circuit trouble isolation and unmodulated sync pulses to keep Zenith receivers in sync for this test, make color trouble shooting a snap. Sturdy all-steel construction for rugged, heavy duty in the field or shop. Another Best Buy in profit-building service instruments from Sencore at

\$149⁹⁵

COMPARE THESE FEATURES: SEE WHY THE CG135 IS IN A CLASS BY ITSELF

- Solid state construction employs high priced GE "Unijunctions" to develop six "jump out proof counters" that guarantee stable patterns at all times with no warm-up
- Standard RCA licensed patterns as shown on schematics throughout the industry
- Handy universal color gun interruptors on front panel
- Lead piercing clips insure non-obsolence
- CRT adaptors optional
- Crystal-Controlled 4.5mc Sound Carrier Analyzing Signal to insure correct setting of fine tuning control
- RF output on Channel 4 adjustable to Channel 3 or 5 from front of generator when Channel 4 is being used
- No batteries to run down; uses 115 V AC
- Less than one foot square, weighs only 8 lbs.

professional quality — that's the difference!

SENCORE

426 SOUTH WESTGATE DRIVE • ADDISON, ILLINOIS

... for more details circle 126 on postcard

TECHNICAL DIGEST

capacitor, the diode must be reversed biased. A positive voltage is placed on the cathode through a voltage divider network, R607 and the horizontal hold control. As the hold control is changed in resistance, the reverse voltage across the diode increases or decreases which changes the diode capacitance and the frequency of the oscillator. Any correction voltage from the AFC circuits also changes the capacitance of the diode and corrects for frequency errors.

L601 is the main frequency-determining component in the circuit. To adjust this coil, the horizontal hold control should first be set to mid-range and the AFC correction voltage shorted to ground at the junction of R601, R602 and R603. With a station tuned in, L601 is adjusted until the picture is steady or slowly drifting horizontally. When the AFC short is removed the picture will lock in.

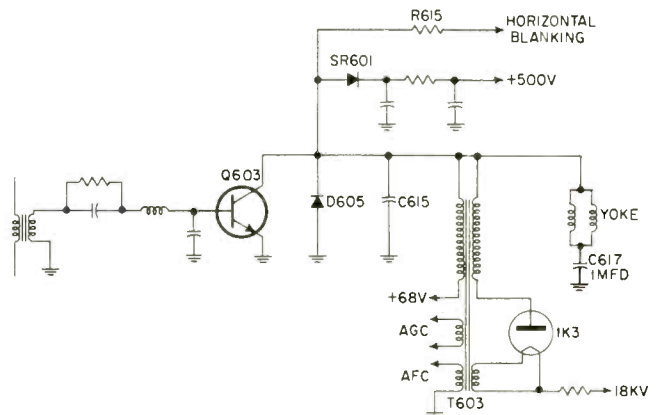

The oscillator signal is coupled through another winding of T601 to the base of the horizontal driver. A thermistor, R610, is placed in series with the base to compensate for temperature changes within the oscillator transistor. As the temperature of Q601 changes, the collector current and the frequency of oscillation will change. The collector current increase is coupled to R610 which causes the thermistor resistance to decrease. This produces a heavier load across the secondary winding and causes a small change in the inductance of T601. The inductance change is such as to correct the frequency drift of the oscillator and to stabilize the collector current.

The driver stage is either cut off or driven into saturation by the base signal. The output signal appears as a rectangular waveform and is transformer coupled to the base of the horizontal output stage. When the driver is cut off by the base signal, T602 tends to ring as a result of the collapsing field in its windings. This can produce voltages which may exceed the ratings of the transistor and destroy it. D604 serves to limit the positive peaks of the ringing voltage to a safe value. The diode serves a second purpose: the rectified peaks are filtered and added to the supply voltages used with the phase splitter stage.

The horizontal output stage has three main functions: it supplies the yoke with the correct horizontal scanning currents, it develops the high voltage for the anode of the CRT and develops a +500v supply voltage for the CRT. In addition, auxiliary windings on the high voltage transformer supply pulses to the AGC and AFC circuits. Blanking pulses are also coupled out of this stage.

Q603 acts as a switch which is turned "on" or "off" by the rectangular waveform on the base. When the tran-

UNDER 18

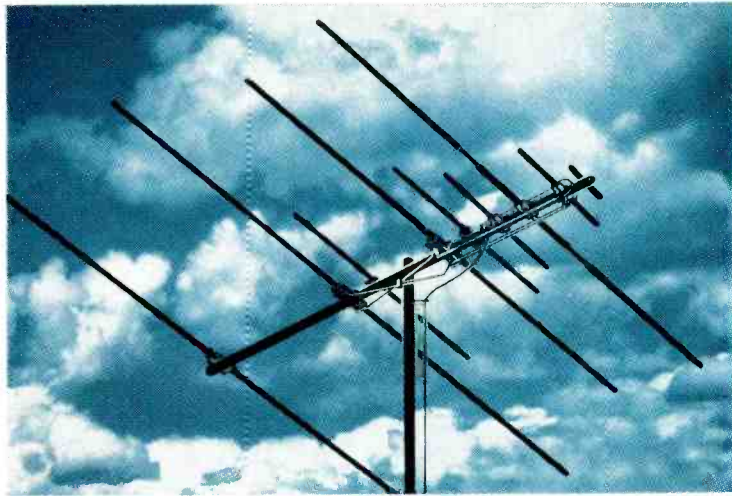

There is now a good 82-channel COLOR antenna for city and suburbs...that lists for only \$17.⁵⁰

Remember the name. The Channel Master Crossfire **Color-Star**

That's important.

Because even if it's only price that interests you, that's not the main reason you'll be interested in us.

On price alone, the new Channel Master Color-Star stacks up against any comparable 82-channel antenna you can name for medium to strong signal areas.

But if its overall UHF and VHF performance you want—in color or black-and-white—the Color-Star shapes up as decidedly superior.

Of course, there's its unique dual-function VUtronic element design

(the patent is pending). For the first time a driven UHF element is used to support a parasitic high band VHF director. (Which also acts as a UHF reflector.)

This electronically interleaves both the UHF and VHF sections on a single antenna. So the antenna is more compact—practically a foot shorter than it would be otherwise.

Still it's in the VHF section that you can see the difference (where it really counts). The Color-Star employs Proportional Energy Absorption. This is the exclusive Channel

Master Crossfire principle that produces maximum signal power on both the high and low bands.

A unique "Golden Overcoat" provides lasting protection against corrosion. And our U-V Band Splitter is included (Model 0032).

To repeat: When you sell the Color-Star you lead with your price—but you wrap up the sale with performance.

That keeps everyone happy.

CHANNEL MASTER

ELLENVILLE, NEW YORK

... for more details circle 109 on postcard

Also available. A complete line of 82-channel Ultradyne Crossfires for every area.

**"TAKING THE
COUNTRY BY
STORM!"**

**THE
ALL NEW
IMPROVED
SENCORE
TC136 MIGHTY MITE IV**



Now Americas Number ONE Tube Checker . . .

Checks compactrons, novars, nuvistors, 10 pins and the latest 10 pin used in many new color TV sets, plus over 1200 foreign tubes. The Mighty Mite is so popular because it checks each tube for:

- **GRID LEAKAGE** of as little as 1/2 microamp or 100 megohms
- **EMISSION** at tubes full rated cathode current
- **SHORTS** of 180K or less between elements

With These New Exclusive Mechanical Features . . .

- New third hand set-up book holder.
- New removable hinged cover
- New taut band meter

Get your Mighty Mite from your distributor now, and join the more than 30,000 Mighty Mite users the world over. **\$74.50**

SENCORE

426 SOUTH WESTGATE DRIVE • ADDISON, ILLINOIS

. . . for more details circle 127 on postcard

TECHNICAL DIGEST

sistor is turned on, yoke current increases in a linear manner and moves the beam from near the center of the screen to the right side and C617 becomes charged. At this time the transistor is turned off by a negative voltage on its base which causes the transformer to oscillate. A high reactive voltage in the form of a positive pulse is developed by T603 which quickly reverses the current through the yoke and moves the beam to the left side of the screen. This pulse is stepped up by the high voltage secondary winding, rectified and filtered to produce the 18kv supply to the CRT anode.

During the negative half-cycle of oscillation, the damper diode, D605, becomes forward biased. Capacitor C617 can now discharge through the yoke and damper diode to ground. The discharge rate is linear and the beam is moved from the left side of the screen to the center. The transistor then becomes forward biased by the base signal and the beam is moved on to the right side as before.

C617, in series with the yoke, also serves to block dc currents through the yoke and to provide "S" shaping of the current waveform. "S" shaping compensates for stretching at the left and right sides of the picture because of the curvature of the CRT face and the deflected beam do not describe the same arc.

The positive pulse developed during retrace time is rectified by SR601 and filtered. This produces +500vdc which is used by the focus control, the LDR Range adjustment, and the brightness control. A portion of this positive pulse is coupled through R615 to the emitter of the video output stage to provide horizontal blanking of the CRT.

PHILCO

Table Model Radios N721, N880 & N881—Production Change

In later production of these radios, a ground lead was added between the ground side of oscillator coil T1 and the center lug of the 12BE6 oscillator tube. The lead is located on the copper side of the perma circuit panel.

This was added to remove oscillation causing a hissing noise on the high end of the dial.

CHEVROLET CAPRICE

Stereo Multiplex—Adapter Changes

As shown in photo, late production "Caprice" stereo multiplex adapters use a 'Y' cable extension for ease of connection to the console control interconnecting cable. The old method was the 7-pin and 9-pin sockets. The part numbers for the 'Y' cable and the sockets are also shown.

NEW
(MODEL 7299561)

OLD
(MODEL 7296341)

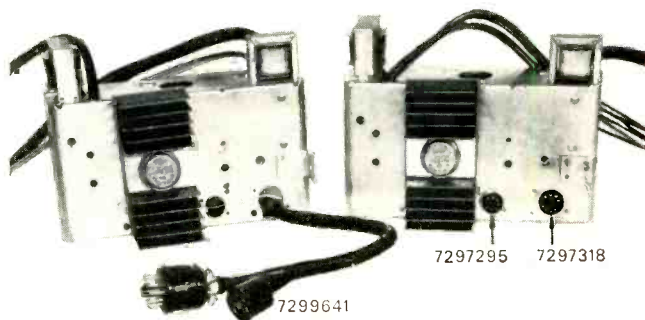

Listen!

Now Jensen brings you 9 auto rear seat speaker kits



They're designed for all popular makes of cars on the road today. New connectors make them faster and easier to install than any other kit.

Oversize air gap clearance, dust drain holes, and solid domes eliminate call-backs.

Jensen's nine new models are available in two lines—deluxe and economy. And they're both packaged in Jensen visual Show Pack for display mounting and in standard cartons for off-the-shelf sales.

Don't pass up profits! Ask your Jensen representative for complete details. Or write Jensen Manufacturing Division, The Muter Company, 6601 S. Laramie Ave., Chicago, Ill. 60638

jensen

Over
10 million
cars
need one
here!

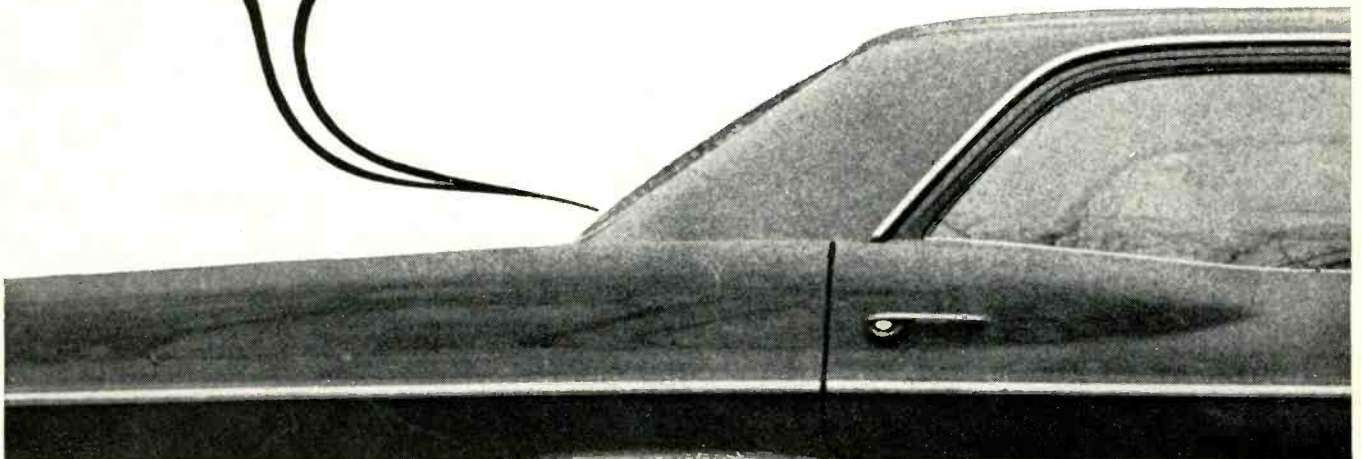

... for more details circle 116 on postcard

Win fabulous prizes in big Krylon® “dealer’s choice” sweepstakes!

121 GIVEN AWAY

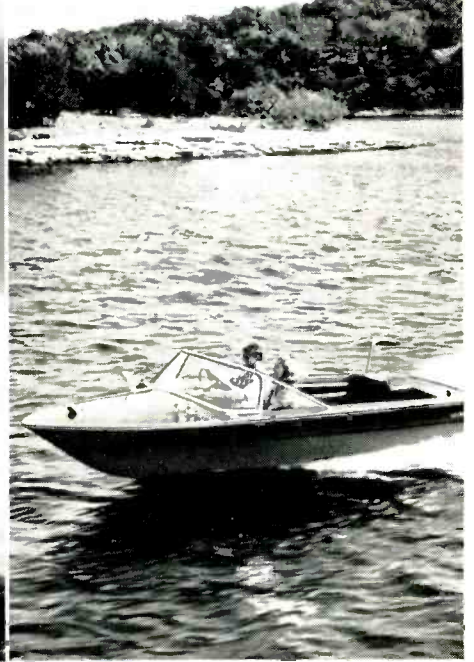

FIRST PRIZE — DEALER'S CHOICE OF

1966 FORD MUSTANG OR **TRIP TO EUROPE FOR TWO** OR **LONE STAR BOAT, MOTOR AND TRAILER**

The sporty one with the racy lines that gives you top power and performance.

A three-week vacation to see the sights of London, Paris, the Riviera — all fully paid.

For fishing or relaxation, here's just what the doctor ordered.

4 SECOND PRIZES

Choice of:
RCA 25" Color TV
Console or Autumn
Haze Mink Stole

6 THIRD PRIZES

Choice of:
Vespa Motor Scooter or
RCA Stereo Hi-Fi Console
with AM/FM Radio

10 FOURTH PRIZES

Choice of:
American Tourister
2-Piece Luggage Set or
RCA Tape Recorder

100 FIFTH PRIZES

Choice of:
2 Hathaway Shirts or
Kodak Instamatic
Camera Outfit

**All Krylon dealers are eligible.
Nothing to solve. Nothing to write about.
Good luck. (Sweepstakes close July 31, 1966)**

Here's one game of “dealer’s choice” where you can't lose! Not only do you have a chance to win a big prize. In addition, you're a sure profit-winner when you sell Krylon. Krylon is far and away America's No. 1 Spray Paint—the fastest mover, the biggest money-maker...and there's no better time to order than right now when your jobber is offering this extra-profit deal. If you order now...you get 12, yet you pay for only 11 (either cans or cases).



**BORDEN
CHEMICAL**

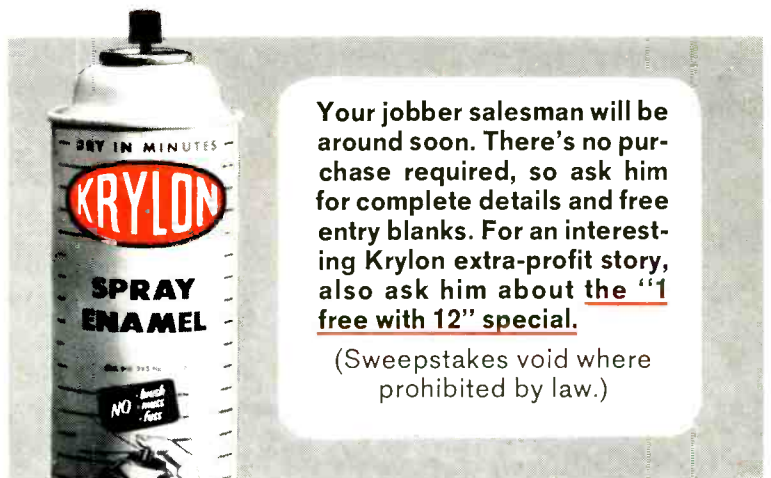

Your jobber salesman will be around soon. There's no purchase required, so ask him for complete details and free entry blanks. For an interesting Krylon extra-profit story, also ask him about the “1 free with 12” special.

(Sweepstakes void where prohibited by law.)

... for more details circle 108 on postcard
ELECTRONIC TECHNICIAN

Methodical Troubleshooting

Develop organized servicing and repair procedures and boost your labor productivity

■ Too many heads are being used in the TV-radio business today to push over decaying brick walls. A bulldozer is infinitely better equipped to do this job. Heads are more useful for designing, planning and organizing.

Higher labor productivity is becoming a major competitive factor in the home entertainment service business today. The more jobs you can perform every year, the higher your annual income — the more secure your business becomes. And this can be achieved only with well planned work methods, techniques that result not only in getting more work done — but higher quality work. It does not follow that a higher rate of productivity means lower quality work. The secret is organized, efficient work methods.

The Methodical Approach

Although every skilled technician or service manager must develop his own efficient troubleshooting and repair methods, based on a knowledge of electronic circuit theory and practical experience, certain basic logical procedures have already evolved through trial and error — through combined past experiences.

We already know, for example, that the troubleshooting procedure begins with trouble symptoms; followed by efforts to accurately determine what defective part or parts can cause these symptoms. This is not done entirely by a system of mental deduction or by induction. It is done primarily by a rapid series of scientific checks — using properly selected test instruments. This means an organized method of isolating the fault to a small area

and then to one or more defective parts. How is this done?

Recorded data shows that defective tubes account for approximately 80 percent of TV-radio breakdowns. Because of this high percentage, great care must first be given to eliminating defective tubes. But it is surprising how many defective tubes are allowed to remain in sets until a lot of time has been wasted probing in other areas. Many sets have been pulled to the shop because a haphazard, unorganized servicing approach caused technicians to overlook this important, initial consideration.

After you are absolutely certain that defective tubes are not involved — if necessary substituting suspected tubes with two or three different new tubes — then the next logical step is *visual inspection* of suspected components. Many overheating and charred resistors, arcing leads, defective tube sockets and other malfunctioning components can be located by using your normal senses — sight, hearing, touch and smell.

Where large resistors are employed, you can often tell if they are open merely by touching them lightly and quickly with your finger. They will be cool if open. If they are good and conducting current, they will be warm and even hot — depending on their wattage rating and particular use in the equipment. Of course, if a resistor is in a leaking or shorting circuit, you can burn a finger if you allow it to linger too long on the resistor.

If you cannot locate the fault after careful “sensing,” then move to the next logical step: get out the manufacturer’s schematic and study

it, familiarize yourself with the physical layout and circuit design. With the symptom constantly in mind, study the circuit and determine which particular component *could* cause (and probably is causing) the trouble symptom. After deciding which test instrument is best suited to the particular problem, you then narrow the search down to the defective circuit by making the proper checks.

Which Test Instrument?

Most suspected components can be checked with a VTVM or VOM. But your scope can be a great time-saver when checking for loss of video, sync trouble or when checking horizontal or vertical waveforms.

Since the advent of transistorized radio and TV circuits, the signal generator has also come back into its own as an invaluable servicing instrument. This is especially true when isolating trouble to a defective stage in either TV or radio, when a loss or decrease in signal has occurred. The ohmmeter is very useful also in checking from point-to-point in printed circuits, checking open tube socket connections, checking the resistance of various parts and for locating leakage and short areas.

Practical Cases

Let's attempt to apply organized troubleshooting methods to a few actual sets that come into the shop. The first set has a snowy picture. Tubes were substituted in the home before the set was pulled. A quick

visual inspection of the tuner is made and no badly charred or overheating resistors are discovered. The next logical move (depending on the type of AGC or tuner involved) may require grounding the AGC line at the point where it goes into the tuner. If the picture becomes clear, the AGC delay resistor is probably open (See Fig. 1). Most AGC delay resistors have a value between 8.2 and 22M — depending on the particular set's design. When the AGC delay resistor opens, the negative AGC voltage applied to the tuner becomes high enough to cut off the RF amplifier — causing little or no signal or a snowy picture.

If the tuner resistors are defective, grounding the AGC line would have no effect on the picture quality and the signal would not change. In this case, a more thorough tuner check would be necessary: a check for open resistors, coils or poor tuner contacts, for example. If burned resistors are discovered, check for leaking or shorting feed-throughs or ceramic capacitors.

Suppose the next set comes in with no high voltage. A visual check shows the horizontal output tube plate is running "cherry red." This symptom can indicate that the horizontal oscillator stage is not operating properly. A check of the drive voltage at the HOT grid will decide this issue. The proper negative grid voltage at this point is usually from -20 to -45v—depending on the TV chassis design. Here again, an exact, original manufacturers schematic is helpful in determining what

the proper grid drive voltage should be.

After this check, the tube's plate lead should be disconnected and the drive voltage rechecked to determine if a noticeable change has occurred in the drive voltage.

If the TV has a shorted yoke or flyback, the negative voltage measured at the HOT grid will be lower than normal. When the plate cap is disconnected, the voltage will rise from 10 to 20v — if the horizontal oscillator is operating properly. If you have a flyback tester, now check the yoke and flyback to see which one is defective. If a flyback/yoke tester is not on hand, the parts should be substituted to determine which one is at fault.

The aforementioned checks can help you decide whether the trouble is in the horizontal oscillator or the horizontal output stage. Of course, if you have one of the modern "analyst-type" instruments having circuit-substitution facilities, you can speed up the process of isolating a defective stage. If the trouble is located in the horizontal oscillator circuit, then the likely cause will usually be an open plate load resistor or a shorted feedback capacitor.

If the horizontal oscillator uses PC boards, look for the following possible defects:

1. A break in board leads.
2. Internal tube socket breaks between socket terminal connections and the point where the terminal connects to the board.

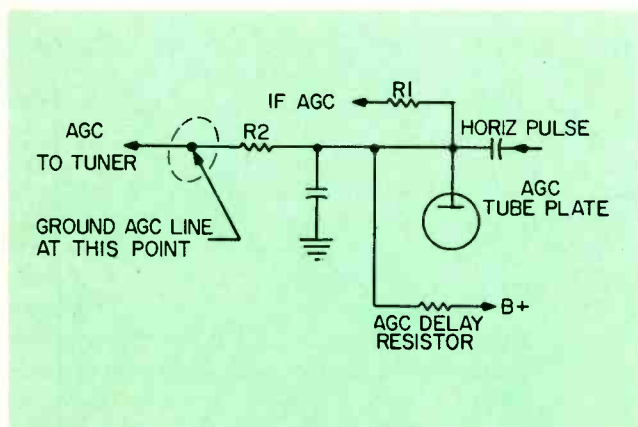

Fig. 1—In many TV sets a quick check can be made to isolate a fault to either the tuner or a defective AGC delay resistor by grounding the tuner AGC line.

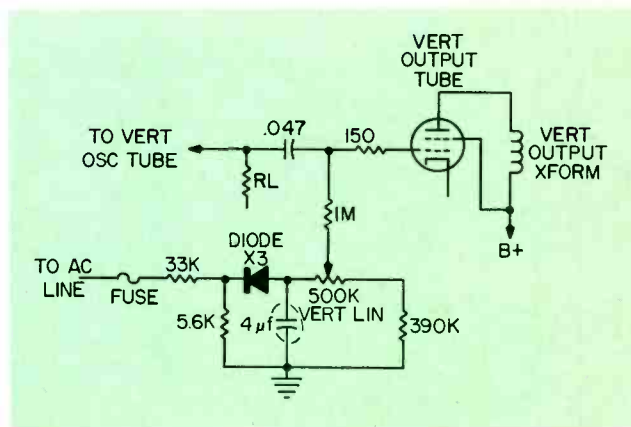

Fig. 3—An opened 4µf filter here caused severe vertical foldover.

Table 1

1. Careful visual interpretation and inspection of symptoms and components.
2. Apply Electronic Theory and practical experience to analyzing symptoms and causes.
3. Use schematic as a practical aid to isolating trouble.
4. Use test instruments to isolate trouble to the defective stage, circuit or component.
5. Always be on the alert for new circuit innovations that may throw you a curve if not carefully noted.

3. Horizontal oscillator coils breaking where the coil lead is soldered to the PC board.

4. Open resistors or bad connections in small packaged RC networks which are frequently used.

A point-to-point check with an ohmmeter, while slightly flexing the PC board, is the best method to locate defects on printed circuit boards.

Packaged RC networks can frequently give you trouble if you're not alert. For example, in one set a grounded 560K resistor in the horizontal PC network opened and caused poor vertical linearity (See Fig. 2). It took a while to detect the fault. In this case, the picture was severely compressed at the top and attempts to expand the top of the picture, by adjusting the vertical linearity control, proved useless. This was true because the vertical output tube bias was being obtained through a voltage divider from the horizontal output tube grid. When the 560K resistor opened, too much negative voltage was applied to the vertical circuit — causing the poor vertical linearity.

Another somewhat similar vertical circuit difficulty also proved frustrating. In this circuit the vertical output tube bias is obtained from a diode connected to the ac line. This ac voltage is rectified, filtered and then applied to the vertical output tube grid (See Fig. 3). A $4\mu\text{f}$ filter in the circuit was open. This caused the picture to have severe vertical foldover and a slow pulsating increase and decrease in picture height took place.

It is apparent from these few examples that technicians must employ systematic servicing procedures. It is understood that every technician will, through individual experience, develop his own shortcuts and organized methods of work. Most service jobs can, however, be successfully negotiated by following the five basic steps listed in Table I. Devote a few minutes each evening to analyzing the new circuits reviewed in a technical magazine or manufacturer's schematics and servicing data. It will help you cut hours off your troubleshooting time. ■

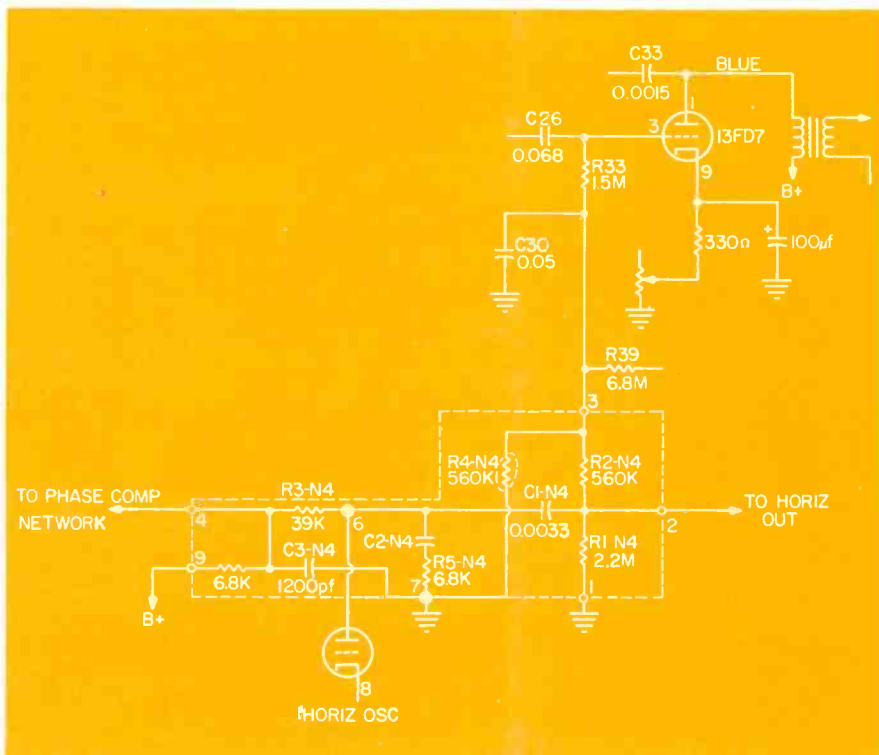

Fig. 2—A grounded 560K resistor in a PC network opened and caused a very unusual problem.

HOMER DAVIDSON PUSHES COLOR TV

■ "I opened this business 18 years ago with a week's pay check, guts and a lot of hard work."

We were listening to Homer Davidson, owner of Davidson Radio and TV. His 1800-sq. ft store is located on highway 20 in Fort Dodge, Iowa, one of the fastest growing areas of the state.

"We grossed \$108,000 last year in this 30,000 population town," Mr. Davidson continued, "and we service TVs, car radios and anything electronic, including industrial and medical electronic equipment."

The firm began selling and servicing color TV almost 10 years ago and was thoroughly prepared to take full advantage of the antenna and color-set boom when it got under way more than a year ago.

"The first four years, back around '48 to '52, were very lean," Mr. Davidson declares. "But now we are cashing in on antennas and color. Even monochrome sets are still going strong," he added.

The shop will soon begin to sell, install and service auto tape players, which are becoming popular with an increasingly larger number of car owners. And Mr. Davidson says car radios and stereo sets help round out his total sales.

The owner keeps his store open from 8 a.m. to 6 p.m. daily with a

late opening until 9 p.m. on Mondays.

Business Approach

"Today," Mr. Davidson went on, "you have to be more than a good technician. You have to be a sharp businessman, too. For example, we have two used-set counters here. One is loaded with used TV sets. The other with used radios, rotators, car radios, converters, small table stereos. You'd be surprised how many working dollars come from those used-set counters and go toward reducing overhead costs. We keep a dozen used TV sets lined up at all times. We repair these items with those lost half hours' between regular jobs."

Mr. Davidson feels you should make "sharp purchases" but not fall into the trap of overstocking. He thinks many TV technicians overstock when they first go into business.

"I've seen one after another load themselves down with 'luxury type' test instruments which they didn't know how to use and never learned. The instruments collected dust," he declares. "They bought a lot of stock and then starved through slack periods. Within two or three years they all went broke. More than 20 TV-radio businesses have gone under in

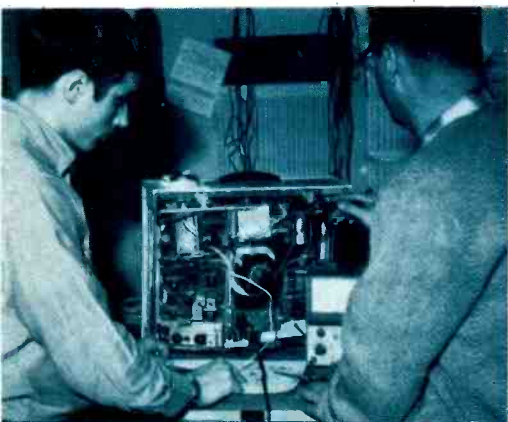

Owner Davidson (right) takes voltage measurements on a defective portable TV while apprentice Long observes.



Homer Davidson's store is located along a busy highway.



Technician Richard Adkins switches on a set in the color display room. In the small room, sets are stacked to use the space effectively.

18 years in business

this town the last eighteen years. Many were considered good service shops, too.

"Watch and take all 10th-of-the-month discounts," Mr. Davidson advises. "Check all invoices, add them up and tally them out. Most electronics distributors are honest but we can all make mistakes.

"Have a look at those in-warranty parts. Do this the first working day of every month. Make sure that credit follows through. Just a few in-warranty parts, today, can add up into big wasted dollars. Keep a close watch over your books — no matter who keeps them."

Mr. Davidson thinks too many service-dealers cut their profit margins unnecessarily.

"Don't cut your profits on those color and B/W sales," he warns, "especially in this day and age. You have to make a decent profit to stay in business. Let the other fellow do it if he wants to. It's a disgrace to see people in this business make only \$25 to \$50 on a color set sale. Good color installations take up a lot of time. A good businessman makes a fair profit."

Mr. Davidson also believes service-dealers should plan for and attempt to influence future events.

"Keep a tally sheet of sales and repairs for the past year and then

work toward a higher goal for the current year."

He is convinced that every service-dealer should get away from his business occasionally, away from the constant grind and customer problems.

"Don't forget to take a few days off — at least two weeks vacation a year," he recommends, "even more time, if possible. Sometimes we are too close to our own business and can't see our mistakes. When on vacation, pick up a few pointers from other TV-radio service-dealers. We all like to make a lot of money, and today it takes several cash-registers-full just to pay the taxes. But too many hours on the job can buy you a room in a mental institution, a hospital or space in the ground."

Service Policies

Davidson Radio and TV has three regular technicians and one apprentice.

"If every service-dealer in the country kept at least one apprentice on training at all times, we would not now be short of technicians," the store-owner believes.

Mr. Davidson, with the apprentice's help, does most of the bench work and takes care of in-store sales. The three regular technicians install

antennas and make house calls.

Bench charges run around \$6 an hour. A regular house call is also \$6. The minimum bench charge for TV repairs is \$12.50. If an estimate is not approved on a portable TV, a \$5 charge is made. A \$7.50 charge is made on a regular TV if a customer rejects the estimate.

"We do very few 'minimum' repair jobs. About 95 percent of our repair estimates are for complete overhaul," Mr. Davidson says. "And the minimum repair for a table radio is \$2.75. Minimum repair charges for transistorized radios is \$4.50.

"Quick service is a must today," Mr. Davidson finds. "Don't let sets clutter up the shop for three or four weeks. Repair it today. Do the best possible repair job. Deliver the set and collect the bill. Repair bills in that charge-out drawer do not ring your cash register.

"Most people do not complain about repair bills if you itemize the bill — labor and parts — and give them a good repair job. Price does not bring in new business, but good clean, quick service will," Mr. Davidson believes.

Davidson Radio and TV is a member of a state and national technicians association. Mr. Davidson is president of the Northwest Iowa chapter of TSA. ■

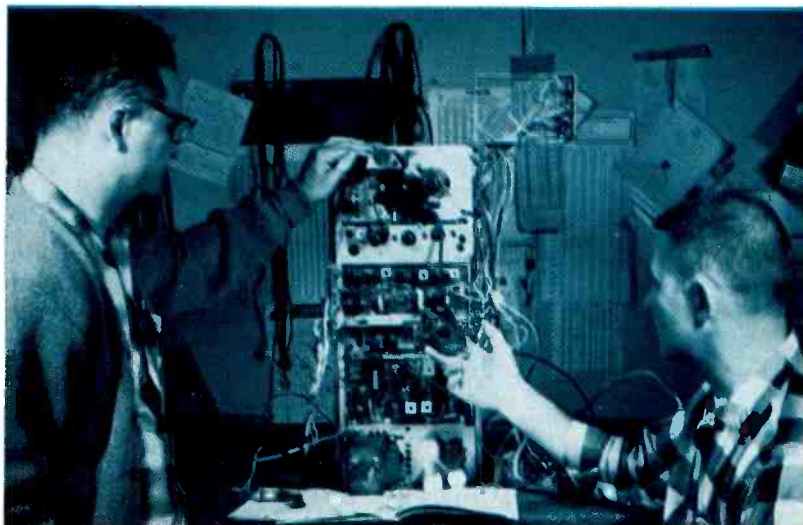

Technician Roger Messerly (right) and owner Davidson discuss a color TV problem. The high voltage cage has been removed from the set. Note the burned flyback transformer.



Technician Messerly checks sync circuit in a color set with 'analyst.'

■ A previous article covered a number of compressor-type audio amplifiers. This is the concluding part of this two-part series.

The equipment described here features low harmonic distortion — ranging from less than 1 percent to approximately 2 percent, according to manufacturer's specifications.

One manufacturer provides four different units. The first has a traditional two-stage, push-pull circuit which combines maximum simplicity and effectiveness. No meter is supplied (although available as an accessory) and no attenuators are included. A dual/average time-constant switch is provided. Threshold and compression ratio are variable. The input and output can be either 150 or 600Ω. The second unit is a plug-in model, requiring an external power supply delivering 6.3vac @ 1.55 amp and 300 vdc @ 77ma. The third is a complete, powered

unit in rack mount. Otherwise, the second and third units are identical.

The fourth unit by this manufacturer is completely transistorized and it reduces gain by placing a photoresistor across the input signal path and by driving a lamp with output signal. As the lamp brightens, the PR's impedance decreases, shunting the signal. Advantages are minimum distortion and no balancing is required. When the input signal is removed, an expander circuit decreases noise output by 10db. With high gain, the unit can be driven direct from a mike. This is a plug-in model, requiring 160ma @ 50vdc. Input impedances are 30, 150 or 600Ω, and output matches 150 or 600Ω. The front panel contains a gain control, compressor and expander switches.

Plug-In Modules

A second manufacturer provides

two plug-in module units (no power supplies) designed as accessories to a special line of commercial/industrial amplifiers. They may, of course, be modified slightly to fit other amplifier brands.

Essential details of the circuit of one module is shown in Fig. 1. It will accommodate any one of the following signals: Microphone (5mv), magnetic phono (2.2mv), tape head (1mv), or another amplifier (250mv). These inputs are high-impedance, unbalanced, although a balanced 600Ω line-input transformer is available as an accessory, as are various low-impedance mike transformers.

Whatever the input, it eventually appears across R409, which sets the compression threshold. Signal is then amplified by V401 and V402 and appears at R434, which sets the output level. The signal at output is approximately 300mv, high

VOLUME LIMITING IN PA & BACKGROUND MUSIC SYSTEMS



Langevin AM5301 'Leveline.'



ITA's ARC-1A amplifier.



RCA's BA25A AGC amplifier.

Understanding sophisticated

impedance. At V401, a portion of the plate signal is fed to V403's grid. This sample of program material is amplified by V403 and rectified by D1/D2. Note that R431 biases the diodes so they won't conduct until signal rises above a certain point. This fixes the compression point. The resulting dc is filtered by C418 and R430 and furnishes grid bias for the two amplifier stages V401/V402. Function switch S1 changes the value of "R" in the control line, and this alters the grid bias to V401/V402 to shift their operation upward or downward on their transfer curves. The result is three degrees of compression: 2:1, 6:1, and 40:1. The last is actually full limiting.

The other module is slightly different. V400A and "B" are used as phono and mike preamps, as similar to the previously mentioned unit, but their output is fed out of the

unit to the mixer bus on the associated main amplifier. The output of this bus, containing all input signals from whatever source, is then fed to the controlled-gain amplifier stages, V401/V402. Hence, all program inputs to the mixer bus receive volume limiting. Also, its action is fixed at full limiting—40:1 compression ratio. Otherwise, it is identical to the previously mentioned module.

AGC Amplifiers

A three-stage, push-pull circuit is used in another manufacturer's unit (Fig. 2). It has a 6386 input/gain-controlled stage, 12AR7A intermediate, and 12BH7A output. A "VR" tube is used for operating stability. This model is normally supplied as an averaging device but can be modified to alter recovery time. Input and output are both 600Ω, and attenuators are provided at both ends.

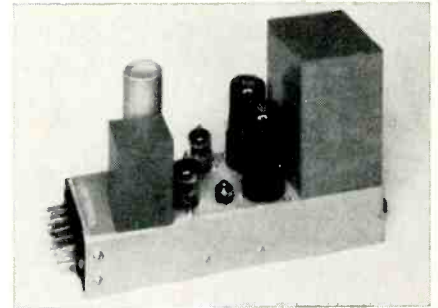

G-E's BA9A 'Unilevel.'

audio amplifier equipment

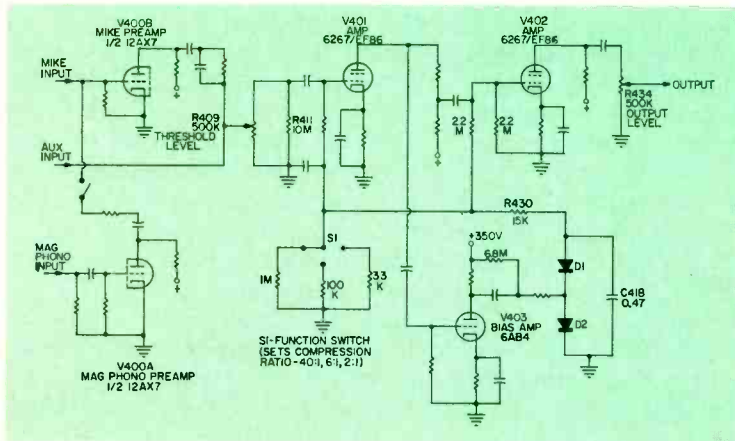

Fig. 1—Simplified schematic of Harman-Kardon module, M4.

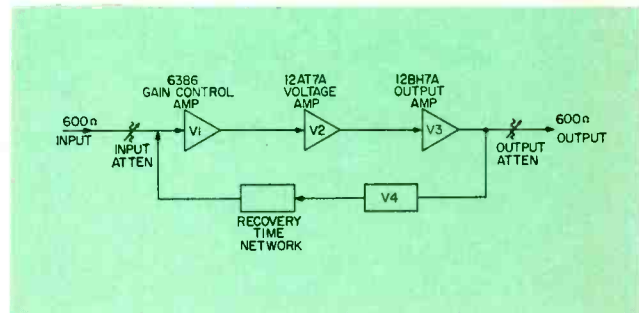
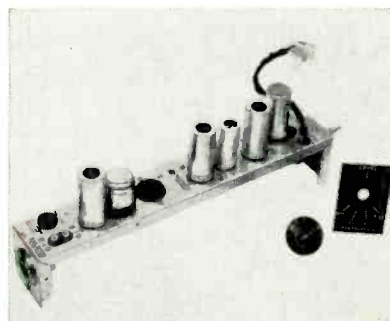
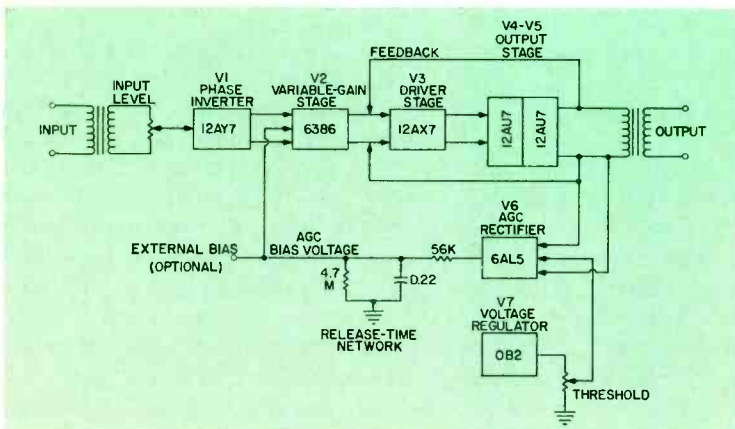

Fig. 2—Block diagram of ITA AGC-1A.



Harman-Kardon module, M4.

Fig. 3—Block diagram of RCA's BA25A AGC amplifier.

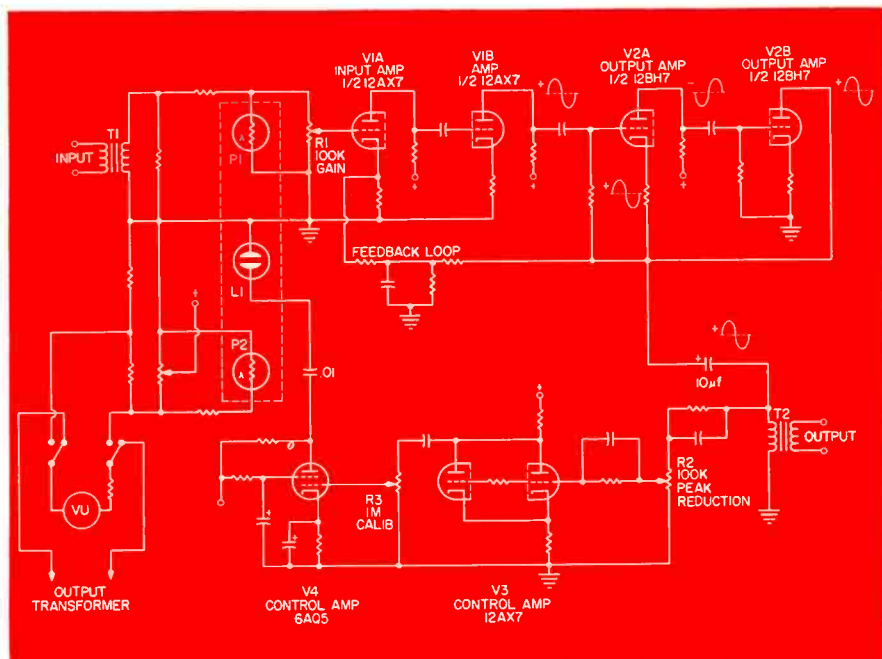

Fig. 4—Simplified schematic of Teletronix LA-2.

Another manufacturer provides a unit employing a three-stage, push-pull circuit, with a 6ES8 as the variable-gain controlled stage. An interesting feature includes a tertiary winding on the output transformer to supply feedback to the 12AY7 intermediate stage, resulting in a very stable circuit. The output tubes are 6005's (premium 6AQ5's) and the output transformer is double-wound to minimize leakage and hum. Up to 6W output can be obtained at a speaker if the unit is strapped as a monitor. It can also be used as a lower-level stage in a music or PA system. Threshold and compression are continuously variable, and a dual/average time-constant switch is provided. It has no power supply, since this is a plug-in unit intended for an integrated system. Required power: 6.3vac or dc @ 1.5 amp, and 300vdc @ 90ma. No attenuators are supplied and no meter (but kit is available). Both the input and output match 150 or 600Ω.

An elaborate AGC amplifier circuit is shown in Fig. 3. It is completely push-pull. The first stage is

a low-noise 12AY7, which extends the input range quite low — compression can begin with as little as -60dbm at input. This means a microphone can drive it directly. The second tube, which is the variable-gain stage, is the familiar 6386. The third is a 12AX7, and the last is a pair of 12AU7's as output. Negative feedback is used around driver and output stages. The control circuit uses a VR tube across the threshold-voltage supply and a 6AL5 rectifies the control voltage. The release time constant is fixed and rather slow, making the amplifier an averaging component. Note the provision, however, for inserting remote bias voltage to the 6386 stage, making it possible to remotely control gain.

An input potentiometer, threshold control, and metering switch are provided on the front panel. Though no meter is supplied, the switch selects input signal, gain reduction and various tube currents for monitoring by an accessory meter. Input and output match 150 or 600Ω, and the chassis is a plug-in unit designed for a companion, rack-mount shelf.

Leveling Amplifier

An unusual circuit shown in Fig. 4 is provided by another manufacturer. Incoming audio appears across P1, a photoresistor, and R1, the gain control, in parallel. V1A and V1B are cascaded voltage amplifiers which deliver the signal to V2, the output voltage. V2 is a piggy-back cathode follower — actually a direct-coupled, push-pull stage. As the polarized waveforms indicate, V2A's grid signal is inverted at the plate and fed to V2B, which again inverts and amplifies it. But V2B's plate is fed from V2A's cathode; hence positive-going signals add at this junction. They are coupled by a 10µf electrolytic to T2, the output transformer. A portion of this output voltage is tapped off and fed, via an RC network, to R2, the peak reduction control, and then to the grid of V3. The control voltage is amplified by V4 and fed to lamp L1, which is physically situated near P1. When the signal at output increases, so does the control voltage fed to L1. With an increase in L1's brilliance, the resistance of P1 *decreases*, attenuating the incoming audio. Compression occurs without distortion and without thump, as P1 is merely resistive. The VU meter has two functions: Besides monitoring output level, it gives an indication of the degree of compression. This is accomplished by P2, another photoresistor, mounted close to L1 and connected across the "B" supply and to the VU meter. Because of similar mounting, the resistances of P1 and P2, as affected by L1, are equal, and the meter reads accurately.

The negative feedback loop of 19db around the signal-amplifier stages minimizes distortion and establishes operating stability. The unusual output circuit maintains very low phase distortion and excellent frequency response. Input and output match 50, 150, 250, or 600Ω. Gain and peak reduction are adjustable from the front panel, which also contains a meter-transfer switch. Two LA2's may be paralleled for stereo; an interconnection between attenuator circuits is provided which insures that compression occurs simultaneously and equally in both channels. ■

■ The April issue of *ELECTRONIC TECHNICIAN* covered present Federal Communications Commission (FCC) rules covering CB radio. It also detailed how single-sideband (SSB) CB equipment could boost effective radiated power (ERP) and *double* the CB frequency spectrum—creating 46 instead of 23 channels. This is the concluding part of a two part series covering these subjects.

SSB Frequency Stability

Frequency stability is required in SSB operation and it is usually necessary to maintain the carrier frequency and the injected local oscillator frequency between 100 and 200Hz. These two frequencies must remain within this rather slim range to produce an audio sound similar to the original transmitted audio, and if a greater shift occurs, the audio will sound either higher or lower.

The Citizens Radio Service has a tolerance of 0.005 percent which would result in a variation of $\pm 1350\text{Hz}$ as we have seen. Improving frequency stability to 0.001 is not difficult and (with present crystals) would allow a total variation of $\pm 270\text{Hz}$.

This is not quite good enough for standard SSB operations. It would be possible, however, with a frequency adjusting capacitor on the receiver (after "netting" same-frequency stations), to make adjustments necessary to establish frequency variations between the transmitter and receiver within a 200Hz range. This is entirely practicable and feasible.

Single-Sideband Circuits

Ordinary AM has a carrier component plus two sidebands. Suppressing the carrier results in double sideband suppressed carrier (DSBSC) operation. Removal of the carrier results in double sideband operation (DSB), and, of course, single-sideband operation

The New Look in Citizens Band Radio

Single-sideband circuits, selective calling, encoding and decoding equipment explained



Fig. 4: 90-code selective calling encoder console generates two-tone sequential signals. Decoder alerts selected mobile receivers. Courtesy Bramco.

Fig. 1—Single-sideband operation mode schematic.

The New Look...

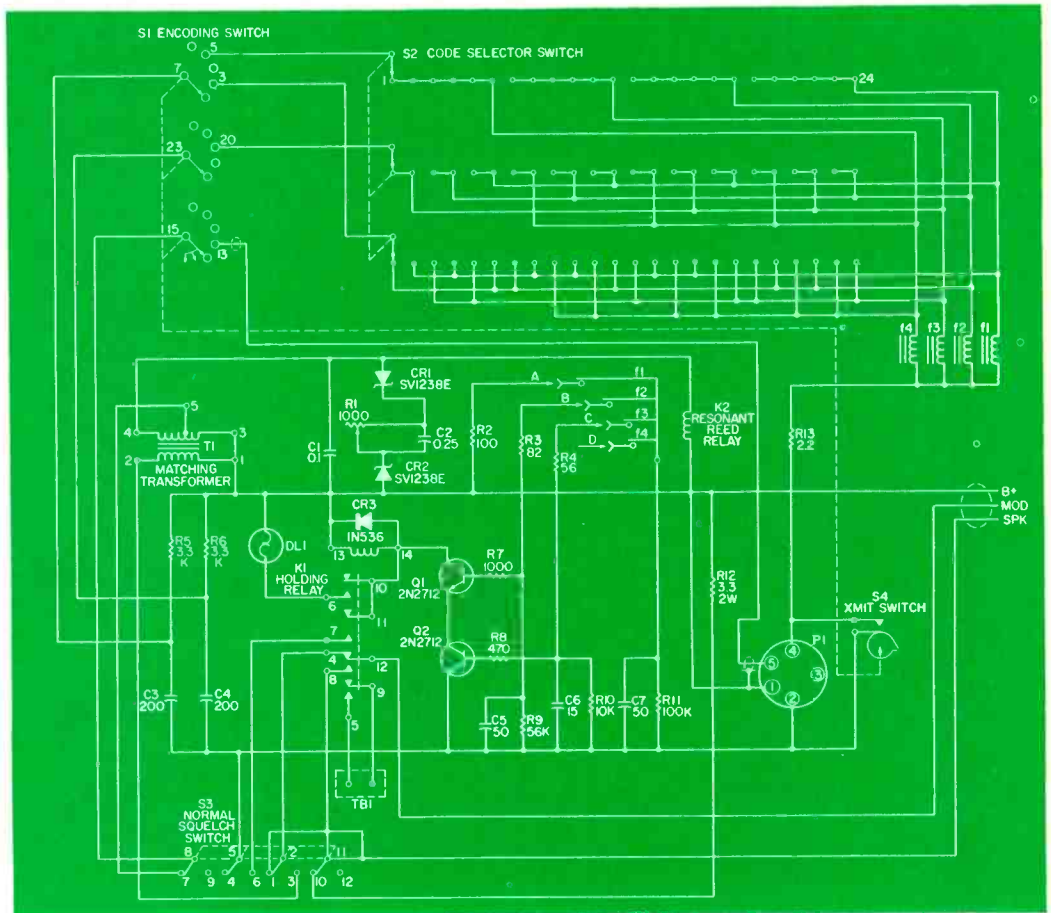

is SSB, as previously specified. The SSB mode of operation can be obtained (Fig. 1) by using a balanced modulator fed push-pull for RF and parallel for audio. The plates are connected in parallel. Hence, the pure carrier components will cancel since they are out of phase. Only sidebands appear in the output and double-sideband, without carrier. By attenuating one sideband, SSB output is produced.

A typical system is shown in Fig. 2 as an unbalanced modulator. "A" and "B" represent the push-pull audio input to the pair of 6AQ5's which drive the modulation transformer, T1. "C" is the RF drive fed to the 12BH7 grids in push-pull. V1 has 180v on its cathode and V2 has the same voltage on its plate. The V2 cathode and V1 plate go to ground through the modulation transformer secondary.

With RF applied and no audio, V1 cannot conduct, V2 does conduct and produces a small unmodulated carrier output. With modulation, however, a large audio signal appears across the T1 secondary. Positive portions of this audio allow V1 to conduct and reduce the conduction of V2; negative parts of the audio increase the V2 conduction. This circuit produces DSBSC,

both sidebands and a small or reduced carrier. In this way modulated power output is 4.5w, unmodulated power output is 1.6w which provides stronger signals.

Selective Calling

The technique of selective calling on CB, borrowed from other radio services, makes it possible to contact one station out of a group on the same frequency without alerting the others. Various audio tones are used for coding calls. The schematic of a typical selective calling system is shown in Fig. 3. It is designed to provide 24 codes for selective calling. The transmit codes are selected by a dial on the front of the unit. The receive code is set up inside the unit by changing four wires. The time cycle to send a code is well within the time limit set by the FCC.

A three tone sequential coding system is used and tones are generated by a four channel resonant reed relay which is also used in the decoder. Normal frequencies are 266.0, 288.6, 312.6 and 339.6Hz.

Encoding

As shown in Fig. 3, S1 is the encoding switch and

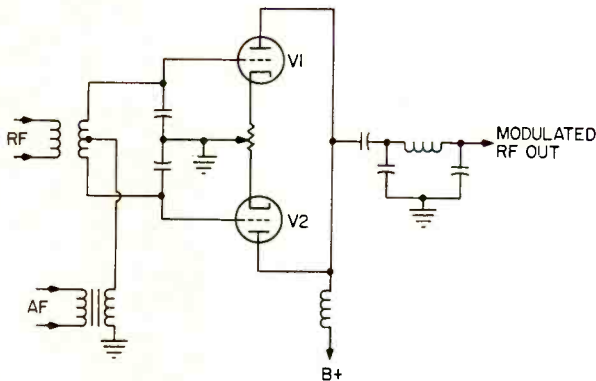

Fig. 2—Typical unbalanced modulator system.

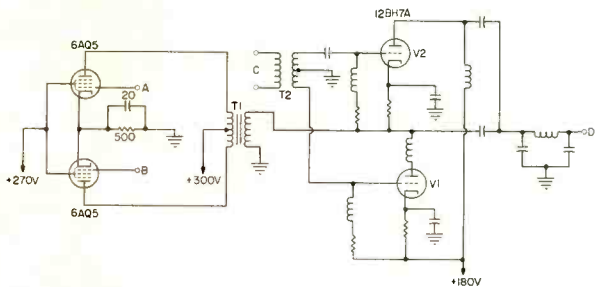

Fig. 3—Typical three-tone sequential selective calling system.

S2 is the code selector. To generate tones, capacitors C3 and C4, tied to S1, are charged through resistors R5 and R6. When the code-call lever is pushed down, S4 closes and locks up until the lever returns to its normal position. The timing motor connected to this lever also turns the wiper of S3, a wafer switch deck. S2 is shown in position for generating code 1.

As S1 is returned by the timing motor, capacitor C3 discharges into reed exciting coil f4. This coil (part of an electromagnet) causes the reed to be pulled down slightly from its normal position. As the field collapses, the reed is released. The vibration produces a sine wave at the reed relay coil output. This output is fed to the audio input through a section of wafer switch S1 and matching transformer T1; the tone output modulates the transmitter.

As the timer continues to rotate S1, capacitor C4 discharges into coil f3, producing the same action as previously described. In the meantime, C1 has been charged again and is now discharged through f2, generating the last of the three tones. The capacitors discharge through f4, f3, f2 and f1 in a sequence which depends on the position of S2.

Decoding

To decode the incoming signal S1 is placed in the squelch position. The transceiver audio output is connected across a 3.3Ω load and into a matching transformer. The transformer secondary is connected across the resonant reed relay coil. Two zener diodes, CR1 and CR2, are connected back-to-back across the output.

These diodes limit the reed relay input to 16v. Potentiometer R1 is the sensitivity adjustment and may be used to increase this voltage. Capacitor C2 is used to shape the output when R1 is in the circuit. Capacitor C1 resonates the reed relay coil and helps to shape the output waveform.

If the frequency of reed "A1" is applied to the coil, reed "A" will vibrate, causing the contact between "A" and the relay frame to close. When this occurs, capacitor C7 charges through resistor R2. As the 2nd tone of the code is applied, reed "B" makes contact and capacitor C7 discharges through R3 into C5. The 3rd tone of the group causes reed "C" to make contact. Capacitor C7 now discharges into C6 through R4. As C5 charges, it applies forward bias to transistor Q1—part of an AND gate. When C6 is charged, it applies forward bias to Q2, the other half of the AND gate, which then allows current to flow through to holding relay, K1.

One pair of the K1 contacts are used in a lock-up circuit. This reconnects the transceiver speaker to the audio output and restores normal operation to the unit. Also, a lamp, DL1, is connected at this time. This is a flashing lamp which serves as an attention getting device in case no one is in the room when the code is received.

Resistors R2, R3 and R4 are used to limit the current through the resonant reed relay contacts. Resistors R9, R10 and R11 are used to set the time constants of capacitors C5, C6 and C7. In case a series of wrong codes are applied, the time constants are set so false triggering will not occur.

When a transmitter sends the proper code, when the unit is in the squelched position, the receiver applies it to the coil of a resonant reed relay. The relay picks out the tones and applies them to a decoding circuit. This circuit, when the proper code is applied, picks up a relay which turns on a flashing lamp in the unit. This relay also connects the speaker of the unit to the output transformer. The relay will remain closed until the squelch-normal lever is placed in the normal position. One set of the relay contacts is also connected to a terminal strip on the back of the unit. These contacts may be used to turn on some external device: a buzzer or bell. The contacts are rated for 3amp at 30 or 115vac.

Two cable connections are required, one has a plug which connects to the microphone jack on the front of the unit. The microphone is then plugged into the mating connector on this new plug. The other cable is a three conductor cable for Bt, the modulator, and the speaker. ■

Bob shows 'Scoot' a few in-home servicing tricks

■ Bob and Scoot bounced along in the service truck for the first time together. Scoot had made a few calls alone; Bob had hired a new shop man and it was now Scoot's job to learn all about house calls — with Bob.

Although most shops put their less experienced men on outside calls, Bob felt that his best men should be there. Mistakes, he said, could be "Kept Private" in the shop, but there was no room for mistakes in a customer's home. The big profits were in the jobs that could be done in the home — the better the man, the better the chance that he could get the set repaired without "pulling" it.

Not only that, but sometimes a set should be removed when it wasn't. Again, a more experienced man would be more valuable.

Scoot had worked his way up from a Saturday worker to a full-time shop helper and finally to a first-class technician. For Bob, Scoot had become the most valuable man he had. The first stop today concerned a distortion complaint in a stereo set. Bob rang the bell.

Phono Distortion

"You should have gotten more

information on this one over the phone, Scoot. We really hardly know what instrument and parts we need to bring on a call like this. Let's see — you've got the make, model, the symptom and that's all. You should have found out when the set distorts, whether it does it on all program sources, how old the set is, where and when it was bought and if the set has ever been serviced."

The door opened and a pretty blonde girl smiled at Bob and then Scoot. She was about six. "Is your mother home?" Bob asked.

"Yes she's home. Mommy said it was probably the man who would fix the record player. Will it take both of you? Are you going to take it with you?"

"Well, sweetheart, we'll just have to wait and see."

Bob wiped his feet carefully and Scoot followed suit. The little girl's mother appeared and greeted them.

"The set is over here. It's beginning to sound awful when I play records—the radio works fine." Bob shot a knowing glance at Scoot.

"How old is the set, Mrs. Wilke?"

Bob and Scoot learned the set was about six months old and that records were played five or six hours

'Door To Door'



each day. Mrs. Wilke knew that because she stacked ten records on every morning and turned them over once — she said it helped her get through her house work. On some weekends the set was used more than on others.

Bob slid a record from the record jacket he had brought in under his arm. He placed it on the phonograph scratchy-side up so the good side would not be damaged if the stylus were chipped or worn. With between 750 and 1000 hours on this stylus, it could be in bad shape, Bob thought.

“Ever have the stylus changed, Mrs. Wilke? Some of these new needles wear faster than the old ones since the tip is smaller. Of course, the weight on some of them is less and it kind of balances out.”

“No. When we bought the set, the salesman told us it was a permanent diamond needle.”

The set had warmed up and Scoot cringed to the distorted music. Bob lifted the tone arm and put it on the arm rest.

Pressure Gaging

Bob then busied himself in the caddy and came up with a stylus pressure gage. With the stylus gage

supporting the stylus, Bob bounced the tone arm a few times on the gage and announced “6 grams — that’s too much for a changer like this.”

Mrs. Wilke said that was the way it was set up when the dealer delivered it and she had been assured that everything was OK. Bob told her that the weight could have been bumped some way though he knew it was unlikely. He explained what he thought the trouble was, that even a diamond needle isn’t “permanent,” and instructed Scoot to put a new stylus in the cartridge. He also told his customer that some or all of her records might have been permanently damaged by the worn stylus. The stylus was installed in a few seconds and Scoot started to adjust the stylus pressure. He lowered the tone arm onto the gage and read 4 grams. Scoot gave Bob a puzzled look and Bob intervened and bounced the stylus gage, too. It read about 6½ grams; he bounced it again and it read 5 grams; on still another bounce it read 6 grams.

Bob saw that Scoot still looked puzzled and explained that arm-bearing friction had to be overcome and that bouncing the arm helped.

He told Scoot this should be done three or four times — taking an average reading.

The tone arm used on this particular set was dynamically balanced so Bob moved the pressure adjuster to zero and set the counterbalance on the rear of the arm till the arm “sec-sawed.” He then set the adjuster for 3 grams (as it was before) and weighed the arm again. It was 3 grams this time. He explained that the counter-balance was not properly set even though the stylus pressure control was set properly. “This results in too much weight whether the balance or the actual gage is mis-set,” he said.

The test record was played and sounded good. One of Mrs. Wilke’s records was put on and it also sounded OK.

“I’d advise you to have the stylus checked again in six months, Mrs. Wilke,” Bob said. “With the weight properly adjusted you should have no trouble getting six months’ use from the stylus.” The stylus was a plug-in type so Bob showed Mrs. Wilke how to remove it so she could bring it to the shop for checking.

When the boys had left, Bob explained the counter-balanced tone arm and why it was used. He also

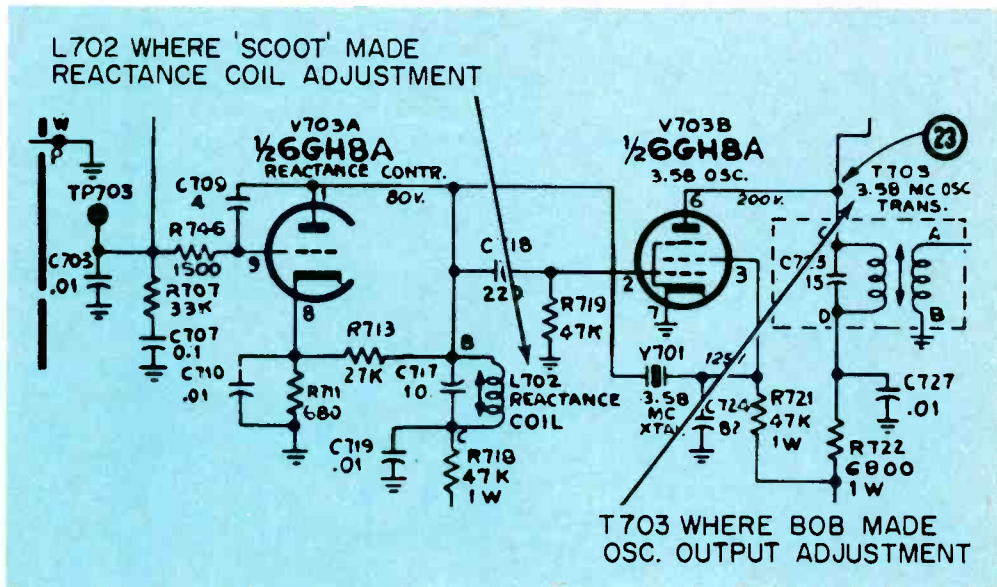
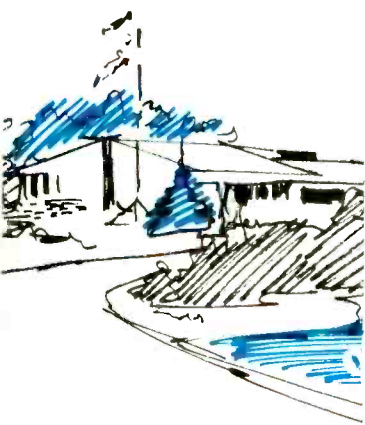

'Door Door'

To

told Scoot that the call they just completed was a perfect example of why he should make sure the tool kit always had a complete stock of replacement styli.

Color Set Call

The next call was only four blocks away. This was a color TV call. The complaint was no-color after the set had warmed up about 30 minutes.

"This one sounds like a shop job," Scoot said.

"Maybe not. You know these things can sometimes be hurried up."

In the house Bob and Scoot connect the color bar/dot generator to the set and waited for the set to warm up. Bob passed the "time of day" with Mrs. Witherspoon and her octogenarian father.

"All set," Scoot announced. "The color looks good."

"It's always that way to start," Mrs. Witherspoon said.

"Let's give it a good checkout, Scoot," Bob suggested. "First, turn the chroma down on the generator. With that much signal the color may never drop out."

Bob turned the fine tuning back slightly and the color suddenly disappeared.

"The fine tuning seems kind of narrow, doesn't it, Bob?"

"Yes, it does. Open up the color killer."

Scoot opened the color killer and the set displayed a weak rainbow, out of sync. With the chroma control up, the color was strong but still out of sync. Bob reset the fine tuning and the color again snapped in lock.

"I've seen it do that, too," Mrs. Witherspoon said.

"I think we've found the trouble, Mrs. Witherspoon," Bob said. "A lot of these circuits drift when new and then work OK."

Scoot was already at work. He checked to be sure the killer was wide open and turned the chroma control up full. He turned the fine tuning down until the picture

dropped out of color sync. While checking the layout chart glued inside the cabinet he reached for an alignment tool. He watched the screen in a small mirror while he adjusted the reactance coil for the 3.58MHz burst oscillator. The colors snapped into sync and Bob reduced the fine tuning a little more. Scoot centered the reactance coil adjustment until it was half way between dropping out of sync on either side.

"It was quite a way off, Bob," Scoot said. "Maybe we had better check the oscillator output, too."

"Let me do it, Scoot."

Scoot scratched his head as Bob took the alignment tool and reached into the set. Bob watched in the mirror but Scoot wasn't sure he knew what was going on.

"Button it up, Scoot."

Scoot reset the fine tuning and the color killer. He made sure the set looked and sounded good on all the regular channels. Bob gave Mrs. Witherspoon the bill and both men left. When they were out the door Scoot pounced on Bob.

"How in the world did you make that oscillator adjustment without a meter?"

"It's simple, Scoot. I'm glad to see you remembered how to adjust the reactance coil with only a color signal. When I showed you that I didn't feel like burdening your mind with the other.

"The reactance coil adjustment, if it's done carefully, is actually more accurate than specified by most manufacturers — you know, the grid-grounding procedure. I'm afraid I can't say as much for the 3.58MHz output adjustment. All

you do is weaken the signal with the fine tuning, the same as you do for a reactance coil adjustment, and tune the output coil for maximum color. Really, Scoot, it's only a rough adjustment but it's generally adequate."

"Well, I'll be darned! Say, don't you think it's time for coffee? There's a 'mud shop' right over there."

"OK, Scoot. I guess you've earned it. But I'm warning you, the day has just started."

Post Mortems

"You know, Scoot, what we've done so far is a good example of how a poorly equipped technician could have wasted a lot of time. On our first call, let's say that we didn't have a stylus for that stereo. We might have decided to take that unit to the shop because we wouldn't know for sure whether another call with a stylus would solve the problem. A hand-held microscope isn't always the answer either.

"And our second call — if we automatically assumed that the problem was an intermittent, the set would have been pulled for shop checks. Even though some of our competition seems to thrive on taking sets to the shop and charging a fancy pickup and delivery, I don't want it. Every time a color set is removed, you're taking a chance of causing another trouble and even necessitating another set-up on the color tube. Not only that, you create expense for the customer and leave room for him to become suspicious. In this business we can't afford it."

"Yeah. Hey, Bob, on that last one, how did you know that the reactance coil was off?"

"Well, I didn't know for sure until we opened the color killer. Then you could see the color again. You see, when the 3.58MHz oscillator goes out of sync the killer goes into operation. It's just like losing the burst since the oscillator signal is used to detect the burst signal. Understand?"

"I'm not sure, Bob. Let's get that cup of coffee and talk this over for an hour or so."

"Oh Boy! For some reason, I wish this were the last cup instead of the first." ■



Transistorized TVs...

conduct which causes the reverse voltage differential on the diode to decrease. At some point, the diode conducts and places almost the same AGC voltage on the IF as on the tuner.

Sync and Noise Rejection

Although it may be too early to judge, there's a strong probability that noise rejection circuits will disappear from solid-state TV sets. Noise rejection, immunity, cancelling and gate circuitry have the sole function of removing or reducing noise pulses from the sync so that spurious triggering of either horizontal or vertical oscillators is not possible. In well designed transistorized sync separators, the noise immunity is far better than in tube circuitry and additional noise rejection is rarely necessary.

When noise cancelling circuits are used they generally take the same form as those found in tube sets. An exception is one circuit which uses a peak noise detection transistor that is normally non-conducting. When a noise peak is present the transistor conducts and drives the video amplifier base into cutoff. This effectively removes any possibility of noise.

Most noise rejection circuits are adjustable so that they can be set not to engage on video or sync but to operate on anything larger. The noise control circuitry is usually adjusted in the same manner as tube circuits: Open noise control (for minimum effect) and minimum AGC. Next, set noise control just "short" of picture pulling, or bending.

Vertical Sweep

Although tube type vertical systems usually have a two stage oscillator/output system, it is not uncommon to see three transistors in solid-state vertical output systems. (At least one manufacturer uses three size and linearity controls.) When a two stage oscillator/output stage is used, a sync amplifier is frequently employed. When the sync amplifier is omitted, a driver stage is generally used between the oscillator and the output stage.

The blocking oscillator is the most commonly used circuit, but it is anticipated that the multivibrator and SCR (used as a switch) may eventually be introduced. Four basic blocking oscillator types are being used—depending on the output system. (Whether a driver is used and whether there is a phase inversion or not.) The four basic types are shown in Fig. 2. Four types of output circuitry which develop a sawtooth from the blocking oscillator are shown in Fig. 3.

Capacitor C_t is the charge capacitor which allows the transistor to begin conduction after discharge through the base-emitter diode. Capacitor C_s is the saw-forming capacitor which turns the pulse-like waveform into a sawtooth.

Sync is generally injected at the base and the result is to "hurry" transistor conduction (in sync) just before it would conduct, because of the natural discharge of the C_t capacitor.

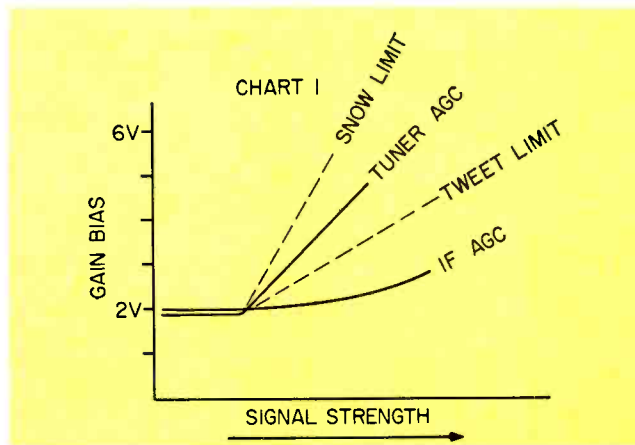
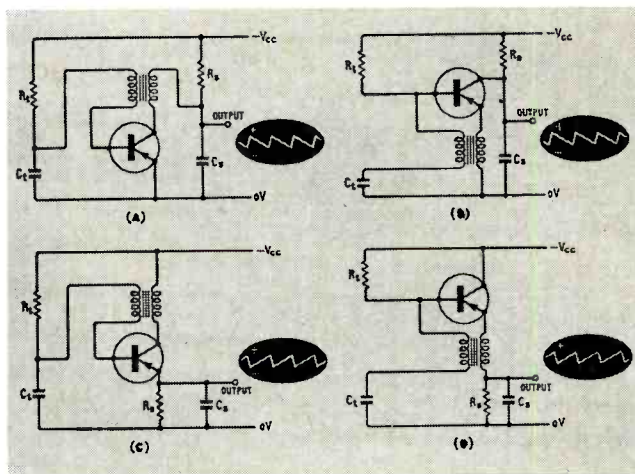

Chart 1. Tuner and IF AGC curves showing AGC limits.



In practice, the vertical output circuit involves more parts; for example, height and linearity controls. A diode is frequently used in the vertical output circuit to suppress voltage overshoot. The diode may be located in the transformer primary or secondary.

Driver stages are conventional amplifier stages and the output stages are usually operated in a class "A" fashion. Although the output transformer could be omitted in transistor vertical circuits, it is generally employed. Power conservation is sometimes gained by driving the deflection coils in parallel with a choke used as the load.

Horizontal Sweep and HV

The horizontal section in a solid-state TV receiver performs the same functions as the tube type receiver, but more stages are often involved. For example, the block diagram of a typical horizontal section is shown in Fig. 4. Notice that the AFC amplifier and the driver are additions and are not used in tube sets.

As in the vertical section, the blocking oscillator is the most commonly used generator. The multivibrator is also used in many sets, however. Unlike the vertical section which used a class "A" output stage, the horizontal output acts more like a switch since, at horizontal frequencies, a square wave rises across the yoke in a sawtooth manner.

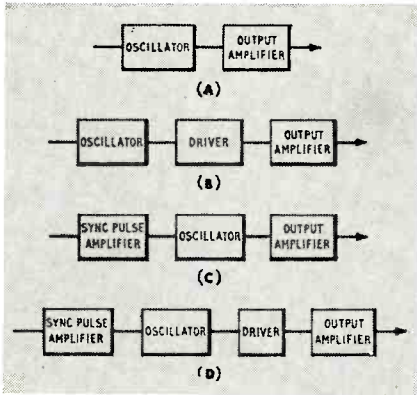

Fig. 2—Four basic transistorized TV vertical sweep circuit arrangements. (A)—Oscillator and output amplifier. (B)—Oscillator driver and output amplifier. (C)—Sync amplifier, oscillator and output amplifier. (D)—Sync amplifier, oscillator, driver and output amplifier.



Fig. 4—Block diagram of transistorized horizontal sweep section.

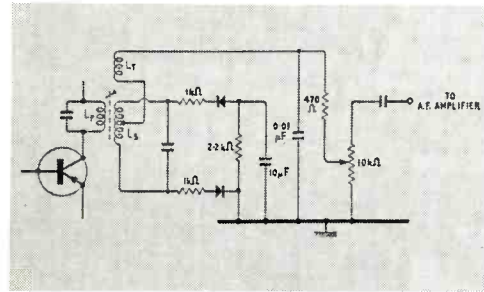
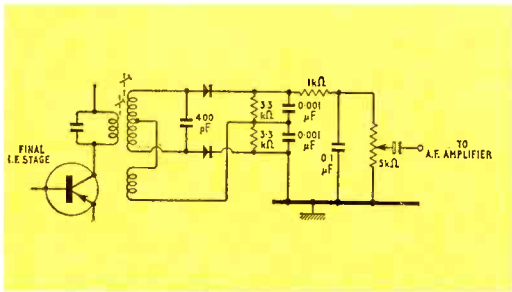

Fig. 5 (Left)—Transistorized Foster-Seeley sound detector used in a Sony TV.

Fig. 6 (Right)—Transistorized FM ratio detector used in Matsushita TV.

Fig. 3 (Left)—Four types of transistor output circuits which develop a sawtooth from the blocking oscillator. (A)—Collector coupled negative sawtooth. (B)—Emitter-coupled negative sawtooth. (C)—Collector-coupled positive sawtooth. (D)—Emitter-coupled positive sawtooth.

The diode AFC system is common in every way to tube type AFC systems. The only problem experienced with this system, when employed with transistors, is the development of insufficient voltage to control the oscillator effectively. Fortunately, another problem presents itself in these systems and the two can be licked simultaneously: The AFC section cannot be loaded. When the AFC section is connected directly to the oscillator, the AFC diodes are often loaded to the point of uselessness. Consequently, the stage between the AFC circuits and the oscillator may be called either an AFC amplifier or a buffer stage.

Whether the manufacturer was more interested in loading or amplifying is determined by the type of transistor amplifier used. If a common-collector circuit is employed, the input impedance is higher but the gain is lower. If a common-emitter is employed, the gain is higher but the input impedance is lower.

Similarly, a buffer amplifier may be used to connect the oscillator and the output stage. Its purpose may be to amplify, invert, match — or some combination of these. A transformer may also be employed.

The switching function given to the output transistor is more complete than the switching function when a tube is used, because the impedance of the transistor in the ON state is considerably lower than the tube in the same state.

The damper diode in transistorized equipment is, of course, solid-state. The conventional arrangement used in tube sets is generally employed in low B+ sets where the damper is effectively in series with the power supply. This arrangement is commonly used in portables.

Table model or line operated sets often have B+ supplies which are much higher than required to operate the horizontal circuits, and the parallel damper is often used. When the parallel damper is employed, it is usually located directly across the output transistor. Some sets use a combination of both parallel and series damper arrangements. In troubleshooting, the operation can be considered identical.

High voltage is developed in a solid-state power supply in the same manner as in tube sets. The flyback pulse is increased through an auto transformer and rectified in either a solid-state rectifier or by an electron tube diode.

Sound Sections

Sound and audio sections in solid-state TVs are conventional. Just as in tube-type circuitry, a 4.5MHz IF is employed. The sound detector may be unfamiliar to many technicians since it will either be a ratio detector or a Foster-Seeley type. Both use two diodes and a tertiary-wound coil, but the ratio detector can be recognized by the large filter placed across the detector load; usually about 10μf. Both types are shown in Fig. 5 and 6.

The audio amplifier is also conventional and will be similar to amplifiers used in other transistorized audio equipment. The total audio amplifier complement may have as few as two transistors or as many as four. If a push-pull output is used, five transistors may be employed.

The final part of this series will discuss practical troubleshooting procedures to be used on transistorized TV sets. ■

YOU & COLOR TV

TEKLAB REPORT

Increase your scope's diagnostic efficiency by using

■ The color TV boom has finally made the screwdriver obsolete as a diagnostic tool and the "VTVM-alone" technician hasn't become much richer. With continually rising overhead costs, our only salvation for increased productivity is the proper application of a wideband scope. To use your scope effectively, however, you must know how to apply the proper probes to whatever job may come to hand.

A modern scope equipped with the proper probes can help you diagnose troubles quickly in almost every section of a color TV set. Its use is contingent on a thorough knowledge of scope principles and operation. Armed with this knowledge and with a lot of practice on both normally and abnormally operating color sets, technicians should be able to rapidly troubleshoot both B/W and color TVs. One important point to remember when troubleshooting with a scope is the proper application of the different probes that may be used with the instrument.

Beginning with the tuner on a normally operating color set, we will demonstrate how to use a scope and the correct probe to diagnose various trouble symptoms.

Although a station signal is adequate for most checks, in this case we will use a flying spot scanner for the signal source. This scanner (Analyst) is used because it furnishes exactly the same kind of signals available on-the-air through a TV set—minus constant variations taking place in station signals. The Analyst and receiver are set on channel 4 and the RF output is fed into the set's antenna terminals with the controls set for a 10v P-P signal at the video output tube grid.

Using the Demodulator Probe

The scope is connected to the first

video IF tube grid through a demodulator probe and locked at the vertical sync rate. The detected signal is illustrated in Fig. 1. Although

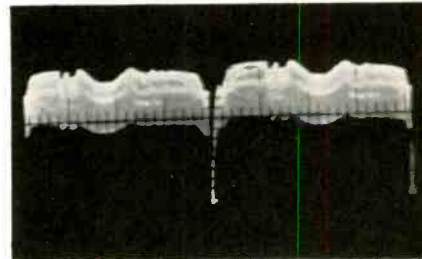

Fig. 1—Using demodulator probe at grid of first video IF.

the probe distorts the signal somewhat, it tells us that the tuner is operating. When the probe is moved to the 2nd IF grid, a similar waveform is viewed. Because of the loading effect of the probe, amplitude comparisons to determine gain cannot be made. This check is used only for signal tracing to determine the presence or absence of a signal. The output of each IF can be checked in this manner. It is a very easy way to quickly isolate a defective stage when tuner or IF problems arise. Neither a direct nor low capacity probe can be used in this situation.

The circuit diagram of a typical demodulator probe is shown in Fig. 2. In essence it is a video detector. The main disadvantage of this type probe is HF signal component distortion. A wide band probe could be designed to pass the HF components without distortion, but a probe of this type, using a cathode follower circuit for impedance matching, would probably be too expensive for ordinary service work. Its use is generally confined to laboratory applications.

Low Capacity Probe

With the color set still operating normally, we now want to view the signals as they appear after passing

the proper probes

through the video detector. We can no longer employ the demodulator probe, of course, because the set's video detector demodulates the signals.

If a high capacity direct probe is used, it would give us incorrect scope readings besides causing improper receiver operation. The low impedance of the direct probe loads the high impedance grid circuits when the probe is connected. This situation is corrected by using a high impedance, or as it is usually called, a low capacity probe. A major disadvantage of a low capacity probe is that it attenuates the signal but in most cases this does not present too great a problem as an adequate signal is available in most TV circuits. As a matter of convenience, the probe is usually designed to have an attenuation ratio of 10 to 1. This ties in directly with the decade attenuator system found in modern scopes. After the scope is calibrated with a direct probe, a 10 to 1 low capacity probe may be used without recalibrating. The decimal point of the result is shifted one place to the right. A typical low capacity probe is shown in Fig. 3.

To show the effect on the waveform, we attached a demodulator probe to the video output tube grid (Fig. 4). The correct waveform

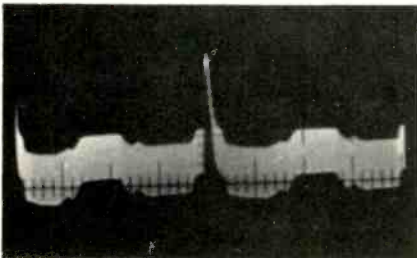

Fig. 4—Demodulator probe incorrectly applied.

taken with the low capacity probe and photographed from the scope screen, is shown in Fig. 5.

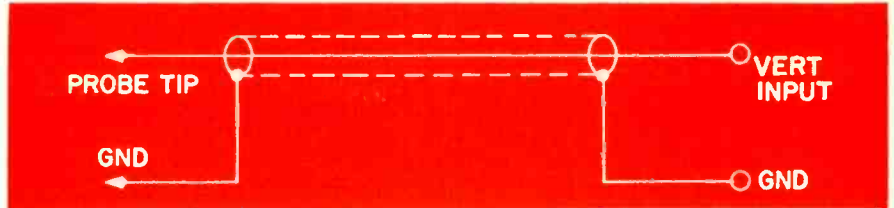

Fig. 13—A direct probe.

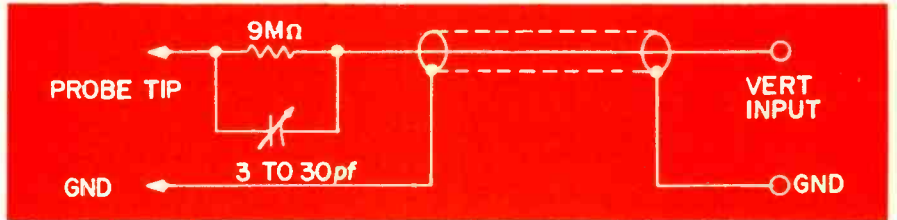

Fig. 3—A typical low capacity probe.

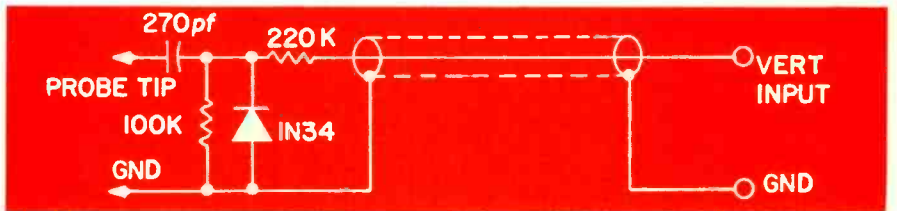

Fig. 2—Scope demodulator probe.

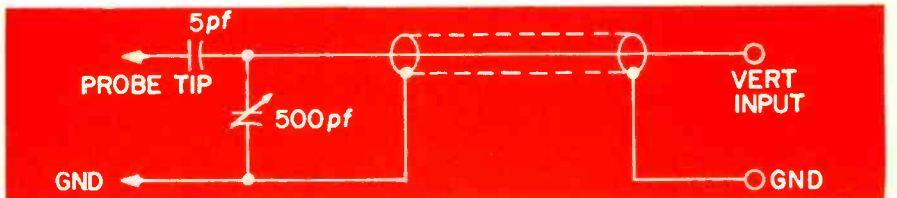
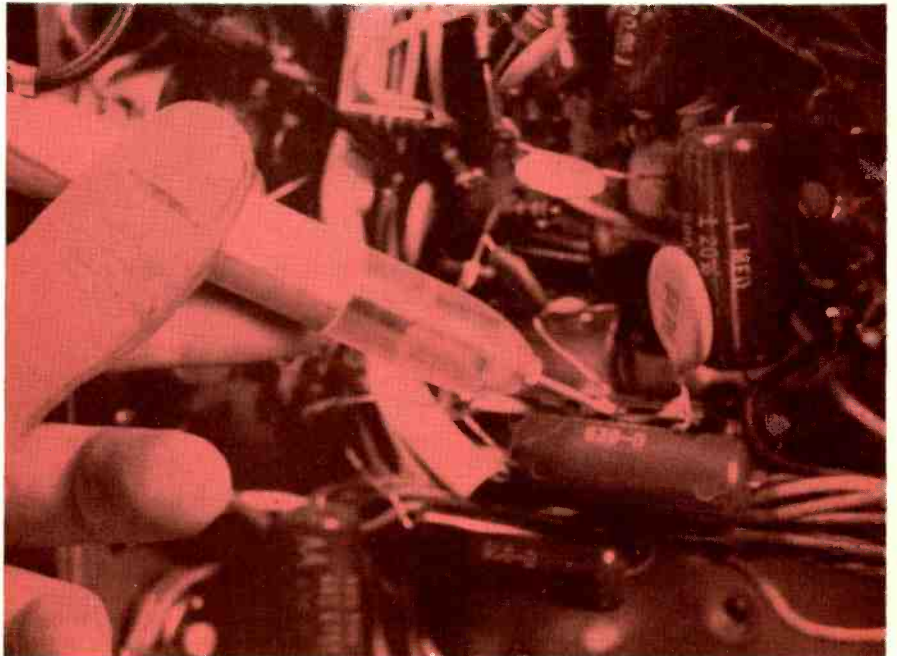

Fig. 14—A high voltage capacity-divider probe.



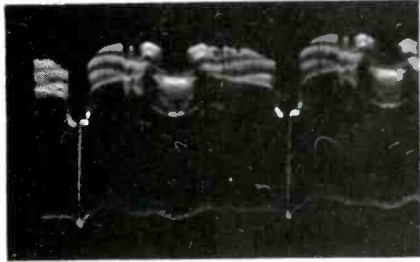

Fig. 5—Detected signal at grid of video output using low capacity probe.

A keyed rainbow color signal is fed into the antenna terminals and the signal is observed at the same test point through a low capacity probe (Fig. 6). With the color gen-

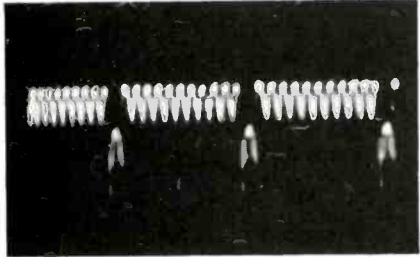

Fig. 6—Chroma signal at grid of video output tube.

erator set at 100 percent modulation, you will have chroma signals of about 2v P-P at this convenient test point. This voltage may vary in different manufacturers' chassis.

The low capacity probe should be used throughout the sync section. A typical sync waveform, from the Analyst, is shown in Fig. 7. This waveform, locked at the horizontal sync rate, was taken at the input

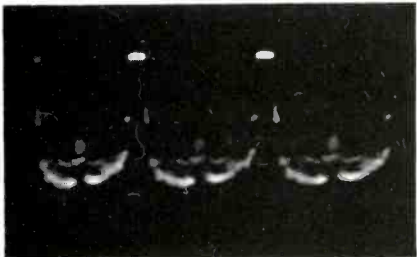

Fig. 7—Composite signal as applied to grid of sync separator, locked at horizontal sync rate.

to the sync separator. The vertical portion, after integration, is seen in Fig. 8. This is taken at the vertical discharge tube cathode and locked at the vertical sync rate.

The waveform in Fig. 9 illustrates

the differentiated horizontal sync pulse, taken at the common terminal of the horizontal phase detectors.

The low capacity probe should also be used throughout the receiver's chroma section. Chroma signals at the input to the chroma IF stage are shown in Fig. 10. The burst

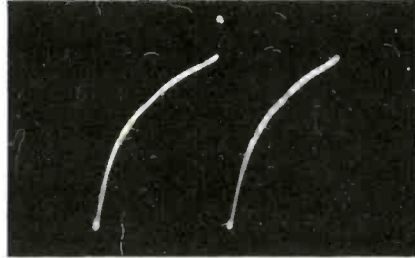

Fig. 8—Vertical sync pulses appearing at input of vertical oscillator.

signal is shown in Fig. 11. The red demodulator output is illustrated in Fig. 12.

The low capacity probe should be used in the sync and chroma sections except the direct probe may be used in the lower impedance cir-

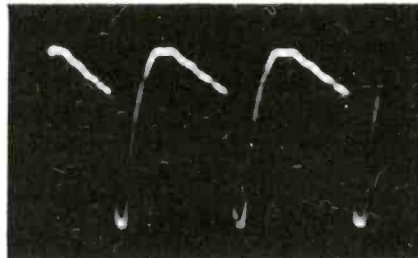

Fig. 9—Horizontal pulses fed into horizontal phase detector.

uits, across a cathode resistor, for example. A typical direct probe is shown in Fig. 13, page 57.

High Voltage Capacitive — Divider Probe

A special type probe has been developed for measuring high ac

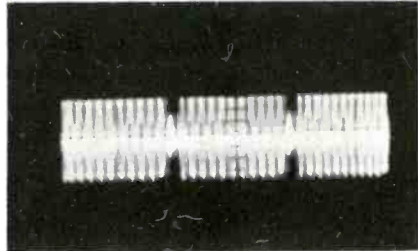

Fig. 10—Chroma signal input to first color IF.

voltages in TV sweep sections. This probe, shown in Fig. 14, consists of two capacitors. C1 is a low capaci-

tance, high voltage type and C2 is a high capacity, low voltage type. These two capacitors in series act as a voltage divider with the largest voltage drop appearing across C1.

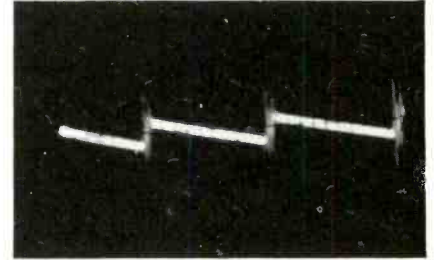

Fig. 11—Burst amplifier output.

The voltage waveform which appears across C2 can then be observed. Voltage from this point to ground will be well within the scope's rating.

C2 is usually made adjustable so the attenuation ratio can be properly set. A ratio of 100 to 1 is com-

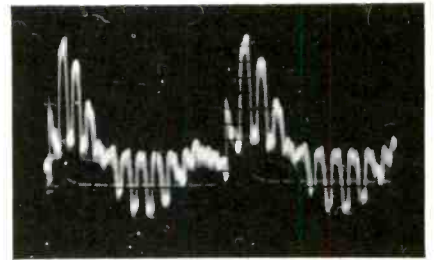

Fig. 12—Waveform appearing at red CRT grid.

mon for a probe of this type. This again simplifies scope calibration.

The HV probe will distort the 60Hz vertical frequency and its attenuation factor is too great for use in low signal level circuits. It is limited to waveform measurements in the horizontal output tube plate circuit. Since the pulse at the HV rectifier plate exceeds the probe's rating, it cannot be used at this point.

Another scope probe, for alignment work, consists basically of a resistor in series with the scope cable. The probe acts as a low pass filter and sharpens the marker pips on a TV response curve. No special probe is needed since an ordinary 50K resistor will suffice.

We believe you will be well repaid in your future troubleshooting work if you devote a little spare time observing the waveforms in a normally operating TV with a scope and proper probes. ■

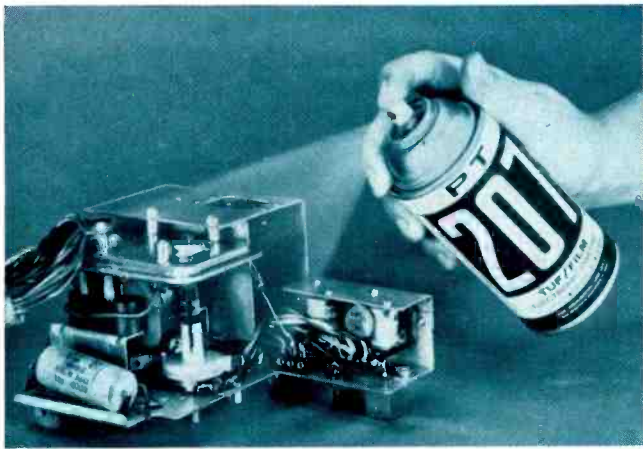

'Kleen-All' by Colman.



'Contact Shield' by Channel Master.



'Color Lube' by Chemtronics.



Silicone Spray by Sprayway.

■ Technical advances in home entertainment and industrial electronic equipment — color TV, Hi Fi and many new and complicated electronic instruments — has placed increased demands on Aerosol spray manufacturers for improved electronics service aids. Many products in this area have been up-graded to meet new requirements. And new types have been developed to meet additional needs. A number of canned, bottled and tubed products have been designed to meet specialized needs. Literally scores of chemical cleaners, cleaner-lubricants, plastic repair kits and cement items, refrigerants for quickly detecting defective components, plus silicone

greases for use with solid-state components, have been developed.

Many cleaner-lubricants use silicone-additives to assure effective heat-resistant lubrication to application points. Products are made non-flammable and some are safe to use around most plastic products and frequency-sensitive components.

Corrosion preventatives are another group developed to preserve metal surfaces against weather and salt-spray erosion. These are effective on all types of metal surfaces — steel, iron, brass, copper, aluminum, etc. They are especially useful on TV/FM antenna installations to make them last longer and remain efficient under various adverse weather conditions.

Special "dry" type cleaners have also been designed for relay contacts — leaving no oily residues. These are generally in the "degreaser" category and can be used to "flush out" unsealed small motor bearings and clean metal gears and small metal drive mechanisms.

All of the various types, aside from those designed for general applications, should be carefully selected to serve the specific purposes for which they were developed, and manufacturers' directions should be followed explicitly. One type, for example, is designed to be used on non-arcing contacts. The same brand, with a different number, was developed for use on heavy contacts where arcing is present. This is only one example to show that these products should always be selected carefully. If they are, you will have a better chance to obtain efficient results. ■

Spray It— Cement It—Fix It!

Select the product
to fit the specific need
for which it was developed



'Plas-T-Pair' by Rawm.



'Jif' by GC Electronics.

Major Manufacturers

of Electronic Service Aids, Cleaners,
Cleaner-Lubricants and Cements

Borden Chemical, Krylon Div., Ford & Washington, Norristown, Pa.
Channel Master, Ellenville, N.Y.
Brobst-Whitfield, 1627 W. Fort St., Detroit, Mich.
Chemical Electronic Engineering, Matawan, N.J.
Chemtronics, Inc. 1260 Ralph Ave., Brooklyn, N.Y.
Colman Electronics Products, Amarillo, Texas.
Electronic Chemical Corp., 813 Communipaw Ave., Jersey City 4, N.J.
GC Electronics, 400 S. Wyman St., Rockford, Ill.
Injectorall Co., 4 N. Road, Great Neck, L.I., N.Y.
Miller-Stephenson Chemical Co., Inc., Danbury, Conn.
Product Techniques, Inc., Downey, Calif.
Quietrole Co., Spartanburg, N.C.
Rawm Co., Inc., Spooner, Wis.
Sprayway Inc., 7644 So. Vincennes Ave., Chicago, Ill.
Walsco Electronics, Div. of GC Textron, Rockford, Ill.

Portable Transistor Tape Camera

Commercial quality TV pictures can now be obtained from a hand-held battery-powered recording camera.

It is said the transistorized TV tape camera has a greater picture taking sensitivity than film cameras and produces broadcast quality recordings. Size and weight of the camera makes it possible for one person to shoot TV programs, complete with sound.

Weight of the camera unit, complete with TV pick-up tube, active TV viewfinder and microphone, is 7 pounds. The shoulder-worn recording mechanism weighs 11 pounds. It holds a supply of 1 in. wide magnetic tape and rechargeable batteries weighing 12 pounds. The batteries are only 2 in. sq by 7 in. long.

It was said the recording camera is the result of a technical breakthrough which is termed "Conisoan," recording. The word describes both the path of the magnetic tape and the synchronization system that assures broadcast picture stability. A motor with printed circuit armatures, directs the magnetic tape at 10 ips around an inverted three-piece, flat-top cone. Tape stretch and friction around the cone are almost eliminated by an air cushion. The cone's entire mid-section con-



tains a single recording head which rotates within the moving "collar," of tape. One effect of the cone and the rotating center section is that the recording head essentially never leaves the tape. This eliminates electrical head-to-head switching necessary for multiple head recorders previously in use.

A digital computer type servo control system checks on the head-to-tape speed relationship 15,750 times per sec. This assures that tape recorded programs, or even short news flashes, will have the same picture stability and quality as the best live TV, the announcement said.

Mechanical simplicity and extensive use of solid state integrated circuits, has permitted drastic reduction in the recorder's size.

In addition to up-to-the minute TV news reports, the camera will permit TV stations to greatly expand their coverage of local topics ranging from school sports and government meetings to a participant's view of sport parachuting. All this will be complete with "on-location" sounds at a cost said to be far lower than conventional silent film. The system was designed by the Westel Co. of Redwood City, Calif.

Robert L. King, an executive of the company, says, "We also see numerous applications for the transistorized camera/recorders in educational, scientific, industrial and military fields."

Mr. King told newsmen witnessing the first demonstration, that the TV recording cameras are now in production for early delivery to broadcasters.

TV-Radio Pioneer Passes

One of America's electronics pioneers died recently (Jan. 31, 1966) of a heart condition in Los Angeles. He is Ralph L. "Doc" Power who along with men like Dr. Lee DeForest combined vision and talents to build and promote the electronic marvels which make life easier and will soon take man on his first trip to the moon.

Dr. Power was born on August 28, 1894, in Portland, Maine, the son of the former Valerie M. Murphy and Frank H. Power. During World War I he was a Warrant Officer on the staff of "Blackjack" Pershing, famed American leader of the U.S. Army.

He graduated from Los Angeles High School and Boston University where he obtained his doctorate in philosophy.

Among the schools in which he taught were William and Mary in Virginia, and the University of Southern California, Los Angeles. He was a radio announcer for the Don Lee stations in the early days of the medium and later worked on all Los Angeles newspapers. He was one of the first radio editors of the Los Angeles Times. In addition, his by-line appeared in Radio TV Weekly trade magazine for over 30 years.

As Secretary-Treasurer of the West Coast Electronic Manufacturers Assn. he put that fledgling group on its feet and a paying basis over ten years ago. He was honored with a life membership of Alpha Kappa Psi in 1951 and also made an honorary member of the Institute of Radio Engineers in Australia, where he spent much of his time before the last war.

Just prior to his passing he had covered an electronics convention at Palm Springs, Calif., for a client.



He operated a public relations consulting business until his death and handled California Chasis Corp., Jim Lansing Sound, Sprague Electronics and was the only person alive who was able to render advice to H. Leslie Hoffman, top man at Hoffman Electronics, whom he served for over twenty years as a consultant.

There was never a radio, TV or electronics convention in recent years in the West that "Doc" was not a familiar figure and member of the working press in attendance. He was respected and loved by multitudes in the business.

He resided with Morse Peterman, a friend for 30 years and an artist of many talents, at 580 Crane Blvd., in Los Angeles. Periodically he and Peterman would take trips around the world, or across the seven seas and usually on slow tramp steamers.

As one electronics/space reporter put it: "When I came to California before World War II the first man I met was "Doc" Power. He went out of his way to guide me on my new career in Los Angeles and kept in touch for years. He was father confessor to many of today's successful executives and a great guy."

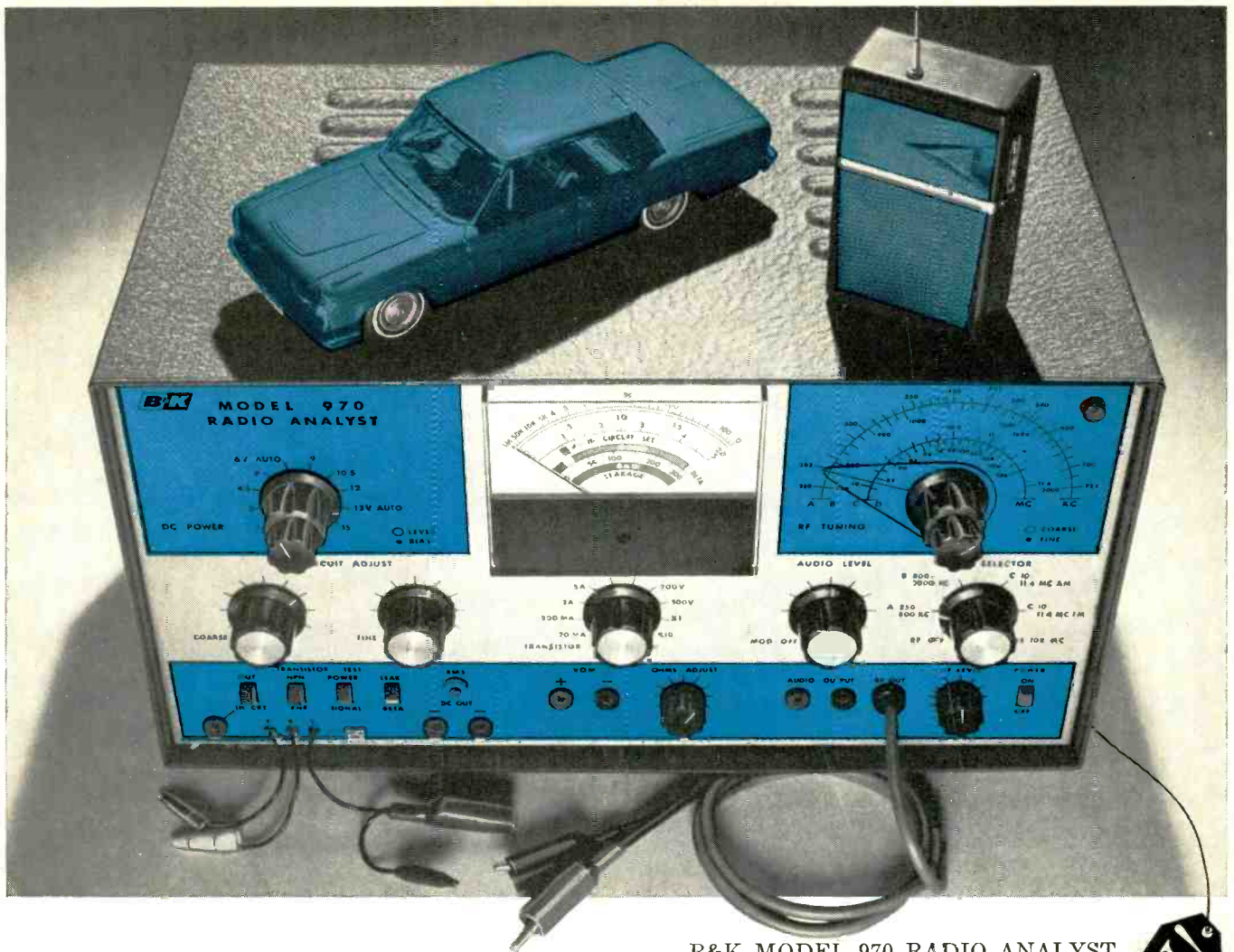

B&K MODEL 970 RADIO ANALYST

SERVICE AM & FM AUTO AND TRANSISTOR RADIOS AT A PROFIT!

NEW!

Jobs that used to be unprofitable now go so quickly that you can make good money handling them! There are millions of auto radios and transistor radios in the field—portables, auto and table models, plus hi-fi and communications equipment. Instead of turning them away, you can turn them into money-makers with the B&K Model 970 Radio Analyst.

The 970 is effective because it's *accurate* and *complete*. Using the famous B&K signal injection technique, this all-in-one instrument provides the required dc power, lets you test power and signal transistors in and out of circuit; generates RF and audio signals, and includes a rugged, accurate VOM. Four functions in one compact package—with solid state reliability, B&K professional quality.

LOW INVESTMENT—QUICK RETURN

See your B&K Distributor or write for Catalog AP22-R

Net \$199⁹⁵



B & K MANUFACTURING CO.
DIVISION OF **DYNASCAN CORPORATION**
1801 W. BELLE PLAINE AVE. • CHICAGO, ILL. 60613

Export: Empire Exporters, 123 Grand St., New York 13, U.S.A.

FEATURES:

BUILT-IN POWER SUPPLY

Auto Radios—High current, low-ripple, for transistor, hybrid, and vibrator types.

Transistor Portables—1½ to 12 volts for battery substitution—plus separately variable voltage tap for bias.

QUICK AND ACCURATE TESTING OF POWER AND SIGNAL TRANSISTORS

In-Circuit—stage by stage DC signal injection and sensitive metering of power supply current.

Out-of-Circuit—Direct Beta and Leakage meter scale readings. Easy balancing or matching.

VERSATILE SIGNAL GENERATORS

RF Generators—provide broadcast and IF frequencies for both AM and FM bands.

Audio Generator—for AM or FM modulation of the RF signals, and for troubleshooting audio circuits.

RUGGED VOM

Volt-OHM-Milliammeter—with rugged, taut band meter—provides correct ranges for easy, fast servicing of all home and auto radios, as well as transistor portables.

... for more details circle 107 on postcard

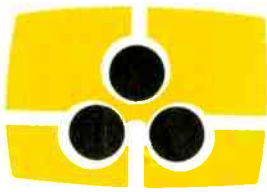

COLORFAX

Owens-Illinois Expansion

Owens-Illinois, Inc., Toledo, Ohio, announces a multi-million dollar expansion in its two television bulb plants which will increase by 25 percent its capacity to produce glass picture tube envelopes for the rapidly growing TV industry.

A glass melting furnace placed in operation at the company's Columbus, Ohio, plant was for the manufacture of bulbs for use here and abroad, Alec M. Turner, executive vice president and general manager of its Consumer and Technical Products Div. indicated.

Conversion to television bulb production of an existing glass melting furnace at the company's Muncie, Ind., plant is scheduled to be completed by next summer, according to Mr. Turner. When the conversion is completed, the Muncie plant's production, like that at Columbus, will be devoted entirely to television bulbs, it was understood.

The facilities at Columbus and Muncie will include significant improvements in glass processing and technology, Mr. Turner indicated. "Their completion will give us increased flexibility in meeting the needs of the TV industry," he said.

"The expansion at the Columbus and Muncie plants will bring to eight

the number of furnaces now melting glass for the production of color and black and white picture tube bulbs," he added.

The executive said the U.S. television industry is expected to produce more than 4½ million color sets this year, compared with 1965's 2½ million, while black and white set production is expected to be down slightly from last year's total of 8.1 million sets.

Philco Focus Coil Production Change

Some early production Philco 25in. color sets using the 16QT85A chassis will contain a focus coil less the tuning stick. The focus coil can be adjusted by a standard hex head alignment tool. Later production sets will incorporate the focus coil with tuning stick.

Focus adjustment procedure for focus coils without tuning sticks:

1. Rotate focus coil tuning core maximum counterclockwise
2. Rotate tuning core clockwise until picture is in focus

Once picture is in focus do not turn core any further, since continuous turning will place the picture out of focus and back into focus on a second peak. If you maintain focus on this

second peak, serious damage to the focus coil may result because of overheating. The correct focus peak is the first peak from the maximum counterclockwise position. Later production sets, using the focus coil with tuning stick, will incorporate a stop so that it can only be adjusted to the first peak.

Magnavox T919 Color Circuitry

The composite signal is fed from the output of the 1st video amplifier to the grid of the bandpass amplifier (V707A).

If the signal being transmitted is a B/W transmission, a positive horizontal pulse is applied to the color killer plate. During this monochrome transmission, V706A conducts on each of these pulses. Each pulse places a negative charge on the plate side of C727. As the capacitor discharges, a negative voltage is developed and applied to the grid of the bandpass amplifier, thus cutting it off. The color killer control determines the amount of plate current which will flow in the killer tube. This in turn determines the amount of bias developed and applied to the bandpass amplifier.

If the transmission is a color signal, the bandpass amplifier must conduct and to do this the color killer must be cut off. This is accomplished by the bias voltage developed by the killer detector circuit which uses two diodes (CR701A & B).

The burst amplifier is normally biased to cut off and also turned on by a portion of the same horizontal pulse which is normally used to turn on the color killer. As the burst amplifier is turned on, a 3.58MHz burst signal is coupled to the grid through the capacitor, C728. The burst signal is amplified and appears across the burst transformer.

Two burst signals are coupled from the secondary of the burst transformer to the killer-detector diodes through the capacitors C744 and C745. These two signals are 180deg out of phase. Simultaneously, a third signal is applied to the junction of these diodes from the 3.58MHz oscillator transformer secondary, through choke L709. The phase relationship of the third signal to the other two signals is such that both diodes will conduct. Because of this relationship, how-



Color TV Cameras

More than 600 color television cameras with a value in excess of \$40 million are scheduled to be produced and delivered by the Radio Corp. of America this year to meet the unprecedented demand for color TV broadcast and studio equipment.

FINCO-AXIAL[®]

COLOR-KIT



FINCO-AXIAL COLOR-KIT, Model 7512 AB

High performance Indoor and Outdoor Matching Transformers convert old-fashioned and inefficient 300 ohm hook-ups to the new Finco-Axial 75 ohm color reception system.

List price for complete kit . . .
7512AB \$8.95

7512-A Mast mounted matching transformer . . . list \$5.40

7512-B TV Set mounted matching transformer . . . list \$4.15

FINCO-AXIAL SHIELDED COLOR CABLE, CX Series

Highest quality, 75 ohm swept coaxial cable (RG 59/U) complete with Type F fittings, weather boot ready for installation.

Available in 25, 50, 75 and 100 foot lengths. List price . . . \$5.55, \$8.65, \$11.50 and \$14.20.

Write for Color Brochure # 20-349



**the
complete
color TV
reception
system**

For the best color TV picture

*eliminates color-fade, ghosting and smearing!
Improves FM and Stereo, too!*

QUICK, EASY INSTALLATION

ENJOY brilliant "TV-Studio" color reception today by changing over to the new Finco-Axial Color Reception System. NOW, color fade, ghosts and smears are a thing of the past. Finco-Axial shields color sets against signal loss . . . eliminates outside interference and mismatch problems.

THE FINNEY COMPANY 34 WEST INTERSTATE STREET, DEPT. 110, BEDFORD, OHIO

. . . for more details circle 112 on postcard



COLORFAX

ever, one diode will conduct more heavily than the other — developing a negative voltage at the junction of the two load resistors and coupling it to the color-killer grid. This negative voltage biases the color killer to cut-off so that even if the horizontal pulse is present at its plate, the tube will not conduct and thus allows the band-pass amplifier to conduct.

The bandpass amplifier must amplify only the chrominance portion of the incoming signal. This information is contained in the frequencies between 3.08MHz and 4.08MHz. This chroma information is coupled from the 1st video amplifier plate by an 18pf capacitor. The small size of this capacitor blocks the relatively low frequencies of the luminance signal which is also present at the plate of the 1st video amplifier.

To prevent the burst signal from being amplified by the bandpass amplifier, a positive pulse is applied to the blanker tube grid. As this stage conducts a positive pulse is developed across its cathode resistor, which (being common to the bandpass amplifier), cuts off the bandpass amplifier during the time the burst signal is present on its grid. Thus, only the chroma information is passed to the demodulators.

The phase detector circuit compares the phase of the transmitted burst signal with the 3.58MHz oscillator. Under normal operating conditions, when the two signals have the correct phase relationship, the two diodes (CR702A & B) will conduct

equally. If the oscillator signal tends to advance or retard its phase relationship with the incoming signal, the two diodes become unbalanced. Thus one diode will conduct more heavily than the other and the necessary correction voltage is applied to the reactance tube grid and to the 3.58MHz oscillator.

The reactance tube functions as an electronic variable capacitor. If a positive correction voltage from the phase detectors is applied to this tube, the effective capacitance across the 3.58MHz crystal increases — resulting in a lower oscillator frequency. A negative correction voltage from the phase detectors decreases the effective capacitance across the 3.58MHz crystal — resulting in a higher oscillator frequency. A reactance control coil, located in the plate circuit of the reactance tube, off-sets any inherent capacity in the tube itself and also sets the free-running frequency of the 3.58MHz oscillator.

The purpose of the 3.58MHz oscillator is to re-create the 3.58MHz sub-carrier required to demodulate the sub-carrier sidebands. This reinserted signal must have the same phase and frequency as that which was suppressed at the transmitter. The oscillator portion of this tube consists of the cathode, grid and screen-grid with the screen functioning as the oscillator plate. The CW signal is then electron-coupled to the plate and through the transformer to the demodulators. The secondary winding is followed by a phase-shifting network to derive two CW signals. The "X" signal, coupled directly to the "X" demodulator, is in phase with the chroma signal and the "Z" signal is approximately 85deg out of phase with the "X" signal and is coupled to the "Z" demodulator.

The "X" and "Z" terminology has no special meaning except to differentiate between the R-Y and B-Y axis. A certain amount of phase shift from the R-Y and B-Y axis is developed because of the common cathode resistor of the color-difference amplifiers. Hence, it is necessary to shift the CW reference signals to compensate for this phase shift. Since these two signals are out of phase and each demodulator will conduct when its reference signal reaches its peak positive value, the "X" demodulator will conduct approximately 85deg ahead of the "Z" demodulator.

As the chroma signal phase shifts to correspond to a new color, the plate current of these demodulators is also affected. This increase or decrease in current also affects the R-Y and B-Y sections of the 6MD8 tube which in turn either increases or decreases the conduction in the red and green guns of the CRT. Simultaneously, since the green signal is made up of portions of each demodulator output, the G-Y section of the 6MD8 increases or decreases — conduction thus controlling the green gun in the CRT. The output from each demodulator is a series of 3.58MHz pulses varying in amplitude according to the chroma signal at the control grid of the demodulators. These 3.58MHz pulses are filtered in the plate circuit of the demodulators — leaving only the demodulated signals which are then applied to the color difference amplifier for amplification before being applied to the individual CRT grid.

The individual CRT beams are modulated by the phase and amplitude variations of the color signal on the grid and by the amplitude of the luminance signal on the cathode. These beams then combine to produce the desired picture.

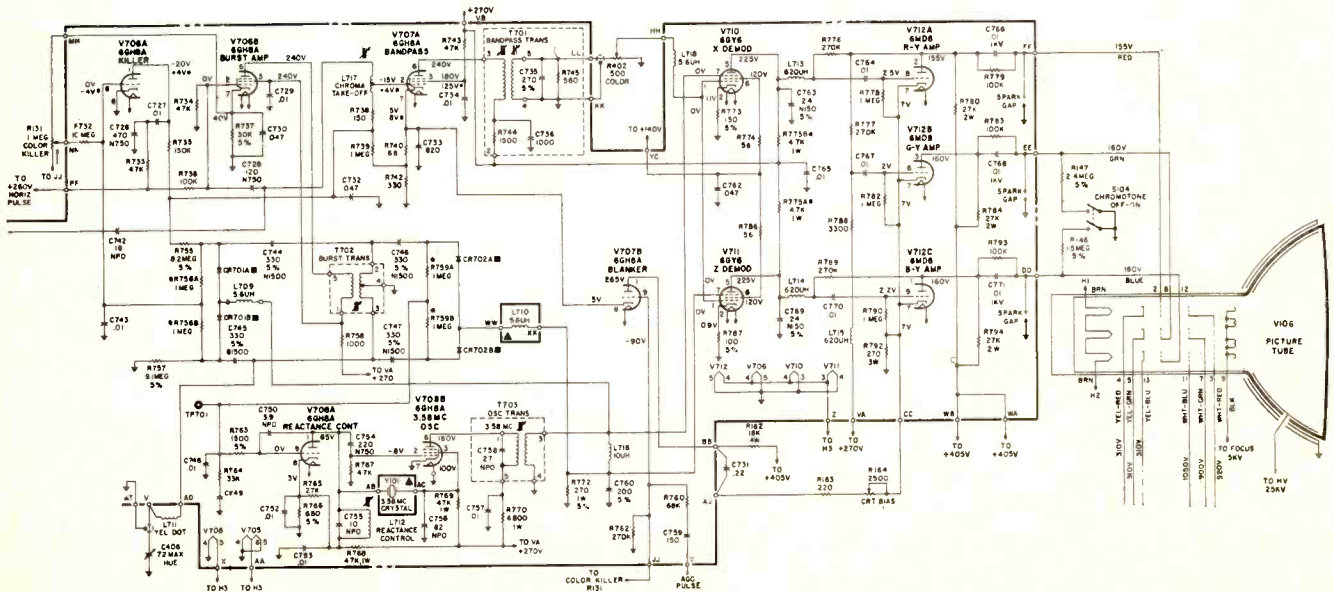



Zowie! Here's big news for "Mister Right"—the independent service dealer who carries Sylvania tubes.

Every time you order Sylvania picture or receiving tubes from a participating distributor, you receive Sylvania Means Business (SMB)-Mister Right dealer certificates. They're redeemable for an exciting selection of gifts. For yourself, your family, your home.

You get certificates for your purchases of receiving tubes and every SILVER SCREEN 85®, color bright 85™ or COLOR SCREEN 85 picture tube.

So you're a winner in two ways: big profits and top-quality prizes. Sylvania Means Business.

See your participating Sylvania Distributor for all the details. Sylvania Electronic Tube Division, Electronic Components Group, Seneca Falls, New York 13148.

SYLVANIA
SUBSIDIARY OF
 GENERAL TELEPHONE & ELECTRONICS **GTE**

NEW PRODUCTS

FOR MORE INFORMATION CIRCLE NEW PRODUCT NUMBERS ON POSTCARD INSIDE LAST COVER.

Studio Tape Recorder 700

A studio tape recorder is introduced which uses two capstan drives to carry the tape instead of the conventional single capstan. It is said to have a starting time measured at less than 0.01sec, and a stopping time equal to 1/2 in. of tape at 7 1/2 ips running speed. This quick reaction permits



ultra-precise programing and editing. Over a 30-minute span of tape, the initial and second runs are said to coincide within ± 2.0 sec permitting tight multiple recordings. Response is ± 1 db from 50 to 15kHz at 7 1/2 ips and ± 1 db from 50 to 7.5kHz at 3 3/4 ips. \$1200 and up. Tape-Athon.

Inverter 701

A solid state inverter has been introduced which changes 12v battery current to 117v filtered ac.



Capacity 450 to 500w. The unit is housed in a heavy gage copper clad case with carrying handle. Terado.

Semiconductor Cartridge 702

A line of semiconductor transducer cartridges is introduced. These cartridges are available in three versions: Standard stereo, miniature stereo and standard mono. They contain a chip of silicon semiconductor material, so arranged that its resistance is varied by straining it as a result of stylus motion. They are said to have 10v

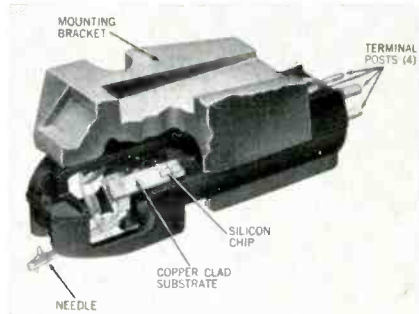

impedance, high output and a frequency response starting at dc. Price \$19.50 to \$23.50. Sonotone.

Flat and Rotor Wire 703

A packaging system for flat twin-lead wire and rotor cable is said to be tangle-free. A precise length of twin-lead or rotor wire is dispensed



while the remaining wire stays firmly in place. The package also permits the user to see and handle the wire in its display form. Available in 50, 75 and 100ft lengths. Saxton.

Heat Sink 704

A heat sink is announced which is claimed to have high heat dissipation due to fin design and mounting. These units mount directly on a chas-

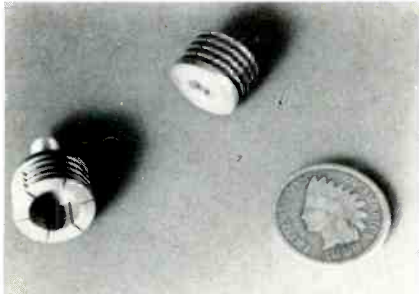

sis or printed circuit board. They are made of black anodized aluminum. 30¢ and up. Vemaline.

FM Receiver 705

A solid state FM receiver is announced. The receiver has a tuning meter, automatic stereo-mono FM switching, and separate fusing in each output circuit preventing damage in



the event that any two speaker leads should accidentally short. The output transformer has been eliminated. 8 1/2 in. deep. Audio Dynamics.

CB Transceiver 706

Announced is a five-channel CB transceiver small enough to fit under the dashboard. It may be used for



base station or portable field use. 2 1/2 x 6 3/16 x 8 3/4 in. Weighs 5lb. E. F. Johnson.

Color TV 707

A 23-in. rectangular color TV, with two-speed tuning on UHF/VHF,

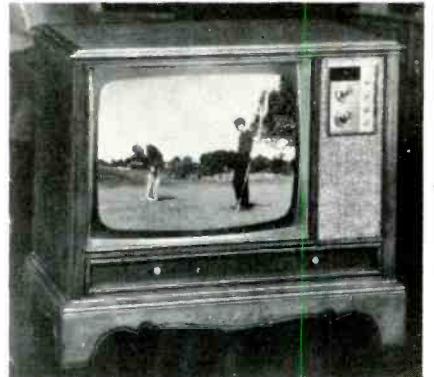

is announced. It also features permanent dial reference points for quick color tuning. The set also includes automatic color balance, solid-state rectifiers, and compactron multi-function tubes. G-E.

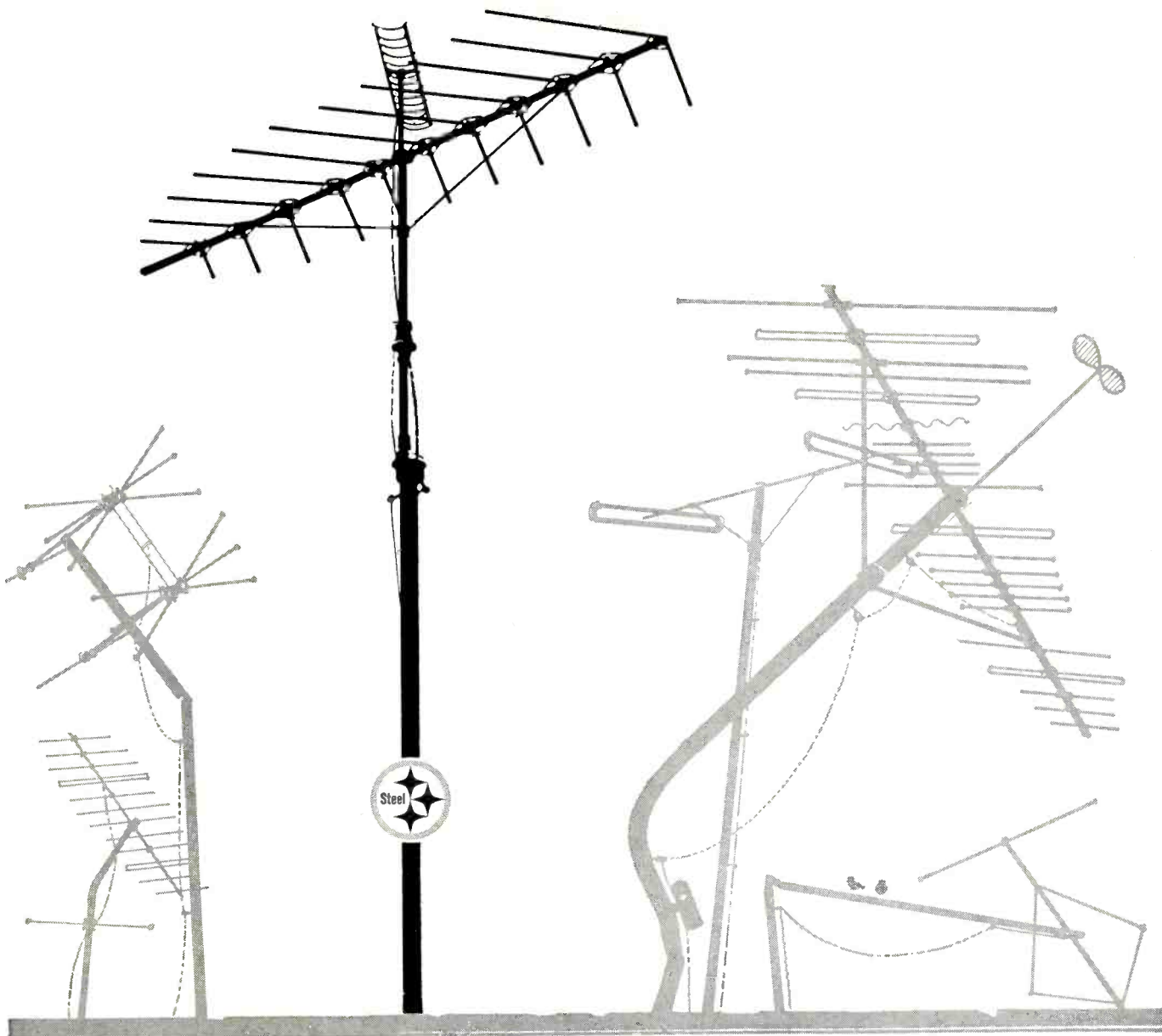

Put a tower of strength in your TV antenna sales program

Looking for TV masts and towers with features that help you sell? Consider masts and towers made from Armco ZINCGRIP® Steel Tubing. They're steel-strong to keep antennas aligned through heavy ice and wind. And they're zinc-coated to resist rust and maintain their good looks for years.

Get names of manufacturers who offer TV masts and towers made from Armco ZINCGRIP Steel Tubing. Fill in the coupon and mail it today.

 Armco Steel Corporation
 Department E-1556, P. O. Box 600
 Middletown, Ohio 45042

Send me names of manufacturers of TV masts and towers
 made from Armco ZINCGRIP Steel Tubing.

 Name

 Firm

 Street

 City State ZIP Code

ARMCO STEEL 

... for more details circle 103 on postcard

Microphones

708

A microphone is introduced which is said to feature a unidirectional pickup pattern that provides maximum rejection of feedback, uniform rejection of extraneous, unwanted sounds from the side and rear, as well as minimum pickup of reverberation and other undesirable effects of room acoustics. It also features a shock-mounted cartridge to reduce clothing



and cable noise and a very flexible two-conductor, small diameter shielded cable which can be easily concealed if desired. It can be secured to any flexible or fixed mounting using 5/8 in.—27 threads. List \$70. Shure.

Audio Generator

709

Announced is an audio generator said to produce a very low-distortion sinewave signal over a very wide range of frequencies. It is suited for testing audio amplifiers for gain and frequency response, as a signal source



for various bridge measuring circuits or for modulation of RF signal generators. The frequency-determining elements are not continuously variable but are set by positive-setting detent switches that select combinations of 1% resistors and 2% capaci-

tors which comprise the frequency-selecting network. This method of tuning provides setting to any individual frequency between 1Hz and 110Hz. The output level of this instrument can be set from 0 and 10v RMS with a meter. 120v, 50/60Hz, 40w. 8½ x 12½ x 9 in. 13lb. Kit \$49.95; factory-wired \$69.95. Eico.

Rubber Cables

710

A type rubber has been made available for use on cables. The material is a copolymer of butadiene and styrene which can be used to replace silicone rubber cables. The material is said to offer high resilience good



abrasion resistance, excellent temperature range (-75°F to +140° F). It also has low water absorption and good electrical properties. Resistance to acids and bases is good. Various conductor types and color codings are available. Birnbach.

Magnetic Switches

711

Magnetic reed toggle switches are available in 1 or 2 pole and rated at ½ amp up to 250v. They require

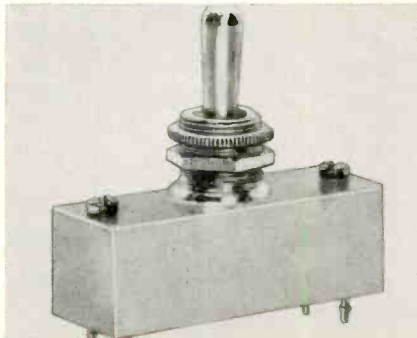

low operating forces. Rhodium contacts, hermetically sealed in pure nitrogen, make them ideal for hazardous duty usage. Weight 1 oz. \$5 to \$10. Hart Mfg. Co.

This man made an extra \$6000 last year rebuilding picture tubes.

You can make even more. Just this easy:

1. Realize there is an exploding demand for rebuilt picture tubes right where you live.
2. Send for the free full-facts story on how Windsor equipment can make you money in this lucrative, virtually untapped market.

That's it. Windsor will show you how to rebuild any tube made — black-and-white or color.

And, as has happened to so many others, we may just change your entire way of life — the way you'd like it. So don't wait. Contact us direct, or circle our number right now.



WINDSOR ELECTRONICS, INC.
999 North Main Street
Glen Ellyn, Illinois 60137

... for more details circle 131 on postcard

NEW PRODUCTS

Connector

712

Protected single lead connections are provided by this new plug and receptacle. The terminals are automatically crimped to wires and snap lock



into single wire housing. Detents in housing secures the mating units for fool-proof connections. Molex.

CB Transceiver

713

Announced is a CB transceiver for which a sensitivity of less than 1mv for 10db signal-to-noise ratio is claimed. Output power is a minimum of 3w. The CB20 measures 7 x 6 x 2 1/8 in., and weighs just 4lb. Five crystal-controlled channels are available, and transmit and receive crystals for one channel are provided. The unit contains 12 transistors, 8 diodes

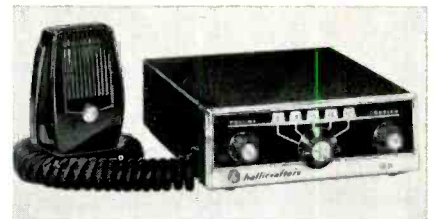

and 1 zener regulator. List \$99.95 Hallcrafters Co.

Guitar Amplifiers

714

Two all-transistor music instrument amplifiers, designed for the student market, are introduced. The guitar



amplifiers offer a 5w solid-state amplifier and a 9 in. oval speaker in a luggage-styled case. Perma-Power.

Combination Probe

715

A versatile combination probe does the work of four different probes, according to the maker and serves



as dc, acΩ, RF, and lo-cap. A rotating probe head with detent action, enables technicians to select the probe function required. Mercury.

TV/FM Booster Coupler

716

A 4-set booster coupler has been introduced for 75Ω coax hook-up. It provides a 6db gain to each of four

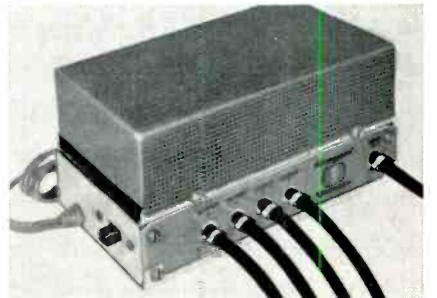

outputs and is said to take up to 400,000 microvolts of signal input (200,000 per band) without cross modulation. Winegard.

NEW! HALLMARK SS All solid state



FCC Rules Part 95 Applicable to Operation

- 12 channel, crystal-controlled
- Modular design, "plug-in" circuits

You've been waiting for this engineering breakthrough! It's the truly sensational Hallmark SS, featuring Hallmark's renowned top performance in a small sized, advanced design, all solid-state CB. The Hallmark SS uses all top quality, American-made components in a unique modular design concept. Pre-aligned "plug-in" circuits virtually eliminate field maintenance problems.

Among the many other features are: noise-immune, ultrasensitive squelch; compression amplifier for high modulation (95% to 100%); 4 watts RF power output; optional operation from any widely used AC or DC source; and optional, fully-regulated DC power supply. The Hallmark SS can also be operated as a basic public-address amplifier.

This low-cost unit gives new meaning to "solid state" in Citizens Band. Write today for complete information.

HALLMARK INSTRUMENTS

Sales Office: P. O. Box 502, Richardson, Texas 75080 (AC 214) AD 1-3453
Plant: 1601 W. Broadway, Lubbock, Texas 79401

Distributor inquiries invited.

New T/C/I Eagle



30 watt, two-way radio for long-range operation in the 25 to 50 mc business band. AC or DC operation, with transistorized mobile power supply for low power drain. Rugged hand-wired reliability. Small compact size fits any vehicle. FCC type accepted.

A DIVISION OF The Nova Corporation

... for more details circle 114 on postcard



"Rather powerful, I'd say."

No one has ever offered a line equivalent to this

IRC's VIDOR has done it again. They're here with the only high power battery line in America today.

Up to now you couldn't even get a high power battery line—from anybody. But now it's here. Only VIDOR has it. And the same great quality you expect from the British (you know about Garrard, Rolls-Royce and Wilkinson).

Talk about profits, listen to this. They'll last up to three times longer than other standard carbon zinc types, so you can sell VIDOR high power for those that want the best, which it is, and get *top dollar*.

Or you can discount and still get a bigger profit than you can selling any other battery.

VIDOR high power batteries have the kind of product - profit - quality story you haven't heard before. And VIDOR is here to stay (they're already here with transistor and general purpose battery lines).

If you haven't heard about VIDOR, you should. And quick. The quicker you do, the more money you'll make. Call your IRC representative for all the profitable details today.

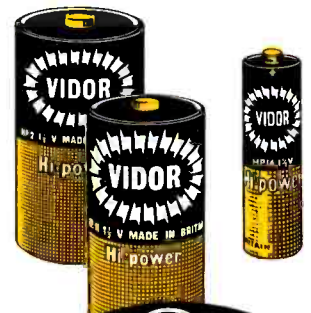

Consumer & Distributor Products Division, IRC, Inc., Philadelphia, Pa. 19108.

... for more details circle 115 on postcard

A MODERN EXECUTIVE NEEDS CULTURE, TOO!

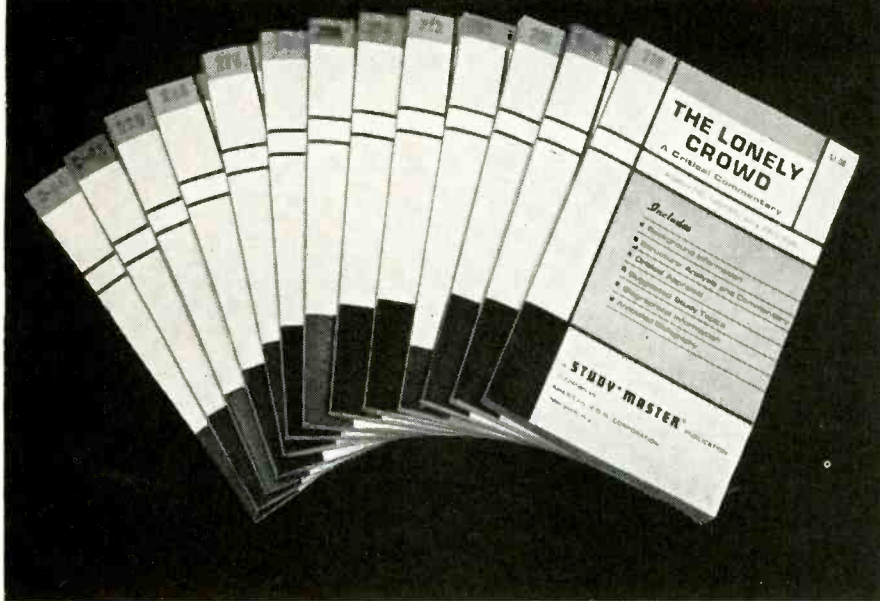

Refresher course in the Great Books

Whether company head or man "on the way up," the modern executive is expected to have a broad background of both knowledge and experience. And his knowledge should encompass cultural familiarity in addition to specialized knowledge of his own business.

12 Great Works — Expertly Condensed

That is why the special Executive's Reading Kit has been put together. It consists of twelve volumes of the famous Study*Master® Outline Guides, each a condensed outline of one of history's greatest literary works. In the aggregate, it provides an easily assimilated background of some of the world's greatest literature. This great — but inexpensive — library of literature, especially selected for executives, can be employed while traveling or at leisure moments to enrich your knowledge, enhance your vocabulary, while providing interesting, meaningful reading.

| | |
|----------------------|----------------------------|
| Macbeth | The Divine Comedy |
| Hamlet | Lord Jim |
| Oedipus the King | The Odyssey |
| Crime and Punishment | The Wasteland |
| The Lonely Crowd | Paradise Lost |
| War and Peace | Gandhi — Concise Biography |

The entire package of twelve volumes is available at only \$9.95

STUDY * MASTER®

Publications

Education Division ET-1
148 Lafayette Street
New York, N. Y. 10013

Money back if not satisfied.

Name _____
Address _____
City _____
State _____ Zip _____

NEW PRODUCTS

Pocket Socket

717

Announced is a 4-in-1 patented nut and bolt driver that changes size. The tool comes in two ranges: one with 1/4, 5/16, 3/8 and 7/16-in. sizes; the other with 3/6, 7/32, 9/32 and 11/32

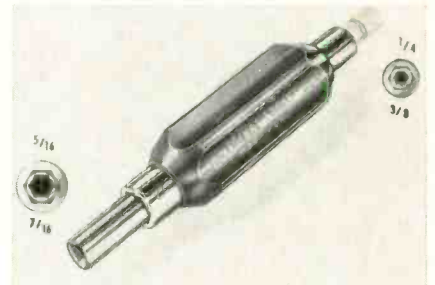

in. sizes. The tool is made of carbon steel. Pocket Socket.

Sewing and Lacing Needles 718

The sewing and lacing of telephone and electric cables has been simplified through the introduction of 3 tools.

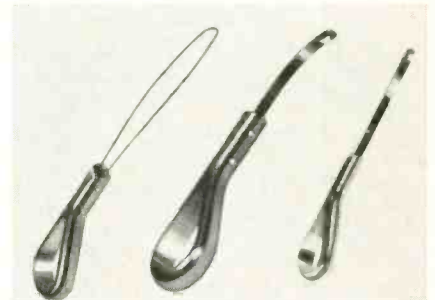

No. N2257 is an 8in. long wire loop lacing needle, no. N287 is a curved cable sewing needle 5 5/8 in. long and no. N298-7S is 7in. long, similar to N287 except that it has a straight notched blade. Handles are anodized aluminum. Neuses.

Reverb Accessory

719

A compact unit which incorporates a 4-transistor circuit is designed to be used with a standard reverberation

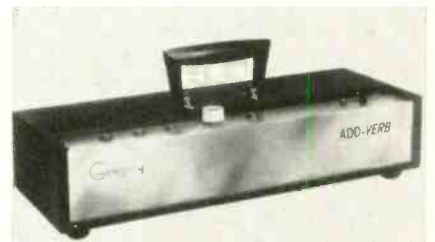

unit employed with musical instrument amplifiers but may be used with Hi Fi amplifiers, phonographs and tape recorders. It is 17 x 4 1/4 x 6 3/4 in. and weighs less than 5 lb. List \$59.95. Gregory.

be sure
be right
insist on

ASTATIC

REPLACEMENT CARTRIDGES and NEEDLES

including all the
New Shroud Models

we are proud of everything we make ...
we put our name on everything we sell!

improved and engineered
to perfection by ASTATIC

- Only ASTATIC guarantees ...
- Quality and Dependability
 - The Industry's ONLY Complete Replacement Guides
 - Over 600 Needle Types
 - Over 200 Cartridge Types

your favorite Jobber
features ASTATIC
because all good jobbers
feature Astatic



ASTATIC CORPORATION • CONNEAUT, OHIO 44030, U.S.A.

In Canada: Canadian Astatic Ltd., Toronto, Ontario

Export Sales: Roburn Agencies, Inc., 431 Greenwich Street, New York 13, N.Y., U.S.A.

... for more details circle 105 on postcard

NEW PRODUCTS

Scissor Clamp

720

A stainless steel scissor clamp with plastic coated handles is announced.

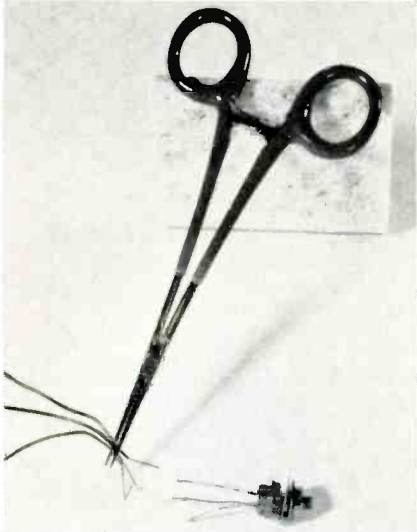

It has a locking clasp, tempered blades and fine serrated jaws. The clamps are available in 5 or 6in. lengths with either straight or curved tips. Hunter Tools.

Semiconductors

721

A line of transistors and diodes are mounted on a two-color pilfer-proof card, each component encased in a clear, see-through plastic, en-



abling the purchaser to examine the part. The reverse side of each card is a replacement and interchangeability guide suggesting suitable substitutions for the semiconductor mounted on the front of the card and basing diagram for the unit supplied. Semitronics.

Magnetic Tape

722

Introducing a mylar-base recording tape on a 2 $\frac{3}{8}$ -in. reel for which triple playing time is claimed without sacrifice of quality. This tape is a result of continuing growth in sales of miniature portable recording equip-

ment. The reels are packaged in special self-mailers. The use of a recently-developed oxide formulation provides an output of 5db more than any other extended-play tape, assuring high output without distortion. The tape may be interspliced or programmed with standard tapes without causing differences in playback level, according to the company. TP3 pro-

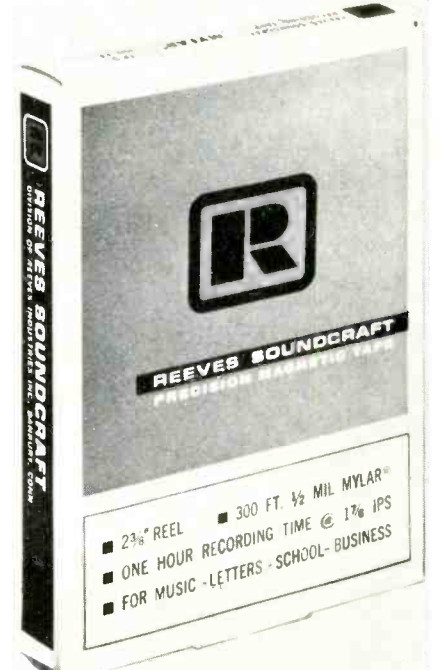

vides 300 ft of 0.5 mil mylar on each 2 $\frac{3}{8}$ -in. reel. This gives 64 minutes of playing time at the 1 $\frac{1}{8}$ speed, or 32 minutes at 3 $\frac{3}{4}$. Reeves.

Walkie Talkie

723

A 10-transistor walkie talkie with superheterodyne circuit is introduced.



It comes with an 8-section telescoping antenna extending 56 $\frac{1}{2}$ in., a push-to-talk button, on-off volume control, carrying strap, plus a shoulder strap. It operates on 7 regular penlight batteries. \$34.95. Olson.

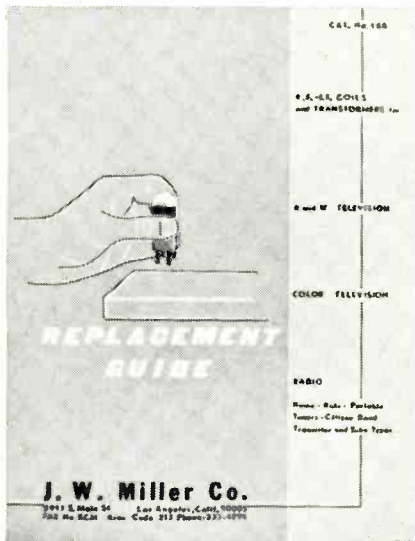

NEW Coil Catalog & Replacement Directory No. 166

New 168-page catalog gives specifications and prices for the most complete line of RF and IF coils. Replacement directory cross references coils for all known TV sets, radios and car radios.

For your free copy, call on your local distributor or write directly to:



J. W. MILLER COMPANY

5917 SO. MAIN STREET • LOS ANGELES, CALIFORNIA 90003

SEE YOUR LOCAL DISTRIBUTOR FOR THE FULL LINE OF RF AND IF COILS, CHOKES, FILTERS AND TRANSFORMERS.

... for more details circle 120 on postcard

Tweezers

A tweezer that resists hydrofluoric acid is introduced. It is virtually unaffected by inorganic acids, alkalis, oxidizing agents or organic compounds. The tweezer resists heat up to 390°F, has a low dielectric constant, is resistant to radiation, nonflammable, impermeable and non-absorbent. Engineering and Electronic.

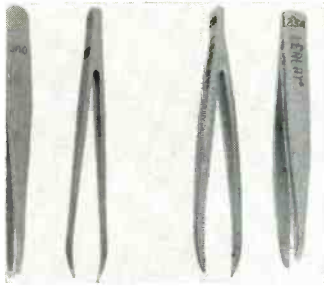

724

Paging System

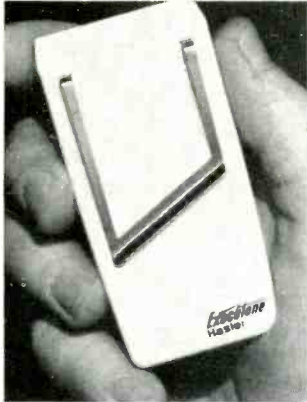

page receiver. He then goes to the nearest telephone, and dials a pre-determined "reply number." Executone.

This unit makes it possible to reach people anywhere in a plant by means of compact receivers worn in the pocket or on the belt. If a person being called via an internal dial telephone is away from his desk, the caller merely dials a single digit plus the called person's number. The person being called is alerted by a discreet tone signal coming from his miniature pocket

725

Power Supply

A dual power supply with silicon solid-state construction is announced. The plus and minus voltages are independently adjustable from 8 to 16v with a current rating of 100 ma for each section. Operates at temperatures to 120°F ambient. Electronic Design Lab.



726

Antenna Couplers

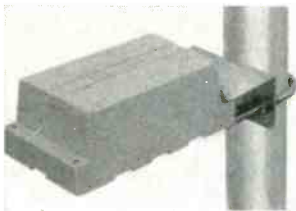

the VHF antenna if desired. It can also be used inside as a splitter. Winegard.

Model CA314 will couple three separate antennas (VHF, UHF and FM) on the same mast, providing a single downlead into the home or building. The VHF circuitry is ac passive to allow use of preamplifier on

727

Bookshelf Speaker

A bookshelf size speaker, said to give full base response down to 45Hz is announced. The dome-type tweeter provides a high range to 20Hz, the announcement said. Nominal impedance: 8Ω. Power: 6w minimum to 50w. Size: 11 7/8 x 7 3/4 x 8 1/4 in. Price: \$56. Audio Dynamics.



728



"My shop's been loaded... since I got my FCC License."

"And I could kick myself for not getting it sooner. I'm pulling in all kinds of mobile, marine and CB business that I couldn't touch before; have even had some calls to work on closed-circuit television, I've hired two new men to help out and even with them, I'm two weeks behind."

And so it goes. Once you have that FCC ticket, you open the door to all kinds of new business. And that's not all. The knowledge you need to pass the FCC exam gives you a fundamental understanding of all electronics. You'll find you can do more work in less time...work on almost any kind of electronics gear.

What's the best way to get a Commercial FCC License...and still keep up with your work? Thousands of men will tell you "Cleveland Institute of Electronics." CIE has been preparing men for FCC License exams since 1934. What's more, they back their Home Study Licensing Programs with this remarkable money-back offer:

A CIE FCC License course will quickly prepare you for a Commercial FCC License. If you fail to pass the FCC examination...on the very first try...after completing your course, CIE will refund all your tuition. You get an FCC License...or your money back!

And only CIE offers you new, up-to-the-minute lessons in all these subjects: Logical Troubleshooting, Laser Theory and Application, Micro-miniaturization, Single Sideband Technique, Pulse Theory and Application, Boolean Algebra, and many more.

Send coupon today for CIE's FREE informative book "HOW TO GET A COMMERCIAL FCC LICENSE." Cleveland Institute of Electronics, Dept. ET-23, 1776 East 17th Street, Cleveland, Ohio 44114.

NEWS FOR VETERANS: New G.I. Bill may entitle you to Government-paid tuition for CIE courses if you had active duty in the Armed Forces after Jan. 31, 1955. Check box in coupon for complete information.

MAIL COUPON TODAY FOR FREE BOOK

CIE Cleveland Institute of Electronics
1776 East 17th Street, Cleveland, Ohio 44114

Please send FREE book, "How To Get A Commercial FCC License."



Name _____ (please print)
 Address _____
 City _____ State _____ Zip _____
 Occupation _____ Age _____

Veterans check here for GI Bill information

Accredited Member National Home Study Council
A Leader in Electronics Training...Since 1934

ET-23

NEW PRODUCTS

UHF/VHF Splitter/Mixer 729

A unit is introduced which can either mix the signals from separate UHF and VHF antennas for a single

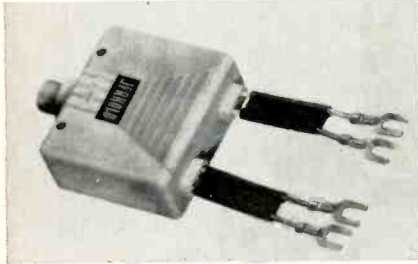

download, or split the signals from a single download for separate UHF and VHF TV set inputs. List for 300Ω download model is \$4.95. List for 75Ω download model \$7.95. Jerrold.

Headphones 730

A pair of sensitive lightweight headphones has been introduced for audio communications use. They have a fully adjustable covered headband, foam filled, washable, replace-



able ear cushions and dynamic elements, 4 to 16Ω, 100Hz to 10kHz. \$13.95 net. Superex Electronics Corp.

TV/FM Wallplates 731

A line of combination TV and FM

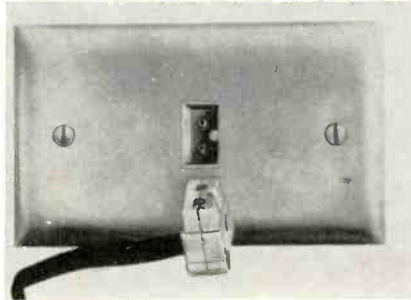

wallplates are said to incorporate an exclusive design feature. The TV and FM components incorporate receptacles recessed in flush mounted wallplates, providing a slim compact installation. A TV and FM plug is keyed to fit the receptacle, permitting easy connection to receivers. The plug attaches to the connector line in seconds without soldering, providing a permanent installation and insuring proper polarity. Slater Electric.

Adjustable Speaker 732

A screwdriver—adjustable WATTS/IMPEDANCE switch and built-in transformer are features of a recently announced wide angle paging and talkback speaker. The cobra-flare horn is made of fiber glass. Labor-saving features are said to include: screw-to-line terminals, a terminal cover plate which is also a cable



strain relief clamp and omni-directional, three-way adjustable mounting bracket. Power: continuous to 30w. Frequency response, 250Hz to 14kHz. Dispersion, 120 deg x 60 deg. Dimensions: 6 x 14 x 12 3/4 in. Shipping weight 6 lb. List: \$56.85. Atlas Sound.

Variable Transformers 733

A line of variable transformers for single or three phase, 120 or 240v service is said to provide single unit constant current ratings to 1.4kva, ganged unit ratings to 5.0kva. For 120v service, single type 116B has a

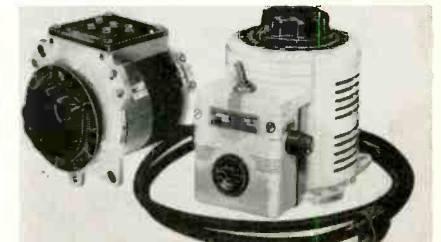

rated output of 0-140v, 10amp; type 117B of 0-120v, 12 amp. For 240v duty, single type 216B has a rated output of 0-280v, 3.5amp; type 217B of 0-240v, 5amp. Available in manual or motorized assemblies in open or enclosed construction. These compact units have a base designed for maximum mounting flexibility. Superior.



**NON-DRIFT
COLOR LUBE**

**CLEANS TUNER
BETTER**

**SAFE FOR
PLASTICS**

**NON-
FLAMMABLE**

**TEST AFTER TEST HAS PROVEN
COLOR LUBE TO BE THE BEST
TUNER CLEANER
FOR ALL COLOR TV SETS!**

CHEMTRONICS inc. 1260 RALPH AVENUE
BROOKLYN, NEW YORK 11236

... for more details circle 110 on postcard

Public Address Speakers 734

A horn system has been introduced which is of fibreglas construction for indoors or outdoors environment. It uses a single high-efficiency trans-

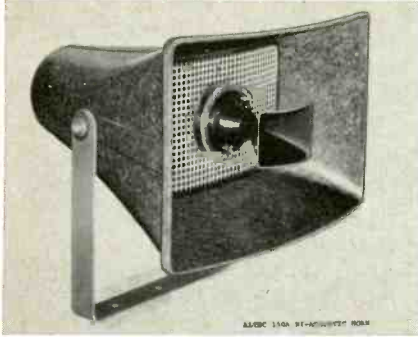

ducer with two sound paths emanating from both sides of the diaphragm. The horn system has a distribution of 120 deg horizontal and 90 deg vertical, 8Ω impedance, and 150Hz to 12kHz response. Altec Lansing.

Microphone Mixer 735

Announced is a portable microphone mixer for operation on either batteries, 110 or 240vac. Four low impedance microphones can be fed into the mixer. Each channel has its own volume control and built-in pre-



amp. A master output volume control and ON/OFF switch are provided. Other features include an output jack for connection to a reverberation unit and separate ON/OFF switch. Size: 9 x 8 x 6in. Weight 5½lb. American Geloso.

Soldering Iron Control 736

A soldering iron control unit is introduced which is said to provide a reliable temperature setting from 400 deg to 1000 deg as the dial is turned from position 1 to position 7.

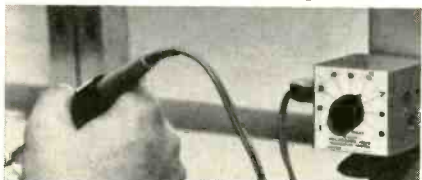

The controlled outlet may also be used for any other device with a total power drain not to exceed 500w. Hunter.

Why break your back



Let the Ungar HOT-VAC De-Soldering Tool do the tough jobs

Trouble melts away. The new Ungar Hot-Vac gives you finger tip control for printed board rework and repair. Hot-Vac makes it possible to remove components 50% faster than any other method. One hand operation frees the other for component handling. A special ungarized white coating on the

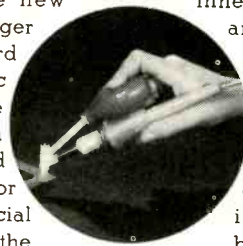

inner surface of the Hot-Vac tip and solder collector prevents sticking and clogging. A pffft-squeeze of the bulb discharges molten solder. Your local Ungar distributor will be happy to give a Hot-Vac demonstration and complete information, or send coupon below for detailed literature.

SEND FOR COMPLETE INFORMATION ON HOT-VAC TODAY!

Ungar Electric Tools, 2701 W. El Segundo Blvd.
Hawthorne, California 90252 • Dept. E. T. -6

Name (Please Print) _____ Title _____

Company _____

Address _____

City _____ State _____ Zip _____



... for more details circle 130 on postcard

brand new
...and very important...

QUAM COLOR TV REPLACEMENT SPEAKERS PREVENT COLOR PICTURE DISTORTION

OFTEN CAUSED BY STRAY
MAGNETIC FIELDS FROM
ORDINARY LOUDSPEAKERS

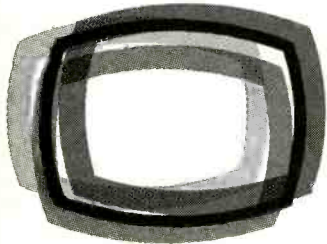

When you use an ordinary loudspeaker in a color TV set, you're looking for trouble... picture trouble. The external magnetic fields from standard loudspeakers will deflect the primary color beams, causing poor registration and distorted pictures.



QUAM RESEARCH SOLVES THIS PROBLEM

An entirely new construction technique, developed in the Quam laboratories, encases the magnet in steel, eliminating the possibility of stray magnetic fields and the problems they cause! These new Quam speakers have been eagerly adopted by leading color TV set manufacturers. Quam now takes pride in making them available for your replacement use. Five sizes (3" x 5", 4", 4" x 6", 5 1/4", 8")... in stock at your distributor.

QUAM

QUAM-NICHOLS COMPANY

234 E. Marquette Rd. • Chicago, Ill. 60637

... for more details circle 123 on postcard

NEWS OF THE INDUSTRY

Philco Appoints Manager

William R. Mitchell has been named San Francisco district manager for Philco Corp.'s Sales and Distribution Div. Mr. Mitchell, district manager in New Orleans since February, 1962, replaced Robert W. Stockman, who resigned. Glenn Smith, sales manager in the New Orleans district under Mr. Mitchell, has been named district manager there.

Carl E. Lantz, vice president and general manager of the division, said the changes were effective immediately.

Semitron Names Reps

Lawrence Rivman, general sales manager of Semitronics Corp., announces the appointment of two new reps. In the New England area the company will be represented by Robert Smith Co., 59 Verndale St., Brookline, Mass. For upstate New York, it will be covered by Callahan Ferguson Co., 107 Greenhedge Dr., Camillus, N.Y.

RCA's 1965 Profits Rise

Sales and earnings of the Radio Corp. of America in 1965 set new records for the fourth consecutive year, paced by the best quarterly results in the company's history for the final three months of the year.

Profits after taxes amounted to \$101,161,000, an increase of 23 percent over the previous high of \$82,495,000 in 1964, it was reported in the company's 46th annual report.

Total sales rose 13 percent to \$2,057,117,000 from \$1,812,459,000 a year earlier, surpassing the \$2 billion level for the first time. Both earnings and sales for 1965 exceeded earlier year-end estimates.

Earnings per common share for the year rose to \$1.73 from \$1.37 in 1964 after retroactive adjustment for the three-for-one stock split in January, 1964, and the 10 percent stock dividend paid Feb. 1, 1965.

Enjoying the greatest single quarter in its 46-year history, the corporation earned \$34.9 million, or 60 cents a common share in the final three months of 1965 on sales of \$586.5 million. It marked the 19th consecutive quarter in which profits were higher than those of the comparable period a year earlier. The previous quarterly earnings high was \$26.7

million, or 44 cents a share set in the fourth quarter of 1964. The former quarterly sales peak of \$506.7 million was established in the third quarter of 1965.

Admiral Appoints Omaha Distributor

The appointment of Aberdeen Distributing Co., as Admiral distributor in the Omaha, Neb. territory was announced by Clarence B. Flinn, vice president independent distributors. David H. Gorrell, formerly regional sales manager, is general manager of the new distributorship which is located at 3805 N. 16th St., Omaha, and covers 71 Nebraska counties and 7 counties in West Central Iowa. Aberdeen Distributing will handle the sales and service of color and black and white TV receivers, stereo high fidelity instruments, radios, refrigerators, freezers, room air conditioners, ranges and dishwashers.

enter now!

new **Simpson**
INSTRUMENTS THAT STAY ACCURATE

260® VOM applications
contest



Send in your ORIGINAL test application (for Simpson's famous 260 VOM) NOT ALREADY described in our new book, "1001 Uses For The 260®..." You can get a copy from your Electronic Distributor; list price, \$1.00. He also has entry rules. Contest ends Dec. 31, 1966.

Grand Prize: One week at the famous Tropicana in Las Vegas. **Other Prizes:** Goof-proof VOMs and Diode Meter Protectors.

SIMPSON ELECTRIC COMPANY
5208 W. Kinzie St., Chicago, Ill. 60644

ITT Earnings Hit Record

All-time record sales, were reported by International Telephone and Telegraph Corp. They also indicated record net income and earnings per share for 1965.

Earnings per share increased 13 percent over 1964 and total sales and revenue for the ITT Worldwide System increased 11 percent, Harold S. Geneen, chairman and president, reported.

Consolidated worldwide sales and revenues for 1965 rose to \$1,782,939,000, an increase of 11 percent over the previous record of \$1,601,543,000 in 1964, after restatement to include all companies acquired in "pooling of interests" transactions in 1965. It represented a gain of 133% over the \$766 million reported for 1959, the first year of the new growth program.

Consolidated net income rose to an all-time peak of \$76,110,000, equal to \$3.58 per average common share, a record high. This was an increase of 13 percent over restated 1964 earnings of \$3.16 per share, of 15 percent over \$3.11 per share as reported in 1964.

Net income for 1965 was 14 percent over the 1964 total of \$66,831,000 after restatement to include companies acquired in "pooling of interests" transactions, and 162 percent over the amount reported for 1959. Expenditures for new facilities and equipment last year totaled \$146 million, a record for any single year in the Company's history. About 75 percent of such expenditures was financed internally through retained earnings and depreciation.

Sprague Electric Sales and Earnings

Sales of Sprague Electric Co. in the year ended December 31, 1965, reached a record high of \$107,077,249, as compared with \$85,699,862 in 1964. Net income

after taxes from operations in 1965 increased to \$4,935,541, against \$3,746,703 in 1964. On a per share basis, net income in 1965 was \$3.04 on the 1,623,387 shares outstanding, compared with \$2.37 from operations on 1,582,110 shares outstanding in 1964. In 1964 the company had a non-recurring investment credit adjustment of \$400,831, applicable to 1962 and 1963, that is not included in the 1964 earnings figure from operations. With this figure included, net income for 1964 was \$4,147,534, equal to \$2.62 per share.

Color—B/W Sales Set Record

A 101 percent increase in distributor sales of color TV sets combined with a 13 percent rise in sales of portable/table model black-and-white sets offset a decline in monochrome consoles and combinations in 1965 and pushed total volume to a record 10.8 million, according to the Electronic Industries Assn.'s marketing services department.

A 13 percent increase in portable and table models brought total monochrome TV receiver sales by distributors up 4.5 percent during 1965 to reach more than 8 million. Console and TV-phonograph combination models, on the other hand, were down 18.8 percent and 49.9 percent respectively.

All models of color TV receivers made substantial gains in distributor sales during 1965. Console models, reaching more than 2 million units in sales, were up 93 percent. Distributor sales of table and portable models increased 145 percent while TV-phonograph combinations were up 125 percent during 1965. Total sales of color TV receivers by distributors amounted to 2.7 million during 1965, an increase of 101 percent from sales of 1.4 million during the previous year.

ZENITH LOG PERIODIC ANTENNAS

offer high
signal gain and
ghost rejection

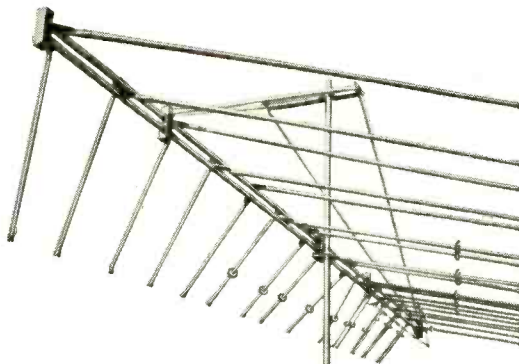

All-channel VHF/UHF/FM and FM Stereo

Developed by the University of Illinois antenna research laboratories, each Zenith log periodic antenna works like a powerful multi-element Yagi . . . not on just one or a few channels, but across the entire band it's designed for.

Order Zenith antennas and all genuine Zenith replacement parts and accessories from your Zenith distributor.

BUILT TO THE QUALITY STANDARDS OF ZENITH ORIGINAL PARTS

Also Zenith periodic antennas for

- UHF • VHF
- FM AND FM STEREO
- PLANAR HELICAL UHF

ZENITH
®
*The quality goes in
before the name goes on*

. . . for more details circle 133 on postcard



**EFFICIENT!
SAFE!
FAST!**

AUTOMATIC STAPLE GUNS



For Fastening Any
Inside or Outside

Wire Up to 1/2" in Diameter

- UP TO 3/16"
No. T-18
- UP TO 1/4"
No. T-25
- UP TO 1/2"
No. T-75

- Telephone wire
 - Intercom wire
 - Bell wire
 - Thermostat wire
 - Radiant heating wire
 - Hi-Fi, Radio & TV wires
- Tapered striking edge gets into close corners!

Available in:
Brown, Ivory, Beige,
Monel, Bronze, Natural



... for more details circle 104 on postcard

NEW! TYMETER® 24 HOUR CLOCK

"Time at a Glance"



\$15

#100-24H

Here's the most remarkable clock you've ever used! The greatest advance in Time Telling since the dial face clock... outdates all other ways of Time Telling. Easy-to-read numerals register every second, minute, 10-minute and hour. Walnut or ebony plastic case. 4" high, 7 3/4" wide, 4" deep. Wt. 3 lbs. 110V 60 cy. AC. One Year Guarantee.

At Your Local Dealer, or
ORDER DIRECT FROM

**TYMETER ELECTRONICS
PENWOOD NUMECHRON CO.**
7249 FRANKSTOWN AVE., PITTSBURGH 8, PA.

... for more details circle 121 on postcard

ADVERTISERS INDEX

| | |
|------------------------------------------|-----------|
| American Telephone & Telegraph Co. | 79 |
| Amperex Electronic Corp. | 3rd Cover |
| Arco Electronics | 33 |
| Armco Steel Corporation | 67 |
| Arrow Fastener Co., Inc. | 82 |
| Astatic Corporation | 73 |
| B & K Manufacturing Co. | 26 |
| B & K Manufacturing Co. | 61 |
| Borden Chemical, Krylon Div. | 38 |
| Channel Master Corp. | 35 |
| Chemtronics, Inc. | 76 |
| Clarostat Mfg. Co., Inc. | 69 |
| Cleveland Institute of Electronics | 75 |
| Finney Company, The | 63 |
| Gavin Instruments, Inc. | 2nd Cover |
| Hallmark Instruments | 70 |
| IRC, Inc. | 71 |
| Jensen Manufacturing Co. | 37 |
| Jerrold Electronics Corp. | 28 |
| Jerrold Electronics Corp. | 31 |
| Lectrotech, Inc. | 82 |
| Miller Company, J. W. | 74 |
| Pennwood Numechron Co. | 82 |
| Philco Corporation | 20 |
| Quam-Nichols Company | 80 |
| Quietrole Company | 82 |
| Radio Corporation of America | 4th Cover |
| RCA Electronic Components & Devices | 24 |
| RCA Sales Corporation | 29 |
| Sarkes Tarzian Tuner Service | 19 |
| Sencore, Inc. | 23 |
| Sencore, Inc. | 34 |
| Sencore, Inc. | 36 |
| Simpson Electric Company | 80 |
| Sprague Products Company | 25 |
| Sylvania Electric Products, Inc. | 27, 65 |
| Triplett Electrical Instrument Co. | 30 |
| Ungar Electric Tools | 77 |
| Windsor Electronics, Inc. | 68 |
| Winegard Company | 22 |
| Zenith Sales Corporation | 81 |

new color generator with vectorscope



ONE YEAR
WARRANTY

LECTROTECH V7

A complete color generator with 4 major exclusives for faster, more accurate servicing of color TV. Exclusive Color Vectorscope accurately measures color demodulation to check R-Y and B-Y plus all ten color bars for color phase angles and amplitude. Self-calibrating—adjust timing circuit without use of external test equipment. Solid state reliability. Produces all patterns. RF at channels 3, 4 or 5. Red-Blue-Green gun killer. All circuits voltage regulated to operate under wide voltage ranges.

18950
Net

See your distributor or write Dept. ET-6



LECTROTECH, INC.

1221 W. Devon Ave., Chicago, Illinois 60626

... for more details circle 119 on postcard

NEW! **QUIETROLE'S**
BIG THREE AEROSOLS
For Electronic Servicing

HARMLESS TO PLASTICS

MARK-II
For Tuners

SPRAY-PACK
For Controls & Switches

SILITRON
For General Use

Zero effects on capacity and resistance. Non-flammable... non-conductive... non-corrosive. All include free five-inch plastic extender.

Yes! Quietrole is still available in bottles with an eye dropper!

manufactured by
QUIETROLE COMPANY
Spartanburg, South Carolina

... for more details circle 124 on postcard

ELECTRONIC TECHNICIAN

If you think
all replacement tubes are alike,
you've got a surprise coming

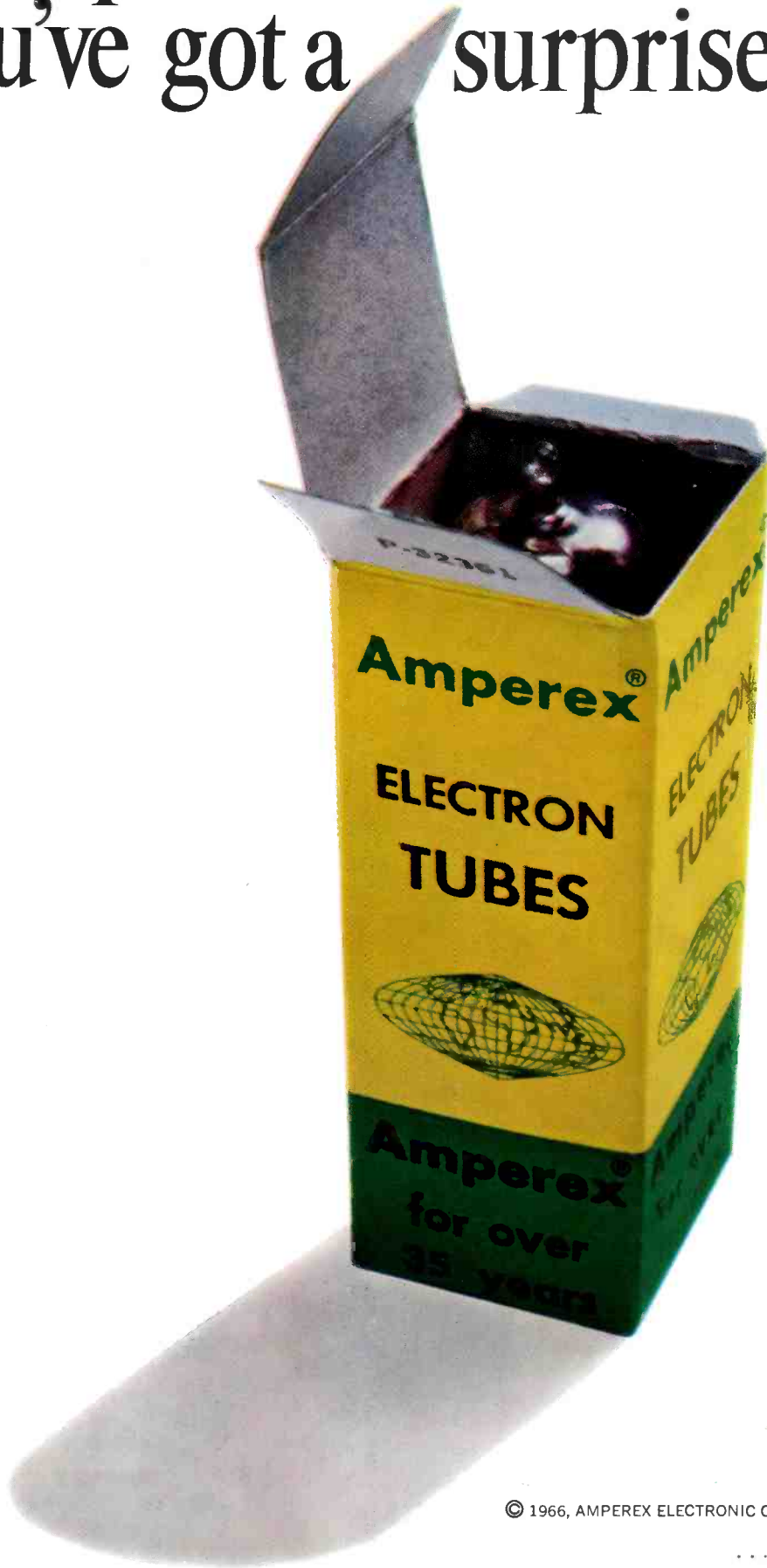

© 1966, AMPEREX ELECTRONIC CORP., HICKSVILLE, L. I., NEW YORK 11802

... for more details circle 101 on postcard

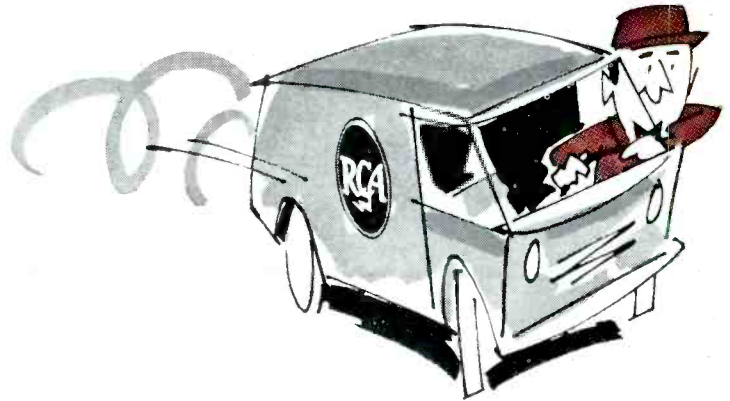

Poor convergence?



...check the horizontal and vertical output stages first

Sometimes the problem of misconvergence can be due to changes of characteristics in the horizontal and vertical output circuits. If the set has poor convergence here's a short check list of preliminary steps that may save you some valuable time. So, take a few moments and follow these easy steps...

1. Check the raster to see that it fills the entire screen. If it does not, check the height and width adjustments, the vertical and horizontal-output tubes, and the high-voltage section.
2. Measure the high voltage with your RCA VTVM or VOM, and high voltage probe. Rotate the brightness control and check voltage at various levels. Voltage should hold at all settings. If it does not, check the high voltage regulator circuit.
3. With your convergence-pattern generator, set up a crosshatch pattern. Then check and adjust linearity, if required. The crosshatch rectangles should be of uniform size. If not, adjust the vertical and horizontal linearity until you get a uniform effect.
4. Re-check items 1, 2, and 3.
5. Check color purity. If required, degauss the set and reset purity.

If these checks do not clear up the misconvergence, then make convergence adjustments as described in the service data.

For more satisfied customers, you'll find your local RCA Distributor your best source for top quality RCA receiving tubes for color TV.

RCA ELECTRONIC COMPONENTS AND DEVICES, HARRISON, N. J.



The Most Trusted Name in Electronics