

16 pages

CIRCUIT DIGESTS

See Last Page

# TECHNICIAN



50¢

September • 1951

Caldwell-Clements

# You are more apt to get the volume control you need from **your IRC<sup>®</sup>** distributor than from any other source

Whether you need a special exact duplicate control or a standard replacement carbon or wire-wound control, you are almost sure to find it at your IRC Distributor.

He carries the most versatile line of controls in the industry. He offers you better, more complete replacement coverage. He can supply an almost endless variety of combinations of resistance elements and shafts.

He can take care of your needs far more frequently than any other source.

And you can depend upon IRC quality and dependable performance. Exact duplicate TV and Auto Set controls (over 850 of them) are specified to manufacturers' procurement prints—they will fit and operate without modification.

Make your IRC Distributor Your Volume Control Headquarters.

**BIGGEST  
BARGAIN IN  
VOLUME  
CONTROL  
COVERAGE IN  
THE INDUSTRY**



New IRC Dealer Parts Stocks No. 21 and No. 22 afford you amazing coverage of not only exact duplicate controls but also standard carbon and wire-wound control coverages. As much as \$1245 coverage for an amazingly low investment! See your IRC Distributor today!

*Wherever the Circuit Says*



**INTERNATIONAL RESISTANCE CO.**

Dept. 574, 401 N. Broad St., Phila. 8, Pa.

In Canada: International Resistance Co., Ltd.  
Toronto, Licensee

# TECHNICIAN & Circuit Digests

TELEVISION • ELECTRONIC • RADIO • AUDIO • SERVICE

SEPTEMBER, 1956

ALBERT J. FORMAN *Editor*  
M. CLEMENTS *Publisher*  
O. H. CALDWELL *Editorial Consultant*  
SIDNEY C. SILVER *Managing Editor*  
A. O'ROURKE *Assistant Editor*  
CHARLES F. DREYER *Art Director*

### BUSINESS DEPARTMENT

480 Lexington Ave., New York 17, N. Y.  
Telephone PLaza 9-7880

H. A. REED *General Sales Manager*  
BERNARD BLOCK *District Manager*  
N. McALLISTER *Production Manager*  
JOHN J. BORGHI *Controller*  
A. H. POND *Asst. Controller*  
W. W. SWIGERT *Credit Manager*  
M. RUBIN *Circulation Manager*  
M. SOKOL *Circulation Records*

P. H. DEMPERS *District Manager*  
201 N. Wells St., Chicago 6, Ill.  
Telephone RAndolph 6-9225

CHRIS DUNKLE & ASSOCIATES  
*California Representative*

3257 W. 6th Street, Los Angeles 5, Calif.  
Telephone DUnkirk 7-6149

3077 Turk St., San Francisco 18, Calif.  
Telephone EXbrook 2-0377



TECHNICIAN & CIRCUIT DIGESTS, Sept. 1956. Vol. 64, No. 3. \$50 a copy. Published monthly by Caldwell-Clements Co. Publication office, Emmett St., Bristol, Conn. Editorial, advertising and executive offices, 480 Lexington Avenue, New York 17. Telephone PLaza 9-7880.

Entered as second class matter at the Post Office at Bristol, Conn., June 10, 1954. Subscription rates: United States and Canada, \$4.00 for one year; \$6.00 for two years; \$8.00 for three years. Pan-American and foreign countries; \$7.00 for one year; \$10.00 for two years; \$14.00 for three years. Copyright 1956 by Caldwell-Clements Co., New York. Title registered in U. S. Patent Office. Reproduction or reprinting prohibited except by written authorization of publisher. Printed in U.S.A. by Hildreth Press, Inc., Bristol, Conn.

### FRONT COVER

Television antennas, one of the largest selling and most important products in the servicing industry, are depicted in typical metropolitan and suburban locations. We're not sure whether the fringe area model shown will actually work; it's the artist's conception of the improved high-gain types which have made reception possible for so many viewers.

### FEATURES and ARTICLES

TV Antenna Sales: Boost Business \$2,000 to \$8,000 (Editorial) . . .	35
"Tuning in the Picture" . . . . .	36
\$ in Election PA Work . . . . . A. R. Clawson	38
Let's Look at Capacitors . . . . .	39
TV Remote Control . . . . .	44
"Tough Dog" Corner . . . . . P. Skinner, R. Lipzen	45
Chasing External Ghosts: Causes and Cures . . . . . L. A. Williams	46
Shop Hints . . . . . C. Garrett, G. Hoffman, A. Kinckiner, S. Clark	49
TV Antennas: Where Do We Go from Here? . . . . . H. Harris	50
Test and Setup Procedures for Two-Way Mobile Radio . . . . . F. A. Bramley	52
Latest Test Instruments . . . . .	54
New Antennas & Accessories . . . . .	56
New Audio Products . . . . .	60
Opportunity Is Knocking on Your Door! . . . . . J. C. Sarayotes	62

### DEPARTMENTS

Editor's Memo . . . . .	4	New Products . . . . .	54
Letters to the Editor . . . . .	16	Audio News Letter . . . . .	64
News of the Industry . . . . .	22	Catalogs & Bulletins . . . . .	67
Reps & Distributors . . . . .	30	New Books . . . . .	69
Calendar of Coming Events . . . . .	37	Association News . . . . .	71

### CIRCUIT DIGESTS

75

### IN THIS ISSUE

(16 pp. latest schematics—see last page)  
GENERAL ELECTRIC: 9-in. Portable TV Chassis "T" line  
MONTGOMERY WARD: Portable Radio: Model GEN-1090A  
MOTOROLA: TV Chassis TS-537  
RCA-VICTOR: Color TV Chassis CTC5, CTC5A  
TRAVLER: TV Chassis 627A6  
TRUTONE Table Radio: Models D2684A, D2685A  
WESTINGHOUSE: Transistor Portable Radio Chassis V-2278-1

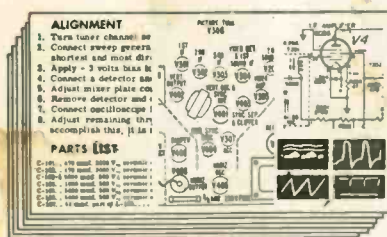

# RAYTHEON *TUBES*

*are the best you can buy...*





#### INSTRON WIRE TESTING

Testing of grid lateral and filament wire on the Instron Tester for specified physical properties as tensile strength, yield point, breaking point and proportional limit insures better tube quality and uniformity for Raytheon tubes.

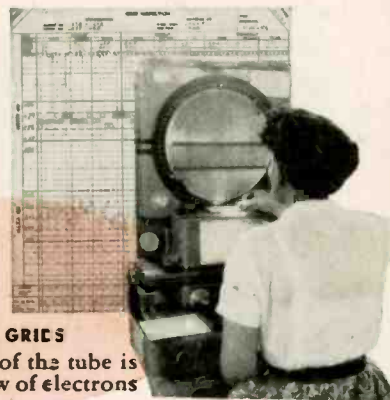

#### COMPARATOR INSPECTION OF GRIDS

One of the most critical parts of the tube is the grid which controls the flow of electrons to the plate.

Continuous comparator inspection of critical parts such as the above grid (magnified 20x) supplies information for better quality control and guards against deviations from Raytheon's high quality standards.

# here's why

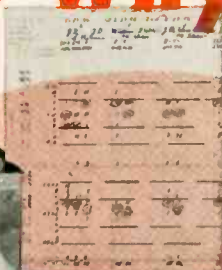

#### WEIGHING CATHODE COATING

The weight and O.D. of the cathode coating are controlled by periodic measurements with precision instruments. Here, an operator is checking the weight of cathode coating at the operation.

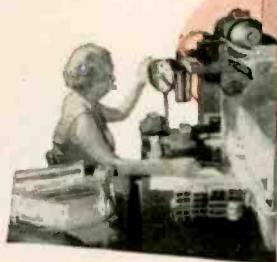

#### HEATER COATING CHECK

Heater wire must have uniform and closely tolerated coating thickness to insure short and uniform warm-up-time and durability. Raytheon makes continuous inspections of the heater wire coating to make certain of uniformity.



#### LIFE TESTING

Representative tubes of all tube production lots are put on life test which measures tube performance under simulated actual conditions to ensure original and continuing performance of Raytheon tubes.



#### 1ST FINISHED TUBE TEST

All Raytheon tubes undergo a rigid 100% First Test where they must pass strict requirements on both physical and electrical characteristics.

These girls are testing tubes for excessive noise and microphonics, inoperative tubes, specified electrical characteristics and physical appearance.



#### ENGINEER CHECKS DESIGN CHARACTERISTICS

Behind all these quality activities stands a large group of experienced, capable engineers whose sole concern is maintaining and developing Raytheon tube quality performance. This engineer is measuring tube design characteristics with the purpose of developing a tube for a customer with special applications.

These and many other vital tests and checks add up to  
**UNIFORMITY OF CHARACTERISTICS THROUGH RIGID QUALITY CONTROL**

### RAYTHEON MANUFACTURING COMPANY

Receiving and Cathode Ray Tube Operations

Newton, Mass. • Chicago, Ill. • Atlanta, Ga. • Los Angeles, Calif.

Raytheon makes all these: { Receiving and Picture Tubes, Reliable Subminiature and Miniature Tubes, Semiconductor Diodes and Transistors, Nucleonic Tubes, Microwave Tubes.



## Editor's Memo

There's a company in Brooklyn which manufactures sales promotion novelties. One of the items in their line is a wooden nickel. Thanks to high cost of labor, materials, overhead and the like, the cost of one of these wooden nickels is now 6¢.

Perhaps it's one of the signs of our times that the real cost of a product or service is often higher than might be expected. TV service is no exception. Take the case of Mrs. Typical Housewife, who buys a new name-brand 24-inch TV set for \$120 (that's the current "dumped inventory" price in several cities). A major breakdown or two and she has a legitimate repair bill of at least \$40—which is one-third or more of her investment. So she thinks the service is overpriced.

Explaining the justice and necessity of a high service bill takes patience. For one thing, almost all service that demands skilled work, precision parts and costly instruments have a high repair-to-investment ratio. Watch repair may be cited for one. The complexity of the equipment, years of training and time required are among other factors. Concerning the labor portion of the bill, try to keep a more exact log on time spent.

So whenever you're concerned about presenting a very large bill (most techs I know are, a few actually delight in watching the customer's face) which reflects the real—not the apparent—value of your work, don't be foolishly tempted to cut the bill or reduce the labor and make up for it by padding the parts. In the first case you're throwing away profit; in the second you're tempting fate . . . and the district attorney. Just remember the Brooklyn novelty manufacturer who asks 6¢ for every one of his wooden nickels—and he gets it.

Apropos of a few passing thoughts on the turmoil in some segments of our young industry, this election year brings to mind an old political anecdote. Three men at a table were heatedly debating which of their professions were older (though I doubt any claimed title to the oldest). Each claimed his own as the older. One man was a doctor, one a lawyer, and the last a Communist.

"Obviously," said the doc, "taking Eve from Adam's rib was a medical action, so medicine is older."

"Oh no," parried the attorney, "even before Adam, some force had to bring order out of the chaos. So law was actually first."

"Aha!" shouted the Communist triumphantly, "and where do you think the chaos came from?"

Seriously, whether you're a Democrat, Greenback, Independent, Liberal, Republican, Prohibitionist, Vegetarian or What-Have-You, don't forget to register to vote.

*Al Foman*

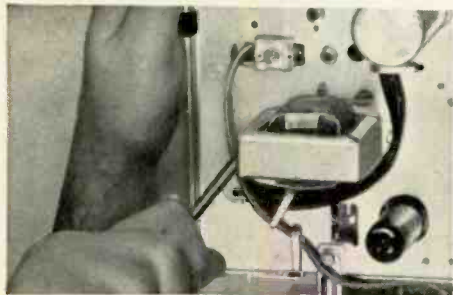
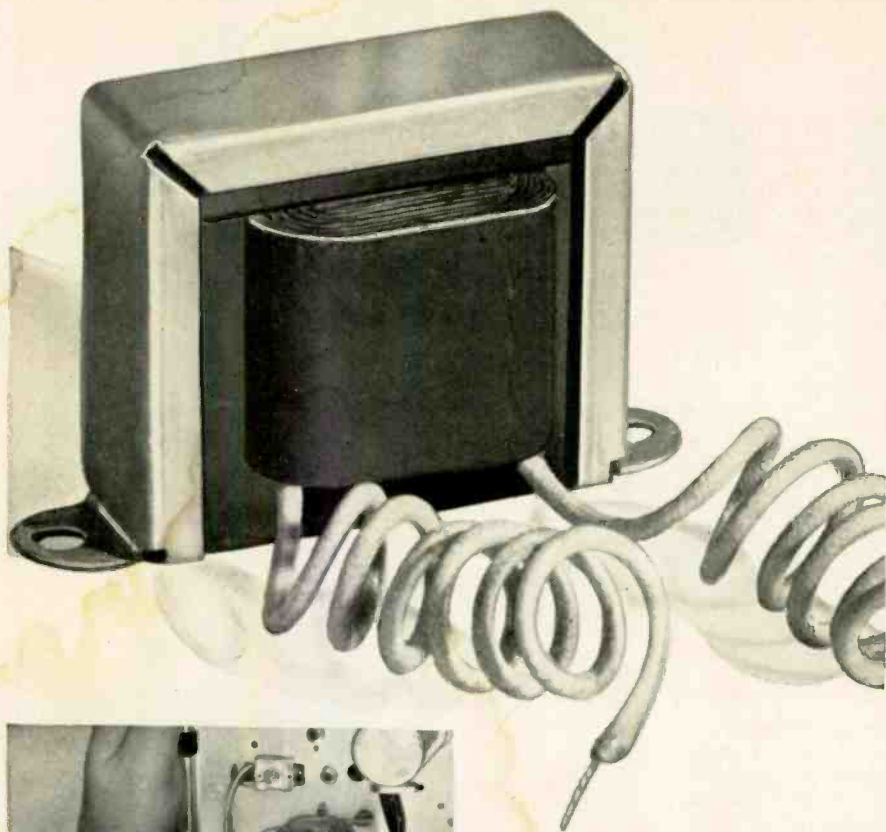

always  
replace with

# RCA SERVICE PARTS

... your bench-time goes **DOWN!**

... profits go **UP!**

RCA Service Parts are factory-tailored to fit right, install fast. You can depend upon their true-to-the-original design to keep your service calls short, your profits high.

This RCA inductor, for example, has exactly the same inductance and dc resistance values as the part originally built into an RCA Victor television receiver. This means optimum "Q", proper power-supply filter action—correct TV set performance. And, because all RCA Service Parts—like this inductor—install easily, they help cut daily bench-time by hours.

So, keep your servicing on-the-go, profitably. When you need a replacement part for an RCA Victor TV receiver, radio, or "Victrola" phonograph, ask your RCA Distributor for an RCA Service Part.



## SERVICE PARTS

RADIO CORPORATION OF AMERICA, HARRISON, N. J.

RCA VICTOR PRODUCTS • RCA SERVICE PARTS—made for each other!

# **CHANNEL MASTER**

## **Explodes a Spectacular Campaign of NATIONAL CONSUMER MAGAZINE ADVERTISING**

THE FIRST PROGRAM OF ITS KIND IN TV ANTENNA HISTORY

**2-Page Spreads . . . Full-Page Ads . . .  
Full-Color Ads . . .**

*reaching into millions of American homes on  
the pages of these outstanding magazines:*



**CHANNEL MASTER REVOLUTIONIZES ANTENNA MERCHANDISING!** With large-scale national advertising and traffic-building local promotions, Channel Master now places TV antennas on the same retail level as traffic appliances. It's actually a **NEW WAY** for you to sell antennas — and sell more of them. Climb aboard the Channel Master brandwagon and tie in with these profit-making promotions. Get details from your Channel Master distributor.

**NEW MARKETS . . . NEW CUSTOMERS . . . FOR THESE 2 GREAT NEW ANTENNAS**



# CHANNEL MASTER® "Showman"

new "Metro-Dyne" tuning  
obsoletes  
"Rabbit-Ears"

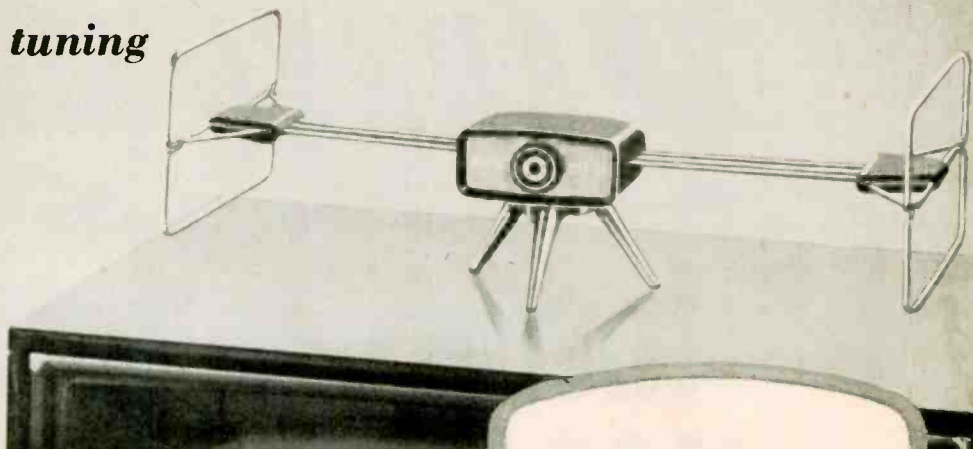

## the first basic indoor antenna improvement in over 10 years

Channel Master sets an exciting new trend in TV antennas with the Showman. In appearance (so important in the sale of indoor antennas) the Showman is in a dazzling class by itself. Yet, it's a complex electronic instrument—the most powerful indoor antenna yet developed by modern science!

The SHOWMAN is perfect for color reception, tops for black-and-white. And, it provides excellent FM reception, too!

**ACTUALLY TUNES OUT "GHOSTS" AND "SNOW"!  
MORE EFFECTIVE THAN ANY OTHER INDOOR ANTENNA!**



Metropolitan areas, where indoor antennas are most frequently used, are often subject to the most severe "ghosting" problems. Only the SHOWMAN, with its sensational new Metro-Dyne tuning, can overcome this difficulty. You'll be amazed at the job it does on all kinds of interference. Test it for yourself! Demonstrate it for your customers!

Channel Master stands squarely behind every SHOWMAN you sell. An unconditional money-back guarantee assures your customer of complete satisfaction.

**UNCONDITIONAL  
MONEY-BACK  
GUARANTEE**

"High fashion" packaging. Attractive, convenient. Ideal for display.

Available in three "decor designs"—to blend with any setting.

Mahogany and Gold model no. 3900	Blond and Gold model no. 3901	Ebony and Silver model no. 3902
----------------------------------------------	-------------------------------------------	---------------------------------------------

what makes the  
"Showman" different?

**FABULOUS  
"METRO-DYNE"  
TUNING!**

*The Metro-Dyne 12-Channel  
"Variable Inductance" Tuner*

Ordinary switch-type antennas work by connecting various elements into different combinations. METRO-DYNE tuning, on the other hand, is "variable inductance" tuning, using the same tuning principles as any TV set. It is the first broad band antenna which can be tuned to a specific channel so that it exhibits the bandwidth characteristics of a single-channel Yagi. This selectivity cuts down tremendously on "electronic noise" and interference. A built-in auto transformer maintains a constant 300 ohm impedance match.

**EASY OPERATION:** the Showman is calibrated by channels. Just turn it to the same channel number as the TV set. No arms to adjust; no guesswork or error.



**CHANNEL MASTER CORP.** ELLENVILLE, N.Y.

the world's largest manufacturer of television antennas and accessories

Copyright 1956, Channel Master Corp.



# CHANNEL MASTER®

# T-W

the world's first  
"Travelling Wave" antenna

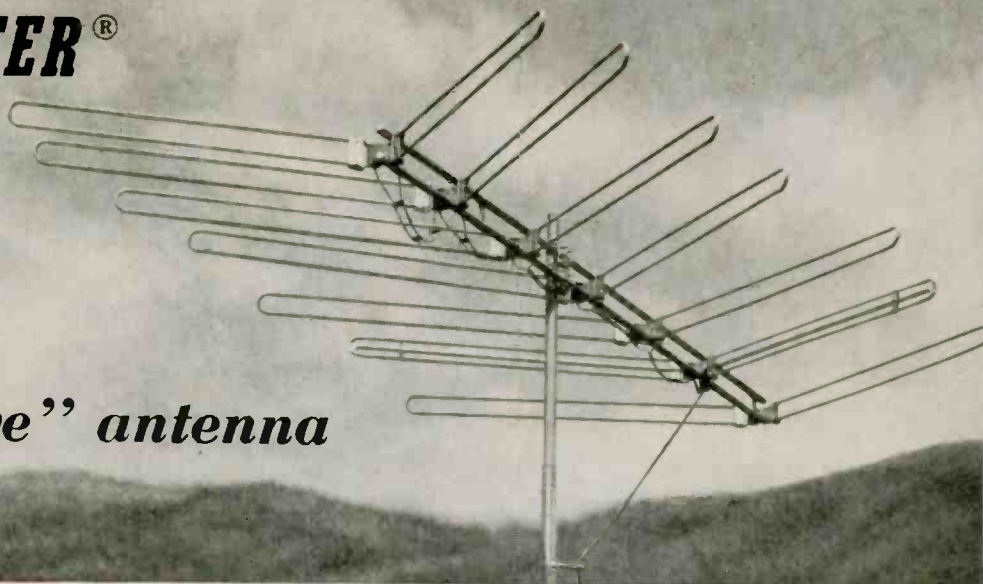

### WHAT THE "TRAVELLING WAVE" PRINCIPLE MEANS—

- ideal phase relationships on all channels
- optimum impedance matching on all channels
- equal flow of current in all dipoles on all channels
- fullest use of transmitted energy on all channels

IN SHORT — FABULOUS PERFORMANCE  
ON ALL CHANNELS

### SENSATIONAL 3- AND 5- ELEMENT MODELS!

Amazing T-W performance for suburban and near-fringe areas, too! Wonderfully compact and rugged!

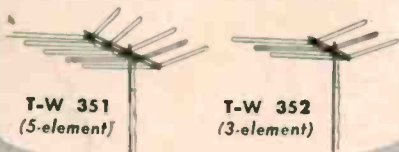

## revolutionary new design provides picture quality never before possible

After two years of research—a completely new kind of VHF antenna, operating on revolutionary new electronic principles. The T-W is Channel Master's greatest antenna achievement.

### ALL THREE — IN ONE ALL-CHANNEL ANTENNA

#### 1 HIGHEST GAINS

Most powerful all-channel antenna ever developed. A single-bay T-W 350 (7-element) actually **OUTPERFORMS—**



any wide-spaced 5-element Yagi on each low band channel.



any stacked 10-element Yagi on each high band channel.

#### 2 TOP FRONT-TO-BACK RATIOS

Low Band:

Better than 10:1 on every channel. **HIGHER THAN ANY 10-ELEMENT SINGLE CHANNEL YAGI ON ALL CHANNELS!**

High Band:

From 5:1 to 12:1. **HIGHEST RATIOS OF ANY SINGLE ALL CHANNEL ANTENNA.**

#### 3 GREATEST MECHANICAL STRENGTH

The most rugged antenna ever built. "Twin Truss" design amplifies the strength of every component. And new mechanical features add still greater durability . . .

"Twin Booms" . . . Two full-length crossarms—really rugged and rigid.

2 "Super-Nests" One heavy-duty mast clamp on each crossboom .  
A TOTAL OF 4 U-BOLTS! Antenna cannot move.

"Line-Lok" . . . . . Twinlead can't possibly tear away from terminals.

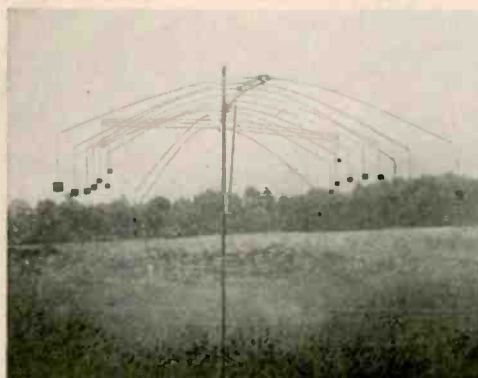
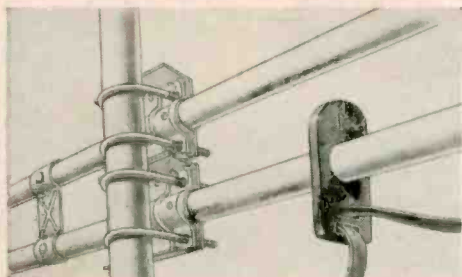

### PROOF OF THE SUPERIORITY OF "TWIN-TRUSS" CONSTRUCTION

Look at the dramatic result when equal weights are hung on a T-W and a standard 10-element Yagi!

Write for complete technical literature.

© - Trade Mark Reg. U.S. Pat. Off.

# 4 big ways to beat high insulating costs

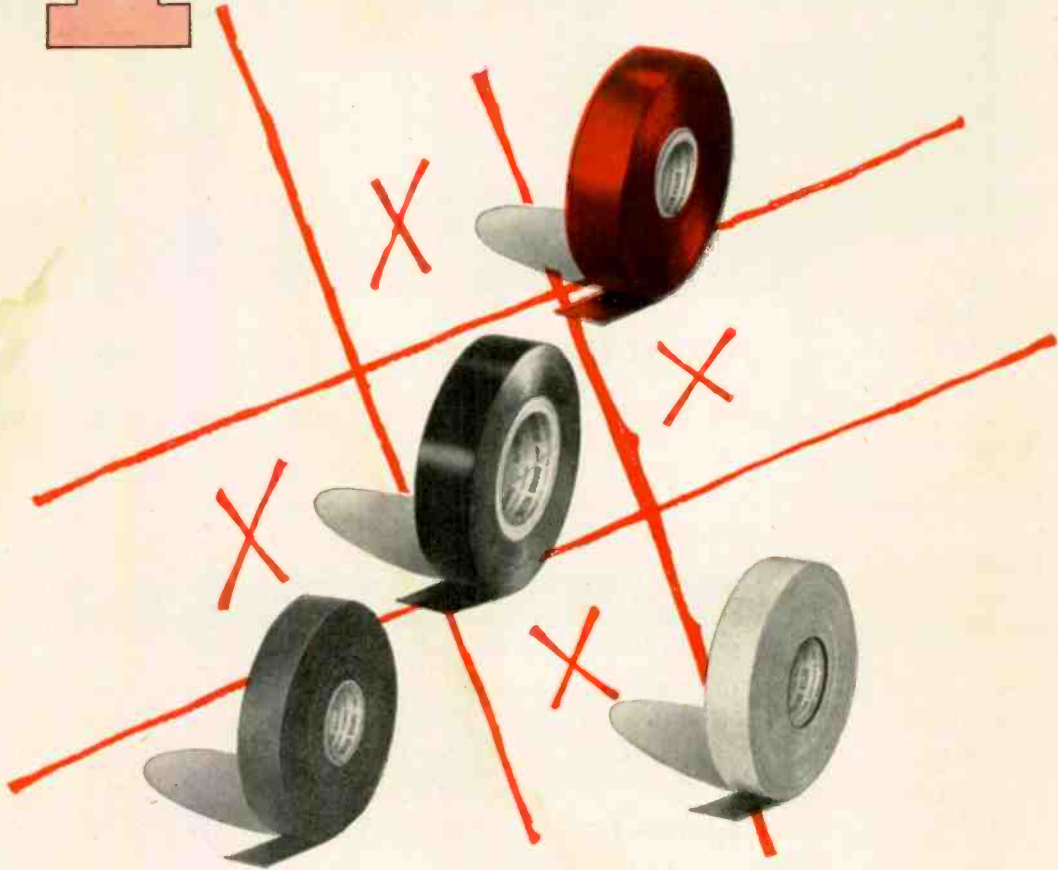

## Tool up with

### **DUTCH BRAND'S BIG FOUR ELECTRICAL TAPES**



**Send for this new Big Four booklet now!**

Here are facts that you can turn into dollars and cents! Dutch Brand's big, new "Big Four" booklet is packed with new ideas and methods for beating high electrical insulating costs. It tells how you can use Dutch Brand plastic tape, friction tape, rubber tape and vinyl color tape to improve electrical work . . . make jobs easier, faster and safer. You'll see exactly what these tapes will do . . . and find out how to choose the right tape to meet specifications of the job. Get a copy of this easy-to-read, well illustrated booklet for every department concerned with electrical insulation.



**Johns-Manville**

**DUTCH BRAND**

**P R O D U C T S**

7800 WOODLAWN AVENUE - CHICAGO 19, ILL.

Superior's New Streamlined Model TC-55

# TUBE TESTER



**FOR** The Experimenter or Part-time Serviceman, who has delayed purchasing a higher priced Tube Tester.  
The Professional Serviceman, who needs an extra Tube Tester for outside calls.  
The Busy TV Service Organization, which needs extra Tube Testers for its field men.

**CHECKS FOR SHORTS AND LEAKAGES BETWEEN ALL ELEMENTS** — Model TC-55 provides a super sensitive method of checking for shorts and leakages up to 5 Megohms between any and all of the terminals. Continuity between various sections is individually indicated. **"FREE-POINT" ELEMENT SWITCHING SYSTEM** — Model TC-55 incorporates a newly designed element selector switch system which reduces the possibility of obsolescence to an absolute minimum. Any pin may be used as a filament pin and the voltage applied between that pin and any other pin, or even the "top-cap." **ELEMENTAL SWITCHES ARE NUMBERED IN STRICT ACCORDANCE WITH R.M.A. SPECIFICATION** — The 4 position fast-action snap switches are all numbered in exact accordance with the standard R.M.A. numbering system. Thus, if the element terminating in pin No. 7 of a tube is under test, button No. 7 is used for that test.

Speedy, yet efficient operation is accomplished by: 1. Simplification of all switching and controls. 2. Elimination of old style sockets used for testing obsolete tubes (26, 27, 57, 59, etc.) and providing sockets and circuits for efficiently testing the new Noval and Sub-Minar types.

Model TC-55 comes complete with operating instructions and charts. Housed in rugged steel cabinet. Use it on the bench — use it for field calls. A streamlined carrying case, included at no extra charge, accommodates the tester and book of instructions.

**\$26<sup>95</sup>**  
**NET**

Superior's New Model TV-12 **TRANS-CONDUCTANCE**

# TUBE TESTER



TESTING TUBES

- ★ Employs improved TRANS-CONDUCTANCE circuit. An in-phase signal is impressed on the input section of a tube and the resultant plate current change is measured. This provides the most suitable method of simulating the manner in which tubes actually operate in Radio & TV receivers, amplifiers and other circuits. Amplification factor, plate resistance and cathode emission are all correlated in one meter reading.
- ★ NEW LINE VOLTAGE ADJUSTING SYSTEM. A tapped transformer makes it possible to compensate for line voltage variations to a tolerance of better than 2%.

## ALSO TESTS TRANSISTORS!

- ★ SAFETY BUTTON—protects both the tube under test and the instrument meter against damage due to overload or other form of improper switching.
- ★ NEWLY DESIGNED FIVE POSITION LEVER SWITCH ASSEMBLY. Permits application of separate voltages as required for both plate and grid of tube under test, resulting in improved Trans-Conductance circuit.

### TESTING TRANSISTORS

A transistor can be safely and adequately tested only under dynamic conditions. The Model TV-12 will test all transistors in that approved manner, and quality is read directly on a special "transistor only" meter scale.

Model TV-12 housed in handsome rugged portable cabinet sells for only

**\$72<sup>50</sup>**  
**NET**

Superior's new Model TV-11 STANDARD PROFESSIONAL

# TUBE TESTER



- Uses the new self-cleaning Lever Action Switches for individual element testing. Because all elements are numbered according to pin-number in the RMA base numbering system, the user can instantly identify which element is under test. Tubes having tapped filaments and tubes with filaments terminating in more than one pin are truly tested with the Model TV-11 as any of the pins may be placed in the neutral position when necessary.
- The Model TV-11 does not use any combination type sockets. Instead individual sockets are used for each type of tube. Thus it is impossible to damage a tube by inserting it in the wrong socket.
- Free-moving built-in roll chart provides complete data for all tubes.
- NOISE TEST: Phono-jack on front panel for

plugging in either phones or external amplifier will detect microphonic tubes or noise due to faulty elements and loose internal connections.  
**EXTRA SERVICE** — The Model TV-11 may be used as an extremely sensitive Condenser Leakage Checker. A relaxation type oscillator incorporated in this model will detect leakages even when the frequency is one per minute.

The model TV-11 operates on 105-130 Volt 60 Cycles A.C. Comes housed in a beautiful hand-rubbed oak cabinet complete with portable cover

**\$47<sup>50</sup>**  
**NET**

Superior's New Model TV-40

# PICTURE TUBE TESTER



Tests all magnetically deflected tubes . . . In the set . . . out of the set . . . In the carton!!  
A complete picture tube tester for little more than the price of a "make-shift" adapter!!

The Model TV-40 is absolutely complete! Self-contained, including built-in power supply, it tests picture tubes in the only practical way to efficiently test such tubes; that is by the use of a separate instrument which is designed exclusively to test the ever increasing number of picture tubes!

### SPECIFICATIONS

Tests all magnetically deflected picture tubes from 7 inch to 30 inch types • Tests for quality by the well established emission method. All readings on "Good-Bad" scale • Tests for inter-element shorts and leakages up to 5 megohms • Test for open elements.

Model TV-40 comes absolutely complete — nothing else to buy. Housed in round cornered, molded bakelite case. Only . . .

**\$15<sup>85</sup>**  
**NET**

# SHIPPED ON APPROVAL NO MONEY WITH ORDER — NO C. O. D.

We invite you to try before you buy any of the models described on this and the following page. If after a 10 day trial you are completely satisfied and decide to keep the Tester, you need send us only the down payment and agree to pay the balance due at the monthly indicated rate. (See other side for time-payment schedule details.)

**NO INTEREST  
OR FINANCE**

**CHARGES ADDED!**

If not completely satisfied, you are privileged to return the Tester to us, cancelling any further obligation.

**SEE OTHER SIDE!**

Cut out and mail TODAY! ▶

All prices net, F.O.B., N.Y.C.

FIRST CLASS

Permit No. 61430

New York, N. Y.

BUSINESS REPLY CARD

No Postage Stamp Necessary if Mailed in the U. S.

POSTAGE WILL BE PAID BY —

MOSS ELECTRONIC DIST. CO., INC.

3849 TENTH AVENUE

NEW YORK 34, N. Y.

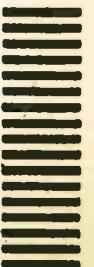

The **FIRST** POCKET-SIZED  
**VOLT-OHM MILLIAMMETER**



USING THE NEW "FULL-VIEW" METER.  
71% MORE SCALE AREA!!

Yes, although our new FULL-VIEW D'Arsonval type meter occupies exactly the same space used by the older standard 2 1/2" Meters, it provides 71% more scale area. As a result, all calibrations are printed in large easy-to-read type and for the first time it is now possible to obtain measurements instead of approximations on a popular priced pocket-sized V.O.M.

**SPECIFICATIONS**

6 A.C. VOLTAGE RANGES: 0-15/30/150/300/1500/3000 Volts. 6 D.C. VOLTAGE RANGES: 0-7.5/15/75/150/750/1500 Volts. 2 RESISTANCE RANGES: 0-10,000 Ohms, 0-1 Megohm. 3 O.C. CURRENT RANGES: 0-15/150 Ma., 0-1.5 Amps. 3 DECIBEL RANGES: -6 db to +18 db, +14 db to +38 db, +34 db to +58 db.

Compact — 3 1/4" x 5 7/8" x 2 3/4"

**\$15.85**  
NET

The Model 770-A comes complete with self-contained batteries, test leads and all operating instructions.

Superior's New  
Model TV-60

**20,000 OHMS PER VOLT**

**ALL METER**



**SPECIFICATIONS**

8 D.C. VOLTAGE RANGES (At a sensitivity of 20,000 Ohms per Volt) 0 to 15/75/150/300/750/1500/7500/30,000 Volts.  
7 A.C. VOLTAGE RANGES: (At a sensitivity of 5,000 Ohms per Volt) 0 to 15/75/150/300/750/1500/7500 Volts.  
3 RESISTANCE RANGES: 0 to 2,000/200,000 Ohms, 0-20 Megohms.  
2 CAPACITY RANGES: .00025 Mfd. to 30 Mfd.  
5 D.C. CURRENT RANGES: 0-75 Microamperes, 0 to 7.5/75/750 Milliampere, 0 to 15 Amperes.  
3 DECIBEL RANGES: -6 db to +58 db.

**AUDIO SIGNAL TRACER SERVICE:** Functions in the same manner as the R.F. Signal Tracing service specified at right except that it is used for the location of cause of trouble in all audio and amplifier systems.

**FEATURES**

Giant recessed 6 1/2 inch 40 Microampere meter with mirrored scale. Built-in Isolation Transformer. Use of the latest type printed circuit and 1% multipliers assure unchanging accurate readings.

Model TV-60 comes complete with book of instructions; pair of standard test leads; high-voltage probe; detachable line cord; R.F. Signal Tracer Probe and Audio Signal Tracer Probe. Pliofilm bag for all above accessories is also included. Price complete. Nothing else to buy. **ONLY**

**R.F. SIGNAL TRACER SERVICE:** Enables following the R.F. signal from the antenna to speaker of any radio or TV receiver and using that signal as a basis of measurement to first isolate the faulty stage and finally the component or circuit condition causing the trouble.

**\$52.50**  
NET

**SUPER METER**



A COMBINATION  
VOLT-OHM MILLIAMMETER PLUS CAPACITY REACTANCE INDUCTANCE AND DECIBEL MEASUREMENTS

**ADDED FEATURE:**  
Built in ISOLATION TRANSFORMER reduces possibility of burning out meter through misuse.

**SPECIFICATIONS**

D.C. VOLTS: 0 to 7.5/15/75/150/750/1,500/7,500 Volts  
A.C. VOLTS: 0 to 15/30/150/300/1,500/3,000 Volts  
OUTPUT VOLTS: 0 to 15/30/150/300/1,500/3,000 Volts  
D.C. CURRENT: 0 to 1.5/15/150 Ma. 0 to 1.5/15 Amperes  
RESISTANCE: 0 to 1,000/100,000 Ohms 0 to 10 Megohms

CAPACITY: .001 to 1 Mfd. 1 to 50 Mfd. (Good-Bad scale for checking quality of electrolytic condensers.)  
REACTANCE: 50 to 2,500 Ohms 2,500 Ohms to 2.5 Megohms  
INDUCTANCE: .15 to 7 Henries 7 Henries to 7,000 Henries  
DECIBELS: -6 to +18 +14 to +38 +34 to +58

**\$28.40**  
NET

The Model 670-A comes housed in a rugged crackle-finished steel cabinet complete with test leads and operating instructions.

Superior's New Model TV-50

**GENOMETER**

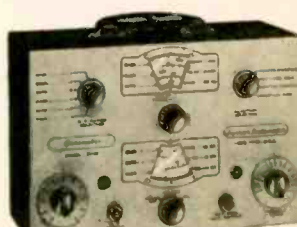

A versatile all-inclusive GENERATOR which provides ALL the outputs for servicing A.M. Radio • F.M. Radio • Amplifiers • Black and White TV • Color TV

**R. F. SIGNAL GENERATOR:** Provides complete coverage for A.M. and F.M. alignment. Generates Radio Frequencies from 100 Kilocycles to 60 Megacycles on fundamentals and from 60 Megacycles to 180 Megacycles on powerful harmonics. • **VARIABLE AUDIO FREQUENCY GENERATOR:** In addition to a fixed 400 cycle sine wave audio, the Genometer provides a variable 300 cycle to 20,000 cycle peaked wave audio signal.

• **BAR GENERATOR:** Projects an actual Bar Pattern on any TV Receiver Screen. Pattern will consist of 4 to 16 horizontal bars or 7 to 20 vertical bars. • **CROSS HATCH GENERATOR:** Genometer will project a cross-hatch pattern on any TV picture tube. The pattern will consist of non-shifting horizontal and vertical lines interlaced to provide a stable cross-hatch effect. • **DOT PATTERN GENERATOR (FOR COLOR TV):** The Dot Pattern projected on any color TV Receiver tube by the Model TV-50 will enable you to adjust for proper color convergence. • **MARKER GENERATOR:** The following markers are provided: 189 Kc., 262.5 Kc., 456 Kc., 600 Kc., 1000 Kc., 1400 Kc., 1600 Kc., 2000 Kc., 2500 Kc., 3579 Kc., 4.5 Mc., 5 Mc., 10.7 Mc., (3579 Kc. is the color burst frequency.)

MODEL TV-50 comes absolutely complete with shielded leads and operating instructions.

**\$47.50**  
NET

**SHIPPED ON APPROVAL**  
**NO MONEY WITH ORDER — NO C. O. D.**

MOSS ELECTRONIC DISTRIBUTING CO., INC.  
Dept. D-295, 3849 Tenth Ave., New York 34, N. Y.

Please send me the units checked. I agree to pay down payment within 10 days and to pay the monthly balance as shown. It is understood there will be no finance or interest charges added. It is further understood that should I fail to make payment when due, the full unpaid balance shall become immediately due and payable.

- Model TC-55..... Total Price \$26.95  
\$6.95 within 10 days. Balance \$5.00  
monthly for 4 months.
- Model TV-12..... Total Price \$72.50  
\$22.50 within 10 days. Balance \$10.00  
monthly for 5 months.
- Model TV-60..... Total Price \$52.50  
\$12.50 within 10 days. Balance \$8.00  
monthly for 5 months.
- Model TV-11..... Total Price \$47.50  
\$11.50 within 10 days. Balance \$6.00  
monthly for 6 months.
- Model TV-40..... Total Price \$15.85  
\$3.85 within 10 days. Balance \$4.00  
monthly for 3 months.
- Model TV-50..... Total Price \$47.50  
\$11.50 within 10 days. Balance \$6.00  
monthly for 6 months.
- Model 670-A..... Total Price \$28.40  
\$7.40 within 10 days. Balance \$3.50  
monthly for 6 months.
- Model 770-A..... Total Price \$15.85  
\$3.85 within 10 days. Balance \$4.00  
monthly for 3 months.

Name .....

Address .....

City ..... Zone ..... State .....

All prices net, F.O.B., N.Y.C.

We invite you to try before you buy any of the models described on this and the preceding page. If after a 10 day trial you are completely satisfied and decide to keep the Tester, you need send us only the down payment and agree to pay the balance due at the monthly indicated rate.

**NO INTEREST**  
**OR FINANCE**  
**CHARGES ADDED!**

If not completely satisfied, you are privileged to return the Tester to us, cancelling any further obligation.

**SEE OTHER SIDE!**

◀ Cut out and mail TODAY!

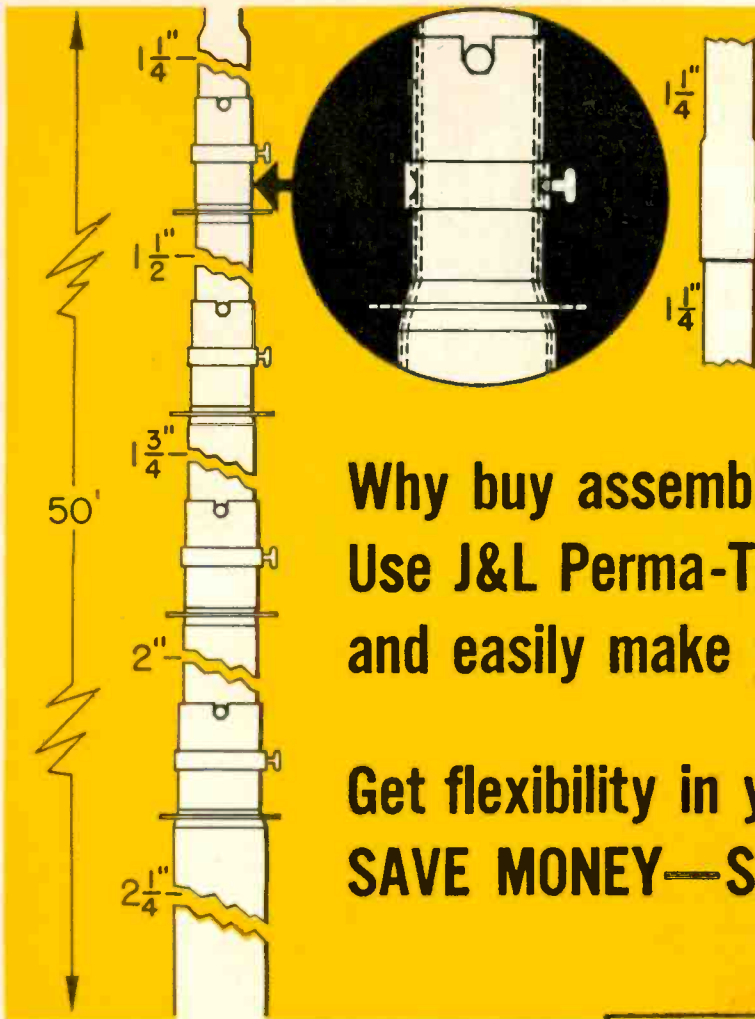

Same 1 1/4-inch piece of Perma-Tube can be used for telescoping masts or with another 1 1/4-inch piece to make smaller 2-piece masts.

**Why buy assembled telescoping masts?  
Use J&L Perma-Tube in 10-foot lengths  
and easily make your own**

**Get flexibility in your stock  
SAVE MONEY—SAVE SPACE**

### Only J&L Perma-Tube offers:

- Joint design which provides instant field assembly.
- Machine-fitted joints that insure close tolerance for high strength and rigidity.
- Guy wire ring position that eliminates all binding and guy wire interference.

Buy only a carton each of five different sizes of Perma-Tube (1 1/4 to 2 1/4-inch) and make any telescoping TV mast up to 50 feet in height. Hardware—cotter keys or bolts, clamps and guy rings—may also be secured from your distributor.

You can now "tailor-make" your own TV masts up to 50 feet high by using standard 10-foot lengths of 16-gage Perma-Tube—and save money. Five diameters are available in easily-handled cartons from your local distributor. Largest base section OD is 2 1/4 inches and each telescoping section is 1/4-inch smaller, the smallest section having an OD of 1 1/4 inches.

Corrosion-resistant Perma-Tube is treated with Vinsynite—then coated both inside and outside with a metallic vinyl resin base. It's made of a special, high-strength, J&L steel tubing. A 10-foot section of 1 1/4 inch diameter by 16 gage is capable of supporting a weight at its center point of 200 pounds with a minimum of deflection and permanent set.

**J&L Perma-Tube — best for strength and rust protection**

**Jones & Laughlin**  
STEEL CORPORATION · PITTSBURGH



THOUSANDS OF SERVICE DEALERS

SATISFY CUSTOMERS  
SAVE REPEAT CALLS

# MAKE MONEY EVERY DAY with B&K



## DYNA-QUIK MODEL 500 DYNAMIC MUTUAL CONDUCTANCE TUBE TESTER

### Tests over 95%

OF ALL POPULAR TV TUBES\*—IN SECONDS

It's easy and profitable to check all the tubes in a TV set with DYNA-QUIK—on every service call. Cuts servicing time. Creates more on-the-spot tube sales. Saves repeat calls, protects service guarantee.

DYNA-QUIK 500 measures true dynamic mutual conductance, completely checks tubes with laboratory accuracy under actual operating conditions right in the home.

Tests each tube for shorts, grid emission, gas content, leakage, dynamic mutual conductance and life expectancy. One switch tests everything. No roll charts. No multiple switching. Makes complete tube test in as little as 12 seconds. Large 4½-inch plastic meter shows tube condition on "Good-Bad" scale or in micromhos on scales calibrated 0-6,000 and 0-18,000. Used in home or shop, DYNA-QUIK is a proved money-maker!

\*Including new 600 mil series tubes.

NET \$109<sup>95</sup>

Dyna-Quik 500. Easily portable in luggage-style carrying case. Size: 15¼ x 14¼ x 5½ in. Weighs only 12 lbs. Has 7-pin and 9-pin straighteners on panel.

DELUXE—PORTABLE

## CRT MODEL 400

Tests and repairs  
TV Picture Tubes



NET \$54<sup>95</sup>

Deluxe CRT 400. With 4½-in. plastic meter. Weighs only 5 lbs. Luggage style carrying case. Size: 11 x 7½ x 5".

Also available in economy model CRT 200 with 3-in. meter at \$39.95 net.

Quickly spots and corrects picture tube troubles right in the home, without removing tube from set. Restores emission, stops leakage, repairs interelement shorts and open circuits. Life test checks gas content and predicts remaining useful life. Grid cut-off reading indicates picture quality customer can expect. Eliminates tube transportation, cuts service-operating costs. Also saves money on TV set trade-in reconditioning. Earns dollars in minutes—pays for itself over and over again.

Proved In Use by Servicemen Everywhere.

See your B & K Distributor or send for facts on "Profitable TV Servicing In the Home" and Informative Bulletins 500-104-T



B & K MANUFACTURING CO.  
3726 N. Southport Ave. • Chicago 13, Illinois

LINE UP WITH "LINE-OUT" THE HOTTEST TV ACCESSORY OF THE YEAR

# FOR THE FIRST TIME



A Co-Channel Filter that eliminates "Venetian Blinds"

# JERROLD LINE-OUT<sup>®</sup>

PAT. PENDING

The Jerrold Line-Out is a revolutionary co-channel filter that electronically "erases" TV co-channel "Venetian Blinds".

Its principle of operation is new—but simple. A thirty db filter in the Jerrold Line-Out unit removes the co-channel beat frequency caused by an offset carrier of another TV station on the same channel, thus eliminating "Venetian Blinds" from the TV screen. Two models are available. Model V10 is designed for use when the carriers of the co-channel stations are offset by 10KC. Model V20 is designed for 20KC offset carriers. The Jerrold Line-Out is not effective if the co-channel interference is so strong that it produces sync instability or picture sliding.

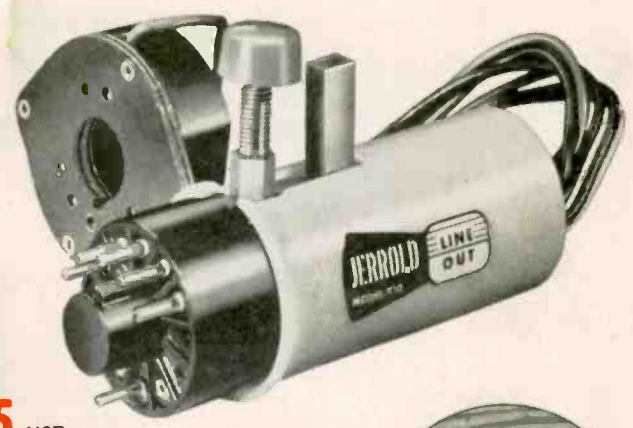

15.95 LIST

The Jerrold Line-Out can be installed in a matter of minutes. No wires to cut—no soldering necessary. Simply remove the plug on kinescope, insert the Line-Out in series and plug back in. Adjust tuner on Line-Out to eliminate "Venetian Blinds"—set it and forget it. The Jerrold Line-Out does not affect reception of any stations when co-channel interference is not present.

*The Line-Out is typical of Jerrold's continuing research program to improve TV reception in fringe areas.*

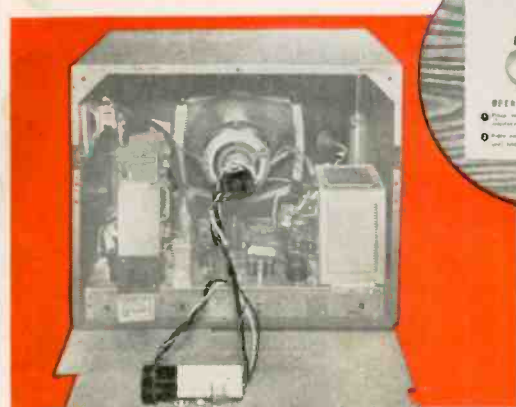

See Your Jerrold Distributor Today.

**JERROLD** ELECTRONICS CORPORATION / 2218 Chestnut Street Philadelphia 3, Penna.

## New RCA WR-46A Video Dot/Crosshatch Generator.

Produces stable, sharp patterns at high-level video output for convergence adjustments.

Saves installation time; enables more precise convergence adjustments.



Magnified view shows sharply defined Dot pattern produced by WR-46A on typical picture tube.

PRICE...  
\$179.50\*

- high-level video output permits direct connection to grid or cathode circuits of color picture tubes—eliminates pattern distortion which may be caused when generator signals are fed through rf, if, or vf channels—results in clean, extremely sharp pattern display
- permits simultaneous display of pattern with broadcast picture in background to assure that convergence adjustments are made at correct horizontal and vertical scanning rates
- switch-selection of four types of patterns is provided: "V" bars for vertical dynamic tilt and amplitude convergence adjustments; "H" bars for horizontal dynamic phase and amplitude convergence; Crosshatch for simultaneous check of "V" and "H" convergence adjustments; Dots for center-screen static-convergence adjustments and for "touching up" dynamic convergence
- has Brightness Equalizer Control for "V" and "H" elements in crosshatch pattern
- vertical sync is frequency-divided from horizontal sync, resulting in interlaced scanning and exceptional freedom from "jitter", "crawl", and "sync-hunting"
- light weight • portable.

# Simplify, Speed-up Color TV Servicing!

## RCA WR-61B Color-Bar Generator.

Provides crystal-controlled signal source for trouble-shooting, and adjusting color-phasing and matrixing circuits.

WR-61B simplifies the usually complex measurement of the relative gains of the 3 chrominance channels (R-Y, B-Y, G-Y). With the WR-61B the relative gains of these channels can be measured at the output of each demodulator stage. This simplified method of measuring gain is possible because the subcarrier output of the generator is constant for all color-phase angles. Curve A shows WR-61B output as it would appear on a 'scope. Curve B shows the output signal of one of the demodulators.

Outstanding features of WR-61B: generates signals for producing 10 different color-bars simultaneously—including bars corresponding to R-Y, B-Y, G-Y, I, and Q, signals

- excellent signal source for localizing trouble ahead of or following the 2nd detector
- accepted as a standard for checking accuracy of color-phasing in many TV stations and network operations
- light weight • portable.

\*User price (optional)

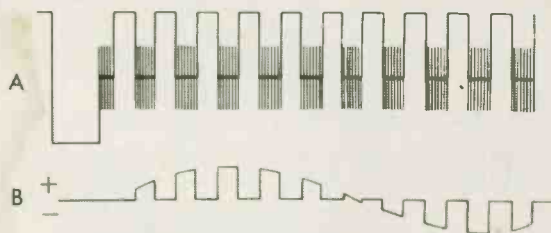

PRICE...  
\$247.50\*

RCA TEST INSTRUMENTS ARE AVAILABLE THROUGH YOUR RCA DISTRIBUTOR.



## TEST EQUIPMENT

RADIO CORPORATION OF AMERICA, HARRISON, N. J.





## The Equation that Shook the World!

A hasty scrawl on a scrap of paper ushered in the Atomic Age. Through this equation, Dr. Albert Einstein revealed to mankind the awesome secret of atomic fission, with all of its tremendous power for good or evil.

This is the kind of a world we live in . . . a world where knowledge is power in a truer sense than ever before. It is an exciting world.

Univac® has added a new dimension to the world of science, processing data with a speed that crowds many lifetimes of research into a few hours.

Squarely in the midst of this exciting world are the engineers and scientists of Remington Rand Univac. Their potential for growth and achievement (and the rewards that go with them) is unlimited. *You can be one of them.*



® Registered in U. S. Patent Office

### Immediate Openings for:

**ELECTRONIC DESIGN ENGINEERS** — Must have degree and be experienced in pulse circuitry, digital computers, or data processing equipment.

**ELECTRO-MECHANICAL DESIGN ENGINEERS** — Should have bachelor's degree in Engineering. However, extensive mechanical design background may substitute for some college. Men selected will do basic preliminary design and layout of small mechanisms. Requires original ideas and application of logical analysis to design problems.

Send complete resumé to:

## **Remington Rand Univac**

DIVISION OF SPERRY RAND CORPORATION  
at any one of these four plant locations

D. A. BOWDOIN  
Dept. PS 25  
2300 W. Allegheny Ave.  
Philadelphia, Pa.

FRANK KING  
Dept. NS 25  
Wilson Avenue  
South Norwalk, Conn.

J. WOODBURY  
Dept. SS 25  
1902 W. Minnehaha Ave.  
St. Paul W4, Minn.

CAL BOSIN  
Dept. YS 25  
315 Fourth Ave.  
New York City



with **UTICA®**  
**"Cushion Throat" Pliers**

Here's a simple and effective way to control cut ends of wire—keep them from flying or falling into a chassis.

The UTICA® "Cushion Throat" is a tough, rubbery red plastisol coating bonded right beside the cutting edge of UTICA® pliers. As the pliers close, the cushion grips the short end of wire and holds it tightly.

The "Cushion Throat" is specially valuable in electronics work—makes it possible to cut inside chassis without danger of wire snips causing a short. Grips spring or hard wire, too—gives extra safety on every cutting job!

Order from your distributor, today!

Only \$1 list additional—applied to most UTICA diagonal or side-cutting pliers.

Exclusive UTICA Patent.



**U T I C A**

THE HALLMARK OF QUALITY  
 UTICA DROP FORGE & TOOL CORP.  
 UTICA 4, N. Y.

UTICA (when referring to hand tools) is a trade mark registered in the U. S. Patent Office.

# LETTERS

## To the Editor

### Jobber Trade-In Gyp

Editor, **TECHNICIAN**:

Sometime ago I wrote to the \_\_\_\_\_ Company (name withheld, not a **TECHNICIAN** advertiser), asking for a trade-in price on my signal generator toward a new Precision E200C. In their reply, they stated that if it was in good condition, they would allow me \$22.50. This was acceptable to me, so I checked over every part and solder joint until I was sure it was in tip-top shape on all bands. It was well packed and forward to the \_\_\_\_\_ Company. Later I received a letter from said company saying they find the unit in need of considerable repairs to make it saleable because a wire was broken off the filter condenser and the r-f attenuator did not work in the second position. They went on to say the minimum repair charges would be \$7.50. Knowing this to be untrue, I told them to return the unit.

After receiving the unit, I checked and saw that the wire was deliberately broken off the filter condenser by moving the condenser up and down. They wore a groove in the condenser's outer cardboard container as it rubbed against a protruding chassis screw. To disable the step attenuator, they deliberately bent the contacts of the second position so the slider arm would miss the contacts. Anybody with no experience would have seen these defects were deliberately produced. They had put in these defects to back up their claims. In other words, all they intended to offer me in the first place was \$15; the \$22.50 was just a come-on. Had they offered me \$15 in the first place and not been dishonest, I would have accepted it. This raw deal has cost me express charges both ways, plus replacing the parts they broke. If my experience can prevent other **TECHNICIAN** readers from being taken in as I was, my blunder would be well worth it.

JOSEPH N. PICARDI

Joe's TV & Radio Service  
 McKeesport, Pa.

• We're shocked! If other readers having similar experiences will contact us, we'll try to take corrective action.—Ed.

### Raps NATESA Bill

Editor, **TECHNICIAN**:

NATESA of Houston, which we read is forming a licensing bill, is not the only association here. We have over 2000 members, with offices in seven states and England. Their bill is an attempt to grab power, but price fixing is still illegal. Our bill will be fair to all, and the State of Texas has granted us a charter to form a board of trade to maintain standards in our field.

ROBERT RUSSEL, Pres.

Electronic Technicians Association  
 Houston, Texas

### Screwy Service Charges

Editor, **TECHNICIAN**:

I am at a loss to understand the service charges you present (May 1956 issue, p. 37) unless most shops are operating at a loss. While you report the national average for a basic house call charge as \$3.93, other such surveys I have seen indicated that most shops making house calls for less than \$5 were either losing money or just barely getting by—which might be true! Of course, the "basic charge" figure may be deceptive. Some shops in this area use \$3 as basic for minor adjustments without removing the back of the set. Actual service will run \$4 to \$5. Could it be that a majority of the shops you contacted are selling more tubes than are needed—or are padding their tube prices? For our last 50 house calls at our regular \$4.50 service charge, the total average was \$7.12, which is 7¢ less than your lowest area with a basic charge of \$3.30. There's something screwy here somewhere!

G. J. HORNADY

Quality TV Service  
 High Point, N.C.

### Lost Gold Mine

Editor, **TECHNICIAN**:

Can you imagine the sickening feeling I experienced when I finally came upon my misplaced March issue of **TECHNICIAN**? I have waited a long time for a single source of valuable literature, and now I may have let a gold mine slip through my fingers by not sending the request card in.

MARION R. DELFERT

St. Louis, Mo.

• The early bird gets the proverbial worm! But in every issue new products and bulletins are described, and you can get these in the coming months simply by writing to us.—Ed.

### Mail TV Service

Editor, **TECHNICIAN**:

Someone should be able to make a nice profit by mail answering requests for troubleshooting information if the symptoms, chassis number and the like are given. It usually takes weeks to get a reply from the set manufacturer, and sometimes your request is ignored.

HAROLD B. HEPNER

Delaware, Ohio

### Readers Are Writers

Editor, **TECHNICIAN**:

Is it your policy to accept articles written by your readers? Your acceptance of a "Tough Dog" story not too long ago prompted me to follow this idea through.

ALFRED CONSIGLIO

Bronx, N.Y.

• You bet! Best idea is to submit a detailed outline before going ahead with the complete manuscript. Authors earn recognition through byline credit, plus cash payment. For reader-authors, solid technical know-how is more important than writing experience.—Ed.

**ATTENTION ALL SERVICE DEALERS!**

Beginning September 1st at your Philco Distributor

# **SKY'S THE LIMIT** for **PRIZES** and **PROFITS** with **PHILCO** **PARTS AND ACCESSORIES**



Your choice of . . . 600 valuable prizes . . . Philco parts . . . accessories . . . test equipment . . . all-expense-paid vacation trips. Yours **FREE** with purchase of Philco receiving tubes, parts and accessories during this exciting event. Merely register at your Philco Distributor. He'll give you a "Flight Log" in which your prize points will be recorded. Each time you purchase Philco receiving tubes, parts or accessories, he'll enter the points earned by those purchases in this book. You'll be amazed how quickly your points will accumulate . . . and how many prizes you'll earn. Get started today. Concentrate your purchases on Philco and profit two ways.

**NOW FOR THE FIRST TIME...**

For black and white or color TV...an instrument that pinpoints chassis or picture tube trouble *without removing either unit from cabinet*

## **PHILCO *Service King***

Now, at last, a multi-purpose, portable instrument that simplifies service and saves you time and money. Completely eliminates the task of removing chassis or picture tube from the cabinet for trouble shooting. Also permits checking new CR tubes without removal from original cartons. In addition, the new Philco "Service King" is unmatched for features.

*Tests both color and black and white picture tubes and receivers • Rejuvenates picture tubes • Clears picture shorts • Aids in setting up color purity, white balance and matrix circuits • Measures DC voltage, anode voltage and resistance • The Philco "Service King" is available now at your Philco Distributor •*



**PHILCO CORPORATION ACCESSORY DIVISION**

PHILADELPHIA 34, PENNSYLVANIA

This combination of **CDR ROTORS**  
and the **Biggest TV Spot Campaign**  
in our history

**PRE-SELLING** your customers

opens the door

for you to



**CORNELL-DUBILIER**  
SOUTH PLAINFIELD, N. J.



**THE RADIART CORP.**  
CLEVELAND 13, OHIO



There's more in store  
for you...when you feature  
**CDR ROTORS**

Proven the popular favorite  
the complete line...  
a model for every need!

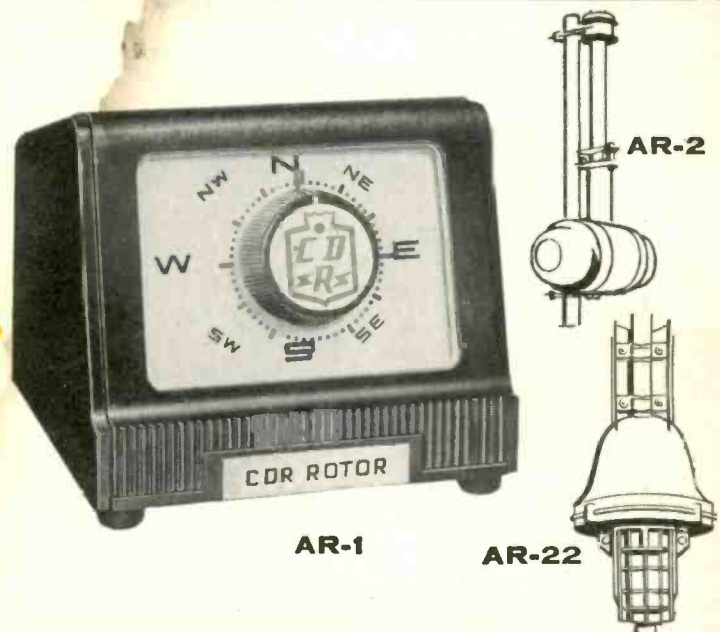

featuring

**CDR AUTOMATIC Rotors**

An outstanding group of rotors... three proven and tested models... ALL 40% SHARPER TUNING than ANY other automatic rotor. Handsome cabinet... dependable performance... proven and tested by thousands and thousands of satisfied users.



- TR-12** a special combination value consisting of complete rotor, including thrust bearing. Handsome new modern cabinet with meter control dial, uses 4 wire cable.
- TR-11** same as TR-12 without thrust bearing.
- TR-4** the heavy duty rotor complete with handsome modern cabinet with METER control dial, uses 4 wire cable.
- TR-2** the heavy duty rotor with plastic cabinet featuring "compass control" illuminated perfect pattern dial, uses 8 wire cable.



**CORNELL-DUBILIER** South Plainfield, N. J.



The **RADIART** Corporation, Cleveland 13, Ohio

**WIDE**

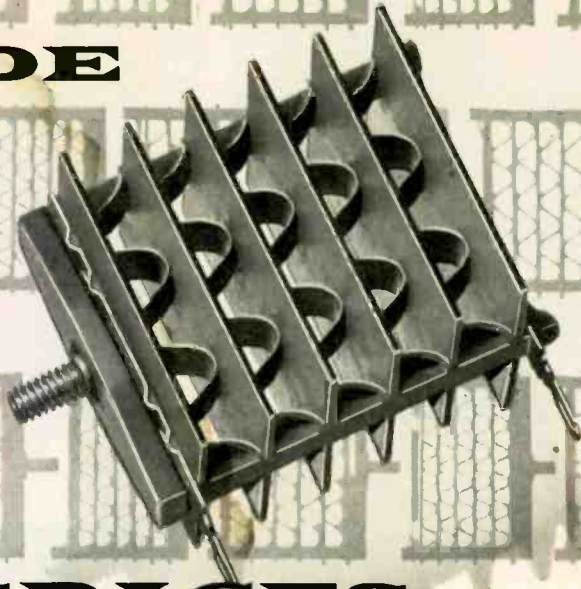

**OPEN**

**SPACES**

**keep operating temperatures down—dependability up!**

RCA SELENIUM RECTIFIERS utilize modern design—*full surface ventilation* with no chance of center-core hot-spots. Note the corrugated spring-steel separators which provide positive multiple-area contacts with each plate. This open construction facilitates free-flow of air and efficient cooling of the plates, and minimizes the possibilities of overheated components in compact TV, radio, and phonograph designs.

The one-piece assembly-yoke with the molded mounting stud prevents *twisting* or *squeezing* the stack during installation. Rigid construction minimizes the possibility of "barrier" breakdowns—*gives greater assurance of dependability in operation.*

So, when you need a replacement selenium rectifier, ask your distributor for a dependable, long life RCA SELENIUM RECTIFIER. Available now in 12 types, ratings from 65 Ma to 500 Ma.



## SELENIUM RECTIFIERS

Radio Corporation of America • Harrison, N. J.

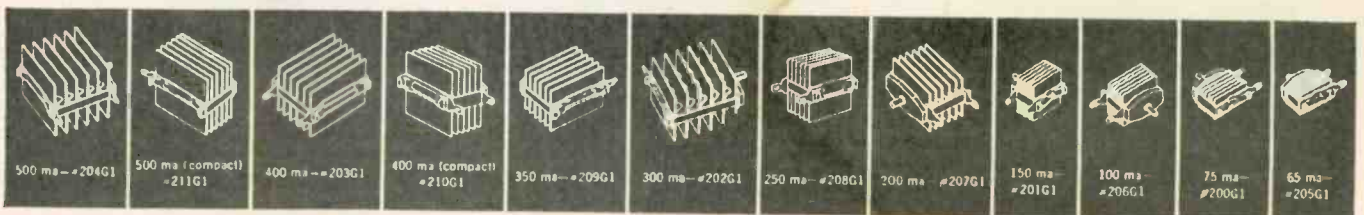

Another *Snyder* Antenn-engineered Original  
PHILADELPHIA

# ATTIC TORQUE-TENNA<sup>®</sup>

with exclusive interceptor discs

An INDOOR ANTENNA  
with OUTDOOR  
EFFICIENCY

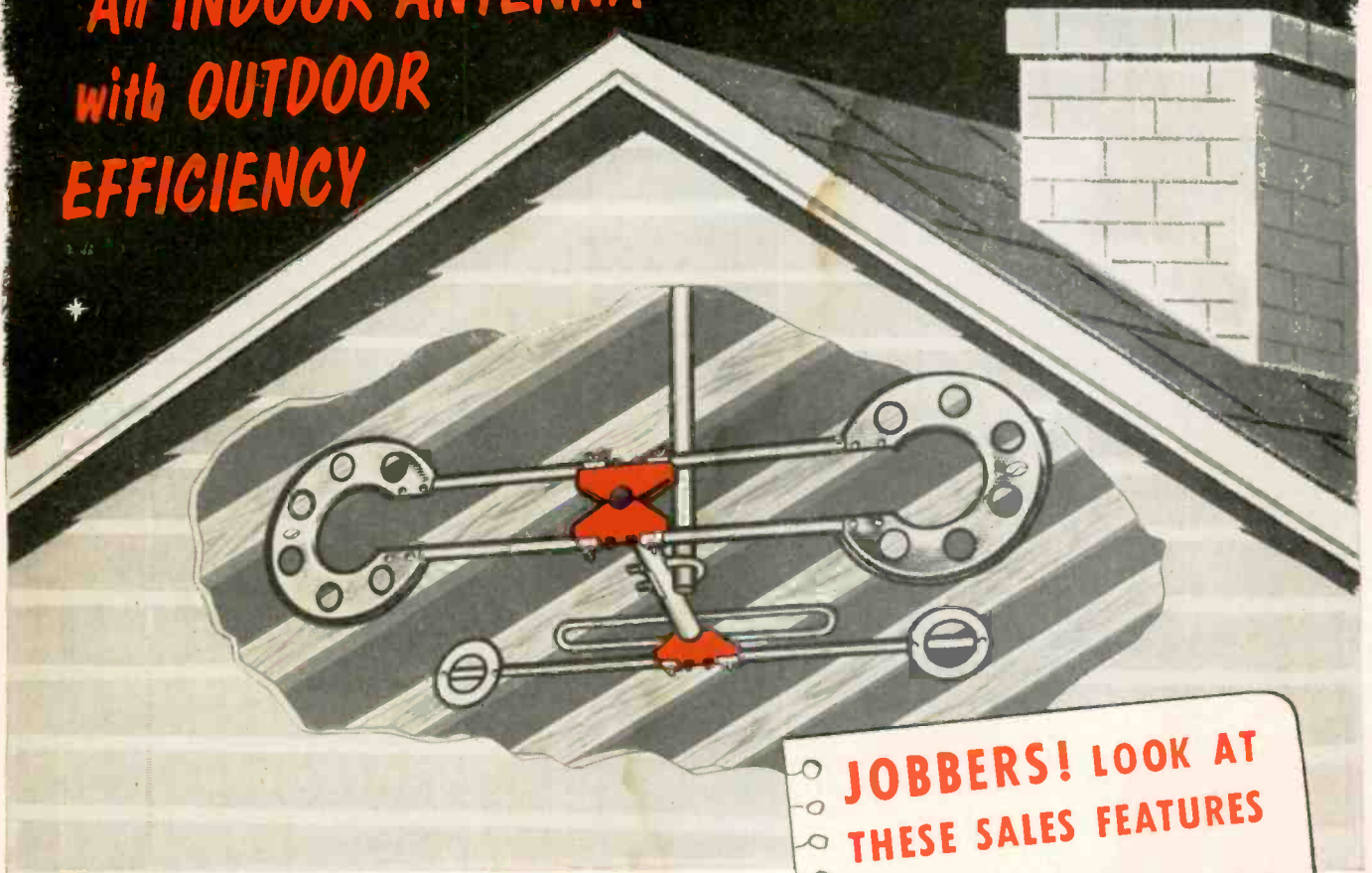

**AX-100A** COMPLETE KIT **\$995**  
Nothing Else to Buy

1 MAST SECTION; 3 WALL STANDOFF INSULATORS  
35' TWIN-X CABLE; 1 ADJUSTABLE MOUNTING BASE

**ATTENTION TECHNICIANS!**

1st time in electronic history a  $\frac{1}{2}$  wave length resonant antenna with only a  $\frac{1}{4}$  wave length physical dimension.

**JOBBERS! LOOK AT THESE SALES FEATURES**

- ✓ Makes every building contractor a market for built-in antennas
- ✓ Opens a big replacement market
- ✓ Offers an exclusive "hideaway" installation
- ✓ Handles easily because of light weight and small size
- ✓ Recommended for METROPOLITAN and SUBURBAN areas within 20 miles of television stations

# SNYDER

**MANUFACTURING CO.**  
PHILADELPHIA • LOS ANGELES • TORONTO

... another  
**MALLORY**  
service-engineered  
product



the leading  
**BATTERY**  
**LINE**  
for miniature  
transistor radios

Mallory Mercury Batteries are your best bet for the big new market offered by new "pocket-size" transistor portable radios—

**First in performance.** Mallory pioneered the mercury battery—the powerful, long-life power source that helped make these new radios possible.

**First in value.** Mallory Mercury Batteries cost less per hour of operation. They're fast-moving, good profit-makers for you . . . good value for your customers, too!



**SPECIAL INTRODUCTORY  
BATTERY MERCHANDISER**

Because of the remarkable shelf life of Mallory Mercury Batteries, now for the first time you can stock batteries without fear of inventory loss. This introductory assortment covers all popular transistor portables. No extra charge for the display unit! Order yours today!

P. R. MALLORY & CO. Inc.  
**MALLORY**

P. R. MALLORY & CO. Inc., INDIANAPOLIS 6, INDIANA

- Capacitors
- Vibrators
- Resistors
- Power Supplies
- Controls
- Switches
- Rectifiers
- Filters
- Mercury Batteries

**News of the Industry**

**LITTELFUSE**, which is expanding its plant 50%, has promoted **WALTER CLEMENTS** to jobber sales manager, and **ANDY KALATA** to customer service manager.

**ASTRON** highlighted reliability theme in WESCON display.

**BENJAMIN H. BALLARD** is the new sales manager of consumer products for **NATIONAL CO.**

**FERRODYNAMICS CORP.**, Lodi, N.J., has recently been formed and set up a plant to make magnetic recording tape. President is **FREDERICK I. KANTOR**, vp **O. LOUIS SEDA**.

**ERIE RESISTOR** has appointed **FRED RICH** factory sales rep in New York.

**FEDERAL TELEPHONE & RADIO** has purchased certain assets of a subsidiary of **ELECTRONICS SPECIALTY CO.**, including a scope and instrument line.

**JOHN RIDER PUBLISHER** has named **JACK GILBERT ASSOCIATES** to handle advertising.

**AUDIOGERSH** has moved to larger quarters at 514 Broadway, New York 12, N.Y.

**CORNELL-DUBILIER** has presented **ALLIED RADIO** with a plaque for handling firm's line without interruption for 35 years.

**CBS-HYTRON** has appointed **DR. HANG C. LIN** as senior engineer in charge of Semiconductor Applications Lab.

**SYLVANIA** appointments are **JOHN N. McCAUL**, supervisor of sales service engineering for electronic products; **JOHN POMEROY**, S. Calif. district manager for distributor sales; **JEROME R. STEEN**, semiconductor quality manager. Firm has opened a 87,000 sq. ft. warehouse and office at 6505 E. Gayhart St., Los Angeles.

**GENERAL ELECTRIC** has opened a new district office for tubes and components at 3 Penn Center Plaza, Room 925, Phila., under **FLOYD S. ANDERSON**, and one at 1208 Bank of Lansing Bldg., Lansing, Mich., under **JOHN E. McELFRESH**.

**ALLIANCE MFG.** has leased, with option to buy, 81,000 sq. ft. in three buildings, formerly occupied by **McKaskey Register**. Firm plans to spend \$50,000 in remodeling.

**National Television Week**  
Sept. 23-29



**L. J. BATTAGLIA** has been named marketing manager of the newly formed **RCA Components Div.**

**MARK SIMPSON MFG.** has appointed **WARREN DEMOTTE** ad manager and director of sales promotion. Promotions include **MURRAY TROTINER** to distributor parts sales manager, with **ARTHUR CALLAHAN** as asst.; **SAMUEL BERMAN** to vp; **IRVING KELMAN** to treasurer.

**AMPHENOL** has purchased **Exact Metal Specialties Co.**, a screw machine firm.

**SNYDER MFG.** appointments are **MILTON SCHINDLER** promoted to director of West Coast sales, and **ROBERT COHEN** named to field sales executive staff. Pres. **BEN SNYDER** announced new experimental sales plan where field sales officials work in each other's markets to produce fresh viewpoints.

**TRIAD TRANSFORMER** has opened third plant of 16,000 sq. ft., bringing total area to 70,000 sq. ft.

**Check Them Guns, Pardner**



Dead or alive, old soldering guns and irons are checked into Weller's "Old Gun Round-Up" for a \$2 reward (trade-in allowance, that is) on a new 200-275 watt dual-heat gun.

**CBS-COLUMBIA** has discontinued making radio and TV sets.

**MARTY BETTAN** has resigned from **CHANNEL MASTER**, where he covered New York City & Westchester sales, and became national sales manager for **ALL CHANNEL**.

**UTRAD CORP.** has been formed to continue transformer production of **UTAH RADIO PRODUCTS**. Latter firm has retained **HENRY P. GLASS ASSOC.** to design line of speaker baffles.

**JENSEN MFG.** has published first of four "Rep Reporters" to acquaint reps with 1956-57 program.

(Continued on page 28)

...another  
**MALLORY**  
service-engineered  
product

to prevent  
"middle age hum"



use capacitors with . . .

# Etched Cathode

**Etched Cathode** construction

is standard in *all* Mallory FP's, and in popular Mallory metal and cardboard tubular electrolytics . . . *at no extra cost!*

Your Mallory distributor can tell you why this *extra* performance feature is important to you and to your customers.



P. R. MALLORY & CO. Inc., INDIANAPOLIS 6, INDIANA

- Capacitors
- Vibrators
- Resistors
- Power Supplies
- Mercury Batteries
- Controls
- Switches
- Rectifiers
- Filters

# NEW!

## CATCHES ALL LEAKY CAPACITORS

**IN-CIRCUIT**  
... CHECKS  
ALL COUPLING  
CAPACITORS  
FOR  
LEAKAGE

**OUT-OF-CIRCUIT**  
... CHECKS  
ALL CAPACITORS  
FOR LEAKAGE  
AND  
CAPACITANCE

# Simpson

MODEL 383A

## CAPACOHMETER

**IN-CIRCUIT**

CAPACITOR LEAKAGE TESTER



Here is the first *complete* "testing package" for all paper, mica, and ceramic capacitors. With this *one* instrument—the Simpson Capacohmeter—you can: (1) detect most borderline capacitors *in-circuit* by means of the exclusive Simpson *Pulse Test*; (2) measure leakage of defective capacitors, including coupling capacitors, in ohms; (3) determine the capacitance directly, of good capacitors, from 10.0 uuf to 10.0 uf.

With *this* instrument, most tests can be made *in-circuit*. All tests are made under load conditions. There is no fussing with bridge circuits and balancing controls. Readings are indicated on a large 4½" meter with better than 10% accuracy. But that's not all. You can use the Simpson Capacohmeter to test for leaky wiring, sockets, and transformers . . . to measure distributed capacitance of wiring to ground . . . to "high-pot" good components . . . and many other tests which you will discover.

Model 383A with leads and Operator's Manual . . . **\$89<sup>95</sup>**

See your Jobber, or Write

**SIMPSON ELECTRIC COMPANY**

5200 W. Kinzie St., Chicago 44, Illinois  
Phone: ESTebrook 9-1121

In Canada: Bach-Simpson Ltd., London, Ontario

WORLD'S LARGEST MANUFACTURER OF ELECTRONIC TEST EQUIPMENT



this is



# ... the new remote control TV tuner by **ALLIANCE**



Retail  
Price  
**\$19<sup>95</sup>**

**Switches Stations,  
tunes each channel!**



**A New, Fast-Selling Package  
Item that All TV Viewers Want!**

**3 minute installation by customer**

Every viewer a prospect.

A natural companion to the Alliance Tenna-Rotor . . . at a price that's right!

**Performs a double service—switches stations and tunes each channel!**

Needs no tools or wire—safe!—no need to touch back of TV set. Fits nearly all popular makes. Comes with 90-day guarantee.

Backed by the same kind of potent TV advertising and intensive merchandising which made Alliance Tenna-Rotor the No. 1 TV accessory.



Handsome, compact display carton shows "IT" in non-breakable black plastic with gold trim.

Write the Factory

**THE ALLIANCE MANUFACTURING CO., INC.**

(Division of Consolidated Electronics Industries Corp.)

**ALLIANCE, OHIO**



OH! MISTER . . .  
WONDERFUL!

new, exciting

**WARD**  
*Silveramic*

®

**CHROME  
FIBERGLAS**

**AUTO AERIAL**

**THE MOST AMAZING NEW DEVELOPMENT IN THE AUTO AERIAL INDUSTRY**

WARD again leads the way with another new product. A Fiberglas auto aerial with a chrome finish — LOOKS like chrome, FEELS like chrome, SOUNDS like chrome and has all the revolutionary characteristics of fiberglas. Proved resistant to chemicals and water.

This finish is not a surface paint, but an exclusive method developed only by Ward.

**SILVERAMIC PASSED THESE THREE SEVERE TESTS:**

1. 30 DAYS EXPOSURE to sea water, gasoline, acids, alkalis, toluene and ethyl alcohol.
2. 3000 HOURS of salt spray at 98° F. This is equivalent to over 20 YEARS OF DRIVING.
3. IMPACT RESISTANT to 160 inch-pounds.

**Model TGF-1 CHROME**

38" long—54" lead cable. Famous "8-Ball" mounting. Individual shipping weight: 1 lb. List price: \$5.95.

**also—Dura-ramic  
IN FULL COLOR!**

Six complementary colors to mix or match—with the same flexible, indestructible fiberglas features.

**YELLOW • RED • BLUE •  
GREEN • TAN • WHITE**

**WARD**

**PRODUCTS CORPORATION  
DIVISION OF THE GABRIEL CO.**

1148 EUCLID AVE. • CLEVELAND 15, OHIO

FOR ADVANCED-  
ENGINEERED

# VR tubes

IT'S



Have you and your customers exacting requirements for stable voltage? Try the reliabilized CBS 6626 and 6627. There are no better VR tubes made. They represent the most advanced engineering concepts in gaseous voltage-regulator tubes. They eliminate sudden discrete voltage shifts in voltage-reference circuits.

It's only natural that CBS VR tubes should be the finest. CBS specializes in VR tubes . . . has made over 20 millions of them. CBS has originated many VR types; for example, the OB2, USN-OA2WA, USN-OB2WA, 6830, 6831 . . . as well as the 6626 and 6627. CBS offers the widest line of 105-volt and 150-volt VR tubes: commercial and military . . . miniature and GT . . . for voltage regulation and voltage reference.

It makes good sense to think of CBS when you think of VR tubes. Be sure of up-to-the-minute design and tightly controlled quality. Follow the leaders, specify the leader. For stable, reliable, advanced-engineered VR tubes . . . always make it CBS.

Seen the new CBS VR Tube Manual? A complete, informative, easy-to-read eight pages. Includes data, theory, and application on voltage regulation and voltage reference. Write for free Bulletin E-267 today.



CBS-HYTRON, Danvers, Massachusetts

A Division of  
Columbia Broadcasting System, Inc.

## News of the Industry

(Continued from page 23)

HUGO SUNDBERG, vp of **OXFORD ELECTRIC**, has been elected chairman of the RETMA Speaker Section.

**THOMAS ELECTRONICS** has appointed HENRY SCHMALZ chief engineer.

**HARMAN-KARDON** has acquired an additional plant.

**DU MONT LABS.** has added MAJ. GEN. RAYMOND C. MAUDE to assist in directing armed services program, and JOSEPH P. GORDON as asst. director of tube research.

**UNITED CATALOG** has appointed J. WAYNE CARGILE Midwest district manager.

**PHILCO** has launched a second campaign to further unseat the multimillion dollar racket in television and radio receiving tubes.

### Believe It or Not!

*The following news release received by TECHNICIAN is printed word for word in its entirety. Since the claims made leave the editors breathless, no further editorial comment is made.—Ed.*

Ordinarily, when the TV set goes on the blink, the owner will call in a service man or hasten to the local tube dealer with a bag full of tubes among which he hopes will be the defective one.

However, by using the TROUBLE SHOOTER, Mr. Set Owner becomes his own trouble shooter. By turning the dial to the difficulty encountered, the slide rule index pin-points the tube or tubes that may need replacing. He removes the tubes has them tested and replaces them and his set is working like new again. So saving himself the cost of a service call, or the bother of pulling every tube in the set just to find the defective one. Replacing the tube is as easy as replacing a light bulb. The usual technical knowledge has been so simplified that anyone can do his own trouble shooting quickly and easily without any previous electronic knowledge or wading through a book.

The TV TUBE TROUBLE SHOOTER retails at \$1.00. It is distributed by Maple Enterprises, Box 42, Dept. 31, Hillside, N. J.

National Television Week  
Sept. 23-29

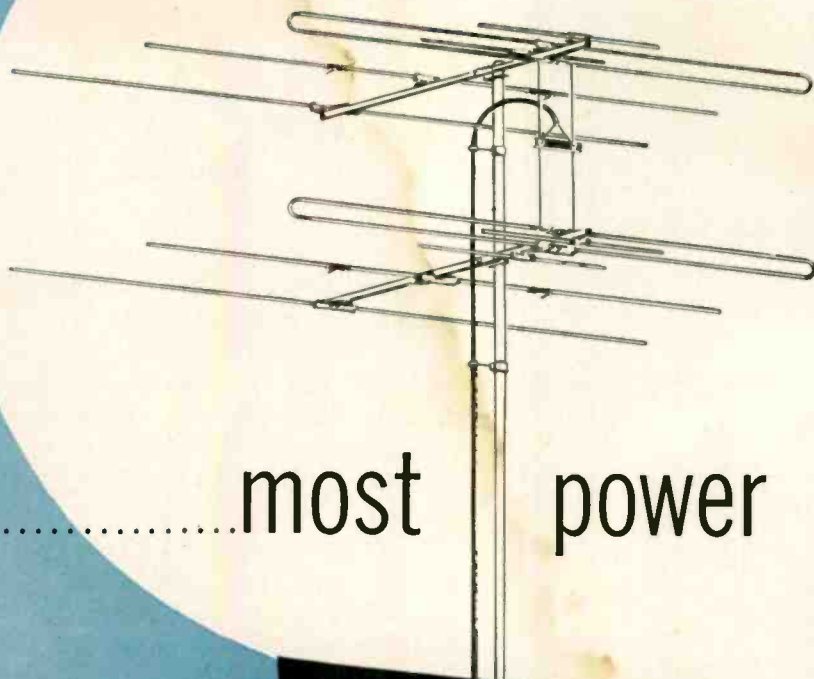

.....most power

**AMPHENOL**

**POWERAY**

PATENT PENDING

for better fringe area reception . . .

AMPHENOL's Poweray is not just another VHF antenna. It's a totally new design, engineered for fringe and deep-fringe area reception. Poweray's sleeve dipole principle assures *power*—the high gain needed to pull in signals miles away. Gain, directivity and impedance match are all precision balanced for distortion-free tv pictures. AMPHENOL has built other selling features into the Poweray: pre-assembly for easy put-up, aluminum rust-free construction, tight spring-locks on the elements.

On your next fringe area installation, use Poweray. Discover for yourself why Poweray is so outstanding!

AMPHENOL ELECTRONICS CORPORATION  
chicago 50, illinois

**AMPHENOL**



*If your goal is profits . . .*

## **STOCK AND DISPLAY RCA RADIO BATTERIES ALL YEAR**

Portables, once as seasonal as football, are now becoming as all-year-'round as the calendar. And when portables play, batteries get right into the game!

Join the varsity sales team. Check your stock. Signal your RCA Distributor for the pay-dirt numbers—the types that build-up the sales yardage fast. Then kickoff for a season of winning sales performance with a powerful line-up of RCA Batteries. And, with RCA's hard-hitting promotional material and national advertising supporting your efforts, you're sure to roll up a winning score in sales and profits with RCA Batteries.



## **RADIO BATTERIES**

RADIO CORPORATION OF AMERICA • CAMDEN, N. J.



# BEST FOR COLOR TEST!

*Another Hycon  
test help...*



**MODEL 622 5" SCOPE**  
with automatic triggered sweep, first really new scope development in years. Fewer adjustments, no sync problems.

There's just one way to test the new color TV sets... WITH NTSC COLOR PATTERN. That's what Hycon's Model 616 Color Bar/Dot Generator offers... a! standard colors, sequences and patterns easily selected and graphically shown in actual color right on the control panel. For color TV, get ready... GET HYCON!

*"Where Accuracy Counts"*  
**Hycon ELECTRONICS, INC.**  
A Subsidiary of Hycon Mfg. Company  
321 SOUTH ARROYO PARKWAY  
PASADENA, CALIFORNIA

**MAIL,**  
please,  
for Catalogs  
616 and 622

HYCON ELECTRONICS, INC. Dept. T-9  
P.O. Box 749 Pasadena, California  
Please send me the new model 616 and 622 catalogs..

Name \_\_\_\_\_  
Address \_\_\_\_\_  
City \_\_\_\_\_ State \_\_\_\_\_

## Reps & Distributors

ASTATIC CORP. has appointed two new reps: PASTON-HUNTER in upper New York, DOUGHERTY ENTERPRISES in Hawaii.

STANDARD COIL has named SCHEEL INTERNATIONAL of Chicago as export sales rep.

SYLVANIA's new tube distributor in Kentucky is STANDARD DISTRIBUTORS, Owensboro.

PYRAMID ELECTRIC rep appointees are EDWIN A. SCHULZ CO. of Indianapolis, and JACK F. MCKINNEY SALES CO. of Dallas.

RMS EXPORT SALES representation in Canada goes to SOL BUDD & ASSOC., Toronto

D. R. BITAN CO., New York rep, will move to 104 South Central Ave., Valley Stream, Long Island, N. Y., on Oct. 1, 1956 after 20 years at the same address. New phone is Locust 1-2444-5-6-7-8.

ASTRON has appointed three new reps for their capacitor-filter lines: SAMUEL N. STROUM CO. of Seattle for Wash. and Ore.; Sid Lohmann of Detroit for Mich.; and FRANK W. TAYLOR CO. of DeWitt for upstate N. Y.

SIMPSON ELECTRIC has named the Milwaukee rep firm of E. A. DICKINSON & ASSOC. to cover Wisconsin.

SENTINEL RADIO, now a wholly-owned subsidiary of MAGNAVOX, has signed up its first new distributor, LAPPIN ELECTRIC of Milwaukee.

HI-LO TV ANTENNA will have SAM LEVINE of Elkins Park, Pa., rep territory of Southern N. J., Eastern Pa., Del., Md., and D. C.

THOMPSON PRODUCTS has announced the appointment of the WILLIAM CONNORS CO. of Denver to the rep territory of Mont., Idaho, Wyo., Utah, Colo., N. M. and Western Neb.

RADIO ELECTRIC SERVICE CO.'s Allentown, Pa., store is moving to larger quarters located at 1313-19 Linden St.

TRIPLETT ELECTRIC has appointed four new sales reps: GEORGE PETTIT CO. of River Forest, Ill., to cover distributors in Chicago and NE Ill.; AL QUACKENBUSH of Chicago for distributors in Eastern Wis., Eastern Iowa and NW Ill.; KNOBLOCK & MALONE of Chicago for industrials in E. Wis., N. Ill. and E. Iowa; and LEN FINKLER of Port Credit, Ont., for Quebec, N.B., N.S., Prince Edward Island, Newfoundland, and most of Ontario.

(Continued on page 67)





**TOPLINER '40** \*

Cat. No. 2540. 3 working elements on low band.  
9 working elements on high band.



**TOPLINER '60** \*

Cat. No. 2560. 6 working elements on low band.  
13 working elements on high band.



**TOPLINER '50** \*

Cat. No. 2550. 5 working elements on low band.  
10 working elements on high band.



**TOPLINER '70** \*

Cat. No. 2570. 8 working elements on low band.  
19 working elements on high band.

# Topliner Trade-mark antennas

# TOP 'EM ALL!

Taco again introduces an original antenna design, engineered for results. The Topliner represents better performance than any other antenna now on the market. And, best of all, you get this extra performance at no increase in cost.



FEATURING THE EXCLUSIVE



**TOPS** IN GAIN PER DOLLAR!  
**TOPS** IN DEPENDABILITY PER DOLLAR!  
**TOPS** IN DIRECTIVITY PER DOLLAR!

## TACO TOP LINE FOR '57

TECHNICAL APPLIANCE CORPORATION, SHERBURNE, N. Y.  
IN CANADA: Heckbusch Electronics, Ltd., Toronto 4, Ont.

\* Pat. Pending

FOR THOSE WHO RECOGNIZE QUALITY

# TRIO'S 1957

## ZEPHYR ANTENNAS

**FOR DISTANCE**  
**ZEPHYR MITE**  
THE POWER PACKED PAIR

**FOR EXTREME DISTANCE**  
**Zephyr**  
THE POWER PACKED THREESOME

**FOR THE MAXIMUM**  
**ZEPHYR ROYAL**  
THE POWER PACKED FOURSOME

featuring the

**WING**  
DIPOLE

DOUBLE TRANSPOSITION  
PHASING

STAGGER TUNING

REJECTOR PHASING

**WING**  
DIRECTOR



COPYRIGHT 1956 TRIO MFG. CO.

EXPORT SALES DIV., SOH EL INTERNATIONAL INC., 4937 N. Lincoln Ave., Chicago, U.S.A. Cable Address: PA354HEEL

# HOTPOINT ENTERS THE TV FIELD

... in a *BIG* way!

Hotpoint, one of the biggest names in Appliances, is now in TV.

With 129 of the nation's best distributors, huge production and spectacular advertising, Hotpoint TV will be among the top ten by Christmas.

You'll see a lot of Hotpoint TV in days to come. You'll need to know about these sets, and Hotpoint announces this program to make that information easy-to-get.

## HOTPOINT TV INFORMATION AND HELPS FOR SERVICEMEN

**Hotpoint TV Distributors** are your **service contacts**. They're anxious to help you every way they can. They want your friendship.

**Service manuals** and supplementary TV service notes are available from your Hotpoint Distributor.

**Service training schools** will be held for you and your servicemen by the distributor.

**Factory specialists** will maintain daily contact with distributors. This factory-distributor relationship offers you a factory answer to any problem, usually immediately.

**Genuine parts** will be available from your Hotpoint TV Distributor.

### GET ACQUAINTED NOW!

Send the coupon at right to us and we will pass it along to the Hotpoint TV Distributor in your area. He will contact you and provide you with all the information you will need. There is no obligation, this is simply a good-will service by Hotpoint for TV servicemen. Send now!

# Hotpoint

HOTPOINT CO., (A Division of General Electric Co.)  
Chicago, Illinois

Hotpoint Co., TV Service Dept.  
227 S. Seeley, Chicago 12, Ill.

I'll need Hotpoint TV service information, so please have the distributor in my area contact me.

Name \_\_\_\_\_

Firm \_\_\_\_\_

Street Address \_\_\_\_\_

City \_\_\_\_\_ State \_\_\_\_\_

# MILLIONS of lead-ins need replacing now!

Get your share  
of the profits  
WITH

## Federal's "ALL-STAR" LEAD-IN TEAM

### TV SERVICEMEN:

- Check your installation records
- Call or circularize customers
- Sell better picture reception
- Replace with Federal Lead-in

The U. S. has approximately 38,000,000 TV sets in operation today. Millions of these sets—*installed years ago*—require lead-in replacement. These millions of weather-beaten, inefficient lead-ins are a golden opportunity for increased sales. Literally tens of millions of feet of wire are begging to be replaced . . . !

Federal's "All-Star" lead-ins are outstanding examples of the quality-control, ruggedness and dependability built into every foot of Federal cable. Whatever the run requirements or the local conditions, there's a Federal type to give TV customers a new high in performance . . . *give you extra profits!*

Get your share of the big lead-in replacement market . . . with Federal's "All-Star" Lead in Team . . . "Certified by a World of Research" . . . through the International Telephone and Telegraph Corporation.

"America's leading producer of  
solid dielectric cable"

# Federal



A DIVISION OF



### High Volume-Low Price TV Lead-in

TV-1190

**Economical and Efficient**  
TV-1190—300-ohm heavy-duty lead-in with 90 mil. web. Has 7/#28 copper strands. Economical and highly efficient. Insulated with Federal-developed "silver" polyethylene for long life. Also available in brown.

TV-2000

**Another Low-cost Leader**  
TV-2000—300-ohm dumbbell-shaped lead-in with 55 mil. web. Has 7/#30 copper strands. A high-value, low-cost type for the average installation. Cinnamon-brown color is protection against ultra-violet.

### "Quality-Controlled" TV Lead-in & Cable

TV-1182

**Heavy-duty Type**  
TV-1182—300-ohm deluxe type heavy-duty long life lead-in with 7/#28 copper strands, 100 mil. web. Available in "silver" or brown polyethylene. Resists weather, heat, sun. Very low line loss in fringe areas.

TV-1184

**Quality plus Economy**  
TV-1184—300-ohm dumbbell-shaped, standard, economy type lead-in with 7/#28 copper strands, 70 mil. web, for urban areas with no unusual conditions. Cinnamon-brown color is highly effective in resisting ultra-violet.

TV-1188

**Rotor Lead-in**  
TV-1188—Rugged, dependable, long-life rotor lead-in. Weather-resistant. Insulated with "silver" vinyl. Three 7-strand conductors of .0121 AWG soft bare and one conductor of .0121 AWG tinned soft bare.

### Community TV Lead-in

59/U  
Type

**Secondary Lead-in**  
59/U Type—73-ohm coaxial lead-in. Highly efficient as a Community TV pole-to-house tap-off. Meets all needs wherever a high-grade installation is a must. Ideal for use with unbalanced input TV receivers.

For data on other types, write Dept. D-454A

### Federal Telephone and Radio Company

A Division of INTERNATIONAL TELEPHONE AND TELEGRAPH CORPORATION  
COMPONENTS DIVISION • 100 KINGSLAND ROAD • CLIFTON, N. J.

In Canada: Standard Telephones and Cables Mfg. Co. (Canada) Ltd., Montreal, P. Q.  
Export Distributors: International Standard Electric Corp., 67 Broad St., New York

# TECHNICIAN

## & Circuit Digests

CALDWELL-CLEMENTS CO., 480 LEXINGTON AVENUE, NEW YORK 17, N. Y.

## TV Antenna Sales: Boost Your Business \$2,000 to \$8,000

If you've had the harrowing experience of installing an antenna on a slippery, wind-blown roof in the dead of winter, no doubt you've also had the ironic feeling that the job would have been a push-over if it had only come along before the weather turned bad. What you may not have realized is that you were probably responsible in part because you didn't promote antenna sales months earlier.

As if menace to life and limb weren't bad enough, failure to push antenna jobs often robs a shop of an added \$2000 to \$8000 in annual business. For those techs operating on very slim profit margins, missing the extra dollar volume may conceivably hurt more than the physical hazard.

A surprisingly large percentage of existing antenna installations (estimates run from 25% to 50%) should be repaired or replaced. These are the systems which have either deteriorated through exposure to wind, snow and airborne corrosives, or have been made obsolete by new technical advances which offer much superior reception both in indoor and outdoor antennas.

### Computing Business Gain

Now let's do a little simple arithmetic to see how much extra income you can gain by a properly planned program of antenna sales. Take a small shop that makes 25 calls per week. Experience indicates that a solid sales approach can sell 5% to 10% of these calls on new installations they didn't recognize were needed, but about which they'll be pleased as punch once the improved reception is seen.

A mere 5% or 10% of calls over and above regular antenna sales may not seem like much, but just tote up the extra dollars involved. For the 25-call-per-week shop it means an average of 1.25 to 2.5 more antenna jobs. Multiply this by 50 weeks and the national average of \$32.60 per job and you get a gross income boost of about \$2000 to \$4000 per year. That's for the small shop and the fellow with ordinary sales ability. For larger shops making more calls, or for the tech who has the velvet sales touch, this income-plus should run \$8000, and even higher.

### Sales Techniques

The sales methods employed in garnering that extra \$2000 to \$8000 are quite straightforward and simple to use.

1. Keep your antenna installation service in the public eye. This may include: window streamers, counter displays, direct mail cards, calling cards and ads. Some antenna manufacturers supply much of the material required for this phase of the promotion.

2. Keep alert to worn antennas that are reducing picture quality, and be ready to make the installation without delay. Not only does this mean stocking some antennas, but carrying them in your truck along with allied accessories.

3. Keep an eye on the future. Most of the hundreds of thousands of customers planning to buy color sets now view black-and-white. A worn or poorly designed antenna can cause what seems like an insignificant reduction in monochrome picture quality; this same imperfection would be intolerable in color.

4. Keep a "dramatic demonstrator" on hand if possible. This might take the form of a quickly rigged antenna system for showing reception improvement, "before and after" photos, or any of a thousand sales clinchers.

5. Be prepared to discuss new design's better performance, corrosion, storms, etc.

### The Big Kickoff

September is the start of the fall selling season, a kind of business New Year, and a whopping big one it's slated to be. Color TV programs every night, the elections, a continued boom in audio, TV set sales shooting past the 7,000,000/year mark, radio sales climbing beyond 14,000,000 . . . all contributing to a service volume well over \$2 billion annually. Servicing competition will be keen—and why shouldn't it? There's a nice piece of cash in it this coming year for the fellow who'll hop on his bicycle and go after it!

# Tuning In the

**PROBLEMS PLAGUING TV SERVICE** were aired last month in informal meeting between top TV trade magazine editors and New York State's consumer counsel, Dr. Persia Campbell. Could be possible prelude to licensing legislation. Five key problems cited: 1. Consumers do not understand that set warranty covers only parts, not labor. Set makers have tried to make this clear, but who reads the fine print? 2. How does consumer obtain services of reliable technician? Manufacturers state they require their distributors and dealers to provide service or recommend someone. But how can this be administered? 3. Among legitimate consumer complaints, how many are due to technical incompetence, how many to dishonesty? Is it widespread, and could legislation cure it? 4. Obtaining certain parts, particularly special mechanical assemblies, can be difficult. Delays arouse customer's ire. 5. Consumer confusion over prices. Poll of women's clubs showed they thought \$3 was a fair TV service charge. Other problems included low technician incomes, cut-price competition, equipment complexity, etc.

## GI's TALK THROUGH THEIR HATS



Cpl. Harry Mikus reports back to his squad through tiny combat radio built into his helmet. Mike slips under helmet when not in use. Rugged FM radio (inset) developed by Signal Corps weighs 1 lb., uses transistors, has 1 mi. range with auxiliary antenna atop helmet. Without this antenna, it is preset for short range to prevent enemy interception. U. S. Army photo.



**FOUR-POINT PROGRAM** proposed by **TECHNICIAN** editor for New York State action to attack servicing ills covered: 1. Stricter policing of bait ads. 2. Give quasi-official recognition to service associations to support self-policing and strengthen them to attract more good members. 3. Through educational system, expand technical training program to upgrade technicians. 4. Inform public of realistic cost of TV service, skill and equipment required, etc.

**RADIOFABRIKANTFORENINGEN** is sponsoring a radio and television exhibition in Copenhagen as we go to press. The tongue-twisting title stands for "Radio Manufacturers Association"—and we bet there will be few among you fellows who'd deign to try to pronounce it.

**INADEQUATE STOCKS OF PARTS**, inattention to small orders and attempts to "load" dealers with tubes and components are some of the reasons why dealers in many small and more or less isolated cities have switched wholesalers and brands. The pressure to switch has come from service managers and technicians. One large New England merchant recently dropped a fast-selling TV make he'd handled for years because of the "lousy" service by a distributor some 75 miles away.

**TECHNICIANS AND SERVICE OUTFITS** handling those coin-operated TV (and radio) sets in motels, tourist cabins and the like should suggest the use of explanatory signs in such lodging places, since the coin boxes are nearly always hidden from sight at the rear of the sets. A **TECHNICIAN** editor on a field trip ran into a beefing tourist who claimed that the TV sets "didn't work in three of the places." Asked if he'd "fed" the meter, the tourist looked bewildered, and finally said "no." Signs would bring in more revenue and cause fewer nuisance service calls.

# Picture .....



**ARE YOU HEP TO CAPACITOR INFO?** Do you know how one works? The materials used? The color code for temperature coefficient? The meaning of power factor? Just dig the real cool special feature in this issue, "Let's Look at Capacitors." It's the end!

**WATCH THAT ROOF-CLIMBING EXPEDITION!** Accidental falls are only surpassed by motor vehicle accidents as a killer. Last year 19,800 persons in the U. S. were killed, and 450,000 industrial workers temporarily or permanently disabled by falls. For a copy of the booklet, "Falls Aren't Funny," and a brochure listing anti-fall campaign materials, write the National Safety Council, 425 N. Michigan Ave., Chicago 11, Ill.

**"AUDIOPAGE" MINIATURE RECEIVER** weighs one ounce and is smaller than a cigarette lighter. Made by Philco to list at \$79.50, the unit operates on the magnetic induction principle in a field set up by a wire loop around the area. No FCC license is required. It is expected to find application where paging is needed, but general public address system is not desirable.

**HOW LONG AGO** were commercial TV receivers on the market? Ten years? Fifteen years? Guess again. Twenty-five years ago in the Oct. 1931 issue of **RADIO RETAILING**, edited by Dr. O. H. Caldwell, some 30 models of scanners and receivers made by seven companies were listed. Prices ranged from \$37.50 for a scanner kit to \$475 for a complete deluxe system with 2 ft. sq. projected picture. The standard was 60 lines, 20 frames. The whirling discs produced direct view pictures as large as 7 in. sq.

## CALENDAR OF COMING EVENTS

- Sept. 11-12: Second RETMA sponsored Conference on "Reliable Electrical Connections," Philadelphia, Pa.
- Sept. 14-16: NATESA TV-Radio-Electronic Service Industry Convention, Sheraton Hotel, Chicago, Ill.
- Sept. 17-21: Instrument Society of America's 11th Annual Instrument-Automation Conference and Exhibit, New York City Coliseum.
- Sept. 24-25: Fifth Annual Industrial Electronics Symposium, Hotel Manager, Cleveland, Ohio.
- Sept. 26-30: High Fidelity Show, New York Trade Show Building, New York City, N. Y.
- Oct. 1-3: National Electronics Conference and Exhibition, Hotel Sherman, Chicago, Ill.
- Oct. 1-3: Canadian IRE Convention and Exposition, Automotive Building, Exhibition Park, Toronto, Canada.
- Nov. 2-5: High Fidelity Show, Palmer House, Chicago, Ill.
- Dec. 5-7: Second IRE Instrumentation Conference, Biltmore Hotel, Atlanta, Georgia.
- Dec. 10-12: Eastern Joint Computer Conference, Hotel New Yorker, New York, N. Y.

**NATIONAL TELEVISION WEEK, Sept. 23-29**, carries the slogan: "Celebrating the finest home entertainment in sight." TV manufacturer, broadcaster, dealer and advertising associations (RETMA, NARTB, NARDA and TBA) are the joint sponsors. Promotional material is being made available to dealers. Should be a fine sales booster.

**WITH THE SEPTEMBER PICK-UP** in business right ahead, look for TV sets to sell at a more rapid pace than during August, but when the year winds up, TV unit sales are likely to be 3 to 4 percent behind last year's volume; dollar volume will be down also. Radios, Hi-Fi and phonos promise to run quite far ahead of last year's figures.

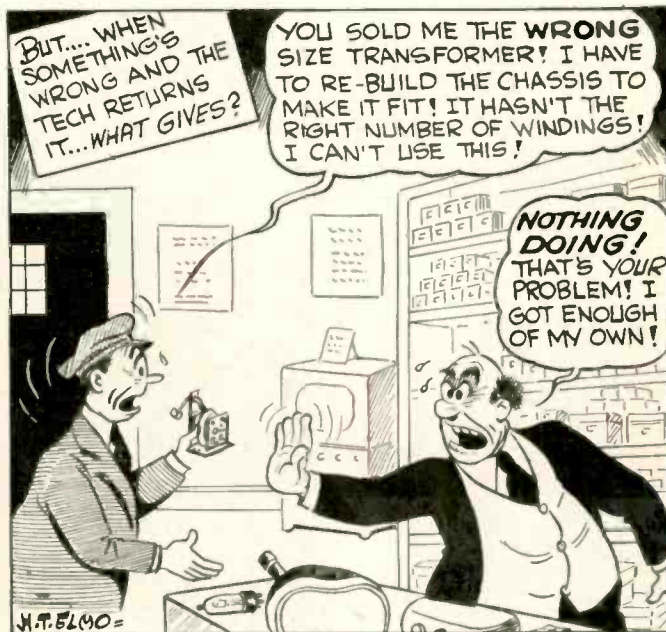
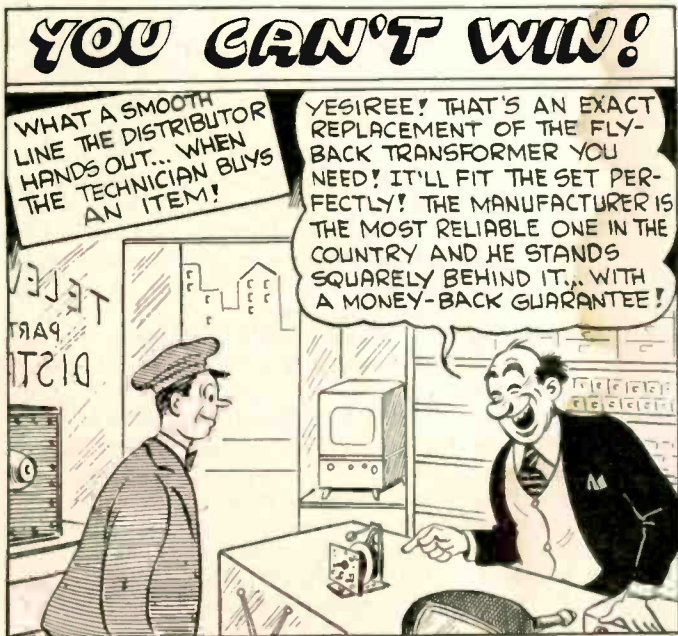

# \$ in Election PA Work

Start the Ball Rolling Now to Cash in on the Coming Campaign

A. R. CLAWSON

• More sound equipment than ever before will be sold, serviced and rented for use in the forthcoming political activity. Don't wait to make plans—your peak load will be during the last two weeks.

Contact local political leaders now to try to schedule your sound rentals with a minimum of conflict. If conflicts can't be avoided, you can assemble and offer for use substitute sound systems, which will be described. Get the names of independent factions. In states where the campaign money that one political party may spend is limited by law, the smaller groups can be important sources of revenue. Though they may be set up by the regular parties under such banners as "Independent Citizens for Jones," their lack of overt affiliation with the established parties makes it possible for them to spend funds beyond the limit prescribed by law for the parent body.

Some of the less obvious campaign activities could be used as a sales or rental argument for tape recorders, especially the miniature ones. The various parties often make it a point to send observers to meetings, speeches and conferences of opposing factions. The accounts these people bring back are often insufficiently accurate or complete to be of value. A tape recorder will keep an accurate record of remarks

by opponents as well as by the observer. Political clubs also give many social affairs, especially near election time. Each shindig is a chance to sell or rent tape recorders, PA amplifiers, speakers, phonograph equipment, microphones and an endless list of accessories.

## Auxiliary Auto Systems

Now is the time to repair those left-behind "dogs" whether they be phonographs, portable radios or nearly anything else. On election eve itself, radios can be rented out to the general public as well as to the politically minded. In addition, phonographs, tape recorders and even radios can be used as temporary sound systems, with little modification, to solve double- and triple-date problems.

Almost all political functions play the national anthem and some popular music—the latter as "bait" for the speeches. Phonographs are generally used for this purpose, but why not get extra mileage by recording this material on reels of tape to go along with recorder rentals?

Speeches may be handled on phonograph or tape-recorder amplifiers after a temporary modification permitting use of a high-impedance, high-output microphone. A single-pole double-throw switch can bring the microphone into the circuit in place of the phono pickup or playback head, as Fig. 1 illustrates. The common arm of the switch connects to the "hot" lead disconnected from the pickup or head. Use a shielded cable to extend this lead, as well as the one going to the head from the switch.

## Microphone Setup

For best results use a uni-directional type of microphone to minimize the problem of acoustic feedback. If a low-impedance pickup or playback head is used in the equipment, either a low-impedance mike or a high-impedance mike with a matching transformer can be used. If the microphone shows any appreciable pickup from its rear, tape a

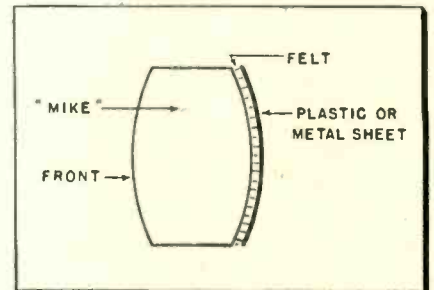

Fig. 2—Felt and plastic liner on the rear cover of the microphone cuts down feedback.

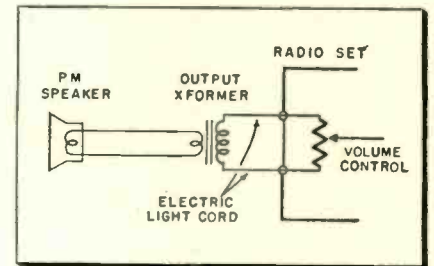

Fig. 3—Small PM speaker and output transformer make mike input for radio-set PA.

piece of plastic to its back cover, as shown in Fig. 2, and line it with felt. This is a precaution against acoustic feedback during use.

Ordinarily, the speaker that comes with the piece of equipment that is being used will be removed and mounted in a separate baffle box. In this way, its rear can also be shielded to reduce feedback. A felt-lined plastic back similar to the one described for the microphone may be used on an ordinary speaker housing with like results. To get broader coverage, two permanent-magnet speakers may be hooked up with their voice coils in series without serious loss of quality or volume in most cases.

Where small gatherings are involved, a little ingenuity will turn a radio into a suitable PA system. Simply use a small permanent-magnet speaker as the microphone. It will be essentially uni-directional, as desired, especially if it is enclosed in a small box. Connect the two sides of one end of a suitable length of ordinary line cord to its terminals. The two sides of the line

(Continued on page 66)

Fig. 1—Adapting phono or recorder for PA. If cable from pickup or head terminates in jack, plug-in mike can be used instead of switch.

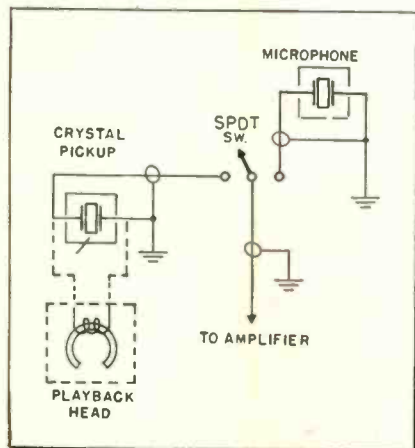





• All capacitors (condensers) are made up of two conductors, close to each other but not touching. The space between them is filled by some insulating medium, known as a dielectric. This medium may be air, mica, glass, ceramic, paper, plastic, or any other non-conductor. The symbol used for a capacitor is shown in Fig. 1A, with a very simple air-dielectric example in Fig. 1B.

In the latter, a battery is connected to the capacitor so that each battery terminal goes to one of the conductors or plates. When the switch is closed, electrons flow from the negative terminal of the battery on to plate 1, placing a negative charge on that plate. Since like charges repel each other but opposite charges attract, free electrons on plate 2 are driven into the wire leading back to the positive terminal of the battery.

This action, which constitutes a current flow in a completed circuit, is only momentary. As soon as the plates are charged to the battery output voltage, flow ceases. The capacitor, now fully charged, prevents further current flow and thus fails to complete the circuit. Except for the brief period of charge, then, a capacitor blocks dc.

If the switch is now opened, the capacitor will hold its charge, acting like a one-cell battery, until a conductive path is provided, as by the shorting of a wire across the plates. Such shorting action will permit the oppositely charged plates to neutralize each other quickly, and the capacitor will be discharged.

If we substitute an ac generator for the battery shown in Fig. 1B, the capacitor will alternately charge

and discharge in step with the reversal of the ac voltage. In effect, the capacitor will continue to complete the circuit, and appear to pass ac without blocking. However, this will only hold true if the ability of the capacitor to charge and discharge given quantities of electrons (its capacitance) is properly matched to the voltage and frequency of the ac source.

### How Capacitance Is Determined

The capacitance of any given unit is principally determined by three factors: The size of the plates, the distance between them, and a property of the insulating material between them known as its dielectric constant. Where the plates are made larger or the space between them is decreased, capacitance is increased. Smaller plates and wider spacing decrease capacitance.

Air has a dielectric constant of 1, and based upon this value, the constants for other materials are derived. The dielectric constant of glass, for example, is about 7.5. This means that, if we were to insert a sheet of glass between the plates of the unit shown in Fig. 1B in place of air, the quantity of charge the unit could take, or its capacitance, would be increased about 7.5 times.

The formula for calculating capacitance of a given unit is

$$C = 0.224 \frac{KA}{d} (n-1)$$

where  $C$  is capacitance in  $\mu\text{f}$ ,  $K$  is the dielectric constant,  $A$  is the area of one side of one plate (the smaller, if they are of unequal area) in square inches,  $d$  is the separation between plate surfaces in inches, and  $n$  is the number of plates.

### Capacitors in Parallel and Series Connection

If three capacitors of the same size are wired together in parallel (Fig. 2A), they act as though they were a single capacitor with the plate area (and consequently the capacitance) increased threefold. When we connect capacitors in this way, then, capacity of the combination increases, and we can determine total capacitance simply by adding the values of the individual units together.

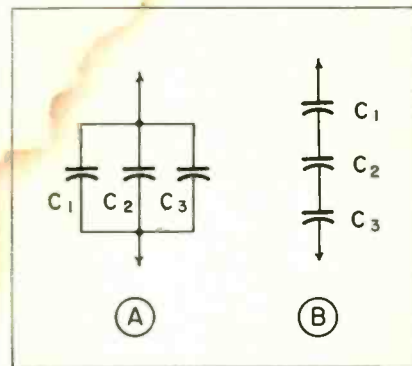

Fig. 2—Capacitors in parallel and series.

If we were to connect the same three capacitors in series (Fig. 2B), there would be no such effective increase in plate size. However, as we go from one unit to another, the spacing factor ( $d$ ) would increase. Multiplying  $d$  in the formula by 3, we would find that the combined capacitance would decrease to  $1/3$  that of a single capacitor. We determine total series capacitance by adding the reciprocals of the value of each unit and dividing this total into 1. The procedure is described in the following formula:

$$C_{(total)} = \frac{1}{\frac{1}{C_1} + \frac{1}{C_2} + \frac{1}{C_3}}$$

It has been said that capacitors can block or impede the flow of dc but permit the flow of ac. In practice, the larger a capacitor is, the less it will tend to impede ac. There are differences in the tendency of a capacitor to impede ac depending on the frequency of the ac voltage. Zero frequency ac may be considered dc. In this case, the impeding or blocking by a good capacitor is essentially complete. As we go up in frequency, blocking becomes less effective and passage of alternating current becomes easier.

This tendency to impede, or impedance, is known as capacitive reactance in the case of a capacitor. It differs from resistance (another form of impedance) in that resistance, measured in ohms, remains the same for all frequencies. Capacitive reactance, also measured in ohms, decreases as the ac frequency increases, according to the following formula:

$$X_c = \frac{1}{2\pi f C}$$

Fig. 1—Capacitor symbol and basic structure.

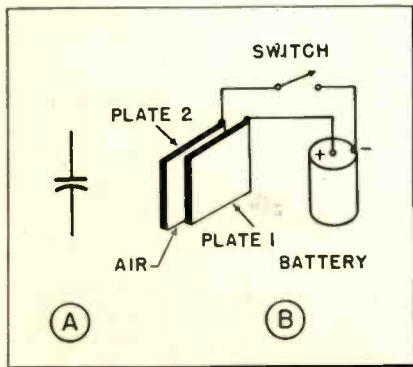

**ASTRON** *"Staminized"*  
**CAPACITORS ARE**

**rugged**

ASTRON CAPACITORS HAVE THAT BUILT-IN "NO-CALL-BACK" CONSTRUCTION!



Only the very finest of raw materials pass Astron's "Selected Purchasing System". Astron's special production techniques build extra rugged capacitors that create complete customer satisfaction . . . your key to repeat business and more profit.

You can put your trust in Astron, for behind each Astron capacitor is the meticulous quality control that insures you of real staying power . . . over 10 separate production line tests are performed, plus a 100% final inspection before any capacitor is sent out by Astron . . . your guarantee of top performance.

There is an Astron "Staminized" Capacitor built especially to fill the specific, exacting replacement requirements of any job you tackle.



Safety Margin  
"SM"™ Minimite\*



Safety Margin  
"SM"™ Twist Prong



Safety Margin  
"SM"™ Cardboard Tubular



Blue-Point (R) Molded  
Plastic Paper Tubular

**FREE Servicing Aid**



Save time, use handy Astron pocket-sized Replacement Catalogue and Pricing Guide (AC-4D) — Write Today!

**ASTRON**  
**C O R P O R A T I O N**

255 GRANT AVENUE EAST NEWARK, N. J.



\*Trademark

WEST COAST WAREHOUSE: 9041 WEST PICO BLVD., LOS ANGELES - EXPORT DIVISION, ROCKE INTERNATIONAL CORP., 13 EAST 40TH ST., N. Y., N. Y. - IN CANADA: CHARLES W. POINTON, 6 ALCINA AVE., TORONTO, ONTARIO

where  $X_c$  is capacitive reactance in ohms,  $\pi$  is 3.14,  $f$  is the frequency in cycles per second, and  $C$  is capacitance in farads.

## Performance & Rating

There are numerous factors which determine how well a capacitor will perform in a particular application. Also, there are a number of designations which describe this component's rating. Among the most important considerations are:

**Capacitance**—Also referred to as capacity. Ability to store an elec-

trical charge. Unit of measure is the farad (one coulomb of charge raised one volt in potential). The farad is too large for ordinary use. The microfarad (abbreviated  $\mu\text{f}$  or  $\text{mfd}$ ), one millionth of a farad is commonly used, as well as the micromicrofarad ( $\mu\mu\text{f}$  or  $\text{mmfd}$ ), which is a millionth of a microfarad. Capacitance is determined by capacitor geometry and dielectric constant. For a given applied voltage, the greater the capacitance the more charge stored.

**Insulation Resistance**—Resistance when dc voltage is applied. Generally rated in megohms for small

capacitance, and megohms  $\times$  microfarads for large capacitance. Typical resistance values range from 50 megs to many thousand megohms, depending on type of capacitor. Insulation resistance decreases rapidly as temperature increases.

**Leakage Current**—Flow of direct current through capacitor which depends on insulation resistance and applied voltage.

**Power Factor**—Relation of phase between voltage and current (cosine of vector phase angle), expressed in percent as resistance divided by impedance of capacitor at operating frequency. It is an indication of how much unit will heat up in an ac circuit. Perfect capacitors (no heat) would have 0% power factor (abbreviated p.f.). Typical p.f. may be of the order of 1% for many types, with the particular exception of electrolytics which may range from a few percent to over 60%.

**Resistance**—Generally refers to ac resistance (not capacitive reactance), measured in ohms at operating or power line frequencies. It may range from 100 ohms or less to more than 20 megohms.

**Temperature Coefficient**—Characteristic describing how much the capacitance will decrease (negative coefficient) or increase (positive) with temperature. Particularly applied in rating ceramic capacitors. Designated as N for negative or P for positive, followed by number representing parts per million per degree Centigrade ( $\text{ppm}/^\circ\text{C}$ ).

**Temperature Range**—The range of temperatures which allows capacitors to be used at rated voltage. Beyond this range they should be derated; that is, operate at lower than rated voltage to prevent breakdown. Typical temperature range is  $-20^\circ\text{C}$  to  $+85^\circ\text{C}$ , although certain types may operate over  $-65^\circ$  to  $+150^\circ\text{C}$  range. Capacitance, power factor and other characteristics do change over the temperature range.

**Tolerance**—Permissible capacitance variation, expressed in percent generally, from assigned value at given temperature and frequency. Uncoded capacitors, except electrolytics, are usually  $\pm 20\%$ . Color coded units are available in 10%, 5%, 3%, and 2%. Since many circuits will function over a large range of capacitance values, particularly

Fig. 3—Capacitor markings for interpreting color codes.

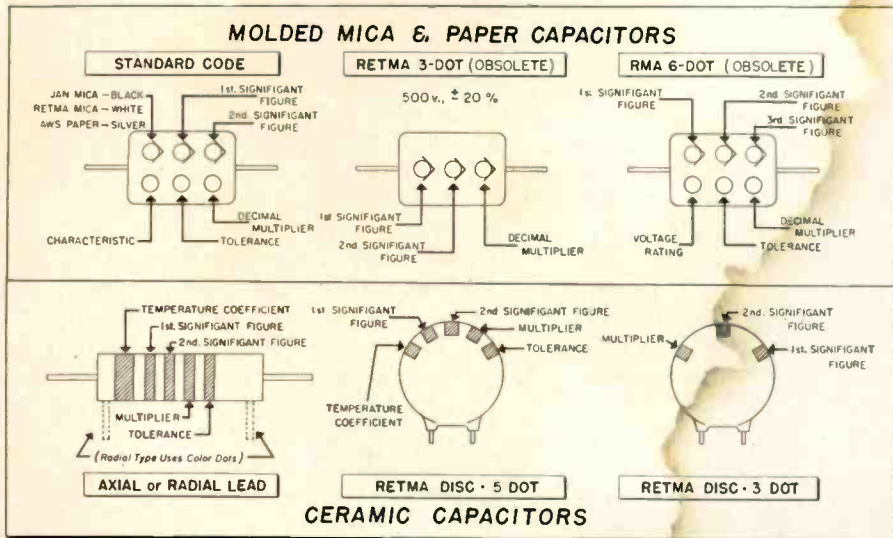

## CAPACITOR COLOR CODES

Color	Significant Figure*	Decimal Multiplier*	Cap. Tolerance ( $\pm$ )		Temp. Coeff.** (ppm/ $^\circ\text{C}$ )
			$> 10 \mu\text{f}$ (%)	$\leq 10 \mu\text{f}$ ( $\mu\text{f}$ )	
Black	0	1	20	2.0**	0
Brown	1	10	1		-30
Red	2	100	2		-80
Orange	3	1000	3***		-150
Yellow	4	10,000			-220
Green	5		5	0.5**	-330
Blue	6				-470
Violet	7				-750
Gray	8	0.01**		0.25**	30
White	9	0.1**	10	1.0**	500
Gold		0.1***	5***		
Silver		0.01***	10***		
None			20***		

\*Capacitance value (significant figure  $\times$  decimal multiplier) is read in  $\mu\text{f}$ .

\*\*Applies only to ceramic capacitors.

\*\*\*Applies only to molded paper or molded mica capacitors.

NOTE: Many capacitors, particularly electrolytics and paper tubulars, have ratings printed on them, and do not use color codes.

ASTRON "Staminized" CAPACITORS ARE - -

# clearly marked

Astron . . . truly a quality capacitor to the last detail.

You, as a specialist in replacement parts, must capture the complete confidence and respect of your customer. Astron takes every step to insure this. Designs are accurately tested, production techniques are carefully inspected, quality controls strictly enforced and protective guards built-in to govern staying power of each capacitor - - finally clear, easy-to-read markings for quick, positive identification.

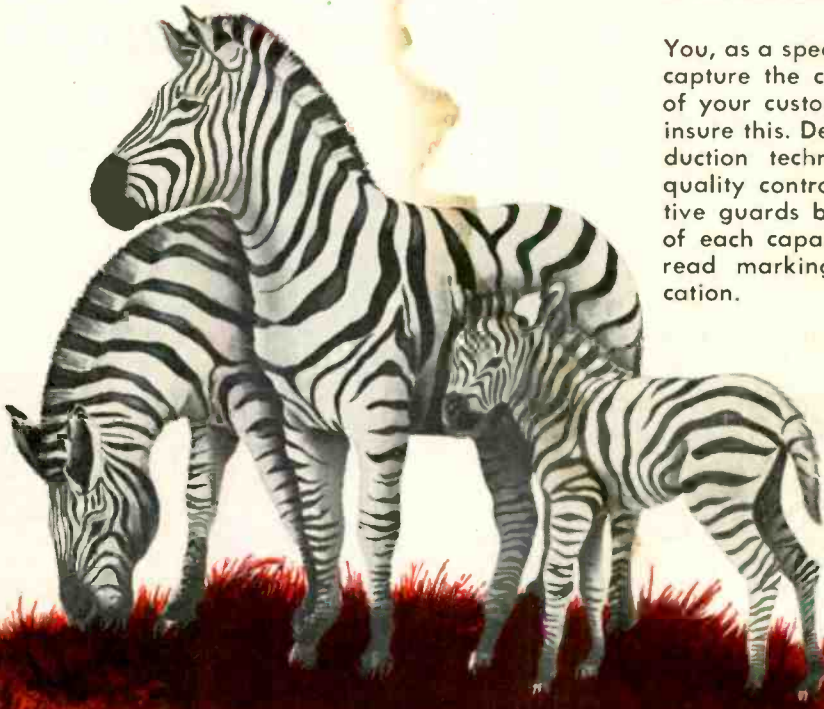

You can put your trust in Astron, for behind each Astron capacitor is the meticulous quality control that insures you of top performance and the elimination of call backs.

Remember, your reputation is our business. Build it, guard it, protect it - - Buy Astron

\*Trademark



FREE Servicing Aid

Save time, use handy Astron pocket-sized Replacement Catalogue and Pricing Guide (AC-4D) — Write Today!



**ASTRON**  
CORPORATION  
255 GRANT AVENUE EAST NEWARK, N. J.

Export Division: Roche International Corp., 13 East 40th St., N. Y., N. Y.

In Canada: Charles W. Pointon, 6 Alcina Ave., Toronto 10, Ontario

increases, tolerances such as +30%, -10% are not uncommon. For small capacitance, eg., 0.001  $\mu\text{f}$ , +60%, -25% may be acceptable in certain circuits.

**Voltage Rating**—Also referred to as dc or peak working voltage. Maximum voltage to be applied to capacitor at a given temperature to prevent dielectric breakdown. For ac this means the voltage peak, which in a sine wave is about 1.4 times the root-mean-square (rms) voltage. Although 150 to 600 volt ratings are very common in TV-radio-audio, capacitors rated 4 volts to 20,000 volts are also employed. For use in higher than rated temperature, voltage should be derated.

## CAPACITOR TYPES

Since capacitors are employed in practically all electronic equipment, a great many different types are required, resulting in a large variety of shapes, structures and compositions.

### Composition

**Paper**—This most widely used type consists of multi-layer paper tissue dielectric rolled between thin metal foil conductors such as aluminum. They are impregnated with oil, wax or plastic resin. Units may be encased in sleeves or molded exterior consisting of plastic, ceramic, cardboard or metal, and sealed to keep out moisture. In common electronic applications values range from 0.001 to 1  $\mu\text{f}$ ; large commercial units to 50  $\mu\text{f}$ . Most popular structure is tubular. Variation of this type is the improved metallized paper capacitor, in which an extraordinarily thin film of metal is deposited on lacquered paper dielectric by means of a high temperature vaporization process.

**Electrolytic** — This workhorse among capacitors provides high capacitance in small volume, and may be obtained generally from 1 to over 1000  $\mu\text{f}$ , values that would result in impossibly large units for other types. They are commonly made in tubular or can types such as twist prong or screw base. Contained in the can is an etched aluminum foil treated electrochemically to form an anode dielectric film. Separating the foil capacitor plates are paper spacers which absorb the liquid or paste-electrolyte whose function is to provide a conductive path between the plates and to keep the anode dielec-

tric film functioning. A relatively recent development improves low temperature and aging characteristics by employing the metal tantalum instead of aluminum, and replacing the aqueous electrolyte with a solid semiconductor type. Electrolytics not used for a long time may become leaky, but may be restored through "forming" by applying half rated voltage, and building up to rated voltage.

**Ceramic**—Employing ceramics such as metal oxides (something like pottery clay) as dielectric, these capacitors offer a wide variety of controllable characteristics making them useful for very high voltage (eg., 20 kv), temperature compensating, coupling and numerous other similar applications. Commonly found in tubular, disc, plate, door-knob, button, and trimmer forms. They should not be confused with paper dielectric capacitors encased in ceramic sleeves. Ceramic capacitors generally range from one-half to several thousand  $\mu\text{f}$ .

**Mica**—A flaky translucent mineral which separates into thin layers, mica is used as a dielectric in capacitors formed into molded postage stamp or variable trimmer forms. Small feed-through and large can versions are also employed. Capacitance generally ranges from 0.000005  $\mu\text{f}$  miniatures to 10  $\mu\text{f}$  for husky transmitting types. In lower values they are often interchangeable with ceramic types. Voltage ratings go over 35 kv in some industrial types.

**Plastic**—Materials such as mylar are used in place of paper dielectric to improve voltage and other characteristics. See section headed "Paper" for related data.

**Air**—Variable tuning capacitor consisting of rotor and stator of interleaving plates. Capacitance range up to few hundred  $\mu\text{f}$  is varied by changing amount of plate area that is meshed.

**Vacuum**—Metal plates, fixed or variable, are enclosed in an evacuated glass and metal envelope. Generally used in high voltage transmitting applications.

**Glass**—Similar to fixed mica types, encased in glass, often in postage stamp form. Variable trimmer type is made in piston structure.

## CAPACITOR CIRCUIT APPLICATIONS

Described on following page

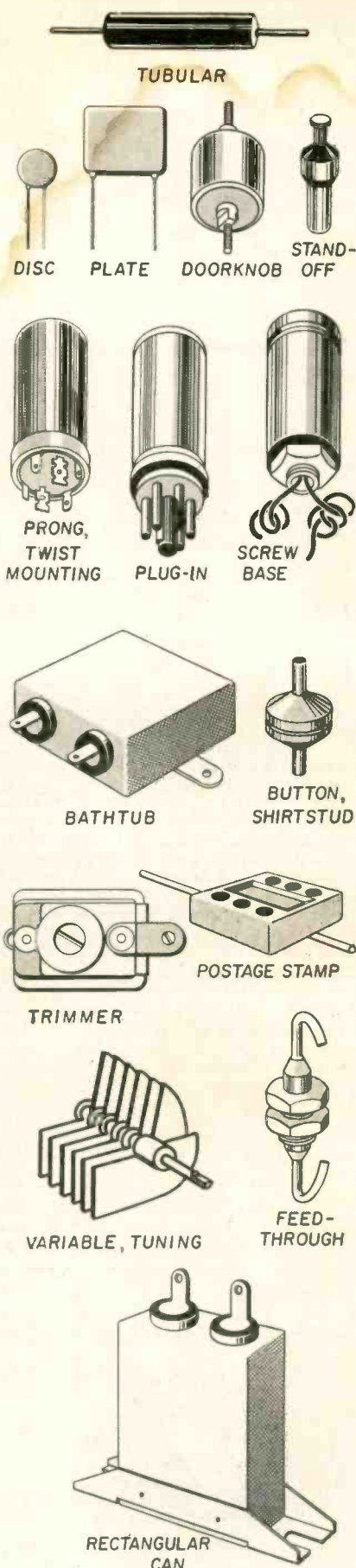

Fig. 4—Popular capacitor structures

# Let's Look at CAPACITORS

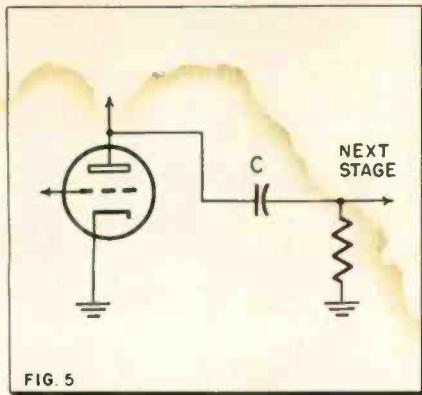

FIG. 5

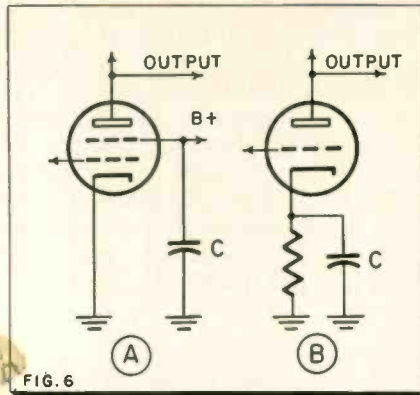

FIG. 6

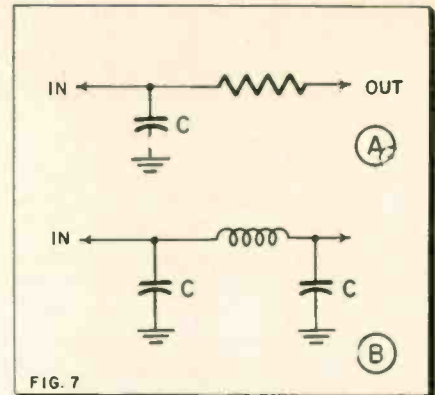

FIG. 7

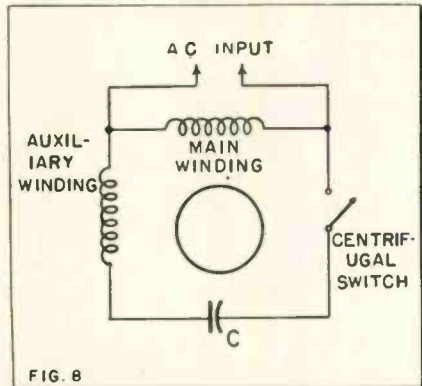

FIG. 8

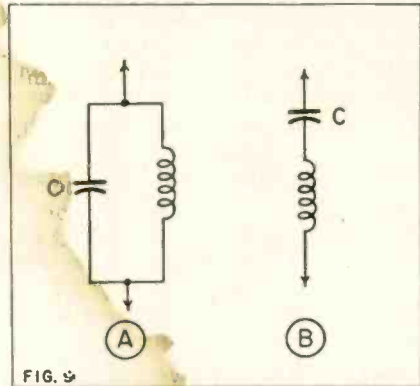

FIG. 9

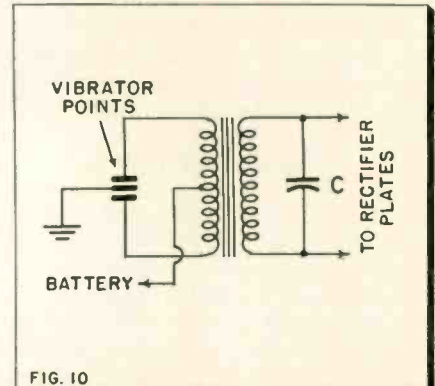

FIG. 10

Fig. 5—A blocking or coupling capacitor in series with signal path transfers audio or r-f signal from one stage to another. It blocks dc at plate of 1st stage, preventing it from getting through, but passes ac efficiently. Fig. 6—A bypass or decoupling capacitor, used in shunt, removes signal from a point in a radio or TV circuit but leaves dc unaffected. A—Undesired signal at screen grid is bypassed to ground by coupling action, but blocking effect leaves B+ unaffected. B—Bypass grounds cathode signal, leaves needed dc bias unaffected. Fig. 7—Elementary RC filter in A removes ripple or signal, is characteristic of those used in radio and TV agc lines. B—In power supply filters of radio and TV sets, a choke may supplant the resistor, and another capacitor at the choke or resistor output improves filtering.

Fig. 8—Starting capacitor for motor is one of many industrial applications. It decreases starting current, increases starting torque. As motor approaches running speed and capacitor is no longer needed, rotational force throws open switch, disconnecting capacitor. Fig. 9—Used with an inductor, a capacitor forms a tank, or a circuit resonant at one frequency. These appear in transmitters, receivers, and many types of test equipment including generators and grid-dip meters. A—Parallel resonant circuit presents high impedance, minimizes current flow. B—Series tuned circuit produces minimum impedance, allows maximum current flow. Fig. 10—Buffer capacitor across secondary of vibrator transformer, found in power supplies of auto radios and mobile communications equipment, suppresses spurious signal, etc.

## TV Remote Controls

•More and better TV remote control devices are being placed on the market, and Mr. Consumer is showing growing interest in these step-savers. Unlike the early post-war units, which were complex and costly, the new remotes are compact and fairly simple mechanisms. The variety of different engineering designs indicate a high degree of ingenuity.

Wire-connected "Dial-O-Matic" TV control.



The DuMont "Dial-O-Matic," styled like a telephone, provides for channel selection while automatically muting the set. It also permits remote control of brightness and volume. This device is connected to the receiver by a multi-conductor flat ribbon line which can be placed under the rug. To operate, just dial the channel number. By the way, DuMont engineers estimate "Dial-O-Matic" can save 29 miles of walking per year.

One of the most interesting controls is the 8-oz. Zenith "Space Commander," which uses no wires, no batteries, no radio waves, no tubes, no transistors . . . and no flashlights. Still its four buttons control on-off, audio muting, and turning channel selector to left or right. The secret lies in its all-mechanical construction with tuning fork arrangement. Pressing one of the buttons causes the tuning fork to be struck, giving off a pre-tuned supersonic note of about 40 kc. Each button has its own



Supersonic "Space Commander" control.

frequency, according to unofficial reports, and the supersonic vibrations actuate the control mechanism up to 40 ft. away at the receiver.

Motorola's "Transituner" employs one transistor operating at 2.8 mc to transmit the radio control signals to the receiver up to 25 ft. away. In conjunction with the company's line of automatic fine tuning sets (utilizing a spring-loaded preset device at (Continued on page 70)

# "Tough Dog"

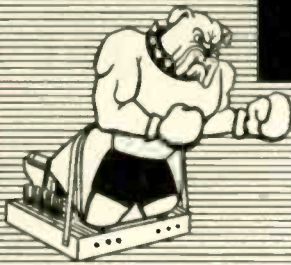

## Corner

### Difficult Service Jobs Described by Readers

#### Erratic Search-Tune Radio

The most interesting thing about this problem is that we used a piece of equipment that would scarcely be considered test equipment under ordinary circumstances.

The unit that gave us trouble was a Cadillac model 7264165 signal-seeking car radio. For about ten minutes after it was turned on, the complaint went, it would keep searching, refusing to stop on any one station. After warm-up, it would work properly until again permitted to cool to non-operating temperature.

Since tube substitution was to no avail, the set was pulled and set up on the bench, where it worked well. It was permitted to cool off overnight but, when tried the next morning, it continued to work flawlessly. Its particular difficulty was making a "cold" start in the auto (this happened during the winter). In our shop we happened to be keeping a refrigerator operating to store cream for our coffee and to keep bottled

soda cold. Since this box had a sizable freezing compartment, the radio was placed in this chamber overnight. Sure enough, when the cold set was tried in the morning, the trouble showed up, with the set seeking continuously, whether the selector bar was depressed or not. It was now possible to test the set while it was defective.

A quick voltage check around the trigger circuit showed normal voltage readings when the selector bar was depressed. However, when the selector bar was released, the expected change in voltage readings did not take place. Readings were the same as though the bar were depressed. With power off, a resistance check showed a reading of 12,000 ohms from pin 6 (plate) of the 12AU7 trigger tube to ground at all times. As the schematic shows, a 12,000-ohm resistor connects pin 6 of the trigger tube to the selector bar switch, but this switch is only supposed to return the other end of the resistor to ground when the selector

bar is depressed. A check from the switch end of this resistor to ground when the bar was not depressed showed zero resistance however, indicating that the switch remained closed at the wrong times. Careful examination showed that excessive solder on the switch terminals was shorting them together, although the switch was in the open position, when temperature would drop low enough.—Paul Skinner, Lebanon, Ohio.

#### Vertical Linearity Puzzle

An RCA KCS88B was originally brought into the shop because it would not produce a raster. After routine troubleshooting restored the raster and picture, it became immediately obvious that vertical linearity was very poor, with scanning lines

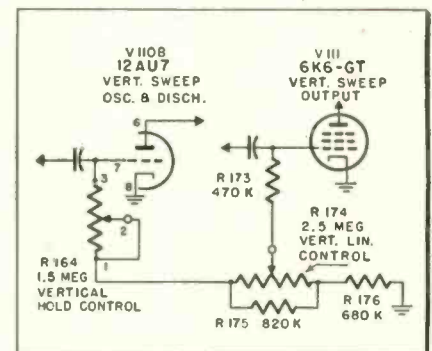

Leakage—but where?—caused nonlinearity.

at the top of the raster being widely spread. Adjustment of vertical controls could not normalize the linearity.

Substitution and check of tubes and coupling or wave-shaping capacitors in both the vertical oscillator and output stages were to no avail, so the resistors in these stages were tackled next. All checked out until R-176 in the schematic was reached. Instead of 680K, a reading of 150k was obtained across this component. However, when this resistor was removed from the circuit

(Continued on page 66)

This erratic search-tuning trigger left a tech cold—till he used the cool treatment himself.

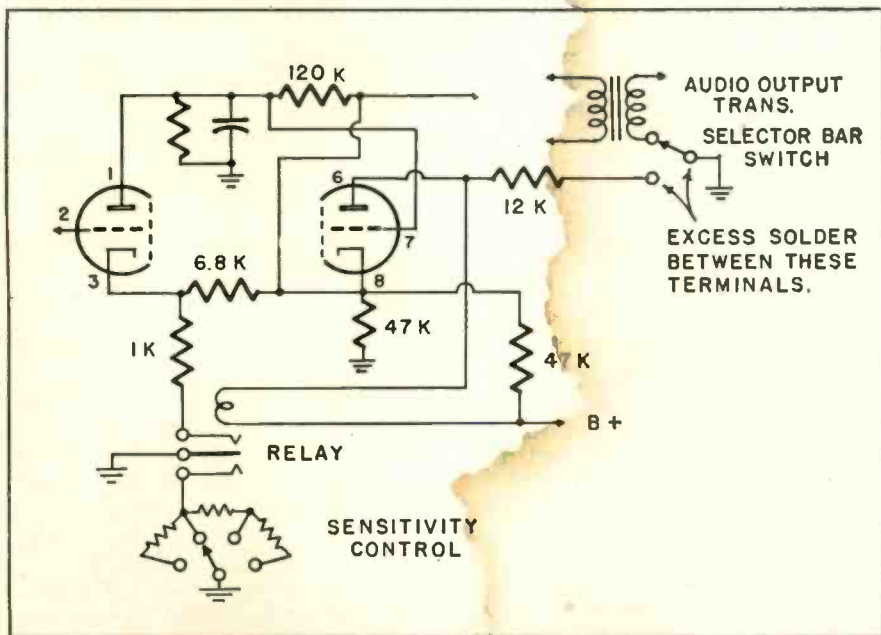

EXCESS SOLDER BETWEEN THESE TERMINALS.

# Chasing External Ghosts:

## Reflecting Surfaces, Disturbances in the Antenna System,

L. A. WILLIAMS

•If there is any service activity that can be fraught with more frustration and time-wasting than troubleshooting intermittents, it is that of catching up with a ghost on the TV screen. However, much valuable time, especially away from the shop, can be saved with a proper analysis of the ghost and where it may be found. A knowledge of what produces the ghost and where that "what" is helps immensely.

Before anything else, prove that the ghost is due to the reflection of a signal from some external object(s) or due to the transmission line and its matches or lack of such matches. Try adjusting the fine tuning; if the ghost alters its appearance, it is not an external ghost.

Then make this simple check: Merely disconnect the transmission line. Touch a finger to an aerial terminal, or hook up an indoor antenna temporarily. If the appearance of the ghost has changed, for the same brightness and approximate contrast of the picture, then Mr. Ghost comes from some place other than inside the TV receiver. Naturally, the tuning is the same as with the line connected to the set. Without adjustment to the same brightness and contrast, some internal ghosts may not show up; hence that qualification.

There remains the possibility of direct pickup by the tuner. If this is the case, movement of the technician in the neighborhood of the set will change the intensity of the

Fig. 1—Pix with several ghosts discernible.

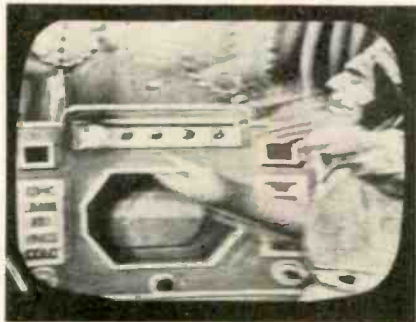

ghost, or the apparent main signal—often the main signal seems to be the ghost as it may be weaker! Furthermore, the finger or the test antenna will alter the appearance of one of the signals—the one entering the aerial terminals. Remedy is a better antenna, possibly combined with shielding and grounding of the tuner.

Fig. 1 shows a picture that is particularly ridden with ghosts. Close examination of some of the picture elements will indicate that, in addition to the principal image, there are at least two ghosts, and probably more.

### Finding Ghost Path Length

The distance between the main image and any ghost on the screen can help us find the source of the reflecting entity that produces that ghost. A little calculation shows us how. Electromagnetic waves travel at a speed of 186,000 miles per second, and there are 5280 feet per mile. That means the rate of travel is 985 million ft. per sec.—or 985 ft. per microsecond ( $\mu\text{sec}$ ).

Now, how long would a microsecond be on the screen? Well, the scanned or unblanked portion of each line of horizontal information is roughly 53.3  $\mu\text{sec}$ . Since part of the picture edges are masked off, we may use 50  $\mu\text{sec}$  as the visible length of each line. Let us assume, for the sake of simplicity, that the picture tube in question has a horizontal measurement across its face (this will not be the usually used diagonal measurement) of 20 in. Therefore, each inch across the face of the tube represents 50  $\mu\text{sec}$  divided by 20, or 2.5  $\mu\text{sec}$ .

Now suppose we measure ghosts #2 and #3 on this screen, and find that they are 1 in. and 2 in. respectively from the main image, #1. This gives us a total delay time of 2.5  $\mu\text{sec}$  for the #2 signal, and 5  $\mu\text{sec}$  for the #3 signal. Conversion into feet (multiplication by 985) gives a total path length of 2450 ft. for the #2 signal and 4300 ft. for the #3 signal.

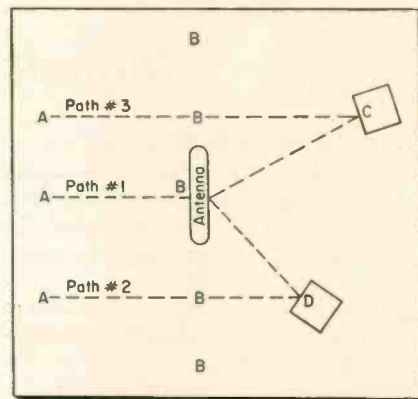

Fig. 2—Reflected signal paths for ghosts.

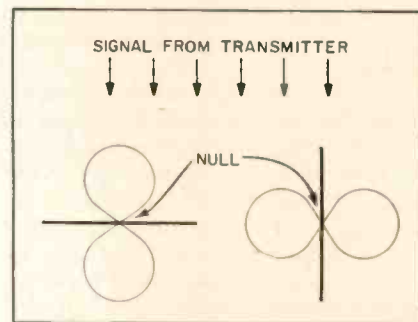

Fig. 3—Properly oriented dipole (A) may be blown about by wind (B) to be null oriented.

Fig. 2 shows how ghosts can occur. A direct signal follows path #1 and is intercepted at line B by the antenna. Another wave along the #2 path crosses line B and is reflected at D to return to the antenna along line B for the #2 ghost. The linear distance between the aerial at B and the reflecting surface D will be approximately  $2450/2=1225$  ft. For the longer delay of ghost #3 we might have the path BCB with a distance of approximately  $4300/2$  ft. away from the antenna, or less than 2650 ft. away.

### Ghost Reflection Angle

These distances are being called approximate because they will depend also on the angle at which signal approaches and bounces off such reflecting surfaces as buildings C and D. With a sharp (acute) angle, like that formed along path #3



# Causes and Cures

## May Be Outside Agencies. How to Check.

(BCB), the distance from the reflecting surface to the antenna is indeed close to half the total length of path BCB. However, with a wider angle like that made by path #2 (BDB), note that the distance from the reflecting surface back to the antenna is quite a bit more than half the length of BDB. In other words, the distance would be more than 1225 ft. away.

### Antenna Orientation

The obvious answer to an improperly oriented antenna is to properly position it. However, this may not be enough.

If the ghost-reflecting surfaces are from the rear, then a system with a better front-to-back ratio may be required. A director or a reflector or both may be added to the array. In case of adding both such elements, note that the antenna impedance is lowered with the addition of more elements and that a match to the transmission line must be made else more ghosts will arise to plague the installation.

In choice of antenna for ghosts from another direction than nearly backwards, the overall pattern of pickup must be considered for the particular antenna. The side lobes may be very important contributors to the total signal strength in some aeriels and these will yield ghosts if any reflected signals happen to be coming in on the beam from the side. Temporary orientation while watching the ghost will tell if such a condition exists, as side lobes are rather sharply defined.

### Side Lobe Reception

If side-lobe reception is particularly annoying, ie., many ghosts, from different channels that transmit from different locations, then an antenna rotator installation may be the answer. The rotator can orient the array for best reception on each station.

Inspection of the existing antenna for proper orientation may be accomplished without physically moving it, by merely inspecting its direc-

tion of pickup visually. Fig. 3A shows a normal direction of pickup for the simple dipole, with its "figure-8" pickup pattern. A similar pattern exists for the folded dipole. Pickup is always at a maximum at right angles to the conductors of the antenna or array. The null-oriented antenna, see Fig. 3B, may pick up more ghosts than direct signal. Such null orientations arise after heavy winds and may be suspected immediately if there are many ghosts with a very poor direct signal.

Reflected wave phenomena appear on transmission lines from antenna to the set antenna terminals in numerous forms. There is the obvious mismatch of a 70-ohm antenna connected to a 300-ohm twin ribbon, or a set designed for 300-ohm input connected to a coaxial line of some 70 odd ohms characteristic impedance. Also, there is the case of the one terminal disconnected at the antenna (or at the set) with the mismatch resulting in a ghost as well as loss of signal strength.

### Impedance Matching

Although impedance mismatches just described are really discontinuities, we go into detail on other types in which the uniformity of the transmission line is altered to produce ghosts on all or perhaps only one channel.

A perfectly matched transmission line without discontinuities of any sort has a uniform decay of both voltage and current along its length from its start to its finish. If some irregularity exists, there will be a standing wave produced which is superimposed on the normal decay curve. The irregularity may (in effect) be a capacity across the line, a resistance in series, an inductance in series or shunt, or a resistance in shunt, or added capacity to ground from one side of the line. Anything that disturbs the normal constants of the normal line, in short, will cause such a reflection, and will result in a ghost.

When capacitance or inductance is added that should not be there, one or more tuned circuits, or tuned

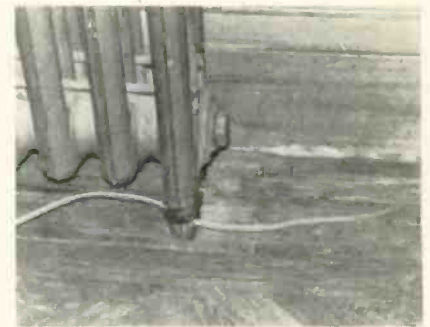

Fig. 4—Capacitive load on transmission line is imposed by taping it to leg of radiator.



Fig. 5—Taping line to pipe results in signal attenuation (shunt capacity) and mismatching.

stubs, are effectively set up. While these stubs are often instrumental in producing mismatches with resultant ghosts on some channels or in some cases, they may also produce beneficial matching in other cases.

For this reason several errors in installation may or may not mean anything! The handy radiator leg to tape the line to (so the housewife won't disturb it in sweeping) is one example, see Fig. 4. Or the water pipe serving the same purpose (Fig. 5) which could be the antenna mast just as well. Or perhaps added capacity might take the form of the storm window sash of Fig. 6 or any similar metal window.

Due to the high Q of such stubs, the effect may be noted only on one channel in most cases. The tinfoil

slider used to match a slightly mismatched line to the set may work well on one channel—but produce a ghost on another channel. Always check all channels after such a remedy is tried for one channel. Such a remedy may be required due to variation in input impedance of the set at different frequencies (channels). A similar stub or slider may be required to match the transmission line to the antenna whose impedance may vary appreciably from the channel for which it is chiefly cut to other channels. For example, an antenna cut for channel 3 will not be matched to channel 2 or to channel 6. A ghost may be produced on



Fig. 6—Storm or other metal windows can mismatch line, as well as tacks shown on line.

either if the signal strength is appreciable. The remedy is a stub for each channel that causes trouble at the antenna, receiver, or both as may be required. Use due precaution that you do not provoke another spook though!

### Ghosts from Line Capacity

Capacity to a tack or tacks in the center of the line or to staples may produce a similar effect. The capacity to the tack and from it to the other side of the line (other conductor) effectively forms a capacity across the line. Fig. 6 shows some examples of such tacks. One tack could produce a ghost on one channel, while still another tack might produce the ghost on another channel. Such tuned "stubs" are very critical. The remedy is to shift slightly all tacks and metal objects near the line while observing the ghost.

Even the lead-in insulators will sometimes produce a small ghost. Remedy is to pull the line through the insulator a little and tape it securely in position. An inch usually suffices.

Fig. 7 further illustrates the use of tacks and another common source of ghosts, the telephone wire alongside. This produces a ghost because

it unbalances one side of the transmission line to ground, like adding a capacity to ground on that conductor. Such possible unbalance to ground is a further reason why it is advisable to twist the lead-in about one twist or more per running foot both inside the house and outside it. The twist further serves to minimize noise pick-up.

Another discontinuity can result from wooden windows banging a line against a wooden sill. The line is mashed out of shape, and both the shunt capacity and the distributed inductance are disturbed. The line must be uniform and such banging with shape distortion may not only spread out the conductor but break the strands, which introduces resistance not intended to be present.

### Chimney Soot Shunts Line

The shunt resistance of lead-ins is ordinarily quite high—into the hundreds of megohms. This may not be true when a line is near a hot stream of carbon-laden gas, as it would encounter with chimney mountings. The deposited soot and carbon particles may form an actual shunt resistance of rather low value on such an installation even after only one winter season—and the summer hot



Fig. 7—More tacks to change line characteristics, as well as phone line to unbalance it.

water heater puts in its smaller share of the dirty work as well. Furthermore, the accumulation may provide a sort of tinfoil-slider effect even though it may not alter the shunt resistance between conductors. An otherwise matched line may become mismatched on one channel or more as a result, with no impairment of the resistance of the line itself.

There is also the lightning arrester which may give trouble due to a collection of particles across it, or it may give rise to a single-channel ghost due to the capacity effect. If it should happen to fall at the proper point for such a ghost, then a clue would be that the ghost has been present ever since the arrester was

installed, or since the length of the line has been changed. A piece cut off or added to the line could change the position of the arrester with respect to the end so as to produce a ghost. The remedy is to cut off a small piece of line, or add one short length to remove the ghost. Now, make a check on the other channels after such a remedy to see that more trouble elsewhere has not arisen.

We have the discontinuity due to the fraying of the wire at the roof edge, or gutter, or parapet, etc. The line wires need not be frayed to produce the ghost. Damage to the insulation such that the shunt capacity is appreciably changed is sufficient. Now it seems foolish to replace the entire lead in if only one section becomes frayed or covered with soot. That may be so, but any splice made must not disturb the spacing or the insulation or the series resistance of the conductors. The penalty may be a ghost. Preferably, replace the entire lead-in!•

### TV Check Tube Saves Time

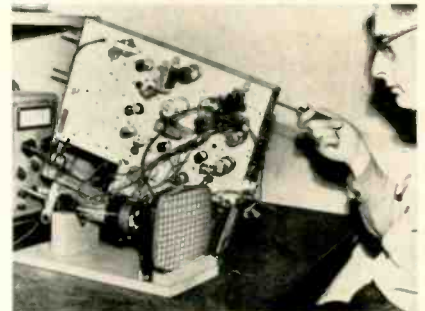

The 8XP4 self-focusing check tube substitutes for set's crt to speed testing. Sylvania reports this 90° crt may be used with electrostatic and virtually all magnetic focus types.

### Biggest Little Tube



Built to the proportions of a 6BK7 (though 84,000,000 larger) this 200,000-gal. water tank at General Electric's new Owensboro, Ky., tube plant under construction is 80 ft.

# SHOP HINTS



## Tips for Home and Bench Service by Readers

### Neck Shadow Remedy

Many cases of picture tube neck shadow can't be completely removed by the ordinary methods, such as deflection yoke positioning, adjustment of centering magnets, focus coil positioning, and correct ion-trap magnet settings. These unremovable neck shadows are most often caused by slight irregularity in the construction of the picture tube itself, with the electron gun structure being out of alignment with the tube neck. Where round picture tubes are in use, there should be little difficulty in eliminating a shadow due to such a defect.

Assume that the shadow is evident in a portion of the screen as shown to the left in the accompanying illustration. Rotate the tube about a quarter of a turn one way or the other, so as to place the portion of the screen most subject to shadow in the normally unused area above or below the picture. Other controls may then be adjusted for best picture. If some shadow still exists, turn the tube either way until it disappears. Sometimes it will be found that better results can be obtained by using the bottom of the tube in which to "lose" the shadow instead of the top, or vice versa. If no change can be achieved at all with this method, at least one other objective is accomplished: this

would tend to establish the fact that the picture tube itself is not the cause of the neck shadow. To achieve proper adjustment, it is often necessary to lengthen the second-anode lead so that the tube can be rotated to best position.—*Charles Garrett, New London, Connecticut*

### Ion-Trap Technique

When a picture tube has to be replaced, or even sometimes when a new set is being installed and set up, finding the proper position for the ion-trap magnet is a haphazard and often time-wasting procedure. The adjustment can be simplified greatly if the ion-trap assembly is started about one-half inch from the base of the tube, with the magnet itself in line with the socket keyway. While this positioning may not result in perfect adjustment, it will be close enough so that the optimum point can be found quickly from this starting point.—*George Hoffman, Washington, Wisconsin.*

### Inaccessible Adjustments

Sometimes the manufacturer of the TV set, showing little concern for the service technician, will mount i-f transformers and other tunable coils directly under the bell of the picture tube, where alignment or other adjustment is prac-

tically impossible without taking the set apart. With some of these adjustments, a little ingenuity will eliminate the need for dismantling.

For example, in the case of bifilar i-f transformers having cores with threaded brass spindles, the slotted spindle is generally brought through the top of the chassis and is often all but inaccessible, being under the pix tube bell or the yoke assembly. If the core is screwed all the way out of the coil form and a slot is cut with a fine hack saw in the molded end, it is generally easy to align the set from the underside. Bifilar i-f transformers are mentioned because one end of these units is often open. The idea is equally applicable to tunable i-f chokes and other units.—*Al Kinckiner, Philadelphia, Penna.*

### Stand for Shop Meter

So that our meters don't get lost in the confusion of littered benches and so that we don't have to crane



"Rocking-chair" stand makes meter handy.

our heads around the corners of TV chassis to see the readings, we keep our meters parked atop rocking-chair wood stands, like the one in the photo. The backs of these stands are tilted back to slope the meter's scale upward toward eye level. Attached to the bottoms are small metal buttons so that the stands can glide easily across the surface of the shop benches.—*Stanley Clark, East Bradenton, Florida.*

Easy cure for neck-shadow problems due to inherent gun misalignment works on round pix tubes.

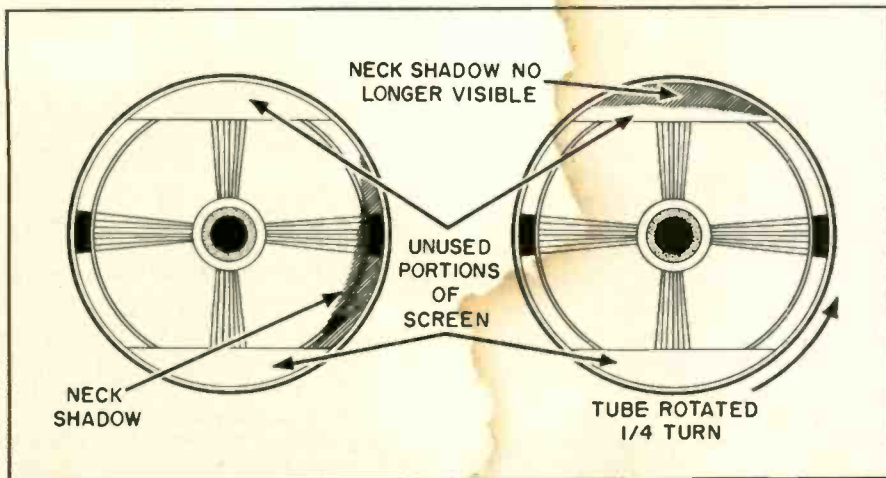

# TV Antennas:

## Terminated travelling

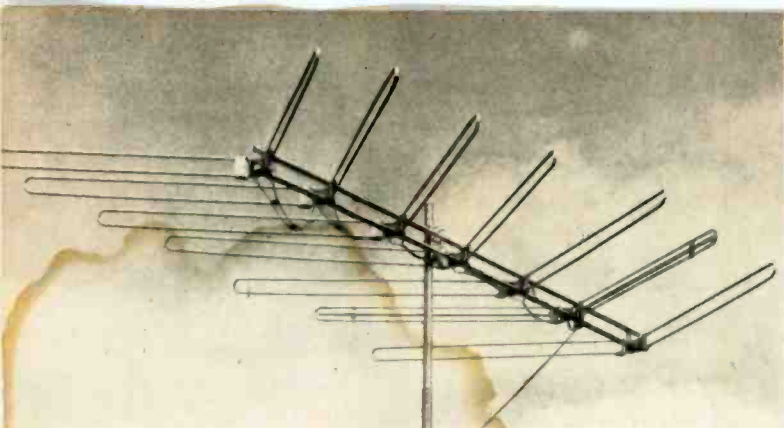

Fig. 1—Seven-element terminated travelling wave antenna.

• As commercial TV enters its second decade, the self-appointed prophets who predicted the impending disappearance of TV antennas have themselves apparently disappeared into the special limbo occupied by those who said, "the wheel, the lever, and the inclined plane can't last."

The parade of advancing types has continued: dipole and reflector, conical, fan, yagi, dipole and screen, and up to broadband VHF yagis. This latter class has been the most powerful type of multi-channel antenna created to date, and practically every antenna manufacturer makes a version of this basic type for never-ending fringe areas.

The great acceptance of the yagi type by service technicians, however, should not conceal the fact that the broadband yagi still has limitations, despite much study and development.

1. GAIN: Broadband yagis are not the "ultimate" in high gain design. One of the basic theoretical conditions for maximum antenna performance in a multi-element antenna is that every element must receive an equal amount of current in the proper phase relationship. The broadband yagi cannot fulfill this vital condition on more than one or two channels.

2. FRONT-TO-BACK RATIO: Even the best broadband yagis cannot always cope with co-channel and adjacent channel problems because of the inherent limitations of

Fig. 2—Difference between conventional folded dipole and "hairpin" or "fat" type.

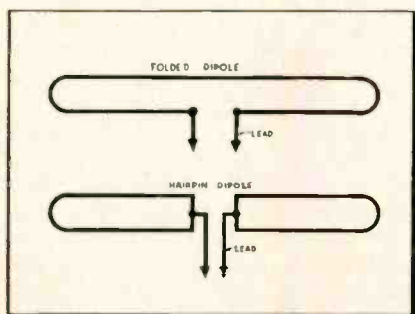

HAROLD HARRIS  
CHANNEL MASTER CORP.

the yagi's parasitic elements, which should be variable with frequency; but in a yagi they are fixed. Therefore, the front-to-back ratio is limited.

3. MECHANICAL STRUCTURE: Yagi design calls for a series of single tubular elements which extend from the crossboom, supported on one end much like a diving board. Under conditions of wind or ice this "springboard" action may lead to element breakage.

### Terminated Traveling Wave Antenna

A new antenna design which overcomes the yagi limitations noted is embodied in the terminated travelling wave type (Fig. 1). Features include:

1. Six of the seven elements are "driven."

2. Phasing harness is in two sections, each with a different impedance (Z).

3. Despite its appearance, the antenna has no conventional folded dipoles: a) Five dipoles are "hairpin" or "fat" dipoles (Fig. 2); b) One is a 3-conductor high Z dipole with a shorting bar; c) One is a folded reflector.

4. All dipoles have a different length.

5. Two different "vee-ing" angles are used.

6. A terminating resistor is employed.

The configuration is a series of "vee'd" dipoles. To understand the theory of its operation, it is necessary to review the basic vee dipole. When this dipole is approximately  $\frac{1}{2}$  wave on the low band, it is about 3 half waves on the high band. Anti-phase high band operation is overcome by the fact that the center section is located  $180^\circ$  in space behind the two outer sections. In effect, the high band dipole operates as shown in Fig. 3. The phase of the current changes  $180^\circ$  as it travels

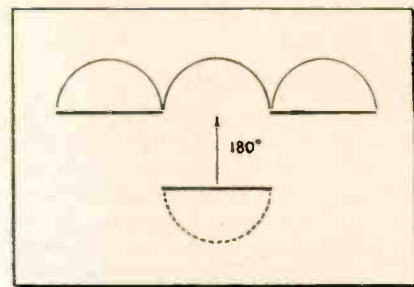

Fig. 3—Current phase changes  $180^\circ$  travelling to point in space abreast 2 outer sections.

to the point in space where it is abreast of the two outer dipole sections. Therefore, the current of all three sections is in phase.

The basic directivity patterns (and consequently, the gain) of an antenna are determined by the phase and amplitude of the current in the dipoles, as well as the position in respect to each other.

### Current Phase

Keeping the operation of the "Vee'd" dipole in mind, we must now think of these dipoles as impedances. Fig. 4 shows each element of the terminated travelling wave antenna as an impedance. The lines connecting the impedances represent the phasing harness.

The harness length between each dipole is greater than the free space distance. When the total electrical harness length of the driven elements is equal to the physical spacing, plus  $180^\circ$ , the result is termed "Increased Directivity Condition." This produces narrower lobes and higher gain than would be obtained if the harness length and physical spacing were of equal dimensions. However, the phase relationship which produces increased directivity is not dependent on harness length alone. The phase in each dipole also depends on its impedance. Therefore, the harness must be cut to compensate for the variations in dipole impedances as described below.

### Current Amplitude

By controlling the impedance of each dipole, we control the flow of current through that dipole. For maximum performance, the value

# Where Do We Go from Here?

*wave design shows improved performance for fringe areas.*

of the impedances shown in Fig. 4 must be such that each dipole receives an equal amount of current. At first glance the solution would seem to be that all impedances should be equal. However, these impedances occur in a travelling wave antenna and each impedance is separated from its neighbor by a significant portion of a wavelength.

The major achievement in this design is the series of impedances which decrease in magnitude from the feed point to the front end, maintaining this descending series of values for every individual VHF channel.

This is best explained by the concept of reciprocity, which holds that characteristics are the same for both receiving and transmitting. An understanding of this antenna will be simplified by considering it, for the time being, as a transmitting antenna.

Referring again to Fig. 4, it will be seen that the dipole of highest impedance must be at the feed point, with the impedances of the other dipoles in descending order. Since the dipole at the feed point has the highest  $Z$ , only a small controlled amount of the total current flows through it (about 1/6 the total) and most of it continues down the harness. The impedance at the next dipole is the highest of all the remaining dipoles. The major portion of the current continues down the harness, with each impedance (dipole) getting a portion of the remaining current.

In a travelling wave antenna any current which is not absorbed is reflected back up the harness, producing rear lobes. A terminating resistor absorbs whatever power the dipole impedances do not. This resistor, together with the folded parasitic reflector provides front to back ratios higher than 10:1 (relative voltage) on all channels.

Descending impedance values over the entire frequency range is achieved by "tapering" the lengths of the dipoles so each gets shorter from the feed point to the resistor. The theory behind this is shown in Fig. 5, a typical spiral curve of di-

pole impedance. The horizontal line indicates resistance of 0 to infinity. Inductive reactance is indicated by the area above the line, and capacitive reactance by the area below. Wherever the spiral crosses the horizontal line the impedance is purely resistive, and the dipole is resonant. Points A, B, C, and D represent the 1st, 2nd, 3rd and 4th harmonics—or in effect, what happens when a dipole is  $\frac{1}{2}$ , 1,  $1\frac{1}{2}$ , and 2 wavelengths long. It is important to note that the dipole's characteristics are about the same between points A and B and between points C and D. The arc AB represents the impedance on the low band; arc CD, the high band.

Looking at the actual antenna it will be seen that the problem of having a very high impedance at the feed point was solved by using a specially designed 3-conductor "controlled impedance" dipole. The precise impedance desired is obtained by a shorting bar across the 3-conductors.

The next dipole is a hairpin type, which has better impedance characteristics than either a folded or straight type. It is cut to a full wave on channel 6. Its characteristics, Fig. 6A, show that this dipole has its greatest low band impedance on channel 6, with the impedance decreasing with frequency. The same is true of the high band. The second dipole from the feed point is shown in Fig. 6B. Since the remaining dipoles are progressively shorter, the frequency points of channels 2, 6, 7, and 13 would be farther to the left. In other words, the shorter the dipole, the lower the impedance on each VHF channel. Comparing Fig. 6A and 6B, which represent dipoles A and B in Fig. 7, note that on any channel, the impedances of the dipoles decrease from the feed point to the shortest dipole. This guarantees that the current will be divided equally between all dipoles.

Three- and five-element versions may also be used for near-fringe.

Another feature is the increased structural strength resulting from hairpin dipole construction instead of "springboard" simple dipoles. •

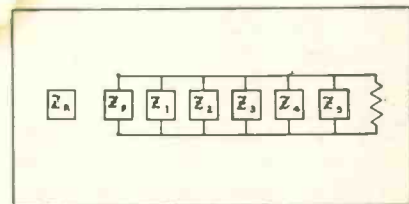

Fig. 4—Dipoles represented as Impedances. Connecting lines represent phasing harness.

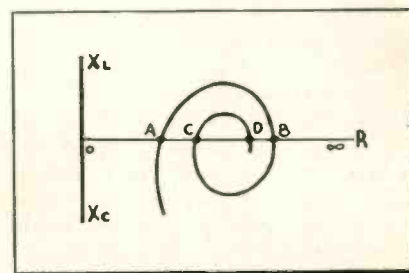

Fig. 5—Typical dipole impedance spiral.

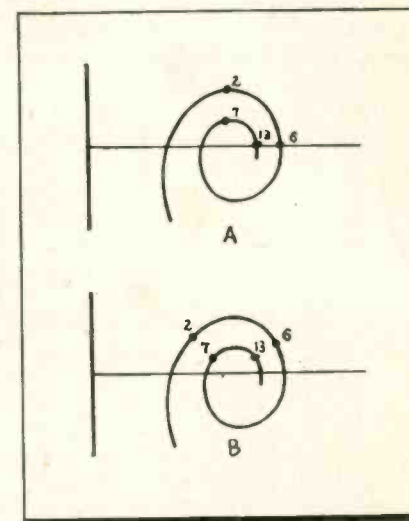
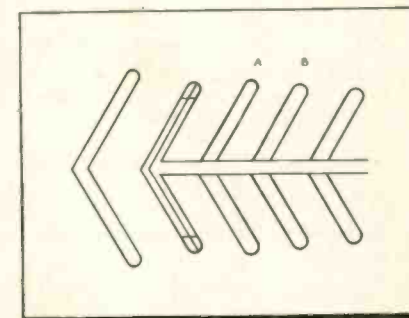

Fig. 6—Impedance characteristics of dipoles (a) near feed point, and (b) second from feed.

Fig. 7—Position of dipoles noted in Fig. 6.



# Test and Setup Procedures

## Equipment Needed; How It Is Set Up for Rapid Work;

FRANK A. BRAMLEY  
REGIONAL SERVICE MANAGER  
MOTOROLA, INC.

• Having the right test equipment, and having it set up for ease and speed of use is extremely important in servicing two-way radio equipment. In addition to the usual procedures followed in maintaining broadcast radio and TV receiving equipment, two-way maintenance requires the measurement of frequencies, modulation deviation, r-f power output, and plate power input to the final amplifier. Measurement of the forward and reflected power in antenna transmission lines is also important as a check on efficiency of the antenna system.

To some extent, maintenance is simplified because there are comparatively few variations of basic models in common use. The technician soon becomes familiar with

circuit constants (current, voltage and power) and knows what are the most likely causes of improper values.

As a servicing aid, most manufacturers bring all metering points out to a single socket into which a standard metering device can be fitted. Usually the proper shunts and multipliers are built into the equipment so that a standard meter plus a circuit selector switch is all that is required externally to give on-scale readings.

Although some maintenance must be performed "on location," many jobs should be taken to the shop. Out-of-shop work is usually more time consuming and inefficient.

An efficient shop must be adequate in terms of bench space, heat and light, test equipment, and voltage and power supplies. Also, arrangement of test equipment is very important. Two-way radio, because

of its semistandard design, lends itself to maintenance on ingeniously laid out test benches. Characteristics of efficient bench arrangement are: a minimum of connections, meters at eye level or below, freedom from entangling wires, ease of connection of power and test equipment.

A complete check of two-way radio performance includes the following measurements: 1. Nominal power supply voltage—110/120 volts ac, 6 and/or 12 volts dc. 2. Power output—R-F power in watts into a standard load. 3. Audio input—Voltage across the transmitter input required to produce full modulation and proper limiter operation. 4. Carrier frequency. 5. Carrier deviation due to modulation. 6. Audio quality as observed in a loudspeaker. 7. Operation at other than standard voltage. 8. Receiver sensitivity in microvolts. 9. Operation at elevated temperatures.

To make these measurements, the following instruments are required: Standard VHF signal generator, frequency meter, deviation meter, r-f wattmeter, VOM (20,000 ohms per volt), VTVM (11 megohms input resistance), capacity bridge, audio signal generator, special meter for particular make of equipment, and heat lamp in gooseneck fixture.

### Special Meter

The special meter mentioned toward the bottom of the list is generally available through the manufacturer of the two-way equipment, and is designed to work with that equipment. An example is Motorola's P-8501-A portable test set, which is supplied with an adapter cable that fits the manufacturer's mobile equipment. It is a 50-microampere 2000-ohm meter which, with the selector switch, permits all essential transmitter and receiver checks when plugged into the radio.

These instruments plus the usual accessories, when assembled and wired as suggested here, will enable you to make all of the necessary measurements with only four connections. Just connect the power

Fig. 1—This is the way the bench setup recommended in the text looks when it is complete.

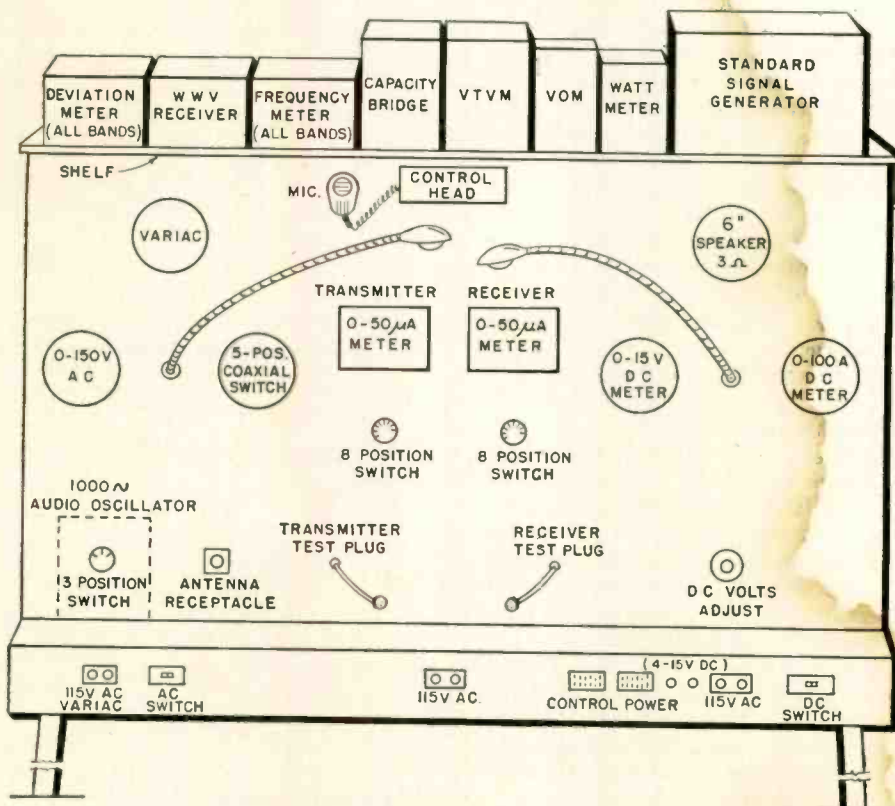

# for Two-Way Mobile Radio

## Sequence of Important Checks and How To Make Them

and control cables, the antenna line, the transmitter test plug, and the receiver test plug. By merely manipulating test equipment controls, you can make the measurements without changing a single connection.

### Setting Up A Test Bench

1. Connect a cable attached to a standard test plug for the make of equipment through a suitable switch to permit selection of each test point on a receiver. Attach a large, 0-50  $\mu$ a meter to this test setup and mount it on the panel as shown in Fig. 1. Note that the cable emerges near the bench level and the meter can be viewed without raising your eyes.

2. Do the same for your transmitter test plug and provide a separate 0-50  $\mu$ a meter for it. Mount the second meter and switch to the right of the receiver setup as shown. In this way, you can meter the transmitter and receiver without changing connections.

3. Install a standard control head for the equipment on the test panel near the top center. Bring out all connections from it to a set of heavy duty receptacles mounted on the front of the bench as shown.

The standard head is the same as the one mounted under the dashboard in the case of trunk-mounted radios. It consists of a microphone, speaker, a press-to-talk button and, like the separate control preamplifier for an audio amplifier, it includes all operating controls.

### Control Head Wiring

Since there are numerous models of equipment in service, some compromise control head wiring must be worked out that will enable you to test all on one head. One way of accomplishing this is to provide sufficient conductors between the control head and bench receptacles so that special adapter cables can be used. Make only as many special adapters as there are models of equipment in common use in your area.

4. Provide antennas for each major frequency band on which you have equipment and bring the leads from these antennas to a coaxial switch and coaxial relay.

5. Wire the switch to pick up the 40 mc, 150 mc, and 450 mc, antennas on positions #1, #2 and #3, as shown in Fig. 2.

6. Connect the coaxial relay common contact to position #4 on the coaxial switch.

7. Connect your standard VHF signal generator to the coaxial relay so that it will be connected to coaxial switch only when the relay coil is de-energized. (The purpose of the relay and switch is to facilitate, during service, a choice of connections of antenna, generator or wattmeter.)

8. Connect the r-f wattmeter to the remaining connection on the coaxial relay. The Termaline wattmeter is an example of the type used here for r-f power output measurements.

9. Connect the coil of the coaxial relay to the keying circuit on your control head so it will operate when the transmitter is keyed.

10. Connect the common terminal of the coaxial switch to the antenna terminal on your test bench.

### Using Coaxial Relay

(Some auxiliary information will throw light on steps 6 to 10 and on the terminology used. The reason for the coaxial relay is to prevent accidental keying of the transmitter while the signal generator is in the circuit, as damage to the generator might result. The relay is connected to the control head so that pressing the push-to-talk button automatically transfers the wattmeter or dummy load to the fourth position. Transmitter keying serves three purposes. First, it operates a relay that connects the antenna to the transmitter rather than to the receiver. Second, it removes B-plus from the receiver. Third, it supplies B-plus to the transmitter. Lights on the control head indicate when the radio set is on and when the transmitter is on.)

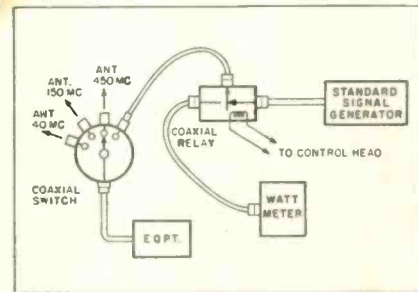

Fig. 2—Method of connecting the dummy load or the antennas to the transmitter output.

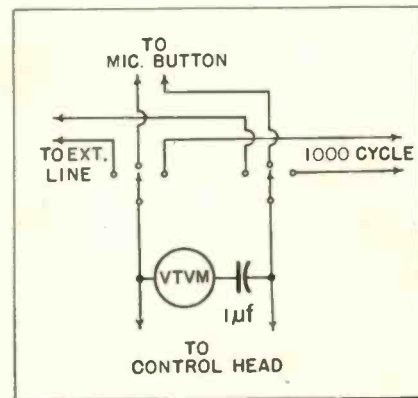

Fig. 3—Circuit provides choice of three inputs into transmitter microphone circuit.

11. Connect an audio signal generator (1000 cps) through a 2-circuit, 3-position switch. Then you may inject 1000 cps directly into your transmitter microphone circuit in position 1, or the microphone itself in position 2, or an external line in position 3. (See Fig. 3.) If an ac VTVM or db meter is provided and left connected across the circuit through a 0.5-mfd condenser, you will have continuous assurance that proper audio level is being injected for audio output and deviation measurements.

12. Provide an adequate dc power supply with continuously adjustable output voltage from about 4 to 15 volts, with 80 amperes at 6 volts and 40 amperes at 12 volts. Have both an ammeter and a voltmeter across the line at all times. Use large, accurate meters.

13. Provide one or two ac outlets (Continued on page 65)

# Latest Test Instruments

## B&K PIX and PATTERN GEN →

The Dyna-Scan Model 1000 picture and pattern video generator is a complete flying spot scanner. It produces a composite video and sync signal that operates any standard black and white or color TV receiver on any VHF channel. By placing a slide film transparency in front of scanning tube, any picture is completely reproduced. Can be used with any number of TV receivers. Operates on 110-120 volt 60 cycle ac. User's net price \$199.95. B&K Mfg. Co., 3731 N. Southport Ave., Chicago 13, Ill. (TECHNICIAN No. 9-6)



## Precision SERIES CHECKER →

Series string filament checker, Model SS-10, completely self-contained and battery-powered, provides a quick check of filament continuity for receiving and TV picture tubes. SS-10 also checks set fuse continuity, ac circuit continuity in TV sets, and pilot lamps. The instruments versatility is extended by a pair of built-in pin straighteners for miniature 7-pin and Noval 9-pin tubes. Compact in size (1" deep x 3½" wide x 5⅞" long), it sells for \$6.50. Precision Apparatus Co., 70-31 84th St., Glendale 27, L.I., N.Y. (TECHNICIAN No. 9-7)



## Weston STANDARD →

DC laboratory standard (1/10 of 1%), claimed to have a far greater degree of shielding than any previous instrument in this class is known as the Model 325. It incorporates the perfected "Cormag" self-shielded core, and a special shield around the entire mechanism. No measurable error in a 5 oersted field, making it unnecessary to position unit in relation to earth's magnetic field, or in presence of current carrying conductors. Weston Electrical Instrument Corp., 614 Frelinghuysen Ave., Newark 5, N. J. (TECHNICIAN No. 9-8)



## RCA GENERATOR & ADDER

Video dot-cross-hatch generator (Model WR-46A) designed for checking and adjusting static and dynamic convergence in color TV sets, as well as vertical-and-horizontal deflection linearity of both color and b&w sets, has high-level output sufficient to drive a picture tube directly. Another instrument is an r-f-i-f-v-f marker adder (Model WR-70A). It is designed for sweep-frequency alignment of both black-and-white and color TV receivers. It provides a choice of four different markers. For use with existing TV marker generators. RCA Components Div., Radio Corp. of America, Harrison, N.J. (TECHNICIAN No. 9-9)

## EMC TRANSISTOR CHECKER

Low-cost transistor checker, Model 210, checks all PNP and NPN transistors, measures gain and three ranges, and measures leakage on a two-color "Poor-Good" scale. It also checks crystal diodes. Supplied with batteries. Available at \$10.95 (wired and tested) and \$7.95 in kit form. Electronic Measurements Corp., 280 Lafayette St., New York, N.Y. (TECHNICIAN No. 9-10)

## Federal FLUX METER

Magnetic flux meter, called a 3-D Flux Meter, unit with built-in 3600-rpm degenerator measures three magnetic spatial components. It is equipped with a long thin probe which permits measurements in narrow spaces. Range from 2 to 1000 gauss in two full-scale settings of 200 to 1000 gauss. Magnetic fields ranging from that of the earth up to 10,000 gauss can be measured. Instrument Div., Federal Telephone & Radio Co., 100 Kingsland Rd., Clifton, N.J. (TECHNICIAN No. 9-11)

## Rodale NEON TESTER

Redesigned model of "Tattelite" neon tester, incorporating pocket clip, is handier to use and gives a longer service life than previous models. Designed to test ac or dc from 110 to 550 v. It will also serve as a pilot light. Rodale Mfg. Co., Inc., Dept. TT, Emmaus, Pa. (TECHNICIAN No. 9-12)

## AEE MONITOR

Known as the Moniscope, the instrument has been designed as a direct means of obtaining continuous visual indication of signal modulation. The modulated signal being measured may be viewed directly upon the face of the 2-inch crt either in the form of a wave envelope pattern or that of a trapezoidal pattern. The Moniscope may be loosely coupled to a radio telephone transmitter. American Electronics Enterprises, 3603 E. 10th St., Long Beach, Calif. (TECHNICIAN No. 9-13)

## FOR MORE TECHNICAL INFORMATION ON NEW PRODUCTS OR BULLETINS

use this convenient coupon. Enter below the reference numbers for all items desired.

New Products Editor  
**TECHNICIAN & Circuit Digests**  
 480 Lexington Ave.  
 New York 17, N. Y.

Please send me more information on the following items:

.....  
 My company letterhead or business card is enclosed.  
 Name .....  
 Address .....  
 Firm ..... My position .....  
 City ..... State .....  
 Business address (if different from above) .....



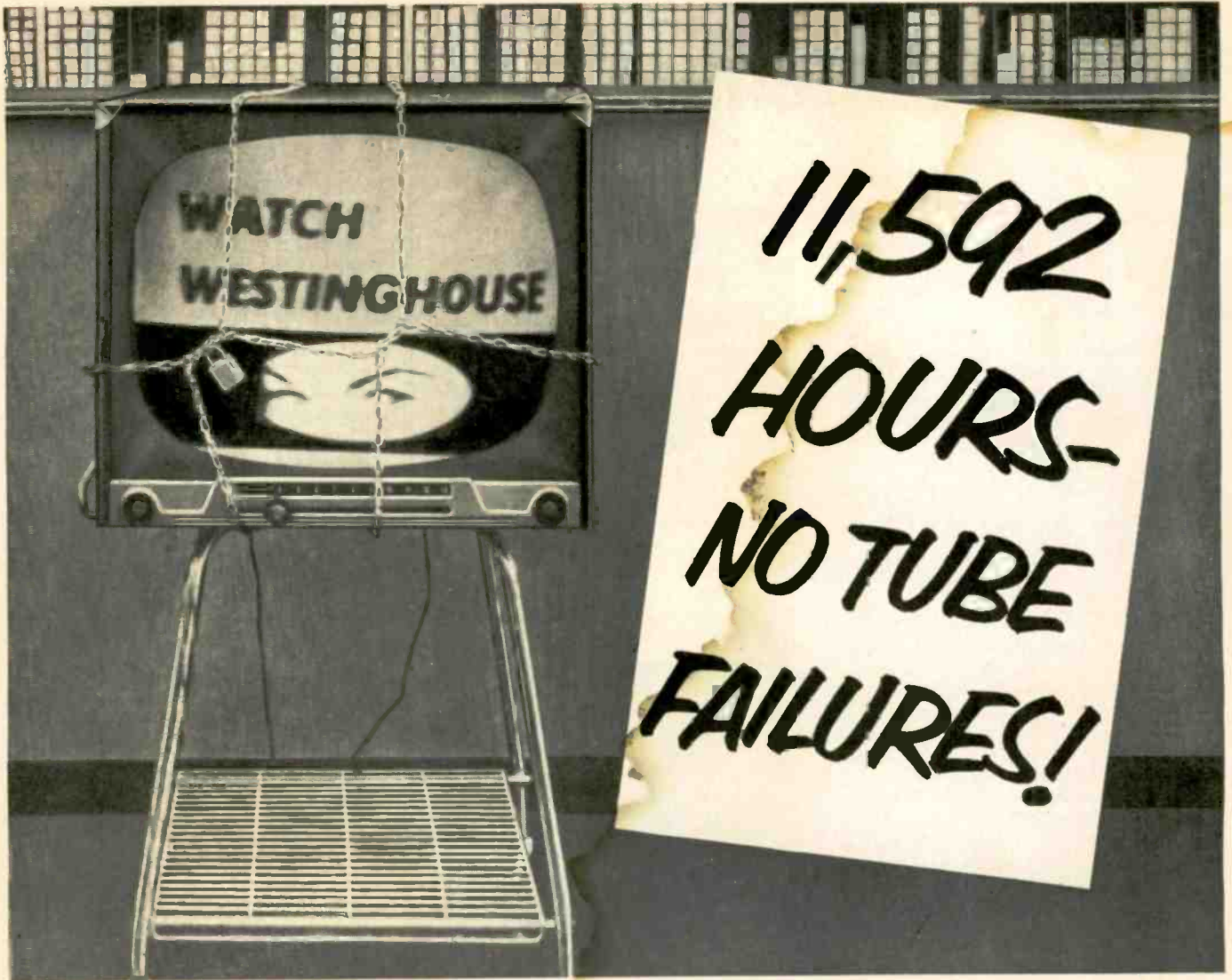

At the Lew Bonn Company, lock and chain are still on this now-famous TV set. And the total useful life of its Westinghouse RELIATRON Tubes is still to be discovered.

## Westinghouse 11,000-hour Locked-TV Marathon Shows how "Pre-Ship" tube test cuts call-backs

On April 25, 1955, the Lew Bonn Company set out to demonstrate the superior performance of Westinghouse RELIATRON® Picture and Receiving Tubes . . . and to prove the benefits of the Westinghouse policy of testing every tube in the warehouse *before final shipment!* They started one of the most amazing marathons in years!

A TV set, chained and locked, was put on display in the showroom of the Lew Bonn Company, Minneapolis. The set was equipped completely with Westinghouse Reliatron tubes—all taken right from stock!

Here's what happened: at first check, 5,472 hours later, all tubes were reported perfect. At second check, 8,784 hours (or over *six years'* viewing time) later, still no failure! After 9,144 hours, still perfect! Now the tubes have chalked

up 11,592 hours—and they're still going strong!

*What made possible this superior tube performance?* Westinghouse manufacturing quality, for one thing! For another, PRE-SHIP TESTING . . . rigorous, six-step testing of tubes for shorts, open circuits, excessive gas, loose mounts, defective glass, and bad seals—all the common causes of call-backs—all done at the local warehouse, *just before the tubes are shipped to your distributor!*

This unique testing policy is insisted upon by Westinghouse as the only way of assuring quality-perfect tubes every time . . . the best way to eliminate costly call-backs, win customer confidence. Stock up on Westinghouse tubes—"pre-ship tested" to guarantee dependability and top performance. Call your Westinghouse distributor today!



**WATCH WESTINGHOUSE**  
WHERE **BIG THINGS** ARE HAPPENING FOR YOU!

6ET-4115

# New Antennas & Accessories

## Taco CO-PHASER →

No. 815 "Co-Phaser" eliminates "venetian blind" as well as co-channel and/or adjacent channel interference. Easily installed. Balanced time delay circuit, with level control, provides cancellation of interference. Cancelling signal is obtained by a second antenna, usually on same mast with prime antenna. Elimination of interference is done by introducing secondary sampler signal, of equal signal strength 180° out of phase to that picked up by prime antenna, into "Co-Phaser." Technical Appliance Corp., Sherburne, N.Y. (TECHNICIAN No. 9-40)

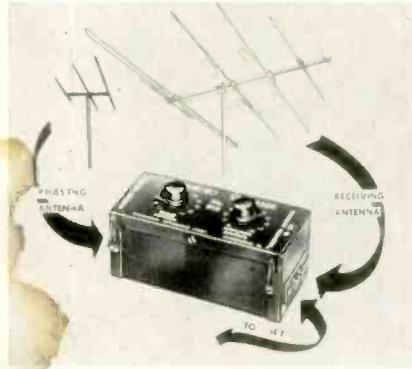

## Jerrold CO-CHANNEL FILTER →

High "Q" filter, named "Line-out," eliminates "venetian blinds" caused by co-channel TV interference, retails at \$15.95. Attached to inside back of TV set. Model V-10 eliminates 10 channel offset frequency which produces bars by beating with 15,750 cps line frequency; model V-20 eliminates 20 kc interference, attenuates beat at least 30 db without distorting desired signals. It is tunable over  $\pm 2$  kc range. CRT socket from "Line-Out" is plugged into pix tube's neck. Jerrold Electronics Corp., 23rd & Chestnut Sts., Philadelphia 3, Pa. (TECHNICIAN No. 9-49)



## Winegard TV ANTENNA →

The "303" VHF TV antenna, stresses these features: a) The ends of all elements are crimped. b) Booms are plugged. c) It boasts hi-impact polystyrene insulators. d) Has 300 ohm driven element to insure 100% signal transfer to transmission lines. e) Streamlined appearance of top quality aluminum construction. f) Has metal phasing lines. Can be used conveniently with top performance in the city—single bay—and in the country—double bay. Winegard Co., Burlington, Iowa. (TECHNICIAN No. 9-42)

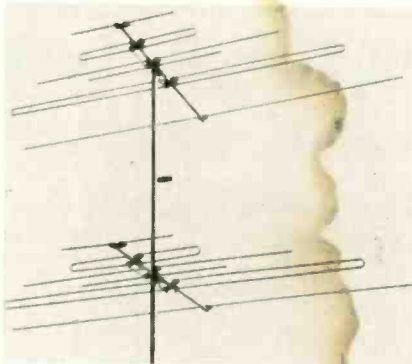

## Rohn FOLD-OVER TOWERS →

No. 30 and No. 40 communication towers are now being converted into fold-over type towers for use in TV installation, amateur radio, experimental work, antenna testing and other operation, boom and reel, and cable mechanism heavy duty towers more suitable for this type work than regular TV towers. These towers utilize standard sections with the addition of special hinged section, boom and reel, cable mechanism. Rohn Mfg. Co., 116 Limestone, Bellevue, Peoria, Ill. (TECHNICIAN No. 9-43)

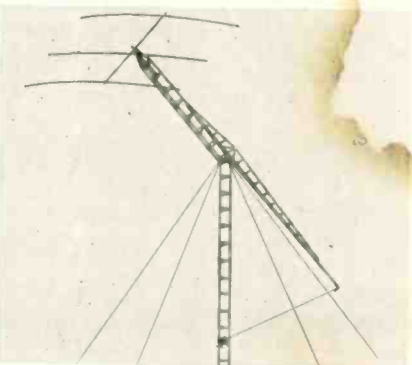

## Snyder ATTIC ANTENNA

Antenna which can either be suspended from an attic ceiling or constructed to stand upright is the AX-100A Attic Model, a modification of the Torque-Tenna outdoor model. The new attic antenna can be quickly unfolded and assembled. Reflector discs help eliminate ghosts. It comes with a one-mast section, adjustable swivel base for ceiling suspension, and 35 ft. of Twin-X cable. Retail \$11.95. Snyder Mfg. Co., 22nd and Ontario Sts., Philadelphia, Pa. (TECHNICIAN 9-44)

## RMS YAGI

All-channel yagi antenna, the "Big Big Shot," Model BBS-400 features two folded dipoles (for channels 2 and 4), reflector for channel 2, and a director for channel 6 to produce gain of a 5-element broad band yagi. Two electrically isolated high band dipoles develop maximum in-phase currents on channels 7-13. Uses special phasing harness. Lists at \$37.25; stacked model BBS-800 is \$75.25. Radio Merchandise Sales, Inc., 2016 Bronxdale Ave., New York 62, N.Y. (TECHNICIAN No. 9-45)

## Davis 10-ELEMENT YAGI

The "Bandmaster" has a vswr uniformly less than 1.6 to 1 on all channels. Improvement of picture quality is credited to the low vswr. Bandmaster is a ten-element all-channel yagi, embodying a focused decapole "space-coupler" for the high band and a twin-driven compensated "space-coupler" for the low band. Straight-through elements have no joints at high current points. Davis Electronics, 4002 W. Burbank Blvd., Burbank, Calif. (TECHNICIAN No. 9-46)

## Helix ANTENNA ROTATOR

Low-priced antenna rotator Model H-1 requires no electric motor. It employs the age-old mechanical principal of a flat spiral 360° rotation. A slotted cross arm within the housing is moved downward by an easy pull on the manually operated steel cable. As the slotted arm moves downward, the antenna is rotated. Design of arm and helix causes antenna to lock in any position to prevent drift. Retail price is \$24.90. Helix Rotor Co., 220 Live Oak, Marlin, Texas. (TECHNICIAN No. 9-47)

## Tenatronics ANTENNAS

New line of communication and auto antennas will be manufactured, as well as a full line of accessories. Included are both regular and heavy duty equipment, and front, rear and side-mounting auto types. Top cowl model is the "Canonball." Tenatronics, Ltd., 811 Union Commerce Bldg., Cleveland 14, Ohio. (TECHNICIAN No. 9-48)

# New Motorola® *Transistor* POWERED Car Radio

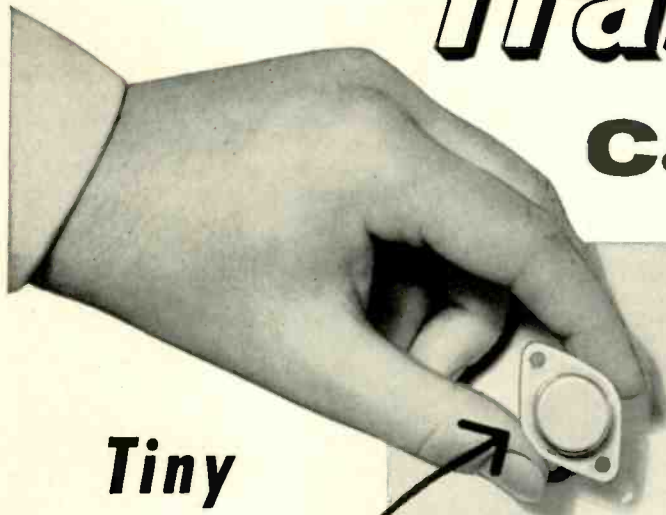

**Tiny transistor replaces 15 vital car radio parts**

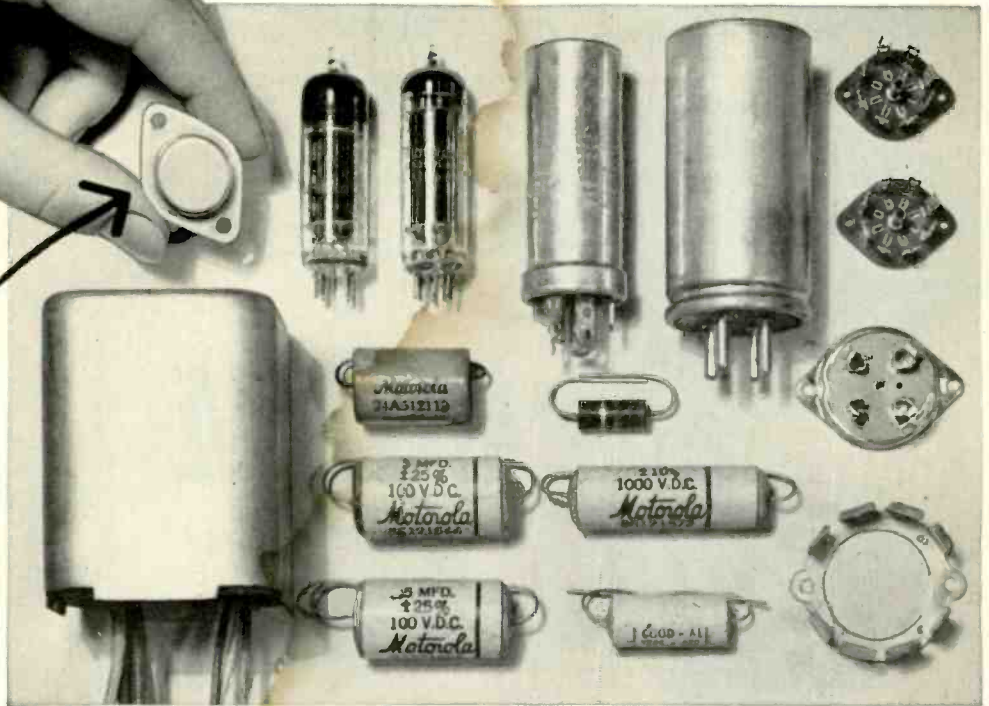

**WITH A "GOLDEN HEART THAT WON'T WEAR OUT"**

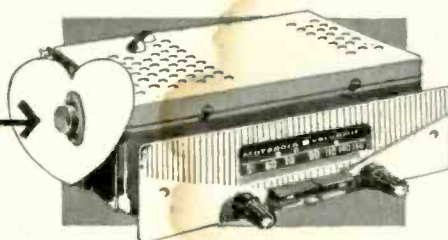

*Motorola Transistor-Powered Car Radio. (Model 6TAS-8, 12 volt) \$99.95. Other new models from \$39.95*

**PLUS—NEW TWIN BAR STATION FINDER** Most automatic tuning of all! Electronically picks and pinpoints any station. Twin Search Bars move station selector either right or left from any point on the dial.

**Most trouble-free car radio ever built**—The amazing transistor heart won't ever wear out. And it replaces 15 parts that do wear out in conventional sets. (Including the vibrator and vacuum tubes.)

**Cuts battery drain 50%**—Transistors use hardly any power. Even with the engine off, this radio can play for hours without running down the battery.

**Fits most cars**—Custom fits instrument panels of most cars. Takes just a few minutes to put in. (Or, Motorola's Installation Depot can do it for you, in most cities.)

**Here's how you fit in**—Every fourth car lacks a radio. Car radio sales are up 30% . . . and still growing. And now, Motorola has produced the hottest car radio ever. Advertised in *Reader's Digest* (to reach every third American). Now's the time to get into the plus-profit car radio business. Send this coupon today. No obligation.



## MOTOROLA

World's Largest Exclusive Electronics Manufacturer

Motorola, Inc., Dept. T-9  
4545 W. Augusta Blvd.  
Chicago 51, Illinois

Attn.: Car Radio Department  
Please give me all facts about the Motorola Car Radio business. Thank you.

Name \_\_\_\_\_

Firm \_\_\_\_\_

Street \_\_\_\_\_ City \_\_\_\_\_ State \_\_\_\_\_

# New Products for Technicians

## Centralab's "RADIOHMS"

Versatile 1/4 watt miniaturized controls in 28 selections, all with a tolerance of 20%, have resistance ranges from 1000 ohms to 2.5 megohms. Model JP has a plain round shaft 1/8" in diameter and 1/2" long. It's bushing is 1/4"-32,-1/4" long. Model JL has a screwdriver slotted shaft 1/8" long. Centralab, Div. Globe-Union, 900 E. Keefe Ave., Milwaukee 1, Wisc. (TECHNICIAN No. 9-4)

## Alliance MOTOR

A new fractional horsepower motor designed for maximum life and minimum noise. Particularly suited for low torque continuous duty application, this new motor is factory lubricated and sealed, thus requiring no periodic attention by consumer. Present models are designed for 110 v.-60 cycle ac operation. Alliance Mfg. Co., Inc., Alliance, O. (TECHNICIAN No. 9-29)

## Wall "PENCIL" SOLDERING IRON

A new "Pencil" soldering iron ideal for delicate precision work on printed circuits, regular radio and TV circuits and all intricate electrical work. Claimed to be one of the smallest and lightest soldering irons, it weighs only one ounce, has a 1/8" tip and is just 7 1/2"

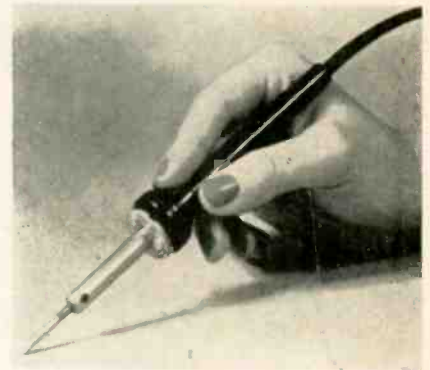

long. It has thermostatic action without fragile thermostats, which controls heat so perfectly that excessive fusing and tip-burning are eliminated. Operates on 110-120 v., ac or dc. Comes with either copper or special "Walloy" tip. Wall Mfg. Co., Grove City, Penna. (TECHNICIAN No. 9-23)

## Utica BOX JOINT PLIERS

A duck bill wiring pliers, 931-8, and a needle nose assembly pliers, 982-8, are now being produced with box joint assembly. The use of the box joint on these two pliers keeps the jaws in perfect alignment, according to the manufacturer. Both the wiring pliers and the

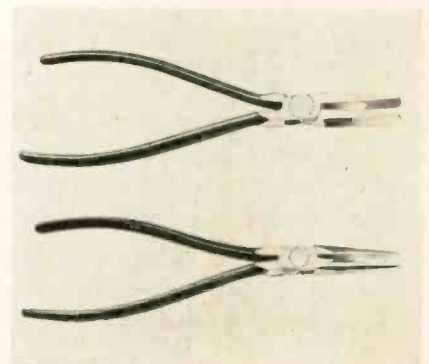

assembly pliers are made of alloy steel and have electronically hardened jaws. Also have long thin heads for hard-to-get-at places, and slender handles, shaped for comfort. Utica Drop Forge & Tool Corp., 2415 Whitesboro St., Utica 4, N.Y. (TECHNICIAN No. 9-24)

Radio-TV  
servicemen  
prefer

## QUAM *Adjust-a-Cone* SPEAKERS

Because they know from actual field experience that Quam speakers give longer, trouble-free operation.

*Quam Speakers have been built under the same management for over 30 years.*

\*Brand Name Surveys; Survey of brand preferences of electronic replacement components, April 1956, reported Quam Speakers preferred by almost twice as many servicemen as the next most popular brand.

**QUAM-NICHOLS  
COMPANY**

226 East Marquette Road  
Chicago 37, Illinois

*QUAM, the quality line,  
for all your speaker needs*

## New Tubes & Components

### RCA AUTO RADIO TUBES

Seven new receiving tubes are for use in 1957 and other automobile receivers in which transistors are used in the output stage and in which electrode voltages for both tubes and transistors are obtained directly from a 12-v. battery. The 12AD6 is a 7-pin pentagrid converter. The 12AE6 and 12AJ6 are multiunit 9-pin miniatures, each containing two diodes and a medium-mu triode. The 12AF6 and 12BL6 are 7-pin remote-cutoff pentodes for r-f and i-f amplifiers. The 12F8 is a multiunit 9-pin miniature containing two diodes and a remote-cutoff pentode. It is intended for AM detector and avc. The 12K5 is a 7-pin high-perveance power tetrode. Each of the 7 types has a 12.6-v./0.15-amp heater except the 12K5 which has a 12.6-v./0.4-amp heater. RCA Tube Div., Radio Corp. of America, Harrison, N.J. (TECHNICIAN No. 9-1)

### Sylvania MINIATURE TUBES

Four new 9-pin miniature tubes for use in both b & w and color TV receivers are designated the 5CL8, 6CL8, 5CM8 and 6CM8. All have controlled heater warm-up time for series heater strings, the 5CL8 and 5CM8 being 600 ma. and the 6CL8 and 6CM8 being their 450 ma. counterparts. The 5CL8 and 6CL8 are triode-tetrodes for oscillator mixers in VHF tuners. With the elimination of both the shield and beam plate, both may be used in those sets where it is costly to provide the usual double cathode triode-pentodes. The 5CM8 and 6CM8 are high mu triodes, sharp-cutoff pentodes. The pentode section of each tube features high transconductance, sharp-cutoff and low number one grid-to-plate capacity, and may be used as i-f, video or agc amplifiers, as well as reactance tubes. Sylvania Electric Products, 1740 Broadway, New York 19, N.Y. (TECHNICIAN No. 9-2)

### Int. Rect. 1-KV SILICON DIODE

High voltage diodes are available in peak inverse voltage classifications of 600, 800 and 1,000 v, with half wave dc output currents of 125 ma at 75°C ambient. Operating temperature range is from minus 55°C to plus 150°C ambient. The diodes occupy a volume of only 1/16 cu. in. (3/8" dia x 9/16" long) and are provided with pigtail leads. They are hermetically sealed. Bulletin SR-138 gives details. International Rectifier Corp., El Segundo, Calif. (TECHNICIAN No. 9-3)

### Astron FILTER

Miniaturized r-f noise suppression filter, style No. AF 1046, incorporates 4 toroid coils and a capacitor section. The rugged construction enables it to withstand great amounts of shock and vibration as well as severe climatic conditions. Astron Corp., 225 Grant Ave., E. Newark, N.J. (TECHNICIAN No. 9-5)

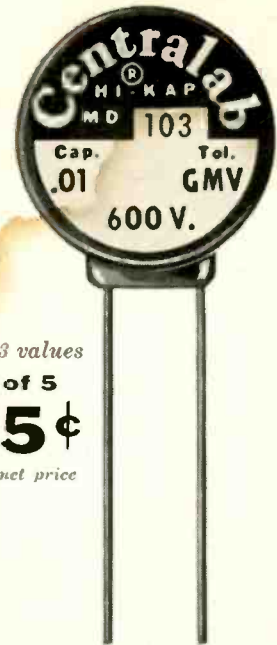

Available in 53 values  
**Package of 5**  
**only 75¢**  
*suggested net price*

# TWENTY-FIVE YEARS!!!?

*For long life . . .  
 there's nothing like*

## Centralab Type MD Molded Ceramic Disc Capacitor

The only completely insulated ceramic disc capacitor —2500 V.D.C. breakdown to ground.  
 Life expectancy, 25 years in normal operation.  
 Nine ways better than ordinary discs.  
 Conservative rating provides extra margin of safety.  
 One-piece construction won't chip, crack, or break.  
 Leads can't pull out.  
 High leakage resistance; low moisture absorption.  
 Catalog 29 gives detailed facts. Send coupon today.

## Centralab

A DIVISION OF GLOBE-UNION INC.  
 902 E. Keefe Avenue, Milwaukee 1, Wisconsin D-5617

Send me free Centralab Catalog 29.

Name \_\_\_\_\_  
 Company \_\_\_\_\_  
 Address \_\_\_\_\_  
 City \_\_\_\_\_ Zone \_\_\_\_\_ State \_\_\_\_\_





# Time for REPLACEMENT?

Specify  
**OXFORD**  
SPEAKERS

Speakers is our prime business and we supply more of the BEST manufacturers of original equipment. Since we have quality replacement speakers for any and every application . . . you will actually better the original sound with OXFORD SPEAKERS.

Why wait . . . find out TODAY why more and more servicemen are switching to OXFORD SPEAKERS . . . when it's time for replacement!

*Our latest catalog is available . . . write today!*

*...at better jobbers!*

## OXFORD ELECTRIC CORPORATION

Distributor Sales Division

556 West Monroe Street, Chicago 6, Ill.

In Canada: Atlas Radio Corp., Ltd., Toronto

Export: Roburn Agencies, New York City



SERVICE MEN KNOW THERE IS JUST ONE

## HUSH

Reg. U.S. Pat. Off.

Chemically engineered for tuners and switching mechanism



Hush comes in a 6 oz. pressure can with sufficient pressure to reach all contacts to wash-away that dirt, leaving clean and positive contacts, protected with a lasting lubricant film.

**\$2.25** net

Hush also available in 2 oz., 8 oz. and 32 oz. containers.

See your distributor or write to

CHEMICAL ELECTRONIC ENGINEERING, INC. Matawan, New Jersey

## EVER-QUIET

Reg. U.S. Pat. Off. Pend.

Since 1949 the Original Volume Control & Contact Restorer

EVER-QUIET is a free-flowing liquid that leaves no powder residue. Scientifically designed to seep around the shaft and penetrate the control or potentiometer, cleaning the contacts and leaving a safe protecting film. Harmless to metals, wire or carbon. Will not affect inductance, capacitance or resistance.

2-Ounce Bottle with Handy Dispenser (32 oz.)

only **59c**



# New Audio

## Jensen DRIVER UNITS

Series of Hypex driver units guaranteed for life are designed for commercial and public address application. Response has been shaped to give emphasis to 3-5 kc, which is important in high efficiency sound projection. The D-30 is rated at 30 watts speech and music,



D-40 at 40 watts. The DD-100-watt Superpower Driver Unit is claimed as the first double acting integrated sound chamber driver unit and it is also the first 100 watt unit available. Jensen Mfg. Co., 6601 S. Laramie, Chicago 38, Ill. (TECHNICIAN No. 9-14)

## Telex "3-D" HEADSET

Tele-Fi is a lightweight headset with three-dimensional hearing. 30% better understanding is accomplished by inducing a one millisecond time-lag between ears. Tele-Fi weighs only 1/2 oz. Frequency response is 60 to 6,000 cycles. Comfortable listening at 1 mw input.

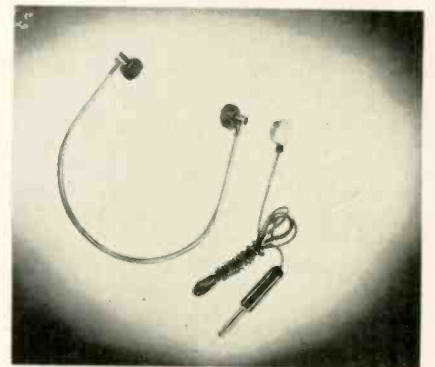

In two impedances: 128 ohms (No. 18035) and 1,000 ohms (No. 18020). Continuous single plastic tone arm achieves time delay in reception of sound by ear opposite receiver. Telex, Inc., Electro-Acoustic Div., 1633 Eustis, St. Paul, Minn. (TECHNICIAN No. 9-15)

# Products

## Goodmans SPEAKERS

Midax mid-high frequency and Trebax high frequency speakers have been added to line. Midax is a middle high frequency driver and exponential, flared horn with frequency coverage to 8 kc. Impedance is 15 ohms. 5.0 and 0.75 kc crossovers. Price is \$58.80. Trebax is a tweeter with a built-in horn. Frequency response extends to 15 kc. 5.0 kc crossover. Impedance is 15 ohms. Rockbar Corp., 650 Halstad Ave., Mamaroneck, N. Y. (TECHNICIAN No. 9-18)

## Regency AMPLIFIER KIT

HF-50K "do it yourself" audio amplifier kit offers 50 watts of power for \$74.50 and about four hours assembly time. Frequency response:  $\pm 0.2$  db, 20 to 20,000 cps,  $\pm 1$  db, 5 to 100,000 cps. IM distortion: less than 1% at rated output, less than 0.2% at normal listening levels. Harmonic distortion: less than 1%, 20 to 20,000 cps up to 50 watts. Damping factor: 15. Regency Div. I.D.E.A., Inc., 7900 Pendleton Pike, Indianapolis 25, Ind. (TECHNICIAN No. 9-19)

## Fairchild PICKUP

New 225 series "Micradjust" diamond stylus pickup based on high compliance moving coil principle is flat to 20,000 cps with smoothly decreasing response beyond. Its low impedance (200 ohms) design provides average output of 5 mv which will drive modern amplifiers without a step-up transformer. Nominal impedance is 200 ohms. Three models: 225A, 1.0 mil; 225B, 2.5 mil; 225C, 3.0 mil. Audiophile net: \$37.50. Fairchild Recording Equip. Co., 154 St. & Powells Cove Blvd., Whitestone 57, N. Y. (TECHNICIAN No. 9-20)

## Walco DISCLOTHS

Discloths, 112 sq. in. anti-static record cloths, rid records of dust, leave them static-free from play-to-play. Made by Philips of the Netherlands, for dealer resale. Walco Products, Inc., 60 Franklin St., East Orange, N. J. (TECHNICIAN No. 9-21)

## Recoton NEEDLES

Additions to replacement needle line include six more types, catalog nos. 454 through 458, at \$2.50 to \$4.50 list, plus 458SD sapphire-diamond standard-micro combination at \$30 list. Among the changers and players in which they may be used are those made by Garrard, Collaro, Monarch, Plessey, Emi, Fentone, Majestic, Blaupunkt and Telefunken. Recoton Corp., 52-35 Barnett Ave., Long Island City 4, N. Y. (TECHNICIAN No. 9-22)

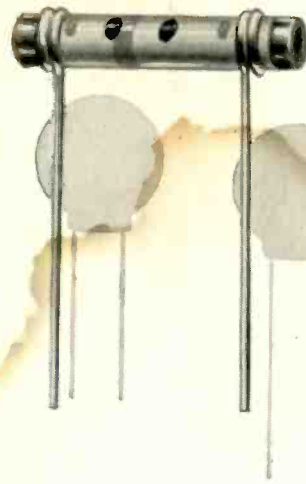
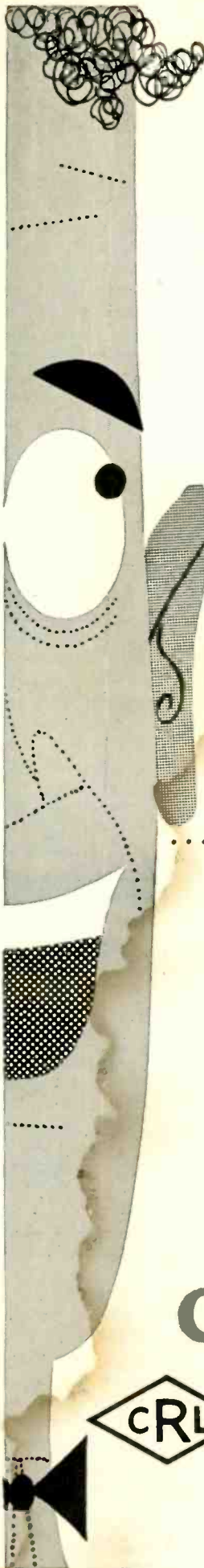

# REST IN PEACE

*You'll bury your problems  
... when you install*

## Ceramic Capacitors bearing the famous CRL trademark

No call backs with Centralab — here's why: 100% tested at double rated voltage — for assurance of long life, even under heavy overloads.

Tough, extra heavy insulating coat—for resistance to moisture, heat, vibration.

Catalog 29 shows the industry's *most complete line* of ceramic capacitors — including the *only truly* insulated, molded disc capacitor. Tear out coupon and mail today for your free copy.

# Centralab

A DIVISION OF GLOBE-UNION INC.  
9021 E. Keefe Avenue, Milwaukee 1, Wisconsin D-5618

Send me free Centralab Catalog 29.

Name \_\_\_\_\_

Company \_\_\_\_\_

Address \_\_\_\_\_

City \_\_\_\_\_ Zone \_\_\_\_\_ State \_\_\_\_\_



# IT'S Blue Chip



# Quality

Tung-Sol Magic Mirror Aluminized Picture Tubes mirror twice the light to create a picture twice as bright. They bring out the best in every set. Install these superior tubes and see the difference . . . the difference that pays off in smooth, callback-free service and satisfied customers. Tell your supplier you'd rather have Tung-Sol Tubes.

*Blue Chip Quality*

**ts TUNG-SOL®**

Magic Mirror Aluminized  
**PICTURE TUBES**

TUNG-SOL ELECTRIC INC., Newark 4, N. J. Sales Offices: Atlanta, Columbus, Culver City, Dallas, Denver, Detroit, Melrose Park (Ill.), Newark, Seattle.

## Opportunity Is Knocking

JAMES C. SARAYIOTES  
ADVERTISING COUNSELOR  
JFD MFG. CO.

• Scene: Bill Williams TV-Radio Shop around the corner. TV sets, in various stages of repair, are on the floor, in wall racks, and on the work bench. Several different type radios, a few phonographs and a high fidelity audio amplifier can also be spotted tucked away under the bench. A customer is patiently waiting inside the door with a personal portable radio under his arm. The service shop owner is on the phone . . . "Yes, 'mam, our man is on the way down now . . . Sorry, 'mam, couldn't help the delay but you'll have your set back in 30 minutes. Thank you." He hangs up the phone, waits on the customer, then begins to check the sheaf of bills on his desk. The repairman on the bench calls him to point out something to him. Just then the phone rings again. Bill Williams picks it up with a sigh. "Yes, 'mam. . . ."

Does this recreated drama evoke memories?

Perhaps you draw on like situations as ample justifications for lack of attention to the most neglected facet of your operation: advertising and sales promotion. Frankly, you are kidding nobody, but yourself.

According to the U.S. census of business for the Dept. of Commerce, radio-TV service outlets in 1955 earned the dubious distinction of being among those retailer groups with the most failures.

I can hear you saying that it's very easy to talk about sales promotion and merchandising, but you simply don't have the time or the money even if you knew what to do.

Stop right there.

In my trips around this wonderful country, I have had the opportunity to visit and chat with many service technicians, big and small. Some were small and didn't have the inclination to grow. Some were small but the owners were fired with the ambition to get ahead. Others were large and prosperous and were continuing to push back their business horizons.

### *Following A Merchandising Plan*

Most of them started in business as a small 2-4 man operation. The dealers who got ahead had followed a considered advertising and merchandising plan and were continuing to follow one. Initially, none of these operations had the time or the money for salesmanship and showmanship. But they got out of their rut and on the track with a realistic blueprint of action in mind. So can you!

Let us consider the problem of time.

Set aside 2 hours per week—even if it means skipping a movie or a bowling date or a little sleep—and write down the answers to these questions.

1. *Do the members of my staff use smart salesmanship?* This doesn't call for high-powered courses at the local university—only practiced common sense. A one-hour session per week, every week, either after hours, in the shop or at home will work wonders. Many leading TV receiver and tube manufacturers are excellent sources of sales training material. Company representatives are often made available by such manufacturers to dealers especially for this purpose.

2. *Do the members of my staff practice good customer relations?* Quality workmanship is not enough. Don't take for granted that your servicemen are keeping your



## on Your Door!

customers happy. Perhaps their appearance or speech can be improved. People like to do business with pleasant, sincere human beings, not smart alecks or "snow-job" artists. Honesty and courtesy are prerequisite attributes for repeat business.

3. *Does my store reflect my business personality?* We like to think of ourselves as knights in shining armor. Under the hard cold light of self-analysis we discover unexpected chinks in our facade. What kind of impression does your prospect or customer gain upon first entering your sales room or shop? Dr. Ernest Dichter and other leading proponents of motivational research have proved conclusively that most people think with their emotions and not with their brains. Orderliness, cleanliness, attractiveness are essential to store showmanship. Judicious display of sales promotion devices invites customer inquiries, often leads to closed sales.

### Promotional Ideas

4. *What am I doing to promote business?* When was the last time you mailed a postal card to your past or present group of customers? Longer than you care to think, perhaps. If you knew the surprisingly high percentage of TV set owners in a community who don't know the name of a local service company you would be appalled. Have your telephone operator, or your wife, or your daughter or a part-time school worker, spend one-half hour a day addressing service specials or service reminder cards to past, present, and future customers—and you'll see results. Distribution of "Handy TV hint" cards, bulletins or handbills house-to-house in your area promotes business and establishes your name as the one to remember for electronic servicing.

5. *What advertising ideas have I come up with recently?* Your telephone directory listing is not a key item. People often call the serviceman nearest their homes. Have you ever offered a free TV antenna check-up to your neighborhood TV set owners? Perhaps you can offer members of your staff a commission for each call or inquiry they make that leads to an antenna sale. The sales increase you will realize will more than compensate for the extra time involved in the free antenna inspections which will frequently provide you with needed sales ammunition.

Offer easy payment terms, financed locally, as an added inducement for making needed set repairs. Offer vacation specials on radio or TV repairs. The national TV serviceman weeks offer another made-to-order opportunity on which to capitalize while the nation's attention is focussed in your direction. At this point, doubtless you would like to call my attention to that aforementioned tremendous trifle—money.

If you will review the above suggestions you will discover that only remarks nos. 4 and 5 involve expenditure of funds—and only very moderate sums at that. If you do not have the margin to create an advertising surplus, then you should raise your prices 3-5%. Perhaps it will cost you some business. However, when compared with the new sales increase you will enjoy by virtue of the consistent and effective advertising merchandising it will afford you, you will see the wisdom of it.

Now the age of color is here, and awaits your cultivation of its vast sales potential. It is the key that will unlock great new set and antenna replacement markets. It's opportunity knocking on *your door!* Will you be able to answer? •

# IT'S Tung-Sol



# Quality

Tung-Sol receiving tubes for TV, radio and Hi-Fi replacement are exactly the same as those supplied to leading independent set makers. This one quality—Blue Chip Quality—is your assurance of long, trouble-free service that keeps customers with you year after year. Tell your supplier you'd rather have Tung-Sol Tubes.

*Blue Chip Quality*

**ts TUNG-SOL<sup>®</sup>**  
**RECEIVING TUBES**

TUNG-SOL makes All-Glass Sealed Beam Lamps, Miniature Lamps, Signal Flashers, Picture Tubes, Radio, TV and Special Purpose Electron Tubes and Semiconductor Products.

*As easy to use as a pencil*



**WALL**  
INDUSTRIAL  
SOLDERING IRONS  
*give you*

More  
BTU's...  
Faster  
HEAT...  
Higher HEAT  
CONTINUITY

Exclusive  
**THERMOSTATIC ACTION...**

Guaranteed for the life of the iron!  
Prevents excessive tip burning!

than ANY OTHER  
soldering irons of equal tip size

Proved 4 times faster on the production lines of America's leading electronics firms. Complete range of sizes... scientifically designed... individually tested... for easier, surer precision work or heavy duty soldering. Operate on 110-120 volts, AC or DC! Model 18T illustrated, \$6.25 list.

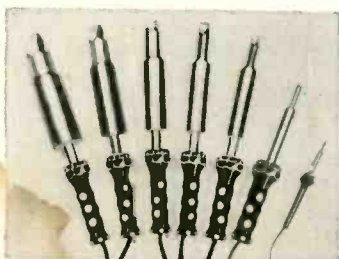

Write for FREE Catalog



**WALL** MANUFACTURING CO.  
Grove City, Pennsylvania  
OVER 20,000,000 SOLDERING PRODUCTS SINCE 1864

**Audio NEWS LETTER**

How's the audio business? What are the prospects? Somewhere between fabulous and sensational, say the experts. Pres. John Bentia of Alliance Mfg. forecasts phono and record changer business up at least 25% this year. By 1960 he expects 14,000,000; by 1962 more like 18,000,000 annually.

The hi-fi component business should zoom from \$50,-000,000 this year to ten times that by 1961, predicts Ed Altshuler of American Electronics. Incidentally, AE has come up with a wonderful tape stereo system using Herman Miller cabinets, Craftsman tuners & amplifiers. List is (ahem) \$1913, without speakers.

That fourth record speed, 16 rpm, now being built into many phonos, is the target for background music as well as talking books. Audio Book Co. is issuing 7-in. discs at \$1.69 list with 40 min. playing time. We overheard an engineer say there was a possibility with 8 rpm....

New York hi-fi show, Sept. 27-30 at the New York Trade Show Bldg., 36 St. & 8 Ave., will feature 79 exhibit firms, reports Rek-O-Kut's George Silber, pres. of Institute of High Fidelity Manufacturers.

DON'T MISS "\$ in Election PA Work" and "New Audio Products" in this issue.

Hi-Fi Shows coming up: Sept. 7-9, Cincinnati, Sheraton Gibson Hotel; Sept. 14-16; Atlanta, Henry Grady; Oct. 12-14, Miami, McAllister; Oct. 25-27, New Orleans, Roosevelt.

The big Los Angeles High Fidelity Show will be held Feb. 6-9, 1957, at a site still to be determined. More info from Institute of High Fidelity Manufacturers, P. O. Box 284, Mineola, N. Y.

A non-partisan Jensen Mfg. Co. installed triax speakers at both Democratic and Republican conventions.

sell

**RECOTON**

**REPLACEMENT NEEDLES**



on every job!

It's easy to sell famous Recoton Replacement Needles on every service call you make! Everyone buys phonograph needles — and Recoton's have 100% consumer acceptance. Easy to carry in Recoton's smart, professional #100 Kit, complete with eye loupe and tools, all Recoton Replacement Needles are easy to find, too, without guessing, and best of all, easy to install. That's why more service men recommend — and sell — **RECOTON Replacement Needles on every job!**

**RECOTON CORPORATION**

52-35 Barnett Avenue  
Long Island City 4, N. Y.

## Two-Way Radio

(Continued from page 53)

connected through a variable-voltage transformer capable of supplying at least 250 watts. An added refinement would be an ac voltmeter permanently connected to this line.

14. Provide a connection to measure the audio output voltage across the speaker voice-coil line. This may be available already, or added to one of the positions on the receiver test microammeter. It will usually be simpler to insert a small rectifier in series with the meter switch position used for this measurement rather than to use a separate meter. These audio measurements will be found invaluable in detecting weak audio tubes or other audio troubles.

15. This setup could even provide for measurement of recovered audio developed from measured amounts of deviation. Such measurements are seldom made because of the scarcity and cost of signal generators having FM modulation, but a constant sine wave audio voltage applied to the base station would be an adequate substitute.

All portable instruments should be arranged on a shelf at eye height, connected semi-permanently and provided with suitable test leads. The most frequently used meters should be rather low on the back panel so that they may be viewed without lifting the eyes much from the bench, yet high enough to prevent damage by equipment cases on the bench.

The ac outlets, the 6 and 12 volt dc terminals, and the sockets for the control and power adapter cables should all be on the front edge of the bench just under a slight overhang. One or two gooseneck incandescent lamp holders should be mounted under the top shelf to place light in hard-to-get-at places. These should be in addition to adequate fluorescent general lighting.

Of the instruments on the shelf, only the VOM and VTVM need ever be moved, the others being permanently connected through the coax switch or arranged to have adequate test leads attached.

The only auxiliary piece of equipment should be a receiver for WWV which may in some cases be a part of your frequency meter. Other pieces of equipment, if any, will be so rarely used that they should be stored in a closet.

The audio oscillator and the dc

power supply can be mounted under the bench.

### Measurements

**Power Input:** An accurate, continuously connected meter can save hours of looking for troubles that only exist because of high or low input voltage. "A" power supplies, power lines, and even batteries vary greatly in output with load; the voltage must be continuously checked.

**Power Output:** Both r-f and audio power outputs are easily measured. No tube tester is listed because none

is required. If the output is normal when a standard dc input is supplied, all of the tubes are all right. If the output is not normal, the tubes should be checked by substituting for each tube one known to be good.

**Audio Input:** There is a minimum audio input voltage required to fully modulate the transmitter. With an adjustable voltage source at 1000 cps and a VTVM connected across the line, you will instantly know the modulation capabilities of the transmitter audio system by concur-

(Continued on page 72)

## How to increase your income

- ▶ Two-way radio
- ▶ Microwave relay
- ▶ Home electronics
- ▶ Industrial electronics
- ▶ Radar

Find out how you can increase your monthly income by installing and maintaining the types of electronic devices listed above.

Anyone now in the radio-television servicing field can qualify. A Commercial FCC license will open the door to new profit areas . . . and the work is interesting.

Don't limit yourself to receiver servicing. Prepare yourself to handle the more profitable jobs in electronics. Fill out the coupon below and mail it TODAY. The information is free!

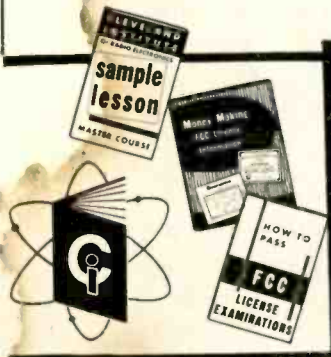

Cleveland Institute of Radio Electronics  
Desk T3, 4900 Euclid Bldg., Cleveland 3, Ohio

Please rush the Free booklets to

Name .....

Address .....

City .....

Member National Home Study Council

# the Talk of the Industry



an amazing new service tool...

at a Fantastically Low Price!

## BOSIPT

SOLD ONLY THROUGH DISTRIBUTORS

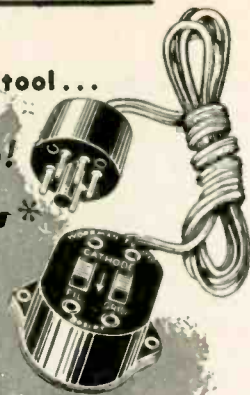

No more need for expensive, elaborate equipment to repair picture tubes. The convenient BOSIPT\* does the job in two minutes without removing the chassis. Easy to set up—easier to use, it repairs filament-to-cathode and grid-to-cathode shorts in a jiffy. Restores brightness control operation. There's no bulky testing case, no extra leads required.

See your favorite Local Parts Jobber

- \* **B**oths **O**n **S**horts **I**n **P**icture **T**ubes
- PAYS FOR ITSELF** — with the first use.
- REPAIRS PICTURE TUBES** — in the set.
- GIVES LONGER PICTURE TUBE LIFE** — to regular customers.
- TWO MINUTE OPERATION** — saves \$40 tube.
- SIMPLE AND EASY TO USE** — and fits into your kit.

\$5.95 list



**WORKMAN TV INC.** TEANECK, N. J.  
Manufacturers of Electronic SPECIALTIES

## \$ in Election P A

(Continued from page 38)

cord at its other end are then connected to the low-impedance secondary (speaker) winding of a small output transformer. The high-impedance winding of this transformer—ordinarily the primary or output-tube plate winding—now becomes the secondary, which is connected across the volume control of the radio. See Fig. 3. (The extra transformer should not be a great distance from the radio.) You now have a PA system.

There is also the problem of supplying power for equipment intended for use on standard house current when in the field. An inverter may be used to operate from an automobile battery, for this purpose. If it is desired to minimize the drain on the battery or the inverter, there are available spring-wound phonographs with crystal pickups to eliminate the operation of a phono motor.

Conversely, you may have equipment on hand designed for mobile use, but be put in a position where you have to operate it indoors. In this case, you can use a filament transformer of appropriate rating to step down the house voltage. Long-term operation of such a hook-up, however, is not recommended. •

## "Tough Dog" Corner

(Continued from page 45)

wiring and then checked, it read its correct value of 680k.

Before R-176 was returned to the circuit, examination was made of the control-grid circuit from which it had been severed. A study of the circuit shows that, with the resistor in question disconnected, the reading between any of the other components in the control-grid circuit and ground should be infinite resistance. However, application of the ohmmeter probes between the chassis and the control-grid terminal lugs of V110B or V111 did give a resistance reading, indicating definitely that leakage was occurring between one of the components and ground.

Leakage was first suspected between one of the grid socket terminal lugs and the chassis. However, when R-164 and R-173 were disconnected from their respective socket lugs, an infinite-resistance reading was obtained between these lugs and

## EARN EXTRA PROFITS

### Rich-Wil 98 "RADIO CONTROLLED" ELECTRIC OPERATORS

FOR RESIDENTIAL GARAGE DOORS PROVIDE TODAY'S GREATEST OPPORTUNITY FOR:

- YEAR 'ROUND SALES
- STEADY, HIGH PROFITS

Now you can offer the modern, practical way to eliminate the minor irritations and "back-breaking" lifting involved in opening and closing garage doors... sell the Rich-Wil 98 Electric Operator with remote controls. Fits all 8' to 18' one piece or sectional doors with track-type hardware. Now's the time to "cash-in" on today's hottest home-appliance market with America's only QUALITY unit at an ECONOMICAL price... the Rich-Wil 98.

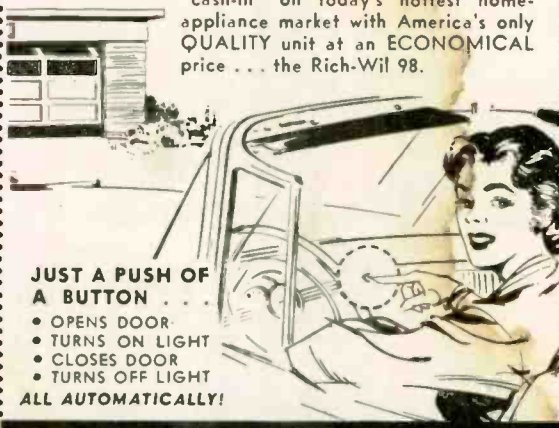

JUST A PUSH OF A BUTTON...

- OPENS DOOR
  - TURNS ON LIGHT
  - CLOSSES DOOR
  - TURNS OFF LIGHT
- ALL AUTOMATICALLY!

Outstanding features of the Rich-Wil 98 Electric Operator...

- Terrific Volume Potential
- High Profit Margin
- Quality Units—Economical Price
- Choice of Controls
- Quick—Easy Installation
- Dependable, Trouble-free Operation
- Guaranteed Customer Satisfaction
- Nationally Advertised
- Backed by a Firm with over 40 Years Experience in the Electric Operator Field.



Write today for complete information, prices and discounts.

**RICH-WIL DIVISION**  
RICHARDS-WILCOX MFG. CO.  
4007 THIRD ST. • AURORA, ILLINOIS

ground. This narrowed down the trouble to either the hold control or the linearity control. After the connection between these two was unsoldered, the leakage was definitely established to be in the linearity control.

Disassembly of the control established no cause for the leakage and, after re-assembly, the leakage was no longer present. However, to insure freedom from a recurrence, the control was replaced and good linearity was easily set up.—Robert Lipzen, Los Angeles, California.

## Catalogs & Bulletins

**BOOKS, TRAINING AIDS:** Catalog 1B-56 (Fall-Winter '55-56) presents in 24 pages the library of technical and vocational books on all aspects of radio-TV-electronics, electricity, audio, etc. Sheet also available on 35mm film strips based on some training books. John F. Rider Publisher, Inc., 480 Canal St., N. Y. 13, N. Y. (TECHNICIAN No. B9-20)

**AUTO AERIALS:** Illustrated 8-page catalog showing complete line including front, rear and side mounts, and chrome and fiber glass aerials. Section shows dealer displays. Ward Products Corp., Div. of The Gabriel Co., Dept. 56, 1148 Euclid Ave., Cleveland 15, Ohio. (TECHNICIAN No. B9-21)

**REPLACEMENT CARTRIDGE KIT:** RK-56 Kit containing 3 cartridges provides replacements for 218 cartridges of seven manufacturers. Companion brochure describes Slendyne "535" Dynamic microphone. Shure Brothers, Inc., 222 Hartrey Ave., Evanston, Ill. (TECHNICIAN No. B9-22)

**HI-FI TUBES:** Brochure containing complete line of tube types for audio applications with characteristics and typical operating conditions. Amperex Electronic Corp., 230 Duffy Ave., Hicksville, L.I., N.Y. (TECHNICIAN No. B9-23)

**PICTURE TUBE GUIDE:** Revised and up to date guide provides pertinent data for 258 magnetically deflected picture tubes, regardless of make. Bold-face print indicates differences among similar tube types. Bulletin PA-2 available through CBS tube distributors or Advertising Service Dept., CBS-Hytron, Salem, Mass. (TECHNICIAN No. B9-24)

**AUTO RADIO REPLACEMENT GUIDE:** Chart containing trade names, manufacturers' part numbers, catalog numbers, capacitance values, voltages, sizes and list prices for every popular auto-radio on the market. Aerovox Corp., New Bedford, Mass. (TECHNICIAN B9-25)

(Continued on page 68)

# THE ALL-PURPOSE OSCILLOSCOPE

(MODEL 983)



A high gain, wide band scope which accurately reproduces waveforms comprising a wide band of frequencies.

No scope offers equal versatility and profit-making possibilities. High sensitivity of 15 millivolts per inch RMS makes it ideal for setting resonant traps, signal tracing in low level stages, as a general null indicator, phase characteristic measurements, sweep frequency visual analysis. At your distributor, or write for bulletin—R-36-A. WESTON Electrical Instrument Corporation, Newark 5, N. J. A subsidiary of Daystrom, Inc.

**WESTON** test equipment  
*The Quality Line*

# KESTER



Absolutely non-corrosive and non-conductive, KESTER "RESIN-FIVE" CORE SOLDER contains an activated type of resin that gives you that fast, positive action on all your jobs . . . including the most difficult.



**KESTER SOLDER COMPANY**  
4264 Wrightwood Avenue • Chicago 39, Illinois  
Newark 5, New Jersey • Brantford, Canada

# SOLDER

# CORNING LOW-POWER RESISTORS

available now through

**ERIE**  
*distributors*

for Service Replacements

Corning Low-Power Resistors Types LP-4 and LP-5 have been especially designed for radio, TV, and similar applications. They have the highest resistance range of any low-power resistors on the market, and are used by leading manufacturers. They are stable and non-inductive, and impervious to moisture and dirt. Resistance spiralling is automatic and is electronically controlled.

For complete service information and prices . . . see your Erie Distributor.

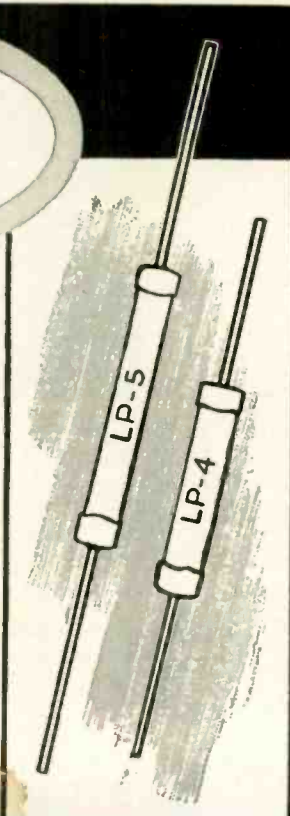

**ERIE**  
*electronics*

ERIE ELECTRONICS DISTRIBUTOR DIVISION  
ERIE RESISTOR CORPORATION  
Main Offices: ERIE, PA.  
Factories: ERIE, PA. • LONDON, ENGLAND • TRENTON, ONTARIO



## Catalogs & Bulletins

**TV REPLACEMENT CAPACITOR MANUAL:** 63-page pocket-size booklet covering 6,000 TV sets made by 88 manufacturers. Divided in two sections, electrolytic and ceramic, manufacturers are listed alphabetically with Sprague replacements fully described. Manual K-102 free from Sprague distributors or for 10 cents from Sprague Products Co., 65 Marshall St., North Adams, Mass. (TECHNICIAN No. B9-1)

**ELECTRONIC EQUIPMENT:** 64-page book listing complete Walsoc line of 2,500 electronic products: alignment tools, chemicals, electronic hardware plus several new aids for technicians. Free Walsoc Electronics Corp., 3225 Exposition Place, Los Angeles 18, Calif. (TECHNICIAN No. B9-3)

**CONTROL GUIDE:** No. 4 in a series of pocket sized control guides listing up-to-date replacement control information. Priced at 20 cents, available from Centralab distributors or Centralab, Div., Globe Union Inc., 900 E. Keefe Ave., Milwaukee 1, Wisc. (TECHNICIAN No. B9-4)

**TECHNICAL MANUAL:** 10th edition of Sylvania's Technical Manual covering latest material on its industrial tube line, "Sylvania News" and complete listing of renewal items. \$2.00 Sylvania Electric Products Inc., 1100 Main St., Buffalo 9, N. Y. (TECHNICIAN B9-5)

**SERVICE AIDS:** 80-page catalog describing thousands of radio-TV service aids, including such new products as "Klipzon" self-holding prods and connectors, printed circuit repair kits, phono drive kits. Catalog No. 157 available free from distributor or General Cement Mfg. Co., 919 Taylor Ave., Rockford, Ill. (TECHNICIAN B9-10)

**GUIDE FOR TV PICTURE TUBES:** "Quick Selection Guide for TV Picture Tubes" is a booklet to help designers select a particular tube from the 211 tube types now on the market. Classifies each tube by size, bulb structure and deflection angle. General Electric Tube Sales, One River Rd., Schenectady 5, N. Y. (TECHNICIAN B9-7)

**NEEDLES:** "Jenselector Junior" is a 12-page needle-finding chart containing information on currently used techniques for removing needles from cartridges, needle-switching methods and phono speed combinations. Free. Jensen Industries, Inc., 7333 West Harrison, Forest Park, Ill. (TECHNICIAN B9-13)

**ELECTRONIC EQUIPMENT:** Catalog on complete line of Perma Power's TV tube britener, voltage regulator, radio controlled garage door opener, battery eliminator and line of electronic accessories. Perma Power Co., 4727 N. Damen Ave., Chicago, Ill. (TECHNICIAN B9-14)

free →

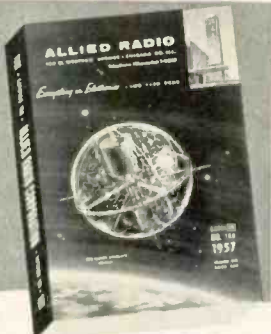

## 1957 ALLIED ELECTRONIC SUPPLY GUIDE

For Service Technicians and Engineers

Get the up-to-date 1957 ALLIED Catalog. Packed with the world's largest selection of radio parts and accessories, test instruments, famous KNIGHT-KITS, Hi-Fi systems and components, P.A. systems, tubes, tools—everything for service work and industrial electronic application. Save time and money—depend on ALLIED for everything in Electronic Supplies.

FREE

Send for 356-Page Catalog Today

**ALLIED RADIO**

ALLIED RADIO CORP., Dept 25-J-6  
100 N. Western Ave., Chicago 80, Ill.

Send FREE 1957 ALLIED Catalog

Name \_\_\_\_\_

Address \_\_\_\_\_

City \_\_\_\_\_ Zone \_\_\_\_\_ State \_\_\_\_\_

our  
36th  
year

SERVICEMEN  
WHO PUT PRIDE  
IN THEIR WORK  
"ALWAYS  
SPECIFY  
STANCOR"



**CHICAGO STANDARD  
TRANSFORMER CORPORATION**

3513 Addison Street • Chicago 18, Illinois

## New Books

**TRANSISTORS IN RADIO AND TELEVISION.** By Milton S. Kiver. Published by McGraw-Hill Book Co., Inc., 330 W. 42 St., New York 36, N.Y. 324 pages. Hard cover. \$6.50.

The growing use of transistors in radios and audio devices, plus the prospective inclusion in TV, make it imperative for electronic technicians to have a clear understanding of how these semiconductors operate, associated components and circuits, and techniques for servicing. This well written volume, adequately illustrated, provides practically all the essential technical information required.

After examining point-contact and junction types, the text discusses transistor amplifiers, oscillators, radio and TV receivers and new developments. The 20-page section on servicing transistor circuits is perhaps a bit too short, in view of the subject's importance and the author's extensive servicing knowledge. Experiments with transistors, a limited bibliography and data tables round off what is one of the best books on the subject.

**PICTURE BOOK OF TV TROUBLES (Vol. 6, Horizontal & Vertical Sync Circuits).** By John F. Rider Laboratories Staff. Published by John F. Rider Publisher, Inc., 480 Canal St., New York 13, N.Y. 120 pages. Paper cover. \$1.80.

This sixth in a projected series of eight volumes follows the earlier successful process of correlating TV troubles with the pix symptom and faulty component, as well as the scope waveform. The text is divided into two parts: common channel and dual channel sync circuits. The sync clipper and noise eliminator are also covered. Many common failures (and some tough dog uncommon ones too) are discussed in detail, showing what happens when a component is open, shorted, leaky or changed in value. Since horizontal and vertical sync circuits are often troublesome, this book should be a most informative and practical aid to the TV tech.

**SUPERHETERODYNE CONVERTERS AND I-F AMPLIFIERS.** By Alexander Schure. Published by John F. Rider Publisher, Inc., 480 Canal St., New York 13, N. Y. 56 pages. Paper cover; \$0.90.

Clear explanations of heterodyning action, of the theories underlying the operation of mixers, converters and i-f amplifiers, are presented without mathematics. Suitable for service techs as well as students, this 12th volume in the Electronic Technology Series includes a section on practical alignment.

(Continued on page 70)

National Television Week  
Sept. 23-29

for service and lab. work

### Heathkit PRINTED CIRCUIT OSCILLOSCOPE KIT FOR COLOR TVI

① Check the outstanding engineering design of this modern printed circuit Scope. Designed for color TV work, ideal for critical Laboratory applications. Frequency response essentially flat from 5 cycles to 5 Mc down only 1½ db at 3.58 Mc (TV color burst sync frequency). Down only 5 db at 5 Mc. New sweep generator 20-500,000 cycles, 5 times the range usually offered. Will sync wave form display up to 5 Mc and better. Printed circuit boards stabilize performance specifications and cut assembly time in half. Formerly available only in costly Lab type Scope. Features horizontal trace expansion for observation of pulse detail — retrace blanking amplifier — voltage regulated power supply — 3 step frequency compensated vertical input — low capacity nylon bushings on panel terminals — plus a host of other fine features. Combines peak performance and fine engineering features with low kit cost!



MODEL  
0-10  
\$6950.  
Shpg. Wt.  
27 lbs.



MODEL  
TS-4  
\$4950.  
Shpg. Wt.  
16 lbs.

### Heathkit TV SWEEP GENERATOR KIT ELECTRONIC SWEEP SYSTEM

② A new Heathkit sweep generator covering all frequencies encountered in TV service work (color or monochrome). FM frequencies too! 4 Mc — 220 Mc on fundamentals, harmonics up to 880 Mc. Smoothly controllable all-electronic sweep system. Nothing mechanical to vibrate or wear out. Crystal controlled 4.5 Mc fixed marker and separate variable marker 19-60 Mc on fundamentals and 57-180 Mc on calibrated harmonics. Plug-in crystal included. Blanking and phasing controls — automatic constant amplitude output circuit — efficient attenuation — maximum RF output well over .1 volt — vastly improved linearity. Easily your best buy in sweep generators.



# SAVE with SECURITY

Because Wright Wire Strand comes to you pre-measured and uncoils without snarling, it gives to you unique economy. Quality wire, perfectly stranded and heavily galvanized, the bright Wright way. SAVE with Wright.

Sold only through wholesale Electronics and Hardware Distributors. If not obtainable from your local distributor please write us.

Prompt deliveries from stocks in Worcester, Chicago, Atlanta, New Orleans, Houston, Dallas and Los Angeles.

**G. F. WRIGHT STEEL & WIRE CO.**  
249 Stafford St. • Worcester, Mass.

# COMING NOV. 15

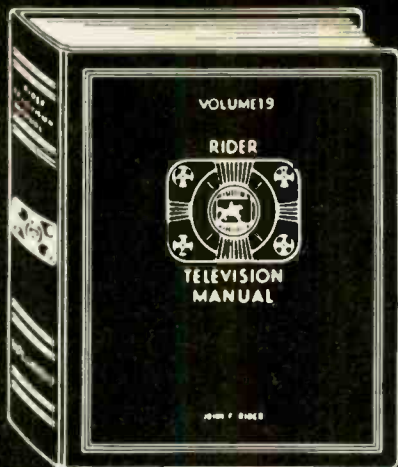

## RIDER'S TV 19

LIMITED PRINTING-

tell your jobber to  
reserve your copy now!

INDIVIDUAL TV DIAGRAMS

ask your jobber  
about Rider's

# SDO

(ESS-DEE-O)

... you'll like it!

JOHN F. RIDER Publisher, Inc.  
480 Canal Street, New York 13, N. Y.

## New Books

(Continued from page 69)

**PRINCIPLES OF COLOR TELEVISION.** By Hazeltine Labs. Staff. Edited by Knox McIlwain and Charles E. Dean. Published by John Wiley & Sons, Inc., 440 Fourth Ave., New York 16, N.Y. 595 pages. Hard cover. \$13.

Now that color TV is entering a truly mass market, thanks to simplified design, lower prices and many more programs, color receivers will be entering service shops in increasing numbers. Therefore, it behooves TV techs to have a fairly complete understanding of the new medium, and there is probably no volume that can provide a more comprehensive description.

The well-written, highly technical text is divided into 18 major sections. It starts with light and color, goes into characteristics of the eye, and then the production of the composite color signal. This is followed by sections on gamma, FCC standards, receivers, decoders, test methods and glossary of terms. While this book is no substitute for one concentrating on servicing color, the information contained is the foundation of all specialized information on the subject.

**SERVICING RECORD CHANGERS.** By Harry Mileaf. Published by Gernsback Library, Inc., 154 W. 14th St., New York 11, N. Y. 224 pages. Paper cover, \$2.90; hard cover, \$4.60.

What with new speeds, new record sizes, new spindle hole sizes, multiple spindles, and the problems of intermixing, automatic changers have undergone a great deal of alteration during a relatively few years. Differences between one and another, once quickly bracketed into three or four neat categories, have become bewildering. On the other hand, comprehensive reference works on changers, none having appeared in a few years, have failed to keep up with new developments. Thus this timely book is a welcome addition to the literature. Well illustrated with many action, exploded, and step-by-step views—the only ways in which changer operation can be visualized—the volume gives solid operational coverage with emphasis on service.

**SIMPLIFIED RADIO SERVICING BY COMPARISON METHOD.** By M. N. Beitman. Published by Supreme Publications, 1760 Balsam Rd., Highland Park, Ill. 110 pages. Paper cover; \$1.50.

For the learner with some background already in electronics, this text attempts to cover the practical ground in service procedures for all types of radio receivers, including AM, FM and communication types, and other varieties of electronic equipment, such as intercoms, PA gear and other sound systems. Emphasis is placed on minimum use of test equipment and minimum theory.

## TV Remote Controls

(Continued from page 44)

the tuner shaft), this remote brings in each channel exactly tuned.

The "It" TV remote control (April 1956 *TECHNICIAN*, p. 50) is now being manufactured and distributed by Alliance Mfg. Co., Alliance, Ohio. Battery operated motor drive attaches directly to tuner shaft in a



"It" drive motor (l) mounts on tuner shaft. Batteries are in remote control box (r).

few minutes without tools. No wires to connect, and no need to remove back of set. Complete with 20-ft. cord in self-display carton, "It" channel changer-tuner retails for \$19.95.

## Association News

### ARTS (Ill.) Adds Officers

Two new posts, that of trade and press representative and that of historian, have been created by Associated Radio & TV Servicemen of Illinois, 433 S. Wabash St., Chicago 5. Stephen Jacyna will fill the former position, with the latter going to Anthony Mallin. Growth of the group has resulted in the need for the new functions; in addition, it is hoped that these posts will provide experience for their holders that will qualify them for higher administrative office.

### Moch Resigns TESA Post

As a result of a recent illness, Frank J. Moch has resigned the presidency of TESA-Chicago, which he has held for the past eight years. He is succeeded by Joseph Blink, formerly 1st vp. Mr. Moch will retain the post of Chairman of the Board, as well as the presidency of NATESA.



# TRIAD SUB-MINIATURE AUDIO TRANSFORMERS

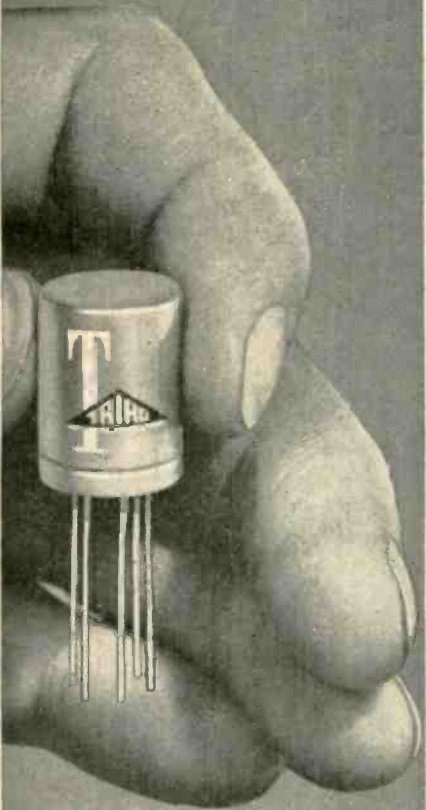

TRIAD's versatile series of sub-miniature hermetically sealed audio transformers are specially designed for audio use transistor applications and printed circuits. Featuring extremely small size, they incorporate all the construction features that have made TRIAD the symbol of quality in transformers.

Type No.	List Price	Impedance — Ohms	
		Primary	Secondary
JZ-1	\$19.65	600/250/50	60000
JZ-5	20.20	30/12/4	50000
JZ-7	19.65	30/12/4	1000
JZ-13	19.65	15000 (1 Ma.)	135000 C. T.
JZ-15	19.65	20000 (.5 Ma.)	1200/600/100
JZ-25	19.10	10000 (1 Ma.)	200
JZ-26	19.10	1000 (5 Ma.)	50

Write for Catalog TR-56F, listing TRIAD's complete line of quality Transformers.



4055 REDWOOD AVE., VENICE, CALIF.



### Minn. Univ. Study

Minnesota Television Service Engineers extended invitations to other associations to attend the Aug. 6-8 study on "Problems and Needs of Television Service Establishments," held at the Univ. of Minnesota.

### New IRTSA Officers

New officers for Indianhead Radio-TV Servicemen's Assoc., Eau Claire, Wis., are: Pres. Earl Kratch, VP Upton St. Clair, Sec. Richard Presnel, Treas. Vernon Christian, Bd. of Dir. Sherwood Stolp and Earl Struve. IRTSA Cor. Sec. C. W. Stiemke reports the association's battle against pix tube insurance companies is paying off, one firm withdrawing from the field, a court case pending against another.

### Texas Fair

The Fourth Annual Clinic and Fair, sponsored by the Texas Electronics Assoc., Aug. 24-26 in Houston, had some of the top industry leaders scheduled to appear, including Dr. Allen B. DuMont, Philco vp Henry Paiste, Sylvania vp Arthur Chapman, RCA sales manager Joe Bannon, Westinghouse sales manager T. B. Kalbfus and many others. Well over 1000 attendance was expected, reports TEA Pres. Van J. Roark.

### Ky. Techs Form Assoc.

KTRTA, the Kentuckiana Television & Radio Technicians Assoc., has been formed with headquarters at 2519 Portland Ave., Louisville 12, Ky. Officers are Pres. Harold Flood, VP Ira Masden, Sec. James Hall, and Treas. Melvin Brown. There are 15 members on the Board of Directors; no officer can succeed himself. KTRTA will cooperate with national associations. They have 31 members, a goal of 150 by the end of the year.

### RTASCV Service Charges

To clarify some of the confusion resulting from non-standardization of service charges, the Radio & TV Assn. of Santa Clara Valley, in the July issue of its monthly publication, RTA, publishes a schedule of suggested minimum charges for service and repair of monochrome TV receivers in and out of the shop. The list has been approved by Local 202 of the International Brotherhood of Electrical Workers and other associations in California. Address the publication care of DAAC Publications, 123 South 3rd St., San Jose, Calif.

# NEW



## Vo-Tron IF-Kit 5000

KEY COMPONENTS FOR BUILD-IT-YOURSELF 6-TRANSISTOR RADIO

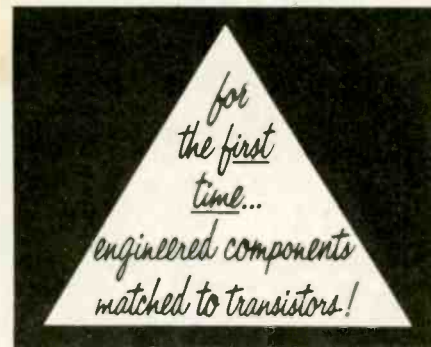

**First** to mass-produce high-performance subminiature IF Transformers and Oscillator Coils for leading makes of all-transistor radios, Vokar now offers these same quality components in kit form—matched to such popular PNP type transistors as GE, RCA, Raytheon and General Transistor.

**IF-KIT 5000** contains 3 455KC Transformers, 1 455KC Oscillator Coil and a specially designed and tested superheterodyne circuit. Included is a list of readily available parts which will help you to assemble a powerful 6-transistor radio without searching for matched components.

only  
**\$8.95**  
LIST

VOKAR CORPORATION  
DEXTER, MICHIGAN  
RUSH full details including literature.

Name \_\_\_\_\_  
Firm Name \_\_\_\_\_  
Street \_\_\_\_\_  
City \_\_\_\_\_ State \_\_\_\_\_  
(My Jobber) (City)



## VOKAR

VOKAR CORPORATION  
DEXTER 2, MICHIGAN

# YOU CAN STOP A FLUCTUATING VOLTAGE CONDITION



## WITH THIS ACME ELECTRIC AUTOMATIC VOLTAGE STABILIZER

If you're harassed with a television or other electronic equipment installation that just won't operate right, chances are that a fluctuating voltage condition exists and prevents tubes and other components from functioning properly.

One sure way of making voltage behave is with the Acme Electric automatic voltage stabilizer. Regardless whether the input voltage ranges from 95 to 130 volts, the output voltage will automatically be corrected to 115 volts  $\pm$  3%.

Another feature to remember, this unit uses no current unless the TV set is in operation. An automatic relay disconnects primary circuit under "no load" conditions and automatically connects circuit when load is applied to the secondary circuit. Secondary voltage is indicated on voltmeter while unit is in operation. Furnished complete, ready to plug-in. See this Acme Electric Automatic Voltage Stabilizer at your dealer.

ACME ELECTRIC CORPORATION  
889 WATER STREET CUBA, NEW YORK



## Two-Way Radio

(Continued from page 65)

rent observation of a modulation index meter. Modern transmitters have limiters to prevent overmodulation; input voltages must be maintained between reasonable limits if the limiters are to work properly. Application of a known input voltage simplifies the adjustment of limiters and enables more accurate modulation measurement.

**Carrier Frequency and Deviation:** The Federal Communications Commission requires that these measurements be made at regular intervals. Many technicians fail to realize, however, that today's narrow communication channels and ultra-selective receivers require adjustment to tolerances more strict than those imposed by the FCC. Frequency tolerances of .005 to .01% are too broad for good communications.

The transmitter and receiver must be tuned to each other for good communications. Although both are commonly crystal tuned, circuit constants will affect crystal frequency. Both transmitter and receiver should be checked at least as often as the equipment comes in for a bench check.

### Quality & Sensitivity

**Audio Quality:** A listening check is important. Is the audio clear, understandable, crisp? Is there hum, hiss or crackle?

**Receiver Sensitivity:** One of the most revealing measurements. Relative sensitivity is determined by introducing a signal voltage from a standard VHF generator into the antenna connection and noting the voltage, in microvolts, required to reduce receiver noise by 20 db.

With this one measurement, which can be made in less than a minute, more can be found out about a receiver than could be determined by hours spent testing tubes and making routine "adjustments." This measurement will tell you whether tube replacement or adjustments are needed.

**Parts Checking:** The need for a VOM and a VTVM is obvious. A capacity bridge is also useful because, while failure of capacitors is not frequent in communications equipment, it is desirable to detect incipient failures if possible. It is costly to guess about parts failures in communications equipment. A

(Continued on page 74)

HQ For the 5 TOP-QUALITY brands of

# STANDARD BRAND TUBES

AT SENSIBLE PRICES!

- 90-day RETMA guarantee ● First quality only
- Brand new ● Individually boxed
- No rebrands, rejects, or rewashed "bargains"

**FREE!** Newest handy air-mail order form for your ordering convenience. Write for your free copy

- Lists ALL popular TV & radio types
- Makes mail-ordering a real pleasure
- Orders over \$25.00 (with remittance) post-paid.

TYPE	EACH	TYPE	EACH	TYPE	EACH
024	.60	6A56	2.25	7E7	1.20
1AX2	1.15	6AS8	1.20	7E7	1.20
1B3GT	.95	6AT6	.60	7F8	1.20
1H5GT	.80	6AT8	1.10	7G7	1.15
1L4	.85	6AU4GT	1.10	7H7	.85
1L6	1.10	6AU5GT	1.30	7I7	1.35
1LA4	1.00	6AU6	.75	7K7	1.20
1LA6	1.00	6AU7	.90	7L7	1.15
1L84	1.00	6AV5GT	1.25	7M7	.95
1L6	1.00	6AV6	1.50	7N7	1.00
1LC6	1.00	6AW8	1.60	7P7	1.30
1LD5	1.00	6AX4GT	.90	7Q7	1.30
1LE3	1.00	6AX5GT	.90	7R7	1.30
1LG	1.00	6BA7	.70	7X7	1.00
1LH4	1.00	6BA7	.70	7Y4	.70
1LN5	1.00	6BC4	1.60	7Z4	.70
1N5GT	.95	6BC5	.75	12A4	.85
1O5GT	1.15	6BC7	1.25	12A5	.70
1R4	1.00	6BD5	1.40	12A05	.75
1R5	.85	6BD6	.75	12A16	.65
1S4	.90	6BE6	.75	12A17	1.00
1S5	.75	6BF5	.90	12AUG	.70
1T4	.85	6BF6	.90	12A07	.85
1T5GT	1.05	6BGG6	1.85	12AV6	.65
1U4	.80	6BH6	.90	12AV7	1.05
1U5	.75	6B16	.85	12AW6	1.00
1V	.95	6BK5	1.15	12AX4GT	1.00
1W2	.70	6BT4	1.30	12AX7	.90
1X2B	1.00	6BL7GT	1.25	12A75	1.75
2AF4A	1.40	6BN6	1.15	12A77	.95
2D21	1.00	6B06GT	1.45	12B1A	.90
2X2	.50	6B07A	1.30	12BA6	.70
3A3	1.10	6BR7GT	1.25	12C17	.95
3A4	.55	6BY5G	1.30	12BD6	.75
3A5	.75	6BZ6	.80	12BE6	.75
3AL5	.70	6C4	.60	12BF6	.70
3AUG	.75	6C5	.80	12BH7A	1.00
3AV6	.65	6C85	4.50	12B06GT	1.45
3BA6	.75	6C86	.85	12B7	.90
3BC5	.80	6CD6G	1.00	12B7A	1.05
3BE6	.75	6CF6	.90	12C17	1.10
3BN6	1.05	6CG7	.90	12CA5	.80
3BY6	.90	6CL6	1.20	12CUG	1.45
3BZ6	.80	6CM6	.85	12L6	.80
3C85	.85	6CS6	.75	12SA7GT	1.00
3CF6	.85	6CU6	1.45	12SC7	.95
3CS6	.80	6DC6	.95	12S17	.75
3LF4	1.20	6DE6	.80	12SK7GT	.80
3O5GT	.85	6E6	.85	12L7GT	1.00
305GT	1.00	6F5	.85	12SN7G1A	.85
3S4	.80	6F6G	.80	12S07GT	.75
3V4	.85	6H6	.75	14A7	.85
4B07A	1.30	6I4	3.95	14A77	1.00
4BZ7	1.35	6I5	.75	14B7	.95
5AN8	1.05	6J6	.70	14C7	1.00
5AN8	1.10	6J7	.95	14E6	1.20
5A05	.75	6K6GT	.75	14F7	1.30
5A8	1.10	6K7	.90	14G7	1.00
5AY8	1.15	6K8	1.25	14H7	1.00
5AW4	1.15	6L6G	1.35	14I7	1.00
5AZ4	.60	6L6GA	1.30	14J7	1.00
5BK7	1.10	6M6	1.75	14K7	1.00
5I6	.95	6N7	1.20	14L7	1.00
5T4	1.75	6O7	1.00	14M7	1.00
5T8	1.10	6S4	.70	14N7	1.00
5U4G	.70	6S8GT	1.10	14O7	.95
5U4GB	.75	6SA7GT	1.00	14P7	1.00
5U8	1.10	6SC7	1.00	14Q7	1.25
5V4G	1.00	6SF7	.95	14R7	1.35
5V6GT	.70	6SG7	.90	19F8	1.20
5W4GT	.70	6SH7	1.05	25A5GT	1.30
5X4G	.80	6SJ7M	.85	25B5	1.10
5X8	1.05	6SK7GT	.85	25B06GT	1.45
5Y3GT	.60	6SL7GT	1.10	25C6GA	1.85
5Y6	.65	6SN7G1A/B	.90	25CUG	1.45
5Z3	.90	6S07GT	.75	25L6GT	.85
5Z4	1.25	6S7	.75	25W4GT	.85
6A7	1.15	6SS7	1.00	25Z5	.80
6AM8	1.15	6T4	1.30	25Z6GT	.85
6A8GT	1.10	6T8	1.10	35A5	.75
6B3	.70	6U8	1.10	35B5	.70
6AC5GT	1.15	6V3A	1.50	35C5	.70
6AC7	1.15	6V6GT	.75	35L6GT	.65
6AD7G	1.55	6V6M	1.35	35W4	.55
6AF4	1.35	6W4GT	.80	35Y4	.75
6AF6G	1.20	6W6GT	.95	35Z5	.60
6AC5	.80	6X8	1.20	41	.85
6AD7	1.35	6X5GT	.55	42	.75
6AH6V	1.05	6X8	1.20	43	.85
6AJ5	1.75	6Y6	.95	50A5	.75
6AK5	.80	7A6	.80	50B5	.75
6AK6	.80	7A7	.85	50L6GT	.75
6AL5	.65	7A8	.80	50X6GT	.90
6AL7GT	1.65	7AC7	1.00	50Y6GT	1.00
6AM4	1.55	7AH7	1.00	50Z7GT	.90
6AN8	1.15	7B4	.80	70L7GT	1.55
6AN8	1.50	7B5	.70	80	.65
6AN8	1.20	7B6	1.00	117L7GT	2.50
6A05	.75	7B7	.80	117N7GT	2.00
6A06	.60	7B8	.90	117P7GT	2.00
6A07GT	1.25	7C5	.80	117Z3	.80
6A05	.75	7C6	1.00	117Z4GT	1.15
6AS5	.80	7C7	.85	117Z6GT	1.15
				5642	1.00

We stock over 1000 other types including Diodes, Transistors, Transmitting and Special Purpose types. WRITE!

TERMS: 25% with order balance C.O.D. All merchandise guaranteed. F.O.B., N.Y.C.  
**BARRY ELECTRONICS CORP.**  
Dept. T

512 Broadway, N. Y. 12, N. Y.  
Call us day or night 24 hour telephone service  
WAlker 5-7000

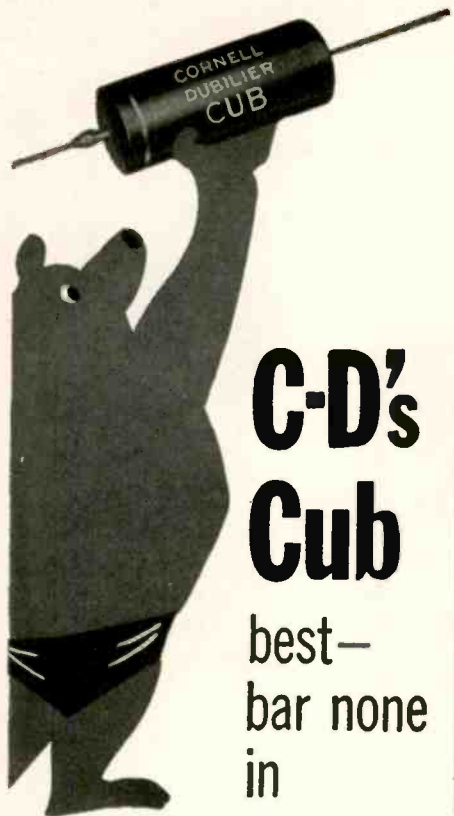

# C-D's Cub

best—  
bar none  
in

## molded tubular capacitors

The C-D "Cub" capacitor has proven itself the best on the market today—by out-lasting, out-performing, out-selling any other replacement capacitor for radio or TV. For consistent high quality—always rely on C-D, the only tubulars with the built-in extras required in servicing sets today. That's why distributors *who know*, carry the complete C-D line.

Special! "Cub-Kit" with bonus plastic service dispenser. IT'S FREE!

Ask your C-D Distributor. He's listed in your local Classified Telephone Directory.

CONSISTENTLY  
**CORNELL-  
DUBILIER**  
DEPENDABLE



THERE ARE MORE C-D  
CAPACITORS IN USE TODAY  
THAN ANY OTHER MAKE.

PLANTS IN SD. PLAINFIELD, N. J.; NEW BEDFORD, WORCESTER AND  
CAMBRIDGE, MASS.; PROVIDENCE AND HOPE VALLEY, R. I.; INDIANAPOLIS,  
IND.; SANFORD AND FURQUAY SPRINGS, N. C.; SUBSIDIARY, RADIART  
CORP., CLEVELAND, OHIO.

## ADVERTISERS INDEX

September 1956

Acme Electric Corp. ....	72
Alliance Manufacturing Co., Inc. ....	25
Allied Radio Corp. ....	68
Amphenol Electronics Corp. ....	28
Astron Corp. ....	40, 42
Barry Electronics Corp. ....	72
B & K Manufacturing Co. ....	12
CBS-Hytron ....	27
Centralab, Div. of Globe-Union, Inc. ....	59, 61
Channel Master Corp. ....	5, 6, 7
Chemical Electronic Engineering, Inc. ....	60
Chicago Standard Transformer Corp. ....	68
Cleveland Institute of Radio Electronics ....	65
Cornell-Dubilier Electric Corp. ....	18, 19, 73
Electro Products Laboratories ....	73
Erie Resistor Corp. ....	68
Federal Telephone & Radio Co. ....	34
Federated Television Mart, Inc. ....	74
Heath Co. ....	69
Hotpoint Co. ....	33
Hycon Electronics, Inc. ....	30
International Resistance Co. ....	Cover 2
Jensen Industries, Inc. ....	74
Jerrold Electronics Corp. ....	13
Johns-Manville Products, Dutch Brand Div. ....	8
Jones & Laughlin Steel Corp. ....	11
Kester Solder Co. ....	67
Mallory & Co., Inc., P. R. ....	22, 23
Merit Coil & Transformer Corp. ....	74
Moss Electronic Dist. Co., Inc. ....	9, 10
Motorola, Inc. ....	57
Oxford Electric Corp. ....	60
Philco Corp. ....	17
Quam-Nichols Co. ....	58
Radiart Corp. ....	18, 19, 73
Radio Corporation of America ....	4, 14, 20, 29, cover 4
Raytheon Mfg. Co. ....	2, 3
Recoton Corp. ....	64
Remington Rand Univac ....	15
Richards-Wilcox Mfg. Co. ....	66
Rider, Publisher, John F. ....	70
Simpson Electric Co. ....	24
Snyder Mfg. Co. ....	21
Sprague Products Co. ....	Cover 3
Technical Appliance Corp. ....	31
Triad Transformer Corp. ....	71
Trio Mfg. Co. ....	32
Tungsol Electric, Inc. ....	62, 63
Utica Drop Forge & Tool Corp. ....	16
Vokar Corp. ....	71
Wall Mfg. Co. ....	64
Ward Products Corp. ....	26
Westinghouse Electric Corp. ....	55
Weston Electrical Instrument Corp. ....	67
Workman TV, Inc. ....	66
Wright Steel & Wire Co., G. F. ....	69

While every precaution is taken to insure accuracy, we cannot guarantee against the possibility of an occasional change or omission in the preparation of this index.



Overlooking  
**25%**  
of the profitable  
radio repair  
business?



## Electro

MODEL D-612T

### DC POWER SUPPLY

lets you service

### TRANSISTOR AUTO RADIOS

(services 6/12V  
tube-vibrator radios, too)  
\*1 out of 4 radios is an auto set

An Electro exclusive

FOR PRICES AND DATA SEND COUPON TODAY!

Electro Products Laboratories  
4501-Y Ravenswood Ave., Chicago 48, Ill.

Rush descriptive and technical data on MODEL  
D-612T Power Supply for Transistor Auto  
Radios.

Name \_\_\_\_\_

Address \_\_\_\_\_

City \_\_\_\_\_ Zone \_\_\_\_\_ State \_\_\_\_\_

623 Canada: ATLAS RADIO LTD., Toronto

MERIT, first in exact and universal replacement transformers, yokes, coils—the only manufacturer of transformers, yokes and coils who has complete production facilities for all parts sold under their brand name.

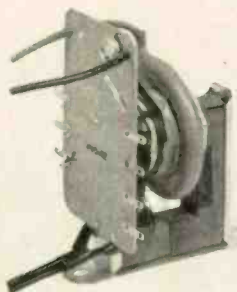

HVO-42 FOR EXACT REPLACEMENT IN CBS-COLUMBIA. Another in the complete MERIT line of exact and universal replacements—the only single source for all your transformer and coil requirements.

# Merit

MERIT COIL & TRANSFORMER CORP.  
4427 NORTH CLARK STREET  
CHICAGO 40, ILLINOIS



## Two-Way Radio

(Continued from page 72)

capacity bridge capable of measuring leakage of the order of 10,000 megohms on paper capacitors, and of measuring quantitatively leakage and power factor as well as capacity of electrolytics is a must.

The capacity of electrolytics can be measured without removing them from the circuit, and, if allowance is made for the resistance likely to be in parallel with them, a good guess can be made as to power factor. A little experience will enable you to tell quickly whether an electrolytic is near the end of its useful life so that it can be replaced before it fails.

### Operating Conditions

**Operation at Non-Standard Voltages:** Intermittent troubles are often caused by improper operating voltages. If this is the case, the trouble will not be found unless the equipment is checked at unusually low or high supply voltages.

**Operation at Elevated Temperatures:** Electronic equipment sometimes exhibits faults only at temperatures higher than those that are reached while the equipment is exposed for service. For this reason, an ordinary heat lamp mounted in a gooseneck socket is recommended as a means of quickly raising the temperature to the failure point. Move the lamp gradually across the chassis in order to localize the general area of the trouble. The temperature of any portion of the chassis can usually be raised beyond any field-encountered temperature in one or two minutes. Assuming that the lamp is within one or two inches of the chassis, if failures do not occur in three minutes, the heat lamp should be removed lest the equipment be damaged.

**Antenna System:** A thru-line wattmeter is recommended as a means of checking the antenna system. The amount of forward and reflected power measured with it is an indication of the working efficiency of both the transmission line and the antenna. However, caution should be exercised in the use of any SWR or power indication instrument in order to avoid drawing incorrect conclusions. It is important to become thoroughly familiar with the use and limitations of such instruments, and their calibration should be checked often. •



"By Jove! Now how do you suppose he knew that Lady Peabody was carrying the JENSEN NEEDLES?"

## TOP QUALITY PARTS

FOR RADIO AND T.V. SERVICEMEN

### SELENIUM RECTIFIERS

300 M.A.—79¢ ea. 400 M.A.—1.19 ea.  
350 M.A.—79¢ ea. 500 M.A.—1.39 ea.

### FILTER CONDENSERS

#### RADIO PACKS:

40-20-20 MFD-150V, 100-25V..... 29¢  
50-30 MFD, 20 MFD, 25V..... 29¢  
40-40 MFD-150V, 250-25V..... 29¢  
60-40-40 MFD-150V, 20-26V..... 29¢

#### T. V. PACKS:

250 MFD-150V, 50 MFD-150V..... 29¢  
250 MFD-150V, 120 MFD-150V..... 50-25V 29¢  
140 MFD-300V, 40 MFD-250V,..... 100-50V 39¢  
140 MFD-350, 5 MFD-300V,..... 200-200V, 30-150V 39¢

### TRANSFORMERS

455 KC. I.F. MINIATURE..... 39¢  
Vertical Output, Equiv. Merit 3080.. 98¢  
Vertical Output, Equiv. Merit 3036.. 89¢  
Vertical Blocking, Equiv. Merit 3003.. 49¢

### TUBE SPECIALS

6AC7 —.65 | 6SJ7 —.55 | 6C4 —.28  
6AK5 —.49 | 6AG7 —.49 | 6V6G —.29  
6SN7 —.69 | 12SH7 —.39 | 6SL7 —.69  
2AF4A—.98 | 4BQ7A—.98 | 6AF4A—.98

### SPEAKERS

4" P.M. SPEAKER..... .98  
10" P.M. HEAVY SLUG, INDIVIDUAL BOXED, R.C.A. BRAND.. 2.49

No order Too Small. Merchandise shipped within 24 hours of receipt of order. 25% deposit required with order. F.O.B. Brooklyn.

## FEDERATED TELEVISION

MART, INCORPORATED

513 Rogers Ave., Dept. T, Brooklyn 25, N. Y.

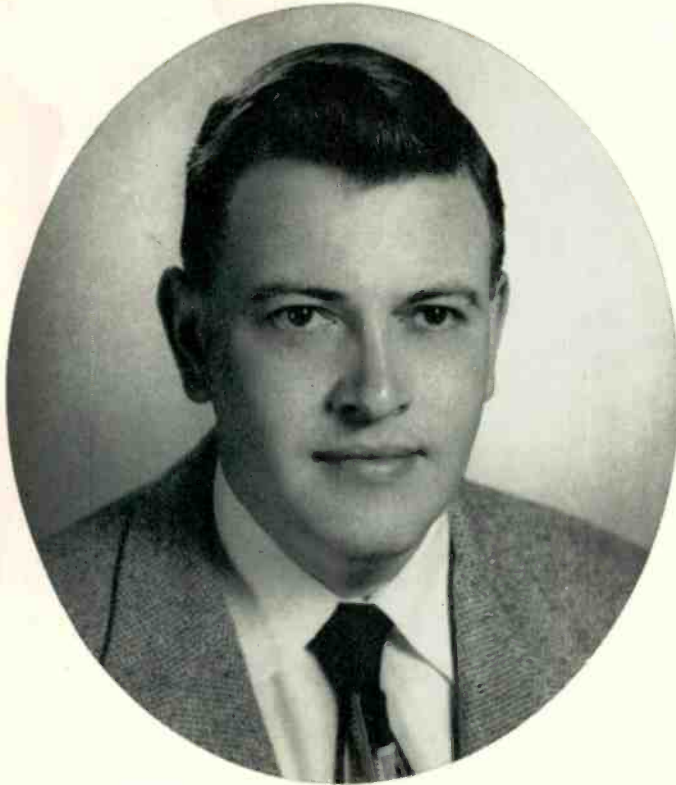

KEN PRICE, field engineer for the Sprague Products Company, has had years of experience in operating his own TV and radio service organization, as owner of an antenna manufacturing company and as a capacitor production engineer. With this intimate knowledge of both sides of the parts picture, he has won wide recognition for his helpful advice to service technicians.

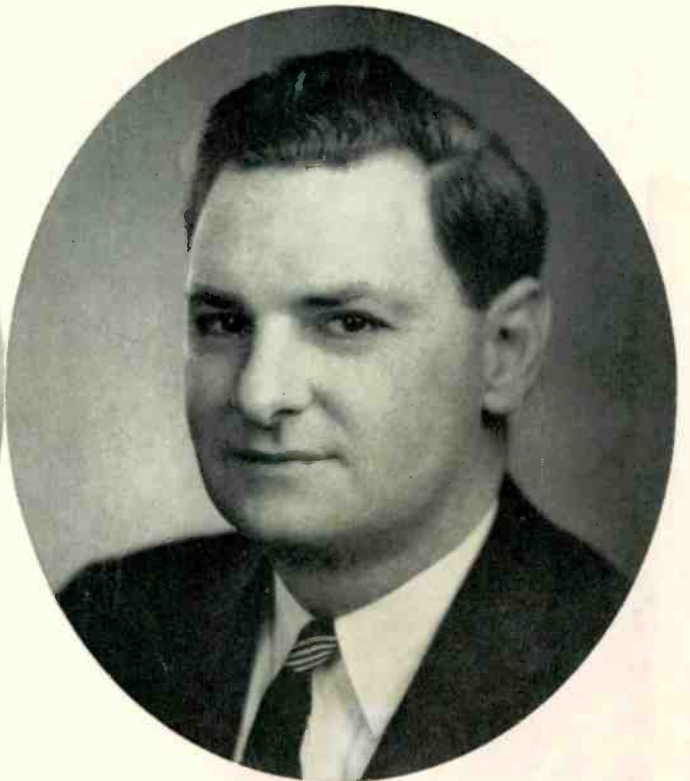

AL COUMONT, now Assistant to the President of Sprague Products Company, has been well known in the industry for the past 25 years. His staff activities at RETMA, for which he received a national award, included management of its national training programs for service technicians in trade schools and through technicians' associations and groups.

These **2** Men Will Help You

## KEEP UP-TO-DATE IN ELECTRONIC SERVICING

**JUST ASK** your electronic parts distributor. He's the key to your area being one of the first to take advantage of Sprague's new educational program.

Designed to keep you up to date on fast changing conditions in the electronic parts industry, this new program is a major expansion of Sprague's past educational efforts. Both Al Coumont and Ken Price will work closely with local service associations and vocational schools all over the country, giving sound advice on many of the problems which confront you daily.

In a simple straight-forward manner that pulls no punches, you'll get all kinds of information you just can't find in books but need to know for your day-to-day work. And, most important, you'll be able to ask questions on the problems that stump you.

Ken and Al are setting up their fall program of talks NOW. If your distributor or service association does not have them scheduled for your area, ask them to call Harry Kalker, Sprague Products Co., 65 Marshall Street, North Adams, Mass. It's a talk you won't want to miss!

**don't be vague...insist on**

# SPRAGUE<sup>®</sup>

WORLD'S LARGEST CAPACITOR MANUFACTURER



*It's a fact...*

*9 out of 10 top-selling replacement TV tubes are original RCA tubes.*

Manufacturers of TV sets have given RCA tube-type leadership by using RCA-designed tubes in their equipment. Experience has shown these manufacturers that RCA-designed tubes are top in performance. Service dealers know, too, that the company which knows how to design tubes knows how to build them BEST. So follow the lead of smart service technicians everywhere—say “RCA brand, only” on *all* your tube orders and get tubes that are tops in quality and performance.



**RECEIVING TUBES**

RADIO CORPORATION OF AMERICA, HARRISON, N. J.

\*NEMA REPORT for year of 1955