

*Read Frequency 28
When Radio Specifications*

OCTOBER • 1940

RADIO

*and
Television*

RETAILING

RADIO MONTH NEWS

NEW STATION SETTINGS

ALL ABOUT AUTOMATICS

PERIOD CABINET HELP

PARTS CREDITS

PHOTOSALES IDEAS

RECORD RETAILING

OUTSIDE SELLING TIPS

APPLIANCE SHOWMANSHIP

MODERN MANAGEMENT

PERSONAL SET CIRCUITS

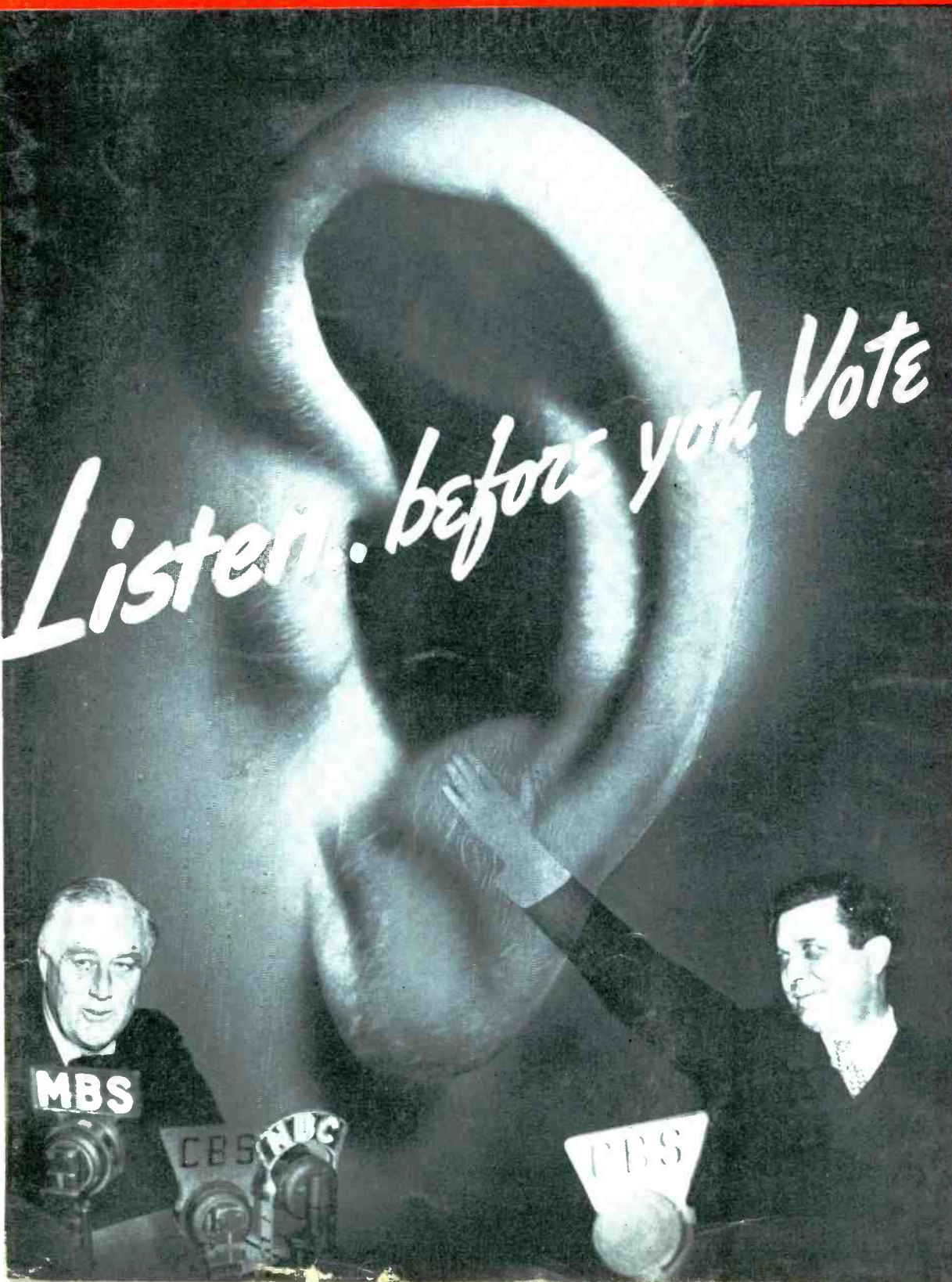

Listen... before you Vote

A
McGRAW-HILL Publication
Price 25c

Get the Greatest Coverage Ever Offered
Standardize on

P. R. MALLORY & CO., Inc.
MALLORY

Replacement CONDENSERS

The Mallory line of Replacement Condensers gives you a host of tangible economies and consequently an opportunity for better profits. The complete line has been specifically developed around an exhaustive study of *all* types used in original equipment. You can be sure of exact replacements for every need . . . on any radio you may be called upon to service.

Mallory Tubular Condensers not only give you complete replacement coverage, but provide the only adequate answer to the servicing of inexpensive compacts. With over 50 ratings . . . common anode . . . common cathode and separate sections where sizes permit, Mallory Tubular Condensers will prove exceptionally profitable . . . and completely satisfactory.

*FP (Fabricated Plate) Condensers, made by Mallory, have set new records for efficiency and performance. Accurately checked field returns from 1,000,000 FP Condensers . . . used in original equipment by representative radio manufacturers, disclose that only 512 were returned as defective. That's only 5/100ths of 1%! No wonder radio service engineers hail FP Condensers as the greatest engineering advance ever made.

Mallory Type BB Condensers likewise afford Fabricated Plate Construction, with its many advantages. These smaller sizes are encased in a heavy drawn aluminum can, and well insulated with an attractive cardboard cover. Strong internal construction safeguards against troublesome open circuits.

See your Mallory distributor today. You'll find him well stocked with the full Mallory line . . . and with all the information about it.

P. R. MALLORY & CO., Inc.

INDIANAPOLIS INDIANA

Cable Address — PELMALLO



*TRADE MARK REG. U. S. PAT. OFF.

Use

P. R. MALLORY & CO., Inc.
MALLORY
APPROVED
PRECISION PRODUCTS

Include

VIBRATORS • VIBRA PACKS • CONDENSERS • VOLUME CONTROLS • ROTARY SWITCHES • SINGLE AND MULTIPLE PUSH BUTTON SWITCHES • RESISTORS RADIO HARDWARE

RADIO

and Television RETAILING

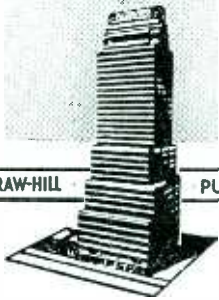

A McGRAW-HILL

PUBLICATION

OCTOBER 1940

W. MacDONALD..... Editor
 W. CARL DORF.....Associate Editor
 VIN ZELUFF.....Technical Editor
 A. XIQUES.....Assistant Editor
 HARRY PHILLIPS.....Art Director

LEE ROBINSON Manager
 R. E. McGRAW...Sales Promotion Manager
 K. R. GROENER.....Western Manager

THE RADIO MONTH	15
NEWS PHOTOSHORTS	16
ALL ABOUT AUTOMATICS	18
IDEAS FOR SELLING.....	22
RECOGNIZING PERIOD CABINETS	24
IMPORTANCE OF UNIT VOLUME	26
NEW STATION FREQUENCIES.....	28
RECORD RETAILING	31
DEFENSE OF OUTSIDE SELLING	32
APPLIANCE SHOWMANSHIP	33
PARTS CREDITS	36
NEW PRODUCTS	38
ON THE NEWSFRONT.....	44
CIRCUITS OF THE MONTH.....	53
PERSONAL PORTABLE CIRCUITS.....	59
SERVICING AUTOMATIC CHANGERS.....	63
TRICKS OF THE TRADE.....	66
LETTERS TO THE EDITOR.....	68



SALES STATIC . . . ??*!!;:!!!!

McGRAW-HILL PUBLISHING CO., INC.

RADIO and Television RETAILING, October, 1940, Vol. 25, No. 10. Published monthly, price 25c copy. Allow at least ten days for change of address. All communications about subscriptions should be addressed to the Director of Circulation, 330 West 42nd Street, New York, N. Y.

Subscription rates—United States and possessions, Canada, Mexico and Central American countries \$1.00 a year, \$1.50 for two years, \$2.00 for three years. Great Britain and British Possessions 12 shillings a year, 24 shillings for three years. All other countries \$2.00 a year, \$4.00 for three years. Printed in U. S. A. Entered as Second Class Matter, April 29, 1939, at Post Office, Albany, N. Y., under the Act of March 3, 1879. Cable address "McGrawhill, New York." Member of A.B.P. Member of A.B.C. Copyright 1939 by McGraw-Hill Publishing Co., Inc., 330 West 42nd Street, New York, N. Y.

Branch Offices: 520 North Michigan Ave., Chicago; 68 Post St., San Francisco; Aldwych House, Aldwych, London, W.C.2; Washington; Philadelphia; Cleveland; Detroit; St. Louis; Boston; Atlanta, Ga.

JAMES H. MCGRAW
 Founder and Honorary Chairman
 Publication Office
 99-129 North Broadway, Albany, N. Y.
 Editorial and Executive Offices
 330 West 42nd Street, New York, N. Y.

JAMES H. MCGRAW, JR., President
 Howard Ehrlich, Executive Vice President
 Mason Britton, Vice Chairman
 B. R. Putnam, Treasurer
 D. C. McGraw, Secretary
 J. E. Blackburn, Jr., Director of Circulation

Stromberg-Carlson Telephone Manufacturing Company

GENERAL OFFICE AND
FACTORY
100 CARLSON ROAD
TELEPHONE CULVER 260
ROCHESTER, NEW YORK.

MANUFACTURERS OF
TELEPHONE APPARATUS
CABLES AND SUPPLIES
RADIO APPARATUS

BRANCH SALES OFFICES
564-70 WEST ADAMS STREET
TELEPHONE STATE 4236
CHICAGO, ILLINOIS
2017 GRAND AVENUE
TELEPHONE HARRISON 6618
KANSAS CITY, MISSOURI

ROCHESTER, NEW YORK



Look at it this way

Last Season's
**BIG VALUE
BIG SELLER** had:

BROADCAST BAND
SHORT WAVE
LABYRINTH
CARPINCHOE SPEAKER
HIGH FIDELITY
FINE CABINET
11 TUBES (including Tuning
Indicator, Power Rectifiers,
Inverter Tubes, etc.)

AND IT \$175 F. O. B.
SOLD FOR Factory

—at only \$17.50 down
it was easy to sell

The model 535-M Stromberg-Carlson radio shown at the right is a typical example of why the Stromberg-Carlson line for 1941 has been given such a tremendous reception. To date, sales of this model are already far ahead of the comparable 1940 model, shown at left, which it replaced . . . in spite of the fact that it sells for more money. Such is the tremendous pulling power of FM!

If you want bigger sales and bigger profits, start now to sell the radio that's built for the future as well as the present—Stromberg-Carlson with built-in FM band!

All Stromberg-Carlson FM Receivers are licensed under Armstrong Wide-Swing Frequency Modulation patents.

This Season's
**BIGGER VALUE
BIGGER SELLER** has:

BROADCAST BAND
SHORT WAVE
LABYRINTH
CARPINCHOE SPEAKER
HIGH FIDELITY
STILL FINER CABINET,
WITH DOORS
15 TUBES (including Tuning
Indicator, Power Rectifiers,
Inverter Tubes, etc.)

PLUS FM

the biggest, most important feature in years, that actually makes 'em want to trade-in their old sets . . . a costly feature that's equivalent to a second set within a set . . .

AND IT SELLS \$19950 F. O. B.
FOR ONLY Factory

—at \$19.95 down it is
even easier to sell!

**THE 535-M WITH FM ADDED
...WITH MORE EYE-APPEAL
...WITH MORE TUBES...
IS EASIER TO SELL AT A
HIGHER PRICE!**



*And Now at Radio's Peak Season That Means Extra Profit in Volume!
"There Is Nothing Finer than a Stromberg-Carlson"*

The Talk of the Industry

P. R. MALLORY & CO. Inc.

MALLORY

Tubular Paper Condensers are "Color-Coded" for Easier Service



200 VDC



400 VDC



600 VDC



1000 VDC



1600 VDC*



2000 VDC

The Official
RMA Color Code
Tells You the Voltage



Here's another new Mallory feature that leads the way to faster . . . easier and more profitable service. The new line of Mallory Tubular Paper Condensers now comes to you dressed in brilliantly colored labels. Capacities are completely legible . . . and voltages instantly identifiable by the bottom band of color . . . properly coded to RMA specifications. This color-code band goes clear around the condenser. You can spot the voltage no matter how the condenser is placed in the set.

Naturally every Mallory quality factor remains the same. The new Mallory Tubular Paper Condenser labels are merely applied *over* the customary heavy cardboard tube and thick wax coating.

See these Mallory Tubular Paper Condensers today. You'll agree that now America's finest line has become America's finest looking line as well.

P. R. MALLORY & CO., Inc., INDIANAPOLIS, INDIANA

Cable Address: PELMALLO

★Application made to RMA to adopt this color-coding for 1600 VDC. No color has yet been assigned to this voltage by RMA.

Use

P. R. MALLORY & CO. Inc.
MALLORY
APPROVED
PRECISION PRODUCTS

Include

VIBRATORS • VIBRAPACKS • CONDENSERS • VOLUME
CONTROLS • ROTARY SWITCHES • SINGLE AND
MULTIPLE PUSH BUTTON SWITCHES • RESISTORS
RADIO HARDWARE

NOW THAT YOU'VE SEEN THEM ALL, YOU'LL AGREE

Farnsworth
IS SUPREME IN
COMBINATIONS

YOU'VE "shopped" the market . . . compared lines . . . and now the verdict is in! **FARNSWORTH IS FIRST IN THE COMBINATION FIELD** **FIRST** in tone . . . you can *hear* the difference and *demonstrate* it to your customers. **FIRST** in cabinet styling . . . with a wide variety of models to satisfy *every one* of your customers. **FIRST** in values . . . every model more than *competitively* priced. **FIRST** in performance on records and radio . . . "Overseas Tested" for better foreign reception.

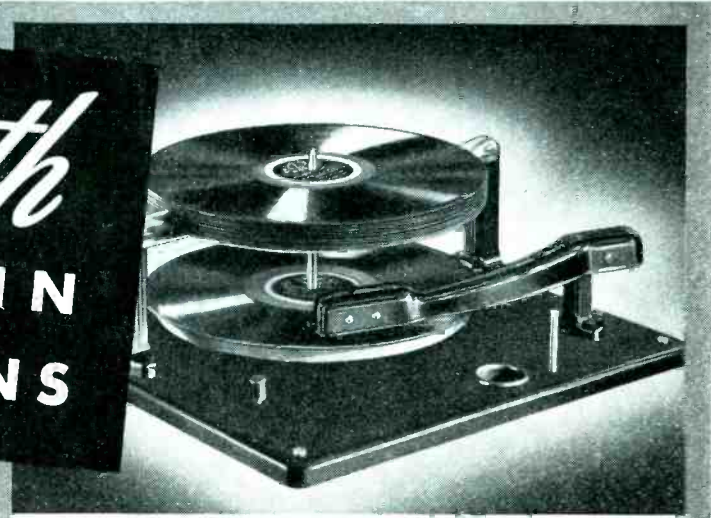

THE HEART OF THE FARNSWORTH LINE

It's **SENSATIONAL** . . . the great new Capehart-Farnsworth record changer, made by the acknowledged masters of the industry! Dealers say it's one of the greatest sales-builders in history. Quiet service-free mechanism. Plays fourteen 10-inch or ten 12-inch records automatically. Customers see it, *play* it, then **BUY** it!



ONLY FARNSWORTH HAS THE COLORTONE

Another big **SALES-MAKER**. Show your customers how this amazing, visual device lets *them* produce 80 different tone combinations . . . suit the tone to their own taste . . . then watch them **SELL THEMSELVES ON FARNSWORTH**.

HERE'S A FARNSWORTH THAT TOPS EVERYTHING!

An outstanding example of up-to-the-minute Farnsworth styling is the popular "classic" Chairside automatic radio-phonograph. Always good for a dramatic demonstration. Customers sit in a chair, tune in and relax comfortably to either records or radio. A splendid performer and a beautiful piece of furniture (in blond or walnut) at a list price that brings in the customers. Don't miss this big profit-maker—see it—let your customers see it—you will sell it, for there's nothing quite like it on the market.

**DON'T DELAY
ANOTHER
DAY!**

Farnsworth also offers breath-taking values in consoles, table models, portables and home recording. You're actually losing money every day you delay . . . with the big holiday season still ahead. Get the money-making facts from your Farnsworth distributor *today!* Or wire, phone or write . . . Farnsworth Television & Radio Corporation, Fort Wayne, Indiana.

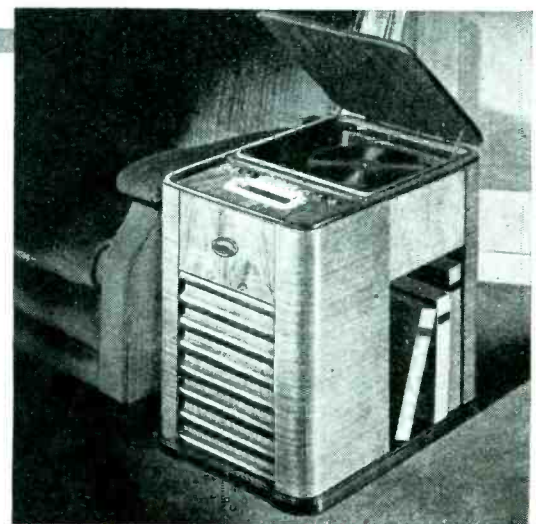

FARNSWORTH •

MAKERS OF RADIOS AND TELEVISION TRANSMITTERS AND RECEIVERS, THE CAPEHART, THE CAPEHART-PANAMUSE AND FARNSWORTH PHONOGRAPH-RADIO COMBINATIONS.

FAMOUS HOMESTAKE GOLD MINE CHOOSES

RAYTHEONS

FOR ITS COMMUNICATIONS SYSTEM

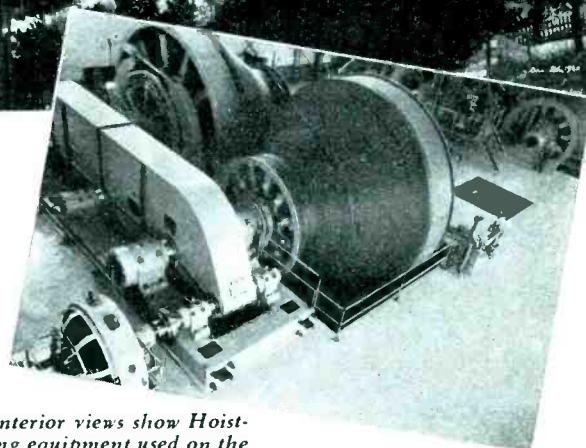
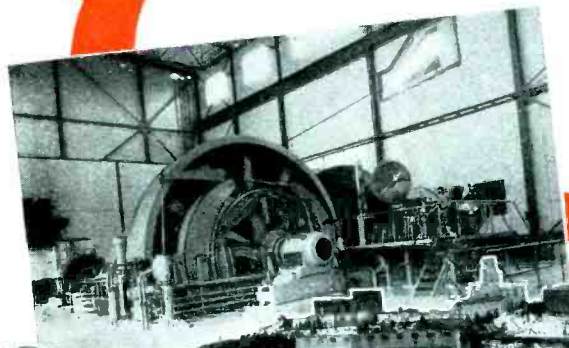

FEW realize the vast scope of the operations of the Homestake Mining Company located at Lead, South Dakota. This company is one of the largest gold producers on the North American continent. For many years Homestake has successfully and scientifically mined, milled and treated lower grade ores. The operations at Homestake, where over 2,000 men are employed, embrace wide flung lumber camps, hydro-electric plants, pumping stations, sawmills and many other diversified activities necessary and vital in the production of a large tonnage of gold ore.

Included in its complete modern equipment is a communications system that is a marvel in its field. Conversations to and from cages while moving up and down the shaft! Automatic signals which show the exact location of the cages at all times! So intricate, so sensitive, is the mechanism that no chances can be taken on tubes. Safety depends upon proper equipment. The tubes must be absolutely reliable, and must function at topnotch efficiency at all times. So it was inevitable that RAYTHEONS were chosen.

This is just another example of the preference for RAYTHEONS wherever there is a tough tube job to do. And the reason is that RAYTHEONS are the development of the world's foremost tube engineers . . . specialists who devote their time exclusively to designing better tubes and to pioneering in new developments for future tube needs.

That's why RAYTHEONS deliver, wherever installed, with a service unsurpassed and that's why thousands of successful servicemen everywhere handle them. There's one for every purpose, for RAYTHEON makes them all. And they cost no more!

Interior views show Hoisting equipment used on the Ross Shaft through which more than 2,000 tons of ore are hauled to the surface every 24 hours.

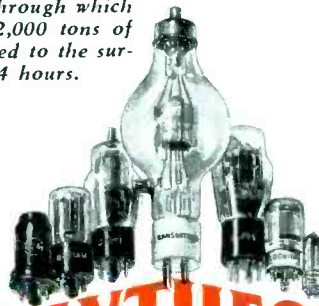

RAYTHEON

MAKES THEM ALL

NEWTON, MASS. NEW YORK CHICAGO
SAN FRANCISCO ATLANTA

"WORLD'S LARGEST EXCLUSIVE RADIO TUBE MANUFACTURERS"

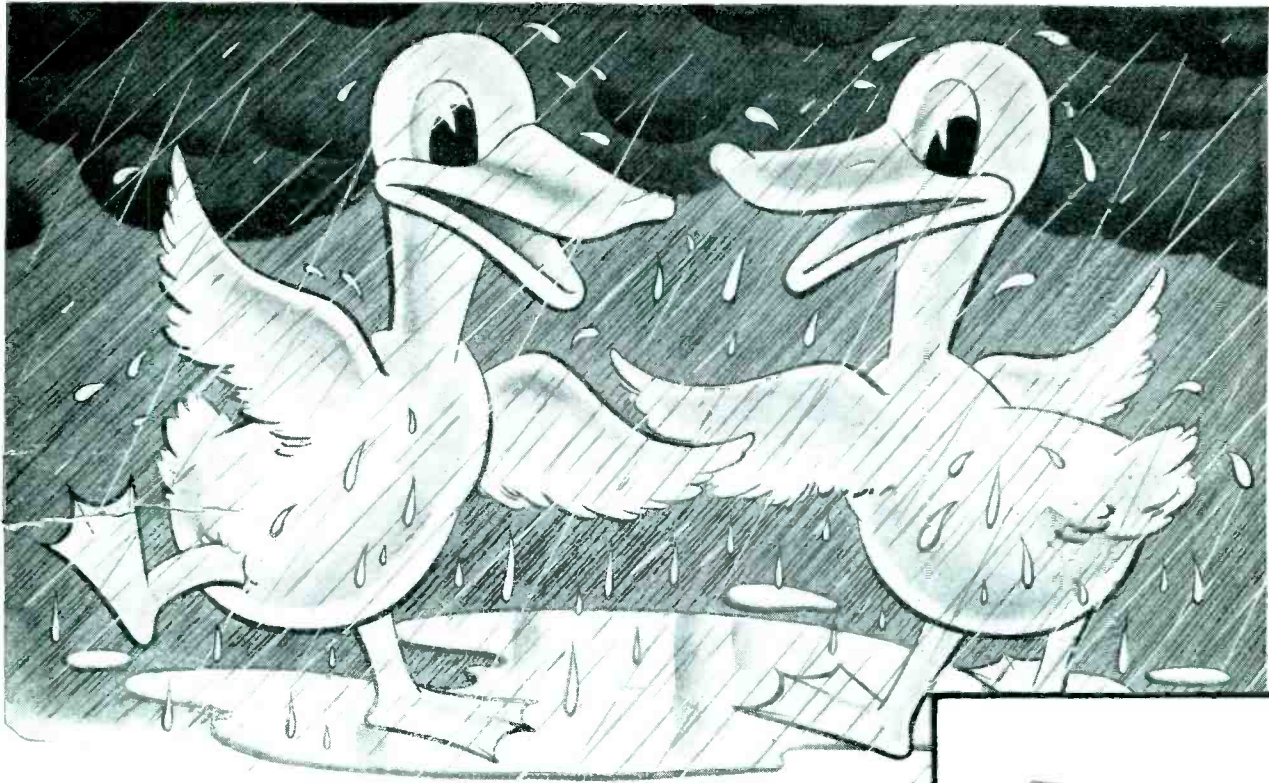

UTAH TRANSFORMERS AS WEATHER RESISTANT *as a duck's back*

A duck's back has nothing on Utah Transformers when it comes to weather resistance. They're built to stand up—even under extremely high humidity and other atmospheric conditions. They keep right on performing—when many other transformers would break down.

This satisfactory performance of Utah Transformers, standard equipment in millions of receivers the world over, is traced to a non-corrosive, protective coating of cellulose acetate which provides absolute insulation—prevents breaking down.

Utah Transformers are uniformly dependable because of precision manu-

facturing and the use of other scientifically selected materials such as high silicon content steel, used in all laminations. Fully guaranteed, these transformers are individually boxed, with complete instruction sheets.

The Utah Transformer line is completely described in the new illustrated catalog, together with facts about other Utah Products. We'll be glad to send you a copy, without any obligation. Write us today. Utah Radio Products Company, 810 Orleans Street, Chicago, Ill. Canadian Office: 560 King Street West, Toronto. In the Argentine: Ucoa Radio Products Company, S. R. L. Buenos Aires. Cable Address Utaradio, Chicago.

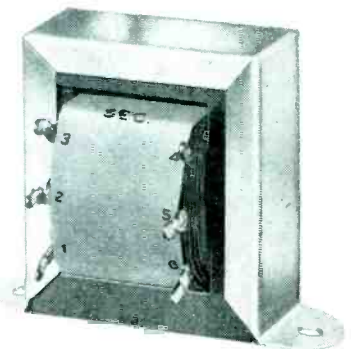

Utah No. 5999, Universal Output

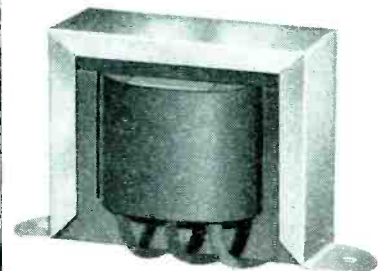

Utah No. 8311, Universal Input



TRANSFORMERS

SPEAKERS • VIBRATORS • UTAH-CARTER PARTS



★ **RCA Victor 10X.** This instrument provides reception of broadcast and 1712 kc. police band... 5 RCA Victor Tubes... Built-in Magic Loop Antenna... 5-inch speaker... plug-in for Record Player... Roto-Base... AC-DC operation. \$14.95*



★ **RCA Victor 16X-11.** Superb American and foreign reception... 2-band, angle-vision dial for easy tuning... extra built-in short-wave antenna for foreign reception, plus all the other features of Model 15X. \$19.95*



★ **RCA Victor 16X-3.** Spinet style cabinet of beautifully grained, striped mahogany veneer, hand-rubbed to a high lustre. The ends and fluted grille are finished in walnut. Contains all features of Super Six Model 15X. \$22.95*



★ **RCA Victor 16X-13.** Superior American and foreign reception... extra built-in antenna for short-wave reception... 2-band, angle-vision dial... cabinet of figured oriental wood veneer with full-length grille. Has all features of Super Six Model 15X. \$24.95*



★ **RCA Victor 16X-14.** Beautifully styled wooden cabinet... stabilized electric tuning for five stations... underwriters' approval... American and foreign reception... extra built-in antenna for short wave. Contains all features of Super Six Model 15X. \$29.95*

*5 new RCA Victor Super Sellers
join the successful Super Six!*

HOT? Say—
in cabinet beauty...
in features...in price...
in quality—they're hotter
than the Sahara
in summer!



RCA Victor
RCA Manufacturing Co., Inc., Camden, N. J.
A Service of the Radio Corporation of America

★ **RCA Victor Super Six Model 15X.** The success of this sensational model inspired the five other super-sellers shown on this page. This instrument has big, continental style, plastic cabinet... 6 RCA Victor Tubes... Radio frequency stage for better sensitivity... big, edge-lighted dial... unique bull's-eye pointer... music-speech tone control... plug-in for record player attachment... RCA Victor Roto-Base... powerful 5-inch permanent magnet dynamic speaker... improved superheterodyne circuit... popular 1610-1712 kc. police band... extra large built-in Magic Loop Antenna... big knobs for easy tuning... automatic volume control... special hi-stability i-f transformers... connection for exterior antenna... 16-to-1 vernier tuning... AC-DC operation... \$16.95* Available also in antique ivory finished cabinet with underwriters' approval as Model 16X-2. \$19.95*



Trademark "RCA Victor" Reg. U. S. Pat. Off. by RCA Mfg. Co., Inc.

*All prices f.o.b. factory subject to change without notice.

AXIAL LEAD

RESISTORS

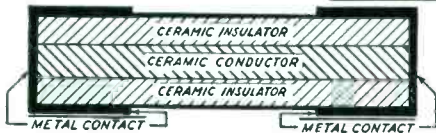

Magnified cross section showing the important and exclusive Centralab features:

Note center core of resistance material surrounded by a dense shock-proof ceramic providing strength and protection against humidity.

Both core and jacket are fired together at 2500 degrees F. into a solid unit . . . hard and durable as stone.

Pure copper covers the resistor ends for contact.

AXIAL LEAD RESISTORS

Completely insulated

Designed to fit into limited space without danger of shorting to the chassis or other parts. Same resistor bodies are used as in Radial Lead units, millions of which are now in use . . . only difference is in method of making end contact. End leads brought through bakelite insulation. Will withstand five times rated load without permanent change.

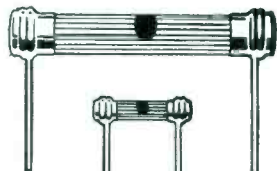

RADIAL LEAD RESISTORS
90% Insulated

The ceramic body of all Centralab resistors is in itself an insulator of the highest quality. Only the radial leads where attached to the body are uninsulated. Electrical characteristics of the Axial and Radial lead types are identical.



Old Man Centralab continues to score a bulls eye with the millions of Fixed Resistors that are doing duty in new and replacement jobs the country over. Manufacturers, experimenters, hams and service men continue to believe (and justly so) that Centralab's unique method of uniting the resistance material with the ceramic body makes for a resistor of unusual strength and efficiency under any and all conditions. Available in either Radial or Axial Lead . . . color coded (R.M.A.) in convenient sizes and ratings.

Always insist on CENTRALAB.

CENTRALAB: Division of Globe Union Inc., Milwaukee, Wis.

by
Centralab

Here's a
"MORE FOR THE MONEY" . . .
Sales Story that Really Clicks!



RADIO plus PHONOGRAPH
plus **RECORD-MAKER** —
 That's Today's Supreme
 Entertainment Value . . .

Tell It Most Convincingly with

ROCK-OLA
Recorders

• No sales story will move more merchandise in profitable volume than a "more for the money" appeal, *properly supported by fact*. On that basis Rock-Ola Recorders stack up as sure-fire sales winners . . . letting you offer "more for the money" in entertainment, fun and thrills, in the form of an instrument that combines radio, phonograph, and home record-maker . . . letting you give "more for the money" in features, in performance, in beauty of appearance and in value. Get the whole Rock-Ola story — prices, discounts, merchandising co-operation, point-of-sale display material, from the distributor in your locality. Or, send the coupon direct to us for full facts.

Model RA-4, one of 6 Console Models (3 available with automatic record changer). Prices from \$79.50 (for model shown) to \$169.50.

8 Models
 EACH ONE SPECIALLY
 MADE FOR HOME
 RECORDING

... and Rock-Ola Recording Discs

To supply dealers with quality discs in the popular price range, Rock-Ola is manufacturing its own line of noninflammable, long-life, noise-free discs. Available to dealers in a self-display merchandiser which stocks and displays discs and needles. Your distributor has full details on the Rock-Ola Merchandiser Deal.



Model RA-1 Portable Recorder - Radio - Phonograph. Lists at \$65.50.



Model RA-2 Table Console Recorder - Radio - Phonograph. Lists at \$59.50.

ROCK-OLA MANUFACTURING CORPORATION
 800 N. Kedzie Avenue, Chicago, Illinois

Rock-Ola Manufacturing Corporation
 800 No. Kedzie Ave., Dept. RR-10, Chicago, Ill.
 Please send me full details on:
 Rock-Ola Recorders; Rock-Ola Discs

Name _____
 City and State _____
 Distributor's Name _____

THESE WIRES ARE ALWAYS TIGHT...

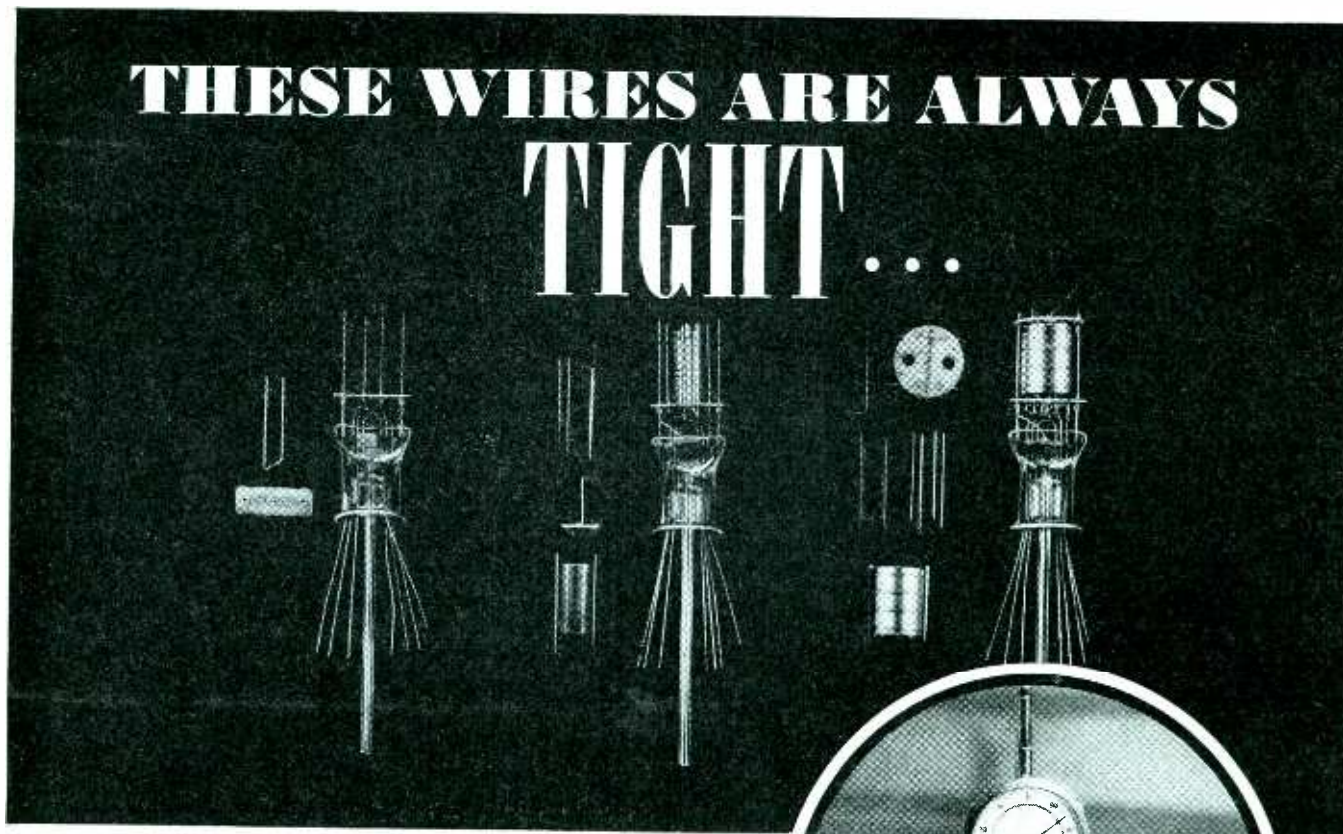

Thanks to SYLVANIA'S Tapered-pin Gauge



IN Sylvania Radio Tubes, mica wafers with tiny holes pierced through them hold support wires firmly in position. They cannot “wobble”; they cannot “jiggle”—if the tubes are to pass Sylvania’s rigid requirements.

To make sure that each hole in the mica will exactly fit each wire in the tube, Sylvania engineers, in cooperation with quality watchmakers, devised an amazingly accurate tapered pin

gauge. With this instrument, Sylvania measures the size of the holes. A variation of one ten thousandth of an inch (.0001) shows up on the dial of the gauge.

The development and use of the tapered pin gauge is but one of hundreds of Sylvania’s daily operations which make Sylvania Tubes outstanding in quality. . . . Hygrade Sylvania Corporation, Emporium, Pa.

SYLVANIA
SET-TESTED RADIO TUBES



ALSO MAKERS OF HYGRADE LAMP BULBS AND MIRALUME FLUORESCENT LIGHT FIXTURES



Type CA
Cabinet Avail-
able with 15"
or 12" Speaker.

NEW HIGH FIDELITY EXTENDED RANGE REPRODUCERS WITH

Bass Reflex

2 Models are with New Type J Dual Loud Speaker and Frequency
Living Network 2 Models with PM12-CT, 12" Loud Speaker. 1 Model
with PM8-CT, 8" Loud Speaker.

All with BASS REFLEX. Dealer price range, complete Reproducers, \$17.70
to \$56.55*. . . All Loud Speakers are Permanent Magnet . . . All Loud
Speakers are available separately . . . All Cabinets are available separately.

With the advent of Frequency Modulation in addition to the amazing
interest everywhere in the reproduction of sound at High Fidelity there is
a demand for these new products. Foresight together with Jensen engi-
neering skill and facilities made these products possible. Write at once
for Catalog No. 119; note the scope and wide price range of this new
line and observe that each product is characteristically Jensen in every
detail of performance ability, appearance and value. Jensen Radio Mfg.
Co., 660 South Laramie Ave., Chicago. (cable address JERAD, Chicago)
*Dealer price, Loud Speakers only, from \$5.40 to \$27.90.

Type MT
Cabinet
Available
with 15",
12" or 8"
Speaker.

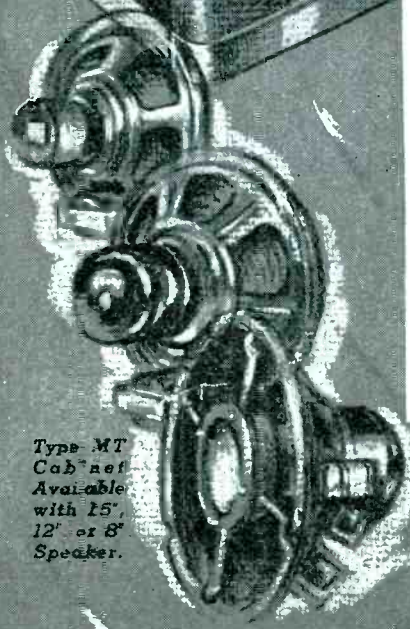

Jensen
High Fidelity
REPRODUCERS

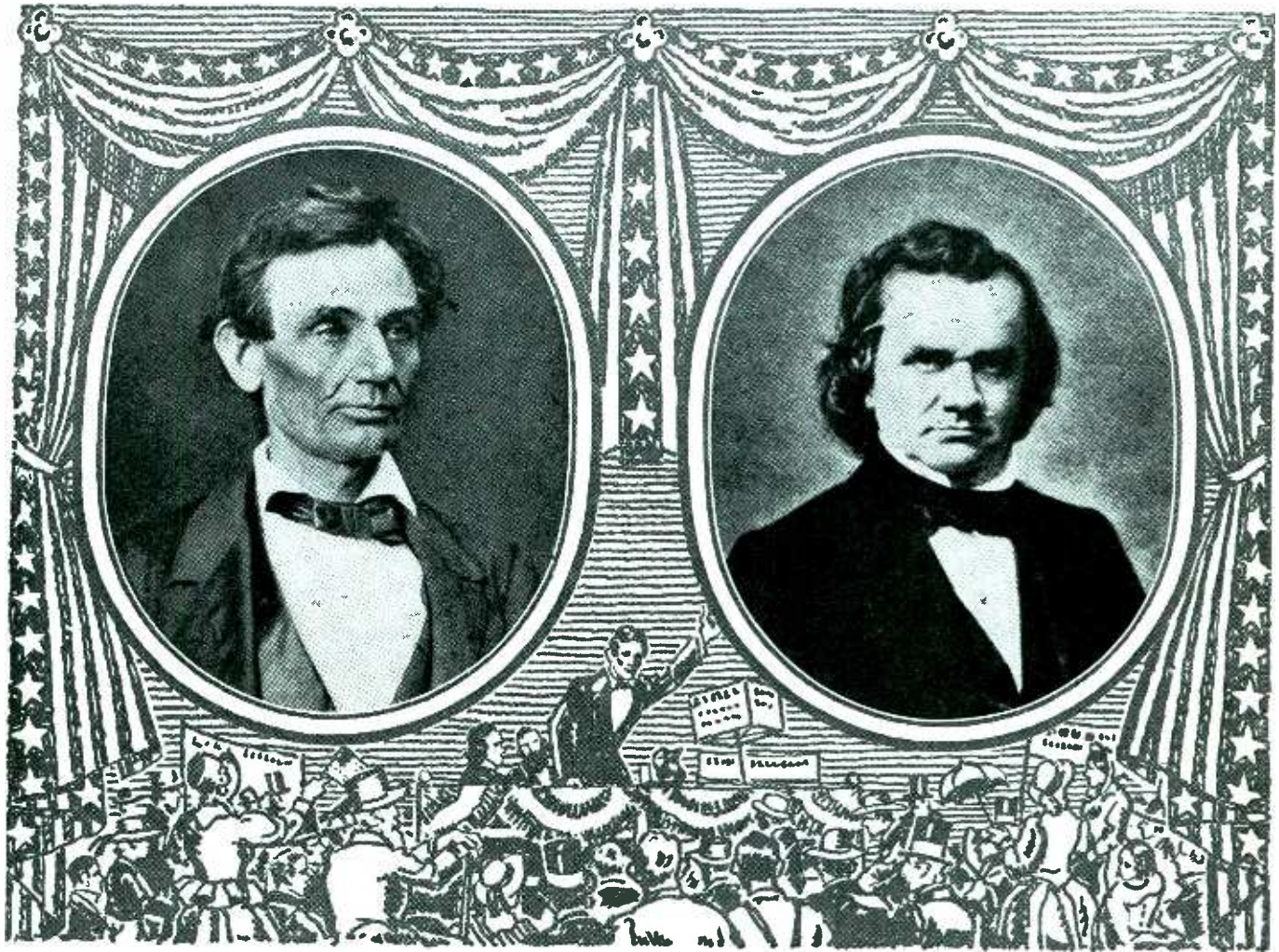

Through Radio, All America Could Have Judged the Lincoln-Douglas Debates

IN 1858, Abraham Lincoln, then an Illinois lawyer, debated states' rights and the vital slavery question with Stephen A. Douglas. These debates have been called the most important in American history—yet only a few thousand people in Illinois were able to hear them. Other Americans were kept in ignorance until, weeks and months afterwards, the speeches were sketchily reported in the journals of the day.

Today, with the miracle of radio, statesmen are able to speak directly to millions of Americans, keeping them constantly informed on the vital issues affecting our nation. And as a result, we are the best informed people on earth.

Two great networks of the National Broadcasting Company, an RCA Service, operate a total of 35 hours a day, broadcasting important news matter as well as entertainment and educational programs.

Instant communication to and from leading nations of the world is provided through R. C. A. Communications, Inc. And in RCA Laboratories, fountain-head of radio progress, engineers are continually at work pioneering new developments in radio and sound. These developments are made available to RCA licensees, so that America and the world may enjoy better radio receivers, records, transmitting apparatus and other radio and sound equipment.



Radio Corporation of America

Radio City, New York
 RCA Manufacturing Company, Inc.
 Radiomarine Corporation of America
 National Broadcasting Company
 R.C.A. Communications, Inc.
 RCA Laboratories
 RCA Institutes, Inc.



Entirely Automatic

VOLT-OHM-MILLIAMMETER

A NEW
CONCEPTION OF
PUSH BUTTON
TESTING

MODEL 1200-F

Push-button switching by a new, simpler way makes the Model 1200-F an entirely automatic Volt-Ohm-Milliammeter. All buttons are arranged for maximum speed and minimum switching; with an individual color for each kind of measurement. Ranges are progressively arranged and pressing the button at the top of any color combination immediately gives the maximum range for measuring any unknown value. To shift to a lower range, or any other kind of measurement, simply push another button and you have your reading instantly before you. There can be no confusion in making settings and automatic switching will help you in avoiding costly overloading. Only one button need be pressed for any range and test setting. Ranges: DC 0-10-50-250-500-1000 at 25,000 ohms per volt. . . . AC 0-10-50-250-500-1000 at 1000 ohms per volt. DC Milliampere 0-1-10-50-250. . . . 0-50 DC Microampere. . . . Resistance 0-1000 Low Ohms, shunt type circuit; 0-300,000 ohms; 0-3 and 0-30 Megohms, series type circuit. Self-contained batteries for all ranges. RED • DOT Lifetime Guaranteed Instrument. Plug-in rectifier simplifies replacement in case of accidental damage. Metal case with rich brown suede enamel finish. Panel with attractive three-tone finish. Dealer Net Price \$27.84

Model 1200-A . . . Selector Switch Operated . . . 2,000 Ohms per Volt DC . . . Volt-Ohm-Milliammeter . . . Dealer Net Price \$21.84
 Model 1200-C . . . Selector Switch Operated . . . 5,000 Ohms per Volt DC . . . Volt-Ohm-Milliammeter . . . Dealer Net Price \$22.84



\$27.84
DEALER NET PRICE

Model 1200-E . . . Selector Switch Operated . . . 25,000 Ohms per Volt DC . . . Volt-Ohm-Milliammeter . . . Dealer Net Price \$25.84

MODEL 1600-E ULTRA SENSITIVE TESTER

DC Volts—0-10-50-250-1000 at 25,000 ohms per volt. AC—0-10-50-250-1000 at 1000 ohms per volt. Plug-in copper oxide rectifier easily replaced in case of overload. Current 0-50 Microampere; 0-1-10-50-250-500 Milliampere. Resistance 1/2 to 500, Low Ohms, shunt type circuit; 20,000 and 200,000 ohms; 2 and 20 Megohms. In Portable Case . . . Dealer Net Price \$25.50

Model 1600-E for panel mounting, less case . . . Dealer Net Price \$21.00

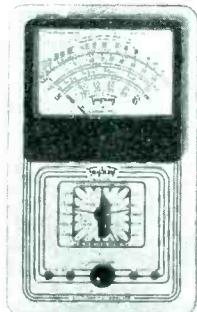

* * * * * Write for catalog on complete line of test equipment. Triplet also manufactures electrical measuring instruments in more than 25 case styles. Section 2010 Harmon Drive,



MODEL 666

VOLT-OHM-MILLIAMMETER

A complete pocket-size Volt-Ohm-Milliammeter with AC-DC Voltage ranges: 0-10-50-250-500-1000 at 1000 ohms per volt; DC Milliampere 0-1-10-50-250; Low Ohms 1/2 to 300; High Ohms to 250,000 with provisions for higher readings by external batteries. Molded case and panel. Dealer Net Price \$14.00

THE TRIPLET ELECTRICAL INSTRUMENT COMPANY
Bluffton, Ohio



Not down a note on profits

Two major reasons why radio-phonograph combinations offer you *bigger profit opportunities* are . . . *first*, public demand for combinations is greater than ever, and *second*, combinations sell at higher prices, thereby returning you a larger profit per unit!

Then, too, combinations help make your sales task easier . . . with a radio-phonograph model you're offering the prospect **extra entertainment value!** You're giving the prospect a sound

tangible reason for spending more money.

You make this effective sales approach doubly effective when you back it up with the truly brilliant radio performance provided by the Westinghouse 21st Birthday Combinations shown below. Here are outstanding radio-phonograph values! Outstanding in styling, cabinet beauty, and performance. Why not make this your biggest money-making season? Write or phone your nearest Westinghouse Distributor today!

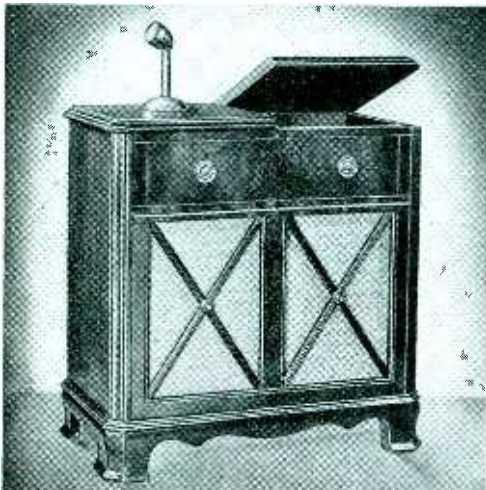

RADIO-PHONOGRAPH AND HOME RECORDER MODEL WR-486

Superb 9-tube radio. Automatic Phonograph. Makes recordings, either of radio programs or by microphone. Push-button tuning. 12" Dynamic Speaker. Beautiful hand-rubbed walnut cabinet.



MODEL WR-480

Plays 10" or 12" records. "Easy-lift" lid. Push-button Tuning. Self-starting motor. Crystal pick-up.



MODEL WR-478

Plays 10" or 12" records. Self-starting motor.

← MODEL WR-484

Automatic Record Changer. Push-button Tuning.

MODEL WR-482 →

Built-in Antenna. 6 tuning buttons. Automatic Record Changer.

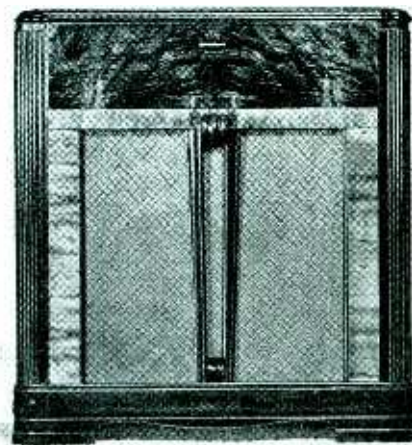

Westinghouse Precision RADIO

The RADIO MONTH

OCTOBER

1940

RADIO'S 20TH BIRTHDAY will be nationally celebrated November 11-30 under the sponsorship of NAB, RMA, RSA and NRPDA, immediately on the heels of the "Listen Before You Vote" campaign so effectively organized by these groups and actively supported by *Radio Retailing* (See front cover. Also suggested windows in September issue). Just two decades ago first real broadcasting began and the industry has since "donated" so much to the public that it need feel no false modesty about blowing its own horn.

MANUFACTURER INVENTORIES should wind up the year in good shape. Sales in January, February, March and April were particularly hot and while business did not live up to this early promise in the three months following, August and September shipments again headed for the highspots with everything pointing toward an impressive unit and dollar volume in the final quarter. As we write it is estimated that unit sales are already nearly a million ahead of the first 9 months of 1939. On the books are impressive new totals for compacts and combinations, with the ratio of larger models leading last year in the latter classification. Straight console sales leave something to be desired and recorders have apparently not yet reached their stride. Both may bolster before Christmas. Personal portables, despite high initial interest, are something of a holiday sales enigma to manufacturers and there is considerable speculation as to whether or not they will produce substantial holiday business.

NEW CAR SETS are appearing on the market in considerable

number as we go to press, with several lines already announced, others near ready for showing to the trade. Unveilings are in some instances months earlier than usual. Reason: Car sales are going like a house afire and set makers think radio dealers can cash in on much accessory business muffed by auto showrooms.

DEBT MORATORIUM to be enjoyed by men drafted for military training may be cause for worry among such retailers as credit clothing houses. We doubt if it will have any noticeable effect on installment radio or electrical appliance business because (a) most radios and major appliances are purchased by "family" men likely to be exempt and (b) the total number of men to be initially called is relatively insignificant by comparison with our total potential prospect list. Even in the case of national guardsmen there appears to be a tendency to gamble on credit among retailers in certain other fields.

SENSIBLE SELLING-UP involves intelligent effort to pry more money out of the prospect than he originally intended to spend, going about the delicate business in a manner which permits graceful backtracking to the model initially inquired about when the operation doesn't "take." Intelligent selling-up avoids reducing the ratio of sales to number of walk-in prospects. We gather that this ratio is about 35 per cent in radio and appliances, 40 per cent in the furniture business. More about it in an early issue.

SOUND OPERATORS are busily at work building their own trade Associations in some of our larger cities, which we very much like. In others there has been



AUTO SHOW INNOVATION—On their way to New York's annual exhibit are Lincoln, Zephyr, Mercury, Ford and Nash cars equipped with radios tuned by depressing a foot button

considerable outside urging toward Unionism. Apparently one of the first jobs tackled by Associations is establishment of minimum rental rates, which is as it should be. Local groups can establish rates suitable to operators in a specific area whereas it is much more difficult and perhaps impossible to lay down rates for the entire nation. We know this is true because we've frequently, in trying to help start the ball rolling in the right direction, burned our Editorial fingers.

COIN PHONOGRAPH FANS are in for a surprise one of these days when they drop a nickel into a strange slot. We hear that at least one of the record makers is now releasing highhat to operators in relatively swank neighborhoods, emphasizing light classical and dinner music.

SEPTEMBER SPECIAL issue of *Radio Retailing* containing suggestions for aggressive retail Fall campaigns, quality merchandise sales aids, brought a flood of commendatory letters. Thanks for the praise, gentlemen. We thought we "had something there" too but it's the reader's reaction that really counts.

Mac
W. MacDonald
EDITOR

PHOTOShorts

Pictures from the News
to help you SELL



MUSIC ON THE HIP

Next summer, no mountain vacation for us. Not if the seashore can be consistently depended upon to delight both eye and ear as Frances Marie Burke (1940 Miss America) and a personal portable did during this Atlantic City PhotoShort news shot

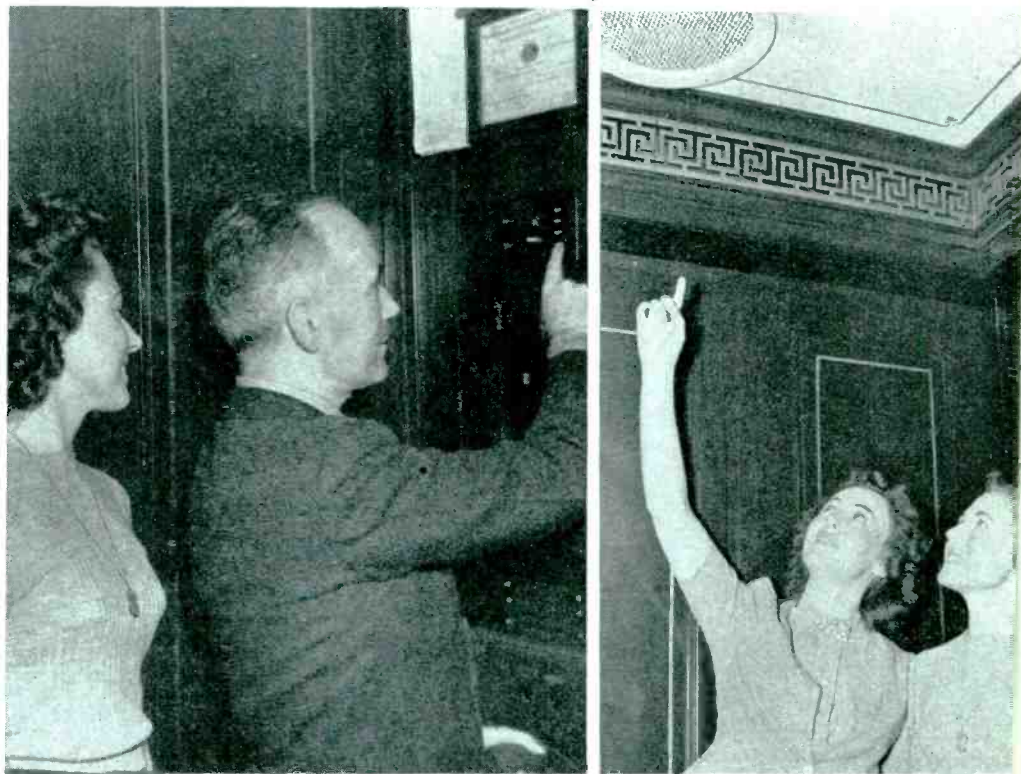

RADIO WITH A LIFT

So far as we know, this Philco job in a Philadelphia office building represents the first radio installation designed exclusively for the entertainment of tired businessmen riding up and down in elevators. Set and loop are fixed at top of shaft while push-button controls and speaker in the car operate via wired remote control over standard elevator cables

LILLIPUT NETWORK

Dramatic demonstration for large audiences is the G-E setup pictured here. AM wireless record-player and nearby receiver at right illustrate conventional transmission and reception while FM wireless record-player and matching receiver at left do likewise for new noiseless system. Miniature towers hold transmitter antennas, constitute effective staging



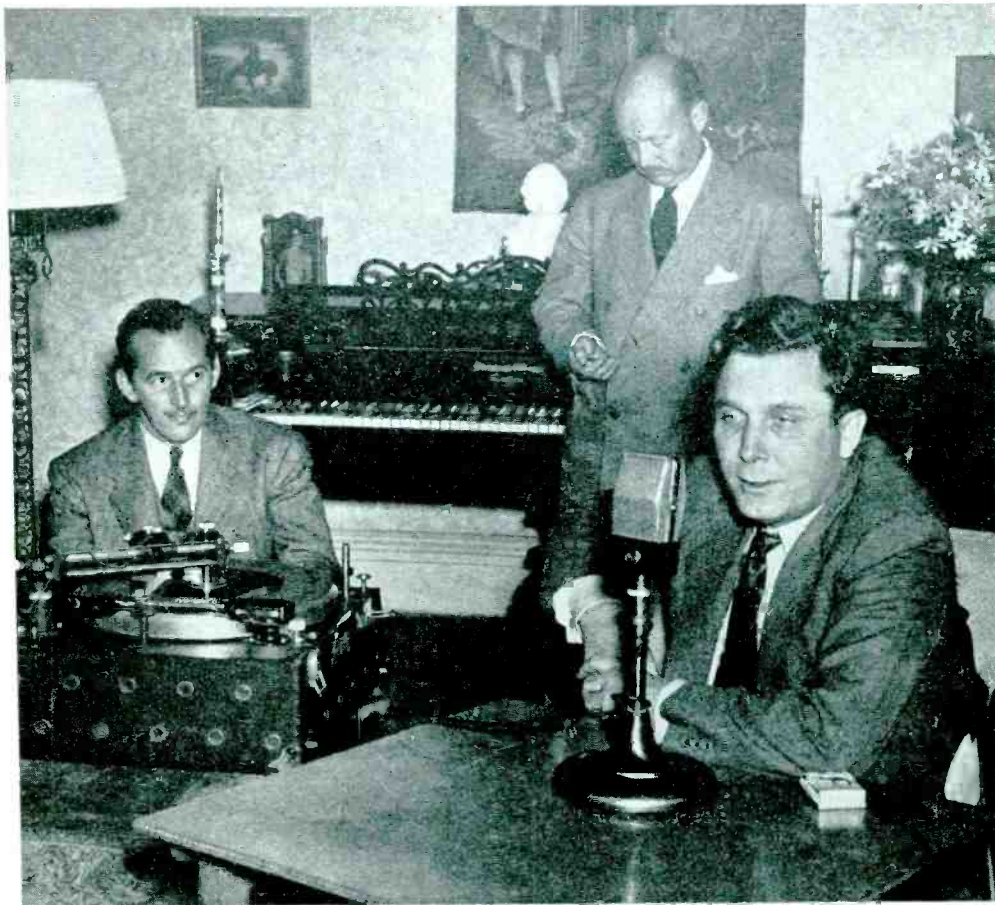

PICK-A-BACK SELLING

Picture the power of Paul R. Becker's sales approach with Motorola's "Bike Radio" for the MotoTrunk Company of Wichita. He lugs this wheel from town to town on a back-of-car bracket, dismounts, pedals right into stores. Says retailers could effectively use same stunt to sell consumer (Below)

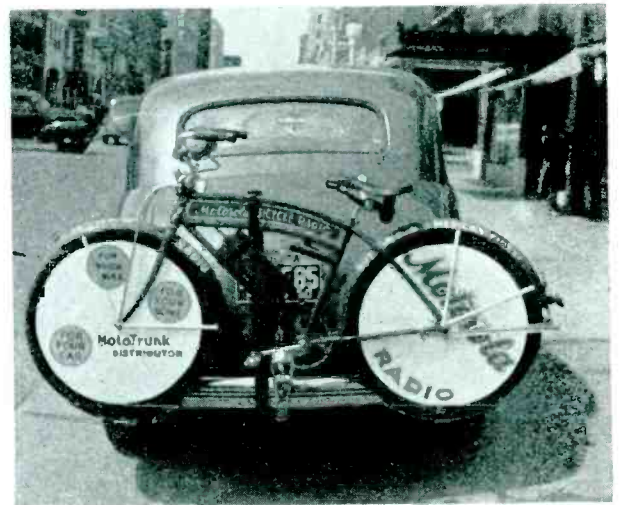

RUSH RUSHVILLE RECORDING

On sale for 50¢ at 40,000 radio and drug stores, newsstands, late last month went autographed Wendell Willkie records, 10-inch double-faced discs sandwiching "A Personal Message for Every American" between vocalized "America" and "Columbia, the Gem of the Ocean." Republican presidential candidate is here shown making the original at his home in Indiana

FLYING SERVICEMAN

Capehart service superintendent Cutler Brown of Los Angeles' Birkel-Richardson Company lays claim to number one air-hour honors for retail technicians. Says he's kept busy hopping to such places as Palm Springs, Phoenix, Bakersfield, Santa Barbara, San Diego and Reno (552 miles from L.A.) despite comparative freedom from trouble of machines because firm has over 200 in use at points remote from city that do deserve periodic checkup and testing

GOOD IDEAS SPREAD FAST

First recording of nightclub guest voices to come to our attention was the scheme introduced by Chicago's "Ivanhoe" (RR May '40) but a good idea spreads fast. Here's Maestro Woody Herman of the Hotel New Yorker's Ice-Terrace Room pulling the same publicity stunt with RecordDisc blanks. (The gal, again, is '40's Miss America)



All About *NEW*

DE LUXE MERCHANDISE once beyond reach of most wage earners comes down in price. Production economies broaden market

EARLY "Cylinder and Gooseneck" PHONOGRAPH

ONE OF THE MOST important merchandising moves in recent radio business history is the current effort of manufacturers to broaden the market for automatic record-changing radio-phonographs. This is attempted by risking heavier schedules on such machines, anticipating quantity production savings and passing these along in advance to the consumer.

The gamble is a good one if movement of records is any criterion. Popular platter sales appear headed for another new peak. Classical discs have made really phenomenal gains. Albums are coming into even more widespread use. Part of this increased interest in recorded music may be attributed to lowered lists but checkup indicates that the picture looked extremely promising even before cuts went into effect.

Then, too, market surveys point toward a resumption of consumer interest in better tone and better furniture, features most readily included in the larger instruments. And public purchasing power (RR17Sept) continues at high water mark so that such tastes may be more generally gratified.

Re-Styled Promotion Advisable

This latest trend calls for re-styled manufacturer and dealer promotion.

Until this season automatic record-changing radio-phonograph promotion has been aimed almost exclusively at extreme upper-bracket equipment purchasers. It has been largely assumed that this class of merchandise was hopelessly out of



CROSLY 318F \$149.95

TYPICAL
MACHINES
OF TODAY



G-E J805
STROMBERG-CARLSON 535PL \$325.00

reach for most medium wage earners. Now such is no longer the case for, while truly deluxe machines carrying lists perhaps prohibitively high for the average man are sensibly continued for sale to the carriage trade, semi-deluxe automatics are also available at such attractive prices that it is but a short step up from manually operated types and not much more of a jump from certain straight radio consoles.

The most important thing to remember when preparing promotion of any sort for the holiday season is that *the middle-class prospect can now afford semi-deluxe instruments.* Since the early months of this year there has been evidence that the trade is once more endeavoring to sell "up from the bottom." Reversing the English, it is probably more to the point to suggest that it



AUTOMATIC Phono-Radios

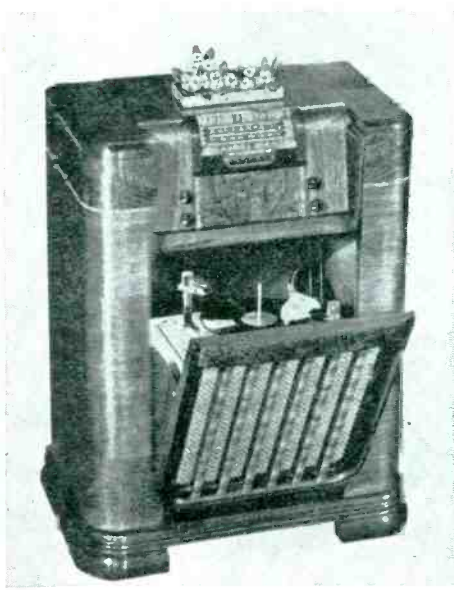

PHILCO 608P \$129.95



RCA VICTOR V205 \$150.00



CONCERT GRAND 8D7 \$180.00



FARNSWORTH BK73 \$99.95



ZENITH 105590

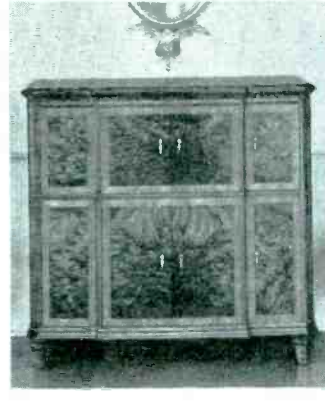

CAPEHART 406K



ADMIRAL 6287

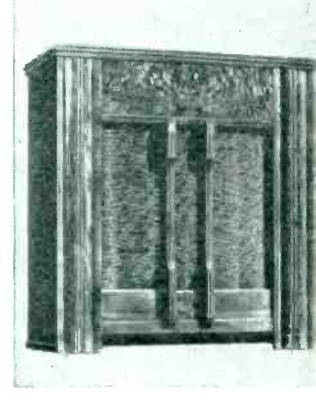

ROCK-OLA RA5 \$129.95

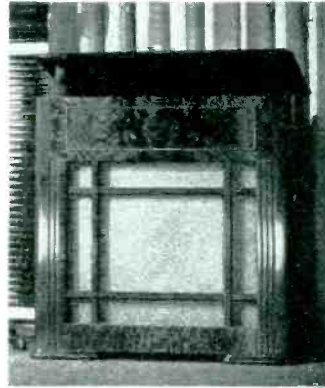

SONORA KSA96



WESTINGHOUSE WR486



SENTINEL 216JY \$169.50



BRUNSWICK 276 \$289.50

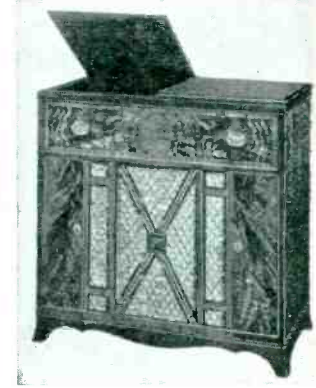

PILOT HR 92 \$149.50



MOTOROLA 58FRC \$49.95

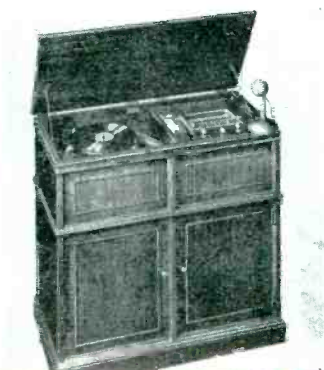

FEDERAL 306 \$169.95



WILCOX-GAY A94 \$179.95

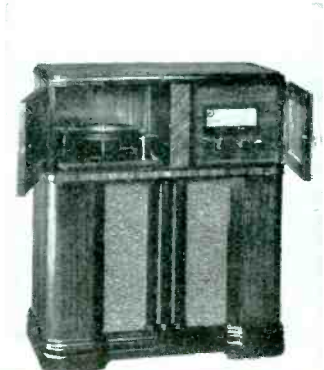

HOWARD 718APC \$129.50



FADA 194APC \$139.95

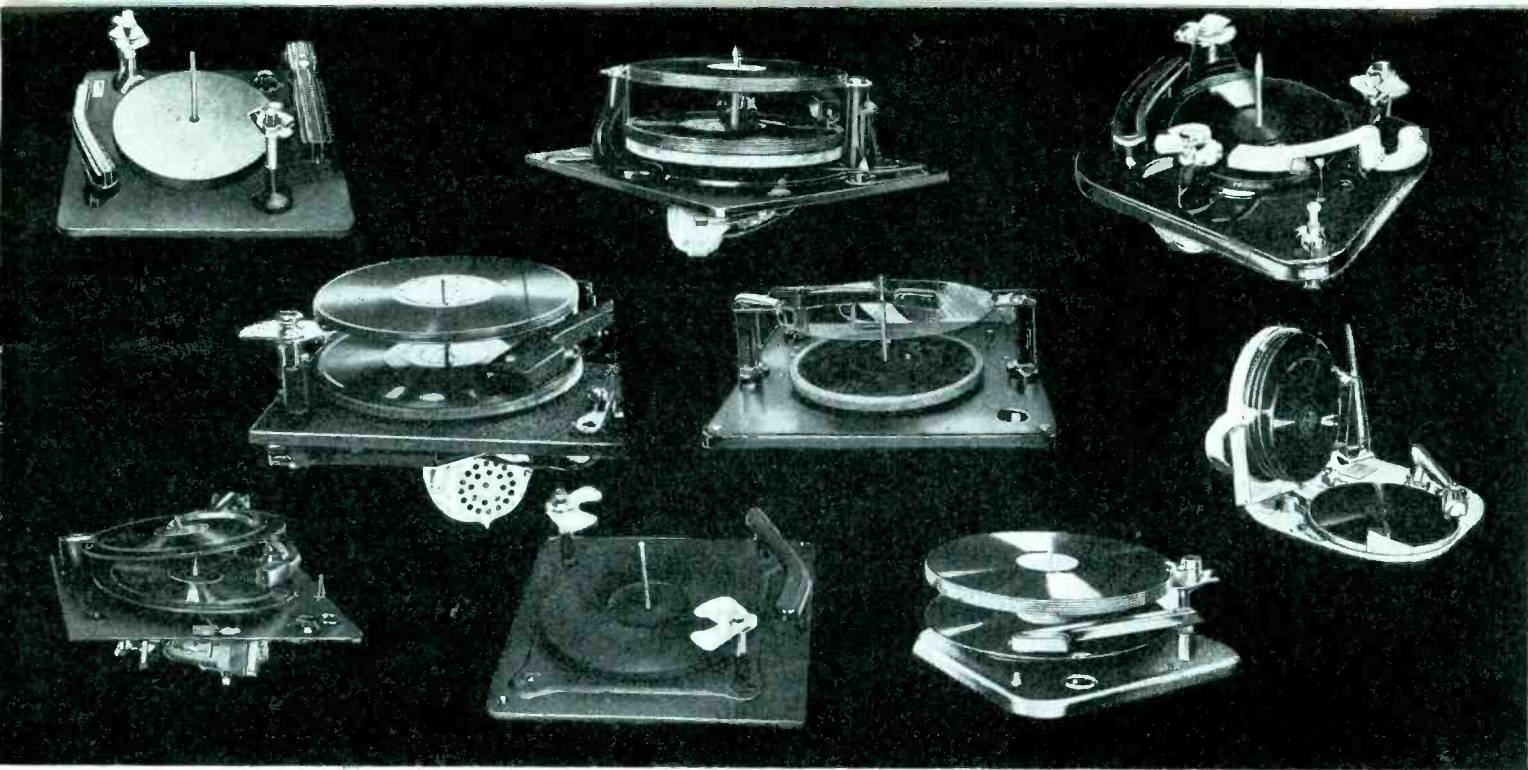

MODERN Record-Changing MECHANISMS (See page 63 for technical operating details)

Left to Right:
 Top Row...Seeburg...General Industries...Webster-Chicago
 Middle Row...RCA...Farnsworth...Capehart
 Bottom Row...Garrard...Erwood...Motorola

now has a beautiful opportunity to sell "down from the top."

Emphasis of upper-bracket merchandise is especially desirable between now and early December because most men planning purchase of "family" radios for Christmas must be sold well before the actual holiday. (*Radio Retailing* plans to feature small, "packaged", gift and novelty radio promotional ideas in a special November pictorial.)

Suggested Holiday Sales Approach

Investigation discloses that the public in general is still not aware that automatic record-changing ra-

dio-phonographs are now available at moderate cost. More surprising, not a few queried by our field staff were wholly ignorant of the fact that there are such things as home machines which automatically change records.

Part of this blind-spot among middle-class prospects is undoubtedly due to the fact that dealers themselves have until recently been apathetic about deluxe equipment, have gone to little trouble to familiarize themselves with its features and less to acquaint the public. First step toward extended sale of automatics, therefore, is for the trade itself to become more familiar with the features of the excellent new semi-deluxe merchandise it now has to sell.

While many people who initially indicate interest in manually operated radio-phonograph combinations, straight radio consoles and even table type radios may be sold up to the new automatics best bet is undoubtedly dealer concentration upon present owners of simpler record playing devices. Store demon-

stration to customers who regularly come in to hear discs, mass demonstrations at club meetings wherever such cooperation can be arranged, direct-mail circulars to the entire list of neighborhood record buyers, all these things should produce business.

And in all such promotional work, may we repeat, it is of particular importance that the trade stress the point that *the middle-class prospect can now afford semi-deluxe instruments.*

The public is once more softening up to the "quality" story.

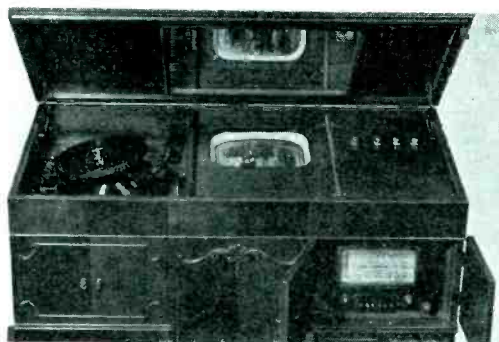

ANDREA 8F12



EMERSON 372 \$199.95
 DE WALD 815 \$149.50

ANSLEY

Aylesbury

BELMONT

801

\$129.95

MAGNAVOX

50

\$265

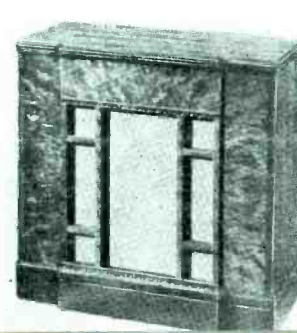
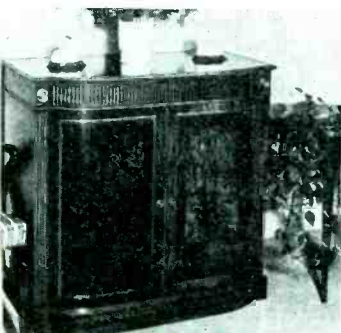

Automatic Phono-Radio SPECIFICATIONS

MODEL	RECORD LOAD	PLAYS CHANGER (MIN.)	MADE BY	CABINET	TUBES	LINE	PRICE
AIR KING PRODUCTS CO. INC., 1523-C3rd St., Brooklyn, N. Y. AIR KING							
4130	10-12, 12-10"	50	Gen. Inst.	Table	5	ac	\$49.95
ANDREA RADIO CORP., 48-20 48th Ave., Woodside, L. I. ANDREA RADIO							
8F12-	8-10, 7-12"	33		Console	33	ac	
ANSLEY RADIO CORP., 4377 Bronx Blvd., N. Y. C. ANSLEY DYNAPHONE							
25Ax	8-10, 8-12"		Garrard	Console	14	ac	\$260
					16	ac-de	to 465
21Ax	8-10, 8-12"		Garrard	Console	12	ac	225
					14	ac-de	to 430
17A7x	10-12, 12-10"		Web-Chi.	Armchair & Consoles	8	ac	179.50
					9	ac-de	to 364.50
BELMONT RADIO CORP., 5921 W. Dickens Ave., Chicago, Ill. BELMONT							
671	14-10, 10-12"	45	Seeburg	Console	6	ac	\$59.95
796	10-10, 8-12"	30	RCA	Console	7	ac	79.95
801†	14-10, 10-12"	50	Seeburg	Console	8	ac	129.95
BRUNSWICK RADIO & TELE. DIVN., 206 Lexington Ave., N. Y. C. BRUNSWICK PANATROPE							
284	8-10, 8-12"	40	RCA	Console	6	ac	\$99.50
286	8-10, 8-12"	40	RCA	Console	6	ac	119.50
285	8-10, 8-12"	40	RCA	Console	7	ac	179.50
285-1	8-10, 8-12"	40	RCA	Console	7	ac	179.50
280	8-10, 8-12"	40	RCA	Console	7	ac	189.50
282	8-10, 8-12"	40	RCA	Console	7	ac	199.50
275	8-10, 8-12"	40	RCA	Console	11	ac	279.50
276	8-10, 8-12"	40	RCA	Console	11	ac	289.50
277	8-10, 8-12"	40	RCA	Console	11	ac	299.50
CONTINENTAL RADIO & TELEVISION CORP., Chicago, Ill. ADMIRAL							
62-B7	10-12, 12-10"	40	Seeburg	Console	7	ac	
57-B7	10-12, 12-10"	40	Seeburg	Console	7	ac	
04-K5§	7-12, 8-10"	30	RCA	Mantle	5	ac	
58-A11	10-12, 12-10"	40	Seeburg	Console	12	ac	
59-A11	10-12, 12-10"	40	Seeburg	Console	12	ac	
R58B11†	10-12, 12-10"	40	Seeburg	Console	12	ac	
R59B11†	10-12, 12-10"	40	Seeburg	Console	12	ac	
CROSLEY CORP., Cincinnati, Ohio. CROSLEY							
28AZ†	14-10, 10-12"	50	Seeburg	Console	8	ac	
29AT	14-10, 10-12"	50	Seeburg	Console	8	ac	
29BA	14-10, 10-12"	50	Seeburg	Console	8	ac	
30BC	14-10, 10-12"	50	Seeburg	Console	7	ac	
31BF†	14-10, 10-12"	50	Seeburg	Console	9	ac	
34BH†	14-10, 10-12"	50	Seeburg	Console	9	ac	
DEWALD RADIO MFG. CORP., 440 Lafayette St., N. Y. C. DEWALD							
816	10-10, 10-12"		Seeburg	Console	8	ac	\$124.50
815	10-10, 10-12"		Seeburg	Console	8	ac	149.50
EMERSON RADIO & PHONOGRAPH CORP., 111 Eighth Ave., N. Y. C. EMERSON							
372	8-10, 7-12"	40	RCA	Console	8	ac	\$199.95
374	14-10, 10-12"	60	Seeburg	Console	5	ac	99.95
370	14-10, 10-12"	60	Seeburg	Console	8	ac	129.95
371†	14-10, 10-12"	60	Seeburg	Console	7	ac	149.95
ESPEY MFG. COMPANY, 305 E. 63rd St., N. Y. C. ESPEY							
WQXR	8-10, 8-12"	40	Garrard	Console	10, 13, 16	ac-de	\$265.00
433	8-10, 8-12"	40	Garrard	Console	8	ac-de	175.00
423	8-10, 8-12"	40	Garrard	Console	16	ac-de	275.00
45	8-10, 8-12"	40	Garrard	Console	10	ac-de	275.00
FADA RADIO & ELECTRIC CO., 30-20 Thomson Ave., L. I. C. FADA							
184APC§	7-12, 8-10"	31	Gen. Inst.	Console	7	ac	\$99.95
185APC§	7-12, 8-10"	31	Gen. Inst.	Console	8	ac-de	109.95
194APC§	10-12, 12-10"	40	Gen. Inst.	Console	10	ac	139.95
195APC§	10-12, 12-10"	40	Gen. Inst.	Console	11	ac-de	149.95
FEDERAL RECORDER CO., INC., 630 S. Wabash Ave., Chicago, Ill. FEDERAL							
306†	10-12, 12-10"		Gen. Ind.	Console	9	ac	\$160.95
301†	10-12, 12-10"		Gen. Ind.	Console	6	ac	139.95
FARNSWORTH RADIO & TELEVISION CORP., Fort Wayne, Ind. FARNSWORTH							
BK73	14-10, 10-12"	50	Capehart	Chairside	7	ac	\$99.95
BK77	14-10, 10-12"	50	Farnsworth	Console	7	ac	99.95
BK78	14-10, 10-12"	50	C-F	Console	7	ac	109.95
BK85	14-10, 10-12"	50	C-F	Console	8	ac	129.95
BK87	14-10, 10-12"	50	C-F	Console	8	ac	139.95
BK89	14-10, 10-12"	50	C-F	Console	8	ac	139.95
BK108	14-10, 10-12"	50	C-F	Console	10	ac	199.95
BK107	14-10, 10-12"	50	C-F	Console	10	ac	179.95
BK88	14-10, 10-12"	50	C-F	Console	8	ac	129.95
BK110	14-10, 10-12"	50	C-F	Console	11	ac	235.00
BK106	14-10, 10-12"	50	C-F	Console	10	ac	169.95
BK112	14-10, 10-12"	50	C-F	Console	11	ac	275.00
BK111	14-10, 10-12"	50	C-F	Console	11	ac	245.00
GALVIN MFG. CORP., Chicago, Ill. MOTOROLA							
58FRC	8-10, 7-12"		Motorola	Table	5	ac	\$49.95
62FI	8-10, 7-12"		Motorola	Console	6	ac	79.95
83FI	8-10, 7-12"		Motorola	Console	8	ac	114.95
93FI†	12-10, 10-12"		Seeburg	Console	9	ac	179.95
103FI†	12-10, 10-12"		Seeburg	Console	10	ac	249.95
GENERAL ELECTRIC CO., Bridgeport, Conn. GENERAL ELECTRIC							
J709	8-10, 7-12"			Console	7	ac	
J718	8-10, 7-12"			Console	7	ac	
J728	8-10, 7-12"			Console	7	ac	
J808	8-10, 7-12"			Console	8	ac	
J809	8-10, 7-12"			Console	8	ac	
J818	8-10, 7-12"			Console	8	ac	
J828	8-10, 7-12"			Console	8	ac	
HOWARD RADIO COMPANY, 1735 Belmont Ave., Chicago, Ill. HOWARD							
718APC	8-12, 10-10"	30		Console	12	ac	\$129.50
308APC	8-12, 10-10"	30		Console	8	ac	99.95
302RAS†	8-12, 10-10"	30		Console	7	ac	149.50

MODEL	RECORD LOAD	PLAYS CHANGER (MIN.)	MADE BY	CABINET	TUBES	LINE	PRICE
302RA†	8-12, 10-10"	30		Console	7	ac	169.50
568RA†	8-12, 10-10"	30		Console	10	ac	199.50
MAGNAVOX CO., INC., Ft. Wayne, Ind. MAGNAVOX							
724§x	15-10, 12T.M.	60		Console	12-28	ac	\$395.00
624§x	15-10, 12T.M.	60		Console	12-28	ac	365.00
424§x	8-10, 12T.M.	45		Console	12	ac	298.50
501§x	15-10, 12T.M.	60		Console	12	ac	265.00
34G §	15-10, 12T.M.	60		Console	12	ac	235.00
51A1§#	15-10, 12T.M.	60		Console	20	ac	285.00
498	15-10, 12T.M.	60		Console	9	ac	198.50
488	15-10, 12T.M.	60		Console	9	ac	198.50
38G§	8-10, 12T.M.	45		Console	9	ac	198.50
32D	10-12, 12-10"	50		Chairside	9	ac	165.00
47	10-12, 12-10"	50		Console	8	ac	139.50
PHILCO RADIO & TELEVISION CORP., Philadelphia, Pa. PHILCO							
605	10-12, 12-10"	40	Web.-Chi.	Console	6	ac	\$89.95
607	10-12, 12-10"	40	Web.-Chi.	Console	6	ac	109.50
608*†	10-12, 12-10"	40	Web.-Chi.	Console	9	ac	129.95
609*†	10-12, 12-10"	40	Web.-Chi.	Console	9	ac	159.95
610*†	10-12, 12-10"	40	Web.-Chi.	Console	10	ac	179.95
611*†§	15-10, 13-12"	60	Web.-Chi.	Console	10	ac	225.00
616*†§	15-10, 13-12"	60	Web.-Chi.	Console	15	ac	395.00
PILOT RADIO CORP., 37-06 36th St., L. I. City, N. Y. PILOT							
HR192	8-10, 8-12"	35	Gen. Ind.	Console	11	ac	\$149.50
HA192	8-10, 8-12"	35	Garrard	Console	11	ac	169.50
HA191	8-10, 8-12"	35	Garrard	Console	11	ac-de	179.50
HA1424	8-10, 8-12"	35	Garrard	Console	11	ac-de	210.00
HA1524	8-10, 8-12"	35	Garrard	Console	9	ac	199.50
LA1424	8-10, 8-12"	35	Garrard	Console	11	ac-de	249.50
LA1524	8-10, 8-12"	35	Garrard	Console	9	ac	249.50
PA1424	8-10, 8-12"	35	Garrard	Console	11	ac-de	239.50
PA1524	8-10, 8-12"	35	Garrard	Console	9	ac	239.50
HD192†	8-10, 8-12"	35	Gen. Ind.	Console	11	ac	169.50
LD192†	8-10, 8-12"	35	Gen. Ind.	Console	11	ac	199.50
HFM12	8-10, 8-12"	35	Gen. Ind.	Console	12	ac	249.50
LFM12	8-10, 8-12"	35	Gen. Ind.	Console	12	ac	299.50
RCA MANUFACTURING CO., INC., Camden, N. J. RCA VICTROLA							
V170§	7-12, 8-10"	32	RCA	Console	6	ac	\$89.95
V200§	7-12, 8-10"	32	RCA	Console	7	ac	99.95
V201§	7-12, 8-10"	32	RCA	Console	7	ac	115.00
V205§	7-12, 8-10"	32	RCA	Console	9	ac	150.00
V405§	7-12, 8-10"	32	RCA	Console	9	ac	180.00
V300§	7-12, 8-10"	32	RCA	Console	10	ac	225.00
V301§	7-12, 8-10"	32	RCA	Console	10	ac	275.00
V302§	7-12, 8-10"	32	RCA	Console	10	ac	300.00
VHR202†§	7-12, 8-10"	32	RCA	Console	8	ac	150.00
VHR207†§	7-12, 8-10"	32	RCA	Console	10	ac	200.00
VHR407†§	7-12, 8-10"	32	RCA	Console	10	ac	230.00
ROCK-OLA MFG. CORP., 800 N. Kedzie Ave., Chicago, Ill. ROCK-OLA							
RA2	12-10"	60		Portable	5	ac	\$59.95
RA5†	12-10"	60		Console	7	ac	129.95
RA9†	12-10"	60		Console	9	ac	169.95
RA7†	12-10"	60		Console	9	ac	169.95
SENTINEL RADIO CORP., Evanston, Illinois. SENTINEL							
220F	8-10, 7-12"	34	RCA	Console	7	ac	\$99.50
220M	8-10, 7-12"	34	RCA	Console	7	ac	99.50
220J	8-10, 7-12"	34	RCA	Console	7	ac	119.50
221F	8-10, 7-12"	34	RCA	Console	8	ac	119.50
221M	8-10, 7-12"	34	RCA	Console	8	ac	119.50
221J	8-10, 7-12"	34	RCA	Console	8	ac	139.50
216FY†	14-10, 10-12"	50	Seeburg	Console	7	ac	139.50
216MY†	14-10, 10-12"	50	Seeburg	Console	7	ac	139.50
216JY†	14-10, 10-12"	50	Seeburg	Console	7	ac	169.50
SONORA RADIO & TEL. CORP., 2626 Washington Ave., Chicago, Ill. SONORA							
FSA96†	8-10, 7-12"	30		Console	6	ac	
KXF95	8-10, 7-12"	30		Console	6	ac	
STEWART-WARNER CORP., Chicago, Ill. CONCERT GRAND							
7A8	14-10, 10-12"	50	Seeburg	Console	7	ac	\$99.95
7A9	14-10, 10-12"	50					

IDEAS

Morse Flashes Reed

ANDY REED, radio and appliance dealer of Monrovia, California, hit on the idea of installing a radio tower sign above his store with the lightning symbol of flashes worked out in metal and installed at top of mast.

The tricky part of the sign is the fact that the flashing section is so controlled that it *flashes out the name of the store in the Morse code*. Immediately after it was erected people in the street were attracted to the flashing symbols at the top of the tower and noted at once the different intervals of flashes. The daily newspaper carried a story about the sign with a query on the variations of lighting and its significance.

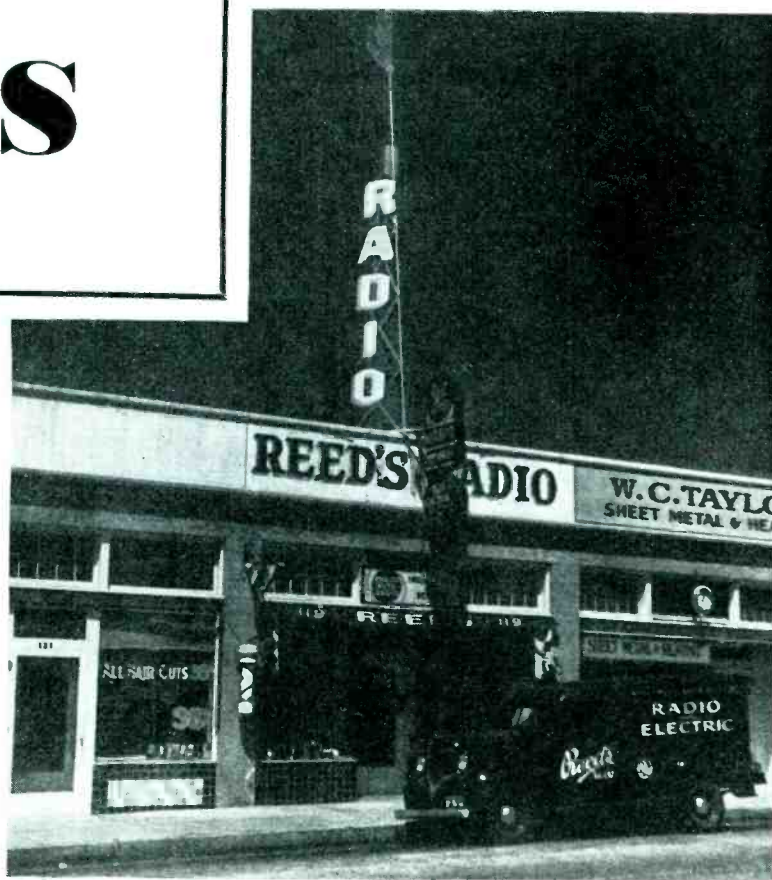

The dealer found this publicity "a natural" and, what was particularly gratifying, here was real news promotion supplied without cost. It

was cause for considerable discussion until local amateurs came forward and explained the code characters of the flashing sign.

Recording Studio Promotes Store Traffic

NORBERT J. BEIHOFF, Milwaukee retailer says a recording department has a definite place in any good size music store. However, it is his belief that it is a

specialized business and should be placed under the direction of a man who has experience along these lines.

This dealer was fortunate enough to obtain the services of Stanford Meisel, a speech student, who is attending and recording speeches at the University of Wisconsin. All recordings are supervised under Meisel's direction from 3 to 6 P.M.

every day and all-day Saturdays. Using this system of direction and setting these definite hours for recording, has put the department on a paying basis.

The department attracts professional orchestras, vocal students and others, promoting profitable store traffic. The store carries 4 recording instruments. Walls of the studios are packed with Rockwool and the ceilings covered with Celotex, eliminating echo and minimizing transmission from room to room.

Four Steps To A Successful Demonstration

MORTIMER H. FOGEL, New York City, with many years of experience in merchandising radios, finds the following four points extremely important in properly demonstrating a receiver. If the procedure is adhered to carefully he says you will have the prospect's order and check and what he be-

lieves is very important will be a satisfied purchase, the customer will have bought the style of merchandise and the model to provide the reception desired.

(1) Wide range of merchandise now available, priced anywhere from \$6.00 to \$600.00, makes it imperative that you first know the type of



set your prospect is interested in. Saves your time and minimizes confusion in your customer's mind. Some prospects can be queried on this while others must be approached in a subtle manner, otherwise you might cause resentment. So courteously inquire where they live, what are the general results in that location and what type of set are they using at present.

(2) Don't hurry the demonstration. Provide the prospect with a chair. Make it comfortable for him. One foot out the door will not get you the order.

(3) Always keep in mind that it is poor business to sell an instrument that will not live up to the customer's expectations. If he has the wrong impression about certain features, better explain now. This is the cue to "sell up."

(4) When demonstrating, know your program. A good orchestra demonstrates high-fidelity in an impressive manner when preview is made on a quality set. Points out how the distinctive tones of the various instruments are distinguishable on the good set and lost in the cheaper job.



Portable Recorder Opens Door for New Prospects



IT is the experience of the Marconi Bros. Music store of Metropolitan New York that the display of a semi-professional type recorder in the window acts as a sure traffic stopper. The window shopper is intrigued by the gadgety-looking control panel and its professional appearance, where curiosity killed the cat it is in this case the door-opener for a new prospect.

After the features and applications of the machine are explained it is surprising how many new applications are discovered for this type of recorder. Music studios, band leaders, radio artists and others. Leads to the sale of combination home recording instruments, also boost sales of discs, accessories and other merchandise.

Radio Dealer Talks Turkey

AT Thanksgiving time Leyden-Jameson, Inc., Denver radio retailer, installs three large live turkeys in the show window of its store. A microphone, sound system and outside speaker amplifies the turkeys' gobbling for the benefit of the street traffic.

The idea in back of it all, is to award turkeys to customers proportionate to the size of their purchase. A little turkey with a small set and a big fellow for the console. Every now and then a store salesman steps up to the mike and delivers a short discourse on the quality of the turkeys and likewise the new line of receivers just received, ending up with the invitation to come into the store and "talk turkey."

New Campaign Idea Pushes Portables

BUT in Seattle, Washington, the MacDougall-Southwick store has been promoting a great deal of consumer interest in portable radios by tying in with a Sperry "Drifted Snow" flour competition.

Here's a combination promotion plan that has eye appeal, as evidenced by the display shown in the illustration and a tie-in with 3-way attractive compact sets, bound to get results.



HEPPLEWHITE

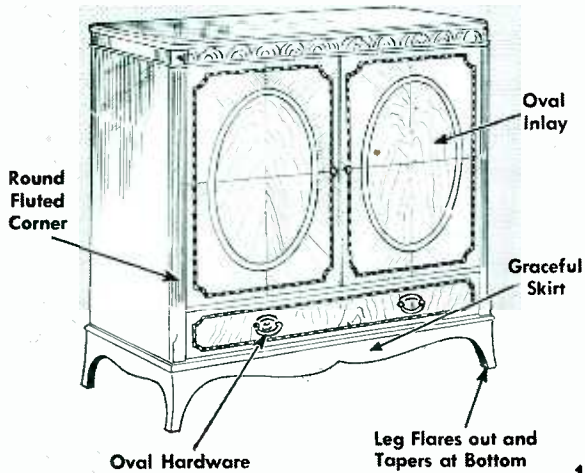

1

REGENCY

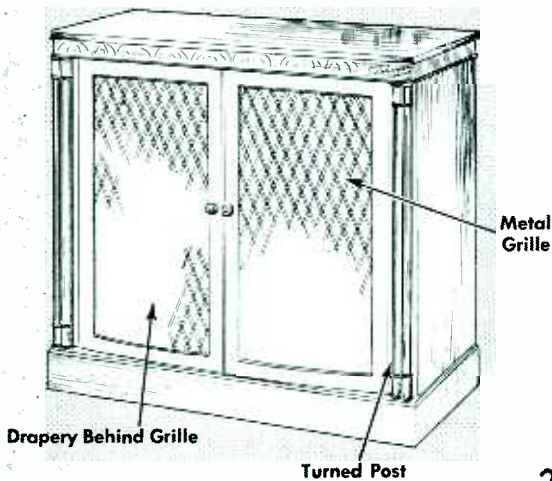

2

LOUIS XVI

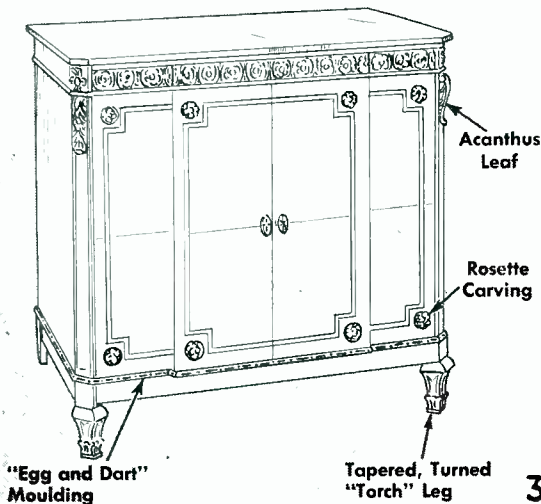

3

How To Recognize PERIOD

NUMBER 1 . . . 18th Century English and French

TO BE A HOME every house must have personality. Such a home beckons warmly, bows with dignity or sparkles with vivacity, reflecting the individuality of its owner. Thus furniture has the power to impart character to a home.

To express character to the fullest, furniture must be authoritative in design, expert in execution and in keeping with its environment.

Many characteristics of fine furniture today come down to us from the furniture of the past.

Within the limits of this article, it would be unwise to attempt to cover the entire range of period styles. Of necessity, the furniture of earlier times, as well as some of the later but less important periods, must be omitted. For the same reason, the periods treated are not described in complete detail but will enable you to recognize those designs which have survived through the centuries. Similarly, our comments are confined to 18th Century furniture of English and French design.

Each furniture period, or style, contains certain characteristics which distinguishes it from all other periods and styles. These differences are most often apparent in the construction and shape of the leg, and also are frequently observed in the treatment of corner posts, the hardware, the moulding and carving, the selection (or absence) of grille work, and lastly the *choice of woods* for main panel work and for inlays.

Hepplewhite

Illustration #1 is a Hepplewhite commode.

The gracefully shaped legs which flare out and taper at the bottom were always in perfect proportion to the balance of the piece. The Hepplewhite legs as shown in the illustration are also generally known as concave.

Another Hepplewhite characteristic is the *graceful skirt* as shown in the illustration around the bottom of the cabinet.

Oval inlays, bordered with inlaid lines and contrasting woods are Hepplewhite traditions.

Oval hardware is usually characterized on Hepplewhite designs.

Round fluted corners typify Hepplewhite.

Mahogany was one of Hepplewhite's favorite woods. George Hepplewhite was born in England—date unknown—and died there in 1786.

Regency

Regency furniture is in great demand today throughout the nation. Regency design is the last of great English 18th Century styles and made its debut in 1793 when George, Prince of Wales, later George the IV, served as Regent.

The outstanding features of Regency designs were *turned posts*, with classic beads trimmed in black and gold. Illustration #2 is a typical Regency commode.

Metal also played a permanent part in the form of *grille work* or as separate brass ornaments. The hardware used on Regency furniture corresponds with the metal grille work.

Mahogany was the favorite wood. *Draperies* were used behind the

CABINETS

By **H. L. WEISBURGH**

Director of Sales,
Brunswick Radio & Television Div.,
The Mersman Bros. Corporation

metal grille work on the doors so as to harmonize with the carpets and drapes in the home.

Louis XVI

The influence of Louis XVI on furniture styling was apparent throughout his reign in 1774 to 1793. It is often said that Louis XVI was for France what Hepplewhite was for England. He strongly favored a return to classic orderly lines but avoided a too stern dignity by a most refined use of ornamentation.

Illustration #3 is a Louis XVI commode. Note how the legs have been tapered and turned into a torch effect.

The classic mouldings showing the egg and dart are typical Louis XVI characteristics.

The rosette carvings around the top part of the cabinet, as well as on the door panels, are Louis XVI designs.

The acanthus leaf is still another Louis XVI carving as shown in the illustration on the door posts.

Walnut was the favorite wood and the carvings and mouldings are embellished with gilding. However, the ornamentation influence never transgressed beyond its legitimate limitations. Fancy veneers were generally used on Louis XVI furniture.

Queen Anne

The style called Queen Anne was in vogue from the year 1690 to 1750 and was founded during the reign of William and Mary lasting through the reign of Queen Anne, George the I and George the II.

The furniture was light and graceful and marked the ascendancy of the curved over the straight line as shown in the Queen Anne commode in illustration #4.

One of the main Queen Anne characteristics was the introduction of the "cabriole leg" which is both convex and concave.

Another Queen Anne characteristic in furniture styling was the duck foot, some times referred to as a pad foot.

A shell was used for ornamentation and you will note from the illustration the shell was carved on the legs, as well as, above the doors.

Queen Anne hardware always harmonized with the carvings. The curved block front as shown in the illustration is an authentic Queen Anne design.

Sheraton

Thomas Sheraton, known as one of the great master cabinet-makers of the 18th Century, was a man of rare genius, great versatility and refinement. These characteristics were reflected in the pieces he designed. The commode in illustration #5 is an authentic reproduction.

Sheraton designs are known for elegant simplicity of line and form, combined with daintiness of detail.

The dainty square tapered legs were employed by Sheraton with outstanding success.

Sheraton also achieved fine results in the use of fluting which appears on the drawer fronts in the commode illustrated herein. This fluting is often referred to as "tambour." These were made by laying

(Continued on page 67)

QUEEN ANNE

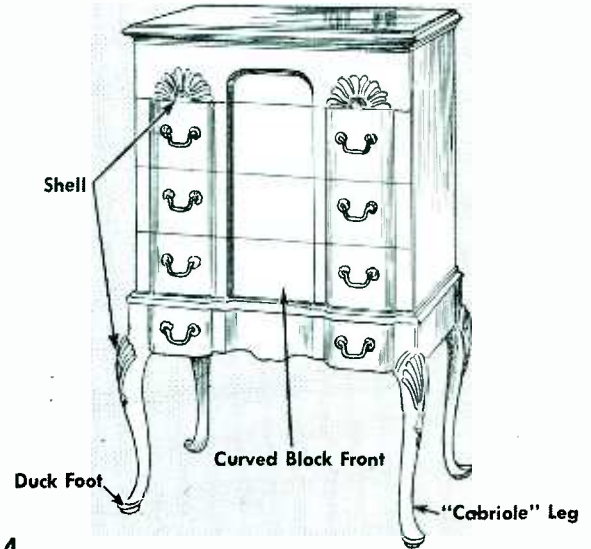

4

SHERATON

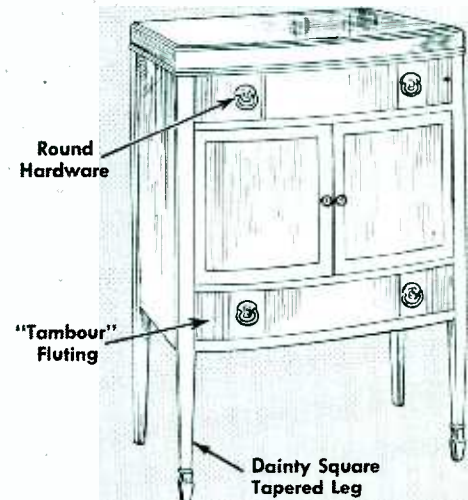

5

LOUIS XV

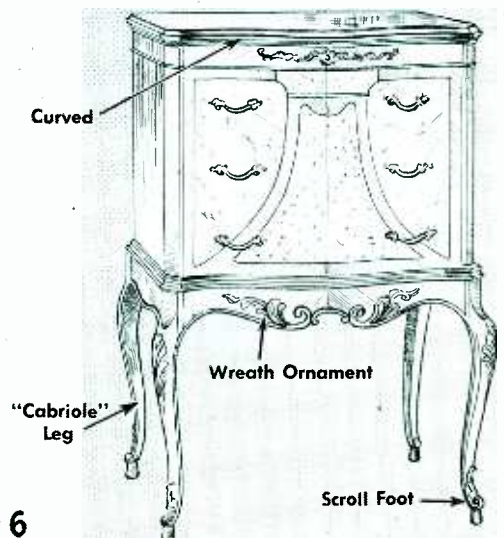

6

The Importance of

SMALL SET SALES cannot profitably be neglected even in the midst of a strenuous sell-up campaign

EDITOR'S NOTE: In presenting "A Study of Average Sale Level vs. Gross Profit Rate" on page 18 of *Radio Retailing's* September issue it was stated that . . . "Net profit obviously hinges upon more than just gross profit rate or even higher dollar 'take' per sale."

Promised was . . . "a coming installment of Mr. Coshland's Modern Management article series outlining the importance of unit volume obtainable by selling inexpensive sets to people who actually cannot afford to buy better and for auxiliary use."

Here is that article.

LAST MONTH we presented figures showing that dealers whose average dollars-per-sale is high also obtain a higher gross profit rate than those with low average dollars-per-sale.

Thus these dealers enjoy a three-fold advantage:

1. *They need sell fewer units to obtain a given volume goal.*
2. *Their gross profit, in dollars, when that goal is reached, is greater.*
3. *Certain expense rates decline because of the higher average dollars-per-sale.*

These facts are of tremendous importance. Keep them constantly in mind as the guiding influence in your "selling-up" efforts.

Less Sales Resistance

On the other hand, small sales also have an important bearing on overall net profit, and must continue to occupy a prominent spot in your merchandising plans.

Let's see why.

In the first place, remember that

about three out of every four home sets sold in 1939 were table models. Their average price, probably about one-fourth that of consoles, undoubtedly was the greatest single determining factor responsible for this sales performance.

It becomes evident, then, that the lower the price the less sales effort you need on each sale.

Given a large enough potential market, you should be able to expand your volume to any desired level through price appeal alone. Whether you would thereby obtain greater net profits would depend, of course, upon your efficiency in getting your advertising dollar to

bring in the sales dollar without sacrificing too much gross profit.

Cost Not Only Reason

In the second place, some customers have good reasons other than price for demanding table models. Many families now want a small second set for the bedroom or the kitchen. Another factor is portability. A third is that in recent years there has been a trend toward smaller apartments in cities, requiring more compact furnishing.

You must not allow the lower price and smaller gross profit to prevent your landing such sales. A lost sale is a lost customer—and

Why It Takes BOTH Kinds

Potential gross profit if stores having \$55 average radio sale increased volume 20 per cent by swelling sale of sets in lower price brackets

	Actual at Present	Proposed 20% Increase in \$ Volume	Potential Total
Number of Sales	43	16	59
Amount of Sales	\$2,353.33	\$470.67	\$2,824.00
Average Sale	54.73	29.42	47.86
Gross Profit	986.05	167.70	1,153.75
Gross Profit	41.9%	35.6%	40.9%

RECORD *Retailing*

POPULAR DISCS are only the beginning. There are six other important types

By G. T. MOWBRAY

IN AUGUST we took up the matter of what one had to know to sell popular discs intelligently. (Ed. Note: The September issue of *Radio Retailing* presented supplementary "Capsuled Dance Band Data.")

There are six other classifications that represent considerable business. Again, however, it is necessary that the salesperson know at least enough about such discs for intelligent discussion with the average customer.

Standard

Records classified as "Standard" represent an enormous market as this music has universal sentimental appeal.

Among the component divisions are: American folk songs such as those of Stephen Foster; familiar folk melodies of foreign origin; band records, including the marches of Sousa and others; the works of Gilbert & Sullivan, Victor Herbert, and other composers of light opera.

As practically every one has heard the leading compositions in this category since childhood, we believe dealers will not have to study this music. However, if it should be necessary, your public library has many collections of these melodies and radio programs using this type of material are legion.

Classical

The "Classical Group" which includes Symphonies, Concerti, Chamber Music, Operas is currently the fastest growing branch of the business.

To serve regular buyers intelligently, and to assist in the education

(Continued on page 66)



BOOKCASE TYPE—Designed by Irving J. Ritterman of Beverly Hills, California, this record library combines beauty with accessibility. A speaker is hidden behind a wall panel while the player is located in a closely adjoining room

Three Prize-Winning LIBRARIES

ALL FOR \$2—Highly original, this combination machine and disc storage cabinet was designed by a friend for Alice McWeeney of Nashua, New Hampshire.

ORIENTAL NOTE—Also homemade, Walter L. Rhinehart's Arlington, Virginia setup features bamboo trim and a central painting. *Photos from RCA-Victor*



In Defense of OUTSIDE SELLING

By CASWELL ODEN

LAST MONTH, to avoid a discussion of many different types of dealers and stores, I assumed the necessity of outside solicitation and selling; you and I went into business under circumstances which demanded it. But, as you well know, many dealers carrying radio and other household specialties are getting along without it.

The inference here is that outside selling, while perhaps all right for those who must have it, may not always be worth the consideration of those who can get along without it!

I have never cared for the inference, knowing it to be unsound and misleading. Perhaps it has even kept some of you from capitalizing on the business which is always waiting outside for those who go after it.

Big Stores Can Coast

Just because some dealers are getting along without outside solicitation does not mean that they should be! Outside selling is just as desirable for those who can get along without it as it is for those who can't!

Those facts are self-evident, and yet they are not as clearly understood as it would seem they should be. So suppose we examine a couple of dealers, typical operators who are getting along without the benefit of doorbell-pushing. We can't cover the whole field but we'll look at two, a big one and a small one.

Here is a furniture dealer, carrying a full line of appliances. He has no outside salesmen—but he has seven collectors. The store business is very small, but the collectors produce a lot of business.

The collectors are not salesmen. This is no reflection on their ability, since they don't have to be salesmen

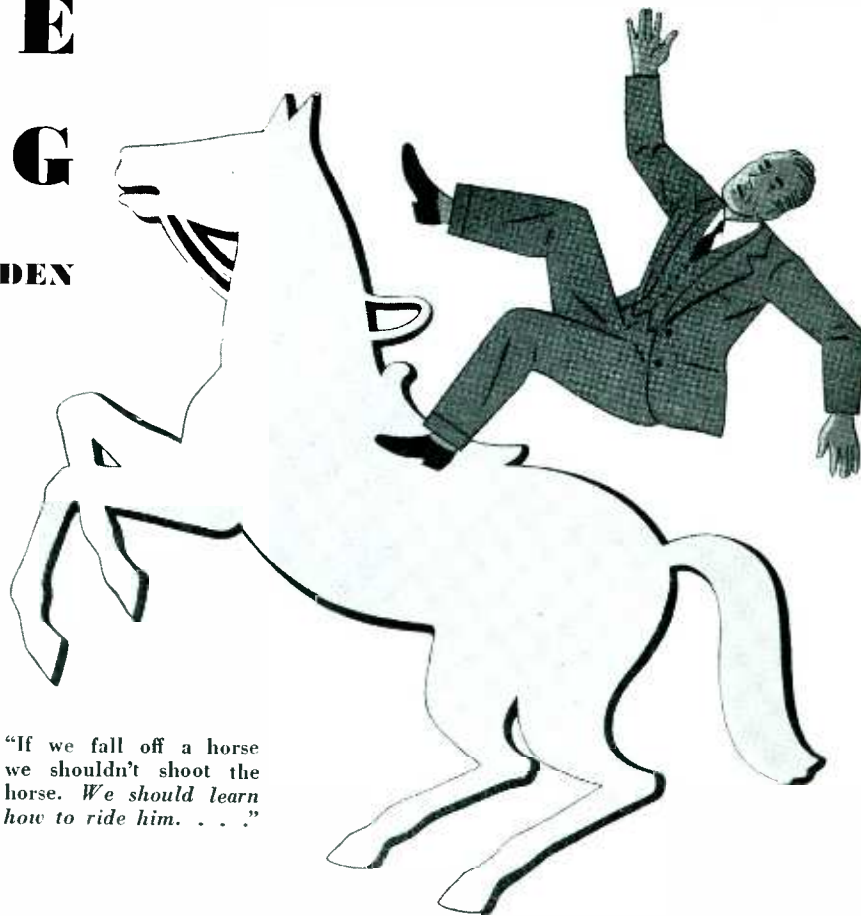

"If we fall off a horse we shouldn't shoot the horse. We should learn how to ride him. . . ."

—but the fact still remains that they are not. However, each one has his own customers under his thumb, so to speak, and when a customer needs something (enough to mention it, usually), the collector has no trouble selling it. Not by salesmanship (most cases); not even by being able to meet price competition (some cases)—but simply because of the good-will, the confidence, which constant personal contact has developed.

This is salesmanship of a sort, of course. It is selling yourself instead of the merchandise. And that is how this furniture dealer is getting along without outside salesman. But why is he doing it? We'll come to that in a moment.

So Can Small Dealers

Here is a small appliance dealer, carrying radio, refrigeration, washers. He has no collectors, naturally. But he also has no outside salesmen (I have one in mind), and yet he is doing a nice business.

Now, most of the dealers in this category have outside selling, good or bad, but this one hasn't. He is his one and only salesman, having a girl in the store to do the clerical work, answer the phone, and wait on the occasional walk-in. And it is a fact that a dealer, working this way, can survive on an amazingly small volume of business—if he chooses to do so. He's practically a salesman working for around 35 or 40 per cent instead of 15, plus overhead and more responsibility. But the one in question is not merely surviving; he is doing a good job. How?

Well, he's been in business for 25 years and has sold merchandise to around 6,000 customers, even though some finance company did the collecting. He solicits this large customer list by mail, taking about a year to cover it—200 this week, 300 next, and so on. And the response from this alone keeps him so busy that he is rarely in the store.

True, he knows a few salesmen, working elsewhere, who come in

with contracts now and then (for something he sells that they don't), and he has an almost negligible store business, but it is the response from his customer list that keeps him busy.

But Why Do They Try

So there they are, the large and the small, getting along without outside solicitation, and we see *how* they are doing it. But *why* are they doing it?

Well, in the first place, they are getting along without outside solicitation because they *can*. That is obvious; otherwise they wouldn't be in business. But everybody wants more business than he's getting, so we must ignore that reason. The real reason, or at least the reason which interests us here, is that they are getting along without it because they don't know *how* to get along with it.

That furniture dealer doesn't have to pass up outside selling just be-

cause his collectors are getting business. He could have an outside sales force too! And that appliance dealer doesn't have to pass it up simply because he is so well established that he can *coast* on his mailing list!

I said it keeps him busy. It does. Moreover, when you consider the type of business it is (credit was good before) and the quality of the leads (people who *ask* you to call are pushovers, wrap-ups, sure sales in 11 cases out of 10), he is spending his time in the very *best* way he could. But that's *his* time we're talking about. How about the time of the *other* ten men he could have working for him?

Back to Specialty Methods

Please let me be very frank. Sometimes I'm afraid I may sound a little too inspirational, and I don't want to. I don't think specialty selling is the best job on earth! If a dealer is doing a nice business without much promotion, that is fine.

Heaven knows that I like "easy" business just as much as anybody else. But I know from experience that outside selling is one of the best ways in the world to get business (although requiring the most sales ability) and I don't like to see dealers try improper *methods*, fail, and then toss outside selling *itself* aside as being too tough.

If we fall off a horse and break an arm—we shouldn't shoot the horse. We should learn how to ride him!

Then how, by heck, *do* we ride him? We went about it in the right way last month. We pay men salaries, because we can't get them otherwise (but see to it that they earn them). We close their business for them, because they can't close it themselves. I'm not going to bore you with all that again. But the *most* important thing is that we keep canvassing *separated* from closing.

This method of outside selling has *fundamental* advantages.

APPLIANCE Showmanship



SHEET SUSPENDS WASHER—When the J. C. Penney store of Boise, Idaho staged a "white sale" it killed two birds with one stone by suspending a washer from a sheet in the window. Demonstrated strength of the sheet and gave the appliance department publicity



NOVEL IRONER USE—Publicizing of this picture among photographic fans did an Illinois dealer's appliance business no harm. It shows Mrs. Paul D. Wilson of Danville using her automatic flatplate ironer to dry 50 eight-by-ten prints an hour

REA REFRIGERATION DISPLAY—Here's the way the Kerrville Armature Works of Kerrville, Texas featured refrigeration, other appliances and radios during a show staged by the Rural Electrification Administration in the San Antonio area





Tell the "

PHILCO



PHILCO ALL YEAR 'ROUND FOR

HOME RADIO • PHONOGRAPHS • TELEVISION • AUTO RADIO • RADIO TU

World" about your big

CO JUBILEE

and cash-in on the greatest
profit-promotion you've ever had!

You've got "hot" merchandise!

We don't have to tell you the 1941 Philco line is running away with the show! You know every single Philco Radio and Radio-Phonograph is a tremendous value, packed with sensational exclusive features the public wants and demands. And your record-breaking sales prove it!

You've got "hot" Jubilee Offers!

And what offers! The radio industry has never seen anything like this great Philco Jubilee Promotion! For Philco enables you to PLUS the biggest radio and radio-phonograph values with sensational gifts that close the sale quick!

Now make sure you get all the "hot" advertising material and USE IT!

You've got the merchandise and the offers for a tremendous and profitable business. Don't fail to get it—be sure you tell the "world" you are celebrating with Philco. Your distributor has dozens of advertising helps that should be working for you right now—Ad Mats, Circulars, Special Displays, Broadcast Announcements, Direct Mail—all on the Philco Jubilee Specials. Be sure to get yours and cash-in on your biggest profit opportunity of the 1941 radio season.

SEE YOUR PHILCO DISTRIBUTOR NOW!

R PROFITS ALL YEAR 'ROUND

BES • PARTS • REFRIGERATORS • AIR CONDITIONERS • DRY BATTERIES

PARTS Credits

BY HAROLD F. JENKINS

Fred C. Harrison Co.

IN THE EARLY DAYS of broadcasting, the repairman obtained replacement parts directly from the various set manufacturers. Next came mail-order parts houses that originally offered salvage and surplus stocks purchased from set factories at giveaway prices. (Soon, progressive manufacturers were on the market with complete lines of trade-named replacement parts and mail-order houses immediately started featuring these lines.) Finally, there was an additional group of "on-the-spot" parts jobbers, serving their particular city plus surrounding trade area, with salesmen making regularly scheduled trips.

Today's distributing setup consists of a number of large metropolitan mail-order houses selling over the counter and serving sparsely settled sections of the country by mail and approximately five hundred independently owned on-the-spot concerns.

Early Jobbers Too Loose

When the growth of localized jobbers was at its peak, competition became extremely keen among them.

Long credit terms and other inducements were offered servicemen to get business. Especially prevalent was the habit of being lenient in offering credits and then also being easy in collection methods. Servicemen with assets of almost no value were generously given a "sky's the limit" rating. With jobber profits and factory discounts large, operators of parts establishments felt that

No PUNCHES Pulled

THIS ARTICLE, spotlighting a trend of vital importance to the parts industry, is delivered straight from the shoulder.

JOBBERS AND SERVICEMEN alike are urged to read it closely.

SOME READERS will undoubtedly be in disagreement. Writes the author: "These will probably be the ones most vitally concerned"

losses from poor accounts could be absorbed.

Then came a definite turning point. Manufacturing methods became more efficient, resulting in lower costs which were passed along to jobber, serviceman, and consumer. Immediately resulting was the beginning of parts house failures. Many concerns had grown from service shops that had gradually turned to jobbing. With little or no business experience, the operators suddenly found that most of their profits from the lush years were tied up in uncollectable accounts.

Associations Take A Hand

Today, the relationship between radio servicemen and the 500 or so distributors that have weathered past storms is changing rapidly. The tightening of credits has been found to be absolutely necessary.

Due to a better understanding between jobbers, and to trade organizations such as the National Radio Parts Distributor's Association, jobbers now realize that the days of "dog eat dog" are at an end. Credit troubles are being given serious study. As a result, the "floating" serviceman who once bought from a jobber until his credit was no longer good, then changed to a competing jobber (again running up a bill) is due for a setback. Credit check ups on questionable accounts is now customary.

Some Individual Cures

Individual credit tightening by distributors, apart from organization work, has already shown excellent results.

One eastern jobber, knowing that his collections are directly in proportion to collections made by his servicemen customers, is working with them, offering plans for more efficient collection from the ultimate radio owner.

Another jobber, having a large amount outstanding in overdue ac-

counts, has radically changed his whole collection system. As with many, his past policy had been to render monthly statements, on many of which he received only a payment on account. Subsequent purchases gradually built up the balance until the total bill became too high to collect except over a long period of time, if at all.

This year, on the first of June, with each statement, he included the following form, obvious to all as a mimeographed form.

CHANGE OF OPERATING POLICY

Beginning at once, on all accounts 10 days or more past due, orders received by mail will be shipped C.O.D. unless accompanied by check to cover.

This does not apply to orders given our salesmen upon their regular call at your shop. Method of payment of such orders will be left to the discretion of the salesman.

Substantial and regular payments on your present account will be expected.

A large part of this jobber's business is obtained from surrounding towns covered by his salesmen every two weeks. He had found that the reason some accounts were growing too large was because of mail orders sent between salesman calls, and over which his representative had no definite control. This notice has served its purpose without creating hard feeling.

All Must Play Ball

In conclusion, the following suggestions are offered:

For the *serviceman*: Try to improve credit standing with your parts jobbers. To render your customers satisfactory service, you must have a source from which you can quickly obtain any of the hundreds of replacement parts which might be needed. Your jobber can carry and furnish you with these parts only if he has operating capital sufficient to keep them in stock. Whether or not he has this capital is entirely up to you.

To the *jobber*: Don't hesitate to exchange credit ratings with competitive concerns.

Special low deposits on all N. U. Triplet Deals to November 30th

TRIPLET
TUBE TESTER
Model 1620
\$12.50
DEPOSIT

and it's Yours
on N.U. DEAL

TRIPLET TUBE TESTER
MODEL 1620

Has new lever-type flexible switching giving individual control for each tube prong . . . Filament voltage switching from 1.1 to 110 takes care of present and future tubes with filament voltages up to 117-volt types . . . Giant 6-inch scale RED•DOT lifetime guaranteed indicating instrument . . . Neon short test . . . Separate line voltage meter . . . Speed Roll Chart can be spun from one end to the other in less than four seconds . . . Housed in wooden case of graceful proportions with sockets, knobs and markings in ivory.



TRIPLET
MODEL 1620
Regular Dealer
Price \$37.84

YOU TOO CAN HAVE THE
"Best Equipped Shop in Town"

Get it the National Union way . . . you deposit \$12.50, immediate delivery is made on Triplet Model 1620 Tube Tester. You sign agreement to purchase 875 points over a 2 year period. On completion you receive bill of sale and your deposit is refunded as a merchandise credit.

☆ ☆ ☆

National Union purchase points can be taken in Tubes, Condensers or Batteries. All products the finest in quality, thoroughly guaranteed and competitively priced.

☆ ☆ ☆

Ask Your Jobber or Write to

NATIONAL UNION RADIO
57 STATE STREET, NEWARK, N. J. Corp

National Union Radio Tubes are known as the radio service dealer's tubes because they are used by more service dealers than any other make.

☆ ☆ ☆

You too can have the best equipped shop in town, just get your equipment the easy "N. U. Way" — Remember National Union has the finest sales helps and promotional pieces to help you sell yourself to your community and make more money.

☆ ☆ ☆

Special low deposit on all Triplet Testers until Nov. 30th, 1940.

Over 50,000
completed deals
your guarantee
of complete
Satisfaction



J. E. STAGE, Longview Radio Sales & Service Co., Longview, Wash. Think your Free Equipment Plan great—Have signed 20 N U Equipment Deals—have been using N U program 9 years. N U tubes all check alike—rarely have to make replacements.



MATHEW J. BERLOWITZ Juneau Radio Shop, Milwaukee, Wisconsin. I find in checking my records I signed 29 contracts. There is no better way for a serviceman to painlessly acquire good service equipment. In my 10 years of exclusive dealing with N U their products have always been satisfactory.



E. J. MAGINOT, Boston, Mass. In my opinion, and in the opinion of many other service engineers with whom I am associated, N U enjoys a prestige which needs no apology. Modern radio sets demand modern testing equipment. N U supplies it the easy way.

The Best Equipped
Shop in Town
Gets the Business

Copyright

New Products...



G-E JB-410 Camera-type, 4-tube portable radio resembles a collapsible camera. Enclosed in a deep maroon carrying case with plastic panels and simulated leather banding. Measures approximately 8 x 4 x 4 inches, and weighs 4½ lbs., including batteries. Features a 3-inch Dynapower speaker; built-in beamscope antenna, located in the lid. The lid latch acts as a power switch, when it is fastened, the power is cut off. Receives standard American broadcasts and has a maximum power output of 150 milliwatts. List price \$19.95. General Electric Co., Bridgeport, Conn.

PHILCO 226C Table model with modernistic cabinet of sliced walnut with Holly and Zebrano inlays has 6 tubes, including the new, noise reducing converter and oscillator tube. Features electric pushbuttons and easy-to-read illuminated dial.



SENTINEL 227-P The new *Lightweight Champion* portable radio weighs 4½ lbs., and measures 4¾ x 8¾ x 4 inches. Receiver has 4 tubes; tunes 540 to 1600 kc. Available in streamlined, plastic tenite case with leatharette trim. Complete with batteries, \$19.95 list price. Shoulder strap extra equipment. Sentinel Radio Corp., 2020 Ridge Ave., Evanston, Ill.

PHILCO 260F Console model, has 7-tube superheterodyne, features 6 electric pushbuttons; speaker; horizontal dial with important foreign stations named and located. Philco Radio & Tele. Corp., Philadelphia, Pa.



ADMIRAL 43-B4 This 4 tube, 1½ volt, super-heterodyne features a 6-inch speaker, a tuning range from 535 to 1730 kc., iron core i.f. transformer, soft gold escutcheon and large slide rule dial with easy-to-read etched glass scale. Table type cabinet, designed to accommodate battery below chassis. List \$27.50.

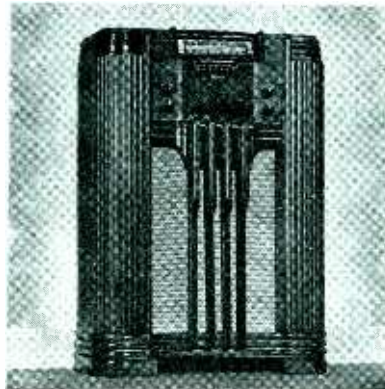

MEISSNER Handsome walnut-finish table model FM set is 22¾ inches wide, 12¼ inches high, and 11 inches deep. Features an 8-inch dynamic speaker; five-position tone control provides choice of output response. May also be connected as a converter to feed the audio system of a larger receiver if desired. Meissner Mfg. Co., Mt. Carmel, Ill.



EMERSON 375 Plastic table type, 5 tube ac-dc superheterodyne with *Miracle Tone* is available in four colors: Mexican-onyx, Blue-onyx, Brazilian-onyx, or red-onyx with contrasting plastic grille bars. Covers standard American broadcasts and police. List \$17.95.



ADMIRAL 61-K7 Table type, radio-phonograph and recorder model featuring a 6-tube ac. superhet, 6-inch speaker; phonograph plays 10 and 12-inch records; recorder has magnetic cutting head and microphone. List \$99.95. Continental Radio & Tele. Corp., 3800 Cortland St., Chicago, Ill.



EMERSON 368 Console, *Miracle Tone*, 6 tube superhet features 12-inch speaker, American, foreign and police broadcasts; 6 pushbuttons. Cabinet is of Bantwood, combining selected and matched butt-walnut and heart walnut. List price \$49.95. Emerson Radio & Phono. Mfg. Co., 111 Eighth Ave., New York, N. Y.

STROMBERG-CARLSON Table type model 500-S is equipped for ac-dc operation, standard broadcast reception, and has built-in loop. Features airplane type pointer dial; dynamic speaker. Measures 8 1/2 x 14 1/4 x 7 7/8 inches.



STROMBERG-CARLSON Attractive console model 520-L features built-in knob-controlled shielded loop, pushbutton tuning. Equipped with standard broadcast and American and foreign short wave reception. Has 12-inch speaker and provides for phonograph, television and FM connection. Stromberg-Carlson Tel. Mfg. Co., 100 Carlson Road, Rochester, N. Y.



RCA V302 This model is one of a series of new deluxe instruments. Features the Tone Guard; 15-inch speaker. It has 10 tubes plus Magic Eye, and a 20 watts output. Cabinet is designed in regal 18th century design in Sheraton style, and is available in both walnut and mahogany with figured stripe and crotch veneers.



RCA 15BP-6 Pick-me-up battery table type radio is equipped with telescoping handle. Features 5 inch speaker, built-in loop antenna. Cabinet is conservatively designed with horizontal grilles. Covers the standard American broadcast. Measures 8 3/4 x 11 3/4 x 5 1/3 inches. RCA Mfg. Co., Camden, N. J.

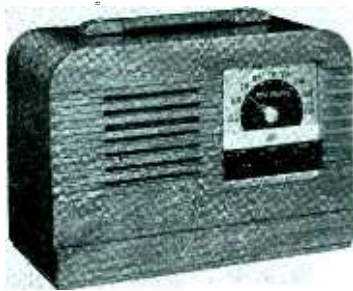

MOTOROLA 526W Table type 1 1/2 volt farm radio, housed in an attractive walnut veneer cabinet, features 5 tubes, 6-inch speaker and covers 2 bands. Measures 9 3/4 x 19 x 10 5/8 inches.



MOTOROLA 52BK Modern designed, console farm radio of walnut veneer. A 5-tube, 1 1/2 volt battery operated superhet features a 3-gang condenser; incorporates an 8-inch speaker and covers 2 bands. Galvin Mfg. Corp., 4545 Augusta Blvd., Chicago, Ill.

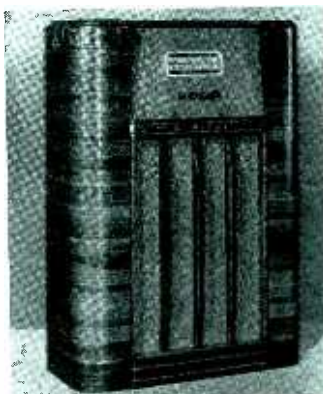

MAJESTIC T101L-A Straight radio table model comprising single band coverage with conservative cabinet design. Features 5 tubes, 5-inch speaker, 1.5 watts power output. Measures 13 1/4 x 7 1/4 x 5 1/4 inches.



MAJESTIC H191-A Portable radio model incorporating 5 tubes, 4-inch speaker, 1.2 watts power output on ac-dc, 250 milliwatts on batteries. Measures 12 1/4 x 8 x 7 inches. Majestic Radio & Tele. Corp., 50th & Rockwell Sts., Chicago, Ill.



STEWART-WARNER 5Y1 Portable radio, ac-dc or battery, is equipped with built-in antenna; 5-inch speaker. Special connection has been provided so ear-phones can be attached. Has 5-tubes, manual tuning and full vision dial. The case is covered with imitation alligator with genuine leather handle.

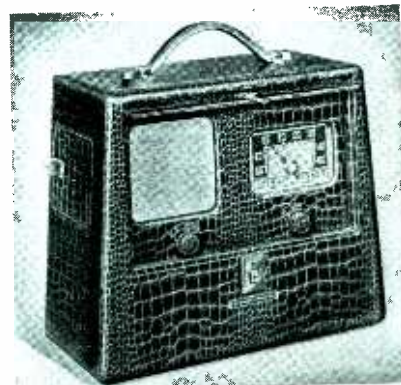

STEWART-WARNER 8F7 Console type model with top and waterfall dial panel of sliced American center matched walnut; wrap-around ends of paired stump walnut; center band of Rosewood decal; lower side panels in paired sliced American walnut. A 7-tube receiver with 10-inch speaker and 3-position tone control, base compensation. Covers two bands, broadcast and foreign. Stewart-Warner Corp., 1836 Diversey Parkway, Chicago, Ill.



FADA 115 New series of catalin group, 5 tube, ac-dc superheterodynes with Fa-Da-Scope loop antenna and handle. Choice of 5 color combinations. Price \$19.95. Fada Radio & Elec. Co., 30-20 Thompson Ave., Long Island City, N. Y.

SONORA KW-78 Streamlined plastic electric phonograph includes built-in 2-tube amplifier; speaker; volume control; 78 R.P.M. self-starting rim-drive motor; crystal pick-up. Plays both 10 and 12-inch records. Measures 9 3/4 x 12 3/4 x 6 1/2 inches.



SONORA KT-87 Here is a 5-tube ac-dc superhet, *Comeo* model, housed in a two-tone (tan and red-brown) plastic cabinet. Features the built-in Sonoroscope and 5-inch speaker. Measures 10 3/4 x 6 3/8 x 6 1/2 inches. Sonora Radio & Television Corp., Chicago, Ill.

SETCHELL CARLSON 589 Conservatively styled cabinet, sealed with a durable lacquer finish. Receiver is a 5-tube superhet with 6-inch electric dynamic speaker. Operates on 100 volts to 125 volts a.c. only; has 3 gang tuning condenser. Easy tuning Coaster dial. Setchell Carlson, Inc., 2233 University Ave., St. Paul, Minn.

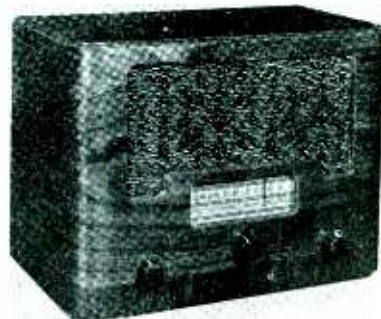

Compare!

MAGNAVOX CABINET INNOVATIONS

Here is an instrument cabinet to blend harmoniously into other fine furnishings - a cabinet that embodies the features home decorators have most wanted - completely concealed speaker grille, non-obstructive doors, permanent place for decorative accessories.

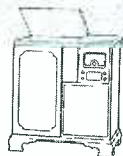

GEORGIAN COMMODE \$198.50

There is no other instrument—at anywhere near this price—that has a deluxe 15-record intermixing changer which starts at the touch of a button, stops automatically after last record, and has new Pianissimo Jeweled Pickup for longer record life without needle changes.

That has international range radio with 12-watt undistorted beam-power output, push-button tuning, high-fidelity band expander, interference rejector, scratch filter, automatic volume control, and individual bass and treble controls.

That is equipped with the new Magnavox Duosonic 12-inch speaker, with two moving cones and beauty of tone that can't be matched by anything outside of the Magnavox line.

That is, in every minute detail, a fine piece of authentically styled furniture with all exposed solids in genuine Mahogany or Walnut.

The other 15 Magnavox traditional furniture models are equally outstanding—at \$89.50 to \$460 each a peerless value in its price class. You need this line to command the quality business in your community!

Magnavox direct-to-dealer franchises open in many cities for qualifying merchants. Write for details!

**THE MAGNAVOX COMPANY, INCORPORATED
FORT WAYNE, INDIANA**



FARNSWORTH BT-600 Handsome table type receiver covers three wave bands. Receiver has 6 tubes, including rectifier, and is equipped with universal power transformer, providing range from 90 to 275 volts; 8-inch speaker.



FARNSWORTH BC-601 This 6-tube, a-c. superheterodyne console radio features three wave bands, tone control, television bridge and phonograph connection, five watt output. Incorporates a 12-inch reverberation insulated speaker. Farnsworth Tele & Radio Corp., 3700 Pontiac St., Ft. Wayne, Indiana.



WEBBER 200MM Portable or counter type dynamic tube tester has all of the Webber series 200 features, including the *Three-In-One* direct reading test for tube performance. This shows the effect of Mutual conductance, power output, and emission. Panel finished in four colors for easy reading. Measures 10 x 13 1/2 x 5 1/2 inches. Price \$30.50. Metal cover complete with snap locks is available dealer net \$1.75. Earl Webber Co., 4358 W. Roosevelt Road, Chicago, Ill.

G-E JFM 90 FM translator, to be used in conjunction with an AM set, is housed in a walnut cabinet, standing 9 high, 15½ wide, and about 8 inches deep. It has its own dial scale with a tuning range of 42 to 50 mc., and six tuning keys. Has a power consumption of approximately 55 watts; 9 tubes. List price \$49.95. General Electric Co., Bridgeport, Conn.

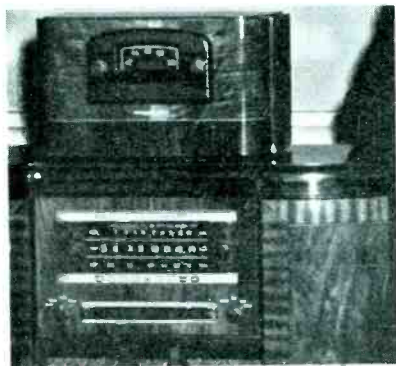

COLUMBIA Electric portable phonograph, Model P1, comes in brown simulated pigskin. Features 115 volts 60 cycle operation, rim drive, speed 78 r.p.m. Crystal pickup. One tube amplifier and 6½-inch speaker. Includes a demountable speaker which can be attached to the wall. Retail price \$35.00, f.o.b. New York City. Columbia Recording Corp., 799 7th Ave., New York, N. Y.



AUTOCRAT EPP-9 Electrically operated portable phonograph will play 10 and 12-inch records with cover closed. Has record holder in lid, metal corner guards, and 3 tube amplifier. Operates on 110 volt ac. 60 cycles. Covered with brown rawhide grain, list price \$17.50 complete. Autocrat Radio Co., 3855 North Hamilton Ave., Chicago, Ill.

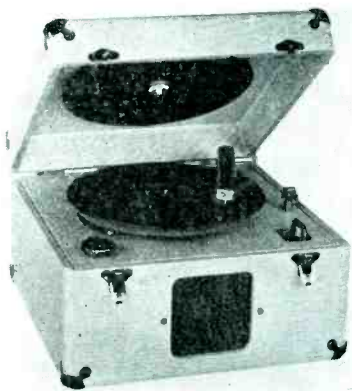

MOTOROLA Introduces new metal base recording discs available in three sizes 6½, 8, and 10 inches. Packed in cartons of five, and list at 20c, 30c and 40c each respectively. Galvin Mfg. Corp., 4545 Augusta Blvd., Chicago, Ill.

Combined Radio and Inter-Call System



RADIO DORAFONE

• • • Opens **NEW PROFIT Opportunities** For You

HERE'S a brand new product . . . a *good* radio set combined with an efficient inter-call system . . . which creates many *new* prospects for you—in *homes, offices, factories, hospitals, etc.* Sell them a radio and give them an inter-call system, all in one compact unit.

For Homes Radio Dorafone affords radio entertainment, saves time in answering door calls and protects against undesirable entry to your home.

For Offices, Factories, Hospitals, etc.

Modern business demands radio news, market reports, etc. Modern times demand private, speedy communication between executive and subordinate departments.

Some additional uses Kitchen to sick room. Kitchen to amusement room. Farm home to barns, granary, etc. Telephone operator to sales floor and service department. Hospitals, clinics, garages, offices, creameries, feed mills, restaurants, lumber yards and numerous other places where radio reception is desirable and contact between two departments is necessary. Additional external speakers can be used by incorporating a selector switch.

Write or Wire for complete detailed specifications.

Setchell Carlson, Inc.

2233 University Ave.,

St. Paul, Minn.

New York Sales:

BEN JOSEPH
258 Broadway
New York, N. Y.

MICHAEL WOLFE
1530 E. Genesee St.
Syracuse, N. Y.

Export Sales:

HARRY J. SCHEEL
Merchandise Mart
Chicago, Ill.

Cable Address
"Airvoice"

California Sales:

E. J. WATKINS
580 Market St.
San Francisco, Cal.

M. D. EALY
1425 S. Flower St.
Los Angeles, Cal.

ESPEY RC-20 Electric phonograph with automatic record changer. Plays fourteen 10 or ten 12-inch records. Rim drive motor, 78 R.P.M., for 115 volts ac. 60 cycles. Amplifier power output nearly 2 watts. Espey Mfg. Co., Inc., 305 East 63rd St., New York, N. Y.

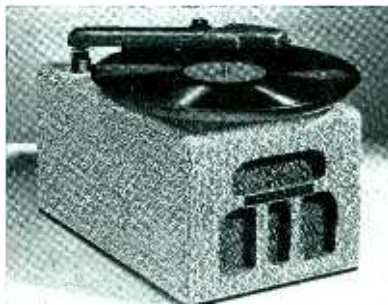

TALK-A-PHONE G-45 Presenting a low cost record player with built-in amplifier designed for high quality reproduction of both 10 and 12-inch records. Amplifier uses 3 tubes with beam power output. Delivers a 2-watt power output. Includes a 78 r.p.m. rim-drive motor, crystal pick-up. Weighs about 9 lb. Talk-A-Phone Mfg. Co., 1847 S. Millard Ave., Chicago, Ill.

FLUSH WALL 5P Specially designed radio to fit into the wall when installed the panel attached is flush with the wall and all wires concealed. Panels can be obtained in practically any color. Panel measures 8 3/4 x 11 1/4-inches and the steel box is 3 3/8-inches deep with 1/2-inch K.O.'s. To service radio, remove wall plate and swing set out on its hinges. Price \$29.95. Flush Wall Radio Co., 57 State St., Newark, N. J.

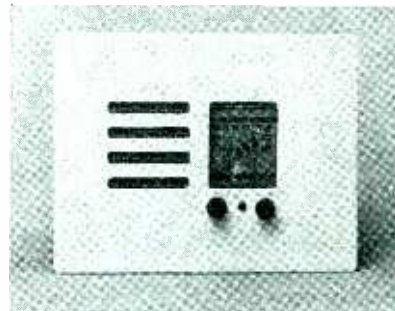

Look to Webster Electric First

Regardless of whether the new products you will manufacture this year are designed to sell at a mass or class market price, Webster Electric is ready to serve you as never before.

Webster Electric Reproducers cover the entire range. The line includes both crystal and magnetic types for home or exacting professional use. It includes both permanent and semi-permanent sapphire as well as standard steel needle models.

The crystal cartridges designed for standard mounting include a wide range of voltage and frequency characteristics as well as a model designed especially for severe humidity conditions.

In addition to a line of complete reproducers and cartridges, Webster Electric also has available flat and upright type recorders in which is employed the famous Webster Electric "Knife Edge" bearing.

The entire line of phonograph recording and reproducing equipment will be the superlative results of years of experience in designing and building toward fine tonal quality. Look to Webster Electric first in this year's designs.

Licensed under patents of the Brush Development Company

Licensed by Electrical Research Products, Inc., under U. S. Patents of American Telephone and Telegraph Company and Western Electric Company, Incorporated

WEBSTER ELECTRIC COMPANY, Racine, Wisconsin, U. S. A. Established 1909.
Export Dept.: 100 Varick St., New York City. Cable Address: "ARLAB", New York City

Webster Electric

"Where Quality is a Responsibility and Fair Dealing an Obligation"

MANUFACTURERS OF TELEPHONE INTERCOMMUNICATION AND PAGING SYSTEMS • POWER AMPLIFIERS AND SOUND DISTRIBUTION EQUIPMENT • RADIO PHONOGRAPH PICKUPS • IGNITION TRANSFORMERS AND FUEL UNITS FOR OIL BURNERS

BELDEN A new line of soldering equipment has been announced by this company. The 80-watt iron, 8110, and the 100-watt, 8113, for light service jobs have 3/8-inch tips. Each comes supplied with stand including tip cleaner. The 150-watt heavy duty iron, 8116, comes with stand only and has a 1/2-inch tip. Belden Mfg. Co., 4689 W. Van Buren St., Chicago, Ill.



RADIO CITY Rolindex chart for tube tester modernization can be easily attached to existing tube testing equipment. Measures 11 x 3 3/4 x 3 inches. The chart roll is easily replaced by up-to-date charts, available from R.C.P., as new tube types require. Radio City Products Corp., 88 Park Place, New York, N. Y.

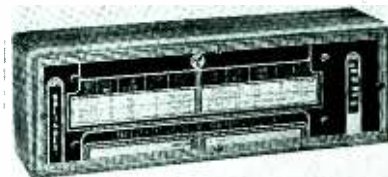

ALLIANCE K-800 Phono-motor, designed specifically for 25 cycle operation, is adapted to the standard friction drive assembly as used on this company's popular Model 80, thus allowing interchangeability in mounting. Available for 110 or 220 volt, in 8 or 9-inch turntable sizes. Alliance Mfg. Co., Alliance, Ohio.

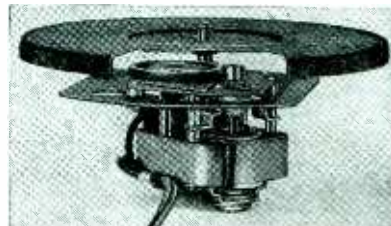

HOTPOINT Two new refrigerators by this company called the *Special Norman*, a 6 cu. ft. capacity, and the 8 cu. ft. *Special Tudor*. Each includes the 1940 *Use-Value* features, such as the defrost indicator, automatic interior flood light, meat pan, 6-way cold storage compartment, split shelf, vegetable drawer, fruit basket, and water bottle. The 8 cu. ft. model has 2 split shelves to accommodate the farm families in storing a 3 gallon milk can. Edison General Elec. Appliance Co., Inc., 5600 W. Taylor St., Chicago, Ill.



NASH-KELVINATOR Introduction of this specially equipped, 8.2 cubic foot refrigerator, designed specifically for the farm home, is announced by this company. The space available is flexible enough to hold a 5 gallon milk can and a tub containing 20-dozen eggs. Incorporates 5 half-length removable shelves. Kelvinator Division of Nash-Kelvinator Corp., Detroit, Michigan.



HARRY ALTER 341 The *Humidome*, a portable humidifier, measures 16 1/4 x 15 x 13 1/2 inches. Features a copper lined water reservoir with a 5 gallon water capacity. Has a 38 watt motor current consumption. The air volume is 140 cubic feet per minute. List price \$39.50, ac. only. The Harry Alter Co., 1728 So. Michigan Ave., Chicago, Ill.



GENERAL CEMENT Here is a contact and attenuator service kit, No. 777. It is convenient for cleaning noisy attenuators, tuners, all-wave switches, variable contacts, etc. Kit consists of special contact cleaner and special corrosion resistant lubricant. List price \$1.00. General Cement Mfg. Co., 919 Taylor Ave., Rockford, Ill.

F-M needs You— and You need this Complete Line



The immediate future of Frequency Modulation lies in the energetic efforts of the Radio Jobbers, Dealers, and Servicemen—the technical men who know what it's all about. Here, then, is YOUR opportunity to get in on the ground floor of this promising new phase of the radio industry!

In order to do this successfully, however, YOU must be prepared—with full information on the subject—with a complete line of sets and parts to meet every demand.

Meissner places this material "right in your lap." The beautiful, walnut-finish Table Model F-M set shown is 22 3/4" wide, 12 1/4" high and 11" deep. Has full-quality, 8" P-M dynamic speaker; five-position tone control provides choice of output response. May also be connected as a converter to feed the audio system of a larger receiver if desired.

CONSOLE MODEL

For highest-quality, noiseless, static-free reproduction of F-M Broadcasts, this big Console Receiver is the finest obtainable. Its powerful, 12-tube chassis, with built-in super-sensitivity, together with a special high-fidelity P-M dynamic speaker in the large bass-reflex tone chamber, assure the discriminating listener of maximum satisfaction. The walnut-finished cabinet is 41" high, 30 1/4" wide and 15 1/2" deep. Rich, two-toned veneers provide a beauty seldom seen except in the highest-priced receivers.

CHASSIS AND PARTS

The same 12-tube chassis used in both of the receivers described above, is available separately for use in "Custom-Built" installations. Requires 110 watts at 117 volts, 60 cycles; 6 watts undistorted output; 170-kc selectivity; 10-mv sensitivity. Special 4.3-mc I-F and Discriminator Transformers, as well as complete RF-Mixer-Osc. Tuning Assembly, covering 42 to 50 mc, are also available for those who build their own.

FREE SALES HELPS

New counter literature describing the Meissner F-M Receivers is now ready. Order a quantity now and be prepared for early fall sales. New 1941 General Catalogs will be ready soon. Write at once for your supply.

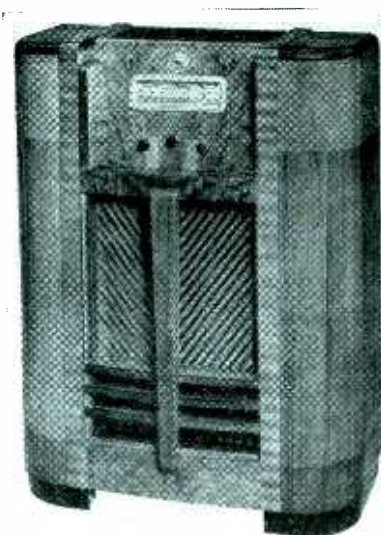

NEW 1941 CATALOG FREE

Every Dealer-Serviceman needs this up-to-date listing of the entire line of Meissner receivers, kits, replacement coils and hundreds of other daily requirements. Send a postal card TODAY for your free copy.

ADDRESS DEPT. R-10

Meissner MT. CARMEL ILLINOIS
"A FAMOUS NAME FOR TWO DECADES"



NO BEGINNER—Joseph D. R. Freed, radio pioneer and engineer, returns to the manufacturing field as head of Freed Radio Corp. Producing the new Freed-Eisemann FM sets

Stewart-Warner Convention

To meet Oct 16-19. Over 400 Dist. to preview new '41 boxes

CHICAGO—The annual national convention of the refrigerator division, Stewart-Warner Corp. was set for Oct. 16 to 19 inclusive at Indianapolis and French Lick Springs. This announcement was made by Joseph C. Elliff, assistant general sales manager of the company.

The morning session of the first day of the convention held in Indianapolis will be devoted to the presentation of the new 1941 line. Luncheon will be served in the plant. During the afternoon distributors will tour the Indianapolis plant, where the refrigerators are made. Charles R. D'Olive, manager of the appliance division will present the line and will conduct the meeting. According to D'Olive, "usual convention arrangements seldom provide guests with the time or opportunity to know thoroughly the product they sell; therefore, this company will reverse usual convention practices and enlarge upon its successful "Quality Lane" 1939 presentation by opening the Indianapolis refrigerator plant for inspection by the entire group of convention guests.

At the close of the afternoon the convention will be transported en masse to French Lick Springs where the merchandising, advertising, and sales programs for the coming year will be presented. While this is going on in French Lick Springs the service managers, who will remain in Indianapolis, will attend a special service convention of their own.

An attendance of more than 400 Stewart-Warner refrigerator distributors, key dealers and factory representatives is expected.

Crosley Names Crossin

CINCINNATI—The appointment of J. F. Crossin as manager of the refrigeration division of the Crosley Corp. was recently announced by Robert I. Petrie, v.p. and general sales manager. Prior to coming to Crosley he was sales manager for the Waring Corp.

On the Newsfront

Dr. Goldsmith Heads New Tele Panel

Enlists research workers to study picture quality and other subjective aspects

WASHINGTON—The National Television Systems Committee through its chairman, Dr. W. R. G. Baker, has announced the organization of a panel of experts to study the subjective aspects involved in the transmission and reception of television broadcasting.

Under the chairmanship of Dr. A. N. Goldsmith, this panel #2, has been assigned the study of physiological and psychological factors in the determination of television system characteristics.

In order that the panel functions most effectively it includes in its membership research workers and scientific investigators in those fields of fundamentals which underlie television, such as optical experts, photographic scientists, specialists in the study of picture quality, psychologists active in the field of optics, biophysicists, ophthalmologists, physiological opticians, radio and television engineering specialists, and investigators of the theory and practice of television picture scanning. The membership of the panel follows: Professor Frank A. Geldard,

University of Virginia; Professor Arthur C. Hardy, Massachusetts Institute of Technology; Dr. LeGrand H. Hardy, New York City; Professor Selig Hecht, Columbia University; Dr. Lloyd A. Jones, Eastman Kodak Co.; Professor Knox McIlwain, University of Pennsylvania; Dr. Pierre Mertz, Bell Telephone Laboratories; Dr. Kenneth Ogle, Dartmouth Medical School; and Dr. Harold A. Wheeler, Hazeltine Service Corporation.

The panel membership is already at work studying such fundamental questions as brightness, color, aspect ratio, fineness of picture structure and many other problems in this field.

Philco Tele Program

W3XE to televise football games

PHILADELPHIA—The full schedule of home football games of the University of Pennsylvania will be televised this fall by the Philco Radio and Television Corp., in cooperation with the University, the Atlantic Refining Co., and N. W. Ayer & Son. The televising of a full schedule of collegiate games is believed to be a "first" in radio and the experience should open the door to several new ideas in tele programming and technique. The first game televised was on Saturday, October 5, with the University of Maryland as Pennsylvania's opponent.



COAST DISTRIBUTORS CELEBRATE—Golf, good food and music made up the day's program at the second annual barbeque of San Francisco and Oakland distributors. The affair was held at Opal Cliffs, Cal. and was presided over by genial host and chef Cliff Bettinger, Pacific division manager of Philco Corp.



IT'S A PHONO MOTOR—R. F. Doyle, seated, president of the Alliance Manufacturing Co., holds a conference with his assistant, Porter Turner, center, and chief engineer W. H. Schneider, right. Object of discussion is a new twenty-five cycle phonograph motor all set for announcement to the trade

W2XOR Beams Program

To test beam of light as link with FM transmitter

NEW YORK—Radio programs flashing along a beam of light between studio and transmitter is the goal of WOR's latest experiments with its FM station, W2XOR.

The beam of light will originate on the roof of WOR's studios in New York City and will be aimed across the city at the lofty tower of 444 Madison Avenue where the FM transmitter is located, 43 stories above the street. A sensitive photoelectric cell on the roof of this building, equipped with a telescopic sight, will be focused into this beam of light. Across this light beam, more than a mile long, will travel programs to be broadcast over the FM station. It has long been a known fact, that light can be modulated, much as radio waves, and converted back to sound on the receiving end.

The new test circuit to serve as a link with the FM transmitter, is being undertaken to provide an emergency circuit between studios and transmitter, should anything happen to the existing telephone wire link. Research will also include work with infra-red rays which can pierce foggy weather or rain that blocks normal light.

NRPDA Meeting Held

BOSTON—Under the auspices of the National Radio Parts Distributors Assn. the New England jobbers held a meeting on September 17, in the Hotel Manger, Boston to discuss many interesting subjects, such as: cooperative advertising of the New England jobbers; the "Listen Before You Vote campaign" and others.

In attendance were: W. H. Childs, L. A. Crosby; A. J. Smith; Mike Scott, Samuel R. Joseph; Alan Joseph; Milton Deutschmann; A. W. Mayer; G. O. Lloyd; and Henri Jappe.

G-E Holds 3-Day Specialist's Meeting

NEW YORK—General Electric's radio and television field specialists assembled from all over the country, gave headquarters engineers and designers their own ideas of what 1941 receivers should be like, as to performance, style, and price.

Although plans for sets to be introduced next year are well under way, Perry Hadlock, manager of the receiver division, and Ray Barhydt, commercial engineer, solicited written specifications as part of this novel clinic on proposed sets, and placed the majority opinions of the specialists on the agenda for immediate action. This was only one of the features of a recent three day meeting of the radio specialists held in the G-E Institute at Bridgeport.

A detailed discussion of frequency modulation and its current and future effects on the whole radio picture, was presented on the first day of the meeting by Dr. W. R. G. Baker, manager of the radio and television department.

At the conclusion of the second day's meeting, the group departed for New London and a day's deep sea fishing. Chairman of the three-day meeting was sales manager A. A. Brandt.

New receivers introduced at the meeting included a camera-type radio in a plastic case.

Sales Managers Club Names New Officers

CHICAGO—New chairman is John Robinson of Crowe Name Plate and Mfg. Co., succeeds Herbert W. Clough of Belden Mfg. Co., retiring chairman. Vice-Chairman is Win Hartford of Thordarson Electric Mfg. Co. and Helen Staniland of Quam Nichols Co. continues as secretary and treasurer. Appointments were made at regular meeting of the club on September 10th.



RIDES THE AIRWAYS—Lee Cox, holding map, western sales manager for Norge Division, Borg-Warner Corp., pilots his own ship and has covered 170,000 miles of business flying. With Cox are: left Howard E. Blood, president, g.m. of Norge; and Peter Sues and William Lancaster, sales managers for Leo J. Meyberg Co. of Los Angeles and San Francisco



PROUD PROPRIETOR—Ed Berndt, radio dealer of Syracuse, snapped while standing in the doorway of his store. That's National Union's Ed. DeNike on the left

Noble Joins Motorola

CHICAGO—Daniel E. Noble, professor of electrical engineering at the University of Connecticut and an authority on frequency modulation has just resigned his position with the school to accept the directorship of Research and Advanced Development for Motorola Radio, it was announced by Paul V. Galvin, president of the Galvin Mfg. Corp.

He is best known in communication fields for his practical application of frequency modulation to the State of Connecticut's police radio communication system of which he has been consulting director for the past year.

He is to start immediately upon the design and development of FM equipment for the Motorola factory.

RCA Appoints Dunlap

NEW YORK—Orrin E. Dunlap, Jr., radio editor of the New York Times for the past eighteen years, has just joined the executive staff of the Radio Corp. of America as manager of the department of information. He succeeds Horton H. Heath, who has been appointed director of advertising and publicity.

He has been associated with wireless since 1912, when he built an amateur station. He is the author of several books on radio.

Horton H. Heath joined RCA in 1936 and was named manager of department of information in 1939. Formerly associated with the Larkin Co. of Buffalo, and various advertising agencies. In 1935 he was a member of the editorial staff of *The New Yorker* magazine.

Murray, Columbia's New V. P.

NEW YORK—James W. Murray has been appointed executive vice-president and general manager of the Columbia Recording Corp. according to a recent announcement by Edward Wallerstein, president. He comes to Columbia with a very colorful career in the record industry. First experience in the industry dates back to 1928 when he was controller of the old Columbia Phonograph Company.

78 S-W Dist. Meetings

Kelsey addresses them all at once

CHICAGO—Sales organizations of 78 Stewart-Warner distributors met October 5 at the same hour, each in their own home town, saw three new radio models (deliveries were synchronized).

Stewart-Warner's L. L. Kelsey addressed all 78 meetings simultaneously. . . . by means of a special recording.

Features FM Sets

NEW YORK—Macy's department store in New York City has just installed a special display on frequency-modulation receivers. A separate section has been

set aside for the exhibition of FM sets which is enhanced by an attractive sign painted on the wall highlighting the features of FM. The receivers displayed comprise: Stromberg-Carlson, Freed-Eisemann and General Electric.

Publishers Apply for FM License

NEW YORK—According to a special study made by FM Broadcasters, Inc. the newspapers are scheduled to play an important part in frequency-modulation broadcasting. Of the 38 organizations which have so far filed applications for an FM license, seven are newspapers.

Beside networks, and stations applicants, many civic and religious groups are also represented in the list.



ARTHUR A. BRANDT—Just appointed sales manager for G-E radio and television receiver line

G-E Ups Brandt

NEW YORK—Arthur A. Brandt, for the past three years prominently associated with the advertising and promotional activities in connection with General Electric radio, has just been appointed radio sales manager. The appointment was announced at a recent meeting of field radio specialists held at Bridgeport by Perry Hadlock, manager of the receiver division.

During the past year G-E's radio receiver sales have been the responsibility of three regional sales managers: H. A. Crossland on the Pacific coast, George Peterson for the middle western territory, and Fred Ray in the east. Ray was recently relieved of his duties to take charge of the new deluxe radio line. With the new set-up, Brandt will be general sales manager and from his headquarters in Bridgeport will work closely with eastern distribution outlets. The other two regional sales managers will report to him.

G-E Stages Preview of New Deluxe Line

BRIDGEPORT—The General Electric Co. held a preview of its new "Musaphonic" deluxe line of radio receivers recently at The Manor House, New York City. They point out that "Musaphonic" is a new word closely related to radio, music and furniture and in the new instruments is to represent the ultimate in musical instruments. Many new conveniences of operation and frequency modulation are incorporated in the new sets.

Crosley Dist. Elects Officers

CINCINNATI — Crosley Distributing Corporation's board of directors has elected the following officers: Lewis M. Crosley, president; Raymond C. Cosgrove, vice president and general manager; Robert I. Petrie, v.p., and general sales manager; George E. Smith, v.p., secretary and treasurer; and John J. Hope, Jr., assistant treasurer.

Guy Flaig is manager of the Cincinnati office, C. S. Tay of the Chicago branch; Fielding Robinson, of New York and C. V. Dilard of Dayton and Columbus.

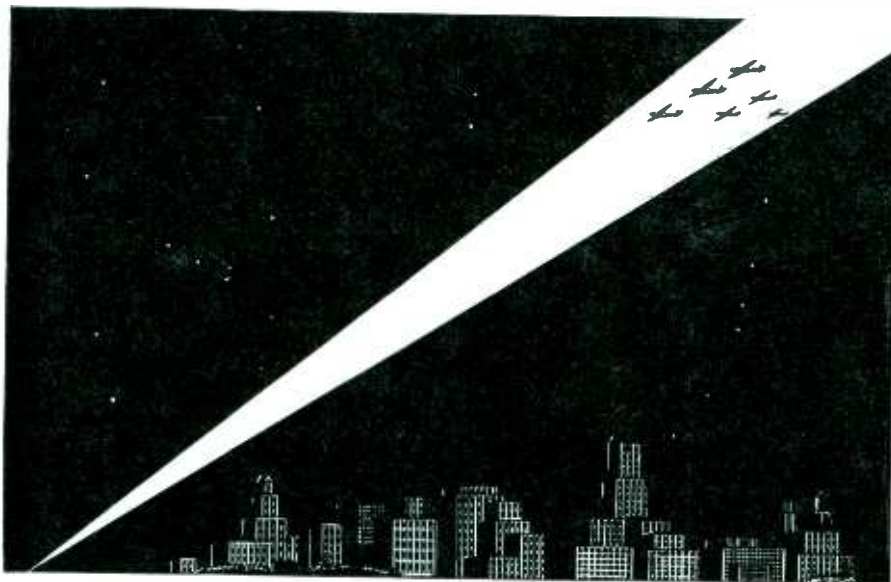

LIGHT WHERE IT'S NEEDED WHEN IT'S NEEDED

A modern, anti-aircraft battery is useless until enemy planes are picked out of the black by the powerful beams of the searchlights. Without light . . . where it's needed, when it's needed . . . the skill of the gunner is wasted.

In radio servicing, even the most skillful trouble-shooter must have a thorough knowledge of every detail of construction and wiring of the particular set on which he is working in order to do his job quickly and efficiently. That is why "Every Successful Service Shop has a Complete Set of RIDER MANUALS."

They provide, in the most convenient form, everything a serviceman needs to know about any radio receiver—data on alignment, I-F peaks, operating voltages, parts lists and values, voltage ratings of condensers, wattage ratings of resistors, coil resistance data, gain data, etc.

Like the searchlights, RIDER MANUALS provide light for the trouble-shooter . . . where it's needed, when it's needed . . . at a cost of less than a nickel a day! Fill in any missing volumes of RIDER MANUALS at your jobber's—today!

JOHN F. RIDER PUBLISHER, Inc.

404 Fourth Avenue New York City

Export Division: Rocke-International Elec. Corp., 100 Varick St., N. Y. C. Cable: ARLAB

DO YOU HAVE ALL E/even?

A complete set of RIDER MANUALS is "must" equipment for every up-to-date service shop.

Vol.	Price	Covering	Vol.	Price	Covering
XI	\$10.00	Up to May 15, 1940	VI	\$7.50	1935-36
X	10.00	1939-40	V	7.50	1934-35
IX	10.00	1938-39	IV	7.50	1933-34
VIII	10.00	1937-38	III	7.50	1932-33
VII	10.00	1936-37	II	7.50	1931-32
			I	7.50	1920-31

You NEED RIDER MANUALS

Tartak Directs U. Teletone

Both organizations will operate independently

NEW YORK—Paul H. Tartak, president of the Oxford-Tartak Radio Corp. has just acquired a substantial interest in the United Teletone Corp. manufacturers of Cinaudagraph speakers. As the new president Tartak will direct general policies of the firm. The two companies will operate independently, with United Teletone continuing to manufacture the Cinaudagraph reproducers. R. O. Hall was elected vice-president and will manage the plant. Executive offices will be at 2 Selleck St., Stamford, Conn.

Motorola Launches Home Radio Ad Campaign

CHICAGO—Following a successful campaign on its automobile radio receivers, the Galvin Mfg. Corp., makers of Motorola sets, have started a national advertising campaign with full-page copy in national magazines and newspapers, on its complete line of home receivers.

Full pages in color appeared in the *Saturday Evening Post*, Sept. 17, and in *Life*, Oct. 7th. These two advertisements to be followed by dominant space in these and other publications. Copy theme throughout Motorola's magazine and newspaper ads stresses their record as a producer of automobile radios. Motorola's selling story is based on the fact

that engineers capable of solving radio reception problems in such high speed vehicles as automobiles and stratoliners of the air are specially qualified to bring to home radio a totally new conception of tone quality, sensitivity and selectivity.

Glover Joins Jensen

CHICAGO—Ralph P. Glover, formerly chief engineer for Shure Brothers, joined the Jensen Radio Manufacturing Company September 3, will work with

sales manager Thos. A. White coordinating technical and sales aspects of the firm's recently expanded promotional program.

Now Standard Arcturus

NEWARK—Arcturus Radio Tube Corp. 720 Frelinghuysen Ave., Newark, N. J., reports the sale of its business, including the Arcturus name, good will and radio tube inventory to the Standard Arcturus Corporation, 60 Park Place, Newark, N. J.



SOUND SPECIALISTS—Pictured herewith is the new streamlined sound truck of the Clingaman Radio Co., well known parts distributors of Peru, Ind. Considerable planning and thought was given to the sound equipment and likewise to the design of the truck

A Preview of Christmas



Our inside information department reports that all signs point toward an enormous DECCA business this Christmas Season. After the greatest summer volume in the history of DECCA, our three big factories are building up toward maximum production, and, try as we may, it appears that it's going to be difficult to give perfect service this holiday season unless you help us by— **ANTICIPATING YOUR STOCK NEEDS FOR DECCA RECORDS FOR CHRISTMAS NOW!!**

Complete lists of all Christmas merchandise are available at branches and we urge you to secure your lists and place your orders as quickly as possible.

DECCA Records



YOU CAN SELL MORE RADIO SETS THIS YEAR —if you follow these 6 rules

- 1 Give a good demonstration of the new home recording feature. It's the quickest way to convince your customer that he ought to have a new set.
- 2 To make good demonstrations give each of your salesmen a Presto STELLITE cutting needle for his own exclusive use. It will assure him of 100 or more perfect demonstrations at a fraction of a cent each.
- 3 Use only PRESTO BLUE LABEL DISCS for demonstrating recording. It isn't worth while to save a few cents on the demonstration disc and take a chance of killing a \$150.00 sale.
- 4 Sell each customer a PRESTO HOME RECORDING KIT with his set. Start him off right. It will save you free service calls. It will help him make good recordings from the beginning... make him a regular disc customer.
- 5 Use the PRESTO COUNTER DISPLAY. Show your customers you carry the highest quality discs and needles. Everyone who comes into your store this Fall is a probable buyer.



- 6 Use the Presto window and wall posters, advertising mats, direct mail order cards. They'll bring you new customers, more business.
- JOBBERS**—write today for full information on Presto recording accessories—price sheets for your salesmen's folders, free broadsides to mail to your dealers, free merchandising aids for your dealers.

PRESTO RECORDING CORPORATION
242 W. 55th St., New York, N. Y.
World's Largest Manufacturers of
Instantaneous Sound Recording Equipment

AIN'T IT A GRAND AND GLORIOUS FEELING?



NTSC Completes Sub-Committees

To study all tele systems

WASHINGTON—Dr. W. R. G. Baker, chairman of the National Television Systems Committee announced the completion of the personnel on all nine panels or sub-committees.

In planning its work, the National Television Systems Committee has arranged for the study both of the many tele systems used abroad and those proposed or have been in actual service in this country so as to assist in laying a sound ground work for an American system of television broadcasting.

The NTSC has recognized the fact that for the expeditious development of engineering standards essential to a nationwide system of television broadcasting it is necessary that the broad problem be so sub-divided as to allow of the attack being made simultaneously by as many groups of experts as are available and can be directed to the study of these problems.

Majestic Names Byrne S. M.

CHICAGO—Majestic Radio & Television Corp. has just appointed Harry Byrne sales manager in charge of sales and advertising of its home set division. Byrne has been connected with Majestic in various sales and merchandising capacities for the past four years. He states the company is now completely reorganized and is controlled and operated by DuMont Television Laboratories, subsidiary of Paramount Pictures, Inc.

New Kelvinator Unit

DETROIT—Announcement of the formation of a new Kelvinator factory sales unit, which will be known as the Commercial, Parts and Service Sales Divi-

sion, was made by Frank R. Pierce, general sales manager of the Kelvinator Division of the Nash-Kelvinator Corp. Thomas A. Farrell is to head the new department. For the past twelve months he has been the eastern sales manager.

National Ad Drive on RCA Victrolas

CAMDEN—Virtually every leading national magazine is included in the big schedule of four-color and black and white advertisements announcing the new '41 RCA Victrola instruments to the public.

Several of the ads have already appeared, led off by a four-color double-page center spread in the *Saturday Evening Post*. David J. Finn, advertising manager, declared: "This ad schedule, backed up by extensive cooperative newspaper space, radio time, direct mail campaigns, and practically every other form of sales promotion, will concentrate on the Victrola line, "however, radio consoles, table models, and the new 'Personal' radio will also receive substantial support."

Musicraft Has Larger Quarters

NEW YORK—The Musicraft Records, Inc., announced the removal of its plant and studio to 242 West 55th Street, New York City. Former address 10 West 47th Street. Paul Puner, v.p. says big uplift in record and accessory business necessitated more spacious quarters.

Dopkins New Crosley D. S. M.

CINCINNATI—Robert I. Petrie, v.p. and general sales manager, The Crosley Corp. announces the appointment of Loyd Dopkins as district sales manager for New Jersey. Prior to joining Crosley he used to be district manager of the Detroit Michigan Stove Co.

Emerson Holds Convention

Introduces new "Patriot" and ten other models, rounding out '41 line

NEW YORK—At a meeting of its eastern distributors, held at the Hotel Roosevelt in New York City early in October, Ben Abrams, president of the Emerson Radio and Phonograph Corp., made a stage presentation of a new radio which is aptly called "The Patriot."

In connection with the introduction of this new set, Emerson is featuring a large broadside describing "The Patriot." In addition there is an "Uncle Sam Hat" window and store display, newspaper publicity, and other helps. Other models presented included a number of new 3-way portables starting at \$19.95.

Charles Robbins, general sales manager, left immediately after the presentation for a coast-to-coast air tour to cover distributor meetings in principal cities with a view to arranging for simultaneous nationwide dealer introductions of the new "Patriot" model.

FM Station Has 12 Hr. Program

NEW YORK—One of the first FM stations to present a complete and specially originated schedule of frequency modulation programs is W1XPW the FM transmitter of station WDRC, Hartford, Conn. Up to now W1XPW has relayed only WDRC programs but with the new sked there are 12 hours of daily programming from 11 AM to 11PM. This experimental FM station is also maintaining a completely separate FM staff.

Expands Plant Facilities

NEW YORK—Radio City Products Co. has just increased its factory floor space by approximately 35 percent. States this further increase in space created by greatly expanded business in service equipment.

Permo Builds Addition

CHICAGO—Permo Products Corp. has just started construction on an addition to its plant at 6415 Ravenswood Ave., Chicago, Ill. When completed, will double present factory floor space and increase production facilities by fifty percent.



NO COMPLAINTS—Genial Ken Burcau, Radiart's sales manager, gives his best smile for the cameraman. Don't look now but there's a magazine at his right and it looks like R.R.

SEE The Signal

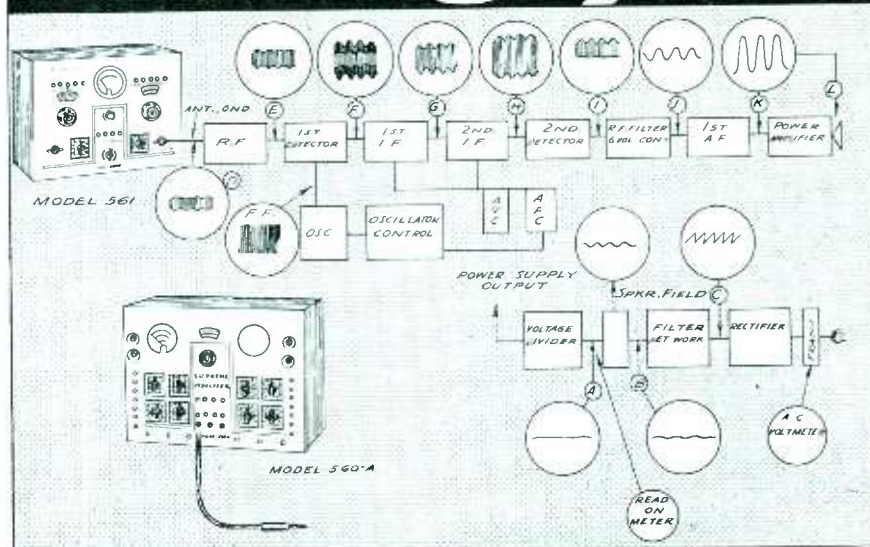

VEDOLYZER MODEL 560-A

Not only see the signal but see the QUALITY.

What happens to the signal between the antenna and speaker of a typical superheterodyne? Does it pass the RF, Mixer and Intermediate stages free of distortion? Can you actually see the QUALITY of the signal as it is converted and amplified through the successive stages?

Can you check the QUALITY of the generator signal at the antenna post (D)? Is it amplified free of distortion to the input of the first detector (E)? Did the first detector produce a modulated signal with similar characteristics of the supply signal (F)? In addition to the gain of the I.F. stages, can you immediately see distortion which can be caused by defective tubes and open by-pass condensers? Do these stages have excessive hum, possibly originating at the first detector as modulation hum, or is it introduced by a defective component of the power supply (G, H, and I)? Is the second detector rectifying or is it introducing distortion caused by a defective tube which will not show up

on a standard tube tester or signal tracer which indicates amplitude only? Do you have a smooth sinusoidal waveform at the outputs of the audio amplifiers such as J, K, and L, or is it ragged, indicating tube or hum distortion which can be readily located by a dynamic signal analyzer which will indicate the condition or QUALITY of the signal as well as the gain or losses?

The Model 560-A Vedolyzer is not a mere signal tracer, it is a complete Dynamic Analyzer which will show you what the signal looks like in addition to indicating the existence, absence, gain or amplitude.

Testing for hum, distortion and any of those troubles which require more than an ordinary signal tracer is just part of the routine for the Vedolyzer. Think of the requirements you will have to meet before you purchase dynamic testing apparatus. You will need more than a signal tracer to determine the QUALITY of the signal—The Vedolyzer is a revelation in meeting the full requirements of the modern service laboratory—an instrument for COMPLETE DYNAMIC ANALYSIS.

SUPREME

For full information on Model 560-A and complete Catalog of new, 1941 SUPREME test equipment, write
SUPREME INSTRUMENTS CORP.
 DEPT. RR-10
 GREENWOOD, MISSISSIPPI

BLITZKRIEG!

Clarion's 5-point sales attack is smashing sales records in Sound. Be sure you are on the winning side. Join forces with Clarion now.

Wire or write for Clarion's exclusive distributorship deal for increased P.A. sales and profits.

Clarion PUBLIC ADDRESS Equipment
 TRANSFORMER CORP. OF AMERICA • 69 WOOSTER ST., NEW YORK

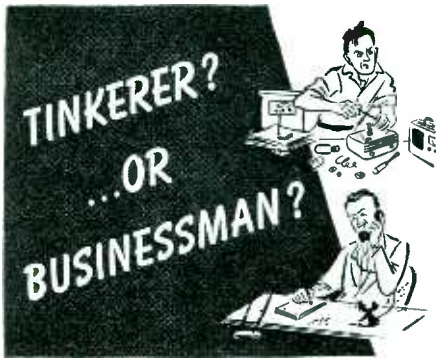

LESS Time to Repair Radios...
Means MORE Time to Build Business!

RCA RIDER CHANALYST



Yesterday's servicing methods were good enough... *for yesterday*. But progressive servicemen *today* demand methods that fix sets quicker. They spend less time bending over receivers—more time going out after business... developing business-getting ideas... *building* their business.

Signal-tracing with the Rider Chanalyst takes less time!

Greatest advance in radio servicing instruments since servicing began, the RCA Rider Chanalyst uses the newest method of attack: *the signal itself*, common to every radio. It's an investment worth investigating! Ask your RCA Distributor for on-the-circuit proof of the Chanalyst's effectiveness by means of the Dynamic Demonstrator.

"Line 'em up" Faster, Easier, Better!
NEW RCA A. C. TEST OSCILLATOR
No. 167 . . . \$34.50 to servicemen

- ★ New, Accurate, Easy-Reading Dial
- ★ 100-30,000 KC. Fundamentals: 6 Bands
- ★ Full 1.0 Volt Maximum Output
- ★ 30%, 400-Cycle Internal Modulation

Over 380 million RCA Radio Tubes have been purchased by radio users. In tubes, as in parts and test equipment, it pays to go RCA All the Way.



RCA
Test Equipment
RCA Manufacturing Co., Inc., Camden, N. J.
A Service of the Radio Corporation of America



ACTIVE AMATEUR—*Harold Ballam*, well known manufacturer's representative finds sufficient time to actively operate his rig and keep right up in line with the latest transmitting and receiving equipment. He has just joined J. E. Muniot in the Southern Sellers Organization, New Orleans. Used to be with Shuler Supply Co.

Fausett's New Address

ATLANTA—Floyd Fausett radio manufacturer's agency, formerly of Jackson, Miss., is now located at 441 Hopkins St., S. W. Atlanta, Ga. To represent nationally known manufacturers for many states in the south.

Distribution News

STROMBERG-CARLSON—Fred N. Anibal, sales manager announced that *Burt Doris* is the new rep. to contact west coast distributors. He will cover from Phoenix to Salt Lake City to Spokane and Seattle, and from this city to San Diego. He will make his home in San Francisco. *William L. Mollands*, who has been with S-C sales and service departments for more than five years received the post of sales representative for the southeast and will call on the trade in the states of Alabama, Georgia, Florida and South Carolina. *J. J. Skinner & Co.*, newly organized Cleveland firm has just been appointed distributor for Cleveland and outlying territory. The *H. Poll Electric Co.*, 512 Erie St., Toledo, Ohio, is to distribute this company's radio merchandise in northwest Ohio.

RCA—The *Bliss-Strawn Distributing Co.* received appointment as distributors of RCA-Victor radios, records and parts for the Detroit district. The newly formed company operates branches in Detroit, Toledo and Grand Rapids to serve the lower Michigan and the northwest Ohio territories.

ATLAS—*Herb Erickson*, located at 14 Biltmore Ave., Asheville, N. C., has been appointed by Atlas Sound Corp. as its southeastern sales rep. calling on jobbers in North and South Carolina, and Tennessee.

JANETTE—*Stearns, Perry and Smith*, 51 Chardon St., Boston, Mass., is the new Janette district agent for the Boston territory.

NEW STERLING POCKET METERS

TEST "A" AND "B" BATTERIES
OF PORTABLE RADIO SETS

YOU
NEED
THIS
LINE
NOW!



No. 42A STERLING
Graphic General Tester

for all "A" and "B" batteries of Portable Radio Sets. Designed especially for dealers and servicemen. Old type testers won't do. Dealer's Net Price . . . \$3.60

Featured by All Leading Distributors

Write for bulletin No. 515-0 describing the complete line.

THE STERLING MFG. CO.
9205 Detroit Ave. Cleveland, O.

SO!~
they use
RADIART
on **POLICE**
CARS, too

POLICE, AIRCRAFT
and OTHER MOBILE
COMMUNICATIONS

AMATEUR
PUBLIC ADDRESS

- RADIART
AERIALS
- RADIART
VIBRATORS
- RADIART
VIBROWATTS
100 WATTS

STANDARDS OF COMPETITION

RADIART

WRITE FOR
BULLETIN 840

THE RADIART CORPORATION
CLEVELAND, OHIO

Dealer Helps

NEW CAMPAIGN AIDS—*P. R. Mallory & Co.* has just brought out several displays and aids as a part of its campaign on tubular paper and oil impregnated condensers, "True Blue" vitreous resistors and noise filters. There are suggested sales letters and postal card forms, a booklet of color inserts, point of sale counter display card and other helps.



DISPLAY PIECE—The latest full-color *Philco* display piece is life size and calls attention to the photo-electric radio phonograph installed in the tilt-front cabinet.

SALES HELPS—*Rock-Ola Mfg. Corp.* offers two new folders attractively printed with full details on their complete receiver line, also streamers, tags, a report pad and a large lay-out sheet on the *Rock-Ola* mat and cut service.

NEW CATALOG—*Allied Radio Corp.* has just released a new 212 page radio catalog for 1941. Contains a special 40 page radio section introducing 83 new receivers. Also a public-address section with details on systems ranging from 7 to 75 watts. Describes numerous parts.

RESISTOR FOLDER—*Ward Leonard Electric Co.*, Mount Vernon, N. Y., will mail on request their new, revised circular No. 507, which describes their complete line of resistors.

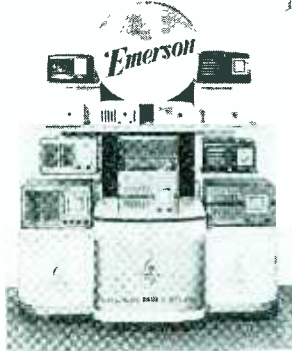

TABLE TYPE DISPLAY—*Emerson Radio and Phonograph Corp.* announces this large attractive display stand with provisions for ten table sets and the combination radio-phono model displayed in the center.

MARINE FOLDERS—*Hallcrafters* releases two new folders with complete information on its ship-to-shore radio-telephone equipment. Available by writing to *The Hallcrafters, Inc.*, 2611 So. Indiana Ave., Chicago, Ill.

DEALER BOOKLET—Book on dealer and service helps for *Raytheon* tube dealers. Has valuable technical information and illustrates a multitude of dealer displays.

THREE COLOR MERCHANDISER—*RCA Victor* has a new three-tier display stand with a bulletin board frame at the top to hold double spread magazine ads featuring table models. Measures 6'4" high x 10" deep x 30 1/2" wide.

RECORDER AID—*Permo Products Corp.* have a 10-power magnifying glass, mounted in a protecting rubber holder, extremely useful for inspecting playback needle points, recording needles and record grooves. The magnifier will be sent to all engineers, manufacturers and jobbers upon writing with their letter-head and enclosing 10¢ to cover the handling and mailing cost.

LEAFLET—"The Facts About Frequency Modulation" is the title of a bulletin by *Benjamin Gross*, Pres. of *Gross Sales, Inc.*, 570 Lexington Ave., New York City, factory representatives for *Stromberg-Carlson* radios. Written for the trade.

If you recognize the finer things in instruments—

THE word "quality" is used more in advertisements than any other... and yet we all know that the place to look for it is not in advertisements, but in PRODUCTS!

You who have used testing instruments for a number of years recognize quality—or the absence of it—the moment you get your eyes and hands on testing instruments. Indeed *Simpson Testers* owe their meteoric rise to the fact that so many service men DO recognize the FINER THINGS in instruments.

If you know testing equipment you owe it to yourself to inspect *Simpson* instruments like those briefly described here. That is all we ask. The rest we leave to the instruments!

A handsome new catalog covers the advanced *Simpson* line. Ask for your copy.

SIMPSON ELECTRIC CO.
5216 Kinzie St., Chicago, Ill.



MODEL 260—The outstanding value in a high sensitivity set tester for television and general servicing. Ranges to 5000 volts—both A.C. and D.C. at 20,000 ohms per volt D.C. and 1000 ohms per volt A.C. Resistance readings from 10 megohms down to 1/2 ohm and five Decibel ranges from -10 to +52 D.B. Dealers net price \$27.50

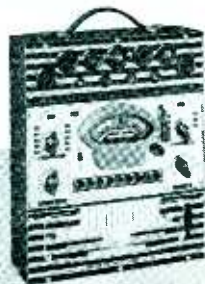

MODEL 400—Never before have so many features been combined in a tester. "Unit design" guards against obsolescence; visual guide ties in speed-roll chart with switches; three-way switching broadens scope. Your name engraved free on panel. Dealers \$36.00 net price



MODEL 300—A handsome, precision tube tester at a remarkable price. Filament voltages of .5 to 120 V. Tests locals, single ended tubes, bantams, midjets, miniatures, ballast tubes, gaseous rectifiers, Christmas tree bulbs, etc. Has neon short check; "good" and "bad" markings; percentage scale; tube charts in cover. Dealers \$26.50 net price



MODEL 320—Giant tester with 9-inch illuminated meter. Has 50 ranges... nine A.C. and nine D.C. voltage ranges; six milliamperage ranges; five resistance ranges; four capacity ranges; seven decibel ranges. Entirely A.C. operated. All voltage ranges have resistance of 1,000 ohms per volt. Test leads included. Rack mountings available. Dealers net price \$37.50



MODEL 240—A remarkable value in a pocket size (5 1/4 x 2 7/8 x 1 3/4") 3,000 volt, self-contained tester. Four A.C. and five D.C. voltage ranges at 1,000 ohms per volt: 0-15—150—750—milliamps; 0-3000—300,000 ohms. Dealers \$14.75 net price

SIMPSON INSTRUMENTS THAT Stay ACCURATE



**FIRST
INTRODUCED
IN 1936**

Still Tops for 1941!

Owners of Model 772 have experienced the true economy of buying correctly designed instruments which measure in fundamentals

Servicemen who purchased one of the original Model 772's over four years ago have found this super-sensitive Analyzer "up-to-the-minute" all during this period ...and find it still "tops" in the field for today's and tomorrow's measurement needs.

It more than met the test requirements of all A.M. receivers... despite the refinements and circuit changes during these many years. It met the requirements of television, too; and today, it is the outstanding instrument for F.M. servicing... because of its high sensitivity, its sound design and construction, and because it measures in fundamental quantities. There are no trick circuits or gadgets to cause early and costly obsolescence. It is a fundamental instrument that, with usual instrument care, will remain in full service indefinitely.

Be sure to get all the facts on Model 772 and other WESTON fundamental test equipment. Write to Weston Electrical Instrument Corporation, 581 Frelinghuysen Avenue, Newark, New Jersey.

THE WESTON MODEL 772 Super-Sensitive Analyzer

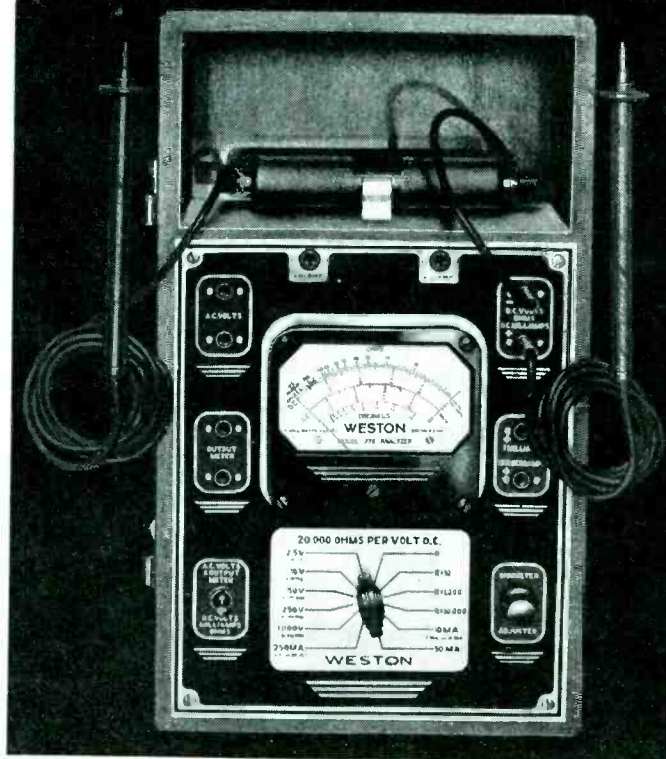

Laboratory Standards... Precision DC and AC Portables... Instrument Transformers... Sensitive Relays... DC, AC, and Thermo Switchboard and Panel Instruments.

WESTON

Specialized Test Equipment... Light Measurement and Control Devices... Exposure Meters... Aircraft Instruments... Electric Tachometers... Dial Thermometers.

FOR OVER 52 YEARS LEADERS IN ELECTRICAL MEASURING INSTRUMENTS

AVC in Generator

The general practice in realignment of a receiver is to set the volume control on full and the signal generator at very low output to prevent AVC action. This results in alignment at high sensitivity because of the low minimum bias on the i-f and r-f stages.

When the receiver is operated in the home, however, the local broadcast stations usually create a much higher bias on these tubes through the action of the AVC. This higher bias condition changes the input capacity of the controlled tubes and thereby varies the resonance points from the original adjustment on the bench.

Alignment at a definite value of AVC voltage would seem to be indicated for alleviation of this condition and a voltage supply for this purpose is included in the E-200 signal generator of Precision.

Obtained from the 4100 ohm resistor in the negative return the voltage may be varied by a front panel control from zero to 50 volts. By disconnecting the main AVC line this voltage can be fed to the controlled stages for fixed bias alignment.

The generator contains a 6SJ7 as the r-f oscillator in an electron coupled oscillator circuit, modulation from the 6C5 400 cycle audio oscillator being injected through the suppressor grid to the electron stream. A dual r-f output system permits varying loads or r-f control settings with essential stability of the oscillator frequency.

As shown in the diagram switch 3 permits selection of several outputs; unmodulated r-f, 400 cycle modulated r-f, externally modulated r-f and 400

Service Department

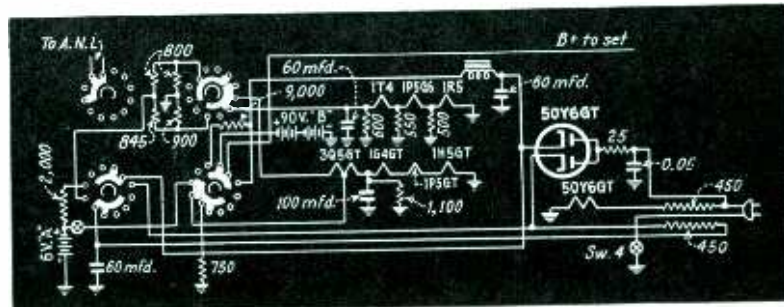

cycle sine wave audio. Variation of the 500 M ohm control provides change in the percentage of modulation from zero to 100% for signal substitution applications.

Six bands are covered by switch 1, and unused coils are shorted out to prevent deadspots in the fundamental frequency range of 90kc through 22 mc.

Portable Battery Charger

Average battery life extended to between 400 and 500 hours of operation is the claim of Hallicrafters in the Sky Traveler three way all wave portable recently announced.

A four position power switch, shown in battery position in the diagram, connects the batteries for portable operation to the radio circuits, the six volt A battery feeding the center of the 3Q5GT filament for series parallel operation.

For ac-dc operation the power switch connects the cathodes of the 50Y6GT rectifier together and feeds the B voltage to the set filtered by the choke shown. The filaments receive their power from the rectifier through the 450 ohm resistor located in company with the rectifier filament dropping resistor in the line cord. After filtering by the high capacity electrolytics this voltage is applied to the tubes through the voltage divider system composed of the 800 and 900 ohm resistors near the switch in the diagram.

Because of the higher plate voltage and need for additional bias on the power tube this resistor network supplies 4.5 volts to three tubes and 7.5 volts to the series of four tubes.

When the power switch is placed in the charge position the two cathodes of the rectifier tube are separated, one supplies charging voltage to the B battery through the filter choke and the 9000 ohm current limiting resistor and the other cathode provides the charge to the six volt A battery through the 450 ohm resistor. Here the 2000 ohm resistor limits the current and provides the proper voltage drop to the A battery now shunted by the 750 ohm resistor. The power drain when charging at 115 volts ac or dc is about 25 watts and it is not recommended to charge the batteries more than twelve hours at any one time.

An additional 1.5 volt battery is employed in the receiver circuit as a filament supply for a beat oscillator but no provision for charging this is incorporated.

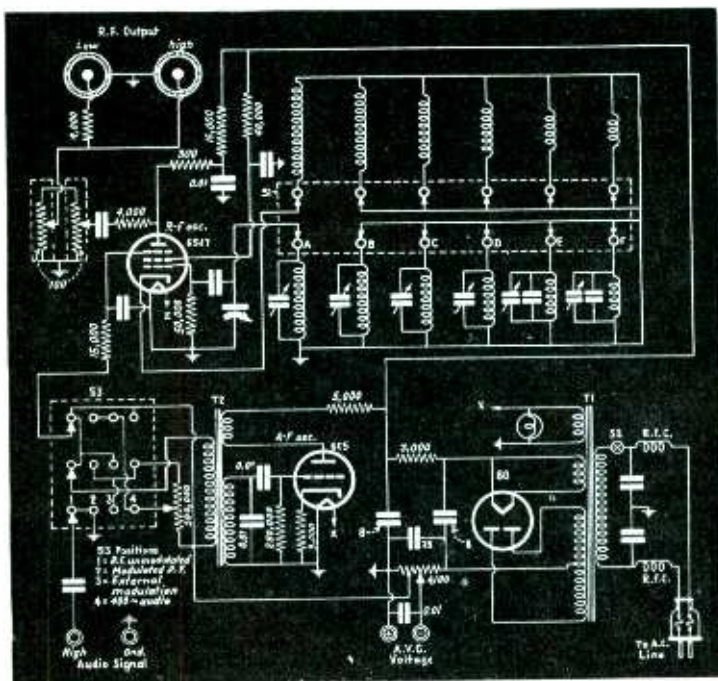

Pickup Vibration

Phono needles and pickups vibrate mechanically and set up sound waves that may reach the ear at the same time as those from the speaker, resulting in apparent distortion to the listener.

Operation of the pickup further away or in a covered box or cabinet will decrease the intensity of these secondary sound vibrations at the listening positions but in some cases the box or cabinet will actually act as a sounding board and intensify the sound vibrations.

An acoustic network around the opening of the phonograph compart-

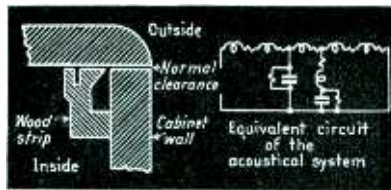

ment is employed by RCA as a tone guard in some models. It acts as a low pass filter to reduce passage of the high frequency sound that is generated and radiated directly into the air by the vibrating parts of the pickup.

A mechanical view of the construction and the equivalent electrical cir-

cuit are shown. The series elements of the filter are formed by the normal slit between the cabinet and the cover. The shunt elements are the slots formed in the wood strip and cabinet wall.

If a conventional cabinet and lid assembly is assumed to have a flat response frequency of unity or zero db, the response frequency of the filter, relative to this curve, is essentially flat to 700 cycles, 5 db down at 1000 cycles, reaches its peak of -43 db about 4000 cycles, rising to -26 db at 10,000 cycles.

Tone Control Circuit

Bass compensating circuits of recent years have boosted lows by cutting highs at low volume control settings to overcome deficiencies of the human ear. Critical listeners, interested in "brilliant" operation of their radios, often object to the noticeable bass at low levels.

Several manufacturers employ a tone control circuit this year that will appeal to this type listener, Motorola, in model 62T1, use the circuit shown. The tapped volume control is connected as the diode load resistor and audio shunt. The 33M ohm resistor and .01 condenser attenuate highs at low volume levels and provide normal

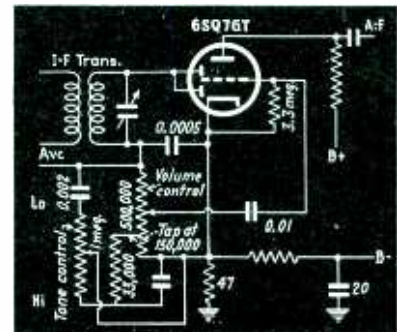

bass compensation when the one meg tone control is set at medium or low positions. In the latter position the .002 condenser bypasses highs as they are supplied by the diode, allows essentially lows to feed through the audio system.

When the tone control is set for treble or high operation it shorts out the .01 mfd condenser of the bass compensation circuit and prevents attenuation of the highs. Although the 33M ohm resistor is now connected from the control tap to ground it has no effect on the audio frequency range. The high total resistance of the tone control is now in series with the .002 mfd condenser and prevents it from bypassing highs.

Dual Loudspeakers

Due to absorption by furniture, carpets and draperies, much of the high frequency output of a loudspeaker

BIG in Value

ONLY \$18.85

MODEL 432-A TUBE TESTER



The Outstanding Tube Tester Value . . . Checks all type tubes including Loctals, Bantam Jr., 1.4 volt Miniatures, Gaseous Rectifier, Ballast, 117-Volt Series, etc. Direct Reading GOOD-BAD Meter Scale. Neon shorts test. Separate line voltage meter. Professional-appearing Counter or Portable Case with roomy compartment for tools, etc., \$18.85 Dealer Net.

Readrite
RANGER

MODEL 432-A-742 . . . Combination Tube Tester (432-A) and Volt-Ohm-Milliammeter with 16 Ranges . . . Dealer Net Price . . . \$27.85

MODEL 739 . . . AC-DC Pocket Volt-Ohm-Milliammeter with Selector Switch . . . Molded Case . . . AC and DC Volts 0-15-150-750-1500; DC MA 0-1.5-15-150; High and Low ohms scales . . . Dealer Net Price . . . \$9.90

BIG BOY MODEL 860



An AC-DC Volt-Ohm-Milliammeter with all the ranges you want . . . easily readable on the large 7" instrument with extra-long 6" scale. DC Volts 0-10-50-250-500-1000 at 5000 ohms per volt; AC Volts 0-10-50-250-1000 at 1000 ohms per volt; DC Ma., 0-1-10-100; Resistance ranges: 0-1500 ohms shunt type circuit; 0-750,000 ohms and 0-7.5, 0-15 megohms. (Battery included for 1500-ohm range). Dealer Net Price . . . \$17.85

MODEL 510



A Handy Pocket-Size All-Purpose Volt-Ohmmeter . . . Ranges: 0-300 DC Volts; 0-10,000 ohms. Complete with battery . . . Dealer Net Price . . . \$2.25

Write for Catalog—Section 1020 College Ave.,

READRITE METER WORKS

BLUFFTON, OHIO

Manufacturers

Why Not Have the
LATEST and BEST!

WEBSTER-CHICAGO'S New Manual Recorder with Playback

- Double Rim Drive Motor
- Patented Noiseless, Powerful, Constant Speed Motor
- Webster-Chicago Famous Pickup in 1 Oz., 2 Oz. and 3 Oz. Types
- Patented Friction Drive Recording Arm with Choice of Crystal or Magnetic Cutting Head



DELUXE RECORD CHANGER

Exclusive principles with a minimum of working parts. Will play sixteen intermixed 10 and 12 inch records.

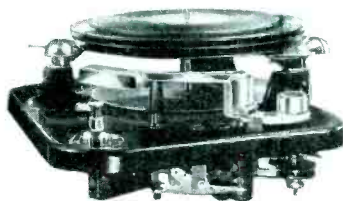

POPULAR STANDARD RECORD CHANGER

Featuring jam-proof mechanism with noise-free operation. Plays ten 12 inch or twelve 10 inch records.

Write or Wire Today for Details, Address Section O-8

5622 Bloomingdale Ave.
Chicago, Illinois

WEBSTER-CHICAGO
CORPORATION

"The Sound of Tomorrow"

GET "In The Groove"!



for **BIGGEST NEEDLE PROFITS**

WITH THE
PFANSTIEHL
Finest Phonograph Needle

4000 and more PERFECT PLAYS

... from one needle ... over twice the life of former fine quality needles.

LONGER RECORD LIFE • Special "break-in" feature protects all records first to last.

TRUER REPRODUCTION • Formed-to-groove point picks up finer vibrations—plays all of the music on the record.

ELIMINATES SURFACE NOISES • High finish friction-free bearing surface eliminates practically all surface noise.

For biggest needle profits, stock the needle that tops the field. Write today for full details.

FREE "Break-in" Record BOOSTS SALES

... the newest thing in the entire home phonograph needle field.



A special record that you give free with each Pfanstiehl needle you sell, "form-fits" the point to the individual machine. Assures perfect performance. A tremendous sales influence. Get full details.

PFANSTIEHL CHEMICAL COMPANY • METAL DIVISION
111 LAKEVIEW AVENUE WAUKEGAN, ILLINOIS

PINCOR CONVERTERS

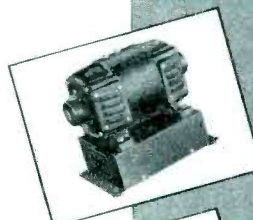

AK with filter

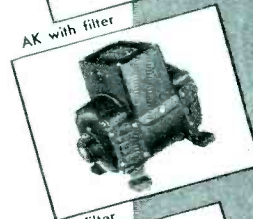

BK with filter



YR less filter



"Satisfied" SAY
THOUSANDS OF CONVERTER USERS

Where uninterrupted operation of such A.C. electrical equipment as gaseous signs, power amplifiers, motors, radios, musical instruments, etc. depend upon your converters, play safe by using Pincor Rotary Converters. They give thousands of hours of trouble free service, even under the most adverse conditions.

Available with or without filter for converting 6, 12, 32, 115, 230 or special voltages D.C. to 110 or 220 volts A.C. 40 to 5000 KVA. Quiet, smooth, light weight and compact. Send for NEW complete catalog today.

PIONEER GEN-E-MOTOR CORPORATION

DEPT. R-1, 466 WEST SUPERIOR ST., CHICAGO, ILL.
EXPORT ADDRESS: 25 WARREN ST., N. Y., N. Y.
CABLE: SIMONTRICE, NEW YORK



The IDEAL REPLACEMENT UNITS at SENSATIONAL PRICES

The Models 80 and K "Even-Speed" Motors are self-starting, light weight motors, ideally fitted for the rising replacement market. They are interchangeable in mounting; quickly and easily installed, and fit practically all standard phonograph and combination models.

SPECIFICATIONS

"Even-Speed" Model 80 (illustrated above) is available for operation on 110 or 220 volt, 50 or 60 cycle source at 16 watts input in 8", 9", or 10" turntable sizes; Model K for 110 or 220 volt, 25 watt operation in 8" or 9"

turntable sizes. Both are exceptionally quiet in operation—no gears—smooth, positive friction rim drive. Excellent regulation characteristics for uniformity of table speed. Amply proportioned bearings—large oil reserves. Forced ventilation for cool operation. Slip type fan precludes possibility of injury. Mounting plate maintains correct turntable height regardless of mounting board thickness.

WRITE FOR PRICES

Mail a postcard today for prices and complete details on the "Even-Speed" Models 80 and K. Address Dept. C.

ALLIANCE MFG. CO., ALLIANCE, OHIO

BUSINESS OPPORTUNITY

If you have \$2,000 and experience in the radio and appliance field—retail or service, you are ideally situated to own a profitable business or to expand your present one. Thorough investigation by your banker or lawyer is invited. Proposition has nationwide acceptance. Give name, address, phone number and age. Replies strictly confidential. Write Box BO-144, Radio and Television Retailing, 330 W. 42nd St., New York, N. Y.



fails to reach the listeners' ears. To alleviate this condition a 6½ inch speaker is mounted in the new G.E. receivers along with a larger speaker. The small diameter aids in this respect, for the center of the speaker is thereby nearer the chassis shelf. This all helps to get the high frequencies nearer to the ear level.

Another problem is that of obtaining adequate distribution of the high frequencies over a wide angle. This is due to the fact that the cone radiates the high frequencies in the form of a beam. The width of this beam depends upon the ratio of the diameter of the diaphragm to wave length of the sound to be radiated; the larger this ratio, the sharper the beam. If a single speaker is chosen of sufficiently large diameter to be a good low frequency unit, the high frequencies will be correspondingly restricted to a narrow beam.

Most receivers make use of the improved efficiency of the loudspeaker at its fundamental resonance to compensate for the limited baffle area which the cabinet provides. It often results in a peaked low frequency characteristic which is unpleasant because of the dominance of this narrow range of tones (boom). This condition is much less severe when two dissimilar speakers are used, as their resonances are staggered to provide this compensation over a wider frequency range with greater uniformity. A further advantage of the combined speakers is that their frequency characteristics may be made complementary to each other. By proper choice of units one speaker will fill in where the other is deficient.

For successful operation of multiple speakers equal consideration must be given to the type of drive. First is the question of series or parallel connection of the two speakers. This is answered largely by the type of output stage driving them. If the amplifier is a constant current source, such as is approximated by a pentode or beam power output stage, the speakers should be connected in parallel. This will prevent the power delivered at resonance from rising due to the shunting effect of the speaker which is off resonance.

Meter Level Indicator

Circuits of new models that contain neon bulbs and tuning eye tubes as audio level indicators have appeared in recent issues of RR.

To complete the level indicator family a meter type, employed by Presto in the model K, is shown.

A 6F5 and 6FS5 are found in the first audio stages, a 6N7 phase inverter feeding the push-pull 45 stage. The output transformer has a low impedance winding to feed a magnetic cutting head. A copper oxide rectifier

and a milliammeter are connected across this winding to show the audio voltage developed across the cutting head, the series resistor acting as a multiplier.

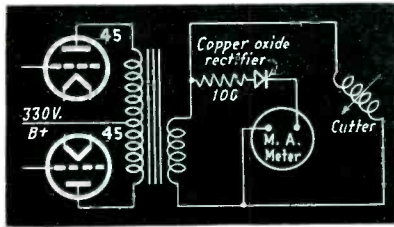

While recording the meter needle should kick about half scale for proper operation. A jack is also provided for monitoring with headphones across this winding. Since the phones will present a very high impedance ratio they will not affect the cutting head circuit and will operate at low volume for comfortable monitoring. When the speaker voice coil is connected across the winding the level meter is disconnected by a switch.

Parallel Resistance Percentage

by Earle Travis

Servicemen often have occasion to parallel resistors to obtain certain re-

Oxford

The Finest in Small Speakers

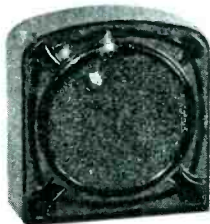

Model 3ZM-CA List 3.50

3" Permagan Cabinet

Oxford's newest cabinet model 3ZM-CA in attractive bakelite cabinet measures only 4" x 4" x 1 7/8". Excellent response makes this unit ideal for extension speaker.

IDEAL FOR INTERCOM.

This 3" unit is also available under Model 3ZM-CM with special "MIKE" transformer for simple intercom. systems. List 4.50.

See your jobber for complete OXFORD Literature



quired values but are quite often more interested in the percentage decrease in resistance of a circuit rather than its actual joint resistance value. This has necessitated finding the actual resultant value, subtracting this from the present value and then dividing to find the percentage of decrease.

This curve short circuits the paper work, shows quickly the percentage decrease in value of a parallel combination of resistors or a series combination of condensers.

To use, simply divide the value of the present resistor by the value of the proposed shunting resistance. Call this K, find it in the K column and proceed horizontally until you strike

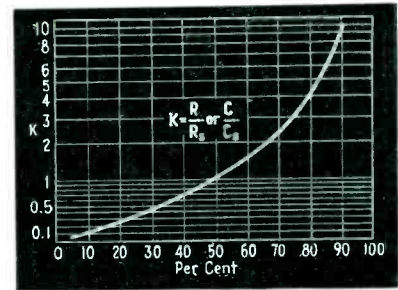

the curve, drop vertically and read the percentage.

If you already know the percentage decrease your circuit will permit use the chart backwards and find K. Divide present resistance by K to

THE FIRST REAL MOVE TOWARD VOLUME CONTROL STANDARDIZATION

The Control You Need... When You Need It!

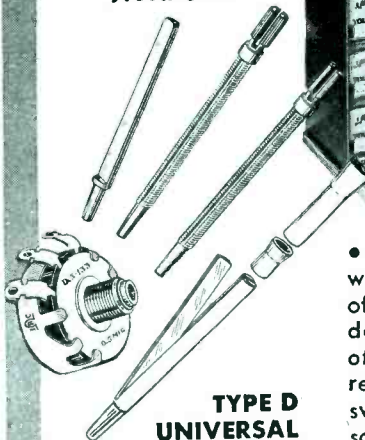

TYPE D UNIVERSAL CONTROLS

Small enough to fit almost anywhere — large enough for real dependability. Type D's have every construction feature of the larger IRC Type CS Controls PLUS the added advantage of Tap-in Shafts which make them practically universal in application. Just select the needed control, tap in the proper shaft and the job is done — easier, quicker and with the same assurance of quality performance.

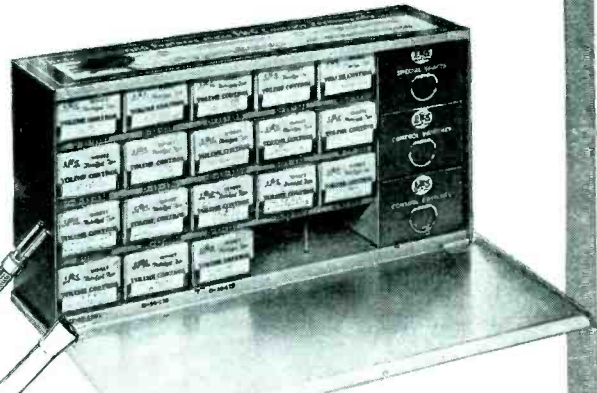

- These 18 IRC Type D Universal Controls with 6 switches and 5 extra tap-in shafts of special design equip you for quick, dependable service on from 60% to 75% of all replacements!
- You pay only the regular net price, \$14.97, for the controls, switches and shafts!
- You get the handsome IRC All-Metal Cabinet complete with cover, at not one cent of extra cost!
- You have the controls you need when you need them—and the Cabinet makes it easy to keep your stock always complete!

... That, in brief, is the story behind this latest IRC development—one that makes it possible to handle the big majority of service calls from a small stock of controls at an absolute minimum investment. You save time—you speed up work—you frequently avoid the need for more costly specials—you give your customers the utmost in volume control dependability. See this Cabinet at your jobber's, or write for details.

INTERNATIONAL RESISTANCE CO.

401 North Broad Street, Philadelphia, Penna.



L-C CHECKER

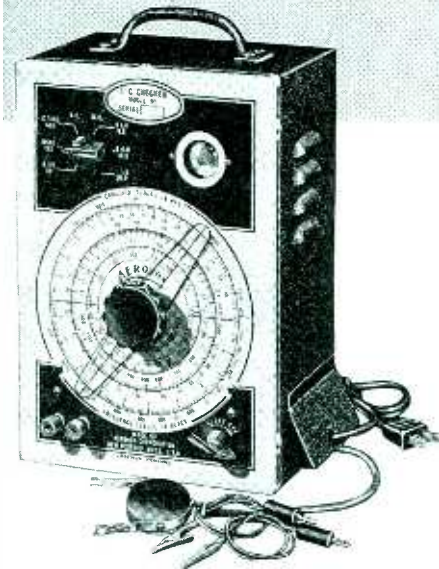

● More than ever before, this is the "must" instrument for the serious radio worker. Since its introduction a year ago as a handy and versatile means of checking condensers in their own circuits and under operating conditions, this instrument has found many further uses in checking inductances, circuits, antenna systems, oscillators, etc. For example:

Some more uses . . .

- Aids preliminary tuning of transmitters and receivers.
- Serves in neutralization of transmitters.
- Measures L to C ratio of transmitting and receiving tuned circuits.
- Determines standing waves along transmission line.
- Determines natural period of transmission lines and antennae.
- Checks activity of quartz crystals.
- Checks frequency of r.f. amplifiers, r.f. chokes and transmission circuits.
- Checks FM of i.f. transformers and alignment of FM of i.f. channels.
- Measures inductances and capacitance; distributed capacity of inductances; checks effective capacity of condensers, etc. etc.
- Yet it costs but \$29.50 net, including tubes!

Ask to See It . . .

- Local jobber can show you the L-C Checker. Examine it. Try it. Get one for your radio work—or write us direct for literature.



obtain the value of the shunting resistor needed.

The same procedure may be followed in finding the percentage decrease in capacity for series condenser operation. To avoid juggling the decimal point of small capacities figuring may be done in terms of micro-microfarads.

Gimmie

One large manufacturer has incorporated a little known part in recent radio receiver models. Similar devices have been, and are at present, employed by other manufacturers but no formal appellation has been brought forth until this date.

Fundamentally a capacitance unit, its schematic designation has temporarily misled service engineers into visualization of its properties as being inherently of an inductive nature but recent research along this line of thought has proven otherwise.

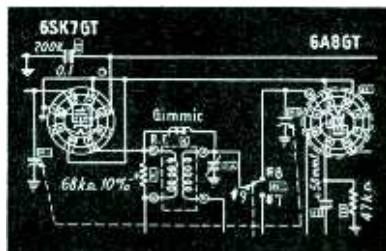

As shown in diagram the most important function to be attributed to it is the transfer of radio frequency but conventional design of capacitances of the particular range of value at which it operates most efficiently may often result in very critical details of construction.

The peculiar mechanical design of the newly named device permits rapid and efficient construction by even the layman, and this, as well as the resistance to breakdown encountered, leads us to believe that this new part will not soon appear on the replacement parts market.

Audio Frequency

TINY TUBE TAPPER

Cork and half inch wide rubber tubing . . . push cork into 3 or 4 inch length of tubing, even with end. Slip over blade of screwdriver, "poke" away safely at small tubes and parts when hunting that noise bug. Leave on screwdriver for protection when carried in pocket.

Getting your RADIO OPERATOR'S LICENSE

made easier

—if you prepare for exams this direct, tested way

Bring all your radio training, experience, and study before you in quick, direct review—make sure you know key points of all theory and practice as covered in the new style Government examinations. Nearly 1300 questions, with full, correct answers, given in this book, make you confidently familiar with the essentials of all commercial license tests.



Just Out

RADIO OPERATING QUESTIONS AND ANSWERS

By A. R. Nilson

Chief Instructor, Nilson Radio School;
Lieut. (Technician) (Communications)
U.S.N.R. (Retired)

and J. L. Hornung

Formerly Radio Instructor, N. Y. U.

Seventh Edition

415 pages, 5 x 7 1/2, 87 illustrations, \$2.50

This book gives an answer to every question in the FCC Study Guide and Reference Material for Commercial Radio Operator License Examinations. Here is a wealth of concise information on radio communication—theory, apparatus, circuits, laws and regulations, etc.—classified exactly as in the six elements on which all professional radio operator license examinations now are based.

1. Questions on Basic Law
2. Basic Theory and Practice
3. Radiotelephony
4. Advanced Radiotelephony
5. Radiotelegraphy
6. Advanced Radiotelegraphy

Appendix of operating abbreviations, rules governing commercial operators, and radio laws.

For twenty years thousands of men have used previous editions of this book with success. Now more than ever this seventh edition helps you get a quick command of all the information needed to pass tests.

10 DAYS' FREE EXAMINATION

MAIL THIS COUPON TODAY

McGRAW-HILL BOOK CO., INC.
330 W. 42 St., N. Y.

Send me Nilson and Hornung—Radio Operating Questions and Answers for 10 days' examination on approval. In 10 days I will send \$2.50 plus few cents postage or return book postpaid. (Postage paid on orders accompanied by remittance.)

Name

Address

City and State

Position

Company

(Books sent on approval in U. S. and Canada only.)

transformers is employed in the RCA set, also found in Emerson. Flash-light cells for A power are common practice unless otherwise noted.

Sonora provide jacks for head-phone operation, when the phone tips are inserted the speaker voice coil is disconnected for private reception. The capacity of the dead end coil in the oscillator circuit is employed as the grid condenser, used so frequently in the larger ac sets today. Three flash cells provide about 25 hours of operation in this model and 50 hours of B service can be expected from the 45 volt battery.

Single Flash Cell

A 45 volt B battery is also employed by Automatic, filament power supplied by a single flash cell that may be quickly changed through a hole in the back cover.

Majestic eliminate one tube by the use of the type 1D8GT, which performs the functions of second detector, avc, audio-driver and power output-stage. A coupling coil is incorporated in the loop for connection of an external antenna and ground.

Strap type loops do not compose the main tuning inductance since body movement would detune the first detector stage. Philco isolates the antenna loop from the tuned circuit, use a coil to couple loop and first detector. Emerson connect the loop in the low r-f side of the tuned circuit. Since the major portion of the inductance is composed of L1, this minimizes detuning effect of wearer.

Replacement

Parts when replaced need to be placed in the same positions they originally occupied. Changes in mechanical sizes or location of lead wires may alter circuit capacities enough to affect the original alignment adjustments.

In view of the low power supplies and necessarily limited antenna pickup all possible gain needs to be utilized and realignment would be advisable after completion of part replacements.

Batteries

Because the flash cells need replacement more often than the B battery be sure to try new A batteries before replacing the B block. It is well to advise customer to remove batteries when set is not to be used for a long period of time and thus avoid damage to the case by swelling of the battery.

Customers who attempt to replace the batteries have managed to break the leads and injure parts so servicemen would do well to carefully inspect these sets for broken components when brought in for repair. Corroded parts may also be found.

OHMITE Ohm's Law Calculator

Solves any Ohm's Law Problem with one setting of the slide

Here's the handiest Ohm's Law Calculator you've ever seen! Specially designed for you by Ohmite Engineers. Gives the answer to any Ohm's Law problem in a jiffy, with one setting of the slide. No decimal points to worry about because all values are direct reading. Simple as can be. Does not require any knowledge of a slide rule to operate. Nothing else like it. Smaller than

any such calculator ever available. Size 4 1/4" x 9". Covers the range from .1 ohm to 10 megohms, also the range of currents, wattages and voltages commonly used in radio and commercial work. A setting of the slide also tells the stock number of resistor or rheostat you may need. Available to you for only 10¢ to cover handling cost. At your Jobber, or send 10¢ in coin now.

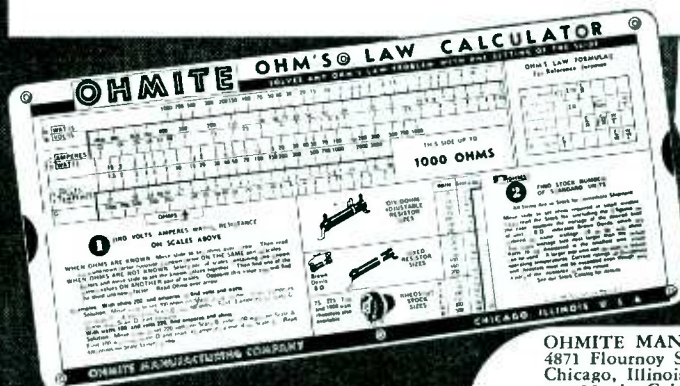

It's
NEW

It's
Complete

Be Right with OHMITE
RESISTORS - RESISTOR TAP SWITCHES

OHMITE MANUFACTURING CO.
4871 Flournoy Street
Chicago, Illinois
10¢ in Coin enclosed. Send
Ohm's Law Calculator.

Name
Address
City State
Radio Ret.-Oct

Simplest

WAY TO REPLACE BALLASTS

- 4 STANDARD TYPES of Amperite Regulators replace over 200 types of AC-DC Ballast Tubes now in use.
- Not to be confused with ordinary dropping resistors. Amperite actually regulates.
- Amperite Regulators are equipped with a patented Automatic Starting Resistor which prevents initial surge and saves pilot lights.
- Amperite AC-DC Regulators; List \$1.00. Amperite Replacements for 2V Battery Set ballasts List \$1.25

WRITE FOR REPLACEMENT CHART "S"

AMPERITE Co. 561 Broadway, N. Y. C.

AMPERITE



• The combination of high tensile strength that assures a lasting bond, and faster, cleaner work made possible by quick-acting flux of pure water-white rosin, has given Gardiner Rosin-Core Solders an outstanding reputation for efficiency and economy on radio work by expert or amateur. Yet, due to modern production methods and big sales, Gardiner Solders cost less than even ordinary kinds. Made in various alloys and core sizes . . . and in gauges as small as 1/32 of an inch . . . in 1, 5 and 20-lb. spools.



4808 S. Campbell Ave. Chicago, Ill.

**WE HAVE FOUND *RCP*
TEST EQUIPMENT INDISPENSABLE
IN OUR TRAINING PROGRAM!**

"We have been using various test equipment manufactured by your company over a period of many months," writes Radio-Television Institute of New York. "Its durability, flexibility, and all-around utility makes it indispensable in our training program."

You will find that among test equipment users who make it a point to check the entire field carefully before purchasing, there RCP Test Equipment is usually in service, rendering consistently *dependable* performance. Naturally, there is more profit for you in the test equipment experts select.

Model 309SC TUBE TESTER

*Test all new
miniature tubes*

Tests all tubes—old and new—miniature, ballast, and tubes with filament voltages up to full line. Indicates noisy tubes and hot interelement shorts and leakage between all individual elements. Spare socket provision for future base arrangements. Individual tests of each section of all-multi-purpose tubes. Continuously variable adjustment for all line voltages from 105 to 135. Simple and speedy to operate. Double fused line — Celluloid tube chart covers. **\$16.95**
Dealer Net Price.....
Combination Portable Counter Model 309SP..... \$18.95



**"25-in-1" RCP Model 446
MULTI-RANGE TESTER**

3 inch square D'Arsonval meter accurate within 2%

- DC voltmeter 0/5/50/250/500/2500
- DC milliammeter 0/1/10/100/1000
- DC ammeter 0/10
- AC voltmeter 0/10/100/500/1000
- 3 range ohmmeter 0/500/100,000/1 Meg.
- Meter sensitivity 1 Milliamper or 1000 ohms per volt.

It's the equivalent of 25 complete instruments. In a class with testers selling for twice the low RCP price. Selector switch operated, complete with batteries. Dealer Net Price. **\$9.95**



Model 702

SIGNAL GENERATOR

Capable of even finer performance than RCP's famous former signal generator. Has all latest improvements in circuit and mechanical design. Extremely wide all wave coverage continuously variable from 95 Kilocycles to 100 Megacycles. Sine-wave, 30% modulation at 400 cycles, from self-contained independent 400 cycle circuit. Attenuation of 500,000 to 1 in approximate microvolts by means of five step ladder attenuator. Dealer Net Price. **\$22.95**



Right now write *for catalog No. 124. Discover the profit-possibilities in RCP's complete line of dependable Test Equipment for every need and every purse.*

**RADIO CITY PRODUCTS COMPANY, INC.
88 PARK PLACE NEW YORK, N. Y.**

RCP
**dependable
TEST
instruments**

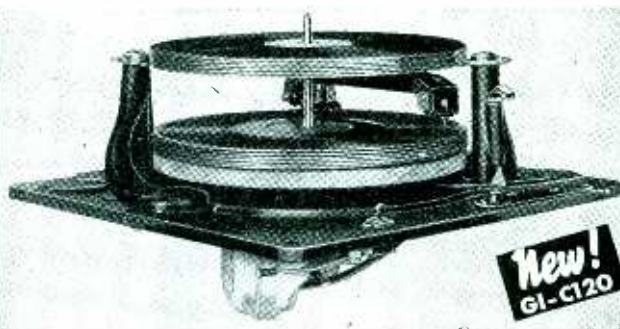

**New!
GI-C120**

**New Easy-Playing
Changers Sell Sets**

MORE and more sales of automatic combinations and record changer installation jobs begin with demonstrations of the new, simplified, easy-to-operate GI-C-120 Record Changer. Customers like its *one-lever* adjustment for changing from one size record to another and for manual playing. They like its streamlined, extra-smart appearance, too.

Built for convenience and for highly satisfactory playing under all conditions. Made by the world's largest phonograph motor manufacturer. Delivered ready to install. Order today, for testing.

The GENERAL INDUSTRIES CO.
Dept. 437 Elyria, Ohio



**MAKE POLITICAL CAMPAIGNS
PAY YOU A PROFIT!**



**RENT OR SELL BELL
COMBINATION
MOBILE SYSTEMS**

This portable, high-fidelity 15-watt amplifier and phono unit operates on 6 volt D. C. or 110 volt A. C. current. Can be used anywhere! It's a favorite of campaigners, speakers and performers! Has two 10" P. M. speakers . . . tone compensator . . . two input channels . . . inverse feedback . . . beam power output tubes! Neat, compact, easy to use and service! **LOW** in cost! And the Bell line includes many other types, sizes and capacities. Get details!

**BELL
SOUND SYSTEMS**

Include a complete line of Public Address Systems for permanent or portable installation; Intercommunication Systems; Sound Recorders; Specialized Equipment. The sound equipment you need—at prices you know are right.

**WRITE FOR
CATALOG**

BELL SOUND SYSTEMS, INC.
1183 Essex Ave., Columbus, Ohio
Export Dept. 5716 Euclid Ave., Cleveland, O.

How RECORD CHANGERS Operate

OPERATING principles of typical mechanisms outlined for servicemen

SERVICEMEN at work require knowledge of both mechanical and electrical features of radio receivers.

The following paragraphs explain features of record changing mechanisms now incorporated by various set manufacturers in automatic combinations and will help in understanding others encountered.

Suspension of the load of records above the turntable is the general practice but dropping them when needed on the turntable is accomplished in several ways.

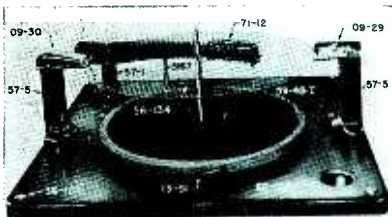

Farnsworth with transparent record

In the photograph on this page a transparent record is shown about to fall in the Farnsworth changer. The posts 57-5 support the shelf mechanisms 09-30 and 09-29. The record load is vertically aligned against the upper portion of 09-29 shelf and rest also on the shelf portion of 09-30.

When the pickup is out beyond the turntable a small rod or "trigger" pushes out of the shelf assembly 09-30 and against the edge of the bottom record. This slides the record horizontally till its edge clears the shelf. The opposite rim of the record has slid into the slot in the shelf assembly 09-29 and the edge of the hole in the center of the record is free to move horizontally since it slides into a cut out portion of the spindle on which the records are stacked.

Release of the one record rim from the shelf 09-30 allows the falling record to follow down the spindle on which the records are stacked.

The changer will accommodate 12 inch records by rotation by hand of the record shelf assemblies to present another shelf surface to the larger diameter. On the new surfaces another trigger in shelf 09-30 and another slot



Top view of Motorola

in shelf 09-29 will operate in the same manner.

For manual operation of single records these shelf assemblies may be rotated outward for direct access to the turntable.

Motorola

The turntable in the Motorola mechanism is keyed to a small drive pulley which in turn drives a large 3 inch pulley through a spring belt, both

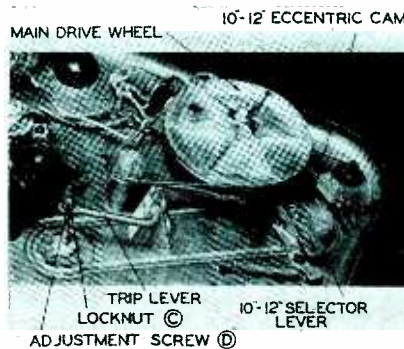

Motorola mechanism underneath

of these units being located on top of the base plate shown in the top view.

The 3 inch pulley transmits power by direct drive to another small pulley located under the mounting plate. This second small pulley in turn drives the large 4 inch main drive wheel also located under the mounting plate.

When the turntable revolves all of these pulleys and wheels also revolve, regardless of whether or not the changer is going through a cycle of changing a record.

When the needle enters the eccentric groove on the record the pickup

oscillates causing the automatic change switch to make contact, energizing a small electromagnet. This pulls an armature back, permitting a drive pawl which is mounted on the cam wheel to fall down and engage in one of the notches on the upper surface of the main drive wheel. Since this wheel is already revolving the engagement of the pawl now causes the cam wheel to revolve with it.

In the first few degrees of revolution it opens a circuit breaker switch,



RCA top view of mechanism

automatically opening the magnet circuit and thus de-energizing it.

Next the pickup elevating pin rides up on an inclined section of the cam, raises pickup from record and swings it out beyond the edge of the record.

The cam wheel continues its revolution and a roller on the end of the trip lever rides up an inclined section. The other end of the trip lever bears against the push rod which operates the record release near the top of the spindle, causes it to push the next record off its support, dropping it to the turntable.

The cam continues to revolve, the



Bottom view of RCA

groove in the top bringing the pickup back over the edge of the record and settling needle on first groove. As the needle touches the record the drive pawl hits the magnet armature which forces it up, disengaging it from the notch in the drive wheel. The cam wheel stops, the turntable continues to revolve and the record is played.

RCA Changer

When the pickup needle on the RCA changer enters the eccentric or spiral groove at the inside of the record the pickup arm swings in the groove and this motion acts through a friction clutch to start the cycle.

The pickup arm is lifted and swung out clear of the records, and the record holder posts start to turn. Each post has a "knife" and a "shelf". The knives enter between the bottom record and the rest of the stack.

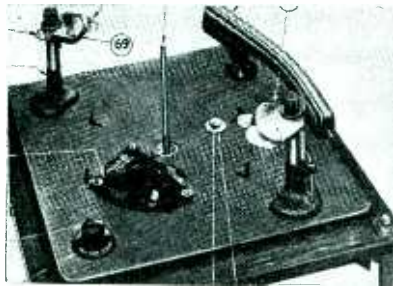

Seeburg with turntable removed

Continuing to turn the shelves move from under the bottom record and it drops on the turntable, while the rest of the stack of records are supported by the knives.

The pickup arm is then moved to position and lowered to the record, while the record-holder posts turn back to their original positions so that the records rest on the shelves and the knives are in position to separate the next record from the stack. The cycle is completed when the pickup arm comes down on the record.

The knife on each record post is raised slightly when a 12-inch record presses down against a ball point screw that projects through a hole in the record holder shelf on each post.

In playing a mixed group of 10 and 12 inch records the index lever is set at 10. When the pickup arm moves out during the cycle of operation the record discriminating lever at left of the rear post is moved to its forward position, toward the spindle, and sets the correct landing position of the pickup needle for a 10 inch record.

If a 12 inch record drops down it pushes the record discriminating lever back and sets the correct landing position for a 12 inch record.

Seeburg

Another mechanism that employs a similar method to separate the records is that used by Seeburg.

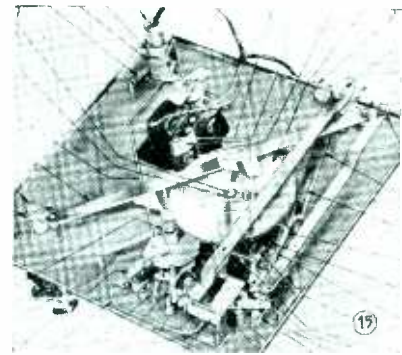

Seeburg underneath view

Selector arms, controlled by lever rods underneath the motor board automatically divide the records, contain flexible fingers which adjust themselves to the record thickness of 10 or 12 inch discs.

The tone arm will move into records without a lead-in groove while the trip feature of the changer mechanism operates on either a closed circle of 3 3/4 inch diameter or an eccentric groove.

Webster

Driven by the cam groove (visible on under side in photo EF) of the cam gear, is the Webster Standard mechanism. As cam lever is forced by the pawl, out underneath the lift, the lift rises and forces the roller

PROFESSIONAL RECORDER

Conceded everywhere as THE professional machine for professional use and results. Undisputed leadership for over 6 yrs. as the standard all-purpose recorder. Time tested all over the world by schools and colleges, stations, recorders and laboratories. Engineered for long and continuous service. Heavy and rugged, weighs approx. 225 lbs., 16 in. turntable, 100% synchronous motor, new full freq. cutting head, patented lead screw, belt drive. A marvel of performance, long life and dependability. At your dealer or jobber.

UNIVERSAL MICROPHONE CO., Ltd.
Inglewood, Calif., U. S. A.

HAVE YOU EVER SEEN ALL THE CLIPS THAT MUELLER OFFERS?

**Special Clips for Every Use
Solid Copper—Insulated Clips**

Send for Free Samples & Catalog 701
MUELLER ELECTRIC CO., 1584 E. 31st, Cleveland, O.

Election Campaign Hits New High—Dealers Clean Up!

with **QUALITY RADIO** Since 1920

Sentinel

COMPLETE LINE . . . BATTERY AND ELECTRIC SETS

Full Merchandising Co-operation

SENTINEL RADIO CORPORATION
Dept. RR-10 2020 Ridge Ave., Evanston, Ill.

At last . . .

An A-B-C BOOK on RADIO with a sound technical background

- NOW you can learn practical radio at home
- Prepare yourself with a good foundation for study of any of radio's specialized branches
- Get a start in the most inexpensive way possible toward a job as radio serviceman, radio operator, or radio or sound technician.
- Here is a book to give you a complete introduction to practical radio — enabling you to handle radio apparatus understandably, construct workable sets, and know the theory needed in following the more advanced literature and specialized training of technical and commercial radio. An amazingly clear, step-by-step treatment, excellently fitted for home-study use.



Watson, Welch and Eby's

UNDERSTANDING RADIO

A Guide to Practical Operation and Theory
601 pages, 5½ x 8, 406 illustrations, \$2.80

THIS book covers the radio field from the very beginning—no previous knowledge of radio or electricity is necessary—and gives you a complete basic understanding of radio receivers and transmitters including the ability to construct and test the various types, and a knowledge of the principles that make each part work and how they work together. Has close likeness to personal instruction, combining instructions, construction, experiments, and explanation of results at every step.

MANY FEATURES

- non-mathematical
- shows how to construct much of your own equipment
- dictionary of technical terms following some chapters, etc.

• Seldom if ever have you seen a book that helps you progress so easily yet thoroughly—developing theory and practice side by side in a way to adequately prepare you for more advanced study.

10 DAYS' FREE EXAMINATION

Mail this coupon today

McGraw-Hill Book Co., Inc., 330 W. 42 St., N. Y.

Send me Watson, Welch and Eby—Understanding Radio for 10 days' examination on approval. In 10 days I will send \$2.80 plus few cents postage or return book postpaid. (Postage paid on orders accompanied by remittance.)

Name

Address

City and State

Position

Company RR 10-40
(Books sent on approval in U. S. and Canada only.)

into the under groove in the cam gear. The motion is transferred to the rear changer shaft at ED through the cam connecting rod EH, thence through the changer connecting rod FG to front changer shaft BB.

As cam lever is forced out, at the beginning of the change cycle, against link FO, it causes the link to push upward on pickup plunger, thus lifting needle from the record.

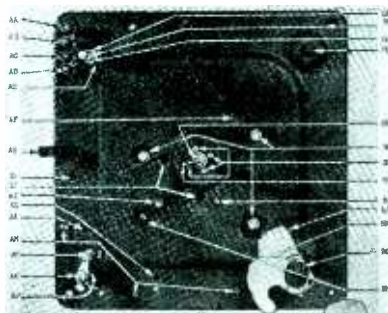

Webster-Chicago top view

The same pressure upon link FO works, through guide arm, to force stud down into the groove on the cam gear. This rotates the pickup arm while the pickup plunger holds it up off the record. It is rotated out beyond the turntable until selector plates BK have dropped the next record, then rotated back to proper position to start playing.

Record Starting

Travel of pickup arm toward record pin is stopped by action of the lever hub. Stopping takes place as lug on the lever hub strikes the shoulder on rod FP. This enables the entire mechanism rotated by cam action on guide arm to travel on past the proper point of rotation for record starting, while the pickup arm itself, which is held rigid to lever hub, is accurately stopped at proper record starting point.

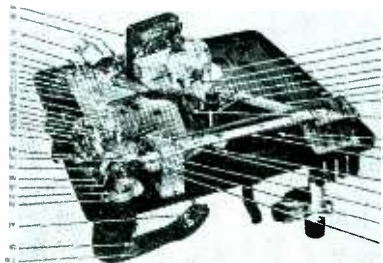

Webster-Chicago bottom view

If needle comes down on the sound track insert screwdriver through hole AH. Turn screw on needle adjusting cam FM very slightly counter-clockwise. If needle comes down out beyond edge of record turn screw clockwise.

FREE! Turner Mike Catalog—Showing Way to New Sales and Profits

Including such favorites as

Turner 99 Dynamic

The toughest, most reliable and efficient mike in the entire Turner line, and the first choice for professionals who insist on the most for their money. This unit was chosen official microphone for WUSA, California Exposition. The \$29.50 List price is right, and discounts assure real profits on a mike with no returned-goods headaches. It's only one of the many mikes in the new Turner Mike Catalog. Send for yours today! The sure way to cash in!



22X Crystal Moves Right Out!

It's got eye appeal, and price appeal! Full tilting head, removable cable set, rich brushed chrome finish, rugged and fully protected. Priced to sell on sight, and engineered to stay sold!

Send Today for Your Free Microphone Catalog

The TURNER Co.

915 17th St. NE., Cedar Rapids, Iowa

Crystals Licensed under Patents of The Brush Development Co.



GREENOHMS for that extra OVERLOAD FACTOR

200-watt adjustable Greenohm. Note clean-cut construction.



Wire-wound. Unique cold-setting inorganic cement coating.

Wire unimpaired in production. No corrosion. No weakening.

Maximum heat conduction and radiation.

10, 25, 50, 80, 100 and 200 watt ratings. Fixed and adjustable.

★ Inorganic cement coating. You can spot them in better-grade amplifiers, transmitters, oscillographs and other assemblies that must stand up. ★ Ask for Greenohms. ★ Or write for latest data to Clarostat Mfg. Co., Inc., Dept. RR, 285-7 N. 6th St., Brooklyn, N. Y.



Do you Know How to Record a Violin?

This FREE 16 Page Booklet



PERMO POINT TELLS HOW!

The makers of FIDELITONE—the world's finest phonograph need e—have just released a booklet full of engineering facts and instructions on home recording. A copy is yours for the asking from your Radio Parts Jobber, music store—or send the coupon.

Fidelitone
PERMO RECORDING STYLUS FIDELITONE REPRODUCING NEEDLE

Will cut more than 200 enamel discs! Will play more than 4,000 home recording discs!

PERMO PRODUCTS CORPORATION
6417 Reynolds Ave., Chicago, Ill.
Please RU* Home a FREE copy of "Permo Printers or Better Recordings."

Name _____
Address _____
City _____ State _____

SEARCHLIGHT SECTION

Address copy to the
Departmental Advertising Staff

Radio and Television Retailing
330 West 42nd St., New York City

REPRESENTATIVE AVAILABLE

Manufacturers' representative in Brazil is open to represent manufacturers of radio material and broadcast supplies of all kinds. Pan Americana De Representacoes, Rua Araujo Porto Alegre, 70, Rio de Janeiro, Brazil.

TRICKS of the TRADE

PHILCO 54

Weak . . . check volume control for change in resistance.

Intermittent oscillation . . . check condenser pack, number 7 in schematic, for partial open.

PHILCO 37-610

Crackles at low volume . . . connect a .001 mfd condenser from arm of volume control to ground.

PHILCO 507

Fades after several minutes of playing . . . check .09 mfd condenser in series with one meg resistor from grid of 75 tube for partial open. Condenser is moulded in bakelite case and few sharp taps may be necessary to show defect when chassis is out of cabinet.

RCA 62

Intermittent . . . i-f transformer opens. Defective one can be removed by taking complete tuning gang off chassis and releasing lugs on i-f can. Realignment of i-f stages must be done while gang is removed. Temporary leads from condenser gang to set may be used for operation of r-f, oscillator and first detector stages before re-assembly.

**RCA 125 and 225
GE M62 and M655**

Improve selectivity and sensitivity . . . replace untuned third i-f transformer with standard tuned output transformer. Mount vertically inside chassis in place of old unit or horizontally on back flange of chassis. No trouble should be experienced from oscillation.

SILVERTONE 126209, 126211

Intermittent, noisy . . . unsolder coil ends of antenna and oscillator coils, scrape off enamel insulation and resolder.

SILVERTONE 126211

Intermittent . . . anchor securely coupling condenser C29, .25 mfd in speaker compartment. Leads snap from vibration.

STROMBERG CARLSON 260L

Intermittent cutout . . . plate winding of second i-f transformer, number P27915, grounds and opens plate winding. When testing with voltage removed, ground clears and coil heals. Replace transformer.

ZENITH 6MN495 (40 Nash Special)

Low volume, no sensitivity . . . check trimmers in second i-f transformer for short to mounting.

RECORD RETAILING

(Continued from page 31)

and development of new buyers. dealers must know the proper pronunciations of names of compositions, composers, conductors, artists and musical terms; also the meaning of the titles and terms. This information can be obtained from musical dictionaries and beginners books sold by most specialty bookshops and available at public libraries. Close attention to the remarks of commentators and announcers on Symphonic and Operatic radio programs will help you perfect your pronunciation and give you much other valuable information.

Manufacturers' literature including catalogs, and especially the leaflets in album sets, constitute another rich information source. Music appreciation courses are available through some YMCA branches, high schools, and colleges, and one manufacturer has a periodic course of instruction for dealers, but these courses are available in comparatively few communities, therefore most dealers will have to educate themselves.

Hillbilly

Hillbilly records include "hoe-down" singing, country dance tunes, oldtime dance, and some semi-religious items.

Recently some popular novelty and Hit Parade numbers by Hillbilly Bands have sold well. Much of this talent is broadcast on the networks and should be followed closely. However, as there are wide sectional differences in the popularity of tunes and talent the record broadcasts of local stations should be tuned in to determine the preferences in specific localities as such programs are invariably based on listeners' requests.

Coin machines are a growing factor in this field also, therefore, cooperation with local operators should prove mutually beneficial.

Sacred

Sacred records include hymns, some semi-religious songs, and Negro Spirituals, although many of these are also listed as Race music. Many of the items on the Sacred

list are every-day music in thousands of rural homes, therefore this is an important field for record dealers in such areas.

As popularity is variable in different sections, the local broadcasts are the best source of guidance.

Race

Race records are sold largely to the colored trade, include "low-down blues" of the Deep-South type, and certain more humorous than religious "spirituals."

Hot Harlem records don't come under this heading. Kansas City or "Boogie-Woogie" style recordings originally fell into the group, but this style has been modernized and most of the recent recordings are listed with popular records.

Coin machine operators with colored locations are the most reliable source of information on local preferences.

Foreign

Foreign records are sold mainly in foreign-language communities. Dealers in such sections are usually familiar with the items that sell, since they are mostly the old-folk

melodies.

Recent recordings have been pepped up with modernized treatment and in some languages there are recordings of songs currently popular in foreign lands. Foreign-language broadcasts which abound in these localities, are naturally based on popular requests, consequently offer the easiest method of checking regional tastes.

PERIOD CABINETS

(Continued from page 25)

a series of fine beads in a vertical position.

Sheraton often used *round hardware* with inlaid designs of flowers and urns.

Holly inlay was frequently used by Sheraton for decorative purposes. Sheraton had a special liking for mahogany and referred to it as the "Royal Wood." Sheraton designs were frail looking because of the slenderness of support. Nevertheless, his pieces were sound and would last as long as massive de-

signs of other cabinet makers. The Sheraton influence is seen in furniture today more than that of any other cabinet maker.

Louis XV

Louis XV furniture was created and flourished between 1715 and 1774.

Life generally was gayer and less serious in those days, and furniture styles accurately reflected this by favoring a curved, feminine style avoiding the straight line effect which was almost entirely eliminated. The commode as shown in illustration #6 is a typical Louis XV design.

The exclusive use of the *cabriole leg* and *scroll foot* characterize Louis XV furniture.

Curved drawers called "serpentine," which are concaved and convexed, also typify Louis XV design.

Inlays of rare woods were generally used on Louis XV furniture. Some of the woods used were East India Rosewood, Thuya Burl from Algeria and highly figured walnut. Gilding was used extensively. *Wreath ornaments* were widely used.



Remember—University has pioneered in the design and construction of Reflex Loudspeakers of High Power and Efficiency for many years.

Remember—University's intensive specialization in the field of high efficiency loudspeakers means dollars and cents in continued customer satisfactions.

GUARANTEED THREE WAYS

1. Guaranteed breakdown proof.
2. Guaranteed to give customer satisfaction.
3. Guaranteed to live up to University high standards of performance.

FOR ALL HIGH POWER PUBLIC ADDRESS INSTALLATIONS

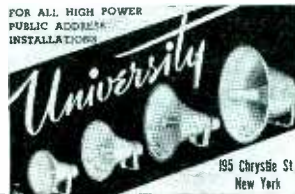

195 Chrysler St New York

RECOTON

SUPERIOR

cutting needles

insure better record performance

Give at least 10 perfect plays per needle. Made with special shaft and rounded point for hi-fidelity performance with minimum surface noise. Fine, distortionless tone. Write for literature.

RECOTON Corp., 178 Prince St., New York, N. Y.



Ken-Rad has been making radio tubes since the beginning of broadcasting. Every year more dealers find it advantageous to sell Ken-Rad Dependable Radio Tubes.

Ken-Rad Tube & Lamp Corp.
Owensboro, Ky.

INDEX TO ADVERTISERS October, 1940

	Page
Aerovox Corp.	58
Alliance Mfg. Co.	56
Amperite Corp.	61
Bell Sound Systems, Inc.	62
Brach Mfg. Co., L. S.	60
Centralab Div. Globe Union, Inc.	8
Clarostat Mfg. Co., Inc.	65
Columbia Recording Corp.	30
Decca Records, Inc.	47
Emerson Radio & Phonograph Corp.	3
Farnsworth Television & Radio Corp.	4
Galvin Mfg. Corp.	Back Cover
Gardiner Metal Co.	61
General Industries Co., The	62
Greenlee Tool Co.	60
Hygrade-Sylvania Corp.	10
International Resistance Corp.	57
Jensen Radio Mfg. Co.	11
Ken-Rad Tube & Lamp Corp.	67
Magnavox Co., Ltd.	40
Mallory & Co., Inc., P. R.	Inside Front Cover, Insert 2, 3
McGraw-Hill Book Co., Inc.	58, 65
Meissner Mfg. Co.	43
Mueller Electric Co.	64
National Union Radio Corp.	37
Ohmite Mfg. Co.	61
Oxford-Tartak Radio Corp.	57
Permo Products Co.	66
Pfanstiehl Chemical Co.	55
Philco Radio & Television Corp.	34, 35
Pioneer Gen-E-Motor Corp.	55
Presto Recording Corp.	48
Radiart Corp.	50
Radio City Products Co.	62
Radio Corp. of America	12
Raytheon Production Corp.	5
RCA Manufacturing Co.	7, 50
Readrite Meter Works	54
Recoton Corp.	67
Rider Publisher Inc., John F.	46
Rock-Ola Mfg. Corp.	9
Seeburg Corp., J. P.	Inside Back Cover
Sentinel Radio Corp.	64
Setchell Carlson, Inc.	41
Simpson Electric Co.	51
Sterling Mfg. Co.	50
Stromberg-Carlson Telephone Mfg. Co.	2
Supreme Instruments Corp.	49
Transformer Corp. of America	49
Triplett Electrical Instrument Co.	13
Turner Co., The	65
Universal Microphone Co., Ltd.	64
University Laboratories	67
Utah Radio Products Co.	6
Webster-Chicago, Inc.	55
Webster Electric Co.	42
Westinghouse Electric Supply Co.	14
Weston Electrical Instrument Corp.	52
Wilcox-Gay Corp.	67

Although Radio & Television Retailing takes every precaution to insure accuracy, we cannot assume responsibility for an occasional change or omission in the above index.

McGraw-Hill Publishing Company, Inc.
Publication Office: 99-129 North Broadway, Albany, N. Y. Editorial and Executive Offices: 330 West 42nd Street, New York, N. Y.



More About Discount Houses

An apology for not writing sooner commending your article on the discount racket. Any move toward helping this condition should receive hearty support from legitimate retailers. Criticism, in fact anything less than enthusiastic support, from anyone other than the offenders themselves, is deplorable.

Any retailer who operated a setup of normal sales, service and display facilities should be overjoyed at the appearance of this move in the right direction. So, we hasten to add our applause with the hope that the good work may be continued to the ultimate benefit of the retail trade.

Perhaps the word "upstairs" was mischosen, because in this vicinity the worst offenders are large electrical supply houses who easily handle tremendous in-the-carton turnover as a mere sideline. Volume-mad distributors love these outfits, even handling their service for them! Yet, these same distributors keep yelling for retail dealer "cooperation" and "representation" of their merchandise with large floor stocks and sales promotion. And the distributors themselves don't miss a chance to sell a single unit at *top discount* to the individual who flourishes an order "from his firm."

The individual would be just as satisfied with less discount, but as a result of top discount sales, the impression among the general public has come to be that if 40 per cent and more is wide open to them, the retailer's profit must be enormous. This makes for close and unprofitable bargaining when the retailer does get a prospect. For instance, a customer who must buy on time. This customer knows he could get at least 40 per cent off with cash, so the dealer must make 50 and 10 or more.

"Only Suckers Pay Retail Prices." The *retailers* must be the suckers if they are too apathetic to support a movement to improve their own chances for better business!

ARLINGTON, MASS. C. W. FARRINGTON
Farrington Radio Co.

Dealers Will Have To Help

The September issue has just arrived. On page 18 you ask: "*What's Wrong With This Picture?*" In a beautifully furnished home setting, abounding in costly rugs, sofas, couches, tables, curtains, etc. we find a measly table model radio, cost \$10.

What is wrong with it? The manufacturer and only the manufacturer. From the lowest type manufacturer who only makes junk to the top knottchers in the industry there seems to be a race as to who can make the most sets at \$10.

Do we dealers want them? No. Is there a living in selling them? Again, no. Is there any musical value in a little two-

by-two box. No. Then why does the manufacturer insist on loading us up with them?

We have got to have a cleaning up in the radio industry. Who will have the courage to pioneer this cleanup?

WALDEN, N. Y. J. A. A. SOHNS
Sohns Music Shop

The set was too cheap for the room, of course. But we do not think manufacturers alone are responsible for this condition. The depression required some price reducing. And dealers themselves frequently took the easiest way. Sell-up is an all industry job, not one that can be solved by any single branch.

"Sales Static" Blowups

I have a suggestion for the fellows who want "blow ups" of your "Sales Static" cartoons.

Get an album of fairly good quality containing about 15 to 25 pages (post-card albums are good, if they have plain covers) and have the cover lettered by your local sign artist with some title such as "Smile With Us" or, maybe, "Strange, But True", or "Can It be? . . . It is!" Then, each month, paste cartoons on a page, one or two to each page, allowing the book to lay out on the counter where customers usually stand or wait for sets.

It will only be a short time before the truth will sink in, in this way and customers will begin to wonder if they are of the type to whom the cartoons refer. Result, improvement of your clientele.

I know this idea works because I have been using it in my store for several years. I'd be pleased to hear from some other men about results after they try the scheme.

CHICAGO RAY PENTECOST
Metropolitan Radio Service

We've been printing these "Sales Static" cartoons for years but, truthfully, think about them as a means of helping dealers and technicians let off steam. But if we hear about many more readers showing them to consumers with good results we'll even change the style a little to make them more effective in this direction.

Walk In With Watt

I have been a subscriber to *Radio Retailing* for three years or more and in some of your past issues I've read articles on how to increase business by utilizing any pretext to get into homes.

Why not have a serviceman make a house-to-house canvass with a good watt-meter, checking the amount of power drawn by radios and appliances? I think this will surely get men in homes and, at the same time, uncover many items of equipment obviously drawing more power than they would if in good condition and therefore in need of repair or replacement.

Has anyone ever tried this?

JACKSONVILLE, FLA. ANGELO P. BRESCIA

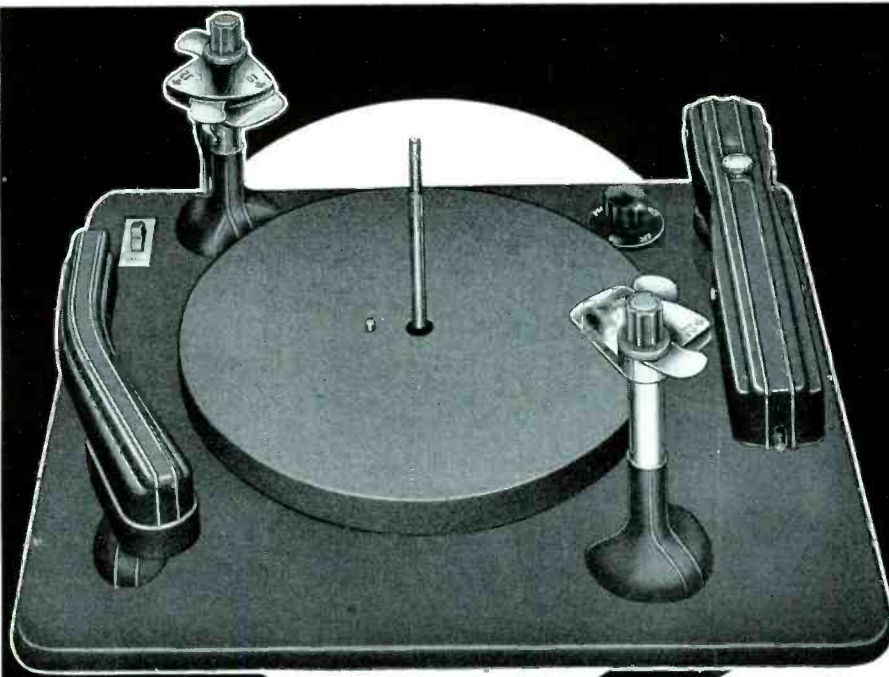

*On their
Merits . . .*
FIRST CHOICE OF
THE NATION'S LEADING
MANUFACTURERS

Record Changers and Recorders

PRECISION MADE BY

Seeburg

SEEBURG RECORD-O-MATIC

It bears the stamp of approval from every leading maker of radio-phonograph combinations, for only Seeburg's exclusive features can give their products the dependable, flawless performance the consumer expects.

Record-O-Matic has the simplest automatic changer mechanism. Handles fourteen 10" or ten 12" records, gravity type. Is compact—14" long, 14" wide, 3" deep. No screws or brackets on top surface. Cutting head assembly contains no steel stampings—all parts cast for rigidity; hardened cone bearings at all essential points; lead screw has support bearings at each end; larger main bearing and ball thrust to carry weighted turntable; 1 3/4 oz. pressure crystal pickup in aluminum tone arm gives long record life; crystal or magnetic

cutting heads; cutter has plunger type, automatic engagement with lead screw; separate switch for manual play-back frees tone arm from automatic mechanism—any size record may be played manually. Additional information on the Record-O-Matic, the Model J Seeburg Automatic Record Changer handling fourteen 10" or ten 12" records and the Model H Changer handling fifteen mixed 10" and 12" records will be sent on request. Seeburg experience and engineering integrity guarantee quality throughout.

FINE MUSICAL INSTRUMENTS SINCE 1902



Seeburg

J. P. SEEBURG CORPORATION 1500 DAYTON STREET CHICAGO

BEST BUYS! IN Motorola



**1941 AUTOMATIC
PHONOGRAPH-RADIOS
and HOME RECORDERS**

MODEL 93FI MIRACLE INSTRUMENT 10 BIG FEATURES

- Makes Records of your Voice or Musical Talent.
- Makes Records of Favorite Radio Programs.
- Makes Records of your Voice blended with the accompanying Music from your Radio.
- Re-records—makes Duplicate Records from your own Records or professional Records.
- Plays professional Records and any Records you make.
- Can be used as a Public Address System.
- Automatically Changes twelve 10" or ten 12" Records.
- 3 Bands—American, Police, Amateur, Aircraft and Foreign Stations.
- 9 Tubes, including Rectifier—Push-Pull—3-Gang Tuning.
- Has Electric "Feather-Touch" 6 Push Button Tuning.

Motorola SUPREME PERFORMANCE is in the HEART OF THE SET

It's the Heart of the Radio . . . the works . . . that delivers supreme radio performance. And Motorola has plenty of "Heart." TONE . . . SENSITIVITY . . . and SELECTIVITY that only 3-gang Tuning can deliver. *Make these 3 Tests Yourself . . . Discover Motorola's Heart!*

- 1** Listen to Motorola's Concert Quality Tone. You'll find a pure, radiant, rich, sweet and full.
- 2** Check Motorola Sensitivity. You'll get many more stations—much greater distance.
- 3** Prove Motorola Razor-Sharp Selectivity. Get the stations you want sharply and clearly—one at a time.

MODEL RWI—PORTABLE RECORDER with EXCLUSIVE RECORD DUPLICATOR and WIRELESS PLAYBACK

Makes Home Recordings and also duplicates records. Plays back home talent and professional records the "Wireless Way" through any Standard Broadcast Radio.

- Crystal Pick-Up and Cutting Head . . . Cuts and Plays up to 12" Records.
- High Quality Crystal Microphone.
- Powerful Constant Speed Rim Drive Turn-Table.
- Uses 5 Radio Tubes—Size 15" wide, 6" high, 10" deep.
- Duplicating Pedestal Included—For Duplicating Any Professional or Home Records.
- Fabric Covered Portable Carrying Case Extra.



Nationally Advertised

FULL-COLOR PAGES IN
SATURDAY EVENING POST AND LIFE
NOW RUNNING

WRITE OR WIRE YOUR DISTRIBUTOR

GALVIN MFG. CORPORATION . . . CHICAGO