

RADIO RETAILING

INCLUDING
SERVICE
AND
INSTALLATION
SECTION

Home Entertainment Merchandising

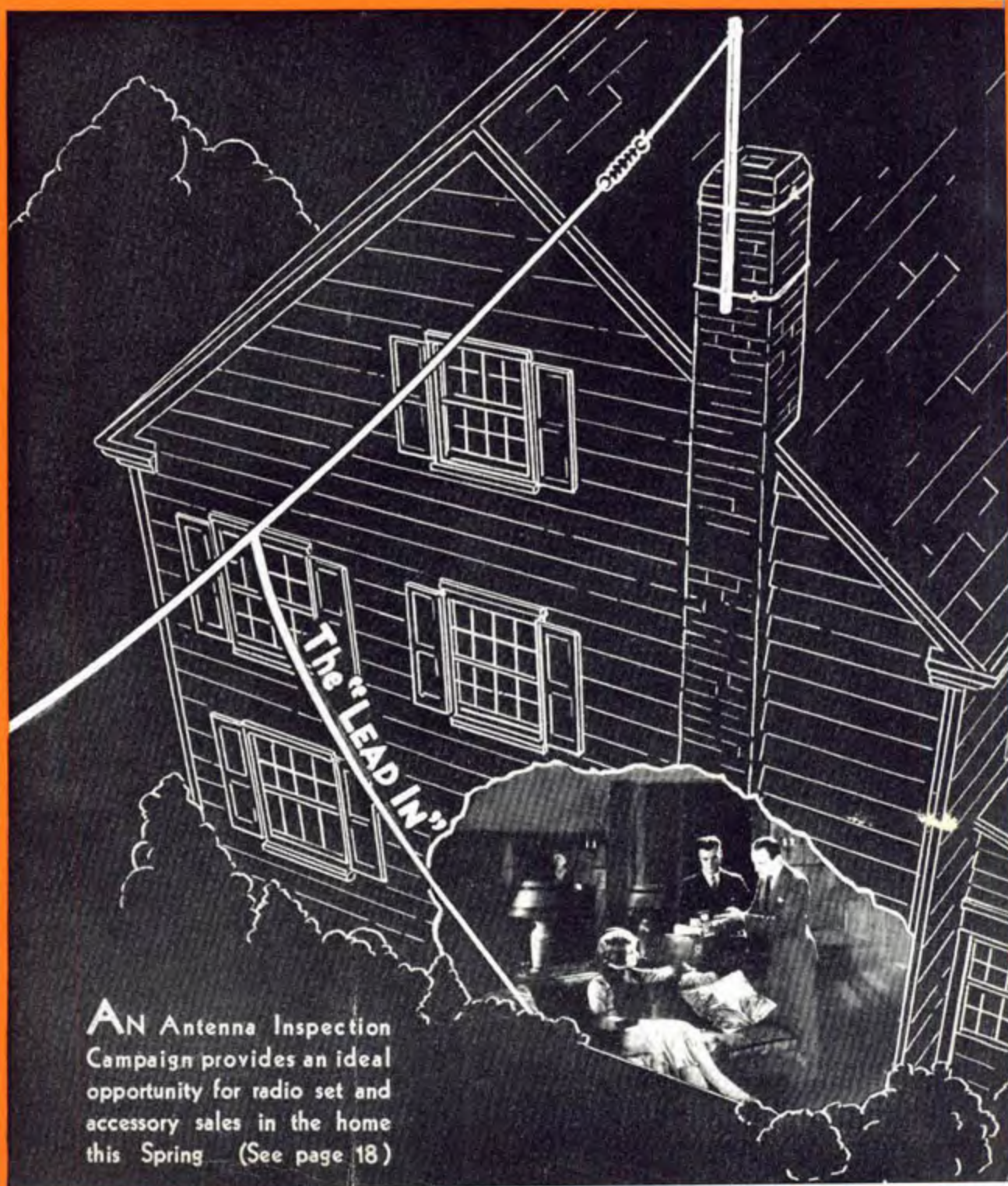

AN Antenna Inspection Campaign provides an ideal opportunity for radio set and accessory sales in the home this Spring (See page 18)



WORTHY

OF THE MASTERS OF MUSIC

PHYSICALLY a radio tube may be just so much glass and metal. But put it in a set . . . set it to work reproducing the music of some famous orchestra . . . and it becomes a fine musical instrument.

Because they know this, the makers of Sylvania Tubes are determined that their product shall be worthy of the masters of music. Sylvania engineers put the same care into the designing, manufacturing, and inspecting of radio tubes that the old craftsmen put into the finishing of a fine violin. Sylvania sells no "seconds". Every tube must be a "first" . . . as good as can be built!



There is a reason why this is so. The Hygrade Sylvania Corporation is and always has been management owned. The men who control its destinies have only one loyalty . . . to the success of their business and of its customers.

When you buy Sylvania Tubes you have the whole-hearted support of the financial, engineering and sales departments of the company. You benefit by continued national advertising, by well-developed circuit design laboratories, by fair price protection policies. Write us. A letter will bring further details. The Hygrade Sylvania Corporation, Sylvania Division, Emporium, Penna.

Sylvania

(Reg. U. S. Pat. Off.)

THE SET-TESTED RADIO TUBE

© 1931, H. S. C.

Radio Retailing, May, 1925. Vol. 17, No. 5. Published monthly. McGraw-Hill Publishing Company, Inc., 320 West Forty-second Street, New York, N. Y. \$2 per year, 25 cents per copy. Central and South American countries, \$2. Foreign, £1, U. S. Currency, or 15 shillings. Canada (including Canadian duty), \$2.50. Entered as second class matter April 19, 1925, at the Post Office at New York, N. Y., under the Act of March 3, 1879. Printed in U. S. A.

THE INTERNATIONAL KADETTE

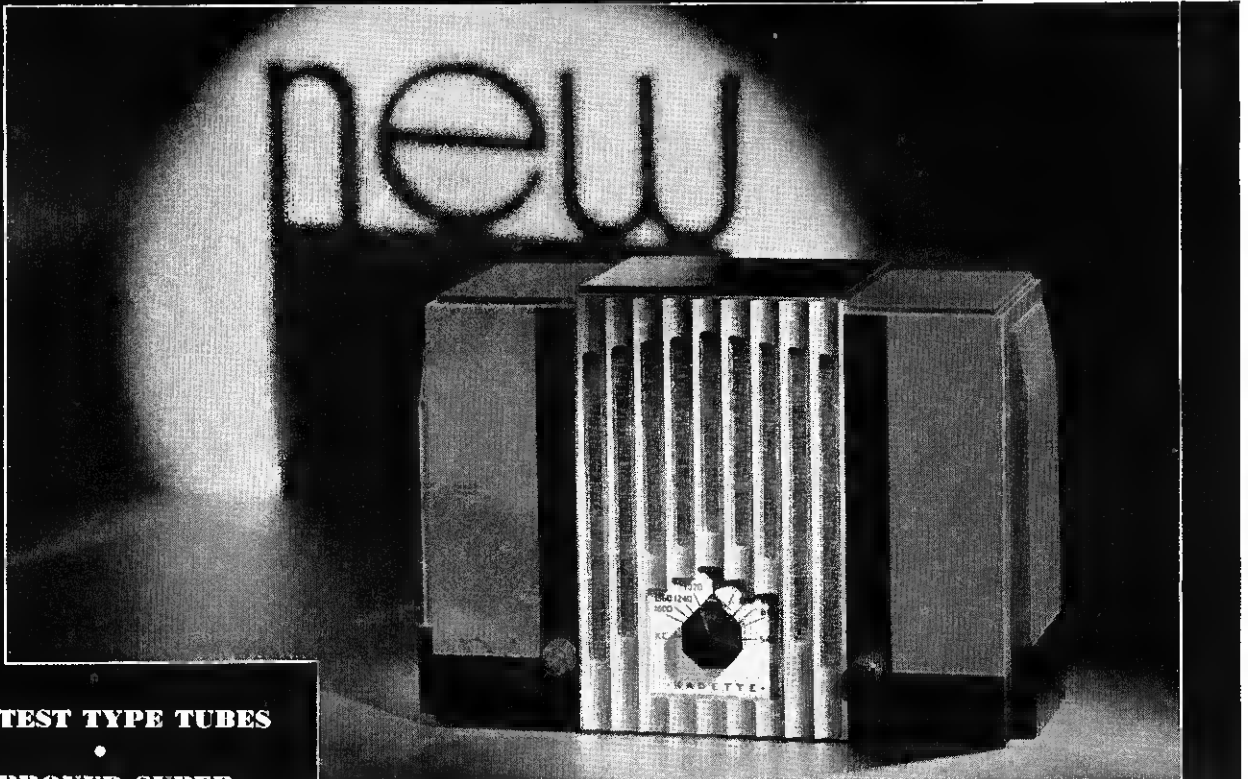

5 LATEST TYPE TUBES

•
**IMPROVED SUPER-
HETERODYNE CIRCUIT**

•
DYNAMIC SPEAKER

•
TONE CONTROL

•
**AUTOMATIC
VOLUME CONTROL**

•
**WORLD'S
SMALLEST CHASSIS**

•
**INCREASED POWER
AND SELECTIVITY**

•
**CALIBRATED IN
KILOCYCLES**

•
**ILLUMINATED
GRILLE AND DIAL**

•
**WEIGHT
LESS THAN 6 POUNDS**

•
**UNIQUE FACTORY
SERVICE POLICY**

TAKES ANOTHER BIG STEP FORWARD

The original Kadette was one of the biggest "hits" the radio industry has known. It galvanized sales. It piled up profits for thousands of dealers. Now, International—always a step ahead—announces its latest achievement. A new model—modern as the next minute—in design, features and performance.

In newness and sheer beauty of design, the new Kadette steps far ahead of traditional ideas. Contrasting planes of color—a fluted grille, finished in satin aluminum—unique illumination for dial and grille (on De Luxe model only)—all express a modern symmetry that establishes a new concept of fine appearance.

Although the Kadette is the world's smallest 5-tube super-heterodyne chassis, sensitivity, selectivity and tone quality have been immeasurably heightened. Operating only on 110 volts A.C. or D.C.—any cycle—the benefits of a.v.c.—tone control and superior quality is achieved.

Dealers—wire for details! Here's another radio sensation—a quality built product for quality minded people.

Originated and Manufactured by
INTERNATIONAL RADIO CORPORATION
ANN ARBOR, MICHIGAN



\$25⁰⁰

**COMPLETE WITH TUBES
DE LUXE MODEL \$2.50 EXTRA**

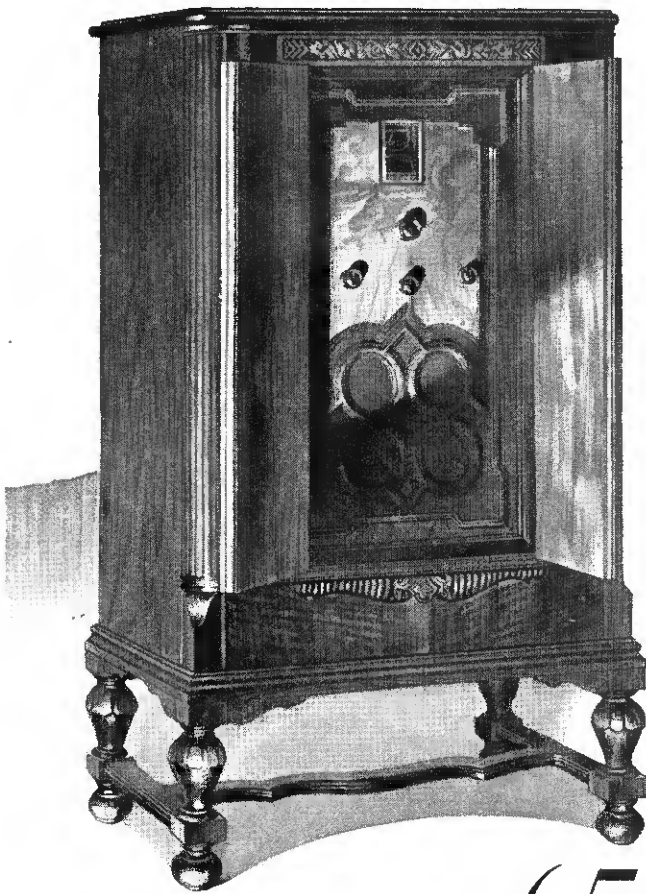

No. 49

**WITH THESE NEWEST
STROMBERG-CARLSONS
YOU CAN DEMONSTRATE—**

1. Faithful reproduction of *fundamental* tones through seven octaves of musical range.
2. A large reserve of distortion-free power for percussion instruments and to meet surges of volume.
3. Every instrument in its proper proportion even at low volume—low tones fully heard at all levels of volume.

*"There is nothing finer than a
Stromberg-Carlson"*

They Sell by
COMPARISON!

65% sales increase in March

A few days after dealers received the first of the new Stromberg-Carlsons congratulations flooded the factory.

And now, March sales figures reveal that the public is enthusiastic. Starting with the first comparative demonstration, sales jumped . . . until at the end of March—usually a month of receding sales—Stromberg-Carlson sales were more than 65% higher than in February.

Only radios with unusual . . . and demonstrable . . . qualities could make such a showing. The new Stromberg-Carlsons have introduced an entirely new quality of radio reception. Using 2 new tubes in a new circuit design these models produce 6 times the undistorted power of any previous Stromberg-Carlson and make possible reproduction of deep bass and high treble fundamental tones as never before.

Any radio dealer will do well to seek the Stromberg-Carlson franchise . . . radios that sell because their superiority is apparent and that yield a sure profit because each unit of sale is large enough to pay expenses and have something left.

Prices of Stromberg-Carlsons range from \$125 to \$567.50 (East of Rockies)

STROMBERG-CARLSON TELEPHONE MFG. CO., ROCHESTER, N. Y.



1894

Stromberg-Carlson



1933

MAKERS OF VOICE TRANSMISSION AND VOICE RECEPTION APPARATUS FOR MORE THAN THIRTY-FIVE YEARS

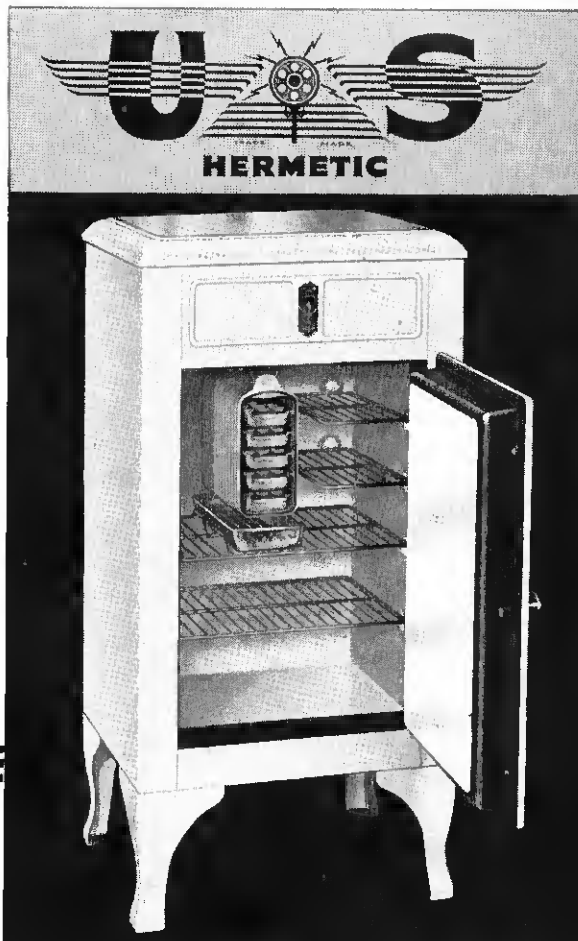

U. S. HERMETIC

represents a basic quality in refrigeration comparable to the value standard in radio which made the U. S. Radio and Television Corporation one of the world's largest builders of receiving sets.

VALUE FEATURES

- Hermetically Sealed**, no couplings, no seals to leak.
- Exclusive Roto-Pulse Unit**, has only three moving parts, requires no oiling.
- 10-Point Cold Control**, enables selection of temperature and freezing speeds.
- Safe-D-Froster**—unit defrosts without loss of refrigeration.
- Porcelain Cooling Unit**, compact, accessible, easy to clean.
- Abundance of Ice Cubes**, from 63 to 126 cubes, depending on model.
- 4-Position Adjustable Door-Handle**; hardware of distinctive design.
- Automatic Dome Light**, operates with opening of door.
- One-Piece Vitreous Porcelain Lining**, rounded corners, moulded shelf supports.
- Automatic Overload Protection** against excessive line voltages.
- Steel Cabinets**; complete welding results in one-piece construction.
- Broom High Legs**; improved appearance and easy cleaning.
- Marine Table Top**, an essential convenience combined with beauty.

Priced
FOR TODAY
Built
FOR THE YEARS

BECAUSE they offer an instantly recognized *extra quality*... more value per dollar; in the accepted range of investment... U. S. Hermetic refrigerators embody the most powerful sales appeal in today's price-conscious market.

And you, Mr. Dealer, whose aim is profit, consider the meaning of that extra value:—*Easier sales*, because the quality is quickly demonstrated... *Profitable sales* because hermetic sealing and the exclusive Roto-Pulse unit, bar all possibility of service "grief"!

Engineered to the finest precision, built to the most exacting standards, thoroughly tested and "run in," permanently oiled, then sealed against the possibility of local service, the Roto-Pulse is assurance to you and your customers of dependable, enduring operation.

Check U. S. Hermetic from every angle—you will be convinced of the *extra value* it embodies. May we give you all the facts? *SEND THE COUPON* or write, now.



SIX MODELS
\$99.50 up F.O.B. MARION, IND.

U. S. RADIO & TELEVISION CORPORATION, MARION, INDIANA
 Gentlemen: Without obligation to me, please send full details regarding the profit opportunity with U. S. Hermetic refrigerators.

Name _____

Street _____

City _____

State _____

More **NEW** THAN EVER

LOOK AT ALL THESE OUTSTANDING FEATURES

- Marvelous New,
Force-Feed, Chilled Oil
Lubrication System**
Stewart-Warner's Latest Development
- Two-Cylinder Compressor**
- Latest Type, Fully Adjust-
able Pull-Out Shelves**
- Newest Type Defroster**
- 12-Point Cold Regulator**
- Enclosed Freezing Unit**
- Plenty of Ice Cubes**
- Double Depth Dessert Tray**
- Automatic Interior Light**
- All Porcelain Interiors**
- New "Protected" Insulation**
Sealed in a Moisture-Proof Container
- New Stream-Line Design**
- Modern Chromium Hardware**
Newest, Semi-Concealed Hinges
Invisible Latch with Finger-Touch Release



STEWART-WARNER

DRAMATIC features OFFERED IN THE INDUSTRY!

Backed by a remarkable "Built-Around-the-Dealer" Sales and Finance Plan that is geared to his actual operating methods

Price attraction—feature attraction—value attraction—a refrigerator that you can sell with real enthusiasm. That's the foundation of Stewart-Warner's Program for 1933.

Then—Discounts based on actual retail operations—carefully figured to leave the dealer a real profit after every item of selling cost has been counted.

Next—a remarkable retail Finance Plan—that lets him take 100% advantage of all time payment sales. That's a real profit-maker, a real life-saver for the dealer in a business where 90% of all sales are made on "easy payments."

—And finally, a complete retail Merchandising and Advertising Plan as used by some of the most successful profit-making retailers of the country.

With this outstanding line, brimming with up-to-the-minute features—offered at a price women are willing to pay—backed by this complete Built-Around-the-Dealer Profit Selling Plan—you can win and win big in 1933. Get the

facts about this superb line which carries the prestige and public acceptance of a nationally known and nationally advertised name.

**100%
STEWART-WARNER
BUILT**

A RED HOT PRICE LEADER IN OUR STANDARD LINE AT **\$8975**

Electric REFRIGERATORS

STEWART-WARNER CORPORATION R.R.-5
1826 Diversey Parkway, Chicago
I'd like to know all about your 1933 Refrigerator Sales "Set-up."

Name
Store
Address
City State

Built for PERFORMANCE COLONIAL

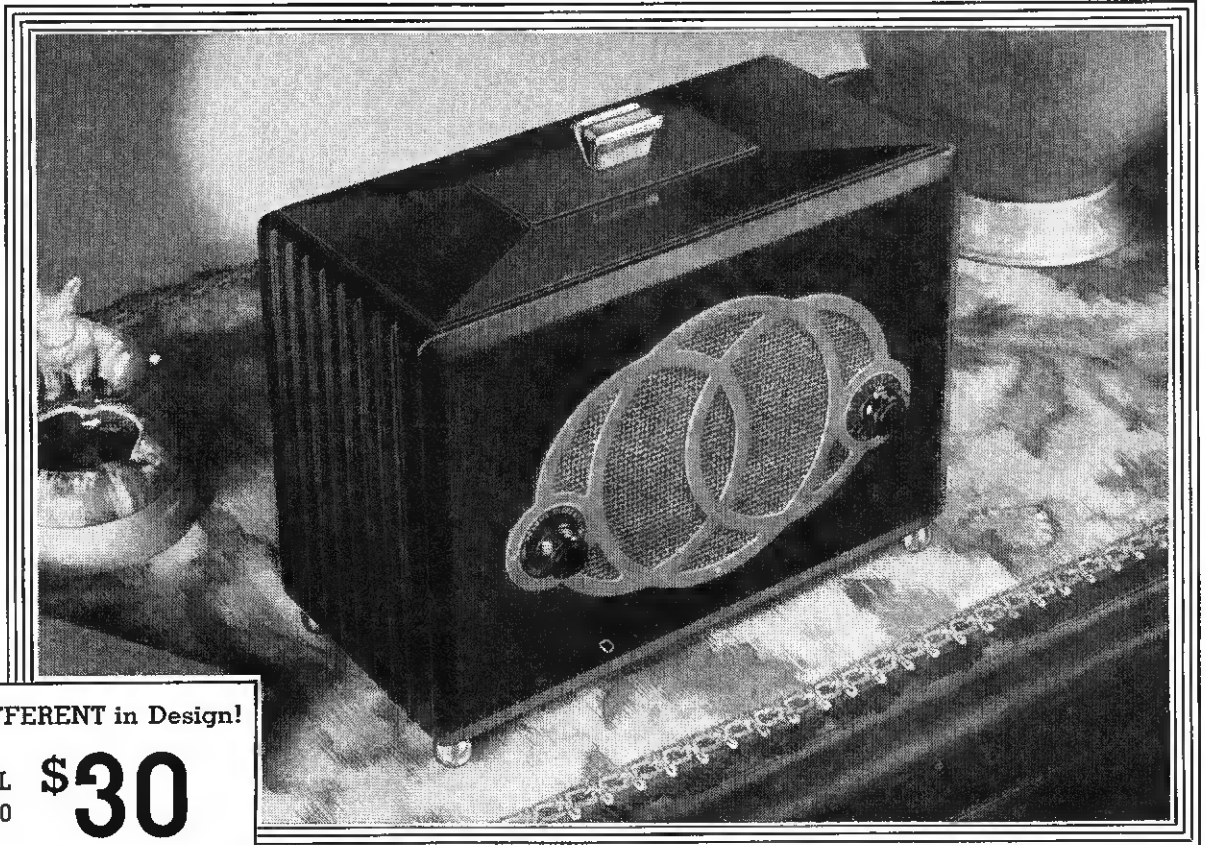

Really DIFFERENT in Design!

COLONIAL Model 300 **\$30**

COMPLETE

with R.C.A. Tubes and Built-in Aerial

[10¼" wide—8½" high—
4¾" deep]

Designed in the popular contemporary style, this cabinet will immediately take the fancy of owners of modern furnishings, or of those who want to add a modern touch to a room. Constructed of satin finished ebony black Durez with polished chromium grille and trimmings. Here is a headliner for window display—advertising feature—SALES—and PROFIT!

(Prices slightly higher
West of the Rockies)

NOW . . . through the engineering genius of Dr. Fulton Cutting and his associates, every limitation commonly found in compact receivers has been overcome. Here is PERFORMANCE that will satisfy, even under the difficult reception conditions of the summer months. *Consult the nearest of the 76 Graybar branch houses for full details.*

COLONIAL RADIO CORPORATION
Buffalo, New York

...these smart new AC-DC COMPACTS



WE OFFER

THESE BIG FEATURES:

POWER for Nationwide Use...

This set is a powerful radio receiver. Into it has been built both power and extreme selectivity. Designed by Dr. Fulton Cutting, it utilizes the most thorough application of every electrical and mechanical development. *It will deliver satisfactory performance in the districts requiring consistently good distance reception, as well as the crowded broadcasting areas requiring fine selectivity.*

5-tube SUPERHETERODYNE .. Full DYNAMIC Speaker ..

Operates from either Direct or Alternating Current on any commercial frequency. Complete engineering knowledge has made possible the utilization of all the new tubes to their maximum efficiency. Tube complement: 1-6A7, 1-6B7, 1-77, 1-43, 1-25Z5. The 25Z5 tube in this set actually **DOUBLES** the voltage and increases the power output. (1½ watts output on DC—2 watts on AC).

3-Gang Condenser...

Broadcasting conditions make necessary the use of 3-gang condenser to insure universally satisfactory selectivity.

Automatic Volume Control...

To prevent fading and blasting, an extremely efficient A. V. C. method is incorporated.

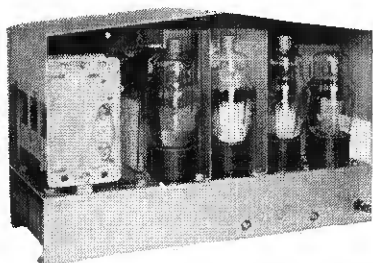

**COMPLETELY
SHIELDED
CHASSIS**

A ruggedly constructed steel enclosed chassis. Mechanically sound—scientifically designed for proper heat dissipation and electrical shielding. Full Dynamic Speaker. Reduction drive station selector permits ease in tuning. Range includes many police calls.

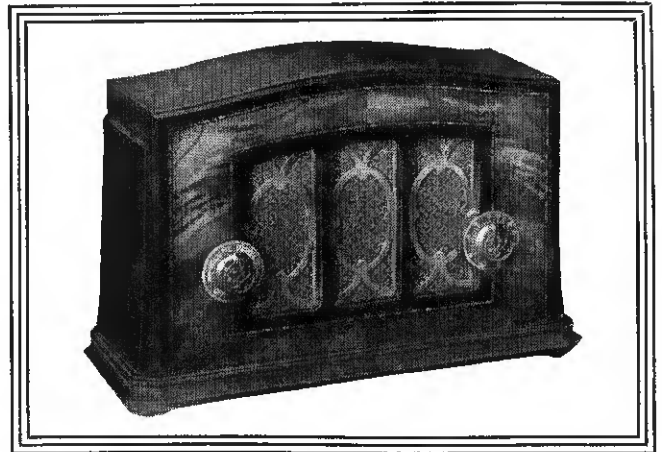

Colonial Model
279

\$27⁹⁵

COMPLETE
with
R.C.A. Radiotrons
and Built-in Aerial

[11½" wide—7¾" high—5½" deep]

A cabinet of universal appeal—designed in the restrained early 19th century English tradition. Strongly constructed of solid American walnut, with choice figured butt walnut veneers, inlaid with marquetry of holly, ebony black and vermillion. Attractive pieced-hardwood grille.

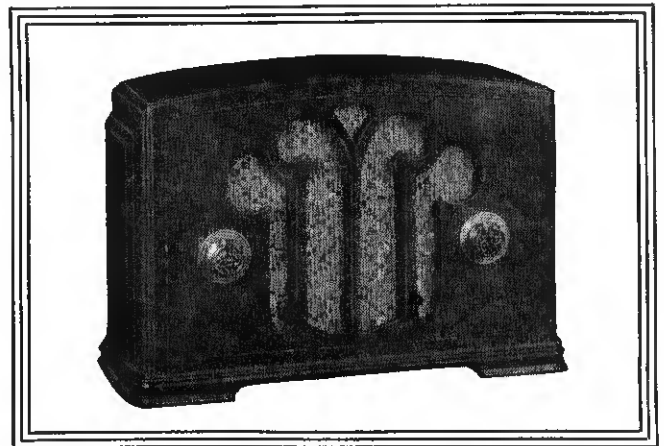

Colonial Model
250

\$25

COMPLETE
with
R.C.A. Radiotrons
and Built-in Aerial

[11¼" wide—7¾" high—5½" deep]

Handsome butt-walnut cabinet, in simple, popular design that appeals to everyone, harmonizes with any surroundings. Durably built of selected walnut veneers. Marquetry inlay of holly, ebony black and vermillion.

5-Tube Superheterodynes with Dynamic Speakers

(Operate on both AC and DC—110 volts—25 to 60 cycles.)

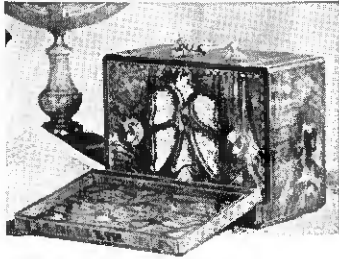

MODEL 30—A smart Portable that's "at home" anywhere. Complete with tubes and aerial. **\$30**

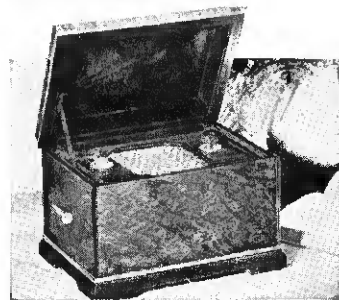

MODEL 300—Superb Radio Chest in Sequoia burl veneers. Complete with tubes and aerial. **\$30**

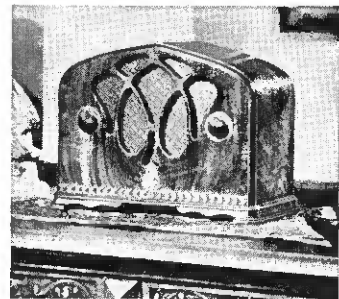

MODEL 250—Handsome design in modified Gothic. Burl walnut. Complete with tubes and aerial. **\$25**

Operate on ANY Current ANYWHERE
—6 volt and 32 volt as well as 110 and 220—AC and DC—any cycle

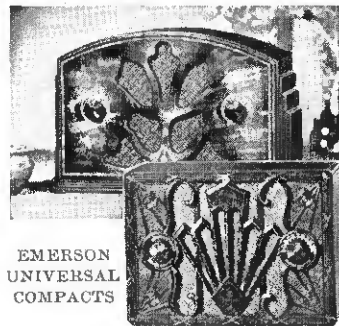

EMERSON UNIVERSAL COMPACTS
MODEL 25A—the radio that set a new style. Complete with 4 tubes and aerial. **\$25**

MODEL 20A — finest grade bakelite cabinet. Amazing value. Complete with 4 tubes and aerial. **\$17.95**

Emerson

PROTECTS YOUR PROFIT



IN THESE 2 WAYS:

1. Emerson offers a full profit margin on EVERY model in the line! No short "Loss Leader" discounts.

2. Emerson prices will NOT be reduced. Emerson AC-DC Universal Compact sets have proved their consumer appeal. They meet every requirement of BEAUTY, PERFORMANCE, PRICE. You can stock Emerson with the full assurance that prices will not be lowered—that your profit will be secure. You will, in fact, be wise to anticipate future requirements inasmuch as rising costs of materials may necessitate early advances in price.

Emerson is definitely "out in front" in sales. Nearly half of the AC-DC compacts so far produced in this country have been Emerson sets! Emerson has been the successful pioneer in this tremendous new market which has not yet begun to show its richest results. Emerson will stay "out front" because we have won the confidence of dealers everywhere by always protecting the dealer's profit.

NOTE: If you do not know your nearest Emerson jobber, write us for his name and full particulars on the Emerson line.

EMERSON RADIO AND PHONOGRAPH CORP.
641 Sixth Avenue :: NEW YORK, N. Y.



6-Tube SUPERHETERODYNE with Dynamic Speaker, 3-Gang Condenser, Automatic Volume Control

Emerson Model 35 — Operates from any lamp socket on either AC or DC current, 110 volts, 25 to 60 cycles. Most unusual cabinet, of Sheraton design, with finest burl walnut veneers. Tubes used: 3—78, 1—76, 1—43, 1—2525. Only 8 3/4" Wide, 10 1/2" high, 5" deep. Weighs 9 pounds. COMPLETE with Cunningham tubes and Aerial. **\$32.50**

All Emerson Radio Sets are also adaptable for 220 volts.

Majestic makes a national PROCLAMATION

ELECTRO-SEALED
COLD DOME



See the
Majestic
"Spread"
Saturday Evening Post
May 27-out May 22

The COLD DOME! That's the big new idea that Majestic is flinging across two pages in the Saturday Evening Post, May 27, and blazoning in newspapers in 52 cities.

The Majestic Cold Dome, Electro-Sealed, is the powerful symbol of Majestic Refrigeration—trouble-free, dependable, backed by an unconditional 3-year guaranty. The biggest *basic* refrigeration feature in the industry.

Watch Majestic. Watch Majestic advertising. Majestic's New Policy means *action*—and profit—for Majestic dealers.

If you want action, there's a place for you on the Majestic side!

GRIGSBY-GRUNOW COMPANY, CHICAGO

Majestic

ANNOUNCES:

A SUPER AUTO RADIO

OUT-PACING THE FIELD IN QUALITY

MAJESTIC TWIN SIX

Greatest advance yet registered in auto-radio engineering . . . 6 tubes, 3 tube performance . . . 6-inch dynamic speaker . . . all-electric . . . all-in-one . . . super-heterodyne . . . automatic volume control . . . tone control . . . airplane dial . . . jack for extension speaker . . . on-and-off light indicator . . . remote control . . . Majestic Spray Shield tubes . . . extreme sensitivity and selectivity . . . utmost compactness—7 x 7 x 12 inches . . . bigger dealer discounts . . . \$54.50, complete with tubes and suppressors, Federal tax paid.



**MODEL 66
"TWIN SIX"**



WITH THE
NEW AIRPLANE
DIAL



A TEAM-MATE FOR "TWIN SIX"

MAJESTIC 116A

America's leading
auto radio
selling under \$50

\$49⁵⁰

Complete with tubes
and suppressors;
Federal tax paid

BUSINESS IS GOOD FOR MAJESTIC DEALERS

CUSTOMERS COME BACK TO DEALERS WHO SELL **TUNG-SOL** RADIO TUBES

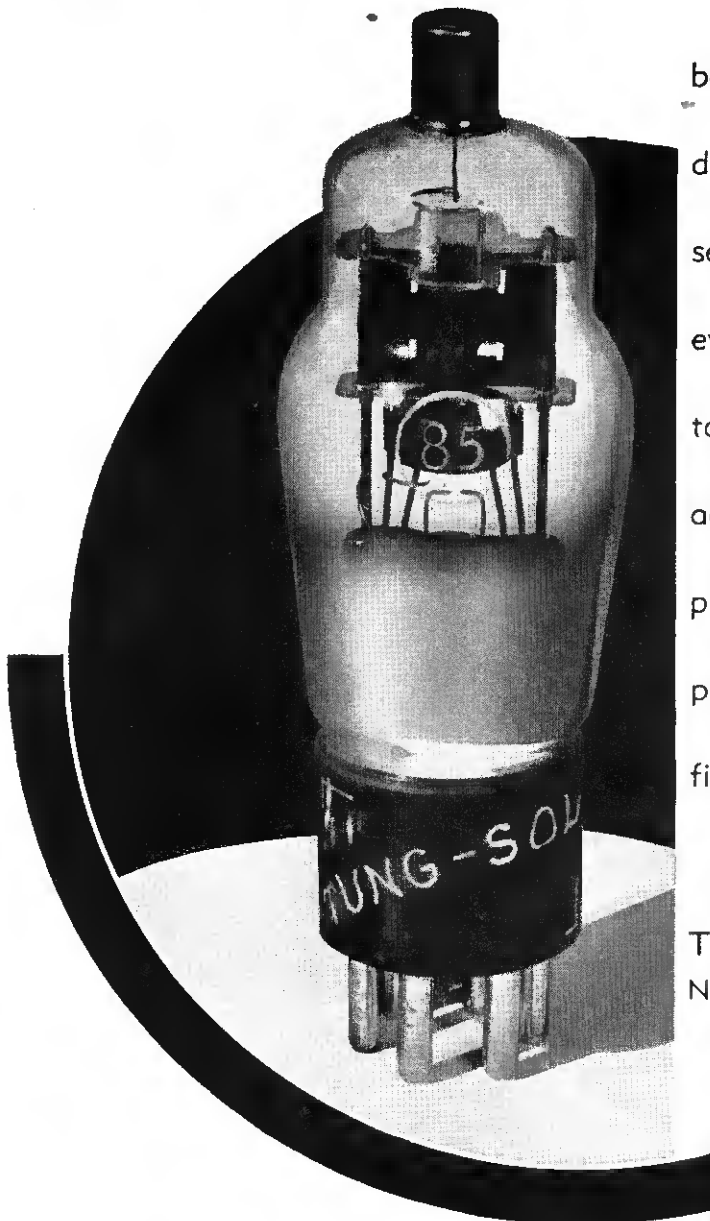

because in the first place, the product itself delivers 100% satisfaction . . . and in the second place, the price of that product is everywhere the same. . . . There is no need to "shop around." . . . This is one of the advantages of selling under the Tung-Sol plan. . . . If you don't know all about that plan, now is a good time to write and find out!

TUNG-SOL RADIO TUBES Inc.
NEWARK, N. J.

Atlanta
Boston
Charlotte
Chicago
Cleveland
Dallas
Detroit
Kansas City
Los Angeles
New York
St. Paul



G-E's *New* AUTO RADIO

retails for only **\$34⁹⁵***

GOOD old-fashioned "sell" is built right into G-E's new Auto Radio!

Its mighty attractive price-tag—only \$34.95*—includes a generous profit opportunity for you. And G-E's famous monogram plus the full General Electric guarantee *plus* that remarkably low price are powerful sales medicine—and they're only the beginning!

Extra Sales Punch

The new G-E Auto Radio is wonderfully compact . . . can be installed in less than an hour (one-bolt mounting—only two electrical connections) . . . removal of six easily accessible screws permits quick servicing . . .

And in addition . . . a remote control box for either dashboard or steering post . . . automatic volume control . . . new improved dynamic speaker . . . two-point tone control on speaker minimizes interference . . . combination lock switch and volume control on control box.

Write today for complete details. Address Section R-445A, General Electric Company, Merchandise Dept., Bridgeport, Conn.

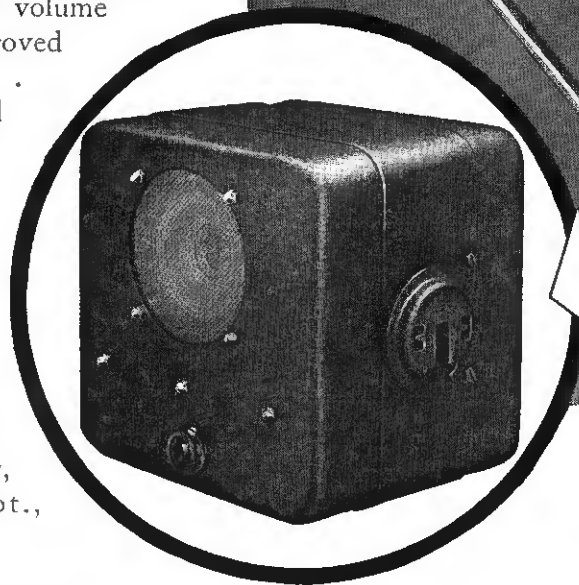
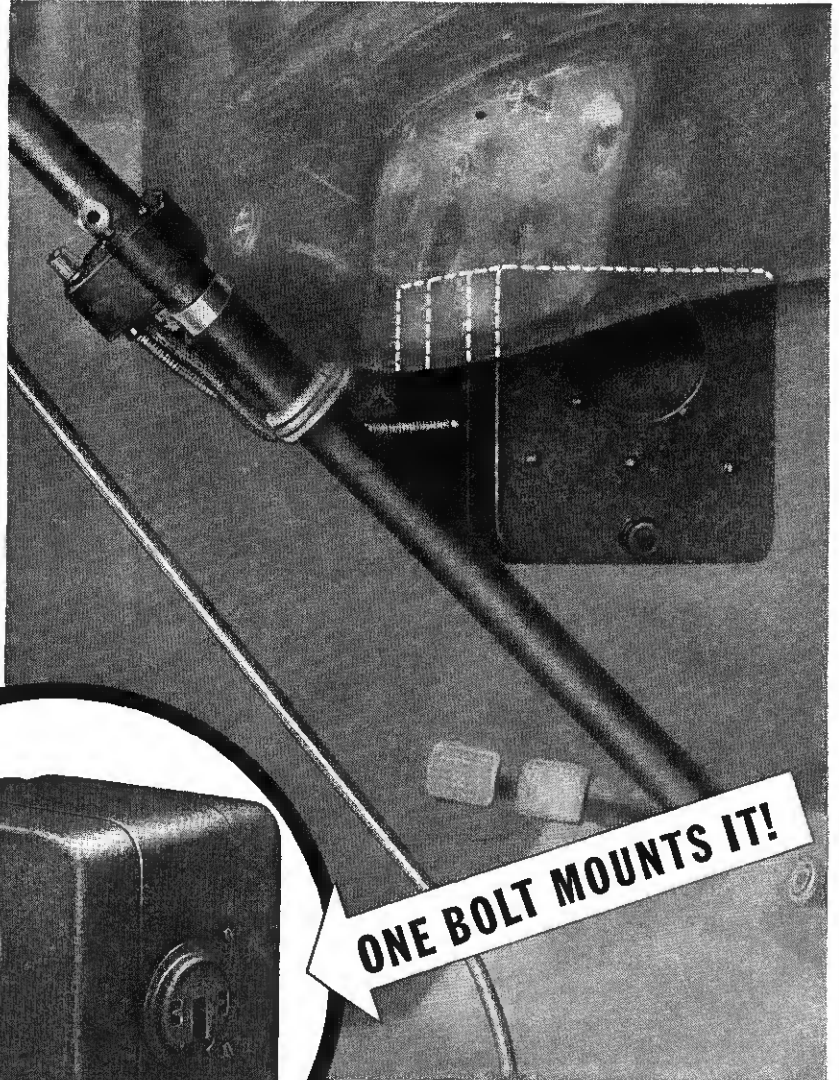

ONE BOLT MOUNTS IT!

*Price slightly higher Denver and West

GENERAL  **ELECTRIC**
AUTO RADIO

SENSATIONAL G-E SUCCESS PERMITS PRICE REDUCTIONS!

“Good Old Days” Rush of Re-Orders Taxes Production, Lowers Cost of G-E Low-Price Line



MODEL L-50, table set. Five-tube superheterodyne, 110—125 volts, 25—133 cycles, AC, or D C. New tubes. Dynamic speaker. Additional switch for police calls. Good selectivity and sensitivity. Shipped in standard package of four. List price **\$2475**

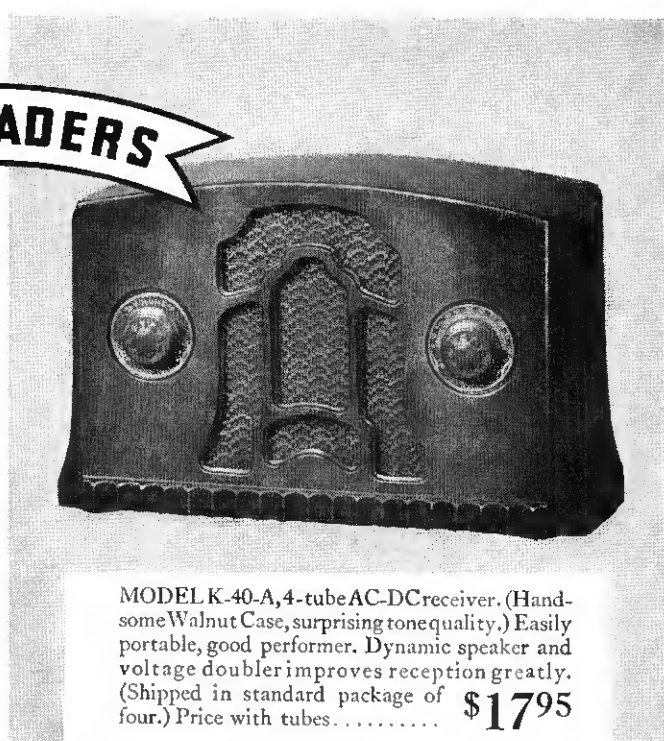

MODEL K-40-A, 4-tube AC-DC receiver. (Handsome Walnut Case, surprising tone quality.) Easily portable, good performer. Dynamic speaker and voltage doubler improves reception greatly. (Shipped in standard package of four.) Price with tubes **\$1795**

TWO LEADERS

EVEN General Electric is surprised!

Following last month's announcement of G-E's "New Deal in Profits"—the new, bigger-profit low-price radio line—orders have been streaming into Bridgeport at a regular 1929 clip!

Naturally, this rush is enthusiastic recognition, by dealers, of marvelous new profit opportunity—and, by customers, of unusual radio value, backed by that greatest guarantee of electrical perfection, the G-E monogram.

Boom Lowers Prices

But . . . the immediate result of this phenomenal boom is *another* piece of good news for you—lower retail prices! Just look at the new, revised price tags on these K-40-A and L-50 sets!

Get in on this *sure* business that's flocking toward the G-E monogram! Ask your G-E Distributor for all details and prices of the new, low-price G-E line. Or write to Section, R-445 General Electric Co., Merchandise Dept., Bridgeport, Conn.

A REAL BUSINESS-WITH-PROFIT LOW PRICED RADIO LINE

K-41—4 tubes, AC-DC, Metal Case . . .	\$12.95*
K-40A—4 tubes, AC-DC, Walnut Case . . .	17.95*
L-50—5 tubes, AC-DC, Superheterodyne	24.75*
L-51—5 tubes, AC-DC, Superheterodyne	24.75*
K-50—5 tubes, Superheterodyne	19.95*
K-51—5 tubes, Superheterodyne Chest . . .	31.50*
K-54—5 tubes, Superhet. Radio-Phonograph Combination	49.95*
K-60—6 tubes, Superhet. Table Model . . .	29.95
K-65—6 tubes, Superheterodyne Console, 6 legs.	49.95*
J-87A—8 tubes, Superheterodyne Console	89.50
K-106—10 tubes, Color Radio Console . . .	129.50
B-40—Auto Radio, Superheterodyne . . .	34.95*

*Price slightly higher Denver and West

GENERAL  ELECTRIC RADIO

And In Auto Radio—SUPREME!

SIX TUBE—ALL ELECTRIC—SINGLE UNIT—HIGH GAIN—SUPERHETERODYNE.

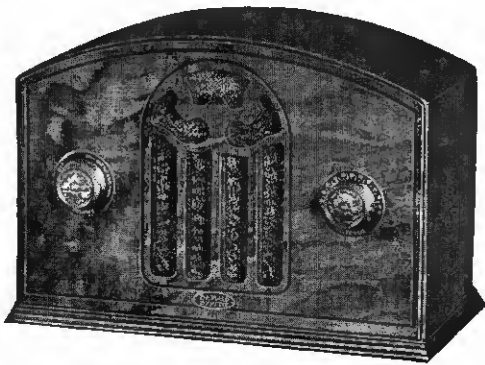

THE VERSATILE NEW **\$1795**
Model 414

The Everywhere-Set that works wherever there's electric current—home, office, hotel, camp, college, yacht, steamship and automobile—on 6, 32, 110 or 220 volts—AC-DC—25 or 60 cycles—four tubes that sound like six. (Carrying case available.)

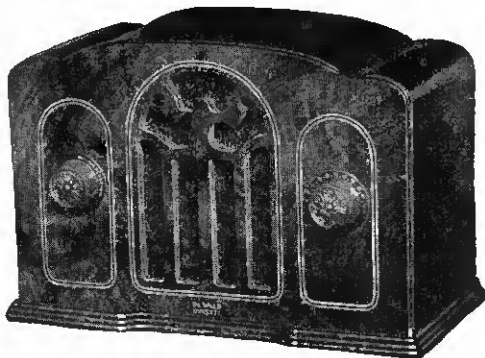

THE GREAT NEW **\$2500**
Model 550

Identical in chassis with Model 551—it has the same astonishing performability as that new "giant among the midgets." Cabinet only is different.

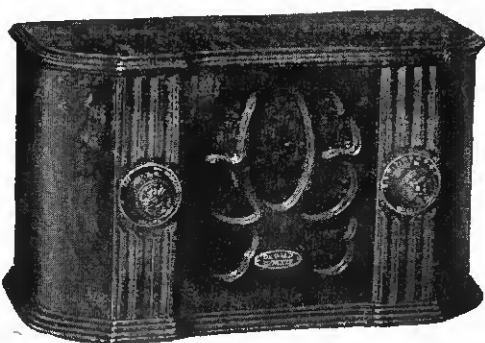

THE SENSATIONAL NEW **\$2750**
Model 551 Deluxe

Leader of the compacts—superheterodyne—hair line tuning to 10 kilocycles—110-220 V.—AC-DC—25-60 cycles—new type tubes—circuit-matched aerial—new tone dynamic speaker—new heatless chassis—beautiful, distinctive cabinet.

R. C. A. TUBES ON ALL MODELS

When you compare the DeWald Motortone—you first have to find something to compare it with, in *price*, in *performance*, in *profit*.

Three holes to drill, two wires to connect. That's all to install. And one wing nut instantly removes it for service.

100% Automatic Volume Control—hairline tuning—distortion-proof reception—consol toned dynamic speaker—positive remote control. Illuminated dial—Lock Switch, and Volume Control. Size 9¼ in. high x 7½ in. wide x 6½ in. deep, using new tubes, 78, 6A7, 85, 37, 41, 84.

When they talk about auto radio to *you*, ask them to tie *those* specifications, at **\$39.95!**

DEWALD

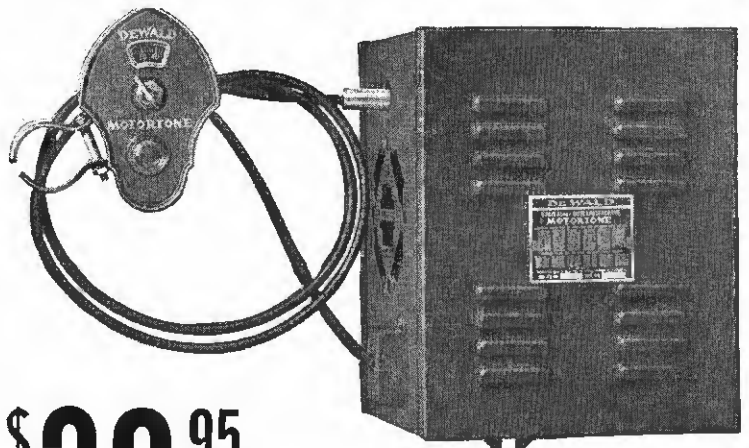

\$39⁹⁵

SIX TUBE MOTORTONE

Trade Mark Reg.

a product of

PIERCE-AIRO, Inc.

520 Sixth Avenue

New York, N. Y.

O. H. CALDWELL, *Editor*

RAY V. SUTLIFFE, *Managing Editor*
W. W. MACDONALD, *Technical Editor*
T. H. PURINTON, *Assistant Editor*

M. E. HERRING, *Publishing Director*
HARRY PHILLIPS, *Art Director*
P. WOOTON, *Washington*

June – *Planning Time*

and in

September – ACTION!

THE radio industry has had its full share of the depression blues. Now the time for shaking off the fetters of despondency has arrived. Next month, when the Radio Manufacturers Association meets in Chicago, should be made the starting point of a new radio "deal." It is the opportune time for the laying of new plans for the rehabilitation of our business—plans which should reach their fruition in September, the beginning of a new radio season.

To take advantage of this new spirit, the radio industry needs to get together once more, look itself over, and realize that it is still a going concern with a big mission to fulfill in public entertainment and with many opportunities ahead for business and profit.

THE time for this rekindling of selling spirit, this re-infusion of morale, is, we repeat, during the month of June when the RMA meets at Chicago. A rousing meeting of the radio trade at Chicago in June, under the glamorous stimulation of Chicago's World's Fair with its forward-looking exhibits and buildings, would do the trick. Or the radio industry might find encouragement and stimulation from looking at itself through the pages of a magazine reflecting the industry's picture to all who have a part in radio. Both are needed *in June*.

In June, also, plans should be started for a nationwide campaign designed to re-sell radio to the public. Such a nationwide Radio Jubilee Week, for the latter part of September, in which broadcasters and the radio trade could cooperate, already has been talked about. Such a campaign to take shape in the form of special dealer display materials, special broadcasts and special advertisements in the newspapers. This campaign not only would focus attention on radio once more but should revive the demand for new and better radio sets. These plans for September must, of course, be gotten under way next month.

In June we sell the radio industry on itself. In September we sell radio to the public under the definite stimulation of planned, cooperative promotional activities.

We'll Buy Your Time Paper IF.....

ARE YOU having trouble financing your time payment accounts, Mr. Radio Dealer? If you formerly relied upon the services of a contract purchase corporation it's likely that you are, because radio paper right now isn't any too popular. What's the reason—and what can be done about it?

Our statement with respect to the resale market for radio time payment contracts is based upon a survey of this situation recently conducted by *Radio Retailing*. Actual figures, covering the amount of radio paper handled by two of the leading purchasers of this type of security, were obtained for the past four years. Averaging these we find that 1929 was the peak year, represented by the arbitrary percentage figure 110. On this comparison basis the amount of radio paper purchased for the year 1930 fell to 60, for 1931 it was 36.5 and for last year—4.4. In other words, this branch of the business of the discount houses practically has ceased to function.

Why this drastic decrease? It cannot be entirely ascribed to the decline in the volume of business enjoyed by the radio trade over that same period. No, a major cause is that radio paper no longer is acceptable to the big-time financing houses. "Because," to quote a leading executive with one of these corporations, "the credit of the average radio dealer is too uncertain and the unit price of his average transaction is too low. In other words, the necessary fixed handling charge bulks too high, thus rendering the discounting of such a time payment contract mutually unprofitable."

How, then, can the dealer continue to finance his time contracts and thus be encouraged to push the sale of higher priced sets? How can radio paper again be made an attractive "buy" for the discount houses?

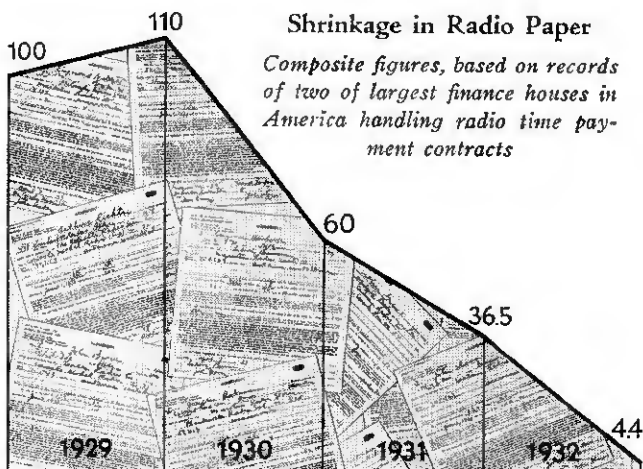

The banker previously quoted was kind enough to give us his viewpoint over the luncheon table the other day. Inasmuch as it is the financier whose sayso will be final in this matter, and as this gentleman is particularly well informed, radio manufacturers and dealers will do well to consider his suggestions.

This sharp shrinkage in the amount of acceptable radio time paper has been due to the drastic drop in the average unit of sale, to the many failures in the retail field, and to the fact that today the majority of radio set transactions are on a cash-and-carry basis, said this banker.

"However, the financially strong radio dealers are still pushing the larger sets and using the midgets, whenever possible, as 'bait.' For the most part the better class of merchants carry the small accounts themselves and offer us paper on sets selling for \$50 and up. This is a sound practice from our viewpoint as well as from that of the dealer," he continued.

BASIS ON WHICH TIME PAPER IS STILL ACCEPTABLE

In spite of present conditions the finance houses are still interested in radio paper, providing the dealer is in a position to meet certain necessary conditions, it appears. These conditions are as follows:

A minimum volume of \$6,000 a year. "This does not necessitate the extension by the banker of a \$6,000 line of dealer credit, as this instalment paper is being constantly liquidated. A credit line of approximately \$3,500 would take care of this offering."

Terms—A minimum of 15 per cent of the purchase price and \$5 a month. A minimum finance charge of \$8 per transaction. "We don't object to 'midget' paper if there is not too much of it offered."

"But many radio dealers, today, are unable to meet these requirements, reasonable and necessary as they are," we stated. "What must the radio industry do to again place its retail outlets in a favorable trading position with respect to the banking interests?" we asked.

"Get back to the simple common sense fundamentals of a healthy manufacturer-dealer relationship and of sound merchandising," he replied. "There is no other remedy."

"Sooner or later the radio industry will have to abandon this present mad orgy of price cutting and of selling to Tom, Dick and Harry and build up a smaller number



More than ever, the better sets must be sold on time —But the bankers are wary these days—How can the radio industry meet this situation?—A financier gives remedies

of selected retail outlets. Specifically, I can only repeat and re-emphasize those admirable policies for stabilization which your own magazine, *Radio Retailing*, has so persistently been advocating. For years I have been very close to the radio industry. Many of my best friends are among its top executives. Based on this intimate knowledge, I am glad of this opportunity to do what I can to point the way out—from the financier's viewpoint."

This prominent banker, who prefers not to be quoted by name, then listed the following policies as absolutely essential to the rehabilitation of the radio industry in the eyes of the financial world:

MANUFACTURERS

(a) Limit the number of dealers in a given territory. Wherever practicable grant an exclusive retail franchise—based on a population sufficiently large to produce a substantial volume of business.

(b) Protect these selected dealers against unwarranted and frequent price and model changes.

(c) Protect the dealer in his financing commitments—and, incidentally, the finance houses—by guaranteeing to buy back those sets on which the balance of the time payments are non-collectible due to the manufacturer reducing prices on same. Sounds radical. But it's done in the washing machine industry. Why should the dealer hold the bag through no fault of his own?

(d) Having thus created loyal dealers, teach them how to sell on a quality basis.

DEALERS

(a) Forget the price argument and sell up.

(b) Support your manufacturer by not demanding that he meet every competition price threat that appears.

"The preceding suggestions by no means cover the situation," our friend continued. "They are presented merely as an indication of the type of policies which must be adopted to put the radio industry on a sound financial footing. They represent the bankers' appraisal of your business. They indicate the steps to be taken if you would again have us help you finance the sale of the higher priced consoles."

Here, then, from yet another high source, comes the self-same message to the radio industry: This price war is leading to inevitable self-destruction. Right-about face. The path to profit is clearly defined—but it lies in the opposite direction to that we now are taking.

Nine-out-of-Ten NEED

New ANTENNAS!



NINE out of ten radios have poor antennas. Don't take our word for it. Look them over in any residential district.

Hung from precariously fastened poles, swinging loosely against buildings and other wires, poorly insulated, lacking lightning arrestors (still required by Fire Insurance underwriters), most of the aerials in use today are a positive handicap to the instruments they are intended to aid. This is especially true in large apartment buildings, where roof conditions have driven many to short indoor wires and "trick" plugs that still further impair reception.

Hurried installations by dealers who have cut corners to keep expenses within bounds, by an industry anxious to minimize installation requirements, erection of wires by cash-and-carry customers and people who move . . . these are responsible for the unsightly, inefficient conglomeration of wires seen everywhere. Even the public senses that something is wrong.

Take this tip from The Editors: The time is ripe for an industry-wide antenna renovation campaign. And we don't mean philanthropy. Such a drive would not only be of genuine benefit to the public *but could be made profitable to the trade*. For what the store-bound dealer needs more than anything else right now is a plausible excuse for calling on the consumer, an "ice-breaker" which will permit new business to be developed in the home.

We urge servicemen, in spare time, to do this:

1. Repair, re-string, renovate antennas. (Even good systems need attention after a winter's pounding).

2. Install modern transmission-line systems wherever noise-pickup is troublesome, or where customers are willing to pay a few dollars extra for the last word in reception.

3. *Once in the home, sell set repairs, modernization jobs, new models.*

This will require outside selling, yes. But not of the "cold-turkey" variety so cordially disliked by technicians. It is a legitimate, respectable job for skilled mechanics, and can provide much work for servicemen, ordinarily hard-hit when shop repairs taper off during the

summer period, as well as needed revenue for the stores.

Radio Retailing plans to do its bit. Editor O. H. Caldwell, beginning the first week in May, will broadcast a weekly series of talks in the interest of better radio reception over the NBC and Columbia networks. His stuff is clever. Demonstrations of today's electronic wonders, calculated to draw people to their sets, open each broadcast. Then discussion is gracefully steered to the need for good antennas, and quality sets.

Here are the titles of two of the scheduled talks:

"The Electric Violin"—Tuesday, May 9, at 9:45 p.m. (NBC "Blue" Network)

"The Electricity of Growing Plants"—Monday, May 15, at 8:30 p.m. (NBC "Blue" Network)

During these and subsequent broadcasts, given popular titles in order to insure a large audience, the following subjects will be discussed:

Why even the best radio receiver is handicapped by a poor aerial.

How to eliminate man-made static by using special antennas.

Lightning arrestors,—how they safeguard you and your radio set.

Shielded conductors,—their increasing importance in modern reception.

Why good insulation is necessary all the way from the far end of the antenna to the set.

Locating antennas for minimum interference.

Discussion of these and related topics, which are rarely brought to the attention of radio listeners, should do much toward paving the way for recommended home calls. When servicemen, or salesmen, arrive at the front doorstep their mission will not be entirely unknown.

We are making a real contribution to help dealers keep business alive this summer. But the effort is wasted unless you take advantage of the broadcasts in your own neighborhood. So, we urge you to—

Get out and make these calls!

Antenna renovation jobs, modern transmission-line installations, new set sales return a worthwhile profit.

Clipping

the

ADS (April)



BOSTON The new RCA and GE little fellows were adequately christened . . . R. H. White and Hovey's splashed the \$12.95 editions . . . Jordan-Marsh, Gilchrist's and Berman broke the \$19.95's . . . Morgan bargained-it with an unidentified \$14.95 Freshman console, also a Steinite midget, \$10.85 . . . Harvey featured Stromberg 36 for \$97.50.

CHICAGO Windy-city dealers dispensed ad pennies lavishly . . . Wieboldt jubileed Philco's a.c.-d.c. superhet down to \$14.95 (originally \$25); slashed an all-electric Transitone to \$39.95; labelled a Clarion 14-tuber (once \$129.50) a "buy" at \$49.50 . . . The Fair took a full-page to tell the world about Philcos in a one-day sale involving liberal trade-in offers netting these prices: 80B, \$15 with free table, 71B, \$29.50; 71H, \$49.50; "X", \$59; 71D, \$59.95 and DeLuxe, \$149 . . . Fish Furniture ballyhooed RCA peewees at \$12.95 and \$19.95; an unbranded 10-tube super at \$39.75 . . . Majestic Stores boosted a \$49.95 Majestic console, neglecting to mention which one . . . Hartman bragged-up a \$34.75 Heritage (?) . . . Goldblatt's used the words "Baby Grand" in connection with a \$10.95 non-Philco . . . The Boston Store disposed of some 12-tube Zeniths (worth \$157.50) for \$69.50 . . . Marshall Field took the quality tack to sell AK 10-tubers at \$99.75 . . . Lyon & Healy followed suit with \$310 RCA RAE84's, ran Stromberg, Capchart and Howard institutional copy.

CINCINNATI May-Stern kept in the public eye with a \$14.99 Crosley midget, type Fiver D at \$18.99, dumped floor samples, Jackson, Syrene and DeWald sets for \$10 . . . Midwest countered with consoles of its own brand for \$26.75 and \$29.50 . . . Wurlitzer joined the price party with a \$10 whatsit, 9-tube Philco (formerly \$89.75) at \$37 . . . Fantle talked up police calls, suggesting a US \$17.95 or Crosley Fiver D \$18.99 midget . . . Greenwald hitched its wagon to an allwave orphan at \$15.75 . . . Checker used genuine RCA bottles as a 39c. leader.

CLEVELAND Wurlitzer threw a boatload of hybrids, several well known brands, into the ring: \$14 console (RMA guaranteed), \$29 phono-combination complete with 50 discs, \$33 allwave outfit, SM X and Y models at \$23, plus mis-

cellaneous Crosleys, Philcos, Victors, Victories at cut prices . . . Mayer-Marks plastered the papers with Philco copy, featuring special allowances ranging from \$20.50 on the 71X to \$4 on the 80B . . . Newman-Stern took equal space to clear out Bosch models, prices: 144A, \$15.95; 305A, \$19.95; 405H, \$42.50; 236A, \$34.95, etc., two-carload stock . . . An 11-tube Stewart-Warner went under the hammer for \$69.50, Sparton 10-tube super \$39 at Atlas Stores . . . Higbee also had some Bosch sets at \$39.95, Philco lowboys at \$48.75 and a General at \$11.95 . . . Sears pushed the usual Silver-tone, featuring a \$39.95 console . . . Bing's pushed Philco 81B at \$29.50 . . . May sandwiched copy on a \$49.95 Crosley (\$119.50 value) in with furniture . . . Kurtz sold a Philco midget, table and upholstered bench combination for \$20 . . . Taylor boomed a Clarion 14-tuber at \$59.50 net, featuring: \$30 trade-in allowance . . . Liberty Electric stuck new RCA 5-tubers up top of candelabra floor lamps, sold the weird combinations for \$20.95.

DALLAS Furniture stores did all the advertising that was done . . . Hart concentrated on Philco Junior Baby Grands at \$18.75, a consolette at \$37.50, gave the Lazy-X a break at \$100, cleared GE table models and Stewart-Warner combinations at \$19.95 and \$39.75 . . . Home mixed Philco \$18.75 midgets in with lawn-mowers, sofas and what have you . . . Sanger kept up to date with a Navigator universal at \$14.95 . . . Haverty had 1933 Majestics at \$49.50 and \$69.50 . . . Sears featured a \$44.95 Silver-tone allwave . . . Skillern's Drug hypodermic-ed the Temple trade mark, sold a console for \$19.95.

DAYTON Wurlitzer spent the most money, staging a Beverly console at \$19, Philco 80 at \$16.85 and then \$17, Sparton 13 at \$27 . . . Rex took space to push the Detrola at \$16.95 less installation, one of the few auto-radio advertisers of the month . . . Dayton Furniture sold Philco 20's for \$17.95 and \$10 Jellope consoles . . . Rike's announced a half-price buy on Kolster, gave \$20 allowances against SM Queen Anne desk models . . . May closed out floor samples and demonstrators at bargain prices . . . Spencer had a Gloritone midget for \$17.95 . . . Elder & Johnston sold Crosley Septets for \$39.99 .

DENVER Mont-Ward went into an advertising trance about a 7-tube \$29.95 allwave console . . . Frumess sold the new RCA all-metals 45c. down, 50c. weekly, tacking an extra dollar on the list . . . American Furniture tried Philco Junior Baby's at \$19.50, Baby Grands at \$32.50.

DES MOINES O'Dea Hardware gave its radio business a shot in the arm with Zenith 210's at \$49.95; 240's at \$78.75 . . . Mail-Order Ward advised Iowans to save 40 per cent by kicking in for a \$29.95 console of unadvertised origin . . . Younkens hooked 'em on RCA (licensed) tubes at 49c. and 79c.

DETROIT People's Outfitting tied the new RCA startlers in with a Sanabria television show (free cigars to gentlemen) . . . Boyer's Haunted Shacks offered International universals at \$11.95, using an ad illustration that doesn't look like the familiar brand to us . . . Hudson's rode the universal model wave with a \$12.95 manufacturer's closeout . . . Weil tucked a \$39.95 Philco console offer in the corner of a baby carriage ad . . . Serlin sold Kennedy allwave combinations of the 10-tube variety for \$39.50, offering a \$35 allowance as bait . . .

KANSAS CITY Jenkins Music saw possibilities in RCA'S new table radio-fonograf (ritzy spelling is theirs) at \$49.95, tailed in the \$12.95 line, devoted some space to Howard 10-tubers at \$69.50 . . . Wurlitzer sold RCA R76's with Havlin electric clocks for \$59.95, Philco 7-tube highboy (\$65 value) at \$39.95 . . . KC Power recommended the GE K50 at \$19.95 and universals at \$19.95, "just a few pennies a day" . . . Davidson's had Philco Junior Baby's at \$18.75

(Please turn to page 33)

Your OLD CUSTOMER



MONDAY
Sell him a set
at his own front
door

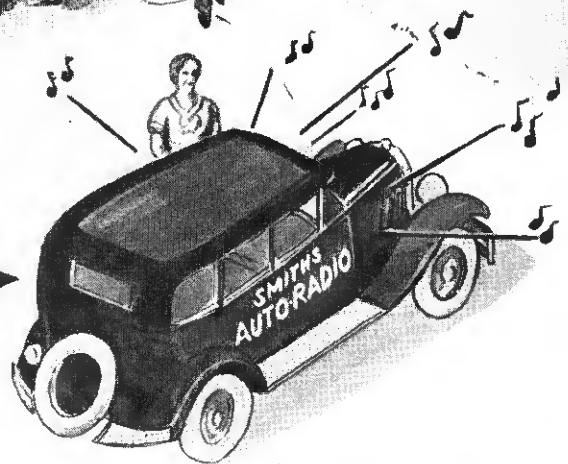

NEARLY everybody with an automobile is a prospect for auto-radio . . . And who *hasn't* a car? Price reductions, the elimination of B-batteries has brought this latest convenience within reach of all. And consumer interest climbs by leaps and bounds.

Operate a set in traffic, park with the radio

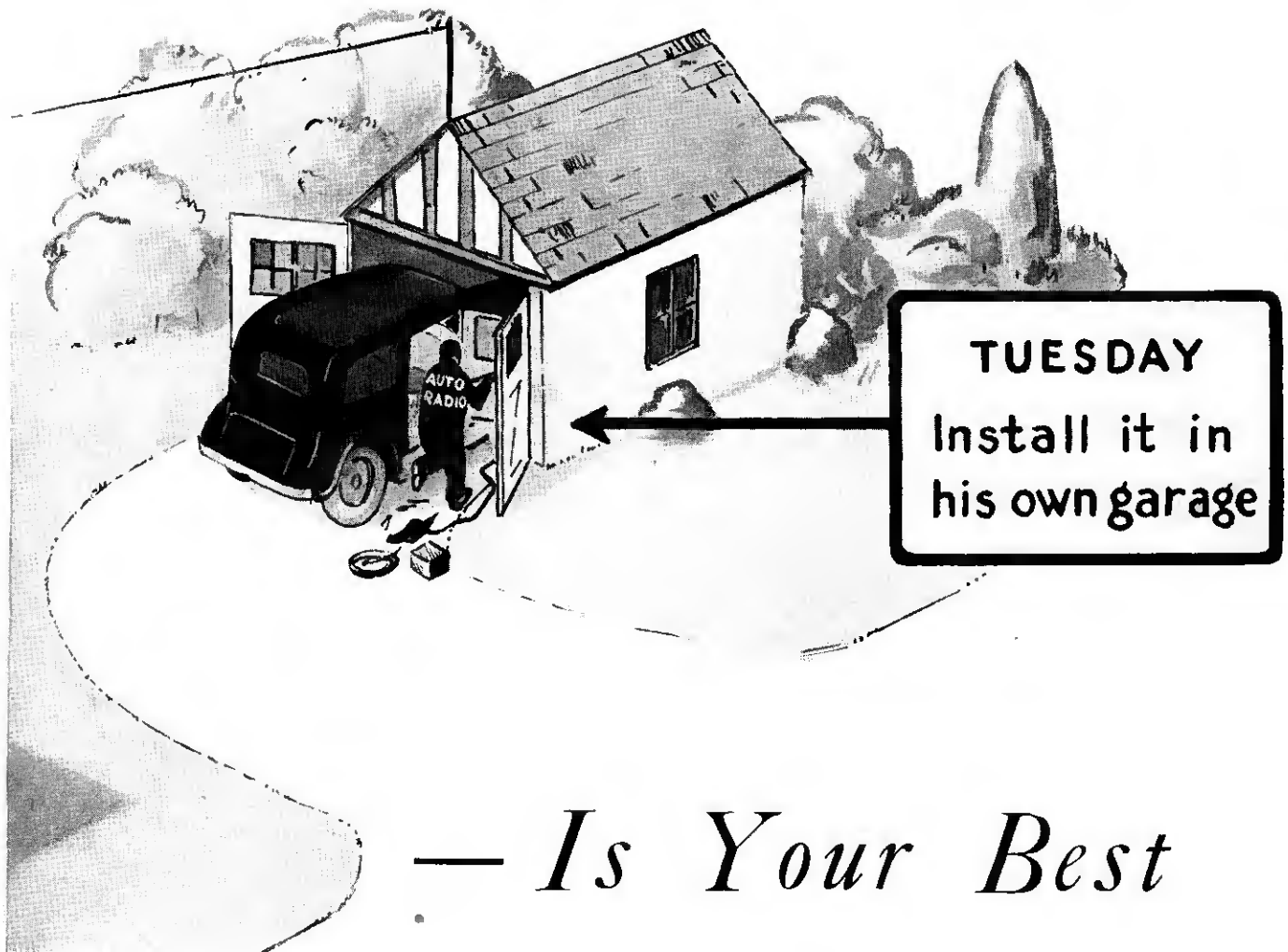

Auto-Radio — *Is Your Best* PROSPECT

running wherever there is a crowd. Watch people really *want* auto-radio, have it next on that this is no high-pressure sales job. Many people really *want* auto-radio, have it next on their list of purchases.

Who are the best prospects? People to whom you have already sold home sets, of course. You know them. They know you. A friendly spirit (we hope) prevails. And you know their credit standing. That's why we say: Drive right out to your old customer's home. Invite yourself in. Then invite him and his family out.

Sell him a set at his own front door.

DON'T let lack of installation facilities hold you back, even if you haven't a garage, object to curbside methods or dislike farming out part of the work. Make a positive *advan-*

tage out of this handicap. It's not difficult.

Gasoline Alley dislikes leaving the apple of its eye in a strange garage where callous mechanics may scratch it up, smear the upholstery with grease or mistreat the motor. Nine out of ten men would prefer to have the job done at home, where they can keep an eagle-eye on the Duco. Explain how this plan makes possible savings in time and overhead. Point out that it permits of a "hand tailored" job, with everything placed and adjusted the way the customer wants it.

It isn't any harder for your serviceman to install auto-radio away from the shop. All he needs is a bagful of tools, an electric drill, accessories and wire. Suppression noises are positively *easier* to run down and cure out in the sticks, away from electrical interference.

Install it in his own garage!

Tested Sales Service Ideas

Murder in a Show Window

H. F. Curtze of Boulder, Colorado, attracted citywide attention recently with a "murdered man" window display tying in with a new broadcast mystery play. A dummy was arranged, sprawled out face down in sand heaped in the window, mercurochrome "blood" trickling from its side. A bloodstained handkerchief lay beside the body, a revolver not far away. A newspaper, folded to display the word "Dead" (part of an old headline) also formed part of the display.

A sign, the first two words of which read "Who Killed . . ." lettered large enough to be read from a passing car, announced the new broadcast feature scheduled to go on the air during the week, pointed out that only with a really good radio could full benefit of the program be obtained.

The window, needless to say, stopped traffic. And the local paper gave it 4½ inches of publicity.

Repair Work In Window Pulls

Service Editor:

Early in February we put a man in a white smock into our front window servicing receivers. We installed a bench, testing meters and all the flashy equipment we could lay hands on.

The result of this publicity stunt has been well worth while. Old battery and trickle-charger sets are being dug out of cellars and brought in to us for estimates on repairs and the work is performed while the owner of the set looks on. Store traffic has increased, exposing our new merchandise to public view. And two garages have accepted our bid to do their auto-radio installations.

C. A. HOBERDIER

Five Little Push Buttons

In five convenient, but inconspicuous, locations in the store of the Prest Electric Company, San Bernardino, Calif., are little push buttons. Here's why:

"Today's visitor to the radio sales room is a slippery fellow," states R. O. Prest. "He wants to know about the operation and price of this and that set but is prepared to flee on the slightest provocation. If another prospect comes in and there is not available a spare clerk to immediately wait upon him, the first customer feels that he is in the way and uses this as an excuse to depart. Likewise, the second visitor, seeing that all the sales people are occupied, may turn around and walk out.

"So the busy clerk at once summons assistance from

the rear of the store or from the service department—by unobtrusively pushing the nearest button. And assistance comes soon enough to prevent either the newcomer or the person being served from leaving. The longer you hold a prospect, for a demonstration, the greater the possibilities of making a sale."

Downtown Stores Stage Radio "Block" Party

Just at this time last year downtown radio merchants of Denver, Colorado, staged a radio "block party" that centered the attention of everyone in town on newly announced receivers. Speakers were placed in doorways and on sidewalks from Broadway to Larimer street, a distance of one mile, on Fifteenth and Sixteenth Streets and on many sidestreets just off the "main drag." Between 8 and 8:30 p.m. all sets were tuned to the one station and as a result pedestrians and motorists enjoyed the unique sensation of listening to music no matter which way they turned.

The idea was originally planned for just radio dealers but the idea appealed to others as well and as a result many department stores, shoe stores, etc., hired sets for the occasion.



This Display Sold Sets

"Equipment like this is used in the broadcasting stations," read a sign placed with this public address display in the lobby of an Akron, Ohio, theatre. Sun Radio arranged it with the management, put a microphone on the stage and invited people to step up and listen to their own voice sent back by a speaker mounted in the rear of the auditorium.

The stunt attracted a crowd, to the benefit of both dealer and theatre. It added to Sun's prestige and focused attention on the midget set at the left of the display.

a Message to all Radio Owners

Now, there's no need to pay double repair bills because of the inexperience of others. In the interest of efficient and reliable radio repair service, an organization known as *Associated Radio Craftsmen* has been formed. Its members are men of wide experience and broad schooling who have successfully passed the high standards adopted by the association. The next time your radio goes bad call an *Associated Radio Craftsman* if you want to make sure your radio will be fixed right the first time. True, all good radio men do not belong to this association, but *only* thoroughly capable and proven craftsmen can belong!

Insist on Seeing This Card. It Identifies a Qualified Radio Man Who Knows His Business!

MEMBER 	ASSOCIATED RADIO CRAFTSMEN INCORPORATED OF HOUSTON, TEXAS
	THIS CERTIFIES THAT JOHN DOE
has successfully proved his technical and practical qualifications as a Radio Service Man by passing the examination of this Association, which recommends him to the Radio Trade and to owners of Radio Receivers as a duly qualified Radio Service Man.	
JOHN DOE	JOHN DOE
President, Associated Radio Craftsmen, Inc. Member's Sig.	

This Ad Sponsored by the Following Radio Concerns:

Acme Radio Service	"Pals of the Air"
Beacon Radio Service	Radio Central, Inc.
Finger Radio & Furn. Co.	Reliable Radio Service
Foley Brothers	S. O. S. Radio Service
Harris Radio Service	Star Electric & Eng. Co.
Harrison Radio Service	Stowers Furniture Co.
Houston Radio Repair	Southwestern Victor Dist. Co.
Kidd-Russ Co.	Straus-Frank Co.

Co-Op Ad Helps Houston Servicemen

Sixteen radio stores, cooperating with Associated Radio Craftsmen, Houston, Texas organization of 80 servicemen, ran this cooperative ad recently to raise the standard of service rendered local radio fans.

Houston has been having a lot of trouble with inefficient servicemen, many being part-time workers from other fields, not having the knowledge necessary to insure satisfactory work. Accredited members, of the service association must pass a 20 question test arranged by the directors, attend regular education meetings.

Installs "Sign-Baffleboards"

Radio Retailing Magazine:

A lot of stores in the big cities now own midget sets which they use either to attract or to entertain customers. I have hit on a way to advertise my service business through these receivers.

I approach the storekeepers and tell them that the tone quality of their midgets can be materially improved by the addition of a larger baffleboard. Then I offer to install one free of charge if they will permit me to paint an ad for my shop on the new baffle. If they agree I remove the speaker from the cabinet, mount it on a 3 by 3 baffle and paint my sign.

This is working out well in several local bargain shops. The tone improvement pleases the storekeepers and the advertising pleases me.

BORIS S. NAIMARK

Another Co-Op Service Ad

A leading tube manufacturer has been running standardized 4 in. by 5 in. ads in many newspapers, from coast to coast. Four South Bend, Indiana, service organizations . . . Radio Clinic, Louie Chikar's, Radio Service Company and J. P. Kennedy . . . tied in with the local insertion by taking 42c. worth of space each, having their names and addresses placed above the tube ad under this type line: "Your radio will be serviced correctly by these dealers."

The manufacturer's ad attracted attention to the service copy, which was so small that it would not ordinarily have been seen.

DX Cards Help Shortwave Sales

Roy Stewart, Alhambra, California, radio dealer, is also an amateur radio station operator. He has discovered that acknowledgment cards from foreign amateurs are excellent attention-attractors for a display window and stir up interest in both shortwave receiving equipment and transmitting supplies.

He Puts His Picture On the Letters

Writes W. S. Combs about the sales letter reproduced on this page: "Several weeks ago we mailed out 400 copies to a list of customers and prospects and the results were unusual by comparison with previous attempts.

"We had forty-nine direct responses wherein the individuals spent from fifteen minutes to an hour in our showroom, resulting in the following sales:

Refrigerator	\$129.50
"	89.50
Radio	139.50
"	89.50
"	27.50
Sweeper	59.50
Mix Master	19.50
Total	\$554.50

The total cost of mailing was \$40, ten cents apiece, which was cheap when the result is considered. Photo Letters, Inc., of this city helped us to get up the copy."



Majestic Appliance Company

SALES AND SHOWROOM
636 Washington Road, Mt. Lebanon
PITTSBURGH, PA.
CE 4848 2279

Dear Mr. Bartley:

Here is a "face to face" invitation for you to visit us during our annual Open House Sale, which begins May 22. Purpose? Simply to get better acquainted. I have had my picture taken, to go along with this letter for this special occasion as a token of my sincerity. Won't you respond by visiting our store next week. It will make us feel that we really are making friends in this community. I assure you the primary purpose is not to sell merchandise.

I'll be looking for you.

Sincerely,

MAJESTIC APPLIANCE COMPANY

Outside Selling...

By

Ray V. Sutcliffe

Managing Editor

FOUR DEALERS Say "NO!"

"OUTSIDE SELLING doesn't pay, especially at this time and with these prices. We've tried it many times and always lost money. I keep in touch with all worthwhile prospects."

"Yes, I guess my set does need new tubes. I'd like a new radio if I could afford it. Never had a radio salesman call at my home or ask me to buy."

These conflicting viewpoints, from dealer and set owner, have many times been voiced to the writer. So frequently, during the past six months, that we decided to do a little first-hand investigating.

Hempstead, Long Island, was the area chosen for these personal interviews. This township—population 23,000—is sufficiently near New York City to be subjected to the competition of the cut-price houses, yet far enough away to be self-contained. It is a community largely composed of average income citizens.

Four radio dealers dominate this market: a music house, a combination gift-camera-stationery-radio store, a branch of a radio chain and a radio specialist. We discussed this subject with the proprietors of these typical radio outlets—strictly from the angle of the opportunity for *creating* new business. In other words, cold canvassing under present economic conditions and with

the prices of receivers being what they are. Here is the gist of their observations:

DEALER A

"The trouble is that those who might be sold insist on an exorbitant trade-in allowance. Cold turkey canvassing puts the dealer on the defensive and creates ill will. Besides, we accumulate too many poor credit accounts. Can't cover expenses. We keep in touch with our customers by mail and telephone. If anyone wants radio in this town we'll hear from him."

DEALER B

"My mailings go out once a month to my store list and to selected telephone names. This pays, but a salesman can't get by. Must make ten calls for every interview—and then he only stirs up trouble. Saturation is so high that it must be a replacement sale at a trade-in allowance loss. Cold canvass is all wet. You must talk their terms, not yours."

DEALER C

"We're all one big family in this burg, everyone knows everyone else and they all know the Blank Radio

... Will It PAY?



OUT OF
50 CALLS 26
HEMPSTEAD
HOUSEWIVES SAID

*“We’ve Never
Been
Called On”*

Company. Tried it twice and it didn't work. Can't get good salesmen to ring door bells on radio. Margin too low. We follow the newspapers for new comers to Hempstead and phone them.”

DEALER D

“Sounds good, but in actual practice doesn't check out. We're radio specialists with an established clientele and they come to us. Yes, there are many homes we haven't called on, but while people might tell you that they are a prospect for a new set, try and pin them down to a real order at a fair profit.”

Then We Interviewed Fifty Housewives.

One mile from the business center of Hempstead is the suburb of West Hempstead, consisting of about 300 single family dwellings. I called on fifty of these home owners. It took three days.

The approach was that of a radio man who was interested in opinions concerning programs and in the condition of their sets. “Just a get-acquainted call. Could I be of service?”

Three people refused to be interviewed at all. Twenty-three answered my questions at the front door. The

balance, 24, invited me in and waxed cordial and confidential, once they were convinced of my sincerity.

IN GENERAL—All had radio sets, mostly consoles. Five were quite new, six were not over two years old. Thirteen were well out of date. With 18 of the 24 receivers there were indications that the r.f. condenser gang needed alignment. Fifteen of the 24 obviously could stand some fresh tubes.

At some time, during 70 per cent of these living-room conversations, the housewife volunteered the information that her set was too old, that she would like a new one if she could afford it, or that she knew some of the tubes must be worn out.

In but five cases, and the question was always put by the writer, did the housewife know the name of a radio dealer in Hempstead with whom she could do business.

“Run of the Mill” Replies

“I used to get WTAM like a local, now it is indistinct. Is it the station or my set?” *Answer: It was the set.*

“Now just what is the *real* object of your visit? How am I to know that you won't end up by trying to sell me
(Please turn to page 33)



"I'll Take the Same"

Prices on the larger sizes of electric refrigerators have been drastically reduced . . . and beer's here! Added together what's the answer? . . . A new market for summer sales — **THE ROADSIDE STAND.**

"Radio Retailing" offers ten dollars for usable letters telling in your own language: "How I Sold My First Roadside Stand Customer an Electric Refrigerator."

A Sales-Producing Set-Up

How a radio dealer organized his refrigeration department

JUST what type of an organization and what kind of sales effort should the average radio dealer put behind his refrigeration activities? The set-up of the S. C. Radio Shop, Charleston, S. C., offers an excellent answer to this question based, as it is, on a two-year successful experience. For ready reference we present it in itemized form:

TERRITORIES—Every man gets an exclusive district, putting him in business for himself. The city is divided into seven zones, with a supervisor in charge over all.

GETTING MEN—Advertising for men brings the raffle. The best material comes to "S. C." or is recommended.

"TRIAL HORSE"—"We have a small territory which we call our 'trial horse.' Into it we send the recruits. While it is small it is a good block to work in. If a man sticks and does his best he then gets a larger and permanent district."

TIME ELEMENT—It takes about 60 days for a man to get into the money class and accumulate a good prospect list. Even then, the supervisor must continue to help close most of the prospects.

A WORKING SCHEDULE—Most sales come from cold canvassing or call-backs on persons recommended by customers. Therefore the day is scheduled: three hours cold turkey; three hours on call-backs on live prospects or on customers and the balance of the time for closings and night conferences with family groups.

INTENSIVE TRAINING—Twice a year this concern conducts a special training course. It runs for two weeks, two hours an evening, from Monday to Friday, inclusive.

"I instruct the men myself," states R. B. Aldrich.

"Also get a factory representative to help. I am a great believer in using a blackboard and chalk to get things across. Likewise the salesman must use paper and pencil when he is selling the prospect. People remember what they see.

"There are really only two major things to stress in selling an electric refrigerator—first, the idea, next the merchandise. We emphasize the closing. If a dealer doesn't train his men to be letter perfect in closing, giving them every possible 'reason why,' he will lose 40 per cent of his possible volume."

GET-TOGETHERS—A staff meeting every morning for half an hour and a general sales meeting, for an hour, every Monday for review of details and specimen sales demonstrations.

QUOTA BOARD—In the sales office is a blackboard with each man's quota for the month. Also a place to record his net sales and reverts. The man who leads for the month gets a gold star button and a special bonus. He is called "The Salesman of the Month."

CUSTOMER AID—For furnishing the names of persons who buy, customers get a choice of four premiums, such as a nice scarf. The ten-coupon book plan also has been used with considerable success.

ADVERTISING—Spends five per cent of gross sales on publicity. Favors local newspapers and direct mail, in relative proportions of approximately 70 to 30 per cent.

Beer Coolers



In the Game

Alert to every merchandising opportunity, C & D Auto & Radio Supply Co., Cincinnati, is exploring this new market for refrigeration. RADIO RETAILING has a list of the makers of this type of equipment. Yours for the asking.

Selling *TUBES* by Mail

"Follow-Up" Cards That Produce Results

A SURVEY of many methods for increasing replacement tube business reveals that the use of "reminder" cards is universally well regarded. "Because of low lists and narrow margins on tubes the cost of selling must be held down. The penny follow-up more than pays its way," declare the dealers whose adaptations of this idea are here described.

Time to Retune

Here's a stunt that's worked well for over a year for Alhart Electrical Company, Rochester, N. Y. Quoting A. E. Royer, of that concern, "Remembering the old days when a man came with his satchel to tune the piano, we established the idea of 'retuning' the radio. We kept this method as simple as possible, letting the customer be the judge on tone improvement as, one by one, new tubes were substituted for old in the set. A special allowance of 10 per cent many times induced the customer to order all the tubes replaced.

"As to the method of approach: Accompanying this is a sample of the 'retuning' card offered free to hundreds of persons selected from the city directory. Because of this complimentary offer and the personal identification on each card we find that prospects respond, even though months have elapsed since the presentation of the card."

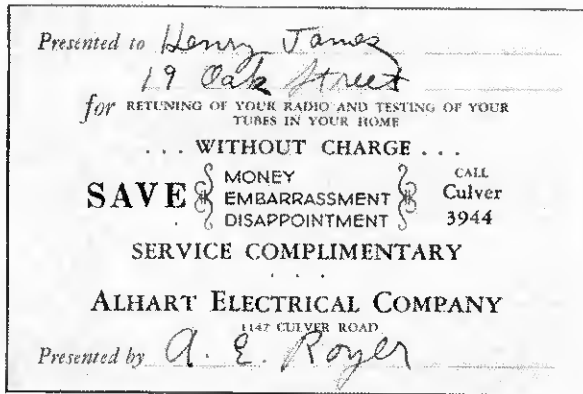

"Something to Think About"

Joseph Bishop, Philadelphia, favors a circular headed: "Something to Think About." It features honest service. He states, "The more simply you present your point the better the results. I distributed 2,600 of these circulars. Within a week I obtained 29 repair jobs and on these jobs installed 18 (Sylvania) tubes."

Every Five Months

If you were a radio customer of the Hart Furniture Company, Dallas, Texas, you would receive a reminder, five months after date of set purchase, that a free tube

test was now the order of the day. Two thousand people get such a message monthly and it is credited with selling more tubes than any other one advertising effort.

Hart boasts that it never has cut prices on radio supplies. It's easier to sell them at list, on a monthly charge account basis, says this large furniture house.

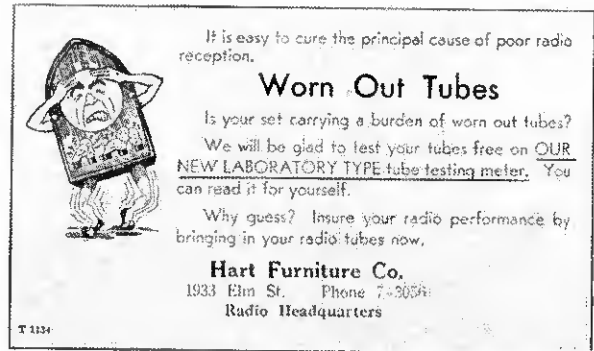

Card Attached to Set

Arlington Radio Service, Arlington, Mass., finds that it pays to attach a card to each set sold. Carries model number, instructions for operating and space for name and address of customer. Also offers a free check of tubes and installation whenever returned to dealer. Says Arlington, "These checks take little time, they frequently mean another job for the service man and almost always the sale of one or more tubes."

A Program Reminder

Here's a copy suggestion we like very much, because it sells programs, something most dealers overlook. Credit for this thought goes to W. E. Brewerton, Rochester, N. Y. This tube selling idea was a prize winner in a recent contest conducted by Hygrade-Sylvania.

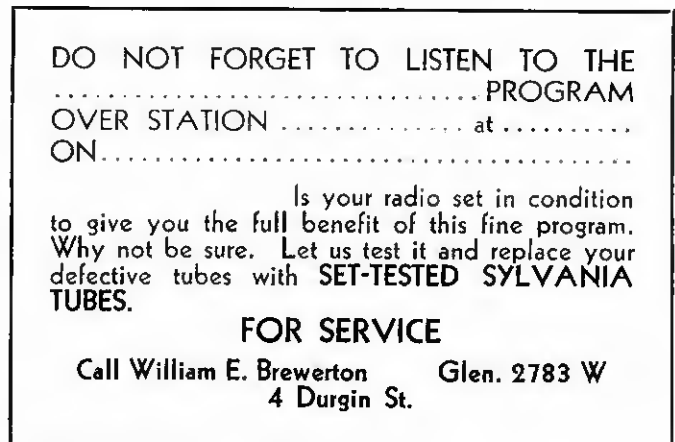

Viewing the Sub-Midget from

The EDITORIAL Angle

THE advent of the "sub-midget" has radically altered the entire picture of radio merchandising. During the past ten months our industry has had to rapidly adjust itself to many major upheavals—to changes in price level standards, in distribution policies, in size, design and performance of sets—and the end is not yet!

The following editorials present some of the aspects of this problem. They suggest matters which should be thoroughly discussed by the membership of the Radio Manufacturers Association when it meets in Chicago on June sixth.

SIZE, PRICE, PERFORMANCE

MIDGETS have been steadily shrinking—in price as well as in size. But, despite present cigar-box proportions and "toy" prices, sets with even fewer tubes will soon make their appearance. Within the next few months three-tube types, using combination detector-power output tubes, will be introduced, and two-tubers are not an impossibility.

Let them come. Let's plumb this midget trend to the very bottom. For, with further reductions in size and price, will come further reduction in performance. The smaller sets cannot possibly have the sensitivity, selectivity, tone or refinements of multi-tube consoles.

Price alone has not prevented the merchandising of consoles in competition with midgets. The chief difficulty has been that the midgets have been too darn good. There has not been sufficient difference in performance between the two to justify the marked difference in price. *The public thinks the little set is just as good as its big brother. Our problem is to make the difference clear.*

Fortunately, any further reduction in size and

price will make obvious this factor of performance. The public will not expect the vest pocket set to compete with larger models. Peewees will be recognized for what they are: conveniently small, inexpensive receivers, suitable for office or auxiliary home use. The console will stand out by comparison as a finished musical instrument for entertainment purposes. And there will then be a clearly defined place for both, where in the past each has encroached upon the territory of the other.

DISTRIBUTION

THIS growing tendency among manufacturers of small sets to increase volume by placing their wares in the hands of merchants not in any way affiliated with the radio industry or interested in its welfare is unsound and unnecessary. Why cheapen radio by associating it with shaving creams, cigars, haberdashery or what have you? It is a penny wise, pound foolish policy.

There are at least 20,000 experienced radio dealers in the United States. These able radio men now provide more than enough contact points with the buying public—providing they are properly utilized and supported by the set makers.

And if further retail coverage is felt necessary let the manufacturer delegate this job of appointing sub-dealers to these radio retailers already within the industry and who have stood by him in past times of stress and taken substantial losses by so doing.

This deplorable tendency to jump hither and yon reflects a shortsighted outlook. It is an attempt to secure immediate volume regardless of consequences.

What defensive measures can the radio dealer take to protect himself against this onslaught from the rear? Just one thing. Protest to his suppliers, at once, singly and collectively, against this practice. Register the fact that if the set manufacturer will not protect the radio dealer then said manufacturer must expect to lose the loyal support of his most valuable outlet.

If, under certain conditions, the retail radio trade cannot give adequate consumer coverage then let it be empowered to grant sub-agencies, to place sets in all places where they will be seen, to contact the butcher, the baker and the candlestick maker.

Play fair with the radio dealer, Mr. Manufacturer.

NOMENCLATURE

WITH the difference in performance of midget and console becoming more marked, we suggest the adoption of a nomenclature which will describe these two types of sets by performance values rather than size. To date there has been little to make clear to the public the wide difference in the reproduction service they deliver.

The small, personal radios bring in voice transmissions distinctly even if, as in the telephone, the full tones are missing. But if the customer appreciates real music and wants to enjoy the great orchestras in all their rich overtones and harmonics, then he should have adequate baffleboard area and uncrowded assemblage of tubes and parts. So let the dealer differentiate these two types in his sales talks by referring to the sub-midgets and the sets of known better reproduction quality respectively as:

“SPEECH RADIOS” and “MUSIC RADIOS”

If this distinction, in advertising and in sales talks, be established the public soon will become

conscious that there is a difference. “Speech” radios will then go on to wider fields of utilitarian usefulness; while the market for quality receivers will be preserved for the *musical enjoyment* of cultural America.

TONE

HERE is a “family” of curves, plotted by a well-known laboratory, showing the tonal response of four radio sets: a 1933 quality console, one of the best “cigar-box” midgets, a typical 1924 receiver and a laboratory model of the same year. (Relative “loudness” is not indicated.)

The deficiency of the midget (dimensions $9\frac{1}{2}$ by $6\frac{3}{4}$ by $4\frac{1}{4}$ inches) as a reproducer of tones below 500 cycles is clearly evident. It is not as good as laboratory instruments of 9 years ago and exhibits characteristics remarkably like a typical 1924 receiver, “peaking” near 1,000 cycles.

A cigar-box set usually has adequate selectivity. It may have sufficient sensitivity. It can provide surprising clarity of speech. And musical programs are pleasingly interpreted. As a “second set,” as an accessory for the office or summer camp, and in homes that cannot afford better, it has a definite place. *But as a faithful reproducer of all musical tones, in direct competition with consoles, it simply does not measure up.*

No one yet has found a way to do without a speaker baffle.

The Difference in Tone Quality Between Large and Small Sets

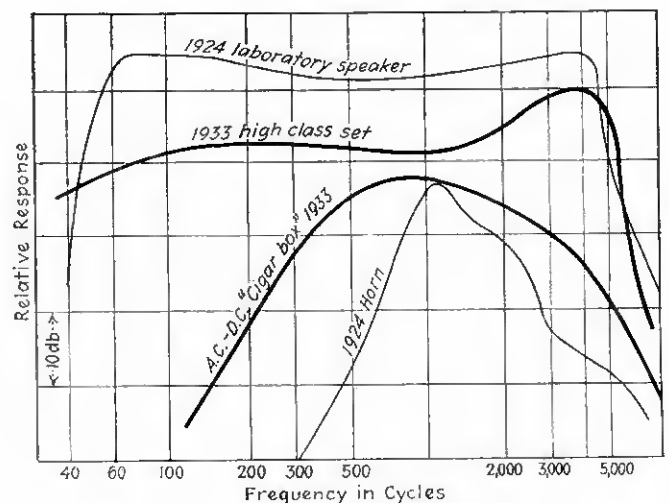

News of the Month

RMA DIRECTORS ANNOUNCE PLANS FOR JUNE CONVENTION AT CHICAGO

Details covering the two-day convention of the Radio Manufacturers Association, to be held at the Stevens Hotel, Chicago, June 5-6, were discussed and program plans perfected during a special meeting of the Board on April 25. The usual meeting of the RMA Board of Directors will be held Monday, June fifth. Division meetings for the election of new directors will be held the morning of June 6. Tuesday afternoon the entire membership will gather in the ball room of the Stevens, to be followed by an informal dinner.

NEXT MONTH—AT CHICAGO

Radio Manufacturers Association Convention

Natl. Assoc. of Music Merchants Convention

Both June 5-6 at the Stevens Hotel

Also the opening of "A Century of Progress"

Thursday, June 1

Sentinel Launches "Gold Bond Plan"

To protect its dealers against price declines and also as an aid to selling, Sentinel Radio Corporation, Chicago, announces its "Gold Bond Plan." Included in the sale of each set will be a certificate guaranteeing the purchaser a definite trade-in value for that set any time within one year from date of purchase. The amount of this allowance—

face value designated on the bond—to be equal to 40 per cent of the original purchase price. While the bond states that the trade-in preferably should be made with the dealer from whom the set originally was purchased, its acceptance is optional but is definitely binding on the manufacturer.

Among the advantages claimed for this radical proposition are: eliminates necessity of price cutting, furnishes outstanding talking point, gives chance to sell same customer two sets within the year, provides advertising feature and makes dealer's time paper more acceptable to contract purchase houses.

Lou Sullivan in Charge of Wurlitzer's Eastern Branch

The Lyric radio, Mohawk refrigerator and Mohawk washing machine (Wholesale Division) of the Rudolph Wurlitzer Mfg. Co., has established headquarters at 1033 Chestnut St., Philadelphia, Pa.

"Lou" Sullivan, who has been directing activities for the past three years from the factory at North Tonawanda, will now make Philadelphia his general sales headquarters.

This move, according to those acquainted with present Wurlitzer plans, presages a concentrated drive on the eastern market. The new arrangement lends authority to reports that Wurlitzer's combination of Lyric radios, Mohawk refrigerators and washers, has proved effective in the East, where a steadily growing sales organization has been at work distributing these products.



Hay, Young Feller!

This snapshot just received from Harold Wrape, organizing factor and first president, St. Louis Radio Trades Association; prime mover and first president, National Federation of Radio Association; recently retired president of the Missouri Athletic Association and, incidentally, a radio jobber of good repute and long standing. Congratulations, old friend, but how come you are making this kind of hay in the spring of the year?

National Radio Show in New York, Sept. 20-30

Good news! The radio industry will not be without the trade stimulating effect of a national show next fall. Sponsored by the Electrical Association of New York, plans are well along for holding a public display of radio and electrical products at Madison Square Garden, New York, Sept. 20-30. The latest in radio sets and accessories, refrigeration, air conditioning and industrial and domestic electric appliances will be exhibited with all the showmanship and publicity-creating stunts of former years.

D. W. May, president of the May Radio & Television Corporation, is chairman of the Committee on Arrangements. Under such able and influential leadership the success of this year's Show is assured. Facilities for the entertainment of radio dealers and jobbers are contemplated.

"Friends of Majestic" Prove Loyal

The "Friends of Majestic" campaign, recently inaugurated by the Grigsby-Grunow Company to help their dealers sell Majestic refrigerators, has already proved a great sales stimulator, according to Harry Alter, assistant general sales manager. The plan consists of getting owners of Majestic refrigerators and radios to turn over to the dealers names of qualified prospects and to do this with a profit to themselves. In return for their efforts, they will be awarded with gifts of nationally advertised merchandise.

Radio and Communications Building, Radio World's Fair, Chicago

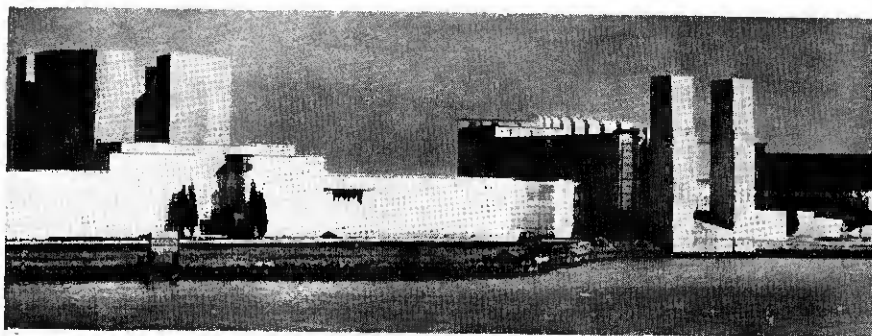

The Radio and Communications Building (left) and the Electrical Building at Chicago's 1933 World's Fair—A Century of Progress Exposition. Visitors will view exhibits dramatizing the epic story of radio, wire communication and of electricity, and be given an insight into the generation and utilization of electrical energy.

This group is one of the most impressive on the Exposition grounds. At night its illumination employing brilliance, color and soft glows will be reflected in the waters of the lagoon which it faces.

Siegling Claims "Oldest Music House" Title

Who is the oldest music house in America? The March issue of *Radio Retailing* quoted Philip Werlein, Ltd., New Orleans, La., as laying claim to the "oldest music house in the South" title. Now, from Charleston, S. C., comes a clear ringing challenge. Siegling Music House, Inc., not only claims this honor but asserts that it is the oldest music house in America.

Concerning this first dispute there seems to be no question but that president Rudolph Siegling is right. His forefathers established this business in 1819; Werlein's date is 1842. Credit where credit is due. But how about national honors? Mr. Wurlitzer, et al, let's hear from you.

Component Parts Exhibition at Chicago, June 26-28

The "Component Parts Exhibition," under the auspices of the Institute of Radio Engineers, will be held at the Hotel Sherman, Chicago, June 26-28 inc. This date coincides with the "Engineers' Week" at the Century of Progress Exposition.

Due to the fact that this exhibition will be attended only by technical radio men, the showing will be exclusively of set components, measuring instruments, laboratory equipment and manufacturers' aids. A man qualified to answer technical questions will be in charge of each booth.

Mrs. Scott's Boys, Eddie and Gleason, Sell 1,000 Sets



Scott Brothers Electrical Co. ranks third in sales volume among Denver's radio outlets. Sold over 1,000 sets in '32—and turned stock 20 times. Some of the reasons why:

Runs small ads daily to move used sets

Stresses sincerity and reliability above all else

Finds that the simple virtues count more than 1,000 words

Nothing spectacular in this, is there? But they're making money.

RCA Radiotron Gives Extra Tubes —PHILCO EXTRA DOLLARS

What may prove to be the opening guns in a tube price war between two recognized leaders in this industry is seen in the announcements last month by RCA Radiotron and by Philco of special concessions to the trade on tube purchases.

As announced by RCA Radiotron, its new tube bonus plan, effective April 3 and continuing for 8 weeks, offers, in addition to regular dealer discounts, the following tube bonus: With an order for 10 tubes, one type 45 free; with an order for 25 tubes, two 201A's and one 27 without extra cost; with an order for 50 tubes the dealer gets six extra tubes and with an order for 100, the bonus is an even dozen of assorted types 201A, 27 and 45.

An additional bonus applying on the total quantity of Radiotrons billed to dealers during this period is also provided for. The jobber is not forgotten in this deal and receives 19 assorted tubes free with each order for 100. Also extra discounts on quantities of 1,000 or more.

Not to be outdone, the Philco Radio and Television Corporation announced, on April 11, a series of special discount bonuses to the dealer ranging from 10% on 10 tubes to 25% on an order for 100 tubes. Quoting C. E. Carpenter, Manager Tube Sales Division of this concern: "All these bonuses are in addition to the extremely low net prices listed . . . You get this bonus now — in extra dollars—not in extra tubes. Cash in your pocket not tubes on your shelf."

Enthusiasm High at Hartford Meeting of Service Men

One hundred and twenty-five radio dealers and service men of central and southern Connecticut gathered recently, at the headquarters of Hatry and Young, radio parts jobbers, Hartford, Conn., in a meeting devoted to discussion of the radio noise problem as it relates to the radio service business.

The group was the largest radio service and dealer gathering ever assembled in Hartford, indicating the importance that wide-awake radio men attach to the elimination of man-made static. The discussion of the evening centered on suppressing radio interference at its source.

The speakers were greeted with enthusiasm and with a rapid fire of questions. If this meeting may be taken as a criterion, parts jobbers in other cities will do well to follow the example of Hatry and Young in sponsoring get-togethers for local dealers and servicemen.

Many New Radio Bills in State Legislatures

From 43 state legislatures in session this year has come an unusual volume of new radio legislation, making Paul B. Klugh, chairman of the RMA Legisla-

tive Committee, one of its busiest officers. While much state legislation on radio has been proposed very little has been enacted, partially due to effective opposition.

In Missouri, California and Connecticut bills have been proposed to levy "luxury" sales taxes on radio and other products. Chairmen of the various state legislative committees of RMA, generally local radio jobbers of prominence, are cooperating in opposing such legislation.

1932 British Radio Sales Show Increase

According to statistics recently compiled by the *Wireless and Gramophone Trader*, London, 1932, was a banner sales year for British radio manufacturers.

Factory-made receivers, all types, totaled 1,436,849; retail value £19,323,198 (approximately \$67,631,193). Tube sales ("valves") totaled, at list prices, £2,854,000 (\$9,989,000). The grand total for all radio products sold for domestic use grossed £36,627,000 (\$128,193,500).

Six hundred thousand new customers were added to the listener population of the British Isles last year.

"An important fact which emerges from this exhaustive survey is that while radio prices dropped still lower during 1932 many more people purchased better grade sets, with the result that the year's trading, though showing an increase of *only* [the italics are ours] 170,000 in set sales, brought in £7,000,000 additional cash turnover," according to *Wireless Trader*.

Tung-Sol Launches "Idea" Contest

A first prize of \$50 goes to the dealer whose idea for selling tubes wins the approval of the judges in Tung-Sol's (Newark, N. J.), latest contest campaign. Second prize, \$25. And \$10 "for any and all other ideas reprinted and distributed."

O. H. Caldwell, editor of *Radio Retailing*, will be one of the solons. All entries must be mailed by midnight, May 31.

Ragsdale Sales Mgr. for Stewart

The Stewart Radio and Television Company, Detroit, announces the election of L. H. Ragsdale to the post of vice-president in charge of sales and advertising. Stewart manufactures automobile sets exclusively.

Otto Goldsmith S.M. for Sheffield

The sales management of Sheffield Radio and Television Corp., Brooklyn, N. Y., is new in the charge of Otto Goldsmith, formerly with Wildermuth. Direct dealer contact will be handled by David Kanarek.

REALISM IN SOUND REPRODUCTION DEMONSTRATED LAST MONTH

Perfect reproduction of orchestral music with the illusion of hearing each separate instrument from its proper position on the stage—binaural reception—was demonstrated April 12 by Bell Telephone engineers at the American Academy of Music in Philadelphia and again at Constitution Hall, Washington, D. C., on April 27. Seated in the auditorium and facing an empty stage, hidden by its curtain, the editor of *Radio Retailing* heard selections played by the Philadelphia Symphony Orchestra under the direction of Leopold Stokowski. The effect was as if the orchestra was in its normal position on the stage. Actually the musicians were playing in the foyer; their music being reproduced by loud speakers hidden behind the curtain and the sonority electrically controlled by Dr. Stokowski from a seat in the auditorium. All tones and overtones present in the original music were reproduced in their correct relative intensities. This necessitated a range of pitch from three octaves below middle C to nearly six above.

To achieve these various effects two complete microphone, amplifier, speaker and wiring systems were employed. Thus "depth" and "color" or, as sometimes expressed, "background," was made possible.

Another development in sound engineering recently has been demonstrated—this time in the realistic reproduction of voice and music from phonograph records. Electrical Research Products, Inc., a Western Electric affiliate, has practically perfected a balanced system which involves the use of a new kind of record wax, a new pick-up, special amplifier circuits and the use of three or more specially designed speakers mounted on a large baffle area.

As demonstrated to the writer last month, in New York City, the tonal effect was one of utmost clarity, volume flexibility (without overloading distortion), range and fidelity. Plans for the commercial introduction of these new records and of the phonograph instrument have not yet been determined.

The elaborate nature of this apparatus should qualify it for presentation as a deluxe or quality musical instrument for music lovers having at least a moderate income.

Lynch Leases New Quarters

The Lynch Manufacturing Company with offices in the General Motors Building and factory at Cranford, N. J., has been forced to co-ordinate its manufacturing and sales organization and has leased enlarged quarters in the Radio Building at 51 Vesey Street, New York City.

President Lynch attributes a large portion of the gain in his company's sales to the increasing popularity of antenna equipment for broadcast receivers as well as a very rapidly growing interest in antenna products used in connection with short waves. He believes that the vast improvement in short wave reception which these prod-

ucts bring about is going a long way toward popularizing the use of short wave receivers for securing broadcast programs from foreign countries with practically the same volume of clarity as we have been having from local broadcast stations.

St. Louis RTA Elects Julian Sampson President—Plans Advertising Campaign

Julian E. Sampson has been reelected president of the St. Louis Radio Trades Association, this being his second successive term. The management of this unusually active organization will again be in the hands of William Mackle, who has served in this capacity for many years.

It is of interest that while many other local radio associations are now affiliated with the electrical appliance industry, the St. Louis RTA has gone right along keeping its group intact and promoting many cooperative plans.

Among its new activities is an appropriation for an advertising campaign, including newspapers and broadcasting, which is designed to get the dealer in touch with prospects. The air publicity promises to be particularly effective as it offers free advice on how to improve old sets and bring them up to maximum efficiency. A free call by a capable Association service engineer is given where the problem cannot be explained over the air. By this procedure the Association office determines where and what sets are inoperative. Much business resulted from a week's trial, made before planning the larger program. Under the new program the Association will broadcast every afternoon and evening and will advertise in the press three times a week.

The 1933 Radio and Electric Show is scheduled for October, third week. Altogether it looks like a big year for the St. Louis association.

Pacent Purchases Assets of Companies Bearing Name

To safeguard and perpetuate a well known name in radio, in conjunction with the established line of radio essentials and sound reproducing equipment and for the radio, electrical, automotive and general household devices now being developed by his laboratory staff, Louis G. Pacent, personally, has purchased the assets of the Pacent Electric Co., Inc., and its subsidiary, the Pacent Reproducer Corp. He now heads the Pacent Engineering Corporation with headquarters at 79 Madison Avenue, New York City. The new organization will manufacture and market the complete lines of the former companies and will introduce other devices and accessories.

"The organization of the Pacent En-

gineering Corporation, following my resignation as general manager of the two Pacent companies early this year," states Mr. Pacent, "was originally for the purpose of rendering a research and engineering service to clients. Various laboratory developments already completed, however, together with a demand for Pacent products, led me to purchase the assets of the two Pacent companies. With the good will, trade mark, patents, tools and equipment, and the already established lines of radio and sound reproducing devices and accessories, my new organization now becomes a manufacturing and merchandising venture under my direct, personal supervision.

"Associated with me are R. L. Lewis, former sales manager of both Pacent companies and now general sales manager of the new company and Harry L. Likel, former research engineer of both Pacent companies and now in charge of our research and engineering activities."

Connelly to Distribute Zenith in Northwest

The F. B. Connelly Co., with offices in Seattle, Spokane, Portland and Billings, will distribute Zenith sets in the states of Washington, Oregon, Idaho, Montana and part of Wyoming.

This well known concern was founded in 1904. Kenneth A. Connelly is its general sales manager.

Pomeranz with Radio Chassis

Radio Chassis, Inc., New York City, announces the appointment of "Nat" Pomeranz as advertising and sales promotion manager. Mr. Pomeranz was formerly with *Radio News* and later consultant radio engineer for the New York Police Department.

Auto-Radio Listing Corrections

On page 24 of the April issue the list price of the auto-radio set of the Automatic Radio Manufacturing Co. Inc., Boston, Mass., was inadvertently given as \$19.95 whereas the correct list price is \$27.95.

Under the listing of the Stewart Radio and Television Co., Detroit, Mich., the words "all-electric" should be inserted in the column, "Type B-Power Supply."

Belmont in New Building

"Open House" was held April 15 by the Belmont Radio Corp., Chicago, to celebrate its move to new and enlarged headquarters at 1257 Fullerton Avenue. This occasion also marked its fifth anniversary.

Fada Radio and Electric Corp., Long Island City, N. Y., announces that its advertising campaigns henceforth will be prepared and placed by United Advertising Agency, New York City.

The Fada account will be directed by "Lou" deGarmo, veteran radio man, whose commercial experience dates to the days of 1920.

Clipping the Ads (Continued from page 19)

... Jones sold Clarion 14-tube deluxes at \$59.50 (allowance of \$30 on old sets) ... Sears whooped it up on a \$14.95 console at one time sold for \$62.

MINNEAPOLIS Donaldson's Day was celebrated typographically with a couple of columns on Majestic Pirate Chests at \$9.95, Detrola long and short wave table models at \$11 ... Milby and Sather ran a classy ad on RCA'S R28 at list ... The Dayton Company boosted the same company's Tonalite line at \$129.50.

NEW ORLEANS Maison Blanche introduced GE's metal model to Canal Street shoppers ... Holmes had AK 155's at \$24.90, Philco Travelite (regularly \$25) at \$17.95 ... Sterchi's took time out of refrigeration campaigning to slip over a few Crosley Fiver's at \$19.99 ... Sears modestly labelled the Queen Anne Silvertone at \$49.50, the outstanding radio value in America.

NEW YORK Gimbel introduced a nifty number, a midget radio built into the bottom of a table lamp at \$25 ... Busch's Kredit (jewellers) went for the GE vest-pocket models in a big way ... Ludwig Baumann advertised an AK 81 auto-radio (less installation) for \$29.80, advertised a 6-leg console with unidentified works for \$25, had a \$10.94 universal ... Davega cut the universal market to the bone with a \$9.94 offering, frankly admitting that it didn't like to do it, but had a reputation to preserve ... Nussbaum advertised everything but battleships in a crowded 4 by 10½ panel, featuring the new low tube prices and Crosley Mayor's at \$22.95 ... Michaels furniture opened a new store in Jamaica with a flourish, bringing 'em in with \$10 trade-in offer on \$34 6-leg console straight from somebody's loft.

PITTSBURGH These boys are certainly trying! ... May-Stern advertised Philco table models, Emerson universals at \$11.94, GE midgets (regularly \$24.95) at \$19.95, Steinite midgets at \$9.27 and a dozen closeout models of other makes ... Spear moved a few Philco X's at \$70, Ze-

niths (once worth \$102.50) at \$59.50; reconditioned consoles of many brands at a \$20 flat rate ... Wilken's (jewellers) became radio conscious largely as a result of the RCA \$12.95 offer ... Kappels pushed the same model at list, also an unbranded imitation at \$11.95 ... Boggs & Buhl presented the Voco Radio (midget) at \$24.75 ... Friends ran a coupon sale on a \$39.50 console ("This coupon worth \$15.70 tomorrow") ... Frank & Seder offered the classy modernistic Lyric universal for \$24.95 ... Gas & Electric Shops tucked a Philco midget ad in with refrigerator and oil-burner copy.

RICHMOND Thalheimer broke out in a rash of ads on the RCA midget line, recommending them for parlor, bedroom and bath ... Walter Moses duplicated ... Phillip Levy concentrated on an \$18.75 Philco midget ... Adkins Furniture went RCA ... Rountree tried to pry loose a few dollars with \$10 to \$40 allowances on Majestic 344's ... Dabney & Bugg confined its effort to Philco Juniors at \$18.75, Baby Grands, at \$30.

ROCHESTER Howe & Rogers scooped in some business by cutting Bosch personal chests to \$24, a \$69.95 job to \$39.50 ... Hickson was satisfied with a small service ad ... Rochester Gas and Electric praised home products, running space on Stromberg's new \$97.50 console ... People's Outfitting had Majestic Pirate Chests at \$12.85, an 11-tuber at \$139.50 and a 7 at \$49.50 ... Sears cleared out Silver-tones by cutting as much as 60 per cent.

ST. LOUIS Goldman stuck to Philco exclusively, selling a former \$59.95 model at \$39.95 ... Union-May-Stern cleared out floor samples and demonstrators of all makes and models in stock ... Famous-Barr bragged about 12-tube SM's at \$39.75, \$29.95 (originally \$69.50) Kennedy consoles and somebody's Federal midget at \$8.88 ... Wurlitzer ran a special on an assembled console, long and short waves for \$24.95 ... Franklin Furniture cut Zenith 7-tube baby's (formerly \$49.95) to \$24.95.

Outside Selling—Will It Pay? (Continued from page 25)

something?" *Answer: I told the exact truth. Confidence can be won only by frankness.*

"What do you think of the XYZ line?" *Note: This man was a live prospect.*

"My set is four years old but it works fine. Nothing needed, thanks."

"My set undoubtedly needs attention." Gleaned from a doorstep interview.

"A service man left his circular here the other day—but I don't know him and hesitate to take a chance." *Note: Apparently serviceman did not make a confidence-building contact.*

"Know of no radio dealer around here."

"Moved here a year ago. Never had a radio dealer call on me."

"How can I slow down my record turntable to 33 revolutions per minute?"

"Wait a minute Let me turn on my set. What does that noise sound like to you?" *Answer: A 227 tube was defective, in first audio stage.*

"How often should I have the tubes looked after?"

"Is the (BLANK) Radio Company reliable?"

"Where can I trade this set in for a better one?"

"Do you know of a good radio dealer?"

"Just how out-of-date is my set?"

"Thanks for calling—and for explaining about WJZ's fading."

Ten Were Asked These Questions

How old is your set? ... *The average age was three years and six months.*

If a radio dealer called at your door to acquaint you with the service he could render and to discuss reception conditions, would you admit him? ... *Six said: "Yes," four, "No."*

Is your set operating satisfactorily? ... *Five said: "No." Two, "Yes." Two didn't know and one hadn't listened for some time.*

On what do you base your opinion? ... *Two replied: "Poor tone." One, "Weak reception." Two, "Noisy," and two, "It suits me."*

Would you be interested in discussing the purchase of a new set? ... *One, "Yes." Three, "Yes, if I could afford it." Balance, "No."*

Would you be interested in having your present set inspected? ... *One, "Yes." Three, "Yes, if absolutely no obligation." Balance, "No."*

Have you any radio dealer in mind to whom you would turn for service or advice? ... *Three, "Yes." Seven, "No."*

TUBE TIDINGS

May, 1933

E. T. Cunningham, Inc.—RCA Radiotron Co., Inc.

Harrison, N. J.

Fred Levin, Easton, First Prize Winner in Lewis Radio Contest

Mr. Max Lewis, of the Lewis Radio Company in Philadelphia, recently announced the winners of the Cunningham Sales Building Contest, in which dealers were asked, "How can a dealer increase his Cunningham Radio Tube sales?" The first prize was awarded to Fred Levin of Easton, Pa. Second prize goes to Ridge Radio in Philadelphia.

Mr. Levin not only suggested an idea, but offered proof of its power to increase tube sales. He took the 'phone book and called every person from A to Z. Out of the first 250 calls, Mr. Levin reported: "I sold 3 radios; got 67 prospects for radios; 19 repair jobs, which ran into over \$100; and sold exactly 213 Cunningham Radio Tubes."

Puts Debtors to Work

Ridge Radio, realizing that they had many accounts on their books which are hard to collect in these lean times, established a house-to-house selling drive, in which the debtors did the selling and for which the debtors received 20% commission on sales. Ten per cent went to pay off their indebtedness and the other ten per cent they kept. The plan not only increased Cunningham tube sales but cleaned up bad accounts and gave the debtors something extra with which to live on.

Local Adv. Popular

NEW LOW PRICES

ON
RCA RADIOTRONS

as much as

43% OFF!

Tube	New Price	Tube	New Price
UX-201-A	\$.70	RCA-45	\$.85
RCA-26	.75	RCA-71-A	.85
UY-227	.80	RCA-80	.80

EFFECTIVE MARCH 22, 1933

**EVERY TUBE GUARANTEED
AND METER TESTED**

Single column mats for dealer advertising in local papers are now offered *FREE* on request by Cunningham and Radiotron. We suggest writing for them.

Cunningham - Radiotron Offers an Attractive Deal on Rider's Manual

Tube Sales Jump, RCA Reports Sales Response from Bonus Plan

The New Tube Bonus Plan, which gives the dealer the equivalent of a substantially increased discount on Cunningham Radio Tubes and RCA Radiotrons, has resulted in marked increase in sales since its effective date of April 3. Under the plan, dealers are given preliminary bonus tubes, in accordance with a specified schedule, at the time of purchase. Additional bonus tubes for performance against the total quantity of Cunningham Radio Tubes or RCA Radiotrons shipped and billed during the period of April 3-May 27, 1933 (preliminary bonus tubes not included) will be given at the end of the period.

The Bonus Plan has become very popular among dealers who see in it an opportunity to enlarge their profit margin. If you are not thoroughly acquainted with the plan, get in touch with your nearest Cunningham or RCA Radiotron Distributor and have him go over the plan with you in detail. The extra profit which you can have makes it worth your while.

Two Tube Types Added— 2A6 and 6A4 Make Appearance

The 2A6, a new Duplex-Diode Triode designed primarily for use in a-c operated receivers has just been announced by the Cunningham-Radiotron organization. When used in appropriate circuits, the 2A6 performs the simultaneous functions of automatic volume control, detection, and amplification. The 2A6 is identical to the 75 with the exception of heater voltage, which is 2.5 volts for the 2A6.

The 6A4, or LA, another new tube from the Cunningham-Radiotron Laboratories, is a filament-type output-pentode designed primarily for use in automobile radio receivers, or sets operated from a d-c supply line. A single 6A4 is capable of 1.4 watts output, while two 6A4's in push-pull give about 2.8 watts output.

Jig-Saw Puzzles Widely Used to Promote Tube Sales

The jig-saw puzzle craze is still maintaining its place in home entertainment. To date the RCA Radiotron Company and E. T. Cunningham, Inc., have shipped 100,000 puzzles to dealers for their use in the stimulation of new tube sales. Dealers report that the free puzzle offer is sure fire customer bait and that the low price of the puzzle makes the whole proposition extremely attractive and valuable. If you have not ordered your puzzles, do it now while they last. Order from your distributor—25 puzzles—4 different subjects—and a giant two-color window streamer, all for the amazingly low cost of \$1.20.

Advertisement

Three Volumes in One a Feature; Volume Three Also Available

Officials of E. T. Cunningham, Inc., and RCA Radiotron Company have just announced two extremely attractive deals to radio service accounts. One proposition involves Rider's Complete Perpetual Trouble Shooter's Manual; the other, Volume 3 of Rider's Manual. These two valuable books are actually being offered on a plan whereby radio service accounts may obtain them without cost. As *Radio Retailing* was going to press, the details of the two offers were being mailed to Cunningham and Radiotron Distributors.

Rider's Perpetual Trouble Shooter's Manual is the accepted standard of the radio service fraternity. Radio service men writing to leading set manufacturers for service notes and information on their radio sets find themselves referred to Rider's Manual for information.

Recognizing the importance of bringing all of the information contained in these three volumes together into one volume, it was suggested to Mr. Rider that the contents of these three volumes be printed on light weight, strong bond paper, producing in a three inch book of 2800 pages and 6000 diagrams what is now contained in three volumes about 10 inches thick. An additional feature of the one volume is the section in that volume where information on each manufacturer is presented on continuous pages—not scattered through the book.



A book, similar to the above, is available to Radiotron Dealers.

The complete Rider's Manual will be the most complete, authentic, and indispensable collection of radio and radio tube data in existence. Written and edited by the man famed for his encyclopaedic grasp of radio facts and principles. Consult your RCA Radiotron or Cunningham Radio Tube Distributor for complete information.

Radio Retailing, May, 1933



H. C. BROWN



H. H. KRONEN



J. A. MILLING

New Territories for Successful Merchandisers

E. T. Cunningham, Inc., and the RCA Radiotron Company recently announced a shifting of territories for some of their field men. H. C. Brown, New England District Manager, is moving from Boston to Utica, New York, and will be responsible for sales in the state of New York, except for New York City. W. H. Allen, who operated in Buffalo, will be moved to New York City. H. H. Kronen of the New York City District Office will make new headquarters in Boston, working in conjunction with W. J. Hill. J. A. Milling has been removed from the Southern Office in Atlanta and will now report to the Chicago Office. D. C. Patrick, formerly with the Chicago Office, is now making his headquarters in

Kansas City. All of these men have shown themselves to be successful tube merchandisers, and their past experience will be of great help to them in their new territories.

10 Cathode Tubes to Show Set Operation at World's Fair

Elaborate preparations are in progress for the RCA-Cunningham exhibits at the long heralded World's Fair in Chicago, June 1st to November 1st. The RCA exhibits will occupy a total area of 10,000 square feet in Radio Hall.

One of the most interesting exhibits will be an actual visual demonstration of what happens in a 10-tube superheterodyne receiver circuit. Cathode ray oscillographs placed at each stage of the circuit where a radio tube functions will show the wave form of the output from each particular stage in the set.

The wave form of the incoming radio signal is shown first. The increased strength of the incoming signal is then shown after it has been amplified by the radio frequency amplifier tube. The wave form of the oscillator output is next shown, and then the combination of the oscillator output and radio-frequency signal is shown in the output from the first detector. Next, the effect of intermediate frequency is shown. Finally, the second detector separates the audio-frequency component from the radio frequency signal and passes the audio signal on to the output tubes.

Cunningham-Radiotron Win Praise

"I wish to commend your organization for its splendid cooperation with the radio service men. I find RCA far ahead of others in this respect and have for years only recommended Radiotrons to my customers because of their superior quality." So runs a communication from W. C. Frame, Salem, Iowa.

A letter from Henry Findlay, Brooklyn, New York, to E. T. Cunningham Inc., runs as follows: "For the past seven or eight years I have been patronizing Cunningham Radio Tubes and recommending them to my various customers. I have found them unparalleled in giving efficient service. I may add that during this time Cunningham Tubes have been my only standby—I can afford to install them with a 90-day guarantee and feel safe in so doing."

New Log Builds Tube Sales

The new RCA Radiotron Radio Log and the Cunningham Radio Log have both won the complete approval of the trade as valuable sales aids. In the words of one dealer, "When it comes to something which I can offer the customer as a permanent record of my name, address, and telephone number, the Cunningham Radio Log fills the bill perfectly." Another dealer writes of the RCA Radiotron Radio Log, "Everything about it has human appeal and more interest than the daily newspaper."

The tube sales increases which other dealers are enjoying through the use of these Radio Logs you too can have—and at a bargain price. Place your order now, \$2.50 per 100. In lots of 1,000, \$2.25 per 100. In lots of 2,500 or more, \$2.00 per 100. Prices with or without imprint.

In studying the construction of an RCA Radiotron or Cunningham Radio Tube, you may have noticed the holes in the tiny mica disc which act as spacers for the element supports. If the spacing of these holes does not check within one one-thousandth of an inch, the disc is rejected.

Such infinite care reflects itself in the success of your radio tube business. When you sell RCA Radiotrons or Cunningham Radio Tubes and use them in your service work, you immediately establish a reputation as a reliable radio merchant.

Advertisement

Radio Pictorial News Service Popular

The center spread of GOOD NEWS which is devoted to a Pictorial News Service of radio and radio stars, has won popular approval in the trade. Favorable comments from dealers in all sections of the country have been coming in expressing their appreciation for the real pictorial news service which they are using in their windows to attract attention.

If you are not receiving your copy of the combined GOOD NEWS and Pictorial Radio News Service, write to the Radiotron or Cunningham at Harrison, New Jersey, and ask to be placed on the mailing list.

RCA Tube Sales Up in Foreign Markets



Mr. N. A. Woodford, of the Export Sales Division, reports that, despite exchange difficulties and intense competition between American and European manufacturers, South American imports of RCA Radiotrons

have shown a very encouraging increase during the past year.

During the summer months of last year, Mr. Woodford worked with the distributors of Argentina, Uruguay, and Brazil making radical changes in distribution policies, which in no slight way have accounted for this favorable increase in sales.

Mr. Woodford, at the present time, is making a two months' trip to the major markets of the West Indies and Mexico. Visits to Cuba, Porto Rico, and Mexico are definitely scheduled, with the possibilities of visits to other smaller markets.

Guarding Cunningham-Radiotron Quality

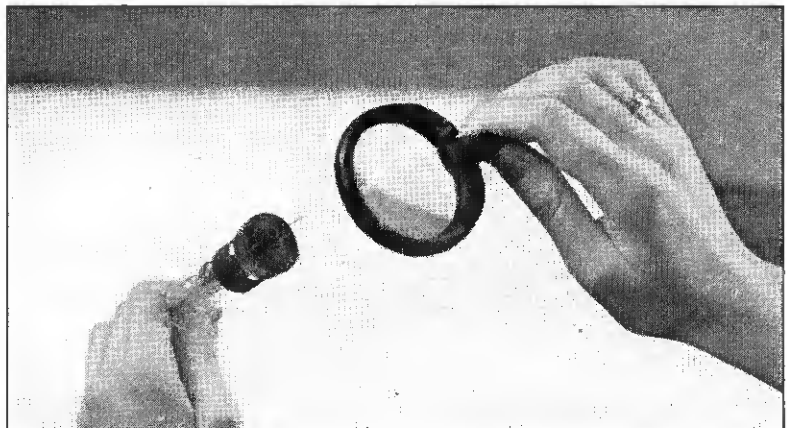

NEW MERCHANTISE

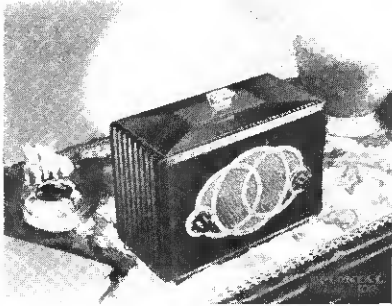

Colonial Receivers

Three a.c.-d.c. compact models are being placed on the market by the Colonial Radio Corp., Buffalo, N. Y. Each is a 5 tube superhet with a.v.c. and using the following tubes: 6A7, 6B7, 77, 43 and 25Z5.

Model 300 is a striking chromium and black set designed along modernistic lines. Constructed of satin-finished black Durez with polished chrome grille and trimmings. \$30.

Model 279 of early 19th century period is solid American walnut. \$27.95.

Model 250 is butt walnut with marquetry inlay of holly, ebony black and vermilion. \$25.—*Radio Retailing*, May, 1933.

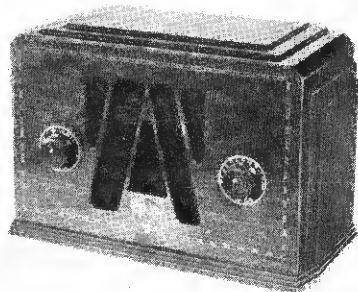

Grebe Synchronette

Listing at \$27.50, a five tube superheterodyne, "the Synchronette," can be obtained from A. H. Grebe & Co., 117 Liberty St., New York City. The tube equipment consists of 2-77's, 78, 25Z5, and 43. It operates on a.c. or d.c. and is encased in a walnut cabinet with marquetry inlays. Size—10½x5x7¼ in.—*Radio Retailing*, May, 1933.

Clarion A.C.-D.C. Set

The Hazeltine automatic volume control circuit is incorporated in the new model 420 a.c.-d.c. superhet of the Transformer Corp. of America, 2309 South Keeler Ave., Chicago.

The set features "dual" automatic volume control and has five tubes, namely, 6A7, 75, 25Z5, 78 and 43. The tuning range covers from 540 to 1720 k.c. The cabinet is American walnut with inlaid marquetry.—*Radio Retailing*, May, 1933.

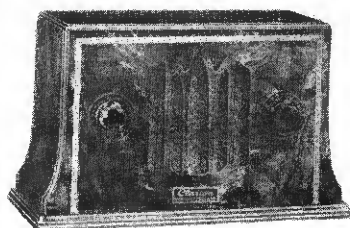

U. S. Radio Line

The following tubes are used in the new model 3092 a.c.-d.c. compact of the United States Radio & Television Co., Marion, Ind., 6F7, 78, 75, 43, and 25Z5. It is a superhet and measures 7¼x9¼x5 in. The cabinet is figured stump walnut, with inlaid design. The tuning range includes the regular broadcast stations and one police channel.

U. S. Radio also offers a new battery ensemble, a midget model complete with self-contained batteries, Model 3086. The batteries supplied are one A-battery, three B-batteries, and a C battery. It is a 5 tube superheterodyne with the following tubes; 230, 2-232, 234 and 233.

At the same time this company announces another battery model No. 3084 with the same chassis but without battery kit.—*Radio Retailing*, May, 1933.

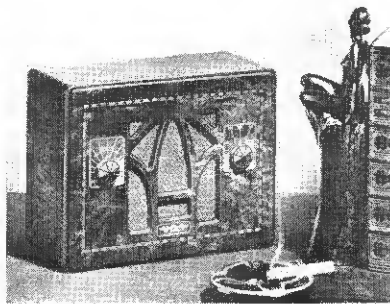

Philco Auto Radio

A one piece, compact automobile radio, in which the receiver, speaker and vibrator are housed in one shielded container, which may be quickly installed on the dash, is now being made by the Philco Radio & Television Co., Philadelphia, Pa. This set lists at \$39.95. To install it is necessary to drill only three holes in the dash and bolt the set in place. The control is mounted on the steering column.—*Radio Retailing*, May, 1933.

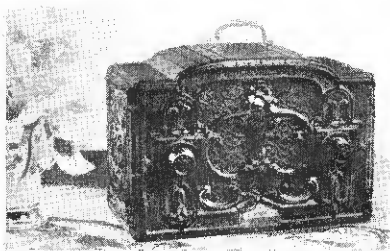

GE Radio Line

The latest additions to the line of the General Electric Co., Bridgeport, Conn., are:

Model L-50 at \$24.75—an a.c.-d.c. set with hand carved effect cabinet, jewel case design. It is a five tube superhet.

Model L-51 is the same set enclosed in two tone walnut cabinet.

Model K-51 is a table chest model with hand-carved effect cabinet and sliding doors. Also a five tuber.

Model K-54 uses the same set in combination with a phonograph which plays all types of records and lists at \$49.95. The table model cabinet is of the humidior type.

Model K-41 is a four tube a.c.-d.c. set with t.r.f. circuit listing at \$12.95. The cabinet is metal and the tuning range includes police calls.

Model K-40A in a different cabinet but with the same circuit, lists at \$17.95.—*Radio Retailing*, May, 1933.

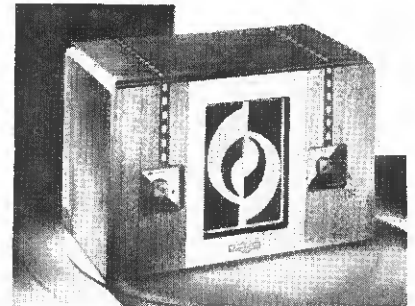

Majestic A.C.-D.C. Sets

The new a.c.-d.c. series of the Grigsby-Grunow Co., 5801 Dickens Ave., Chicago, incorporates a superhet circuit using the following tubes; 2-G-57AS, G-58AS, G-43, G-25Z5, G-46A1. Both of these models are compact, light in weight. The "De Luxe Travel Super-Six" comes in a walnut cabinet inlaid with Harewood and Marquetry. The highly polished aluminum grill ornament adds a distinctive touch. A suede traveling case is available at \$2.50.

The "Super-Six Knockabout" is furnished in leatherette travelling case. Both carry a list of \$29.50.—*Radio Retailing*, May, 1933.



Super-Fadalette

Following on the heels of the Fadalette, comes word from the Fada Radio & Electric Corp., Long Island City, N. Y., of the "Super-Fadalette" with several added features.

There are two models, 106 and 107. Both are 5 tube superhets for a.c. or d.c. operation with a receiving range covering from 75 to 200 meters. The tubes employed are F6A7, F78, F6B7, F43 and F25Z5. The F6A7 and F6B7 are dual purpose tubes. Both sets have a.v.c.

Model 106 in a wood cabinet covered with art leather in green, brown, red or ivory is \$24.95.

Model 107 in a walnut cabinet is \$26.95.—*Radio Retailing*, May, 1933.

Pierce Airo Sets

A complete family of DeWald a.c.-d.c. receivers, including three compacts, one mantel type and one console, has been placed on the market by Pierce-Airo, Inc., 519 6th Ave., New York City.

Model 551 is equipped with a 25Z5, 77, 78, 44 and 43, and comes in a walnut cabinet. \$30. Model 550 at \$25 is essentially the same with a few minor cabinet changes.

Model 54-A while not a superheterodyne is a five tube set which works on 6, 32, 110, 220 volt a.c.-d.c. as well as on farm lighting circuits, in automobiles, etc. \$25.—*Radio Retailing*, May, 1933.

RCA Victor Line

To create new radio sales during the summer months, the RCA Victor Co. Inc., Camden, N. J., has introduced a complete line designed to meet summertime requirements.

Beginning with the lowest price models, there is a 4 tube a.c.-d.c. set in either a metal or wood cabinet selling at \$12.95 and \$19.95, respectively.

These are followed by 6 "Carryette" receivers with 5 tube chassis, ranging in price from \$19.95 for Model R-28; \$21.50 for Model 28A; \$24.95 for the two chest models; to \$29.95 for the Tambour and Sheraton models.

Then there are two 6 tube sets—a table and a console—with visual tuning indicator. There are R-37 and R-38, priced at \$29.95 and \$49.95.

Model RE-40 is a table model radio-phonograph combination which lists at \$49.95. The electric phonograph plays either 33 $\frac{1}{3}$ or 78 r.p.m. records. 5 tube chassis is incorporated.

There are also two attractive "furniture" models. Model R28F is a Duncan Phyfe table. \$44.50. Model 28G, a night table of walnut veneer with a lower shelf for books, is selling for \$37.50. Each has 5 tube set.

Model R-90 is a 10 tube Bi-Acoustic superhet with Tonalite control system.—*Radio Retailing*, May, 1933.

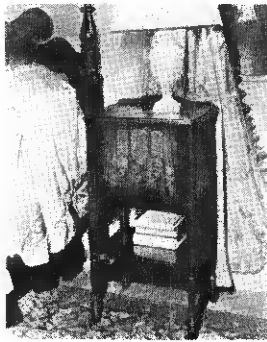

G-M Photo-electric Installation

Standard photo-electric control equipment can be obtained from the G. M. Laboratories, Inc., 1731 Belmont Ave., Chicago, to make automatic drinking fountains.

To get a drink all you have to do is to bend over. These are becoming quite universally used in offices, theatres, etc.—*Radio Retailing*, May, 1933.

New Philco Lazy X

A new low priced Lazy X radio supplements the line of Philco Radio & Television Co., Philadelphia, Pa.

This set combines the inclined sounding board with the controls in a small portable cabinet which can be moved to any point in the room. With it one can select stations and control both tone and volume. This set also brings in police and airplane calls.

The model number is 19TX and the list price is \$65.—*Radio Retailing*, May, 1933.



Radio Retailing, May, 1933

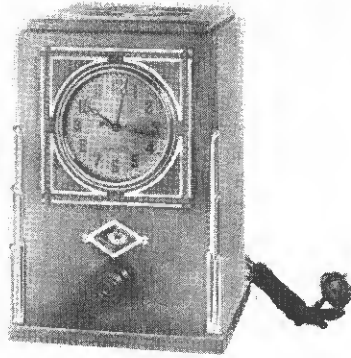

Velco Clock Radio

Done in Moderne styling with chromium fittings, the Model K of the Velie Engineering Co. Inc., Newark, N. J., may be had in six colors as well as black. An electric clock is built in.

This set is a five tube superheterodyne measuring 7 $\frac{1}{2}$ in. deep by 11 in. high, by 7 $\frac{1}{2}$ in. wide. The list price is \$27.50.—*Radio Retailing*, May, 1933.

DeVry B-Eliminator

The standard B power supply unit for auto radios made by Herman A. DeVry, Inc., 1111 Center St., Chicago, Ill., delivers 220 volts at 40 mils. Special units for larger auto radio sets deliver up to 250 volts at 50 mils.

A feature of this eliminator is its size—smaller than the average cigar box.

Claimed for this device is conversion to an absolute alternating current instead of a mere interrupted current; a.c. current created has a nearly perfect wave form with a constant frequency of 150 cycles regardless of load; use of an entirely new non-metallic composition for its contact, which permits a 500% overload.—*Radio Retailing*, May, 1933.

ICA Short Wave Converter

A one tube short wave converter which when attached to the set brings in police calls, aviation reports, news from ships at sea and other short wave features, is now being made by the Insuline Corp. of America, 23 Park Place, New York, N. Y. This converter utilizes the entire receiving circuit of the set and employs a 227 tube which draws power from the set through adapters furnished with each converter. It is enclosed in a metal casing with crackle finish. List price \$8.—*Radio Retailing*, May, 1933.

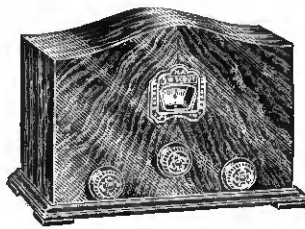

Lynch Products

A short wave antenna set can be obtained from the Lynch Mfg. Co., 1775 Broadway, New York City. A system, which in technical parlance is called a "doublet antenna," connects the receiver by means of a transposed transmission line. An important consideration is that the insulating unit must be of superior construction and the engineers of Lynch in co-operation with Isolantite, Inc., have developed products suitable for this use.

Although designed for short wave reception, this antenna is equally effective on regular broadcast waves.

Lynch also makes a resistance measuring device. \$4.—*Radio Retailing*, May, 1933.

Fordson Midget

Model 6T "Goldentone" superheterodyne offered by the Fordson Radio Mfg. Corp., 11702 Livernois Ave., Detroit, Mich., uses two 58's, 55, 2-59's and an 80. It has a.v.c., composite oscillator and first detector, one stage i.f., 2nd detector combining diode rectification with a.v.c., triode amplification and a dual 59 amplifier. Comes in a walnut veneer cabinet 16x14x19 in. and the speaker is a 6 in. Sonochorde.—*Radio Retailing*, May, 1933.

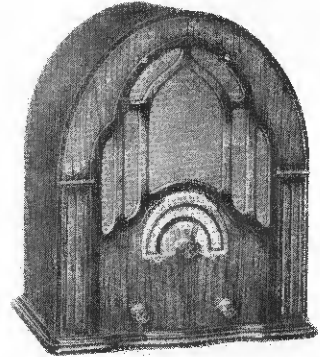

GE Auto-Radio

A one piece auto-radio set which can be attached with one bolt, is being made by the General Electric Co., Bridgeport, Conn. Ignition interference has been eliminated by double shielding of the vibrator power supply, complete shielding of the entire equipment, and the use of a tone control. It is a four tube set (78, 6A7, 6B7 and 89). The use of tubes with multiple functions results in seven tube performance. This set has a.v.c. The list price is \$34.95.—*Radio Retailing*, May, 1933.

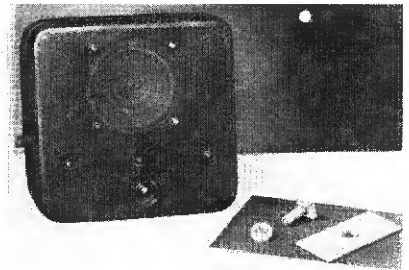

Carrying Case for Midgets

A suedine carrying case with rust-proof zippers can be obtained from the Leather Products Co., 785 Main St., Bridgeport, Conn. It is available for all makes of radio. Retail prices range from \$1.25 to \$1.75.—*Radio Retailing*, May, 1933.



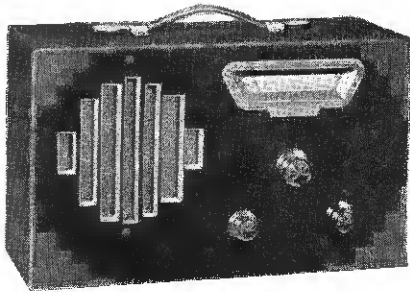

"Auto-Letric" Portable Auto Radio

An all-electric portable set which operates on six volt storage battery or 110 volt a.c. or d.c., is being made by the Automatic Radio Mfg. Co., 1201 East Lake St., Minneapolis, Minn.

It is a completely self-contained set which can be quickly installed in the car or home. A circuit with plug-in arrangement automatically makes necessary changes from 6 volt to 110 volt operation.

The set is a five tube superheterodyne using 2-39's, 36, 38 and a KR1. It will receive police calls. \$39.50.

The cast aluminum cabinet measures 13½x8x4½ in. Finished in antique bronze with carrying strap.—*Radio Retailing*, May, 1933.

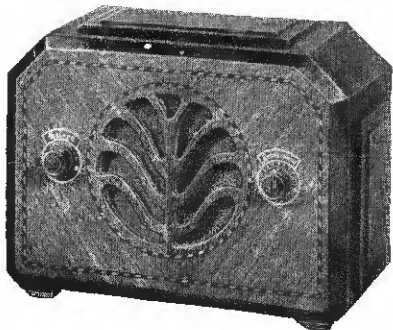

Halson Receiver

Model 43B-A of the Halson Radio Mfg. Corp., 45 Lispenard St., New York City, is a four tube set using a 43, 25Z5, 36 and 39. It is an a.c.-d.c. set in a butt walnut cabinet. Also available in a metal cabinet as Model 100D and in a different type wooden cabinet Model 51A.

Model 20-A is a five tube super using 43, 25Z5, 77 and 2-78's. This set picks up long and short wave as well as police calls. Also an a.c.-d.c. model.

The prices are \$11.95, \$13.95, \$15.95 and \$18.88.

Halson offers an auto radio set with B eliminator. It is a six tube superheterodyne listing at \$29.50.—*Radio Retailing*, May, 1933.

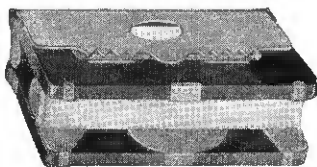

Neon Lightning Arrestor

L. S. Brach Mfg. Corp., 55 Dickerson St., Newark, N. J., has developed a Neon lightning arrestor for the protection of radio broadcasting and other low-voltage circuits. This arrestor can also be used in protection of cable wires and coil shunting by being placed across the terminals of relays, resistors, etc.

An important feature is its compact size, ½ in. wide by 1½ in. long, arranged to mount on a ½ in. center.—*Radio Retailing*, May, 1933.

Fay Electric Floor Machine

A compact electric floor machine that not only polishes but also waxes, scrubs and resurfaces wooden, linoleum, rubber, cork and plain and patterned floors, and known as the Fay Diamond Model, has been introduced by the Fay Company, Inc., 130 Madison Ave., New York City. It is designed to place 20 lb. of weight directly over its two revolving brushes, giving it the necessary weight, balance and speed to easily and quickly take care of floor surfaces in homes, hotels, show rooms, etc.

Standard equipment includes the two sets of brushes, 25 ft. length of cable, lambs wool wax applicator and a quart can of special liquid wax. Extra accessories are available for scrubbing, for rough tile floors, etc.—*Radio Retailing*, May, 1933.

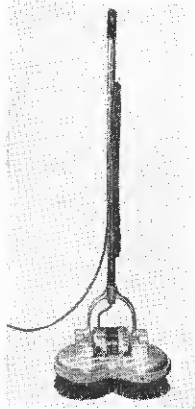

Amplex Du-Plex

The "Du-Plex" made by the Amplex Instrument Laboratories, Inc., 132 W. 21st St., New York City, acts as an aerial eliminator and as an antenna intensifier. It is said to have capacity equal to 150 ft. of aerial. Quickly attached. Lists at \$2.—*Radio Retailing*, May, 1933.



Powerack

Mounted at the head of the motor in such a position that a grooved wheel rotates with the fan belt which turns over the armature of the charging generator of the car the Powerack delivers 110 volts a.c. To excite the field of the Powerack unit, a small amount of current is needed, and this is taken directly from the low side of the charging battery. It is available in different forms and models, delivering 110 volts a.c. at different wattages.

When installed a two way outlet appears on the dashboard of the car, so that an a.c. radio can be plugged into the Powerack.

It can be used with the gasoline motor on a motorboat. Where gasoline motors are not available, it is powered by its own gasoline motor. It also comes equipped with a motor which operates from a 32 volt source. Made by Radio Chassis, Inc., 112 W. 18th St., New York.—*Radio Retailing*, May, 1933.

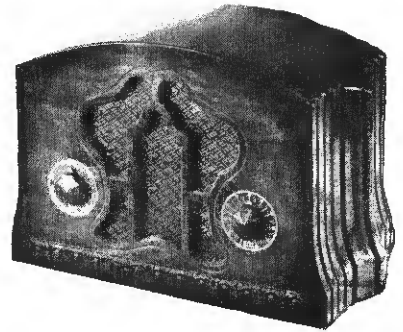
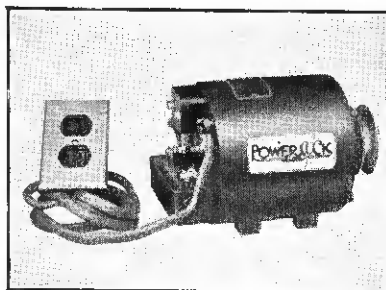

Balkeit Radios

Two midgets have been added to the line of the Balkeit Radio Co., 904 Blackhawk St., Chicago, Ill.

Model 65-S is a five tube a.c.-d.c. superhet listing at \$27.50. The tubes used are a 25Z5, 6C6, 6D6, 75, 43. Special line cords furnished for 6, 32 or 220 volts.

Model BM4 is a compact four tube set using a 56, 57, 53 and 47. It is 10 in. wide by 12 in. high. \$15.—*Radio Retailing*, May, 1933.

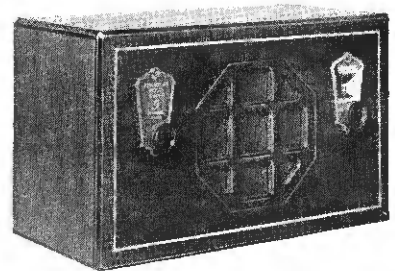

American Bosch Super Five

Classified as a super five, the new five tube Personal radio of the United American Bosch Corp., Springfield, Mass., is a superheterodyne with full a.v.c. The circuit is designed around the new double diode triode tube. The retail price is \$24.95.—*Radio Retailing*, May, 1933.



Stewart-Warner Refrigerators

To supplement their standard line, the Stewart-Warner Corp., Diverser Blvd., Chicago, announces a De Luxe line of electric refrigerators. Suggestions from housewives are responsible for many of the improvements in the new line. A special force feed, chilled oil lubricating system which protects the inbuilt precision of the moving parts, and insures long life of all working parts, is a feature.

Stream-line cabinets show the practical application of modern art. The dual door latch is concealed and a finger-touch push or pull on the handle opens it. An interior light is provided, the shelves are adjustable, and the freezing control provides twelve freezing speeds.

Four models are available. Model No. 45 4½ cu.ft. capacity; 55, 5½ cu.ft.; 65, 6½ cu.ft., and 77, 8 cu.ft.—*Radio Retailing*, May, 1933.

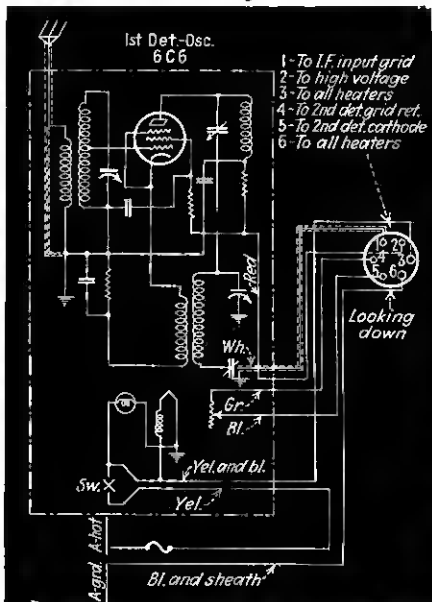

control head fastened to the steering column and carrying electrical leads only to remaining circuits and storage battery (The GM smoking-stand remote-control used a similar principle).

The "mixed" signal appearing in the output of the electron-coupled first detector-oscillator is fed to the i.f. stage, located in the main chassis, through an individually shielded lead. Volume control is accomplished at the steering-post by means of a variable resistor cabled in series with the second detector grid return, permitting manual variation of bias voltage. Antenna currents are brought to the detector-oscillator via the customary shielded lead in the windshield column. Heater, pilot light supply and switch wiring may be readily traced.

The entire control cable, including battery leads to and from the switch, is completely shielded. This is not shown.

6F7

The new type 6F7 combines a small triode and a pentode with internally connected suppressor in the one envelope. Triode and pentode elements are entirely separate except for a common cathode sleeve. Separate emitting sur-

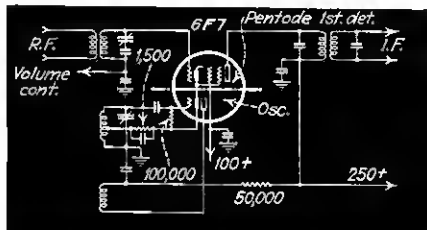

faces are provided on the sleeve for each set of elements.

The tube is at its best as an oscillator-first detector in superhets. The triode may be used in orthodox oscillator circuits but inasmuch as its active cathode surface is connected to that of the pentode by the common sleeve it is convenient to return the cathode to ground

through an oscillator coil, accomplishing the "mixing" in this manner.

The pentode control grid is of the remote cut-off type, hence the output of the detector may be varied by introducing a volume control in the grid circuit, without fear of distortion. Average characteristics of the tube when used as a combined oscillator and first detector are as follows:

Heater volts	6.3
Heater current	0.3
Pentode plate volts	250
Pentode plate current	5.5
Pentode screen volts	100
Pentode screen current	1.5
Triode plate volts supply (through 50,000 ohms)	250
Triode plate current	2.75
Triode grid leak	100,000 ohms
Conversion conductance	550 ohms
Plate impedance	600,000 ohms

The tube uses a small seven-pin base. Looked at from below, reading clockwise from the two large heater prongs, connections are: Heater, heater, pentode plate, pentode screen, triode plate, triode grid, cathode. Cap connection is the pentode control grid.

2A6

Type 2A6 is a new duo-diode triode with a 2.5 volt, 0.8 ampere heater. It is identical in all other respects to type 75 (RR42Apr). Mark this on your "Black & White" tube socket diagram chart for reference until the new one is published.

The tube will probably be used chiefly in connection with resistance-coupled audio-frequency amplifiers. Average characteristics under different plate voltage conditions are shown in the following table. The values indicated are recommended by tube manufacturers and set makers may be expected to digress slightly:

GRID RESISTOR (Megohms)	BIAS VOLTS	SELF-BIASING RESISTOR (Ohms)	PLATE LOAD (Megohms)	PLATE CURRENT (Ma.)
-------------------------	------------	------------------------------	----------------------	---------------------

Plate Supply Volts=180

0.25	-1.25	4,900	0.25	0.25
0.25	-1.20	7,100	0.50	0.17
0.50	-1.30	5,450	0.25	0.24
0.50	-1.30	9,000	0.50	0.14

Plate Supply Volts=250

0.25	-1.30	3,170	0.25	0.41
0.25	-1.30	5,200	0.50	0.25
0.50	-1.35	3,380	0.25	0.40
0.50	-1.35	5,600	0.50	0.24

Plate Supply Volts=100

0.25	-1.05	10,500	0.25	0.10
0.25	-1.05	15,400	0.50	0.07
0.50	-1.10	11,550	0.25	0.09
0.50	-1.05	15,000	0.50	0.07

Plate Supply Volts=135

0.25	-1.05	6,200	0.25	0.17
0.25	-1.10	9,150	0.50	0.12
0.50	-1.05	5,850	0.25	0.18
0.50	-1.10	10,000	0.50	0.11

These operating values should be useful to servicemen as sets using the 2A6 will probably be encountered in the field prior to the release of servicing bulletins.

Inexpensive Mixer and Pre-Amplifier

By J. J. Bressler
Federated Purchaser, Inc.

Much has been written about mixing circuits. These units usually consist of four or more transformers and the necessary constant impedance pads and

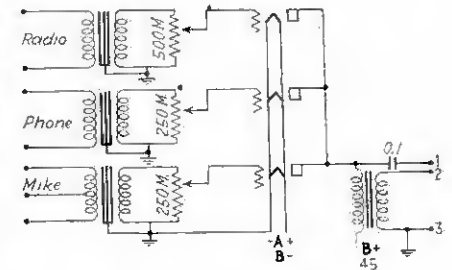

are based upon commercial telephone circuits used long before public address and radio were known. Very little, however, has been done to bring mixing circuits within the price range of the average serviceman and small public address operator.

Here is a circuit which allows the use of inexpensive units, most of which are usually to be found in shop "odds and ends" boxes. Even where parts must be purchased the system permits a considerable saving when compared with special mixing equipment. Due to the novel design of the circuit constant impedance is always maintained and no loss in quality incurred. The values set forth are arbitrary and may be varied to suit individual requirements.

The only critical factors are the primaries of the matching transformers. These must of course match the devices with which they are associated, radio output, phonograph pickup, mike and pre-amplifier output. The latter unit should have a primary impedance of about one-third the impedance of one tube. When using type 30's, a single 71A or 45 type tube-to-line transformer or a single choke of approximately 30 henries inductance will be ok.

Terminals 1 and 3 may be shunted with approximately 100,000 ohms and connected directly to the grid of the first amplifier tube. Or the secondary of the output transformer (terminals 2 and 3) may be of any desired impedance for connecting to a circuit-matching input transformer in the amplifier. Or it may be a high-impedance secondary for connecting directly to the grid of the input tube.

ONE OF THE CHAINS PUMPS its sound broadcasts into the air via the 7-meter Empire State television transmitter, designed to pass an extraordinarily wide band of musical frequencies, evidently to keep the station on the air. We checked quality with a super-regenerative "ham" receiver the other night. What a revelation in tone. This may eventually be the medium for higher quality local broadcasts.

Fixed Resistors

How to measure noise, voltage-coefficient, values.
Importance of humidity, load, ageing characteristics

By **JESSE MARSTEN**

Chief Engineer,
International Resistance Company

THE grid leak was about the only fixed resistor employed in sets made in the early radio days. If it displayed resistance of the order of magnitude desired, it was considered satisfactory. Other characteristics were rarely examined. Since then the rapid progress in radio set development has necessitated a parallel improvement in the characteristics of all component parts.

This development was especially important for resistors since the field of application in radio receivers broadened out considerably. To cite a few present-day applications, they are now used as grid leaks, fixed bias resistors, coupling resistors, voltage dividers, filter resistors; they must operate under conditions of wide voltage variation and must be able to dissipate power. Almost every circuit in the receiver contains a resistor.

In view of this, the radio resistor has undergone a very extensive development in the laboratories of responsible manufacturers with the object of improving all characteristics and providing a resistor which will be stable and permanent under all conditions of service. It is useful to know what these characteristics are that a good radio resistor must possess, and how these are determined.

It might be pointed out that not all characteristics are quickly determined by a short test. Some of them take time, and others require equipment not always at hand. For the information obtained from the lengthy tests, the serviceman must generally depend upon the reliability and integrity of the manufacturer.

Accuracy of Resistance Value

In many circuits voltages are fixed by a resistor, for example the grid bias resistor fixes the bias voltage on a tube. In such cases it is important that resistors be accurate to within the toler-

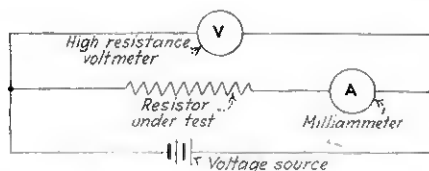

Fig. 1—Volt-Ammeter Method of Measurement

ances required. In any event one of the marks of a reliable resistor is that its value be within the limits specified by the manufacturer. This is determined by a simple resistance measurement on a Wheatstone bridge or ohmmeter. Another method used is the volt-ammeter method shown in Fig. 1. The voltage across the resistor and current through it are measured. The resistance value is then given by Ohm's law.

$$\text{Resistance} = \frac{\text{Volts}}{\text{Amperes}} = \frac{1000 \text{ Volts}}{\text{milli-amperes}}$$

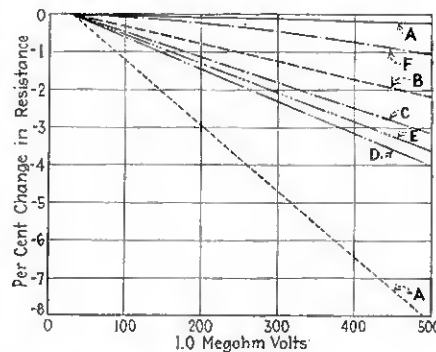

Fig. 2—Voltage Coefficient of Various Resistors

A high resistance voltmeter having a resistance of 1000 ohms per volt or more, should be used in such measurements and the position of the milliammeter should be as indicated, otherwise there will be a considerable error, when measuring high value resistors, due to the current through the voltmeter.

A good resistor should not only be within the accuracy tolerance specified by the manufacturer but should be within this tolerance when measured at any voltage up to its rating. Obviously, if a resistor measures 1 megohm at 10 volts and also measures 800,000 or 900,000 ohms when measured at 200 volts, it cannot be said to be a fixed resistor. Its value will vary with the voltage at which it is measured. A good resistor will measure up to the same value no matter what the voltage, so long as the rating is not exceeded. Voltage coefficient is determined by measuring the resistance at different voltages by any of the methods given in the preceding para-

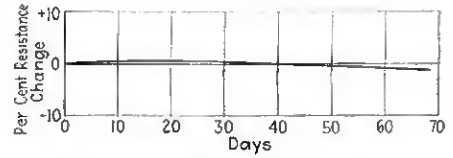

Fig. 3—Shelf Test on 100,000 Ohm Unit

graph and plotting the resistance against voltage at which the measurement was made. The curve for an ideal resistor would be a horizontal line, representing the same value for all voltages. The greater the departure from a horizontal line the greater the voltage coefficient, and the poorer the resistor. Figure 2 shows a comparison of voltage coefficients for different types of resistors. Such a measurement is simple to make.

The value of a resistor with low voltage coefficient will be apparent to the service man. The same value of resistor may be used in different positions at different voltages. A 500,000 ohm grid leak may only have a few volts across it, whereas a 500,000 ohm coupling resistor may have as much as 200 volts across it. No service man wants to be annoyed having different kinds of 500,000 ohm resistors for use at specified voltages. He wants to be able to pick a 500,000 ohm resistor which will have this value at any voltage and be able to use it at any voltage in any circuit position. This means a low voltage coefficient resistor.

Knowing that a resistor has a certain value, and has this value at any voltage, we are confronted with the question which determines the merit of the resistor: Will it retain this value after being placed in service? The answer to this depends upon the following:

1. Aging Characteristics
2. Humidity Characteristics
3. Load Characteristics

Aging Characteristics

Aging characteristics are determined in much the same way that shelf life of batteries is determined. The value of the resistor is measured daily, the resistor not being in use. All resistors show a certain amount of aging—even wire wound resistors do this. That is why, for extremely high precision, where small fractions of a percent are important, it is necessary to age wire. The smaller this aging, the more constant and dependable the resistor is. Aging must be determined over long periods of time in order that variations in season and weather be taken into account. It is important that the same method of measurement be used throughout the test so that uniform and

Article Number 2

SELECTING REPLACEMENT PARTS

This is the second of a series prepared to help servicemen select repair parts for fitness and quality (Electrolytic Condensers, RR41Mar). Power Transformers will be discussed in an early issue.

consistent results will be obtained. Fig. 3 illustrates the results of an age test on a high quality resistor.

Humidity Characteristics

Radio sets and similar equipment are used throughout all seasons of the year and in all climates. Resistors must be capable of retaining their value within reasonable limits when subjected to high degrees of humidity, whether load is applied or not. A radio set which is idle during the summer months is subjected to high humidity. When put in service again it should operate with entire satisfaction. This will not be the case if the various parts are susceptible to moisture. In the case of radio resistors the effect of humidity is to increase the range of the resistor. A poor resistor may increase in value as much as 50% or 100%. A good resistor should not increase in value more than about 10% to 15% when subjected to a severe humidity test. Equipment for this test is generally not available to the service man and the reputation of the manufacturer is the best guide here.

The method of test for this characteristic is briefly as follows. A humidity chamber is kept at a temperature of 40° C by means of thermostatic regulation. The humidity in the chamber is controlled at 90% relative humidity by means of a saturated solution of sodium tartrate. There are other methods of maintaining the humidity, but the above is a satisfactory one. The test consists of measuring the resistor dry and then placing it in the humidity chamber for 100 hours. The resistor is then removed from the humidity chamber and measured. A good resistor will not change more than about 10%. Fig. 4 illustrates the change in resistance, under such a test, of high quality resistors.

The above test tells the behavior of a resistor under humidity conditions when no load is applied to the resistor. The behavior of a good resistor will be substantially the same when load is applied. A precaution to be observed in making this test is that d.c. should be employed and the polarity of voltage applied to the resistor should be kept the same throughout the test. This duplicates actual operating conditions in a set and will show up any objectionable electro-chemical reactions which might develop.

Frequently it is possible to detect a poor resistor in a very simple manner by making a humidity test. When a good resistor is removed from a humidity chamber and measured on a Wheatstone Bridge, no trouble is encountered. It may not be possible, however, to measure a poor resistor in this way, because electro-chemical reactions at the terminals may set up variable voltages at the contacts. The bridge in such cases cannot be properly balanced, and the needle of the galvanometer will swing erratically.

Load Characteristics

All radio resistors change in value to some degree when subjected to normal rated load. This change due to load only should be small. It is characteristic of a good resistor that when the load is removed and the resistor is allowed to cool off it will return to within one or two percent of its original value.

This shows that the resistor has the quality called "Permanence."

Some resistors may show this characteristic for the first few days of a test. This is not sufficient data, however, for drawing the conclusion that it is good. A life test should be made which will last for at least 1,000 hours in order to ascertain whether this characteristic is present. Furthermore, such a test should be made operating intermittently. The usual satisfactory test

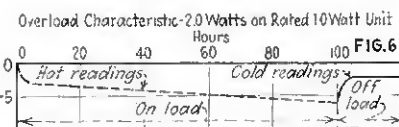
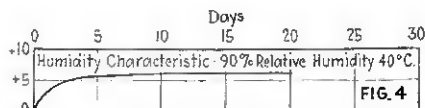

Performance Curves on 100,000 Ohm Metallized Resistors

is one where the load is applied for 1/2 hours and is off for 1/2 hour. This cycle should be continued for at least 1,000 hours. The object of the intermittent operation is to permit the unit to undergo a heating and cooling cycle, which in some resistors has been a source of trouble.

Fig. 5 illustrates the behavior of a high quality resistor. The dotted line shows the percent change in the value of the resistor while it is still hot, and the full line shows the percent change in the value of the resistor after cooling. It will be observed that the change while under load is only 3 1/2 percent, while the resistor returns to within one percent of its original value. Another fact to be observed is that the curves are close to horizontal lines, showing that the values are quite constant over the life test and show no wide erratic swings, or progressive increase in change of value.

Another test sometimes employed to

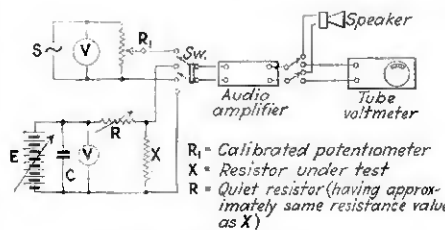

Fig. 7—Noise Test Setup

determine behavior under load is an overload test. This is a short time test and as generally made the overload is applied continuously for 100 hours. Readings are taken daily while the resistor is hot. At the end of the test the resistor is allowed to cool off and a final reading taken. The usual overload varies from 50% to 100%. Under such a test a good resistor should not show a permanent change exceeding 10%.

Figure 7 shows a curve giving the behavior of a good resistor under such a test.

Noise

Noise in a radio receiver or amplifier may sometimes be traced to defective or faulty resistors. All radio resistors display a certain amount of microphonic noise, which, when listened to, sounds like a hiss or rush. When this noise is continuous, even, it is not objectionable. It is the erratic crackles which cause trouble, and this is most often due to faulty high resistance contacts at the terminals of the resistor. This noise will be evident only when direct current flows through the resistor.

It is possible to measure noise quite simply. Fig. 7 shows the circuit set up. A high quality audio amplifier having an overall voltage amplification of 1000 or more is used with a rugged V.T. Voltmeter reading up to 3 volts on its output. A speaker or phones may be used for a listening test. A battery supplies the rated load to the resistor X under test, which is in series with a quiet wire wound resistor having about the same value as X. X is then connected to the input of the audio amplifier, which should be isolated from the d.c. supplied by battery E, by means of a condenser. (This is necessary to prevent the application of external bias to the first a.f. tube. In the amplifier shown both bias and blocking condenser are provided internally.) The noise developed by resistor X can then be heard in the speaker or phones, and can also be measured by the V. T. Voltmeter. If the voltmeter needle fluctuates erratically the resistor is very noisy. The actual reading is also a measure of the amount of noise developed under the load.

If desired this can be actually measured by a comparison with a known source of voltage S. S may be a 60 cycle voltage fed to the amplifier through a calibrated attenuator R1. The attenuator is adjusted until the output voltmeter registers the same value as was registered by the noise developed by the resistor X under test. Knowing the value of the 60 cycle voltage necessary to give the same output voltage, we can say that the resistor has so many volts noise. As an illustration, suppose the resistor under test is a 100,000 ohm, 1 watt resistor. R is adjusted to be 100,000 ohms and E is adjusted so that the voltage across X is the voltage at which it is desired to measure noise. The DPDT switch is thrown so X is connected to the amplifier. The amplifier gain is adjusted so that a good deflection is obtained, say about 2 volts. The DPDT switch is now thrown to the 60 cycle source S, which is 1 volt as measured by a voltmeter, let us say. The attenuator R1 is adjusted until the V.T. voltmeter reads 2 volts as before. Suppose the attenuator R1 setting is such as to give an attenuation of 1,000 times. Then the a.c. voltage applied to the

amplifier is $\frac{1}{1000}$ volt and since this gives the same output as the resistor X under test, we may say that the noise of the resistor is $\frac{1}{1000}$ volt.

SHOP SHORTCUTS

Volume-Compensated Tone Control

By Morris Chernow

The dropping out of low musical frequencies when volume is turned down low is a common phenomenon, although a few modern sets make provision for boosting these tones automatically. A booster accessory which can be easily attached to most sets (certain resistance-coupled types are not adaptable) is not difficult to make.

As shown in the circuit diagram it consists of a 50,000 ohm potentiometer

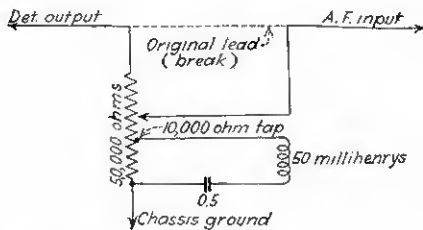

tapped at 10,000 ohms, a 0.5 mfd. condenser and a 50 millihenry inductance. The condenser and coil form a resonant A.F. circuit. Simply break the set connection from detector output (plate) to first audio grid and insert the device as shown, grounding the third leg. Turn the original volume control of the set to maximum and leave it there, using the new control exclusively. It may of course be mounted in the place of the old control on the panel although in some instances use of both the original and new control to prevent cross-talk by strong locals is recommended.

The resonant coil may be simply 750 turns of fine wire on a two-inch wood or composition form.

Pulley-less Antenna Pulleys

By A. B. Clark

Trouble with pulleys on the top of antenna poles can be avoided by using screw-type porcelain bracket insulators for this purpose instead. These are equipped with

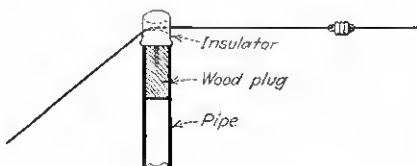

a galvanized screw about 2½ in. long and have a smooth hole through which the pull-up wire may be threaded.

Screw the insulator into the very top of wood poles, first banding the end of the support to prevent splitting. A small hole

should be drilled before the insulator is twisted home. If iron pipes are used as supports plug the end with wood to accommodate the insulator screw.

Solid pull-up wire can be used and if carried back makes a good guy. Electrical supply jobbers have the insulators.

Bridge Measures Small Capacities, Matches I.F. Coils

By Paul E. Grivet

A recently purchased box of fixed mica condensers marked .0005 mfd. turned out to be an assortment of sizes between .00233 and .000374! So I made a bridge that they might be properly calibrated.

The principal parts were three straight line capacity variable condensers with .001 mfd. maximum. Two of these were mounted to operate on one dial by using the drum and tuning band from an old battery set, giving me two ratio arms. The other was mounted to operate on an independent dial and was provided with a switch by means of which it could be completely removed from the circuit. The ratio arms were

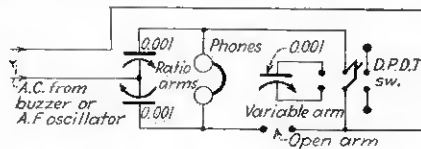

adjusted so that when one condenser was entirely engaged the other was entirely disengaged.

When measuring small condensers the ratio dial was set at 50, giving a 1:1 ratio. The unknown condenser was inserted in the open arm of the bridge and the single variable arm dial turned until minimum sound was heard in the phones. With a 0-100 dial in the single variable arm small capacities between .0001 and .0009 may be read directly on this dial in mfd. if a calibrated scale is made. Values above and below should not be attempted with any expectation of accuracy because their reading will be either too near the ends of the dial or beyond its range. In this case the ratio arms must be changed to get an appreciable reading on the single dial.

Coils in intermediate transformers with condensers in parallel may be checked for short-circuited turns against one another without removing them from the cases or disconnecting the condensers. This may be done by putting identical windings of each transformer in each arm of the bridge and obtaining a balance by rotating the ratio arm dial. When checking coils the variable arm condenser is switched out. If i.f. transformer windings supposed to be alike do not balance at 50 on the ratio dial then there is something wrong and a new transformer should be substituted in one arm to detect the defective unit.

A high-frequency buzzer makes a good driver for the bridge. I use a dynatron audio oscillator with one stage of a.f. amplification, however, this same unit being on hand for modulation of r.f. and i.f. oscillators.

Bumpers As Auto-Radio Aerials

By Charles Craddock

Bumpers, front or rear, make good auto-radio antennas if properly insulated. I use ordinary flexible sheet fiber insulation or

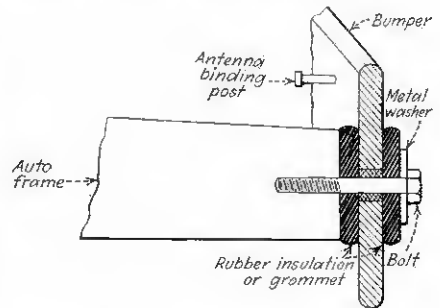

hard-rubber grommets for the purpose, in some cases enlarging the bumper holes to give proper clearance.

A binding post is mounted where most convenient for connection of lead-in to bumper. The lead-in is shielded. Split-bumpers are joined together with braid bonding and all parts which might generate noise should be so handled.

Adjustable Bench Lighting

By Joseph E. Soos

Our shop bench is equipped with an adjustable lighting system which makes it possible to pull a drop-lamp right over work on any part of it and quickly to raise and lower the lights to suit the repairman's taste.

A piano-steel wire (steel binding wire used by electric motor repair shops for armature work will do) is strung from wall to wall, lengthwise 5 feet above the

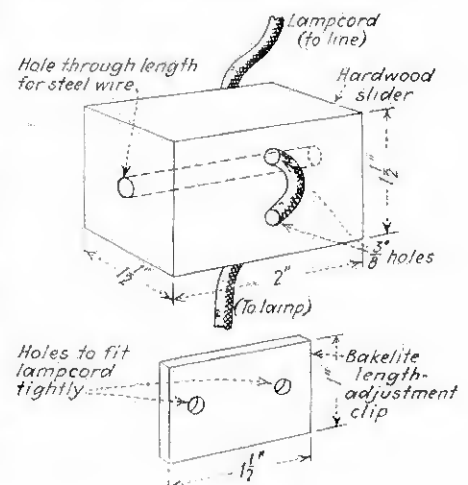

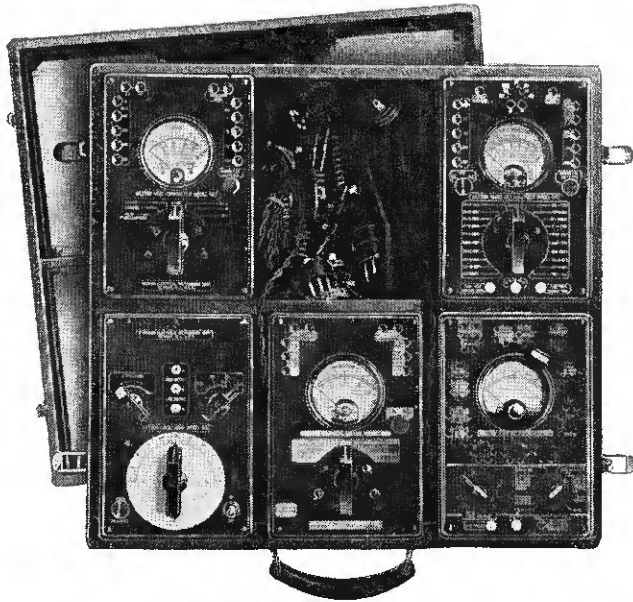

Now—
all 5 in one set
... to satisfy every service requirement

COMPACTLY housed in a single carrying kit, Weston now offers the complete set of 5 Standardized Service Units: Analyzer, Volt-Ohmmeter, Test Oscillator, Tube Checker and Capacity Meter. The combination is a portable laboratory that makes intelligent servicing of any set easy and certain. It contains every instrument for making both Point-To-Point and Tube Checker-Analyzer tests as desired.

With the addition of this 5 unit set Weston has rounded out its line of Standardized Service Unit combinations. Those who prefer the Tube Checker-Analyzer method will want the set containing the Test Oscillator, Tube Checker and Analyzer. For those who prefer the Point-To-Point method Weston offers the kit containing a Test Oscillator, Capacity Meter and Volt-Ohmmeter.

Bear in mind that each unit is entirely independent and can be bought and used separately. It can then be combined in the multiple unit case at some later date. We will be glad to furnish detailed description. Write to Weston Electrical Instrument Corporation, 581 Frelinghuysen Ave., Newark, N. J.

WESTON·JEWELL
Radio Instruments

Weston Electrical Instrument Corporation
 581 Frelinghuysen Ave. Name.....
 Newark, N. J. Address.....

Please send me further information on Weston-Jewell Service Equipment. _____

On the Spot in emergencies

AD-A-SWITCH
 is the Emergency Control!

With a skeleton stock of CLAROSTAT AD-A-SWITCH Controls over 70% of volume control replacements can be handled.

because
 One control can serve either for plain or switch type.

because
 The shaft is completely insulated from the contact arm.

because
 The combined length of shaft (with the mounting bushing) is 1 1/8"—sufficient to take care of most requirements.

because
 Standard AD-A-SWITCH Controls are available in all tapers and electrical characteristics.

because
 AD-A-SWITCH is recognized and adopted as THE ONLY EMERGENCY CONTROL rendering maximum service with minimum investment.

A helpful VOLUME CONTROL and RESISTOR GUIDE is available upon request.

TERRITORIES OPEN FOR AGGRESSIVE JOBBERS

CLAROSTAT Mfg. Co., Inc.

287 North 6th Street, Brooklyn, N. Y.

"AD-A-SWITCH" was originated by Clarostat

Making the Radio Doctor's Work Easy

DOCTORS usually can't tell if a patient is a prospect for an appendectomy (high-class surgical word for appendicitis operation) just by looking at him. But if a man exhibits swollen cheeks, the old family doctor usually says, "Mumps" in a hurry.

THAT'S what we like about this "Renovise-Your-Antenna" campaign. You don't need to drag a lot of tube testers into the patient's front parlor. You just take a squint at a chap's aerial, discover in nine cases out of ten (better than Forhan's "four-out-of-five") that it's n. g., ring the door bell and say, "Mr. Billingham, I can see by your antenna that you're not getting the radio reception you deserve . . ." And so you chalk up another sale of repair service, parts, antenna equipment or eliminators or perhaps even a new set sale.

THIS nice weather is certainly duck soup for the radio dealer or service organization that goes outdoors to sell.

Radio Retailing

center of the bench. 110 volt supply leads to the suspended and shaded lamps are carried through two holes in a hardwood block "slider" through which a lengthwise hole has been drilled for the steel wire. Inserted in the lampcord between the slider and the lamp is a small bakelite "adjuster" which permits the lamps to be held at any height. The cord simply goes through one hole and out the other and can be kinked to hold it in place.

Saw-Cutting Carbon Resistors

By B. O. Bass

Because many sizes of resistors are required to repair modern receivers it is almost impossible for the serviceman to keep a complete stock. I do about 95 per cent of my work with just four sizes, 100,

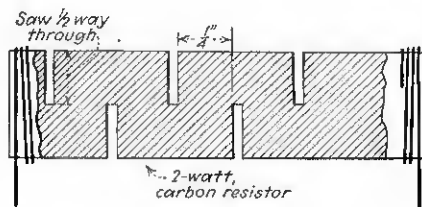

500, 2,500 and 25,000 ohms. Two-watt, wire-mounted carbon resistors are used.

The resistance of these stock sizes can be increased to five or six times the original value by cutting first on one side and then on the other with a hack-saw blade, thus increasing the effective length of the unit. I am careful not to saw more than half way through the resistor on any one cut as this would weaken it mechanically. Frequent tests with an ohmmeter are made while sawing.

Increases in resistance as great as 10 times the original value are possible by sawing alternately on four sides if the finished unit is to be used well below rating. Most carbon resistors will carry double rated load, I find.

22's Can Be Reactivated

By A. W. Dugan

Type 22 tubes can be reactivated by placing them in the 201-A socket of a reactivator and running the filament voltage up to 3.4. It will be necessary to remove the tubes periodically to note progress in a tube checker.

Aligning A.V.C. Sets and Supers

By Albert D. Jacobson

If a receiver requiring alignment is automatic volume control equipped, it is not necessary to have an output meter to do the job. Connect the high-resist-

ance d.c. voltmeter of your analyzer between ground and the cathode prong of one of the r.f. or i.f. tubes. As a broadcast station is tuned in the reading will decrease and as resonance is passed the reading will increase. This response is independent of the modulation of the station's carrier and for the purpose of aligning is equal, if not superior to, the use of an output meter.

The dial should be set at the frequency of a nearby station and the station tuned in with the trimming condensers, using the voltmeter to indicate exact resonance. On some sets the cathode connection of the automatically controlled tubes is considerably above ground potential, in which case the second detector cathode will serve. In using the detector connection the voltmeter reading will increase with resonance and in some cases a full-scale of fifty volts or more will be necessary due to the high bias on this tube.

The i.f. transformers in a super can be aligned without an oscillator working at their frequency if an accurately calibrated oscillator covering the broadcast band is available. "Beat" its output against a series of broadcast stations and make a curve so that intermediate points may be readily found. If the i.f. transformers are to be adjusted to 175 kc. tune in a nearby station and remove the oscillator tube from the set. Then couple the local oscillator to the first detector and set it at the station's frequency plus 175 kc. Assuming the station to be operating at 790 kc., set the oscillator at 965 kc. Using the voltmeter in the cathode circuit of the second detector adjust the i.f. transformers to resonance, which will be indicated by a maximum reading on the meter.

Police Calls On B. C. Sets

By M. Glenn Gassard

Where it is possible to "get at" the coils of a t.r.f. receiver, police calls may be tuned in without altering wiring. Simply slip a tight loop of push-back wire (ends soldered together) over each coil and move these until stations desired are received.

Inductance is decreased as the loops are moved to the center of the coils and increased when they are near the end.

Indoor Antennas Cause Fading

By M. G. Goldberg

A large number of complaints about fading, the most troublesome thing in radio servicing today, are caused by the use of indoor antennas of both the picture-moulding type and the "trick" systems utilizing light lines for pickup.

The sudden switching on or off of electrical appliances such as refrigerators, cleaners, washers and even ordinary lamps increases or decreases the length of wiring in the field of the antenna and sometimes

"QUICK HENRY, THE CC_{L3}!"

Fly-spray is fatal to variable condensers, according to Roger H. Hertel, solidified precipitation permanently changing capacity so that alignment becomes impossible.

Swabbing each individual plate with CC_{L3} (whatever that is) sometimes avoids gang replacement.

even tunes to the frequency of stations being received detuning the signal.

We have cured many cases of fading that have stumped others for weeks by simply installing a good outside antenna.

UV Adaptors for the 30

By G. H. Whitfield

In our territory there are still a lot of old battery sets using UV sockets in operation and customers want them re-vamped to use type 30 tubes. Where installation of new sockets is not practicable we make adaptors out of old tube bases by drilling out the prongs to receive those of the 30's and moving the pin up $\frac{1}{4}$ in.

The tubes are held in place in the adaptors either by soldering a metal washer up tight on one of the prongs or by tapping a set-screw into the side of an adaptor prong. Be sure the large holes are drilled on the side away from the pin when using these adaptors.

The adaptor-equipped 30's can now be plugged into the UV sockets of the old set. It will be necessary simply to change filament resistor values and provide proper bias.

Soldering Iron Saver

By T. B. Shinn

Some months ago in *Radio Retailing* I saw an item concerning the construction of a device which cut a 60 watt lamp in series with a soldering iron through a jack system, to keep it from overheating when left floating on the line.

Arcs across the switch used to cut the

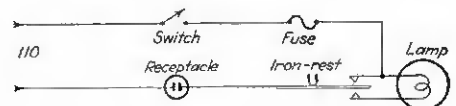

lamp in and out blow the lamp early in life and the device (RR38Jan) can be improved by using a double-pole switch which breaks the line circuit before cutting in the lamp each time.

Our "Tricks of the Trade" column is apparently a bullseye. Many men have written in asking for more . . . so this month there are 30 of them on the next page, page 47. Want us to keep it up?

Automobile Radio Sales Bring Greater Demand For **OHIOHM** Spark Suppressor Sets



JUST in time with the spring opening, Ohiohm Spark Suppressor Sets are reduced in price — permitting greater profits and increased sales.

FOR ELIMINATING IGNITION INTERFERENCE ON RADIOS INSTALLED IN AUTOMOBILES.

Furnished for 4, 6 and 8 cylinder cars. Condensers designed to withstand unusual conditions of temperature and vibration. Spark suppressors enclosed in glazed porcelain tube eliminating accumulation of dirt. Porcelain made of special non-moisture absorbing material to prevent shorting.

WRITE TODAY!

This is the time to get under way. The fastest growing market in radio today.

THE OHIO CARBON CO., 12508 Berea Rd.
Cleveland, Ohio

Ohiohms are made in Canada by C. C. Meredith & Co., Ltd.
Bay St., Toronto.

Who's Going to Sell the 7,728,000?

OUR pet statistician, a man conservative to the core, shyly placed on our desk, the other day, his estimates of the number of nine types of radio replacement parts that will be sold in this year of grace 1933. The total of these nine parts alone is 7,728,000! Mind you, too, these figures include only nine of the many radio replacement parts and do not include the resistors, condensers and other gadgets that are manufactured into new sets. Here's the estimate:

Item	Units to be sold in 1933
Tone and Volume Control	
Variable Resistors	900,000
Fixed Resistors	3,000,000
Grid Leaks	50,000
Condensers, Electrolytic	400,000
Condensers, Paper	1,900,000
Condensers, Variable	238,000
Transformers	750,000
Radio Frequency Coils	280,000
Filter Chokes	210,000

Total of these typical parts... 7,728,000

Of course no one manufacturer, no one distributor, no one dealer or no one service organization is going to sell all of these replacement parts. But there is such a thing as getting a bigger-than-usual share.

THE wise dealer and service organization will be the one who'll *sell* radio repair service and use quality replacement parts—the only kind that will bring customer satisfaction and repeat business. The wise parts manufacturer will, of course, be the one who tells his story and the story of his products to the radio distributors, dealers and service organizations who read

Radio Retailing

just as you are reading it now

TRICKS of the TRADE

RADIOLA 60, 62, 66, 17, 18, 33. Rear bearing for gang condenser shaft is simply hole drilled in plate. Wear permits wobble and resulting frequency change sounds like motor-boating, especially at high-frequency end. Secure piece of brass $\frac{3}{64}$ in. thick, $\frac{3}{8}$ in. wide and $3\frac{1}{2}$ in. long. Bend it at right angles $\frac{3}{8}$ in. from one end. Holding the brass horizontally, the short "leg" down, insert it from side to side under the shaft between the second and third condenser, jamming it firmly between shaft and base.

ZENITH 70. Where trouble is experienced in cutting down the volume of loud locals connect the unused "off" position lug of the r.f. gain control resistor (not the antenna resistor section) to one of the 27 first audio grids. This provides antenna, r.f. and a.f. volume control.

MAJESTIC 70. Dial cable replacements are easily made if the proper template is used. Cut a 36 in. length, 4 in. wide from $\frac{1}{2}$ to 1 in. thick board. Drive a wire nail almost home in the exact center of the broad side and one near each end, $15\frac{1}{2}$ in. from the center. Lay a length of suitable cable material alongside the nails and form and solder two single and one double loops around the nails to match the anchor pins on cable sheaves.

AIRLINE, GULBRANSEN 9. Severe cases of oscillation are curable by removing the gang-condenser rotor-rod, sandpapering it where it contacts the frame, sandpapering spring contacts and adjusting screw.

CROSLEY Showbox. No r.f. plate voltage. Shorted 5 mfd. condenser bypassing B-supply lead is reported as most common cause.

AK 96, 99. Set dead, neon tuning indicator inoperative, 180 volts on i.f. tube grid. Remove coil shield, i.f. shield, and look at the small grid resistor tucked in near the first detector plate coil. Its insulation frequently breaks down, permitting a short. Wrap it in cardboard or fibre.

CROSLEY Totem. Smoke. Heat from filament resistor melts filter condenser compound. Re-mount resistor and plate choke. Takes 20 minutes.

U. S. 8. Excess oscillator plate voltage, or none at all, is traceable to change in value of 50,000-ohm plate resistor. Replace with unit having 2-watt rating, instead of original 1-watt size. Drifting of i.f. transformers due to moisture absorption is also reported.

DAYRAD 381. Burnout of the input voltage control by insertion of tubes in incorrect sockets may be avoided by wiring a $2\frac{1}{2}$ volt pilot light in series with one side of the line. In addition to its

fuse action the lamp also shows when the meter is on and off. A 110 volt neon glow lamp wired across the line after the control resistor makes a good adjustment indicator. It glows when at 110, goes out on less and is too bright above.

AIRLINE Alexander. If you can't align check center-tap resistor of $2\frac{1}{2}$ -volt winding. It should be 150-ohms but sometimes changes value enough to cause oscillation.

VICTOR 32. Open speaker fields are often easily repairable. Remove cover and look for burned or broken wire. Usually these are accessible.

CROSLEY Roamio. New sets which are insensitive except at trimming adjustment points should be examined for reversal of first detector antenna and grid coils. These are small units of the choke type.

BRUNSWICK S14. Hum. Look for loose power transformer laminations. Number of laminations in 60-cycle job varies. If line ballast tube glows slightly when everything else checks ok the core is too small.

SONORA 28. Frailty of chassis permits plate coil in first r.f. transformer to twist out of line. Symptom is oscillation with volume control full on. Twist coil back into line.

LYRIC 70, 73, 75. Hum is commonly traceable to shorted 0.5 mfd. by-pass located in filter pack and connected to red 25,000-ohm resistor. Condenser is not connected to common ground so external replacement is simple. Hum, with distortion is traceable to short of either 0.5 mfd. audio by-pass units. Locate by tracing lead to green 1,200-ohm resistor connected to cathode of first audio.

PIERCE-AIRO 724. Weak reception with oscillation. Before making any adjustments look for open cathode by-pass condenser in first and second radio stages. These are single unit. Turn chassis upside down, look on radio-frequency coil partitions. Unit is one located nearest rear of chassis. Use 0.5 mfd. replacements.

SPARTON 69A, 79A, 930, 931, 301. Fourth section of band-pass selector, just preceding r.f., sometimes cannot be tuned to resonance with first three sections, producing weak reception and loss in selectivity. Give first, second and third selector trimmers 3 turns clockwise. This makes slightly less tuning capacity necessary for given frequency and fourth section selector can now be adjusted for resonance. Balance set in customary manner with oscillator and output meter and re-adjust kilocycle scale on dial by loosening it on shaft and re-setting.

MAJESTIC 102, 103. Fading. Traceable to pickup transformer located on right of cabinet midway between shelves supporting chassis and speaker. If card-

board covering one end of unit is found to be warped one of the terminal lugs generally makes contact with the transformer core. Vibration from speaker thus causes trouble. Unsolder the lead from the terminal lug and bring the wire up directly through the hole in the cardboard and resolder in place.

PHILCO 511. Excessive hum. Where parts check ok hum can be removed by shielding the detector, grounding the shield.

TEMPLE. Repair parts, circuit diagrams can be obtained from Lester A. Bolden, 2515 West 59th St., Chicago.

APEX 46, 47, 48. When these models lack volume screw a small piece of tin under stator supports of tuning condensers. Tune as trimmers by raising up or down. No plate voltage on one 45 indicates blown audio choke. It may be shunted with no appreciable change in tone. Smoke from power transformer, set dead. Unsolder rectifier leads and run them through spaghetti. Resolder.

AK 35, 45, 52. Lack of volume. Drill one eyelet on second r.f. transformer support and turn just far enough out of line to keep set under oscillation at high frequencies.

CROSLEY SHOWBOX. Fading. Try soldering a piece of wire on bottom of aerial lug and fastening the other end under the screw at the top of the aerial and ground strip. Distortion or dead set. Apply heat with soldering iron to the case of the a.f. condenser. Then push back high potential terminals.

SM 30B. No reception. Check 300,000 ohm resistor in the detector plate circuit.

MAJESTIC 90. Common troubles are the shorting of the detector filter condenser or opening of the 2,000 ohm filter choke. A 2,000 ohm resistor can be substituted for the choke.

TEMPLE 8-60, 8-80, 8-90. Hum. Poorly matched 45's is usually the cause.

CROSLEY 706. No plate voltage on r.f. tubes. Caused by shorting of .5 mfd. condenser.

CLARION 260, 280, 300. These models may be equipped with phono pickup by simply inserting a 5,000 ohm type in the grid lead to the audio type 56. Place a switch across the pickup so that it may be shorted out when not in use.

VICTOR R32, RE45, 57. To repair cones take an old one and cut out a piece $1\frac{1}{8}$ round. Take a piece of old panel and cut out two pieces the same size, drilling a $\frac{3}{8}$ hole through the center of both. Coat the cone with glue. Now take the two panel pieces and put over the cone with the piece of old cone. Put a $\frac{1}{8}$ bolt through the center holes, tighten and let dry.

CROSLEY BAND-BOX. Variables slip on their shaft in this model, making the set squeal and howl. Trouble is often difficult to find as condensers are mounted upside down.

ATWATER KENT RADIO

fires opening gun

Full Speaker MODEL 165

For the first time—a 5-tube super-heterodyne (including the new 2A5 and 2A6 tubes) gives power to use—and use to FULL advantage—the full-sized 8½-inch Atwater Kent Speaker.

3 watts of undistorted output—5 tuned circuits—3 gang condensers—vernier station selector—automatic volume control—tone control—two-range switch covering all broadcasting and all local police—beautiful walnut cabinet 14½" high, 12½" wide. *It outclasses every set of its type on the market!*

\$29⁹⁰

Prices slightly higher in Rocky Mountain region and West



TWO SETS—planned for 1934—ready for you **NOW**—because they're straight down the alley of **TODAY'S** demand.

FIRST: a small radio that beats every radio of its type on the market. It is Model 165—see the picture. Mark it well, for it introduces a new standard of 5-tube performance. The **FULL-SIZED**, 8½-inch Atwater Kent Speaker, with three watts of undistorted output, delivers a tone and volume never before heard from a small radio.

SECOND: a combination **BROADCAST AND SHORT WAVE** radio in a full-sized, full performance console. Reaches everything between 540 and 20,000 kilocycles. Highly selective, and sensitive even at tremendous distances. Introduced **NOW**, it will be a god-send to listeners who are asking for better summer reception. It is Model 808—see the picture. We believe it will be a bigger seller than even the famous Model 480.

AND LOOK! To bring top-notch **ALL-WAVE** reception to those who prefer a small radio, Atwater Kent engineers have adapted this identical chassis and full-size speaker to a convenient table model cabinet at a *lower* price. It is Model 708—see the picture.

ATWATER KENT RADIO

of new season!

ALL WAVE Model 808

Combination BROADCAST and SHORT WAVE console that sets a new high for all-wave performance at a sensationally low price.

8-tube advanced super-heterodyne circuit using the new 2A5 and 2A6 tubes, giving tremendous power and sensitivity at every wave length between 540 and 20,000 kilocycles. All 8 tubes work at FULL capacity at every tuning range. Full-sized Atwater Kent Speaker and every known feature that contributes to ease of operation and satisfactory long-distance reception. This remarkable chassis is placed in a gorgeous cabinet of figured walnut.

\$69⁹⁰

Also the complete Model 808 chassis and full-size speaker are offered as MODEL 708 **\$59⁹⁰** in the table-model cabinet at

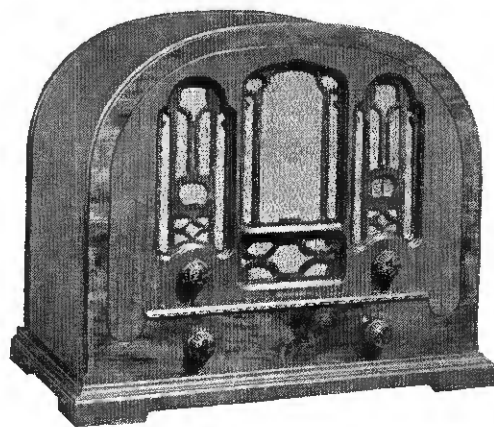

These low prices are based on today's commodity costs and are not guaranteed against advance.

Prices slightly higher in Rocky Mountain region and West

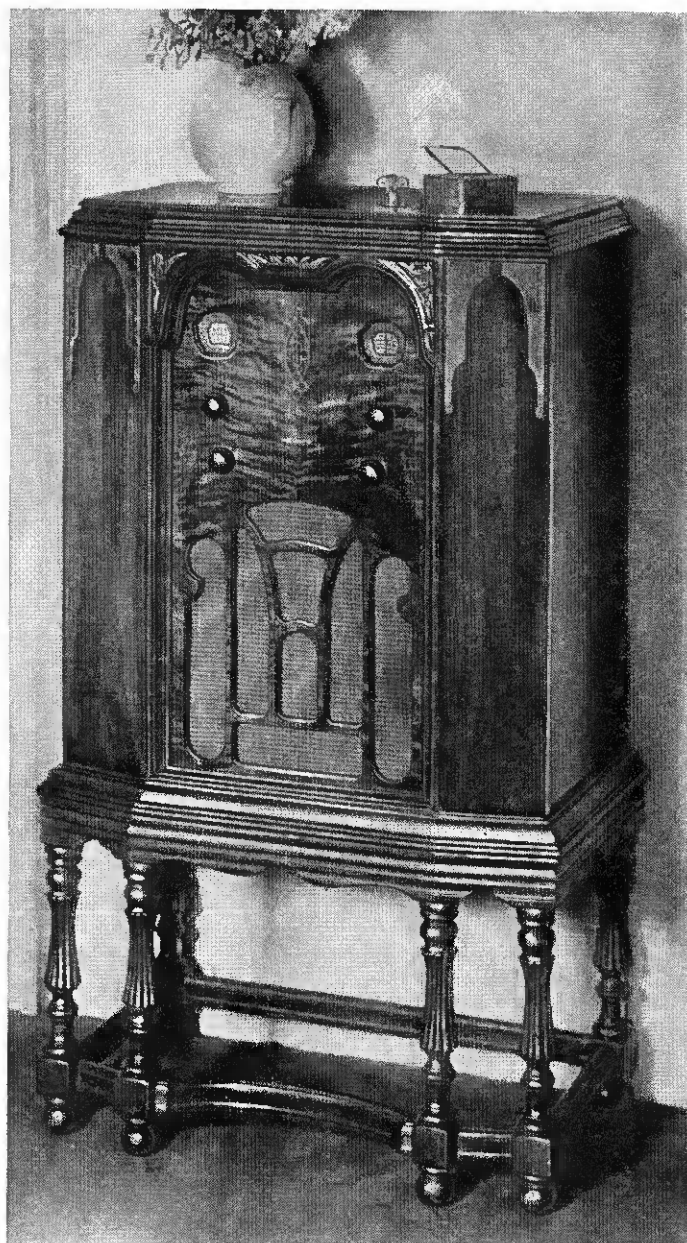

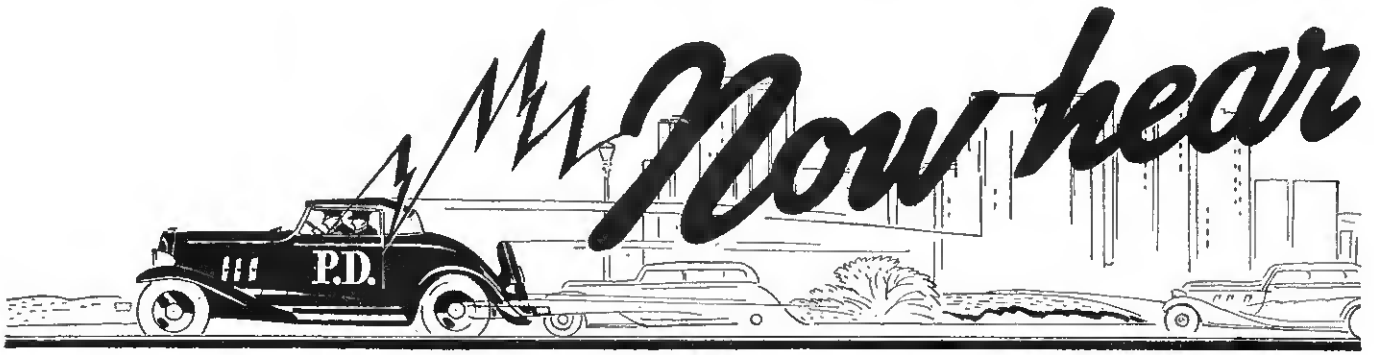

ONE MORE BIG SELLING POINT

Models R-28 Series, R-37, R-38 and RE-40, in addition to their stellar performance, have new frequency range extension up to 2800 kilocycles, which include all "Police Bands." No addition in cost.

THESE popular models...already fast, popular sellers...now have another big advantage! They are equipped with an extended frequency range—allowing you to hear police calls. Another

added feature that helps you sell them.

The regular programs come in just the same—so this "Police Band" is extra value for the money. This line will move fast all summer long. Look them over:

RCA Victor Keeps Stepping Ahead

R-28. "Cathedral." One of the Carryette Models. Walnut-veneered, hard-finished and waxed. Fits on any shelf, dressing table or nook. Plus "Police Band."
Suggested List Price \$19.95

R-37. Table Model. Superhet., electro-dynamic speaker, automatic volume control. Visual volume control setting. Six tubes—new type Radiotrons. Plus "Police Band."
Suggested List Price \$29.95

R-38. One of the finest cabinets ever made in the low-price class. Same features as R-37, including "Police Band."
Suggested List Price \$49.95

RE-40. The new "Radio-Fonograf." Regular superhet. radio, five tubes, synchronous type motor, two speed turntable—2 in 1 music. Plus "Police Band."
Suggested List Price \$49.95

Prices slightly higher in Canada and west of Rockies

Write or phone or see your RCA Victor distributor immediately
RCA Victor Company, Inc., Camden, New Jersey

RCA Victor Radio Sets



RADIOS • PHONOGRAPH COMBINATIONS
VICTOR RECORDS

thrilling Police calls!



for these RCA Victor Sets

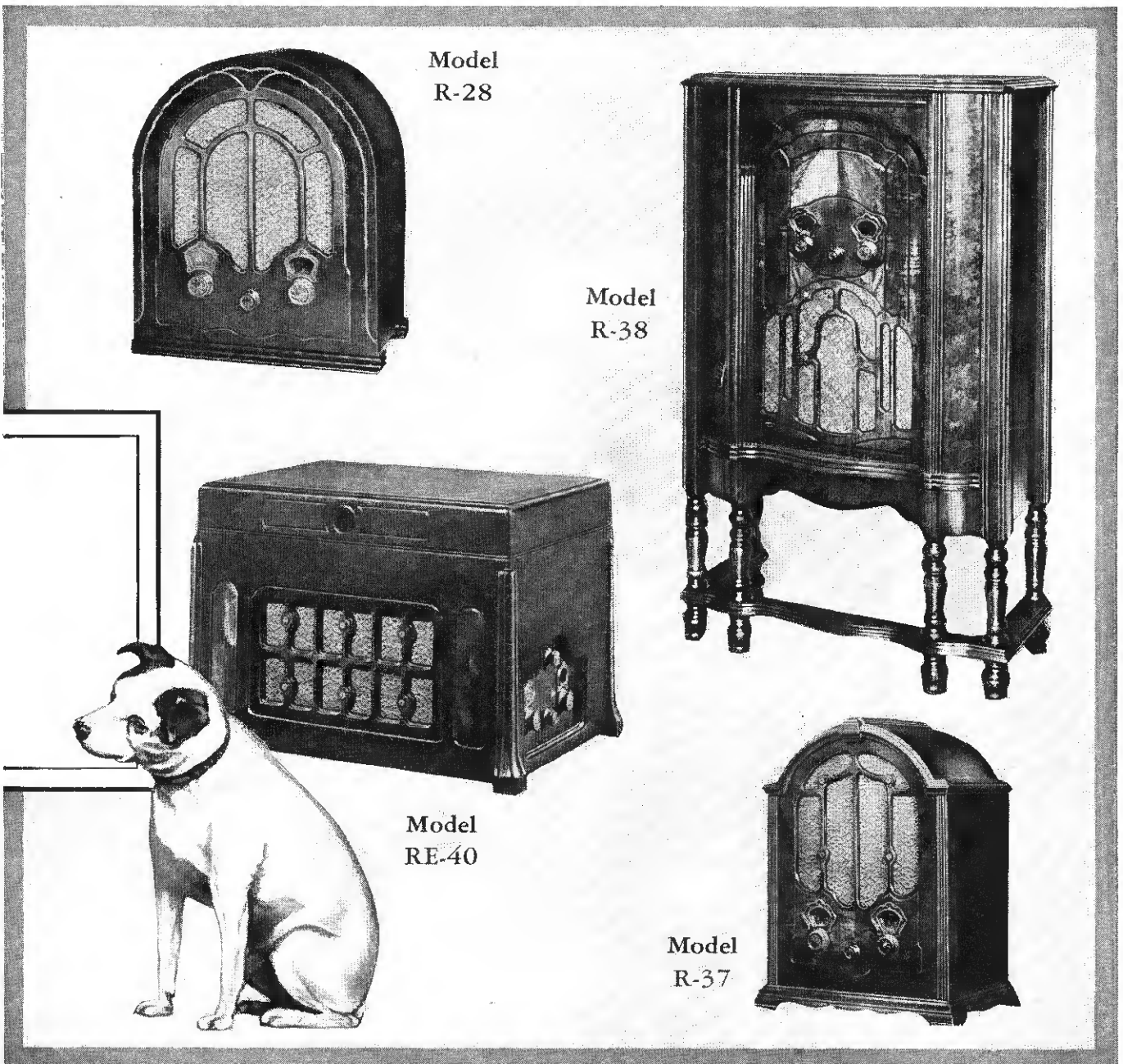

Model R-28

Model R-38

Model RE-40

Model R-37

The advertisement displays four distinct RCA Victor radio models. Model R-28 is a wall-mounted unit with an arched top and decorative glass panels. Model R-38 is a tall, ornate floor-standing cabinet with a similar arched top and glass front. Model RE-40 is a rectangular, boxy portable set with a metal grille on the front. Model R-37 is a smaller, compact floor-standing unit with an arched top and glass front. A dog is shown sitting in the lower-left corner of the product display area.

Announcing

THE NATIONAL ELECTRICAL EXPOSITION FOR 1933

Radio, Refrigeration Air Conditioning, Domestic and Industrial Appliances

SPONSORED BY

The ELECTRICAL ASSOCIATION of N. Y. Inc.

COMMITTEE ON ARRANGEMENTS:

D. W. MAY, <i>Chairman</i> President May Radio & Television Corp.	B. R. GATES Eastern Manager Premier Vacuum Cleaner Co.
J. H. McKENNA, <i>Vice Chairman</i> Eastern Sales Mgr. A. J. Lindemann & Hoverson Co.	E. B. INGRAHAM President Allen-Ingraham, Inc.
J. H. JOSEPH, <i>Advisory</i> President E-J. Electric Installation Co.	H. C. CALAHAN N. Y. Manager General Elec. Supply Corp.
J. J. DONOVAN Gen. Mgr. Air Condition Div. General Electric Co.	A. LINCOLN BUSH Treasurer Commercial Radio Sound Corp.
E. J. HEGARTY Eastern Mdse, Manager Westinghouse Elec. & Mfg. Co.	H. LINDE President Triangle Radio Supply Co.
RALPH NEUMULLER Managing Director Electrical Ass'n. of N. Y. Inc.	

When? September 20th to 30th, Incl.,
1933.

Where? Madison Square Garden, New
York City.

Will you be there? A complete folder,
showing floor plans of exposition space,
costs, etc., is yours for the asking. Write to

Joseph Bernhart, *Manager*,
NATIONAL ELECTRICAL EXPOSITION,
Madison Square Garden,
New York, N. Y.

1933 WILL REWARD COURAGE



KEN-RAD'S vigorous well-planned advertising and merchandising methods get results for Ken-Rad dealers and distributors. Today, only 22% of the potential replacement tube business is going to radio tube dealers. Your share of the remaining 78% tube business is yours for the effort. Ken-Rad will help you. Write for details.

Ken-Rad

• Radio Tubes •

DEPENDABLE LONG LIFE

The Ken-Rad Corporation, Inc., Owensboro, Ky.
Division of the Ken-Rad Tube and Lamp Corporation.

memo for mfrs.

One More Spring

has rolled around. And Spring and Summer proverbially are the seasons when salesmen think of fishing, baseball parks, golf and the many other fancies that take a man off the job of selling. Fortunate, isn't it, that in Spring, Summer and the other two seasons, the advertising pages of Radio Retailing continue to carry, unobstructed, their message to readers*, just as this page has reached you.

*20,000 of them—distributors, dealers and sales executives of radio manufacturing companies.

EMERSON "B" POWER UNIT

Replaces "B" batteries. Maintains original volume, tone and reception qualities.

For

Auto Radios

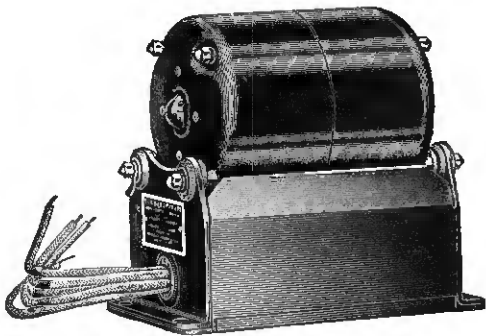

For auto radios, police cars, air-planes, busses, motor boats, etc.

Now \$19⁵⁰

LIST

Operates from standard 6 volt "A" battery. Low voltage tap provides "B" voltages for 180-90 volt or 135-67½ volt sets. Uses but 2 amperes current and only when set is operating.

A New Unit to Operate from 32 volt, D.C., Farm Lighting Plants

\$24⁵⁰ List

For suburban homes, farms, summer cottages, club houses, etc.

Adjustable sliders supply voltages of 22½, or 45, 67½, 90, 135, and 180 volts as required by set.

Current consumption only about ½ ampere or about 15 watts. Unit is complete and easily installed in place of "B" batteries.

Ask your jobber for full information. Made by the makers of the famous Emerson fans and motors.

THE EMERSON ELECTRIC MFG. COMPANY
2018 Washington Avenue, Saint Louis
9 South Clinton St., Chicago
17 East 42nd Street, New York City

COUNTRY CLUB

The
SMART
MIDGET

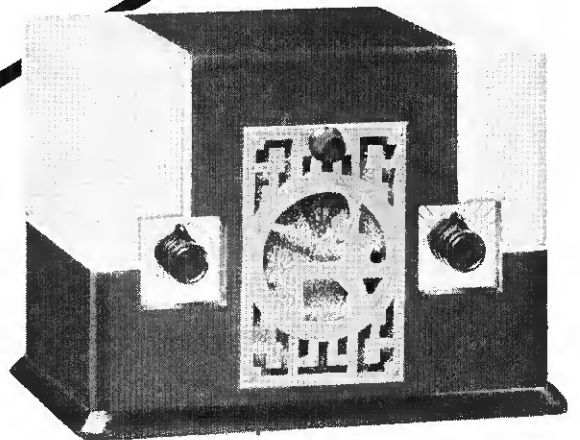

(Copyrighted)

STRIKINGLY NEW

Develops a new field for radio sales

DESIGNED IN DISTINCTIVE
MODERN SIMPLICITY

Beautiful Color Combinations, highly lacquered finishes in black with rose, ivory, orchid, or green corners and chromium attachments. Cabinet is solid maple.

REAL COLOR HARMONY FOR ANY HOME

5 tube superheterodyne for A.C.— D.C. Long and short wave — dynamic speaker.

Fully Licensed

Sold direct to dealers only

INTRODUCTORY OFFER

Carton of four receivers—(one of each color)
Retailers are selling these sets at \$25.00 to \$32.50 each.

\$62⁰⁰

ACT QUICKLY WHILE THEY'RE NEW

CLUB RADIO

28 E. Jackson Blvd.

Chicago, Ill.

WHY DO YOU

WHY, for that matter, do you shave the same way each morning? *Habit's* the answer of course.

Habit's the reason for this condition in the radio industry, too: This year there'll be no Trade Show at the R. M. A. meeting in Chicago and R. M. A. will sponsor none of the hotel room exhibits that some manufacturers are planning to hold. Yet because each June in years past there's been a Trade Show and a Trade Show Issue of *Radio Retailing*, our 20,000 readers expect a Trade Show Issue in 1933—it's a habit with them.

“But how can you have a Trade Show Issue without a Trade Show?”, we asked. “Have a Trade Show *on paper!*”, advised readers and advertisers of *Radio Retailing*.

AND so in June we're going to do just that: *Radio Retailing's* June Issue will be a “Trade-Show-on-Paper.”

Our editors will, as usual, interpret the trends of the coming radio season. In cases where manufacturers will announce June models of sets, tubes, parts and accessories, these will be described and illustrated in the June “Trade-Show-on-Paper” Issue. The Radio Manufacturers' Association meeting in Chicago next month, replacing the habitual monster convention, will be covered by the editors. New industry problems and developments will be thoroughly covered so

PART YOUR HAIR

that in June 20,000 readers will receive a real "Trade-Show-on-Paper" in their June Issue of *Radio Retailing*.

AND in the advertising pages of *Radio Retailing's* June "Trade-Show-on-Paper" you'll have the customary mid-year messages from the leading manufacturers of radio sets, tubes, parts, accessories and allied equipment like refrigerators and other household electrical appliances. Where these manufacturers announce new models they'll tell you about the new merchandise. In other words, your June "Trade-Show-on-Paper" issue of *Radio Retailing* will be a complete guide to the summer and fall activities in the radio industry, whether you travel to Chicago for the June activities out there or whether you stay right at your desk or counter at home.

ADVERTISERS, because of the special interest in our June "Trade-Show-on-Paper" Issue, will find it desirable to send in their advertisements early to insure good positions for their advertisements.

Radio Retailing

a McGraw-Hill publication

330 West 42nd St., New York, N. Y.

*Largest Total and Paid Circulation of Any
Radio Trade Publication*

T
H
E
S
A
M
E
E
A
C
H
D
A
Y
?

PACENT Carries On!



RADIOFORMERS
LINE FILTERS
PHONOVOXES
RECORDOVOX
COMPENSATING
PHONOVOX
PHANTOM
ANTENNA
E.T.C., E.T.C.

Louis Gerard Pacent has personally purchased the principal assets of the former Pacent Companies. His new organization will manufacture and market Pacent Essentials as well as new products developed by its research laboratory. A radically new merchandising policy brings new opportunities for profit to radio dealers and service men.

Write for details of the new and enlarged line of Pacent Essentials, as well as our "New Deal" Merchandising Plan.

PACENT ENGINEERING CORP.
Louis Gerard Pacent, Pres.
79 Madison Avenue :: New York City

PACENT

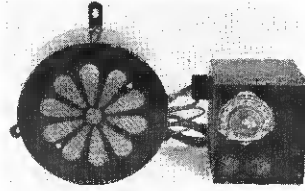

Here's Value

\$14.50 Complete

Special Offer direct to Dealers

Gets Police Calls
Full Tone Dynamic Speaker
Full Shielding in All-metal Case
Easy Installations—Mounts on Steering Post
Illuminated Full Vision Dial
Complete with latest type Tubes
Separate Speaker, Cables and Mounting Brackets

Also available complete line a.c.-d.c. sets.
Direct-to-dealer prices \$7.95 and up.

LONDON RADIO

130 W. 17th St., New York City

This direct-to-dealer offer good only for 45 days. After this period set is available only through jobbers at standard discounts. 90 day guarantee.

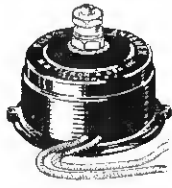

ANTENEX INDOOR RADIO AERIAL

Millions of radio sets have aeriels that need replacement. Money's to be made in "renovizing" aeriels. ANTENEX, a guaranteed indoor aerial can be sold easily in the store and by service men. Write us, too, for prices on Auto Radio Aeriels, also insulators, lead-ins and NEW Short Wave Antenna.

Eliminates all outside wires
Reduces static—noise—interference

Retails for **\$1**

M. M. Fleron & Son, Inc., 113 Broad St., Trenton, N.J.

DEALERS! SERVICE MEN! A New Deal on Public Address The Miles "Rent First" Plan!

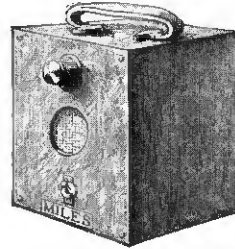

The Miles Rental Unit.
Complete Rental Portable
P.A. System Type 709

With the Miles Plan any reputable dealer or service organization can make **CONTINUOUS PROFITS** on Public Address. All it requires is a few hours a week and an investment of less than \$25.00. Dealers from all sections report profitable results right from the start. We receive hundreds of leads daily which are turned over to Miles authorized dealers.

A few authorized dealerships still available.

DON'T SEND FOR THE MILES PLAN UNLESS YOU ARE WILLING TO FOLLOW ITS PROVEN STEPS.

MILES REPRODUCER CO.
246 W. 23rd St., New York City

SEARCHLIGHT SECTION

SALESMEN WANTED

MEN! Big money selling Radio Cop, sensational. New police shortwave adapter, entirely contained in tube base, gets police calls, airplanes, amateurs, etc. Sample, net \$1.25. City Radio Service, B226, Elmira, N. Y.

REPRESENTATION AVAILABLE

MANUFACTURERS: If you have a line that has sales possibilities in the southeast, I offer representation by a man with a proven record, actively contracting the jobber outlets, amply financed and a real worker. Write me, RA-177, Radio Retailing, 330 West 42d St., New York City.

BUSINESS OPPORTUNITIES

THE SYMONS DRY GOODS COMPANY, Pioneer Cash Department Store of Butte, Montana, has available space to lease for furniture, floor coverings, music and radio and automobile accessories departments. Application desired only from concerns or individuals of reputation and good financial standing. For information address The Symons Dry Goods Company, Butte, Montana.

MANUFACTURERS' AGENTS WANTED

CONDENSERS

A few sales territories open to established sales organizations actively contacting wholesalers or distributors. High quality product with good sales and income possibilities.

MORRILL AND MORRILL
30 Church St., New York

JOBBERS and DEALERS

We are offering these features to you on our Diamond Radio Tube deal. These tubes are manufactured under the closest supervision. Guaranteed for a period of three months and are RCA licensed with a money back guarantee.

Our discounts range as high as 80%.

Our complete line and prices on Diamond tubes is as follows:

201A...19	234...35	250...70	83...35
112A...25	222...55	551...35	84...32
171A...24	236...32	55...32	85...32
226...24	237...30	56...30	89...32
227...24	238...32	57...32	X199...25
224A...30	239...32	58...32	X120...15
235...30	41...32	59...32	210...80
245...25	42...32	75...35	182...45
280...24	43...40	77...35	183...45
247...35	2525...35	78...35	484...35
230...32	1273...35	79...35	485...35
231...32	44...32	KR1...75	6A7...35
232...35	46...32	281...65	401...90
233...55	49...32	82...30	403...100

Minimum order—25 assorted tubes.
20% with order. Balance C.O.D.

RADIO TUBE EXCHANGE OF AMERICA
123 Liberty Street, New York City

DEALERS and SERVICE MEN

Genuine Grebe factory made parts in stock for all model Grebe receivers manufactured prior to 1933. Power transformers for sets using from 4 to 12 tubes. Also audio transformers and filter chokes.

Write for descriptive data and parts price list.
GREBE RADIO SALES & SERVICE CO.
137-28 Jamaica Ave., Jamaica, N. Y.
(Owner former Gen. Fact. Mgr. of A. H. Grebe & Co. Inc.)

SPECIAL NOTICE:

To the Radio Industry

Advertising in connection with legitimate offers of surplus stocks and discontinued models of radio merchandise is acceptable in this section of "Radio Retailing."

Extreme care will be exercised by the publishers to prevent the use of advertising in the Searchlight Section to encourage price cutting on current models of merchandise or equipment. Nor will advertising which invites violation of the dealer's contract with the manufacturer be acceptable.

All merchandise offered in the Searchlight Section must be accurately and fully described and must be available on order.

HUGE SAVINGS IN USED PUBLIC ADDRESS EQUIPMENT

Send for bargain lists, Motion Picture and Sound Systems

SALES ON SOUND CORP.
Dept. RE, 1600 Broadway, New York

PRICES GOING UP—BUY NOW!

JEWEL 4-TUBE RECEIVER MODEL 100

Tubes Used

(2-224A) (1-247) (1-280)

A complete set of "Universal" Tubes for this Model 100 set is \$1.75 extra.

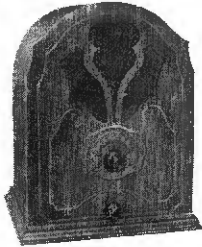

SELLS ON SIGHT

This set has every feature that the large sets have. They meet absolutely no sales resistance. Each demonstration sells a set. The small yet resonantly powerful dynamic speaker handles every tone as though it were of auditorium size. The high powered output of the 247 Pentode makes this speaker per-

form like a major! The neatly tailored cabinet finished in two tones enhances the beauty of any surroundings. This cabinet is entirely of wood and features a trim lyre grille, and a handsome and decorative border design. The volume control and switch combined makes the operation of this receiver extremely simple. An illuminated full vision dial allows quick sighting of station locations. This four tube set outshines many of its class.

At **\$6.95** Less Tubes

VICTOR AMPLIFIER AND POWER SUPPLY

As used in Victor Models R 32, 42, RE 75 and 45

Servicemen, here is a real profit-maker! No doubt there are thousands of these Victor receivers in your locality. You probably have at some time or another replaced in these receivers a condenser block or power transformer or both. On your next call advise your customer that for his own safety and saving to purchase an entire new power pack for a little more than a power transformer. Another point—it's just half the trouble to install a new power pack as to replace the power transformer.

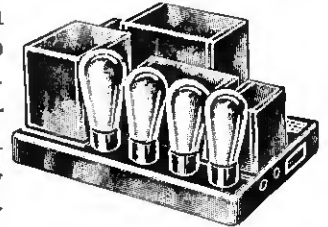

OR

Why not approach a small neighborhood roadhouse, dance hall, or beer garden owner on buying from you an entertainment system using this Victor amplifier, a speaker and a microphone or phonograph?

Cat. No. 62 Only **\$4.49**

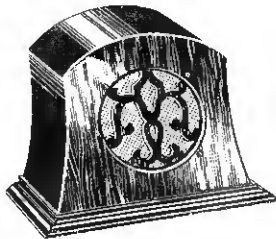

GOthic MODEL
CAT. No. 718

\$3.75

UTAH MAGNETIC SPEAKERS

Here are speakers that add a touch of beauty to any surroundings. No—these speakers are not just ornaments but a real powerful fine quality reproducer. They will handle high and low volume levels with the same brilliance of tonal quality. The reproduction of these speakers rivals that of many dynamics. These Utah speakers are rated among the more powerful in magnetic speakers. Its ability to handle large amounts of volume without a blast or rattle. And yet when sensitivity is required for low power reception the Utah will reproduce with perfect fidelity.



LIBRARY MODEL
CAT. No. 719

\$3.95

VICTOR REPLACEMENT CONE AND VOICE COIL ASSEMBLY

Guaranteed to Fit!

For Models, R32, R52, RE45, RE75

A new supply of Victor cones exact in every detail to the original. The voice coil is wound to the same specifications submitted by Victor.

Cat. No. 6519

Our Price, 95c



REPLACEMENT AUDIO TRANSFORMER

Fits in any receiver. Easy to mount and simple to wire. Mounts either flat or upright.

A bargain at **29c**

Cat. No. 7782

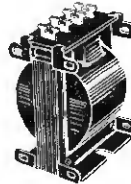

SEND YOUR ORDERS TO ANY OF OUR BRANCHES LISTED AT LEFT

RADIO BARGAIN NEWS
Dealers & servicemen's Buying Guide

You will find this book an indispensable adjunct to your business. It has 104 pages featuring 3,000 items.

Federated Purchaser Inc.

25 PARK PLACE

NEW YORK, N. Y.

The Following Distributing Units Maintained for Your Convenience:

JAMAICA, L. I.
93-26 Merrick Road
PHILADELPHIA
2909 Broad Street

CHICAGO, ILL.
1331 S. Michigan Ave.
BRONX, N. Y.
534 E. Fordham Road

NEWARK, N. J.
273 Central Avenue
ATLANTA, GA.
631 Spring Street, N.W.

CONTENTS for MAY, 1933

Copyright, 1933, by McGraw-Hill Publishing Company, Inc.

	Page
<i>In June—and September</i> <i>An Editorial</i>	15
<i>We'll Buy Your Time Paper IF—</i>	16
<i>Nine Out of Ten</i>	18
<i>Reviewing the Ads</i>	19
<i>Auto-Radio</i> <i>A Pictorial</i>	20
<i>Sales and Service Ideas</i>	22
<i>Outside Selling—Will It Pay?..By Ray V. Sulliffe</i>	24
<i>Refrigeration—New Markets</i>	26
<i>For Those Who Sell Tubes</i>	27
<i>Four Viewpoints on the Sub-Midget</i>	28
<i>News of the Month</i>	30
<i>New Things to Sell</i>	36
SERVICE SECTION	
<i>Circuits of the Month</i>	39
<i>Fixed Resistors</i> <i>By Jesse Marsten</i>	41
<i>Shop Shortcuts</i>	43
<i>Tricks of the Trade</i>	47

INDEX TO ADVERTISERS

This index is published as a convenience to the reader. Every care is taken to make it accurate, but *Radio Retailing* assumes no responsibility for errors or omissions

	Page		Page
Atwater Kent Mfg. Co.....	48-49	Pacent Eng. Corp.....	56
Clarostat Mfg. Co.....	44	Pierce-Airo Mfg. Co.....	14
Club Radio.....	53	Radio Chassis, Inc.....	58
Colonial Radio Corp.....	6-7	RCA Radiotron Co.....	34-35
Crosley Radio Corporation, Inside Back Cover		RCA Victor Co., Inc.....	50-51
Cunningham, Inc., E. T.....	34-35	Stewart-Warner Corp.....	4-5
Emerson Elec. Mfg. Co.....	53	Stromberg-Carlson Tel. Mfg. Co..	2
Fleron & Son, Inc., M. M.....	56	Tung-Sol Radio Tubes, Inc.....	11
General Electric Co.....	12-13	United States Radio & Television Corp.....	3
Grigsby-Grunow Co.....	9-10	Weston Elec. Instr. Corp.....	44
Hygrade-Sylvania Corp. Inside Front Cover			
International Radio Corp.....	1		
Kelvinator Corp.....	Back Cover		
Ken Rad Corp., Inc.....	52		
London Radio.....	56		
Miles Reproducer.....	56		
National Elec. Exposition.....	52		
National Union Radio Corp.....	58		
Ohio Carbon Co.....	46		

SEARCHLIGHT SECTION

Classified Advertising

	Page
Classification.....	56
Employment.....	56
REPAIRING.....	56
RADIO STOCKS	
Federated Purchaser, Inc.....	57
Grebe Radio Sales & Service Co.....	56
Radio Tube Exchange of America.....	56
Sales on Sound Corp.....	56

McGraw-Hill Publishing Company, Inc., 330 West 42d Street, New York, N. Y. Branch offices: 520 North Michigan Ave., Chicago; 833 Mission St., San Francisco; Aldwych House, Aldwych, London, W. C. 2; Washington: Philadelphia; Cleveland; Detroit; St. Louis; Boston; Greenville, S. C. James H. McGraw, Chairman of the Board; Malcolm Muir, President; James H. McGraw, Jr., Vice-President and Treasurer; Mason Britton, Vice-President; Edgar Kobak, Vice-President; H. C. Parmelee, Vice-President; Harold W. McGraw, Vice-President; B. R. Putnam, Secretary. Member A.B.P. Member A.B.C. Printed in U. S. A.

This Summer's **BIG SELLER**



DELIVERS 110 VOLTS A. C. 0 IN YOUR CAR

Get full details of the interesting POWER/CK proposition, which is going to be the "big business stimulator" this summer. This remarkable invention harnesses the wasted energy in your car and delivers 110 Volts A.C. current to your dashboard, to be used for radio, lighting and current for other electrical appliances.

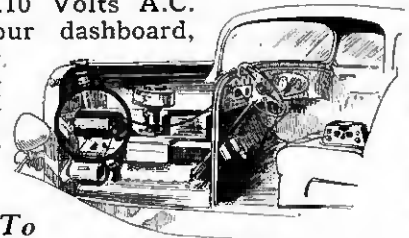

Write Today To

RADIO CHASSIS, INC.
116 W. 18th St., N. Y. C.

EXPORT DEPT.
1457 BROADWAY
NEW YORK CITY

FREE
thru
NATIONAL UNION
THE IMPROVED UNAMETER

TESTS 116 TYPES OF TUBES WITHOUT ADAPTERS

A remarkable tube tester housed in handsome fabricoid carrying case. Available in portable or counter model. Simple efficient tests. English reading meter. Short indicator. Built to take care of future tube types without adapters. Ready reference tube chart shows testing positions for 116 types. Own it Free through the National Union offer. Small deposit and tube purchases only requirements. Ask!

OTHER NATIONAL UNION FREE OFFERS

You can also get an Oscillator and Output Meter, Two Service Manuals, Unabridge (Resistance Tester), Readrite Tube Tester, Bench Kit box, Hickok Ohm-Capacity-Volmeter. Equip your shop the easy National Union way at no cost. Small deposit on some items. Write now for profit's sake!

National Union Radio Corporation of N. Y.
400 Madison Avenue, New York City.

RR 5

I'm interested, send details of offers.

Name

Address

A finer... More Powerful AUTOMOBILE RADIO

**With Class "B" Amplification
and the Amazing New
Crosley Synchronode Power Unit
that Eliminates "B" Batteries**

at a price never before heard of . . .

**FITS
ANY
CAR**

\$49.95
WITH TUBES
Tax Paid

**Nothing "extra"
to Buy . . .**

Completely Installed
Including Suppressors For 3 Cylinders.

THE new Crosley Roamio "99" has taken the country by storm. The already large demand for automobile radio sets has been enormously increased. Here is opened to automobile dealers and salesmen a great possibility for expansion in their business. Think what it means to be able to offer the new Crosley Roamio for \$49.95 installed! Count the cars . . . that's the size of your market for this amazing set . . . this powerful 6 tube superheterodyne with class "B" amplification and Quiet Automatic Volume Control uses the latest automobile type 6-volt heater tubes, with full floating moving coil dynamic speaker, remote

control . . . and the greatest advance step in automobile radio—the Crosley Synchronode Power Unit that gives almost unbelievable results. Here is the newest and finest of all automobile radio sets. Compare it with any other regardless of price. Sensitive. Selective. Beautiful tone. Above all—the most simple of any to install and service. Chassis is easily and quickly removed for inspection.

At the price, this is one of the sensations of radio history. No wonder that thousands of owners of all makes of cars who see it say: "That is exactly what I want in my car."

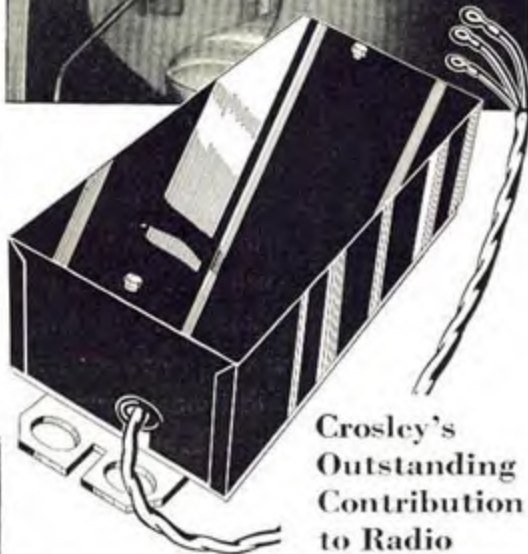

**Crosley's
Outstanding
Contribution
to Radio**

The Synchronode Power Unit is an exclusive Crosley development—the invention of the Crosley Engineering Division. It eliminates the "B" batteries and incorporates a method—used only by Crosley—of electrically controlling or delaying the timing of the vibrator in order to synchronize its action with the voltage interruptions. In this manner—and in this manner only—can the contacts be operated at zero voltage. Sparking at contact points is positively eliminated; consequently there can be no burning of contact points. As a result, the life of the Crosley Synchronode vibrator is tremendously increased. In fact, it is limited only by normal wear. This is the first type of "B" eliminator which does away with tubes, bearings, brushes, and high-speed rotating parts.

Features of the Crosley Roamio "99"



Here are the various units of the Crosley Roamio "99". They are: The remote control, the chassis, the Synchronode Power Unit (above), and the speaker. The universal mounting bracket (not shown) is designed to fit mounting holes which are standard in cars of the General Motors and Chrysler groups.



Quick removable chassis. Mountable in 3 positions—at left, right, or over steering post. Dimensions: 6 1/4 x 7 1/4 x 7 1/4. May be removed in few moments.



Placed where most convenient—right, left, or on top of steering post, this remote control governs every function of the Roamio.



Special Crosley full floating dynamic power speaker is one reason for the fine and powerful tone of the Crosley Roamio.

To Dealers and Agents: Here is a sales opportunity with a market as large as the number of cars in your community. The Crosley Roamio "99" fits any make car. Ask for interesting fact-story of this remarkable set and learn what successful dealers and salesmen are doing. Write or wire factory direct.

Montana, Wyoming, Colorado, New Mexico and west, price slightly higher.

The Crosley Radio Corporation

POWEL CROSLLEY, Jr., President

CINCINNATI

Home of "the Nation's Station" - WLW

YOU'RE THERE WITH A CROSLLEY

CROSLLEY ROAMIO "99"



Dust off
the cash register!

With this new Kelvinator water cooler

\$99⁵⁰
installed

You Can Make
**REAL
MONEY**



IT'S NEW! It's a *world-beater* for VALUE!
And it is going to be a real MONEY MAKER
for every Kelvinator dealer and distributor!

Here's just the cooler thousands of prospects have
been waiting for. Engineered by Kelvinator—designed
by Kelvinator—and built by Kelvinator—to sell at a price
within the reach of all—it is the greatest value on the
market. And it offers a *profit-potential* unequalled in
the industry.

Here's an opportunity—*your opportunity*—to make
some real money. Get this great new Kelvinator
line for your town before some one else beats
you to it. Wire, write, or phone NOW!
KELVINATOR CORPORATION, 14263 Plymouth
Road, Detroit, Michigan. Factories also in London,
Ontario, and London, England.

(702)

Kelvinator