

RADIO RETAILING

HOME ENTERTAINMENT MERCHANDISING

This Lower Price Level

... Is it justified? ... Or is it a Menace?

A summarization of opinions, obtained from recent field surveys,
and frank comment from dealers on this vital matter, in this issue

OTHER FEATURES:

How Widening the Broadcast Band Will Affect Sales

Radio Stars . . . *They will be seen as well as heard*

RMA Asks That Licensed Manufacturers be Protected

"Radio Magic" . . . *How dealers can demonstrate it*

Servicing Unusual Circuits

No Trade Show in '33

HERE'S A STORY THAT GOES ON FOUR LEGS!

IT COULDN'T STAND UP!

Our artist went theoretically into the furniture business and built an experimental two-legged table, which even theoretically fell down! He learned that furniture manufacturers must be right after all, building their tables with four legs — just like Eveready four-pillar Tubes.



COUNT' EM! 4, NOT 2!

We're not the two-legged creatures we think we are! At least, so far as balance goes. On two legs we'd be like a man on stilts. It's the four-square support of heel, toe, heel, toe, that keeps us firmly upright. That's why Eveready Raytheons have four pillars! For firm balance!



TRY THIS YOURSELF!

Wild-eyed idealists who insist they can balance a glass of water on two fingers will find, once they try it, that their ideas (and themselves) are all wet. What a difference two more fingers make! And what a difference the two extra pillars of Eveready Raytheon 4-pillar Tubes make!



DID YOU EVER SEE A TWO-LEGGED CHAIR?

We've seen one — a war-scarred veteran that had lost two legs in life's unceasing battle. But it never could hold us quite so securely as the good old four-legged kind. And that's why we balance the vital elements of Eveready Raytheons on *four* pillars!

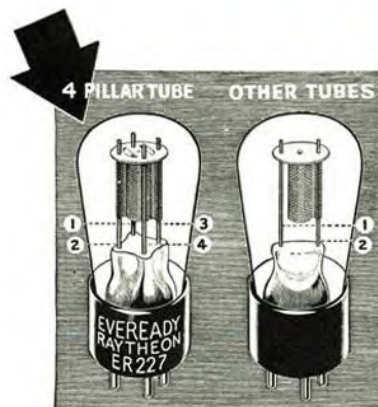

EVEREADY Raytheon advertising for fall and winter, 1932, is based on four-square reasoning. Four supports are surer than two. A few of the reasons-why, appearing in pithy newspaper advertisements, are given above.

Notice the four strong pillars. The fragile parts cannot move even a hair's breadth from their fixed position. All other tubes have only two supports. Jolts and vibration often impair their accuracy.

Such homely examples will bring people into your store for demonstrations. Be ready for them. This four-legged campaign is one of the most startling things done in radio advertising for many a day. Capitalize on it!

NATIONAL CARBON COMPANY, INC.
General Offices: New York, N. Y.

Branches: Chicago New York San Francisco

Unit of  and Carbon Corporation

EVEREADY RAYTHEON 4-PILLAR RADIO TUBES

Radio Retailing, November, 1932, Vol. 16, No. 5. Published monthly. McGraw-Hill Publishing Company, Inc., 330 West Forty-second Street, New York, N. Y. \$2 per year, 25 cents per copy. Central and South American countries, \$3. Foreign, \$3. U. S. Currency, or 15 shillings. Canada (including Canadian duty), \$2.50. Entered as second-class matter April 10, 1925, at the Post Office at New York, N. Y., under the Act of March 3, 1879. Printed in U. S. A.

YOU CAN'T BEAT *Emerson* FOR QUALITY RADIO AT LOW PRICE!



EMERSON Model M-755

7-Tube Superheterodyne in charming Gothic cabinet of burled walnut, rich two-tone finish. Latest engineering—Superheterodyne Circuit—New type of Tubes—Stage of R.F. ahead of First Detector—Duo-diode Detector—Seven Tuned Circuits—Tone Control—Eight-inch Dynamic Speaker—Super Control R.F. Pentodes—Pentode Output Tube. 17½" high, 13½" long, 10½" deep. **\$39.50**

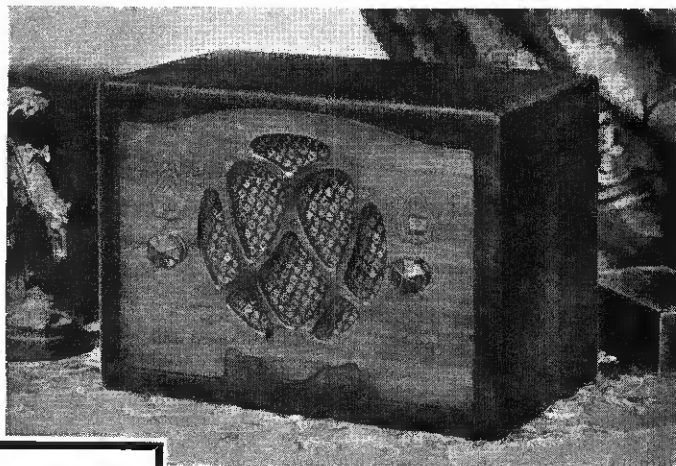

EMERSON Radio Chest

L-559 (A.C.)
L-459 (D.C.)

A cabinet of unique beauty and appeal. The A.C. Model is a 5-tube T.R.F. Receiver. The Direct Current Model effectively utilizes four tubes. Both have latest type tubes, three tuned stages, three-gang condenser, dynamic speaker, single dial control, pilot light. 15¼" long, 10" high, 10½" deep. **\$34.50**

RETAIL PRICE

\$16.75

COMPLETE

with Cunningham Tubes—Including Tax

New Emerson Model L-458

Here's the final answer to the demand for a good-looking compact radio, capable of **QUALITY PERFORMANCE** at a *rock-bottom* price. This set makes use of no obsolete parts!—it is of the very latest engineering design—employing new type of tubes (1 No. 58, 1 No. 57, 1 No. 347 and 1 No. 380)—Large size Transformer—Single Dial Control—Full size Dynamic Speaker. Highly sensitive, it offers volume and clarity of tone superior to many 6 and 7 tube sets.

The cabinet is finely constructed and finished in a beautiful two-tone walnut. Measures 12½" long, 9¼" high, 7½" deep. Has all of the rich simplicity and good taste that characterize the best of modern furniture design.



EMERSON Model L-556 (A.C.) Model L-456 (D.C.)

Regal Gothic cabinet with rich two-tone effect in light and dark walnut finish. 15½" high, 13¼" long, 8½" deep. **\$29.50**
Chassis same as "Radio Chest."

EMERSON Model L-557
5-Tube A.C. (or 4-Tube D.C.) T.R.F. Compact Receiver **\$27.50**

EMERSON Model L-460
4-Tube A.C.—T.R.F. Receiver Charming Gothic Model **\$22.50**

All Prices are RETAIL—COMPLETE with Cunningham Tubes, Incl. Government Tax.

DEALERS: Again . . . Emerson Radio has "scooped" the industry in designing a radio line to exactly meet the selling requirements of the year. Pre-tested in many of the country's leading stores, the new Emerson line has proved a consistent best-seller. With new fidelity of **TONE**, latest 2½ volt tubes, beauty of cabinet work—and the right price for quick turnover at a *profit*—Emerson presents "America's Greatest Value" and an unparalleled opportunity for alert dealers.

✍ Write or wire for full information and discounts. If there is no Emerson jobber in your territory, give name of principal jobber you deal with now.

Also ask for details about the World's SMALLEST and MOST COMPACT RADIO SET—DESIGNED TO OPERATE ON ANY CYCLE, D.C. OR A.C. CURRENT—which will be released soon!

JOBBERs: The Emerson line is now signed up with important jobbers throughout the country—many of whom already handle higher-priced radio lines. A few territories are still open. Wire for jobber franchise information.

EMERSON RADIO AND PHONOGRAPH CORPORATION
Telephone: WAtkins 9-2264
Factory and General Office: 641 Sixth Avenue—New York, N. Y.

Know your FIXED COSTS

IT is "fixed" items of expense—items which are practically the same in handling a low-priced set as a high-priced one—that really determine whether or not you make money.

Do you know this obscure but vital factor in your store? Do you know where the sale of a "cheap" radio may be leaving you in point of actual profit—or loss—after you have charged against the sale such "fixed" costs as credit work, collection work on time-payment sales, display space, delivery, service, etc.—costs that are practically the same in dollars on every set regardless of its price? Study—and find out on which radios your "fixed" costs eat up all or more of the apparent profit.

The fine Stromberg-Carlson line carries prices which show a margin of net profit *above* those "fixed" costs on every sale.

STROMBERG CARLSON TELEPHONE MFG. CO.,
ROCHESTER, N. Y.



No. 24



No. 37

Stromberg-Carlson's full-featured radios range in price from \$143 to \$407.50. Telektor types from \$310 to \$567.50. Prices, East of Rockies.



1894

Stromberg-Carlson

MAKERS OF VOICE TRANSMISSION AND VOICE RECEPTION APPARATUS FOR MORE THAN THIRTY-FIVE YEARS



1932

"There is nothing finer than a Stromberg-Carlson"

He's YOUR SALESMAN in 9,886,198 HOMES



New and dramatic sales device brings Nation-wide response to SYLVANIA'S new program

IMAGINE a salesman that could go into nearly ten million homes . . . actually put a new tube in place of a bad one in the family radio . . . and let people hear the difference it makes!

Certainly you'd want this man to work for you!

And this is just what FRANK LUTHER and his SYLVANIANS do in Sylvania's sensational new musical program "Back Home with Frank Luther"!

In this program a way has been found to prove to people the difference between a bad and a good tube. Frank Luther and Allen Prescott don't merely tell them — they show them! — let them hear for themselves! At the left is a picture and a part of the radio script showing how they do it.

The Frank Luther Program is a part of Sylvania's steady, continued radio advertising now being broadcast over big stations in eleven important cities. A booklet on ending Radio Noises, designed to help not only Sylvania but the whole radio industry, is offered FREE at the end of each program. Thousands of these booklets have been sent out. A recent analysis of 10,000 inquiries taken at random shows that radio owners from every state but Nevada have written in.

If you want . . . you can secure a copy of this booklet for yourself. Just sign and mail the coupon. It puts you under no obligation.

FREE The interesting booklet on Radio Noises that is being sent to thousands of set owners . . .

PROGRAM - "Back Home With Frank Luther And His Sylvaniaans"
Luther! (over CRACKLING NOISE) Ouch! My poor ears! For heaven's sake AL, TAKE OUT THAT BAD TUBE.
Prescott: Oh! Out it comes and in goes a new Sylvania... (NOISE OUT)
Luther: Well that stopped the noise all right!
Prescott: Right - and the moral is --- When you hear a noise like that, go to your Sylvania Dealer and HAVE YOUR TUBES TESTED!

● The picture shows Allen Prescott proving to Frank Luther that a single bad tube can ruin even a good radio . . .



Sylvania

REGISTERED U. S. PAT. OFF.

THE SET-TESTED TUBE

HYGRADE SYLVANIA CORPORATION,
SYLVANIA DIVISION, EMPORIUM, PENNA.

R-11

Gentlemen:

- A. Please send me the Sylvania Noise Booklet
- B. Please tell me about Sylvania "Dealer-Profit" Plan

NAME _____
FIRM NAME _____
ADDRESS _____
CITY _____ STATE _____

All American Bosch prices complete with tubes, U. S. tax paid. All AC console models equipped with twin speakers.

THE GRAND OPERA—Model 312G. Vibro-Power 12 tube triple action superheterodyne, cabinet de luxe. \$178.95.

THE GRAND CONCERT—Model 312C. Vibro-Power 12 tube triple action superheterodyne. \$147.95.

THE WORLD CRUISER—Model 260C. Vibro-Power 10 tube double action multi-wave superheterodyne, in cabinet de luxe, long and short wave. \$132.95.

THE WORLD ROVER—Model 260R. Vibro-Power 10 tube double action multi-wave superheterodyne, for long and short wave broadcasts. \$105.95.

THE MANSION—Model 250M. Vibro-Power 10 tube double action superheterodyne. \$95.95.

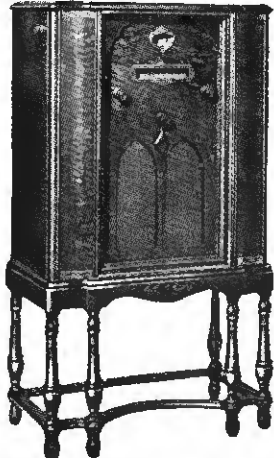

THE PATRICIAN—Model 250P. Vibro-Power 10 tube double action superheterodyne. \$95.95.

THE EMPIRE—Model 242E. Vibro-Power 8 tube double action superheterodyne. \$69.95.

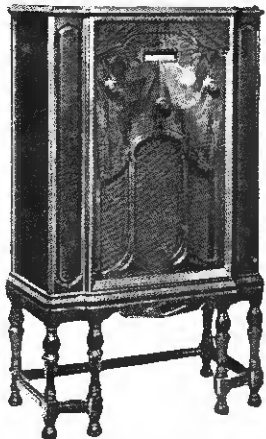

THE SALON—Model 242S. Vibro-Power 8 tube double action superheterodyne. \$69.95.

THE FIRESIDE—Model 226F. Vibro-Power 8 tube superheterodyne Air Cell receiver. \$99.95.

THE METROPOLITAN—Model 224D. Vibro-Power 8 tube superheterodyne for DC current. \$84.95.



PERSONAL RADIO CHESTS—Models 200A, and C (Bombay Chest above). With police signal switch. \$49.95.

PERSONAL RADIO—Model 236A. New 6 tube superheterodyne. \$45.95.

PERSONAL RADIO—Model 205A. New 5 tube set. \$34.95. With Police Switch, \$39.95.

MOTOR CAR RADIO—For battery operation as low as \$59.95. All electric model with Magmotor \$85.90.

SHARE IN
the
LIMELIGHT
OF

The
**AMERICAN
BOSCH**
*RADIO STAR
POPULARITY POLL*

... and \$10,000.00 PRIZE CONTEST
to bring radio prospects into your store

ON October 14th began the first nation-wide poll, to determine the most popular radio stars on the air. It is being conducted by American Bosch in leading newspapers and through American Bosch dealers from Coast to Coast. It will stir the public's interest in radio and in the new 1933 Vibro-Power sets developed by American Bosch.

In addition to the magnificent Gold Cups to be awarded to the most popular radio stars, \$10,000 in prizes are offered for the best 50 word essays telling "Why My Favorite Radio Star Sounds More Lifelike Over an American Bosch Vibro-Power Radio."

This timely double-drive is directing the interest of radio buyers to the great radio sensation of the year—Vibro-Power. Into the stores of American Bosch dealers they are

coming to hear this revolutionary radio triumph. They are listening to their favorite programs, brought in matchlessly by American Bosch Vibro-Power Radio Sets. They are discovering for themselves American Bosch leadership in tone... clarity... volume... cabinet-work.

If you are an American Bosch dealer you are already profiting by the enthusiasm which this popularity poll and prize contest are arousing. If not, there is still time to share, for the contests do not close until December 4. There is still time to have these prospects coming to your stores. Get in touch with the nearest American Bosch distributor, or wire us for full information.

UNITED AMERICAN BOSCH CORP.
SPRINGFIELD MASSACHUSETTS
Branches:
New York Chicago Detroit San Francisco
Manufactured under patents and applications of R.C.A.

**AMERICAN BOSCH
VIBRO-POWER RADIO**

In the Palace
of the Sultan
of Morocco



ARCTURUS BLUE Tubes

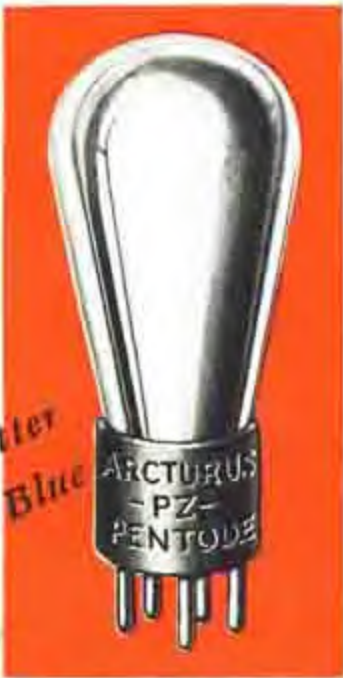

ANY Set is Better
with Arcturus Blue

Literally, the whole world listens-in with Arcturus Blue Tubes . . . North, South, East and West . . .

The Sultan of Morocco's radio is equipped with Arcturus Blues. So are sets from Mexico to Madagascar; from Spitzbergen to Melbourne.

Not only have the people of 77 countries adopted Arcturus as their own . . . it is also a fact that more American set manufacturers use Arcturus as standard equipment than any other tube . . . signal tribute to the outstanding quality of Arcturus.

It is no wonder that more and more radio dealers and jobbers depend upon the BLUE tube to win the approval of their customers.

ARCTURUS RADIO TUBE CO., NEWARK, N. J.

Here's a
**POLICE
 RECORD**
 to be proud of!

List Price **\$19.95**
 Complete including
 relay and cable . . .
 nothing else to buy.

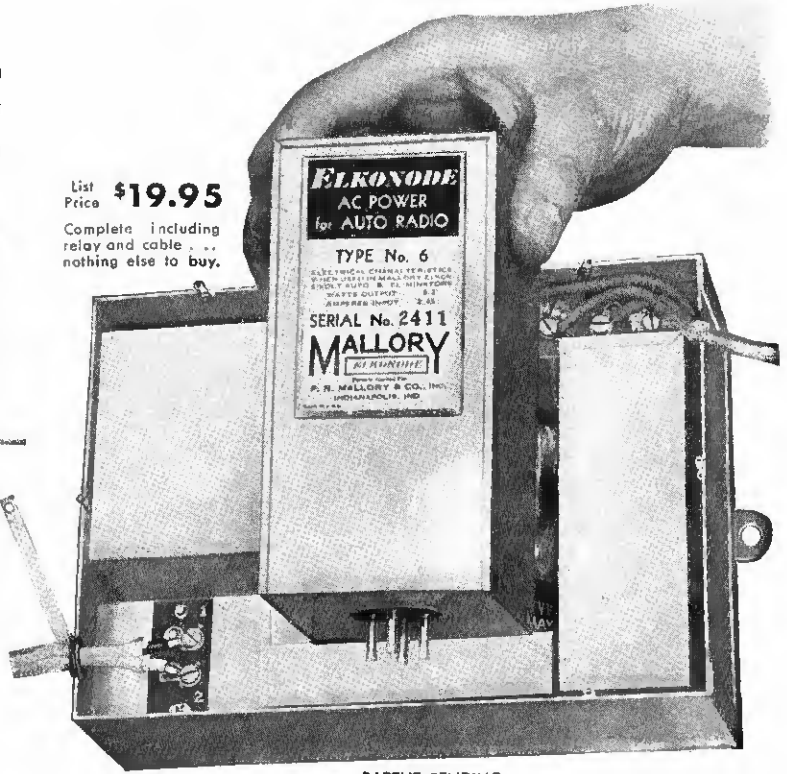

*Mallory-Elkonodes Give 24 Hour
 Service on Police Cars that
 Protect Lives and Property*

Most people would be ashamed of "a police record!" We're proud of ours—and so are the police departments throughout America who have *lengthened and strengthened* the long arm of the law with Mallory-Elkon "B" Eliminators and Mallory-Elkonodes.

Radio reception on police cars *must be good—must be dependable—must be capable of rendering twenty-four hour service!* Mallory performance has won the highest praise from many of America's most outstanding police departments for *just this kind of service!*

The qualities that have made Mallory-Elkon "B" Eliminators and Mallory-Elkonodes popular with police departments will make them *popular with your customers — and profitable to you.*

P. R. MALLORY & CO., Incorporated
 INDIANAPOLIS, INDIANA

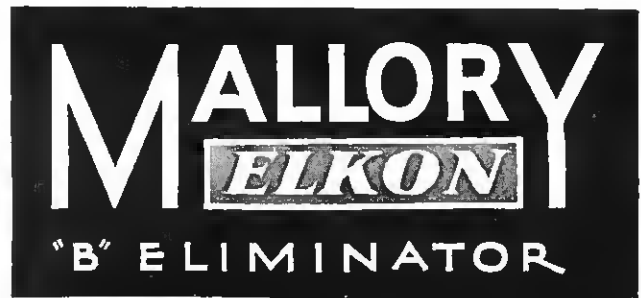

COLONIAL

announces **NATION-WIDE DISTRIBUTION** for an Outstanding 1933 Radio Line through the resources of **Graybar**

Again COLONIAL takes an important step forward in radio merchandising—in presenting an entirely new line, manufactured for and sold only by the GRAYBAR ELECTRIC COMPANY. The line is priced right for quick turnover in the low and medium price fields. The five models offered—designed by Dr. Fulton Cutting and his engineering staff—utilize all of the latest technical developments. The production and engineering facilities of the Colonial Radio Corporation offer every assurance of permanent satisfaction for Graybar dealers and their customers.

\$39⁷⁵
TO
\$99⁵⁰
COMPLETE



• GET IN

TOUCH WITH YOUR NEAREST GRAYBAR OFFICE FOR FULL INFORMATION

AKRON, OHIO	255 James St.	FLINT, MICH.	118-122 E. 3rd St.	NEWARK, N. J.	284 Halsey St.	SAN FRANCISCO, CAL.	9th and Howard Sts.
ALBANY, N. Y.	448 No. Pearl St.	FORT WAYNE, IND.	921 Barr St.	NEW HAVEN, CONN.	227 Water St.	SALT LAKE CITY, UTAH	167 West 2nd South St.
ASHEVILLE, N. C.	Coxe Street	FORT WORTH, TEXAS	1605-1607 Commerce St.	NEW ORLEANS, LA.	601 So. Peters St.	SAVANNAH, GA.	570 Indian St.
ATLANTA, GA.	167-173 Walton St., N. W.	GRAND RAPIDS, MICH.	39-43 Ortawa Ave., N. W.	NEW YORK, N. Y.	180 Varick St.	SEATTLE, WASH.	King and Occidental Sts.
BALTIMORE, MD.	106 South St.	HAMMOND, IND.	5020-24 Hohman St.	NORFOLK, VA.	233 East 42nd St.	ST. LOUIS, MO.	1220 Spruce St.
BEAUMONT, TEXAS	Cypress and Hickory Sts.	HARRISBURG, PA.	122 Chestnut St.	OAKLAND, CAL.	231 Tazewell St.	ST. LOUIS, MO.	St. Louis Mart Bldg.
BIRMINGHAM, ALA.	1529-31 First Ave., N.	HARTFORD, CONN.	51 Chapel St.	OKLAHOMA CITY, OKLA.	222-24-9th St.	ST. PAUL, MINN.	464 Robert St.
BOSTON, MASS.	287 Columbus Ave.	HOUSTON, TEXAS	Commerce and Chartres Sts.	OMAHA, NEB.	603 West Main St.	SPOKANE, WASH.	152 South Post St.
BROOKLYN, N. Y.	58-3rd Ave.	INDIANAPOLIS, IND.	400 W. Ohio St.	PEORIA, ILL.	1120 Capitol Ave.	SYRACUSE, N. Y.	327 North West St.
BUFFALO, N. Y.	77-79 Swan St.	JACKSONVILLE, FLA.	12th and Main Sts.	PHILADELPHIA, PA.	910 Cherry St.	TACOMA, WASH.	1115 A Street
CHARLOTTE, N. C.	1201 W. Morehead St.	KANSAS CITY, MO.	1644 Baltimore Ave.	PITTSBURGH, PA.	37 Water St.	TAMPA, FLA.	416 Ellamae St.
CHICAGO, ILL.	500 So. Clinton St.	KNOXVILLE, TENN.	708 North Broadway	PORTLAND, ORE.	Park and Flanders Sts.	TOLEDO, OHIO	1700 Canton St.
CINCINNATI, OHIO	310 Elm St.	LOS ANGELES, CAL.	309 East 8th St.	PROVIDENCE, R. I.	194-196 Richmond St.	WASHINGTON, D. C.	1119-14th St., N. W.
CLEVELAND, OHIO	1010 Rockwell Ave.	LOUISVILLE, KY.	514 West Main St.	READING, PA.	413 Washington St.	WICHITA, KANSAS	323 South Wichita St.
COLUMBUS, OHIO	55-57 E. Chestnut St.	MEMPHIS, TENN.	242 South 2nd St.	RICHMOND, VA.	6th and Cary Sts.	WORCESTER, MASS.	50-52 Portland St.
DALLAS, TEXAS	Austin and Wood Sts.	MIAMI, FLA.	68 N. E. 20th St.	ROANOKE, VA.	Salem Ave. & 6th St.	YOUNGSTOWN, OHIO	211 Chapel Place
DAVENPORT, IOWA	124 East 4th St.	MILWAUKEE, WIS.	778 North Milwaukee St.	ROCHESTER, N. Y.	186 North Water St.		
DAYTON, OHIO	20 Madison St.	MINNEAPOLIS, MINN.	413-17 South 4th St.	SAN ANTONIO, TEXAS	Hackberry and Duval Sts.		
DENVER, COLO.	18th and Blake Sts.	MT. VERNON, N. Y.	6-8 North St.				
DETROIT, MICH.	55 West Canfield Ave.	NASHVILLE, TENN.	313-315-8th Ave., So.				
DULUTH, MINN.	320 West 1st St.						
DURHAM, N. C.	303 So. Duke St.						

COLONIAL RADIO CORPORATION
New York City Office—444 Madison Avenue
Factory—Buffalo, N. Y.



DEALER PROFIT

Year in . . . Year Out

ADVANCED engineering . . . alert merchandising . . . and a sound policy underlying all distributor and dealer relations, have set U. S. Radios apart as a consistent and increasingly profitable line. U. S. leadership has been built upon dealer success with the outstanding values in the U. S. line.

Every new feature in radio, refined and developed to achieve a quickly recognized superiority in performance, is included in the 1933 line of U. S. Radios. Now, at the outset of a new season of brilliant broadcasting, is the time to cash in on the genuine profit possibilities of this line. A complete range of models, from \$33.50 to \$150, tax paid. Some U. S. features:

NEW
U.S. Battery
Model 69
Tone quality and performance equal to fine A.C. sets . . . permanent magnet dynamic speaker and latest engineering features; economical to operate. Complete with 9 tubes
\$69.50
tax paid, less batteries

- ★ *Automatic Silent Tuning .*
- ★ *Class B Amplification . . .*
- ★ *Triple Grid Tubes*
- ★ *Matched Dual Speakers . .*
- ★ *4-Indicator Illuminated Dial*
- ★ *Distinctive New Cabinets .*

Write or wire now for complete information, without obligation.

U. S. RADIO, APEX MODEL 19B, 9 tubes, Matched Dual Oversize Speakers, and other new features, splendid cabinet design. **\$75⁰⁰**

United States Radio & Television Corporation
MARION, INDIANA



U. S. HERMETIC REFRIGERATOR. \$99.95 to \$169.95 f. o. b. factory. The first hermetically sealed refrigerator at anywhere near this price range . . . Exclusive Roto-Pulse Unit with three year guarantee . . . five models, three sizes. A new value standard in Electric Refrigeration.

O. H. CALDWELL, *Editor*

M. E. HERRING, *Publishing Director*
P. WOOTON, *Washington*

RAY V. SUTLIFFE, *Managing Editor*
W. W. MAC DONALD, *Technical Editor*

T. H. PURINTON, *Assistant Editor*
HARRY PHILLIPS, *Art Director*



U.S. RADIO

To keep us afloat—

MR. MANUFACTURER... please

“Stabilize model and price policies . . . Fewer models and model changes . . . Make radical announcements not oftener than once a year

“Cut the ‘give-away’ sets out of your line

“Grant territorial protection . . . And make every effort to keep out of our markets current merchandise offered at less than suggested lists

“Consult us before formulating sales policies

“Go on record as subscribing to these policies”

Signed,

YOUR RADIO DEALER

LIFE PRESERVER

Setting

How the E. H. Diehl Company of Huntington, W. Va., has met changing conditions with new merchandise and new merchandising methods



E. H. DIEHL
a man with vision



1919 *Bought the modern bicycle establishment of Carter & Turner, continuing a purely store business*

1923 *Started selling radio parts and accessories (displayed on the balcony) over the counter*



FROM \$7,500 worth of bicycles in post-war 1919 to an \$85,000 radio, refrigerator and washer business in depressed 1931 . . . from a conservative, store-selling dealer to a high pressure outside sales specialist—this is the 13-year saga of the E. H. Diehl Company of Huntington, West Virginia; a story replete with merchandising adventure and experience.

It is a far cry from the pedal-pushing days, when Diehl & Leblanc (successor to Carter & Turner) spent its time punching the keys of the shop cash-register,

to today, when this energy has been transferred to the doorbells of Huntington housewives. Somewhere along the thorny path dealer Diehl learned not only how to gauge his market for new appliances but also how to select, train and manage an outside sales crew. And, in the interim, this man arrived at certain merchandising truths which now determine the character of his business. The most striking of these we quote:

“Refrigerator salesmen can sell radio. Radio salesmen cannot always sell refrigeration.”

the PACE

By
W. MacDonald

"Commission men cannot be held in line by any rigid, 'army' plan. It is better to pick them carefully, train them well and then turn them loose on their own initiative."

"The easiest appliance to sell is not necessarily the easiest to make money on."

"It is always well to have something new to sell to the 'paid-ups.'"

From the very beginning Diehl has happily met changing conditions with new merchandise and new merchandising methods. Here is his story, in greater detail.

SOON LEANED TOWARD OUTSIDE SALES

Three years after Diehl bought his bicycle business, KDKA started broadcasting. Within 6 months—vision has always characterized this concern—he was in the radio business, displaying parts and accessories in the balcony of the little, mainstreet store. It was quickly discovered that people bought where they could get how-

to-build advice. So a set-wiring school was promptly instituted and for more than a year the building fairly reeked of soldering paste.

Then manufactured sets were introduced and in one season the company sold 52 Radiola portables plus speakers for \$235 apiece. In order to move some of these it was necessary to demonstrate them in customer's homes and Diehl soon realized that volume could be achieved by outside selling. He tried it himself. And when the soundness of the policy became evident 14 mill-workers were hired on a 10 per cent commission basis to sell radio part time. This was an important milestone for the company has majored in outside selling ever since. By 1929 radio was the big thing in Diehl's business life and six full-time outside men moved \$72,000 worth of merchandise in that year from a new, sidestreet store. Floor traffic was no longer a factor.

The managerial plan was simple and remains essentially unchanged today. Experienced outside men are hired wherever possible and are required to give complete references. These are rather carefully investigated. The men are required to report, either personally or by phone, each morning. They are required to sign for merchandise taken out on demonstration. They are asked to turn in the names of definite prospects rather than a complete record of all calls, more for their own

(Please turn to next page)



1929

Majored in radio with a crew of six outside salesmen

1932

Now has added refrigerators, washers and ranges to sell to radio "paid-ups"



protection than anything else. Otherwise, they are left pretty much to their own devices.

No sales meetings are held unless new merchandise is received, or some local situation requiring group attention arises. The men work in open territories. They are protected for only one month on prospects. No sales quotas are established but new additions to the crew must produce tangible business within 30 days to remain with the company. Diehl himself is not adverse to helping the men close occasionally but will not continue to bolster up the work of any man as he considers his own independent sales important. All the men have to do is sell. The company delivers, installs and does the general work of mopping up.

No matter how carefully devised, rigid "army" plans of controlling men fail to keep them in line. Ways of circumventing rules are invariably found and such plans accomplish little more than convincing salesmen that they are employed on a distinctly cold-blooded basis. This is Diehl's firm conviction. So he prefers to pick his men carefully, train them well, check up on them personally and otherwise trust to luck. Oddly enough two of his old-timers eloped with merchandise just a short time ago while comparatively new hands have proven as honest as the day is long.

THEN ALONG CAME THE DEPRESSION

While reduced commissions breed irregularity among salesmen in times of depression, necessitate closer supervision, the company has always found it possible to hire good men. Today, the \$105 average monthly earning, it is pointed out, looks quite as attractive to men who would have difficulty landing salaried jobs as did a \$210 average just three short years ago. Salesmen continue to work for the concern on commission alone although a trolley-pass, paid for by the management, is provided weekly for each man to help out in this period when earnings are at low-ebb.

Late in 1929 Diehl experimented with the then new Polaris refrigerator. Service proved troublesome, radio sales were too good to require bolstering, so the line eventually was dropped. But by the following year he began to feel the pinch of depression. Radio sales fell off sharply, repossessions increased and the concern knew that it faced at least a temporary decline in volume. Two things were desirable. First, overhead must be reduced to the lowest possible figure and, second, new items susceptible of sale to radio "paid-ups" should be added.

Operating economies were accomplished by such moves as reducing salesmanager McClure to the ranks, Diehl taking over the job of directing the crew, and expenses were eventually pounded down below 25 per cent of the gross. Refrigeration came back into the fold when a Norge distributor agreed to ship a small, trial stock on consignment, conditional upon the company's handling the product on an orthodox dealer basis in the event that it moved the original shipment. Maytag washers simultaneously came into the store.

Just as he had tried outside selling himself back in 1924 before turning the job over to a crew, Diehl, with the assistance of McClure, tackled this new job of selling refrigeration and washers, actually trying these in the

field as an ordinary salesman. The results convinced him that the appliances could be successfully handled by his crew and in 1931 the company split an \$85,000 volume in three very nearly equal parts, securing a sales increase rather than the threatened decline. Selling expense did not rise materially, overhead rising to 28 per cent, where it now stands. And radio, not the new appliances, was responsible for even this slight rise, the management believes.

Refrigerator salesmen can usually sell radio without any great amount of training while experienced radio salesmen do not always click immediately on refrigeration. This fact was forcibly brought home to Diehl when he noted, soon after taking on boxes, that his sales and McClure's, completely eclipsed those of any crew member. Experience further bore out this finding later in the year as new men were hired and put to work. It eventually led to the introduction of a unique "rotation" training policy. New men are now invariably started out on radio and only when they have shown their ability to sell this merchandise are they permitted to tackle refrigerators and washers.

This has a double advantage. It starts green hands out with a line Diehl is convinced still has the least actual sales resistance (even though other merchandise is for the moment more profitable due to the highly competitive condition within the radio industry itself) and it prevents beginners from needlessly foisting costly refrigerator trial-installations on the company. It is expensive enough to deliver Clarions and Philcos on trial, this dealer contends, and absolutely prohibitive to so handle any number of the more bulky types of merchandise.

Salesmen, when finally released on all three lines, receive 10 per cent on refrigerators and radio, 12 per cent on washers. The company looks forward to the possible day when discounts on refrigerators will permit increased sales compensation, which it believes the resistance justifies.

AND SO, TO THE FUTURE

Refrigeration was an acknowledged godsend in 1931, as were washers, and will continue to represent an important part of this radio dealer's business in the future. But conditions have again changed. Not even refrigeration provides the volume and profit Diehl desires today, and so—still setting the pace—he has bought a sample stock of Estate ranges. With these he will attempt to kill two birds with one stone: increase his volume and at the same time cut selling costs by putting ranges into the homes of friendly radio, refrigerator and washer "paid-ups."

Priced from \$76 to \$275, these new appliances, it is felt, will provide satisfactory operating margin. Also, the bulk of the pioneering expense has already been borne by the local power company whose presence in the field will probably help rather than hinder sales.

At the outset Diehl has 9 leads in which he feels confident there is potential business. Once more he will personally embark into the unknown, exploring its mysteries before turning the new product over to the tender mercies of his crew. And as he shoves off we sincerely wish him——

Good luck!

Inexpensive and easy to install—this Thanksgiving harvest window will exert more than usual attention value. All credit to George R. Post and Son, Butler, N. J., for this contribution

“Gravely speaking”—this is a “knock ‘em dead” idea. “It brought in a lot of tubes for testing and sold a bunch of tubes for replacements,” says Schlafer Hardware Company, Appleton, Wisconsin

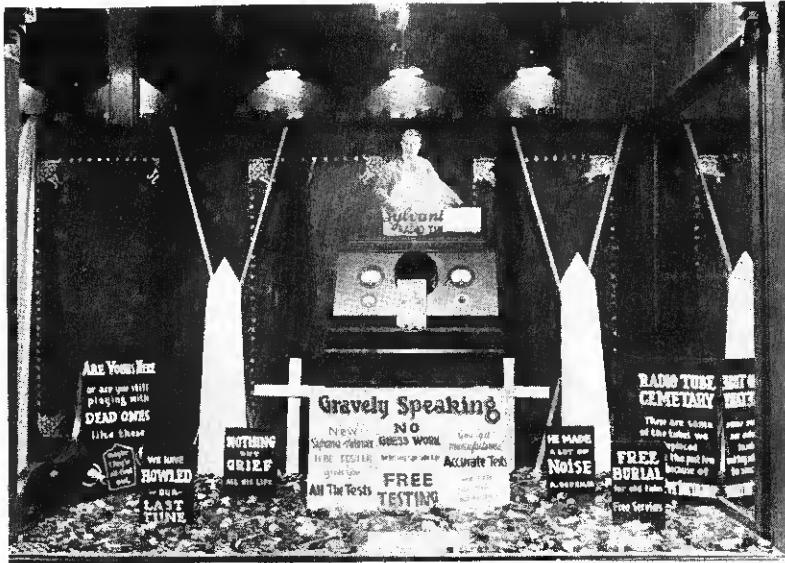

Unique
WINDOW
trims to
Stop Them

...and Perfect
STORE
demonstrations to
Sell Them

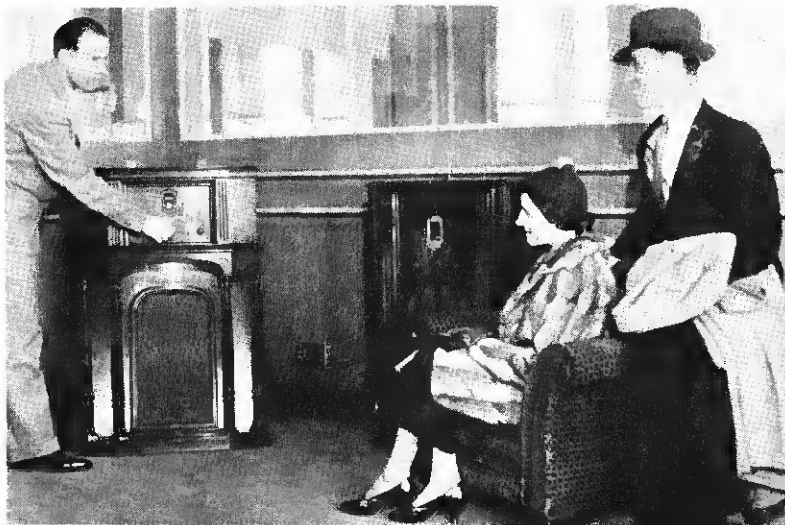

One hundred and fifty antenna outlets, all connected to one master, shielded aerial system high up on the roof, and each set having its own coupling unit, that's the key to the perfect store demonstrations the Meier and Frank Company, Portland, Oregon, give its radio prospects. Sets are grouped on 8-in. platforms. Both floor and platforms are thickly carpeted. The radio salesman in this department store doesn't have to preface his demonstration with an apology. Can demonstrate local and distant stations any time—and on any set with full beauty of tone and volume

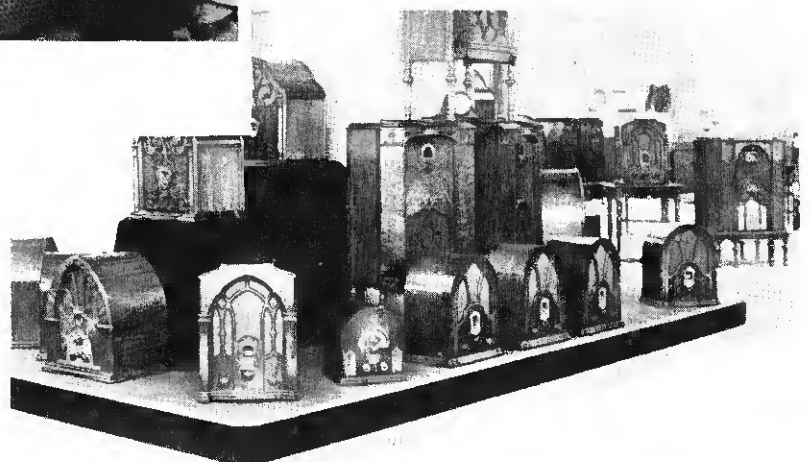

The Under \$20

“Radio Retailing” takes the stand that \$20 is a matter of vital importance cussed frankly and in the open. As lowing expressions of opinion, obtained by attempt has been made to represent

“It has Merchandising MERIT”

THE extremely low-priced set does not, as a rule, prevent the sale of higher priced models—where the prospect can afford a better article. This, at least, was the opinion of 55 per cent of all dealers who expressed themselves to *Radio Retailing* on this point within the past three weeks. Thirty-six per cent, however, answered “Yes” to the question: “Has the sale of this model kept you from making sales of other models of higher price”; while 9 per cent were undecided on this point.

“It has merchandising merit,” is the substance of the following letters favoring this recent wider introduction of the less-than-\$20 set:

Situation Under Control

To date, 30 per cent, in units, of our dealers’ sales have been in the \$18.75 model. I cannot find that the introduction of this set has interfered with the sale of any of the higher priced numbers in our line. I do know that our total dollar business is 300 per cent greater than a month ago—although less than last year. I know, also, that most of these little midgets have been sold to people who could not afford a higher priced set and who otherwise would not have purchased.

This ratio of 30 per cent in units does not appear to be on the increase. The situation is under control. It is increasing store traffic and, I think, the sale of higher priced models.

Of course, dollar margins are narrower but the transactions are for cash and I look upon it as so much extra business and an effective means of combating the inroads of the loft artists.

A LARGE EASTERN DISTRIBUTOR.

Yankee Philosophy

We feel that this low-price set is in keeping with the times. At this time when there is no call for high-priced sets, we are glad to keep up our gross sales by handling this volume unit. We can’t get enough of these little sets to keep any in stock, so fast do our customers take them away from us.

A CONNECTICUT RADIO DEALER.

And There You Are!

We are selling the \$18.75 set on time, and believe it is a very good item for a hardware dealer to handle in this way. It would take a lot of hardware to total \$18.75 and

we are glad to get the business. We admit that we are not making any money, but we are keeping busy and making sales. And there you are.

A HARDWARE DEALER IN CENTRAL MASSACHUSETTS.

Ratio 25 Per Cent

Ratio in units of the low priced sets to all other sales is 25 per cent. We welcome having a model of this type and price because it means additional business otherwise not obtainable and it means also an opportunity to “sell up” which generally transpires where the prospect has the money.

I do not see that it is making the public “lowprice conscious” any more so than in the past and obviously this little set is not expected to compete in quality with the console.

A LARGE FURNITURE HOUSE.

Detroit a Midget Market

Detroit is virtually a midget market today and the gross profit on Philco, Jr. is comparable to that of other midget sets.

A DETROIT CHAIN OUTFIT.

Sold Five \$80 Sets Through It

Proper advertising brings people to the store—affords opportunity to sell higher priced sets. Sold five sets, average list about \$80, through a window display of Philco Jr. sets.

NEW JERSEY INDEPENDENT.

Have Cleaned Up Our TB's

This set has caused us to make sales on higher priced sets by switching the customer and we have cleaned up our TB and sample sets.

LARGE DETROIT FURNITURE CONCERN.

An Excellent Second Set

People come to us continually to buy a second set for the bed room, kitchen or nursery. Naturally they do not want to pay much. These low price sets seem to fill the bill. So far I have sold more than I readily can get.

My men are cautioned never to sell a set for less than \$30 if the customer can pay more.

Over 50 per cent of my low price sales go to persons already owning a radio set.

AN ARKANSAS TRAVELER.

Price Level

the marketing of sets listing for less than to the industry and should be dis-contributing material, it presents the fol-mail and in personal interviews. Every fairly both sides of this controversy

“It is a Merchandising THREAT”

SALES of this new model have not been up to expectations or sufficient to increase materially normal volume or store traffic. It has not enabled us to sell up to any appreciable degree. Sets under \$30 are not profit-builders and, in many instances, they must be sold on terms the same as the more expensive consoles.

The preceding summarizes the opinions of 33 out of 38 radio dealers personally interviewed during the latter part of October in the states of Virginia, West Virginia, Maryland and the District of Columbia. The other five dealers were neutral or preferred to wait awhile longer before committing themselves.

In addition to this face-to-face investigation, *Radio Retailing* questioned by mail 100 active merchandisers. Over 90 per cent of the replies disapproved the widespread featuring of nationally known sets at \$20 and less.

“No!” the dealers declared, in response to the question: “Are the discounts under which this set is being sold sufficient to show a profit?” (86%) And again an emphatic “No!” to the question: “Does the lower price produce additional volume sufficient to offset lower profit per unit sale?” (95%).

Specifically:

Take Mr. and Mrs. Jones

Mr. and Mrs. Jones can see no reason why they should pay more than \$25 for a fairly respectable radio and indeed the dealer has to do a lot of selling to get most people up to the \$50 mark and as for selling consoles above \$90, it's an event in the life of the average dealer today.

A MICHIGAN MERCHANT.

Is Killing the Goose

A large part of our future radio business must come from customers already owning a set, where, therefore, a trade-in deal is necessary. Where is our margin for this, or for servicing, on sets selling for less than \$35? The cost of doing business has not been reduced in proportion to the selling prices of sets. We cannot afford to take a loss on a trade-in.

When a manufacturer markets a set for less than \$35 he is simply killing the goose that lays the golden eggs. You

cannot sell enough low-priced sets to offset the loss in the sale of higher priced models on which there is a decent profit. If a real low-priced set is demanded there will be plenty of second hand ones to supply this market.

CARBONDALE, PA.

Are Not in Fighting Mood

Apparently the radio manufacturers are making no effort to buck the trend of lower price merchandise.

A FORMER PRESIDENT, NFRA.

The Goblin Will Get You

Surely the majority of radio sales come from communities such as this. If so, the manufacturer is now engaged in the process of cutting his own throat. If not, then the radio business will be centralized in the cities and will develop into a mail order business, to the ultimate strangulation of the retailer. To the manufacturer of such merchandise I would say, “The Goblin will get you if you don't watch out.”

DEALER IN COMMUNITY OF 2,500.

Dealers Are Sore

Furniture dealers are selling some of these sets on some of their accounts that owe them so much now that they cannot turn them down. I think you will find most dealers that know their cost of doing business pretty sore at these low priced sets.

AN OLD TIME DEALER, COLUMBUS, OHIO.

Have Ourselves to Blame

The radio journals have consistently waged a good fight against low priced sets and we jobbers appreciate your efforts. But, apparently, we distributors have not coordinated in fighting this matter the way we should—and have only ourselves to blame for present conditions.

A VERY WELL KNOWN JOBBER.

Sure Hurts

We do not carry (blank) but this price sure hurts the radio business here.

LAPORTE, INDIANA, DEALER.

Other Manufacturers Are Following

One concern started it. Now the other set makers are following suit, spoiling business for everybody.

WELL KNOWN CHICAGO DEALER.

J. P. KENNEDY RADIO MAGICIAN



*Using semi-scientific
South Bend dealer
local Kiwanis . . .
service jobs . . .*

I HAVE just put over the most effective advertising stunt of my ten years in radio merchandising . . . a radio "magician" act presented before a meeting of the local Kiwanis luncheon club. The idea, I think, is original.

My audience comprised the most active business and professional men in South Bend, Indiana; men who usually have money to buy but are generally difficult to approach. To this group I have already sold one \$89.50

console and four service jobs as a direct outgrowth of the talk. The publicity obtained has, in addition, produced leads which will set me up for the next thirty days.

It was easy to arrange the program with the club secretary; novel entertainment is always a welcome change from the usual run of after-dinner speakers. The talk was easy to deliver; semi-scientific facts with which I must be familiar are of intense interest to laymen. And I am assured that I provided the most interesting program the membership had been treated to in months.

THE "PROPS"

The equipment, or "props," that I used in connection with the talk included: A midget superheterodyne. A two-tube modulated oscillator with a closed-circuit jack in the grid-return of the first r.f. tube. An electric phonograph turntable and pickup. A simple hand microphone made of an earphone. And a $\frac{1}{2}$ watt neon bulb connected across the secondary of a 1 to 3 audio transformer. These were all arranged in advance on a demonstration table, along with my most impressive looking meters and test instruments. During the luncheon

RADIO RIDES ON
A LIGHT BEAM

Modulating a flash-light-beam with the output of a radio, Dr. V. K. Zworykin, RCA-Victor engineer, shows how music may be transmitted on light and reproduced again by a photo-cell equipped audio amplifier.



tific tricks as the "bait", delivers unique sales talk to sells \$89.50 console and four secures widespread publicity

which preceded my talk, I sat next to the president of the club and answered his questions about myself: how I had worked my way through college repairing radios; what interesting problems the work presented and many other details I thought might be of interest. When the time came for my "act," he gave me a five-minute introduction that put me on a par with Edison, DeForest and Marconi.

Then I started to talk.

The first part of my program consisted of a brief description of the oscillator, which I described as a "miniature broadcast transmitter." To illustrate my explanation of the manner in which radio waves were projected into the ether, the oscillator was tuned back and forth over the broadcast band and the squeal-signal picked up by the midget.

The modulator tube was then turned off and the phono-pickup output plugged into the grid-return circuit of the oscillator. A piece of No. 14 wire projecting upward from the oscillator case served as a transmitting aerial. A strip of lead-foil taken from an old by-pass condenser, and attached to the underside of the demonstration table with thumb-tacks running under the oscillator and across the table under the set acted as a capacity ground circuit. The set required only a few feet of pickup wire.

USES MINIATURE TRANSMITTER

When the oscillator carrier was modulated with a phonograph recording, amazingly good reproduction was obtained from the set. In fact, the reception was so good that I couldn't help inserting the remark that only a good set could do so well with a weak signal of less than $\frac{1}{10}$ watt power.

I then tuned in a local radio station and again using the phonograph and oscillator as a miniature broadcast station, demonstrated the effect of blurring and fading caused by the signal of one station interfering with that of another. This opened the subject of fading and with the aid of a piece of charcoal and a strip of white wrapping paper, it was easy to illustrate the theory of fading wherein the signal reflected from a strata of ionized air reaches the set out of phase with the wave reaching the set along the earth.

Then I continued: "There is something uncanny, almost human about radio. Take, for example, this oscillator." (As I talked I had tuned the oscillator a few cycles below the frequency at which the radio set was receiving a program). "As I bring my hand near this part of the instrument called the grid circuit, it howls as if in protest against my using it for demonstration purposes." Actually, body-capacity tuned the oscillator to nearly the same frequency as that of the station coming in on the radio set and the heat note rose and

(Please turn to page 33)

TALKING
THROUGH HIS
HAT

Using an ordinary radio receiver plus the driving mechanism of a magnetic cone speaker R. F. Norris, C. F. Burgess Laboratories, demonstrates that sound waves will radiate from any hard surface



Why Widening the Broadcast Band Would Make TODAY'S Receivers

Proposals now being considered at Madrid International Conference to employ long-waves and short-waves outside range of existing receiving sets, would, if carried out, automatically create demand for new sets covering proposed range of 150 to 1750 kilocycles (2000 to 171.2 meters).

SUPPOSING that at one single stroke the radio sets now in use in sixteen million American homes could be rendered obsolete. Supposing that favorite programs and favorite stations could not be tuned in on existing dials, but that new sets would have to be provided to reach out and receive broadcasters operating in the long-wave area or on the short-waves below 200 meters.

Immediately a tremendous new market for listeners' radio receivers would be created, precisely as the public rushed to dealers' stores to buy new wide-range, all-wave sets capable of picking up the new broadcasts.

Something like this situation may be now in the making as the result of the conferences now proceeding in Madrid, where there is a strong European influence being exerted to widen the band to include many channels now in use by other services.

A glance at the accompanying radio spectrum will show the place now assigned to American broadcasting, and also the use made of the long waves by certain leading European stations which are listed.

EUROPEANS BOOST FOR CHANGE

The International Broadcasting Union, composed largely of European broadcasters, is recommending widening of the present band to include 540 kc., and also the authorizing of broadcasting on the long-wave bands from 150 to 285 kc., and from 370 to 460 kc. Furthermore it will urge that under conditions where marine services will not be interfered with, broadcasting shall also be permitted on the channels 540 to 460 kc. These recommendations would thus make a continuous broadcasting band from 370 to 1,500 kc. (114 10-kc. channels), in addition to some fourteen additional European channels in the long-wave broadcasting range.

Advance proposals submitted by the United States, for consideration by the Madrid conference, apparently opposed extension of the broadcast band into the lower frequencies, but indicated that favorable consideration might be given to the high-frequency area, between 1,500 kc. and 1,715 kc. This would add some twenty channels to the short-wave end of the broadcasting dial. Since these advance recommendations were originally offered by the American group, however, the National Association of Broadcasters has been actively

working to revise the official American position, so that extension into the high-frequency region alone will not be advocated by the United States delegates.

PRESENT "MUSHING" AND FADING WOULD BE IMPROVED

Advocates of the lower frequencies or longer wavelengths for broadcasting use, point out that fading and interference would be greatly reduced on these channels and that the service range of such long-wave stations would be limited only by the power used,—instead of by fading, which is now playing such havoc with reception at distances of 30 to 50 miles, after nightfall. The long-wave advocates insist that if broadcasting is to undergo periodic "mushing" and distortion over wide service areas, for a term of years at each sunspot minimum (as at present) it will be better to move broadcasting for rural service to the low-frequency channels, where the fading range is a matter of 300 miles or so, instead of 40 miles. With high-power stations (500 kw. to 1,500 kw.) on such channels, they estimate it would be possible to serve the whole continental United States with a dozen transmitters.

Extension of the broadcast band in the direction of the higher frequencies is not looked on with as much favor by the broadcasters, as by the set makers, who have already produced some 1932 radio receivers to reach to 1,750 kc. There is still a strongly entrenched "social sense" among broadcasters, that the longer the wavelength, the more aristocratic the assignment! Although some of the larger stations now operating in the 1,400's are getting good coverage, most station operators are firm adherents to the maxim "the better, the fewer" when it comes to kilocycles. The high-frequency waves also seem to give trouble in built-up city sections, in failing to cover regions of tall buildings.

CANADA, MEXICO AND CUBA

The unsolved international situation on the North American continent is one compelling reason why some extension of the broadcast band may be necessary. By special agreement, the State Department has recently consented to a large increase in the number of channels to be used by Canada, and this will be at the expense of United States broadcasters. Mexico and Cuba are yet to be heard from, officially, but there seems every likelihood that these two republics to the south of us will soon demand some proportionate share of the broadcasting channels used on the continent. Of course, their regional stations can operate on channels shared with Canada, without interference. But the recent move to install 75-kw. transmitters along the Mexican border, if extended in Mexico and Cuba, whether by local or American capital, is bound to compress the existing stations in the present broadcast band, unless extension of the band, or synchronizing come to the rescue.

Radio manufacturing executives, looking for new developments that will stimulate now buying of sets have been hopeful that out of the broadcast extension, there

OBSOLETE

would come an immediate demand for new sets capable of tuning in programs from 150 kilocycles, as the extreme upper limit, to 1,750 kilocycles on the short-wave end.

Undoubtedly the Madrid conference will make recommendations which will authorize some extension of broadcasting, whenever there is demand for it. So complete is the dependence upon the broadcasting stations, however, that the utilization of these new waves will depend entirely upon the willingness of stations to pioneer into new channels where as yet no audience exists. Pressure on the stations will produce the moves in this direction, and the inevitable shake-up of wavelengths on the North American Continent may be the agitation that starts the avalanche rolling into new radio territories.

Certain it is, that a reassignment of broadcast stations into channels outside the present familiar band, would result in improved transmission for the public and in the overnight obsolescence of millions of sets now in the hands of the public, with the consequent demand for millions of new all-wave receivers. A tremendous volume of set sales would thus be created for radio manufacturers, jobbers and dealers.

But the date when this boon of radio re-equipment is to be handed to the radio industry and radio dealers of America, is still hidden behind a group of factors, international, technical and economic.

At this writing Paul B. Klugh, of Chicago, RMA director, is in Spain officially representing American radio interests. A report of last minute progress at the International Radio-Telegraph Conference will be found in the news section of this issue

The left hand column shows the relation of radio and broadcasting to the many other forms of electromagnetic waves which our senses recognize as heat, light, X-rays, gamma rays, etc.

On the right is an enlarged chart of the radio spectrum, showing the assignments as made by the Federal Radio Commission to the various services of broadcasting, marine, ship-to-shore, amateur, television, airplane, police, pick-up, experimental, etc.

The charts shown are reproduced from the magazine "Fortune," which prepared the diagrams from information furnished by "Radio Retailing" and "Electronics"

THE ETHER SPECTRUM

THE RADIO SPECTRUM

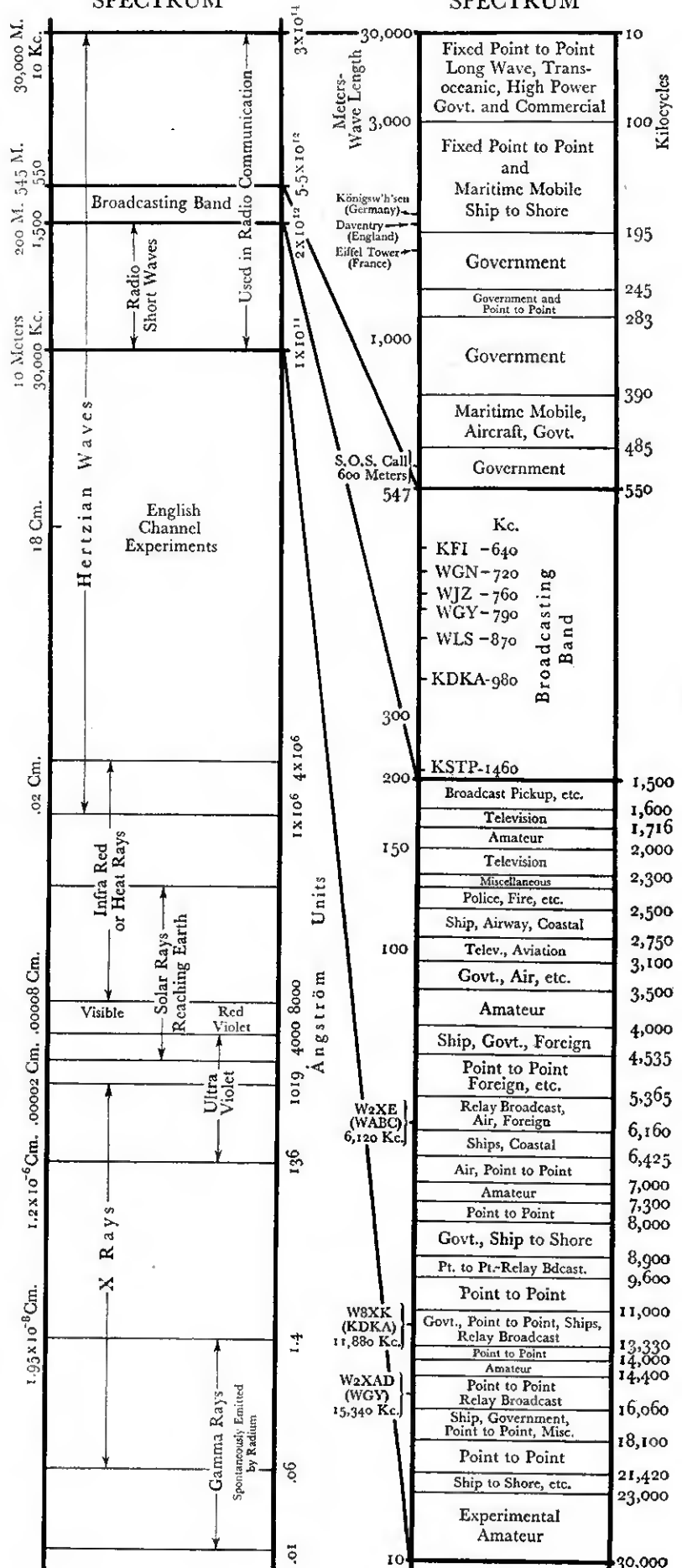



BING CROSBY featured in the "BIG BROADCAST"

*Radio's Most Popular Stars
 As They Appear in Scenes
 from Paramount's.....*

"The BIG

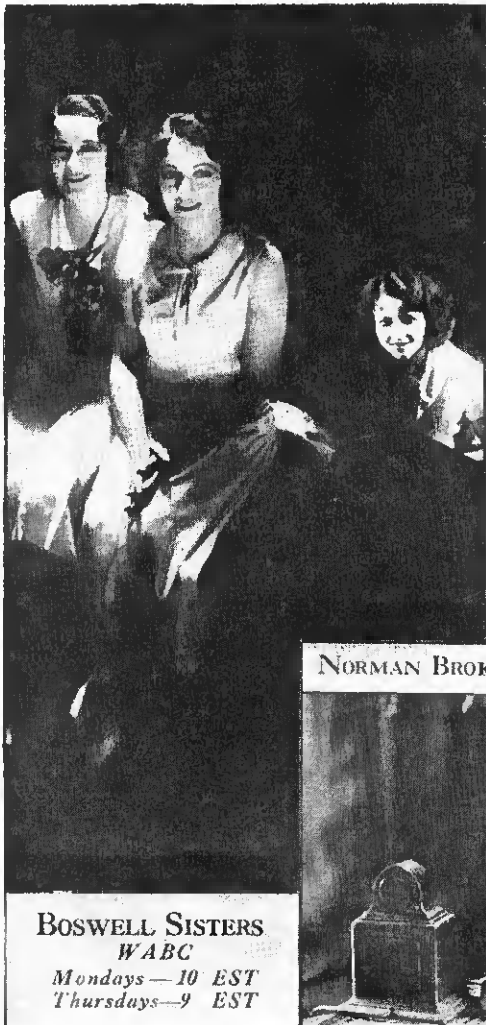

BOSWELL SISTERS
 WABC
 Mondays—10 EST
 Thursdays—9 EST



KATE SMITH WABC—8:30 EST
 Mon., Tues., Wed.

TED COLLINS
 announcing



NORMAN BROKENSHERE announcing

STREET SINGER WABC Tuesdays—9 EST
 Fridays—10 EST

See Them On The Screen



VINCENT LOPEZ
who personally announces



VINCENT LOPEZ ORCHESTRA *WEAF Wednesdays 12:05 AM—Fridays 12:30 AM EST*

BROADCAST

DALE WIMBROW
announcing



MILLS BROTHERS *WABC — 9:15 EST
Mondays—Thursdays*



BURNS AND ALLEN *WABC Wed. 9 EST*

WILLIAM BRENTON
announcing



CAB CALLOWAY AND ORCHESTRA
WJZ Wed. and Fri. at midnight

Hear Them On The Air

EDITORIAL OBSERVATIONS

"Say It Isn't So"

Editor's Note: The following editorial appeared in a recent issue of the "Tulsa World." Many of our readers are meeting this same sentiment in their daily rounds and should be in a position to overcome this sales resistance. "Say it isn't so," they are asking of us. We herewith comply with this demand.

HOW MUCH dust is going to be taken off radio sets in the next few weeks? The question is very important to radio. Its answer will show the extent of revulsion against the serious abuses which radio has developed. That radio 'entertainment' has sunk to a very low level is not denied. Will it continue to deteriorate, or do the radio magnates have sense enough to start the necessary reformation now?

"The fact is that broadcasting companies have, for the last year, given their audiences little that intelligent people can appreciate or even tolerate. There must be a mighty wading through tooth paste and tears and 'heart' and 'dart' stuff before anything worth while can be found. The radio programs of the next few weeks will be watched with interest. The blatancy of advertising and the persistent insults to intelligence may persist. If so, radio dealers and repairmen will suffer.

"A great many people already allude to radio with disgust and think of the coming months with apprehension. Just how wise are the magnates? Can they afford to ignore the intelligence of the country and keep on promoting lotteries, patent medicine, crooners and hogwash?"

"It Isn't So, Sweetheart!"

YOU'RE both right and wrong, Mr. *Tulsa World* Editor. We agree that the odor of "hogwash" still permeates radio's ethereal atmosphere to a nauseous degree, especially from the smaller stations. But the owner of a modern set,

if he possesses even a minor degree of intelligence, perserverance and tolerance, and even if he be located in the "sticks," can tune in, any evening, a wealth of worthwhile music, of instructive programs and of many types of thrilling entertainment offerings.

True, radio "entertainment," in spots, has sunk to a low level. But with some 700 stations, of all kinds and sizes, dependent for their existence on the advertiser's dollar, it just can't be helped. And it's about time that the public accept the situation with good grace and stop its grouching. Why look a gift horse in the mouth if, otherwise, he's sound of wind and limb?

And the sooner our own readers appreciate the practical problems of the broadcasters—the sooner they drive home to their customers the value of the many *good* things that are on the air and tell of the splendid programs now in the making—the sooner will the radio public cease its unreasonable moonings for a sweetheart who is not so unfaithful after all.

BY WAY of pointing up our contention with proof instances—we quote from news items:

"A new policy, limiting the length and nature of sales talks, has been announced by the Columbia Broadcasting System. For example, in a 15 minute program two price mentions can be made provided the time of all sales talk takes no more than 1½ minutes."

"Names emblazoned along Broadway begin to flash across the radio firmament. A large stride in this direction is seen in the formation of the Amalgamated Broadcasting System, Inc., of which Ed. Wynn, the comedian, is president and Arthur Hopkins, stage producer, is director of production. The company enters an hitherto undeveloped market—that of arranging shows for the networks and independent stations. It is reported that Amalgamated already has signed nearly \$1,000,000 worth of show business for air presentation."

"During the past year our (Philco) principal broadcasting has been the concerts of the Philadelphia Orchestra, under Leopold Stokowski, using all stations in a coast-to-coast hook-up. These were actual full-length concert programs direct from the Academy of Music. With these broadcasts we held the air for an hour and three-quarters."

A Campaign to Replace Every Tube

TODAY there are roughly 17,000,000 radio sets in use in the United States. If all these set-owners replaced their tubes once a year,—at six tubes per set, the possible annual replacement market would be a hundred million tubes!

But actual sales for replacement reached only 25,000,000 tubes last year, showing how far the industry and trade falls short of its full-replacement opportunity.

This matter of keeping the tubes in every set in best operating condition is of interest to the broadcasters as well as to the radio trade. Of what avail is it for the broadcasters to spend millions of dollars to put the best of radio tone quality onto the air, unless listeners' sets are in condition to receive these musical values adequately. No radio set can be better than its tubes, and no advertiser's program, whatever its outlay for talent, can be a whit more attractive than the state of the listener's tubes permits.

Other industries have conducted cooperative maintenance and replacement campaigns, but no industry ever had, readymade, all the vast and unique facilities which radio enjoys for carrying out its purpose.

The broadcasters can help over the air; newspaper advertising can carry the message of tube replacement; and streamers on dealers' windows will catch the buying public at the critical moment when it is close to a complete tube stock.

Every group in radio will benefit—broadcasters, manufacturers, jobbers, dealers, and listeners—the sooner such an industry move is gotten underway to stimulate set-owners to "put new radio tubes in every socket, and then listen to the difference!"

Too Many Tube Types

FROM tube makers, as well as from dealers and jobbers, complaints are reaching our desk that the output of new tube types has passed the bounds of necessity. Tube designs, differing but little from those long in production, are complicating the replacement problem, overloading dealers' stocks and inflicting upon the service man the dual task of mastering new circuits and new tube characteristics.

In suggesting that set and tube executives apply

the brakes to this trend, let it be understood that we do not discourage the engineering of new tubes which mark a distinct and necessary technical advancement. But, as in the release of new receiver models, the first consideration must be that of dealer welfare—rather than a selfish interest which, at best, can be but short-lived.

Free Electricity

GET this picture: You are building a new house out in the country. Your new home has nearly every modern convenience but, alas, there is no electricity. So you prepare to light with oil.

Then along comes a stranger. "Mister," he says to you, "I represent the American power industry. If you will wire this house my company will give you all the current you can use, free for the rest of your life."

Would you wire? You most certainly would.

This is precisely what the radio industry offers the consumer . . . buy a set and get the programs free. For the public, this is the most open-handed generosity in history. For the manufacturer, jobber and dealer it represents the best sales approach imaginable.

And yet we still spend millions narrowly trying to sell the "wiring," even the superiority of one brand of wire over another, when we are really giving something away. Stupid? This is stupidity without precedent!

"An Opportunity Neglected"

"MAY I congratulate *Radio Retailing* on its endeavor to bring the radio manufacturer and broadcaster together with the ultimate object of stimulating listener interest by providing unusual programs?

"As you say: 'The men who build and sell radio sets carry on their business without regard to the broadcasting service which is radio's life blood.

"This point cannot be too strongly emphasized. With few exceptions, the industry has almost entirely neglected its opportunities to contribute radio programs to the listener. This is the one thing it can do to make the ownership of a radio a social necessity in every type of home. It would do more, in my opinion, than any other single step to stimulate the sale of sets."

PAUL W. KESTEN, *Director of Sale Promotion,*
Columbia Broadcasting System.

Answering Your Questions

Resistance-coupled push-pull, twin-83s, variable-mu audio and other unusual circuit features briefly explained

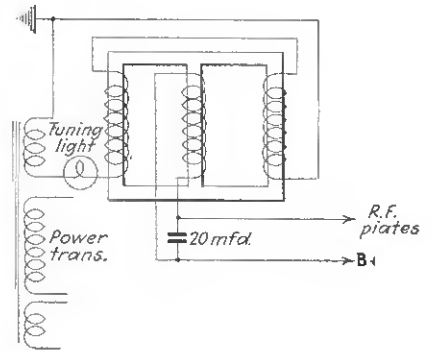

IN CONTACTING receiver manufacturers to obtain data for *Radio Retailing's* 8th Annual "Specifications" issue (published last month), a number of unusual circuit features were brought to our attention, some of them new, others interesting modifications of old ideas.

These, for the most part, are not fully understood by servicemen, owing to their comparatively recent commercial introduction. So, for the benefit of *SHORTCUT* readers, we present brief explanations of a number of the most unique. This "advance dope" will, we trust, prove helpful.

RESISTANCE-COUPLED PUSH-PULL—In the Majestic 300 chassis and also in the Columbia C-90, two 47's operating in push-pull are driven by a 57 first a.f. stage via resistance-coupling.

Now, it is necessary that the grids of push-pull tubes be fed with signal voltages which are equal in magnitude but exactly opposite in phase, or polarity. In conventional circuits this is accomplished simply by utilizing a center-tapped input transformer, the grids being fed from the two extremes of the secondary winding, which are obviously out of phase. In the resistance-coupled system diagrammed, the trick is accomplished by feeding one of the 47's through a "phase-changing" stage, making use of the fact that a signal, in passing through a vacuum-tube is "rotated" exactly 180°.

If the audio output lead from the 57 first a.f. stage is traced through the .05 mfd. coupling-condenser it will be seen that it goes directly to one pentode grid and also to the control grid of the 58, which is connected as a triode having a gain of 1. The signal output of the 58 builds up across its associated 100,000 ohm resistor and is then fed through the .10 mfd. coupling condenser to the 47,

The two output tubes are fed in proper phase without the use of an input transformer in a novel manner. One 47

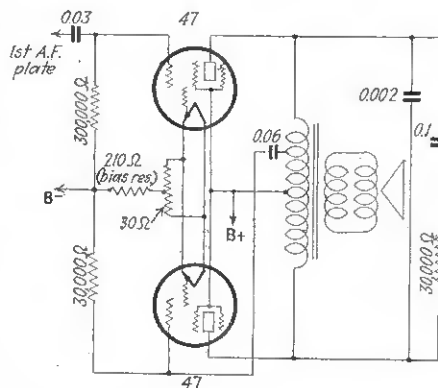

receives its signal input through a .03 condenser direct from the plate of the first a.f. stage 57, to which it is resistance-coupled, while the other 47 is energized through a .06 condenser from a tap suitably placed on the primary of its own output transformer. The directly driven pentode, it might be said, actually drives the grid of its team-mate. The energizing tap, servicemen should note, is taken on the transformer primary half associated with the directly driven tube.

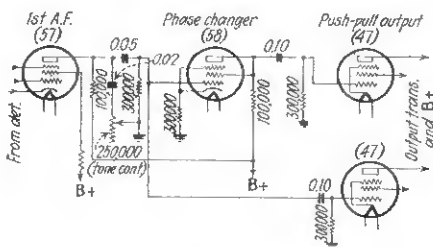

reversed in polarity but otherwise identical to the signal supplied the other push-pull tube.

"BRIDGE" INPUT PUSH-PULL—Especially flat response from 60 to 8,000 cycles is claimed for Capehart's Colunaire amplifier which uses "bridge" input to two 47's working in push-pull.

REACTANCE RESONANCE INDICATOR—Referring to the accompanying schematic (from Majestic 300 and Columbia C-90 chassis) it will be seen that a reactor having three windings on three respective legs of a common iron core is employed in a novel manner.

The windings on the two outside legs are connected in series with the half-ampere pilot light and its power supply source, while the center leg is in series with the plates of the r.f., first detector and i.f. tubes. Thus, when the set is turned on and the tubes warmed up, but no station tuned in, a relatively large plate current flows through the center

winding of the reactor. This saturates the iron core so that the reactance of the two outer windings is quite low and sufficient current flows through the pilot light to brightly illuminate it.

When a station is tuned in, however, the receiver's automatic volume control system develops a bias voltage across a 50,000 ohm resistor, this control voltage being applied in the conventional manner to the control grids of the r.f., first detector and i.f. tubes. When highly biased, the amplification of the tubes so controlled decreases and also, simultaneously, does their plate current. This reduction in plate current, flowing through the center winding of the reactor, relieves the saturation of its core and increases the reactance of the outer windings. This, in turn, reduces the current flowing through the pilot light by about 5 mils. and so the light dims appreciably when a station is tuned in.

The two outer windings, it will be noted, are connected so that they oppose each other, insofar as relationship to the center leg is concerned. This prevents a.c. flowing in the pilot light circuit from being induced into the plate circuit of the tubes through the center winding. A 20 mfd., electrolytic condenser by-passes the center winding as a further safeguard.

TWIN-83 RECTIFICATION Atwater Kent achieves the unusual in model 812, equipped with two type 83 heavy-duty rectifiers. Class B amplification, with which the set is equipped, alternately requires much current and then none at all, depending upon signal input, so the factory evidently decided to go "whole-hog" and equip with the huskiest possible power unit.

Thus we find that the 812 has, in

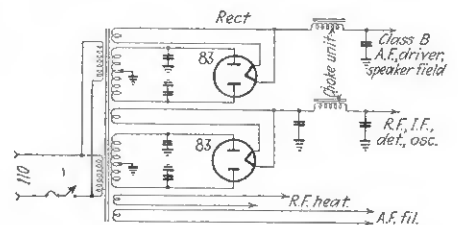

effect, two separate power transformers, primaries and all, and two separate filters. One 83 supplies d.c. to the final push-push stage, its 46 driver and the speaker field. The other furnishes operating potential to the remaining tubes in the r.f. portion of the receiver. This, it is pointed out, prevents all possibility of variation in a.f. load being communicated through the power unit

to the more voltage-sensitive portions of the circuit.

Model 612, also new, is similarly equipped with twin-83s but these are handled in a slightly different manner. There is but one power transformer and this has separate high-voltage and filament windings for the two rectifiers. And one of the 83s, equipped with a two-section filter choke, operates the Class B tubes and driver while the other, operating the r.f. tubes, filters through the speaker field.

VARIABLE-MU AUDIO—Servicemen who are puzzled by the use of a type 35 variable-mu tetrode (more generally found in r.f. stages) in the first a.f. socket of Fada's all-wave KY chassis will find this explanation helpful.

The 35 not only furnishes an amplification gain of 30 but also forms part of the receiver's automatic volume control system. An avc circuit capable of maintaining the audio output level to an 8 decibel change for an antenna signal variation of 20,000 to 1 (approximately 86 decibels) is obtained in this receiver by applying control voltage developed in

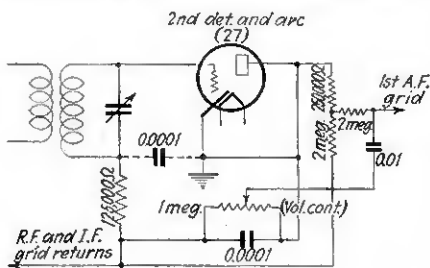

the second detector-avc circuit not only to the r.f. and i.f. grid-returns but also to the first a.f. stage. R.f. and a.f. control is thus accomplished simultaneously and the 35 just happens to be particularly suitable for such control as it can be operated at high or low input levels without distorting appreciably.

The path followed by d.c. (not to be confused with a.f. voltages which flow in the ordinary manner) secured through signal rectification by diode action may be traced around the circuit from grid to cathode-plate through the series 125,000 ohm, 2 megohm and 250,000 ohm resistors. Due to the voltage drop introduced by the flow of this d.c. through the resistors the point to which the r.f. and i.f. grid-return (and indirectly the 1st a.f. grid-return) is attached becomes more negative as signal strength increases, or as the manual control is varied, reducing amplification.

R.f. grid return is provided by a .0001 mfd. condenser between low potential end of the coil and the cathode.

A.F. "OFF-CARRIER" SUPPRESSOR—Suppression of amplification between carriers is accomplished in the first a.f. stage of Capehart's new Combinaire receiver in an interesting fashion.

The set is equipped with a 57 second detector connected to operate as a diode rectifier, its control-grid, suppressor-grid and cathode performing this function. The plate plays no part in detection but is, nevertheless, supplied with operating potential. Thus plate current increases when a signal is received and

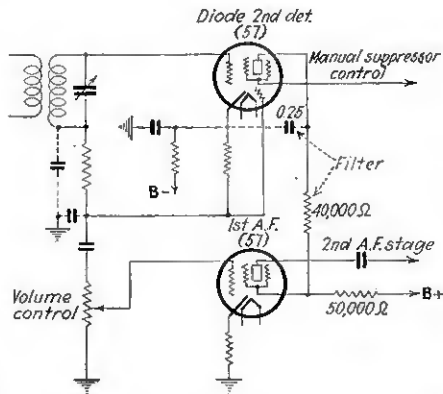

this current flows through a 50,000 ohm resistor, producing a voltage drop which is communicated to the screen of the first a.f. amplifier fed through this same resistor.

Normally supplied with screen-voltage sufficiently high to limit amplification, the first a.f. tube is relieved of this "blocking" voltage when a received carrier increases detector plate current, introducing a drop in the series resistor. And, conversely, when the carrier is detuned plate current declines, voltage drop through the resistor is reduced and the first a.f. tube's screen again receives blocking voltage.

Detector plate current may be manually adjusted to permit a.f. amplification at any desired input signal level by varying the detector screen voltage through a 25,000 ohm manual suppressor control resistor (not shown). A .25 mfd. condenser and 40,000 ohm resistor prevent a.f. currents from circulating in the suppressor control circuit.

FOUR TUBE SUPER—A number of requests have been received for a circuit diagram of Philco's new midget super, one showing the important constants. This circuit is reproduced here with in some detail.

It will be noted that no intermediate frequency tube is employed, the circuit comprising a detector-oscillator, a second detector and an a.f. pentode, plus the usual fullwave rectifier. Sensitivity is understood to be about 70 microvolts at the high-frequency end of the

PUSH-PULL DIODE AVC—Two 56s, plates and grids tied together, are used in the Sparton model 14 super as a push-pull diode second detector and automatic volume control circuit. Variation of rectified signal voltage through a 250,000 ohm resistor provides the necessary automatic bias values and it is interesting to note that this same resistor, being provided with a variable arm, is utilized also as the manual volume control.

Several other models are equipped with similar diode detection circuits but with separate avc tubes, while the model 34 uses a duo-diode type 70 as the second detector, accomplishing practically the same job as the two 56s of the model 14 in a single double-grid tube.

Model 34, incidentally, is an automobile receiver and the number 70 tube a double-grid tetrode not unlike the "Wunderlich" series, having a 6.3 volt, .3 amp. heater and a six-prong base. The two control grids with which the tube is equipped are fed from opposite ends of a center-tapped input coil, producing push-pull diode rectifi-

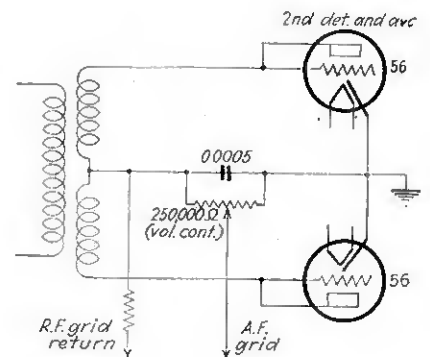

cation, while automatic volume control voltage is obtained across a 100,000 ohm resistor in series with the plate circuit. Unlike the model 14 diagrammed, this resistor is not used as a manual volume control. Gain is varied by means of a potentiometer in input circuit to the first a.f. stage.

Models 27 and 28 have four 47 output pentodes in push-pull parallel.

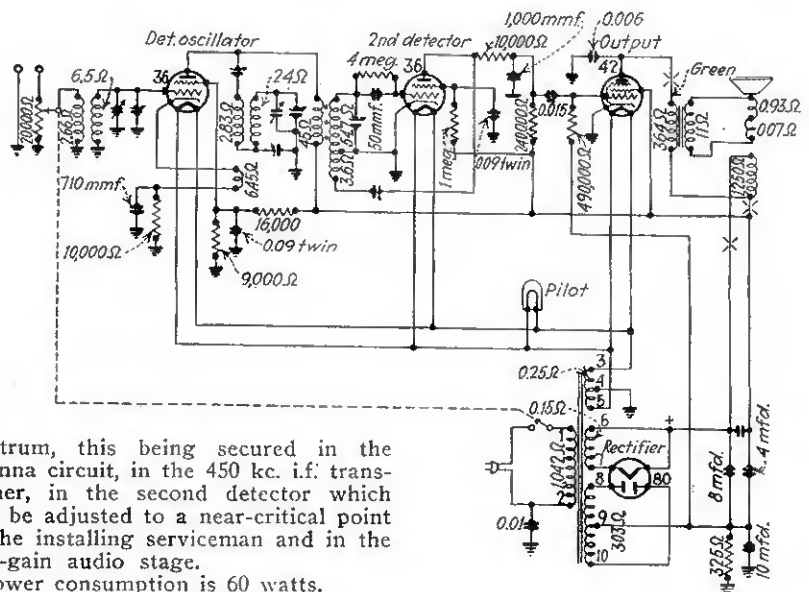

spectrum, this being secured in the antenna circuit, in the 450 kc. i.f. transformer, in the second detector which may be adjusted to a near-critical point by the installing serviceman and in the high-gain audio stage.

Power consumption is 60 watts.

SERVICE SHORTCUTS

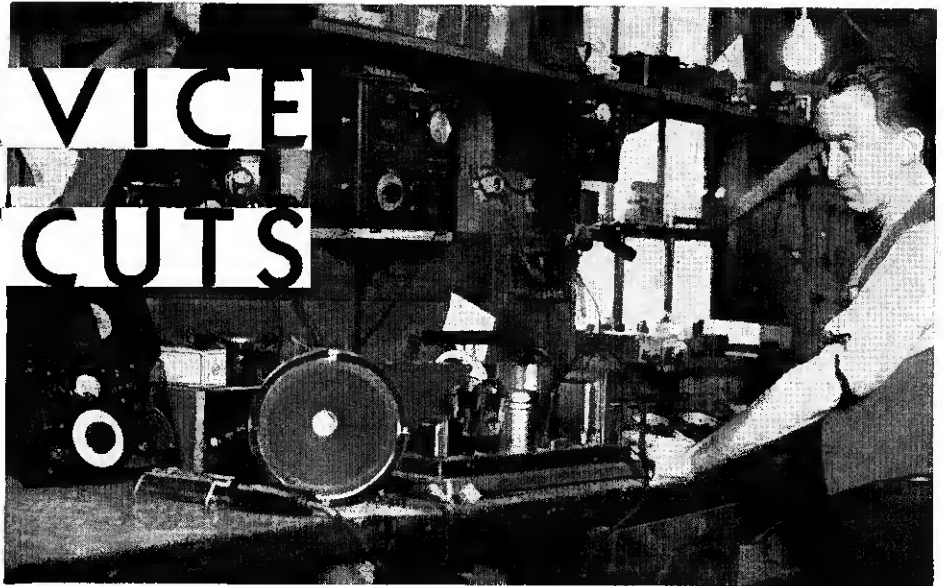

Tube Numbering That Means Something

The RMA is seriously considering a new three-character system of marking radio receiving tubes which may shortly come into general use in place of the present meaningless type numbers. Easily grasped, the system makes it possible to roughly identify all tubes by their designations without resorting to complicated charts. A detailed description of the plan follows.

The first numeral is to be definitely related to filament, or heater, voltage.

0 to 2 volts	1
2.1 to 2.9	2
3.0 to 3.9	3
4.0 to 4.9	4
5.0 to 5.9	5
6.0 to 6.9	6
etc.	

The second character is to be a letter, arbitrarily assigned to distinguish tubes having the same filament voltage and same number of elements from each other. The first tube of a given type to be marketed will be classified "A," the second "B" and so on. Thus a 24 would be a 2A5 while the later 35 would be a 2B5.

The third character is to correspond with the number of usable elements having external connections.

Following is a table which shows old and new designating numbers of standard receiving tubes:

OLD	NEW	OLD	NEW
10	7A3	44	6F5
WD11	1A3	45	2A3
WD12	1B3	46	2D4
14	14A5	47	2B4
15	1A5	49	1D4
17	14A4	50	7B3
18	14B4	51	2B5
19	1B5	52	6C4
20	3B3	55	2C6
22	3A4	56	2C4
24	2A5	57	2A6
26	1C3	58	2B6
27	2A4	59	2D6
29	2C5	64	6G5
30	1D3	65	6H5
31	1E3	67	6B4
32	1A4	68	6I5
33	1B4	69	6J5
34	1C4	71	5D3
35	2B5	80	5E3
36	6A5	81	7A2
37	6A4	82	2B3
38	6B5	83	5F3
39	6C5	85	6A6
40	5E3	89	6B6
41	6D5	99	3A3
42	6E5	201A	5A3
43	25A5	112A	5C3

Practical 175 Kc. Oscillator

By Joseph E. Soos

Here is a circuit diagram of a 175 kc. oscillator used in my shop. It employs a type 30 tube and is completely encased in an old brass shield taken from a battery radio. Batteries could have been external, with the leads to the oscillator shielded. 22½ volts is sufficient plate potential for a strong signal.

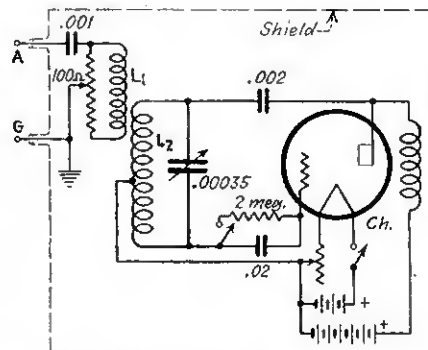

The main oscillator coil, L2, is wound in the slot of a wooden form having the dimensions shown in the attached drawing. It should consist of exactly 196 turns of No. 21 s.c.e. wire wound 14 turns to the layer, tapped at the 98th turn. The pickup coil, L1, is 14 turns of No. 21 s.c.e. wire basket-weave wound to 4½ inches in diameter, squared off and fitted around the main coil. A coil wound in haphazard fashion in the hand, securely tied with

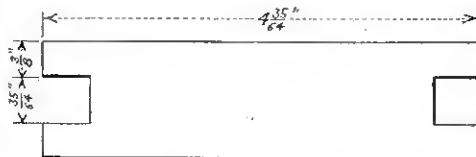

string, will do if basket-weaving forms are not available.

To calibrate the device I selected a superheterodyne known to have accurate dial calibration. The oscillator was connected to the input circuit of this set and the receiver tuned to exactly 875 kc. Then

the oscillator dial was rotated until it produced the loudest possible signal.

The device may of course be used to generate signals within the broadcast band of frequencies by selecting the proper harmonics.

A Replacement Mercury Switch

By W. T. Golson

Several makes of automatic record-changing phonographs employ a liquid mercury switch of the tilting variety as part of the changing mechanism. These frequently become cracked, allowing air to seep through the glass and foul the mercury.

To replace these switches where the time required to secure delivery from the factory cannot be spared secure a small pill-bottle having approximately the same dimensions as the original switch tube, a rubber stopper and two ordinary sewing needles. Fill the bottle about ¾ full of mercury, insert the stopper as tightly as possible and then push the needles through it as far apart as possible. Solder flexible leads to the protruding eyes of the needles and then coat bottle and needles with molten wax.

Fasten the completed unit to the switch tipping frame in the same manner as the original mercury unit.

Knob-Removing Cord

By R. L. Wittman

To remove contrary tuning and adjusting knobs of the slip-on type take a piece of heavy cord about 9 in. long and tie the ends together, forming a loop. Now tie a knot approximately in the center of the loop, thus forming the cord into two loops.

Slip one loop behind the knob and the other on your fingers and pull. The knob will come away without damage to either finger-nails or cabinet.

High D.C. Voltage from a 6-Volt Battery

By M. Chernow

An old B-eliminator may be quickly and cheaply converted into a device for obtaining high d.c. potentials from a 6-volt storage battery. The same device also provides high a.c. potentials which are useful in the shop.

Disconnect the 5-volt filament winding which normally heats the 280 rectifier and short the two socket filament terminals together as shown in the accompanying diagram. Leave the high positive lead to the filter circuit untouched. Plug a BR rectifier in this socket.

Now, connect a high-frequency buzzer, the contacts of which are shunted by a 1. mfd. high-voltage condenser, in series with the 5-volt winding and a storage battery. Thus connected the 5-volt winding becomes the primary winding while the original primary is left open. High-voltage d.c. may now be obtained from the output circuit of the device while high-voltage a.c. is present across the original primary leads.

Using a Majestic eliminator and the primary of a Ford spark-coil for an interrupter the output will be approximately 190

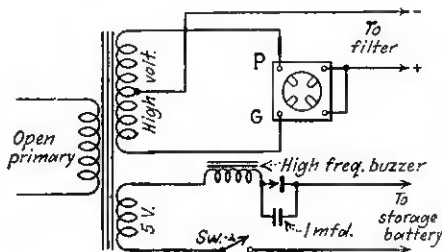

volts d.c. Adjustment of the vibrator points is not unduly critical. Current output is largely determined by the character of the buzzer used.

About Neon Sign Transformers

By J. P. Kennedy

Most transformers for neon signs have a twenty to forty per cent power factor. This results in high current drain that causes pitting and corrosion of control

switches in the circuit with the result that noise from poor electrical contact affects radio reception, to say nothing of the sign owner's monthly power bill.

The power factor can be corrected, brought nearer to 100 per cent, by connecting paper condensers across the line close to the transformer primary. Between 8 and 12 microfarads is usually sufficient. The proper capacity can be determined by noting when the product of the current times the voltage equals actual watts indicated on a watt-meter.

3.8 Volt Pilots

By Ralph L. LeBrun

Number 13 Mazda focussing 3.8-volt flashlight lamps work out fine where 2.5-volt pilot lights repeatedly burn out due to excess voltage. They are also handy when 2.5-volt bulbs are not immediately available.

Try the number 13, too, in Spartan sets using 3-volt filament type 485 tubes.

Dial Drive Cable Idlers

By George Randolph

Dial drive cable idlers on Eveready, Bosch and similar chassis sometimes are lost. Ream out the thread of a battery thumb-nut and it will be found to run smoothly on the stub shafts, a good substitute for the factory made idlers.

Curing Cone Rattles

By A. W. Dugan

If shellacking a cone and centering its apex fails to remove objectionable rattle press the rubber of a lead-pencil firmly to the extreme edge of the cone where it is clamped or glued in place. Try the pencil pressure on top, bottom and sides, being careful not to press so hard that the cone is damaged, until a point is reached where the rattle ceases.

If the cone is glued, smear shellac heavily between frame and cone at this point and let it dry. If it is clamped, loosen the clamp enough to permit the insertion of a small soft-wood shim.

MICROPHONE DOPE

"SHORTCUTS" is indebted to the Mayo Instrument Company for the following helpful suggestions concerning the use of microphones.

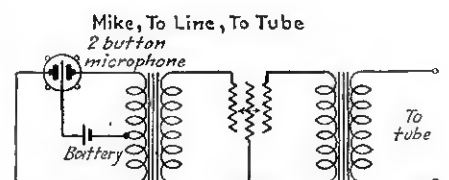
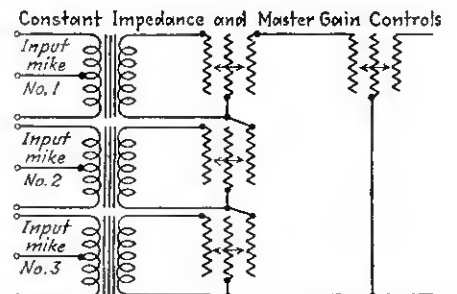
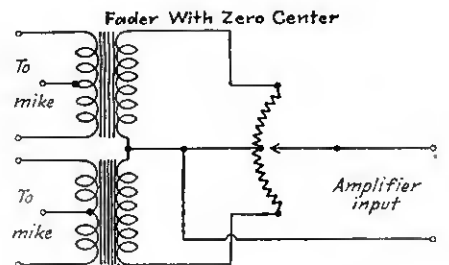
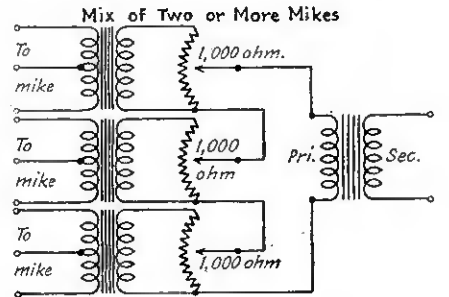
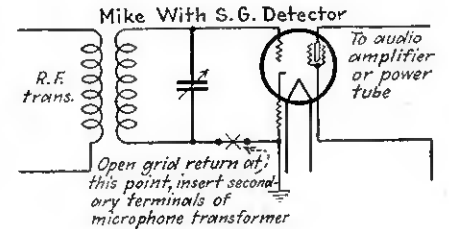
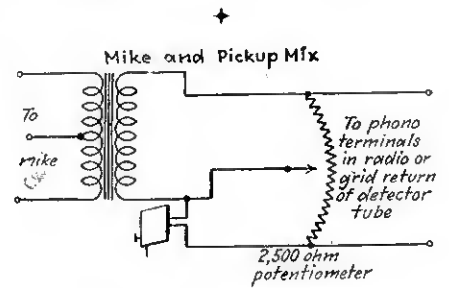

Another Well-Equipped Test Bench

Bill Garlitz of Coraopolis, Pa., sends us this photo of one of his two excellently equipped test benches. Note the set analyzer, tube checker, two oscillators, output meter, battery charger and complement of tools

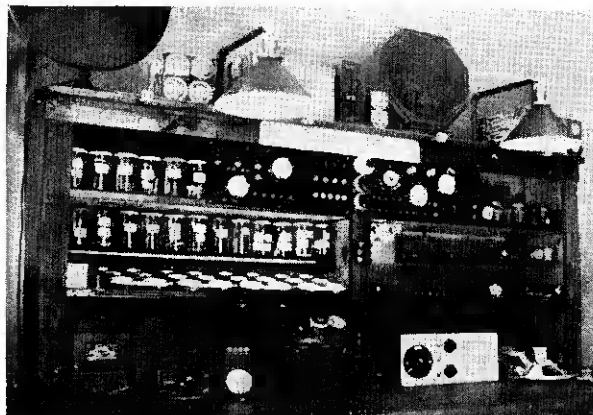

Characteristics of Radio Receiving Tubes

Type	Purpose	Maximum		Cathode			Plate voltage	Plate current ma.	Screen voltage	Grid bias	Plate resistance	Amplification factor	Mutual conductance	Power output m. watts	Load resistance
		Length	Diam	Type	Voltage	Current									
00-A	Detector	4 1/16	1 3/16	Filament	5.0	0.25	45	1.5	0	30,000	20.0	666
01-A	General purpose	4 1/16	1 3/16	Filament	5.0	0.25	90	2.5	4.5	11,000	8.0	725
11	General purpose	4 3/8	1 3/16	Filament	1.1	0.25	135	3.0	10.5	15,000	6.6	440
12		4 1/16	1 7/16												
12-A	General purpose	4 1/16	1 3/16	Filament	5.0	0.25	180	7.6	13.5	5,000	8.5	1,700	260	10,800
20	Power output	4 3/8	1 3/16	Filament	3.3	0.132	135	6.5	22.5	6,300	3.3	525	110	6,500
22	R.F. amplifier	5 3/8	1 3/16	Heater	15.0	0.35	135	1.0	30	1.5	700,000	400.0	570
22	R.F. amplifier	5 3/8	1 3/16	Filament	3.3	0.132	135	1.5	45	1.5	850,000	350.0	300
24-A	R.F. amplifier	5 3/8	1 3/16	Heater	2.5	1.75	180	4.0	90	3.0	400,000	400.0	1,000
26	Amplifier	4 1/16	1 3/16	Filament	1.5	1.05	135	5.5	10.0	7,600	8.3	1,100
26	Detector	4 1/16	1 3/16	Heater	15.0	0.35	90	4.5	1.5	9,000	10.5	1,165
27	General purpose	4 1/16	1 3/16	Heater	2.5	1.75	135	4.5	9.0	9,000	9.0	1,000
28	General purpose	4 1/16	1 3/16	Heater	15.0	0.35	90	7.5	1.5	9,000	10.5	1,165
29	Special detector	4 3/4	1 9/16	Heater	2.5	1.00	180	4.5	3.0	20,700	30.0	1,450
30	Power amplifier	4 1/16	1 3/16	Heater	15.0	0.35	180	22.0	27.0	3,500	3.8	1,100
30	General purpose	4 3/4	1 9/16	Filament	2.0	0.06	180	3.1	13.5	10,300	9.3	900
31	Power amplifier	4 3/4	1 9/16	Filament	2.0	0.130	135	8.0	22.5	4,100	3.8	925	185	7,000
32	R.F. amplifier	5 3/8	1 3/16	Filament	2.0	0.06	180	1.7	67.5	3.0	1.2 Meg	780.0	650	375	5,700
32	Voltage amplifier	4 1/16	1 3/16	Heater	15.0	0.35	135	1.5	3.0	32,000	30.0	940
33	Power amplifier	4 1/16	1 3/16	Filament	2.0	0.26	135	14.5	135	13.5	50,000	70.0	1,450	700	7,000
34	Variable-mu	5 3/8	1 3/16	Filament	2.0	.06	135	2.8	67.5	3.0	600,000	360.0	600
35	Variable-mu	5 3/8	1 3/16	Heater	2.5	1.75	250	6.5	90	3.0	350,000	370.0	1,050
36	R.F. amplifier	4 1/8	1 9/16	Heater	6.3	0.30	180	3.1	90	3.0	350,000	370.0	1,050
37	General purpose	4 3/4	1 9/16	Heater	6.3	0.30	180	4.7	13.5	10,000	9.0	900
38	Power amplifier	4 1/8	1 9/16	Heater	6.3	0.30	135	9.0	135	13.5	102,000	100.0	975	525	13,500
39	Variable-mu	4 1/8	1 9/16	Heater	6.3	0.30	180	4.5	90	3.0	750,000	750.0	1,000
40	Power amplifier	4 1/16	1 3/16	Heater	15.0	0.40	180	21.0	40.5	2,000	3.0	1,500
40	Voltage amplifier	4 1/16	1 3/16	Filament	5.0	0.25	180*	0.2	3.0	150,000	30.0	200
41	Power pentode	4 1/16	1 3/16	Heater	6.3	0.65	167.5	16.5	167.5	12.5	120,000	215.0	1,800	1,200	11,000
42	Power pentode	5 5/8	2 3/16	Heater	6.3	0.65	250	34.0	250	16.5	100,000	220.0	2,200	3,000	9,000
43	Power pentode	5 5/8	2 3/16	Heater	25.0	0.30	95	20.0	95	15.0	45,000	90.0	2,000	900	4,500
44	High cutoff 39	4 1/16	1 9/16	Heater	6.3	0.30	180	6.4	90	3.0	410,000	426.0	1,040
45	Power amplifier	5 5/8	2 3/16	Filament	2.5	1.50	250	34.0	50.0	1,750	3.5	2,000	1,600	3,900
46	Class B amplifier	5 5/8	2 3/16	Filament	2.5	1.75	250	22.0	33.0	2,380	5.6	2,350	1,250	6,400
47	Power pentode	5 5/8	2 3/16	Filament	2.5	1.75	250	31.0	16.5	60,000	150.0	2,500	2,500	7,000
48	General purpose	4 1/16	1 3/16	Heater	15.0	0.35	90	4.5	4.5	9,000	10.5	1,185
48	Output tetrode	5 5/8	2 3/16	Heater	30.0	0.40	95	47.0	95	20.0	10,000	28.0	2,800	1,600	2,000
49	Class B amplifier	4 1/16	1 3/16	Filament	2.0	0.12	135	5.7	20.0	4,000	4.5	1,125	170
50	Power amplifier	6 3/4	2 1/16	Filament	7.5	1.25	350	45.0	63.0	1,900	3.8	2,000	2,400	4,100
							450	55.0	84.0	1,800	3.8	2,100	4,600	4,350
51	Variable-mu	5 3/4	1 3/16	Filament	2.5	1.75	250	6.30	75	3.0	360,000	400.0	1,110
52	Output tube	4 1/16	1 3/16	Filament	6.3	0.30	100	42.0	0	(Designed for Class B operation)
55	Diode triode	4 3/4	1 9/16	Heater	2.5	1.00	250	8.0	20.0	7,500	8.3	1,100
56	General purpose	4 3/4	1 9/16	Heater	2.5	1.00	250	5.0	13.5	9,500	13.5	1,450
57	R.F. amplifier	4 2 3/8	1 9/16	Heater	2.5	1.00	250	2.0	100	3.0	1.5 Meg.	1,500	1,225
58	Variable-mu	4 2 3/8	1 9/16	Heater	2.5	1.00	250	8.2	100	3.0	800,000	1,280	1,600
							250	30.0	28.0	2,500	6.0	1,200	1,250	5,000 A triode
59	3-grid pwr. amp.	5 3/8	2 1/16	Heater	2.5	2.00	250	35.0	250	18.0	45,000	100.0	2,220	3,000	7,000 A pentode
							400	15.0	0	2,000	6.0	1,200	1,250
64	R.F. amplifier	4 1/16	1 9/16	Heater	6.3	0.40	135	3.0	67.5	1.5	350,000	370.0	1,050
							400	15.0	0	2,000	6.0	1,200	1,250
65	R.F. amplifier	4 1/16	1 9/16	Heater	6.3	0.40	135	3.5	67.5	1.5	320,000	320.0	1,000
67	Power amplifier	4 3/4	1 9/16	Heater	6.3	0.40	135	5.0	9.0	8,200	9.0	1,100
58	Output pentode	4 1/16	1 3/16	Heater	6.3	0.40	135	14.0	135	13.5	64,500	90.0	1,400
59	Special detector	4 3/4	1 9/16	Heater	6.3	0.30	180	4.5	3.0	20,700	30.0	1,450
71-A	Power amplifier	4 1/16	1 3/16	Filament	5.0	0.25	180	20.0	43.0	1,850	3.0	1,620	700	5,350
85	Diode triode	4 1/8	1 9/16	Heater	6.3	0.30	250	7.0	20.0	8,300	8.3
89	Triple grid amp.	4 1/8	1 9/16	Heater	6.3	0.40	160	180	82,500	135.0	1,635	1,500	8,000 A pentode
							17.0	20.0	3,000	9.7	1,570	300	7,000 A triode
99	General purpose	4 3/8	1 3/16	Filament	3.3	0.063	90	2.5	4.5	15,500	6.6	425
							180	17.5	4.0	6.5	1,250	8,000
182-B	Power amplifier	4 1/16	1 3/16	Heater	5.0	1.25	200	18.0	29.0	3,330	5.0	1,500
183	Power amplifier	5 5/8	2 3/16	Filament	5.0	1.25	250	25.0	60.0	1,670	3.0	1,800
210	Power amplifier	5 5/8	2 3/16	Filament	7.5	1.25	350	16.0	31.0	5,150	8.0	1,550	900	11,000
							425	18.0	39.0	5,000	8.0	1,600	1,600	10,200
257	Power pentode	5 5/8	2 3/16	Filament	5.0	0.30	110	20.0	110	21.5	41,000	55.0	1,350	800	6,000
401	General purpose	Filament	3.0	1.00	90	3.0	4.5	10,000	8.0	1,000
402	Power output	Filament	3.0	1.50	180	20.0	40.0	2,000	3.0	1,000
291	Two-stage amplifier	5 5/8	2 3/16	Heater	12.3	0.3	120	3.0	Input	11	8,700	6.8	780	20,000
							120	30.0	Output	+11	4,400	11.2	2,550	1,250	3,000
293	Two-stage amplifier	4 7/8	1 3/16	Heater	6.3	0.6	173.5	4.0	Input	6.5	100,000	
							180	17.5	Output	+6.5	1,250	8,000	
295	Two-stage amplifier	6 3/8	2 3/8	Heater	2.5	4.00	250	4.0	Input	14.0	12,000	14.4	1,200	7,500
							250	52.0	Output	3.0	3,000	13.0	4,350	4,500	4,000
483	Power output	5 5/8	2 3/16	Filament	5.0	1.35	180	15.3	40.5	2,450	3.3	1,340
484	General purpose	4 1/16	1 3/16	Filament	3.0	1.30	135	6.0	6.0	8,900	12.5	1,400
485	General purpose	4 1/16	1 3/16	Heater	3.0	1.30	135	5.5	6.0	8,900	12.5	1,400
LA	Output tube	4 1/16	1 3/16	Filament	6.3	0.30	135	12.0	135	9.0	5,260	100.0	700	9,500
KR-5	Output pentode	4 1/16	1 3/16	Filament	6.3	0.30	165	17.0	165	11.0	47,000	100.0	2,100	1,200	8,000
KR-20	Double-grid detector	4 3/4	1 9/16	Heater	2.5	1.00	250	3.5	0	10,000	14.0			

Don Bestor (center)
and His Orchestra

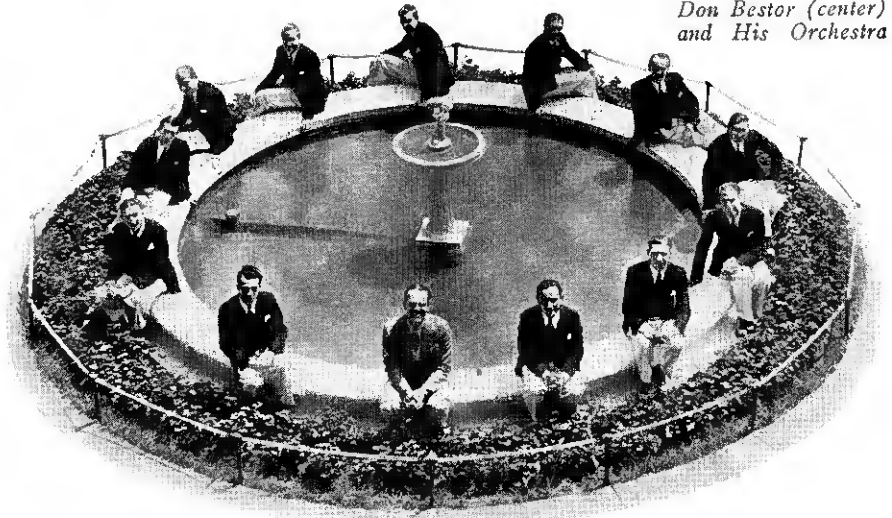

DISCS *Reflect* *New*

DANCE STYLES

Interviews and Reviews by Richard Gilbert

THE other day, in company with E. E. Oberstein, Victor's chief dance band scout, we hied over to the Lexington Hotel where Don Bestor and His Orchestra recently began to tantalize the stepping toes of a portion of New York's dansomaniacs. This orchestra leader has been rotating all over the country, playing the principal hotels and should know, as well as anyone, what the youngsters, grown-ups and prancing octogenarians prefer to accompany their glidings on the slippery floor. The answer, as this genial conductor will tell you, may be found in a pair of lately recorded Victor dance discs.

Slow, well-accented tempo displaying a generally appealing melody makes for popularity. "The trouble with many bands," says the experienced Mr. Bestor, "is that they over-orchestrate a tune. We fit the orchestration and tempo to the melody and not the other way around. The secret, if any, is to obtain the maximum effect with the simplest means. Dancing is the first consideration, listening the second. And, of course, interestingly sustained accents put in the right places will inveigle the most anemic dancer."

It's not as easy as it sounds. But, here is a peculiar deduction—as different from Guy Lombardo's style as they can be—Don Bestor's arrangements bear more than a slight resemblance as regards economy and simplicity. And everyone knows how Guy's records sell.

Bestor's band has just finished a series of new recordings and, if we don't miss our guess, these interpretations will be the rage this winter. W. H. Tyler, of The Gramophone Shop, America's most energetic record emporium, claims, "The late Bestor discs are sensations. *Contented* and *The River Rhine*, for style and recording, are the biggest things of the season. If the next records keep up to present standards, we may expect a real rival for Lombardo."

That Subtle Bass Drum

It can't be impressed too deeply that the various recording studios are up on their toes in search for additional kicks with which to pervade recordings with that ever-desired best selling quality. The manufacturers are not content to grind out the usual variety of hot, slow, fast, sweet, or humorous dance music, as the case may be, always prevalent on the air. A record of a dance tune must have a

punch which won't disappear after the first couple of hearings. And so we find an exceptional curiosity in what is known as microphone technic. The recent Don Bestor registrations introduce a recording innovation which is effective in the extreme. The engineer's took a feather from Ray Noble's war bonnet (the English H. M. V. recording band) and decided to put a spaciousness and tonal quality in a dance orchestra recording which up to now had been only partly evident. In recording Don Bestor and His Orchestra's *Contented* and *Sweetheart Hour* (No. 24135) and *The River Rhine* and *I Guess It Wasn't Meant to Be* (No. 24136) an odd experiment was conducted. A separate microphone was used close to the string bass and a nearby bass drum was gently tapped throughout the recording in perfect synchronization with each bass tone. All of which sounds very simple but the result is truly amazing; Bestor's individual and tantalizing rhythm is further accentuated and in such a way as to provoke the most desultory dancer.

The above Victor records are the discs to feature this month. Their reception will give you a key to the sort of records calculated to arouse public interest. Remember what we said about Guy Lombardo, whose records still outsell those by any other band. Don Bestor is slated to go over big. By the time you read this notice, there will be additional Bestor discs available. Sell 'em to the customers who bought *Contented* (the maestro's own song) and *The River Rhine*.

Brunswick

How's that *Show Boat* album going? Write to Brunswick for the material they are offering to help you sell this new idea in operetta recordings.

Recent Brunswicks which tickled our ears are: *How Deep Is the Ocean* and *Here Lies Love* by Bing Crosby, the last from his own motion picture, "The Big Broadcast" (No. 6406) . . . From the Broadway success, "Flying Colors," *Louisiana Hayride* and *A Rainy Day* (No. 6407) by Freddie Martin and His Orchestra . . . The Dorsey Brothers sizzle in *Sentimental Over You* and *Sing* (No. 6409) . . . Feature Guy Lombardo's *Pink Elephants* (No. 6399) . . . and the Lenox Avenue rhapsody *Underneath the* (Please turn to page 33)

RMA Directors Veto

November, 1932

Arranged for

ONE YEAR MORATORIUM DECLARED— APPROVED SETS TO BE LABELED —FOR FEWER NEW TUBES

*Many Other Progressive Steps Taken
At Commodore Hotel, Oct. 20-21*

THERE will be no Radio Manufacturers Association trade show in 1933, according to a decision of this organization's board of directors at its meeting in New York on Oct. 21. After considerable discussion, which revealed a wide variance of opinion, the board members voted to "skip" the annual trade show next year for the purpose of ascertaining decisively, by the elimination method, if the radio business is impaired or retarded by such action. The annual convention of RMA members will, however, be held as usual.

On the matter of when and how to introduce to the trade and to the public new models there has long been conflicting opinions. Dealers, as well as manufacturers, still are undecided as to whether concerted action at one given time is the best policy.

RMA "Certified" Sets

Receiving sets offered to the public by RMA set manufacturers soon will bear an RMA label certifying official Association approval and manufacture under RMA standards. Only manufacturers who are members of the RMA will be permitted to use this label on their products as another measure to protect "legitimate" manufacturers. Radio dealers and jobbers, and the public also, will be urged to buy RMA "certified" receiving sets.

An RMA label, of attractive design either in metal or paper composition, will certify official association approval by the RMA Engineering Institute. Establishment of this new Engineering Institute was authorized by the association's directors at their New York meeting. The Institute will be under the direction of Franklin Hutchinson, chairman of the RMA Engineering Committee, and will consist of five leading engineers to be approved by the board. The Institute will give its approval to receiving sets of RMA members which are manufactured in accord with specifications adopted by the Institute and the RMA Board.

To Reduce Number of New Tubes

Cooperation between leading set and tube manufacturers to reduce the number of new tubes brought into the market was effected by the RMA Set and Tube Divisions.

Chairman S. W. Muldowny, of the Tube Division, held a preliminary meeting of prominent tube manufacturers to discuss the burdens not only on manufacturers, but on jobbers and dealers evolved from the promotion of new tubes. Later, when a joint conference of set and tube manufacturers was held, it was decided that Chairman Murray, of the Set Division, should advise all receiving set manufacturers and their en-

gineers of the serious difficulties, including loading up of dealers, involved in the promotion of numerous new unnecessary and minor tubes. Set manufacturers will be urged to reduce their demands on tube makers for products embodying only minor or special developments.

"Feature Programs," Aylesworth

Radio manufacturers, jobbers and dealers were urged to direct more of their advertising appropriation and copy for promoting broadcast feature events. Addressing the RMA members at the Commodore Hotel, Merlin Aylesworth, president of the National Broadcasting Company, further stated that he would develop programs of especial interest to automobile radio owners and to business men. He urged that sets better suited to office use be built.

COLONIAL TO BE DISTRIBUTED BY GRAYBAR ELEC.

Negotiations were consummated the early part of October with the Graybar Electric Co. for the exclusive distribution of Colonial radio sets through Graybar's 76 branch houses. This arrangement brings into the industry a combination that should make itself felt as a stabilizing influence.

According to F. G. Carson, vice-president of Colonial Radio Corp., a complete line of sets will be in the hands of the Graybar branch houses within a few weeks and the price range will be from under \$20 to about \$100. Cabinets for the complete line are to be supplied by the Adler Mfg. Co., Louisville.

Distribution of the Colonial line will be aggressively pursued by the Graybar



Promoting Majestic's New Sales Plan

Ray Erlandson, live-wire sales executive for G-G, is busy these days, by air, rail and auto, telling dealers and distributors about Majestic's new sales plans. Safely (?) ensconced within this air liner is Floyd Masters, general sales manager for this concern.

houses, D. H. O'Brien, general merchandise manager of Graybar, states. The Graybar organization has held a somewhat unique position in radio sales since its unit operation maintains careful check upon stocks in dealers' hands, thus making surplus liquidations unnecessary. The broader price appeal inherent in the new line will, it is expected, enable the appointment of many new dealers but care will be exercised against over-population of retail territories. To assist in the distribution, Colonial will put into the field a number of sales promotion men.

Clough-Brengle Co. Organized

Kendall Clough and Ralph Brengle, formerly chief engineer and general superintendent, respectively, of Silver-Marshall, Inc., announce the formation of the Clough-Brengle Co., with headquarters at 1134 West Austin Ave., Chicago. Associated with them will be Ralph P. Glover, who was sound engineer at S-M, and Leon Worner, recently of the same concern. This new concern will manufacture laboratory and production test equipment, amplifiers and accessories for practically every type of radio application.

Lewis Rejoins Pacent

R. I. Lewis, sales manager for Pacent Electric Co., Inc., from 1925 to 1928, has recently returned as general sales manager in charge of all domestic sales. Pacent is starting a drive on its new item, the "Radioformer," an eliminator of man-made static.

1933 Trade Show

Busy Readers

New York, N. Y.

Your Name, Mr. Anonymous Manufacturer

Dear Mr. Anonymous Manufacturer:

Your well written letter tearing the hide off the dealer received and read with much interest. We would like to brief this letter and publish it but you must identify yourself to the writer. I promise your name will be held inviolate. So tell me who you are and your rebuttal to my article, "The Dealer Has His Day in Court," will be printed in the December issue of *Radio Retailing*.

We would like to hear from any other manufacturer who may desire to present his unrestrained comments on the industry. If requested, the signer's name will be held strictly confidential.

RAY V. SUTLIFFE,
Managing Editor.

Fillmore Heads N. Y. Talking Machine Co., in Buffalo



H. P. Fillmore

H. P. Fillmore, for the past three years district sales manager in New York State for the RCA Victor Company, Inc., was recently appointed president of the New York Talking Machine Company, 327 Washington Street, distributors in Buffalo and Rochester for RCA Victor products and RCA Radiotrons. He succeeds E. J. Hendrickson who assumes the position of merchandise manager for RCA Victor at the home office in Camden, N. J.

"Phil" Fillmore, who is well known in local radio circles, has been identified with the radio business since 1922. His genial personality, which has radiated good cheer from the great Northwest to Texas, will be a welcome addition to Buffalo radio circles.

Will Increase Wave Lengths

United States, Canadian, Mexican and Cuban delegates to the International Radio Conference, now in session at Madrid, Spain, agreed, Oct. 20, to seek to increase the number of wave lengths available for radio in North America by reducing the number of ship wave lengths. It was stated that a formula to accomplish this end had been devised which would not jeopardize marine interests.

Radio Retailing, November, 1932

PATENT PROTECTION DEMANDED BY RADIO INDUSTRY LEADERS

AT MEETINGS of radio industry leaders in New York, Oct. 20-21, including the Board of Directors and the Receiving Set, Tube and Parts Divisions of the Radio Manufacturers Association, vigorous measures to improve merchandising conditions and prevent unfair competition were adopted.

Chief among these was the unanimous adoption, by the RMA directors, of a resolution calling on radio patent licensors, including the Radio Corporation of America, to take adequate action against unlicensed manufacturers. The resolution follows:

"Inasmuch as the manufacture and sale, without royalty payments, of unlicensed radio apparatus which infringes patents under which members of this Association are licensed and pay royalties subjects such members to serious disadvantages in competition:

"THEREFORE, BE IT RESOLVED, that the owners of patents under which members of this Association are licensed and pay royalties be requested by this Association to enforce in every proper manner respect for their patents by the manufacturers and vendors of competing apparatus which infringes such patents."

This action follows recent numerous lawsuits instituted by holders of loud speaker patents against many prominent chain store, furniture and other purchasers of unlicensed products and is expected to result in similar action to protect receiving set manufacturers against many unlicensed manufacturers.

Brunswick Engineers, Inc. to Market Brunswick Sets

Brunswick Engineers, Inc., 619 W. 54th Street, New York, has assumed the United Radio Service Company and the Brunswick Radio Factory Service, and are now releasing to the domestic trade the 1933 Brunswick line of sets, sound recording devices, amplifiers and home recording devices.

"Sentinel" Embarks on New Career

Sentinel Radio Corporation, successor to the Radio Division of the United Air Cleaner Corporation, has purchased the good will rights to the well-known trade name, "Sentinel." This new firm, of which R. W. Canfield is vice president, is a subsidiary of the Electrical Research Laboratories, (Erla). Both companies are located in the former factory of United at 9705 Cottage Grove Ave., Chicago, Ill.

ALL-AMERICAN MOHAWK announces the appointment, as jobbing representatives, of Dunham's Music House, Asheville, N. C., and Jesse French Co., of Montgomery, Ala.

Rebroadcast the Football Games



Why not emulate the example of the Shuler Supply Company, Crosley distributor in the New Orleans district? This enterprising firm not only rebroadcasts all the southern football classics, in the manner shown above, but sees to it that its radio dealers place operating sets on the sidewalk before their stores and tie in with suitable window displays

DETECTOR

Business improves—We are supported in this contention by such recent statements as:

"The Clarion factory is going full blast and everybody exceedingly happy." E. J. Dykstra.

"The trend of purchases to the six-legged type of cabinetry has been so marked that production of this particular model has stepped up 35 per cent." Lyric.

"According to report, the Zenith factory is at present 6,000 units behind schedule." Dave Goldman, North American Radio Corp., New York City.

"Our business shows a 300 per cent increase over last month." D. W. May, New York City.

"Radio business in the Northwest tremendously spurred by the holding of the 11th annual Radio Show at Minneapolis Auditorium. Dealers visited the show from the Dakotas, Iowa, Wisconsin and Minnesota."

"The Fada plant is now operating on a full time schedule. Demand has necessitated increasing production at Long Island plant by 83 per cent the first of October and again by 50 per cent, October 17." Frank Andrea.

Additional evidence of the reviving of business conditions is contained in the announcement of the A. A. Schneiderhahn Co., that the company is reopening its Sioux City branch for the distribution of Atwater Kent radios, Leonard electric refrigerators and A.B.C. washers.

The president of this concern, A. A. Schneiderhahn, talked before the Des Moines Advertising Club Oct. 18, taking for his subject: "Radio's Past, Present and Future." Whew!

Arkansas dealers are still talking about the good time they had at 555's annual convention, Oct. 12—held at Little Rock. This "intensified" affair ended with a banquet and vaudeville performance. The theme of the convention, "Bring Back Prosperity," was dramatized by introducing to the astonished multitude a large freight train, drawn by good old engine number 555.

The Muter Company, of which Leslie F. Muter is president, has acquired the name, trade mark, tools and dies of the Leslie F. Muter Company with which he was formerly associated.

New Orleans—Believing free music is a consideration which will tip the scales in its favor, Radio Cab Line, organized with a fleet of 20 cabs, has equipped each with a radio. Drivers are instructed to give the passenger any station he asks for.

C. D. MacKinnon becomes sales promotion manager for Zenith, according to word just received from E. A. Tracey, this concern's new general sales manager. "Mac" has worked with the Aeolian Company and Brunswick in a similar capacity.

Frank Squires, veteran radio engineer has joined Radio Chassis, Inc., in the capacity of chief engineer in charge of design and production.

"This is to raise the ante on your statement that somebody or other was selling radio sets in 76 foreign countries," writes Ovid Riso, Foreign Advertising Department, RCA Victor. "Just look at the attached—and if you can read French you will see something." Clipped to Riso's letter was an RCA ad, with this head:

"22,000 MARCHANDS en 94 pays vendent les postes RCA."

Are we another? You tell us, reader.

CONTESTS

Zenith Contest for Dealers and Their Men

Now Zenith enters the ranks of contest sponsors. Its \$25,000 awards will go only to the trade;—to retail radio salesmen, dealers, radio department manager and distributor's salesmen. Started Oct. 20 and ends Dec. 20—"checks to reach winners on Christmas morning."

Briefly these cash prizes, from \$3,000 to \$50, are for doing two jobs superlatively well—selling Zenith's new sets and telling how to do it.

Full details have been mailed to all eligible candidates. But for further information and official Zenith contest forms, write to Zenith Radio Corp., 3620 Iron St., Chicago.

American Bosch Runs Radio Star Popularity Contest

For the first time in radio, a set manufacturer is running a radio star popularity poll. United American Bosch Corp. is distributing ballots through the newspapers, radio stations and retail radio stores asking for the listener's preference in seven major classifications, from announcers to instrumentalists.

Stars securing the greatest number of official ballots in their respective groups, are to obtain gold cups in token of their leadership for 1932. Each succeeding year, the poll will be repeated with the awarding of similar gold popularity cups.

To insure widest possible balloting, \$10,000 in special prizes is offered to the public participating. It is believed this feature will spur particular interest in the poll, even aside from the natural enthusiasm of radio listeners for their particular favorites.

The Radio Star Popularity Poll began October 16 and ends midnight, December 4. Presentation ceremonies, attended by prominent personages of both radio and the theater, will be held shortly after

Silver's Sales Force Joins Howard Radio Company

Practically the entire sales executive organization of Silver-Marshall, Inc., has been absorbed by the Howard Radio Co., South Haven, Mich. This force, headed by Howard W. Sams as general sales manager, includes Howard C. Briggs, who now acts as assistant sales manager for Howard; Burton Browne, advertising manager; A. L. Sullivan, eastern manager; and E. M. Jacobson, western manager.

The first three mentioned have been associated with Silver-Marshall, now in receivership, since 1929. In June, 1931, largely through the efforts of these gentlemen, S-M inaugurated a factory-to-dealer selling plan, which, in one year accumulated 4,000 accounts. Howard Radio, it is stated by vice-president John Parnham, plans to pursue this same policy—"selling direct to one exclusive dealer in every town and city."

completion of the final tally and announcement of the winners.

With the A K Word Builders

Atwater Kent's word building stunt continues to pull prospects to dealers' stores. E. A. Wildermuth, Brooklyn, N. Y. distributor, for example, reports 20 to 35 requests per day for official entry blanks being made on many of this firm's retailers. This contest closes Nov. 15. A tip to Mrs. Ambitious: Some of your competitors are hitting the 1,000-word mark, so look sharp.

Central Electric, Des Moines, Wins \$500 Raytheon Prize

The Central Electric Company, Des Moines, Iowa, wins the grand prize in the Eveready Raytheon window display contest—\$500 in cold cash. The second best window trim, using 4-pillar tubes, was submitted by Earl Marks, of Portland, Oregon, who gets a check for \$250. Third prize, \$150, goes to Roy's Broadway Auto Service, of Rockford, Illinois. Hundreds of other cash awards are now on their way to the lesser, but lucky, contestants.

Shure Bros. Sponsoring Unique P.A. Contest

To make available to the radio trade profitable ways of selling public address equipment is the purpose of a contest, now in full swing, sponsored by Shure Brothers Company, 337 W. Madison Street, Chicago.

Dealers are invited to write in—about 200 words—the gist of some idea or experience by which the sale of a public address system or systems was achieved. For the winning idea, a complete portable P.A. system. The next eight prizes, valuable radio merchandise. There will be 110 minor awards for the "trailers." This contest closes Nov. 30.

J. P. Kennedy—Radio Magician

(Continued from page 17)

fell in pitch and volume in an eerie manner. I imagined some of my audience shivered.

Having noted considerable interest in my display of meters, I picked up my ohmmeter and an old slide-wire, Wheatstone bridge, explained that the needs of radio necessitated the development of a device for instant determination of resistance that virtually made obsolete the old tedious bridge method of measurement. I then asked a nearby gentleman to hold the test prods of the ohmmeter in his fingers that I might measure his resistance to an electric current.

The reading was approximately 100,000 ohms.

I withdrew the test prods and took from my pocket a piece of 13-gauge aerial wire. I had memorized the data on 13 gauge wire in advance and thus could give some interesting figures rapidly. This wire, for example, had approximately ten ohms resistance per mile. The gentleman tested therefore offered the same opposition to a flow of electric current that a length of wire 10,000 miles long would offer to a flow of current; 10,000 miles of No. 13 wire would weigh 828,000 pounds—more than 400 tons. So I remarked, "I have proven by scientific means that this man weighing less than 200 pounds is electrically equal to more than 400 tons of copper wire." The man was something of a wit and stood up for a bow, remarking that if anybody wanted the equivalent of 400 tons of copper at \$100 a ton, he was available!

My low-capacity tester consists of an oscillator having a meter in the grid circuit for indication of resonance and an inductively-coupled coil with a calibrated condenser across. This was next brought forth. Two wires were extended from the ends of the pickup coil to two gentlemen seated close together in the audience. They were asked to bring their free hands close and the audience was asked to watch the meter on my instrument. As the capacity between the men increased with the movement of their hands the meter reading changed. Actually the capacity of their hands was tuning the resonant coil to the frequency of the oscillator and causing the grid current to dip.

I then explained that this method of capacity measurement could be used to measure extremely small variations in distance, as between the parts of a radio tube, or could be used to determine the electrical capacity between any two conducting mediums or the dielectric capacity between any non-conducting mediums. To make these technical terms more clear, I suggested that at some time in the future this method of measurement might be developed to a point where the density of germs in a given quantity of bacteria might be determined more rapidly than by the present methods employing a microscope.

"SEEING" A WORD

To conclude my lecture, a hand microphone was inserted in place of the phono-pickup in my miniature broadcasting unit, and the primary of the 1 to 3 ratio audio transformer with the neon bulb across its secondary was connected across the plates of the power tubes in the radio set. By tuning the oscillator to the frequency of the receiver and speaking the word LIGHT into the microphone, the neon bulb could be made to flash. Then, holding the microphone near the set and admonishing

the light to remain lighted, I permitted the speaker of the set to feed back a howl in the microphone that caused the neon bulb to glow quite steadily.

I was watching my time limit closely and had just two minutes to finish after this demonstration. This was devoted to a brief sales talk running something like this:

"The only difference between the radio service rendered by my organization and that of others in town, is that we use strictly scientific methods, and precision instruments, some of which you see here. With this advantage we accomplish better results in less time at less cost to you than any ordinary radiotrician could possibly attain. In selling sets, we are unlike most non-technical radio dealers, we do not repeat, parrot-like, the merits of a set as given out by the manufacturer. We first investigate all the claims for the set and determine its true merit.

"Thank you, gentlemen, for your attention."

PLANS MORE SHOWS

I am planning further programs of a more elaborate nature, programs with more old-fashioned "hokum," outright magic of electrical phenomena. Observing the audience on my first presentation, it was easy to see that the slightest hint of anything mysterious, or beyond their comprehension, held attention.

In all probability I will develop a more elaborate show suitable for presentation before large fraternal organizations such as the Elks, Masons, K. of C.'s, Pythians, Eagles, etc. Probably, it will be best to play up the mystic angle and charge the clubs a moderate fee for each show.

Light-sensitive cells may be made to operate relays for a great variety of trick presentations which could be controlled by a flashlight beam. A powerful oscillator feeding the primary of a "Tesla" coil could produce brilliant but harmless high frequency sparks with which a number of tricks could be performed. The old phenomenon of heating a closed circle of metal by induction might be used, with the induction "furnace" under a table, to ignite little circles of the wire from radio tube grids held in the air over the top.

There are countless ways of entertaining people not familiar with electrical phenomena.

Discs Reflect New Dance Styles

(Continued from page 29)

Harlem Moon by the dusky Don Redman and His Orchestra (No. 6401) . . . Duke Ellington steps out again in *Jazz Cocktail* and *Lightnin'* (No. 6404). The entire list is exceptionally brilliant.

Columbia

Columbia's ten-inchers include a new Vallée number, *Me Minus You*, in that maestro's best manner, calculated to soothe. The reverse is as fine an interpretation of the sweeping hit *Let's Put Out the Lights* as we have heard (No. 2715D) . . . Harold Stern of St. Moritz and broadcast fame, couples *'Twas Only a Summer Night's Dream* and *You'll Always Be the Same Sweetheart* (No. 2717), smooth rhythmic numbers . . . You've heard of Maurice Ravel, the Bolero king. Well, feature the new Columbia Masterworks set of Ravel's recently composed *Piano Concerto*. It's jazzy and full of scintillation and ésprit. A good number to introduce to Ellington enthusiasts and Gershwin admirers.

NEW MERCHANTISE

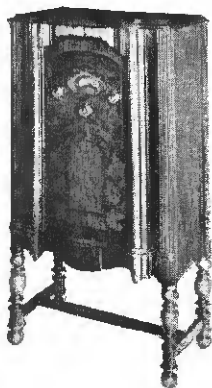

Colonial Line

Offered by the Colonial Radio Corp., Buffalo, N. Y., and distributed exclusively through Graybar branches, are:

Model C-495, a six tube superheterodyne console, embodying the use of the latest high gain and super control variable-mu r.f. pentode tubes and a pentode power output tube. The frequency range, as in all Colonial models, is from 520 to 1765 k.c. \$49.50 complete.

Model C-595 console with 9 tubes is \$59.50.

Model C-695, 10 tube console, employs r.f. pentodes for the oscillator, r.f. and the two i.f. stages. It has two audio stages and two power pentodes in the output stage. \$69.50.

Model T-397, is a 6 tube superhet midget. \$39.75.

Model C-995 is a 12 tube superheterodyne with 6 of the new r.f. pentodes. Includes such features as super power Class "B" output and noiseless inductive a.v.c. The cabinet has sliding doors and is of the six legged type. \$99.50.—*Radio Retailing*, November, 1932.

Radio Receptor "Recorder"

For dealers to make voice recordings for their customers, as well as recordings of speeches at banquets and affairs, and for police departments to record conversations or examinations of suspects, the model RM-1 Recorder is offered by the Radio Receptor Company, Inc., 106 Seventh Ave., New York, N. Y.

The device is portable, measuring 20x20 in. and not only records the voice, but also plays back the record by throwing a switch. Provision is made to control the intensity of the recording by means of a visual level meter. The amplifier is housed in the same cabinet. The price, complete with microphone and tubes, is \$250.—*Radio Retailing*, November, 1932.

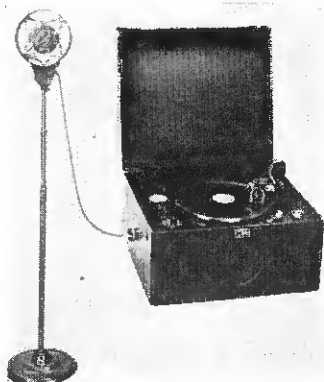

Sentinel Radios

Sentinel Radio Corp., successor to the Radio Division of the United Air Cleaner Corp., 9705 Cottage Grove Ave., Chicago, announces its 1933 line.

Model 412 4-tube t.r.f. midget (258, 247, 257, 280), is \$24.50, complete.

Model 513, "Personal Type", 14 in. long x 6 1/2 in. deep, takes a 255, 257, 258, 247, and 280. \$34.50.

Model 614, (85 to 550 meters), has a.v.c., and the following tube equipment; two 258's, 257, 255, 247, 280. \$44.50.

Model 1016, 10 tube superheterodyne console with Class B amplification, noise suppression circuit and a.v.c. is \$74.50. Tubes: 255, 256, 257, 280, three 258's, and three 246's.

Model 1017, same chassis but with two speakers and a more elaborate cabinet, is \$89.50.

Model 816, all-wave, battery operated superhet console priced at \$75, complete with tubes but less batteries, uses two each of the 232, 230, 234 and 49 types. 20 to 550 meters—single tuning dial. This set has a.v.c. and Class B amplification, and may be used on an A battery of the air cell, primary or storage battery types.

Model 814, same chassis, midget cabinet, \$59.50.

Model 521, "Car Radio", combines the radio and speaker in one unit so that it may be placed in any convenient place. In servicing, the entire set can be removed. The tube equipment includes 289, 285, 238, and two 239's. Price \$39.50, with tubes.—*Radio Retailing*, November, 1932.

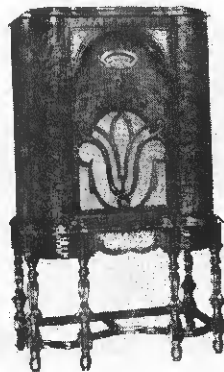

Radiart Sets

A four and a five tube set are offered by the Radiart Corp., 13229 Shaw Ave., Cleveland, Ohio.

Model 41-A uses a 57, a 58, a 47 and an 80. It has illuminated dial, combined volume control and on-and-off switch and tone control. The price is \$22.50 complete with tubes and tax paid.

Model 52-A is a five tube superheterodyne, with a circuit incorporating the 2 1/2 volt heater tubes, silent full automatic volume control and tone control. Tube equipment—one each of the 57, 58, 47, 55 and 80 types. List price \$32.50 with tubes and tax paid.—*Radio Retailing*, November, 1932.

Skyhawk Sets

A mantle type cabinet and a six-legged console are being made by the Republic Industries, Ashland, Ohio. The trade name is "Skyhawk."

Model MS midget listing at \$36.50, covers a range of from 75 to 550 meters and takes a 58, two 57's, a 47 and an 80 tube.

Model N, the six-legged console, has a standard range and utilizes three 58's, three 56's, a 55, a 47 and an 80. \$84.50.—*Radio Retailing*, November, 1932.

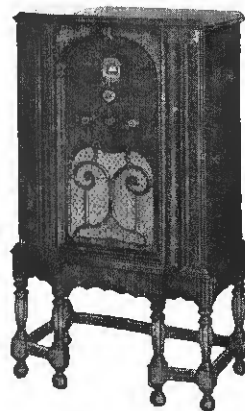

Lyric Model SA-91

Utilizing the same superheterodyne circuit as employed in the Model SA-90, the All American Mohawk Corp., North Tonawanda, N. Y., has just launched its new console SA-91. The cabinet is of larger proportions than previously used, and is of the six-legged type.—*Radio Retailing*, November, 1932.

Emicon Electronic Musical Instrument

The "Emicon" is an electronic musical instrument of the "solo" type, having a keyboard of thirty-two keys arranged according to the standard musical "tempered scale." It may be attached directly to the audio stage of any radio set, P.A. system, talking motion picture amplifier or similar equipment. By simply turning a button, the tone quality may be varied from that of a string instrument to that of brass or reed instruments.

Technically, the Emicon consists of an audio oscillator of the gas discharge type, with the keys making contact in series with the main circuit through resistors of the proper value to produce the pitch of each note. The tone quality is secured by filtering out overtones by means of a tone control. By the use of a potentiometer as a tuning button, the pitch of the instrument may be raised or lowered over a range of five full notes, enabling the player to tune in to correct pitch on incoming radio programs. Incoming radio programs can be accompanied or it can be played as the solo instrument. The retail price is \$59.50. Emicon, Inc., 2 West 46th St., New York City.—*Radio Retailing*, November, 1932.

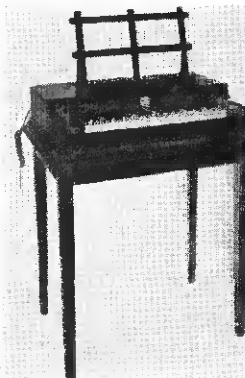

New Merchandise continued on page 36

taking America by **STORM!**

L. TATRO 32 VOLT

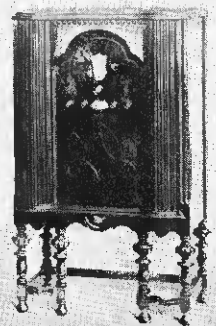
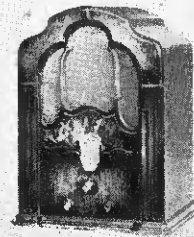
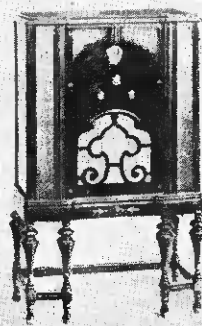
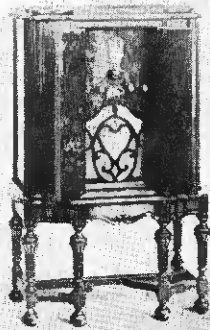

Admiral

Captain

Ensign

Commander

ALL Electric for FARM LIGHT PLANTS SUPERHETERODYNE

This great line of receivers brings you the biggest money-making opportunity in the entire Radio industry. Now you can profitably develop a new market of tremendous response—you can offer Farm Light Plant Owners modern Radio reception for the first time.

INVESTIGATE TODAY the unusual possibilities of the L. Tatro—we have a unique money-making proposition for jobbers and dealers. A telegram or letter will bring complete facts.

L. TATRO 32 VOLT FEATURES

ALL ELECTRIC—NO BATTERIES.

MULTI-TUBE. ALL LATEST TUBES.

DUO-DIODE DETECTION. UNSURPASSED TONE.

AUTOMATIC VOLUME CONTROL. NO FADING.

L. TATRO PRODUCTS CORPORATION

DECORAH • IOWA



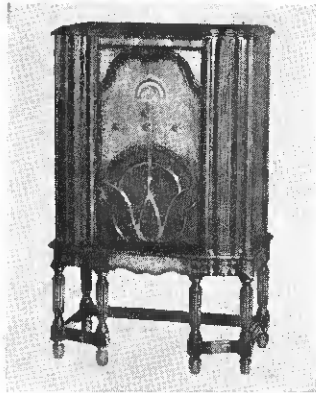

U. S. Models

A 9-tube superheterodyne battery receiver, incorporating Class B amplification, two-volt tubes, a.v.c., tone control, permanent magnet dynamic speaker, has been added to the line of the United States Radio & Television Corp., Marion, Ind. The tubes employed are one 234, two 232's, and six 230's. The set may be used with air-cell, dry cell or wet A-batteries, designed for use with tubes of this type.

The cabinet is of the six legged highboy type and the price is \$69.50 including tubes, tax paid, but less batteries.

A Gloritone model, No. 24, is also ready. It is a four tube superhet midget using two 57, one 247 and an 80. It carries a list price of \$17.95, including tubes and tax.—*Radio Retailing*, November, 1932.

Motorola Auto Radio Tube Tester

Although especially designed for auto radio tubes, the tester of the Galvin Mfg. Co., 847 W. Harrison St., Chicago, is flexible enough to test any type tube, either home or auto radio. No adapter is needed. It is portable and may be used in the dealer's own meter or in conjunction with the new Motorola utility meter described below.

The Utility Meter while especially adapted for auto radio service, is also used for other radio service. It is a combination voltmeter, ohmmeter and ammeter. As a voltmeter it has a range of from 0 to

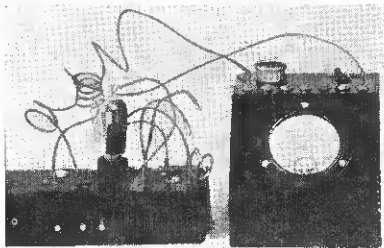

1½ volts d.c., 0 to 10 volts, d.c., and 0 to 200 volts d.c. All voltages based on 1,000 ohms per volt. As an ohmmeter; 0 to 1,000 and 100 to 100,000 ohms. As an ammeter; 0 to 1 milliamps, 0 to 10 milliamps, 0 to 100 milliamps, and 0 to 10 amperes.

By inserting a special rectifying plug all the above voltages and currents may be changed to read a.c. Also when using the 0 to 200 volt tap a super-sensitive output meter is available.—*Radio Retailing*, November, 1932.

"Radioformer"

To eliminate man-made static by preventing its being picked up by the lead-in by shielding it, the Pacent Electric Co., 91 Seventh Ave., New York City, has brought out the "Radioformer." The signals received by the antenna are taken by the Radioformer and put into its special shielded transmission line, eliminating noise picked up near the ground. It is easy to install. Built according to designs worked out by Amy, Aceves & King, Inc., under whose license Pacent operates.—*Radio Retailing*, November, 1932.

Crosley Receivers

Production is well under way on the new "Chief" 12-tube superheterodyne console of the Crosley Radio Corp., Cincinnati, Ohio.

Class "B" amplification, mercury vapor rectifier, static control with manual adjustment, meter tuning, a.v.c., and continuous tone control are some of the features of this set. It uses the 2½ volt heater type tubes, and has dual speakers. \$139.50 complete tubes. Tax included.

Two new and unusual sets are the "Jewel Case" and the "Book Case," designed to bring sets into the "package merchandise" and gift shop field.

The Jewel case is made of solid oak decorated with carvings. It has the new 5 tube superhet chassis. \$34.75.

The Book Case model, illustrated, represents a set of antique leather bound volumes titled, Music, Religion, Politics, etc. The book backs are mounted on two swinging doors which open to reveal the switches and dials. Dimensions 10½x13½x8 9/11 in. Price and chassis same as Jewel case.

The "Fiver" midget, listing at \$19.99, is another new addition, as a lowboy, \$29.99.—*Radio Retailing*, November, 1932.

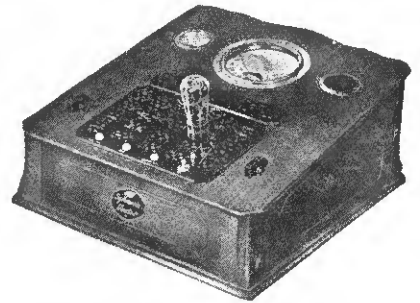

Sylvania 678 Analyzer

Built to specifications by the Jewell-Weston Co., the new model 678 tube checker of the Hygrade Sylvania Corp., Emporium, Pa., tests all the latest type tubes and has special removable panel and wiring providing for easy changeover to test new types as they are announced. Tests both plates of rectifier tubes and a new arrangement makes fuse replacement possible and easy by merely removing the short check bezel. It is a direct-reading tester with a three-color meter and comes in a high lighted American walnut case of counter size.—*Radio Retailing*, November, 1932.

Thayer Continuous Phonograph

In addition to the console model, George R. Thayer Co., Inc., Binghamton, N. Y., offers a counter-model continuous phonograph 15 in. wide by 27 in. long by 28 in. high. Same mechanism as the larger model. It is completely automatic, plays up to ten records in consecutive order, replays full load of records indefinitely, is equipped with an anti-overload device, and may be had for coin operation.—*Radio Retailing*, November, 1932.

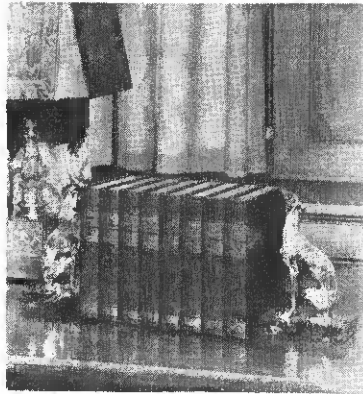

Alden Seven Prong Plug

Now that the seven prong tube has been announced, the Alden Mfg. Co., 715 Center St., Brockton, Mass., has designed an adaptor plug which, when inserted in a tube checker socket, makes possible the testing of tubes having the new 5, 6 and 7 prong bases. It is small enough so that it can be used with plenty of room to spare wherever the tubes themselves will fit.—*Radio Retailing*, November, 1932.

Pines B-Eliminator

A new model B-battery eliminator which, it is claimed, will deliver its full-rated voltage even after thousands of hours of service, is now being made by the Pines Winterfront Co., 1135 N. Cicero Ave., Chicago. This eliminator requires only two bolts for mounting under the floor boards or on the dash, and measures 5½x8x6½ in. deep. It employs the same ball bearing rotor that has stood up in laboratory tests. This new unit is very nearly universal, so that it is possible with five models to do the work formerly requiring fourteen.

Models of Pines eliminators formerly listing at \$30 are now priced at \$21.95.—*Radio Retailing*, November, 1932.

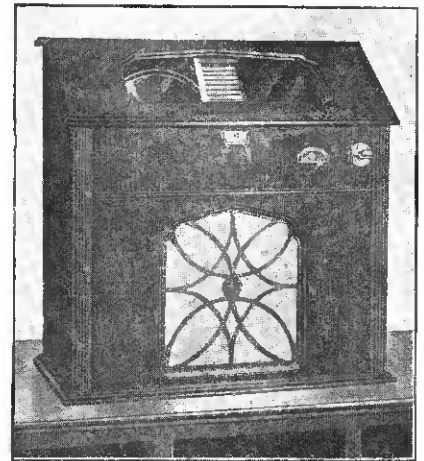
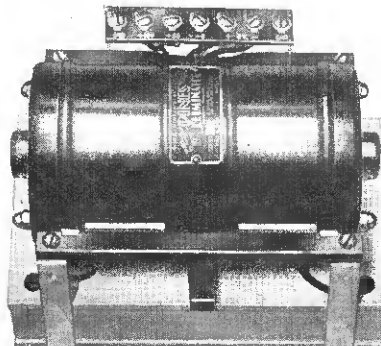

Crescent 32-Volt Sets

A 32-volt electric radio for farm lighting plants can be obtained from the Crescent Mfg. Co., Minneapolis, Minn. It comes in a low boy or midget type cabinet.

The circuit has four tuned stages of r.f. amplification, detector and 2 stages of audio, the last stage incorporating 2 type 233 pentode tubes in push pull. In addition to these tubes there are four 232's and a 30. The speaker is an electro-dynamic, especially designed for 32 volt operation. The prices are Model 32 midget, \$73 and Model 32-70 console, \$88.

Crescent also makes 2-volt battery sets. Model 2-70 using four 232's, and three 230's. It can be operated on a dry cell or air cell batteries. \$79.50. May also be had as a midget.

The "Car-Electric" portable radio for autos, camps, boats, etc., is a 7-tube job in an antique bronze wrinkle lacquer case. It can be used in the automobile by using a connector cable furnished to connect to the car storage battery. When used in the home another cable is furnished for this operation. There is nothing else in the set to change. \$59.50.—*Radio Retailing*, November, 1932.

New Merchandise continued on page 38

ATWATER KENT RADIO

YOU radio dealers have been fighting for years for quality merchandise that would net you a living profit.

On this hard-fought field, you won.

It is unthinkable that you are now going to let the fruits of victory get away from you.

Is there a living profit—or any real profit—in a “bargain” set thrown together at a bargain price, with the margin shaved closer than your face in the morning?

And how long would your customers who expect *progress* and *improvement* in radio be satisfied with performance and workmanship below the standard of past years?

You know where Atwater Kent stands!

Every radio that bears this trusted name

is a better radio than the one that went before.

Every 1933 Atwater Kent represents the highest possible quality of workmanship and materials and the most advanced improvements.

**NO
BACKWARD
STEP!**

Every Atwater Kent price is the lowest price at which completely modern, satisfying radio can be sold.

And every sale of an Atwater Kent yields the retail merchant his fair profit.

That is where Atwater Kent stands, and the precious goodwill of trade and public, built up through ten years of progres-

sive, responsible radio manufacturing, is not going to be sacrificed to make a bargain holiday.

Let the Tonebeam light your way!

Last call for great Prize Contest

Closes November 15. A national sensation! \$5,000 first prize, 53 other cash prizes, for longest lists of words made from “Atwater Kent Tonebeam,” accompanied by short, simple statement on subject mentioned on entry blank. Keep supplied with entry blanks (from your distributor) for the last-minute rush. Only Atwater Kent dealers have blanks. Public comes to them for blank and demonstration of 1933 models.

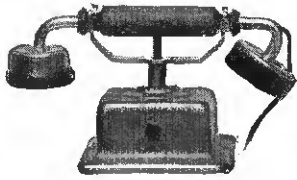

French Phone

Especially seasonable at this time as a Xmas item is the french duplex cradle Phone of the Connecticut Telephone & Electric Corp., Meriden, Conn. This phone has many uses and two, three or four phones may be connected together utilizing a code of rings for the different locations. They may also be used in conjunction with duplex wall phones.

The light green base of the phone contains the operating mechanism. The hand phone is dark brown, making a pleasant two-tone effect. List price, \$7.50 per pair.—*Radio Retailing*, November, 1932.

Freshman-Belmont Sets

Model 80-B 8-tube all-wave superheterodyne, covering a band of from 15 to 545 meters, and made by the Belmont Radio Corp., 520 N. Michigan Ave., Chicago, has spotlight full-vision dial, "wizard" dual and automatic volume control, and is housed in a six-legged cabinet.

Model 41-A midget is a 4-tube set, while model 51-C is a 5-tube superheterodyne.

Model 110-B 11-tube superheterodyne low-boy has two speakers, a.v.c., and wizard dual control. The cabinet is of the six-legged type.

Other sets made by Belmont are Model 80-A, eight tube auto-radio; Model 58 5-tube for direct current; Model 78, 7-tube superhet for d.c., and Model 55-A, for either alternating or direct current. No switches or changes are necessary.

All these sets carry the trade name Freshman-Belmont.—*Radio Retailing*, November, 1932.

Gates Condenser Mike



Model G bullet type condenser microphone for either table or suspension operation is said to have a uniform response from 30 to 8,000 cycles. It uses two 864 tubes in connection with a special condenser head sealed to prevent sudden humidity changes from seriously affecting the frequency response or freezing the diaphragm. It is made by the Gates Radio and Supply Co., Quincy, Ill., and carries a net price of \$75.—*Radio Retailing*, November, 1932.

Franklin Auto-Radio

Arrangements have been made with national chains of service stations to install and service all Franklin auto radio sets without extra charge.

The set is a six-tube superheterodyne, priced \$64.50 complete with tubes, B-battery and box, spark plug suppressors, distributor suppressors, generator condenser and antenna. As stated above, there is no additional charge for installation. Franklin Radio Corp., Dayton, Ohio.—*Radio Retailing*, November, 1932.

Packard Record Changer

J. E. Capehart, formerly connected with the Capehart Corp., and now president of the Packard-Capehart, Inc., Fort Wayne, Ind., announces the Packard record changer No. 8. Briefly, the specifications are: all steel construction; heavily copper plated; plays eight 10 in. records automatically and 12 in. records manually; any record may be repeated; repeats last record; two-speed motor.

It has a flat-type flexible pick-up, volume control and master switch. For 110 volt a.c. 60 cycle operation the list price is \$47.50, tax additional. *Radio Retailing*, November, 1932.

"Perfectone" Auto-Radios

A 7-tube super deluxe auto radio with a.v.c., a 5-tube standard model and a "midget" type set may be obtained from Perfectone, Inc., 2005 S. Michigan Ave., Chicago.

Each has steering gear remote control, illuminated dial and dynamic speaker. The midget model has "finger tip" control as it may be attached to the steering column. This model is \$18.50 to the dealer.

This company also makes sets for boats and airplanes.—*Radio Retailing*, November, 1932.

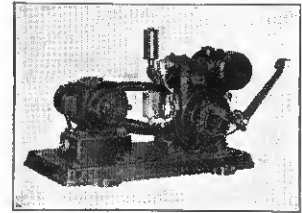

Janette Electric Plants for Sound Trucks

Gas-engine driven generators for use with sound truck amplifiers can be obtained from the Janette Mfg. Co., 555 W. Monroe St., Chicago. These units consist of a single cylinder, 4 cycle, air-cooled gasoline engine connected to a generator delivering 110 volt, 60 cycle, a.c. The entire unit is mounted on a cast-iron base and when ordered for sound truck service comes equipped with filter and shielding. Available in five sizes, developing 300, 500, 750, 1250 and 1800 watts, respectively.—*Radio Retailing*, November, 1932.

Universal Microphones

The baby microphone of the Universal Microphone Co., Inglewood, Cal., is an exact replica of station microphones (carbon). It weighs one pound and is a single button microphone of 200 ohms resistance—mounted in a die-cast mounting 3½ in. high. It is finished in highly polished nickelplate and includes prong adaptor for connection to tube, pin plugs for connection to jacks or binding posts, and twenty-five feet of cord. Many dealers are finding this item a good holiday season number and many are using them as a free offer with new sets.

Universal also makes a lapel miniature microphone, Model BB two-button "super mike," and a new floor stand.—*Radio Retailing*, November, 1932.



Weston Exposure Meter

Light intensity measurement has been placed on the same basis as the measurement of amperes or volts by the Weston Electrical Instrument Corp., Newark, N. J., using their newly developed "Photronic" photoelectric cell. The latest use this electric eye has been put to is in the universal exposure meter for photographic use, in which brightness measurements are taken directly from the scale of an instrument easily read by the layman. It gives accurate exposure information for both "stills" and "movies," and is independent of climate conditions and intensity of light.—*Radio Retailing*, November, 1932.

Ohiohm Resistors and Suppressor Sets

Ohio Carbon Co., 12508 Berea Rd., Cleveland, Ohio, has brought out a suppressor set to eliminate ignition interference.

Set No. 74 for 4 cylinder cars contains 4 model XP, 1 model XD suppressors, 1 model CA condenser, \$3.50; Set No. 76 for six cylinder cars has the same equipment except that it contains six model XP suppressors, \$4.50; and model 78 for eight cylinder cars has 8 model XP suppressors, \$5.50.

This company also makes "Protect-O-Packed" resistors, the wire leads of which are so packed as to prevent their being bent or kinked. A variety of kits and unit packages are available for all uses.—*Radio Retailing*, November, 1932.

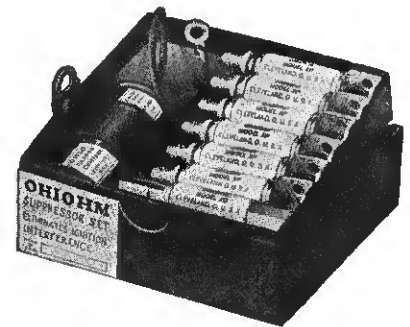

Utah Full Wave B-Eliminator

Some of the features of the new full wave auto B-eliminator the Utah Products Co., 812 Orleans St., Chicago, has brought out are full wave rectification and adjustable intermediate B voltage (intermediate voltage can be adjusted with a screw driver and without replacing resistors). An automatic A power control relay to control the "B" power unit, from the present radio switch is built in.

The vibrator unit used is new in circuit and design, and has no adjustments. Current is divided between two sets of contacts and will continue to operate through extreme battery voltage vibration. Even should stoppage occur through battery drop, very little current drain would result. It is not necessary to observe polarity in connecting the storage battery to the input terminals of the eliminator, as no harm can result because of reversal of polarity. The Utah B-eliminator measures 6¼x7¼x2½ in. and weighs 7½ lb. It is available for 6, 12 and 32 volts.

The list price is \$20 complete with tube, built-in relay and cables.—*Radio Retailing*, November, 1932.



Home Broadcasting Mike

With the "Studio" microphone attached to any radio set, the operator is permitted to cut out the broadcast program and substitute his own voice. It is particularly suited to "hoax" programs and is also adaptable to use by dealers in addressing store or street crowds through a radio set.

It can also be used in home phonograph recording work. It is made by the Microphone Labs., 718 Mission St., San Francisco, Calif., and lists at \$1.50.—*Radio Retailing*, November, 1932.

Professional control by ANYONE ★ ★ ★ GUESSWORK ELIMINATED

Today's radio buyers are *demanding* visual controls worked out with a simplicity that makes anyone a *professional* operator. Far more completely than any other, the new 1933 Zenith gives them.

On the new Zenith's highly illuminated Auto Type Escutcheon, on a rectangle only 4 x 6 inches, *all* controls are visual and all are within focus of the eye.

Dialing, tuning, volume control, tone adjustment . . . in every operating feature the eye guides the ear. Every

control is exact to micromatic precision . . . every one is simplicity itself . . . with the new Zenith a child becomes an expert tuner.

Show your customers this little escutcheon. Demonstrate it. You'll show him six powerful selling points that will make 1933 radio profits. You'll demonstrate exactly what he's been looking for in a radio.

Then clinch the sale by telling him the prices . . . lowest prices in history for quality radio.



★ (1) This full-circle 8-inch logging dial gives precision tuning. There are dials on some radios 4, 3, and even 2 inches in length. How can such dials be divided with 95 wave channels and be easily read?

★ (2) The Shadowgraph, the modern invention by which anyone can tune to the resonant peak of the broadcast wave. Makes anyone an expert tuner of all stations.

★ (3) With this indicator the volume may be pre-set, a necessity to avoid blasting when the tubes warm up. The knob which controls it has Zenith's famous tone-volume equalizer, which automatically emphasizes treble and bass as power is reduced.

★ (4) With this knob, police calls and the new Canadian station at Windsor, Ontario, which are beyond ordinary radios, can be reached. All Zenith radios tune from 540 to 1750 kilocycles, thus giving 121 channels, 26 more than the ordinary radio.

★ (5) Between-station noise suppressor and local noise suppressor. Operates automatically. When set can be operated manually as sensitivity control.

★ (6) With this indicator and the knob which controls it, Zenith's visual Treble tone adjuster is operated. Makes sure of tone coloring most pleasing to the listener's ear.

A CHALLENGE . . . We challenge anyone to name a single demonstrable improvement in radio not found in the new 1933 Zenith line; and we further challenge anyone to name another radio line which contains all the improvements found in the new Zenith 1933 line.

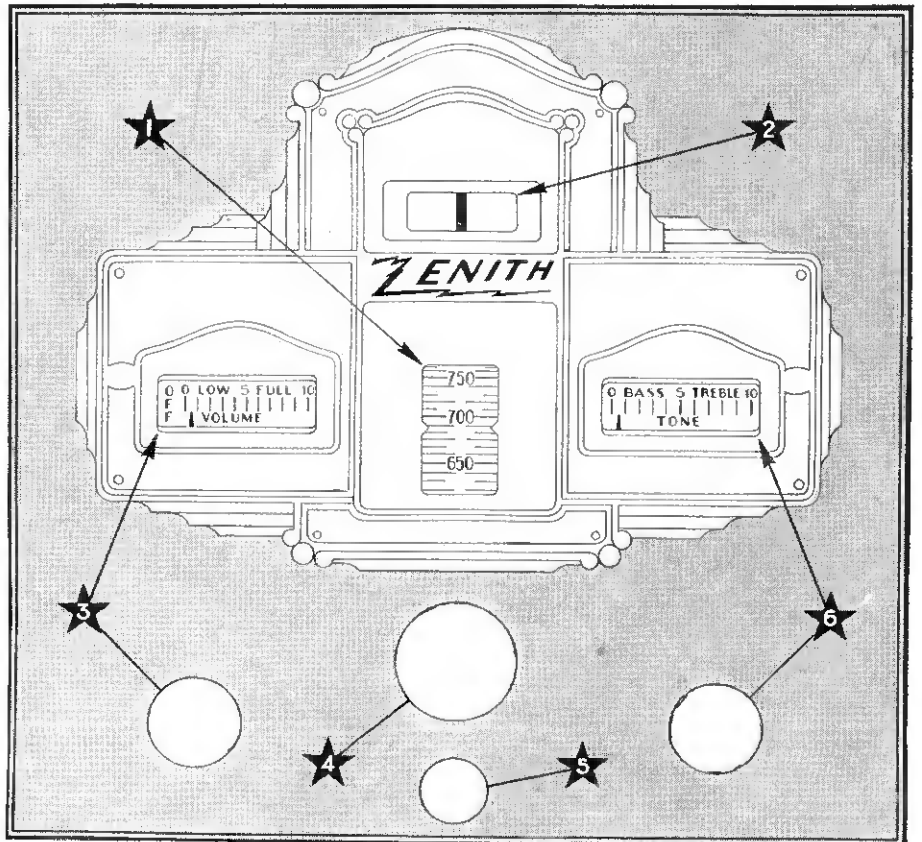

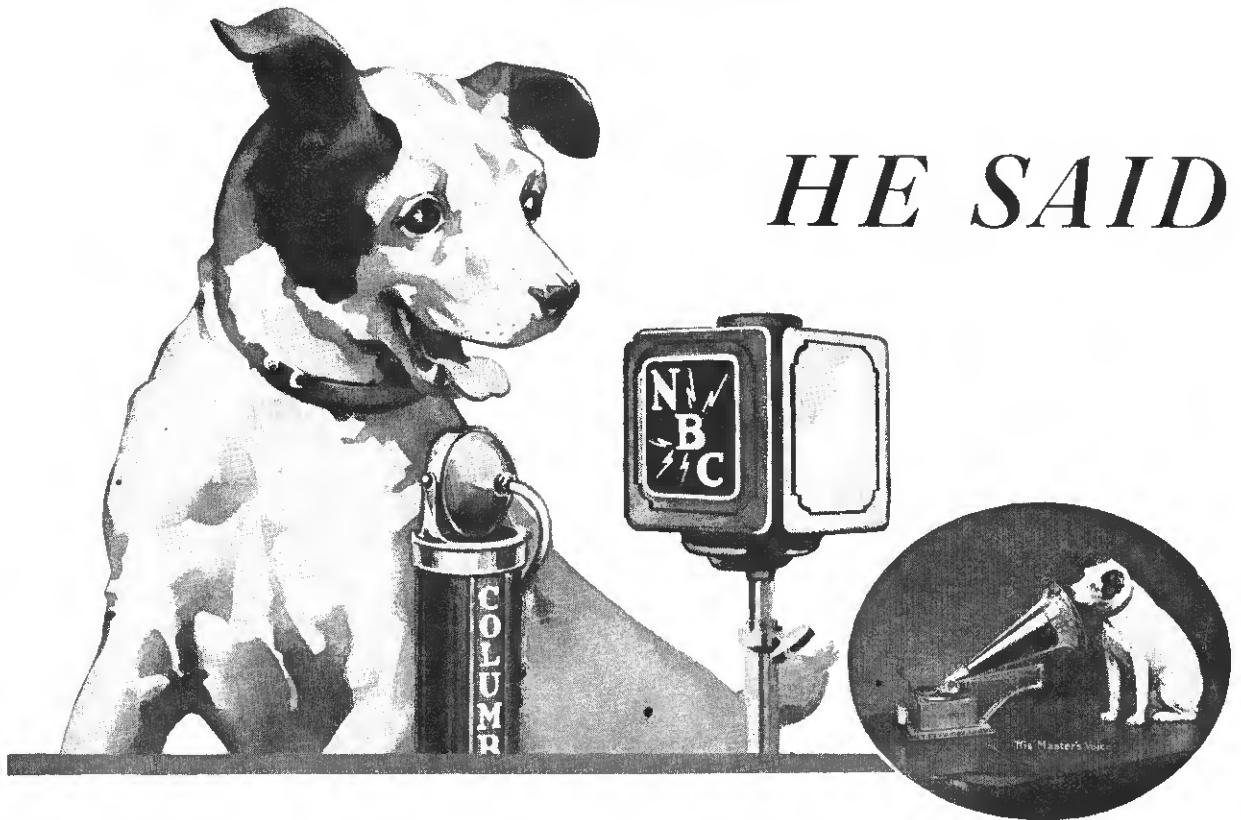

HE SAID

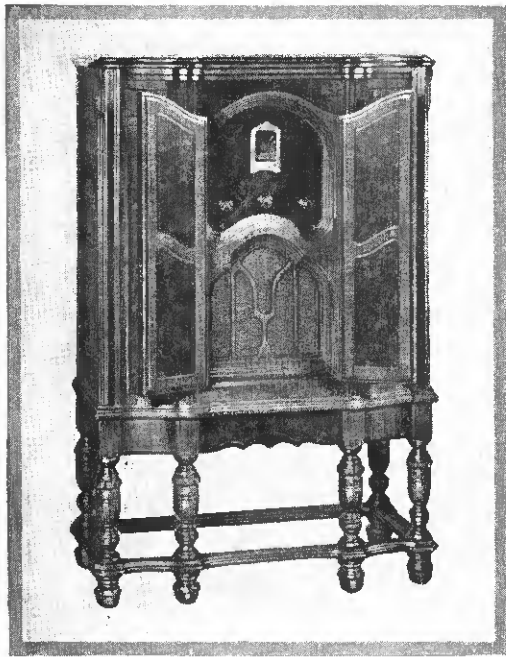

THE NEW R-78 "BI-ACOUSTIC"

12-tube Superheterodyne with "B" Amplification, Advanced Automatic Tone Compensator, Tone Equalizers, Dual Automatic Volume Control, Noise Suppressor, Micro Tone Control . . . Nine Great Improvements in all. List price complete, with RCA Radiotrons . . . **\$149.75**

MEEET a fellow who's proved to be the world's best radio salesman—the Victor Dog!

Everybody knows him. Everybody knows he stands for the best in music. Everybody has seen him. Now . . . they're hearing him—through big national magazines and a long list of newspapers.

He's working day and night for you. Telling your trade about Bi-Acoustic Radio. Telling them what two more octaves of music mean . . . telling what 266 extra glorious musical tones mean . . . telling them about the nine new features!

And telling them—in every ad—that *there's nothing like a demonstration* to show what Bi-Acoustic can do! *That* means they come in *your* store.

And he's right. For Bi-Acoustic Radio does its own selling. Place it side-by-side with any radio—



RCA Victor

“Listen, World!”

..they listened..and bought!

How the return of the Victor Dog plus the great “Bi-Acoustic”—produced by Radio Headquarters—brought new life to sales!

and it tells its own tale. Feature by feature it out-matches all comers. And that’s *proved*—in dollars and cents—by the increased sales dealers report in all parts of the country.

Bi-Acoustic Radio and the Victor Dog have gone over!

Better talk to your distributor. Better see the schedule of advertising that is back of Bi-Acoustic. Better see the line . . . available in many models featured by prices anyone can pay. Because if you don’t get the dope—you’re not only missing out on a profitable line—but on the most powerful piece of radio promotion the industry ever had working for it!

The RCA Victor Co., Inc., Camden, N. J.

“RADIO HEADQUARTERS”

A Radio Corporation of America Subsidiary



RAE-84—A 12-tube “Bi-Acoustic” Radio-Phonograph with Improved Automatic Record Changing, Home Recording, Long Playing Record Device, “B” Amplification, Full Range Pickup, Advanced Automatic Tone Compensator, Tone Equalizers, Dual Automatic Volume Control, Noise Suppressor, Micro Tone Control.
List price complete, with RCA Radiotrons . . . **\$310.00**

Bi-Acoustic

TWO MORE OCTAVES

Radio

Radios
Phonograph
Combinations
Victor Records

In the 15,000 (Tung-Sol) tubes we have used in the past few months there has been less than twenty defective tubes in all.

Tung-Sol are the only tubes that we have been able to sell at full price without having our customers tell us that they can buy them cheaper elsewhere.

TRANSCONTINENTAL RADIO CO.
Los Angeles, California
August 22, 1932.

Tung-Sol Lamp Works Ltd.,
1816 So. Flower St.,
Los Angeles, Calif.

Gentlemen:

It is with great pleasure that we comment on your wonderful tubes, especially your new type tubes.

The trouble we have had with your tubes has been very slight. In the 15,000 tubes we have used in the past few months in assembling our radios, including replacements to dealers, there has been less than twenty defective tubes in all.

This, we are sure, is a real record experience with Radio Tubes. Therefore, we are taking great pleasure in congratulating you on the wonderful product you are putting on the market. We are wishing you continued success in the distribution of such an outstanding product.

Yours truly,
TRANS-CONTINENTAL RADIO CO.
Walter Vincent
Manager

TRANSLANTIC RADIO STORES, INC.
Wholesale and Retail
Radio Sets and Supplies
70-77 CONVLANDY STREET
New York, N. Y.

June 5th, 1932.

Tung-Sol Lamp Works Inc.,
General Motors Bldg.,
New York, N. Y.

Gentlemen:

We are pleased to advise that we have now handled Tung-Sol Radio Tubes for one year on a consignment basis, and we are very well satisfied with the line.

Tung-Sol are the only tubes that we have been able to sell at full list prices without having our customers tell us that they can buy them cheaper elsewhere. It is a real good tube and one that we like to sell, not only on account of the large profit, but because they stay good.

The replacement policy of Tung-Sol is excellent as it enables us to give a six months unconditional guarantee. Our records show that of all the different tubes that we carry in stock, we have fewer Tung-Sol returned than of any other make.

We can highly recommend Tung-Sol Tubes to any dealer, and can assure him that after he has had the line for a year, he will write you the same kind of a letter as we have.

Yours very truly,
Transatlantic Radio Stores, Inc.
L. Ross
Trans.

North Hollywood Electric Shop
11220 Hollywood Blvd.
North Hollywood, California

Tung-Sol Lamp Works Ltd.,
1816 So. Flower St.,
Los Angeles, Calif.

Gentlemen:

I hereby accept my 100% approval concerning the Tung-Sol consignment plan of distribution for Radio Tubes.

Tung-Sol has shown this firm a real co-operative spirit, along with a very high class line of Radio Tubes.

With 45 different radio tubes used in broadcast reception today we feel that no other plan could be more adequate to solve the situation.

Tung-Sol deserves the co-operation of every Radio dealer in their honest effort.

Yours for Success,
James W. Warner
James W. Warner

Hereby accept my 100% approval concerning the Tung-Sol consignment plan of distribution for Radio Tubes.

READ THESE LETTERS

from successful Tung-Sol dealers. They tell their own story. The quality of Tung-Sol—and the Tung-Sol Consignment Plan operate together to produce increasing repeat business with profits unimpaired by price competition. For complete details regarding the Tung-Sol proposition write—

TUNG-SOL RADIO TUBES INC.
NEWARK, NEW JERSEY

Licensed under patents of R. C. A.

Atlanta
Baltimore
Boston
Charlotte
Chicago
Cleveland
Dallas
Detroit
Kansas City
Los Angeles
New York
St. Paul

Radio Operator aboard the Southern Cross from California to Australia.

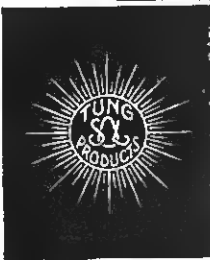

The biggest dollar's worth G-E EVER OFFERED!

THE NEW J-87 CONSOLE
—Eighteenth Century English cabinet, 41-7/16 inches high, 25-1/4 inches wide, 12-3/8 inches deep. Full-size Electrodynamic Speaker. 8-tube Superheterodyne. Push-pull Pentode output. New type Automatic Volume Control. And *extended tuning range*—permitting the reception of broadcasts on 540 kilocycles. Price with tubes

\$79.50



JUST IN TIME FOR THE BIGGEST MONTHS OF THE YEAR!

CHALK UP another win for G-E Radio—a brand new victory in *value!*

It's the biggest dollar's worth G-E ever offered. A big, beautifully-made full-size console set that you can sell for the amazingly low price of \$79.50.

In laboratory tests against radios costing almost twice as much, the results have been just what G-E engineers were working for—*its tone is as amazing as its price!* You can urge your customers to "believe their own ears" on that.

Eight tubes. And features that make

it superior to any 8-tube set you ever listened to! It has the new *Duo-diode triode* tube, with vastly improved automatic volume control—

It has an extended tuning range, which permits reception of broadcasts on the 540 kilocycle channel—

It has a full-size electrodynamic speaker, and push-pull pentode output—providing greater undistorted volume.

Only \$79.50—it's the biggest buy in radio! And one of the biggest reasons why the G-E franchise gives you

the biggest chance of getting your share of the \$40,000,000 that will be spent for radio in the next two months. If you aren't already a G-E dealer, now is the time to join up—mail the coupon!

● *The G-E Circle—a program of special interest to women—is on the air every weekday (except Tuesday) at 6:45 P. M., Eastern Standard Time.*

Section R-6811, GENERAL ELECTRIC CO.
Merchandise Dept., Bridgeport, Conn.

Without obligation, kindly send me further information about the General Electric Radio dealer franchise.

Name.....

Address.....

City.....State.....

**GENERAL  ELECTRIC
RADIO**

Built on Bed-rock

COMING into the radio business last spring, without any boom-era hangover, Columbia has had an unusual opportunity to establish a solid basis for success. And it hasn't missed that opportunity. Columbia has profited by the mistakes of others, and built on a bed-rock foundation—on *sound business principles* set up by its own management.

These principles are the very opposite of those which led the radio business to disaster. High-pressure production and high-pressure distribution have no place in today's radio market. So under Columbia's methods, only enough sets are produced to meet the demand . . . and only as many sets are distributed as can be sold. As a result, the prevalent trade-evils of

overloading, distress-merchandise, price-cutting, are avoided.

In a word, Columbia has shown the way to *stability* in the radio business. A number of distributors and dealers have recognized this fact. Many old-time Columbia record-dealers, for example, familiar with Columbia's traditional fair-deal policies, have taken on the new line of radios. Well-established firms all over the country enthusiastically welcome this chance to stabilize their businesses.

Here is Columbia then . . . a progressive company under independent leadership—following fundamentally sound practices—and presenting a first-rate line of instruments. You are a responsible distributor or dealer, who wants to see a return to reason, and a return to profits, in the radio business. How about getting together with Columbia? For complete information, write to the Columbia Phonograph Company, Inc., 55 Fifth Avenue, New York, N. Y.



Three Outstanding Values in Testing Equipment



**Pattern 540
Portable Tube Seller**

Aggressive dealers find this instrument a big help in building tube and receiver sales. The popular single reading meter—in conjunction with a colored dial that enables the set owner to read the exact condition of tubes himself—creates confidence. Comparisons with new tubes are easily and quickly made, so the most skeptical customer is easily convinced. The Pattern 540 is easy to carry for home testing. The cover may be removed for counter service. Detailed description of the Pattern 540 is provided in Bulletin W-J.

**Weston Model 677
Tube Seller**

This new Weston Model combines eye appeal with real tube merchandising value and convenient operation. A single reading on the large meter indicates operating condition of all types of tubes. Reading is in terms of Satisfactory, Doubtful, and Unsatisfactory, so that customers can see and interpret the reading themselves.



The Model 677 tests all types of tubes without adaptors, yet due to a special socket design, a compact instrument is provided requiring minimum counter space. Complete description of the Model 677 is furnished in Bulletin W-J.

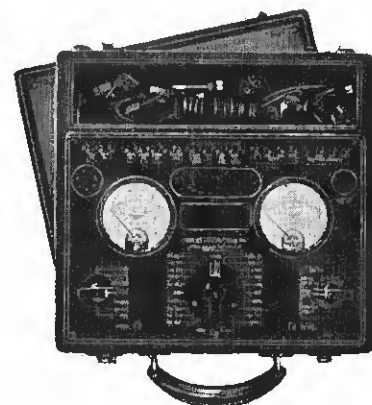

**Pattern 444
Set Analyzer**

More and more dealers are turning to effective radio servicing, not only as a source of additional income, but as a key to new set business.

Servicemen equipped with the Jewell Pattern 444 Set Analyzer have an advantage in any service program. The professional appearance of this well finished instrument creates prestige. The facility with which it enables a serviceman to check every phase of receiver performance is inspiring to customers!

The Pattern 444 provides adequate facilities for testing all types of receivers quickly and accurately, including those equipped with the latest tubes. Furthermore, all instrument ranges of the two high-grade meters are available through pin jacks for independent testing.

The Pattern 444 presents a value in facility of operation and reliability of performance not to be had in any other instrument at a comparable price. Every dealer and every serviceman should have complete information covering this thoroughly proven set analyzer. Write for Bulletin W-J, sent free on request.

**Weston
Standard
Service
Units**

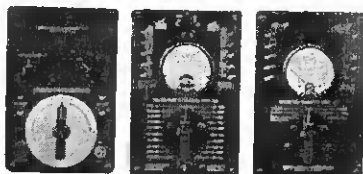

Every dealer and serviceman should have complete information covering Weston Standardized Service Units, the latest development in service equipment. Write for literature describing the set analyzer, oscillator, and volt ohmmeter now available in this new Weston standard size.

Write for the
Weston-Jewell
radio catalog today



WESTON JEWELL

Weston Electrical Instrument Corporation,
Jewell Electrical Instrument Company,
581 Frelinghuysen Ave., Newark, N. J.

Please send me the following literature:

The new Weston-Jewell Bulletin

Bulletin describing Weston Standardized Service Units.

Name

Address

It's hard for a Hungry citizen



to be a Good

CITIZEN

THE boy whose stomach is empty cannot be expected to do good work at school. Babies undernourished through another winter may be handicapped by frail bodies through life. The hungry father of a hungry family is hardly the man to seek employment with persistence, or to do well on the job when he gets it.

Before you can save a man's soul it is often necessary to feed his body. You have no right to expect the civic virtues of patience, courage and honesty from starving, freezing men and women. If they preserve a just attitude towards the laws of the city in which they live, it is a miracle.

This winter, as never before, it is the duty of all who are well-clad, well-housed, and well-fed to help the less fortunate. The fact that you gave last year, and the year before, does not lessen your responsibility. The fact that you cannot afford a large contribution must not deter you. The upturn of business with a gradual improvement of economic conditions does not remove the crisis of this moment. Emergency appropriations by the federal government amount to \$300,000,000, but they meet only half the increased national needs for human relief.

The rest is up to you!

How will your dollars be used? First of all, they will feed the hungry, and relieve the absolute want of the unemployed.

They will be used, also, to take care of the sick and aged. They will help to maintain hospitals, orphanages and schools. They will make possible clinics and visiting nurses.

The dollars you give are invested in the forces of civilization right in your community!

WELFARE AND RELIEF MOBILIZATION, 1932

The Welfare and relief Mobilization for 1932 is a cooperative national program to reinforce local fund-raising for human welfare and relief needs. No national fund is being raised; each community is making provisions for its own people; each community will have full control of the money it obtains.

Give through your established welfare and relief organizations, through your community chest, or through your local emergency relief committee.

Newton D. Baker, Chairman, National Citizens' Committee

This winter, as never before, support your local Community Campaign

Did You Take Advantage—

... of this money making opportunity?

The Studio Microphone is an all year sales booster. Dealers everywhere are profiting from it. . . . Especially attractive for Christmas—an inexpensive popular appeal gift.

The Studio Microphone is a genuine instrument for home entertainment "broadcasts". Pressure of a finger on the cutout button substitutes the owner's voice for the broadcast program—the voice comes through the radio clear and resonant. This attractively finished, brand new, home entertainer makes satisfied owners . . . mystified and amused friends will multiply your profits. Gives every home its own "Radio Santa Claus".

REAL DEALER PROFIT—Lists at \$1.50—your delivered price is \$10.00 per dozen—\$9.00 in 3 doz. lots—still lower prices in larger orders.

Send \$1.00 NOW for your sample. We'll even credit your remittance against your first order.

THE MICROPHONE LABORATORIES
718 Mission St., San Francisco, Calif.

FLERON RADIO AERIAL ACCESSORIES



The Complete Line from One Source
M. M. FLERON & SON, Inc. TRENTON, NEW JERSEY

Reaching Out Everywhere for Sales for YOU...

Whoever Wins!
You Win the Business of the Radio Fans who Want their Sets in Order.

RADIO FANS WANT Results!
YOU CAN GIVE them SERVICE RESULTS with OHIOHM Cooperation.

Clear up those blurry signals!
ASK for the OHIOHM Story . . .

OHIOHM

Everywhere — wherever radio men or radio users cast their eyes — OHIOHM Resistor advertising is to be found. Even police chiefs are reached with the story of OHIOHM Suppressor Sets for automobile radios.

QUALITY TALKS

Consider every point of resistor value and you'll find OHIOHMS check perfectly. Accuracy . . . Permanency . . . Absence of noise . . . Mechanical strength . . . Straight wire leads . . . Color coded and printed values . . . Every worthwhile point!

Ask us to send you the complete story — how we help jobbers, dealers, service men — the right package to fit each need — the free helps.

OHIOHM RESISTORS

THE OHIO CARBON COMPANY, Cleveland, Ohio
Ohiohm Resistors are made in Canada by C. C. Meredith & Co., Ltd., 67 Bay Street, Toronto

SOMETHING NEW! CLEANAIRE ICE-BOX and REFRIGERATOR DEODORIZER

Absorbs and destroys food odors. Stops tainted foods. A 50c. item. Add it to your line.

Beyond the Blue Horizon waits a rising market

OUT beyond Sandy Hook and the Golden Gate lies an opportunity for American radio and American radio manufacturers. Export sales of U. S. radio apparatus have increased 2,100% in the past ten years. Significant, too, is the fact that although radio sales in the United States dropped from over eight hundred millions of dollars in 1929 to about three hundred million dollars last year, export sales declined only slightly.

Another indication of the export market for American radio goods is the rising tide of inquiries that *Radio Retailing* is receiving from radio merchants and importers in foreign lands, asking where they can buy this piece of radio equipment and that item of radio supplies.

Radio merchants abroad are interested in American methods of radio selling and American radio sets, tubes, accessories, parts and allied equipment, including public address systems, electric phonograph pick-ups and turntables, other home-entertainment merchandise and allied lines. Likewise American dealers, distributors and manufacturers in the radio industry have an interest in radio markets abroad and in the methods that foreign merchants are using to sell radio in their countries.

Radio Retailing's December 1932 issue will be its "Export Issue." The magazine will go as usual to its regular subscriber-readers in America, Canada and in other foreign lands. But in addition, extra copies of the magazine will be sent to all the worthwhile radio trade outlets in those

foreign nations into which American radio products can profitably be imported. Special editorial material will make the Export Issue of extreme importance to both foreign and domestic readers.

AMERICAN manufacturers who are now enjoying a healthy export business in radio and those manufacturers who want to build up an export business both have an unrivalled opportunity in *Radio Retailing's* December Export Number. Through the advertising pages of this gala issue, these manufacturers can tell their sales stories to foreign radio merchants and importers. In the same issue these manufacturers can advertise to American radio dealers and distributors almost a full month before Christmas—and last-minute trade buying will feature this Christmas radio season. Good feature of *Radio Retailing's* December Export Number, so far as manufacturers are concerned, is that in spite of the extra foreign circulation of the issue, regular advertising and color rates will prevail. There will be no extra charge for the valuable foreign circulation.

For American radio and allied product manufacturers we have prepared a circular about export opportunities and our Export Number. Copies will gladly be sent to manufacturers who address

Radio Retailing

a McGraw-Hill publication

330 West 42nd Street, New York, N. Y.

SEARCHLIGHT SECTION

EMPLOYMENT and BUSINESS OPPORTUNITIES—SURPLUS STOCKS—DISCONTINUED MODELS

UNDISPLAYED—RATE PER WORD:
Positions Wanted, 5 cents a word, minimum \$1.00 an insertion, payable in advance.
 (See ¶ on Box Numbers.)
Positions Vacant and all other classifications, 10 cents a word, minimum charge \$2.00.
Proposals, 40 cents a line an inserton.

INFORMATION:
Box Numbers in care of our New York, Chicago and San Francisco offices count 10 words additional in undisplayed ads. Replies forwarded without extra charge. Discount of 10% if one payment is made in advance for four consecutive insertions of undisplayed ads (not including proposals).

DISPLAYED—RATE PER INCH:
 1 inch.....\$7.50
 2 to 3 inches.....7.25 an inch
 4 to 7 inches.....7.00 an inch
Rates for larger spaces, or yearly rates, on request.
 An advertising inch is measured vertically on one column, 3 columns—30 inches—to a page. Radio Retailing

REPAIRING

GUARANTEED microphone repairs—any make or model, 24-hour service. Stretched diaphragm double button repairs, \$7.50. Others, \$3.00. Single button repairs, \$1.50. Write for 1933 Catalog with diagrams. Universal Microphone Co., Ltd., Inglewood, California.

WANTED

WANTED—We want to buy 500 Midget Radios. Write to the Eastern, 9th & Broadway, Los Angeles, California.

LEGAL NOTICE

STATEMENT OF THE OWNERSHIP, MANAGEMENT, CIRCULATION, ETC., REQUIRED BY THE ACT OF CONGRESS OF AUGUST 24, 1912

Of Radio Retailing, published monthly at New York, N. Y., for Oct. 1, 1932.
 State of New York } ss.
 County of New York }

Before me, a Notary Public in and for the State and county aforesaid, personally appeared C. H. Thompson, who, having been duly sworn according to law, deposes and says that he is the Secretary of the McGraw-Hill Publishing Company, Inc., publishers of Radio Retailing, and that the following is, to the best of his knowledge and belief, a true statement of the ownership, management (and if a daily paper, the circulation), etc., of the aforesaid publication for the date shown in the above caption, required by the Act of August 24, 1912, embodied in section 411, Postal Laws and Regulations, printed on the reverse of this form, to wit:

1. That the names and addresses of the publisher, editor, managing editor, and business managers are: Publisher, McGraw-Hill Publishing Company, Inc., 330 West 42d St., N. Y. C. Editor, O. H. Caldwell, 330 West 42d St., N. Y. C. Managing Editor, Ray V. Sulliffe, 330 West 42d St., N. Y. C. Business Manager, M. E. Herring, 330 West 42d St., N. Y. C.

2. That the owner is: (If owned by a corporation, its name and address must be stated and also immediately thereunder the names and addresses of stockholders owning or holding one per cent or more of total amount of stock. If not owned by a corporation, the names and addresses of the individual owners must be given. If owned by a firm, company, or other unincorporated concern, its name and address, as well as those of each individual member, must be given.) McGraw-Hill Publishing Company, Inc., 330 West 42d St., N. Y. C. Stockholders of which are: James H. McGraw, 330 West 42d St., N. Y. C. James H. McGraw, Jr., 330 West 42d St., N. Y. C. James H. McGraw, 330 West 42d St., N. Y. C.

MANUFACTURERS' AGENTS WANTED CONDENSERS

A few sales territories open to established sales organizations actively contacting wholesalers or distributors. High quality product with good sales and income possibilities.

MORRILL AND MORRILL
 30 Church St., New York

SPECIAL NOTICE:

To the Radio Industry

Advertising in connection with legitimate offers of surplus stocks and discontinued models of radio merchandise is acceptable in this section of "Radio Retailing."

Extreme care will be exercised by the publishers to prevent the use of advertising in the Searchlight Section to encourage price cutting on current models of merchandise or equipment. Nor will advertising which invites violation of the dealer's contract with the manufacturer be acceptable.

All merchandise offered in the Searchlight Section must be accurately and fully described and must be available on order.

LEGAL NOTICE

McGraw, Jr., and Malcolm Muir, 330 West 42d St., N. Y. C. Trustees for: Harold W. McGraw, James H. McGraw, Jr., Donald C. McGraw, Curtis W. McGraw, Curtis W. McGraw, 330 West 42d St., N. Y. C. Donald C. McGraw, 330 West 42d St., N. Y. C. Anne Hugus Britton, 330 West 42d St., N. Y. C. Mason Britton, 330 West 42d St., N. Y. C. Edgar Kobak, 330 West 42d St., N. Y. C. Grace W. Mehren, 33 West Grand Ave., Chicago, Ill. J. Malcolm Muir and Guaranty Trust Co. of New York, Trustees for Lida Kelly Muir, 524 Fifth Ave., N. Y. C. F. S. Weatherly, 271 Franklin Road, Brookline, Mass. Midwest Corporation, Madison, N. J. Stockholders of which are: Edwin S. Wilsey, Madison, N. J. Elsa M. Wilsey, Madison, N. J.

3. That the known bondholders, mortgagees, and other security holders owning or holding 1 per cent or more of total amount of bonds, mortgages, or other securities are: (If they are none, so state.) None.

4. That the two paragraphs next above, giving the names of the owners, stockholders, and security holders, if any, contain not only the list of stockholders and security holders as they appear upon the books of the company but also, in cases where the stockholder or security holder appears upon the books of the company as trustee, or in a capacity other than that of a bona fide owner; and this affiant has no reason to believe that any other person, association, or corporation has any interest direct or indirect in the said stock, bonds, or other securities than as so stated by him.

5. That the average number of copies of each issue of this publication sold or distributed, through the mails or otherwise, to paid subscribers during the six months preceding the date shown above is (This information is required from daily publications only.)

C. H. THOMPSON, Secretary.
 MCGRAW-HILL PUBLISHING COMPANY, INC.
 Sworn to and subscribed before me this 29th day of September, 1932.

[SEAL] H. E. BEIRNE, Notary Public N. Y. Co. Clk's No. 293, 4th No. 3B1192, Notary Kings Co. Clk's No. 636, Reg. No. 3125. (My Commission expires March 30, 1933)

FREE

13th ANNIVERSARY RADIO CATALOG



124 pages containing the most complete listing of radio items for the dealer and serviceman at real bargain prices.

Send for your copy now!

AMERICAN SALES COMPANY

Wholesale Radio Distributors
 RR-44 West 18th Street, New York City

SERVICEMEN-DEALERS

"Send 25c. for our Handbook and Catalog"
Complete Stock of NEW Radio Replacement Parts
 Hard to Get Parts—We have them. Send us your repair work for estimate.
GRANT RADIO LABORATORIES
 6521-R South Halstead St., Chicago, Ill.

MICROPHONE REPAIRS

Any make carbon or condenser, 24-hour service. All repairs guaranteed for six months. Stretched diaphragm \$8.75, others \$1.50 per button. Condenser Microphones \$9.00. WRITE FOR NEW 1932 CATALOGUE.

MAYO INSTRUMENT CORPORATION
 281 E. 137th St., New York City

HUGE SAVINGS IN USED PUBLIC ADDRESS EQUIPMENT

Send for bargain lists. Motion Picture and Sound Systems.

SALES ON SOUND CORP.
 Dept. RR, 1600 Broadway, New York

"Opportunity" Advertising:

Think "SEARCHLIGHT" First!



RADIO CONSTRUCTION LIBRARY

Including Construction of Short-Wave and Television Sets

By MOYER and WOSTREL

3 Volumes, 1087 pages, 6 x 9, 605 illustrations

FREE EXAMINATION

Easy terms
 Send this coupon

McGraw-Hill Book Co., Inc., 330 West 42d Street, New York. Gentlemen:—Send me the RADIO CONSTRUCTION LIBRARY, all charges prepaid, for 10 days' Free Examination. If satisfactory, I will send \$1.50 in ten days and \$2.00 a month until \$7.50 has been paid. If not wanted I will return the books at your expense.

Name.....
 Home Address.....
 City and State.....
 Name of Company.....
 Occupation.....
 FRR11-32
 (Books sent on approval in U. S. and Canada only.)

Volume 1. **Practical Radio**. Presents the fundamental principles of radio so clearly and simply that anyone of average training will be able to understand and apply them. Deals with recent developments in television, including devices for its practical application. Latest types of photo-electric cells and neon glow tubes for television services, newer types of receiving tubes especially those for operating with alternating current, etc.

Volume 2. **Practical Radio Construction and Repairing**. Discusses fully all the elemental principles of radio construction and repair. Includes such subjects as: Sources of electricity for radio tubes—Audio frequency amplifiers—Construction of impedance coupled and "Universal" four type receiving sets—Short-wave receiver—The television receiver—and many others.

Volume 3. **Radio Receiving Tubes**. Clearly explains the essential principles underlying the operation of vacuum tubes. Includes complete information on the newest types of radio tubes and improvements which have been made in tubes already in general use. Gives complete descriptions of apparatus required for radio receiving sets and for industrial equipment; also of devices utilizing radio receiving tubes as essential parts.

NEW "B" POWER

FOR AUTOS - BOATS, ETC.

RETAILS AT
\$ 13.65

DEALERS—A quick selling replacement item for Auto Radio and home sets — no more "B" batteries — every motorist wants one. Small, size 3½x 5½x5½, weight 5 lbs. Output 35 milliamperes 180 volts at only two amp. "A" Batt. drain. Taps for 135 and 90 volt control grid. Universal mounting — fully guaranteed — **Usual Big Dealers Discounts—Write Your Jobber or Direct.**

PREMIER ELECTRIC COMPANY
Dept. No. 114, 3800 Ravenswood Ave., Chicago, U. S. A.

Earn Big Money



REPLACE BURNT-OUT and DEFECTIVE BALLASTS

Millions of Sets including M-A-JESTIC and other standard lines need Ballast Replacements **NOW.**

JOBBERS—DEALERS

Send for our plan outlining Ballast Replacement Market and Money Making Plan. Also Volume Control Replacement Data Book.

CLAROSTAT Mfg. Company
287 North 6th Street, Brooklyn, N. Y.

Only Reliable Products
Can Be Continuously
Advertised

\$5.00
Complete Kit

More Profit
Lower Price
Easier to Sell
Easier to Install
Better Results

LYNCH "NO-STAT" ANTENNA SYSTEMS

Eliminates Man-made static and permits the use of several receivers on a single antenna.

Special Offer: Dealers and Service organizations—A sample LYNCH "NO-STAT" will be sent at our special price of \$2.50. Clip this to your letterhead, enclose check or money order for \$2.50. After December 15th the "NO-STAT" will be obtainable only through your jobber at regular discounts from \$5.00 list.

LYNCH MFG. CO., INC.
1775 Broadway, New York, N. Y.



New!

a totally different
Replacement Resistor Guide

with these important new features

1. Complete data for over 925 modern radio receivers.
 2. Resistance value and wattage listed for each unit.
 3. New simplified system of listings saves time and prevents errors.
 4. Complete technical discussion of resistor uses in modern receiver design.
- Get your copy today! Enclose fifty cents with the coupon below, or ask your jobber for it. Free with the Continental Replacement Resistor Kit.

End Resistor Troubles This Easy Way

Why take chances of losing profits and customer's goodwill by installing replacement resistors of unknown brand? When buying resistors, look for the green Continental "Certified" label.

CONTINENTAL CARBON Inc.

13902 Lorain Ave., Cleveland, Ohio
Canadian Factory—Toronto, Ont.

Enclosed please find fifty cents, for which I am to be sent, postage prepaid, one copy of the New Continental Replacement Resistor Guide.

Name

Address

City..... State.....

Change DC to AC with

JANETTE ROTARY CONVERTERS

For Farms—Ships—City
Apartments—Automobiles

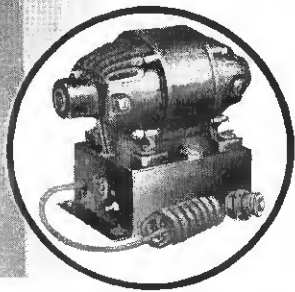

Wherever the current supply is DC, use JANETTE Rotary Converters to operate your AC receivers.

JANETTE Converters are filtered to give radio results as good as, or better than, that obtained with central station AC. Built to outlast the radio set.

Available in 15 sizes. Capacities from 20 to 2500 watts. Input voltages of 6, 12, 32, 115 or 230 volts. Standard machines deliver 110 volts, 60 cycles AC.

MAIL COUPON FOR DETAILS

JANETTE MFG. CO.
655 W. Monroe St.,
Chicago, Ill.

Gentlemen: Please send prices and details on your:

Rotary Converters

Auto-B-Power (B-eliminator for auto-radio)

Gas Engine Generators

Name

Address

City..... State.....

Below: Gas engine-operated JANETTE 110-volt, 80-cycle generator. Capacities: 300 to 2250 watts. Ideal for sound-trucks, amplifiers, P.A. systems, etc.

**Over 3000
Items Like
These in the
November**

**“RADIO
BARGAIN
NEWS”**

Prices in RADIO BARGAIN NEWS are consistently lower—that's why thousands of radio dealers and servicemen thruout the world have made Federated their replacement parts headquarters.

But price is not everything—prompt service is paramount in servicing, and we are equipped to give it to you. Our customers know this. “We are sending you a testimonial of thanks” writes the Radio Shop of LaFayette, Ind., “for your prompt service on all our orders and the quality of the goods you handle.”

If you have been skeptical about radio parts mail order houses, or have not availed yourself of the Federated service for some reason, why not start now and save 25 to 50% on your replacement parts?

The November issue of RADIO BARGAIN NEWS contains 108

Audio Transformer
With Pick-Up Coil Winding
For Replacement in Victor Sets
Can be used for any tube of high impedance.
Has special winding for phonograph pick-up. Magnetically shielded preventing inter-stage feed back.
CATIO 3 1/2 x 1.
Cat. No. 2581
Our Price **29c**
4 for \$1.00

Push-Pull Audio Transformer Pack
Can be used with 245 and 247 Tubes.
Output Matches Moving Coil on All Dynamic Speakers.
Cat. No. 5744
Our Price, Per Pack **59c**

Extraordinary Offering of Genuine Merphon 8 Mfd. Inverted Type Electrolytic Condensers
A most fortunate scoop of the wet type famous Merphon Electrolytic Condensers enables us to offer them to you at 80% of the regular list price. The 8 Mfd. inverted type is used in 90% of the receivers on the market today. The threaded stud is insulated and the chassis or may not be grounded to the washer and nut. 1-13/32" in diameter, 4 1/2" long. Regularly sold for 98c.
Cat. No. 7369
Our Special Price, Each **29c**
7369 Per Dozen

30 Henry Choke
RCA Victor—150 Mils. 200 Ohms
3524ash in high.
Weights 3 1/2 lbs.
Cat. No. 5474
Our Price **29c**
4 for \$1.00

Universal Replacement Power Transformer for 4 or 5 Tube Midgets
For sets using up to 2-224, 225, 251, 227, 24, or 37 tubes for a combination of same; 1-245 or 247 and 1-280 tubes.
Supplies the following voltages: 2 1/2, 5, 10, 25, 50, 100, 150, 200, 250, 300, 350, 400, 450, 500, 550, 600, 650, 700, 750, 800, 850, 900, 950, 1000, 1100, 1200, 1300, 1400, 1500, 1600, 1700, 1800, 1900, 2000, 2200, 2400, 2600, 2800, 3000, 3200, 3400, 3600, 3800, 4000, 4500, 5000, 5500, 6000, 6500, 7000, 7500, 8000, 8500, 9000, 9500, 10000.
Size: 2 1/2" x 3 1/2" high. Weight 2 lbs.
Cat. No. 5502
Our Price **95c**

Frost 10,000 Ohm Potentiometer
Graphite Element. Only 1/16" thick. 1 1/2" flat shaft with 3/8" thread and locknut. Will fit all 100 knobs.
Cat. No. 5634
Our Price, Each **29c**
4 for \$1.00

Three Stage Push-Pull 245 Amplifier
Using 2-56's, 2-45's and 1-280 Tubes
Output: 4 Watts
Size: 14" long, 10" wide, 8" tall
Shipping weight, 3 1/2 lbs.
Cat. No. 120
Our Price, Less Tubes **\$2.25**
This amplifier has three stages, two of which are 245 type tubes. Output stage is two 45's in new voltage ratio circuit and single 280. This push-pull and the rectifier is providing for the use of high and low impedance inputs and high and low impedance outputs. Use with angle button microphone or low impedance phonograph pick-up. The high impedance input is suitable for use with the plate of a radio tube or with a 500 ohm resistor. The input can be reconnected, or with high impedance pickup.

pages of radio replacement parts for all types of receivers on the market at lowest prices in radio history. We carry one of the largest stocks in the country including Acratost Condensers and Resistors; Power Transformers; Volume Controls; Acratone Power Amplifiers of 4 to 30 Watts output; RCA, Cunningham and Arcturus Tubes; Universal Microphones; Janette and Esco Converters; Hicoek, Weston and Readrite Analyzers and meters—over 3,000 items in all.

RADIO BARGAIN NEWS
Dealers & Servicemen's Buying Guide

You will find this book an indispensable adjunct to your business. It has 106 pages featuring 3,000 items.

Federated Purchaser Inc.

25 PARK PLACE NEW YORK, N. Y.

The Following Distributing Units Maintained for Your Convenience:

JAMAICA, L. I. 92-26 Merrick Road	MT. VERNON, N. Y. 51 East 3rd Street	NEWARK, N. J. 273 Central Avenue
PHILADELPHIA 2909 Broad Street	ATLANTA, GA. 631 Spring Street, N.W.	

Fill in and mail this coupon back to our main office at once for a Free copy of Radio Bargain News.

Name

Address

City State.....

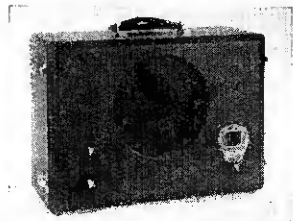

ANSLEY UTILITY RADIO

**THIS NEW
8 TUBE SUPERHETERODYNE
WORKS ON BOTH
A.C. and D.C.
No Aerial or Ground Needed**

**AUTOMATIC VOLUME CONTROL.
SILENT TUNING.
PUSH-PULL 89 TYPE AMPLIFICATION.
EIGHT-INCH DYNAMIC SPEAKER.
Easily Adapted for 110-220 Volt
A.C., D.C., 25-60 Cycle Operation**

Huge New Markets! Colleges, Hospitals, Hotels, Apartments, in addition to Homes needing a radio, easily moved from one room to another, Vacationists, Theatrical and Travelling People.

*Sold Through Franchised Dealers Only.
Exclusive Territories Rapidly Being Closed.*
WRITE TODAY.

ANSLEY RADIO MFG. CO.
147 W. 23d ST., N. Y. C.

World-Wide Sales Representatives: Flake Radio & Television Co.

ONLY 22 per cent of the potential replacement tube business is going to radio tube dealers. This is because tubes are changed only about *once in every five years*, as shown by recent and reliable statistics.



Ken-Rad advertising and merchandising is aimed to change this, to get for its dealers and distributors their share of the untouched 78 per cent of this enormous market.

Ken-Rad Radio Tubes

DEPENDABLE LONG LIFE

The Ken-Rad Corporation, Inc., Owensboro, Ky.
Division of Ken-Rad Tube and Lamp Corporation

CONTENTS for NOVEMBER, 1932

Copyright, 1932, by McGraw-Hill Publishing Company, Inc.

<i>To Keep Us Afloat</i>	Page 9
<i>Setting the Pace</i>	10
<i>Unique Window Trims</i>	13
<i>The Under \$20 Price Level</i>	14
<i>Radio Magic</i>	16
<i>Widening the Broadcast Band</i>	18
<i>The Big Broadcast</i>	A Pictorial 20
<i>Editorial Observations</i>	22
<i>Answering Your Questions About New Circuits</i> ..	24
<i>Shortcuts</i>	26
<i>Characteristics of Radio Receiving Tubes</i>	28
<i>Discs Reflect New Dance Style</i>	29
<i>News of the Month</i>	30
<i>RMA Makes Important Decisions</i>	
<i>Detector</i>	32
<i>New Merchandise</i>	34

INDEX TO ADVERTISERS

This index is published as a convenience to the reader. Every care is taken to make it accurate, but *Radio Retailing* assumes no responsibility for errors or omissions

Ansley Radio Mfg. Co.....	Page 52	Premier Elec. Co.....	Page 49
Arcturus Radio Tube Co.....	5	RCA Victor Co., Inc.....	40-41
Arwater Kent Mfg. Co.....	37	Stromberg-Carlson Tel. Mfg. Co.	2
Clarostat Mfg. Co.....	49	Tatro Prod. Corp., L.....	35
Colonial Radio Corp.....	7	Tung-Sol Radio Tubes, Inc.....	42
Columbia Phonograph Co.....	44	United American Bosch Corp....	4
Continental Carbon Co.....	49	United States Radio & Television	8
Crosley Radio Corporation, Inside Back Cover		Corp.	
Cunningham, Inc., E. T. Back Cover		Weston Elec. Instr. Corp.....	45
Emerson Radio & Phono. Corp... 1		Zenith Radio Corp.....	39
Fleron & Son, Inc., M. M.....	47		
General Electric Co.....	43		
Hygrade-Sylvania Corp.....	3		
Janette Mfg. Co.....	49		
Jewell Elec. Instr. Co.....	45		
Ken Rad Corp., Inc.....	52		
Lynch, Inc., Arthur H.....	49		
Mallory Co., P. R.....	6		
Microphone Labs.....	47		
National Carbon Co., Inside Front Cover			
Ohio Carbon Co.....	47		

SEARCHLIGHT SECTION

Classified Advertising

Classification	Page
AGENTS WANTED.....	50
REPAIRING.....	50
RADIO STOCKS	
American Sales Co.....	50
Federated Purchaser, Inc.....	51
Grant Radio Laboratories.....	50
Sales on Sound Corp.....	50

CROSLEY

Scores 6 More Hits!

A 5-tube superheterodyne—factory balanced—neutralized—non-regenerative—full floating dynamic speaker—many features hitherto only found in sets selling at much higher price—a beautiful cabinet with genuine walnut overlay . . .



The Crosley SEXTET
A 6-tube superheterodyne complete with tubes . . . list **\$34.95**
(Tax Paid)

Cabinet front panel of figured oriental walnut veneer. Birds-eye maple overlay on arch. Reeded pilasters. Dimensions: 16 3/8" high, 13 1/4" wide, 8 3/4" deep.

CHASSIS SPECIFICATIONS

Six tube superheterodyne employing automatic volume control, new 2 1/2 volt heater type tubes. Three gang tuning condenser. Pentode output. Continuous static and tone control. Full floating moving coil dynamic speaker and other late developments.

The Crosley FIVER

This is the last word in a small radio. Inbuilt sensitivity. Factory balanced. Excellent tone. Truly a "5" in the price range of a "4". Experience proves that the public demands five tubes. Whistles and birdies common in four-tube receivers are virtually eliminated through the use of five tubes. For that reason five-tube radios have outsold four-tube models even when there was a price differential of six or seven dollars between the two. You know this from your own experience.

Five-tube neutralized superheterodyne employing new 2 1/2 volt heater type tubes. Illuminated dial. Volume control. On-off switch. Full floating moving coil dynamic speaker and other recent developments. Chassis completely balanced and non-regenerative. Cabinet of Gothic design beautifully finished in Adam brown with front panel of stump walnut veneer.



\$19.99
TAX PAID

This super-performing 6-tube chassis is also available in an attractive console model—

The Crosley Sextet Lowboy
\$39.95 complete (Tax Paid) Dimensions: 40" high, 24 3/8" wide, 13 1/2" deep.

This fine 5-tube chassis is also available in a beautiful console model—

The Crosley Fiver Lowboy
\$29.99 complete (Tax Paid) Dimensions: 40" high, 24 3/8" wide, 13 1/2" deep.

The Crosley BOOK CASE

(Library Universal)



Suggestive of its function as a bringer of knowledge and entertainment this marvelous receiver represents a set of books bearing these titles: Music, religion, education, news, politics, sport, entertainment, humor. It is so real in appearance that many persons, glancing casually at it, will try to remove one of the art volumes for closer study. Book backs are covered with a fine grade of leatherette of antique coloring. Backs and sides are embossed and embellished with gold, as are the titles and the name, "Library Universal." The book backs are mounted on two doors which swing open permitting the radio to be operated in the same manner as a conventional table model set. Dimensions: 10 1/2" high, 13 3/4" wide, 8-9/11" deep. Chassis: 5-tube superheterodyne as described under the Crosley Jewel Case.

With all its beauty, charm and novelty, this lovely set will move speedily at the low list price of . . . **\$34.75** (Tax Paid)

Here is something new, fresh and captivatingly beautiful. A solid oak chest decorated with replicas of rich carvings—a faithful reproduction of an old Italian cassone. Crosley craftsmen have here caught the spirit of fine old-world treasure chests. So well designed that it reflects the good taste of its owner in any environment. When not in use it appears as a chest for valuable papers, a jewel case, or an expensive cigar humidor. Lid is raised to turn radio on and left open a few inches to reflect the sound into the room. Dimensions: 9" high, 14 1/2" wide, 9" deep. Compared with its beauty, the list price is startlingly low . . . **\$34.75** (Tax Paid)

CHASSIS SPECIFICATIONS
Five-tube superheterodyne of most modern type using new heater type tubes that makes possible a performance never before possible in a radio of this size. Balanced image suppressor. Combined volume control and on-off switch. Illuminated hair-line shadow dial with vernier drive and Crosley full floating moving coil dynamic speaker.



Montana, Wyoming, Colorado, New Mexico and west, prices slightly higher.

THE CROSLEY RADIO CORPORATION

Powel Crosley, Jr., President

CINCINNATI

Home of "the Nation's Station"—WLW

YOU'RE THERE WITH A CROSLEY

CROSLEY RADIO

