

# Radio Retailing

*The Business Magazine of the Radio Industry*

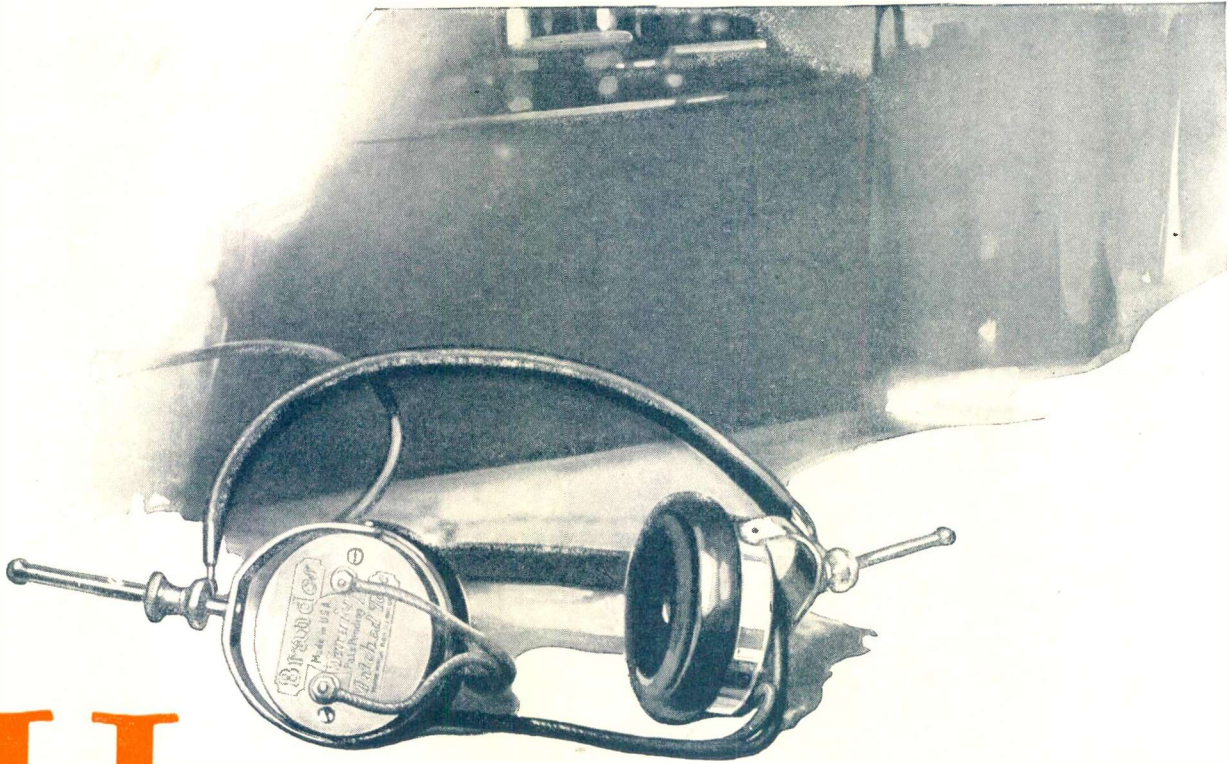

*In This Issue —* ◻ *Selling Radio All Summer Long*  
◻ *The Farm Market* ◻ *Store Operating Costs*  
◻ *Complete Specifications of Kits*



# Headsets are really like speedometers

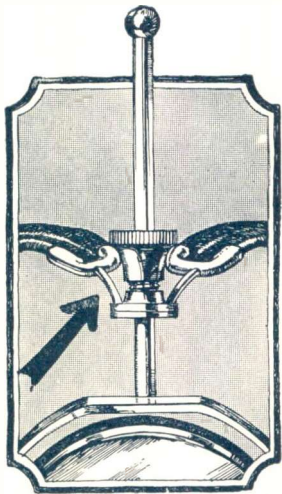

The clutch on a Brandes Headset makes it possible to raise or lower the ear pieces — and to fasten them easily. It keeps the headset permanently adjusted.

You can sell a Brandes Headset with every radio receiver. It is as important a part of the set's equipment as the speedometer is of the motor car's.

An automobile isn't considered complete without a speedometer. When a man wants to know what his car can *really* do, he needs one. When the radio fan wants to find out just what distance his set can get — on goes the headset.

Form the profitable habit of selling a Brandes Headset with every radio set.

# Brandes

# Bradleystat

PERFECT FILAMENT CONTROL

The result of more than twenty years' research and experience in the manufacture of graphite disc rheostats for radio, mines, mills, etc.

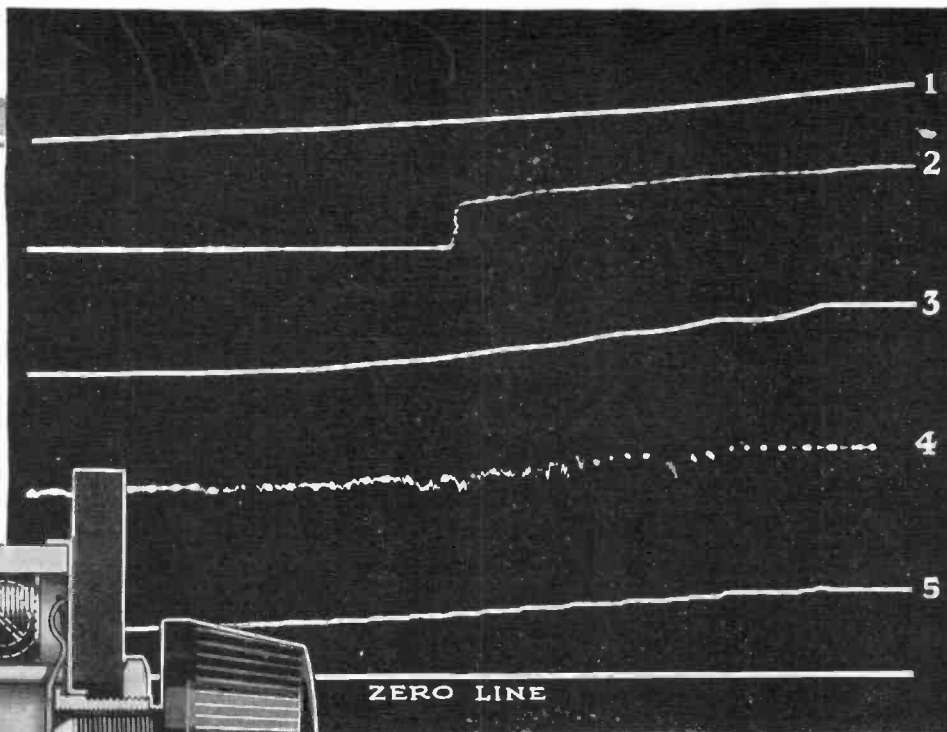

Use the same Bradleystat for ALL Radio Tubes without changing connections

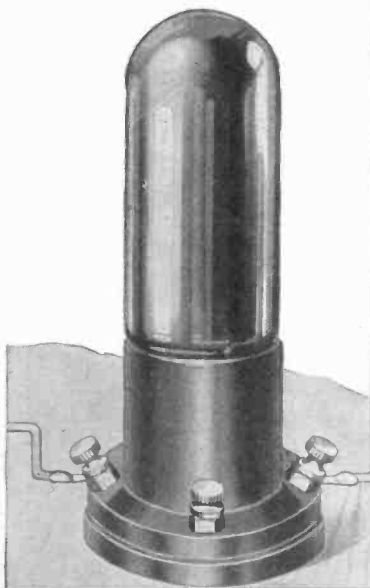

## Amazing Performance makes the Bradleystat a big seller!

Radio dealers know that Bradleystat advertising is creating a continuous demand for this exceptional graphite disc rheostat. Real performance, however, keeps the Bradleystat sold and creates repeat business for the Bradleystat dealer.

The above control curves, produced automatically by an electric oscillograph at the University of Wisconsin, show graphically the noisy, scratchy control curves of wire and carbon powder rheostats, Nos. 2, 3, 4, and 5. Compare these with curve No. 1, showing the smooth noiseless control of the Bradleystat, using graphite discs.

It's no wonder every Bradleystat user is a booster. Get your share of this attractive radio business, by getting a Bradleystat stock, to-day!

Mail the Coupon for Latest Data

**Allen-Bradley Co.**

Electric Controlling Apparatus

489  
Clinton  
St.



Milwaukee,  
Wis.

Mfrs. of graphite disc rheostats for over twenty years.

Allen-Bradley Co.  
489 Clinton St., Milwaukee, Wis.

Please send us your latest dealer literature on the Allen-Bradley line of Perfect Radio Devices.

Name.....

Address.....



## “Eveready Radio Batteries are the best moving products in my shop”

“ALL you have to do to sell Eveready Radio Batteries is to display them. They bring people into my shop—and the best part of it is, once a customer always a customer.”

In these words Mr. A. H. Smith, of Waukegan, Ill., sums up his success with Eveready Radio Batteries, which strikingly parallels the experience of radio and battery retailers throughout the country. Dealers everywhere who employ the simple sales policy of displaying Eveready Radio Batteries are meeting with better than good sales results.

Eveready Radio Battery national advertising creates consumer acceptance for Ever-

eady “B” Batteries, making it easy for you to complete the sale. And the high quality built into every Eveready Battery insures satisfying performance—“they last longer”—batteries and customers too!

Wherever there is radio there is a demand for Eveready Batteries. Order them from your jobber, stock them, display them, sell them. Get the attractive Eveready window display material. It's free for the asking. Order from your jobber. Manufactured and guaranteed by

NATIONAL CARBON Co., Inc.  
 New York San Francisco  
 Atlanta Chicago Dallas Kansas City  
 Canadian National Carbon Co., Limited  
 Toronto, Ontario

**EVEREADY HOUR**  
**EVERY TUESDAY AT 8 P. M.**  
*Eastern Standard Time*

For real radio enjoyment, tell your customers to tune in the “Eveready Group.”  
 Broadcast through—

WEAF New York	WEAR Cleveland
WJAR Providence	WSAI Cincinnati
WEI Boston	WWJ Detroit
WFI Philadelphia	WCCO { Minneapolis
WGR Buffalo	WCCO { St. Paul
WCAE Pittsburgh	WOC Davenport

# EVEREADY

## Radio Batteries

—they last longer

# Sold TO Authorized Freshman dealers only!

The 1925-1926 Line of

## New and Improved **FRESHMAN MASTERPIECE**

Five-Tube Tuned Radio  
Frequency Receiving Sets

For sale by a selected group of dealers throughout the United States;—one exclusive dealer only in a specified territory.

**No More Cut-Throat Competition  
No More Losses On Installment Sales**

**THE GREATEST VALUES  
EVER OFFERED**

are made possible by our improved manufacturing facilities and our policy of selling direct to authorized dealers.

A complete line of the world's most beautiful radio receiving sets, ranging from the improved 5 tube tuned radio frequency receiver, listing at \$39.50, up to the handsome Franklin Console, of vigorous lines and fine proportions, at \$115.00.

The Freshman Masterpiece line will be supported by a tremendous advertising program, which includes local advertising in every community, over the name of the Authorized Freshman Dealer, as well as the leading radio, general and farm publications.

*Write, telegraph or call at either of our offices for complete data and information.*

**Chas. Freshman Co. Inc.**  
*Radio Receivers and Parts*  
**FRESHMAN BUILDING**  
**240-248 WEST 40TH ST.-NEW YORK, N.Y.**  
Chicago Office: 327 So. LaSalle Street

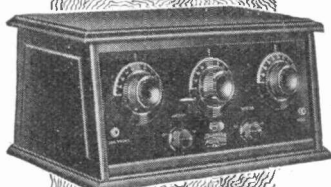

**Model 5-F-2**  
Massive cabinet with sloping panel.

\$39.50

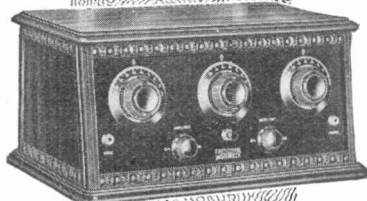

**Model 5-F-4**  
Genuine solid Mahogany. Sloping panel.

\$49.50



**Concert Model**  
Genuine mahogany contains full-throated loud speaker.

\$75

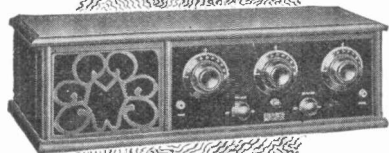

**Model 5-F-5**  
Built in loud speaker. A tremendous value.

\$60

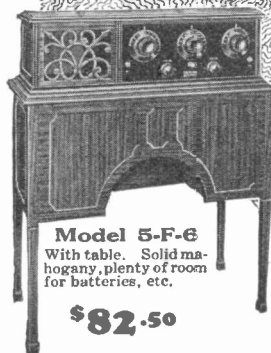

**Model 5-F-6**  
With table. Solid mahogany, plenty of room for batteries, etc.

\$82.50

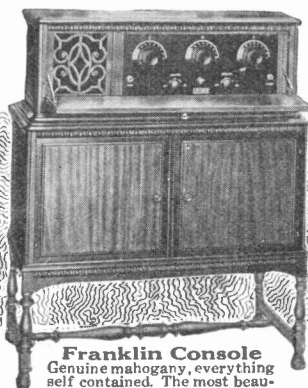

**Franklin Console**  
Genuine mahogany, everything self contained. The most beautiful radio on the market.

\$115



\$20

**Master "B" Eliminator**  
Works from light socket—cuts out "B" batteries.

# Complete Service for the Radio Manufacturer

IT is natural that the McGraw-Hill Company, the world's largest publishers of radio, electrical, business and engineering publications should have the most complete sales and advertising service available to the radio industry.

Do you realize how the three parts of McGraw-Hill service for the radio manufacturer cover every possible need?

1<sup>ST</sup>



## Radio Retailing

the business magazine of the radio industry. Every branch of the industry agrees that it is the most helpful, constructive radio trade publication, giving practical sales help and reaching all known retailers, jobbers and manufacturers of sets, parts and accessories. "Radio Retailing" carries your sales and educational advertisements to the industry.

2<sup>ND</sup>



## The Radio Trade Directory

"where to buy in a flash." It lists and classifies every radio part, sets and accessory. Issued quarterly and distributed free of charge to every radio parts dealer, jobber and manufacturer—over 20,000 in all. Referred to by them whenever they are in the market for material of any kind. The Directory is the logical medium for "catalog" advertisements. It is the one carrier that places the manufacturer's "buying data" before the buyer at the psychological moment—the moment when he is ready to buy.

3<sup>RD</sup>

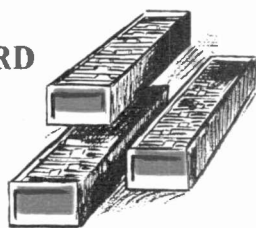

## Mailing Service

Accurate lists of the legitimate members of each branch of the field, including a jobbers' list with complete data on each firm. A mailing service that includes the addressing and mailing of all types of sales literature for radio manufacturers.

HERE is a complete sales and advertising service for manufacturers—a service that can only be given by the largest business publication house in the world, an organization with fifteen million dollars in resources. McGraw-Hill service includes a staff of radio and merchandising experts who have had valuable experience in dealing with radio manufacturing, marketing and publicity problems. Their advice and counsel are at the service of the radio manufacturer or distributor and his advertising agent.

## The McGraw-Hill Company, Inc.

New York—Chicago—Philadelphia—Cleveland—St. Louis—San Francisco—London

# When YOU want PROFITS and your CUSTOMERS want PERFORMANCE

sell

## GENERAL RADIO PARTS

In buying radio apparatus your customers know that Radio is a Science depending upon definite electrical principles. They know that to get good reception they must use instruments that are scientifically correct—electrically and mechanically.

The parts buyers today are experimenters who can intelligently compare relative merits of different parts—they are no longer "bargain hunters". Bitter experience has turned them from parts with a price appeal to reliable apparatus with a quality appeal as well.

The apparatus manufactured by the General Radio Company has been developed by experienced radio engineers after exhaustive research and careful study of actual operating conditions.

All General Radio parts are constructed to meet the most exacting requirements of radio reception and are of the same high standard of material and workmanship as the laboratory precision instruments manufactured by the General Radio Company.

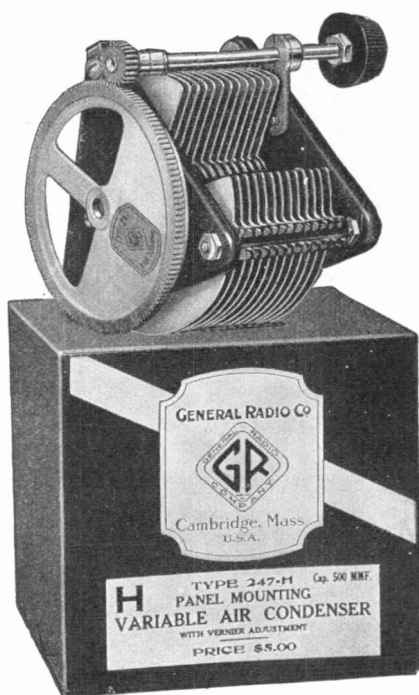

The Prices of General Radio Parts are as low as the highest quality of materials, workmanship, and efficient manufacturing methods permit.

When you re-adjust your stock of parts to meet future demands remember that since 1915 the General Radio Company has been the pace setter in advanced radio design. The General Radio Company introduced to popular use the first low loss condenser, which began the era of "low loss" parts so much talked of today. The first closed core audio transformer was a General Radio—and today the new type 285 audio transformer is the standard of excellence in audio amplification.

The time is now at hand for successful dealers to concentrate on a well-rounded and well-established line of parts. Why not pick a leader and a winner? Naturally, General Radio!

### DEALERS

ask your jobber

or write us today

for our Parts

Catalog No. 920-R

and Price Sheets

# GENERAL RADIO CO.

Cambridge, Mass., U. S. A.

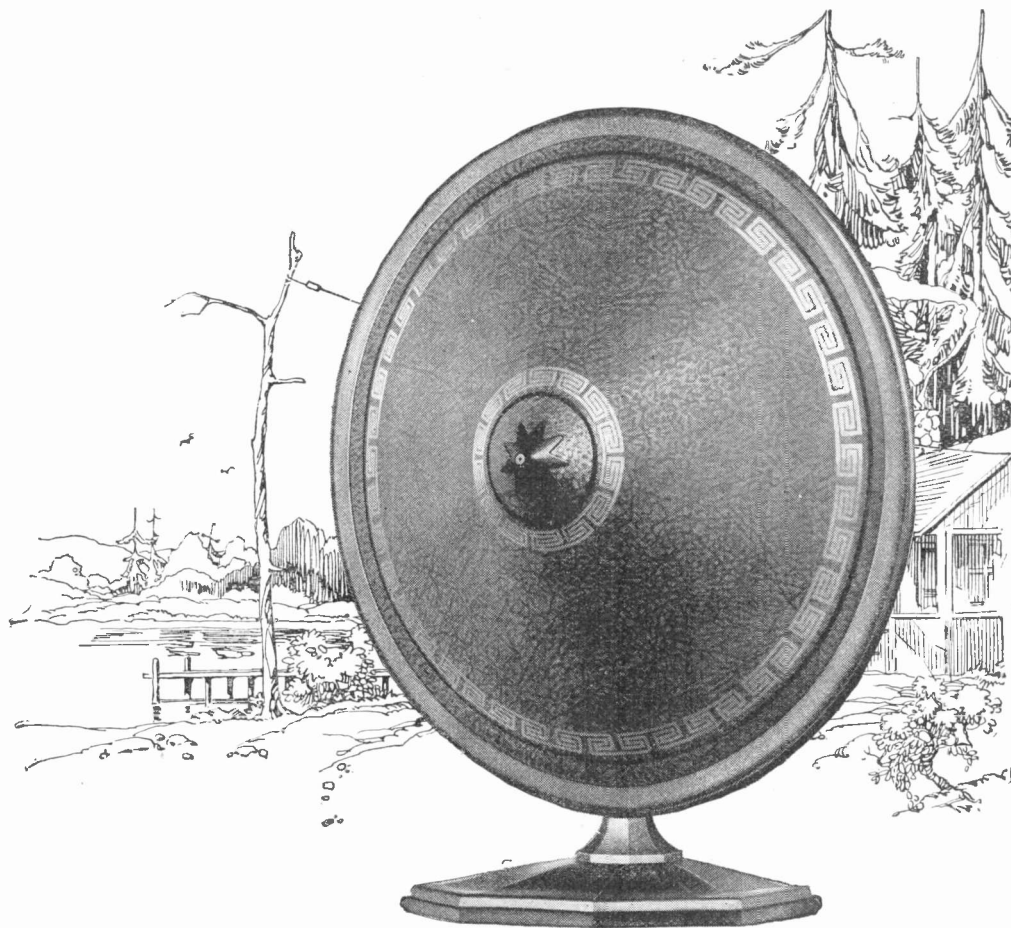

# The Crosley Musicone

a startling improvement in looks and tone over loud-speakers  
Already replacing thousands

In camp or home, this remarkable development of radio reproduction will greatly increase the delight in radio.

It is a new idea. It diffuses the sound. Upon hearing it for the first time one is at loss to locate the source of the music. Its perfection of reproduction is uncannily real.

Its price, like all Crosley products, is very low because of the half-million production plans under which it is being built. Your jobber can supply you now. Put in a stock of Crosley Musicones and cash in on the big demand.

*Crosley owns and operates station WLW, Cincinnati, the first remotely controlled super-power broadcasting station.*

*Crosley manufactures receiving sets which are licensed under Armstrong U. S. Patent No. 1,113,149, and priced from \$14.50 to \$65, without accessories.*

**The Crosley Radio Corporation**

*Powel Crosley, Jr., President*

6130 Sassafras Street, Cincinnati

**\$17.50**

Add Ten Per Cent  
West of Rocky Mountains

**CROSLEY**  
*Better—Costs Less*

**The Marvels of Radio!**  
*Incredible to those  
who don't know!*

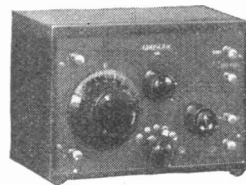

## The Crosley 1-Tube 50

Crosley's development of the famous Armstrong regenerative circuit enables you to "roam" the country and enjoy the thrill of picking up distant stations just as though you owned a multi-tube set,—all with one tube and at \$14.50, without accessories.

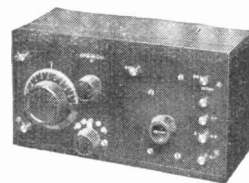

## 2-Tube Crosley 51

Same as wonderful Crosley 50 with additional tube amplifier. Local and nearby stations on loud-speaker always and distance up to 1500 miles under average conditions. Much greater range with head phones. \$18.50, without accessories.

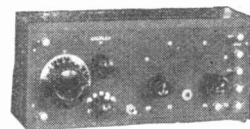

## 3-Tube Crosley 52

A larger set for those who want greater reception range on the loud-speaker. Operates on three tubes, using wet or dry batteries. Consistent loud-speaker range 1500 miles or more. \$30, without accessories.

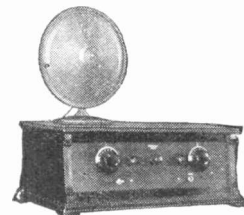

## The Crosley Trirdyn Special

3-Tubes do the work of 5

A unique circuit combining tuned radio frequency, regeneration and reflexed amplification that equals in results the work of 5 and 6 tubes. None re-radiating. \$65 without accessories.



# ANNOUNCING Indiana Hyperdyne Radio Apparatus

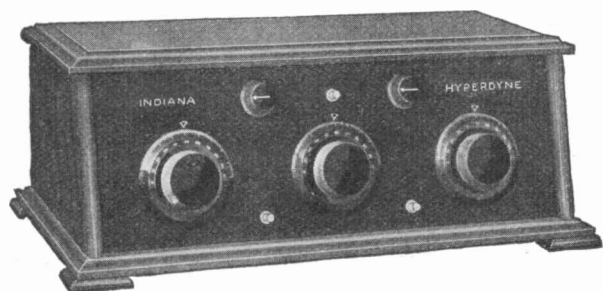

## Model 500—5 Tube Receiver *Solid Mahogany Cabinet*

Beautiful hand rubbed finish. Size 24-in. x 8-in. x 12-in. 15° sloping front.

A high grade De Luxe long distance set, using our own sterling parts. Retails, less accessories.....\$62.50

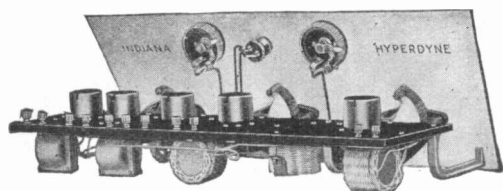

## Model 600—5 Tube Set Up Kit

Same units assembled complete to panels as in our Model 500 receiver. Front panel finished in beautiful crystal lacquer. Complete, less cabinet assembled, ready for wiring. Retails.....\$37.50

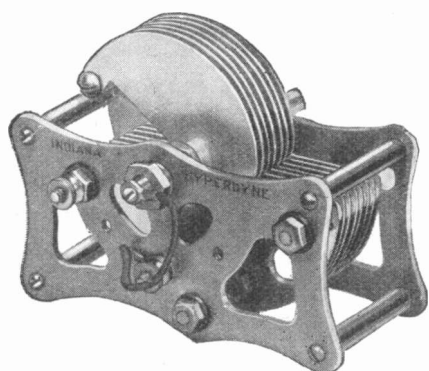

## Variable Condenser

*Built Mechanically and Electrically Correct*  
**Low Loss Design**

High frequency straight line-curve plates.

- No. 400—15 plate .0003 retails.....\$3.50
- No. 401—25 plate .0005 retails..... 4.25
- No. 402—45 plate .001 retails..... 5.50

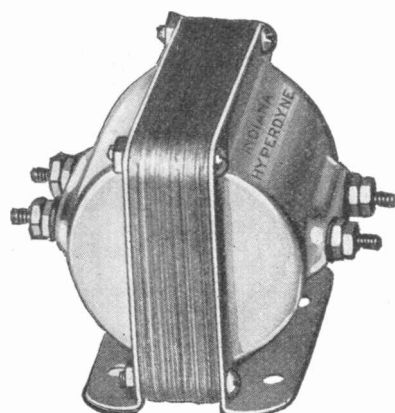

## Audio Transformer High Efficiency

Completely Enclosed.  
Standard Ratio 3 to 1.  
Model 450—Retails, \$3.50  
Other Ratios Supplied.

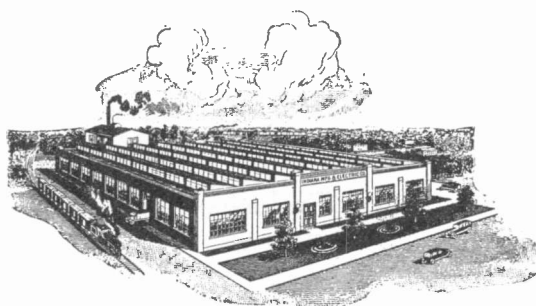

### Jobbers and Dealers

We manufacture all our parts in our own modern plant.

Our surroundings are favorable to making high grade apparatus at popular prices. Build a trustworthy radio business.

*Write for Circulars and Discounts*

**INDIANA MFG. & ELECTRIC CO.—Dept. 7**  
MARION, IND., U. S. A.

*The Radio You Dealers  
Have Been Waiting For*



Licensed under U. S. Navy Patents

## Stewart-Warner Radio

### THE FIRST COMPLETE RADIO ENSEMBLE

*Just what you have been waiting for—Just what you would expect Stewart-Warner to produce—A complete group of perfectly matched radio units that gives unheard-of performance!*

STEWART-WARNER Radio—the *ensemble* radio—is now ready!

The good news has been hard to keep! Extreme secrecy has guarded every move and discovery of Stewart-Warner engineers, who have for more than two years been engaged in the solution of a tremendous problem—the *perfection of radio!* Yet for months the radio world has been a-tremble with the rumor that “something revolutionary in radio is about to be announced.”

So the announcement of Stewart-Warner Radio is not a surprise because everybody has been expecting it. You know you, yourself, have been waiting for a concern like Stewart-Warner to take the uncertainties, disappointments and troubles out of radio and give you only real results.

Stewart-Warner Radio is done this for you, and we offer as

Stewart-Warner Radio Instruments; Models and Prices to fit every need. Stewart-Warner Reproducer, \$25.00. Stewart-Warner Radio Tubes, each, \$3.00. Batteries, Aerial and Ground Equipment for this ensemble can be secured from authorized Stewart-Warner Radio Dealers.

our contribution to radio progress the complete group of perfectly matched Stewart-Warner Radio units.

The term “Stewart-Warner Radio” signifies this complete group, or ensemble, which includes:

1. The complete line of Stewart-Warner Instruments in which is incorporated, for the first time, the great, five-tube U. S. Navy circuit;
2. The Stewart-Warner Reproducer which we have built to give perfect harmony with Stewart-Warner Instruments;
3. Stewart-Warner Radio Tubes, which are so skillfully designed that they perform with ease the most difficult of all tube functions—that of radio frequency amplification;
4. Batteries, aerial and ground equipment complete the ensemble.

### Exclusive Stewart-Warner Wholesale Radio Distributors

#### ARIZONA

Phoenix, 245-47 W. Adams St.

#### CALIFORNIA

Fresno, 1412 Broadway  
Los Angeles, 1366 S. Figueroa St.  
Oakland, 326 23rd St.  
Sacramento, 1516 J St.  
San Diego, 811 Front at F St.  
San Francisco, 1450 Van Ness Ave.

#### COLORADO

Denver, 1153 Bannock St.

#### CONNECTICUT

Hartford, 45-47 Wells St.

#### DIST. OF COLUMBIA

Washington, 1117 14th St., N.W.

#### FLORIDA

Jacksonville, 907 Main St.

#### GEORGIA

Atlanta, 399 Peachtree St.

#### ILLINOIS

Chicago, 1826-52 Diversey Pkwy.  
[Executive Offices]  
Chicago, 1312 Michigan Ave.  
[Branch Office]

5657 Broadway  
[Branch Office]

#### INDIANA

Indianapolis, 510 Capitol St.

#### IOWA

Des Moines, 1600-1602 Locust St.

#### KENTUCKY

Louisville, 953 S. Third St.

#### LOUISIANA

New Orleans, 1322 St. Charles Ave.

#### MARYLAND

Baltimore, 1117 Cathedral St.

#### MASSACHUSETTS

Boston, 1111 Commonwealth Ave.  
Springfield, 761 Main St.

#### MICHIGAN

Detroit, 7321 Woodward Ave.  
[Branch Office]

Grand Rapids, 710-712 Monroe Ave.

#### MINNESOTA

Minneapolis, 116-18 Second Ave., S.  
St. Paul, 231 W. Sixth St.

#### MISSOURI

Kansas City, 1827 Grand Ave.  
St. Louis, 3206 Locust St.

#### NEBRASKA

Omaha, 2043-45 Farnam St.

#### NEW JERSEY

Newark, 332-336 Plane St.  
West Hoboken-Jersey City, 3778  
Hudson Blvd.

#### NEW YORK

Albany, 338 Central Ave.  
Brooklyn, 1060 Bedford Ave.

Buffalo, 1224 Main St.  
New York, 37-43 W. 65th St.  
[Branch Office]

Rochester, 3 Charlotte St.  
Syracuse, 516 E. Genesee St.  
Utica, 257 Elizabeth St.

#### OHIO

Cincinnati, 224 E. Seventh St.  
Cleveland, 2309 Chester Ave.  
Columbus, 300 E. Long St.  
Toledo, 609-611 Huron St.

#### OREGON

Portland, 495 Burnside at Fourteenth St.

#### PENNSYLVANIA

Harrisburg, 1133 Mulberry St.  
Philadelphia, 1419 N. Broad St.  
Pittsburgh, Baum Blvd. and  
Millvale Ave.  
Scranton, 123 Franklin Ave.

#### RHODE ISLAND

Providence, 110 Broadway

#### TENNESSEE

Memphis, 241 Monroe Ave.

#### TEXAS

Dallas, 2122-24 Jackson St.  
El Paso, 709 Texas St.  
Houston, 1711 Main St.  
San Antonio, N. Alamo at Fifth St.

#### UTAH

Salt Lake City, 69 W. 4th South St.

#### VIRGINIA

Richmond, 1615 W. Broad St.

#### WISCONSIN

Milwaukee, 582-584 Jefferson St.

#### WASHINGTON

Seattle, 1515 Broadway  
Spokane, First and Jefferson Sts.  
Tacoma, 735-737 Broadway

# Why Stewart-Warner Radio Dealers Cannot Fail to be Successful!

## The Stewart-Warner Radio Dealer's Franchise Offers 100 per cent Sales Protection to Dealers Who Can Qualify—Apply by Coupon Below

**S**TEWART-WARNER is in the radio business to stay, and to give service. We are building a nation-wide organization of exclusive Stewart-Warner Radio Dealers. We are furnishing our dealers with a complete line of the finest radio equipment that it is possible to produce—everything that their customers will require. We are providing absolute sales protection and fair trade practices for all Stewart-Warner Radio Dealers by a sound, sensible distribution policy, never before offered. We are, through our representatives in the field, personally assisting every dealer in his business, insuring him of success.

Stewart-Warner is distributing its Radio Products to dealers through its own, long established organization of Exclusive Stewart-Warner Wholesale Distributors. For years Stewart-Warner has zoned the country into 55 distributing territories, with fixed boundaries, based on buying centers, freight rates, transportation routes, wholesaling habits and newspaper influence. One of these exclusive Stewart-Warner Wholesale Radio Distributors is established in each territory with an exclusive franchise.

These Distributors positively *will not* wholesale Stewart-Warner Radio Products to any one except dealers holding Stewart-Warner Radio Franchises. Stewart-Warner stands alone in offering, and in its ability to give dealers this 100 per cent sales protection against sales by distributors straight to consumers. Our Radio Dealers will be given the same opportunity to conduct a successful business as are Stewart-Warner Accessory Dealers. We pledge it—and our word is backed

by years of sound business dealings with thousands of successful dealers.

Furthermore, every Stewart-Warner Wholesale Radio Distributor maintains a corps of factory-trained radio experts—both sales and technical—whose explicit duties are to make a 100 per cent success of every Stewart-Warner Radio Dealer. Our Radio Dealer Franchise carries with it this expert aid—this service that insures a profitable business for every retailer of Stewart-Warner Radio.

The Stewart-Warner Radio Dealer Franchise is a valuable contract for which every dealer should strive. There are certain qualification requirements. We want dealers who will make a real business of radio. We want only men of foresight who can look ahead and see the radio industry after the weeding-out process is over.

Fill out the application blank below and mail it to us. Our representative will call with some information very interesting to you.

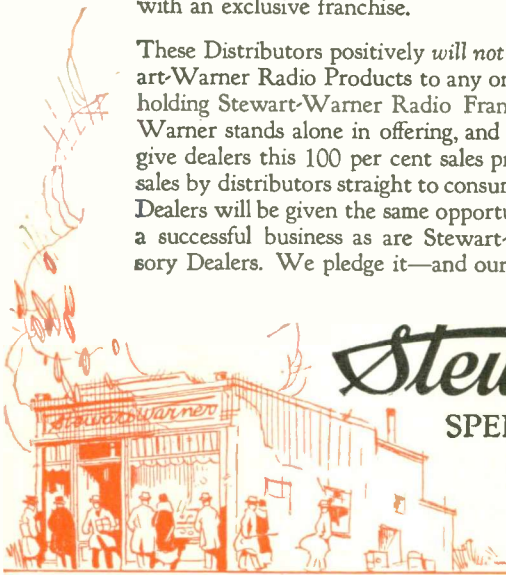

# Stewart-Warner

SPEEDOMETER CORPORATION

CHICAGO, U. S. A.

© 1925. Stewart-Warner Speed. Cor'n



### Application for Stewart-Warner Radio Dealer Franchise (CONFIDENTIAL)

As an aid to us in considering your qualifications and in giving us a record, will you please answer the following questions?

What is your present business? \_\_\_\_\_

How long have you been in this business? \_\_\_\_\_

Do you now handle radio? Yes  No

If so, what kinds? \_\_\_\_\_

How many sets did you sell in the last 12 months? \_\_\_\_\_

What was the amount of this annual business? \$ \_\_\_\_\_

What was your total business in all lines for the last 12 months? \$ \_\_\_\_\_

State any other qualifications on a separate sheet and attach.

Radio Division  
Stewart-Warner Speedometer  
Corporation  
1820 Diversey Pkwy., Chicago, Ill.

Gentlemen:—I want to be considered in connection with a Stewart-Warner Radio Dealership and to discuss the details with your representative.

If you only want a copy of Booklet just check here

Date \_\_\_\_\_

Name \_\_\_\_\_

Address \_\_\_\_\_

City \_\_\_\_\_ State \_\_\_\_\_



## Advertise in America's Most Responsive Market

**E**XPERIENCED Radio advertisers agree that the Philadelphia field, because of its exceptionally high percentage of individual home-owners, offers an unusually responsive market for intensive advertising of Radio products.

They are also convinced through profitable experience that the Radio Columns of the Public Ledger—Morning—Evening and Sunday (including the Saturday Evening Public Ledger Weekly Radio Magazine—the only separate Radio Tabloid published in Philadelphia) reach this Radio keen and Radio educated public—quickly—effectively—and economically.

*Circulation 300,000 Daily and 300,000 Sunday. Rate, Morning and Evening, 60c per line, Sunday and Evening, 75c.*



# PUBLIC LEDGER

MORNING—EVENING—SUNDAY

Independence Square  
PHILADELPHIA

New York  
Detroit

Chicago  
San Francisco

St. Louis  
London, Eng.



# parts

*are the backbone  
of radio*

So says one of our foremost radio magazines. Parts are indeed the backbone of a radio business because they sell when sets do not!

No parts are in more active and constant demand than Dubilier standard devices. The dealer who stocks them has a healthy, active, twelve-months-a-year business—and generous profits!



# Dubilier

CONDENSER AND RADIO CORPORATION

# The New Pooley

**POOLEY**  
RADIO CABINETS  
*with*  
**ATWATER KENT**  
RADIO

1320  
R-2

**Model**  
**1320-R-2**

Stuart Style. Finished in American Walnut or English Brown Mahogany—special Oriental Burl, Rosewood and Walnut inlays. Height 50 $\frac{3}{4}$ "., width 29 $\frac{3}{4}$ "., depth 15 $\frac{1}{2}$ ". Equipped with Model 20 Atwater Kent 5 tube set.

**Model**  
**1600-R-2**

Italian Style, Duotone finish. American Walnut or English Brown Mahogany. Height 41 $\frac{1}{2}$ "., width 34 $\frac{1}{4}$ "., depth 16 $\frac{1}{2}$ ". Equipped with Atwater Kent 5 tube Model 20 Compact Set.

Models shown both open and closed

1600  
R-2

*Here are the designs  
—newly created*

**C**ABINETS of such superb design, workmanship and finish that they leave the prospective owner nothing to desire but possession. A unique combination of Pooley craftsmanship and Atwater Kent Radio.

For you who would like to avoid the vortex of competition by being above it, do not Pooley Cabinets with Atwater Kent Radio suggest the means? Examine them—compare them—study your market. There is great business ahead. Are you lined up for it?

These new Pooley models are ready for immediate shipment. We are emphatically told and we believe that an extraordinary volume of business awaits this line. Business has started on them even this early—and briskly.

The nation-wide advertising of Atwater Kent Radio and of Pooley Radio Cabinets with Atwater Kent Radio give dealers who handle the Pooley line a support unparalleled.

*The Women's side of it*

Women are marching into the radio question. They are intensely interested in the appearance of their homes. They want radio in cabinets that go with or add to their furniture. You've found that out already—and women's sentiment on this point is growing fast.

Pooley Cabinets meet that sentiment—in the home, in your window, in your store. Pooley Radio Cabinets mean business.

Pooley cabinets are sold through carefully selected dealers in each district. Orders should be placed now to insure delivery. See your jobber or write for information direct to Radio Sales Department A.

# Radio Cabinets-

## A few points worth knowing

**A**LL wood fully seasoned. Panels laminated in 5 plies, cross-grained, to prevent warping, cracking and shrinking. Finished in beautiful and rare burl woods.

All cabinet tops stationary—nothing to lift up—no bric-a-brac to remove. (Put this idea up to any woman.)

Pooley finish is permanent, not easily marred, easy for the housewife to preserve.

All designs are authentic; developed and executed by masters of good taste and skill.

Construction—seen or unseen—of Pooley invariable standard. These cabinets will never disappoint their owners or you.

All Pooley Cabinets have ample room for "A" and "B" batteries and battery charger. Battery compartment is ventilated.

Cabinets equipped with the latest Atwater Kent 5-tube receiving sets. Panel model sets installed in Pooley sliding device for immediate access to tubes.

Receiving sets and reproducing units completely wired ready to attach to antenna and ground, with special cable for ease in connecting batteries.

### The Built-in Pooley Floating Horn

Each cabinet contains the built-in Pooley Floating Horn (patent pending) with the celebrated Atwater Kent Reproducing Unit—a combination which produces a volume, clarity, and truth of tone surpassing anything radio science has yet developed.

## THE POOLEY COMPANY

Radio Sales Department A  
1602 Indiana Avenue, Philadelphia, U.S.A.

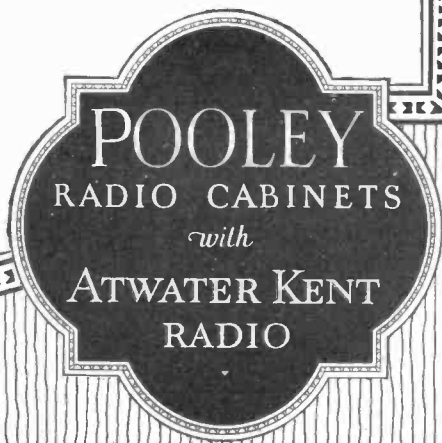

### Models 1110-R-2 & 1120-R-2

Stuart Style, Duo-tone finish. American Walnut or English Brown Mahogany. Height 52½", width 33", depth 15½". Model 1110-R-2 equipped with Model 10 Atwater Kent 5 tube open receiving set. Model 1120-R-2 equipped with Model 20 Atwater Kent 5 tube Set.

### Console Model 1400-R-1

Louis XVI Style, Duo-tone finish. English Brown Mahogany. Height 31½", width 34", depth 15¾". Will accommodate any Atwater Kent Set. Space for set 28½" by 10½".

# The New Pooley

POOLEY  
RADIO - PHONOGRAPH  
*with*  
ATWATER KENT  
RADIO

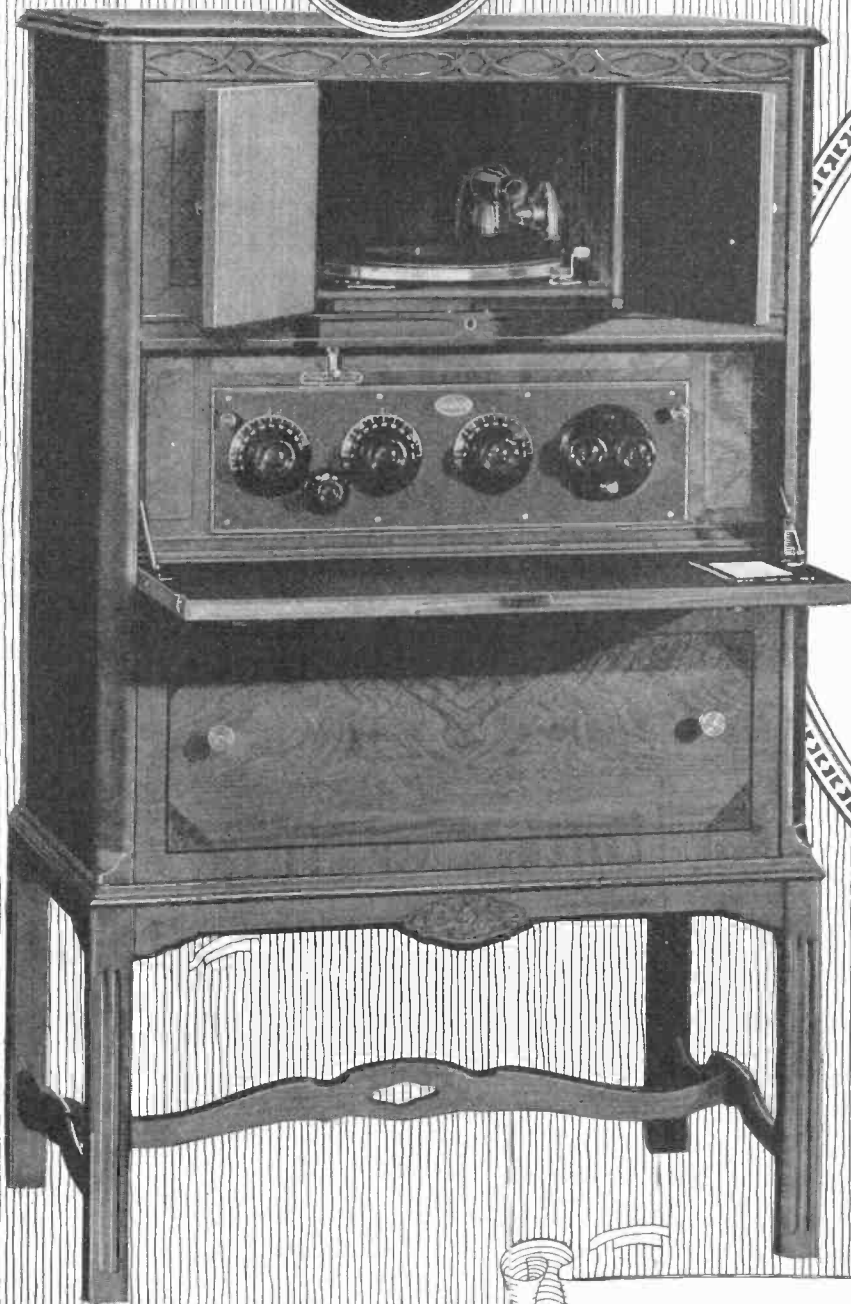

Model  
1500-R-3

## Exclusive Pooley Features

**EQUIPMENT:**— latest model Atwater Kent 5-tube receiving set—the Model 20 Compact; built-in Pooley Floating Horn with Atwater Kent Reproducing Unit; Pooley Phonograph installed in horn—nickel plated sound box; new improved Pooley tone arm playing any standard record; turntable brake; speed regulator; needle rest; needle tray.

Top of cabinet stationary—grille opens to operate phonograph, can be closed while record is playing.

Radio set installed in sliding panel affording ready access to tubes.

Ample space for both "A" and "B" batteries and battery charger, with special shelf compartment for record albums.

**Design:**— Chinese Chippendale in American Walnut or English Brown Mahogany, duo-tone, of selected burl woods.

Overall dimensions:—50" high, 30" wide, 18" deep.

Model 1500-R-3



# Radio-Phonograph

It fills the eye with beauty, the ear with entertainment. It offers every resource of radio and phonograph in a cabinet that adds charm to any home. The last word in modern musical instruments—in appearance and performance.

*Count on Pooley for what's new and good*

THE Pooley Radio-Phonograph itself shows it. The many exclusive Pooley advantages embodied in the new model prove it.

Here they are. They all count heavily in day by day satisfaction.

—Phonograph built in the horn—a Pooley invention, patent applied for. A unique convenience because it—

—Does away with lifting the top. Grilles slide back to allow putting on records.

—Set is installed in special Pooley sliding panel, giving immediate access to tubes.

—Built-in Pooley Floating Horn, with the celebrated Atwater Kent Reproducing Unit—developing a tone quality superior to anything produced heretofore in radio and phonograph science. Like fine violins, Pooley horns are made of imported spruce of flawless grain and faultless quality.

—The shift from radio to phonograph is by simple movement of a lever.

All this is combined in a Pooley Cabinet—an artistic creation in the Chinese Chippendale style produced by Pooley master craftsmen. It is the latest and greatest achievement of 25 years of making high grade cabinet phonographs and of 42 years of building furniture of quality. Pooley quality is a fact—not just a talking point.

This new model is ready for immediate shipment. It's the most remarkable proposition put on the market since radio or the phonograph first appeared.

The new Pooley Radio-Phonograph will be sold through a comparatively few, carefully selected dealers in each district. Orders should be placed now to insure delivery. See your jobber or write for information direct.

**THE POOLEY COMPANY**

Radio-Phonograph Sales Department A

1602 Indiana Avenue

Philadelphia, U. S. A.

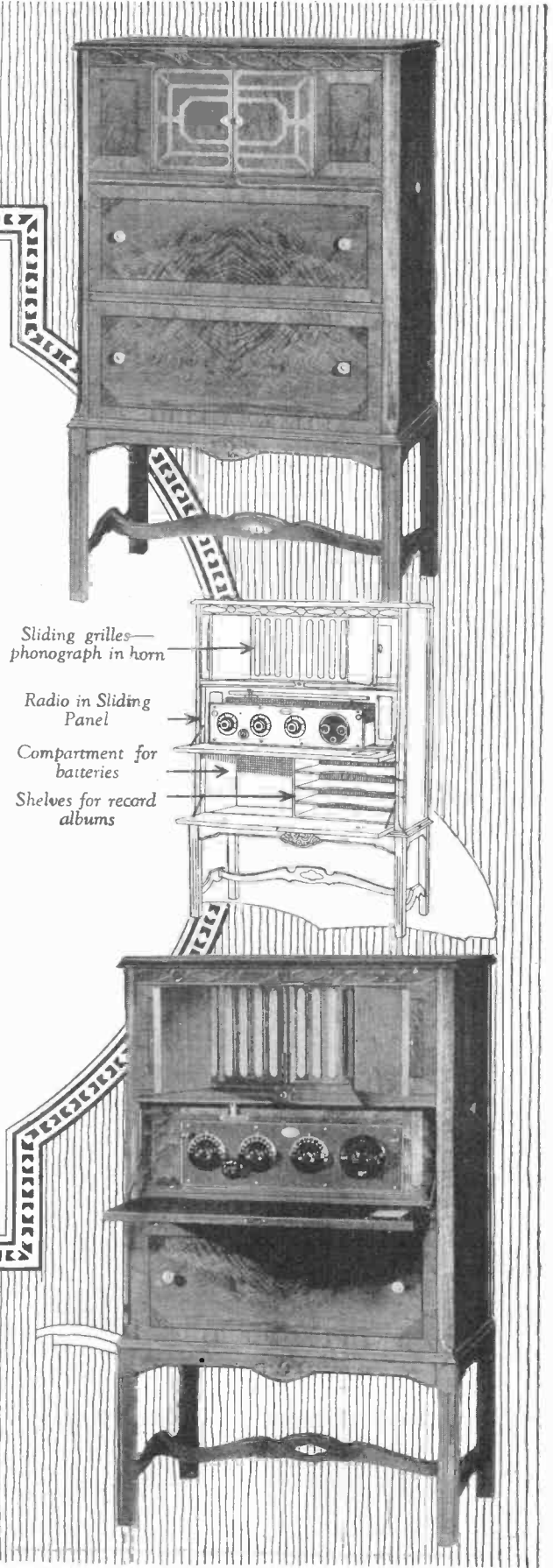
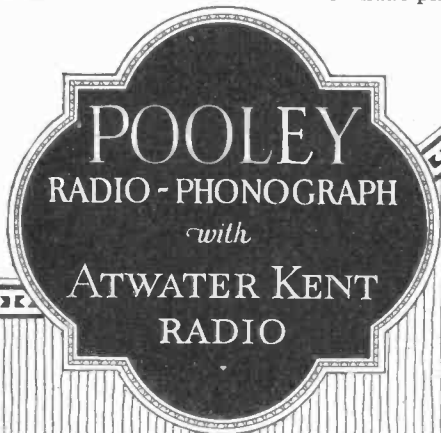

Sliding grilles—  
phonograph in horn

Radio in Sliding  
Panel

Compartment for  
batteries

Shelves for record  
albums

# ATWATER KENT RADIO

*Let's push the selling season ahead!*

AMONG many new trails blazed in Radio by Atwater Kent, the following are outstanding:

1. Backed by twenty-two years' experience in making electrical instruments, Atwater Kent was the first radio manufacturer able to provide men and machines for large scale *quality* production.
2. The Atwater Kent Open Receiving Set was the first set so distinctive in design and workmanship that it immediately established an enviable

reputation for quality. Open Set sales still thrive.

3. Atwater Kent was the first radio manufacturer to use billboards nationally. The name is branded deep on the public mind.

*And now* for the first time in the history of the industry a radio manufacturer will drive his advertising straight through the summer. That manufacturer is Atwater Kent.

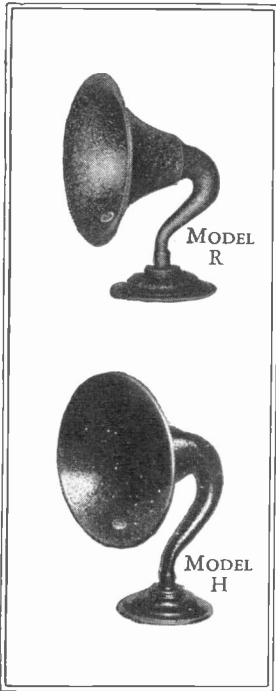

AND this summer advertising campaign belongs to every Atwater Kent dealer. If you will stay with Radio this summer, Radio will stay with you.

**Magazines**—7,000,000 American homes will be reached this summer—not once, but again and again—with Atwater Kent selling messages in ten of the great national and class magazines.

**Billboards**—Atwater Kent billboards will blanket America and Canada—reminding, persuading, selling!

**Dealer Helps**—New booklets for your counters, direct mail material, new window trims, and cut-outs—display material of all kinds is available to identify you with Atwater Kent advertising.

**Broadcasting**—Every Thursday night from 9 to 10 (Eastern Daylight Time) the Atwater Kent Radio Artists will broadcast their now famous programs from the following eleven high-power stations:

- |                        |                       |                                 |
|------------------------|-----------------------|---------------------------------|
| WEAF . . . New York    | WCAE . . . Pittsburgh | WSAI . . . Cincinnati           |
| WJAR . . . Providence  | WGR . . . Buffalo     | WOC . . . Davenport             |
| WEEL . . . Boston      | WEAR . . . Cleveland  | WCCO . . . Minneapolis-St. Paul |
| WFI . . . Philadelphia | WVJ . . . Detroit     |                                 |

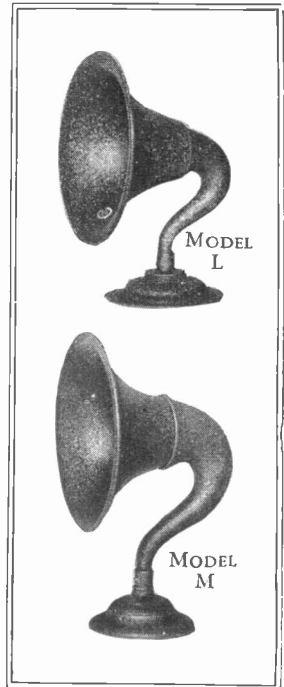

Atwater Kent is doing its part—generating the power. Do your part—throw the switch. Let's push the selling season ahead!

Write for further detailed information ATWATER KENT MFG. CO. · PHILADELPHIA, PA.  
A. Atwater Kent, President

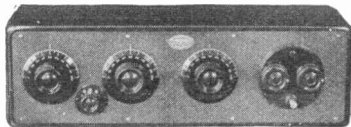

MODEL 20 COMPACT

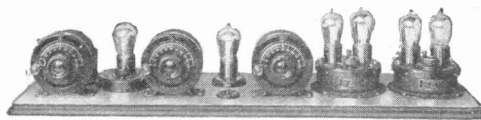

MODEL 12

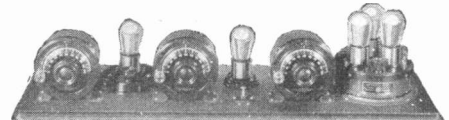

MODEL 10

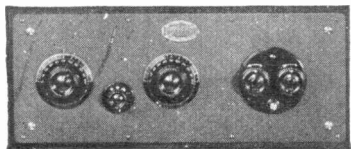

MODEL 19

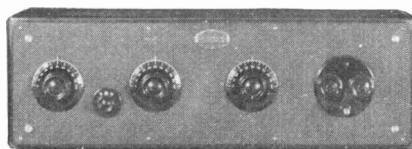

MODEL 20

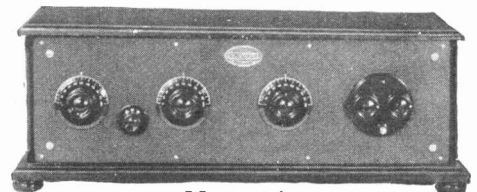

MODEL 24

**Radio Retailing's Offices in London — Center of British Radio Buying**

Situated at No. 6 Bouverie Street, just off famous Fleet Street, the McGraw-Hill headquarters are in a section of London that abounds with historic lore. Nearby is the Blackfriars' Bridge across the Thames, Ludgate Hill, St. Dunstan's Church, the Law Courts and Record Office.

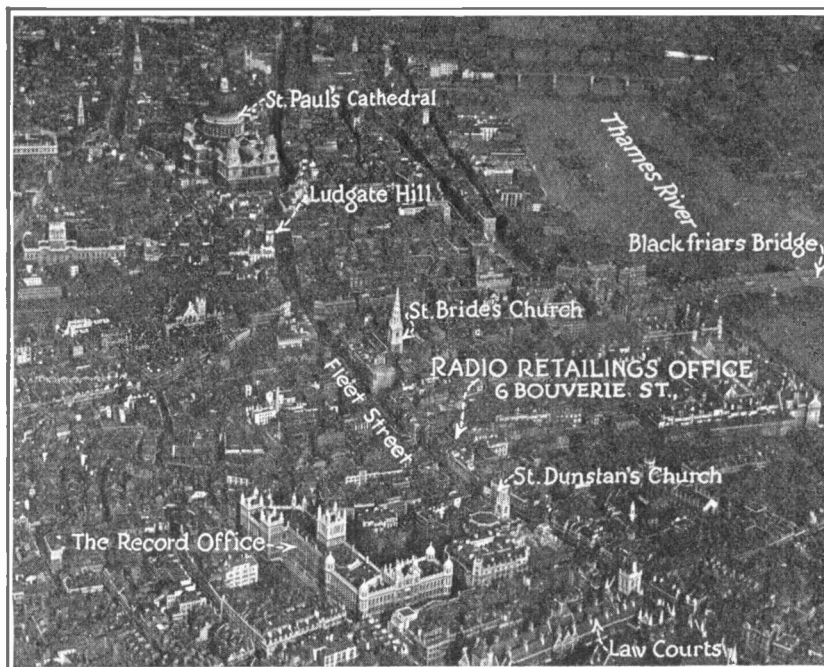

**This Issue Goes to Radio Trade of Europe, the Orient and South America**

In addition to its regular monthly international coverage, several thousand extra copies of this month's edition of “Radio Retailing” are being mailed to an especially prepared list of radio dealers and jobbers all over Europe, the Orient, Africa and South America.

# Radio Retailing

The Business Magazine of the Radio Industry

## Contents for June, 1925

“Ask 'Em to Buy” <i>Campers, Auto Owners and Those Who Stay at Home are Good Prospects — They'll Buy If You Ask Them.</i>	523	Operating Costs of Radio Stores	540
Putting Hot Weather on the Profit Side of the Ledger <i>Practical Aids and Suggestions to Help You Sell More Radio This Summer</i>	526	“Radio Retailing” Analyzes Actual Figures on What It Costs Exclusive Radio Stores to Sell Radio	
How Dealers Are Selling Radio to Farmers <i>Des Moines Conference Develops Plans to “Radio-ize” the Farming Districts</i>	530	Complete Specifications of Radio Kits <i>Dealer's Buying Guide Continued with Listing of Makers of Knockdown Kits</i>	545
“Go Out and Sell the Key Citizens” <i>Illinois Dealer Makes the Leading Residents Objects of an Intensive Sales Barrage</i>	533	“Radio Retailing” Conducts a “Radio Round-Table” <i>Chicago Dealers, Jobbers and Manufacturers Sit Around the Lunch Table and Talk Radio</i>	548
“What I Would Do” <i>“If I Were a Radio Manufacturer,” by M. M. Reinhard, “If I Were a Radio Dealer,” by Powel Crosley, Jr.</i>	536	“This Business of Ours” <i>Timely Topics Pertinently Put Forth by Major J. Andrew White</i>	552
Hunting Trouble on Service Calls <i>A “Service Testing Chart” That Enables You to Locate Trouble in a Radio Receiver</i>	538	What They Say About “Dumping” <i>Expressions of Opinion from the Trade and About the Trade</i>	558
		The Editors Have This to Say— <i>“The Encouraging Effects of a Discouraging Situation”</i>	560
		New Merchandise for the Dealer to Sell	562
		What the Trade Is Talking About	572

McGRAW-HILL COMPANY, INC., Tenth Avenue at 36th Street, New York, N. Y.

JAMES H. MCGRAW, President  
 ARTHUR J. BALDWIN, Vice-President  
 MALCOLM MUIR, Vice-President  
 E. J. MEHRREN, Vice-President  
 MASON BRITTON, Vice-President  
 JAMES H. MCGRAW, JR., V.-P. and Treas.  
 C. H. THOMPSON, Secretary  
 Cable Address: “Machinist, N. Y.”  
 Copyright, 1925, by McGraw-Hill Company, Inc.

Electrical World Journal of Electricity Ingenieria Internacional  
 Industrial Engineer Engineering and Mining Journal-Press  
 Engineering News-Record Coal Age American Machinist  
 Electrical Merchandising Power Electric Railway Journal  
 Bus Transportation Chemical & Metallurgical Engineering

**RADIO RETAILING**

O. H. CALDWELL, Editor  
 M. CLEMENTS W. C. ALLEY L. E. MOFFATT  
 F. R. CLAUSS R. M. DAVIS O. RISO H. A. BAUKAT  
 H. S. KNOWLTON, Boston P. WOODSON, Washington, D. C.  
 C. GRUNSKY, San Francisco  
 Contributing Editors: EARL WHITEHORNE, J. ANDREW WHITE,  
 S. J. RYAN

WASHINGTON, D. C., Colorado Bldg.  
 CHICAGO, 7 South Dearborn St.  
 PHILADELPHIA, Real Estate Trust Bldg.  
 CLEVELAND, Leader-News Bldg.  
 ST. LOUIS, 713 Star Bldg.  
 SAN FRANCISCO, 883 Mission Street  
 LONDON, E. C., 8 Bouverie St.  
 Annual subscription rate is \$2 in United States and Canada.

# A Summer Day

with "Tireless Tom,"—  
the Restless Radio Retailer

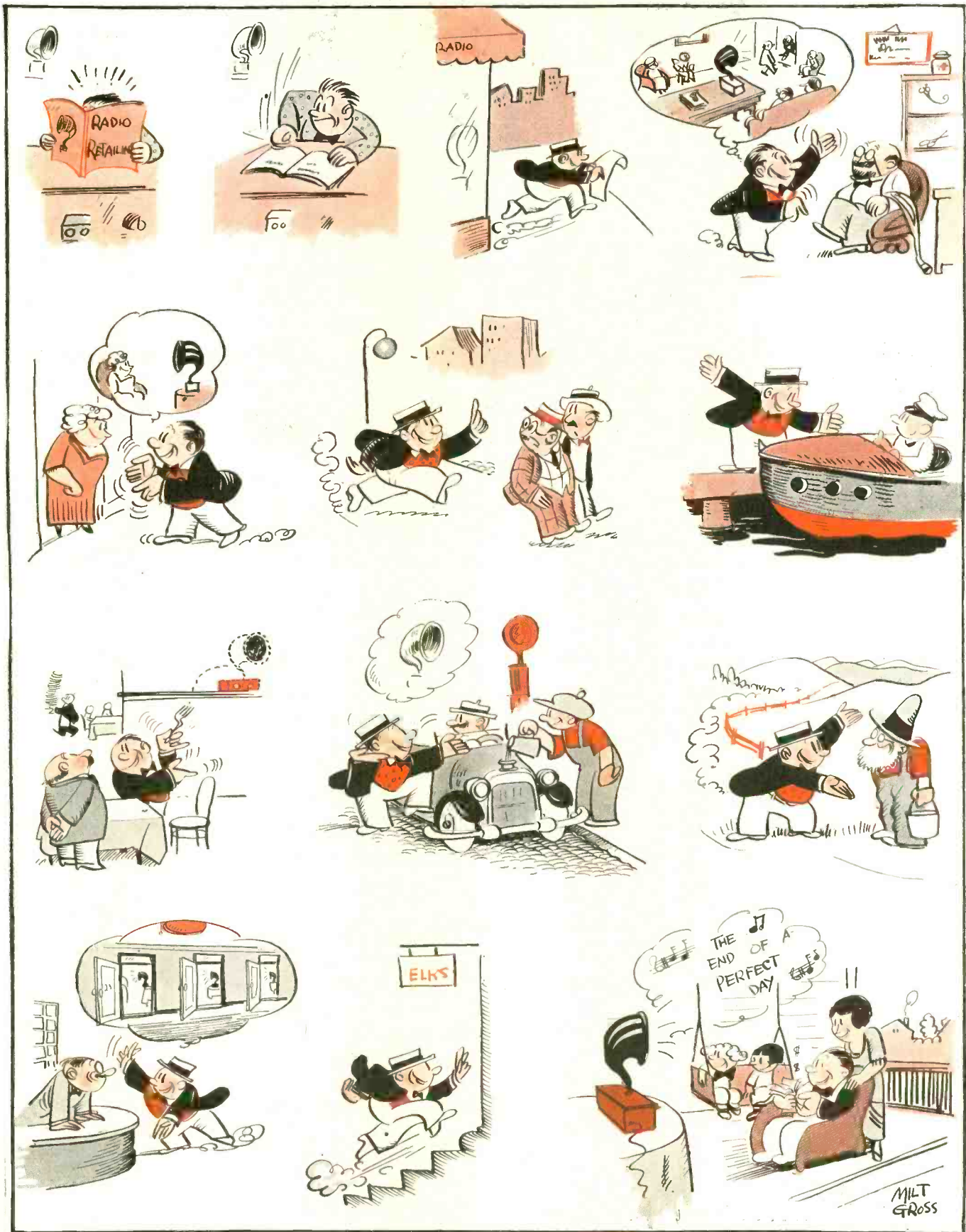

*They Didn't Come Into the Store to Buy—  
So "Get Out and Sell 'Em!" was Tom's Battle-Cry.*

# Radio Retailing

With Which Is Incorporated *Electrical Retailing*

VOLUME 1

JUNE, 1925

NUMBER VI

## "Ask 'Em to Buy"

*The public has not stopped buying radio—They have simply omitted to go into radio stores and make the purchase—Take the set into their homes and Ask 'Em to Buy It*

IT IS agreed that radio set demand slows up during the summer. It is also agreed that there is a summer set business and a pretty large summer accessory business. Just how large is not yet determined because many radio retailers have not in the past sold aggressively in the summer. The radio dealer who has sold and sold hard during the summer season has found that there is business. His order books and his bank balance show it.

The slackening of demand can be, in part at least, compensated by an increasing of sales activity. The experience of dealers in other lines has conclusively shown this. The electrical dealer knows that if he waited for the public to walk in and buy washing machines and vacuum cleaners off his floor that he would be waiting most of the time. He has to pursue the elusive customer dollar winter as well as summer. The public will buy when it is asked and it must be asked in a sufficiently energetic manner.

Some years ago the automotive accessory business faced a slump in consumer demand.

They met it by a sales idea that had as its slogan, "Ask 'em to buy." The garage man, when he sold oil or gas, looked over the customer's car and suggested the purchase of some accessory which the customer did not have. The customer bought. "Ask 'em to buy" has made salesmen out of garage owners and attendants and has sold millions of dollars in equipment and accessories.

THERE is a very big message for the radio dealer in that industry's experience. Radio set owners use their sets in the summer and buy tubes and batteries. They can be sold accessories by the dealer who takes the opportunity to ask his customers to buy something whenever he sees them. Sell them accessories: chargers, current supply devices, new loudspeakers, head sets, loops. Suppose a dealer advertised that he would give a free inspection to any radio set. His salesmen, hungry for prospects, would welcome the chance this would give them to get into customers' homes. The inspection would be bona fide and would put into and keep into service many sets that have devel-

**When you see them sitting out on the front porch—Ask 'Em to Buy**

**When you see them coming home from the links or a hike—Ask 'Em to Buy**

**When you see them planning a vacation trip or picnic—Ask 'Em to Buy**

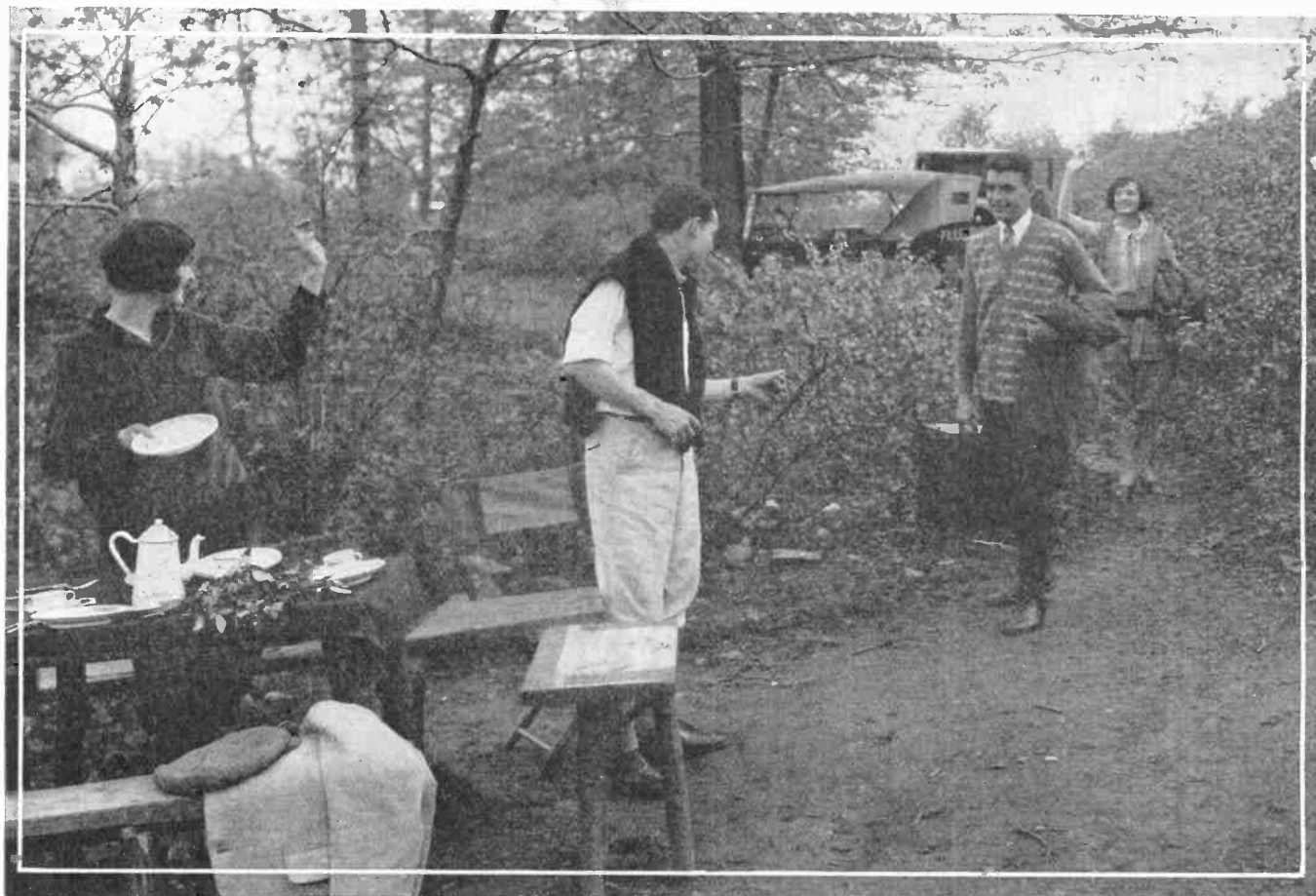

oped some little trouble. The salesman would take this opportunity to check up on the accessories owned by the customer and he could "ask 'em to buy" and usually sell them on accessories which would make their set more complete. He could get new set prospects by a tactful inquiry as to friends who were interested in radio. The dealer may also, with great profit, study the summer radio set markets: the front porch market, the summer camp market, the motor tourist market, the farm market.

And he can instill into his sales force the big idea that people will not buy additional accessories unless they are asked.

"Ask 'em to buy."

#### *The "Front Porch" Market*

**O**F THE twenty-four million American families, twenty million have front porches. The other four million live in cities like New York and Chicago and spend the summer at the shore or in the country where they use somebody else's front porch. But the overwhelming majority enjoy the summer at home and spend at least a part of their

evenings in their summer living room: the front porch. Get the typical picture of an American family's summer evening: Dinner is at six and all over by seven. The flivver is waiting and the family piles in for an early evening drive out the new boulevard and back by the river road. Cool, rested, refreshed they are home by eight o'clock or not much later. If the family owns a radio set it is now tuned in and cut of the ether comes just what they want: music. If they do not own a set isn't this the time to sell them one? If there ever is a psychological moment, it is when they have just returned from a ride, a hike or a round of golf. Cool, comfortable, good humored, wanting amusement and wanting it in their own pleasant surroundings, this family is



simply "waiting to be sold." And they can be sold by the dealer who will "ask 'em to buy."

### *The "Summer-Camp" Market*

ONE essential to the summer cottage or camp is music. Music to dance to or to sing to or just to sit and listen to. For years this summer camp market has absorbed a large proportion of the older "trade-ins" in the piano and phonograph field. But now a good radio set can be installed in summer camp or cottage at a moderate cost and bring the best and most varied entertainment to the vacation party.

Here is a fertile field for the dealer who will "ask 'em to buy." This market can be advertised too, and better yet, a salesman with a few sets in a car can make a good many miles in a day and cover a number of camps and cottages. A demonstration on the spot will bring summer sales and winter prospects.

### *The "Motor Tourist" Market*

WHEN the family starts touring in the family car they take their home with them on the running board. Tents to sleep in and folding cots to sleep on, cups and plates, knives and forks, a coffee pot and a dish pan, flashlights for exploring in the dark and citronella to keep mosquitos at



bay. Father buys a lot of fancy fishing tackle and mother invests in a complicated cooking stove that resembles the result of a misalliance between a tire pump and the gas range. A lot of things are bought because they are indispensable and still others because the sporting goods man is a mighty clever salesman.

Now the one single purchase that will add most to the fun of this trip is a portable radio. Compact and self-contained it will take up but little room and it will make a lot of difference in the cool of the evening.

The family usually doesn't make a secret of the motor trip being planned, and the dealer that gets to father when he is in this holiday mood will not find him hard to sell. If he doesn't know that he needs a portable radio he certainly should be told. The whole family will help you sell him.

Go after the "Front Porch" Market

The "Summer Camp" Market

The "Motor Tourist" Market

—"Ask 'Em to Buy"

# Putting Hot Weather on the

*Practical Ideas, Aids and Suggestions to Make the Summer Months Help You Sell More Radio Sets, Parts and Accessories*

## **Establishes "Sub-Dealers" in Rural Towns**

F. E. Conrad, proprietor of Conrad's Radio Shop, Reading, Pa., sells radio to farmers in isolated communities by appointing "sub-dealers" in rural towns. He usually chooses someone who is popular and "knows everybody" or perhaps a dealer in some other line, working on a ten per cent commission basis for leads, the actual sales being closed by Conrad or his regular salesmen.

## **Personal Calls Follow Direct Mail Campaign**

The radio department of the McWilliams Department Store, Wilkes-Barre, Pa., is mailing radio circulars to residents of summer resorts and farmers in the vicinity of Wilkes-Barre. These will be followed up by personal calls. This store also employs outside salesmen who make a house-to-house canvass, getting names of prospects. A report is turned in on each prospect and the salesman also reports why the prospect cannot be sold, if no sale results. A salary of \$25 a week, and five per cent commission is paid.

## **Demonstrates Portables On Porches of Summer Homes**

Last summer, the Frank Foster Radio and Electric Company, Wilkes-Barre, Pa., took a portable set out in an automobile and toured the resorts and summer homes, giving demonstrations in homes and on porches when there were several people sitting outside. Only a few minutes were spent on each demonstration, but the dealer's card was left in each place and an average of one sale out of every 25 such demonstrations was made. No sets were left on free trial.

## **Many Broadcasting Features Planned This Summer**

A Connecticut dealer states that business can not be boosted this year for the simple reason that the programs have no outstanding features. If he would take the trouble to look things over, he would find plenty of

opportunity to tie-up with broadcast specialties.

Morning programs for the women, stock quotations for Dad in the early evening, sporting events, polo, races, swimming meets and similar events will interest the "sport" of the family. Remember that the baseball scores are broadcast every evening, and arrangements are under way which may lead to the broadcasting of at least one big league ball game a week. Then there are the regular evening features including many of the best dance orchestras. This summer will also probably witness the broadcasting of many of the horse races. The features are there all right. It is up to the dealer to capitalize them.

## **"Let 'em Do Their Own Tuning"**

A New Haven dealer reports that he has generally found that the best way to sell radio sets is to let the prospect do his own tuning. The very "feel" of the dials and the power to bring in stations several hundred miles away at will, generally makes a radio fan right then and there.

In order to take full advantage of this fact it is a good plan to have a set working in the store all the time and allow customers to tune it as they see fit. One dealer tried this stunt with a set on the sidewalk, but could not continue it because of the "manhandling" the set received. This is a good indication, though, of the popularity of tuning in your own set.

## **Service Man Gets Names of Customer's Friends**

A Wilkes-Barre, Pa., dealer, requires his service man, whenever the latter goes out on a call, to get the names and addresses of several friends of the person he goes to see, who might be interested in the purchase of a radio receiver. The regular salesman then follows up the leads obtained.

## **Girls Make Canvass To Get Prospects' Names**

Last year, a dealer in Scranton, Pa., sent out ten girls to make a house-to-house canvass, and find out who had no radio sets

and who would be interested in purchasing one. These girls did no selling whatever, the names and addresses of those interested they reported to the dealer, whose regular salesmen followed up the leads. So many good prospects were obtained that he has plenty of leads left over to work on this summer.

This dealer sends a salesman to the prospect's home, often far out into the rural districts, and gives a home demonstration. If interest is shown the set is left for several days' free trial. The salesmen get \$25 a week salary and five per cent commission.

## **Factory Workers As Part Time Salesmen**

Herbert Freeman, radio dealer of Allentown, Pa., has established contacts with employees of several factories in Allentown, men with hundreds of fellow-workers and who know radio. These sell radio to their friends on a ten to fifteen per cent commission basis. As one-quarter of Allentown's population are factory workers, many sales result from these contacts.

## **Radio Dealer Has Theater Ticket Agency**

A Scranton, Pa., dealer has co-operated with local legitimate and vaudeville theatres and also concert halls, the high school, etc., and established a theatre ticket agency in his radio and music shop, as a means of bringing more people into the store. The theatre tickets are handled without charge, the dealer feeling repaid by the advertising received. This works out particularly well when someone who is well known over the radio makes a local personal appearance.

## **Dealer Establishes "Free Radio School"**

The Baltimore Radio Company, Wilkes-Barre, Pa., has established a free "radio school," inviting customers to build their sets in the school, under the instruction of their radio expert, the profit resulting from the increased sale of parts. With the close of the regular school term, many boys find time to go to the "radio school" and build sets from parts they purchase in the dealer's store.

## **Public Demonstrations Get Attention**

Be on hand for local outings and picnics. Have a set ready to operate. Do not neglect the Boy Scouts. A tie-up with them in a local celebration will mean both fun and local popularity, and probably also money in your cash register. Be on hand for the "beauty" and popularity contests. Offer prizes. Sets that have been stickers can



*Don't Forget the Automobile Battery Has Six Volts and Can Be Made to Run Any Storage Battery Set*



# Profit Side of the Ledger

—Gleaned by "Radio Retailing" from a Country-Wide Survey of Actual Methods Dealers Have Used to "Slam the Summer Slump"

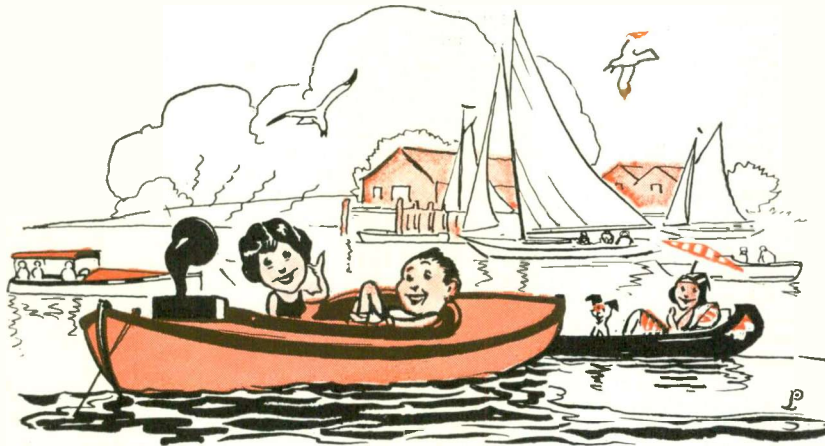

A New York Dealer Plans to Equip His Motorboat with Radio and Make a Play for the Boat and Bungalow Trade

sometimes earn more in publicity this way, than any value they could bring on sale.

If the resort near you boasts of rolling chairs, get the best-looking girl in town to ride up and down with one of your sets going full blast. "Tip off" the newspaper men before hand. Any of the present-day loop sets will work well in such a demonstration.

Do not neglect the "sidewalk tea-wagon" stunt either. One New York dealer has a complete set, loop, batteries and loud speaker mounted on a tea wagon in front of his store, playing merrily. Occasionally a clerk will go out and move it over to the other end of the storefront without turning it off, or push it a little way down the street and back—a crowd always collects and follows.

## Makes a Radio Store Out of a Motorboat

One of the salesmen in the employ of H. P. Baran of New York, is the owner of a motorboat. It is planned that this season the boat shall become a floating radio store, with a complete stock of radio sets, loud speakers, batteries, tubes, etc.

With this equipment demonstrations will be given at the various yacht and boat clubs and at the popular anchorages. One set will be installed complete, ready for use at any time.

The idea is one that can be applied in part at least by many dealers in towns near coasts, lakes or rivers.

## Make Up Adapters for Automobiles

Be sure to call customers' attention to the fact that the six-volt storage battery in the average automobile may be used successfully for a radio A battery. Make up some

ten-foot lengths of twisted flexible wire with a bayonet-plug attachment on one end so that this may be plugged into the dash light socket and the other end attached to the A battery posts on the radio set. Having a radio-equipped auto standing in front of the store each day is a good way to bring inquiries and sales. Show the public a practical demonstration of how it can be done. The radio set may be hung on springs from the top or it may be mounted over the instrument board or on the seat.

A Brooklyn jobber has a radio set in his closed car all the time and when he takes the family out for an evening, a small loud speaker fits nicely on the front seat.

## The Newspapers for Summer Advertising

Newspaper advertising should not be given up by the radio dealer during the summer, and even though the space is reduced it should be used consistently and

continuously. If the newspapers are full of cut-rate advertisements play up the quality of your product and the service you are able to give. A series of advertisements calling attention to the uses of radio in summertime should not be overlooked. In each case emphasize the value of your product.

## Paving the Way for House Salesmen

Why not have some folders printed, calling attention to your radio offerings in stock, together with the prompt service possible? This last point is the deciding factor in many cases. Such literature can be distributed to home letter boxes by school boys, but if this is done, make sure that the booklets are actually put in the proper places and not deposited in some ash can. The boys should be carefully picked. An even better scheme is to have your radio story printed on tags which may be looped over door knobs, where it is possible to get visible evidence of what the boys have done. Such tags will have to have strings attached and must be on slightly heavier cardboard and will therefore cost more than the folder, but they have a greater attention value.

## Loans Radio Equipment to Other Stores

A prominent New Jersey dealer makes it a point, during the summer season, to co-operate with the automobile agencies in town, and loan them radio displays to exhibit with their cars. It has been found that many auto dealers are given to elaborate displays, showing their cars in various places and settings, and a radio receiver prominent in the layout gives just the right finish to the scenes. The radio dealer is, of course, given credit for the equipment.

This idea can be applied to other types of establishments as well. Other classes of retail stores, which do not sell radio, but which are situated on lines of traffic that do



Several Dealers Have Inaugurated "Radio Schools" to Instruct Prospects and Boost the Sale of Parts and Sets

not reach your store, might be willing to make some agreement of mutual benefit whereby your store loans a radio display for his window and you get credit, and he loans other equipment (furniture, camp equipment, etc.), receiving credit, of course, in your window. In many cities, recently, the Western Union Telegraph offices have been featuring the "applaud radio artists by telegraph" idea in their windows, tying up with a display of radio receiving apparatus borrowed from a dealer who, in return, is given publicity in the window.

### Points On Getting Outside Salesmen

There is one man in every town or city who knows and is known by everyone. He is the post man. Many times he is anxious to pick up a few dollars "on the side" and will be glad of the opportunity to devote his evenings to selling radio. Give him a ten per cent commission, or more if you can stand it, and your line will be introduced into every home on his "round." In another case of this kind a milk man did so well at selling radio sets that he gave up his job and went into radio entirely.

If you are going to take on solicitors of any kind, make sure that they do not misrepresent or exaggerate the goods they are selling. A few dealers have run into this, much to their sorrow, and while the sales were high, the sets did not stay sold for any length of time. The selling contest is dangerous for this very reason.

And don't forget the business men in their offices, when planning an outside campaign.

### Getting Summer Publicity to Boost Sales

If your local newspaper has a radio department, it is well to determine whether or not articles are being planned on the construction of portable sets. Very frequently the radio editor may be up against a hard problem in finding material, and a wide awake dealer may make arrangements to furnish the editor with a series of such

articles. Usually there is at least one man in the store who is capable of getting up such an article, for which he may receive a sum ranging from \$10 to \$25. If no "writer" is available, the set should be made up and taken to the radio editor for examination. If he approves of it the dealer not only has a talking point but the chances are good that the editor will write it up himself. Such articles can be tied up with advertising in the paper and with window displays in which the article is given a conspicuous place. This is one of the finest ways to excite public interest in portable sets and one which is certain to move a number of parts. The set planned should, of course, be small and light.

### Sells Sets to Other Local Merchants

Another dealer in Scranton, Pa., makes a specialty of selling sets to other merchants in town, engaged in a different line of business, the set to be given as the prize in a contest. For instance, if a store has a special sale or an anniversary celebration, tickets are given away with every purchase and at the end of a certain period of time, the set is awarded in some way, such as to the contestant who solves a puzzle or wins a trial of skill. The radio dealer gets no publicity, but sells the set to the other merchant outright.

### High-Priced Sets Sell Best in Summer

A radio "go-getter" in White Plains, N. Y., is the United Electrical Shop, where John K. Cooper outlined what they were doing. This dealer did very well last summer and is out to beat the record this year. He uses the mails to solicit trade and gets his names from the telephone book and from a real-estate dealer.

He is a firm believer in the selling qualities of the higher-priced sets, especially for summer use, and says that they seem to "stay sold" better than the cheap sets. He is planning to send out an automobile with a

"super" in it, this set to be used for demonstration purposes. Mr. Cooper employs five service men and gives three free service calls after installing. After that, service costs \$2 a visit. This dealer already has had several orders for "re-installing" sets which were put in last winter and which it is now planned to equip permanently with concealed wiring. The shop does very little business on the installment basis. It carries a complete line of electrical accessories and maintains list prices.

### Rents Public Address System to Clubs

A public address system is being used by the Zwiebel-Stenger Company, of Wilkes-Barre, Pa., to pep up the summer gross. The system was purchased at a cost of \$1,200, and has paid for itself in less than a year and shown a small profit. The system is rented to local merchants for special occasions, to organizations, clubs and lodges for entertainments, municipal officials for public meetings, etc., for the sum of \$75 for three hours.

### Signs to Play Up Summer Radio

Have a sign painter make up a series of placards for your store and windows, calling attention to the uses of radio in the summer time. These may start off with such slogans as "Take a Radio on Your Vacation," "Dance to Radio Music This Summer," "This Is a Radio Summer," and so on. Smaller signs may call attention to particular applications of radio for the bungalow, the motorboat, the camp, the hike, the canoeist, the motor tourist, summer restaurants and ice-cream parlors and other local variations which come to mind. Preparations for such signs should be started early.

### Specializes On Selling to Industrial Employees

A radio dealer in Toronto, Canada, has made a specialty of selling sets to industrial concerns for installation in the employees' rest rooms. One recent installation led to the sale of fifteen others to employees who heard the set.

Another Toronto dealer installed a set in the homes of ten department heads in a local factory, left them for a month, serviced them once a week and sold the entire ten before the month was out. The dealer then interviewed lesser employees and used the names of those already sold as recommendations.

### Sells Automobile Tires in Warm Weather

"Put in a sideline that sells during the summer," is the advice of Frank Megargee, radio dealer of Scranton, Pa. Megargee operates broadcasting station WGBI, but finds it necessary to sell a well-known make of automobile tire during the summer, to augment radio. To increase his warm weather radio trade, Megargee offers "Free Inspection" of any radio set in the owner's home, making it profitable by the sale of tubes, batteries and other accessories, where needed. It is also part of Megargee's policy to cut down on newspaper advertising during slow periods.



One way of bringing your store and business to the attention of a greater number of people is to loan a radio exhibit to other types of retailers, such as the

automobile dealer, to tie in with their own display. The radio merchant who makes the loan is given credit by means of a large sign in the window.

# Broadcast Tie-Ups That Will Boost Sales



Church services through the air make every church a prospect. This Massachusetts parish purchased a set for use while the minister was away on his vacation. The congregation enjoyed the more elaborate services broadcast from a larger church and were given the opportunity to hear a famous preacher.

A. Atwater Kent (left), president of the Atwater Kent Manufacturing Company, recently sent his voice through the ether for the first time, when broadcasting was done by the Navy Department from the dirigible, Los Angeles. The photo shows Mr. Kent and A. D. Silva, engineer of the Atwater Kent company, who designed the equipment used on the Los Angeles while he was a member of the U. S. Signal Corps, just after alighting from the air journey. The dirigible's gondola may be seen in the background.

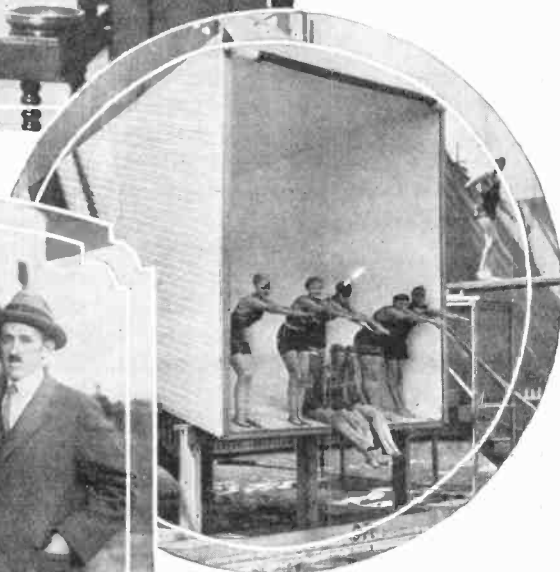

The giant reproducer seen in the circle above was installed by a swimming pool at Palm Beach, Fla., to entertain patrons last winter. Not only did it supply entertainment but made a popular diving-board.



Broadcasting of baseball games direct from the diamond, and also of the daily scores, is an air feature which many dealers have used to advantage in selling sets and getting publicity. Hank Gowdy, veteran catcher of the N. Y. Giants, is seen telling radio fans all about the game.

At the right is shown how an enterprising New York dealer is capitalizing broadcast features by mounting a receiver on his auto and letting the crowds at popular summer resorts listen in. And the program that gets the biggest crowd is the baseball score.



# How Dealers Are Selling Radio to Farmers

The Farmer Buys a Money-Making Tool in Radio and Can Be Sold Radio in Summer as Well as Winter

By L. E. MOFFATT

The following account of what radio means to the farmer and how radio is being sold to him by local dealers is a condensation of a part of the great amount of interesting information presented at a Radio-on-the-Farm conference held in Des Moines, Iowa, April 28 and 29. At this important and interesting meeting The Meredith Publications were hosts to some sixty representatives of leading radio manufacturers and advertising agencies, jobbers and dealers in radio who are in close contact with the farm market, directors of stations broadcasting to the farmer, members of the faculties of State Agricultural Colleges, representatives of U. S. Department of Commerce and Bureau of Agricultural Economics and others including a farmer who gave the gathering a straight-from-the-farm story of what radio means to the farmer.

L. E. Moffatt, associate editor of "Radio Retailing" who, by invitation, was present at this conference has not tried to report the meeting. For the benefit of radio dealers to whom

the farm market represents a great and immediate opportunity, he has tried to condense into this one article the high spots from a number of the addresses and discussions.

**R**ADIO is to the farmer what the ticker is to the broker. All day, from 8:45 in the morning on, he receives weather reports, market reports, crop reports, receipts at the market centers of cattle, hogs, milk, butter, grain, produce and all the other crops. From this information on the air he plans his day's work, he sells at the time when prices are best for the products on his farm.

For 365 days in the year, radio is the most useful instrument he can possess in getting the greatest profit from his farm. The farmer's wife benefits equally as much. She gets, by radio, lectures and detailed instruction on those parts of the farm management that constitute her province—suggestions and instruction ranging from decorating her home, to making cheese and improving the laying power of the helpful hen.

In cities radio is primarily amusement, on the farm it is primarily an instrument of use and its value can be measured in dollars and cents. Entertainment is also important to the farmer and to his family, but what makes radio a twelve-month selling proposition to the great farm market is this fact of its vital usefulness. It is just as important in the operation of a farm as the automobile, in many ways of more use and importance than anything that has ever been offered the farm dweller.

The large number of non-commercial agencies that serve the farmer are already broadcasting "on the air" and are urging the farmer to buy and use radio receiving sets. These non-commercial agencies include the U. S. Government with a radio program backed by some \$25,000,000; state agricultural colleges which use radio for broadcasting extension courses and much information essential to the farmer; and state departments of markets

**Type of Radio Sets Owned by Farmers in 13 States**

	Tube Sets	Crystal Sets	Do Not Give Kind
	Per Cent	Per Cent	Per Cent
Iowa	86	8	6
South Dakota	95	..	5
Nebraska	89	5	6
Illinois	92	3	5
North Dakota	100	..	..
Minnesota	93	3	4
Kansas	80	3	17
Indiana	95	1	4
Wisconsin	97	..	3
Missouri	82	7	11
Ohio	92	4	4
Michigan	94	1	5
Oklahoma	100	..	..
Total	90	4	6

100% = Total Number Who Have Radio Sets

All figures in this article are taken from statistics compiled by the Meredith Publications, Des Moines, Ia.

**Percentage of Rural Population in 13 States Having Radio Sets**

	Per Cent
Iowa	18
South Dakota	12
Nebraska	22
Illinois	19
North Dakota	17
Minnesota	13
Kansas	14
Indiana	11
Wisconsin	10
Missouri	16
Ohio	12
Michigan	11
Oklahoma	4
Total	14

100% = Total Replies to Question

which broadcast hourly market and crop reports. Now all these non-commercial agencies are not only putting on the air all through the day and every day in the year matter of vital usefulness to the farmer, but they are actually doing missionary work to induce the farmer to buy radio receiving sets. It is one of the most remarkable tributes to radio and its practical usefulness that for the first time in history the U. S. Government is actually recommending to the farmer the purchase of a farm tool: Radio.

County agents employed by States and the U. S. Government and numbering thousands are talking radio to

farmers and urging its adoption as an indispensable aid to greater farm profits.

One of the most striking elements in this work that is being done to make radio a necessity on the farm is the immense enthusiasm of these volunteer radio missionaries. College president and faculty, state and government officials, directors of broadcasting stations are all giving their best thought, their time, energy and personal service to spreading the idea of the great use and

up to the minute. Now it is only a step for the farmer who is getting these essential reports with more or less difficulty from his bank or telephone company to getting them over his own set with all the other advantages the ownership of a set means to him. Radio service has been demonstrated to him.

**Radio Clubs and Community Sets**

In many of the smaller towns the business men and farmers have formed a radio club and bought a receiving set which is used and enjoyed by the entire community. These community sets are wonderful missionaries in selling the radio idea to the townspeople and farmers.

A typical case is Frost, Minnesota, where fifty-three business men and farmers subscribed, something over a year ago, \$10 each, toward the purchase of a community radio set and equipment. During the day, weather, crop and market reports were received, and bulletins conveying this information posted, also any farmer could get this information by calling up the bank or the general store. With this set, the world series came for the first time to Frost and several hundreds of farmers and townspeople gathered every day to get the games play by play. Placed out of doors in the summer evenings, the set provides entertainment and instruction to the crowd that gathers.

The audience sits on the grass; reception is, on the average, good; and driving back to the farm the family sell father on the idea of a radio at home.

This community set was the first set in Frost, and from its demonstration of what radio means to the farmer and small town dweller one

	Average Distance
Iowa	79.1
South Dakota	173.8
Nebraska	109.9
Illinois	91.1
North Dakota	276.2
Minnesota	122.2
Kansas	124.4
Indiana	74.6
Wisconsin	47.0
Missouri	83.7
Ohio	72.1
Michigan	102.4
Oklahoma	117.6
Total	103.9

Average miles based on total number who answered question.

Makes	Per Cent Own
Crosley	22.99
Atwater Kent	10.05
Airline	7.66
Radiola	6.35
Western Electric	5.50
Westinghouse	4.07
Freed Eisemann	3.35
Kennedy	2.03
Michigan	1.91
Freshman	1.79
Miraco	1.32
Fada	1.32
Zenith	1.32
Neutrodyne	1.32
De Forest	1.20

100% = Total Number Who Mention Makes

benefit of radio to the farmer and his family.

Just one instance is the personal activity of B. B. Jones, in charge of Market News, Department of Markets, State of Wisconsin. Mr. Jones has actually gone out into the field and personally called on bankers, cheese factories, cream-buying stations, produce buyers, and "sold" them the idea of radio market news service.

At his instance, dozens of small-town bankers have installed radio sets to receive weather and market reports. These reports are typed out and posted on bulletin boards in the banks and in many cases the banks have adopted as a further service, the practice of not only giving these reports over the telephone on request but of sending out a general telephone call at certain stated hours and reading the reports over the telephone. Some of the local telephone companies have adopted this same service.

The farmer in localities thus served is learning that radio broadcast market reports are the only reports that are really useful to him, and that a dependence on the reports published in his local paper is often unprofitable to follow because they cannot be

dealer in this town of 252 inhabitants sold sixty-eight radio sets.

Another radio missionary is the farmer who owns a set. He invites his neighbors over for the important broadcasting events, to hear the returns of the world series, the inaugural address, important speakers; and in the afternoon groups of farm women gather to get the home economics lectures and other matter of special interest to them. Every farming community can show many instances of a gain or loss in actual money through having or not having a radio set. Some instances cited by B. B. Jones are not only interesting in themselves but are the most effective possible sales arguments for anyone selling radio to the farmer.

Here is one. In Wisconsin the cabbage crop is an important one and is usually not marketed until the farmer judges the market to be right as to price offered. Sales are made

	Homemade Set			Manufactured Set		
	Average Cost per Set	Range of Costs		Average Cost per Set	Range of Costs	
		Lowest	Highest		Lowest	Highest
Iowa	\$62.11	\$3	\$200	\$114.54	\$6	\$285
South Dakota	56.42	20	110	98.55	25	225
Nebraska	61.54	3	150	119.74	6	240
Illinois	50.77	2	160	105.21	10	750
North Dakota	74.55	15	180	109.11	25	500
Minnesota	51.34	6	135	96.47	4	200
Kansas	49.59	5	125	98.62	5	185
Indiana	46.33	5	105	105.33	20	500
Wisconsin	73.27	11	175	117.52	5	285
Missouri	38.36	2	125	81.75	20	300
Ohio	64.02	5	175	107.56	3	250
Michigan	49.34	3	115	99.98	10	224
Oklahoma	78.33	35	125	125.33	40	200
Total	\$54.17	\$2	\$200	\$104.82	\$3	\$750

Average cost based on total number who give cost per set.

to county or local produce dealers who send buyers into the country and who buy the whole crop at an agreed price determined, theoretically, by the market but also determined by the cleverness of the buyer. This buyer often depends for a good buy on the farmer's market information being slower than that of the buyer. Mr. Jones related the case of a farmer with some hundred tons of cabbage to sell who was called on by a buyer and offered a price two dollars a ton higher than the published market. The farmer thought that Heaven had sent him something and closed the deal in a hurry, fearing the buyer would get wise to the market as shown in the weekly paper just received.

But later in the week, the farmer was shocked to learn that the day he sold, the actual market for cabbage was ten dollars on a ton higher than the published market of the week before. How did his neighbor know all this? The neighbor who had a radio set was able to inform the buyer of the actual market when he called. So the farmer without the radio market service lost \$800 on his cabbage.

This advantage of hourly market reports has been used by farmers with radio sets to advantage in a falling grain market. Some grain buyers who depend on telegraphic market reports have raised loud cries because they bought on their last telegraphic quotation only to learn a few hours later that the market was well below the price they paid. The farmer with the radio set had beat them to the information by some hours.

In small towns there are located

numbers of grain and produce buyers who must have market report service. These buyers receive a telegraphic market report service which costs them \$84 a year. Radio gives them an hourly service that gets this vital information to them ahead of the telegraphic service. These buyers offer another sizable market for radio sets.

Although this dollars and cents value of radio to the farmer and the small town business man is what makes radio selling to this market a twelve months' business, the entertainment value of radio is just as great for the farmer as for the city man. If we are stressing here the farmer investment in radio on the basis of the service that radio is to him in his business, it is because this is the angle of radio on the farm which will enable the dealer to close the sale right now in the summer time.

#### A Summer Radio Market

For the summer radio market with the farmer is practically as great as the winter market and chiefly on account of this dollar value of radio. The farmer's year is divided between the planting and growing season and the harvesting and marketing season. The first roughly between May 15 and August 15 and the latter between August and May. During the planting and growing season, weather reports are of the most value to the farmer's business. During the harvesting and marketing season weather reports and market news are useful. Weather reports will often enable the farmer to save a growing crop by taking precaution against unseasonable frost, in harvest against bad weather; and no farmer can market

to the best advantage today without the reports of receipts at primary markets which determine the trend of prices, nor can he sell on the farm without the hourly market service coming to him by radio.

Because of this daytime use of radio on the farm the broadcasting condition is vital. Does the farmer get all this service or will interference and static cut it down? The farmer is getting it. Investigation shows that the average distance from a broadcasting station in the middle and northwestern states is 100 miles, with the greatest average distance in this section 276 miles. Stations broadcasting to the farmer are increasing their power for summer daylight broadcasting. The average range for these stations is now 400 miles and the important station WCCO at Minneapolis will use 5,000 watts when necessary for summer broadcasting. The farmer will get the use of his set because this super power will cut through and get it to him.

The typical attitude of the farmer is summed up by Miss Neale S. Knowles, director of Home Economics Extension, Iowa State College of Agriculture. Miss Knowles is a radio enthusiast because she knows farmers and farm women and what radio means to them. She has asked many farm people if they have radio sets and has heard the question asked by other farm people countless times. Her account of the answer contains the big message for the radio dealer. The answer in the majority of cases is "No, not yet."

Now to what extent has the farmer bought radio?

Many investigations have been made and are now being made to determine this fact. The figures gathered show a range from 5 per cent to 14 per cent of farm houses with some sort of radio set. This percentage will vary greatly in different parts of the country, but it is unlikely that even in the most prosperous farming sections there are more than 14 per cent of the farms with radio sets.

Farm radio use is growing rapidly just as city radio use is. The survey made by the U. S. Department of Agriculture in 1923 indicated an average of fifty-one radio sets per county on farms and in 1924 an average of 128 per county on farms. Showing that in one year farm radio use had more than doubled.

The farmer is buying radio. He is not being sold. Hundreds of thou-

(Continued on Page 556)

Number of Tubes per Farmer's Set

	One Tube	Two Tubes	Three Tubes	Four Tubes	Five Tubes or More	Average Number of Tubes
	Per Cent	Per Cent	Per Cent	Per Cent	Per Cent	Per Cent
Iowa	21	10	31	11	27	3.2
South Dakota	10	17	32	36	5	3.1
Nebraska	3	16	33	11	37	3.7
Illinois	22	14	28	17	19	3.0
North Dakota	11	11	47	8	23	3.2
Minnesota	26	11	29	14	20	2.9
Kansas	15	14	35	10	25	3.2
Indiana	10	25	25	19	21	3.2
Wisconsin	19	12	30	18	21	3.1
Missouri	29	23	25	10	13	2.1
Ohio	21	9	34	15	21	3.1
Michigan	22	12	28	19	19	3.0
Oklahoma	..	25	42	8	25	3.3
Total	19	15	31	14	21	3.0

100% = Total Number Who Have Tube Sets



Make Your Telephone Earn Its Keep—Take Down the Receiver Now and Call Up

SHOULD the radio merchant depend upon store sales only, or must he today take the merchandise to the customer's home and sell it to him in his own parlor?

Certainly the great merchandising advantage of a department store is in its heavy store traffic. Thousands who come daily into department stores come in expecting to buy, or at least in the mood to be sold. This is the general experience in most merchandise lines carried by department stores but, curiously it is not true of radio. At least not in the experience of the leading department store of Decatur, Ill., the Wm. Gushard Company—90 per cent of whose radio sales are made *outside* the store.

The whole experience of this store with radio is another example of the fact that no matter what advantages the merchant may possess in location, prestige and display, radio today must be sold by aggressive outside selling methods. This policy of "going out after them" is not new with the Gushard company, for Guy C. Hawkins, manager of the radio department has been selling phonographs and pianos "outside" during the past four years. And for a year before he put in radio Mr. Hawkins had been filing away more and more phonograph prospect cards marked "Will not buy phonograph; interested in radio." And when he put in

only source of radio leads. It is a good selling maxim that the more prospects located, the more sales will follow. So the first activity of the new radio department was in building prospect lists. The local telephone book was used and all the professional men in the city — doctors, lawyers, dentists, were written form letters. The store's list of charge accounts was also used and these customers were, in addition, called on the telephone, as well as being sent form letters. And especially active sales work was concentrated on the men in the city who are leaders in various activities, the kind of men that everyone knows.

In a city of this size (Decatur has a population of 40,000) personal acquaintance is very wide and this plan of going after the well known citizen proved the best kind of selling strategy.

One of the questions that people ask the salesman is "Who else

*Phone First—Then*

## "Go Out and Sell the Key Citizens"

Selling to Homes Found Necessary by Decatur, Ill., Merchant, Regardless of Store's Advantages of Traffic, Prestige or Display

radio, these cards has bought one?" Mr. Hawkins' list formed a prospect list of "well knowns" provided a sufficient and convincing answer to this question, and the telephone and personal calls, followed by demonstrations in the home, sold a number of these "key," or prominent, citizens.

This list was not the new radio department was in building prospect lists. The local telephone book was used and all the professional men in the city — doctors, lawyers, dentists, were written form letters. The store's list of charge accounts was also used and these customers were, in addition, called on the telephone, as well as being sent form letters. And especially active sales work was concentrated on the men in the city who are leaders in various activities, the kind of men that everyone knows.

"Ten sales of this sort," said Mr. Hawkins, "were worth more to us than \$250 worth of advertising." The fact that these men owned sets

*Your Home Town's Leading Citizens to Make Arrangements for a Home Demonstration*



## *To the Use of Telephone and Personal Solicitation*

the William Gushard Company, Decatur, Ill., is able to attribute 90 per cent of its radio sales.

The business and professional men of Decatur, such as the city officials, physicians,

lawyers and dentists, people that meant something in the community, were made the targets of a strong attack by direct mail, telephone and personal solicitation. Read how these "key" prospects are sold.

was the strongest kind of endorsement. They are looked up to as community leaders. Their opinions are considered better than the ordinary man's, and their purchase of a particular set immediately puts a wonderful stamp of approval on that set.

### **Expert Radio Service Essential**

From the start Mr. Hawkins recognized the importance of service in handling radio. He engaged a service man with a long experience in electrical and radio work and service is one of the sales arguments the Gushard salesman uses. Free service is liberally given and the service man's contact with the user develops many good new leads. The satisfied user is the best possible source of leads and the attentive follow-up from the service angle produces more satisfaction and consequently more leads than would even a system of paying for leads.

A periodical "service check-up" has also been found by the Gushard company to pay in the number of new leads obtained and in the satisfaction the store's customers get from this attention.

The Gushard service man calls, looks over the set and makes whatever adjustments may be necessary, answers the questions which the radio user usually wants to ask and if new batteries or tubes are needed takes an order away with him. This friendly contact often reminds Mr. Customer that one of his friends has been talking about buying a radio set and the company gets another lead.

In making home demonstrations Mr. Hawkins has found it the best policy not to leave the set in for an extended trial period. If on the evening set for demonstration weather conditions are not favorable to good reception the customer is called up and the matter explained and another date set. After one

good evening's demonstration, the sale should be closed or the set brought back to the store.

Like other selling rules, however, this one works best when it is broken. Mr. Hawkins tells of one radio sale made to an old phonograph customer who could not be made to see the entertainment value of radio. This was one of Mr. Hawkins' key men, a barber who knows most of the men in town and who is well known for his interest in music and his collection of phonograph records. The difference between this man as a booster and this man as a skeptic would have an appreciable effect on radio sales so Mr. Hawkins set out to convert him. Driving past the shop at closing time Mr. Hawkins took his reluctant prospect to his own home and there gave him a demonstration of good radio performance. This broke the ice and a similar set was installed on demonstration in the barber's home and left there until the prospect had sold himself on it.

### **Window Displays Without Price Cards Bring in the Most Prospects**

Good window displays are frequently used by the radio department. Results in store inquiries are carefully checked up to determine the type of window display that pays best. By a comparison of a window showing high priced radio sets both with and without price cards it was found that more people were drawn into the store by the window without prices than by the window wherein prices were shown.

Mr. Hawkins explanation of this is that people are interested in the high-priced sets but that when the price is shown on them in the window the price looks bigger than the set.

If however they can be brought in to ask the price, the salesman has

a chance to show them where the price is justified and to show them all that they are getting for the money.

Another way of putting it is that in the window they are "looking at merchandise," and the Gushard salesman "sells them entertainment." For it is the policy of this store to keep away from talk about mechanical details. Music and entertainment is sold just as it is sold with a phonograph.

### **Selling the Higher Priced Sets Is All Up to the Salesman**

The higher priced sets are pushed in this store both because they give more satisfaction to the customer and more profit to the company and to the salesman.

One of the most interesting viewpoints Mr. Hawkins brings to merchandising radio is on this question of what price sets sell the best.

Selling the high priced set as against the lower-priced equipment is in Mr. Hawkins' experience as much up to the salesman as to the customer.

"There are two kinds of salesmen," explained Mr. Hawkins, "one that I call the \$400 man and the other the \$100 man. I mean by that, the salesman who is not afraid to name a high price to the customer and the salesman who is not sure of himself and who thinks that if he approaches his prospect on a lower priced product that he increases his chance to make a sale.

"This \$100 salesman forgets that with the best class of people he lessens his chance to make the sale, because they really want the best and expect to pay the price for it. They are offended when the salesman assumes that they are interested in something cheap.

"The real salesman is the man who approaches his prospect on the best and highest priced piece of merchandise that he has to sell. It is easy to turn from this to cheaper items if necessary, but the note of quality has been struck and the customer is pleased at being put in the class of a quality buyer.

"Our stock is chiefly of higher priced sets and our average sale is over \$200. Now don't assume from this that our sales are all made to wealthy people. They are not by any means but this goes to show that the average buyer wants quality and will pay for it if the salesman sells him quality instead of trying to sell him on a price."



# New York's Latest Radio Shop

**New "Landay Hall" Is a Veritable Radio Palace**

Landay Brothers, long established music dealers of New York City, recently opened "Landay Hall," their tenth retail radio and music outlet in the Metropolitan district. "Landay Hall" is situated on Forty-second Street, near Sixth Avenue, and its elaborate decorations and equipment have already made it famous throughout the East. It is devoted exclusively to the retailing of radio and music merchandise. At the right is the main radio display room on the second floor.



At the left is the foyer of the ground floor, making it the corner of an "L". There are two entrances to "Landay Hall," one on Forty-second Street and one on Sixth Avenue. Both lead into this foyer. A prominent New York artist painted the wall friezes at the side of the staircase especially for "Landay Hall."

The main display room is lined with demonstration booths such as those shown at the right. Each booth is glass-enclosed and soundproof. "Landay Hall" is a tribute to the success of radio retailing as a trade and augurs well for the future of the industry. When a merchant spends thousands of dollars to make his place of business as attractive as "Landay Hall," it is a sure indication that he has supreme confidence in the future of the merchandise he sells.

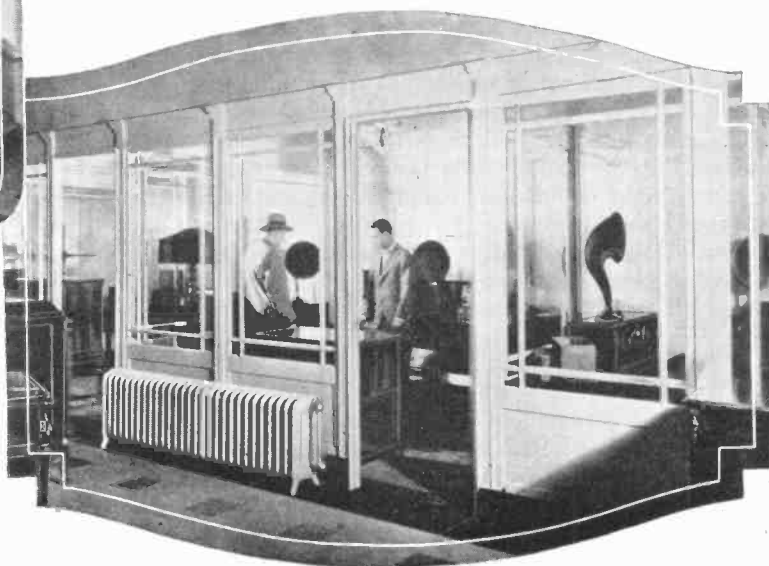



For the past three years, Mr. Reinhard has been manager of the Temple of Music, Scranton, Pa., and has built up an outstanding music and radio trade. Previously, Mr. Reinhard was credit manager of the New York Talking Machine Company.

# What I Would

## A Radio

### Manufacturer

- ¶ Give Each Jobber an Exclusive Zone
- ¶ Limit Retail Outlets to "Authorized Dealers"
- ¶ Would Not "Dump" Sets at Reduced Prices
- ¶ Would Not Overstock Jobbers

By M. M. REINHARD  
 Manager, Temple of Music,  
 Scranton, Pa.

**A** SURPLUS of wholesale and retail radio outlets has very nearly caused the death of radio. If I were a radio manufacturer today, the first thing I would do would be to cut down the number of jobbers handling my products, giving each jobber a zone to work in, and see that the jobber, in turn, gave his dealers a more or less exclusive franchise. In towns of 40,000 to 50,000 and under, only one dealer could sell my sets. In larger cities, I would proportion the number of dealers according to the population, one dealer for every 35,000 or 40,000 people.

The distribution problem is the most serious factor confronting the radio trade today. The present state of confusion, cut-throat competition and selling to everybody who wants to buy, has got to stop. It is a matter of self-preservation for manufacturers to exercise very careful judgment as to who shall job and who shall retail their sets.

#### Present Distribution Makes for Lack of Confidence

I would take into consideration the fact that the retailer must service and advertise my products. Under present conditions, the retail discount of 35 per cent does not permit of giving service and making a living profit, nor does the present distribution system give the dealer enough confidence to advertise any one make of set, knowing that "the fellow down the street" can

buy the same set, sell it at cut prices and profit by the other dealer's advertising. Taking these things into consideration, along with my policy of protected distribution, I would give the retail trade a discount of 40 per cent, with the stipulation that the retailer give my product a fair degree of advertising.

#### Would Never "Dump" His Product at Cut Prices

I would never "dump" my product on the market in order to raise money, as I believe this absolutely kills the future sale of any sets of the make that has been "dumped." If, as a manufacturer, I expected to continue as a manufacturer, I would give my regular retail outlets the benefit of any reductions in price that I might contemplate. And if I were going to "dump" I would take the name and trademark off the sets, feeling that I owed at least that much to the dealers who had purchased my products in the past and thus helped me achieve success.

I would not manufacture and market a "kit" of parts whereby an amateur could build a set approximating the set my factory put out. It has been my experience in many cases, that the sale of parts to build a certain make of set, has spoiled the sale of the factory-built set, besides giving questionable satisfaction to the customer. If a "Jones" set could not be built from "Jones"

(Continued on Page 547)

# Do If I Were—

## A Radio Dealer

- ¶ *Study Ways of Selling Radio*
- ¶ *Base My Sales Policy on Service, Not Price*
- ¶ *Send House-to-House Salesmen Out to Sell Radio*
- ¶ *Get Out of the Store and Sell Radio Myself*

By **POWEL CROSLY, Jr.**  
President, Crosley Radio Corporation,  
Cincinnati, Ohio

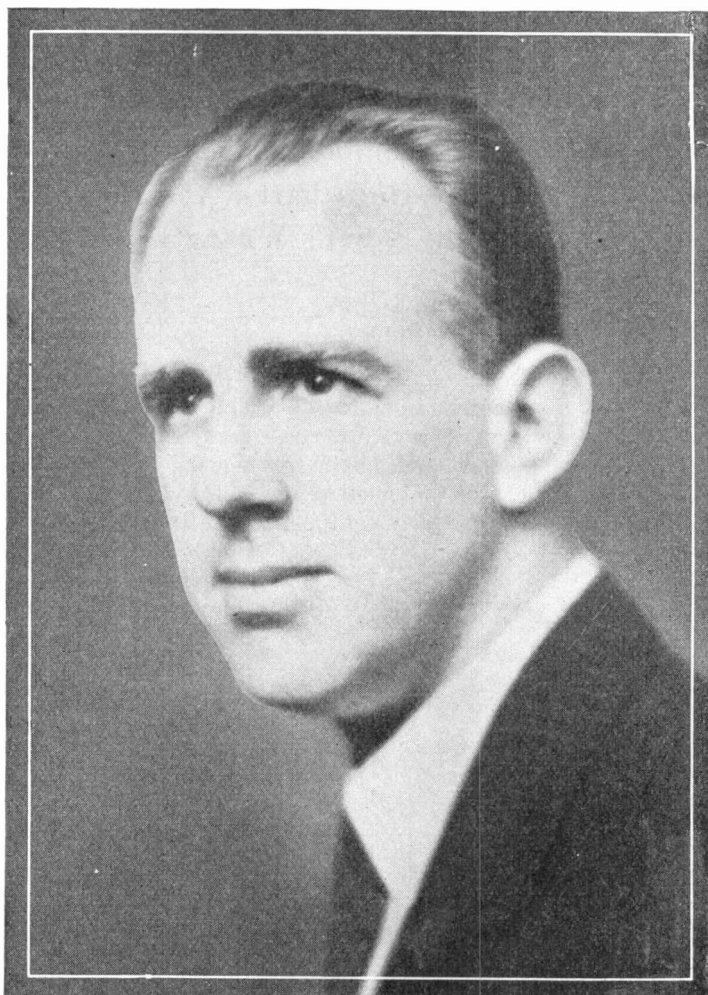

*Powel Crosley has often been spoken of as the "Henry Ford of radio" because of the production methods he has instituted in his plant in Cincinnati. He made his first receiving set three years ago, but already more sets are made in the Crosley factory than in any other one place in the world.*

THE most important thing a radio dealer can do at this time is to carefully study ways and means of selling radio apparatus. The rapid growth of the radio business has spoiled most dealers. Too many of them have been satisfied to open a store, put merchandise on the shelves, and leave it to the public to come in and take it away. That is one reason why the radio business has its peaks and valleys. The public, unfortunately, has a concentrated season during which it sells itself on radio to an extent that people will come in and buy radio apparatus. Then, suddenly, the public slows down.

The dealer who has been rushed to wrap up and hand over radio sets is then at sea. People have stopped coming into his store in as large numbers as before, and he thinks the radio business has gone to the eternal bow-wows. He loses sight of the fact that there is only a faint line of demarcation between the radio public, who are sold sufficiently to come in and buy, and the great big remaining unsold proportion of people who would be pushed over that line by the slightest selling effort.

### "Get Out of the Store and Sell"

If I were a radio dealer, I would pattern my sales efforts along the lines necessary to sell phonographs, pianos, washing machines and vacuum cleaners. The

vacuum cleaner dealer who waits for people to come in and buy vacuum cleaners would starve to death. The job of direct selling through salesmen who call on people to sell them vacuum cleaners, is infinitely harder than the effort required by salesmen to sell radio sets, therefore, the first thing I would do would be to regard my store as a mere service station. I would carry the campaign of sales directly into the homes of prospects. Radio lends itself particularly well to selling in the home, because of its appeal to the entire family. The romance of radio has prepared the way for the salesman. Every member of the household knows what entertainment and enjoyment radio offers and is already wanting it.

### Would Organize a Staff of Outside Salesmen

Therefore, I would consider every house in town a prospect and organize a staff of high class selling men, districting them in the community so that they would cover all the residence streets intensively. And my idea would not be to make a flying canvass, rather to send a man to talk to every household and find the way to sell them right now the radio equipment they should have. I would organize these selling men behind a careful program and under a sales manager who can see the bigness of the opportunity and the necessity for

(Continued on Page 547)

# Hunting Trouble on Service Calls

"Trouble-Shooting" Is Simplified by Use of a Service-Testing Chart—An Efficient and Speedy Method of Finding What's Wrong with a Set That Won't "Percolate"

By EDGAR H. FELIX

**A** SERVICE man who goes about his task in a business-like manner proves to your customer that you know your business. A service man cannot be efficient in his task unless he is properly equipped

with essential tools and supplies and unless he is instructed in the art of carrying out a trouble hunt in a systematic manner.

If your service man spends his time in asking the customer a large number of questions and then begins his work by diving ruthlessly into the receiving set, he is almost certain to lose the customer's respect for you. If information is volunteered to the service man, he should accept it, but he should confine his questioning to only one or two points.

First, we will list the equipment which the service man should have and then consider the process of trouble-finding, step by step. Only minor repairs should be attempted in the customer's residence. If a fundamental fault is found within the receiving set and it cannot be repaired by a few minute's work, the set should be taken back to the shop, re-conditioned and returned.

## Equipment for the Service Man

The service man who is called upon to walk or ride on the street car to the scene of complaint is not able to carry more than a certain amount of tools and accessories. For this reason, the list given at the left is limited to materials which can be carried in a large brief case or small suitcase.

The following additional equipment is suggested if a service automobile or motorcycle is available, or if the service man has to take an out-of-town trip:

1. Tube testing set
2. Set of B batteries of correct size for receiver, if known; otherwise two large 45-volt B batteries
3. Six dry cell A batteries
4. 4½-volt C battery
5. Fully charged 6-volt A battery.

With this equipment, the service man is able to make replacements of those parts which are most likely to cause trouble and in 95 cases out of 100 to place the set again in operating order.

## Upon Reaching the Customer's Home—

After introducing himself, the service man should make only one inquiry and that is whether the receiving set still functions sufficiently well to make the local stations audible. If it still functions, the trouble is most likely to be due to depreciation of tubes or batteries; if it does not, to breakage or disconnection.

If the receiving set still functions with good quality, although signals

(Continued on Page 544)



## What Your Service Man Should Carry

*A tube tester and a kit of tools containing the following equipment:*

1. Voltmeter for measuring "A" battery
2. Voltmeter for measuring "B" batteries
3. Hydrometer
4. Long nosed pliers
5. Short nosed pliers
6. Long screw driver
7. Small screw driver for removing dials
8. Pocket flashlight
9. Test buzzer soldered to a flashlight cell with long flexible leads terminating with test clips
10. Small soldering iron, solder flux and alcohol torch. (An electric iron is not suitable for antenna repairs)
11. Coil of flexible strand insulated wire for battery connections
12. 200 feet aerial wire
13. Small set of flat wrenches, fitting variable condenser, socket and jack nuts
14. Complete set of spare tubes for receiver to be tested; if tube requirements are not known, six 6-volt tubes and six 4-volt tubes
15. Set of phones with plug.

*These Seventeen Steps Should Get Results for the "Trouble Shooter"*

Part being tested	Test	Expected result	If result is not obtained
A battery circuit.	Snap on filament switch; turn rheostats on full; if filament control jacks are used, insert plug in last stage.	All tubes should light to full brilliancy. If so, proceed at once to B battery tests.	Continue with detailed A battery tests.
(a) A battery.	Measure battery voltage at battery terminals.	Should show adequate voltage for tubes.	If storage battery, test with hydrometer; if low, place on charge or replace with charged battery; if dry cell, replace.
(b) A battery leads.	Measure battery voltage at A battery binding posts.	Voltmeter should show adequate voltage for tubes and correct polarity.	Repair or replace A battery leads.
(c) A battery switch.	Test voltage at socket filament terminals with rheostats on full and filament switch on.	Voltmeter should show full battery voltage.	Short circuit filament switch; filament control terminals on jacks, if filament control jacks are used; if voltmeter responds, short circuited element is defective.
(d) Rheostat.	Connect voltmeter at socket filament terminals, with A battery switch on; rheostat on full.	Voltmeter should show full battery voltage.*	Short circuit rheostat terminals; if voltmeter then indicates, look for defective contact or wiring.
(e) Socket contacts.	Replace tubes with tested tubes.	Tube should light to full brilliancy.	Test voltage on filament socket prongs by inserting screwdriver and making spark; if no spark, preceding tests should be repeated; if spark results, bend socket prongs upward.
(f) Tube filaments.	Replace with tested tubes; if they light return original tubes.	Tubes should light.	Replace if burned out; test customer's tubes with tube tester and replace all tubes no longer giving rated plate current.
B battery circuit.	Measure B battery voltage at set binding posts.	Voltmeter should show at least 15 volts per battery; with reflex sets, 17.	Measure voltage at batteries; if OK, trace leads; if voltage is low, replace with new batteries.
Wiring up to amplifier circuit.	Plug phones to detector jack; with tubes lit, withdraw plug.	Good click in phones.*	Broken wiring or defective contact in set; or defective tubes. First, replace all tubes with tested tubes and repeat test. If this does not remedy, examine jack connections, socket contacts with tubes and repeat test. Short circuit primary of first audio transformer and repeat test. Test wiring with buzzer and battery. If no break can be located, set should go back to shop.
Amplifier circuit.	Plug phones in first amplifier jack with tubes lit.	Good click in phones.	Trace wiring, B battery amplifier connections contacts in tube sockets, jack connections, C battery voltage and connections. If these are OK, short circuit secondary of first transformer; if test then produces loud click-transformer burned out.
	Repeat preceding test with second stage, after positive result is secured with preceding stage.	Soft click in phones.	Transformer burned out or defective connection or contact, as above.
Loudspeaker unit.	If loud signals are heard with phones in last stage, plug in loudspeaker and adjust unit.	Good reception.	Unit burned out or defective plug or cord.
Tubes.	Replace tubes, first one at a time, with tested tubes, listening with phones.	Good reception when defective tube is replaced.	Go ahead with next test.
	Replace all tubes with tested tubes.	Good reception; test customer's tubes with tube tester and replace all defective tubes.	If all A, B & C battery and amplifier tests have given expected result and set is not repaired by this test, leave tested tubes in sockets and proceed with antenna tests.
Antenna system.	Disconnect antenna connection from set and test with buzzer for ground.	No buzz.	If buzzer shows antenna is grounded, examine carefully for ground; test lightning arrestor.
	Look for break in lead in or corroded connection. Thoroughly inspect ground lead and connection.	Discovery of defective antenna or ground lead.	If insulated lead-in wire is old, parallel with temporary lead-in. If successful results are not secured, proceed with tests.
Tuning circuits.	Examine all connections to tuning elements; see that condensers work; replace grid leak; inspect grid contact on tube socket.	Discovery of defect.	If all A, B, C battery, tube and antenna tests have shown expected result and search does not reveal trouble, take set back to shop.

\*Do not proceed beyond this point until a positive result is obtained with this test.

# What It Is Costing "Exclusive Radio Dealers" to Do Business

First Available Figures Compiled from Business Statements of Stores Located in Ten Different States Indicate Average Expense Is 20.5%—What Better Buying Methods, Cost Control and Increasing Stock Turn Can Do for Individual Dealers

By M. CLEMENTS  
Managing Editor, "Radio Retailing"

THE "average" dealer who sells radio exclusively does a net business of \$31,599 a year. Of this amount he spends 74 per cent for cost of merchandise, draws 8.7 per cent as salary, pays 3.8 per cent for sales clerk hire, gives the landlord 4.1 per cent for rent and pockets a net profit of 5.5 per cent.

To get the facts on this average dealer, so that radio merchants can use his operating percentage as a gauge in their own businesses, *Radio Retailing* has gathered cost information from radio stores ranging in net sales from \$8,274 to \$94,208, situated throughout the country.

There are many lessons behind the figures given on the various indi-

vidual returns making up this average statement, but before interpreting them let us inspect the average statement, in order to make clear the allocation of each expense. In looking over these figures, here's what we find:

	Total	Per Cent
Net sales.....	\$31,599	.....
(This includes all merchandise which remained sold. Returned goods and allowances deducted.)		
Cost of merchandise sold.....	23,372	74
(Includes freight and express "in")		
Margin.....	8,227	26
(Cost of merchandise subtracted from net sales.)		
Deduct		
Rent and overhead.....	1,315	4.1
(Includes light, heat, water)		
Publicity.....	590	1.8

(Advertising, window trims, decorations of store, etc.)		
Sales clerk hire.....	1,217	3.8
(All selling expenses, such as tags, wrapping paper, etc.)		
Administrative expense.....	2,773	8.7
(Owner's or manager's salary, bookkeeper's salary, office supplies, etc.)		
Cost of service.....	291	0.9
(Salary of service man, traveling expenses)		
Other costs.....	294	0.9
(Taxes, insurance, depreciation)		
Total expense.....	6,483	20.5
Profit or loss.....	1,744	5.5
Average inventory.....	5,933	.....
Stock turn.....		7.8

Three weaknesses known to exist in radio retailing are substantiated by the small ratio of margin to net

## Sales, Profits and Operating Costs for

Store	Net Sales \$	Cost of Merchandise Sold		Margin		Rent and Overhead		Publicity		Sales Clerk Hire	
		\$	%	\$	%	\$	%	\$	%	\$	%
A	94,208.24	73,399.44	77.8	20,808.80	22.2	4,151.94	4.4	1,931.77	2.0	4,033.91	4.2
B	50,672.25	40,025.10	79	10,647.15	21.0	1,246.15	2.4	1,360.00	2.6	1,000.00	1.9
C	45,020.30	30,005.10	66.6	15,015.20	33.3	2,015.20	4.4	750.00	1.6	1,500.00	3.3
D	30,052.30	22,040.05	73.4	8,012.25	26.6	812.25	2.7	200.00	.7	300.00	1.0
E	26,209.48	20,168.86	76.5	6,040.62	23.5	1,278.38	4.8	129.00	.5	1,920.76	7.3
F	20,009.50	15,008.25	75	5,001.25	25	651.25	3.2	300.00	1.5	625.00	3.1
G	17,998.00	11,639.20	64.4	6,358.80	35.3	1,384.80	7.6	300.00	1.6	1,400.00	7.7
H	13,548.25	8,623.50	63.8	4,924.75	36.2	783.00	5.7	704.00	5.2	525.25	3.8
I	10,003.20	6,501.15	65	3,502.05	35	502.05	5	100.00	1	500.00	5
J	8,274.24	6,310.12	76.4	1,964.12	23.7	329.18	3.9	127.28	1.5	374.00	4.5
Average	31,599.57	23,372.07	74	8,227.40	26	1,315.42	4.1	590.20	1.8	1,217.89	3.8
High	94,208.24		79		36.2		7.6		5.2		7.7
Low	8,274.24		63.8		21		2.4		.5		1
Average for Music-Store Radio Departments (See April Issue, Radio Retailing)					24.8		5.4		5.1		8.1
Average for 9 Department-Store Radio Departments (See February Issue, Radio Retailing)					26.7		3.7		4.4		9.1

sales, which is 74 per cent. They are: (1) list prices are not always obtained, (2) unsuitable merchandise is sold, resulting in numerous returns from customers, and (3) buying of slow moving stock, the two latter necessitating mark-downs.

A desirable margin for dealers to shoot at is 35 per cent. Stores G, H, and I are getting this, proving that they are making the most of manufacturers' discounts which average 35 per cent. Store H, with a maximum margin of 36 per cent, represents an ideal small-store set-up. This store is located in a residential section of a large city, and is not afflicted with price-cutting competitors. Its margin reflects buying ability and a sense for gauging the public's acceptance of new sets or equipment.

**How Margins Are Widened**

Illustrative of this buying technique was the demand for a well known loudspeaker last winter. Manufacturing facilities for this product were limited, requiring piecemeal distribution to dealers in lots of ten. Instead of sitting back and being content with a "half-day" supply, as it turned out later, this dealer scoured the entire market within a radius of 200 miles of his city and managed to corral 200 loudspeakers of this make, which he sold at full list price. Still another reason that would account for this wide margin is that the dealer may purchase

direct from certain manufacturers, giving him a special discount.

Now contrasted to this high of 36 per cent is store B with the apparently profitless margin of 21 per cent. His expense item of 14 per cent tells a significant story of efficient management and cost control. This dealer can slash prices to his heart's content, if he so desires, and still keep his head above water, as his overhead is pared down to a minimum. Few dealers could match his showing of 1.9 per cent for "sales clerk hire," either. Even combining this latter figure with owner's salary, which is usually done where the proprietor is also salesman, the total selling expense is but 6.9 per cent. He could attain this low only

by employing part-time salesmen during the winter rush and letting out everyone when business began to drop in the spring.

**Selling Expense of 21 per Cent Too High**

This abnormal selling expense is counterbalanced in the average statement, by store G, which has a combined manager-clerk percentage of 21. This dealer is able to continue in business only because he is getting list prices for his merchandise, permitting a margin of 35 per cent. His own salary, 13 per cent, is what his total selling expense should be. Or if he wants to keep his salesman there is but one alternative and that is to attempt to double his net sales.

**Here Are Average Operating Figures Gathered from Stores in Ten States**

	Per Cent
Cost of Merchandise .....	74
Margin .....	26
Owner's Salary (Administration) ..	8.7
Rent and Overhead .....	4.2
Sales Clerk Hire .....	3.8
Publicity (All Types of Advertising)	1.8
Service and Other Costs .....	2
<b>Total Expense</b>	<b>20.5</b>
<b>Profit</b>	<b>5.5</b>

**Stores Selling Radio Exclusively**

(Net sales = 100 per cent)

What Did You Pay Yourself or Manager	Cost of Service		Other Costs		Total Expense		Profit or Loss		Average Inventory	Stock Turn	
	\$	%	\$	%	\$	%	\$	%			
7,445.52	7.9	272.00	.25	1,266.11	1.3	19,111.25	20.3	1,697.55	1.7	18,932.07	4.9
2,550.00	5.0	915.00	1.8	450.00	.8	7,521.15	14.8	3,126.00	6.1	10,500.00	4.3
3,600.00	8.0	1,000.00	2.2	500.00	1.1	9,365.20	20.8	5,650.00	12.5	7,000.00	6.4
3,600.00	12.0			150.00	.5	5,062.25	16.9	2,950.00	9.8	3,100.00	9.7
2,050.00	7.8	201.36	.76	56.87	.21	5,636.37	21.5	404.25	1.5	2,000.00	13.
1,850.00	9.2	200.00	1.	350.00	1.7	3,976.25	19.8	1,025.00	5.1	2,500.00	8.
2,400.00	13.3					5,484.80	30.4	874.00	4.8	2,500.00	7.
2,070.00	15.6	72.00	.53	85.00	.63	4,239.25	31.3	685.50	5.0	1,550.00	8.7
1,200.00	12.	250.00	2.5	50.00	.5	2,602.05	26.	900.00	9.	1,100.00	9.
962.00	11.6			42.00	.5	1,834.46	22.2	129.66	1.5		
2,773.75	8.7	291.03	.92	294.99	.93	6,483.30	20.5	1,744.19	5.5	5,433.20	7.8
	15.6		2.5		1.7		31.3		12.5		13.
	7.8		.5		.5		14.8		1.5		4.3
	4.4						22.2		2.6		3.7
	4.3						24.8		1.9		5.

In order to pay himself a salary of \$2,400 and a clerk \$1,400, his net sales should not be less than \$30,000.

Rental expense is usually the next largest item to that of selling expense. The average shown, 4 per cent, is quite in keeping with small store practice. Radio stores, generally, must be on the lanes of traffic, and these strategic locations are costly. Five per cent is not unusual, but if it goes above that the dealer should make a strenuous effort either to increase his sales or take on a sideline which would not require much floor space. Store H, with a rental percentage of 7.6, is as much out of pace with its rental percentage as it is with its selling expense. If the dealer is unable to increase his volume he should rent out half of his store.

Store B, with a rental percentage of 2.4 per cent, makes the best showing in the group. Judging from the rental paid and net sales, this dealer has a corridor-type store on a main business artery.

#### Publicity Expense, 1.8 per Cent

All types of newspaper, circular and direct-by-mail advertising, window trimming and store decorations come under "publicity." The average, given in the table, 1.8 per cent, is altogether too low, and should not be considered by the reader as a criterion. Practically all radio stores are new, as is the product they are selling. In order to establish themselves in the confidence of the community, and to offset the suspicion on the part of the public that has followed in the wake of exaggerated and "gyp" advertising, the dealer should not hesitate to boost this appropriation up to 5 per cent.

Selling expense, rental expense and publicity are so closely interwoven that if one is neglected the other two

### Tell Your Service Man to Ask 'em to Buy—

**Voltmeters**  
**Ammeters**  
**Hydrometers**  
**Extension cords**  
**Lightning arresters**  
**Lamp socket aerial plugs**  
**Batteries and tubes**  
**Distilled water**  
**Battery service**

will be affected. Most of the stores in the accompanying table could handle a fifty per-cent greater volume of sales without any appreciable increase in total expense. To get this increase in trade, which is the pressing need of store G, something should be done. Newspaper advertising this time of year may be unproductive, unless it is for a clearance sale. Instead of putting \$150 or \$200 in circulars or advertisements, this dealer could hire young men or women to dig up "leads" by taking a musical survey of his neighborhood (see Page 526), charging their salaries and incidental expenses to publicity.

If the stores shown in the table are unable to increase their sales volume through different means of publicity, the next step would be to multiply stock turn. The average turnover for all stores, 7.8 per cent, while exceeding that obtained in other retail fields, is not large enough, when considering the inventive stage which radio is in today. New models and developments break so rapidly that it is not infrequent that sets become obsolete in three months' time.

By specializing on faster moving goods and governing all purchases according to past sales, resulting,

let us say, in a stock turn of 10 times, store A, with its present turn of 4.9 per cent, would be able to release nearly \$9,000 of working capital for other undertakings. The secret of making profits from increased stock turn is that the working capital can be used in developing other lines.

#### Excessive Turnover Undesirable

Store E, with its stock turn of 13 times, brings up the question of extremes, however. Too rapid a turnover may hurt profits, as the dealer, in his effort to keep down interest charges and obsolete goods, may run out of leaders, thereby losing business and customers also. In addition to keeping ample stock for store and window display purposes, the dealer should be governed by the various factors of seasonal buying trends and delays likely to occur between the time of ordering and receiving replacements. Quantity purchases, resulting in bigger discounts, are to be considered also. Generally speaking, the dealer who is giving first thought to getting a stock turn every six weeks is making more money than the dealer who is primarily interested in getting quantity discounts. Invariably the latter overstocks, each article in turn accumulating its share of interest, insurance and other operating expenses.

In the case of store E, 13 stock turns are quite possible, as this dealer is in close proximity to his jobbers and is able to get replacements at a few hours' notice.

To get up near this figure, or at least a stock turn of 10 times, the dealer should do the following: Clear out all slow-moving stock; install a perpetual inventory system; budget purchases according to past sales, and establish a turnover bogey and stock limit for each line.

## Give Head Set Demonstrations on the Sidewalk

Most people who have listened in on head phones will attest that they are generally much clearer as well as more sensitive than the average loud speaker. Last year one dealer desired to move the head phones he had in stock and connected up half a dozen pairs so that people passing the store could stop and "listen-in" with them. At the same time a loud-speaker was bringing in the same program with great volume, but less distinctly. Signs called attention to the excellence of the head sets, and it was entirely unnecessary to point out the difference in clearness between the speaker and the phone. With a pair of head phones it is estimated that 50 per cent more stations can be picked up and brought in on any set than by tuning in with the loudspeaker alone.



A "Radio Hitching Post" Will Stop the Passing Crowds



# "Radio School" Brings Added Trade

San Antonio Music Dealer Finds "Free Instruction Classes in Radio" Create New Customers for Parts and Sets as Well

**T**HAT the man who knows how to drive an automobile will never be entirely happy without a car is the theory upon which the automobile companies have established schools for driving in connection with most of their local salesrooms. Moreover, when the time comes for purchasing a machine, he will count himself under obligation to the firm which has given him the instruction and all odds are in favor of his making the purchase from this concern.

The same philosophy has led the San Antonio Music Company, San Antonio, Tex., to establish a free radio school in connection with its radio department. Both are under the charge of Robert G. Barrera, assisted by his wife. Classes are held twice a week, on Mondays and Fridays, between 7 and 8 p.m., in the store. The course of study is designed to cover a six months' period.

The instruction is aimed to meet the needs of the new purchaser of radio who wants to understand something of the instrument with which he is dealing. Lectures are given to explain in simple language the radio terms with which the beginner must be familiar. No attempt is made to use engineering or scientific language—in fact, the idea is to present the matter in so simple a form that it will be understood and not merely memorized. There follows instruction in building and repairing sets—with the actual construction of sets by the pupils if they wish. Throughout, the desire is to meet the needs and wishes of the student—in other words, to make radio understandable to him.

These courses have been well attended, from 25 to 30 pupils making up an average class. Some are customers who have recently purchased sets and wish to understand them thoroughly, some are amateurs who wish assistance in putting together a set of their own—and some are merely getting acquainted with radio for the first time. All of these offer excellent prospects for later sales, whether parts, accessories or complete sets. The number of more ex-

## Get Them Started on Radio

by teaching them all about it in language they can understand, is the selling philosophy of the San Antonio Music Company, San Antonio, Texas.

The free instruction classes in the "radio school" this dealer has inaugurated, bring not only an increase in the sale of parts, but get new prospects for sets too.

pensive sets which have been sold to those first making contact with the store through these classes is alone sufficient to justify their existence, not to mention the sale of parts for the sets actually constructed in the school.

In addition to these regular courses, Mr. Barrera is a writer of numerous articles on radio in the press in which the similar aim of making radio understandable to the lay reader is carried out.

During a recent Radio Show held in San Antonio, a "trouble shooting

department" was a feature of the booth of the San Antonio Music Company. This was given considerable publicity in the newspapers and attracted many who were in need of assistance. Many of these who possessed unsatisfactory sets were excellent prospects for later models which could give them more satisfaction.

## Interesting the Women in Radio

This department was presided over by Mrs. Barrera and was advertised as being particularly designed to meet the needs of the woman radio fan. Information was not denied the male seekers after knowledge, however, and both Mr. and Mrs. Barrera were on hand to answer any questions.

The radio school, which was just opening its spring term was also announced at this time, advantage being taken of the newspaper publicity available during this period to spread interest in the classes.

Cooking schools have long been a favored method of introducing electric ranges and particular brands of food stuffs. In Mr. Barrera's opinion, the radio school is no less helpful in building up new—and permanent—radio business.

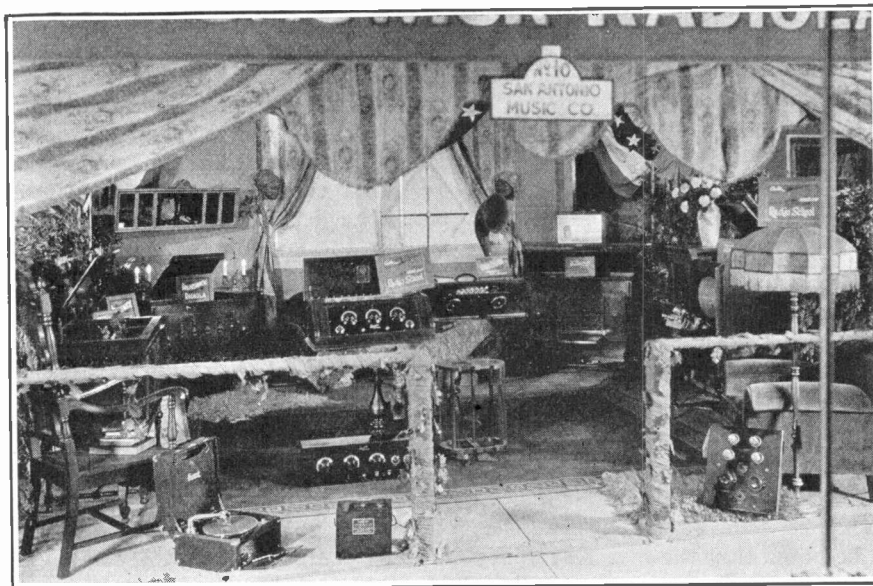

A "trouble-shooting department" was one of the features of this display made by the San Antonio Music Company at a recent radio exposition at San Antonio, Tex. Here

the fan's trouble questions were answered and his set tested, thus serving to bring the dealer and his facilities to the attention of a great number of radio owners.

## *A Well-Trained, Well-Prepared Service Man*

creates an excellent impression of your store in the customer's mind. The service man is the point of contact between your business and your radio customers after a set has been purchased. Upon your service man depends whether you hold or lose many customers.

Even though your service man may be a whirlwind, call this article, with its unique testing chart, to his attention. Does he always take a voltmeter with him when he goes out

on a call? And a hydrometer, pliers, screw-driver, extra batteries, extra tubes, a flashlight, earphones, solder and soldering iron, wire, small wrenches?

Give him this testing chart, reproduced on another page; make him study it, learn it, study it yourself, and put him through the tests outlined. When he has thoroughly absorbed the intent of the chart, you can rest assured that your service man is the best in town.

*(Continued from Page 538)*

are very much weaker than normal, the repair man should proceed as follows, making the necessary replacement which the tests indicate:

1. Test A battery voltage and replace if low.
2. Test B battery voltage and replace if low.
3. Replace tubes with tested tubes; listen in with phones plugged in detector jack.

Having taken these preliminary steps and found that the receiver repowered with good batteries and tested tubes, is not restored to working order, his next step should be an inspection of the antenna system, making certain that the aerial is not grounded and that the ground connections are good. The antenna and its lead-in should be inspected for broken or corroded connections. In nine cases out of ten, the three tests listed and the antenna system inspection leads to a discovery of the trouble. The next resort is following the routine given in the systematic trouble chart.

If reception is of full volume, but distorted, the following are the preliminary points to be examined:

1. Condition of A, B and C batteries.
2. Polarity of battery connections.
3. Quality of grid leak and condenser.
4. Adjustment of loud speaker unit.

Having satisfied himself on these points, the service man should proceed with a detailed inspection.

Although the systematic inspection chart calls for many tests, it will be noted that the first test under each main head is one which eliminates a number of succeeding tests if a positive result is secured from it.

Do not hand this chart to a service

man and expect it to be useful to him. Study it yourself and then explain the purpose of systematic routine inspection to him. Then give him the necessary tools and make him carry out each test on a set which is completely wired for use. Read each test to him, make him perform it and secure the expected result. Explain what happens when the expected result is not obtained. Then continue with the next test.

The first time the entire series of tests is gone through will take forty-five minutes; the third time, less than fifteen minutes. Then ask him to take the chart home and read it a few times. If your instruction is sympathetic and helpful and your man ordinarily intelligent, the time he needs to make a service inspection as a result of this training will be cut in half.

### How to Use the Chart

The standardized service call chart takes him to the most likely cause first, beginning with the A battery, the B battery, the tubes, the antenna system, and then narrowing down to difficulties within the set itself. The first column of the chart indicates the part of the receiver being tested; the second, the method used to make the test; the third, the result if the part tested is in good condition; the fourth, what to do if expected result is not obtained.

Do not proceed from one test to the next until a positive result from all preceding tests has been attained. A negative result means a trouble has been located.

The trouble man's task can be somewhat lightened if the complaining customer is asked certain questions by the person receiving the complaint before the call is made. Having the answers to these ques-

tions, the service man can go out with the certainty that he has the replacement materials most likely to be needed. They are:

1. What size and voltage B battery do you use?
2. What kind and number of tube do you use?
3. What kind of A battery supply do you use?

Major repairs, such as touching condenser plates, burned out transformers, broken connections which are not found upon first inspection and difficulties of a serious character which require more than an hour's work at the customer's residence should not be attempted by the service man unless long traveling distance to the job makes it absolutely necessary.

Following the systematic method outlined above, it is remarkable in how many instances the trouble is located almost immediately. This permits more calls per day and it makes a good impression on the customer. A trained and systematic service man is worth half a dozen electrical experimenters.

### "Meet the Farmer on His Own Home Grounds"

If a radio dealer is to succeed at selling radio sets to farmers, he must meet the farmer on his own home grounds, the farm. It is hard to entice the farmer to a shop or place of business and sell him, for that is not how he wants to be sold. He is sometimes suspicious of circular letters and often of advertising. That is the selling philosophy of one radio dealer in Kansas, who is successfully serving the rural market.

The best way to prospects is through the public schools, this dealer has found. Circular letters are sent to all the teachers and board members in the township, stating the dealer would like to give a free radio concert in the school. A date is arranged, if possible on a school night, and the set is installed before the children leave, so that they carry the news to their parents. Of course, the concert is advertised beforehand, as well.

When one of these concerts is given, two or three extra sets are taken along, and are often sold before the evening is over. After the concert, names are always secured for further solicitation, and further demonstrations are made on the farm. Usually, an evening with the most skeptical prospect will convince him.

File "Radio Retailing's" Listings Each Month—  
You Will Find Them an Invaluable  
Buying Guide.

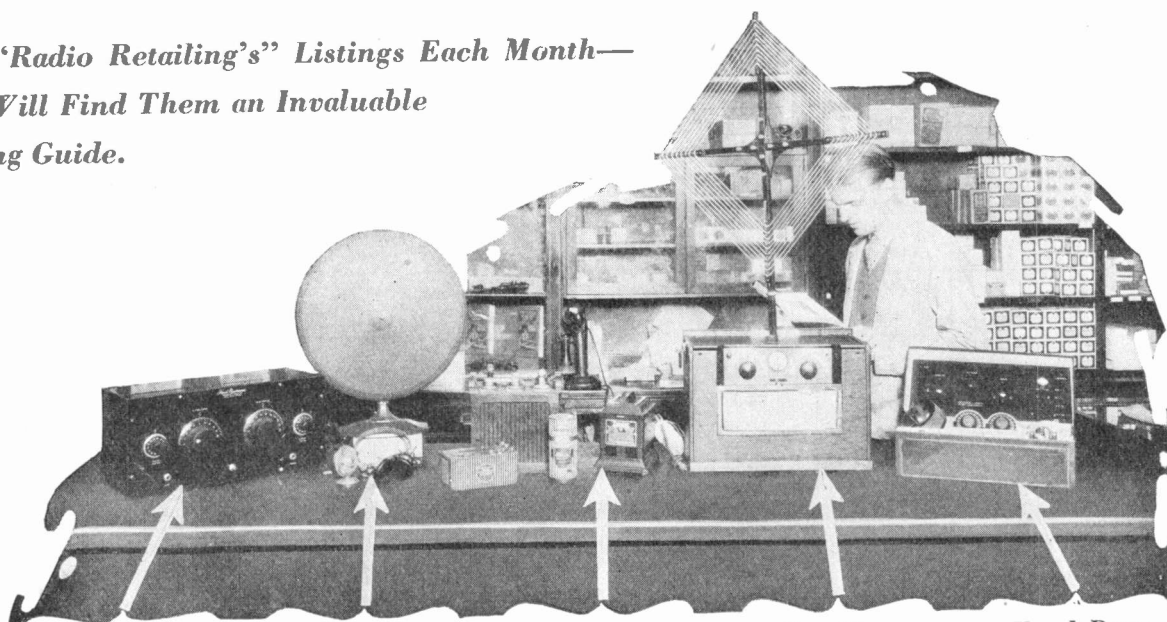

For Radio Sets  
See February Issue,  
Pages 154-159

Loudspeakers,  
Earphones,  
Phonograph Units  
March Issue,  
Pages 253-255

Batteries,  
Chargers,  
Eliminators,  
Power Units  
April Issue,  
Pages 360-365

Portable  
Receivers,  
and Loop  
Antennas  
May Issue,  
Pages 448-451

Knock-Down  
Receivers,  
This Issue,  
see Below

## "Radio Retailing's" Complete Kit Specifications

LISTINGS of radio products, with the name and address of the manufacturer, together with complete information concerning each product is a monthly feature of *Radio Retailing*. This service is wholly for the benefit of readers and is without charge of any kind whatsoever to the manufacturers listed. It is *Radio Retailing's* desire to make these lists a complete, representative

directory of radio products, so that, by keeping and filing the lists each month, the dealer will always have at hand the information he wants to know about any radio set, reproducer or accessory. Manufacturers are invited to send specifications of their products for representation in these lists, which will be revised, brought up-to-date and published in rotation.

Name of Manufacturer	Trade Name	List Price	Type of Circuit	No. of Tubes	Stages Audio Amp.	Panel	Type of Instructions Furnished	Weight, Lb.	Assembled Kit Ready for Opr. + Accessories	Other Equipment Furnished
F. A. D. Andrea, 1581 Jerome Ave., N. Y. C.	Fada	\$72.00	Neutrodyne	5	2	7x24 Bakelite Drilled	Blue Print Pictorial	18	Yes	
Acme Apparatus Co., 37 Osborn St., Cambridge 39, Mass.	Acmeflex	65.00	Reflex	4	3	7x21 Bakelite 7x24 Metal	Blue Print	25	Yes	Panels Drilled
		80.00		5	2		Pictorial	30		
A. C. Electrical Mfg. Co., Dayton, Ohio	A-C-Dayton	72.50	Balanced R.F.	5	2	7x24 Bakelite Drilled	Blue Print Pictorial	13	Yes	Mahogany Cabinet
Apex Electrical Mfg. Co., 1416 W. 59th St., Chicago, Ill.	Mietrodyne	97.50	Super-Het.	7	2	7x18 Drilled	Blue Print Pictorial	10	Yes	
Amsco Products, Inc., 416 Broome St., N. Y. C.	Meleo Supreme K.D.	90.00	Meleo Supreme	4	1	8x22 Bakelite Drilled	Blue Print	18	Yes	
		100.00		5	2		Pictorial		No	
		45.00		4*					Yes	
Baldwin-Pacific & Co., Pacific Bldg., San Francisco, Cal.	Pacific Ranger Model-A	75.00	45,000 Cycle Super-Het.	8	2	Optional	Blue Print Pictorial Manual		Yes	
Birch Field Radio Corp., 110 W. 40th St., N. Y. C.	Little Dyn- O-Might	20.00	T.R.F.	4	2	7x10 Bakelite Drilled	Manual	8.75	Yes	Screwdriver Spintite wrench Oak cabinet
Bremer-Tully Mfg. Co., 532 So. Canal St., Chicago, Ill.	B-T Nameless	26.50	T.R.F.	3-5*		Separate	Blue Print Pictorial		No	
Cleveland Products Co., 714 Huron Rd., Cleveland, Ohio	Kennedy	70.00	T.R.F.	5	2	7x26 Bakelite Drilled	Blue Print Pictorial	15	Yes	Mahogany Finished Cabinet
Danziger-Jones Inc., 25 Waverly Pl., N. Y. C.	Telos	60.00	T.R.F. and Reflex	4-7	2 Resistance coupled	No	Blue Print Manual	8	Yes	Subpanel, screws nuts, etc.
Dewitt-LaFrance Co., Inc., 54 Washburn Ave. Cambridge, Mass.	Super-Het. Coil Kit	15.00	Super-Het.	*			Manual		No	
Elgin Radio Supply Co., 207 E. Chicago St., Elgin, Ill.	Elgin Super-Reinartz	46.60	Regenerative	3	2	6x12 Bakelite Drilled	Blue Print Pictorial	7		
Electrical Research Labs., 2500 Cottage Grove Ave., Chicago, Ill.	Erla Circloid Model K-8	49.50	T.R.F.	5	2	Drilled Apparatus Mounted	Pictorial	9.25		
Forman & Co., 366 Greenwich St., N. Y. C.	Unxld	15.00	T.R.F.	*	2	7x18 Bakelite Drilled		2.5	No	
		30.00		3				7.5	Yes	
		38.00		5				8.5	Yes	
Freshman Co., Chas., 240 W. 40th St., N. Y. C.	Freshman Master Piece	10.00	T.R.F.	*			Blue Print Pictorial	3		
Hanscom, A. T., Woonsocket, R. I.	Superunit	37.50	Super-Het.	4	2	Yes	Blue Print Pictorial	5	Yes	
		75.00		6				12		

\* Kit contains apparatus for fundamental circuit only i.e. condensers and R.F. transformers.

## Radio Kits—Continued

Name of Manufacturer	Trade Name	List Price	Type of Circuit	No. of Tubes	Stages Audio Amp.	Pane	Type of Instructions Furnished	Weight, Lb.	Assembled Kit Ready for Opr. + Accessories	Other Equipment Furnished
Harkness Radio Corp., 727 Frelinghuysen Ave., Newark, N. J.	Reflex	35.00	Reflex	2	2	7x12 Celeron Drilled	Blue Print	9	Yes	
	Counterflex	39.50	Counterflex	3	2	7x18	Pictorial	9	Yes	
Jones Radio Mfg. Co., 40 W. 25th St., N. Y. C.	Jos. W. Jones	50.00	Untuned R.F.	4	1	15x10.5 Bakelite	Pictorial	5	Yes	Loud Speaker
Jamieson, H. E., Rivera, Cal.	Superuna	18.00	Variation of Autoplex Super. Reg.	1		7x12 Hard Rubber Drilled	Blue Print		Yes	15 ft. Litz
Liberty Electric Corp., Stamford, Conn.	Liberty R-40	27.50	Super-Het.	8	2		Blue Print Pictorial		No	
Lee Electric & Mfg. Co., 220 80th St., San Francisco, Cal.	Lemco	25.00	Reflex	2		Yes Drilled	Pictorial	6	Yes	
Lincoln Radio Corp., 224 N. Wells St., Chicago, Ill.	Lincoln	21.50	Regenerative	1	2	7x12 7x18 Bakelite Drilled	Blue Print	5.5	Yes	
		40.00		Pictorial			8	Yes		
Langbein-Kaufman Radio Co., 511 Chapel St., New Haven, Conn.	Super Selector	50.00	T.R.F.	4	2	7x18 Celeron Drilled	Blue Print Pictorial	10		
Martin-Coupland Co., Providence, R. I.	Marco Rasla Marco R.F. Kit	37.50	Reflex R.F. with Regeneration	3	2 0	No No	Pictorial	6	Yes	
		17.00		Blue Print			3	No		
Nazeley Co., 571 Hudson St., N. Y. C.	Roberts	53.00	Reflex	2	1 and 2 Push- Pull	7x18 Celeron Drilled 7x21	Blue Print		Yes	
		70.00		Pictorial				Yes		
Phoenix Radio Corp., 5 Beekman St., N. Y. C.	Ultradyn Model L-2	30.00	Super-Het.	8	2		Blue Print Pictorial			
Pinkerton Radio Corp., 1834 Broadway, N. Y. C.	Pinkatone	87.00	Super-Het.	7-9	1	7x24 Bakelite Drilled	Blue Print Pictorial			
Rosenbloom Co., Wm., 11 Deering Rd., Mattapan, Mass.	W.R. Super-Het.	10.00	Super-Het.	8			Printed instructions	3	No	
Richardson Radio, Inc., 128 University Pl., N. Y. C.	Richardson	49.00	T.R.F.	5	2	7x18 Hard Rubber Drilled	Pictorial		Yes	Marked battery Leads
Radio Receptor Co., 106 Seventh Ave., N. Y. C.	Receptrad Multiflex	50.00	T.R.F. and Reflex	4	3	7x24 Bakelite Drilled	Blue Print Pictorial	13	Yes	
Radio Industries Corp., 131 Duane St., N. Y. C.	Rico-dyne Tropadyne	38.75	R.F. Longwave	5	2	7x18 Bakelite	Blue Print	23	Yes	Wire, nuts, screws, etc.
		28.75		Pictorial			12	Yes		
Ray-Dee-Arcraft Mfg. Co., 1005 Tribune St., Redlands, Cal.	Ray-Dee- Arcraft	35.00	Regenerative Reflex	3	2	7x18 Formica Drilled	Blue Print Pictorial	14	Yes	
Samson Electric Co., Canton, Mass.	Sampson Sampson T.C.	22.50	Super-Het. R.F. with Regeneration	8	2 2	No Formica	Manual	2½	No	
		65.00		Pictorial			10	Yes		
Shamrock Mfg. Co., 314 Market St., Newark, N. J.	Counterflex	39.50	Harkness Reflex	3		7x18 Drilled Rubber	Blue Print	11	Yes	
	Reflex	35.00		2	2	7x12	Pictorial	8	Yes	
Stadeker Mfg. Co., 299 W. Illinois St., Chicago, Ill.	Superselector	49.50	T.R.F. and Regeneration	4	2	7x18 Electrasote	Blue Print		Yes	
Silver-Marshall, Inc., 105 So. Wabash Ave., Chicago, Ill.	Silver-Super	72.65	Super-Het.	7	1	7x18 or 7x24 Bakelite	Blue Print Pictorial	28	Yes	Panel drilled with or with- out meter hole
Sweeney Radio & Electric Co., Sweeney Bldg., Kansas City, Mo.	Sweeney W-H-B	125.00	Super-Het.	7	1	7x30 Celeron 7x26	Blue Print Pictorial	26	Yes	Panel drilled cabinet
	Sweeney 5-N	90.00	Neutrodyne	5	2			24	Yes	
Thompson Mfg. Co., Inc., R.E. 30 Church St., N. Y. C.	Thompson Type K-40	72.00	Neutrodyne	5	2	7x20 Bakelite Drilled	Blue Print	12	Yes	
Tested Radio Products, Inc., 224 W. 49th St., N. Y. C.	Haynes Griffin DX	15.00	Three Circuit	1		7x15 Drilled	Pictorial		Yes	
Telephone Maintenance Co., 20 S. Wells St., Chicago, Ill.	Telmaco Portable Type P-1	80.00	Reflex	4	3	5.5x17.5 Formica Drilled	Blue Print Pictorial	26	Yes	Case, Loop built in Speaker
Tanner Radio Co., 528 W. Washington St., Los Angeles, Cal.	Neutroflex	31.00	Reflex	2	2	7x12 Celeron Drilled	Blue Print Pictorial	5	Yes	
Tuska Co., C. O., Hartford, Conn.	Superdyne	60.00	Superdyne	4	2	6x21½ Formica Drilled	Blue Print Pictorial		Yes	
Victoreen Radio, Inc., 6526 Carnegie Ave., Cleveland, Ohio	Victoreen	80.00	Super-Het.	7 or 8	1 or 2	7x26 Bakelite Drilled	Blue Prints	12	Yes	
Wel-Bilt Mfg. Co., 102 Chambers St., N. Y. C.	Welbilt	25.00	Three Circuit	3	2	7x18 Hard Rubber Drilled	Blue Print Pictorial	8	Yes	
Workrite Mfg. Co., 1812 E. 30 St., Cleveland, Ohio	Workrite	70.00	Neutrodyne	5	2	Drilled	Blue Print Pictorial		Yes	

\*Kit contains apparatus for fundamental circuit only i.e. condensers and R.F. transformers.

## "If I Were a Radio Manufacturer"

By M. M. REINHARD

(Continued from Page 536)

parts, anyone wanting a "Jones" set would have to buy the factory-built product, with its greater value to the customer and greater profit for manufacturer, jobber and retailer.

There is too much of everything in radio today. Too many manufacturers making too many different models, too many jobbers, too many retailers, too much boastful advertising resulting in the public being educated to demand too much from the average set, too many broadcasting stations and too much price-cutting.

If I were a manufacturer I would make but three models and these embodying a five-tube tuned radio frequency circuit, to sell at \$100, \$150 and \$200. My cabinets would be of the semi-console type, with a built-in reproducer. And these I would market to an exclusive jobber in each territory who must sell them to a limited number of "authorized dealers," situated far enough apart so as to prevent cut-throat competition. And I would not force my jobbers to become overstocked with my products, and would rebate to them and to dealers who become overstocked.

## "If I Were a Radio Dealer"

By POWEL CROSLY, JR.

(Continued from Page 537)

its methodical development. Such an effort, of course, should be supported by carefully planned advertising that will build up interest ahead of the salesman and support their personal work.

I would employ these salesmen on a commission, supervise them carefully and have them make a daily report of their calls. The results of such a real selling campaign, even in the summer months, would astound the average dealer. That comparatively small percentage of dealers who have tried it, know that it works. I would sell on easy payment contracts, asking about one-third of the purchase price in cash, and the balance in six or eight months. I would endeavor to concentrate the house-to-house campaign in the fall so that the bulk

of the easy payment selling would be done before Christmas and payments would not extend into the summer months when the vitality of radio enthusiasm is low.

The second thing that I would do if I were a radio dealer, is to be sure of the quality of service that I rendered to the people who bought radio sets from me. Above all else I would make sure that they were satisfied with whatever I sold them. My service department would be maintained on a profitable basis through the sales of accessories. I would recognize that it is necessary to have a reasonable margin of profit in order that I might legitimately service the apparatus I sold. I would not attempt to compete with that dealer who acknowledges his inability to serve by reducing his initial profit in order to make temporary sales. Such dealers frankly admit their inability to meet honest competition, to service their merchandise properly, and are satisfied to take a precarious profit on an individual sale, rather than to perform a service.

## "Pay No Attention to Cut Price Competitors"

I would not envy my competitor who had lost sight of the fundamental necessity of a living profit and fair service to his customers, nor would I pattern my business on his business methods. I would, instead, go on my own way, building good will in the community for my business, knowing that right dealing in the long run spells success. I would prefer to have people say to me—"He sells honest merchandise, takes care of his customers, and renders real service," than to have them say they could buy cheaper in my store.

One last and very important thing that I would do, is to study carefully the products I sold. I would eliminate lines that could not perform satisfactorily. I would cast my lot with the lines of one or two manufacturers, whom I believed were going to continue to exist in the radio business. I would stand behind those lines, regardless of the temporary opportunity to cash in on products of a questionable nature that might momentarily be in demand, and at the end of the season my shelves would be clear. I would not have my year's profit tied up in a miscellaneous assortment of slow-selling or non-selling merchandise which had been tried and found wanting.

## Don't Forget the Fourth of July!

Independence Day next month offers another opportunity for the radio dealer to secure some excellent advertising at very slight cost. There is probably no town or hamlet in the country, no matter how small, that does not have some sort of a patriotic program.

But how many will have an opportunity to hear the program from Washington, D. C., as it will be sent out over the air, with, in all probability, a speech by President Coolidge?

Therefore, radio dealers will be performing a public service, as well as securing invaluable advertising for themselves, if they arrange to make public broadcasts of the Independence Day celebration at the nation's Capitol.

Install a powerful receiver in some public place, either the steps of the City Hall, or in a public park, first getting official permission to do so, and announce the program well in advance. Get the co-operation of local organizations, and if a local program is planned, see if they will arrange the time so that your radio program can tie in with the local exercises.



# "Radio Retailing" Conducts a Radio Round-Table

Chicago Radio Men Discuss Retailing and Time-Payment Problems;  
Suggest Practical Plans for Summer Selling

**T**HE man with the most worthwhile views on retailing radio is the man who is dealing every day with the problems in distributing radio which come up in his own business. He cannot theorize; he must be practical.

To bring together a number of such men who are successfully manufacturing, jobbing and retailing radio for a discussion of practical problems in a practical way, was the object of *Radio Retailing* in inviting such a group to a meeting held in Chicago on the evening of April 21. The number had to be kept small in order to hold the discussion to a free give-and-take basis, but the attendance was in a great measure representative of all the trades who are dealing in radio. Among those present were men with a background of experience in the electrical, the music, and the automotive industries, from which experience they are successfully dealing with the new and knotty merchandising problems of radio. To keep the discussion within the subjects which could have the greatest common interest to all present and develop the most practical suggestions, an agenda of outstanding radio problems had been prepared in the form of the ten questions reproduced herewith.

There was a very free discussion of these questions in which practically every one present took part. The transcript of the stenographic notes consists of nearly a hundred typewritten pages. From this we have selected for publica-

tion some of the practical experiences recounted and the usable suggestions put forth.

H. A. Lewis, business manager of *Radio Retailing*, was the chairman of the meeting and in opening the discussion, said in part:

"Gentlemen, I suppose the first question is: why the meeting collectively? In talking with you individually we found that each had certain questions, certain problems that were in your mind and the curious thing was that we found the manufacturers and jobbers and dealers were all talking and thinking along the same lines. There have been meetings of manufacturers and meetings of jobbers and of dealers with their own groups. This is a rather different sort of gathering because we have here not only manufacturers of sets, parts and accessories, but we have jobbers and several kinds of retailers and a representative of a time-payment banking organization.

#### Down Payments on Time Sales

"Now, what is said here is not for publication without the individual's consent. This is a private, free-for-all party. There are no set speeches and no speakers. There are ten points which sum up the problems for discussion. Out of this round-table free-for-all discussion we can clarify our own thinking and state the essential problems and leave out the unessential problems."

Mr. Hindringer (Lyon & Healy): On your question number one, time payments; we do not believe it possible to take less than 25 to 33 1/4 per cent down nor to extend the period of payments longer than eight months. Radio changes so rapidly that if you extend your period beyond that length of time you run into the possibility of not making collections.

Now, on door-to-door selling, we find the only method that has been successful is by actually demonstrating sets in the home.

As to the question of salesmen, we find that getting men who are not too well posted but who know enough about sets to make themselves understood intelligently is the best policy. These men make better salesmen than some men who know much more about radio. When I was running our retail end, some of my best salesmen knew very little about radio. The "good listener," the man who is not too talkative, is the one who makes the most sales.

Our commission men are all required to service their own sales. In that way they are able to keep in touch not only with the man they have already sold but also the friends of their customers. For instance, after a man has sold a set he goes back in about two weeks and asks how the set is working. "Fine," is the usual answer. "Any of your friends heard it?" "Oh, yes, so-and-so heard it and is very

## The Ten Outstanding Radio Problems Discussed at Chicago Meeting

**IS IT** a fact that the so-called public acceptance of radio has resulted in slot-machine selling? Has the dealer, in consequence, sensed the fact that in order for radio to become more nearly a twelve months household specialty he must do a creative merchandising job?

1. Is it true that such creative merchandising involves:

1. Time payments: Question: What are proper credit terms? Are present terms equitable and fair?
2. Door-to-door selling: Question: What is the dealer to do to get the necessary men? What must he pay them? How is he to train and supervise them?
3. Anticipating the purchasing requirements of his public on price range, engineering requirements and style factors.
4. Service that maintains sets in satisfactory use and thereby extends entire radio market.

2. 1925: What specific things can be sold during the summer and what practical order getting methods can be suggested that can be given publicity at this time? Is there a practical

suggestion in the successful "Ask 'em to Buy" campaign conducted by the automotive trades?

3.

Have the manufacturers and jobbers been too much opportunists in the selection of their dealers, resulting in their getting dealer opportunists rather than merchandising dealers?

4.

Have jobbers properly increased their working capital to handle radio on a yearly basis or have they merely rearranged their business to finance radio purchases without increased capital; with a resulting detriment to all their other lines and a detriment to radio by holding radio to a seasonable basis?

5.

Has the nature of the manufacturers' radio advertising merely sought to capitalize on a predicated public demand rather than seeking to create and maintain a continuing market?

6.

Is it a fact that because of dealer's refusal to anticipate his requirements by ordering suf-

ficiently far ahead manufacturers are forced to speculate dangerously on demand? Would a flattening out of the manufacturers' sales and production curve through anticipation of dealers' requirements result in a benefit to the industry by the reduction of seasonal dumping?

7.

Where and how does the electric lighting company fit into the radio picture?

8.

What can or should be done to organize local dealers into associations for interchange of retail credit information and the practical improvement of local trade conditions?

9.

What can the existing trade associations do for the improvement of conditions? Are any new general associations necessary?

10.

What can the trade press do for the improvement of conditions?

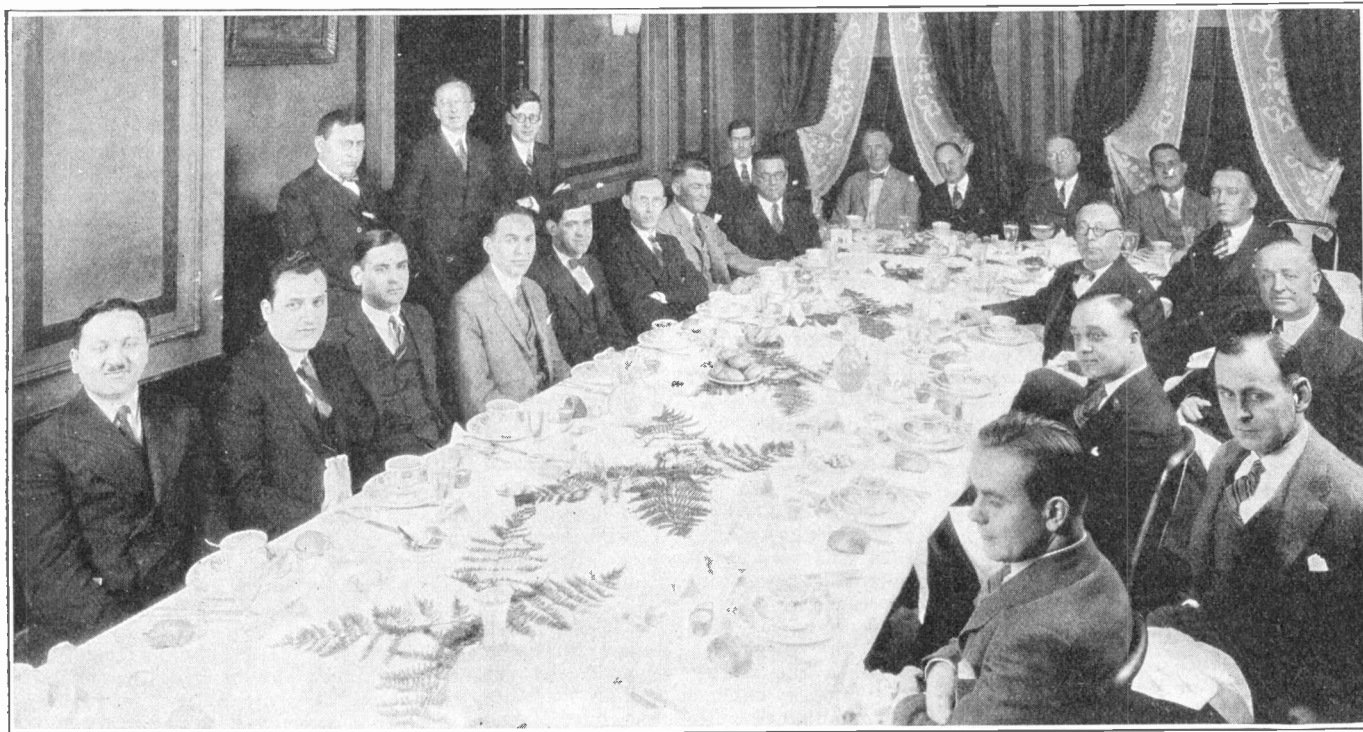

### The "Radio Round Table" Getting Into Action

House to house selling, time payments, vacation radio markets and the importance of "ask 'em to buy" were among the topics discussed at this meeting of Chicago radio merchandisers and manufacturers. Workable selling plans and practical suggestions were put forward by these men who speak with the authority of successful experience. Left to right (seated) are Charles Bass, Bass Camera Company; Herman Goodman; C. M. Brown; L. A. King, Operadio Corp.;

W. P. Roche, manager retail radio department, Lyon & Healy; J. C. Tully, Pres. Bremer-Tully Mfg. Co.; J. H. Francis, *Radio Retailing*; H. H. Roemer, manager sales promotion, Zenith Radio Corp.; H. R. Hall, Chicago Manager, Music Master Corp.; J. A. Duncan, sales manager, Illinois Electric Co.; C. P. Hindringer, manager wholesale radio department, Lyon & Healy; M. J. Kennedy, Secy., National Music Merchants Assn.; C. L. Sleininger,

sales manager, Howard Mfg. Co.; E. A. Edkins, manager electric shops, Commonwealth Edison Co.; F. T. Chase, Vice-President, Zinke Co.; C. R. King, Herbert H. Frost, Inc.; T. P. Joy, McGraw-Hill Radio Trade Directory; E. K. Marshall, All-American Radio Corp.; M. A. Drew, Commercial Credit Co. Standing left to right, H. A. Lewis, manager *Radio Retailing*, T. K. Webster, Jr., Pres. Ekko Co.; L. E. Moffatt, associate editor *Radio Retailing*.

interested." Most of their prospects and actual sales are gotten that way.

**Mr. Moffatt:** Is your policy to leave a set on trial or to close after one demonstration?

**Mr. Hindringer:** A quick close after demonstration is best. Otherwise people shop and give another salesman a chance to change their mind for them. Radio is so different from anything else. We might say that we are all liars about reception. For instance, a customer has had a demonstration and says to another man the next morning, "I got such and such a place on my set," and the other fellow will be sure and say, "That's nothing, I get everything every night."

**Mr. Roemer (Zenith Radio Corp.):** To leave a set on trial in a prospect's home, where the set can be attacked in the absence of your salesman, is certainly contrary to good practice. It is an indefensible presentation of your merchandise. In your absence the prospect does not want to admit his inability to operate your set—he therefore calls in someone from the neighborhood—and there is always that radio bug who knows about every set that is made—and the result is, if he is unable to operate your set immediately he accuses the set because he cannot consistently admit his inability to locate the trouble or operate the set since he is called in in the capacity of an expert.

**Mr. Moffatt:** How does the question of long-term payment come into the selling picture? What should the down payment be?

**Mr. Hindringer:** Get all you can.

**Mr. Bass:** Get all you can is right, and if your prospect looks as if he has got money you can get half down. In every case where we took as little as 25 per cent down we had some trouble.

**Mr. Moffatt:** Does the fact that you are selling in the spring or the fall make a difference?

**Mr. Hindringer:** We shorten the terms of payment in selling after the first of the year.

**Mr. Drew (Commercial Credit Co.):** We require the down payment to be 25 per cent. We will allow as long as twelve months but very strongly recommend eight or ten months, and preferably six.

**Mr. Edkins (Commonwealth Edison Co.):** We require 25 per cent down and spread the balance over six months with a 6 per cent carrying charge.

**Mr. Moffatt:** Do you ask a larger down payment in the spring?

#### What Is Happy Medium Between Period and Cash Invested?

**Mr. Edkins:** No, although as one of the gentlemen just remarked, a wise policy is to get all you can down. The one who has a considerable equity in the set he has purchased is less liable to "renig" on his payments than if he had paid only a small amount down.

**Mr. Bass:** As an experiment we tried advertising \$25 down—not 25 per cent—on any set up to \$150. Of these sales we had to take back, within two months, three out of five. There was a great deal of fault-finding from these sales. The class was very poor

and many were turned down.

**Mr. Kennedy (National Music Merchants' Assn.):** On the question of the term of payments, I hope that radio does not get into the class of piano and phonograph sales. Pianos are sold on as long as thirty months' time. Radio is going eventually to get into the same condition unless payments are kept high enough to start with.

**Mr. Moffatt:** There seems to be a tendency to extend the period of payments on most of the things that are sold on time payments. This is the case on washing machines and other electrical appliances.

**Mr. Edkins:** There is a reason for that and I have often wondered where the economic intersection between the two lines comes. Take the people we sell these appliances to. Most of them are salaried people with fixed, inflexible incomes. They have so much to spend for rent, for household, for insurance, and so on. When they get through with their fixed expenses, they have so much to play with, and that class of citizen, if he wants to buy something that costs more than he can pay cash for, naturally purchases the things he wants on easy payments. Now, the easier the first payment is, or the longer period of time over which he has to divide up the deferred payments, the fewer the repossessions.

On the other hand, there must be a point where whoever is financing it has got so much cash tied up that it becomes too great a burden to carry. If we could strike the happy medium,

if we could find out just where it was economically feasible to extend the payments to the maximum point without tying up too much capital, it seems to me that the extended payment, particularly where it is fortified by a rigorous credit investigation, is really a necessary factor in selling this class of merchandise in any considerable volume.

The higher you put your down payment and your subsequent payments, the shorter period over which these payments are divided, the more you restrict your possible buying public. A very large class of people cannot afford it. They may think they can afford more and they may be induced to try to buy something at a higher rate, but they very quickly discover they cannot keep the payments up, and that results in many repossessions.

*Mr. Hindringer:* For the year 1924 probably 70 per cent of our radio business was done on the time payment basis and we had only about eight repossessions and three suits to collect for the entire year.

#### Obsolescence Fixes Limit at Ten Months

*Mr. Duncan* (Illinois Electric Co.): Obsolescence is really the point you have got to look out for, I think. It is suicide for a dealer to undertake to sell radio for a period greater than ten or twelve months at the extreme. We advise our dealers to sell on ten months' time.

*Mr. Lewis:* You mean that you work with the dealer?

*Mr. Duncan:* Yes. And I would like to ask a question if I may. We feel that weekly time payments are advisable with the class of customers Mr. Edkins speaks of. I would like to know the feeling of some of the other men.

*Mr. Bass:* We don't encourage weekly payments.

*Mr. Drew:* There is too much expense involved from a finance point of view. If a dealer desires to collect his time payments weekly we require him to make them himself. If monthly we will collect them for him. The cost of making the collections weekly would be so great as to wipe out any profit we would have in the business.

#### Bankers Making Terms More Conservative

*Mr. Lewis:* Mr. Drew, is it true that the discount houses are going to try to establish the term of payment for radio?

*Mr. Drew:* Only inasmuch as they are for other things sold on time. At a recent association meeting of the automobile finance men they agreed to eliminate the 16 months' period which has been common in Chicago and also to require 30 per cent down instead of 25 per cent. This shows a tendency to make the business more conservative. I think what Mr. Duncan said about a radio set becoming obsolete is the greatest factor in keeping the period of time down. Radio sets drop in price. A man might owe more on his set bought a while ago than a new one would cost him and he would say, "I will let the company have this one back and buy a new one."

*Mr. Lewis:* Did you have many such cases?

### Tell Your Salesman to Ask 'em to Buy—

Head sets  
Dry battery tubes  
Small size B batteries  
Battery chargers  
Indoor antenna  
Parts for a portable set  
A portable case  
Steps of amplification  
Phonograph attachments  
Time switches for automatic control

*Mr. Drew:* No, we didn't, but some of the dealers did. Our experience for 1924 was very satisfactory. Repossessions didn't amount to more than one per cent.

*Mr. Francis:* Mr. Drew, I have heard that the discount people are using radio in the winter as an outlet for their money which is used in the summer to finance automobile sales. And that when the automobile business is active in the summer they are no longer interested in purchasing radio paper.

#### Financing Rates Similar for Autos, etc.

*Mr. Drew:* I think that the automobile situation has some bearing on radio. Radio provides a good winter outlet for the money, the same as oil burners and other appliances. But we do not refuse to buy radio paper because it is summer. I would like to say one thing in addition. It has been said that the rate for financing radio paper is too high. The same could be said for automobiles, refrigerators and furnaces, and anything sold on time. The rates are practically the same, so if the rates are too high for radio they are too high for the automobile business, and I think the manufacturers will admit that time payments on automobiles practically made the industry. The same thing will probably be true of radio. This fall will see a great increase in time sales of standard radio sets.

*Mr. Francis:* Then you would carry the season through the summer? You do not restrict your dealers to any season of the year?

*Mr. Drew:* No, several of our dealers are doing just as much business now as in January and February. They are exceptional dealers, of course. Our purchases of radio paper have declined somewhat but it is still a worthwhile business.

*Mr. Lewis:* Shall we discuss the question of outside salesmen?

*Mr. Duncan:* We believe that most dealers will have to use house-to-house methods on radio as they have on appliances, in order to get volume. To a certain extent it is a process of evolution. Organs were sold from house-to-house and later on salesmen came along and traded the piano for, the organ. Those methods are now being used successfully in selling radio and I think Mr. Drew will bear me out in the statement that successful dealers

are using house-to-house salesmen on a commission basis.

*Mr. Roemer:* I had an interesting experience in California recently that bears on selling in the home. A salesman had a prospect who was interested, or thought he was interested in a low price set. The salesman wanted to sell the higher priced set but his prospect was ready to buy the cheaper one and would not consider the super. The salesman asked me what he should do. "Sell him what he wants," I advised, "get the small set into his hands. Put it in a conspicuous place, but at the same time have one of the big handsome sets in your car and after you have made your demonstration on the small set simply tell him you have one of the other sets that you would like to test for reception in that locality. Then get the big set in and place it on his library table or in a position which you have sized up as being advantageous." The salesman followed this out and after he had demonstrated the two sets the customer bought the expensive one; he could not see the cheaper one. It is always easier to sell in this way by bringing the set into the home. I also advise him further that when making a demonstration he should always endeavor to get the prospect to invite in a number of guests. He will naturally promise an interesting radio party in such an event in order to get his friends to come in. A demonstration of this kind therefore, carries an appeal to the others who are present and besides, introduces the salesman in a friendly way which gives him other prospects to work on in his sales endeavor.

#### Service Man Leads Way to Sales

One of the best means for getting radio leads is by following up service. The greatest way to get to the set owner for further prospects is by testing out his set with him. I have seen it work out in all kinds of homes. A millionaire will get down on his knees with the service man in front of his set and with their heads together grow very chummy as they operate the dials and discuss radio. Radio service men are smoking better cigars today than they ever did in their lives before—the man of the home forgets class entirely and will treat a service man equally as well as his best friend. A service man can supply the sales department with material impossible to obtain otherwise when it comes to sales information and leads.

*Mr. Hindringer:* Speaking of selling by demonstration, we have had cases where there were three sets sold in one evening because the customer receiving the demonstration had friends in the house. One customer leads to another. I don't know of any other industry where you can get as close to as many people as in radio. The biggest men will fall for you when it comes to radio. I have made more friends in three and a half years in radio than I have in all the 25 years I have been with Lyon & Healy.

#### Appealing to the Women Prospects

*Mr. Sleininger:* I would like to ask how long we must overlook the housewife in buying and selling radio sets. I have always felt up to this time



that we have been dealing with the man or the boy and I feel right now that we are at the stage of the game where beautiful cabinets and devices that look nice in the home are going to appeal to the housewife. I think we have in the housewife a real buyer of radio sets.

*Mr. Roche* (Lyon & Healy): We find that sixty per cent of our sales of combination radio and phonographs are made to the ladies. And we find that we don't have to demonstrate them in the home. The ladies come to the store and hear a demonstration there and of the several hundred combination radio and phonographs we have sold we have had no returns. I think we repossessed one and that was due to a customer who had financial losses.

*Mr. Francis*: A point that seems to me to be of interest to the general situation of dealers handling radio is their general financial situation. Mr. Tully, could you tell us about that?

*Mr. Tully* (Bremer Tully Co. Mr. Tully is on the radio committee of the Electrical Credit Men's Association): I can't tell you very much about individual dealers. We do not sell to dealers ourselves and the dealers handling radio that get into the records of the credit associations are not confined exclusively to radio. They are in electrical and other lines and whether their situation is due to their handling radio would be hard to tell. But in general, radio dealers are good credit risks.

*Mr. Lewis*: They are considered good risks?

*Mr. Tully*: Yes, I will say they are better risks than the ordinary dealer in a line of quick turn-over business.

**Limited Lines Vs. Miscellaneous Lots**

*Mr. Roemer*: I would like to ask a question of the gentleman representing the discount houses on the point of risk. Which is the better risk, the dealer who confines his merchandise to one or two, possibly three lines, or the dealer who takes up every new thing that comes out?

*Mr. Drew*: The dealer who handles one or two or possibly three lines of sets and who pushes those sets and turns his stock over rapidly seems to have the best success. We find, however, that the dealer who is a business man, if he has a hardware store or a music store or an electrical store, is a better credit risk than the man who has just gone into the radio business.

*Mr. Lewis*: Gentlemen, we have a definite problem before us in the summer of 1925. We are at the first of May. What definite things are there we can do as an industry or as a trade to stimulate business all the way through the season just before us? Has anyone worked out a definite plan, any dealer, manufacturer or distributor who can suggest certain specific things to the trade in order to keep the volume up this summer?

*Mr. Duncan*: We are suggesting to the daily papers, to the radio editors, that they give publicity to summer broadcasting. We have better broadcasting than ever before, the manufacturers and jobbers of equipment and accessories are all making an effort to make these programs more interesting and they are being sent out by

higher powered stations. The daily papers should emphasize the fact of how much better reception is this year than it was a year ago due to the fact that we have better stations. We are urging the radio editors on different papers to broadcast this fact at every opportunity.

*L. A. King* (Operadio Co.): There is also a large set market in the summer to the people who have never experienced summer static. Even though the idea has been put before them that radio will not be as good in the summer, still these people will buy if their desire to own a set is at all appealed to. Emphasize the pleasure in owing and using a set instead of the possible interference from static.

**Portable Sets for Vacationists**

*Mr. Edkins*: It seems to me that what we all need at this moment is a concrete suggestion as to how we can jazz up our sales during this lull period. I had an experience last summer that gave me an idea which is not at all original. It may have been tried by everyone around this table. I had two or three friends who were going away on a vacation buy portable sets on the assumption that it would be a source of entertainment and amuse-

ment in the evenings for fellows going to fishing camps, and so on, and they came back, every one of them, very enthusiastic about it. We are planning this spring and summer to feature the idea of vacation radio, the radio set up in the woods, on the lakes, and so on. We are going to build some display windows with a typical camp scene and the right sort of picturesque background. We will fill in with electrical supplies, flashlights and so on that lend themselves to that sort of display. Now, the man goes up, we will say, to a little cottage on some river. He has many evenings when a radio set will give him a lot of pleasure. I think everyone who has tried it will agree that with a radio set up on the mountains or lakes you are simply amazed at the clearness of the reception on those nights when the stars are out in the sky and you sit on your little porch at night and turn the dials. I tell you it is a great treat. That is a very simple human idea that will find response in the minds of a great many people if properly presented. It has occurred to me that a little advertising on the theme of the radio set being just as important on the vacation as your fishing kit, might build up summer business.

**Keeping the Household Happy—with "Radio in Every Room"**



With a radio program issuing merrily forth from a loud speaker in every room, the era of unhappy households has passed. From one set in the parlor, by means of wired outlets to other rooms of the house, it is possible to have music from cellar to garret, and at very slight cost, about \$3 for each outlet. It works to the dealer's advantage by enabling him to sell several speakers

with every set. Here's a new way of keeping cooks, preventing divorces, keeping the young folks at home and making even husbands happy. This illustration is reproduced from a recent issue of the *Town Crier* and parallels the radio-in-every-room idea suggested in the January number of *Radio Retailing*, and which has since received country-wide recognition.

# This Business of Ours

- ¶ *"Dumping" and Its Aftermath*
- ¶ *Using "Trade-ins" to Meet Price Situations*
- ¶ *Some Advice on Buying Policies*
- ¶ *Help Mr. Hoover Secure Fewer Stations and Better Programs*

A Monthly Department of Retail Radio Comment

By J. ANDREW WHITE

THE mental state of the radio retailer, right now, seems to me to reflect something of the puzzlement of that stone-breaker, sitting alongside the road gazing disconsolately at the large pile of flints still to be broken. A clergyman happened along, so the story runs, and after a cheery greeting remarked that the laborer had a deal of work to get through yet. "Right," came the weary response, "them stones are like the Ten Commandments. You can go on breaking 'em, but you can't get rid of 'em."

Now—no preaching—but isn't it obvious that smashing a market to pieces is no way to get rid of radio sets?

Take New York, as an example. Radio retail sales there are absolutely demoralized. Blast after blast of spectacular advertising, full pages and double spreads in the newspapers, have carried to the public the news that the most famous standard sets are now worth anything down to one-third of their value of a few weeks ago!

Some sets were sold. The flurry lasted a few days. Then the business went into the doldrums.

The reaction was easily foreseen. Mr. and Mrs. Public read, looked, and wondered. "There is something new coming out," they reasoned, "let's wait."

And that's what they're doing.

The normally slack season has been advanced, and the period of minimum sales volume expanded.

Now, what's it all about? Everybody knows the one-word answer: Over-production.

The remedy for which is, as any bright schoolboy would give it, the

manufacturer unloads on the dealer—at a price—and the dealer passes the bargain along to the public.

There is a sales precept (in department stores, at least) that the one sure stimulant to slow business is the bargain sale. It's sound, too—for staples!—and un-trademarked goods. But radio is "machinery," an entertainment luxury, and receivers are sold largely because of trademark prestige, or good-will for the circuit employed. Destroy confidence in either, by the suggestion, even, of obsolescence, and . . . well, it's a long climb back.

LIVE and learn. That's one way of looking at the radio business. But there are some retailers who are not of the act-on-impulse, shoot-the-works type; there are in this industry far-sighted men who have at least a nodding acquaintance with the fundamentals of sound merchandising. And they see receivers as machinery, highly trademarked articles, luxuries. Let's look around.

The automobile industry, will serve as an example.

In its early stages, twenty years ago—I was in the business then—there was plenty of price-cutting. The situation is somewhat different now. Every standard manufacturer is zealous in protection of his list price; it may be lowered, every now and then, but slashed figures and bargain sales are "out"—not only is there no connivance, there is no tolerance with such practices.

The motor industry knows over-production, slack seasons, periods of depression. But it meets the issue in a common sense way. At such

times, the exchange value of the turned-in used car, soars! That is all there is to it.

Can this be done in radio? It can. It has. It works, too.

I am not theorizing. In one of the stores with which I am associated the soundness of this policy has been proved.

Business was falling off. We took a good neutrodyne set, one we had confidence in, and advertised it with an unqualified endorsement. The list price, \$195, was featured; and with it, a headline offer, "\$75 for your old radio set." That was the allowance for 4- or 5-tubers; a deduction of \$60 applied to the 3-tube variety. Any set was taken in, whether manufactured or home-made. The turn-in value applied to the old set, stripped; time payments were allowed on the new purchase.

THE plan met with complete and unqualified success. The advertising space used was relatively small; there were few ads; yet the sets kept on selling themselves long after the insertions had ceased. And the significant thing is, the highest grade retailers followed suit.

They say radio has no precedents. Well, let's get some. There's one; established and workable. A sound sales policy, which you can take or leave, according to whether you are in the business for a day, or to stay.

The moral is: no one was hurt. The prestige of the set was increased, for its price was maintained in a falling market. The thought of possible obsolescence was offset by the offer to take in the customer's old set, for a better one. Yet,

through the generous turn-in allowance the public got a real bargain, at a time when the market demanded special offers.

The aftermath—the hundreds of used sets were placed on sale at sensational figures. They were priced in groups; as low as \$10! (It was all right with us; we could have afforded to give them away.) They went like hot cakes. The bargain hunters had a “find.” Yet, once again, no one was hurt. No prestige suffered—for these were *used* sets; second-hand; cast-offs. The original offer, and the follow-up, made friends of Mr. and Mrs. Public, not skeptics.

The selling season is short enough; the least the conscientious retailer can do is to avoid those things which yank the foundation right out from under it.

**N**OW turning, for the moment, from the thought of sales; there are always things to be learned about buying.

I have been asked to set up some guide-posts for purchasing. That's a large order; a book could be written on the subject. Within the space limitations, however, the negative side may be glanced at, to advantage.

An almost universal conception of buying appears to be, that everything begins and ends with the long discount. We will deal with that.

A manufacturer's salesman presents a specially attractive proposition. The discount is unusually large, the publicity plan comprehensive and engaging; there may be co-operative advertising in it, for the dealer. The set, or device, or whatever it is, is going to be given a great “play” by the radio writers; perhaps the opening guns have even been sounded. An order is placed; this is merchandise, and the dealer is a merchant.

Now, why has the extra discount been offered, and all the other trimmings? Because a new article is to be introduced. (We are not now considering overproduction and overstocking.)

**G**UIDE post No. 1 is, before placing the order, have the new article *thoroughly tested* by a competent technician. Forget the whole thing, if he doesn't report favorably. Even if it is hard, later on, to see a competitor cashing in, when the publicity breaks; just keep watch and you'll find his gain is loss, when customers both woebegone and infuriated, come trooping back with

their grief. This has happened so many times, to my knowledge, that I have lost track of the count. The stockrooms and shelves of stores all over the country bear silent witness to the hazard in buying stuff that didn't stand up.

Guide post No. 2 is, don't let the discount blind you to the matter of supply. On this point, here is a concrete illustration:

An accessory was placed on the market some six months ago; an advance showing was given to the trade. It was a corking piece of merchandise, backed by a manufacturer of highest integrity. A selected few dealers were offered the opportunity to deal direct, at distributors' discount. The minimum order required was very small, a point which the salesman eloquently stressed. But the dealer I have in mind had his technician's highly favorable report to bolster up his own estimate of the article as good merchandise. So he was interested in the maximum order he could place, not the minimum. He learned that they were one and the same—everybody to get the same quantity, the policy of treating all alike being one of the things that the salesman was blissfully happy about.

But the dealer knew radio; and his store. The quantity offered was woefully inadequate for an article of its merit, even if new. It was evident that the manufacturer had made a bad guess on the potential

market. He passed up the offer, and immediately placed firm orders, at the shorter discount, with every distributor that he could find. When the article was released to the public he had corralled a supply more than fifty times as great as if he had taken up the manufacturer's offer and the longer discount. A market shortage appeared, as he had anticipated; and as he had the stuff, he cleaned up.

This is an instance of what constitutes legitimate, sound merchandising. It is one of many that could be cited to prove three basic principles of purchasing: that the article must be right (a) technically; (b) as merchandise; (c) as to supply.

It illustrates, too, that the distributor can be a useful fellow; if you buy regularly, he will help out in a pinch, and in the long run will be found worth while sticking to, despite offers to deal direct at a better discount.

**A**ND now, back to selling again; or rather, sales influence. In the May issue I didn't finish up what I had to say about fewer stations and better programs. The subject is timely; Secretary Hoover has announced his intention to call another national radio conference. Let us make sure that the matter of station limitation is rated a subject of major importance.

Limiting the number of stations is a Department of Commerce job. A

### Major White Broadcasts Boat Race

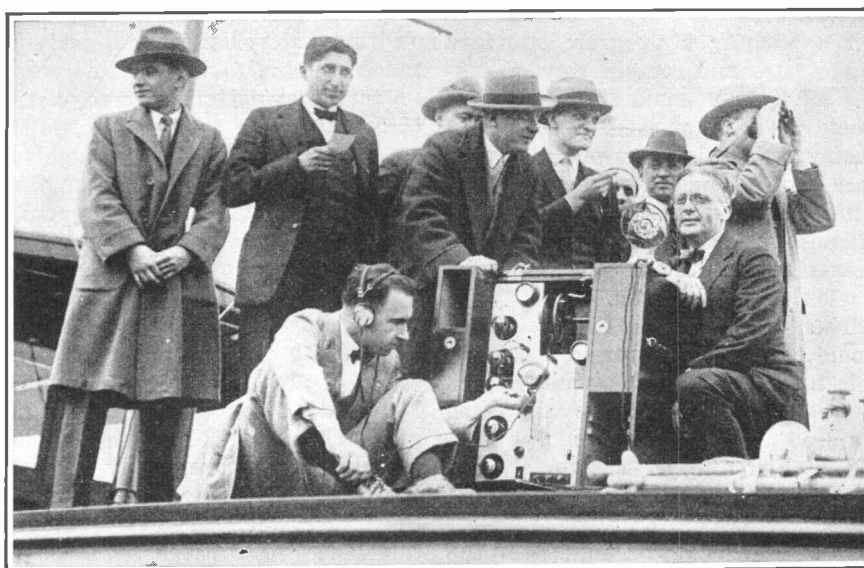

In addition to being a radio retailer and editor, Major White is one of the best known announcers east of the Mississippi. His specialty is sports and he is the first announcer to send a boat race over the air.

Station WJZ, New York, did the broadcasting and the event was the recent Child's Cup Regatta, rowed on the Hudson River. The transmitting instrument was mounted on a motor boat and kept pace with the shells.

ten kilocycle separation is necessary and even with staggering of the wave bands geographically, there are only 86 different wave lengths available anyhow. Secretary Hoover's department, as we all know, is handicapped by an obsolete radio law; but it is a fact nevertheless that all broadcast licenses are temporary and revokable permits. So it is easy enough to stop cluttering up the air with stations; it can be done by limiting this number in accordance with the available and workable wave bands. And splitting up operating periods into time allocations for those broadcasting on the same bands, is a supplementary remedy.

Whether or not definite discretionary powers have actual existence in fact in the statutes, is of relatively small consequence. Right is might. I can think of but one instance in radio where a license withdrawal was successfully challenged; and then it was an empty victory, for the station had no real mission to fulfill and soon closed up voluntarily. There is no question that the right and fair thing can be had, if we of the industry want it, ask for it. Suppose a standard was set for programs (that is, a degree of excellence in entertainment); there is no reason why something reasonable of that kind could not be enforced. Phonographs and mechanical pianos were thrown out of broadcasting studios on an early Department of Commerce ruling. Initial resentment greeted this edict, and there were mutterings that the authority for this arbitrary action didn't exist; but the mechanicals went out nevertheless.

Establishing a program standard is the sure and certain way of taking off the air some stations which would never be missed. Let the industry ask this—the public would back it up!—and it would go through with the accustomed dispatch and fairness which has been gratifyingly characteristic of our radio administration in Washington.

Then perhaps our entertainment would come to us through a reasonable number of Class A and B outlets—say 100 stations in all. One hundred is plenty, even for the DX-er. Listening to each for a scant five minutes, would take eight hours!

**I**T IS the program that sells the sets.

I repeat, that every retailer I have talked to agrees with me on this. If this isn't so I don't know

what I am talking about, and you might as well turn the page and go on to something else.

Otherwise it might be well to stop and determine what these features are, which raise the sales to high peaks.

I will give you a few offhand: A sporting event, a political convention, a national ceremony, a philharmonic concert, a play picked up from the stage—to mention a few of the occasional broadcastings, which are events. Next, and of equal importance, because they stabilize sales, are outstanding features such as the spectacular entrance of the Victor artists; the Brunswick hour, too; the once-a-week programs by the talented presentation casts of motion picture palaces; ditto the famous dance orchestras; the shows, parties and frolics given with a popular performer featured; the single singers and instrumentalists and teams and ensembles whose distinctiveness makes them something to look forward to on such and such a night of the week. The preachers with personality—how many and diversified are the things which “get across!”

And why? Solely and simply because they are talented. They instruct—interestingly—or entertain.

Just as the mechanicals were ruled out of the broadcasting studios, it is time now for so-called “programs” to rid themselves of song-pluggers and novices, and all those who haven't the training or qualifications for holding the attention of the tremendous audiences radio makes possible.

As it is now, there are too many stations with too many hours to fill (with whatever they can get!) too much competition—and absolutely no intelligent attempt at regulation, co-ordination or co-operation, so that we don't have to hear the same tune over and over again—a dozen times a night, every night in the week!

**G**OOD programming is a subject too important for us to mince matters; I have no sympathy with the broadcast directors' so-called problem in securing talent. If he don't know how to fill his program, shorten it. If he is no judge of talent, there are plenty of people who are qualified to make the selections. Showmen, members of entertainment committees and toastmasters know their job; certainly the broadcast director, with his tremendous audience, should know his even better.

The whole thing is a matter of the application of common sense. Raising the program standard and lessening the number of stations will increase the sales of sets.

Isn't that what we want?

Well . . . If we are to get anywhere, the voice of the industry must be heard in Washington.

Mr. Hoover and his associates will listen; they always have; you can bank on that. And they will do anything reasonable we ask. But we must make the request emphatic!

What do you say? You! not the other fellow—shall we do something definite, concerted, about it? An idea like this can rest, simmer along, get nowhere. To put it over means a lot more work. I wonder if you can be equally frank with me in saying that your main reason for being in business is to sell radio receiving equipment, and all being in the same boat, nothing is too much trouble in helping to get the craft on an even keel.

You have views on the subject of less stations and better programs. Call in the stenographer and get them off your chest. Send them to Washington if you prefer; or pass them along to me; I give you my assurance that they will be analyzed and tabulated and presented—the whole mass of opinion in impressive form—where it will get the recognition it warrants.

Come on . . . now.

## Uses Taxes to Advertise Radio Exposition

A novel way of advertising a radio exposition was carried out last year by the Pacific Radio Trade Association for its annual exposition at San Francisco. Another radio show is planned for the coming summer (August 22-29) at the Civic Auditorium.

A concession for taxicab service at the show was given to one of the San Francisco taxicab companies, who, in turn, placarded 500 cabs with radio show posters. In addition, ten days before the show, two cabs were outfitted with receivers and loud speakers and cruised around the business districts, advertising the show.

The taxi company estimated a loss of \$400, because of having the two machines inactive, but figured the advertising they received more than made up for it.

# "Personality Windows" That Sell

Putting personality into the radio window display was easy for the Rousseau Electric Company, Worcester, Mass. Photographs of prominent radio announcers, and their studios, were exhibited. Emil L. Rousseau, president of the company, wrote to the various announcers for the pictures, and they responded readily to the request. Many passers-by went into the shop to see if they could buy extra prints of their "radio favorites."



An effective tie-up with the "Radio for Every June Bride" idea was made last year by the radio dealers of Los Angeles, Cal. A radio wedding was staged over a local broadcasting station, and various stores presented the bride with wedding gifts for publicity purposes, prominent among which were several radio sets. These were prominently displayed in the windows of a large downtown store, together with credit cards for the stores making the gifts.

Here is a display, depicting radio in the camp, that was made from borrowed theatrical scenery. The background is an old "woodland drop" with a tent painted in. The "trees and flowers" at the sides are the "wings" of a stage setting, borrowed from a local theater.

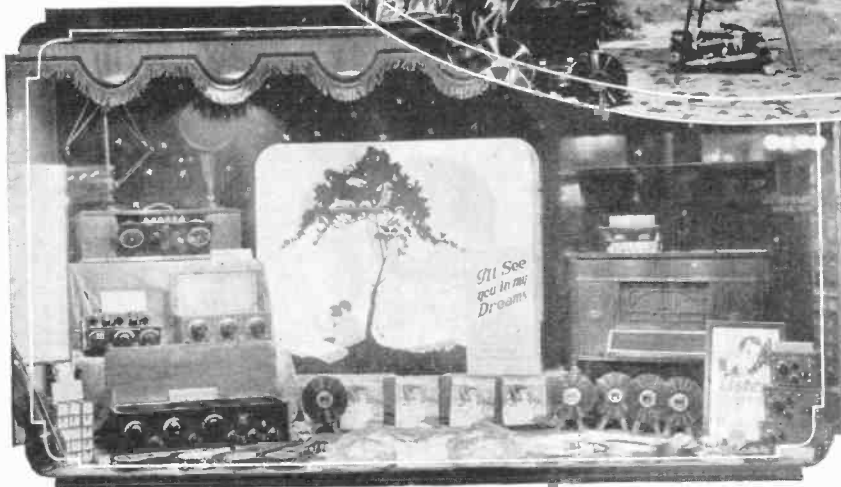

Irving Shalek, a music-radio dealer of Chicago, Ill., features one line to sell the other. He ties up his music and radio departments, by featuring the sheet music of popular songs and putting across the idea that the radio owner can hear them over the air regularly. The art panels seen in the display were painted by Shalek himself, which proves that a variety of talents comes in handy when selling radio.

## Radio on the Farm

Radio on the farm differs from radio in the city because to the farmer, radio is an instrument of the highest dollars-and-cents practical value.

Because of this fact radio can be sold the farmer in the summer nearly as easily as in the winter.

High-power daylight broadcasting assures summer reception for the vital information coming to the farmer by radio.

The dealer who goes into the country, installs, and demonstrates to the farmer, will keep his summer radio

business at its regular winter levels.

The farmer is not buying on a price basis. He is buying for results and will buy the same equipment as the city man.

Farm radio servicing is not excessive. The farmer has had lots of experience in keeping mechanical and electrical equipment in service and is on the whole servicing his own radio set.

The farm market is the dealer's great opportunity today. Go out and "Ask 'em to Buy!"

## How Dealers Are Selling Radio to Farmers

(Continued from Page 532)

sands of farms will be radio equipped just as soon as the dealer organizes to sell them. And the dealer who is organized to sell the farmers, who is going out today into the rural dis-

tricts and demonstrating to the farmer, is keeping his radio business at winter levels.

Where the farmer is buying radio is shown by several interesting figures lately reported. The fact seems pretty well established that the farmer is buying radio as he buys his other merchandise through the dealers in the small towns. An investi-

gation in Wisconsin shows that 75 per cent of the radio business of small town dealers is done with farmers.

At a recent meeting of the Northwest Radio Trades Association, jobbers in the Twin Cities made the statement that 75.3 per cent of their sales of radio went to small towns and that their small town dealers records show 60 per cent of their sales were made to farmers. Another investigation made in cities and towns of from 40,000 down to 1,000 population shows that an average of half of all radio sets sold in those towns are now bought by farmers.

## The Dealers' Opportunity

The situation today is that the dealer who wants farmer business can get it. Never probably has there been for the dealer in towns of 1,000 to 25,000 such an opportunity for immediate profitable business. This doesn't mean waiting until fall for the farmer to stand in line before the

## McMillan Arctic Expedition to Make Short-Wave Sending Tests

Before the McMillan Arctic Expedition sails in June, it is hoped to have

1,000 amateurs equipped with short-wave transmitters in addition to the many thousands who have short-wave receivers, so that the United States and the expedition may be in constant touch.

With the co-operation of the Zenith Radio Corporation, John L. Reinartz will accompany the expedi-

tion and make short-wave tests during the 24-hour daylight periods in the North. Reproduced herewith are the wiring diagrams for both the transmitter and the receiver to be used. Featuring these two hook-ups and the parts necessary to build them, may bring in added dollars for many dealers this summer.

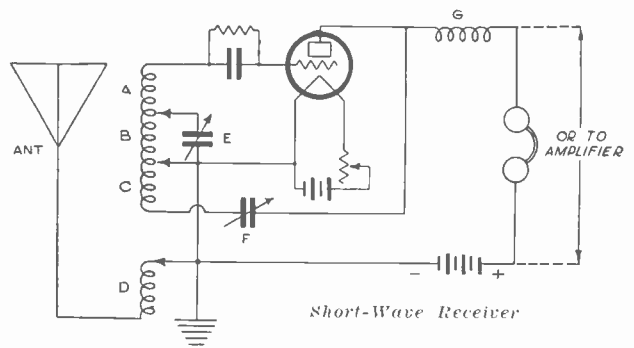
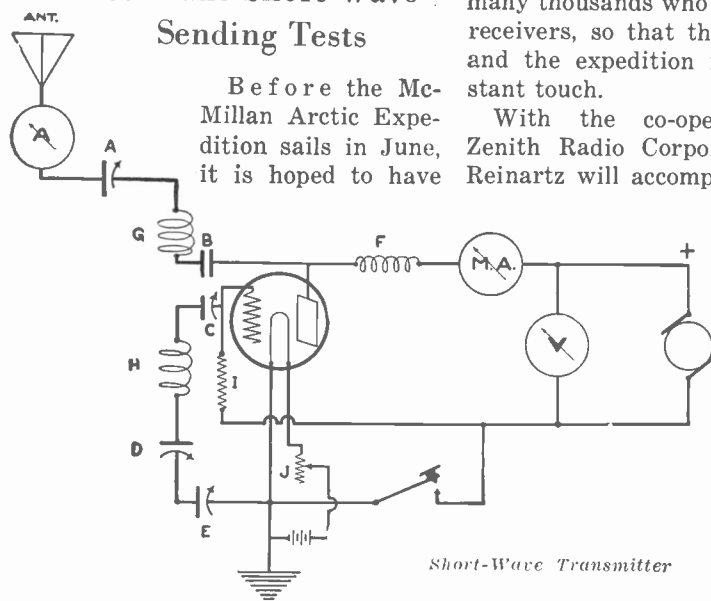

The Reinartz-Zenith short-wave transmitter may be constructed from standard parts. The framework should be made of any hard wood which has been boiled in paraffine to drive out all moisture. Bakelite or rubber should not be used. Plate and filament voltages suitable for the particular type of power tube used, should be supplied.

Condensers A, C, D and E are transmitting variable condensers capable of withstanding the plate voltage, and are of about 250 MMF. capacity. B is a fixed condenser of 1,000 MMF. suitable for the plate voltage used.

Coils G and H are edgewise wound helices about six inches in diameter, supported on three glass rods. Twelve turns on each coil should be used for 40 meters and 5 turns on each for 20 meters.

F is a single layer choke coil one inch in diameter and four inches long, wound

full of No. 24 D.C.C. wire. The grid leak, L, may be about 10,000 ohms.

In operation, condensers A and D are set alike and at a low value of capacity. Condenser E is then varied until maximum antenna current is obtained. Condenser C is used to adjust the plate input, and to secure stable operation. Coils G and H are usually placed about twelve inches apart. The key is placed in the circuit as shown at K in the diagram. The antenna should be a vertical wire about 35 feet high, and should be well insulated.

The Reinartz-Zenith short-wave receiver will cover any range desired on the short-wave band. It is necessary to keep very short leads in the grid and plate circuits, in order to reach as low a wave length as possible.

The tuning inductances, designated by the coil ABC and coil D may be wound on a form about 3½ inches in diameter in

either the Lorenz fashion, or as a single layer winding on a cardboard tube. Coil D is the antenna coupling coil and should consist of five turns of about number 16 D.C.C. wire for the 20- and 40-meter bands, and ten turns for the 80-meter band. Coil ABC is really a single coil tapped in two places, as shown in the diagram. Each part, A, B and C, have three turns each for the 20-meter band, six turns each for the 40-meter band, and twelve turns each for the 80-meter band. Three coils are required to cover the entire range from below twenty meters to over eighty meters.

Coil G is a radio frequency choke coil which may consist of a form one inch in diameter and three inches long wound full of any wire in the neighborhood of number 30 D.C.C. Condensers E and F should have about five plates each. Either a dry cell or storage battery tube may be employed with 45 volts on the plate.

dealer's counter and carry radio sets out under his arm. It means that the dealer must take the set out into the country, installing it on a farm home, gathering in the family and then selling it on the payment terms that meet the farmer's financial situation. And the dealer does not have to wait for a hypothetical "season" to do this, he can and should do it now. The farmer needs radio in the summer, but it must be sold to him in his home.

There are some live dealers in towns of 500 to 40,000 who are cultivating this farm market by aggressive direct selling methods successfully today.

In Centerville, Iowa, a town of 10,000 population, there are five radio dealers, three of whom are actively engaged in selling radio to the farmer by going into the country, putting up an aerial and demonstrating a set. Three days is the usual trial period, but the salesman's call to close is made only after a night when reception has been good.

In Hooper, Nebr., a town of 1,000 population, a dealer, L. J. Vierson, has no store and depends entirely on personally selling the farmer. This dealer specializes on the higher-priced sets chiefly for the reason that his gross margin on these is sufficient to cover the expense of this kind of selling.

#### Group Demonstrations Best Way to Interest Farmers

The best time to sell the farmer is from seven to nine o'clock in the evening. This period after the family supper and before the family bedtime is when the farmer can give his whole attention to the set demonstration. This shortens the salesman's day and makes only one demonstration possible, but a radio salesman for a dealer in Madison, Wisconsin, has turned this into an actual selling advantage. This salesman spends his day putting in the set and in calling on other farmers in the neighborhood and inviting them to hear this demonstration. He gets as a rule five families gathered for each demonstration and will average better than one sale per demonstration.

Much study has been given to the question as to what price set the farmer will buy. The studies so far indicate that the sets the farmer has bought range in price from \$3 to \$750 with an average price of between \$100 and \$150. As few similar studies have been made of the price that the city man pays for his set



S. J. Ryan

Now Consulting Editor of "Radio Retailing" and "Electrical Merchandising"

Mr. Ryan is one of the best-known merchandising executives in the department-store field. Moreover, he is the man who built the largest independent retail radio and electrical appliance business in this country, doing annually over a million dollars, at a profit.

His practical experience as a big store executive, has covered many lines of merchandising,—with J. N. Adam & Company, Buffalo, the J. L. Hudson Company, Detroit, the Kresge Department Stores Corporation, New York, L. S. Plaut & Company, Newark, N. J., the Palais Royal, Washington, D. C., and others.

Mr. Ryan is now giving his full time to initiating, for the McGraw-Hill merchandising papers, complete studies of the distribution methods and costs of retailing radio and electrical goods, as fundamental to solving the present distribution problems in these industries. He is also available for consultation and advice on practical merchandising problems, with readers, advertisers and agencies.

these averages probably mean very little.

The studies indicate that the farmer is as various and as unstandardized in his purchasing habit as any other class of purchaser. There is an indication that when the farmer comes in to a shop for radio and that when he pays cash for his outfit that he is inclined to buy lower priced sets than when he is sold by demonstration and on some kind of deferred payment plan. This also is a close parallel to the city purchaser. So there cannot be made with even approximate accuracy any statement as to any particular price and kind of set the farmer is buying. The fact is he buys the same sets at the same

price range as do his cousins who reside in the large cities.

One group of public utilities in the Dakotas who had been retailing radio sets, tried out the plan of sending their appliance salesmen into the country and selling radio sets to the farmers on time payments. They found that the farmer of the type they had expected to buy a \$100 set would buy a set of a \$200 value when the time payment convenience was offered.

#### Different Payment Terms Necessary in Selling the Farmer

The big difference between the farmer and city man is in the primary reason for the farmer buying radio. The farmer buys it as an indispensable instrument in his business. There is only one difference in the best way to sell the farmer from the best way to sell the city man. Both can best be sold by solicitation and a demonstration and on divided payments but the farmer who does not receive his income monthly cannot pay on monthly installments. The farmer can sometimes buy for cash or give a note which can be discounted at his local bank. But with the big majority of potential farm buyers the payment method that will most appeal is the one whereby he can make one down payment and pay the balance after he has marketed his crops.

This condition can be met and any dealer can sell on this basis. At least one of the time payment finance bankers has a Farmers' Plan whereby this can be handled. Paper can be discounted on which a payment of 25 per cent down has been made, the balance to be paid in one payment at the end of six months; or a two payment contract can be discounted on which 25 per cent is paid down, the balance in one payment at the end of four months and a last payment at the end of eight months from date of contract.

One more suggestion in selling the farmer; prices should be quoted complete, including all accessories and installation.

The farmer has a rooted suspicion of "extras." His experience has been unpleasant with equipment sold him at a price which did not include everything and which when accessories were purchased added up to more than he had expected to pay. The dealer will avoid argument and complication by pricing the radio set for the farmer complete with everything needful for operation.

# What They Say About "Dumping"

*The Radio Trade Seethes with Bitterness Over the Practice of "Dumping"—The Cry from Dealers and Jobbers Alike Is, "We Want Protection"—In These Signed Statements from Representative Dealers, Jobbers and Manufacturers, the Solution, with But Few Exceptions, Is Said to Be the Exclusive Franchise System*

## Dealers Will Fear to Buy from Those Who "Dump"

BY FRED WILSON

Wilson and Son, Newark, N. J.

The slump in radio sales today is directly due to the manufacturers, who have not, as yet learned their lessons, and who keep on in excess production at a time when the market cannot absorb any more sets.

With the coming of warm weather, people are bound to go out-of-doors more and there will always be a drop in radio sales in the spring, but the almost total lack of business at the present time is due to this condition, coupled with certain ambitious manufacturers who have made more sets than can be sold, and who are forced to "unload" at almost any price in order again to have a liquid capital.

This year, the conditions have been worse than ever before, and the "slump" hit even sooner than expected, which is entirely due to the financial embarrassment of some manufacturers who are forced to move huge stocks for almost any price.

Fortunately, such a condition cannot last for long and I expect to see a revival of interest as soon as the great price-reducing wave has passed. Some of these manufacturers will go out of business, which will be a good thing for radio, and those who manage to hang on will find themselves in an embarrassing position when production is resumed in the fall. Dealers who have suffered owing to these special sales, will not buy further goods made by those concerns for the simple reason that they will be afraid of a similar situation next spring.

## Advocates Fewer Dealers with Exclusive Territory

BY T. O. MILLER

Zwiebel-Stenger Sales Company,  
Wilkes-Barre, Pa.

Authorized dealers with exclusive territory is the only solution to the jumble which radio distribution methods are in at this time. Jobbers should take this season of overproduction to heart and not load up with stock. And manufacturers should not make their jobbers take on too heavy a burden.

The present system whereby anybody may sell any set, wholesale or retail, for almost any price he wants to sell it at, has proven futile. Some degree

of protection must be offered if manufacturers expect the radio industry to progress and expand.

Every Tom, Dick and Harry jumped onto the radio bandwagon and manufacturers thought the more jobbers they had and the more dealers they had, the more successful they became. Their boast was, "We sell more sets and have a wider distribution than any other set manufacturer." It was that very thing that acted as a boomerang and hit manufacturers hard when it got back to them. The trouble was, though, that it also hit jobbers, dealers and all the rest of the industry as well.

The result is that we have confidence in very few manufacturers. Some are making a sincere effort to right things and they are to be commended. But the majority are still selling to anybody who will buy and shutting their eyes to the fact that one dealer who has enough confidence in a line to get behind that line and push it, is worth more than ten dealers who sell the line at cut prices.

Right now, it is useless to spend money to put any manufacturer's product across, because there are probably four or five other dealers in the same town who will profit by the money you spend. Advertising a set today is like putting money into your competitor's pocket. Until I am guaranteed protection, I will certainly make no special effort to sell radio. When I have an exclusive agency for a set, then I will do my utmost to boost and sell that line. And I won't do it until I do get protection.

## Manufacturer Foresees Exclusive Agencies

BY WALTER ECKHARDT

President of the Music Master Corporation  
Philadelphia, Pa.

The coming trend in radio distribution will be toward exclusive wholesalers and exclusive retailers of a line. A Packard dealer sells only the Packard car. So it will be with radio.

The reason why radio dealers and jobbers have gotten into the habit of selling some of this and that and the other kind too, is, of course, because the radio manufacturers have habitually committed themselves too heavily and fallen behind on deliveries. No one could foresee the miscellaneous growth of the clamorous demand for radio. No large manufacturer ever anticipated the extent of the business that would come pouring in. So he failed to keep

his retailers supplied, and the jobber and the dealer tried to save their skins by ordering from many sources.

We will see before so very long, in my opinion, a complete change of plans. Manufacturers will learn not to over-commit themselves and therefore will be able to make good on deliveries. Jobbers, because they will find that they can rely on the promises of their suppliers, will begin to specialize on the best line they can sign on. And dealers will be quick to grasp the opportunity to become the exclusive local headquarters for a nationally advertised line. Then radio will settle into its real stride.

## Exclusive Franchises Will Protect Dealers

BY F. E. CONRAD

Owner of Conrad's Radio Shop,  
Reading, Pa.

There can be no adequate advertising or merchandising of radio as it is today. The distribution policies of the majority of manufacturers, whereby their product is given the widest possible retail circulation, has re-acted to the detriment of the entire trade.

Why should I, a radio dealer, buy, advertise and try to sell a set for \$250 when my nearest competitor sells that identical set for \$195? Under present conditions, what protection have I got that will enable me to form a definite sales policy regarding any particular manufacturer's line? What guarantee have I got that my competitor won't sell the same set which I have spent hundreds of dollars to push in my locality? Or, that a big department store in a neighboring city won't cut that same set to the bone, and do it with the co-operation of the manufacturer himself?

What inducement do most radio manufacturers offer their retail outlets? None. There have been too many willing and eager to buy their output. But that condition is changing. Manufacturers who have made no attempt to control their output in the past now find no market among legitimate dealers for their sets and have had to resort to "dumping" to department stores. No dealer is going to buy a set or the product of any manufacturer who has "dumped" his sets, because the "dumping" has ruined the sale of those sets in every locality. I, for one, will certainly never buy the product of a manufacturer who thinks so little of his regular outlets as to ignore them and



sell direct to a large retailer at greatly reduced prices. That is not my idea of an honest, square-dealing policy.

The only solution is the giving of exclusive franchises, or a policy approximately it, and the establishment of "authorized dealers and authorized service stations." Every new industry has had to come to it eventually—the automobile and the phonograph—and radio is no exception. The cry of radio dealers all over the country is, "We Want Protection," and the radio industry will continue in its present chaotic state until we get protection!

## Trade Will Settle Into Approved Channels

BY ELMER E. BUCHER

Sales Manager, Radio Corporation of America, New York City

The Radio Corporation has felt from the beginning that as the public gradually gauged relative values in radio sets, and as dealers determined public reactions, trade conditions would settle into approved and recognized channels. The radio industry, up-to-date, has been singularly free from artificial restraints.

It was a new industry, and many thousands of people, young and old, with preparation and without, with and without ability or rightful claim to recognition, regarded it as their opportunity.

Exclusive franchises and restricted territory are simply the "weeding out" process, put into merchandising terms. Natural economic processes are working in that direction, as well. The dealers who have no sense of responsibility towards the public, gradually will weed themselves out of the picture, if the early history and subsequent development of other American industries are repeated in radio.

So long as there are irresponsible manufacturers, miscalculating market requirements, "dumping" practices probably will continue, but my own feeling is that the public, which is the real arbiter of quality of merchandise and trade standards, is turning more and more to radio products of proved merit and towards dealers of standing and reputation.

## Dealers Should Sell Fewer Lines of Receivers

BY LEO POTTER

President, Thermiodyne Radio Corporation, New York City

The Thermiodyne Radio Corporation has always adhered to the policy of taking on a few selected jobbers in various territories, to whom we have made territorial allotments. Thermiodyne receivers are never cut in price because of our policy of not overloading the jobber.

It is my firm belief that if retailers, wherever they may be located, would make up their minds to handle one, or not more than two, lines of receivers and push them to the exclusion of all others, that the respective manufacturers they endeavored to do business with would gladly see to it that they had a measure of exclusivity which would accrue to their advantage.

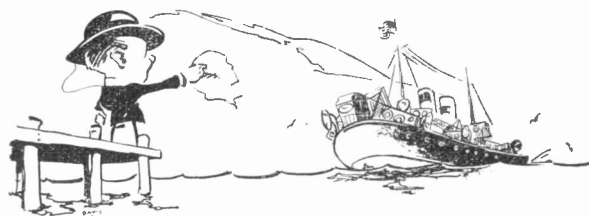

## This Issue of "Radio Retailing" Reaches Radio Merchants All Over the World

**B**ACK in 1918 the exports of radio and telegraph apparatus from the United States amounted to less than \$400,000. Broadcasting came along in 1921 and in 1922 export sales of radio alone had reached \$2,897,799. In 1923 radio exports from this country rose to \$3,448,112 and in 1924 radio export sales reached the remarkable figure of \$6,030,914.

Interest in radio is growing in foreign lands. The public in these countries is demanding more broadcasting and foreign governments are lifting restrictions, thus opening the way for American radio products.

As a means of introducing American radio selling practices and American radio products in foreign radio

markets, the publishers of *Radio Retailing* are sending a copy of this issue to all known foreign radio dealers and jobbers, foreign broadcasting stations and foreign radio clubs. By bringing to their attention American radio practices and products, it is hoped that radio men in foreign countries will benefit and that they will in turn send to America for those products in which America leads.

The publishers appreciate the assistance of numerous manufacturers and of the U. S. Bureau of Foreign and Domestic Commerce in making it possible to distribute this issue of *Radio Retailing* to radio markets all over the world.

If, however, the dealer will continue to do indiscriminate buying of "that" and "this" receiver, which may or may not have a right to exist, and which may be manufactured by a company that is incapable of doing a national job, which eventually means failure for the manufacturer and a disgruntled, dissatisfied consumer, then there is no hope of ever attaining uniformity of merchandising methods in the industry. No dealer can logically select five or six different types of receivers and push them all successfully. It merely leads to confusion in the mind of the prospective customer, and leaves the dealer in a position where he is incapable of claiming superiority for any one of the products that he is handling.

Let the dealer make up his mind that "this" or "that" receiver is the best that he can procure for his territory, and let him push that product to the exclusion of all others, and he will make money provided the company behind the product will give him advertising, an absolute guarantee for the product, and service. Furthermore, he will have to be in a financial position to take a certain quota for his territory, otherwise he would be working a hardship upon his jobber who has committed himself to his territory allotment. Price-cutting under the contemplated system would be cut to a minimum because there would be little or no overproduction, in view of the certainty with which the manufacturer would be enabled to plan the forthcoming production. At the present time, most manufacturers who have no assured distribution are compelled to make a "guess" as to what their prospective productions are to be.

It is but a question of time, and a very short time at that, when those dealers who are to remain in the industry will signify to their jobbers what their requirements for the coming season will be, thereby enabling the jobber to make his commitments with an amount of certainty which he is unable to do at the present time.

## Will Sell Through Exclusive Agencies

BY T. F. W. MEYER

Sales Manager, Jewett Radio & Phonograph Company, Detroit, Mich.

With the advent of summer, Jewett products will enter upon a new era of distribution. The number of our distributors will be greatly reduced, likewise the number of dealers. Those who will receive franchises to merchandise Jewett products will get an iron-clad contract, guaranteeing them a specific territory in which to do business, unhampered by competition with any other Jewett distributor. They will be absolutely protected against price-cutting or any other practice which will tend to lessen the value of their merchandise.

Even in such Metropolitan centers as New York and Chicago, there will be only one distributor to serve the trade. It will be the duty of this distributor to allot the franchises to the dealers, but the Jewett Company will reserve the right to pass on each franchise. This policy of merchandising radio apparatus is a forerunner of what ultimately will become standard radio merchandising practice.

# The Editors Have

## *Encouraging Effects of a Discouraging Situation*

THE series of gigantic sales of radio merchandise from Coast to Coast at greatly reduced prices during the past three months largely by department stores, has set the radio world by the ears. These public offerings of many well-known brands, usually at about half the retail prices prevailing immediately before the sales—and incidentally at about half the prices many dealers had them still marked in stock—have excited interest amongst the purchasing public, and something akin to consternation amongst jobbers and many retailers. The result is a deplorable situation that, in our opinion, was largely unnecessary.

Let us examine the causes of the present condition and the effects, present and future. Radio is still an infant industry—There are no precedents by which the degree and the duration of the public demand can be measured with any sort of accuracy. It is quite apparent now that there was an unabsorbed production upon the part of many manufacturers. This situation was greatly aggravated by a cessation of the public demand immediately after the holidays, months in advance of the anticipated time. The result was almost inevitable. Manufacturers overloaded with merchandise which was not moving, and pressed for cash, sought established agencies through whom they felt these goods could be disposed of quickly and who were in a position to give them that which they sorely needed—cash.

Now as to the effects: The immediate effect has been a major disturbance of trade with resultant losses to manufacturers, jobbers and retailers. These losses have proved well-nigh disastrous to some merchants. The severest loss of all, in our opinion, has been the permanent destruction of values in the public mind, of the particular merchandise sold and the danger of this being extended to all radio merchandise. The experience of the past in similar cases proves the second thought of the public is that the former prices were not justified and manufacturers, jobbers and retailers have been profiteers. Conversely the agencies who have distributed the reduced merchandise are usually classed by the public as benefactors.

## *Proves That Demand for Radio Continues*

THE future effects however are, in our opinion, very encouraging to the entire industry. In the first place and most important of all, the general public has been benefited, even though at severe loss to all producing and distributing agencies of radio. A reduction of some sort was inevitable and, although we do not approve of the methods used, we derive consolation from the fact that many more thousands of families are today enjoying the benefits of radio than would otherwise have been the case. The more radio merchandise sold, the more will be purchased. Less than 20 per cent of the homes in this country are equipped with

radio today and there never will be a point of saturation.

Secondly, the magnitude of the sales at this season proves conclusively that radio can be sold at any time and that price is a more important factor than season.

Thirdly, a lasting lesson has been learned by manufacturers in the matter of production and by jobbers and retailers in the matter of stock control. No agency or combination of agencies can hope to control the law of supply and demand, but intelligence can control production and stock so as to keep the possibility of loss at a minimum. Large stocks always mean large losses, but neither are we advocating a hand-to-mouth buying policy, with its resultant increased costs to manufacturers in production and to retailers in lost sales. The trade should come to a common-sense realization that radio is an infant industry, though a lusty one—that its limitations are not thoroughly understood by the general public—that the vagaries of their demand must be reckoned with,—and that its future possibilities are comprehended only by a very few and by them but dimly.

## *Individual Dealers*

### *Do 80 per Cent of Business*

FINALLY, what effect will the present situation have on methods of distribution? As a people we are prone to place undue emphasis upon mere size. We are continually talking, if not boasting, about the largest this and the largest that. Size quickens our imagination. We marvel at those huge emporiums of trade, the department stores, and those far-flung distributing systems, the chain stores. But we sometimes lose sight of the fact that all the department stores and chain stores of every kind *combined* do less than twenty per cent of the business of this country. In other words, over eight out of every ten dollars of merchandise sold today is sold through retailers that are not department or chain stores. Furthermore statistics prove that efficiently managed independent stores can and *do* operate as economically as chain and department stores, service for service and quality for quality. This insures their permanency.

The present situation is bound to repeat itself, even though in not so aggravated a form. If the manufacturer produces more than the demand warrants he must suffer, but that is no reason the major distributive system should be punished for his sin. The machinery is in existence to take care of just such a situation.—the regular retail machinery.

The possibilities of what come to pass were known in advance to many manufacturers and jobbers and to some, at least, of the retailers. It was not a question of whether a loss had to be taken—that was inevitable. The question was how to absorb that loss with least disturbance to the greatest number. We submit that the method pursued was to the benefit of the few and to the detriment of the many. The situation called for constructive co-operation on the part of manufacturers, of jobbers and of all retailers of radio, especially those who distribute by far the greater bulk of the nation's goods—the specialty and neighborhood stores.

# This to Say—

## *The Responsibility of Manufacturer and Jobber*

**I**N a movement of this kind the manufacturer and the jobber must take the lead. The jobber, especially, was in an ideal position in this instance to render signally constructive service to the two factors upon whom he depends for his very existence, the independent retailer and the manufacturer. Co-operative efforts of this kind, though of a more permanent nature it is true, are numerous in the grocery, drug, hardware, notions, clothing, furnishings and ready-to-wear fields. They can be successfully applied to radio.

In this particular case the financial condition of the individual retailer was known and a sufficient number would have participated in an effort having so many self-evident advantages. The matter of advertising was simply one of allocation. The cost of the publicity had to be and *was* absorbed somewhere between the price at which the manufacturer disposed of the merchandise, and the price at which it was purchased by the public. In the matter of distribution the advantage, in our opinion, lies with the independent dealers considered as a whole. Distribution is largely a matter of consumer contact. A vigorous campaign by the independent dealers *as well as the agencies used* would have served the purpose intended better, assured the approval of the public toward *all* distributors of radio instead of a chosen few, and permitted the jobbers and the independent retailers to "average" their costs on the stocks of merchandise on hand and absorb their losses through the increased volume.

We appreciate the very considerable effort it would have required upon the part of all concerned to put over such a plan of marketing the surplus, but in this case self interest would, we are certain, have assured success and the permanent benefits derived would have justified the effort. The effort should have been made and the independent dealers should have had the opportunity of participating. "The greatest good to the greatest number" is a mighty good business axiom. The situation is bound to repeat itself. *Radio Retailing* stands ready to assist retailers, jobbers and manufacturers to prepare the necessary machinery *now* to handle it properly when it arrives.

## *The Profit Is in the Last 10 or 15 Per Cent*

**W**HAT'S happening to our old friend the "summer slump?" Merchants the country over are "viewing with alarm" the gradual passing of this venerable institution. Everyone realizes now that the "summer slump" is about one part "season" to one part "psychology." Even in radio, just as soon as we question its existence, it begins to fade away.

The quota system is one of the greatest foes to the summer slump. Remember how insurmountable, in the war days, the Liberty Loans and other drives seemed at first? Yet quotas in various forms got the answer every time. The *profit* in every stock is *tied up in the last 10 or 15 per cent*. So the difference between

operating at a profit or a loss during the summer months is usually a matter of doing just about that much more business. It's worth the extra effort.

## *Without Courtesy*

### *No Store Can Prosper*

**T**OO much prosperity ruins a man's manners. It is a pity—but it's true. And so the radio store has gotten rather a bad reputation for lack of courtesy, attention and that spirit of helpfulness that modern shoppers expect and demand from modern stores.

The selling has been easy in the radio store—first the small boys, clamoring for parts, then the grown-ups seeking sets and paying anything to carry them away. It is no wonder that many a radio-store salesman has let his manners get slack.

But no enduring retail business can be built up in a store that is not pleasant to trade in. People simply won't come back. Why should they? Here is something, therefore, that the radio retailer must check up. Without courtesy no store can prosper.

## *Don't Overlook the Hospitals*

**H**ERE is an interesting figure. In the 7,000 hospitals of the United States and Canada, there are every day about 650,000 patients.

Not only will it pay dealers and manufacturers of electrical and radio equipment to sell radio sets, flashlights, water heaters, and electrical appliances to hospitals for the sake of the sales themselves, but in addition such installation of radio and electrical equipment in hospitals cannot help having indirect sales influence on the 650,000 patients, most of whom get out (or hope to get out) of the hospital some day, and so in time become active consumers of electrical and radio apparatus "on their own."

## *As "Radio Purchasing Agent" for Your Community*

**M**UCH has been written in text books and trade publications to show the merchant how to increase his turnover, how to decorate his windows, and so on. But few students of merchandising have defined the real place of the retailer in the local business world so clearly as did the Congressional Joint Commission of Agricultural Inquiry when it said in its report on Marketing and Distribution, "the retailer is the purchasing agent for his community."

Now a purchasing agent with a whole community as clients is a highly important job. A purchasing agent buys only what his firm wants and can use. If he doesn't, out he goes. And furthermore, if he doesn't buy it at a right price he goes out faster still. This is true with the merchant. If he doesn't buy what his firm, in this case the community wants, out of business he goes. And if he can't buy merchandise to sell at the right price, he goes out sooner than he expects.



# What's New in Radio and

This editorial section is prepared purely as a news service, to keep readers of "Radio Retailing" informed of new products on the market.

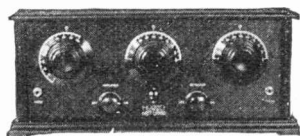

## Tuned Radio Frequency Receiver

*Radio Retailing, June, 1925*

Five outstanding features of the "Hubco Baby Grand" says the Baltimore Hub-Wheel & Manufacturing Company, Fallsway at Gay Street, Baltimore, Md., makers, are beauty, volume, selectivity, distance and clarity. The conventional two-step tuned radio frequency circuit is used, but the receiver was designed to provide a high grade receiving set at a price well within the means of the average income. All standard parts are used, the maker points out, and not only is the receiver an engineering success, but very pleasing to the eye as well. Intended retail price \$60.

## Radio Furniture

*Radio Retailing, June, 1925*

The Kelton manufacturing Company, of Worcester, Mass., has started the manufacture of radio furniture. Cabinets with built-in loud speakers; console tables with radio battery compartments, and a unit system of adding on to the furniture as the equipment increases in size, are some of the distinctive features of its product. According to the manufacturer individual patterns are designed for each radio manufacturer so that the furniture will be distinctive and the price in harmony with the value of the set.

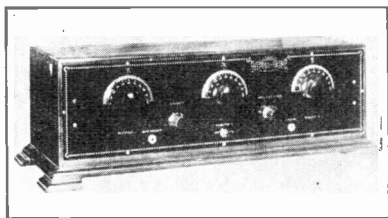

## Five-Tube Receiver

*Radio Retailing, June, 1925*

Two stages of tuned radio frequency amplification and two stages of audio frequency amplification are used in the "Wipple-Raine" receiver made by the Wipple-Raine Company, Cincinnati, Ohio. The overall dimensions are 9 1/2 in. x 9 3/4 in. x 28 1/2 in. Three dials are used for tuning as is shown in the illustration. The panel is of Formica and the dials and knobs of Bakelite. The intended retail price is \$88.

## Seven-Tube Portable Receiver

*Radio Retailing, June, 1925*

Entirely self-contained is the model 103-A portable receiver made by Lytton, Inc., Lytton Building, Chicago, Ill. Compartments for storage A and dry B batteries are placed on each side of the loudspeaker. During transportation the loop folds up and fits inside the case, and an added feature is the plug-in attachment for the charger which automatically disconnects the battery from the set and puts it on charge. The intended retail price less accessories is \$190, with accessories \$225. The portable battery charger has an intended retail price of \$25.

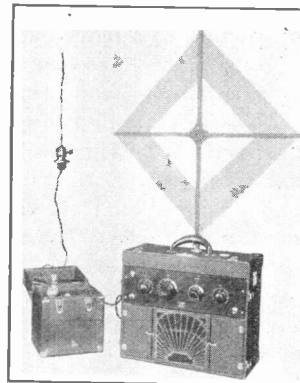

## Five-Tube Receiver

*Radio Retailing, June, 1925*

By the use of a straight line wavelength curve condenser, the Edward Jones Agencies, 640 Natoma Street, San Francisco, Calif., distributors, state that unusual selectivity, distance and tone qualities are properties of the "Radio-graph II." The receiver employs five tubes in a tuned radio frequency circuit which, it is said, operates best with a "hard" tube instead of the regular detector tube. The wavelength range covers a band of from 200 to 600 meters, and an antenna 100 feet long, including lead-in, is recommended. The cabinet is solid mahogany, finished in two-tone English brown. Intended retail price \$150.

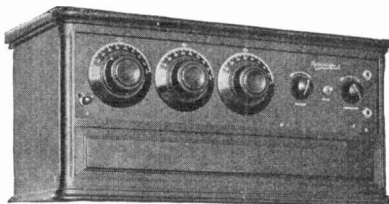

## Panel Type Phonograph Receiver

*Radio Retailing, June, 1925*

Using one stage of tuned and neutralized radio frequency, detector and two stages of audio frequency amplification, the Stromberg-Carlson Telephone Manufacturing Company, Rochester, N. Y., offers the No. 3-A and 3-B receivers. The former has a panel 14 1/2 in. x 17 13/32 in. and the latter 15 1/4 in. x 16 27/32 in. The sockets and coils are designed for use with UV-199 type tubes. A calibration curve is also furnished with each receiver. The only difference between the two receivers is the size of the panel. In the illustration the panel can be seen mounted in a phonograph cabinet.

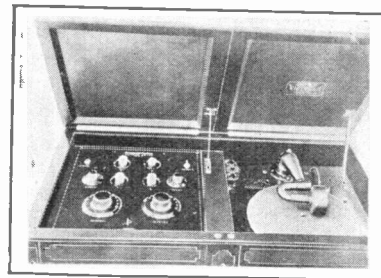

## Three-Tube Reflex Receiver

*Radio Retailing, June, 1925*

With built-in loud speaker, battery compartment, and using one stage of radio frequency amplification, the type "MRS-3" receiver made by the Marathon Radio Corporation, 133 First Street, San Francisco, Calif., has remarkable selectivity according to the maker. Dry cell tubes are used with the conventional plate voltages. The manufacturers also make three models of tuned radio frequency receivers at various prices. Intended retail price of type MRS-3, \$80, MR-3, \$65, MX-5, \$100, MR-5, \$140, MP-5, \$170.

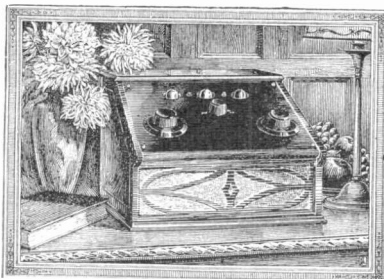

# Where to Buy It *News of Latest Products Gathered by the Editors*

*It should be noted that all announcements appearing on these pages are published without advertising considerations of any kind whatsoever.*

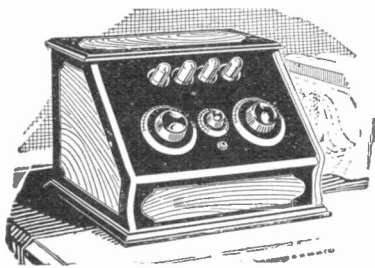

## Four-Tube Set

*Radio Retailing, June, 1925*

Using one stage of non-reflex radio frequency, detector, and two stages of audio-frequency amplification, the four-tube Neutrodyne receiver manufactured by Gilfillan Brothers, Inc., 1815 West Sixteenth Street, Los Angeles, Calif., is said to have unusual selectivity and tone quality. This receiver will cut through local stations and tune in distant stations only a few meters apart. Employing type UV-199 tubes, the set may be operated on dry cells, and a compartment in the back for batteries makes it entirely self-contained. In a cabinet with a two-tone American walnut finish, it has an intended retail price of \$65.

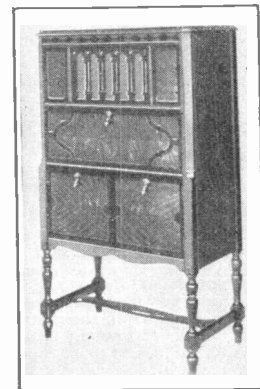

## Five-Tube Cabinet-Radio Receiver

*Radio Retailing, June, 1925*

A five-tube, two-dial, tuned radio frequency set is being made by the Knickerbocker Talking Machine Company, 831 Broadway, N. Y. The set is encased in an upright cabinet with the loudspeaker built in. The overall dimensions are 46 in. x 26½ in. x 14 in. There is ample room in the lower tier for all batteries as well as the charger. Furnished in butt walnut or mahogany. The intended retail price, complete with set, is \$150.

## Phonograph Panel

*Radio Retailing, June, 1925*

Built to fit any standard phonograph, the five-tube tuned radio frequency panel receiver made by the Marwol Radio Corporation, 85 Mercer Street, New York City, is said to have a high grade of selectivity, ease of operation. The same principal as is used in other Marwol receivers is used with equal results in distance, quality of tone, and selectivity. Intended retail price, \$70. Other Marwol receivers in different types of cabinets, vary in price from forty to eighty dollars. A kit consisting of parts necessary to construct a five-tube set is also a Marwol product and retails at \$15.



## Radio Console

*Radio Retailing, June, 1925*

In the new console, made by the Excello Products Corporation, 4820 West Sixteenth Street, Cicero, Ill., the shelf bearing the receiver is raised by lifting the dome. The mechanism is balanced, thereby raising and lowering the shelf vertically. The grill at the left is hinged, so that it can be raised when the cabinet is open providing a knee space for the operator. A tone chamber is built into the cabinet with the opening at the grill at the right. The storage battery compartment has a door at the rear of the cabinet. Any receiving set which has overall dimensions not exceeding 32 in. x 10½ in. x 12 in. can be accommodated.

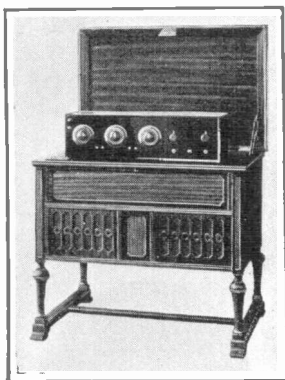

## Loud Speaker Unit

*Radio Retailing, June, 1925*

The California Nightingale Unit, Master type, is made by the Stentorfone Company, 784 Ceres Avenue, Los Angeles, Cal. The mechanism is housed in an attractive, mahogany color, all Bakelite shell. The intended retail price, including rubber adapter fitting for phonographs and horns, is \$18.80.

## Crystal Set

*Radio Retailing, June, 1925*

The "Master M-2" crystal set offered by the Radio Specialties Company, 34 Golden Gate Avenue, San Francisco, Cal., contains an inductively coupled double tuned circuit, with an amplicite crystal, and the dial readings may be logged similar to a neutrodyne. Great selectivity and volume are claimed for the set. The intended retail price is \$15.

## Five-Tube Receiver

*Radio Retailing, June, 1925*

"Royal Sixteen" is the name of the five-tube receiver now being made by Colin B. Kennedy Company, St. Louis, Mo. Two stages of tuned radio frequency are used with two tuning controls. A unique feature, is the graduated selectivity control, which needs to be set only once to suit local conditions. The set will operate very well on an indoor aerial or loop and a special jack is provided for loop use. The upright cabinet is in two-toned mahogany or walnut, has a built-in reproducing unit and tone chamber, and space for all batteries including charger and has overall dimensions of 50 in. x 28 in. x 15½ in. The intended retail price less accessories is \$235.

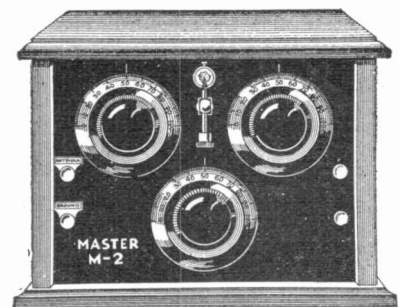
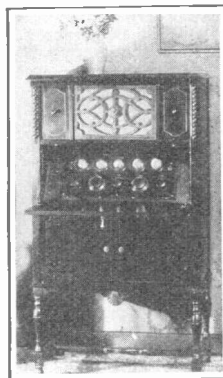

# What's New in Radio and Where to Buy It—

## Socket Contact

*Radio Retailing, June, 1925*

The F. R. Zierick Machine Works, 207 Canal Street, New York City, are making a socket contact which is stamped out of one piece of .025 gauge phosphor spring bronze. The lug is tilted at a suitable angle for sub-panel work and is furnished in nickel plate, tin, and plain finish to be used with any socket. This company also manufactures copper lugs, bus bar, T connections and ground clamps.

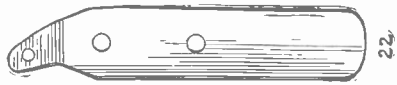

## Loop Aerial

*Radio Retailing, June, 1925*

The "Ampliflex" loop is of the solenoid type, 39 in. wide and 43 in. high which collapses on the same principle as a tripod by simply turning one thumbnut. It is made by the Ampliflex Radio Corporation, 39 Massachusetts Ave., Arlington, Mass., and is wound with silk covered Litzendraht wire arranged with taps so that 3, 4, 6, 9, 10 or 13 turns may be used. Mahogany is used with all of the metal fittings nickel plated. A table is furnished showing the combination of taps to be used for different size condensers in order that various wave length ranges may be covered. The intended retail price is \$12.

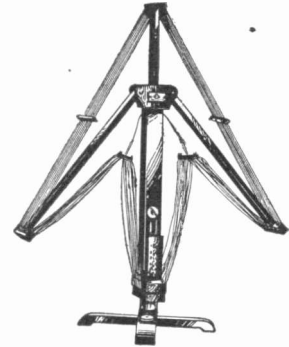

## Binding Post Plates or Markers

*Radio Retailing, June, 1925*

The Etching Company of America, 1520 Montana Street, Chicago, Ill., is making a line of binding post name plates, sunken silver on black. There are approximately fifty different markings available, including antenna, loop, C battery minus, detector B plus, B 45 volts plus, etc.

## Loudspeaker with Low and High Frequency Units

*Radio Retailing, June, 1925*

Incorporated in the Radiola Super-VIII receiver is now a new type of loudspeaker—the Doublette—which employs two separate units instead of the usual single unit. One of these units is known as the "low frequency unit" designed to reproduce frequencies from 150 to 1,500 cycles approximately, and the "high frequency unit" which is made to reproduce frequencies from 1,500 to 4,000 cycles approximately. When these units are combined, the frequency range is from 150 to 4,000 cycles, thus permitting the faithful reproduction of both the low and high frequencies and consequently, the natural quality of the human voice and the overtones of music.

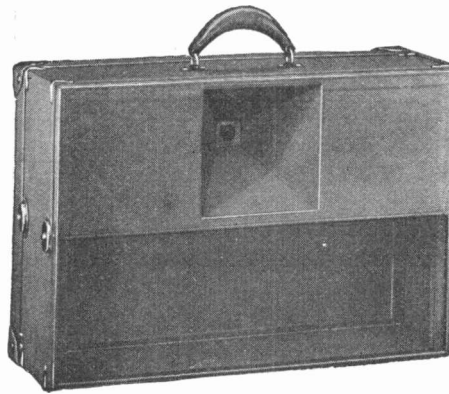

## Portable Radio Case

*Radio Retailing, June, 1925*

Now is the time to think of taking that radio set to camp for the summer. For this purpose the Knickerbocker Case Company, 228-238 North Clinton Street, Chicago, Ill., has prepared a black artificial leather covered case, with removable back and front, equipped with a wood horn for loud speaker. The panel space provided is 21 in. x 7 in. with a deep cover for dials, and straps to hold a collapsible aerial. There is also battery space on both sides of the horn. The intended retail price is \$12.50.

## Radio Pliers

*Radio Retailing, June, 1925*

The Smith and Hemenway Company, 114 Coit Street, Irvington, N. J., has recently placed on the market two types of pliers for radio assembly work. Radio side cutter and reamer No. 39,

cuts wire, makes loops, reams holes in wood, rubber or metal. It is made in a 5-in. size with spring handles which are knurled. Radio plier No. 40 has a snipe nose for making loops in wire, tightening terminals, etc.; is equipped with cutting edges and is also made in a 5-in. size. The intended retail price is \$1 each.

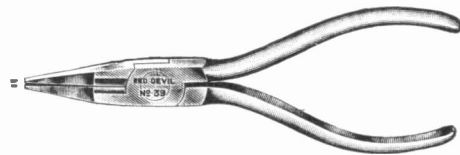

## Blow Torch

*Radio Retailing, June, 1925*

The No. 66 "Lenk" automatic blow torch recently brought out by the Lenk Manufacturing Company, 34-36 Portland Street, Boston, Mass., may be used to advantage for small soldering work. Operates on denatured alcohol. Overall dimensions are 6 1/2 in. x 2 3/4 in. x 1 1/4 in. Intended retail price is \$1.75.

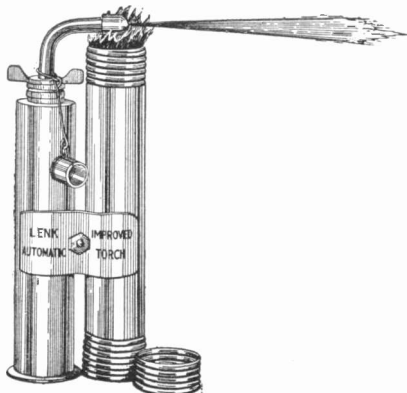

## Six-Tube Receiver

*Radio Retailing, June, 1925*

The Model 55 MacFadden tuned radio frequency receiver is manufactured by MacFadden and Company, Twenty-second and Arch Streets, Philadelphia, Pa. It consists of three radio-frequency stages tuned by a single dial, with antenna tuning also on a single dial, making a two dial control; detector, and two stages of audio frequency. The cabinet is constructed with battery compartments and a front which lowers to be used for writing purposes. Intended retail price, without accessories, \$160.

## Loudspeaker

*Radio Retailing, June, 1925*

The new loudspeaker built by the Stewart-Warner Speedometer Corporation of Chicago, is so designed and constructed that it covers the entire musical scale with full, rich tone volume and without distortion or scratching noises. The horn is made from fibre and is vulcanized on its outer surface. The core of the horn is allowed to remain soft which absolutely prevents the horn from vibrating at any note.

It is finished in a dark walnut, leather-like surface, and stands on a metal base which is deep green with gold-bronze high-lighting.

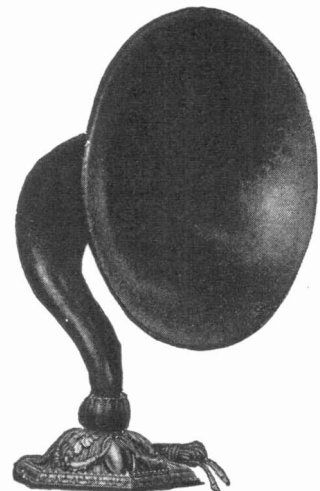

# News of Latest Products Gathered by the Editors

## Lightning Arrester

*Radio Retailing, June, 1925*

The air gap of the lightning arrester made by the Simplex Radio Company, 1013-15 Ridge Avenue, Philadelphia, Pa., is entirely closed and sealed in a brown glazed porcelain housing. Heavy terminals are provided that will permanently hold the wires in place. Mounting is accomplished through two screw holes in the flanged base. The intended retail price is \$1.50.

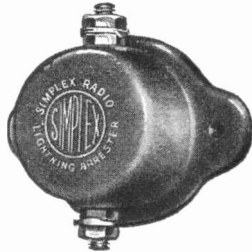

## Receptacle Jack

*Radio Retailing, June, 1925*

A receptacle jack that can be mounted flush in the wall, baseboard, or in a regular outlet box is the product of the Carter Radio Company, 209 South State Street, Chicago, Ill. The jack is of the open-circuit type and provided with screws so that connections can be made without the use of a soldering iron. The intended retail price is \$1. Another type is also made which has an intended retail price of \$2.

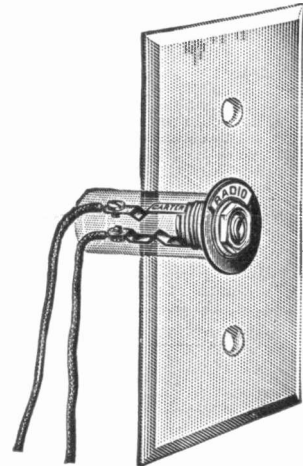

## Voltmeter

*Radio Retailing, June, 1925*

Service of a new kind will soon be placed before the public in the form of a voltmeter manufactured by Dongan Electric Mfg. Company, Detroit, Mich. These instruments are to be designed for panel and clamp mounting and also in the portable type. Voltage ranges from 0-7 to 0-100 volts permit the testing of either A or B batteries. This voltmeter mounted on the panel of any type set will tell the operator immediately the condition of his batteries and prevent the possibility of permitting the batteries going dead from neglect just when he wanted to hear "that programme."

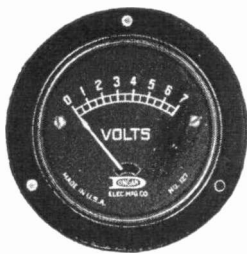

## Panel Light

*Radio Retailing, June, 1925*

An entirely new radio accessory has been brought out by the Radiolite Company, Hume Mansur Building, Indianapolis, Ind., in the form of a light for radio sets. It is finished in bronze and can be obtained with three different styles of adjustable brackets in order that it may be clamped onto any size cabinet.

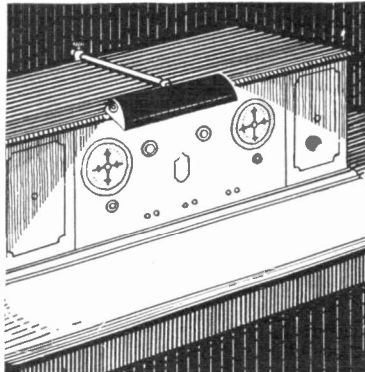

## Variable Grid Leak

*Radio Retailing, June, 1925*

The Radio Foundation, Incorporated, 150 East Fifty-third Street, New York City, offers the "Nonoise" variable grid leak. Variation in resistance, from  $\frac{1}{2}$  to 7 megohms, is obtained by simply rotating the leak with the fingers. The intended retail price is 85c. Amplifier resistances are also made on the same principle at the same price.

## Fixed Condenser

*Radio Retailing, June, 1925*

The "Micamold" mica condenser is made by the Micamold Radio Corporation, 1087 Flushing Avenue, Brooklyn, N. Y. Moulded in mica under a pressure of fifty tons per square inch makes it moisture proof and noiseless. The capacities are guaranteed accurate and range from .00005 mfd. to .006 mfd. The grid condenser has its leak clips as an integral part of the condenser thereby eliminating a loose contact. The intended retail prices range from 35c. to 75c.

## Battery Charger

*Radio Retailing, June, 1925*

Charging at a rate of eight or ten amperes on a discharged battery and tapering down to five amperes automatically, the Niles Battery Charger made by the Niles Manufacturing Company, Ypsilanti, Mich., is constructed so as to utilize both halves of the cycle, with quiet operation and long life of vibration contacts. It has the advantage of being able to charge both A and B batteries by simply throwing a switch mounted on the charger. At a charging rate of ten amperes it consumes sixty-four watts and is furnished with an eight foot cord for attachment to the light socket, and a six foot cord, with clips, for connecting to the storage battery. It has a crystallized finish, an ammeter to check up on the charging rate, operates on 110 volts, 60 cycles A.C. and is built in two models, Model A, for six volt batteries, Model AB for six and twenty-four volt batteries, with intended retail prices of \$19 and \$21 respectively.

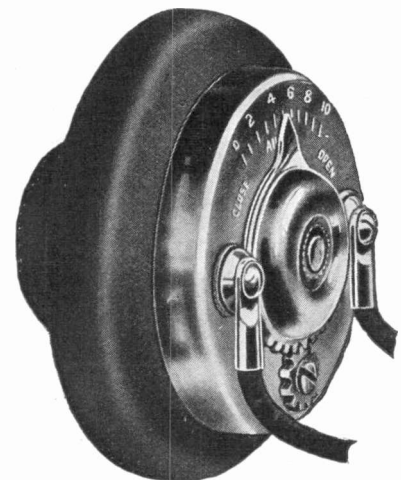

## Reproducer Unit

*Radio Retailing, June, 1925*

In the order to keep the diaphragm from buckling and always in line with the pole pieces, the type "B" semi-adjustable speaker unit, made by the Mozart-Grand Company, 235 Elizabeth Avenue, Newark, N. J., is designed with a self locking sector and pinion micrometer adjustment. Adjustment is made by rotating the knob on the back of the unit, the spacing being indicated by a pointer and scale. This enables the user to return to the same adjustment after any change has been made. The unit is made in three models which have an intended retail price of \$6 each.

# What's New in Radio and Where to Buy It—

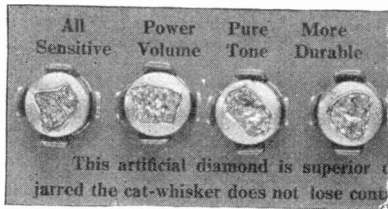

### Crystal Detector

*Radio Retailing, June, 1925*

The "Bug," an extremely sensitive crystal detector made by the Hearwell Electric, 53 Devonshire Street, Boston, Mass., is a synthetic diamond and comes in either an open or semi-fixed mounting with an adjustment screw. The crystal is sensitive over its entire surface and has double the life of a natural crystal. The intended retail price of the open type is 50c., and that of the semi-fixed, 75c. This company also makes a crystal receiver, an electric light socket aerial, and a flat window lead-in, with respective intended retail prices of \$3.50, \$1, and 50c.



### Non-Inductive Resistance

*Radio Retailing, June, 1925*

For use in resistance-coupled audio-frequency amplifiers, a non-inductive resistance has been designed by the Crescent Radio Supply Company, 1-3-5 Liberty Street, Jamaica, New York. The manufacturers point out that these resistances, when used in place of iron core audio transformers, eliminates all distortion and produce pure tonal quality. They are easily mounted, said to reduce B battery consumption and in some cases eliminate the necessity of a C battery. Made in 12,000, 48,000, 50,000 and 100,000 ohm sizes, with an intended retail price of \$1.50.

### Storage Battery

*Radio Retailing, June, 1925*

A semi-solid electrolyte, which absorbs a large part of the gases formed during activity, is the outstanding feature of the battery built by the Siplone Battery Company of America, St. Paul, Minn. For radio use it is made in both "A" and "B" forms. The manufacturer points out that the plates cannot be warped or buckled.

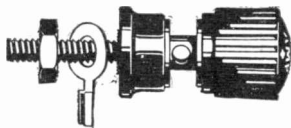

### Binding Post

*Radio Retailing, June, 1925*

In addition to irremovable knob and unbreakable moulded collar, the "Read 'em" binding posts, made by the Marshall-Gerken Company, 25-29 Ontario Street, Toledo, Ohio, incorporate many other desirable qualities. The brass shoulder, designed to prevent the collar from breaking, also is knurled so as to "bite" into the panel and hold the post permanently in position. The cross-drilled hole is so placed that the knob will not cut connecting wires when tightened. The post is offered in twenty-one markings, with new ones to be added from time to time. Display cartons holding seventy-five posts, and small refill cartons holding ten posts make stock taking quick and simple. Intended retail price of binding posts 15c. each.

### Soldering Iron Operating From Battery

*Radio Retailing, June, 1925*

That it heats instantly on the current from any 6- or 12-volt battery is claimed by the American Bureau of Engineering, Inc., 2632 Prairie Avenue, Chicago, for its "Ambu" soldering iron. As one terminal of the battery is connected to the job and the other to the battery, the current flows only when the iron and the job are in contact. The complete outfit consists of the soldering iron with carbon-tip holder and wire with clip for attaching to battery terminal; connecting wire with two clips for connecting other battery terminal to the job; package of six carbon tips; supply of wire solder; solder paste. Intended retail price, complete, \$2.25.

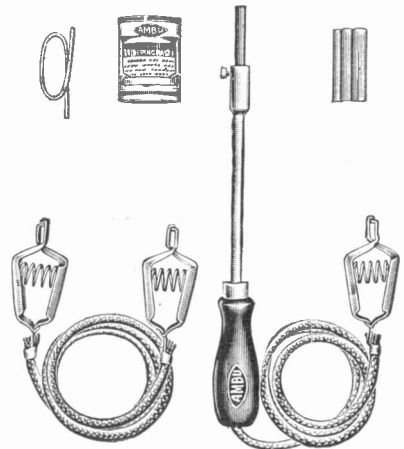

### B Battery Eliminator

*Radio Retailing, June, 1925*

Better reception, steady plate voltage variable from zero to fifty for detector, and zero to 110 volts for amplifier, are a few features pointed out by J. Thomas Rhamstine, 503 East Woodbridge Avenue, Detroit, Mich., maker of the Rhamstine B Rectifier. The rectifier is supplied by the ordinary house lighting current of 110 volts at 60 cycles a.c. The upkeep is very low the manufacturer states, costing approximately one third of a cent an hour; and by using a vacuum tube to effect the rectification, requires little or no attention. The rectifier is 6 in. square, weighs 10 pounds, and has an attractive crystalline finish. Intended retail price \$25.



### Vernier Dial

*Radio Retailing, June, 1925*

Obtaining a ratio of 100 to 1 by the use of a total of five parts is the feature claimed by Otto R. Gischow Company, Inc., 125 West Fifty-first Street, New York City, of the new "Gee-Haw" dial. The reduction is accomplished by friction. It is fastened to standard shafts by the use of a screwdriver and has no backlash. The diameter of the graduated dial is 4 in. and that of the vernier control knob 2 in. The intended retail price is \$3.

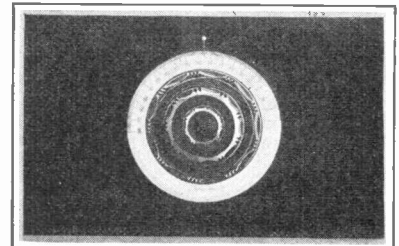

### Cabinet Speaker

*Radio Retailing, June, 1925*

An attractive cabinet speaker in two shades of wood is manufactured by the Vincennes Phonograph Company, Vincennes, Ind. The horn, which is a half-round bell shape, is designed to give perfect reproduction. The front of the sound chamber is covered by an attractive grill work and the cabinet harmonizes with most types of receivers. Intended retail price, \$25.

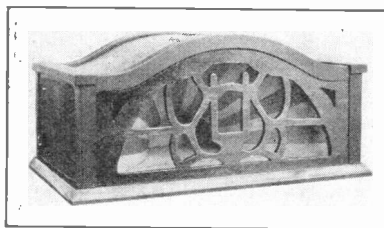

### Three Circuit Tuner

*Radio Retailing, June, 1925*

The Bel-Tone Radio Company, 161 Jamaica Avenue, Brooklyn, N. Y., is manufacturing the "Major Tuner," which is of the three circuit low loss type. Complete constructional details with a picture wiring diagram are furnished with each tuner. Intended retail price is \$4.

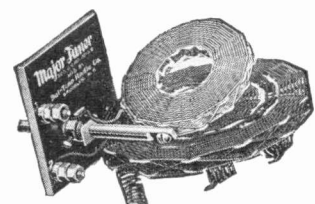



# News of Latest Products Gathered by the Editors

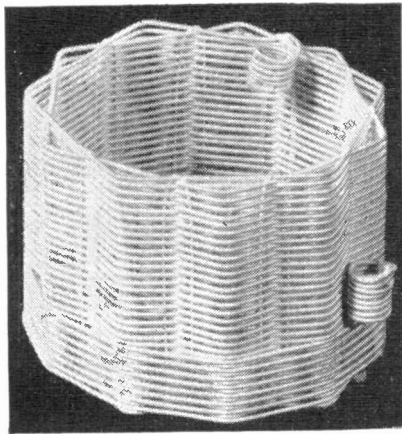

### Low Loss Coil

*Radio Retailing, June, 1925*

A minimum amount of distributed capacity between turns, larger wire than most coils in order to reduce losses from eddy currents, and minimum insulation thereby reducing dielectric losses, all help to make the "All-Henry" coil one of the most efficient coils on the market, the All-Henry Coil Company, Norwalk, Calif., maker, claims. The coil is not limited to one circuit but may be used in several different types of tuned radio frequency circuits. It is supplied with a small bakelite strip and angle for mounting which permits mounting at any angle in order to procure zero coupling between coils. Intended retail prices are \$2.25, \$2.50, and \$3.00 for the various types.

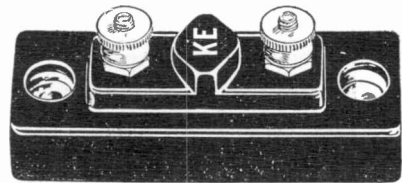

### Lightning Arrester

*Radio Retailing, June, 1925*

The K-E weatherproof lightning arrester of the Kirkman Engineering Corporation, 484 Broome Street, New York City, is intended for indoor or outdoor use. A barrier is provided between the binding posts to prevent signal being drained into the ground by rain. The manufacturer points out that it has been approved by National Board of Fire Underwriters. Intended retail price, 50c.

### Combination Rheostat and Potentiometer

*Radio Retailing, June, 1925*

A rheostat and potentiometer combined on one frame, with a single hole mounting, is the new product of H. H. Frost, 154 W. Lake Street, Chicago, Ill. The rheostat is of the vernier type, with the winding inside the frame of bakelite and the vernier wire around the outside of the frame. The potentiometer winding is placed on the outside and all binding posts are grouped at the top. The contact between the center arm of the potentiometer and the stationary arm is made with a stiff phosphor bronze spring.

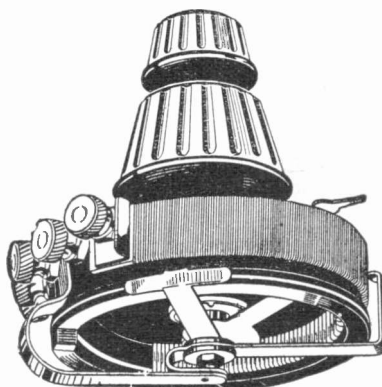

### Variable Condenser

*Radio Retailing, June, 1925*

The micrometer adjustment construction of the straight line variable condenser made by Barrett and Paden, 1314 Sedgwick Street, Chicago, Ill., will be found to meet the requirements of those who need a fine adjusting condenser. The plates move on a horizontal plane and rough adjustment is obtained by pushing a release button on the stem, and pulling the sliding element back and forth without rotating the dial. Graduations on the stem are numbered from 1 to 10, and on the dial from 0 to 100, thus allowing stations to be logged on even the most critical adjustment. It occupies a panel space of 3 1/2 in. x 2 1/2 in. and is made in capacities of .00025 mfd., .00035 mfd., and .0005 mfd. The intended retail price is \$6. A low loss, three circuit tuner adjusted on the same principle is also made by this company and has an intended retail price of \$8. When used with a .00025 mfd. condenser it has a range of from 200 to 600 meters.

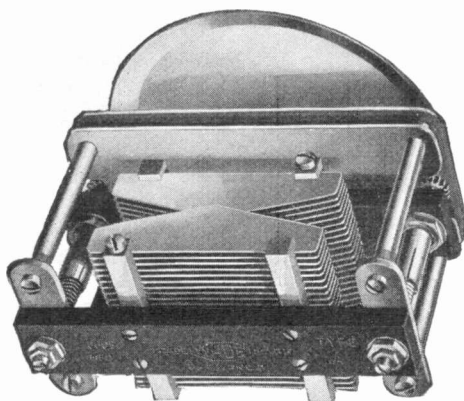

### Variable Condenser

*Radio Retailing, June, 1925*

With both sets of plates specially insulated from the frame, the new Wade "Square Law" condenser, made by the Wade Manufacturing Company, 1819 Broadway, New York City, is available in four sizes. Angular cutting of the plates gives perfect straight line wave length curve, says the maker. Standard frame allows interchanging of plate units so that condenser capacity may be changed by replacing plates. The plates are stamped brass, soldered together in one unit. A grounding terminal is also provided on the frame. The illustration clearly shows the construction.

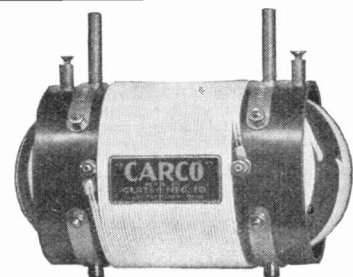

### Low Loss Turner

*Radio Retailing, June, 1925*

Three sizes of low loss tuners, covering wave bands of from 40 to 125, 75 to 200, and 175 to 600 meters have been placed on the market by the Carter Manufacturing Company, 1728 Coit Avenue, East Cleveland, Ohio. Naturally, only the latter tuner will interest the broadcasting fans, but the others will prove a boon to the amateur radio fraternity. According to the maker of these coils, their efficiency is due to the special single layer, multiple wound inductance. While the tuner is of the three-circuit variety, it is not limited to one circuit, as its flexibility lends itself to various uses. Intended retail prices are \$5, \$6 and \$6.75.

### Alkaline Storage Battery

*Radio Retailing, June, 1925*

Long life, non-fluctuating current, a steady voltage, and a non-corrosive solution, are a few advantages pointed out by the Edison Storage Battery Company, Orange, New Jersey, for its alkaline solution storage batteries. In place of the usual lead plates, these batteries have nickel and iron elements encased in steel containers, which insures protection from the buckling and warping of plates. Over-charge or short circuits have no permanent effect on the battery, and no fumes are released during charge or discharge. The batteries are made for both filament and plate supply, the A battery having a capacity up to 150 amp.-hr., and is priced from \$11.80 to \$78.50. The B batteries are built in twenty-two and one half and forty-five volt units with a capacity of 2,000 milli-ampere-hours, and are priced \$13.60 and \$24.75 respectively.

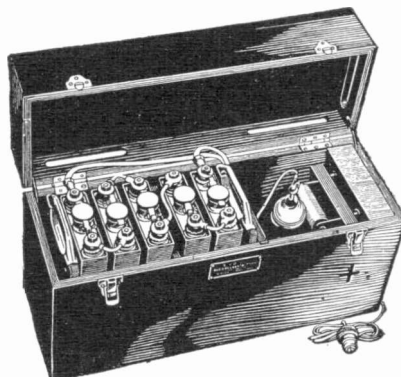

### Radio Tubes

*Radio Retailing, June, 1925*

Guaranteed, tested, protected by a serial number, and actually operated in a receiving set before being shipped are the Supertron Radio Tubes made by the Supertron Manufacturing Company, 32 Union Square, New York City, according to the makers. For all types the intended retail price is \$2.

# What's New in Radio and Where to Buy It—

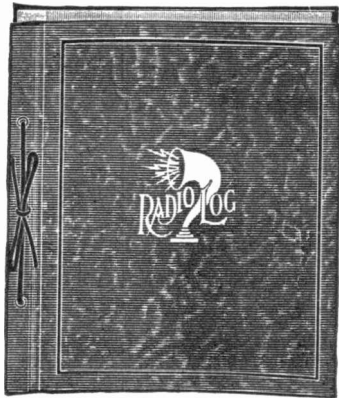

## Radio Log

*Radio Retailing, June, 1925*

A very attractive loose-leaf radio log is manufactured by the Peerless Album Company, 636 Broadway, New York. It contains a complete list of broadcasting stations in the United States and Canada, and has specially ruled paper on which stations heard, dial numbers, etc., may be listed. A place is also provided so that newspaper clippings of interest may be preserved and indexed. Other sheets are provided so that data concerning the set may be recorded for reference. The intended retail price is \$1.

## Battery Leads

*Radio Retailing, June, 1925*

To improve appearance and remove possibility of short circuits the Columbia Radio Corporation, 155 North Union Street, Chicago, Ill., has placed a set of battery leads on the market known as the "Multicolucord." This consists of five leads with different colored insulation woven into one cable, and covered with a black mercerized cotton sleeve. Being six feet in length, the batteries may be placed at some distance from the set, and all unsightly wires are removed. Tinned lugs are soldered on the ends of the wires to facilitate battery connections. Intended retail price, \$1.

## Loudspeaker

*Radio Retailing, June, 1925*

The new loudspeaker of A. T. Gruenberg, 10715 One Hundred and Eleventh Street, Richmond Hill, L. I., is made on the same principle as a guitar and is placed upright on a pedestal. It is furnished with a French polish finish, in mahogany with natural front. The intended retail price is \$50. A floor lamp model is also made with the unit concealed in the stem.

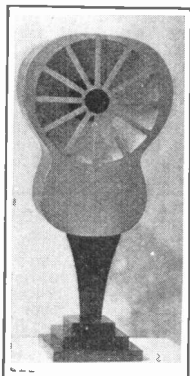

## Cabinet Type Loud Speaker

*Radio Retailing, June, 1925*

Recently brought out by the Jewett Radio and Phonograph Company, Detroit, Mich., is a cabinet type loud speaker with the unit of the "Jewett Vemco" design. One of the several improvements is the cadium plated interior of the unit, which eliminates all sweating. The grill is easily removed and may be bent and twisted without damage, the manufacturer says, as it is made of special material. The horn floats within the cabinet, being thoroughly padded on three sides with piano felt, and there is a resonance chamber below the horn which adds to the tone quality.

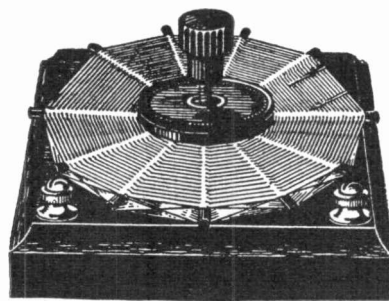
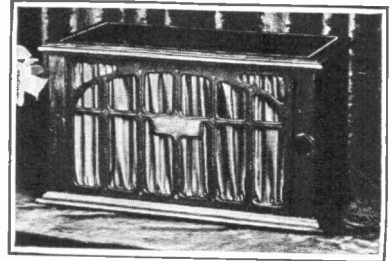

## Wave Trap

*Radio Retailing, June, 1925*

An inductance of the low-loss type, with a micrometer adjusted variable condenser, composes the wave trap or static eliminator made by the Steinite Laboratories, Atchison, Kan. The manufacturer points out that it is particularly valuable in overcoming the difficulty of tuning out nearby stations while attempting distant reception. It can be used with any type of crystal or tube set operated on either an indoor or outdoor antenna as it is independent of the tuning system. The intended retail price is \$1.

## Condenser

*Radio Retailing, June, 1925*

Ease of operation, efficiency, and flexibility in mounting are three features pointed out by the Nelson Tool Company, 105 West Fortieth Street, New York City, manufacturers of this sliding, low loss condenser. Variation of capacity is accomplished by means of a rack and pinion device which acts as a two to one ratio vernier. Heavy plates and a minimum amount of insulation are also pointed out together with the slide feature. The condenser is made in four sizes ranging from eleven plates to forty-one plates and from \$4.50 to \$6.00 in price. A special dial is made for this condenser with a 360-degree scale. Intended retail price of dial, three-inch size, 75 cents; four-inch size, \$1.

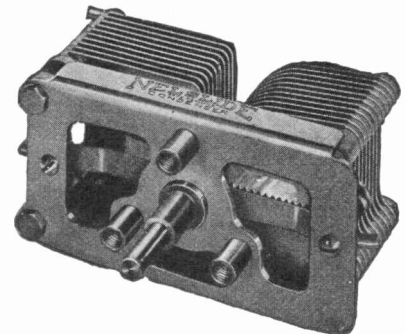

## Audio Frequency Transformer

*Radio Retailing, June, 1925*

Audio frequency transformers that have their binding posts underneath to permit concealing the wiring under a sub-panel, are now available for use in home-built sets, it is announced by Thordarson Electric Manufacturing Company, 500 West Huron Street, Chicago. Aside from the neater assembly, this type of mounting makes possible, that in many cases the leads can be shortened. The sub-panel mounting type Thordarsons are identical, except for the location of the binding posts, with the Thordarson standard type audio transformers and come in the same three ratios, viz.: 2:1, 3:1 and 6:1, with intended retail prices of \$5, \$4 and \$4.50 respectively.

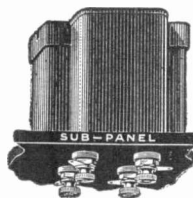

## Ground Clamp

*Radio Retailing, June, 1925*

A new type of ground clamp which forces its way into the metal that it is attached to is made by the Giant Clamp Works, 331 West Madison Street, Chicago, Ill. The illustration shows the manner in which the clamp is used. Nickel plated malleable iron forms the body of the clamp, while the screws are of steel. The intended retail price is 25c.

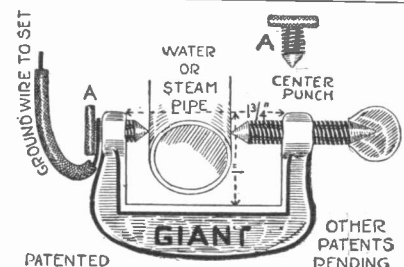

# News of Latest Products Gathered by the Editors

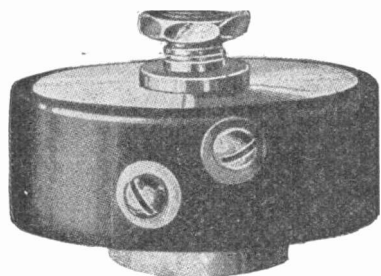

### Variable Resistance

*Radio Retailing, June, 1925*

The "Clarostat" is a variable resistance whose element is highly pulverized graphite mixed with very fine mica, and is made by the American Mechanical Laboratories, 285-287 North Sixth Street, Brooklyn, N. Y. It can be mounted on a panel by use of a hole of  $\frac{3}{8}$  in. diam., has a maximum carrying capacity of 22 watts, and retains its resistance setting at any desired point. It has many uses in circuit work as described in the booklet issued by the manufacturer, and has an intended retail price of \$2.25.

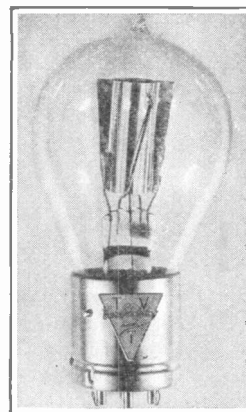

### Rectifying Tubes

*Radio Retailing, June, 1925*

The tube illustrated is of the Z-50 type, a two element tube without filament, which is one of the new series made by the Schicklerling Products Corporation, 401 Mulberry Street, Newark, N. J., for use in B battery eliminators. A standard base is employed and the tube is used for B battery supply, safely passing 50 m.a. at 300 volts. Helium is the principle gas, used in conjunction with several others, that fills the tube. The combination of metals which form the anode and cathode is such that as the tube operates, gas is given off as fast as it is used up. During rectification there is a 100-volt drop within the tube, which gives 160 volts available as there is another drop of 40 volts in the reactance. The life of the tube is said to be 1,000 to 2,000 hours. Intended retail price \$5.

The Z-150 tube, similar in construction to the Z-50, has a larger capacity as it passes 150 m.a. at 600 volts. This tube is intended for amateur radio use. Another type is the S-1000 with five elements to be as a rectifying tube in an A, B and C battery eliminator. Intended retail price \$6.

### Tube Tester

*Radio Retailing, June, 1925*

The "Sterling" home tube tester is made by the Sterling Manufacturing Company, 2831 Prospect Avenue, Cleveland, Ohio. In order to test any tube the set is turned on as usual, the tube to be tested taken from its socket, placed in the tube tester and the tester plug inserted in the socket. The tester button is then pressed to give a reading on the meter, which reading is compared with a chart furnished to determine the efficiency of the tube. Intended retail price \$8.50.



### Power Amplifying Transformer

*Radio Retailing, June, 1925*

The Thordarson Electric Manufacturing Company, 500 West Huron Street, Chicago, Ill., has recently placed on the market the Interstage power amplifying transformer as something entirely new in amplifiers. It is inserted in a power amplifying circuit, between a pair of standard input and output power amplifying transformers, and is said to give a tone quality that more than compensates for the additional cost involved. Full directions and wiring diagrams are supplied with each transformer.

### Steel Aerial Mast

*Radio Retailing, June, 1925*

A new series of "Hercules" masts is being made by S. W. Hull and Company, 2048 East Seventy-ninth Street, Cleveland, O., in three standard lengths of 20 ft., 40 ft., and 60 ft. A specially designed foundation does away with the use of concrete and permits all sizes to be erected in the earth or on the roof as desired. They are tested at the factory to withstand a 500-pound pull at the top and each mast outfit is furnished complete with guy-wires and mast-head pulley. The intended retail prices are respectively, \$10, \$25 and \$45.

### Tube Adapter

*Radio Retailing, June, 1925*

In order to use standard base tubes in sets equipped with sockets for 199 tubes, the Clearstone Radio Electrical Supply Company, 70 Audubon Avenue, Providence, R. I., has placed on the market a tube adapter. In order to use the adapter the sequence is, insert the tube in the adapter first and then the adapter in the set. Intended retail price \$1.

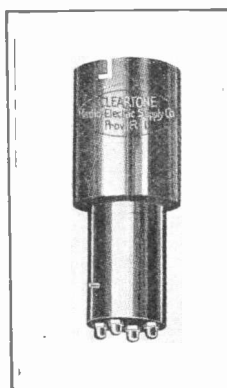

### Multi-Plug

*Radio Retailing, June, 1925*

Fitted with seven contacts, the Jones "Multi-Plug" made by Howard B. Jones, 614-18 South Canal Street, Chicago, Ill., is convenient to use where it is desired to run all the connections to the set in one cable. All multi-plugs are interchangeable and can be used with Jones sockets of all three types, which are, panel mounting, bracket type and the binding post type. Furnished with an 8-foot cable the intended retail prices are in order, \$4, \$4.50 and \$5. Wrong connections are impossible due to a key and key slot.

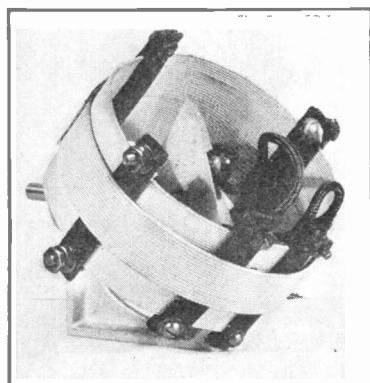

### Three-Circuit Tuner

*Radio Retailing, June, 1925*

The Thurman "Vario-Trans-Coupler" is a three-circuit tuner made by Radio Requirements Company, 70-72 North Second Street, Philadelphia, Pa., of "skip-wrap" wire with a cone shaped rotor. Pigtail connections are of standard lamp cord. The shaft and collar are made of rolled brass with a special phosphor bronze spring to secure the proper tension. Intended retail price is \$5.50.

### Radio Tube

*Radio Retailing, June, 1925*

Developed for use with resistance and reactance coupled amplifiers, is the "Hi-Constron" tube Model 101A, made by the Cleartron Vacuum Tube Company, 25 W. 44th Street, New York City. The rating of the tube is as follows: filament volts—5, filament amperes—.25, plate volts—90 to 135, amplification constant—20. The intended retail price is \$3.



# What's New in Radio and Where to Buy It—

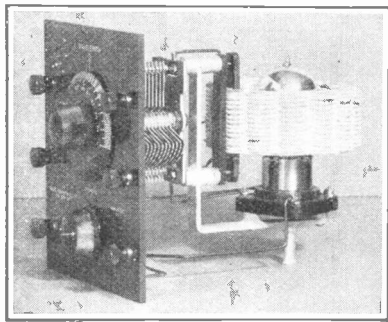

## Radio Frequency Amplifier

*Radio Retailing, June, 1925*

A low-loss radio frequency amplifier that can be placed before any receiver using a three-circuit tuner, is being made by the Radio Engineering Laboratories, 27 Thames Street, New York City. The condenser setting is said to be similar to that of the condenser in the set. It is furnished complete, less tube and cabinet, at an intended retail price of \$13.50.

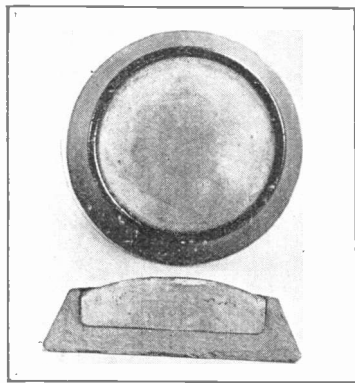

## Shock Absorber

*Radio Retailing, June, 1925*

The elimination of microphonic tube noises, and reduction of body capacity, may be accomplished by the use of the cabinet type radio shock absorber points out the maker, the Green Rubber Company, Greensburg, Pa. The absorber consists of a hard rubber base with a sponge rubber cushion. Intended retail price, \$1 for set of four.

## Collapsible Aerial

*Radio Retailing, June, 1925*

The aerial made by E. B. LaSalle, 61 South Washington Street, Batavia, Ill., is in the form of an umbrella. Containing 85 ft. of specially covered wire it is recommended for use where space is a factor to be considered and also for camping. The intended retail price is \$10.

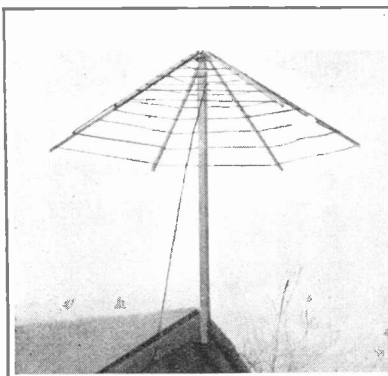

## Cord Tap Outlet

*Radio Retailing, June, 1925*

A fixed outlet that may be used with an extension cord for charging radio batteries from house current, is the product now being offered by the Beaver Machine and Tool Company, 625-643 North Third Street, Newark, N. J. As is shown in the illustration, this receptacle can be screwed securely to the wall, eliminating the nuisance of long loose wires on the floor. The intended retail price is 50c.

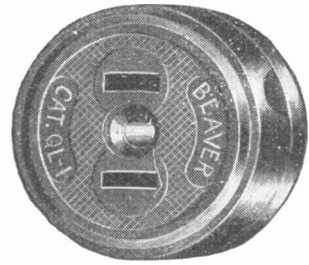

PIN TIP No. 630

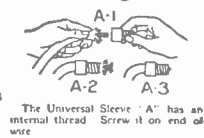

The Universal Sleeve "A" has an internal thread. Screw it on end of wire.



EYE TIP No. 631

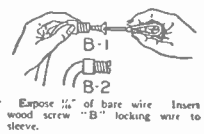

Expose 1/2" of bare wire. Inserts wood screw "B" locking wire to sleeve.

## Cord Tips

*Radio Retailing, June, 1925*

A series of cord tips which can be connected without the use of solder is being made by the Barkeley Electric Manufacturing Company, Middletown, O. The tips unscrew and inside there is a wood screw which inserts in the wire core until the head sets, making a good electrical contact as well as a firm mechanical joint. The parts are of brass or copper, nickel plated and all types of terminals are interchangeable on the same universal sleeve. Intended retail price 5c.

## Five-Tube Receiver

*Radio Retailing, June, 1925*

The Stewart-Warner Speedometer Corporation, 1826 Diversy Parkway, Chicago, Ill., has placed on the market a complete line of radio receiving sets. The instrument shown is Model 305—a five tube set in which is incorporated the U. S. Navy circuit. There are three tuning controls, mounted on a sloping front panel. The cabinet is finished in dark walnut. In this instrument, the special Navy tuned radio frequency circuit is said to have been developed to a high stage of perfection.

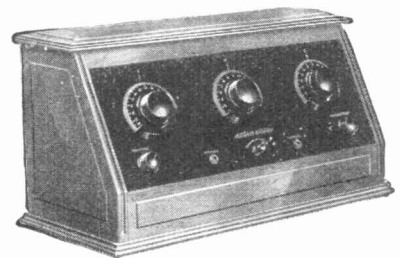

## Tube Socket

*Radio Retailing, June, 1925*

The Leich Electric Company, Genoa, Ill., has placed a socket on the market of improved design. The shell is made of brass, nickel plated, with a finger-like spring, opposite the holding slot, which protrudes from the wall to provide proper pressure on the tube base to keep it from tipping. The base is of punched bakelite with the terminal springs riveted to it. The intended retail price is 75c.

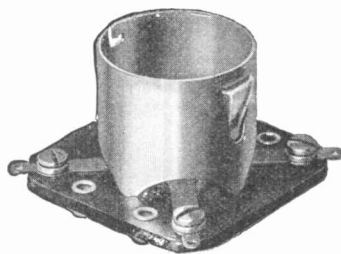

## Audio Frequency Transformer

*Radio Retailing, June, 1925*

The "Rauland-Lyric" audio frequency transformer, made by the All-American Radio Corporation, 2650 Coyne Street, Chicago, Ill., has been designed to give amplification entirely free from distortion. The slight clouding of overtones which is nearly always present due to transformer distortion, is claimed to have been entirely eliminated in this transformer. It may be used in all stages with equal success. The intended retail price is \$9.

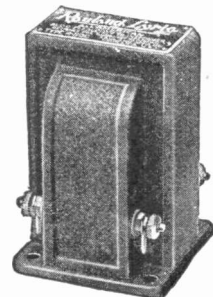

## Variable Grid Leak

*Radio Retailing, June, 1925*

The "Eagle" No. 250 variable grid leak has a micrometer adjustment and is made by the Eagle Electric Manufacturing Company, 38-52 South Eighth Street, Brooklyn, N. Y. It is adjustable from 0 to 50 megohms. The intended retail price, unmounted, is 75c.



# News of Latest Products Gathered by the Editors

## Vacuum Tube Rejuvenator

*Radio Retailing, June, 1925*

A tube rejuvenator, for home use, which will keep radio tubes at full efficiency at all times, according to the maker, has been placed on the market by the Jefferson Electric Company, 501 South Green Street, Chicago, Ill. Alternating current is used and the voltage pre-adjusted, leaving nothing to guess work. A socket for standard base tubes and also one for the UV-199 type are mounted on the top of the black enameled case as are also the control switches. Extension cord and plug are provided for connection to the house current. Made in two types, for 25-40 and 50-133 cycles. The intended retail price each is \$7.50.

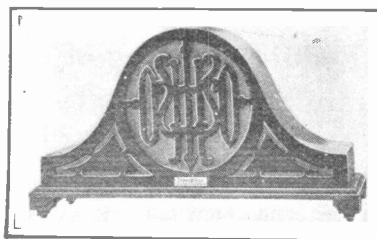
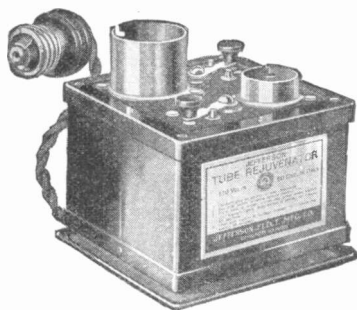

## Cabinet Type Loudspeaker

*Radio Retailing, June, 1925*

The "Strad-O-Vox" loudspeaker made by the Sterling Cabinet Works, Inc., Winfield, N. Y., combines beauty in construction with true tone quality, asserts the manufacturer, and owes its success to the dual sound chamber used and the "Dictograph" reproducing unit, the sound chamber being constructed entirely of wood. With three different models to choose from, it is possible to match the speaker with any receiver and select the one that harmonizes the best. The models are the standard, the special, and the de luxe, at intended retail prices of \$25, \$30 and \$45 respectively.

## Vernier Instrument Control

*Radio Retailing, June, 1925*

A vernier instrument control is being manufactured by the American Instrument Works, 613 Fulton Building, Pittsburgh, Pa. The scale remains stationary with the indicator moving around the edge of the dial. As the control knob is low, clear-vision of the scale is not interfered with when operating. With the exception of the knob, the entire instrument is of metal. Mounting is accomplished by the one-hole method. A metal template is furnished. The intended retail price is \$2.50.

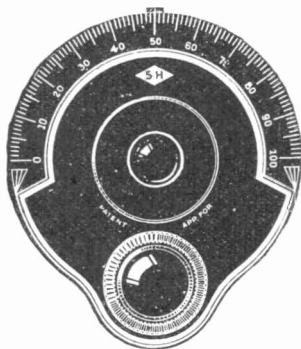

## Radio Tube

*Radio Retailing, June, 1925*

"Nutro" tube type 201-A is the product of C. A. W. Laboratories, 608 Chestnut Street, Philadelphia, Pa. It is a 6-volt tube drawing .25 amp. filament current and uses a coated filament. It is a guaranteed tube and has an intended retail price of \$3.50.

## Fixed Condenser

*Radio Retailing, June, 1925*

The "Kapaciton" condenser is claimed superior by the Kapaciton Company, 26 Elliot Place, Jersey City, N. J., manufacturer, due to uniform pressure. The pressure straps are drawn together parallel with each other and with the condenser surface. As all sides of the clamping arrangement are open, a soldered connection from the pressure straps all the way through to the metal foil is possible. These condensers are made in various capacities from 0.001 mfd. to 0.006 mfd., with or without straight or angled mounting lugs, which make it possible to mount the condenser in any position. The intended retail prices are 45c. to 85c.

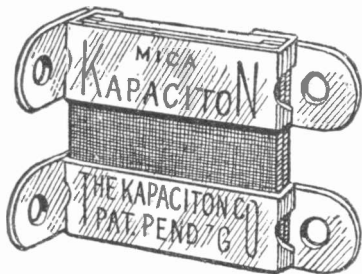

## Antenna Lead-in Insulator

*Radio Retailing, June, 1925*

Lightning protection and better antenna insulation is obtained by use of the insulator made by the Philadelphia Rust-Proof Company, Montgomery Avenue and Howard Street, Philadelphia. By preventing the lead-in wire from swaying and touching the roof, and holding it away from the house wall, better distance and volume is obtained, the maker points out. The insulator consists of a brown porcelain spool held in a pressed steel bracket, flanged at the base so it can be mounted on any convenient surface with nails or screws. The intended retail price is 10c.

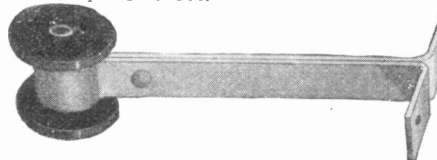

## Duo-Control Jack

*Radio Retailing, June, 1925*

One "Duo-Stage" control jack, made by the Leich Electric Company, Genoa, Ill., controls two stages of amplification either with or without filament control. When the plug is pushed in until the tip makes contact with the sleeve spring, the first stage is cut in the circuit. Then by pushing the plug the rest of the way in the second stage is cut in. The intended retail price without filament control is 80c., with filament control, \$1.20.

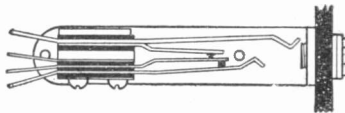

## Receiving Tube Operated from A.C.

*Radio Retailing, June, 1925*

The "McCullough" a.c. tube, made by the McCullough Sales Company, 963 Liberty Avenue, Pittsburgh, Pa., uses a large area "heating" element of rugged construction, instead of the usual filament. A small 75-watt transformer, which this company will supply at an intended retail price of \$8, is needed to supply current for the heating element. The rating given the tube is 4 volts at 1 amp. with a maximum of 150 volts on the plate. When more than one tube is used, the heating elements are connected in parallel. Although the connections for the heating elements are at the top of the tube a standard base is used and the grid return is taken from the usual terminal. It operates on any frequency from 25 to 60 cycles and is claimed to eliminate the a.c. hum entirely. The intended retail price is \$6.

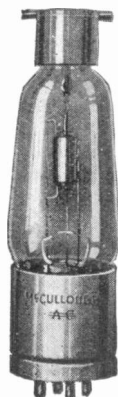

## Storage Battery Circuit Breaker

*Radio Retailing, June, 1925*

It is expected that the new 1925 National Electric Code, as being now prepared by the National Board of Fire Underwriters, will require that all wet A radio storage batteries must be protected against short circuit by a small circuit breaker or fuse, of not larger than 15-amp. capacity. As shorts are more or less frequent on radio sets where changes are being made, it is easily seen that a circuit breaker is the more logical piece of apparatus to use. In view of this fact, Bruno H. Ahlers, 8524-8526 Eighty-ninth Street, Woodhaven, L. I., has brought out a small circuit breaker which measures 4 in. x 2 1/2 in. x 3 1/4 in. It has its overload coils wound for a continuous current carrying capacity of six amp., and the armature is set to trip the breaker open at twice its rated current value. Adjustments are provided so that this trip setting can be changed if desired. It is incased in black, glazed porcelain with connections concealed in the base.

# What the Trade Is Talking About

## National Electrical Code Requires Fusing of Radio Storage Batteries

The National Electrical Code Committee at its recent meeting revised the rules on Radio Equipment. These new rules and amendments go into effect when the new Code is published, which will be about the latter part of July. Probably the most important of these revisions is new rule 3702-o which reads as follows: "Storage battery leads shall consist of conductors having approved rubber insulation. The circuits from storage batteries shall be properly protected by fuses or circuit breakers rated at not more than 15 amperes and located preferably at or near the battery."

## International Broadcasting to Feature Radio Show

The Fourth Annual National Radio Exposition, to be held at Grand Central Palace, New York, September 12-19 inclusive, will exhibit many new models and features for the first time, according to officials of the show. Elaborate educational plans are being made for the jobbers and dealers who, it is already indicated, will attend the exhibition in large numbers.

A conference hall is being erected on the third floor of the Palace, in which trade bodies will meet during the show. Numerous prizes will be offered for the best window displays, service and sales suggestions. Arrangements are being made for an "Industrial Dinner" in which the radio industry will participate. An invitation has been forwarded to Secretary Hoover to deliver a public address on this occasion which, it is expected, would strike the keynote of radio development for the coming season. The event will be made of world-wide importance by arrangements to broadcast the principal addresses through high power stations, not only to the radio public of the United States, but to Europe as well. The leading foreign diplomats stationed in Washington, who will be invited to the dinner, will be given the opportunity to talk to their home countries by means of international broadcasting. Efforts will be made, also, to obtain reciprocal messages through the air from the important capitals of Europe.

## Many New Broadcasting Stations Licensed

An average of twenty-five new broadcasting stations continue to be licensed each month by the Department of Commerce. Those licensed last month, which are of interest to the retail radio trade, are as follows:

KFWD, Arkansas Light and Power Company, Arkadelphia, Ark., 500 watts, 266 meters. WIBH, Elite Radio Stores, New Bedford, Mass., 5 watts, 209.7 meters. WJBC, Hummer Furniture Company, La Salle, Ill., 100 watts, 234 meters. WNAB, Shepard Stores, Boston, Mass., 100 watts, 250 meters. WNAV, People's Telephone and Telegraph Company, Knoxville, Tenn., 500 watts, 233 meters. WODA, O'Dea's Radio Shop, Paterson, N. J., 25 watts, 202.6 meters.

Other 500 watt stations include: KFVE, Film Corporation of America, St. Louis, 240 meters, KFVJ, First Baptist Church, San Jose, Cal., 226 meters, KFVK, Chamber of Commerce, Sacramento, Cal., 248 meters. WBAK, Pennsylvania State Police, Harrisburg, Pa., 275 meters. WMBB, Trianon Ballroom, Chicago, Ill., 250 meters. WSMB, Saenger Amusement and Maison Blanche Company, New Orleans, La., 319 meters.

## Electrical League Hears Address on Fundamentals of Radio Marketing

O. D. Street, vice-president of Thomas F. Logan, Inc., in a recent speech before the New York Electrical League, brought out many points of fundamental interest to radio distribu-

tion. Some of the high spots of this speech are as follows:

1. Dealer, jobber and manufacturer must each understand the problems which the others have to contend with.

2. While the responsibility of the manufacturer is great, the responsibility of the dealer and jobber is just as vital.

3. Successful marketing does not depend on how well one agency in the distributive chain functions, but on how well the entire machine functions. Mutual confidence is necessary.

4. No permanent success is possible without quality—quality of merchandise and quality in merchandising it.

5. For the quality of the goods and for advertising it nationally and to the trade, the manufacturer is responsible. Salesmanship is a responsibility of all three agencies — manufacturer, jobber and dealer.

6. No merchant can be expected to take advantage of advertising who has not grasped its power and sensed its importance.

7. Success in radio marketing depends on the merchant's ability to comprehend and capitalize the incomparable opportunity radio offers him. His success depends on how well he serves rather than on how many he sells to.

8. Radio is blessed with a fat endowment—universal public acceptance—but it is the very richness of the harvest which may lead us into merchandising tactics which are unsound. These we must guard against if radio is to be organized soundly as an industry.

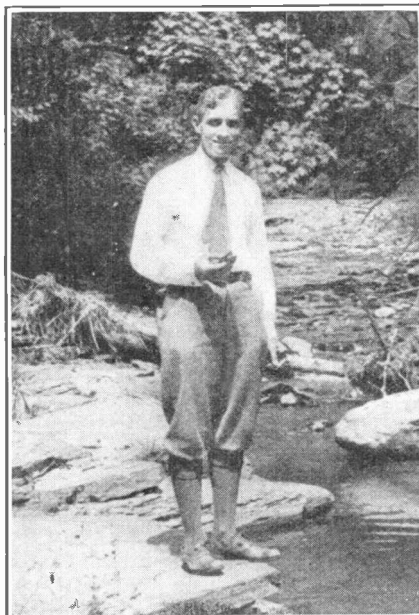

There's never been a gun fired yet that didn't have a man behind it to fire it. The man behind the big Stromberg-Carlson gun is Roy W. McCanne, president, and who, for the last eleven years has been general manager of the corporation. Roy's favorite sport is to take off his shoes and golf stockings and go wading in "th' ole swimmin' hole" at his summer home at Canadagua Lake, N. Y. The photo was taken just after Roy had put the socks back on. It is also rumored that he likes to go fishing only because of the keen delight he takes in digging up the worms for bait.

## Says Ontario Offers Lucrative Market

The Province of Ontario, Canada, is an unusually good market for radio receiving apparatus, according to a report from Consul Felix Johnson, Kingston, Ontario, to the Department of Commerce.

An American radio firm, with an active agent, could profitably start a drive in the agricultural section of Ontario, Mr. Johnson says. There is only one live radio dealer in Kingston, the report continues, and a great rural radio market is waiting to buy radio apparatus from the man who comes and sells it to them.

The best method to pursue, in the Consul's opinion is to send a live salesman into the Ontario Province with a high-priced loop set in his car, and canvass the farm territories. The sale should be made on a cash basis, or on notes. The salesman should call at the local bank and elsewhere as to the financial standing of the farmer who wants to pay via notes.

Guy M. Robinson, formerly assistant sales manager of the Crosley Radio Corporation, has opened a retail radio shop in Miami, Fla.

## Radio Exposition Will Be Held in Spain

A radio exposition will be held in the Ice Palace, Madrid, Spain, during November, at which time radio apparatus and telegraph material will be exhibited, according to a report to the Department of Commerce.

American manufacturers are invited to display their products. While the development of radio in most of Spain has been slow, it is believed that the coming exposition will do much to increase the use of sets in some sections. This is a highly competitive market with Italy, France and England offering sets of all values.

The Radio Laboratories, Upper Montclair, N. J., has completed the installation of equipment to make adequate tests of all kinds of radio apparatus. It is possible to obtain all data necessary to rate the equipment under test. The testing service also includes a report of the defects found and means for their correction suggested. The facilities of the laboratory are open to dealers, jobbers and consumers, as well as manufacturers.

The Thermodyne Radio Corporation, New York City, has added George B. Alley to its sales staff. Mr. Alley was formerly in the retail radio trade and was head of a group of three radio stores in New York and Western Connecticut.

The General Insulate Company, 1010 Atlantic Avenue, Brooklyn, N. Y., molders of "Insulate" and "Hi-Heat" (bakelite) is making extensive additions to its plant.

The Tridot Electric Company an-

nounces the appointment of the Aerodyn Company, 1780 Broadway, New York City, as sole sales agent for "Tridot" gridleaks. Two thousand square feet of additional floor space have been acquired to provide for the firm's expansion.

The Connewey Electric Laboratories have taken possession of their new plant at 406-408 Jefferson Street, Hoboken, N. J., which will be known as the Magnatron Building. The new plant has been almost entirely refitted with the latest machinery necessary for the manufacture of "Magnatron" tubes.

The Chas. Freshman Company, Inc., of New York City, has opened a factory, office and warehouse at 327 South La Salle Street, Chicago, Ill., which is under the direct supervision of S. Freshman, vice-president of the company.

The Sutcliffe Company, Inc., 220 South Fourth Street, Louisville, Ky., announces the lease of a new building, which will increase the company's floor space nearly 300 per cent. New plans include a special salesroom for the demonstration of receivers of all makes.

The Kodell Radio Corporation of Cincinnati, has appointed John F. Church as chief radio engineer. Mr. Church first studied radio at the Massachusetts Institute of Technology and Boston Tech, after he had enlisted in the Marine Corps. He was formerly connected with the Western Electric Company and the Harmony Manufacturing Company, and is at present, in addition to his duties as chief radio engineer at the Kodell Radio Corp., supervisor of the 1,000-watt broadcasting station, WKRC.

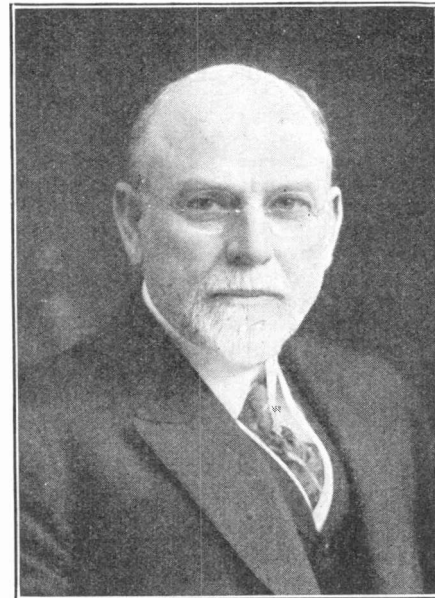

JAMES H. MCGRAW  
President, McGraw-Hill Company,  
publishers of *Radio Retailing*

## The McGraw Awards for Electrical Men

Four awards, to be given to the four men of the electrical industry who have contributed the most important service to the trade during 1924, have been inaugurated by James H. McGraw, president of the McGraw-Hill Publishing Company, and are to be known as The McGraw Awards. In each case, the award is a bronze medal and a purse of \$100 in gold, and it is Mr. McGraw's plan to make the awards on an annual basis.

A "Manufacturers' Medal," a "Jobbers' Medal," a "Contractor-Dealers' Medal," and a "Medal for Co-Operation" will be awarded each year, to the men who, in their respective branches, have made the greatest stride forward during the year, for the betterment of the electrical industry.

Each contestant must submit the record of his contribution to electrical progress before September 1, 1925, addressed to The James H. McGraw Awards, Society for Electrical Development, 522 Fifth Avenue, New York City. Prominent men of the electrical trade will act as judges.

The Magnavox Company, Oakland, Cal., announces the appointment of the Munson-Rayner Corporation as exclusive distributors of Magnavox radio products for the Pacific Coast States. The corporation has offices located at 86 Third Street, San Francisco, and 643 South Olive Street, Los Angeles. It is their intention very shortly to open a branch office in the Pacific Northwest. The Munson-Rayner Corporation's territory will include the states of Washington, Oregon, California, Arizona, the upper panhandle of Idaho and the western half of Nevada.

The Amber Manufacturing Corporation, makers of the "Marv-O-Dyne" five-tube, tuned radio frequency receiver, has moved to larger quarters at 599 Eleventh Avenue, New York City.

## Radio Expositions Ahead

August 22-29: Pacific Radio Exposition, Civic Auditorium, San Francisco, Cal.

September 5-12: Third Annual National Radio Exposition, Ambassador Auditorium, Los Angeles, Cal.

September 12-19: Fourth Annual National Radio Exposition, Grand Central Palace, New York City.

September 14-19: Second Annual Radio World's Fair, 258th Field Artillery Armory, Bronx, New York City.

September 14-19: Pittsburgh Radio Show, Motor Square Garden, Pittsburgh, Pa.

September 14-19: Winnipeg Radio Show, Royal Alexandria Hotel, Winnipeg, Canada.

September 23-October 4: International Radio and Wireless Exhibition, Geneva, Switzerland.

October 5-10: Northwest Radio exposition, St. Paul Auditorium, St. Paul, Minn.

October 5-11: Washington Radio Show, Convention Hall, Wash., D. C.

October 10-16: National Radio Show City Auditorium, Denver, Col.

October 12-17: St. Louis Radio Exposition, Coliseum, St. Louis, Mo.

October 12-17: Second Annual Montreal Radio Show, Windsor Hotel, Montreal, Canada.

October 17-23: Brooklyn Radio Show, Twenty-Third Regiment Armory, Brooklyn, N. Y.

October 19-25: Second Annual Cincinnati Radio Exposition, Music Hall, Cincinnati, O.

October 24-31: National Radio Exposition, American Exposition Palace, Chicago, Ill.

November 2-7: Second Annual Toronto Radio Show, King Edward Hotel, Toronto, Canada.

November 3-8: Detroit Radio Show, Arena Gardens, Detroit, Mich.

November 9-15: Milwaukee Radio Exposition, Civic Auditorium, Milwaukee, Wis.

November 17-22: Second Radio World's Fair, Coliseum, Chicago, Ill.

December 1-6: Boston Radio Show, Mechanics' Hall, Boston, Mass.

## Yale Omitted from Battery Listings

The Yale Electric Corporation, Brooklyn, N. Y., was omitted from the list of radio batteries in the April issue of *Radio Retailing*. Yale manufactures three types of six-volt storage "A" batteries, in 60, 90 and 120 ampere sizes, listing at \$16.50, \$19.20 and \$23.50, respectively. A C battery, the "3 in 1," is also made, selling at 60c. A one-and-a-half volt dry cell A battery is marketed to sell at 45c.

Seven models of dry cell B batteries are made by Yale. Four 22½ volt sizes, Nos. 1515, 1517, 1512V and 1528, list, respectively, at \$1.50, \$1.90, \$2 and \$1.75. The \$2 battery is tapped from 16½ to 22½. Three 45 volt batteries are included in the catalogue, Nos. 3045V and 3044 sell for \$3.75, and No. 3016 Double Duty sells for \$4.75. The last two are tapped off from 22½ to 45, while No. 3045V is tapped from 16½ to 45 volts.

## Freshman Announces New Sales Policy

The Charles Freshman Company, Inc., of New York has announced a new sales policy for the coming season. This concern, manufacturers of the line of "Freshman Masterpiece" sets, has decided to eliminate the jobber and distributor in the sale of its products. Freshman sets will be sold to authorized Freshman dealers, carefully selected, and granted an exclusive franchise in their territory. In towns of approximately 25,000 and under, one representative dealer will be appointed to exclusively handle the line, and in larger cities, additional dealers will be granted franchises in proportion to the population and trading area.

With the realization that the trend in radio buying is leaning strongly to-

wards furniture effects, the company has placed a complete line of Freshman receivers on the market, ranging in price from a five tube radio frequency set, in a cabinet with sloping panel, at \$39.50, up to the Franklin Console at \$115. The Franklin Console is composed of two separate units, one of which is a receiving set with built-in loud speaker, and the other the console for batteries and accessories.

Among the other models which will shortly be sold through Freshman authorized dealers is the Concert Model listing at \$75. This model includes a loud speaker.

Henry Baukat, who is a radio operator of a number of years' experience, and a graduate electrical engineer from Union College, Schenectady, New York, is now in charge of "New Radio Products" pages and specifications, listings of radio parts, accessories, etc., for *Radio Retailing*. Mr. Baukat comes from an electrical family, his father being a well-known electric-railway engineer and operating executive.

The Zenith Radio Corporation of Chicago, Ill., is moving into its new factory at Chicago. The factory is situated in the central manufacturing district and is a four story structure containing 185,000 square feet of space to be occupied exclusively by Zenith. Zenith is also moving its executive offices from the McCormick Building, to the Straus Building at Michigan and East Jackson Boulevard. The company also plans to put radio station WJAZ back on the air in the near future and has leased space in the Straus Building for use as a studio.

Ben J. Aplin, 30 Church Street, New York City, has been appointed representative for the Shaw Insulator Company of Irvington, N. J. This company specializes in custom moulding of bakelite, condensite, and redmanol.

## Additional Broadcasting Stations

Five additional broadcasting stations whose licenses are of interest to the radio trade have been given call letters by the Department of Commerce.

They are: WENR, of the All-American Radio Corporation, 2650 Coyne St., Chicago, Ill. The wave length is 266 meters and the power 10 watts; WDOD, Chattanooga Radio Co., Inc., 540 McCallie St., Chattanooga, Tenn., 256 meters, 50 watts; WIBE, Martinsburg Radio Broadcasting Co., 145 So. Queen St. Martinsburg, W. Va., 209.7 meters, 5 watts; WOWL, Owl Battery Co., 901 Carondelet St., New Orleans, La., 270 meters, 100 watts; WIBD, X-L Radio Service, 223 Van Buren St., Joliet, Ill., 200 meters, 50 watts.

The Jewett Radio and Phonograph Company, Detroit, Mich., will open WJR, its new broadcasting station, on July 1. The transmitter is housed in a two-story tapestry brick and stone building, located on the grounds of the new Jewett factory, just within the city limits of Pontiac, Mich., and is of the latest Western Electric 5,000-watt type. A lake comes up almost to the edge of the 200-foot aerial towers and is used to advantage for obtaining a good ground system. It is the intention of the company to do most of its broadcasting from Detroit studios, although the second floor of the transmitter building will be completely fitted up for handling concerts.

Ernest W. Sawyer of New York has taken offices in the Charles C. Chapman Building, Room 1418, at Eighth Street and Broadway, Los Angeles, Calif. Mr. Sawyer represents several Eastern manufacturers of parts, accessories and sets. At the present time he is introducing the Silver Marshall super heterodyne kit in the West Coast country.

C. Brandes, Inc., has moved to its new factory at 200 Mt. Pleasant Avenue, Newark, N. J., where Brandes products will be made in the future, and where the executive offices will also be located. The sales and advertising departments will be located at 237 Lafayette Street, New York City.

The Radio Trades Association of Southern California has announced completion of plans for the Third Annual National Radio Exposition to be held at the Ambassador Auditorium, Los Angeles, Cal., Sept. 5 to 12, inclusive. The committee in charge is headed by J. A. Hartley, of the Braun Corporation, Los Angeles. Also on the committee are Carl A. Stone, past president of the Radio Manufacturers' Agents' Association; J. W. Booth, manager of Barker Brothers' radio and music departments; Les Taufenbach of Western Radio, Inc.; Harry S. Mason, of the Electric Equipment Company; Lombard J. Smith, C. H. Mansfield, of the Fitzgerald Music Company; W. D. Scott, of the H. H. Frost Company, Inc.; and George W. Hall, of the Platt Music Company. Waldo T. Tupper has been appointed exposition manager.

The Ray Isler Radio Company, of Rochester, N. Y., announces a reduction in the retail list price of its radio receiver to seventy dollars.



William Dubilier, head of the Dubilier Condenser and Radio Corporation, which has just occupied a new factory in the Bronx, New York City, is so happily married that he prefers to spend most of his time at home, when he is not at work in the laboratory of his new factory. Mr. Dubilier is

essentially a home lover, and he and Mrs. Dubilier spend many of their leisure hours at home, either listening to a radio program or putting in one of their beautiful gardens. The Dubiliers take great pride in the landscape work of their home, most of which they have done themselves.



## "Victrola-Super Heterodyne" Ready for Fall Market

The Victor Talking Machine Company of Camden, N. J., on May 19, made public its plans to enter the radio field, working in conjunction with the Radio Corporation of America.

The contract between the Radio Corporation and the Victor company provides that the former will manufacture the same catacomb and parts used in the present Radiola for Victrola application.

J. G. Paine, counsel for the Victor company, in telling of the plans of his company stated that "there are two services which the talking machine performs which radio does not. Similarly there are services which radio performs and the talking machine does not. To take an obvious example, when one hears a remarkably fine performance through the phonograph he may repeat it as often as he pleases—the same artist, the same song, the same quality. One may hear the most excellent performances on the radio but he may never hear the same program again by the same artist under the same conditions. That is the part played by the talking machine.

"On the other hand a great speech, sermon or football game have their highest interest at the moment of their giving. That is the part radio plays."

Mr. Paine said that the Victor Company plans to take a part in actual broadcasting. "It is not our intention to withhold great voices or great artists from the air," he said, "but this phase of the situation is not without difficulties. A first requisite is that artists will be willing to co-operate and co-operate at such compensation as may be commercially practicable."

David Sarnoff, vice-president and general manager of the Radio Corporation of America, said: "It has not been easy to draw up a contract covering two such rapidly developing arts. Both are on the threshold of development; however, no revolutionary plans are in sight. Nevertheless, no standard apparatus today includes final developments in radio."

The Radio Corporation had been supplying the radio equipment for the Brunswick - Balke - Collender Company for over a year. The super-heterodyne has been included in the Brunswick combination machine. J. L. Bernard of the Radio Corporation of America said that they would continue to manufacture sets for the Brunswick Company. The artists of the Brunswick Company have been broadcasting through WJZ and stations of the General Electric and Westinghouse Companies.

Radio stocks continue depressed, practically all of them registering either a one- or two-point drop from last month. Victor and RCA showed great activity prior to the announcement of the working agreement between the two companies. The bullish tone subsided immediately after profit-taking by insiders, however.

Successful liquidation through "dumping" on the part of several overstocked manufacturers was reflected in an upward turn on the Curb in one or two instances. Aside from these tem-

Radio Stock Quotations					
Stock	Div.	Authorized Cap. Stock	Current Market	1925	
			May 23	High	Low
			Close		
Amer. Tel. & Tel.	2½Q	900,000,000	138½		
DeForest		*250,000	23	34	18½
Dubilier		*500,000	15½	35½	12½
Freed Eisemann		*300,000	8	33½	7½
Chas. Freshman	50cQ	*225,000	10½	28	9½
Garod Corp.		*100,000	3	2	3
Gen. Elec. Com.	1Q	185,000,000	281½	320	227½
Hazeltine	1¼Q	*200,000	17	51½	15½
Inter-Ocean		*100,000	4½	14	3½
Jones		*250,000	2	9	2
Liberty		*150,000	8½	9	7½
Music Master		*500,000	9½	21½	8½
Radio Corp. A Com.		*1,500,000	56½	77½	48½
Radio Corp., Pfd.	87½cQ	*25,000,000	50	51½	50
Rova		*150,000	3½		
Sleeper		*110,000	4½	19½	4½
Thermodyne		300,000	7½	22½	6½
Thompson		*140,000	6	25	5½
Victor			87	116½	65
Ware		60,000	12½	40½	8

\*Shares—all others are in dollars.

porary easing spells no upturn movement in stocks is anticipated until late summer.

## "Radio and Talking Machine Men" to Sell Fewer Lines

A group of resolutions of great import in marking the trend in radio distribution, was adopted at a meeting May 13, of the Radio and Talking Machine Men, Inc., in New York City. The most important resolution was the decision of the members, most of whom are music and radio dealers in the Metropolitan area, to handle only four lines of radio receivers. The resolutions, as adopted, read as follows:

1. Success in business comes from concentration. It is therefore that we recommend that the general handling of sets by dealers should be discontinued. A dealer should handle the products of no more than four manufacturers; and these products should cover the field in price, style and hook-up; thus, by confining themselves to four products, the proper presentation and

sales push can be put behind the products of the manufacturer. Proper representation given to manufacturers will encourage them in their future development. In selling the four products we earnestly urge that the dealers employ every precaution to select manufacturers who use proper merchandising methods and whose past can commend itself to the dealer, to the end that the industry can as rapidly as possible be put on a real business basis and be taken out of its gold-mine rush days.

We believe that a real dealer's franchise proposition, backed by an earnest endeavor by the manufacturer to make the franchise a valuable one, may be the solution of the difficulties of the trade. At this time, however, we make no recommendation that there be a general issuance of franchises.

2. For the dealer's own protection, he should handle only such sets as are standard, nationally advertised and steer clear absolutely from any stenciled merchandise. Such merchandise becomes practically valueless as soon as the height of the season is passed and his profits then are tied up in unmovable inventory on which great losses are taken. Very frequently the dealer makes a handsome profit during the season and gives it all back in the way of losses on inventory at the end of the season, having gotten nothing more than a mere living out of his hard work. Standard merchandise purchased at a living discount and backed by a manufacturer of reliable standing, financially and otherwise, is profit insurance.

3. We recommend that all dealers be prepared to give proper service upon sets sold, and that the service portion of their business be stressed in advertising and window displays; so that the public will have an assurance that after a set is installed in their home the dealer service will stand back of the set, and see to it that it continues to function properly. The proper service given to a consumer will develop the dealer's good will and bring him an endless amount of repeat business, thereby assisting in the reduction of his percentage overhead and the increase in his net profit. An investment made now in service work and a service department will reap a big return. In lieu of a home service department, arrangements can be made with certain well-known service organizations now being used by some of the leading retailers.

4. We recommend that an immediate effort be made to train yourselves and your clerks so that intelligent service and advice shall be given not only to purchasers in regard to the operation and maintenance of their sets, but also to all prospective purchasers.

5. We recommend that all sets that are advertised for sale or displayed in store windows or in stores, be advertised and marked under their "stripped" price only and never equipped; unless the set is one of those in which the parts are made by the manufacturers of the set, in which event the set shall be marketed under its complete price, fully equipped. When advertising complete sets, all accessories should be named.



David Sarnoff and the Radio Corporation of America are synonymous. To think of one is to think of the other. At the age of 34 he is vice-president and general manager of the RCA. And less than 15 years ago he was a wireless operator! He was born in Russia, coming to America at the age of nine. According to his intimates, he has no hobbies other than his job.

6. We earnestly recommend to the manufacturers of the country that there be only one discount price offered to dealers, regardless of the quantity purchased, and that the price offered should enable a dealer to make a fair profit; also that at no times should the manufacturer offer further discounts for quantity purchases, thus putting all dealers on an equally fair basis.

7. We desire to call to the attention of the manufacturers of the country the fact that more jobbers do not necessarily mean more business; that there should be fewer and better jobbers. That they should earnestly endeavor to see to it that those receiving jobbers' discounts are real jobbers and not the purchasing agents for chain stores, department stores, etc.

8. We earnestly recommend to all manufacturers that if they change their models or their prices they notify their jobbers and dealers in writing at least ninety days in advance of the change and at termination of said ninety days that a satisfactory adjustment be made.

In addition to the members of the association, representatives of more than twenty leading radio manufacturers attended the meeting. These men included: W. T. Eastwood, Herbert Brennan and Benjamin Gross, Stromberg-Carlson Company; William Ingersoll, De Forest; T. H. Melhuish, Radio Corporation of America; Harry Beach, Brunswick-Balke-Collender Company; J. B. Renwick, Jr., Adams-Morgan Company; W. J. Gaynor, Zenith; E. P. H. Allen, David Grimes Company; L. Gruen, Federal; S. O. Martin, Sonora; Gordon Sleeper, Sleeper Radio Corporation; Robert W. Porter, Thompson Manufacturing Company; Arthur Freed and Alex. Eise-mann, Freed-Eisemann Corporation; R. M. Klein and H. Linde, F. A. D. Andrea Company; Messrs. Waters and Dittmer, Pathe; Lawrence Gardner, Garod; Charles Lawson, Dayton Fan and Motor Company; Robert Harris, Adler Manufacturing Company; Col. Mapes and J. W. Jones, J. W. Jones Company; Mr. Lauriston, Colin B. Kennedy Company; Mr. Fink, Ware Radio Corporation; C. B. Cooper, Crosley Radio Corporation. V. W. Collamore, of the Atwater Kent Company phoned regret at his inability to attend.

### Shaw at Head of Seven Companies

Henry M. Shaw has recently been elected president of the General American Radio Manufacturing Company and affiliated companies, the General American Radio Corporation, the Yunk Glass Manufacturing Company, the Lamp and Wire Products Manufacturing Company, and the Transadyne Radio Company. In addition to being president of these concerns, Mr. Shaw is also head of the Shaw Insulator Company, Newark, N. J., and the Pioneer Radio Tube Laboratories, of Orange, N. J. The former president of the General American Radio Corporation, Lewis J. Selznick, who held that office for a number of months, remains as a director of the company. The directors of the General American Radio Corporation are: Warren S. Stone, chairman, Dr. John Yunk, Samuel R. Stone, R. D. Hickock, A. Claus, L. J. Selznick, and Frank Shaw.

The Carter Radio Company has just moved its office from 209 South State Street to its factory at 300 South Racine Avenue, Chicago.



M. Rypinski's hobby seems to be thinking. At least, his friends say they don't know of any other. So, as it's a pretty hard matter to get a picture of a man thinking, we did the next best thing, which was to snap him at his desk signing a friendly letter to the trade. He doesn't play golf, suffers a weight handicap in tennis, is far from a card shark, though is reputed rather good at Mah Jong and getting KGO, so the only thing left for him to do is think. Oh, yes, by the way, he's vice-president of C. Brandes, Inc.

The All-American Radio Corporation occupied its new factory at Belmont, Tripp and Kenosha Avenues, Chicago, Ill., on June 1. More than 100,000 square feet of floor space is provided for the manufacture of All-American transformers. This concern was founded in 1919 by E. N. Rauland and carried on under the name of the Rauland Manufacturing Company until last January, when it was taken over by the All-American Corporation. Radio station WENR was recently opened by the company. It is planned shortly to market a complete line of radio receiving sets.

The Champion Carbon Manufacturing Company, Cincinnati, Ohio, manufactures and markets dry cell A batteries under the trade name of "Champion" and not "Ace," as erroneously listed in the April issue of *Radio Retailing* under the heading of "A Batteries—Dry Cell." The "Ace" batteries are made by the Carbon Products Company, Lancaster, Ohio.

The Findley Electric Company, of Minneapolis, announces the opening of its new location at 111 South Sixth Street on May 18. A feature of the store will be a large basement display room where local dealers may bring prospective customers for demonstration. A careful selection of sets has been made and provision has also been made for the handling of any customers sent in by outside dealers.

The Electric Lighting Supply Company, 4000 Piedmont Avenue, Oakland, Cal., has been taken over by A. L. Clarke, as sole owner. This business was formerly operated by B. Ray Fritz as a contractor-dealer. Mr. Clarke will have an electrical appliance and supply shop, and will specialize in radio.

### Jewett Appoints Six New Distributors

The following distributors have recently been appointed by the Jewett Radio and Phonograph Company, Detroit: Carolinas Auto Supply Company, 221 North College Street, Charlotte, N. C.; Southern Auto Supply Company, 1519 L Street, N. W., Washington, D. C.; Radio Appliances, Inc., 1420 Main Street, Columbia, S. C.; Isaac Walker Hardware Company, 512 S. Washington Street, Peoria, Ill.; Franklin H. Clark, 901 Fifth Street, Sioux City, Ia.; Charleston Hardware Company, Charleston, W. Va.

The Mohawk Electric Corporation, Chicago, writes that it has contracted for an extensive billboard advertising campaign to begin early next fall.

The Crosley Radio Corporation, Cincinnati, Ohio, will hold the third annual convention of Crosley distributors in the corporation's auditorium at Cincinnati, July 7 and 8. At that time, the new Crosley "Sales and Service Stations" policy will be presented in detail. Those attending the convention will inspect the Crosley factory, with its output of 6,000 sets daily.

The Jewett Radio and Phonograph Company, Detroit, Mich., has added George A. Eckweiler to its staff as sales engineer of the manufacturers' equipment division.

The All-Henry Coil Company, formerly of Minneapolis, Minn., is in the process of moving to its new factory at Norwalk, Calif., where it expects to be established after July 1.

Walter C. Russ, prominent patent lawyer and engineer of New York City has been appointed vice-president and general manager of the Independent Radio Manufacturers, Inc. Mr. Russ is a graduate of Stevens Institute of Technology and the New York Law School.

H. Coleman and Company is the new name of the Penn Gas and Electric Company which has just moved into its new building at 40 North Seventh Street, Allentown, Pa., where expansion has made it necessary to occupy the entire building. The personnel of the company remains the same, only the name and address being changed. Coleman and Company are wholesalers of radio products and electrical appliances and fixtures.

The United States Department of Commerce has approved the Zenith-Reinartz short wave circuit for amateur and general use. This is the circuit that is to be used on the MacMillan expedition to the North Pole to keep the expedition in touch with the United States. Tests will be made to see whether the short wave is the solution to the problem of daylight reception.

Walter B. Fulghum, formerly connected with the Victor Talking Machine Company, has been appointed general sales manager of the Crosley Radio Corporation, Cincinnati, Ohio.

# Some Questions—and an Answer

How you can insure utmost possible profit from your socket and dial purchases

**S**UCCESSFUL radio merchants are now planning next season's stocks.

When you check up on your net profit after the next active radio season, what will you find that your sockets and dials have contributed—or deducted?

### The "carry-over" problem

Have you carried over a considerably greater stock than desirable of a variety of items? Every merchant often does, unfortunately.

For your next season, however, may we make this constructive suggestion?

### Constructive suggestion

Some of the reasons for too great carry-over are the initial purchase of too many brands of sockets and dials; too much stocking of sockets and dials that are perhaps different in a minor degree in construction or price but which duplicate in their uses; and too little consideration for the healthy sales advantage which concentration upon a carefully selected adequate stock gives you.

Whether or not you standardize on the Na-Ald line, we urge you to select your sockets and dials with an eye to concentration on the fewest adequate number of sockets and dials—and the efficient use of your jobber as a reserve stock depot.

### Some Na-Ald products in most stores

Now, frankly, we can suggest this sound procedure freely because as specialists in sockets and dials, and the largest manufacturers of them, we have discovered that few radio stores can get along without some portion of the Na-Ald socket and dial line. Good judgment suggests, consequently, that Na-Ald is a profitable line for you to standardize upon.

### Smallest stock needed for Na-Ald line

Candid investigation will show you that the Na-Ald line is skillfully designed to give the retailer completeness within the smallest possible stock requirements—and in addition unique merchandising and profit opportunity.

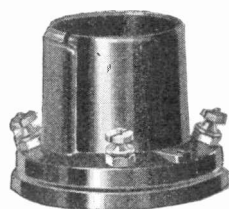

No. 400

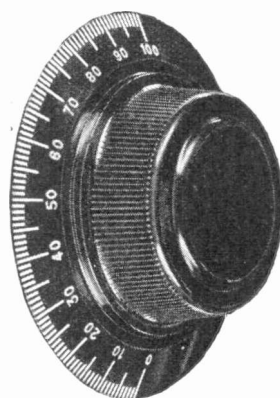

No. 3044

New features are about to be announced. The tabulation below will give you advance information.

### Unique features

Nowhere else can you secure in sockets and dials what the Na-Ald line offers. Check the following points for completeness—and yet remember that the line and its distribution is so planned that only a minimum stock investment is necessary.

#### Sockets—

For every tube—and, for example, even for latest "Radio Broadcast" hook-up.

Cushion mounted.

For small space.

For sub-panel mountings.

Adapters for all requirements.

Priced to produce greatest sales volume.

The only socket with side-scraping, self-cleaning, double contact.

By test, the lowest loss and the lowest capacity.

#### Dials—

A new and unique vernier.

A massive five inch dial.

Handsome two, three and four inch dials.

Mahogany finished dials.

Dials in a variety of colors for better selling and display.

Dials reading clock-wise and counter clock-wise.

The only dial scientifically designed and "stop-watch tested" for easiest and quickest operation.

While all this is fundamental in the insurance of minimum carry-over and greatest net profit, the most vital factor remains.

### Na-Ald known as standard

Radio users know Na-Ald as the leading socket and dial line. Anyone who knows the name of any socket or dial knows Na-Ald. Advertising, wide distribution, attractive packages, unique display and quality insure this.

You can properly standardize on Na-Ald because it is already standard in the minds of the radio public. Na-Ald is the fastest selling brand of sockets and dials.

Stock investment in Na-Ald is like money in a good security—sound, listed in all the markets, and readily saleable.

Concentrate on Na-Ald sockets and dials. And send the coupon for data on the new developments.

ALDEN MANUFACTURING CO.  
Dept. A-6, Springfield, Mass.



ALDEN MFG. CO.  
Dept. A-6, Springfield, Mass.

In my consideration of plans for next season, I should like further data on the Na-Ald line of sockets and dials and, particularly, advance information on the new developments you mention.

Name .....

Firm .....

Street .....

City ..... & ..... State .....

My jobber is .....

# How Manufacturers Promote Dealer Sales

New "Dealer Helps" Offered to the Radio Retailer by the Manufacturer to Increase the Merchant's Radio Profits

## Another Monthly Service

The Zenith Radio Corporation, 310 South Michigan Avenue, Chicago, issued in May, Vol. 1, No. 1 of the "Zenith Radiogram"—a monthly dealer publication. The purpose of this little publication, as expressed by the company is:

" . . . to assist through the exchange of ideas in the betterment of retail merchandising as will build for substantial and permanent establishment through a lasting dependable confidence through Zenith organization—from factory to distributor, dealer and to the consumer.

Beginning with the June issue, "The Zenith Radiogram" will devote pages 4, 5, 6 and 7 to Zenith dealer and consumer experiences, advertising helps, window trims, interior



For the use of "Standardyne" dealers for the Fall season, the Standard Radio Corporation, Worcester, Mass., has prepared an unusually large assortment of sales

helps, including a series of window cards or cut-outs. There are three of these cards, here illustrated, lithographed in six colors, each picturing a distinct radio appeal.

displays, etc. Dealers are requested to send copy and photographs of interesting and educational material for publication in the booklet.

## For Your Radio Window

Among the sales aids distributed by the Standard Radio Corporation, Worcester, Mass., is a series of window display cards. These cards are three in number, lithographed in six colors and each card presents a distinctly different type of appeal. The smallest card is a window cut-out displaying prominently the popular "Standy" figure which is the trade mark of the company's products. The second card is a cut-out showing the "World at Your Finger Tips" slogan, while the third card is the largest display of all and presents both the small model "Standardyne" and the console model.

Colored cardboard cutouts of this type will make the duller window more attractive.

## A New Way to Demonstrate Reproducers

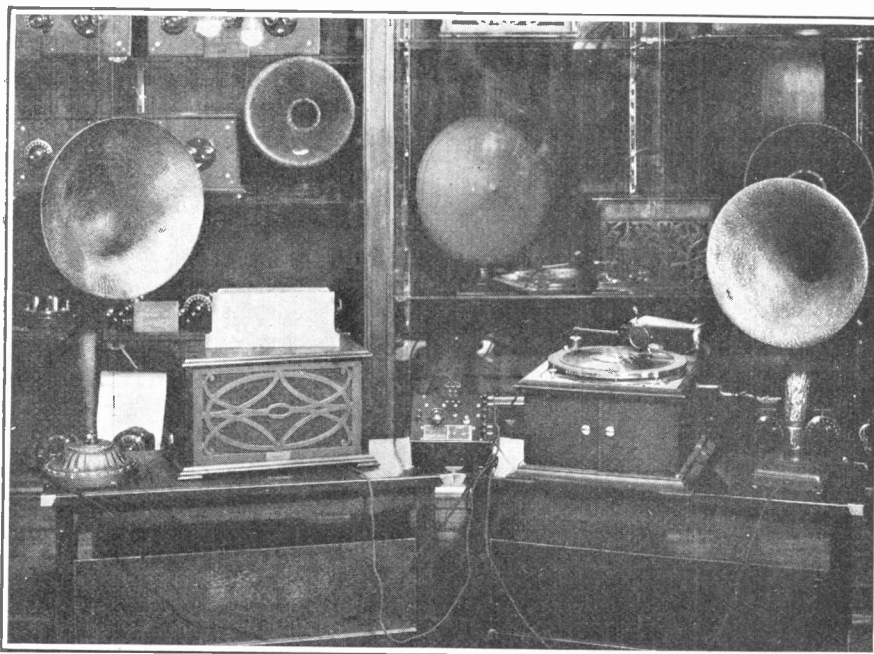

The "Comparaphon" is a new product to demonstrate the merits of several loudspeakers without the aid of broadcasting. It reproduces a phonograph record electrically through any radio speaker. The principal purpose of the Comparaphon is to demonstrate loud speakers in the dealer's store at any hour of the day.

The Comparaphon test is obtained simply by placing the small Bristol Phonograph Microphone on a turntable, then plugging

it in to the control box. A six-volt battery and the loud speakers to be tested are connected to the control box. By means of a selector switch the music from the Comparaphon is put through the different loud speakers and in this way a true demonstration is given the customer. The Comparaphon itself consists of a small box about 5½ in. x 7 in. x 2½ in. and is made by the Bristol Company of Waterbury, Conn.

## "The Longer You Wait, the More You Miss"

Emphasizing the things that one misses by not having a radio in the home imbues the prospective purchaser with a desire to have that which others are enjoying, the Radio Corporation of America explains in announcing a series of three form letters prepared for dealer use. This line of approach, the company thinks, brings better results than merely pointing out the mechanical perfection of a receiver.



# Exide

## RADIO BATTERIES

For many years millions of people have been constantly reminded, by full-page color advertisements in the Saturday Evening Post and other influential magazines, that the Exide is the best buy on the battery market.

# Will today's purchaser be your customer tomorrow?

THE man who made his first purchase from you today formed an opinion of your store. On this opinion will depend his future patronage. Of the things that influenced his judgment, the most important is the type of merchandise you sell.

There are names he knows, and merchandise he cannot question.

There's an even chance that in his car is an Exide Battery; for more cars leave the factories equipped with batteries of Exide make than with those of any other

make. He knows these batteries.

For years he has been constantly reminded by Exide advertising that the Exide is the best buy on the battery market. Even though he knows little about radio, there is one radio accessory that he knows he can bank on—the Exide Battery.

It pays any radio merchant to tie to names and merchandise that hold the confidence of the many. These names and merchandise help make today's customer your customer tomorrow. *Display Exide Batteries.*

THE ELECTRIC STORAGE BATTERY CO.  
Philadelphia

Exide Batteries of Canada, Limited  
153 Dufferin St., Toronto



Compact Exide 2-volt "A" Battery for low-voltage tubes. Made also in 4-volt size.



The new rugged, good-looking Exide 6-volt "A" Battery with one-piece case.



Exide rectifier for economical recharging of "B" battery from house current.

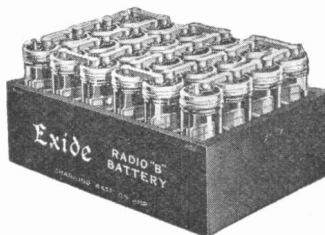

Exide 48-volt "B" Battery in glass jars. 6000 milliamper hour capacity. Made also in 24-volt size.

FOR thirty-seven years the makers of Exide Batteries have been developing reliable storage batteries.

For every radio set there are effective, good-looking Exide Batteries, especially designed and built to bring out the best reception from any radio set.

For the merchant who seeks to reduce servicing hazards, who looks to the future of his business, there is prestige and profit aplenty in the Exide line.

**FOR BETTER RADIO RECEPTION, USE STORAGE BATTERIES**

# GRAND CENTRAL PALACE

## 4th Annual NATIONAL RADIO EXPOSITION

Grand Central Palace, New York

September 12th - 19th incl.

- the *fourth successive* national exposition representing *all* the leading manufacturers of the radio industry;
- the *only* great radio exposition of 1925 to be held in the *metropolitan center* of New York;
- the *greatest spectacle* of the year in the scientific, industrial and business progress of radio!

Business Office:  
AMERICAN RADIO EXPOSITION CO.  
522 Fifth Avenue, New York

HAROLD BOLSTER, *Director*  
J. C. JOHNSON, *General Manager*

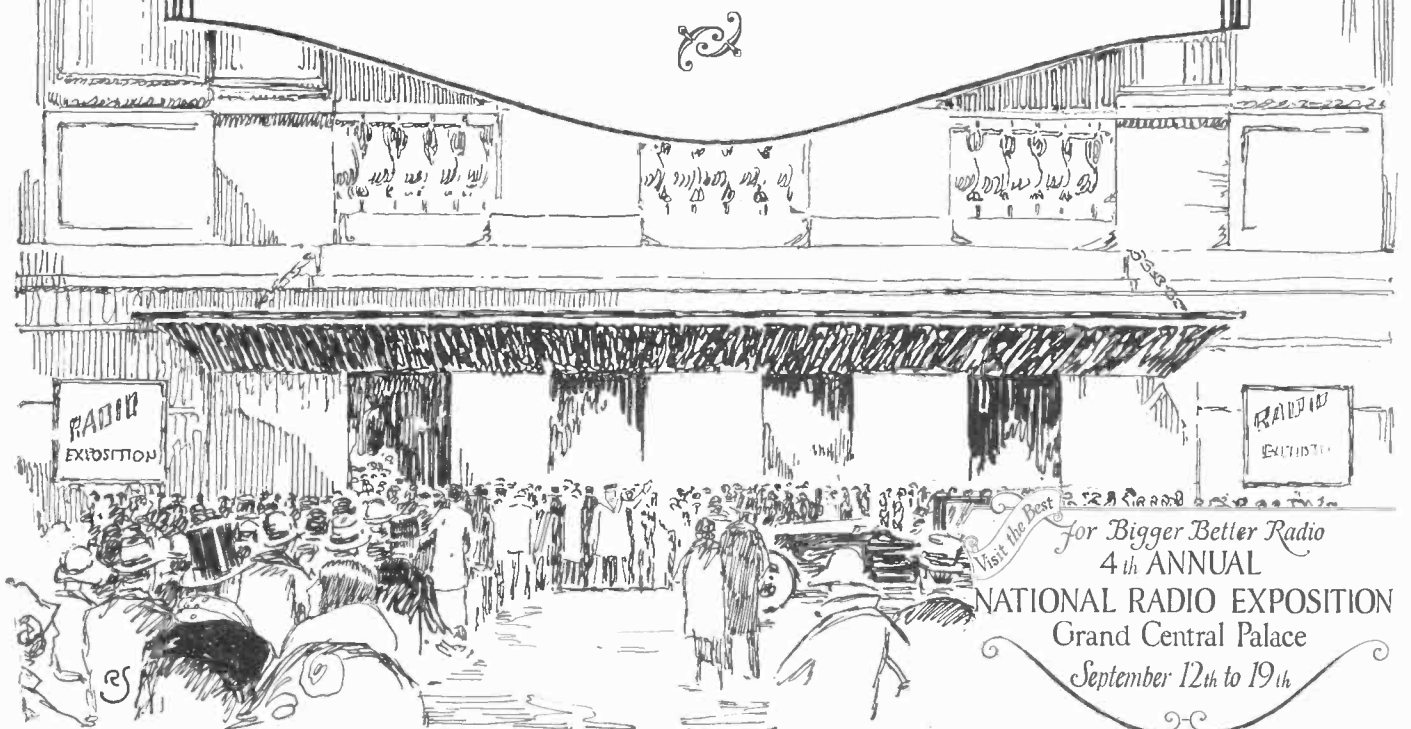

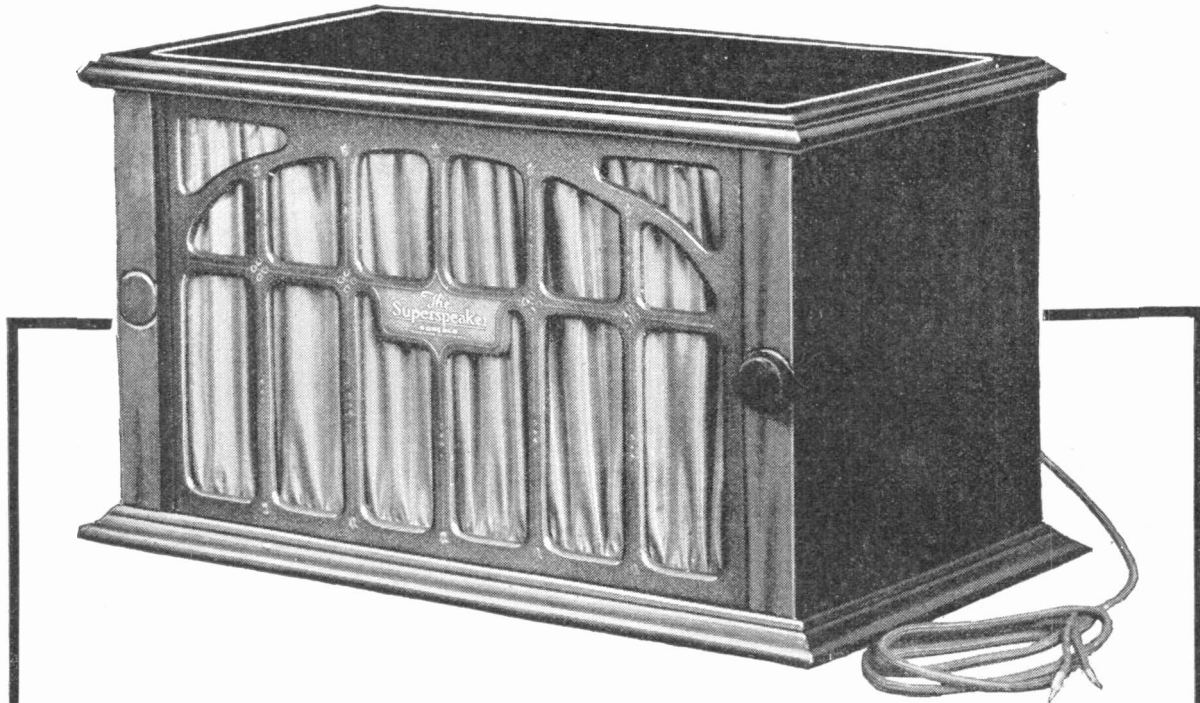

## And Now— The Superspeaker Console

In Performance, it's a Superspeaker—enough said.

In Appearance, it's the finest piece of Radio cabinet work you have ever seen.

Just what you'd expect from two years' experiment and development by an organization with a record of leadership in the field of loudspeakers.

See it! Listen to it! Discover for yourself that here is the Cabinet Speaker you can whole-heartedly endorse.

Of finest American Walnut or the new Clairemount Mahogany—Top inlaid with Arlington Ivory—Leather composition grill, richly draped with silk—Volume controlled by ebony knob—Superspeaker-Vemco Reproducing unit—Superspeaker-material concealed horn with full floating mounting. Overall size  $10\frac{1}{4} \times 17\frac{3}{4}$  inches, 10 inches high. Price, \$40; west of Rockies, \$42.50.

JEWETT RADIO & PHONOGRAPH COMPANY  
5696 TELEGRAPH ROAD PONTIAC, MICHIGAN

Factories: Allegan, Michigan—Detroit, Michigan—Pontiac, Michigan

Canadian Sales Offices:  
Walkerville, Ontario

Export Sales Offices:  
116 Broad St., New York City



*The Jewett Superspeaker—*  
All that the name implies  
Recommended by experts  
everywhere. Price \$30.00.

*The Jewett Superspeaker  
Console—*A handsome cabi-  
net with Superspeaker per-  
formance. Enough said. Price  
\$40. West of the Rockies,  
\$42.50.

*The Jewett Superspeaker Highboy—*  
Houses Radio set and all batteries. Su-  
perspeaker built in. Takes Radio into  
the realm of fine furniture. Price \$130.00.

*The Jewett Vemco Unit—*Makes  
a loud speaker out of your phono-  
graph. The Reproducer used in  
the Superspeaker. Price \$12.00.

*The Jewett Micro-Dial—*Makes  
tuning 50 times as accurate. Fits  
any set. Needs only a screwdriver  
to install. Price \$3.50.

*The Jewett Parkay Cabinet—*With  
parquetry top. Puts the amateur on a  
par with the most exclusive cabinet  
worker. All sizes, prices to correspond.

# Jewett Quality Products

Yes indeed—  
it's Nationally Advertised!



# JEFFERSON TUBE REJUVENATOR

*brings you summer  
radio profits!*

The man, woman or child hasn't been born who, once having purchased a radio, is not interested in getting continuously good results from it.

That is why the Jefferson Tube Rejuvenator has "taken" so readily. Used once a month, it keeps tubes at full efficiency—improves radio reception and increases the life of tubes.

Our current national advertising emphasizes the value of using a Jefferson Tube Rejuvenator to improve summer reception. Here is a most extraordinary avenue of summer radio profits!

Take full advantage of our powerful summer advertising in the important national publications shown above. Stock and display the Jefferson Tube Rejuvenator. Get these profits now. Order today from your Jobber. Fully guaranteed.

**Jefferson Electric Manufacturing Co.**  
501 S. Green St., Chicago, Ill.

Makers of Jefferson Radio, Bell Ringing and Toy Transformers; Jefferson Spark Coils for Automobile, Stationary and Marine Engines; Jefferson Oil Burner Ignition Coils and Transformers.



**\$7.50**  
List Price

\$10 in Canada



Attached to any a. c. electric light socket, the Jefferson Tube Rejuvenator "brings back" weak tubes in just 10 minutes. Takes large or small tubes—201-A, 301-A, UV-199, C-299. Operates on alternating current only.



**Music  
Master**  
Resonant Wood  
Insures  
Natural  
Tone  
Quality



*Yes*

*you can almost  
see the artist*

*MUSIC MASTER'S* outstanding eminence of true, natural, vivid Radio Recreation is achieved by perfect balance of three essential elements.

- precision reproducing instrument of unequalled delicacy, accuracy and refinement.
- heavy cast aluminum tone chamber, eliminating over-vibration and developing sound waves without distortion.
- wood bell—for only wood gives vibrant resonance, imparts tonal brilliance and assures re-creation of natural quality and life-like characteristics of music, song and speech.

Music Master is tested for musical quality, by musicians, through every stage of amplification, and is the supreme re-creating

*Musical Instrument of Radio  
There IS no Substitute*

Music Master Radio Products are now, and shall always be, of highest quality, fairly priced to the public, liberally margined to the trade to yield the dealer a handsome *net profit*, and well advertised to move the goods. It pays to handle Music Master—the most merchantable item of radio. There IS no exception.

Model VI \$30  
14" wood bell

Model VII \$35  
21" wood bell

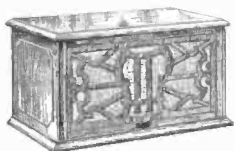

Model VIII, mahogany cabinet with full floating wood bell \$35

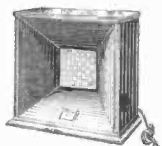

Model V, metal cabinet, mahogany finish, wood bell \$18

Connect Music Master in place of headphones. No batteries. No adjustments.

Prices of all models slightly higher in Canada.

**Music Master Corporation**

Makers and Distributors of High-Grade Radio Apparatus  
Tenth and Cherry Streets

Chicago PHILADELPHIA Pittsburgh  
[Canadian Factory: Kitchener, Ontario]

**Music** **Master**  
*RADIO* *REPRODUCER*

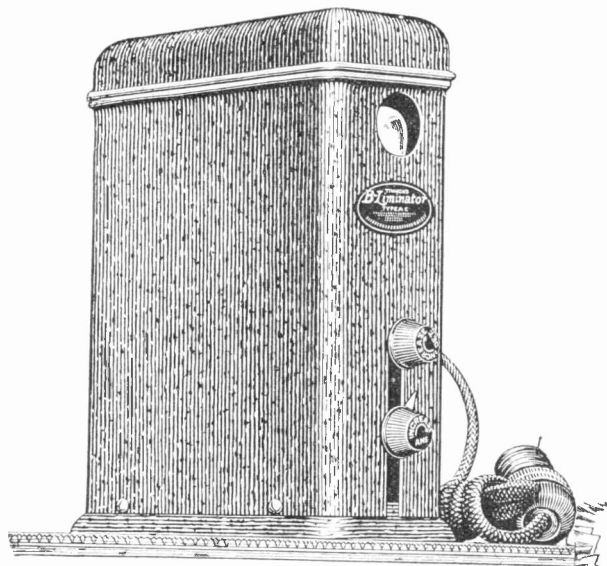

PATENTED MAY 15, 1923

## TIMMONS *B-Limiter*

PRICE \$35  
With Special Tube

### A Real Summer Demand for the Timmons B-Limiter which will operate your Cash Register and your Customer's Sets

#### Three Real Reasons for Pushing B-Limiters Now

- (1) Last summer's sales on tubes and batteries show that sets ARE used during the warm weather, even though new sets and other accessories move slowly.
- (2) There are thousands of "fans" who bought their sets in mid-winter and whose "B" batteries must now be replaced.
- (3) Thousands, also, of sets bought this spring with complete equipment "at a price." Small "B" batteries die young, you know.

There's a folder containing letters from actual users of the B-Limiter on a variety of circuits. Also an attractive display sign for your window. Ask us for both.

TIMMONS RADIO PRODUCTS CORPORATION  
Germantown, Philadelphia

# TIMMONS *Radio Products*



*The NEW MODEL  
2 ampere size is  
a big seller—for*

charging all types of radio storage batteries ordinarily used in the home.

This includes 2, 4 and 6 volt "A" storage batteries—and 24 to 96 volt "B" storage batteries in series.

No attachments are needed. This size is effective, too, for charging a 6 or 12 volt auto battery—which makes it twice as easy to sell to the man who has both an auto and a radio set. List price (East of the Rockies) \$18.

*The 5 ampere Tungar  
is a big seller—for*

- charging extra large "A" batteries.
- charging large size auto batteries.
- experimental radio stations.
- radio batteries used in schools, colleges, clubs and churches where the radio set is in continuous use for long periods.

List price \$28

Attachment for charging 2 and 4 volt radio "A" batteries \$1.25

Attachments for charging 24 to 96 volt radio "B" batteries \$3.00 each.



# Tungar

REG. U.S. PAT. OFF.

**BATTERY CHARGER**

*Tungar—a registered trademark—is found only on the genuine. Look for it on the name plate.*

# GENERAL ELECTRIC

GENERAL ELECTRIC COMPANY    MERCHANDISE DIVISION    BRIDGEPORT, CONNECTICUT

# BRISTOL TRADE MARK AUDIOPHONE REGISTERED LOUD SPEAKER

Represented by Branches in

## NINE PRINCIPAL CITIES

- BOSTON  
Old South Bldg.
- NEW YORK  
114 Liberty St.
- PHILADELPHIA  
Widener Bldg.
- PITTSBURGH  
Frick Bldg.
- BIRMINGHAM  
Age-Herald Bldg.
- DETROIT  
Book Bldg.
- CHICAGO  
Monadnock Block
- ST. LOUIS  
Boatman's Bank Bldg.
- SAN FRANCISCO  
Rialto Bldg.

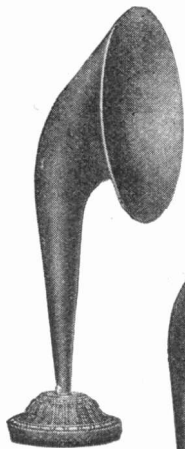

Model S  
\$25.00

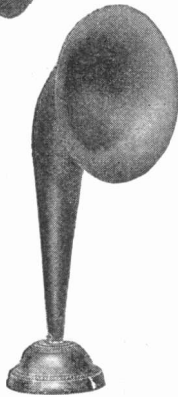

Model J  
\$20.00

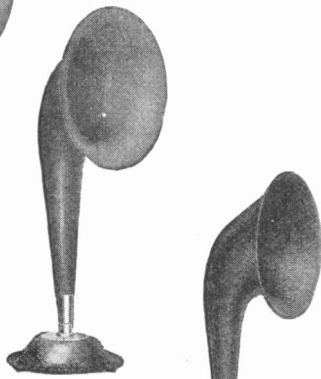

Baby Grand  
\$15.00

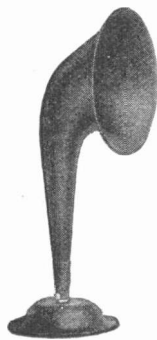

Baby \$12.50

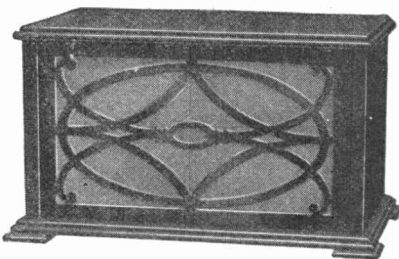

Model C \$30.00

Send for Bulletin AL-3022  
showing the Bristol line.

The Bristol Company, Waterbury, Conn.

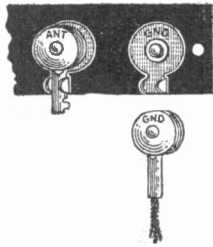

View showing NU-WAY Snap Terminal assembled. Note how snap is attached to wire merely by closing down the small prongs.

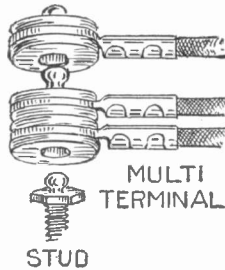

**TERMINAL**  
Just snap  
it on—

Here's a new business-getter for you—the NU-WAY Snap Terminal. It affords a quick, sure way of making contacts on terminal boards, phones, batteries and many other devices. Each terminal is clearly marked, making wire tracing unnecessary and thus preventing the possibility of burning out tubes. Closing down the small prongs

on the terminals quickly fastens them to wires.

You sell *simplicity, speed and perfect contact* when you sell NU-WAY Snap Terminals. Your customers will find many more uses for them. Let us send you more complete information.

**THE HATHEWAY MFG. CO.**  
Bridgeport, Conn.

Metropolitan N. Y. Representative—C. A. Olmstead, 107 Halsey St., Newark, N. J.

## Anywhere in the World

*Murdock Neutrodyne Sets  
Will Sell.*

FIVE TUBES

A NEUTRODYNE five-tube set with  
loudspeaker built in for \$100 retail.

Also Model No. 101 without Loud Speaker. Retail at \$92.50.

And Model No. 110 with Loud Speaker having an  
adjustable Loud Speaker Unit. Sells at \$110 retail.

A Murdock product carefully built in a fine  
mahogany cabinet, with compartment for "B"  
batteries.

Dealers will be interested in our propo-  
sition—let us send you complete data.



# MURDOCK

Wm. J. MURDOCK Co., Chelsea, Mass.

Announcing

# HOOD

EXTRA QUALITY  
HARD RUBBER

## RADIO PANELS

A HIGH QUALITY PANEL AT ATTRACTIVE PRICES

HOOD Radio Panel has been developed and designed especially for radio purposes. It is a low loss panel made of highest grade material and excels in electrical and mechanical properties. Furnished in black, mahogany and new Florentine finish. Write for sample of this most beautiful and serviceable panel. Hood panel, packed in Hood envelopes are now in distributor's stock at all convenient points. Write us for name of nearest distributor, prices, samples, etc.

HOOD RUBBER CO.—HARD RUBBER DEPT.—WATERTOWN, MASS.

\$2.00  
ALL  
TYPES

# A GUARANTEED! Guarantee!

Identified by a serial number on each SUPERTRON tube

A guarantee without means of identification means unassured satisfaction—it means nothing more or less than “may-be”—think it over.

## Buy SUPERTRONS with Absolute Assurance

A Guarantee Certificate bearing a Serial Number accompanies each SUPERTRON tube which has a number that corresponds with the Guarantee Certificate.

SUPERTRON is all a tube can possibly be  
At the Public Demand Price \$2.00



SUPERTRON MFG. CO., INC.

32 Union Square, New York

Export Division: The M. Simons & Son Co., 220 B'way, N. Y.

REG. U.S. PAT. OFF.  
**SUPERTRON**  
A GOOD TUBE.

# "Connecticut"

*What this word  
means to you—*

A **State** famous for craftsmanship in the industries that made electricity the magician of modern life.

A **Company** of outstanding reputation, for reliability, for craftsmanship, for ability to deliver the goods.

Creator and pioneer in some of the most important developments of the electrical industry.

**Connecticut** means *character, capacity, experience*, embodied in the products of the Connecticut Telephone and Electric Company, of Meriden.

**Connecticut** means to you opportunity to handle Radio parts that you can guarantee as *right*. It means satisfied customers, and *sure profits*.



**Connecticut  
Universal  
Transformer**

A masterpiece of workmanship. Producing volume and clarity of tone, unaffected by climatic conditions.



**Connecticut  
Triple Range  
Condenser**

A big seller. Three condensers in one. Smallest on the market. Very low cost.



**Connecticut  
Telostat**

An efficient potentiometer for stabilizing control, and a variable grid leak.

The achievements of thirty years of telephone manufacture, since 1894, back Connecticut's radio products.

Head Sets—Radio Switches—Battery Switches—Single Hole Mounting Radio Switches—both in push-and-pull and toggle types.

Exceptional in Quality of Construction, in Performance, in Price.

**Connecticut**  
**TELEPHONE & ELECTRIC**  
**Company**

MERIDEN, CONN.



The new Sangamo Mica Condenser, actual size; accuracy guaranteed within 10 per cent. of marked capacity, and guaranteed to sustain that accuracy. Solidly molded in smooth brown bakelite, this condenser sets a new standard of neat compactness.

## We guarantee that you can sell Sangamo Mica Condensers

*An amazingly liberal offer to radio dealers*

WE know that you don't want to tie up another dollar in radio stock in the off season, but, — here is a Mica Condenser that is so superior in sustained accuracy, mechanical strength and pleasing appearance that it will sell quickly wherever it is shown to set builders.

So we propose that you put in a small stock at our risk. We will take back any unsold Sangamo Mica Condensers that are in unbroken packages at the end of 60 days after purchase, if you wish to return them. You risk absolutely nothing. If the condensers sell rapidly, as we expect, you make a good profit; if not, your money will be refunded. You know the reliability of Sangamo — a large, long-established manufacturer of electric meters that are used all over the world.

These condensers are solidly molded in smooth, brown bakelite; as attractive as the finest finished radio parts, and improving the looks of any set.

The capacity is guaranteed to be within 10 per cent. of marked capacity, and they hold that accuracy under all conditions. The intense heat of soldering does not affect them.

Sangamo Mica Condensers are so impervious that they can be boiled for hours in hot water, exposed to corrosive gas fumes, or to salt-laden air, without the slightest effect upon their accuracy.

These condensers are being extensively advertised to set builders. They are rapidly becoming popular. Be sure you have them out on display, where they can be seen and sold.



Order from your jobber—he will protect you and we will protect him.

Made in all standard capacities with or without resistor clips, and sold at surprisingly reasonable prices for high quality.

**Sangamo Electric Company**  
Springfield, Illinois

RADIO DIVISION, 50 Church Street, New York

SALES OFFICES—PRINCIPAL CITIES

For Canada—Sangamo Electric Co. of Canada, Ltd., Toronto  
For Europe—British Sangamo Co., Ponders End, Middlesex, Eng.  
For Far East—Ashida Engineering Co., Osaka, Japan

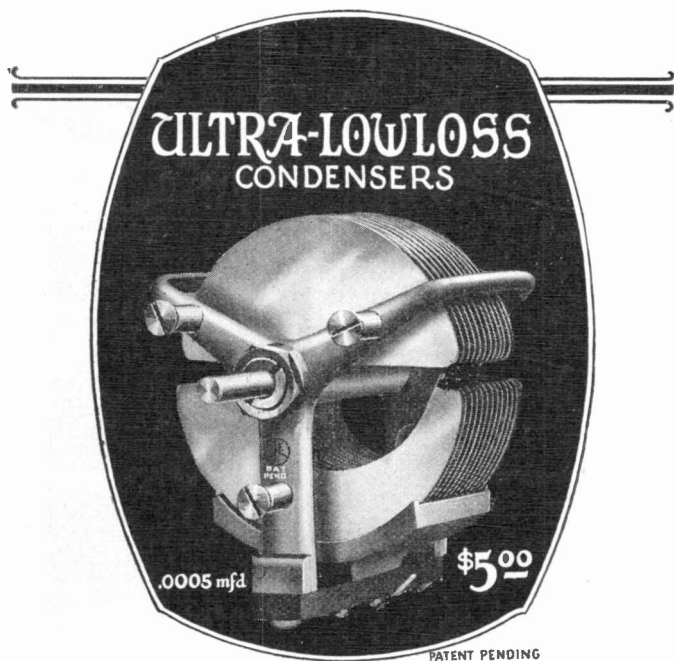

*You can promise*  
**RESULTS**  
*to customers who buy the*  
**ULTRA-LOWLOSS**  
 CONDENSER.

Sales reports everywhere are showing the Ultra-LowLoss Condenser as an outstanding leader in summer selling. Designed by R. E. Lacault, E.E., A.M.I.R.E., originator of the famous Ultradyn Model L-2 and backed by intensive advertising in all of the best radio magazines.

Specially constructed with Cutlass Stator Plates which produce a straight line wavelength curve. This separates the stations evenly over the dial—each degree on a 100 degree scale dial representing approximately 3½ meters. Simplifies the tuning of any set.

Individual in its design and built throughout along scientific principles to overcome the losses so common with other condensers. Ultra-LowLoss Condensers are approved by Popular Science Institute of Standards and leading radio engineers.

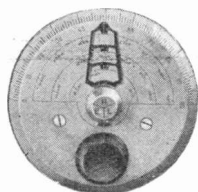

**ULTRA-VERNIER**  
 TUNING CONTROL

Another sales builder for your parts business—designed by R. E. Lacault. A real Vernier, operates with one control, gives accurate results. Designed for pencil marking on dial. Simple to mount—geared 20 to 1. Finished clockwise or anti-clockwise. Silver finish, \$2.50 Gold finish, \$3.50

**ULTRA-LOWLOSS**  
 CONDENSER

PHENIX RADIO CORP., 114-116 E. 25th St., N. Y. City

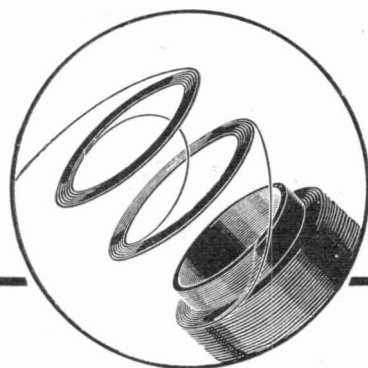

*Famous* **Samson** *Helical Winding*

By laying the wire in helical, or spiral wound discs—one on top of the other—instead of in layers like a spool of thread, SAMSON Transformers have unequalled efficiency, especially in tone quality. By this method of winding no paper insulation between wires is needed and capacity effect is reduced to an absolute minimum. Only SAMSON Transformers can have Helical Wound Coils.

**Samson**  
*Helical Wound*  
**Transformers**

A Proved Success—Well and Widely  
 Advertised—Cleanly Merchandised

**There's Profit in Quality**

Progressive radio dealers recognize that future profits will come from quality products, well advertised and sold on a sound merchandising policy. SAMSON Transformers are growing steadily and rapidly in popularity with users because of their quality and with dealers because of the clean way in which they are merchandised.

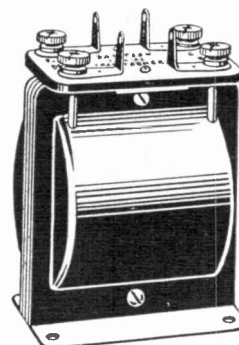

*This is but one of our several Quality Radio Products*

Send for SAMSON "Authorized Dealer" Plan  
 a new, bigger-profit-maker for reliable dealers

**Samson Electric Company**  
 Manufacturers Since 1882  
 Canton, Mass.

Sales Offices in 20 Principal American Cities

MAIL THIS COUPON

SAMSON ELECTRIC CO.  
 Main Office, Canton, Mass.

Gentlemen:  
 Please send me at once, without obligation, complete details of the SAMSON "Authorized Dealer" Plan by means of which I can make more money handling your products. Also send catalog of SAMSON Radio Products.

Name.....

Address.....

City..... State.....

# ACCURATUNE

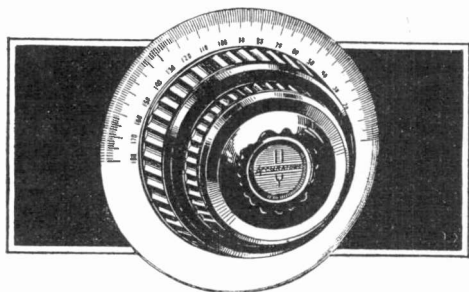

*Absolutely essential  
for sensitive sets*

**GEARED  
80 to 1**

European Branch  
Office:  
Gaston E. Mar-  
baix  
27 Anning St.,  
London, E. C. 2.

Geared 80-to-1, the Accuratune finds any station within the scope of the set, provides added volume and clarity, and discourages interference. New features include our patented friction clutch, which disengages gears for coarse tuning, and meshes them for vernier adjustment; also new gear mesh and extra long center bushing.

*Write for liberal dealer discounts and descriptive folder.*

**MYDAR RADIO COMPANY**  
8 CAMPBELL ST., NEWARK, N. J.

## Sell Them A Knickerbocker Radio Case *To Build Their Own Portable*

**\$12.50**

*Retail*

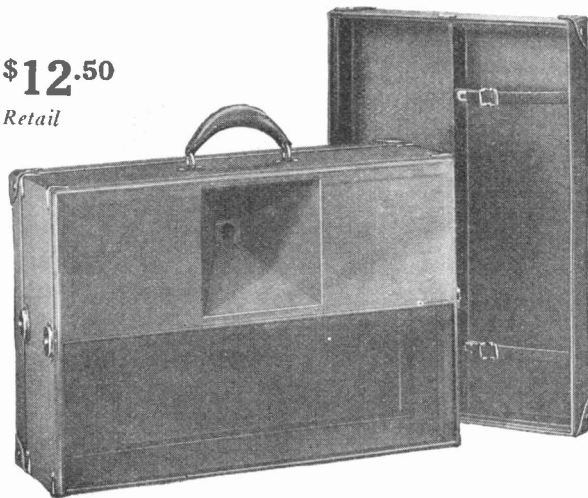

High Grade Black Artificial Leather Covered. Removable Back and Front. Wood Horn for Loud Speaker. Space for Panel 21-in. x 7-in. Deep cover for Dials and Straps to Hold Collapsible Aerial. Battery space both sides of Horn.

**Liberal Discount to Dealers**

**KNICKERBOCKER CASE COMPANY**

*Specialists and Original Designers of Radio Cases—  
all kinds, any quantity.*

228-238 N. Clinton St., Chicago

## Now Here [ Practical Glass Panels and Cabinets

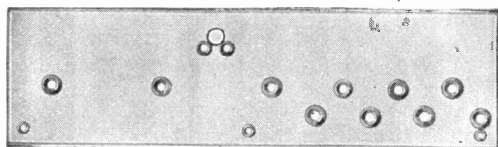

*May be  
Drilled  
For Any  
Hook Up*

7x21-in. Clear Panel only. Drilled for Bremer Tully 3 Tube Hookup. \$7.50 List.  
7x26-in. Clear Panel only. Drilled for Bremer Tully 5 Tube "Nameless." \$10.00 List.

All equipped with Hornig Safety Bushing (Pat. Appl.)

Manufacturers or jobbers of sets or kits, let us make up a panel or two or a cabinet for display purposes. Don't delay—the radio shows are coming early this year.

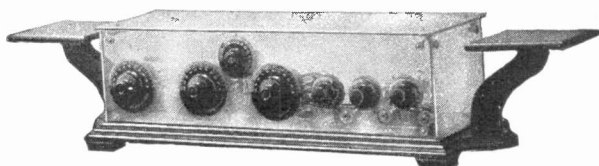

*If Your Jobber Can't Supply You, Write to the Factory.  
Ask for Our New Bulletin*

**A. W. HORNIG** 3925 Dickens Ave.,  
CHICAGO, ILL.

We are prepared to handle export business efficiently.

# Slagle Radio

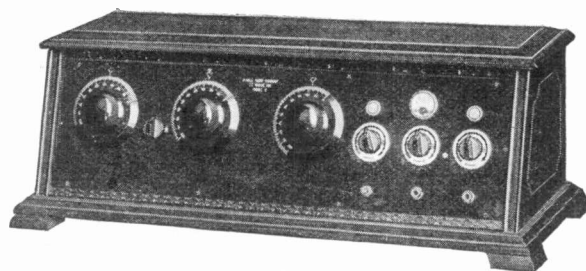

**FOREIGN DEALERS!**  
**Here's a Real Profit Builder!**  
**Quality Sells Best!**

The news of the unusual receiving quality, the tone clearness of the SLAGLE RADIO travels almost as fast as the radio wave. Every demonstration is sure to make a sale because the SLAGLE RADIO is built right and guaranteed to be a better outfit, it's one of the finest on the market today.

**Extra careful packing  
for foreign markets.**

**Reliable distributors  
wanted.**

**Slagle Radio Company**  
Fort Wayne, Indiana, U. S. A.



# PREMIER

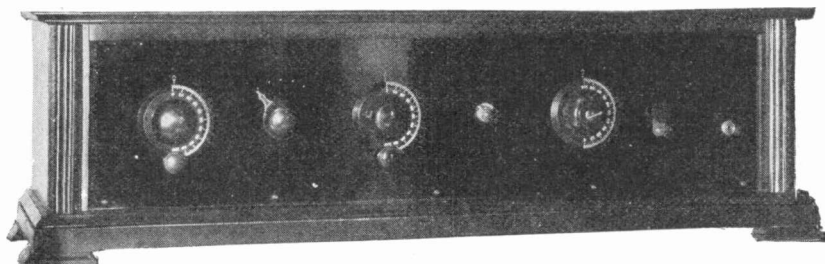

## Try This Test Upon Your Hardest Prospect

Select the hardest prospect you know, the one who thinks all radios make funny noises and can't be depended upon to get what he wants, the one who has decided not to buy a set "until they have been perfected"—then get just one Premier set and demonstrate it to him.

The tone quality of Premier always wins

admirers. A demonstration seldom fails to make a sale. The distance and selectivity would be notable if they were not overshadowed by the wonderfully clear tone that distinguishes Premier. Complete description, prices and our direct-to-dealer exclusive franchise sales plan will be sent you upon application.

## The Premier Radio Corporation

DEFIANCE, OHIO

### Summer Static

*Now overcome by volume*

Static is diminished in proportion to the amount of volume which a radio set delivers, experts agree.

Kellogg transformers give volume with added clarity of tone.

The Kellogg radio frequency transformer is of the low loss type, having many important features. It will operate at all wave lengths with .00035 to .0005 variable condensers. For best results, use the Kellogg .0005 low loss variable condenser. Kellogg R. F. Transformers at all dealers—\$2.35.

Kellogg audio frequency transformers give greater volume with clearer reproduction, due to the high quality materials and expert workmanship used in the Kellogg process of manufacture. Kellogg audio frequency transformers are made in both shielded and unshielded types ranging in price from \$3.50 to \$4.50.

For attractive proposition ask your jobber's salesman or write direct to us.

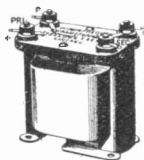
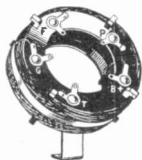

**KELLOGG SWITCHBOARD & SUPPLY CO.**

1066 W. Adams St., Chicago, Ill.

## ASSURED Radio Results

YOU'RE right in being cautious now in planning next season's sales. Play safe. Follow the present trend of placing Weston Instruments on the best radio sets. Supply these same instruments for your customers who aren't lucky enough to possess them.

It's a wise dealer who sells real radio pleasure, makes tubes last longer, improves reception, makes it possible for the radio enthusiast to get the best out of his set—by means of the Model 301 Filament Voltmeter for panel mounting.

There is another—the Weston Radio Plug—which makes the quickest change from headset to loud speaker.

Investigate—Write for the booklet "Weston Radio Instruments". Get set on instruments famous the world over.

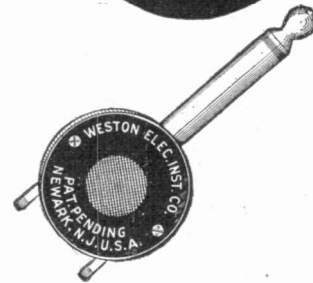
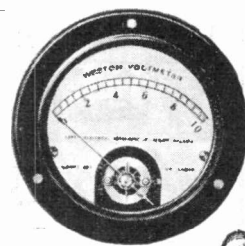

WESTON ELECTRICAL INSTRUMENT CORPORATION  
25 Weston Ave., Newark, N. J.



STANDARD THE WORLD OVER  
**WESTON**  
Pioneers since 1888





Your greatest asset is the confidence of your customers. Strengthen that bond by selling them Pacent merchandise, the finest that money can buy.

*40 Leading Manufacturers now using Pacent Radio Essentials as standard equipment on sets.*

# Pacents

## RADIO ESSENTIALS

**PACENT ELECTRIC COMPANY, Inc.**  
91 Seventh Ave., New York City

Washington	Chicago	Buffalo
Minneapolis	Birmingham	Jacksonville
Boston	Philadelphia	Detroit
San Francisco	St. Louis	Pittsburgh

*Canadian Licensees: R. H. White Radio Company  
Hamilton, Ont.*

**DONT IMPROVISE - PACENTIZE**

## Elektron Radio Tubes

(Tipless)

**Bakelite Bases**

---

List Price



**Fully Guaranteed**

---

**\$3<sup>00</sup>**

200	201A	199
-----	------	-----

A REAL TUBE MADE by an organization with years of experience, and capable of giving you the best possible combination, quality and service.

Territory now open to Jobbers and Dealers. Our unusually large discounts mean more profit to you.

## Lectrodio Corporation

186 Market St., Lynn, Mass.  
*Radio Tube Specialists*



Dealers who make the Harry Alter Company their source of supply have, at all times, access to complete stocks of the products of America's leading manufacturers...and prompt deliveries from these stocks.

## The HARRY ALTER CO.

OGDEN at CARROLL AVENUE · CHICAGO

*Wholesale Distributors for*

Radion Panels	Benjamin Products
Freshman Receivers	Hold-Heet Appliances
Acme Kitsets	American Beauty Irons
Premier Parts	Appleton Fittings
Signal Apparatus	Duraduct Products
Balkite Chargers	Save Lamps
Brandes Headsets	Wadsworth Switches
Dubilier Condensers	Inland Glass
Carter Apparatus	Liberty Stoves
Pacents Parts	Dim-A-Lite Sockets
Allen-Bradley Parts	Burgess Batteries
Cunningham Tubes	Master Motors
Remler Parts	Rasla Reflex Sets
Weston Meters	Howard Rheastats

All-American Transformers

*— and many others nationally advertised and nationally known*

**Sell this special antenna with every set!**

*Note the many strands*

Greatest possible capacity and conducting surface, with less resistance, it actually increases range and volume.

It makes an excellent indoor antenna too! Made in copper, tinned copper, enameled copper. Put up in coils of 100 and 150 feet.

*Ask your jobber for literature and sales-pulling prices!*

**ROSS WIRE COMPANY**  
9 Charles Street, Providence, R. I.

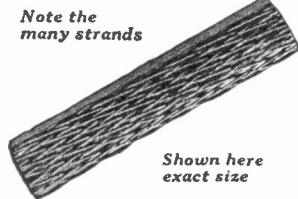

*Shown here exact size*

# RADIO ANTENNA

## THE WINDHAM WIRE FORMER

Forms loops for No. 4, 6, 8 and 10 screws, makes easy radius right angle bends, has flat jaws and wire cutters. A complete tool for those who build their own.

**Price \$1.25**

(Patents pending)

**THE GOYER COMPANY**  
Willimantic, Conn.



Because  
They Are  
Matched



SET builders want them because they are **MATCHED**. Engineers specify them because they are **MATCHED**. Dealers sell them easily and with profit, protected by a guarantee that is a new departure in merchandising.



Ask your jobber about  
**DUPLEX MATCHED CONDENSERS**  
or write to the  
**DUPLEX CONDENSER & RADIO CORP.**  
34 Flatbush Avenue Extension Brooklyn, N. Y.

**DUPLEX MATCHED CONDENSERS**

Radio Owners Need  
These Specialties!



A tightly-braided, long wearing cord for loud speakers. Packed in attractive container with Universal plug. Interesting show card in silver and black with each order of one dozen. This item is a real convenience—and it sells! List price \$1.75

**5-Wire Battery Cables**

Each wire a different color to assure the right connection. Perfectly insulated wires with clips and lugs to fit every need. Also made special for set manufacturers' specifications. Length five feet. List price \$1.00

**Telephone Cords**

Five and six foot single and double Cords to fit every type of head set or loud speaker.

**Spaghetti Tubing**

Also of genuine "Blue Ribbon" quality—which means made right to sell profitably.

Your Jobber Sells "Blue Ribbon" Specialties

**Crescent Braid Co., Inc.**

Makers of Extension Cords and Battery Cables for Radios  
Providence, Rhode Island

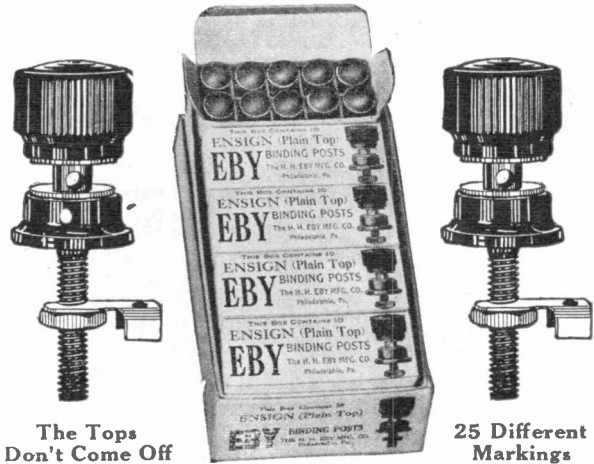

The Tops Don't Come Off

25 Different Markings



**BINDING POSTS**

are round, naturally; yet they can boast five distinct points that all wide-awake dealers appreciate.

1—Built-in superiority. 2—Proper packaging. 3—National advertising. 4—A consistent demand at 15 cents retail. 5—A worth-while profit.

Our name is on the base of every genuine EBY post. Furnished either plain or engraved in twenty-five different markings. Your jobber can supply you.

The H. H. EBY MFG. CO.  
Philadelphia, Pa.

**H a m i l t o n**  
The Wonder Portable and Home Set Combined

\$125  
less tubes and batteries.

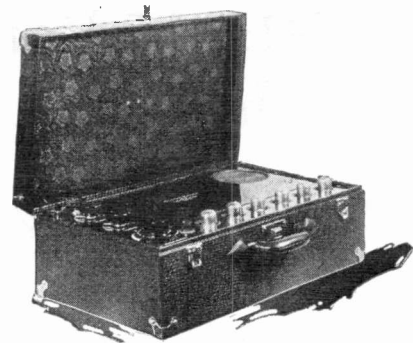

These features will sell portables for you—

The Hamilton embodies in a portable the qualities found in the most expensive of instruments!

A six-tube non-reradiating receiver employing three stages of transformer-coupled Radio Frequency Amplification, Detector and two stages of Audio. It operates without aerial or ground.

Only one tuning control. It is highly selective, has exceptional volume and sets a new distance record among portables.

It is entirely self-contained, light in weight, and compact. Inside and out, workmanship is of the finest.

It has the outward appearance of a very high grade suitcase.

Get our proposition (without obligation) and full details!

**HAMILTON RADIO, INC.**

Office: 7 Hamilton Place, Broadway at 137th St., New York City.  
Factory: 12 Diagonal St., Long Island City.

Highest efficiency gained through the use of standard parts selected after exhaustive tests.

- THORDARSON Audio Transformers
- ACME Radio Transformers
- U. S. L. Condensers
- UTAH Loud Speaker
- BENJAMIN Sockets
- FORMICA Panelling Etc., Etc.

## RADIO CABINETS

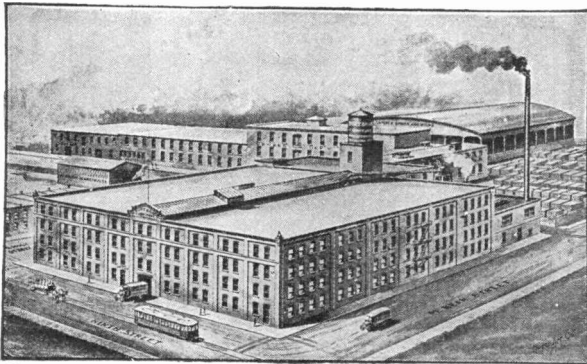

Fifty Years  
of Building Furniture

Let Us Build  
Your

## Radio Cabinets

Aside from our regular line of cabinets, we are building them by the thousands for large users of cabinets. With substantial orders, we build special, exclusive designs.

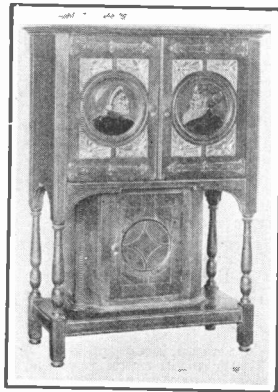

**BURT BROS., INC.**

2000 S. 9th Street, Philadelphia, Pa.

## Another Good Reason Why Radio Dealers Should Stock NATIONAL Velvet Vernier Dials and Condensers—

"I am very well pleased with my NATIONALS and their fine Velvet Vernier Dials," writes Mr. Surber.

L. C. FRANTON

AMERICAN FORCE AND  
STYLISH

### SURBER'S HARDWARE

DEALERS IN  
HARDWARE - FURNITURE - IMPLEMENTS  
STOVES - LINOLEUMS - RUGS

FRANCESVILLE, INDIANA  
November 28, 1924.

The  
National Company, Inc.,  
Cambridge, Mass.

Dear Sirs:

I have at hand the December Q 3 T, and note the National's advertisement of condensers. The records shown are indeed remarkable but I believe that you would be interested in knowing of my DX.

I use a 2-tube low-loss tuner, with two National condensers. With this receiver I have heard either or both New Zealand and Australia eleven mornings out of thirteen. I have carried on two way communication with 24AA, 24AC, 22AC and A3BQ. I have also heard 24AX and two other Australians. These distances come close to 8,000 miles.

I am very well pleased with my Nationals and their fine Velvet Vernier Dials.

Wishing the National Company the best luck and continued success, I am

Very truly yours,

*Stanley Surber.*  
Stanley Surber, 9-272

**NATIONAL COMPANY, Inc.**

Cambridge, Mass.

Manufacturers of the genuine and justly famous Browning-Drake Transformer. Patents Pending.

## U. S. Patent Granted DURHAM Variable High Resistance



This plunger  
now fully  
protected

The trade has been long familiar with the DURHAM plunger adjusted Variable High-Resistance — formerly labeled "Pat. Pending." Under U. S. Letters Patent No. 1,526,191, date Feb. 10, 1925 DURHAM & CO., Inc. now enjoy sole rights to manufacture, sell or license the plunger adjusted type of Variable High Resistance. Said rights will be adequately defined against all infringers.

**DURHAM & CO., Inc.**  
1930 Market St., Philadelphia,

Canadian Distributors: De Forest Radio Corp., Ltd., Toronto

## RADIO (H&K) PARTS

"The Line Complete"  
from Insulator to Ground Clamp

DEALERS see stable profits in this complete, standardized line. It's the one way out of a duplicated, disjointed stock. With a smaller investment it means better service to set owners—in parts that work perfectly together.

**Loud Speaker Units**  
**Transformers—Audio and Radio**  
**Rheostats and H. R. Leaks**  
**Condensers—Variable and Fixed**  
**Potentiometers and Switches**  
**Sockets—Bakelite and Porcelain**  
**Headsets, Plugs, Jacks, etc.**

They are  
all stan-  
dardized,  
interchange-  
able,  
radio-elec-  
trically  
balanced.

Every one of substantial Quality; every basis for growth and stability in your parts-business. Catalogue 4W will inform you fully.



**HART AND HEGEMAN**  
HARTFORD CONN. U.S.A.



### Satisfied Customers Are Your Best Salesmen

The Jefferson Transformers you sell today are building a priceless good will for you. If your customers are satisfied, be sure they will boost you. The remarkable quality of Jefferson Transformers delights radio enthusiasts. And they remember where they purchased Jeffersons. That means continuous patronage—added profits. The policy of the Jefferson Electric Mfg. Co., undoubtedly the largest manufacturer of small transformers in the world, to confine itself exclusively to the manufacture and sale of transformers and coils has allowed

them to perfect quality and performance to the utmost.

The result is, Jefferson Transformers are really unequalled in the entire radio field for greatest amplification and total absence of distortion.

It's profit-wisdom for you to stock Jefferson Transformers TODAY. See your jobber.



Jefferson Electric Mfg. Co.  
501 S. Green St., Chicago, Ill.

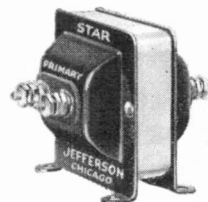

Makers of Jefferson Radio Tube Rejuvenators; Radio, Bell Ringing and Toy Transformers; Jefferson Spark Coils for Automobile, Stationary and Marine Engines; Jefferson Oil Burner Ignition Coils and Transformers.

# JEFFERSON TRANSFORMERS

## Money in your pocket—the Master Fore Battery Charger

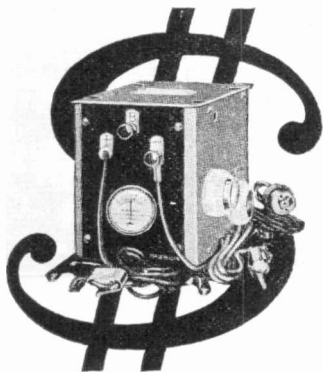

Rapid turnover with a handy margin of profit for you. For your customers, a dependable and economical battery charger for practically every requirement. The Master Fore Battery Charger charges any 6-volt Radio or Automobile Battery, also Radio "B" Batteries up to 48-volts in series and up to 120-volts in multiple. Easily operated by anyone—a big sales builder for you.

Fill in, clip and mail the coupon now—**TODAY**

Manufactured by  
**Fore Electrical Mfg. Co.**  
5255 N. Market Street,  
St. Louis, Mo.

Sales Department  
**The Zinke Company**  
1323 S. Michigan Ave.,  
Chicago, Ill.

### RADIOGRAM

Fore Electrical Mfg., Co., St. Louis, Mo., Manufacturers The Zinke Company, Chicago, Ill., Sales Department.

Send me free of charge complete information on how to make more money with the Master Fore.

Name .....

Address .....

City .....

State .....

Charges both A and B Batteries

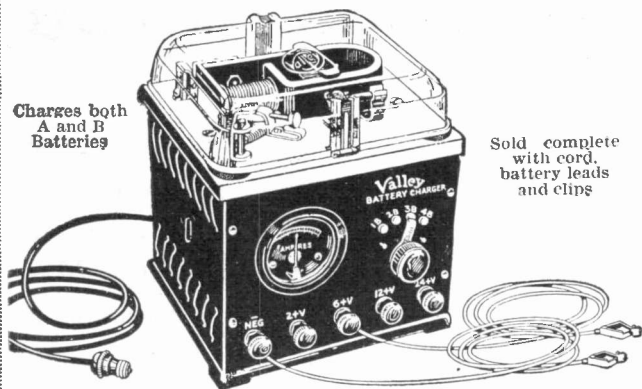

Sold complete with cord, battery leads and clips

## Sell a Winner

It's just a small margin — that difference between profit and no profit. In radio chargers, sell a winner and be sure of that margin.

The Valley is the radio battery charger with ten points of superiority — ten selling points which move it for you. That's why it's a winner.

If you are not handling Valley Chargers you are missing sales, that's all. But that's enough for the progressive radio retailer. Order from your jobber or write us for information.

VALLEY ELECTRIC COMPANY  
3157 S. Kingshighway—Saint Louis, Mo.

# Valley Battery Chargers

## Why we call the Karryadio Portable Case

TRADE MARK  
**Your Summer Salesman**

Karryadio not only sells itself but enables you to sell units, parts, kits, and other radio accessories. It supplies the missing link in your summer business.

**\$15.00**

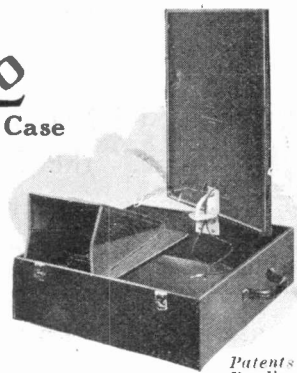

Patents Pending

The Greatest Value Ever Offered Your Set Building Customers

Embodying three essential portable features of instant appeal to set builders.

### PIVOTING LOOP-COVER

the cover contains a low-loss loop with center tap and is so designed that it can be turned in any direction—to pick up the different stations.

### COLLAPSIBLE HORN—

closed occupies a space only an inch thick and can rest on top of the batteries—opened it measures six inches square, giving wonderful volume and tone—standard for most loud speaker units.

### COMPACT DESIGN—

ample room for every need of a Radio set, yet the case is a convenient size. Covered with good black leatherette, the case measures 18 3/4-in. long x 14 3/4-in. wide x 5 3/4-in. thick. The case takes the standard 18-in. panel.

Feature the Karryadio Case This Summer—It Pays Because It's in Demand

**ARMLEY RADIO CORPORATION**  
68-70 Fleet Street, JERSEY CITY, N. J.

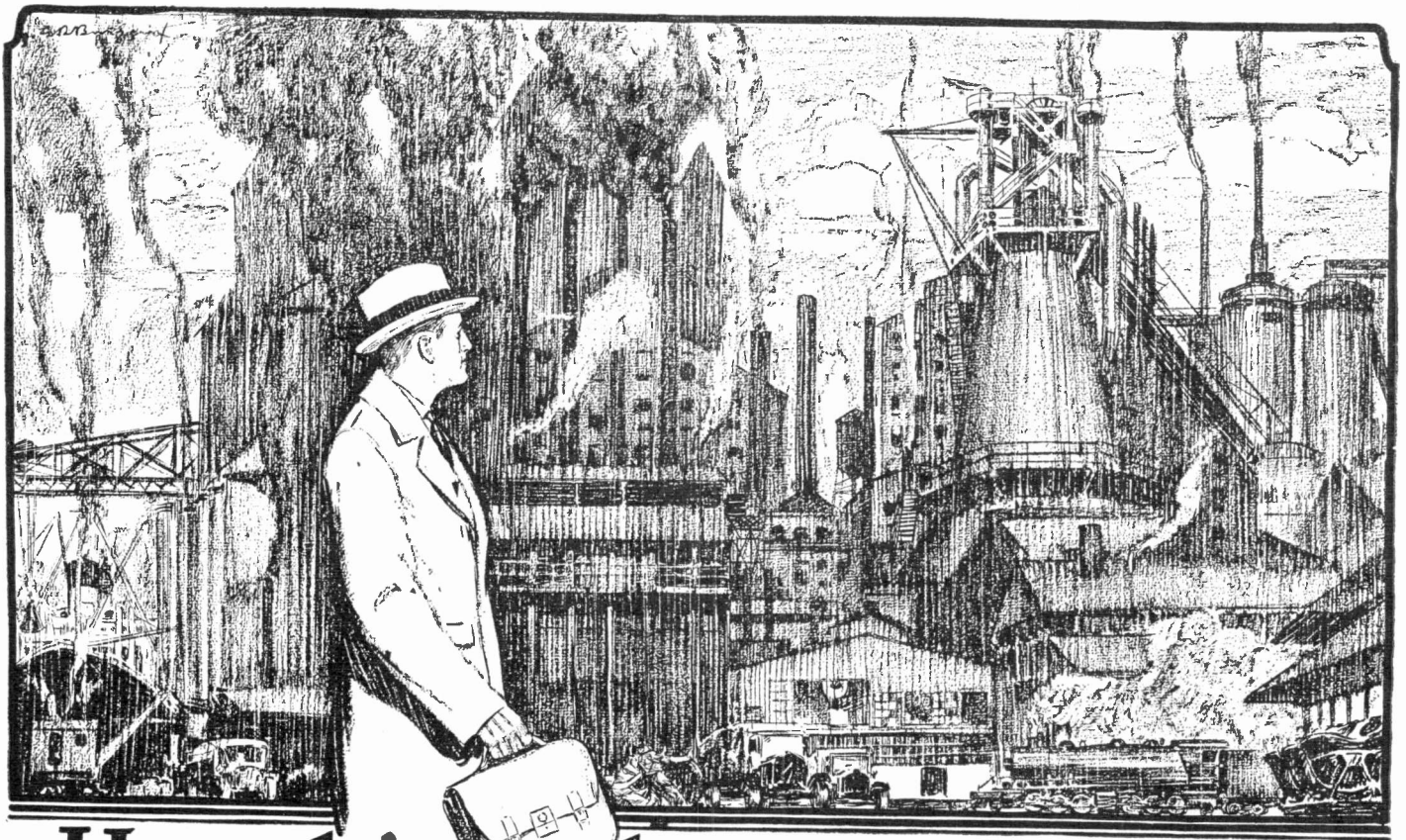

## How big does the *Industrial Market* look to you?

**M**EASURED by the yardstick "volume," the industrial market as a whole staggers the imagination. The figures are so stupendous, they require a rearrangement of the powers of comprehension before one can think in comparable terms.

Measured by the number of potential buyers, the industrial market becomes alluringly small, for 95% of all industry's purchases are made by 115,000 plants. These include everything from the great industrial works to the little shops with a big future. The remaining 5% is widely scattered, of uncertain stability and low potential. They are beyond the border line of profitable selling.

The obvious economy of selling only where sales are profitable, points directly to the need for concentration of sales and advertising on worth-while markets. Market determination and sales analysis loom big as the first steps toward lower cost of distribution.

Scientific selling simply means the study of markets and the intelligent cultivation of those buyers whose purchases are large enough to justify the effort to sell them.

### *Four principles of Industrial Marketing*

As a preliminary to selling, four basic facts should be determined (1) What are the worth while markets (2) What are the

buying habits of these markets (3) What is the most direct approach to them (4) What appeals will have the greatest influence on their buying.

The classification of industrial markets is not difficult. Industry's needs are known and buying habits are well established.

Any manufacturer selling to industry can segregate his prospects with certainty. He can reach them directly and with a definite knowledge of what appeals influence their buying. Information which will aid him

selling and advertising are many of America's Industrial Leaders. Among them also, are numerous smaller manufacturers whose real success started when they changed from promiscuous selling to concentrated effort.

*A service of unique value*

The McGraw-Hill Company has been of definite assistance to many of these manufacturers. They were able to bring to the consideration of plans a fifty years' knowledge of industry, unique and unmatched.

Other manufacturers who desire to fit their sales and advertising plans to present-day needs and opportunities, are invited to counsel with the McGraw-Hill Company.

A recent survey of the buying habits of industry has been published under the title of "Industrial Marketing". This

to do this is available through the McGraw-Hill Company.

Numbered among the manufacturers who are following these principles of scientific

graphic analysis will be sent, upon request, to any manufacturer (or advertising agent) whose market embraces the industries served by the McGraw-Hill Publications.

McGraw-Hill Company, Inc., New York, Chicago, Philadelphia, Cleveland, St. Louis, San Francisco, London, Publishers of

# McGraw-Hill Publications

REACHING A SUBSTANTIAL MAJORITY OF THE POTENTIAL BUYERS IN THE INDUSTRIES THEY SERVE

Electrical  
ELECTRICAL WORLD  
JOURNAL OF ELECTRICITY  
ELECTRICAL MERCHANDISING  
RADIO RETAILING

Mining  
COAL AGE  
ENGINEERING & MINING  
JOURNAL PRESS

Industrial  
POWER AMERICAN MACHINIST  
CHEMICAL & METALLURGICAL  
ENGINEERING  
INDUSTRIAL ENGINEER

Overseas  
AMERICAN MACHINIST  
(EUROPEAN EDITION)  
INGENIERIA INTERNACIONAL

Construction & Civil Engineering  
ENGINEERING NEWS-RECORD  
Transportation  
ELECTRIC RAILWAY JOURNAL  
BUS TRANSPORTATION

This advertisement is the second of a series to appear in the following newspapers—*New York Times, Philadelphia Public Ledger, Pittsburgh Gazette-Times, Cleveland Plain Dealer, Detroit Free Press, Chicago Tribune* and *New York Herald-Tribune*; in the following advertising papers—*Printers' Ink, Advertising and Selling Fortnightly, Sales Management*; and also in all of the McGraw-Hill Publications. The purpose of these advertisements is to arouse a national appreciation of the need for improving industrial sales efficiency, also to awaken a keener interest in the correct principles of industrial advertising and selling.





# SEARCHLIGHT SECTION

## SURPLUS STOCKS—BUSINESS OPPORTUNITIES

**UNDISPLAYED—RATE PER WORD:**  
 Positions Wanted, 6 cents a word, minimum \$1.25 an insertion, payable in advance.  
 Positions Vacant and all other classifications, 10 cents a word, minimum charge \$2.00.  
 Proposals, 40 cents a line an insertion.

**INFORMATION:**  
 Box Numbers in care of any of our offices count 10 words additional in undisplayed ads.  
 Discount of 10% if one payment is made in advance for four consecutive insertions of undisplayed ads (not including proposals).

**DISPLAYED—RATE PER INCH:**  
 1 to 3 inches.....\$8.65 an inch  
 4 to 7 inches..... 6.40 an inch  
 8 to 14 inches..... 6.20 an inch  
 Rates for larger spaces, or yearly rates, on request.  
 An advertising inch is measured vertically on one column, 3 columns—30 inches—to a page.

Radio Retailing

### BUSINESS OPPORTUNITY

#### Department Store Opportunity

Radio-Musical Instrument and Sporting Goods departments. An extraordinary opportunity is afforded a thoroughly experienced man to rent these departments in the best store in Elizabeth, N. J. Established forty years, this store occupies a new seven story building and is doing a business of over \$2,000,000 yearly. These departments can be rented on 12½% guaranteed rental basis. The store owners furnishing light, heat, delivery and porter service, plus a desirable accessible location. Act quickly if you feel you are a man who can do a big business. Levy Bros., 76-84 Broad St., Elizabeth, N. J.

#### Department Store Radio Space For Rent

in oldest store, city of 60,000 population. Radio business established in the store enjoying good trade. Excellent opportunity for two young men who thoroly understand radio and are good salesmen. We will make a good proposition to the right parties. Write or call

**GEO. A. DUCKER CO.**  
 Joliet, Ill.

“Searchlight”  
 is  
 Quick Action  
 Advertising

Your Overstock is a Dead Investment—Move it at a Profit !!!  
**Use the Radio Dealers' Overstock Exchange in Radio Retailing**

What have you to turn into cash NOW? Get it into the “Exchange” of the next issue of RADIO RETAILING. The cost will be small.

### \$ CASH PAID \$

We buy for cash, all electrical and radio goods, surplus stock, radio sets, parts, loud speakers, electric fans and motors, etc. We buy any quantity—No stock too large for us. Manufacturers and jobbers send us your close out lists.

**STUART MASS. RADIO SURPLUS CORPORATION BOSTON MASS.**

Subscribe now  
 to  
**Radio Retailing**

Special  
 Introductory Offer

**\$1.00**

Regular Price \$2.00

Postage to Countries Outside U.S. and Canada \$1.00 Extra

Radio Retailing  
 Tenth Avenue and 36th St., New York, N. Y.

Here is \$1.00. Please enter my subscription to begin with the next issue.

Name .....

Address .....

City ..... State .....

6-25

Molded Bakelite  
 for  
**Radio**

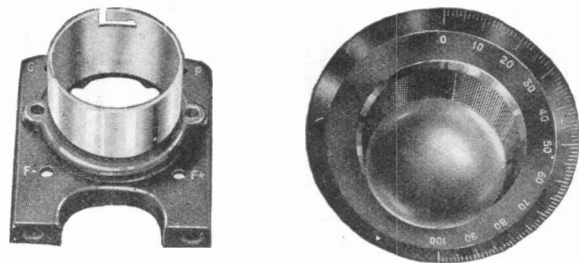

Bakelite and Condensite knobs, dials, socket bases, rheostat bases, condenser end plates, and other parts, produced by our large and experienced Molding Organization.

**American Insulator Corp.**  
 52 Vanderbilt Avenue, New York City

# SHOCKPROOF

## *right under the guns!*

A modern battleship stripped for action is hardly a safe place for a radio tube! The terrific recoils of heavy guns jar and sway the whole ship, often breaking the incandescent lamps left in their sockets.

When Lt. Hill, on board the U. S. S. Medusa, installed Cle-Ra-Tone Sockets in his radio set, he was testing their shock absorbing qualities in the extreme. And his letter, reproduced at the right, proves that Benjamin Cle-Ra-Tone Sockets were worthy of his confidence.

Radio sets in your community may never be subjected to such nerve-shattering, lamp-breaking bombardment—but rumbling street traffic, indoor footsteps, mechanical and human activities set up vibrations to a surprising extent and cause microphonic distortions in radio sets by disturbing the tube filaments.

Cle-Ra-Tone Sockets prevent the transmission of this outside vibration to the filaments by "floating" the radio tube above all jars and shocks. Delicately adjusted springs do this! There are no soft rubber parts to deteriorate. The Bakelite construction assures high insulation and sturdiness. Contact points to tube terminals are perfect and permanent. Handy soldering lugs simplify wiring. Stiff bus wiring does not affect the flexibility of the supporting springs.

Now—more than ever before—your customers understand the cause of irritating noises in their sets and that the only way to banish them is with the shock absorbing features of the Cle-Ra-Tone Sockets.

Intensive advertising in the best radio periodicals is keeping customer enthusiasm at the highest point. Display the Cle-Ra-Tone—tie up with its salesmaking popularity and watch your sales grow!  
The good profits will keep you enthusiastic all the year round!

Benjamin Electric Mfg. Co.,  
Chicago, Ill.

Dear Sir:

Recently my ship conducted a test firing of its five inch guns, one of which is just outside and below my stateroom.

During gun firing all lamps are removed from their sockets, as the shock can be counted upon to break the filament and frequently the glass itself.

During the firing I placed trust in the five Benjamin Cle-Ra-Tone Sockets in my radio, leaving the tubes in during the test. And although no more than thirty feet from the muzzle of a 5-inch naval rifle, the tubes were uninjured and are in perfect condition.

(Signed) C. E. Hill, Jr.,  
Lt. (jg) U. S. Navy

U. S. S. Medusa,  
Repair Ship with the Fleet.

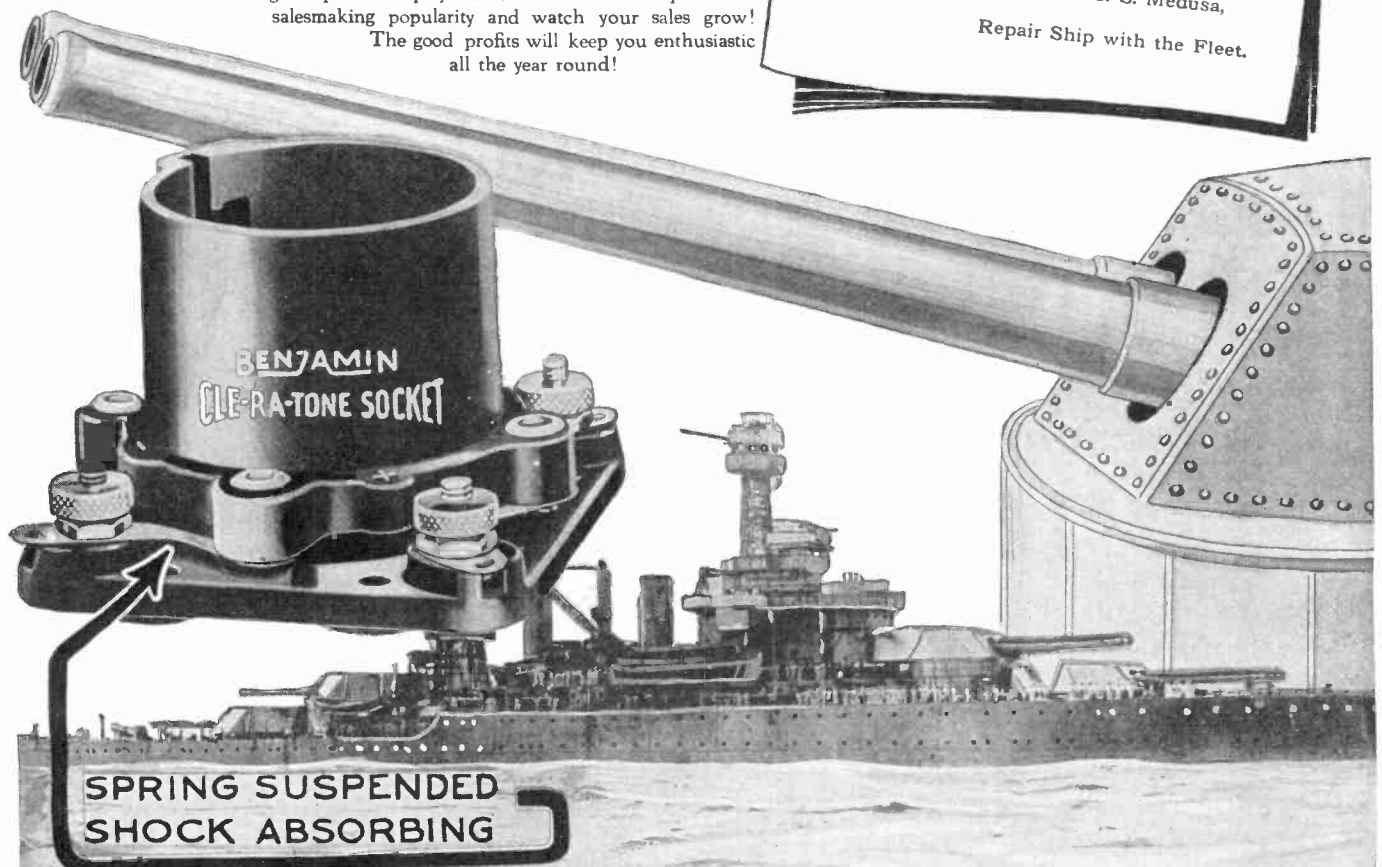

### Benjamin Electric Mfg. Co.

247 W. 17th St., New York

120-128 So. Sangamon St., Chicago

448 Bryant St., San Francisco

Manufactured in Canada by the Benjamin Electric Mfg. Co. of Canada, Ltd., Toronto, Ontario

# APCO RADIO

"A" Battery Charger, No. 77

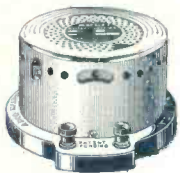

A new model, with several important improvements. Complete with clips, plug, wire, etc. List. \$18.50.

"B" Battery Charger, No. 88

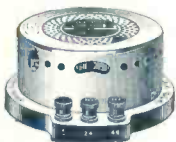

Charging rate from 200 to 400 milli-amperes on 24 or 48 volts—full charge overnight. A highly finished charger for those wanting the best. List. \$10.00.

Rectodyne, No. 66



Gives "B" Battery current from the lamp socket. A complete unit in handsome mahogany case. List. \$44.00. D.C. Type. \$32.50

Radio Switch, No. 55

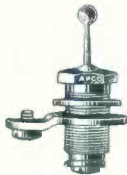

Of the toggle arm type, positive in action, neat in appearance. Brass heavily nicked and polished. List. 35c.

Resistor, No. 59



From 10 to 10,000,000 ohms. For all purposes and circuits. Packed five in a carton. List. 50c.

**T**WO years ago Apco entered the Radio field—and sold, the first year, nearly one million dollars' worth of Battery Chargers.

Today the Apco-Radio Line includes the ten high-grade specialties shown on this page.

All Apco products are of the best material. And their design, workmanship and *performance* assure satisfied customers.

Stock Apco — display Apco — talk Apco and you'll sell Apco. Quick turnover and a jump in sales volume will prove it pays!

"A" Battery Charger, No. 79

A modification of No. 77, with a reduced capacity output of two amperes instead of five—but of genuine APCO quality. List. \$12.50.

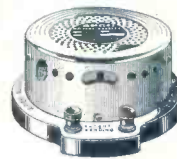

"B" Battery Charger, No. 89

A self-polarizing, positive mechanical charger using light bulb resistance. To meet demand for a low priced "B" Battery Charger. Charges 100 volts in 8 to 10 hours. List. \$4.00.

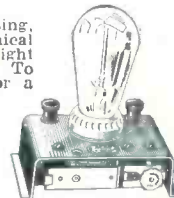

"B" Eliminator Kit, No. 65

For those who prefer to build their own "B" Battery Eliminators. Contains parts used in APCO Rectodyne. List. \$30.00.



Audio Transformer, No. 53

Completely shielded for mounting close together. In any ratio from two-to-one to ten-to-one. With top or side terminals. List. \$4.50.

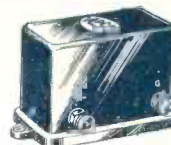

Battery Clip, No. 67

Overcomes effect of sulphation of the battery terminals, making a permanent contact. Will fit any battery post and built for many years' service. List. 10c.



## Apco Manufacturing Co.

Factory and Main Offices: Providence, Rhode Island

—APCO Branches—

Apco Mfg. Co., Electrical and Export Office, 154 Nassau St., New York City.

Apco Mfg. Co., 1438 S. Michigan Ave., Chicago.

Apco Mfg. Co., 2005 E. 15th St., Kansas City, Mo.

Canadian Factory: Apco Canadian Co., Ltd., 3150 Jeanne Mance St., Montreal.

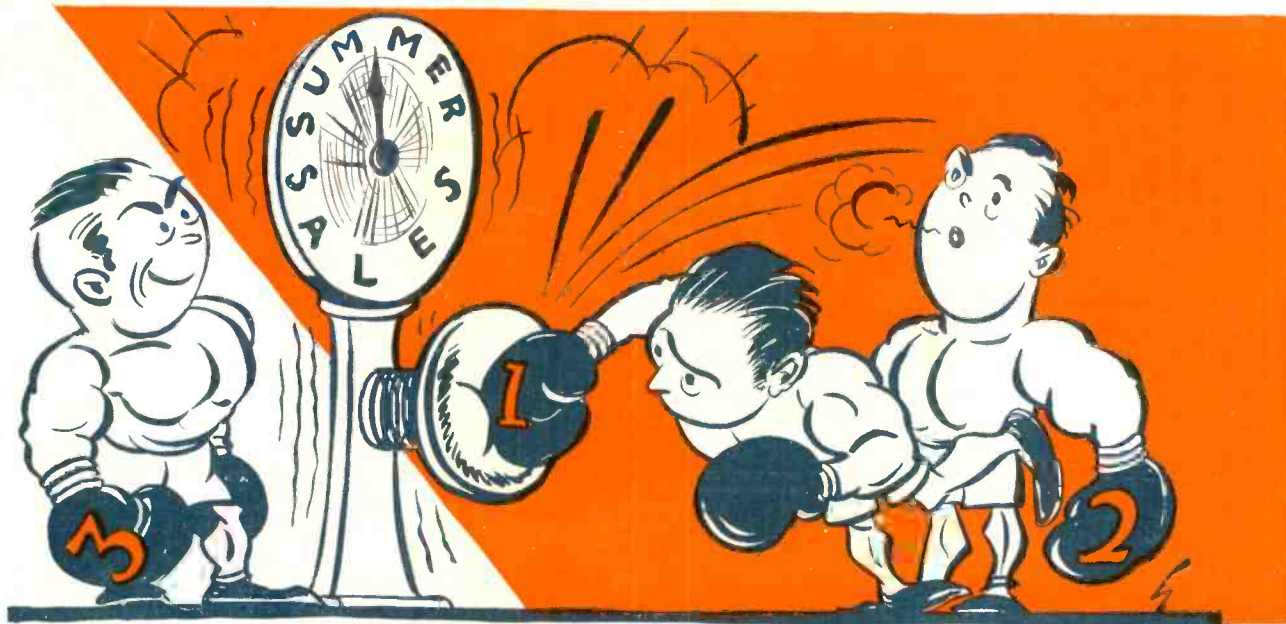

# Three BIG BOOSTS for Summer Sales

1

### RCA Leadership

—which means public confidence, readier buying. This leadership is recognized not only in the quality of Radiolas and Radiotrons, but in the many contributions of RCA to radio progress—including broadcasting.

2

### A Summer Campaign

that started on May 16th with a series of six Saturday Evening Post pages in five weeks. The campaign, in periodicals of many types will sell Radiolas for the dealer straight through the summer.

3

### The New Portable Radiola

Super-Heterodyne in two models. These sets make ready prospects of the men who own motorboats, automobiles, summer homes and camps. They will open new markets—bring in new profits.

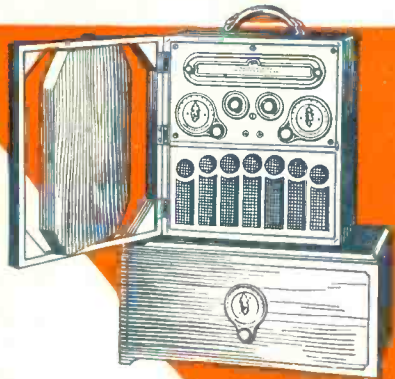

Radiola 26; complete except batteries. List \$225

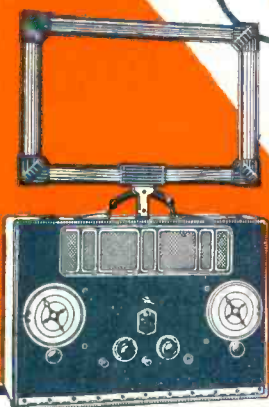

Radiola 24; complete except batteries. List \$195

Radio Corporation of America  
Chicago, Ill.      New York, N.Y.      San Francisco, Cal.

# Radiola

REG. U.S. PAT. OFF.

PRODUCED ONLY BY RCA

