

TRACKING THE MAN-MADE SATELLITE

JUN 27 A.M.

RADIO & TV NEWS

**JULY
1957
35 CENTS**

World's Leading Electronics Magazine



**Including
HIGH-FIDELITY
FEATURES**

**TRANSISTORIZED
WIRELESS MICROPHONE**

**SUMMER SERVICE:
ROOM AIR CONDITIONERS**

**ALL ABOUT AUDIO & HI-FI
Room Resonance & Stereo**

**PORTABLE TAPE RECORDER
AMPLIFIER**

**1957 AUTO RADIOS:
FORD**

**ELECTRONIC CROSSOVERS
FOR HI-FI**

**CHOOSING A
COLOR-BAR GENERATOR**

**SEA-GOING HI-FI
(See Page 42)**



Get all this extra value . . .

When you buy

RAYTHEON

ALUMINIZED PICTURE TUBES

for your replacement work



- ✓ **LONG LIFE ALUMINIZATION**
- ✓ **CROSS-CHECK QUALITY ASSURANCE**
- ✓ **CORONA INHIBITOR**
- ✓ **FULL ONE YEAR WARRANTY, BACKED BY RAYTHEON NAME**
- ✓ **THOROUGH, QUALITY WORKMANSHIP**
- ✓ **PROMPT, EFFICIENT DISTRIBUTOR COOPERATION**
- ✓ **SATISFIED CUSTOMERS**

because they enjoy:
WHITER WHITES
BLACKER BLACKS
CRISPER PICTURES
SHARPER CONTRAST
LONGER LIFE



RAYTHEON MANUFACTURING COMPANY

Receiving and Cathode Ray Tube Operations

Newton, Mass. • Chicago, Ill. • Atlanta, Ga. • Los Angeles, Calif.

Raytheon makes all these } Receiving and Picture Tubes, Reliable Subminiature and Miniature Tubes, Semiconductor Diodes, Power Rectifiers and Transistors, Nucleonic Tubes, Microwave Tubes



Excellence in Electronics

You Can Train at Home for Good Jobs, Career Opportunities

Find out What N.R.I., Oldest, Largest, Home Study Radio-TV School can do for You

Whether you're on the "OUTSIDE" and want to get in; or on the "INSIDE" and want to advance, N.R.I. has specialized training for you.



J. E. SMITH,
FOUNDER

Training plus opportunity is the ideal combination for success. And today's opportunity field is Radio-Television. Over 125 million home radios plus 30 million sets in cars plus 40 million TV sets mean top money, top jobs for trained Radio-TV technicians.

More than 4,000 Radio and TV broadcasting stations offer interesting and important positions for technicians, operators. Color television, portable TV sets, Hi-Fi, other developments, assure future growth.

N.R.I. IS TESTED WAY TO BETTER PAY

If you want to gain knowledge and skill for success and security, find out what N.R.I. offers. Since 1914—for more than 40 years—N.R.I. has specialized in training ambitious men at home in spare time for Radio-TV. As the outstanding leader, you are assured dependable training when you enroll with N.R.I. You are backed by the record and reputation of the oldest and largest home study Radio-TV school. With an N.R.I. diploma, you command respect because you are a skilled operator equipped to do important work.

ADD TO YOUR INCOME STARTING SOON

Whether you know very little or whether you have some knowledge of Radio-TV, N.R.I. training can help you. We send you easy-to-understand, illustrated texts. As part of our Servicing Course you get many kits to build Radio Receiver, Multi-tester, other equipment that "brings to life" what you study. Soon after starting many N.R.I. Students earn \$10, \$15 a week extra fixing neighbors' sets in spare time.

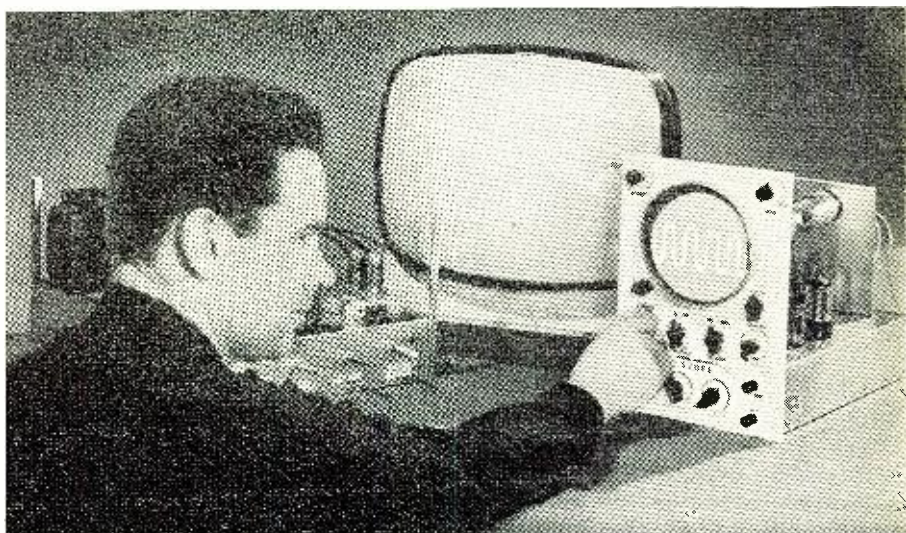

N.R.I. SUPPLIES EQUIPMENT FOR PRACTICAL EXPERIENCE. 17" picture tube, all tubes, parts to build UHF-VHF Television Receiver, a 5" high definition Oscilloscope and a Television Signal Generator supplied with Advanced TV Training.

N.R.I. Communications Training provides the practical knowledge you need for a career in Broadcasting. We send kits to build a Transmitter, Signal Generator, etc.; practice methods, procedures required of licensed Commercial Radio-TV operators.

TV SERVICE EXPERTS EARN TOP PAY, TOP JOBS

N.R.I.'s All Practice Professional TV Servicing Course is designed for the man who wants to reach the top in TV Servicing. Not for beginners, this course is for the man with a knowledge of basic theory, either from Radio-TV serv-

icing experience or planned training. We send you 17" picture tube, components for TV Receiver, 5" TV Oscilloscope and a TV Signal Generator. You learn methods to diagnose and correct TV Service problems quickly, correctly, with confidence.

SAMPLE LESSON AND CATALOG SENT FREE

Mail coupon today. Check the Radio-Television training that interests you. We will send you Sample Lesson and Catalog. Address: National Radio Institute, Dept. 7GE, Washington 16, D. C.

MAIL COUPON NOW

NATIONAL RADIO INSTITUTE, Dept. 7GE, Washington 16, D.C.

Please send information on opportunities and training checked below. (No salesman will call.)

Radio-TV Servicing Training.

Radio-TV Communications Training.

Advanced TV Servicing.

Name-----Age-----

Address-----

City-----Zone-----State-----

Accredited Member, National Home Study Council

RADIO & TV NEWS is published monthly by Ziff-Davis Publishing Company, William B. Ziff, Chairman of the Board (1946-1953), at 64 E. Lake St., Chicago 1, Ill. Entered as second-class matter July 21, 1948, at the Post Office, Chicago, Ill., under the act of March 3, 1879. Authorized by Post Office Department, Ottawa, Canada, as second-class matter. SUBSCRIPTION RATES: one year U. S. and possessions, and Canada \$4.00; Pan American Union Countries \$4.50; all other foreign countries \$5.00.

CONTENTS

JULY, 1957

VOL. 58 ■ No. 1

Publisher

OLIVER READ, D. Sc., WIETI

Editor

WM. A. STOCKLIN, B. S.

Technical Editor

MILTON S. SNITZER

Service Editor

SIDNEY C. SILVER

Associate Editor

P. B. HOEFER

Assistant Editor

J. JUSTER

Television Consultant

WALTER H. BUCHSBAUM

Art Editor

HERBERT ASCHER

Art and Drafting Dept.

**J. A. GOLANEK
JAMES A. ROTH
MILTON WHELPLEY**

Advertising Director

L. L. OSTEN

Advertising Manager

MURRAY GOLDMAN

Midwest Adv. Manager

JOHN A. RONAN, JR.

Western Adv. Manager

JOHN E. PAYNE



ZIFF-DAVIS PUBLISHING COMPANY

B. G. Davis, President; William Ziff, Administrative Vice-President; H. J. Morganroth, Vice-President; Michael H. Froelich, Vice-President; Michael Michaelson, Vice-President and Circulation Director; George Carney, Secretary-Treasurer; Albert Gruen, Art Director.

Executive Office: 366 Madison Ave.

New York 17, N. Y. MU 7-8080

Editorial Office: 1 Park Ave.

New York 16, N. Y. MU 5-6367



Member
Audit Bureau of
Circulations



BRANCH OFFICES: Midwestern Office, 64 E. Lake St., Chicago 1, Ill., John A. Ronan, Jr., manager; Western Office, Room 412, 215 W. 7th St., Los Angeles 14, Calif., John E. Payne, manager.

EDITORIAL—INDUSTRY NEWS

For the Record.....	O. Read	8
Spot Radio News.....	Washington Correspondent	14
New Television Station Grants.....		14
Tracking the Man-Made Satellite.....	Max Gunther	31
Super-Radars for Missile Ship.....		37
IGY World Warning Agency.....		100
Sunspots Aid Radio Signals.....		107
Super-Power SSB Army Transmitter.....		117
Heart Microphone Monitors Murmurs.....		123

HIGH FIDELITY AND AUDIO

All About Audio and Hi-Fi—Room Resonance and Stereo (Part 3).....	G. A. Briggs	34
Power Ratings for P.A. Driver Units.....	Lawrence J. Epstein	38
Sea-Going Hi-Fi.....	R. J. Carrington	42
This Month's Cover.....		43
Transistorized FM Wireless Microphone.....	Louis E. Garner, Jr.	45
Electronic Crossovers for Hi-Fi.....	John F. Keidel	54
Portable Tape Recorder Amplifier.....	J. E. Pugh, Jr.	57
Certified Record Revue.....	Bert Whyte	60
Hi-Fi—Audio Product Review.....		82
Transistor Intercom System.....	W. F. Palmer	94
FM Converter for Intercarrier TV.....	Bruce Morrisette	108
Sound on Tape.....	Bert Whyte	112

SERVICING

Television-Radio

War Against Interference.....		36
1957 Auto Radios: Ford.....		40
TV Sound Can Be Improved.....	Kenneth Bramham	44
A Nose for Servicing.....	John J. Savigny	48
Summer Service: Room Air Conditioners.....	Joseph Derman	49
All Your Eggs in One Basket?.....	William Leonard	56
The Packard-Bell Color TV Line.....	Walter H. Buchsbaum	61
Mac's Service Shop.....	John T. Frye	67
Factors Determining Tube Life.....	Prof. A. V. J. Martin	111
Antenna News.....		116
Service Industry News.....		118

Test Equipment

Choosing a Color-Bar Generator.....	A. R. Stamiti	62
Practical Techniques of Square-Wave Testing.....	E. G. Louis	64
New Tube Tester Data.....		96
Multi-Purpose Tone Generator.....	Tracy Diers	120
Test Leads and Cables.....	Robert B. Gary	136

AMATEUR

Super Selectivity with Crystals.....	Richard F. Burns, W9NVC	52
--------------------------------------	-------------------------	----

DEPARTMENTS

Within the Industry.....	24	Manufacturers' Literature.....	124
Technical Books.....	104	What's New in Radio.....	126
Sales Aids.....	140		

Copyright © 1957 by Ziff-Davis Publishing Company. All rights reserved.

SUBSCRIPTION SERVICE. All communications concerning subscriptions should be addressed to Circulation Dept., 64 E. Lake St., Chicago 1, Ill. Subscribers should allow at least four weeks for change of address. Include your old address as well as new—enclosing, if possible, an address label from a recent issue of this magazine.

CONTRIBUTIONS: Contributors are advised to retain a copy of their manuscripts and illustrations. Contributions should be mailed to the New York Editorial Office and must be accompanied by return postage. Contributions will be handled with reasonable care, but this magazine assumes no responsibility for their safety. Any copy accepted is subject to whatever adaptations and revisions are necessary to meet the requirements of this publication. Payment covers all author's, contributor's, and contestant's rights, title, and interest in and to the material accepted and will be made at our current rates upon acceptance. All photos and drawings will be considered as part of the material purchased.

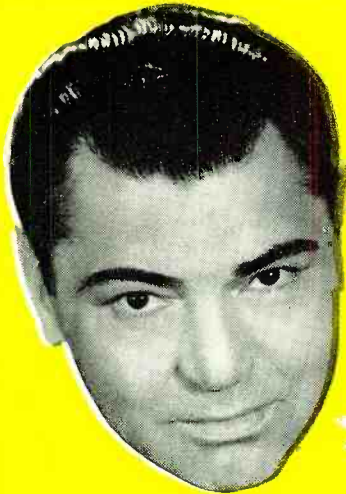

Jack Dempsey

The former world's heavyweight boxing champion says: "I know the value of good training, and believe me, for 25 years, DeVry has been one of America's outstanding electronics training centers! The Employment Service is 'tops' tool!"

THESE DEVRY TECH GRADUATES VERIFY WHAT DEMPSEY SAYS



NICK BARTON, Illinois, a DeVry graduate, now has his own business and tells us he is "literally snowed with work."

GEORGE D. CROUCH, California, was a retail store clerk. He took the DeVry program, and today is in business for himself.



EDWARD HAHN, Illinois. Now an electronics technician with Televiso, Inc. DeVry Tech training helped him prepare for his present position.

"If You Want to Make More Money Full or Part Time in TELEVISION RADIO • ELECTRONICS DeVry Tech Has An Answer," SAYS JACK DEMPSEY

NO TECHNICAL EXPERIENCE NEEDED— YOU CAN LEARN IN YOUR OWN HOME!

Great opportunities are found in Electronics—one of today's top fields. Good jobs in modern plants, TV — Radio studios, offices and laboratories await trained men who can build, install, operate and service Electronic equipment. And equally exciting are the possibilities for starting your own servicing shop. The coupon below will bring you full details — Free!

HERE'S HOW TO GET STARTED!

You can get Television-Radio-Electronics training right in your own home. You don't need previous technical experience, advanced education, or exceptional "aptitude." And the training DeVry Tech provides is "tops." What's more, DeVry helps you get started toward a job, or a servicing shop of your own!

TOO GOOD TO BE TRUE?

Not at all! Our files show that many men—high school graduates, truck drivers, store clerks, unskilled workers—now have the better jobs they wanted because of their DeVry diplomas. Age is no barrier — DeVry trains men 17 — 55.

TWO GREAT TRAINING CENTERS — CHICAGO and TORONTO

If you can come to either of DeVry's training centers—Chicago or Toronto — you can prepare under the close guidance of friendly, experienced instructors. You can use valuable equipment similar to that found in the field. Write today for complete information.

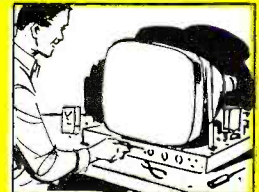

EARN AS YOU LEARN—by servicing radio and TV sets at home before you complete the training.



LIVE-WIRE EMPLOYMENT SERVICE — puts you in touch with job opportunities—even helps you establish a service shop of your own.

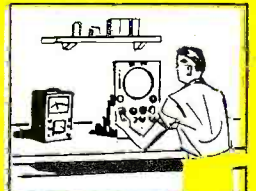

BUILD TEST EQUIPMENT—You assemble your own high quality test equipment to help you earn money servicing Radio and TV sets in your spare time.

A SAMPLE LESSON IS YOURS FREE!

See for yourself how DeVry trains you for real opportunities in Electronics. We'll also give you a free copy of an interesting booklet, "Electronics and YOU."



ARE YOU OF DRAFT AGE?

We have valuable information for every man of draft age; so if you are subject to military service, be sure to check the coupon.

"One of America's Foremost Electronics Training Centers"



Accredited Member of National Home Study Council

DEVRY TECHNICAL INSTITUTE
CHICAGO 41, ILLINOIS
FORMERLY
DEFOREST'S TRAINING, INC.



MAIL TODAY FOR FREE FACTS

DeVry Technical Institute
4141 Belmont Ave., Chicago 41, Ill., Dept. RN-7-N
Please give me a FREE Sample Lesson and your booklet, "Electronics and YOU."

Name Age

Street Apt.

City Zone State

Check here if subject to Military Training.

DeVry Tech's Canadian Training Center is located at
#1080 626 Roselawn Avenue, Toronto 12, Ontario

For electronic technicians:

THE FUTURE'S IN FLORIDA...

THE FUTURE'S IN MISSILES...

THE FUTURE'S WITH RCA!...

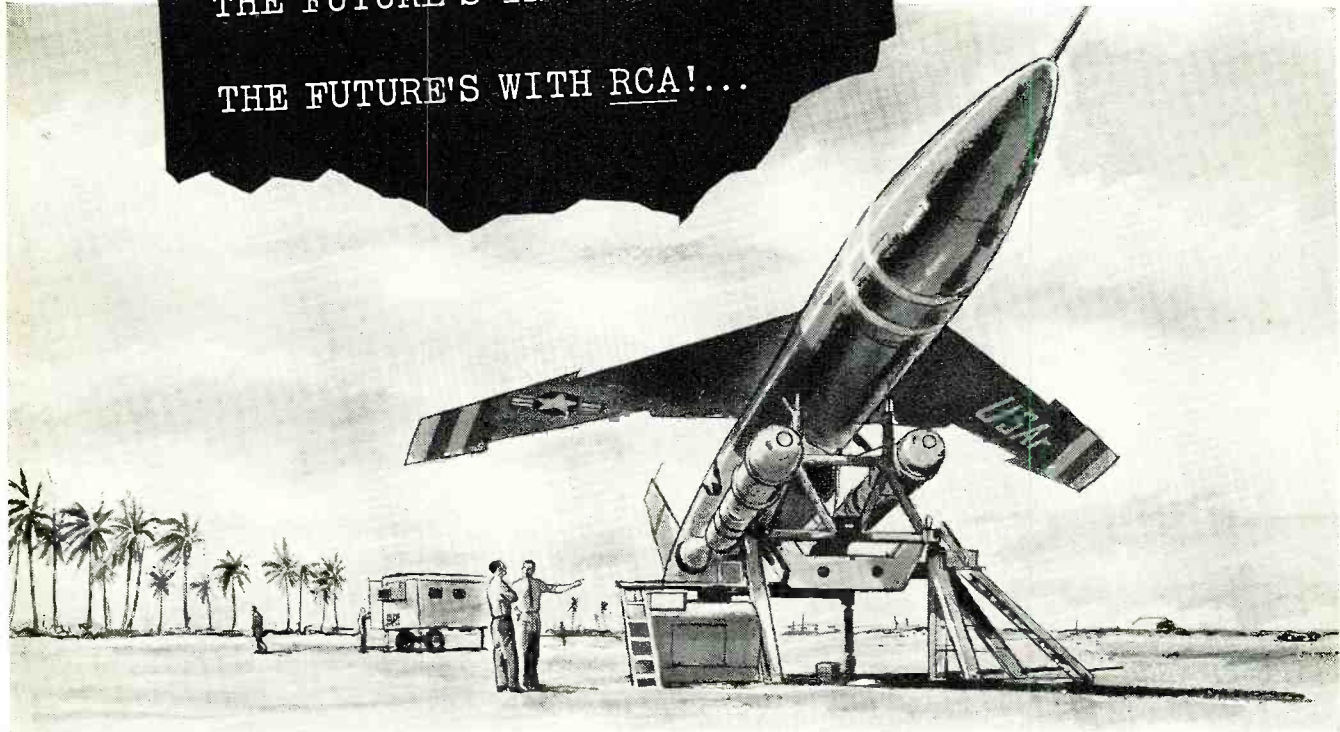

Missiles, the weapons technology of the future . . . delightful year 'round climate . . . combine these job factors in your career as an RCA electronic technician at Patrick Air Force Base on Florida's central east coast. At the Missile Test Project you'll help test most every type of missile being developed. You'll also contribute to the Vanguard Satellite's launching and tracking.

RCA is opening an unusually wide variety of positions for technicians on all levels. A basic knowledge of electronics will qualify you for many of them. Among facilities are the latest electronic and optical data acquisition and transmission systems. You'll enjoy RCA's complete benefit program . . . relocation assistance, too. And just imagine life in Florida's wonderful climate!

Make *your* future in these field or shop assignments:

**RADAR—RADIO — TELEMETRY
TIMING — INSTRUCTION
ELECTRONIC TEST EQUIPMENT**

Mail the coupon for booklet which describes our Florida missile program and its advantages.



RCA SERVICE COMPANY, INC.

Mr. H. N. Ashby, Employment Mgr., Dept. N-16G
RCA Service Co., Inc., Missile Test Project
P. O. Box 1226, Melbourne, Fla.

Please send me brochure with the information on RCA employment advantages in Florida.

Name _____ Age _____ Married Yes No

Address _____ U.S. Citizen Yes No

Electronics Experience (Include Mil. Service & Tech. Schools)

Earliest Date Available _____

UNIVERSITY ANNOUNCES THE VERSATILE

MODEL

CLH WIDE-ANGLE PROJECTOR

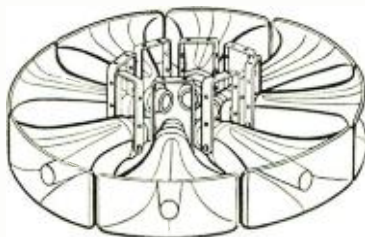

PATENTS
PENDING

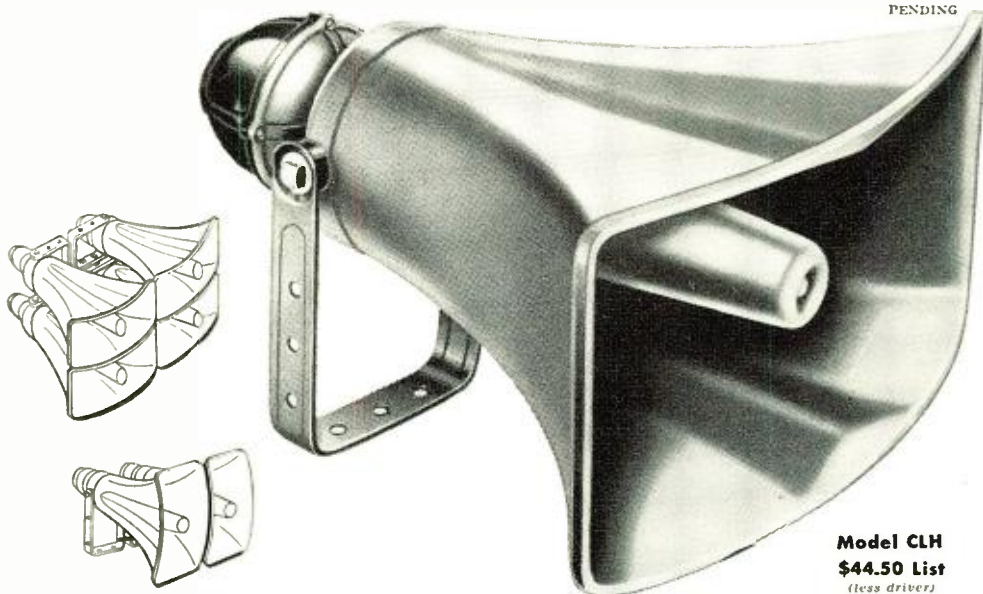

Model CLH
\$44.50 List
(less driver)

EXCLUSIVE OMNI-DIRECTIONAL MOUNTING

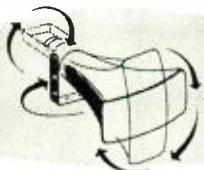

Horn bell rotates full 360° on its axis, while the 'U' mtg. bracket provides better than 180° vertical and 360° horizontal adjustment of projector positioning. Thus, sound can be distributed in any direction regardless of projector location.

"TUNE OUT" ECHO & REVERBERATION



The unique pin-point adjustment possible with the CLH at last provides the long-awaited answer to coverage of "dead spots" and control over troublesome echo and reverberation—regardless of structural or physical placement limitations!

USE SINGLY OR STACKED

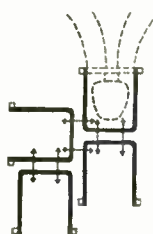

The 'U' mounting bracket of the Model CLH is specially designed to link two or more projectors into any configuration, achieving exactly the sound distribution pattern required. Even diagonal or alternating projections are just as easy to achieve as "standard" patterns.

VERSATILITY & ADAPTABILITY UNLIMITED



Meets every soundcasting requirement. Use the CLH wide-angle projector with any University driver to get exactly the frequency response, efficiency and power handling capacity you need. Here is dependable performance and real economy—for actual dollar savings you can count on year after year.

THE MOST COMPLETE SELECTION
OF DRIVERS IN THE INDUSTRY NOW
AVAILABLE FOR USE WITH THE CLH



Model PA-50. Features extended high and low frequency range, highest continuous duty power capacity, greatest conversion efficiency, husky built-in multi-match transformer with terminals conveniently located at base of unit. The answer to the toughest sound problem. Nothing finer!

Response: 70 to 10,000 cps. Power Capacity: Full Range 50 watts; Adjusted Range* 100 watts; List Price: \$57.50.



Model PA-HF. For applications requiring the greatest power handling capacity, maximum sensitivity, widest range frequency response, plus rugged lifetime construction. Completely die-cast aluminum housing. Increased sound output cuts amplifier requirements in half!

Response: 70 to 10,000 cps. Power Capacity: Full Range 50 watts; Adjusted Range* 100 watts; List Price: \$47.50.



Model SA-30. "Battleship" construction for maximum durability against abuse or in hazardous environments. Completely die-cast aluminum housing and built-in matching transformer for connection to high impedance lines or "constant voltage" systems.

Response: 80 to 10,000 cps; Power Capacity: Full Range 30 watts; Adjusted Range* 60 watts; List Price: \$47.50.



Model SA-HF. Will deliver that extra punch needed to cut through heavy noise. Use for speech or high quality music.

Response: 80 to 10,000 cps.; Power Capacity: Full Range 30 watts; Adjusted Range* 60 watts; List Price: \$36.00.



Model MA-25. Low in cost, high in quality, featuring high efficiency magnet, tropicalized 2" voice coil, "rim-centered" breakdown-proof bakelite diaphragm.

Response: 85 to 6500 cps.; Power Capacity: Full Range 25 watts; Adjusted Range* 50 watts; List Price: \$27.50.

*Program response adjusted to horn cut-off.

ACCESSORIES



2YC CONNECTOR



PMA ADAPTER

2YC Connector enables two driver units to be used with one CLH trumpet for up to 200 watts output. Now you can get the Super-Power you want...when you want it, using standard stock drivers.

PMA Adapter fits standard 1/2" dia. threaded pipe to the CLH 'U' mounting bracket. Takes the headache out of mounting on pipe!

LISTEN

University sounds better



UNIVERSITY LOUDSPEAKERS, INC., 80 SOUTH KENSICO AVENUE, WHITE PLAINS, N. Y.

July, 1957

**no other plier
does so many jobs
SO WELL**

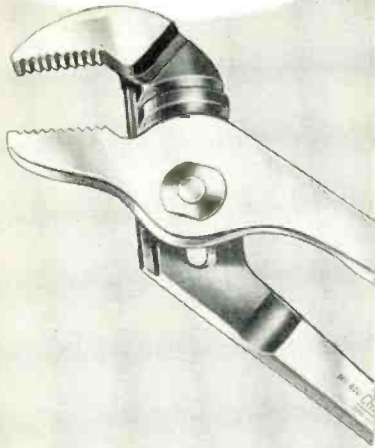

CHAN NEL LOCK

No. 420

**GRIPS LIKE A
PIPE WRENCH**

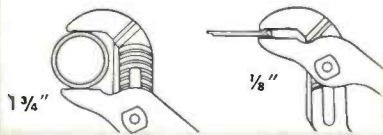

Help yourself to a Channellock No. 420 . . . the handiest plier of them all. With this handy plier, you can grip anything from a cotter pin to a 1 3/4" hex nut. And what gripping power! Just like a pipe wrench. What's more, Channellock is streamlined . . . easy to use in hard-to-get-at places. This all-round usefulness is the reason why Channellock is the favorite plier of craftsmen everywhere. It'll be your favorite, too . . . for the same reason. Ask your hardware man for a Channellock No. 420.

BE SURE IT'S A GENUINE CHANNELLOCK



CHAMPION DEPARTMENT TOOL Co. MEADVILLE, PA.



THE GEOPHYSICAL YEAR AND ITS SATELLITE

JULY 1, 1957, marks the beginning of an 18-month period in history that will never be forgotten. It is known as the International Geophysical Year and only those individuals who have access to scientific information actually know the full magnitude of the program that lies ahead. Most of the scientific research laboratories and colleges in this country and those in 50 other nations, will unite in a combined effort to study important geophysical and solar problems. Although the greatest emphasis will be on the study of outer space (by means of the satellite), many scientific expeditions will be made to study the polar regions, oceanography, etc.

Since the dawn of history man has wanted to fly and to reach out into the unknown world. He has learned to fly and now he is about to realize the most fantastic desire of all—that of conquering outer space. The astronomer, geophysicist, and the astrophysicist have one interest in common—to study outer space without having to look through the atmosphere. The satellite, which literally will be an observation platform in outer space, will solve the basic requirement of this group by placing their instruments beyond the atmosphere.

Some time during this Geophysical Year, most likely the early part of 1958, the United States government will launch the first of six planned satellites from Patrick Air Force Base in Florida by means of a three-stage rocket. The satellite itself is a highly polished, silvery sphere, 20 inches in diameter and weighing 21.5 pounds. It will fall into its orbit somewhere between 200 and 1500 miles above the earth.

Some of the weight of this satellite will be made up of electronic equipment. There will be various types of equipment aboard. For example, temperature measuring instruments both on the surface of the satellite and its interior, ionization and mechanical pressure gauges, microphones to listen for meteor impact, films on the outside of the sphere which will measure erosion from meteor contacts, a geiger counter to check cosmic rays, photon counter, ionization chamber to measure the sun's radiation, a magnetometer to measure strength of magnetic fields, photocells to check the earth's cloud cover, and complete radio transmitting equipment to transmit (on 108 mc.) all information to monitoring stations around the world.

Actually, the satellite will be visible to the naked eye only prior to dawn and just after dusk. It will appear as a tiny silvery moon in the sky. Almost to the point of fantasy, this silvery sphere will travel through a temperature change from warm to very cold up to 60 miles above the earth and then will reach a possible temperature of beyond 1200 degrees centigrade at altitudes of 150 miles and more. It will travel at a speed of 18,000 miles per hour, circling the earth about sixteen times during a 24-hour period.

It is hard for anyone to believe that this is possible. Yet, according to all scientific development work, there is little doubt in anyone's mind that the program, as planned, will be successful. The first satellite may stay in its orbit one or two hours or it may stay up several weeks or more. Succeeding satellites should remain in their orbits for longer periods. Eventually an observation platform will be projected as a permanent, simulated planet which some day will be manned.

What will this mean to you as an individual? Probably nothing directly unless you're planning a trip to the moon. Indirectly, yes. It is expected that the co-ordinated effort will lead to a number of major breakthroughs in such fields as meteorology, aurora and air glow, cosmic rays, oceanography, seismology, gravity, solar activity, glaciology, geomagnetism, and ionospheric physics. There is no doubt that it will lead to better navigation, improved radio communications, and better weather forecasting. It is not too remote to say that some day, as a result of these studies, planned weather will be possible. In addition, what is learned from this great scientific experiment is sure to make itself felt in the near future in such unrelated fields as air conditioning and air travel, as well as a very great variety of specialized fields that have been tapped for contributions in the design of the satellite.

It will certainly lead to a much greater knowledge of the universe around us. A better understanding of the sun's role and the effect of outer space on our earth is definitely in the cards. Needless to say, it is hoped that the greater knowledge thus gained will lead to a higher standard of living and an era of permanent peace throughout the world.

As always, RADIO & TV NEWS will keep you abreast of these developments as they take place. . . . O.R.



Save on Famous knight® HI-FI



THE VERY BEST FOR LESS: Knight Custom components are built to ALLIED'S own special high standards to deliver outstanding musical quality with distinguished appearance at money-saving minimum cost. Each unit is unconditionally guaranteed for one full year.

EXCLUSIVE WITH
ALLIED

NEW



Sensational Knight "Tri-Fi" 3-Way 12" Hi-Fi Speaker

MORE FOR YOUR
HI-FI DOLLAR

ALLIED'S
SPECIAL PRICE **\$49⁵⁰**

- Heavy 1 $\frac{3}{4}$ -Pound Alnico-V Magnet
- 3 Radiating Elements for Smooth Response
- Compression-Type Horn-Loaded Tweeter
- Response, \pm 5 db, 35-15,000 Cycles!

equal to the best

Here's incomparable Hi-Fi speaker value—the new 3-way type Knight "Tri-Fi" combining a 12" cone for bass reproduction, a special conical radiator for mid-frequencies and a built-in compression-type tweeter for highest frequencies. Includes L-pad tweeter level control with calibrated dial and control knob. Full 1 $\frac{3}{4}$ -pound woofer magnet for solid bass response; heavy rattle-proof frame. Overall range is \pm 5 db, 35-15,000 cps. First crossover at 2,000 cps; automatic crossover from mid-range to tweeter at 4,000 cps. Cone resonance: 50 cps; power capacity, 25 watts program material; impedance, 16 ohms. Diameter 12-1/16"; depth, 8". *Unconditionally guaranteed for one full year.* Shpg. wt., 12 lbs.

81 DX 839. Knight "Tri-Fi" Speaker, only **\$49⁵⁰**

Only \$4.95 down on our Easy Terms

SAVE!

Knight "Tri-Fi" Speaker Installed in Knight-Klipsch Enclosure



Comes to you ready to play—complete with Knight "Tri-Fi" speaker installed in handsome Knight-Klipsch enclosure. Enclosure is designed to use walls of room to extend bass range; "Tri-Fi" speaker covers entire spectrum of audible sound. Enclosure measures 32 x 21 x 14 $\frac{1}{2}$ ". Speaker impedance, 16 ohms; power handling capacity, 25 watts. Available in Blonde or Mahogany finish. You save \$12.50 over the price of the separate units! Shpg. wt., 44 lbs.

Save **\$12.50**

ALLIED'S
SPECIAL
PRICE **\$99⁵⁰**

94 DZ 787. Blonde finish.
94 DZ 786. Mahogany finish.

ALLIED'S OWN KLIPSCH-
LICENSED ENCLOSURE

Each, only **\$99⁵⁰**

*Only \$9.95 down
on our Easy Pay terms*

TOP VALUE knight HI-FI COMPONENTS

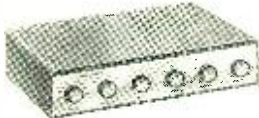

ONLY
\$94⁵⁰

DeLuxe 24-Watt Amplifier "Space-Saver" design; response, \pm 0.75 db. 20-40,000 cps; 12-position compensation; variable damping; loudness control; rumble filter; tape head input; hum balance. U.L. Approved. 30 lbs.

Model 94 SZ 709. Net. **\$94.50**



ONLY
\$99⁵⁰

DeLuxe Basic FM-AM Tuner. Matches DeLuxe amplifier; AFC; tuning meter; tuned RF on FM and AM; FM discriminator; 2 cathode followers; exceptional sensitivity. FCC Approved Radiation; U.L. Approved. 17 lbs.

Model 94 SX 711. Net. **\$99.50**



ONLY
\$64⁵⁰

"Bantam" 12-Watt Amplifier. Response, \pm 0.5 db, 20-20,000 cps; 3-position compensation; variable damping; loudness control; built-in preamp; tape head input; 7 inputs; "Space-Saver" design. U.L. Approved. 18 lbs.

Model 94 SX 708. Net. **\$64.50**



ONLY
\$74⁵⁰

"Bantam" Basic FM-AM Tuner. Matches "Bantam" Amplifier; AFC; FM limiter and discriminator; output level control; RF stage; high sensitivity; temperature-compensated oscillator. FCC Approved Radiation; U.L. Approved. 13 lbs.

Model 94 SX 710. Net. **\$74.50**

EASY TERMS AVAILABLE

Save \$44.72 On This Quality Knight "Space-Saver" Hi-Fi Phono System

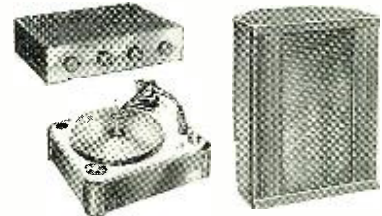

ONLY
\$199⁵⁰

Top value in a superb Hi-Fi music system. You save \$44.72 over cost of individual components. No cabinets required. Includes Knight 12-Watt "Bantam" Amplifier; Garrard RC 121-4 Changer and base, with G.E. RPX 052-A Triple-Play Cartridge (diamond-sapphire styli); Knight-Klipsch enclosure with Knight 12" Tri-Fi speaker installed (specify Blonde or Mahogany finish). Easy to install anywhere. Shpg. wt., 92 lbs.

92 PA 505. Knight Phono System.
Only **\$199⁵⁰**

Only \$19.95 down on our Easy Terms

order from **ALLIED RADIO**
America's Hi-Fi Center

FREE

SPECIAL VALUE SUPPLEMENT NO. 165



Send for it. Packed with top values in Hi-Fi systems and components; Recorders and supplies; all-new Public Address systems and components; super-value build-your-own Knight-Kits; Amateur equipment; electronic tubes and parts; tools, books, etc. **FREE**—send coupon today for your copy of ALLIED Supplement No. 165.

.....
 ALLIED RADIO CORP., Dept. 1-G7
 100 N. Western Ave., Chicago 80, Ill. OUR
36th
YEAR
 Ship the following KNIGHT Hi-Fi equipment.....
 \$..... enclosed. (All prices Net F.O.B. Chicago)
 Send FREE ALLIED Supplement No. 165
 Name.....
 Address.....
 City..... Zone..... State.....

**Systems
Career:** a
laboratory
for
learning

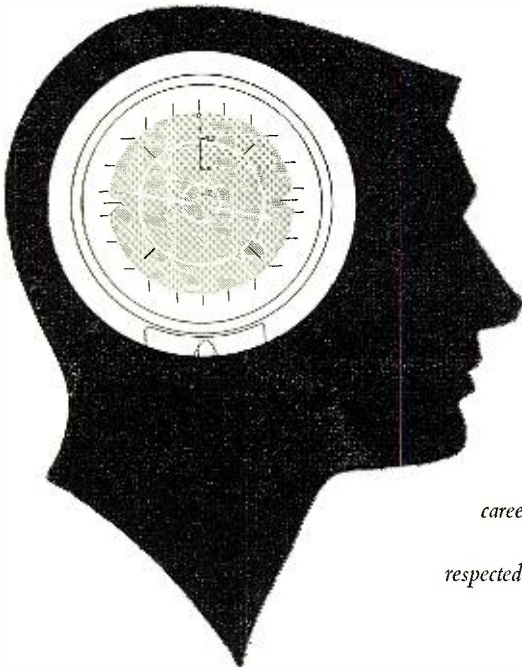

*... an exciting and rewarding
career awaits the E.E. or Physics
graduate who joins this highly
respected Engineering team.*

As a Field Engineer at Hughes, through training and assignment you will become familiar with the entire systems involved, including the most advanced electronic computers. With this knowledge you will be ideally situated to broaden your experience and learning for future application in either the military or commercial field.

The national respect which Hughes commands in the field of advanced electronics is in no small part due to the technical support provided by the Field Engineers. Other contributors to the suc-

cess of the Field Service and Support Division are the Technical Manuals Engineer, Training School Engineers, Technical Liaison Engineers, and Field Modification Engineers.

This Hughes activity is a highly trained organization of expert engineers, giving support to the armed services and air-frame manufacturers using the company's equipment. Locations are in Southern California, continental U.S., overseas. We invite you to join this team. For further information write us at the address below.

HUGHES

VACATIONING IN
SOUTHERN CALIFORNIA?
YOU ARE INVITED
TO VISIT HUGHES.

**Some extra advantages for
Field Engineers include:**

Training at full salary for 3 months before assignment.

Generous moving and travel allowance between present location and Southern California (Culver City).

Additional compensation plus complete travel and moving on assignments away from Culver City.

Ideal living conditions in the unsurpassed climate of Southern California.

Reimbursement for after-hours courses at UCLA, USC, or other local universities.

Employee group and health insurance paid by company, retirement plan, sick leave, and paid vacations.

Scientific Staff Relations

RESEARCH AND DEVELOPMENT LABORATORIES
HUGHES AIRCRAFT COMPANY
Culver City, California



... by and for the technician, **\$1.50 net**

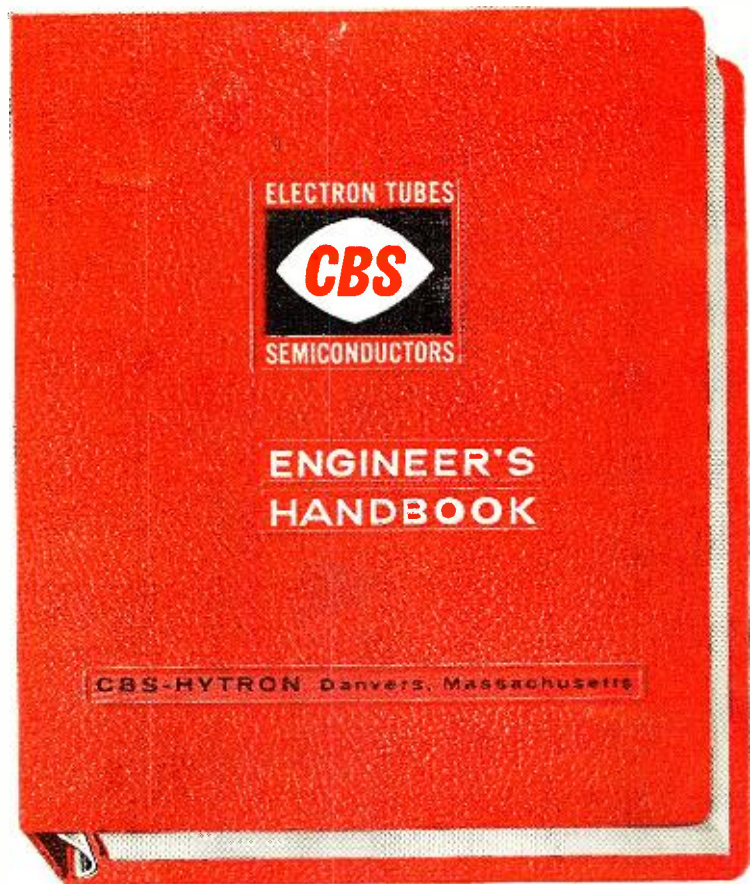

... by and for the engineer, **\$7.50 net**

Two new CBS handbooks

The new CBS Technician's Handbook and Engineer's Handbook are complete. They contain data for receiving, special and picture tubes as well as crystal diodes and transistors. Designed for on-the-job use, they are single, compact, handy volumes that lie flat. They feature modern styling for quick, easy reference. Supplementary services are available. Ask to see these Handbooks at your CBS Tube distributor's. You will want them both.

CHECK THESE FEATURES

Technician's Handbook

- Comprehensive data for all popular types
- Reference data for seldom-used types, grouped by application
- All popular special-purpose tubes and semiconductors
- 450 pages
- Handy 5¼ by 9 inches
- Rugged plastic binder
- Appendix especially prepared for service technicians

Engineer's Handbook

- Complete RETMA engineering design data
- Seldom-used types tabulated for quick reference
- 300 two-color design curves
- 650 pages, two colors
- Handy 8¼ by 9¾ inches
- 16-ring metal binder
- Appendix includes description of terms, symbols, characteristics ratings, etc.

*Reliable products
through Advanced-Engineering*



tubes • semiconductors

CBS-HYTRON, Danvers, Massachusetts
A Division of Columbia Broadcasting System, Inc.

10,000 SERVICEMEN HAVE THEIR SAY-

SURVEY SHOWS SERVICE DATA PREFERENCE

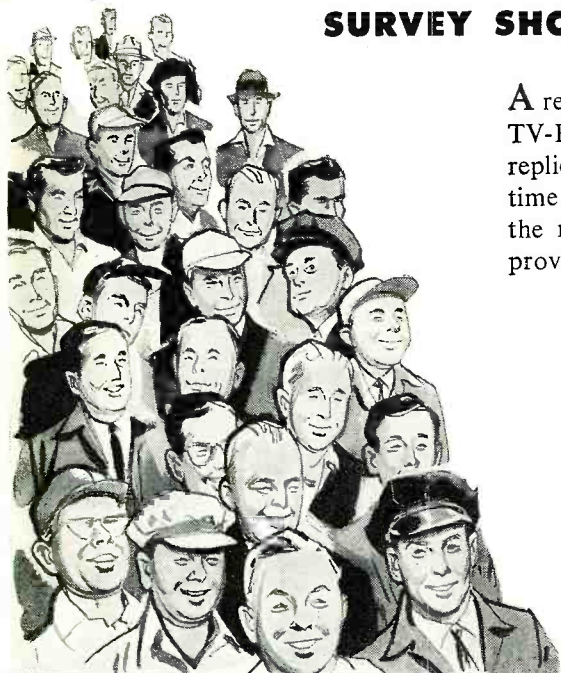

A recent Howard W. Sams survey among the nation's TV-Radio Service Technicians produced over 10,000 replies to an all-inclusive questionnaire. These men took time out to answer over 100 separate questions. Among the many valuable facts disclosed, the following will prove most significant to every Service Technician:



Q. HOW FREQUENTLY DO YOU USE SERVICE DATA IN YOUR WORK?

Answer: Over seven out of ten servicemen (74%) state they use service reference material on all work, including TV, Radio and associated servicing.

Q. WHAT SERVICE DATA DO YOU PREFER?

Answer: Over eight out of ten servicemen (82%) prefer PHOTOFACT.

Q. WHY DO YOU PREFER PHOTOFACT?

Answer: **COMPLETENESS** (the overwhelming reason given). **COMPLETE, UNIFORM, ACCURATE DATA** on over 28,000 TV, Radio, Record Changer, Recorder, Amplifier and Tuner models—for faster, easier, more profitable servicing.

COMPLETENESS and exclusive features make PHOTOFACT the overwhelming choice of Servicemen

COMPLETE Schematic Coverage

Famous "Standard Notation" uniform symbols (exclusive with PHOTOFACT) are used in every schematic. Diagrams are large, easy to read and handle. Waveforms and voltages are shown right on the schematic for fast analysis. Transformer lead color-coding and winding resistances appear on the schematic. Schematics are keyed to parts lists and to parts on chassis photos.

COMPLETE Photographic Coverage

Photos of all chassis views are provided for each model (exclusive with PHOTOFACT); all parts are numbered and keyed to the schematic and to the parts lists for quicker parts identification and location.

COMPLETE Tube Placement Charts

Both top and bottom views are shown. Top view is positioned as seen from back of

cabinet. Blank pin or locating key on each tube is shown. Charts include fuse location for quick service reference.

COMPLETE Alignment Instructions

Complete, detailed alignment data is standard and uniformly presented in all PHOTOFACT Folders. Alignment frequencies are shown on radio photos adjacent to adjustment number—adjustments are keyed to schematic and photos.

COMPLETE Tube Failure Check Charts

Shows common trouble symptoms and tubes generally responsible for such troubles. Series filament strings are schematically presented for quick reference.

COMPLETE Parts Lists

Detailed parts list is given for each model. Proper replacement parts are listed (with

installation notes where required). All parts are keyed to chassis photos and schematics for quick reference.

COMPLETE Field Service Notes

Each PHOTOFACT Folder includes time-saving tips for servicing in the customer's home—hints for quick access to pertinent adjustments, safety glass removal, special advice covering the specific chassis, etc.

OUTSTANDING EXTRA FEATURES

Each and every PHOTOFACT Folder is presented in a standard, *uniform* layout for quick, easy use. PHOTOFACT also maintains an inquiry service bureau for the benefit of its customers.

COMPLETE!
PHOTOFACT covers over 28,000 TV, Radio, Changer, Recorder, Amplifier and Tuner models—most complete coverage available.

Whatever servicing method you prefer—checking of waveform, voltage or resistance—you'll find all the information you need at your finger-tips in PHOTOFACT. For only 2½¢* per model, PHOTOFACT helps you solve your service problems in just minutes—helps you service more sets and earn more daily!

*Based on the average number of models covered in a single set of PHOTOFACT Folders.

Over **14,000,000** PHOTOFACT Folder Sets are in use earning more daily for thousands of Service Technicians

FREE FOR SERVICE TECHNICIANS ONLY

Fill out and mail coupon today for free subscription to the Sams Index—your guide to virtually any receiver model you may ever have to service. We'll also send you our plan showing how you can own the PHOTOFACT Library the Easy-Pay-Way.

HOWARD W. SAMS & CO., INC.

Howard W. Sams & Co., Inc.
2203 E. 46th St., Indianapolis 5, Ind.

Put me on your mailing list to receive the Sams Photofact Index and Supplements. My (letterhead) (business card) is attached.

Send me the details of the Easy-Pay Plan.

I'm a Service Technician: full-time; part-time

My Distributor is: _____

Shop Name _____

Attn: _____

Address _____

City _____ Zone _____ State _____

6 months
from today

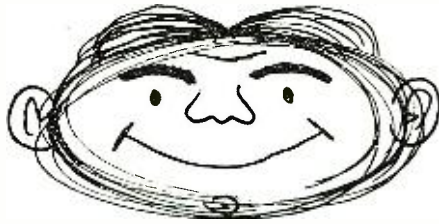

WHICH WILL YOU HOLD...

OR



add technical training to your practical experience. Get your FCC license quickly!

then use our effective

Job Finding Service!

We Guarantee

Your FCC License

If you fail to pass your Commercial License exam after completing our course, we guarantee to continue your training without additional cost of any kind until you successfully obtain your Commercial License.

Here's proof FCC Licenses can be secured in a few hours of study with our training at home in spare time.

Name and address	License	Time
John H. Johnson, Boise City, Okla.....	1st Class	20 weeks
Prentice Harrison, Lewes, Delaware.....	1st Class	27 weeks
William F. Masterson, Key West, Fla.....	2nd Class	24 weeks
J. A. Niedeck, Bethlehem, Pa.....	2nd Class	8 weeks
Gerald J. Collier, Columbus, Ohio.....	2nd Class	16 weeks

Employers Make Offers Like These

to Our Graduates Every Month

Broadcast Station in Illinois: "We are in need of an engineer with a first class phone license, preferably a student of Cleveland Institute of Radio Electronics; 40 hour week plus 8 hours overtime."

West Coast Manufacturer: "We are currently in need of men with electronics training or experience in radar maintenance. We would appreciate your referral of interested persons to us."

Our Trainees Get Jobs Like These Every Month



CHIEF ENGINEER

"Since enrolling with Cleveland Institute I have received my 1st class license, served as a transmitter engineer and am now Chief Engineer of Station WAIN. I also have a Motorola 2-Way Service Station. Thanks to the Institute for making this possible."

Lewis M. Owens, Columbia, Ky.

TEST ENGINEER

"I am pleased to inform you that I recently secured a position as Test Engineer with Meipar, Inc. (Subsidiary of Westinghouse) A substantial salary increase was involved. My Cleveland Institute training played a major role in qualifying me for this position."

Boyd Daugherty, Falls Church, Va.



Names of Trainees in Your Area
Provided on Request

Carl E. Smith, E.E., President

CLEVELAND INSTITUTE OF RADIO ELECTRONICS
Desk RN-7, 4900 Euclid Bldg., Cleveland 3, Ohio

Get these valuable
Booklets

FREE!

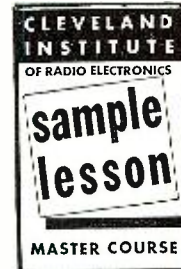
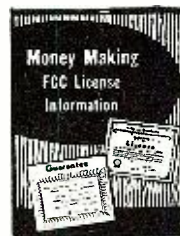

Accredited by National Home Study Council

Cleveland Institute of Radio Electronics

Dept. RN-7, 4900 Euclid Bldg., Cleveland 3, O.

Please send Free Booklets prepared to help me get ahead in Electronics. I have had training or experience in Electronics as indicated below:

- | | |
|---|---|
| <input type="checkbox"/> Military | <input type="checkbox"/> Broadcasting |
| <input type="checkbox"/> Radio-TV Servicing | <input type="checkbox"/> Home Experimenting |
| <input type="checkbox"/> Manufacturing | <input type="checkbox"/> Telephone Company |
| <input type="checkbox"/> Amateur Radio | <input type="checkbox"/> Other _____ |

In what kind of work are you now engaged? _____

In what branch of Electronics are you interested? _____

Name _____ Age _____

Address _____

City _____ Zone _____ State _____

Special Tuition Rates to Members of Armed Forces

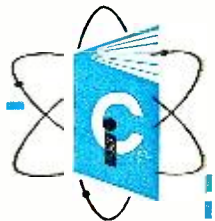

BUILD THE BEST— BUILD ALLIED'S OWN knight- kits

LOWEST COST because our giant buying power passes biggest savings on to you... you do the easy assembly, get professional results and **SAVE!**

knight-kits

EASIEST TO BUILD because KNIGHT-KIT "Step-and-Check" instruction manuals are marvels of clarity—it's just like having a good instructor at your side.

knight-kits

MONEY-BACK GUARANTEE: When properly assembled, KNIGHT-KITS fully meet published specifications, or we refund your money.

EASY TERMS AVAILABLE

NEW knight-kit HI-FI VALUE 30-WATT DELUXE AMPLIFIER KIT



- New Printed Circuit Switches!
 - Three Printed Circuit Boards!
 - 8 Inputs • Full Equalization!
 - Full 30 Watts • Custom Case!
- Model Y-762 **\$74⁹⁵**

A Hi-Fi triumph at low cost! Linear-deluxe Williamson-type power amplifier circuit (flawless response $\pm 1/2$ db, 15-100,000 cps at full 30-watt level!); equalization for all records, within $1/2$ db of recommended accuracy; 2 exclusive new printed-circuit switches; 3 printed-circuit boards for quickest, easiest, error-free construction; separate continuously variable Level and Loudness controls; 8 inputs for every signal source; DC on all filaments of preamp tubes; exclusive 3-way speaker selector switch (use speakers of mixed impedance without mismatch!); Power Amplifier Distortion—Harmonic, 0.55% at 30 watts—IM, 0.74% at 20 watts; rumble filter switch; variable damping. With beautiful "space-saver" case—ready for easy, money-saving assembly. Shpg. wt., 32 lbs.

Model Y-762. Net F. O. B. Chicago... **\$74⁹⁵**

See our Supplement No. 165 for additional knight-kit Hi-Fi values

free SUPPLEMENT

featuring **knight-kits**
Send for our FREE Supplement No. 165 featuring 45 great Knight-Kits, including Test Instruments, Hi-Fi, Hobbyist and Amateur kits. Write for your copy today.



ORDER FROM

ALLIED RADIO

Dept. 01-G7, 100 N. Western Ave., Chicago 80, Ill.



* Presenting latest information on the Radio Industry.

By RADIO & TV NEWS
WASHINGTON EDITOR

A REMARKABLE OPTICAL ELECTRONIC light-amplifying technique, with a sensitivity 1000 times greater than a standard TV camera, has been developed, as the result of a research program of the Air Research and Development Command, under the sponsorship of ARDC's Aeronautical Research Laboratory at the Wright Air Development Center in Dayton, Ohio.

Called the *cat eye*, this powerful electronic tool is expected to provide a means for answering the questions about the *canals* on the planet Mars. It may also provide the answers to other questions that have long concerned astronomers. This may be accomplished by taking better photographs than previously possible, even with the finest telescope, using conventional photographic methods.

Conventional photographs of planets and other heavenly bodies taken even with the best telescopes suffer from the *jitters*. The *jitter* is caused by tremors of air masses in the earth's atmosphere which affect the resolution of distant objects such as planets and galaxies, because the light is deflected first in one direction and then in another. An example is the shimmering of starlight seen on a clear night. This shimmer causes the photographs to blur, since conventional photographic techniques require exposures of several seconds for Mars, and even longer pe-

riods for more distant planets or the stars.

By using the *cat eye*, ARDC experts say, with a telescope of only 24-inch diameter, it is expected that pictures of Mars may be made in a few thousandths of a second, thereby shooting between the tremors in the atmosphere.

To the human eye, light appears to be steady and continuous. Actually, it is composed of many separate photons, each of which is a separate small train of light waves. The human eye detects only about one photon in twenty, enough to see by daylight or lamplight.

In comparison, the *cat eye* contains a transducer which collects and converts photons much more efficiently than the human eye. It permits a useful total light amplification of several-hundred-million times. Also, the latest transducer is especially improved in sensitivity in the red and near infrared portions of the spectrum, which are most suitable for observations of planets.

Work on the *cat eye* light amplifier concept began at ARDC's Wright Air Development Center in the summer of '53. A research working model was constructed and successfully flight-tested. During the test flight airborne observers were able to see the ground clearly on a moonless night.

The electronic gear featured in the

NEW TELEVISION STATION GRANTS

An additional listing of new construction permits and changes that have been made in station call letters. List continued next month.

STATE	CITY	CALL	CHANNEL	FREQUENCY	POWER*
Missouri	St. Louis	11	198-204	316
Texas	Victoria	19	500-506	20

NEW CALL LETTER ASSIGNMENTS

STATE	CITY	CALL	CHANNEL	FREQUENCY	POWER*
Illinois	La Salle	WEEQ-TV	35	596-602	...
Indiana	Ft. Wayne	WANE-TV (Formerly WINT-TV)	15	476-482	...
"	Indianapolis	WLWI	13	210-216	...

* ERP = (effective radiated power, kw.)

BURTON BROWN/NEW YORK

**FOR
RELIABILITY...
WHICH
CAPACITOR
DO YOU
PREFER?**

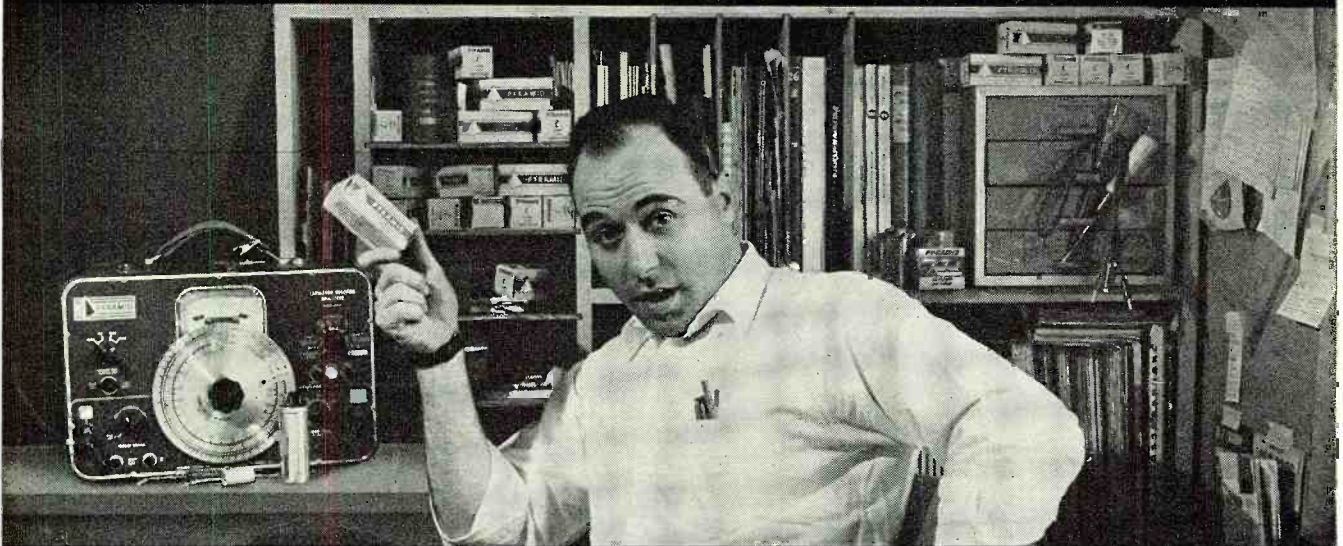

**PYRAMID...
SAID
4:6
OUT OF
EVERY 6
SERVICEMEN**

**CAPACITORS—RECTIFIERS
FOR ORIGINAL EQUIPMENT—FOR REPLACEMENT**



PYRAMID ELECTRIC COMPANY

1445 HUDSON BLVD., NORTH BERGEN, NEW JERSEY

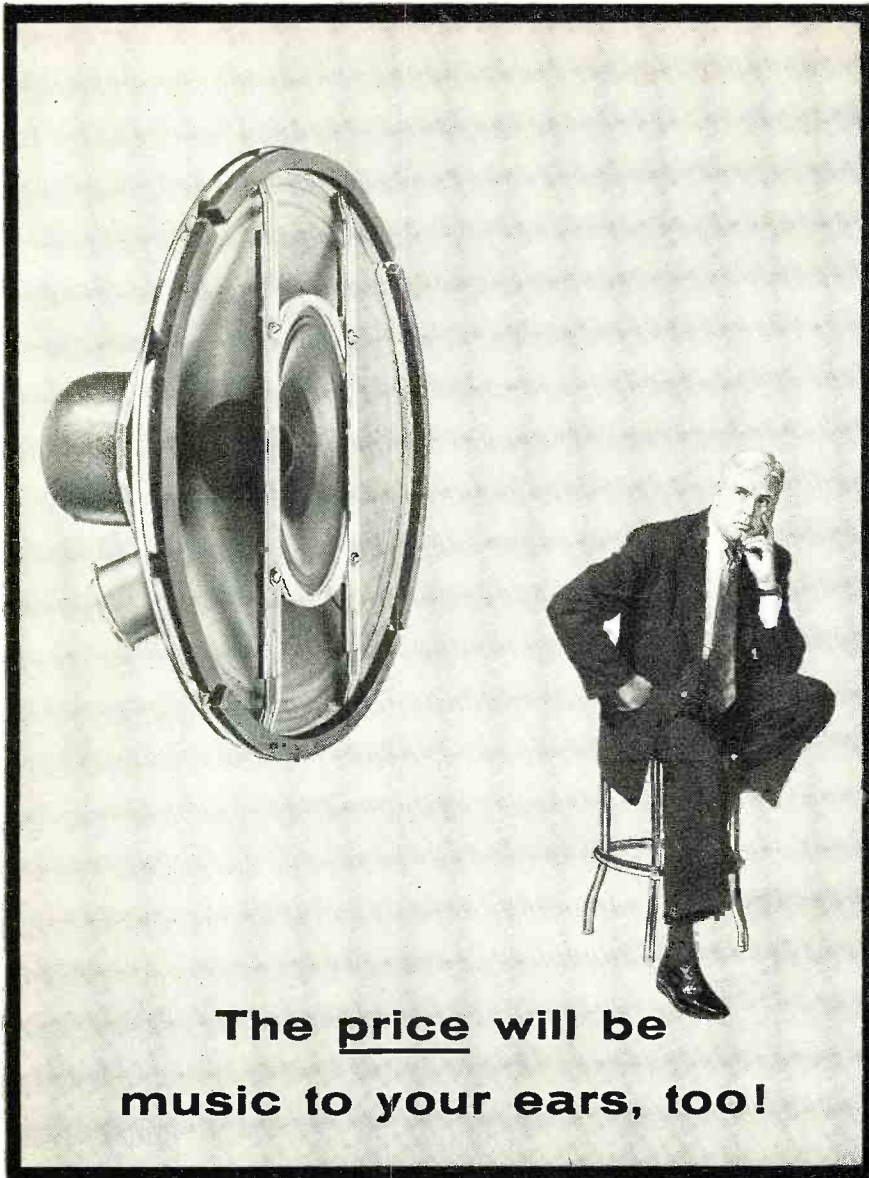

**The price will be
music to your ears, too!**

NEW SONOTONE CA-12 12" CO-AXIAL LOUDSPEAKER

40-14,000 cycles—elliptical cone tweeter—complete dividing network. And the price...\$19.50. That's right, \$19.50. Yet it out-performs speakers selling at three times the price. Interested? Listen to the CA-12 and be convinced.

Ask your dealer for a demonstration, or send your name and address for full details.

Electronic Applications Division

SONOTONE® CORPORATION

ELMSFORD, N. Y.

SONOTONE CORPORATION, Dept. LN-77, Elmsford, N. Y.

NAME _____

ADDRESS _____

CITY _____ ZONE _____ STATE _____

their desired route; and furthermore, it will provide the information necessary for vectoring the new turbo-prop and jet aircraft along routes which will permit them to climb rapidly to the higher cruising altitudes at which they are designed to operate.

It will also be possible, by observing the positions of aircraft approaching the airports, to plan and control more efficiently the approach sequence, in order to have a continuous flow of aircraft into and away from the terminal without the resultant delays which now occur when it becomes necessary to stack aircraft.

Briefly, the procedures at the air-traffic control center will be: Immediately when a departing plane appears upon the controller's radar indicator, the pilot will be advised to fly a heading which will route him away from possible conflict with other aircraft; and when it is evident that he is separated horizontally by at least five miles from other aircraft, which are at the altitude he intends to climb through, he will be cleared to climb to the appropriate altitude. The progress of the departing aircraft will be monitored until it has proceeded out of range of the radar.

An inbound aircraft will be first detected and identified at the outer edge of the radar, and its progress monitored to approximately 20 miles from the airport, at which time, if required, the controller will commence vectoring the aircraft over the most expeditious route to the final approach to the airport, at all times maintaining five-mile separation between the aircraft at the same altitude. Once the aircraft is positioned upon the final approach, the pilot will utilize existing approach facilities to align his aircraft with the runway, and the air-traffic controller will continue to monitor the position of the aircraft with respect to the other airliners in the area.

The altitude coverage of the new radar system, in normal operation with a fixed antenna tilt, is on the order of 15,000 feet. This can be increased at will by tilting the antenna so as to raise the angle of the beam. The antenna can be tilted to the desired angle by remote control from the display position of the radar setup. It is therefore possible to have radar coverage of high-flying aircraft, though at the expense of the low-angle coverage. The antenna tilt angle in use is indicated at the display position.

The peak power of the radar system in use at the Montreal airport is 250,000 watts; the system operates in the X band where the wavelength is 3 centimeters long or just a little more than one inch. The antenna's beam width in the horizontal plane is about .5 degree, resulting in high definition.

For close-range operation (less than 15 miles) the equipment can be set up to emit 2000 pulses per second, each pulse being under ten-millionths of a second in duration. For ranges above 15 miles, the pulse rate is 500 per sec-

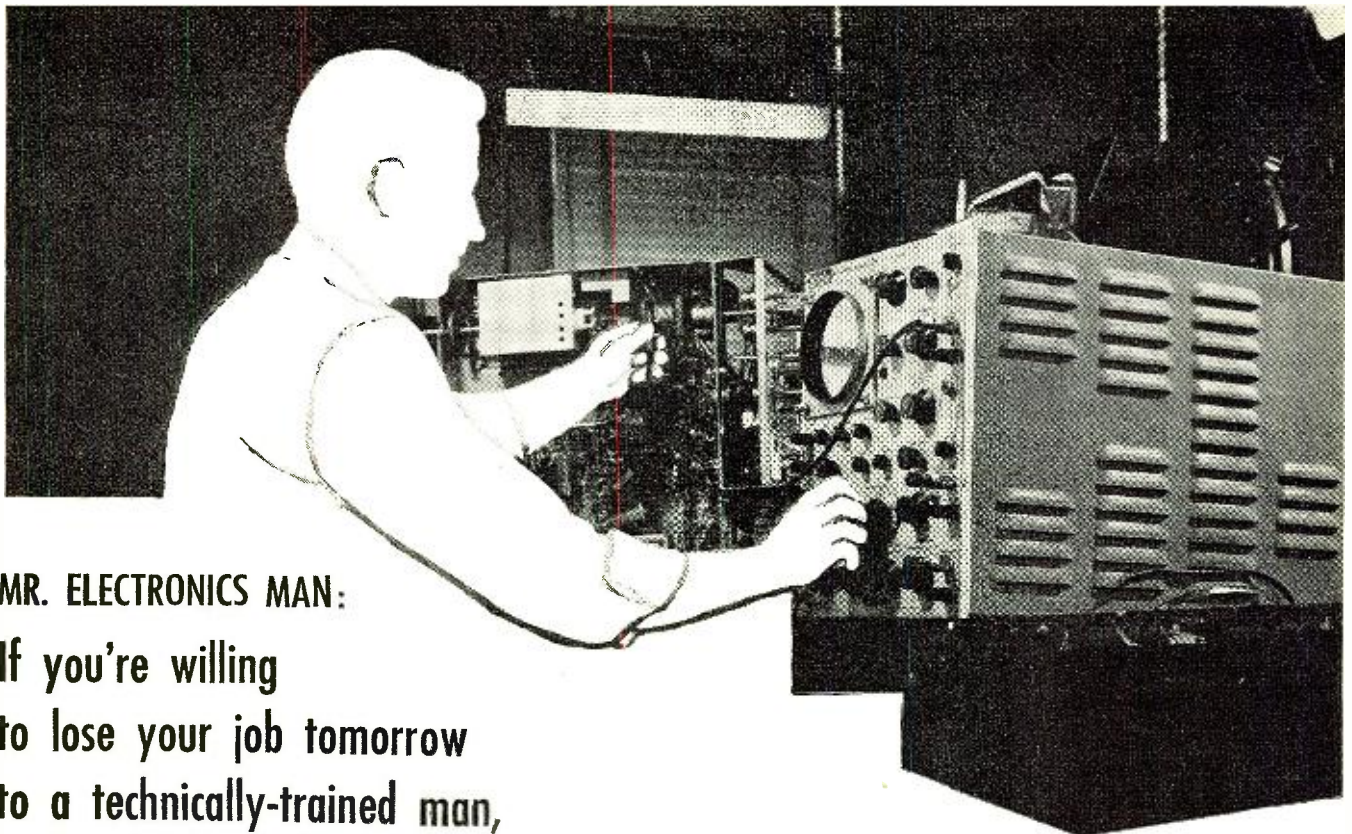

MR. ELECTRONICS MAN:

**If you're willing
to lose your job tomorrow
to a technically-trained man,
don't read this!**

But, if you're interested in an honest-to-goodness career in the vigorous young electronics industry, here's how you can step ahead of competition, move up to a better job, earn more money, and be sure of holding your technical job even if the brass is firing instead of hiring.

The "how" is CREI training in radio-television-electronics. You don't have to be a college graduate. You *do* have to be willing to study—at home. You can do it while holding down a full-time job. Thousands have. However, you must have some prior electronic experience, either in military service, professional employment, experimenting, or ham operating. Since 1927 CREI has provided alert young men with the technical knowledge that leads to more responsibility, more job security, more money. More than a quarter century of experience qualifies CREI to train you.

What qualifies *you* for CREI? If you have a high school education, you're off to a good start. If you have a knack for math, so much the better. If you are currently working in some phase of the electronics industry, you'll get going faster. But remember this: CREI starts with fundamentals and takes you along at your own speed. You are not held back by a class, not pushed to keep up with others who have more experience or education. You set your own pace. Your CREI instructors guide you through the lesson material and *grade* your written work personally. You master the fundamentals, then get into more advanced phases of electronics engineering principles and practice. Finally you may elect training at career level in highly specialized applications of radio or television engineering or aeronautical radio.

How good is CREI training? Here are a few ways to judge. Ask an

electronics engineer, if you know one. Ask a high-school or college physics teacher. As a radio station engineer. Check up on our professional reputation: CREI home study courses are accredited by the Engineers' Council for Professional Development; CREI is an approved member of the National Council of Technical Schools. Ask personnel managers how they regard a man with a CREI "ticket." Look at this partial listing of organizations that *pay CREI* to train their own personnel: United Air Lines, Canadian Broadcasting Corp., Trans-Canada Airlines, Douglas Aircraft Co., Glenn L. Martin Co., Columbia Broadcasting System, All-American Cables and Radio, Inc., Gates Radio Co., Canadair Ltd., Federal Electrical Corp., and U. S. Information Agency (Voice of America). Finally, ask a CREI graduate to tell you about our Placement Bureau, which currently has on file more requests for trained men than we can fill.

What's the next step? The logical one is to get more information than we can cram into one page. The coupon below, properly filled out, will bring you a fact-packed booklet called "Your Future in the New World of Electronics." It includes outlines of courses offered, a resume of career opportunities, full details about the school, and tuition details. It's free.

Note: CREI also offers Residence School instruction, day or evening, in Washington, D.C. New classes start frequently. If you are eligible for training under the new GI Bill of Rights, check the coupon for full information.

CAPITOL RADIO ENGINEERING INSTITUTE

ECPD Accredited Technical Institute Curricula • Founded 1927
Dept. 117-D, 3224 16th St., N. W., Washington 10, D. C.

Please send me your course outline and **FREE** illustrated Booklet "Your Future in the New World of Electronics" . . . describing opportunities and CREI home study courses in Practical Electronic Engineering Technology.

CHECK FIELD OF GREATEST INTEREST

- Electronic Engineering Technology
- Broadcast (AM, FM, TV) Engineering Technology
- Television Engineering Technology
- Aeronautical Electronic Engineering Technology

To help us answer your request intelligently, please give the following information:

EMPLOYED BY

TYPE OF PRESENT WORK

SCHOOL BACKGROUND

ELECTRONICS EXPERIENCE

Name

Street

City Zone State

CHECK: Home Study Residence School Veteran

NEW

at Ward...

REAR FIN ANTENNA

Newest, smartest, pace-setting rear fin on the market. Heavy chrome plated—3 sections extend to 27". 15-ft. lead with built-in signal booster.



MODEL NO. TFL-1

Also available as dummy mount.
—Model TFD-1

... AND HERE'S MORE!

NEW FENDER PADS ... for 1957 cars

Fender Pads—

For mounting 8-Ball mount antennas on front fenders of 1957 cars. C-61

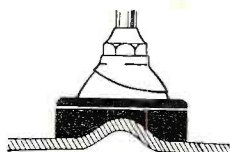

Fender Pads—

For mounting Tear Drop mounts on front fenders of 1957 cars. C-62

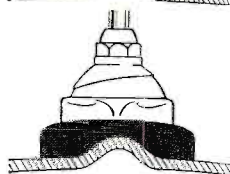

Fast-Selling Ward



Model TF-56MO

TEAR DROP MOUNT

The fastest selling style leader of them all ... the replacement antenna with original equipment styling. Mounts completely outside the car ... easily ... quickly. Heavy chrome plate ... 3 sections extend from 22" to 56".

Just a few of Ward's new quality leaders that have joined the famous Ward family—8-Ball, Majorette, and Silveramic®. Order *TODAY*. For complete information, write: Dept. RTN-7.

See us in ROOM 509A—1957 Electronics Parts Distributors Show

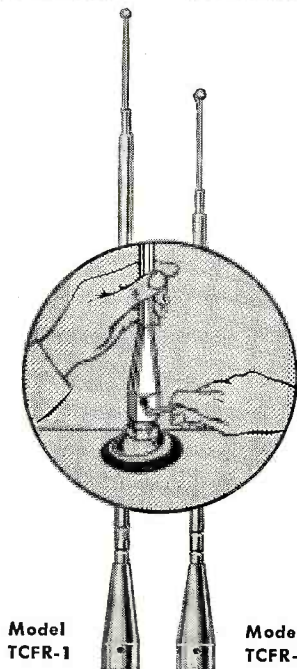

Model TCFR-1

Model TCFR-2

Smart NEW Replacement Masts

No need to disturb the mast. Just slip on and tighten. Easiest, quickest replacement ever developed. Bell-shaped collar on mast fastens to stub of original antenna mast with set screws.

Ward PRODUCTS CORPORATION

DIVISION OF THE GABRIEL COMPANY

1148 EUCLID AVE. • CLEVELAND 15, OHIO

IN CANADA, ATLAS RADIO CORPORATION • 50 WINGOLD AVE. • TORONTO, ONTARIO

ond, each two/one-millionth of a second long. The ability of the radar to employ a very short pulse and high repetition rate for short range provides a high degree of definition in the immediate area of the airport.

The receiver portion of the equipment is arranged to provide both linear and logarithmic amplification. The log characteristic is very useful in detecting aircraft in rain, where it might not be possible to detect them if only the linear characteristic were available.

WITHIN THE SCOPE of the natural English language, an infinite number of different sentence structures is possible. One might expect that some of these structures occur much more frequently than others and account for the bulk of the sentences actually used. Information about such occurrences would be of interest in many fields, scientific as well as literary, and the question has therefore often been discussed. More specifically, information is needed on the statistical frequency at which different structures occur. The complexity of this problem is such, however, that little or nothing appears to have been definitely established concerning it.

Recently, the Bureau of Standards completed a brief exploratory study of the problem with the help of an automatic digital computer (SEAC—the Standards Electronic Automatic Computer).

Although only a small sample (500 sentences) was studied, some of the results are believed sufficiently interesting to justify further investigation along the same lines. The research is being supported by the U. S. Patent Office.

PENDING THE OUTCOME of the nationwide investigation of the u.h.f. and v.h.f. channel problems, there has been little grant activity at the Commission's offices. Only a few authorizations have been issued, as the table on page 14 discloses.

THERE IS HARDLY A MONTH that passes that does not see some new electronic products developed or introduced, thus declared an industry expert recently during an address before a marketing group.

For the consumer, it was said, these developments offer the promise of a richer, fuller life—better aids to better living and the world's wealth in entertainment and culture. To business and industry, these advances mean greater efficiency and productivity.

In addition, it was noted, our national security is constantly being strengthened because of the increasingly effective electronic devices and weapons being devised to guard us on the ground, at sea, and in the air.

And industry benefits, too, as it provides these new services and makes possible the advances—advances that spell a brighter future for all. . . L. W.

RCA offers you the
 finest training
 at home in
Radio-TV
 electronics,
TV servicing,
Color TV

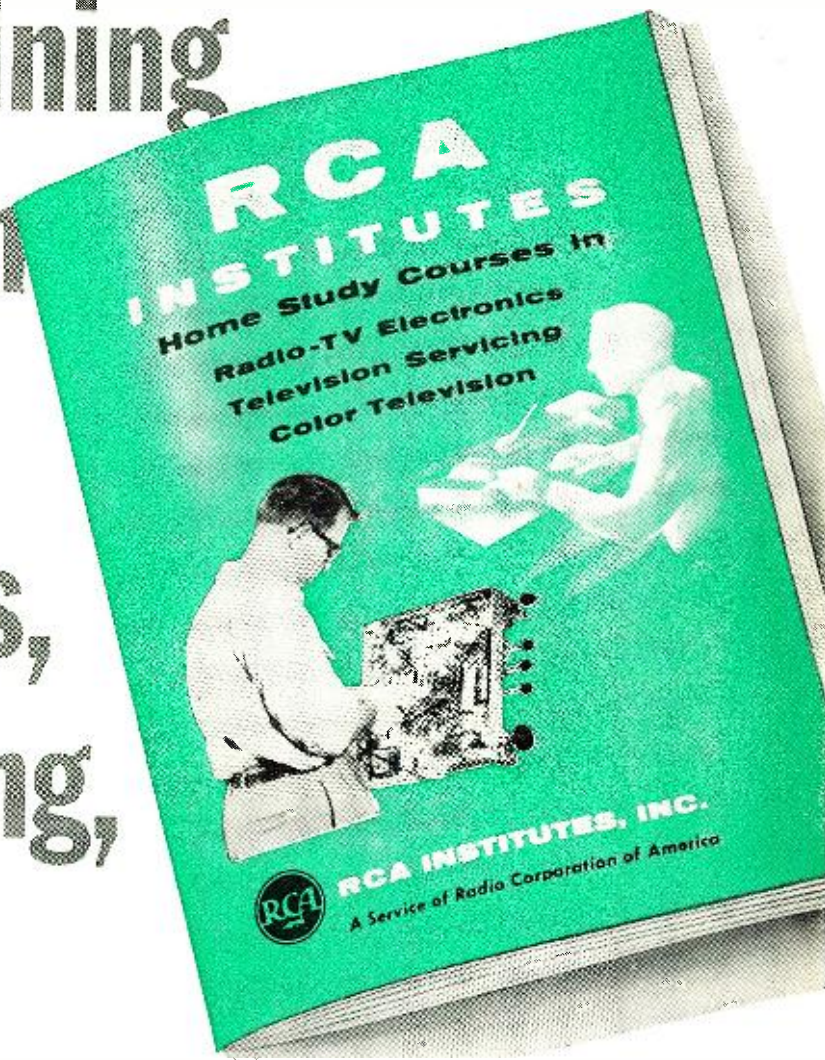

**SEND FOR THIS FREE
 BOOK NOW!**

Pay-as-you-learn. You need pay for only one study group at a time. Practical work with very first lesson. All text material and equipment is yours to keep. Courses for the beginner and advanced student.



RCA INSTITUTES, INC.
 A SERVICE OF RADIO CORPORATION of AMERICA
 350 WEST FOURTH STREET, NEW YORK 14, N.Y.
 In Canada—RCA Victor Company, Ltd.,
 5001 Cote de Liesse Rd., Montreal 9, Que.

RCA Institutes, Inc., Home Study Dept. N-77
 350 West Fourth Street, New York 14, N. Y.
 Without obligation, send me FREE 52 page CATALOG on Home Study Courses in Radio, Television and Color TV. No Salesman will call.

Name.....
 Please Print

Address.....

City..... Zone.... State.....

KOREAN VETS! Enter discharge date.....
 To save time, paste coupon on postcard



Giant over-the-horizon antenna designed by Bell Telephone Laboratories for "White Alice," Air Force Alaskan defense communications network.

*How UHF radio
got seven-league
boots*

THE huge antenna systems which project ultra-high frequency radio communications beyond the horizon began when a Bell Telephone Laboratories engineer became intrigued with a strange phenomenon. Although these radio waves were supposed to be useful only over line-of-sight distances, the waves displayed a mysterious tendency to take off in a giant stride to antennas beyond the horizon.

This phenomenon had been studied both here and abroad, but no practical use was seen until the engineer became interested and thoroughly sifted the experimental data. He came up with the stimulating conclusion that over-the-horizon transmission is far stronger and much more dependable than was generally supposed. Further he predicted that it could be utilized to supply dependable broadband communications. He and his associates at Bell Laboratories confirmed the prediction experimentally, then drew up requirements for the first over-the-horizon UHF transmission system.

This pioneer work at Bell Telephone Laboratories has greatly increased the usefulness of UHF communications. For example, over-the-horizon transmission now provides critically important communications between remote military outposts in the Arctic and in the far north.

For the Bell System it can provide important new links for telephone conversations and television.



Kenneth Bullington, B.S.E.E., University of New Mexico; M.S., Massachusetts Institute of Technology; recipient of the 1956 Morris Liebmann Memorial Prize and the 1956 Stuart Ballantine Medal for his contributions in the field of over-the-horizon ultra-high frequency radio transmission.

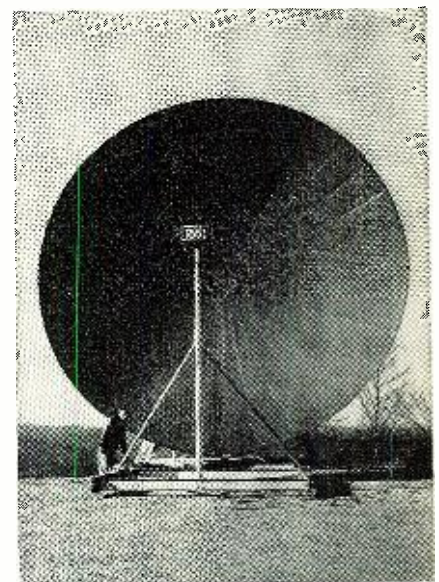

Experimental antenna used in early over-the-horizon UHF radio transmission research. Research extended transmission from 30 miles line-of-sight to 200 miles.

BELL TELEPHONE LABORATORIES



WORLD CENTER OF COMMUNICATIONS RESEARCH AND DEVELOPMENT

RADIO & TV NEWS



SPEAKERS

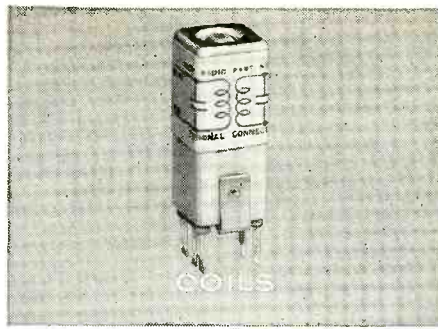

COILS

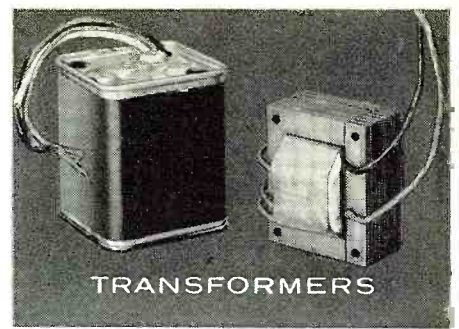

TRANSFORMERS

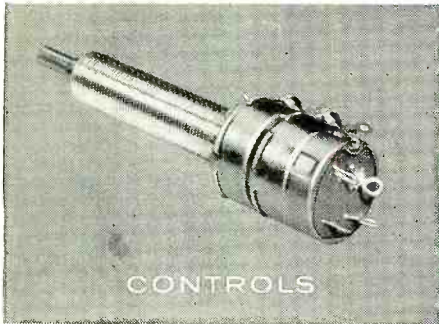

CONTROLS



TRANSISTORS

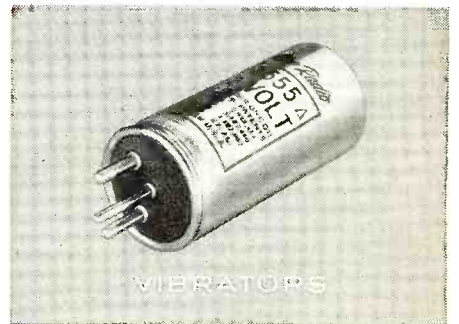

VIBRATORS

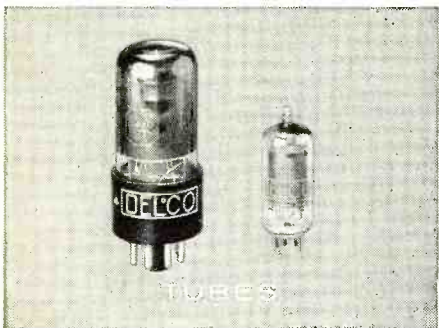

TUBES

**From
DELCO
RADIO:**



IRON CORES

a complete line of replacement parts

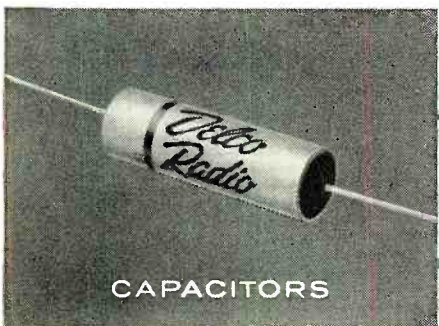

CAPACITORS



RESISTORS

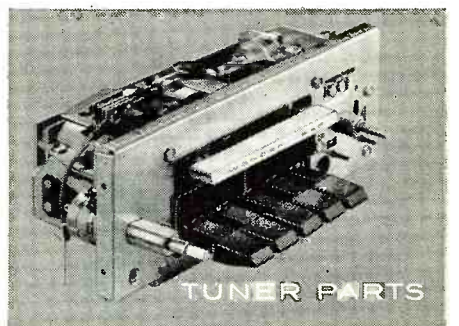

TUNER PARTS

for your Delco Radio service work!

It's one-stop service from the world leader in auto radio! Your Delco Electronic Parts Distributor gives you fast delivery on all items, *plus* a truly profitable Delco Radio independent dealer program that includes:

1. *A technical training program conducted by factory engineers.*
2. *An attractive warranty policy.*
3. *Plenty of attractive dealer identification.*

Delco Radio also offers a wide selection of Special Application Parts for your convenience and profit. Get the facts today.

DELCO



RADIO

DIVISION OF GENERAL MOTORS, KOKOMO, INDIANA



A GENERAL MOTORS PRODUCT — A UNITED MOTORS LINE
Distributed by Electronics Distributors Everywhere

GUARANTEED PERFORMANCE SPECIFICATIONS

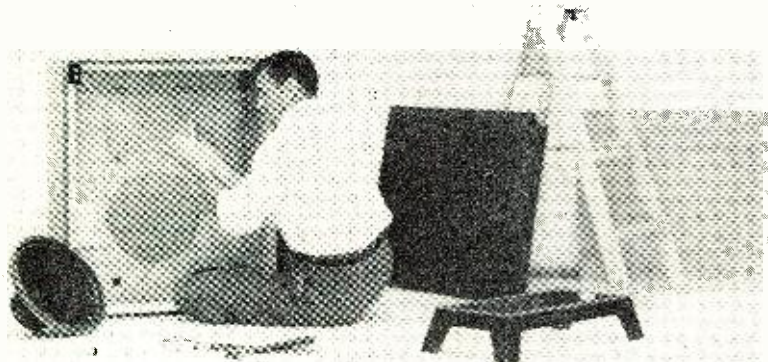

An Altec Lansing Exclusive!

802C DRIVER and 811B HORN

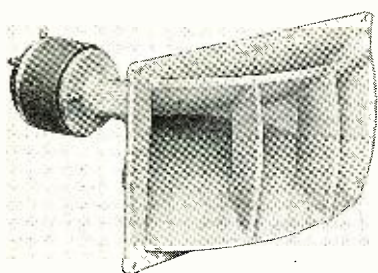

power:	30 watts
guaranteed range:	800-22,000 cycles
impedance:	16 ohms
distribution:	Hor., 90° Vert., 40°
dimensions:	8 $\frac{5}{8}$ " H; 18 $\frac{3}{8}$ " W; 16" D
price:	802—\$57.00 811—\$27.00

N-800D NETWORK



impedance:	16 ohms
hf attenuation:	4—1 db steps
crossover:	800 cycles
dimensions:	8 $\frac{1}{2}$ " H; 5 $\frac{1}{2}$ " W; 3 $\frac{1}{2}$ " D
price:	\$42.00

803A SPEAKER

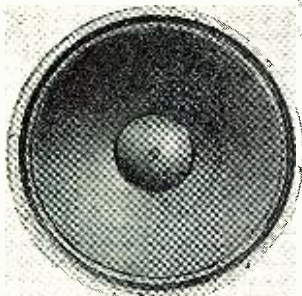

power:	30 watts
impedance:	16 ohms
guaranteed range:	30-1600 cycles
mag. weight:	2.4 lbs.
v.c. diam.:	3"
cone res.:	45 cycles
dimensions:	Diam., 15 $\frac{5}{8}$ "; Depth, 7"
price:	\$60.00

A SOUND REPUTATION SECOND TO NONE

1515 S. Manchester Ave., Anaheim, Calif.
161 Sixth Avenue, New York 13, New York



Membership comprises two representatives each from advertising and promotion managers of Institute members, sales executives of member companies, technical press, and member advertising agencies serving member clients.

* * *

ROBERT J. BROWN has been named sales manager for the *Mincom Division of Minnesota Mining and Manufacturing Company.*



In 1954 Mr. Brown joined the electronics division of *Bing Crosby Enterprises*, predecessor company of this division. Previously he had been engaged in electronics sales for *International Business Machines Corp.* A graduate electronics engineer, he worked in an engineering capacity at *Bendix Aviation Corp.* and *Sperry Gyroscope Co.*

Formerly assistant sales manager of this division, he will operate from its new headquarters at 11701 Mississippi Avenue, West Los Angeles, Calif.

* * *

COLORADO RESEARCH CORPORATION, a subsidiary of **CARRIER CORPORATION**, plans to move into a new, one-story laboratory and office building in Broomfield Heights, 15 miles northwest of Denver. Occupancy is scheduled before the end of the year . . . The general sales offices of the **SENTINEL RADIO COMPANY** are relocated at 2131 Bueter Road, Fort Wayne, Indiana . . . Construction has begun on a new facility at the Waltham Laboratories of **SYLVANIA ELECTRIC PRODUCTS INC.** for expanded research and development in missile systems. The new 40,000 square foot building is scheduled for completion in October . . . **ZENITH RADIO CORPORATION OF CALIFORNIA**, a wholly owned subsidiary of **ZENITH RADIO CORPORATION**, announces the relocation of its general offices to 3107 Wilshire Boulevard, Los Angeles, Calif. . . . **COMMUNICATION DEVICES COMPANY** announces the removal of its offices and laboratories to a newly equipped building at 269 East Shore Road, Great Neck, Long Island, N. Y. . . . Construction is under way on an ultramodern manufacturing and repair plant for the **WESTINGHOUSE ELECTRIC CORPORATION** at Compton, Calif. The concrete and steel building, which is expected to be completed by November, is located on a seven-acre site in the Rancho San Pedro industrial area. The building will have 80,000 square feet of plant area, and 8000 square feet of office space . . . A midwestern regional office located in the Palmolive Building, 919 North Michigan Ave., Chicago, Ill., has been established by the computer division of **BENDIX AVIATION CORPORATION** . . . Approximately 40,000 square feet of manufacturing and warehouse space have been added to the **SEL-SON ELECTRONIC TUBE CORP.** plant in Darby, Penna. . . . **TRACERLAB, INC.** has dedi-

RADIO & TV NEWS

WE TRADE HIGHER!

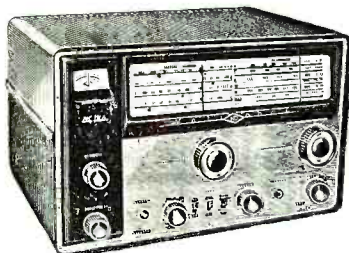

NATIONAL NC-188 RECEIVER.
Less speaker. Net.....\$159.95



HALLCRAFTERS SX-100 RECEIVER.
Less speaker. Net.....\$295.00

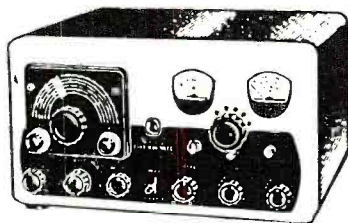

JOHNSON "500" TRANSMITTER.
Kit Form. Net.....\$699.50
Wired and Tested. Net.....\$879.50

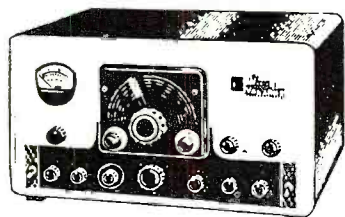

JOHNSON VALIANT TRANSMITTER
Kit Form. Net.....\$349.50
Wired and Tested. Net.....\$439.50



SPARKY SAYS
HEY! LOOK!
HOW ABOUT THIS?



20A

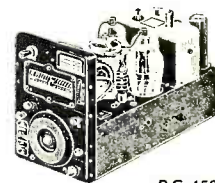

BC-458

BUY THIS PACKAGE DEAL AND GET A
BRAND NEW BC-458 FOR ONLY 50¢

PACKAGE NO. 1

Central Electronics 20A in kit form	\$ 199.50
BC-458 conversion kit	15.00
Deluxe case and panel kit	10.00
BC-458 - BRAND NEW	.50
OUR SPECIAL PRICE	\$ 225.00

PACKAGE NO. 2

Central Electronics 20A in wired form	\$ 249.50
BC-458 conversion kit	15.00
Deluxe case and panel kit	10.00
BC-458 - BRAND NEW	.50
OUR SPECIAL PRICE	\$ 275.00

WE OFFER YOU ALL THIS

- ▶ **HIGHER TRADES**
- ▶ **EASIER TERMS**
- ▶ **FREE CATALOG**
- ▶ **SWIFTER SERVICE**
- ▶ **AN HONEST DEAL**

WRITE FOR FULL DETAILS ABOUT OUR TIME PAYMENT PLAN

All prices f. o. b. St. Louis • Phone CHestnut 1-1125



WALTER ASHE RADIO COMPANY
1125 Pine Street, St. Louis, Mo.

OUR 35TH YEAR

Rush "Surprise" Trade-In Offer on my.....
for.....
(show make and model of new equipment desired) RN 7-57

Send NEW 1957 Walter Ashe catalog.

Name.....
Address.....
City..... Zone..... State.....

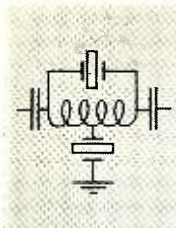

From this exclusive **HIGH FREQUENCY** filter originates the cleanest signal on the air!



Hallicrafters new HT-32 transmitter features 5.0 mc. quartz crystal filter...new bridged-tee modulator...high stability...gear-driven V.F.O.

• Forget your old ideas about SSB signal clarity! The HT-32 establishes *entirely new standards* with two major achievements of the world famous Hallicrafters laboratories—yours exclusively in the HT-32:

1. 5-0 mc. quartz crystal filter. Result of a 3-year research program, the crystal filter system now is commercially practical at *high frequencies*. System cuts unwanted sideband 50 db. or more!
2. New bridged-tee modulator. Temperature stabilized and compensated network provides carrier suppression *in excess of 50-db*. Patented diode application develops sideband energy from audio voltage. World's most stable modulator.

These and many other features make your decision *clear*—compare the HT-32 with any other transmitter available. Your supplier has all the details. Stop by and see him today.

ADDITIONAL FACTS ABOUT THE HT-32

- SSB, AM or CW output on 80, 40, 20, 15, 11-10 meter bands.
- High-stability, gear-driven V.F.O.
- 144 watts peak power input.
- Distortion products down 30 db or more.
- Complete band switching.
- P.T.O. direct reading in kilocycles.
- C.V.I. suppressed.



Available with convenient terms from your Radio Parts Distributor.

cated an ultramodern building in Waltham, Mass., thus consolidating its east coast operations under one roof . . . **BRUSH ELECTRONICS COMPANY** has established a factory branch office at 1960 South LaCienega Blvd., Los Angeles, Calif. . . . The electronic products sales department of **SYLVANIA ELECTRIC PRODUCTS INC.** has consolidated its east central and central equipment sales regions into a single area to be known as the mid-western equipment sales region with headquarters in Melrose Park, Ill. In addition, this company has broken ground at Amherst, N. Y. for a new multi-million-dollar research and development center for the company's electronic systems division. Completion of the 100,000 square foot building is scheduled for February, 1958.

* * *

HUGO SUNDBERG has been elected by the board of directors of *Oxford Electric Corporation* as president and member of the board. He succeeds Mr. Joseph D. Ceader, who was elected chairman of the board.



Mr. Sundberg has been in the electronic, radio, television, and allied fields for many years and is well-known throughout the industry for his knowledge of manufacturing and merchandising of electronic components, including speakers and transformers.

Prior to his election, he had been vice-president and general manager of the firm and its subsidiaries.

* * *

PAUL JACKSON, president of *Jackson Electrical Instrument Company* of Dayton, Ohio, died after an extended illness.

Mr. Jackson was a pioneer in the manufacture of test equipment for the radio and television servicing industry. The business which bears his name was incorporated in 1933 to manufacture tube testers and other equipment.

Mr. Jackson also held many patents in the field.

* * *

RADIO - ELECTRONICS - TELEVISION MANUFACTURERS ASSOCIATION'S Trade Show Survey Committee is studying the effectiveness and the utility of the constantly increasing number of trade shows in the electronics industry.

A questionnaire asks RETMA members the number of trade shows in which they have participated during 1955 and 1956. Among other things, it also seeks to determine the number of shows or exhibits in which individual companies took part during the same period. The survey is aimed at determining the cost to manufacturers of these exhibits and their opinion as to the value of trade shows.

The questionnaire represents the first of a series of activities planned by the committee which views with

(Continued on page 106)

NEW! 12-WATT Williamson-type HIGH FIDELITY INTEGRATED AMPLIFIER HF12 with Preamplifier, Equalizer & Control Section



KIT \$34⁹⁵ WIRED \$57⁹⁵

Compact, beautifully packaged & styled. Provides complete "front-end" facilities and true high fidelity performance. Direct tape head & magnetic phono inputs with NARTB (tape) & RIAA (phono) feedback equalizations. 6-tube circuit, dual triode for variable turnover bass & treble feedback-type tone controls. **Output Power:** 12 w cont., 25 w pk. **IM Dist.** (60 & 6000 cps @ 4:1): 1.5% @ 12 w; 0.55% @ 6 w; 0.3% @ 4 w. **Freq. Resp.:** 1 w: ± 0.5 db 12 cps - 50 kc; 12 w: ± 0.5 db 25 cps - 20 kc. **Harmonic Dist:** 20 cps: 2% @ 4.2 w; 1/2% @ 2.5 w; 30 cps: 2% @ 11 w; 1/2% @ 6.3 w; 40 cps: 1% @ 12 w; 1/4% @ 9.3 w; 2000 cps: 1/2% @ 12 w; 10 kc: 1% @ 10 w; 1/2% @ 6 w. **Transient Resp:** excellent square wave reproduction (4 usec rise-time); negligible ringing, rapid settling on 10 kc square wave. **Inverse Feedback:** 20 db. **Stability Margin:** 12 db. **Damping Factor:** above 8, 20 cps - 15 kc. **Speaker Connections:** 4, 8, 16 ohms. **Tone Control Range:** @ 10 kc, ± 13 db; @ 50 cps, ± 16 db. **Tubes:** 2-ECC83/12AX7, 1-ECC82/12AU7, 2-EL84, 1-EZ81. **Size:** HWD: 3 5/8" x 12" x 8 1/4". 13 lbs. **COMING SOON**

NEW! 50-WATT Ultra-Linear HIGH FIDELITY POWER AMPLIFIER

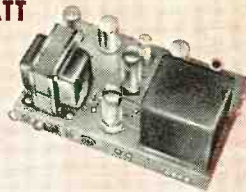

HF50 KIT \$57⁹⁵ WIRED \$87⁹⁵

Like the HF60 shown below, the HF50 features virtually absolute stability, flawless transient response under either resistive or reactive (speaker) load, & no bounce or flutter under pulsed conditions. Extremely high quality output transformer with extensively interleaved windings, 4, 8, & 16 ohm speaker connections, grain-oriented steel, & fully potted in seamless steel case. Otherwise identical to HF60. **Output Power:** 50 w cont., 100 w pk. **IM Distortion** (60 & 6000 cps @ 4:1): below 1% at 50 w; 0.5% @ 45 w. **Harmonic Dist.:** below 0.5% between 20 cps & 20 kc within 1 db of rated power. **Freq. Resp.:** at 1 w: ± 0.5 db 6 cps - 60 kc; ± 0.1 db 15 cps - 30 kc at any level from 1 mw to rated power; no peaking or raggedness outside audio range. All other specs identical to HF60 below. Matching Cover E-2 \$4.50.

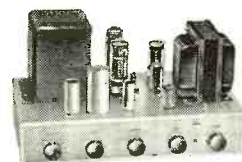

NEW! 50-WATT Ultra-Linear HIGH-FIDELITY

INTEGRATED POWER AMPLIFIER HF52 with Preamplifier, Equalizer & Control Section

KIT \$69⁹⁵ WIRED \$109⁹⁵

Combines a power amplifier section essentially identical to the HF50 power amplifier with a preamp-equalizer control section similar to HF20 below. Provision for use with electronic crossover network & additional amplifier(s). See HF50 for response & distortion specs; HF60 for square wave response, rise-time, inverse feedback, stability margin, damping factor, speaker connections; HF20 for preamplifier, equalizer & control section description. Hum & noise 60 db below rated output on magnetic phono input (8 mv input for rated output), & 75 db below rated output on high level inputs (0.6 v input for rated output). Matching Cover E-1 \$4.50.

The specs are the proof... 7 NEW BEST BUYS by



HIGH FIDELITY PREAMPLIFIER

#HF61A KIT \$24⁹⁵, WIRED \$37⁹⁵

With Power Supply: #HF61 KIT \$29⁹⁵, WIRED \$44⁹⁵

Will not add distortion or detract from the wide-band or transient response of the finest power amplifiers at any control settings. High quality feedback circuitry throughout plus the most complete control & switching facilities. Heavy-gauge solid brushed brass panel, concentric controls, one-piece brown enamel steel cabinet for lasting attractive appearance. Feedback-type, sharp cut-off (12 db/octave) scratch & rumble filters. Low-distortion feedback equalization: 5 most common recording curves for LPs & 78s including RIAA. Low-distortion feedback tone controls: provide large boost or cut in bass or treble with mid-freqs & volume unaffected. Centralab printed-circuit Senior "Compentrol" loudness control with concentric level control. 4 hi-level switched inputs (tuner, tv, tape, aux.) & 3 low-level inputs (separate front panel low-level input selector permits concurrent use of changer & turntable). Proper pick-up loading & attenuation provided for all quality cartridges. Hum bal. control. DC superimposed on filament supply. 4 convenience outlets. Extremely flat wideband freq. resp.: ± 1 db 8-100,000 cps; ± 0.3 db 12-50,000 cps. Extremely sensitive. Negligible hum, noise, harmonic or IM distortion. **Size:** 4-7/8" x 12-5/16" x 4-7/8". 8 lbs.

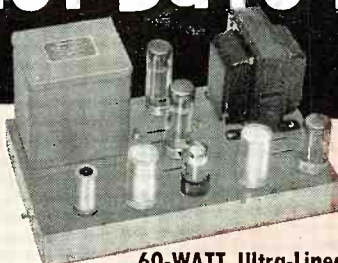

60-WATT Ultra-Linear

HIGH FIDELITY POWER AMPLIFIER #HF60 with ACRO TO-330 OUTPUT TRANSFORMER

KIT \$72⁹⁵ WIRED \$99⁹⁵

Superlative performance, obtained through finest components & circuitry. EF86 low-noise voltage amplifier direct-coupled to 6SN7GTB cathode coupled phase inverter driving a pair of Ultra-Linear connected push-pull EL34 output tubes operated with fixed bias. **Rated power output:** 60 w (130 w peak). **IM Distortion** (60 & 6000 cps @ 4:1): less than 1% at 60 w; less than 0.5% at 50 w. **Harmonic Distortion:** less than 0.5% at any freq. between 20 cps & 20 kc within 1 db of 60 w. **Sinusoidal Freq. Resp.:** at 1 w: ± 0.5 db 5 cps - 100 kc; ± 0.1 db 15 cps to 35 kc at any level from 1 mw to rated power; no peaking or raggedness outside audio range. **Square Wave Resp.:** excellent from 20 cps to 25 kc, 3 usec rise-time. **Sensitivity:** 0.55 v for 60 w. **Damping Factor:** 17. **Inverse Feedback:** 21 db. **Stability Margin:** 16 db. **Hum** 90 db below rated output. **ACRO TO-330 Output Transformer** (fully potted). **Speaker Taps:** 4, 8, 16 ohms. GZ34 extra-rugged rectifier (indirectly-heated cathode eliminates high starting voltage on electrolytics & delays B+ until amplifier tubes warm up). **Input level control.** Panel mount fuse holder. Both bias and DC - balance adjustments. Std octal socket provided for pre-amplifier power take-off. **Size:** 7" x 14" x 8". 30 lbs. Matching cover Model E-2 \$4.50.



COMPLETE with Preamplifier, Equalizer & Control Section 20-WATT Ultra-Linear Williamson-Type HIGH FIDELITY AMPLIFIER #HF-20

KIT \$49⁹⁵ WIRED \$79⁹⁵

A low-cost, complete-facility amplifier of the highest quality that sets a new standard of performance at the price, kit or wired. **Rated Power Output:** 20 w (34 w peak). **IM Distortion** (60 & 6000 cps @ 4:1) at rated power: 1.3%. **Max. Harmonic Distortion** between 20 & 20,000 cps at 1 db under rated power: approx. 1%. **Mid-band Harmonic Distortion** at rated power: 0.3%. **Power Response** (20 w): ± 0.5 db 20-20,000 cps; ± 1.5 db 10-40,000 cps. **Freq. Resp.** (1/4 w): ± 0.5 db 13-35,000 cps; ± 1.5 db 7-50,000 cps. 5 feedback equalizations for LPs & 78s. **Low-distortion feedback tone controls:** large boosts or cuts in bass or treble with mid-freqs. & volume unaffected. **Loudness control** & separate level set control on front panel. **Low Z output** to tape recorder. 4 hi-level switched inputs: tuner, tv, tape, aux.; 2 low-level inputs for proper loading with all cartridges. **Hum bal. control.** DC superimposed on filament supply. **Extremely fine output transformer:** interleaved windings, tight coupling, careful balancing, grain-oriented steel. 8 1/2" x 15" x 10". 24 lbs. Matching cover Model E-1, \$4.50.

NEW COMPLETE with FACTORY-BUILT CABINET - 2-WAY HI-FI SPEAKER SYSTEM #HF51 \$39⁹⁵

See the "BEST BUYS" NOW IN STOCK at your nearest distributor. Fill out coupon on other side for FREE CATALOG.

Prices 5% higher on West Coast.



Genuine 2-way book-shelf size speaker system. **Jensen** heavy duty 8" woofer (6.8 oz. magnet) & matching **Jensen** compression-driver exponential horn tweeter with level control. Smooth clean bass & crisp extended highs free of coloration or artificial brilliance. **Factory-built** tuned bass reflex birch hardwood cabinet (not a kit) constructed to high quality standards. Neutral acoustical grille cloth framed by a smooth-sanded solid birch molding. **Freq. Resp.** measured 2 ft. away on principal axis in anechoic chamber with 1 watt input - **Woofer:** ± 1 db 80-1800 cps; **Tweeter:** ± 2 db 2800-10,000 cps; **Crossover Region:** 1800-2800 cps, shift in level over this region depends on tweeter level control setting. **Power-handling capacity:** 25 watts. **Size:** 23" x 11" x 9". 25 lbs. **Wiring Time:** 15 min.



84 Withers Street, Brooklyn 11, N. Y.

Turn page for other EICO ad.

the specs prove it . . .
your **BEST BUY** is

EICO®

for COLOR & Monochrome TV servicing

FREE CATALOG

shows you **HOW TO SAVE 50%**
on 50 models of top quality
professional test equipment.
MAIL COUPON NOW!



NEW!
TV-FM SWEEP
GENERATOR &
MARKER #368

KIT \$69⁹⁵ WIRED \$119⁹⁵

Entirely electronic sweep circuit (no mechanical devices) with accurately-biased inductor for excellent linearity. Extremely flat RF output; new AGC circuit automatically adjusts osc. for max. output on each band with min. ampl. variations. Exceptional tuning accuracy: edge-lit hairlines eliminate parallax. Sweep Osc. Range 3-216 mc in 5 fund. bands. Variable Marker Range 2-75 mc in 3 fund. bands; 60-225 mc on harmonic band. 4.5 mc Xtal Marker Osc., xtal supplied. Ext. Marker provision. Sweep Width 0-3 mc lowest max. deviation to 0-30 mc highest max. dev. 2-way blanking. Narrow range phasing. Attenuators: Marker Size, RF Fine, RF Coarse (4-step decade). Cables: output, scope horiz., scope vertical. Deep-etched satin aluminum panel; rugged grey wrinkle steel cabinet.

**NEW! RF
SIGNAL GENERATOR
#324**

KIT \$26⁹⁵ WIRED \$39⁹⁵



150 kc to 435 mc with ONE generator! Better value than generators selling at 2 or 3 times its cost! Ideal for IF-RF alignment, signal tracing & trouble-shooting of TV, FM, AM sets; marker gen.: 400 cps audio testing; lab. work. 6 fund. ranges: 150-400 kc, 400-1200 kc, 1.2-3.5 mc, 3.5-11 mc, 11-37 mc, 37-145 mc; 1 harmonic band 111-435 mc. Freq. accurate to ±1.5%; 6:1 vernier tuning & excellent spread at most important alignment freqs. Etched tuning dial, plexiglass windows, edge-lit hairlines. Colpitts RF osc. directly plate-modulated by K-follower for improved mod. Variable depth of int. mod. 0-50% by 400 cps Colpitts osc. Variable gain ext. amplifier: only 3.0 v needed for 30% mod. Turret-mounted coils slug-tuned for max. accuracy. Fine & Coarse (3-step) RF attenuators. RF output 100,000 uW; AF sine wave output to 10 v, 50-ohm output Z. 5-way jack-top binding posts for AF in/out; coaxial connector & shielded cable for RF out. 12AU7, 12AV7, selenium rectifier; xmfr-operated. Deep-etched satin aluminum panel; rugged grey wrinkle steel cabinet.

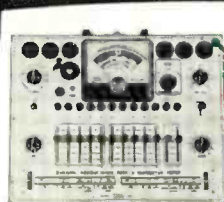

**NEW! DYNAMIC
CONDUCTANCE
TUBE & TRANSISTOR
TESTER #666**
KIT \$69⁹⁵ WIRED \$109⁹⁵

COMPLETE with steel cover and handle.

SPEED, ease, unexcelled accuracy & thoroughness. Tests all receiving tubes (and picture tubes with adapter). Composite indication of Gm, Gp & peak emission. Simultaneous sel of any 1 of 4 combinations of 3 plate voltages, 3 screen voltages, 3 ranges of continuously variable grid voltage (with 5% accurate pot). New series-string voltages: for 600, 450, 300 ma types. Sensitive 200 ua meter. 5 ranges meter sensitivity (1% shunts & 5% pot). 10 SIX-position lever switches: freepoint connection of each tube pin. 10 pushbuttons: rapid insert of any tube element in leakage test circuit & speedy sel. of individual sections of multi-section tubes in merit tests. Direct-reading of inter-element leakage in ohms. New gear-driven rollechart. Checks n-p-n & p-n-p transistors: separate meter readings of collector leakage current & Beta using internal dc power supply. Deep-etched satin aluminum panel; rugged grey wrinkle steel cabinet. CRA Adapter \$4.50



NEW!
COLOR
and Monochrome
DC to 5 MC LAB & TV
5" OSCILLOSCOPE
#460

KIT \$79⁹⁵ WIRED \$129⁵⁰

• Features DC Amplifiers!

Flat from DC-4.5 mc, usable to 10 mc. VERT. AMPL.: sens. 25 rms mv/in; input Z 3 megs; direct-coupled & push-pull thruout; K-follower coupling bet. stages; 4-step freq-compensated attenuator up to 1000:1. SWEEP: perfectly linear 10 cps-100 kc (ext. cap. for range to 1 cps); preset TV V&H positions; auto. sync. ampl. & lim. PLUS: direct or cap. coupling; bal or unbal. inputs; edge-lit engraved lucite graph screen; dimmer; filter; bezel fits std photo equip. High intensity trace CRT. 0.06 usec rise time. Push-pull hor. ampl., flat to 400 kc, sens. 0.6 rms mv/in. Built-in volt. calib. Z-axis mod. Sawtooth & 60 cps outputs. Astig. control. Retrace blanking. Phasing control.



**NEW! PEAK-TO-PEAK
VTM #232 & UNI-
PROBE (pat. pend.)**

KIT \$29⁹⁵ WIRED \$49⁹⁵

Half-turn of probe tip selects DC or AC Ohms.

Uni-Probe - exclusive with EICO - only 1 probe performs all functions!

Latest circuitry, high sensitivity & precision, wide ranges & versatility. Calibration without removing from cabinet. New balanced bridge circuit. High Z input for negligible loading. 4 1/2" meter, can't burn-out circuit. 7 non-skip ranges on every function. 4 functions: ±DC Volts, -DC Volts, AC Volts, Ohms. Uniform 3 to 1 scale ratio for extreme wide-range accuracy. Zero center. One zero-adj. for all functions & ranges. 1% precision ceramic multiplier resistors. Measure directly peak-to-peak voltage of complex & sine waves: 0-4, 14, 42, 140, 420, 1400, 4200. DC/RMS sine volts: 0-1.5, 5, 15, 50, 150, 500, 1500 (up to 30,000 v with HVP probe & 250 mc with PRF probe). Ohms: 0.2 ohms to 1000 megs. 12AU7, 6AL5, selenium rectifier; xmfr-operated. Deep-etched satin aluminum panel, rugged grey wrinkle steel cabinet.



5" PUSH-PULL
OSCILLOSCOPE
#425
KIT \$44.95
Wired \$79.95



7" PUSH-PULL
OSCILLOSCOPE
#470
KIT \$79.95
Wired \$129.50

Pix Tube Test Adapter \$4.50



Sep. volt-
meter &
ammeter

KIT
\$29.95
Wired
\$38.95

6V & 12V BATTERY ELIMINATOR &
CHARGER #1050



Sep. hi-gain RF
& lo-gain audio
inputs.
Special noise
locator. Calibra-
ted wattmeter.

KIT \$24.95
Wired \$39.95

DELUXE MULTI-SIGNAL TRACER #147



20,000 Ohms/Volt
MULTIMETER #565
KIT 24.95
Wired 29.95

1000 Ohms/Volt
MULTIMETER
#536
KIT \$12.90
Wired \$14.90



Reads 0.5 ohms
-500 megs, 10
mmfd-5000 mfd,
power factor.

KIT
\$19.95
Wired
\$29.95

R-C BRIDGE & R-C-L COMPARATOR
#950B



VTVM PROBES	KIT	Wired
Peak-to-Peak	\$4.95	\$6.95
RF	\$3.75	\$4.95
High Voltage Probe-1		\$6.95
High Voltage Probe-2		\$4.95

SCOPE PROBES	KIT	Wired
Demodulator	\$3.75	\$5.75
Direct	\$2.75	\$3.95
Low Capacity	\$3.75	\$5.75

TURN PAGE
FOR MORE
EICO VALUES

EICO®

Send for
FREE CATALOG
now

EICO, Brooklyn 11, N.Y. R-7

Show me **HOW TO SAVE 50%** on Test Equipment and Hi-Fi. Send me **FREE Catalog** and name of neighborhood distributor.

Name.....
Address.....
City..... Zone..... State.....

Prices 5% higher on West Coast

BROOKLYN 11, N.Y.

Tracking the Man-Made Satellite

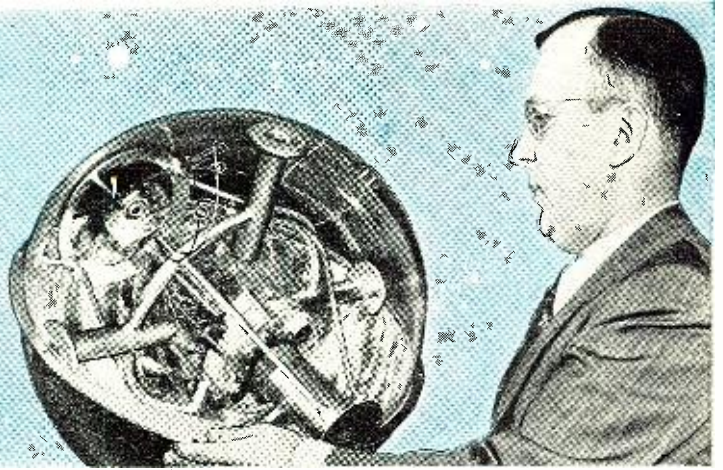

Dr. John P. Hagen, director of "Project Vanguard," is shown here with a full-scale cutaway model of the earth satellite designed by scientists working under his direction at the Naval Research Laboratory in Washington, D. C. The instrumentation shown inside includes telemetering equipment which will transmit a radio signal to earth after satellite has been sent into space. Information is then relayed to computer.

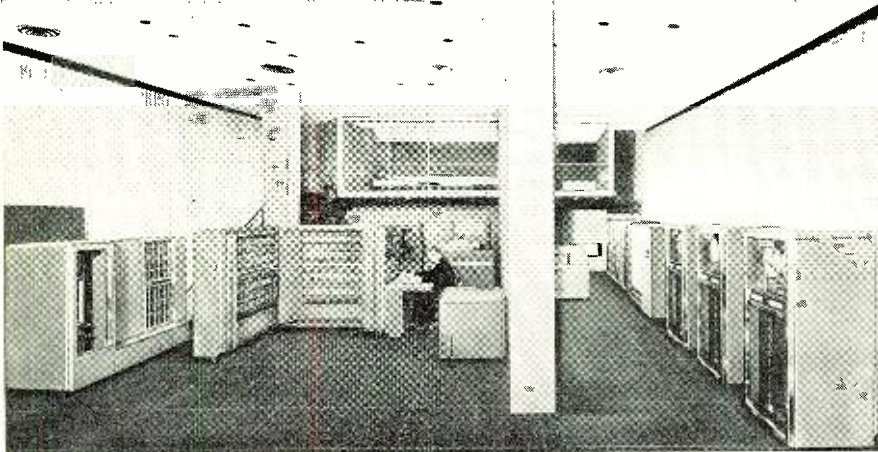

Over-all view of the IBM 704 Electronic Data Processing Machine which will calculate and predict the course of the earth satellite at tremendous speeds. This installation has been made at the "Project Vanguard" Computing Center in Washington, D. C. Radio signals emitted by the satellite will be relayed to this Center, where machine will process the information and compute sphere's orbit.

By **MAX GUNTHER**

A complex and elaborate "recording system" will be used to keep track of the tiny sphere after it is launched in space.

SOME time during the International Geophysical Year that begins July 1, 1957, there will culminate one of the most ambitious experiments—and certainly the best-publicized—in all scientific history. From the Patrick Air Force Missile Test Center on Cape Canaveral, Florida, a tiny, man-made moon will be launched. It will be carried by rocket to a height of 200 to 300 miles, then pushed horizontally to a speed of 17,000 to 18,000 miles an hour. If all goes well, it will then settle itself in an elliptical orbit around the earth, there to stay for several weeks, or perhaps a year, or perhaps even longer. Science will have taken its first major step into outer space.

Nobody has ever tried anything like this before; hundreds of uncontrollable variables make the outcome of the experiment impossible to predict. One of the largest imponderables is the path that the satellite will take. At this stage of the moon-making art, it is impossible to control or foretell the exact speed of the satellite, its height above the earth's surface, the inclination of its orbit to the equator, or the orbit's

shape. Thus, the tiny globe, measuring less than two feet in diameter, could easily become lost to view in the sky like a toy boat misplaced in the Atlantic Ocean.

To forestall any such comi-tragic ending to the experiment, scientists plan to make wide use of electronic tracking and computing equipment. At the heart of all satellite-watching operations will be the fastest large-scale digital computer manufactured by *International Business Machines Corporation*—the "704" Electronic Data Processing Machine.

The 704 computer installation will be housed in Washington, D. C., in a large building already beginning to fill up with equipment. This equipment will include not only a central data-processing or calculation unit, but also a platoon of subsidiary units to handle such functions as printing, reading, recording, and conversion from one form of data-input (such as punch cards) to another (for example, magnetic tape). This high-powered installation will be served by its own power supply. It will also have its own air-conditioning

system to carry off the heat it generates in operation.

Heading the staff of the computer installation will be Dr. Paul Herget, noted astronomer who is director of the Cincinnati Observatory and a consultant to the Naval Research Laboratory. Dr. Herget is familiar with *IBM* equipment, having used the 704 computer's forerunner, the 701, in a widely applauded planet-tracking operation two years ago. By carefully computing the orbit of a minor planet named "Athalia," which had been discovered by astronomers and subsequently lost again, Dr. Herget and the 701 pointed to the precise spot in the sky where "Athalia" ought to be. It was.

To understand how the Vanguard Computing Center will operate, it is useful to know exactly where it fits into the satellite program as a whole. Like numerous other International Geophysical Year (IGY) programs, the satellite experiment is designed for the specific purpose of expanding scientific knowledge of the earth. Scholars and scientists in many fields will observe the satellite, gleaming information from it on such subjects as solar radiation, cosmic rays, meteors, the earth's gravitational field and atmosphere. The actual launching of the moon, a task dubbed "Project Vanguard" because it must precede all other parts of the satellite program, will be carried out by the U. S. Army, Navy, and Air Force, under general Navy management. The launching has been made a military responsibility simply because the military services have had more practice than anyone else in building and firing rockets.

Three rocket stages with a length of 72 feet and a maximum diameter of 45 inches are expected to put the man-made moon in its orbit. The first stage, a Viking-like rocket carrying several

tons of liquid fuel, will push the satellite up to a height of 35 to 40 miles. The second stage, also a liquid-fueled rocket and probably—like the first stage—controlled from the ground, will blast upward to 130 or 140 miles, reaching a speed of more than 10,000 miles an hour. After the second-stage fuel burns out, the momentum of the assembly is expected to carry it somewhere between 200 and 300 miles above the earth. The second-stage rocket hull will be jettisoned, and the third stage will begin to fire.

Now an extremely critical set of maneuvers will take place. They will not be controllable from the ground, but will depend entirely on pre-set automatic devices. These devices are counted on to direct the final rocket on a course roughly parallel with the earth's surface, and to hold it on that course until it reaches a speed as near as possible to the desired 17,000-plus miles per hour.

Finally, the satellite will be ejected from the rocket to travel space on its own. Like the natural moon, it will be held in its orbit by a compromise of centrifugal force and the earth's gravity. The shape of the orbit will be determined by the direction and speed at which it leaves the last rocket. Too great a deviation from the desired speed and direction will result in the satellite's (1) cutting down into the top layers of atmosphere, where friction will cause it to disintegrate in white heat like a meteor; or (2) establishing an orbit that carries it so far away from the earth as to make effective observation extremely difficult or virtually impossible.

If all goes as planned, the artificial moon will settle into an orbit somewhere between these extremes. It will travel in the same general direction as the earth's rotation, most probably at an inclination of 30 to 45 degrees to the equator. Thus, it will be seen to rise in the west and set in the east. It is expected to circle the earth roughly once every one and one-half hours. Scientists assume that, unlike the natural moon, it will meet just enough resistance from air and other particles to slow it down gradually, until finally it drops into denser atmosphere and burns up.

Since the satellite's orbit cannot be predicted prior to the launching, there is no way in which observers can be told now where to look for it in the sky. The tiny moon may be visible for brief periods under certain conditions at dawn and dusk, when it reflects the sun's rays at just the right angle, but this cannot be counted on as a foolproof way to keep track of the satellite. Some means must be provided to keep it under continuous observation. This is where the electronic computer center comes in.

Inside the satellite will be, among other instruments and devices, a miniature radio transmitter from which will emanate a continuous signal. This signaling system is named "Minitrack," in reference to the midget size of the

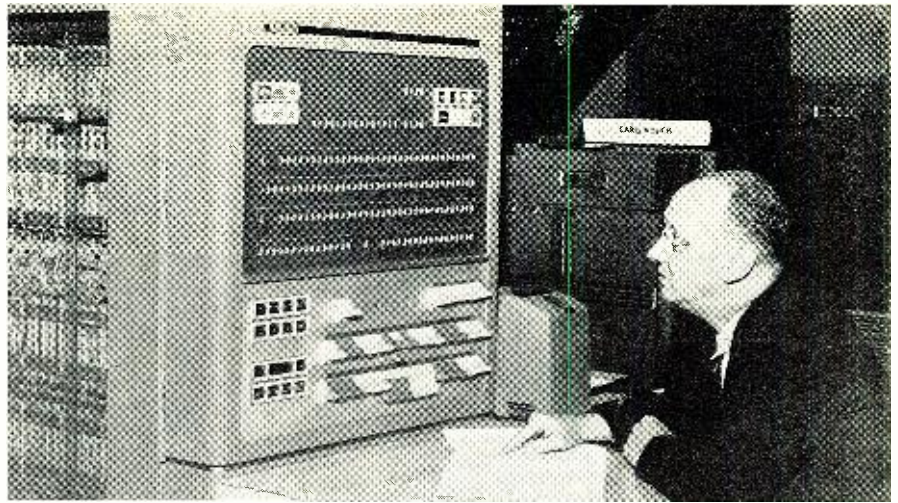

Dr. Paul Herget at the console of the IBM 704 Electronic Data Processing Machine. He heads the "Project Vanguard" Computing Center in Washington where this system is being used to predict and calculate the orbit of the man-made earth satellite.

equipment. Its signal will be picked up by a series of ground Minitrack stations located roughly in a north-south line extending from the mid-latitude region of the U. S. to the latitude of Chile in South America. Each station will take several readings as the satellite passes overhead; the readings will each consist of a precise placement of the satellite in the sky as measured from the station, together with an exact time of measurement.

These readings will be relayed from the Minitrack stations to a communications center in Washington, D. C. From here, the readings will go by direct teletype to the Vanguard Computing Center.

Immediately upon receipt at the Computing Center, the Minitrack measurements will be translated into punched-card form. The cards will then, in most cases, be fed directly into the 704 computer for a complex series of calculations. Cards can be used effectively when there is a relatively small amount of input data, as in the case of the satellite measurements, to be subjected to a large amount of manipulation in the computer. If the input data were greater—as in the case of business accounting records, for example—the punched-card data would be transferred to magnetic tape, which can be "read" electronically at vastly higher speeds than can cards.

Taking the Minitrack sightings as points along the satellite's orbit, the computer will, in effect, connect the points with a line and thus calculate the full orbit. It will continually recalculate the orbit throughout the life of the satellite. As the midget moon completes more and more revolutions, and as ever more measurements are made, the computer's accuracy will steadily increase. Before long, the calculated orbit will even include perturbations, or "wiggles," caused by variations in the earth's gravitational field, attraction of the natural moon and other heavenly bodies, and other

factors—perhaps including some not now foreseen.

The computer will have other jobs to do besides marking out the satellite's true orbit. One of the most complex tasks will be that of calculating the man-made moon's shadow path on the earth's surface, or, to put it more accurately, the path traced on the surface by an imaginary vertical line drawn from ground to satellite. The computer will be able to predict this shadow path in advance. Then, by carrying its calculations still further, it will be able to work out a useful—in fact, indispensable—timetable for the benefit of official visual tracking stations and individual scientific observers participating in IGY. The computer will tell each of these observation posts exactly where and when to aim its telescope so that the satellite passes through the field of vision. Without this precise timetable, telescopic observers would have small hope of catching the tiny moon. It will traverse the sky at a rate of one degree, or roughly two diameters of the natural moon, per second.

These calculations are not easy. While the satellite is in its orbit, it will be independent of the earth's rotation beneath it. Each time the little moon completes a circle, the earth will have rotated 1400 to 1600 equatorial miles to the east. Thus, if the satellite is launched at an angle of 40 degrees to the equator, its shadow path after twenty or thirty revolutions will be a curved line that weaves back and forth between 40 degrees north latitude and 40 degrees south, crisscrossing itself many times.

If a precise telescope-aiming timetable were worked out by human computers with paper and pencil, they could never keep pace with the fast-moving satellite—much less get ahead of it and predict its course. It will take an electronic computer, capable of such feats as multiplying or dividing approximately 4700 ten-digit numbers per second, to keep up with the required pace.

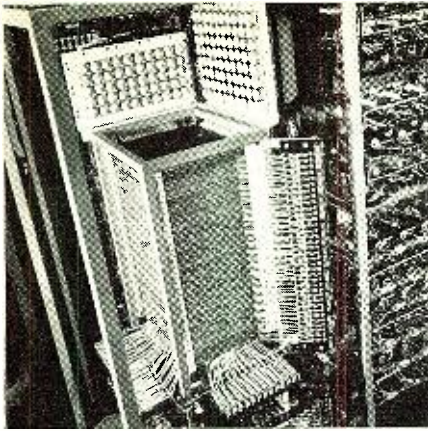

The magnetic core storage unit of the IBM 700 series computer. This is the "memory" of the machine. Many frames of magnetic core arrays, consisting of tiny cores strung on copper wires, provide high-speed storage unit.

In making its calculations, the computer will rely principally on a high-speed magnetic core storage, or "memory." This storage will contain the computer's instructions, now being worked out and programmed in the computer by Vanguard and IBM experts. When the various tracking-station data are submitted to the computer, it will act on the data in accordance with its memorized instructions.

Essentially, the computer's storage function works by means of doughnut-shaped cores, about the size of pinheads, which are strung on a complex of wires in such a way that several wires pass through each core. Combinations of electrical impulses on these wires alter the magnetic states of the cores. A line of cores, some magnetized and some neutral, represents a number or other collection of symbols in much the same way as a combination of dots and dashes stands for a word in Morse code.

Up to 32,768 of these "words" can be stored in the 704's high-speed magnetic core memory. Additional "words" can be held in auxiliary storage by attaching magnetic drum units. The 704 can also control ten magnetic tape units with a capacity of 900,000 "words" each.

The results of the Vanguard 704's computations will flow from the machine in three principal forms. Some of the information will come out in printed form, by means of a direct printer attached to the 704. Some will be on magnetic tape, for printing later on a tape-to-print device. Still other information will be presented in visual form on an ingenious device known as the Cathode-Ray Tube Output Recorder. This device will picture the computer's calculations graphically. It will show, for example, the actual shape of the satellite's orbit as plotted by the 704. It will also show the shape of the shadow path, or any other aspect of the satellite's travels that can usefully be displayed in visual form.

This recorder actually incorporates

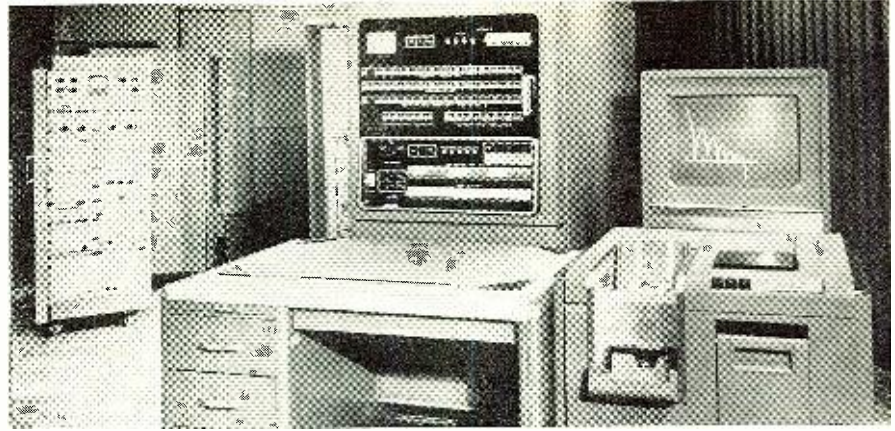

The IBM 740 cathode-ray tube output recorder (CRT), a visual display unit which pictures the output of the 704 Electronic Data Processing machine in the form of engineering symbols, words, numbers, or geometrical figures. The orbit of the earth satellite can be plotted on the screen of the tube as the information is being computed by the machine. With this unit, "Project Vanguard" scientists will trace the course of the satellite over the face of the earth below the orbit of the device.

two cathode-ray tubes. One, a 21-inch tube, is used for immediate display of information worked out in the computer. The other, a seven-inch tube, is designed to work with a 35-mm. camera for recording purposes. This recording device will be used to advantage in the satellite program. Photographs of the midget moon's shadow path, together with marked-off arrival times, will be superimposed on maps of regions having favorable observing conditions.

In the U. S., people living in the southern half of the country will have the best chance of seeing the satellite. The angle of inclination at which it will be launched has not yet been announced, but a general assumption is that the angle will neighbor 40 degrees. The 40th parallel runs through Philadelphia in the east and about 150 miles north of San Francisco in the west; thus, moon-watching conditions will be most probably favorable east, west, or south of these cities.

Visual observation of the satellite will become increasingly important as time goes on. Some weeks after the artificial moon is launched, if it stays in orbit that long, the batteries powering its Minitrack transmitter will die. From then on, all measurements will have to be made optically, or by other means that require no help from the satellite itself. Long before this time, however, the computer will have reached a fine enough degree of accuracy in its orbit calculations so that the tiny sphere, though no longer calling out its own position, will never be lost in the sky as long as it continues to revolve.

Where will be the profit in this program, aside from the sheer excitement of it? The profit, scientists hope, will lie in a flood of new and useful knowledge that can be had from this and other satellites almost certain to be launched in years to come. Many observation posts, not directly connected with Project Vanguard, will be watching the satellite as it speeds around the planet. The Smithsonian Institu-

tion, for example, plans a large-scale moon-watching operation, as do numerous universities and other scholarly and scientific bodies throughout the world. Most of them will be aided by the Vanguard Computing Center.

The satellite's orbit itself will offer much information to observers. The earth is not a perfect sphere; nor is its mass uniform throughout. The perturbations of the satellite's orbit, subjected to various calculations, will add to present knowledge of these irregularities. Another area of inquiry is the nature of space at the 200-mile-and-up level. It is supposed to contain tiny meteoric particles that fall in a continual rain toward the earth, as well as highly rarified air. The drag effects of these substances will be measurable in the satellite's orbit, thus offering a clue to their density.

Inside the satellite will be about ten pounds of instruments (total weight of the sphere: a little over 20 pounds). These instruments will gather data about the sun's radiation, cosmic rays, and other phenomena that scientists have not been able to assess accurately because the earth's atmosphere interferes. Sensitive receiving equipment on the ground will pick up the data recorded by the space-travelling instruments.

Though the first man-made satellite has not yet left the ground, scholars and scientists are already speculating delightedly about future moons. As the science of rocketry progresses, it is altogether likely that fuels will be developed to provide more thrust per pound. At present, it takes a colossal tonnage of propellant to hoist a 20-pound sphere into an orbit; the satellite itself is only a minute fraction of the vehicle's total weight. As new fuels are developed, it may be possible to launch larger satellites, capable of carrying more instruments and gathering more data for science. Whatever is done in the field in years ahead, however, there is almost certain to be an electronic computer handling a key phase of the program.

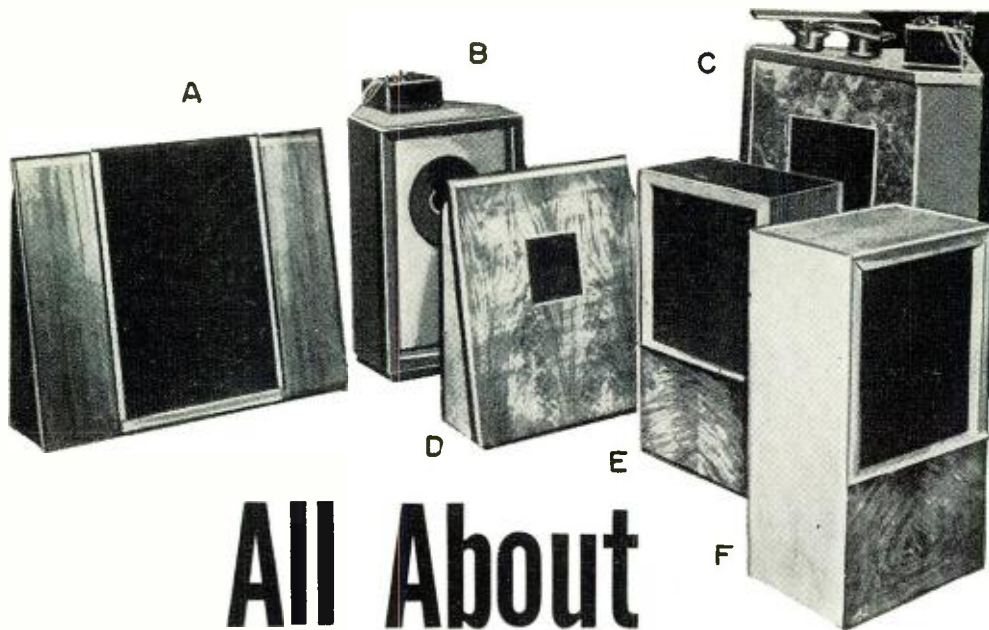

Room Resonance & Stereo

By

G. A. BRIGGS

Managing Director

Wharfedale Wireless Works Ltd.



All About Audio and Hi-Fi

Part 3. Observations on reducing room resonances and providing 2-channel sound with multiple speakers.

IT SEEMS to me that the excellent results obtained from two-channel operation are, to some extent, due to the use of two loudspeakers which break up room resonance; therefore, similar room control can be achieved with single-channel output. I would not say that this is half way to stereo, but I think we could label it "demi-semi stereo."

The main difficulty (at least to my ear) is with solo items, as it is rather disconcerting to hear two Victoria de Los Angeles's instead of one; but judicious orientation of the extra speaker, e.g., towards a corner, overcomes objectionable directional effects. A back-to-back set-up also gives excellent results with simple radiators. A few weeks ago I heard a demonstration of the Philips "Novosonic" system at Century House, London, and I was greatly impressed by the way in which room resonance was overcome by the judicious placing and spacing of one bass enclosure and two treble speakers working with a crossover at 300 cycles.

Added to this, our technical director, Mr. R. E. Cooke, recently returned from Denmark with his head all full of new and interesting ideas and developments. Now the main purpose of Mr. Cooke's visit was to spend some time with my friend David Hall, formerly Music Director, Classics Division, Mercury Record Corporation, U. S. A., and now lecturing at the University of Copenhagen.

I was most interested to learn that David Hall listens, at home, to several

speakers at a time in order to overcome room resonance, two of them being reflex cabinets with an acoustic filter similar to the units shown in Figs. 8 and 10. One is placed under the grand piano and the other under a desk. I quote Mr. Hall as follows:

"The reflex cabinet in the desk knee-hole is the thing for good bass, especially since the desk is *very* heavy and does not resonate."

I attach great importance to what he does, for the following reason. Prior to our first Carnegie Hall demonstration in 1955, I was anxious to have some guidance as to which American records would suit the hall (Carnegie, not David!). Mr. Hall gave us a list of some 30 records of various makes, and when I later compared the program with this list I was amazed to find that every commercial record used had been recommended thereon. This shows almost uncanny knowledge of acoustics and the effects of recording and reproducing characteristics.

As a result of these and similar experiences, I have carried out a number of listening tests at home, which I will now proceed to describe. My yardstick for judging reproduction is a very simple one: the arrangement which sounds least like listening to loudspeakers is the best.

It is necessary to include another plan of my own listening room to show the disposition of the half dozen speakers used in the tests. (See Fig. 9.) The corner speaker referred to as A in Fig. 7 of Part 2 now becomes C.

Fig. 8. Photograph of speakers outlined in Fig. 9 (A) Three-speaker system used in tests described in Part 2. (B) "Super 12" in Electro-Voice "Aristocrat" cabinet. (C) Three-way corner system. (D) Ten-inch speaker on sand-filled 28" x 24" baffle. (E), (F) Ten-inch speaker in 2 cu. ft. bass-reflex enclosure with acoustic filter.

A photograph showing all the speakers assembled in a corner of the room is reproduced in Fig. 8. I have already explained that Mrs. Briggs is case-hardened, but before readers start sending her letters of sympathy I must add that the present conglomeration of speakers is unusual, even for me.

The speakers used in the test were Wharfedales, but the findings would hold true with any reasonably good specimens of any make. In fact, a potent argument in favor of the use of two speakers of different size and shape is that inequalities tend to be smoothed out. It is obvious that if you have a cabinet speaker which honks a bit in the bass, and you add an open baffle speaker in parallel, you reduce the honking by about half. As we have already agreed that room honking is reduced, we seem to be approaching the millenium of double loudspeaker demand. Even the rather boxy tone of the average radio set can be improved by simply adding an external speaker with no cabinet or baffle, thus removing half the sound from the box or resonator. The speaker units are shown externally in the diagram to indicate the direction in which they were facing. Any speaker could be switched on or off at will. My general opinions are as follows, but other rooms would produce different results.

1. Two speakers are much better than one, but three are only slightly better than two on large works. More than three not worth the space used.

2. Speakers A and C gave best results on chorus, orchestra, and organ. Then A and B, then B and C, then C and D.

3. Speakers C and D were best on solo items, and very satisfactory on

everything. Probably the best all-round acoustic set-up.

4. Speakers *B*, *D*, and *F* facing towards the left could be added to *A*, *C*, or *E* without producing disembodied effects on solos, and yet with beneficial results on all types of music.

5. Speaker *B* being very sensitive and directional was always preferred *not* facing straight into the room. Improved transient response from the high-flux magnet system could be heard when this "Super 12" came on.

6. The piano always sounded best with open mounting associated with *A*, *C*, or *D*. Cabinets like *B*, *E*, and *F* give a slightly "boxed-in" effect on this instrument. Speaker *A* alone was better than *B* and *E* or *E* and *F* together, but a cabinet/baffle combination was very good.

7. Baffle *D* with reflex cabinet *E* was better than the two cabinets *E* and *F* on practically all types of music.

8. Cabinets *E* and *F* were preferred standing back-to-back.

9. Most cabinet speakers used singly, other than corner models, give best results when pointing towards a corner or at an angle of 45 degrees to a hard wall, so that the sound is splashed into the room.

10. With two speakers, phasing often makes a big difference in the results. Always try reversing the leads to one speaker. In some positions, out-of-phase connection will be best.

11. For optimum bass, side-by-side (in-phase) placing is obviously best, but this arrangement is the least effective in killing room resonance.

No doubt many readers already possess a spare loudspeaker which could be mounted on a baffle and pressed into service for experiments on the lines indicated. Unlike stereo, equal sensitivity is not necessary, but the extra unit must at least be loud enough to make its presence felt to some extent.

Baffle *D* used in these tests was made from two sheets of $\frac{1}{4}$ inch plywood 28 x 24 inches with a $\frac{1}{2}$ inch layer of sand between them. Two side pieces in $\frac{1}{2}$ inch plywood 9 inches wide at the base and narrowing to 4 inches at the top support the baffle and provide a reasonable backward slope. The associated speaker unit should have a cone resonance below 40 cps for satisfactory performance.

Although a simple baffle is recommended for the second speaker in these tests, and the size described gives very good results with a suitable 10" unit, of the two I still prefer the reflex cabinet with acoustic filter for single speaker use on most types of program material. For one thing, there is more "beef" in the bass.

Stereo

As the domestic use of two-channel recording and reproduction appears to have made more progress in America than in Great Britain, I will confine my remarks to the expression of a few opinions which I have formed on the experience I have had so far.

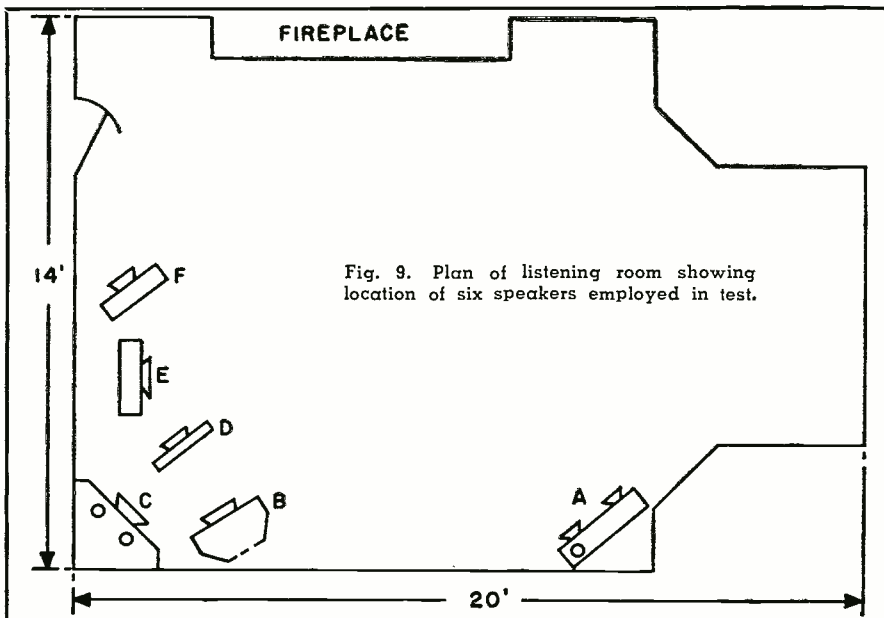

Fig. 9. Plan of listening room showing location of six speakers employed in test.

I am firmly of the opinion that the undoubted step forward in natural reproduction, which is possible with two channels, is due to sweeter top and fuller and rounder bass rather than to true stereophonic effects. When I hear the woodwind in an orchestra I am concerned (a) with what they play; (b) with how they play it; and, (c) with how it sounds. I am not the least bit interested in where they sit.

I agree that some stereo recordings used with directional loudspeakers, correctly placed, give very lifelike results to listeners also correctly placed. We played a couple of HMV "Stereosonic" tapes (7½ ips) in the Royal Festival Hall, London, in May, 1956, and my estimate is that about 1000 people out of 2500 heard something far superior to the best we did with single channel tape at 30 ips, but the remaining 1500 heard something unbalanced and unsatisfactory. Admittedly, the difficulties are far easier to overcome in small rooms (three channels are really necessary for large halls), but placing two loudspeakers and, say, half a dozen listeners ideally in a fully furnished room is not easy.

But if we forget stereo and use omni-directional loudspeakers we can have some glorious sound and sit where we like! Mr. A. R. Sugden of Brig-

house, Yorkshire, has given convincing demonstrations on these lines, and we demonstrated "Stereosonic" tapes at the 1956 Audio Fair in London using the speaker systems shown in Fig. 10. (The tweeters face upward.)

These views received strong confirmation recently when Allen E. Stagg, manager of *International Broadcasting Company*, London, played for me some two-channel orchestral recordings just made with a newly acquired *Amper* 300 machine (speed 15 ips). No special attempts at stereophonic depth had been made—in fact, the microphones were placed above the orchestra—with the result that excellent sound could be heard irrespective of the location of the listener.

One of the main virtues of two-channel operation is that studio and listening room coloration is reduced to a minimum. Also, in view of the ever prevailing difficulty of achieving perfection, "two channel" is a safer and sounder cognomen for the whole system than "stereo." Even movie houses, which went over to three-channel stereo with such a bang a few years ago, seem to be slipping and merely piping doctored sound levels into the various channels. I suppose they have decided that good stereo will not replace a good story. (To be continued)

Fig. 10. Photograph of two speaker systems used to demonstrate two-channel sound.

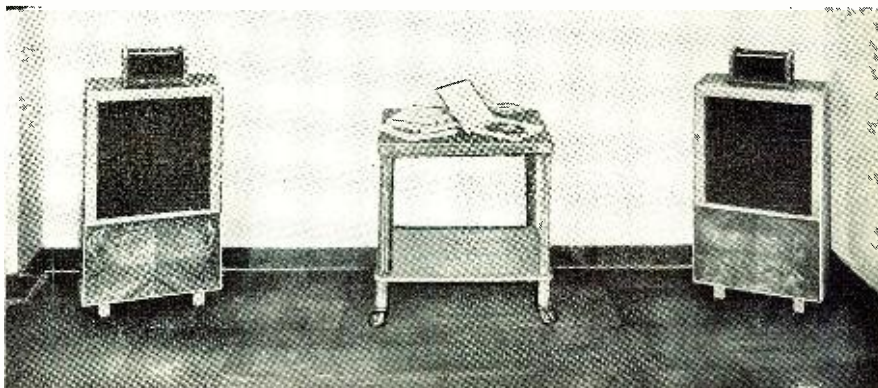

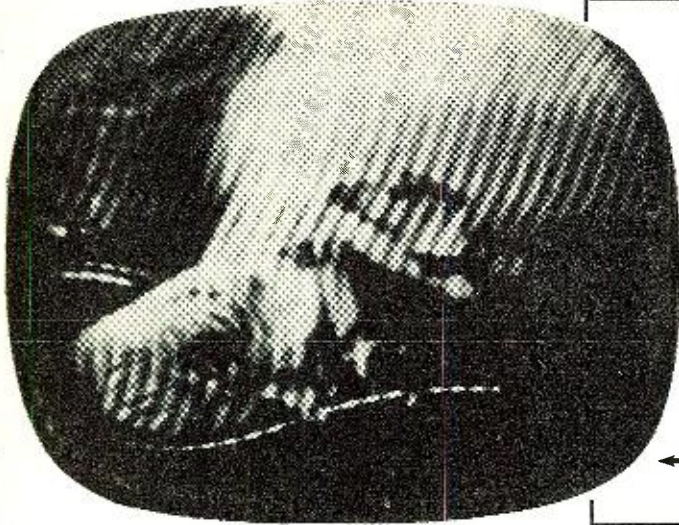

INTERFERENCE SOURCE	NUMBER OF CASES
Heating pads.....	409
TV receivers	190
Wiring, electric	164
Radio receivers	146
Door-bell transformers	86
Fluorescent lights	79
TV receiver installations.....	76
TV receiver radiation.....	71
Butter conditioners	51
Neon signs	46
Refrigerators	37
Radio stations	29
Voltage irregularity	29
Electric flashers	28
A. C. modulation.....	27
House wiring	25
Universal motors	24
Amateur radio stations.....	24

← Sine-wave signals produce herringbone patterns. Look for oscillatory rather than random-noise equipment as source.

War Against

Interference

TVI sleuths turn up data on likely sources that upsets popular notions. Cures can be profitable.

AN IRATE farmer in the midwest whose favorite TV programs are being obliterated by interference goes to the FCC with a demand that the culprit be found. FCC sleuthing turns up the fact that the equipment causing the interference is an electrified fence put up to contain a flock of chickens—on the complainant's property. A woman elsewhere in the country lodges a similar complaint. Her own electric blanket is found to be the cause. Once more the local radio amateur and the doctor who owns diathermy equipment are exonerated.

In a report entitled "Pertinent Information on Interference," Ray E. Meyers, chairman of the Cooperative Interference Committee of Los Angeles, sheds interesting light on the sources of interference. The report also indicates that, armed with the proper information, the service technician who considers himself harassed with woes about which he can do little, can actually turn successful remedial techniques into income.

"Interference is caused by many devices, conditions, and circumstances difficult for the layman to understand," says the report. "In many cases the cause may be so simple that even the well-qualified engineer may overlook a rather obvious solution.

"Seldom is interference caused by a deliberate act. This type of interference is illegal and in violation of Federal laws. Unfortunately, the majority of cases are due to poorly engineered equipment, or erratic conditions which may develop in the operation of the best equipment available. Owners of such equipment appreciate being notified of this type of operation. In most cases, this would

preclude an official citation by the FCC."

The committee, which includes among its members persons with responsible positions in the aircraft, electronics, communications, and power industries, as well as radio amateurs, has done a good job in amicably adjusting complaints against reputed offenders. In a survey of some 2600 or more cases made by the Interference Bureau of Los Angeles, results were

equipment, thermostats, electric saws, electric fences, shaver rectifiers, aquarium heaters, and miscellaneous devices.

Although not indicated in the table, one additional fact is certainly worth special note. In 483 cases—very nearly one out of five—the device generating the interference was one operated by the complainant! Also worth comment is the fact that fewer than 1 per-cent of the trouble makers were radio amateur operators.

C.I.C. members are asked to keep themselves abreast of the problem by familiarizing themselves with a list of recommended publications on the problem and also, especially if they are amateurs, by assuring themselves that their own equipment is TVI-proof. The committee makes other more specific recommendations. The remainder of this article consists of some

of these, excerpted from the Meyers report.

A simple absorption filter (band elimination filter) is useful in the case of adjacent-channel interference where the interfering signal is narrow-band, such as c.w. modulated or unmodulated, and where the affected receiver is too broad or is poorly aligned.

(Continued on page 110)

EDITOR'S NOTE: Formed in 1954, the Cooperative Interference Committee of Los Angeles, a voluntary organization operating in southern California, has received commendation from the Federal Communications Commission for its significant contribution to the cause of locating and suppressing or reducing radio and TV interference. Its work has turned up some surprising information on the causes of interference exonerating many scapegoats of the past. Following its successful efforts, some 15 similar committees have been formed throughout the nation.

For this article, we are indebted to Mr. Ray E. Meyers, chairman of the committee, from whose report the story has been adapted. His report, in turn, was based on data supplied by the Interference Bureau of Los Angeles.

tabulated to determine the most frequent sources of trouble. In the accompanying table, the eighteen interference-generating sources that were responsible for nearly 95 per-cent of the complaints are given in the order of frequency. Little more than 5 per-cent of complaints, not listed, were traced to street lights, electric blankets, sign flashers, electric welding

Super-Radars For Missile Ship

Long-secret radar now in active service with the fleet for guidance of its deadly Terrier missiles.

A LONG-SECRET class of super-radars, now in service with the fleet for guidance of its Terrier missiles, was revealed recently by the Navy.

Subject of speculation since first displayed aboard the guided missile cruiser "USS Canberra," massive, turret-like antennas for the new radars have radically changed the contours of the nation's fighting ships. Although the radar antennas, which resemble gigantic searchlights, attracted considerable attention during President Eisenhower's recent trip on the Terrier-equipped "Canberra," the structures were identified only recently. Only limited, general information regarding the new AN/SPQ-5 radars has been released.

Developed for the Navy by *Sperry Gyroscope Company*, of Great Neck, N. Y., the long-range, high-altitude missile guidance radar systems came into fleet use only after years of successful tests.

Rear Admiral F. S. Withington, chief of Navy's Bureau of Ordnance, said that the new super-radars were a part of the Navy's program directed toward providing the fleet with highly reliable missiles to combat supersonic jet aircraft. "Our new radar systems," he said, "are giving exceptionally high performance for tenacious, stable guidance of supersonic missiles, whether fired singly or in salvos at individual

or multiple enemy attackers." He confirmed that the two SPQ-5 systems aboard the "Canberra" combine many automatic radar functions in each unit. Either system can control the missiles from a single launcher or battery, which fires the Terrier missile, or both radars can track different target groups simultaneously.

The SPQ-5 radar systems include flexible modes of scanning the air space many miles beyond the horizon, providing the advantage of early warning. Individual targets can be selected from close-flying groups and tracked at great distances while the missiles are launched and guided with "extreme accuracy."

Concurrently, *Sperry* announced that a new manufacturing facility at Charlottesville, Virginia, *The Sperry Piedmont Company*, is producing the super-radars for the Navy. Completed in October, 1956, the new \$2 million plant includes special facilities to accommodate the massive radar antenna "barbettes" used aboard ship.

Two cruisers, the "USS Boston" and the "USS Canberra," have been converted to Terrier-equipped missile ships and have joined the fleet. The "USS Topeka," the "Providence," and the "Springfield" now are being converted to carry the missile. The photo at top right is a blown-up view of one of the radar turrets. —30—

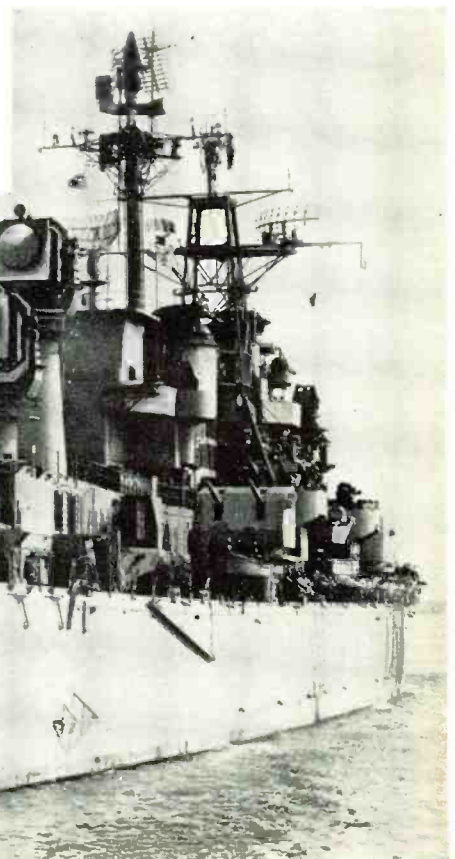

Power Ratings For P. A. Driver Units



By **LAWRENCE J. EPSTEIN**
University Loudspeakers, Inc.

The power race is on. Lack of information, industry-wide standards, and use of confusing terminology makes the choice of p.a. driver units difficult for the uninitiated. Here are some of the facts.

← A montage of driver units. The large trumpet is University's "Cobreflex" with a SA-HF driver. It is a 16-ohm unit with a horn cut-off frequency of 200 cycles-per-second. The combination has a 30-watt "full range" power capacity; but with a 50 microfarad capacitor wired in series with the driver, the "adjusted range" power capacity would be 60 watts.

diaphragm when reproducing high-level, low-frequency passages. In such cases, protection of the driver unit by adequate horn loading is important. Fractured diaphragms, broken voice coil leads, and excessive distortion can result from improper selection of horn and driver units, especially when working with church chimes, carillons, and organ music. *For these and other reasons it is extremely important, when judging specifications of competitive driver units, to take note of how the manufacturer qualifies the power capacity rating.*

Even the experienced sound man may be misled by advertising claims and specifications not so much by what is said as by what is *not*. As a practical guide to better understanding of "power capacity" ratings, as well as to provide an informed approach to the use of drivers in accomplishing field requirements, the writer now endeavors to establish, through use, a standard of power capacity reference:

"Full Range" Power Capacity

This is by far the most common method of operation in the field. Although a driver may itself be capable of full rated frequency response, the actual acoustical output of driver and trumpet combination will be considerably influenced by the low-frequency limit of the *horn* used, below which the output drops drastically. With an amplifier operating for wide-range response, substantial low-frequency electrical energy *enters* the driver unit, but very little of it may end up as sound energy, due to the horn's limiting or "cut-off" characteristic as it is

TALK about the horsepower race in the automotive field; the boys in Detroit seem to have just about reached practical limits, so now all eyes on the makers of public address drivers!

There was a time when we had to pour audio power into a p.a. speaker because the relatively low efficiency of cone speakers in parabolic horns simply wouldn't turn out enough sound level to handle expanding requirements. Then came the highly efficient, exponential reflex trumpets, powered by "driver units" capable of several hundred per-cent more sound output with far less input power. Amplifier requirements took a nose dive. But, alas, man and progress are not to be restrained, and now the industry is of late being introduced to 50-, 85-, and even 100-watt driver units!

To the experienced and enlightened sound technician who knows how much just a few clean watts of audio into a truly efficient driver can accomplish, the thought of 100-watt driver units conjures up questions deserving of a few candid answers.

Absence of industry-wide standards for evaluating the performances of loudspeakers makes the comparison of driver unit specifications difficult for the uninitiated. Power handling capacity is an indication of the ability of a driver to withstand an amount of electrical input power, of a certain nature, for some length of time, without

danger of driver breakdown. The power handling capacity is not necessarily an indication of sound output. It is possible, for example, to design a driver rated at 40- or 50-watts input which would produce no more sound output than a more *efficient* driver rated at 25 or 30 watts.

"Gauss," a measure of flux density existing in the voice coil gap, is sometimes used by inference to indicate the efficiency of the driver unit. This, too, is misleading since the magnet itself is only a part of the motor mechanism, while the *conversion* efficiency is dependent upon the manner in which the magnet energy is employed; the weight, shape, size, and mounting of the diaphragm, as well as voice coil and suspension design, heat dissipation, are other more obscure factors. Sound pressure measurements presumably would be the answer, providing there were a common basis of measurement. Even forgetting for the moment differences in laboratory constants, a difference in the horn size used for the measurement, distance from the sound pickup device, frequency at which the measurement is taken, are just some of the factors which would affect the sound pressure measurements.

For music reproduction, good low-frequency response (barring reverberation problems) is usually desirable along with the highs. Of particular importance is the ability of the driver to withstand extreme excursions of the

commonly referred to in manufacturers' specs. The cut-off of a horn is determined by the flare design and air column length. Thus the larger, longer trumpets will baffle a driver to lower frequencies more efficiently than smaller models. At best, the biggest horns for use in p.a. have an air column length of 6½ feet and are capable of response down to 85-100 cps. With a driver mounted to a more typical horn with, say, a 150 or 200 cycle cut-off and thus operating without much loading at the lower frequencies, the driver mechanism endures relatively severe electrical and mechanical punishment which can lead to eventual breakdown . . . unless the driver is rated to take a given amount of input power under such conditions. The writer therefore proposes that an expression such as "full range" continuous duty power capacity be used to denote application of a given driver to horns without regard to cut-off. One manufacturer actually life tests drivers on raw 60-cycle a.c. without any horn load, and, accordingly, rates his drivers on a continuous duty basis.

"Adjusted Range" Power Capacity

Obviously then, if the low-frequency energy below the cut-off of the horn used could be eliminated from the program signal source or from the driver input, the low-frequency overloading condition is eliminated too, and the driver may be rated for substantially greater input. In such case, the power rating could be *doubled*. If wide-range frequency response is not required elsewhere in the speaker distribution lines, the amplifier bass tone control (or low-frequency filter, if any) can be adjusted to eliminate some desired amount of lows. It is a good idea to make certain of the actual attenuation by testing amplifier output with an audio signal generator and output meter. If the amplifier cannot be adjusted or altered, or if wide-range program is also required elsewhere in the distributing system where "high fidelity" speakers are in use rather than "p.a." types, a *non-polarized* capacitor of proper value can be inserted in series with the driver of the p.a. speaker not requiring hi-fi performance, to attenuate *input* low-frequency energy and thereby achieve higher power capacity.

The graph of Fig. 2 shows what, in general, takes place. Note that while the series capacitor produces a steady roll-off below the established cut-off frequency, the roll-off actually begins to occur about one octave above the cut-off point, resulting in a loss of 3 db at the "cut-off" fixed by the value of capacitor.

The scale at the bottom of the graph represents: *attenuation at any frequency ÷ frequency of cut-off*. For example, assuming that we have already calculated a value of capacitor to provide cut-off at 200 cycles, and we want to know, from the graph, what the attenuation looks like at 600 cycles, we divide 200 into 600 and get the answer

of 3, which the graph shows will not be affected at all. If we wanted to know what happens at 40 cycles, we divide 200 into 40 and get .2 for an answer. The graph shows that at .2 there will be an attenuation of about 14 db below the cut-off frequency attenuation.

While limiting amplifier response or applying a series capacitor will increase the power handling capacity of a driver, it should be borne in mind that there will often be discernible aural differences as compared to operating without the limiters, due to the roll-off rather than sharp cut-off characteristics. Therefore, it is preferable to restrict these methods to *voice* reproduction. If the stated power rating or warranty of a driver unit is given in specifications with some qualification with respect to horn size or input response restricted to horn cut-off, you may be certain that such rating is actually the "adjusted range" capacity. To find the "full range" power rating it would be safest to divide the given rating by two.

The chart of Fig. 1 provides the proper size of capacitor for series connection to a driver to double its power capacity rating. Capacitors for operation up to 25-watts input should have a "working voltage" rating of no less than 50; up to 50 watts input, 75 to 100; and up to 100 watts input or better, 150 or 175 volts.

Using the Chart

1. To determine the capacitor for a 70-volt (or 25-volt) "constant voltage" system, first determine the value of impedance which corresponds to the power tap being used:

$$\text{Impedance} = \frac{70^2 \text{ (625 for 25 v. system)}}{\text{Wattage tap being used}}$$

2. If the impedance is known (or calculated according to the formula), find the correct level line on the chart by referring to the table which identifies the impedance being used.

3. Find the horn cut-off on the horizontal scale of the chart, and intersect the selected level line at that point.

4. Follow that point horizontally to the vertical scale and note the number thus indicated.

5. Finally, multiply that number by the factor alongside the impedance

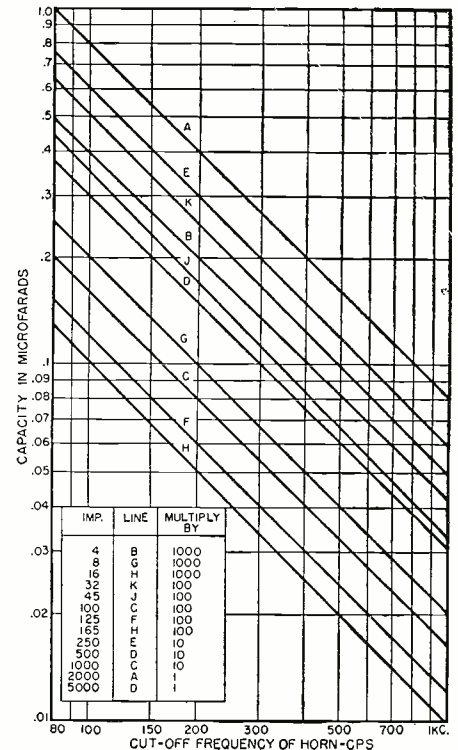

Fig. 1. Values of series capacitor required for various cut-off frequencies.

level line in the table. The resulting answer is the value of capacitor in microfarads. Because of commercial availability, values within 5% will suffice.

Note: Odd capacitor values can be achieved by paralleling capacitors to *add* value; or placing capacitors in series to *reduce* values. When they are in series, the resulting value equals $1/(1/C_a + 1/C_b)$.

Sound Pressure Level

One of the most revealing measurements of a speaker is its output on some specific basis. A driver that withstands greater input power is of no general value if it does not produce more sound for a given input. It takes a change of 3 db in sound to *detect* the difference. Power to a given speaker must be *doubled* to get 3 db more output. Obviously, then, higher power

(Continued on page 130)

Fig. 2. Response with and without a series capacitor in lead to driver unit.

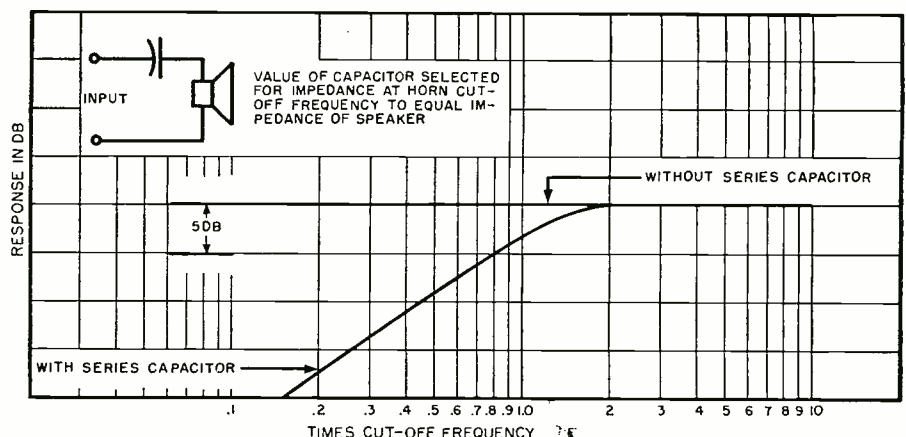

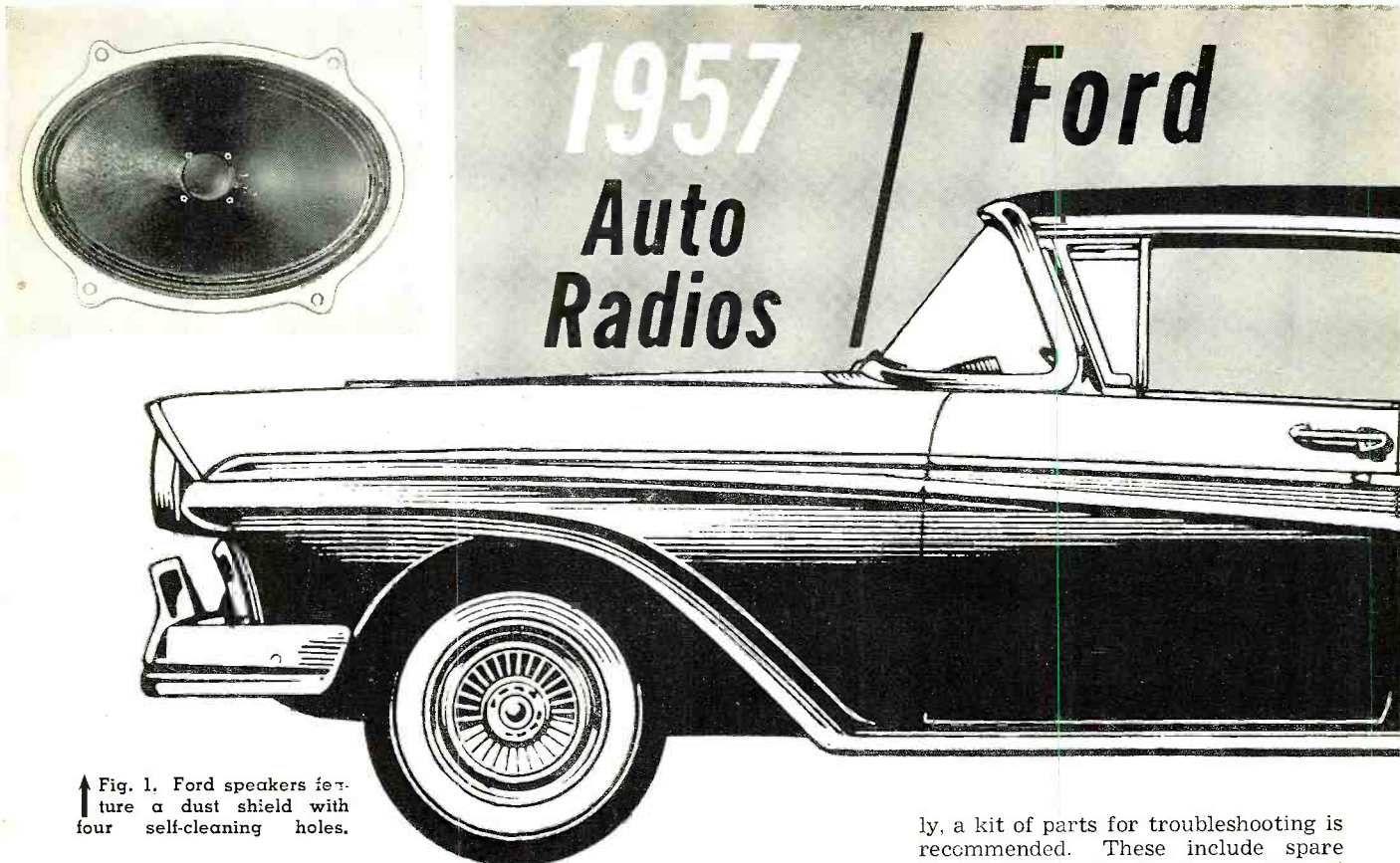

↑ Fig. 1. Ford speakers feature a dust shield with four self-cleaning holes.

A systematic check can pinpoint many faults without chassis removal. Dismantling itself is no problem.

IF READERS of our other presentations on this year's car receivers have retained any doubts as to the established position of transistors, low-voltage miniature tubes, and printed circuits in this field, the three basic radios used in the 1957 *Fords* do nothing to encourage such hesitation. All three models follow the noted trends.

Some innovation also appears in the speakers used. Continued reliable performance from these components is assured by the use of a sealed magnetic structure and incorporation of dirt-release holes. The four release holes can be seen near the apex of the cone in Fig. 1. Vibration of the speaker in ordinary use propels foreign particles out of these openings, but the valve-like action provided by the small size of the openings impedes the return of dirt and dust.

One of the receivers available for all *Ford* cars except the "Thunderbird" is the 75MF. This push-button hybrid includes among its five tubes a 12BL6 r.f. amplifier, a 12AD6 converter, a 12AF6 i.f. amplifier, a 12AJ6 detector—1st audio stage, and a 12K5 audio driver. A 2N176 audio output transistor is mounted on a heat sink at one side of the chassis.

Another five-tube unit also using low-voltage tubes in a hybrid design is the 75BF. It uses a 12AF6 as the r.f. amplifier, but otherwise follows tube line-up of the 75MF up to the 1st i.f.

stage. This is followed by a 2nd i.f. amplifier (12CN5), which feeds a 12J8 detector—1st audio tube. The usual audio driver for the transistor is here omitted, with the 12J8 directly feeding the 2N176.

For those who like their auto radios with plus features, Model 78MF provides search tuning and push-pull transistor output, supported with eight low-voltage tubes. Two 12AD6's are used as the r.f. amplifier and converter. The two-stage i.f. strip employs a pair of 12AF6's; and the detector—1st audio portion is handled by a 12AJ6. The conventional 12K5 audio driver feeds the push-pull 2N176 pair of transistors. The trigger amplifier for the search tuner, a 12AE6, feeds the 12K5 control tube, which operates the relay.

As with most auto radios, a defective receiver, once it has been determined that the fault is in the circuit itself, can be handled on the service bench with no more difficulty than is experienced with any other radio. Two problems must be faced first, however. The first of these involves prior determination of whether the symptom under examination is actually traceable to the receiver. Then, if it is indeed found to be in the circuit, the business of getting the chassis out of its secure position behind the dash panel (and subsequently that of returning it in satisfactory fashion) must be faced.

To attack the problem systematical-

ly, a kit of parts for troubleshooting is recommended. These include spare 5- and 7.5-ampere fuses, one each of every tube type used in the receivers, a spare speaker, a spare antenna with lead, and a set of suppression equipment. All parts except fuses should be pre-tested and marked so that they will not be left in the radio inadvertently during substitution tests. Thus armed, the technician is ready to localize symptoms with the receiver still mounted.

No reception: The fuse is checked first. If it is blown, a new one is tried. If this also blows, the next step is removal to the bench. If it does not blow, check to see whether the tubes are lit. If they are not, the availability of voltage at the A lead (see Fig. 3) should be checked with a meter. If tubes are lit, the substitute antenna should be tried to see whether the trouble can be isolated to this section. Similarly, the substitute speaker can be tried. To avoid damage to the transistor, never operate the radio without a speaker.

If none of the measures noted localizes the trouble, step-by-step substitution for each tube is the final test before removal to the bench becomes mandatory. Check of the output transistor(s) should not be attempted with the radio in the vehicle. This component is not considered a likely source of trouble in any case.

Noisy or erratic reception: To isolate, it is important to know *when* the noise occurs. If it is present when the engine is not running, the defect is probably in the receiver. However, all leads to and from the chassis (Figs. 2 and 3) should be checked first for secure connections. If noise is present

only when the engine is running, and even when the vehicle is not in motion, check the suppression equipment. More detailed reference will be made to this equipment later in connection with Fig. 4. Also make sure that the receiver is properly grounded both to its support bracket and to the contact with the instrument panel. Noise that occurs only when the auto is in motion may be due to intermittent contact to automobile ground, through either the support bracket or the instrument panel. However, also keep in mind the fact that, if there is intermittent contact with the antenna or another part of the antenna system, similar indications will result. These other possibilities should also be checked when the noted symptoms are present.

Distorted or garbled sound: Before dismantling the radio, it is a good idea to check the speaker and individual tubes by substitution. Sometimes, if the speaker is improperly mounted, bending or twisting may throw the voice coil out of alignment. Mounting nuts should be tightened by hand only. If wrench or pliers are used for this operation, there may be a tendency to overtighten, with poor sound resulting.

Some cases of weak reception can also be corrected without chassis removal. The antenna trimmer, which is accessible externally (Fig. 3), may be misaligned. It should be adjusted with the antenna fully extended. When the search tuner tends to run continuously without stopping on certain stations, it is well to remember, the actual trouble may also be poor sensitivity. In this connection, note that poor sensitivity and the other symptoms that may result from it can be evident when the auto's battery voltage is low. A check of battery voltage may often save the job of dismantling the radio for a bench check.

Suppression equipment: When it becomes necessary to check or install suppression equipment, make certain that all paint and dirt are removed from between capacitors and the vehicle and that all nuts and bolts are tight. The lead shown as Item A in Fig. 4 is the high-voltage distributor-to-coil wire. The generator suppressor capacitor is shown as Item B. To remove or install it, it is not necessary to remove the bolt. The latter need only be loosened enough to slide the mounting bracket under the lock washer. The capacitor for the voltage regulator is shown at C, and the bonding clip is located as shown in Item D.

To get at the static collectors, the front hub grease caps, as shown, must be removed. Make sure that the cotter key is bent away from the spindle center hole so that it will not interfere with the static collector. The bonding cable—this applies to 8-cylinder models only—is shown in heavy outline in Item E.

Physical considerations: When tube substitution is necessary, access is obtained simply by removing the bottom cover of the receiver. This should present no problem. The tubes may then

be found, protruding downward from the chassis plate and within convenient reach. When the receiver itself has to be taken out, the most advantageous position to assume for this chore is in the center of the front seat, directly in front of the receiver dial. Be sure that the ignition switch is off. As a preliminary step, the air-duct assembly on the right hand should be removed to get it out of the way.

The three leads connecting to the radio—the antenna lead, the A lead, and the pilot-light lead—should now be disconnected, and the fuse withdrawn from its holder. Next remove the control knobs, bezel-mounting nuts, bezel, and the panel-mounting nuts. The leads are shown in Figs. 2 and 3. The hardware should present no problems.

The lockwasher on the stud at the right side of the chassis is then removed, and the mounting bracket is pushed away from the stud. Now the bolt from the other bracket, at the lower left of the chassis, is also removed.

Now the receiver is free of its mounting, but must still be maneuvered out of the space in which it is located and into the clear. To complete removal, grasp the chassis with both hands, push it forward, and tilt it toward the toe-board until it clears the instrument panel. This completes the job.

To get the receiver back into position, the dismantling procedure is reversed with very little change. The entire unit is guided into position with both hands but, once it is oriented, it is steadied in place with one hand while the other is used to install the panel-mounting nuts finger-tight only.

While it is thus held, slide the right-hand mounting bracket over the stud at the right side of the chassis, and install the nut and lock washer here. Be sure that all cables and wires are clear of the chassis, else you may have to perform partial dismantling again

when you find that leads cannot be connected properly because they have become caught. Now you can install bolt and lock washer to the stud on the left side. Getting the bezel and the hardware in place is a relatively simple matter. Next the speaker plug, A lead, antenna lead, and fuse are returned to place. Be sure that they are securely connected. Last, don't commit the common oversight of forgetting to put the air-duct in place.

-30-

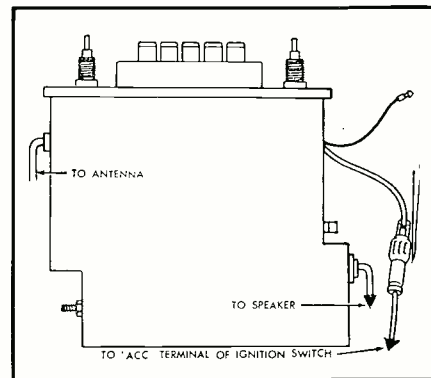

Fig. 2. Location of leads to receiver.

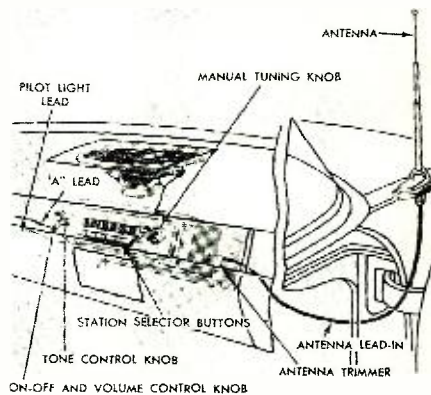
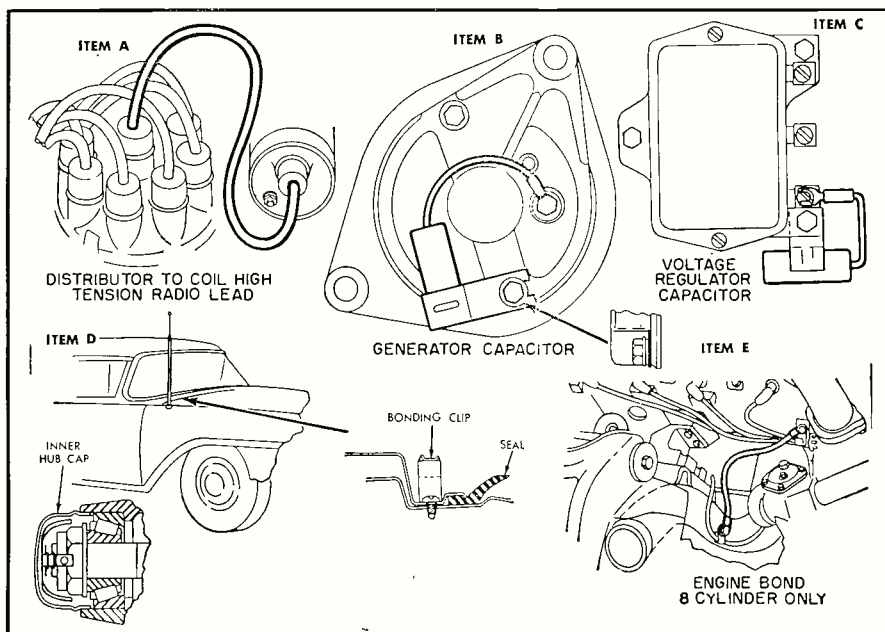

Fig. 3. The receiver and the dashboard.

Fig. 4. Details for installing or checking noise suppression equipment. See text.





"Compadre" under way. The only external signs of her electronic gear are the ship antenna for the radiotelephone rig and the broadcast antenna between the masts.

By **R. J. CARRINGTON**
Altec Lansing Corp.

Sea-Going Hi-Fi

Here is how one boat owner is taking his hi-fi with him on long cruises or short week-end trips.

WITH the great popularity of boating today and the rapidly increasing popularity of high fidelity, it seems only natural that the two should combine and that hi-fi should go to sea. The myriad pleasures of boating are certainly enhanced by a fine high-fidelity system, and who can think of a better place to enjoy hi-fi than some secluded anchorage completely free from distracting sounds and a long, long way from any neighbor who might complain if the volume is turned up.

Of course, marine high fidelity can't be achieved by selecting components and hooking them up as though the boat were a house. A marine installation presents some special problems and has certain distinct operational limitations. No record player or turntable can be used when the boat is under way. Engine vibration and roll of the boat will send even the finest stylus and arm scurrying across a record in a singularly destructive manner, blessing that disc forever with regularly spaced pops and bangs. The normal directional FM dipole antenna will not stay in proper orientation to station transmitters while the boat plies different courses or drifts leisurely around its anchor. Only the finest electronic equipment will operate reliably under marine conditions of extreme humidity, salt air, vibration, and motion. Most important of all is the fact that the boat must supply its own electrical power; that this power is limited in

quantity and is time-consuming to replace.

The author was in a fortunate position when installing his sea-going high fidelity. The "Compadre" was in the process of being converted to a yacht, hence there were no existing batteries, voltage, or wiring to worry about. Since the "Compadre" is a husky boat, there were no problems of size or weight in the electrical layout; only money. From the standpoint of convenience it seemed at first that a 110-volt system would be the most desirable, but two complete 110-volt battery banks proved to be unreasonably expensive and bulky. A single bank was ruled out because the failure of one battery could endanger the operation of all the electrical gear on the boat and actually prove perilous to the safety of the craft at sea. With this exclusion of 110 volts it was obvious that 32 volts was the best choice because of the ready availability of motors, lights, appliances, etc., in this voltage.

Once the voltage was selected, it was necessary to calculate the total ampere-hour capacity needed to meet the boat's demands. Under way this is no problem since the cruising generator on the main engine is constantly replenishing any drain. At anchor, however, the constant putt-putt-putting of the auxiliary generator is distracting, to put it mildly.

Final calculations and experience showed that the "Compadre" lying at

anchor in full commission (refrigerator, deep freeze, water pressure pumps, stove blowers, electrical accessory motors, and the normal use of lights, hi-fi, and radio) has a twenty-four-hour average power consumption of 110 ampere-hours at 32 volts. The battery system finally selected consists of three independent 32-volt banks each having a 130 ampere-hour capacity. Normally these three banks are connected in parallel for a total capacity of 390 ampere-hours. It is possible, however, for the boat to operate efficiently from any single bank for 24 hours without generating.

Battery charging is accomplished by any of three methods. At dockside, it is done with a 15 ampere trickle charger working from shore power; under way, it is accomplished by a 3 kilowatt cruising generator mounted on the main propulsion engine; and at anchor, a 1 kilowatt auxiliary generator is used.

In addition to the 32-volt wiring throughout the boat there is a complete 110-volt circuit which can be operated from shore power when tied to a dock. Under way or at anchor, this system operates through an ATR 32-volt to 110-volt inverter of 160-watt continuous or 200-watt intermittent capacity. This capacity is adequate to operate the high-fidelity system and for small power tools and appliances. A heavy duty switch in the engine room connects the 110-volt wiring to either the shore power connections or the inverter.

An Altec 339D 18-watt amplifier was selected as the "heart" of the hi-fi system for a variety of reasons. Its con-

struction is sturdy enough to stand the constant vibration and motion of shipboard use; all of the capacitors used are of the type which are sealed against moisture, and its efficiency, comparing line power drain to watts output, permits sufficient audio power within the limitations of the inverter and battery system.

As sound sources, a *Garrard* changer with *G-E* diamond stylus was selected for use at anchor and at the dock. For music under way and for the recording of native bands while cruising the Mexican and Central American coasts, the choice was a *Magnacorder* portable tape recorder which can be easily removed from its shipboard location and carried ashore along with its associated equipment. For radio reception in Southern California waters an *Altec* 306A AM-FM tuner was the choice.

Installation of the components is conventional except that it is necessary to bolt them in place in order that they not come adrift in a seaway.

The conventional dipole antenna for the FM section of the tuner is completely inadequate at sea due to its directional characteristics and the constantly changing direction of the boat with its varying orientation to the FM transmitters in the area. This directional problem was solved by placing two flat dipole antennas flush on the cabin top in opposed positions so that they form an "X" and provide completely non-directional reception.

The selection of loudspeakers involved two factors: quality and efficiency. With the basic limitation in amplifier power, speakers which are so low in efficiency as to require a terrific amplifier output were ruled out. The final selection was an *Altec* 700 "Melodist" two-way system for the main cabin and *Altec* 408A "Biflex" speakers for the after deck and the owner's stateroom below decks. Each of these three speakers is equipped with an "L" pad for individual level control.

The after deck speaker was mounted in a porthole which was reversed so that it now opens out onto the deck and can be closed and dogged to protect the speaker from the elements during bad weather. The 8-inch "Biflex" in the owner's cabin is mounted in a two-cubic-foot bass reflex and the "Melodist" system in the main cabin is enclosed in its integral enclosure and mounted permanently into the bookcase above the system components.

In addition to the AM-FM tuner, a battery-powered *Zenith* short-wave receiver was added to the equipment line-up. With its more restricted frequency range it is superior to a high-fidelity tuner for intelligible reception over the great distances required when cruising the southern Mexican coast 1000 to 1500 miles from the desired stations. This short-wave receiver also covers the 2.5, 5, 10, and 15 megacycle frequencies of station WWV over which the National Bureau of Standards broadcasts the standard time signals so necessary to accurate celestial navigation. The receiver is also used

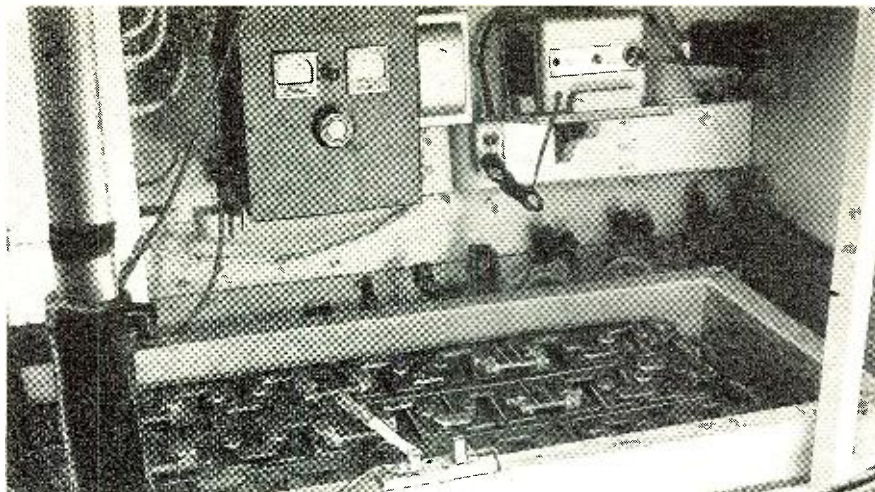

The three 32-volt battery banks in engine room. Trickle charger and inverter are mounted above. Knife switch controls cylinder head heaters used for engine starting.

to monitor the international calling and distress frequency (2182 kc.) as required by the FCC while the radiotelephone is in use. It has the advantage, as a general marine monitor, of placing no drain on the ship's electrical system and its own drycell battery has an operating life of approximately 1000 hours.

The *Zenith* receiver is equipped with two conventional copper wire antennas. The one for local station reception is 12 feet long and mounted on the cabin top. One 42 feet long is stretched between the two signal masts for long range reception. Each of the antennas can be switched to either the short-wave receiver or the AM section of the tuner.

Other electronic gear on the "Compadre" includes a 35-watt crystal-controlled *Raytheon* transmitter and receiver. Channels are provided for radiotelephone (ship-to-shore) communication over telephone company's coastal station, KOU, at San Pedro, California; for the two ship-to-ship communication frequencies, 2638 kc. and 2738 kc., and for the marine and aircraft international calling and distress frequency, 2182 kc. This 35-watt transmitter, which is located in the after end of the main cabin, is used for communications in local waters. Forward, near the helm, is a 150-watt *Sonar* transmitter for use in more dis-

tant communications while cruising. This *Sonar* unit has the same frequencies as the 35-watt *Raytheon* and the additional facility for communication with the Pacific high seas radiotelephone station, KMI, in San Francisco, on the 8 megacycle band.

Also placed near the helm for operational convenience is a *Raytheon* depth sounder, of 25-fathom range, which is used on entering and navigating unmarked harbors and coves and as a navigational aid in coastal cruising. Naturally the boat is equipped with an autopilot to hold her on course automatically.

It seems that modern day sailors must replace the knowledge of sailmaking and marlin-spike seamanship so necessary to their predecessors with a basic understanding of electricity and electronics, for modern cruising boats like the "Compadre" have more electronic devices than the normal home and must make their own power—and the crew can't call the service technician if anything goes wrong at sea. Sea goin' electronics, whether operational or high fidelity for pleasure, must be of the highest quality to assure reliability and long life. But the safety of electronic navigational devices and radios cannot be denied and the pleasures of high fidelity on a long cruise or a week-end trip make them all worth while.

-30-

This Month's Cover

All of the comforts are enjoyed by R. J. Carrington and his guest, Lyn Terry, aboard his converted yacht. The "Compadre" carries a full complement of electronic gear both for entertainment and ocean-going safety. The center of operations is the helm with a depth indicator nearby, autopilot control above the compass binnacle, battery condition meter, and the various engine controls. In addition to this navigation gear, the boat carries an AM-FM tuner, record changer, portable tape recorder, 18-watt power amplifier, short-wave receiver, and an elaborate speaker system with installations throughout the ship. The cover photo is by Peter J. Samerjan.



-30-

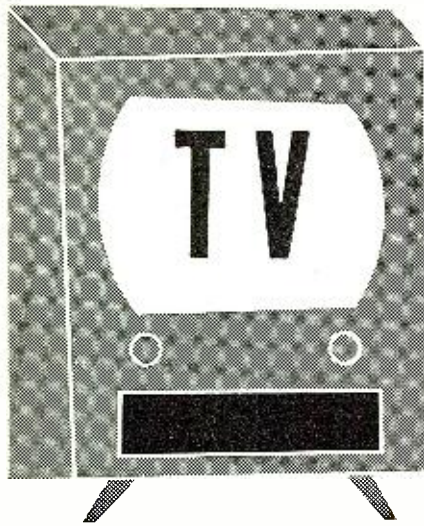

Sound

Can be improved

By KENNETH BRAMHAM

There are many ways of achieving gratifying improvement of the sound from most TV sets.

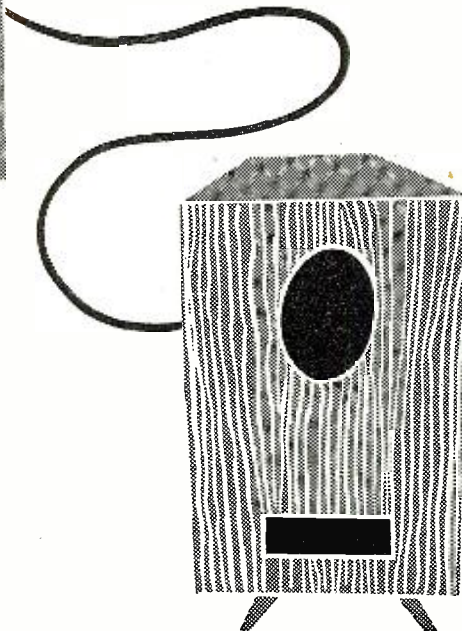

DESPITE a continuing quest for better television reception, which has engendered new antenna design, aluminized picture tubes, color, and a host of other developments, the audio portion of the receiver remains, by and large, relatively neglected. In many

cases, the audio portion of the transmission is delivered to the viewer-listener through the cheapest possible speaker, powered by the minimum circuitry that will provide a pallid but usable facsimile of an FM transmission that was originally of good quality.

The improvements that can be made to the audio portions of TV receivers vary over a wide, unlimited range. They include, at one end, the simple addition of a better speaker and, at the other, the installation of a completely separate FM system tuning over the TV bands. Between these extremes, there are several ways of obtaining satisfying results at low cost. Often modification of the existing audio circuit and the addition of an adequate speaker system will be suf-

ficient, without resort to additional chassis.

A typical TV receiver audio circuit is shown, in part, in Fig. 2. It will be noted that no cathode bias is used in the 6T8 triode circuit, which results in clipping of the audio signal and extreme distortion at high signal levels. Biasing the cathode of this tube with a small resistor would improve the operating conditions of the triode—but would also bias the a.g.c. clamping diode in a positive direction and thus destroy its function.

An alternative arrangement is shown in Fig. 1. Here a negative voltage is taken from the receiver power supply and applied to the grid of the 6T8. Variations in make and models of receiver may require slight changes in the value of R_2 to provide the amount of bias needed to eliminate clipping at normal listening level. This value will usually be on the order of 1 to 2 volts negative.

The voltage-divider arrangement whereby a low "B+" supply of 100 to 150 volts is taken from the cathode of the audio-output tube complicates any proposed improvement to this section of many television receivers. Such a "stacked-B+" circuit has discouraged many an individual bent on extracting better sound from an existing system. However, the existence of this circuit does not mean that no improvement can be made, but only that the final result must produce a low "B+" supply of correct voltage, as given by the manufacturer in his service information.

Referring again to Fig. 2, we see that grid 1 of the output tube receives a positive bias from the "B+" supply. This voltage must be negative in relation to the cathode by approximately 10 volts under "no signal" conditions for good audio. A v.t.v.m. reading should be taken of this voltage and adjustments in value of R_1 , R_2 , and R_3 made to provide the correct operating conditions. In measuring this voltage, it is advisable to connect the v.t.v.m. directly between grid and cathode, rather than to attempt to take separate readings to chassis on a 150- or 200-volt scale. This procedure must be repeated after any changes are made to the circuit.

Capacitor C_1 in the output-transformer circuit of the original set is normally on the order of .02 μ fd., and very effectively removes such unwanted sound as the "hash" associated with poor film copy. This treble cut is not so desirable with live programs and C_1 can be reduced, in most cases, to .001 μ fd. if a simple tone-control circuit, R_4 and C_2 , is installed prior to the audio output stage. (R_4 may have a value of .5 meg. and C_2 may be a .005- μ fd. unit.) A simple alternative which may be more practical in some receivers is the installation of a small, single-pole, single-throw switch in series with C_1 .

An improved audio circuit which can be built into many receivers is shown in Fig. 3. While it is not seriously intend-

(Continued on page 143)

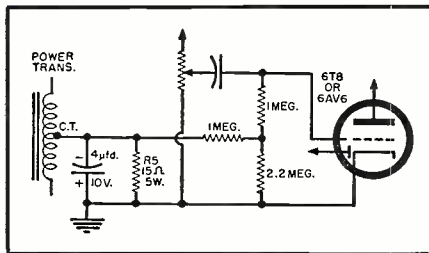
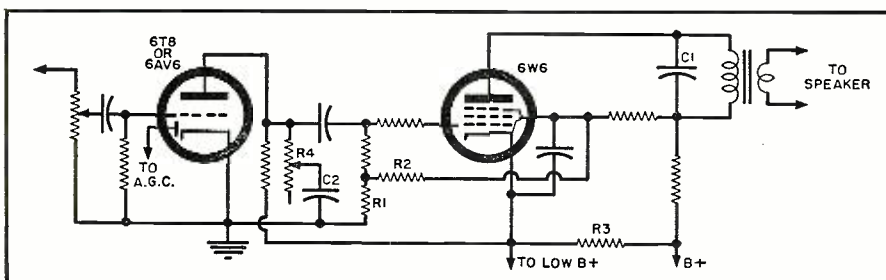

Fig. 1. Improved first audio amplifier.

Fig. 2. Conventional audio amplifier and output circuit in TV receivers.



Transistorized FM Wireless Microphone

By LOUIS E. GARNER, JR.

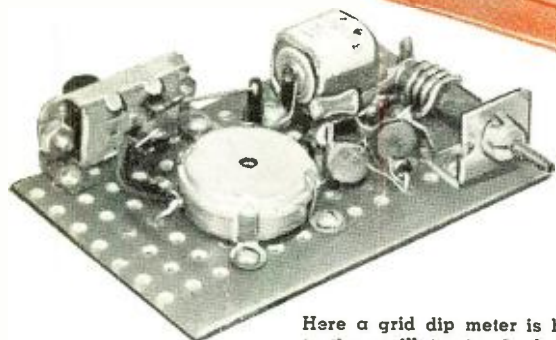

Here a grid dip meter is being coupled to the oscillator to check its frequency.



Stuck into pencil eraser is new tetrode transistor that can oscillate above 200 mc.

Simple one-transistor circuit operates in standard FM broadcast band and employs new tetrode transistor.

EQUIPMENT for v.h.f. has always been of especial interest to most electronics workers, whether they are engineers, experimenters, students, gadgeteers, or technicians. More recently, with the increasing availability of transistors, interest in transistor circuitry has pre-empted interest in most other electronics fields. What is more natural than to combine v.h.f. and transistor circuitry into a single piece of equipment?—a transistorized "FM wireless microphone."

Unfortunately, it was only recently that transistors suitable for v.h.f. work became available.

When the transistor was first announced in 1948, it seemed to offer a solution to several of the pressing problems confronting the radio-electronic industry since it was but a fraction of the size of a vacuum tube, much lighter, and had more modest power requirements.

In addition to all of its other characteristics, the early *point-contact* units had fairly good frequency response. It wasn't too long before commercially manufactured units were available which could be used as oscillators at 50 megacycles and higher (*RCA* type 2N33).

But the point-contact transistor had a number of disadvantages. It was noisy, difficult to manufacture, expensive, and unstable in some types of circuits due to a negative resistance characteristic.

The invention of the *junction* transistor in 1951 supplied industry with a unit which overcame the disadvantages of the point-contact transistor while retaining most, but not all, of its ad-

vantages. The junction transistor was easier to manufacture and thus less expensive, it had low noise, and was just as small as the earlier unit. In addition, the junction transistor had high efficiency and, because it didn't have a negative resistance characteristic, was more stable in practical circuits.

The junction transistor unfortunately had a limited frequency response. The early units were suitable only for audio frequencies. Later, improvements in design, in manufacturing techniques, and in selection methods, permitted the commercial production of junction transistors suitable for use at low to medium radio frequencies.

Today, junction transistors are available for use as amplifiers up to 20 or 30 megacycles.

The Tetrode Transistor

Even though improvements in physical design and in manufacturing techniques extended the upper frequency limit of the common junction transistor to moderate radio frequencies, commercial units still weren't suitable for use at v.h.f. It was the invention of the *tetrode* transistor in 1952 that broke the "frequency barrier." Theoretically, *junction tetrode* transistors can operate into the hundreds of megacycles.

Although invented in 1952, it has only been in the past year or two that junction tetrode transistors have been available as commercially manufactured products and, for a good portion of that time, virtually the entire available production went to the Armed Forces.

The approximate construction of a junction tetrode transistor is shown in Fig. 1A, while the schematic symbol for this device is given in Fig. 1B. Pin connections for the *General Electric* type ZJ7-2 (3N30) tetrode transistor are shown in Fig. 1C.

Physically, the chief difference between a grown junction triode transistor and the junction tetrode unit lies in the addition of a second base lead connection (*Base 2*). If this connection is ignored, the tetrode will function

Fig. 1. (A) The approximate construction. (B) schematic symbol. and (C) base pin connections for the General Electric 3N30 (ZJ7-2) junction tetrode transistor unit.

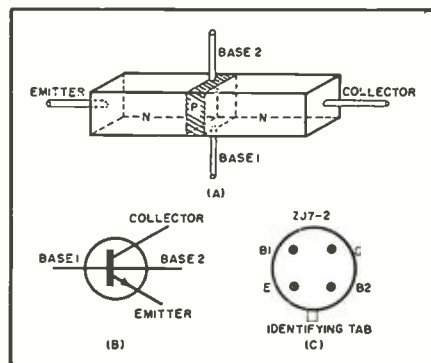

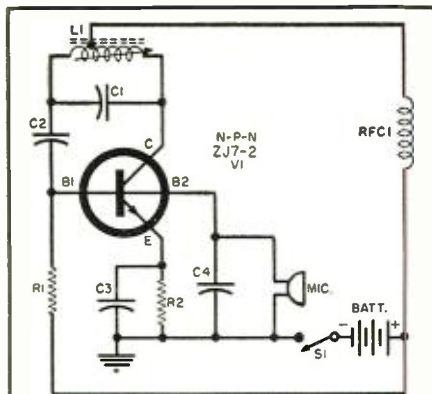

*R*₁—12,000 ohm, 1/2 w. carbon res.
*R*₂—220 ohm, 1/2 w. carbon res.
*C*₁—25 μfd. tubular ceramic capacitor
*C*₂—50 μfd. tubular ceramic capacitor
*C*₃—0.0015 μfd. disc ceramic capacitor
*L*₁—FM wave trap coil from TV receiver (see text)
*RFC*₁—High-frequency r.f. choke (Ohmite Z-144)
*S*₁—S.p.s.t. slide switch
Mic.—1000 ohm transistor microphone, 1" dia. (Shure No. MC-11)
Batt.—6-volt battery (Burgess Y4, see text)
*V*₁—“n-p-n” tetrode transistor (General Electric Type ZJ7-2, 3N30)

Fig. 2. Complete schematic diagram of the FM wireless microphone described here.

quite well as a triode transistor, and will have operating characteristics typical of a triode.

Two factors limiting the frequency response of the triode transistor are its base resistance and its interelectrode (emitter-to-collector) capacity. The addition of the second base lead permits both of these values to be reduced.

In practice, bias currents of opposite polarity are applied to the two base leads (*Base 1* and *Base 2*). The presence of a bias of opposite polarity on, say, *Base 2* forces major emitter-to-collector conduction to take place in the immediate vicinity of *Base 1*. This results in a drop of both base resistance and of interelectrode capacity, thus extending the upper frequency limit of the unit.

Since the two base electrodes require voltages of opposite polarity with respect to each other and to the emit-

ter, many of the early junction tetrode circuits specified the use of two, and frequently three, independent power sources (batteries). However, the author, in his “Transistor Circuit Handbook,” described a basic high-frequency tetrode oscillator circuit which required but a single power supply (battery). A modified version of this circuit, suitable for use as an FM wireless microphone in the range of 88-108 megacycles (FM broadcast band), is given in Fig. 2.

The FM wireless microphone is essentially a low-power frequency-modulated radio transmitter. Referring to Fig. 2, a *G-E* type ZJ7-2 (3N30) tetrode transistor is used as a high-frequency r.f. oscillator.

In operation, the feedback necessary to start and sustain oscillation is obtained by means of a tapped inductance coil *L*₁. The circuit's operating frequency is determined by a resonant circuit made up of *L*₁, fixed capacitor *C*₁, and various distributed capacities, including the interelectrode capacities of the transistor. This last capacity is extremely important, for it is by varying this capacity that we are able to achieve frequency modulation of the oscillator.

The tuning coil, *L*₁, is isolated from the rest of the circuit by an r.f. choke (*RFC*₁). Capacitor *C*₂ serves as a d.c. blocking capacitor and to couple one side of the r.f. coil (*L*₁) to one of the base electrodes (*B*₁).

Base bias currents of opposite polarity are obtained in a unique fashion. Bias for the first base (*B*₁) is obtained through resistor *R*₁. This makes *B*₁ positive with respect to the emitter electrode. The second base (*B*₂) is returned directly to circuit ground through the dynamic microphone (*Mic.*) which, in turn, is bypassed for r.f. by capacitor *C*₃.

The emitter is “floated” above circuit ground by means of emitter resistor *R*₂, bypassed by *C*₃. Since the electron flow is from the negative terminal of the battery, through the “on-off” switch, *S*₁, through *R*₂, from emitter to collector of the transistor, through part of *L*₁, and through the r.f. choke

(*RFC*₁) back to the positive terminal of the battery, the voltage drop across *R*₂, due to emitter current, makes the emitter slightly positive with respect to circuit ground.

But the second base (*B*₂) is returned directly to circuit ground as far as d.c. is concerned. Thus, the emitter is slightly positive with respect to *B*₂, or, which means the same thing, *B*₂ is slightly negative with respect to the emitter.

Thus, we have established the basic conditions for tetrode operation, that is, *B*₁ is positive with respect to the emitter and *B*₂ is negative with respect to the emitter.

One of the operating characteristics of the junction transistor is that its interelectrode capacities change with changes in applied operating bias currents. The tetrode transistor is no exception. Thus, the audio signal obtained from the microphone and applied to *B*₂ causes a slight change in *B*₂'s instantaneous bias. This, in turn, changes the interelectrode capacities of the transistor.

As we have seen, the interelectrode capacities help determine the operating frequency of the oscillator, and changes in these capacities can shift the oscillator's instantaneous frequency, effecting the desired frequency modulation with an audio signal.

It is possible for a slight amount of amplitude modulation to occur simultaneously with the frequency modulation, but any such modulation is small due to the essentially linear operation of the transistor itself. Non-linear operation is necessary for satisfactory amplitude modulation. In any case, whatever amplitude modulation occurs is cancelled out by the limiting action of the FM receiver with which the unit is used.

The circuit's operating power is obtained from a single six-volt battery (*Batt.*), controlled by a s.p.s.t. switch, *S*₁.

The construction details of the author's model are clearly evident in the photographs. All parts are mounted on a small piece of perforated Bakelite board, which serves as a flat “chassis.”

Below “chassis” view of the wired unit showing transistor.

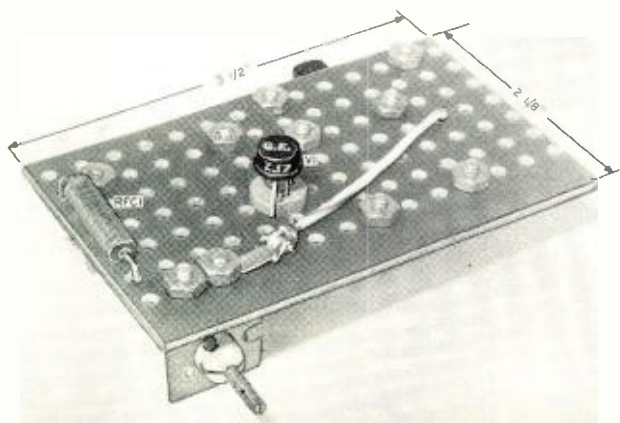

Above “chassis” view showing remaining components in circuit.

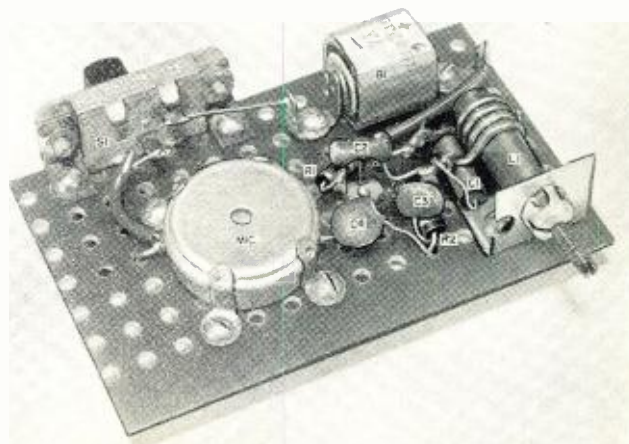

The completed instrument is mounted in a small plastic box.

Except for the battery and the transistor itself, all the components needed for assembling the FM wireless microphone are standard and should be readily available through local distributors or through the larger mail-order supply houses advertising in this magazine.

The ZJ7-2 (3N30) junction tetrode transistor, while a standard type, is a relatively new unit and, because of this, may not be stocked by all parts distributors. If unavailable through regular outlets, this unit may be ordered directly from *General Electric Company, Semiconductor Products, Electronics Park, Syracuse, N. Y.*

(Editor's Note: It is expected that the initial price set for this new transistor will not be lower than about \$30. However, according to G-E, just as soon as there is an increase in the production schedule for this unit, the price will be reduced accordingly.)

The subminiature 6-volt battery shown in the photographs is a type Y4, a developmental battery produced by the *Burgess Battery Company, Freeport, Illinois*. However, any standard 6-volt battery may be used as a substitute for this unit. Suitable types are the *Burgess* type Z4, *RCA* types VS310 and VS307, and *Mallory* type TR-115R. Some changes in circuit layout may be necessary to accommodate different sized (or shaped) batteries.

Tuning coil L_1 consists of four turns of No. 18 tinned bus bar on a form $\frac{1}{4}$ " in diameter, with the turns spaced the diameter of the wire. A powdered iron slug permits an adjustment of inductance and of the unit's operating frequency. The tap is made $1\frac{1}{2}$ turns from the "base end" of the coil. The coil used in the author's model was salvaged from an old TV receiver and served as an FM "wave-trap" in its earlier installation. Except for the tap, no modifications in the original coil were made.

Small "L" brackets, secured with 4-40 machine screws and nuts, were used for mounting the "on-off" switch (S_1) and the coil (L_1). The miniature microphone (*Mic.*) and the small battery (*Batt.*) were held in place with small brackets shaped from soldering (ground) lugs and mounted with 4-40 screws and nuts.

Although a socket is specified for the transistor, the ZJ7-2 tetrode is supplied with moderately long leads and may be permanently soldered into position. If this construction technique is employed, the usual precautions to avoid heat damage should be followed, the lead being soldered is grasped with a pair of pliers between the connection terminal and the body of the transistor. The soldering is completed as quickly as possible, using a hot, clean, well-tinned iron, with the pliers serving as a "heat sink" to absorb excessive heat.

Although the circuit is non-critical—as with any v.h.f. circuit, good layout and wiring techniques are essential to

☆
The FM wireless microphone is shown here with a table model FM receiver which is used to pick up the signal generated.

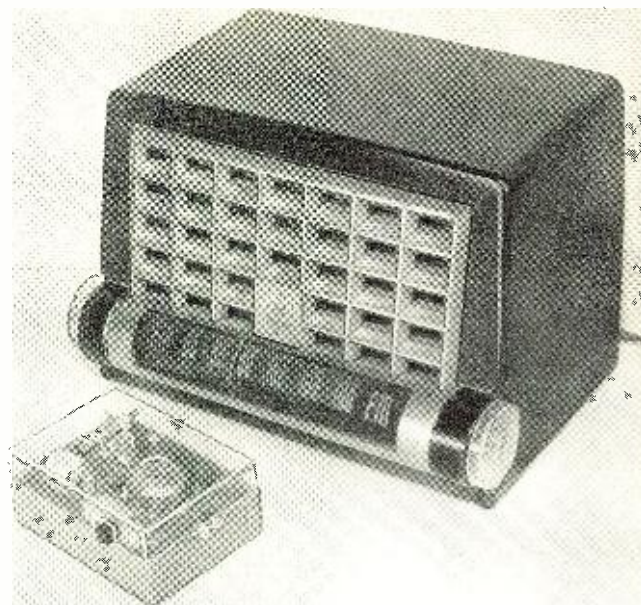

proper operation. All signal leads must be kept as short as is practicable. "Lap" type joints are recommended for all soldered connections.

When the wiring is completed, all connections and components should be double-checked for possible errors before the battery is installed or the unit turned on. Correct battery polarity must be observed.

Adjustment and Applications

The FM wireless microphone is designed to operate within the FM broadcast band (88-108 mc.). Its exact operating frequency can be set by adjusting L_1 's "slug," while its range can be shifted to different parts of the band by varying the size of fixed capacitor C_1 . The author's model, using the values specified in the parts list, operates from 89 to about 98 megacycles.

If available, a high-frequency grid-dip meter may be used for a preliminary "check out" of the completed instrument. The unit is turned on and placed near the pick-up coil of the grid-dip meter. The meter itself is used as an absorption wavemeter and tuned slowly over the band.

Although the power output of the FM wireless microphone is very small, close coupling should permit a definite indication on the meter. The author obtained an easily identified upswing on his *Millen* grid-dip meter when checking his model.

Of course, the unit can also be checked out on any standard FM broadcast band receiver. The receiver is turned on and allowed a normal "warm-up" time. Its volume control is turned up full. The FM wireless microphone is held fairly close to the receiver (3 or 4 feet away) and turned on. No "warm-up" time is needed! While the operator talks, sings, or whistles into the microphone, the receiver is tuned slowly over the band. (L_1 's "slug" should be in mid-position.)

Since there is no separate audio stage, the microphone is designed to be

held fairly close. The operator should speak in a moderately loud voice, but he doesn't have to "yell."

In some cases, depending on the sensitivity of the receiver with which the instrument is used, it may be possible to obtain audio feedback between the receiver's loudspeaker and the instrument's microphone as the signal is tuned in. This will result in a "squealing" similar to that experienced with p.a. systems when audio feedback takes place.

The author obtained feedback and "squealing" with the instrument about 4 or 5 feet from a relatively insensitive FM receiver.

Note that no antenna is shown either in the schematic diagram, or in the photographs of the author's model. Using the radiation of the oscillator coil (L_1) alone, it was possible to pick up the FM wireless microphone at distances of 25 to 30 feet from a relatively insensitive table model FM receiver. With a more sensitive receiver, or a high quality tuner, reception at 50 to 100 feet, or more, should be feasible.

While a simple antenna may be added, if desired, the author recommends that the use of an antenna be avoided if at all possible. FCC regulations specify that the signal strength of an unlicensed device shall be not more than 15 microvolts/meter at a distance of wavelength divided by 2π (6.28) from the radiating source. At 100 megacycles, this comes out to just about *one and a half feet!*

In use, the FM wireless microphone should be adjusted to an operating frequency which falls at a "dead" spot on the FM receiver's dial.

REFERENCES

1. Wallace, Schimpf & Dickten: "A Junction Transistor Tetrode for High Frequency Use," Bell Telephone Laboratories Monograph No. 2089.
2. Garner, Louis E., Jr.: "Transistor Circuit Handbook," Coyne, distributed by Howard W. Sams & Co., Inc.
3. Thomas, D. E.: "F-M Transistor Transmitter," *Electronics*, April, 1956, pgs. 220, 222. Abstract from Bell Laboratories Record of February, 1956.

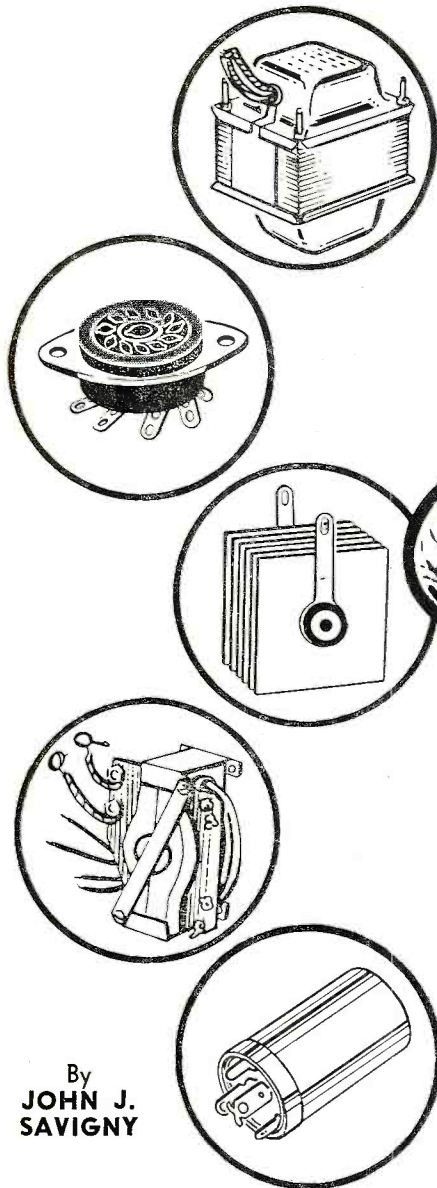

A Nose for Servicing

By
**JOHN J.
SAVIGNY**

You were born with a cost-free, maintenance-free troubleshooting accessory. Learn how to use it.

MANY systems have been evolved for servicing radio and TV. Some are designed to equip the inexperienced technician with as nearly a fool-proof system as possible to lead him to the fault eventually, even if the route is sometimes laborious and time-consuming. Signal tracing, voltage measurement, resistance measurement, and the like all have their merits. These techniques have been deservedly honored by long-time practice. However, they are not the only techniques available to us; other methods, less universal in application, are often extremely useful.

Many practicing technicians soon learn the value of audible and visible clues. For instance, the customer can often supply information that leads directly to, or at least hints at, the trouble. The quality or lack of sound very often tells the exact trouble. For example, a radio that has absolutely no

sound frequently has an open voice coil or output transformer. Of course if, in taking the receiver apart, we find a handful of resistor chips in the cabinet we will not rush for the oscilloscope, but rather look for the damaged resistor which may indicate a heavy overload.

The successful technician learns to apply to the receiver that system or combination of systems that experience tells him will most quickly lead to the faulty component, after analyzing the information he has picked up from the customer and from visual and audible clues that come his way while handling and examining the set.

One set of clues often overlooked, forgotten, or not fully appreciated is that group indicated by certain distinctive scents associated with the trade. Very often these too can lead us directly to the trouble, or at least speed our discovery of the fault and

save us time in selecting, assembling, and using the necessary equipment.

No technician is ever likely to forget the overpowering and unmistakable odor of the first power transformer he encountered that was really cooked. This clue is conclusive and final. In a case like this, we can quickly find the cause from the few possible ones and can probably give a rough estimate of the cost of repairs for the customer without even removing the back of the receiver.

In the case of the burned power transformer, as in the case of most odors associated with various defects, it is difficult to convey a fully adequate impression of what the sense of smell can recognize. We can go as far as saying that the smell of burning is present, for example, but this may not be enough to establish immediate recognition the first time a cooked transformer is encountered. However, once the technician is alerted to possibilities, he is well on his way, and can file the odors in his memory after the first encounter for future use.

Another distinct olfactory clue is that of the exploded dry electrolytic capacitor, which can be described as pungent. Once encountered, it is likewise not easily forgotten. This clue also points to a very few probable causes which can be narrowed down with less equipment in less time.

A third and less obvious smell is that of a cooked composition resistor which, although less persistent, is no less distinctive and is equally effective in leading the technician to the trouble.

When selenium rectifiers go, the strong stench that results, often compared to the odor of rotten eggs, leaves little doubt as to which component has been affected.

Searing Bakelite is not too commonly found but should lead us, with a little directional sniffing, to the cause. This will most often be an arc in the output stage of a high-power audio amplifier, and can be discovered as a charred track in the tube socket or base. Overheated Bakelite will sometimes blister, providing a corroborating visual sign. Here again the underlying cause will probably be an open capacitor and can be easily located with little or no equipment.

There are other possible faults that will give tell-tale odors, and they are associated with overheating, arcs, shorts, grounds, and excessive currents. It is in the discovery of troubles that are not visible because of shield cans or other obstructions that the olfactory clue is most helpful. For example, the primary of an antenna coil will occasionally take 110 volts as a result of the breakdown of capacitors and the use of grounded antennas. This defect may not be visible and may even continue to leave a reasonable resistive reading, but can sometimes be tracked down through the odor left by the burnt varnish and cotton insulation.

Television is, of course, subject to

(Continued on page 122)

Summer Service

CONDENSER FAN WITH SLINGER RING

REFRIGERANT CONDENSER

VIBRATION ISOLATOR

COMPRESSOR OVERLOAD PROTECTOR

HERMETICALLY SEALED MOTOR COMPRESSOR

ROTARY SWITCH AND COVER

FRESH AIR DAMPER

JET SCOOP

TWO-SPEED FAN MOTOR

EXHAUST DAMPER

EVAPORATOR BLOWER WHEEL

SOUND INSULATED OUTLET DUCT

By **JOSEPH DERMAN**
Engineer, Service Department
Emerson Quiet-Kool Division



Fig. 1. This cut-away view of a modern room conditioner will help the technician correlate components in the unit's operating cycle with the actual layout.

HEATING ELEMENT

FUSIBLE LINK THERMAL PROTECTOR

REFRIGERANT EVAPORATOR

CONTROL KNOB OPERATES SWITCH AND DAMPERS

THERMOSTAT SLIDE KNOB

AIR FILTER

FRESH AIR GRILLE

Room Air Conditioners

Electronic technicians can ride the hot-weather business slump with air-conditioner work. An expert tells what goes wrong and where to look.

THE ROOM air conditioner may be just another electrical appliance to tax the already overburdened house wiring, but it can also afford the electronic technician a source of income during the TV slack period.

Troubleshooting in air conditioning requires a systematic approach similar to that used in TV or radio. In air conditioning, it is helpful to think in terms of localized but related functions and systems, as we think of block diagrams in TV circuits. The electrical circuits supply power to the fan and the compressor. The inside room air brings the excess heat and humidity to the air conditioner, where the refrigerant system provides the means of transferring this undesirable heat and moisture to the outside air. The contact between the air-conditioning unit and the outside must be intimate.

Let us consider each function in turn. Essentially the basis of mechanical refrigeration is the well-known principle that evaporation causes cooling. This is so because the heat energy that is required for change of state from a liquid to a gas must be drawn from somewhere. It may be the fire under the pot of boiling water or the human skin from which, say, a drop of alcohol evaporates. To cool a room, then, all we need is a liquid for evaporation. Water, though cheap, is impractical. There are other more suitable liquids, called refrigerants, that absorb heat more efficiently from their surroundings as they evaporate.

The refrigerant that is now used very widely in room air conditioners is Freon-12. It is fortunate, indeed, that this chemical, suitable for use as a refrigerant because of its property of evaporating at temperatures as low as -21.6° F. at atmospheric pressure, is also non-toxic, non-irritating, non-explosive, and odorless. A human being would not be harmed if he were in an atmosphere which contained as much

as 30% (by volume) of Freon-12. In the presence of an open flame, however, Freon-12 breaks down chemically, and produces gases that are extremely irritating to the nose and throat. Also used in the latest units is a new, related chemical with essentially the same properties, Freon-22.

All modern air-conditioning units contain a compressor, which is the mechanical means of driving the Freon around a complete path or circuit as shown in Fig. 2. The room side of this circuit contains the evaporator, an arrangement of copper tubing and surface-extending fins made of copper or aluminum. It is in this circuit element that the liquid Freon evaporates and thus absorbs heat of the room air as this air rushes over the tubing and between the fins. The compressor acts to draw all of the vapor out of the evaporator, in the direction shown, into itself. There the vapor is compressed (and raised in temperature to above that of the outside air). Then it is forced into the condenser, an arrangement of copper tubing and fins similar to that of the evaporator. At the condenser, another heat transfer occurs; namely, the heat of the compressed Freon now flows to the outside air that circulates about the condenser fins.

As the Freon progresses through the copper tubing of the condenser and as its heat is given up to the outside at-

mosphere, the Freon condenses and again becomes a liquid. The copper capillary tubing is of much smaller bore (inside diameter) than the tubing of the evaporator or condenser. It thus controls the rate of flow of the Freon through the system as well as separating the high pressure in the condenser side from the low pressure of the evaporator side.

The capillary tubing leads to the evaporator, where all of the delivered Freon liquid will evaporate. This cycle keeps repeating, yielding much cooling with a small amount of Freon.

With this much of an idea as to how the basic cooling system operates, it would be a good idea to examine a modern window conditioner (Fig. 1) to establish some idea of physical arrangement.

The Air System

You can see now, from the lower portion of Fig. 2, where the air streams fit into the picture. The room air is brought into the conditioner by means of a special type evaporator blower fan, and is made to come in intimate contact with the evaporator. In the latter unit, not only is the heat of the room air given up, but also the water vapor, which is responsible for humidity of the room air, is deposited. This latter action takes place because the cooler the air, the less moisture it can

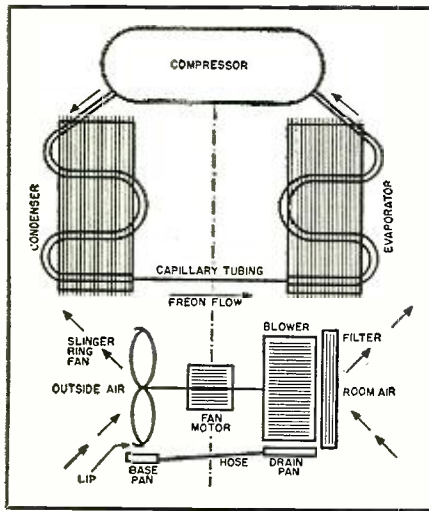

Fig. 2. The closed system through which the refrigerant moves as it goes through the evaporation-condensation cycle is at the top. The associated air-flow system is at the bottom of the illustration.

hold. The condensate (water that has condensed out on the evaporator) is collected and piped to a pan beneath the condenser.

A second fan found in the air-conditioning unit is the condenser fan. This propeller device is of the slinger type, having a lip about the blade tips so arranged that it can scoop up the condensate and sling it against the condenser to aid in cooling and thus liquefy the vapor Freon.

Another important element in the system is the air filter. It is inserted in the unit on the room side and removes dirt, pollen, and other foreign particles from the room air—sometimes from the outside air as well. Let us merely say now that, when this filter is very dirty, it may seriously interfere with the air flow and consequently with the entire cooling operation.

The Electrical System

Generally there are two induction-type motors in the air conditioner: one is used for the compressor while the other operates the fans. It may be recalled that this type of motor has a.c. applied to the windings on its stator,

or stationary winding. The alternating field set up by the applied voltage influences the rotor, or rotating member, setting it in motion. Motors of this type are the most widely used in a.c. applications, because they are rugged, simple in construction, and require no commutators.

An important consideration with the induction-type motor, however, is that it will not start on the usually available single-phase a.c. supply unless special techniques are used. Two favorite techniques found in air conditioners are the shaded pole and capacitor dividing.

The Shaded Pole: This method of adapting the induction motor to the single-phase line is used on very low or fractional horsepower motors, like those found in electric clocks—and fan motors of air-conditioning units. In construction (see the upper right-hand portion of Fig. 3), a single, closed turn of heavy copper bus, the starting (shaded) winding, is embedded around a portion of each stator pole. The a.c. power is brought to the main or running winding, which encircles the entire stator pole. The effect of the shaded pole on starting is to set up a magnetic field out-of-phase with the field established by the main (running) winding.

An alternating field is thus created that is sufficient to start the motor. At full speed, the starting winding becomes ineffective, only the running winding being necessary for continued operation. It is interesting to note that, with a given set of windings, there will be only one final speed. To obtain an additional speed, it is necessary to have an additional winding. This is actually done on some units.

Capacitor Dividing: In larger motors, such as the compressor uses, the rotating magnetic field in the rotor is developed by splitting the single phase with a capacitor and starting winding circuit that is placed across the main (or running) winding. Here also this starting circuit becomes ineffective when the motor reaches speed—but by means of a cut-out device; namely, the starting relay. In the illustration (Fig. 3, lower right), the initial surge of current through the relay coil closes

the normally open contacts and thereby completes the starting circuit (starting winding and starting capacitor). After starting is accomplished, with the aid of the running winding, the current through the relay decreases as the compressor comes up to speed. The relay contacts open and the running winding alone remains in the circuit.

The components of the electrical system may now be discussed.

The Fan Motor

Whether designed for 115 or 230 volts, the fan motor is of the single-phase induction type using the shaded-pole starting principle, as explained. One fan motor may be used to rotate both fans by using a double-ended shaft, or two fan motors may be used. This is a design consideration.

Sealed Motor-Compressor

This hermetically sealed unit is an achievement of modern production, being compact, efficient, and noise free. Because the motor-compressor is totally enclosed, air-tight, leak-tight, and assembled under conditions of meticulous cleanliness, it has been known to provide 15 years of trouble-free service. The compressor is of the reciprocating type. The motor is a single-phase, induction unit using split-phase (capacitor) starting as explained.

Starting Relays

As the name implies, these relays serve the purpose of assisting in the starting operation by momentarily inserting the starting circuit. The current type, shown in Fig. 3, depends on the initial rush of current through the relay coil to close the contacts momentarily, and thus insert the starting circuit. The voltage type, shown in Fig. 4, has its contacts normally closed. With the voltage applied, and after the compressor motor has almost reached full speed, the contacts open to remove the starting capacitor.

In this account, it is not possible to consider all possibilities that can be explored when a conditioner ceases to function properly. It will be assumed, for example, that the horsepower rating of the unit is adequate to meet the load at hand. Nor will the question of a heat-load survey, which is a detailed evaluation of cooling requirements, be raised. We will assume that a unit which has been properly chosen for its load and properly installed has developed trouble after some period of satisfactory operation, and that the technician has been called in. With this orientation, some common symptoms can be treated.

Fuse Blows Repeatedly: The line fuse should immediately be checked to see if it is of the thermal-delay or time-lag type and of the correct rating for the particular unit. This type of fuse is necessary because the induction motors of the air conditioner require a starting current that may be three or four times the normal running current. Only the delay type of

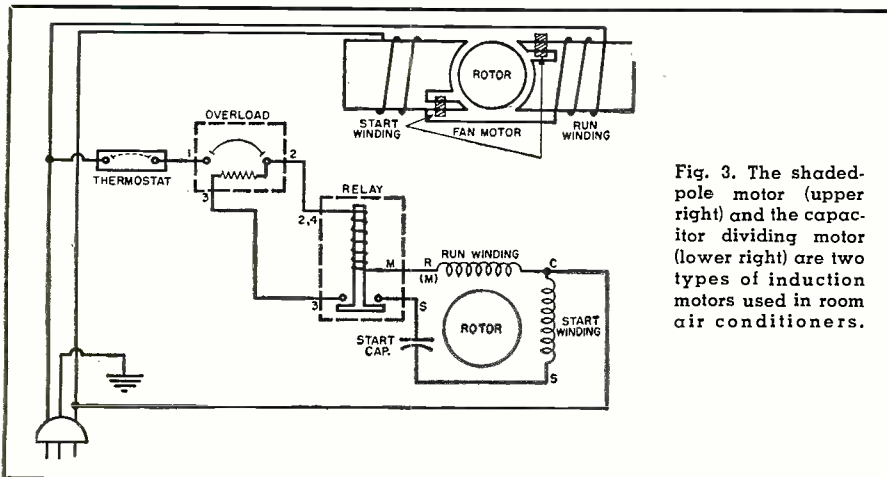

Fig. 3. The shaded-pole motor (upper right) and the capacitor dividing motor (lower right) are two types of induction motors used in room air conditioners.

fuse permits the initial surge to pass without blowing and yet guards against a sustained short.

If the delay type of fuse blows, the reason may be low line voltage at the unit. The voltage at the conditioner should be within $\pm 10\%$ of the rated value under conditions of full load. This is another requirement characteristic of induction-type motors; namely, that low voltage (and to a lesser degree over-voltage) may cause a severe current drain. (To minimize line voltage drops, use a cable of AWG #14 wire or better as an extension cord if necessary.) Of course, a dead short or even a low-resistance short in the electrical wiring or components may cause the fuse to blow. Shorts to be investigated with the aid of the familiar ohmmeter can appear with respect to the chassis or across the lines and are located by familiar step-by-step methods.

A more serious condition causing blown fuses is an inoperative compressor. Whether the compressor is itself defective—possibly stuck—or whether an associated component is faulty, the net effect is the same: if the compressor does not run, the current drain will be excessive.

Fig. 5 shows the test cord widely used to check the operation of the compressor directly. Electrical components are removed from the terminals of the compressor and power is applied by means of this test cord. A good capacitor of rating identical to that of the start capacitor of the air-conditioning unit must be used in the cord. Note that the start lead "S" does not have a clip. This serves as a reminder not to keep this lead connected to the start winding for more than a few seconds.

If the compressor operates now, then some circuit component is at fault. If, however, the compressor is found to be defective, the air conditioner will have to be removed to the repair shop. It can be appreciated, by examining the simplified electrical circuits, that a defective start winding or start capacitor will prevent the compressor motor from going into operation. This, in turn, will cause high current drain. A component substitution method (for the capacitor) or an ohmmeter check can be made on both the start winding and start capacitor.

Unit apparently operates but cooling is inadequate: A single factor may cause this condition or many factors may contribute to the same net effect. It was stated previously that the air stream on the room side brings the heat and moisture to the air conditioner. The evaporation of the liquid Freon is facilitated and cooling accomplished. The filter must be clean enough to allow sufficient room air to reach the evaporator. A dirty filter is a very frequent source of trouble.

In fact, any reduction of the flow of room air to the air conditioner brought about by obstructing draperies, clogged filter, fan motor not running, evaporator blower slipping on its shaft, frost on the evaporator, and the like will seriously interfere with the cooling effect

of the air conditioner, although the unit may itself be sound.

The outside air stream, as explained, is instrumental in liquefying the Freon gas. Here, too, any interference with the air flow—dirty condenser, fan motor not operating, condenser slinger fan slipping on its shaft, obstructed outside louvers, and the like—will seriously impair the working efficiency of the unit. It was also stated that the collected condensate aids in liquefying the Freon gas, by being picked up by the slinger ring and directed against the condenser. If the slinger ring does not scoop up water, or if the hose from the drip pan is clogged, or is off its spud, or if the tilt of the conditioner is such as to prevent the accumulation of water under the condenser fan, the cooling action will be reduced materially.

The electrical and physical shortcomings mentioned can be rectified without too much difficulty. The frost on the evaporator, however, usually is evidence of the escape of some Freon from the system, and means that the unit should be removed to the shop. Caution should be exercised here since an obstructed air stream, electrical shortcomings, and low temperatures may also cause freeze up. These should be eliminated first.

Another possible source of noise is the compressor. It is secured by tightened hold-down bolts in transit. In the case of units of $\frac{3}{4}$ horsepower or more, however, three of the four bolts must be loosened for proper operation. Check to make sure that this has been done. Also, there are external spring and rubber shock mounts on the compressor. These are also worth checking.

Another important consideration is the installation. The air conditioning unit must actually be sealed in at the window. For most effective operation, the amount of air exchange with the hot outside air must be at a minimum; *i.e.*, all leaks must be sealed.

Other Troubles

The compressor goes on and off: The thermal cut-out is merely doing its job of protecting the compressor against overload. This current overload may be developed by the compressor attempting to work too hard under such conditions as high or low voltage, obstructed air streams, improper operation of condensate system, or partial short in the electrical system. The thermal overload could also be ac-

Fig. 5. This handy test cord, easily made up, is in common use for checking the operation of the compressor.

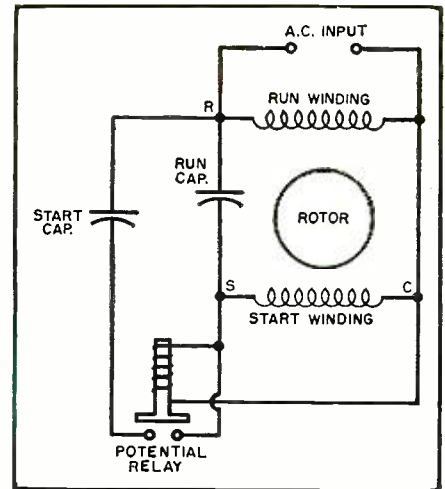
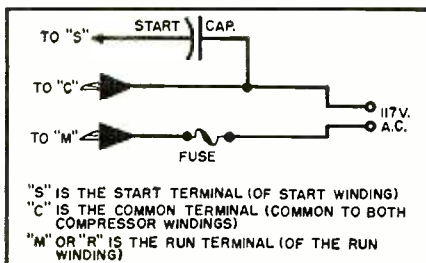

Fig. 4. The voltage or potential relay, across the start winding but in series with the start capacitor, has its contacts normally closed. As the motor comes up to speed, its windings open to remove start capacitor from the circuit.

tuated by an usually high temperature on the exterior of the air conditioner. An awning over the unit may eliminate this difficulty.

In this connection, don't forget that the thermostat also turns the compressor on and off. If the compressor is cycling too frequently, the thermostat may need checking, or it may be that the cooling load is so light that the thermostat is easily satisfied. Since constant "on-off" operation of the compressor is not desirable, it is a good idea to keep the door of the room slightly ajar when the load is light. The small increase in the load thus produced will prolong the "on" periods and cut down excessive cycling.

Unit noisy: Examine for loose mechanical parts, vibrating tubing, striking of misaligned blades. Loose parts can be secured; vibration of tubing can be located by touch and minimized by wrapping that portion of tubing firmly with heavy lead gasketing material. The motor mounts or fan mounting should be examined to see if adjustments can be made to alleviate troubles arising in these units.

Fan operates but compressor does not: An examination of the conventional circuit will readily suggest a point-to-point check procedure to see where the voltage is lost. A simple but convenient device is to use a jumper wire to short out individual components such as the selector switch, thermostat, relay, and others. This is all well and good providing the compressor is itself satisfactory.

The air conditioner is an accepted appliance in the modern home and its value as an aid to health, comfort, and cleanliness has been accepted widely. If selected properly, installed correctly and given moderate attention, it will provide its owner ample return for his investment. Servicing the air conditioner requires a working knowledge of the principles of its operation. This endeavor can also be varied and interesting.

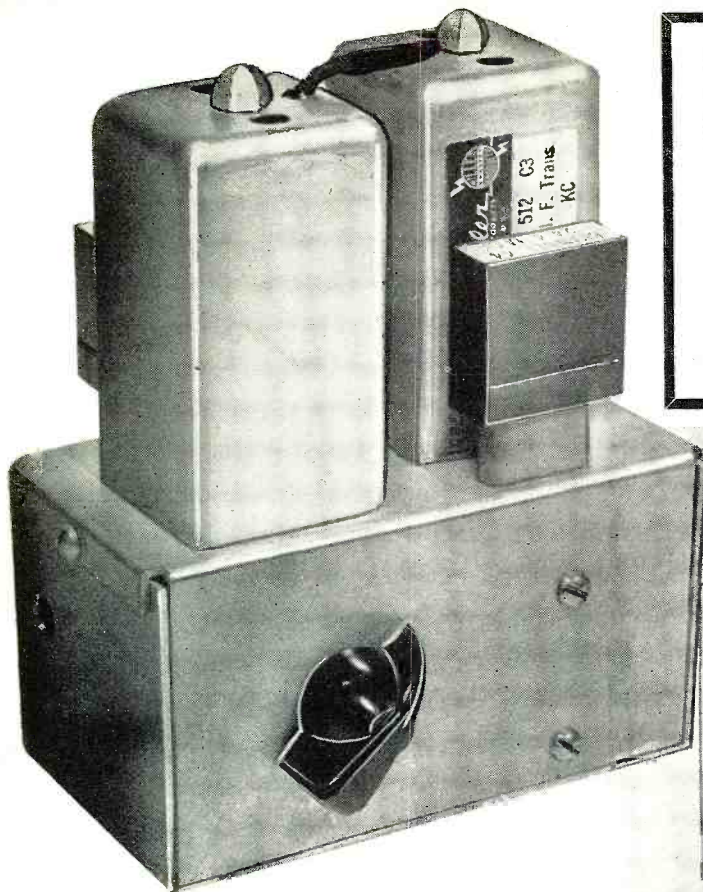

Super Selectivity with Crystals

By RICHARD F. BURNS, W9NVC

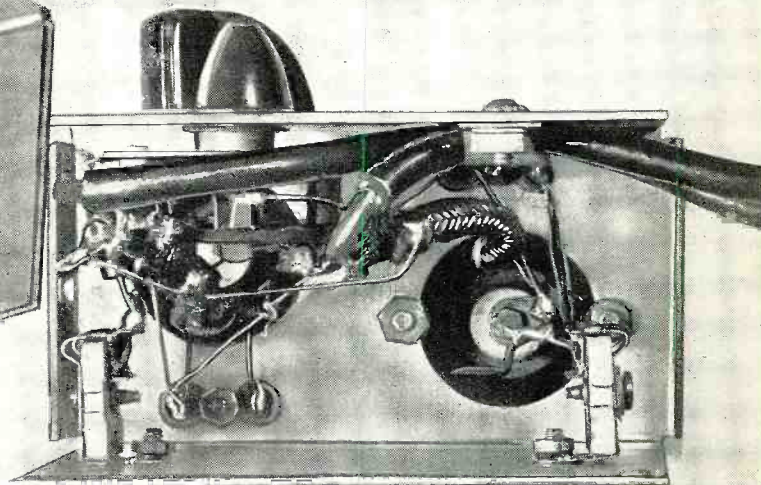

Views of crystal filter described below.

Improved c.w., phone, and single-sideband reception for your receiver with an effective crystal filter.

BECAUSE of excessive crowding in the amateur bands, an i.f. stage filter in the communications receiver is considered a necessity by most amateur radio operators today and it is for this reason that radio manufacturers include a filter as standard equipment with their higher-priced communications receivers. In their striving for extreme selectivity, manufacturers have resorted to crystal filters, mechanical filters, complicated coil and capacitor filters, and dual conversion in conjunction with a low second i.f. The crystal filter, in one form or another, is still the favorite among hams, however, because of its simplicity, stability, and relative low cost. The filter to be described rivals the best narrow-band mechanical filters available today insofar as selectivity characteristics are concerned; has no greater passband insertion loss than a mechanical filter; and can be constructed for less than the cost of an additional i.f. stage, if the FT-241-A crystals now available on the surplus market are utilized.

The filter circuit itself is a modification of the pilot frequency selecting filters used extensively by the British Post Office Department. It can be constructed from standard i.f. stage parts and presents few constructional diffi-

culties, as can be seen from the photographs. Alignment of the filter may present some problems; but, if the instructions given in the text are followed, success is assured.

The filter consists of two "half-lattice" filter sections connected "back-to-back" in a configuration designed to make it possible to insert the filter into the i.f. section of any receiver having the appropriate i.f. frequency with a minimum of impedance matching difficulty. In addition to impedance matching ease, the "back-to-back" configuration has several advantages over the conventional crystal filter circuit which employs one crystal in conjunction with a phasing capacitor in a single section "half-lattice": Twice the discrimination possible with the usual commercial crystal filter may be obtained; and, since the attenuation outside the maximum rejection frequencies is so much greater than that obtainable with the conventional filter, the external phasing control may be eliminated—the maximum rejection frequencies being permanently fixed by trimmer adjustment during the alignment procedure. Much of the inconvenience experienced with phasing out undesired signals with the conventional filter is thus avoided, since the filter is always in correct operating condition

and may be merely switched in and out of the circuit like a mechanical filter.

Theory of Operation

In operation, each "half-lattice" section of the filter will have a maximum attenuation point ("rejection slot") at the frequency where the reactance of the crystal arm is equal to that of the capacitor arm. It will attenuate in the region where the reactances of the crystal and capacitor arms are most nearly equal and will have a passband where the reactances of the arms are of opposite sign. This is illustrated in Fig. 1. In practice, due to resistance in the circuit, stray coupling, impedance mismatch, and other factors, the attenuation vs frequency curve of one section of the filter will have the form of the dashed curve shown in Fig. 2.

As to the bandwidth possibilities of this type of filter, it should be noted that the difference between the parallel resonant frequency of the crystal and its shunt capacitance—($f_0 - f_c$) in Fig. 1—is one limiting factor. With a given value of crystal shunt capacitance, the smaller this difference, the smaller will be the possible maximum bandwidth of the filter. Thus, we may make the filter as narrow as we like by increasing the crystal shunt capacitance, but, with the FT-241-A crystals, we are limited to a maximum passband width of approximately one kilocycle at the 3

All Your Eggs

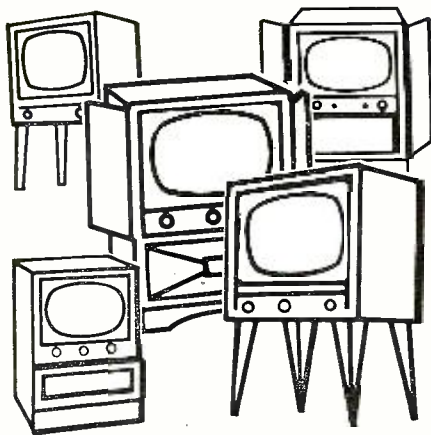
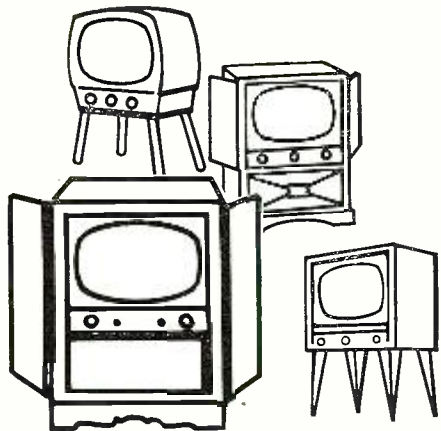

In One Basket?

By **WILLIAM LEONARD**

A service-industry leader questions the wisdom of diversification. Here is one view on his stand.

IN A RECENT issue of "ETAT News," Vern La Plante questioned the wisdom of urging small service dealers to diversify their activities. In his letter Mr. La Plante, who is chairman of the Electronic Technicians Association of Toledo, said: "In this age of specialization, it is hard to understand why Mr. John Rider and Mr. Paul Wendel advocate diversified service in order for independent service shops to survive and be able to compete with factory and captive service.

"It is known that some small independent service shops repair only one or two popular makes of receivers, and they enjoy a profitable business. Others specialize in record changers, tape recorders, etc., and others in communications equipment.

"While diversified service might be good and profitable for a large, well equipped shop, it might well be the death knell of the small, one- or two-man shop."

Mr. La Plante's line of reasoning about the need for specialization in the small one- or two-man shop would be very sound if we were operating in a static economy. Then the small dealer could be sure that the same brands and the same types of products would still be with us five or ten years from now. But, in our dynamic economy, the service dealer who concentrates his attention and effort on a single type of product or consumer service builds his future on quicksand. He is in constant danger of being submerged by the tide of change that is part and

parcel of the rapidly changing electronics industry.

The trend of the television service business during the past few years should make every small service dealer wary of product or activity specialization. TV is a young industry. Ten years ago everyone said it would kill radio within a decade. Today TV is flourishing while radio is booming.

In a span of less than ten years, including a period when its progress was impeded by a freeze on expansion, TV set sales have reached a point of virtual market saturation. During the past two years many well-known and respected brand names have disappeared from the scene. Sets bearing the names *Crosley*, *Stromberg-Carlson*, *Capehart-Farnsworth*, *CBS-Columbia*—to mention just a few—are now orphans that will soon be replaced by one of the surviving brands.

During the boom days an independent service industry that was capable of handling the maximum work load of servicing and installing consumer sets came into existence. As the business levelled off, the quality of the sets improved. This decreased the normal incidence of service per set and, of course, decreased the number of service calls per set.

Concurrently with the levelling off of sales, TV programs started to lose some of their appeal to the general public. Statistics show that the time spent by the average family in watching TV programs has dropped as much as seventeen per-cent in some areas.

This means less set use and a longer time interval between service calls.

Improved sets plus a gradual falling off of public interest in TV results in a decrease in the over-all volume of TV service calls. Then self-service tube testers were installed in drug stores and other convenient traffic locations. That made it easy for set owners to test their own tubes and save money on service charges. With case histories of eight out of every ten service jobs completed in the home by the simple replacement of burned out or defective tubes, the independent service industry was highly vulnerable to lose a portion of this easy business.

The fourth factor to thrust its way into the consumer service market, at the expense of the independent service shop, is the steady expansion of factory service either through direct factory depots or the manufacturer's product distributors. Captive service will deprive independent service shops of a much larger share of the consumer service business, particularly in metropolitan areas.

Financial agencies, in their reports to investors, take a dim view of the prospects for consumer TV for the current year. While they are very optimistic over the prospects for the electronics industry as a whole, they feel that consumer TV will continue to founder until color television starts to move.

In the light of these trends and developments, the shop that specializes in consumer TV service is operating in a steadily diminishing market. This market will continue to deteriorate for the independent shops until some new development, such as an upsurge in consumer interest in color TV, adds a new impetus to the need for service.

The operator of even the smallest type of service business should look upon his operation as a business as well as a technical activity. From a business standpoint, it is not economically sound to continue to specialize in a field that is steadily deteriorating. On the other hand, it is unwise to take on just anything to accomplish diversification. The servicing of automatic appliances, for instance, requires specialized knowledge and skills. No electronic service technician or dealer should solicit this kind of work unless he is trained to handle it. This kind of diversification often has been accomplished through the merger of electronic and appliance service shops.

In a survey conducted a couple of years ago on supplementary activities handled by TV service shops, the returns indicated that small service dealers have found more than two hundred ways in which to diversify their activities to lift some of the overhead burden off the back of their TV servicing work.

Based on a survey of community needs in the area surrounding his shop, one dealer revamped the front part of his building to house a greeting card and novelty center! Managed by his

(Continued on page 142)

Portable Tape Recorder Amplifier

By J. E. PUGH, JR.

THE current requirements as well as the impedance levels of the transistor and the tape recorder are of the same order of magnitude and, as a result, some interesting simplifications in the design of a recording and playback amplifier are possible.

The amplifier to be described was designed for portable use for voice and medium-quality music recordings with the aim toward simplicity, versatility, low battery drain, and small size and weight. It was designed for use with the *Shure* Model 815 combination record and erase head, but any other head can be used as it is a very simple matter to adjust the bias, record, and erase currents where the requirements are different.

A calibrated potentiometer at the input permits any input signal in the range from 1 millivolt to 3 volts to be recorded and thus includes practically all of the usual signal sources.

The maximum output level is approximately 100 milliwatts into a built-in 3" PM speaker. A jack is provided so that an external 3.2-ohm speaker can be used, and a second jack permits monitoring of the signal across the recording coil.

The current drain on B_1 is about 45 ma. for record and erase and about .5 ma. for playback. The "at rest" drain on B_2 is 7 ma. At full output it is increased to about 35 ma. (on peaks) by the class B output stage. With ordinary intermittent use the batteries should last at least 300 hours.

The entire system, including amplifier, speaker, and batteries, is housed in a "Fleximount" #29442 (4" x 5" x 6") aluminum case and weighs 3½ lbs. One pound of this weight is accounted for by the batteries.

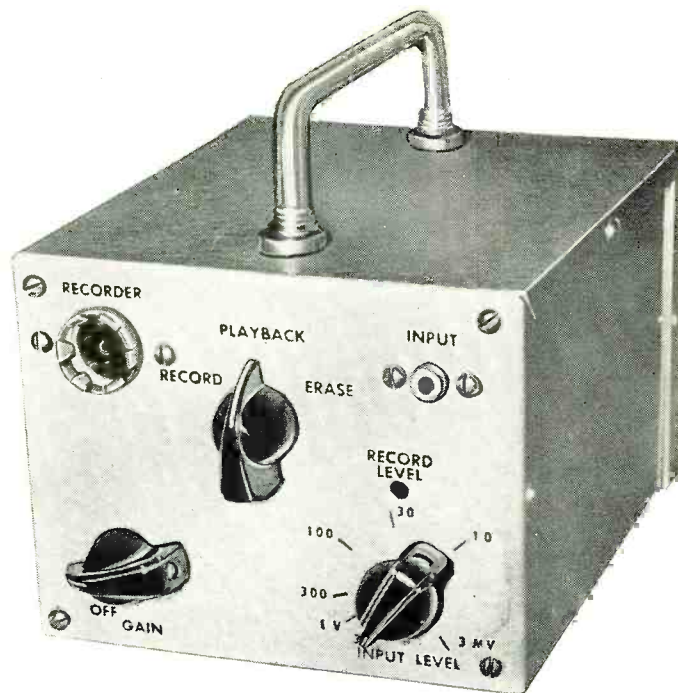

Fig. 1. Front over-all view of the transistorized portable tape recorder amplifier.

Transistorized circuit features simplicity of design, small size, lightweight, adequate tone for many uses.

Although the unit was designed to be used as a recording and playback amplifier, it makes an excellent general purpose amplifier as is. Simply turn it on and use it.

A shielded phono pin-jack on the front panel is used for the signal input, and a shielded 4-conductor jack is used to connect the recording and erase heads into the amplifier. This second jack, J_1 , is indicated in the schematic diagram by showing its terminal numbers, 1 to 4, on the ends of the recording and erase coils.

The function selector is a three-pole, three-position rotary switch with the three functions being "Record," "Playback," and "Erase." In the "Record" position the input jack, J_1 , is con-

nected to the amplifier input, the erase coil is energized by B_1 , and the recording coil is connected to the output of the amplifier.

In the "Playback" position the input jack is disconnected, the erase coil is de-energized, the recording coil is switched from the recording amplifier output to the playback amplifier input, and a resistive load is connected into the output circuit of V_0 to replace the recording coil.

In the "Erase" position the recording coil is disconnected, the amplifier input is grounded, the erase coil is once again energized, and the resistive load remains in the recording amplifier output circuit.

The recording and erase coils are



Fig. 2. Bottom view of the completed unit with the bottom of the aluminum case removed to show the batteries and the general over-all layout.

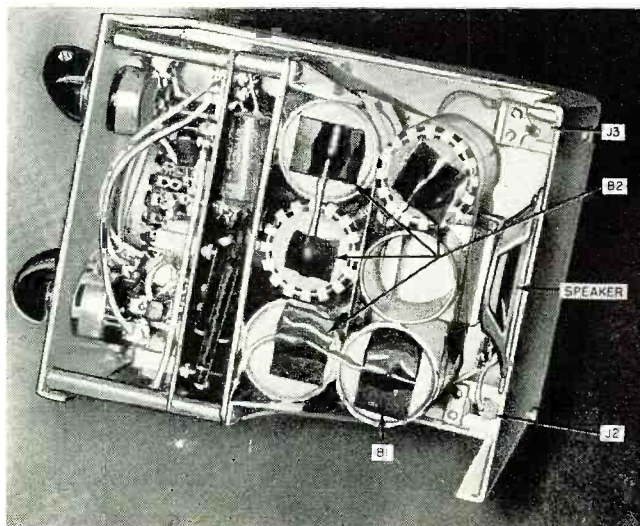

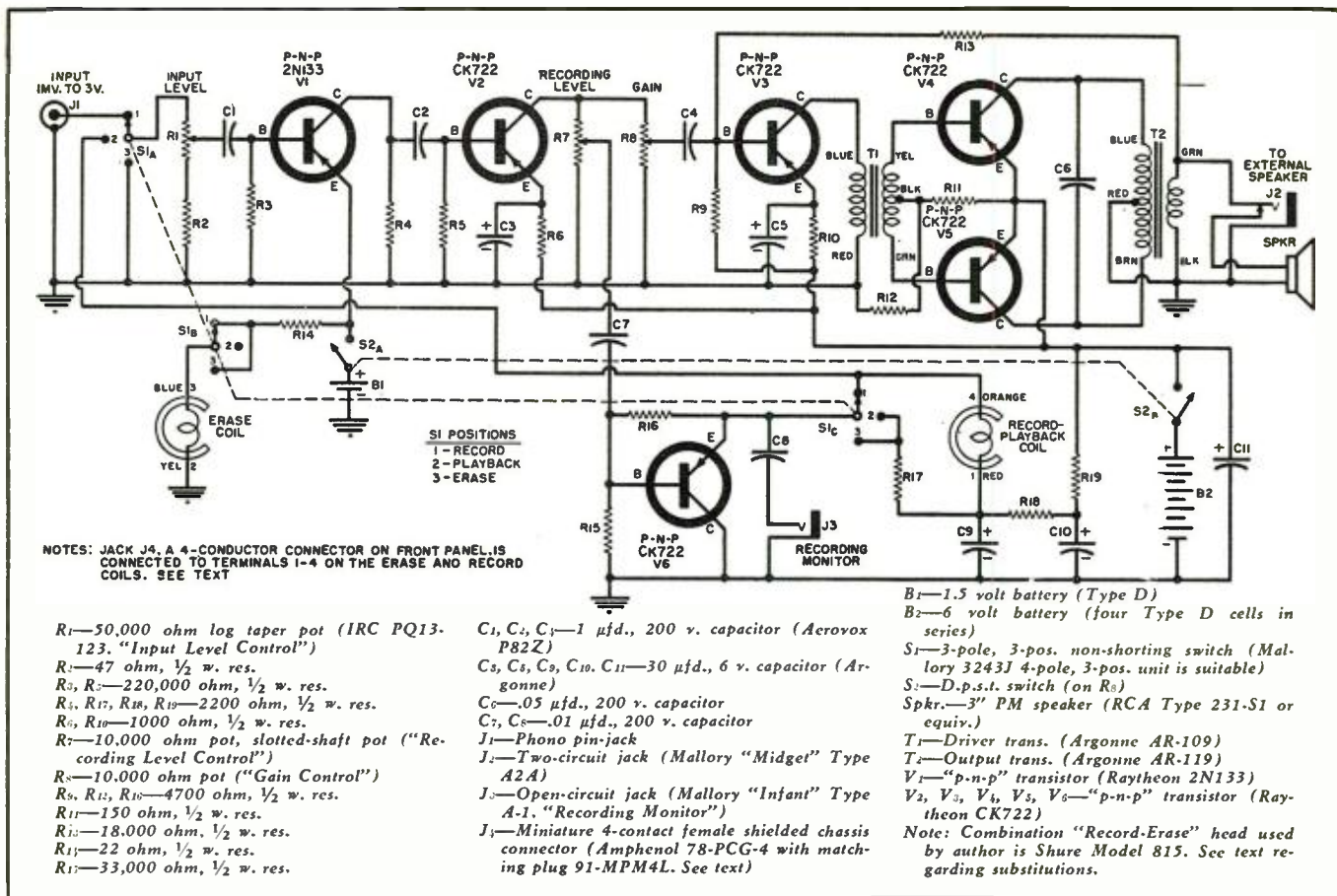

Fig. 3. Complete schematic diagram of unit. Note the use of d.c. bias and erase for simplicity and minimum battery drain.

both contained in the same head and are both energized with direct current. A d.c. bias and erase was selected for this application because of its simplicity and minimum battery drain. The very large power requirements for a.c. erase rule out this method for most portable applications. For example, the Model 815 head requires 1.5 watts at 25 kc. for a tape speed of 3.75 ips, which is increased to 3.9 watts at 50 kc. for a tape speed of 7.5 ips. For d.c. erase only 15 milliwatts are required.

In the case of the recording coil bias the a.c. power requirements are not so extreme but are still great enough to make d.c. bias desirable for many portable applications. For example, 55 milliwatts at 25 kc. are required for a tape speed of 3.75 ips and 160 milliwatts at 50 kc. for a speed of 7.5 ips. In contrast only 20 microwatts are required to meet the manufacturer's specifications for d.c. bias, although a power of 125 microwatts is used in this system for improved performance.

The erase current is determined by the B₁ voltage (1.5 volts) and R₁₄ (22 ohms) in series with the d.c. resistance of the erase coil (12 ohms). At full battery voltage this current will be 44 ma. and will drop to 30 ma. when the battery is down to 1 volt. This range is sufficiently close to the manufacturer's recommended value of 35 ma. for good erasure.

The recommended bias current for the recording coil is .35 ma. but much

better results were obtained at .85 ma. using Reeves "Soundcraft" tape. The value of current required depends on both the recording head and the tape being used, and since the level is determined by the V₆ emitter current, it can be adjusted by varying the ratio of R₁₅ to R₁₆. This current ordinarily will not need to be changed except where a different model recording head is used. Bias stabilization is used on V₆ to hold the recording-coil bias current at a constant level.

The input signal to the amplifier—both external signal and the signal from the recording head—is applied to R₁ and R₂. R₁ is a calibrated potentiometer and is used by setting it to the point corresponding to the level of the input voltage. When R₁ is set at this point, the input to V₁ will be just below the value needed to saturate V₂ on both positive and negative peaks. Fixed resistor R₂ is 1/1000th the value of R₁, and it limits the maximum usable signal to about 3 volts. This resistor makes adjustment to the 3 volt range easier because of the relatively small value of resistance involved. In addition, the use of a logarithmic taper for R₁ minimizes the problem of crowding at the low resistance end of the potentiometer.

The first two amplifier stages are used in both the recording and playback sections. The first, V₁, uses a low noise transistor (a Raytheon 2N133 with a noise figure of 6 db) as a common emitter amplifier with a collector

voltage of 1.5 volts at .3 ma. When used for playback R₁ will be set at the "top" position (3.0 mv.) in Fig. 3, and at this point the input impedance of the amplifier is 1700 ohms, which is a good match for the 1450-ohm impedance of the recording coil.

V₁ is RC-coupled to V₂, a CK722 connected as a common emitter amplifier. The load for V₂ consists of two 10,000 ohm potentiometers in parallel. The first, R₇, is used to adjust the signal level to V₆, the final stage in the recording amplifier section, and it will ordinarily be adjusted to give the maximum undistorted recording level at the time V₂ is just approaching the saturation point. This stage (V₆) is connected as a common-collector amplifier to provide a current gain and coupling between V₂ and the recording coil. The current gain of this stage is about 23 with an input impedance of 34,000 ohms and an output impedance of 250 ohms—both of which are satisfactory.

The coupling capacitor C₇ is fairly small (.01 μfd.) so as to reduce the low-frequency signal level into the recording coil. This is done to compensate for a characteristic of the recording head that causes distortion at a lower current at low frequencies than at the highs.

R₁₇ is used as a load for V₆ to replace the recording coil during playback as otherwise the input circuit of V₆ will cause a change in the frequency characteristics of the playback am-

plifier—the degree of change depending on the setting of R_7 . The RC network consisting of C_6 , C_{10} , R_{18} , and R_{19} is used as a decoupling filter to prevent a low-frequency oscillation during playback.

When using a microphone for recording it may be necessary to reduce the speaker output to the point of being almost inaudible to prevent acoustical feedback, and occasionally it is desirable to make a check on the quality of the signal at the recording coil. For these reasons jack J_3 is provided so that a pair of high-impedance headphones can be used for listening.

The driver and output stages (V_3 , V_4 , and V_5) are conventional in most respects. Resistors R_8 and R_{13} are used for bias stabilization and R_{12} serves the additional function of negative feedback resistor. When the feedback network was added, a 100 kc. oscillation of fairly high level occurred in the driver and output stages. Placing C_6 across the primary of T_2 stopped this oscillation and since it is small (.05 μ fd.), it causes no noticeable change in the tonal quality of the playback amplifier.

The speaker is a good quality 3" unit that uses a 1.47-oz. magnet. A speaker using a smaller magnet can be used but ordinarily such a unit will be harder to drive.

Construction

The construction of this amplifier is based on turret-type terminal lugs mounted on a suitable insulator base. This type of construction has most of the advantages of printed circuits and, in addition, has a few of its own. For example, the printed circuit method permits only two conductor planes, the two surfaces of the insulator base, while this method permits several planes as can be seen in Fig. 4. Also the expense, effort, and construction time are all less for the turret-lug method, and while a well constructed printed circuit board probably has a neater appearance than any other type of construction, the facilities for such excellence in construction are usually

not available to most experimenters. On the other hand, it is possible to obtain excellent results with turret terminals using only a hacksaw, file, and hand drill.

Several types of inexpensive turret terminal lugs are available from *Newark Electric Company*, Chicago, and *The Radio Shack*, Boston, but only one type, the *USECO 1300T* (see Fig. 4), was used for this project. It is a double turret type with a 4-40 threaded portion on one end for mounting purposes. The mounting hole is made with a #33 drill—or $\frac{3}{64}$ " if fractional size drills are used.

Although any 4-40 nut can be used for fastening the lugs, the most compact arrangement is obtained by using nuts that are $\frac{3}{16}$ " across the flats. These nuts will permit a minimum spacing of $\frac{1}{4}$ " between terminal centers, and they are available in the *Walsco* package of 4-40 steel hex nuts (Item #8804-N). Where feedthrough to the lower side of the panel is required, a solder lug is placed under the nut (see Fig. 5). If available, use #4 solder lugs—otherwise #6 lugs can be used but will need to be trimmed with diagonal cutters in cases where the spacing between terminals is too close.

For a low-frequency, low-voltage application, such as this amplifier, the insulator boards can be almost any insulation material with a moderate strength, a high softening point, and a maximum thickness of $\frac{1}{8}$ ". Bakelite will be satisfactory and Masonite can be used with care. Polystyrene and Lucite have such low melting points that they are not recommended for this project.

Two such boards will be needed—one for mounting the terminal lugs and the other for mounting the batteries. They should be cut about $\frac{1}{8}$ " smaller than the inside dimensions of the case to allow wires to the batteries and speaker to pass between.

No attempt was made to obtain the extreme in miniaturization as can be seen from the layout in Figs. 4 and 5. By using all miniature parts, includ-

ing batteries and speaker, and by crowding the components the case size probably can be reduced by about half. However, any reduction in battery size should be weighed carefully as the erase coil and the output stage (on peaks) both have fairly large current needs and will reduce battery economy considerably if low capacity batteries are used.

The layout shown in Figs. 4 and 5 was planned for simplicity and neatness and to give a minimum of long wires and crossover points. None of the dimensions is critical although the spacing between the closest lugs (transistor terminals) must be great enough to allow the hex nuts to be tightened.

The "Recording Level Control," R_7 , is of the slotted type for screwdriver adjustment. It is mounted on the terminal board and is adjusted through a small hole in the front panel since it ordinarily will not be touched once it is adjusted.

The speaker grille is made in the aluminum case by drilling a series of $\frac{1}{8}$ " holes over the area in front of the speaker cone. A neat arrangement can be obtained by making four rows, spaced 45°, across the diameter of the cone. An in-row spacing of $\frac{3}{16}$ " between holes will be sufficient to allow adequate passage of sound.

After all parts, except transistors, are wired to the terminal board and to the front panel of the case, the interconnecting wires should be added. These wires should be soldered to the terminal board first (see Fig. 4) and then to the parts mounted on the case, with the exception of the wire to the terminal in the lower right corner of Fig. 4. This wire is connected to the sliding contact on R_7 first and then to this terminal.

After the interconnecting wires have been soldered to the terminal board, the transistors can be soldered in place. First melt a small amount of solder on the head of each of the lugs to which the transistor leads will be connected. Then cut the leads to a

(Continued on page 88)

Fig. 4. Top view of completely assembled terminal board.

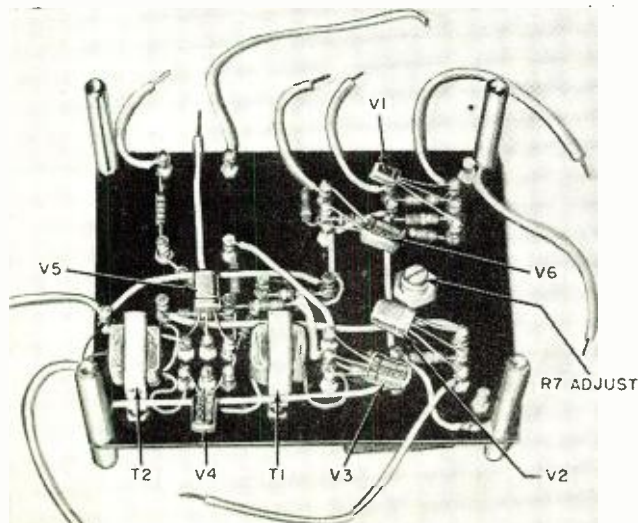
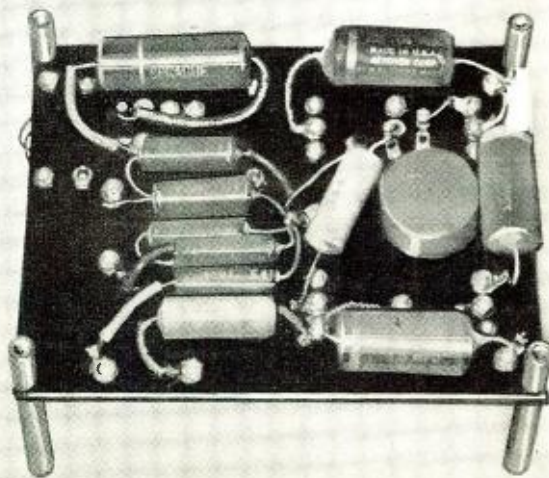

Fig. 5. Bottom view of board shows mounting of capacitors.



Certified RECORD REVUE

By BERT WHYTE

THE really big news this month comes from England. A number of readers there were kind enough to write me about the recent London Audio Fair and they enclosed a pamphlet with a most sensational message. In big bold type the title of this pamphlet was "Connoisseur introduces Stereophonic Sound on Disc"! Yessir, it's true! This is the first breakthrough in the long-anticipated *monogroove* stereo disc. The pamphlet went on to give a brief description of the system. Basically it is the old *Western Electric* deal of simultaneous lateral and vertical recording, but presumably with the "bugs" that beset that system all ironed out.

Does it really work? From the enthusiastic comments in the letters I have received, it would appear that it most assuredly does and, in fact, *A. R. Sugden*, manufacturer of the *Connoisseur* line of turntables who is fostering this project, is far enough advanced so that the special cutter which is necessary is being offered for sale to interested record companies and the necessary special pickup cartridge has been announced even to the point of a provisional price of approximately \$48.00! I intend to bring you a complete report on this sensational development, after I have managed to get more direct news about the system, right from the "horse's mouth" in England.

To say that this is upsetting the apple-cart of the record companies is putting it mildly, as rather obviously the first company that can get these new recordings into the field will have a wonderful sales tool and talking point. Actually, the appearance of this system will probably add stimulus to the stereophonic disc research which has been going on in this country for some time. There is nothing like a little competition to keep the pot boiling!

More logically, it would appear that several organizations would abandon a certain approach to the problem of the stereo disc and concentrate on either adopting the new system or pursuing the same line of reasoning. You can be sure that even if this report from England is highly colored and overenthusiastic, no one is going to take the chance of letting a competitor get a jump on what would most certainly be another vast new source of record revenue. The important thing is that the monogroove stereophonic disc has reached the point where it is "off the ground." As soon as I get the dope from England, I'll pass it on to you.

BORODIN
SYMPHONY #1 IN E FLAT
RIMSKY-KORSAKOV
CAPRICCIO ESPAGNOL

Philharmonia Orchestra conducted by Alceo Galliera. Angel 35346. RIAA curve. Price \$3.48 standard pack.

Borodin is best known for his popular "2nd

Symphony," but quite obviously he also wrote a first symphony. *Angel* has resurrected it from oblivion and a listen to it confirms the wisdom of this judgement. There is nothing really earth-shaking in it, but it is an exciting piece, full of Borodin's typically incandescent scoring, with a full measure of his beloved quasi-oriental effects. In these days when so much Russian repertoire is subjected to seemingly endless duplication, this interesting new facet of Borodin makes for a refreshing change. And if duplication we must have, then the "Capriccio Espagnol" on the reverse of this disc is an example of how it should be done. This is really a first rate performance, the orchestra plays with fine precision and high spirit, and the recorded sound is live and brilliant, quite possibly the most spectacular sound to be found on any *Angel* disc. Highly recommended.

STRAUSS, RICHARD
BURLESKE FOR PIANO AND
ORCHESTRA
FRANCAIX, JEAN
CONCERTINO FOR PIANO AND
ORCHESTRA
HONEGGER
CONCERTINO FOR PIANO AND
ORCHESTRA

Margrit Weber, pianist, with Berlin Radio Symphony Orchestra conducted by Ferenc Fricsay. Decca DL9900. RIAA curve. Price \$3.98.

This is a perfectly delightful recording of some of the most scintillating, light weight, "modern" music for piano and orchestra. The two concertinos are typical of the "avant-garde" French composer of the early 1920's and 1930's. The music is very gay and witty, quite saucy and impertinent in its brash atonality and dissonance. It is also easy to discern that both Francaix and Honegger were concerned with American jazz and employed derivative variations of it in their scores. The Strauss "Burleske" is a product of his early youth and although a very lightweight and ebullient score, there is more than a hint that he was to become one of the supreme masters of orchestration.

Margrit Weber is wholly convincing in her performance, maintaining a light airy touch appropriate to the scores. Ferenc Fricsay is an ideal conductor for this type of repertoire and his support of Miss Weber is most exemplary. The engineers have contributed an excellent balance between piano and orchestra and have endowed the disc with a bright, clean piano sound augmented by generally good orchestral sound in the large acoustic perspective they favor. The tympani in the "Burleske" lack

The opinions expressed in this column are those of the reviewer and do not necessarily reflect the views or opinions of the editors or the publishers of this magazine.

the articulation and projection they should have, but this is a minor point. For those of an inquiring mind this disc should prove to be a stimulating experience.

HOUSE OF THE LORD
The Roger Wagner Chorale. Capitol P8365. RIAA curve. Price \$3.98.

Most religious music on LP records has been performed either by tasteless hillbillies or smug, saccharine-voiced revival singers. No doubt many people who have wanted honest renditions of popular hymns and other religious works have been repelled by these versions and have despaired of ever finding something suitable. Well, they need not look any further than this disc. This is a collection of well-known religious works representing several variations of the Christian and Jewish faiths. Included are such staples as "The Lord's Prayer," "A Mighty Fortress Is Our God," "Ave Maria," "Kol Nidrei," "Oh God, Our Help In Ages Past." "Panis Angelicus," and others.

They are stunningly performed by the superb Roger Wagner Chorale, whose faultless articulation, precision of ensemble, and massed tonal beauty imbue these works with new interest and vitality. The sound is simply splendiferous . . . a warm, ultra-sonorous vocal blend, astonishingly "live" in the spacious acoustics.

TCHAIKOVSKY
SYMPHONY #1 (WINTER
DREAMS)

Vienna Philharmonica Orchestra conducted by Hans Swarowsky. Urania 8008. RIAA curve. Price \$3.98.

Here is one of the first fruits of the newly re-vitalized *Urania Records*. This company, which built up a large and impressive catalogue in the early days of LP, has been out of production for some time. The astute Hal Neely of *American Sound Corp.* bought the company and set about rectifying some of the errors that had been committed and in ruthlessly culling the catalogue of all dead wood. The remaining recordings have all been re-mastered employing the latest techniques of cutting and now all *Urania* records conform to the RIAA curve. Much new material has been recorded and, in general, the company is now back on a solid footing.

This is the fifth recording of this rarely heard "1st Symphony" of Tchaikovsky and, everything considered, it is about the most satisfactory. Swarowsky is no Beecham in this repertoire, but his reading is honest and forthright and he commits no unpardonable sins. The music itself deserves more consideration in the concert hall, being a spritely interesting score that contains much material which is a forerunner of the great 4th, 5th, and 6th symphonies. Soundwise this is a generally clean recording with excellent balance and spacious acoustics. One might quibble about a degree of wiriness in the string reproduction, although it is easily corrected with bass and treble tone controls. If you are not familiar with this music and you like Tchaikovsky, this should afford a welcome change from the over-ridden warhorses.

HI-FI HI-JINKS WITH STRAUSS
Vienna State Opera Orchestra conducted by Anton Paulik. Vanguard SRV-104. RIAA curve. Price \$1.98.

This is another terrific demonstration record buy from *Vanguard*, featuring their renowned interpreter of the music of the Strausses, Anton Paulik. It would be hard to imagine anything more appropriate for lazy summer listening, than this gay and sparkling music so wonderfully evocative of the Vienna of yesteryear. A potpourri of works by Johann
(Continued on page 91)

The Packard-Bell

COLOR TV

Line

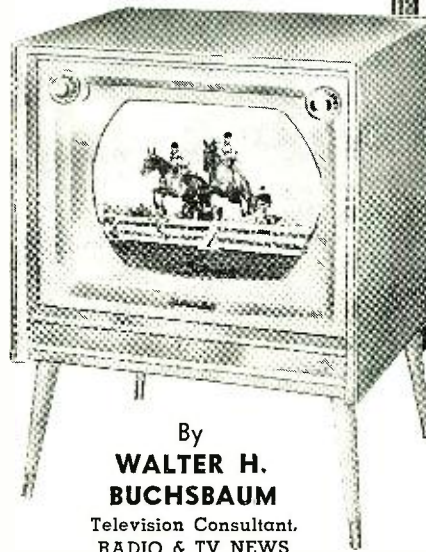
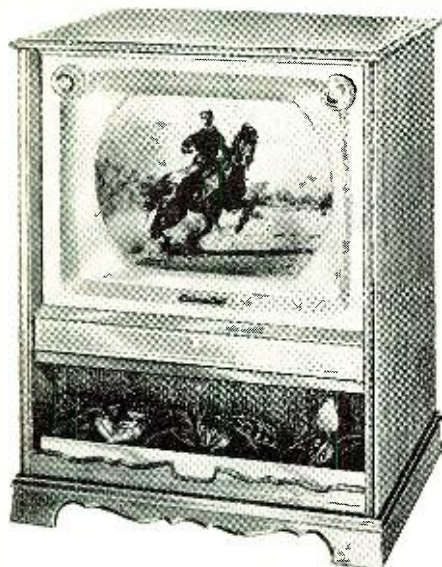

By
WALTER H. BUCHSBAUM
Television Consultant.
RADIO & TV NEWS

Three of the four available Packard-Bell cabinet styles are shown here.

Four models, all using the same basic deluxe chassis, feature simplified consumer controls.

ONE OF the oldest west-coast manufacturers of radios and TV sets, *Packard-Bell*, has joined the growing ranks of color-receiver producers with a line of four cabinet styles, each using the same chassis and 21-inch color picture tube. While not in the lowest price range, all four models are competitively priced. The mahogany table model with legs has a list price of \$595 and the blonde oak version lists at \$625. Consoles range from \$695 for the mahogany to \$725 for the colonial maple finish. Since *Packard-Bell* stresses quality cabinet work and produces most of its own cabinets, the various list prices reflect mainly the difference in wood crafting and finishing. The sound system of the table models has a single, side-mounted 6" x 9" oval speaker, while the two console models use two 6" x 9" speakers mounted side by side on the conventional front baffle board. Aside from this, all four models are identical in circuitry, construction, and adjustments.

Controls

Only two dual controls are available for normal manipulation by the set owner, and these can be seen from the illustrations. At the upper left is the "on-off," volume, and brightness control, while the channel selector and fine tuning are at the upper right. Just below the screen, a hinged subpanel gives access to six more controls which

the customer can adjust if necessary. These are the horizontal and vertical holds, contrast, tone, and the hue and color gain controls. In the manufacturer's instructions to the set owner, it is anticipated that, once the controls under the subpanel are set, they are not likely to require adjustment for long periods of time. Because of the various automatic control circuits used in the chassis, some of the color adjustments, such as background, gray balance, and color balance, may indeed be rarely used.

The full array of conventional color adjustments for installation and servicing by qualified technicians is available, but the customer would have to remove the back cover and the subpanel in order to get at the secondary controls. Adjustment of all these controls must be made very carefully and with reference to the manufacturer's instructions. The service technician will check these settings under all signal conditions encountered in the particular installation because the various automatic circuits can only function properly when carefully adjusted. Especially sensitive are the noise threshold controls, the a.g.c. threshold, automatic color-gain controls, and the color-killer threshold setting.

Construction

The *Packard-Bell* models 21CT-1 and 21CC-1 both use the same type 98C-1 chassis, which is a single pan mounted horizontally below the picture tube. About 60% of the circuitry is in the form of printed wiring, divided into five separate sub-assemblies. An additional sub-assembly contains the color-

demodulator section, and that is wired in the conventional manner. In these sets, the picture tube assembly is mounted to the cabinet and not to the chassis. To change the picture tube, the entire chassis as well as the tuner must be removed first. The tuner and a bracket containing the "on-off," volume, and contrast controls are mounted separately in their respective upper corners of the cabinet and are connected by cables to the main chassis. The tuner used is a *Standard Coil* "Neutrode" turret tuner, which features good noise figure and can be adapted for u.h.f. reception by the insertion of the proper coil boards. The power supply has a transformer and two 5U4 rectifiers followed by a two-section pi filter. Two separate fuses protect the "B+." A total of 29 tubes plus the picture tube is used as compared to 26 or fewer in some sets.

The circuitry and operational features of the new *Packard-Bell* color sets are in many respects similar to other sets previously described in this magazine, but there have been some significant changes. In general these novel circuits are intended to insure better performance rather than a saving in cost. Like most manufacturers, *Packard-Bell* is more concerned with producing a quality color set which will require a minimum of servicing rather than bringing the price down.

Service Policy

At least for the beginning of the color TV era, *Packard-Bell* offers a factory service contract, factory branch installation, and separate servicing
(Continued on page 137)



Choosing A Color-Bar Generator

By A. R. STAMITI

*Knowing what features you need is as important
as knowing what the available instruments offer.*

THE question of what type of color generator to purchase is uppermost in the minds of many forward-thinking service managers and independent service operators who realize that, within a few short years, color receivers may well rival the number of monochrome receivers now in use. As with other test equipment, a color generator must be able to "pay its own way" if it is to justify its cost. As an aid in resolving whether your particular operation requires the addition of a color-bar generator, ask yourself the following questions regarding such a prospective purchase:

Is there a definite need for this equipment in my operation? Will the equipment be used in the shop or must it be portable enough to take on a home service call? Is the equipment's cost within my price range and, if so, how long before it will pay for itself? Will the addition of the equipment permit servicing color receivers with greater ease and saving of time than is possible with equipment now on hand?

Is there any reason to believe that this equipment will be obsolete within the next eighteen to twenty-four months? Will this equipment perform just one operation, or is it versatile in that it can be used on several basic operations? Are the function controls clearly marked and intelligently

grouped for ease of operation? Does the equipment have a professional appearance since many of my customers will see it? Does it have all the necessary functions required for the complete job? Are the primary frequency determinants of the generator crystal controlled?

The answers to the first four questions will be determined primarily by the type and scope of the individual service operation. These four, and some of the others that follow, will also be influenced by such factors as the facilities provided by equipment already in the possession of the operator. For example, the fact that he already owns a generator providing either a white-dot or cross-hatch pattern, or both, may influence his choice, as would prior possession of facilities for supplying certain reliable frequency standards which may already be incorporated in other instruments.

To assist the technician in arriving at answers that will help him, the tabulation of characteristics of color generators available for service applications has been included in Table 1. Information appearing on this chart has been compiled from manufacturers' literature. Note that the presence or absence of certain features should not be taken to mean that one instrument is necessarily better than another, for a particular shop's needs. The factors

just noted, as well as others to be discussed, must be given due weight.

Let us now examine some points in detail:

Price: The price of test equipment is important to the service operator because it will partly determine whether this equipment is a profitable investment. It should be remembered that test equipment must eventually be "resold" to the customer so that, after the equipment has been in use for a given period of time, the equipment has not only paid for itself but its further use results in a new profit for the organization. The purchase price of new equipment should be pro-rated on cost-per-call basis so as to amortize the cost of the equipment within a reasonable period of time.

Size, weight: This information will give some indication as to the portability of the equipment, or whether it is feasible to use this equipment for customer service calls as well as in the shop.

NTSC transmission levels: Inclusion of this feature insures that the specific color generator will produce a standard NTSC compatible signal, which means that the signal produced is usable for servicing *both* monochrome and color television receivers. This feature makes the generator equivalent to both a monochrome and color transmitting station. It is a primary requisite that assures accurate signals for alignment of chroma circuitry and is a safeguard against equipment obsolescence. Although receiver design may change, standards for the signal have

been fixed by the FCC. When the signal from this type of generator is used to align critical chroma circuitry, correct hue and saturation levels when any receiver is tuned to a color telecast will thus be assured.

Availability of convergence signal: This is a feature which adds to the versatility of the unit. Some equipments offer only a rainbow or color pattern of some type; a unit that also provides convergence signals will be more flexible in that it can be used either for alignment or installation and will insure a quicker return for dollars invested. This will be especially important where some other means for obtaining a convergence signal is not already on hand.

Number of crystals: The basic function of crystals as used in electronic devices is to assure minimum possible frequency error. Generally the number of crystals used in the unit will give an indication of how reliable, stable, and accurate the various output frequencies of the unit will be, just as the number of jewels in a watch gives an indication of its accuracy.

Sound carrier: It is essential that the various signal carriers be properly located on the response curves prior to attempting alignment of chroma circuits. The sound-carrier feature of the equipment should be used in the following manner: The color receiver fine-tuning control should be tuned accurately to eliminate the nominal 900 kc. beat pattern resulting from the

heterodyning of the sound carrier and the chroma information; when this is done there is positive assurance that the tuner is adjusted to the correct point so as to position the picture carrier and color subcarrier. If this is not done properly, the chroma presentation appearing at the demodulators will be changed entirely. A color set improperly aligned in this respect will reproduce incorrect hue and saturation levels when tuned to a standard color-broadcast signal.

Crystal control of r.f. carrier versus variable channel operation: Crystal control of the r.f. carrier simply implies that the primary frequency determinant of the r.f. oscillator is a crystal cut to a specific frequency. Another channel can be selected on this type of equipment only by inserting a new crystal cut to a different channel frequency. By contrast, the variable-channel-operation type of generator may be switched to another channel merely by turning a switch to a new position. The tuned circuits of this type are usually of the "lumped-constant" variety. Therefore, the variable-channel type sacrifices some accuracy and stability to present to the operator a greater range of channels on which to select the output. While the crystal-controlled variety offers output on only one channel, it has the advantages of accurate and stable frequency determination. However, most manufacturers of crystal-controlled instruments offer a choice of several crystals.

Variable phase and amplitude of video: Generators incorporating this feature provide both positive- and negative-polarity video output (sync positive or sync negative). This feature again increases the versatility of the unit in that video signals of the correct phase and amplitude can be injected into the receiver at several points, such as the detector or video-amplifier stages, which require different polarity signals for correct operation. This feature becomes an invaluable time saver when attempting to isolate a defective stage by a signal-tracing method.

G-Y signal at 90°: This signal provides a convenient means for checking the alignment and operation of a G-Y demodulator stage; for, if this signal is injected into the G-Y demodulator, it should produce a null or zero output for that stage, provided that the G-Y phase-shift coil and associated circuitry are aligned and performing correctly. This feature will find greater utility in later production color receivers, many of which incorporate the G-Y demodulator.

Separate R-Y, B-Y, I, and Q signals, available separately: These facilities provide a positive check on the operation of the various demodulators used in color receivers. For example, if the R-Y—B-Y demodulation axis is employed, it is a relatively simple matter to check the operation and alignment of each demodulator by injecting the

(Continued on page 138)

Table 1. Currently available color-pattern generators designed for service use, with performance features and prices.

MANUFACTURER & MODEL	Price	Size	Weight in Pounds	NTSC Transmission Levels	Convergence Signals Available	Number of Crystals	Sound Carrier	Crystal Control R.F. Carrier	Variable Channel Operation	Variable Phase & Amplitude Video	G-Y at 90°	Separate I, Q, R-Y, B-Y	3.58 MC. Sub-Carrier Available Separately	Y Signal Separately	Blower Fan	Voltage Regulated Pwr. Sup.
GENERAL ELECTRIC ST-16A	\$895.00	9x19 ¹ / ₄ x13	40	Yes	Dots, Cross-hatch	4	Yes	Yes	No	Yes	No	Yes	Yes	Yes	Yes	Yes
HICKOK 655XC	495.00	16 ³ / ₄ x18 ³ / ₈ x7 ¹ / ₂	34	Yes	None	3	Yes	No	Yes	Yes	No	Yes	Yes	Yes	No	No
HICKOK 656XC	495.00	16 ¹ / ₄ x18 ³ / ₈ x7 ¹ / ₂	42	Yes	Dots, Cross-hatch, V. Bars, H. Bars	3	Yes	No	Yes	Yes	No	Yes	Yes	Yes	No	Yes
HICKOK 660	239.50	10 ¹ / ₂ x10 ¹ / ₂ x5 ¹ / ₄	15	No	Dots, Cross-hatch	2	No	No	Yes	Yes	No	No	No	No	No	Yes
HYCON 616	485.00	8 ¹ / ₂ x11x10 ³ / ₄	26	Yes	Dots, Cross-hatch, V. Bars, H. Bars	4	Yes	Yes	No	Yes	Yes	Yes	No	Yes	Yes	No
JACKSON 700	295.00	6 ¹ / ₂ x9 ¹ / ₂ x10 ¹ / ₄	30	Yes	None	2	Yes	No	Yes	Yes	No	Yes	No	Yes	No	No
JACKSON 712	395.00	6 ¹ / ₂ x9 ¹ / ₂ x10 ¹ / ₄	32	Yes	Dots, Cross-hatch	2	Yes	No	Yes	Yes	No	Yes	Yes	Yes	No	No
PHILCO 7100	269.50	13 ³ / ₈ x11 ¹ / ₈ x9 ³ / ₄	18	No	Dots, Cross-hatch, V. Bars	4	Yes	Yes	No	Yes	No	No	No	Yes	No	Yes
PRECISION E-440	225.00	11 ¹ / ₂ x13x6 ⁵ / ₈	19	No	None	4	Yes	Yes	No	Yes	No	No	No	No	No	No
RCA WR-61A	247.50	9 ³ / ₄ x13 ¹ / ₂ x7 ¹ / ₂	17	No	None	4	Yes	Yes	No	Yes	No	No	No	No	No	No
TELONIC CB-2	375.00	10x12x9	25	Yes	None	2	Yes	No	Yes	Yes	No	Yes	No	No	No	Yes
TRIPLETT 3438	229.50	6 ¹ / ₄ x11 ¹ / ₂ x15 ¹ / ₂	16	No	Dots, Cross-hatch, V. Bars, H. Bars	2	No	No	Yes	Yes	No	No	No	No	No	No
TRIPLETT 3439	249.50	6 ¹ / ₄ x11 ¹ / ₂ x15 ¹ / ₂	16	No	None	2	Yes	Yes	No	Yes	No	No	No	No	No	No
WINSTON 150	49.95	4x5x7	3	No	None	0	No	No	Yes	No	No	No	Yes	No	No	No

Practical Techniques of Square-Wave Testing

By
E. G. LOUIS

A square-wave generator and an oscilloscope are useful tools in designing and servicing wide-band amplifiers. What troubles to look for with certain scope patterns.

BY MEANS of a Fourier analysis it is possible to show that an "ideal" square wave, Fig. 1 (Curve 1) consists of a fundamental (Curve 2) sine wave whose frequency is equal to that of the square wave, together with the 3rd (Curve 3), 5th, 7th, 9th, and higher odd harmonics, the amplitude of each decreasing in direct proportion to its order. Theoretically, a perfect square wave consists of a fundamental together with an infinite number of higher odd-harmonic signals.

If such a square-wave signal is applied to the input of an electrical circuit, whether a filter network, amplifier, or other system, and the system does not respond equally well to the fundamental and all higher harmonics, then the output signal obtained will be distorted in a fashion indicative of the response characteristics of the system under test. This is the basis of the square-wave test technique.

Since not only the fundamental, but all higher harmonics are applied simultaneously, and an indication of the system's response to this wide range of signals is obtained at once, square-wave testing provides an extremely rapid method for checking such network characteristics as frequency response, phase shift, transient response, etc. Because of the speed with which the square-wave test technique can be applied and information obtained, this method becomes quite valuable not only as an aid in the production testing and servicing of electronic equipment, but can be applied with equal, if not greater, value to the requirements of the practical design engineer.

In the past, the technique of square-wave testing has been confined largely to testing high-fidelity audio amplifiers and wide-band amplifiers with a bandwidth of perhaps several hundred kilocycles or 1 megacycle. With wide-band oscilloscopes now commercially available at prices within the reach of even the moderate sized experimental laboratory, and with square-wave generators on the market delivering square waves with fast rise times to frequencies as high as 1 megacycle, this valuable and easily applied technique can be applied to a very much greater extent. It may be used for checking not only audio amplifiers, transformers, and similar systems, but also for the check and design of wide-band scope and radar amplifiers, video amplifiers, and similar wide-frequency-range networks.

Since the techniques of square-wave testing and analysis can be applied in the same fashion irrespective of the end result in view, whether servicing, design, or production test, we will try to simply outline the basic technique, with the major emphasis on the application of the technique in the design and service of wide-band amplifier circuits.

Equipment Required

Fundamentally speaking, only two pieces of equipment are required to apply the square-wave test technique,

a square-wave generator and an oscilloscope. The square-wave generator may consist of a sine-wave generator and a suitable clipper amplifier where audio circuits and comparatively narrow-band circuits are to be checked. Where the response of video amplifiers and similar wide-frequency-range systems are to be checked, however, it is best to obtain a specially designed square-wave generator.

In general, the square-wave generator should deliver perfect square waves with a short rise time at frequencies from the lowest frequency response of the system to be studied to a frequency one-tenth the highest frequency response of the system. For practical laboratory work, a square-wave generator delivering signals from 50 cps to about 500 kc. or 1 mc. with a rise time of at most .1 microsecond

(and preferably less) will be found suitable. These signals may be available over a continuously variable range, or only at four or five "spot" values within this range. The output voltage should be easily varied from under 1 volt to at least 8 to 10 volts. Output impedance should be low, 600 ohms is about the highest that can generally be tolerated, particularly at high frequencies.

The oscilloscope used must have characteristics that are superior to the system under test. From a general viewpoint, its vertical amplifier should be flat below the lowest frequency square wave to be used in testing to a frequency ten times higher than the highest frequency signal to be used (within 1 or 2 db). It should not, in itself, cause any appreciable tilt or overshoot to any square-wave signal applied to its input within the range to be used for test purposes. The vertical amplifier should have a sensitivity of at least .5 volt/inch (peak-to-peak) and preferably more.

A linear time base should be available within the scope which permits observation (with expanded sweep if necessary) of one cycle of both the highest and lowest frequency square waves to be used in testing.

Applying the Technique

The basic set-up used for square-wave testing is illustrated in block diagram form in Fig. 2. A square-wave signal is applied to the input of the system to be tested, and the input and output signals observed on a cath-

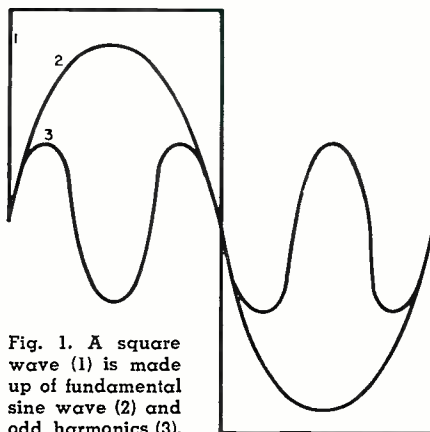

Fig. 1. A square wave (1) is made up of fundamental sine wave (2) and odd harmonics (3).

ode-ray oscilloscope. Deviations from the original square-wave shape indicate certain characteristics of the system under test.

Test leads, both to and from the equipment, should be as short as possible, otherwise, with high-frequency signals, or signals with a short rise time, unnatural peaking and overshoot may be introduced due to resonance in the connecting leads themselves.

The output signal should be observed at a point where the loading of the CRO will not appreciably affect the circuit parameters. If a high-impedance, low-capacity probe is used with the scope, then individual stage characteristics can be observed.

Limitations of Test Technique

Since a square wave contains only a fundamental and higher harmonics, it is not ordinarily employed for checking the response of a system at frequencies lower than its fundamental value. The exception to this is the case of a network whose response is such that the fundamental of the square wave is changed in some manner with respect to its higher frequency components. Such a condition may cause a change in the square-wave shape indicative of the system's response at lower frequencies.

Only odd harmonics of the square wave are present as part of the entire signal, hence any sharp dips or holes in the response characteristics of the system at specific frequencies falling between the odd harmonics may not show up in a square-wave test. However, the response of most amplifiers varies in a smooth manner and this limitation is minor.

In general, a square-wave test will not indicate distortion due to overload or overdrive on an amplifier, unless the overload distortion varies with frequency. The square wave is simply made more "square," and a sine-wave signal still must be used for such tests.

Finally, since it is almost physically impossible to produce a "perfect" square wave, and very difficult to detect changes in the square wave because of deterioration of signals higher than the tenth harmonic, square-wave signals should be available, and used, at approximately decade values. The exact number of signals required for a complete test will depend on the bandwidth of the system under test.

From a practical viewpoint, signals of 50 cps and 1 kc. are suitable for testing usual amplifiers and transformers. For checking wide-band amplifiers generally used in the lab, frequencies of 50 cps, 1 kc., 10 kc. and 100 kc. may be used. For checking video amplifiers, signals of 50 cps, 1 kc., 10 kc., 100 kc., and 500 kc. may be used. Signals as high as 1 mc. may be used for checking special pulsing circuits.

Response to L. F. Square Waves

Typical patterns that may be obtained when a low-frequency square wave is applied to an amplifier or network are shown in Fig. 4. A basic

triode, resistance-coupled amplifier stage is shown in Fig. 3.

If the amplifier responds perfectly to the input square-wave signal, neither attenuating nor accentuating the higher harmonics and causing no phase shift, a perfect output square wave will be obtained which, except for amplitude, is identical with the input signal, as shown in Fig. 4A.

A boost at the fundamental frequency of the square wave with respect to its higher harmonics, but with no phase shift, will result in the rounded signal shown in Fig. 4B. Conversely, a loss at the fundamental frequency will result in a general dip in the square wave as shown in Fig. 4C, while a dip in the response curve, causing a loss of a particular harmonic, will result in a dip at one or more points in the square wave, as shown in Fig. 4D.

Leading phase shift at low frequencies, but without appreciable signal loss, displaces the fundamental with respect to the harmonics, resulting in a tilted square top as shown in Fig. 4E. This is generally due to too low time constant in the RC coupling network (C_{g1} - R_g in Fig. 3). If a loss of signal accompanies the phase shift, then the flat top will curve downward as well as be slanted, as shown in Fig. 4F. An extreme case of too low a time constant in the coupling network may cause differentiation of the signal, allowing only the higher harmonics to pass and resulting in a peaked signal as shown in Fig. 4G. Such a signal may also be obtained due to high-frequency leakage around an attenuator circuit.

Where low-frequency compensation is added to the amplifier stage (R_c - C_c in Fig. 3), over-compensation may result in the phase lagging at low frequencies, causing the square wave to tilt in the opposite direction, as shown in Fig. 4H.

Irrespective of whether leading or lagging phase shift causes the square wave flat top to tilt (Figs. 4E or 4H), the amount of tilt depends on the degree of phase shift. A 10% slope will be obtained when the phase shift is 2° at the fundamental frequency of the signal.

From a design viewpoint, conditions shown in Figs. 4E, 4F, or 4G generally

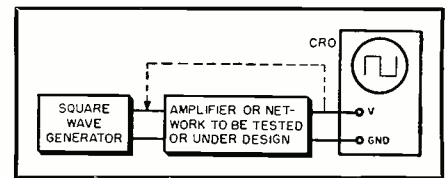

Fig. 2. Setup for square-wave tests.

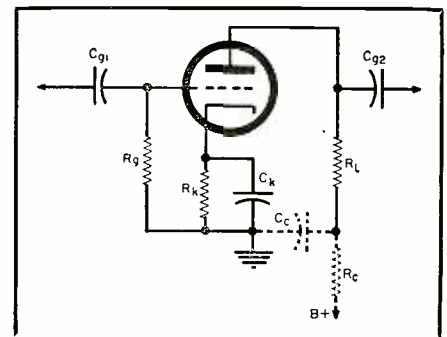

Fig. 3. Basic triode amplifier circuit.

indicate (in Fig. 3) either that C_{g1} or R_g , or both, should be increased in value, that C_k should be made larger, or that insufficient low-frequency compensation has been added. This, in turn, means that either C_c should be made smaller or R_c should be made larger (with respect to R_L). If the condition shown in Fig. 4H is obtained, then the amount of low-frequency compensation should be lowered, by either reducing the value of R_c or increasing the value of C_c .

From a servicing viewpoint, conditions indicated in Figs. 4E, 4F, or 4G generally indicate (again in Fig. 3) either that C_{g1} or R_g has become lower in value (usually C_{g1} will have partially opened . . . fully open would result in Fig. 4G); that C_k has lost capacity, that C_c has increased in capacity (unlikely) or that R_c has dropped in value (which may happen due to overload). The condition of Fig. 4H indicates, generally, that C_c has lost capacity or developed high power factor. It may also indicate that R_c has increased in value, but this is not very likely.

The response of the amplifier to both low- and high-frequency signals must be considered before a full analysis of circuit operation can be made. Both

Fig. 4. Typical patterns obtained with low-frequency square wave applied.

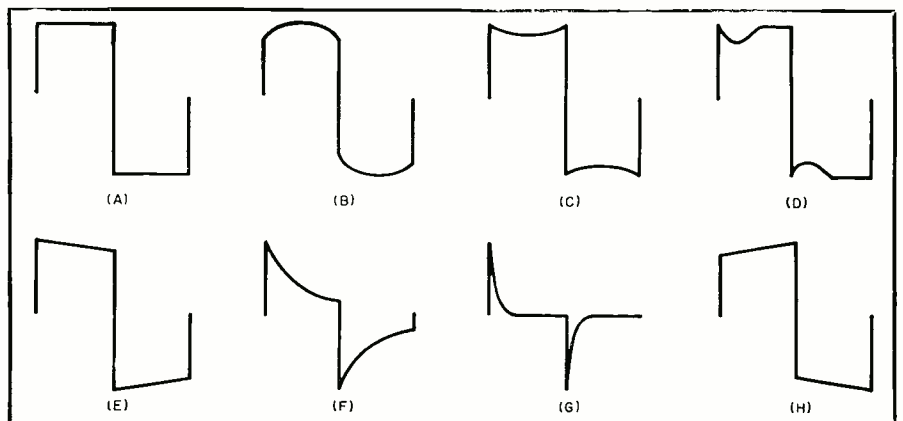

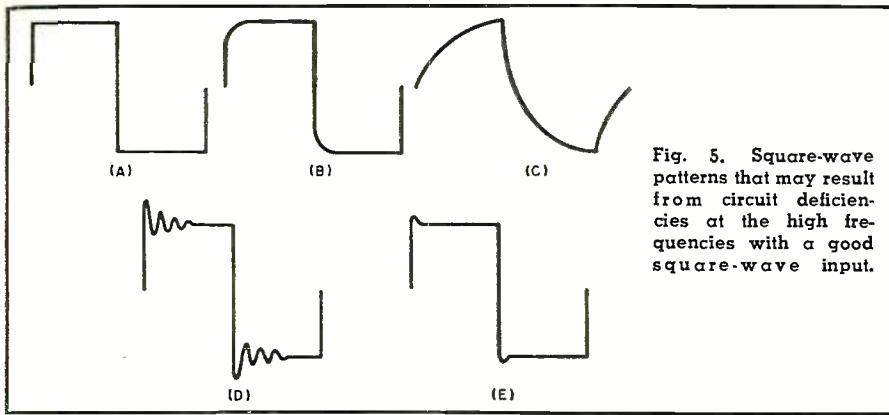

Fig. 5. Square-wave patterns that may result from circuit deficiencies at the high frequencies with a good square-wave input.

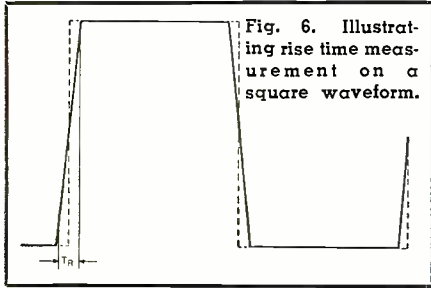

Fig. 6. Illustrating rise time measurement on a square waveform.

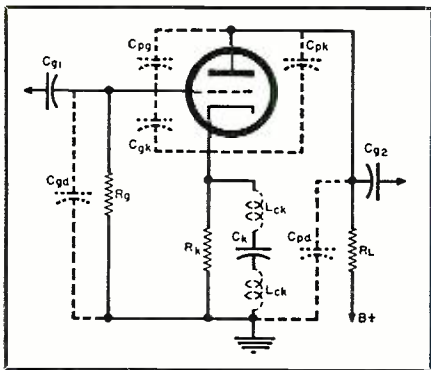

Fig. 7. Distributed capacities and inductances in basic amplifier circuit.

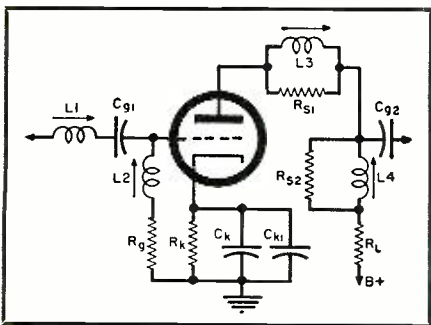
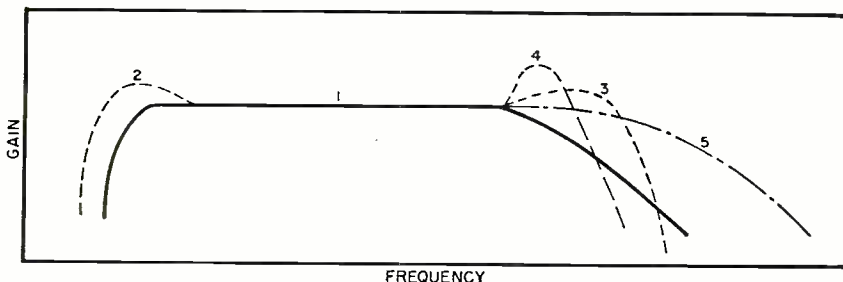

Fig. 8. Series and shunt peaking coils compensate for high-frequency losses.

Fig. 9. Basic amplifier response curves showing effects of compensating circuits.



FREQUENCY

good indication of uniform frequency response of an amplifier or network, irrespective of whether rounding of the square wave occurs or not.

An increase in rise time in a square wave is shown in Fig. 6.

A simple relationship, accurate enough for most practical design work, between rise time and uniform frequency response of an amplifier, is as follows:

$$\text{Maximum } f \text{ (uniform response in mc.)} = \frac{1}{2T_r}$$

in microseconds. (This relation holds true only where artificial means, such as peaking coils, are not used to shorten the rise time.)

From a design viewpoint, conditions shown in Figs. 5B or 5C indicate that the high-frequency response of an amplifier is not sufficient. This can be improved by reducing the effect of distributed capacities shown in Fig. 7 by making R_L as small as is practicable for the gain desired, and then by using series and shunt peaking coils, as shown in Fig. 8, to offset these capacities. To obtain reasonable gain with a low R_L , it may be necessary to go to tubes having high mutual conductance. In such a case, the stage gain is equal to the product of the load resistance and tube mutual conductance.

Distributed capacities are reduced by keeping leads short, parts and leads above the chassis, and using miniature parts where economically feasible.

The inductance of the peaking coils is generally chosen so that resonance will occur with the distributed capacities in the circuit at frequencies higher than the highest frequency at which uniform response is desired in the amplifier. In better amplifiers, these coils are usually made adjustable so that each unit may be adjusted for best response for the individual distributed capacities in that unit.

If these coils resonate at too low a frequency, or if insufficient damping (R_{s1} and R_{s2} in Fig. 8) is used, a severe overshoot may occur, or an oscillatory wave train may be set up, as shown in Fig. 5D.

Often a slight amount of overshoot (about 5% maximum) is desirable, as it tends to shorten the rise time of the amplifier. Thus, the condition shown in Fig. 5E would not always be considered objectionable.

A loss of higher frequency signals may occur if there is inductance in the electrolytic capacitor used for cathode bypass (L_{ck} in Fig. 7), due to degeneration across R_k and the loss of gain at these frequencies. In practical design, this can be offset by bypassing the electrolytic with a small capacitor (around .005 μ fd.), as at C_{k1} in Fig. 8.

From a servicing viewpoint, conditions illustrated in Figs. 5B and 5C may indicate that a peaking coil has become shorted or open (if shunted with a damping resistor) or that R_L has increased in value. In some cases

(Continued on page 133)

"SO WHERE were you all day yesterday?" Barney demanded of his boss, Mac, even before the latter had time to take off his hat and put on his shop coat.

"I just wanted to see if you could run the shop all by yourself," Mac said teasingly.

"Well, you found out I can; but quit beating around the bush. Why weren't you down here?"

"I suppose I'll have to tell you. Here is what happened. Last week, when I was down at the distributor's in Center City, I met a Mr. Marshall, who is a field engineer for the company that makes that color TV set I have. Since a branch of this company also makes service instruments, I thought it was a golden opportunity to get his advice on the number and kind of service instruments we must have to get started in color TV service. We want to buy what we need to do a good job, but we certainly do not want to load up with a lot of fancy, expensive equipment we can do without.

"Mr. Marshall and I hit it off very well, and he seemed to take a genuine interest in my questions. One thing led to another, and finally he suggested that if he could get permission from his supervisor he would come up with all his test equipment and 'show me the works' as far as the things that had to be done to a color set were concerned and the instruments used to do these things. Then I could make up my own mind as to what instruments I needed.

"You can imagine how quickly I jumped at a chance like this. I never pass up an opportunity to watch *any* expert working at his specialty, and a chance to see a thoroughly trained man operating on a color set was almost too good to be true. I promised him a home-cooked chicken dinner with all the trimmings if he could make it. He called me that night and said it was a deal and that he would be up yesterday."

"How come you didn't say a mumbling word to me about this?" Barney demanded in deeply injured tones.

"Because I knew you would want to be right there at the house watching him, too, and someone had to keep store."

"Well, I think it was pretty sneaky of you," Barney muttered.

"If it makes you feel any better, I've felt guilty about it all along; but I didn't know what else to do. Anyway, Mr. Marshall blew in about ten-thirty yesterday morning, and we spent the first quarter of an hour lugging in equipment. Then he rolled up his sleeves, pulled the back off that poor color set, and started doing everything to it you can imagine. First he gave a random twist to every adjusting knob and screw he could find—and he found lots of them! He said he wanted to simulate the worst possible condition: that in which some character with more brass than brains had tinkered with the receiver until purity, convergence, matrixing—in fact, every-



By JOHN T. FRYE

WATCHING AN EXPERT

thing—was completely out of adjustment, and it was necessary to start from scratch."

"What did he do first?"

"Got the receiver working as it should for black-and-white reception with regard to vertical and horizontal hold, size, and linearity adjustments. Then he connected up the dot generator and adjusted the red, blue, and green d.c. controls and the lateral magnet until he had white dots in the center of the screen. He paid no attention to those away from center at this time. Then he retracted the neutralizing magnets around the edge of the screen into their housings and proceeded to 'degauss the kine' as he called it."

"Did that mean he demagnetized the kinescope?"

"That's right. He had a doughnut coil about a foot in diameter that he said consisted of about 425 turns of #20 enameled wire. This had a long cord on it that he plugged into the a.c. line. He moved this all around the face of the tube, and you should have seen the beautiful patterns that came and went while he was doing this. Then he backed away about seven or eight feet, turned the coil at right angles to the set, and unplugged it."

"Having thus got rid of any magnetized condition on the kinescope or its associated hardware, he was ready to make color purity adjustments. He did this by turning down the blue and green screens and by adjusting the yoke and the color purity magnet on the neck of the tube until he had a uniformly red screen. The blue and green screens were checked and found to be free of impurities, too. Then he tuned in a black-and-white picture. There were a couple of tinted areas around the edge of the picture, and he adjusted the neutralizing magnets near these until they disappeared. Finally he checked the red, blue, and green fields again to make sure these last adjustments had not contaminated their purity."

"How long did it take him?"

"Not much longer than it takes me

to tell about it. Of course, he was talking all the time, explaining exactly what he was doing and why. For example, he showed me that if the neutralizing magnets were screwed too far, either out or in, they would go beyond the range of the threads, and then no amount of turning the adjusting screw would cause the magnets to move as they should. However, turning the screw would wobble the magnet a bit and might make you think you were doing some good. He demonstrated that all you had to do was push the magnet in or out, as required, until the pawl engaged the threads again; and then turning the adjusting screw would have the positive effect it should.

"He also explained that after the kinescope had once been degaussed, this operation should not be repeated again unless the kinescope had been subjected to a strong magnetic field, as might happen if it were touched with a magnetized screwdriver, or if the set were transported a considerable distance through the earth's magnetic field. Any small contamination of purity as might be noticed if the set were moved from one side of the room to the other should be corrected with the neutralizing magnets."

"How long did it take him to complete the convergence job?"

"Well, that's an interesting story. For my benefit, he followed the service manual exactly so that I might be able to understand every operation; and in much less than half an hour he had it very close—so close, in fact, that when you were six or eight feet from the screen you could see no fringing. He explained that a practical service technician should stop right there, for from that point on you could spend hours trying to eke out just a trifle better convergence and possibly never achieve it. However, in this case, since he wanted to demonstrate as near perfect convergence as could be obtained, he would try 'touching up' some of the controls set earlier in the step-by-step routine that normally should not be moved afterward.

(Continued on page 131)

HEATHKIT ETCHED CIRCUIT, PUSH-PULL

5" Oscilloscope Kit

COLOR TV

The previous Heathkit oscilloscope (Model O-10) which was already a most remarkable instrument, has been improved even further with the release of the Heathkit Model O-11. It incorporates all the outstanding features of the preceding model, *plus* improved vertical linearity, better sync stability, especially at low frequencies, and much-improved over-all stability of operation, including less vertical bounce with changes in level. These improvements in the Model O-11 circuit make it even more ideally suited for color TV servicing, and for critical observations in the electronic laboratory. Vertical response extends from 2 CPS to 5 MC without extra switching. Response only down 2.2' DB at 3.58 MC. The 11-tube circuit features a 5U1 cathode-ray tube. Sync circuit functions effectively from 20 CPS to better than 500 kc in five steps. Modern etched circuit boards employed in the oscilloscope circuit cut assembly time almost in half, permit a level of circuit stability never before achieved in an oscilloscope of this type, and insure against errors in assembly. Both vertical and horizontal output amplifiers are push-pull. Built-in peak-to-peak calibrating source — step-attenuated input — plastic molded capacitors and top-quality parts throughout — pre-formed and cabled wiring harness — and numerous other "extra" features. A professional instrument for the serveshop or laboratory. Compare its specifications with those of scopes selling in much higher price brackets. You can't beat it!



MODEL O-11

Shpg. Wt.
21 Lbs.

\$69⁵⁰

- * An improved model of what was already an outstanding instrument.
- * Personalize it — hand-assembled in this price range.
- * Incorporates the extra features required for color TV servicing.

Extra!

A FULL YEAR TO PAY

SEND FOR DETAILS OF HEATH
TIME-PAYMENT PLAN.

**5
BIG
REASONS
WHY**

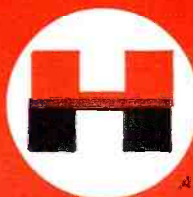

**HEATH
COMPANY**

A SUBSIDIARY OF DAYSTROM, INC.

BENTON HARBOR 15, MICH.

1 FEWER DOLLARS BRING MORE REAL QUALITY.

- Factory-to-you sales eliminate extra profit margin.
- "Build-it-yourself" eliminates labor charge.
- Heath purchasing power cuts component costs.

2 PERSONAL SERVICE ASSURES CUSTOMER SATISFACTION.

- You deal directly with the manufacturer.
- We are interested in you before and after sale.

Heathkits®

ARE YOUR BEST BUY...

3 PROVEN DESIGNS MEAN RELIABLE PERFORMANCE.

- Research and development efforts concentrated on kits only.
- All kits guaranteed to meet advertised specifications.

4 EVERY KIT BACKED BY WORLD-WIDE REPUTATION.

- The world's largest manufacturer of electronic equipment in kit form.
- Producer of more than a million electronic kits for the home workshop and industry.

5 EASY TIME-PAYMENT PLAN TO FIT YOUR BUDGET.

New HEATHKIT ETCHED CIRCUIT

5" Oscilloscope Kit

- * Brand new model with improved performance specifications.
- * Full 5" scope for service work at a remarkably low price.
- * Attractively styled front panel in charcoal gray with sharp white lettering.
- * Easy to build from step-by-step instructions and large pictorials. Not necessary to read schematic.

GREATEST SELECTION . . .

Whether your particular special interest is in servicing, ham-radio, high-fidelity, or just experimenting—there are Heathkits to fill your needs. You can equip an entire service shop or lab, buy a complete ham station or high-fidelity system, or set up a really deluxe home workshop, by choosing from the more than 70 different "do-it-yourself" electronic kits by Heath. Just glance through the kits displayed in this ad, and you will get some idea of the tremendous array of low-priced, high-quality electronic equipment available.

This new and improved oscilloscope retains all the outstanding features of the preceding model, but provides wider vertical frequency response, extended sweep-generator coverage, and increased stability. A new tube complement and improvements in the circuit make these new features possible. Vertical frequency response is essentially flat to over 1 mc, and down only 1½ DB at 500 kc. The sweep generator multivibrator functions reliably from 30 to 200,000 CPS, almost twice the coverage provided by the previous model. Deflection amplifiers are push-pull, and modern etched circuits are employed in critical parts of the design. A 5BP1 cathode-ray tube is used. The scope features external or internal sweep and sync, one volt peak-to-peak reference voltage, 3-position step-attenuated input, adjustable spot-shape control, and many other "extras" not expected at this price level. A calibrated grid screen is also provided for the face of the CRT, allowing more precise observation of wave shapes displayed. The new Model OM-2 is designed for general application wherever a reliable instrument with good response characteristics may be required. Complete step-by-step instructions and large pictorial diagrams assure easy assembly.

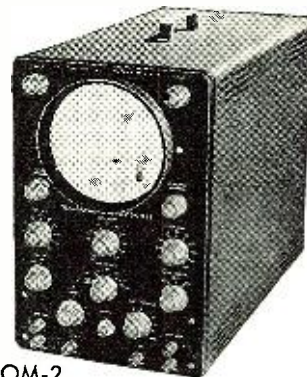

MODEL OM-2

\$42⁵⁰

Shpg. Wt.
21 Lbs.

HEATHKIT LOW CAPACITY PROBE KIT

Oscilloscope investigation of high frequency, high impedance, or broad bandwidth circuits encountered in television requires the use of a low-capacity probe to prevent loss of gain, circuit loading, or waveform distortion. The Heathkit low-capacity probe may be used with your oscilloscope to eliminate these effects. It features a variable capacitor, to provide correct instrument impedance match. Also, the ratio of attenuation can be varied.

No. 342

\$3⁵⁰

Shpg. Wt. 1 Lb.

HEATHKIT ELECTRONIC SWITCH KIT

This handy device allows simultaneous oscilloscope observation of two signals by producing both signals, alternately, at its output. It features an all-electronic switching circuit, with no moving parts. Four switching rates are selected by a panel switch. Provides actual gain for input signals, and has a frequency response of ± 1 DB from 0 to 100 kc. Sync output provided to control and stabilize scope sweep. Will function at signal levels as low as 0.1 volt. This modern device finds many applications in the laboratory and service shop. It employs an entirely new circuit, and yet is priced lower than its predecessor.

MODEL S-3

\$21⁹⁵

Shpg. Wt. 8 Lbs.

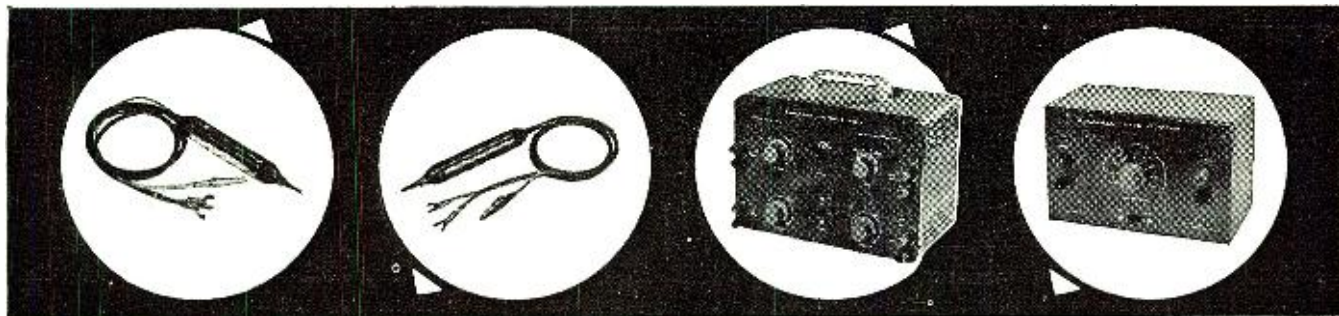

HEATHKIT SCOPE DEMODULATOR PROBE KIT

Extend the usefulness of your oscilloscope by employing this probe. Makes it possible to observe modulation of RF or IF carriers found in TV and radio receivers. Functions much like an AM detector to pass only modulation of signal, and not the signal itself. Among other uses, it will be helpful in alignment work, as a signal tracer, and for determining relative gain. Applied voltage limits are 30 volts (RMS) and 500 volts DC. It uses an etched circuit board to simplify assembly.

NO. 337-C

\$3⁵⁰

Shpg. Wt. 1 Lb.

HEATHKIT VOLTAGE CALIBRATOR KIT

This entirely new voltage calibrator produces near-perfect square wave signals of known amplitude. Precision 1% attenuator resistors assure accurate output amplitude, and multivibrator circuit guarantees good, sharp square waves, as distinguished from clipped sine waves. Output frequency is approximately 1000 CPS. Fixed outputs selected by panel switch are: .03, 0.1, 0.3, 1.0, 3.0, 10, 30, and 100 volts peak-to-peak. Allows measurement of unknown signal amplitudes by comparing to known peak-to-peak output of VC-3 on an oscilloscope. Will also double as a square wave generator at 1000 cycles for determining gain, frequency response, or phase-shift characteristics of audio amplifiers. Equally valuable in the laboratory or in radio and TV service shops.

MODEL VC-3

\$12⁵⁰

Shpg. Wt. 4 Lbs.

HEATHKIT ETCHED CIRCUIT VACUUM TUBE



\$24.50

Shpg. Wt.
7 lbs.

- * Easy to build — a pleasure to use.
- * 1% precision resistors employed for high accuracy.
- * Etched circuit board cuts assembly time in half.

Voltmeter Kit

The fact that this instrument is the world's largest-selling VTVM says a great deal about its accuracy, reliability, and overall quality. The V-7A is equally popular in the laboratory or service shop, and represents an unbelievable test equipment bargain, without a corresponding sacrifice in quality. Its appearance reflects the performance of which it is capable. A large 4½" panel meter is used for indication, with clear, sharp calibrations for all ranges. Front panel controls consist of a rotary function switch and a rotary range selector switch, zero-adjust, and ohms-adjust controls. Precision 1% resistors are used in the voltage divider circuits and etched circuits are employed for most of the circuitry. This makes the kit much easier to build, eliminates the possibility of wiring errors, and assures duplication of laboratory instrument performance. This multi-function VTVM will measure AC voltage (rms), AC voltage (peak-to-peak), DC voltage, and resistance. There are 7 AC (rms) and DC voltage ranges of 0-1.5, 5, 15, 50, 150, 500, and 1500. In addition, there are 7 peak-to-peak AC ranges of 0-4, 14, 40, 140, 400, 1400, and 4000. 7 ohmmeter ranges provide multiplying factors of X1, X10, X100, X1000, X10K, X100K, and X1 megohm. Center-scale resistance readings are 10, 100, 1000, 10K, 100K ohms, 1 megohm, and 10 megohms. A DB scale is also provided. The precision and quality of the components used in this VTVM cannot be duplicated at this price through any other source. Model V-7A is the kind of instrument you will be proud to own and use.

HEATHKIT Etched Circuit RF PROBE KIT

This RF probe extends the frequency response of any 11-megohm VTVM so that it will measure RF up to 250 megacycles within ± 10%. Employs printed circuits for increased stability and ease of assembly. Ideal for extending service and laboratory applications of your Heathkit VTVM. Shpg. Wt. 1 Lb.

No. 309-C

\$3.50

HEATHKIT 20,000 OHMS/VOLT VOM KIT

Sensitivity of this instrument is 20,000 ohms-per-volt DC and 5,000 ohms-per-volt AC. Measuring ranges are 0-1.5, 5, 50, 150, 500, 1500, and 5000 volts for both AC and DC. Also measures current in the ranges of 0-150 microamperes, 15 ma, 150 ma, 500 ma, and 15 a. Resistance ranges provide multipliers of X1, X100, and X10,000, resulting in center scale readings of 15, 15,000, and 150,000 ohms. DB ranges cover from -10 db to +65 db. Housed in attractive black bakelite case with plastic carrying handle, this fine instrument provides a total of 25 meter ranges. It employs a sensitive 50 microampere, 4½" meter and features all 1% precision multiplier resistors. Requires no external power, and is, therefore, valuable in portable applications where no AC power is available.

MODEL MM-1

\$29.50

Shpg. Wt. 6 Lbs.

ETCHED CIRCUIT PEAK-TO-PEAK PROBE KIT

Use this peak-to-peak probe with your 11-megohm VTVM to measure peak-to-peak voltages directly on the DC scales of the instrument. Will measure p-to-p voltages in the frequency range of 5 kc to 5 mc. Employs etched circuit boards for increased circuit stability and simplified construction. Extend the usefulness of your VTVM. NOTE: Not required for the Heathkit V-7A VTVM.

No. 338-C

\$5.50 Shpg. Wt. 2 Lbs.

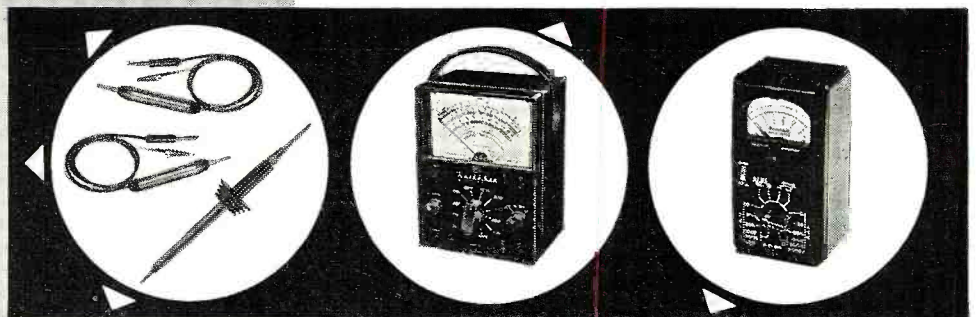

HEATHKIT 30,000 VOLT DC HIGH VOLTAGE PROBE KIT

This probe provides a multiplication factor of 100 on the DC ranges of the Heathkit 11-megohm VTVM. Precision multiplier resistor mounted inside the two-color plastic probe body. Plenty of insulation for completely safe operation, even at highest TV potentials. Designed especially for TV service work.

No. 336

\$4.50

Shpg. Wt. 2 Lbs.

HEATHKIT HANDITESTER KIT

The Model M-1 measures AC or DC voltage at 0-10, 30, 300, 1000, and 5000 volts. Direct current ranges are 0-10 ma, and 0-100 ma. Ohmmeter ranges are 0-3000 (30 ohm center scale) and 0-300,000 ohms (3,000 ohms center scale). Uses a 400 microampere meter for sensitivity of 1000 ohms-per-volt. A very popular test device for the home experimenter, electricians, and appliance repairmen, and for use as an "extra" instrument in the service shop. Its small size and rugged construction make it perfect for any portable application. Easily slips into your tool box, glove compartment, coat pocket, or desk drawer. Top quality, precision components employed throughout.

MODEL M-1

\$14.50

Shpg. Wt. 3 Lbs.



HEATH COMPANY
A Subsidiary of Daystrom, Inc.
BENTON HARBOR 15, MICH.

HEATHKIT NEW AUDIO VACUUM TUBE

Voltmeter Kit

CONTROLLED QUALITY . . .

Incoming parts inspection, and inspection of material coming off of our own production line assures you of the finest "build-it-yourself" kit that money can buy. Each kit contains all the components you need for assembly—and you can have confidence in the quality of the parts themselves. In addition to this inspection procedure, an extensive proof-building program for each new kit guarantees easy-to-follow instructions and reliable performance.

This brand new AC vacuum tube voltmeter emphasizes stability, broad frequency response, and sensitivity. It is designed especially for audio measurements, and low-level AC measurements in power supply filters, etc. Employs a cascode amplifier circuit with cathode-follower isolation between the input and the amplifier, and between the output stage and the preceding stages. An extremely stable circuit with high input impedance (1 megohm at 1000 CPS). Response of the AV-3 is essentially flat from 10 CPS to 200 kc, and is usable for tests even beyond these frequency limits. Increased damping in the meter circuit stabilizes the meter for low frequency tests. Nylon insulating bushings at the input terminals reduce leakage, and permit the use of the 5-way Heath binding post.

The extremely wide voltage range covered by the AV-3 makes it especially valuable not only in high-fidelity and service work, but also in experimental laboratories. AC (RMS) voltage ranges are 0-.01, .03, .1, .3, 1, 3, 10, 30, 100, and 300 V. Decibel ranges cover -52 DB to +52 DB. An entirely new circuit as compared to the previous model. Employs 1% precision multiplier resistors for maximum accuracy. Handles AC measurements from a low value of one millivolt to a maximum of 300 volts.

- * Brand new circuit for extended frequency response and added stability.
- * Ten accurate ranges from 0-.01 to 0-300 volts.
- * Modern, functional panel styling. "On-off" switch at both extreme ends of range switch.

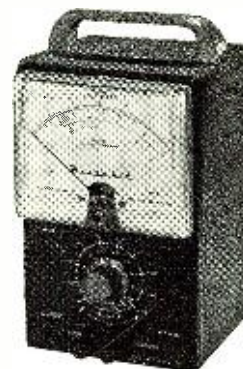

MODEL AV-3

\$29⁹⁵

Shpg. Wt. 5 Lbs.

HEATHKIT AUDIO WATTMETER KIT

This instrument measures audio power directly at 4, 8, 16, or 600 ohms. Load resistors are built in. Covers 0-5 MW, 50 MW, 500 MW, 5 W, and 50 W full scale. Provides 5 switch-selected DB ranges covering from -10 DB to +30 DB. Large 4½" 200 microampere meter and precision multiplier resistors insure accuracy. Frequency response is ± 1 DB from 10 CPS to 250 kc. Functions from AC power line. Use in the audio laboratory or in home workshop.

MODEL AW-1

\$29⁵⁰

Shpg. Wt. 6 Lbs.

HEATHKIT AUDIO ANALYZER KIT

This multi-function instrument combines an AC VTVM, an audio wattmeter, and an intermodulation analyzer into one case, with combined input and output terminals and built-in high and low frequency oscillators. The VTVM ranges are .01, .03, .1, .3, 1, 3, 10, 30, 100, and 300 volts (RMS). Wattmeter ranges are .15 MW, 1.5 MW, 15 MW, 150 MW, 1.5 W, 15 W, 150 W. IM scales are 1%, 3%, 10%, 30%, and 100%. Provides internal load resistors of 4, 8, 16, or 600 ohms. A valuable instrument for the engineer or serious audiophile.

MODEL AA-1

\$49⁹⁵

Shpg. Wt. 13 Lbs.

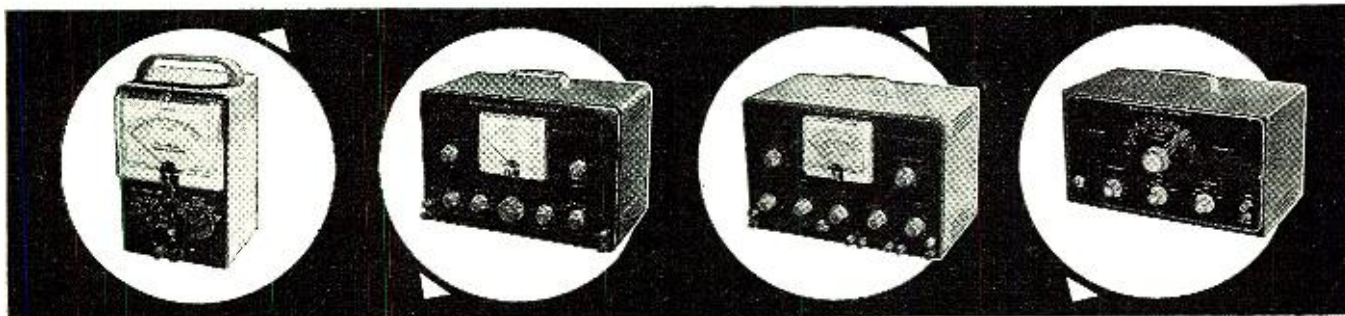

HEATHKIT HARMONIC DISTORTION METER KIT

The HD-1 is equally valuable for the audio engineer or the serious audiophile. Used with a low-distortion audio signal generator, this instrument will measure the harmonic content of various amplifiers under a variety of conditions. Functions between 20 and 20,000 CPS, and reads distortion directly on the panel meter in ranges of 0-1, 3, 10, 30, and 100 percent full scale. Built-in VTVM for initial reference settings and final distortion readings has voltage ranges of 0-1, 3, 10, and 30 volts. 1% precision resistors employed for maximum accuracy. Features voltage regulation and other "extras". Meter calibrated in volts (RMS), percent distortion, and DB.

MODEL HD-1

\$49⁵⁰

Shpg. Wt. 13 Lbs.

HEATHKIT AUDIO OSCILLATOR KIT

Producing both sine waves and square waves, the Model AO-1 covers a frequency range of 20 to 20,000 CPS in three ranges. An extra feature is thermistor regulation of output for flat response through the entire frequency range. AF output is provided at low impedance, and with low distortion. Produces good sine waves, and good, clean square waves with a rise time of only two micro-seconds for checking square wave response of audio amplifiers, etc. Designed especially for the serviceman and high-fidelity enthusiast. A real dollar value in test equipment.

MODEL AO-1

\$24⁵⁰

Shpg. Wt. 10 Lbs.

HEATHKIT



MODEL
AG-9

\$34⁵⁰

Shpg. Wt.
8 Lbs.

- * Less than 0.1% distortion — ideal for hi fi work.
- * Large 4½" meter indicates output.
- * Step-type tuning for maximum convenience.

Audio Generator Kit

This particular audio generator is "made to order" for high fidelity applications. It provides quick and accurate selection of low-distortion signals throughout the audio range. Three rotary selector switches on the front panel allow selection of two significant figures and a multiplier for determining audio frequency. In addition, it incorporates a step-type output attenuator and a continuously variable attenuator. Output is indicated on a large 4½" panel meter calibrated in volts and in db. Attenuator system operates in steps of 10 db, corresponding with the meter calibration. Output ranges are 0-.003, .01, .03, .1, .3, 1, 3, and 10 volts rms. A "load" switch provides for the use of a built-in 600 ohm load or an external load of higher impedance when required. Output and frequency indicators accurate to within ± 5%. Distortion is less than .1 of 1% between 20 cps and 20,000 cps. Total range is 10 cps to 100 kc. New engineering details combine to provide the user with an unusually high degree of operating efficiency. Oscillator frequency selected entirely by the switch method means that accurate resetability is provided. Comparable to units costing many dollars more, and ideal for use in critical high fidelity applications. Shop and compare, and you will appreciate the genuine value of this professional instrument.

HEATHKIT RESISTANCE SUBSTITUTION BOX KIT

The RS-1 contains 36 10% 1-watt resistors ranging from 15 ohms to 10 megohms in standard RETMA values. All values are switch-selected for use in determining desirable resistance values in experimental circuits. Many applications in radio and TV service work.

MODEL RS-1

\$5⁵⁰

Shpg. Wt. 2 Lbs.

HEATHKIT CONDENSER SUBSTITUTION BOX KIT

This kit contains 18 RETMA standard condenser values that can be selected by a rotary switch. Values range from 0.00001 mfd to 0.22 mfd. All capacitors rated at 400 volts or higher. Capacitors are either silver-mica, or plastic molded.

MODEL CS-1

\$5⁵⁰

Shpg. Wt. 2 Lbs.

HEATHKIT AUDIO GENERATOR KIT

The Model AG-8 is a low cost, high performance unit for use in service shop, or home workshop. It covers the frequency range of 20 cps to 1 mc in five ranges. Output is 600 ohms, and overall distortion will be less than .4 of 1% from 100 cps through the audible range. Output is available up to 10 volts, under no load conditions, and output remains constant within ±1 db from 20 cps to 400 kc. A five-step attenuator provides control of the output. Precision resistors are employed in the frequency determining network.

MODEL AG-8

\$29⁵⁰

Shpg. Wt. 11 Lbs.

HEATHKIT DECADE CONDENSER KIT

Precision, 1% silver-mica capacitors are employed in the Model DC-1 in such a way that a selection of precision capacitor values is provided ranging from 100 mmf (.001 mfd) to 0.11 mfd (110,000 mmf) in 100 mmf steps. Extremely valuable in all types of design and development work. Switches are ceramic wafer types.

MODEL DC-1

\$16⁵⁰

Shpg. Wt. 3 Lbs.



HEATHKIT DECADE RESISTANCE KIT

The Model DR-1 incorporates twenty 1% precision resistors arranged around five rugged switches so that various combinations of switch positions will provide a total range of 1 ohm to 99,999 ohms in 1-ohm steps. Switches are labeled "units," "tens," "hundreds," "thousands," and "ten thousands." Use it for ohm-meter calibration in bridge circuits as test values in multiplier circuits, etc.

MODEL DR-1

\$19⁵⁰

Shpg. Wt. 4 Lbs.

HEATHKIT VARIABLE VOLTAGE REGULATED POWER SUPPLY KIT

This power supply is regulated for stability, and the amount of DC output available from the power supply can be controlled manually from zero to 500 volts. Will provide regulated output at 450 volts up to 10 ma, or up to 130 ma at 200 volts output. In addition to furnishing B-plus, the power supply provides 6 volts AC at 4 amperes for filaments. Both the B-plus output and the filament output are isolated from ground. Ideal power supply for use in experimental work in the laboratory, the home workshop, or the ham shack. Large 4½" panel meter indicates output voltage or current.

MODEL PS-3

\$35⁵⁰

Shpg. Wt. 17 Lbs.



HEATH COMPANY
A Subsidiary of Daystrom, Inc.
BENTON HARBOR 15, MICH.

BONUS PERFORMANCE . . .
 If a single word had to be selected to describe Heath Company advertising policy, it would be "conservative." By this we mean that the performance specifications and features are not exaggerated, and that the descriptions are accurate. We specify performance on the conservative side so you can be sure of equaling or exceeding our specifications. In almost every instance our kits will do more than we claim. Extra care in construction, and calibration against an accurate standard can extend performance well beyond advertised levels.

HEATHKIT

Signal Generator Kit

- * No calibration required with pre-aligned coils.
- * Modulated or unmodulated RF output.
- * 110 mc to 220 mc frequency coverage.

Here is an RF signal generator for alignment applications in the service shop or the home workshop. Thousands of these units are in use in service shops all over the country. Produces RF signals from 160 kc to 110 mc on fundamentals on five bands. Also covers from 110 mc to 220 mc on calibrated harmonics. RF output is in excess of 100,000 microvolts at low impedance. Output is controllable with a step-type and a continuously variable attenuator. Front panel controls provide selection of either unmodulated RF output or RF modulated at 400 cps. In addition, two to three volts of audio at approximately 400 cps are available at the output terminals for testing AF circuits. Employs a 12AU7 and a 6C4 tube. Built-in power supply uses a selenium rectifier.

One of the most outstanding features about the Model SG-8 is the fact that it can be built in just a few hours, even by one not thoroughly experienced in electronics work. Complete step-by-step instructions combined with large pictorial diagrams assure successful assembly. Pre-aligned coils make calibration from an external source unnecessary.

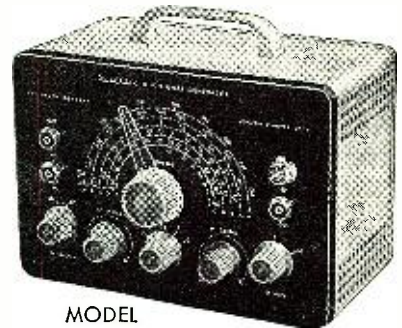

MODEL SG-8

\$19⁵⁰ Shpg. Wt. 8 lbs.

HEATHKIT LABORATORY GENERATOR KIT

This laboratory RF signal generator covers from 100 kc to 30 mc on fundamentals in five bands. The output signal may be pure RF, or may be modulated at 400 cycles from 0 to 50%. Provision for external modulation has been made. RF output available up to 100,000 microvolts. Output controlled by a fixed step and a variable attenuator. Output impedance is 50 ohms. Panel meter reads RF output or percentage of modulation. Incorporates voltage regulated B+ supply, double shielding of oscillator circuits, copper plated chassis, and other "extras."

MODEL LG-1
\$48⁹⁵

Shpg. Wt. 16 lbs.

HEATHKIT TV ALIGNMENT GENERATOR KIT

This improved sweep generator model provides essential stability and flexibility for work on FM, monochrome TV, or color TV sets. Covers 3.6 mc to 220 mc in four bands. Provides usable output even on harmonics. Sweep deviation from 0-42 mc, depending on base frequency. All-electronic sweep circuit eliminates unwieldy mechanical arrangements. Includes built-in crystal marker generator providing output at 4.5 mc and multiples thereof, and variable marker covering 19 to 60 mc on fundamentals and from 57 to 180 mc on harmonics. Effective two-way blanking.

MODEL TS-4A
\$49⁵⁰

Shpg. Wt. 16 lbs.

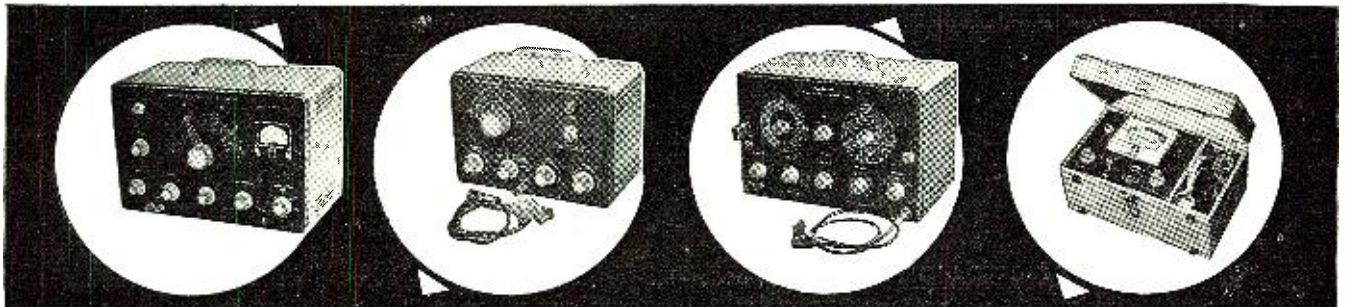

HEATHKIT LINEARITY PATTERN GENERATOR KIT

This instrument supplies information for white dots, cross-hatch pattern, horizontal bar pattern, or vertical bar pattern. It feeds video and sync signals to the set under test, with completely controlled gain, and unusual stability. Covering channels 2 to 13, the LP-2 will produce 5 to 6 vertical bars and 4 to 5 horizontal bars. The dot pattern presentation is a *must* for the setting of color convergence controls in the color TV set. Panel provision made for external sync if desired. Use for adjustment of vertical and horizontal linearity, picture size, aspect ratio, and focus. Power supply is regulated for added stability. Essential in the up-to-date TV service shop.

MODEL LP-2
\$22⁵⁰

Shpg. Wt. 7 lbs.

HEATHKIT CATHODE RAY TUBE CHECKER KIT

This instrument checks cathode emission, beam current, shorted elements, and leakage between elements in electro-magnetic picture tube types. It eliminates all doubt for the TV serviceman, and even more important, for the customer. Features its own self-contained power supply, transformer operated to furnish normal test voltages for the CRT. Employs spring-loaded switches for maximum operator protection. Large 4 1/2" meter indicates CRT condition on "good-bad" scale. Luggage-type portable case ideal for home service calls. Special "shadowgraph" test permits projection of light spot on screen. Also gives relative check of picture tube screen coating.

MODEL CC-1
\$22⁵⁰

Shpg. Wt. 10 lbs.

HEATHKIT



MODEL
TC-2

\$29.50

Shpg. Wt.
12 Lbs.

- * Attractive counter-style cabinet.
- * Wiring-harness simplifies assembly.
- * Large 4½" meter with two-color "good-bad" scale.
- * Separate tube element switches prevent obsolescence.

HEATHKIT PORTABLE TUBE CHECKER KIT

This portable tube checker is identical, electrically, with the Model TC-2. However, it is housed in an attractive and practical carrying case, finished in proxylin impregnated material. The cover is detachable, and the hardware is brass plated. This rugged unit is ideal for home service calls or any portable application.

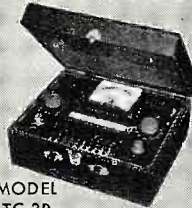

MODEL
TC-2P

\$34.50 Shpg. Wt.
15 Lbs.

HEATHKIT DIRECT READING CAPACITY METER KIT

Operation of this instrument is simplicity itself. One has only to connect a capacitor to the terminals, select the proper range, and read the capacity value directly on the large 4½" meter calibrated in mmf and mfd.

Ranges are 0 to 100 mmf, 1,000 mmf, 0.01 mfd, and 0.1 mfd full scale. Precision calibrating capacitors supplied. Not susceptible to hand capacity effects. Residual capacity less than 1 mmf. Especially valuable in production line checking, or in quality control.



MODEL CM-1

\$29.50

Shpg. Wt.
7 Lbs.

Tube Checker Kit

This fine piece of test gear checks tubes for quality, emission, shorted elements, open elements, and filament continuity. Will test all tube types normally encountered in radio and TV service work. Sockets provided for 4, 5, 6, and 7-pin large, rectangular, and miniature types, octal and loctal types, the Hytron 9-pin miniatures, and pilot lamps. Condition of tubes indicated on a large 4½" meter with multi-color "good-bad" scale. An illuminated roll chart is built right in, providing test data for various tube types. This tester provides switch selection of 14 different filament voltage values from 0.75 volts to 117 volts. Individual switches control each tube element. Close tolerance resistors employed in critical test circuits for maximum accuracy. A professional instrument both in appearance and performance.

The Model TC-2 is very simple to build, even for a beginner. It employs a color-coded cable harness for neat, professional under-chassis wiring. Comes with attractive counter style cabinet, and portable cabinet is available separately. At this price, even the part-time serviceman can afford his own tube checker for maximum efficiency in service work.

HEATHKIT TV PICTURE TUBE TEST ADAPTER

Designed especially for use with the Model TC-2 tube checker. Use it to test TV picture tubes for emission, shorts, etc. Consists of 12-pin TV tube socket, 4 ft. cable, octal connector, and necessary technical data. Not a kit.



MODEL 355

\$4.50

Shpg. Wt.
1 Lb.

HEATHKIT VISUAL-AURAL SIGNAL TRACER KIT

Although designed primarily for radio receiver work, this valuable instrument finds extensive application in FM and TV servicing as well. Features a high-gain channel with demodulator probe, and a low-gain channel with audio probe. Will trace signals in all sections of a radio receiver and in many sections of a FM set or TV receiver. Uses built-in speaker and electron beam eye tube for indication. Also features built-in wattmeter and a noise locator circuit. Provision for patching speaker and/or output transformer into external set.

MODEL T-3

\$23.50

Shpg. Wt. 9 Lbs.



HEATHKIT CONDENSER CHECKER KIT

The Model C-3 consists of an AC powered bridge for both capacitive and resistive measurements. Bridge balance is indicated on electron beam eye tube, and capacity or resistance value is indicated on front panel calibrations. Measures capacity in four ranges from .00001 mfd to .005 mfd, .001 mfd to .5 mfd, .1 mfd to 50 mfd, and 20 mfd to 1000 mfd. Measures resistance in two ranges, from 100 ohms to 50,000 ohms, and from 10,000 ohms to 5 megohms. Selection of five different polarizing voltages for checking capacitors, from 25 volts DC to 450 volts DC. Checks paper, mica, ceramic, and electrolytic capacitors. Indicates power factor of electrolytic condensers.

MODEL C-3

\$19.50

Shpg. Wt. 7 Lbs.



HEATH COMPANY

A Subsidiary of Daystrom, Inc.

BENTON HARBOR 15, MICH.

PIONEER DESIGN . . .

New and unique approaches to instrument and equipment designs are a Heath Company tradition. We concentrate all our development efforts on kit projects, since this is our prime activity—and not just a sideline. This logically results in more efficient, more reliable circuit designs—and you benefit from this constant engineering progress. Buying from the undisputed leader in the electronic kit field assures you of completely modern equipment, with outstanding advanced design features.

The Model IB-2 is a completely self-contained unit. It has a built-in power supply, a built-in 1000 cycle generator, and a built-in vacuum tube detector. Provision has been made on the panel for connection to an external detector, an external signal generator, or an external power supply. A 100-0-100 micro-ampere meter on the front panel provides for null indications. Measures resistance from 0.1 ohm to 10 megohms, capacitance from 10 mmf to 100 mfd, inductance from 10 mh to 100 h, dissipation factor (D) from 0.002 to 1, and storage factor (Q) from 0.1 to 1000. 1/2 of 1% decade resistors employed for maximum accuracy. Typical accuracy figures are: resistance, $\pm 3\%$; capacitance $\pm 3\%$; inductance, $\pm 10\%$; dissipation factor, $\pm 20\%$; storage factor, $\pm 20\%$. Employs a Wheatstone bridge, a Capacity Comparison bridge, a Maxwell bridge, and a Hay bridge. Special two-section CRL dial provides maximum convenience in operation. Use the Model IB-2 for determining values of unmarked components, checking production or design samples, etc. A real professional instrument.

HEATHKIT

Impedance Bridge Kit

- * 1/2% precision resistors and silver-mica capacitors.
- * Battery-type tubes, no warm-up required.
- * Built-in phase shift generator and amplifier.

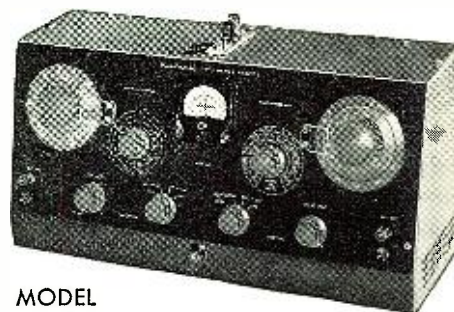

MODEL
IB-2

\$59⁵⁰ Shpg. Wt.
12 Lbs.

HEATHKIT "Q" METER KIT

The Q Meter permits measurement of inductance from 1 microhenry to 10 millihenries, "Q" on a scale calibrated up to 250 full scale, with multiplying factors of 1 or 2, and capacitance from 40 mmf to 450 mmf, ± 3 mmf. Built-in variable oscillator permits testing components from 150 kc to 18 mc. Large 4 1/2" panel-mounted meter is feature. Very handy for checking peaking coils, chokes, etc. Use to determine values of unknown condensers, both variable and fixed. Compile data for coil winding purposes, or measure RF resistance. Distributed capacity, and Q of coils.

MODEL QM-1
\$44⁵⁰

Shpg. Wt. 14 Lbs.

HEATHKIT ISOLATION TRANSFORMER KIT

This device isolates equipment under test from the power line. It is rated at 100 volt-amperes continuously, or 200 volt-amperes intermittently. AC-DC sets may be plugged directly into the IT-1 without the chassis becoming "hot." Additionally, since the IT-1 is fused, it is ideal for use as a buffer between the power line and a questionable receiver, or a new piece of equipment. Protects main fuses. Features voltage control, allowing control of the output from 90 volts to 130 volts. Panel meter monitors output voltage. A very handy device at an extremely low price.

MODEL IT-1
\$16⁵⁰

Shpg. Wt. 9 Lbs.

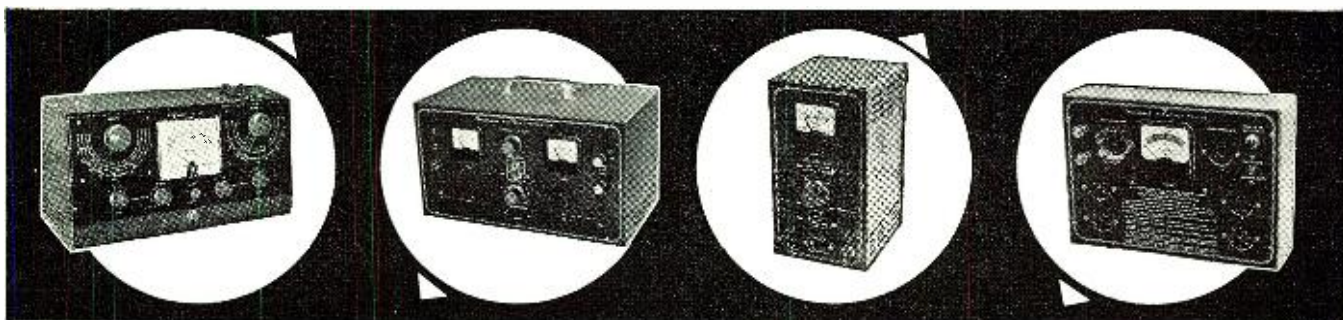

HEATHKIT 6-12 VOLT BATTERY ELIMINATOR KIT

This completely modern battery eliminator will supply DC output in two ranges for both 6-volt and 12-volt automobile radios. The output is variable for each range, so that operating voltage can be raised or lowered to determine how the receiver functions under adverse conditions. Range is 0-8 volts DC or 0-16 volts DC. Will supply up to 15 amperes on the 6-volt range, or up to 7 amperes on the 12-volt range. Two 10,000 microfarad output filter capacitors insure smooth DC output. Two separate panel meters indicate output voltage or output current. Makes it possible to test automobile radios inside at the workbench. Will also double as a battery charger.

MODEL BE-4
\$31⁵⁰

Shpg. Wt. 17 Lbs.

HEATHKIT 6-VOLT VIBRATOR TESTER KIT

This instrument functions very much like a tube checker, to test auto radio vibrators. Vibrator condition is indicated on a simple "good-bad" scale. Tests for proper starting and overall quality of operation, of both interrupter and self-rectifier types of 6-volt vibrators. The model VT-1 is designed to operate from any battery eliminator capable of delivering continuously variable output from 4 to 6 volts DC at 4 amperes or more. It is an ideal companion unit for the Heathkit Model BE-4 battery eliminator. The construction book for the VT-1 contains vibrator test chart for popular 6-volt vibrator types. A real time saver!

MODEL VT-1
\$14⁵⁰

Shpg. Wt. 6 Lbs.

HEATHKIT DX-100 PHONE AND CW



**MODEL
DX-100**
Shpg. Wt.
107 Lbs.

\$189⁵⁰

Shipped motor freight unless otherwise specified. \$50.00 deposit required on c.o.d. orders.

- * Phone or CW on 160, 80, 40, 20, 15, 11 and 10 meters.
- * Built-in VFO, modulator, and power supplies.
- * High quality components used throughout for reliable performance.
- * Features 5-point TVI suppression.

HEATHKIT COMMUNICATIONS TYPE ALL BAND RECEIVER KIT

This receiver covers 550 kc to 30 mc in four bands, and is ideal for the short-wave listener or beginning amateur. It provides good sensitivity and selectivity, combined with good image rejection. Amateur bands clearly marked on illuminated dial scale. Employs transformer type power supply—electrical bandspread—antenna trimmer—separate RF and AF gain controls—noise limiter—headphone jack—and automatic gain control. Has built-in BFO for CW reception.

CABINET: Fabric covered cabinet with aluminum panel as shown. Part 91-15A. Shipping weight 5 lbs. \$4.95

MODEL AR-3
\$29⁹⁵

INCLUDING NEW
EXCISE TAX
(Less Cabinet)
Shpg. Wt. 12 Lbs.



HEATHKIT VFO KIT

You can go VFO for less than you might expect. Here is a variable frequency oscillator that covers 160, 80, 40, 20, 15, 11, and 10 meters with three basic oscillator frequencies, that sells for less than \$20. Provides better than 10 volt average RF output on fundamentals. Plenty of drive for most modern transmitters. Requires a power source of only 250 VDC at 15 to 20 ma. and 6.3 VAC at 0.45A. Incorporates a regulator tube for stability. Illuminated frequency dial reads frequency directly on the band being employed. Temperature-compensated capacitors offset coil heating.

MODEL VF-1

\$19⁵⁰

Shpg. Wt. 7 Lbs.

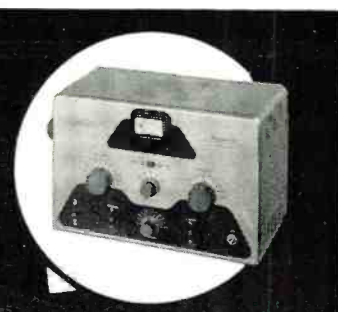

EASY ON THE BUDGET!

You can buy Heathkits on an easy time-payment plan that provides a full year to pay. Write for complete details and special order blank.



HEATH COMPANY

A Subsidiary of Daystrom, Inc.

BENTON HARBOR 15, MICH.

NEW HEATHKIT CW TRANSMITTER KIT

The brand new Heathkit Model DX-20 Transmitter is one of the most efficient little rigs available today. Featuring an entirely new circuit, it is ideal for the novice, and even for the advanced-class CW operator. A 6DQ6A final amplifier provides plate power input of 50 watts. A 6CL6 oscillator is employed, and a 5U4GB rectifier. The transmitter features one-knob bandswitching to cover 80, 40, 20, 15, 11 and 10 meters. It is designed for crystal excitation, but may be excited by an external VFO. A pi network output circuit matches antenna impedances between 50 and 1000 ohms. Front panel controls are functionally located for your convenience. If you appreciate a good signal on the CW bands, this is the transmitter for you!

MODEL DX-20

\$35⁹⁵

Shpg. Wt. 18 Lbs.

DOLLAR-SAVING ECONOMY . . .

There would be no particular achievement in selling inexpensive merchandise at a low price—although it is being done every day. However, there is something to crow about when, through tremendous purchasing power and factory-to-you distribution, Heath Company can offer top-quality equipment, using name-brand components, at such low prices. This is real economy, as opposed to the so-called "bargains". Needless to say, there is a big difference.

HEATHKIT PHONE AND CW

Transmitter Kit

- * 6146 final amplifier for full 65-watt plate power input.
- * Phone and CW operation on 80, 40, 20, 15, 11, and 10 meters. Pi network output coupling.
- * Switch selection of three crystals — provision for external VFO excitation.

The DX-35 features a 6146 final amplifier to provide 65 watts plate power input on CW, with controlled carrier modulation peaks up to 50 watts on phone. In addition, it is a most attractive transmitter. Modulator and power supplies are built-in, and the rig covers 80, 40, 20, 15, 11, and 10 meters with a single band-change switch. Pi network output provided for matching various antenna impedances. A 12BY7 buffer stage provided ahead of the final amplifier for plenty of drive on all bands. 12BY7 oscillator and 12AU7 modulator. Provision for switch selection of three different crystals. Crystals reached through access door at rear. Front panel controls marked "off—CW—stand-by—phone", "final tuning", "antenna coupling", "drive level control", and "band change switch". Panel meter indicates final grid current or final plate current. A perfect low-power transmitter both for the novice, and for the more experienced operator. A remarkable power package for the price. Incidentally, the price includes tubes, and all other components necessary for assembly. As with all Heathkits, comprehensive instruction manual assures successful assembly.



MODEL DX-35

\$56⁹⁵ Shpg. Wt.
24 Lbs.

HEATHKIT ANTENNA IMPEDANCE METER KIT

This instrument employs a 100 microampere panel meter and covers the impedance range of 0-600 ohms for RF tests. Functions up to 150 mc. Used in conjunction with signal source, such as the Heathkit Model GD-1B grid dip meter, the Model AM-1 will determine antenna resistance and resonance, match transmission lines for minimum standing wave ratio, determine receiver input impedance, etc. Will also double as a phone monitor. A very valuable device for many uses in the ham shack.

MODEL AM-1

\$14⁵⁰

Shpg. Wt. 2 Lbs.

HEATHKIT "Q" MULTIPLIER KIT

The QF-1 functions with any receiver with an IF frequency between 450 and 460 kc that is not AC-DC type. Operates from the receiver power supply, requiring only 6.3 VAC at 300 ma. and 150 to 250 VDC at 2 ma. Simple to connect with cable and plugs supplied. Provides additional selectivity for separating two signals, or will reject one signal and eliminate heterodyne. A big help on crowded bands. Provides an effective Q of approximately 4,000 for sharp "peak" or "null". Tunes to any signal within the IF bandpass of the receiver, without changing main receiver tuning dial.

MODEL QF-1

\$9⁹⁵

Shpg. Wt. 3 Lbs.

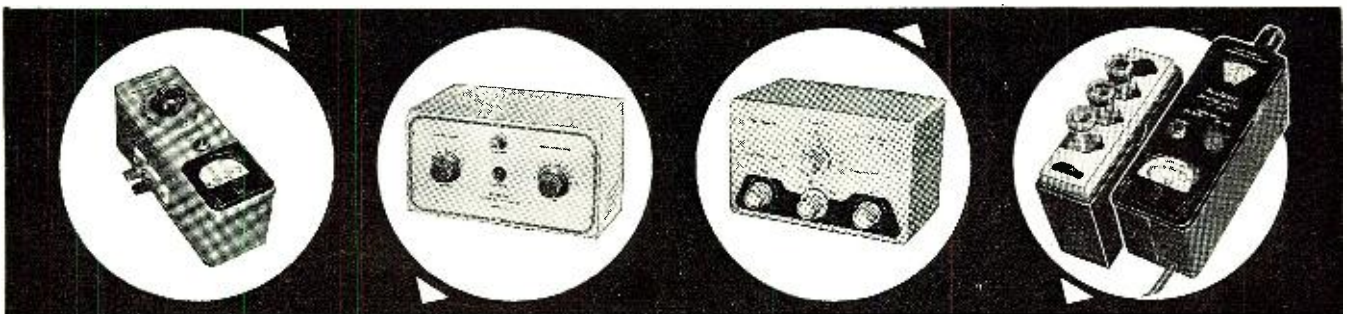

HEATHKIT ANTENNA COUPLER KIT

This device is designed to match the Model AT-1 transmitter to a long-wire antenna. In addition to impedance matching, this unit incorporates an L-type filter which attenuates signals above 36 megacycles, thereby reducing TVI. Designed for 52 ohm coaxial input. Handles power up to 75 watts, 10 through 80 meters. Uses a tapped inductor and variable capacitor. Neon RF indicator on front panel. Copper-plated chassis—high quality components throughout—simple to build. Eliminates waste of valuable communications power due to improper matching. A "natural" for all AT-1 transmitter owners.

MODEL AC-1

\$14⁵⁰

Shpg. Wt. 4 Lbs.

HEATHKIT GRID DIP METER KIT

The grid dip meter was originally designed for the ham shack. However, its use has been extended into the service shop and laboratory. Continuous frequency coverage from 2 mc to 250 mc with pre-wound coils. 500 microampere panel meter employed for indication. Use for locating parasitics, neutralizing, determining RF circuit resonant frequencies, etc. Coils are included with kit, as is a coil rack. Front panel controls include sensitivity control for meter, and phone jack for listening to zero-beat. Will also double as an absorption-type wavemeter.

MODEL GD-1B

\$19⁹⁵

Shpg. Wt. 4 Lbs.

HEATHKIT BROADCAST BAND



MODEL BR-2
(Less Cabinet)
Shpg. Wt. 10 Lbs.

\$18⁹⁵

INCLUDING NEW
EXCISE TAX*

ATTENTION BEGINNERS . . .

This kit is an ideal "first project" if you have never built a Heathkit before. A good chance to "learn by doing."

- * Miniature tubes and high-gain IF transformer.
- * Rod-type built-in antenna. Good sensitivity and selectivity.
- * 5½-inch PM speaker.
- * Provision for phono jack.
- * Transformer-operated power supply.

Receiver Kit

You need no previous experience in electronics to build this table-model radio. The Model BR-2 receiver covers 550 kc to 1620 kc and features good sensitivity and selectivity over the entire band. A 5½" PM speaker is employed, along with high gain miniature tubes and a new rod-type built-in antenna. Provision has been made in the design of this receiver for its use as a phonograph amplifier. The phono jack is located on the back chassis apron. A transformer operated power supply is featured for safety of operation, as opposed to the usual AC-DC supply commonly found in "economy radio kits." Don't let the low Heathkit price deceive you. This is the kind of set you will want to show off to your family and friends after you have finished building it.

Construction of this radio kit is very simple. Giant size pictorial diagrams and detailed step-by-step instructions assure your success. The construction manual also includes an explanation of basic receiver circuit theory so you can "learn by doing" as the receiver is built. The manual even provides information on resistor and capacitor color codes, soldering techniques, use of tools, etc. If you have ever had the urge to build your own radio receiver, the outstanding features of this popular Heathkit deserve your attention.

CABINET: Proxilyn impregnated fabric covered plywood cabinet available for the BR-2 receiver as shown. Complete with aluminum panel, reinforced speaker grill, and protective rubber feet. Shipping weight 5 lbs., part No. 91-9A. \$4.95*

HEATHKIT PROFESSIONAL RADIATION COUNTER KIT

This sensitive and reliable instrument has already found extensive application in prospecting, and also in medical and industrial laboratories. It offers outstanding performance at a reasonable price. Front-panel meter indicates radiation level, and oral indication produced by panel-mounted speaker. Meter ranges are 0-100, 600, 6,000 and 60,000 counts per minute, and 0-.02, .1, 1 and 10 milliroentgens per hour. The probe, with expansion cord, employs type 6306 bismuth counter tube, sensitive to both beta and gamma radiation. It is simple to build, even for a beginner.

MODEL RC-1

\$79⁹⁵

Shpg. Wt. 8 Lbs.

HEATHKIT CRYSTAL RECEIVER KIT

The crystal radio of Dad's day is back again, but with big improvements! The Model CR-1 employs a sealed germanium diode, eliminating the critical "cat's whisker" adjustment. It is housed in a compact plastic box, and features two Hi-Q tank circuits, employing ferrite core coils and variable air tuning capacitors. The CR-1 covers the standard broadcast band from 540 kc to 1600 kc, and no external power is required for operation. Could prove valuable for emergency signal reception. This easy-to-build kit is a real "learn by doing" experience for the beginner, and makes an interesting project for all ages.

MODEL CR-1

\$7⁹⁵

INCLUDING NEW
EXCISE TAX*
Shpg. Wt. 3 Lbs.

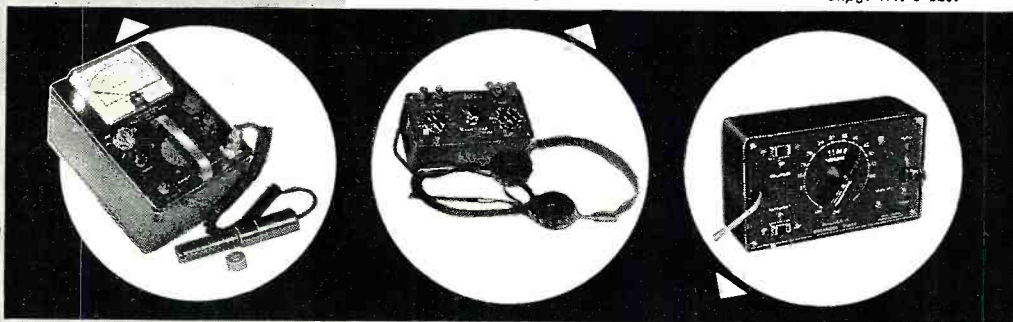

* Amazing new circuit for high efficiency.

- * Compact, portable and rugged.
- * Stable circuit requires only one 67½ volt "B" battery and two 1½ volt "A" batteries.

HEATHKIT ENLARGER TIMER KIT

The Model ET-1 is an easy-to-build device for use by amateur or professional photographers in controlling the timing cycle of an enlarger. It covers the range of 0 to 1 minute with a continuously variable, clearly calibrated scale. The timing period is pre-set, and the timing cycle is initiated by depressing the spring-return switch to the "print" position. Front panel provision is made for plugging in the enlarger and a safelight. The safelight is automatically turned "on" when the enlarger is "off". Handles up to 350 watts. The timing cycle is controlled electronically for maximum accuracy and reliability. Very simple to build in only one evening, even by a beginner.

MODEL ET-1

\$11⁵⁰

Shpg. Wt. 3 Lbs.



HEATH COMPANY
A Subsidiary of Daystrom, Inc.
BENTON HARBOR 15, MICH.

COMPREHENSIVE INSTRUCTIONS . . .

The step-by-step assembly instructions provided with each Heathkit are the finest available anywhere. Each manual begins at the beginning, and assumes no previous training or experience on the part of the kit builder. This means that our kits can be built successfully by anyone who can follow instructions. As a matter of fact, new manuals are tested by having the kit built by someone in our office who has had no previous experience in electronics. This is your guarantee of complete and thorough instruction material.

HEATHKIT HIGH FIDELITY

Preamplifier Kit

- * 5 switch-selected inputs, each with its own level control.
- * Equalization for LP, RIAA, AES, and Early 78's.
- * Separate bass and treble tone controls, and special hum control.
- * Clean, modern lines and satin-gold enamel finish.

Literally thousands of these preamplifiers are in use today, because the kit meets or exceeds specifications for the most rigorous high-fidelity applications, and will do justice to the finest available program sources. Provides a total of 5 inputs, each with individual level controls (three high-level and two low-level). Frequency response is within 1 DB from 25 CPS to 30,000 CPS, or within 1½ DB from 15 CPS to 35,000 CPS. Hum and noise are extremely low, with special balance control for absolute minimum hum level. Tone control provides 18 DB boost and 12 DB cut at 50 CPS, and 15 DB boost and 20 DB cut at 15,000 CPS. Cabinet measures only 12-9/16" W. x 3¾" H. x 4¾" D, and it is finished in beautiful satin-gold enamel. 4-position turnover and 4 position roll-off controls provide "LP," "RIAA," "AES," and "early 78" equalization, and 8, 12, 16, and 1 flat position for roll-off. Derives operating power from the main amplifier, requiring only 6.3 VAC at 1 ampere and 300 VDC at 10 MA. Easy to construct from step-by-step instructions and pictorial diagrams provided.

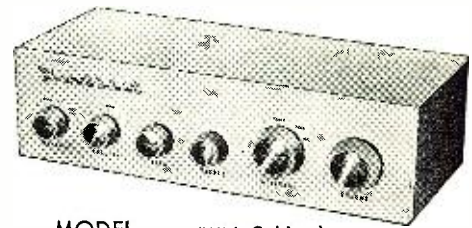

MODEL WA-P2 (With Cabinet)
Shpg. Wt. 7 Lbs.

\$19⁷⁵

HEATHKIT HIGH FIDELITY FM TUNER KIT

- * Illuminated slide-rule dial covers 88 to 108 MC.
- * Modern circuit emphasizes sensitivity and stability.
- * Housed in attractive satin-gold cabinet to match WA-P2 and BC-1.

This amazing new FM tuner can provide you with real high-fidelity performance at an unbelievably low price level. Covering 88 to 108 MC, the modern circuit features a stabilized, temperature-compensated, oscillator, A.G.C., broadbanded

IF circuits, and better than 10 UV sensitivity for 20 DB of quieting. A high gain, cascaded, RF amplifier is used ahead of the mixer to increase overall gain and reduce oscillator leakage. It employs a ratio detector for high efficiency without sacrifice in high-fidelity performance. IF and ratio transformers are pre-aligned, as is the front end tuning unit. This means the kit can be constructed by a beginner, without elaborate test and alignment equipment. The FM-3A is designed to match the WA-P2 preamplifier and the BC-1 AM tuner. An illuminated slide-rule dial is employed for frequency indication. Step-by-step instructions and large pictorial diagrams assure success.

MODEL FM-3A
\$25⁹⁵
INCLUDING NEW
EXCISE TAX
(With Cabinet)
Shpg. Wt. 7 Lbs.

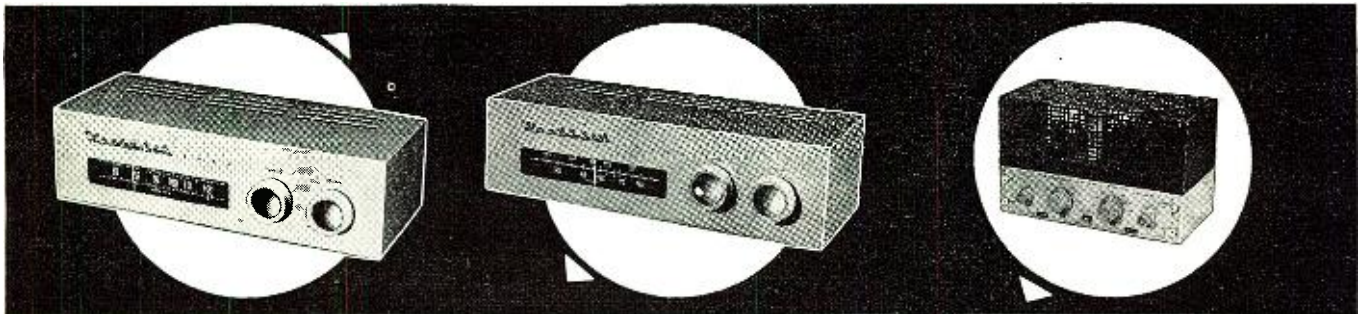

HEATHKIT BROADBAND AM TUNER KIT

This AM tuner has been designed especially for high-fidelity applications. It incorporates a low-distortion detector, a broadband IF, and other features essential to usefulness in high-fidelity. Special voltage-doubler detector employs crystal diodes for low distortion. Sensitivity and selectivity are excellent. Audio response is ± 1 DB from 20 CPS to 2 kc, with 5 DB of pre-emphasis at 10 kc to compensate for station roll-off. Covers the standard broadcast band from 550 to 1600 kc. Incorporates a 10 kc whistle-filter and provides a 6 DB signal-to-noise ratio at 2.5 UV. RF and IF coils are pre-aligned, and power supply is built-in. Incorporates AVC, two outputs, and two antenna inputs.

MODEL BC-1
\$25⁹⁵
INCLUDING NEW
EXCISE TAX
(With Cabinet)
Shpg. Wt. 8 Lbs.

HEATHKIT ELECTRONIC CROSS-OVER KIT

This unusual device functions to separate low frequencies and high frequencies so that they may be fed to separate amplifiers and to separate speakers. This eliminates the need for conventional cross-over circuits, since the Model XO-1 does the complete job electronically. Cross-over frequencies of 100, 200, 400, 700, 1,200, 2,000 and 3,500 CPS are selectable with front panel controls on the XO-1, and a separate level control is provided for each channel. Minimizes inter-modulation distortion problems. Handles unlimited power, since frequency division is accomplished ahead of the power stage. Attenuation is 12 DB per octave, with sharp "knee" at cut-off frequency.

MODEL XO-1
\$18⁹⁵
Shpg. Wt. 6 Lbs.

HEATHKIT ADVANCED-DESIGN

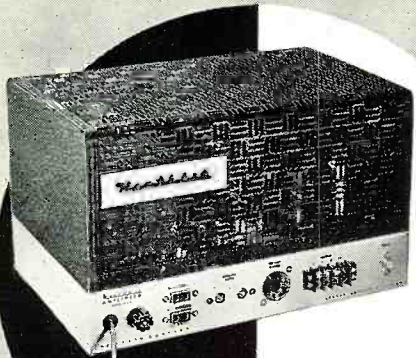

MODEL W-5M
Shpg. Wt. 31 Lbs.
Express Only

\$59.⁷⁵

MODEL W-5

Consists of Model W-5M plus Model WA-P2 pre-amplifier.

Shpg. Wt. 38 Lbs.
Express only... \$79.50

- * Full 25 watt output with KT-66 output tubes.
- * All connectors brought out to front chassis apron.
- * Protective cover over all above-chassis components.

HEATHKIT DUAL-CHASSIS—WILLIAMSON TYPE HIGH FIDELITY AMPLIFIER KIT

This 20-watt high-fidelity amplifier employs the famous Acrosound Model TO-300 "ultra-linear" output transformer and uses 5881 output tubes. The power supply is built on a separate chassis, and the two chassis are inter-connected with a power cable. This provides additional flexibility in mounting. Frequency response is ± 1 DB from 6 CPS to 150 kc at 1 watt. Harmonic distortion is only 1% at 21 watts, and 1M distortion is only 1.3% at 20 watts. (60 and 3,000 CPS). Output impedance is 4, 8, or 16 ohms. Hum and noise are 88 DB below 20 watts. A very popular high-fidelity unit employing top-quality components throughout.

MODEL W-3M: Shpg. Wt. 29 Lbs. Express only... \$49.75

MODEL W-3: Consists of Model W-3M plus Model WA-P2 pre-amplifier. Shpg. Wt. 37 Lbs. Express only... \$69.50

HEATHKIT 7-WATT AMPLIFIER KIT

This amplifier is more limited in power than other Heathkit models, but it still qualifies as a high-fidelity unit, and its performance definitely exceeds that of many so-called "high-fidelity" phonograph amplifiers. Using a tapped-screen output transformer of new design, the Model A-7D provides a frequency response of $\pm 1\frac{1}{2}$ DB from 20 to 20,000 CPS. Total distortion is held to a surprisingly low level. Output stage is push pull, and separate bass and treble tone controls are provided. Shpg. Wt. 10 lbs.

MODEL A-7E: Similar to the A-7D, except that a 12SL7 tube has been added for pre-amplification. Two inputs, RIAA compensation, and extra gain.

MODEL A-7D

\$17.⁹⁵

INCLUDING NEW EXCISE TAX

\$19.⁹⁵†

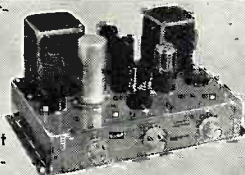
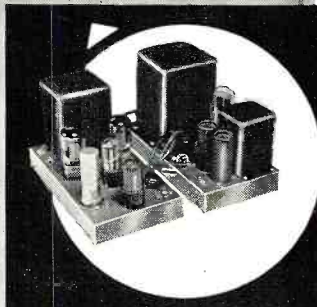

HIGH FIDELITY

Amplifier Kit

This 25 watt unit is our finest high-fidelity amplifier. Using a special design peerless output transformer, and KT-66 output tubes by Genalex, the Model W-5M provides performance characteristics unsurpassed at this price level. Frequency response is ± 1 DB from 5 to 160,000 CPS at 1 watt. Harmonic distortion is less than 1% at 25 watts and 1M distortion is less than 1% at 20 watts (60 and 3,000 CPS, 4 to 1). Hum and noise are 99 DB below 25 watts. Damping factor is 40 to 1. Input voltage for 5 watts output is 1 volt. Tubes employed are a pair of 12AU7's, a pair of KT-66's and a 5R4GY rectifier. Measures 13-3/32" W. x 8 1/2" D. x 8 1/4" H. Output impedance is 4, 8, or 16 ohms. Featured, also, is the "tweeter saver" which suppresses high frequency oscillation, and a new type balancing circuit requiring only a voltmeter for indication. This balance is easier to adjust, and results in a closer "dynamic" balance between output tubes. The Model W-5M provides improved phase shift characteristics, reduced IM and harmonic distortion, and improved frequency response. Conservatively rated high-quality components are used throughout to insure years of trouble-free operation. No technical background or training is required for assembly. Step-by-step instructions are provided for every stage of construction, and large pictorial diagrams illustrate exactly where each wire and component is to be placed. An amplifier for music lovers who can appreciate subtle differences in performance. Just ask the audiophile who owns one!

HEATHKIT SINGLE CHASSIS—WILLIAMSON TYPE HIGH FIDELITY AMPLIFIER KIT

The 20-watt Model W-4AM Williamson type amplifier is a tremendous high-fidelity bargain. Combining the power supply and main amplifier on one chassis, and using a special-design output transformer by Chicago Standard brings you savings without a sacrifice in quality. Employing 5881 output tubes, the frequency response of the W-4AM is ± 1 DB from 10 CPS to 100 kc at 1 watt. Harmonic distortion is only 1.5% at 20 watts. Output impedance is 4, 8, or 16 ohms. Hum and noise are 95 DB below 20 watts.

MODEL W-4AM: Shpg. Wt. 28 Lbs. Express only... \$39.75

MODEL W-4A: Consists of Model W-4AM plus Model WA-P2 pre-amplifier. Shpg. Wt. 35 Lbs. Express only... \$59.50

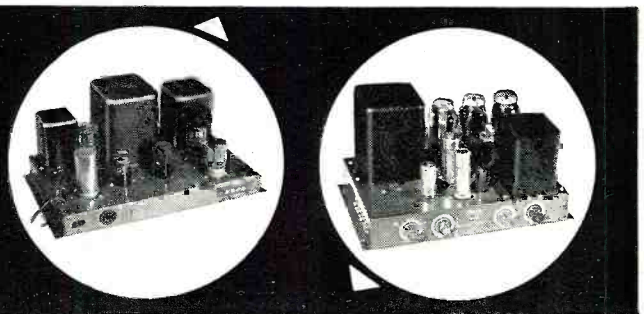

HEATHKIT 20-WATT HIGH FIDELITY AMPLIFIER KIT

This high-fidelity amplifier features full 20-watt output using push pull 6L6 tubes. Built-in preamplifier provides 4 separate inputs, selected by a panel-mounted switch. It has separate bass and treble tone controls, each offering 15 DB boost and cut. Output transformer is tapped at 4, 8, 16, and 500 ohms. Designed primarily for home installations, but also used extensively for public address applications. True high-fidelity performance with frequency response of ± 1 DB from 20 CPS to 20,000 CPS. Total harmonic distortion only 1% (at 3 DB below rated output).

MODEL A-9B

\$35.⁵⁰

Shpg. Wt. 23 Lbs.



HEATH COMPANY

A Subsidiary of Daystrom, Inc.

BENTON HARBOR 15, MICH.

HEATHKIT HIGH FIDELITY

Range Extending SPEAKER SYSTEM KIT

All prices marked with a † include a new federal excise tax that now applies to receivers, tuners and some amplifiers, even though they may be in kit form. Since the tax is in effect as of July 5, 1956, we have no choice but to reflect it in our kit prices. This note is just to let you know we are not increasing our prices on some kits, but merely including this new tax in them.

Thank you,
HEATH COMPANY

- * High quality speakers of special design — 15" woofer and compression-type super-tweeter.
- * Easy-to-assemble cabinet of furniture-grade plywood.
- * Attractively styled to fit into any living room.
- * Matches Model SS-1.

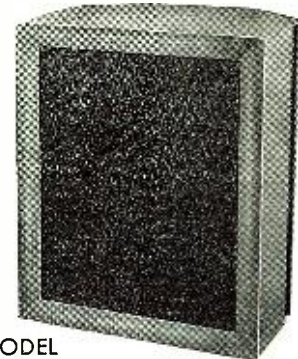

MODEL
SS-1B

\$99⁹⁵

Shpg. Wt. 80 Lbs.

This range extending unit is designed especially for use with the Model SS-1 speaker system. It consists of a 15" woofer, providing output between 35 and 600 CPS, and a compression-type super-tweeter that provides output between 4,000 and 16,000 CPS. Cross-over frequencies are 600, 1,600, and 4,000 CPS. The SS-1 provides the mid-range, and the SS-1B extends the coverage at both ends of the spectrum. Together, the two speaker systems provide output from 35 to 16,000 CPS within ± 5 DB. This easy-to-assemble speaker enclosure kit is made of top-quality furniture-grade plywood. All parts are pre-cut and pre-drilled, ready for assembly and the finish of your choice. Complete step-by-step instructions are provided for quick assembly by one not necessarily experienced in woodworking. Coils and capacitors for proper cross-over network are included, as is a balance control for super-tweeter output level. The SS-1 and SS-1B can provide you with unbelievably rich audio reproduction, and yet these units are priced reasonably. The SS-1B measures 29" H. x 23" W. x 17½" D. The speakers are both special-design Jensens, and the power rating is 35 watts. Impedance is 16 ohms.

HEATHKIT HIGH FIDELITY SPEAKER SYSTEM KIT



MODEL
SS-1

\$39⁹⁵

Shpg. Wt. 30 Lbs.

- * Special design ducted-port, bass-reflex enclosure.
- * Two separate speakers for high and low frequencies.
- * Kit includes all parts and complete instructions for assembly.

This speaker system is a fine reproducer in its own right, covering 50 to 12,000 CPS within ± 5 DB. However, the story does not end there. Should you desire to expand the system later, the SS-1 is designed to work with the SS-1B range extending unit — providing additional frequency coverage at both ends of the spectrum. It can fulfill your present needs, and still provide for the future. The SS-1 uses two Jensen speakers; an 8" midrange-woofer, and a compression-type tweeter. Cross-over frequency is 1,600 CPS, and the system is rated at 25 watts. Nominal impedance is 16 ohms. The cabinet is a ducted-port bass-reflex type. Attractively styled, the Model SS-1 features a broad "picture-frame" molding that will blend with any room decorating scheme. Pre-cut and pre-drilled wood parts are of furniture grade plywood. The kit is easy-to-build, and all component parts are included, along with complete step-by-step instructions for assembly. Can be built in just one evening, and will provide you with many years of listening enjoyment thereafter.

HEATH COMPANY A Subsidiary of Daystrom, Inc. **BENTON HARBOR 15, MICH.**

ORDER BLANK

NOTE: All prices subject to change without notice.

Enclosed find () check () money order for
Please ship C.O.D. () postage enclosed for _____ pounds.

On Express orders do not include transportation charges — they will be collected by the express agency at time of delivery.

ON PARCEL-POST ORDERS include postage for weight shown. ORDERS FROM CANADA and APO'S must include full remittance.

Name _____

Address _____

City & Zone _____ State _____

(PLEASE PRINT)

SHIP VIA

- Parcel Post
- Express
- Freight
- Best Way

QUANTITY	ITEM	MODEL NO.	PRICE

Where else but in
a Tandberg
 could you receive
 such Tape Recorder
 Values



- Speeds—1½, 3¾, 7½ ips—without audible wow or flutter at any speed.
- A hand-rubbed furniture cabinet and luggage transport case in one unit.
- Microphone included has flat response within 3db to 13,000 cps.
- Balanced Playback Amplifier with measured distortion of under 1% at 2 watts, 5% at 3.3 watts.
- High quality, high fidelity, Goodmans Speaker with a wide-range frequency response.
- Playing time up to 4 hours, 16 minutes at 1½ ips on standard 1,200 ft. roll of tape.
- Superior built-in quality to provide better than ever audio performance at the Incomparable Value Price of \$299.50.

Ask your dealer for a demonstration or write for full information to:



Tandberg

10 E. 52nd St., New York 22, N. Y.

Hi-Fi-Audio Product Review

COMPACT SPEAKER SYSTEM

Eico, 84 Withers St., Brooklyn 11, N. Y. is marketing a new bookshelf-size, two-way speaker system, the Model HFS-1.

Featuring a Jensen heavy-duty 8" woofer and matching Jensen compres-



sion driver exponential horn tweeter in a factory-built tuned bass reflex cabinet, the system is said to provide smooth, clean bass and crisp, extended, natural highs. Over-all response is ± 6 db from 70 to 12,000 cps. Power handling capacity is 25 watts.

The unit can be wired in approximately 15 minutes. The visible surfaces of the 23"x11"x9" cabinet are smooth-sanded, clear-grain birch. The neutral acoustical grille cloth is framed by a smooth-sanded solid birch picture molding. The cabinet may be finished in any accepted furniture treatment.

NEW AMP-PREAMP KIT

Tech-Master Corporation, 75 Front Street, Brooklyn, N. Y. is now marketing a 60-watt amplifier-preamplifier kit, the Model 19K.

Undistorted power is guaranteed to be 60 watts at any frequency from 20 to 20,000 cps while IM distortion is below 1% at 60 watts and below .25% at



all ordinary listening levels. According to the company, there is enough reserve power to drive a wide-range electrostatic speaker without distortion. The preamplifier provides compensation for all recording characteristics.

The kit comes complete with instructions and pictorial diagrams. The cir-

cuit is housed in a low silhouette cabinet combined with upright tube and transformer positions for optimum ventilation. The front panel is styled in black and gold and the over-all size of the unit is 14¼"x10¼"x5¼". The cabinet is available as an accessory at additional cost.

RECORD SPRAY

Permo, Incorporated, of 6415 N. Ravenswood Ave., Chicago 26, Ill., has developed and is marketing its new "Fidelitone Lubri-Stat" record spray which protects not only discs but the needle with which the record is played.

The new spray eliminates static electrical build-up and coats the record grooves with a microscopic lubricating film to reduce the coefficient of friction, thereby reducing record and needle wear. The product is supplied in 6-ounce spray cans.

"SWITCHBOARD" INTERCOM

Fanon Electric Co., Inc., 98 Berrian St., Brooklyn 8, N. Y., has added the "Monitor" Model FM-6 to its line of intercom systems.

Designed to be used in conjunction

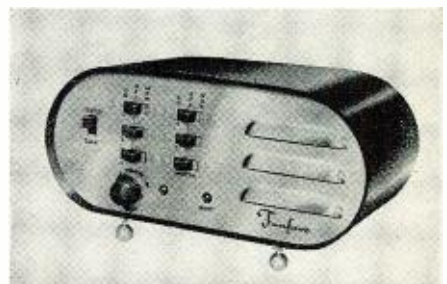

with up to five remote stations and permitting conversation between the master and any one or all of the remotes, the new unit incorporates a special feature which permits direct remote-to-remote communication. This innovation thus allows the unit to operate as a "switchboard" in small establishments.

The "Monitor" is housed in a modern cabinet which is available in several decorator colors. It has a satin-copper front panel. Write the manufacturer for full details and prices.

NEW ISI ENCLOSURE

International Scientific Industries Corporation, 2374 East Hiway 24, Colorado Springs, Colo., has recently released a new speaker system which represents a radical departure from standard practice.

The system offers smoothness over the range from 30 to 15,000 cps; absence of coloration; sharp, clean, tran-

When you build your High Fidelity sound system, use **THE VERY BEST**

LOUDSPEAKERS YOU CAN GET

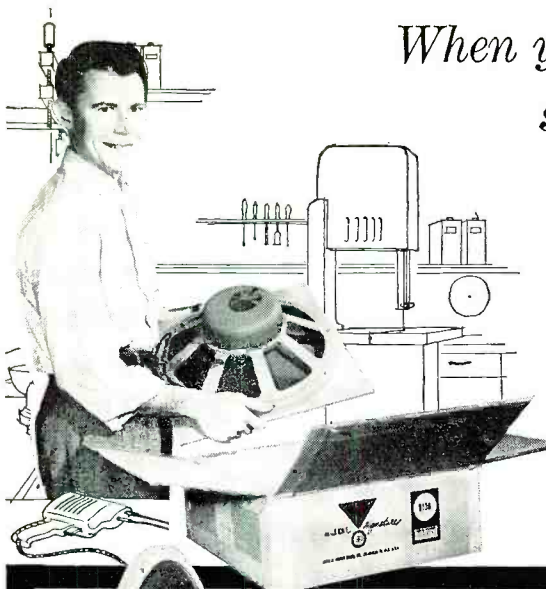

You are planning to build, or improve, your high fidelity sound system. Unstintingly, you will pour out your enthusiasm, time, and energy to get the finest music reproduction you can bring into your home. Get a loudspeaker that will do full credit to your handiwork... Install a JBL Signature Extended Range Loudspeaker, or two-way speaker system, in your enclosure.

JBL Signature Loudspeakers are made with the same careful craftsmanship, the same precision forming and fitting that you yourself would use if you set out to make the finest loudspeaker the world had ever heard. JBL Signature precision speakers are the most efficient loudspeakers made.

With a JBL Signature Loudspeaker in your high fidelity system, you can exhibit your components with pride, confident that those you have made yourself are being demonstrated in the most effective way possible.

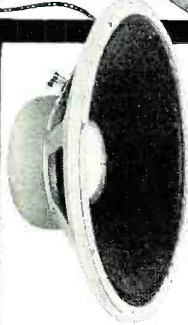

MODEL D130—15" extended range loudspeaker The only 15" extended range speaker made with a 4" voice coil is the world-famous JBL Signature D130. The large voice coil stiffens the cone for crisp, clean bass; smooth, extended highs. Your basic speaker, the D130 works alone at first, later becomes a low frequency driver when you add a JBL Signature high frequency unit and dividing network to achieve the ultimate excellence of a JBL Signature two-way system.



MODEL D208—8" extended range loudspeaker A precision transducer in every sense of the word, the famed JBL Signature 8" D208 is made with the same care and precision as the larger units in the James B. Lansing Sound, Inc., line. If space and cost are major considerations, the D208, properly enclosed, provides the most lastingly satisfactory sound you can get. It is widely used in top quality systems where extension speakers are desired for areas other than the main listening room.



MODEL D123—12" extended range loudspeaker With outstanding "presence" and clean response throughout the entire audio spectrum, the D123 features an unusual shallow construction. Only 3 3/8" deep, it is designed to mount flush with the wall, between studding, in any standard wall or partition. Frequently, the D123 is used in multiples in "infinite baffle" wall installations. In this case the JBL Signature 075 is a logical high frequency unit to add when you advance to a two-way system.



MODEL 175DLH high frequency assembly The acoustical lens is only available on JBL Signature high frequency units. The 14 element lens on the 175DLH disperses sound within the listening area over a 90° solid angle, smoothly, with equal intensity regardless of frequency. The acoustical lens is the greatest contribution to lifelike high frequency reproduction in 20 years, and it was developed for use with high fidelity equipment by James B. Lansing Sound, Inc. In addition to the lens, the 175DLH consists of a high precision driver with complex phasing plug and a machined aluminum exponential horn. Designed for crossover at 1200 cycles with the JBL Signature N1200 Network.



MODEL 075 high frequency unit Another exclusive for James B. Lansing Sound, Inc. is the ring radiator in the JBL Signature 075 high frequency unit. A ring, rather than a diaphragm, radiates into the annular throat of an exponential horn. The result is high frequency reproduction of unmatched smoothness and clarity, absolutely free of resonances and strident peaks. The horn is beautifully machined from aluminum, the entire unit a gratifying, solid piece of fine craftsmanship. Designed for crossover at 2500 cycles with the JBL Signature N2500 Network.

JBL Signature two-way systems are available as kits

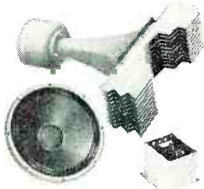

086 KIT This two-way system is made up of units which have been acclaimed by impartial authorities as the finest available anywhere today. Included in the kit are the 150-4C Low Frequency Driver, N500H Network, 375 High Frequency Driver, 537-509 Horn-Lens Assembly. These are the same units—including the serpentine acoustical lens—which are used in The Hartsfield... units designed originally for installation in the most modern theaters in the world.

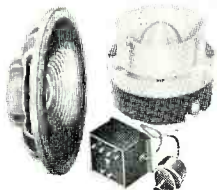

002 KIT Including some of the newest speakers made, the JBL Signature 002 Kit includes a D123 for low frequency reproduction, N2500 Network, 075 High Frequency Unit. The 002 Kit is moderately priced, yet gives the user all the advantages of a two-way system made with independent drivers.



001 KIT Probably the most popular high quality two-way system on the market, the JBL Signature 001 system consists of a 130A Low Frequency Driver, N1200 Network, 175DLH High Frequency Assembly. The D130 may be substituted for the 130A without disturbing the balance or coverage of the system.



There are many more kits and loudspeakers in the JBL Signature line. Whatever your needs, you will find exactly the right unit or system in the complete JBL Signature catalog. Send for your free copy. A limited number of technical bulletins are also available. Please ask only for those in which you are vitally interested.

JBL means JAMES B. LANSING SOUND, INC.

2439 Fletcher Drive • Los Angeles 39, California

Please send me the following:

- Free Catalog of JBL Signature Products
- Name and address of Authorized JBL Signature Audio Specialist in my community

TECHNICAL BULLETINS ON:

- D130 D123 D208 175DLH 075 130A 150-4C

Name _____

Address _____

City _____ Zone _____ State _____

**MORE POWER
with LESS
DISTORTION**



EL84 / 6BQ5

Mullard
MADE FOR MUSIC

When operated in a single-ended output stage, the EL84/6BQ5 can deliver an output of up to 5.7W, and two EL84's in pentode push-pull yield an output of up to 20W. This tube makes possible the higher peak powers and low distortion required for present day High Fidelity equipment, tape recorders, AM/FM radios, etc. The EL84 requires unbelievably low drive voltage thereby eliminating the necessity of preceding high gain stages. The EL84 has a very high mutual conductance of 11,300 μ mhos and a plate dissipation of 12W.

OTHER Mullard TUBES
designed specifically for High Fidelity:

EL34/6CA7	High-power pentode, 100 W PP
EL37	High-power pentode, 69 W PP
EF86/6267	Low-noise input pentode
ECC81/12AT7	Low-noise medium μ dual triode
ECC82/12AU7	Low-noise low μ dual triode
ECC83/12AX7	Low-noise high μ dual triode
EZ80/6V4	Miniature rectifier cathode type, 90 ma.
EZ81/6CA4	Miniature rectifier cathode type, 150 ma.
6Z34	Bantam rectifier cathode type, 250 ma.

Mullard

Available at all leading distributors.
For detailed technical data and application information write:



Trade Mark Mullard, Ltd.

INTERNATIONAL ELECTRONICS CORP.
81 Spring Street, New York 12, N. Y.

World's Most Complete Range of audio tubes

sient response; and balanced sound, according to the company. Excellent bass response is provided without resorting to resonant devices or horn loading. The enclosure measures 14" x 9 $\frac{3}{4}$ " x 22". The system will handle 50 watts of program material throughout its full frequency range.

The company will supply additional details and full specs on request.

MADISON FIELDING TUNER

Madison Fielding Corporation, 863 Madison St., Brooklyn 21, N. Y., has

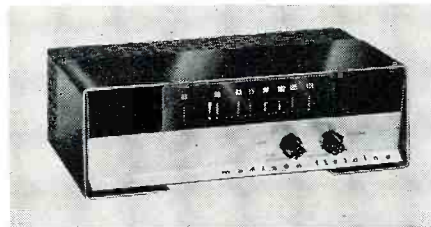

just introduced a new FM tuner featuring dynamic micro-beam tuning as its FM-15.

Frequency response is uniform within ± 1 db from 20 to 20,000 cps. Drift is 20 kc. from a cold start with complete stability after one minute. Three controls are provided, including a station selector, level control, and "on-off" switch. The circuit uses eight tubes including the tuning indicator and rectifier. Flywheel tuning and diffused front panel illumination are added features. The cabinet measures 12 $\frac{1}{4}$ " x 6 $\frac{1}{4}$ " x 4". A data sheet on the FM-15 is available on request.

"TRI-FI" SPEAKER

Allied Radio Corporation, 100 N. Western Ave., Chicago 80, Ill., is now marketing a new 12" high-fidelity speaker which has been designated as the "Knight Tri-Fi."

Featuring three concentric radiators, one for reproduction of bass, one for



the middle-range frequencies, and one for treble, this new reproducer is said to provide excellent sound quality. It comes complete with a high-frequency level control and a built-in crossover network. The frame construction is extremely rigid and a heavy Alnico V magnet assures high efficiency and clean reproduction.

Power capacity is 25 watts and fre-

**BUILD THE SUPERB
PERI-50**

50 WATT—
100 WATT PEAK

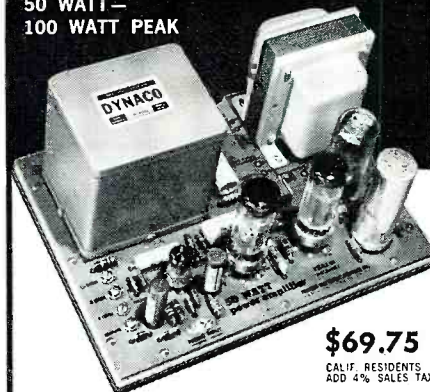

\$69.75
CALIF. RESIDENTS
ADD 4% SALES TAX

Now YOU can re-create in your own home the breathtaking realism in sound that has been known only to design engineers!

The PERI-50 engineering is "built in" through the revolutionary new deep-etched copper circuit board—a development of Printed Electronic Research Inc.

The DEEP-ETCHED copper circuit board replaces all wiring and guarantees that every PERI-50 AMPLIFIER built will perform exactly like the laboratory original—whether built by amateur, audiophile or electronic engineer!

EVERYTHING PROVIDED—including an Ungar soldering iron and solder! All components literally "plug in" to the self-contained circuit board. No schematics to follow (although provided).

ANYONE can build and hear the laboratory realism of the PERI-50 AMPLIFIER in 90 minutes or less.... utilizing the most advanced circuitry and the incomparable Dynaco Output Transformer for unsurpassed transient response and stability.

**GUARANTEED TO PERFORM
TO THESE SPECIFICATIONS:**

- POWER OUTPUT** 50 watts cont. — 100 watts peak.
- DISTORTION** — Intermodulation distortion less than 1.0% at 50 watts, less than 0.25% at 35 watts.
- FREQUENCY RESPONSE** 6 cps to 60,000 cps within ± 0.5 DB, ± 0.1 DB from 20 cps to 35,000 at any level from 1 milliwatt to 50 watts.
- POWER RESPONSE** less than 0.1% harmonic distortion at 50 watts from 20 cps to 25,000 cps add flat within 1 DB.
- SENSITIVITY** 50 watts output from 0.75 volt RMS input 100 watts output from 1.0 volt RMS input.
- SQUARE WAVE RESPONSE** essentially undistorted on speaker load at frequencies 20 cps to 35,000 cps. Damping Factor — 15. Output impedances 8 ohm and 16 ohm.
- TUBE COMPLEMENT** Two EL-34, one 6AN8 one 5U4.

ORDER DIRECT FROM
PRINTED ELECTRONIC RESEARCH INC.

4212 LANKERSHIM BLVD. NO. HOLLYWOOD, CALIF.
CHECK OR MONEY ORDER C.O.D.
SEND FREE BROCHURE DEPT. A-2

Name
Address
City Zone State

quency response is 35 to 15,000 cps, ± 5 db. Diameter of the speaker is $12\frac{1}{16}$ " and the depth is 8". Impedance is 16 ohms. The speaker is catalogued as the 81 DX 839. Further information is available on request.

"WIRE-LESS-COM"

Mark Simpson Manufacturing Co., Inc., 32-28 Forty-ninth St., Long Island City 3, N. Y., has added a two-station wireless intercom to its Masco line of audio equipment.

The "Wire-Less-Com" is designed to be plugged into any regular a.c. or d.c. power outlet. It uses less current than a 25-watt bulb, is safe and fool-proof, and carries UL-approval.

Each compact unit measures just $6\frac{1}{2}$ " x $3\frac{3}{4}$ " x $4\frac{1}{2}$ " with a carrying handle installed on each charcoal gray cabinet for added convenience. Write the company for a data sheet on this new intercom.

SR-300 HI-FI SYSTEM

Sargent-Rayment Co., 4926 E. 12th St., Oakland 1, Calif., has added the SR-300 to its line of high-fidelity equipment.

The "Maywood" combines an AM-

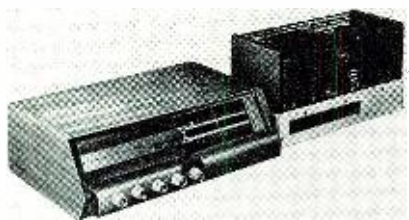

FM tuner, preamp-tone control, and 20-watt amplifier on two chassis. The tuner and controls are on one chassis, the amplifier and power supply are mounted on a "hide-a-way" chassis. The system needs only a record player and speaker to become a complete high-fidelity music center.

Amplifier response is ± 5 db from 15 to 70,000 cps, IM distortion is .75% (40 to 12,000 cps 4:1). The tuner offers FM a.f.c. on and off control, fully balanced wide-band FM detector with preceding limiter for maximum capture ratio, and bass and treble boost and attenuation of 15 db from 40 to 15,000 cps with only 1 db variation at mid-frequency. The three-position phono switch offers AES, LP, or RIAA equalization.

The tuner and control portion of the system come cabineted in a modern enclosure which fits in with any decor. An illustrated brochure on the "Maywood" is available on request.

60-WATT AMPLIFIER KIT

Lafayette Radio, 165-08 Liberty Ave., Jamaica 33, N. Y., has added a 60-watt "Ultra-Linear" amplifier to its line of hi-fi kits.

Using a low-noise HF86 voltage amplifier directly coupled to a cathode-coupled 6SN7GTB phase inverter driving push-pull EL34's in "Ultra-Linear" connection, the amplifier has a rated

KLH

Research and Development Corporation

A newly formed organization devoted to the design and manufacture of high quality sound reproduction equipment for the home.

The staff of KLH has had years of experience in the design and production of loudspeakers and loudspeaker systems. KLH will soon start producing a loudspeaker system using the Acoustic Suspension principle under license from Acoustic Research, Inc.

In order to make information available on the new system, KLH is preparing a comprehensive report on its performance. Meaningful information on the performance of loudspeakers can be obtained by measurements, providing that intelligently designed procedures are followed. The report in preparation describes and analyzes the results of such measurements and, in addition, describes the theory of operation of the forthcoming system. We will be glad to forward a copy of the report in response to your request.

KLH RESEARCH & DEVELOPMENT CORP.

30 CROSS STREET

CAMBRIDGE, MASSACHUSETTS

**FOR SOUND
SATISFACTION**



... use

**RCA
GOLD LABEL
SPEAKERS!**

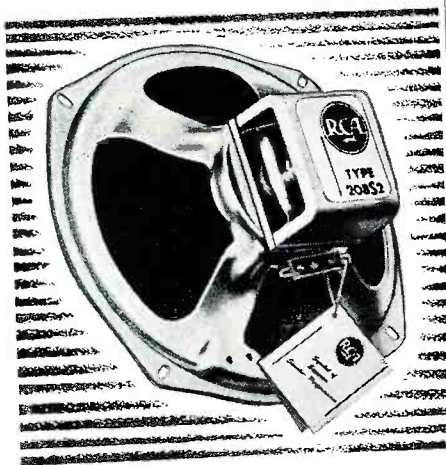

Replace dead speakers with live RCA Gold Label Speakers. They're short on installation time . . . long on customer satisfaction. All types built to RETMA size standards REC 148 . . . mounting hardware is included on most smaller sizes . . . For all your speaker requirements . . . play it smart and safe! Be sure you ask for RCA Gold Label Speakers . . . at your local distributor.



**RADIO CORPORATION
of AMERICA**

COMPONENTS DIVISION

CAMDEN, N. J.

output of 60 watts with 120 watts on peaks. IM distortion is .6% at 60 watts and .15% at 30 watts. Frequency response is 16 to 90,000 cps ± 1 db at 60 watts and 2 to 220,000 cps ± 1 db at 1 watt. Damping factor is 17. The output transformer is an *Acrosound* TO-330.

The chrome-plated chassis measures $6\frac{7}{8}$ " x 14" x $7\frac{1}{4}$ ". The kit, KT-120, includes all parts, tubes, diagrams, and assembly instructions.

CROSSOVER NETWORK

Racon Electric Co., Inc., 1261 Broadway, New York 1, N. Y., has developed a new network which provides a wide

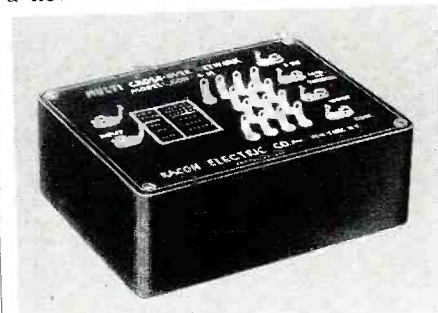

choice of crossover points for use in two- or three-way speaker systems.

The Model CON-4M provides crossovers at 300, 600, 1200, and 5000 cps in two-way systems, depending on the cut-off of the upper range speaker, and in three-way systems the mid-range speaker may cross over at 300, 600, or 1200 cps and the tweeter at 5000 cps. Other combination may be selected as desired.

The unit is a full half-section type with an attenuation of 12 db per octave. Free literature is available on request.

NEW AMPLIFIER TUBE

A new audio amplifier tube, the *Genalex* KT88, has been introduced by *British Industries Corp.* of Port Washington, N. Y.

Developed and manufactured by the *General Electric Company* of England, the new tube is a more powerful version of the popular KT66, with up to

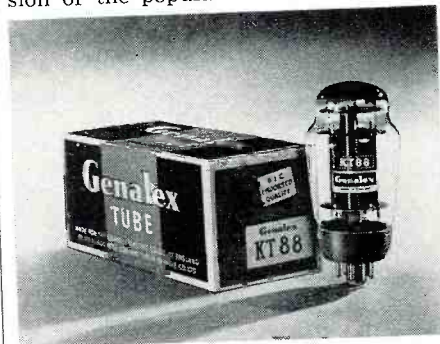

twice the output and even lower distortion. In line with the trend toward more compact amplifiers, the new tube is considerably smaller than the KT66. With fixed bias, an output of 100 watts may be obtained from a pair of KT88's with a plate supply of 560 volts.

The KT88 fits a standard octal socket. Dept. K-22 of the company will

supply full information on the tube to those making their requests direct.

OUTDOOR SPEAKER

Quam-Nichols Company of Chicago has announced the availability of a new outdoor theater speaker which is highly resistant to moisture and abrasion yet has practically the same response characteristics as an untreated paper cone.

Made of a plastic-impregnated synthetic fabric, the "Humi-Gard" cone is now being offered as standard equipment on all of the firm's outdoor speakers. It can also be supplied with any $3\frac{1}{2}$ ", 4", 5", or $6\frac{1}{2}$ " speaker in the company's line on special request at no additional charge.

ORCHESTRA BELL KIT

Electronic Organ Arts, Inc., 4878 Eagle Rock Blvd., Los Angeles 41, Calif., is now offering a modern version of the "glockenspiel" which is so designed that it can be connected to any organ console, piano, or accordion. Its clear tones are produced by metal solenoids striking 30 precision-ground bars.

The pitch ranges from G above middle C to the top of the standard organ keyboard. The orchestra bells can also be used for tuning organs and are easily mounted in a hardwood box, speaker cabinet, or behind a tone open-

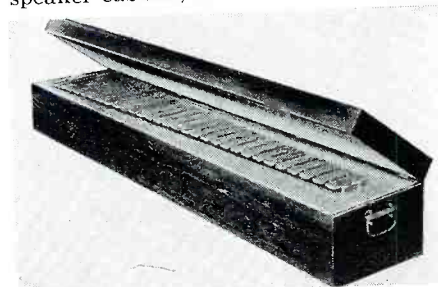

ing. Amplification can be added for large rooms or noisy locations.

The unit comes in kit form complete with assembly instructions.

NEW TONE ARMS

Argonne Electronics Mfg. Corp., 27 Thompson St., New York 13, N. Y., is currently offering two new tone arms, the AR-600 12" viscous-damped transcription arm, licensed by CBS; and the AR-34 which starts and stops phono motors when used with single-play turntables.

The AR-600 contains a sealed-in silicone damping fluid which assures accuracy of the damping action and prevents leakage. Automatic stylus pressure compensation is achieved by using individually designed cartridge adapters. No additional "weights" are required. The single, jeweled point, pivot support offers smooth action. Cartridge changeover is instant and solderless.

The second unit actuates the phono motor automatically when the arm is placed in the play position. When the record is concluded, the arm automatically returns to its rest and turns the motor off. The AR-34 comes equipped

RADIO & TV NEWS

with a turnover crystal cartridge and dual sapphire styli. It can be used on all four current phono speeds.

NEW "C-SLOT" REEL

Audio Devices, Inc., 444 Madison Ave., New York 22, is now supplying

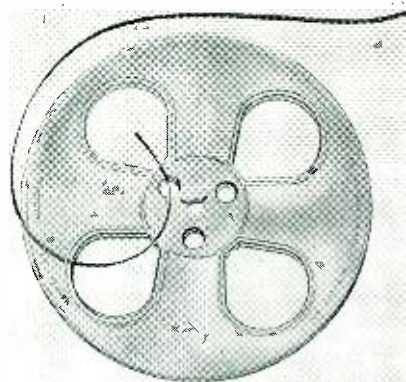

its 7" Audiotape on its new "C-Slot" reels at no extra charge.

With the new reel, no kinks or twists are made in the tape and no tape-ends are left sticking up. Since the slot is self-locking, there is no need to turn the reel by hand. During unwinding the tape slips out easily without binding.

AUDIO CATALOGUES

LAFAYETTE HI-FI GEAR

A 16-page catalogue which illustrates and describes high-fidelity equipment for the audiophile, hobbyist, and experimenter is now being offered by *Lafayette Radio*, 165-08 Liberty Ave., Jamaica 33, N. Y., as its Catalogue HF-250.

The publication includes "do-it-yourself" speaker systems, cabinets, cabinet kits, components, and complete hi-fi systems. Each unit listed is pictured and described in sufficient detail to permit mail ordering of the product.

The catalogue is available without charge on request.

"ABC'S OF MICROPHONES"

Electro-Voice, Inc., of Buchanan, Mich., is offering free copies of its 24-page booklet, "The ABC's of Microphones," to all interested persons.

Designated as Bulletin 246-76, the new publication covers the basic types of microphones, generating elements, the selection of the correct mike, application data for a wide range of uses, and catalogue information on the full E-V line.

Audiophiles will find this a handy reference source for pertinent microphone information.

SPEAKER DATA SHEET

Quam-Nichols Company, Marquette Road and Prairic Ave., Chicago 37, Ill., has issued a one-page, two-color data sheet on its coaxial, extended range, high-frequency and low-frequency speakers for hi-fi applications.

Details for building the recommended bass reflex enclosure are supplied along with the correct dimensions for each size and type of speaker. —30—



AMERICA'S LEADING FM TUNER • IN SENSITIVITY, APPEARANCE AND WORKMANSHIP

*The Most Sensitive FM Tuner
In All the World!*

THE FISHER Gold Cascode FM Tuner FM-90X

IF EVER an instrument represented the finest efforts, and greatest success of radio design engineers — the FM-90X is it! In one overwhelming sweep, it has rendered all other FM tuners in its price range OBSOLETE! But performance is not all that the FM-90X offers. Its die-cast, three-dimensional, brass control-panel and its large, brilliantly illuminated glass dial scale — make it a magnificent addition to your high fidelity system.

AMERICA'S ONLY FM TUNER WITH

- GOLD CASCODE RF AMPLIFIER
- FOUR IF STAGES
- DUAL DYNAMIC LIMITERS
- TWO TUNING METERS
- PLUS: SILVER-PLATED RF SECTION
- PLUS: WIDEST-BAND DETECTOR

SIZE: 13 $\frac{3}{8}$ " wide x 8 $\frac{3}{8}$ " deep x 6 $\frac{1}{8}$ " high. SHIPPING WEIGHT: 15 pounds

FM-90X, Gold Cascode FM Tuner = \$169.50
MAHOGANY OR BLONDE CABINET: \$17.95

Prices Slightly Higher in the Far West

WRITE FOR COMPLETE SPECIFICATIONS

FISHER RADIO CORP. • 21-23 44th DRIVE • L. I. CITY 1, N. Y.

Pilot

offers you a new, easy approach to a superb component high fidelity system

3-in-1 COMPONENT UNITS

FM-AM Tuner
Preamp-Audio-Control
Power Amplifier
in one enclosure



HF-42

20 watts output with less than 1% distortion (40 watts peak)
\$209.50 complete

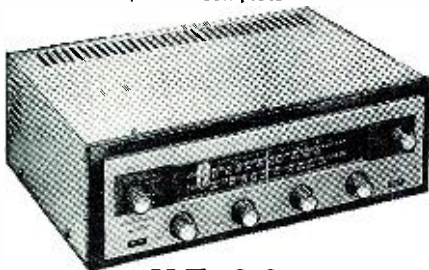

HF-30

12 watts output with less than 1% distortion (24 watts peak)
\$169.50 complete

FEATURES

include: Beacon tuning — tuned RF for perfect quieting even with fringe signals — AFC — built-in-antennas — phono equalization — bass and treble controls — tape recorder output — 20-20,000 cycle response, ± 1 db — handsome brushed brass enclosure. Model HF-42 also features separate tape head input with equalization, and DC voltage on preamp tube heaters.

PILOT RADIO CORP.

Dept. DY-7, 37-06 36th St., L. I. C. 1, N. Y.

Please send me folder describing 3-in-1 Component Units, and other Pilot Components.

NAME _____

ADDRESS _____

CITY _____ ZONE _____ STATE _____

Portable Recorder Amplifier

(Continued from page 59)

convenient length and solder rapidly to the correct lug holding each lead with long-nose pliers until the terminal lug is cool to the touch.

The long threaded spacers can be made from $1\frac{7}{8}$ " lengths of $\frac{1}{4}$ " diameter brass rod, such as the piece that remains after shortening a potentiometer shaft, or three "store-bought" $\frac{3}{8}$ " x $\frac{1}{4}$ " diameter spacers can be assembled using $\frac{9}{32}$ x $\frac{1}{2}$ " studs. These spacers and the short ones are mounted on the terminal board as shown in Figs. 4 and 5, and the whole assembly is mounted in the case after the interconnecting wires are soldered to the parts mounted in the case.

Next the batteries are taped to the second insulator board and wired together. A spacer, about $1\frac{1}{4}$ " diameter and $1\frac{1}{4}$ " long, is taped into the top layer of batteries as shown in Fig. 2. This leaves a gap for the speaker magnet frame with a battery on each side. After this, the wires from the battery switch (S_{2A} and S_{2B}) can be soldered to the batteries and the complete assembly mounted on the short spacers which have already been mounted on the terminal board.

Adjustment

First check that the gain of the first two stages is normal. To do this set R_1 (the "Input Level Control") at zero resistance (full counterclockwise) and with an oscilloscope connected to the V_2 collector see that the V_2 saturation point is reached with an input signal of approximately 3.5 volts r.m.s. This point will be indicated by a flattening of the positive and negative peaks of the waveform. Now connect the oscilloscope to the "hot" lead from the recording coil and set the input signal to 3.0 volts. Adjust R_7 until the waveform becomes distorted. Now vary the signal generator frequency and at the same time keep R_7 backed off to the edge of the distortion point until the frequency where distortion is peaked is found. This frequency will be close to 300 cycles using the Model 815 head. Back R_7 off until the signal across the recording coil is about 90% of the level at which distortion begins. This setting will be near the midpoint of R_7 .

The next step is to calibrate the "Input Level Control" (R_1). After the knob has been positioned and tightened the pointer position at the zero resistance end of the control is marked with a pencil. This will be the "3 volt" position. Rotate the control fully clockwise and this position will be labelled "3 millivolts." With an accurate ohmmeter measure the resistance from arm to ground. Now set the control to read 30% of this maximum resistance value and label this setting "10 millivolts." The 10% resistance point will be labeled "30 mv.," the 3% point "100 mv.," the 1% point "300

Transistorized Modulator

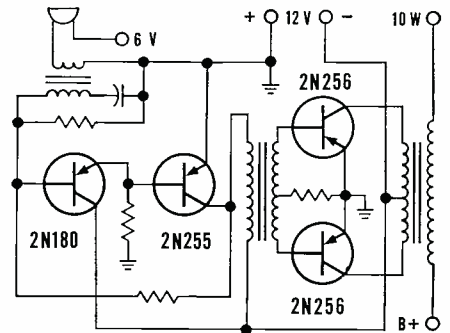

Now radio amateurs and experimenters can build a mobile transistorized modulator. Simple circuit features: pre-driver, driver, and final amplifier with low-cost CBS 2N255 and 2N256 power transistors . . . 10 watts output (modulates 2E26) . . . instant-heating . . . low drain . . . for use with transmitter or sound system.

CBS alloy-junction, germanium power transistors 2N255 (6-volt) and 2N256 (12-volt) are useful also in many other economical amplifiers . . . fixed or mobile. Let the second edition of CBS Power Transistor Applications, Bulletin PA-16, help you put them to work. Free, it gives complete data and seven detailed circuits, including the mobile modulator. Pick it up along with your 2N255 and 2N256 transistors at your CBS Tube distributor's.



2N255 . . . \$2.90 net

2N256 . . . \$3.35 net

CBS-HYTRON

Semiconductor Operations, Lowell, Mass.
A Division of
Columbia Broadcasting System, Inc.

mv.," and the .3% point will be the "1 volt" position.

To Use

To use the amplifier, apply the signal to be recorded to J_1 and set R_1 to the point corresponding to the signal level. For example, if the signal is the output from a radio receiver, with a maximum amplitude of 1 volt, the control will be set at the "1 volt" position. Where the input voltage is unknown, adjust the gain control until the signal from the speaker is at a very low level so that the driver and output stages will not be overdriven when the following adjustment is made. Now adjust the "Input Level Control" until the signal just starts to sound distorted (due to overdriving V_2), back it off slightly, and start to record.

To operate on playback simply set the function switch to "Playback" and set the "Input Level Control" to about 3 millivolts. To use the amplifier as a general purpose amplifier, disconnect the recorder plug (to reduce battery drain), connect the signal source to the input jack, set the selector switch to "Record," and adjust the "Input Level Control" to correspond to the signal level.

Variations

Different operating conditions may make slight changes in the amplifier desirable. For example, if the input signal will normally be below the range of 1 to 3 millivolts, another stage of amplification will be needed. This stage can use a CK722 between V_1 and V_2 . R_1 and R_2 should be removed from the input circuit and connected across R_1 to regulate the input to the added stage. C_1 should now go directly to S_{1A} . To make space for this amplifier stage move R_1 toward the center of the terminal board (see Fig. 4) and place the terminal lugs between V_1 and V_2 .

In cases where a.c. bias for the recording coil is preferred to the d.c. system, a 25 or 50 kc. transistor oscillator using a pair of CK722's in push-pull can be located in the upper left corner of the panel shown in Fig. 4.

The power requirements for a.c. erase are too great for use in a system of this type, but in cases where large battery drain is permissible (for fixed and semi-portable uses) an oscillator using a power transistor can be used.

This system was intended primarily for recording the voice and medium-quality music and it is satisfactory for such uses. If better quality recordings are needed, the coupling capacitors should be increased to 10 μ f. or greater, a treble boost network should be used in the recording amplifier, and a bass boost system should be added to the playback amplifier.

Bias stabilization is used only where necessary, but if the amplifier is to be used outdoors where temperature extremes are often encountered, it may be advisable to stabilize all stages to prevent loss of performance. -50-

July, 1957



for hi-fi
and binaural
listening...

BRUSH CRYSTAL HEADPHONES

All models available with special cords for binaural listening. Brush Crystal Headphones are designed for exceptionally flat response through 10,000 cycles. Smooth air-tight fit for excellent bass response. Lightweight and comfortable. Sold by quality conscious dealers everywhere.

BRUSH ELECTRONICS
DIVISION OF CLEVITE CORPORATION
Cleveland 14, Ohio



COMPANY

IT'S MOBILE TIME



The Bell Products CM 1 Carbon Mike is a high output Mobile Mike designed for rugged use—yet low priced.

*9.95 with coil cord.

SEE YOUR DISTRIBUTOR OR WRITE:

BELL PRODUCTS CO., ST. LOUIS 8, MO.

NEW

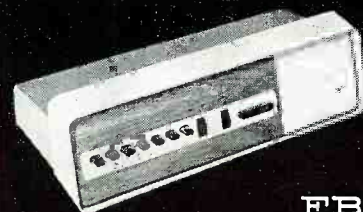

FB-1

INTERCOM

Up to 12 station masters and remotes. Incorporates feedback circuits for speaker damping and low distortion. Modern styling to suit any interior. For new detailed brochure, write



FISHER BERKELEY
CORPORATION

5633 Grove Street
Oakland 9, California



There was an old woman
Who lived in a shoe
Had so many children
She knew not what to do

The children were naughty
And so filled her with dread
That the little old woman
Wished she were dead

A simple solution
Which brought happiness
Was the prompt installation
of Norelco . . . F.R.S.

These wonderful speakers
(Twin-coned and true)
Produced marvelous music
Throughout the shoe

The effect . . . tranquilizing
The children . . . asleep
Now the little old woman
Good order can keep

For the full throated music
Resounds through the shoe
The children are spellbound
As you will be too

So go to your dealer
Do it today
And find out how "Hi-Fi"
Your victrola can play



*Norelco *F.R.S. Speakers are available in 5", 8" or 12" sizes in standard impedances. Priced from \$6.75 to \$59.98. Blueprints are available for the do-it-yourself enclosure builder. Norelco Enclosures are available in three sizes, priced from \$33.75 to \$119.95.*

ADD TO . . . and improve any sound system with Norelco® *FULL RESPONSE SPEAKERS

Write today to Dept. G7 for brochure and prices of these unique speakers



NORTH AMERICAN PHILIPS CO., INC.
High Fidelity Products Division
230 Duffy Ave. Hicksville, L. I., N. Y.

Electronic Crossovers

(Continued from page 55)

channel makes use of a high-pass filter, whereas the low-frequency channel uses a filter of the low-pass type. Each network contains a two-section *RC* arrangement similar to those shown in Fig. 2. These filter networks are variable and provide a 12 db-per-octave roll-off slope (see Fig. 2) after the slope approaches a straight line. The 12 db-per-octave figure results in effective cut-off action. If the slope were greater than 12 db, the system may have a tendency to ring on transients.

The composite frequency response characteristic will be of uniform amplitude if the overlapping roll-off curves intersect at the half power or -3 db point. Due to the normal variation in component tolerances, however, designers may place the intersection somewhat below this value to avoid any possibility of a peaking up in the resultant response at the crossover point. One version of a filter network offers separate control of crossover frequency points; another has ganged controls that track together, keeping both crossover points at the same value. Level controls work in conjunction with the filter circuits to raise or lower the amplitude of their respective bandpass characteristics.

Typical Circuit Operation

The circuit diagram of the *Heath Model XO-1* electronic crossover is given in Fig. 3. The signal from the preamplifier enters at the input and is applied to both the high- and low-frequency level controls. If desired, the crossover unit may be bypassed or made inactive by the use of a switch. First, let us consider the action of the high-frequency section. From the high-frequency level control a given amount of signal may be applied to the grid of the 12AX7, V_{1A} . But the signal impressed at the grid of V_{1A} must first

pass through a single-section *RC* high-pass filter. The capacitor in this network is switched to obtain various high-channel cut-off values. This section of V_{1A} functions as a voltage amplifier which, in turn, feeds its output through another single-section *RC* high-pass filter network (also acting as a coupling network) to the grid of V_{1B} , the cathode follower output stage. A capacitor in this network is switched to obtain various low-frequency cut-offs.

The two high-pass filter networks are enclosed in a feedback loop of approximately 14 db. Feedback sharpens the roll-off in the region of the cut-off frequency. The resultant response curve of the over-all channel is one which has flat response down to the cut-off frequency then bending in a sharp knee with a 12 db-per-octave slope thereafter. The switch which selects the coupling capacitor values offers a choice of seven cut-off frequencies in the high-frequency channel (100, 200, 400, 700, 1200, 2000, and 3500 cps).

Operation of the low-frequency channel is similar to that of the high-frequency section. The exception is that the two filters contained within the low-frequency circuitry are low-pass, rather than high-pass filters. The capacitors are switched in these networks to provide the same seven choices of cut-off frequency available with the other channel. Network insertion loss and the 14 db of feedback used around each amplifier reduces the gain of both sections to unity; however, no gain is required. Cathode follower outputs permit using long output cables without adversely affecting frequency response.

A self-contained power supply uses a 6X4 rectifier in a full-wave arrangement. "B plus" and filament voltages are supplied to all circuits from this unit. The heaters are balanced by two 47-ohm resistors center-tapped to ground, thereby reducing hum to a very low level. -50-

Ground has been broken for the construction of a new 142,000 square foot plant for Heath Company, world's largest manufacturer of electronic equipment in kit form, Robert Erickson, president, announced recently. The modern one-story building will house all of Heath's operations and, upon completion, will be one of the largest plants in the nation devoted to specialized direct mail selling. It will be located on a 16-acre tract in St. Joseph, Mich., the twin city adjoining Benton Harbor.

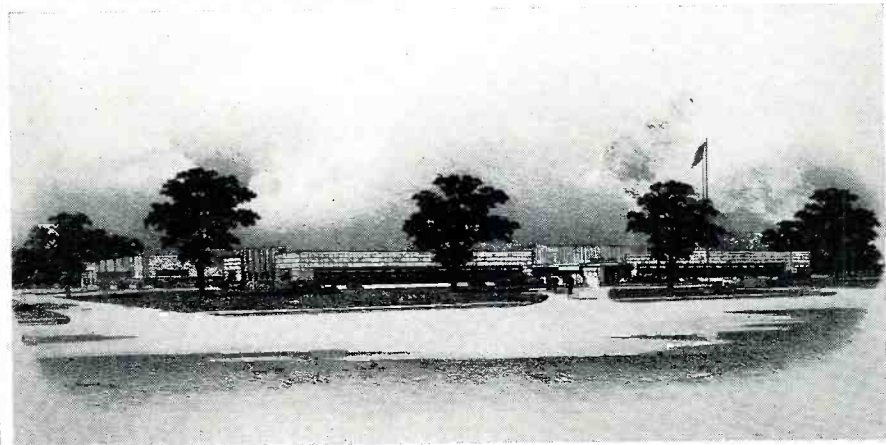

SR-100 DELUXE AM-FM TUNER with outstanding engineering features found only in the most expensive tuners. Advanced functional styling with cantilevered control panel and slanted slide rule dial for easy viewing.



OUTSTANDING FEATURES: Two positions AM; bridged "T" 10 KC whistle filter with zero attenuation at 8 KC, -55 db at 10 KC; the famed SR two tube AM detector with only .45% harmonic distortion at 100% modulation. Two position FM (AFC on and off); sensitivity 3 uv for 20 db quieting on FM, 20 uv on AM. Incorporates large ferrite loopstick; cathode follower output; one pound flywheel.

SARGENT RAYMENT

SR-200 DELUXE 25 WATT CONTROL AMPLIFIER with exclusive SR features: **VARIABLE RUMBLE FILTER** for "picking" out low frequency interferences. **VARIABLE SCRATCH FILTER** eliminates high frequency interferences at exact point source.

9 POSITION SLIDE RULE DIAL. Another SR first. Functional and beautiful, it does away with the normal visual complexities.

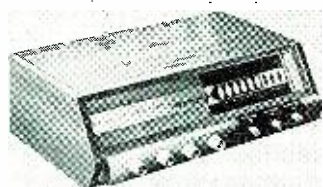

OUTSTANDING FEATURES: Bass and treble boost and attenuation 15 db at 40 and 15 KC with only 1 db variation at mid-frequencies. Feedback around every tube. 1.5% 1M and .3% harmonic distortion at 18 watts. 6 position equalization with feedback compensation for both upper and lower frequencies. Phono - AES, LP, FFRR, EUR, RIAA, 6th position for tape deck input. Variable contour (loudness) control.

For new illustrated brochure, write to Sargent-Rayment Co., 4926 E. 12th St., Oakland 1, California.

July, 1957

Certified Record Revue

(Continued from page 60)

Strauss, Junior and Senior, and by Josef Strauss, the record contains such favorites as the "Radetsky March," "Roses of the South," "Tales from the Vienna Woods," and "Village Swallows." As usual, the performances by Anton Paulik are superb and unexceptionable; the playing the Professor receives from his orchestra nigh perfect.

Since this is quite deliberately conceived as a demonstration showpiece of *Vanguard* quality, the sound is magnificent. Strings are clean with that glossy sheen that lends presence, brass is bright and open, woodwind smooth and accurate of intonation, and percussion is precise, weighty, and of robust impact. Frequency and dynamic range are ultra-wide, transients clean and virtually distortionless. Wrap all this up in the superb acoustics of the Musik Verein in Vienna and then ask the ridiculously low price of \$1.98 for the record and it should sell like the proverbial hotcakes!

THE BEGGAR'S OPERA

Words by John Gay, music by Pepusch and Austin. Soloists and members of The Old Vic Company and The Pro Arte Orchestra conducted by Sir Malcolm Sargent. Victor LM-6048. RIAA curve. Price \$7.96. Two discs.

This immensely popular work has always been extremely difficult to produce and assemble a properly dedicated cast. All objectives have not been met with complete satisfaction in this album, but it is as close to being definitive as we are likely to get. The singers are all in good voice if somewhat less than perfect in their acting. On the other hand, the spoken parts are acted in stellar fashion by the artists of the famous Old Vic Company. The orchestra plays very well, Sir Malcolm's conducting knowing and devoted, and the sound very well balanced with all voices easily understandable. A work like this takes time to properly appreciate, so here we have another summertime special. So trot out your patio speaker and hammock, keep some tall frosty glasses nearby, and indulge yourself!

VERDI AND TOSCANINI

The NBC Symphony Orchestra conducted by Arturo Toscanini. Victor LM6041. RIAA curve. Price \$7.96. Two discs.

Quite by coincidence this album was issued just prior to the death of the beloved Maestro. A more fitting tribute to his genius could not have been deliberately conceived. That Toscanini was the supreme master of the music of Verdi is accepted without question. Here in this album is the audible testament of that mastery. Taken from broadcasts and recording sessions as far back as 1943, the Maestro conducts his fabulous NBC Symphony Orchestra in such works as the Overture to "La Forza Del Destino," the "Sicilian Vespers Overture"; Act 4 of "Rigoletto" with Jan Peerce, Leonard Warren, Zinka Milanov, Nan Merriman; the "Ballabili" dances from Act 3 of "Otello"; and the "Hymn of the Nations," which was taken from the old Office of War Information film. In all of these he displays his incredible ability to stay note-perfect within the composer's intention and yet kindle a vital spark in the performances, which blazes into the incandescent excitement that is so uniquely the essence of a Toscanini reading.

It was a younger and more virile Toscanini in 1943 and I don't think it would be amiss to say that it was during this period that the NBC Orchestra was at its highest pinnacle. Their playing was sheer magic, a sort of collective virtuosity that had to be heard to be

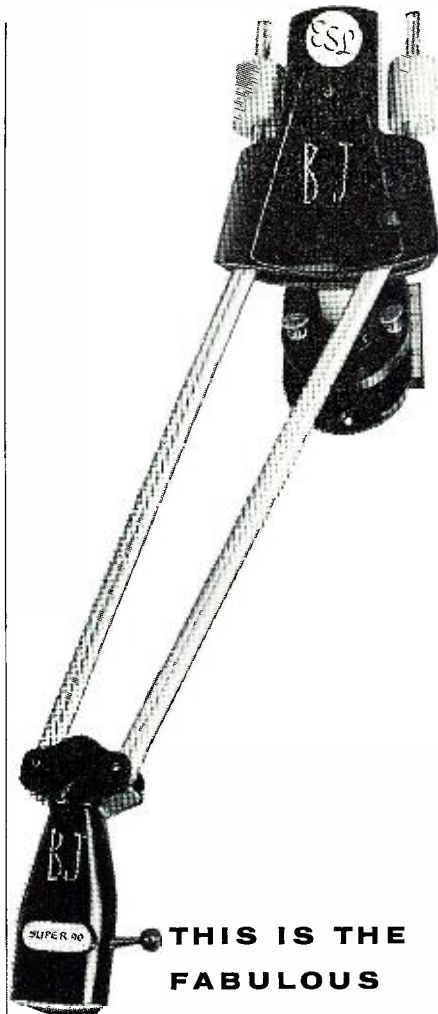

THIS IS THE FABULOUS ALL-NEW



'SUPER 90'

the world's most advanced phono arm

ONLY \$33

write for free details



Famous for the ESL cartridge

WHY THE DYNAKIT

50 WATT HI-FI AMPLIFIER KIT

SOUNDS BEST!

1. New High Stability Circuit

Superior transient response with greater clarity and definition. Designed for all speaker loads including electrostatic.

2. Pre-Assembled Printed Circuit Board

Assures fool-proof assembly in less than 3 hours and guarantees faithful reproduction of performance specifications.

3. Superior Components Featuring the A-430 Dynaco Transformer

And of course the following minimum specifications that can be exceeded by any home constructor. . . .

Power Output: 50 watts continuous rating, 100 watts peak. Distortion: under 1% at 50 watts, less than 1% harmonic distortion at any frequency 20 cps to 20 kc within 1 db of maximum. Response: Plus or minus .5 db 6 cps to 60 kc. Plus or minus .1 db 20 cps to 20 kc. Square Wave Response: Essentially undistorted 20 cps to 20 kc. Sensitivity: 1.5 volts in for 50 watts out. Damping Factor: 15. Output Impedances: 8 and 16 ohms. Tubes: 6CA7/EL-34 (2) (6550's can also be used) 6 AN8, 5U4GB. Size: 9" x 9" x 6 3/4" high.



(Complete including protective cover and all component parts)

Dynakit
Mark II

\$69.75

Slightly higher in West

NEW! DYNA BIASET now included in all Dynakits. Simplifies bias adjustment and assures optimum operating conditions.

Available through leading Audio and Electronic Parts Distributors

Dyna Co., Dept. RN, 617 N. 41st St., Phila. 4, Pa.

believed. As you might imagine, the sound in this album is quite variable. Some of it is the infamous 8H sound and some is from other locales. None of it is really wide-range hi-fi, but the RCA engineers have done a remarkable job of resuscitation with what they had, and the result is highly listenable. But here is one case, that were the sound a dozen times poorer, the album would still be worth owning as a legacy from a mighty titan of music . . . Arturo Toscanini.

KHACHATURIAN CONCERTO FOR VIOLIN AND ORCHESTRA

Ruggiero Ricci, violinist, with London Philharmonic Orchestra conducted by Anatole Fistoulari. London LL1537. RIAA curve. Price \$3.98.

The Khachaturian violin concerto is supposed to be the exclusive province of the great David Oistrakh, but on the basis of this new recording by Ricci it would seem that some modification in this viewpoint is necessary. Technically impeccable, possessed of a big, fluent romantic tone and displaying exquisite taste and musicianship, Ricci must surely be adjudged as a peer of Oistrakh. Allow Oistrakh the point that he has somewhat more feeling for the score and that is the one slight area of superiority. In matters of sound, this London disc has a more open, brighter projection, with sharper orchestral detail than the Oistrakh Angel recording.

SCHUBERT SCHUMANN LIEDER RECITAL

Kirsten Flagstad, soprano, with Edwin McArthur, pianist. London LL1546. RIAA curve. Price \$3.98.

It is not very often that I review recordings of lieder in this department, but this one is certainly worthy of the attention of anyone who professes to like beautiful singing. Here with the simple scoring of voice and piano is the best opportunity anyone could have to study the beauty and artistry of the voice of the incomparable Kirsten Flagstad. That lieder is not the long suit of Madam Flagstad is freely admitted. She does not have the breadth of expression of a Lotte Lehman. But she is nonetheless highly satisfactory in such Schubert standards as "Der Erlkonig," "Ave Maria," and "Dem Unendlichen" and in the Schumann pieces like "Der Nussbaum" and "Liedeslied." The real attraction here is that lovely warm voice, still rich and resonant and amazingly free from the ravages of age. Endowed with some of London's finest wide range hi-fi recording, this disc will be treasured by admirers of Kirsten Flagstad and by voice enthusiasts everywhere.

CASELLA LA GIARA (SUITE SINFONICA) RESPIGHI

THE PINES OF ROME
Orchestra of the Academia Di Santa Cecilia, Rome, conducted by Fernando Previtali. London LL1575. RIAA curve. Price \$3.98.

The "Pines of Rome" here receives a competent but not overly distinguished reading and while the sound is generally quite good, it is outgunned by several of the competing versions. The treasure on this disc is the premiere recording of the suite from Casella's ballet "La Giara." Casella was a contemporary of Respighi, but there is little in common in their writing. "La Giara" is largely folk-derived and abounds with rustic atmosphere and gay peasant dances. Previtali seems to have a better feeling for the Casella piece and he moves everything along at a brisk pace. This work has much in it that will appeal to the hi-fi fan—bright punchy brass, a wide variety of percussion of notable im-

TWO NEW ANNUALS FOR ELECTRONICS HOBBYISTS!

(Compiled by the editors of
POPULAR ELECTRONICS)

FOR THE HI-FI FAN:

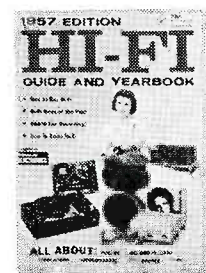

THE
WORLD'S
MOST
COMPLETE
HI-FI
GUIDE!

164 pages—

9 big chapters covering tuners, tapes, changers, tone arms, needles, amplifiers, preamplifiers, loudspeakers, enclosures—and much, much more.

Plus a helpful Yearbook Section which discusses the latest trends in high fidelity . . . lists outstanding records, artists, all FM stations, Hi-Fi shows, and includes a directory of free Hi-Fi literature.

**NOW ON SALE AT YOUR
FAVORITE NEWSSTAND!**

Price: 75¢

FOR THE EXPERIMENTER:

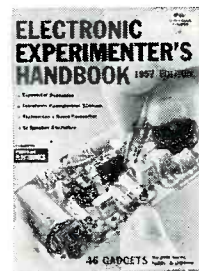

LEARN HOW
TO BUILD
DOZENS OF
HANDY
ELECTRONIC
DEVICES!

The ELECTRONIC EXPERIMENTER'S HANDBOOK will show you, via easy-to-follow, fully illustrated instructions, how to build exciting electronic devices such as:

- Your Own Hi-Fi AM Tuner
- Thermistor Fire Alarm
- Electronic Gardening Gadgets
- A Device That Kills TV Commercials
- Electronic Toys
- Geiger Counter
- Transistorized Light Meter
- Your Own Lie Detector

NOW ON SALE EVERYWHERE!

Price: \$1.00



Ziff-Davis Publishing Co.,
366 Madison Avenue, New York 17, N. Y.

RADIO & TV NEWS

pect and accuracy, large tonal masses and wide dynamics. An interesting little novelty for the balletomane.

ELGAR
ENIGMA VARIATIONS
PURCELL
SUITE FOR STRINGS

Halle Orchestra conducted by Sir John Barbiroli. Mercury MG50125. RIAA curve. Price \$3.98.

This recording is another in the series *Mercury* recorded in England with its newly acquired Halle Orchestra. The "Enigma Variations" is generally acknowledged to be Elgar's masterpiece and Sir John Barbiroli who conducts it here has long been identified with the work. Consisting of a set of fourteen variations on a theme, they afforded Elgar full scope for his exceptional talent as an orchestrator. The variations thus run the gamut of orchestral color from the lightest and most delicate of sound textures to the most grandiose and massive tonal structures in which the full resources of the orchestra are employed along with heavy organ pedal.

Sir John's reputation in this work is well founded, as his performance is superb. The matter of tempo is very important here and he has essayed a pace which neither drags nor is taxing to the orchestra. His handling of dynamics and phrasing, in a work which could lead one into all sorts of conductorial mannerisms, is masterful. Some of the orchestral effects in the variations are quite overwhelming, especially when heard with the outstanding hi-fi sound afforded by the *Mercury* engineers. "Variation 7," for instance, begins with a very heavy, rapid figure on the tympani which rises to a huge *crescendo* and is accompanied by an up-scale rushing sweep of the strings and then devolves into some huge full-throated fanfares for trumpets and trombones.

The sound throughout is of the usual *Mercury* degree of excellence. String tone is smooth yet has plenty of good attack and "bite" when needed. The woodwind have a lush, butter-smoothness. Brass is very huge, bright, and brazen and percussion range from the hard smash and coruscating overtones of the cymbal to the characteristic timbre of heavy strokes on the tuned tympani, to the solid whump of the very large bass drum. This is wonderful music which I urge you to become acquainted with if it's new to you.

The Purcell "Suite for Strings" is typical of the writing of that great composer. Stately passages follow dance-like themes and change again in the bright atmosphere of the scoring. Not the spectacular hi-fi *tour-de-force* that the "Variations" are, this is nonetheless a superb recording with very rich, ultra-clean string tone. All-in-all, an outstanding record and I venture to predict that "Variation 7" will really separate the men from the boys in terms of hi-fi systems!

This is all for this month but we will have a whole new batch of recordings to report on for next month. Now that the recording industry has become aware of the fact that music knows no season as far as the disc buyer is concerned, goodies stream from the record presses the year around.

Another stimulus to summertime sales is the many music festivals throughout the country. When a music lover hears a particularly good performance at such a concert he is very likely to beat a path to his dealer to pick up a copy of the recording to add to his collection and serve as a permanent and worthwhile souvenir of the occasion.

Alert dealers are scanning festival programs to insure having an adequate stock to meet this sudden demand.

-30-

July, 1957

*** after 3,000 HOURS**
(equal to more than 3 years average use)

WOW and FLUTTER 0.17%

*** After 3000 hours of operation in a closed, unventilated box... with no additional lubrication or adjustment of any kind... a stock Starlight turntable was submitted to a prominent nationally affiliated Testing Laboratory.**

The REPORT:
(#135264, dated May 9, 1957)
Wow and Flutter 0.17%
Rumble Minus 43 db.
Original laboratory report in an file for inspection.

The METZNER

Starlight HIGH FIDELITY TURNTABLE



Starlight's patented center-drive system — with no slapping belts, no noisy pulleys, no growling idlers — is ready to bring you years of whisper-quiet, trouble-free operation! And, despite its low price tag, Starlight contains every worthwhile feature known to the turntable art . . . plus many extras found in no other turntable at any price! Ask for — and insist on — a competitive demonstration at your nearest dealer.

Only \$59.50

Model 60 turntable only. \$97.00
Model 672 (illustrated) Complete unit with model 60 turntable, base and push-button transcription arm. 22.50
Model 07 push-button transcription arm. 17.50
Model 002 (blonde) and Model 004 (ebony finish) 1" laminated hardwood base 17.50

- * Illuminated Stroboscope — reads while the record is playing.
- * Continuously variable speed control — precise setting for all 4 speeds.
- * Rumble and noise more than 40 db below NARTB standard reference level.
- * Wow and flutter less than 0.2% RMS. Conforms to NARTB standards.

See Starlight today . . . you'll learn why it is the first choice of discriminating music lovers

Sold by Leading Hi Fidelity Dealers . . . EVERYWHERE!

Prices include Fed. excise tax where applicable.

Metzner **ENGINEERING CORP.**
1041 N. SYCAMORE AVE., HOLLYWOOD 38, CALIF.

ONLY \$18.75



Adjust-A-Volt
PA-3 VARIABLE TRANSFORMER

The highly efficient new Adjust-A-Volt PA-3 is a modern, deluxe variable auto-transformer designed for servicemen, model shops, laboratories or other applications where variable A.C. voltage is needed. Max. load rating 0.4 KVA. Max. output current 3.0 A. Delivery from stock of your jobber.

STANDARD
ELECTRICAL PRODUCTS CO.
2240 E. THIRD ST. • DAYTON, OHIO

ROUND, SQUARE, KEY and "D" OPENINGS QUICKLY MADE with Greenlee Radio Chassis Punches

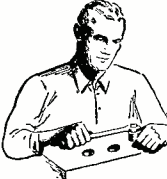
Save hours of hard, tedious work . . . cut accurate holes in chassis for sockets, plugs, controls, meters, panel lights, etc. with GREENLEE Punches. In 1-1/2 minutes or less make a smooth hole in metal, bakelite or hard rubber. Easy to operate . . . simply turn with ordinary wrench. Wide range of sizes. Write for details. Greenlee Tool Co., 1887 Columbia Avenue, Rockford, Ill.



Transistor Intercom System

By

W. F. PALMER

Sylvania Electric Products Inc.

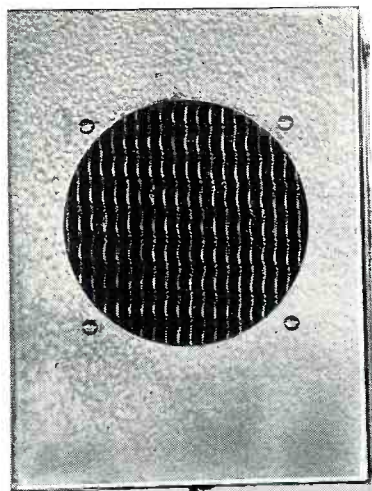

The master control unit is shown below, with one of the remote units at the left.



Flexible intercom or surveillance system using two transistors in bias-stabilized circuit at reduced dissipation provides long, trouble-free service.

TRANSISTORS lend themselves naturally to use as amplifiers in intercommunication systems. Their low power consumption, combined with high efficiency, permits continuous stand-by operation at negligible cost. The circuit described consumes about one-half watt of power and can be operated continuously for a full year at a total cost of about twenty-five cents.

In addition to regular intercommunication service, this unit may be used in surveillance systems—as in “babywatching” and “burglar alarm” systems. For instance, the coverage of a watchman may be multiplied by using a large number of pick-up speakers in series without an appreciable sacrifice of input signal from any one of the speakers.

The amplifier uses only two transistors and one transformer. One of the transistors is a Sylvania 2N68 or 2N101 power transistor which will deliver considerable output power with low distortion and high gain, even when used in low-voltage, high-current applications. The second transistor is one of the smaller, well-known 2N35's. Transformer interstage coupling is used to provide isolation and a reserve of gain.

Note that the power transistor is a *p-n-p* type requiring a negative collector supply voltage, while the 2N35 is an *n-p-n* type requiring a positive supply. Both can be operated from a common power supply by simply inverting

one of the stages with respect to the other in order to provide each with a collector voltage of the proper polarity.

Power Supply

Since the output stage is operated class A, an a.c. operated power supply is used to eliminate the cost and inconvenience of replacing batteries every few weeks. A battery may be used, of course, in portable applications or where a.c. power is not available.

A small 6.3 volt filament transformer is used as a power transformer. A unit rated at 1 ampere was used only because a smaller one was not available. Since the total drain of the amplifier is only about 60 milliamperes, one rated as low as a quarter of an ampere will be more than adequate, if obtainable.

A high-conduction germanium diode makes an excellent rectifier since its efficiency is very high, even when operated at this low voltage. This diode is followed by a *pi*-section *RC* filter which reduces the 60-cycle ripple to a sufficiently low level. If a center-tapped 12.6 volt transformer is available, full-wave rectification may be used, requiring another 1N455, of course. The 3.3 ohm resistor limits the peaks of current through the rectifying diode to reasonable values.

The Amplifier

An interesting feature of this design is the direct loading of the collector of

the 2N68 by a 45-ohm intercommunication loudspeaker. It is not an optimum load, but is so nearly so that the cost of an output transformer is not warranted. The speaker voice coil can carry the 50 ma. (approximately) of d.c. current with ease and only a slight “pop” is heard when switch S_2 is operated. This is not a disadvantage since when the switch is returned to the “listen” position during a conversation, the sound indicates to the person at the remote station that it is his turn to speak.

The same type of loudspeaker is used as a microphone. As the gain of the amplifier was high enough, and low cost is desirable, no input matching transformer was used, (although a 50-ohm to 1000-ohm unit might be added, if desired, for other applications of the amplifier). Because this high degree of mismatch exists, many 45-ohm loudspeakers may be series-connected to the amplifier input and used as one remote station without seriously reducing the input signal current from any one of the speakers. This feature is useful in case one wishes to monitor a number of remote locations at the same time, although the power output into the higher load may not be enough to provide satisfactory volume for two-way use if more than two or three speakers are employed.

The design of the input stage is more or less conventional. A variable series resistance functions as a volume control by reducing signal current to the base of the 2N35. The operating bias (approximately 1 ma.) of the 2N35 is well stabilized by the use of a 2700 ohm resistor and an appropriate base voltage divider. The emitter resistor corre-

sponds to a cathode bias resistor in tube circuitry and is bypassed for a.c. by a 50- μ f., 6-volt capacitor. The collector of the 2N35 is transformer-coupled to the base of the output stage.

The 2N68 output transistor is also bias-stabilized and, as it is resistance-loaded by the loudspeaker and is operated well within ratings, a very long service life may be expected. Note that the transistor is chassis-mounted to minimize its temperature rise and, therefore, that the chassis is not grounded, but floats at collector potential because the collector of the 2N68 or 2N101 is internally connected to the cooling fin. (The mounting surface should be clean and free from burrs.) As low-impedance circuits are involved, this technique will not cause any complications.

The value of collector current drawn by this stage is not critical but, if necessary, may be adjusted by changing the 1000-ohm resistor for one of another value. (For the values shown, all 2N68's available drew 40 to 60 ma.) A low resistance will increase I_c and *vice versa*. For a value of 50 ma., about 50 milliwatts of a.c. power is delivered to the speaker before clipping occurs. This is adequate for most intercom applications, but it may be increased if somewhat higher collector currents are drawn. (There is a limit, however, unless the supply voltage is also increased, since clipping due to collector "bottoming" may otherwise occur.)

Switching

If only one remote station is required, S_3 and S_4 may be omitted and the two speakers connected directly to S_2 . S_3 and S_4 may have any desired number of positions. The corresponding poles of each are tied together and to the appropriate loudspeaker. The other terminal of each loudspeaker is connected to the negative power supply terminal which is *not* tied to the chassis. The single-pole, five-position switches shown are suitable for five-station systems, though other types may be used if the number of positions available at least equals the number of stations required.

If S_3 and S_4 are both set for the same station, oscillation may result. Transposing either primary or secondary leads of the interstage transformer will make the system degenerative rather than regenerative.

The switches S_3 and S_4 may be so positioned that any one station may be heard at any other station. However, two-way conversations may take place only between the master station and a remote station, since S_2 is located at the master station. For example, in a home intercom, the master station might be located in the kitchen so that two-way conversations may be held with any other station. However, if the switches were properly set, one could, for example, "baby-watch" from a patio, workshop, or wherever another remote station is located.

It will usually be necessary to run only one wire to each remote station

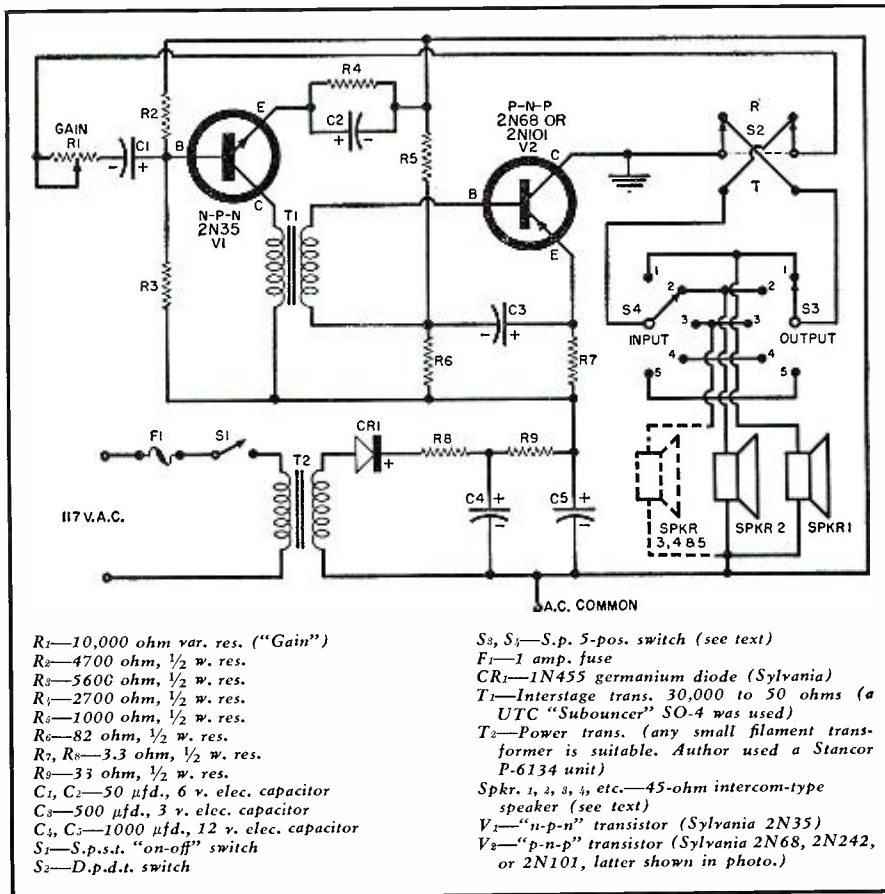

Complete schematic diagram of transistorized intercommunication system which uses one low-power and one high-power transistor in a bias-stabilized circuit.

if water or steam pipes, metal heating ducts, or a good ground path are available. (The negative power supply terminal should be connected to this ground lead, not the case or chassis.) Number 18 AWG copper "bell wire" will be quite satisfactory. If hum pick-up should be severe, due to proximity of unshielded power lines, etc., it may be necessary to use a twisted pair or a shielded conductor or to relocate the connecting lines. The stations of this

system were housed in readily available metal cases for convenience, but any suitable enclosures may be used. Where wooden housings are used, a sheet of aluminum or galvanized iron may be used as a chassis, and adequate ventilation should be provided. Since very little heat is generated, a few relatively small holes in inconspicuous locations will be sufficient and no special precautions are required where a metal case is used.

-30-

Inside view of master unit. Note the simplicity of the layout employed here.

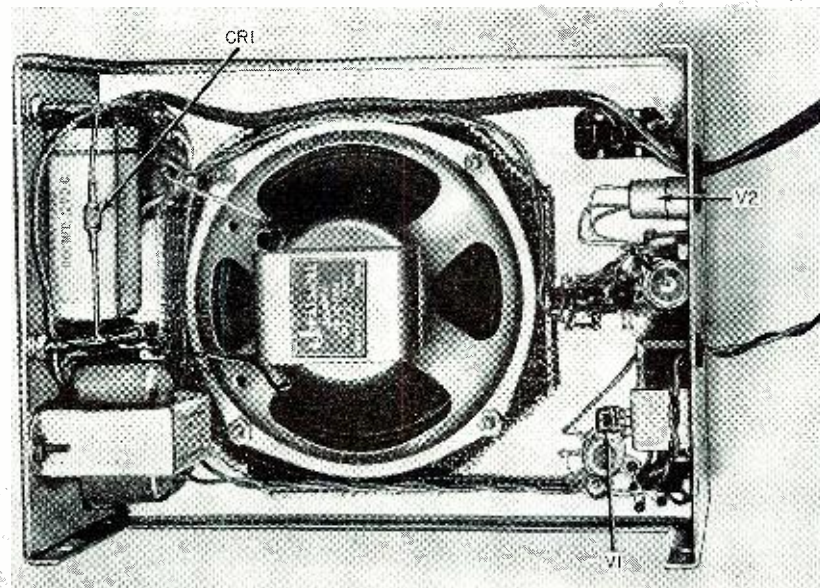

**BUILD THE BEST—
BUILD ALLIED'S OWN
knight-kits®**

Here is a typical Knight-Kit value—available only from ALLIED—one of 45 great Knight-Kits you'll find in our special Supplement No. 165. Write for your FREE copy today.



knight-kit HI-FI VALUE

25-WATT LINEAR-DELUXE AMPLIFIER KIT

Model
Y-755
\$44.50

Luxury quality at modest cost! Williamson-type circuit delivers 25 watts of virtually flawless response. Can be used with any tuner or preamp with a full set of controls (for volume, tone and equalization). Printed circuit wiring board for simplified assembly; balance control for precise matching of output tubes; variable damping control. Response: ± 0.5 db, 10-120,000 cps at 20 watts. Harmonic Distortion: 0.15% at 30 watts. Intermodulation: 0.4% at 20 watts. Output Impedances: 4, 8 and 16 ohms. 6 1/4 x 14 x 9" deep. Chrome-plated chassis. With all parts, tubes and easy-to-follow instructions. Shpg. wt., 25 lbs.

Model Y-755. Net., F.O.B. Chicago \$44.50
Y-759. Metal top cover for above. \$4.25

OTHER knight-kit HI-FI VALUES



FM HI-FI TUNER KIT
Model Y-751
\$37.75

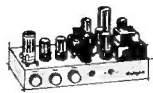

10-WATT HI-FI
AMPLIFIER KIT
Y-753 \$23.50

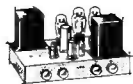

20-WATT HI-FI
AMPLIFIER KIT
Y-750 \$35.75

See our Supplement No. 165 for other
knight-kit Hi-Fi values

free SUPPLEMENT

featuring knight-kits

Send for our FREE Supplement No. 165 featuring 45 great Knight-Kits, including Test Instruments, Hi-Fi, Hobbyist and Amateur Kits. Write for your copy today.

**ORDER FROM
ALLIED RADIO**

Dept. 01-G7, 100 N. Western Ave., Chicago 80, Ill.

New Tube Tester Data

Many new settings appear on this list, as well as a number of revised settings for old types.

WESTON MODEL 981, Type 3

Tube Type	Fil.	Mult.	Bias	Selectors	Sens.	EP	Rej. Pt.	Remarks
0A4		R		01003-0300	30	E		No leak check
1A4	2	1	30L	63400-7000	39	C	490	Grid Cap; F.
1A5	1.5	2	40L	06345-0700	43	C	550	F.
1AH4	1.1	1	9H	34756-0060	34	C	500	F; X1.
1V6	1.1	D	0	33670-0600	10	B		F; Pent.
	1.1	D	0	00073-3600	30	B		F; Triode.
2BN4	0.6a	4	18L	15763-KG00	35	D	1130	G ₁ K ₁ & G ₂ K ₂ ; X4.
3B24	2.5	R		60000-7000	40	E		Plate Cap; F.
3B28	5.0	R		60000-7000	20	E		F; Special Plate Cap.
3B29	2.5	R		60000-7000	34	E		Plate Cap; F.
4BC8	0.6a	4	20L	35176-PGK0	34	D	950	P ₁ G ₁ K ₁ & P ₂ G ₂ K ₂ ; X4.
4BQ7	6.3	4	21L	35176-PGK2	35	D	1000	P ₁ G ₁ K ₁ & P ₂ G ₂ K ₂ ; X4.
4BS8	0.6a	4	20L	35176-PGK2	36	D	1200	P ₁ G ₁ K ₁ & P ₂ G ₂ K ₂ ; X4.
4BZ8	0.6a	4	12L	35176-PGK0	29	D	1400	P ₁ G ₁ K ₁ & P ₂ G ₂ K ₂ ; X4.
5AS8	0.6a	4	20L	45176-0203	28	D	950	Pentode; X4.
	0.6a	D		00076-3010	35	A		Diode.
5AT8	0.6a	4	17L	00176-3425	36	D	750	Pentode X4.
5BR8	0.62	4	11L	00076-3415	40	C	1160	Pe; X3.
		4	9L	53176-0000	31	D	1130	TR; X5.
6AG7	6.3	8	27L	27151-4630	42	D	1220	X6.
6AK5	6.3	4	21L	51763-4K00	37	D	1650	X4.
6AL5	6.3	D		K3761-2P00	39	A		P ₁ K ₁ & P ₂ K ₂ .
6AM8	6.3	8	17L	15476-3002	37	F	1140	X4.
6AS6	6.3	4	21L	51763-4200	45	D	1040	First Grid; X2.
6ASS	6.3	4	20L	45176-0203	28	D	950	Pentode; X4.
	6.3	D		00076-3010	35	A		Diode.
6AT8	6.3	4	17L	00176-3425	36	D	750	Pentode; X4.
	6.3	4	8L	53176-0000	35	C	970	Triode; X4.
6AU6	6.3	4	9L	52763-4100	45	C	1300	X2.
6AU8	0.6a	4	11L	15376-0000	43	D	1090	Tr; X2.
	0.6a	4	15L	00076-1543	28	D	1170	Pe; X4.
6AW8	0.6a	8	20L	00076-1543	34	D	1140	Pentode; X5.
	0.6a	2	20L	15376-0000	25	F	1400	Triode; X2.
6AZ8	6.3	2	41L	00076-0135	40	D	1100	Tr; X2.
	6.3	4	21L	34176-5000	34	D	1000	Pe; X4.
6BA8	0.6a	8	27L	00076-1543	40	D	1200	PE; X5.
	0.6a	2	23H	15376-0000	31	F	900	TR; X2.
6BE6	6.3	4	0	51763-3000	37	C	1200	Whole Tube.
6BH8	0.6a	4	15L	00076-1543	28	D	1170	Pe; X4.
	0.6a	2	18H	15376-0000	38	D	1100	Tr; X2.
6BN4	6.3	4	18L	15763-KG00	35	D	1130	G ₁ K ₁ & G ₂ K ₂ ; X4.
6BQ7	6.3	4	21L	35176-PGK2	35	D	900	P ₁ G ₁ K ₁ & P ₂ G ₂ K ₂ ; X.
6BR8	0.62	4	11L	00076-3415	40	C	1160	Pe; X3.
		4	9L	53176-0000	31	D	1130	TR; X5.
6BS8	6.3	4	20L	35176-PGK2	36	D	1200	P ₁ G ₁ K ₁ & P ₂ G ₂ K ₂ ; X4.
6BV8	6.3	4	10H	15376-0000	30	F	930	TR; X4.
	6.3	D		00076-P ₁ K ₃		A		TR; X4.
6BZ7	6.3	4	19L	PGK76-3510	41	D	1430	P ₁ G ₁ K ₁ & P ₂ G ₂ K ₂ ; X3.
6BZ8	6.3	4	12L	35176-PGK0	29	D	1400	P ₁ G ₁ K ₁ & P ₂ G ₂ K ₂ ; X4.
6CB5	6.3	4	50H	4715G-K640	36	D	1250	Plate Cap.
								P ₁ G ₁ & P ₂ G ₂ ; X4.
6CG7	0.6a	2	19H	PGK76-3510	34	F	850	P ₁ G ₁ K ₁ & P ₂ G ₂ K ₂ ; X2.
6CM6	6.3	4	23H	40576-G103	42	D	910	G ₁ & G ₂ ; X3.
6CM7	0.6a	2	20H	00176-3500	30	F	670	Triode 1; X2.
	0.6a	4	18H	30076-0051	42	F	980	Triode; X3.
6DQ6	6.3	4	49H	07045-0610	44	D	1470	Plate Cap; X3.
6L6GB	0.6a	4	35H	27345-0610	40	F	1300	X3.
6U8	6.3	4	11L	05476-3100	40	C	1160	Pe; X3.
	6.3	4	9L	30076-0015	31	D	1130	Tr; X5.
6V3	6.3	R		01076-0K00	23	E		K ₁ & K ₂ ; Leak on Plate.
								P ₁ G ₁ & P ₂ G ₂ ; X2.
6Z7	6.3	4	0	0735G-P610	45	D	810	X2.
12AB5	13	2	28H	40576-5143	35	F	1370	
12AT7	6.3	4	18L	35166-PGK7	40	F	1220	P ₁ G ₁ K ₁ & P ₂ G ₂ K ₂ ; X3.
12AU7	6.3	2	19H	35166-PGK7	34	F	730	P ₁ G ₁ K ₁ & P ₂ G ₂ K ₂ ; X2.
12AX7	6.3	2	18L	35177-PGK6	47	F	1000	P ₁ G ₁ K ₁ & P ₂ G ₂ K ₂ ; X6.
12AY7	6.3	1	36L	35166-PGK7	37	F	1150	P ₁ G ₁ K ₁ & P ₂ G ₂ K ₂ .
12BR7	6.3	4	18L	35166-0007	35	F	920	TR; X4.
	6.3	D		00066-3P17	37	A		P ₁ & P ₂ .
12C5	0.6a	4	25H	15765-4300	42	C	1220	X4.
12DQ6	13	4	49H	07045-0610	44	D	1470	Plate Cap; X3.
21A6	20	4	40H	05176-0041	32	D	950	Plate Cap; X4.
25CA5	27.5	8	15H	1576G-4300	41	D	1200	G ₁ & G ₂ ; X5.
75	6.3	1	20L	73001-6000	37	F	720	Grid Cap.
78	6.3	2	28L	73421-6000	42	D	1100	Grid Cap.
232/32	6.3	2	15L	73400-6000	48	C	450	F; Grid Cap.

JUST RECEIVED! ASB-5 'SCOPE INDICATOR



BRAND NEW, including all tubes, together with 5 BP1 'Scope Tube. Originally used in Navy Aircraft RADAR equipment. Easily converted for AC operation. **VALUE \$250.00!**
OUR LOW PRICE \$15.95

ASB-5 RECEIVER FOR 420 Mc BAND!

As featured in "CQ" for October 1956. Easily converted, makes a marvelous receiver for 420 Mc band, with RF amplifier! Supplied complete with all tubes. **OUR LOW PRICE \$1495**
Tuning Knob for ASB-5 Receiver \$1.29

ASB-5 INDICATOR \$16.95

MN26Y BENDIX DIRECTION FINDER 150-325 Kc; 325-695 Kc; 3-4.7 Mc. Complete with tubes, motor. **\$26.95**

BRAND NEW Used, like new, incl. tubes and dynamotor. **\$18.95**

BENDIX DIRECTION FINDER

12-tube remote control Navigation Direction Finder and communications receiver. 150 to 1500 Kc in 3 bands, 28 V. DC input. Ideal for commercial navigation on boats and planes. Complete installation comprises:
MN-26-C Receiver, used, with 12 tubes. **\$16.50**
MN-26-C With 12 Tubes, **BRAND NEW \$24.95**
MN-20-E Rotatable Loop. **4.25**
MN-52 Azimuth Control Box. **2.95**
All necessary accessories for above in stock.

TS-16/APN TEST SET. **BRAND NEW**, complete with all cables. **\$12.95**

DETROLA BEACON RECEIVER



BC-1206A. A dandy little receiver for 200 to 400 Kc Band. Uses 135 Kc iron core IFT. Complete with six tubes: 6SK7, 6SA7, 6K7, 6SQ7, 2-25L6's. **Used \$4.99**

NAVY RECEIVER TYPE ARB

Four Band. 195 to 9050 kc. Low Freq., Ship, Broadcast—40 to 80 meters. Includes tubes and dynamotor, for 24 volt operation. Easily converted for 110 V., 12 V., or 6 V. Schematic included. Excellent Condition. Overall: 8 1/4" x 7 1/4" x 15 1/4". Wt. 30 lbs. **COMPLETE WITH ALL TUBES, \$21.50**
Special.

BC-906 FREQ. METER—SPECIAL!

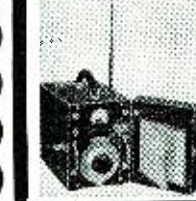

Cavity type, 145 to 235 Mc. **BRAND NEW** in original factory packing, complete with antenna. Manual included. **OUR LOW PRICE \$8.88**

BC-221 FREQ. METER. **\$129.50**

BC-221 FREQ. METER CASE

Aluminum Case for BC-221 or TS-164 Freq. Meters. Shock Mounted. **BRAND NEW \$3.99**
Original 1000 Kc Crystal for BC-221. **BRAND NEW \$8.45**

DYNAMOTOR VALUES!

Type	Input	Output	Used	BRAND NEW
DA-19-A	28V 11A	400V .400A	\$4.99	\$6.95
DM-28	28V	224V .07A	2.95	4.95
DM-32A	28V 1.1A	250V .05A	2.95	5.95
DM-33A	28V 5A	575V .16A		
	28V 7A	540V .25A	1.95	3.95
DM-34D	12V 2A	220V .080A	4.25	5.50
DM-37	25.5V 9.2A	625V .225A	5.95	8.95
DM-40	14V 3.4A	172V .138A	1.75	3.45
DM-53A	28V 1.4A	220V .080A	3.95	5.95
DM-64A	12V 5.1A	275V .150A		7.95
PE-73C	28V 20A	1000V .350A	8.50	11.50
PE-86	28V 1.25A	250V .050A	2.95	5.24
PE-103	6/12V Input, 500V @ 160 Ma output. With cables and plugs, excellent, like new.			\$24.50

2 VOLT BATTERY "PACKAGE"



1—2V. 20 Amp. Hr. Willard Storage Battery **\$2.45**
1—2V. 7 prong Synchronous Plug-in Vibrator **1.49**
1—Quart Bottle Electrolyte (for 2 cells) **1.45**
ALL BRAND NEW!
Combination Price **\$4.99**

Willard 6-Volt Midget Storage Battery 3 Amp. Hour. **BRAND NEW**. 3 5/8" x 1-13/16" x 2 3/8". Uses Standard Electrolyte. **Only \$2.22**

ARC-5/R28 RECEIVER
1 meter Superhet, 100 to 156 Mc in 4 crystal channels. Complete with 10 Tubes **\$18.95**
BRAND NEW
110 V AC Power Supply Kit for above **\$9.75**

ARC-5/T-23 TRANSMITTER
100-156 Mc Includes 2-832A, 2-1625 \$19.95
Tubes. **BRAND NEW**
SPECIAL Limited quantity ARC-5/T-23 xmitters. **BRAND NEW**, less tubes **\$7.95**
OFFER! Excellent Used, less tubes **\$5.95**

ARC-5 MARINE RECEIVER-TRANSMITTER
Navy Type Comm. Receiver 1.5 to 3 Mc **\$16.95**
BRAND NEW With 6 tubes
Navy Type Comm. Transmitter 2.1-3 Mc **\$12.45**
BRAND NEW With 4 tubes and Xtal.

SCR-274 COMMAND EQUIPMENT

ALL COMPLETE WITH TUBES Excellent Brand Type Description Used NEW
BC-453 Receiver 190-550 KC. \$9.95 \$11.95 \$14.95
BC-454 Receiver 3-6 Mc. 7.19 8.29 11.95
BC-455 Receiver 6-9 Mc. 5.25 7.95 9.95
RC-456 Modulator 2.24 2.75 4.24
BC-456 3-Receiver Control Box 1.49 1.95
BC-451 Transmitter (Control) Box 1.25 1.49
BC-456 Xmit 3-Mc (like new) 6.95 8.88
BC-457 TRANSMITTER—4-5.3 Mc. complete with all tubes and crystal. BRAND NEW \$7.88
BC-458 TRANSMITTER—5-3 to 7 Mc. Complete with all tubes and crystal. BRAND NEW \$7.88
BC-459 TRANSMITTER—7-9.1 Mc. complete with all tubes and crystal. BRAND NEW \$11.95
ARC-5/T-23 TRANSMITTER—3 to 4 Mc. BRAND NEW complete with all tubes & crystal \$8.88

110 VOLT AC POWER SUPPLY KIT

For All 274-N and ARC-5 Receivers
Can be assembled quickly and easily, on pre-drilled chassis. Plugs into the rear of any model 274-N receiver and delivers 24 volts as well as "B" voltage. Complete Kit of parts with metal case, instructions. Factory wired, tested, ready to operate **\$7.95**
SPRINED TUNING KNOB for 274-N and ARC-5 RECEIVERS. Fits BC-453, BC-454 and others. **Only 49c**

LORAN APN-4

FINE QUALITY NAVIGATIONAL EQUIPMENT
Determine exact geographic position of your boat or plane! Complete, **BRAND NEW** installation consists of: JD-6B/APN-4 Receiver; R-9B/APN-4 Receiver; PE-206 Inverter; Set of Plugs; Visor for Indicator; Operation manual. **\$129.50**
COMPLETE. BRAND NEW.

APN-9A LORAN Receiver Indicator, less tubes, NEW (demilitarized) **\$29.50**

SCR-522 2-METER RIG!

Terrific buy! VHF Transmitter-receiver, complete with all components: 100-156 Mc, 4 channels. Xtal. controlled. Amplitude modulated voice. They're going fast! Excellent condition.
SCR-522 Transmitter-Receiver, complete with all 18 tubes. \$33.33
COMBINATION . . . Special
Receiver Only, with all tubes **\$19.50**
Transmitter Only, with all tubes **\$22.25**

FREE!

Schematic Diagram included FREE with each piece of equipment shown on this page. Schematics for any of these units also available separately at 50c each.

I-95-M FIELD STRENGTH METER

Tunes 100 to 155 Mc. Made for Signal Corps. **\$34.50**
Like New

AN/ARR-2 RECEIVER

BRAND NEW—A Terrific Value! Tuning Range 234 to 258 Mc. Tubes: 7-9001, 3-8AK5, 1-12AB. Schematic included. Only a few at this low price. **\$8.88**
Complete. With 28 V 1.6A Dynamotor, complete **\$12.98**
110 VOLT AC POWER SUPPLY KIT for above **\$9.75**

WRITE FOR FREE CATALOG!

Please include 25¢ deposit with order—Balance C.O.D. 50¢ Handling Charge. All orders under \$3.00 All shipments F.O.B. Our Warehouse, N.Y.C.

G & G Radio Supply Co.
Telephone: CO 7-4605
51 Vesey St., New York 7, N. Y.

SIG. CORPS FIELD INTERPHONE KIT

Sensational Value!

Cost to Govt. More than \$12.95
OUR PRICE \$500.



BRAND NEW
In Original Packing

Here's what you get: H-22/U Handset with 5' Kinkless cord, equipped with "talk-listen" battery switch, PL-68 plug and P-0-053B plug; 14' flexible plated steel conduit, 3/4" diam.; all-metal control box with switches, 1 1/2" in. posts, pilot indicator; 3-lb. box of costly hardware; many accessories and spares, including: 4 indicator lamps, 2-wire sealing compound, toggle switches, gaskets, large roll friction tape, complete technical manual—and it's all yours, for only \$12.95.

Ham Special! Famous BC-645 XMITTER-RECEIVER

With **MANUAL** for Easy Conversion to **CITIZEN'S BAND!**



Makes wonderful mobile rig for 420-5.0 Mc. Easy to convert for phone or CW 2-way communication. This swivel rig originally cost over \$1000—yours for practically a song! You get it all, in original factory carton, **BRAND NEW**, complete with 17 tubes, less power supply. Conversion Instructions Included. **\$29.50**
Shpg. wt. 25 lbs.

PE-101C DYNAMOTOR for BC-645, has 12-24V input (easy to convert for 6V Battery operation) **\$7.95**

UHF ANTENNA ASSEMBLY, for BC-645. Complete set of 10 Plugs for BC-645 **\$5.50**

CONTROL BOX for above. **\$2.25**
SHOCK MOUNT for above. **1.25**
CONVERSION BOOKLET. Instructions for most useful surplus rigs. **\$2.50**

BRAND NEW SPECIAL PURPOSE TUBES

Original Individual Packing

JAN CRP-730A MAGNETRON, Raytheon	Each	Lots of 12	Lots of 100
Type 6J6W	\$4.45	\$5.15	\$41.00
1625	.26	2.75	21.50
1628	.16	1.75	13.50
1629	.27	3.05	23.95
826	.44	4.95	39.50
21724B	.35	3.95	29.50
VR105	.79	8.88	70.00
VR150	.79	8.88	70.00
80021	5.95		
RK65	.725		

NEW! Cathode Ray Tubes NEW!

3CP1	\$1.18	5BP4	\$2.22
3FP7	1.18	5CP1	2.45
5BP1	2.22	5FP7	1.44
		9LP7	1.88

BC1206-C BEACON RECEIVER

195 to 420 Kc. made by Setchel-Carlson. Works on 24-28 volts DC. 135 Kc. IF. Complete with 5 tubes. Size 4" x 4" x 6". Wt. 4 lbs. **BRAND NEW \$8.88**
Brand New, less tubes. **\$5.95**
USED, with tubes. **\$5.95**
USED, less tubes. **2.95**

BRAND NEW SELSYNS

Operates from 57 1/2 volts, 400 cycles. New tested. Conversion diagram for 110 volts AC included. 2J1G1 Selsyn Control Transformer. 2J1H1 Selsyn Differential Generator. Each **\$2.95**
Caps for Above. **1.44**

DYNAMIC HANDMIKE, with "Press-to-talk" Switch, cord and plug—**BRAND NEW**, only. **\$2.95**

DYNAMIC HEADPHONES, 600-ohm impedance, with large earphone cushions, cord and phone plug. **BRAND NEW**, special. **\$3.95**

HI-LO IMPEDANCE MATCHING TRANSFORMER for headphones. 600 ohms to 8000 ohms. With plug and jack. **BRAND NEW \$97c**

HI-FI DYNAMIC HEADSET with Cushions Freq. Range: 40-14000 CPS. No Distortion. **BRAND NEW \$5.95**

MICROPHONES

Model	Description	Used	BRAND NEW
T-17	Carbon Hand Mike	\$5.45	\$7.95
T-30	Carbon Throat Mike	.33	.69
T-45	Army and Navy Lip Mike		1.33
RS-38	Navy Type	2.45	4.95
T-24	Carbon Mike		5.95
TS-9	Handset		4.95

HEADPHONES

Model	Description	Used	BRAND NEW
HS-23	High Impedance	\$2.25	\$4.35
HS-33	Low Impedance	1.99	4.65
HS-30	Low Imp. (featherwt.)	1.49	2.25
H-16/U	High Imp. (2 units)	2.75	7.95
CD-307A	Cords, with PL55 plug and JK26 Jack		.99

BC-442 ANTENNA RELAY

Wonderful Value! Consists of 3/4 amp 2" RF Ammeter (antenna current indicator), 0-10 scale, Transmitter-Receiver switching relay, in aluminum case with associated components. **BRAND NEW \$2.24**

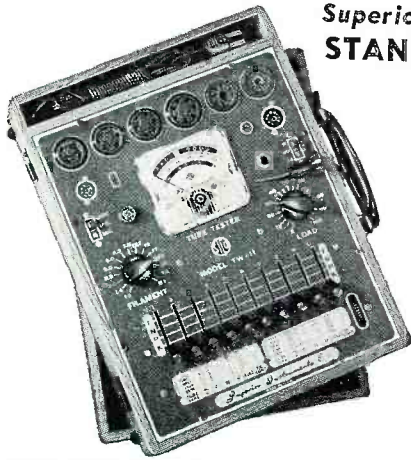

**Superior's New Model TW-11
STANDARD PROFESSIONAL**

UBE ES ER

- Tests all tubes, including 4, 5, 6, 7, Octal, Lockin, Hearing Aid, Thyatron, Miniatures, Sub-miniatures, Novals, Sub-minars, Proximity Fuse types, etc.
- Uses the new self-cleaning Lever Action Switches for individual element testing. Because all elements are numbered according to pin-number in the RMA base numbering system, the user can instantly identify which element is under test. Tubes having tapped filaments and tubes with filaments terminating in more than one pin are truly tested with the Model TW-11 as any of the pins may be placed in the neutral position

- when necessary.
- The Model TW-11 does not use any combination type sockets. Instead individual sockets are used for each type of tube. Thus it is impossible to damage a tube by inserting it in the wrong socket.
- Free-moving built-in roll chart provides complete data for all tubes. All tube listings printed in large easy-to-read type.

NOISE TEST: Phono-jack on front panel for plugging in either phones or external amplifier will detect microphonic tubes or noise due to faulty elements and loose internal connections.

EXTRAORDINARY FEATURE

SEPARATE SCALE FOR LOW-CURRENT TUBES—Previously, on emission-type tube testers, it has been standard practice to use one scale for all tubes. As a result, the calibration for low-current types has been restricted to a small portion of the scale. The extra scale used here greatly simplifies testing of low-current types.

The Model TW-11 operates on 105-130 Volt 60 Cycles A.C. Comes housed in a beautiful hand-rubbed oak cabinet complete with portable cover.

\$4750
NET

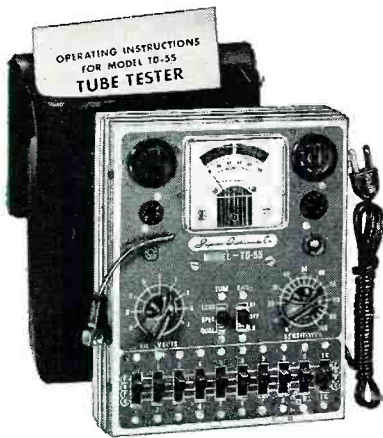

**Superior's New
Model TD-55**

FOR TUBE TESTER

The Experimenter or Part-time Serviceman, who has delayed purchasing a higher priced Tube Tester. The busy TV Service Organization, which needs extra Tube Testers for its field men.

Speedy, yet efficient operation is accomplished by:

1. Simplification of all switching and controls.
2. Elimination of old style sockets used for testing obsolete tubes (26, 27, 57, 59, etc.) and providing sockets and circuits for efficiently testing the new Noval and Sub-Minar types.

You can't insert a tube in wrong socket

It is impossible to insert the tube in the wrong socket when using the new Model TD-55. Separate sockets are used, one for each type of tube base. If the tube fits in the socket it can be tested.

"Free-point" element switching system

The Model TD-55 incorporates a newly designed element selector switch system which reduces the possibility of obsolescence to an absolute minimum. Any pin may be used as a filament pin and the voltage applied between that pin and any other pin or even the "top-cap."

Checks for shorts and leakages between all elements

The Model TD-55 provides a super sensitive method of checking for shorts and leakages up to 5 Megohms between any and all of the terminals. Continuity between various sections is individually indicated. This is important, especially in the case of an element terminating at

more than one pin. In such cases the element or internal connection often completes a circuit.

Elemental switches are numbered in strict accordance with R.M.A. specification.

One of the most important improvements, we believe, is the fact that the 4 position fast-action snap switches are all numbered in exact accordance with the standard R.M.A. numbering system. Thus, if the element terminating in pin No. 7 of a tube is under test, button No. 7 is used for that test.

The Model TD-55 comes complete with operating instructions and charts. Housed in rugged steel cabinet. Use it on the bench — use it for field calls. A streamlined carrying case, included at no extra charge, accommodates the tester and book of instructions.

\$2695
NET

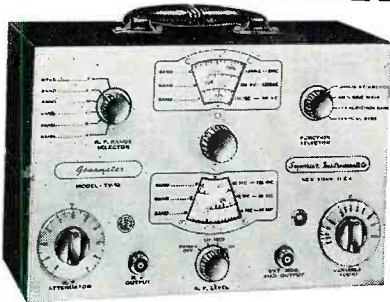

**Superior's New
Model TV-50**

GENOMETER

A versatile all-inclusive GENERATOR which provides ALL the outputs for servicing:
A. M. Radio • F. M. Radio • Amplifiers • Black and White TV • Color TV

7. Signal Generators in One!

- ✓ R.F. Signal Generator for A.M.
- ✓ R.F. Signal Generator for F.M.
- ✓ Audio Frequency Generator

- ✓ Bar Generator
- ✓ Cross Hatch Generator
- ✓ Color Dot Pattern Generator
- ✓ Marker Generator

R. F. SIGNAL GENERATOR: The Model TV-50 Genometer provides complete coverage for A.M. and F.M. alignment. Generates Radio Frequencies from 100 Kilocycles to 60 Megacycles on fundamentals and from 60 Megacycles to 150 Megacycles on powerful harmonics.

VARIABLE AUDIO FREQUENCY GENERATOR: In addition to a fixed 400 cycle sine-wave audio, the Model TV-50 Genometer provides a variable 300 cycle to 20,000 cycle peaked wave audio signal.

BAR GENERATOR: The Model TV-50 projects an actual Bar Pattern on any TV Receiver Screen. Pattern will consist of 4 to 16 horizontal bars or 7 to 20 vertical bars.

CROSS HATCH GENERATOR: The Model TV-50 Genometer will project a cross-hatch pattern on any TV picture tube. The pattern will consist of non-shifting horizontal and vertical lines interlaced to provide a stable cross-hatch effect.

DOT PATTERN GENERATOR (FOR COLOR TV): Although you will be able to use most of your regular standard equipment for servicing Color TV, the one addition which is a "must" is a Dot Pattern Generator. The Dot Pattern projected on any color TV Receiver tube by the Model TV-50 will enable you to adjust for proper color convergence.

MARKER GENERATOR: The Model TV-50 includes all the most frequently needed marker points. The following markers are provided: 189 Kc., 262.5 Kc., 456 Kc., 600 Kc., 1000 Kc., 1400 Kc., 1600 Kc., 2000 Kc., 2500 Kc., 3579 Kc., 4.5 Mc., 5 Mc., 10.7 Mc., (3579 Kc. is the color burst frequency.)

The MODEL TV-50 comes absolutely complete with shielded leads and operating instructions.

\$4750
NET

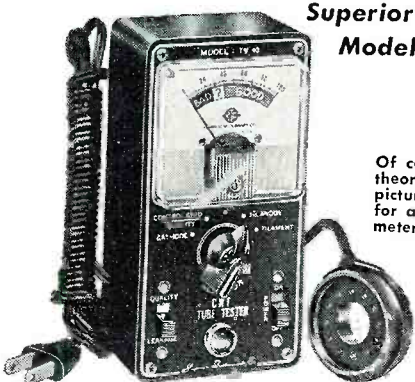

**Superior's New
Model TV-40**

PICTURE TUBE TESTER

NOT A GADGET—NOT A MAKE-SHIFT ADAPTER, BUT A WIRED PICTURE TUBE TESTER WITH A METER FOR MEASURING DEGREE OF EMISSION—AT ONLY \$15.85

Of course you can buy an adapter for about \$5—which theoretically will convert your standard tube tester into a picture-tube tester; or a neon type instrument which sells for a little more and is supposed to be "as good as" a metered instrument. Superior does not make nor do they

recommend use of C.R.T. adapters or neon gadgets because a Cathode Ray Tube is a very complex device, and to properly test it, you need an instrument designed exclusively to test C.R. Tubes and nothing else.

Tests ALL magnetically deflected tubes . . . in the set . . . out of the set . . . in the carton!!

- Tests all magnetically deflected picture tubes from 7 inch to 30 inch types.
- Tests for quality by the well established emission method. All readings on "Good-Bad" scale.
- Tests for inter-element shorts and leakages up to 5 megohms.
- Test for open elements.

EASY TO USE: Simply insert line cord into any 110 volt A.C. outlet, then attach tester socket to tube base (on trap need not be on tube). Throw switch up for quality test . . . read direct on Good-Bad scale. Throw switch down for leakage tests. Model TV-40 C.R.T. Tube Tester comes absolutely complete—nothing else to buy. Housed in round cornered, molded bakelite case. Only

\$1585
NET

EXAMINE BEFORE YOU BUY!
USE APPROVAL FORM ON NEXT PAGE

For the first time ever: ONE TESTER PROVIDES ALL THE SERVICES LISTED BELOW!

Superior's
New Model **76**

IT'S A
CONDENSER BRIDGE

with a range of .00001 Microfarad to 1000 Microfarads
(Measures power factor and leakage too.)

IT'S A
RESISTANCE BRIDGE

with a range of 100 ohms to 5 megohms

IT'S A
SIGNAL TRACER

which will enable you to trace the signal from antenna to speaker of all receivers and to finally pinpoint the exact cause of trouble whether it be a part or circuit defect.

IT'S A
TV ANTENNA TESTER

The TV Antenna Tester section is used first to determine if a "break" exists in the TV antenna and if a break does exist the specific point (in feet from set) where it is.



Specifications

✓CAPACITY BRIDGE SECTION

4 Ranges: .00001 Microfarad to .005 Microfarad; .001 Microfarad to .5 Microfarad; .1 Microfarad to 50 Microfarads; 20 Microfarads to 1000 Microfarads. This section will also locate shorts, and leakages up to 20 megohms. And finally, this section will measure the power factor of all condensers from .1 to 1000 Microfarads. (Power factor is the ability of a condenser to retain a charge and thereby filter efficiently.)

✓RESISTANCE BRIDGE SECTION

2 Ranges: 100 ohms to 50,000 ohms; 10,000 ohms to 5 megohms. Resistance can be measured without disconnecting capacitor connected across it. (Except, of course, when the R C combination is part of an R C bank.)

✓SIGNAL TRACER SECTION

A built-in high gain pentode voltage amplifier, plus a diode rectifier, plus a direct coupled triode amplifier are combined to provide this highly sensitive signal tracing service. With the use of the R.F. and A.F. Probes included with the Model 76, you can make stage gain measurements, locate signal loss in R.F. and Audio stages, localize faulty stages, locate distortion and hum, etc. Provision has been made for use of phones and meter if desired.

✓TV ANTENNA TESTER SECTION

Loss of sync., snow and instability are only a few of the faults which may be due to a break in the antenna, so why not check the TV antenna first? The Model 76 will enable you to locate a break in any TV antenna and if a break does exist, the Model 76 will measure the location of the break in feet from the set terminals. 2 Ranges: 2' to 200' for 72 ohm coax and 2' to 250' for 300 ohm ribbon.

As Design Engineers, we the undersigned would like to say that the Model 76 is in our opinion the best combination unit of its kind we have been privileged to design. Although it is comparatively a low-priced tester, it will, after you become acquainted with its multiple services, be your most frequently used instrument.

**S. LITT
L. MELENKEVITZ**

Model 76 comes complete with all accessories, including R.F. and A.F. Probes; Test Leads and operating Instructions. Nothing else to buy.

\$26⁹⁵
NET

**SHIPPED ON APPROVAL
NO MONEY WITH ORDER — NO C.O.D.**

Try any of the instruments on this or the facing page for 10 days before you buy. If completely satisfied **then** send down payment and pay balance as indicated on coupon. **No Interest or Finance Charges Added!** If not completely satisfied return unit to us, no explanation necessary.

MOSS ELECTRONIC DISTRIBUTING CO., INC.
Dept. D-353 3849 Tenth Ave., New York 34, N. Y.

Name
Address
City Zone.....State.....

All prices net, F.O.B., N. Y. C.

<input type="checkbox"/> Model TW-11..... Total Price \$47.50 \$11.50 within 10 days. Balance \$36.00 monthly for 6 months.	<input type="checkbox"/> Model 76 . . . Total Price \$26.95 \$6.95 within 10 days. Balance \$5.00 monthly for 4 months.	<input type="checkbox"/> Model TD-55 Total Price \$26.95 \$6.95 within 10 days. Balance \$5.00 monthly for 4 months.
<input type="checkbox"/> Model TV-50..... Total Price \$47.50 \$11.50 within 10 days. Balance \$36.00 monthly for 6 months.	<input type="checkbox"/> Model TV-40..... Total Price \$15.85 \$3.85 within 10 days. Balance \$4.00 monthly for 3 months.	

BUILD THE BEST—
BUILD ALLIED'S OWN
knight-kits

Here is a typical Knight-Kit value—available only from ALLIED—one of 45 great Knight-Kits you'll find in our special Supplement No. 165. Write for your FREE copy today.

knight-kit INSTRUMENT VALUE
5" GENERAL-PURPOSE SCOPE KIT



Model
Y-146
\$49⁵⁰

Feature for feature, the world's best scope kit value. Equal in performance to wired units several times its price. Ideal for radio and TV servicing, audio work and hundreds of other applications. Phantastron sweep circuit provides extreme sweep linearity; retrace blanking on all ranges eliminates retrace lines; vertical sensitivity is three times that of comparably priced scope kits. Printed circuit and laced wiring harness speed assembly. **SPECIFICATIONS:** Vertical Response— ± 3 db, 3 cps to 1.5 mc.; ± 6 db to 2.5 mc. Vertical Sensitivity—.025 rms v/inch. Sweep—15 to 150,000 cps in 4 ranges. Horizontal Sensitivity—.07 rms v/inch. Vertical Input Imp.—3.3 meg shunted by 45 mmfd. Calibrating Voltage: 1 volt peak-to-peak, applied by push-button switch. Complete with 5" CRT, wire, solder, etc. $9\frac{1}{4} \times 13\frac{3}{4} \times 17\frac{3}{4}$ ". Shpg. wt. 28 lbs. Model Y-146. Net, F.O.B. Chicago.... **\$49⁵⁰**

OTHER knight-kit INSTRUMENT VALUES



5" WIDE-BAND SCOPE KIT
Y-144 \$69⁰⁰



VOLTAGE CALIBRATOR KIT
Y-136 \$12⁷⁵



HIGH-GAIN SIGNAL TRACER KIT
Y-135 \$26⁵⁰



TV-FM LINEAR SWEEP GENERATOR
Y-123 \$44⁷⁵

See our Supplement No. 165 for 18 other knight-kit instrument values

free SUPPLEMENT
featuring knight-kits



Send for our FREE Supplement No. 165 featuring 45 great Knight-Kits, including Test Instruments, Hi-Fi, Hobbyist and Amateur Kits. Write for your copy today.

ORDER FROM
ALLIED RADIO

Dept. 01-67, 100 N. Western Ave., Chicago 80, Ill.



Control room at Bureau of Standards forecasting center at Fort Belvoir, Virginia.

IGY World Warning Agency

Will provide data on unusual activity in cosmic rays, aurora, earth's magnetism, propagation disturbances.

BEGINNING July 1, 1957, the National Bureau of Standards radio forecasting center at Fort Belvoir, Va., will serve as the focal point of a world-wide communications network for the International Geophysical Year. From this point, warnings will be flashed to scientists throughout the world to redouble their observational efforts in anticipation of unusual activity in cosmic rays, aurora, earth magnetism, and radio propagation disturbances. The warnings will be based mainly on world-wide observations of the surface of the sun and on soundings of the ionosphere.

In addition to the NBS station at Ft. Belvoir, the international network includes the radioteletype network of the World Meteorological Organization, virtually all the commercial communications facilities throughout the world, government facilities, and special broadcasts by stations WWV and WWVH and their counterparts in other countries. This elaborate and far-reaching network has been set up so that IGY scientists, no matter how remote the site of their work, can conduct their experiments simultaneously.

Because it is not economically feasible for scientists to make intensive world-wide observations every day during the IGY, a series of regular World Days has been selected in advance for detailed simultaneous observations. These will be supplemented by two types of warning—Alerts and Special World Intervals—which the World Warning Agency will issue when major solar-terrestrial disturbances are

expected. If solar conditions justify a warning, the World Warning Agency will issue messages to Regional Warning Centers in The Netherlands, France, Germany, Japan, and the USSR, and then to Associate Warning Centers in Australia, Antarctica, and Alaska. From these centers, the warning will be flashed to every IGY field station throughout the world. The center in Virginia will also serve as the Western Hemisphere Regional Warning Center.

The Ionosonde sounds the ionosphere for unusual activity. The data obtained from the unit is recorded by camera at top right.

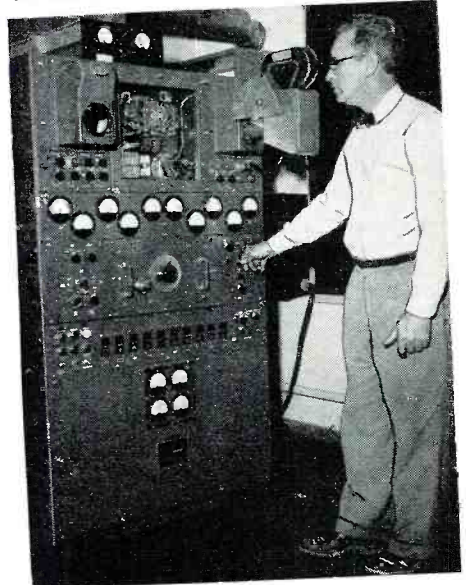

RADIO & TV NEWS

STANDARD LINE

MANUFACTURERS
ORDERS INVITED
EXPORT ORDERS
INVITED

Below Is A Partial List—Send For FREE Complete List and Order Form

QZ4	.42	5AT8	.79	6BK7	.75	7A4	.46	12J5	.39
1A7GT	.42	5J6	.79	6BL7GT	.74	7A5	.52	12L6	.59
1B3GT	.40	5U4G	.48	6BN6	.57	7A6	.44	12SA7	.47
1C5GT	.66	5U8	.79	6BQ6GT	.79	7A7	.44	12S67	.54
1C6	.25	5V4G	.57	6BQ7	.75	7A8	.44	12S17	.44
1C7G	.42	5V6GT	.49	6BY5G	.57	7A7	.69	12SK7	.47
1D5GP	.45	5X8	.79	6C4	.36	7B4	.43	12SL7GT	.59
1H4G	.46	5Y3	.38	6BZ7	.40	7B5	.40	12SN7GT	.56
1J6GT	.45	5Y4G	.42	6C6	.50	7B6	.41	12SQ7	.39
1L4	.45	5Z3	.44	6CD6G	1.17	7B7	.42	12V6GT	.44
1L6	.54	6A7	.56	6CU6	.79	7C4	.40	12W6	.59
1LA4	.55	6A8	.46	6D6	.47	7C5	.41	12X4	.36
1LA6	.46	6AB4	.44	6E5	.43	7C6	.42	14A7	.44
1LB4	.58	6AC7	.66	6F5	.36	7C7	.44	14B6	.44
1LC5	.48	6AF4	.75	6F6	.37	7E5	.44	14Q7	.44
1LC6	.46	6AG5	.49	6H6	.37	7E6	.44	19T8	.69
1LD5	.56	6AG7	.68	6I4	1.59	7F7	.65	19B6G	.117
1LE3	.56	6AH4G2	.69	6J5	.38	7F7	.58	25BQ6GT	.84
1LH4	.63	6AH6	.70	6K7	.38	7G7	.74	25CA5	.79
1LN5	.46	6AK5	.53	6L6	.67	7N7	.58	25CD6	.129
1NSGT	.49	6AL5	.41	6N7	.59	7Q7	.64	25CU6	.99
1R5	.50	6AM8	.79	6Q7	.39	7X7	.64	25L6GT	.46
1S5	.45	6AN8	.79	6S4	.39	7Y4	.34	25W4GT	.42
1T4	.50	6AQ5	.45	6S7	.40	7Z4	.59	25Z6	.36
1U4	.46	6AS5	.47	6SA7	.47	12A4	.40	27	.24
1U5	.45	6AS7G	2.25	6SB7Y	.75	12AB5	.59	35B5	.47
1V2	.70	6AT6	.38	6SC7	.47	12AQ5	.49	35C5	.47
1X2	.66	6AT8	.79	6SG7	.40	12AT6	.40	35L6GT	.46
2A3	.49	6AU4GT	.64	6SH7	.42	12AT7	.65	35W4	.38
2A7	.54	6AUSGT	.60	6SI7	.42	12AUG	.42	35Y4	.38
2D21	.95	6AU6	.42	6SK7	.49	12AU7	.58	35Z4	.40
3A4	.50	6AU8	.79	6SL7GT	.56	12AV6	.41	35Z5GT	.38
3A5	.50	6AV5GT	.64	6SN7GT	.56	12AV7	.66	39/44	.25
3AL5	.52	6AV6	.38	6SQT	.40	12AX4GT	.64	50A5	.47
3AU6	.52	6AW8	.89	6SS7	.40	12AX7	.62	50B5	.47
3BZ6	.57	6AX4GT	.65	6T4	.85	12AZ7	.62	50C5	.47
3BC5	.57	6AX5GT	.56	6T8	.67	12BA7	.45	84/624	.44
3BN6	.57	6BA6	.46	6U5	.54	12BA7	.59	117L7GT	1.25
3CB6	.57	6BC5	.49	6U8	.79	12BE6	.45	117N7GT	1.25
3Q4	.55	6BC8	.89	6V3	.79	12BH7	.59	117P7GT	1.25
3Q5GT	.56	6BD5GT	.52	6V6GT	.45	12CA5	.59	117Z3	.36
3S4	.46	6BE6	.45	6W4GT	.39	12CUG	.79	117Z6GT	.61
3V4	.55	6BF5	.39	6W6GT	.52	12DQ6	.79		
4BQ7	.75	6BG6G	1.17	6X4	.38				
4BZ7	.75	6BH6	.50	6X5	.38				
5AM8	.79	6BJ6	.46	6X8	.74				
5AN8	.79	6BK5	.67						
5A95	.49								

Receiving Tubes Sent Parcel Post

- Any 10" Tube\$10.75
- Any 12" Tube.....\$12.75
- Any 14" Tube.....\$14.75
- Any 16" Tube.....\$16.75

All Picture Tubes sent Railway Express F.O.B. our warehouse. Sorry, no A.P.O. shipments.

Standard Line PICTURE TUBES Guaranteed One Year

- Any 17" Tube.....\$17.75
- Any 19" Tube.....\$20.75
- Any 20" Tube.....\$20.75
- Any 21" Tube.....\$22.75

FREE 12" TV SET

with every receiving tube order of \$100.00 or more!

FREE 16" TV SET

with every receiving tube order of \$200.00 or more!

FREE!

TWO SET COUPLER WITH EVERY TUBE ORDER OF \$8.50 OR MORE!!

Bonus TV sets are shipped complete with cabinet and picture tube F.O.B. our warehouse. With slight adjustments and minimum labor they can be restored like new.

REMEMBER—You Buy Quality When You Buy Standard. Quality Never Shouts—It Always Whispers.

Thousands of TRADE-IN TVs

Reconditioned By Factory Trained Technicians! Guaranteed To Be In Working Condition When You Receive Them!

10"	\$25.00	19"	\$56.00
12"	\$30.00	20"	\$63.00
14"	\$35.00	21"	\$70.00
16"	\$42.00	24" (when available)	\$95.00
17"	\$49.00	27" (when available)	\$129.00

Get yourself a second set or buy some for re-sale! FREE BONUS... two set coupler given with each set. All TVs sent motor freight or Railway Express F.O.B. our warehouse. Sorry, no A.P.O. shipments.

We Are Not Selling Price—We Sell Only Quality

Used Tubes, Electrically Perfect Factory Seconds, Brand New Factory Seconds and New and Used Jan Surplus Tubes

STANDARD LINE

ELECTRIC COMPANY

432 HARRISON AVENUE, HARRISON, N. J. • Phone: HUmboldt 4-4997

FREE! LAFAYETTE CATALOG



ELECTRONIC CATALOG PACKED WITH MONEY SAVERS

Packed with the largest selection of Electronic, Radio and T.V. Parts, and equipment, PA, Hi-Fi systems, tubes, antennas, Transistor Kits, parts and components, Test Equipment, new build your own kits, tools, books, Microscope, drafting equipment, Binoculars, Telescopes, All Radio, TV and Ham supplies — ALL AT GREAT SAVINGS — For the economy minded servicemen, dealer, engineer and technician **CHUCK FULL OF BUYS! SEND FOR YOUR FREE COPY TO-DAY.**

PROFESSIONAL TRANSCRIPTION TURNTABLE AND VISCOUS-DAMPED TONE ARM THE FINEST TRANSCRIPTION TURNTABLE AND TONE ARM FOR THE PROFESSIONAL USER AND THE AUDIOPHILE



**PK-300 TURNTABLE
PK-90 TONE ARM
AND G.E. CARTRIDGE WITH GENUINE DIAMOND AND SAPPHIRE STYL.**

72.50

PK-300

ILLUMINATED BUILT-IN STROBOSCOPE & VIEWER

COMBINATION

DEAL



PK-90

LATEST IMPROVED MODEL PK-300 TRANSCRIPTION TURNTABLE

New 3-speed instrument with built-in stroboscope and viewer for exact speed determination, and magnetic brake for instantaneous speed variation. Precision engineered to meet professional standards for wow, rumble and flutter content, Heavy 12" cast aluminum rim-driven turntable. Variable speed control permits adjustment of each speed within $\pm 7\%$ using efficient frictionless magnetic brake. Heavy-duty constant speed 4-pole induction motor freely suspended and isolated by shock-mountings to eliminate vibration transference. R-C filter network suppresses "pop" in speakers. Truly a delight for the connoisseur. Size: 13 1/2" x 14" and requires 2 3/4" clearance above and 3 3/4" below motorboard. For 110-130V and 60/50 cycle AC. Power consumption 12 watts. Handsome hammertone gray finish. Shpg. wt., 20 lbs.

PK-300

.....Net **49.50**

PK-90 VISCOUS-DAMPED TONE ARM

This transcription arm assures dependable and stable operation, utilizing the "floating action" principle of "viscous-damping." The arm is supported at a single point by a pivot and jewel bearing having negligible friction. Damping is accomplished by a silicone fluid occupying the gap between a ball and socket. This damping control permits high compliance and negligible tracking error, and prevents damage to either record or stylus should the tone arm be accidentally dropped. Low frequency resonance, skidding and groove-jumping are likewise minimized. The tone arm accepts all records up to 12" and accommodates virtually all hi-fi cartridges by means of precisely engineered adapters which simplify installation and provide proper stylus pressure.

This tone arm is a quality companion to the PK-300 with matching finish. Shpg. wt., 2 1/2 lbs.

.....Net **15.95**



High Frequency Tweeter WITH ACOUSTIC LENS DIRECT IMPORTATION MAKES THIS PRICE POSSIBLE!

- FREQUENCY RESPONSE FROM 2000 CPS TO BEYOND AUDIBILITY
- LOUVERED ACOUSTIC LENS FOR UNIFORM SOUND DISPERSION
- HANDLES 25 WATTS OF POWER
- PRICED EXCEPTIONALLY LOW

14.95

New high frequency tweeter featuring a louvered acoustic lens for uniform sound dispersion and capable of handling up to 25 watts of distortion-free power. The directional tendency of high frequency notes is overcome by the natural wide dispersion angle of the short horn and the acoustic lens which disperses and radiates the high notes smoothly throughout the entire listening area. The lens is detachable for panel mounting, with a separate base for the tweeter furnished for external mounting where desired. Aluminum voice coil has 16 ohms impedance. Size: 4 1/4" long x 3" diameter, lens extends 2 1/2". Requires a crossover network, preferably one with a level control, such as the LN-2. With full instructions. Shpg. wt., 5 lbs.

HW-7

.....Net **14.95**

METAL-CASED CONE TYPE HI-FI TWEETER FREQUENCY RESPONSE 2000 -16,000 CPS HANDLES 20 WATTS OF POWER

Highest quality cone type high frequency tweeter having a range from 2000 to 16,000 cycles. Especially efficient at higher end of audio spectrum where other cone type tweeters tend to lose clarity and volume. Entirely closed in a metal case with a base so that it can stand by itself or be mounted on a flat surface with mounting bracket. Rated to handle 20 watts of power. A crossover network is required; the Lafayette LN-2 is ideal. Voice coil impedance 8-16 ohms. Size: 3 1/8" x 2 1/8" x 3" Diam. Shpg. wt., 3 lbs.



5.95 Net

HK-3

.....Net **5.95**

CROSSOVER NETWORK

- CAPACITIVE-INDUCTIVE NETWORK WITH CROSSOVER AT 2000 CPS
- BUILT-IN LEVEL BRILLIANCE CONTROL



8.75

The frequencies above 2000 cycles are channeled to the high frequency tweeter by means of the high-Q inductance and capacitance comprising this efficient crossover network. The highs and lows are brought into acoustic balance by means of a continuously variable level-brilliance control. Control has a 2 1/2 ft. long cable for remote mounting. Network matches 8-16 ohm speakers with insertion loss reduced to a minimum. Enclosed in metal case 6" L x 2 3/8" H x 2 3/8" D. With full instructions. Shpg. wt., 5 lbs.

LN-2

.....Net **8.75**

3 WAY CROSSOVER NETWORK

Carefully designed and engineered to Lafayette's own specifications. Insertion loss is well below the acceptable minimum. Crossover is at 350 and 5000 cycles. Permits full enjoyment of any 3 way system. Properly balances woofer-mid range speaker and tweeter inputs. Complete with 2 continuously valuable "presence" and "brilliance" controls for tonal adjustment and full instructions. 8"L x 3 3/4"H x 2 3/4"W. Shpg. wt., 7 lbs.



14.95

LN-3

.....Net **14.95**

16" PROFESSIONAL TRANSCRIPTION TONE ARM VISCOUS-DAMPED



EXCLUSIVE SEALED . . . LEAKPROOF OIL CHAMBER

New!

Net Only . . . 29.50

Every important tone arm design and construction feature has been incorporated into this fine, professional 16" transcription unit. Viscous damping is controlled by a specially designed and completely enclosed silicone oil chamber that cannot leak or pill over in any position. This exclusive feature is not found in competitive viscous damped tone arms. Groove jumping and skipping, and tone arm resonance are eliminated. Perfect compliance is achieved at all speeds with correct stylus pressure. Record and stylus cannot be damaged when tone arm is accidentally dropped. The amount of damping and stylus pressure is controlled by convenient, variable viscosity adjustments mounted on the arm. Various interchangeable metal weights can be added easily to each plug-in cartridge holder to compensate for differences in cartridges. Also has height and level adjustments. Cartridge holders, weights, adjustable height pickup rest, wire leads, and mounting instructions are supplied with the unit. Shpg. wt., 3 1/2 lbs.

PK-170. 16" Transcription Tone ArmNet

29.50

LAFAYETTE HI-FI LP TEST RECORD



Ideal for audiophile who is building a bass reflex speaker enclosure, or wants to check the components already in use. Two-side, 12" LP record covers cartridge and stylus test, turntable rumble test, average and minimum recording levels, stylus and tone arm resonance check, equalization checks, sound effects, tuning bass reflex enclosures, and a group of delightful music box selections. Specially recorded with painstaking care at 33 1/3 RPM, and master cut on a mechanism that produces the quietest grooves in the industry. Complete with instructions for use and colorful protective envelope. Shpg. wt., 1 lb.

PR-10. Hi-Fi Test RecordNet

2.25

Lafayette
Radio

**165-08 LIBERTY AVE.
JAMAICA 33, N. Y.**

DEPT. RG2

NAME _____

ADDRESS _____

CITY _____

ZONE _____

STATE _____

SEND FREE LAFAYETTE CATALOG

CUT OUT AND MAIL TODAY!

BUILD THE BEST— BUILD ALLIED'S OWN knight-kits®

Here is a typical Knight-Kit value—available only from ALLIED—one of 45 great Knight-Kits you'll find in our special Supplement No. 165. Write for your FREE copy today.

knight-kit HOBBYIST VALUE 10-CIRCUIT TRANSISTOR LAB KIT

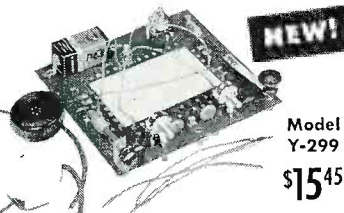

Model
Y-299
\$15.45

One of the most remarkable kits ever developed! You go from one exciting project to another... each circuit has a practical use, and helps to teach you how transistors work. One side of the printed circuit board is screen-printed to show where all components go—after you solder the basic parts in place, you change from one circuit to the next merely by inserting "plug-in" leads into the proper jacks on the board—no additional soldering! Makes any of these 10 circuits: 2-stage AM radio; photo-electronic relay; wireless broadcaster; code practice oscillator; electronic switch; audio amplifier; capacity-operated relay; electronic timer; voice-operated relay; electronic flasher. Includes all parts, 2 transistors, dual headphones (also serve as mike), relay, photocell, battery, "plug-in" circuit leads, guide cards, instruction manual. 3 lbs.
Model Y-299. Net, F.O.B. Chicago... \$15.45

OTHER knight-kit HOBBYIST VALUES



"SPACE-SPANNER" BC/SW
RECEIVER KIT
Y-243 \$15.95



"RANGER" SUPERHET
BROADCAST RECEIVER KIT
Y-735 \$17.25

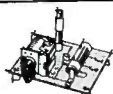

TRANSISTOR
RADIO KIT
Y-765 \$4.35

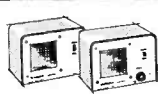

2-STATION
INTERCOM KIT
Y-295 \$14.75

See our Supplement No. 165 for 12 other knight-kit hobbyist values

free SUPPLEMENT featuring knight-kits



Send for our FREE Supplement No. 165 featuring 45 great Knight-Kits, including Test Instruments, Hi-Fi, Hobbyist and Amateur Kits. Write for your copy today.

ORDER FROM ALLIED RADIO

Dept. 01-67, 100 N. Western Ave., Chicago 80, Ill.

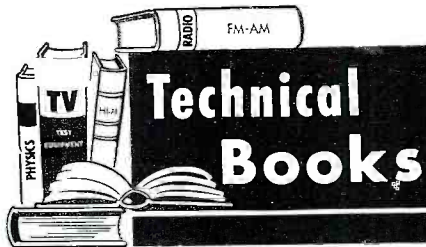

"WHO'S WHO IN ELECTRONICS" compiled and published by *Electronic Periodicals, Inc.*, 2775 S. Moreland Blvd., Cleveland 20, Ohio. 500 pages. Price \$10.00. Thumb indexed.

This is a completely revised and up-to-date listing of electronic component and equipment sources. There are over 25,000 listings with separate sections devoted to a geographical listing of 3000 firms and their principal products; an alphabetical listing of nearly 4000 companies with addresses, phone numbers, top personnel, products, tradenames, and distribution patterns, a separate tradename listing; a compilation of some 800 manufacturers' representatives, their addresses, phone numbers, territories covered, and products handled; about 2200 distributors listed geographically, products handled, territory served, company executives, phone numbers, and branches.

Manufacturers whose products meet or exceed military specifications are specially designated. Procurement personnel and others charged with the responsibility of locating sources of supply for electronic components and gear will certainly find this volume invaluable.

"VALVE & TELEVISION TUBE EQUIVALENTS" by B. B. Babani. Published by *Bernards Ltd.*, London. 67 pages. Price 5 s. Paper bound.

This is a manual of equivalent receiving, transmitting, and industrial tubes covering the products of British, U. S., and European manufacturers. An index of all tubes appears first with an appropriate reference to the line on which the data appears in the relevant section. Service (Army, Navy, Air, Force, and U.S.A. types) tubes are given their commercial equivalents in special tables, invaluable to those converting surplus gear or troubleshooting such equipment.

"INTERNATIONAL ELECTRONIC TUBE HANDBOOK" compiled by the editors of *Radio Bulletin*. Published by *De Muiderkring*, Bussum, Netherlands. 334 pages. Soft binding. Third edition.

This compact, pocket sized book represents an interesting departure from usual tube data presentations in that each tube is dealt with in connection with a specific circuit for which the tube is especially well suited.

In addition, the material is divided into eight different sections, distinguished by the use of eight different colors, covering diodes, triodes, tetrodes and pentodes, output tubes, frequency converters, combination tubes, thyratrons, and cathode-ray tubes.

In keeping with the "international" nomenclature in the title, instructions for using the tables are presented in nine languages and the tubes covered include both those of European and U. S. manufacture. This is an interesting and valuable addition to the engineer's library.

"ENERGY" by Sir Oliver Lodge. Published by *John F. Rider Publisher, Inc.*, New York. 54 pages. Price \$1.25. Paper bound.

This basic text by the well-known British physicist, Oliver Lodge, was originally published in 1929 and since its subject matter is truly basic, it was well worth reprinting.

The publisher has not tampered with the original treatment to any great extent, the changes being confined to modernizing the presentation without altering the basic concepts. New photographs and diagrams have, of course, been incorporated but the whole tone of the text has been retained.

Laymen and students will find this book of interest as the treatment is non-mathematical and the examples of "energy" are set forth in terms of daily and familiar experiences.

"WAVE PROPAGATION" edited by Alexander Schure. Published by *John F. Rider Publisher, Inc.*, New York. 52 pages. Price \$1.25. Paper bound.

This is Vol. 11 in this publisher's "Electronic Technology Series" and deals with the composition and transmission of electromagnetic waves. The text material describes and illustrates wave reflection and refraction, normal tropospheric propagation and scatter propagation. The text material is expanded and amplified by means of a generous serving of sketches and diagrams.

"AUTO RADIO SERVICE DATA MANUAL" compiled by Sams Staff. Published by *Howard W. Sams & Co., Inc.*, Indianapolis. 226 pages. Price \$3.95. Spiral bound. Vol. 6.

This newest volume in the publisher's series covers forty-five auto radio chassis (78 models) as produced during late 1955 and 1956. Each chassis is covered completely with a photograph, parts list, alignment data, a schematic, and service hints included.

A cumulative index covering the five earlier volumes has been appended to facilitate location of the wanted information.

"MASTERING THE MORSE CODE" by Martin Schwartz. Published by *American Electronics Co.*, 1203 Bryant Ave., New York 59, N. Y. 32 pages. Price 50 cents. Paper bound.

This is a simple book for the beginner and, as such, requires no previous experience in code.

The text is divided into five chapters dealing with the nature and use of International Morse Code, the code alphabet, how to send, how to receive, and an appendix which covers hooking

up a key, making a code practice oscillator, hooking up a buzzer, and monitoring.

The book is clearly written, easy to understand, and well illustrated. The beginner will find this helpful.

* * *

"AUTO RADIO REMOVAL" compiled by Sams Staff. Published by *Howard W. Sams & Co., Inc.*, Indianapolis. 102 pages. Price \$2.95. Spiral bound.

If all of the energy expended in removing radio receivers from auto dashboards were available to mow the lawn, henpecking would become a lost art. Seriously, though, most technicians would evince greater interest in auto radio servicing if it weren't for the time-consuming and frustrating job of getting the set on the bench in the first place.

This is the first in a new series of volumes which will deal explicitly with the problem. Volume 1 covers 1955 production and provides step-by-step instructions for the removal of radios, power supply units, and speakers. For every auto covered, there is a list of tools required, a phantom view of the dash panel with the radio in place which enables the technician to locate the chassis mounting nuts or bolts, cables, antenna lead, speaker leads, etc.; and a photo of the actual removal.

Also included is rear-seat speaker

data—whether a cut-out is provided, size speaker needed, and if control of the speaker must be added or is included in the radio.

If this book doesn't earn its publisher a special niche in "service heaven," there is no justice.

* * *

"SCIENTIFIC FRENCH" by William N. Locke. Published by *John Wiley & Sons, Inc.*, New York. 112 pages. Price \$2.25. Spiral bound.

As head of the department of modern languages at the Massachusetts Institute of Technology, the author was well aware of the problems of today's engineer who is expected to keep abreast of the technical developments in electronics throughout the world.

The structural elements of scientific and technical French are covered concisely in this pocket-sized manual. The no-nonsense approach and the elimination of all extraneous material makes this book especially valuable to the busy engineer. No time is wasted on "tourist phrases" but rather every word counts. With a good French dictionary at hand, the engineer could get the gist of most technical material by using this volume judiciously.

* * *

"ELECTRICAL ENGINEERING CIRCUITS" by Hugh Hildreth Skilling. Published by *John Wiley & Sons, Inc.*,

New York. 711 pages. Price \$8.75.

Dr. Skilling, from his vantage point on the faculty of Stanford University, has had over 25 years to assess textbooks used in college engineering courses. This volume represents the author's accumulated experience in teaching a.c. circuit fundamentals to several generations of students. The presentation is lucid and the level appropriate.

Designed to cover a full year's study the first fourteen chapters and the last two contain standard material. Four interim chapters deal with advanced topics which may be introduced at the discretion of the instructor. Among the non-standard material treated are network theorems, loop and node equations of networks, locus curves and other graphical methods, resonance of high-"Q" circuits, impedance and admittance functions, poles and zeros in the complex frequency plane, the transform concept, and Laplace transformation.

This book is suitable for college level engineering courses and for practicing engineers who want to brush up on the fundamentals.

It is only fair to warn prospective users of this text that a strong mathematical background is a "must" and that the author makes no concessions to those shaky in math.

-30-

AC BEACON RANGE RECEIVER



BC-1206 RECEIVER
195 to 420 KC. Housed in Grey Hammertone Cabinet with 117 Volt 60 cycle Power Supply and 4" Speaker. On & Off Switch, Pilot Light, Etc. As illustrated... **\$34.95**

AC POWER SUPPLY & SPEAKER in Cabinet only...\$25.00

BC-1206 RECEIVER Only... **\$9.95**

DYNAMOTOR—to operate BC-1206 from 12 volt...\$4.95

POWER SUPPLIES For SURPLUS RECEIVERS

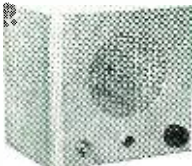

117 Volt 60 cycle Power Supply for Comm/ARC-5 Receiver—with 4" Speaker. No conversion of receiver required, plugs directly to set. Also can be used for other sets requiring 250 VDC 50 MA & 24 VAC 1 A. Gray hammertone finished cabinet... **\$18.95**

117 Volt 60 cycle Power Supply for various sets requiring 220 Volts 80 MA & 24 VAC 2 A., such as BC-603, 683, 348, etc. Gray hammertone finished Cabinet—Less Speaker...\$17.95—With Speaker... **\$19.95**

RT-19/ARC-4 REC.-TRANS.

144 to 148 MC RECEIVER-TRANSMITTER—Easily converted to 2 meters. Uses 2/6AC7, 3/12S7, 2/12SQ7, 2/12AB, 4/6N7, 2/6V6, 2/1614, 1/832, & 2/6L6 tubes. Conversion does not require all the tubes to be used. Power required 350 VDC & 12 VDC. Price—Less tubes and Dynamotor—with Schematic and conversion information... **\$12.95**

METERS:

DC AMMETER HOYT—

In portable metal case, with Test Leads, 4 1/2", Fan Mirrored Scale 0-15 ADC... **\$3.95**



DB METER—10 to Plus 6—Westinghouse 3" NC-35 Imp. 600 ohms @ 1000 cycle... **\$4.95**
0-3 RF AMMETER IS-128: 2 1/2" Rd... NEW: 2.95
0-8 Amp RF Thermocouple IS-89: 2 1/2" Rd... 4.95
0-15 AC-DC—2 1/2" Rd.: IS-122... 4.95
0-500 MA DC—2 1/2" Rd.: IS-22... 4.95

DYNAMOTORS & GENERATORS:

INPUT VOLTS:	OUTPUT VOLTS:	STOCK NO.	PRICES USED:	PRICES NEW:
12 VDC	220	DM-34	\$2.95	\$4.95
12	225	D-402	5.95	8.95
12	225	DM-35	9.95	
12	230	PE-133		4.95
12	540	DA-12		14.95
12	230	DA-14		8.95
14	220	DM-24	4.95	7.95
14	1030	260		
14	515	215	DM-42	4.95 9.95
14	250	50	DM-25	2.95 4.95
14	230	90	DM-32	2.95 5.95
24	250	60	DM-32	2.95 5.95
12	250	60	12V/DM-32	4.95
24	250	60	PE-86	8.95
28	1000	350	PE-73	8.95

12 to 24 VDC PM Dynamotor—Supplies 24 VDC 2 A, from 12 VDC, also 500 V 50 MA. @ 6 VDC will supply 12 VDC & 250 V 50 MA. **\$4.95**

ANTENNA EQUIPMENT



MAST BASES—INSULATED

MP-22 BASE—(Illustrated) Ins. spring action; direction of bracket can be raised or lowered easily. Wt. 9 lbs. **\$2.95**
MP-48 BASE—Insulated type with heavy coil spring. Needs 1 3/8" mtg. hole. Wt. 11 1/4 lbs. **\$4.95**
MP-83—Insulated type w/heavy coil spring and 5" dia. Ins. Requires 2" hole for mounting. Wt. 8 1/2 lbs. **\$3.95**

SECTIONS FOR ABOVE BASES:

Tubular steel, copper coated painted, in 3 ft. sections, screw-in type. MS-53 can be used to make any length with MS-52-51-50-49 for taper. Any section... @ 60¢ Each
Larger Diameter Section: MS-54... 75¢
WHIP ANTENNAS—5 Ft. w/Rigid Base \$1.50—6 Ft. No Base \$1.50—10 Ft. Throw Out \$1.50—94" Telescoping \$1.00—18 Ft. 3 Sections, Telescoping \$5.95—20" Telescoping (Chrome) 50¢.

COAXIAL CABLE & CONNECTORS

CD-1071 CORD—With PL-259 Plugs each end. 50 ohm coax 2 Ft. long. Prices: 59¢ Each—Or in Lots of 10 @ 50¢ Ea.
PL-259—Plug. Ea. End & 32"—RG-54/U—58 ohm .50¢
SO-239 Chassis Conn. 1/PL-259 (Removed)... 3 for \$1.00
UG-21/U—Plug ea. end & 32"—RG-11/U—75 ohm .50¢
UG-22/U—With 4" Coaxial Cable... 50¢
RETRACTABLE CORD—6 Ft.—6 for \$5.00—95¢ Each
CABLE—Rubber Covered, 7 Cond. #20 Shielded (2 separate shielded)—35 Ft...\$2.50

HANDSETS & MICROPHONES:



HANDSET with Retractable Cord—Butterfly Sw., PL-68 & PL-55 Plugs H-22/U... New: **\$4.95**
TS-9 HANDSET—Push to talk Sw. No Plugs. Used: \$2.95... New: **4.95**
TS-13 HANDSET—Push to talk Sw. w/PL-68 & PL-55. Used: \$3.95; New: **5.95**
HANDSET HANGER—Rubber covered... 1.50
F-1 BUTTON CARBON MIC.—High Gain—F/desk, car, hand use. Complete... New: **1.95**
RS-38 CARBON MIC. with PL-68 Plugs... \$2.50
T-17 MICROPHONE... New: \$3.95—Used: **4.50**
H-1 F1 CRYSTAL PHONE—30-10,000 cycle. Single unit, Rubber Cushion—No Head Band or Cord. Brush #B6-2. Pries... NEW: Ea. \$2.95—Two Units... **5.00**
HS-23 HEADSET—2000 ohm. Rubber Cushion... **2.95**
HS-30 HEADSET—Hearing Aid Type—250 ohm... **2.95**

EE-8 FIELD TELEPHONE

Ideal for private telephone system for two or more phones, up to 17 miles. Hand ringer, generator with handset, carrying case. Uses 2 flashlight batteries. **\$14.95**
USED—Checked...
WIRE—Weatherproof Twisted Pair: 500 ft. \$4.75—135 ft. \$1.00—2500 ft. \$19.95. Per Foot at 1 1/2¢.
COMBAT WIRE—Rubber covered W-130... \$.01 per Ft.

SCR-625 Army MINE DETECTOR

• For Prospectors, Miners, Oil Companies, Plumbers, etc. An ideal portable unit for locating all types of buried metal objects up to 24" or more, depending on size and ground condition. Detection by means of a tone. Packed in a chest. Operating weight approx. 15 lb. Shipping wt. approx. 40 lbs. **\$39.95**
Complete with batteries...

FM RECEIVER—30 to 50 MC



• Government Surplus RE-CEIVER, converted to receive 30 to 50 MC FM. Continuous tuning and Push Button tuning on 10 Pre-set channels. With 10 Tubes, Speaker, Phone Jacks, Squelch Circuit, etc. Size: 11 1/2" H x 6 3/4" W x 12 1/2" D. Power required 220 VDC 80 MA and 12 or 24 VDC. Stock No. **\$34.95**
3050. Used—Checked.
DYNAMOTOR—12 V for above: New: \$4.95—Used: \$2.95
AC POWER SUPPLY for the above...\$17.95

Address Dept. RN • \$5.00 Order Minimum, & 25% Deposit on C.O.D.'s • Prices are F.O.B. Lima, Ohio

FAIR RADIO SALES 132 SOUTH MAIN ST. LIMA, OHIO

ATR SHAV-PAK NEW, LOW PRICE!



SHAVE IN THE COMFORT
OF YOUR CAR,
Boat or Plane!

Specially Designed for
Operating Standard A.C.
Electric Shavers in
Automobiles, Buses,
Trucks, Boats, and
Planes.

Plugs into
Cigarette Lighter
Receptacle on Dash
LIST PRICE \$9.95

\$6.63
DEALER
PRICE

TYPE	INPUT D.C. VOLTS	A.C. OUTPUT 60 CYCLES	OUTPUT WATTAGE	DEALER PRICE
6-SPB	6	115 volts	15	6.63
12-SPB	12	115	15	6.63

Introducing ATR MIGHTY MIDGET portable INVERTER

WITH GREATER OUTPUT

DICTATE REPORTS ACCURATELY-PROMPTLY!

make your car, boat or plane
a "rolling office"

with ATR INVERTERS



Plugs into
Cigarette Lighter
Receptacle on Dash

for changing your
storage battery
current to A. C.

Household
ELECTRICITY

Anywhere
in your own car!

\$1330
DEALER
PRICE (AND UP)

LIST PRICE \$19.95

ATR INVERTERS . . .

especially designed for operating
standard 110 volt A. C. . . .

- DICTATING MACHINES • TAPE RECORDER
- ELECTRIC RAZORS • WIRE RECORDERS

TYPE	INPUT D.C. VOLTS	A.C. OUTPUT 60 CYCLES	OUTPUT WATTAGE	DEALER PRICE
12-DME	12	115	40-50	13.30
12U-RHG	12	115	150-175	59.97

Inverters Available for 6, 12, 28, 32, 110 & 220
D.C. Input Operation

See your jobber or write factory today
for complete information

ATR AMERICAN TELEVISION & RADIO CO.
Quality Products Since 1931
SAINT PAUL 1, MINNESOTA - U.S.A.

Within the Industry

(Continued from page 28)

alarm the rising number of industry exhibits and trade shows. Another plan involves a tabulation of forthcoming industry shows and an effort to obtain from members a listing of shows at which they intend to exhibit products. The compilation will then be furnished to all member-companies for their information.

* * *

THOMAS ALLINSON has been elected vice-president of marketing of *Daystrom, Inc.*

Prior to joining the organization he was general manager and director of marketing of the *Berkeley Division of Beckman Instruments, Inc.* He had also been associated with *Marchant Calculators, Inc.* and the *Kellogg Switchboard & Supply Co. Division of I. T. & T.*



In his new capacity, Mr. Allinson will be responsible for over-all planning of marketing and sales for the company and its nine operating divisions.

* * *

LEO STAMLER has been appointed staff engineer with the industrial sales department of *Servo Corporation of America* . . . **DONALD C. POWER** and **ROBERT E. LEWIS** have been elected directors of *Sylvania Electric Products Inc.* . . . **ALLAN W. FRITZSCHE** is now chairman of the board of the *General Industries Co.* . . . **WILLIAM B. MULLEN** is with *Zenith Radio Corp.* in the capacity of sales training manager . . . *Datamatic Corp.* has elected **DANIEL McBRIDE** and **ALEX J. McFARLAND** as treasurer and secretary of the firm, respectively . . . **DR. ROYAL WELLER** has joined *Stromberg-Carlson*, a division of *General Dynamics Corp.*, as vice-president in charge of engineering . . . *Clevite Research Center* announces the appointment of **DANIEL R. CURRAN** as head of the electronics division's electric wave filter section . . . **JOHN JIPP** has been elected an officer of *Ampex Corporation*. He is manager of the instrumentation division . . . **RICHARD DeSTEFANO** has been named by *Minneapolis-Honeywell Regulator Co.* to direct nation-wide sales of the company's proximity switches . . .

ROBERT G. CALOGERO has been appointed staff assistant in the distributor sales department of *Raytheon Manufacturing Company's* receiving and cathode-ray tube operations . . . *Insuline Corp. of America*, a subsidiary of *Van Norman Industries, Inc.*, announces the following change in top management: **JAMES L. LEWIS**, president, and **PAUL C. EBERHARDT**, vice-president. Both of these gentlemen are vice-presidents of the parent organization . . . **Z. GOODMAN** has been pro-

moted from sales manager to vice-president of *Pioneer Electronics Corp.* . . . *DuKane Corp.* elected **DR. JOHN T. RETTALIATA**, president of the Illinois Institute of Technology, and **J. McWILLIAMS STONE, JR.**, vice-president of the corporation, as directors for one year . . . **JOHN H. CHILES, JR.**, and **B. M. BROWN** have been elected vice-presidents of the *Westinghouse Electric Corp.* . . . **ROBERT G. MIDDLETON** has been appointed to the post of international director of technical information for *Radio Electronic Television Schools* . . . *General Transistor Distributing Corp.* has appointed **HARRY A. FRIEDMAN** as assistant sales manager . . . *The Hallcrafters Company* announces the appointments of **STANLEY RENDELL** as works manager and **FREDERICK TROWBRIDGE** as director of service operations . . . **JAY J. NEWMAN** is now manager, new product and market development, *RCA components division* . . . The election of **SAMUEL M. KINNERY, JR.** as secretary of *Daystrom, Inc.*, **ROY SANDQUIST** as treasurer, and **ROBERT R. WHELAN** as assistant secretary are announced by the firm . . . **JACK NIESI** has been appointed vice-president in charge of product sales for *Insuline Corp. of America* . . . **MARVIN C. GROSSMAN** is now sales manager of the high-fidelity division of *H. H. Scott, Inc.* . . . **W. RAYMOND PARSHALL** has been elected treasurer of *Van Norman Industries, Inc.* . . . *The Magnavox Company* announces the appointment of **RICARDO MUNIZ** as coordinator of manufacturing and engineering, television-radio-phonograph division . . . *The Datics Corp.* has announced the election of **BEDFORD WYNNE** as vice-president . . . *Ampex Corporation* announces the appointment of **NEAL K. McNAUGHTEN** to the position of manager of the professional products division . . . **FRED HOLLAND** has been appointed sales engineer for *Merit Coil & Transformer Corp.*

* * *

JOHN JAY HOPKINS, founder and chairman of the board of *General Dynamics Corporation*, died recently of cancer at the age of 63.

Best known as an advocate of the extensive use of nuclear energy, Mr. Hopkins was instrumental in building an industrial empire which last year topped the one billion dollar mark in net sales.

Among the divisions of *General Dynamics* is *Stromberg-Carlson*, which was acquired in 1955.

* * *

MATHIAS KLEIN & SONS, tool maker to the electronic industry, is celebrating its 100th anniversary this year.

The firm, whose headquarters are in Chicago, was founded by Mathias Klein, who came to this country from Germany in 1857. The family of the original founder still owns and operates the firm, his grandson serving as president, and two of his great-grandsons acting as vice-president and secretary and assistant secretary. -50-



John H. Nelson, radio weatherman, studies sunspot activity at skyscraper observatory.

Sunspots Aid Radio Signals

Radio weather forecasts improve the reliability of overseas circuits.

RESULTS of a 10-year study of solar radio disturbances released recently by John H. Nelson, of *RCA Communications, Inc.*, relegated to the scrap-heap the popular belief that sunspots are always bad for overseas radio communications. Of course, severe sunspot activity can cause sudden ionospheric disturbances that may result in poor or no signals, but by knowing in advance possible sunspot activity, it is possible to maintain reliable service. This usually involves an increase in operating frequency to prevent signal loss. At the same time it is possible to even reduce operating power.

Radio hams and TV DX-er's have long known that during periods of peak sunspot activity, such as exists at the present time, some very long distance contacts may be made. *RCA Communications* is taking advantage of this knowledge, coupled with Mr. Nelson's observations and forecasts, to maintain reliable radio contact with its overseas stations. Ordinarily, the bulk of such traffic is carried on 13 or 14 mc. or lower. When Mr. Nelson gives the word, the frequencies are shifted upward to 18 to 24 mc.

The National Bureau of Standards also supplies, over station WWV, a continuous forecast of ionospheric conditions. These forecasts, however, are only for some 6 hours in advance while the forecasts used by *RCA* are for 30 hours in advance. These latter forecasts are also unique in that they take into account the positions of the various planets since Mr. Nelson believes these have an influence on radio conditions.

-30-

July, 1957

NEW PHAOSTRON EXPANDED SCALE AC Voltmeter

Available now from distributors in 90V to 130V Range, AC Rectifier Type in all custom styles and sizes.

3 1/2" or 4 1/2" rectangular meter

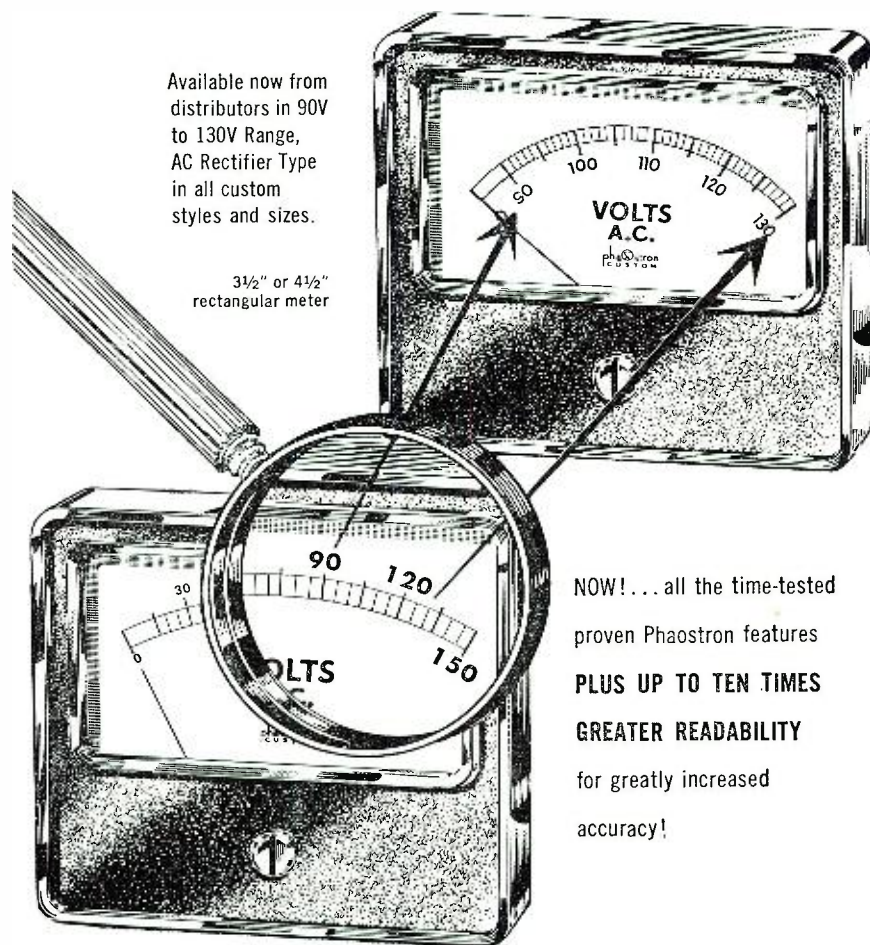

NOW!... all the time-tested proven Phaotron features **PLUS UP TO TEN TIMES GREATER READABILITY** for greatly increased accuracy!

2 1/2" or 3 1/2" square meter

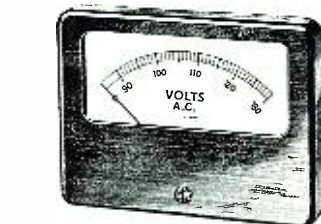

6" rectangular meter



2 1/2" or 3 1/2" round meter

All meters available with illuminated dial on special order.

Phaotron has squeezed down that under 90V portion of the scale, where you don't need it, and expanded the section where you need it most—between 90 and 130V. Precisely calibrated 1 volt scale increments provide greater reading accuracy. Wide frequency range—linearity—true rms reading and Phaotron craftsman construction.

Phaotron Custom Panel Meters, with expanded scale, 90V to 130V AC rms, are available in nine types at your Parts Distributor. For special requirements for AC or DC expanded scale meters, write to Product Development Dept. for practical recommendations.

PHAOSTRON

PHAOSTRON INSTRUMENT & ELECTRONIC CO., 151 PASADENA AVE., SOUTH PASADENA, CALIF.

FM Converter for Intercarrier TV

By BRUCE MORRISSETTE

Simple, easily constructed converter permits TV set to receive standard FM broadcast stations.

IN THE early days of television, some deluxe TV receiver manufacturers, such as *Du Mont* and *Crosley*, brought out sets that provided reception over the FM broadcast band as well as the regular twelve v.h.f. picture channels. The FM band now lies between channels 6 and 7 in the frequency spectrum (occupying 88-108 mc., just above channel 6). These sets were equipped with continuous tuners and employed the dual-channel picture and sound i.f. system then universally in use. The sound portions of these receivers were, in effect, complete FM receivers independent of the picture sections of the set. All that was necessary to bring in the FM broadcast programs was to design a tuner which covered the 88-108 mc. range, and the famous *Mallory* "Inductuner" became one outstanding example of such a tuner.

Then, around 1947, came the intercarrier system, with its single i.f. channel for both picture and sound, its economy of parts, its relative immunity to picture-sound drift, and its other advantages. The manufacturers shifted over wholesale to the new method, so that today only the rarest TV receiver employs dual picture and sound i.f. channels, and the v.h.f. continuous tuner is becoming obsolete. The FM feature has been lost.

To understand this condition, the reader needs only to be reminded that while early dual-channel TV sets amplified and detected the TV picture signal and its accompanying sound signal (which is an independent, frequency-modulated sound carrier) entirely separately, the intercarrier receiver derives its sound from the simultaneous presence in a single picture-sound channel of *both* the picture and the sound carriers. These two carriers are separated by 4.5 mc., and as the sound carrier is modulated, a varying 4.5 mc. beat note is developed in the TV receiver detector stage. This modulated 4.5 mc. note now contains all the sound information present in the original sound carrier, and after further amplification and detection feeds the audio system of the TV receiver.

Now since an FM broadcast signal is not accompanied by a picture carrier and thus has only its single center frequency lying between 88 and 108 mc., no 4.5 mc. beat note is developed by an FM station in any intercarrier set, so that even if one were to add a continuous tuner to an intercarrier receiver no sound would emerge from the set as it was tuned through the FM band.

Thus the modern TV set is absolutely dependent upon the presence of a picture signal to produce sound. To illustrate this, consider what happened when KSD-TV on channel 5 in St. Louis had to shut down its video transmitter briefly for repairs, although its sound transmitter continued to function. Sound announcements were made to explain what was happening, but no one could hear them, because there was no picture carrier for the sound carrier to beat against. That is, no one could hear the sound except those whose old-fashioned split-channel TV sets were still in operation!

New Conversion Principle

It occurred to the author that the way to bring in FM programs on an

intercarrier TV set is simply to *insert* a pure unmodulated r.f. carrier with the same 4.5 mc. separation from the FM broadcast carrier that a regular TV picture carrier has from its associated sound carrier. The TV receiver will then develop the varying 4.5 mc. beat note essential for audio operation in the intercarrier system, and the FM broadcast stations, many of which provide such attractive programs as hour-long, commercial-free performances of concert music and the like, will come through. Fidelity is even better than with the TV sound, since the r.f. inserted carrier corresponding to the picture center frequency is unmodulated and there is no possibility of hearing the annoying 60-cycle interference caused by sync pulses and referred to usually as "intercarrier buzz."

Experiment has fully demonstrated the soundness of this idea of carrier insertion. In the first model of the author's FM converter based on the principle, FM reception was obtained by using the r.f. system of the TV receiver tuned to channel 6, which lies closest to the FM band. A small, stable, one-tube high-frequency oscillator tuning the FM band was then loosely coupled to the TV antenna terminals. When this oscillator was tuned exactly 4.5 mc. below (or above) the desired FM station frequency, and when the TV receiver oscillator was properly adjusted, either by using the fine tuning control, or by resetting the channel 6 oscillator slug in the TV tuner, the FM station came in perfectly.

This arrangement works very well if only one FM station is to be received, and if the receiver's oscillator can be peaked for optimum performance on channel 6. The FM converter may then be left set, and whenever the TV receiver is tuned to channel 6, the FM program is heard. The author, however, desired to tune in at least two FM stations, one at 91.5 mc. and one at 99.1 mc., and also wished to leave channel 6 free for use as a u.h.f. conversion channel, since both channels 5 and 4 are now occupied in his area.

Further experimentation showed that the addition of a mixer crystal across the TV antenna posts would produce clear, undistorted harmonics of FM programs which would come in over a useful variety of settings in the channel 8 to channel 13 range. The perfected version of the FM converter supplies a hum-free carrier tunable from approximately 90 to 115 mc. to provide carrier insertion 4.5 mc. *above* the FM station frequency desired. The oscillations were placed *above* the FM station frequencies to avoid any possible interference with channel 6. Since the inserted carrier is unmodulated, it does not have to be on the low side of the FM carrier, and all considerations of shape and symmetry of the i.f. response curve become meaningless, as only the 4.5-mc. difference fre-

Fig. 1. Schematic for the basic converter.

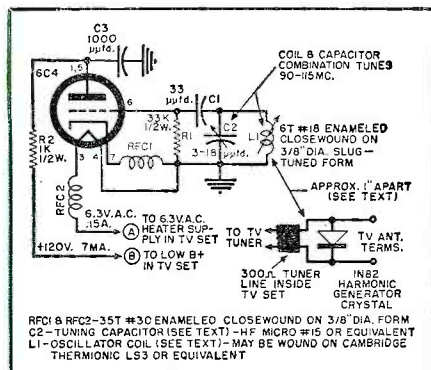

quency is of importance in this case.

Harmonic production in the crystal feeds the FM-plus-inserted-carrier combination to the higher TV channels, from 8 to 13. Channels 11 and 12 seem to be the best all-around conversion channels, but others should be tried, and whichever gives the best reception for a given station adopted. The fine tuning control should be adjusted as channels are tried, and one must disregard occasional images from the lower v.h.f. television stations in the vicinity, or even, in some cases, picture or sound images from u.h.f. stations (here the FM unit is working as a rudimentary u.h.f. converter). At the proper FM settings, reception is absolutely interference-free.

Building the FM Converter

In its simplest form, the FM converter is constructed on a small aluminum chassis plate attached to the rear of the TV set near the antenna terminals of the set. Power is obtained from the TV set. A bar knob for tuning extends through the fiber back of the receiver, together with a toggle switch to cut out the picture tube heater during the reception of FM, and that of the FM oscillator tube during normal TV reception. No dial calibrations are provided, although marks could be made on the fiber back to indicate various FM settings. The harmonic crystal is left mounted across the antenna terminals by its pigtail leads and does not affect regular TV reception. Coupling to the crystal results from physical proximity to the FM oscillator coil. The antenna input system of the TV set should provide a d.c. return path for the crystal. If it does not, shunt a 5000-ohm, 1/2-watt resistor across the crystal terminals. Of course, if single FM station reception using channel 6 for conversion is desired, no crystal is needed.

Fig. 1 gives the circuit and parts values. The oscillator is a two-terminal Colpitts with a stable, clean output. The 6C4 tube socket is mounted by a screw through one of its holes to the bracket that comes attached to the *HF Micro* #15 tuning capacitor, and a three-point terminal strip is attached with a screw to the other socket hole, giving an assembly that is supported entirely by the capacitor mounting shaft. Coupling between oscillator coil L_1 and the piece of 300-ohm lead connecting the antenna terminals to the TV tuner is varied by drawing the lead close to the coil with a piece of string. About 1" seems to be the best spacing.

Some knowledge of the circuit of the TV set to which the converter is added is necessary to identify the proper take-off point for the FM oscillator "B plus." Usually the receiver i.f. "B plus" bus carries the proper voltage (around 120 volts). If in doubt consult *Rider's* manual or *Sam's* "Photofact" folder for the set in question. The heater voltage is easy to secure and may be taken from any

convenient socket, or from the lead to the picture tube heater that must be interrupted if the FM-TV toggle switch shown in Fig. 2 is to be added.

The small r.f. chokes may be wound using about 35 turns of #30 enameled wire closewound on any 3/8" form, or on the body of a 1/2-watt resistor of 100,000 ohms or more. The coil L_1 may be wound on any convenient form such as that indicated in the schematic, or may even be spacewound, as long as the coil-and-capacitor combination, L_1-C_2 , will tune from 90 to 115 mc. A grid-dip meter or other frequency-measuring device is helpful here, although the values shown should permit tuning the FM band without difficulty. Any good crystal, either germanium or silicon, will work. The regular TV antenna will also work well for FM, eliminating any problem there.

Self-Powered FM Converter

Several considerations may arise to make the built-in FM converter described undesirable or impractical. For example, the TV set may use a series heater connection system that provides no convenient source of 6.3 volts a.c. for the 6C4 FM tube. Or the TV set may have a chassis that is not at circuit ground (some *Motorola* TV sets have this arrangement) so that the ground points of the FM converter cannot be allowed to touch the TV chassis. Again, the builder may not wish to remove the TV set from its case or take the trouble to locate the 6.3 volt a.c. and 120 volt d.c. supply points, or he may be uncertain as to just what circuit his set employs. He may wish to use his FM converter with two or more sets, and may wish to have a neat calibrated dial to tune in FM stations.

In all these cases, the remedy is to build the self-contained unit as described here. The only connection required between this self-powered device and the TV set is to place the FM converter output clip across the TV antenna terminals. Since a precautionary 5000-ohm resistor is shunted across the crystal inside the converter, it is not even necessary to determine whether the TV set to be used provides a d.c. crystal return path.

The self-powered converter is built in a 4" x 4" x 2" utility cabinet with built-in chassis deck. A miniature TV booster type of power transformer is mounted in any convenient way and a small aluminum bracket is used to mount the 6C4 tube adjacent to the tuning capacitor. Fig. 3 diagrams the power supply, with connections as indicated to the unit of Fig. 1. The only additional components are the crystal and its shunting resistor (see Fig. 4), which connect through a short length of 300-ohm lead to a clothespin type TV clip that is clamped across the antenna terminals of the TV receiver.

A *Millen* #10039 dial which takes no mounting space behind the panel makes a neat front appearance. The

large tuning knob that comes with the *Millen* dial must be changed to a smaller one or it will extend below the bottom of the cabinet. The dial is calibrated either by tuning in FM broadcasting stations and indexing them on the dial face (the best method) or by zero-beating the output of the FM converter against known frequencies from a signal generator, heterodyne frequency meter, or the like. If megacycle calibrations are to be indexed on the dial face, they must be exactly 4.5 mc. below the true oscillator frequency at the index points. A separate unit of this type may be carried to a friend's house or mailed after calibration to a distant friend or relative, since the calibrations will be absolutely independent of the TV set used.

Thus for a few dollars' worth of parts and an hour or so of construction time, the attractions of FM broadcasting may be made available on any current intercarrier TV set. Similarly, a unit could be designed for the police band or other special services between channels 6 and 7. The experimentally-minded may try shifting the inserted carrier down to correspond to the picture i.f. center frequency (such as 21.5 or 45.75 mc.) and tuning stations with the TV fine-tuning control while leaving the converter oscillator fixed. As in war, measures lead to counter-measures. The intercarrier system seemed destined to eliminate the reception of ordinary FM broadcasts from TV receivers, but the author's inserted carrier method restores the possibility. For negligible expense, TV manufacturers could provide an "FM" switch point, with a small knob for FM station tuning, allowing millions to enjoy FM broadcasts as well as TV programs. Will they do it?

-50-

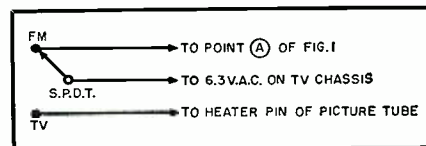

Fig. 2. Connections for the TV-FM switch.

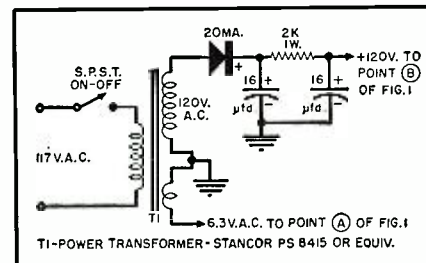
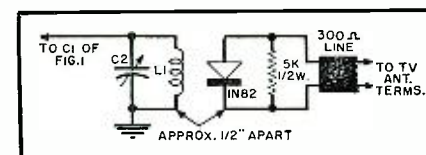

Fig. 3. Self-contained unit's power supply.

Fig. 4. Circuit installed near oscillator coil of the self-contained converter unit.



BUILD THE BEST—
BUILD ALLIED'S OWN
knight-kits

Here is a typical Knight-Kit value—available only from ALLIED—one of 45 great Knight-Kits you'll find in our special Supplement No. 165. Write for your FREE copy today.

NEW knight-kit HI-FI VALUE SENSATIONAL PREAMPLIFIER KIT

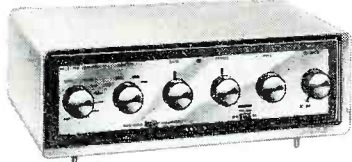

- Printed Circuit Switches!
- 8 Inputs • Self-Powered
- 2 Printed Circuit Boards!
- With Custom Styled Case

Model Y-754
\$3875

Advanced Hi-Fi design at new low cost! Features precise equalization guaranteed within 1/2 db of recommended accuracy! Exclusive new printed-circuit switches and two printed-circuit wiring boards for easy, error-proof construction; built-in power supply; response, ± 0.5 db, 10-50,000 cps; 8 inputs (including Tape Head); separate Bass and Treble controls; separate Level and Loudness controls; Rumble Filter Switch; DC on all tube filaments; 2 extra AC outlets. With beautiful custom styled case. Complete with step-by-step instructions for easy, money-saving assembly. Shpg. wt., 12 1/2 lbs.

Model Y-754. Net F.O.B. Chicago **\$3875**

OTHER knight-kit HI-FI VALUES



FM HI-FI TUNER KIT
 Y-751 **\$3775**



30-WATT AMPLIFIER KIT
 Y-762 **\$7495**



10-WATT HI-FI AMPLIFIER KIT
 Y-753 **\$2330**



20-WATT HI-FI AMPLIFIER KIT
 Y-750 **\$3575**

See our Supplement No. 165 for other knight-kit Hi-Fi Values

free SUPPLEMENT
 featuring knight-kits



Send for our FREE Supplement No. 165 featuring 45 great Knight-Kits, including Test Instruments, Hi-Fi, Hobbyist and Amateur Kits. Write for your copy today.

ORDER FROM ALLIED RADIO

Dept. 01-67, 100 N. Western Ave., Chicago 80, Ill.

War Against Interference
 (Continued from page 36)

In many cases, interference to TV channel 2 (54 to 60 mc.) is caused by an amateur station operating on the 6-meter band (50 to 54 mc.). This interference is due to the inability of the receiver to reject the adjacent signal. A suitable absorption filter or "stub" can be made from a length of 300-ohm twin-lead. Attach a 54-inch length to the antenna terminals on the back of the TV receiver along with the regular antenna leads. With the interference showing itself, cut off 1/4 inch of the free end of the length of twin-lead. Continue cutting off 1/4-inch pieces until the interference disappears. Dress the remaining length in a manner which will not affect its electrical characteristics. Do not roll it up. Fasten the stub to the cabinet if feasible.

When interference is of a broadband type, such as that generated by ignition systems, arcing contacts, etc., it may be partially eliminated by installing a high-pass filter as close to the input transformer of the receiver as possible. In the case of a TV receiver, a 50-mc. high-pass filter will exclude signals below 50 mc. to which the receiver may ordinarily be susceptible.

In cases where the TV i.f. system is picking up interference, it can sometimes be corrected by re-alignment. In other cases it may be necessary to shield the i.f. system more completely.

An absorption filter is useful when the interference occurs at the "image frequency" of the receiver. This is determined by multiplying the i.f. by two and either adding to or subtracting from receiver oscillator frequency.

Occasionally interference is picked up in the audio circuits of the receiver by rectification in a grid circuit. This may be eliminated by inserting an RC filter in the grid circuit as close to the socket as possible. The filter consists of a 100,000-ohm resistor in series with the grid wiring and a 500-μfd. capacitor directly across the tube socket from grid to cathode. In stubborn cases, increase the capacitor to .001 μfd. and reduce the grid resistor used by the manufacturer (not the 100,000 ohms you have added) to one-half its present value.

Where interference is shown to be caused by pickup on the antenna lead, install shielded wire and connect the shield to the chassis of the set. —30—

MARYLAND HAMFEST

THE annual picnic and hamfest of the Maryland Emergency Phone Net will be held at Braddock Heights Park, Braddock Heights, Md., on Sunday July 7th from 10 a.m. to sundown.

There will be the customary prizes, a "rummage" sale and auction, a program for the XYL, and other special events. Registration is 50 cents for adults with children under 12 admitted free. Contact Ivan H. Loucks, W3GD, for more information on the event. —30—

CROWN
 Professional Tape Recorder

GUARANTEED PERFORMANCE

CROWN IMPERIAL
 Tops in Performance!

Dual Track **\$449⁵⁰** Complete in case

Write for literature.
 Address Dept. RN-6

Standard and Stereo models
 INTERNATIONAL RADIO & ELECTRONICS CORP.
 ELKHART, INDIANA

Take it 10 days FREE

biggest collection of transistor applications ever!

TRANSISTORS HANDBOOK

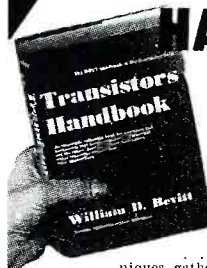

by William D. Bevitt
 Transistor Applications Engineer CBS-Hytron

Just published! A quick reference, a guide, and how-to-do-it manual on transistors all in one! 410 non-technical pages and 380 step-by-step pictures . . . dozens of tested practical circuits you can use or adapt right now . . . up-to-date ideas and techniques gathered from ham shacks and labs . . . all written for you by a pioneer in transistors who makes understanding and using these mighty midgets easy!

HOW TO: protect transistors when wiring circuits; connect transistors in 3 basic amplifier circuits; build inexpensive testers; make receivers, oscillators; use transistors in gate circuits; and much, more more!

HIGHLIGHTS: 56 types of on-the-market transistors, their number, maker, operating characteristics, specific applications.

scores of circuit diagrams, showing examples of good transistor circuit design
 410 information-packed pages; 380 illustrations; ready-reference index.

APPLICATIONS: Amplifiers—card translator—computer—hearing aids—hi-fi—intercoms—megohmmeter—miniaturized receivers—oscillators—phase detector—phototransistors—radar—telephone—transmitters—TV—musical instruments—phono amplifiers—radio—transmitter—etc., etc.

FREE TRIAL. Let us put the "Transistors Handbook" into your hands for 10 days. Read it, follow its pointers, use the circuits. You must agree that this Handbook has the most information on transistors . . . or send it back and you don't owe one cent. Mail coupon now.

— SEND NO MONEY —

Prentice-Hall, Inc., Dept. 5741-J3
 Englewood Cliffs, New Jersey

Send me a copy of TRANSISTORS HANDBOOK to use 10 DAYS FREE. Within 10 days I'll either return book and owe nothing, or will keep it and remit \$3 down (plus small postage charge) and then \$3 a month for two months in full payment.

Name

Address

City Zone State

SAVE! Send \$9 with this coupon and we pay postage. Same return privilege; refund guaranteed.

Factors Determining Tube Life

By PROF. A. V. J. MARTIN

Reduced service life is often due to high voltage.

SOME of the tubes used in modern electronic circuits are exceptionally hard-working components, especially in television receivers. It is a well-known fact that some of them have a relatively short service life, mainly because of the operating conditions (high power, pulse operation, etc.).

However, there are several common factors which influence the average life of all tubes, namely, excessive heater voltage, irregular heater voltage, and excessive plate dissipation.

The effect of heater overvoltage is shown in Fig. 1A for a 6.3-volt tube. It does not take into account the probability of the heater opening up but only the exhaustion of the oxide film which constitutes the cathode. The life of the tube at the nominal voltage of 6.3 is taken as 100%.

More frequently, the overvoltage fluctuates around an average value. An unstable heater voltage is extremely detrimental to tube life, as seen in Fig. 1B where curve 2 refers to a tube which is alternately normally and excessively heated. For comparison, curve 1 refers to a tube having a constant heater voltage equal to the average value of the irregular voltage of curve 2.

Fig. 1C shows the effect of plate overload which is evidently less detrimental since an overload of 50% reduces tube life by only 25%.

The conclusion is evident. The best way to insure maximum tube life is to operate all tubes well within their design ratings.

-30-

Fig. 1. (A) Effect of high heater voltage on tube life. (B) How fluctuating voltage shortens the life of a tube. (C) The effect of plate overload on tube longevity.

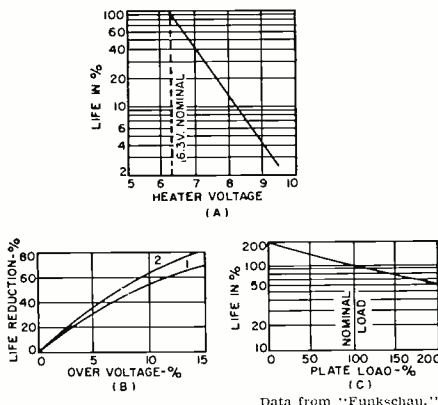

Sell More Antenna Replacements with the new **CHANNEL MASTER®** TV Antenna Check-Up Kit

Who says antenna sales must slow down during the Spring and Summer months? Channel Master offers you a **brand new concept in antenna merchandising** that's sure to perk up your antenna business. It's the nationally advertised "TV Antenna Check-Up Kit" — designed to **build store traffic** for you by making present TV owners aware of their faulty antenna installations.

This 3-piece consumer literature kit includes:

- 16-page illustrated booklet "Better Pictures On Your TV Set"
- 10-point check-up folder "Spotting Antenna Trouble"
- Literature about the TW Antenna

Use these kits as free giveaways or mailing pieces to build store traffic.

CALL YOUR CHANNEL MASTER DISTRIBUTOR NOW! He also has Posters, Streamers, and Newspaper Mats to help you merchandise the "TV Antenna Check-Up Kit."



Tie-In with Channel Master's High-Powered National Advertising in America's Leading Magazines

CHANNEL MASTER CORP. ELLENVILLE, NEW YORK

Copyright 1957 Channel Master Corp. Reg. U.S. Pat. Office and Canada

ZYTRON "QUALITY BRAND"
RADIO & TV RECEIVING
TUBES
BRAND NEW
INDIVIDUALLY BOXED
Terrifically **LOW PRICED!**
Send **TODAY** for Complete Catalog
ZYTRON TUBE CORPORATION
220 West 42nd Street - New York 36, N. Y.

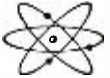
ENGINEERING 
B.S. DEGREE IN 27 MONTHS
Prepare for unlimited opportunities of the Electronic Age! Earn your B.S. DEGREE IN 27 MONTHS in Aeronautical, Chemical, Civil, Electrical or Mechanical Engineering; in 36 MONTHS in Mathematics, Chemistry, Physics. Intensive, specialized courses. Comprehensive training in electronics, television, advanced radio theory and design, math, nuclear physics and elec. eng. Engineering Science preparatory courses. Low rate. Graduates in demand. Spacious campus; 20 halls, dorms, gym, playing field. Earn part of your expenses in Fort Wayne while studying. G.I. approved. Enter Sept., Dec., March, June. Catalog.
INDIANA TECHNICAL COLLEGE
977 E. Washington Blvd., Fort Wayne 2, Indiana
Please send me free information on B.S. ENGINEERING DEGREE IN 27 MONTHS as checked.
 Electronics Chemical Aeronautical
 Civil Mechanical Electrical
B.S. DEGREE IN 36 MO. IN Math. Chem. Physics
Name
Address

NEW JIFFY ZERO

**SPOTS TROUBLE
WITH A
SPRAY!**

Instant freezing
isolates thermal inter-
mittent defects in 3 seconds!
Saves hours of hide and seek!

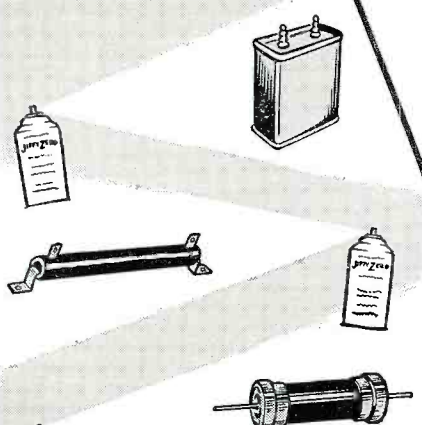

ALSO INSTANT-FREEZE AND INSTANT-TEST
Cold solder junctions, Transistors, Condensers,
Semi-conductors, Shrink-fit metals and alloys

HOW JIFFY ZERO WORKS

1. JIFFY ZERO is the new, approved, liquid refrigerant that freezes components in a jiffy.
2. Those parts damaged by heat are restored to life, for a minute or two, by the instant freezing.
3. This off-on-off action instantly tells you which parts are good, which are bad.



one 3-second p-h-t-t may save
you three man-hours of labor!

JIFFY ZERO is non-
toxic, non-inflammatory, \$2.75
non-corrosive, and
non-conductive

See your Dealer or Distributor

FILL IN THIS COUPON NOW!

TO: ARCO ELECTRONICS, INC. Dept. R 7
111 S. Vermont Avenue, Los Angeles, Calif.

I am interested in your JIFFY ZERO instant
freezing spray.

Enclosed find check or M.O. for \$2.75. Please
send full-size can at once.

Kindly send additional data.

I am a distributor dealer technician
ham

Name _____
(PRINT OR USE TYPEWRITER)

Address _____

City _____ Zone _____ State _____

Sound on Tape

By BERT WHYTE

DESPITE all the whoopla about stereophonic tape, monaural tape continues to be produced. The companies issuing monaural tape quite rightly feel that because there are vastly greater numbers of monaural tape machines in use as compared to stereo units, a profitable market exists and will continue to exist for the single-channel product. This viewpoint seems logical on the basis of the brisk sales most tape producers are enjoying. And there would seem to be little doubt that this situation will continue for some time. Yet there are problems connected with the monaural tape market which, if left unrecognized and unsolved, may well cause its untimely demise.

As long-time readers of my record column know, I have always championed and have been enthusiastic about recorded tape in all its forms. I'm certainly no crepe-hanger! In spite of this, I feel constrained to sound a note of warning about the future of monaural tape. Although accurate figures are hard to come by, it would appear that by the end of 1957 there will be more than 2 million tape machines in use in this country. To be sure, not anything like the 60-odd million phonographs in this country, but still, a very respectable market. However, of the 2 million machines, less than 100,000 are of high quality "hi-fi" or professional types. Herein lies danger signal number one. As long as monaural recorded tapes continue to be substantially costlier than an LP disc, their sales potential will be limited to the small "high quality" group.

Does this sound a little confusing? It isn't really when you realize that the average tape machine costs less than \$175.00. With monaural recorded tapes ranging in price between \$7.95 and \$12.95, it wouldn't take many tapes to equal the purchase price of the average machine. This is just plain economically unfeasible for the average tape machine owner. Furthermore, one cannot hope that the superior quality of the tape will justify its price to this group; for unfortunately with the limited quality of the tiny amplifier and speaker used in these tape machines, the superior sound quality is not audibly evident.

The only saving grace for the recorded tape manufacturer in this market is its size . . . and human nature. People are always curious and enough of them will buy one or even two tapes to satisfy this curiosity. While this initially will account for substantial tape sales, it is, of course, a limited market. On the other side of the picture, the small group who own the

Ampexes, Magneacords, Berlants, etc., are no happier with the price structure of recorded tape than their less affluent brethren . . . but since this group usually has associated high quality hi-fi equipment and can thus appreciate the sonic virtues of tape, they may grumble . . . but they do buy recorded tapes.

Thus between the curious in the large group and the hi-fi enthusiast in the small group, the recorded tape industry is enjoying good sales. The question is, how long will the sale of monaural tapes hold at respectable levels? You see, due to the more or less "avant garde" or experimental nature of the small high quality group, most of them are planning to advance to stereophonic sound. Indeed if more stereo heads and electronics were readily available as conversion kits for the better quality tape machines, this change-over would be greatly accelerated. For the large group with the inexpensive machines, stereo also has its fascinations. In fact, since stereophonic sound is so demonstrably better even with the restricted audio systems of these units, it is becoming a highly desirable item. Of course, conversion to stereo is proportionately as expensive or more so, for the owners of the low-priced machines, as it is for the owners of the high quality machines. Even assuming that low-priced stereo conversions were generally available, stereophonic tapes suffer from the same bug-a-boo as monaural tapes . . . the price is too high for mass market acceptance.

So where does this leave us? It would appear that were monaural tapes priced on at least an equal basis with LP discs, a substantial new market could be found among owners of the average inexpensive tape machine. Applying the same reductions to stereo tape would accelerate acceptance in the high quality market and make impressive gains in the low-priced field. There is no doubt that many monaural tape machines will continue to be sold and many monaural tapes will be sold to the owners of these machines. However, in my own opinion, monaural tapes sales will continue on a rising curve for some time, reach and hold a plateau and then diminish rapidly as stereophonic sound becomes widespread. Price is the key to the entire tape picture. If monaural tape prices are trimmed to market size, that sales plateau I mentioned can probably be held for a considerable time. If stereo tapes are similarly treated, the potential of this market is tremendous. I don't pretend to know all the economics of tape production. Admittedly it is more expensive, at least at present, to produce a tape as compared to a disc. But I submit that a reduction is possible and, in the case of monaural tape especially, a practical necessity. Looking hard and realistically at the stereophonic tape market, I think it is fairly safe to say that the balloon will never get far off the ground unless there is a substantial

price reduction in the cost of tapes.

Last month I mentioned that I would tell you about some stereophonic theory and some new ideas in speaker placement. Unfortunately, some data I wanted has not yet been made available to me, and in the interests of accuracy and completeness, we will have to delay this discussion.

One last note to any tape manufacturers who may read this . . . a tape review column is no good without material to review. SOOOOoooo, if you are producing any tapes monaural or stereophonic that you feel especially proud about, shoot me a copy and I'll be glad to bend an ear!

**LISZT
PIANO CONCERTO #1**

Artur Rubenstein, pianist, with RCA Victor Orchestra conducted by Alfred Wallenstein. Victor BCS-31, stacked stereo, 7" reel, 7.5 ips. NARTB tape curve. Price \$8.95.

Ament my comments on tape prices, RCA has recently issued a spate of tape recordings of shorter works which carry a substantially lower price than that which prevailed in its first few releases. Spanning a range between \$6.95 and \$10.95, and consisting mainly of "pop" classics, this should stimulate the stereo enthusiast who has been stymied by high prices. This Liszt "Piano Concerto" is a case in point. It certainly is a popular work, there is the attraction of the incomparable Rubenstein at the keyboard, and it sells for a relatively modest price. Do you get your money's worth? Decidedly!

As noted in my review of the disc version, Rubenstein takes this work at a brisk tempo and gives a very robust, bravura performance, quite in keeping with the romantic nature of the Liszt scoring. In my review of the disc I carped a bit about the support Rubenstein received from Alfred Wallenstein. Now here is the same performance, but with the magic of stereo, Wallenstein seems far less offensive. Crazy? Perhaps so, but although one can still point an accusing finger, in the stereo version Wallenstein appears to be the secure accomplished conductor that we know.

Soundwise, we have a parallel situation. The disc was a pretty good recording, but by no means sensational. In this stereo version it seems entirely different. Instead of a rather small-boned piano sound and a somewhat less than athletic orchestral accompaniment, we have a piano sound imposing in its vigorous projection and massive tonal grandeur and an orchestra that seems more properly proportioned and with far greater sonic impact. Piano here is not ultra-close but nonetheless is not lacking in detail.

The acoustic perspective is large and spacious and the over-all result is more of a "concert hall" balance than is usual with most piano concerto recordings. Nice string sound from the orchestra and, for once, the famous triangle from whence this concerto derives its nickname is not grotesquely over-amplified. It sounds out nice and



**NOW! Hi-Fi units also available.
WIRED AND TESTED . . .
Ready-to-hear!**

ARKAY
takes the blind spots
out of kit buying!

NEWS! . . . If you've always wanted to save the money and have the fun of building your very own HI-FI system or radio, here's sensational news:

ARKAY the world's leading name in audio kits now lets you "HEAR IT—BEFORE YOU BUILD IT" . . . ARKAY takes all the gamble out of kit building . . .

See your favorite ARKAY dealer . . . ask for a demonstration unit of any model in the line . . . examine it, play it, give it any test you wish . . . then compare and you'll agree that an ARKAY kit is easiest to build and the best dollar value!



**ARKAY
6 TRANSISTOR
PORTABLE
SUPERHET
KIT**

This model TR-6 is a completely newly designed "powerhouse" with push-pull Class B output providing clear, crisp output better than 275 milliwatts. Construction is extremely simple because of advanced engineering technique employed. Electrical Rating: 9 volt transistor energizer. Tuning range: 540-1620kc. IF amplifier: 455kc. Transistor Complement: (X1) oscillator-converter, (X2) 1st IF Amp, (X3) 2nd IF amp, (D1) diode detector-AGC takeoff, (X4) class B driver (X5) class B output, (X6) class B output. Case: stunning saddle-stitched lexon leather.

**Model TR-6—\$37.50
Fed. Ex. Tax Incl.**

**ARKAY
MODEL HFT-7
HI-FI AM-FM
TUNER**



Tops in performance! 4UV sensitivity for 20db quieting. Automatic Frequency Control with provisions for AFC erase. Allows pinpoint, high selectivity tuning. Foster-Seecley discriminator, high efficiency AM loop stick antenna and temperature compensated oscillator circuit. Tube complement: (2) 12AT7, (1) 6BE6, (1) 6BA6, (2) AU6, (1) 6AL5; selenium rectifier.

**Model HFT-7—KIT \$32.00. WIRED AND TESTED \$56.95.
Model FM-6 (FM only)—KIT \$25.75. WIRED AND TESTED \$44.95.**

Cover for above \$3.95—Fed. Ex. Tax Incl.

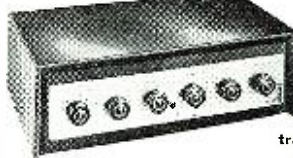

**ARKAY
30 WATT
AMP-
PRE-AMP**

with
transistorized
Front end

Here's the talk of the HI-FI field! For use with reluctance pickup, assures you of high-gain low noise front end, gives the finest in reproduction. Record equalization for more than 30 labels (LP, RIAA and Europ). Uses 2 Mullard EL34's. Power: 30 watts @ 1% IM Freq. Response: ±1/2db-10-40,000 cps. Hum: -120db below rated output. Inputs: for phono, tuner, tape, Aux 1 and 2 provided by front panel selection (Tape output unaffected by bass treble and loudness). Controls: (6) Func. selector, loudness, bass, treble, level and 5 position balance 2 AC outlets. Cabinet: Ebony with rose gold panel.

Model FL-30—KIT \$49.95. WIRED AND TESTED \$74.95.

SEE THE OTHER AMPLIFIERS IN THE ARKAY LINE

**ARKAY
ALL-
TRANSISTOR
PERSONAL
PORTABLE
KIT**

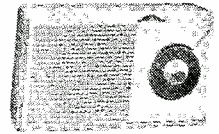

Printed Circuit
with Printed
Component
Layout Board

A kit builder's dream, employing all the latest techniques. Uses 5 transistors plus crystal diode. Printed Circuit and component layout board cuts construction time, eliminates errors. Consists of converter, 2 stages of IF amplification, diode detector, audio driver and class A power amp output stage. Subminiature components used throughout Loudspeaker: 2 3/4" Alnico V Power output: 150 mill audio system Battery drain: 5.5Ma. Earphone Jack for pvt. listening. Cabinet: Hi-impact styrene (unbreakable). Dimensions: 5 1/2 x 3 1/8 x 1 3/8".

**Model TR-5—\$31.45. Fed. Ex. Tax Incl.
Carrying Case \$1.75**

SEE 'N HEAR the unmatched quality of the ARKAY line at your dealer. Ask for the new, big FREE CATALOGUE of AUDIO, HI-FI AND TV units.

*Prices 5% higher West of Miss.

ARKAY · 120 Cedar Street · N. Y.

PICTURE TUBE MANUFACTURING CO. FOR SALE

Valued at \$17,500, will sacrifice for \$5,980.00. All New Equipment in excellent condition. Has capacity to earn \$35,000.00 a year profit. This capacity can be increased by adding more exhaust ovens. For further information, write to this address:

Advertiser % Box 558, Radio & TV News
366 Madison Ave., New York 17, N. Y.

AGUE SENDING SPEED
AGUE RECEIVING SPEED

Be a "key" man. Learn how to send and receive messages in International Morse code. Communicate with operators around the globe. Learn at home quickly through famous Candler System. Used by best operators. Qualify for Amateur or Commercial License. Write for FREE BOOK.
CANDLER SYSTEM CO.
Dept. 2-H, Box 928, Denver 1, Colo., U.S.A.

2 WAY PORTABLE RADIO SET

Sends—Receives up to 10 miles as shown
or hundreds of miles with outside antenna! 80 and 50 meter amateur radio bands (novice) also Aircraft and overseas broadcasts (3 to 8 mc.) POWERED WITH SELF-CONTAINED PORTABLE RADIO BATTERIES. NO AC PLUG-INS NEEDED! Take it with you everywhere you go—
Keep in contact with home, friends, Has 5 watt crystal controlled transmitter—Sensitive Regenerative Receiver. Send receive switch. Wt. only 3 lbs. Size, only 6" x 4" x 4".
TESTED—PROVEN—SIMPLY FIFID—PRACTICAL—Full information given on quick easy to get license.



SEND ONLY \$3.00 (call, ck, mo) and pay post- for postpaid delivery. Complete kit includes all parts, tube, coils, plastoid cabinet, easy instructions. (Set of batteries—\$2.95; crystal \$1.25). COMPLETELY WIRED AND TESTED POSTPAID \$19.95. A regular \$49.95 value—Order now before price goes up. GUARANTEED—AVAILABLE ONLY FROM:
WESTERN RADIO Dept. BNT-7 KEARNEY, NEBR.

Easy way to brush up your

CALCULUS!

Klaf's CALCULUS REFRESHER only \$2.00

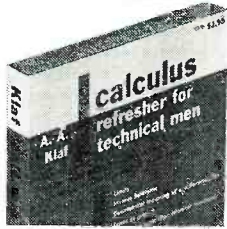

Send right away for this most useful book. Written for technical men by a practicing engineer, Klaf's **CALCULUS REFRESHER FOR TECHNICAL MEN** will brush up your calculus in terms of 756 most important topics. Detailed questions and answers start with simple definitions, end covering differential, integral calculus: tangents, maxima & minima, growth, curvature, various kinds of integration, many other important topics. Emphasis is practical rather than theoretical, and hundreds of practical examples are worked out in electricity, engineering, etc. 566 problems also included, odd-numbers answered. Presentation is clear, detailed, easy to follow. "MOST EFFECTIVE." **Electronics.** "Ideal for engineer who studied calculus, wishes new meticulously progressive treatment to clear up uncertainties from lack of use." **Electrical World.** "Useful 2nd text for students." **Mechanical World.** 180 figures, 436 pp., 5 1/2 x 8. Sturdy paper binding. **\$2.00**

(Also, Klaf's **TRIGONOMETRY REFRESHER**, just as good as the calculus vol., 639 pp., 5 1/2 x 8. Paper bound. **\$2.00**)

Payment in full must accompany order. Please add 10¢ postage per book on orders less than \$5.00.

SATISFACTION GUARANTEED. Return books within 10 days for money back.

Dept. 110, Dover Publications,
920 Broadway, N. Y. 10, N. Y.

Please send me:

...CALCULUS REFRESHER, \$2.00

...TRIG. REFRESHER, \$2.00

I am enclosing \$... in full payment.

Name

Address

City State

Trigonometry refresher also available!

THE BEST SURPLUS BARGAINS COME FROM KOPELOVE

RT-7/APN-1 Altimeter Transceiver—You can't beat this for a value.

Like new. Complete with 14 tubes including 4 acorns, 27 volt **\$4.95**
Dynamotor and case. Includes famous wobblator unit. Only



TS-16/APN Test Set—Used for aligning and calibrating ARN-1, APN-1 and other radio altimeters. Has 28-volt vibrator supply, audio generator, other valuable parts. Complete with all cables and wood case. Now only **\$7.95**
TS-3/AP Wave-Meter Watt-Meter—Cavity tuned 2400 to 3400 mc. Measures frequency and peak power. With cables. New condition. Only **\$29.95**

TS-3A/AP Wave-Meter Watt-Meter—Only **\$69.95**
TS-170-ARN-5 Test Oscillator—Complete test transmitter or signal generator for Glide Slope Receivers or other UHF applications. 330 mc range. Modulated 90 to 150 cycles. Only **\$14.95**

TS/92 Amplifier Alignment Unit—Crystal detector receiver, 110 v 60 c power supply. Complete with cables. Only **\$19.95**
I-203 Output Meter—New condition. Only **\$18.95**
BC-906D Frequency Meter—144-225 mc. Battery operated. Complete with case. Only **\$6.95**
I-196B Signal Generator—Used with BC-906D. Battery powered oscillator. Complete with case. Used. Only **\$3.95**
T-20/AR-5 Transmitter—4-5.3 mc. Brand new, complete with tubes. Only **\$5.00**
BC-1206-CM Aircraft Receiver—200-400 kc. Operates on 24 vdc. Used. Complete. Only **\$5.00**
Minimum order \$3.00. All items shipped F.O.B. our warehouse. On C.O.D.'s, include 25% with order. Ohio resident add 3% Sales Tax. All items subject to prior sale.

KOPELOVE ELECTRONICS COMPANY
Dept. RN-757 1919 East First Street Dayton 3, Ohio

TELEVISION

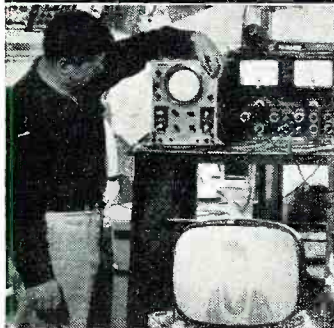

Industry needs Electronic Trained Men Now! Qualify for **BIG PAY JOB**, 9 short months. No other type of training can compare with actual shop practice you get at Healds under expert instructors.

Bachelor of Science Degree, 27 Months

- Electronics Engineering (B.S. Degree)
- Electrical Engineering (B.S. Degree)
- Television Technician (9 Months) Color TV
- Electronics Technician (12 Months)
- Mechanical Engineering (B.S. Degree)
- Civil Engineering (B.S. Degree)
- Architecture (B.S. Degree)

Heald College ranks FIRST West of the Mississippi in "Who's Who in America"

Approved for Veterans

DAY AND EVENING CLASSES

Register Now. Write for Catalog.

(No Obligation.)

Your Name

Address

City

State

AT HEALDS YOU LEARN BY DOING IN MODERN ELECTRONICS LABORATORIES

HEALD ENGINEERING COLLEGE

Van Ness at Post, RTN
San Francisco, Calif.

clear all right, but not with the intensity of Big Ben! Directionality was good with the piano staying in place just left of center and "hole-in-the-middle" effects were negligible. All in all, with the combination of the virtuosic Rubenstein, "pop" appeal, and luscious stereo sound, this tape should be a best-seller.

LISZT

MEPHISTO WALTZ

Chicago Symphony Orchestra conducted by Fritz Reiner. Victor ACS-25, stacked stereo, 7" reel, 7 1/2 ips. NARTB tape curve. Price \$6.95.

This is the least expensive stereophonic tape thus far issued by Victor, and it should attract a lot of customers. However, it is also the most limited in playing time and some people will undoubtedly be shocked when they see the small amount of tape needed for the music. Actually it looks far worse than it really is, mostly due to Victor's clever new packaging. They are using a specially designed 7-inch reel with the very large standard NARTB hub usually found only on 10 1/2 inch reels. The idea here, of course, is that on many of the less expensive stereo playback machines which are coming on the market, on the normal-sized hubs as the tape approaches the last few minutes considerable wow or flutter can occur. With the large NARTB hub this trouble is minimized. In this new packaging the familiar printed leader is no more, the reel itself being labeled with the pertinent information. Tape boxes have been dolled up with photos or art work on the cover and with program notes on the back cover. Recorded tape is indeed coming of age! Oh, yes, . . . the music!

This is one of the really outstanding performances of the "Mephisto Waltz." Reiner imbues it with a great deal of verve and high spirit and this tired old warhorse gets up and starts to prance. Heard in the lush fullness of stereophonic sound, the work becomes newly interesting. The engineers have used the fabulous Orchestra Hall acoustics to good advantage. The recording is somewhat more close-up than is usual so that the "liveness" factors of the hall reverb do not obscure orchestral detail or definition. String sound is so smoothly clean with wonderful clarity in the contrabassi, and the brass sound for which Orchestra Hall is so famous is at one and the same time crisply brilliant and full-blown rich and sonorous.

Directionality is good although the score does not aid this very much. "Hole-in-the-middle" here was missing to a very satisfying degree, so that one heard the woodwind and horns in their proper perspective. Few people can fail to like this superior stereophonic tape.

HANDEL

MESSIAH (EXCERPTS)

Zimble Sinfonietta conducted by Thompson Stone with chorus of the Handel and Haydn Society of Boston

with Adele Addison, soprano; David Lloyd, tenor; Lorna Sydney, contralto; Donald Gramm, bass. Boston BO7-9-BN, stacked stereo, 7" reel, 7.5 ips. NARTB tape curve. Price \$11.95.

Boston is one of the *Livingston Tape* affiliates and this "Messiah" was first released on *Unicorn Records*. As far as performance and participants are concerned, they are quite good, but not of the order of excellence of the Boult on *London* or the Sargent on *Angel*. But, and this is a big but, this is so overwhelmingly better with the stereophonic sound that any shortcomings simply melt away. This is what stereo was made for . . . a big chorus, soloists, orchestra, and organ. I have read a few critiques about this tape in which the reviewers stated that they were unhappy with the sound. They liked the stereo all right, but felt that the recording still sounded a little restrained and dullish. I can't be absolutely sure but chances are that these gentlemen listened to the tape on one of the small stereo systems. It does indeed sound "smallish" as I found out when I deliberately played it on a small rig. But play this on a couple of king-sized speakers through a pair of 60-watt "Macs" and the difference is astounding! The whole thing comes to life and the experience is breathtaking.

This is the first time I've ever felt that a sound system was doing true justice to the "Messiah." Put out the lights and listen to this in the dark and then you'll enjoy the big chorus

spread across the end of your room, the different choirs properly positioned, the soloists in proper balance, as is the orchestra and organ. The interplay between the choirs makes a stunning demonstration of directionality.

Taking advantage of the wonderful Boston Symphony Hall acoustics, the engineers have made a recording which is an accurate reflection of the real thing. The only qualification is that it must be played at a good room-filling level over a big rig. The chorus is superbly articulate, all the orchestral instruments sound out brilliantly, and the organ is properly sonorous. As you can imagine when everything gets wound up in the famous "Hallelujah" chorus, the effect is tremendous and the whole house shakes! Here at last is the mass and weight, the tonal magnificence that has always been needed to add that little fillip of "awesomeness," which is part of the live performance. If you own the right equipment, don't miss this tape.

BACH

**TOCCATA AND FUGUE IN D MINOR
PASSACAGLIA AND FUGUE IN C
MINOR**

Carl Weinrich playing the organ of the Varfrukyrka at Skanninge, Sweden. Sonotape SWB 8001, stacked stereo, 7" reel, 7.5 ips. NARTB tape curve. Price \$12.95.

I have commented before on the excellence of recording and the superb interpretations of Carl Weinrich in

this series of Bach works which are appearing on *Westminster* records and on monaural and stereophonic *Sonotapes*. Here in what are undoubtedly the two best-known and most popular of Bach organ works, we have an opportunity to assess how they sound when recorded stereophonically. The result is sheer pleasure and a deeper appreciation of the genius of Bach. The complex tonal structures that are the essence of these works are revealed with new clarity and understanding. The quality of this recording is an engineering *tour-de-force*.

The stereo captures the airy spaciousness of the church and yet limns every note for maximum definition. This definition extends throughout all the registrations and from pedal to top. Most astounding in a tape duplicated at 7½ ips is the awesome pedal in the first few bars of the "Passacaglia." This, gentlemen, is a genuine 27-cycle note, which I assure you is on the tape. I say this because very, very few speakers are capable of producing this tone fundamentally, and therefore you may not hear it on your system. You may think you are hearing it when actually all you are getting is frequency doubling or resonance.

Of course, big pedal isn't everything, and you'll find plenty of wonderful music, flawlessly recorded on this tape for your stereo enjoyment. One of the most outstanding organ recordings available in any medium. -30-

**We Have OVER 1000
USED TV SETS**

At All Times In Our Huge Warehouse Buy one or more of these WORKING TV's to sell or use as your own second set! All Sets in GOOD WORKING condition!

Your Choice—Console or Table Model

10"	...\$23.00	15"	...\$58.00
12"	...\$28.00	20"	...\$64.00
14"	...\$33.00	21"	...\$72.00
16"	...\$40.00	24"	...\$99.00
17"	...\$46.00		

When ordering TV's, state whether table model or console is desired. Also preference on make of set. All TV's sent railway express F.O.B. Newark. On any quantity WIRE or CALL today!

FREE BONUS ANTENNA GIVEN WITH ANY TV SET ORDER!!

FREE RCA "CHEATER" CORD GIVEN WITH ANY TUBE ORDER OF \$7.00 OR MORE!!

FREE POSTAGE in U.S.A. and Territories on orders over \$5.00. 25¢ handling charge on orders under \$5.00. 25% deposit required on C.O.D.'s. Please send approximate postage or freight on Canadian and foreign orders. Subject to prior sale.

SEND for our **FREE** complete TUBE & PARTS LIST and order blank.

Brand New Factory Seconds! Electrically Perfect Factory Seconds! Used Tubes! New and Used Jan Surplus Tubes!

40¢
FOR ANY
TUBE
we will not be
undersold

VIDEO

Apology to Readers of Radio & TV News
Due to the tremendous response to our wonderful values in tubes, our huge staff at Video Electric Co. was unable to adhere to our same Day Shipment policy. For this reason, some orders were delayed a number of days. We at Video wish to offer our profound apologies for any inconvenience caused our customers. We are attempting to remedy the situation at once.

PROMPT SHIPMENT ON ALL ORDERS

\$3700 DON'T PAY MORE FOR SET TESTED LONG LIFE DEPENDABLE RADIO & TV TUBES For BUY VIDEO INDIVIDUALLY BOXED ALL GUARANTEED FOR ONE YEAR OR YOUR MONEY BACK

Some Standard Brand—Others With Famous VIDEO Brand

0A2	5B4G	6HG7	12A7T
0A3	5U8	6J4	12AU6
0A4	5V4G	6JS7	12AU7
0B2	5V6GT	6L6	12AV6
0C2	5Y3	6K6GT	12AV7
0Z4	5Y4G	6L6	12AX4GT
1A7GT	6AB5	6N7GT	12AZ5
1B3GT	6B7	6S4	12AZ7
1C7G	6AG5	6S7G	12B4
1F4	6AF7	6S7	12B6
1H4	6H4GT	6S7	12B8
1HS0T	6AK5	6C87	12BH7
1L6GT	6AL5	6SF5	12BY7
1L4	6AW8	6S7	12C6
1L6	6AN4	6S7	12SA7
1L66	6N8	6S7	12SC7
1LCS	6AQ5	6J7GT	12SH7
1LH4	6AQ7GT	6S7GT	12SJ7GT
1LH5	6A35	6S17GT	12SK7
1N5GT	6AS7G	6S7GT	12SN7GT
1S4	6AT6	6S7	12S07
1S6	6AU4GT	6S7	12V6GT
1T4	6AL5GT	6S7	12X4
1U4	6ALC	6T8	14A7
1U5	6BU5AT	6U4GT	14B6
1V2	6AV7	6U7G	14C7
1X2	6AX4GT	6U8	19SC8G
2A7	6AK5GT	6V3	14T8
2D21	6B6	6V6GT	21A
2Z2	6CC5	6W4GT	25A4V5GT
3A4	6BC7	6W5GT	25B06GT
3A5	6BE6	6X4	25C06GT
3AL5	6BF5	6X5GT	25C06
3AU5	6BG6	6X8	25L6GT
3B5	6BH6	6Y6	25W4GT
3B8	6B18	7A8	25Z6GT
3Q4	6BK5	7A7	35L6GT
3S0GT	6K7	7B5	35W4
3V4	6L7GT	7B7	35Y4
4E27	6BN6	7C5	35Z3
4E27	6C05GT	7C6	35Z3
4E27	6C7	7C7	35X5GT
5A7H	6BY5G	7F7	50A5
5AN8	6Z7	7F8	50B5
5AQ7	6C4	7N7	50C5
5AT8	6C55	7Q7	50L6GT
5AW4	6CD6G	7Y4	8D
5AZ4	6C6	7Z4	117N7GT
5B	6C56	12A6	117P7GT
5T4	6CU6GT	12AH7GT	
5T8	6E5	12AT6	

ELECTRIC COMPANY
79 CLINTON PL. NEWARK, N. J.
Phone HUmboldt 4-9848

BUY DIRECT FROM FACTORY

TRANSVISION

Oldest Name in Electronic Kits

SPLIT/KITS

PAY AS YOU WIRE

INVEST SLIGHTLY MORE—but—
BUILD THE BEST!

- **A FEW DOLLARS GETS YOU STARTED:** Each Kit is "split" into a few packages, or stages, which you buy one-by-one as you wire.
- **EASIEST TO ASSEMBLE**
- **FREE educational aids**
- **Money-Back Guarantee**

A COMPLETE LINE OF

- **TV KITS**
- **INSTRUMENT KITS**
- **HI-FI KITS**
- **HI-FI Speaker Systems**
- **HI-FI CABINETS**

A wide assortment to house any make Hi-Fi units. Exquisitely styled, beautifully finished. Cannot be equalled anywhere.

Write for Complete Catalog



NEW!
Transistorized
VTVM—VOM KIT
\$3695 for Kit

Only \$10 gets you started. This covers the 1st stage. Balance in 2 stages; pay as you wire... Also, factory wired for \$69.

New TV KIT

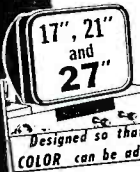

Learn TV while building a **DELUXE TV SET**
Only \$15 gets you started. Balance in easy stages. Profit 3 ways: Learn by doing; save up to 50% on a **DELUXE TV SET**; prepare for **COLOR TV**.

FREE: A TV Course of Study with Kit. Prepared by a recognized educator, this course alone is worth many times the cost of the TV Kit.

TRANSVISION, INC.,
NEW ROCHELLE, N. Y.

TRANSVISION, INC., NEW ROCHELLE, N. Y. Dept. N

I'm enclosing \$_____ deposit. Send the following: _____

Send FREE copy of your latest Catalog.

Name _____

Address _____

City _____

State _____

118

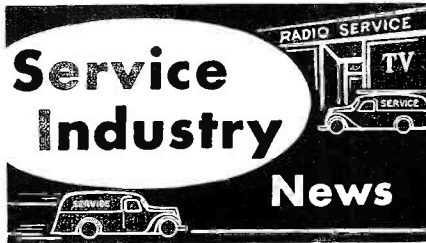

THE ANNUAL Radio-TV-Electronic Service Industry Convention and Institutes, the seventh to be sponsored by NATESA, will take place at the Sheraton Hotel, 505 N. Michigan Ave., Chicago, August 16 through 18. Directors and alternates will converge on the city from all points in this country, as well as from Alaska, Canada, Venezuela, and the Panama Canal Zone. Non-members are invited to participate.

Three special institutes, one each on business, technical matters, and association activities, will be conducted by representatives of various phases of the over-all industry. The convention is open to all persons in the electronic industry, whether in service or out of it and without regard as to whether they are or are not NATESA members.

FTRSAP Presents Plaque

The Federation of Television-Radio Service Associations of Pennsylvania recently awarded its annual plaque for 1956 to Paul H. Wendel, writer and lecturer. Presentation was made by John S. Doyle, chairman of the Pittsburgh chapter of FTRSAP, the Electronic Service Dealers Association of Western Pennsylvania.

This chapter is the newest and largest affiliate of the parent organization in the Keystone State Federation. A large delegation from the Steel City attended the presentation banquet. The award was made for "outstanding contributions and untiring efforts in behalf of the independent electronic service profession."

In his remarks, Wendel deplored the let-down in the drive toward unity in the service industry, but also stressed his belief that the real industry power can only be developed through strong local and state-wide associations. He contends that most problems must be resolved on the local and state levels. He also outlined a program for strengthening associations through the Television Technicians Lecture Bureau. He sees the Bureau as a central liaison agency between associations throughout the country and between service and industry, assisting in association program planning and with association publications.

Motorola Backs Independents

David H. Kutner of *Motorola*, addressing attendees at the Midwest Electronic Service Fair, sponsored by the Indiana Electronic Service Association in Indianapolis, lauded the role of the independent service industry. He feels that its future is virtually unlim-

ited and that opportunities are just beginning. He also stated that continued existence of independent service is important to independent manufacturers, and indicated that these two segments are natural allies. He also stressed the importance of good business practice and methods, along with sound technical ability, as necessary for success. Salesmanship, advertising and promotion, intelligent planning, and tie-in with cooperative promotional efforts with other segments of the industry were some of the points he highlighted.

Minnesota Standards

A system of standards for qualifying radio and television service technicians has been adopted on a state-wide basis in Minnesota. The standards were developed by the Minnesota Television Service Engineers, Inc., in cooperation with the Radio-Television Service Association of Minneapolis.

Intended to serve as a guide for employers of radio and television apprentice servicemen and technicians, the system of standards has received the cooperation and approval of the Minnesota Apprenticeship Council, Industrial Commission of Minnesota, and the Bureau of Apprenticeship, U. S. Department of Labor.

Association Elections

Wayne Lemons, owner of the *A-1 Television Co.* of Buffalo, Missouri, was elected president of the Television Electronic Service Association of Missouri at its recent annual election. Other officers elected to serve for the next year include: secretary, Edward Engle, *Engle Radio & TV Service, Inc.*, Crystal City; treasurer, Warren Callison, *Callison Radio & TV*, Warrensburg; regional vice-presidents, Northeast, Dennis Houghton, *Peoples Radio*, Columbia; Southeast, Howard Freiner, *Empire TV Service Corp.*, St. Louis; Northwest, M. C. Crane, *Crane Radio & TV*, St. Joseph; Southwest, Arent Patterson, *Patterson Radio & TV*, Springfield. Three new directors were elected: Howard Seiggen, *Howard's Parts & Service*, Kansas City; Mac Metoyer, *A-1 Radio & TV*, Kansas City; and Jack Mulford, *Jack's Television*, Springfield.

Howard Bogue of Arlington, Calif., was elected president of the Citrus Belt Chapter of the Radio-Television Technicians Association, Inc., at its annual meeting. Officers to serve with him include: vice-president, Earl Brisk of Arlington; secretary, Al G. Kirstein of Norco; treasurer, Milt Franklin of Riverside. The RTTA is affiliated with the California State Electronic Association.

King's County Television Service Association of Seattle, Wash., selected Harold Hart to serve as its president for the coming year. Clayton Fallar was elected to the post of vice-president, and Ray Murphy was named for the dual job of secretary-treasurer.

Ned Gramlich of *Sunset TV* was elected president of the San Francisco

RADIO & TV NEWS

TV Service Guild. Elected to serve with him were Andy Cerisier of *Andy's TV* as vice-president; Mack Kunsman of *Jamke TV* as secretary; and Mrs. Marion Bories of *Bories TV* as treasurer. Terry Straus of *Westlake Town & Country TV* was approved as the Guild's delegate to the California State Electronics Association, with Ed Finnerty of *Finnerty's TV* standing by as alternate delegate.

The Electronic Service Association of Detroit, Mich., elected Joseph Rosson to serve as president for the next year at its recent annual meeting. The following officers will serve with him: Art Shaul, vice-president; Ed Kahn, treasurer; Dale Brock, recording secretary; Howard Larsen, corresponding secretary; and Bill Johnson, sergeant-at-arms. Pete Wroblewski, John Button, and A. Johnson were elected to the board of trustees. The new officers of ESA paid high tribute to their retiring president, Ralph Carewe, for his work and accomplishments on behalf of the association. Mr. Carewe was presented with the gavel he had used as president, suitably mounted and engraved.

Everett Siemond of Ladysmith, Wis., was elected president of the Indian-head Radio-TV Servicemen's Association at its recent annual meeting. Clyde Struve of Cadott was named vice-president. Other officers are Richard Presnell of Bloomer, secretary, and Vernon Miendel of Bloomer, treasurer. Kenneth Wheeler of Chippewa Falls, who was appointed chairman of the program committee, promised the members a good educational program during the 1957-58 season, the program to include lectures, demonstrations, and other practical service material.

C. H. Ramm of *Ramm's Radio Shop*, Tallahassee, Florida, is president of the recently formed Tallahassee TV & Electronics Association. The new organization is made up of dealers and technicians who will seek to encourage better business practices in TV servicing in that area.

By mail ballot, the members of the Electronic Service Dealers Association of Western Pennsylvania recently elected the men to serve on its board of governors and board of trustees. The eleven members of the board of governors include R. Barozzinni, G. Oswald, W. Cornelius, N. Falk, J. Doyle, J. Gonsowski, B. Bregenzer, F. Datillo, T. Thompson, H. Cohen, and R. McClory. John Doyle was selected by his fellow board members to serve as its chairman. H. Danko, H. Schaupp, and C. Colerich were elected to serve on the board of trustees. Tom Scholler was named executive secretary; N. Jackson was elected to serve as recording secretary; C. Barovsky was named treasurer, with K. Scheldt serving as assistant treasurer.

George Roberts was elected chairman of the Indiana Electronic Service Association, replacing Robert M. Sickels. The latter has served since I. E. S. A. was organized over a year ago, in April 1956.

-50-

MOBILE-RADIO MAINTENANCE PAYS BIG MONEY!



LAMPKIN 105-B
MICROMETER FREQUENCY
METER. Price \$220.00 net.



LAMPKIN 205-A
FM MODULATION METER.
Price \$240.00 net.

Your regular test equipment plus these two Lampkin meters can put you in the business. There's plenty of opportunity close to your own home!

ACT NOW

Send coupon for free book.
Let "How to Make Money in
Mobile-Radio Maintenance".

LAMPKIN LABORATORIES, INC.,
MFM Division, Bradenton, Florida
At no obligation to me, please send
 Free booklet Data on Lampkin meters.

Name _____

Address _____

City _____ State _____

LAMPKIN LABORATORIES, INC.

MFM Division
BRADENTON, FLORIDA

New profit-builder for you...

Metaltone... Metaltone* Trade Mark

the new kind of sprayhammer finish paint

...sprays a hammered-metal-looking finish on wood, leather, metal, etc.

- * **PROTECTS**... flexible coating resistant to water, acids, alkali, corrosion.
- * **GREAT DO-IT-YOURSELF** item for home, car, crafts, workshop, furniture, appliances, etc.

FULL 40% PROFIT

Six beautiful colors... Silver, Blue, Copper, Charcoal Gray, Golden Chartreuse, Green... and Clear Plastic. Assorted colors packed in special counter display carton.

Suggested list\$21.48 Doz.

Your cost\$12.89 Doz.

40% PROFIT FOR YOU\$ 8.59 Doz.

Also packed in solid colors in plain shipper.

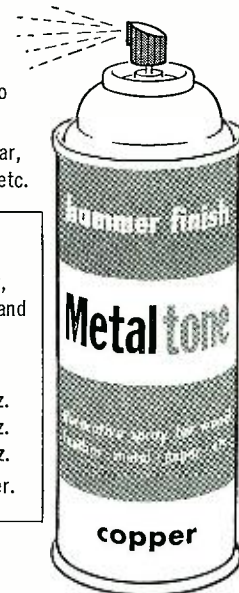

Ask your local distributor or write for further information about METALTONE.

FLAMEMASTER CHEMICALS, INC.

Division of Ideal Chemical Products, Inc., Culver City, Calif.

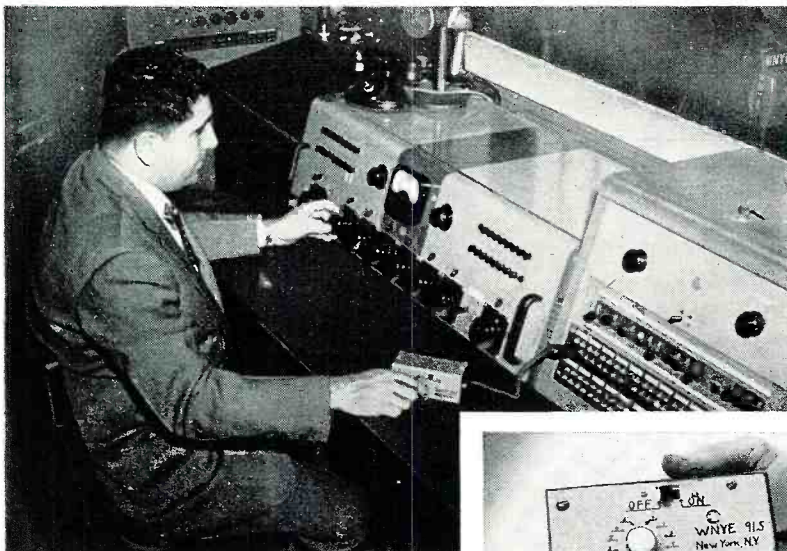

Broadcast engineer using audio tone generator, equipped with standard balanced line patch plug, for a quick line check.

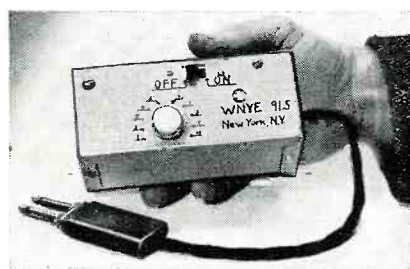

Multi-Purpose Tone Generator

By

TRACY DIERS
Staff Engineer, WNYE

Built for broadcast station use, this transistorized unit has many home hi-fi and amateur applications.

AS PART of its regular testing equipment most radio stations have several sine-wave audio generators in the racks. Oscillators of this type generate a low-distortion sine wave suitable for testing equipment but, as any busy broadcast engineer knows, it's a tough job to get one where it's wanted when the remote engineer calls for tone to level his telephone lines in a hurry. For example, the regular station oscillators may all be in service at the moment or it may be necessary to use a veritable "rats' nest" of patchcords to connect the oscillator to the line to be checked. In short, it often takes a considerable amount of time and effort to prepare for a test which can be accomplished in 10 seconds once the equipment is set up.

At station WNYE (New York) the problem has been solved by building small, hand-sized, portable oscillators which can be plugged into any line, studio console, or program amplifier input. High-fidelity fans will also find an oscillator of this sort handy for signal tracing, measuring stage gain, etc. A slight change in the original idea is all that is necessary and this is described later. And, of course, an ingenious "ham" will find many uses.

The hook-up is simple, as Fig. 1 shows. A Colpitts oscillator uses a transistor to generate a sine wave. The frequency is controlled by inductance T_1 and the two capacitors C_1 and C_2 . An amplifier follows the oscillator and it also protects the oscillator from abnormal loads which could stop oscillation. Thus this little tone generator is capable of working into any input from 50 ohms to high impedance.

Parts placement is unimportant; any layout convenient to the constructor may be used. The parts were attached to a phenolic board approximately $4\frac{1}{2} \times 2$ ". Soldering transistors is a risky business so sockets were used; small files can be used to cut the socket holes in the phenolic board after pilot holes have been drilled. A *Stancor* transformer (No. A3332) makes an excellent inductance for the project, it is moderately priced and provides a well-shaped sine wave. For those who wish to really miniaturize this tone generator, transistors in the transistor subminiature class may be used. Only the more expensive, good-quality miniature transformers are suitable as the undesirable ones will saturate easily and distort the wave. Because of this the instrument was built up in the larger version and provides a good wave at moderate cost.

The output potentiometer is one of the new miniature transistor types available from the mail-order houses for approximately 49 cents. The entire assembly was placed in a metal box, $5 \times 2\frac{1}{4} \times 2\frac{1}{4}$ ". A *Bud* "Minibox" CU 2104 is a good choice.

Photos show the unit disassembled. In one view the board has been wired up and is ready to be installed in the larger half of the two piece metal box. The two large screws are used to support the phenolic board rigidly. Brass sleeves on the screws hold the board at the proper height.

These screws are $1\frac{1}{2}$ " long and the sleeves are $1\frac{3}{16}$ " long to clear the height of the transformer which is installed upside down in the final assembly. Photos also show the 3-volt

battery held in place by a small aluminum strap; the miniature output potentiometer and the "on-off" slide switch are also visible.

Those who have worked with transistors will appreciate the important role played by resistors R_1 and R_2 in Fig. 1. Having made several of these tone generators we can say that they work well if the stated values are used. If the tone generator is constructed using the recommended values, the results will be quite satisfactory for most purposes. However those having the necessary test equipment can improve the quality of the sine-wave output. A procedure will now be described which takes into account the individual idiosyncracies of the transistors involved:

First wire up the oscillator portion of the generator. Oscillator is composed of T_1 , C_1 , C_2 , R_1 , R_2 , and R_3 . Connect a 100,000 ohm potentiometer where R_1 should be. Connect a current measuring meter in series with the battery wire going to ground. This meter should be a 0 to 1 ma. type, preferably capable of reading microamps. Connect the vertical input of an oscilloscope; high side to take-off point marked "X," low side to ground. Now vary the potentiometer while watching the scope and the meter. A setting will be found where oscillation will take place with a good sine wave and reasonable current drain to the transistor. Typical figures for a 2N107 are: current drain, 300 μ a. and .01 volt output. Under these conditions harmonic distortion will be 3% or better.

Now wire up the amplifier portion of the tone generator and temporarily substitute a 2-megohm potentiometer for R_4 . The meter must now be connected in the circuit in such a way that it measures only the current flow-

ing to the amplifier transistor. This current will be the sum of base and collector currents. Turn the output volume control R_5 up to maximum and connect the vertical input of the oscilloscope across the output terminals of the tone generator. If the 2-megohm potentiometer is now varied, a position will be found where the sine wave is good and the current drain to the amplifier transistor is low. Typical for this stage would be current drain, 100 μ a. and output voltage into the high impedance load of the oscilloscope, .04 volt.

When the optimum values of R_1 and R_2 have been determined in this way by experiment, remove both R_1 and R_2 temporary potentiometers from the circuit and carefully measure their resistances without disturbing their settings. When the resistances are known install small fixed resistors of equal values.

All these measurements are, admittedly, a bit involved but they will assure best output. However, for ordinary broadcast line checking and simple audio signal tracing for the hi-fi fan and also for many "ham" operations this involved measurement procedure is unnecessary. Simply use the parts that are specified in Figs. 1 and 2.

The 2N107 is not the only transistor which can be used in this gadget. Several units have been built using whatever transistors happened to be handy. The generator illustrated here was made using type CK721's as oscillator and amplifier. Some changes will be necessary to start oscillation and these changes will almost always be in the values of C_1 and C_2 . For a CK721 or CK722, C_1 should be .01 μ fd. and C_2 should be .02 μ fd. For best results determine R_1 and R_2 by experiment. Other transistors will oscillate if the correct values of C_1 and C_2 are found by experiment.

If the tone generator is constructed using the specified values, its frequency will be approximately 1100 cycles. The output frequency may be considerably changed by using different values for C_2 . Table 1 shows the various possibilities.

Frequencies above 1100 cycles are

C_2	APPROX. OSC. FREQ.
.02 μ fd.	1100 cps
.01 μ fd.	1000 cps
.03 μ fd.	750 cps
.06 μ fd.	600 cps

Table 1. Effect of C_2 on frequency.

on an experimental basis. Some transistors will go to three or four thousand cycles. A selector switch can be included in the circuit to change frequency by selecting an assortment of capacitors for C_2 . When frequency is changed from the specified 1100 cycles some distortion of the sine-wave output can be expected. This is caused by the fact that a simple oscillator such as this has varying output with change of frequency. When the oscillator output rises too high for class "A" operation of the amplifier stage, the sine-wave output of the tone generator will show an increase in harmonic distortion.

It is possible to maintain a good sine wave throughout all frequency changes. Some experimentation with R_1 is necessary. A value can be found which will tolerate changes in oscillator level.

This instrument was designed for quick checks at a single frequency and this it does well. For broadcast operations the output of the generator is brought out through a regular balanced patch as Fig. 1 shows. For use in hi-fi or "ham" operations the usual unbalanced shielded microphone cable may be used. The mike cable "hot" wire and the shield may end in alligator clips. If used for supplying tone to a ham transmitter during on-the-air testing, then the short length of mike cable can terminate in the usual microphone plug. This can be plugged into the conventional speech amplifier input.

"Ham" speech amplifier and hi-fi equipment can be readily checked for serious distortion (greater than the tone generator itself), dead stages, and stage gain quite easily. A v.t.v.m. or high-resistance voltmeter may be used for stage gain measurements or signal tracing but a scope must be used for distortion testing. Simply feed the signal to the stage being tested and

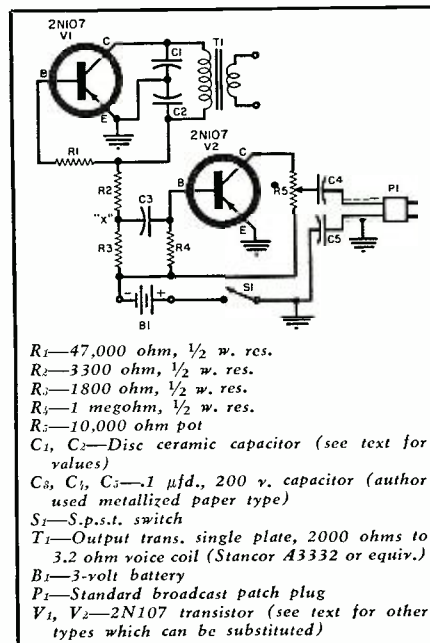

- R_1 —47,000 ohm, 1/2 w. res.
- R_2 —3300 ohm, 1/2 w. res.
- R_3 —1800 ohm, 1/2 w. res.
- R_4 —1 megohm, 1/2 w. res.
- R_5 —10,000 ohm pot
- C_1, C_2 —Disc ceramic capacitor (see text for values)
- C_3, C_4, C_5 —1 μ fd., 200 v. capacitor (author used metallized paper type)
- S_1 —S.p.s.t. switch
- T_1 —Output trans. single plate, 2000 ohms to 3.2 ohm voice coil (Stancor A3332 or equiv.)
- B_1 —3-volt battery
- P_1 —Standard broadcast patch plug
- V_1, V_2 —2N107 transistor (see text for other types which can be substituted)

Fig. 1. Schematic diagram of tone generator, shown here with balanced output.

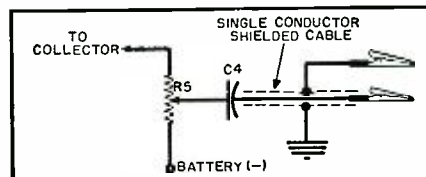

Fig. 2. Alternate output circuit for use with unbalanced hi-fi and ham gear.

check the output in the usual way by means of a meter or a cathode-ray oscilloscope.

The tone generator may be used in broadcast line checking and will work into any impedance input. However, the low impedances encountered in broadcast applications, in the range of 50 to 500 ohms, may cause distortion of the wave. This is unimportant for simple checks but, if desired, it can be considerably corrected by introducing resistance in series with the output connector attached to the volume control slider. The value may range from 1000 to 100,000 ohms.

—30—

Parts layout is not critical, but space must be left for the transformer when the wired chassis is mounted into place.

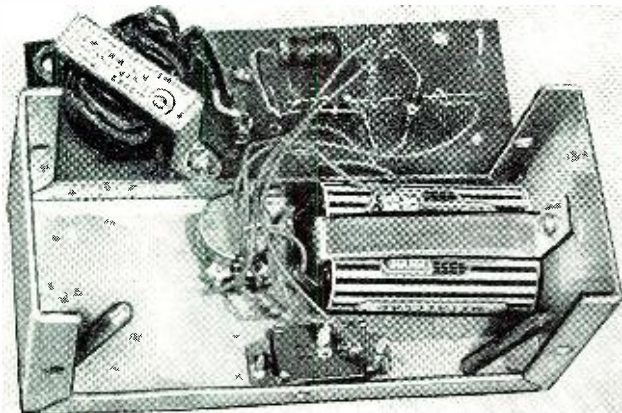

After components have been wired, chassis is mounted on spacer screws. All ground connections are made directly to metal box.

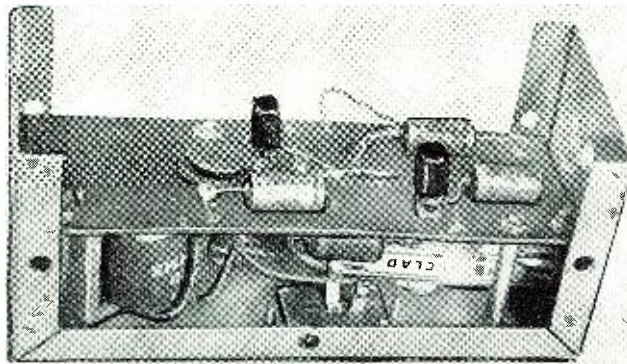

QUARTZ CRYSTALS

**Fast Service—
Unconditional Guarantee!**

Crystals ground and etched to your specified frequency at the lowest cost in the industry—supplied in popular FT-243 holders, 1/2" pin spacing, .093" pin diameter—also in DC-34 holders, 3/4" pin spacing, pin diameter .156 or FT-171 holders, pin spacing 3/4" with banana plug pins (fits 5-prong tube socket).



In FT-243 holders from 1005KC to 9000KC. In DC-34 or FT-171 holders from 1100KC to 8000KC (specify holder wanted).

Tolerances:
.01% 1.50
.005% 2.50

NOW—hermetically sealed overtone crystals in HC6/U metal holders, pin spacing .486", pin dia. .050"—pin diameter .093" also available. Specify diameter wanted, otherwise .050 supplied.

3RD OVERTONE CRYSTALS

10 to 30 MC .005 tolerance..... \$3.85 ea.
30 to 54 MC .005 tolerance..... \$4.10 ea.

5TH OVERTONE CRYSTALS

55 to 75 MC .005 tolerance..... \$4.25 ea.
75 to 90 MC .005 tolerance..... \$5.50 ea.
(Write for quantity prices)

NOVICE CRYSTALS 80 meter band within 1KC of specified frequency from 3701KC to 3749KC in 40 meter band from 7152KC to 7198KC within 1KC of specified frequencies 99¢, in FT-243 holders.

ANY AMATEUR BAND CRYSTAL from 3500KC to 8650KC, 05% tolerance 99¢ (Add 5¢ per crystal for postage & handling.)

MARINE FREQUENCY CRYSTALS

.005 Tolerance—available in FT-243 holders, or MC7 (pin spacing 3/4", dia. .125") holders.

2009	2182	2670	2977	
2110	2406	2738	3021	\$2.50 ea.
2126	2637	2953	3093	
2174	2638	2961	3193	

SPECIAL! RADIO CONTROL CRYSTALS

27.255 MC sealed crystals..... \$2.50 ea.

Stock crystals in FT-243 holders from 5675KC to 8650KC in 25KC steps 50¢.

FT-241 lattice crystals in all frequencies from 370KC to 540KC 50¢.

200K Crystals	2.00
455K Crystals	1.00
500K Crystals	1.00
1000K Frequency Standard Crystals	3.50
Dual socket for FT-243 crystals	.15

Low frequency FT-241 crystals from 880.20KC to 1040.62KC in steps of 1040 cycles 75¢

(Write for complete listing.)

Texas Crystals

The Biggest Buy in the U.S.

8538 W. GRAND AVENUE · RIVER GROVE, ILL.
ALL PHONES—GLADSTONE 3-3555

Terms: All items subject to prior sale and change of price without notice. All crystal orders MUST be accompanied by check, cash or M.O. WITH PAYMENT IN FULL. NO C.O.D.s. Postpaid shipments made in U.S. and possessions only. Add 5¢ per crystal for postage and handling charge.

A Nose for Servicing

(Continued from page 48)

the same odor-associated faults as radio and other electronic gear, but in addition we encounter here a new type of scent. Up to this point we have considered only those odors connected with overheating, all of which may be classified as unpleasant.

In the horizontal-output circuit and in its associated high-voltage circuit supplying anode voltage to the picture tube, we often run into corona discharge and the related smell of ozone. Although individual reactions vary, this is often considered a stimulating and even pleasant odor, associated by many with the fragrance of fresh air. Since it is one of the few pleasant experiences the nose is likely to encounter when used as a troubleshooting device, perhaps we should pause briefly here to inhale some of this clean air.

When this clue occurs, it can often be of great help to us. If the corona discharge is strong enough, it may produce a faintly visible glow, in blue if the path is through air, but possibly of some other color depending on the material through which the discharge path travels. There may also be a hissing sound, faint or fairly prominent, depending on how strong the discharge is. However, the glow is difficult to see except in subdued light, and even then it may be hidden from view by obstructing components. As for the hiss, if present, it may be that other receiver sounds are strong enough to mask it. For this reason, the characteristic odor is often the first clue to this symptom that comes to our attention, and it is worth being on the alert for it.

The cause may be higher-than-normal voltages, dampness, or some sharp protrusion, often from a soldered connection that is not too smooth. The cause may also be a combination of two or all three of these. Incidentally, if the presence of ozone is noted even where it is not related to the immediate fault for which correction is being sought, the symptom should nevertheless be investigated. The cause should be eliminated, as it may be the warning sign of a developing fault that may become serious.

We cannot, of course, service by the sense of smell alone, or even primarily. It is simply another tool available to the intelligent technician to supplement those he already has. There is even the danger of jumping to false conclusions, for scents, like other clues, can also be misleading. We must be careful, for example, not to jump to conclusions because a customer has complained of an unpleasant smell in a defective set. It is not entirely unheard of for technicians to run into such cases where the complaint can be traced to the presence of electrocuted vermin in the chassis, but the discovery may be of little use in troubleshooting.

The ALL NEW "20 POUNDER" MYSTERY PACKAGE

of ELECTRONIC PARTS
It's Another THRILLING
HERSHEL SURPRISE. 20
pounds of BRAND NEW usable
Govt. Surplus.
Worth \$40.00 Perfect Gift for
Hams, etc.
\$3.95 NOTE Send
Enough
Postage
to Cover Mailing
costs.
EXCESS REFUNDED
SATISFACTION GUARANTEED

BUTTERFLY CONDENSERS

YOUR CHOICE
\$4.95

These units make the finest tuners for Ultra-high frequency transmitters, receivers, frequency meters, and oscillators.

TYPE A 4 1/4" Dia. TYPE A-100-330 MC- Antenna Type	TYPE B 4 3/4" Dia. TYPE B-132-485 MC
TYPE C 2 1/2" Dia. TYPE C-300-1000 MC- Uses 308AS wire	TYPE D 2 1/2" Dia. TYPE D-300-1000 MC- Cip for 308A Ev.

RELAYS

3VDC 11-OHMS D.P.D.T.
3A. CONTACTS \$1.29

6VDC 24-OHMS D.P.S.T.
8A. CONTACTS \$1.95

110VAC 15A. CON-
TACTS S.P.S.T. \$1.75

TELEPHONE TYPE 7500-
OHMS S.P.D.T. 2A.
CONTACTS \$2.49

OIL CONDENSER

\$1.65

2 MFD. 3000
VDC. Pyranol
Oil W/Mounting
Brackets-
1-1 Mfd. 3000 VDC.
New, removed from
equip. 4 3/4" x 4 1/4" x 2 1/2"

GE Pyranol Oil CONDENSER

12 MFD. 300
VAC. 60 CY.
Removed from
equip. NEW. **95¢**

PHOTO ELECTRIC CELL

95¢

GE Vacuum
Cell, used in
A. M. P. R. O.
Sound Pro-
jector. Also useful
for opening garage
doors and Alarm
Systems.

RCA Output Transformer

P.P. 6L6'S 25
WATTS.
Pri. 5000 ohms
out SEC.
±1 500 ohms,
±2 600 ohms
Silestone 15 to
15,000 cy. flat.

\$1.95

ALL-PURPOSE FIL. TRANSFORMER

PRI. 117 v.
60 cyc. sec.

6.4 V.....12A
6.4 V.....15A
6.4 V.....20A
6.4 V.....25A
6.4 V.....30A
6.4 V.....35A
2.5 V.....175A

BRAND NEW **\$4.95**

Hi Gain Dynamic Mike Kit

Uses UTC
Transformer &
Western
Electric Mike, ideal
for Hams, PA., CAP,
Recording Mobile Equip.
50 DB 80 to 7500
CPS. Diagram Furnished.

\$1.95

SWING CHOKE

\$5.95

2H-7H 550 MA.
Thoradson T48003.

100 ASSORTED CRYSTALS

FT-243 FT-241A FT-171B
Type Holders FREQ.
RANGE 2015 KC to 38.1
MC.
\$50.00 Value **\$7.95**
HOTTEST BUY IN
THE U.S.A.

AUDIO CHOKE

60H-1MA. 4,500 ohms.
15,000 turns of 44 wire.
Size: 1 1/4" x 1 1/4" x 1 1/4".
Ideal for radio control,
planes, boats, etc. **95¢**

ALLIGATOR CLIP

Piercing type with
5 Ft. cord and
spade lug. Ideal
test clip. TL-137. **2 for 25¢**

TERMS: Cash with order or 25%
DOWN—BALANCE C.O.D.
ALL PRICES NET F.O.B. DETROIT
MINIMUM ORDER \$2.00

TYler 8-9400

HERSHEL RADIO CO.

5249 GRAND RIVER Detroit 8, Michigan

EASY TO LEARN CODE

It is easy to learn or increase speed with an Instructograph Code Teacher. Affords the quickest and most practical method yet developed. For beginners or advanced students. Available tapes from beginner's alphabet to typical messages on all subjects. Speed range 5 to 40 WPM. Always ready—no QRM.



ENDORSED BY THOUSANDS!

The Instructograph Code Teacher literally takes the place of an operator-instructor and enables anyone to learn and master code without further assistance. Thousands of successful operators have "acquired the code" with the Instructograph System. Write today for convenient rental and purchase plans.

INSTRUCTOGRAPH COMPANY

4711 SHERIDAN ROAD, CHICAGO 40, ILLINOIS

RADIO & TV NEWS

Heart Microphone Monitors Murmurs

Inserted inside heart and connected to scope, pattern of sounds may be viewed.

A TINY microphone, so small that it can be passed through an artery or vein directly into any part of the heart, promises great help for heart specialists, seeking to diagnose and determine the exact location and extent of heart defects. The heart microphone and its applications were the subjects of a recent paper presented by Dr. H. L. Moscovitz of Mount Sinai Hospital, N. Y. The development of the unit and the techniques for using it has been a joint project of *Gulton Industries, Inc.* of Metuchen, N. J., and the hospital.

A microphone of ultra-sensitive design, measuring only 1/20 inch in diameter and 3/4 inch long, is inserted into the tip of a standard cardiac catheter and connected by cable to an oscilloscope. Passed into the heart through a vein or artery, the device can be manipulated by the physician to the exact location he wants to pick up precise sounds of the heart beat and the blood-flow. The heart microphone permits physicians to diagnose sounds of a heart ailment directly from the point of defect, rather than indirectly by stethoscope through the chest wall.

The heart microphone picks up heart sounds directly and eliminates interference of extraneous noises such as breathing, digestive activity in the stomach, and the normal outside sounds of the examination room. Additionally, it assures accurate recording of the heart sounds despite the physician's own hearing defects, and eliminates the natural inaccuracies inherent in the use of a stethoscope, due to the necessity of the heart sounds traveling first through the lungs and body tissues of the chest walls before reaching the stethoscope and finally the doctor's ears. The sound energy shows a visual pattern of heart sound on a scope.

Heart microphone, occupying only 3/4 inch at magnified tip of standard heart catheter, can be inserted into any of the four chambers of heart for direct sound readings.

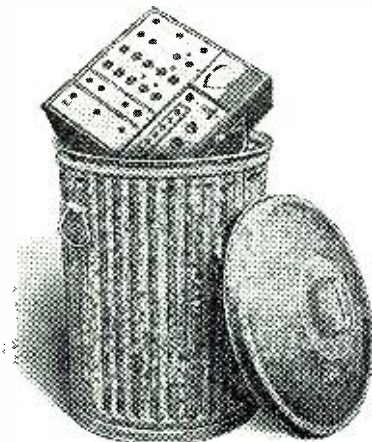

NEW AUTOMATION PUNCHED CARD TV TUBE TESTER CANNOT BECOME OBSOLETE

Speed-test complete set of tubes in minutes with the new DynaMatic Tube Tester

- So simple to use—a customer can operate it!
- LIGHTEST and SMALLEST Gm tester available. Take it on ALL house calls.
- Perforated plastic cards set up socket pin connections and test voltages.
- Permits full-complement tube testing.
- DynaMatic is a dynamic mutual conductance tester—NOT an emission checker.
- Accurately measures mutual conductance in micromhos on 2 ranges, 0-6000, 0-18000.
- Also checks battery tubes



136-10 31st Road
Flushing 54, N. Y.

Perfo
SYSTEM
Model DM456
Dealer Net 149.95

● NOTICE! ●
Rad-Tel Tube Co.
Has Moved To
Larger Quarters At
55 Chambers St., Newark 5, N. J.
New Larger Quarters To Serve You Better!

NOW... buy brand new Rad-Tel tubes and parts with complete assurance of the speediest possible service. No waiting, no delays—Rad-Tel's new, modern facilities give you better-than-ever service!

"MOVING DAY" SPECIALS! CONDENSERS

8 mfd, 475 V, tubular	10¢ ea.
20 mfd, 450 V, can	20¢ ea.
40 mfd, 450 V, can	20¢ ea.
250 mfd, 350 V, can	20¢ ea.

Write for Free, Complete Catalog of Tubes and Parts

—EXPORT INQUIRIES INVITED—



Not Avail. With Any Other Tube Mail Order Co.

TERMS: 25% deposit must accompany all orders—balance C.O.D. All shipments F.O.B. Irvington warehouse.

No Handling Charge With This Ad!!

PLEASE: Send full remittance. Allow for postage and save C.O.D. charges. Unused money refunded. Subject to prior sale.

55 Chambers St. Newark 5, N. J.



Only from famous COYNE do you get this modern up-to-the minute TV Home Training. Easy to follow instructions—fully illustrated with 2150 photos and diagrams. Not an old Radio Course with Television tacked on. Includes UHF and COLOR TV. Personal guidance by Coyne Staff. *Practical Job Guides* to help you EARN MONEY QUICKLY IN A TV-RADIO SALES AND SERVICE BUSINESS—part time or full time. COSTS MUCH LESS—pay only for training—no costly "put together kits."

SEND COUPON FOR FREE BOOK

SEND COUPON BELOW for Free Book and full details including EASY PAYMENT PLAN. NO COST OR OBLIGATION—NO SALESMAN WILL CALL.



B. W. COOKE, JR. PRES. **COYNE ELECTRICAL SCHOOL** FOUNDED 1899

A TECHNICAL TRADE INSTITUTE OPERATED NOT FOR PROFIT
500 S. Paulina Dept. B7-HT5 Chicago 12, Illinois

COYNE ELECTRICAL SCHOOL
Television Home Training Div.
500 S. Paulina St., Chicago 12, Ill., Dept. B7-HT5

Send FREE BOOK and details of your Television Home Training offer.

Name _____

Address _____

City _____ State _____

BUILD THE BEST— BUILD ALLIED'S OWN knight-kits

Here is a typical Knight-Kit value—available only from ALLIED—one of 45 great Knight-Kits you'll find in our special Supplement No. 165. Write for your FREE copy today.

knight-kit HOBBYIST VALUE PHOTO-ELECTRONIC RELAY KIT



Model Y-702 \$13.50

Build your own modern, dependable photo-electric system at low cost! System consists of relay kit and light source. Ideal as counter, announcer, burglar alarm (can be set to ring bell continuously when beam is broken) and for hundreds of other uses. An ultra-sensitive system, easy to assemble and capable of professional results.

Relay Kit Only. SPST contacts, rated 1 amp. Supplies 6.3 v. at 0.6 amps for alarm, counter, etc. Max. counting rate: 600 per minute. Uses sensitive cadmium selenide photocell. Usable distance from light source below: White, 250 ft; deep-red filter, 125 ft. With 5696 thyratron tube. Size, 5 x 3 x 5". Shpg. wt., 2½ lbs.

Model Y-702. Net, F.O.B. Chicago... \$13.50

Light Source Kit Only. Sealed-beam bulb; capped filament; removable dark red filter. 6 x 6 x 4". Shpg. wt., 3½ lbs.

Model Y-703. Net, F.O.B. Chicago... \$6.75

OTHER knight-kit HOBBYIST VALUES



WIRELESS BROADCASTER KIT
Y-705 \$9.50



50 W/SEC. ELECTRONIC PHOTOFLASH KIT
Y-244 \$28.50



PHONO AMPLIFIER KIT
Y-790 \$8.95

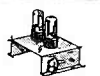

PHONO OSCILLATOR KIT
Y-760 \$5.85

See our Supplement No. 165 for 12 other knight-kit hobbyist values

free SUPPLEMENT featuring knight-kits



Send for our FREE Supplement No. 165 featuring 45 great Knight-Kits, including Test Instruments, Hi-Fi, Hobbyist and Amateur Kits. Write for your copy today.

ORDER FROM ALLIED RADIO

Dept. 01-G7, 100 N. Western Ave., Chicago 80, Ill.

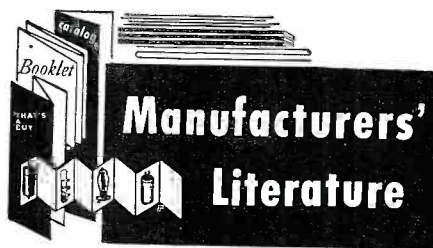

ELECTRONIC DEVELOPMENTS

The Office of Technical Services, U. S. Department of Commerce, Washington 25, D. C., has announced the publication of two reports of interest to the electrical and electronics industries.

Based on research sponsored by the Armed Forces, the first publication covers transistor feedback amplifier design. Written by G. L. Benning, the 29-page publication (PB 121556) is priced at 75 cents a copy. The second report, entitled "Lovotron—A Low Voltage Triggered Gap Switch," is written by E. H. Cullington, W. G. Chace, and R. L. Morgan and is available for 50 cents a copy as publication PB 121061.

All orders to the OTS should be accompanied by payment in full.

VECTOR PRODUCTS

Vector Electronic Company, 3352 San Fernando Road, Los Angeles 65, Calif., has issued a series of catalogue and data sheets which describe a variety of socket-turrets, socket-strips, plug-in units, tube-socket test adapters, socket extenders and adapters, zip terminals, experimenter's chassis, and other specialized components for prototype, production, and service engineering.

Write the company outlining the application for which the product is desired and the firm will forward the appropriate data sheet.

SILICON IN ELECTRONICS

Aries Laboratories, Inc., 41 E. 42nd St., New York 17, N. Y., has published a 20-page monograph entitled "The Relationship of Silicon and Its Properties to the Electronics Industry" as a public service.

Available on letterhead request, this publication is a basic, mathematical treatment of this material which makes possible better transistors, rectifiers, computers, and instruments.

Characteristics of silicon in rectifiers, solar batteries, transistors, etc., and the methods of device fabrication are all covered by Dr. Donald R. Mason, consultant to *Aries*.

CALIFORNIA CHASSIS DATA

California Chassis Co., 5445 E. Century Blvd., Lynwood, Calif., has issued a two-color, 20-page catalogue covering its line of cabinets, racks, and accessory units.

Catalogue No. 357 pictures and describes an extensive assortment of enclosures and foundations for a variety of construction and production applications. The company makes well over 400 different models, styles, and sizes

of metal chassis, most of which are described in the catalogue. It is free on request.

TRANSISTORIZED INSTRUMENTS

Kay Electric Company, 14 Maple Ave., Pine Brook, N. J., has issued a four-page data sheet on its complementary new line of all-transistorized instruments.

The publication describes and pictures the "Audiolator," the "Minilator," the "Transifier," the "Transiprobe," "Transiply," and "Transvolter" which are transistor versions of a b.f.o., multi-crystal-controlled oscillator, wide-band video amplifier, probe, power supply, and voltmeter, respectively.

The data sheet is available without charge on request.

TRIAD TRANSFORMERS

Triad Transformer Corporation, 4055 Redwood Ave., Venice, Calif., has released copies of its new 30-page general catalogue, TR-57.

Included in the publication are specifications and physical details on a complete line of transformers for audio, amateur, receiver, power and instrumentation applications. The catalogue is indexed by classification and type numbers to facilitate location of the exact transformer for the job requirement.

Write the manufacturer direct for a copy of this catalogue.

NEWARK SUPPLEMENT

Newark Electric Company, 223 W. Madison St., Chicago 6, Ill., has issued Supplement No. 67 covering hundreds of industrial, audio, amateur, television, and radio equipment items and components.

The 32-page publication carries pictures and complete descriptive data on a variety of items for the service technician, the hobbyist, experimenter, ham, and industrial maintenance technician. Copies of the flyer are available without charge either from the Chicago office or from the West Coast sales division at 4736 W. Century Blvd., Inglewood, Calif.

"TANTALYTIC" DATA

General Electric Company, Schenectady, N. Y., has issued a four-page bulletin which describes its line of micro-miniature capacitors for low-voltage, direct-current applications where large capacitance values are required in a small space.

The publication includes ratings and dimensions on the company's "Tantalytic" units. Copies of folder GEA-6065C will be supplied without charge on written request.

NEW NEMA STANDARDS

The National Electrical Manufacturers Association, 155 E. 44th St., New York 17, N. Y., has announced publication of a revision of standards covering a wide range of products and applications in the semiconductor industry.

The revision, entitled "NEMA Standards for Metallic Rectifiers," is an amplification of the 1953 publication. Copies are priced at \$3.50 each and may be ordered direct from the association.

MOTORS AND FANS

Ashland Electric Products, Inc., 32-02 Queens Blvd., Long Island City 1, N. Y., has just issued a 14-page catalogue covering its line of specialty motors, fans, and blowers for the electronics and instrumentation fields.

The publication provides full details, physical specifications, and electrical characteristics on a line of synchronous, torque, induction, and gear motors; centrifugal blowers; and axial fans. Both standard and custom models are available to order for commercial or military applications.

The catalogue will be forwarded on request to the company.

ALLIED FLYER

Allied Radio Corporation, 100 N. Western Ave., Chicago 80, Ill., has released its supplement No. 165 covering hundreds of new and specially priced items as well as standard components and equipment.

Designed to be used with its 1957 Catalogue 160, this new 72-page publication carries details on several new releases, including the "Knight" FM tuner kit, a 2-transistor pocket radio kit, p.a. amplifier, and a "Tri-Fi" speaker. A complete listing of the "Knight-Kit" line is also carried in the flyer.

The company will supply free copies of this flyer upon written request.

TRANSITRON BULLETIN

Transitron Electronics Corporation, Melrose 76, Mass., is now distributing a packet of engineering data sheets on its line of silicon voltage regulators and references.

The folder includes a four-page data sheet on application notes and design information while individual specification and rating sheets on three types of silicon regulators are also enclosed in the folder.

Write the manufacturer direct for full details on these subminiature, miniature, and power type silicon voltage regulators.

TUNG-SOL SEMICONDUCTORS

The Semiconductor Division of *Tung-Sol Electric Inc.*, 95 Eighth Ave., Newark 4, N. J., has issued a series of data sheets on its line of germanium transistors.

A separate sheet is devoted to each type with details on recommended applications, physical specifications, mechanical data, absolute maximum ratings, and small signal parameters. Typical operation is provided in tabular and graph form.

The folder which encloses the sheets provides useful information on power ratings, standard transistor symbols, a conversion chart, as well as distribution information.

Enjoy the Prestige of A Field Assignment with BENDIX RADIO!

**ELECTRONIC
FIELD
ENGINEERS**

Engineering degree or
equivalent experi-
ence in electronic
systems re-
quired.

**FIELD SERVICE
TECHNICIANS**

Technical school, plus
three years experi-
ence required.
Military ex-
perience ac-
ceptable.

Pride in your work and your recognition in the field—that's important to the "inner man". The opportunity to advance rapidly and to grow in your profession—that's important to your future! Excellent starting salaries and field allowances—they're important to the family! You will obtain all these advantages when you choose a field assignment with the leader in its field—Bendix Radio!

Simply drop us a postal card stating education & experience. We'll arrange for a personal interview.

Address:
MR. O. A. BOWMAN
Field Engineering

Bendix Radio

DIVISION OF BENDIX AVIATION CORP.
SMITH & GREENSPRING AVENUES
BALTIMORE 9, MARYLAND

U. S. Crystals offers the most complete line of guaranteed crystal frequencies for the novice, amateur, technician, and the experimenter.

NOVICE BAND FT-243 FUNDAMENTAL OR DC-34 FREQUENCIES **99c**

YOUR CHOICE OF FREQUENCIES!

80 METERS 3701 through 3748 in steps of 1 KC. FT-243 or DC-34.

40 METERS 7150 through 7198 in steps of 1 KC. FT-243 only.

DOUBLING TO 40 MTRS. 3576 thru 3599 in steps of 1 KC. FT-243 or DC-34.

15 METERS 5276 through 5312 in steps of 1 KC. FT-243 or DC-34.

FT-241 SSB. Matched Pairs.....pr. \$1.95

FT-241 Sgls. Side Band low freq'cy Crystals—

370 KC to 540 KC.....ea. 49c

DC 34/35 from 1690 to 4440 KC.....ea. 49c

AN/TRC-1 FT-241 holders from 729-1040 KC—

1000 KC excluded.....49c

FT-241 200 KC or 500 KC.....ea. \$1.00

FT-243 1000 KC Marker Std.....ea. \$2.95

100 KC FT-249 RCA VC-5.....ea. \$4.95

160 Meter—FT-243 1005-1999 KC ea. \$1.99

Marine and C.A.P.

ALL FREQUENCIES AVAILABLE NOW!

2009 - 2182 - 2637 etc. Tol. .005% ea. \$2.99

SPECIAL - FT-243 XTALS.....ea. 49c

from 2015 to 8750 frequency

SEND FOR FREQ. LISTING & CATALOG

Include 5c per crystal for post. & ins. Calif. add 4% Tax. No C.O.D.'s. Prices subj. to chge. Ind. 2nd choice; sub. may be nec. Min. Ord. \$2.50.

U. S. CRYSTALS, INC.

1342 So. La Brea Ave., Los Angeles 19, Calif.

Another
Sencore
Time-
Saver

SENCORE FILAMENT CHECKER

MODEL FC-4



- ★ COMPLETELY NEW
- ★ MORE VERSATILE
- ★ LOWER COST



Quickly finds any open filament. Especially handy for servicing series filament TV sets and radios; only checker that checks all octals, locals, 7 and 9 pin miniatures automatically.

**Only
\$295**
DEALER NET
WITHOUT LEADS
\$2.75

Continuity and voltage tester — no switches, merely plug in test leads.

AT LEADING DISTRIBUTORS
EVERYWHERE
Mfg by



SERVICE

INSTRUMENTS CORP.

171 OFFICIAL RD., ADDISON, ILL.

POPULAR
SENCORE
PRODUCTS

- Transistor Tester
- Leakage Checker
- Filament Tester
- Voltage Regulator
- Bias Supply

AIREX
THE HI-FIDELITY
SUPERMARKET

WHERE THE
PRICE IS
ALWAYS RIGHT

RECORD CHANGER BARGAIN

LATEST WEBSTER AUTOMATIC CHANGER: Inter-mixes 10"-12" records. Automatic shut-off. Heavy duty 4 pole motor. With line cord and plugs, less cartridge..... **\$19.95**

NEWEST MODEL MONARCH 4 SPEED CHANGER: 4 pole motor, intermix, manual player position, automatic shut-off. British made. Complete with Ronette dual sapphire styli cart. **\$24.95**
Base for above—\$3.95; 45 spindle—\$2.49

GENUINE RELUCTANCE CARTRIDGE GE RPK 052A. Triple play .003 mill sapphire & .001 mill diamond. Clip-in Stylus. Stylus pressure pressure 6-8 grams..... **\$16.59**

NATIONALLY FAMOUS RELUCTANCE CART TYPE OSO. Triple play sapphire needles for all records, clip-in stylus, stylus pressure pressure 6-8 grams..... **\$6.95**

NEW BOGEN DB 20 DF HI-FIDELITY AMPLIFIER KIT

Kit version of the most famous 20 watt amplifier on the market. Rated No. 1 by leading research organizations. Complete versatile control of sound reproduction in a single amplifier. 5 position loudness contour selector; 7 position record equalizer; DC on preamp filaments; 7 feed back loops; rumble filter; variable damping factor; response 20-20,000 cps \pm 7 db; hum—75 db; distortion 0.3% at 20 watts. Complete with full step-by-step pictorial & schematic instructions & all tubes & parts..... **\$69.50**
Above model factory wired..... **\$108.00**
Factory wired, less damping factor..... **\$99.00**
Cover for above amplifier..... **\$6.25**



Grommes Hi-Fi Amplifier Kits

10 Watts, 18 watts peak. Resp. 20-20,000 cps 1 db. Preamp., 4 inputs. Hum—80 db. 2% Harm. Dist at 10 watts. Complete with detailed step by step instruction manual, all resistors, condensers, tubes, wire & solder. Easy to make, 2-12AX7, 2-6V6, & 5Y3. Bass & Treble boost. Limited quantity. **\$24.95**



FM-AM TUNER KIT

Easy to assemble. Professional quality performance. 3 double tuned IF stages, Fosterley discriminator, automatic frequency control, automatic frequency rectifier, distortion less than 1% 7 tubes—70DB. Sensitivity 6 microvolts for 20 dB quieting on FM & 20 microvolts on AM. FM selectivity 200KC band width 8 DB down; AM SKC band width 5 DB down. 5 1/2" high x 9 1/2" wide x 8" deep. Complete with step-by-step instructions..... **\$31.95**
FM TUNER ONLY—\$25.50 • COVER—\$3.95
These units are ideal in combination with any of the Hi-Fi Amplifier kits listed above.

MULLARD HI-FIDELITY TUBES

Type	Replaces	Price	Type	Replaces	Price
EL34	6CA7	\$4.35	ECC82	12U7	\$2.20
EL37	6L6; 5881;	\$3.50	ECC83	12AX7	\$2.50
	K66	\$3.50	EF86	2729;	\$2.75
EL84	6R5	\$2.40	G232	5V4; 5U4	\$2.95
ECC81	12AT7	\$2.60			

Nationally Known Utah Speakers

12" coaxial, exclusive built-in crossover network assures a frequency response from 35 to 17,500 cps, 12 watt cap, 8 OHMS impedance. Reg. \$24.95..... **\$12.88**

FAMOUS NORELCO SPEAKERS

Model 9762M—12" twin cone coaxial type, full response speaker. Frequency range 35 to 18,000 cps. Flux density 11,000 GAUSS, 30 watt capacity. Impedance 8 OHMS. One of the finest quality speakers on the market today. Reg. list \$99.50..... **\$39.95**

MODEL 9770M—8" TWIN CONE COAXIAL

Full response speaker. Range 75-19,000 cps without baffle. Flux density 11000 gauss. 10 **\$9.90**
watts. Regularly \$16.50.....

EICO HI-FI AMPLIFIER KIT

60 watt ultralinear power amplifier with Acrosound TO-330 output transformer. 160 watt peak. Hum 90db. Response at 60 watt \pm 1db 15 cps to 35 KC. 4, 8 & 16 ohm taps. Push pull EL 34. EF 86 low noise voltage amplifier direct coupled to 6SN7GTB cathode coupled phase converter. Output tubes operated with fixed bias. Sensitivity .55V for 60W. Damping factor 17. Inverse feed-back 21db. Will work with any self-powered or external powered pre-amp. Send for complete EICO catalog.. **\$72.95**

SESSIONS CLOCK TIMER

Can be used to turn on Hi-Fi equipment, tape recorders, radios, TV sets, etc. 15 AMP capacity. 2 hour delay-off feature. Manual or automatic set. Reg. \$12.50..... **\$3.95**

We are national distributors for

- Berlant-Concertone • Bogen • Fisher
- Harman-Kardon • Jensen • Pentron • Pilot
- Fairchild • Pickering • Hartley • Karlson
- Rek-o-kut • Sherwood • University, etc.

If you are building a Hi-Fi System, SEND US YOUR LIST OF COMPONENTS. We will give you a PACKAGE QUOTATION ON THEM. Hi-Fi Yearbook—\$1.95 (Refundable with purchase from yearbook).

All merchandise is brand new, factory fresh & guaranteed. Mail & phone orders filled on receipt of certified check or MO of 20% of items as a deposit. Balance C.O.D. F.O.B. factory N. Y. Prices & specifications subject to change without notice.

AIREX RADIO CORP.

64 Cortlandt St., N.Y. 7, N.Y., CO 7-2137

What's

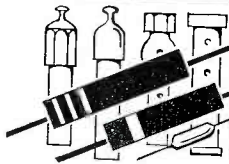

New in Radio

CONELRAD ALARM KIT

Heath Company of Benton Harbor, Mich., has added a simple, easy-to-build Conelrad alarm, Model CA-1, to its extensive line of kits.

Complying fully with FCC regulations for amateurs and designed to be used with any radio receiver that has



a.v.c., when the monitored station goes off the air the Model CA-1 automatically cuts a.c. power to the transmitter and lights a red indicator. A manual "reset" button re-activates the transmitter.

The circuit features its own heavy-duty 8 amp. relay, a thyatron tube to activate the relay, and a built-in power supply with transformer isolation. A neon lamp indicates the presence of "B+" in the alarm circuit. The unit is simple to install. A sensitivity control adjusts to various a.v.c. levels. The receiver volume control can be operated without affecting alarm operation.

MINIATURE ELECTROLYTICS

P. R. Mallory & Co., Inc., 3029 E. Washington St., Indianapolis 6, Ind., has announced the availability of a

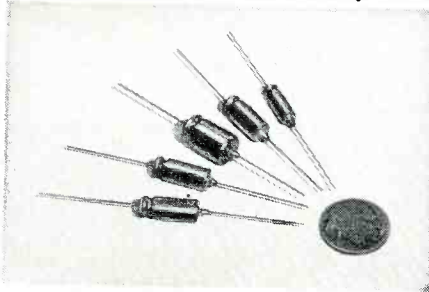

new line of low-cost subminiature aluminum-cased electrolytic capacitors which has been designated as the TT series.

These units can be used for replacement service in all miniature electronic equipment or for original equipment applications in transistor and battery powered units.

The line is being offered in more

than 30 capacity and voltage ratings from 1 to 110 μ fd. and from 1 to 50 working volts. The smallest of the line measures only 3/16" diameter by 1/2" long. They are designed to withstand temperatures from -20 to 65 degrees C. Complete information and ratings are available from the company's distributors.

CEMENT SAMPLER KIT

General Cement Mfg. Co., 400 S. Wyman St., Rockford, Ill., has assembled a "sampler kit" of various types of cements to enable engineers and others engaged in production, research, and development work to select the most suitable adhesive.

The kit includes 14 two-ounce bottles, each with a brush-in-top cap and sealed for full protection until needed. Such items as Bakelite, vinyl, Neoprene, fabric, rubber, wood, and other plastics may be fastened securely with these cements.

Distribution is being handled by regular parts outlets. The kit is catalogued as the No. 345.

50-WATT SOLDER PENCIL

Hexacon Electric Company, 213 W. Clay Ave., Roselle Park, N. J., is mar-

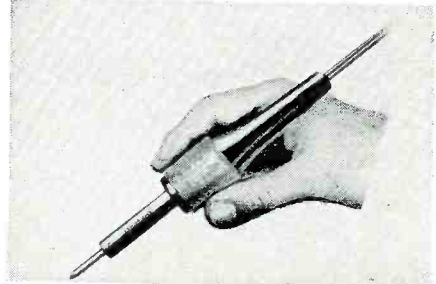

keting a new soldering pencil equipped with a long-life 1/4" tip and rated at 50 watts.

Capable of doing the work of a 100-watt iron, yet weighing but two ounces, the new stainless steel alloy used for the element housing insures a cool handle and maximum soldering efficiency, according to the company.

Designed and recommended for constant-duty, 24 hours a day on fast production lines, the new pencil will operate on a.c. or d.c. It is available for 110 or 220 volts and is catalogued as the No. 24S.

BATTERY ELIMINATOR KIT

One of the instruments in a new line of kits being introduced by Paco Electronics Company, Inc., 70-31 84th St., Glendale 27, N. Y., is the Model B-10 battery eliminator kit.

The instrument provides both 6 and 12 volt outputs and incorporates over-

load protection. Voltage output is continuously variable. The unit also doubles as a battery charger.

The heavy-duty, louvered steel cabinet has a two-color panel. The case measures 7" x 11½" x 6⅝" over-all. The company will supply full details on this and other kits in the line, upon request.



inet has a two-color panel. The case measures 7" x 11½" x 6⅝" over-all. The company will supply full details on this and other kits in the line, upon request.

CR TUBE RESTORER

Circuit Manufacturing Co., Inc., 6211 Market St., Philadelphia, Pa., is in production on a new cathode-ray tube restorer which is said to return the tube to normal brilliance in some 33 cases of tube failure.

Marketed as the "Nu Life Kinecure," the device contains elements which correct open cathode, open control grid, shorted control grid to cathode, and shorted cathode to filament. In addition, the unit overcomes 29 other single or combination of causes of low emission or slow heating in CR tubes. The restorer can be used in series or parallel operation or in electrostatic focus CRT's.

Distribution is being handled through parts jobbers with additional details available from the manufacturer on request.

VIBRATOR TEST ADAPTER

Pomona Electronics Co., Inc., 1126 W. Fifth Ave., Pomona, Calif., is now offering a vibrator test adapter which is designed to be used with any standard tube tester.

The "Peco" adapter is of compact durable phenolic construction. A working vibrator will show approximately



equal brilliance on both lights of the adapter, with one or both lights not illuminated indicating a vibrator defect.

The device will instantly show when

New Macmillan BOOKS ON RADIO AND TV

Matthew Mandl's

HANDBOOK of BASIC CIRCUITS TV, FM, AM \$7.50

Now one book answers all electronic circuit questions. Schematics and descriptions of 136 circuits for TV, FM, AM, Hi-Fi and PA systems are arranged alphabetically for quick reference. Each is treated as a separate unit telling purpose, characteristics, use and function, clearly and briefly. It's an extra tool to help you make money by saving you time.

Edward Noll's

CLOSED CIRCUIT and INDUSTRIAL TELEVISION \$4.95

Get in on the ground floor of a fast growing field. Learn how to set-up, operate, maintain and construct every part of a closed-circuit system in terms written for technicians. Every step explained for quick understanding. You can actually make a closed-circuit TV system for use in your own home, simply and inexpensively. Learn how from a master.



FREE EXAMINATION

Study Mandl's HANDBOOK OF BASIC CIRCUITS (\$7.50) and Noll's CLOSED-CIRCUIT and INDUSTRIAL TELEVISION (\$4.95) for 10 days FREE. If not satisfied return them. Otherwise we will bill you the price of each plus a small delivery charge. Fill in and mail the coupon now!

THE MACMILLAN COMPANY, Dept. RE6 (RT2), 60 Fifth Ave., New York 11, N. Y.

Please send me on 10-day approval book(s) checked:

- HANDBOOK OF BASIC CIRCUITS TV, FM, AM \$7.50
 CLOSED-CIRCUIT and INDUSTRIAL TELEVISION \$4.95

Check or M.O. enclosed Bill me later (return privilege guaranteed)

Name

Address

City & State

Distributed in Canada by Brett-Macmillan Ltd. 25 Hollinger Rd., Toronto 16

BEWARE OF IMITATIONS

There Is Only One Original, Dependable
NO-NOISE TUNER-TONIC
with PERMA-FILM

Cleans, lubricates, restores all tuners, including water type. Won't change or affect capacities, inductance or resistance. Won't harm insulations or precious metals, nor attack plastics. Eliminates all noise, oxidation and dirt indefinitely. For television, radio and FM.

Non-toxic, non-inflammable, insures trouble-free performance.

\$3.25

Extra economical because a small amount does the job!



Volume Control and Contact Restorer with Perma-Film



Cleans, lubricates, protects NOT A CARBON-TET SOLUTION. Still available in the new 6 oz. spray can. Net to servicemen \$2.25

\$1.00

Also available in 8 oz. bottles and quart cans.



ELECTRONIC CHEMICAL CORP.

813 Communipaw Avenue Jersey City 4, N. J.

GET INTO ONE OF THESE TOP OPPORTUNITY FIELDS

ELECTRICITY

- Electronics of

TELEVISION

- Radio-Color TV

TRAIN IN THE GREAT SHOPS OF

COYNE

OLDEST, BEST EQUIPPED SCHOOL OF ITS KIND IN U. S.

Veterans and Non-Veterans—Prepare for a better job NOW that offers a real future, too! Get practical training in TELEVISION—RADIO—ELECTRICITY—ELECTRONICS—(Refrigeration & Electric Appliance Repair can be included). Learn on real equipment—no advanced education or previous experience needed. Lifetime employment service to graduates.

Finance Plan—enroll now, pay most of tuition later. Part time employment help to students.

FREE BOOK Clip coupon for Big Free Illustrated Book. No salesman will call. Act NOW.

B. W. COOKE, JR., President

COYNE

FOUNDED 1899

ELECTRICAL SCHOOL
A TECHNICAL TRADE INSTITUTE OPERATED NOT FOR PROFIT
500 S. PAULINA ST., CHICAGO, Dept. B7-85H
ELECTRICITY • TELEVISION • RADIO • REFRIGERATION • ELECTRONICS

B. W. COOKE, JR., Pres., COYNE ELECTRICAL School
500 S. Paulina St., Chicago 12, Ill., Dept. B7-85H

Send FREE BOOK and details on:

- TELEVISION-RADIO
 ELECTRICITY-ELECTRONICS

NAME

ADDRESS

CITY.....STATE.....

LM FREQUENCY METER

Heterodyne, crystal calibrated, modulated with calibration book \$49.50
125KC to 20,000KC—Exc. . . . ea.
less calibration book—\$29.50

LORAN APN-4

FINE QUALITY NAVIGATIONAL EQUIPMENT

Determine exact geographic position of your boat or plane! Complete, BRAND NEW installation consists of: LD-5B/APN-4 Indicator; R-9B/APN-4 Receiver; PE-206 Inverter; Set of Plugs; Visor for Indicator; Operation manual; \$129.50
Brand New, Export packed. . . . \$149.50
12 VDC Installation. . . . \$149.50
ID6B INDICATOR, R98 RECEIVER, \$39.50
Excellent
I-222-SIGNAL GEN. and Heterodyne wave-meter. 110VAC-60 cycle, 8-15MC and 135-230MC.
BRAND NEW. . . . \$39.50
Exc. . . . \$29.50

RM29 CONTROL UNIT

Containing ringer, 3 pos. locking type selector for monitor, direct or radio control. May also be used as portable battery operated telephone.
BRAND NEW, 6.95 2 for \$12.00
Used, 4.95 2 for 9.00
TS-13 HAND SET for above. exc. 5.95

DYNAMOTOR—12 volt for command ARC or ARA receivers, 200 VDC 60MA
BRAND NEW. \$4.95

COAXIAL CABLE

50 ohm—330 ft. lengths. New \$9.95
60 ft. lengths. New \$1.95 ea.
5CP1—Brand new. \$1.75 each

T-20 4 to 5.3 MC New
T-21 5.3 to 7 MC \$5.95
Used \$3.95

T-23 100-156 MC
New \$16.95
Used 9.95
3 to 4 mc. like new. 5.95

RECEIVERS Excellent
190-550 KC Used \$9.95

3 CM-X Band Airborne Search Radar

Brand new Rec. & Trans. with Parabolic Antenna; complete with amplifiers, indicators, control box, lens, junction box, connectors.
Tube complement consists of: 723—2 ea., 5U4—2 ea., 1B22—4 ea., 3B24—3 ea., 5U4—30 ea., 6J6—11 ea., 6AK5—4 ea., 6SL7GT—2 ea., 724A—1 ea., 725A—1 ea., 807—1 ea., VR-105—4 ea., VR150. (government acquisition cost over \$4000.00) Ship. wt. 35.0 lbs.
YOUR SPECIAL PRICE. \$69.50
F.O.B. Penna. warehouse
28VDC Inverter for above
exc. \$9.95

BC 923 MOBILE FM RECEIVER, 27-38.9 MC

Complete with built-in loudspeaker, squelch control, speaker phone switch, sensitivity control, variable (Permeability) tuning for each channel of 4 channels permits pre-setting of 4 frequencies. Exc. \$34.50
Used \$29.50
Measurement Corp. Model 78F SIGNAL GENERATOR: 15 to 50 MC—1 Microvolt; 100,000 Microvolts—110 Volt 60 cycle. BRAND NEW
F.O.B. Chicago—\$49.50
GN-38B HAND CRANKED GENERATOR, Alnico magnet. NEW \$3.95
OSCILLOSCOPE 1D59/APA-11 EXC. \$39.50
MODULATOR with tubes. 2 ea. 813; 1 ea. 807; 1 ea. 5R4; 2 ea. 6AG7; 1 ea. 604 EXC. \$14.95

Sweet Oscilloscope Deals

INDICATOR UNIT. For conversion to test scope, nanalyzer, analyzer, etc. Double deck chassis. 5CP1 mounted in tube shield. Less small tubes and crystal, but complete with 5CP1. \$9.95
Exc. Cond. each
Cornl. w/27 Tubes, Crystal & 100KC \$29.50
ASB-7 Radar Indicator Unit: For conversion to test scope or for use as modulation monitor. Has standard test-scope CR tube, H Cent, V Cent, Brill. Foc. Gain, and range selection switch. External power source was used. Tubes: 4-6AC7, 3-6H6, with 1-5BP1. New. \$9.95

UHF TRANSCEIVER, APG-5

2500 Mc complete with 2C43, 2C40, 3E29, 1B27, VR105, 5Y3, 6AL5, 2 each \$29.50
2X2 and 8 each 6AK5 \$4.95 ea.
Cavity Only, New, less tubes. \$2.95
Radio Receiver 11-tube UHF tunable 234-258 MC
Complete with schematic.
7 ea. of 9001, 1 ea. of 12A6, Like new
Less Tubes. \$2.95

RAX Navy Aircraft Receiver 200-1500 Kc. Used exc. \$14.95

WRITE FOR NEW BULLETIN
ALL ITEMS F.O.B. CHICAGO
25% Deposit required with orders

R W ELECTRONICS

2430 S. Michigan Ave., Chicago 16, Ill.
Dept. N, PHONE: CALumet 5-1281-2-3

contacts are sticking or open and will indicate starting voltage. The Model 4A checks any standard 4-prong vibrator which has a 6 or 12 volt A base shunt-driven coil while the Model 3D is used to check any standard 3-prong vibrator with a 12-volt D base shunt-driven coil.

AMECO MONITOR

American Electronics Co., 1203-05 Bryant Ave., New York 59, N. Y., is now offering a compact, easy-to-install Conelrad monitor, Model CD-1, which is designed to be attached to any home receiver having a.v.c.

Housed in a black Bakelite case with brushed copper panel, the new unit is supplied completely wired and tested.



When the broadcast station goes off the air, a loud and clear tone is immediately sounded in the receiver. A twin-triode 12AU7 and two transformers are used in this new "Ameco" unit. A monitor switch allows the receiver to function normally or turns on the Conelrad alarm system. The device can also be used as a code practice oscillator.

The company will forward a data sheet on the Model CD-1 on request.

TUBE BRITENER

Anchor Products Co., 2712 W. Montrose Ave., Chicago 18, Ill., is in production on a heavy-duty, multi-purpose

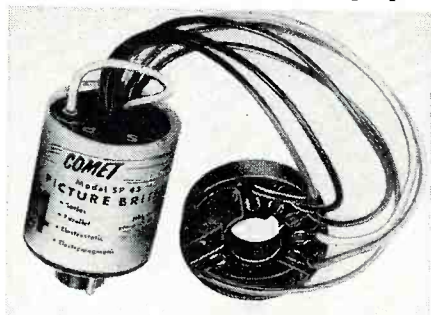

picture tube britener, the "Comet SP43."

Designed to be used with either series or parallel wired filament circuits and for tubes requiring either electro-magnetic or electrostatic picture tube focusing, the unit may be quickly installed and fits all makes of TV receivers.

RADIO FOR SMALL PLANES

Nova-Tech, Inc., 1721 Sepulveda Blvd., Manhattan Beach, Calif., is offering a moderately priced transmitter-receiver which has been especially

designed for the private plane market.

The "Air-O-Ear" TR-102 consists of a 10-channel v.h.f. transmitter, a v.h.f.

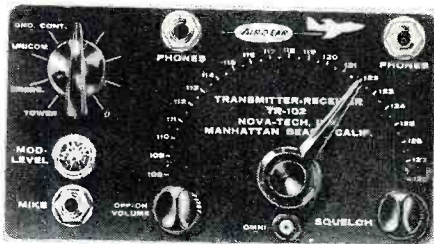

receiver tunable from 108 to 128 mc., a built-in modulator, and a power supply. The instrument uses high-power crystals and conforms to the newest CAA high-density zone requirements. Range is 50 to 150 miles.

A special ignition suppressor permits operation with unshielded ignition systems. Other features include a noise squelch control, front panel plug-in for "Omni," front panel modulation indicator for the transmitter, and two headset jacks. It comes complete, ready to operate, with antenna and crystals.

"METER-GUARD"

Electronic Development Laboratories of 71 Nassau St., New York 38, N. Y., has come up with a unique item for the service technician.

Known as "Meter-Guard," the new device safeguards service meters by eliminating damage while the instrument is in use, prevents dropped tools from harming the meter, prevents loose, cracked, and broken meter glasses, keeps dirt out of the meter movement, prevents breakage when the instrument falls on its face, and stops meter damage during transit.

The guard unit slips over the meter case and forms a complete invisible shield for the delicate meter. Units to fit Simpson's Models 260, 276, 303, and 880 instruments are available. Write the manufacturer for a data sheet describing this product.

PHOTOELECTRONIC SYSTEM KIT

Allied Radio Corporation, 100 N. Western Ave., Chicago 80, Ill., has added a low-cost photoelectronic system to its "Knight" line of kits.

Consisting of two separate units—an extremely sensitive photoelectronic relay and a powerful long-distance light source—it can be used to turn on an electrical device whenever its beam of light is interrupted.

The sensitivity of the cadmium selenide cell used in the circuit permits operation as far as 250 feet from its matching light source and when used with the "unseen light" red filter supplied, its effective range is 125 feet. The equipment is designed to operate from 105-120 volts, 50 or 60 cycles a.c. It is housed in a professionally styled, two-tone blue case.

The kit comes complete with all parts, tubes, photocell, and detailed instructions for assembly and use. The relay kit is Stock No. 83 Y 702, while the light source, complete with sealed-

beam bulb and infrared filter, is catalogued as Stock No. 83 Y 703. Write the company for full details.

MOBILE POWER CONVERTERS

Terado Company, 1068 Raymond Ave., St. Paul 14, Minn., is now offering two new and specially designed mobile power converters which have been developed specifically for operating television receivers.

The "Supreme" and "TV Special Chief" permit television receivers to be operated anywhere off a car battery or a boat power system. The "Supreme" model has a constant output capacity of 175 to 200 watts and is equipped with a fan-cooled vibrator. It is easily installed with a remote control and switch, signal light, and plug-in outlet

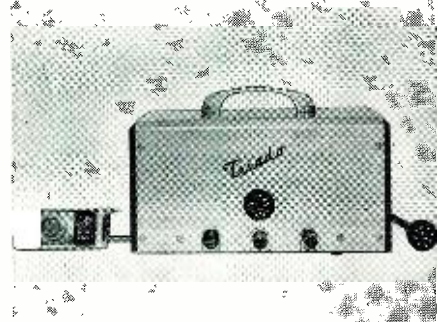

just under the dashboard of the car. It is designed for use with 12-volt battery systems.

The second unit can be mounted under the dash with remote control unnecessary. It has its own plug-in receptacle and will handle 100 to 125 watts. It, too, is designed for 12-volt battery systems. Both converters provide 110-volt, 60-cycle a.c. output.

Full details on these and other converters in the company's line will be provided upon request to the manufacturer.

VACUUM-TUBE PREHEATER

Service Instruments Corp. (Sencore), 171 Official Road, Addison, Ill., has developed a vacuum-tube preheater that will accommodate up to 20 tubes at a time and handle the latest types of series filament tubes.

The Model FP22 incorporates a

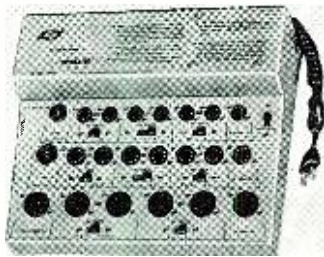

quick heat switch which increases filament voltages by 10%, thus accelerating gassy and intermittent conditions. Both 7- and 9-pin miniature tube straighteners are also provided.

The instrument is designed to save service time as the tubes from a suspected section or from an entire re-

ceiver can be inserted in the preheater and allowed to heat for as long as necessary. The tubes are then inserted in a tube checker while they are hot. A 10 ampere transformer permits up to 20 tubes to be preheated at one time for an indefinite period.

TINY INSULATED TERMINALS

Sealectro Corporation, 610 Fayette Ave., Mamaroneck, N. Y., has developed a line of subminiature insulated "Press-Fit" stand-offs and feedthroughs.

Dispensing with threads, nuts, washers, lockwashers, and seals by taking full advantage of the Teflon insulation and press-fit installation, the new units range in size from .093" in diameter and from .250" to .5" over-all height, depending on whether they are stand-offs or feedthroughs.

A manual covering these subminiatures as well as miniature terminals, breakaway connectors, and test point jacks is available from the manufacturer on request.

WUERTH "SURGISTOR"

Wuerth Tube-Saver Corporation, 9125 Livernois Ave., Detroit 4, Mich., has developed a unique device which eliminates destructive in-rush currents in all electronic equipment and is now offering it as the "Surgistor."

This compact component combines the functions of a resistor and a relay.

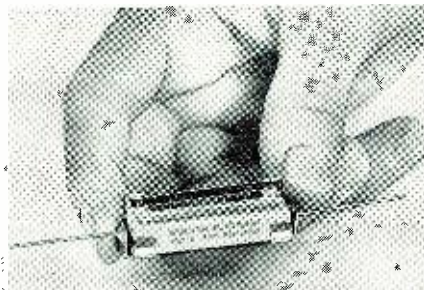

It is easily connected directly into the power line circuit of any device. It limits current until the tube heaters are warmed sufficiently to accept the full voltage without damage. In addition, "B+" voltages are temporarily reduced to prevent cathode "stripping."

NEW BEAM POWER TUBE

The Electron Tube Division of *Radio Corporation of America*, Harrison, N. J., has announced the development of a new beam power tube of the 7-pin miniature type which has been designed specifically to operate as a class A amplifier in the audio output stage of TV and radio receivers.

The RCA-6DS5, when used in cathode-bias circuits, can deliver a maximum-signal power output of approximately 3.6 watts with a peak a.f. grid No. 1 voltage of only 9.2 volts. Cool operation of grid No. 1, made possible by structural design, minimizes grid emission. Because of this feature, the 6DS5 can be used with cathode bias and a relatively large value of grid No. 1 circuit resistance. This feature is particularly significant in TV receivers

8 NEW

PRODUCTS

... just a few of the many
new B-T precision
engineered products



FIELD STRENGTH METER Model FSM-1

A portable precision instrument for accurate measurement of RF signals. Continuous tuning from 54 mc to 216 mc covering VHF-TV, FM, mobile, aircraft, ham, industrial and CD. Use of B-T UHF converter extends range to entire UHF band. **\$310 net**

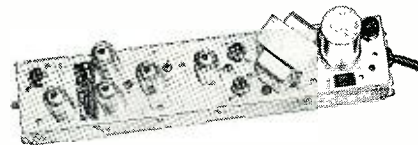

3 MASTERLINE CRYSTAL-CONTROLLED CONVERTERS

Model MVC: Hi-to-Lo channel VHF converter.

Model MLC: Lo-to-Lo channel VHF converter.

Model MUC: UHF to VHF converter.

List \$300 Each

Extremely stable, self-powered with two matched 75 ohm outputs. All channel VHF mixing network. Flat within 1/2 db over full 6 mc output. For color and black and white TV.

4 INDOOR TV SYSTEM TAPOFFS

Easy to install, matched low cost tapoffs

Model TO1-75: single isolated tapoff for recessed mounting. For RG-11/U or RG-59/U, with 75 ohm jack. **List \$4.50**

Model TO1-300: has 300 ohm terminals. **List \$4.50**

Model TO2-75: two 75 ohm outlets from RG-11/U or RG-59/U cable. **List \$9.00**

Model TO2-300: two 300 ohm isolated outlets from RG-11/U or RG-59/U cable. **List \$9.00**

sold by electronic parts distributors
for further information use coupon below

BLONDER-TONGUE LABS, INC.
9-25 Alling Street, Newark 2, N. J.

Please send me literature covering:

Field Strength Meter Masterline Converters
 Indoor TV System Tapoffs

Name.....
Address.....
City..... Zone..... State.....

STAN-BURN E-D-A-R-K-E

FIRST TIME EVER IN KIT FORM!
Build yourself the famous

BOGEN DB20 DF AMPLIFIER

The finest 20 watt amplifier of 3 dozen brands tested by a famous consumer testing organization. Ideal for any home installation. Build it yourself and save up to one third of the regular price. Detailed STEP-BOOK makes it easy to assemble. All parts packaged in easy steps. No guesswork. No mistakes. All wires pre-cut to proper length.

KDB20 DF Specifications—CONTROLS—Sep. 5
—position loudness contour selector: 4 input pos., 7 record equaliz. pos; contin. var. damping fact. control. sep. cont. bass & treble controls. volume control. 0.3% dist. @20 W.; peak 30 watts. response, 20-20,000 cps = 0.7 db.

COMPLETE WITH DETAILED INSTRUCTIONS
ALL PARTS, TUBES AND
SOCKETS Only **\$69.50**
Shipped freight prepaid

CATHODE RAY TUBE SPECIALS ONE YEAR GUARANTEE

G.E.	Type	STAN-BURN	G.E.	Type	STAN-BURN
\$15.80	10BP4	\$10.00	\$30.75	170P4	\$20.50
19.10	12LP4A	13.95	33.90	17GP4	21.50
18.75	12QP4	10.50	24.75	17LP4	18.00
20.75	14CP4	13.75	37.00	19AP4A	24.00
33.75	15DP4	14.50	28.35	20CP4A	18.95
32.20	16DP4A	18.50	32.10	20CP4B*	21.95
23.50	16AP4	15.25	36.00	21AP4	25.00
27.20	16KP4A*	18.75	30.90	21FP4	21.15
31.50	16LP4A	15.25	29.75	21MP4	26.25
23.50	17BP4	15.75	100.00	24AP4	56.00
27.50	17BP4B*	18.75	46.60	24CP4A*	39.00
			48.20	24DP4A*	39.00

*Aluminized—Inquire for any tube not listed
Stan-burn CRT tubes RCA licensed—Mfd. by Lincoln
All orders of 6 or more STAN-BURN CRT subject to
10% additional discount
Prices subject to change without notice

\$20 WORTH OF ELECTRONIC PARTS IN GRAB-BAG
consisting of: Porcelain sockets, coils, speaker trans
resis. cond. ONLY \$1.98 (plus 50¢ postage)

TAPE RECORDERS—Famous Brand
SPECIAL SPECIAL
List Pr. \$249.95 \$169.00 List Pr. \$129.95 \$79.95
List Pr. 199.95 129.00 List Pr. 79.95 59.95
Write for complete illustrated details.

KITS: We stock the following manufacturers complete line of kits—see reference pages.

EICO see pages 29, 30 ARKAY see page 113
QUALITY see page 138 ELECTRO-VOICE see page 17
All domestic kit orders will be shipped prepaid. Send us your list. Order by Manufacturer and Model Number of item.

RECORD CHANGERS

Collaro and Garrard changers will be shipped prepaid.
All others shipped F.O.B. N.Y.C.

COLLARO		
RC 456	with GE RPX050 cart.	\$33.81
RC 456	with GE RPX052 Diam/Sap.	41.85
RC0456	with Ronnett Cart.	55.37
		36.80
GARRARD		
RC 88	with GE RPX050	\$53.41
RC 88	with GE RPX052 Diam/Sap.	61.45
RC 98	with GE RPX050	74.97
RC 98	with GE RPX052 Diam/Sap.	66.15
RC 98	with RPX052 Diam/Sap.	74.19
RC 98	with RPX052 Diam/Sap.	87.71
	45 R.P.M. Spindles	\$2.98 ea.

FREE! 32 page illustrated booklet
—"Speaking of Loudspeakers," by University Co. Packed with info on the history and mysteries of speakers. Write today to Dept. RN-7.

HI-FI DIAMOND NEEDLES—1 Yr. Guar.
SINGLE DIAMOND NEEDLES \$9.49 ea.
DIA/SAPP TANDEM (Dual Needles) \$11.49 ea.
Shipped PPD. (Specify cartridge make)

NEW—AUDAX TONE ARM KIT—
Accommodates any make cartridge.
For all popular cartridges, specify make. Shipped PPD.
KT-12-12" KIT . . . \$14.55 Fact. Assem. \$24.00
KT-16-16" KIT . . . 17.55 Fact. Assem. 30.00
Assemble in 20 minutes. Save 50%.

WHY PAY MORE? HI-FI COMPONENTS • KITS
• RECORD PLAYERS • TAPE
RECORDERS • TUNERS •
AMPLIFIERS • SPEAKERS •
ELECTRONIC PARTS & TUBES
• Etc.

Top brand nationally adv. merchandise in this and other Radio & TV mags. is yours at low cost. Send us your list. Give Mfr's name and Model No. of item. Write for '57 catalogs to Dept. RN-7 today.

Export inquiries and offers invited. Balance C.O.D. All prices F.O.B. NEW YORK Warehouse. Minimum order \$5.00. Write for our latest price list and Hi-Fi Catalog RN-7. All Prices Subject to Change Without Notice

STAN-BURN RADIO and ELECTRONICS CO.
558 CONEY ISLAND AVE. • B'KLYN 18, N. Y.

where the audio output tube is driven directly by the FM detector tube.
Full specs on this new tube are available from the company direct.

TUBE-TRANSISTOR CHECKERS

Precision Apparatus Co., 70-31 84th St., Glendale 27, N. Y., has announced the availability of two new items of test equipment.

The Model 640 cathode conductance tube tester was specifically designed to provide service technicians with a moderately priced unit of the emission type. It will handle all modern TV and radio tubes and has a 10-lever element selector system.

The second instrument is the Model 660, which incorporates all of the tube

testing features of the Model 640 and provides, in addition, comprehensive tests on all r.f., a.f., power, and tetrode transistors for their most important characteristics. It also tests crystal diodes for both forward and reverse current as well as CRT's.

MICROMINIATURE POT

Bourns Laboratories, Inc., 6135 Magnolia Ave., Riverside, Calif., is now offering the Model 220 "Trimpot Jr.," which features microminiature size, 2-watt power rating, and humidity-proof construction.

Measuring but 3/16" x 3/16" x 1", 17 units can be mounted in 1 square inch of panel space. Resistances from 100 to 20,000 ohms are available. -30-

P. A. Driver Power (Continued from page 39)

capacity should, in enlightened design, be coupled with greater efficiency as well, so that the resultant gain in output will be a combination of both the increased input power and increased efficiency and hence worthwhile from a practical viewpoint. The chart in Fig. 3 shows the relationship between increases and decreases in power input to a speaker vs sound output in db.

As a practical example, let us take a good but modestly priced driver unit, the University MA-25, for instance, which produces 127 db on a 6 1/2 foot air column reflex trumpet with 25 watts input. If we were to use a series capacitor and double the input power to 50 watts, sound output would rise to 130 db. Yet, a University SA-HF driver, at only a few dollars more cost, at 30 watts input yields the same 130

db, of which only a small portion (.8 db) was due to the five extra watts input, the greatest increase being due to the higher efficiency of the second unit. Now if we were to apply the "adjusted-range power" input of 60 watts to this model, the sound pressure would go from 130 db to 133 db.

It becomes obvious that driver units designed to complement higher input power with increased efficiency provide far more economical means of doubling sound output than by increasing power input. A 25-watt p.a. amplifier might cost around \$50, while a 50-watt amplifier with comparable features would run around \$85. In the examples used, the difference in dealer cost of the two drivers is only five dollars!

So, next time you're planning a sound system and comparing driver unit specifications, get all the facts, and make certain you understand the terms used. Maybe some day soon we may all be speaking the same language, but until then . . . -30-

Fig. 3. Table of various power ratios as related to decibel gain or loss.

POWER RATIO	± DB	POWER RATIO	± DB
1.000	0	0.251	6.0
0.977	0.1	0.224	6.5
0.955	0.2	0.200	7.0
0.933	0.3	0.178	7.5
0.912	0.4	0.159	8.0
0.891	0.5	0.141	8.5
0.871	0.6	0.126	9.0
0.851	0.7	0.112	9.5
0.832	0.8	0.100	10
0.813	0.9	0.0794	11
0.794	1.0	0.0631	12
0.708	1.5	0.0501	13
0.631	2.0	0.0398	14
0.562	2.5	0.0316	15
0.501	3.0	0.0251	16
0.447	3.5	0.0200	17
0.398	4.0	0.0159	18
0.355	4.5	0.0126	19
0.316	5.0	0.0100	20
0.282	5.5		

db gain = original power input ÷ increased power input
db loss = decreased power input ÷ original power input

Mac's Service Shop
(Continued from page 67)

"I am still not sure if he did it deliberately to make his point or if it just worked out that way; but pretty soon he had the thing so far off that he said the only sensible thing to do was start all over, take each step in turn, do each operation right while you are at it, and never go back. And that is what he ended up doing, too."

"Knowing when to quit is important in a lot of things," Barney observed. "I was watching men nailing asbestos shingles on the house next door, and I noticed very few shingles broken, even though they are quite brittle. I asked one of the fellows how they managed this, and he told me: 'The whole secret is to drive in each nail until you feel it needs just one more light tap—and then don't take it!' I guess that's the way with convergence, huh?"

"Exactly! After the convergence was set up, Mr. Marshall spent the rest of the afternoon showing me how kinescope temperature, screen, and background adjustments were made, how color a.f.c. and matrix alignment was done, how the color-killer threshold control was set, and how to do some other things that I'm ashamed to admit I can't remember. He wanted to show me how to do a complete alignment job on a color set, too, but we ran out of time. Candidly, I was sort of glad. By this time all I could see in front of my eyes were those little triangles outlined by red, green, and blue dots speckle the screen when you're working with dynamic convergence."

"Did you decide what instruments we need?"

"Yes. I'm convinced that if we have a good dot generator and a dependable bar generator we can make out very well with what we already have. The dot generator is absolutely necessary for establishing convergence; the bar generator seems to me to be a 'must' to understand what you are doing when trouble crops up in the color circuits."

"How are you doing with that color set?"

"As far as the set is concerned, so far—knock on wood!—not a thing has gone wrong with it; and we are really giving it a workout. Incidentally, I notice one big difference between it and our old black-and-white receiver, although the difference is more a matter of recent improvement in TV sets in general than a difference between color and black-and-white receivers. The color set causes practically no interference with radios, even those quite close to it. The black-and-white receiver puts 'birdies' on almost all stations on every receiver in the house. This shows the manufacturers are really complying with the FCC requirement about stopping interference produced by the horizontal oscillator."

"What do you think about color reception in a fringe area by now?"

"In my experience, it compares very favorably with black-and-white reception. I'll admit that noise in the picture is more noticeable when the snow is technicolored, but once you get over the novelty of it, this does not seem to bother much. And, anyway, there are a lot of nights even out here when we have practically no snow in the picture, and then that color is really something."

"Does fading affect a color picture more than it would a black-and-white one?"

"Below a certain level it does. As long as the signal is strong enough to operate the a.g.c. circuit, the color picture is no more affected than a black-and-white picture; but when the signal falls below that level, on my receiver at least, the colors become garish and sort of run together just before the picture fades clear out. But then a picture that weak could not be watched with any satisfaction in black-and-white, either."

"A technician friend of mine was telling of a funny experience he had last spring when a freak ice storm hit his area, which has about the same signal strength we have. Black-and-white set owners took the snowy, weak pictures they got from their ice-coated lead-ins in stride, and he got few calls from them; but he says every color set owner in town called and complained the color programs were coming through in black-and-white! Apparently the ice was attenuating the color burst just enough to kill the color. I made a mental note that when we install any antennas for color, we want to make sure the lead-in running across a roof is set up on high enough stand-off insulators to keep it out of the snow!"

This 75-foot transmitting antenna belongs to Australia's first TV station, TCN-channel 9 at Willoughby, a suburb of Sydney. The antenna was imported from Holland in sections, assembled, tested, hauled vertically up the center of the 486-foot tower and bolted into position—in 3 weeks.

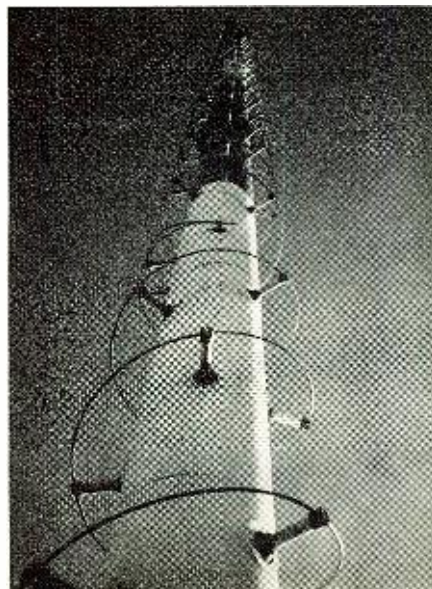

**HARVEY has it...
TELREX '56
Beam Antennas**

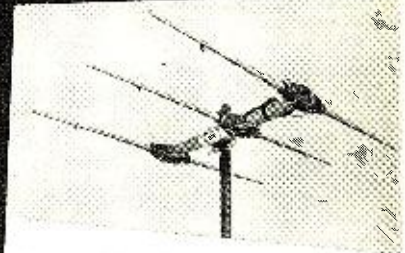

Commercial grade arrays at amateur prices; superior in performance, design and construction to any other antenna. Hair-pin resonated, precision tuned, matched and calibrated. Provide highest signal-to-noise ratio possible; 75% reduction in precipitation static.

FEATURES

- Extremely rugged elements of advanced sectional design; taper-swaged to reduce useless wind drag and silhouette by 55%.
- Special sturdy molded element support made of Borg-Warner "Cyclocac", a very high impact thermoplastic resin; holds, insulates and capacity-couples element to the boom for automatic dissipation of precipitation static.
- Stainless-steel airplane-type clamp, holds element sections firmly in exact position.
- Precisely constructed and the famous Telrex "Balun" help produce outstanding performance per element, clean-cut balanced pattern and minimum TVI.
- Single, heavy-wall aluminum boom is small in size, rugged in strength, and light in weight.
- Stainless steel "Hairpin" grounding lug provides element grounding at voltage node for lightning protection.

"SERIES 56" SPECIFICATIONS AND PRICES

Telrex No.	Meter Band	Ele. Elements	Gain db	Shdg. Wt. Lbs.	Amateur Net Each
1/2 M-15C	3 1/2	15	13.2	17	\$ 29.00
1 1/2 M-5C	1 1/2	5	17.9	7	6.95
1 1/2 M-15C	1 1/2	15	16.2	14 1/2	31.00
2M-3C	2	3	9.4	2 1/2	5.95
2M-5C	2	5	14.5	7	7.25
2M-5C	2	5	17.7	4	12.50
2M-10C	2	10	13.5	11	13.75
2M-100H†	2	10	14.5	13	33.50
2M-12C	2	12	16.2	25	39.25
6M-3D	6	3	9.4	7	16.25
6M-4C	6	4	9.7	10	19.75
6M-6C	6	6	13.7	20	57.50
6M-56-135§	6	5	12.7	53	149.00
1030-S	10	3	7.0	9	36.50
10M-56-79†	10	8	8.9	27	96.00
10M-56-120†	10	4	10.1	35 1/2	144.00
10M-56-185§	10	3	11.9	17	220.00
10M-56-235§	10	6	12.7	50	290.00
15M-56-67†	15	2	4.8	20	80.00
15M-56-99†	15	3	6.9	23	117.00
15M-56-118†	15	4	8.7	27	140.00
15M-56-198§	15	4	11.1	61	235.00
15M-56-245§	15	5	11.9	81	285.00
20M-56-79	20	8	1.8	26	89.00
20M-56-112†	20	8	8.7	33	130.00
20M-56-149§	20	3	9.0	56	175.00
20M-56-168§	20	6	9.3	83	198.00
20M-56-235§	20	4	10.4	74	275.00
20M-56-265§	20	4	11.2	91	305.00
40M-56-180	40	9	3.4	56	180.00
40M-56-365§	40	3	8.3	150	365.00

†Circular polarized ‡Deluxe Model
§Super Deluxe Model

**Harvey has in stock
the New Tri-Band Antennas
for 10-15-20 Meters**

**MAIL ORDERS SHIPPED
SAME DAY AS RECEIVED**

Include with payment an allowance for shipping charges. Prices subject to change without notice.

HARVEY Estab. 1927
**RADIO
CO., INC.**
1123 Avenue of the Americas JU 2-1500
(6th Ave. at 43rd St.) N.Y. 36, N.Y.

Get
Your First Class Commercial
F.C.C. LICENSE
in
12 Weeks!

F.C.C. License—The Key to Better Jobs

An FCC commercial (not amateur) license is your ticket to higher pay and more interesting employment. This license is Federal Government evidence of your qualifications in electronics. Employers are eager to hire licensed technicians.

Grantham Training is Best

Grantham School of Electronics specializes in preparing students to pass FCC examinations. We train you quickly and well. All courses begin with basic fundamentals—NO previous training required. Beginners get 1st class license in 12 weeks.

Here's Proof! A few of our recent graduates, the class of license they got, and how long it took them:

Name	License	Weeks
B. A. Willms, 1401 E. Muriel, Orlando, Fla.	1st	12
David Seigler, 216 Dowling, Walterboro, S. C.	1st	10
W. D. Mains, 6332 S. Paramount, Rivera, Cal.	1st	12
Paul Schuett, 1314-20th Av., Longview, Wn.	1st	10
Robert Todd, 216 West End Av., Cambridge, Md.	1st	13
Dan Breese, Station KOVE, Lander, Wyo.	1st	12
Lawrence L. Alzheimer, Collins, Montana	1st	4
Joe C. Davis, Station WABO, Waynesboro, Miss.	1st	11
Paul Chuckray, 6874 Weber Rd., Affton, Mo.	1st	11
W. Reynolds, 238½ Washington Bl., Venice, Calif.	1st	12

Learn by Mail or in Residence

You can train either by correspondence or in residence at either division of Grantham School of Electronics—Los Angeles, Calif., or Washington, D.C. Our free booklet, "Opportunities in Electronics," gives details of both types of courses. Send for your free copy today.

OUR GUARANTEE FCC-TYPE EXAMS

If you should fail the FCC exam after finishing our course, we guarantee to give you additional training at NO ADDITIONAL COST. Read details in our free booklet.

TWO COMPLETE SCHOOLS: To better serve our many students throughout the entire country, Grantham School of Electronics maintains two complete schools—one in Los Angeles, California and one in Washington, D. C. Both schools offer the same rapid courses in FCC license preparation, either home study or resident classes.

MAIL TO SCHOOL NEAREST YOU

(mail in envelope or paste on postal card)

↓ Grantham Schools, Desk 76-K ↓

1505 N. Western Ave. OR 821-19th Street N.W.
Los Angeles 27, Calif. OR Washington 6, D. C.

Please send me Your free booklet, telling how I can get my commercial FCC license quickly. I understand there is no obligation and no salesman will call.

Name

Address

City State

I am interested in Home Study, Resident Classes

Crystal Filter
(Continued from page 53)

The crystals used were of the FT-241-A surplus variety, but any set of crystals whose series-resonant frequencies are equal and close to the receiver i.f. frequency may be used. It isn't necessary that the crystals be of the same cut, but a difference in crystal shunt capacitance will affect the position of the attenuation peaks; hence, only the crystals which are to be ultimately used in the filter should be used during the alignment process.

Alignment

After the filter has been constructed, it is advisable to make a few simple continuity tests with an ohmmeter just to be certain that none of the transformer leads has been broken and that no high resistance solder joints have been made. A high resistance connection may ruin the performance of the filter.

The ideal filter alignment set-up is indicated in Fig. 5. A commercial signal generator, a grid dipper, or the b.f.o. in the receiver may be used as the signal generator indicated in the diagram. The b.f.o. would, of course, have to be variable and rewired so as to inject a signal into the grid of one of the i.f. stages preceding the filter, if the receiver were to be used as the amplifier indicated in the test set-up diagram. It is naturally preferable to align the filter in the receiver for which it is intended, since the tuning of the input and output circuits will depend upon the circuits to which they are connected. An SX-43 receiver was used as both the amplifier and voltmeter in the lab here—the S-meter being used as the v.t.v.m. indicated in the diagram.

The filter is aligned in three steps: First, the input section to the point marked A (see Fig. 3) is aligned. Second, the output section of the filter, from A through T₂ is aligned, and; third, the filter is connected to the receiver and both filter and receiver are adjusted.

In the first step, the lead connecting the two transformer center taps is cut at the point marked A in Fig. 3. A signal at the crystal frequency is fed into the filter by means of the input coax and the primary and secondary of T₁ are peaked—measurement being made with the crystal in place by means of the test set-up of Fig. 5; output from A going through coax to the amplifier as indicated in the diagram. The phasing capacitor, C_s, is varied so as to place the rejection slot on one side of the i.f. frequency. The closer

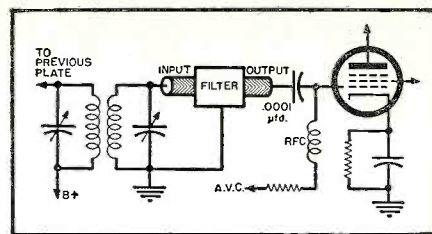

Fig. 6. Filter in a.v.c.-controlled stage.

the rejection slot is to the i.f. frequency, the narrower will be the bandwidth of the filter and the less will be the attenuation outside the rejection frequencies. Half-a-kilocycle from the i.f. frequency is a satisfactory setting.

In the second step, the filter is turned around and the identical procedure as was used for the input section is followed to align the second section of the filter.

The third step consists in re-connecting the two transformer center taps and adjusting the transformer capacitors once more after the filter is installed in the receiver. If the receiver has no a.v.c. applied to the i.f. stage into which it is desired to insert the filter, the filter may be simply inserted in series with the grid of the i.f. tube, re-adjusting the transformers to resonate at the i.f. frequency. If the stage has a.v.c. voltage applied to the grid circuit, the circuit of Fig. 6 is recommended—the a.v.c. voltage being fed to the grid through the r.f. choke. In any event, some provision must be made for the grid return.

If the filter is correctly aligned and the crystals are of the correct frequency, an attenuation vs frequency curve similar to that of Fig. 4 should result. If the FT-241-A crystals are used in the filter, do not take it for granted that the frequencies will be exactly as stated in the specifications. In checking a dozen crystals for frequency variation, over two kilocycle spread was observed in one channel number. It is advisable to purchase half-a-dozen crystals so as to obviate the necessity for edge grinding the crystals to frequency.

In operation, the desired signal is tuned in without the filter—the b.f.o. being adjusted so as to give a good note with the signal in the center of the i.f. passband—and the filter is switched in or out at will. The r.f. gain control is run at as low a level as possible, to prevent ringing, and the audio gain is used to adjust the volume. —30—

HINT FOR EXPERIMENTERS

By CHARLES ERWIN COHN

IF YOU are building a small experimental circuit and need a quick, convenient source of filament voltage or other low-power a.c. voltage, use your tube tester.

To do this, take an old tube base and wire it to the filament pins. Set up the switches properly and set the filament voltage control for the voltage required. Plugging the tube base into the proper socket will make the voltage available. Enough power can be drawn to operate a couple of small tubes. —30—

Fig. 5. Set-up used to check the filter.

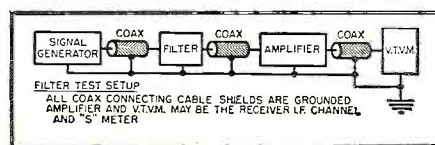

Square-Wave Testing

(Continued from page 66)

it may indicate an open in C_{s1} (Fig. 8).

The condition shown in Fig. 5D may seldom be encountered, but generally indicates that a damping resistor across a peaking coil has opened.

The condition of Fig. 5B, at higher frequencies, together with the condition shown in Fig. 4H at lower frequencies, would indicate that C_0 (Fig. 3) has become open or dropped in capacity. Thus, it is practical to use a combination of conditions to indicate a specific defect.

Square waves, observed with a cathode-ray oscilloscope, provide an efficient and extremely rapid technique for testing and servicing systems designed to pass a band of frequencies. The technique can also be used to good advantage in design and production engineering, for adjusting circuits for proper operation, and for determining optimum values of components.

The basic relationship between the frequency response of an amplifier or network and its effect on square waves can be obtained by referring to Fig. 9.

A simple resistance-coupled amplifier may have the response shown in Curve 1. With this type of response curve, a low-frequency square wave will appear as in Fig. 4E; at middle-range frequencies, as at Figs. 4A or 5A; while a high-frequency square wave will appear as at Fig. 5B.

If low-frequency compensation is added, resulting in a boost at low frequencies as shown in Curve 2, middle-range and high-frequency square waves will appear as previously, but low-frequency square waves will generally be tilted in the opposite direction as shown in Fig. 4H. With the proper amount of compensation, a perfectly flat-top low-frequency square wave may be obtained, but this is frequently difficult to maintain in production unless each unit is adjusted individually.

When a peaking coil is used to provide a boost at high frequencies, the over-all response may appear as shown in Curves 3 or 4, depending on the frequency of peaking and the amount of damping. With a response as shown in Curve 3, a high-frequency square wave may appear as in Fig. 5E, while middle and lower frequency square waves will remain as previously. If the response is as in Curve 4, a high-frequency square wave will appear as in Fig. 5D, and a middle-range frequency square wave as in Fig. 5E.

If high-frequency compensation is obtained by reducing distributed capacities, a high-frequency square wave can be made to approach the input signal in form, as in Fig. 5A, and the response curve becomes as shown in Curve 5. Note that the response falls off smoothly at higher frequencies.

The same result can be obtained by reducing R_L , but this results in reduced over-all gain.

-50-

July, 1957

NEW! REVOLUTIONARY!

BULLET

SWIVEL ANTENNA

by TENNA

★ MOUNTS ANYWHERE!

The "mast section" of the "Bullet" swivels to permit either top cowl, top fender, side cowl, side fender or rear deck mounting. Available with vertical masts for front mounting and graceful sweep-backs for rear mounting. Extra mounting pads furnished for curved surfaces.



Brilliantly chrome plated from base to tip. The Bullet adds a sparkling touch of beauty to even the most beautiful of today's beautiful cars. Packaged in lovely black and gold display carton. All 15' cables listed below are equipped with 75MMF ceramic condensers to provide finest reception.

THE TENNA MANUFACTURING CO.
CLEVELAND 25, OHIO

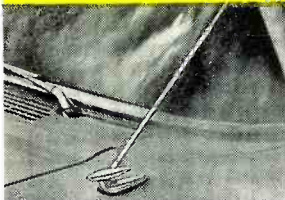

FRONT FENDER, SWEEP-BACK

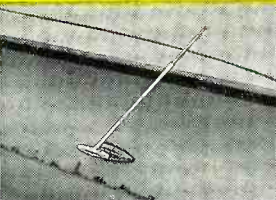

SIDE FENDER, SWEEP-BACK



REAR FENDER, SWEEP-BACK

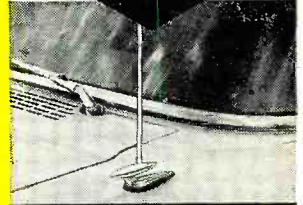

FRONT FENDER, VERTICAL



TRUNK DECK, SWEEP-BACK

2 Models
Vertical
and
sweep
back

Both
swivel
to meet
EVERY
MOUNTING
NEED!

MODEL

JA-1
JA-2
JA-3
JA-4
JA-5
JA-6

DESCRIPTION

Single Rear, Active
Single, Dress-Up
Dual Rear, Active
Dual, One Active
Front, Vertical
Front, Sweep-Back

CABLE

15'
None
15'-6'-3'
4'
4'

BC348 OWNERS

Replace your worn volume control for smooth, noise free operation. New Signal Corps BC348 potentiometer \$1.95 postpaid.

ARC5 OWNERS

New Signal Corps. Right Angle geared Drive for Command Set Receivers does away with sharp bends in tuning cable and allows much smoother dial operation. Individually factory boxed. 75c postpaid.

L. I. RADIO CO.

8309 Lockheed St. Houston 17, Texas

TAPE RECORDERS

Tapes—Accessories
Nationally Advertised Brands
UNUSUAL VALUES
Send for Free Catalog

DRESSNER
69-02 RA-174 St.
Flushing 65, N. Y.

MERITAPE

Low Cost, High
Quality Re-
cording Tape—
in boxes or
cans.

GET INTO ELECTRONICS

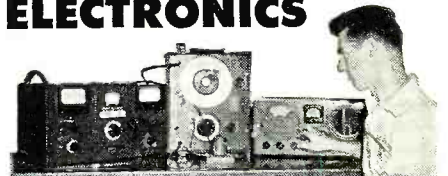

Valparaiso Tech trains for top flight positions. Technical representatives, field engineers, sales and specialists in communications, missiles, computers, radar, automation, color television. Basic and advanced theory and laboratory. Major companies visit school for our graduates. 21 months' course. High school graduate or equivalent. Dormitories—campus. Start September, January, April, July. G. I. approved. Write for Catalog.

VALPARAISO TECHNICAL INSTITUTE
Dept. RD Valparaiso, Indiana



Is a Degree Essential for an Electronic Engineering Career?



"Student" Fred Gunther in the IBM school

Fred Gunther has no degree. Yet, today, at IBM, Fred is a Technical Engineer working on America's biggest electronics project. His story is significant to every technician who feels that lack of formal training is blocking his road to the top.

Let's go back to 1950 and watch Fred Gunther, at 18, as he goes about the business of determining his life's work. Fred spent almost a year trying his hand at various jobs. None of these turned out to be the one that Fred wanted to devote his life to. So, still undecided about his career, Fred entered the Navy for a four-year hitch.

Fred learned something very valuable in the Service, as have many other men who eventually discover the electronics field. His aptitude tests revealed him as an excellent electronics prospect, and he received ten months' training in electronics fundamentals and radar. Upon his discharge in 1955, he was an Electronics Technician, First Class.

Something even more important to Fred's career occurred during his Service hitch. He began to hear such terms as "automation" . . . "data processing" . . . "electronic computer." "Then, one evening, while glancing through the paper," he recalls, "I spotted a story about *Project SAGE*."

What is Project SAGE?

SAGE means Semi-Automatic Ground Environment. It is part of America's radar warning system—a chain of defense that will ultimately ring our country's entire perimeter. At the heart of this system are giant electronic computers, which digest data filtered in from Texas towers, picket ships, reconnaissance planes, ground observers. The computers analyze this information for action by the Strategic Air Command and other defense units. These computers are the largest in the world. Each contains perhaps a million parts—occupies an entire city block. They are built for the Project by IBM.

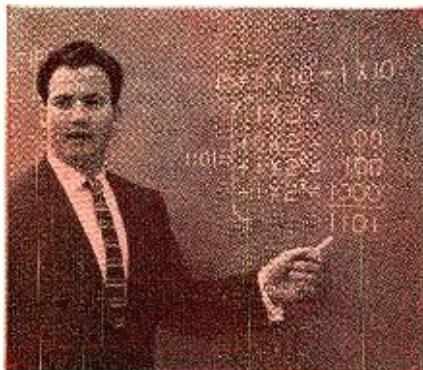

Answering instructor's questions

Fred joins IBM

SAGE fascinated Fred, for it embodies the most advanced electronic concepts. And, when he learned that IBM would train him for six months, at full salary, plus a living allowance, to become a Computer *Units* Field Engineer, he seized the opportunity. Fred started his new electronics career in the IBM school, with twenty other technicians. He attended classes 8 hours a day. Courses consisted of some 20 subjects—computer circuitry and units, maintenance techniques—everything he would need to become a full-fledged Computer *Units* Field Engineer.

Assigned to McGuire AFB

His six months' training completed, Fred was assigned in May, 1956, to McGuire Field, where the first of the giant SAGE computers is located. Here he assisted in the cable installation for this vastly complicated electronic giant. He helped to set up the computer, interconnect its many sections, check it out and make it ready for operation. Fred spent five months

July, 1957

at McGuire, but his education was not yet completed.

Becoming a Computer Systems Engineer

"I like to think it was due to my interest and grade of work," Fred says, "but at any rate, last October I was invited to return to Kingston for further training—to become, in fact, a Computer *Systems* Engineer. Naturally, I was proud and pleased, for this training would give me a much greater range of understanding . . . make me more valuable to the company and myself . . . and give me a chance to assume actual engineering responsibility." Fred completed the



At the operating console of the computer

Computer *Systems* course. After several months of outstanding work in his new capacity, he received a *third* promotion—to Technical Engineer—in a field engineering liaison group.

What does the future hold?

What does the future hold for Fred Gunther, now that he has become a Technical Engineer? "It's hard to even set a goal in a field as rapidly moving as this," Fred says, "but with my IBM training back of me, the future sure looks good. I've advanced from Radar Technician to Computer *Units* Field Engineer to Computer *Systems* Engineer to Technical Engineer in two years—and received a valuable electronics education besides!"

How about YOU?

Since Fred Gunther joined IBM Military Products and the Project SAGE program, opportunities are more promising than ever. This long-range program is destined for increasing national importance, and IBM will invest thousands of dollars in the right men to insure its success.

If you have 2 years' technical schooling—or equivalent experience—IBM will train you for 6 months as a *Computer Units Field Engineer*.

If IBM considers your experience equivalent to an E.E., M.E., or Physics degree, you'll receive 8 months' training as a *Computer Systems Engineer*.

After training, you will be assigned to an area of your choice within the United States. You receive *salary*, not wages, plus overtime pay. In addition, every channel of advancement in the entire company is open, and IBM is a leader in a field that is sky-rocketing in growth. And, of



Home to the family, Pemberton, N. J.

course, you receive the famous IBM company-paid benefits that set standards for industry.

WHY NOT WRITE—today—to:
Nelson Heyer, Room 4307
Military Products Division
IBM Corp., Kingston, N. Y. ?

You'll receive a prompt reply. Personal interviews arranged in all areas of the United States if your résumé of experience and education indicates you have the qualifications.



- DATA PROCESSING
- ELECTRIC TYPEWRITERS
- MILITARY PRODUCTS
- SPECIAL ENGINEERING PRODUCTS
- TIME EQUIPMENT

Your choice of school
is highly important
to your career in



**INDUSTRIAL
ELECTRONICS**



**RADIO-
TELEVISION**



**ELECTRONICS
COMMUNICATIONS**

Become an
**ELECTRICAL
ENGINEER**

or an

**ENGINEERING
TECHNICIAN**
at

MSOE in Milwaukee

Choose from courses in:

ELECTRICAL ENGINEERING

Bachelor of Science Degree
in 36 months—
Communications or
Electrical Power.

ENGINEERING TECHNICIAN

Associate in Applied Science
degree in 18 months—
Electronics Communications or
Electrical Power.

MSOE—located in Milwaukee, one of America's largest industrial centers—is a national leader in electronics instruction—with complete facilities, including the latest laboratory equipment, visual aid theater, amateur radio transmitter—offers 93 subjects in electrical engineering, electronics, radio, television, electrical power, and electricity.

Advisory committee of leading industrialists. Courses approved for veterans. Over 50,000 former students. Excellent placement record. Previous educational, military, and practical experience is evaluated for advanced credit.



QUARTERS BEGIN SEPTEMBER,
JANUARY, APRIL, JULY

Choose wisely—your
future may depend on it.
Mail coupon today!

MILWAUKEE

SCHOOL OF ENGINEERING

Dept. RT-757, 1025 N. Milwaukee St.
Milwaukee, Wis.

Please send free illustrated career booklet
(please print)

I'm interested in.....

Name..... Age.....

Address.....

City..... State.....

Are you eligible for veterans educational
benefits?.....

Discharge date.....

MS-57

TEST LEADS AND CABLES

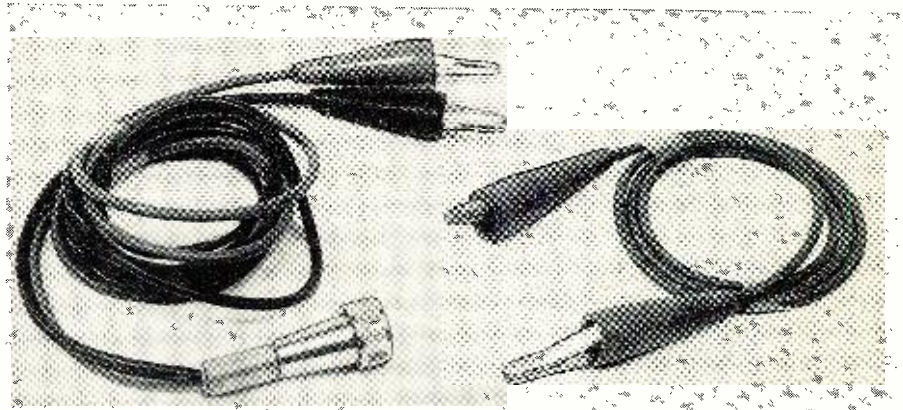

Fig. 1. On the left is shown a test lead that can be used with the coaxial input of oscilloscopes and meters. The lead on the right is a simple connector type needed in various lengths.

By **ROBERT B. GARY**

Got a minute? Make up these test leads for your service shop or lab, they will save time later.

SUMMER is usually the time when business slacks off and the average radio & TV service technician has a chance to sit down and take a look around the shop. Some of the most frequent projects for the slow summer season are a general cleanup of the shop, disposal of junk, overhaul of test equipment, and preparation for the busy fall season. Such preparations usually consist of bringing tube and parts stock up-to-date, but there are a number of additional chores that can be done in the slack season which will pay dividends when the shop is busy and every minute saved means extra jobs and extra income. The test leads and cables described in this article can be wired up at the service technician's leisure with very little expense, and will prove really helpful when fall and the big rush come around.

First, obtain some red and some black rubber-covered, test lead wire,

some alligator-type clips with red and black rubber covers, test tips, banana plugs, and other hardware to fit your instruments.

Now, the first things to make are some ordinary clip leads. For real efficiency it is good practice to provide at least six clip leads for each technician. By making one red and one black of each size, much confusion and doubling up is avoided. Typical lengths are 30 inches, 20 inches, and 8 inches.

Many service technicians feel that plain alligator clips without insulating jackets are satisfactory, but with jackets on both clips it is possible to use these test leads for "B+" or any other connection without turning the power off which, of course, saves time. Fig. 1 shows a typical clip lead at the right.

Also shown in Fig. 1 is a useful variation of the clip lead. Here, two leads have been soldered to a coaxial

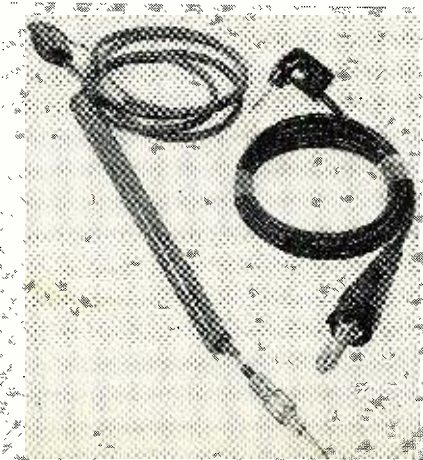

Fig. 2. Test prods and leads such as shown here should be made for the various instruments and meters in the shop. The prod on the left includes a resistance in the tip for isolation purposes.

Fig. 3. Useful test setup for probing hum sources and defective capacitors.



connector which fits an oscilloscope input connector. The advantage of this arrangement is that there is less capacity between the two lead wires than there would be for a coaxial cable. It should be pointed out, however, that for pulse observation a special low-capacity probe and coaxial cable should be used.

Meter leads can also be made up to permit the most efficient use of the various instruments. Fig. 2 shows a typical combination for the v.t.v.m. The black lead at the right is used as the ground lead and ordinarily remains clipped to the chassis, while the red probe is touched to various points in the circuit. In order to use the v.t.v.m. to measure oscillators or limiters without loading down the circuit, a 1-megohm resistor is added in series in the red probe as shown. Input resistance to most v.t.v.m.'s is on the order of 10 megohms, so that the addition of the series resistor has little effect on reducing the sensitivity of the meter. In most cases, the construction of such a lead would not be necessary since the v.t.v.m. is usually supplied with its own isolating probe. In this case, the calibrations on the meter scale are such as to take into account the voltage drop in the probe resistor through which measurements are made.

Another clip lead combination, shown in Fig. 3, serves to check for hum, regeneration, and oscillation. Wherever a bad filter or decoupling capacitor is suspected, the parallel combination of the 40 μ f. electrolytic and the .1 μ f. paper capacitor is sure to provide adequate a.c. filtering. It is a simple matter, in a TV set where hum is the complaint, to clip the black lead to the chassis and probe with the red lead until the hum disappears and the defective part is located. The addition of the paper capacitor is required since the electrolytic may have considerable inductance and be a poor filter for frequencies above the audio range.

In many instances of i.f. or tuner alignment, good grounds are essential. Some technicians use a large piece of sheet metal on the bench to provide good grounds but this is undesirable when "hot" chassis are serviced. One simple and effective grounding method is to connect a length of $\frac{3}{4}$ -inch wide copper braid from the rear of the bench to a waterpipe or other good ground. A number of braid leads with heavy alligator clips are brought from this main ground bus to the various test instruments and the receiver under test. This assures good grounding. The test instruments can be left grounded at all times.

The summer is a good time to get the shop antenna system into perfect order. Check over all transmission lines, junctions, and antenna leads for each test bench. Although clip leads can, of course, be used to connect the antenna, the 300-ohm terminals are standardized on most TV receivers and a permanent antenna connector cable

is preferable. A particularly handy item to use in this connection is the *Walsco* "Quick Klip" which is essentially a polystyrene clothespin with metal clips to fit on any 300-ohm terminal.

Many TV receivers have the speaker mounted in the cabinet and removing it is cumbersome, especially in consoles. One solution is to use a 6-foot length of a.c. line cord with alligator clips at both ends. This permits quick connection between the set and speaker, irrespective of the type of plug used in the set. Another solution is to mount a good PM speaker somewhere above the test bench and provide a set of clip leads from the voice coil of this test speaker to the TV receiver.

In some TV receivers the picture tube mounts in the cabinet while the chassis can be removed for servicing. This requires a long high voltage lead to connect from the original high voltage lead to the second anode at the picture tube. Such a lead can be made up using high voltage cable and a standard rubber covered anode clip at one end, while the other end is terminated in a regular alligator clip and rubber jacket. A convenient length for this high voltage extension cable is approximately 3 feet.

Listed here are only a few of the many uses for handy clip leads, cables, and connectors in the busy service shop. In looking around your own shop and thinking of the various test setups used, you will undoubtedly find many other applications for test leads and cables.

Packard-Bell Color TV

(Continued from page 61)

through its own service organization. The initial contract offered to a color set customer covers delivery, installation to a satisfactory existing antenna, and 90 days unlimited service. The cost for this is \$39.95 with additional labor and material charges for installing a satisfactory antenna. After the 90-day period, unlimited service including all parts is available at the rate of \$7.50 per month for the first year and \$12.95 per month for the second year. By breaking the service contract up into monthly installments, the customer is not faced with a relatively heavy charge in advance and has the right to cancel any time. This seems to be a desirable feature and may well be duplicated by other service organizations.

Aside from the service contracts offered, each set is covered by the standard 90-day warranty on parts and 1-year picture-tube replacement guarantee. Although the manufacturer has established his own service organization in some communities, he does not restrict customers to this factory service exclusively, especially in areas where no local factory branch is available. In line with this, *Packard-Bell* will provide service data on its color sets to qualified technicians.

BUILD 16 RADIO CIRCUITS AT HOME \$22.95

with the New DELUXE 1957 only

Progressive Radio "Edu-Kit" only

A PRACTICAL HOME RADIO COURSE

NOW ALSO INCLUDES:

- ★★★ TRANSMITTER
- ★★★ SIGNAL TRACER
- ★★★ SIGNAL INJECTOR
- ★★★ CODE OSCILLATOR

- No Knowledge of Radio Necessary
- No Additional Parts or Tools Needed
- Excellent Background for TV



REG. U.S. PAT. OFF.

FREE Set of Tools, Pliers-Cutters, Tester, Soldering Iron, Alignment Tool.

WHAT THE "EDU-KIT" OFFERS YOU

The 1957 "Edu-Kit" offers you an outstanding PRACTICAL HOME RADIO COURSE at a rock-bottom price. You will learn radio theory, construction and servicing. You will learn how to build radios, using regular schematics; how to solder and wire in a professional manner; how to service and trouble-shoot radios. You will learn how to work with punched metal chassis as well as the new Printed Circuit chassis. You will learn the principles of RF and AF amplifiers and oscillators, detectors, rectifiers, test equipment. You will learn and practice code, using the Progressive Code Oscillator. You will build 16 Receiver, Transmitter, Code Oscillator, Signal Tracer and Signal Injector circuits. These are not unprofessional "bread board" experiments, but genuine radio circuits. In brief, you will receive a basic education in Electronics and Radio, worth many times the small price you pay, only \$22.95 complete.

PROGRESSIVE TEACHING METHOD

The Progressive Radio "Edu-Kit" is the foremost educational radio kit in the world, and is universally accepted as the standard in the field of electronics training. The "Edu-Kit" uses the modern educational principle of "Learn by Doing." You begin by building a simple radio. Gradually, in a progressive manner, and at your own rate, you construct more advanced multi-tube radio circuits, learn more advanced theory and techniques, and do work like a professional radio technician.

THE KIT FOR EVERYONE

You do not need the slightest background in radio or science. The "Edu-Kit" is used by young and old schools and clubs, by Armed Forces Personnel and Veterans Administration for training and rehabilitation.

One of the most important aspects of the "Edu-Kit" is the Consultation Service which we provide. We welcome students to send us their problems, whether related to any of the material covered in the "Edu-Kit" course, or encountered in other experiences in the field of electronics.

THE "EDU-KIT" IS COMPLETE

You will receive all parts and instructions necessary to build 16 different radio and electronic circuits, each guaranteed to operate. Our kits contain tubes, tube sockets, variable, electrolytic and paper dielectric condensers, resistors, tie strips, coils, hardware, tubing, punched metal chassis, instruction Manuals, etc. In addition, you receive Printed Circuit materials, including Printed Circuit Chassis, special tube sockets, hardware and instructions. You also receive a useful set of tools, pliers-cutters, an alignment tool, professional electric soldering iron and a self-powered dynamic Radio and Electronics Tester. The "Edu-Kit" also includes code instructions and the Progressive Code Oscillator. You will also receive lessons for servicing with the Progressive Signal Tracer and the Progressive Signal Injector, a High Fidelity Guide, FCC Amateur License Training Book, and a Quiz Book.

All parts, components, etc., of the "Edu-Kit" are 100% unconditionally guaranteed. Brand new, carefully selected, tested and matched. Designed for universal use, the "Edu-Kit" operates on your regular house current, whether AC or DC. Everything is yours to keep. The complete price of this practical home Radio and Electronics course is only \$22.95.

TROUBLE-SHOOTING LESSONS

You will learn to trouble-shoot and service radios, using the professional Signal Tracer, the unique Signal Injector, and the dynamic Radio and Electronics Tester. Our Consultation Service will help you with any technical problems.

J. Stasaitis, of 25 Popple-shoot and service radios, writes: "I have repaired several sets for my friends, and made money. The "Edu-Kit" paid for itself. I was ready to spend \$240 for a course, but I found your ad and sent for your kit."

FREE EXTRAS

- Set of Tools • Radio Book • Radio and Electronics Tester • Electric Soldering Iron • Pliers-Cutters • Alignment Tool • Test Instruction Book • Hi-Fi Book • TV Book • Quiz Book • Membership in Radio-TV Club • Consultation Service • FCC Amateur License Training • Printed Circuitry

90-DAY UNCONDITIONAL MONEY-BACK GUARANTEE

ORDER FROM AD—RECEIVE FREE BONUS RESISTOR & CONDENSER KITS WORTH \$7

- "Edu-Kit" Postpaid. Enclose full payment of \$22.95
- "Edu-Kit" C.O.D. I will pay \$22.95 plus postage.
- Send me FREE additional information describing "Edu-Kit." Include FREE valuable Radio & TV Servicing Manuals. No obligation.

Name _____
Address _____

PROGRESSIVE "EDU-KITS" INC.
497 Union Ave., Dept. 67E, Brooklyn 11, N.Y.

SIGMA 5F RELAY

16,000 ohm in dual 8,000 ohm coils. (Can be paralleled) SPDT adjustable silver contacts. Adjustable armature tension. Operates on 500 microamperes or less. Ultimate in a sensitive relay. Ideal for precision control work. **\$3.95**

Write for quantity prices.

REDMOND BLOWER

110V. 60 cyc. .3 Amp. 1600 Rpm. 3 3/4" Blower wheel—Outlet 2" Diameter. Suitable for cooling Transm. tubes, etc. **\$7.95**
2 for \$15.00

FRAM FREQ. METER

110 Volt—58-62 Cycles with 9 reeds. **\$10.95**

G. E. RELAY CONTROL

(Ideal for Model Controls, Etc.)

Contains a sigma midget 8,000 ohm, relay (trips at less than 2 MA), high impedance choke, bi-metal strip, neon pilot and many useful parts. The sensitive relay alone is worth much more than the total **\$1.10** ea. **\$9.25**
low price of... **\$1.10** ea. for **\$9.25**

RELAYS

Sealed Claire SPST. Norm. closed 3000 ohm coil 4 ma. **95c**
Claire Telephone Type 11,300 ohm coil DPDT cont. 10 amp 125V. Sens. 4MA. ea. **\$3.95**
Cutler Hammer Contactor—110V 60 cy. 4 pole s.t. Norm. open 25 amp contacts. ea. **\$6.95**
Hermetically Sealed Relay Coil 110V AC 60 cy SPDT Contacts 5 Amps. ea. **\$1.85**
12 Volt DPDT DC Relay **\$1.35**
Each
Cramer Time Delay Relay, 220V 60 cy. 45 sec. adj. 2 pole DT. **\$6.95**
G.E. Plug in Relay 5 prong 2000 ohm coil 4 mil. SPDT (Sigma 4F). ea. **\$2.50**
Telephone type relay 12 V. DC @ 10 multiple pole single throw. Normally open. **\$1.25**
Dynamotor Starting Relay, 12VDC 30 amp contacts **\$1.50**

OIL CONDENSER SPECIALS BRAND NEW

2 MFD 600 VDC .80	4 MFD 2500 VDC 4.95
4 MFD 600 VDC .85	1 MFD 3000 VDC 1.85
6 MFD 600 VDC .85	1 MFD 4000 VDC 14.95
8 MFD 600 VDC .95	6 MFD 4000VDC 16.95
10 MFD 600 VDC 1.10	1 MFD 6000 VDC 6.45
12 MFD 600 VDC 1.50	5 MFD 7500 VDC 1.49
2 MFD 1000 VDC .85	2 MFD 10,000
4 MFD 1000 VDC 1.35	1 MFD 15,000 VDC 39.95
1 MFD 1500 VDC .75	1 MFD 15,000 VDC 29.50
1 MFD 1500 VDC 1.75	1 MFD 25,000 VDC 49.50
2 MFD 1500 VDC 1.95	5 MFD 330 AC (1000 DC) 2.50
6 MFD 1500 VDC 1.95	8 MFD 680 AC (2000 DC) 2.35
10 MFD 1500 VDC 3.50	
24 MFD 1500 VDC 6.95	
1 MFD 2000 VDC .85	
2 MFD 2000 VDC 1.50	
4 MFD 2000 VDC 3.50	

PANEL METERS

G.E., WESTINGHOUSE, W.E., SIMPSON, etc.

1 1/2" 0-5 Amps RF with Thermocouple. 3.95

2" METERS

0-200 Micro DC. .495
0-1 Ma (Scale 0-5 ma & 0-120 VDC) .345
0-1 Ma DC .395
0-15 Ma DC .295
0-35 Ma DC .295
0-50 Ma DC .295
0-100 Ma DC .295
0-250 Ma DC .295
0-500 Ma DC .295
0-5 Amps DC .295
1E-3e Volts DC .249
0-300 V DC .325
0-150 Ma RF .349
0-3 Amps RF .349
0-4 Amps RF .295
0-9 Amps RF .295
0-15 Amps RF .295
0-15 Volts AC .349
0-150 V. AC .395
5 Meter .395

3" METERS

0-50 Micro DC .795
0-100 Micro DC .695

CHOKE—FULLY CASED

10 HENRY 80 Mil (unshielded)	90c
6 HENRY 150 Mil	\$1.50
8 HENRY @ 200 Ma	1.95
10 HENRY @ 315 Ma	3.50
3 HENRY @ 630 Ma	3.50
6 HENRY 450 Mil	4.95
7.5 HENRY 650 Mil (Thordarsen com. series)	6.95

REPEATING MESSAGE TAPE RECORDER

(A commercial machine 110 V. 60 cy)

Magazine capacity 2 1/4 minutes. Uses Standard tape at 3 3/4 R.P.S. Relay actuated—comes in case 13"x13"x6" with 3 tube amplifier and 2 rectifiers. Suitable for carnivals, sales promotions, amateurs, demonstrations, sound effects, etc. Made by G.E. to sell for \$180.00.

YOUR COST—BRAND NEW only **\$49.50**

RECORDING ADAPTER \$9.95
MICROPHONE 5.95
SPEAKER 8.50

All merchandise sold on a 10 day money back guarantee basis

Min. Order \$3.00—25% with Order—F.O.B. New York

PEAK

ELECTRONICS COMPANY

66 W. Broadway, New York 7, N. Y., WO-2-5439

Choosing a Color Generator

(Continued from page 63)

correct signal and noting the output of each on an oscilloscope, or even on the three-gun picture tube itself. Bear in mind that, inasmuch as R-Y and B-Y are in quadrature, the R-Y demodulator will null on a B-Y signal and the B-Y demodulator will null on an R-Y signal.

3.58 mc. signal available separately: The availability of a separate 3.58 mc. signal makes possible several additional uses of the equipment. This signal can not only be used as a marker frequency when attempting alignment, but also can be used to inject a 3.58 mc. signal corresponding in frequency and phase to the color subcarrier reference oscillator if trouble is suspected in that circuit.

"Y" signal available separately: The term Y signal, as referred to here, indicates the brightness or luminescent component of the NTSC color signal, and does not pertain to such video signals as are produced by dot or cross-hatch generators. This feature further expands the use of the equipment for the Y signal can not only be used to provide a graduated monochrome signal for color receivers, but can be used to check the reproducing capabilities of monochrome receivers as well. It should be remembered that a color receiver must first produce a suitable black-and-white picture before it can reproduce a good color picture. In some instances, a technician may otherwise waste valuable time troubleshooting chroma sections when the difficulty actually lies in such "monochrome" circuitry as a.g.c., sync, or video-amplifier stages. By making use of the Y signal feature, it can readily be determined whether the chroma or monochrome circuitry is at fault.

In order for a color receiver to reproduce correct hue and saturation levels, the brightness component of proper amplitude is necessary for each color. This component is lacking in generators which use the "side-lock" principle to develop a color pattern. NTSC-type color generators produce white by adding the three primary colors. If a generator does not produce white, it is usually a rainbow type of generator. The output signal from such an instrument will display a pattern that will indicate whether the chroma stages are functioning, and may also be used to set up the customer operating controls; however, inasmuch as the color bars displayed do not have the correct brightness component, they are therefore color difference signals which appear dim and bluish compared to colors produced according to NTSC standards. There is no indication of luminance and chrominance signal registration, for no component of the rainbow signal passes through the Y channel. The hue of yellow has the largest brightness component (89%), and blue the lowest

YOUR COPIES OF

RADIO & TV NEWS

ARE VALUABLE!

Keep them neat . . . clean . . . ready for instant reference!

Now you can keep a year's copies of RADIO & TV NEWS in a rich-looking leatherette file that makes it easy to locate any issue for ready reference.

Specially designed for RADIO & TV NEWS, this handy file—with its distinctive, washable blue Kivar cover and 16-carat gold leaf lettering—not only looks good but keeps every issue neat, clean and orderly.

So don't risk tearing and soiling your copies of RADIO & TV NEWS—always a ready source of valuable information. Order several of these RADIO & TV NEWS volume files today. They are \$2.50 each, postpaid—3 for \$7.00, or 6 for \$13.00. Satisfaction guaranteed, or your money back.

Order direct from:

JESSE JONES BOX CORP.
Dept. RN
Box 5120, Philadelphia 41, Pa.
(Established 1843)

30 Watt Hi-Fi Super Lin Kit

AMP-PREAMP with TRANSISTORIZED FRONT END

FREQUENCY RESPONSE:

± 1 db 10-40,000 cps.

TUBES: uses (1) 6AL6.

(1) 12AU7, (1) 12AU7.

(2) EL34's, (1) 5V4-GB.

SHIPPING WEIGHT 26 lbs.

Sale Price... **\$42.00**

12 Watt Williamson TYPE AMP. KIT—15-40,000 CPS. Only... **\$26.00**

CUTICK ELECTRONICS HI-FI RADIO T.V. PARTS

171 Washington St., Worth 2-5866, New York 7, N. Y.



BE QUALITY WISE... BUY QUAL-KITS!



HI-FI AMP. KIT

Complete 6 tube-10 watt amplifier. Push-pull beam power output, built-in pre-amp. 5 position selector switch, 3 position record equalization, LP, RIAA, Eur. Response 1/2 db. 20-20,000 cps. Output 10 watts at less than 2% IM. Low noise level and harmonic distortion. **\$28.50**

Every kit complete with 28 page fully illustrated instruction and assembly manual. Cover and legs optional.



HI-FI AM-FM TUNER KIT

Advanced 7 tube circuit plus Rectifier for full sensitivity and selectivity. Distortion less than 1%. Sensitivity is 5 uv for 30 db quieting on FM, 25 uv AM. Armstrong FM Circuit with limiter. Foster-Seeley Discriminator. 20-20,000 cps response. Full AFC control — no drift. Easy assembly. **\$28.95**

Add 10% Fed. Tax Write for FREE catalog and name of nearest dealer carrying these remarkable units.

QUALITY-ELECTRONICS

319 Church St. Dept. T-7 New York 13, N. Y.

(11%); hence yellow is most affected by the loss of the Y component, and blue the least.

When using a rainbow generator, it is necessary to advance the brightness control until an artificial brightness component is introduced. This means that the brightness component will then be at the same amplitude for each color-difference bar, and that only one bar at a time can be adjusted for true color; that is, with the proper per-cent of brightness. However, it is possible to work out a procedure for progressively adjusting the over-all pattern through varying degrees of brightness so that one color at a time has the correct per-cent of luminance component.

Although the rainbow pattern does not provide the versatility found in other types, some prospective purchasers may find it a convenience as a quick-check indicator on house calls. Already there are some shops that have acquired generators of both kinds for different functions.

Voltage-regulated power supply: This feature insures stable operation where conditions of varying a.c. line voltage are a problem.

It is not possible to make a flat recommendation of a single combination of features that will be best for all service organizations. However, time spent in a thorough investigation of individual requirements and an intelligent examination of the alternate units available for purchase will safeguard the long-term profitability of investing in the color generator finally chosen.

-30-

One of the three anechoic chambers at Convair's new acoustics laboratory in San Diego. The lab will be used for acoustic research and testing in connection with jet aircraft programs. Engineers Gerard Bosco, left, and Frank Dalzell, kneeling, measure the sound-absorbing properties of the test chamber. Walls, floor, and ceiling of the chamber are lined with glass fiber, shaped into patterned wedges. Floor grating is removed during test of jet aircraft sample materials and components for sound-attenuating and sound-reflecting properties.



July, 1957

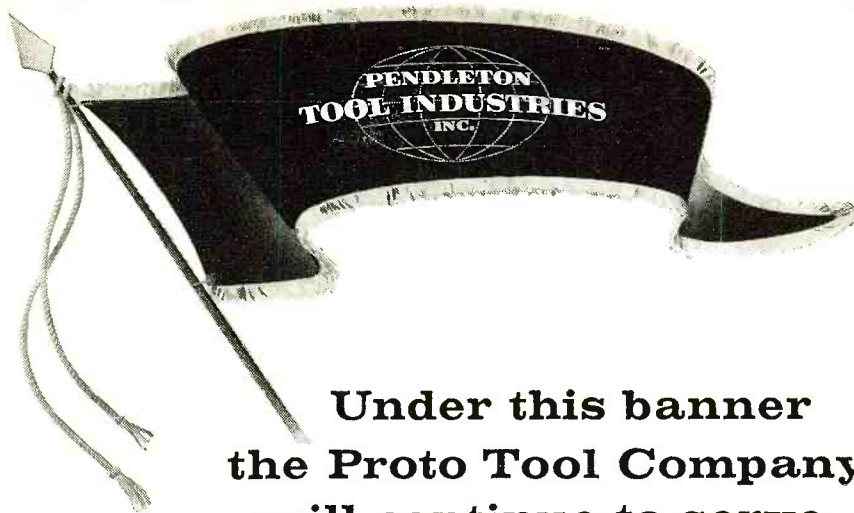

Under this banner the Proto Tool Company will continue to serve the needs of all industries

Founded in 1907, PROTO is the World's largest producer today of high-quality hand service tools. Leadership is attributable mainly to the *professional* quality of PROTO tools—resulting from intensive research, field-tested designs, special alloy steels, and superior manufacturing.



DIVISION OF



2209 SANTA FE AVE.
LOS ANGELES, CALIF.



583 ALLEN STREET
JAMESTOWN, NEW YORK

PROTO means
PROfessional
TOols!

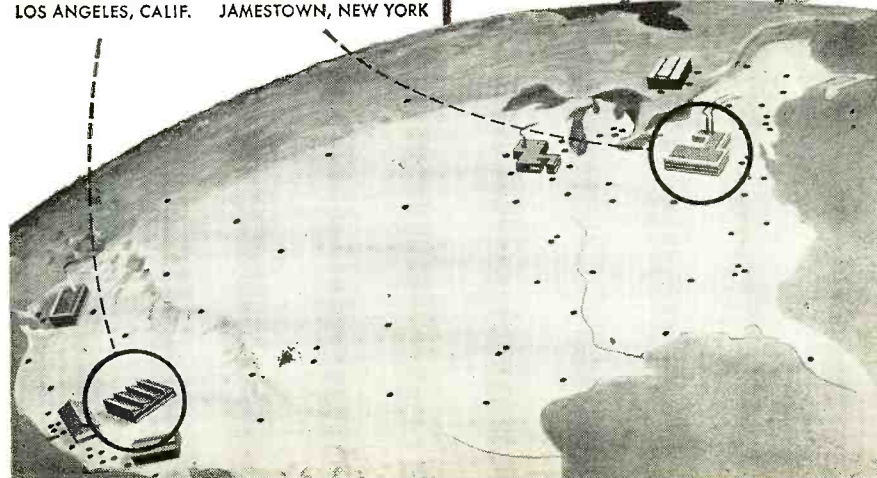

Examine FREE

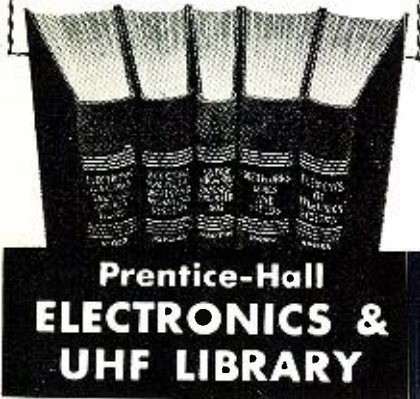

**Prentice-Hall
ELECTRONICS &
UHF LIBRARY**

Edited by W. L. EVERITT

5 VOLUMES 1662 ILLUSTRATIONS

Pay Easy Installments If You Keep the Set

Turn to this new, up-to-date Library with complete confidence, for dependable facts on any phase of modern electronic theory and practice. These volumes, by outstanding authorities, give you thorough guidance—clearly written, logically arranged, profusely illustrated.

Electronic Fundamentals and Applications
By Prof. John D. Ryder, Dean, College of Engineering,
Michigan State University

Complete, logical, easy-to-follow treatment of (a) physical principles underlying electron tubes, (b) characteristics of vacuum tubes, (c) all basic tube circuits. Includes: Electron Ballistics, Cathode-Ray Tubes, Diode Rectifiers, Triodes, Multi-Element Tubes, Small-Signal Amplifier Circuits, Audio-Frequency Amplifiers, Radio-Frequency Amplifiers, Oscillator Circuits, Modulation Systems, Wave-Shaping Circuits, Gaseous Conduction, Gas Diodes, Gas Control Tubes and Circuits, Photoelectric Cells, Solid-State Electronics.

Electromagnetic Waves and Radiating Systems

By Prof. Edward C. Jordan, Head, Dept. of Electrical Engineering, Univ. of Illinois

Covers entire field of electromagnetic engineering. Includes propagation as well as radiation and transmission. Full treatment of UHF transmission lines, wave guides, antennas, slot antennas, radiation and diffraction, ground-wave and sky-wave propagation.

Ultra High Frequency Engineering
By Thomas L. Martin, Head, Dept. of Electrical Engineering, Univ. of Arizona

Theory and technique of ALL the new fields of electronic engineering: Radar, Telemetry, Electronic computing, Facsimile, Television, Blind landing systems, Pulse-time modulation, Ionosphere measurements . . . and the others.

Networks, Lines and Fields

By Prof. John D. Ryder, Dean, College of Engineering,
Michigan State University

Network transformations and theorems. Resonance. Impedance transformation and coupled circuits. Filters. General transmission line. High-frequency line. Equations of the electromagnetic field. Radiation. Transmission and reflection of plane waves at boundaries. Guided waves between parallel planes. Wave guides.

Elements of Television Systems

By George E. Anner, Univ. of Illinois
Complete basic theory, plus current practice, covering: Closed TV systems. Commercial Teletesting Systems, Color TV Systems. Gives clear exposition of all phases of picture transmission, including the new technique of dot interlace.

SEND NO MONEY—EXAMINE FREE

Just mail coupon below to get complete 5-Volume Set on 10 DAYS' FREE TRIAL. If not completely satisfied, return in ten days and owe nothing. Or keep the set and pay only \$7.50 down and \$8 a month for five months until full price of \$47.50 is paid. Decide for yourself—without risk or obligation—just mail coupon to examine Library ten days free.

Prentice-Hall, Inc., Dept. 5741-J2
Englewood Cliffs, N. J.

Send me the Prentice-Hall ELECTRONICS & UHF LIBRARY (5 Volumes) for ten days' free examination. If fully satisfied in ten days I will send you \$7.50 plus few cents postage and then \$8 a month for five months until full price of \$47.50 is paid. Or I will return the Library in ten days and owe nothing.

Name

Address

City and State



TUNER CONTEST

The Sargent-Raymont Co. is running a contest in an effort to obtain one of its original hi-fi tuners (the Model No. Seven) built in 1928. The contest is open to anyone who may still own one of these models. It ends on August 31,

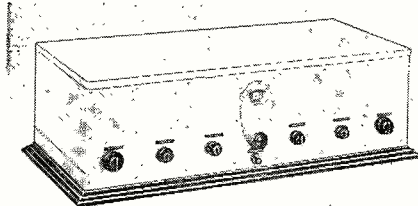

and the grand prize is a new 1957 model of the winner's choice.

Entries must be made in the form of a recognizable snapshot of the unit, with the contestant's name and address on the back of the photo. The entry bearing the earliest postmark and appearing to be in the best condition in the judges' opinion will be awarded the prize. The winner will be notified by mail and asked to ship the unit to the firm at its expense. The decision of the judges will be final.

TAPE DISPLAY MERCHANDISER

A self-selling "Irish" recording tape merchandiser has been introduced by ORRadio Industries, Inc.

According to the company, this "Money Maker Pack" was developed primarily for the dealer who wants to stock recording tape but doesn't want

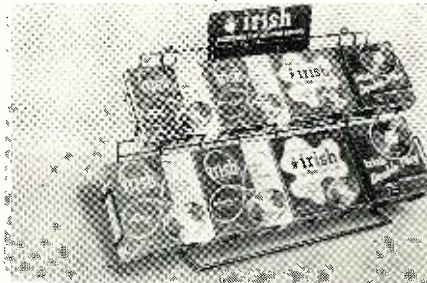

to carry an extensive inventory. However, it has found acceptance also from dealers who are already stocking tape.

Displaying 20 assorted reels of the company's tape, the merchandising rack forms a colorful, eye-catching display which invites browsing and stimulates impulse buying. The rack of sturdy wrought iron does not have to be assembled as it comes in one piece. Other features are its convenience and its versatility. On the counter it takes up only two square feet of space or it can be used as a wall merchandiser as well.

**NATIONAL COMMUNICATIONS
RECEIVER**

RBL-5. 6 Band. 15-600 KC Long Wave. Self Contained 115 VAC—60 Cycle Power Supply. Ship. Wt. 100 Lbs. Brand New **\$59.95**

NAVY TUNING MONITOR #HT55180
4" x 6" x 5". 115V AC. DC Input. 7-70 KC. Compl. w/tubes and tuning eye. Used to Monitor Xmtr. Ship. Wt. 5 Lbs. Brand New. **\$4.95**

TEST SET TS-182/UP
RF Signal Generator. Calibrated Dial, Attenuator, Meter + 2" C.R. Tube Indicator—self powered 115V—60 Cy. Cables and Probe included. 50 Lbs. Exc. Cond. **\$24.95**

ARC-5 XMTRS
Exc. Cond. w/all tubes. 3—4 MC—**\$5.95**; 4—5.3 MC—**\$5.95**; 5.3-7 MC—**\$4.89**.
807 w/5933—Ruggedized Version of 807. Boxed New. **\$1.59 ea.—Doz. \$15.00**.

NATIONAL HRO POWER SUPPLY
Standard Rack Panel Mount. 115 VAC input—230 VDC—.075A, and 6.3V—.3A. output. New. **\$14.95**

PINCOR ROTARY CONVERTOR
W910B input 115 VDC—output 115 VAC—60 Cy. .605A. Near New. **\$19.95**

WESTERN ELECTRIC REGULATED POWER SUPPLY
KS15093L1 Input 115 VAC—50/60 Cy. output. 115/120 VDC—.2 Amp. Rack Mt.—**\$29.95**
New/Compl. W 6 tubes.

- Hi-Speed Root Counter 5 Digit—Gd. Cond. \$1.49
- Subminiature Transistor Xformers. 3 for \$1.00
- 12V—.3A. Fila. Xformer Compact. \$1.49
- 5. VCT—13A. Fila. Xformer—New. \$1.95
- 170, Mirror Scale 0-1 Mil. 4" Sq. Meter, New. . . \$9.95
- Cased Choke 10 Henry 300 Mil. Merit (Navy). . \$3.49
- 6.3V—20A. Fila. Xformer. Cased—Compact. Utah. . \$3.95
- Carbon Deposit Precision Resistor Kit—
1/2-1-2 Watts—Bag of 50. \$1.00
- 6-AX Connectors PL-259 (Male) or 50-239 (Female) 3 for \$1.00
- Collins Modulation Xform. 807, 6L6, Cased. . . \$1.95
- Collins Mike to Grid. Small, Cased. \$1.29
- VR Tubes 105 or 150 New, Jan. 3 for \$2.00
- Acorn Tubes. 954, 955, 956—Jan. 4 for \$1.00
- Klystron—Sperry—SMX-32 New \$50.00
- Klystron—Sperry—SMC-11A New \$50.00
- UHF Oscillator Assembly w/Condenser Mike. . \$2.95
- Steatite Acorn Sockets—New. 6 for \$1.00

REX RADIO SUPPLY

88 Cortlandt Street New York 7, N. Y.

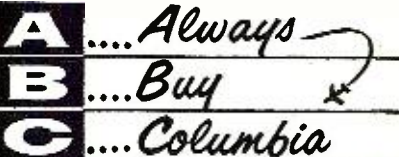

"If You Ain't Got It—Get It!
If You Have Got It—Sell It!"

We're giving away lots of green dollar bills for the following:

- APN-4 ARN-7 OMNI ARN-14
- ARN-6 SCR-718C ARC-3 ARC-27
- RTA1B AVQ-9 ART-13 GRC
- TS Equip. ARC-1 ADF PRC
- APN-9 MN-62 TRC

FRA FREQUENCY SHIFT TELETYPE CONVERTER. Like new. Lim. Quant. **\$39.95**

LM FREQUENCY METER
195-30,000 Kc. Same as BC-221, only modulated. With original calibration book. **\$49.50**
crystal, etc. Excellent condition.

METERS! ALL EXCELLENT!
0-1 ml. 3-inch, round, W.E. Only. \$2.99
0-150 V.A.C. 2-inch, round, G.E. 2.99
0-2 mil 2-inch, round, General Electric. . . 2.49
0-3 amps. DF. 2-inch, round, Sparton. . . . 2.99
BEDEE METER: 0-1 MA. 4" square. Cased in lucite. A beauty! Orig. cost \$18.00. \$7.95
Our clean-out price.

COMMAND GEAR—EXCELLENT COND.
BC-453 REGR. 19-.55 MC Q 5'er **\$12.95**
BC-455 REGRV. 6-9.1 MC. 40 meters. . . 4.95
BC-457 XMTR. 4-8 MC. Special. 2.95
BC-458 XMTR. 5-3.7 MC. It's a steal! . . . 2.95
4-5.3 MC. XMTR. Brand new, boxed. Only 4.95
5-3.7 MC. XMTR. Sparkling new! Boxed! 4.95
BC-456 MODULATOR. Excellent cond. 4.95
BC-442 ANTENNA SWITCHING RELAY: with vacuum capacitor. New, low price 3.49
TRIPLE RECEIVER RACK. With shock mount. 2.50
DOUBLE XMTR. RACK With shock mount ALL PLUGS! For SCR-274N or SCR-25. Ea. 1.00
1625 TUBES: For spares. New, boxed. Ea. 25
TRIPLE RECEIVER CONTROL BOX. 95
BC-450 TRANSMITTER CONTROL BOX. Only. 95
18 FT. FLEX CABLE TACH SHAFTS. To control receiver remotely. Special. 1.95
All orders FOB Los Angeles. 25% deposit required. All items subject to prior sale. MINIMUM ORDER \$3.00.

NEW CATALOG! Are you on our list for free copy?
All orders FOB Los Angeles. 25% deposit required. All items subject to prior sale. MINIMUM ORDER \$3.00.
TO EXPEDITE YOUR ORDER MAIL TO DEPT. R.

Columbia ELECTRONICS
2251 W. WASHINGTON BLVD.
LOS ANGELES 18, CALIFORNIA
RADIO & TV NEWS

Tapes included in the deal are the "Brown Band," for all home recorders; the professional type "Green Band"; the Long Play; and the Double Play.

The "Money Maker Pack" is packaged in two cartons—the rack in one carton, the merchandise in another. A supply of sales aids is also included in the package. The rack merchandiser, valued at \$7.00, comes to the dealer at no cost.

NEW "EFFICIENCY" POSTER

An unusual training poster has been issued by *Ersin Multicore Solders*.

This attractive, colorful 18" x 24"

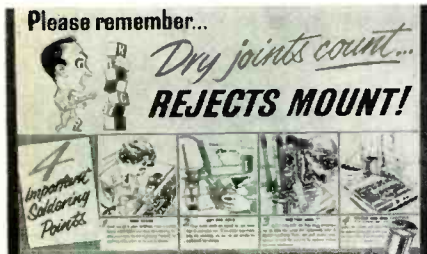

sheet is addressed to assembly line operators and illustrates dramatically how to do a more effective soldering job, eliminating costly rejects, and adding to production efficiency.

The poster is designed to be useful in any plant, regardless of what brand of solder is used. It appeals to the employee's pride of accomplishment.

Manufacturers of electronic equipment may have copies free of charge by writing on company letterhead to Dept. K-23, *Multicore Sales Corp.*, 80 Shore Road, Port Washington, N. Y.

NEW PACKAGE DESIGN

A new package design is being introduced by the distributor division of *P. R. Mallory & Co., Inc.*, Indianapolis.

In addition to its simplicity and ready recognition value, the new design incorporates an interesting system



of color coding. The end tabs of the cartons will be printed in a different color value for each of the firm's component lines. As a result, when cartons are stacked in inventory, groups of vibrators, controls, capacitors, mercury and zinc-carbon batteries, and other product lines are readily distinguishable.

The color coding principle employed in the cartons is being well received by the trade as a means of speeding up stock picking and inventory checking.

The company's vibrators are the first product being shipped in the new packages.

—30—

July, 1957



sturdy, steel PERMA-TUBE TV masting is corrosion proof

Perma-Tube, most famous name in TV masting, stays strong because it is corrosion proof. Perma-Tube is treated with vinsynite—then coated with a metallic vinyl resin base both *inside* and *outside*.

Perma-Tube is guaranteed to be free from rust in a salt spray test of 500-hours minimum to ASTM Specification 13 117-49T. Longer mast life is assured.

Resistance to bending in Perma-Tube is greater than in galvanized masting. Machine-fitted joints speed field assembly, insure close

tolerance for strength and rigidity. *Joints are stronger than the tubing itself.*

Five diameters of fitted joint Perma-Tube are available, ranging from 2½" OD to 1¼" OD. Telescoping masts can also be erected up to 50 feet high, using 10 foot lengths of high strength J&L 16-gauge Perma-Tube.

Get complete details on popular Perma-Tube TV masting. Write to the Jones & Laughlin Steel Corporation, Dept. 495, 3 Gateway Center, Pittsburgh 30, Pa.



Jones & Laughlin

STEEL ... a great name in steel

BUILD THE BEST—

BUILD ALLIED'S OWN

knight-kits

LOWEST COST DESIGN FOR GREAT SOUND
POWER PROTECTS YOUR INVESTMENT
YOU DO THE EASY PARTS AND WE ASSIST
YOU THROUGHOUT

knight-kits

EASIEST TO BUILD...
Step-and-Chisel...
marks of clarity...
and included...

knight-kits

MONEY-BACK GUARANTEE: When properly
assembled, KNIGHT-KITS will meet your
highest...
money...

EASY TERMS AVAILABLE

knight-kit HI-FI VALUE SENSATIONAL HI-FI FM TUNER KIT



Model Y-751 ★ Deluxe custom hi-fi styling
★ AFC and Flywheel tuning
★ Printed circuit—easy wiring

\$3775

The best-looking, best-performing tuner kit your money can buy. Covers 88 to 108 mc; features AFC (with special disabling circuit); pre-adjusted RF coils; pre-aligned IF's; cascode broad-band RF amplifier; drift-compensated oscillator; illuminated lucite pointer. Sensitivity is 10 microvolts for 20 db of quieting across entire band. Ideal for use with Knight-Kit 20-Watt Amplifier or any amplifier with phono-tuner switch. 13 x 8 x 4". Complete, ready for easy assembly. Shpg. wt., 12 lbs.

Model Y-751. Net, F.O.B. Chicago **\$3775**

See our Supplement No. 165 for additional knight-kit Hi-Fi values

free SUPPLEMENT

featuring knight-kits
Send for our FREE Supplement No. 165 featuring 45 great Knight-Kits, including Test Instruments, Hi-Fi, Hobbyist and Amateur kits. Write for your copy today.



ORDER FROM

ALLIED RADIO

Dept. 07-G7, 100 N. Western Ave., Chicago 80, Ill.

All Eggs in One Basket?

(Continued from page 56)

wife, the center soon became a profitable adjunct to his business. His service business grew along with the greeting-card business to the point where he could profitably use two technicians to help him.

Another dealer reported unusually good results from a key-making machine he installed in the front window of his shop. This dealer had one employee who handled outside calls while he took care of shop work on TV and radio sets brought in by customers. He promoted the key-making facilities extensively after he put in the machine. The traffic developed by this promotion also brought added volume for his TV service department. Within six months he found it necessary to hire another technician to handle outside calls.

During the past six months, hundreds of small service dealers took a new look at the do-it-yourself trend in their areas and decided that "if you can't whip 'em, join 'em." They set up self-service testers in do-it-yourself centers in their shops and set out to recapture the business they were losing to drug stores. The dealers who promoted the centers aggressively have been happily surprised with the results they have achieved. They found that do-it-yourselfers prefer to patronize a place where they can get expert advice. The results have been healthy increases in over-the-counter tube sales, more calls for home service, and better customer satisfaction.

We live in a dynamic age in which all businesses, large and small, must be ready and willing to change to suit the needs of the times. Television service should be viewed as a business that will continue to operate in a state of flux for a long time to come. Wise dealers will seek ways and means to break away from TV service as their sole source of revenue.

PHOTO CREDITS

Page	Credit
31, 32, 33.....	International Business Machines
34, 35..	Wharfedale Wireless Works Ltd.
37.....	Sperry Gyroscope Company
38.....	University Loudspeakers, Inc.
40, 41.....	Ford Motor Company
42, 43 (top).....	Altec Lansing Corp.
45 (bottom right).....	General Electric Co.
49.....	Quiet-Kool Div., Emerson
54, 90.....	Heath Company
61.....	Packard-Bell
94, 95.....	Sylvania Electric Products Inc.
100.....	National Bureau of Standards
107.....	RCA Communications, Inc.
117.....	U. S. Army Photo
123.....	Gulton Industries, Inc.
131.....	Australian Information Bureau
139.....	Convair Div.

ERRATA

In the article "A New Hi-Fi Speaker System" which appeared in our April, 1957 issue, the two graphs shown at the top of page 55 were inadvertently interchanged. Note the different vertical scales used.

In the article "Photoflash Synchronizer Checker" which appeared in our April 1957 issue, the selenium rectifiers were incorrectly shown in the diagram (page 69). Both rectifiers should be reversed.

DON'T BUY A THING—

until you send for our free flyer!

DON'T SELL A THING—

until you offer it to us!



We will pay \$\$\$\$ for an AN/ARN-6 or AN/ARC-3 or any of their components. Also for AS-313 LOOP

Phone us collect on ABOVE ITEMS

Stanley 7-0406

SIMILAR FABULOUS PRICES FOR:

APR-9 ARC-1
ARN-7 ART-13 PARTS
BC-788-C I-152C
LP-21-AM LM, or
MO-18A or MC-907 from
these loops R-65/APN-9
TEST SETS 1-100,
TS-117, -125, -147, -148,

-488. What else have you? ? ?

ARROW SALES, INC.

Western Mailing Address:
Box 3007-R NORTH HOLLYWOOD, CALIF.
Central Mailing Address & Sales Showroom:
2441 S. MICH. AV., Dept. R., CHICAGO 16, ILL.
California Distributors' Stores
G. L. Electronics, Inc., 1632 Venice, Los Angeles
P.A.R.T.S., 8905 San Fernando Rd., Sun Valley

SCHEMATICS—CONVERSIONS FOR SURPLUS GEAR

NEW LIST DI MANY ADDITIONS!

Send stamped, self-addressed envelope for List D. Add 25¢ for chart explaining AN nomenclature. DO IT TODAY!

R. E. BOX 1220
GOODHEART BEVERLY HILLS, CAL.

a TERRIFIC BARGAIN in a

SOLA CONSTANT-VOLTAGE TRANSFORMER
Ends fluctuating line voltage!



Big Discount Off...

the factory price at a 1-input 2,000 VA unit! And here's another bonus! This Air Forces 2,000 VA overstock, Sola Cat. No. 30768, has 4 inputs! 90-125 V., 190-250 V., 60 cy. or 50 cy. Isolated secondary is constant 115.0 V. ± 1% from no-load to full-load of 17.4 amp. So, if you choose, use it as a 220-115 V. step-down. And slash \$97.50 off the factory 1-input price!

Brand new in original wood box. 4 cu. ft. Ship. wt. 25.4 lbs. F.O.B. Pasco, Wash., Only... **\$147.50**

THE M. R. COMPANY
P. O. Box 1220-A Beverly Hills, Calif.

BARGAIN HUNTING? TV SERVICEMEN!
Write for SENSATIONAL CATALOG
HENSHAW RADIO SUPPLY
3619 TROOST KANSAS CITY, MO.

ELECTRONICS

PREPARE FOR A GOOD JOB!
BROADCAST ENGINEER
RADIO SERVICING AUTOMATION

TELEVISION SERVICING
BLACK & WHITE—COLOR

APPROVED FOR VETERANS AND SURVIVORS OF VETERANS
BUILDING AIR CONDITIONED
SEND FOR FREE LITERATURE

BALTIMORE TECHNICAL INSTITUTE
1425 EUTAW PLACE, BALTIMORE 17, MD.

TV Sound Can Be Improved

(Continued from page 44)

ed to compete with the many excellent amplifier circuits currently available, it does have the advantage of push-pull output combined with a voltage-divider "B+" circuit for those receivers that are designed for such an arrangement. No feedback loop is included in this circuit. Although desirable, the additional stage of amplification it might make necessary may overcrowd and complicate the installation. As it stands, very little additional current will be required to operate this circuit, but it is nevertheless advisable to check the receiver power-supply components for signs of deterioration before going ahead. Actually only two of the three tubes shown will be additional.

No exact layout for this amplifier can be given, as available space will vary with make and model of receiver; however, it should be simple to install a new output transformer in the place of the original one installed, add one more output-tube socket as close as possible to the original, and install a nine-pin miniature socket as close as is convenient. One tube-socket mounting bolt should be made to carry a five-tiepoint strip to facilitate wiring. Some or all of the filter capacitors used may be already included in the receiver, in which case duplication would only add to the expense and bulk of new material. Since the value of C_6 is not critical, this electrolytic capacitor can be taken from the existing circuit.

When wiring has been completed and checked, the receiver should be switched on and grid and cathode voltages should be checked. Some adjust-

ment in the values of R_8 and R_{12} may then be required to give correct operating conditions and to provide a low "B+" supply of correct voltage to the rest of the receiver.

Improvement in the speaker system, after any of the foregoing modifications have been made, will be well worth while. In the case of table-model receivers, very little can be done without building some form of enclosure of sufficient size to take an improved speaker. This can be in the form of a base on which the receiver itself can be placed.

In the case of the console receiver, a great deal can be done at very little expense to transform the lower portion of the cabinet into an adequate enclosure. This enclosure will generally be no larger than five cubic feet, about optimum volume for a good many speakers. Where less space is available, good results can be procured with a pair of 6-inch speakers, properly phased, or by using one of the better low-priced oval types. The ingenuity of the builder will be the main factor governing the type of enclosure, but the infinite baffle is adequate and requires only complete sealing and lining of the enclosure with sound-absorbing material. Carpet felt may be used for this purpose and will be found stiff enough to seal small areas without the use of plywood or other solid materials.

After completing any improvement to audio reception, a final FM alignment check should be made, visually if possible. With the audio-output capabilities improved, departures from good alignment that might not have been noted with the original audio system may be more conspicuous, and whatever additional improvements can be obtained in this direction become worth while. —50—

Fig. 3. An auxiliary amplifier that can be integrated with the TV receiver.

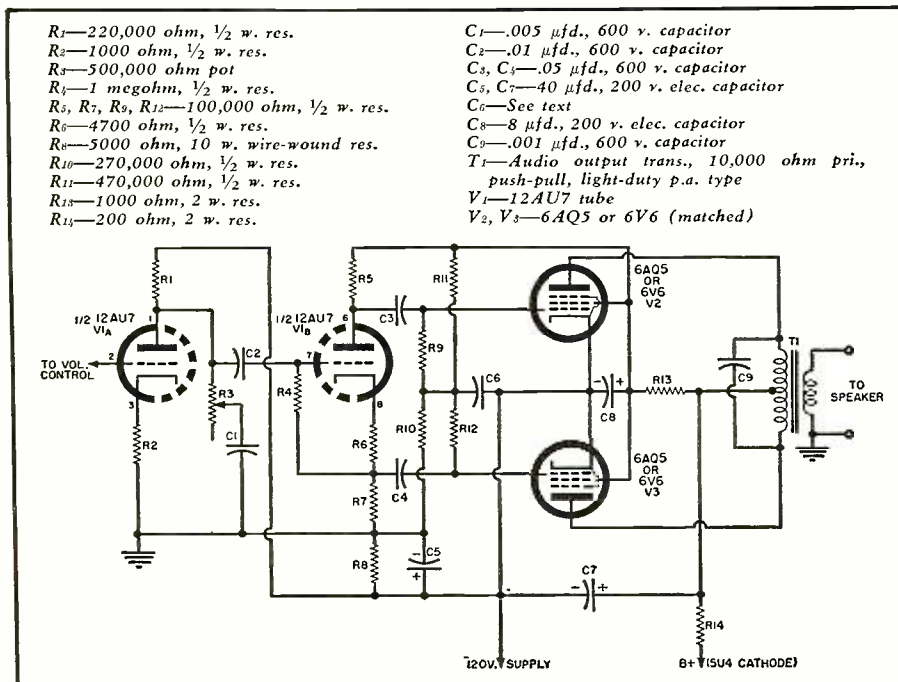

'SCOPES ARE "GOLD MINES"

... When you learn to use them RIGHT... on all kinds of service jobs!

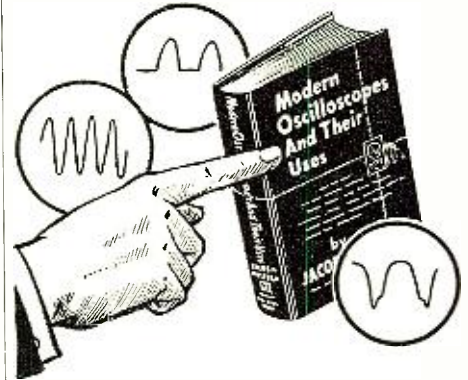

THIS GREAT BOOK TELLS ALL YOU NEED TO KNOW ABOUT THEM!

Big 2nd Edition

Contains Latest Data and More Than 30 Extra Pictures.

Includes use of 'scopes in color TV... black and white TV... Radio... Industrial Electronics... Teaching... even in atomic energy work!

Here's the "secret" of servicing any radio or Television set ever built... easier, better and faster!

In plain language, MODERN OSCILLOSCOPES AND THEIR USES brings you the data on 'scopes that you really need. It teaches you when, where and exactly how to use oscilloscopes on all types of jobs.

You learn how to handle tough jobs easier and faster than you may

have thought possible. Every detail is clearly explained—from making connections to adjusting components and setting the controls.

WORK EASIER—BETTER—FASTER

Equally important, you learn how to analyze oscilloscope patterns accurately and in less time. Almost 400 illustrations including dozens of pattern photos make every step perfectly clear.

This famous book—now in its revised 2nd Edition—is more widely used than any other of its type. That's because it gets right down to "brass tacks" in a way you can hardly fail to understand. No complicated mathematics. No involved theoretical discussions. You learn exactly how to use your oscilloscope on all types of AM, FM and television service (including color TV). You learn each step of the work fully—from locating troubles fast to handling tough realignment jobs.

PRACTICE 10 DAYS FREE!

Dept. RN-77, RINEHART & CO., INC.
232 Madison Ave., New York 16, N. Y.

Send 2nd Edition of MODERN OSCILLOSCOPES for 10-day FREE EXAMINATION. I will then remit \$6.50 (plus postage) promptly in full payment or return book and owe you nothing. (SAVE! Send \$6.50 with order and we pay postage. Same 10-day return privilege with money refunded.)

Name

Address

City, Zone, State.....

OUTSIDE U.S.A.—Price \$7.00, cash with order. Money back if you return book in 10 days.

Classified

RATE: 50¢ per word. Minimum 10 words. September issue closes July 10th. Send order and remittance to: RADIO & TELEVISION NEWS, 366 Madison Ave., N. Y. C. 17.

RADIO ENGINEERING

COMPLETE radio, electronics theory & practice; television; broadcasting; servicing; aviation, marine, police radio, 18 or 21 months. Catalog. Valparaiso Technical Institute, Dept. N, Valparaiso, Ind.

FOR SALE

TELEPHONE Extension in your car. Answer your home telephone by radio from your car. Complete diagrams and instructions. \$1.25. Q. Carrier Co., 734 15th St., N.W., Washington 5, D. C.

EAVESDROP with a pack of cigarettes. Miniature transistorized radio transmitter. Complete diagrams & instructions. \$1.25. Q. Carrier Co., 734 15th St., N.W., Washington 5, D. C.

POCKET Six Transistor Speaker-Radio, Complete \$42.95. Electronic Outlet, Wolcott Ave., Lawrence, Mass.

TRADEIN TVs—ship anywhere, 10 inch \$8. 12 inch \$11. 16 inch \$17. 17 inch \$22. 19 inch \$25. Packing \$3 at Justin Bros., Newport, Delaware.

DIAGRAMS! Repair Information! Radios—amplifiers—recorders \$1.00. Televisions \$1.50. Give make, model, chassis. TV Millie, Box 101RA, Hicksville, New York.

DIAGRAMS—Radios, Amplifiers, Changers, \$1.00 Each. Television Service Data \$2.00. Unknown Models, Give Tube Layout and Part Numbers. Cable Electronics Corp., 851 10th Ave., New York, N. Y. (Formerly Kramer's Radio Service).

DIAGRAMS for repairing radios \$1.00. Television \$2.00. Give make, model. Diagram Service, Box 672-RN, Hartford 1, Conn.

TUBES—TV, Radio, Transmitting And Industrial Types At Sensibly Low Prices. New, Guaranteed, 1st Quality, Top Name Brands Only. Write For Free Catalog or Call Walker 5-7000, Barry Electronics Corp., 512 Broadway, New York 12N, N. Y.

COMPLETE Television Sets \$11.95. Jones TV, 1115 Rambler, Pottstown, Pa.

TV SETS—10 to 21" —\$12 Up. Catalog available others. Surplus Appliances RFD 2, Able Park, Putnam Valley, N. Y.

MARINE Crystals Since 1933. Free Literature. Airmail delivery. Discounts. C-W Crystals, Box 2065, El Monte, Calif.

PRINTED Circuits: Design and construct your own. Wonderful for transistor units. Copper boards, etching compound, and all instructions \$2.00. Dawntronics, SDM, 2051 Lansing, Denver 8, Colorado.

WANTED

EARLY battery radios, crystal sets, parts, magazines, tubes, etc. Paul Thompson, 1300 So. Main, Las Vegas, Nevada.

CASH Paid! Sell your surplus electronic tubes. Want unused, clean transmitting, special purpose, receiving, TV types, magnetrons, Klystrons, broadcast, etc. Also want military & commercial lab test and communications gear. We swap too, for tubes or choice equipment. Send specific details in first letter. For a fair deal write, wire or telephone: Barry, 512 Broadway, New York 12, N. Y. Walker 5-7000.

WANTED: Short Wave & Communications Receivers. New or Used. All types Electronic Tubes. Highest Cash Prices Paid. Write or Phone: North Radio Co., 62 Cortlandt St., New York 7, N. Y.

CYLINDER and old disc phonographs. Edison Conqueror, Idellia, and Oratorio models. Berliner Gramophones and Zono-ophones, Columbia cylinder Graphophones, and coin-operated cylinder phonos. Want old catalogues and literature on early phonos prior to 1919. Will pay cash or trade late hi-fi components. Box 50 % RADIO & TELEVISION NEWS.

WANTED: Receiver R5/ARN-7, MN-62A Transceivers, RT18/ARC-1, AN/ARC-3, BC-788C, I-152C, Collins, Bendix equipment, Test Sets, Dynamotors, Inverters. We pay highest prices. Advise quantity, condition, price first letter. Aircraft Radio Industries, Inc., 15 East 40th St., New York City, telephone LBxington 2-6254.

WANTED: Signal Generators TS-403, TS-497, TS-621, SG-3/U, TS-437, TS-510, TS-588, TS-608, etc.; TS-186 Frequency Meters, AN/APR-4 Tuning Units, other "APR" Receivers, ARC-3, other Surplus; also Hewlett-Packard and other laboratory quality equipment, Weston, etc. instruments; technical manuals; for quick cash or swap for Zenith Transistor Portables, etc. LIT-TELL, Firhills, Box 26, Dayton 9, Ohio.

MAGNETS—Reliable supplier for Alnico core magnets 1 1/2" long, 1/4" diameter, wound with 39 B and S size enameled magnet wire, winding 3/4" long, total diameter 1/2"—Kohler & Campbell, Inc., Granite Falls, North Carolina.

ART—13/T47A Transmitters, \$175.00; ART—13/T47 Transmitters, \$125.00; BC-788 C Altimeters, \$175.00; ARC-3 Transceiver Complete, \$325.00; R5/ARN-7 Radio Compass, \$175.00; BC-348 Rec'r Modified, \$25.00; BC-348 Rec'r Unmodified, \$50.00; ARC-1 Transceiver, \$300.00; BC-342 Rec'r, \$50.00; BC-312 Rec'r, \$40.00; I-152-C Indicator, \$50.00. Ship Via Express, C.O.D. Subject To Inspection To H. Finnegan, 49 Washington Ave., Little Ferry, N. J.

REPAIRS AND SERVICING

HIGH vacuum pumps for repumping TV picture tubes that have been fitted with new guns. Induction heaters and equipment for processing TV tubes and sealing in guns. Write Windsor Company, 999 North Main, Glen Ellyn, Illinois.

HIGH Fidelity Speakers Repaired. Amprite Speaker Service, 70 Vesey St., N. Y. 7, N. Y. Ba. 7-2580.

YOUR Sapphire needle retipped with a genuine Diamond only \$8.95. Send needle only. Packard Radio, 67 Littlefield, Pawtucket, R. I.

TAPE RECORDERS

RECORDING Tape—1800' \$1.84, 1200' \$1.44. Guaranteed. Catalogue. Broadcast Tape, Box 231, Wallingford, Conn.

RECORDERS, HiFi, Tapes, Free Wholesale Catalog. Carston, 215-R E. 88 St., N. Y. C. 28.

TAPE Recorders, Tape. Unusual Values. Free catalog. Dressner 69-02 R, 174 St., Flushing 65, N. Y.

RECORDERS Wholesale! Tapes: 1200' \$1.39; 1800' \$1.85. Towers—155, Philadelphia 5.

TAPE Capstan. Custom made precision 32 ounce capstan and bearing assembly for tape deck. \$8.95 Manufacturers closeout. A. Allen, 1040 La Mirada St., La Habra, California.

HIGH FIDELITY

MATCHED-RESISTORS. 1 Watt paired within 1/10 of 1%. Pair 60¢ postpaid. Audio Fidelity, 377 Headlands Rd., Painesville, Ohio.

DISGUSTED of "Hi" Hi-Fi Prices? Unusual Discounts on all your High Fidelity requirements. Write now. Key Electronics Co., 120 Liberty St., New York 6, N. Y.

DISCOVER our "Six Unique Services" and Rock Bottom Prices on Hi-Fi; Stereo. Write The Silver Trumpet, 406R Walnut, Alexandria, Indiana.

CORRESPONDENCE COURSES

USED Correspondence Courses and Books sold and rented. Money back guarantee. Catalog free. (Courses bought.) Lee Mountain, Pisgah, Ala.

BUSINESS OPPORTUNITIES

EXCELLENT Business Opportunity: Hospital coin-operated pillow radios. Cost \$79.95. Sell very reasonable. Make offer. John Springer, 187 Connelville Street, Uniontown, Penna.

INSTRUCTION

MATHEMATICS. All levels. Correspondence. UCSM, 2406 W. Garfield, Milwaukee, Wisconsin.

LEARN Morse Code quickly, easily! Beginner's new, sensational manual, only 50¢. American Electronics, 1203 1/2 Bryant Avenue, New York 59, N. Y.

ENGINEERING Degrees, EE Option Electronics earned by home study. Residence classes also available. Pacific International University (American College of Engineering), 5719-C Santa Monica Boulevard, Hollywood 38, California.

LEARN While Asleep! Details free. Research Association, Box 610-RT, Omaha, Nebraska.

STUDY At Home For Commercial Radio Licenses. Very Reasonable Fee. Free Sample Lesson. Write Radio License Aids, Box 159, Buzzards Bay, Mass.

MISCELLANEOUS

DECALS—Trademarks, Service, Sales, etc. Write Allied Decals, Inc., 8378 Hough, Cleveland, Ohio.

BUSINESS Cards for TV Servicemen. Free cuts. Raised printing. Details Free. Polart Company, 20115 Goulburn, Detroit 5, Michigan.

FINEST Quality Embossed Business Cards—Black & White \$4.50 per 1000—2-Color, \$5.50 per 1000. Please remit with order. Chad-Ohr Press, Dept. S, 317 E. 48th Street, New York 17, N. Y.

HQ for the 5 TOP QUALITY brands of

TUBES

AT SENSIBLE PRICES!

- Individually boxed ● First quality only
 - Brand New ● 90-DAY RETMA guarantee
 - No rebrands ● No private brands ● No rejects
- WRITE FOR LATEST TUBE CATALOG FREE!

1B35	4.50	6L299	1.00	2051	1.45
1Q22	44.50	307A	.60	5517	1.15
CL-2	10.00	355A	11.00	5636	2.00
2B1	2.95	357A	14.00	5636A	2.05
2C35	2.00	371B	.75	5642	1.00
2C39A	11.00	403A	1.20	5675	4.35
2C40	7.00	403B	3.25	5651	1.40
2C51	2.25	404A	12.50	5654	1.40
2C53	9.75	416A	25.00	5675	8.00
2E24	4.16	417A	3.00	5678	1.85
2K25	13.50	417A	3.50	5687	1.85
2K45	35.00	417A/5842	12.00	5691	4.75
2K55	15.00	417A	12.00	5692	4.50
3B24	1.50	450TH	44.00	5693	4.75
3B24W	4.75	KU-610	3.50	5703WA	4.50
3B29	4.75	WL/655/656	90.00	5718	2.00
3B91	1.95	6L673	12.50	5725	2.00
3C23	3.95	703A	1.10	5730	1.75
3C31	1.00	717A	1.40	5744	1.25
3C45	35.00	CK722	.90	5749	1.25
3J30	25.00	7750TL	32.50	5763	1.25
3K20000LK	Write	800	1.00	5812	1.00
*4-65A	15.00	803	2.00	5814	1.00
*4-125A	30.25	805	4.00	5819	25.00
*4-125B	35.00	807	2.00	5820	1.00
*4-400A	45.00	807W/5933	1.75	5876	8.00
4B24/EL3C	4.50	813	9.50	5881	2.95
4X500A	75.00	814	1.25	5910	1.25
*4PR60A	4.00	836	1.25	5915	.50
5C22	25.00	837	1.25	6111	4.95
6AK5W	1.20	838	1.20	6112	1.25
6C21/450T	13.50	872A	1.00	6161	52.50
6J4	1.75	917	1.30	6201	3.00
6L6	3.20	918	1.10	6350	10.00
FG32	4.95	927	1.00	6039	9.00
*35TG	2.00	930	1.50	8008	3.25
VCS0/22V	8.00	954	.40	8022	1.00
RK-60/1641	1.25	956	.35	9001	.75
RK-65/5D23	1.25	957	.35	9002	.60
HY69	2.25	958A	.45	9003	1.35
RKR72 or 73	3.25	991	.25	9005	1.50
E123A	1.95	CK1005	.35	9006	.20
VXR-130	1.50	CK1028	2.35	*(Surplus)	

and many others, over 1000 types in stock! WRITE! WE ARE FACTORY AUTHORIZED DISTRIBUTORS OF CBS-HYTRON, EIMAC, PENTA, etc.

2 COLOR TUBE CARTONS

Keeps your tube stock neat. New safety partition prevents tube breakage. Distinctively lithographed in glossy red and black. The most distinctive tube carton available today. Minimum quantity: 100 of any one size. Write for case lot prices.

SIZE FOR TUBE PER 100
Miniature...6AU6, etc...\$1.00
GT...6SN7, etc...1.25
Large GT...6B3, etc...2.50
Large G...5U4G, etc...2.00

WHITE GLOSSY BOXES
Completely blank. No printing or color. Otherwise same as above. Same high quality, same low prices. Specify "WHITE" when ordering. When color is not stated, 2 color cartons will be shipped.

TUBE STACKERS
White glossy only. Ministacker holds 10 Mini. tube cartons; "GT" stacker holds 10 "GT" cartons.
SIZE PER EACH
Ministacker...13¢
GT...10¢

\$10.00 Per Case of 100 FOB NYC. (All cartons & stackers f.o.b. NYC)

AIRPORT or PHOTOGRAPHIC FLASH EQUIPMENT

Flash visible up to 3 miles, even in bright sunlight. May be used for portable (48 lbs.) photo-flash, visual signals, experiments, etc. Consists of a very high voltage converter, electronic flash lamp & holder, cables, mounting brackets, spare parts kit with extra flash lamp included, and detailed technical manual. Unused, complete. Some require minor touch-up. Can be made to operate from 115 VAC. 60 cycles with circuit modifications. All tested & working when shipped.

Model AN/VVX-1 for 6 or 12 v. DC \$75.00
Model AN/VVX-1X for 24 or 48 VDC \$65.00

WRITE FOR "BARRY'S GREEN SHEET" FREE!

NOTE: Even Barry is not infallible! Try as we might to prevent it, on rare occasions, our sources of supply do send in a bad tube that escapes our careful examination. So if at any time one does slip by to you, please advise us at once so that we can make prompt and cheerful correction.

TERMS: 25% deposit with order, balance C.O.D. All merchandise guaranteed. F.O.B. N.Y.C. Subject to price variation and stock depletion
MINIMUM ORDER \$10.00
TRADES ACCEPTED—OPEN MON. TO SAT.

BARRY ELECTRONICS CORP.
512, Broadway, Dept. RN, N.Y. 12, N.Y.
Phone: Walker 5-7000

TUBE

SPECIALISTS to the WORLD

SELECT THE TUBES YOU NEED FROM ONE OF THE MOST COMPLETE TUBE INVENTORIES IN THE WORLD

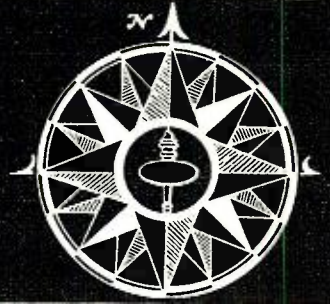

First Quality — Fully Guaranteed — No Seconds

RECEIVING TUBES

XMITTING TUBES

GRAND OPENING

Visit our newly opened BARGAIN STORE in our own warehouses. SEE FOR YOURSELF !! Forty thousand square feet of warehouse space loaded with a tremendous variety of resistors, condensers, chokes, transformers, headsets, microphones, test sets, receivers, transmitters. EVERYTHING IN ELECTRONICS. ROCK BOTTOM PRICES

ATTENTION!!!!

Hundreds of hard-to-find tube types available in addition to this listing. Same low, low prices. We have one of the largest and most comprehensive tube inventories in the WORLD. If the tubes you want are not listed here, write to us and we'll answer by return mail.

0A2	.69	6AD7G	1.50	6L6G	.98	12BF6	.60
0A4G	.95	6AF4	1.23	6L7	.95	12BH7	.89
0B2	.65	6AF6G	.85	6N7	.89	12BK5	.95
0Z4	.49	6AG5	.72	6Q7	.85	12BQ6GT	1.35
1A3	.68	6AG7	.98	6Q7GT	.79	12BY7	.90
1A7	.52	6AH4	.85	6R7	.85	12BZ7	.95
1AD4	1.20	6AM6	.85	6R7GT	.68	12CA7	.69
1AE4	.92	6AJ5	1.49	6S4	.57	12CU6	1.35
1AX2	.95	6AK5	.69	6S8GT	1.05	12H6	.59
1B3GT	.79	6AK6	.75	6SA7	.79	12J5GT	.65
1C5GT	.52	6ALS	.58	6SA7GT	.79	12K7GT	.85
1G4	.65	6AL7	.95	6SB7Y	.87	12K8	.69
1G6GT	.49	6AM4	1.50	6SC7	.72	12Q7GT	.75
1HG5T	.58	6AM8	1.10	6SF5	.69	12SA7	.69
1J6GT	.69	6AN4	1.50	6SF5GT	.69	12SA7GT	.69
1L4	.74	6AN5	2.75	6SF7	.92	12SC7	.75
1L6	.79	6AN8	1.15	6SG7	.65	12SG7	.79
1LA4	.79	6AQ5	.57	6SH7	.74	12SH7	.65
1LA6	.85	6AQ6	.50	6SH7GT	.59	12SJ7	.65
1LB4	.85	6AQ7	1.15	6SJ7	.69	12SK7	.69
1LC5	.79	6AR5	.70	6L7GT	.59	12SL7	.85
1LC6	.79	6AR6	2.15	6SK7	.64	12SN7	.75
1LD5	.85	6AS5	.70	6SK7GT	.59	12SQ7	.59
1LE3	.79	6AS6	1.95	6SL7GT	.75	12SR7	.59
1LG5	.85	6AS7G	2.35	6SN7GT	.75	12V6GT	.73
1LH4	.85	6AS8	1.15	6SQ7	.59	12WG6T	.87
1LN5	.79	6AT6	1.05	6SQ7GT	.59	14A4	.95
1NSGT	.59	6AT8	1.52	6SR7	.55	14A4	1.30
1QS5T	.95	6AU4	1.05	6ST7	.75	14A7	.75
1R4	.65	6AU5	1.10	6ST7	.95	14A7	.95
1R5	.65	6AU6	.65	6T8	.95	14F7	.95
1S8	.65	6BA7	.85	6U5	.85	14B6	.69
1S5	.65	6AV5	1.20	6U6	.95	14C7	.95
1T4	.65	6AV6	.53	6V3	1.25	14E6	1.05
1T5	.69	6AX4	.79	6V6	1.10	14E7	1.15
1U4	.67	6AX5	.69	6V6GT	.59	14F7	.85
1U5	.59	6B4G	.95	6W4GT	.65	14F8	1.10
1V2	.65	6B8	.67	6W6GT	.79	14H7	.85
1V6	1.49	6BA7	.55	6X8GT	.49	14N7	.85
1X2A	.85	6BC4	1.50	6X8	.95	14O7	.85
2A3	.95	6BC5	.68	6Y6G	.89	14R7	1.20
2A6	.59	6BC7	1.20	7A4	.79	14S7	1.10
2X2	.49	6BD5	1.35	7A5	.69	14W7	1.25
2X2A	1.35	6BD6	.73	7A6	.78	19BG6G	1.89
3A7	1.05	6BE6	.63	7A7	.75	19T8	.95
3A4	.50	6BF5	.82	7A8	.75	25AV5	1.25
3A5	.64	6BF6	.68	7AD7	1.65	25AX4	1.05
3AL5	.65	6BG6G	1.75	7AF7	.89	25BK5	.95
3AU6	.70	6BH6	.79	7AG7	.95	25BQ6GT	1.25
3AV6	.60	6BI6	.69	7AH7	.95	25C6D6	1.75
3B4	2.95	6BK5	1.95	7B4	.75	25C6G	1.30
3B7	.39	6BK7	1.05	7B5	.65	25L6GT	.65
3BC5	.80	6BL7	1.05	7B6	.75	25W4GT	.72
3BN6	1.05	6BN6	1.10	7B7	.75	25Z5	.75
3BY6	.75	6BQ6GT	1.15	7B8	.85	25Z6	.62
3CB6	.80	6BQ7A	1.15	7C5	.75	30	.30
3CF6	.85	6BK7	1.20	7C6	.75	32L7	.85
3D6	.39	6BV5G	1.25	7C7	.79	35A5	.69
3LF4	.85	6BZ7	1.20	7E7	1.15	35B5	.68
3Q4	.65	6C4	.38	7F7	.85	35C5	.68
3Q5	.75	6C5	.46	7F8	1.10	35E5	.68
354	.65	6C5GT	.48	7G7	1.10	35G5	.68
3V4	.69	6C6	.49	7H7	.79	35L6	.65
4BQ7A	1.30	6C8C	.85	7J7	1.25	35W4	.44
4BZ7	1.35	6C8S	4.40	7K7	1.15	35Y4	.65
5AM8	1.05	6C8E	.68	7L7	1.10	35Z3	.65
5AN8	1.10	6CD6G	1.75	7N7	.85	35Z5	.59
5AQ5	.75	6CF6	.90	7Q7	.95	35Z5	.59
5AS8	1.10	6CG7	.85	7R7	.95	41	.75
5AT8	1.10	6CL6	1.10	7V7	.95	42	.69
5AV8	1.15	6CM6	.85	7W7	.95	43	.79
5AW4	1.10	6CS6	.75	7X7	.90	43	.79
5AZ4	.60	6CU6	1.30	7Y4	.65	50A5	.68
5J6	.90	6D6	.59	7Z4	.65	50B5	.68
5R4GY	1.45	6DC6	.95	12A4	.85	50C5	.68
5T4	.90	6E5	.75	12A6	.57	50L6	.62
5U4G	.55	6F5	.59	12A8GT	.79	50X6	.85
5U8	1.10	6F6	.85	12AH7GT	1.05	50Y6	.78
5V4G	.58	6F6GT	.69	12AL5	.65	50Y7	.78
5V6GT	.70	6F7	.85	12AQ5	.70	50Z7	1.25
5W4GT	.65	6F8G	.72	12AT6	.48	70L7	.75
5X4G	.75	6G6G	.72	12AT7	.92	75	1.15
5X8	1.05	6H6	.59	12AUG	.62	77	.47
5Y3GT	.49	6HG6G7	.49	12AV7	.75	78	.57
5Y4G	.65	6J4	2.55	12AV6	.55	78	.57
5Z3	.69	6J5	.48	12AV7	.95	80	.59
5Z4	.89	6J5GT	.47	12AW6	.95	81	1.85
6A3	.95	6J6	.68	12AX4	.85	83	1.19
6A6	.82	6J7	.82	12AX7	.75	83V	.95
6A7	.65	6J7GT	.65	12AY7	1.15	84/GZ4	.49
6A8	1.95	6K6GT	.65	12AZ7	.85	117L/M7	2.45
6ABGT	.59	6K7	.74	12B4	.85	117N/P7	2.45
6AB7	.95	6K7GT	.59	12BA6	.60	117Z3	.68
6AC5	1.05	6K8GT	.95	12BA7	.89	117Z4	1.05
6AC7	.85	6L6	1.69	12BB6	.70	117Z6	.95

0A3/VR75	.86	5J2P	6.35
0B3/VR90	.73	5I5	9.95
0C3/VR105	.68	5LP1	7.40
0D3/VR150	.68	5NP1	4.95
1B22	1.25	6AC7W	1.45
1B23	2.68	6AK5W	1.45
1B24	4.85	6AL5W	.95
1B27	12.95	6AQ5W	1.70
1B35	3.45	6AS6W	2.69
1B38	33.50	6BF7W	3.45
1B40	3.45	6C4W	6.75
1B41	14.95	6C21	14.95
1C21	1.89	6F4	2.65
1N21	1.35	6I4WA	4.30
1N21B	1.45	6J5WGT	3.30
1N23	.68	6J6W	2.20
1N23B	1.40	6J6WA	3.90
1N34	.42	6K4	2.20
1N34A	.48	6SN7WGT	1.85
1P21	29.50	6X4W	1.20
1P22	1.25	6X5W	1.35
1P23	1.85	7BP7	1.45
1P24	1.45	12DP7	14.95
1P25	64.50	15E	1.45
1P28	8.95	15R	.49
1P30	1.95	28D7	.95
1P32	1.95	100TH	6.25
1P39	1.45	100TL	8.25
1P40	1.25	211	.45
1P41	2.45	249B	2.95
1P42	2.35	249C	1.95
2AP1	4.95	250TH	18.95
2B22	1.95	250TL	14.75
2C21	1.39	262B	4.95
2C34	.25	274A	3.45
2C36	21.50	274B	.85
2C39A	10.95	304TH	12.95
2C40	9.45	307A	12.95
2C43	10.25	307A	1.10
2C51	2.95	307A	2.65
2C53	10.75	350B	2.95
2D21	.65	371B	.85
2D21W	1.95	393A	4.50
2E22	3.15	WL417A	2.95
2E24	2.40	434A	14.95
2E26	3.25	434A	2.95
2G21	1.55	450H	47.50
2G21	2.45	450TH	35.00
2J31	14.00	575A	12.50
2J32	12.50	705A	.68
2J33	14.00	707A	4.95
2J34	14.00	707B	3.95
2J36	14.95	715B	2.95
2K23	97.50	715C	10.95
2K33A	56.90	717A	.35
3AP1	2.90	721A	.65
3B24	1.50	723A/B	8.45
3B24W	4.95	725A	2.95
3B25	4.95	726A	4.95
3B26	7.45	726B	1.64
3B27	3.45	755B	32.50
3B29	5.95	803	32.50
3BP1	2.45	804	65.00
3C22	59.50	806	65.00
3C23	3.45	807	1.18
3C24	1.48	808	1.25
3C25	5.95	809	2.20
3C45	5.95	810	10.50
3D21A	2.95	811	2.75
3E21	3.25	811A	3.25
3E29	9.00	812	2.75
4-65A	16.95	812A	3.25
4-125A	24.95	813	3.95
4-250A	36.50	814	1.95
4C27	8.95	815	1.95
4C28	17.45	816	1.15
4C35	13.45	826	.65
4E27	8.50	828	7.42
4X150A	22.45	829B	7.95
4X150C	31.95	830B	.65
5B1	2.35	831	5.75
5BP4	1.95	832A	7.95
5C22	27.50	833A	42.50
5CP1	1.95	836	1.45
5CP1A	8.45	837	1.25
5CP7	7.95	838	.69
5D21	7.45	845	4.85
5F7	1.20	851	8.95
5I29	29.40	860	2.75
5J30	17.25	861	12.95
5J33	6.95	866A	1.15
5JP1	12.45	872A	1.25

876	.72	5687	2.65	6099	1.35
878	.48	5692	5.10	6101	1.45
884	.95	5693	4.65	6113	1.25
885	.95	5696	.90	6146	4.75
902	2.45	5702	1.95	6161	69.50
918	1.65	5703	.95	6187	3.95
923	1.25	5704	1.95	6189	2.25
925	1.50	5718	2.75	6263	11.45
927	.95	5718A	4.75	6264	11.45
930	1.19	5719	2.15	6359	2.95
931A	2.95	5725	1.45	8005	4.75
954	.25	5726	.60	8008	3.95
955	.35	5727	1.25	8012	.98
956	.35	5732	2.95	8013	2.65
957	.35	5744	1.75	8013A	3.75
958A	.35	5751	1.45	8014	67.50
959	1.32	5762	99.50	8020	1.25
991	.29	5763	1.25	8025	1.45
1603	2.95	5783	4.45	9001	.82
1616	.50	5787CK	4.05	9002	.60
1619	3.30	5794	5.95	9003	1.20
1622	1.45	5812	2.70	9004	.35
1624	.95	5814	.95	9005	1.39
1625	.29	5819	32.50	9006	.25
1626	.19	5820	495.00		

ACTUAL SIZE

complete with selector switch...

TRIPLET

ELECTRICAL INSTRUMENT CO.
Bluffton, Ohio

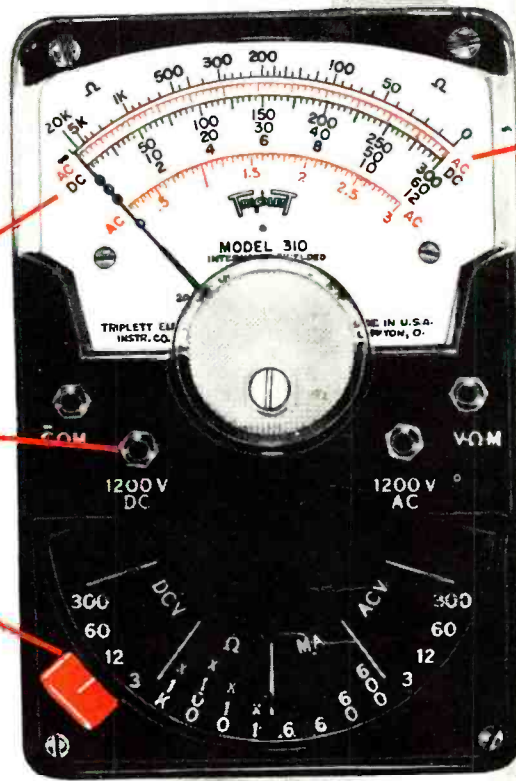

• 5,000 ohms per volt. A.C.

• 20,000 ohms per volt. D.C.

• BANANA-TYPE JACKS—positive connection and long life.

• EXCLUSIVE SELECTOR SWITCH speeds circuit and range settings. The first and only miniature VOM with this exclusive feature for quick, fool-proof selection of all ranges.



CARRYING CASE

Handsome leather carrying case with adequate space for Model 310 tester and accessories. Trouser belt slips through loop on back of the case for out-of-the-way carrying. MODEL 369 CASE—U.S.A. Dealer Net..... \$3.20

Model **310** MIGHTY MITE

the only complete miniature

V-O-M (AC-DC)

LOOK AT ALL THESE RANGES

DC VOLTS: 0-3-12-60-300-1200 at 20,000 Ohms/Volt.
AC VOLTS: 0-3-12-60-300-1200 at 5,000 Ohms/Volt.
DC MICROAMPERES: 0-600 at 250 Millivolts.
DC MILLIAMPERES: 0-6-60-600 at 250 Millivolts.
OHMS: 0-20,000-200,000 (200-2000 at center scale).
MEGOHMS: 0-2-20 (20,000-200,000 Ohms at center scale).
OUTPUT: Convenient chart in instruction book.
SEE IT AT YOUR JOBBER
AND IT'S ONLY ONE OF TRIPLET'S MIGHTY NINE VOM LINE!

ONLY **\$34⁵⁰** Dealer Net

DURTON BROWNE ADVERTISING



631
Combination
V-O-M—VTVM



630-NA
For Best Testings
Around The Lab,
Production Line
or Bench



630
The Popular
All-Purpose
V-O-M



630-A
A Good Lab and
Production Line
V-O-M



630-T
For Telephone
Service



666-HH
Medium Size
For
Field Testing



625-NA
The First V-O-M
With 10,000
Ohms/Volt AC



666-R
Medium Size
With
630 Features

... another
P. R. MALLORY & CO. INC.
MALLORY
service-engineered
product



Etched Cathode

stops
costly
"call-backs"

Some capacitors develop hum after a few weeks' service. The reason is loss of capacitance—caused by build-up of cathode oxide film.

This can't happen in Mallory FP capacitors . . . because they have *etched cathode* construction. Standard in all FP's and also in popular Mallory tubular electrolytics, etched cathode prevents gradual capacitance loss that can lead to annoying hum and costly call-backs. And you get this extra value in Mallory capacitors *without premium price*.

See your Mallory distributor for full facts about what etched cathode does for capacitors. It's another good reason why you're always sure of top performance when you use Mallory!

P. R. MALLORY & CO. Inc.
MALLORY

P. R. MALLORY & CO. Inc., INDIANAPOLIS 6, INDIANA

• Capacitors • Vibrators • Resistors • Controls • Switches • Filters

• Rectifiers • Power Supplies • Mercury and Zinc-Carbon Batteries