

# RADIO & TELEVISION NEWS

AUGUST  
1954  
35 CENTS  
In U. S. & Canada



*World's Leading Electronics Magazine*

## IN THIS ISSUE

**TWO-IN-THE-HAND**

**DUPLEX-CONTROLLED THYRATRON  
FOR PHOTOGRAPHY**

**RECEIVING TUBES  
FOR COLOR TV**

**AUTO RADIO SERVICING**

**TRACING THE WAVEFORM**

**COMPLETING  
THREE TUBES ON 2 METERS"**

**A HEAVY-DUTY  
AUDIO AMPLIFIER**

**VACUUM-TUBE TESLA COILS**

**FUNDAMENTALS OF COLOR TV**

**THE CBS PATCHING BAY**

(See Page 72)



AN-24-15703-15  
SHERMAN PARK BR. LIBRARY  
5085 EASTON AVE  
ST LOUIS 13 MO

# BE A RADIO-TELEVISION TECHNICIAN

America's Fast Growing Industry Offers You a Bright Future



**J. E. SMITH, President,**  
National Radio Institute,  
has trained more men for  
Radio-Television than any  
other man. Our 40th Year.

## I Will Train You at Home in Spare Time for Good Paying Jobs in RADIO-TELEVISION

### I Trained These Men



Extra Money in Spare Time  
"Four months after enrolling I averaged \$10 to \$15 a week servicing sets in spare time. Now have full-time business."—William Weyde, Brooklyn, New York.

Business Continues to Grow  
"Becoming an expert electrician as well as Radiotrician. Impossible without your course. Business continues to grow."—Philip G. Brogan, Louisville, Kentucky



Broadcast Engineer at WLPM  
"I am Broadcast Engineer at WLPM. Another technician and I have opened a Radio-Television service shop in our spare time."—J. H. Bangley, Jr., Suffolk, Va.

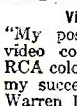

Video Control Engineer  
"My position with WNBT is video control engineer on the RCA color project. I owe a lot of my success to your textbooks."—Warren Deem, Malverne, N. Y.



### TELEVISION is Making Good Jobs, Prosperity

Radio, even without Television is bigger than ever. 115 million home and auto radios and 3000 Radio Broadcasting Stations give interesting jobs to service technicians, operators, engineers. NOW ADD TELEVISION. 25 million TV homes and the total growing rapidly. 200 Television stations on the air, hundreds more under construction. Color Television soon to be a reality. All this adds up to good pay now, a bright future for men who qualify.

### America's Fast Growing Industry Offers You GOOD PAY - BRIGHT FUTURE - SECURITY

Training PLUS opportunity is the PERFECT COMBINATION for job security, advancement. When times are good, the trained man makes the BETTER PAY, gets PROMOTED. When jobs are scarce, the trained man enjoys GREATER SECURITY. NRI training can help assure you and your family more of the better things of life.

#### Start Soon to Make \$10, \$15 a Week Extra Fixing Sets

An important benefit of my Radio-Television training is that you can start to cash in fast. I start sending you special booklets that show you how to fix sets the day you enroll. Multitester you build with parts I send helps you discover and correct troubles, helps you make money fixing neighbors' sets in spare time while training. Many NRI students make \$10, \$15 a week extra this way. My training is practical, complete. You benefit by my 40 years' experience training men at home. My well-

illustrated lessons give you basic principles you need, and my skillfully developed kits of parts "bring to life" things you learn from the lessons.

#### Find Out About This Tested Way to Better Pay — Mail Coupon

Without obligating you in any way, I'll send an Actual Lesson to prove that my training is practical, thorough. My 64-page book, "How to be a Success in Radio-Television", shows what my graduates are doing, earning. It gives important facts about your opportunities in Radio-Television, tells about kits I furnish for practical experience. You don't have to leave home or give up your job to take NRI course. You learn at home in your spare time on terms as low as \$5 a month. Many of my graduates make more than the total cost of my training in just two weeks. Mail coupon below now to J. E. SMITH, President, National Radio Institute, Dept. 4HE Washington 9, D. C. Our 40th Year.

### You Practice Broadcasting-Servicing with Kits of Parts I Send



Nothing takes the place of practical experience. That's why NRI training is based on learning by DOING. My training includes specially developed kits of parts you use to build equipment and get practical experience on circuits common to both Radio and Television. Shown at left is the low power Broadcasting Transmitter you build as part of my Communications Course. Also shown is modern Radio you build as part of my Servicing Course. My free book tells about other equipment you build. Mail coupon. All equipment is yours to keep.

AVAILABLE TO  
**VETERANS**  
UNDER GI BILLS

### Good for Both—FREE

Mr. J. E. SMITH, President  
National Radio Institute, Dept. 4-HE  
Washington 9, D. C.

Mail me Sample Lesson and 64-page Book FREE.  
(No salesman will call. Please write plainly.)

Name..... Age.....

Address.....

City..... Zone..... State.....

**VETS** Write in date of discharge

The ABC's of  
SERVICING

How to Be a  
Success  
in RADIO-  
TELEVISION

RADIO & TELEVISION NEWS is published monthly by Ziff-Davis Publishing Company, William B. Ziff, Chairman of the Board (1946-1953), at 64 E. Lake St., Chicago 1, Ill. Entered as second-class matter July 21, 1948, at the Post Office, Chicago, Ill., under the act of March 3, 1879. Authorized by Post Office Department, Ottawa, Canada, as second-class matter. SUBSCRIPTION RATES: Radio & Television News—one year U. S. and possessions, and Canada \$4.00; Pan-American Union countries \$4.50; all other foreign countries \$5.00. Radio-Electronic Engineering, Edition—One year U. S. and possessions, and Canada \$6.00; Pan-American Union countries \$6.50; all other foreign countries \$7.00. Postmaster—Please return undelivered copies under form 3589 to 64 E. Lake St., Chicago 1, Ill.

Editor and Asst. Publisher  
**OLIVER READ, D.Sc., W1EYI**

Managing Editor  
**WM. A. STOCKLIN, 8 S.**

Technical Editor  
**H. S. RENNE, M. S.**

Service Editor  
**CHARLES TEPPER**

Assistant Editors  
**P. B. HOEFER**  
**M. C. MAGNA**

Television Consultants  
**WALTER H. BUCHSBAUM**

Short-Wave Editor  
**KENNETH R. BOORD**

Art Editor  
**FRANK SAYLES**

Draftsmen  
**A. A. GANS, W2T5P**  
**J. A. GOLANEK**

Advertising Manager  
**L. L. OSTEN**

Midwest Adv. Manager  
**JOHN A. RONAN, JR.**

Western Adv. Manager  
**JOHN E. PAYNE**



*First in radio-  
television-audio-electronics*

Average Paid Circulation over 230,000

Radio News Trademark Reg. U. S. Pat. Office • Television News Trademark Reg. U. S. Pat. Office

Reg. U. S. Pat. Off.

## CONTENTS

## AUGUST, 1954

Two-in-the-Hand (Part I).....	Rob Wagner, W6WGD	31
A U.H.F. Booster.....	J. W. Steidley, W4IYB	35
A Sound-Controlled Thyatron for High-Speed Photography.....	Peter J. Vogelgesang & James Hilmanowski	36
Receiving Tubes for Color TV.....	Walter H. Buchsbaum	38
The RCA Model SV-1 Preamp.....	Leon A. Wortman	39
Fundamentals of Color TV—The Color Signal (Part 6).....	Milton S. Kiver	42
The Design and Construction of Vacuum-Tube Tesla Coils.....	R. A. Kawcyn & T. C. Marshall	45
Completing "Three Tubes on 2 Meters".....	Byron G. Wels, K2AVB	46
A Heavy-Duty Audio Amplifier.....	Serge L. Krauss	48
Certified Record Revue.....	Bert Whyte	50
Audio—Custom Built.....	David H. Mann	51
Auto Radio Service Checkpoints.....	John B. Ledbetter	52
Using Calibrated Variable Inductances.....	John T. Frye, W9EGV	54
TVI Troubleshooting (Part 4).....	Carl J. Quirk	56
1954 TV Receiver Specifications.....		58
A Simple TV Linearity Pattern.....	Robert B. Gary	59
Tracing the Waveform.....	George Fleishman	60
Mac's Radio Service Shop.....	John T. Frye	62
Radio Servicing in South Africa.....	N. C. Holman	71
The CBS Patching Bay.....		72
"Old Timer" Ormsby.....	C. Howard Bowers	83
New TV Stations on the Air.....		116
New TV Grants Since Freeze Lift.....		116
Radio-TV Service Industry News.....		122

## DEPARTMENTS

For the Record.....	The Editor	8	What's New in Radio.....	74
Spot Radio News.....		18	Technical Books.....	103
Within the Industry.....		26	Manufacturers' Literature.....	106
Short-Wave.....	K. R. Boord	64	New Audio Equipment.....	118

COPYRIGHT 1954  
(All Rights Reserved)

**ZIFF-DAVIS PUBLISHING COMPANY**  
WILLIAM B. ZIFF (1898-1953) FOUNDER  
Editorial and Executive Offices  
366 Madison Ave., New York 17, N. Y.  
VOLUME 52 • NUMBER 2



Member  
Audit Bureau of  
Circulations

**SUBSCRIPTION SERVICE:** All communications concerning subscriptions should be addressed to Circulation Dept., 64 E. Lake St., Chicago 1, Ill. Subscribers should allow at least four weeks for change of address.

**CONTRIBUTIONS:** Contributors are advised to retain a copy of their manuscripts and illustrations. Contributions should be mailed to the New York Editorial Office and must be accompanied by return postage. Contributions will be handled with reasonable care, but this magazine assumes no responsibility for their safety. Any copy accepted is subject to whatever adaptations and revisions are necessary to meet the requirements of this publication. Payment covers all author's, contributor's, and contestant's rights, title, and interest in and to the material accepted and will be made at our current rates upon acceptance. All photos and drawings will be considered as part of the material purchased.

**RADIO & TELEVISION NEWS**



COVER PHOTO: CBS' unique patching panel at Hollywood's "Television City." The multi-pin cable plug permits centralized control of various TV studio facilities. (Ektachrome by Peter J. Samerjan)

### ZIFF-DAVIS PUBLISHING COMPANY

President  
**B. G. DAVIS**

Vice-Presidents  
**H. J. MORGANROTH**  
**M. H. FROELICH**

Secretary-Treasurer  
**G. E. CARNEY**

Circulation Manager  
**M. MICHAELSON**

### BRANCH OFFICES

CHICAGO 111  
64 E. Lake St. • AN 3-3700

LOS ANGELES 1141

Staller Center, 900 Wilshire Blvd., Mich. 9826

All Electronic Parts  
YOURS TO KEEP!

Now!  
Work over  
**300**  
practical projects  
WITH THESE  
PARTS...

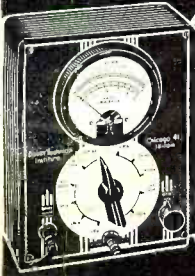

MULTIMETER



**5** INCH  
"SCOPE"

.... TO  
HELP YOU LEARN

# TELEVISION

**RADIO-ELECTRONICS** Now... at home in spare time you can get BOTH the very training and subsequent Employment Service you need to help you start earning real money in America's thrilling, multi-billion dollar opportunity field of Television-Radio-Electronics. Now that Television is coming to almost every community, here is a chance of a lifetime to prepare to cash in on one of Television's great expansions.

D.T.I.'s amazingly practical home method enables you to set up your own HOME LABORATORY. You get many Electronic parts which you mount on individual bases with spring clip connectors. Tops for experimenting! Add or remove parts in a jiffy. No wasted hours of soldering and unsoldering for each project. You spend *minimum* time to get *maximum* knowledge of important circuits that really work. In fact, you get exactly the same type of basic training equipment used in our Chicago training laboratory—one of the nation's finest.

## Build and KEEP This VALUABLE TEST EQUIPMENT

Your home laboratory projects also include building and keeping a versatile 5 inch Oscilloscope and precision Jewel Bearing Multi-Meter. These quality commercial test instruments help you EARN WHILE YOU LEARN and will prove mighty valuable, should you later decide to start your own full time TV-Radio service business. You also build and keep a quality 21 inch TV SET.

## D.T.I. Provides EVERYTHING YOU NEED to master TELEVISION

In addition to your home laboratory and easy-to-read lessons, you even use HOME MOVIES—a wonderfully effective and exclusive D.T.I. training advantage. You watch hidden actions... see electrons on the march. Important fundamentals... become "movie clear," helping you learn faster... easier... better.

Full time Residential training in D.T.I.'s great Chicago laboratories also available. MAIL COUPON TODAY for all facts. (If subject to Military Service, you'll especially welcome the information we have for you.)

D.T.I.'s Training is available in Canada

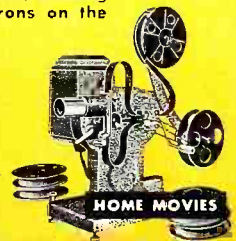

**89 WAYS TO EARN MONEY**

**MAIL COUPON TODAY!**

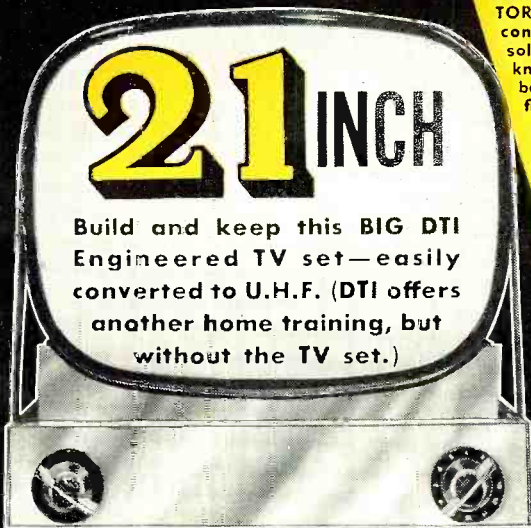

Build and keep this **BIG DTI** Engineered TV set—easily converted to U.H.F. (DTI offers another home training, but without the TV set.)

"ONE OF AMERICA'S FOREMOST TELEVISION TRAINING CENTERS"



**DEVRY TECHNICAL INSTITUTE**  
AFFILIATED WITH  
**DEFOREST'S TRAINING, INC.**  
CHICAGO 41, ILLINOIS

### DEVRY TECHNICAL INSTITUTE

4141 BELMONT AVE., CHICAGO 41, ILL. DEPT. RN-8-K

I would like your valuable information-packed publication showing how I can get started toward a good job or my own business in Television-Radio-Electronics.

Name \_\_\_\_\_ Age \_\_\_\_\_

Street \_\_\_\_\_ Apt. \_\_\_\_\_

City \_\_\_\_\_ Zone \_\_\_\_\_ State \_\_\_\_\_

# SCIENTIFICALLY DESIGNED...

**FOR BETTER TV RECEPTION**

**...BETTER PICTURE QUALITY**



Scientifically designed to give top performance, Philco television antennas are products of extensive research into receiver requirements in all types of locations. Field tested electrical and mechanical designs provide

proper gain, directivity, bandwidth and impedance... long life and ease of installation. Now a wide choice of Philco television antennas give you better picture quality... build complete customer satisfaction... more sales for you!

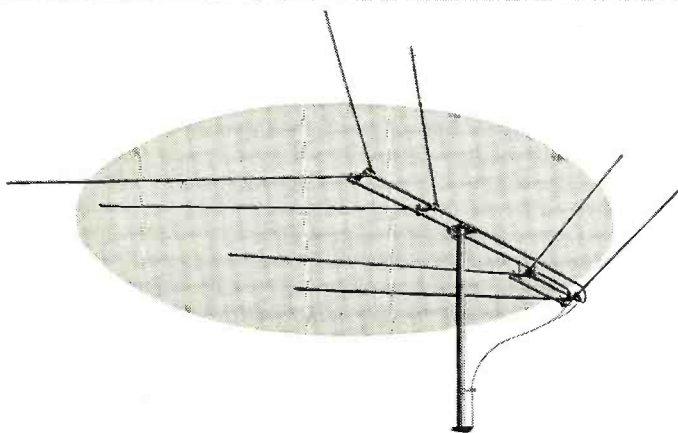

**PHILCO ALL-CHANNEL UHF-VHF TROMBONE ANTENNA:** The ideal antenna for areas having both UHF and VHF stations. The Philco Trombone can be stacked for VHF fringe area use. Completely pre-assembled at the factory... all-aluminum construction with dowelled elements: Part No. 45-1880.

**PHILCO TWO-BAY SUPER CONICAL ALL-CHANNEL ANTENNA:** Strong signal pickup on VHF channels 2 through 13, UHF channels 14 through 83... ideal reception in fringe areas... all-aluminum: Part No. 45-3096-2. Fringe area single bay design: Part No. 45-3096.

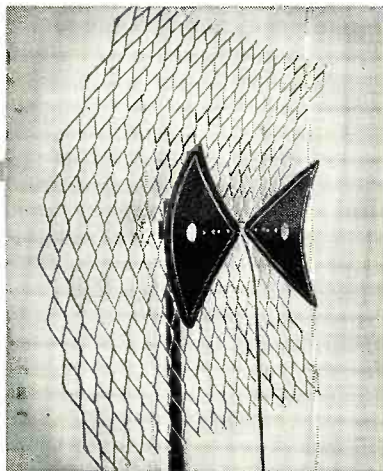
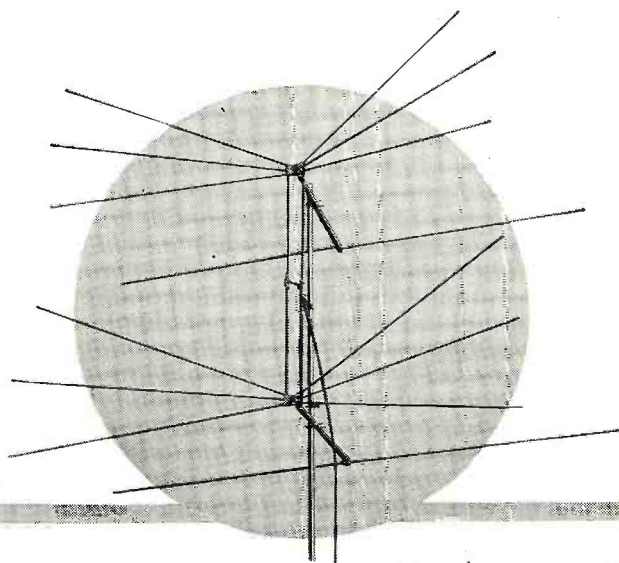

**PHILCO PARAFLECTOR ALL-CHANNEL UHF ANTENNA:** Pre-assembled, all-aluminum... 8 db to 10 db gain... outstanding fringe area performance... immediate mounting on existing masts: Part No. 45-3071. Bow Tie, Part No. 45-3069 and Bow Tie with reflector, Part No. 45-3070 provide top quality pictures in many UHF areas.

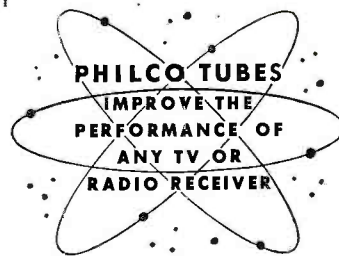

# PHILCO CORPORATION

# PHILCO

... SUPER PERFORMANCE



# ANTENNAS

**PHILCO VHF "V" ANTENNA:** Adequate reception on all VHF channels in most localities . . . heavy chrome plated three-section brass tubing . . . weighted plastic base holds antenna fully extended in any direction: Part No. AD-2643. Also available with aluminum tubing "V": Part No. AD-2643-1.

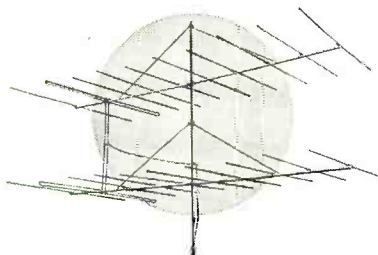

**PHILCO TWO-BAY VHF LOW BAND YAGI ANTENNA:** 10 elements . . . all-aluminum . . . factory pre-assembled. Top performance on channels 2 through 6 . . . 13 db to 15 db gain on various channels. Single bay Part No. 45-3112-2 through 6. Stacked version uses stack-harness Part No. 45-3267.

**PHILCO HIGH BAND VHF YAGI ANTENNA:** Pre-assembled, all-aluminum, 10 elements . . . high gain in fringe areas on channels 7, 8, 9, 10, 11, 12, or 13 . . . 10 db to 12 db gain on various channels . . . eliminates co-channel station interference: Part No. 45-3112-7 through 13.

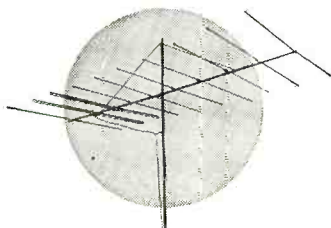
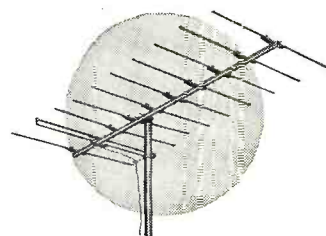

**PHILCO BROAD BAND VHF YAGI ANTENNAS:** All-aluminum, factory assembled for quick installation . . . high gain plus adequate band width. Three broad band models cover channels 2 to 6 . . . 4, 5, 6 . . . or 7 through 13: Basic Part No. 45-3112.

**PHILCO GOLDEN YAGI UHF ANTENNA:** Designed for 300 ohm operation . . . all steel construction . . . 11 db to 12 db gain on various channels . . . "Cronak" coated components resist salt air . . . humidity . . . six models cover entire UHF spectrum: Basic Part No. 45-1996.

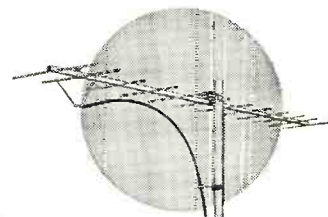

## ← PHILCO HEAVY DUTY ANTENNA ROTORS: →

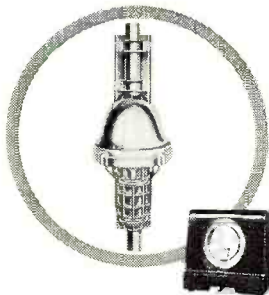

**PHILCO MODEL P-4:** Supports antenna installations weighing up to 150 pounds . . . completely weather sealed . . . factory lubricated for life . . . uses 4-wire rotor cable . . . modern direction meter control cabinet: Part No. 45-1974.

**PHILCO MODEL P-11:** Easily handles two-bay arrays . . . mounts on masts up to 1 5/8" in diameter . . . accurate direction control . . . heavy duty motor . . . streamlined design . . . uses 4-wire rotor cable . . . modern direction meter control cabinet: Part No. 45-1994.

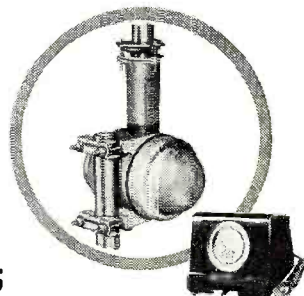

A complete line of powerful Philco TV antenna rotors as low as \$39.95

## ACCESSORY DIVISION

'A' AND ALLEGHENY AVE. • PHILADELPHIA 34, PA.

Completely New

# 666

## VARIABLE D\* CARDIOID DYNAMIC for TV and BC



### OUTPERFORMS ALL OTHERS

Combines ruggedness of single dynamic element with new acoustic principle. Eliminates pick-up of ambient noise, unwanted reverberation and equipment rumble. Uniformly smooth response 30-15,000 cps, laboratory controlled. Highest front-to-back discrimination. Virtually no proximity effect. Output —57 db. E-V Acoustalloy diaphragm. Blast filter. Detachable clamp-on swivel stand coupler. Weighs only 11 oz. 7½" x 1½". TV gray. 20' cable. 50 ohms. Readily changed to 150 or 250 ohms.

- Model 666 Microphone. List \$245
- Model 366 Boom Mount. List \$40
- Model 300 Stand Coupler. List \$10
- Model 420 Desk Stand. List \$20

Normal Trade Discount Applies

\*E-V Pat. Pend.

Write for Data Sheet No. 39

# Electro-Voice

BUCHANAN, MICHIGAN

# For the RECORD.

BY THE EDITOR

## THE BATTLE OF THE GUNS

ONLY two major obstacles lie in the direct path of acceptable color TV. The first of these is the price (production and at consumer level) of present receivers employing already out-moded picture tubes. The second is the costly process of manufacturing the tri-color tube in its presently-used form. Only a very few manufacturers have taken the plunge into the color market and none have enjoyed any degree of acceptability.

Programming of color shows has been conspicuous by its absence (as reported in our June editorial) and shows that have been telecast in color have done little to attract the TV viewer except for occasional programs during dealers' store hours. The better colorcasts have been on Sundays or during the evening when showrooms are closed. This haphazard thinking and planning of the industry has resulted in an untenable position with the public by placing the cart before the horse. One well-known manufacturer offered to rent his color TV set at the rate of \$100.00 per month (installation and service included). Let's assume that the customer signed up for 12 months and paid 1200 smackers for the rental. If, with present color schedules, he watched all color programs each week he would chalk up about an hour or a rate of 52 color hours per year.

This figures to cost him about \$23.00 per hour to watch color. This cost, in comparison to seeing Technicolor at the local cinema, is about 45 times greater per hour. Frankly, we'd much prefer to see a good color western in a theater than "Kukla, Fran and Ollie" or "Joe's Other Wife" on a color television receiver.

This preference is based on the average colorcast seen to this date. We do not refer to the occasional well produced color "extravaganza" that was well planned and executed and telecast at an hour compatible with the television viewing audience. Unfortunately, there have been few opportunities to witness the best in color television.

Television studios are rapidly being equipped with the latest color cameras and by Fall it is expected that many

more stations will be due to telecast color through their local network outlets. But until the public is given the opportunity to witness color programs in a dealer's showroom there is little that color programming can do to spark the color parade.

Color programming will have plenty of time to develop in the months ahead.

In the meantime—the battle of the guns continues in the tube laboratories. The color tube is the greatest bottleneck in the industry.

A half dozen or more have emerged from the laboratories and each has been highly touted as the one all manufacturers should adopt for their color sets. But no picture tube has, as yet, been produced economically and with techniques acceptable to mass production. And, equally important, is the lack of color tubes of acceptable sizes that would win public favor.

At no time in history have set manufacturers been in more of a dilemma. Because of the varied circuit requirements for different color tubes, set makers are faced with an almost impossible situation. Many of them refuse to give any consideration to adopting any tube so far produced. They would rather withhold their decision to produce until a tube is developed that will result in not too complicated circuitry, one that provides a 19" or 21" picture and one that is somewhat compatible in cost. And nothing will be gained if low cost picture tubes should require an elaborate and costly circuit to make them perform satisfactorily.

Volume production of color television cannot be realized until larger sized picture tubes are available at reasonable cost to the set manufacturer and, in turn, to the consumer at reasonable selling price. Interchangeability of picture tubes will be a major problem once the industry really starts to produce. The need for standards will be far greater than for any monochrome sets ever produced. Jobbers and dealers will have new inventory problems and technicians new circuits to master. The stakes will be high—but so will the profits in color television. . . . . O.R.

always in stock  
at **ALLIED**

# PRECISION

## TEST INSTRUMENTS

Standard of Accuracy, Quality and Value  
For Over Twenty Years



**Model 612-MCP.** As above, but in open-style portable metal case. 84 FX 444. *Net.*.....\$75.21

### Model 612P Tube Tester

Standard RETMA emission type circuit. Tests all tubes: button 7- and 9-pin types, (sub-miniatures also), dual-capped high freq. types, FM and TV tubes, etc. Permits individual testing of multi-section tubes including tuning indicators, osc-conv., etc. Panel switch selects filament voltages from 0.75 to 117. Free-point lever element selection handles all multiple basing terminations. Has 4 1/2" meter accurate within 2%. Checks for shorts between elements. Noise and condenser test pin jacks. Dynamic "under load" test for A, B and C radio batteries. Sturdy hardwood case with cover and carrying handle; tool compartment. Easy-to-read, high-speed roll chart has provision for adding test setting data. 12 x 13 x 6". For 110-120 volts, 50-60 cycle AC. Shpg. wt., 19 lbs. 84 FX 433. *Net.*.....\$77.91

### Model 10-12P Electronamic Tube Tester

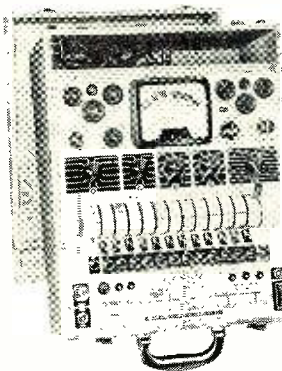

High-quality free-point tube performance tester featuring the reliable Precision Electronamic circuit. Tests all tubes, including 4, 5, 6, and 7-pin octals, loctals, 9-pin novals, acorn, sub-miniatures and television types. Provides 17 filament voltages to 117 volts. Absolute free-point element selection by master lever selector (with single-action return) which locates every tube element regardless of position at tube base. Provides direct facilities for radio battery, ballast, noise, pilot bulb and condenser testing, neon continuity checks, and tests for shorts between tube elements. 4 1/2" meter has 2% accuracy. Double window high-speed roller tube chart; permits adding new tube setting data. For 110-120 volts, 50-60 cycles. In attractive hardwood portable case with removable cover and handle. 13 1/4 x 17 1/4 x 6 3/4". Shpg. wt., 23 lbs. 84 FX 426. *Net.*.....\$105.35

**Model 10-12C.** As above, but in black chrome-trimmed counter-type case. 84 FX 430. *Net.*.....\$110.00

**PTA CR Adapter.** Will test all picture tube types when used with any Precision Tube Tester. Tube need not be removed from set for testing. 84 F 492. *Net.*.....\$6.61

**CR-30 CATHODE RAY TUBE TESTER.** Shows operating condition of TV picture tubes of all sizes and types, without removal from set. Measures actual beam current, not just total cathode emission. Checks all CR tube elements by absolute free-point 14-lever selection system. 4 1/2" meter shows tube condition and proportionate picture brightness. Built-in bridge-type VTVM. Speed roll-chart and test cubic. Hardwood portable case. 6 3/4 x 13 3/4 x 17 1/2" 110-120 v., 60 cycles. Shpg. wt., 22 lbs. 84 FX 448. *Net.*.....\$102.65

### Model EV-10A-MCP VTVM Megohmmeter

Wide-range, true zero-center. Reads: 0-2000-200,000 ohms, 0-2-20-200-2000 megohms. VTVM ranges: 0-3-12-60-120-300-600-1200-6000 DC volts. RF volts (with RF-10A probe): 0-3-12-60-120 v. peak AC, DC and output v.: 0-3-12-60-120-300-600-1200-6000, at 1000 ohms/v. DC current: 0-300 microamps, 0-1-2-6-30-120-600-1200 ma and 0-12 amps. 7" meter. Eight db ranges, -20 to +77. Steel case, 12 x 10 1/2 x 6". With coaxial leads. For 105-125 v., 50-60 cycles. Shpg. wt., 17 lbs. 84 FX 400. *Net.*.....\$97.75

**RF-10A RF Probe.** For above. Shpg. wt., 1 lb. 84 F 419. *Net.*.....\$14.11

### Model E-200-C Signal-Marker Generator

For efficient servicing of all AM, FM, and TV receivers; excellent for TV alignment. Covers 88 kc to 240 mc on eight bands (88 kc to 60 mc on fundamentals). Accuracy within 1%. Highly stable electron-coupled oscillator circuit. Outputs: Unmodulated RF, 400-cycle modulated RF, externally modulated RF, and 400-cycle sine wave audio output. Has 0-100% modulation control. Full vision, no-glare 6 1/2" direct reading dial with 0-100 vernier scale. Supplies 0-50 volts AVC-AGC voltage for alignment by constant bias procedure. Each range hand-calibrated. Complete with coaxial cable, dual LOW-HIGH cable connectors, and valuable 92-page book, "Servicing by Signal Substitution." In black ripple portable steel case. Size: 12 x 10 1/2 x 6". 105-120 volts, 50-60 cycles. Wt., 17 lbs. 84 FX 409. *Net.*.....\$76.93

### Model ES-500A 5" Oscilloscope

An outstanding scope—built to the highest test instrument standards. Features push-pull horizontal and vertical amplifiers, internal phasable beam blanking, 1-volt peak-to-peak voltage calibrator, amplitude controlled positive-negative sync selection (locking circuit), and vertical pattern reversal switch. Uses 5CP1A CR tube. Vertical deflection sensitivity through amplifier, .02 rms volts/inch. Horizontal, 15 rms volts/inch. Response of both amplifiers, 10 cycles to 1 mc. Direct input impedance (horizontal and vertical plates), 3.3 megohms and 15-20 mmf. Input of amplifiers: vertical, 2 megohms; horizontal, 1/2 megohm. Has 3-step, frequency-compensated vertical input, attenuator, plus continuously variable vernier control. Sweep, 10 cps to 30 kc. Has Z-axis modulation input for blanking, timing, etc.; phasing control for line sweep operations. Audio monitoring phone jacks. Removable, rotatable light shield. 8 1/4 x 14 1/2 x 18". With 5CP1A, all tubes, shield, screen, and operating manual. For 110-120 volts, 50-60 cycles AC. Shpg. wt., 44 lbs. 84 FX 449. *Net.*.....\$170.23

**SP-5 Probe Set.** For above. Four probes for general-purpose and specialized TV signal tracing, alignment, wave form analysis, etc. Includes: high imp.-low cap. probe; crystal probe; isolating probe; shielded direct probe. With coax cable and quick-change connector to accommodate probes and plug to scope. Clip-on tips free hands for work. In Vinyl roll case. Shpg. wt., 3 lbs. 84 F 491. *Net.*.....\$23.03

### Model E-400 Sweep Generator

For television and FM servicing. Frequency range is 2-430 mc; harmonically calibrated 240-430 mc. Narrow and wide-band sweep—freq. widths 0-1 mc and 0-15 mc. Permits easy band width setting for both FM and TV; has built-in zero base-line reference. High and low output terminals. Stable variable frequency oscillator beats with either one of 2 fixed frequency oscillators. Has built-in multiple crystal marker-calibrator. Supplied with 2 crystals (2 mc and 4.5 mc). Special socket accommodates 4 crystals. Full vision, 6 1/2-inch dial. Dual RF attenuators provide continuously variable output level control of test signals. Separate output terminal provides synchronized narrow and wide-band sweep. Phasing control. Includes coaxial output cable and other inter-connecting cables. Copper-plated portable case. 10 1/2 x 12 x 6". For 105-125 volts, 50-60 cycles AC. Wt., 24 lbs. 84 FX 433. *Net.*.....\$136.95



All PRECISION instruments over \$45 available on Easy Terms—write for details

### ALLIED STOCKS ALL PRECISION TEST INSTRUMENTS

- We can supply all Precision products promptly, including the following:
- 84 FX 422. Model 10-54-P Tube, Battery and 35 Range AC-DC Tester. Electronamic combination tube and battery tester, and 20,000 ohms/v. DC and 1000 ohms/v. AC circuit tester. In portable case. *Net.*.....\$136.71
  - 84 F 428. Series 85 Multi-range Tester. A quality VOM. *Net.*.....\$39.15
  - 84 F 441. LC-1 Carrying Case for above. *Net.*.....\$9.31
  - 84 F 405. Model 858-P 54-Range Tester, Push-button operation. *Net.*.....\$60.27
  - 84 F 446. Model TV-2 High-Voltage Probe for above testers. *Net.*.....\$14.45
  - 84 FX 417. Model EV-10A-P VTVM in wood case. *Net.*.....\$100.45
  - 84 FX 443. Model EV-20 VTVM, all purpose portable AC-DC. *Net.*.....\$68.35
  - 84 FX 445. Model TV-4 Hi-V Probe for above VTVM's. *Net.*.....\$14.45
  - 84 FX 419. Model RF-10A RF Probe for above. *Net.*.....\$14.11

## FREE Supplement No. 139

Send for our latest 56-page Supplement featuring new releases and special values. Make your selections at ALLIED from the world's largest stocks of tubes, parts, test instruments, audio equipment, amateur gear, industrial components—everything in electronics at lowest prices.

## ALLIED RADIO

ALLIED RADIO CORP., Dept. 1-H-4  
100 N. Western Ave., Chicago 80, Ill.

- Send FREE Supplement No. 139  
 Please ship the following PRECISION instruments.....

Name.....

Address.....

City..... Zone..... State.....





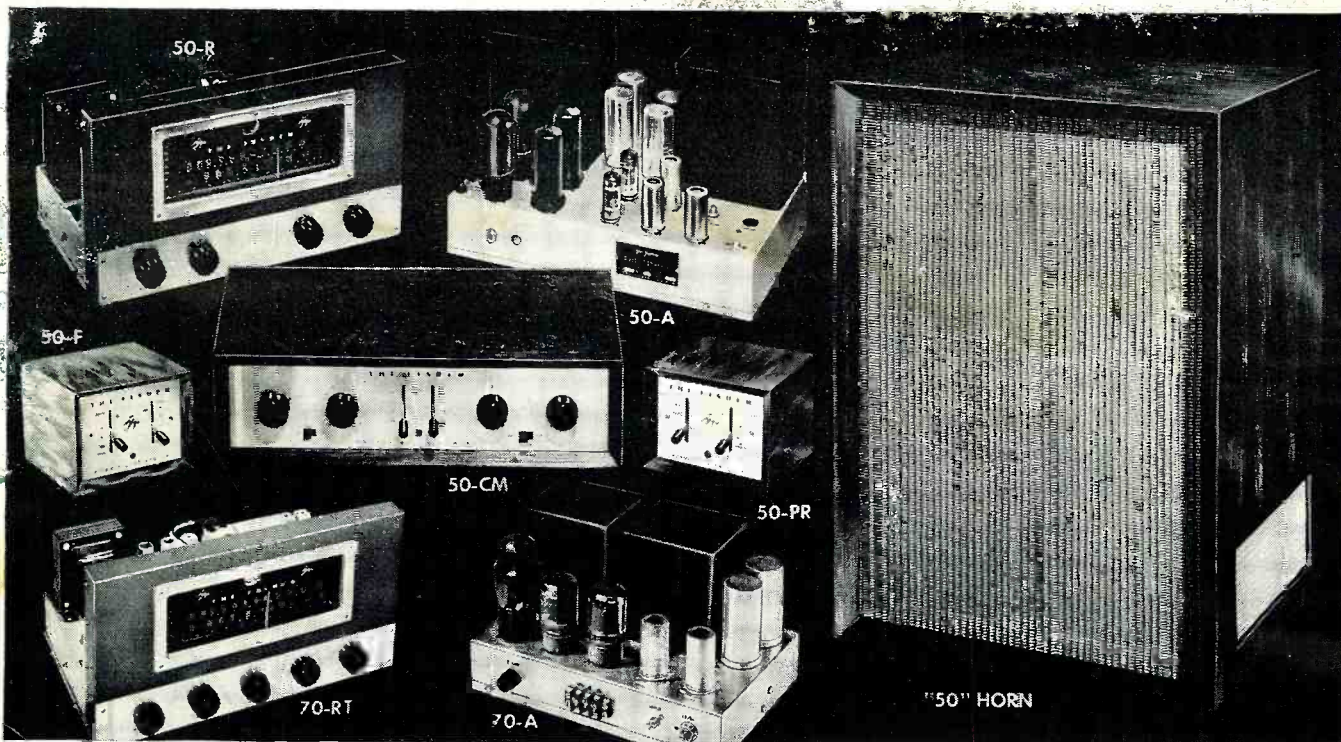

*The Best Costs Less When You Buy*

# THE FISHER

## Custom Audio Components

■ If you are buying 'for keeps' buy the best *first!* Buy FISHER, *quality leader* for seventeen years. Engineered for the professional, functionally designed for home use. "Of the very best!"—*High Fidelity*.

### FM-AM TUNER, Model 70-RT

Features extreme sensitivity, low distortion and low hum. Armstrong system, *adjustable* FM-AFC and AM selectivity. Preamplifier-equalizer, 2 inputs, 2 cathode follower outputs. Six controls. Self-powered. **\$184.50**

### FM-AM TUNER, Model 50-R

Same features as 70-RT above, but designed for use with external preamplifier-equalizer such as 50-C. Hum level better than 100 db below 2 volts output. Fully shielded and shock-mounted. Self-powered. **\$164.50**

### MASTER AUDIO CONTROL, Series 50-C

25 choices of record equalization, plus separate bass and treble tone controls, loudness balance control. Five inputs and input level controls, two cathode follower outputs. Chassis only, **\$89.50** • With cabinet, **\$97.50**

### 25-WATT AMPLIFIER, Model 70-A

50-watts peak! More *clean* watts per dollar. Less than ½% distortion at 25 watts (0.05% at 10 watts.) Response ±0.1 db, 20-20,000 cycles; 1 db, 10 to 50,000 cycles. Hum and noise virtually non-measurable! **\$99.50**

### 50-WATT AMPLIFIER, Model 50-A

100-watts peak! World's *finest* 1A1-triode amplifier. Uniform within 1 db, 5 to 100,000 cycles. Hum and noise 96 db below full output. IM distortion below 2% at 50 watts. Highest quality components thruout. **\$159.50**

### SPEAKER ENCLOSURE, Series 50

NEW! Regardless of the speaker or enclosure you are now using, the "50" Horn will revolutionize its performance. For use with 12" or 5" speaker systems. 50-HM (Mahogany) **\$129.50** • 50-HB (Blonde) **\$134.50**

### PREAMPLIFIER-EQUALIZER, Model 50-PR

*Professional* phono equalization facilities at low cost! Independent switches for LF turn-over and HF roll-off. Output lead up to 50 feet. Can accommodate any low-level, magnetic pickup. Self-powered. **\$22.95**

### HI-LO FILTER SYSTEM, Model 50-F

Does what ordinary *tone* controls cannot do, for it suppresses all types of noise with an *absolute minimum* loss of tonal range. High impedance input; cathode follower output. Use with any equipment. **\$29.95**

*Prices slightly higher west of the Rockies*

WRITE TODAY FOR COMPLETE SPECIFICATIONS

**FISHER RADIO CORPORATION • 39 EAST 47th STREET • NEW YORK, N. Y.**

# YOU be the Judge!

Let the Kay-Townes SUPER-KATY  
prove its superiority over  
**ALL** other TV antennas  
on the market today!



Here's why the famous  
**KAY-TOWNES**

*Super* **KATY**

**wins in every case!**

- FAR REACHING Reception!
- New MOLDED, RIBBED INSULATOR for low water absorption!
- New RIGID Construction to withstand gale-force winds!
- EASY Installation!
- LESS DEPTH on mast!
- Best by Color-Test!  
Super Katy has been proved the best antenna for fine color reception by actual field tests.

Every Super Katy installed  
will bring **NEW SALES!**

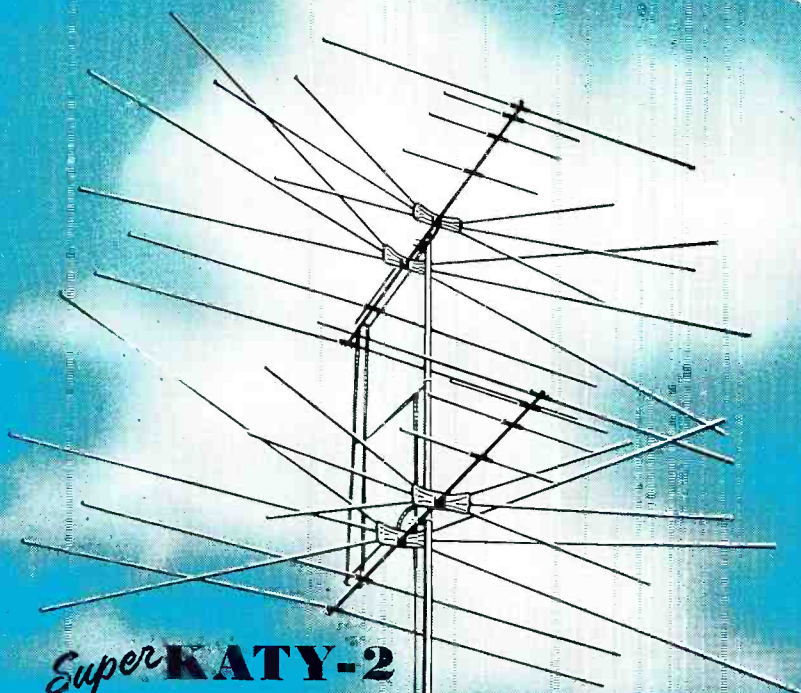

*Super* **KATY-2**

**AMERICA'S TV MOST WANTED ANTENNA**

**"THE BEST SET IS ONLY AS GOOD AS ITS ANTENNA"**

## The long reach, long profit antenna

"Fringe area" dealer-servicemen in every part of the country are reporting outstanding sales and service stories... and, mounting TV consumer demand! The new, revolutionary Super "KATYS" have now convincingly proved every quality and performance claim attributed to them.

Kay-Townes' original SUPER KATY design... now amazingly improved... will out-perform any other competitive antenna on the market today, regardless of type or design principle!

Manufactured and Distributed in CANADA By  
DELHI METAL PRODUCTS, LTD., DELHI, ONTARIO

**KAY-TOWNES**  
**ANTENNA CO.**  
ROME • GEORGIA

*Originators of*  
the **BIG-JACK**  
*the world's most Copied TV Antenna*

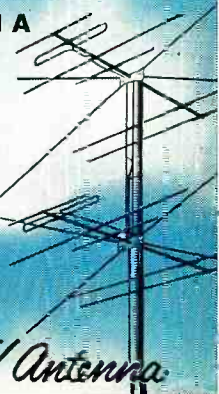

# New service-aids to solve servicing puzzles

# WALSCO

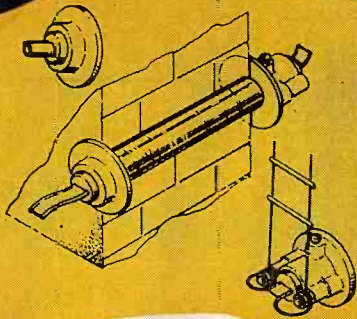

**Walsco Universal Feed-Thru Bushing**  
Fits all standard types of coaxial, tubular and twin-lead wires. Can be terminated to open line, enabling you to bring 300 ohm twin lead through wall and into room. The bushing fits walls up to 14" thick.  
Dealer net \$1.17 (Cat. no. 1551)

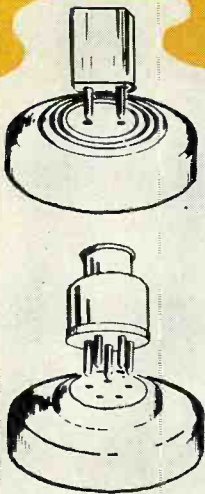

**Walsco TV Lead-In and Rotor Receptacles**  
Used effectively as wall outlets for any type of lead-in or rotator cable. They also fit over and fasten to the inside flange of feed-thru. Matching plugs included.

2 prong (Cat. no. 1552) \$.63 dealer net  
5 prong (Cat. no. 1553) \$.90 dealer net

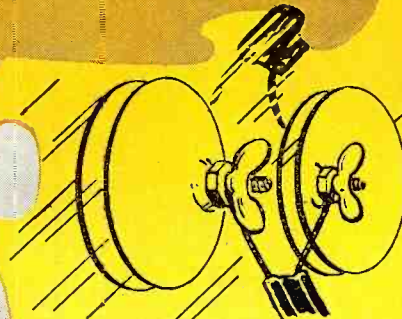

### Walsco Window-Thru Bushing

A new, simple way to bring lead wires into the home without drilling holes, etc. Used effectively on both VHF and UHF. Walsco supplies the adhesive to cement capacitor discs to window pane. A quick, easy, weatherproof installation.

Dealer net \$.59 (Cat. no. 1555)



**Walsco Electronic Chemicals in Spray Cans**  
Just spray it on! "Instant-spray" cans cut chemical application time in half. No messy applicators. Can't leak, break, spill or evaporate... it's air-tight. Insist on WALSCO chemical spray cans containing—Contactene, Tubecoat, Anti-Corona Lacquer, and Wrinkle Varnish.



WALSCO counter displays featuring chemicals in spray cans are at jobbers everywhere.

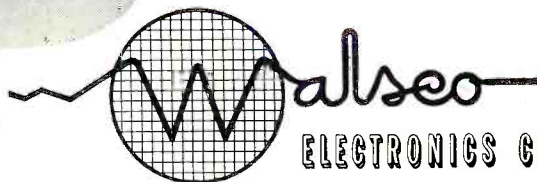

## WALSCO ELECTRONICS CORPORATION

3602 Crenshaw Boulevard, Los Angeles 36, California

Canadian Factory Distributor:  
ATLAS RADIO CORP., Ltd., 560 King St., West, Toronto 2-B

Export Distributor:  
AD AURIEMA, Inc., 89 Broad St., New York 4, N.Y.

# CREI prepares you quickly for success in

*The future is in your hands!*

The signs are plain as to the future of the trained men in the electronics industry. It is a tremendous industry, and—at the *present time* there are more jobs than there are trained men to fill them. But—when there's a choice between a trained and untrained applicant, the trained man will get the job. Your biggest problem is to decide on—and begin the best possible training program.

## CREI Home Study . . . The Quick Way to Get There.



Since 1927, CREI has given thousands of ambitious young men the technical knowledge that leads to more money and security. The time-tested CREI procedure can help *you*, too—if you really want to be helped. CREI lessons are prepared by experts in easy-to-understand form. There is a course of instruction geared to the field in which you want to specialize. You study at *your* convenience, at *your* rate of speed. Your CREI instructors guide you carefully through the material, and grade your written work personally (not by machine).

## Industry Recognizes CREI Training.

CREI courses are prepared, and taught with an eye to the needs and demands of industry, so your CREI diploma can open many doors for you. Countless CREI graduates now enjoy important,

good-paying positions with America's most important companies. Many famous organizations have arranged CREI group training for their radio-electronics-television personnel. To name a few: All America Cables and Radio, Inc.; Canadian Aviation Electronics, Ltd.; Canadian Broadcasting Corporation; Columbia Broadcasting System; Canadian Marconi Company; Hoffman Radio Corporation; Machlett Laboratories; Glenn L. Martin Company; Magnavox Company; Pan American Airways, Atlantic Division; Radio Corporation of America, RCA Victor Division; Technical Appliance Corporation; Trans-Canada Air Lines; United Air Lines. Their choice for training of their own personnel is a good cue for *your* choice of a school.



## Benefits Felt Right Away.

Almost immediately, you feel the benefits of CREI training. Your employer, when informed of your step toward advancement (only at your request), is certain to take new interest in you and in your future. What you learn in CREI Home Study can start helping you do a better job immediately.

- BROADCASTING
- TELEVISION
- MANUFACTURING
- COMMUNICATIONS
- SERVICING
- AERONAUTICAL ELECTRONICS

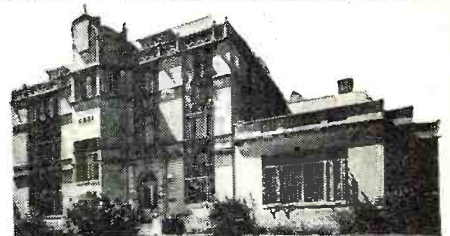

## CREI also offers Resident Instruction

at the same high technical level—day or night, in Washington, D. C. New classes start once a month. If this instruction meets your requirements, check the coupon for Residence School catalog.

## INFORMATION FOR VETERANS

If you were discharged after June 27, 1950—let the new G. I. Bill of Rights help you obtain resident instruction. Check the coupon for full information.

## Get this fact-packed booklet today. It's free.

Called "Your Future in the New World of Electronics," this free illustrated booklet gives you the latest picture of the growth and future of the gigantic electronics world. It includes a complete outline of the courses CREI offers (except Television and FM Servicing) together with all the facts you need to judge and compare. Take 2 minutes to send for this booklet right now. We'll promptly send your copy. The rest—your future—is up to you.



## MAIL COUPON TODAY

### CAPITOL RADIO ENGINEERING INSTITUTE

Dept. 118-A, 3224 16th St., N.W., Washington 10, D. C.

Send booklet "Your Future in the New World of Electronics" and course outline.

CHECK FIELD OF GREATEST INTEREST  TV, FM & Advanced AM Servicing  Practical Radio Engineering  Broadcast Radio Engineering (AM, FM, TV)  Practical Television Engineering  Aeronautical Radio Engineering

Name.....

Street.....

City.....Zone.....State.....

Check— Residence School  Veteran

# CAPITOL RADIO ENGINEERING INSTITUTE

An Accredited Technical Institute • Founded in 1927

3224 16th Street, N.W.

Washington 10, D. C.



Out of the roar of big guns . . .

*a new* **HORIZON** *in high fidelity*

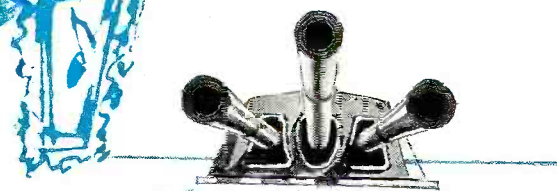

The jarring shocks of gunfire . . . the insidious dampness of salt spray . . . globe-girdling distances and static! National radio receivers have taken

punishment like this 24 hours a day, month-after-month on board 9 out of 10 Navy ships.

National radio equipment has also served the Army, the Civil Aeronautics Administration, industry, the Kon-Tiki

Expedition and radio amateurs throughout the world.

Only a background like this — unmatched by any other high-fidelity manufacturer — could produce the magnificent new HORIZON Criterion AM-FM tuner and inter-matched amplifiers.

*tuned to tomorrow*

**National** 

**FOR COMPLETE SPECIFICATIONS WRITE DEPT. RN-85**

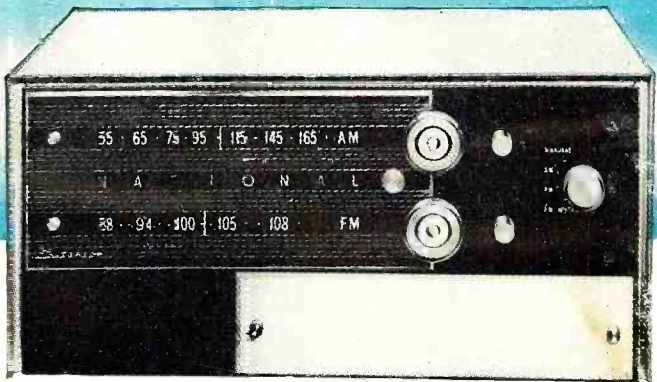

## HORIZON *Criterion*

AM-FM TUNER \$169.95 (SIZE: 16 1/2" x 7 3/4")

Never before a tuner so versatile!  
 You can enjoy full-band AM!  
 You can listen to matchless, drift-free FM!  
 You can hear both at the same time, using dual sound systems!  
 You can receive revolutionary new binaural broadcasts as they are made available in your area! Two gain controls and separate tuning condensers are provided.— one for AM, one for FM!

Exclusive Mutamatic FM Tuning eliminates all hiss and noise between stations, so annoying when tuning conventional tuners! Stations leap out of velvety silence— stay locked in automatically! Superior design eliminates drift.

An exceptional capture ratio rejects all unwanted signals up to 80% of the strength of the desired signal. The FM sensitivity proves the name — "the Criterion" — by which all other tuners are judged.



## HORIZON *10*

10-WATT AMPLIFIER \$79.95 (SIZE: 14 1/2" x 4")

Incorporating the revolutionary new unity-coupled circuit in a 10-watt amplifier design, the HORIZON 10 offers performance never before achieved at such a moderate price!

The built-in preamp-control unit offers a choice of 3 inputs, 3 record equalization curves, a loudness control and separate bass and treble controls.

Harmonic distortion is less than .5%; intermodulation distortion, less than 2% at rated output. Frequency response is  $\pm 1$  db, 20 cps to 20 kcs.; power response,  $\pm 2$  db, 20 cps to 20 kcs. Hum and noise are better than 70 db below rated output on high-level input, better than 50 db on low level input.

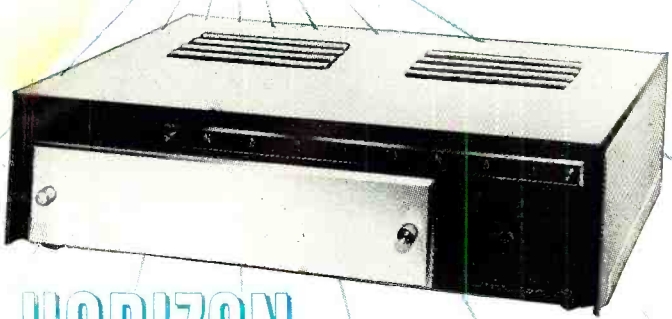

## HORIZON *20*

20-WATT AMPLIFIER \$84.95 (SIZE: 14 1/2" x 4")

To surpass the present high level of amplifier design, National proudly introduces new power amplifiers with a revolutionary new output circuit employing unity coupling.

With unity coupling, the output transformer is no longer required to supply the coupling between output tubes for distortion cancellation as in normal push-pull circuits. Instead, the transformer supplies only the impedance matching between the tubes and the speaker system, thus eliminating impulse distortion created by transformers. Music is reproduced with an unclouded transparency — at all listening levels — never before achieved!

The HORIZON 20 is a 20-watt amplifier with a total harmonic distortion of less than .3% and total intermodulation distortion of less than 1% at full rated output. Frequency response is  $\pm 1$  db 20 cps to 20 kcs.;  $\pm 1$  db 10 cps to 100 kcs. Power response at rated output is  $\pm .15$  db, 20 cps to 20 kcs. Hum and noise is 80 db below rated output.



## HORIZON *5*

PREAMPLIFIER-CONTROL UNIT \$49.95

The HORIZON 5 achieves a new high in frequency response ( $\pm 1$  db, 20 cps to 100 kcs) and voltage output (up to 10 volts) — a new low in distortion (less than .2% harmonic, .3% intermodulation)!

Four inputs, 7 record equalization curves, a loudness-volume control and bass and treble controls are provided.

Entire unit slips quickly, easily into either the tuner or 20-watt amplifier.

# The BACKSTOP

**STOPS co-channel and adjacent-channel interference caused by rear signal pick-up!**

- Highest front-to-back ratio ever built into an antenna!
- No rear pick-up; eliminates "venetian blinds"!
- Largest screen area: 70 square feet!
- Very high all-channel gain. Incorporates basic Champion design, including Tri-Pole, with additional elements!
- Completely preassembled!

Table of Front-to-Back Ratios (Relative Voltage)

Channels	Front-to-Back Ratios
2	9:1
3	10:1
4	11:1
5	20:1
6	18:1

Only Low Band channels shown, since co-channel interference is not encountered on High Band channels.

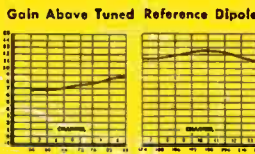
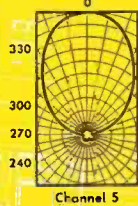

**IMPORTANT** . . . don't be misled by polar patterns representing relative POWER. Remember, power is the square of voltage. All Channel Master polar patterns are presented in relative VOLTAGE.

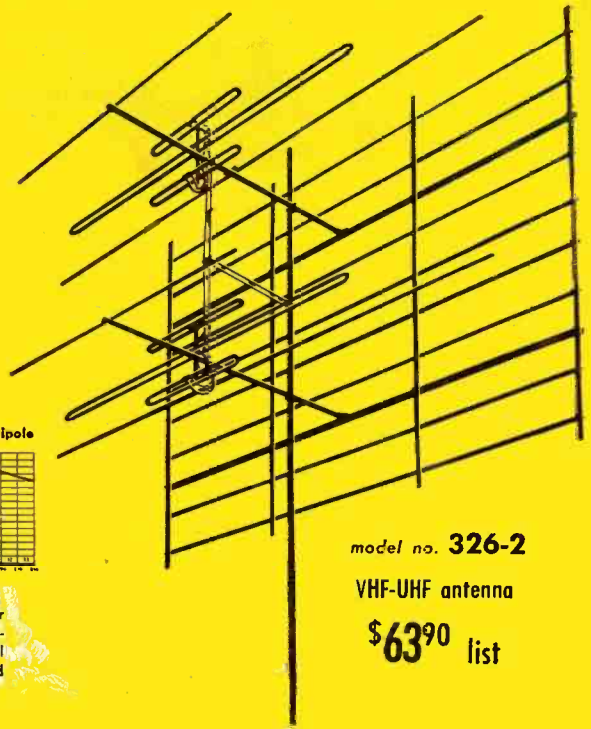

model no. 326-2

VHF-UHF antenna

\$63<sup>90</sup> list

## 2 radical new antennas by CHANNEL MASTER

The most beautiful antenna ever made! The only indoor antenna featuring powerful outdoor design principles — Bow-Tie and Screen.

*Wonder Bow*

\* VHF-UHF indoor antenna

### DESIGNED FOR POWER!

On UHF: For primary and secondary areas. In many cases, performance is equal to actual outdoor installations. Good directivity on all channels.

On VHF: Ideal in areas of strong VHF signals.

### STYLED FOR BEAUTY!

Designed by a well-known industrial designer, the WONDER BOW is proof that indoor antennas can be beautiful as well as powerful. Wins customer approval on beauty alone!

The first gain figures ever to be published for an indoor antenna!



**Gold and black**  
model no. 416

**Silver and black**  
model no. 417



\$835 list



**CHANNEL MASTER CORP.** EL ENVILLE, N. Y.

The World's Largest Manufacturer of TV Antennas

Write for complete technical literature.

Copyright 1954, Channel Master Corp.

\*Pat. No. D-171560

# ADVANCE! Raise your earning power—learn RADIO-TELEVISION-ELECTRONICS by SHOP-METHOD HOME TRAINING

## GOOD JOBS AWAIT THE TRAINED RADIO-TV TECHNICIAN

There is a place for *you* in the great Radio-Television-Electronics industry when you are trained as National Schools will train you at home!

Trained technicians are in growing demand at good pay—in manufacturing, broadcasting, television, communications, radar, research laboratories, home Radio-TV service, and other branches of the field. National Schools Master Shop-Method Home Training, with newly added lessons and equipment, trains you in your spare time, right in your own home, for these fascinating opportunities. **OUR METHOD IS PROVED BY THE SUCCESS OF NATIONAL SCHOOLS TRAINED MEN, ALL OVER THE WORLD, SINCE 1905.**

## EARN WHILE YOU LEARN

Many National students pay for all or part of their training with spare time earnings. We'll show you how you can do the same! Early in your training, you receive "Spare-time Work" Lessons which will enable you to earn extra money servicing neighbors' and friends' Radio and Television receivers, appliances, etc.

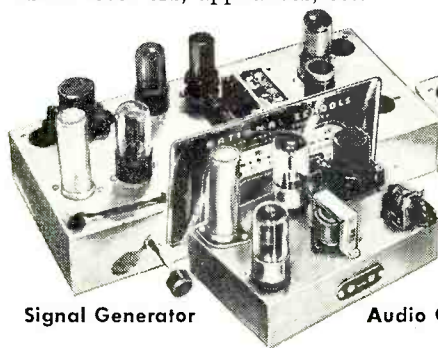

Signal Generator

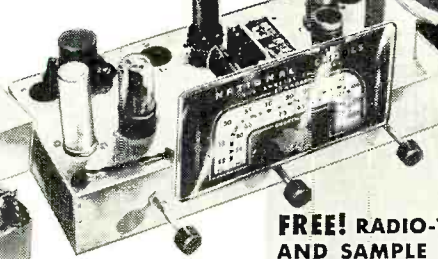

T. R. F. Receiver

Audio Oscillator

## MASTER ALL PHASES!

Get Master Shop-Method Home Training from an Established Practical Resident School with its own Training — almost 50 Years of Successful Experience in Training Ambitious Men.  
**We Bring National Schools To You!**



You also receive this Multitester

Superheterodyne Receiver

## LEARN BY DOING

You receive and keep all the modern equipment shown above, including tubes and valuable, professional quality Multitester. *No extra charges.*

## FREE! RADIO-TV BOOK AND SAMPLE LESSON!

Send today for National Schools' new, illustrated Book of Opportunity in Radio-Television-Electronics, and an actual Sample Lesson. No cost—no obligation. Use the coupon now—we'll answer by return airmail.

**APPROVED FOR VETERANS AND NON-VETERANS**  
Check coupon below

**Both Resident and Home Study Courses Offered!**



## National Schools Training is All-Embracing

National Schools prepares you for your choice of many job opportunities. Thousands of home, portable, and auto radios are being sold daily—more than ever before. Television is sweeping the country, too. Co-axial cables are now bringing Television to more cities, towns, and farms every day! National Schools' *complete* training program qualifies you in all fields. Read this partial list of opportunities for trained technicians:

- Business of Your Own • Broadcasting
- Radio Manufacturing, Sales, Service • Telecasting
- Television Manufacturing, Sales, Service
- Laboratories: Installation, Maintenance of Electronic Equipment
- Electrolysis, Call Systems
- Garages: Auto Radio Sales, Service
- Sound Systems and Telephone Companies, Engineering Firms
- Theatre Sound Systems, Police Radio
- And scores of other good jobs in many related fields.

## TELEVISION TRAINING

You get a complete series of up-to-the-minute lessons covering all phases of repairing, servicing and construction. The same lesson texts used by resident students in our modern and complete Television broadcast studios, laboratories and classrooms!



## NATIONAL SCHOOLS

LOS ANGELES 37, CALIFORNIA • ESTABLISHED 1905  
IN CANADA: 811 W. HASTINGS STREET, VANCOUVER, B.C.

## GET FACTS FASTEST! MAIL TO OFFICE NEAREST YOU!

(mail in envelope or paste on postal card)

**NATIONAL SCHOOLS, Dept. RH-84**

4000 S. Figueroa Street or 323 West Polk Street  
Los Angeles 37, Calif. Chicago 7, Ill.

Send FREE Radio-TV Electronics book and FREE sample lesson. No obligation, no salesman will call.

NAME \_\_\_\_\_ BIRTHDAY \_\_\_\_\_ 19 \_\_\_\_\_

ADDRESS \_\_\_\_\_

CITY \_\_\_\_\_ ZONE \_\_\_\_\_ STATE \_\_\_\_\_

Check here if interested in Resident School Training at Los Angeles.  
VETERANS: Give Date of Discharge \_\_\_\_\_



ATTENTION!!  
Executives and Salesmen!

Shave in the  
Comfort of  
Your Own Car,  
Boat or Plane!

WITH **ATR**

## SHAV-PAK



Specially Designed for  
Operating Standard A. C.  
Electric Shavers in  
Automobiles, Buses,  
Trucks, Boats, and  
Planes.



Keep in  
Glove  
Compartment!

PLUGS INTO  
CIGARETTE LIGHTER  
RECEPTACLE  
ON DASH

**\$12.95**  
LIST PRICE

TYPE	INPUT D.C. VOLTS	A.C. OUTPUT 60 CYCLES	OUTPUT WATTAGE	LIST PRICE
6-SPB	6	115 volts	15	12.95
12-SPB	12	115	15	12.95

DICTATE REPORTS  
ACCURATELY-PROMPTLY!

make your car, boat or plane  
a "rolling office"

WITH **ATR**

## INVERTERS



for changing your  
storage battery  
current to A. C.

Household  
ELECTRICITY  
Anywhere  
in your own car!

Plugs into  
Cigarette Lighter  
Receptacle on Dash

**\$22.50**  
AND UP  
LIST PRICE



**ATR INVERTERS . . .**

especially designed for operating  
standard 110 volt A. C. . . .

- TAPE RECORDER
- WIRE RECORDERS
- DICTATING MACHINES
- ELECTRIC RAZORS

See your jobber or write factory today  
for complete information



**AMERICAN TELEVISION & RADIO CO.**  
Quality Products Since 1931  
SAINT PAUL 1, MINNESOTA—U. S. A.

# Spot Radio News

\* Presenting latest information on the Radio Industry.

By RADIO & TELEVISION NEWS'  
WASHINGTON EDITOR

**THE SIZZLING TRIAL** of the ultra-highs, repeatedly delayed by the Army-McCarthy dispute, completely captured the limelight in Washington, when Senator Charles Potter was able to rap the gavel.

Tagged as a hearing of even more import to the public than the rambling argument in the caucus room by many, including the eminent Senator from Michigan who had been named to serve as chairman, the sessions teemed with fiery, explosive testimony that underscored the impact of the TV probe.

Sparks began to fly on the very first day, when Madame Commissioner Frieda Henneck, in a startling outburst, accused the Senate of pressuring the Commission on oking grants. "If you want me to tell you the truth," she fired away, "when you Senators call this Commission to tell us to hurry up and give us television in our community, and give it to us tomorrow, and in the most unethical manner known to man. . . . I am ready to cry and give up."

Describing typical irksome conditions, Miss Henneck scolded the Senators for permitting applicants to come in after office hours to file and not allowing anyone to compete for the specific channel involved, or she said, asking that two companies be merged without letting the public know about the merger. When a u.h.f. operator defended the Commission for its fair and honest treatment, Miss Henneck said that she was pleased to hear this, but upset about needling by the Senators. "I had no intention of serving on a dishonest Commission, if I'm an honest woman, and I didn't want to see the Commission get all the blame," the attractive member of the FCC lashed out.

Warning Congress that any freeze on the present bands or an all-out shift to the higher frequencies would be suicidal, Dr. Du Mont emphasized that such a move would cost the public millions and millions, and jeopardize the entire telecasting operation.

Reviewing the present situation, Dr. Du Mont told the Senators that currently we have two strongly entrenched national television networks and two relatively weak networks. In addition, he said, we have a group of very strongly entrenched high-

power v.h.f. stations and a group of relatively new low-power stations. Economic self interest has promoted the affiliation of the v.h.f. stations with the two stronger networks, and the weak u.h.f. stations have had to affiliate with the two weaker networks or forego network programming. In addition, the two weaker networks are not in a position to strengthen their programming to a competitive nature, Dr. Du Mont added, because of the inability to reach established audiences in the key markets of the country. Thus, the present situation breeds itself so that the strong are becoming stronger and the weak are becoming weaker.

**THREE PROPOSALS** to solve the problem were offered. The first suggested that each of the networks be required to make primary affiliates of certain u.h.f. stations. In the first 100 markets in the country, the four networks would take turns in affiliating u.h.f. stations exclusively wherever less than four v.h.f. stations exist in any one market. Under such a plan each network would have approximately the same number of affiliates in both v.h.f. and u.h.f. as would each other network in these first 100 markets. The second proposal involved regulation of telecasting stations in regard to source programming. In this plan, each station would be required to relinquish to a network on demand 25% of its networking class A time, 25% of its networking class B time and 25% of its networking class C time. Such a move, it was said, would also provide more and better programs to u.h.f. stations and more and better outlets for the weaker networks.

The third alternate plan suggested by *Du Mont* was an incentive type. In essence, the suggestion allows the networks to have an additional wholly-owned station for each seven primary u.h.f. affiliations maintained, with a top limit of eleven stations to be owned by any one network. Such a plan, it was felt, would result in the successful promotion of major network affiliations for many u.h.f. stations and access to v.h.f. stations for the weaker networks.

Answering the often-repeated query—when will the megawatt powers authorized by the Commission be avail-

RADIO & TELEVISION NEWS



YOU DON'T NEED A FUR  
COAT; JUST SPRAGUE  
CAPACITORS!

## Don't Be Vague... Insist on SPRAGUE

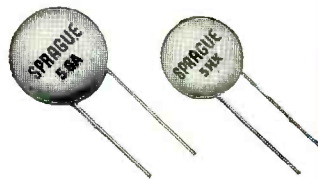

### Insist on Sprague CERAMICS

Tiny, tough, dependable . . . in every application . . . whether discs, plates, buttons, or door knobs. And there's a Sprague ceramic capacitor to meet every service need. You give your customers dependable service, guard yourself against costly call-backs, when you use only Sprague Ceramic capacitors.

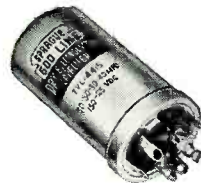

### Insist on Sprague TWIST-LOK\* 'LYTICS

Sprague TVL's fill the top performance bill in the toughest TV circuits. High temperatures, surge voltages, ripple currents won't faze them. Like all Sprague capacitors, Twist-Lok 'Lytics are your first line of defense against expensive call-backs.

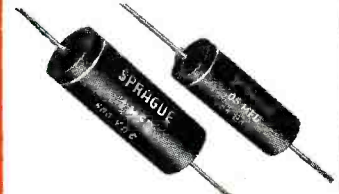

### Insist on Sprague BLACK BEAUTY® TELECAPS®

The most imitated capacitor Sprague ever introduced. But you get Sprague *performance* only when you insist on Sprague Telecaps. Hundreds of millions are in use today as first choice of quality conscientious manufacturers and servicemen. It's the *premium* molded tubular *at no extra cost*.

Accept no substitutes. There is a Sprague Distributor in every sales area in the United States. Write for the name of your nearest source of supply today.

☆ Trademark

# SPRAGUE

Get your copy of Sprague's latest radio and TV service catalog C-609. Write Sprague Products Company\*, 51 Marshall St., North Adams, Mass.

\*Distributors' Division of Sprague Electric Company

**WORLD'S LARGEST  
CAPACITOR MANUFACTURER**

# 200 POUNDS

on a 10 foot television mast  
**PERMA-TUBE supports it safely!**

Place a 10 foot length of 1/4" x 16 gage (.065") wall Perma-Tube between two tables so that 6 inches rests on a table at each end. Place a 200 pound weight at the center point.

What happens? Tests prove that Perma-Tube will support this 200 pound weight with a minimum of deflection and permanent set.

Other materials show serious degrees of permanent set. Why? Because they are not made from the special strength J&L steel that is used to form Perma-Tube Television Masts. And too, Perma-Tube is coated with a metallic vinyl resin—inside and out.

What do the strength and corrosion-resistance of Perma-Tube mean to you? They mean protection for your work and your customers. Freedom from damage due to storms . . . better reception from the sets you install . . . insurance for your reputation . . . increased business and profits for you.

Only GENUINE Perma-Tube supports 200 pounds with a minimum of permanent set... accept no claims from substitute materials. Look for this Perma-Tube Brand.

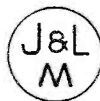

Make this test yourself. Compare Perma-Tube with any other masts—steel or aluminum.



*Jones & Laughlin*  
STEEL CORPORATION — Pittsburgh

able in transmitters—a *G-E* spokesman said that within two years, at the most, such high-powered gear should be ready. Currently, amplifiers can be used to boost the *erp* of equipment to at least 250 kilowatts.

Extolling the intensive experimentation and exploration carried on by *RCA*, executive vice-president Wally Watts testified that thus far his company has spent 16-million dollars in developing the ultra-highs. Noting that for most of the low-band TV broadcasters, years passed before their investments became profitable, Watts added: "We see no reason why those who today are pioneering on u.h.f. should expect that their path will be easier in this comparatively new field than was the experience of v.h.f. broadcasters. His brief also revealed that plans for a full-scale field test of a new method to extend coverage of u.h.f. stations in shadowed areas have been formulated. This system will use a low-power auxiliary transmitter and will be installed near Vicksburg, Mississippi, in cooperation with *WJTV*, Jackson. The sender will be located about 30 miles from the station's main transmitter, and is expected to provide improved service for areas in which reception is now shadowed by geographic elevations.

Some of the broadcasters insisted that the only solution appeared in an eventual move of everyone to the higher bands. One of the owners of *WCAN-TV*, the channel 25 station in Milwaukee, said that present v.h.f. operators should, within the next five years, go upstairs. This he felt, would conclusively resolve the intermixture difficulties, permit set makers to concentrate on one type of chassis and also eliminate all public confusion. In Milwaukee, the Senators were told, viewers have invested over \$30-million in conversions, and at present there are 300,000 receivers capable of picking up the high-band stations.

**THE POSITION** of the set manufacturer was explained by *RETMA's* president, Glenn McDaniel. He reported that the receiver makers feel that the u.h.f. band will open a new era of broadcasting and a much wider market for the industry's products. But, he emphasized, repeating the warnings of others, the way of a pioneer is not easy. In broadcasting it has always been difficult to launch a new service because of the interrelation of programming and set circulation, it was noted. Thus, in this sense, the experience of other broadcast services should encourage the u.h.f. broadcasters in their present programming and financial difficulties.

Reporting on the critical statements now in circulation that the set producers have made too few all-band models, the association head said that actually for awhile industry was optimistic and made many more combo sets than it was possible to sell. The present situation is such, he added, (Continued on page 113)

It's no secret

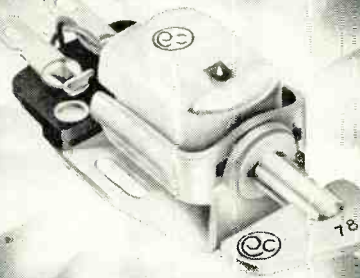

Professionals use Pickering **MAGNETIC** Cartridges

You're in the best of company if you use a Pickering **MAGNETIC** Cartridge. You have this in common with:

1. Leading record companies who use Pickering Cartridges for quality control.
2. Leading FM/AM good music stations and network studios.
3. Leading manufacturers of professional equipment for radio stations, recording studios, wired music systems and automatic phonographs, who install Pickering Cartridges for the maximum performance of their equipment.

***Why*** Pickering **MAGNETIC** Pickups are the Choice of Recording and Broadcast Engineers!

"All modern disc recordings are made with **MAGNETIC** cutters. Within the geometrical and mechanical limitations of recording and reproducing equipment, a Pickering Pickup will re-generate an exact replica of **MAGNETIC** cutter response to the original program of music, speech or sound. This is a fundamentally inherent characteristic of the Pickering Pickup, supported by basic electromagnetic theory and countless

precise laboratory measurements. This is why Pickering **MAGNETIC** Pickups provide the most nearly perfect coupling possible, between reproducing equipment and original program. This is why they sound cleaner . . . less distorted.

"Through the medium of the disc material, the reproducing system is effectively driven by the cutter electrical response itself."



**PICKERING** and company incorporated • Oceanside, L. I., New York

PICKERING PROFESSIONAL AUDIO COMPONENTS

*"For those who can hear the difference"*

. . . Demonstrated and sold by Leading Radio Parts Distributors everywhere. For the one nearest you and for detailed literature write Dept. C-5.

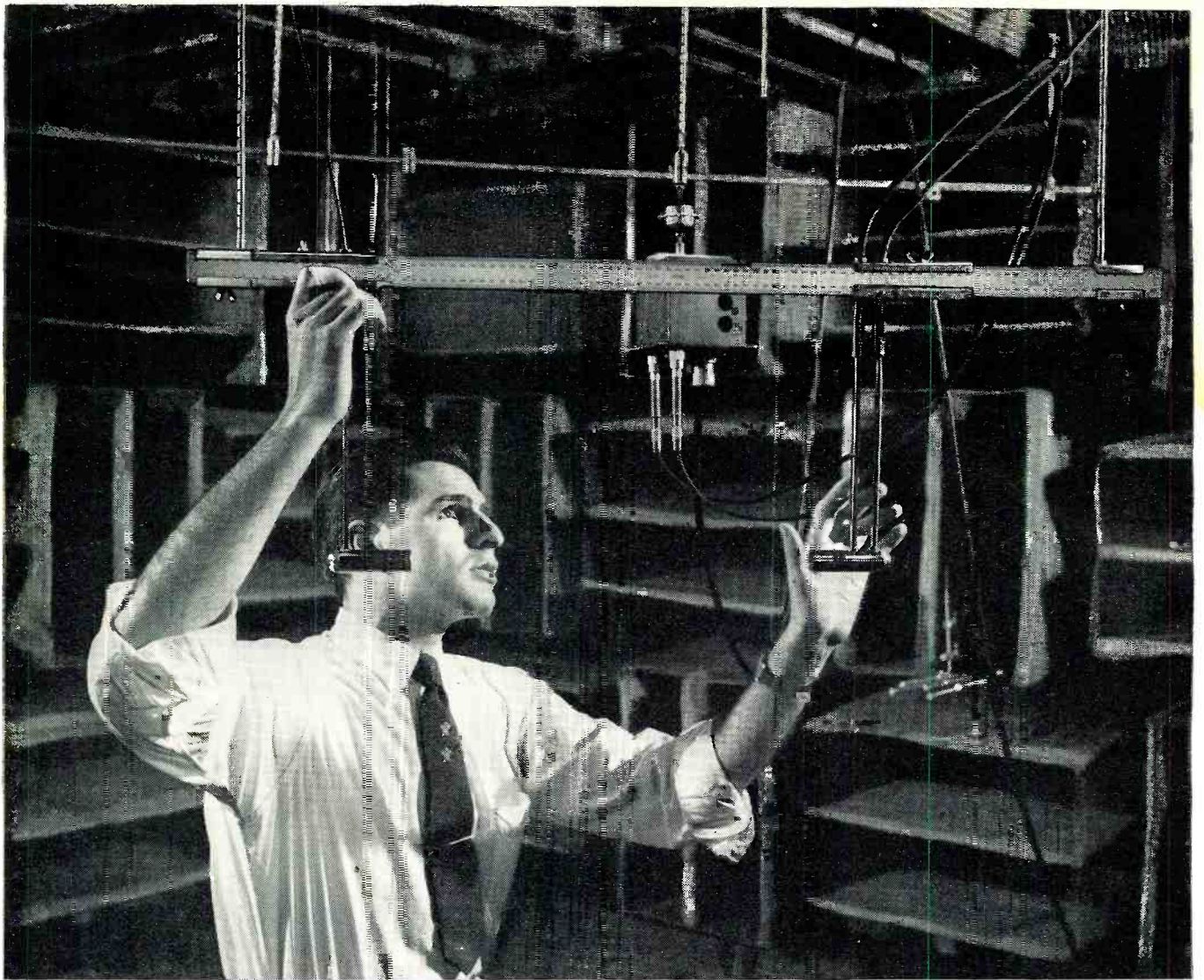

In a quiet room at Bell Laboratories an engineer scales off the distance between two condenser microphones during a calibrating test. Able to measure air pressure variations of a few billionths of an atmosphere, such microphones play a crucial role in the scientific study of telephone instruments.

## SOUND STEPS ON THE SCALES

Those small cylinders facing each other are condenser microphones—measuring tools that play a vital part in making your telephone easier to hear and talk through.

They are being calibrated by an engineer at Bell Telephone Laboratories to give extremely accurate information on the kind of sound your telephone company handles. Armed with these vital fundamental data on what sound *is*, Bell Laboratories scientists

devise the instruments and equipment that transmit it best.

At Western Electric, manufacturing unit of the Bell System, a condenser microphone “listens” as your ear would listen to every telephone before it goes into service. The condenser microphone is but one of many precise tools that Laboratories scientists have developed to make telephone service better and more economical.

**BELL TELEPHONE LABORATORIES**

Improving America's telephone service offers careers for creative men in scientific and technical fields.



**It's New! 3 Years in Development  
-NOW READY FOR YOU!**

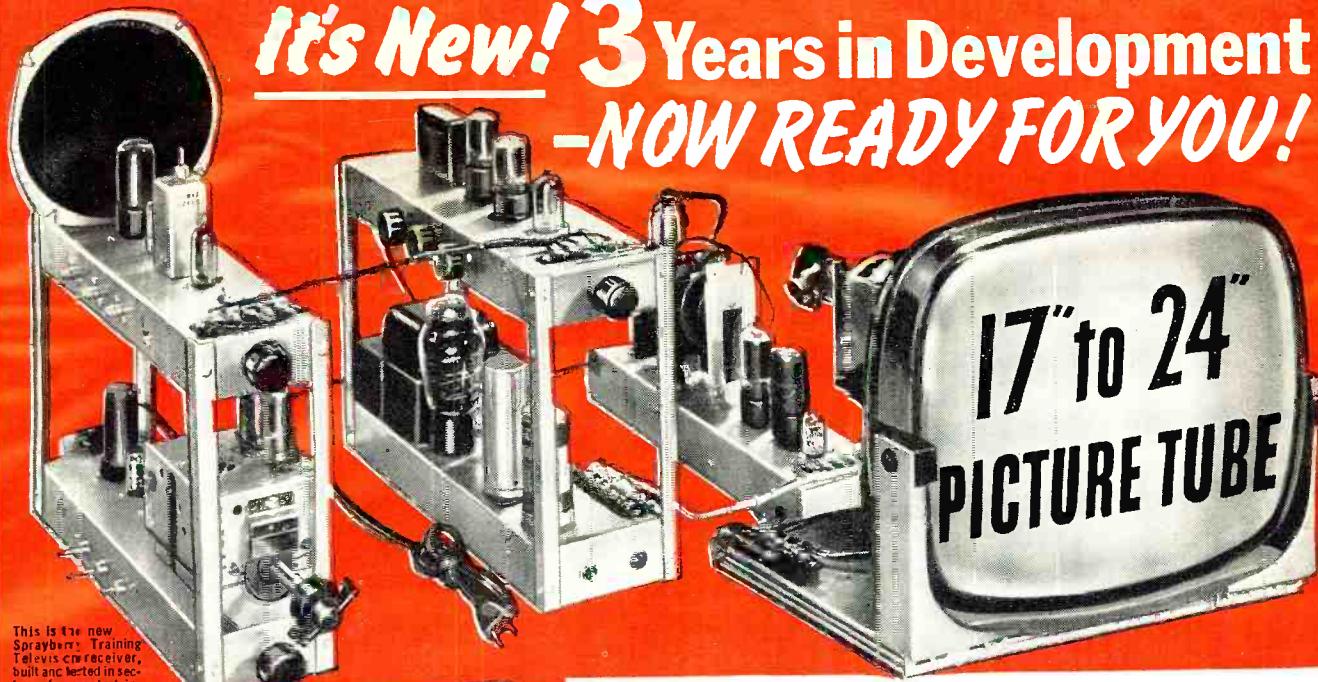

This is the new Sprayberry Training Television receiver, built and tested in sections for greatest instructor value.

**17" to 24"  
PICTURE TUBE**

**New Equipment! New Lessons! Enlarged Course!  
SPRAYBERRY PRACTICAL TRAINING IN**

# **RADIO-TELEVISION**

**3 NO OBLIGATION TRAINING PLANS**

**You have NO MONTHLY PAYMENT CONTRACT to sign  
... pay for this outstanding training as you learn!**



**Fen'k L. Sprayberry**  
President, Sprayberry  
Academy of Radio

The complete facts are so big and so important to any man seeking training in Radio-Television that I urge you to mail the coupon below at once for my big all-new 56 page **FREE CATALOG** and **FREE Sample Lesson**. Get the full story of this remarkable new and up-to-the-second Training Plan. You'll read about my 3 **NO OBLIGATION PLANS** or "packaged unit" instruction for both beginners and the experienced man. You'll learn how I can now prepare you in as little as **10 MONTHS** to take your place in this fast moving big money industry as a Trained Radio-Television Technician. You'll see that you take no risk in enrolling for my training because you **DO NOT SIGN A BINDING TIME PAYMENT CONTRACT**. I have been training successful Radio-TV technicians for 22 years . . . I can prepare you, too, to get into your own profitable Service Shop or a good paying job, even if you have no knowledge of Radio-Television. Mail the coupon . . . I rush full information **FREE** and without obligation. (No salesman will call.)



These photos show only a small part of the training equipment I send my students.

You build the new Sprayberry Tester . . . 8-range Volt-Ohm-Milliammeter readings; plus output meter and condenser and resistor substitution selector.

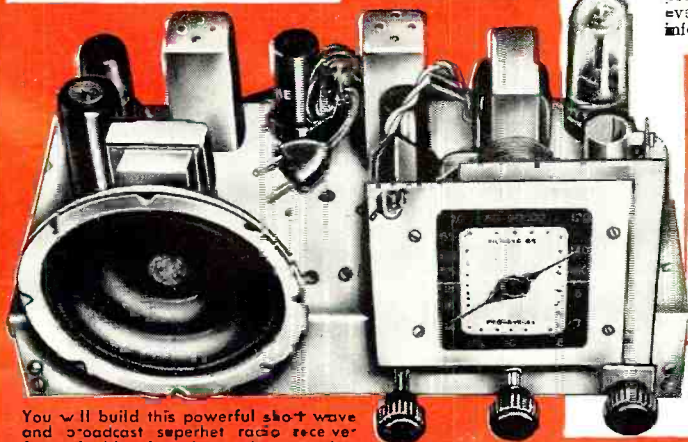

You will build this powerful short wave and broadcast superhet radio receiver for valuable shop instruction practice.

## **NEWEST DEVELOPMENTS**

Your training covers **U H F, Color Television, F M, Oscilloscope Servicing, High Fidelity Sound and Transistors.**

## **PRACTICE AND TRAIN AT HOME WITH 25 NEW KITS OF EQUIPMENT**

You get valuable practical experience in construction, testing and shop practice. You build a powerful 2 band superhet radio, the all-new 18 range Sprayberry multitester, the new Sprayberry Training Television receiver, signal generator, signal tracer and many other projects. All equipment is yours to use and keep . . . and you have practically everything needed to set up a Radio-Television Service Shop.

All your training is **IN YOUR HOME** in spare hours. Keep on with your present job and income while learning. I help you earn extra spare time money while you learn. If you expect to be in the armed forces later, there is no better preparation than practical Sprayberry Radio-Television training. Rush coupon below for all the facts—**FREE!**

**SPRAYBERRY ACADEMY OF RADIO**  
111 NORTH CANAL STREET, DEPT. 25-M, CHICAGO 6, ILLINOIS

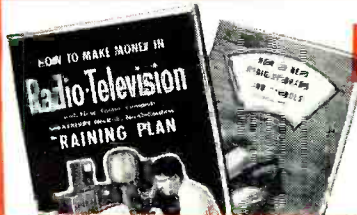

## **FREE CATALOG AND SAMPLE LESSON**

Rush coupon for my catalog "How to Make Money in Radio-Television". **PLUS** an actual sample Sprayberry Lesson without obligation—**ALL FREE**. Mail coupon **NOW!**

**SPRAYBERRY ACADEMY OF RADIO** MAIL THIS COUPON FOR FREE  
Dept. 25-M, 111 N. Canal St., Chicago 6, Ill. **FACTS AND SAMPLE LESSON**

Please rush all information on your **ALL-NEW** Radio-Television Training Plan. I understand this does not obligate me and that no salesman will call upon me. Include New Catalog and Sample Lesson **FREE**.

Name \_\_\_\_\_ Age \_\_\_\_\_

Address \_\_\_\_\_

City \_\_\_\_\_ Zone \_\_\_\_\_ State \_\_\_\_\_



**Better Contrast!  
Longer Life!  
Availability!**

**SYLVANIA**  
*Aluminized  
Picture Tubes*  
**ARE PACKED  
WITH PROFITS!**

**Make old sets like new ... have more satisfied customers!**

**SIZE?**

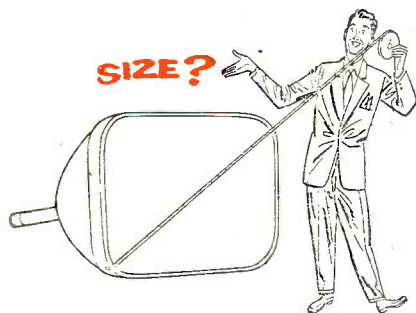

Interested in new sales records? You'll be heading in that direction when you replace old picture tubes with new Sylvania Aluminized Tubes.

Sylvania Aluminized Picture Tubes give terrific performance. They make old sets better and brighter than new by providing whiter whites—blacker blacks . . . a 6-times better picture contrast.

Sylvania Aluminized Picture Tubes are now available in most sizes for all popular TV sets. In other words, with Sylvania Aluminized Picture Tubes, you give your customers the best possible buy *and* the best possible service, including a full one-year warranty.

Remember, millions of set owners see and hear about Sylvania Picture Tubes on the nation-wide weekly television show "Beat The Clock." They know that they are famous for quality and dependability. For full details about aluminized tube replacement, write for Sylvania's "Aluminized Picture Tube Replacement Guide." Address: Dept. 4R-3508, Sylvania NOW!

**COST?**

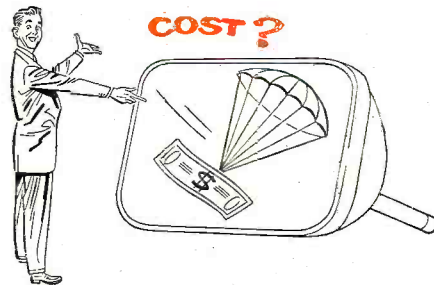

**PERFORMANCE?**



**SYLVANIA**

Sylvania Electric Products Inc.  1740 Broadway, New York 19, N. Y.

In Canada: Sylvania Electric (Canada) Ltd.  
University Tower Building, St. Catherine Street, Montreal, P. Q.

**LIGHTING • RADIO • ELECTRONICS • TELEVISION**

**RADIO & TELEVISION NEWS**

Let me send you FREE  
the entire story

Just fill out the coupon and mail it. I will send you, free of charge, a copy of "How to Pass FCC License Exams," plus a sample FCC-type Exam, and the amazing new booklet, "Money-Making FCC License Information."



CARL E. SMITH, E.E.  
President

I can train you to pass your FCC License Exams in a minimum of time if you've had any practical radio experience—amateur, Army, Navy, radio servicing, or other. My time-proved plan can help put you, too, on the road to success.

# How to Pass FCC COMMERCIAL Radio Operator License Exams

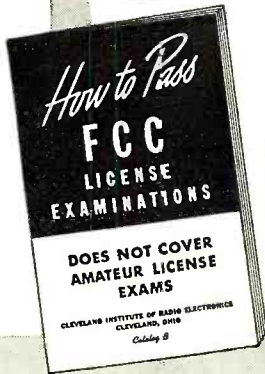

FREE

Tells where to apply and take FCC examinations, location of examining office, scope of knowledge required, approved way to prepare for FCC examinations, positive method of checking your knowledge before taking the examination.



GET YOUR FCC TICKET IN A MINIMUM OF TIME

Get this Amazing Booklet FREE

TELLS HOW

HERE IS YOUR GUARANTEE

If you fail to pass your Commercial License exam after completing our course, we guarantee to continue your training without additional cost of any kind, until you successfully obtain your Commercial license, provided you first sit for this examination within 90 days after completing our course.

WE GUARANTEE

TO TRAIN AND COACH YOU AT HOME IN SPARE TIME UNTIL YOU GET

YOUR FCC LICENSE

If you have had any practical experience—Amateur, Army, Navy, radio repair, or experimenting

TELLS HOW

TV ENGINEERING INCLUDED IN OUR TRAINING & COACHING

Our Amazingly Effective JOB-FINDING SERVICE

Helps GIRE Students Get Better Jobs

Here are a few recent examples of Job-Finding results

GETS FIVE JOB OFFERS FROM BROADCAST STATIONS  
"Your 'Chief Engineer's Bulletin' is a grand way of obtaining employment for your graduates who have obtained their 1st class license. Since my name has been on the list I have received calls or letters from five stations in the southern states, and am now employed as Transmitting Engineer at WMMT."  
Elmer Powell, Box 274, Sparta, Tenn.

GETS CIVIL SERVICE JOB  
"I have obtained a position at Wright-Patterson Air Force Base, Dayton, Ohio, as Junior Electronic Equipment Repairman. The Employment Application you prepared for me had a lot to do with my landing this desirable position."  
Charles E. Loomis, 4516 Genesee Ave., Dayton 6, Ohio.

OURS IS THE ONLY HOME STUDY COURSE WHICH SUPPLIES FCC-TYPE EXAMINATIONS WITH ALL LES-SONS AND FINAL TESTS.

GETS AIRLINES JOB  
"Due to your Job-Finding Service, I have been getting many offers from all over the country, and have taken a job with Capital Airlines in Chicago, as Radio Mechanic."  
Harry Clare, 4537 S. Drexel Blvd., Chicago, Ill.

Your FCC ticket is recognized by employers in the electronic field as proof of your technical ability.

TELLS HOW

Employers make

JOB OFFERS Like These to Our Graduates Every Month

Letter from nationally-known Airlines, "We would also appreciate if you would place the following additional advertisement in your bulletin—Wanted—Superintendent of Communications . . . Salary \$666.66 per month."  
Letter from nationally-known airplane manufacturer, "We need men with electronic training or experience in radar maintenance to perform operational check-out of radar and other electronics systems . . . starting salary . . . amounting to \$329.33 per month."  
These are just a few examples of the job offers that come to our office periodically. Some licensed radiomen filled each of these jobs . . . it might have been you!

HERE'S PROOF FCC LICENSES ARE OFTEN SECURED IN A FEW HOURS OF STUDY WITH OUR COACHING AT HOME IN SPARE TIME

Name and Address	License	Lessons
Lee Worthy 2210 1/2 Wilshire St., Bakersfield, Calif.	2nd Phone	16
Clifford E. Vogt Box 1016, Dania, Fla.	1st Phone	20
Francis X. Foerch 38 Beaulier Pl., Bergenfield, N. J.	1st Phone	38
S/Sgt. Ben H. Davis 317 North Roosevelt, Lebanon, Ill.	1st Phone	28
Albert Schoell 110 West 11th St., Escondido, Calif.	2nd Phone	23

CLEVELAND INSTITUTE OF RADIO ELECTRONICS

CARL E. SMITH, E. E., Consulting Engineer, President  
Desk RN-67 — 4900 Euclid Bldg., Cleveland 3, Ohio

Get All 3 FREE

MAIL COUPON NOW

CLEVELAND INSTITUTE OF RADIO ELECTRONICS

Desk RN-67

4900 Euclid Bldg., Cleveland 3, Ohio  
(Address to Desk No. to avoid delay)

I want to know how I can get my FCC ticket in a minimum of time. Send me your FREE booklet, "How to Pass FCC License Examinations" (does not cover exams for Amateur License), as well as a Sample FCC-type exam and the amazing new booklet, "Money-Making FCC License Information." Be sure to tell me about your Television Engineering Course.

NAME .....  
ADDRESS .....  
CITY ..... ZONE ..... STATE .....

Paste on 2-cent post card or send air mail



# Quality Features OF TUNG-SOL PICTURE TUBES



**Gun** made of best grade non-magnetic steel.

**Glass bead** type assembly is stronger both mechanically and electrically—gives greater protection against electrical leakage.

**Rolled edges** in gun minimize corona.

**Custom built stem** with greater spacing between leads assures minimum leakage.

**Low resistance** of outside conductive coating minimizes radiation of horizontal oscillator sweep frequency.

**Double cathode tab** provides double protection against cathode circuit failure.

**Selected screen composition** resists burning (X pattern).

**Rigid control** of internal conductive coating provides utmost service reliability.

**Designed** for use with single or double field ion trap designs.

**One-piece construction** of parts assures better alignment.

**Maximum dispersion** of screen coating assures uniform screen distribution.

Tung-Sol makes All-Glass Sealed Beam Lamps, Miniature Lamps, Signal Flashers, Picture Tubes, Radio, TV and Special Purpose Electron Tubes and Semiconductor Products.

TUNG-SOL ELECTRIC INC., Newark 4, N. J. Sales Offices: Atlanta, Chicago, Columbus, Culver City (Los Angeles), Dallas, Denver, Detroit, Newark, Seattle.

## TUNG-SOL

RADIO AND TV TUBES



You Can Build A Reputation On Tung-Sol Quality

# Within the INDUSTRY

**JAMES R. BUTLER** has been appointed director of advertising and sales promotion for *Magnecord, Inc.*, Chicago manufacturer of magnetic tape equipment.



In his new position Mr. Butler will direct all relevant activities pertaining to the three divisions of the company covering magnetic tape equipment for amateur, professional, and commercial use.

He formerly served as merchandising and eastern sales manager for *Raytheon* and prior to that was field sales manager and national promotion manager for *Free-Westinghouse* and *New Home*.

\* \* \*

**GRAMER TRANSFORMER CORPORATION** of Chicago has purchased the **HALL-DORSON TRANSFORMER COMPANY** of Chicago, a subsidiary of **CHICAGO STANDARD TRANSFORMER CORPORATION**. No basic personnel changes are contemplated and the complete line of transformers formerly manufactured by the new subsidiary will continue to be available. . . . A group of employees has purchased **BARNES AND REINECKE, INC.**, Chicago design, research and development engineering firm. . . . **INTERNATIONAL RESISTANCE COMPANY** has announced that its wholly-owned California subsidiary, formerly the **GORMAN MANUFACTURING CORPORATION**, will now be known as **IRCAL INDUSTRIES**. . . . **RADIO CORPORATION OF AMERICA** has established a separate division devoted solely to the manufacture and sales of its home TV receivers and another division for radios and phonographs. . . . **WINSTON ELECTRONICS, INC.** has been organized in Philadelphia to design, produce, and market test instruments for electronic service and industry. Initial production will be devoted to color TV test equipment. . . . **ALLEGRO ELECTRONICS CORP.** has been established at 226 New York Ave., Huntington, L. I. to design and manufacture a complete line of phonographs and AM-FM-phono console music systems for the home. James Manfredi is president and Carl D. Volpe, vice-president of the new firm.

\* \* \*

**MICAMOLD RADIO CORPORATION** of Brooklyn has opened the first of its two branch factories being built in Tazewell, Va. The new site occupies 70,000 square feet of space. When both plants are in operation approximately 1000 persons will be employed. . . . **U. S. ENGINEERING CO.** has just completed

a new plant at 521 Commercial St. in Glendale, California. The firm makes a line of printed and etched circuits.

. . . **CONDENSER PRODUCTS COMPANY** of Chicago has expanded its production facilities by taking over 150,000 square feet of space at its parent company's **NEW HAVEN CLOCK & WATCH COMPANY**, New Haven plant. . . . Plans are under way to build a 210,000 square foot plant in Williamsport, Pa. which will be used as a centralized packaging area for the radio tube division of **SYLVANIA ELECTRIC PRODUCTS INC.**

. . . **JENSEN INDUSTRIES, INC.** has moved its factory and office headquarters from Chicago to Forest Park, a west side suburb of Chicago. The new facilities are at 7333 W. Harrison Street. . . . **POTTER & BRUMFIELD** is adding a new, 20,000 square foot all-aluminum building to its main plant in Princeton, Indiana. It is expected to be ready by September 1st. . . . **YARDNEY ELECTRIC CORPORATION**, New York battery firm, has purchased a building at 40-46 Leonard Street in New York. The five-story building has been renovated and will house all of the company's activities. . . . **DELTRON, INC.** has recently moved its manufacturing facilities to larger quarters at 2905 N. Leithgow St., Philadelphia. The firm was formerly located in Glenside, Pa.

\* \* \*

**PETER BUTTACAVOLI**, technical supervisor of the Teleset service department of *Allen B. Du Mont Laboratories'* TV receiver division, has been promoted to manager of field technical services.



His new responsibilities include the administration of technical services, education and service training on a national basis, and customer relations. Field service representatives will report to him in his new capacity.

Mr. Buttacavoli joined the company in 1951, prior to which he was associated with *Western Electric* for ten years.

\* \* \*

**DANIEL NEWMAN** has been named assistant director of service for *CBS-Columbia*. He will be responsible for operations of district service managers, customer relations, and supervision of the company's technicians' training program. . . . **MARSHALL L. REMUND** is the new jobber sales manager of *Jensen Industries, Inc.* . . . *Syntronic Instruments, Inc.* has appointed **BERNARD S. CAHILL** vice-president and chief en-

RADIO & TELEVISION NEWS

# NOW 60 MORE RADIO-TV ITEMS IN YOUR "HARDWARE SUPERMARKET"!

see them  
in the

**G-C**  
**50**  
**LINE**



with the exclusive  
**HINGED COVER  
PLASTIC BOX**  
COVER CANNOT BE LOST

*Glamour Package*  
OF THE  
ELECTRONIC INDUSTRY



**Serve yourself . . . it's faster . . . it's easier!**

Because you liked the ease and convenience of G-C's "hardware supermarket," 60 more popular items have been added to the 240 already included in the G-C 50 Line.

And remember—only G-C has the Hinged Cover Plastic Box . . . the one box that's handiest for stocking your hardware, the one that's easiest to find and the one that's reusable in so many ways when you're through with it!

WRITE FOR your  
free copy of the Big G-C Catalog.  
Send postcard today!

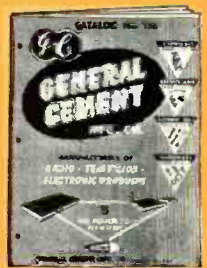

**BUY WHERE YOU SEE THIS G-C DISPLAY!**

*Partial List of 60 New G-C 50 Line Hardware Products*

- Pilot Light Sockets • Banana Plugs • Auto Radio Hardware • Phone Jacks • Alligator Clips
- Test Prod Tips • Spade Lugs • Miniature Sockets • Test Prod Chucks • Phone Tips . . . many others

**GENERAL CEMENT MFG. CO.**  
904 TAYLOR AVENUE • ROCKFORD, ILLINOIS

BUY DIRECT... and SAVE!

'PRE-FAB' **COLLINS** TUNERS

AUDIO PRODUCTS CO.

High Fidelity TUNERS and TUNER KITS

introducing the LATEST DESIGN

**COLLINS CHROMATIC TUNER**

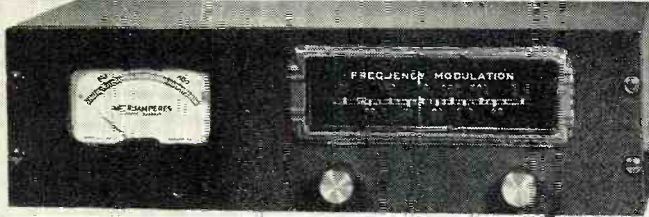

CHECK THESE OUTSTANDING FEATURES

- 4 1/2" tuning meter. Each tuner calibrated in microvolts for direct reading of signal strength.
- Not a kit. Completely wired, ready to use with FM antenna and amplifier.
- Sensitivity 3 microvolts with 20 DB of quieting.
- A.F.C. with disabling switch.
- New, compact, low design. Only 5 1/4" high. Matches latest bookshelf amplifiers.
- Voltage regulator tube for added stability.
- Newly designed front-end using 6BQ7 tube.
- Dual simultaneous audio output—high and low impedance.
- Ultra wide range response, 20 to 25,000 cycles.
- Distortion less than 3/4 of 1%. Hum 50 DB below program.
- Beautiful golden brown metal cabinet completely enclosing tuner.
- 5 1/4"x19" relay rack panel integral part of cabinet.
- Twelve tubes.
- Tone compensated volume control.

Plus many other smaller features which make this tuner the hottest item since high fidelity!

Overall size: 19" W. x 5 1/4" H. x 8 1/2" D. **\$97.50**  
Shipping weight: 15 lbs.

**COLLINS PRE-FAB KITS ALSO AVAILABLE**

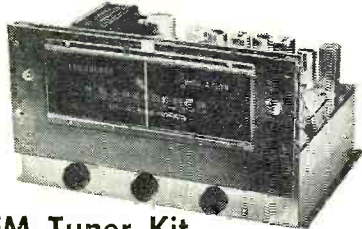

FM Tuner Kit

Shipping weight: 14 lbs. **\$55** with AFC **\$58.50**

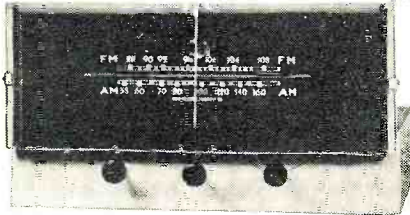

FM/AM Tuner Kit

Shipping Weight 19 lbs. **\$77.50** with AFC **\$81**

**IF-6 Amplifier . . .** 6 tubes Shipping Weight 3 lbs. **\$19.75**

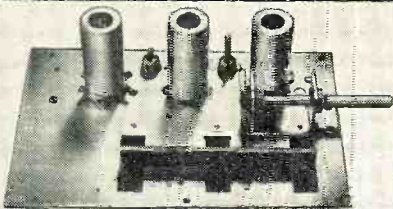

FMF-3 Tuning Unit

Shipping weight: 2 1/2 lbs. **\$15.25** with AFC **\$18.75**

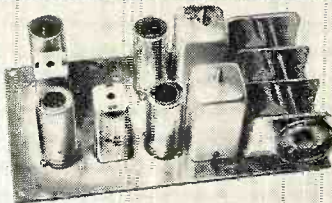

AM-4 Tuning Unit

**\$24.50** Shipping weight: 2 1/2 lbs.

**For Users of Collins Tuners:**  
Receive \$5.00 credit toward the new FMF-3A front end! Mail us your old front end with \$13.75 and we will send you the new, improved FMF-3A with AFC or, remit the full amount of \$18.75 and when we receive your old unit in return a check will be mailed you for \$5.00.

Collins Audio Products Co. is in no way affiliated with Collins Radio Co.

To: Collins Audio Products Co. Inc.  
P.O. Box 368, Westfield, N. J. Dept. RN8  
Tel. WEstfield 2-4390

- Chromatic Tuner
- IF-6 Amplifier
- FM Tuner Kit with AFC
- AM-4 Tuning Unit
- FM/AM Tuner Kit with AFC
- FMF-3 Tun. Unit with AFC

**Mail Coupon Today**

Name \_\_\_\_\_  
Address \_\_\_\_\_  
City \_\_\_\_\_ State \_\_\_\_\_  
Amount for Kit \$ \_\_\_\_\_ See weights, add shipping cost \$ \_\_\_\_\_  
Total amount enclosed \$ \_\_\_\_\_ Check  Money Order

**WHEN YOU THINK OF TUNERS, THINK OF COLLINS AUDIO PRODUCTS**

gineer. He was formerly associated with Pioneer Electric and Research Corp. . . . **JOHN S. MILLS** has been named general sales manager of Crosley radio and television. . . . **ALBERT G. PEIFER** is the new department head in charge of low voltage vacuum tube development at Federal Telecommunication Laboratories. . . . **ALDO LACHMAN** has joined the R. T. Bozak Company of Stamford, Conn. as vice-president in charge of manufacturing. . . . **Jerrold Electronics Corporation** has made two appointments of interest to the industry. **DONALD H. ROGERS**, formerly chief engineer of Blonder-Tongue Laboratories, has been added to the engineering department and **HERBERT JACOBS** has been named general manager for the firm. . . . **HERBERT A. BERNREUTER**, vice-president and general manager of Simpson Electric Co., passed away recently following a long illness. . . . **C. M. GRANGER** has been promoted to general factory manager of the Bendix television division while **KENNETH BROWN** has been upped to the post of TV service manager. . . . **Magnecord, Inc.** has named **ROY WITTE** chief mechanical engineer and **WILLIAM F. BOYLAN** chief electronic engineer. . . . **J. R. PITTLE** has been named sales manager of U. S. Wire & Cable Corp. . . . **Industrial Television, Inc.** has appointed **JOSEPH WEINBERG** to the post of purchasing agent. . . . The appointment of **L. A. CASLER** as vice-president has been announced by *Dalmo Victor Company*.

**W. HAMILTON WALTER**, until recently assistant chief of the Mutual Security Agency in Great Britain, has been named sales manager of *Electric Regulator Corporation* of Norwalk, Conn.



Before joining MSA in 1950 Mr. Walter had over-all responsibility as coordinator of sales for *Raytheon*. A former vice-president in charge of sales for the *North Electric Manufacturing Co.*, he was for 18 years a top sales, staff, and line executive of *Automatic Electric Co.* of Chicago.

**ROBERT L. KLABIN** has been named vice-president and general manager of the newly-created Elizabeth Division of *General Instrument Corporation*.



The Elizabeth Division consists of the company's facility in Elizabeth, N. J. which is devoted largely to metal fabrication and processing.

Mr. Klabin joined the company in 1935 as a cost accountant and rose through the ranks to controller and general manager of the firm's *F. W. Sickles Division* plant in Danielson, Conn.

# Home Study Courses in **TELEVISION SERVICING** offered by **RCA INSTITUTES**



Study Television Servicing—from the very source of the latest, up-to-the-minute TV and Color TV developments. Train under the direction of men who are experts in this field. Take advantage of this opportunity to place yourself on the road to success in television. RCA Institutes, Inc. (A Service of Radio Corporation of America), thoroughly trains you in the "why" as well as the "how" of servicing television receivers.

## FIRST HOME STUDY COURSE IN COLOR TV SERVICING

Now you can train yourself to take advantage of the big future in Color TV. RCA Institutes Home Study Course covers all phases of Color TV Servicing. It is a practical down-to-earth course in basic color theory as well as how-to-do-it servicing techniques.

This color television course was planned and developed through the combined efforts of instructors of RCA Institutes, engineers of RCA Laboratories, and training specialists of RCA Service Company. You get the benefit of years of RCA research and development in color television.

Because of its highly specialized nature, this course is offered only to those already experienced in radio-television servicing. Color TV Servicing will open the door to the big opportunity you've always hoped for. Find out how easy it is to cash in on color TV. *Mail coupon today.*

### SEND FOR FREE BOOKLET

Mail coupon in envelope or paste on postal card. Check course you are interested in. We will send you a booklet that gives you complete information. No salesman will call.



**RCA INSTITUTES, INC.**  
A SERVICE OF RADIO CORPORATION OF AMERICA  
350 WEST FOURTH STREET, NEW YORK 14, N. Y.

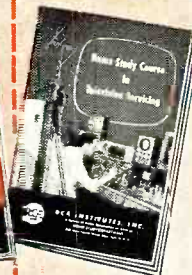
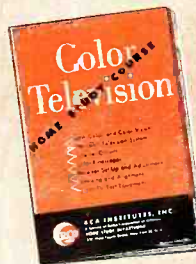

## HOME STUDY COURSE IN BLACK-AND-WHITE TV SERVICING

Thousands of men in the radio-electronics industry have successfully trained themselves as qualified specialists for a good job or a business of their own—servicing television receivers. You can do this too.

This RCA Institutes TV Servicing course gives you up-to-the-minute training and information on the very latest developments in black-and-white television.

As you study at home, in your spare time, you progress rapidly. Hundreds of pictures and diagrams, easy-to-understand lessons help you to quickly become a qualified TV serviceman.

There are ample opportunities in TV, for radio servicemen who have expert training. Mail coupon today. Start on the road to success in TV Servicing.

### MAIL COUPON NOW

RCA INSTITUTES, INC.  
Home Study Dept. RN-854  
350 West Fourth Street, New York 14, N. Y.  
Without obligation on my part, please send me copy of booklet on:

- Home Study Course in TELEVISION SERVICING.  
 Home Study Course in COLOR TV SERVICING.

Name \_\_\_\_\_ (please print)

Address \_\_\_\_\_

City \_\_\_\_\_ Zone \_\_\_\_\_ State \_\_\_\_\_

# NOW... 2 SENSATIONAL EICO SCOPE VALUES!

NEW AMAZING FEATURE PACKED  
7" PUSH-PULL OSCILLOSCOPE

Only **EICO** Has All These Features

**VERTICAL FREQ. RESPONSE:**  
flat  $\pm 2$  db 10 cps - 1 mc  
**VERTICAL SENS.:** .01 volts rms/inch  
**HOR. FREQ. RESP.:** flat  $\pm 0$  db 10 cps - 200 kc, -4 db at 500 kc  
**HOR. SENS.:** .3 volts rms/inch  
**SWEEP RANGE:** 15 cps-100 kc  
**3-STEP FREQ-COMPENSATED ATTENUATOR** eliminates freq. distortion, overloading.  
**CATHODE FOLLOWER** inputs to both amplifiers  
**PUSH-PULL** outputs in both amplifiers  
**RETURN TRACE BLANKING**  
**INT. VOLTAGE CALIBRATOR**  
**V & H TRACE EXPANSION & CENTERING:** 1.5X full screen without distortion.  
**DIRECT CONNECTION** to vert. CRT plates.  
**PHASING CONTROL** of internal 60 cps sine wave sweep.  
**AT FRONT PANEL:** intensity mod. input; 60 cps, sawtooth outputs.



MODEL 470K  
KIT \$79.95. WIRED \$129.50.

**221K VTVM KIT \$25.95. WIRED \$35.95.**  
● AC & DC volts: 0-5, 10, 100, 500, 1000 V (30 KV with HVP-1 probe). ● 5 ohm ranges from .2 ohm to 1000 megohms. ● DC input Z 26 megohms. ● 4 1/2" meter movement in can't-burn-out circuit. ● 1% mult. resistors.  
**HIGH VOLTAGE PROBE \$6.95**  
● Extends range of VTVMs & voltmeters to 30 KV.



**360K SWEEP GEN. KIT \$34.95. WIRED \$49.95.**

● Continuous coverage of all TV & FM freqs. from 500 kc to 228 mc.  
● Sweep width variable 0-30 mc.  
● Crystal marker oscillator, variable amplitude.



**CATHODE RAY TUBE CHECKER 630K, WIRED \$24.95 KIT \$17.95**



● Checks all types of TV picture and C.R. tubes in the set or carton. Bridge measurement of peak beam current (proportional to screen brightness).  
● Detects shorted & open elements.

**214K VTVM KIT \$34.95. WIRED \$54.95.**  
**249 K P-P KIT \$39.95 WIRED \$59.95**



● Large 7 1/2" meter, can't-burn-out circuit.  
● AC/DC volts: 0-5, 10, 100, 500, 1000 (30 KV with HV Probe).  
● 5 ohms ranges from .2 ohm to 1000 megohms.  
● DC input Z 26 megohms.  
● 1% mult. resistors.

Large 7 1/2" meter

**950A-K R-C BRIDGE & R-C-L COMP. KIT \$19.95. WIRED \$29.95.**

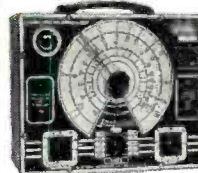

● Measures & tests all resistors; .5 ohm to 500 megohms.  
● Every type condenser, 10 mmf to 5000 mfd.  
● 0-500 DC voltage source for capacitor leakage testing.

**625K TUBE TESTER KIT \$34.95. WIRED \$49.95.**



● Illum. gear-driven "Speed Rollchart."  
● New lever-action switches for individual testing of every element.  
● Tests all conventional & TV tubes.  
**PIX TUBE ADAPTER for Tube Testers \$4.50.** Checks TV picture tubes while in set.

**EICO EXCLUSIVE! 5" PUSH-PULL SCOPE, 425K, Amazing feature-packed economy-priced**  
**Wired, \$79.95. KIT, \$44.95.**

**5" PUSH-PULL V & H amplifiers. Sens: 0.5-1 rms v/in. Useful to 2.5 mc. SWEEP: 15 cps-76 kc. Z-axis intensity modulation. Dual trace positioning controls.**



**SCOPE VOLTAGE CALIBRATOR KIT 495K KIT \$12.95. WIRED \$17.95.**  
● Sq. wave output at power-line freq. with full-scale readings of 1, 1, 10 or 100 V. peak-to-peak  
● Accuracy  $\pm 5\%$  of full-scale on each range.

**12V BATTERY ELIMINATOR KIT 150K KIT \$29.95. WIRED \$38.95.**

● DC output: 0-8 V or 0-16 V.  
● Continuous current rating: 10 A at 6 V, 6 A at 12 V.  
● Intermittent current rating: 20 A at 6 V, 12 A at 12 V.  
● Separate voltmeter & Ammeter.



**NOW! ONLY EICO KITS & WIRED INSTRUMENTS Gives You LIFETIME SERVICE & CALIBRATION GUARANTEE\***

\*at less than our cost of handling (See EICO Guarantee Card enclosed with each Kit & Instrument).

**BAR GENERATOR 352K, WIRED \$19.95 KIT, \$14.95**

● Enables rapid adjustment of TV picture V & H linearity without hard-to-find station transmitted test pattern.  
● Produces 16 V or 12 H bars. Operates on TV channels 3, 4, or 5.

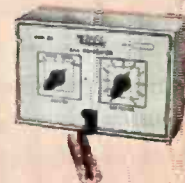

Prices 5% higher on West Coast. Specifications and prices subject to change without notice.

# New! EICO SCOOPS!

**232K PEAK-to-PEAK VTVM with DUAL-PURPOSE AC/DC Uni-Probe\* KIT \$29.95 WIRED \$49.95**



Measures directly p-p voltage of complex and sine waves: 0-4, 14, 42, 420, 1400, 4200 V p-p. DC/RMS sine voltage range: 0-1.5, 5, 15, 50, 150, 500, 1500 v. Ohms: 0-1000 megohms. 7 non-skip ranges on every function. Calibration without removing from cabinet. Zero center. Freq. Resp. 30 cps-3mc. 1% precision ceramic multipliers. Exceptional stability and accuracy. Compact, portable (8 1/2 x 5 x 5"), smart, rugged.

**NEW! UNI-PROBE! Terrific time-saver! Only 1 probe for all functions—a half-turn of probe-tip selects DC or AC-OHMS!**

**249 K PEAK-to-PEAK VTVM with 7 1/2" METER KIT \$39.95 WIRED \$59.95**

**944 K FLYBACK TRANSFORMER AND YOKE TESTER KIT \$23.95 WIRED \$34.95**

Tests all flybacks and yokes, in or out of TV set—in just seconds! Detects even 1 shorted turn! Exclusive separate calibration for air—and iron-core flybacks assures utmost accuracy. Large 4 1/2" meter, 3 colored scales. Compact, portable (8 1/2 x 5 x 5"), smart, rugged.



**315K DELUXE SIG. GEN. KIT \$39.95. WIRED \$59.95.**



● Covers range of 75 kc to 150 mc.  
● 7 calibrated scales: accuracy better than 1%.  
● Bandsread vernier tuning.  
● 4-step RF shielded output multiplier: constant output Z.

**377K SINE & SQUARE WAVE AUDIO GEN. KIT \$31.95. WIRED \$49.95.**



● Complete sine wave coverage, 20-200,000 cps in 4 direct-reading ranges.  
● Complete square wave coverage, 60-50,000 cps.  
● Cathode follower output circuit.

**536K MULTIMETER KIT \$12.90. WIRED \$14.90.**  
**526K MULTIMETER KIT \$13.90. WIRED \$16.90.**



● 1000  $\Omega/V$ ; 31 ranges  
● DC/AC volts: Zero to 1, 5, 10, 50, 100, 500, 5000.  
● DC/AC Current: 0-1, 10 ma; 0.1, 1 A.  
● Ohms: 0-500, 100 K, 1 meg.

**565K MULTIMETER KIT \$24.95 WIRED \$29.95.**  
**555K MULTIMETER KIT \$29.95 WIRED \$34.95.** (1% precision resistors)



● 20,000  $\Omega/V$ ; 31 ranges.  
● DC/AC/Output volts: 0-2.5, 10, 50, 250, 1000, 5000.  
● DC Current: 0-100 ua; 10, 100, 500 ma; 10 A.  
● Ohms: 0-2K, 200K, 20 meg.

**145K SIG. TRACER KIT \$19.95. WIRED \$28.95.**



● Audibly signal traces all IF, RF, Video & Audio circuits from ANT to SPKR or CRT in all TV, FM, AM, etc. without switching.  
● Germanium crystal diode probe responsive to over 200 mc.  
● Integral test speaker.

**320K SIG. GEN. KIT \$19.95. WIRED \$29.95.**  
**322K SIG. GEN. KIT \$23.95. WIRED \$34.95.**



● Fundamentals 150 kc to 34 mc, harmonics to 102 mc.  
● 5-step band switching.  
● Colpitts audio oscillator generates 400 cps pure sine wave voltage.  
● Permits pure RF, modulated RF, or pure AF.

Write NOW for FREE latest Catalog RH-8

Ask your jobber for FREE EICO business building decals.

© 1954

Separate Assembly & Operating Manuals supplied with each EICO KIT!

You build EICO Kits in one evening, but... they last a lifetime!

SAVE OVER 50%! See the famous EICO line TODAY, at your local jobber.

Over-all view of the 2-meter transmitter. It can be used with carbon or crystal mike.

# TWO-IN-THE-HAND

By **ROB WAGNER, W6WGD**  
 Research and Development Lab.,  
 Dalmo Victor Company



**I**F YOUR paycheck is made out to plain "John X. Amateur" and not to "Executive Vice-President Ham," perhaps you're unable to invest a half-month's pay in a commercially-built 2-meter mobile transmitter.

Those who are not technically inclined can save their lunch money until bird-watching becomes boring and a couple of hundred bucks will put 'em on two. On the other hand, the miniature rig to be described may offer a constructional challenge to the fellow who prefers the smell of hot solder to that of the bang-tailed swallow.

The mobile transmitter shown at the top of this page requires only 6"x3½"x2¾" worth of chassis, small enough to mount within the glove compartment of your car or behind the seat of a motorcycle. In spite of its size, the rig runs approximately 20 watts input to the final 2E26, 100% modulated with ten watts of crisp audio from its 1635 class "B" modulator. Just for kicks, two stages of crystal mike preamplification have been added, and there's space left over for spare parts plus two bites of a ham sandwich!

Tube lineup? See Fig. 1, the r.f. schematic. The 6X8 oscillator tube combines half of a 6J6 and a pentode section equivalent to the 6AG5. A garden-variety 8 mc. crystal plus the 6X8 operating as an overtone oscillator/tripler delivers plenty of 72 mc. fire to drive the following 5763.

Doubling to 144 mc. is a cinch for the 5763, the output of which allows the 2E26 final to run up to 20 watts input—approximately 7 watts output.

The series-tuned final employs screen grid neutralization, making the tube easy to "tame" at 2 meters.

Thus far we've used three inches of the six-inch chassis. There's plenty of room left for the modulator, if you have the knack of getting five pounds of gear into a four pound bag!

Why use a crystal mike? This was partly a matter of preference and partly to see if it could be done in the space available. Some hams like good audio quality rather than the some-

## *Part 1. Construction details on a glove-compartment, two meter transmitter featuring class B modulation with carbon or crystal mike and either 6- or 12-volt mobile operation.*

what nasal reverberations of the average graphite button. However, if you wish to be more practical and utilize the carbon microphone, construction of the rig becomes simplified and the parts list diminishes along with the size of the transmitter. Fig. 6 is a carbon mike schematic for use with the 1635 modulator.

If you like the idea of a crystal microphone, let's proceed with the audio lineup. A cascaded 12AX7 preamp mounts next to the 1635 modulator tube, delivering plenty of audio to a 12AU7 parallel-connected driver hidden beneath the chassis with the class "B" driver transformer. (See Fig. 2). The 12AU7 has the reserve power necessary to provide maximum steam with good regulation for driving the modulator grids.

The 1635 is a modernized version of the 6N7; zero bias allows the tube to idle, no signal, at only 10 ma. At 10 to 12 watts peak output, the plate current rises to just 63 ma., thus the 1635 becomes the obvious tube choice for this class of mobile modulator.

Now why not use a clamp tube or similar variable-efficiency device? Well, in this game (and many others) you seldom get something for nothing. Variable-efficiency modulators provide audio by sacrificing amplifier output power. They're hard to beat for savings in parts, tubes, and power supply, and if this article were describing a "Dick Tracy" radio, that's exactly the kind of audio we'd write about.

This rig, however, was designed to poke a really respectable hole in the

ether. Inasmuch as the other guy listens to your sidebands and not to your carrier, it figures that the more sideband power you add to (not share with) your carrier power, the better he'll copy you when band conditions get rougher than usual.

Class "AB" could have been employed, but at a greater cost in higher no-signal plate current, thus for mobile applications, class "B" seems to fill the bill. And when band conditions take a turn for the worse, it's a cinch that the boy with audio power added to his carrier will get the better signal report in East Decalomania.

If you don't care for electronic head-shrinking, the following circuits may still be assembled into a somewhat larger (but certainly no less effective) mobile transmitter.

### The R.F. Section

*The Oscillator:* Have you ever tried an overtone oscillator? It's a trick circuit which might oscillate 'most anyplace, often without benefit of its crystal. In some instances, the overtone oscillator has placed ham CQ's on police, aircraft, and taxicab frequencies, resulting in considerable embarrassment.

This overtone oscillator circuit seems more foolproof than the others. No tapped coils or tickler windings are required; the circuit is straightforward and apparently refuses to self-oscillate. (This one was tuned up over seven mobile months ago and hasn't needed retuning since!)

Fig. 1 shows the circuit's simplicity.

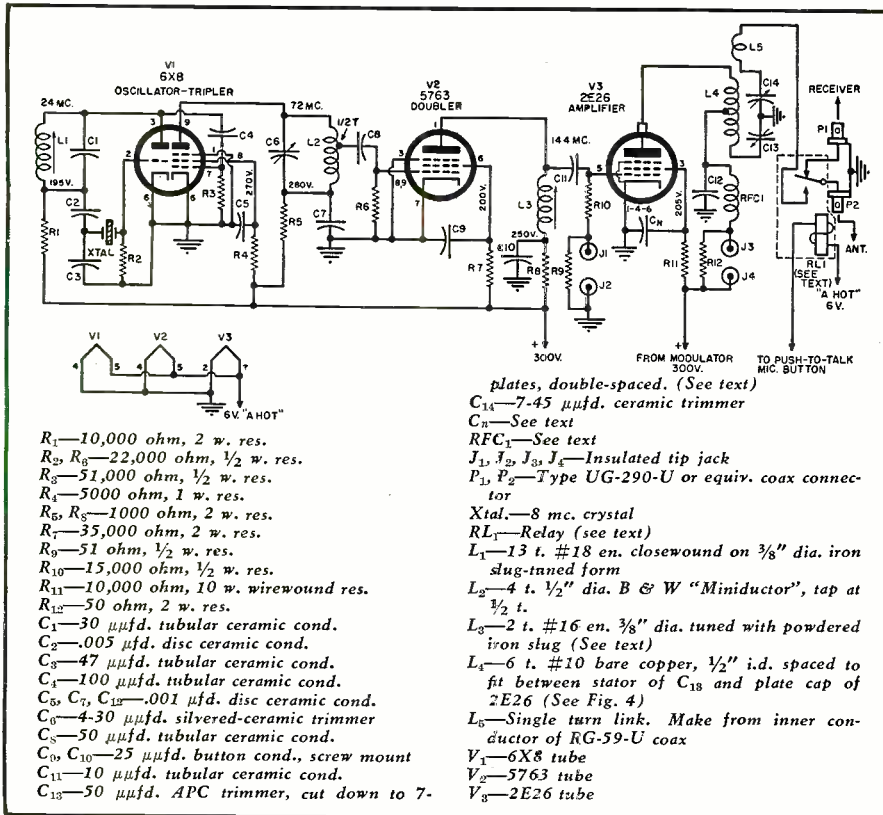

Fig. 1. Schematic of r.f. section showing correct voltage readings, using a 20,000 ohms-per-volt meter to ground, when transmitter final is loaded to 80 ma. @ 300 v.

The 8 mc. crystal receives driving voltage from the junction of the voltage divider network,  $C_2$  and  $C_3$ ;  $L_1$ , the slug-tuned oscillator coil, resonates with  $C_1$  at 24 mc. Slug adjustment is made through the chassis hole adjacent to the crystal socket. See Fig. 5.

The 6X8's 24 mc. triode section drives the pentode tripler through coupling condenser  $C_4$ , providing about 1 ma. of grid current measured through grid bias resistor  $R_5$ .

The pentode delivers several round,

healthy volts of 72 mc. r.f. at the plate end of  $L_2$ , resonated with  $C_6$ . Fig. 2 shows  $L_2$  (the 4-turn B & W "Miniductor") soldered directly to the lugs of  $C_6$ , a 4-30  $\mu$ fd. silvered-ceramic trimmer. This condenser is screwdriver adjusted through a chassis hole between the 6X8 and 5763.

Screen resistor  $R_4$  serves as an r.f. choke only, screen potential being kept almost equal to that of the plate to allow higher power output. Miniature .001  $\mu$ fd. disc ceramic condensers ( $C_5$ ,

$C_7$ ) require minimum space to bypass both plate and screen voltages to ground directly at the tube socket.

$R_1$  provides both r.f. decoupling and voltage-dropping for the 6X8's triode section, while the pentode's plate gets the full whammy of 300 volts. With the stage operating properly, voltages as indicated upon the schematic, Fig. 1, will be measured accordingly. Enough output from the 6X8 at 72 mc. is available to light a single-turn 60 ma. lamp-loop to approximately half brilliance.

**The 144 mc. Doubler:** The 5763 doubler receives grid drive from the oscillator through coupling condenser  $C_5$ . This condenser is tapped down from the plate end of  $L_2$  about a half turn, which form of impedance matching helps deliver optimum power from one stage to the next. Grid bias resistor  $R_6$ , a compromise value, was chosen to allow reasonable doubling action with plenty of plate power output.

Screen dropping resistor  $R_7$  solders directly to the tube socket along with a screw-mounted surplus button condenser,  $C_8$ , the screen bypass to ground.

The 144 mc. plate tank circuit is a "gimmick" installation. With little room to spare, it was necessary to devise a custom-made slug-tuned tank circuit to accommodate the 5763's output section.

Find a slug-tuned coil and remove the molded form, leaving just the bushing which formerly mounted the coil to a panel. Mount the bushing in the front panel of the transmitter, so that a powdered-iron slug, when screwed into the bushing from behind the panel, moves freely in and out of the two-turn plate coil  $L_3$ . This detail may be clearly seen in Fig. 2.

Connect the 10  $\mu$ fd. coupling condenser,  $C_{11}$ , between the top of  $L_3$  and grid pin #5 on the 2E26 socket, and install  $R_{10}$ , the final grid-bias resistor. This assembly constitutes a slug-tuned plate circuit for the 5763 (and for the grid circuit of the 2E26) which resonates at 144 mc. with circuit and coupling capacity plus the 2E26 grid-cathode capacity to ground.

Pull out or push together the two turns of  $L_3$  to find a resonant point within the 2-meter band, remembering to have the 2E26 in its socket during the tuning process.

Grid-dip  $L_3$  to 144 mc., ascertaining that resonance occurs with the slug about half way into  $L_3$ . Apply voltage to the oscillator and doubler only and, using the "lamp-loop" as an output indicator, peak the oscillator, tripler, and doubler coils for maximum output. The lamp-loop should attain full brilliance when both stages are operating properly.

Note that a pair of pin-jacks is placed between the bottom end of  $R_{10}$  and ground, with the 51 ohm,  $\frac{1}{2}$  watt,  $R_8$  shunted across their terminals. The jacks facilitate insertion of test leads from an external milliammeter, upon which to read final grid current. When the meter is removed,  $R_8$  allows grid current to develop normally to ground.

Without plate or screen voltage on

Fig. 2. Bottom view. Note partition in center which shields r.f. from the speech stages and provides a solid mounting post for the driver transformer, T<sub>1</sub>, Fig. 8.

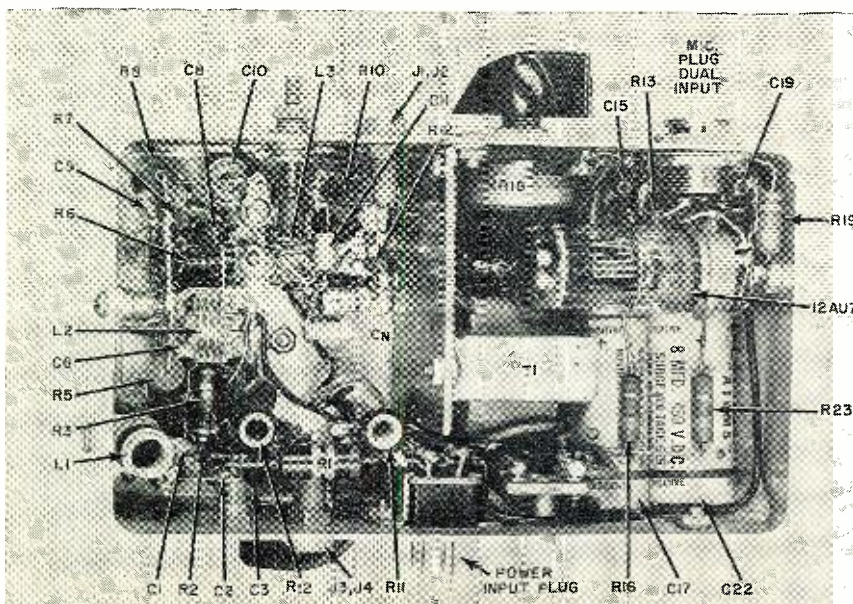

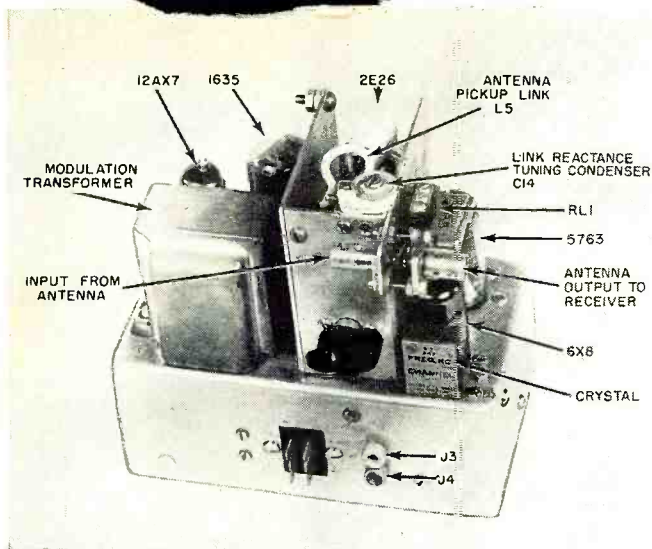

Fig. 3. Rear view.  $J_3$ ,  $J_4$ , next to power plug, facilitate reading of 2E26 plate current with external milliammeter. The knob directly above the jacks tunes the final tank,  $C_{13}$ .

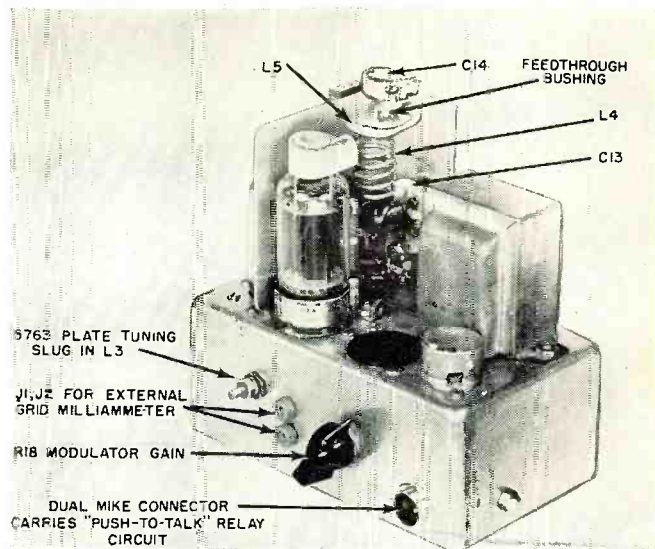

Fig. 4. Rear view with half of shield removed to show final amplifier assembly.  $L_5$  is supported by feedthrough bushing and solders to rotor lug of  $C_{14}$ , whose stator grounds to shield.

the 2E26, its grid current should read at least 2 ma. when all preceding circuits are resonated for maximum output.

**The 2E26 Amplifier:** The 2E26 tube was chosen for two reasons—it delivers plenty of punch and requires a minimum of space. The tube is easily driven at 144 mc. and lends itself nicely to compact construction, as illustrated in Fig. 4.

Series tuning is employed in the output tank, which fits our assembly requirements to a "T" and provides a somewhat higher "Q" as used in this application.

Figs. 3 and 5 illustrate a shield can around the final which not only isolates r.f. from the other stages, but provides a handy mounting panel for the tank condenser, pickup link, antenna relay, and the coaxial antenna connectors. Made from two pieces of  $\frac{1}{16}$ " thick aluminum, the shield comes apart as shown in Fig. 4 to facilitate assembly of the final.

The bottom end of tank coil  $L_4$  solders directly to one stator connection of  $C_{13}$ . The top end of  $L_4$  is soldered into the removable plate cap connector of the 2E26; when assembled with the tube, the tank coil remains rigidly supported from each end. The r.f. choke may be any variety of the v.h.f. choke; it connects between the electrical center of  $L_4$  and "B+." Plate voltage arrives at the final from beneath the chassis into an insulated feedthrough bushing or condenser terminating within the shield can just behind tuning condenser  $C_{13}$ . The feedthrough bushing, a rigid tie joint upon which to mount the r.f. choke, may be seen clearly in Fig. 4.

Pin jacks  $J_3$  and  $J_4$ , make a convenient point at which to read final plate current.

Although  $C_{13}$  grounds to its mounting panel, it's advisable to solder a flexible "pig-tail" of wire from its rotor to some common ground point on the chassis. The stator will be quite "hot" with r.f.

at resonance, thus  $C_{13}$ , a double-spaced condenser having a total of seven plates, may be made from a surplus APC 50  $\mu\text{mf}$ . trimmer by removing alternate plates from rotor and stator.

Screen-grid neutralization requires that resonant capacity be connected directly between the tube socket's screen and cathode pins. With use of the 10,000 ohm  $R_{11}$ , the correct value of neutralizing capacity will be determined by experiment, as described in the following section, "Neutralizing and Tuning."

$L_5$ , the antenna pickup link, mounts directly over the plate end of  $L_4$ . This is not according to "the book," but due to design considerations is the only place to couple the antenna.  $C_{14}$ , a 7-45  $\mu\text{mf}$ . ceramic trimmer, bolts to the top of the shield can, and provides mounting for the ground-return end of  $L_5$ .

The "hot" side of  $L_5$  may be taken through an insulated bushing directly to one contactor of the antenna relay, mounted adjacent to and outside the shield. Details are visible in Fig. 3.

Six-volt miniature relays are often hard to come by, unless you make your own. This becomes an easy process, if you have access to one of the "war surplus" 28-volt devices removed from an ARC-5 transmitter or receiver.

Remove the 28-volt winding from the relay, and fill the coil form with random-wound #29 enameled wire. If the d.c. resistance of the new winding is around 12 ohms, you're back in business with an inexpensive 6-volt relay which should draw no more than .5 ampere. For 12-volt operation, use #37 enameled wire, and measure 25 ohms coil resistance.

In keeping with the transmitter's

Fig. 5. Top view showing assembly detail of antenna pickup coil, reactance tuning condenser, coaxial connectors, and relay. Relay is held to shield with a single bracket and mounts directly over 6X8 oscillator tube. Note size of transformer.

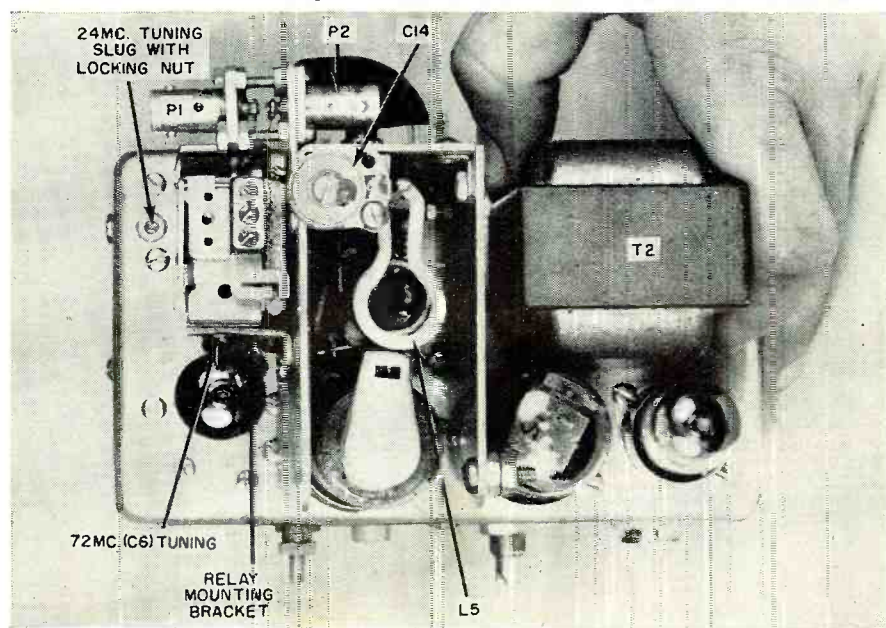



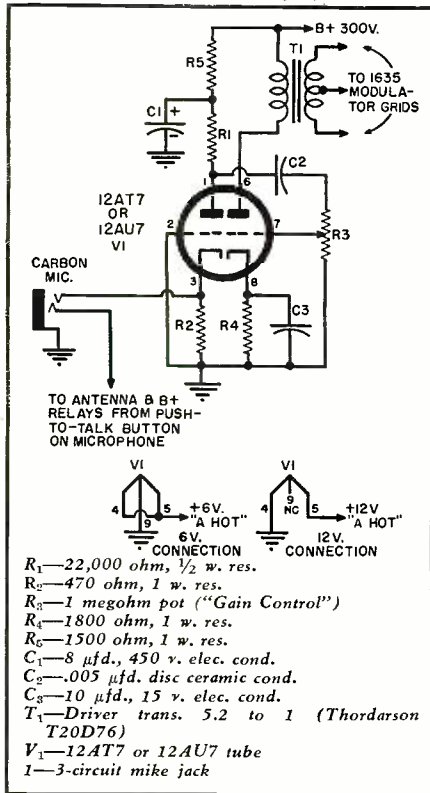

Fig. 6. Carbon mike input amplifier and driver. No mike transformer is used. Output is sufficient to drive modulator to 10 w.

small size, miniature type UG-290-U coaxial connectors are employed as antenna input and receiver link terminals. If you can't buy or borrow these, there's plenty of room outside the shield to mount standard size coax connectors. Figs. 3 and 5 help to clarify the mounting details.

### Neutralizing and Tuning

Screen neutralization requires that

Fig. 8. Crystal microphone class B modulator. Connection at "X" is made when a single power supply is used. Note voltage readings, taken with 20,000 ohms-per-volt meter.

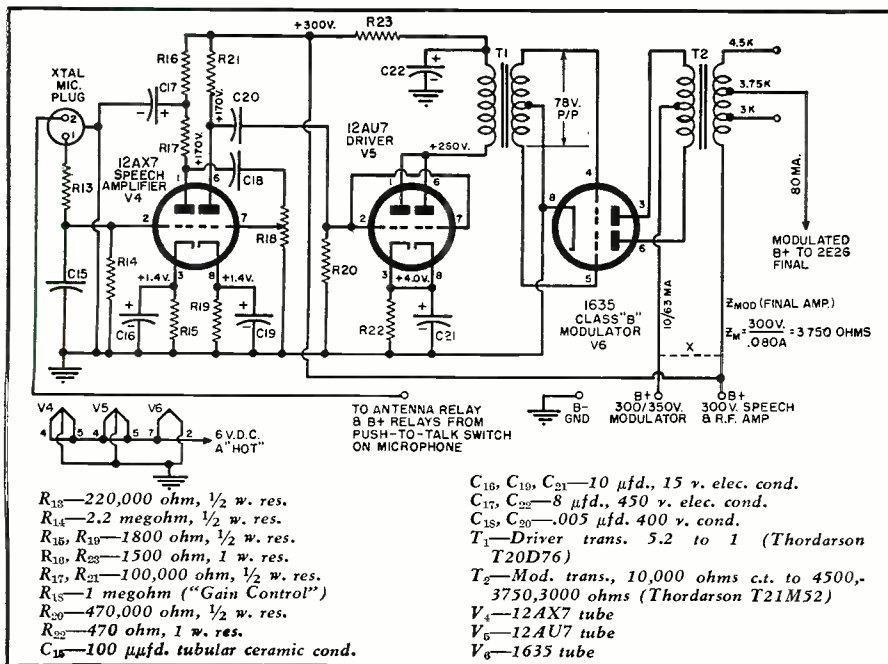

- R<sub>13</sub>—220,000 ohm, 1/2 w. res.
- R<sub>14</sub>—2.2 megohm, 1/2 w. res.
- R<sub>15</sub>, R<sub>16</sub>—1800 ohm, 1/2 w. res.
- R<sub>10</sub>, R<sub>23</sub>—1500 ohm, 1 w. res.
- R<sub>17</sub>, R<sub>21</sub>—100,000 ohm, 1/2 w. res.
- R<sub>18</sub>—1 megohm ("Gain Control")
- R<sub>20</sub>—470,000 ohm, 1/2 w. res.
- R<sub>22</sub>—470 ohm, 1 w. res.
- C<sub>18</sub>—100 μfd. tubular ceramic cond.

- C<sub>16</sub>, C<sub>19</sub>, C<sub>21</sub>—10 μfd., 15 v. elec. cond.
- C<sub>17</sub>, C<sub>22</sub>—8 μfd., 450 v. elec. cond.
- C<sub>15</sub>, C<sub>20</sub>—0.005 μfd. 400 v. cond.
- T<sub>1</sub>—Driver trans. 5.2 to 1 (Thordarson T20D76)
- T<sub>2</sub>—Mod. trans., 10,000 ohms c.t. to 4500-, 3750, 3000 ohms (Thordarson T21M52)
- V<sub>4</sub>—12AX7 tube
- V<sub>5</sub>—12AU7 tube
- V<sub>6</sub>—1635 tube

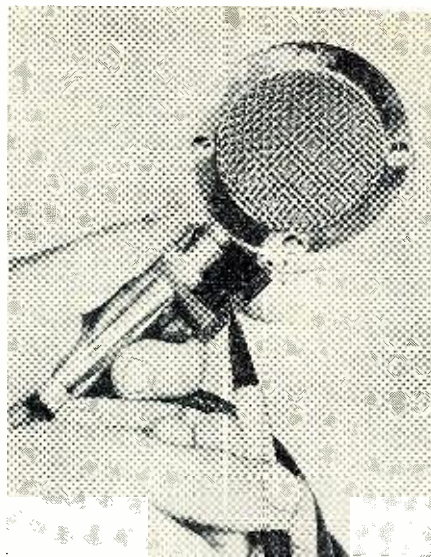

Fig. 7. How Microswitch is attached to a crystal microphone for "push-to-talk" mobile operation. See text for details.

the screen-grid circuit, with its associated components, be resonated to ground at the final's operating frequency.

The capacity required with this rig amounts to 57 μfd., although the amount may vary with individual applications, due to shorter or longer screen lead lengths and different values of screen dropping resistance. A suggested method of variable neutralization control is use of a 7-45 μfd. ceramic trimmer, shunted with about 10 μfd. at the tube socket.

Without applying plate or screen voltage to the final, fire up the oscillator and doubler stages after connecting an external 0-5 milliammeter to jacks J<sub>1</sub> and J<sub>2</sub>. Tune L<sub>1</sub>, C<sub>6</sub>, and L<sub>3</sub> for maximum grid current, which will be in the vicinity of 2 ma.

Swing final tank condenser C<sub>13</sub> through its entire range, noting any fluctuation of grid current. Chances are that the grid current will take a sudden dip as the final tunes through resonance, so change the setting of C<sub>7</sub> and try again. When the stage is neutralized, there should be no grid current variation as C<sub>13</sub> passes through resonance.

Now apply plate and screen voltage to the 2E26, adjusting the slug in L<sub>3</sub> for maximum grid current. With a 0-100 milliammeter plugged into J<sub>3</sub>, J<sub>4</sub>, dip the final. Grid current should drop to approximately 1.5 ma. at resonance, and should rise slightly an equal amount just off each side of resonance. Should the grid current rise sharply at the plate-current dip, the tube requires further neutralization.

With the final neutralized, but not connected to the antenna, the 2E26 plate current should read from between 25 and 35 ma. at the resonant dip. To avoid damaging the 2E26 screen grid, don't operate the transmitter without an antenna or dummy load for more than a short time. The screen draws maximum current when the stage is unloaded, and less current with the plate loaded to its normal operating value.

Now connect a suitable antenna to coaxial connector P<sub>2</sub> and loosely couple antenna link L<sub>5</sub> to the top of L<sub>4</sub>. Apply high voltage and dip the final, which will show a higher resonant plate current value, depending upon the degree of antenna coupling.

Screwdriver adjust C<sub>14</sub>, the link's "reactance tuner-outer" to the point where maximum loading occurs with minimum coupling. Reduce L<sub>5</sub>'s coupling until, at the resonant dip, the plate current reads 80 ma., and you're tuned up to about 24 watts input, with plenty of fire at the ends of the dipole.

Perhaps the length of coaxial line to your antenna is such that C<sub>14</sub> will not "peak" and L<sub>5</sub> must be more closely coupled to the final tank coil. If so, your transmission line may have a fairly low standing-wave ratio. There's still plenty of energy transfer to the transmission line, C<sub>14</sub> being in the circuit to electrically shorten the line to the optimum length, taking advantage of whatever s.w.r. happens to occur at point of coupling.

Even though maximum power output seldom coincides with minimum plate current of an r.f. amplifier at resonance at these frequencies, the foregoing tuning procedure is recommended over that of tuning for maximum power output without regard for amplifier plate current.

### Class "B" Modulator

The 1635 is ideally suitable for delivery of ten plus watts of full, clean audio. Its plate-to-plate impedance, 10,000 ohms, works into the primary of a small Thordarson T21M52 class "B" modulation transformer (See Fig. 5). This particular transformer, even after having been filled with tar, "talks (Continued on page 109)

# A U. H. F. BOOSTER

By J. W. STEIDLEY, W4IYB

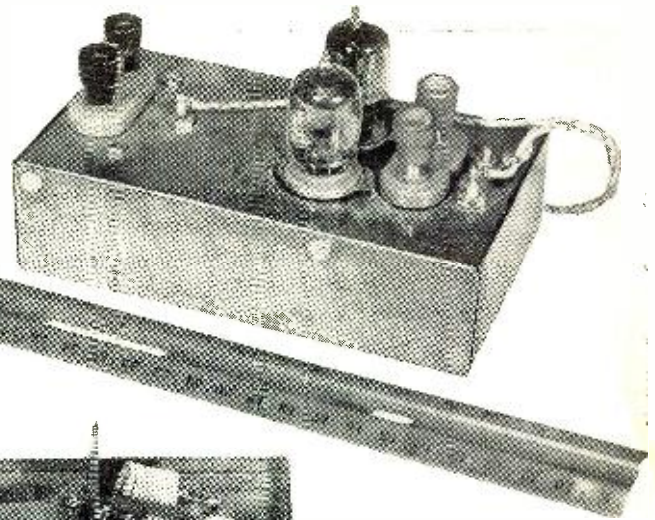
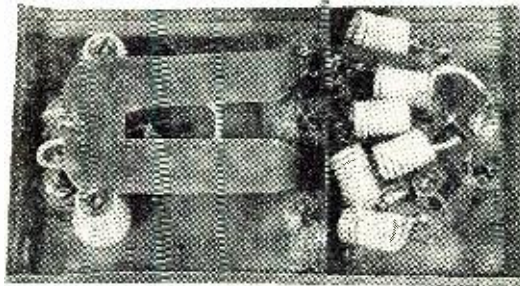

Fig. 1. Top and bottom views of the single-channel u.h.f. booster described in this article. The booster is built on the cover of a copper box and the bottom is completely enclosed. Note the quarter-wave plate line and coupling loop in the bottom view.



*An effective, easy-to-build, single channel u.h.f. TV or 420 mc. ham booster. Standard parts are employed.*

THE shift of one of the major television network's programs to u.h.f. in the Norfolk, Virginia area forced the writer to make the shift also. One of the popular makes of converters was purchased only to find that the signal strength was insufficient to override the mixer noise and the picture was unacceptable. Various antennas, including corner reflectors and 16-element beams, were tried at various heights but all to no avail, and an r.f. amplifier or booster appeared to be the only solution. After several approaches were tried the booster described herein and shown in Fig. 1 was built. It has proven to be effective in that the picture is now completely snow free and equal to or better than that received on v.h.f.

The design is not unique, being a push-pull, grounded-grid triode amplifier, but the performance and ease of construction are surprising. Type 6AJ4 u.h.f. triodes were selected on the basis of the author's ham 420 mc. experience and because of their reasonable price. Other new u.h.f. triodes, such as the 6AM4 or 6AN4, might perform equally well but were not tried.

A quarter-wave plate line,  $L_1$  in Fig. 2, is used for ease of construction and small size. In an earlier design a variable-tuned half-wave line was used, but comparison with the quarter-wave line showed no improvement at frequencies up to channel 33, the highest channel available in this location. On the highest channels the half- or three-quarter-wave line might prove somewhat superior. Variable tuning was also discarded in the interest of simplicity, and the inner slot in the line is cut to exact length for the channel desired, see Fig. 3. In the absence of test equipment it is suggested that the slot be initially cut longer than required for the channel concerned and the length be varied by sliding a flat copper tab gradually closing the shorted end of the slot while watching the picture. When the

proper length has been determined, a piece can be soldered over, or a new line cut out to length. In the author's case the length for channel 15 turned out to be 2 inches.

The output coupling loop is not critical as long as the coupling is kept tight. It consists of a hairpin loop of plastic-covered hook-up wire lying against the under side of the plate line with the loop extending about 1 inch down the slot in the line. The coupling can be altered by varying this distance. The two side wires of

the hairpin are one-half inch apart. See Fig. 1.

The entire booster uses a  $1\frac{1}{2}'' \times 3'' \times 6''$  box. The box, cover, and plate line are constructed of copper flashing which is available at any hardware store or firm carrying building supplies. It cuts easily with either small tin snips or heavy household scissors (preferably not your wife's) and is easily bent and formed between two boards in a vise. The primary advantage in its use is the ease of soldering directly to the chassis. The cover which is used for the actual chassis is constructed in the same manner as the box but with one-half inch sides. It is secured to the box with four sheet metal screws.

Pins 1, 3, 4, 6, and 9 of the 6AJ4 tubes are grounded at the sockets by bending the socket terminals down and soldering them directly to the chassis. The shield (shown in the bottom view in Fig. 1) is notched to accept the sockets and is soldered in place across the sockets so that pins 4, 5, and 6 are on one side of the shield. The heater and cathode r.f.

*(Continued on page 98)*

Fig. 2. Complete schematic diagram and parts list for the u.h.f. booster.

- $R_1, R_2$ —120 ohm,  $\frac{1}{2}$  w. res.
- $R_3$ —See text
- $C_1, C_2$ —100  $\mu$ fd. ceramic.
- $C_3, C_4$ —1500  $\mu$ fd. ceramic feedthrough cond.
- $L_1, L_2$ —See Fig. 3 and text
- RFC<sub>1</sub>, RFC<sub>2</sub>, RFC<sub>3</sub>, RFC<sub>4</sub>, RFC<sub>5</sub>, RFC<sub>6</sub>—9 t. #18 plastic-covered wire, closewound, self-supporting  $\frac{1}{4}''$  dia.
- $V_1, V_2$ —6AJ4 tube

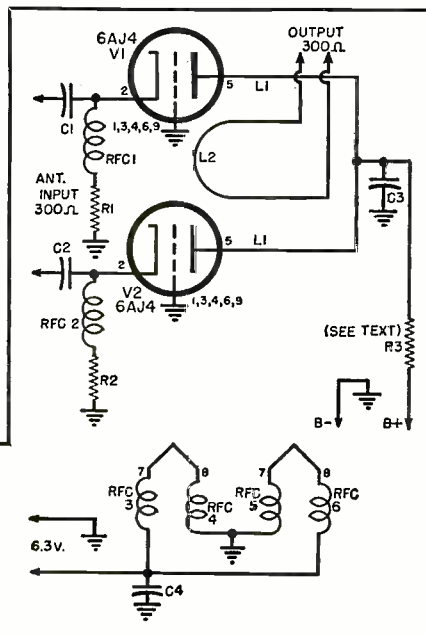
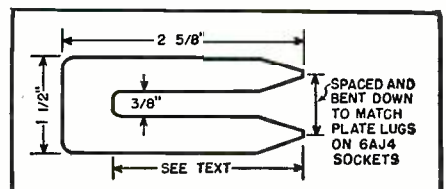

Fig. 3. The quarter-wave plate line used in the booster for  $L_1$  in Fig. 2.



# A SOUND-CONTROLLED THYRATRON FOR HIGH-SPEED PHOTOGRAPHY



The sound-controlled thyatron unit connected to flash lamp of a 100 watt-second electronic unit.

By  
**PETER J. VOGELGESANG** and **JAMES HILMANOWSKI**

*A sound-coupled synchronizing system in which calibrated time delay is provided by sound of action photographed.*

WITH the development of the low-cost, portable electronic flash unit, high-speed photography was made possible for even the most inexperienced amateur photographer. Taking pictures with the electronic flash is only slightly more difficult than using conventional flash bulbs but the results are usually much more spectacular because extremely fast action can be stopped without the slightest blur. However, when a photographer purposely sets out to stop fast action such as an exploding firecracker or a splash of water, synchronization of the flash unit with the action becomes a major problem. Mechanical linkages and electrical contacts are too cumbersome and too difficult to handle to be of much

practical value. A photoelectric system is not much better. But since action is almost always accompanied by sound or at least vibration, a camera synchronized by this medium opens limitless possibilities.

Most advantages of a sound-coupled synchronizing system are immediately apparent, namely, ease of handling and versatility. But one valuable feature of the system, not so easily recognized, is the excellent calibrated time delay provided by the speed of sound. Such a time delay is definitely necessary. For example, suppose a picture is to be taken of a bottle breaking as it strikes a floor. If the flash unit triggers the instant the bottle touches the floor, the resultant photo-

graph would reveal nothing but an unbroken bottle touching the floor. Time is required to allow the bottle to begin to break before the flash unit is triggered. Since the speed of sound in air is approximately 1100 feet-per-second, the delay of sound can be estimated roughly at one millisecond-per-foot. Now, if the bottle requires ten milliseconds to break completely and it is desired to photograph the bottle when it is half broken, the microphone of the triggering unit can simply be moved five feet away from the bottle, thereby allowing about five milliseconds for the bottle to break. Very often, when the over-all speed of the action is unknown, best results can be obtained only by trial and error.

Some interesting photographic actions generate very little sound, such as dropping a marble into a bowl of milk. In these instances, utilization of the sound in air is impractical. But picking up the vibration in the material upon which the bowl is setting is practical, especially if that material is subject to vibration, like a wood table top. But here the time delay is less of a known quantity than in air because the speed of sound in a solid is much greater.

A block diagram of the entire equipment set-up is shown in Fig. 2. The object to be photographed generates a sound which is picked up by the microphone. The microphone feeds an amplifier which, in turn, triggers a thyatron. The thyatron then fires the flash unit.

The basic theory of an electronic flash unit is quite simple. A charge in a very large condenser is discharged through a gas-filled tube, causing extreme ionization of the gas and intense

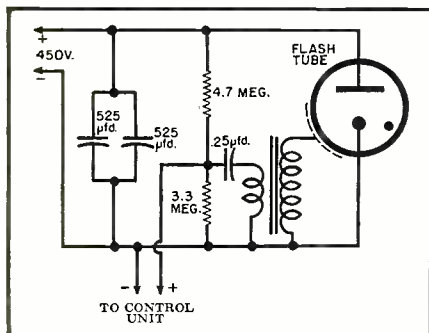
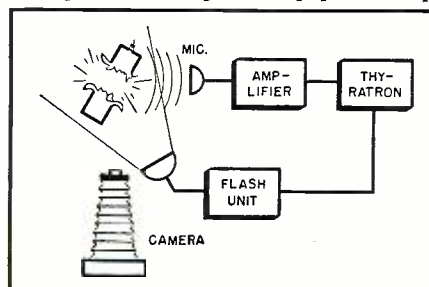

Fig. 1. A typical electronic flash unit.

Fig. 2. Block diagram of equipment setup.



light. However, before the condenser can be discharged through the tube, the gas in the tube must be slightly ionized to start the conduction. This initial ionization is effected by discharging a smaller condenser (.25  $\mu$ f.d.) through the primary of a high voltage transformer (see Fig. 1). The voltage on the secondary of the transformer is sufficient to start the ionization. Normally, the circuit in the primary of the transformer is closed by the switch in the shutter of the camera. The whole function of the sound-controlled thyatron unit is to close this circuit with sound.

The schematic diagram of the sound-controlled thyatron is shown in Fig. 3. The component that actually closes the circuit in the primary of the ionizing transformer is a 2D21 thyatron. This tube is normally prevented from conducting by a 7 volt negative voltage on the grid, but even a momentary rise in grid voltage above approximately four volts negative will allow the tube to conduct, thereby firing the flash unit. The thyatron is connected to the flash unit through a double-pole, single-throw switch. While the equipment is being set up, this switch can be opened to prevent accidental firing of the flash unit.

The sound pickup device is a small PM speaker. The speaker and voice coil-to-grid transformer is used instead of a microphone for two reasons. First, the impedance from speaker to transformer is only four ohms and the speaker can be connected to the transformer with a long length of unshielded cable without danger of hum or spurious pickup. Second, the speaker is more sensitive to vibration than a microphone when placed cone down on the surface of a table or a floor. A potentiometer in the secondary of the transformer is used to adjust the sensitivity of the unit. Adjusted for maximum sensitivity, the unit will be triggered by a snap of the fingers at about six feet. The voltage on the secondary of the transformer is amplified by two triodes of a 12AT7 tube. The triodes are operated without bias, since fidelity is of no importance.

The power supply is conventional. It was found necessary to voltage regulate the power to the amplifier because a sudden change in line voltage could cause the thyatron to conduct. A refrigerator starting at an inopportune moment could trigger the flash unit and ruin a piece of film. Bias for the thyatron is developed from the filament voltage with a small selenium rectifier. Since the load on the bias supply is negligible, the peak d.c. voltage rises in excess of seven volts. Provision has also been made to trigger the thyatron electrically in case the need ever arises. The bias is brought to one point of a three-point terminal strip, where it is jumpered to a point supplying the grid of the thyatron. Removal of this jumper will remove bias from the thyatron, allowing it to fire. By substituting wires and a

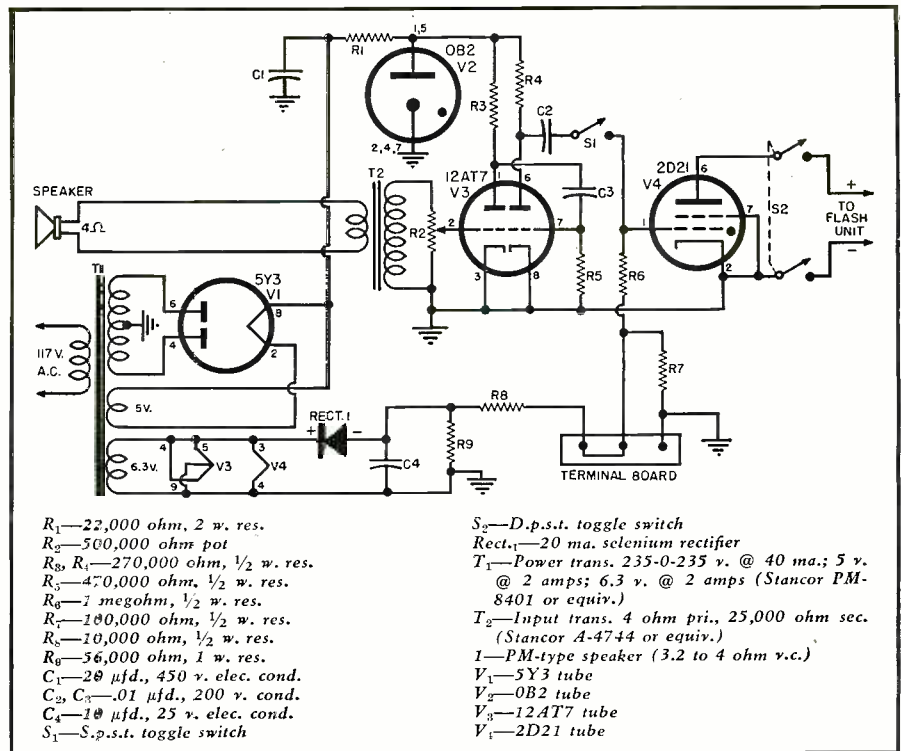

- R<sub>1</sub>—27,000 ohm, 2 w. res.
- R<sub>2</sub>—500,000 ohm pot
- R<sub>3</sub>, R<sub>4</sub>—270,000 ohm, 1/2 w. res.
- R<sub>5</sub>—470,000 ohm, 1/2 w. res.
- R<sub>6</sub>—1 megohm, 1/2 w. res.
- R<sub>7</sub>—100,000 ohm, 1/2 w. res.
- R<sub>8</sub>—10,000 ohm, 1/2 w. res.
- R<sub>9</sub>—56,000 ohm, 1 w. res.
- C<sub>1</sub>—20  $\mu$ f.d., 450 v. elec. cond.
- C<sub>2</sub>, C<sub>3</sub>—.01  $\mu$ f.d., 200 v. cond.
- C<sub>4</sub>—10  $\mu$ f.d., 25 v. elec. cond.
- S<sub>1</sub>—S.p.s.t. toggle switch

- S<sub>2</sub>—D.p.s.t. toggle switch
- Rect. 1—20 ma. selenium rectifier
- T<sub>1</sub>—Power trans. 235-0-235 v. @ 40 ma.; 5 v. @ 2 amps; 6.3 v. @ 2 amps (Stancor PM-8401 or equiv.)
- T<sub>2</sub>—Input trans. 4 ohm pri., 25,000 ohm sec. (Stancor A-4744 or equiv.)
- 1—PM-type speaker (3.2 to 4 ohm v.c.)
- V<sub>1</sub>—5Y3 tube
- V<sub>2</sub>—OB2 tube
- V<sub>3</sub>—12AT7 tube
- V<sub>4</sub>—2D21 tube

Fig. 3. Complete schematic of sound-controlled thyatron for high-speed photography.

switch for the jumper, the unit can be triggered by opening a normally-closed circuit. The thyatron can also be triggered by closing the normally open circuit between the grid and ground. This simply shorts the grid bias to ground. When the unit is triggered electrically, S<sub>1</sub> can be opened to prevent sound from affecting the unit.

The unit is constructed on a 5" x 7" x 2" chassis. Since the plug on the line cord and the plug used to make connection to the flash unit are both conventional 117 volt a.c. plugs, care must be taken not to get the two

plugs mixed. Also, the plug for the flash unit must be inserted in such a way that the positive voltage is connected to the plate of the thyatron. Once the correct polarity is found, a spot of paint on the plug and the flash unit will insure correct polarization thereafter.

This unit has been used repeatedly with unflinching results. Its greatest value is found in the fact that it requires no mechanical connection to the object to be photographed. The uses to which it can be put are limited only by your imagination. —30—

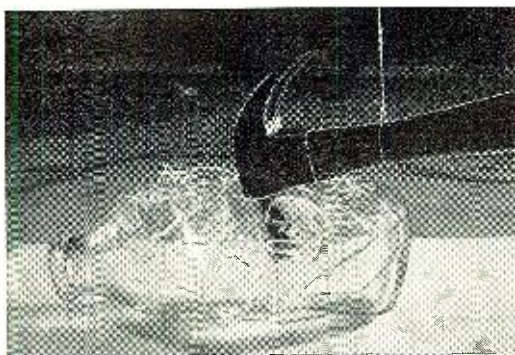

Action shot of hammer breaking a bottle. String tied to hammer was also tied to a Microswitch which triggered the thyatron circuit.

Vibration of bowl as object is dropped into it actuates the sound-controlled relay.

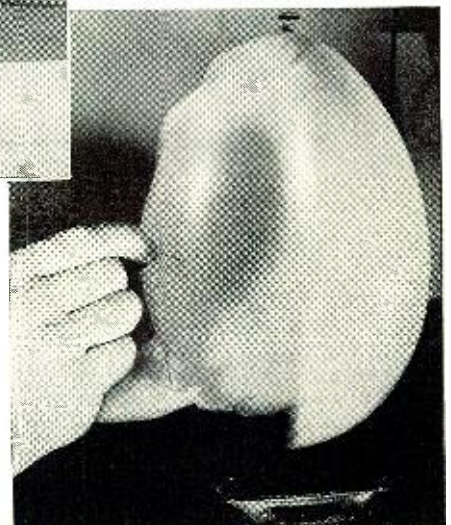
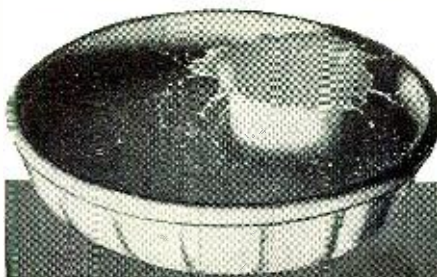

The receding edges of the opening of the balloon apparently move with a speed approaching the speed of sound.

# RECEIVING TUBES FOR COLOR TV

By  
**WALTER H. BUCHSBAUM**  
Television Consultant  
RADIO & TELEVISION NEWS



Fig. 1. Some of the new tubes used in color TV sets. These tubes either perform new jobs or handle greater voltages and currents than heretofore found in TV sets. The unlabeled tube on the left is a 6BJ7.

*Color TV circuits require new types of receiving tubes; the ones described here will be found in many color sets.*

JUST as the advent of monochrome TV brought a host of new, special TV receiving tubes, the approaching production of color TV receivers is heralded by a rash of new and specialized receiving-type tubes. As might be expected, these new tubes either perform functions not previously found in television receivers, or else they are designed to provide simplified and more economical circuitry.

Before describing each of the new tubes, a short discussion on their various functions is in order. The color TV receiver differs from its monochrome counterpart mainly in the video, synchronizing, and sweep sections. Higher voltages and greater power are also needed. Fig. 2 shows in block diagram form the various sections peculiar to a color receiver. Functionally, the color demodulator, matrix, color sync, and dynamic convergence sections are completely different from monochrome circuitry. The demodulator section removes the color information from the color subcarrier and usually employs synchronous detectors or some other phase-sensitive circuit. In the color sync section, the 3.58-mc. color subcarrier burst is converted into a continuous sine wave of the same frequency. This calls for gating, a.f.c., and phase detector circuitry. Dynamic convergence presents less of a problem since this section merely shapes and amplifies portions of the horizontal and vertical sweep. While the matrix circuits are not found in monochrome receivers, their function is simply to add the luminance and color information signals so as to obtain the blue, green, and red signals for the CRT. Included in the matrix section are the three color video amplifiers which are of standard design but, generally, use multiple-element tubes such as pentode-triode combinations or triple diodes (for d.c. restorers).

The horizontal sweep section is included here mostly for its relation to other sections, but basically the same type of circuitry is found here as in monochrome receivers. Improved line-

arity and greater high voltage require new tubes and components in the flyback and high-voltage section. As we shall see, a number of new tubes were developed for this last section. Some tubes used in monochrome receivers have been improved for greater power capacity or simpler construction and have received new numbers.

Starting with the power supply, *G-E* has announced the 5AU4 which is a considerably fortified cousin of the old familiar 5U4 rectifier. The new tube is also an octal type, and its major feature is greatly improved current carrying capacity, resulting in fewer paralleled "B+" rectifier tubes.

For the demodulator section, the first color TV receivers used a 6AS6, which is a pentode in which the suppressor grid has almost as much control as the control grid. Since this is a somewhat special and expensive tube, several new and different gating tubes have been announced. *G-E* is promoting the 6AR8, a sheet-beam

type tube which is used as a synchronous detector to remove the *I* and *Q* signals from the 3.58-mc. color subcarrier. The 6AR8 functions on the same principle as the 6BN6, used as an FM detector in some black-and-white TV receivers. *RCA* has come out with a pentagrid amplifier which can be used as a synchronous detector, the 6BY6. A less expensive version of the older 6AS6 is the newly announced 6DB6 which *CBS-Hytron* expects to put on the market. All three tubes are of the miniature 7-pin type. The color sync section of some late model receivers may be using one or the other of these three new tubes but, in general, the tubes found in this section will be double diodes and double triodes. Some recent new TV tubes like the 6X8 and the earlier 6U8, both containing a triode and a pentode in a single envelope, will appear frequently in the color sync section.

A real innovation resulted from the need for three identical d.c. restorers in the color set. The tube required is a 9-pin miniature containing three separate diodes. *G-E* and *CBS-Hytron* are both promoting their type 6BJ7 triple diode (see Fig. 1) which consists of three identical balanced diodes, each with the same characteristics as a single 6AL5 section. *RCA* is featuring another tube, the 6BC7, which is quite similar except that the degree of balance between diode sections is less stringent. In actual receivers both tubes will be found in essentially the same circuits and are practically interchangeable.

(Continued on page 104)

Fig. 2. Partial block diagram of a color TV receiver showing the sections that require new receiving tube types.

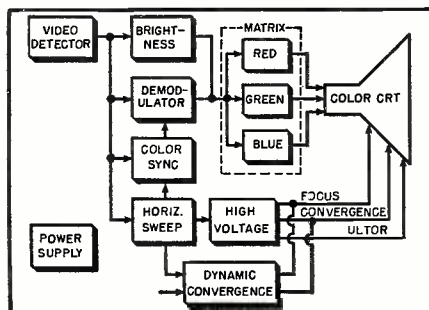

# THE RCA MODEL SV-1 PREAMP

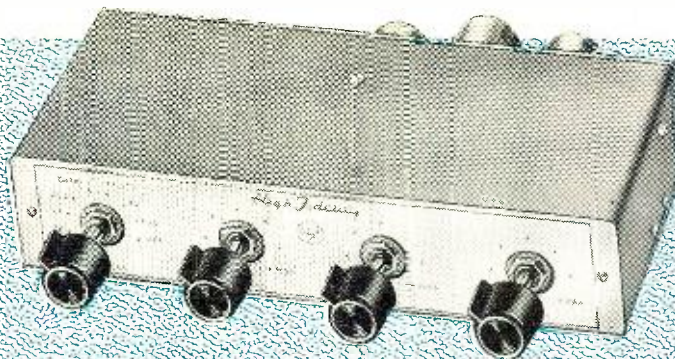
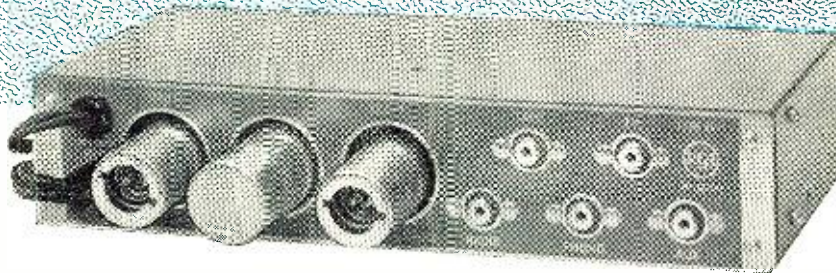

Fig. 1. Front and rear views of the RCA SV-1 preamp. It is housed in a compact cabinet which can be placed remote from rest of the system.



By **LEON A. WORTMAN**  
Radio Corporation of America

*Technical details on a new audio component which has been added to RCA's "intermatched" line of high-fidelity gear.*

RECENTLY, RCA introduced a new group of high-fidelity units which it refers to as the "intermatched" line. The line contains AM-FM tuners, a record changer, variable reluctance pickups, power amplifier, loudspeakers, and enclosures. The control centers of all high-fidelity systems are contained in their preamplifiers and so RCA has included such a unit in its line.

The RCA Model SV-1 preamplifier was specially designed, both physically and electronically, to enable its unobtrusive placement at a chairside for remote control or inside the audio console for local control. See Fig. 1. The preamp-equalizer is contained in a flat rectangular case, finished in delph blue, which measures 9½" long, 5¾" deep, and 2" high. The escutcheon plate is in gold with embossed markings for the four controls: "Selector" (input channels), "Volume," "Bass," and "Treble" which is combined with the a.c. power line switch. The tubes, input jacks, signal output and power cables are at the back. The number of front panel controls has been reduced to a minimum by combining the various "turn-over" equalizers with the input "Selector" switch. This switch is an 8-position, 2-deck rotary assembly. The first four positions reading clockwise are all for the phono input, enabling selection of phono and turnover simultaneously. The remaining four positions are for selection of radio, TV sound, auxiliary, and tape inputs.

The preamp-equalizer performs four main control functions: provides amplification and equalization for magnetic and reluctance type pickups, allows selection of five different pre-connected input channels, controls the volume level of the high-fidelity audio system, and permits continuously variable control of the bass and treble spectra. An interesting feature, which goes along with the modern trend toward the incorporation of magnetic tape recorders in the audio system, is

the provision for feeding any one of four of the five preconnected input channels to the tape recorder while monitoring the sound through the high-fidelity amplifier and speaker.

In designing a unit which must have extended bass response and straight-line high-end fidelity, contingent on very high voltage gain over-all, the project engineer must, from the very start, come face-to-face with the "bugaboos" of hum at the bottom end and noise at the high end of the spectrum. The mechanical layout must preclude capacitive coupling of high-impedance, high-gain circuits which might cause

regeneration or oscillation which would result in noise and distortion and otherwise make the performance of such a unit unsatisfactory. The mechanical layout must also avoid inductive coupling between the relatively low impedance power lines carrying a.c. and the high impedance amplifying-equalizing circuitry carrying the audio signal. Electrically, the design must be such that the unit will operate as satisfactorily with all high-fidelity power amplifiers as with its own companion amplifiers, without encountering the "horrors" of a ground loop.

An interesting application of hum-

Fig. 2. Tone control characteristics when preamp is used in conjunction with RCA SP-10 or SP-20 amplifier. In flat position, response is flat  $\pm .5$  db from 20 to 20,000 cps.

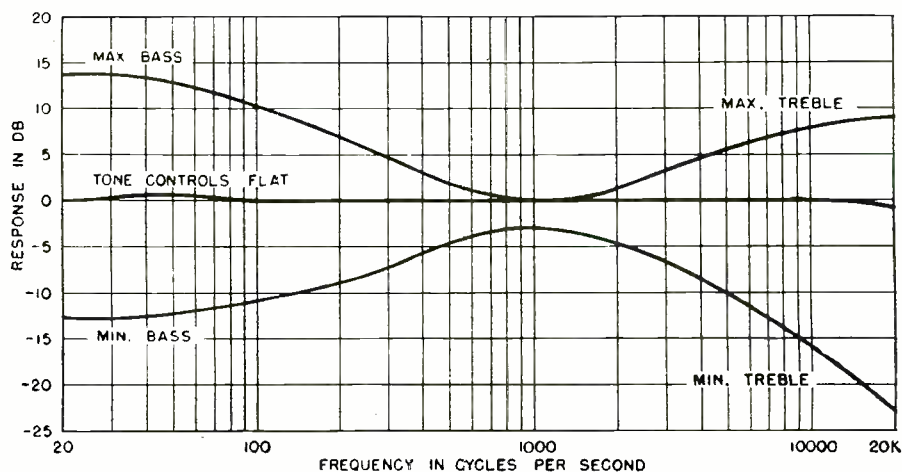

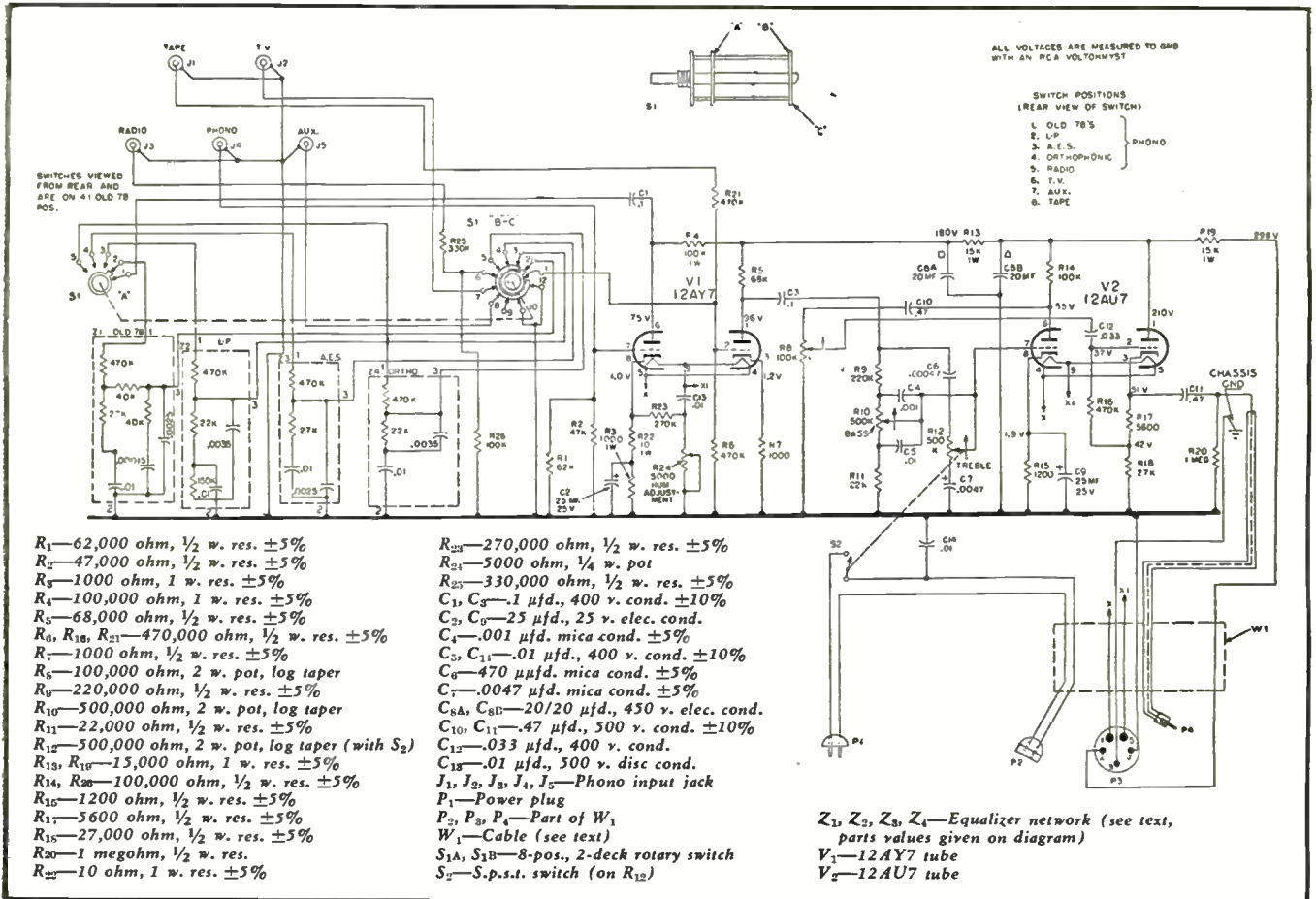

Fig. 3. Schematic of the RCA SV-1 preamp. Although designed to be used with RCA's SP-10 or SP-20 amplifier it will work with other units.

bucking techniques is incorporated in the phono-preamplifier stage of this unit. The network formed by  $R_{23}$ ,  $R_{24}$ , and  $C_{13}$  is part of a bridge which includes the cathode-heater leakage of the 12AY7 high-gain dual-triode. Adjustment of  $R_{24}$ , which has been preset at optimum at the factory, balances the bridge, reducing audible hum to a minimum. The hum adjustment control,  $R_{24}$ , should be reset whenever the 12AY7 is replaced. In adjusting  $R_{24}$ , the first grid of the 12AY7 should be shorted to ground, the "Selector" switch set in one of the four phono positions, and the "Bass," "Treble," and "Volume" controls rotated to "maximum." Should a vacuum-tube voltmeter or other suitable test equipment not be available, this adjustment can be done by ear, listening closely at the loudspeaker for minimum hum.

To achieve ideally minimum hum, there is extensive cable shielding and compartment shielding (see Fig. 4), and carefully planned wiring which utilizes the common ground "bus." As can be seen in Fig. 3, the schematic diagram, the ground bus and chassis are isolated electrically and appear separately at the 5-prong power plug terminals. This permits separation of the ground points between the pre-amplifier and the power amplifier which it feeds in order to obviate a hum-producing ground loop.

To provide optimum voltage output consistent with optimum frequency

response when used for phono playback, the unit is delivered with  $R_2$  (Fig. 3) connected across the phono jack. This is the proper terminal resistance for variable reluctance type cartridges such as the RCA MI-12110, MI-12112, or G-E RPX-050, RPX-052. For use with the Audak and Pickering cartridges, however,  $R_1$ , Fig. 3, is provided with one end soldered to ground and the other end free. When the Audak cartridge is used,  $R_1$  should be soldered directly across  $R_2$ . When a Pickering cartridge is used,  $R_2$  should be disconnected and  $R_1$  soldered in its place. It is recommended that where several different types of pickups are to be used interchangeably the proper resistor should be soldered directly across the output terminals of the cartridge instead of at the phono jack.

To overcome electromechanical difficulties in the recording process, most records are made according to frequency response curves which attenuate the bass and emphasize the treble. Since an over-all flat frequency response is desirable, the SV-1 preamplifier includes circuits which equalize the low and high frequencies during the playback of a record. These are so designed as to complement the equalization which was inserted at the time the recording was made. Because the various record manufacturers use different recording curves, according to the capabilities of their recording equipment and their own theories and

practices of equalization, four different equalizer circuits are provided with characteristics complementary to most of the best high-fidelity record labels on the market. These circuits can be selected by turning the "Selector" switch to one of the positions marked "78," "LP," "AES" and "Ortho." By choosing the correct position many records can be equalized with the tone controls in the "flat" position (pointers at 12 o'clock). However, some records may require slight adjustment of the "Bass" and "Treble" controls (see Table 1). In the schematic diagram it can be seen that the "Selector" switch appears electrically between the two triode sections of the 12AY7. The first triode is operated as the phono pre-amplifier and is connected only when the "Selector" switch is in positions 1, 2, 3, or 4. Equalization for these four positions is selected simultaneously by the  $S_{1A}$  deck of the "Selector" switch. Electrically the equalizer circuitry appears after the output of the first stage of the 12AY7, equalization being accomplished at the grid of the second stage. Fig. 6 gives the fixed curves of the equalizers of the four phono positions.

The variable tone controls are separate and operate independent of one another without interaction. The "Bass" control affords a maximum attenuation of 13 db and a boost of 14 db, with a plateau between 20 and 50 cps. The "Treble" control affords 23

db maximum attenuation and a 9.5 db boost at 20,000 cps. The second stage of the 12AY7 drives a low mu dual-triode tube type 12AU7. The "Bass" and "Treble" tone controls appear at the grid of the first triode section of the 12AU7 which operates as a conventional single-ended amplifier stage. The second section operates as a cathode follower. The "Volume" control is in the grid circuit of this last stage. The nominal load impedance of the output stage is 100,000 ohms.

The rated audio output voltage at the output jack is .5 volt at less than .5% harmonic distortion from 20 to 20,000 cps. At the tape jack it is .045 volt at less than .5% harmonic distortion in the same frequency range. The inputs for the rated outputs include .014 volt (phono), .15 volt (radio), .05 volt (tape), and .03 volt (TV).

The noise level is less than .00035 volt at full gain on the phono position or -57 db below .5 volt. The frequency response of the unit (when used with either the RCA SP-10 or SP-20 power amplifier) with the tone controls flat is 20-20,000 cps  $\pm$  .5 db (radio or TV, Fig. 2); 20-10,000 cps +0 db, -1.5 db at 10,000 cps (tape, Fig. 5); and the required compensation for "Ortho," "AES," "LP," or old "78" rpm recording characteristics (phono, Fig. 6).

The audio outputs of a TV or AM-FM tuner should be connected to their respective "TV" or "Radio" jacks at the back of the preamp-equalizer. The TV tuner should provide an audio output signal of approximately .03 volt. The radio tuner should provide a signal of approximately .5 volt. A crystal-type phono pickup can be connected directly to the "Aux." jack. The impedances of these input jacks are 100,000 ohms.

The "Tape" jack can be used either as an *output* for feeding signal to the recorder or as an *input* for tape playback through the high-fidelity system. This jack is connected between the first and second stages of the 12AY7. Since the "Volume" and "Tone" controls are in the 12AU7 stages, they are effective only during playback. They will not affect the frequency response of the signal being fed out to the "Tape" jack while making the recording. Connections between the recorder and the preamplifier depend, of course, on the particular recorder used. If the recorder *input* jack also serves as the *output* when the recorder is switched to playback, connect to the "Tape" jack of the preamplifier. No other connection is then required. If separate input and output jacks must be used at the recorder, connect the recorder's input to the "Tape" jack and its output to the "Aux." jack. To reduce hum and noise, the recorder output should be taken from a stage preceding its power output tube. However, if such a connection is not available, the speaker output jack of the recorder may be used with good results.

Since the preamp-equalizer is the control center of the high-fidelity sys-

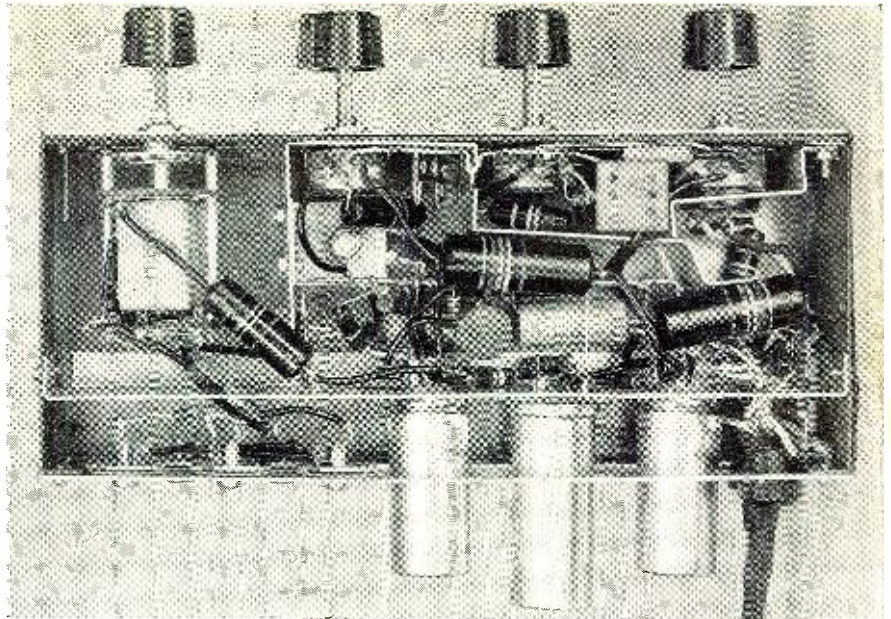

Fig. 4. Underchassis view of the SV-1 preamp. Note the extensive use of shields.

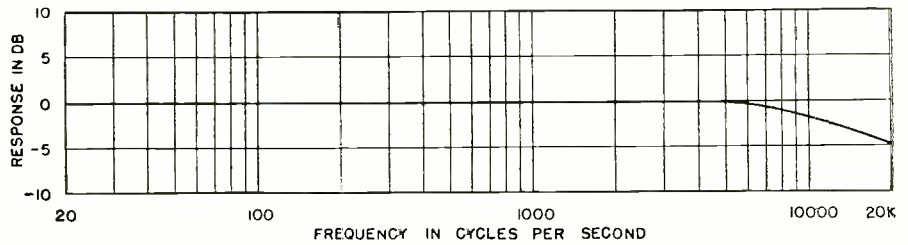

Fig. 5. Frequency response of the preamp's tape output when used with an ECA SP-10 or SP-20 power amplifier (tone controls flat). See text for discussion of response.

78	LP	AES	ORTHO
All older 78 rpm records	Cetra Soria* Columbia* Decca* Haydn Society* London** Oceanic* Tempo* Urania* Vanguard-Bach Guild* Vox	Blue Note Jazz Canyon Capitol Capitol-Cetra Cook Laboratories*** EMS Esoteric*** Mercury M-G-M*** Philharmonia	Atlantic* Bartok* Caedmon** Elektra* Lyricord* Polymusic* RCA Victor Remington* Westminster*

\*Treble control at 10 o'clock. \*\*Treble control at 11 o'clock. \*\*\*Bass control at 1 o'clock.

Table 1. Selector switch position for record equalization for well-known labels.

tem, it should be placed in a spot easily accessible and convenient for operation. The location selected should be near a 117-volt, 60 cps alternating

current outlet and within reach of the cables from associated units. The output and d.c. power cable of the pre-  
(Continued on page 105)

Fig. 6. Phono equalizer characteristics for AES, 78, LP, and Ortho positions.

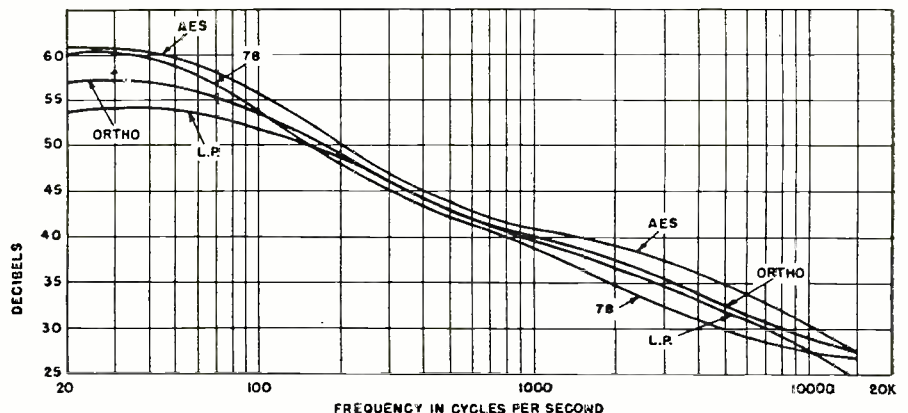



# FUNDAMENTALS OF COLOR TV

## THE COLOR SIGNAL

By MILTON S. KIVER  
Pres., Television Communications Institute

Part 6. How a color television scene is transformed into signal voltages; analysis of the detected video signal.

THUS FAR we have discussed at length the general formation of a color signal and what happens to this signal at various stages in the receiver. We have not, however, gone into any examination of what the color video signal looks like when it is viewed at the video second detector. Since this is something with which the service technician should be familiar, discussion of the remaining sections of a color receiver will be held in abeyance while we analyze color video signals.

Perhaps the best place to start is at the transmitter where a color-bar test pattern is being picked up by a color camera. The test pattern chosen, Fig. 1, consists of four vertical bars in the order of blue, red, green, and white. These represent the three color primaries and white. The light from this color pattern is received by the color camera and the rays from each different primary color are directed to a specific camera tube. That is, the red rays of light go to the red camera tube, the blue light goes to the blue tube, and the green light is sent to the green camera tube. Within each tube, the photosensitive mosaic is activated only by the light received. Thus, on the mosaic of the blue camera tube, for example, the incoming light is focused on the left edge in the same position as the blue bar on the test pattern. Also, a bar appears at the right edge of the mosaic because white contains blue and this blue component affects the blue camera tube. In between these two bars the mosaic surface would be unaffected because there is no blue in the two center bars of the pattern.

By a similar type of analysis we can see that each camera tube would have parts of its mosaic activated and other

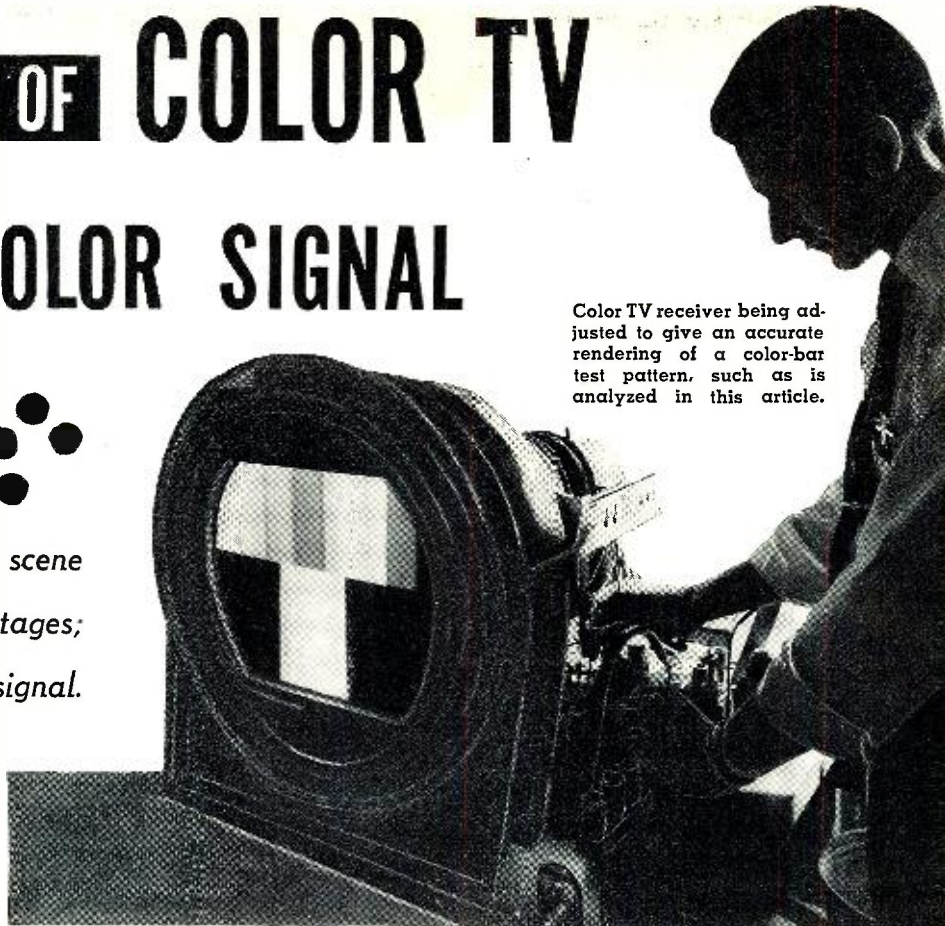

Color TV receiver being adjusted to give an accurate rendering of a color-bar test pattern, such as is analyzed in this article.

mosaic parts quiescent or unaffected.

Now, as the scanning beams (in the camera tubes) scan across one horizontal line of this color pattern, here is what we obtain. At the start, each beam is passing over the portion of the pattern occupied by the blue bar. During this time, an output voltage will be obtained from the blue camera tube only. See Fig. 1A. The red and green tubes are developing zero output because none of this blue light is reaching them.

The next bar to be scanned is the red bar and now the red camera tube becomes active, producing an output voltage while the blue and green tubes render zero output voltage. The third bar is green and the output voltage is now derived from it. The final bar is white and when this is being scanned,

the same voltage output is obtained from the blue, red, and green camera tubes. This is because white contains all three primary colors in more or less equal amounts and all three color tubes are similarly affected.

Figs. 1B, 1C, and 1D show graphically the manner in which the voltage output from each color camera tube varies as the beam moves across the screen from left to right. This, then, is the color voltage information obtained from the scene to be transmitted. The next step is to convert this information into appropriate  $I$ ,  $Q$ , and  $Y$  signals which will then be transmitted to the receiver. To achieve this transformation, the three voltages are fed into a matrix network. (This is similar to the matrix network in the receiver where the reverse action occurs, *i.e.*,  $I$ ,  $Q$ , and  $Y$  are reconverted to equivalent red, blue, and green voltages.)

Within the matrix at the transmitter, the  $I$ ,  $Q$ , and  $Y$  voltages are formed according to the following defining equations:

$$Y = .59G + .30R + .11B \dots (1)$$

$$I = -.28G + .60R - .32B \dots (2)$$

$$Q = -.52G + .21R + .31B \dots (3)$$

(The reader undoubtedly appreciates by now the fact that both  $I$  and  $Q$  signals can be expressed in terms of color-minus-difference voltages or directly in terms of  $R$ ,  $B$ , and  $G$ . All are equivalent.)

Thus, coming out of the matrix at the  $Y$  terminal would be the wave-

**EDITOR'S NOTE:** Part 1 of this series, which appeared in the March, 1954 issue, explained color mixing and its application in color TV. Part 2, appearing in the April issue, described the NTSC color signal. The block diagram of a typical color TV receiver was described in the May issue. The June article in this series described the tuner, sound, and some of the video circuits of a color receiver. Typical chrominance circuits (demodulator, matrix, adders, etc.) were analyzed in the July article.

In view of the many requests received, RADIO & TELEVISION NEWS will publish this series in reprint form. The first three parts are in a single unit (50 cents), the balance will be reprinted in individual parts at 20 cents each. For quantities of 50 or more, write for quotations. Address your inquiries to RADIO & TELEVISION NEWS Reprint Editor, 366 Madison Ave., N. Y. 17, N. Y.

form shown in Fig. 1E. The blue voltage is only 11 per-cent of what it was when it entered the matrix, the red is only 30 per-cent, and the green is only 59 per-cent. For the *I* signal, we take 28 per-cent of the voltage produced by the green tube, 60 per-cent of the voltage from the red tube, and 32 per-cent of the blue tube output. Negative values, required for the green and blue components of the *I* signal, are achieved by passing these components through phase inverters. The *Q* signal formation follows in similar order.

Note that the white bar produces a full output in the *Y* channel, but zero output in the *I* and *Q* channels. In the *Y* channel, the white amplitude is made up of 59 per-cent green, 30 per-cent red, and 11 per-cent blue. When you add .59 plus .30 plus .11, you obtain 1. On the other hand, consider what happens to this white voltage in the *I* and *Q* channels. The scanning of the white bar produces equal voltage output from the red, green, and blue camera tubes with the result that the matrix receives voltages from each of these tubes at the same time. If we assume that each camera tube is providing 1 volt of signal, and this is what the matrix receives, then equation (2) tells us that what finally appears at the *I* terminal at the output of the matrix when the white bar is being scanned is  $-.28$  volt from the green channel,  $-.32$  volt from the blue channel, and  $+.60$  volt from the red channel. The combination of  $-.28$  and  $-.32$  with  $+.60$  produces a net result of zero, which means that all three voltages cancel each other out completely.

This particular situation was purposely selected in order to reduce all color signal output to zero when black, white, or grey are being scanned.

In the *Q* channel we have a similar situation for its voltages, too, cancel out when white is being scanned.

Once the *I*, *Q*, and *Y* signals have been formed, they are sent through appropriate amplifiers until they have been strengthened sufficiently to perform the next step in the formation of a total color video signal. Let us concentrate first on the *I* and *Q* color signals. These are employed to amplitude modulate separate 3.58 mc. color subcarriers, their only difference being a 90° phase difference between them. After this operation has been performed, the modulated *I* and *Q* signals appear as shown in Figs. 1H and 1K. (Negative modulating voltages, such as the  $-.32$  for *I* blue, appear only as a reversal of subcarrier phase. That is, a positive modulating voltage will cause the resulting modulated signal to have one phase, a negative modulating voltage will cause it to have the opposite phase. In outward appearance, however, both modulated waves will possess the same shape or envelope.) These are actually the color sidebands produced by the modulation, the 3.58-mc. carrier having been sup-

pressed in the balanced modulators. The various colors (red, green, and blue) produce different amplitudes on the modulated waves in accordance with their amplitudes in the *I* and *Q* signals.

The next step is to combine these signals into one. Since the 3.58-mc. color subcarriers that were employed in the modulators differed in phase by 90°, their sidebands differ in the same way. Hence, their resultant is not obtained by adding their amplitude arithmetically (as  $3+4=7$ ) but rather by taking the square root of the sum of their squares (as  $\sqrt{3^2+4^2}=\sqrt{9+16}=\sqrt{25}$  or 5). If we follow this procedure for the *I* and *Q* modulated signals of Figs. 1H and 1K, we obtain the result shown in Fig. 1M.

As a sample calculation, consider the blue voltage portion of the *I* and *Q* voltages of Figs. 1H and 1K. The peak amplitude of the *I* blue is  $-.32$  and this figure squared is equal to .1024. By the same token, the *Q* blue is .31 and this squared is equal to .0961. The addition of .1024 and .0961 gives us .1985 and the square root of this number is .44. The remaining calculations are worked in a similar manner, with the results indicated.

The color signals have now been combined and the next step is to add this resultant to the monochrome or brightness signal. Here the addition is straightforward, with the color sidebands extending for equal distance above and below the brightness level. The *Y* component represents the brightness of that color and brightness in a video signal is determined by how far the average level of a video signal is from the black level. (The black level is the reference against which brightness is measured.)

The blue portion of the signal (representing the blue bar on the scanning pattern) has a brightness level of .11. Therefore, the average level of the blue *I* and *Q* (i.e., color) signal is placed 11 per-cent of the distance between the black level and the maximum brightness level. Red has a brightness value of .30 and so it is moved farther away from the black level. Finally, the brightness level of green is .59 and it is positioned 59 per-cent of the distance away from the black level. White has a brightness value of 1 and it is positioned at the farthest point from the black level of the video signal.

The total signal, with *I*, *Q*, and *Y* combined and with sync pulses and a color burst appears as shown in Fig. 1N. In this illustration, several items are of interest. First is the color burst and in the examination of any color video signal this burst must be present in order to insure the proper reproduction of colors in the picture. It is this burst which establishes the frequency of the color subcarrier generator in the receiver and any deviation from its correct phase will result in color distortion (i.e., a shift in color away from its original hue).

Second, the negative tips of the 3.58-mc. modulated blue signal and of the red signal extend beyond the black level well into the blacker-than-black or sync-pulse region. At the other end, the positive tips of the 3.58-mc. modulated green signal extend beyond the point where the brightest level is indicated. These extensions beyond the normal excursions of the video signal are permitted by the FCC standards, but in practice they seldom occur. Actually, they appear only for highly saturated colors and such saturations are almost never encountered. Theoretically, though, they are permissible.

At the video second detector, a good oscilloscope would produce the signal pattern shown in Fig. 1N. Beyond the detector, the color components of the total video signal are shunted off to the chrominance section of the receiver while the monochrome portion is passed through a separate amplifier stage or two. The demodulated *I* and *Q* signals then meet the *Y* signal

Fig. 1. The various stages in the formation of a color TV video signal using a color-bar pattern as a subject.

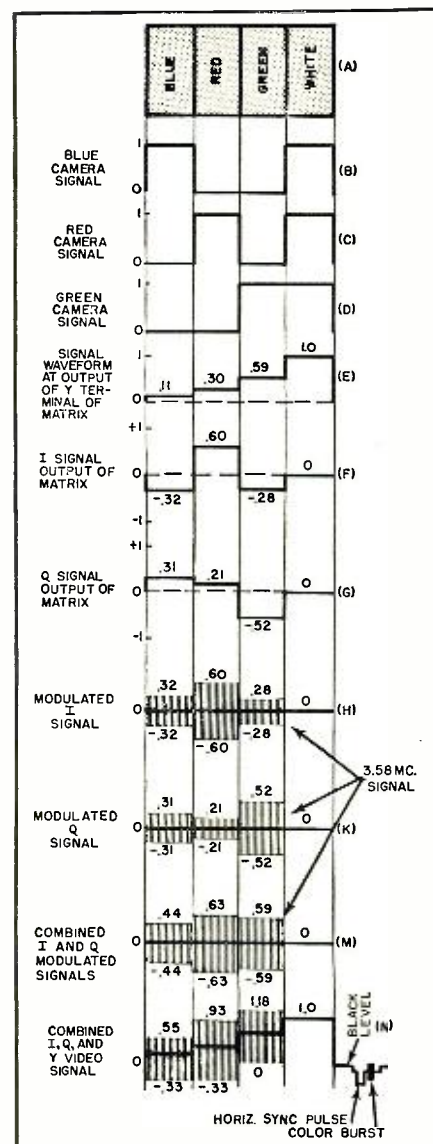

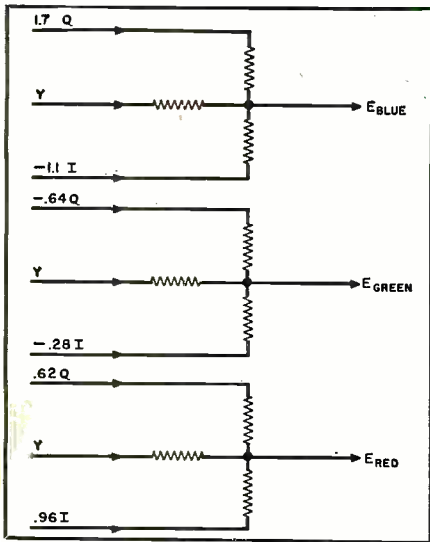

Fig. 2. Matrix circuit for adding I, Q, and Y signals in a color TV receiver to recreate red, green, and blue signal voltages for the picture tube.

again in the receiver matrix network and through the interaction of these three signals, the original blue, red, green, and white bar pattern is re-created on the picture tube screen.

It might be instructive to follow this reconstruction in detail to see how the original colors are re-obtained. It was shown in the discussions of the receiver matrix in Part 5 that:

$$R = Y + .62Q + .96I$$

$$B = Y + 1.7Q - 1.1I$$

$$G = Y - .64Q - .28I$$

Let us consider the blue color first since it appears first on the bar test pattern. From the Y signal we obtain a voltage of .11 volt since this is the average brightness level of the blue bar. From the Q channel we get 1.7Q volts or 1.7 times whatever blue voltage the Q channel possesses. If we refer back to Fig. 1G, we see that the Q voltage when blue was being scanned was .31. (This means 31% of whatever voltage was being delivered by the blue camera tube to the transmitter matrix. If we assume 1 volt of signal was being provided by this tube, then .31 volt of blue voltage was obtained at the Q terminal of the matrix.) Thus, this .31 is now multiplied 1.7 times to provide .527 volt from the Q channel toward the formation of the final blue bar to be presented on the screen. Thus far, then, we have .11 volt of blue voltage from the Y channel and .527 volt from the Q channel. Still to come is the voltage from the I channel. This is  $-1.1$  times whatever blue voltage the I channel possesses. Again, if we refer back to Fig. 1F, we see that the I voltage when blue was being scanned was  $-.32$ . This value, multiplied by  $-1.1$  gives us a total of .352 positive, since the multiplication of two negatives yields a positive. Electronically the multiplication of two negative numbers means that the reversal in polarity that occurred in the transmitter matrix is now being counter-

acted. Adding all three contributions from the I, Q, and Y channels, we obtain:  $.11 + .527 + .352$  which equals .989 or essentially 1 volt of blue signal. Is this the same as the original voltage obtained from the blue camera tube? The answer, of course, is Yes!

The red and green signal values can be obtained in the same manner and the computations and solutions are shown in Fig. 2. For white there would be no contributions from the I and Q channels since it was demonstrated previously that the scanning of white produced no I or Q voltage. White, then, would be obtained solely from the Y signal, which is as it should be.

In the foregoing discussion, a relatively simple color bar pattern was employed. With that knowledge behind us, we are now in a position to examine the video signal produced when the color-bar test pattern of Fig. 3A is scanned. Here we not only have the three primary colors, but mixtures of these colors such as yellow, cyan, and magenta.

The waveforms shown in Figs. 3B, 3C, and 3D indicate how the output voltage from each color camera tube varies as the scanning beam travels across the pattern from left to right. Consider the output from the blue camera tube first. When red, yellow, or green is scanned, the voltage developed by the blue tube is zero because these colors possess no blue. When cyan is reached, the voltage output of the blue tube jumps up to our assumed value of one. Cyan is formed by combining green and blue and it is the blue component which activates the blue camera tube. The output of the blue tube remains steady at 1 volt as the beam moves over the blue bar and the succeeding magenta. The latter color represents a combination of blue and red. When the scanning beam passes over the red

bar, the output of the blue camera tube drops back to zero. It shoots back up again to 1.0 volt when white is reached.

For the red camera tube, an output signal is obtained for red, yellow, magenta, and white. And finally, for the green camera tube, output is present as the beam moves over yellow, green, cyan, and white.

Explanation of the waveform that appears in the Y channel rests, as it did before, on the equation:

$$Y = .59G + .30R + .11B$$

Where a single color appears by itself, the value employed is that which is placed in front of that color in the foregoing equation. The figure of .89 which is indicated for the yellow is derived from the addition of .59 for the green component of the yellow plus .30 for the red component. Cyan, a mixture of green and blue, has a brightness value of .59 plus .11. The brightness value for magenta is similarly formed by addition of .30 from the red and .11 from the blue.

A similar procedure is followed in the formation of the I and Q waveforms. In the I signal, for example, red is .6 as indicated by equation (2). Yellow is a combination color and it is formed by adding .6 for its red component with  $-.28$  for its green component. The result of this addition ( $.6 - .28$ ) is .32. Similarly, for the Q signal, the value for yellow is obtained by adding .21 for its red component and  $-.52$  for its green component as indicated by equation (3). The result of this addition ( $.21 - .52$ ) is  $-.31$ . The remaining color values for both I and Q signals are obtained in the same manner.

The final video signal, formed by the combination of Y, I, and Q is shown in Fig. 3H. Again, the modulation envelope is formed by adding the square root of the sum of the squares of the I and Q values of each color to its Y value. For red, for example, we would add  $\sqrt{.36 + .044}$  or .63 to .3 to obtain a positive excursion of .93. For the negative excursion, subtract .63 from .3. Similarly for the other colors. It is this signal which would be seen at the output of the video second detector in the television receiver.

The presence of combination colors means that when these colors are being presented on the receiver picture tube screen, more than one electron gun is in operation. For example, to present a yellow bar, both the green and red must be activated by the signal. For cyan, the green and blue guns are required and for magenta, red and blue dots must be struck. There are, of course, many, many other combinations of colors and for a large number all three electron guns are operating to some extent. Appreciation of these facts concerning video signals and how they are formed will materially aid the technician in his work on color television receivers.

(To be continued)

Fig. 3. Formation of a color video signal from a more complicated color-bar test pattern than was used in Fig. 1.

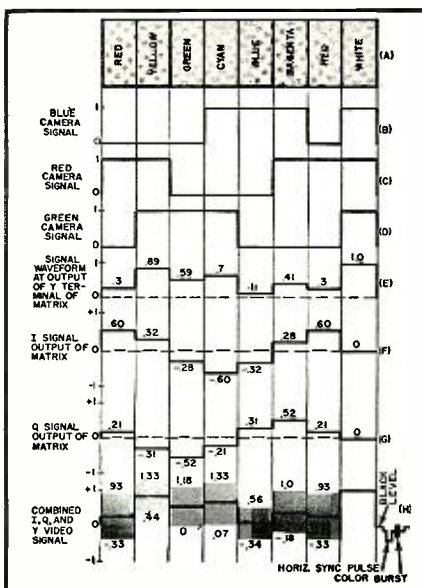

The 1000 watt Tesla unit. The use of vacuum tubes is safer, quieter, and more TVI-proof than the older spark gap apparatus. A test was made with a recent-model G-E receiver located about 20 miles from the three local TV transmitters. This apparatus was operated within 20 feet of the set with no interference except for slight snow on Channel 4. A 14" corona was obtained with the 1000 watt unit. The authors also built 150 and 500 watt units, described herein.

## THE DESIGN AND CONSTRUCTION OF

# VACUUM-TUBE TESLA COILS

By  
**R. A. KAWCYN**  
 and  
**T. C. MARSHALL**

*An interesting project for the experimenter. Mystify your friends by lighting unconnected bulbs and igniting candles.*

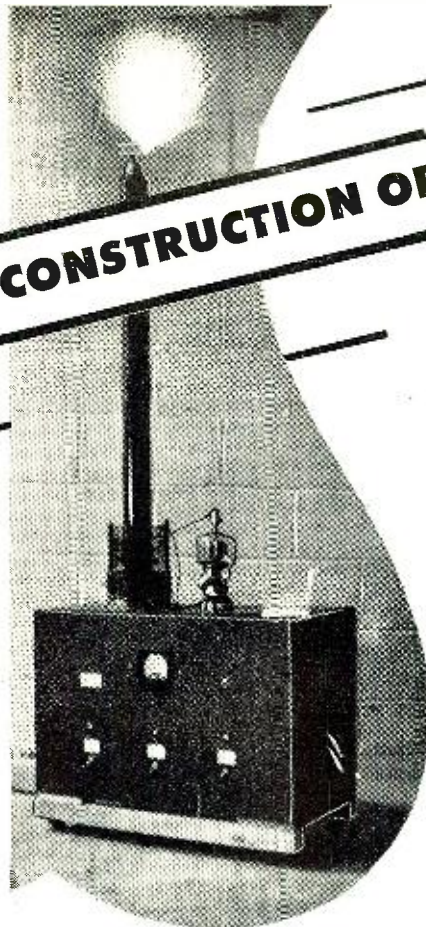

**T**HE experimenter who has tired of reading about color TV, transistor pocket radios, and ultra-fidelity amplifiers may find a Tesla coil giving 100 kilovolt corona discharges and flame arcs that melt steel wire more to his liking.

The circuit of the Tesla coil is simple and almost foolproof, consisting of an r.f. oscillator driving a large air-core step-up transformer; high voltage is built up across the secondary because of its high turns ratio and resonance effects, since the primary of the transformer is tuned to the natural resonant frequency of the secondary coil.

First, decide on the power of the coil, and then obtain a transformer to suit. For small outfits, a power transformer having a high-voltage winding of at least 800 volts at 150 to 250 ma. is suitable; for larger coils, a transmitting-type transformer, which need not have a center tap, is necessary. The secondary should be rated at about 1500 volts at 350 ma. Two smaller transformers, with the secondaries in series and the primaries in parallel, can also be used.

The next thing to consider is the oscillation transformer. The most convenient form to use for the high-voltage secondary coil ( $L_2$ ) is a 2- to 3-foot long cardboard mailing tube 2- to 2½-inches in diameter, the lower end of which fits over a wooden plug mounted on top of the chassis. Before winding, the form must be thoroughly impregnated with melted paraffin; it is then dried and closewound with a single layer of #30 B. & S. gauge d.c.c. or formex insulated magnet wire, leaving three inches of tubing unwound at each end. The coil is then given a half dozen coats of shellac, with a few days drying time between applications. The discharge terminal is a porcelain insulator mounted on a round block of dry, shellacked wood glued into one end of the form, with the lead from the coil attached to the terminal; the other end of the winding is brought to a binding post at the lower end of the coil for a ground connection.

The plate tank ( $L_1$ ), #14 wire, and the grid coil ( $L_2$ ), both concentric with the secondary, are arranged on a

shellacked cardboard form for outfits less than 150 watts, but for larger units the plate coil should be air wound with heavy wire (#9 to #12), threaded through insulating support strips, the turns being spaced the wire diameter. The grid coil is wound on a cardboard form and mounted over the supporting strips about an inch below the plate coil.

For small coils, a pair of surplus triode tubes like the 801A or 10Y are suitable; for larger coils, types 826, 211, and 805 have been successfully used. Because the push-pull connection complicates the circuitry, the tubes are run in parallel.

Construction is most conveniently done on a plywood or Masonite chassis, using adequate insulation where

needed, heavy wire for filament and r.f. leads, and following good construction technique. The filament voltage should be held within 5% of the rated value while the coil is in operation.

The value of the grid resistor is not critical; it can range from 1000 ohms for parallel high mu tubes to 4000 ohms for low mu tubes; it is helpful to use an adjustable resistor to find the best operating conditions.

The plate tank condenser consists of transmitting-type mica condensers having a voltage rating double the applied a.c. and a current rating of at least 3 r.f. amps.; or, lacking these, use heavily shellacked glass plates coated with metal foil for high power coils. If the oscillator does not function, as

*(Continued on page 98)*

**Schematic of the Tesla unit. The use of an external ground is strongly recommended.**

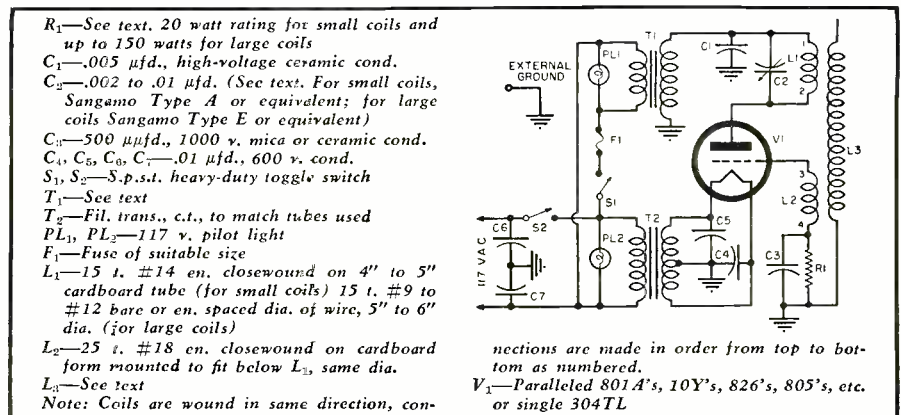

Front view of K2AVB's modulator and power supply added to transmitter of Sept. 1952.



# COMPLETING "THREE TUBES ON 2 METERS"

Right and left hand side views of transmitter rack at K2AVB.

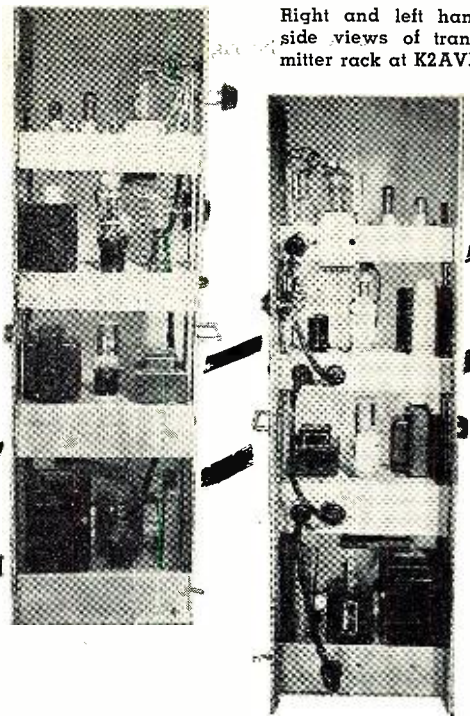

By **BYRON G. WELS, K2AVB**

A companion modulator and its power supply designed to be used with the transmitter originally described in 1952.

IN THE September, 1952 issue of this magazine, there appeared an article by Messrs. Kirchhoff and Bulkley entitled "Three Tubes On 2 Meters." Having recently acquired a Novice license and being more than interested in the higher frequencies, I decided to construct this set.

The instructions set forth in the article were scrupulously adhered to. As the photographs will show, the r.f.

head is the spitting image of the one described in the original article.

The next stage was the modulator. See Fig. 1. As I was rather short of funds, I decided to use Heising modulation and thereby save the cost of a modulation transformer. The 6SJ7 and the 6J5 speech tubes feed into an *Amperex* type 807 which is used as the modulator. Feeling that the entire rig would constitute only three chassis, I

began to envision a compact miniature rack and decided to pile them one on the other. The modulator is built on the same size chassis as the r.f. head. The 6SJ7 and the 6J5 are located near the front of the chassis which makes for short grid leads for the pot and the mike jack. The 807 and choke  $CH_1$  share the rear end of the chassis with the two electrolytic condensers in the middle.

A dual power supply is required for the two high-voltage requirements. One, Fig. 2A, supplies the high voltage to the modulator tube, and then to the plates of the final. The other supply, Fig. 2B, supplies the heater voltage to all the tubes, and the plate voltage for the modulator speech tubes, as well as the multipliers on the r.f. head. The fact that I could not fit five chokes and transformers on a 5"x9½"x2" chassis necessitated two separate power supply chassis. The 300-volt supply, Fig. 2B, is built in a forthright fashion except that we use on this chassis, a separate transformer for a heater supply which furnishes 6.3 volts to all the heaters. Also located on this chassis is a neon indicator to show when the a.c. is turned on. Another point that we might mention now is that all switch controls are brought down to the next chassis. To improve filtering, and also to lower the voltage which was too high, a 500 ohm, 50 watt wirewound resistor was used in lieu of a swinging choke. (Cost problems again!)

The high-voltage power supply, Fig. 2A, uses a novel circuit. The transformers were selected from the author's ten-year accumulation of "salvage." The novelty of the circuit is the use of the wirewound resistor in place of a filter choke. All switches are brought to the front of this chassis. The fuses are at the rear.

Fig. 1. Schematic of modulator designed to be used with the three-tube, 2-meter transmitter described in the September 1952 issue of this magazine. See text.

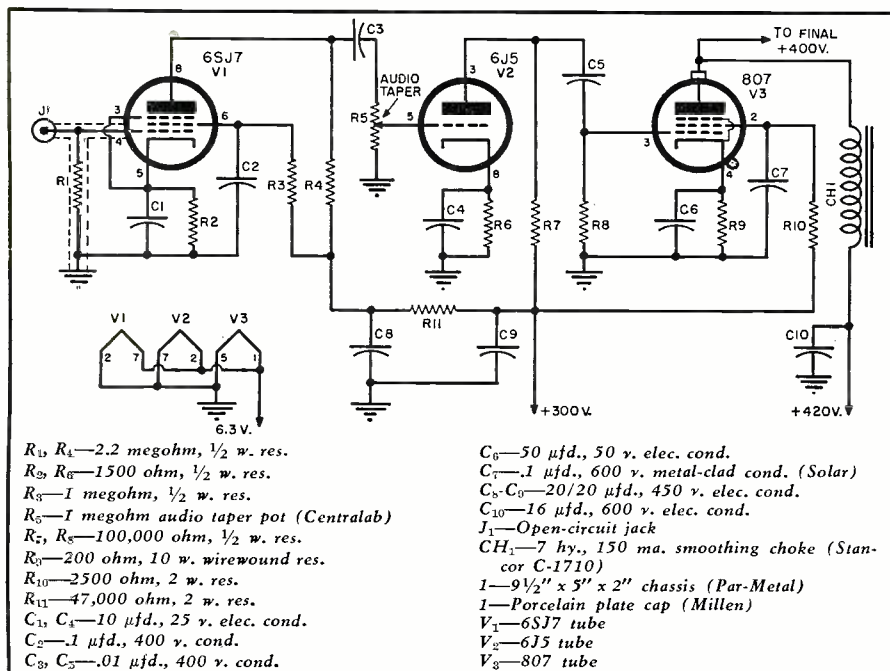

The layout of the . . .g involved making standoffs of brass which are placed so each chassis stands above and clear of the one beneath it. The panels, front and back, are made of 1/8" aluminum and room was allowed at the side for cables. The panels are painted flat black to simulate a professional black anodize. All components are decaled in white.

Turning on the a.c. preparatory to testing showed that all the tubes lighted except for the tubes on the r.f. head. Further investigation necessitated the rewiring of the heater circuit as shown in Fig. 3. This differs from the original circuit of September 1952. This removed the floating ground and all our tubes lighted.

The oscillator triplers and drivers were peaked with a grid dipper, and glyptol was applied to prevent variation.

Anxious for results, we hurriedly built a coaxial antenna using two-inch copper tubing 19" long as a ground plane and a 19" section from an old TV rabbit-ear.

Not having a better means of tuning up, we varied condenser  $C_{14}$  in the original circuit of Fig. 3 until the plates of the *AmpereX* AX-9903 tube stopped glowing red. At this point we assumed that all the r.f. was going into the antenna.

Listening carefully on the two-meter band, we heard a fellow in Wantagh (approximately ten miles) calling "CQ." With strong doubts, and tongue-in-cheek (the antenna was lying on the kitchen floor), we answered his call. Wonder of wonders, he came back, praising the quality of our audio and with questions about our modulator. During our next transmission we noticed the plates of the 9903 beginning to glow again, and compensated by re-tuning  $C_{14}$ . When he came back again, he asked if we were v.f.o. controlled, as

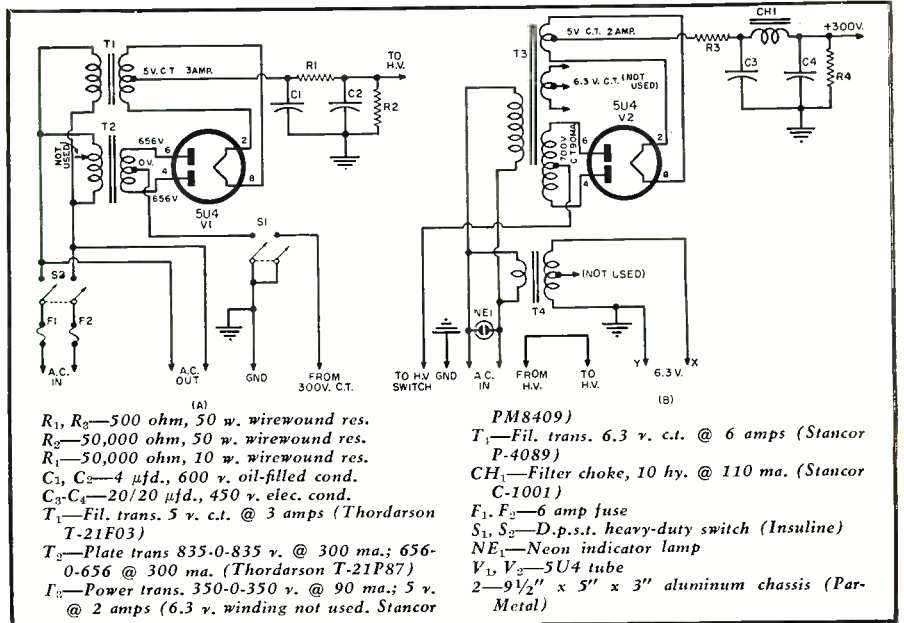

Fig. 2. The schematic diagram of the two power supplies. (Left) The high-voltage unit which feeds through the modulating choke to the plates of the AX-9903. (Right) 300 volt supply for the speech amplifiers, r.f. oscillator, and the 5763 multiplier.

our frequency had suddenly shifted. Glaring balefully at our crystal, we suddenly became aware of the scourge of the ham, parasitics.

We did all that the rule books advise from putting resistors in the final grids, to bypass condensers all over the place. We even changed grid coil  $L_4$  so that it sat between the turns of  $L_3$  rather than straddling them.

The cure was far more simple than we had guessed, and was discovered quite by accident while checking out with a dummy load. The light would glow even with the crystal out. We tried to remove the driver tube, and lo and behold as we grasped it, the light went out. A simple tube shield solved the problem.

In order to facilitate tune-ups with an outdoor antenna, a metering circuit was incorporated in the original unit. The metering jacks in the 9903 circuit were eliminated and replaced by a five-position switch which reads plate and grid current in the 9903 and plate and grid current in the 5763. This provides a convenient means when tuning up the second and third stages as each stage can thus be tuned for minimum grid and maximum plate readings.

Once the unit has been tuned, the switch is left in the position where it reads plate current in the 9903 so that the final can be peaked up while on the air. As the meter used was a 25 ma. unit, various shunts were required to

(Continued on page 97)

Fig. 3. Original transmitter circuit as designed by Kirchhoff and Bulkley and described in article "Three Tubes on 2-Meters", Sept., 1952.

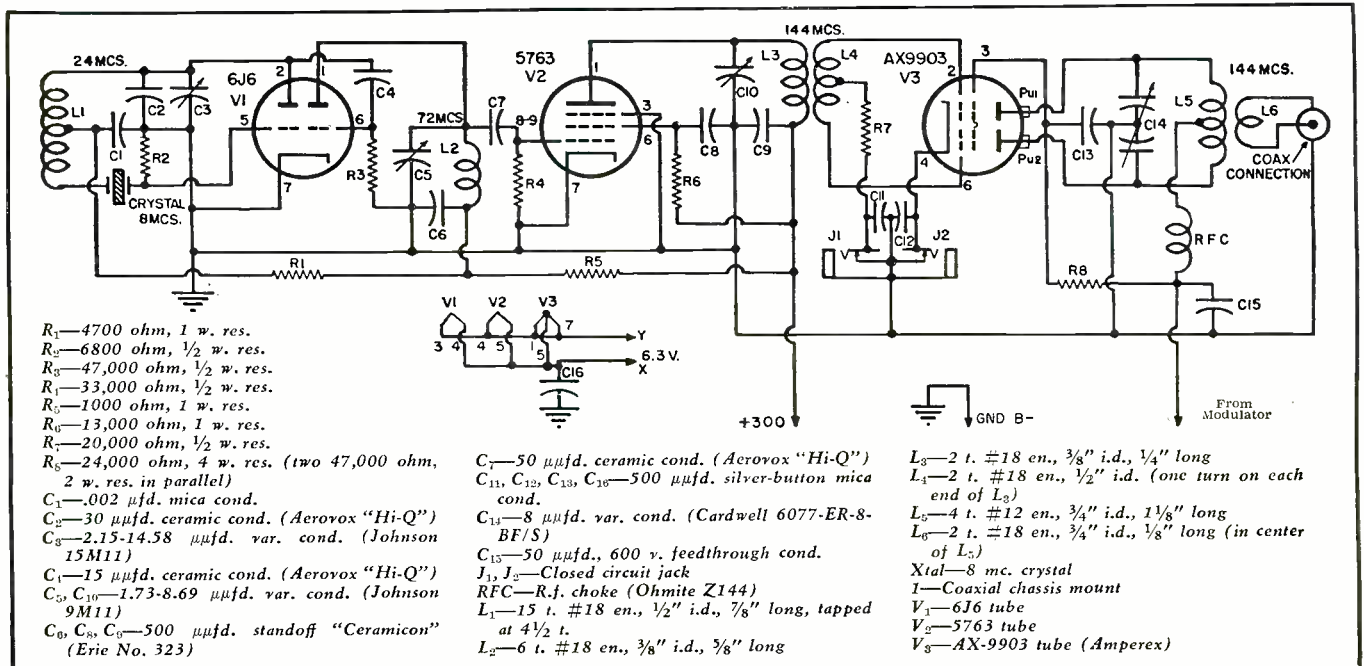

# A HEAVY-DUTY AUDIO AMPLIFIER

By **SERGE L. KRAUSS**  
Design Eng., C. C. Conn. Ltd.

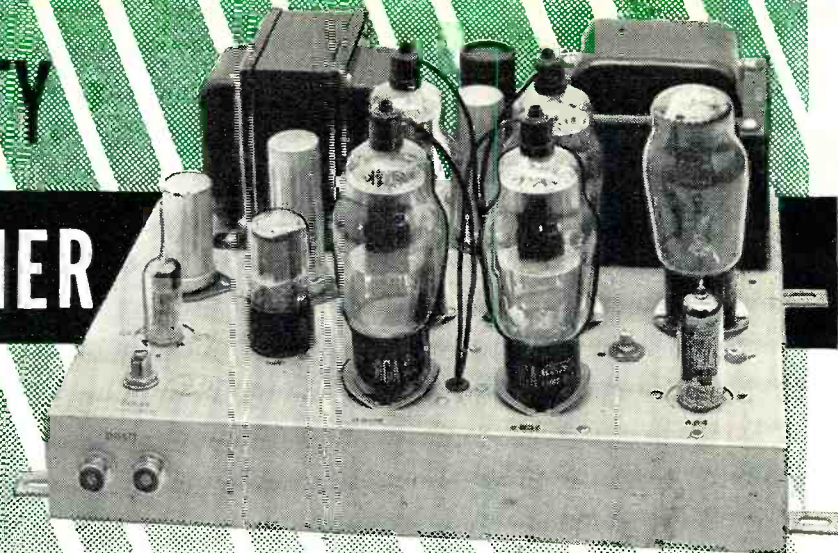

Top-rear chassis view of amplifier. It is assembled on a 10"x 13"x2" steel chassis. This parts placement is recommended as it avoids long hookup runs and reduces possible hum.

**T**HE popular trend in amplifier design is to secure linearity or low distortion at modest power levels. The performance of this type of amplifier is almost invariably demonstrated with musical material which has been recorded using limiting or compressor equipment. When such an amplifier is used for musical sound production (electronic organ) or sound reinforcement, the power output level attainable before clipping of the peaks occurs is only a fraction of the amplifier rating. A test made using ensemble music with one of the popular low distortion amplifiers rated at 20 watts resulted in a 6-watt power level to the speaker at the point of audible clipping of the peaks. Power levels of low order may be satisfactory for private listening, but they are definitely inadequate for auditorium or outdoor use. The better

*Designed for either push-pull parallel or straight push-pull operation providing 30 and 20 watts, respectively, of complex signal power. With sine-wave signal, power capacity of 85 and 60 watts is obtained at less than 1% harmonic distortion.*

quality loudspeakers available today are rated between 20 and 35 watts power handling capacity. For economical distortion-free sound production, the driving amplifier should be capable of providing complex signal power of this order without clipping.

The expansion of popular low distortion amplifier designs by paralleling the output tubes to meet the speaker capabilities would almost certainly result in an expensive combination boat anchor and furnace.

The amplifier to be described was developed to economically provide sufficient complex signal power to utilize the full capacity of present-day loudspeakers. Two versions are presented, one capable of providing 20 watts of complex signal power and the other of 30 watt capacity, obviously the exact capacity depends upon the character of the signal. These amplifiers have a sine-wave signal capacity of 60 and 85 watts respectively at less than 1% harmonic distortion over a wide frequency range. Standard tubes are used within the manufacturers' voltage and wattage ratings for trouble-free, long-life performance.

The basic amplifier design requirement is to provide considerable peak power capability with a nominal average power capability. This requirement is similar to that of providing deflection power in television receivers for which a family of tubes have been developed, so the selection of the output tube was made from this category. The 6BG6G was selected because of its popularity, low heater power requirement, and high plate and screen dissipation rating. The 6BG6G tube is rated for operation with 700 volts and 20 watts on the plate and 350 volts and 3.2 watts on the screen. A pair of 6BG6's with 685 volts on the plate, 320 volts on the screen, and 40 volts bias have a static dissipation of 34 watts (17 watts each) which is well within their ratings. A single 5U4G rectifier with 1100 volts plate-to-plate and capacity filter will supply approximately 685 volts under static conditions and 615 volts at approx. 160 ma. to a pair of 6BG6's at their output overload point of 60

Underchassis view of amplifier. The switch shown at the upper left is optional. It was used to select input voltage taps on the power transformer used by author. It is not required.

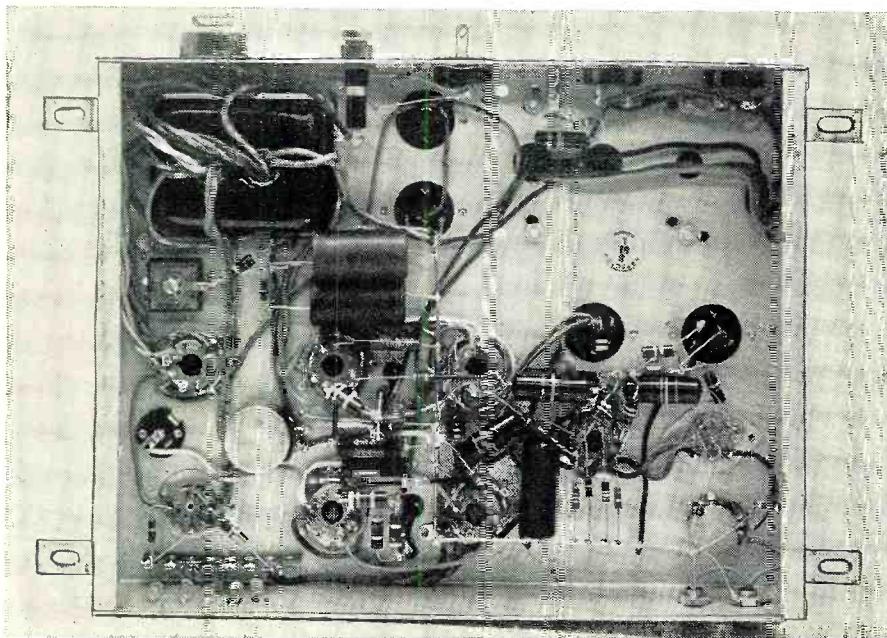

watts sine-wave signal. At 30 watts output the supply voltage is 650 at 105 ma. The full load current rating of the 5U4G coincides with the power requirements at the overload point of the pair of 6BG6's resulting in an extremely simple and economical power supply. Four 6BG6's provide additional peak power handling capacity using a single 5U4G rectifier tube for power, but the average audio power output must be limited to approximately 30 watts to avoid overloading a single rectifier tube. The use of two rectifier tubes and a larger power transformer would obviously allow continuous operation at double the power level of two output tubes, but the increase in peak power handling capacity would be small so the added expense is hardly warranted.

The static power consumption of the amplifier using two output tubes is less than 100 watts, using four output tubes it is less than 150 watts. Low power consumption is an advantage in many ways—operational cost is low, electrical component life is extended, room heating or air conditioning load is minimized, enclosure space and ventilation requirements are small, a number of amplifiers can be operated from a regular convenience outlet without fear of overloading the wiring, and the amplifiers can be operated quite a distance from the power source with relatively little loss in power output due to line voltage drop.

The amplifier circuit is shown in Fig. 1. It has a 6BF6 triode input stage, a 6SN7GT dual triode driver and phase inverter, two (or four) 6BG6G beam type output tubes, a 5U4G rectifier, and a 6S4 voltage regulator. The bias supply uses a selenium rectifier, approximately 20 db of negative feedback is used from the output transformer secondary to the driver stage cathode circuit.

The 6BF6 was selected for the input stage because it is one of the few radio grade tubes that is designed and production tested for audio use. The 6SN7GT was selected for the driver-phase inverter stage, because of its popularity, record of performance, and low cost.

The optimum load impedance for the 6BG6 output tubes is 9000 ohms for two tubes or 4500 ohms for four tubes. The output transformer leakage inductance from full primary to full secondary should not exceed 25 mhy. Either the *Stancor* A-8054 or A-8053 work excellently as the output transformer in this circuit. One of the requirements for efficient operation of beam power tubes is a stable source of screen potential. The screen current of the 6BG6G varies between a fraction of a milliampere, no signal, to as much as ten milliamperes full signal. The use of two "VR" glow tubes for regulation is marginal considering anticipated line voltage variations, so a simple regulator stage using five NE-2 neon lamps as a reference and a 6S4 as a control tube was devised. This method is lower in cost and has

the advantage of lower static power dissipation. The regulation for a current variation of 20 milliamperes is approximately 10 volts, which is entirely satisfactory.

The output tube grid-bias potential is supplied by a tap on the high voltage winding of the power transformer, a half-wave selenium rectifier, and a simple RC filter. A potentiometer and a test jack are incorporated for initial bias adjustment. The bias voltage is set to give a static (no signal) output tube plate current of 25 ma. per tube.

The bias adjustment is made by connecting a low range voltmeter to

the test jack and setting the potentiometer to give a potential of 0.5 volt for two output tubes (or 1.0 volt for four tubes).

The phase inverter is audio fed from a divider separate from the grid and bias circuit of the output tubes, in this way the bias supply ripple is attenuated before it reaches the phase inverter grid.

The high-voltage supply is filtered by two 40  $\mu$ f. tab-mounting electrolytic condensers in series. Individual condenser ratings of 450 volts (900 volts total) are satisfactory since the maxi-

(Continued on page 112)

Fig. 1. Schematic diagram of the power amplifier. Non-critical components are used.

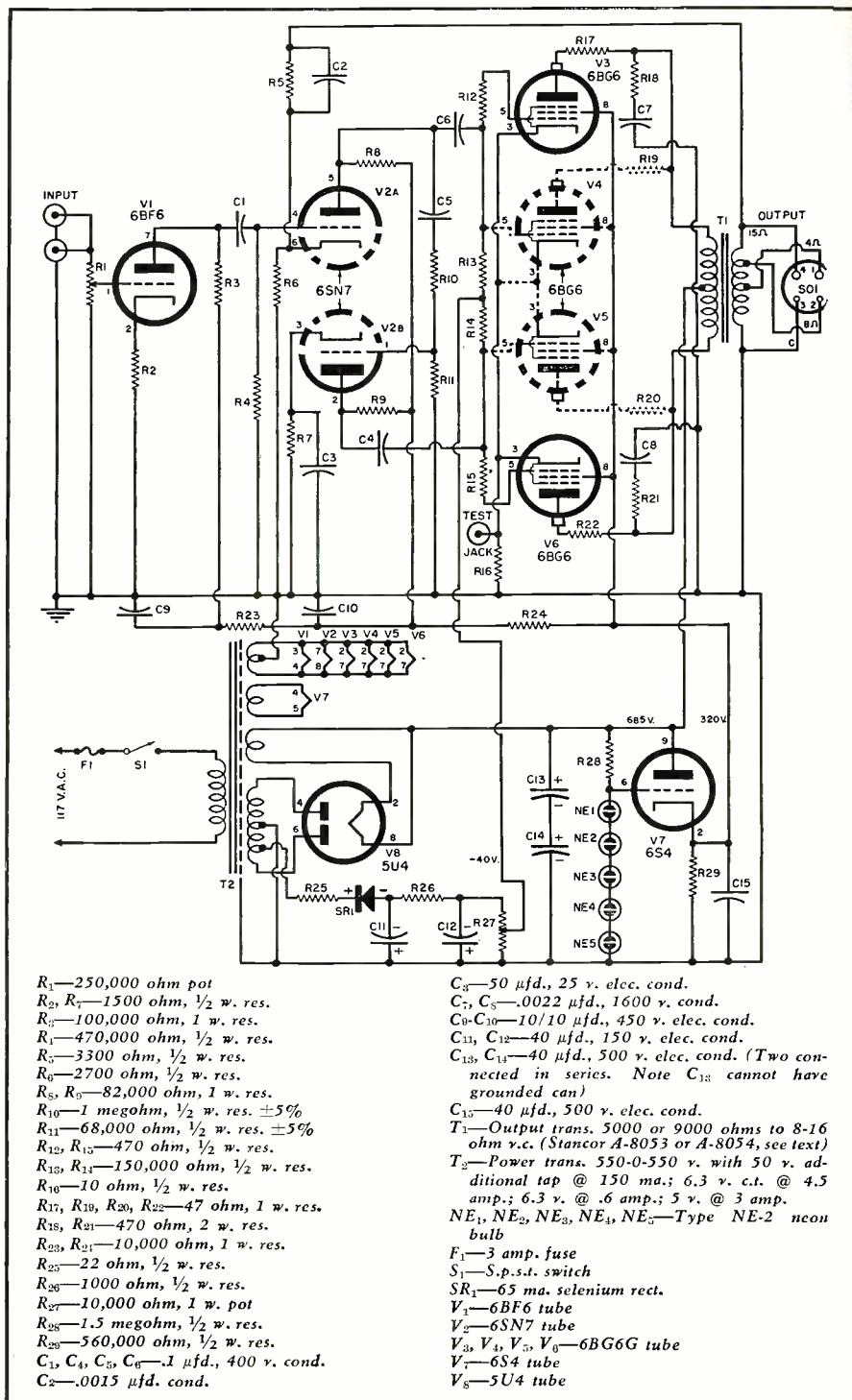

- R<sub>1</sub>—250,000 ohm pot
- R<sub>2</sub>, R<sub>7</sub>—1500 ohm, 1/2 w. res.
- R<sub>3</sub>—100,000 ohm, 1 w. res.
- R<sub>4</sub>—470,000 ohm, 1/2 w. res.
- R<sub>5</sub>—3300 ohm, 1/2 w. res.
- R<sub>6</sub>—2700 ohm, 1/2 w. res.
- R<sub>8</sub>, R<sub>9</sub>—82,000 ohm, 1 w. res.
- R<sub>10</sub>—1 megohm, 1/2 w. res.  $\pm 5\%$
- R<sub>11</sub>—68,000 ohm, 1/2 w. res.  $\pm 5\%$
- R<sub>12</sub>, R<sub>13</sub>—470 ohm, 1/2 w. res.
- R<sub>14</sub>, R<sub>15</sub>—150,000 ohm, 1/2 w. res.
- R<sub>16</sub>—10 ohm, 1/2 w. res.
- R<sub>17</sub>, R<sub>18</sub>, R<sub>20</sub>, R<sub>22</sub>—47 ohm, 1 w. res.
- R<sub>19</sub>, R<sub>21</sub>—470 ohm, 2 w. res.
- R<sub>23</sub>, R<sub>24</sub>—10,000 ohm, 1 w. res.
- R<sub>25</sub>—22 ohm, 1/2 w. res.
- R<sub>26</sub>—1000 ohm, 1/2 w. res.
- R<sub>27</sub>—10,000 ohm, 1 w. pot
- R<sub>28</sub>—1.5 megohm, 1/2 w. res.
- R<sub>29</sub>—560,000 ohm, 1/2 w. res.
- C<sub>1</sub>, C<sub>4</sub>, C<sub>5</sub>, C<sub>6</sub>—1  $\mu$ f., 400 v. cond.
- C<sub>2</sub>—0.0015  $\mu$ f. cond.

- C<sub>3</sub>—50  $\mu$ f., 25 v. elec. cond.
- C<sub>7</sub>, C<sub>8</sub>—0.022  $\mu$ f., 1600 v. cond.
- C<sub>9</sub>, C<sub>10</sub>—10/10  $\mu$ f., 450 v. elec. cond.
- C<sub>11</sub>, C<sub>12</sub>—40  $\mu$ f., 150 v. elec. cond.
- C<sub>13</sub>, C<sub>14</sub>—40  $\mu$ f., 500 v. elec. cond. (Two connected in series. Note C<sub>13</sub> cannot have grounded can)
- C<sub>15</sub>—40  $\mu$ f., 500 v. elec. cond.
- T<sub>1</sub>—Output trans. 5000 or 9000 ohms to 8-16 ohm v.c. (*Stancor* A-8053 or A-8054, see text)
- T<sub>2</sub>—Power trans. 550-0-550 v. with 50 v. additional tap @ 150 ma.; 6.3 v. c.t. @ 4.5 amp.; 6.3 v. @ .6 amp.; 5 v. @ 3 amp.
- NE<sub>1</sub>, NE<sub>2</sub>, NE<sub>3</sub>, NE<sub>4</sub>, NE<sub>5</sub>—Type NE-2 neon bulb
- F<sub>1</sub>—3 amp. fuse
- S<sub>1</sub>—S.p.s.t. switch
- SR<sub>1</sub>—65 ma. selenium rect.
- V<sub>1</sub>—6BF6 tube
- V<sub>2</sub>—6SN7 tube
- V<sub>3</sub>, V<sub>4</sub>, V<sub>5</sub>, V<sub>6</sub>—6BG6G tube
- V<sub>7</sub>—6S4 tube
- V<sub>8</sub>—5U4 tube



# Certified RECORD REVUE

By BERT WHYTE

**B**Y THE TIME you good people read this review, we'll be right in the middle of the "dog" days of August. There was a time when the heat and sticky humidity of the summer meant a rash of "light music," a "thinning out" of our musical diet. Nowadays, neither heat nor humidity, nor anything else seems to stem the insatiable appetite of the public for good music, for the classical repertoire. Witness, the dozens of music festivals which have come into being in the last few years, both here and in Europe. The musical fare offered at these festivals is anything but light. Indeed, one is offered such formidable works as the Berlioz "Requiem" at Tanglewood and "Parsifal" at Bayreuth. The record-playing public seems to be following the same line. Certainly, with a few exceptions, the record companies are issuing material which can hardly be called "light or trite."

Still another factor in the summer "renaissance" of classical music, at least as far as the record companies are concerned, is the vacationing audiophile. Hi-fi fans and music lovers are just like everybody else . . . they have to work and few can find the time to listen. *really* listen, to the records purchased during the winter. So comes the good old summertime and many a music lover spends a good part of his vacation "catching up" on his listening. And the music lover buys records in the summer too! It is true that records are not purchased in the summer months in the large volume common to the wintertime, nevertheless, many a record company is grateful for this phenomenon, which has kept their sales at such respectable summer levels for the past few years.

All the foregoing is by way of telling you that I will not bow to tradition and review only the "light," the "trite," and the inconsequential, merely because it happens to be summertime. Oh, I'll toss in some innocuous fare, here and there, which you can use as an interlude, a good thing to listen to while you're fixing yourself a nice cold drink. In fact, rather than curtail the reviews in any way, I'm going to try and aid you in your summer listening by cutting the length of the individual reviews, so that a greater number of

recordings can be brought to your attention. If you like this idea, send me a card or a note about it. If a majority of you want this new format, I'll continue with it through the September issue.

Before we start with the new recordings this month, there are a couple of other matters on my mind, which you should know about. It won't take but a minute! The first item is this: most of the recordings which I review, are selected by me from the great number of recordings issued each month. You have probably noticed that I rarely give a *really bad* review to any of the recordings which are chosen. This is because of the careful screening, to which all recordings are subjected. I feel that space is far too precious to waste on poor recordings. I'm sure you are more interested in what is good from a musical and technical viewpoint. This is not to imply, of course, that a recording which does not appear in my column is no good. There are so very many new recordings issued every month in this age of LP, that it is well nigh impossible to review them all. The recordings I do review are selected with a view towards the musical interest contained in the work, and the technical excellence of the reproduction. I hope you will agree there is little sense in filling up space with inferior material.

The other little matter is a question of nomenclature. I will be the first to admit that some of you may find the wording of the reviews, anent the technical qualifications and the musical performance, somewhat repetitious. This is quite deliberate on my part, being a concession to understanding and standardization. It has been said and rightly so, that many critics write to impress other critics and the public be damned. I agree that such fatuous displays of erudition, in which some critics indulge, are in very poor taste. I try to use language which is understandable and descriptive. If you come across, "clean, articulate, bright, sharp, close-to, delineate, warm, linear, etc. etc.," too often, I'm sorry. I can see no point in obscuring the meaning

The opinions expressed in this column are those of the reviewer and do not necessarily reflect the views or opinions of the editors or the publisher of this magazine.

and intent of a review by the use of "virtuoso vocabulary."

I realize these two matters I brought up are quite controversial. If you have some ideas on these points, I would be glad to hear from you about them. Your letters are always welcome.

Equipment used this month: *ElectroSonic* pick-up, *Pickering* 190B arm, *Rek-O-Kut* T 12H turntable, *McIntosh* C 108 audio compensator, *McIntosh* 30-watt amplifier, *Jensen* "Triaxial" in *Jensen* folded horn.

## BRITTEN

### SEA INTERLUDES AND PASSACAGLIA FROM "PETER GRIMES" YOUNG PERSON'S GUIDE TO THE ORCHESTRA

**Concertgebouw Orchestra of Amsterdam conducted by Eduard van Beinum. London LL917. RIAA curve. \$5.95.**

For those of you who already own these works on the *Columbia* label, this new edition sort of puts you "on the spot." The problem is twofold. First, both works in this new version are recorded with much greater fidelity of sound. Secondly, both works are contained on one 12" LP, whereas the older editions were on two discs; a ten inch disc for the "Peter Grimes," and a 12" LP for the "Young Person's Guide." Now the question is, do you want a new and superior version of these works on one record thereby consolidating your library a little, or does the music on the "flip" side of the *Columbia* discs weigh heavily enough with you to retain them? Well, that is a matter for you to decide. If by chance you are not familiar with these works, by all means obtain this disc for one of the most delightful treats in modern music. In fact, if you are newly initiated into the mysteries of hi-fi and you're a tyro in the classical field, this version of the "Young Person's Guide to the Orchestra" is virtually a must. By this I mean that through several hearings of this work, you can become familiar with the sounds and uses of most of the instruments comprising a symphony orchestra. If you've never been nearer to orchestration than your local "Joe Jazz and his Slipshod Five," the first experience with a symphony can be overpowering. I can think of no more pleasant or easy introduction to classics than this work. Based on a theme from Purcell's "Abdelazar," Britten takes you by way of variations, through the various choirs and sections of the symphony orchestra. The scoring throughout these variations is clever and masterful, and the work ends with a great fugue in which Britten has woven contrapuntal textures which are truly magnificent. Van Beinum has a more accomplished orchestra at his command than Malcolm Sargent had in the earlier *Columbia* disc, and he makes the most of it. Soundwise, *London* has come up with a record with some really huge sonorities. String tone is clean,

(Continued on page 84)

# AUDIO-CUSTOM BUILT

By DAVID H. MANN



(Above) Closeup of speaker enclosure. By allowing part of cabinet to project into garage, living room space is conserved.

(Right) Mr. Pack removes the front grille of the speaker housing to expose the four loudspeakers used in his sound system.

*How one audiophile blended good sound reproduction with decorative cabinetry.*

**E**UGENE PACK, Salt Lake City communications engineer, has parlayed a hobby into a profitable business just because those who saw the high-fidelity system in his home liked what they saw and heard and asked Mr. Pack to do the same for their homes.

Mr. Pack's one-hundredth custom installation job is one he just completed for his new home. Here he has combined good electronic design and sound engineering practice with eye-pleasing cabinetry.

His speaker system is housed in a back-loaded horn enclosure which is built into the living room wall which is adjacent to the attached garage. Thus the mouth of the speaker projects into the living room while the rear extends into the garage area. The system's amplifier is also located in the garage where it receives adequate ventilation and is handy for repairs and adjustment work. This same technique can be used in any home if closets or other areas are conveniently located near the "audio center."

He uses a Williamson amplifier and a companion equalizer-preamp to provide wide-range, low-distortion output. He has altered the circuit to provide cathode drive to the output stage, thus eliminating two blocking condensers and improving amplifier performance. The preamplifier consists of four stages and uses two 6SN7 tubes. The phono input is applied to the first triode through a UTC LS-10 input transformer. This matches the magnetic cartridge to the grid of the first stage, thus providing additional gain and increasing the signal level above the noise level of the first tube.

The following three triodes are direct coupled. The bass and treble controls are of the degenerative type and are applied to the middle stage while the output is cathode-coupled and of low impedance. The preamp is built on a subchassis to provide the requisite shielding. The two 6SN7's are connected in series with the heater current being supplied by a full-wave selenium rectifier circuit.

The two mid-frequency 8" speakers are *Altec-Lansing* units while the tweeter and driver are made by *Stephens*. The 18" woofer is a *Jensen* model.

The record player cabinet is Provincial in styling and houses the tuner and preamp as well as the turntable with its transcription arm and low-impedance magnetic cartridge.

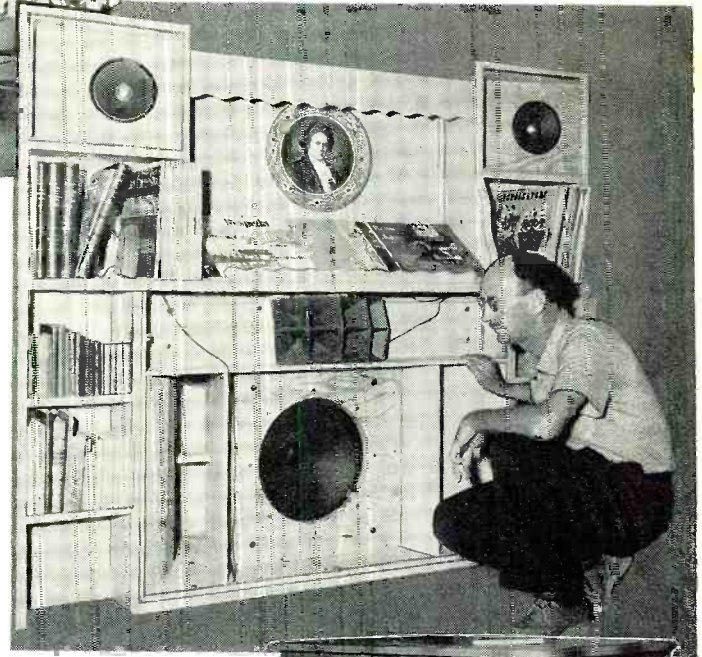

Provincial-style record cabinet houses turntable, tuner, and preamp. Space is provided for tape recorder.

Rear of the back-loading horn enclosure with the amplifier installed above. This part of system projects through wall into a built-on garage. See text.

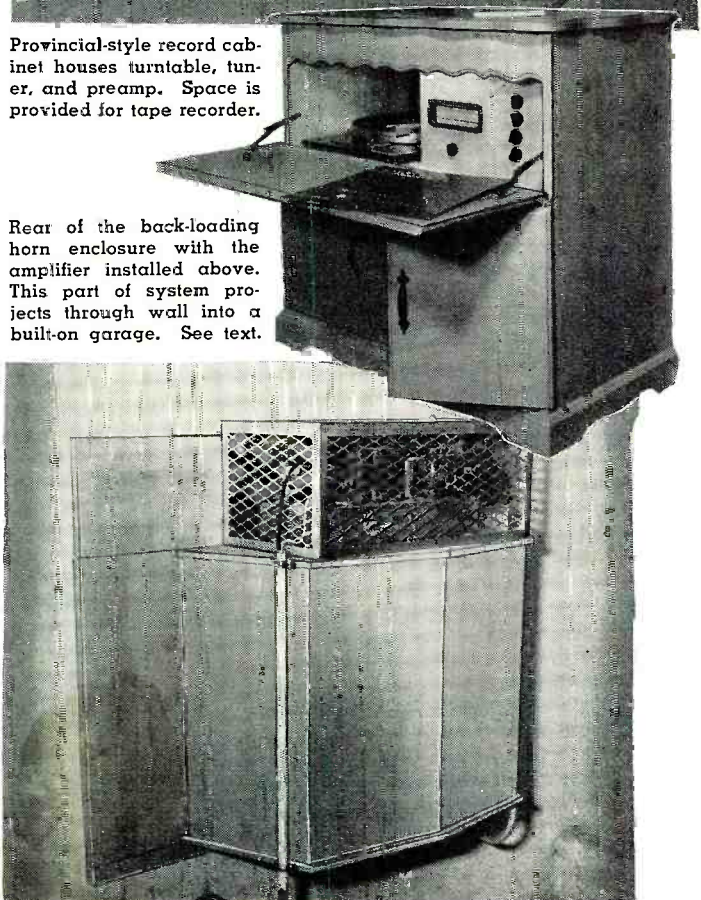

# AUTO RADIO SERVICE CHECKPOINTS

By JOHN B. LEDBETTER

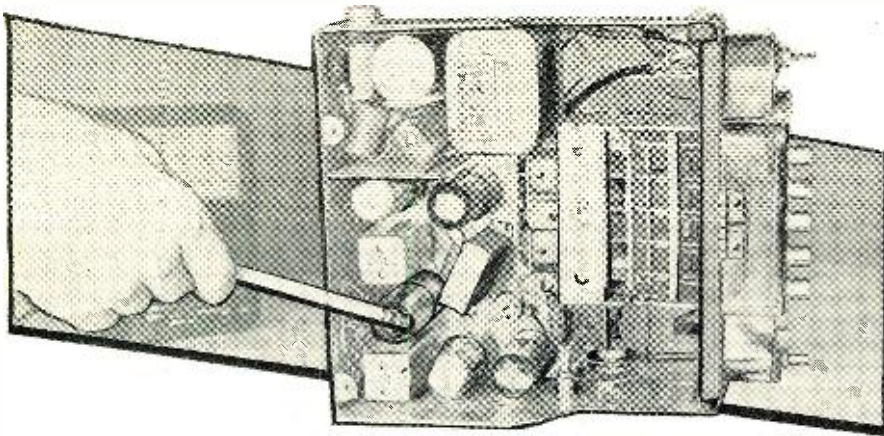

Fig. 1. Tapping tubes with a pencil to check for intermittents and noise. In this case, the radio's cover could not be removed while mounted in the car.

*Some simple preliminary tests can cut down the time required for servicing auto radios. The checkpoints described here account for most auto radio troubles.*

**T**HE first objective in servicing any type of receiver is to isolate or identify the source of trouble as quickly as possible. In auto radio servicing, this calls for operating the set *in the car* until the trouble appears, and then making a few simple preliminary checks to arrive at the probable sources of trouble. Otherwise, you may find yourself putting in a considerable amount of bench time only to find the real trouble in a loose antenna plug, corroded lead-in connection, bad ground to the car frame, etc. The following preliminary checks take up very little time, and you may be surprised at how effective they may be.

*Set does not light up:* Check the fuse. If the fuse is not blown, examine the ends for corrosion or loose connections, and replace the fuse if necessary. If the fuse-holder connections are poor or appear to be cold soldered, heat them with a hot soldering iron and apply new solder. Stretch the spring in the fuse holder, if necessary, to restore proper contact pressure. Check the seating of the fuse. It may be the wrong type; replace it with the correct type and rating.

*Set is intermittent:* Wiggle the antenna and lead-in connections, and check the antenna for loose or intermittently grounding mounting screws. Check the antenna plug at the set for poor or loose fit, cold-soldered connection at the plug tip, or broken or frayed shield connections. Check the tubes by tapping lightly with a pencil, as in Fig. 1. (In some cases the set will have to be removed from its mounting to get the cover off.)

*Receiver is noisy:* Obtain all possible information as to the nature of the

complaint (whether constant, present only while driving, etc.). Check the volume control, tubes, control cables, ground leads, etc., by tapping, moving slightly, or rotating while the set is in operation, and usually with the motor running. If the complaint does not show up after a reasonable warm-up time, try vibrating the set or antenna in an effort to start the trouble. (Avoid over-enthusiasm at this point.) Check all mechanical and electrical connections, remote control connections, plugs, etc.

In many cases, these simple checks will reveal the exact trouble. In any event, they will reduce servicing time by giving a fair indication of where to look for the trouble. The following service notes will suggest further sources of trouble, and should be helpful in cutting servicing time.

## Specific Troubles

*Vibrator dead*—If there is no sound from the vibrator and if the pilot lamp does not light, check for a blown fuse or for a poor connection in the fuse container, or at the "A+" connection at the ignition switch. It is also possible that the "on-off" switch in the receiver is defective.

*Vibrator normal*—If the vibrator sounds normal but there is no sound from the set, look for a burned out or defective rectifier or audio tube (0Z4 tubes in the power supply are frequent offenders). Check also for a shorted condenser (usually the plate bypass in the audio output stage), and check the plate voltages in the 6SQ7 (and similar) audio stages. A common trouble is failure (open condition) of plate supply resistors due to short

leads. When replacing resistors, make all leads long enough to allow for expansion and vibration.

If there is a background hiss from the receiver and if this hiss increases and decreases with the volume control setting, but no stations are received, touch the antenna with a screwdriver. If interfering "pops" are heard, try disconnecting and reconnecting the antenna lead-in. Check also for a defective r.f. or other tube ahead of the second detector. (If the tubes are accessible, feel the envelopes or try removing the last i.f. tube from its socket and work back toward the r.f. or converter tube.) Listen for noise when a tube is removed and reinserted. Trouble usually will be found in the stage just ahead of the one in which the noise last appeared.

If the stations are received normally but are accompanied by hash or vibrator interference, check for broken or loose ground connections, and loose tube shield, or i.f. can shield. In some of the older automobiles, this type of interference may require bonding of fenders, instrument panel, etc., or installation of spark plug and distributor suppressors. See that the usual .5- $\mu$ fd. condensers are connected across the low-voltage ("A+") side of the generator and from the hot side of the ignition switch to ground.

*Vibrator erratic*—If the vibrator acts intermittently and if there is no sound from the set, check for a defective vibrator (sometimes caused by defective buffer condensers) which may not be furnishing enough voltage to operate the receiver.

If there is hash or noise in the set but no station reception, check for a defective vibrator and for defective buffer condensers (generally across the secondary of the power transformer) or rectifier tubes.

If the vibrator sticks, blowing fuses, the points of the vibrator are probably badly pitted. Replace the vibrator. (Filing the points generally is only a temporary measure and should be avoided except in emergencies.) Before replacement, check the buffer condensers. If the set is several years old, or if the buffers look suspicious, replace them as a safety policy.

If a new vibrator does not start properly, or does not start at all, check for low battery voltage, blown fuse, or oxidized points on the vibrator. Note if the pilot light operates. If the vibrator will start when the auto engine is running, this is an indication that the battery voltage is probably low. If the vibrator points are oxidized (this is

RADIO & TELEVISION NEWS

fairly common if the vibrator has been idle or on the shelf for some time), apply about 12 volts a.c. (from pins on your tube-tester socket), and allow the vibrator to run for several seconds to remove the oxidized film.

In several receivers (1950 Dodge and similar), the current drain on the vibrator is rather heavy and ordinary vibrators will not last too long. In making replacements, try a heavy vibrator such as the Philco 83-0026. Also check the buffer condensers for trouble.

**Intermittent reception** — Check the antenna lead-in for proper connection. If a push-type antenna plug is used, see that the plug is in the receptacle properly and making good, solid contact. Wiggle the lead-in at the plug to check for poor or unsoldered connections, breaks, etc. Check for the same condition on bayonet or pin-type plugs, and see that solder is built up sufficiently to make a positive contact. If the plug pins or soldered connections appear to be cold soldered, sweat the connection with a hot iron and flow in a small amount of new solder. Try similar tactics with the lead-in at the antenna end. Move the antenna back and forth and check for a loose or intermittently grounding condition. Tighten or resolder connections as required.

If a portion of the broadcast band is dead or intermittent, check for a defective oscillator tube or possibly a shorting condition between the plates in the condenser-tuned circuits. If a new oscillator tube fails to correct the trouble, check the rectifier tube or measure operating voltages at the oscillator socket. Defective oscillator coupling or padding (mica-type) condensers are other possibilities.

### Noise and Distortion

One common trouble is an extremely noisy volume control that results in high-pitched oscillations and cannot be set at correct volume. This condition indicates a defective volume control. Cleaning usually will not help if the condition is as serious as described here; replacement with a new control of correct taper will usually correct this.

A microphonic "squeal," usually affected by vibration or high volume, may be due to a noisy tube, generally the oscillator (6A7, 6A8, 6AS7, 6BE6, 6K8, or 12BE6, among others), or second detector (75, 6SQ7, 6SR7, 6AV6, etc.). A similar effect can also be caused by an intermittent open or loose lead of one of the coupling condensers.

If the complaint is low volume with distortion during the first half-hour or so of operation, with satisfactory reception thereafter, check for a weak input filter condenser. Bridging a good unit across the suspected condenser is a satisfactory test. (Observe the proper polarity and negative connections, especially in special circuits.)

When the receiver has audio distortion at low levels only, and is normal

at medium and high volume, check the speaker voice coil alignment. If it is rubbing against the pole piece, try to re-align the cone. If alignment is impossible or impractical, replace the speaker. (In emergencies, try bending the speaker frame slightly in one direction or the other with a pair of long-nose pliers while listening to a station at medium volume.) Audio distortion at high volume only indicates a gassy audio output tube or leaky coupling condenser. Also be sure that the speaker cone is properly glued and centered, and that the audio output is not exceeding the speaker's normal power rating.

While on the subject of speaker defects, there are several other complaints that can be caused by damaged speakers. A loose, unglued rim on the speaker cone, a warped cone, or a collection of foreign matter or metal filings lodged in the magnet gap of a speaker may cause occasional distortion and "rasping" notes. If the cone is unglued, reglue with regular speaker cement, making sure that the cone is properly centered. Use speaker shims or small strips of negative photographic film. If neither is available, tune in a station at low volume and move the speaker cone carefully back and forth while exerting pressure against and around the rim of the cone (not against the cone itself). Adjust the cone position for the best apparent quality and freedom of motion. Apply pressure evenly around the rim to properly set the glue. If the speaker has an extra centering spider or disc near the air gap, check this also for unglued condition.

If the speaker cone is warped, try moistening the cone at a point directly opposite the warp. When dry, the cone often will warp an equal amount in the opposite direction and correct the trouble. On smaller speakers, also try warping a corner of the frame by springing or twisting slightly with long-nose pliers.

A frequent complaint is ignition noise. If the usual remedies (.5- $\mu$ fd.

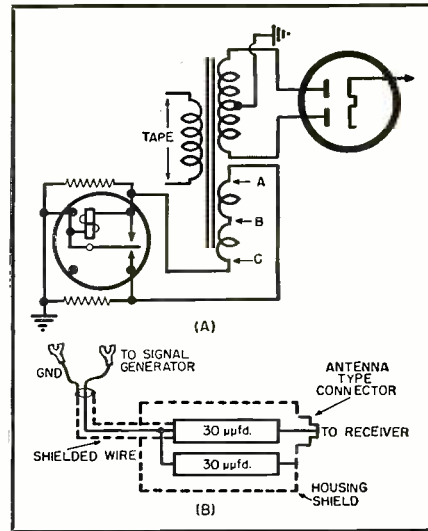

Fig. 2. (A) Circuit for using an ordinary radio power transformer for an auto receiver power supply if the proper power transformer is not available. (B) Dummy antenna for use with auto radios during alignment and touch ups.

condensers across the ignition switch, generator, and other electrical instruments; bonding ground connections; cleaning and tightening ground connections; etc.) do not work, try cleaning the base and insulator of the whip antenna. Corrosion often causes considerable leakage between the antenna and auto body.

If the ignition noise continues to be picked up, even with the antenna removed, the trouble may be pickup via the 6-volt lead. The most practical solution in this case is to run a separate #8 or #12 lead directly from the receiver to the battery, keeping the lead as short as possible and dressing it away from other "A+" wiring to avoid pickup.

A high-pitched noise, present only when the auto is in motion, indicates wheel static. If the noise stops or is reduced when the brakes are applied, install coiled-spring suppressors (available at most distributors) inside the

(Continued on page 100)

Fig. 3. With the set on the bench, probe gently for loose connections.

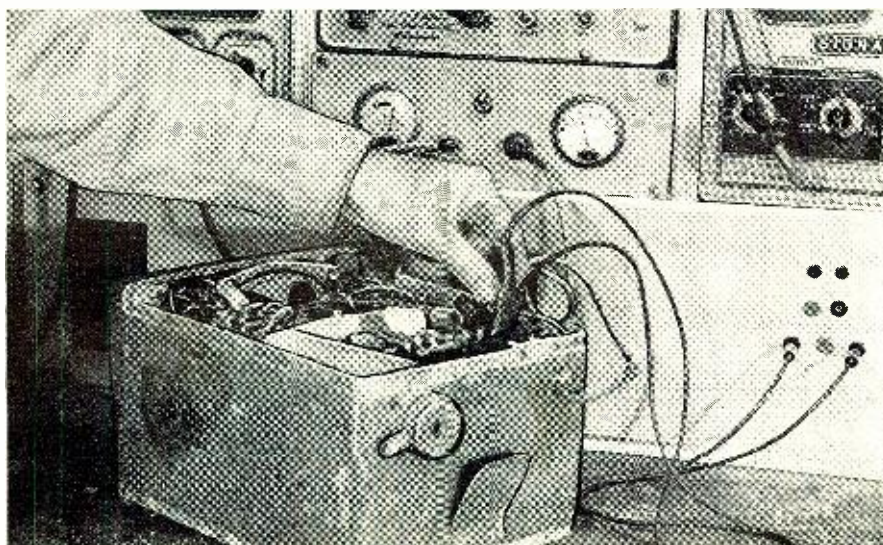

# USING CALIBRATED VARIABLE INDUCTANCES

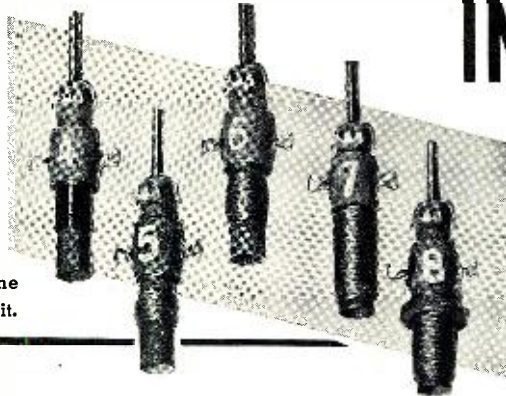

By JOHN T. FRYE, W9EGV

Fig. 1. The eight coils that comprise the United Technical Laboratories' V2 kit.

*A recently-introduced kit of eight slug-tuned coils permits continuous coverage of the range from 1 to 1000 microhenrys.*

**A**N electronic technician can reach into his parts bin and pull out a fixed or variable condenser that will satisfy practically any capacitance need he may have. Fixed resistors and potentiometers from the same source will meet his resistance requirements. In the past, however, when he wanted a certain value of inductance, the picture was considerably different. In this case he was actually faced with the necessity of "rolling his own," with all the chart-thumbing, slide rule slipping, actual winding, and turn-pruning this inevitably entails.

Now, however, thanks to a kit\* of variable inductances that has recently been put on the market, ordinary inductance needs are as easily satisfied as are those of capacitance and resistance. This kit, illustrated in Fig. 1, consists of eight slug-tuned, "Q-Max" impregnated coils that can be adjusted to values covering a continuous range of from 1 to 1000 microhenrys. Each coil has an inductance-change-ratio of roughly three to one, and there is generous overlap between coils. Snap-in, single-hole mountings for inserting in a  $\frac{1}{32}$ " hole are provided.

Individual coil specification sheets are packed with the kit. On every sheet is a graph on which the variable inductance values of a particular coil are plotted against turns of the slug-feeding brass screw. Thirty turns of this screw are required to move the slug from the "clear-out" to the "clear-in" position. In the case of each coil, for a certain number of these turns the change in inductance approaches linearity; and the rated inductance coverage of the coil is restricted to fall within this near-linear range. This permits a straight line drawn on the graph to indicate average coil inductance change. To secure a wanted inductance value, you simply

select the proper coil, consult the graph for that coil, and then turn the slug-adjusting screw in the indicated number of turns from the "clear-out" position.

Besides the graph, the specification sheet provides the following information about the coil: (1) Maximum and minimum values of rated inductance; (2) maximum and minimum values of "Q," together with the frequencies at which this factor was measured; (3) d.c. resistance; (4) distributed capacity; (5) self-resonant frequency with the slug set at the minimum inductance position.

The writer is one of those nasty, suspicious persons who buys a new foot rule and then rushes right home to check it against his steel square before starting to use it; so the first thing he did with the coil kit was to give every coil an electronic third degree with a "Q"-meter and a grid dip oscillator. On the whole, the results were quite satisfactory. It was not supposed that mass-produced coils of this nature would be precisely "on the nose," nor were they found to be; but essential characteristics were as close to specifications as could reasonably be expected. Some "Q" values were found a little lower than specified and some a little higher, but the average was surprisingly close. Incidentally, the "Q" of each coil varies with the setting of the slug, the maximum normally being found at the maximum inductance setting. The lowest "Q" figure given is 50 and the highest 125.

Agreement between actual measured inductance and the values indicated on the graphs was very close in some coils and only fair in others. It was noted, though, that the "reset accuracy"—the ability of the coil to dis-

play the same inductance when the tuning slug was returned to the same position—was excellent. This led to the conclusion that where extreme accuracy was desired it would be worthwhile to hand-calibrate the coils.

All that is needed to do this are a couple of accurate condensers—inexpensive silver mica 5% tolerance units will do nicely—and a grid dip meter. The condenser is connected across the coil with its slug turned clear out, and the resonant frequency of the combination is checked with the grid dip oscillator. Then the slug is turned in five turns and the resonant frequency checked again. This is repeated for every five turns of the adjusting screw until the slug is in the full thirty turns. The resonant frequencies found are next converted to inductance values by using the formula:  $L=25,332/Cf^2$  where  $L$  is the inductance in microhenrys,  $C$  is the capacity of the silver mica condenser in  $\mu\text{fd}$ . plus the distributed capacity of the coil, and  $f$  is the resonant frequency in megacycles. Finally, these inductance values are plotted on the graph furnished for the coil and the points are joined with a smooth curve. The hand-drawn curve is shown dotted in Fig. 4.

Various characteristics of these coils have been described in considerable detail because nothing more will be needed to start dozens of applications popping in the minds of experienced experimenters, amateurs, and technicians. However, since not all readers will be so experienced and because no instructions are furnished with the coils, it may be well to describe a few of the more important applications in each field.

Probably the first use an experimenter will make of the kit is that of direct application. If he wants to try a circuit calling for an inductance of, say, 260 microhenrys, he simply picks out the proper coil, gives the brass screw the indicated number of turns, and there he has a pre-fabricated high-"Q" coil of exactly the specified inductance. Once the circuit is working he may wish to try the effect of increasing or decreasing the inductance.

\* Variable inductance kit, Model V2, manufactured by United Technical Laboratories, Morristown, N.J.

If so, all he has to do is turn the slug in or out. When a certain setting is found to work best, the number of turns required to return the slug to its "clear-out" position will reveal what the optimum value of inductance was.

Again he may wish to determine the maximum and minimum capacity of a tuning condenser. One of the coils, set to a convenient inductance value such as 10 microhenrys, is connected across the variable condenser, and the resonant frequency of the combination is checked with a grid dip oscillator with the tuning unit entirely closed and then with it entirely open. The capacity present at either of the two settings is determined from the formula:

$$C = 25,332/Lf^2$$

Units are the same as before.

After both values of  $C$  have been determined in this fashion, it is only necessary to subtract from each the distributed capacity of the particular coil used, and you have the actual maximum and minimum capacity of the tuning condenser expressed in micro-microfarads.

Naturally the same method can be used to determine the value of a fixed condenser. With coil #2 set to 5 microhenrys, capacities between 1 and 1000  $\mu\mu\text{fd.}$  will fall within the range of the ordinary GDO. If you have been taking the values stamped on ordinary mica condensers for granted, you are in for a rude shock when you start measuring them. This method is excellent for matching condensers closely, as is sometimes necessary.

The experimenter will also find the coils make very handy ready-made, variable r.f. chokes for high frequency circuits. Different coils and different settings of each coil can be tried until the exact value of inductance needed for a certain circuit is found; then the coil may be left permanently installed or another choke of the same inductance may be substituted with the sure knowledge it is the right one to use.

Ham publications often give coil data as so many turns wound for a certain length on a certain size form. You may want to substitute a coil form of different size you have on hand. You can place one of the variable inductances in the circuit temporarily and use the GDO to adjust it to the proper value for covering the desired range, etc. Then, knowing the actual inductance required, you can consult a coil-winding chart to determine the proper winding for the form you wish to use.

Many times an amateur needs an oscillator working on widely separated frequencies. A split-stator tuning condenser may be employed with the coils just as they are in a Colpitts circuit, such as the one shown in Fig. 2, to form the heart of such an oscillator. Almost any twin-section tuning condenser may be employed. If care is taken to make the leads as short as possible, different variable inductances can be clipped into this circuit and adjusted to make it cover a range of from about 2 mc. to well beyond 100

mc. In Fig. 5 the grid dip oscillator is being used to explore the frequency range of a tuning combination of this nature.

Recently the writer wanted a tiny condenser of exactly  $1\frac{1}{2} \mu\mu\text{fd.}$  to supply feedback in a crystal oscillator with which he was experimenting. His "Q"-meter having been loaned, it was decided to put the coil kit to use. A piece of twin-lead was connected across the terminals of coil #1 adjusted to 1 microhenry of inductance. A quick check was made to be sure no one had changed the formula for resonance since last we looked, and it was found still to be:

$$f = 159.16/\sqrt{LC}$$

with units again the same as before.

The distributed capacity of the coil was given as .5  $\mu\mu\text{fd.}$ , and this added to the  $1\frac{1}{2} \mu\mu\text{fd.}$  needed yielded a value of 2  $\mu\mu\text{fd.}$  for  $C$ .  $L$ , of course, was 1  $\mu\text{hy.}$ , and the product of these two gave a figure of "2" under the radical. The square root of 2 is 1.414; 159.160 divided by 1.414 gives an answer of about 112 mc. as the resonant frequency to be expected when the capacity represented by the length of twin lead is  $1\frac{1}{2} \mu\mu\text{fd.}$

Bits were snipped from the end of the twin-lead with the diagonal cutters, and the GDO was used to keep tab on the rising resonant frequency until 112 mc. was reached. Fig. 6 is a picture of this operation. Later, when the "Q"-meter was returned, this twin-lead condenser was checked and found to be as near  $1\frac{1}{2} \mu\mu\text{fd.}$  as could be measured. Twisted lengths of insulated wire could have been used to fashion the small condenser in the same way.

While the writer was working on a high-frequency oscillator, a need was felt for some sort of field strength meter to show the effect of circuit changes on output. A few turns of

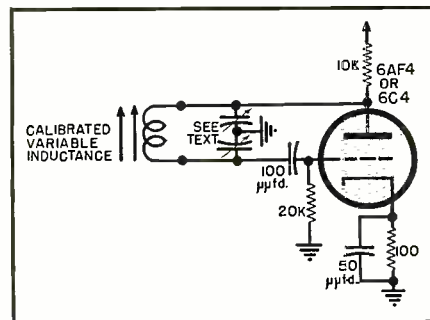

Fig. 2. Colpitts circuit which allows single winding coils to be used as oscillator inductances. See discussion in text.

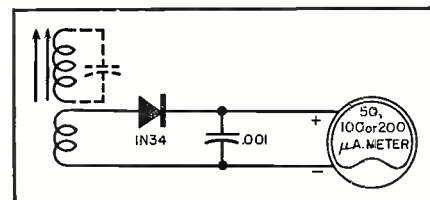

Fig. 3. How a 1N34 crystal diode and a microammeter may be used with a variable inductance to provide a temporary field strength meter or an r.f. probe. See text.

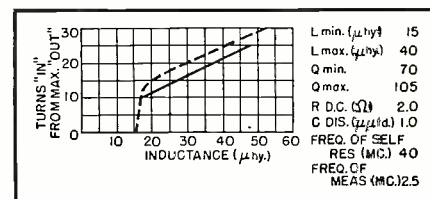

Fig. 4. The chart as supplied with coil 4 in the kit (solid line) and the hand-drawn corrected curve (dotted) for coil.

wire were wound around the bottom portion of Coil #1 and a crystal probe designed for use with low current meters was clipped across this winding. The other ends of the probe leads were

(Continued on page 96)

Fig. 5. Checking tuning range of split-stator condenser and a variable inductance.

Fig. 6. Making a small condenser from a length of twin-lead. See text for details.

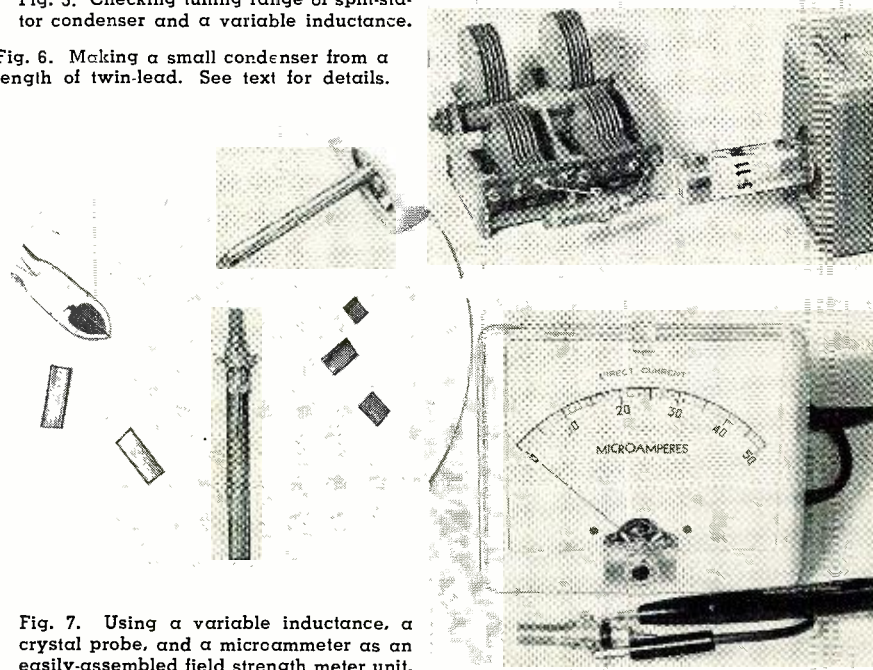

Fig. 7. Using a variable inductance, a crystal probe, and a microammeter as an easily-assembled field strength meter unit.

# TROUBLESHOOTING

Part 4. Concluding article includes some practical circuits and suggestions for eliminating modulated TVI such as that produced by FM and police broadcasting.

By  
**CARL J. QUIRK**

Allen B. Du Mont Laboratories

Author. "A Handbook of Television Interference"

**T**HIS article will discuss specific types of TVI, give their causes, and list some possible cures. Last month's article concerned itself with unmodulated interference, such as oscillator radiation, and discussed the interference effects of video i.f. harmonics and high-channel signals. Now we will investigate frequency-modulated, video-modulated, and burst-type interference.

## Frequency-Modulated TVI

*Adjacent-channel sound interference.* When receiving a weak or distant station, there is a likelihood that the sound carrier of a nearby strong station on the lower adjacent channel will produce a beat of 1.5 mc., as seen in Fig. 5. In this illustration, reception in New Jersey from channel 3 (Philadelphia) is being interfered with by channel 2 (New York). Although this effect may not be quite as annoying as the adjacent-channel video type of TVI, it is sometimes more difficult to eliminate. This is primarily due to the fact that when tuning for best fringe-area reception, the customer will normally tune the video carrier up on the passband in order to achieve a better picture. When he does this, he simultaneously tunes the interfering sound carrier out of its trap, increasing the effective interference.

Most TV receivers have at least one trap tuned to the i.f. of this interfering signal. For example, for 25.75 mc. i.f. sets, this adjacent-sound i.f. trap is tuned to 27.25 mc.; for 45.75 mc. i.f. sets, the trap is tuned to 47.25 mc. It is obvious that the trap must be

properly tuned to this frequency if the maximum attenuation is to be obtained.

*FM broadcast stations.* A very common type of nontunable FM interference comes from harmonics of FM broadcast stations. The FM broadcast band extends from 88 to 108 mc., and the second harmonics of the FM signals range from 176 to 216 mc., right in the upper v.h.f. TV band. For some time many technicians had the idea that the harmonics were generated by the stations themselves. Although this could be true in certain isolated cases, most interference due to harmonics is the direct result of the generation of harmonics within the front end of the TV receiver proper. The elimination of this type of interference involves the elimination or at least attenuation of the fundamental before it gets into the tuner.

In most instances, there will be only one FM station producing interference in this manner. Under these conditions, the problem merely requires that an FM trap be inserted into the transmission line as close to the tuner as possible; the trap is then tuned to eliminate the beat. There are several simple trap circuits which can be used for such conditions. Fig. 1 illustrates several types.

There are cases, however, where several FM stations may interfere with several TV stations. Pasadena, California, is one area where this condition exists. A satisfactory solution is the use of an *m*-derived band rejection filter, such as is shown in Fig. 7. This filter inserted into the input of the

tuner circuit attenuates the entire FM band and, thereby, eliminates interference.

FM broadcast interference can often result when the TV set has poor image rejection and uses a 21-mc. i.f. This occurs particularly on channel 2 where the video carrier is 55.25 mc., and the local oscillator frequency is 81 mc. The latter, plus 21 mc., gives an image frequency of 102 mc. Any FM broadcast signal close to this frequency can, therefore, enter the set and cause TVI. The use of one of the traps shown in Fig. 1 will attenuate the FM interfering signal and eliminate this effect.

*Police interference.* Another type of tunable FM interference occurs as a result of police operating in the region of 41.25 mc. to 45.75 mc. Although as a rule the interference is intermittent since the stations do not broadcast continuously, it still is a cause of extreme annoyance to the customer.

The simplest and most practical solution is to use a high-pass filter which has a cut-off frequency at about 50 mc. This offers adequate attenuation to eliminate this annoying source of interference. Fig. 8 illustrates a schematic of a high-pass filter for this purpose. However, the filter may be inadequate because the TVI may enter by means of the i.f. circuit wiring and not *via* the antenna and transmission line. In such cases, it may be necessary to improve the shielding of the i.f. circuitry.

*Sound i.f. harmonics.* In split-channel TV sets (and less frequently in intercarrier sets), harmonics of the i.f. may find their way back into the front end of the set and produce interference. The interference is, of course, tunable. The source of such harmonics in split-channel sets is the sound detector (usually a discriminator) or possibly the limiter. In the case of intercarrier sets, the source would be the video detector because the level of the sound carrier may be relatively high at this point.

To effect a cure, the service technician should first establish if the source is the i.f. strip by pulling out a sound i.f. tube. If the interference stops, then it follows that the trouble is coming from the output circuit of the sound i.f. strip. The next step is to make sure that the circuit sur-

Fig. 1. Various FM traps for use with both 300-ohm twin-lead and coaxial cable.

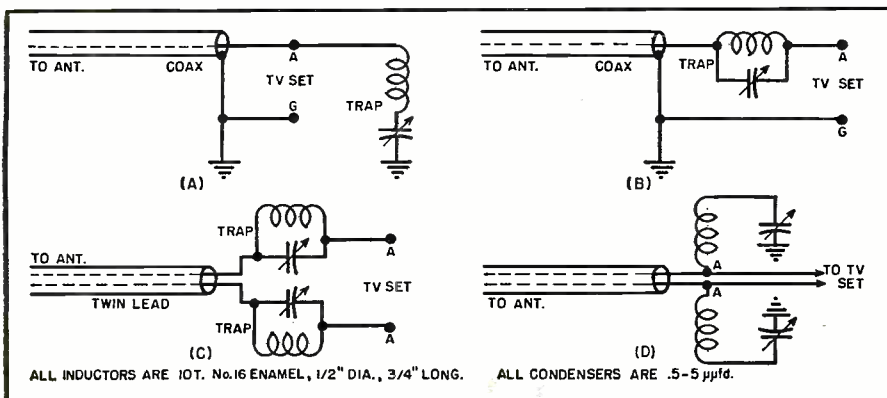



Fig. 2. Interference effect caused by the beating together of a sound i.f. harmonic and the channel 7 video carrier.

rounding the sound discriminator is well shielded. Also, check the bypasses in the "B+" and heater lines. If "B+" for the tuner is obtained from the same point as the "B+" for the sound strip, then another source should be found, or at least better isolation should be provided. If the transmission line feeding the tuner runs anywhere near the sound i.f. strip, then the lead should be redressed and made longer (if necessary) to effect a better dress. If none of these steps prove satisfactory, the only solution may be to change the i.f. to put the beat outside of the band.

Fig. 2 illustrates a low-frequency FM interference which occurred on channel 7. It was the result of the 8th harmonic of a 21.9-mc. sound i.f. interfering with the channel 7 video carrier. Since the video carrier of channel 7 is 175.25 mc., and the harmonic involved was located at 175.20 mc., the beat was only 50 kc. A lead dress change was very effective in eliminating this beat. However, another successful way of eliminating this condition is to change the sound and video i.f.

### Video Modulation

As previously mentioned, one of the most annoying forms of television interference is that which is caused by the video carrier of another TV station. This interference, when really bad, can appear as another picture swinging back and forth across the screen, superimposed on the desired picture information; generally, however, it will appear as diagonal lines.

**Adjacent-channel video interference:** This effect is noticed when an attempt is made to receive a distant station which is one channel lower than a nearby station. (Channels 4 and 5, and 6 and 7 are not adjacent in this sense.)

TV receivers are designed with certain precautions taken to minimize the adjacent-channel video problem. In this regard, receivers will have attenuations of the adjacent-channel video signal ranging from 25 to 50 db. This attenuation is obtained by a combination of the "skirt" selectivity of the i.f. strip in addition to a trap or traps. Optimum tuning of the traps will help to eliminate this condition.

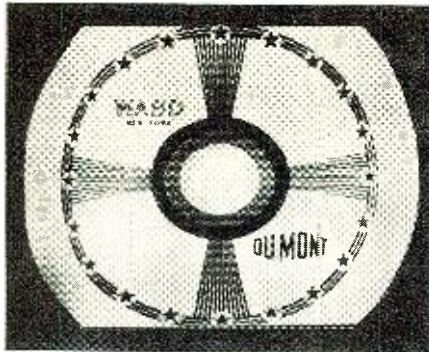

Fig. 3. Venetian blind effect—the black bars move up or down through the picture, due to co-channel interference.



Fig. 5. Appearance of a 1.5 mc. beat interference caused by the sound carrier of a nearby station when the TV set is tuned to a distant station.

**Co-channel interference:** This is, of course, due to two or more stations operating on the same channel being received by one TV set, producing the venetian-blind effect from the beat between the two carriers. (See Fig. 3.) In most places, this venetian-blind effect has been greatly minimized because of a practice followed by stations known as offset-carrier operation. This means that if two stations operating on the same channel are approximately 200 miles from each other, instead of operating exactly on the prescribed frequency, one may operate about 10 kc. higher or lower than the prescribed frequency. The other station will operate on frequency. Then if they interfere with each other, the venetian-blind effect will show up as many fine lines and will be much less disturbing to the viewer. Of course, if the interference is strong, the video modulation will still appear.

The best and most successful method of combating this advanced form of co-channel interference is by the use of directional antenna arrays. Antennas with high front-to-back ratios are especially important if the interfering station is in the opposite direction from the desired station.

**Cross modulation:** In areas where there is a very strong station or several very strong stations, video modulation interference often occurs as a result of severe cross modulation in the front end of the tuner. When this happens, the best remedy is to attenuate the incoming signals by using an

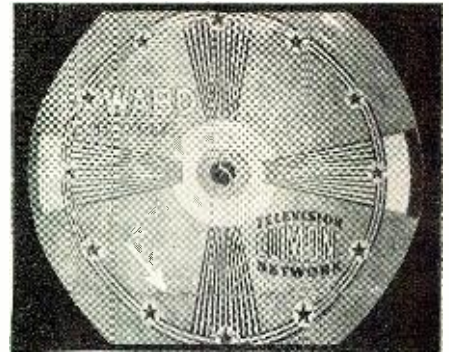

Fig. 4. TVI illustrated here (pointed out by the arrow) is burst type caused by an old-style electric light bulb.

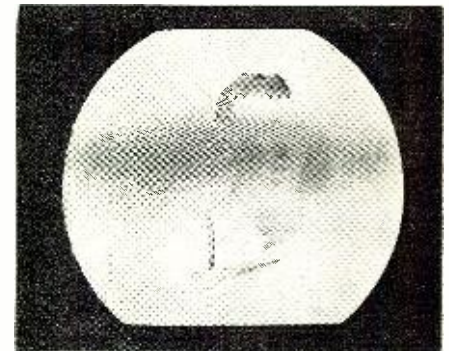

Fig. 6. Effect caused by diathermy interference. Complete shielding and filtering of the diathermy equipment and/or the TV receiver is effective cure.

*L*- or *H*-type attenuator pad in the transmission line at the tuner input.

(Continued on page 121)

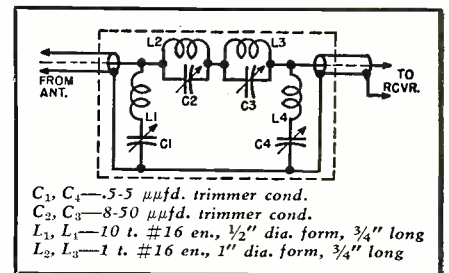
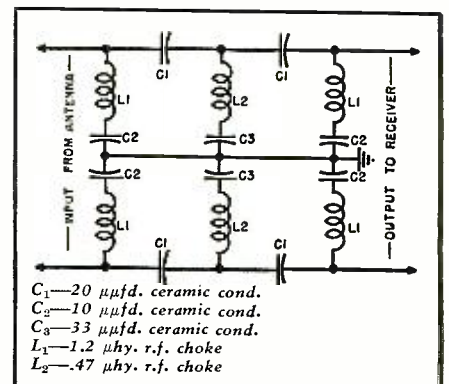

Fig. 7. M-derived band elimination television interference filter useful for rejecting FM broadcasting signals from the input to the tuner of the TV set.

Fig. 8. Schematic diagram of a high-pass filter useful for eliminating police and similar communication signals from the input to the TV tuner.





# 1954 TV RECEIVER SPECIFICATIONS

Continuation of the list of mechanical and electrical specifications on new TV sets for service technicians. See next issue for additional listings.

MFR.	CHASSIS	TUBES							VIDEO I.F. FREQ. (MC.)	H.V. <sup>4</sup> (KV.)	U.H.F. PROVISION	POWER (WATTS)	SPECIAL FEATURES
		TUNER	I.F. <sup>1</sup>	VIDEO <sup>2</sup>	AUDIO	SWEEP <sup>3</sup>	P.S.	CRT					
SENTINEL (Cont'd)	X22	6BQ7A or 6BZ7 6J6	6CB6	1N60 6CL6	6AL5 6AU6 6SN7* 6W6	6BL7, 6CD6 6SN7, 6SN7 6SN7*, 6V3 6V3, 12BH7	1B3 5U4 5U4	24CP4A 24TP4A 27EP4	45.75	18	11	250	10
	XX27	6BZ7 6X8	6CB6 6CB6 6CB6	1N60 12BY7	6AL5 6AU6 6AU6 6AV6 6K6	6AL5, 6AU6 6AU6, 6BE6 6BC6, 6BL7 6SN7, 6SN7 6W4, 12AU7	1B3 5U4 5Y3	21FP4A	45.75	15	11	250	10
SONORA	GBT GFT	6BZ7 or 6U8	6CB6 6CB6 6CB6	1N64 1N64 6AH6	6AU6 6T8 6W6GT or 6Y6G	6AL5, 6AU6 6BQ6GT, 6S4 6SN7GT, 6SN7GT 6W4GT	1B3GT 5U4G	17HP4 21YP4	45.75	14	11	290	5, 6, 10
	BRT	6BC5 6J6	6CB6 6CB3 6CB6	1N64 6AH6	6AU6 6T8 6W6GT or 6Y6G	6AL5, 6AU6 6BQ6GT, 6S4 6SN7GT, 6SN7GT 6W4GT	1B3GT 5U4G	17HP4 17TP4	26.4	14	Strips	290	5, 10
	BST	6BC5 6J6	6CB6 6CB6 6CB6	1N64 6AH6	6AU6 6T8 6W6GT or 6Y6G	6AL5, 6AU6 6BQ6GT, 6S4 6SN7GT, 6SN7GT 6W4GT	1B3GT 5U4G	21MP4	26.4	14	Strips	290	5, 10
SPARTON	21S173A 24U174 24U214	6BQ7 6J6	6CB6 6CB6 6CB6	6AL5 6AU6	6AL5 6AT6 6AU6 6V6GT	6AL5, 6AU6 6BQ6GT, 6SN7GT 6SN7GT, 6V6GT 6W4GT	1B3GT 5U4G 5Y3GT	17HP4 21EP4A	26.25 26.25 26.25	12 12 12	Strips 11 11	220 220 235	
	21S214	6BQ7 6J6	6CB6 6CB6 6CB6	6AL5 6AU6	6AL5 6AT6 6AU6 6V6GT	6AL5, 6AU6 6BQ6GT, 6SN7GT 6SN7GT, 6V6GT 6W4GT	1B3GT 5U4G	21EP4A	26.25	12	Strips	210	
	27D244 27D273 29U244 29U273	6BQ7 6J6	6BA6 6BA6 6CB6 6CB6	6AH6 6AL5 6AU6	6AL5 6AT6 6AU6 6AU6 6V6GT	6AL5, 6AX4GT 6AX4GT, 6BX7GT 6CD6G, 6SN7GT 6SN7GT, 12AU7	1B3GT 5U4G 5U4G 5U4G	24CP4A 27EP4 24CP4A 27EP4	26.25 26.25 26.25 26.25	18 18 18 18	Strips Strips 11 11	325 325 325 325	

1. Video i.f. tubes only. 2. Includes detector and a.g.c. 3. Includes sync section and a.f.c. 4. CRT 2nd anode voltage. 5. Removable safety glass. 6. Local-fringe a.g.c. adjustment. 7. High-fidelity sound. 8. Aluminized picture tube. 9. TV-radio-phono combination. 10. Built-in antenna. 11. 82-channel tuner. 12. Adjustable dial light. \*Part of tube is used in another section.

# A SIMPLE TV LINEARITY PATTERN

By  
**ROBERT B. GARY**

**O**NE of the great drawbacks of the heavy schedule of TV programs is the absence of station test patterns. These symmetrical meaningful patterns could be received during the daytime only a few years ago and were a real help since they allowed the technician to adjust the receiver with a stationary picture. Vertical and horizontal linearity, centering, and even the i.f. bandwidth could be checked by means of the station test pattern. At present, test patterns are rarely broadcast in the large TV centers, or at least they are not on the air during normal working hours. In new TV areas test patterns are still available, but as soon as a station becomes well established, daytime programs are transmitted and the test pattern drops out.

Vertical and horizontal linearity can be adjusted with the aid of a bar generator or an r.f. signal generator, modulated with a sine wave of the proper frequency. These devices have been described in recent literature and while they certainly do the job, they are expensive and must be carried to the customer's home. The method suggested in this article is quite simple, inexpensive, and needs no electronic equipment. The author decided to provide his own test pattern when a station pattern is not transmitted and use it for linearity checks. The principle of the transparent pattern shown superimposed on the TV screen in Fig. 1, is that even in a moving picture, nonlinearities are more noticeable when compared with linear spaces. For example, a slight crowding at the right of the picture may not be noticeable as such. When the mask is placed over the screen, however, the width of a face at the left or in the center can be compared at a glance with that of a face, slightly compressed, at the right. This becomes even more apparent when the person walks across the screen or when the camera pans sideways. Then objects will have different width at the compressed right than elsewhere in the picture. With the vertical lines of the pattern for comparison, horizontal nonlinearities show up much better than with just the original picture.

The center strip of the pattern is used for checking vertical linearity. One method consists of counting the number of horizontal lines which fit into the space of one of the horizontal strips at the bottom and top of the

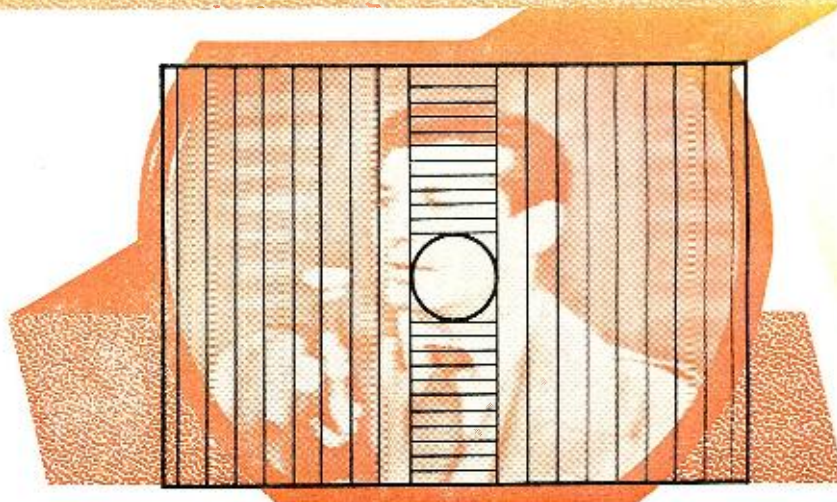

Fig. 1. The linearity test pattern. When used it is taped to the safety glass.

*A simple service tool which can be taken into customer's home and used for alignment when no test pattern is on.*

picture. This will show accurately any vertical distortion, and while this may seem too exacting, on a 21-inch screen only about 10 lines will fit into a  $\frac{1}{2}$  inch space. On smaller-screen receivers the second method is certainly preferable. In this approach the vertical hold control is adjusted until the picture moves slowly from bottom to top. While this takes place, observe the height of a particular object as the entire picture moves through the screen. The object's height at the bottom of the screen may be much less than when the object reaches the top of the screen, indicating compression at the bottom or stretching at the top. Actual adjustment of the vertical linearity with the linearity pattern can be done in less time than it takes to describe.

In the center of the linearity pat-

Fig. 2. Construction details for making a simple TV linearity pattern mask. Dimensions given are for 21" and smaller tubes.

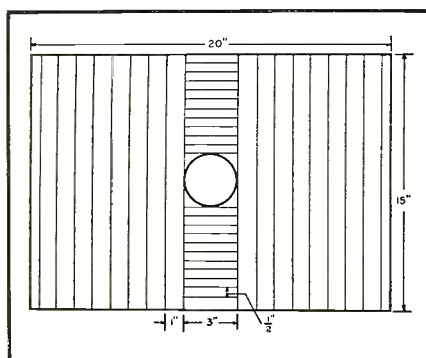

tern we have drawn a circle. This allows quick comparison with any circular object in the picture and it also helps in centering the picture. In many commercials and during quite a few programs the camera is centered on one object. Whether this is a clock, a package of cigarettes or any other object or person, the cameraman always tries to get his target centered in the picture. Similarly we can often center the picture by bringing the camera target near the center of the linearity pattern, into the circle. A good example is a picture of an entertainer, alone on the stage. Adjust centering until the person is approximately in the circle and the correct centering is obtained. This method only holds true when the edges of the picture overlap the screen enough so that no dark strips appear. In many instances the true center of the picture is at the right because the right portion is compressed and the picture is adjusted simply to avoid showing the edges. Such a defect will become quite obvious when the linearity pattern is superimposed on the screen. Other defects which can be located by means of the linearity pattern include jitter, bending of vertical lines, and poor interlace. Jitter, both vertical and horizontal, can be noticed by fixing some stationary object in the picture to the nearest pattern line.

Bending or tilting of vertical lines in the picture are checked by comparing vertical pattern lines. This  
*(Continued on page 102)*

# TRACING THE WAVEFORM



*Signal tracing of the r.f. and i.f. circuits of TV sets  
is one sure way to service many of the "tough dogs."*

**S**IGNAL tracing is a dynamic system of troubleshooting involving the modulated carrier of a transmitter as a signal source and a signal tracing instrument as a signal indicator. For certain obscure troubles due to signal distortion, or for intermittents, signal tracing as a diagnostic system is superior in many ways to the various forms of signal injection. The system of waveform analysis whereby troubles in the video amplifier, sync, and deflection circuits are located, is a form of signal tracing.

Unfortunately, it has not been generally understood that a waveform analysis can be made in the circuits preceding the video detector; nor was it considered necessary to do so. In the light of experience, however, a significant number of obscure troubles originating in the pre-detector circuits appear to require a more efficient method of diagnosis. There is a growing awareness, furthermore, that an oscilloscope, preferably one of high gain and equipped with a demodulator probe, makes an effective signal tracing device for such purposes.

The purpose of this article is to show how the TV signal tracer, in the form of an oscilloscope-demodulator probe combination, is used to troubleshoot the r.f. and i.f. circuits of TV receivers.

The success of any waveform analysis depends on the interpretations a technician gives to departures from normal waveform patterns. Unfortunately, as many technicians have learned, what is considered a normal waveform depends to a certain extent upon the characteristics of his oscilloscope. Then, too, reasonable departures from the normal, due to certain signal conditions and individual re-

ceiver characteristics, have to be recognized. This, in part, may account for the increasing tendency of many receiver manufacturers to provide waveform information in terms of simple drawings instead of actual photographs. Thus, the normal waveform itself is, to a certain extent, the result of an interpretive process.

This interpretive process continues even where the oscilloscope is used with a demodulator probe to signal-trace circuits amplifying modulated r.f. signals. Fig. 1 shows the TV signal tracer connected to the grid of  $V_1$ , a typical i.f. amplifier. The waveform shown on the scope, positive pulse phase or negative picture phase, is normal with the probe demodulator used by the author. The reader may find that with his equipment, the waveform is one of opposite phase (negative pulse phase). This condition must be understood to be a fixed characteristic of the demodulator probe

**Fig. 1. Signal tracing an i.f. amplifier with a demodulator probe and an oscilloscope. The phase of the waveform on the scope depends on probe.**

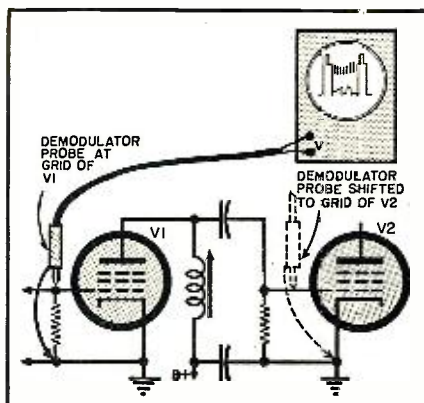

and must be expected whenever and wherever the demodulator probe is used. The depressed level of the horizontal sync pulses is due mainly to the restricted high frequency response of demodulator probes. If, in Fig. 1, the probe were shifted to the grid of  $V_2$ , the waveform will display the same phase characteristics. The only significant change is one of amplitude due to stage gain. Minor changes may occur in the relative levels of the vertical and horizontal pulses. This is to be expected. Furthermore, minor departures from the waveform shown in Fig. 1 should be anticipated under certain signal conditions, and in different make receivers.

Once the general waveform characteristics of a probe-demodulated signal become a recognizable feature to the technician, the signal tracing technique follows the established pattern. If  $V_1$  in Fig. 1 or any of its associated components were defective, the signal waveform obtained from the grid of  $V_2$  would be severely attenuated or deformed, if present at all.

This method of localizing defective i.f. and r.f. amplifiers has shown itself superior, in most cases of obscure troubles, to signal injection or disturbance tests. The simple circuit disturbance tests are sometimes inconclusive because of interaction through the a.g.c. or power supply circuits, or both. In the audio section, the limiting functions of the audio i.f. amplifiers and the ratio detector circuit of most receivers greatly attenuate the effects of most signal injection or disturbance tests. Signal injection or disturbance tests, furthermore, fail completely in problems involving picture aberrations, and sync instability.

Consider the case of an RCA KCS47 chassis with an intermittent bend at the top of the picture. Contrast is normal; vertical sync is good; and the a.g.c. action seemed normal. Tube substitution in the suspected circuits produced no improvement.

A waveform analysis of the composite sync signal at the output of the sync amplifier revealed an unusual condition. As shown in Fig. 2A, a section of horizontal sync pulses immediately following the vertical sync signal was depressed in amplitude. This signal condition was found to exist with the composite video signal at the output of the video detector. Furthermore, at the video detector output, the rest of the horizontal sync pulses, apparently unhampered by sync limiting, were uneven in amplitude, as shown in Fig. 2B.

The signal was followed into the i.f. amplifier with the demodulator probe. A "clean" signal was finally found at the grid of  $V_{102}$ . See Fig. 2C. Substitution of  $V_{102}$  showed no improvement. Voltage readings at the tube socket seemed normal.

At this point it is well to pause and  
**RADIO & TELEVISION NEWS**

consider that without the TV signal tracer, the localization of the defective stage to the third video i.f. amplifier would have been far more of a project than the simple matter it was. Once the defective stage is identified, the demodulator probe is laid aside, and the v.t.v.m. is brought into play.

The break in the case came when a small voltage drop across  $R_{106}$  was discovered. A check into the a.g.c. system for a cause of insufficient control voltage led to  $C_{121}$  which had undue leakage. Apparently the slight loss of a.g.c. voltage permitted the grid of  $V_{102}$  to conduct on positive i.f. signal peaks. The negative charge accumulated on the blocking condenser  $C_{107}$  during the period of the vertical sync signal altering, momentarily, the operating characteristics of  $V_{102}$ . Then for a brief period following vertical sync, during the first few dozen or so horizontal lines (depending upon the discharge time of RC circuit), the amplitude level of the positive peaks of the i.f. signal was lowered, resulting in an attenuated section of horizontal sync information after demodulation.

The above example shows how the diagnostic value of the oscilloscope is extended to circuits passing r.f. signals. The procedure is very simple: Where an unconventional signal has been followed back to the video detector, simply attach the demodulator probe to the scope and trace back through the i.f. and r.f. stages, with due regard, of course, to the interpretive process explained earlier.

The TV signal tracing technique does not minimize the need for technical knowledge and experience; quite the contrary. Consider the situation in a *Magnavox* CT 252 which was serviced for horizontal sync instability. A waveform analysis in the sync circuits revealed a distorted horizontal sync pulse. Fig. 3A shows the distorted horizontal sync pulses in the composite video signal at the detector output. An analysis of the probe-demodulated signal in the various i.f. stages, see Fig. 3B, suggested that distortion of the horizontal sync pulses was occurring in the 1st i.f. amplifier. However, a voltage, resistance, and component check failed to show any operational defect.

At this point, technical background and experience, (some people sum up these qualities as intuition) begin to play their full role. If the i.f. amplifiers are operating properly, could the horizontal sync distortion be the result of external influence? Continuing along these lines of investigation led to an ungrounded *Aquadag* coating in the picture tube. Apparently the horizontal kickback pulse was radiating from the ungrounded *Aquadag* coating of the picture tube into all the i.f. amplifiers beneath it. See Fig. 3C.

In passing, it might be pointed out that the effects of an ungrounded *Aquadag* coating vary considerably from one type of TV receiver to another. In many receivers, its effects are hardly noticeable, while in others

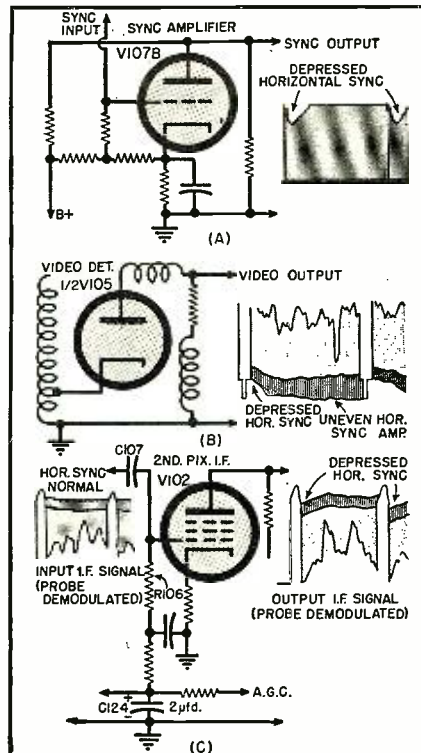

Fig. 2. Tracing a defective signal back through three stages in an RCA KCS47 TV chassis. The horizontal sweep rate of the scope is 30 cps.

it produces sync instability and regulation buzz, often confused with intercarrier buzz.

Those technicians, on the other hand, who place an over-reliance on the case history method to the detriment of new avenues of approach, should consider the following case. An RCA KCS72 was found to have an intermittent black bar across the picture, a few inches below the top; apparently a case of intermittent heater-to-cathode leakage in one of the r.f., i.f., or video amplifier tubes. Vertical sync was none too good. It was serviced in the home and again in the shop for tubes with heater-to-cathode leakage, but without avail. Finally, a scope analysis was made which revealed the waveforms

Fig. 4. An intermittent dark bar near the top of the picture in an RCA KCS 72 chassis gave the detector waveform in (A) due to faulty  $C_{120}$  in (B).

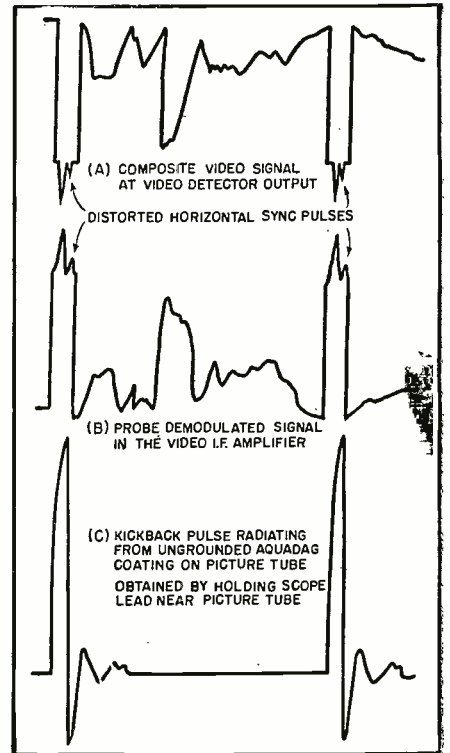
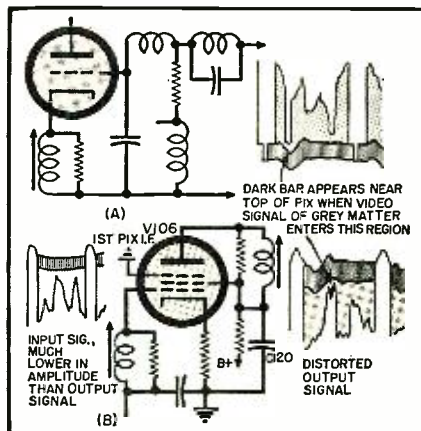
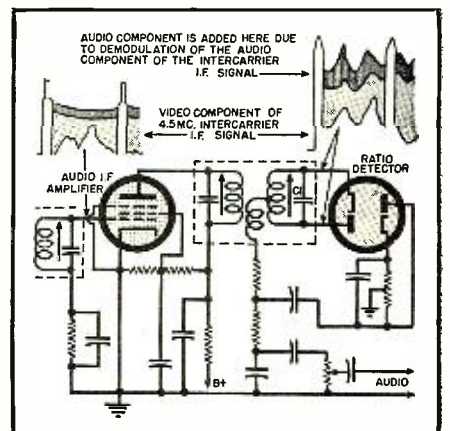

Fig. 3. Analysis of the faulty waveforms causing sync trouble in a *Magnavox* CT 252 TV set. The horizontal sweep rate of the scope is 7875 cps.

shown in Figs. 4A and B. Continuing in the i.f. amplifiers in the manner previously indicated, a clean probe-demodulated waveform was found at the grid of  $V_{100}$ . Subsequent voltage and resistance measurements revealed a leaky condenser,  $C_{120}$ , which had reduced the plate and screen voltages to a fraction of their normal value. Apparently, the positive i.f. signal peaks were extending into a region of early plate current saturation caused by the lowered operating voltages, which resulted in distortion to the i.f. modulation envelope.

As mentioned previously, the use of limiting i.f. amplifiers and ratio detectors in modern receivers of intercarrier (Continued on page 117)

Fig. 5. Both audio and video components are found in the probe demodulated signals at the input to the ratio detector of an intercarrier television receiver.



# MAC'S RADIO SERVICE SHOP

By JOHN T. FRYE

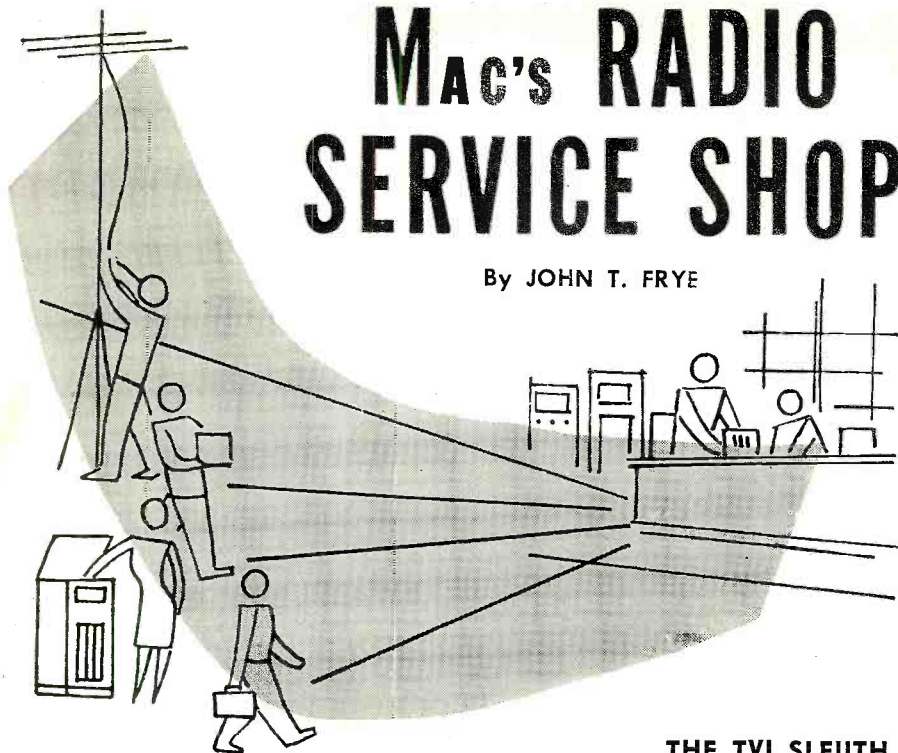

## THE TVI SLEUTH

**B**ARNEY considered returning late from lunch his own peculiar prerogative; therefore he was considerably annoyed when Mac, his employer, did not show up until the youth had been back at the service bench a full hour.

"Have something especially good for dessert?" he inquired sarcastically as the older man entered the service department.

"Nope," Mac replied with a teasing grin. "I simply ran into Joe Smith, radio communications man for a public service company, in the restaurant, and he wanted to show me the new mobile unit he has just built up for running down radio and television interference charged to their lines. I've been riding around with him while he demonstrated it."

"What's it like?" Barney capitulated, deciding to give up being mad in order to satisfy his curiosity.

"The whole installation is housed in a metal-body station wagon that has had ignition noise reduced to a minimum by the use of resistor-type spark plugs, suppressors, heavy bonding to the frame, and a reduced gap in the distributor. A heavy-duty 800 watt alternator is driven off the engine. The ten-volt a.c. output of this is rectified and used to charge the battery. The same output is stepped up by a transformer to 117 volts for powering the receiving equipment. In addition, for operating the equipment when the car's engine is turned off, there is a motor generator that puts out 250 watts at 117 volts a.c. Both of these power sources are voltage regulated.

"What kind of noise-detecting equipment does he use?"

"First, there's a broadcast receiver

with the a.v.c. disabled and with a meter on the output. Next is a communications receiver that tunes from 540 kilocycles to 109 megacycles and can receive both AM and FM signals. Then there are two television receivers with signal strength meters connected to their video detectors. Finally there is a calibrated field strength meter with inputs for either twin-lead or coaxial line. In addition, of course, any special service receiver, such as police, taxicab, airways, etc., can be set in for use if needed. He also has two-way communication with company radio stations."

"What antennas does he use on the receivers?"

"A whip is used for general coverage reception and for picking up strong TV interference. There is a rotating mounting on the rear of the car on which he can place any of his single-channel yagi antennas for determining the direction from which noise is coming on a particular channel."

"Is that all Joe does, ride around and listen for noise?"

"Not by a long shot. As radio communications man, he has to take care of the company's microwave, mobile, carrier telephone, carrier relay, and carrier telemetering equipment. In addition, however, he is on call by any district in which the company operates if the district people are not able to clear up a case of interference by themselves. Since Joe has a full ten years of experience at this interference-sleuthing business, he is darned good at it and gets all the really tough cases. He also runs a complete noise check on any new lines or other equipment as soon as it is

put into service. Then he makes periodic noise surveys over the transmission lines and substations in this half of the state. All the time he is driving around—and he drives about 4000 miles a month—the noise-detecting equipment in that station wagon is running; and if he notices anything unusual, he reports it, together with the pole number where it seems to peak, to the local office of the company."

"He must be a busy cuss," Barney remarked. "How does the company receive interference complaints?"

"A few come through the Public Service Commission. More of them are turned in to the various district offices of the company. Quite often the first report of noise comes from company employees using the carrier telephone for talking from one plant to another over the transmission lines. Since the receivers pick the signal right off the wire, many unusual noisy conditions are immediately noticed in these receivers."

"Is power line noise all he runs down?"

"I should say not!" Mac chuckled. "While it is true that he only goes out on a complaint when someone *thinks* a power line is causing the trouble, he finds the line guilty only one time in ten. That checks closely with a national survey that placed line noise ninth on the list of interference producers. The other nine times Joe finds the interference coming from an oscillating booster, TV set oscillator, neon sign, thermostat, heating pad, oil burner, ignition system, old-fashioned lamp bulb, diathermy, food mixer, blower motor, germicidal ozone or fluorescent lamp, light bulb loose in its socket, defective switch, or what have you."

"Does he always pinpoint the real cause of trouble?"

"No. When he is sure the company lines are not at fault, he usually stops right there. There are good reasons for not identifying sources of interference outside the company property. In the first place, many people owning interference-producing equipment do not take kindly to having this fact spotlighted by the power company. To do so is to run the risk of gaining ill will with a service primarily intended to promote and maintain good will. Secondly, if the power company cleared up every case of interference, no matter what the cause, it would soon become a clearing house for all complaints. It could not possibly take care of all the complaints that would then pour in, nor is there any valid reason why it should try. Quite often, however, it is necessary to find out what is causing the interference to prove the lines are *not*.

"A good example of that," Mac went on, "is contained in an incident that happened one Sunday morning a few weeks ago. Before noon on that day the power company logged between three and four hundred complaints of

(Continued on page 93)

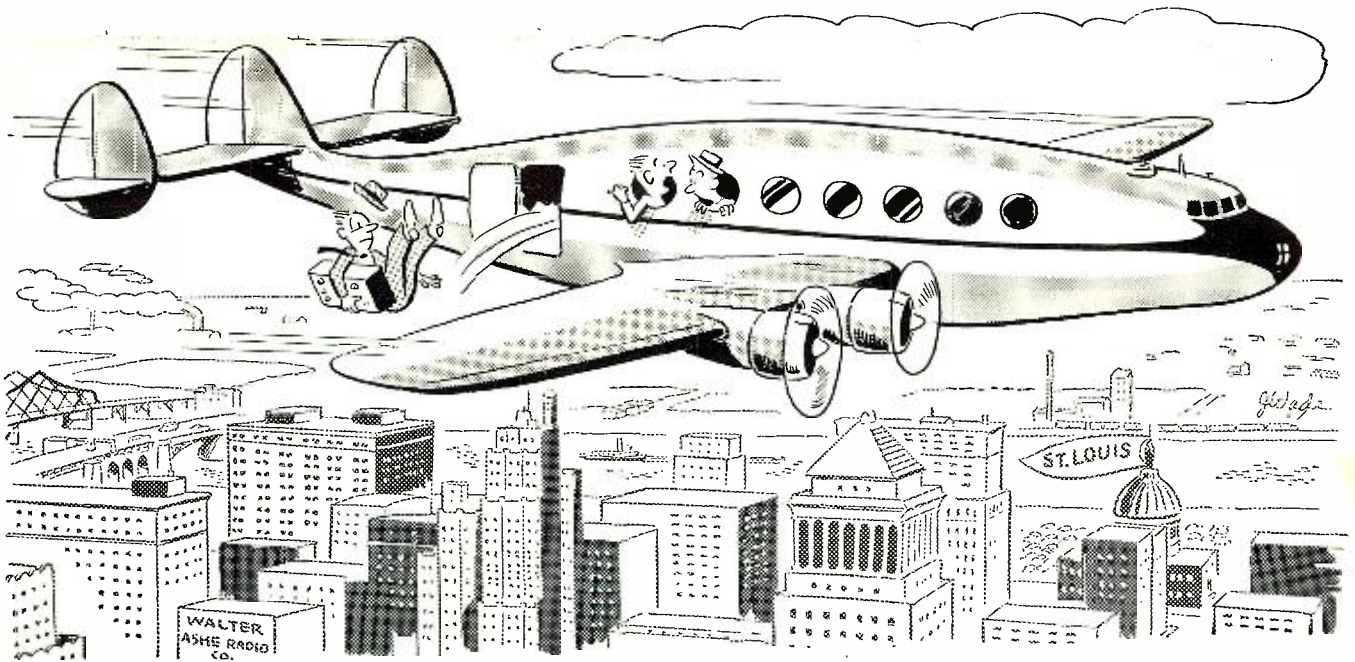

**"Oh well, he was going to drop in on Walter Ashe anyway"**

There's nothing to lose and everything to gain by asking Walter Ashe to make you his money-saving "Surprise" trade-in offer on your used test and communication equipment. So don't delay. Get your trade-in deal working today. Wire, write, phone or use the handy coupon below.

**CENTRAL ELECTRONICS SINGLE SIDEBAND EQUIPMENT**



New multiphase exciter. 160 to 10 meters. 10 watts peak output. Switchable SSB, with or without carrier, double sideband AM, PM, break-in CW. Voice operated break-in. Built-in power supply. With master crystal and coils for one band. MODEL 10B KIT. \$129.50. Wired and tested \$179.50. Extra coils, per band \$3.95

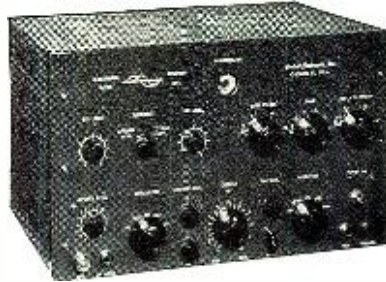

New bandswitching multiphase exciter. 160 to 10 meters. 20 watts peak output. Has features of the 10B plus magic eye carrier null and modulation peak indicator, new carrier level control, new calibrate circuit, new calibrate level control, phone patch input jack. MODEL 20A KIT \$199.50. Wired and tested \$249.50.



NEW BARKER & WILLIAMSON TRANSMITTER. Bandswitching, VFO or crystal controlled. Covers 80 through 10 meters. 135 watts input on phone, 150 watts on CW. TVI suppressed, built-in low pass filter. Wired and tested. MODEL 5100. Net \$442.50.

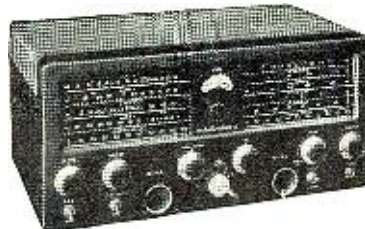

HALLICRAFTERS SX-71. Less speaker. Net \$249.95. Matching speaker. Net \$19.95.

**CENTRAL ELECTRONICS ACCESSORIES**

SIDEBAND SLICER. Improves any receiver with 450-500 kc. IF. Upper or lower sideband reception of SSB, AM, PM and CW at flip of switch. Cuts QRM in half. MODEL A KIT \$49.50. Wired and tested \$74.50.

MODEL QT-1. Speaker anti-trip unit. Plugs into 10B or 20A. Prevents noise or signals from tripping the voice control. Wired and tested. Net \$12.50.

MODEL AP-1 Plug-in IF stage, used with Slicer. Allows receiver to be switched back to normal. Wired and tested. Net \$8.50.

MODEL PS-1. Plug-in prealigned phase shift network. Net \$8.95.



JOHNSON VIKING RANGER TRANSMITTER-EXCITER KIT. 75 watts input on CW, 65 on phone. Bandswitching 160 through 10 meters. Self-contained VFO, modulator and power supply. TVI suppressed. Less tubes. RANGER KIT. Net \$179.50. Wired and tested \$258.00. Kit of tubes for Ranger. Net \$23.92.

All prices f. o. b. St. Louis • Phone Chestnut 1-1125

**Walter Ashe**  
**RADIO CO.**  
 1125 PINE ST. • ST. LOUIS 1, MO.

August, 1954

**FREE CATALOG!**

WALTER ASHE RADIO COMPANY  
 1125 Pine Street, St. Louis 1, Missouri

R-8-54

Rush "Surprise" Trade-In Offer on my \_\_\_\_\_

for \_\_\_\_\_  
 (show make and model number of new equipment desired)

Rush copy of latest Catalog.

Name \_\_\_\_\_

Address \_\_\_\_\_

City \_\_\_\_\_ Zone \_\_\_\_\_ State \_\_\_\_\_





# International SHORT-WAVE

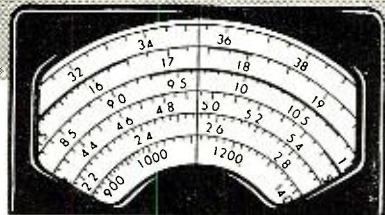

Compiled by **KENNETH R. BOORD**

**R**ECEPTION seems to be holding up well as the summer wanes as is evidenced by this month's reports. *Afghanistan—Kabul Radio*, 9.975, has *English* 1140-1150 sign-off. (Etersv, Sweden)

*Alaska—ALF*, 5.980, Juneau, noted with tests, fair level, at 2240-2330. (During, Alta.)

*Albania—Radio Tirana*, 7.852A, noted with *English* 1400. (Nattugglan, Sweden)

*Algeria—Radio Algerie*, 6.160, heard closing around 1730 lately instead of 1745. (Pearce, England)

*Anglo-Egyptian Sudan—Radio Omdurman*, 4.990AV, is strong closing 1500. (Collett, N. Z.)

*Angola—CR6RA*, 11.862A, Luanda, noted from 1600 at strong level in Portuguese, good music. (Arthurs, Pa., others) Heard in Belgium to 1730 closedown after program of dance music. (ISWL, England)

*Australia—VLI6*, 6.090, Sydney N. S. W., noted 0600 with news, then music. (Morris, Ohio) *VLH15*, 15.230, Melbourne, has improved signal around 2300-0030 with domestic service. (Morgan, Calif.) *VLW11*, 11.840, Perth, noted 2340 with news followed by recordings to 0015 tune-out. (Jones, N. C.) *VLC7*, 7.22, noted 0600-0645 to

the Forces in Japan-Korea. (Esser, Pa.)

*Austria—Radio Osterreich*, Vienna, has been logged near 9.480 at 1140 with popular music and announcements in German, very bad QRM when Cairo comes on air 1320 on 9.475. *Blue Danube Network*, 9.617, Salzburg, noted 1100 with news. (Pearce, England) Scheduled for *Radio Osterreich* is First Program on 6.155 from 2330, on 11.785 from 0000; Second Program 2330-2345, 11.935, 2330-0400, 7.245, 0000-0200, 9.615, 0200-1100, 9.665, 0400-0800, 7.135, 0800-1200, 5.985, 1100-1400, 9.505, 1200-1805, 7.245, 1400-1800, 9.665, 1800-1805, 9.645. (Austrian DX-Club)

*Azores—Ponta Delgada* now uses 11.925 daily 1400-1500. (Ferguson, N. C.; Niblack, Ind.; Pearce, England, others) Heard on 4.845 (*announced*) at 1630 with typical Portuguese music; CWQRM. (Mesquita e Sousa, Portugal)

*Belgium—ORU*, Brussels, was noted recently from 1900 on 9.144 (used to Leopoldville, Belgian Congo, for relay by OTC), 9.705, 9.767, 11.850 all parallel. (Saylor, Va.) Heard at good level over 11.850 now to North America 1900-2200 (*English* from 2000). (Miller, Ga. others) And relayed over OTC, 9.655, Belgian Congo. (Foster, Ill.; Machajewski, N. Y., others)

*Bolivia—CP38*, 9.4425, La Paz, noted 2105 at fair level to sign-off 2125A; all-Spanish. (Ferguson, N. C.; Collett, N. Z.) CP5 noted moved from 5.949 to 5.970, heard from 0600A onwards; now announces mostly as "La Voz de Bolivia," rather than using former "Radio Illimani" slogan. (Stark, Texas; N. Z. DX Times, others)

*Brazil—ZYP23*, 5.045, Petropolis, is good level around 1830 in Portuguese. (Ferguson, N. C.) PRA6, 9.685, *Radio Gazeta*, Sao Paulo, noted 1750 with relay of "A Voz do Brasil," says Fairs, England. ("La Radio Mondiale," France) ZYV40, 2.360, *Radio Cultura de Pocos de Caldas*, verified with colored postcard for Collett, N. Z. (N. Z. DX Times via Winch, Calif.)

*British Honduras—Radio Belize*, 3.300, is fair level at 2130. (Kirby, Mo.) Usually closes 2232A weekdays, 2245A Sun. (Arthurs, Pa.)

*British New Guinea—VLT6*, 6.130, Port Moresby, noted with complete weather broadcast 0355, followed by ABC news relay 0400; fair level in Calif. (West)

*Bulgaria—In* verifying, *Radio Sofia* listed *English* on 7.255, 7.670 at 1500-1515, 1615-1645; on 9.700 at 1745-1800, 2000-2030, 2300-2330. (Knowles, Pa.)

*Cape Verde Islands—CR4AA*, 7.398A, Praia, noted closing 1700 with "A Portuguesa." (Mesquita e Sousa, Portugal)

*Ceylon—Radio Ceylon*, 11.770A, noted from 2030 sign-on; BBC news relay 2100. (Ferguson, N. C.) The VOA relay is noted now over 11.870A from 0930 or earlier parallel with 7.235. (Pearce, England, others) The Commercial Service on 9.52 heard to 1230 closedown at strong level in Calif. (Kapp)

*China—Radio Peking*, 15.08A, is fair 2130-0030 or 0100, mostly in native but with *English* 2200-2230 when is parallel with 11.960; from around 2300, 11.650A is parallel with 15.08A outlet; heard with *English* 0400 on 15.06A, and 0930 on 15.08A, 11.65A. (Morgan, Balbi, California) Fairs, England, has noted Peking on measured 9.062 at 1810 onwards parallel

(Note: Unless otherwise indicated, all time is expressed in American EST; add 5 hours for GMT. "News" refers to newscasts in the English language. In order to avoid confusion, the 24 hour clock has been used in designating the times of broadcasts. The hours from midnight until noon are shown as 0000 to 1200 while from 1 p.m. to midnight are shown as 1300 to 2400.) The symbol "V" following a listed frequency indicates "varying." The station may operate either above or below the frequency given. "A" means frequency is approximate.

This Canadian DX-er, R. E. Fleischman of Montreal, uses a Hallicrafters SX-26.



# Concord Radio

Brings You... **Greatest**  
Antenna Values of the Century!!

## Famous VEE-D-X ALL ALUMINUM YAGIS

Less Than Wholesale Cost!

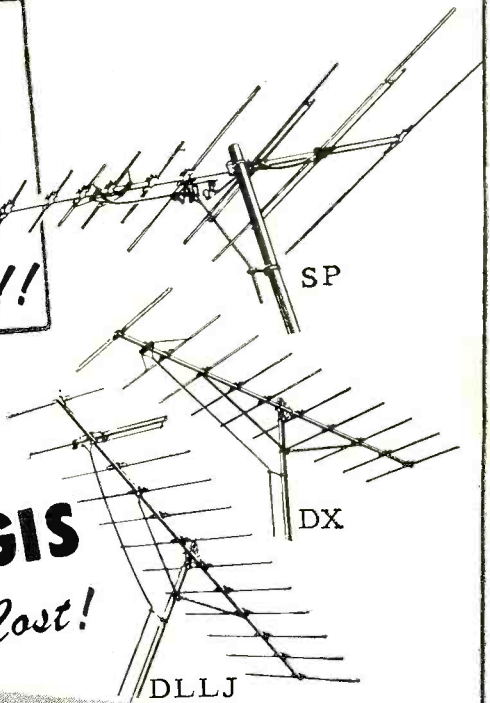

### VEE-D-X 9 ELEMENT ALL-CHANNEL VHF YAGI

THE ONE AND ONLY ALL-CHANNEL VHF YAGI COMBINING  
YAGI POWER, DIRECTIVITY, PLUS ALL CHANNEL PERFORMANCE

#### Model SP

One of the most fabulous antenna values ever offered and the opportunity that you've been waiting for. A chance to solve your stock and inventory problems with one antenna for all single channels. And talk about bargains! This antenna Regularly Lists at \$38.85. You SAVE \$25.90 on every one that you buy! The VEE-D-Xtra Special combines all the desirable features of a yagi, yet with all-channel performance. This one easy-to-install antenna eliminates the need for separate yagis for each channel, individual transmission lines and switches. Provides top performance at lowest cost. The VEE-D-Xtra Special is a 9-element hi-low yagi: 5 elements on high, Delta Matched 4 elements on low, "T" Matched. Hi-low sections are phased together with new isolation filter (MM-25). It is the outstanding all-channel VHF antenna especially wherever interference from unwanted stations must be eliminated. Ideal for use with VEE-D-X Antenna Rotator.  
Shpg. wt. 7 lbs.  
Stock No. 99-G-SP1... List \$38.85... Net \$12.95

Reg. Price  
**\$38.85**  
Now  
**\$11.95**  
ea. Lots of 3  
**\$12.95** ea

### 12 ELEMENT LONG LONG JOHN YAGIS with DELTA MATCH

Channels 7 to 13 Reg. \$18.50 **\$7.95** ea. - Lots of 3

Channels 2 to 5  
Reg.  
**\$41.95**  
**\$12.95** ea.  
Lots of 3  
**\$11.95**

Vee-D-X Long Long John - the King of all Yagis - is the super gain 12 Element yagi guaranteed to outperform all others. Its extra power is ideal for fringe areas. Rugged, pre-assembled construction includes boom bracing that gives extra strength with light weight. High front-to-back ratio. Full 6 mc band width. We don't know how long our supply of these antennas will last at this low, low price. Order early and avoid disappointment.  
Shpg. Wt. Chan. 7 - 13 - 6 lbs. - Chan. 2-5 - 13 1/2 lbs.  
Stock No. 99-G-DLLJ (Specify Channel).

### VEE-D-X "Delta-X" 10 Element All-Aluminum Yagis

Channels 2 to 6 Reg. from \$29.15 **\$7.95** ea. - Lots of 3

Channels 7 and 8  
Reg.  
**\$15.15**  
**\$7.49** ea.  
Lots of 3  
**\$6.95**

This astounding Concord Money Saving Antenna Value features extra-wide spacing to produce 30% higher gain than conventional 10 element yagis. Powered for even higher gain by the famous Xee-D-X DeltaMatch construction; High gain for extra picture power; Drawn tubing for added durability; Excellent front-to-back ratio. Completely pre-assembled for faster, easier assembly. Shpg. wt. Chan. 2-6 - 11 lbs. - Chan. 7 - 5 1/2 lbs.  
Stock No. 99-G-VDX (Specify Channel).

### VEE-D-X All-Aluminum 3, 4, and 8 Element Yagis

It may sound like bragging... but, we've made the most sensational Antenna buy of the decade, and we're passing the savings on to you. Here is an assortment of the finest VEEDX 3, 4, and 8 element all aluminum yagis that are priced in many cases at less than manufacturer's cost. We don't have a full selection of all channels in all types, so order early and assure yourself of an adequate supply of yagis at give-away prices.

#### 3 Element All-Aluminum Yagis Series EC

Channel 7-8-9-10-11-12-13  
List \$8.50 Your Price **\$1.49**

#### Stacked 3 Element All-Aluminum Yagis

Channel 7-8-9-10-11-12-13  
List \$12.50 Your Cost **\$2.49**

#### 4 Element All-Aluminum Yagis

Channel 4-5-6 - List 11.50 ONLY **\$2.25**  
Channel 7-8-9-10-11-12-13  
List \$8.50 ONLY **\$1.98**

#### 8 Element Long John Yagis

Channel 4-5-6 - List \$25.80 **\$7.95**  
Channel 7-8-9-10-11-12-13  
List \$12.95 ONLY **\$4.40**

### 300 OHM TWIN LEAD VIRGIN POLYETHYLENE

**\$1.29** per 100 ft. **\$5.98** per 500 ft. **\$10.99** per 1000 ft.

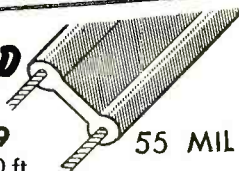

55 MIL

CONCORD RADIO 53 Vesey Street, New York 7, N. Y.

- Check Enclosed
- C.O.D. enclosed please find 25% of total purchase price... check... Money Order.
- Money Order Enclosed
- Send new 1954 CONCORD CATALOG!

Name \_\_\_\_\_  
Address \_\_\_\_\_  
City \_\_\_\_\_ State \_\_\_\_\_

CONCORD RADIO • 53 VESEY ST. • NEW YORK 7, N. Y. • DIgby 9-1132



# Build Your Own Interior - Styled Cabinets

## KITS

by **Cabinart**

presenting the

### paul klipsch-designed REBEL IV . . .



Now you can build your own Klipsch Corner Horn Enclosure and save money — identical in acoustic design to assembled units and easily put together with a minimum of tools. Priced for the home-builder in unfinished birch.

\$36.00\* Net for 12" model

\$42.00\* Net for 15" model

### BASS REFLEX and EQUIPMENT CABINETS

Ideal housing for hi-fi components — removable panels make future changes easier. Loudspeaker cabinet acoustically designed for either 12" or 15" speaker.

Overall dimensions: 33 1/2", 23", 16". Tuner Compartment: 20" H., 21 3/4" W. (inside dimensions), 15 1/4" Deep. Baffle volume: 5 cubic feet.

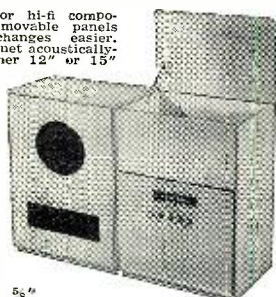

**No. 80 . . . \$27.00\***  
(Equipment Kit)

**No. 8112 . \$18.00\***  
(12" speaker)

**No. 8115 . \$18.00\***  
(15" speaker)

All kits include 5/8" white pine plywood cut to size, baffle pre-cut for 12" or 15" speaker. Saran Plastic AcoustiCloth, Kim-sul Acoustic Insulation. Assembly and finishing instructions, hardware, plastic wood, sandpaper and glue.

### CORNER FOLDED HORN ENCLOSURES

Reproduces a quality of bass heretofore only possible through the use of far more expensive designs.

**No. 61 (12" speaker) . . . \$19.95\***

**No. 63 (15" speaker) . . . \$23.95\***



\* Prices higher West and South.  
Write for free catalog and nearest distributor

**G & H WOOD PRODUCTS COMPANY**  
75 NORTH 11th STREET  
BROOKLYN 11, N. Y.

with 7.496, 6.200 (latter has bad QRM). ("La Radio Mondiale," France) *Radio Peking* advises that the 9.760 frequency was used "only for germ warfare broadcasts" and now has been withdrawn. (*N. Z. DX Times*) Mukden, 3.660A, Manchuria, noted around 0500-0800 in Chinese propaganda, music. (Morgan, Calif.)

**Columbia**—HJKH, 5.075A, Sutatenza, is again being heard in Australia-New Zealand from around 0550 opening. (*Radio Australia*; Sanderson, Australia)

**Costa Rica**—TIFC, 9.647, San Jose, noted 2200 with news, then with other *English* programs; new QRA is Box 2710, San Jose; *wants reports*. (West, Calif., others) Due to electricity shortage, schedule is only 0600-1300, 1700-2300. (Herd, Dela.) TIDCR, 9.615, San Jose, has strong signal in Spanish around 1900. (Foster, Ill.)

**Cuba**—COBZ, 9.03, *Radio Salas*, Havana, good level 1800 to 0030 close-down; COKG, 8.95A, *Cadena Oriental de Radio*, Santiago de Cuba, is good level 1600-0030 close-down; identifies in *English* as well as Spanish at close-down. (Diaz, Ind.) COBX, 11.900, noted 2345 with chimes, then Spanish program of music, good level in Australia. (Sanderson)

**Czechoslovakia**—Prague now uses 9.55 for both the 1930 and 2300 *English* transmissions to North America. (Koral, Levy, Beine, N. Y., others) Signs on *English* for Europe 1400 on 9.504. (Pearce, England)

**Denmark**—Improved signals are widely reported in Copenhagen's two daily transmissions to North America on 9.52—2030-2130, 2200-2300; some weeks the DX program lately has been on Fri. instead of regularly scheduled Tue. (Arthurs, Pa.; Bellington, N. Y.; Saylor, Va.; Esser, Pa., others)

**Ecuador**—HCJB, 11.915, noted at good strength 2215 with religious session in *English*. (Fleischman, Quebec, others) HC2RL, 6.233 *measured*, Guayaquil, noted in clear 2325-2359 close-down with symphonic music, Spanish and *English* announcements at close. (Roberts, Conn.) Plans to increase power soon; purpose is "to give the world in the name of culture the possibility of listening to selected classical music without interruption by commercials," officials state. (URDXC)

**Egypt**—*Radio Cairo* was recently noted in Arabic 1723 on *measured* 7.049. (Ferguson, N. C.) *Test* transmissions over 12.030A are scheduled daily 2300-0200, 0700-0830, 1000-1620 (some days may run longer). (*Radio Sweden*) Cairo, 9.475, noted 1320 with news in French, 1330 in *English*. (Bilocq, Quebec) Strong on 15.315 in *English* for India 0830. (Pearce, England)

**El Salvador**—YSAX, 11.945A, noted in Spanish, fair level, 2100. (Deuring, Alta.)

**Fiji Islands**—ZJV3, 3.980, Suva, noted 0430 at good level with news, music. (Sanderson, Australia)

**France**—Paris, 15.400, noted to 1000, then on 15.350 at 1015 with much

weaker signal. (Stark, Texas) Heard on 11.845 at 1615 in French. (Niblack, Ind.) Noted closing 2000 on 11.700. (Miller, Ga.) Noted on 9.55 at good level in French to Tahiti 0030-0100. (Smith, Ga.) Heard on 11.85A at 1045 with French news to Indo-China. (Bilcoq, Quebec) Heard on 11.92 at 1200 in Arabic. (Pearce, England) Still has *English* for British Isles 1500-1600 over 11.700, 9.620A.

**French Equatorial Africa**—*Radio Brazzaville*, 11.970, noted at good level with news 1745. (Karl, Pa.; Milnes, Ore.) Noted closing 2030 on 9.440. (Diaz, Ind.) The 11.970 outlet is good ending news 1600. (Levy, N. Y., others)

**French Guiana**—"La Radio Mondiale," France, confirms that *Radio Cayenne* is now on 6.200 at 1730-1830, audible in France only after 1800 when *Paris-Inter* closes down, although is *officially listed* on 6.198.

**Germany**—*Overseas Service*, Cologne, for North America 2030-2330 noted now over 7.290, 6.075A. (Bellington, N. Y.) Heard to Latin America on 7.290 at 1930-2000. (Koral, Levy, N. Y.) Heard on 5.980 at 0015 with German news, music. (Sanderson, Australia) AFN, 5.470, noted 1730 with American music, CWQRM. (Mesquita e Sousa, Portugal) Opens 0000 and has AFN news 0100; fair in New Zealand 1300-1500 fade-out. (*N. Z. DX Times*) Stuttgart, 6.030, noted at fair level in German 0945. (Buggins, England)

**Greece**—Athens noted back on 11.718 with news in French 1230, in *English* 1245; off 1300A with Greek National Anthem. (Pearce, England; Niblack, Ind.) Larissa, 6.725, noted 0115 with songs.

**Guatemala**—TGWA, 9.76, noted at good level to 2400 or later. (Richmond, N. Y.) TGNA in verifying listed *active* channels as 1720 kc. (from 1180 kc.). 5.9525, 9.668, 11.850; *inactive* are 15.100, 17.870. (Waltz, Washington State)

**Haiti**—*Radio Haiti*, 10.074A, Port-au-Prince, noted at strong level 1639-1700 with music, announcements in French. (Smith, Ga.)

**Holland**—Hilversum has improved signal on 11.73 during *English* for North America-Europe 1645-1730A. (Miller, Ga.; Beine, N. Y., others) Noted opening 0700 on 11.95A for Indonesia. (Pearce, England)

**Honduras**—HRQ, 6.125, San Pedro Sula, noted 2300 in Spanish. (Niblack, Ind.)

**Hungary**—Budapest, 6.248, noted 1730 with news, music. (Sanderson, Australia)

**India**—AIR, Delhi, noted at good level on 11.96 at 1930 with news. (Niblack, Ind.) Opens 0830 to Southeast Asia over 9.565, 11.960; news 0835. Heard with news 1030-1045 on 9.755. (Pearce, England) VUC7, 7.210, Calcutta, noted at fair strength with native music and announcements 0648, bad ham QRM. (Morgan, Calif.)

**Indo-China**—*Radio France-Asie*, Sai-  
(Continued on page 78)

BUILD YOUR OWN

# Heathkits

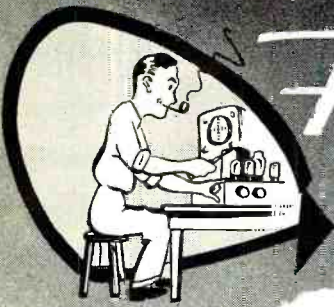

- TEST INSTRUMENTS
- AMPLIFIERS
- RECEIVERS, etc.

- ① Save by ordering direct from manufacturer.
- ② All high quality standard brand components.
- ③ Increased knowledge through actual construction.
- ④ Sound engineering insures excellent performance.
- ⑤ Kit construction is fascinating and enjoyable.



MODEL  
O-9

**\$59<sup>50</sup>**

Shipping  
Wt. 28 lbs.

## Heathkit MODEL O-9 OSCILLOSCOPE KIT

New features unheard of in a kit oscilloscope have been added to the already popular Heathkit series. All top quality components are used including a brand new RCA 5U1 CRT. Ten other first line tubes complete the lineup. Voltage regulation provides a rock steady pattern regardless of normal line voltage variations. A built-in blanking amplifier eliminates the retrace line entirely. Other important advantages are a phasing control, Z axis input, direct connections to the deflection plates, 1 volt peak-to-peak calibration voltage and a calibrated grid screen.

Wiring is simplified by the use of the harness technique which also results in a neat professional appearance. Extremely wide vertical bandwidth allows accurate reproduction of even a 500 KC square wave. Excellent focusing characteristics are made possible by the use of the new RCA 5U1 CRT and a spot shape control. One of the most versatile of test instruments, the Heathkit O-9 Oscilloscope will be invaluable in the radio and TV service shop, as a work project in schools and for all types of circuit investigation work in the laboratory. Its new features make Model O-9 comparable in every way to many commercially built oscilloscopes selling for as much as \$400. Don't pass up this opportunity to add a really fine instrument to your service or experimental lab.

### Heathkit

#### VOLTAGE CALIBRATOR KIT

The use of a Voltage Calibrator will greatly increase oscilloscope usefulness. Provides a convenient method of making peak to peak voltage measurements by establishing a relationship between the unknown wave shape and the Voltage Calibrator. Voltage ranges .01-100 volts peak to peak. The Voltage Calibrator features direct reading scales and a regulated power supply system.



MODEL VC-2

**\$11<sup>50</sup>**

Shipping Wt. 4 lbs.

### Heathkit

#### ELECTRONIC SWITCH KIT

The Heathkit Electronic Switch Kit will further extend scope usefulness by permitting simultaneous observation of two individually controlled traces. Continuously variable switching rates 10 cps to 2,000 cps in three ranges. Will also serve as a square wave generator over the range of switching frequencies.



MODEL  
S-2

**\$23<sup>50</sup>**

Shipping  
Wt. 11 lbs.

## Heathkit VACUUM TUBE VOLTMETER KIT

The beautiful new 1953 Heathkit Model V-6 VTVM, the world's most popular kit instrument, now offers many outstanding new features in addition to retaining all of the refinements developed and proven through the production of over 70,000 VTVM kits. The Heathkit VTVM now features extended voltage ranges with 50% greater coverage on the DC range. New 1 1/2 volt low scale provides well over 2 1/2 inches of scale length per volt permitting faster measurements with greater accuracy. AC and DC ranges are 0-15-5-15-50-150-500-1500 volts (1,000 volts maximum on AC). Ohmmeter ranges are X1, X10, X100, X1,000, X10K, X100K X1 meg. Measures .1 ohm to 1,000 megohms. Other features are db scale, center scale zero adjust and polarity reversal switch. High 11 megohm input resistance virtually eliminates circuit loading.

The low anti-inflation price of this tremendously popular kit includes all tubes, necessary constructional material, test leads and the construction manual.

MODEL V-6

**\$24<sup>50</sup>**

Shipping  
Wt. 6 lbs.

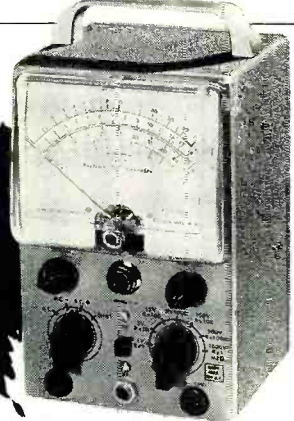

### Heathkit AC VACUUM TUBE VOLTMETER KIT

MODEL AV-2

**\$29<sup>50</sup>**

Shipping  
Wt. 5 lbs.



A new amplifier type AC VTVM that makes possible those sensitive measurements so essential in laboratory or audio work. Ten voltage ranges covering from .01 RMS full scale to 300 volts RMS full scale. Input impedance 1 megohm with frequency response 20-50,000 cycles. Ten DB ranges from -52 to +52 DB. Four diodes in meter bridge circuit for maximum linearity.

### Heathkit

#### HANDITESTER KIT

The ever popular Handitester is now supplied with a Simpson 400 microampere meter movement. Provides AC and DC voltage ranges 0-10-30-300-1,000-5,000 volts. Ohmmeter ranges 0-3,000 and 0-300,000 ohms. DC current measurements 0-10 and 0-100 milliamperes. A completely self contained portable instrument.

MODEL M-1

**\$14<sup>50</sup>**

Shipping  
Wt. 3 lbs.



**HEATH COMPANY • Benton Harbor 15, Mich.**

# HEATHKITS for the ENGINEER

## Heathkit VISUAL AURAL SIGNAL TRACER KIT

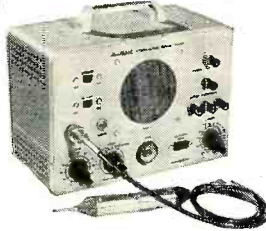

MODEL T-3 **\$23<sup>50</sup>**  
Shipping  
Wt. 10 lbs.

Designed especially for service applications in AM-SW-FM-TV repair work. RF and audio two channel input. More than adequate sensitivity—new noise locator circuit—calibrated wattmeter—substitution speaker—visual signal indication. Can be used with scope and VTVM, checks phono cartridges, phono mechanisms, microphones, tuners, etc. Let the Heathkit Visual Aural Signal Tracer help you.

## Heathkit RESISTANCE SUBSTITUTION BOX KIT

MODEL RS-1  
Ship. Wt. **\$5<sup>50</sup>**  
2 lbs.



Choice of 36 switch selected resistance values 15 ohms to 10 megohms. All standard RTMA 1 watt 10% resistors. Buy several for those lab and service applications.

## NEW Heathkit 20,000 OHMS PER VOLT MULTIMETER KIT

Here is the solution to all service problems requiring a portable measuring device of high accuracy. 20,000 ohms/volt sensitivity on DC and 5000 ohms/volt on AC. Full scale voltage ranges of 1.5, 5, 50, 150, 500, 1500 and 5000. DC current ranges of 150 microamperes; 15, 150 and 500 milliamperes; and 15 amperes. Resistances are measured from .2 ohms to 20 megohms in 3 ranges and decibels from -10 to +65 db.

Model MM-1 uses standard commercially available batteries and is not affected by strong RF fields as encountered in and near transmitting equipment. 1% precision resistors on a very easily wired ring type range switch and a highly accurate Simpson 50 microampere meter fully qualifies the Heathkit Multi-

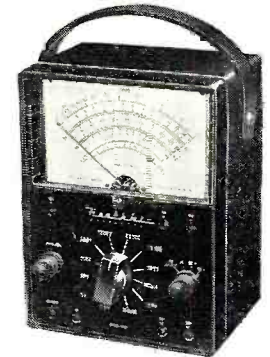

MODEL MM-1  
**\$26<sup>50</sup>**  
Ship. Wt. 6 lbs.

meter for close tolerance laboratory and service work. The meter movement is placed in a recessed position for maximum non-glare readability. The kit includes the attractive black bakelite cabinet, 2 color meter scales, test leads, batteries and all other necessary components. Overall cabinet size is 5 1/2" wide x 4" deep x 7 1/2" high.

## Heathkit CONDENSER CHECKER KIT

An instrument designed solely for its particular job. Not a "sideline" or a multiple function instrument. Measures value and quality of unknown condensers and resistors. Capacity range .00001 mfd to 1,000 mfd. Resistance range 100 ohms to 5 megohms. Sensitive electron beam indicator—five polarizing test voltages—safety spring return leakage test switch. An amazingly accurate instrument at this low price.



MODEL C-3  
**\$19<sup>50</sup>** Shipping  
Wt. 8 lbs.

## Heathkit SIGNAL GENERATOR KIT



MODEL 5G-8  
**\$19<sup>50</sup>**  
Ship. Wt. 8 lbs.

The standard service instrument for alignment work. .1 volts output from 160 KC to 110 MC. Calibrated harmonics up to 220 MC. Internal (400 CPS) and external modulation. Pre-calibrated coils for all 5 bands. Good stability and accuracy. All test leads included.

## Heathkit GRID DIP METER KIT

One hand operation. 5 pre-wound coils cover 2-250 MC. Controlled sensitivity. Usable as an oscillator or an absorption wave meter. Extra low frequency coils available.



MODEL GD-1B  
**\$19<sup>50</sup>**  
Ship. Wt. 4 lbs.

## Heathkit TUBE CHECKER KIT

Checks overall tube quality, filament continuity, and individual elements for shorts and opens. Features chart illumination, harness type wiring, and large 3-color meter scale.



MODEL TC-2  
**\$29<sup>50</sup>**  
Shipping Wt. 12 lbs.

Portable Model TC-2P at \$34.50. Wt. 14 lbs. No. 91-8 Cabinet only at \$7.50. Wt. 7 lbs. No. 355 TV Picture Tube Adapter at \$4.50. Wt. 1 lb.

## Heathkit LABORATORY GENERATOR KIT



MODEL LG-1  
Ship. Wt. **\$39<sup>50</sup>**  
16 lbs.

A professional laboratory instrument designed for extreme accuracy in frequency and output level. Colpitts oscillator operates in 5 ranges from 150 KC to 30 MC. Panel meter calibrated in output voltage and percent of modulation. Output in excess of .1 volts. Features complete shielding of oscillator, buffer and attenuator sections; regulated power supply and 50 ohm output cable. Comparable instruments priced many times higher than the cost of this new kit.

## Heathkit LABORATORY REGULATED POWER SUPPLY KIT



MODEL PS-2  
**\$33<sup>50</sup>**  
Ship. Wt. 20 lbs.

A regulated variable 160-450 volt DC output power supply for the lab or service shop. Accurate voltage and current measurements with large Simpson meter. AC supply 6.3 volts at 4 amperes—standby switch eliminates warmup time. Low hum content—5 tube circuit. AC and DC output voltages isolated from panel for maximum operational flexibility.

## Heathkit AUDIO WATTMETER KIT

Measure output power levels directly with the Heathkit Audio Wattmeter. Flat response to frequencies from 10 CPS to 250 KC. Full scale ranges of 5 MW, 50 MW, 500 MW, 5 W and 50 W. Db calibration from -10 to +48. Uses non-inductive built-in load resistors providing impedances of 4, 8, 16 and 600 ohms. Meter bridge uses 4 germanium diodes.



MODEL AW-1  
Ship. Wt. **\$29<sup>50</sup>**  
6 lbs.

HEATH COMPANY • Benton Harbor 15, Mich.

# SERVICEMAN • AMATEUR • STUDENT

## Heathkit IMPEDANCE BRIDGE KIT

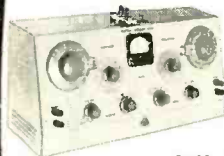

MODEL IB-2  
**\$59.50**

Ship. Wt. 15 lbs.

Modern design with built-in 1 KC generator for AC measurements. A choice of the Wheatstone, Maxwell, Hay or capacitance comparison bridges for measuring resistance, capacitance, inductance, dissipation factor and storage factor.  $\frac{1}{2}$ % resistors and precision mica condensers provide maximum accuracy. Completely AC operated.

## Heathkit DECADE RESISTANCE KIT



MODEL DR-1  
**\$19.50**

Ship. Wt.  
4 lbs.

Individual switch selection of twenty 1% precision resistors in 1 ohm steps from 1 to 99,999 ohms. Sturdy ceramic wafer switches featuring silver plated contacts and smooth, positive detent action.

## Heathkit TELEVISION SWEEP GENERATOR KIT



MODEL TS-3  
**\$44.50**

Ship. Wt. 18 lbs.

Simplify your TV alignment jobs with the new Heathkit TS-3. Full coverage on fundamentals from 4 MC to 220 MC at an output of well over 100,000 microvolts... Automatic blanking and wide range phasing. A triple marker system ranges from 19 MC to 180 MC using a Colpitts oscillator plus the 4.5 MC crystal controlled oscillator for check points (crystal furnished). Provisions are also made for using an external marker. Featured is the new sweep system, using an \*INCREDUCTOR controllable inductor. Sweep width is variable from 0 to 12 MC at the lower RF frequencies and increases to 0-50 MC at the highest... Other advantages are power supply regulation, constant RF output level, independent marker and RF output control circuits, low impedance output and properly terminated output cables. The construction manual is complete in all detail and with a reasonable amount of care, Model TS-3 will serve faithfully for many years to come.

\*Trademark, C.G.S. Laboratories, Stamford, Connecticut

## Heathkit COMMUNICATIONS RECEIVER KIT



MODEL AR-2  
**\$25.50**

(Less Cabinet)

Full coverage from 550 KC to 35 MC on 4 bands, with good sensitivity and selectivity. Features electrical bandspread, BFO, headphone jack, slide rule dial with ham band identification, RF gain control, noise limiter and phone standby-CW switch. Top quality, high gain components used throughout. Pre-wound coils in a shielded turret assembly and a transformer operated power supply assure trouble-free performance.

Cabinet available separately, No. 91-10. Shipping wt. 5 lbs. Price \$4.50.

## Heathkit Q METER KIT



MODEL QM-1  
**\$44.50**

Ship. Wt. 14 lbs.

A typical Heathkit invasion of the laboratory instrument field. Here is the first successful low priced Q meter ever offered in kit form. Oscillator supplies RF in the range of 150 KC to 18 mc. Reads Q directly on calibrated meter scales. Measures Q of condensers, RF resistance and distributed capacity of coils. Calibrate capacitor with range of 40 mmf to 450 mmf with vernier  $\pm 3$  mmf. All measurements made at the operating frequency.

## Heathkit AUDIO OSCILLATOR KIT

MODEL AO-1  
**\$24.50**

Ship. Wt. 11 lbs.

Features sine or square wave coverage from 20-20,000 cycles in 3 ranges. Variable 10 volt output level at 600 ohms impedance. Thermistor controlled linearity—precision multiplier resistors—distortion less than .6%. An outstanding instrument value at this amazing low price.



## Heathkit AMATEUR TRANSMITTER KIT



MODEL AT-1  
**\$29.50**

Ship. Wt. 16 lbs.

Power input up to 35 watts on 80, 40, 20, 15, 11 and 10 meters. Can be crystal or VFO excited. Complete with modulator input socket and VFO power output provisions. Other desirable features are good shielding, AC line filter, key click filter, standby switch and a 52 ohm coaxial output. Model AT-1 is AC operated and is suitable as an exciter for a higher powered rig. Complete with full instructions for construction and use.

## Heathkit DECADE CONDENSER KIT

Switch selected 1% silver mica precision condensers providing capacity range of 100 mmf. to 0.111 mfd. in steps of 100 mmf.

MODEL DC-1  
**\$16.50**

Shipping Wt. 4 lbs.



## Heathkit AUDIO GENERATOR KIT

A new extended range 18 cycles—1 megacycle audio instrument at a remarkably low price. Five continuously variable output ranges—600 ohm output impedance—low distortion figure, less than .4% from 100 cps through audible range.



MODEL AG-8  
**\$29.50**

Ship. Wt. 11 lbs.

## Heathkit BAR GENERATOR KIT



Small, compact and easy to use, Model BG-1 supplies horizontal or vertical bars for TV linearity adjustments. Output cable clips directly to the TV receiver antenna terminals.

MODEL BG-1

Ship. Wt. **\$14.50**  
6 lbs.

## Heathkit BATTERY ELIMINATOR KIT

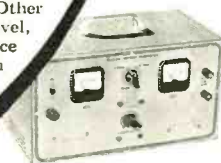

MODEL BE-4  
Ship. Wt. **\$31.50**  
18 lbs.

6 or 12 volt operation with current and voltage constantly monitored. Double protection with a fused transformer and automatic overload relay. Well filtered output and all heavy duty components. Designed for auto radio repair and as a storage battery charger.

## WRITE FOR Free CATALOG

New 40 page 1954 Catalog lists all kits, specifications, schematics and latest price information.

# HEATH COMPANY • Benton Harbor 15, Mich.



# RADIO SERVICING IN SOUTH AFRICA

By N. C. HOLMAN

*Service technicians have unusual problems in South Africa where licensing exists and there is no TV.*

**R**ADIO servicing conditions in South Africa are in many ways similar to those in the rural U.S.A. Most of the well-known American makes of radios are in use, in addition to many of the British and European makes. The standard of servicing rises yearly, and we have our master-minds of the caliber of Mac and Barney. Life goes on at a more leisurely pace than in the States, however, and Barney at any rate would not feel at home. There is no high-pressure advertising, no house-to-house search for customers, and no cut-rate installation.

The service equipment in common use is similar to that used in the average American service shop, as may be seen in Fig. 1. However, the bench is equipped with a large variety of power outlets, since several types of two- and three-pin plugs and connectors are in use. The American type with the flat pins is reserved for 110-volt apparatus, which is occasionally worked with adaptors or line cords from the standard 220-volt a.c. socket.

The shelves have a larger assortment of tubes than the American shop since, in addition to the usual octal, loctal, and miniature types, there are European types which are not substitutes and, in some cases, serve only one make of set. Tube testing is performed as a free service, and a customer will sometimes bring in a handful, the characteristics of which will have to be looked up in different books. Considerable alertness and a wide knowledge of tube types is essential. The common British EF 50, for instance, is similar to the 6K7 except that its heater current is only 200 ma.; consequently, it is a direct substitute for the 6K7 in transformer sets but not in a.c.-d.c. sets.

There are many small coal mines in the Transvaal and Natal, and some of these supply 220 volts d.c. to dwellings in the vicinity, causing a continued demand for the a.c.-d.c. type of set. However, these small sets with their limited gain, and the common delusion that six feet of wire indoors is a suitable antenna, even under an iron roof, cause many complaints of poor reception. Reliance is mainly placed on high-frequency broadcasts in the 42, 60, and 85 meter bands in the country districts. The occasional "wipe out" on these bands is not fully appreciated by customers. The large cities, however, usually have three "medium wave" programs available.

Automobile receivers which receive only the "medium wave" signals give great difficulty to the service technician, since results at beyond 100 miles are usually not satisfactory in the daytime unless they are giving peak performance. However, many locally manufactured converters are in use to take advantage of the high field strength of high-frequency broadcasts. The "Voice of America" and other overseas broadcasts are well received.

Public address is becoming recognized as a necessity at meetings and outdoor functions, and provides the

service technician with a welcome break away from the bench.

Currently, many radiograms (radio consoles) are being brought in to have the new three-speed turntables for microgroove and long-playing records fitted. Many radiograms have very fine locally made cabinets of native "imbuia" wood, with imported chassis and record changer. These are always sold on credit, and some legal knowledge is essential.

A recent law provides that: "No person shall sell, give, or in any manner supply radio apparatus to any other person unless he is the holder of a Radio Dealers License." In addition, a Radio Repairers License is necessary for the shop and, eventually, a Radio Technicians License will be necessary for the employee who does the repairs.

The wages for a radio mechanic have been fixed by a decision of the Industrial Board at 3 shillings and 9 pence per hour (\$.56), plus a "Cost of Living Bonus" which is at present one shilling and 10 pence (\$.25). The fixed maximum charge to the customer is 15 shillings an hour (about \$2.40).

An attempt to operate from a van, advertising "Repairs done in your own home—charge 15 shillings plus parts" has now been made illegal, since the Municipal authorities will not grant a Dealers License except for fixed premises.

Installing and servicing of electric plants (Onan, Kohler, Wincharger, etc.) at farms is a fluctuating business which follows the trend of wool prices very closely.

There is no television as yet, and no decision has been made as to stand-

ards. The fact that the local mains are of 50 cycles as against the U.S. standard of 60 has so far been of no importance, except where public-address systems use a wire recorder. While on the road, the recorder is powered by an inverter at 60 cycles, but on connecting to the mains, the speaker's voice falls to a deep bass. To correct this, the sealed vibrator unit is opened and the armature loaded with solder.

During the war years and after, dealers preferred not to sell tubes or components to customers, but to insist on the radio being brought to the shop. Now, with parts in adequate supply, the home repairer has come into his own again.

In this country, the "minimum service charge" for a home call has not been accepted where only some trifling adjustment is involved; nor can the repairer's experience be added to the bill.

For example, many European tubes still use a metallized paint as shielding in the glass types. If this coating cracks, the i.f. stages are sure to break into oscillation, which may cause complete silence from the loudspeaker, even though it is seemingly an unrelated fault.

The customer, of course, does not appreciate the fact that the radio technician requires much experience to locate this fault—the set owner knows only that one tube has been replaced and, therefore, the charge should be a low one. One method of satisfying the customer in such cases has been to give each repaired radio a thorough preventative maintenance check-up before it leaves the shop.

—50—

The interior of a well-equipped radio service shop in Pietermaritzburg, Natal, South Africa. Much of the equipment shown is produced in the United States.



*Compare* AND YOU WILL CHOOSE . . .

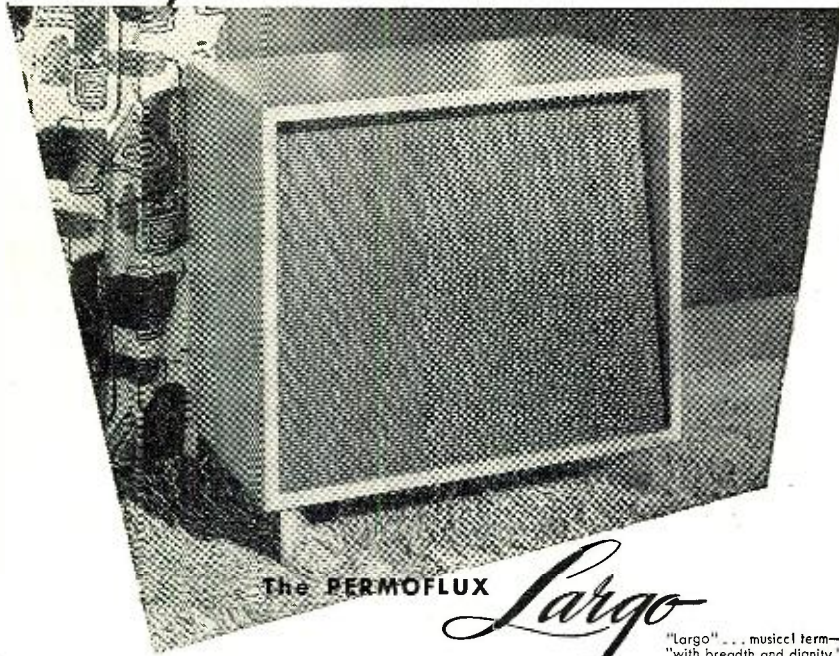

The PERMOFLUX

*Largo*

"Largo" . . . musical term—  
"with breadth and dignity."

**New Specially Designed Horn-loaded High Fidelity Speaker System**

The Largo is a complete wide range speaker system utilizing the new Permoflux 8V81 Super Royal Eight speaker and 32 KTR Super Tweeter in an acoustically advanced enclosure scientifically matched to the speaker characteristics. The enclosure is an entirely new and unique horn-loaded non resonant baffle with horn loading of the speaker back wave accomplished in the cabinet base. Every inch of the cabinet construction serves an acoustically useful purpose.

Baffle and speaker characteristics were matched octave by octave through laboratory tests to provide undistorted reproduction of all frequencies from 35 cycles to 16,000 cycles. Power handling capacity is 15 watts. A high frequency balance control is provided for matching individual room characteristics.

Its low contemporary styling is gracefully proportioned for decorative blending with the finest room decor. Precision constructed of selected 3/4" Mahogany and Korina veneers.

A Permoflux Exclusive: Special connection for headset extension cord for private listening and hard of hearing music lovers.

• The Largo . . . Audiophile Net Price **\$99.75**

Enclosure styled by Contemporary American Furniture.

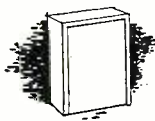

**The Fortissimo**—A 2-way multiple speaker system. Unique "New Dual Driving Point" Enclosure Design surpasses bass and mid-range performance of finest 12 and 15 inch systems. With 2 Super Royal 8 speakers and Super Tweeter. Cabinet beautifully styled in Mahogany or Korina Blonde veneers. Audiophile Net Price **\$218.00**

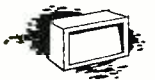

**The Diminette**—A 2-way speaker system featuring full high fidelity performance with minimum cabinet size and low cost. With 2 Royal 6 speakers and Super Tweeter. In Mahogany or Blonde finish. Audiophile Net Price **\$49.50**

Visit your Hi-Fi dealer for a demonstration; also hear the New Super Royal Speaker (8, 12, and 15 inch sizes).

Send today for complete descriptive literature.

**Permoflux**  
CORPORATION

4918 West Grand Avenue  
Chicago 39, Illinois

West Coast Plant

4101 San Fernando Road

Glendale 4, California

## THE CBS PATCHING BAY

*The heavy programming at Hollywood's "Television City" is handled smoothly with centralized control.*

THE master control portion of CBS's Television City technical area provides space for complete switching, monitoring, and control facilities which are capable of handling forty audio and video program sources to twelve output circuits and eighty monitoring locations.

The Television City tele-ciné facilities include eight film chains, each with two audio and video outputs for patching to studios or program control rooms. One film camera is used with each of three Eastman 16 mm projectors, three RCA 35 mm projectors, and two Gray "Telop" projectors.

The tele-ciné portion of this technical area is divided into projection and control rooms. The film projection installation utilizes a separate film camera for each film or slide projector. This arrangement in a plant the size of Television City permits the handling of peak load requirements with flexibility and operating convenience.

A unique feature in the assignment of all projectors to various studios for making film inserts is provided by means of a patching system. A multi-pin cable plug containing audio and video outputs, start-stop circuits, intercom and monitoring circuits associated with a projector camera group may be plugged into any one of four receptacles of each studio on which mating circuits appear. The patching bay, shown on this month's cover, is in the form of a circular base unit containing the projector circuit cables with an eight-sided structure hanging above the base unit containing the receptacles. An open space between the two circuits makes it possible to reach any projector cable from any operating position around the patch bay.

The assignment of a projector to a studio requires only a single connection. The actual operation of a projector unit, after it is loaded with film and assigned, is then under the direct control of the remote studio technical crew. Thus, even though film projection is centralized, the studio retains control of its assigned film projection facilities in keeping with the otherwise almost complete decentralization to the studio control rooms of studio, audio, and video facilities.

The increasing dependence of video stations on network programming has resulted in stepped up schedules at network centers, making centralized control an absolute "must." —30—

RADIO & TELEVISION NEWS



Measures 6 1/4" x 9 1/2" x 4 1/2"

# Superior's new Model 670-A **SUPER METER**

## A COMBINATION VOLT-OHM MILLIAMMETER PLUS CAPACITY REACTANCE INDUCTANCE AND DECIBEL MEASUREMENTS

### SPECIFICATIONS:

D.C. VOLTS: 0 to 7.5/15/75/150/750/1,500/7,500 Volts  
 A.C. VOLTS: 0 to 15/30/150/300/1,500/3,000 Volts  
 OUTPUT VOLTS: 0 to 15/30/150/300/1,500/3,000 Volts  
 D.C. CURRENT: 0 to 1.5/15/150 Ma. 0 to 1.5/15 Amperes  
 RESISTANCE: 0 to 1,000/100,000 Ohms 0 to 10 Megohms  
 CAPACITY: .001 to 1 Mfd. 1 to 50 Mfd. (Quality test for electrolytics)  
 REACTANCE: 50 to 2,500 Ohms, 2,500 Ohms to 2.5 Megohms  
 INDUCTANCE: .15 to 7 Henries 7 to 7,000 Henries  
 DECIBELS: -6 to +18 +14 to +38 +34 to +58

### ADDED FEATURE:

The Model 670-A includes a special **GOOD-BAD** scale for checking the quality of electrolytic condensers at a test potential of 150 Volts.

The Model 670-A comes housed in a rugged, crackle-finished steel cabinet complete with test leads and operating instructions.

**\$28<sup>40</sup>**  
NET

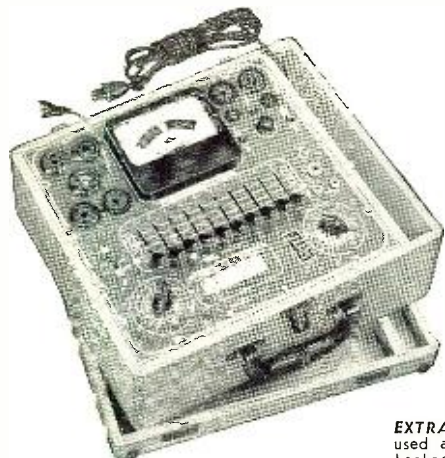

# Superior's new Model TV-11 **TUBE TESTER**

### SPECIFICATIONS:

- ★ Tests all tubes including 4, 5, 6, 7, Octal, Lock-in, Peanut, Bantam, Hearing Aid, Thyatron, Miniatures, Sub-Miniatures, Novals, Sub-minars, Proximity fuse types, etc.
- ★ Uses the new self-cleaning Lever Action Switches for individual element testing. Because all elements are numbered according to pin-number in the RMA base numbering system, the user can instantly identify which element is under test. Tubes having tapped filaments and tubes with filaments terminating in more than one pin are truly tested with the Model TV-11 as any of the pins may be placed in the neutral position when necessary.
- ★ The Model TV-11 does not use any combination type sockets. Instead individual sockets are used for each type of tube. Thus it is impossible

- to damage a tube by inserting it in the wrong socket.
- ★ Free-moving built-in roll chart provides complete data for all tubes.
- ★ Newly designed Line Voltage Control compensates for variation of any Line Voltage between 105 Volts and 130 Volts.
- ★ **NOISE TEST:** Phono-jack on front panel for plugging in either phones or external amplifier will detect microphonic tubes or noise due to faulty elements and loose internal connections.

The model TV-11 operates on 105-130 Volt 60 Cycles A.C. Comes housed in a beautiful hand-rubbed oak cabinet complete with portable cover.

**\$47<sup>50</sup>**  
NET

**EXTRA SERVICE**—The Model TV-11 may be used as an extremely sensitive Condenser Leakage Checker. A relaxation type oscillator incorporated in this model will detect leakages even when the frequency is one per minute.

### SUPERIOR'S NEW MODEL TV-40



# **C.R.T. TUBE TESTER**

★ A complete picture tube tester for little more than the price of a "make-shift" adapter!!

The Model TV-40 is absolutely complete! Self-contained, including built-in power supply, it tests picture tubes in the only practical way to efficiently test such tubes; that is by the use of a separate instrument which is designed exclusively to test the ever increasing number of picture tubes!

### EASY TO USE:

Simply insert line cord into any 110 volt A.C. outlet, then attach tester socket to tube base (ion trap need not be on tube). Throw switch up for quality test . . . read direct on Good-Bad scale. Throw switch down for all leakage tests.

★ Tests all magnetically deflected tubes . . . in the set . . . out of the set . . . in the carton!!

### SPECIFICATIONS:

- Tests all magnetically deflected picture tubes from 7 inch to 30 inch types.
- Tests for quality by the well established emission method. All readings on "Good-Bad" scale.
- Tests for inter-element shorts and leakages up to 5 megohms.
- Tests for open elements.

Model TV-40 C.R.T. Tube Tester comes absolutely complete—nothing else to buy. Housed in round cornered, molded bakelite case. Only . . . . .

**\$15<sup>85</sup>**  
NET

# **SHIPPED ON APPROVAL NO MONEY WITH ORDER — NO C. O. D.**

Try any of the above instruments for 10 days before you buy. If completely satisfied then send down payment and pay balance as indicated on coupon. **No Interest or Carrying Charges Added!** If not completely satisfied return unit to us, no explanation necessary.

August, 1954

### MOSS ELECTRONIC DISTRIBUTING CO., INC.

Dept. D-54 3849 Tenth Ave., New York 34, N. Y.

Please send me the units checked. I agree to pay down payment within 10 days and to pay the monthly balance as shown. It is understood there will be no carrying, interest or any other charges, provided I send my monthly payments when due. It is further understood that should I fail to make payment when due, the full unpaid balance shall become immediately due and payable.

Model 670-A . . . . . Total Price \$28.40  
\$7.40 within 10 days. Balance \$3.50  
monthly for 6 months.

Model TV-11 . . . . . Total Price \$47.50  
\$11.50 within 10 days. Balance \$6.00  
monthly for 6 months.

Model TV-40 . . . . . Total Price \$15.85  
\$3.85 within 10 days. Balance \$4.00  
monthly for 3 months.

Name.....  
Address.....  
City..... Zone..... State.....



Have you had the  
Chassis Touching  
JITTERS  
Lately?



## Adjust-A-Volt

### LR-5 VARIABLE TRANSFORMER

with isolated primary winding lets you service any TV or radio set made without a chance of a "bite" . . . no more chassis touching jitters.



Delivery from stock of your favorite jobber.

This husky 1/2 KVA electro-statically shielded unit is "Must" test equipment for thousands of service men. Intermittent operating TV or radio sets are checked by dropping line voltage to 105 V or lower to detect a faulty oscillator. Also used to cook a set at 130-140 V to break down intermittent part. On any application where either isolation or a variable transformer is needed Adjust-A-Volt will do the job. Black wrinkle finish, jeweled pilot light and convenient fuse. Write for new 18-page catalog listing all types and sizes.

**STANDARD  
ELECTRICAL PRODUCTS CO.**

2238 E. THIRD ST. • DAYTON, OHIO

## WHAT'S New in Radio

The products described in this column are for your convenience in keeping up-to-date on the new equipment being offered by manufacturers. For more complete information on any of these products, write direct to the company involved.

### SUBMINIATURE SWITCH

R. F. Electronics, Inc., 291 North-east 61st St., Miami, Florida is now offering a new precision, low-loss, 12-position subminiaturized switch in its Brown-Hill line.

Only 3/4" square, the new wafer-type selector switch is designed for constant stability in conductivity and where resistance, inductance, and capacitance must be kept to a minimum. The rotor shaft may be had in either 1/8" or 1/4" diameter.

### SNAP-ON MOUNTING

Littelfuse, Inc., 1865 Miner St., Des Plaines, Ill., has redesigned its TV snap-on mounting unit to speed service work.

The innovation consists of substantial cutouts on each side of the holder, facilitating quick and easy replacement of fuses. With the new model, the blown pigtail fuse can be readily snapped on one side and the regular replacement fuse inserted on the other.

Use of the new mounting eliminates cutting out the pigtail fuse, soldering, and the threat of damage from a hot iron. Known as Part No. 350130, the new mounting is available in quantities of 10 and 24.

### NON-INDUCTIVE RESISTORS

K-F Development Company, 2700 Spring St., Redwood City, California is now offering a series of precision resistors in standard value ranges from .1 ohm to 1 megohm.

Wound non-inductively on non-hygroscopic ceramic bobbins and impregnated for moisture protection, these units exhibit low thermal e.m.f. and a temperature coefficient of .000025 ohm per degree C. Nine sizes are supplied ranging in power capability from 1/4 watt to 1 watt, in diameter from 1/4" to 3/4", and in length from 5/16" to 1 1/4". Accuracies of 1%, .5%, and .1% are available.

### PHOTOTRANSISTOR

Radio Receptor Co., 251 W. 19th St., New York 11, N. Y. has developed a new miniature p-n-p phototransistor, the Type RR66.

Although designed specifically for automobile headlight dimmer applications, the new unit can be used for industrial control.

The light sensitive element is hermetically sealed within a glass bulb and is connected to three leads which emerge from a glass header. The bulb diameter is 3/8" x 5/8" high. The spectral response covers the visible range and extends far into the infrared so

that it is especially useful in black light applications.

The company's Seletron and Germanium Division Sales Office will supply additional information on request.

### PLUG-IN RELAYS

A new time-delay relay which combines the hydraulic-magnetic silicone operating principle and plug-in construction has been introduced by Heinemann Electric Co., 753 Plum Street, Trenton, 2, N. J.

The Type F "Silic-O-Netic" unit is compact, lightweight, and hermetically

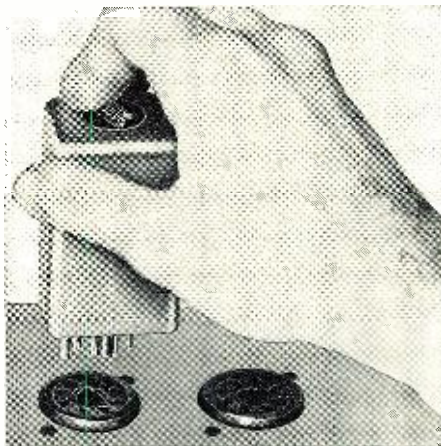

sealed against dust and moisture with an inert gas fill optionally available. The relay is provided with standard delay periods from 1/4 to 120 seconds.

Except for the armature and switch contacts the only moving part is the iron core which is the complete time element. The new relays are provided with either octal-pin or solder-lug terminals for operation on 24 to 220 volts a.c. or 12 to 125 volts d.c.

### SERVICE INSTRUMENT

Radio City Products Co., Inc. of Easton, Pa., has added the Model 657 electronic "Do-All" to its line of service instruments.

The new test unit covers 62 individual electronic range measurements and combines a capacity meter, a high-range ohmmeter in addition to the conventional and low ranges, a vacuum-tube voltmeter, a peak-to-peak v.t.v.m., and an inductance meter.

The d.c. and a.c. voltages are direct reading up to 6000 volts without an external multiplier probe. Capacity ranges are 1 μfd. to 1000 μfd.

The instrument comes with an 8 1/2 inch easy-reading meter. The dial

PREMIER Unconditionally Guarantees All Tubes for One Full Year: We All Know Good Servicemen Avoid Costly Guarantee Replacements

# REMEMBER!! QUALITY CANNOT BE UNDEERSOLD

VERY BEST BRANDS AVAILABLE FOR IMMEDIATE DELIVERY. INDIVIDUALLY BOXED.

1A66... 1.19	2A6... 89c	6A16... 1.89	6B16... 69c	6K5GT... 69	6S0... 59c	7C5... 89	12A7... 79	12N7GT... 95	26... 79c
1A67... 59c	2A7... 89c	6A15... 2.95	6B16... 69c	6K6GT... 59	6S0GT... 59c	7C6... 79c	12A7... 59	12N7GT... 95	27... 79c
1A68... 79	2B3... 89	6A15... 89	6B17... 1.19	6K7GT... 59	6S1GT... 59c	7C7... 79c	12A7... 59	12N7GT... 95	28... 79c
1A69... 79	2B7... 89	6A16... 89	6B18... 1.19	6K8GT... 59	6S2GT... 59c	7C8... 79c	12A7... 59	12N7GT... 95	29... 79c
1A70... 79	2E5... 89	6A15... 89	6B19... 1.19	6K9GT... 59	6S3GT... 59c	7E6... 79c	12A7... 59	12N7GT... 95	30... 79c
1A71... 79	2X2... 89	6A15... 89	6B20... 1.19	6K10GT... 59	6S4GT... 59c	7E7... 79c	12A7... 59	12N7GT... 95	31... 79c
1A72... 79	3A4... 89	6A15... 89	6B21... 1.19	6K11GT... 59	6S5GT... 59c	7E8... 79c	12A7... 59	12N7GT... 95	32... 79c
1A73... 79	3A5... 89	6A15... 89	6B22... 1.19	6K12GT... 59	6S6GT... 59c	7E9... 79c	12A7... 59	12N7GT... 95	33... 79c
1A74... 79	3A6... 89	6A15... 89	6B23... 1.19	6K13GT... 59	6S7GT... 59c	7F7... 79c	12A7... 59	12N7GT... 95	34... 79c
1A75... 79	3A7... 89	6A15... 89	6B24... 1.19	6K14GT... 59	6S8GT... 59c	7F8... 79c	12A7... 59	12N7GT... 95	35... 79c
1A76... 79	3A8... 89	6A15... 89	6B25... 1.19	6K15GT... 59	6S9GT... 59c	7F9... 79c	12A7... 59	12N7GT... 95	36... 79c
1A77... 79	3A9... 89	6A15... 89	6B26... 1.19	6K16GT... 59	6S10GT... 59c	7G7... 79c	12A7... 59	12N7GT... 95	37... 79c
1A78... 79	3A10... 89	6A15... 89	6B27... 1.19	6K17GT... 59	6S11GT... 59c	7G8... 79c	12A7... 59	12N7GT... 95	38... 79c
1A79... 79	3A11... 89	6A15... 89	6B28... 1.19	6K18GT... 59	6S12GT... 59c	7G9... 79c	12A7... 59	12N7GT... 95	39... 79c
1A80... 79	3A12... 89	6A15... 89	6B29... 1.19	6K19GT... 59	6S13GT... 59c	7H7... 79c	12A7... 59	12N7GT... 95	40... 79c
1A81... 79	3A13... 89	6A15... 89	6B30... 1.19	6K20GT... 59	6S14GT... 59c	7H8... 79c	12A7... 59	12N7GT... 95	41... 79c
1A82... 79	3A14... 89	6A15... 89	6B31... 1.19	6K21GT... 59	6S15GT... 59c	7H9... 79c	12A7... 59	12N7GT... 95	42... 79c
1A83... 79	3A15... 89	6A15... 89	6B32... 1.19	6K22GT... 59	6S16GT... 59c	7H10... 79c	12A7... 59	12N7GT... 95	43... 79c
1A84... 79	3A16... 89	6A15... 89	6B33... 1.19	6K23GT... 59	6S17GT... 59c	7H11... 79c	12A7... 59	12N7GT... 95	44... 79c
1A85... 79	3A17... 89	6A15... 89	6B34... 1.19	6K24GT... 59	6S18GT... 59c	7H12... 79c	12A7... 59	12N7GT... 95	45... 79c
1A86... 79	3A18... 89	6A15... 89	6B35... 1.19	6K25GT... 59	6S19GT... 59c	7H13... 79c	12A7... 59	12N7GT... 95	46... 79c
1A87... 79	3A19... 89	6A15... 89	6B36... 1.19	6K26GT... 59	6S20GT... 59c	7H14... 79c	12A7... 59	12N7GT... 95	47... 79c
1A88... 79	3A20... 89	6A15... 89	6B37... 1.19	6K27GT... 59	6S21GT... 59c	7H15... 79c	12A7... 59	12N7GT... 95	48... 79c
1A89... 79	3A21... 89	6A15... 89	6B38... 1.19	6K28GT... 59	6S22GT... 59c	7H16... 79c	12A7... 59	12N7GT... 95	49... 79c
1A90... 79	3A22... 89	6A15... 89	6B39... 1.19	6K29GT... 59	6S23GT... 59c	7H17... 79c	12A7... 59	12N7GT... 95	50... 79c
1A91... 79	3A23... 89	6A15... 89	6B40... 1.19	6K30GT... 59	6S24GT... 59c	7H18... 79c	12A7... 59	12N7GT... 95	51... 79c
1A92... 79	3A24... 89	6A15... 89	6B41... 1.19	6K31GT... 59	6S25GT... 59c	7H19... 79c	12A7... 59	12N7GT... 95	52... 79c
1A93... 79	3A25... 89	6A15... 89	6B42... 1.19	6K32GT... 59	6S26GT... 59c	7H20... 79c	12A7... 59	12N7GT... 95	53... 79c
1A94... 79	3A26... 89	6A15... 89	6B43... 1.19	6K33GT... 59	6S27GT... 59c	7H21... 79c	12A7... 59	12N7GT... 95	54... 79c
1A95... 79	3A27... 89	6A15... 89	6B44... 1.19	6K34GT... 59	6S28GT... 59c	7H22... 79c	12A7... 59	12N7GT... 95	55... 79c
1A96... 79	3A28... 89	6A15... 89	6B45... 1.19	6K35GT... 59	6S29GT... 59c	7H23... 79c	12A7... 59	12N7GT... 95	56... 79c
1A97... 79	3A29... 89	6A15... 89	6B46... 1.19	6K36GT... 59	6S30GT... 59c	7H24... 79c	12A7... 59	12N7GT... 95	57... 79c
1A98... 79	3A30... 89	6A15... 89	6B47... 1.19	6K37GT... 59	6S31GT... 59c	7H25... 79c	12A7... 59	12N7GT... 95	58... 79c
1A99... 79	3A31... 89	6A15... 89	6B48... 1.19	6K38GT... 59	6S32GT... 59c	7H26... 79c	12A7... 59	12N7GT... 95	59... 79c
1A100... 79	3A32... 89	6A15... 89	6B49... 1.19	6K39GT... 59	6S33GT... 59c	7H27... 79c	12A7... 59	12N7GT... 95	60... 79c
1A101... 79	3A33... 89	6A15... 89	6B50... 1.19	6K40GT... 59	6S34GT... 59c	7H28... 79c	12A7... 59	12N7GT... 95	61... 79c
1A102... 79	3A34... 89	6A15... 89	6B51... 1.19	6K41GT... 59	6S35GT... 59c	7H29... 79c	12A7... 59	12N7GT... 95	62... 79c
1A103... 79	3A35... 89	6A15... 89	6B52... 1.19	6K42GT... 59	6S36GT... 59c	7H30... 79c	12A7... 59	12N7GT... 95	63... 79c
1A104... 79	3A36... 89	6A15... 89	6B53... 1.19	6K43GT... 59	6S37GT... 59c	7H31... 79c	12A7... 59	12N7GT... 95	64... 79c
1A105... 79	3A37... 89	6A15... 89	6B54... 1.19	6K44GT... 59	6S38GT... 59c	7H32... 79c	12A7... 59	12N7GT... 95	65... 79c
1A106... 79	3A38... 89	6A15... 89	6B55... 1.19	6K45GT... 59	6S39GT... 59c	7H33... 79c	12A7... 59	12N7GT... 95	66... 79c
1A107... 79	3A39... 89	6A15... 89	6B56... 1.19	6K46GT... 59	6S40GT... 59c	7H34... 79c	12A7... 59	12N7GT... 95	67... 79c
1A108... 79	3A40... 89	6A15... 89	6B57... 1.19	6K47GT... 59	6S41GT... 59c	7H35... 79c	12A7... 59	12N7GT... 95	68... 79c
1A109... 79	3A41... 89	6A15... 89	6B58... 1.19	6K48GT... 59	6S42GT... 59c	7H36... 79c	12A7... 59	12N7GT... 95	69... 79c
1A110... 79	3A42... 89	6A15... 89	6B59... 1.19	6K49GT... 59	6S43GT... 59c	7H37... 79c	12A7... 59	12N7GT... 95	70... 79c
1A111... 79	3A43... 89	6A15... 89	6B60... 1.19	6K50GT... 59	6S44GT... 59c	7H38... 79c	12A7... 59	12N7GT... 95	71... 79c
1A112... 79	3A44... 89	6A15... 89	6B61... 1.19	6K51GT... 59	6S45GT... 59c	7H39... 79c	12A7... 59	12N7GT... 95	72... 79c
1A113... 79	3A45... 89	6A15... 89	6B62... 1.19	6K52GT... 59	6S46GT... 59c	7H40... 79c	12A7... 59	12N7GT... 95	73... 79c
1A114... 79	3A46... 89	6A15... 89	6B63... 1.19	6K53GT... 59	6S47GT... 59c	7H41... 79c	12A7... 59	12N7GT... 95	74... 79c
1A115... 79	3A47... 89	6A15... 89	6B64... 1.19	6K54GT... 59	6S48GT... 59c	7H42... 79c	12A7... 59	12N7GT... 95	75... 79c
1A116... 79	3A48... 89	6A15... 89	6B65... 1.19	6K55GT... 59	6S49GT... 59c	7H43... 79c	12A7... 59	12N7GT... 95	76... 79c
1A117... 79	3A49... 89	6A15... 89	6B66... 1.19	6K56GT... 59	6S50GT... 59c	7H44... 79c	12A7... 59	12N7GT... 95	77... 79c
1A118... 79	3A50... 89	6A15... 89	6B67... 1.19	6K57GT... 59	6S51GT... 59c	7H45... 79c	12A7... 59	12N7GT... 95	78... 79c
1A119... 79	3A51... 89	6A15... 89	6B68... 1.19	6K58GT... 59	6S52GT... 59c	7H46... 79c	12A7... 59	12N7GT... 95	79... 79c
1A120... 79	3A52... 89	6A15... 89	6B69... 1.19	6K59GT... 59	6S53GT... 59c	7H47... 79c	12A7... 59	12N7GT... 95	80... 79c
1A121... 79	3A53... 89	6A15... 89	6B70... 1.19	6K60GT... 59	6S54GT... 59c	7H48... 79c	12A7... 59	12N7GT... 95	81... 79c
1A122... 79	3A54... 89	6A15... 89	6B71... 1.19	6K61GT... 59	6S55GT... 59c	7H49... 79c	12A7... 59	12N7GT... 95	82... 79c
1A123... 79	3A55... 89	6A15... 89	6B72... 1.19	6K62GT... 59	6S56GT... 59c	7H50... 79c	12A7... 59	12N7GT... 95	83... 79c
1A124... 79	3A56... 89	6A15... 89	6B73... 1.19	6K63GT... 59	6S57GT... 59c	7H51... 79c	12A7... 59	12N7GT... 95	84... 79c
1A125... 79	3A57... 89	6A15... 89	6B74... 1.19	6K64GT... 59	6S58GT... 59c	7H52... 79c	12A7... 59	12N7GT... 95	85... 79c
1A126... 79	3A58... 89	6A15... 89	6B75... 1.19	6K65GT... 59	6S59GT... 59c	7H53... 79c	12A7... 59	12N7GT... 95	86... 79c
1A127... 79	3A59... 89	6A15... 89	6B76... 1.19	6K66GT... 59	6S60GT... 59c	7H54... 79c	12A7... 59	12N7GT... 95	87... 79c
1A128... 79	3A60... 89	6A15... 89	6B77... 1.19	6K67GT... 59	6S61GT... 59c	7H55... 79c	12A7... 59	12N7GT... 95	88... 79c
1A129... 79	3A61... 89	6A15... 89	6B78... 1.19	6K68GT... 59	6S62GT... 59c	7H56... 79c	12A7... 59	12N7GT... 95	89... 79c
1A130... 79	3A62... 89	6A15... 89	6B79... 1.19	6K69GT... 59	6S63GT... 59c	7H57... 79c	12A7... 59	12N7GT... 95	90... 79c
1A131... 79	3A63... 89	6A15... 89	6B80... 1.19	6K70GT... 59	6S64GT... 59c	7H58... 79c	12A7... 59	12N7GT... 95	91... 79c
1A132... 79	3A64... 89	6A15... 89	6B81... 1.19	6K71GT... 59	6S65GT... 59c	7H59... 79c	12A7... 59	12N7GT... 95	92... 79c
1A133... 79	3A65... 89	6A15... 89	6B82... 1.19	6K72GT... 59	6S66GT... 59c	7H60... 79c	12A7... 59	12N7GT... 95	93... 79c
1A134... 79	3A66... 89	6A15... 89	6B83... 1.19	6K73GT... 59	6S67GT... 59c	7H61... 79c	12A7... 59	12N7GT... 95	94... 79c
1A135... 79	3A67... 89	6A15... 89	6B84... 1.19	6K74GT... 59	6S68GT... 59c	7H62... 79c	12A7... 59	12N7GT... 95	95... 79c
1A136... 79	3A68... 89	6A15... 89	6B85... 1.19	6K75GT... 59	6S69GT... 59c	7H63... 79c	12A7... 59	12N7GT... 95	96... 79c
1A137... 79	3A69... 89	6A15... 89	6B86... 1.19	6K76GT... 59	6S70GT... 59c	7H64... 79c	12A7... 59	12N7GT... 95	97... 79c
1A138... 79	3A70... 89	6A15... 89	6B87... 1.19	6K77GT... 59	6S71GT... 59c	7H65... 79c	12A7... 59	12N7GT... 95	98... 79c
1A139... 79	3A71... 89	6A15... 89	6B88... 1.19	6K78GT... 59	6S72GT... 59c	7H66... 79c	12A7... 59	12N7GT... 95	99... 79c
1A140... 79	3A72... 89	6A15... 89	6B89... 1.19	6K79GT... 59	6S73GT... 59c	7H67... 79c	12A7... 59	12N7GT... 95	100... 79c

Write for our free BARGAIN CATALOG

### FILTER CONDENSERS

FP Type or Tubular with Leads—Fresh Stocks Always

8 mfd. 450V. .31	8-8 450V. .41
10 450V. .31	10-10 450V. .41
10-10 450V. .41	20-20 450V. .41
20-20 450V. .41	30-30 450V. .51
30-30 450V. .51	40-40 450V. .61
40-40 450V. .61	60 450V. .61
60-40 450V. .81	80 450V. .81
80-40 450V. 1.21	100 mfd. 50V. 1.01
100 mfd. 50V. 1.01	20 50V. 1.21
20 50V. 1.21	25 50V. 1.21
25 50V. 1.21	30 50V. 1.21
30 50V. 1.21	35 50V. 1.21
35 50V. 1.21	40 50V. 1.21
40 50V. 1.21	45 50V. 1.21

# high gain

## CUSTOM uhf YAGI antennas by AMPHENOL

Eight models are available of the AMPHENOL YAGI, each covering a measured section of the UHF band. On each model, single or stacked, the gain is peaked for several channels, as indicated in the part numbers listed below, but there is more than enough gain on either side of these channel groups to make the YAGI extremely useful in multi-station UHF areas.

Gain of the YAGI is very good. The unique extra-wide spacing of the six elements gives up to 11 db gain on each model. Stacked, this gain reaches as high as 14 db. With its single forward lobe, the YAGI has excellent directional response.

The YAGI is completely pre-assembled and installation is easy and fast. Two YAGIs are easily stacked with the 114-066 YAGI Stacking Harness.



Directivity Pattern  
114-054 (24-30)—  
Ch. 27

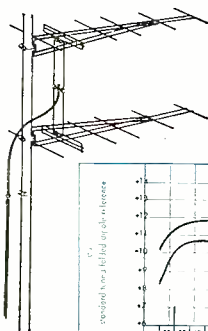

Gain Chart  
114-054 (39-48)

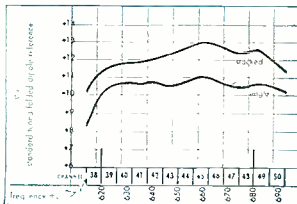

### AMPHENOL Part No.

### For UHF Channels

114-054(14-17)	14 to 20, single; 14 to 23, stacked
114-054(18-23)	14 to 24, single; 14 to 26, stacked
114-054(24-30)	19 to 33, single and stacked
114-054(31-38)	28 to 41, single and stacked
114-054(39-48)	37 to 51, single and stacked
114-054(49-59)	47 to 60, single and stacked
114-054(60-71)	58 to 73, single and stacked
114-054(72-83)	68 to 83, single and stacked



The Industry's Most Complete Antenna Line

position on the selector switches is illuminated only at the measurement to be made at that particular switch setting.

It will measure both low frequency sinusoidal and high repetition rate non-sinusoidal waveforms.

### ROOF MOUNTS AND BASES

Rohn Manufacturing Company, 116 Limestone, Bellevue, Peoria, Illinois is offering a new line of roof mounts and bases to the trade.

The Model TMB (deluxe) and ETMB (standard) roof mounts accommodate all masts from 1" to 2 1/4" diameter including the company's ETM and TM telescoping mast series. Both models are designed to be installed on peak or flat roofs, side walls, or any horizontal surface.

The Model GTMB drive-in ground mount base is suitable for use on 30, 40, or 50 foot masts. It is driven into the ground and the mast affixed to the protruding portion. Additional details are available from the company on request.

### TARZIAN TUNER

The Tuner Division of Sarkes Tarzian, Inc., Bloomington, Ind. is now offering a new compact television tuner, the UV-13, covering both the u.h.f. and v.h.f. channels.

The new unit is comprised of two separate tuners mounted coaxially and plugged together to make a single unit no larger than many standard v.h.f. tuners. Straight-line electrical sequence of compartmented circuits is the basic design feature.

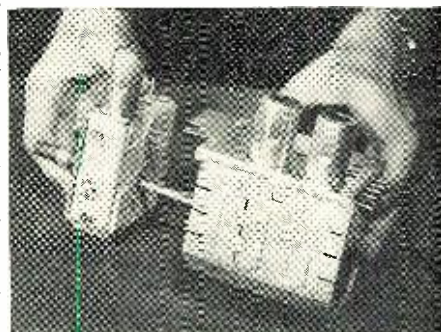

This provides maximum efficiency by eliminating re-

**DON'T YANK OR INSTALL A FLYBACK OR YOKE—TILL YOU CHECK IT WITH THE 944!**



**NEW! EICO 944 FLYBACK TRANSFORMER & YOKE TESTER KIT \$23.95. WIRED \$34.95.**

**A time—and trouble-saving MUST for TV servicemen!**

- Positive check of all flybacks & yokes, in or out of set—fast!
- Uses sensitive grid-dip principle—detects even 1 shorted turn!
- Exclusive separate calibration for air- & iron-core flybacks assures utmost accuracy.
- Checks any inductance of not too low impedance; also usable for general continuity testing.
- Large 4 1/2" 50 ua meter, 3 separate "Good-Bad" scales.



BUY EICO—at your local jobber—and SAVE 50%. Write now for FREE Catalog RF-8

ELECTRONIC INSTRUMENT CO., Inc.  
84 Withers Street • Brooklyn 11, N. Y.

generation, pickup of spurious signals, and other undesired effects due to stray capacity and inductance.

For engineering data on this new tuner, write the Application Engineering Department of the Tuner Division.

#### ELECTRIC JIGSAW

*Kapner Hardware, Inc.*, 2248 Second Avenue, New York 29, N. Y. is now offering a portable electric jigsaw, the "Dalton" Model D-500.

The saw can be used for every type of rough-in work. It can be used to cut any material—wood, plastics, metals, composition boards, hard rubbers, etc. It will saw in any shape including circles, curves, straight lines, and intricate designs and can be used as a rip, crosscut, coping, jib, scroll, band, or keyhole saw.

The Model D-500 has a pistol-grip handle, 4:1 gear reduction, and exposed motor for cool running. A built-in compressor functions as a cooling unit and blows sawdust away from the guide lines. It comes equipped with five different interchangeable blades.

#### 20-METER BEAM

*Telrex, Inc.* of Asbury Park, N. J. has introduced a new, compact, 20-meter, two-band "Mini-Beam" the Model 520.

The new antenna has a maximum element extension of 20 feet and a beam length of less than 7 feet. Efficient compacting is achieved through the use of "Hi-Q" compensating inductors on both the reflector and driven elements. Perfect match to 50-ohm coaxial cable is obtained by means of a balance-to-unbalance transformer link in the driven element compensating inductor.

The "Mini-Beam" has a gain of 4.6 db, a front-to-back ratio of 15 db or better, and a s.w.r. of 1.1:1 to a 50-ohm line.

Department HB of the company will supply additional details upon written request.

#### RING CERAMICS

A new ceramic condenser, designed to provide neat physical layout of electronic and television chassis while occupying a minimum of space, has been released by *Sprague Electric Company*, 237 Marshall St., North Adams, Mass.

Made to fit around 7-pin miniature tube sockets, these "Ring Ceramics" may contain 2, 3, or 4 condenser sections which help to reduce the number of parts handled on the production line.

Available in voltage ratings from 100 to 500 volts d.c. depending on the capacitance rating, these new units are fully described in the company's Engineering Bulletin No. 610 which may be obtained on letterhead request.

#### GRAMER "TINYFORMERS"

*Gramer Transformer Corporation*, 2734 N. Pulaski Rd., Chicago 39, Ill. has entered the distributor field with a line of "Tinyformers."

The line includes transis or-transformers plus a complete line of miniature units for various applications.

The initial line includes seven open types of "Tinyformers," all hermetically sealed and six *Mumetal* shielded; seven open types of super "Tinyformers"; eight open types of subminiatures; six miniatures; six micgets; and twelve small numbers.

#### TUBE TESTER

*Electronics Measurements Corporation*, 280 Lafayette St., New York 12, N. Y. is in production on a tube-tester, the Model 208, which checks all octal,

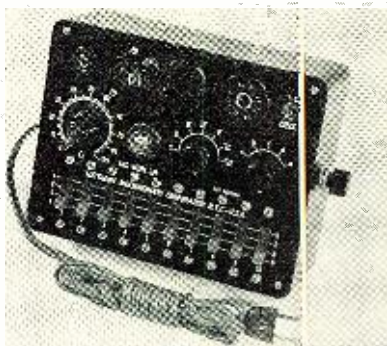

loctal, miniature, and noval base tubes for tube quality as well as shorts, leakages, continuity, or opens irrespective of the location of the defect

A flexible switching system assures complete tube testing of all present and future tubes. The Model 208 incorporates a visual line voltage check to insure accuracy.

Individual sockets are furnished for each tube type to eliminate any possible prong damage.

The unit comes complete with easy-to-understand instructions and tube chart listings.

#### INTEGRALLY MOLDED CABLES

*Alden Products Company*, 31141 N. Main Street, Brockton, Mass has developed a new cabling technique which makes it possible to mold several cable connector components into one integral unit by molding the connectors onto the wire insulation.

The new design is said to reduce

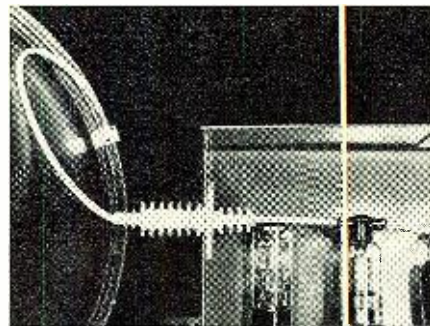

costs, save space, and eliminate the problems of strain relief, wire insulation pull-back, and wire fatigue under vibration. High voltage arc-over at wire holes is eliminated.

The high-voltage potential sources are sealed into the insulating jacket, thus reducing the problems of corona

Wait'll you see what

Centralab

has  
up its  
sleeve!



It's the most important  
development in years  
in  
dual concentric  
controls!

Watch for early

Centralab

announcement  
in this magazine

**Terrific Transmitter-Receiver Buy!  
FAMOUS BC-645 450 Mc.—15 Tubes**



BRAND NEW, in original carton! Easy to convert for phone or CW 2-way communication. **COVERING** these bands: 420-450 Mc Ham Band, 450-460 Mc fixed or Mobile 460-470 GHz Bands, 470-500 Mc TV experimental. Contains 15 tubes: 4-7E7, 4-7H7, 2-7E6, 2-6E6, 2-9E5, 1-WE-316A, Size 10 1/2 x 13 1/2 x 4 3/4". Wt. 25 lbs.

BRAND NEW  
**\$29.50**  
each

CONVERSION DIAGRAM INCLUDED!

**PE-101C DYNAMOTOR** for BC-645, has 12-24V input (easy to convert for 6V Battery operation).....only **\$4.45**

**UHF ANTENNA ASSEMBLY**, for BC-645 ..... **\$2.45**

**CONVERSION BOOKLET**. Instructions for most useful surplus rigs..... **\$2.50**

**McElroy Automatic KEYS**



BRAND NEW Value \$200.00! Suitable for keying transmitter, or for code practice. Has photoelectric cell and sensitive relay. Variable speed motor operates on 110 volts 60 cycles AC. Complete with 2-11726 and 1-11717 tubes, your cost..... **\$19.95**

**HEADSETS**

	Excellent USED	BRAND NEW
HS-23 high impedance.....	\$2.25	\$4.45
HS-33 low impedance.....	1.79	5.45
HS-30 low imp (feather).....	1.49	2.22
H-16/U high imp (2 units).....		7.95
CD-307A cords, with PL55 plug and JK26 jack, 8' long.....		.99

**MICROPHONE BARGAINS**

Western Elec. Brenst Mike.....	Brand New \$1.75
T-45 Navy Lip Mike.....	Brand New \$1.25
T-17 Carbon Hand Mike.....	Brand New \$6.95
T-30 Carbon Throat Mike.....	Brand New \$3.69
T-24 Single Button Carbon Mike.....	Brand New \$3.95

**BEACON RCVR BC-1206-C**

Complete with 5 tubes. Tunes 195 KC to 420 KC. IF Frequency—135 KC. Receiver Sensitivity—3 Microvolts for 1% Milliwatts output. Output Impedance—300 Ohms and 4000 Ohms. Volume Control—50 Gain Control. Power Supply—24-28 Volts Aeroplane Battery. Current—.75 Amperes.  
BRAND NEW..... **\$12.95**

**SCR-274N COMMAND and ARC-5 EQUIPMENT**

All Complete With Tubes—Prices Slashed!

Type	USED	Excellent BRAND NEW
BC-453 Rcvr. 190-550 Kc.....	\$18.50	\$44.50
BC-454 Rcvr. 3-6 Mc.....	9.25	11.25
BC-455 Rcvr. 6-9 Mc.....	8.95	10.95
BC-456 Modulator.....		2.75
BC-457 Xmtr. 4-5.3 Mc.....	12.50	16.50
BC-458 Xmtr. 5.3-7 Mc.....	7.95	9.75
BC-459 Xmtr. 7-9.1 Mc.....	12.95	14.25
BC-456 Xmtr. 3-4 Mc.....	18.95	23.95
BC-450 3-Rcvr. Control Box.....		1.49
BC-451 Xmtr. Control Box.....		1.25
3-Receiver Rack.....		1.79
2-Transmitter Rack.....		1.59
Single Transmitter Rack.....		3.25

**ARC-5/T-23 Transmtr.** with crystals, tubes, circuit diagram. Brand New **\$39.50**

**BRAND NEW**

**MODULATED BC-221-AK FREQ. METER**  
125 to 20,000 Kc with xtal check points in all ranges. Complete with tubes, xtal, calibration charts. Limited quantity, each..... **\$210.00**

**GOULD 6-VOLT STORAGE BATTERY**

Navy Standard, Black Rubber Case. BRAND NEW. 15 Amp. Hour Rating..... **\$6.95**



**GOULD 4-VOLT LEAD STORAGE BATTERY**

(2 Cell) 16 Amp. Hrs. Portable Metal Case. Brand New **\$3.95**

**WILLARD 6-VOLT MIDGET STORAGE BATTERY**  
3-amp hr. BRAND NEW. 3 3/8" x 1-13/16" x 2 3/8". Uses standard electrolyte..... **\$1.95**

**WILLARD 2-VOLT STORAGE BATTERY.**  
20 AMP. HR. BRAND NEW..... **\$2.69**  
1-Qt. Electrolyte, enough for two cells..... bottle **\$1.45**

**DYNAMOTORS**

Type	Input	Output	Exc. Used	Brand New
DM-32A	28V 1.1A.	250V .05A.	\$4.90	\$7.50
DM-33A	28V 5 A.	575V .12A.	1.95	3.49
DM-28	28V 7 A.	540V .25A.		
DM-28	28V	224V .07A.	2.25	4.95
FE-73	28V 20A.	1000V .350A.	9.50	12.50

Please include 25% Deposit with order—Balance C.O.D. MINIMUM ORDER \$3.00. All Shipments F.O.B. Our Warehouse N.Y.C.

**G & G Radio Supply Co.**  
Dept. N-8  
51 Vesey St., New York 7, N. Y., CO 7-4605  
Branch: 16 W. Kinzie St., Chicago, Ill.

suppression and shielding. Only the female contacts are exposed and only at the point of mating where there is a natural damping of corona.

Although originally developed for color TV, these cables have wide application in such fields as high-voltage power supplies, high-voltage rectifier circuits in radar, transmitters, x-ray equipment, etc.

For complete information on these new cables, address your inquiry to Nelson W. Hearn in care of the company.

**NOISE GENERATOR**

*The Hickock Electrical Instrument Company*, 10524 Dupont Avenue, Cleveland 8, Ohio has just introduced a versatile unit for measuring noise factor in any receiver.

Said to be the first noise generator completely self-contained with no additional equipment required, the Model 755 quickly indicates the amount of noise inherent in receivers to permit correction of this interference.

The unit contains two indicating meters and is divided into a v.t.v.m. section and a generator noise section.

**EICO V.T.V.M.**

*Electronic Instrument Co., Inc.*, 84 Withers St., Brooklyn 11, N. Y. is currently offering a new peak-to-peak vacuum-tube voltmeter which is available in both kit and wired form.

This newest addition to the *Eico* line

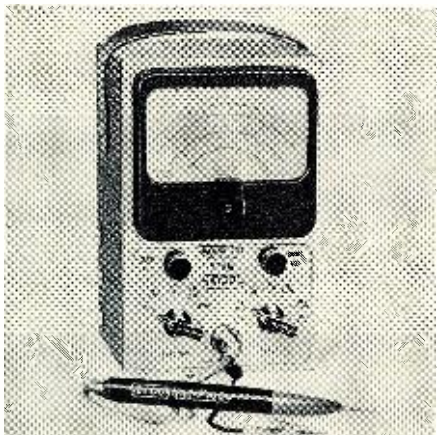

was designed expressly for TV servicing. A dual-purpose a.c.-d.c. "Uni-Probe" is supplied with the unit and performs all functions. The v.t.v.m. features a stable push-pull triode bridge circuit with accuracy unaffected by line voltage variation. It reads peak-to-peak voltage of complex and sine waveforms, r.m.s. voltage of sine waves, d.c. voltage, and resistance. Seven non-skip ranges on each function assure a uniform 3:1 scale ratio between adjacent ranges for wide-range accuracy. It provides center scale zero adjustment for TV-FM alignment and for calibration from outside the cabinet.

The 4 1/2" meter is electronically protected against burnout. The kit has been designated as the Model 232K while the factory-wired unit is the Model 232.

**International Short-Wave**  
(Continued from page 66)

gon, noted back on 9.75A from 9.625 for *English* to Europe 1100. (Balbi, Calif.; Pearce, England, others) Has new weekly feature called the "French Hour" on Sun. 0345 over 15.430. (ISWC, London) This outlet noted 0500 with news by woman, poor level in Calif. (Morgan) Is poor to fair on 11.83 with news 0900. (Balbi, Calif.) *Radio Hue*, 7.205, heard 0834 with woman in French and music, fair level; *Radio Dalat*, 7.265, noted 0653 fair level with Vietnamese music. (Morgan, Calif.) *Radio Hirondelle*, Hanoi, broadcasts on 4.403, 7.408 in French, Vietnamese, Arabic, and African, dialects weekdays 1730-2030, 2230-0130, 0500-1100, Sat. 1730-1100 Sun. (Scheiner, N. J.) Heard on 7.405 at 0600 with news in French, music. (Sanderson, Australia) Both channels good in N. Z. then. (Collett) "Voice of Vietnam," 9.620, Saigon, noted 0500 with Vietnamese program of music, news. (Sanderson, Australia) This one has QRM from XEBR, Mexico, around 0930 when has *English* to 1000 close-down. (Balbi, Calif.)

*Iran—Radio Teheran*, EPB, 15.100, noted 1445 in German, 1500 French, 1515 *English*; closes 1530 with Iranian National Anthem. (Ferguson, N. C.; Buggins, England, others) Now sends verification card. (*Radio Sweden*)

*Israel*—When this was compiled, Tel Aviv, 9.010A, was still on same schedule (did not go on *Summer Time*) with news 1515, "Voice of Zion" session in *English* 1615-1700 closedown (extended Sat. to around 1725); by now, the 50 kw. transmitter may have been brought into operation. (Levy, N. Y.; Pearce, England, others)

*Kuwait*—Fairs, England, says Kuwait is still on 5.000, heard around 1340. (URDXC)

*Liberia*—ELWA is a new station at Monrovia which has now commenced broadcasts in *English*; is owned by the Sudan Interior Mission; power is 1 kw. on m.w.; broadcasts to other parts of Africa using African languages; will begin on s.v. soon. (WRH)

*Luxembourg*—*Radio Luxembourg*, 6.090, noted closing 1800 in French. (Ferguson, N. C.) Now has *English* 1100 on Mon., Tues., Wed., Fri.

*Malaya*—BFEB, 15.435, Singapore, noted almost daily from 0415 opening past 0645 fade-out. (Morgan, Calif.) Heard with identification at 1030. (Stark, Texas) Noted fading in as early as 0515 on 11.820. (Miller, Ga.) Heard on 9.690 at 0430 with news, music. (Sanderson, Australia) *Radio Malaya*, 7.200A, Singapore, heard 0700-0903 with "Jazz Club" at 0830-0900, then news; good level. (Krejny, Japan)

*Mexico*—XEQQ, 9.680, noted closing 1937 and announced would re-open 0525; all-Spanish. (Kahan, Calif.)

*Mozambique*—CRTAA, 7.237AV, noted 0820 with popular music, an-

# CRYSTALS

*Guaranteed to oscillate!*  
*Your choice of frequencies!*  
*Largest selection in the world!*

**NOTE!** EVERY CRYSTAL TESTED FOR ACTIVITY BEFORE SHIPMENT! All numbers listed are FUNDAMENTAL FREQUENCIES with fractions omitted.



## FT-243

Lots of 10 or more. Each..... 69c  
 Lots of 5 or more. Each..... 79c  
 Individually. Each..... 99c

1015	2140	2490	2645	2815	2970	3125	3420	6100	6440	7175	7630	7900	8090
1110	2155	2495	2650	2825	2975	3130	3455	6106	6450	7200	7640	7910	8091.7
1129	2165	2505	2665	2835	2980	3135	3465	6125	6475	7206	7650	7920	8100
1150	2165	2510	2660	2835	2985	3140	3500	6140	6475	7225	7660	7930	8106.3
1195	2175	2515	2665	2840	2990	3145	3510	6142	6500	7240	7666.7	7940	8108.3
1225	2180	2520	2670	2845	2995	3150	3525	6150	6506	7273	7670	7950	8110
1900	2195	2525	2675	2850	3005	3155	3540	6173	6525	7275	7680	7960	8116.7
1915	2305	2530	2680	2855	3010	3160	3580	6175	6540	7300	7690	7970	8125
1930	2305	2535	2685	2860	3015	3165	3585	6185	6550	7306	7700	7980	8130
1940	2320	2545	2690	2865	3020	3170	3640	6200	6573	7325	7710	7990	8133.3
1950	2350	2550	2695	2870	3025	3175	3655	6206	6575	7340	7720	8000	8140
1965	2355	2557	2705	2875	3030	3180	3660	6225	6600	7350	7730	8005	8141.7
1977	2360	2560	2710	2880	3035	3185	3700	6235	6606	7375	7740	8008.3	8150
1980	2365	2565	2715	2885	3040	3190	3760	6240	6625	7400	7750	8010	8158.3
1985	2370	2570	2720	2890	3045	3195	3800	6250	6640	7406	7760	8016.7	8160
2010	2375	2575	2725	2895	3050	3200	3825	6273	6650	7425	7770	8020	8163.3
2015	2390	2580	2730	2900	3055	3202	3885	6275	7000	7440	7780	8025	8166.7
2017	2415	2585	2735	2905	3060	3205	3940	6300	7006	7460	7783.3	8030	8170
2020	2430	2590	2740	2910	3065	3210	3985	6306	7025	7510	7790	8033.3	8173.3
2025	2435	2595	2745	2915	3070	3220	3980	6315	7040	7520	7800	8040	8180
2030	2440	2600	2750	2920	3075	3225	3990	6325	7050	7530	7810	8041.7	8183.3
2040	2442	2603	2755	2925	3080	3230	3995	6335	7073	7540	7820	8050	8190
2055	2450	2605	2760	2930	3085	3235	4000	6340	7075	7550	7830	8058.3	8191.7
2060	2455	2610	2765	2935	3090	3240	4006	6350	7100	7560	7840	8060	8200
2065	2460	2615	2770	2940	3095	3240	4006	6350	7100	7570	7850	8066.7	8206.6
2090	2465	2620	2775	2945	3100	3300	4040	6373	7125	7580	7860	8070	8208.3
2105	2470	2625	2780	2950	3105	3310	4042	6375	7140	7590	7870	8073.3	8210
2125	2475	2630	2785	2955	3110	3320	4050	6405	7150	7600	7880	8075	8226.7
2130	2480	2635	2790	2960	3115	3340	4073	6406	7160	7610	7890	8080	8210
2135	2485	2640	2795	2965	3120	3410	6075	6425	7173	7620	7891.7	8083.3	8225

## FT-243

Lots of 10 or more. Each..... 34c  
 Lots of 5 or more. Each..... 39c  
 Individually. Each..... 49c

4035	4300	4635	4930	5295	5645	5782.5	5906.7	6275	6706.6	6906.6	7625	7975	8475
4045	4330	4680	4950	5300	5660	5800	5907.5	6300	6725	6925	7673.3	8240	8500
4080	4340	4695	4980	5305	5675	5806.7	5925	6306	6740	6940	7675	8250	8525
4095	4395	4710	4995	5327.5	5687.5	5820	5940	6325	6750	6950	7706.6	8273	8550
4110	4395	4735	5030	5335	5700	5825	5950	6340	6763.3	6973.3	7725	8275	8575
4135	4445	4780	5035	5385	5706.7	5840	5965	6350	6775	6975	7733.3	8300	8600
4165	4450	4785	5090	5397.5	5725	5850	5973.3	6373.3	6800	7450	7775	8306	8625
4175	4490	4815	5127.5	5435	5730	5852.5	5975	6375	6806.6	7473.3	7806.6	8325	8650
4190	4495	4820	5165	5437.5	5740	5860	5995	6400	6825	7475	7825	8340	8675
4215	4535	4840	5180	5485	5750	5873.3	6206.6	6406.6	6840	7506.6	7873.3	8350	8690
4220	4540	4845	5205	5500	5760	5875	6225	6425	6850	7525	7875	8375	8715
4255	4580	4852.5	5235	5545	5773.3	5880	6240	6673.3	6873.3	7573.3	7856.6	8400	8740
4280	4610	4880	5245	5582.5	5775	5892.5	6250	6675	6875	7575	7925	8425	8765
4295	4620	4900	5285	5587.5	5780	5900	6273.5	6700	6900	7606.6	7973.3	8450	8800

## FT-241-A

Lots of 10 or more. Each..... 79c  
 Lots of 5 or more. Each..... 89c  
 Individually. Each..... 99c

400	442	446	450	453	456	459	463	466	470	474	477
440	444	447	451	454	457	461	464	468	472	475	479
441	445	448	452	455	458	462	465	469	473	476	480

## FT-241-A

Lots of 10 or more. Each..... 39c  
 Lots of 5 or more. Each..... 44c  
 Individually. Each..... 49c

370	381	391	401	409	419	429	438	490	498	508	518	529
372	383	392	402	411	420	430	481	491	501	509	519	530
374	384	393	403	412	422	431	483	492	502	511	520	531
375	385	394	404	413	423	433	484	493	503	512	522	533
376	386	395	405	414	424	434	485	494	504	513	523	534
377	387	396	406	415	425	435	486	495	505	514	524	535
379	388	397	407	416	426	436	487	496	506	515	526	537
380	390	398	408	418	427	437	488	497	507	516	527	538

## FT-171

Lots of 10 or more. Each..... 79c  
 Lots of 5 or more. Each..... 89c  
 Individually. Each..... 99c

2123	2280	2415	2582	3010	3422.5	3660	3812.5	3980	4245	5225			
2125	2282.5	2435	2630	3015	3500	3667.5	3825	3995	4255	5432.5			
2131	2290	2442.5	2635	3175	3510	3682.5	3870	4122.5	4280	6000			
2145	2300	2467	2725	3202.5	3520	3695	3880	4037.5	4310	6210			
2150	2305	2470	2780	3205.5	3550	3700	3945	4050	4345	7165			
2155	2320	2500	2835	3215	3562	3712.5	3950	4080	4350	7950			
2158	2320	2500	2835	3215	3562	3712.5	3950	4080	4350	8000			
1151.8	1940	2045	2191	2340	2532.5	2911	3237.5	3569	3760	3955	4097.5	4360	8000
1562.5	2010	2065	2220	2360	2545	2940	3250	3570	3790	3966.5	4110	4400	9200
1738	2030	2082	2250	2390	2567	2967	3275	3580	3807.5	3970	412	4325	9590
1746	2040	2105	2260	2405	2557	2990	3400	3637.5	3810	3975	4177.5	5200	

**NOTE!** All items subject to prior sale and change of price without notice. MINIMUM ORDER: \$2.50. All orders must be accompanied by check, cash or M.O. WITH PAYMENT IN FULL. No C.O.D. CALIFORNIA BUYERS add sales tax. INCLUDE APPROXIMATELY 5c PER CRYSTAL FOR POSTAGE. DEALERS & JOBBERS: WRITE FOR SPECIAL QUANTITY DISCOUNTS. All buyers invited to write for FREE crystal catalogue giving complete list of frequencies.

## NOVICE BAND

Fundamental Each..... \$1.25  
 744encies Lots of 10 or more. Each..... 99c  
 Available in EITHER DC-34 OR FT-243. Specify your needs.  
 These crystals come in all frequencies FROM 3701 THROUGH 3748, in steps of 1 KC.  
 Examples: 701, 3702, 3703  
 FOR DOUBLING INTO 7 MC BAND crystals come in all frequencies FROM 3588 THROUGH 599, in steps of 1 KC. Examples: 3588, 3589, 3590..... 3590  
**AVAILABLE IN FT-243 ONLY** Individually. Ea..... \$1.25  
 Lots of 10 or more. Ea..... 99c  
 All frequencies from 7176 KC THROUGH 7198 KC in steps of 1 KC, fractions omitted.  
 Examples 7176, 7177, 7178, etc.

## MISCELLANEOUS & SHIP BAND FREQUENCIES

81.95 KC. C.etal tube type (Used in SCR-534 & SPM-1).....	53.99	2638 KC. FT-243.....	52.99
200 KC. FT-241.....	1.99	2670 KC. FT-243.....	2.99
200 KC. T.ube DC-15 in octal tube base 1/2pe holder.....	1.99	2647 KC. FT-243.....	2.99
327.8 KC. S. d. D-168342. (Used in TSP-1/AB).....	9.95	2670 KC. DC-34.....	2.99
500 KC. FT-241.....	1.99	2738 KC. type 1-C.....	2.99
1000 KC. FT-241.....	2.49	2738 KC. FT-243.....	2.99
1000 KC. T.ube DC-15 in octal tube base 1/2pe holder.....	3.45	2738 KC. FT-243.....	2.99
2000 KC. FT-243.....	1.99	3008 KC. FT-243.....	2.99
2142 KC. D-34.....	2.99	3103 KC. FT-243.....	2.99
2174 KC. FT-243.....	2.99	3188 KC. FT-243.....	2.99
2182 KC. FT-243.....	2.99	3193 KC. FT-243.....	2.99
2500 KC. FT-243.....	1.99	3188 KC. FT-243.....	2.99
2632 KC. FT-243.....	2.99	3203 KC. FT-243.....	2.99
2637 KC. FT-243.....	2.99	5000 KC. FT-243.....	1.99
2638 KC. D-34.....	2.99	10,000 KC. Type SR-5 Biley, in CR-1 holder.....	1.99



## DC-34 & DC-35 CRYSTALS

Your Choice. Ea. only 99c  
 Pin Spacing 3/4". Pin Diameter .1875".

2240	2415	2635	2851	3095	3395	3665	3870	4020	4175	4370
2255	2422	2625	2853	3117	3412.5	3680	3885	4030	4175	4380
2275	2446	2665	2895	3155	3462	3700	3895	4050	4192.5	4397.5
2280	2466	2685	2899	3161	3480	3750	3905	4055	4210	4435
2295	2467	2710	2925	3190	3485	3760	3920	4065	4235	4440
2300	2478	2711	2926	3201	3500	3765	3925	4080	4240	4445
2315	2481	2725	2960	3210	3520	3770	3935	4085	4255	4450
2326	2500	2732	2971	3229	3540	3775	3940	4090	4275	4455
2335	2510	2745	2980	3280	3550	3790	3950	4095	4280	4460
2340	2515	2764	3000	3297	3575	3795	3960	4097.5	4305	4465
2350	2527	2775	3010	3311	3580	3807.5	3965	4115	4310	4470
2360	2548	2776	3023	3317	3610	3825	3985	4130	4	

**IF  
YOU'RE  
INTERESTED  
IN  
HIGH  
FIDELITY...**

*then*

**YOU'LL WANT  
TO KNOW MORE  
ABOUT THE**

**Collaro**

*High Fidelity*

**RECORD CHANGER**

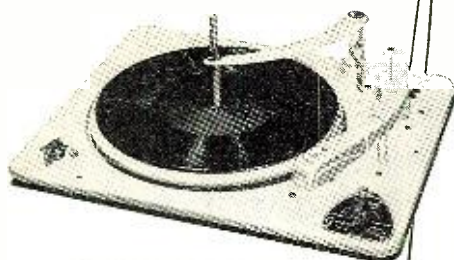

Mail This Coupon Today

ROCKBAR CORPORATION, Dept. MH-4  
215 East 37th Street, New York 16, N. Y.  
Please send me literature describing COLLARO  
High Fidelity RECORD CHANGERS.

NAME.....

ADDRESS.....

CITY.....ZONE.....STATE.....

nounced in *English*, strong signal but bad QRM. (Morgan, Calif.)

**New Caledonia**—Radio Noumea, 6.035A, heard 0245 with news in French, music. (Sanderson, Australia) Is fair level in Virginia around 0230 with French; heavy QRN. (Saylor, Va.)

**New Zealand**—Radio New Zealand, 9.54, noted 0148-0155 with classical music, then bird-call interval; at 0200 began program to Australia and the Islands, parallel over 9.52. (West, Calif.) Noted on 9.54 at 0600 on a Sat. (Miller, Pa.) Heard over ZL3, 11.78, at 2330-2345. (Milnes, Ore.; Arthurs, Pa.) Sometimes is good level around 0130 over ZL8, 9.62. (Kapp, Calif.) Heard on 11.810 at 2300. (Roemer, Ky.)

**Nigeria**—Lagos, 4.800, noted 1645 with native music, closed 1700 with "God Save the Queen." (Mesquita e Sousa, Portugal) Has call in *English* 1430. (Pearce, England) And BBC news relay 1500. (Collett, N. Z.)

**Northern Rhodesia**—Lusaka, 4.826, noted 1255 with religious service; 1301 call, local news, weather report.

**Norway**—Radio Norway noted recently on 7.210 at 2300-2400, news in Norwegian 2315 when gave call in *English*. (Joynes, N. C.) Heard then over 9.610. (Gay, Calif.) LLM, 15.175, Oslo, noted Sun. 1105 in Norwegian, 1200 with "Norway This Week" (*English*). (Morgan, Calif.)

**Okinawa**—Cushen, Collett, N. Z., report the Far Eastern Network (AFRS) at Okinawa on 4.090A from 1300 to fade-out around 1530; relays m.w.

**Pakistan**—Radio Pakistan, 9.645, noted 1950 tune-in with Hindu-type music; news 2000-2005, then more music; 11.885 was parallel but weaker and with bad QRN. (Bellington, N. Y., others) Latest schedule for the External Service is 1945-2030, 11.885, 15.225 to Southeast Asia; 2300-2345, 17.750, 15.335 to East and South Africa; 0415-0530, 9.645, 15.255 to South Asia; 0600-0645, 15.255, 17.750 to Burma; 0745-0830, 15.255 (*English*) to Indonesia; 1030-1130, 6.235, 7.010 Afghan-Persian Service; 1145-1230, same channels, Iranian Service; 1240-1300, 6.010, 9.545, General Overseas Service (slow-speed news in *English*); 1300-1400 Arabic Service, 1415-1500 *English* to Turkey, 1500-1545 *English* to the United Kingdom, all over 7.010, 9.545. (*Radio Australia*)

**Panama**—HORT, 6.060A, noted 0630 at fair level with news in Spanish, music. (Sanderson, Australia) HP5J, 9.607, good around 1830-2200. (Saylor, Va.)

**Paraguay**—ZPA4, 9.735, 1.2 kw., Radio Stentor, Asuncion, operates 1000-2200 in Spanish. (WRH) Patrick, England, says ZPA1, Radio Nacional, Asuncion, is now audible on 5.955 where it moved from 6.275; and that ZPA5, 11.950, is heard well around 1600.

**Peru**—OAX6H, 9.490, Radio Tacna, noted 2130-2200 with Spanish. (West, Calif.) Radio Nacional del Peru, 9.562, Lima, is widely reported now with *English* 2300 (may not be every day).

(Bloomington, Ind.; Smith, Ga.; Church, Calif., others) Heard closing 2400 in *English*, Spanish. (Richmond, N. Y.)

**Poland**—Radio Warsaw uses these channels—5.955, 5.975, 5.995, 6.025, 6.195, 7.125, 7.145, 7.175, 7.255, 9.555, 9.570, 9.585, 9.600, 9.615, 11.740 (*Radio Sweden*)

**Portugal**—Lisbon noted on measured 11.995 at 1413; the 19-m. channel is back on 15.040 with usual program, tuned 0615. (Ferguson, N. C.) Some days lately, Lisbon has been noted near 9.647 around 1600-1700 or later. Heard on 11.915 around 1040, often with sports commentary in Portuguese; has been heard on 3.995A around 1700. (Pearce, England)

**Portuguese India**—Radio Goa plans a 10 kw. transmitter soon to use 13-, 16-, 19-m. bands. (N. Z. DX Times via Winch, Calif.)

**Roumania**—Radio Bucharest, 9.57, 6.145A, widely reported with *English* for North America 2200-2230, 2330-2400. (Weaver, Va.; Kelting, N. Y., others) Has *English* for Europe 1430 on 6.145A, 6.210, 9.252A, 9.570, 12.032; at 1730 on 6.145A, 9.252A, 12.032. (*Radio Sweden*)

**Sao Tome**—CR5SB, 17677, noted Sun. 0700-0800, all Portuguese (Ferguson, N. C., others)

**South Africa**—Johannesburg, 4.895, just readable 2345 with setting-up exercises, with chimes 0000, then news in Afrikaans. (Roberts, Conn.)

**South Korea**—According to Radio Australia, Seoul now uses 2.510, 1 kw., 3.2925, 1 kw., and 7.935, 1 kw. Dorothy Sanderson, Australia, notes the 7.935 outlet at 0500 with Western music, poor level.

**Spain**—Madrid, 9.363, noted in *English* for North America 1800-1840A. (Brooks, Kans., others) And 2205-2245. (Kirby, Mo., others) Good in *English* for Europe 1515-1545. (Roemer, Ky.) FET1, Radio Falange, Valladolid, 7.006, is fair to good level from around 1500 to 1830 sign-off; all Spanish. (Saylor, Va.) Radio Mediterraneo, Valencia, seems to have moved back to 6.995A since is now quite free from interference by Valladolid on 7.006. (*Radio Sweden*) Radio Cuerto de Santa Maria, 7.210, closes 1700 with "Viva Franco! Arriba Espana," and Spanish National March-Anthem. (Pearce, England)

**Spanish Guinea**—Radio Santa Isabel, 7.200, now has *English* daily 1430. (Patrick, England)

**Spanish Morocco**—Radio Dersa, Tetuan, is audible in Sweden on 6.000 at 1800-1900. (*Radio Sweden*)

**Sweden**—Radio Sweden, 9.620, noted at good closing to North America 2140; heard in *English* to Eastern North America 0700-0715 on 11.705 now. (Miller, Ga., others) Heard on 9.535 at 1845 with musical program and news; on 11.705 at 0000 with Spanish news and music. (Sanderson, Australia) Good on 11.705 at 0000-0045 to Western North America. (Koch, Ore.; Johnston, Mich., others)

**Switzerland**—According to announcement, Berne's monthly DX ses-

sion is now on the air *Thursday* instead of *Tuesday*; this on the *first Thursday* of each month. (Ferguson, N. C.) *United Nations Radio*, Geneva, is noted over HBQ, 6.675, with *English* sign-on 1315. (Pearce, England) Berne's 9.535 channel noted strong 1500-1530. (McKee, Ohio) HEU3, 9.665, is fair to good around 1345-1430 in beam to United Kingdom-Ireland. (Kapp, Calif.; Esser, Pa.)

*Syria*—Damascus, 9.555 (moved from 7.235) noted with *English* for Western Europe 1630-1730 closedown; news 1645. (Pearce, England; Bellington, N. Y., others)

*Tahiti*—*Radio Tahiti*, FO8AA, Paapeete, noted 0027 at fair level but with bad QRM; was parallel with FZP-8, 7.120, good strength but with bad heterodyne and other ham QRM; man in French, music; at 0031 said "Ici Radio Tahiti" and played chimes, then had French vocal number. (Morgan, Calif.) Schedule is 2300-0000 Tahitian on 6.135, 7.025; 0000-0200 French, 1700-1715 Tahitian, 1715-1800 French on 7.025, 7.125 (WRH, others)

*Taiwan (Formosa)*—BED29, 6.095, Taipei, noted 0523 Sun. at good strength with *English* religious session past 0530. (Morgan, Calif.) BED4, 11.92, noted to Europe around 1330-1500 closedown. (Pearce, England)

*Tangier*—"Radio Voice of International Evangelism," 7.305, noted 1530 with organ and singing, 1535 call in *English*. (Pearce, England)

*Thailand*—HSK9, 11.670, Bangkok, good signal opening in *English* 0430, then with Thai session to Forces in Korea; the 7.097 outlet noted 0530 with native music and bad QRM. (Morgan, Calif.) Noted over 11.670 in North American Service 2315-0015 sign-off, news 2330-2345. (Krejny, Japan) This one heard 0820 in native at good level in Ohio. (Bishop)

*Trinidad*—VP4RD, 6.085, Port-of-Spain, noted 0500 with organ music, fair level in Calif. (Morgan) Heard on 3.275 at 2130-2200 sign-off. (URDXC)

*Turkey*—TAS, 7.285, noted 1200 with call, then news in Turkish. (Mesquita

e Sousa, Portugal) TAT, 9.515, good in *English* to North America daily 1815-1900. (Beine, N. Y.; Esser, Pa., others) *Technical University of Istanbul*, 7.030, heard 1445 with operatic selections; left air 1505. (Pearce, England)

*Uruguay*—CXA10, 11.90, *Radio Electrica*, noted 2125-2140 in Spanish. (Deuring, Alta.)

*USA*—WRUL, Boston, is scheduled to Europe 1500-1645 except Sat., 15.285, 11.78; to Latin Amer ca 1745-2045 Mon.-Fri., 1745-2000 Sat., 1800-2000 Sun., 15.285, 11.78, 9.385; has financial news 1630, 1815. (Weisburger, Md.; Patrick, England)

*USI (Indonesia)*—Djakarta, 9.71, noted with *English* for Southeast Asia 0930-1030. (Koch, Ore.) YDF8, 9.865, heard to Europe in *English* 1400-1500, news 1415. (Pearce, England) YDU, 4.840, Ambon, Moluccas, s good strength 0500; YDK, 4.855, Palembang, is strong 0900; YDO, 3.250, Sandjarmasin, Borneo, is fair opening 0430. (Collett, N. Z.)

*USSR*—European Service of *Radio Moscow* noted 2200 with classical music, announcements in *English*, French. (Morgan, Calif.) *Radio Moscow* has strong signals on many channels in the 31- and 25-m. bands during *English* to North America 1800-0100, such as on 9.500A, 9.530A, 9.640A, 9.680A, 9.730A, 11.880A, 11.930A; noted on 15.210 in *English* for Southeast Asia 0900-0915. (Machajewski, N. Y.)

Becker, Mich., reports Bakt, Azerbaijan, on 9.840 coming on air 2200 and running to around 2225A (not heard Sat.), good level.

*Vatican*—HVJ, 15.12, noted opening 0745. (Stark, Texas) Heard with news 1000 on 9.645A, 11.68A; announces *English* also for 1315 over 9.645, 7.280, 11.68, 15.12. (Pearce, England)

*Venezuela*—*Radio Nacional*, C.17, Caracas, radiates "The Week in Venezuela" (*English*) Mon. 1830-1900, heard in Britain. (*Radio Sweden*) YVLK, 4.97, Caracas, good in *English* 1830-1900. (Machajewski, N. Y.)

*Yugoslavia*—*Radio Belgrade* has Eng-



## DON'T THROW OLD RADIOS AWAY!

Here's the data you need to fix them FAST and r-i-g-h-t!

There's a "secret" to repairing old radios fast and profitably... and this big RADIO TROUBLESHOOTER'S HANDBOOK is it!

Just look up the old make and model you want to fix. This manual-size, 3 1/2 pound, 744-page Ghirardi handbook tells what the trouble is likely to be... and shows you exactly how to fix it. No useless testing! No wasted time! Even beginners can handle jobs "slick as a whistle."

### THE ONLY GUIDE OF ITS KIND!

Cuts service time in half!

Included are common trouble symptoms and their remedies for over 4,800 models of home and auto radios and record changers. Actual case histories cover practically every model made by 202 manufacturers between 1925 and 1942—Airline, Apex, Arvin, Atwater Kent, Belmont, Bosch, Brunswick, Clarion, Crosley, Emerson, Fada, G-E, Kolster, Majestic, Motorola, Philco, Pilot, RCA, Silvertone, Sperton, Stromberg and dozens more. Gives how-to-do-it data on SPECIFIC jobs—NOT general theory. Includes hundreds of pages of invaluable tube and component data, service short cuts, etc.

### TRY IT 10 DAYS . . . at our risk!

Dept. RN-84, RINEHART & CO., Inc.  
232 Madison Ave., New York 16, N. Y.  
Send Ghirardi's RADIO TROUBLESHOOTER'S HANDBOOK for 10-day free examination. If I decide to keep book, I will then remit the full price of only \$6.50 plus a few cents postage. Otherwise, I will return book postpaid and owe you nothing.

NAME .....

ADDRESS .....

CITY, ZONE, STATE .....

## SEE PAGE 91

### MINIATURIZING??

Metalclad

### PRINTED CIRCUIT KIT

For your Electronic Circuit

6"x6" Copper Clad Phenolic Sheet, Resist Solution, Etch and Instructions. No photography required. Order direct from factory. **\$1.95** No C.O.D.

TRANSCIRCUITS

2105 W. 42d, Kansas City 3, Kansas

# 3 in 1

LIGHTNING ARRESTER

JFD MANUFACTURING CO.  
BROOKLYN 4, NEW YORK



### ULTRA LOW LOSS DESIGNED FOR HIGHEST UHF GAIN

DON'T RUIN your installation with a lightning arrester of high insertion loss. In the arrester that's an asset instead of a liability to your UHF or VHF installation the JFD "3-IN-1" with the ultra low loss compensating coil circuit. Thousands of installations prove the "3-IN-1" gives the lowest insertion loss of any arrester in use today. Patented strain-relief lips and patented saw-tooth washers are exclusive JFD extras at no extra cost.

Write for Form 210.  
No. AT110 with hardware for wall or window sill.....\$1.50 list  
No. AT110S with UL approved stainless steel mounting strap.....\$1.75 list

U. S. Patent Nos. 2,654,857; D-159,330

3 For UHF-VHF operation



# "G" PRESENTING THE *New* GRIP SPINTITE® WRENCHES

FINEST QUALITY  
STEEL SHANK  
AND SLEEVE  
•  
BRIGHT PLATED  
FINISH  
•  
STRONG  
PLASTIC HANDLE

WITH THE EASY "FINGER-CONTROL"  
**GRIP AND RELEASE ACTION**  
FOR THOSE  
**HARD-TO-GET-AT PLACES —**

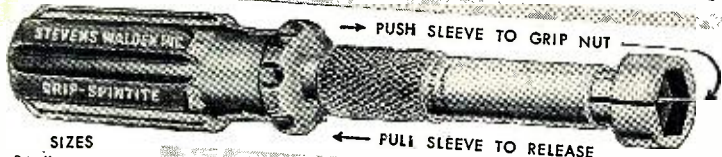

SIZES  
3/16" TO 1 1/16"

BY THE MAKERS OF  
THE ORIGINAL  
**SPINTITE**  
WRENCHES  
OVER 150 STYLES  
AND SIZES

## ONE HAND OPERATION—

- GRIPS nuts or bolts of any material
- HOLDS firmly in any position
- TIGHTENS nut or bolt securely
- RELEASES at the pull of the fingers

101-4

Write for catalogue  
**STEVENS WALDEN Inc.**  
450 SHREWSBURY STREET — WORCESTER, MASSACHUSETTS  
MAKERS OF WORLD-FAMOUS HAND TOOLS FOR OVER 50 YEARS

## OSCILLOSCOPES

ARE  
**"GOLD MINES"!**

... if you learn  
how to use them fully  
on all types of  
service jobs!

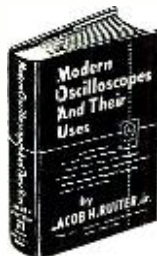

Learn to handle the oscilloscope fully on all types of AM, FM and TV service work—and watch your efficiency and earnings soar!

MODERN OSCILLOSCOPES AND THEIR USES, a fact-jammed 320-page book by Jacob H. Rutter, Jr., of the Allen B. Dumont Laboratories contains exactly the help you need—written in a way you can clearly understand. It shows you how to use your scope for fast accurate work on all types of jobs from troubleshooting to realigning; how to make connections; how to adjust circuit components; how to set controls and how to analyze patterns fast and accurately. 370 helpful illustrations including dozens of pattern photos make things doubly clear.

No other type of specific service training stands to mean so much to you in terms of being able to do better, faster and more profitable work!

- ✓ When, where, why and exactly how to use oscilloscopes
- ✓ How to interpret oscilloscope patterns
- ✓ How to handle tough jobs in less time

## MAIL ORDER 10-DAY FREE EXAMINATION

Dept. RN-84, RINEHART BOOKS, Inc.,  
Technical Division,  
232 Madison Ave., New York 16, N. Y.

Send MODERN OSCILLOSCOPES AND THEIR USES for 10-DAY EXAMINATION. If I decide to keep the book, I will then remit \$6.00 plus a few cents postage in full payment. If not, I will return book postpaid and owe you nothing.

Name .....

Address .....

City, Zone, State .....

Employer's Name & Address .....

OUTSIDE U.S.A.—Price \$8.50 cash only. Money back in 10 days if book is returned.



## ...with new GREENLEE Radio Chassis Punches



Now, in 1 1/2 minutes or less make perfect "Key" or "D" holes for sockets and other equipment. Simply insert GREENLEE Punch and turn with an ordinary wrench... get a "clean" opening in a hurry! Write today for details on these as well as GREENLEE Radio Chassis Punches for round and square openings. Greenlee Tool Co., 1888 Columbia Ave., Rockford, Illinois



No. 732 "Key" Punch



No. 733 "D" Punch



ish 1330-1345, 1745-1800 on 6.100, 7.200; Home Service is relayed daily 0800-1300 over 6.100, 100 kw., and 9.505, 10 kw. The Central Amateur Station, Belgrade, is again on the air over 7.416 daily 0900-1030 with light music, no talks. (WRH)

## Press Time Flashes

I have just received honorary membership in the new Austrian DX Club, Landgutgasse 41/19, Vienna 10, Austria, which offers free membership to anyone, anywhere in the world; is eager to increase membership; when writing, enclose return postage in form of International Reply Coupon. Plans to print a bulletin (in German for present, but may add English section later); president is Heinrich Philipp.

Although reported moved to 11.96, Radio Record, Brazil, was noted recently in Portuguese 1650 on old 9.505 channel; may also use 11.96 (?). (Bellington, N. Y.) Verification from Radio Maroc, Rabat, Fr. Morocco, confirms that the 15.205 channel heard 0730-0930 daily is actually relay by VOA, 50 kw., Tangiers. (Niblack, Ind.) At press time, Radio Australia reported Taipei, Taiwan (Formosa) now has a newscast 0230; heard in Melbourne. And Morgan, Calif., flashed that BED4, 11.92, and BED6, 11.736A, now are announced as used for English to North America announced for 2200-2230, 2330-0000; close in Chinese 0100. Balbi, Calif., says BED7, 7.13, and BED6, 11.736A, now open 0500 which is 1/2 hour earlier than formerly; fair level.

Niblack, Ind., has received word direct from Radio Martinique that its s.w. channel on 9.700 is temporarily off the air.

During June, July, Japan's new (and first) commercial short-wave station tested on alternate days over JJ2KY, 3.925, and JJ2KZ, 6.095, both 500 watts, at 2000-0800; was to officially open August 1 when two 5 kw. transmitters were to be put into use on an extended schedule of 1700-0900 over JOZ, 3.925, and JOZ2, 6.095 (note permanent call-signs). (Radio Australia)

## Acknowledgment

Thanks for the fine reports, fellows! Keep them coming to Kenneth R. Boord, 948 Stewartstown Road, Morgantown, West Virginia, USA. Good listening! . . . . . K. R. B.

## BRASS POUNDERS MEET

THE South Hills Brass Pounders and Modulators have scheduled their 16th annual hamfest for Sunday, August 2nd.

The event will be held at Spreading Oak Grove, South Park, in Pittsburgh, Pa. The affair begins at noon and will continue as long as the attendees want to celebrate.

Prizes, refreshments, and games are on the agenda. For further information on this event, contact W3LDB, 4949 Roberta Drive, Pittsburgh 36.

## "OLD TIMER" ORMSBY

By C. HOWARD BOWERS

MANY of the old time wireless operators we have reported in this column had "hash marks" up to their shoulders before assuming shoreside jobs, but they will now please stand by while we pipe on board, Mr. R. S. Ormsby who made his start as a wireless operator in October 1911 and, after experimenting with a few shoreside deals, went back to his old love, radio operating and says, "After having sailed as radio operator on 25 ships since 1911, I am still going strong as Ship's Clerk and Radio Officer on my 26th ship!" Mr. Ormsby makes his home, between trips, at 1052 Central Avenue, Alameda, California, and would enjoy hearing from any old seagoing acquaintances.

We can do no better than quote extensively from Mr. Ormsby's report. "It was back in 1911, September 28th to be exact, when I obtained my first Wireless Operator's License. Perhaps some of the old timers will remember when R. B. Wolverton issued licenses to applicants in and around San Francisco. My first assignment was the "Charles Nelson" of the Nelson Lumber Company. I was a young lad then and to have this assignment I felt like the biggest "bigwig" on the San Francisco water front. The wireless equipment was manufactured by the United Wireless Company and the "Charles Nelson's" first voyage from San Francisco to Eureka, California was October 11, 1911. The equipment used at that time by United Wireless was a Marconi de-coherer, and what the de-coherer lacked in the ability of detecting the incoming signals, it made up for by having many strands of silk covered Litzendraht wire in loop form running through the glass core of a magnetic coil of very high ohmage enclosed within a beautiful oak case having a front window of beveled plate glass and mounted on the wall, and which had to be wound up with a key to give locomotion to the wire running through the core very slowly, cutting the magnetic lines of force, thus creating weak incoming signals within a pair of Brandes phones.

"On the desk was mounted a double

wound tube of primary wire, constituting the open radiating circuit, while the secondary tube constituting the closed oscillating circuit was wired up to two Fleming valves, having a filament and a plate (no grid). Reception at night was good up to about 200 miles. The transmitting end had a Kilbourn Clark rotary converter, having at the shaft end a revolving gap with two stationary electrodes at opposite ends of the machine which, when running, would create a 240 cycle note, which was considered music to an operator's ears, that is, if the motor was running in synchronism with the producing spark impulses!"

Mr. Ormsby mentions the year 1913 and the strike of wireless operators called by S. J. Konenkamp, the head of the Commercial Telegraphers Association of America. That strike was the beginning of a slow but gradual improvement of conditions and remuneration for the present-day radiomen. "R. S." must have had long range vision to have stayed with it! He also mentioned having been identified with the Colin B. Kennedy Company in San Francisco, to which he contributed his engineering skill in designing battery-operated receivers. Colin B. Kennedy was the "wireless tailor" of 1919-1920. He turned out either assembly line receivers or those made to your order.

Our friend continued on his sea-going job as operator on various vessels including the "Nome City," "Yosemite," "Portland," and the tanker "Roma." In 1934 while in New York aboard a Matson Navigation Company ship he displayed his version of the world's smallest all-wave, battery-operated receiver, which he dubbed "Pigmydyne." It was an oscillating regenerative two tuber in which he used plug-in coils on all frequencies and enjoyed world-wide reception on a small rod antenna. More important, however, is the fact that Mr. Ormsby is still going strong aboard his 26th ship after 23 years of brass pounding!

Thank you, R. S. Ormsby, and continued good luck!

-50-

Shown here are some tools especially designed for service technicians, available from CBS-Hytron. In the top row, from left to right, are a miniature-tube puller made of heat resistant rubber, a pin straightener for 7-pin and 9-pin miniatures, a tool for tuning auto radios when they are out of the car, and a plastic tube-socket locator for miniatures. In the bottom row from left to right are shown: a soldering aid whose forked tip holds wires and unwraps joints, a tube lifter for use in compact radios, probing tweezers of polystyrene for use in checking parts while the set is in operation, and a test adapter which effectively transfers all tube socket terminals to the top of the chassis within easy reach for checking.

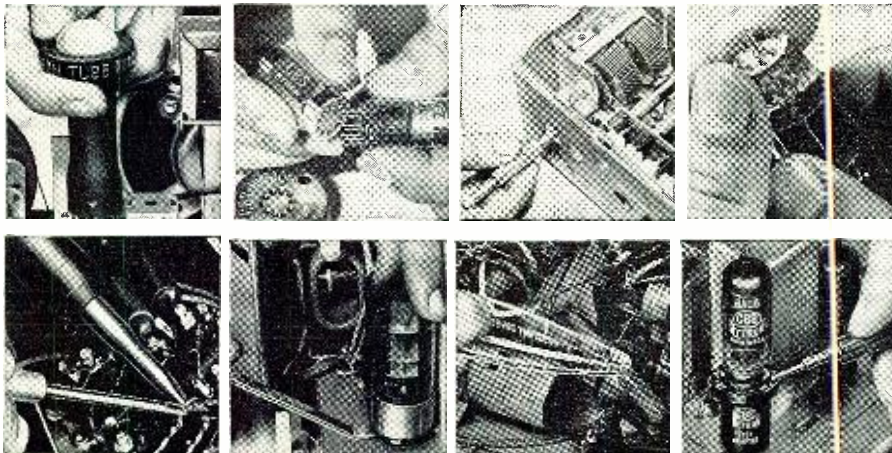

# 3 NEW RIDER BOOKS RELEASED IN JULY!

## 1 TV FIELD SERVICE MANUAL VOL. 2

Edited by Harold Alsberg

The finest practical data for in-the-home servicing. Tube layouts; picture tube adjustments; rear and front controls; tube complement; tuner and horizontal oscillator adjustments; key voltages; tuner dial stringing; trouble symptoms; chart with tubes and parts to check; series filament wiring. Book lies flat, spiral binding. Covers 1947 through 1953. Volume 2 covers: Bendix, Capehart, CBS Columbia, Crosley, DuMont.

Approx. 160 (5½" x 8½") pages, illus. Soft Cover. only \$2.40

**VOLUME 1.** (issued in May) Covers: Admiral, Affiliated Retailers (Artone), Aimee (AMC), Air King, Air Marshall, Allied Purchasing, Andrea, Arvin and Automatic.

128 (5½" x 8½") pages. Soft cover. Only \$2.10

## 2 HOW TO SERVICE TAPE RECORDERS

by C. A. Tuthill

Everything you need to know about what is inside a tape recorder—operation of the recording head, types of electronic circuits, kinds of drive mechanisms used, troubleshooting—and how to service the many types of tape recorders, with practical examples. Also discusses requirements for tape recorder repair shop. Soft cover.

only \$2.90

## 3 SPECIALIZED AUTO RADIO MANUALS VOL. 5-A

INDEPENDENT CAR MANUFACTURERS covers Henry-J, Hudson, Kaiser-Frazer, Nash, Packard, Studebaker, Willys.

Volume 5-A.....only \$3.00

Covers 5 years production (1950 thru 1954) of factory installed car radios. Identical data from other sources is just not available! Contains Parts list, Schematics, Tube layout, Voltages, Trimmer location, Chassis views, Chassis pictures, Dial stringing, and complete installation and removal information. Other volumes now available are:

**VOL. 1-A** (released in May) covers Ford . . . Lincoln . . . Mercury. 208 pages. Only \$3.00

**VOL. 2-A** (released in May) covers Buick . . . Cadillac . . . Oldsmobile. 200 pages. Only \$3.00

**VOL. 3-A** (released in June) covers Chevrolet, Pontiac, GMC Trucks, Chevrolet Trucks. 128 pages.....Only \$1.80

**VOL. 4-A** covers Chrysler, Plymouth, De Soto, Dodge, Dodge Trucks. 176 pages. Only \$3.00

All volumes 8½x11", soft cover.

### WRITE FOR COMPLETE 32 PAGE NEW RIDER CATALOG

Buy these books now from your jobber, bookstore —if not available from these sources, write to:

<b>JOHN F. RIDER</b>		PUBLISHER, INC. 480 Canal Street, New York 13, N. Y.	
In CANADA: Mr. Charles W. Peaton 5826 Gerrard Street, East Toronto, Ontario	Export Agent: Roberts Agencies, Inc. 38 Warren Street New York 7, New York		
West Coast Office: 4218 20th W. Jefferson Blvd. Los Angeles, California	Cable Address: RIDERBOOKS N. Y.		

# 4 LONG-PLAYING (33 1/3 R.P.M.) HI-FIDELITY Masterpieces

for only **10¢**



## BRAHMS

Academic Festival Overture  
*Utrecht Symphony,  
Paul Hupperts, Cond.*

## DUKAS

Sorcerer's Apprentice  
*Utrecht Symphony,  
Paul Hupperts, Cond.*

## WAGNER

Die Meistersinger,  
Prelude, Act 3  
*Zurich Tonhalle Orch.,  
Otto Ackerman, Cond.*

## MOUSSORGSKY

Night On Bald Mountain  
*Netherlands Philharmonic,  
Walter Goehr, Cond.*

(33 1/3 R.P.M.)

### No Strings Attached!

No Need to Buy Any Other Records  
—Now Or Later!

**YES.** You get all four masterpieces for 10¢. Brilliantly performed by world-famous artists. Custom-recorded on purest vinyl plastic. Long-playing (33 1/3 R.P.M.) recordings of such high fidelity that they encompass the entire range of human hearing . . . 50 to 15,000 cycles!

Why do we offer you—for only 10¢—recordings that you could not duplicate in a store for 100 TIMES THAT AMOUNT? (1) To demonstrate the superb quality of our high-fidelity long-playing discs. (2) To show you the advantages of being a trial member. You get advance notice of all Society recordings. You need not buy ANY—unless you want to. You may try them free in your home before deciding to buy them. You pay nothing in advance. And for those you do decide to keep—you pay only the very low member's price of \$1.50 for a long-playing disc, average playing time 40 minutes. But you must act now. This amazing offer may be withdrawn at any moment. Rush coupon with 10¢ at once to: The Musical Masterpiece Society, Inc., Dept. 478, 250 W. 57th St., N. Y. 19, N. Y.

The Musical Masterpiece Society, Inc., Dept. 478,  
250 West 57th St., New York 19, N. Y.

Here is my 10¢. Enroll me as a trial member. Send me the recording of the four masterpieces listed above.

Advise me in advance of all your monthly selections. I may try any of them for 5 days free. I may reject any record before or after I receive it. I shall only pay for those I keep, at the low membership rate of \$1.50 each plus a few cents shipping charges.

Name.....  
Address.....  
City.....Zone.....State.....

478

### Certified Record Revue

(Continued from page 50)

though edgy in spots, brass and woodwinds very bright, and percussion, so important in this work, is very accurate. You get pretty nearly everything ever used in the percussion battery of a modern symphony orchestra. Bass drum, tympani, triangle, tambourine, side drum, Chinese wood blocks, castanets, xylophone, gongs, and even whip-cracks! The "Sea Interludes" from "Peter Grimes" are very atmospheric pieces, depicting work and play in the small fishing village. The opening section is "Dawn" and is a moody, bleak sort of thing suggesting the sea in all its various phases. This is followed by "Sunday Morning," "Moonlight," and "Storm," all cleverly written and appropriately descriptive. As a bonus on this disc is the "Passacaglia," not found in the earlier *Columbia*. "Essentially tragic music, depicting in part the death of a child in the opera, its proper place in the opera is after the "Sunday Morning" scene. But for concert purposes, it is used to conclude the work, and is particularly effective after the noisy strife and tumult of the "Storm." Van Beinum's reading is very close in matters of tempi and expression to Sargent's on the *Columbia* disc. As was the case with the "Young Person's Guide," the sound is superior in all aspects, except perhaps the final moments in the "Sunday Morning" scene where the *Columbia* disc has an edge in the reproduction of the great church bells. All in all, a wonderful disc, highly recommended. The RIAA curve was OK without recourse to bass and treble controls. Surfaces moderately quiet.

### RIMSKY-KORSAKOV RUSSIAN EASTER OVERTURE ANTAR (SYMPHONY #2)

Detroit Symphony Orchestra conducted by Paul Paray. Mercury "Olympian" MG50028. RIAA curve. \$5.95.

As with the preceding recording, here are two works that will be welcomed by those who want modern versions to replace the earlier editions, which coincidentally are also on the *Columbia* label. The "Russian Easter Overture" is the better known of these two works, although "Antar" has its share of knowledgeable admirers. There are few other musical compositions which can equal the "Russian Easter Overture" for sheer orchestral color. In this brilliant portrayal of the traditional Easter festival of the old Orthodox Russian Church, one can sense the beauty and the power inherent in the religion of old Russia, of the Russia before the Communists made the worship of God a crime against the state. Well, politics aside, this is magnificent music and Mr. Paray conducts his ever-improving Detroit Symphony in a spirited and vigorous reading. He essays a tempo somewhat faster than the old

### Solves the SMALL PARTS STORAGE PROBLEM

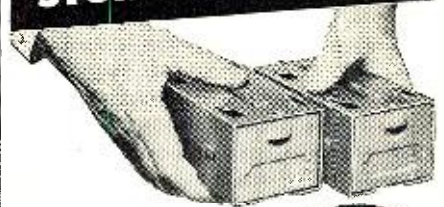

### ALL-STEEL MULTI INTERLOCKING DRAWERS

Multi-Drawers are handy all-steel storage cabinets perfect for storing easily-lost small parts like condensers, small tubes, switches, nuts and bolts! Precision-made, finished in durable two-tone green enamel, complete with card holder. Available at your dealer's in two sizes—42c ea. in the small size (illus.), \$1.28 for the large.

#### EASY TO ASSEMBLE

\*Units interlock rigidly at top, bottom, sides to fit any space.

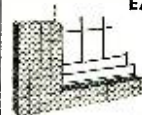

SOME DEALERSHIPS OPEN

\*Once again, enough steel is available to make Multi-Drawers available to new dealers! Write today.

### THE CINCINNATI VENTILATING CO. INC. THIRD & MADISON STS., COVINGTON, KY.

### SAVE! CLOSEOUT SAVE! COMMAND SETS NEVER BEFORE!.. NEVER AGAIN!

"Q"-5's \$ **10<sup>95</sup>**  
190-550KC  
LIKE NEW!..  
XLNT COND!..

### 274N and ARC 5 EQUIPMENT



Type	Revr.	3-6 Mc. Used, with tubes.	8.95
BC-454	Sold as is, Less tubes.	4.95	
BC-455	Revr. 6-9 Mc. Used, with tubes.	7.95	
	Sold as is, Less tubes.	4.95	
BC-456	Modulator. Used with tubes.	3.95	
	Sold as is, Less tubes.	2.95	
BC-696	Xmtr. As is, Less tubes.	9.95	
BC-457	Xmtr. 4-5.3 Mc. Used, with tubes.	6.95	
	Sold as is, Less tubes.	3.95	
BC-458	Xmtr. 5.3-7 Mc. Used, with tubes.	6.95	
	Sold as is, Less tubes.	3.95	
BC-459	Xmtr. 7-9.1 Mc. Used, with tubes.	9.95	
	Sold as is, Less tubes.	5.95	
BC-450	3 Revr. Control Box. Used.	1.49	
BC-451	Xmtr. Control Box. Used.	1.49	
3	Receiver Rack. Used.	1.49	
2	Xmtr. Rack. Used.	1.49	

CASH WITH ORDER. Include 4% sales tax with California orders—plus approximate postage. Excess will be refunded. Approximate shipping weight per unit: 15 lbs.

### SAM'S SURPLUS

1306 BOND STREET

LOS ANGELES 15, CALIF.

**New! New! New!**  
**Popular Electronics**  
**See Page 91**

Ormandy version, injecting a sense of excitement more in keeping with the score. Mr. Paray has honed his orchestra to a still finer edge since we last heard from him. Throughout this reading, the playing of the orchestra is exemplary, with sharp precise attacks and *ritards*. The winds, a little ragged in previous recordings, have been wondrously smoothed. Paray is slowly but surely molding the Detroit orchestra into one of the top rank symphony organizations in the country. In the "Antar" symphony, Paray continues his good work. A work of considerable contrasts, he successfully negotiates the transition from rousing, spirited marches to incredibly lovely and lyrical theme material. Some of Rimsky-Korsakov's most beautiful writing, especially in the quasi-oriental motif, is to be found in this work. In fact, there is so much beautiful thematic material in the first movement and in the "Theme Arabe" in the final movement, it's a wonder to me the pop ballad boys haven't lifted this music and fitted it out with a set of appropriately "goosey" lyrics. Hi-fi fans are in for a treat in the "Antar" and the "Russian Easter" as well. The colorful material just cries out for hi-fi treatment and both works receive the best from the *Mercury* engineers. Bright, brilliant brass with especially sonorous trombones, silky smooth string tone, melifluous woodwinds, all are here in extremely wide range. Percussion plays a large part in these works and in the movement in the "Antar" symphony entitled the "Delight of Power," is to be found a wide array of high percussion sounds. Regular transient feast here with triangles, cymbals, bells galore. Some low, low bass drum thuds in other sections of "Antar." The finale of "Russian Easter" is tremendous. Super wide dynamic range here, so watch your gain control if you have cranky neighbors! Altogether an outstanding disc from both the musical and hi-fi standpoints. RIAA curve was adequate without adjustment. Quiet surfaces.

**FOSS. LUKAS**  
**A PARABLE OF DEATH**  
**MARTINU**  
**INTERMEZZO**  
**MILHAUD**  
**KENTUCKIANA**

Louisville Orchestra conducted by Robert Whitney. Vera Zorina, narrator, Farrold Stevens, tenor, choir of Southern Baptist Theological Seminary in Foss work. Columbia ML4859, NARTB curve. \$5.95.

This trio of modern works is a product of the admirable work the Louisville Fund for Commissioned Music has been carrying out in conjunction with a grant from the Rockefeller Foundation. "A Parable of Death" is a most unusual work. Taken from a poem by the famous Austrian poet, Rainer Maria Rilke, the work is scored for narrator (in this case Vera Zorina), tenor and choir, and symphony orchestra. Admittedly a work of limited appeal, it is nonetheless an in-

August, 1954

LOOK TO THE LITTLE INDIAN  FOR  
 THE **BIGGEST** VALUE IN

**MOLDED PAPER TUBULAR CAPACITORS**

the Sangamo

*Telechief*®



The Telechief will outlive all other tubulars! Major manufacturers' test and stamp of approval prove that

Telechiefs have longer life. They have a final insulation resistance value 10 to 15 times greater than any other paper tubular—because they're molded in HUMIDITITE!



The Telechief outperforms all other molded paper tubulars in moisture resistance... in high temperature operation... in holding its rated capacity under all conditions.



EXTRA VALUE AT NO EXTRA COST! This amazing new capacitor—that meets specifications so tough that no previously existing paper tubular could approach them—is a *premium* tubular at the price of an ordinary one. See your Sangamo Distributor today!

Those who know  choose Sangamo

**SANGAMO ELECTRIC COMPANY**

MARION, ILLINOIS

SC 54.11

# COMCO Salutes

**SPILSBURY & TINDALL LTD.**  
Radio Communications  
VANCOUVER CANADA

A COMCO dealer for seven years, Spilsbury & Tindall have installed and are maintaining many COMCO VHF-FM radio communications systems in western Canada.

Mr. L. H. Potvin, Sales Manager of Spilsbury and Tindall, pointing out the merits of COMCO's model 404-AC-FG low powered base station.



NOTE: Over 150 different COMCO VHF-FM models now certified with U. S. Federal Civil Defense Administration.

ATTENTION DEALERS! Liberal Discount on sales! Write for available territories.



MANUFACTURERS OF RADIO & ELECTRONIC EQUIPMENT

**COMMUNICATIONS COMPANY, Inc.**  
CORAL GABLES, MIAMI 34, FLORIDA

**NOW COYNE TRAINS YOU IN SPARE TIME AT HOME**

## TELEVISION RADIO-ELECTRONICS

Only from famous COYNE do you get this modern up-to-the-minute TV Home Training. Easy to follow Step-by-Step instructions—fully illustrated with 2150 photos and diagrams. Not an old Radio Course with Television tacked on. Personal guidance by Coyne Staff. So practical you can quickly EARN MONEY IN A TV-RADIO SALES AND SERVICE BUSINESS—part time or full time. Not only FINEST TRAINING but COSTS MUCH LESS—pay only for training—No costly extras.

**SEND COUPON for DETAILS FREE**  
SEND COUPON BELOW for Picture Folder and full details including EASY PAYMENT PLAN. NO COST OR OBLIGATION—NO SALESMAN WILL CALL



B. W. COOKE, Pres. **COYNE ELECTRICAL SCHOOL** FOUNDED 1899

A TECHNICAL TRADE INSTITUTE CHARTERED NOT FOR PROFIT  
500 S. Paulina Dept. C4-HT5 Chicago 12, Illinois

B. W. COOKE, President  
**COYNE ELECTRICAL SCHOOL**  
500 S. Paulina St., Chicago 12, Ill., Dept. C4-HT5  
Send FREE Picture Folder and details of your Television-Radio-Electronics Home Training offer.

Name.....  
Address.....  
City..... State.....

## CRYSTALS!

**ALL HAM FREQUENCIES**  
Individually, Ea. .... \$6.75  
5 for only ..... 3.45  
10 for only ..... 5.90  
SINGLE SIDE BAND CRYSTALS ..... EA. .69

**COMPLETE SET—80 CRYSTALS**  
Ranging from 370-516 Kc., 54th Harmonic. INCLUDING 500 Kc. & 455 Kc. crystals. **\$6.95**  
Only ..... Per set

**COMPLETE SET—120 CRYSTALS**  
Ranging from 370-540 Kc., 72nd Harmonic. INCLUDING 500 Kc. & 455 Kc. crystals. **\$9.95**  
Only ..... Per set

200 KC. CRYSTAL ..... Ea. \$1.49  
500 KC. CRYSTAL ..... Ea. .75

### CRYSTAL GRINDING KITS

With Instructions

80 METER KIT ..... \$6.49  
40 METER KIT ..... 5.49  
2 METER KIT ..... 5.49

### \$600 VALUE! SPECIAL! HOT! !

A TRANSCEIVER WITH A RAFT OF USES! Makes an ideal 2-Meter transmitter. Only a few of its many parts include: miniature blower, gear reduction motor easily converted to 110 VAC, over 40 miniature tube sockets, 7 panel coaxial fittings, microswitches, & MUCH MORE! Excellent condition. Original cost over \$600! **IT'S ALL YOURS FOR ONLY \$9.95**

**MS-53 INTERCHANGEABLE ANTENNA MAST**  
New. Per 3 ft. section. .... Ea. 97c

**0-1 THREE-INCH MILLIAMPER METER**  
270° indication. You just by-pass shunt and add scale. ONLY **\$1.95**  
WITH Shunt By-passed ..... 2.49

ARB NAVY RECEIVER. Excel. cond. .... \$27.50  
SCR-518 UHF ELECTRONIC ABSOLUTE ALTIMETER. New. Less tubes ..... 19.95  
TELEPHONE DIAL. Used, excel. cond. .... 1.75  
LATEST TYPE FIELD PHONES. Excellent condition. PER PAIR ..... 19.50

400 MICA CAPACITORS. Assorted. Mounted 10 to a strip. All 400 ..... \$ 1.95  
ARW-2 REMOTE CONTROL RECEIVER. NEW.. 27.50

All merchandise sold as is  
Items subject to prior sale.  
Send for FREE Catalogue!

**J. J. GLASS ELECTRONICS CO.**  
1624 S. MAIN ST., LOS ANGELES 15, CALIF.

tensely interesting novelty. The narrator tells an old legend about a man, a woman, and death. The solo tenor and chorus comment on the story. Vera Zorina narrates in a beautifully modulated voice, never cheapening the narrative with melodrama, although this is a pitfall in which a less astute person could become enmeshed. Stevens has an admirable voice and the choir seems uncommonly well trained. An intriguing and different kind of music you might like. Acoustic perspective is almost too spacious, causing a slight fusion of some elements. Martinu's "Intermezzo" is a spritely, dance like work, with overtones of folk music and this, coupled with a moderate amount of atonality, makes for interesting scoring. Milhaud's "Kentuckiana" is a divertissement on twenty Kentucky airs. Such well-known folk tunes as "Leather Breeches," "Sourwood Mountain," "Barbary Allen" can be recognized, infinitely varied and cleverly transposed by our great French expatriate, Mr. Milhaud. Sure, there is dissonance here, but I'll bet you a jug of aged corn squeezin's, you can't keep your feet still! Altogether delightful and infectious music. Except for the acoustic problem already mentioned, the sound on these compositions is quite good. String tone is clean, brass and percussion sharp and bright. The Louisville Orchestra is excellently disciplined by the versatile Mr. Whitney. A few "flurps" were noted here and there, but on the whole the orchestra is a splendid example of a well trained community symphony orchestra. Certainly the Louisville orchestra is called upon to play more new and modern scores than almost any other orchestra in the country. That they accomplish their difficult season as well as they do is a tribute to the ability of Mr. Whitney. There are many other cities, bigger than Louisville, which do not have symphony orchestras, who would do well to emulate this progressive community. NARTB curve needed a little treble cut, slight bass boost. Surfaces in my copy were quiet.

### PROKOFIEV CHOUT (BALLET SUITE) DE FALLA THREE CORNERED HAT (DANCES)

St. Louis Symphony Orchestra conducted by Vladimir Golschmann. Capitol FDS, P-8257. RIAA curve. \$5.95.

A rarely heard Prokofiev score is the feature of this new Capitol recording. "Chout" or the "Buffoon Suite" as it is also called, is an oddity among the music of Prokofiev. By this I mean that the music contains some of Prokofiev's most interesting writing, yet it is a rare day indeed when this is performed in American concert halls. Many people who know and like the music of Prokofiev, are completely unaware of this brilliantly orchestrated ballet. As with so many other Russian ballet scores, the initial production was under the redoubtable Serge

# Compare! Save!.. on RAD-TEL TUBES and PARTS!

SAME DAY SERVICE • OVER 300 TYPES IN STOCK • NO GIMMICKS, JUST LOW—LOW PRICES!

## 70% to 90% OFF on TUBES INDIVIDUALLY BOXED FULL YEAR GUARANTEE!

**No. 132—Cathode Ray Tube Rejuvenator**  
 Fits all makes of picture tubes. Completely automatic. Easy to install, no tools needed. For A.C. parallel circuits. Your Old Picture Tubes Are Still Useful. List price—\$5.95.  
 Lots of 10 **1.09** each  
 1.39 each

**Wafer Rotary Switch Kit**  
 A choice combination of single, double, etc. from 2 to 8 positions.  
 Special kit of 10 **\$1.39**

**SPECIAL CLOSEOUTS JAN Tubes**  
 1619, 1626, 1629, 615, 7193, 954, 45 spec. **27¢** ea.

**AUTO GENERATOR CONDENSERS**  
 KIT OF 5 **1.00**

**Philco TV BOOSTER**  
 Completely self-contained, including 2 6J6 tubes and 1 for high channels and 1 for low channels and selenium rectifier. Plastic cabinet. In factory-sealed cartons, complete with instructions. No. 125  
**9.95**  
 STANDARD BOOSTER, COMPLETE, \$5.95



**VARIABLE CONDENSERS**  
 Manufactured by Philco, Radio Condenser, etc.  
 2 Gang AM and FM No. 9  
 Contains 2 separate sections for AM and 2 for FM with padders and condensers. With attached slug tuned high frequency coil whose plunger is geared to condenser shaft. Pulley type drive wheel.  
 Each **89c** Lots of 3 **79c**  
 2 Gang AM 3 Gang FM No. 10  
 Equipped with drum pulley and padders.  
 Each **89c** Lots of 3 **79c**  
 2 Gang Superhet No. 11  
 Complete with padders and drum pulley drive.  
 Each **79c** Lots of 3 **69c**  
 3 Gang AM Superhet No. 12  
 Complete with padders and pulley type drive wheel.  
 Each **89c** Lots of 3 **79c**

**No. 96—Famous Standard Coil**  
**Gascode Tuner**  
 Famous standard tuner TV front end. Double the gain with a great reduction in noise. A MUST for fringe area replacement. Includes tubes 6BK7 or 6BQ7 and 6J6.  
 List price \$34.50 **14.95**  
**ANODE CAPS, 19c ea.** Lots of 10 **18c ea.**



**Granco "Star" UHF CONVERTER**  
 Brand new! Latest model! Unit is highly engineered, receives all UHF channels. Coaxial tuned cavity elements complete with 6AF4 oscillator, 6CB6 I-F and crystal mixer. Shipped ready to install and operate. List Price \$29.95. **22.45**

### All New Parts At Old Fashioned SAVINGS!

**No. 82—Hi-Watt RESISTOR KIT**  
 Consisting of 5, 10, 15 and 20 Watt vitreous type resistors by Ward, I.R.C., etc. A top-flight buy!  
 Assorted Kit of 20  
**1.95**  
 Lots of 3 kits **\$1.85 ea.**

**WEN SOLDERING GUN**  
 3 seconds on 120 Volt AC readsies it for any soldering requirement. 250 Watt size. Also cuts plastic tile with special tip. Multi-useful! UL Approved. Built in spot light. **9.71**  
 Each ..... \$12.95  
 Lots of 3, 8-64 Each **11¢ ea.**  
**TIPS**  
 Feraloy Long Life... **35¢ ea.**  
 Standard Tip ..... **11¢ ea.**  
**WEN POLISHER 10.46 ea.** Lots of 3 **9.30 ea.**

**No. 47—CERAMICON KIT**  
 1 kit of 50 assorted ceramic discs, biplates, tubular condensers. All condensers popular sizes, used in T.V. and F.M. sets. A MUST kit.  
 List price—\$10.00  
**1.99** Lots of 5 **1.89 ea.**

**No. 44—10-INCH SPEAKER**  
 2.15 oz.  
**3.95** Lots of 5 **3.60 ea.**

**T. V., RADIO and F. M. COIL KITS**  
 Kit for television servicemen and experimenter consisting of wide coil, peaking coil, 4.5 m.c. ratio coil, 21.9 m.c. IP coil.  
 TV. Standard kit of ten (10).....**99c**  
 TV. Super value; not duplicated.....**\$1.85**  
 Broadcast and short-wave, mid-range to multi-band replacement coils.  
 BC. Standard kit of ten (10).....**99c**  
 BC. Super value; not duplicated.....**\$1.85**  
 Kit of 25.....**\$1.85**  
 BC kits include RF, Osc., IF and detector coils.

**No. 46—HI-VOLTAGE R.F. COIL**  
 4500 Volts  
**RF Transformer**  
 Ideal for TV and Oscilloscope power supplies, using 5" to 7" tubes. This buy is too BIG to be beaten!  
 List price—\$7.50.  
**79¢** Lots of 3 **69c ea.**

**No. 75—Army-Navy HEADSETS**  
 Individually boxed. Very sensitive. Meets both Army and Navy specifications. List price \$16.00.  
 Lots of 3 **2.95** each per set **2.83** each

**No. 107 DOUBLE FLYBACK**  
 TR-172  
**1.89** Each  
 Lots of 3 **1.79** each  
 Up to 15.5KV output. RCA Type Horizontal deflection transformer, with two filament windings for voltage doubler operation. First time at this low price.

Type	Price	Type	Price	Type	Price	Type	Price
OA2	.74	6AU5GT	.82	6X5GT	.37	12SR7M	.49
OA4	.68	6AU6	.46	6X8	.75	12V6GT	.46
OB2	.81	6AV5GT	.83	6Y6G	.48	12X4	.38
OC3	.72	6AV6	.40	7A4	.47	14A4	.69
OD3	.70	6AX4GT	.65	7A5	.59	14A5	.59
OZ4M	.65	6B4	.54	7A6	.69	14A7	.63
1A5	.49	6BA6	.49	7A7	.69	14AF7	.59
1A7GT	.47	6BA7	.57	7A8	.68	14B6	.63
1AX2	.62	6BC5	.54	7AD7	.79	14B8	.63
1B3GT	.73	6BD5	.59	7AF7	.53	14C7	.79
1C5	.43	6BD6	.45	7B4	.44	14E6	.75
1E7	.29	6BE6	.51	7B5	.45	14E7	.88
1G6	.24	6BF5	.41	7B6	.69	14F7	.65
1H4	.30	6BF6	.37	7B7	.49	14H7	.59
1H5GT	.49	6BG6G	1.25	7C4	.59	14J7	.30
1L4	.46	6BH6	.53	7C5	.69	14N7	.84
1LA4	.59	6BJ6	.49	7C6	.59	14R7	.79
1LA6	.69	6BK5	.80	7E5	.59	14S7	.89
1LC5	.59	6BK7	.80	7E6	.30	14W7	.30
1LC6	.79	6BL7GT	.83	7E7	.59	14X7	.69
1LD5	.59	6BN6	.59	7F7	.79	14Y7	.62
1LE3	.59	6BQ6GT	.98	7G7	.89	19BG6	1.39
1LG5	.69	6BQ7	.90	7H7	.59	19T8	.69
1LH4	.69	6BZ7	.90	7I7	.79	19V8	.79
1LN5	.59	6C4	.40	7K7	.69	24A	.39
1N5GT	.67	6C5	.39	7L7	.59	25AV5GT	.83
1P5GT	.57	6C6	.58	7N7	.69	25BQ6GT	.98
1Q5GT	.58	6CB6	.54	7Q7	.66	25L6GT	.51
1R5	.62	6CD6	1.11	7R7	.89	25W4GT	.59
1S4	.59	6CF6	.64	7S7	.79	25Z5	.66
1S5	.51	6CS6	.51	7V7	.89	25Z6	.49
1T4	.58	6D6	.59	7X6	.54	26	.45
1U4	.57	6E5	.48	7X7	.70	27	.39
1U5	.50	6F5GT	.39	7Y4	.69	32L7	.89
1V	.43	6F6	.59	7Z4	.59	35	.58
1X2A	.63	6G6	.42	12A6	.54	35B5	.52
2A3	.30	6H6GT	.41	12A8GT	.61	35C5	.51
2W3	.38	6J5GT	.43	12AL5	.37	35L6GT	.51
2X2	.49	6J6	.52	12AQ5	.52	35W4	.47
3A4	.45	6J7	.43	12AT6	.41	35Y4	.54
3E5	.46	6K5	.47	12AT7	.72	35Z3	.59
3FL4	.69	6K6GT	.45	12AU6	.46	35Z4	.47
3Q4	.48	6K7	.44	12AU7	.60	35Z5GT	.47
3Q5GT	.49	6L6	.64	12AV6	.39	36	.39
3S4	.58	6L7M	.68	12AV7	.73	42	.42
3V4	.58	6N7M	.63	12AX4	.67	45	.55
5U4G	.55	6Q7	.45	12AX7	.63	45Z3	.44
5W4GT	.50	6R7	.69	12AY7	.99	45Z5	.49
5Y3GT	.37	6S4	.48	12AZ7	.59	50A5	.55
5Z3	.45	6S78	1.90	12BA6	.49	50B5	.52
6A6	.51	6S7M	.79	12BA7	.60	50C5	.51
6A7	.69	6S8GT	.53	12BD6	.45	50L6GT	.61
6AB4	.44	6SA7GT	.55	12BE6	.51	50Y6	.49
6AC5	.69	6SD7GT	.41	12BF6	.39	50Y7	.50
6AC7M	.86	6SF5GT	.46	12BH7	.63	55	.49
6AF4	.90	6SG7GT	.41	12BY7	.65	56	.49
6AG5	.56	6SH7GT	.49	12BZ7	.65	57	.58
6AG7M	.99	6SJ7GT	.41	12C8M	.34	58	.60
6AH4	.57	6SK7GT	.53	12H6	.56	70L7	.97
6AH6	.73	6SL7GT	.48	12SC7M	.63	75	.49
6AJ5	.65	6SN7GT	.59	12J5	.42	76	.44
6AK5	.55	6SQ7GT	.46	12J7	.49	77	.57
6AK6	.59	6SR7GT	.45	12K8	.59	78	.47
6AL5	.42	6SS7GT	.42	12Q7	.59	80	.43
6AM8	.78	6T4	.99	12S8GT	.62	83V	.68
6AQ5	.50	6T8	.80	12SA7GT	.65	84/6Z4	.46
6AQ6	.37	6U5	.57	12SF5	.50	85	.59
6AQ7	.70	6U6	.59	12SG7	.51	117L7	.99
6AR5	.45	6U8	.78	12SJ7M	.67	117P7	.99
6AS5	.50	6V6GT	.50	12SK7GT	.63	117Z3	.37
6AS6	1.49	6W4GT	.47	12SL7GT	.57	117Z6	.69
6AT6	.41	6W6GT	.57	12SN7GT	.52	807	.99
6AU4GT	.68	6X4	.37	12SQ7GT	.56	866A	1.39

# RAD-TELTUBE CO. Dept. RN8 115 Coit St., Irvington 11, N. J. "Integrity Is Our Chief Asset"

**TERMS:** A 25% deposit must accompany all orders—balance C.O.D. All shipments F.O.B. Irvington warehouse. **ORDERS UNDER \$10—\$1.00 HANDLING CHARGE.** Subject to prior sale.  
**PLEASE:** Send full remittance... allow for postage and save C.O.D. charges! We refund all unused money!  
 Phone: Essex 5-2947  
 Tubes in Bold Type Cover 90% of Demand

# AIREX'S HI-FIDELITY

1955 CHANNELOC 630FA-3  
WITH TONE CONTROL & FRONT FOCUS  
READY FOR COLOR CONVERTER

3 MONTHS

RMA  
GUAR.  
ON ALL  
PARTS

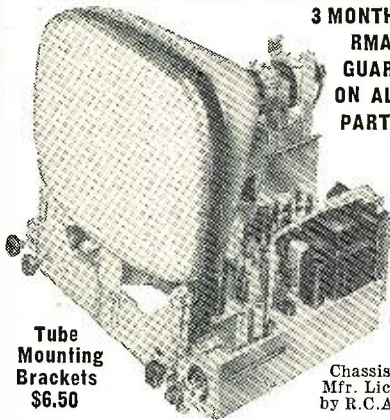

Tube  
Mounting  
Brackets  
\$6.50

Chassis  
Mfr. Lic.  
by R.C.A.

Here is the most powerful fringe area chassis on the market today. Only the Airex 630FA-3 gives you Channeloc. Both picture and sound are locked together to give you perfect synchronization at all times. The perfect chassis for UHF, VHF and DX reception.

THE ONLY CHASSIS WITH 10 WATT  
PUSH-PULL HI-FI AUDIO SYSTEM AT

**\$164.95**

Fed. Tax  
Included

Less C.R. Tube  
and Brackets

Complete with Two Speakers—12" Hi-Fi  
Woofers and Tweeter

With UHF 83 Channel Converter—\$211.90  
Detailed Service Manual & Schematic—\$1

## COMBINATION SAVING!

This Month  
Only

- 630 FA-3 Chassis
  - 17" Picture Tube
  - Mah. Console Cabinet
- With mask, glass, tube mtg brackets FOR THE 3 UNITS

**\$244.95**

Fed. Tax  
Inc.

## TV PICTURE TUBE SALE

Standard Brands. Factory  
New. Guar. 1 year.

- 17" Tube.....\$24.95
- 20" Tube.....\$32.95
- 21" Tube.....\$34.95
- \*24" Tube  
Round.....\$79.95
- \*24" Tube Rect.\$59.95
- \*27" Tube Rect.\$79.95
- \*Guar. 6 months
- Ring and Sleeve  
for 24" Round. \$ 7.50

## MAGNAVOX HI-FI

3 Speed

Record Changer

Dual stylus cart, heavy  
duty 4 pole motor. Inter-  
mixes 10-12".

Each.....\$28.70

Regularly \$54.50

## TV GOLD

PLASTIC MASKS

16" and 17".....\$ 4.95

20" and 21".....\$ 7.95

24".....\$14.95

27".....\$17.95

Granco 82chan.  
UHF Tuner...\$18.95

## BARGAIN

CABINET BUY

Mahogany console cabinet  
cut for 630 FA-3  
Chassis. With mask, glass  
& tube mount. Separ-  
ate brackets.....\$49.95  
In Blond.....\$59.95  
FREE cabinet brochure

## AIR KING

6 Tube Radio Chassis

Superhet. 1 stage R.F., 2

stages I.F., 2 gang con-  
denser. Complete—6 tubes,  
speaker & built-in anten-  
na. Removed from origi-  
nal equip-  
ment.....\$10.95

We Won't Be Beat on Hi-Fi Equip.

## REGAL FM-AM RECEIVER

10 Tubes. Covers  
full FM-AM band.  
10 Watt Push-pull  
audio output. Sepa-  
rate bass and treble controls. Built  
in FM-AM antenna. With 12" Hi-Fi  
speaker \$5 additional.....

**\$49.95**

Also complete line of Tuners, Amplifiers,  
Speakers, Phono Pick-Ups and  
Cartridges and Changers.

- Altec
- Astatic
- Eogen
- Craftsmen
- Electrovoice
- Espy
- Fisher
- Garrard
- Gen'l Electric
- Grommes
- Jensen
- Pickering
- Pilot
- RCA
- University
- V-M
- Webster
- Wharfedale

Send us your requirements  
Full, illustrated catalog available.

All merchandise brand new, factory fresh, guaranteed.  
Mail & phone orders filled upon receipt of certified  
check or money order for \$25 as deposit on TV chas-  
sis. 20% on other items. Balance C.O.D., P.O.E.  
factory N. Y. Prices & specifications subject to change  
without notice. NO FED. TAXES TO PAY.

## AIREX RADIO CORP.

SHOWROOM: 171 Washington St., N. Y. 7  
Cortlandt 7-5218

Diaghilev. Drawn from an old Russian folk tale, the ballet is a highly amusing "comedy of errors." Prokofiev derived a suite of 12 episodes from the ballet, which are generally used in the concert version. The scoring is extremely clever and stems from Prokofiev's "wild" period. There is much dissonance here which, however, adds considerably to the grotesquerie which is so common to this ballet. As with most Russian ballet, this score lends itself admirably to hi-fi sound. *Capitol* has achieved one of its most spectacular recordings in this ballet. Brass is brilliant, and in trombone and tuba, very weighty. String tone is properly clean and incisive, woodwinds very fluent indeed and, as might be expected, some terrific percussion, all of which is very solid and accurate. I would venture to say that the enterprising New York City Ballet could mount a new production of "Chout" which would meet with considerable success. There is another recording of this ballet on LP, on the *Vox* label, but unfortunately the performance was marred by the very poor sound. Golschmann seems to know his way around in this complex score and elicits some fine playing from his orchestra, although it must be admitted there are a number of ragged attacks and other "flurps" in evidence. Much better acoustics, than previous recordings of the St. Louis Orchestra, lend a splendid liveness to the work. The "Three Cornered Hat" dances are given a somewhat linear, straightforward performance by Golschmann, and they are well recorded. The Ansermet version on *London* still reigns supreme, as far as this score is concerned. The RIAA curve sounded OK with a smidgin' of bass boost. Quiet surfaces.

## GRANADOS GOYESCAS EL PELELE

Nikita Magaloff, pianist. London ffr  
LL-954, RIAA curve. \$5.95.

In this colorful score the peculiar amalgam of the Spanish musical idiom with the more classical forms of piano writing is quite evident. While there is much of the figuration and embellishment which has become associated with Spanish music for the piano, Granados' scoring cannot be termed truly derivative. The music is an imaginative depiction of the paintings and tapestries of that mad genius, Francisco Goya. Here you will find some entrancingly beautiful music for piano. Some sections are softly lyrical, while others retain more of the typical Spanish rhythmic flavor. There are three other recordings of this music, none of which is quite as satisfactory as this version. While Magaloff may not have the native fluency of Falgarona on the *Vox* disc, her performance is hardly less effective and she has a thorough and facile technique. The piano sound on this record is truly fabulous. Not a trace of wow or flut-

ter, even in the longer decay periods. Big, big, tone with an astonishing feeling of presence. Close-to recording, quite proper in this kind of work. This is the kind of piano sound that, if you have a really good wide range system and you play the record at the proper level with your door open, neighbors will swear is the real thing! The RIAA curve was adequate without further adjustment.

## LURE OF THE TROPICS

Andre Kostelanetz and his orchestra.  
*Columbia* ML4822. NARTB curve.  
\$5.95.

Well, here is one of those items I promised you as a respite, something to listen to while fixing that nice cold drink. The disc contains eight numbers which have enough musical substance to remain popular for a long time. Such diverse items as "Poinciana," "Jamaican Rhumba," and "Malaguena" are given the lush, super-orchestrated Kostelanetz treatment. The record is advertised as having one of the largest percussion batteries ever set up in an orchestra. There is plenty here all right, but don't look for thundering tympani, because most of the scoring is for the high percussion, cymbals, triangles, bells, etc. A pleasant and innocuous disc well recorded, except for a fault common to many *Columbia* discs, that of anticipatory echo. Either somebody is running too hot on the vu meter and saturating the tape, or the tape is being wound too tightly and, in storage, is causing "print-through." Not really annoying, but it's there to hear. NARTB curve was adequate. Moderately quiet surfaces.

## STRAVINSKY

### LE SACRE DU PRINTEMPS

Pittsburgh Symphony conducted by Wil-  
liam Steinberg. *Capitol* FDS, P-8254.  
RIAA curve. \$5.95.

Unfortunately this arrived too late to include with the *Mercury* version reviewed last month. In this recording we have the other end of the recording pole as compared to *Mercury*. This is a "heavier," concert-hall type of sound, in which some detail has been sacrificed to the over-all sonic picture, which doesn't mean that there isn't some fabulous sound on this disc. There is and how! In the final dance, there is some low, very guttural tuba sound that is terrific on a big speaker system. Brass sound, especially trumpets and trombones, is the best ever recorded by *Capitol*. The percussion is good, but it is here where the superiority in sound of the *Mercury* disc is most apparent. The percussion on this disc has nowhere near the impact or articulation found in the Dorati performance. I think one of the reasons for this and, indeed, one of the reasons for less general cleanness of sound on this disc, is the acoustic perspective. In a work like "Le Sacre," where rhythm is all important, reverb time must be a closely controlled factor. Too much and all the rhythmic elements fuse together and the work

loses much of its distinctive texture. That is unhappily quite evident here. Performance wise, Steinberg has taken the work at a much slower tempo than Dorati, and in consequence with the "heavier" sound, generates much less excitement. The orchestra, under Steinberg's deft direction, is magnificent and negotiates the complex score with polished ease. As I said, this is almost diametrically opposed in matter of sound and performance to the Dorati version, I have no doubt there will be many who will prefer this, shall we say, more orthodox reading. If the *Mercury* disc did not exist, this would certainly be the performance of choice. Quiet surfaces and happy conformity with the RIAA curve completes the picture.

**WAGNER  
TRISTAN UND ISOLDE (LOVE  
DUET)**

Martha Modl, soprano; Johanna Blatter, mezzo; Wolfgang Windgassen, tenor; with Orchestra of the Stadtische Oper, Berlin, conducted by Arthur Rother. Telefunken LGX66004. RIAA curve. \$5.95.

If you do a "double-take" at the name of the recording company on this disc, I won't blame you! It means just what it says, the magic name *Telefunken*. The astute gentlemen who run *London Records*, have made arrangements to distribute the *Telefunken* catalogue in this country, which will be good news to many. *Telefunken* records, back in the old 78 rpm days, were much esteemed for the high quality of sound. Indeed, there are some of their old 78's floating around with sound quality every bit as good as some of the stuff being turned out today. Among their first releases is this ever-popular "Love Duet" from "Tristan und Isolde." The soprano Martha Modl, is not too well known to American audiences, having been heard but once before in the *London-Bayreuth* "Parsifal." Hers is a rather variable talent. At times she amazes with her range and dexterous handling of difficult passages. Other times, she has trouble with seemingly simple parts. On the whole, her Isolde is characterized more by superb drama than by really great singing. Wolfgang Windgassen has been heard from recently in the Bayreuth "Lohengrin." His Tristan holds considerable promise. A little more polishing on some of his rough edges, and he will easily hold top rank among available Tristans. Miss Modl and Windgassen are excellently balanced and their essay of this passionate music has much excitement. If they are not as "perfect" as a Flagstad-Melchior, they are nonetheless convincing. The sound is typical of what *Telefunken* has always striven for; a big, concert-hall liveness. A very smooth sound that is quite different from American endeavors. They are sticklers on matters of balance, and that is very evident in this recording. Not super-wide-range stuff, but adequate for the acoustical qualities

August, 1954

## If you want professional sound quality



Sound engineers know that the selection of a fine amplifier, pickup and speaker system is only part of the story; that unless the turntable is of equal quality, music reproduction must suffer. That is why they insist on such high standards for turntable performance.

## do as the professionals do...

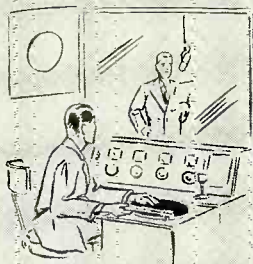

Rek-O-Kut precision turntables are made to conform to the highest standards in the professional field, and they certainly represent the finest you can use in the home. A Rek-O-Kut turntable will make all the difference in the world. The finer your present system, the more apparent the improvement will be. Whether you select the deluxe T-12H or the standard LP-743, the entire performance of your sound system will become a new and thrilling experience.

## use a REK-O-KUT precision turntable

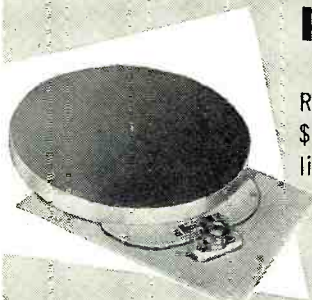

Rek-O-Kut Precision Turntables are priced from \$59.50. Write for specifications and descriptive literature to Dept. J-12

### The REK-O-KUT COMPANY

Manufacturers of Professional Disc Recorders and Specialized Sound Systems.

38-01 Queens Boulevard, Long Island City 1, New York  
Export Division 458 Broadway, New York, U.S.A. Cables: Morhanex  
In Canada: Atlas Radio Corp., Ltd., 560 King Street, W., Toronto 28

## ARKAY KITS WORLD'S FINEST

RADIOS PHONOGRAPHS TV  
TEST EQUIPMENT HI-FI  
Write for FREE Brochure

RADIO KITS, INC. • 120 Cedar St., N. Y. 6

### TV TRADE-IN SETS

- Philco • Emerson • GE • Admiral
  - Motorola • Tele-King • Others
- 10" —\$17; 12" to 17" —\$20 up

Send check or money order now!  
List available—Add \$5 each for packing  
**WASHTEK SERVICE CO.**  
1501 Boston Road, Bronx, N. Y. DA 3-9281

## GET INTO ELECTRONICS



You can enter this uncrowded, interesting field. Defense expansion, new developments demand trained specialists. Study all phases radio & electronics theory and practice: TV; FM; broadcasting; servicing; aviation, marine, police radio. 18-month course. Graduates in demand by major companies. H.S. or equivalent required. Begin Jan., March, June, Sept. Campus life. Write for catalog.

**VALPARAISO TECHNICAL INSTITUTE**  
Dept. RD Valparaiso, Indiana





**SATISFACTION  
GUARANTEED**

From  
**Henry**

New  
**NC98**

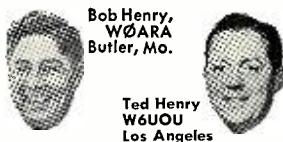
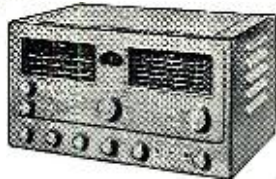

Bob Henry,  
WØARA  
Butler, Mo.

Ted Henry  
W6UOU  
Los Angeles

*We Give...*  
**LONG LONG TRADES  
LOW LOW TERMS  
10 DAY TRIAL  
FAST PERSONAL  
SERVICE**

**ONLY \$1500  
DOWN**

18 monthly payments of \$8.00  
Cash price \$149.95

Now for the first time, a crystal filter, an S-Meter, choice of electrical bandspread on amateur or SWL bands, an RF stage and 2 IF stages.

**We WANT you to be SATISFIED**  
Ask any Ham about Henry  
**We have All National Receivers in stock for immediate delivery, also National parts.**

18  
Cash Monthly Cash  
Down Payments Price

SW-54	\$5.00	\$2.61	\$49.95
NC-88	12.00	6.54	119.95
NC-125	20.00	10.89	199.95
NC-183D	40.00	21.77	399.50
HRO-60	54.00	29.00	533.50

Write, wire, phone or visit either store today.

Butler 1, Missouri  
Phone 395



**Henry Radio Stores**

Bradshaw 2-2917

11240 West Olympic Blvd. Los Angeles 64

**QUARTZ CRYSTALS**

FT-243-.093" PIN DIA.—.486" PIN SPC

FOR HAM AND GENERAL USE • GUARANTEED

4035 5500 5925 6425 7450 7673 7900	1015 6175 7000 7440 8450
4080 5675 5940 6673 7473 7675 7906	2125 6200 7025 8025 8475
4110 5700 5950 6675 7475 7700 7930	3500 6440 7035 8250 8500
4165 5706 5973 6700 7500 7706 7940	3640 6450 7075 8075 8525
4190 5725 6240 6706 7506 7720 7950	3680 6473 7100 8100 8550
4280 5740 6250 6725 7525 7725 7973	3735 6475 7125 8125 8575
4300 5750 6273 6750 7540 7740 7975	3800 6500 7150 8150 8600
4397 5773 6275 6775 7550 7750 8206	3885 6506 7175 8175 8625
4490 5806 6300 6800 7573 7773 8225	6000 6550 7300 8175 8650
4495 5840 6325 6825 7575 7775 8250	6025 6573 7306 8200 8700
4930 5850 6340 6850 7600 7800 8273	6050 6575 7325 8340 8733
5030 5852 6350 6875 7606 7825 8275	6075 6600 7340 8350
5205 5873 6373 6900 7625 7840 8300	6100 6606 7350 8375
5300 5875 6375 6925 7640 7850 8325	6125 6625 7375 8390
5385 5880 6400 6950 7641 7873 8630	6140 6640 7400 8400
5485 5906 6406 6975 7650 7875	6150 6650 7425 8425

49c each - 10 for \$4.00

99c ea. 10 for \$8.00

Low Frequency—FT-241A for SSB, Lattice Filter etc., .093" Pins, .486" SPC., marked in Channel Nos. 0 to 79, 54th Harmonic and 270 to 369, 72nd Harmonic. Listed below by Fundamental Frequencies, fractions omitted.

370 393 414 437 501 522 400 461	5910
372 394 415 438 502 523 440 462	6370
374 395 416 481 503 525 441 463	6490
375 396 418 483 504 526 442 464	6470
376 397 419 484 505 527 443 465	6497
377 398 420 485 506 529 445 466	6522
379 401 422 486 507 530 446 468	6547
380 402 423 487 508 531 447 469	6610
381 403 424 488 509 533 448 470	7350
383 404 425 490 511 534 450 472	7380
384 405 426 491 512 536 451 473	7390
385 406 427 492 513 537 452 474	7480
386 407 429 493 514 538 453 475	7530
387 408 430 494 515 454 476	7810
388 409 431 495 516 455 477	7930
390 411 433 496 518 457 479	
391 412 435 497 519 458 480	
392 413 436 498 520 459	

49c each - 10 for \$4.00

99c each - 10 for \$8.00

Spec.—200 KC without holder—59c, 3 for \$1.50

Spec.—200 KC or 500 KC in FT241A Holder, \$1.79 ea.

**FT 717B BC-610  
2 Banana Plugs  
3/4" SPC**

2030 2220 2360 3202 3570
2045 2258 2395 3215 3580
2065 2260 2415 3237 2545
2082 2282 2435 3250 3955
2105 2290 2442 3322 3995
2125 2300 2532 3510
2145 2305 2545 3520
2155 2320 2557 3550

**BC746 TUNING  
UNITS, CHAN-  
NELS 10 AND 12**

—foundation coils and condenser for 80 meter VFO or exciter—less xtals 98c

SEE ARTICLE BY W3PPQ IN MARCH '54 CQ.

add 20c postage for every 10 crystals (orless)

**SUPER TV BARGAINS**



**UHF CORNER REFLECTOR**  
ONLY \$2.99 EACH IN SINGLE LOTS  
LOTS OF 6 \$3.50 EACH

This hi-gain UHF Corner Reflector can only be offered you at this low, low price for a short time, 8 to 11 db gain across UHF band. Order Model F-6.

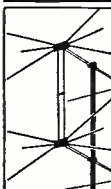

**Tremendous Conical Bargain  
2-Bay 16-Element Array**

**\$4.99 EACH IN LOTS OF 3**

With Hi-Band Adapters. Sturdy 3/8" Elements.

**SINGLE LOTS . . . \$5.30 EACH**  
This conical 2-Bay 16-element array provides ultra-fine fringe reception. Includes sixteen 3/8 inch airplane type aluminum elements. Including hi-band adapters for greater gain on the high channels and is complete with one pair of stacking bars to each array. These are packed in cartons of three 16-element arrays per carton, with tie rods, at \$14.95 per carton. Single 16-element arrays, separately boxed—\$5.30 each

3 Two-Bay Arrays per carton without Tie Rods . . . . . \$13.50 carton

4 Bay Ultra-Fringe Stacking Assembly for Above—Model 4B . . . . . \$1.95 set

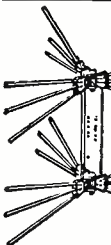

**Fringe Master MOTORLESS DIRECTRONIC**

• NO GHOSTS  
• NO INTERFERENCE  
• ELECTRONICALLY BEAMED

• NO MOTORS NEEDED  
Model AX-599. 15-element, stacked array provides sparkling reception in city or fringe—all channels in all directions. Serviceman's kit provides 15 hi-tensil aluminum elements, 6-position Directronic Beam Selector, 1 set matched stacking bars, 75' TRI-X Cable, universal U-Clamp. Complete Kit . . . \$16.95

**\$16.95**

**NEW SPRING-SUMMER CATALOG AVAILABLE**

ALL PRICES F.O.B. CLEVELAND, OHIO  
Do not remit more than complete purchase price. Pay shipping charges on receipt of goods. 25% deposit on all C.O.D. orders, please. Money-back guarantee.

**National Electronics  
OF CLEVELAND  
THE HOUSE OF TV VALUES  
108 Delco Building Cleveland 3, Ohio**

they are trying to project. Other of the initial *Telefunken* releases are quite good and most interesting, and will be reviewed next month. A little bass and treble boost helped with the RIAA curve. Moderately quiet surfaces.

**TCHAIKOVSKY  
1812 OVERTURE  
ROMEO AND JULIET  
CAPRICCIO ITALIEN**

Concertgebouw Orchestra of Amsterdam conducted by Paul van Kempen. Epic LC3008. NARTB curve. \$5.95.

I was anxious to hear the "1812" on this disc as I had heard a lot of "raves" about the sound. I'm sorry to say, I can't go along with it. The performance is great. Van Kempen takes this overplayed warhorse and really turns in a stunning and exciting reading. His handling of the big climax is masterful, and he never lets the orchestra run away with itself. But the sound! I dial twiddled and threw equalization switches trying to balance this sound, until my arms and ears got tired. Bass is incredibly boomy and mushy, treble the most strident I have run across in ages. Even when I turned the treble completely off, the edge was still in the strings. One of the worst faults was excessive reverb time in the hall, making all the sound and fury of the bells in the finale "run together" and lose texture. Too bad, because the performance is outstanding. I don't like to point fingers or call names, but it occurs to me that the reason the sound is so unbalanced in this recording, is an attempt on the part of *Epic* to appeal to a large segment of the unformed public. By this I mean that on the cheap "rinky-dink," so-called "high-fidelity table model phonographs," with which the public is being bamboozled, this sort of sound is probably pretty good. Since there is really no high- or low-frequency reproduction in these abortions, the excessive bass and treble of this recording show up to good advantage. Maybe I'm all wrong, but this is definitely not the way to build up a following for *Epic* records. The "Romeo and Juliet" and the "Capriccio" also receive good performances at the hands of Mr. Kempen, and the sound is somewhat better balanced. I know the great *Philips* organization can do better than this, and I feel certain this situation will be corrected. As you can understand from the foregoing, any attempt on my part to describe equalization would be pointless. Quiet surfaces.

**BACH, J. S.  
PRELUDE AND FUGUE IN G MAJOR  
TOCCATA  
ADAGIO AND FUGUE IN C MAJOR  
PRELUDE AND FUGUE IN E MINOR  
ACH, BLEIB BEI UNS  
FUGUE IN D MAJOR**

John Eggington, organist, playing organ of the Church of St. Radegonde, Poitiers. L'Oiseau-Lyre OL50012. RIAA curve. \$5.95.

Here is still another of the initial  
**RADIO & TELEVISION NEWS**

# coming in September...

...THE FIRST AND ONLY MAGAZINE ON  
PRACTICAL ELECTRONICS FOR THE  
HOBBYIST, THE EXPERIMENTER AND  
THE NOVICE.

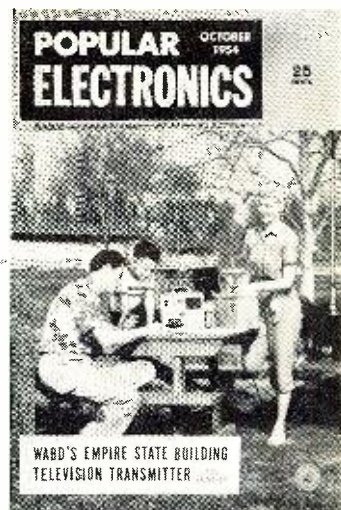

POPULAR ELECTRONICS will provide all the essential information on electronic components, construction, instruments and systems. Yet, it will be written simply enough so that even those with a beginner's knowledge of electronics can readily understand its how-to-build-it, how-to-use-it, how-it-works articles.

**POPULAR ELECTRONICS WILL MAKE THE IDEAL SUPPLEMENT TO YOUR READING OF RADIO & TELEVISION NEWS . . . POPULAR ELECTRONICS WILL MAKE THE PERFECT GIFT FOR THE ELECTRONICS BEGINNERS AMONG YOUR FRIENDS.**

*Every issue will be filled with easy-to-understand articles like these . . .*

- OPPORTUNITIES IN ELECTRONICS
- INTRODUCTION TO HIGH FIDELITY
- PICTURES ON MAGNETIC TAPE
- HOW TO BUILD A BIKE RADIO
- HOW TO LAY OUT A CHASSIS
- HOW RADAR WORKS
- MEET THE TRANSISTOR
- HOW TO SOLDER
- VOICE-OPERATED MODEL TRAIN CONTROL
- BUILDING THE HOME BROADCASTER

(Fill out this form and mail it today.)

THE FIRST ISSUE IS CERTAIN TO BE A SELLOUT AT NEWSSTANDS . . . AND A COLLECTOR'S ITEM IN YEARS TO COME! MAKE SURE YOU AND YOUR FRIENDS RECEIVE YOUR COPIES!

**ORDER YOUR OWN AND GIFT CHARTER SUBSCRIPTIONS NOW AT THE SPECIAL INTRODUCTORY RATE OF ONLY \$1.00 FOR 5 ISSUES (NEWSSTAND PRICE 25c)**

**Please enter my CHARTER SUBSCRIPTION to POPULAR ELECTRONICS**

**INTRODUCTORY RATE: 5 ISSUES—\$1.00**

My Name \_\_\_\_\_

Address \_\_\_\_\_

City \_\_\_\_\_ Zone \_\_\_\_\_ State \_\_\_\_\_

Please enter my Charter Subscription to POPULAR ELECTRONICS.

Please enter a Charter Subscription to POPULAR ELECTRONICS as my gift to:

Name \_\_\_\_\_

Address \_\_\_\_\_

City \_\_\_\_\_ Zone \_\_\_\_\_ State \_\_\_\_\_

Donor's Name \_\_\_\_\_

(to appear on gift card)

I enclose \$ \_\_\_\_\_ for \_\_\_\_\_ Charter Subscriptions at \$1.00 each.

Mail today to

**POPULAR ELECTRONICS**

366 Madison Ave.

New York 17, N. Y.

R 8-4

Wait'll you see what

Centralab

has  
up its  
sleeve!

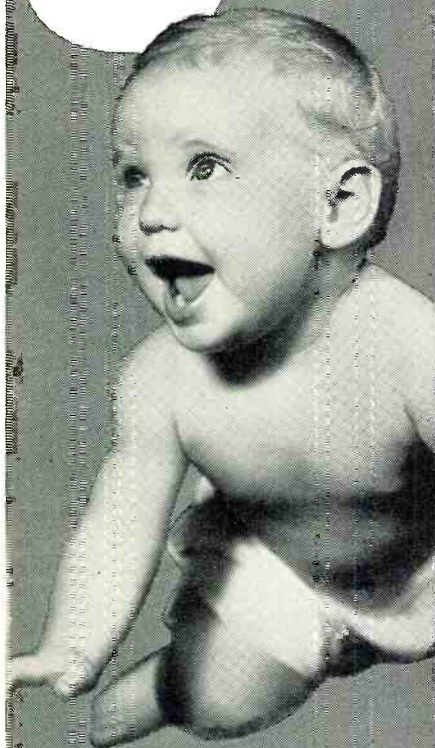

It's the most important  
development in years  
in  
dual concentric  
controls!

Watch for early  
Centralab  
announcement  
in this magazine

recordings in the first release of *L'Oiseau-Lyre*. The organ used is a magnificent instrument, and is shown off to best advantage in these beloved works of Bach. Mr. Eggington is a serious artist who gives straightforward and entirely convincing readings of these masterpieces. Not for him is the "interpretation" and flamboyant registration to which these works have been subjected in less loving and less sen-

sitive hands. Sound is not too wide range, but is adequate enough. Some low pedals, but not to be compared to the huge sonorities found in some other organ recordings. All is very nicely balanced however, an attribute not found in some of the discs with the "bigger pedals." A few db of bass boost helps out the RIAA curve considerably. Quiet surfaces.

-50-

### THE "DISC-CHARGER"

ONE of the most aggravating and annoying phenomena connected with the reproduction of phono discs is the presence of electrostatic charges which attract atmospheric dust to the record surface. These dust particles enter the record grooves and are bound to them by the invisible electric charges built up with each revolution of the disc.

Various attempts have been made to remove this dust, ranging from record brushes to wiping the record with a damp cloth before and after each play. Two West Coast scientists, Sam Messin of the U. S. Naval Air Missile Test Center, Point Mugu, California and J. S. Friedman of Mercury Scientific Products Corp., Los Angeles, decided to tackle this problem from another angle. They decided to investigate the use of radioactive materials for this purpose. It is a well known fact that radioactivity produces radiations which ionize the air, reducing or inhibiting the formation of static electricity.

Their experiments indicated that a minute quantity of radioactive material, when mounted on the pickup arm and allowed to scan the revolving disc, was found to be adequate for the purpose. With this method of scanning, a capsule containing the radioactive material can be produced at nominal cost.

An interesting quality of the radioactive material used is its ability to produce radiations without deteriorating. Its expected half-life is 1600 years,

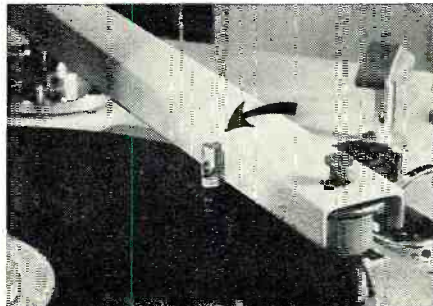

The tiny "Disc-Charger" shown mounted on the side of a standard phono pickup arm.

which means it will then reach half strength!

The final model, which was dubbed the "Disc-Charger" and for which a patent is pending, consists of a lightweight ( $\frac{1}{2}$  gram) plastic body containing the radioactive material and a clip designed to secure the plastic body to any pickup arm. It scans the record surface with an invisible, weightless brush of ionized air. The inventors report that one of the most satisfactory results obtained from this device is the reduction of dust blobs under the stylus. They further report that after only one or two plays, the records no longer produce these dust collections—thus ultimately reducing background noises which formerly increased noticeably with often-played discs.

-50-

The unique "broadcast studio" at the Boone (N. C.) High School. Fiber egg crate separators were fastened to the walls and ceiling of the 7 x 15 foot room with linoleum seal and carpet tacks. According to the chief engineer at the local broadcast station (WTAR), this acoustical treatment provides "broadcast quality" to the programs originating at the school. Teacher Merrill Snyder and student Earl Norris prepare the separators for installation on "studio" ceiling and walls.

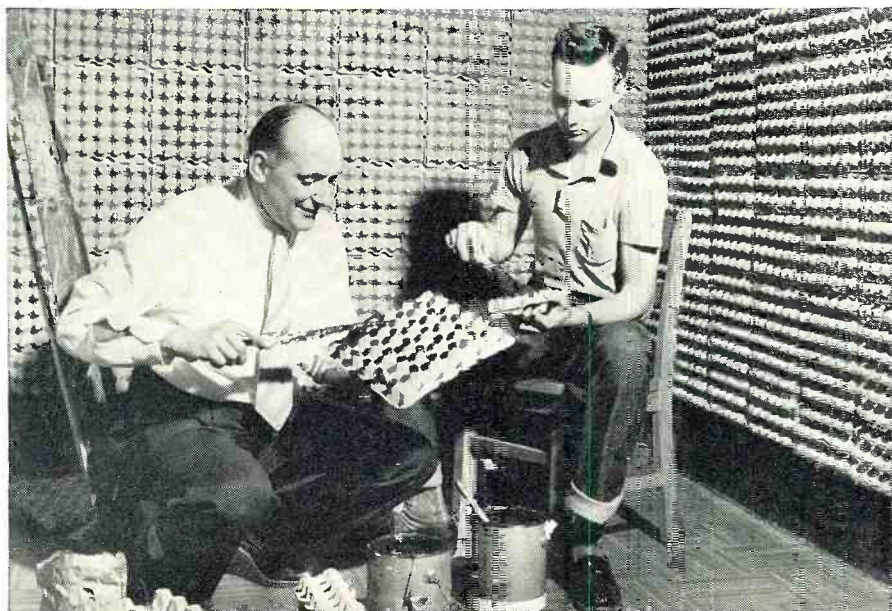

**Mac's Service Shop**  
(Continued from page 62)

interference on channel 6. The district manager called Joe and asked him to see if he could find the trouble. One glance at the TV set in the station wagon was all that was needed to know the interference was not coming from a power line, for it displayed typical r.f. cross-hatching. Nevertheless, since three-hundred-odd persons believed it might be line noise, Joe set out to prove it was not. This was the routine.

"First he looked at a city map and discovered that the outline of the area from which complaints were coming strongly resembled the response pattern of a yagi antenna pointing north with the intersection of the major and minor lobes on the south side of town. Next he took a couple of bearings on the interference with his channel 6 yagi and noted these lines also intersected on the south side. Connecting the signal strength meter to the whip antenna, he drove to that vicinity. By driving back and forth in a criss-crossing pattern while watching the meter, he soon spotted a house that gave a maximum signal of 500 microvolts directly in front of it. No one was home at the house; so Joe briefly opened the line switch at the meter. The interference promptly disappeared.

"This information was relayed to the police, and they managed to find the owner of the house and summon him home. Joe went inside with him and found his TV set turned off, but a one-tube booster on top of the set had been left on. When the TV set was turned on, the booster stopped oscillating; but it promptly started again when the set was turned off. That booster was putting out twenty microvolts of signal strength two miles away!"

"That's one for the book!" Barney exclaimed.

"Here's another Joe calls *The Case of the Methodical Maid*," Mac said. "This case of interference looked like diathermy and came on promptly at eight o'clock each evening and stopped just as promptly at nine. The chief complainant was an elderly doctor. The best Joe could do was pin the interference source down to the single block in which the doctor lived. Signal strength was about the same anywhere inside the block, and the yagi antenna would not give a conclusive directional reading. One evening Joe was parked in the alley of that block, elbows stuck through the spokes of the steering wheel, chin resting on the palms of his hands, staring vacantly up into space while the TV set behind him gave out with the characteristic rasping sound of the interference. He had just decided the only thing left to do was to call out a crew of men and cut off the drops to the houses one at a time, when a little

**SPECIALS For AUGUST Only:**

R-26/ARC-5 REC.—3 to 6 MC—No Tubes—Used \$5.95  
R-27/ARC-5 REC.—8 to 9 MC—No Tubes—Used. 5.95  
BC-455/274N REC.—6 to 9 MC—w/Tubes—Used.. 8.95

**TG-10 KEYS:**

Same function as TG-34A (described below) only larger—using 2/6N7—2/6L6—2/6S7—1/5U4G Tubes and 1/923 Photo Cell. Housed in standard Metal Cabinet, can be removed for 19" rack mtg. Size: 11" H x 24" W x 18 1/2" D.  
**PRICES—NEW: \$29.95 — USED: \$19.95**



**TG-34A KEYS:**

115 or 230 V. @ 50 to 60 cycle—KEYER TG-34A is an automatic unit for reproducing audible code practice signals previously recorded in ink on paper tape. By use of the self contained speaker, the unit will provide code practice signals to one or more persons or provide a keying oscillator for use with a hand key. The unit is compact, in portable carrying case, complete with tubes, photo cell, and operating manual. Size: 10 9/16" x 10 1/2" x 15 13/16". Shipping weight: 45 lbs. Prices—While They Last.

**BRAND NEW: \$24.95 • USED: \$14.95**

**RECORDER FOR CODE TAPES:**

BC-791—Recorder and Amplifier of Code Signals directly from a Radio Receiver or local sending on 7% Paper Tape with ink writing stylus. Tape can be played back on any TG-10 or TG-34 Keyer. Uses 1/117N7GT and 2/117P7GT Tubes. 115 Volt 60 cycle operation. No Tubes, Tape, or Tape Puller included. Tape Puller from TG-10 or TG-34 can be used.

**PRICES—NEW: \$7.95 — USED: \$4.95**

**PRACTICE CODE TAPES:**

Code Training and Practice Inked Paper Tapes on 16 MM 400 ft. Reels for telegraph and radio operation. 15 Reels to a Set, in wood case—for use with TG-34A and TG-10 Keyers. **\$12.95**

**SEPARATE TAPES for following lessons:**

Tape #11—Traffic Tape #8—Code Groups  
Tape #12—Traffic Tape #2—Receiving  
Each on 16 MM Reel, in metal container: \$1.25 Ea.

**BLOWERS—115 VAC 60 CYCLE**

**SINGLE TYPE:** (Illustrated at left) 100 CFM. 2 1/4" intake; 2" outlet. Complete size: 5" x 6". Order No. IC939. \$8.95  
**DUAL TYPE:** 100 CFM. 4" intake; 2" Dis. Each Side. Complete Size: 8" x 6". Order No. IC880. \$13.95  
**COMPACT TYPE:** 108 CFM. Motor built inside squirrel cage. 4 1/2" intake; 3 1/2" x 3" Dis. 7/8" W x 8 3/8" H x 8 1/4" D. Order No. 2C067. \$14.50  
**FLANGE TYPE:** 140 CFM. 3 1/2" intake; 2 1/2" Dis. Complete size: 7 1/2" W x 7 1/2" H x 6 3/4" D. Order No. IC807. \$13.95  
**FLANGE TWIN:** 275 CFM. 4 1/2" intake; 3 1/4" x 3" Dis. Complete size: 11 3/4" W x 8 3/8" H x 8-1/16" D. Order No. 2C069. \$21.95

**TRANSFORMERS—110 V. 60 CYCLE PRI.:**

5 Volt CT-25A—10,000 V. Ins. OPEN FRAME—6" x 5" x 4 1/2". \$7.95  
6.3 V. Amp. 1.25 24 V. I Amp. 1.95  
24 V. 1/2 Amp. 1.50 6, 24, or 30 V. 8 A. 5.95  
Sec. Two 12 V. 4 A. Winding—Gives 12 V. 8 A. or 24 V. 4 Amp. 5.95  
**CONSTANT VOLTAGE TRANSFORMER—115 V. 60 Cycle 80 VA. Sola # 30726. \$14.95**

**PE-101 DYNAMOTOR—**

6 or 12 Volt. (Reprints of original CQ conversion articles—Oct. and Dec., '52 issues—furnished.) This is the Dynamotor the Hams have been talking about! Easily adapted to supply 625 V. @ 150 MA. and 325 V. 125 MA. @ 12 Volts—or 500 V. 90 MA. and 500 V. 110 MA. @ 6 Volts. **NEW: \$4.95**

**SOUND POWERED HEAD AND CHEST SET** — Navy Type—No batteries required—Ideal for TV installations and many other uses. 50 Ft. Cord. Used—TESTED. **\$5.95**

Address Dept. RN • Minimum Order \$5.00 • Prices F.O.B., Lima, O. • 25% Deposit on C.O.D. Orders

**FAIR RADIO SALES** 132 SOUTH MAIN ST. LIMA, OHIO

**LEARN TV SERVICING**  
Send for free 24-page illustrated booklet which tells you how to become a successful TV technician. America's leading TV servicing school offers you a specialized training program that omits non-essential math & design theory. You concentrate on radio & TV servicing only. You get professional training & experience right in our fully-equipped shops & laboratories. Write Dept. R-84.  
Approved for Veterans  
**WESTERN TELEVISION INSTITUTE**  
341 W. 18th St. Los Angeles 15, Calif.

**NEW ITEMS:**

NOTE: The following items are NEW additions to our stock. Each month other new items will be added! If there are any items that do not appear in this ad but have been advertised previously, send us your order today!

**AUTOSYN TRANSMITTER And INDICATING SYSTEM:**



1-82-A Radio Compass Indicator, 5": \$7.95  
MC-217 Autosyn Transmitter.....\$6.95  
Originally operated from 26 V. 400 cycle. Can be operated from 12 V. 60 cycle, and used as a remote indicating system. 1-82, MC-217, and I2 Volt Transformer **\$14.95**

TS-291/U VOLTOHMVOMETER—Meter 3" square. 1000 ohms Per Volt, D'Arsonval Movement—0/300/600 VDC scale and 0-1 Meg. Case size: 3 1/2" x 5 1/2" x 2 1/4". W/Test Leads P/O 1-56 Test Set—**\$7.95**  
NEW

H-55/U HEADSET & BOOM MICROPHONE—Low impedance Headset and Boom Carbon Mic. **\$4.95**  
Lightweight, Used—Tested

TS-9 HANDESET w/Butterfly Sw. Used, Tested...\$3.95  
TS-13 HANDESET w/Sw., PL-68 & PL-55, Used, Tested... 6.95  
TS-10 HANDESET—Sound Powered—Used, Tested 6.95  
WE-1A HANDESET—Chrome Plated Brass, Used, Tested... 3.95  
T-17 CARBON MIC.—w/PL-68—Used, Tested... 6.95  
T-30 THROAT MICS.—Used, "As is"—5 for... 1.00

BC-669—CONTROL BOX RM-21—With CD-513 Cord, Handset Holder, Volume Control, Sw., etc. New \$4.95  
Handset Plug for Control Box: 75c. CD-515 Cord for use from BC-669 to PE-110: \$2.95.

POWER SUPPLY 24 VDC—3 Amp output; 115 Volt 60 cycle input. Completely filtered with 0.75 VDC Output meter & two Tungar Bulbs—Used, Tested...\$12.95

GEARED HEAD MOTOR—110 Volt 60 cycle, 30 RPM. 1/100 HP. Right Angle Drive—Size: 7 1/2" x 4" x 4". Shaft size: 3/16" x 3/4". NEW...\$9.95

GEARED HEAD MOTOR—110 Volt 60 cycle—1.9 RPM. Size: 2 1/2" x 2 1/2" x 2 1/2". Torque: 75 oz. in. NEW...\$9.95  
BD-77C DYN. ARMATURE Only, NEW... 7.95

**ANTENNA EQUIPMENT**

**MAST BASES—INSULATED:**

MP-22 BASE — (Illustrated) Ins. spring action; direction of bracket can be raised or lowered easily. \$2.95  
MP-132 BASE—1" heavy coil spring; 2" Ins. Overall length: 1 1/2". Weight: 2 1/4 lbs. \$3.95  
MP-S-33 BASE—Insulated type with heavy coil spring and 5" dia. Ins. Requires 2" hole for mounting. Weight: 9 lbs. \$5.95  
MP-48 BASE—Insulated type base with heavy coil spring. Requires 1 3/4" mounting hole. Weight: 11 lbs. \$6.95  
MP-37 BASE—Insulated type with heavy coil spring. 7" dia. insulator; requires 1 1/2" hole for mounting. Weight: approx. 10 lbs. \$8.95

**MAST SECTIONS FOR ABOVE BASES:**

Tubular steel, copper coated, painted in 3 ft. sections, screw-in type. MS-53 can be used to make any length with MS-52-51-50-49 for taper. Any section. @ 50¢ Each  
Larger Diameter Section: MS-54...\$75¢

**COAXIAL CABLE & CONNECTORS**

CD-1071 CORD—With PL-259 Plugs each end. Removable Vinylite covering over Plugs, 50 ohm coax 2 Ft. long. Prices: 50¢ Each—Or in Lots of 10 @ 50¢ Each.  
PL-259—Plug ea. end & 32"—RG-54/U—58 ohm...50¢  
UG-21/U—Plug ea. end & 32"—RG-11/U—75 ohm...50¢  
UG-22/U—with 4" Coaxial Cable...50¢  
RG-8/U (SPECIAL) 51.5 ohm. Same size as RG-8/U. Prices: 1 to 100 ft. @ 8¢ per ft.—100 to 500 ft. @ 7 1/2¢ per ft.—500 to 1000 ft. @ 7¢ per ft.—1000 ft. Rols (or more) @ 6 1/2¢ per ft.  
RG-34/U—71 ohm. 145 ft. length...\$15.00

**World's Only Recorder of its Kind**  
**WALKIE-RECORDALL**  
**8-LB SELF-POWERED BATTERY RECORDER**  
\*AUTOMATIC UNDETECTED RECORDING up to 4 hrs.  
\*PICKS UP WITHIN 50 FT. RADIUS.  
\*VOICE ACTIVATED "SELF-START-STOP"  
\*NO WIRES OR PLUGS.  
Records noiselessly in or out of closed briefcase, containing hidden mike while walking, riding, flying. Conferences, lectures, dictation, 2-way phone. Permanent, unalterable, indexed recording at only 3c per hr.  
MILES REPRODUCER CO. INC.  
812 Broadway, N. Y. 3, N. Y. Dept. RN-8

# TELTRON TUBES

Guaranteed! . . . Lowest Prices Ever!

All tubes individually boxed . . . unconditionally guaranteed for one year.

TYPE	PRICE	TYPE	PRICE	TYPE	PRICE	TYPE	PRICE	TYPE	PRICE
024	.45	6A8	.40	6BJ6	.51	6SL7GT	.60	12BZ7	.63
1A7GT	.53	6K7	.40	6BK5	.75	6SQ7GT	.38	12K7	.40
1H5GT	.51	6Q7	.40	6BL7GT	.78	6U8	.76	12SN7GT	.56
1L1	.51	6B4	.43	1H6	.90	6V3	.80	19B6G	1.10
1L5	.54	6AC7	.65	6BQ6GT	.85	6W6GT	.48	19T8	.71
1LC6	.49	6A4GT	.65	6BQ7	.85	6W6GT	.53	25BQ6GT	.82
1N6GT	.51	6AJ5	.96	6BY5G	.60	6X4	.37	25W4GT	.43
1H5	.51	6AK5	.96	6C4	.41	6X5GT	.38	2Z55	.65
1T1	.51	6A05	.48	6CB6	.51	6X8	.80	25Z6GT	.36
1U4	.51	6AH5	.48	6CD6G	1.63	7F8	.49	35B5	.48
1U5	.45	6AT6	.37	6CU6	.93	7N7	.49	35C5	.48
1X2	.65	6AU6GT	.60	6F6	.42	12AL5	.43	35L6GT	.41
2A3	.35	6AV6GT	.60	6F5GT	.44	12AT6	.37	35W4	.33
2A7	.35	6AX1GT	.60	6H6	.50	12AU6	.43	35Y4	.42
304	.53	6AX3GT	.60	6AF4	1.02	12AV6	.42	35Z6GT	.41
3Q5GT	.61	6BA7	.58	6J5GT	.49	12AV7	.73	50A5	.40
3S4	.48	6BR5	.48	6K6GT	.39	12AX4GT	.60	50B5	.48
3V4	.48	6BR5	.46	6L6	.78	12AX7	.61	51C5	.40
5V4G	.49	6BF5	.48	6S4	.41	12AZ7	.65	Type 80	.40
5Y3GT	.30	6BF5	.48	6S8GT	.65	12B4	.72	117Z3	.33
5Y4G	.40	6BR6	1.18	6SA7GT	.45	12BA7	.58	117L6GT	1.20
5Z3	.42	6BH5	.51	6SK7GT	.45	12B7	.61	117Z6GT	.65

**FREE** \$7.20 list value Bonus Box of three 6SN7 tubes and 25 assorted resistors with each order of \$25 or more. **GIFT OFFER!** One 6BG6 tube will be shipped FREE with any order accompanying this ad.

We now have a complete line of special purpose and transmitting tubes in stock. Write for quotations on your requirements—Dept. T.

We guarantee your orders to be shipped the same day they are received!

Minimum order \$10.00. 25% deposit on C.O.D. orders—save parcel post charges. Orders accompanied with full remittance will be shipped prepaid anywhere in continental U.S.A. All orders subject to prior sale.

Send for Free complete tube listing

## SPECIAL! . . . till Sept. 1

TYPE	PRICE	TYPE	PRICE
1B3GT	.55	6T8	.57
5U4G	.40	6W4GT	.35
6AC7	.65	12A7	.53
6AG5	.44	12AU7	.47
6AL5	.28	12BA6	.36
6AU6	.35	12BE6	.40
6AV6	.34	12B7	.62
6BA6	.38	12SA7	.43
6BK7	.78	12SK7	.43
6BQ6GT	.75	12SL7GT	.45
6BZ7	.80	12S7	.35
6J6	.48	25L6GT	.35
6SN7GT	.48	50L6GT	.49

# TELTRON ELECTRIC COMPANY

428 HARRISON AVE.

DEPT. RN8

Phone Humboldt 4-9848

HARRISON, N. J.

rectangle of light in his line of vision winked out. At the same instant the noise stopped, and a glance at the TV screen revealed the broad band of interference was gone.

"In a matter of seconds Joe was ringing the doorbell of the house in which the light had been turned off—the house of the doctor, no less! It was quickly revealed the window from which the light had disappeared was in the maid's room on the third floor. Subsequent investigation revealed that her room was lighted by an ancient tungsten-filament bulb that was the best little interference transmitter you ever saw.

"The thing that threw Joe was the precise timing of the interference. He had been thinking all the time of some mechanical device that was turned on and off with a time clock, or something like that. Talking with the neighbors revealed that the doctor always ate dinner at exactly the same time. The maid cleared off the dishes and retired to her room at exactly eight o'clock. Then she read for precisely an hour before turning off the light and going to sleep."

"Hey, this is more fun than ghost stories," Barney exclaimed. "Tell me another!"

"Okay," Mac agreed, "but it'll have to be a short-short. We've got to get to work. One day a report came in of interference along a brand new 230,000 volt line that had just been erected. Incidentally, Joe tells me the higher the voltage of the transmission line, the less noise you have. It is a lot harder to keep 12,000 and 33,000 volt lines quiet than it is 60,000, 132,000, and 230,000 volt jobs. Anyway, he did not believe the complaint could be justified for he had driven the full length of the line when it was first activated, and there was nary a sound. In fact, he had parked directly under this line and pulled in a TV station forty miles away with just his truck-mounted yagi, and there was not the first trace of interference.

"When he checked the line this time, however, he found there was bad interference peaked on channel 6. Using his field strength meter, he was able to drive right to the cause of the noise: a piece of bailing wire tossed over one of the wires. When that wire was removed and measured, it was found to be exactly one-half wavelength long on channel 6."

"Is it unusual for line interference to be peaked on one TV channel?"

"That's right. Power line interference is of the random noise type and normally covers a broad band of frequencies. Occasionally this band will extend from the broadcast band through the TV channels. In a very few cases it will peak up on the higher frequencies and not be heard on the broadcast band. In the great majority of instances, however, it will be quite strong on frequencies up to about three or four megacycles but cannot be detected at all above thirty megacycles.

SAVE MONEY . . . MAKE MONEY . . .

# LEARN TV

the practical way . . .



## ASSEMBLE A TRANSVISION TV KIT

Pay as You Wire \$ **39**

I WILL HELP YOU to start learning TV the practical way — by assembling a TRANSVISION TV KIT in EASY STAGES. For only \$39 you get PACKAGE #1 (standard first pkg. for all of our kits). This package gives you the BASIC CHASSIS and over 450 TV COMPONENTS with complete Instructions, Drawings, Photos, Service Booklet, and a year's subscription to my "TV and Electronics Notes". When ready, you order the next stage (pkg. #2), etc. Low prices make your complete kit a terrific buy!



**FREE CATALOG** Shows 6 Great TV Kits: EXCLUSIVE: Only Transvision TV Kits are adaptable to UHF. Ideal for FRINGE AREAS. No Previous Technical Knowledge required. Write now!

TRANSVISION, INC., Dept. N8  
NEW ROCHELLE, N. Y.

MAIL THIS COUPON TODAY

Educational Director  
TRANSVISION, INC., NEW ROCHELLE, N. Y. Dept. N8

I'm enclosing \$\_\_\_\_\_ deposit. Send standard kit PACKAGE #1, with all Instruction Material. Balance C.O.D.

Send FREE copy of your new TV Kit Catalog.

Name \_\_\_\_\_  
Address \_\_\_\_\_  
City \_\_\_\_\_ State \_\_\_\_\_

## Editors and Engineers PUBLICATIONS

### BETTER TV RECEPTION

New 2nd Edition

IT COVERS ALL YOU WANT TO KNOW ABOUT

fringe and low-signal areas

BETTER TV RECEPTION has become the standard guide for the installation technician and a popular text for TV enthusiasts.

Book No. E&E-TR2

\$2.50 per copy (paperbound) at our store

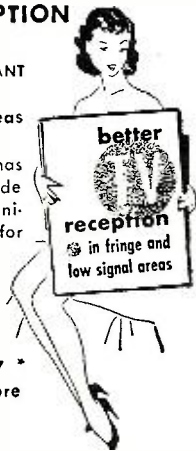

### For Additional Coverage

**RADIOTELEPHONE LICENSE MANUAL.** Typical study questions with concise answers for all commercial U.S.A. radiotelephone operators license. Book No. E&E-RL1 . . . . . \$3.75\*

**RADIO HANDBOOK. GIANT 13TH EDITION.** A one-volume library of radio information with extensive, simplified theory. Detailed how-to-build-it data on dozens of items of practical radio equipment. Book No. E&E-RH13 . . . \$6.00\*

**SURPLUS RADIO CONVERSION MANUAL. VOL. 1.** Practical conversions. Write for list of contents. Book No. E&E-SM1 . . . . . \$2.50\*

**SURPLUS RADIO CONVERSION MANUAL. VOL. 2.** Companion to Volume 1. Book No. E&E-SM2 . . . . . \$2.50\*

\*Plus any tax.

### BUY FROM YOUR DISTRIBUTOR

ADD 10% ON DIRECT MAIL ORDERS TO EDITORS and ENGINEERS, Ltd. BOX 689A SANTA BARBARA, CALIF. Books/notes order from BAKER & SIVLER, Milford, N. J.

"Joe made several other points," Mac said as he ticked them off on his fingers. "For one thing, he wished people could learn interference that shows up on just one channel is practically never from a power line. Neither is interference that produces cross-hatching of the picture or a reversal of the black and white portions. That comes from some r.f. producing gadget, such as an oscillating booster. Secondly, he wants people to know power companies are sincerely glad to know of any unusual noise along their lines, for such noise is often a warning something is going wrong. If they find out what it is promptly, this may save them thousands of dollars in equipment. People who believe power companies do not seriously hunt noise sources are just not being realistic.

"Third, Joe says no transmission line can be made absolutely noise free any more than a gasoline motor can be so completely muffled it cannot be heard running in a quiet room. A good line will not cause any interference to a TV set operating within a few yards of its poles if that set has any kind of a normal signal; but when you try to receive a TV signal of five or ten microvolts right under the line, you will probably see, mixed in with the thick snowflakes produced by the set's own noise, a few sparkles of light that represent noise from the line. Power companies are engaged in constant research and rebuilding to make their lines more and more nearly noise free, but they do not hope to achieve 100% success in this effort.

"Finally, it must be understood that while power companies are doing everything they can to kill their own snakes, they simply cannot use their special noise-locating equipment to run down general complaints of interference not connected with their systems. That is a job for service organizations, TV viewer groups, radio clubs, city governments, or whoever else is willing and able to take on a chore that can be thankless and frustrating, but never dull—at least that's what Joe says!" —30—

### HAMFESTS SCHEDULED

THE seventh annual hamfest picnic of the Baltimore Amateur Radio Communication Society has been scheduled for Sunday, August 15th.

The affair, to be held at Triton Beach, will begin at 10 a.m. Attendees are asked to bring their own picnic lunches. The fee of \$1.00 per person (50 cents for children) will cover bathing, bath-house, lockers, etc.

Write W3JCL, 2208 N. Fulton Ave., Baltimore 17 for full details.

THE Tri-State Amateur Radio Society will hold its annual get-together on Sunday, August 29th at Rural Center, 7½ miles north of Evansville, Ind. on highway 41.

The event gets under way at 10 a.m. (CST) with a basket dinner at noon. A transmitter on 10 and 75 will help guide mobiles. Wilbur Weisling, W9OVB, 719 Main St., Evansville, is chairman. —30—

August, 1954



Leo I. Meyerson, WØGFQ  
C.U. on 10, 20 & 75 Meters

• In keeping with WRL's policy of always giving you MORE WATTS PER DOLLAR, we now offer you a complete 500 watt band-switching 160 through 10 meter transmitter using the popular husky 4-250 A tube in final. Complete TVI shielding and by-passing of RF section and meters. Includes co-ax antenna change-over relay and push-to-talk features. Pi-network final tuning will match any antenna system from 52 to 600 ohms with output impedance selector switch on front panel. This arrangement serves as an ideal antenna tuner. Metering of all stages with 2 — 3" meters. Several safety features included for protection of final tube which is forced air cooled. High level 100% plate modulation. XMTR designed for future use with single side-band exciter. Class B 5514 modulators with separate power supply and 4 stage speech amplifier. New dual high-low voltage power supply for final and exciter. New streamlined compact style hammertone finished cabinet approximately 31" high, 21 ¼" wide and 15" deep. Has provisions for VFO.

# IT'S BRAND NEW...

You asked for it!

## WRL PROUDLY ANNOUNCES 500 Watt Complete Band Switching GLOBE KING TRANSMITTER

YOU GET TOP TRADE-IN VALUE FROM  
WRL. NO ONE CAN MATCH OUR DEALS!



MODEL 500

\$36<sup>78</sup> PER MO.  
(18 MO.)

\$67<sup>50</sup> CASH DOWN

\$675<sup>00</sup> CASH

Other terms can be arranged to suit your budget.  
WE ALLOW TOP PRICES FOR TRADE-INS!

FREE CATALOG

Complete Band Switching  
NEW MODEL 40A  
**GLOBE SCOUT XMTR**  
Ideal XMTR for the Novice or experienced Ham.  
50 WATTS CW — 40 WATTS PHONE  
100 thru 10M with combination pi-network antenna tuner. 100% mod. 100% of final. Has complete power supply. TVI screened cabinet.  
\$8.95 per mo. (12 mos.) \$10.00 cash down  
Wired Tested \$99<sup>25</sup>  
Kit Form \$89<sup>25</sup>

WRITE FOR DETAILED EQUIPMENT SPECIFICATION SHEETS

WRITE - WIRE - PHONE 2-0277 COUNCIL BLUFFS, IOWA

Rush top trade-in value of my \_\_\_\_\_  
Make and model of new equipment desired \_\_\_\_\_

E-Z Pay Plan:  6 mos.  12 mos.  18 mos.  
Please rush:  Globe King,  Globe Scout Catalog Sheets. Rush:  New WRL Catalog.  Reconditioned Equip't. List.

NAME \_\_\_\_\_  
ADDRESS \_\_\_\_\_  
CITY \_\_\_\_\_ STATE \_\_\_\_\_

WRL — BOX 811 — CO. BLUFFS, IOWA

## DON'T FORGET YOUR CHARTER SUBSCRIPTION TO POPULAR ELECTRONICS

SEE PAGE 91

### It's P.A.R.T.S. for PARTS!

J-47 TELEGRAPH KEY. New.....\$1.25

#### CARTER GENEMOTOR

This is the deal that usually sells for \$85.00!  
Input, 5.5 VDC 12 amp. Output, 350 V, 150 mls. Mounted on filtered base with starting relay. NO HUM! F.B. for mobile, aircraft, etc. Perf. cond.....\$17.95

LATCHING RELAY: 6 V. Complete latching type power relay for 6 VDC mobile use. DPDT side has contacts rated at 15 amps. Relay and reset both rated at 6 VDC with 4 ohm coils. New cond .....\$1.95  
PE-103 POWER SUPPLY PLUGS: A scarce item. EACH 50c 3 FOR .....\$1.19  
BC-454-COMMAND RECEIVER: 8-6 MC. Act fast for a hot buy. Like new.....\$9.95  
All shpm'ts. F.O.B. Burbank, Cal. 20% deposit required. VISIT OUR NEW QUARTERS! Ask for FREE LIST giving VT & commercial equivalent tube numbers.

#### P-A-R-T-S, INC.

2005 Empire Ave., Burbank, Calif.  
PHONES: Victoria 9-2834 THornwall 2-5349

## EASY TO LEARN CODE

It is easy to learn or increase speed with an Instructograph Code Teacher. Affords the quickest and most practical method yet developed. For beginners or advanced students. Available tapes from beginner's alphabet to typical messages on all subjects. Speed range 5 to 40 WPM. Always ready—no QRM.

ENDORSED BY THOUSANDS!

The Instructograph Code Teacher literally takes the place of an operator-instructor and enables anyone to learn and master code without further assistance. Thousands of successful operators have "acquired the code" with the Instructograph System. Write today for convenient rental and purchase plans.



## INSTRUCTOGRAPH COMPANY

4711 SHERIDAN ROAD, CHICAGO 40, ILLINOIS

## UHF TRANSMITTER-RECEIVER

APS-13

\$4.95

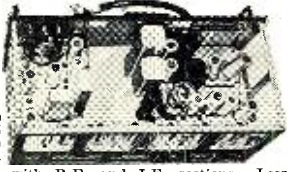

Freq. range  
415-420 MC. 5  
stages of 30  
MC. 1P ampli-  
fier. Complete with R.F. and I.F. sections. Less  
dynamotor, tubes, and tube shields, with schematic.  
Excel. cond.

### ARC-5/R-28 2-METER RECEIVER

Here is the 2-meter superhet you have been looking for! Absolutely one of the BEST available today! Tunes from 100 to 156 Mcs. in four crystal channels. (Easily converted to continuous tuning.) Tube lineup is as follows: 717A—R.F., 717A—Mixer, 2—12SH7—1st and 2nd I.F.—16.9 Mc.

EXCEL. COND. **\$19.95**

See Dec/53 C.Q. for conversion.

### AN-75 PORTABLE ANTENNA—With Base

For portable or vehicular operation. Used as a portable, antenna is clamped to radio housing. On vehicles, it is clamped under hood or to other support. Collapsed length is 12 inches. Extends to 84 inches. Flexible. New.....

**\$1.95**

### MOBILE ANTENNA

Complete 15 ft. antenna with mounting unit. NEW. ADDITIONAL SECTIONS, Ea.....

**\$5.95**  
**\$.50**

### TG-10 CODE KEYS

Self-Contained Automatic unit for code practice signals from an inked type recording. Complete with 7 tubes and electric eye; Audio freq. output of 800 CPS. Size: 11 x 24 x 18 1/2"—110-220 VAC 60 cy.—78 RPM motor can be used for a turntable—Power unit can be used for a P.A. system—wt. 65 lbs. Brand New.....

**\$22.50**



**C.A.P. SPECIAL**  
**BC-625 VHF**  
**TRANSMITTER**  
Freq. range 100-156 MC. With modulation section and speech amplifier. Less tubes & crystals, with conversion dope. Used, good condition. (See Nov/53 C.Q.)

**\$9.95**

### ARB NAVY RECEIVER

105 to 9050 KC. Four Bands, Calibrated Dial, LF-Ship-BC-80 & 40 Meters. Complete with Tubes and Dynamotor. For 24 Volt operation; easily converted to 110 V—12 or 6 Volt. Size: 8 1/4" x 7 1/4" x 15 1/4". Excellent cond. With schematic. **\$19.95**  
DU-1. DIRECTION FINDER LOOP AMPLIFIER for ARB receiver. With tubes and loop. Excellent condition. With schematic. **\$19.95**



**ID6/APN4**  
Made to operate in conjunction with Radio Receiver RO/APN-4. Unit includes one 5" scope tube, crystal controlled standard oscillator, sweep circuits, marker pulses. Excellent cond. Less tubes but with 5" scope tube.....

**\$24.50**

WITH TUBES & CRYSTAL.....**\$39.50**  
DYNAMOTOR SPECIAL: 9 V. input. Output 450 V. 75 mls. With extended shaft and drive gear on one end. New.....**\$7.95**

### BEST HEADSET & MIKE BUYS

H-160 HEADSET. 8,000 ohms.....**\$3.95**  
HS-18 HEADSET. New.....**2.45**  
HS-23 HEADSET. High imp. New.....**4.95**  
HS-30 HEADSET. Featherweight type. Low imp. NEW.....**\$2.49**  
HS-33 HEADSET. Low imp. New.....**1.49**  
HS-38 HEADSET. USED, excel. cond.....**1.49**  
NEW.....**2.50**  
RS-38 MIKE. NEW.....**\$4.95** Excel.....**2.75**

PE-125 POWER SUPPLY: Operates on 12 or 24 V. battery. NEW.....**\$17.95**

T9—MODULATION TRANSFORMER. For BC-610 Transmitter. Pri. 16,000 ohms CT; sec. 8,330 ohms @ 250 ma. Fully shielded steel case. New.....**\$34.50**



**TS-10**  
Sound Powered Handset  
Uses no batteries or external power source. Ideal for TV installation work, extensions, etc., includes 5 ft. cord.

farms, construction projects, connecting outbuildings, etc., includes 5 ft. cord. NEW. Each.....**\$ 9.95**  
NEW. Per Pr.....**18.50**

### FREE HAM FLYER!

Featuring Loads of Special Values  
SEND FOR YOUR COPY TODAY!

All shpts. F.O.B. whse. Calif. residents add sales tax. 25% deposit required. Specify shipping instructions and ADD SHIPPING COSTS TO EACH ORDER. All items subject to prior sale and change of price without notice.

## ARROW SALES INC.

Mailing Address: Box 3878-R, North Hollywood, Cal.  
Office-Warehouse: 7450 Varna Ave., N. Hollywood, Cal.

## Variable Inductances

(Continued from page 55)

connected to a 50  $\mu$ a. meter. Then the inductance, resonated by only distributed and stray capacity, was tuned to the frequency of the oscillator in the vicinity of 70 mc. This temporary lash-up, pictured in Fig. 7, served the purpose admirably. A GDO at a distance of ten feet produced a reading of 15 to 20  $\mu$ a. A v.t.v.m. with its r.f. probe could have been used, or simply a 1N34 could have been employed as shown in Fig. 3. Other coils, with possibly a fixed condenser across them, might be used in the same manner to provide a temporary field strength meter or tuned r.f. probe for use on any frequency.

Service technician uses for the coils are highly practical ones. As a single winding coil, it may be substituted for r.f. chokes, TV i.f. transformers in stagger-tuned strips, peaking coils, ringing coils, trap circuits, etc. A casual inspection of a typical 1954 TV receiver circuit reveals at least nine coils that might be directly replaced with the variable inductances. Furthermore, in glancing over the color TV circuits worked out by the NTSC, one can see several places in which these coils would fit neatly.

By adding another simple winding to a coil, as was done in Fig. 3, a whole new field of application is opened up. As a single example, the writer recently had an old set in which an r.f. transformer had been ruined by a gnawing mouse. An original replacement was out of the question. A primary of twenty or thirty turns was scramblewound on the bottom of coil #7, and this coil was connected in the circuit in place of the defective unit and was adjusted with the GDO until it tracked properly. The result was most satisfactory.

There is little point in trying to catalogue all the uses for this little kit. After you have studied the typical uses given and have read the detailed description of the coils themselves, you are certainly in a position to know whether or not they will be useful to you.

If you do get a set, though, here are a few suggestions:

First, after you have hand-calibrated a set of these coils, they will constitute a dependable and accurate addition to your measuring equipment if you will give them a reasonable amount of care. Do not bounce them around on the floor; keep your fingers off the coil windings. When turning the slug screw, always hold the coil by the metal base mounting so that there will be no danger of loosening the coil form from the mounting.

If at all possible, avoid soldering to the terminals of the coils you have calibrated and intend to use for measuring purposes. The solder connections will take one or two heatings without damage; but if they are heated too

## !! MOTOR SPECIALS !!

ECLIPSE REVERSIBLE MOTOR (Type Y-150, #BJ-8143). 1/4 H.P., 3800 RPM, 24 VDC. Spined 1/2" shaft. O.D. 4" x 8" (ship in 1 lbs.). BRAND NEW. WHILE THEY LAST.....**\$6.95**  
LAST AC-DC DELCO MOTOR (O.D. 2 3/8" x 2 3/4"). 5400 RPM. 57 V. 1/4" shaft.....**\$2.95**  
1/40 H.P. AC MOTOR (Robins & Myers), 115V, 1650 RPM. 5/16" shaft. O.D. 3 1/4" x 3 1/2". With starting condenser. (Ship. wt. 3 lbs.).....**4.95**  
1/17 H.P. G-E MOTOR (Type SD), 1725 RPM, 7 amp. Dble. 3/8" shaft. 110VDC. O.D. 4 1/2" x 3 1/4" (Ship. wt. 13 lbs.).....**3.95**  
BLOWER WHEEL & HOUSING. Use with any small motor. L-R #3 (5 1/2" O.D.), moulded bakelite. With 3" impeller; sec.....**1.95**

PHILCO TV TURRET TUNER (Pt. #76-3109, less coil, contact strips). For '48 & '49 models.....**\$1.49**  
ABOVE TUNER with 3 socket wired RF strip.....**1.98**  
GOLD TV KNOBS, CHANNEL SELECTOR (28 3/4") & FINE TUNING, 2 piece set, 49¢-12 sets/5.00  
18 FT. WHIP ANTENNA, 6 steel tapered screw sections.....**3.75**  
EXTRA EXTENSION SECTS. 2" x 1/2" ea.....**7.75**  
RADIO HARDWARE TREASURE. FULL LB. CAN of Nuts, Screws, Lugs, Washers, etc.....**.89**  
3 lbs. 2.49

## !! TERRIFIC SAVINGS ON PARTS !!

with the NEW ELECTRONIC PARTS KIT. LOADED with new & surplus inventory, odds & ends. WORTH SEVERAL TIMES THE PRICE! 17 lbs. of SOCKETS, 10 NIP COILS, 5 WATCHES, WIRE RESISTORS, CONDENSERS, PIPES & DIAGRAMS, PHOTOFACTS, ETC. ETC. (Ship. wt. 20 lbs.) ALL FOR **\$3.95**

## Wood Cabinet & Chassis Foundation . . .

Beautiful light walnut veneer. Inside: 1 1/2" x 7 1/2" x 6 1/4", 4" sq. dial org. right. PLUS matching 6 tube punched chassis. SET (ATTENTION: SCHOOLS & MFRS. WRITE FOR ATTRACTIVE QUANTITY PRICE) **\$175**

## !! SCOPE PARTS !!

3" CR TUBE SHIELD-3BP1, etc.....ea. **\$1.29**  
5" CR TUBE FRONT BEZEL.....**.98**  
6" CR TUBE SPONGE RUBBER FRONT GAS-KET.....**.69**  
5" SCOPE VISOR—moulded vinyl.....**.98**  
5 1/4" CLEAR CONVEX GLASS LENS—rnd.....**39¢** 6/1.98

"DIRECT FACTORY SPEAKER REPAIRS SINCE 1927"  
Min. Order \$3.00, 20% deposit req. on all C.O.D.'s.  
Full remittance with foreign orders

**LEOTONE RADIO CORP.**  
67 Dey Street,  
New York 7, N. Y.

## STANDARD COIL PENTODE TURRET TUNER

only  
**\$13.19**  
(lots of 3)  
**\$13.99 each**

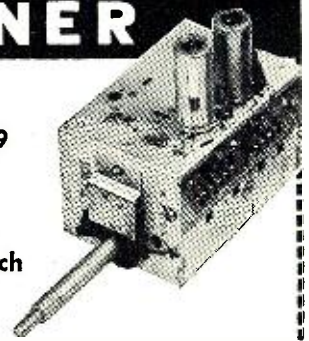

STEVE-EL brings you the tuner used in over 5 million TV sets. Uses a pentode RF amplifier and a dual-triode mixer-oscillator; 25.75 pix IF and 21.25 Mc sound. May be used with either split-sound or inter-carrier as desired. Covers all channels from 2 to 13. Has balanced 300 ohm input.

Supplied with 6J6 and 6AG5 or 6BC5.

**EXTRA SPECIAL**  
16 RP4  
PICTURE TUBE  
**\$16.49**  
Brand new,  
Guaranteed 1 year.

**FREE!**

Write Dept. RN-8 for newest BAR-GAIN BROCHURE Buy STEVE-EL and SAVE!

**STEVE-EL Electronics Corp.**  
61 Reade St. New York 7, N. Y.

often or too long, they are bound to char their moorings and become loose. Use small clips to make temporary connections to the coils.

Finally, it seems rather pointless to go to the trouble to hand-calibrate a coil and then permanently install it in a receiver or other piece of equipment and thus break your measuring set. It is better to keep your original set intact and to purchase individual coils or sets for purely replacement purposes. A replacement coil can always be set precisely to a proper inductance value discovered with a measuring coil by adjusting the former until it resonates at the same frequency as the latter when both are tuned with the same fixed condenser. -30-

### Three Tubes on 2 Meters

(Continued from page 47)

bring it into range for all readings. This meter was actually an unnecessary luxury but, if used, should be left in the cathode of the 9903. The reason for this is that the final tank circuit has a high "Q." This means that the final must be tuned right on the button or audio distortion will result. The tuning is extremely critical so the ability to monitor the plate current through the cathode circuit is a great convenience.

One side of the meter was grounded then the positive leg was brought to the arm of the switch and bypassed by a 500  $\mu$ fd. condenser. Position 1 meters the grid of the 5763. Position 2 is in the cathode to read the plate current. Position 3 is in the grids of the 9903 while position 4 is the cathode. Position 5 is open and removes the meter from the circuit. Be sure to use 100 ohm resistors as shunts for those times when the meter is out of a particular circuit. The shunts are bypassed by .005  $\mu$ fd. condensers.

This rig is completed with copper wire screening to cover the top and sides. After the screening has been painted flat black, the set presents a professional appearance that even the XYL won't object to. The fine QSO's you will get will please you and make all the effort worthwhile. -30-

### MILWAUKEE CLUB ELECTS

The Milwaukee Radio Amateurs' Club, Inc. has elected a new slate of officers for the 1954-1955 term at its annual meeting held recently.

Elden Belanger, W9MDG, was named president; Frank Seboth, W9NLY, first vice-president; Eugene Wille, W9EKU, second vice-president; Edward R. Buchholz, W9VBZ, secretary; and Roman Hudzinski, W9JPS, treasurer.

The board of directors include: F. H. Zolin, W9ONY; K. Eggert, W9MOT; E. Felber, W9RH; W. Herzog, W9LSK; C. H. Kaetel, W9SNK; J. K. Douglas, W9DR; and C. C. Dawson, W9CUW.

The Milwaukee organization is the world's oldest continuously active radio amateur club. -30-

August, 1954

# GREATEST TUBE BUYS

EVERY TUBE GUARANTEED 6 MONTHS

BRANDED—BULK PACKED IN ORIGINAL MFR'S NESTED CARTONS OR INDIVIDUALLY BOXED

EVERY TUBE METER & CHASSIS TESTED FOR TOP QUALITY.

0A4G ...\$ .50	IU4 .....\$ .46	6BF5 ...\$ .69	6S7GT...\$ .37	7Y4 .....\$ .40	22 .....\$ .35
OZ4 .....\$ .49	IU5 .....\$ .38	6BG6G .. 1.10	6SR7 ...\$ .49	7Z4 .....\$ .45	25AV5 .. 1.05
IA4P ...\$ .35	IX2A ...\$ .65	6BH6 ...\$ .45	6T8 .....\$ .57	12A6 ...\$ .39	25B06GT . 75
IA5 .....\$ .30	2A5 .....\$ .39	6BJ6 ...\$ .46	6U7 .....\$ .49	12A7 ...\$ .98	25L6GT .. 40
IA7GT ...\$ .45	2A7 .....\$ .35	6BL7GT...\$ .65	6U8 .....\$ .59	12AT6 ...\$ .31	25Z6GT .. 37
IB3GT ...\$ .65	2X2 .....\$ .39	6BN6 ...\$ .88	6V3 .....\$ 1.04	12AT7 ...\$ .57	32L7GT .. 39
IC5GT ...\$ .39	3LF4 .....\$ .71	6BQ6GT...\$ .89	6V6GT ...\$ .38	12AU6 ...\$ .34	33 .....\$ .29
IC7G ...\$ .35	3Q4 .....\$ .48	6BQ7 ...\$ .88	6W4GT ...\$ .41	12AU7 ...\$ .59	34 .....\$ .29
ID7G ...\$ .35	3Q5GT ...\$ .48	6C4 .....\$ .31	6W6GT ...\$ .41	12AX7 ...\$ .60	35-51 ...\$ .35
IE7GT ...\$ .35	3S4 .....\$ .46	6C5GT ...\$ .41	6X4 .....\$ .35	12AX7 ...\$ .62	35B5 ...\$ .38
IF4 .....\$ .35	3V4 .....\$ .46	6C6 .....\$ .49	6X5GT ...\$ .33	12AY7 ...\$ .72	35C5 ...\$ .38
IF5G ...\$ .39	5U4G ...\$ .49	6CB6 ...\$ .42	7A4 .....\$ .45	12BA6 ...\$ .52	35L6GT .. 42
IH4G ...\$ .35	5V4G ...\$ .76	6CD6G .. 1.05	7A7 .....\$ .45	12BA7 ...\$ .61	35W4 ...\$ .32
IH5GT ...\$ .38	5Y3G ...\$ .36	6E5 .....\$ .76	7B5 .....\$ .46	12BD6 ...\$ .46	35Z5GT .. 49
IJ6 .....\$ .88	6A6 .....\$ .35	6F6 .....\$ .45	7B6 .....\$ .45	12BE6 ...\$ .40	36 .....\$ .32
IL4 .....\$ .47	6A8GT ...\$ .63	6H6GT ...\$ .49	7B7 .....\$ .45	12BH7 ...\$ .41	37 .....\$ .32
IL6 .....\$ .61	6AB7 ...\$ .69	6J5GT ...\$ .34	7C7 .....\$ .53	12H6 ...\$ .49	39-44 ...\$ .35
ILA4 ...\$ .77	6AC7 ...\$ .68	6J6 .....\$ .50	7E5 .....\$ .80	12SA7GT . 58	46 .....\$ .35
ILA6 ...\$ .75	6AG5 ...\$ .46	6J7 .....\$ .49	7E6 .....\$ .60	12SG7 ...\$ .61	47 .....\$ .75
ILB4 ...\$ .77	6AH6 ...\$ .88	6K6GT ...\$ .36	7E7 .....\$ .80	12SH7 ...\$ .49	49 .....\$ .32
ILC5 ...\$ .75	6AK5 ...\$ .69	6K7G ...\$ .49	7F7 .....\$ .64	12SK7 ...\$ .49	50B5 ...\$ .41
ILC6 ...\$ .75	6AL5 ...\$ .34	6L6GA ...\$ .99	7F8 .....\$ .92	12SN7GT . 46	50C5 ...\$ .41
ILD5 ...\$ .75	6AQ5 ...\$ .37	6Q7GT ...\$ .51	7G7 .....\$ .80	12SQ7 ...\$ .49	50L6GT .. 59
ILE3 ...\$ .75	6AQ6 ...\$ .36	6S4 .....\$ .47	7H7 .....\$ .56	12SR7 ...\$ .49	11Z73 ...\$ .39
ILG5 ...\$ .75	6AQ7GT...\$ .69	6SA7 ...\$ .59	7J7 .....\$ .80	12Z3 ...\$ .39	11Z76GT . 70
ILH4 ...\$ .75	6AS5 ...\$ .62	6SA7GT...\$ .61	7K7 .....\$ .80	14A7 ...\$ .53	9003 ...\$ 1.10
ILN5 ...\$ .75	6AT6 ...\$ .36	6SC7 ...\$ .81	7L7 .....\$ .80	14AF7 ...\$ .63	801A ...\$ .35
IN5GT ...\$ .61	6AU6 ...\$ .36	6SF5GT...\$ .58	7N7 .....\$ .57	14B6 ...\$ .45	803 ...\$ 2.95
IQ5GT ...\$ .39	6AV5GT...\$ .79	6SG7 ...\$ .59	7Q7 .....\$ .57	14C5 ...\$ .80	814 ...\$ 3.50
IR4 .....\$ .81	6AV6 ...\$ .36	6SH7 ...\$ .65	7R7 .....\$ .39	14C7 ...\$ .65	836 ...\$ 7.95
IR5 .....\$ .46	6BA6 ...\$ .33	6SJ7 ...\$ .54	7S7 .....\$ .85	14E6 ...\$ .65	866A ...\$ 1.45
IS4 .....\$ .40	6BA7 ...\$ .57	6SK7GT...\$ .39	7V7 .....\$ .87	19 .....\$ .35	
IS5 .....\$ .38	6BC5 ...\$ .46	6SL7GT...\$ .49	7W7 .....\$ .94	19B6G6G . 1.15	
IT4 .....\$ .46	6BE6 ...\$ .37	6SN7GT...\$ .46	7X6 .....\$ .57	19T8 ...\$ .61	

Minimum Order: \$10.00. Terms 25% with order balance C.O.D. Please include postage.

All prices subject to change without notice. F. O. B. New York City. Mail Order Division:

## TRANSAMERICA ELECTRONICS CORP.

115 Liberty Street New York 6, N. Y.

### SPEAKER SALE!!

HEAVY DUTY \* GE \* 6" \* PM

2.98 oz. Magnet

Mounted in 8" x 3 3/4" Round Metal Baffle. (Used—but fully guaranteed.)

FOR—playrooms, porches, music systems, radio shacks, intercommunications, P.A. systems, paging systems and replacement uses.

Original List \$1.95 each  
**NOW \$11.95 3 for \$5.00**

**Cramer Electronics, Inc.**  
 811 BOYLSTON ST. BOSTON 16, MASS.



### 110V, AC POWER SUPPLY FOR ANY 274-N RECEIVER

Just plug it into the rear of your 274-N RECEIVER . . . any model. Complete kit and black metal case, with ALL parts and diagrams. Simple and easy to build in a jiffy. Delivers 24 volts plus B voltage. No wiring changes to be made. Designed especially for the 274-N receiver. **Only \$8.95.** Filament trans. for 274N receivers. Pri. 110V, 60 cy. AC. Sec. 24V @ .6A. An excellent buy at . . . \$1.95 ea.

### SPLINED TUNING KNOB FOR 274N RECEIVERS

An exclusive O-R item manufactured for us. Fits BC-453, BC-454 and other 274N receivers. This is a really hard-to-obtain item. **Only .89c ea.**



**OFFENBACH-REIMUS**  
 1564 Market Street, San Francisco, Calif.



Your  
FREE copy  
is ready!



New

**Centralab**

**Catalog No. 29**

**Handy reference book on  
America's most complete line  
of volume controls, switches,  
capacitors, Printed Electronic  
Circuits\*, seatite insulators**

Revised, 48-page edition keeps you up to date on Centralab's latest developments:

- NEW values in Adashaft\* Radiohms
- NEW Adashaft shafts
- NEW Snap-Tite Controls
- NEW Fastatch\* Dual Concentric Controls
- NEW Senior Compentrol\*
- NEW miniature phenolic rotary switches
- NEW Phenolic Switch Kit
- NEW complete line of standard DD disc capacitors
- NEW miniature disc capacitors
- NEW 3000-VDCW and 6000-VDCW-Hi-Vo-Disc\* Capacitors
- NEW arrangement of capacitor kits
- NEW Precision Attachable Terminal Hi-Vo-Kaps®
- NEW Negative 330 and Negative 1500 TC Tubular Capacitors
- NEW easier-to-read listings on CRL Printed Electronic Circuits
- NEW P.E.C.\* Kits

Ask your Centralab distributor for your free copy of Catalog No. 29. Or send coupon to us today.

\*Trademark

**Centralab**

G-3254A

TEAR OUT COUPON AND MAIL TODAY!  
CENTRALAB, A Division of Globe-Union Inc.  
910H E. Keefe Avenue, Milwaukee 1, Wisconsin

Send me free copy of  
Centralab Catalog No. 29

Name.....

Company.....

Address.....

City..... Zone..... State.....

## Vacuum-Tube Tesla Coils

(Continued from page 45)

shown by the lack of glow in a neon bulb when touched to the tank circuit, try reversing the leads to the grid coil, and then tune the plate circuit by arranging two or three condensers in series and parallel until resonance is reached, when a corona should come from the discharge point. The best output is obtained with the highest value of capacitance that causes resonance. With the coils described, this will require 2000 to 3000  $\mu\text{fd}$ . for coils two feet long, and up to 7000 to 10,000  $\mu\text{fd}$ . for longer coils, although the value may lie within 10% of the correct figure. If the tubes are running too hot after tuning, as evidenced by plate color (a dull red is normal for most tubes), reduce the plate voltage or the grid drive, by removing turns from the grid coil.

Even though the high-frequency discharges from the corona are harmless when received through fluorescent tubes or metal objects held in the hand, do not draw sparks from the corona to the bare hands because of burns, especially in high power coils; furthermore, exercise extreme caution when working with the high voltage circuit.

Because the oscillator operates between .3 and 1 mc., the radiation of the oscillator should have little effect on TV in the vicinity. If there is interference, it is usually caused by v.h.f. parasitics which should be suppressed according to accepted methods. Some, but slight, interference is to be expected from the corona discharge; however, since there will be considerable local interference in the AM broadcast band from radiated harmonics, the coil should be operated with courtesy to the neighbors.

A one kw. coil, constructed as described for about \$35, uses a 304TL and a 2 kv.,  $\frac{1}{2}$  amp transformer to give a 14-inch corona. Under average conditions, a small coil using 801A's and a receiving-type transformer gives a 3-inch corona, two type 826's operated at 1100 volts give a 4-inch corona, and a pair of 805's at 1600 volts gives an 8-inch corona. Since the size of the corona is proportional to the applied plate voltage, as high a voltage as is consistent with the power handling capabilities of the tubes should be used; the d.c. voltage ratings can usually be exceeded up to 30%.

Because each builder will want to use the parts available to him, it is inadvisable to give specific instructions, for although cardboard forms, shellac, and a.c.-fed oscillators may seem haywire today, the use of more deluxe components and circuitry is not justified for the average experimenter.

Experimentation with the coil will reveal the many fascinating demonstrations which can be performed, such as the lighting of fluorescent and neon tubes without wires; in fact the energy

of the discharge sufficient to ignite candles and paper, or to drive a pin-wheel balanced on the discharge point. Even the smallest coil never fails to astound and interest onlookers with such feats as these.

Science teachers, Scoutmasters, Den Mothers, and amateur magicians will all find a Tesla coil unit an interesting project to build and use. —30—

## A U.H.F. Booster

(Continued from page 35)

chokes are symmetrically connected and grounded with the shortest leads possible. The plate line is supported at its side edges by two small ceramic standoff insulators. The heater and plate leads are taken out the top through ceramic feedthrough condensers.

The value of the plate resistor  $R_p$  is not specified in the parts list as its value will depend on the available supply voltage. The voltage at the 6AJ4 plates should be between 100 and 150 volts and the two tubes will draw a total current of approximately 25 ma. Using this current the resistor should be selected to give the desired drop. When using a 150-volt supply, a 1000-ohm resistor is suggested. Many of the television sets manufactured prior to u.h.f. have converter output sockets which provide 6.3 volts a.c. and d.c. plate voltage which may be used for the booster. On many of the sets that don't have this feature, power may be taken from the heater and screen of the audio output tube. If desired the chassis may be widened or lengthened a few inches and a small power supply installed. A suggested circuit is shown in the diagram of Fig. 4.

When a common u.h.f.-v.h.f. antenna transmission line is used the lead to the v.h.f. antenna terminals on the converter or receiver should be attached ahead of the booster. If any deleterious effect on u.h.f. performance is noted when the v.h.f. line is connected to the booster antenna terminals, this can be easily corrected by varying the length of the v.h.f. line a few inches. —30—

Fig. 4. Suggested power supply for the u.h.f. booster for use with TV sets not furnishing an external source of the required voltages. The booster may be plugged into the TV u.h.f. converter.

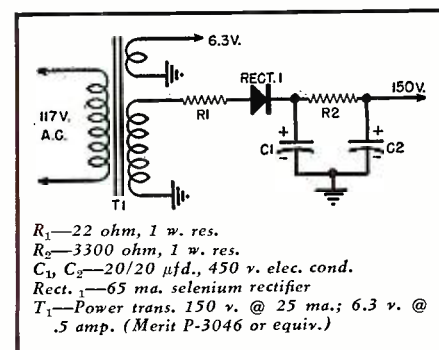

RADIO & TELEVISION NEWS

# Windsor

RADIO & TV  
RECEIVING

# TUBES

GUARANTEED  
ONE FULL YEAR

...FOR PEAK  
PERFORMANCE!



Type	Each	Type	Each
0A2	\$.90	1N64	.75
0B2	.88	1R1	.85
0C3	.95	1R5	.62
1A7GT	.67	1S4	.67
1A7E1	.80	1S5	.32
1B3GT	.89	1T4	.62
1H5GT	.51	1U4	.61
1J6	.93	1U5	.51
1L4	.63	1V2	.45
1L6	.66	1X2A	.74
1LA4	.82	2X2	1.43
1LB4	.80	3A5	.90
1LC5	.82	3LF4	.76
1LC6	.80	3Q4	.66
1LD5	.80	3Q5GT	.72
1LE3	.80	3S4	.61
1LG5	.80	3V4	.64
1LH4	.80	5R1GY	1.00
1LN5	.80	5U4G	.44
1LN5	.80	5V4G	.83
1N34	.90	5Y3G	.37
1N5GT	.63	5Y3GT	.32
1N48	.50	5Y4G	.43

Thousands of Service Organizations and Dealers send us REPEAT orders month after month—they KNOW you can DEPEND on the WINDSOR promise of PEAK PERFORMANCE! Every tube we ship is first carefully tested in our labs, right in a radio or TV set, under actual operating conditions. Each WINDSOR tube is attractively packaged in the famous WINDSOR carton that has gained consumer acceptance throughout America.

BUY—and SELL—WINDSOR TUBES, with CONFIDENCE!

Type	Each	Type	Each	Type	Each	Type	Each	Type	Each
6AB8T	.68	6BE6	.51	6D7GT	.55	7A5	.70	7R7	.70
6A84	.51	6BF5	.66	6E7	.75	7A6	.57	7S7	.92
6AC5GT	.82	6BF6	.43	6S4	.51	7A7	.58	7V7	.92
6AC7	.90	6BG6G	1.47	6S8GT	.75	7A8	.56	7W7	.99
6AF4	1.10	6BH6	.63	6SA7GT	.57	7AD7	1.05	7X6	.62
6AG5	.59	6BJ6	.53	6SC7	.63	7AF7	.63	7Y4	.45
6AH4	.68	6BK5	.67	6SD7	.55	7AG7	.65	7Z4	.50
6AH6	.89	6BK7	.96	6SF5GT	.66	7AH7	.65	12A6	.60
6AL5	1.05	6BL7GT	.94	6SG7	.55	7B4	.70	12AL5	.44
6AN8	.95	6BN6	.98	6SH7GT	.52	7B7	.54	12AT6	.53
6AQ5	.51	6BQ6GT	.98	6SJ7GT	.52	7B5	.51	12AT7	.75
6AQ6	.47	6BQ7	.92	6SK7GT	.55	7B6	.52	12AU6	.47
6AQ7	.75	6BZ7	1.09	6SL7GT	.68	7B7	.58	12AU7	.58
6AR5	.42	6C1	.41	6SN7GT	.59	7C4	1.05	12AV6	.41
6AS5	.85	6C3GT	.44	6SQ7GT	.46	7C5	.56	12AV7	.87
6AS7G	4.50	6CB6	.58	6U4GT	.60	7C7	.58	12AX4	.72
6AT6	.42	6CD6G	2.04	6U5	.72	7E5	.85	12AX7	2.15
6AU5GT	.85	6D6	.62	6U8	.86	7E6	.65	12B4	.66
6AU6	.47	6E5	.75	6V3	1.09	7E7	.85	12BA6	.50
6AV5	.85	6F5GT	.54	6V6GT	.51	7F7	.59	12BA7	.66
6AV6	.41	6H6GT	.55	6W4GT	.50	7F8	.97	12BB6	.51
6AX4	.72	6J5GT	.44	6W6GT	.63	7G5	.85	12BE6	.52
6B8G	.93	6J6	.68	6X4	.37	7H7	.61	12BH7	.69
6BA6	.50	6J7	.70	6X5GT	.36	7I7	.85	12BY7	.77
6BA7	.66	6K6GT	.45	6X8	.82	7K7	.85	12I5GT	.48
6BC5	.58	6K7	.70	6Y6	.64	7L7	.85	12SA7GT	.57
6BD5GT	.98	6L6G	.88	6Z5	.60	7N7	.62	12SH7GT	.67
6BD6	.54	6L6GA	.88	7A4XXL	.57	7Q7	.62	12SK7GT	.55

Type	Each	Type	Each
12SL7GT	.67	25Z6GT	.46
12SN7GT	.59	35A5	.56
12SO7GT	.46	35B5	.53
12V6	.51	35C5	.53
14A7	.58	35L6GT	.52
14AF7	.68	35M5	.33
14B6	.50	35N4	.48
14C5	.85	35P5	.48
14D7	.70	35T3	.33
14E6	.70	35Z6GT	.48
14F7	.69	50A5	.55
14F8	.99	50B5	.52
14J7	.85	50C5	.52
14N7	.75	50L6GT	.52
14O7	.62	50M5	.55
14P7	.62	50N6	.55
14R7	.75	50P5	.43
14S7	.80	50R5	.52
19BB6G	1.53	50S5	.52
19T8	.87	50T6	.52
25AV5	.85	50L6GT	.52
25B6GT	.98	50K6	.55
25L6G	.53	117Z3	.43
25W4GT	.53	117Z6GT	.75

## WINDSOR "WONDER-BEAM" 3-WAY TV ANTENNA

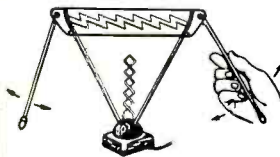

For Average Areas, Fringe Areas, and UHF. Adjustable arms, and new electronic wonder-switch for optimum performance with any TV set!

**SPECIAL PRICE, \$5.69** Each  
Lots of Six, \$5.95 Each  
Singly, \$5.95 Each

## FREE! WINDSOR TUBE CADDY

Most practical service-aid ever designed for Radio & TV repairmen! Now offered FREE with every purchase of \$160.00 or accumulated purchases totaling \$160.00 within 90 days. (You get Caddy credit memo with each purchase.)

- Carries approximately 125 tubes including meters and tools.
- 16 3/4" Long, 8 1/4" Wide, 13 3/4" High. Weighs only 9 lbs.
- Ruggedly constructed with heavy leatherette covering, strong plastic handle, nickel plated hardware, and reinforced with metal clamps.

WINDSOR TUBE CADDY MAY ALSO BE PURCHASED **\$14.95** OUTRIGHT FOR

Note to our Latin-American Friends: "Se Habla Español."

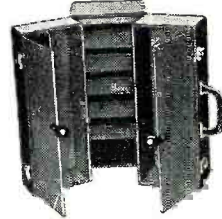

## WINDSOR "BROW-LITE"



Leave Both Hands Free To Work!

World's most useful flashlight! Ideal for Radio & TV Repairmen. Uses standard penlite batteries and bulb. Won't interfere with glasses, rides above them over the brow. Complete with Batteries **\$4.95**

25% Deposit with Order. All merchandise F.O.B. N.Y.C. For orders less than \$10, add \$1 handling cost. Deduct 2% if full remittance accompanying order. All merchandise subject to prior sale and price changes without notice.

## Windsor ELECTRONIC TUBE CO.

2612-N NOSTRAND AVENUE, BROOKLYN 10, N. Y.

Write for Additional Tube Types and Prices. We also stock Special Purpose and Transmitting Tubes at Similar Savings! Dept. N-8.

## NOW! New TELEVISION SPECIALTIES



**CALIBRATED VARIABLE INDUCTANCE KIT**  
8 Permeability Tuned Coils

- WIDE INDUCTANCE RANGE, 1 to 1000  $\mu$ Hy.
- INDIVIDUAL INDUCTANCE CURVE SHEET FOR EACH COIL.
- COMPLETE DATA ON Lmin., Lmax., SELF RESONANT FREQUENCY, Q, R & C.
- ACCURATE UNIVERSAL AND SOLENOID WINDINGS, Q-MAX Impregnation.
- Video Peaking • IF Circuits • Color-TV • Radio or TV Tuning • RF Choke

FEATURING: \$4.50 per box

### IMPORTANT! TELEVISION ANTENNA ACCESSORIES



**TELEVISION INTERFERENCE FILTER**  
Highly efficient 3-section high pass type. Attenuates all frequencies up to 50MC. Eliminates amateur, xray, diathermy, auto and aircraft interference.

TYPE E-1 for 300 $\mu$ . \$4.95

**UHF...VHF CROSS-OVER NETWORK**  
Adapts UHF-VHF antenna to single transmission line. Eliminates antenna switches and duplex lead-ins. Saves time and money on installation work.

TYPE T-1 \$3.95

**TWO-RECEIVER TV COUPLER**  
Allows use of two TV receivers on one antenna. No adjustments or switches. No effect on transmission line impedance.

TYPE R-1 for 300 $\mu$ . \$3.15

Ask about these NEW ITEMS at your local distributor, or write for FREE BULLETIN, giving distributor's name and address.

Engineers **UNITED TECHNICAL LABORATORIES** Manufacturers  
MORRIS TOWN, N. J.

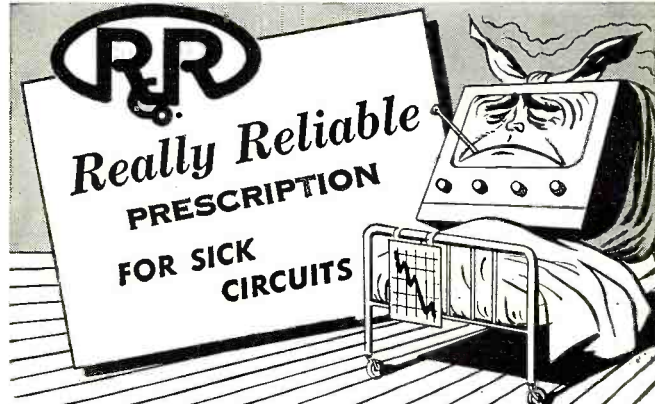

Replace with RRco. rectifiers and diodes and insure long life and dependable performance ahead. Thousands of servicemen agree they're wonderful medicine!

**SELETRON SELENIUM RECTIFIERS**

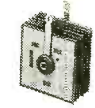

Millions in use in radio and TV... as original equipment and replacements.

**GERMANIUM DIODES**



Video Detectors 1N60 and 1N64. U. H. F. Mixers 1N72 and 1N110. Other R.E.T.M.A. types available too.

We also manufacture germanium transistors.

SEE YOUR FAVORITE PARTS JOBBER  
**Seletron and Germanium Division**  
**RADIO RECEPTOR COMPANY, INC.**  
In Radio and Electronics Since 1922  
SALES OFFICES: 251 WEST 19TH ST., NEW YORK 11, N. Y.  
FACORIES IN BROOKLYN, N. Y.

**Lafayette's Exclusive Sale!**



**3 TUBE  
CIRCUIT**

**alliance**

**CASCAMATIC**

the NEW automatic  
**TV BOOSTER**

**6.25 ea. IN  
LOTS OF 3  
singly, ea. 6.50**



The Alliance Cascamatic TV booster is the latest accessory which combines all the advantages of television boosters in a single unit! Fully automatic — requires no further tuning — no manual control. Automatically turns on and off with set. Completely hidden from view — mounted in back of the set. Instantly installed — requires no further attention. Improves quality of both picture and sound signals. Eliminates noise — improves signal-to-noise ratio. Features famous "California" circuit with three tubes. Works on all VHF channels. Uses two 6J6 tubes and one 6BK7. Attractive metal cabinet 14" x 5 1/4" x 4 1/4". 110-125 volts. 60 cycles A.C. Complete with tubes and instructions. Shpg. wt. 2 1/2 lbs.

**CASCAMATIC TV BOOSTER.**  
In lots of 3. 6.25 ea.  
(single, ea. 6.50)  
List \$29.95

**SMASH PRICE! 29.95**

---

**Lafayette Greatest Tape Buy Ever!**



**1200 FT. REEL  
Genuine Plastic Base  
RECORDING TAPE**

**LAFAYETTE** made a terrific deal with one of the leading manufacturers of recording tape to supply us with their regular tape which sells for almost twice our price. **WE GUARANTEE ABSOLUTE SATISFACTION OR YOUR MONEY BACK.** The finest, professional-quality recording tape obtainable. Highest performance for thousands of playings. Red Oxide Base in a smooth, uniform coating; greater signal strength; with maximum fidelity; uniform frequency response from 40-15,000 cps.

**\$1.89** per roll plus postage (C.O.D.'s accepted)



**STOP-GO SESSIONS TIMER**

The timer that's almost human. Just set this marvelous Sessions electric timer mechanism to switch on or off your radio, television, or electrical appliance automatically. Will turn on your radio at any desired time. Has miracle "Sleep Switch" so that you can play your radio when you go to bed and it turns off automatically at a pre-set time, allowing up to 90 minutes to elapse. With mounting bracket. For 117 volts 50/60 cycles AC.

No. MS-67  
**4.75**

**Lafayette Radio DEPT. RH**

Write for free catalog.

NEW YORK, N.Y.	100 Sixth Ave.
BROOKLYN, N.Y.	542 E. Fordham Rd.
NEWARK, N.J.	24 Central Ave.
PLAINFIELD, N.J.	139 West 2nd St.
BOSTON, MASS.	110 Federal St.

**Auto Radio Checkpoints**  
(Continued from page 53)

hub caps of the front wheels. These suppressors insure good contact between the wheel and axle.

The foregoing tests are ideally suited to the smaller shops because they produce reasonable results and call for a minimum of equipment.

**Replacement of Parts**

Generally, components in auto sets are more or less standard and present no great problem in replacement. Exceptions are (in some cases) the vibrator and power transformer.

Luckily, most distributors carry all popular types of vibrators and a suitable substitution can almost always be made from one of these types. The power transformer is another matter; especially, if you are located in a smaller city or must replace the transformer on an emergency basis. In this case, try to locate a regular radio power transformer (117-volt a.c. primary) having two 6.3-volt windings. Connect both filament windings in series-aiding. (Check this by transposing the leads marked "B" and "C" in Fig. 2A, leaving them in the position giving the greatest voltage reading across both windings.) Tape the primary leads (not together, of course) and connect the secondary winding as shown. The only difficulty in making this type of substitution might be in finding a transformer of this type physically small enough to fit into the space allotted for it.

In conclusion, don't forget to give the receiver a complete alignment check. This should include a quick (but accurate) check of the dial pointer positions at both ends of the dial, a peaking check of the i.f. pre-selector and r.f. trimmers, and a final check of the antenna trimmer (with the set in the car) on about 1400 kc.

The dummy antenna shown in Fig. 2B will be helpful in providing a good match between the set and a signal generator. This type gives a much better balance than the makeshift coupling condenser so often used. —50—

**HAMFESTERS MEET**

**SUNDAY, August 8th** is the date set by the Hamfesters Radio Club of Chicago for its 20th annual picnic and automobile meet.

The affair will be held at Mance Park near the Stinson Airport where members' planes will be parked free during the hamfest.

Plenty of free parking space and picnic tables will be available. Food, refreshments, and beverages can be purchased at the park.

A donation of \$1.00 will be requested prior to the affair with \$1.25 the tariff at the gate.

For tickets write John Ruth, W9CVO, 4460 Oakenwald Ave., Chicago 15, Illinois. —50—

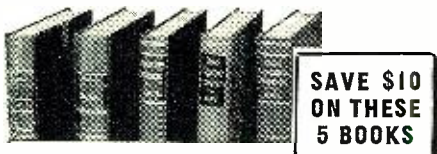

**SAVE \$10  
ON THESE  
5 BOOKS**

**SPECIAL OFFER on this  
COMPLETE RADIO  
ENGINEERING  
LIBRARY**

• 5 Volumes • 3872 Pages • Illustrations

THIS new, up-to-date edition of a famous, 5-volume library covers the whole field of radio engineering . . . includes latest facts, standards, data, and practice to help you solve hundreds of problems in any field based on radio. Books cover circuit phenomena, networks, tube theory, amplification, measurements, etc.—give specialized treatment of all fields of practical design and application.

**SET INCLUDES:** Eastman's Fundamentals of Vacuum Tubes, 3rd Ed.; Terman's Radio Engineering, 3rd Ed.; Everitt's Communication Engineering, 2nd Ed.; Hund's High Frequency Measurements, 2nd Ed.; and Henney's Radio Engineering Handbook, 4th Ed.

**SPECIAL LOW PRICE—EASY TERMS**  
**SAVE \$10.00**—Regular price of books is \$48.00; when bought as a set, you pay only \$38.00, and on easy terms.

**10-DAY FREE TRIAL**

McGraw-Hill Book Co., Dept. RTN-3,  
330 W. 42nd St., N. Y. C. 36

Send me for 10 days' FREE trial, the RADIO ENGINEERING LIBRARY. If not satisfied I will return books. Otherwise I will send \$8.00, plus delivery charges, then; and \$6 a month for 5 months. (We pay delivery if you send \$8.00 first payment WITH coupon; same return privilege.)

Print Name .....

Street .....

City ..... Zone ..... State .....

Employed by .....

This offer applies to U. S. only RTN-3

**Get Your F.C.C. LICENSE Quickly!**

Correspondence or residence preparation for F.C.C. examinations. Results guaranteed.

An FCC commercial operator license means greater opportunities and higher pay. We are specialists in preparing you, in a MINIMUM OF TIME, to pass FCC examinations for all classes of licenses. Beginners get 2nd class license in 5 weeks and 1st class in 3 additional weeks. Write for free booklet.

**GRANTHAM SCHOOL OF ELECTRONICS**  
Dept. 103-B, 6064 Hollywood Blvd., Hollywood 28, Calif.

**NEW . . .**

**POPULAR  
ELECTRONICS**

. . . an ideal supplement  
to your reading of **RADIO  
& TELEVISION NEWS**

. . . a perfect gift for hob-  
byists and beginners in  
electronics.

**First Issue—  
OCTOBER, 1954**

**DON'T MISS IT!**

(see announcement p. 91)



# BOOKS

RADIO • T.V. • AUDIO • ELECTRONICS

## Servicemen for Amateurs Experimenters

**200. HOW TO USE SIGNAL AND SWEEP GENERATORS.** By J. Richard Johnson. A practical handbook for the service technician, the radio amateur and the experimenter. \$2.00

**228. TELEVISION SERVICING.** By Walter H. Buchsbaum. This gives clear simple instructions on the installation and maintenance of every type of TV receiver . . . shows you how to locate and repair every conceivable trouble a TV set can have . . . offers the latest information on the design and construction of TV receivers. It also devotes an entire, new chapter to color television, showing exactly how color TV receivers differ from black-and-white receivers. \$5.95

**229. TECHNIQUES OF TELEVISION PRODUCTION.** By Rudy Bretz. This is a comprehensive handbook for the studio engineer and technician, covering all of the equipment and materials used in producing television programs. \$10.00

**230. THE RADIO MANUAL, Fourth Edition.** By George E. Sterling and Robert B. Monroe. No other single volume now available covers the entire field of radio so thoroughly—from elementary electrical and radio theory to the most advanced applications in AM, FM, and Television Broadcasting, Marine Radio, and Marine Navigational Aids, Emergency Services, State, Federal and International Laws. 820 pages. \$12.00

**232. RADIO TROUBLE SHOOTING GUIDEBOOK, vol. 1.** By John F. Rider and J. R. Johnson. A troubleshooting guidebook that covers AM, FM, troubleshooting, undesired signals, weak signals, distortion, noise, dead receivers. 140 pages. 5 1/2 x 8 1/2. Paper bound. \$2.30

**205. HOW TO TROUBLESHOOT A TV RECEIVER.** By J. Richard Johnson. A step by step guide for newcomers. \$1.80



**206. UHF TELEVISION ANTENNAS AND CONVERTERS.** By A. Lytel. Latest information on all types, covers latest UHF installation techniques. \$1.80

**233. TV TROUBLESHOOTING AND REPAIR GUIDEBOOK, vol. 2.** By Robert G. Middleton. A gold mine of valuable TV service information. Troubleshooting front ends; Servicing the Video I-F strips; Faults in video amplifiers; Trouble analysis in sound I-F and detector systems; Practical pointers in audio amplifier servicing; Trouble in horizontal circuits. 160 pages. 8 1/2 x 11. Paper covered. Price \$3.30

**234. THE RADIO AMATEUR'S HANDBOOK.** Compiled by the American Radio Relay League staff. 800 pages, including catalog section. Price \$3.00

**236. HEARING AIDS, THEIR USE, CARE, AND REPAIR.** By M. Mandl. Provides information needed by users, prospective purchasers, dealers and servicemen. 90 illus. 158 pages. \$3.50

**208. MODERN OSCILLOSCOPES AND THEIR USES.** By Jacob H. Ruiter, Jr., 360 pages, 370 illus. \$6.00

**211. INDUSTRIAL ELECTRONICS; An Introduction to Modern Industrial Electronic Practice.** By Dr. R. Kretzman. \$5.50

**224. RADIO DATA CHARTS.** By R. T. Beatty. Charts required in the design of radio receivers cover such items as frequency, wavelength, inductance, capacity, frequency, self-inductance, r.f. coil windings, reactance of coils or condensers, transformer design, choke and transformer design. The only equipment necessary to utilize any of the nomograms is a straightedge. \$2.00

### 4th Edition

**225. TELEVISION SIMPLIFIED.** By Milton S. Kiver. The most up-to-date, complete, and practical television handbook now available for repair men, radio workers and all who are interested in the practical opportunities a working knowledge affords. \$6.75

**226. TELEVISION AND FM RECEIVER SERVICING.** By Milton S. Kiver. New, third edition of this famous definitive text. \$4.20

**227. TELEVISION REPAIR MAN'S TUBE LOCATION GUIDE.** By William Prior, Jr. Almost every known make of set including over 4000 models are covered with tube location diagrams. Put it in your service kit, in your shop, in the home. Only \$1.00

**221. HIGH FIDELITY SIMPLIFIED, 4th Ed.** By Harold D. Weiler. A non-technical explanation of hi-fi techniques and the necessary components which constitute a hi-fi system. Covers the latest tape recorders and the newest types of enclosures and speaker systems. 208 plates. \$2.50

**222. HOME MUSIC SYSTEMS.** By Edward T. Canby. How to assemble parts at greatest savings. \$4.00

**223. HIGH FIDELITY HANDBOOK.** By Greene, Radcliffe and Scharff. A virtual encyclopedia of step by step instructions, hundreds of diagrams that make it easy, inexpensive to select, install, assemble, and enjoy your own HI-FI system for records, tape, FM, AM, TV. Expert guidance in layman's language. \$4.50

**216. A GUIDE TO AUDIO REPRODUCTION.** By David Fidelman. An A to Z explanation of the reproduction of sound. Discusses all phases of systems and requirements plus design, construction, assembly, and testing of systems and components. Explains in detail the circuitry of preamplifiers and amplifiers; complete discussion of phono cartridges, tuners, microphones, loudspeakers and enclosures. For the radio and TV service technician, engineer and experimenter. Companion volume to Weiler's High Fidelity Simplified. 250 pages. \$3.50

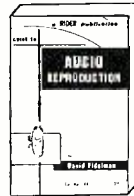

**217. HIGH FIDELITY TECHNIQUES.** By John H. Newitt. For the engineer, home builder of audio gear, service technician, studio personnel and professionals in the audio field. 12 chaps. in easy to read language. \$7.50

**218. RECORDING AND REPRODUCTION OF SOUND, 2nd Ed.** By Oliver Read. A complete presentation of the entire subject of sound. Discusses modern theory and methods used in the recording and reproduction of sound, based upon years of experience and research. Includes charts and Appendix. 810 pages. \$7.95

**237. INTRODUCTION TO COLOR TELEVISION.** By M. Kaufman and H. Thomas. Discusses color wavelengths and frequencies; primary colors and circuits used in a color TV receiver and gives complete explanations as to their operation—setting up and adjustment procedure. \$2.10

**238. HOW TO INSTALL AND SERVICE AUTO RADIOS.** By Jack Darr. This book for service technicians discusses installation problems and special servicing requirements of the automobile radio. It gives information on antenna installation for the car, vibrator testing, noise suppression, and it furnishes a complete list of tools, spare parts, and other equipment needed to do auto radio repairing and servicing. \$1.90

**239. HOW TO LOCATE AND ELIMINATE RADIO AND TV INTERFERENCE.** By Fred D. Rowe. Both radio and television interference are discussed; why they occur and their solutions. \$1.80

*New!*

**240. ELEMENTS OF RADIO.** By Abraham Marcus & William Marcus. New revised edition. \$6.00

**241. TRANSISTORS, THEORY, AND PRACTICE.** By Rufus P. Turner. This handbook of current transistor practice will be welcomed by experimenters since it covers, in non-mathematical terms, practical circuitry using transistors. \$2.00

**242. SOUND REPRODUCTION.** By G. A. Briggs. \$3.50

**243. LOUDSPEAKERS — The Why and How of Good Reproduction** by G. A. Briggs. \$1.60

**244. R.C.A.'s THE RADIOTRON DESIGNERS HANDBOOK.** \$7.00

**245. AUTOMATIC RECORD CHANGER SERVICE MANUAL.** By Sams Staff. \$3.00

### FOR THE YOUNG READER

**231. ALL ABOUT RADIO AND TELEVISION.** By Jack Gould, Radio and Television Editor, The New York Times. The how and why of radio and television are explained clearly and directly in simple language and with over 100 illustrations and diagrams. It shows how a picture is changed into electricity, how to build a foxhole radio, why we have networks, how to communicate with the moon by radar. 160 pages. 6 3/4 x 9 1/8. \$1.95

## When You Want a Book



Your Radio & TV News Book Service will attempt to procure any book in this field for you. Just send title, author and price.

### MAIL THIS COUPON

### NOW

RADIO & TELEVISION NEWS BOOK SERVICE, Dept. R8  
201 East 57th Street, New York 22, N. Y.

I enclose \$..... for which please ship postpaid books circled or indicated below. If not satisfied I can return them within 5 days for refund.

200 205 206 208 211 216 217 218 221 222 223 224 225 226 227 228  
229 230 231 232 233 234 236 237 238 239 240 241 242 243 244 245

Any book not listed..... \$.....

Name.....

Address.....

City.....Zone.....State.....

ALL ORDERS SHIPPED POSTPAID. Sorry, no COD's. Add 3% sales tax with orders for N. Y. C. delivery; add 25¢ per title for delivery outside U.S.A., except for APO's.

**FOR THE FINEST  
SOUND SYSTEMS**

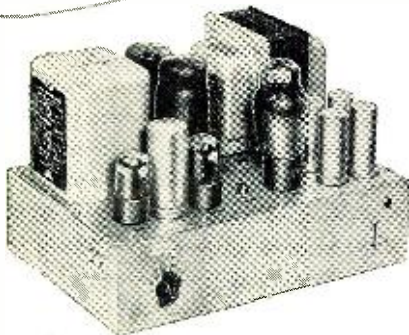

## TRIAD High Fidelity Amplifier Kits

A home music system which will meet true high fidelity standards must necessarily be composed of the very finest components—pickups, turntables, amplifiers, speakers, enclosures.

In this group of components Triad offers High Fidelity Amplifier Kits—built by men with a brilliant background in producing America's finest transformers. Engineered to produce maximum frequency range with minimum distortion, these "do-it-yourself" kits afford obvious economies over complete units—which permits upgrading of other components in the system.

Triad High Fidelity Amplifier Kits include all necessary transformers and chokes, punched sectional aluminum chassis and complete assembly instructions.

In quality and performance they are fitting companions to the finest sound system components available today.

**HF-3 Kit:** Preamplifier. Adequate gain to drive an HF-40 or HF-18 from any commercial pickup or microphone. D.C. filament supply. Complete record compensation and new tone control circuits. List Price—\$32.80.

**HF-12 Kit:** 10-watt power amplifier. Replaces HF-10. Built-in preamp to accommodate all crystal and magnetic cartridges. Complete record compensation and new tone control circuits. Output impedances 4-8-16 ohms or 125-250-500 ohms. List Prices from—\$50.40.

**HF-18 Kit:** "Williamson" type all-triode amplifier. Full power output of 16.2 watts for triode operation or 20 watts for pentode operation from 12 to 60,000 cycles. Frequency response within 0.2 db from 7 to 80 kc. Output impedances 4-8-16 ohms or 125-250-500 ohms. List prices from—\$63.65.

**HF-40 Kit:** Features a full 40-watt amplifier from 20 to 40,000 cycles, using regulated screen voltage and fixed bias on two 6146 output tubes. Output impedances 4-8-16 ohms or 125-250-500 ohms. List from—\$78.35.



Write for  
Catalog  
TR-54A



4055 Redwood Ave. • Venice, Calif.

## TV Linearity Pattern (Continued from page 59)

type of defect is often caused by overloading in the video or sync amplifiers. Sometimes adjustment of contrast or a.g.c. level, or good balance between the two slugs on the horizontal oscillator transformer will correct bending. Poor interlace is usually a hard-to-fix defect, especially because the jumping of the lines is difficult to observe. The center strip of horizontal lines in the linearity pattern is quite helpful in this respect. Just concentrate on the screen picture near one of the horizontal pattern lines. Any "pairing" or loss of interlace will become really noticeable.

### Construction

The linearity pattern shown here was designed for use with 21-inch rectangular and all smaller picture tubes. Its dimensions are shown in Fig. 2, and while they proved to be quite satisfactory, other dimensions or patterns may work equally well. The main features are the equally spaced vertical lines for checking horizontal linearity and the center strip of horizontal lines which help check vertical linearity. It is very important that all lines are straight, parallel, or at right angles, because crooked or leaning lines will give the optical illusion of linearity trouble where none exists.

The author's model of the linearity pattern was made on 1/32-inch transparent acetate and the lines were drawn with India ink. As it turned out, however, India ink chips easily and is not too practical for this application. A special acetate ink designed for plastic surfaces is required. A better, more flexible pattern could be made of thinner material using regular acetate sheets available at most art supply stores. Other materials for making your own linearity pattern include transparent vinyl, polyethylene, lucite, plexiglas, and even heavy gauge cellophane. As long as the material can be rolled up, takes ink, and is transparent, it can be used. The simplest method of fastening the pattern to the TV set consists of four strips of masking or transparent Scotch tape going from the corners of the pattern to the edges of the safety glass.

### Hints on Linearity Checks

Before using the transparent linearity pattern look first to see if the individual horizontal lines at the top and bottom are parallel to the edges of the mask cut-out. Rotate the deflection yoke until this is done, then simply tape the transparent pattern over the safety glass, lining up the vertical lines with the left and right edges of the mask cut-out. Get the transparent pattern as close to the picture tube screen as possible and if considerable space between the two is unavoidable, make all observations

from directly in front of the screen. Ambient light will cause the shadows of the pattern lines to fall on the screen, possibly distorting their position. It is best, therefore, when some air space exists between the pattern and the screen, to turn off other lights in the room.

Vertical linearity adjustments are easy to make on most sets and should be done before the horizontal ones. This permits your eyes to get accustomed to the TV screen and thus makes the horizontal adjustment a bit easier.

The following controls, varying in different sets, have some effect on the horizontal linearity: horizontal linearity; horizontal drive; horizontal peaking; horizontal phase; horizontal locking range; and width.

Other components which can affect the linearity are the output amplifier, damper tube, flyback transformer, deflection yoke, damping resistor (in older sets), linearity coil bypass condensers, and various smaller components in the horizontal sweep section.

Centering of the picture can be accomplished either through centering potentiometers, location of the focus coil and ion trap, location of the deflection yoke and, finally through a special PM centering device. If any adjustments are made on the neck of the picture tube be sure to re-set the ion trap for greatest brightness.

While the transparent pattern described here is not a substitute for a station test pattern, it can be used to facilitate linearity adjustments. It is especially useful for service work in the customer's home because it is so simple and easy to carry. Another feature is that it will prove to many critical customers that linearity is good and no distortion exists where the set owner often imagines it. Used as proof of a good service job or as an aid in efficient adjustment, it certainly is worth the trouble of drawing a few lines on a sheet of transparent material. —50—

## NEON SERVICING AID

By WILLIAM K. COOPER

THE small neon glow testers used by electricians can be used to test for voltage in radio and TV sets when you haven't a voltmeter with you. The rating of a typical tester is 60 to 550 volts a.c., and 90 to 550 volts d.c., which includes most of the voltages found in radio and television low-voltage supplies, excluding heater circuits. They can be used to test for the presence of voltage in "B+" circuits and on tube plates and screens if these elements receive 90 volts or more, and to check transformer high-voltage secondaries.

If the intensity of the glow is noted for several known voltages applied to the tester, a rough estimate of the voltages encountered in receivers may be made. The current drain of these glow lamps is negligible, of course. They are as easy to carry as a pencil and very handy for making quick checks. They are inexpensive, and can be obtained at any hardware or electrical store. —50—

# Technical BOOKS

"ELEMENTS OF RADIO" by Abraham Marcus & William Marcus. Published by Prentice-Hall, Inc., New York. 757 pages. Price \$6.00. Third edition.

It's like meeting an old friend when a new edition of this basic text appears, although like most "old friends" this newest volume has "put on weight" since we last saw it in 1948.

Those of us in the industry realize that electronics has made enormous strides since 1948 and this newest edition reflects these changes not only in the form of added chapters but revised material in the older chapters.

The original material on receiving antennas has been expanded to include the omni-present television antenna. The development of the transistor has prompted the addition of a chapter on basic theory covering this new and exciting component.

As a thorough-going reference and study work this text still remains one of the best in the field and the new "generation" of radiomen will welcome its appearance.

\* \* \*

"SERVICING TV VERTICAL & HORIZONTAL OUTPUT SYSTEMS" by Harry E. Thomas. Published by John F. Rider Publisher, Inc., New York. 168 pages. Price \$2.40. Paper bound.

This specialized text not only covers the horizontal and vertical output systems found in present-day television receivers but discusses the fundamentals of early output systems which formed the basis for the newer circuitry.

The book is divided into eight chapters which cover fundamental conditions, basic vertical and horizontal sweep output systems, circuit functioning of the vertical sweep output system, horizontal output system operation, variations in the systems, the deflection yoke, mechanical features of sweep output system components, and faults in sweep output systems.

The text is lavishly illustrated with photographs and diagrams which serve to amplify the author's explanation. The author's style is concise and clear and TV technicians will find much material of value in this compact work.

\* \* \*

"SPECIALIZED AUTO RADIO MANUAL" by Rider Staff. Published by John F. Rider Publisher, Inc., New York. 182 pages. Price \$3.00. Paper bound. Volume 1-A.

This is the first of the "specialized" series of manuals being released by this publisher to meet the need for complete, factual data on auto receivers.

Volume 1-A deals with radios installed in *Fords, Lincolns, and Mercurys* during the year 1950-1954. Each receiver is pictured, described, and analyzed. A complete schematic dia-

gram and parts list is also included along with alignment data, special service hints, and mechanical details.

Technicians in the auto servicing field can speed their jobs with this and other volumes scheduled in this series.

\* \* \*

"THE WEAR AND CARE OF RECORDS AND STYLI" by Harold D. Weiler. Published by Climax Publishing Co., New York. 56 pages. Price \$1.00. Paper bound.

This handy pocket-sized book contains a wealth of information of interest to every owner of a phonograph and records.

The author covers the selection and advantages of certain types of styli, how records are made, the differences between standard and microgroove discs, dust and grit on records and how they affect reproduction, how to clean records, when to change a stylus, etc.

The text also points out how proper care can increase record life by as much as 60 per-cent. Since "the care and feeding" of favorite records is a very vital topic to most audiophiles, this book will undoubtedly receive a warm welcome.

\* \* \*

"TRANSISTORS, THEORY AND PRACTICE" by Rufus P. Turner. Published by Gernsback Publications, Inc., New York. 138 pages. Price \$2.00. Paper bound.

This little handbook of current

Just Out

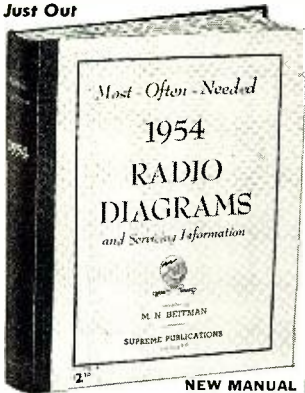

**NEW MANUAL**  
Be prepared to repair quickly all new 1954 radio receivers. In this big single volume you have easy-to-use, extra large schematics, needed alignment data, replacement parts lists, voltage values, and information on stage gain, location of trimmers, and dial stringing, for almost every 1954 radio. Includes auto radios, portables, changers, and all types of home sets. Giant size, 8 1/2 x 11 1/2" manual style, sturdy binding. Price, only... **\$2.50**

# New Supreme 1954 Radio Manual

Now you can benefit and save money with **Supreme** amazing scoop of 1954. This one giant volume has all the service data you need on all recent radio sets. A full year of models of all popular makes, home and auto sets, portable radios, combinations, changers, all included. The full price for this mammoth 1954 manual is only \$2.50, nothing else to buy for a whole year. Other **Supreme** radio service volumes for previous years (mostly at \$2) are described below. Separate **TV** manuals listed at right.

## SUPREME RADIO MANUALS FOR PREVIOUS YEARS

Use **Supreme** manuals to repair all radios faster, easier; save time and make more money. Here is your lowest-priced service data. Covers all years, from 1926-38 to 1954 models, in 14 volumes. Used by 163,000 shrewd servicemen. Most volumes only \$2 each, see coupon. Average volume 192 large pages, 8 1/2 x 11 inches. Quality printing, manual-style binding. Amazing values. Be wise, use these manuals to get all needed diagrams, parts lists, alignment facts, and service hints, at the smallest cost. Send no-risk coupon.

## SUPREME TELEVISION SERIES

Here is your complete source of TV service data. These manuals at only \$3, \$2, and \$1.50 each are amazing bargains and defy competition. Each manual covers a whole year of models, using original factory material. Include giant double-spread circuits and blueprints, alignment procedure, voltage charts, test patterns, wave forms, factory revisions, and helpful service hints. Select volumes from list below and send *no-risk* coupon.

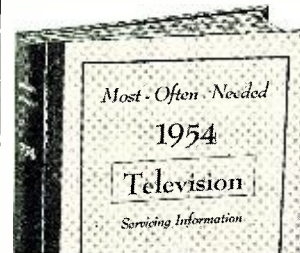

- 1954 TV Manual. New, giant volume of TV factory data. Complete, only \$3
- 1953 TV Manual, \$3
- 1952 TV Manual, \$3
- 1951 TV Manual, \$3
- 1950 TV Manual, \$3
- 1949 TV Manual, \$3
- 1948 TV Manual, \$3
- 1947 FM & TV, \$2
- UHF Manual, \$1.50

## NO-RISK TRIAL ORDER COUPON

**SUPREME PUBLICATIONS, 1760 Balsam Rd., Highland Park, ILL.**

### Radio Diagram Manuals

- 1954 Radio Manual, \$2.50
- 1953 Diagrams
- 1952 Radio
- 1951 Diagrams
- 1950 Manual
- 1949 Radio
- 1948
- 1947
- 1946
- 1942
- 1941
- 1940
- 1939
- 1926-1938 Manual, \$2.50
- Master INDEX only 25¢

**PRICED AT ONLY \$2 EACH**

Rush today Radio manuals checked  at left and TV manuals below. Satisfaction guaranteed.

- Supreme 1954 Television Servicing Manual, only \$3.**
- 1953 TV Manual, \$3.  UHF Manual, \$1.50
- 1952 Television Manual, \$3.  1951 TV, \$3.
- 1950 Television Manual, \$3.  1949 TV, \$3.
- 1948 TV, \$3.  1947 TV & FM, only \$2.
- Television Servicing Course, complete, only...\$3.

- I am enclosing \$..... Send postpaid.
- Send C.O.D. I am enclosing \$..... deposit.

Name: .....  
Address: .....



## TELEVISION SERVICING COURSE

Let this new course help you in TV servicing. Amazing bargain complete, only \$3, full price for all lessons. Giant in size, mammoth in scope, topics just like a \$200.00 correspondence course. Lessons on picture faults, circuits, adjustments, short-cuts, UHF, alignment hints, antenna problems, trouble-shooting, test equipment, picture analysis. Special, only **\$3**

**Supreme Publications**  
Sold by All Leading Parts Jobbers

## COMMAND EQUIPMENT (274N-ARC5, ATA)

	As Is	Exc. Used
196-550 KC .....		\$14.95
1-5-3 mc .....		14.95
3-6 mc .....	\$5.95	9.95
6-9 mc .....	5.95	9.95
3-Rec. Rack .....		1.50
3-Control Head .....	1.00	2.50
BC 458 Transmitter.....	4.95	6.95
459 Transmitter .....	7.95	12.95
456 Modulator .....	1.95	3.95

### A SWEET OSCILLOSCOPE DEAL

ASB-7 Radar Indicator Unit: For conversion to test scope or for use as modulation monitor. Has standard test-scope CR tube, H Cent, V Cent, Brill. Foc. Gain, and range selection switch. External power source was used. Tubes: 4-6AC7, 3-6110, 1-5BP1. Condition good. NEW. **\$9.95**

ASB RECEIVER: Freq. range: 510-555 MC. With tubes. New. Reduced to..... **\$11.95**

ASB TRANSMITTER: Freq. range: 510-555 MC. Complete with tubes. Only..... **4.95**

ASB POWER SUPPLY: New..... **4.95**

ASB ANTENNA SWITCHING UNIT. New. Hot buy! .....

BC-929—Contains power supply 110 V. 400 cycles, has 7 tubes such as 3CP1, brand new, complete with tubes. Each..... **\$14.95**

### VHF TRANSCEIVER

Ideal substitute for SCR-522, freq. range 140-144 mc. crystal controlled, 10 watts. The receiver section has two individual RF sections, feeding a common 3 stage 10mc IF amplifier. Both RF sections may be operated simultaneously, or either one individually. The receiver unit has 13 tubes. The transmitter is of straight forward design. Transmitter unit has 7 tubes, one #832 as final modulated by a pair of 6L6 and push-pull. Complete unit in case less tubes, and diagram less dynamotor. **\$9.95**

EXCELLENT CONDITION. WITH TUBES .....

T-23/ARC-5 Transmitter. 100-156 MC. complete with tubes. Used exc..... **\$29.95**

### ARC-5/R-28 2 MTR RCVR

2 motor superhet, absolutely one of the BEST available today! Tunes from 100 to 156 mcs. in four crystal channels. (Easily converted to continuous tuning.) Complete with 10 tubes. Excellent. **\$17.95**

### WOBUlator BUILD

### TV-FM-AM SWEEP GENERATOR

You can build "Versatile Sweep Frequency Generator" with APN-1 magnetic units..... **\$5.95**

5BP1, 5FP7, 4AP10, 5AP1 .....

### BROADCAST BAND—DIRECTION FINDER and AERO

Ideal for Use in Boats, etc.



MN-26-C Remote Controlled Navigational Direction finder and communications receiver. Manual DF in any one of three freq. bands, 150 to 1500 KC. 24 V. Self contained dynamotor supply. Complete installation, including receiver, control box, loop, azimuth control. Left-Right Indicator, pluss. loop transmission line and flex. shafts, oper. & main. manual.

ALL UNITS BRAND NEW EXCEPT CONTROL BOX .....

**\$69.50**

Hundreds of items in stock.  
WRITE FOR NEW BULLETIN  
AND PRICES.

## R W ELECTRONICS

Dept. N, 2430 S. Michigan Ave.

Chicago 16, Ill.

PHONE: Calumet 5-1281-23

transistor practice will be welcomed by experimenters since it covers, in non-mathematical terms, practical circuitry using transistors.

Readers of this magazine who are familiar with Mr. Turner's straightforward approach to his subject matter, will find in this text the same direct, uncomplicated handling of the material.

The text material has been divided into ten chapters, the first three of which are more or less general. The author then covers amplifiers, oscillators, circuit design, triggers and switches, practical transistor circuits, tests and measurements, and a tabulation of characteristics of commercial transistors.

Those who like to experiment with new circuitry and new components as well as those whose work calls for a knowledge of transistor operation will find this handbook an invaluable addition to their libraries.

\* \* \*

"TV FIELD SERVICE MANUAL" by Harold Alsberg. Published by John F. Rider Publisher, Inc., New York. 120 pages. Price \$2.10. Paper bound. Volume 1.

This is the first in a new series of manuals for the practicing TV technician. Because many set owners are reluctant to part with their receivers for even a short period of time, this manual is designed to assist the technician in making repairs in the customer's home rapidly and effectively.

This particular volume covers Admiral, Artone, AMC, Air King, Air Marshall, Allied Purchasing, Andrea, Arvin, and Automatic receivers manufactured during the period 1947-1953. For each of the models and chassis covered there is an individual listing of trouble symptoms (audio and video) as well as directions for their cure.

Troubles are described and shown pictorially as test patterns in the front of the book. A section on adjustments covers horizontal oscillator, tuner oscillator, picture tube, and a.g.c. adjustments. All of the procedures outlined in the text are those which can be performed in the customer's home. More involved troubleshooting, requiring pulling the chassis into the shop, is not discussed.

This book is jam-packed with practical material all of which is presented in the most concise and usable form possible.

### "STAG HAMFEST"

THE Seventeenth Annual "Stag Hamfest" sponsored by the Greater Cincinnati Amateur Radio Association has been scheduled for Sunday, Sept. 12 at Koplting Grove (Winton Road at Compton Road two miles south of Greenhills, Ohio).

The \$2.50 registration fee includes refreshments during the day, a full picnic dinner, and supper. The event will be held rain or shine. Contact Byrum Henry, W8QBJ, 1120 Elberon, Cincinnati for more details.

## Tubes for Color TV

(Continued from page 38)

Another tube that will find considerable application in the color video section is the RCA type 6AN8 which is a 9-pin miniature containing a medium-mu triode and sharp cut-off pentode in a single envelope. This tube is similar to the previously mentioned 6X8 and may also be found in other receiver sections.

The most radical tube innovations are to be found in the high-voltage section. Since all shadow-mask tubes require at least 20 kv., regulated and with considerable current, new tubes were needed for rectification, regulation, and damping. The new 19-inch color picture tubes use 27 kv. and require at least 1 ma. of current from the high-voltage section. There are presently three new high-voltage rectifiers, all of which will be used in the latest color TV sets. RCA has announced that it will make the 3A2 and the 3A3, both similar electrically. The 3A2 is a miniature, 9-pin type with a top cap for the anode, while the 3A3 is an octal type with top cap. Both are shown in Fig. 1. CBS-Hytron also will produce the 3A3, while G-E has announced the type 2V2 which is similar in appearance to the 3A3 but uses only 2 volts instead of 3 volts for the heater. It might be mentioned here that in the most frequently used high-voltage doubler circuits for color TV receivers a third high-voltage diode is used in lieu of a resistance bleeder. This greatly improves regulation and increases over-all efficiency. The tube used for this purpose is usually the same type as the two doubler rectifiers.

Since the 20 or 27 kv. supply must have excellent regulation, a special tube was designed which performs essentially the same function in the high-voltage section as the shunt voltage-regulator tubes used in electronically regulated d.c. power supplies. Fig. 1 shows the new 6BD4, a special sharp cut-off beam triode which is being offered by RCA and CBS-Hytron. G-E is currently introducing a special pentode, the 6BU5 which is designed for the same application, but uses a pentode circuit for sharp cut-off characteristic.

To provide some idea of the operation of the new high-voltage regulator tube refer to the simplified diagram of Fig. 3, showing a portion of the high-voltage section of a typical color TV receiver. It is interesting to note that the plate of the regulator tube is connected directly to the 20 kv. source while the cathode goes to the "B+" voltage. The regulating action is provided by the change in grid bias due to voltage changes across the bleeder to which the grid is connected. In a typical circuit the plate current will vary from 1 to 0.1 milliampere as the grid voltage varies over about 8 volts. This will change the high voltage by only 300 volts while the load current

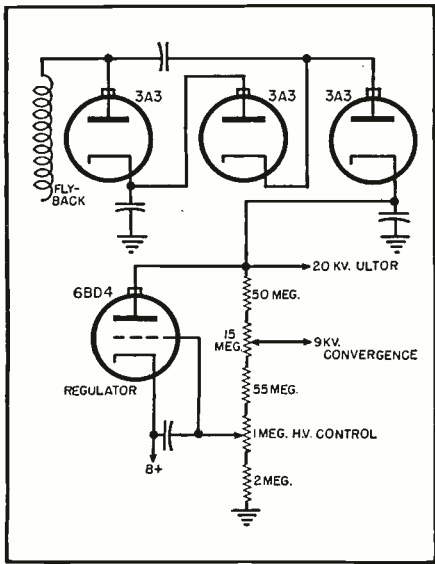

Fig. 3. Partial circuit diagram of a typical regulated high voltage supply for color TV sets. Note the use of a triode (in some cases a pentode) for picture-tube high voltage regulation.

varies from 0.1 to 1 milliamper. In other words, the regulator tube absorbs the difference to keep the high-voltage supply steady. Ordinarily such a large change in load current would occur when a bright white area on the screen, which requires all three color electron beams, suddenly changes to a completely black area.

By adjusting the setting of the grid voltage on the regulator tube, the tube's operating point, and therefore the actual high voltage at the plate of the regulator, is determined. This adjustment is important in setting up the color picture tube for correct operation. The circuit for the 6BU5 pentode regulator is essentially the same as in Fig. 3, except that the screen grid connection is added.

Since this is still the infancy of color TV we can expect many more new receiving-type tubes to be announced in the near future.

### Model SV-1 Preamp (Continued from page 41)

amp-equalizer permits a distance of about 4½ feet between the unit and power amplifier. For greater distances, extension cables may be used. If the extension cable for the audio output from the preamp-equalizer is of a very low capacitance, it may be up to 25 feet in additional length without seriously affecting performance.

External power requirements for the Model SV-1 preamp-equalizer are 250-volts d.c. at 8 ma., and 6.3-volts a.c. or d.c. at 1.2 amps. Most good quality high-fidelity amplifiers can supply this additional plate and heater power from their own power supplies. The d.c. power should be tapped off at a well-filtered point. If a separate power supply is used, it should be thoroughly filtered to keep hum at the very minimum.

August, 1954

# more servicemen prefer

# STANCOR

## REPLACEMENT TRANSFORMERS

### than all other brands combined\*

because they like the . . .

- ease of installation
- completeness of the Stancor line
- availability of accurate replacement information
- rugged, breakdown-proof construction
- quick delivery from distributor's stock

Brand Name Surveys, Chicago, Illinois; brand preference survey of electronic replacement components, May, 1954. Answered by servicemen from all over the U.S.

FREE NEW STANCOR GENERAL CATALOG listing over 500 transformers for TV, radio, high fidelity, communications and other electronic applications. Available from your local Stancor distributor or by writing Standard Division, Chicago Standard Transformer Corporation.

Stancor transformers are listed in Photofac Folders and Counterfacts

## CHICAGO STANDARD TRANSFORMER CORPORATION

3594 ELSTON AVENUE • CHICAGO 18, ILLINOIS

EXPORT SALES: Roburn Agencies, Inc.  
431 Greenwich Street, New York 13, N. Y.

## RECEIVING TUBES

## THREE TOP BRANDS ONLY! AT TREMENDOUS SAVINGS OVER REGULAR WHOLESALE

OTHER TUBES AVAILABLE AT SAME LOW, LOW PRICES

Latest Code Dates	Boxed	Fully RTMA Guaranteed	Brand New Pix Tubes Full One Year Guarantee
0Z4 .62	6AK5 1.30	6BQ7 1.42	12AU7 .85
1B3 .95	6AL5 .63	6BZ7 1.52	12BA6 .73
1X2 1.06	6AQ5 .76	6CB6 .76	12BE6 .78
5U4 .63	6AU6 .67	6I6 .92	12SA7 .80
5Y3 .48	6AV6 .60	6K6 .65	12SK7 .77
6AB4 .80	6BA6 .71	6SN7 .85	12SQ7 .67
6AC7 1.25	6BG6 1.98	6V6GT .75	35W4 .49
6AG5 .83	6BK7 1.28	6W4 .70	35Z5 .51
6AH6 1.40	6BQ6 1.42	12AT7 1.05	50L6 .75

AUGUST SPECIAL! 20CP4—17.95 WITH OLD TUBE	
With Old Tube	With New Tube
10BP4 .10.45	16GP4 .20.45
12LP4 .12.95	16RP4 .18.95
12LP4A .14.50	17BP4 .20.95
12QP4 .12.95	17CP4 .20.95
14CP4 .14.95	19AP4 .23.45
15AP4 .15.95	19AP4A .23.95
16AP4 .18.45	20CP4 .25.45
16CP4A .19.45	20HP4 .26.95
16DP4A .17.45	21EP4 .26.95
16EP4A .20.45	21AP4 .26.95
16FP4 .17.45	21FP4 .27.95

Send for FREE catalog of additional tubes and parts

### STUART ELECTRONICS DISTRIBUTORS

Dept.—R-8

Minimum Order \$10.00

TERMS: 25% Check or Money Order, Balance C.O.D., F.O.B. New York. Satisfaction Guaranteed or money back in 10 days.

149-09 Union Turnpike  
Flushing 67, N. Y.  
Olympia 8-3553, 4352



## MODEL 27-Z TESTER

(Made in Japan)

**\$10.95**

(Plus 25c shipping)

RANGES: AC and DC volts 0-5/25/250/500, DC MA 0-1/10/100/250, Ohms 0-10K, 100K. Black bakelite panel, metal case. Manufacturer claims extreme accuracy and our spot checks show them to be within 1%!

**HEAVY DUTY ALNICO-5 MAGNETRON MAGNET.** 7 1/2 lb. EA. Will lift 30 lbs. From 4750... \$7.49  
**BABY WINCH.** Reversible. 24 V. AC or DC. Bike sprocket or cable drum take-off. For beam, garage door opener, Bar-B-Que, boat rudder control, etc. NEW WITH INSTRUCTIONS..... \$4.95

### RADIO CONTROL

Build receiver from schematic we furnish with our 5 high-peaked, extremely selective AF band-pass filters. Kill interference from other transmissions. Get 5 operations at one R.F. From Air Forces radio-controlled target plane receiver. Sizes 2574, 2575 are: 300, 650, 955, 1390 and 3,000 cps. **\$2.95** All five with schematic. Only.....

**CAN CONTAINING 4 CLARE TYPE K MINIATURE RELAYS.**..... **\$2.95**

### GENERATOR-ALTERNATOR SPECIAL

120V AC PLUS 28.5V DC

Two units in one package, each complete in itself: the removable centrifugal slip clutch and the generator-alternator. Clutch maintains armature speed of 2400 rpm for drive speeds varying between 2400 and 4200 rpm. Outputs 120v, 300 VA, 1 ph. 1080 VA plus 28.5 v, 25 A DC. Drive it from engine or electric motor. With diagram and instructions. **\$9.95**

**GENERATOR-ALTERNATOR** similar to above except that DC output is 200 amps. Ask for 2CM81B1..... **\$12.95**

**115 V. 60 CYC. BRASS-BOUND HEAVY-DUTY SELSYNS.** 1/4 in. diam. shaft. **\$12.95**

PER PAIR. Only.....

Each Additional Unit..... **\$5.95**

**CRYSTAL DIODE.** 1N69, New. J.A.N. approved. **69c**

G.E. 40 ma. EACH..... **\$2.95**

5 FOR.....

### ANTENNA MAST SECTIONS

Each 1 meter long. Screw together. MS-49, 50, 51, 52. New. Each..... **\$3.95**

MS-53. This is the bottom section that fits into use. Use one or more for extra height. Each..... **98c**

### ARB NAVY RECEIVER

105 to 9050 KC. Four Bands. Calibrated Dial, LP-Ship-BC-80 & 40 Meter—Complete with Tubes and Dynamotor. For 24 Volt operation; easily converted to 110 V. 60 cycles. Size 5 3/4" x 7 1/4" x 1 1/4". Tested before shipment. **\$32.50**

With schematic and conversion dope..... **\$32.50**

**DC VOLTAGE CHANGER:** Changes 12 VDC to 24 VDC so you can operate above receiver with no modifications and also take advantage of its 24 V. remote control features. Ea..... **\$5.95**

**ALL ACCESSORIES** to make ARB remote controlled including plugs, flex shafts, etc. (Sold only with order for ARB.)..... **\$9.95**

### \$45.00 HI-FI HEADSET AT \$7.95

Uses annular grooved plastic cones with voice coils as in speakers, and padded chamois ear muffs to obtain spacing for correct acoustical load. Gives fine music reproduction. 600 ohm, checked out with freshly laundered ear pads and long, flexible fabric cord with phone tips. (Shpg. wt. 3 lbs.) **\$7.95**

### 24-HOUR TIME CLOCK SWITCH 90% DISCOUNT!

**HEAVY DUTY SANGAMO MECHANISM:** 115 or 230 V. 60 cycles. Up to 3 "ON"s and "OFF"s. Skip "OFF"s any one or two days you wish. 30A DPST Switch. Controls lawn sprinklers, neon signs, nap-house lights, etc. With **\$4.95** instructions. Guaranteed. (Dealers: Write for quantity discounts.)

**HALF-INCH PIPE SIZE SOLENOID VALVE.** 18 to 24 VDC. 13A. Controls lawn sprinkler with above mechanism..... **\$2.95**

**TRANSFORMER.** 115 V. 60 cycles to 24 V. 6A for above solenoid & many other uses. **98c**

**SELENIUM RECTIFIER.** 250V. 60 ma. full wave. For above transformer & solenoid..... **\$1.50**

### 12 V. RECEIVER DYNAMOTOR

Same as the 24V dynamotors on the back end of your 274-N or ARC-5 command receivers, except that these are made for 9 to 14 volts. Same base plate and plug connections. Output 120V, 60 ma. **\$4.95**

DY-1 ARR-2X, like new, checked out..... **\$4.95**

### 200 AMP 24 V. GENERATOR

For marine—aircraft—farm—amateur—summer home—battery charging—welding—etc. Heavy Duty 24-30 VDC. 4400-8000 RPM. G.E. type 2CM-81B2 (Air Forces P1). Excellent condition. A \$47.50 value for only..... **\$9.95**

### 12 V. DYNAMOTOR

(D. W. Thomas Engineering, Inc.)

NEW! Guaranteed. Ready to use. Continuous duty ratings. Gray finish. 10" x 10" x 10". Connect for either 10" lg. 400 V @ 200 ma. or 600 V @ 200 ma. With base..... **\$9.95**

(Less base.)..... **\$9.95**

Add \$6.00 for base box containing starting relays & filters as shown. Shipping wt. 11 lbs.; with base, 13 lbs.



## G. L. ELECTRONICS, INC.

905 S. Vermont Ave., Los Angeles 6, Calif. Minimum Order \$5.00 Total. 25% Deposit Required All Prices F.O.B. Los Angeles, Calif. Buyers Add Sales Tax GET ON OUR MAILING LIST

## SCHEMATICS—CONVERSIONS FOR SURPLUS GEAR

### NEW LIST! MANY ADDITIONS!

Send stamped, self addressed envelope for List C. Add 25c for chart explaining AN nomenclature.

R. E. BOX 1220  
GOODHEART BEVERLY HILLS, CAL.

# MANUFACTURERS' LITERATURE

The various listings presented in this section are for your convenience. The bulletins, unless otherwise indicated, are available to all our readers. For prompt attention write directly to the manufacturer for this literature.

## GRILLES AND BAFFLES

*Lowell Manufacturing Company*, 3030 Laclede Station Road, St. Louis 17, Mo. has just issued a 16-page catalogue covering its line of speaker baffles, protective speaker enclosures, grilles, intercom enclosures, mounting accessories, and combination speaker baffles and lighting fixtures.

The catalogue pictures and describes, in detail, a wide variety of units designed for all types of construction, both new and existing.

## G-E PUBLICATIONS

The Tube Department of *General Electric Co.*, Schenectady 5, N. Y. has announced five new publications.

ETR-886 is a 12-page, 3-color booklet which lists recommended receiving and cathode-ray tubes for AM, FM, and TV receivers. The ETD-548C is a 20-page catalogue which includes technical data and average characteristics on the 22 miniature and 11 subminiature tubes comprising the company's "Five-Star" line.

The third booklet, ETD-892, describes the new GL-6265 designed for two-way communications systems. An 8-page bulletin, ETD-881, describes the company's GL-2C39-B metal and ceramic "lighthouse" tube while the fifth booklet, ETD-885, describes three new reference cavities, types GL-1Q26-A, GL-6301, and GL-6452 for microwave system use.

## RETMA BROCHURE

The Radio - Electronics - Television Manufacturers Association is currently mailing copies of a brochure outlining its recommended course for TV technician training to industrial and trade school supervisors throughout the country.

The booklet, which is designed to outline the RETMA program and familiarize interested groups with the work to be done locally in the establishment of such training schools, points out that over 219 million radios and 30 million TV sets have been produced in this country and that the opportunities for the trained TV technician have been broadened even further by the growing interest in hi-fi equipment and the advent of color TV.

## TRIAD CATALOGUE

A new catalogue, listing more than 500 transformers, over 60 of which are new items, has been released by *Triad Transformer Corporation*, 4055 Redwood Ave., Venice, California. Catalogue TR-54 features eleven

new amplifier kits, a greatly expanded line of television components, plus additional items in the company's hermetically sealed power component line.

Two new photoflash transformers are included in the list of new items. The catalogue also carries information on the complete line of geophysical transformers made by the company.

## UTC CATALOGUE

*United Transformer Company*, 150 Varick Street, New York 13, N. Y. has announced the availability of its 1954 Catalogue A.

This new 28-page publication includes the company's complete line of transformers for broadcast, amateur, laboratory, and replacement purposes. In addition, the catalogue carries a few of the company's special transformers, reactors, filters, and magnetic amplifiers for military equipment. An amplifier kit, the type MLF, is also pictured and described.

Copies of this catalogue will be supplied promptly and without charge upon request.

## RELAY CATALOGUE

*Magnecraft Electric Co.*, 1442-D W. Van Buren St., Chicago 7, Ill. is now offering a complete relay catalogue containing engineering and dimensional data on long- and short-form telephone-type relays, new midget subminiature units, latching and low-capacitance relays, open, plug-in, dust-proof, and hermetically-sealed models.

The new publication is available without charge on request.

## MILLER CATALOGUE

*J. W. Miller Company*, 5917 S. Main St., Los Angeles 3, California is now offering, without charge, copies of its new general catalogue, No. 55.

The 32-page publication contains hundreds of items of interest to the electronic engineer, service technician, radio amateur, and experimenter. Complete specifications are given on the components and, in many cases, the product is illustrated.

## MAGNETIC RELAYS

The R-B-M Division, *Essex Wire Corporation*, Logansport, Indiana has printed a quick-reference, four-page bulletin showing the various types of open and hermetically-sealed a.c. and d.c. relays in its line.

The bulletin indicates general characteristics including maximum coil re-

## RADIO & TELEVISION NEWS

sistance and power requirements, contact forms available, approximate weight, and dimensions.

For a free copy of Bulletin 560A address your request to W. D. Loux in care of the firm.

#### REFERENCE GUIDE

As handy reference for distributors and service technicians in replacing the company's magnetic tape and wire recording heads, *Shure Brothers, Inc.*, 225 W. Huron St., Chicago 10, Illinois has issued a "Magnetic Recording Head Replacement Chart."

The new publication lists the exact *Shure* replacement for the tape head used in the manufacturer's original equipment. Illustrations of the types of recording heads, recording head dimensions, technical data, and a numerical listing of the company's tape heads are also included.

#### VIBRATOR GUIDE

*James Vibrapowr Company*, 4036 N. Rockwell St., Chicago 18, Ill. has issued a new vibrator replacement guide which incorporates a complete post-war cross reference of auto replacement, communications, and aircraft equipment using vibrators.

#### TV REPLACEMENT

The *Standard Division, Chicago Standard Transformer Corporation*, Addison and Elston, Chicago 18, Illinois has announced the availability of its 1954 "Stancor TV Transformer Replacement Guide."

Available from the company's distributors, the new publication provides transformer replacement data on over 6800 TV models and chassis of 115 manufacturers, as well as information on many "private brand" receivers.

Also included in the guide is a complete catalogue listing of 172 of the company's TV replacement components.

Copies of the guide may, if more convenient, be obtained by writing the company direct.

#### ERIE COMPONENTS

A complete, new sixteen page catalogue of electronic components for distributors, service departments, laboratories, product engineers, and radio amateurs has been issued by *Erie Resistor Corporation*, Erie, Pa.

Known as D-54, this catalogue supersedes previous catalogues and includes a new line of temperature compensating tubular "Ceramicons" and disc "Ceramicons" together with the long-time standard numbers.

Copies are available from distributors or Dept. 8 of the company.

#### MALLORY CATALOGUE

The 1954 edition of *P. R. Mallory & Co., Inc.'s* standard stock catalogue is now ready for distribution.

Designed for use by radio and TV technicians and dealers, the new publication contains 61 pages covering all electric and electronic parts manufactured by the firm. Included are bat-

August, 1954

# What do YOU Want in a TV ANTENNA?

- To receive all VHF Channels 2-13?
- To receive all UHF Channels 14-83?
- To receive all high fidelity FM stations?
- To receive COLOR as well as BLACK-WHITE?
- To receive from ALL DIRECTIONS without rotor motors?
- To perform up to ten times better than existing antennas?
- To receive stations now considered out of range?
- To give better reception more consistently?

Now a completely revolutionary new type antenna has just been perfected that does all these things plus.

It is truly an electronic miracle and is covered by 53 claims in 5 U. S. Patents. The television viewer can, by just a flick of the nine position electronic orientation switch, instantly and automatically beam any television set in any location to the best possible signal on any frequency coming from any direction.

It is now possible to put up just ONE antenna, use just ONE transmission line, pay for just ONE lower costing installation, and receive the finest possible reception from stations in and coming to your area regardless of their direction.

While it performs up to ten times better than existing antennas, in most cases it brings in stations presently considered out of range by existing antennas.

This wonder antenna is called,

# Riviera

## ALL CHANNEL ANTENNA CORP.

47-39 49th STREET, WOODSIDE 77, N. Y.

EXETER 2-1336

### RADIO CONTROL YOUR MODEL

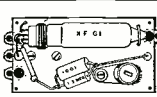
"CUSTOM MIDGET" RADIO LICENSE FREE BAND SETS INCLUDES LONG RANGE	ONLY \$9.98		PLANE BOATS CARS DETAILED INFORMATION & RADIO CATALOGUE 25c SPECIAL "SUPPLY SOURCE DIRECTORY" & \$7.50 SUPPLY COUPON... \$1.00 BOOK "RADIO CONTROL OF MODEL AIRCRAFT" CONTAINS 14 PLANS \$3.98 RADIO CONTROL TRANSMITTER RADIO, RECEIVER RADIO AND CONTROL ACTUATOR ALL 3 GARAGE DOOR EASY ASSEMBLY WITH OUR PARTS AND PLANS \$9.98. PLANS ALONE \$1. DETAILS..... \$1.00 RADIO MODELS BOX 36 DEPT. RT BALTIMORE & MARYLAND
--	-------------	---	--

### ENJOY 3 COLOR TELEVISION FILTER SCREEN NOW

Changes dull eye-straining black and white pictures into beautiful color tones. Seconds to attach. No tools used. Helps eliminate glare. Order direct. Send \$1 for screen size up to 16" \$1.25 size 17" \$1.50 size 20" \$2 size 21" \$2.50 size 24" \$3 size 27" (Also available are single solid color screens in blue, green, or amber.) Prices on solid color screens are 10% less. We pay postage except on C.O.D. orders. Satisfaction guaranteed. Inquiries from dealers also welcomed.

Zingo Products, Johnstown 19, New York

### CORONA RADIO KITS

EASY TO BUILD • EDUCATIONAL EXCELLENT RECEPTION

Broadcast Superhet Kit \$14.75

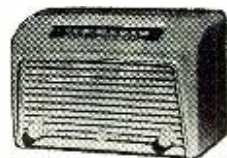

ROCKET 115K—Latest Single Band superhet circuit for ultimate in sensitive reception and tonal quality. Kit includes all necessary parts, punched chassis, attractive bakelite mahogany cabinet, built-in loop antenna, iron core IFS, big Alnico V spkr.; tubes: 12SK7, 12SA7, 12SQ7, 50L6, 35Z5. Automatic vol. control, beam power output. Tunes 540 to 1700 kc. Simple step-by-step instructions included.

Plaza 812K 2-Band AC-DC Super Kit...net \$20.75  
Globemaster 814K 3-Band Super Kit...net \$24.75  
All kits supplied less wire and solder. Please include 25% deposit with C.O.D. orders. Dept. N-8.

CORONA RADIO & TV CO.  
138 LIBERTY ST., NEW YORK 6, N. Y.

# BUILD 15 RADIOS

AT HOME ONLY  
With the New Improved 1954 \$19.95  
Progressive Radio "EDU-KIT"

NOW INCLUDES  
SIGNAL TRACER  
and  
CODE OSCILLATOR

- ABSOLUTELY NO KNOWLEDGE OF RADIO NECESSARY
- NO ADDITIONAL PARTS NEEDED
- EXCELLENT BACKGROUND FOR TELEVISION
- SCHOOL INQUIRIES INVITED
- FREE SOLDERING IRON
- 10-DAY MONEY-BACK GUARANTEE

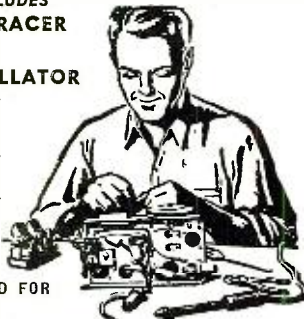

## WHAT THE PROGRESSIVE RADIO "EDU-KIT" OFFERS YOU

The "Edu-Kit" offers you a Home Radio Technician Course at a rock-bottom price. You will learn how to identify Radio Symbols and Diagrams; how to build radios, using regular radio schematics; how to wire and solder in a professional manner. You will learn how to operate Receivers, Transmitters, and Audio Amplifiers. You will learn how to service and trouble-shoot radios. You will learn code. You will receive training for F.C.C. license. In brief, you will receive a practical basic education in Radio, worth many times the small price you pay.

### THE KIT FOR EVERYONE

It is not necessary that you have even the slightest background in science or radio. The "Edu-Kit" is used by young and old; by radio schools and clubs; by Armed Forces personnel and veterans for training and rehabilitation. No instructor is required. Instructions are complete, simple and clear. You cannot make a mistake.

### PROGRESSIVE TEACHING METHOD

The "Edu-Kit" uses the principle of "Learn by Doing." Therefore you will build radios, perform jobs, and conduct experiments to illustrate the principles which you learn. You begin by learning the function and theory of each of the radio parts. Then you build a simple radio. Gradually in a progressive manner, you will find yourself constructing more advanced multi-tube radio sets, and doing work like a professional Radio Technician. The "Edu-Kit" Instruction Books are exceedingly clear in their explanations, photographs and diagrams. These sets operate on 105-125 V. AC-DC. An adaptor for 210-250 V. AC-DC is available.

### The Progressive Radio "EDU-KIT" Is Complete

You will receive every part necessary to build fifteen different radio sets. Our kits contain tubes, tube sockets, chassis, variable condensers, electrolytic condensers, mica condensers, paper condensers, resistors, line cords, selenium rectifiers, tie strips, coils, hardware, tubing, etc. An Electrical and Radio Tester is included. Complete, easy-to-follow instructions are provided. In addition, the "Edu-Kit" now contains lessons for servicing with the Progressive Signal Tracer, F.C.C. instructions, quizzes. The "Edu-Kit" is a complete radio course, down to the smallest detail.

### TROUBLE-SHOOTING LESSONS

Trouble-shooting and servicing are included. You will be taught to recognize and repair troubles. You will build and learn to operate a professional Signal Tracer. You receive an Electrical and Radio Tester, and learn to use it for radio repairs. While you are learning in this practical way, you will be able to do many a repair job for your neighbors and friends and charge fees which will far exceed the cost of the "Edu-Kit." Our Consultation Service will help you with any technical problems which you may have.

### FREE EXTRAS

- Electrical & Radio Tester
- Electric Soldering Iron
- Book on Television
- Radio Trouble-Shooting Guide
- Consultation Service
- Quizzes
- F. C. C. Training

### ATTRACTIVELY GIFT PACKED PROGRESSIVE "EDU-KITS" INC.

497 UNION AVE., BKLYN. 11, N.Y., DEPT. RN-32

- MAIL TODAY—Order shipped same day received.  
10-Day Money-Back Guarantee. Include ALL FREE EXTRAS.
- Send "Edu-Kit" Postpaid. I enclose full payment of \$19.95 (U.S.A. only).
  - Send "Edu-Kit" Postpaid. I enclose full payment of \$20.95 (Outside U.S.A.).
  - 210-250 V. Adaptor for "Edu-Kit"—\$2.50.
  - Send "Edu-Kit" C.O.D. I will pay \$19.95 plus postage. (U.S. only).
  - I wish additional information describing "Edu-Kit." No obligation.
  - Send me FREE Radio-TV Servicing Literature. No obligation.

Name .....  
Address .....

PROGRESSIVE "EDU-KITS" INC.  
497 Union Ave., Bklyn. 11, N.Y., Dept. RN-32

teries, condensers, controls, resistors, rectifier stacks, switches, vibrators, mobile and a.c.-operated power supplies, TV components and equipment, and test gear. Every item is completely described.

Copies of the new catalogue may be obtained from the company's distributors or by writing the Distributor Division, P. O. Box 1558, Indianapolis, Ind. Please specify Catalogue No. 554 when making your request.

## ANTENNA CATALOGUE

Channel Master Corporation, Ellenville, N. Y. has announced the publication of a new general catalogue covering its complete line of antennas and accessories.

The publication illustrates and describes more than 125 different numbers including both v.h.f. and u.h.f. antennas, masting, towers, mounts, interaction filters, and general accessories. Most of the antenna information is supplemented by complete technical data, including gain curves and horizontal polar patterns.

The catalogue is designed in loose-leaf style so that pages may be added or removed as product changes are announced.

## CONELRAD FOR HAMS

The Federal Communications Commission has released details on the new Conelrad plan for amateur radio service which will apply to all radio stations in the amateur service licensed by the FCC within the continental U. S.

Under the plan, amateur stations will receive the radio alert from broadcast stations, unless specifically directed otherwise by the FCC. Upon receiving the alert all ham stations will cease operation unless continued operation is authorized specifically by the FCC.

At the conclusion of a "radio alert" amateur stations may resume normal operation upon receiving the radio all clear as broadcasted from standard, FM, or TV stations or when such stations are observed to be operating in a normal manner upon their assigned frequencies.

During a "radio alert" all ham stations will, unless specifically authorized otherwise, immediately discontinue operation and remain silent. Only amateur stations in the radio amateur civil emergency services (RACES) or such other groups as may be specifically authorized by FCC may transmit during the "radio alert." Such authorized stations or groups must comply with the following rules of operating procedures:

1. No transmission shall be made unless it is of extreme emergency affecting the national safety or the safety of people and property.
2. Transmission shall be as short as possible.
3. No station identification shall be given either by transmission of call letters or by announcement of location (if station identification is necessary to carry on the service, tactical calls or other means of identification will be utilized).

This plan will not be placed in effect officially until Conelrad rules and regulations are approved by the FCC in accordance with the requirements of the Administrative Procedures Act.

## WRITE FOR OUR LATEST CATALOG

605B General Radio Standard Signal Generator	Exc.	\$400.00
723A General Radio 1000 Cycle Vacuum Tube Fork With Power Supply	New	80.00
TS33/AP Test Set Freq. Range 8700 to 9500 MC. For Measuring CW. Pulsed Signals or Radar Sets	Exc.	200.00
726 General Radio Tube Voltmeter	Exc.	125.00
716B General Radio Capacitance Bridge	Exc.	300.00
AN/APR4 Radar Search Receiver Range 38 to 4000 MC. With 5 Tuning units	Exc.	PUR*
Model 686 Weston True Mutual Conductance Vacuum Tube Analyzer	New	500.00
AN/APN4 Loran Set Frequency Range 1700-2000 KC. Complete With 1D6B/APN4 Indicator, R9A/APN4 Receiver, Plugs, Crystal, Mounts, and Plugs	Exc.	160.00
PE-20 Inverter Use With Loran New Kay Mega-Marker Range 19 to 29 MC. Sound Discriminator Adjustment 4.5 MC.	Exc.	14.90
Kay Mega-Ligner An I.F. Marker Produces Pips and "Birdies"	Exc.	100.00
Kay Mega Pepper Crystal Control, No Switching, Pips Simultaneously Visible	Exc.	100.00
General Radio Type 620A Hetrodyne Frequency Meter Panel Mounting 33KC.-33MC.	Exc.	425.00
TS-13AP X-Band Signal Generator, Wavemeter, Wattmeter	Exc.	PUR*
LR-1 Direct Reading Frequency Meter 160-30,000 KC. 115V.AC. 60 CY. With Crystal Calibration	Exc.	1000.00
15E Test Set, Weston Electrical Inst. Co.	Exc.	100.00
Tuning Forks GR-723A 1000 Cycles. New	Exc.	70.00
General Radio Hetrodyne Frequency Meter 720A 10-3000 MC.	Exc.	300.00

\*PUR—Price Upon Request  
NOTE: One of the largest and most complete electronic surplus stocks in the country. We have thousands of tubes, capacitors, plugs, accessories, transmitters-receivers, test equipment, etc. Send us your requirements.

### WANTED

All types of radio and electronic surplus as well as standard test equipment. Please state accurate description, condition, and your lowest price. Explain modifications, if any. We pay freight charges.

## PHOTOCON SALES

417 N. Foothill Blvd. SYcamore 2-4131  
Pasadena 8, Calif. RYan 1-6751  
CABLE: Photocon, Pasadena

## STAN-BURN E.P.A.R.K.E.

### CATHODE RAY TUBE SPECIALS

One Year Guarantee		
G. E.	STAN-BURN	
*10BP4A	.....	\$14.95
*10FP4A	.....	21.10
*12LP4A	.....	18.75
*12QP4A/B1014	.....	21.00
*12UP4B	.....	28.75
*14CP4/B1014	.....	24.50
*15DP4	.....	23.75
*16AP4A	.....	30.95
*16BP4 or B	.....	25.25
*16KP4/16RP4	.....	24.20
*16KP4A	.....	28.35
*16JP4A (N.U.)	.....	25.25
*16LP4A	.....	28.50
*16WP4A	.....	26.50
*16GP4B	.....	31.25
*17BP4A	.....	24.25
*17RP4B	.....	30.30
*17CP4A	.....	23.90
*17CP4B	.....	29.00
*19AP4A	.....	41.50
*20CP4	.....	30.00
*20LP4	.....	37.50
*21AP4	.....	42.00
*21EP4	.....	31.80
*21EP4A	.....	36.35
*24AP4	.....	78.90
*10BP4	.....	\$10.20
*12LP4	.....	11.90
*12LP4A	.....	13.95
*12QP4	.....	11.90
*12JP4	.....	11.90
*12UP4A	.....	14.50
*14CP4	.....	15.60
*15DP4A	.....	17.50
*16KP4A	.....	17.50
*16DP4 or A	.....	17.50
*16JP4 or A	.....	17.50
*16CP4 or A	.....	17.50
*16WP4A	.....	17.50
*16GP4A	.....	23.00
*16RP4A	.....	19.00
*16EP4A	.....	23.50
*16GP4 or A	.....	21.00
*17BP4	.....	18.50
*17CP4A	.....	21.00
*17CP4B	.....	22.60
*19FP4A	.....	24.00
*19AP4	.....	23.90
*19AP4A	.....	24.90
*20CP4	.....	23.95
*21EP4A	.....	25.50
*21AP4	.....	26.50
*24AP4	.....	49.00

### QUANTITY CRT USERS

We will give you DUD allowances if you ship them to us Prepaid 10 CRT's minimum shipment. WRITE FOR DETAILS.

AUTHORIZED DISTRIBUTORS for General Electric, Kenrad, Tung-Sol, National Union, De Wald, Regal, Automatic and General Motors

Automatic Custom-Built Radios for Plymouth, Ford, Chevrolet and many others, always in stock.

We carry a Complete line of HI-FIDELITY and sound equipment. Send us your requests.

We also carry a complete line of popular makes of Radio Tubes at 50/10 discount. Also many other special purpose and transmitting types and all electronic parts and equipment at lowest prices. Send us a list of your requirements for prompt quotations. Terms: 20% with order. Sales C.O.D. All prices F.O.B., NEW YORK Warehouse. Minimum order \$5.00. Write for our latest price list and HI-Fi catalog to Dept. RN-8.

STAN-BURN RADIO and ELECTRONICS CO.  
1697 BROADWAY • NEW YORK 19, N.Y.

RADIO & TELEVISION NEWS



*An Invitation...*

# To men who want to "go places" in TV SERVICING

*Find out about this NEW,  
ALL-PRACTICE WAY  
of becoming a Professional  
TV SERVICEMAN*

If you have some Radio or Television experience, or if you know basic Radio-Television principles but lack experience—NRI's new Professional Television Servicing course can train you to *go places* in TV servicing. This advertisement is your personal invitation to get a free copy of our booklet describing this training in detail.

### **Learn-by-Doing "All the Way"**

This is 100% learn-by-doing, practical training. We supply *all* components, *all* tubes, *including* a 17-inch picture tube, and comprehensive manuals covering a thorough program of practice. You learn how experts diagnose TV defects quickly. You see how various defects affect receiver performance—picture and sound; learn causes of defects, accurately, easily, and how to fix them. You do more than just build circuits. You get practice recognizing, isolating, and fixing innumerable troubles.

You get actual experience aligning TV receivers, diagnosing the causes of complaints from scope patterns, eliminating interference, using germanium crystals to rectify the TV picture signal, obtaining maximum brightness and definition by properly adjusting the ion trap and centering magnets, etc. There isn't room on this or even several pages of this magazine to list all the servicing experience you get.

### **UHF & COLOR TV Making New Boom**

Installing front-end channel selector strips in modern UHF-VHF Television receivers and learning UHF servicing problems and their solution is part of the practice you get. To cash in on the coming color TV boom you'll need the kind of foundation in knowledge and experience this training gives.

### **Get Details of New Course Free**

Once again—if you want to go places in TV servicing, we invite you to find out what you get, what you practice, what you learn from NRI's new course in Professional Television Servicing. See pictures of equipment supplied, read what you practice. Judge for yourself whether this training will further your ambition to reach the top in TV servicing. We believe it will. We believe many of tomorrow's top TV servicemen will be graduates of this training. Mailing the coupon involves no obligation.

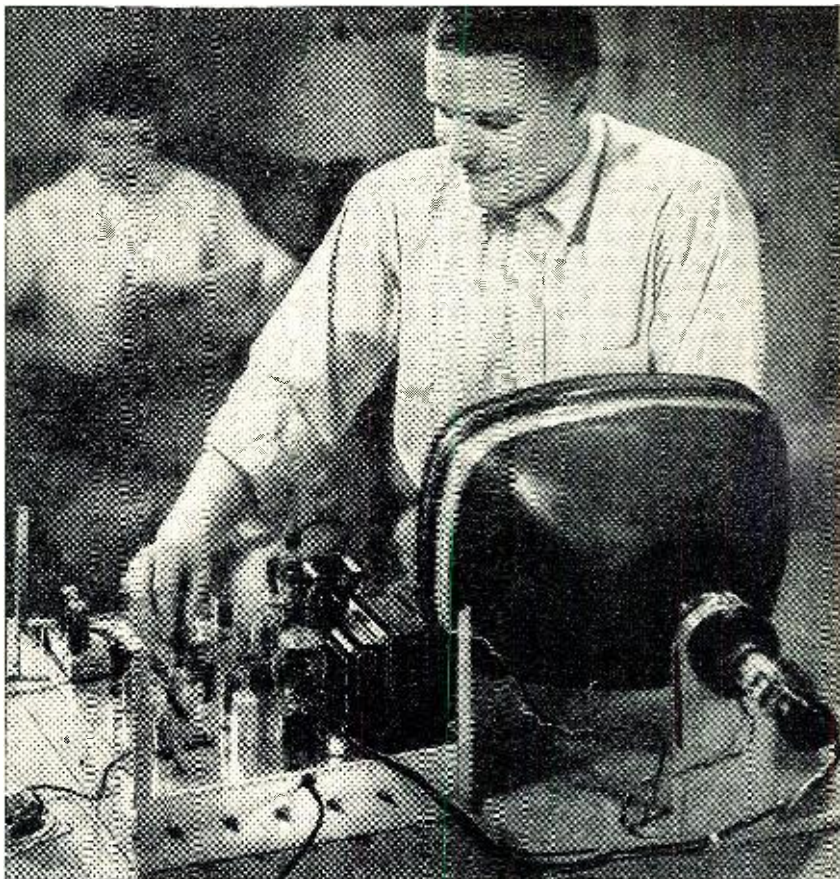

*Train at home easily, quickly, for TV's top servicing jobs. NRI's Professional Television Servicing course includes a 17-inch picture tube and all other tubes and components to build a complete TV Receiver, Oscilloscope, Signal Generator, H.F. Probe. Complete training, including all equipment, available now for a low introductory price—under \$200 on easy terms.*



National Radio Institute, Dept. 4HET  
16th and U Sts., N.W., Washington 9, D. C.

Please send my FREE copy of "How to Reach the Top in TV Servicing." I understand no salesman will call.

Name.....Age.....

Address.....

City.....Zone....State.....

WORLD'S LARGEST MANUFACTURER  
OF CUSTOM BUILT TELEVISION

# MATTISON

**SILVER ROCKET 630 CHASSIS**  
Featuring Syncromatic Tuning  
**NO DRIFT UHF-VHF-DX**

ONLY THE MATTISON 630 ELIMINATES DRIFTING APART OF PICTURE AND SOUND ON UHF, VHF and DX RECEPTION. SELECT YOUR CHANNEL SOUND IS AUTOMATIC. (Syncromatic tuning is an exclusive Mattison 630 Circuit)

Tube Complement:  
29 tubes  
3 rectifiers  
1 CRT

**SILVER ROCKET**  
630 Chassis with  
built in UHF Tuner

**33**

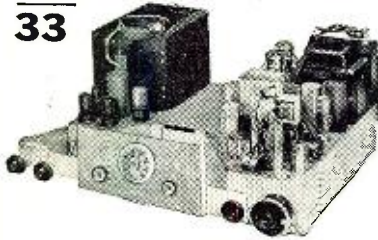

## All Channel UHF Tuner

• UHF Cascade I.F. amplifier adds additional I.F. stage. Very important because UHF transmitters operate with moderate power and RECEIVER must be sensitive to give top notch UHF performance.

**SILVER ROCKET 630 CHASSIS**  
• with TUNEABLE •  
**BUILT-IN BOOSTER**  
for Better DX Reception

Tube Complement:  
28 tubes  
3 rectifiers  
1 CRT

Select Your Channel  
SOUND IS AUTOMATIC!

**32**

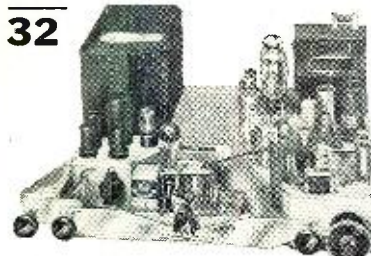

## Tuneable Booster

• Broad band single knob control pre-amplifier built in to eliminate long leads which may cause regeneration and attenuation of signal.  
• ONLY THE MATTISON 630 CHASSIS HAS AN ALL CHANNEL TUNEABLE BUILT-IN BOOSTER THAT INCREASES SIGNAL STRENGTH UP TO 10 TIMES.

ALL CABINETS MADE IN MATTISON'S OWN CABINET FACTORY. AVAILABLE IN EVERY FINISH AND STYLE. WRITE FOR COMPLETE CATALOG.

**DEALERS! SERVICE MEN!** Here is your opportunity to become the "important" TV Dealer in your area for THE FINEST CUSTOM-BUILT LINE OF TV RECEIVERS. FREE!! Write for Mattison's merchandising portfolio explaining the "UNASSEMBLED PLAN" and "\$1,000,000 FLOOR PLAN."



Manufactured with integrity

**Mattison Television & Radio Corp.**  
10 West 181st St., Dept. RN, N. Y. 53, N. Y.

When you buy from Mattison you need only one source of supply! You can buy a Mattison Chassis, a Mattison Cabinet or a complete Mattison TV Set!

# INDEX OF Advertisers

AUGUST  
1954

While every precaution is taken to insure accuracy, we cannot guarantee against the possibility of an occasional change or omission in the preparation of this index.

ADVERTISER	PAGE	ADVERTISER	PAGE
Aaron Electronic Sales	121	Miles Reproducer Co., Inc.	93
Airex Radio Corp.	88	Milwaukee School of Engineering	110
All Channel Antenna Corp.	107	Mosley Electronics, Inc.	125
Allied Radio Corp.	9	Moss Electronic Distributing Co., Inc.	73
American Phenolic Corporation	76	Musical Masterpiece Society, Inc., The	84
American Television & Radio Co.	18	National Company	14, 15
Amplifier Corp. of America	114	National Electronics of Cleveland	90
Angle Genesee	125	National Radio Institute	3, 129
Arkay Radio Kits, Inc.	89	National Schools	17
Arrow Sales, Inc.	96	New Jersey Television Supply Co.	115
Ashe Radio Co., Walter	63	Offenbach & Reimus	97
Atlas Sound Corp.	124	P.A.R.T.S., Inc.	95
Audel Publishers	110	Palley Supply Co.	113
Baltimore Technical Institute	121	Peak Electronics Co.	117
Barry Electronics Corp.	126	Permoflux Corporation	72
Bean, L. L., Inc.	128	Philco Corporation	6, 7
Bell Telephone Laboratories	22	Photocon Sales	108
Bonica Newsreel Club	113	Pickering & Company, Incorporated	21
Burstein-Appeebe Co.	112	Platt Electronics Corp.	120
Cagan Sales, B. C.	109	Popular Electronics	91
Candler System Co.	126	Premax Products	115
Capitol Radio Engineering Institute	13	Premier Radio-TV Supply	75
Centralab	77, 92, 98, 114, 117, 119	Progressive "Edu-Kits," Inc.	108
Century Electronics Co.	113	Q.T. Sales	111
Channel Master Corp.	16	R.C.A. Institutes, Inc.	29, 113
Chicago Standard Transformer Corporation	105	R.W. Electronics	104
Cincinnati Ventilating Co., The	84	Radiomodets	107
Cleveland Institute of Radio Electronics	25	Radio Receptor Company, Inc.	99
Collins Audio Products Co., Inc.	28	Radio Television News Book Service	101
Columbia Electronics	114	Rad-Tel Tube Co.	87
Columbia Electronics Corp.	128	Raytheon Manufacturing Company, 2nd Cover	89
Communications Company, Inc.	86	Rider Publishers, Inc., John F.	83
Communications Equipment Co.	112	Rinehart & Co., Inc.	81, 82
Concord Radio	65	Rockbar Corporation	80
Corona Radio & T.V. Co.	107	Root Electronics	125
Coyne Electrical School	86, 127	Sams & Co., Inc., Howard W.	116, 119
Cramer Electronics, Inc.	97	Sam's Surplus	84
De Vry Technical Institute	5	Sangamo Electric Company	85
Delco Radio Corporation	3rd Cover	Sarkes-Tarzian, Inc.	109, 121
Editors & Engineers, Ltd.	94	Shure Brothers, Inc.	112
Electronic Chemical Corp.	110	Sprague Products Company	19
Electronic Instrument Co., Inc.	(EICO) 30, 76, 123	Sprayberry Academy of Radio	23
Electron Tube Wholesalers, Inc.	127	Stan Bunn Radio & Electronics Co.	108
Electro-Voice	8	Standard Electrical Products Co.	74
Fair Radio Sales	93	Steve-El Electronics Corp.	96
Fenton Company	122	Stevens Walden, Inc.	82
Fisher Radio Corporation	10	Stuart Electronic Distributors	105
G & G Radio Supply Co.	78	Sun Parts Distributors, Ltd.	90
G & H Wood Products Company	66	Supreme Publications	103
G. L. Electronics, Inc.	106	Sylvania Electric Products, Inc.	24
General Cement Mfg. Co.	27	"TAB"	130
Goodheart, R. E.	106	Teltron Electric Company	94
Grantham School of Electronics	100	Transamerica Electronics Corp.	97
Greenlee Tool Co.	82	Transcircuits	81
Hario Sales Co.	127	Transvision, Inc.	94, 115, 124
Harvey Radio Company, Inc.	118	Triad Transformer Corp.	102
Heath Company	67, 68, 69, 70	Tri-State College	111
Henry Radio Stores	90	Tung-Sol Electric, Inc.	26
Hughes Research and Development Laboratories	123	United Radio Co.	126
Indiana Technical College	109	United Technical Laboratories	99
Instructograph Company	95	U. S. Crystals, Inc.	79
JFD Manufacturing Co.	81	Valparaiso Technical Institute	89
J. J. Glass Electronics Co.	86	Video Electric Co.	123
JSH Sales Co.	126	Walsco Electronics Corporation	12
Jones & Laughlin Steel Corporation	20	Washtek Service Co.	89
K & L Radio Parts Co.	126	Western Television Institute	93
Kay-Townes Antenna Company	11	Wholesale Radio Parts Co., Inc.	124
Kedman Company	104	Windsor Electronic Tube Co.	99
Lafayette Radio	100	World Radio Laboratories	95, 111
Leotone Radio Corp.	96	Zingo Products	107
Mallory & Co., Inc., P. R.	4th Cover		
Mattison Television & Radio Corp.	128		
McGraw-Hill Book Co.	100		



## Free Fall Catalog

Ready August 5  
Fully illustrated. 104 pages, showing Hunting Footwear, Clothing, and one hundred and twenty other leather and canvas specialties of our own manufacture for campers and hunters.  
L. L. Bean, Inc.  
121 Main St.  
Freeport, Maine

**URGENT! URGENT!**  
**ELECTRONIC TUBES**  
We Pay Spot Cash for:  
RADIO, TV -all types  
State types, condition  
of merchandise, quantities and price.  
**COLUMBIA ELECTRONICS CORP.**  
115 Liberty Street, N. Y. C.

TV-FM antennas. All types including UHF. Mounts, Accessories. Lowest prices. Wholesale Supply Co., Dept. H, Lunenburg, Mass.

TELEVISIONS, Working. \$25 up. W4API 1420 South Randolph, Arlington 4, Virginia.

DIAGRAMS for repairing radios \$1.00. Record-Changers \$1.50. Television \$2.00. Give Make, Model. Diagram Service, 672-RN, Hartford 1, Connecticut.

SURPLUS at lowest prices ever. Navy Sound Power head and chest sets. Used, guaranteed \$1.95. Dynamotor PE101C NEW \$3.75; Plug .75. Conversion sheet free. Remote Control chassis 179. Western Electric Filter D163011 NEW \$1.00. Quantity Discounts. Free Flyer. Rex Radio, 88 Cortlandt St., New York, N. Y.

SURPLUS Receivers and Transmitters, used, complete with tubes. BC429 \$2.95, BC454 \$4.95, BC453 \$9.95, BC458 \$3.95, BC457 \$4.95, BC696 \$12.95. C.O.D. plus postage. Rogers Trading Co., 2325 Second Ave. No. Birmingham, Ala.

DIAGRAMS—Radio \$1.00; record changers, recorders \$1.25. Television with service data \$2.00. Where model unknown, give part numbers. Kramer's Radio Service, Dept. S53, 36 Columbus Ave., New York 23, N. Y.

TAPE Recorders, Tapes, Accessories. Unusual Values. Dressner, Box 66R, Peter Stuyvesant Station, N. Y. 9.

FREE: Get our monthly electronic lists. Dick Rose, Everett, Wash.

TUBES and equipment bought, sold, and exchanged. For action and a fair deal, write B. N. Gensler, W2LNI, 136F Liberty, N. Y. 6, N. Y.

AN/APR-4, other "APR-," "ARR-," "TS-," "IE-," ARC-1, ARC-3, ART-13, everything surplus; Tubes, Manuals, Laboratory equipment. Describe, price in first letter. Engineering Associates, 434 Patterson Rd., Dayton 9, Ohio.

A.C. BIAS BOX Small Compact Two Tube A.C. Operation Negative Voltage Controlled From 0 to 15 Volt No Special Part Required Circuit & Parts List \$1.00. Colorado Sound & Electronic Service, 170 South Broadway, Denver 9, Colorado.

200 UNMARKED ceramicons. Mixed values \$1.00. Schneider, Box 214, Seaford, N. Y.

RECORDING TAPE, all brands; also used tape (cleanly erased); other bargains. Commissioned Electronics, 2503 Champlain St., Washington, D. C.

ALUMINUM TUBING, Angle and Channel Plain and Perforated Sheet. Willard Radcliff, Fostoria, Ohio.

**WANTED**

WILL buy all ART-13/type T-47A \$200.00; ART-13/type T-47, \$150.00; BC-348 unmodified \$65.00, BC-348 modified \$50.00; APN-9 \$200.00; ARC-3 complete \$600.00; R77 Receivers \$300.00; ARC-1 \$300.00; BC-312 \$60.00; BC-342 \$60.00. Ship via Express C.O.D., subject to inspection to: H. Finnegan, 49 Washington Avenue, Little Ferry, N. J.

TELETYPEWRITERS, tape send-receive or receive only, Model 14, any quantity or condition. Box 540, Radio & Television News."

FREQUENCY modulation transmitter 50 watt that can be converted to center frequency 71.75 MC. Also used T.V. transmitting equipment and diagrams successful experimental units. Zuniga & Cia. Ltda. Apdo. 1967, San Jose, C.R.

**SITUATIONS WANTED**

TELEVISION Parts Manager. Thoroughly Experienced All Brands. Wishes Relocate Florida. Box 541, Radio & Television News.

**RECORDS**

25-50% DISCOUNT on guaranteed factory fresh LP records, and pre-recorded tape. Send 20c for complete LP catalogue. Record Sales, 4710 Caroline, Houston 4, Texas.

**CORRESPONDENCE COURSES**

USED correspondence Courses and Books sold and rented. Money back guarantee. Catalog free. (Courses bought.) Lee Mountain, Pisgah, Ala.

**MISCELLANEOUS**

BUILD your own electronic organ, or miniature electronic brain. Jim Kirk, W6DEG, 1552 Church St., San Francisco 14, Calif.

ALL makes speakers repaired. Amprite Speaker Service, 70 Vesey St., New York City 7.

TEST Equipment repaired and calibrated by Factory staff. All makes. Superior, Simpson, Triplett, Eico. Preempt service. Free estimate. Douglas Instrument Laboratory, 176 Norfolk Avenue, Boston 19, Mass.

REPAIR on all makes of test equipment, and kit construction, starting September first. Write now for free information. Bigelow Electronics, Beulah, Michigan.

August, 1954

**TOP QUALITY TUBES ONE YEAR GUARANTEE BELOW MFRS' PRICES!**

Type	Price	Type	Price	Type	Price	Type	Price
0A2	..99	5Y4GT	..44	12K7	..55	84	..29
0A3 VR75	..99	5Z3	..44	12Q7GT	..58	89/Y	..59
0A4G	..65	6A6	..47	12SB7	..69	64	1172G
0B2	..74	6A7	..62	12SA7GT	..64	64	1172GT
0B3 VR90	..98	6B8	..63	12SC7	..69	69	1051
0C3 VR105.98	..98	6BA4	..49	12SF7GT	..69	69	1051
0D3 VR180	..89	6AB7	..75	12SH7	..75	75	1004
0E3	..43	6AC7	..69	12SL7	..49	49	9004
1A5GT	..43	6AF6	..75	12SK1GT	..75	75	9006
1A7	..45	6AG5	..52	12SL7GT	..49	49	9006
1A85	..59	6AG7	..75	12SN7GT	..58	58	5BP1
1AX2	..59	6AJ5	..89	12SQ7GT	..56	56	5BP4
1B3	..59	6AK5	..49	12T7	..49	49	5C1
1B8GT	..77	6AL5	..30	12T7GT	..55	55	7B7
1C5GT	..43	6B7	..41	12U6	..39	39	14E7
1J6G	..59	6B8	..41	12U6GT	..44	44	14B8
1L4	..45	6B9	..41	12V6	..44	44	14C7
1L4A	..45	6B9A	..41	12V6GT	..44	44	14E7
1L4G	..79	6B9B	..41	12V7	..59	59	14F7
1L8A	..79	6B9C	..41	12V7GT	..59	59	14G7
1L8B	..79	6B9D	..41	12V8	..59	59	14H7
1L8C	..79	6B9E	..41	12V8GT	..59	59	14J7
1L8D	..79	6B9F	..41	12V9	..59	59	14K7
1L8E	..79	6B9G	..41	12V9GT	..59	59	14L7
1L8F	..79	6B9H	..41	12V10	..59	59	14M7
1L8G	..79	6B9I	..41	12V10GT	..59	59	14N7
1L8H	..79	6B9J	..41	12V11	..59	59	14O7
1L8I	..79	6B9K	..41	12V11GT	..59	59	14P7
1L8J	..79	6B9L	..41	12V12	..59	59	14Q7
1L8K	..79	6B9M	..41	12V12GT	..59	59	14R7
1L8L	..79	6B9N	..41	12V13	..59	59	14S7
1L8M	..79	6B9O	..41	12V13GT	..59	59	14T7
1L8N	..79	6B9P	..41	12V14	..59	59	14U7
1L8O	..79	6B9Q	..41	12V14GT	..59	59	14V7
1L8P	..79	6B9R	..41	12V15	..59	59	14W7
1L8Q	..79	6B9S	..41	12V15GT	..59	59	14X7
1L8R	..79	6B9T	..41	12V16	..59	59	14Y7
1L8S	..79	6B9U	..41	12V16GT	..59	59	14Z7
1L8T	..79	6B9V	..41	12V17	..59	59	14Z7GT
1L8U	..79	6B9W	..41	12V18	..59	59	14Z7GT
1L8V	..79	6B9X	..41	12V18GT	..59	59	14Z7GT
1L8W	..79	6B9Y	..41	12V19	..59	59	14Z7GT
1L8X	..79	6B9Z	..41	12V19GT	..59	59	14Z7GT
1L8Y	..79	6B9A	..41	12V20	..59	59	14Z7GT
1L8Z	..79	6B9B	..41	12V20GT	..59	59	14Z7GT

**THIS MONTH'S SPECIALS**

Our new policy brings you greater tube savings than you thought possible! As a GOODWILL offering, we are giving each month a number of popular tube types (listed in extra bold) AT PRICES BELOW OUR OWN COST! Look for these terrific values of additional types each month, in industry-wide publications!

6S07	..41	7F7	..65	12BA6	..47
6SR7	..45	7H7	..59	12BA7	..59
6ST7	..40	7I7	..75	12BD6	..49
6S7GT	..43	7J7	..59	12BE6	..49
6U7G	..45	7N7	..62	12BH7	..65
6UB	..59	7Q7	..61	12BK7	..63
6U8	..59	7R7	..65	12BZ7	..63
6W4GT	..39	7S7	..85	12C8	..34
6W6	..48	7T7	..91	12F5GT	..45
6X4	..36	7U7	..85	12H6	..63
6X5GT	..37	7V7	..44	12J5GT	..39
		7W7	..44	12J7GT	..58

STANDARD BOOSTER, Lots of 3, each...\$5.98  
In single Lots, each...\$6.38  
TRACTOR RADIO, List \$99.75. Special...\$29.77  
HEADPHONES, pair, lots of 3, each...\$3.98  
In single Lots, each...\$2.46  
See JUNE issues of Radio News and Radio-Electronics for illustrations and descriptions.  
Minimum order \$10. Please include 25% deposit with order. Prices subject to change without notice. All prices F.O.B. our warehouse, N.Y.C.  
WRITE FOR TYPES NOT LISTED.

**ELECTRON TUBE WHOLESALERS, INC.**  
140 DUANE STREET • NEW YORK 13, N. Y. • Phone: Barclay 7-7616

**Save More Dough at Harjo**

701A TRANSMITTING TUBE, \$4.95  
DUMONT 3GP1 CATHODE RAY TUBES \$1.79; 3 for \$5  
Same as used in Dumont 224A Oscilloscope. New. With Schematic.

POWER TRANSFORMER, 110V. 60 cy. primary, 150V. 30MA secondary, 6.3-1 amp. Fil. PB for grip dip kits, test equip., etc.—79¢ plus 35¢ for postage and shipping.

CERAMIC CONDENSERS \$1 Post-paid  
Kit of 100 asstd. Brand new, standard brands. \$10 value.

APS 13 Complete 420 MC Radiophone  
When converted with our easy-to-follow schematics and instructions. Range in most cases equal to 2 meters. Fine for communication, ranches, farms, etc., \$3.95  
\$14.95 VALUE  
Complete with RF sections, conversion booklet, and 30 MC I.F. strip, less tubes, dynamotor. Minor parts (not needed for conversion) missing.

Sound Powered HEAD & CHEST SET \$7.95  
Navy type, no batteries needed. PB for TV antenna installation, etc. 20' cord. New. \$25 value!

Western Electric HANDSET \$2.95  
Standard type as used on telephones. Complete with cord. PB for mobile or home telephone systems. Xint. cord.

Ship Band Frequency CRYSTALS, 2142, 2174, 2638, 2670...\$2.49 ea.  
Write for FREE Surplus Catalog. Thousands of items not listed.  
If you don't see it, write.  
All shipments F.O.B. warehouse. Minimum order \$3.00.

**Harjo Sales Co.**  
Dept. RH  
4109 Burbank Blvd., Burbank, Calif.  
P.O. Box 1187, Magnolia Park Sta.  
Cable: Harjo Phone: Victoria 9-2411

**TELEVISION-RADIO Electricity**  
REFRIGERATION-ELECTRONICS  
IN THE GREAT SHOPS OF COYNE

**TRAIN QUICKLY! OLDEST, BEST EQUIPPED SCHOOL OF ITS KIND in U.S.**

Come to the Great Shops of Coyne in Chicago. Get practical training in opportunity fields—TELEVISION-RADIO—ELECTRICITY—ELECTRONICS—vital in Defense Program. Prepare now for a better job in industry or better service rating.

Approved for Veterans  
Finance Plan—Enroll now, pay most of tuition later. If you need part-time work to help out with living expenses while at Coyne, we'll help you get it. Special tuition plan for men of Draft Age.

FREE BOOK Clip coupon for Big Free Illustrated Book. No salesman will call. Act NOW.

B. W. Cooke, President A TECHNICAL TRADE INSTITUTE CHARTERED NOT FOR PROFIT  
Established 1899  
500 S. Paulina, Chicago

**ELECTRICITY ★ TELEVISION RADIO ★ REFRIGERATION ★ ELECTRONICS**

B. W. COOKE, Pres. COYNE School  
500 S. Paulina St., Chicago 12, Ill. Dept. C4-85H  
Send FREE BOOK and full details on:  
 TELEVISION-RADIO  ELECTRICITY  
NAME.....  
ADDRESS.....  
CITY..... STATE.....

**PRICES SLASHED FAR BELOW WHOLESALE!**

Standard brands only! One of largest stocks in U.S. We sell-buy-trade. WRITE FOR FREE CATALOG JUST OFF PRESSES.

1A3	.70	6K7	.75	12SQ7	.65
1A7	.85	6L6	1.40	12SR7	.49
1C5	.80	6L7	.85	25L6GT	.69
1C7	1.00	6L7	.85	48Z5	.69
1C21	1.00	6S4	.60	50L6GT	.69
1LA4	.90	6SA7	.80	8A2	.99
1L6	.90	6SF5	.90	8A2	.99
1LNS	.90	6SF5	.90	8B2	.99
1NSG7	.65	6SF7	1.00	1021	3.50
1R4	.90	6SG7	.75	2051	3.95
1R5	.75	6SM7	.75	2D21	1.15
1X2A	.90	6SJ7	.60	2X2	1.69
3C6	.49	6SK7	.60	3FP7	1.95
3Q4	.60	6SL7GT	.75	3GP1	1.95
3Q5GT	.80	6SN7GT	.85	3HP7	2.95
3S4	.65	6SQ7	.55	5AP1	2.95
3T4	1.40	6SR7	.70	5BP4	2.95
5V4	1.00	6SS7	.90	5FP7	1.95
5X4	.65	6ST7	.65	12AV7	.95
5Y3GT	.65	6T8	.75	11A2	.49
5Y4G	.55	6U8	1.00	304TL	6.95
6A7	1.00	6V6GT	.70	701A	2.95
6AG5	.75	6W4GT	1.00	81A	7.35
6AC7	.90	6X4	.60	809	2.90
6AC7	1.10	6Y6G	.85	811A	3.49
6AC7	1.20	7AC7	.75	813	7.35
6AK5	.75	7C4	.90	829	6.50
6AL5	.55	7C7	.90	830B	1.95
6AQ5	.60	7D7	.90	856A	1.30
6AQ6	.75	7N7	.90	872A	1.95
6AT6	.45	811	2.90	878	2.00
6AU6	1.70	832A	6.50	922	1.30
6AV5GT	1.00	8B5	1.00	923	1.30
6B4G	1.00	878	1.50	931A	4.50
6B6G	1.60	12AG	.75	935	5.50
6BH6	.70	12AT7	.95	954	.49
6BJ6	.70	12AU7	.95	955	.49
6C4	.60	12AX4GT	.85	956	.49
6C6G	1.50	12B7	.80	957	.49
6J4	4.50	12H6	.62	958A	.69
6J6	.70	12J5	.60	959	1.50
6C6	1.00	12K7	.80	1619	1.00
6D6	.85	12K8	.59	1625	.35
6F6	1.10	12SC7	.89	2050	1.30
16F7	1.00	12SH7	.99	2051	.95
6F8G	1.00	12SH7	.70	9001	1.10
6GG6	.85	12SL7GT	.92	9002	.85
6HG	.60	12SN7GT	.80	9003	1.25

Thousands of other types of Transmitting and Receiving Tubes. Prices subject to change without notice. Californians add sales tax. Add postage to order. Minimum order \$5.00.

**SPECIAL! VACUUM CAPACITORS!**

6 mfd. 30KV	10.00	50 mfd. 40KV	14.50
50 mfd. 20KV	10.00	100 mfd. 10KV	12.00
50 mfd. 32KV	12.50	100 mfd. 20KV	14.00

**jsh** SALES CO. **ELECTRONICS**  
Dept. R-G  
7552 Melrose Ave.  
Los Angeles 46, California

**2-METER CONVERTER**

Now you can receive 2-meters on a conventional Short Wave Receiver. Especially designed Push-Pull 6J6 R. F. Amplifier into 6J6 Oscillator-Mixer. Balanced line input, coaxial output. All slug-tuned adjustments, high quality components. Output frequency is 21 to 25 MC. Highly stable oscillator.

The Converter is PRE-WIRED excepting the tuned circuits. Anyone with even the slightest experience can complete in a comparatively short time. . . . SMALL SIZE 5" long, 3 1/4" wide, 3 1/2" deep. . . . AN EXCELLENT BUY OF COMPONENT PARTS ENABLES US TO SELL AT THESE LOW PRICES. . . . WE GUARANTEE SATISFACTORY RESULTS. . . . COMPLETELY WIRED, TESTED, ALIGNED UNITS.



Model 2A (Illustrated) with A.C. Power Supply  
FOR ADDITIONAL DETAILS REFER TO CQ MAGAZINE: PAGE 32, DEC., 1953

MODEL 1A—Without Power Supply—	\$16.95
With Tubes	
MODEL 2A—With A.C. Power Supply—	\$21.95
With Tubes	
IN KIT FORM, LESS TUBES, with COMPLETE SIMPLIFIED INSTRUCTIONS:	
MODEL 1—Without A.C. Power Supply	\$9.95
MODEL 2—With A.C. Power Supply	\$14.45

SEE YOUR LOCAL JOBBER or WRITE US  
**K & L RADIO PARTS CO.**  
1406 VENICE BLVD. LOS ANGELES 6, CALIF.  
• COMING SOON; VFO FOR 2 METERS, HIGHLY STABLE, REASONABLY PRICED.

nicians who operate on their own evenings and Sundays and others operating from their homes and back alley shops. The TSDA of Philadelphia committee that originally initiated this program reports that their members have conducted a 6-months' study of all service advertising that has appeared in both daily and weekly newspapers in the area. The detailed results of this study are to be presented to the various agencies.

The Council is also studying a plan submitted by their financial committee which involves the use of stamps (similar to postage stamps) to be affixed to all bills and service orders left with or mailed to customers by Council members. The purpose of the stamp is to serve as an assurance to the service customer that the work done was in accordance with standards adopted by the Council. The stamps would be made available to the members of the affiliated associations at a small charge. To publicize it, it would be featured on the Council's radio and TV programs and prominently displayed in all members' shops and offices, and on their trucks and cars.

A regional association was recently formed to promote the interests of service businessmen in an area that embraces eastern Montana, northwestern South Dakota, and western North Dakota. It is known as the Tri-State Radio and Television Technicians Association with headquarters in Dickinson, North Dakota. It is the hope of the officers of this new organization that technicians in the entire State of North Dakota will be represented in its membership.

Dale Thomas, president of the Tri-State Radio & TV Technicians Association would like to have helpful ideas for maintaining membership interest in the activities of an association. His address is: Dale Thomas, Dickinson, N. D.

**PHOTO CREDITS**

Page	Credit
31, 32, 33, 34.	Dalmo Victor Company
38 (left).	General Electric Company
38 (second from left), 83.	CBS-Hytron
38 (second from right), 39, 40, 41.	Radio Corporation of America
42	Westinghouse Electric Corp.
48	C. G. Conn Ltd.
54	United Technical Laboratories
57	Allen B. Du Mont Laboratories
71	Arthur Simkin (Ppy) Ltd.

**ERRATUM**  
In the caption accompanying the photograph of World Radio Laboratories' new radio "supermart" salesroom (page 128, June 1954 issue), we incorrectly located the firm in Cedar Rapids, Iowa. The company is at 3415-27 W. Broadway in Council Bluffs, Iowa. Our apologies for "moving" the firm without its knowledge.

**"CAVEAT EMPTOR"**

*tube*  
*(Let the buyer beware)*

Good advice for the modern serviceman! Today more and more used tubes are being sold in the guise of new tubes. They look good and most operate good . . . at first. But too many break-down too soon . . .

Too often cheap prices and extravagant claims have fooled the buyer into purchasing these imitations, instead of the genuine article.

Barry Electronics sells First Quality, Fully Guaranteed, individually boxed, Standard-Brand tubes. Our tubes do not have to be "set or meter checked." They are from original, sealed cartons from the five leading tube manufacturers.

Cheap imitations such as seconds, rewashed bargains, and off-brands result in unnecessary call-backs, expenses, and loss of customer good-will.

You can place your confidence in our New, First Quality, fully-guaranteed STANDARD-BRAND tubes.

**WRITE TODAY FOR THE BARRY HANDY-ORDER FORM. A COMPLETE LISTING OF STANDARD BRAND RADIO & TV TUBES AT OVER 60% DISCOUNT.**

**AUTHORIZED DISTRIBUTORS**  
CBS-HYTRON EIMAC WESTINGHOUSE

**SPECIAL-PURPOSE? WE STOCK OVER 2000 TYPES!**

**TWO-COLORED TUBE CARTONS.** with new Safety Partitions. Prevents Tube Breakage. This Super-Gloss Red and Black Carton is the Most Distinctive Box Available Today! Minimum: 100 any one size. Quantity prices on request.

SIZE	FOR TYPES SUCH AS	EACH
Miniature . . .	(6AU6, 6AL5, etc.) . . . . .	\$1.11
GT . . . . .	(6SN7, 6W4, etc.) . . . . .	.1125
LARGE GT . . .	(1B3, 6BQ6GT, etc.) . . . . .	.015
LARGE G . . .	(5U4G, 6BG6G, etc.) . . . . .	.02

TERMS: 25% with order, balance C.O.D. All merchandise guaranteed. F.O.B., N.Y.C. PHONE: REctor 2-2562

**BARRY ELECTRONICS CORP.**  
136-F LIBERTY ST. N. Y. 6, N. Y.

**SENDING AND RECEIVING SPEED**

Be a "key" man. Learn how to send and receive messages in code by telegraph and radio. Commerce needs thousands of men for jobs. Good pay, adventure, interesting work. Learn at home quickly through famous Candler System. Quality for Amateur or Commercial License. Write for FREE BOOK. **CANDLER SYSTEM CO.** Dept. 2J, Box 928, Denver 1, Colo., U.S.A.

**SAVE \$\$\$**

**THOUSANDS OF BARGAINS**  
Send Stamp for our **GIANT CATALOG**  
**UNITED RADIO CO.**  
58A MARKET ST. NEWARK, N. J.

**Classified**

Rate 50c per word. Minimum 10 words

**RADIO ENGINEERING**  
COMPLETE radio, electronics theory & practice: television; broadcasting; servicing; aviation, marine, police radio. 12 or 18 months. Catalog. Valparaiso Technical Institute, Dept. N, Valparaiso, Ind.

**FOR SALE**

RESISTORS, condensers, micas, electrolytics, tubulars, latest pigtail types, new, every piece usable, some short leads. 5 lbs.—\$5.00, 10 lbs.—\$8.50. Prepaid. Cagan, Box 1152, Rochester, N. Y.

ISOLATION transformers. 35 watt #55R 117v to 117v or 135v plus 6.3v .45a tap 2% x 2% x 3% \$1.95. 10 watt #372 117v to 117v plus 6.3v .6a x 2 1/4 x 1 1/4. Use with Selenium rectifier for 25madc. \$1.35 Empire Electronics Co. 409a Ave. L, Brooklyn 30, N. Y.



the grass roots level where these things happen. Take an active part in your service organizations, local and national, strengthen them with your leadership. By joining forces and co-operating with service organizations, industry groups, and Better Business Bureaus, the problem of the unethical operator can be solved from within. You can count on our help. I am sure we can count on yours."

The Television Service Association of Connecticut, Inc., a recently incorporated organization designed to bring all service groups in that state into a unified association, now has two chapters—one in Hartford and the other in New Britain.

The officers of this new association are F. E. Silverman, president; B. Cohen, vice-president; P. Godek, recording secretary; I. Sherry, treasurer; and J. R. Britney, corresponding secretary. They would like to contact other independent groups in the State of Connecticut for the purpose of coordinating their programs. The address of the TSA, Inc., of Connecticut is P. O. Box 1711, Hartford 1, Connecticut.

The dynamic Association of Television Service Companies of Cincinnati is continuing its program to make the ATSCO emblem the byword for good television service in the Cincinnati area. With the help of Cincinnati's forward-looking newspapers, they were able to clean up TV service advertising in that section. They are reaching the public with their story on television over station WKRC-TV and have started an impressive newspaper advertising campaign.

The Council of Radio and Television Service Associations has embarked on a broad program of activities in the interests of the service industry in the Philadelphia area. Their recently held Color Symposium was financially successful. The monies left after paying the costs of the symposium will be used to finance both a public relations program and technical meetings for members of the Council's affiliated organizations.

The public relations program planned by the Council is in the form of a 13-week TV series of 15-minute programs that will provide the answers to most of the questions about TV operation and service that are of interest to set owners. They report that two of the industry's leading parts manufacturers are helping to underwrite the program with the cost of the props and talent to be paid for out of the Council's funds.

The Council has had its legal advisers prepare an anti-bait advertising ordinance for presentation to the City Council. A series of meetings is planned with the Better Business Bureau, the Pennsylvania State Sales Tax Dept., the Philadelphia Mercantile and Tax Depts., the Zoning Commission, and the Federal Bureau of Internal Revenue, in order to bring into the open the activities of part-time servicers, employed service tech-

August, 1954

LABORATORY DESIGNED for  
UHF and VHF! ... It's NEW!

# MOSLEY

## 2-WAY TV ANTENNA SWITCH

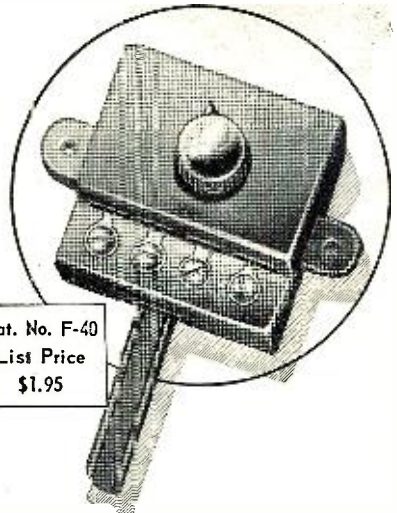

Cat. No. F-40  
List Price  
\$1.95

- Extremely low Standing Wave Ratio — by actual test!
- Positive rotary action!
- Silver-to-silver contacts!
- Compact size!
- Solderless — easy to install!
- Low cost!

Another PREMIUM QUALITY MOSLEY Accessory  
for BETTER TV INSTALLATIONS!

**Mosley**  
Electronics, Inc.  
8622 ST. CHARLES ROCK ROAD  
ST. LOUIS 14, MISSOURI

FIRST QUALITY NEW	TUBES	TOP BRANDS NAME OF MFG. ON EACH TUBE
GUARANTEED ONE YEAR		
1B3 .96	6AT6 .59	6CB6 .76
5U4 .59	6BA6 .71	6CD6 1.89
5V4 .99	6AX4 .92	6J5 .65
5Y3 .49	6BE6 .73	6J6 .90
6AC7 1.21	6BG6 1.89	6K6 .65
6AG5 .81	6BK7 1.19	6S4 .69
6AL5 .63	6BQ6 1.38	6SN7 .85
6AQ5 .76	6BQ7 1.39	6T8 1.05
6AU5 1.19	6BZ7 1.39	6V6 .72
6AU6 .67	6C4 .59	6W4 .69
		12AT7 1.05
		12AU7 .87
		12BA6 .71
		12BE6 .73
		12SN7 .83
		25B06 1.41
		35W4 .49
		35Z5 .51
		50B5 .76
		50L6 .78

**ROOT ELECTRONICS IN-9-1959**  
1600 Nostrand Avenue Bklyn. 26, N. Y.  
Terms: 25% check or money order Bal. C.O.D. F.O.B.

Quick-Wedge  
**SCREWHOLDING**  
SCREWDRIVER

Hold the Screw!  
Drives it, too!

ASK FOR IT AT YOUR DEALER

WEDMAN COMPANY - 253 50th WEST - SALT LAKE CITY 1, UTAH

## ANGLE GENESEE goes to Junior Hi Fi Cabinets

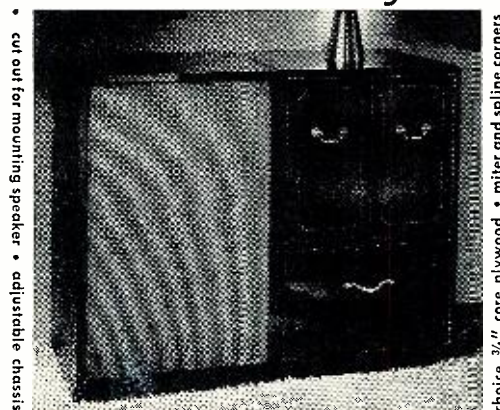

Note. A few dealer franchises still available

- Please send me free complete information on the new "Genesee Junior"
- Please send name of dealer nearest me.
- I am a hi fi dealer. Please contact me about a "Genesee Junior" franchise.

Name .....  
Address .....  
City ..... Zone ..... State .....

choice 3/4" core plywood • miter and spline corners  
mounting rails (Pat. Pending) • removable panels and shelves

Truly a chip off the old A-G block, the "Genesee Junior" features quality advantages of the famous regular Angle Genesee customized line. Designed for the space and budget-conscious audiophile with taste, these junior equipment and speaker cabinets come finished, unfinished or in "Do-it-yourself" kits. Contemporary natural birch or traditional mahogany. Other popular finishes at modest additional cost.

Speaker cabinets as low as \$59.50 completely finished.  
With 15" speaker mounting cut out. 12 J adaptor available for 12" speakers. 21 1/2" wide, 18 1/2" deep, 34" high.

Equipment cabinets as low as \$79.50 completely finished.  
Chassis compartment 15 7/8" deep, 17 3/4" high.  
Record Player shelf 19 3/4" wide, 17" deep.

Send for full details today.

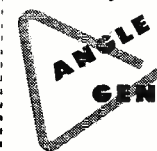

**GENESEE CORPORATION**  
114 Norris Drive  
Rochester, N. Y.

# TRANSMISION

makes this greatest of TV offers—backed by

## MONEY-BACK GUARANTEE:

**\$88** TV SERVICE INSTRUMENT **\$49.95** VALUE FOR—

NEW TV Component Tester performs functions you've always wanted. Look what you get:—  
**FLYBACK** and **YOKE TESTER**, value \$39.00  
**SELENIUM RECTIFIER TESTER**, val. 29.00  
**CRT TESTER** and **REACTIVATOR**, val. 20.00

Total Instrumentation, value..... 88.00  
 ALL 4 in 1 great instrument, net..... 49.95

**SELENIUM RECTIFIER TESTER**

**FLYBACK TRANSFORMER and YOKE TESTER**



**PIC. TUBE TESTER**

**PIC. TUBE REACTIVATOR**

NEVER BEFORE SUCH GREAT VALUE. For only \$49.95 you get 4 testing-and-repair instruments all in one! Compact, weighs only 3 lbs. Does things never been done before! Pays for itself quickly. Prove it yourself!

### TRY IT FOR 10 DAYS

#### on Money-Back Guarantee:

10-DAY TRIAL: Try this Transvision TV COMPONENT TESTER for 10 days. Then, if you are not 100% satisfied, you may return it. Your purchase price, less 10% (our cost of handling and re-packing) will be promptly refunded.

TRANSMISION, INC. • NEW ROCHELLE, N. Y.

RUSH THIS COUPON NOW

TRANSMISION, INC.  
 DEPT. RN-84 NEW ROCHELLE, N. Y.

- Send TV COMPONENT TESTERS @ \$49.95.  
 Enclosed find \$\_\_\_\_\_ deposit Balance C.O.D.  
 Enclosed find \$\_\_\_\_\_ in full.  
 I accept your 10 Day Trial terms.

Name \_\_\_\_\_

Address \_\_\_\_\_

City \_\_\_\_\_ State \_\_\_\_\_

My Jobber Is \_\_\_\_\_

**JOBBER INQUIRIES INVITED**

credit to the service industry as a whole and abide by the decision of the Review Panel as set forth in the by-laws.

16. Keep advertising free of statements of any type that might mislead or deceive the reader.

### Association News

A professionally prepared, twenty-six page report covering the minutes and proceedings of the second annual meeting of the Eastern Television Service Conference, Inc., was released recently by J. Palmer Murphy, executive director of the conference. The meeting, which was attended by delegates from twenty seven of the associations that make up this regional conference, was held at the Bellevue-Stratford Hotel in Philadelphia early in April. Included were reports from the committees on public relations, manufacturers' policies, jobbers and distributors, service problems and related services. The Conference had approved a resolution which provided, "That a regional organization, in which all local, state, and national groups retain their autonomy, be formed and incorporated as the Eastern Television Service Conference, Inc., to provide a closer liaison between all segments of the service industry in the eastern part of the United States and with national service groups, so that we may eventually obtain a semblance of national unity for the television service industry."

Incorporation papers as adopted by the Conference were filed with the Secretary of State of New Jersey at Trenton, N.J., on April 9, 1954, and a charter granted.

The Utah Association of Radio and Television Servicemen, in its drive to enlist the active participation in their association of every forward-looking service businessman in that State, very aptly quotes from a speech given by Kenneth B. Willson, president of the National Better Business Bureau, Inc.

"As I see it, it is not only the responsibility of the industry to do its own house-cleaning, but it makes good sense for the industry to handle the job from within its own ranks. Waging unceasing warfare on the dishonest minority in any group is the decent majority in that group. Just as the Bar associations and the medical and dental associations undertake to free their groups of the unethical practitioner, so must all in the TV service industry assume moral responsibility, not only for striving for high ethical practices, but for combatting bad practices as well.

"Weeding out the unethical serviceman calls for courage and leadership by all who are concerned with the welfare of the industry. It must be recognized as an industry problem and vigorously attacked from within, if the industry is to protect its good name from the corroding influence of the dishonest. It is a job for all, but it starts with you because you are at

## The COMPLETE line



DR Double-Reentrant Projectors

Paging & Talk-Back Speakers

for EVERY



ALNICO-V-PLUS Driver Units

Dual Speakers

## Public Address need!



Tweeters

WRITE NOW for FREE Catalog 553

FULL-GRIP, VELVET-ACTION Mike Stands



1446 39th St., Brooklyn 18, N. Y.  
 In Canada: Atlas Radio Corp., Ltd., Toronto, Ont.

### Equal to \$50 Aerial Systems

### All Directional TV AERIAL

#### 360° DIRECTRONIC SYSTEM

Exclusive Snyder Engineering and designs cut cost to

**\$1895**

COMPLETE with three 3 1/2 ft. masts, 75 ft. 3 cond. cable, Beam selector sw., guy rings and mtg. base. Electronically beams complete 360° rotation to give clear pic. on all channels. You choose direction with directronic selector sw. mounted on or near TV set. Complete double stacked array with 18 hi-tensil double alloy aluminum elements. AX-599 same as TX-599 less masts, guy ring & mtg. base.....\$16.95

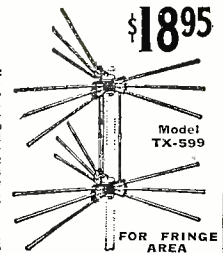

FOR FRINGE AREA

### SNYDER BROAD BAND YAGIS

- Higher Gain Than Conventional Yagis
- For Fringe and Ultra Fringe



High signal level for sharp, bright pictures. Hi-tensil 3/8" aluminum elements: 7 on low band; 9 on high band. Complete with universal U clamps.

RB2-6 for Ch. 2 thru 6 **\$9.95**  
 RB7-13 for Ch. 7 thru 13 **\$4.95**

### SAVE ALMOST HALF ON GERMANIUM DIODES!

Made by the name you think of first when you think of tubes.

IN51.....	<b>29c</b>
IN34.....	59c
IN34A.....	69c
IN81.....	\$1.19

Write for FREE "FYI" Bulletin No. 136



# VIDEO ELECTRIC TUBES COMPANY

AT WHOLESALE

★ 100% GUARANTEED ★

BRANDED! ★ SAME DAY SERVICE!

1A4P	.29	6BD5	.59	7F8	.59
1A7	.49	6BE6	.39	7J7	.59
1B3	.59	6BG6	.99	7K7	.59
1B4P	.79	6BH6	.49	7U5	.49
1C6	.29	6BJ6	.49	7Z4	.39
1E7GT	.39	6BL7	.69	12A7	.39
1F5G	.29	6BN6	.99	12A7	.69
1H5	.49	6BQ6	.79	12A8	.39
1L4	.49	6BQ7	.79	12A9	.59
1L6	.59	6BY5G	.59	12AV6	.39
1LA6	.39	6BZ7	.79	12AV7	.69
1LCS	.39	6C4	.39	12AX7	.59
1LC6	.39	6CB6	.49	12BA6	.39
1N5	.49	6CD6	.99	12BA7	.59
1RS	.49	6CU6GT	.99	12BE6	.39
1S5	.39	6F6	.39	12BH7	.59
1T4	.49	6G7	.69	12S7	.49
1T5GT	.69	6J6	.59	12SK7	.49
1U4	.49	6J8	.79	12SN7	.59
1U5	.39	6K6	.39	12SL7	.59
1X2	.59	6L6	.69	12SQ7	.39
2A3	.29	6N6	.69	14S7	.79
2A7	.29	6S4	.39	19BG6	.39
3AGT	.39	6S8	.59	19B8	.69
3Q4	.49	6SA7	.49	25BQ6	.79
3Q5	.59	6SD7	.49	25L6GT	.39
3S4	.49	6SK7	.49	25W4GT	.39
3V4	.49	6SL7	.59	25Z6	.39
5U4	.39	6SN7	.39	35B5	.49
5V4	.49	6S07	.39	35C5	.39
5Y3	.29	6SR7	.49	35W4	.29
5Y4	.49	6T8	.69	35Z3	.29
5Z3	.29	6U8	.69	35Z5	.29
6AB4	.39	6V6	.49	35/51	.29
6AG5	.49	6W4GT	.39	36	.29
6AJ5	.59	6X4	.29	37	.29
6AK5	.69	6X5	.29	39/44	.29
6AL5	.39	7A4/XXL	.39	49	.29
6AQ5	.49	7A6	.49	50B5	.49
6AS5	.49	7A7	.49	50C5	.49
6AT6	.39	7A8	.49	50L6	.49
6AU6	.39	7AK7	.79	75	.29
6AV6	.39	7B4	.49	76	.29
6B7	.79	7B5	.49	77	.29
6BA6	.49	7B6	.49	80	.29
6BA7	.59	7B7	.49	117L7GT	.99
6BC5	.49	7F7	.59	117Z3	.29

## Surprise Package of Radio & TV Parts

3 lbs. of parts including resistors, controls, coils, IF cans, etc. Easily worth \$10.00

**\$1.95**

**FREE!** with every order of \$20 or more—famous "Oxwall" magnetic screw driver kit. Includes all sizes—Phillips head, long handles to get in those tight spots, etc. 7 screwdrivers in all. May be purchased outright. List value \$4.89 \$1.99 each; 3 for \$5.50

**MINIMUM ORDER \$7.00**

25% deposit with order. Balance COD. If full remittance is sent, please include postage. Excess money will be refunded. We have more than 250 types in stock at all times. Order your other needs at similar savings or write for quotations. Quantity users—write for special discounts!

# VIDEO ELECTRIC COMPANY

79 CLINTON PLACE  
NEWARK, N. J.



*Free!*

Get More Service Calls with  
**EICO DECALS**

WRITE... RPD  
arthur nagel, inc.  
925 E. 55th St., Chicago 15, Ill.

their business so they can work fairly in a clean business atmosphere.

NARDA has succeeded in making the business of retailing television and appliances a potent force in our business structure.

### The Service Story

The widespread activity of the forces of electronic servicing indicates that many hundreds of men in the service business are beginning to discover the power that can be applied through concerted action by associations.

In Atlanta, Ga., the newly formed Radio and Television Service Association of Greater Atlanta, Inc., publicized its membership and announced its "Standards of Practice" to the public in a 1/2 page ad in the *Atlanta Journal*. Forty-six service companies were listed in the ad that announced the formation of the association with the assistance of the Better Business Bureau of Atlanta, Inc. The advertisement stated that "The Association has adopted the following standards of practice and guarantees satisfactory work by its members." The list includes sixteen operating specifications which cover:

1. Maintain a place of business located in a business section and hold a current business license.
2. Use only qualified personnel to assure adequate and proper service.
3. Have available and keep in proper operating condition adequate and reliable test equipment to assure a good job.
4. Maintain an adequate service library.
5. Carry adequate liability insurance to cover all contingencies of damage.
6. Escrow monies collected on contract service to insure completion of service obligations.
7. Inform customer what service charge, estimate, and labor charge include.
8. Service sets in home wherever practical.
9. Use factory-approved methods in doing installation and maintenance work. Use only new parts that are equal to original units.
10. Return to customer all replaced tubes and/or parts when requested to do so.
11. When the exchange of tubes and/or parts is not included in the regular charge, inform the customer of the exact charge to be made for such exchange and give the customer the opportunity to make the exchange and deliver it to the service company if preferred.
12. Issue only guarantees or warranties that are specific as to their application with respect to the effective time, parts, and labor.
13. Give the customer an itemized statement showing materials installed and labor performed.
14. Be honest and courteous and treat each customer in a professional manner.
15. Accept and handle each complaint in a manner that will bring

## Communication Engineers

with  
experience in  
the fields of

**Systems  
Engineering  
Information  
Theory  
Circuit  
Development  
Electro-  
mechanical  
Development  
Equipment  
Engineering**

### THE OPENINGS

Advancements in the fields of wave propagation, translation of information, communication theory, circuit techniques and equipment miniaturization have created a number of new openings for qualified engineers in the Hughes Advanced Electronics Laboratory.

### AREAS OF WORK

The communication group is concerned with the design and development of unique radio communication systems and with exploiting new radio communication techniques. Specialists in propagation phenomena, antenna systems, network theory, magnetic recording, wide-band amplification, and intricate electromechanical devices are active in this program.

*Assurance is  
required that  
relocation of  
applicant will  
not cause  
disruption of  
an urgent  
military project.*

## Hughes

**RESEARCH AND  
DEVELOPMENT  
LABORATORIES**

*Scientific  
and Engineering  
Staff*

CULVER CITY,  
LOS ANGELES  
COUNTY,  
CALIFORNIA

# RADIO-TV Service Industry News

AS REPORTED BY THE  
TELEVISION TECHNICIANS LECTURE BUREAU



(Patent Pending)

## Fen-tone UHF CONVERTER

... breathtakingly beautiful  
... unsurpassed performance

The new Fen-tone creation is indeed a masterpiece of engineering and styling. Small wonder it created a sensation in the 1954 Radio Parts Show. Use the Fen-tone UHF CONVERTER as a lamp, an illuminated aquarium, an illuminated plant vase. You don't "hide" this decorator's dream piece!

List Price \$29.95

Fen-tone VHF Booster of similar design, list price \$29.95

INTRODUCING . . .

Fen-tone "REX"  
3-Speed Automatic  
Record Changer

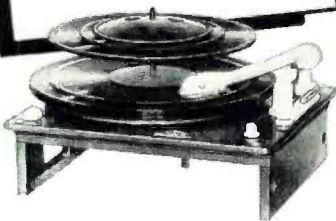

Created by craftsmen whose love for music inspired the finest phonograph instrument ever.

See Your Jobber

Literature on request.

**FENTON Company**

15 Moore Street, New York 4, N. Y.

THE most significant development that has occurred in the service industry in many years is the crystallization of new service associations in all sections of the country. And it is interesting to observe that these associations are being launched with forceful, dynamic programs that, if continued, will go far to eliminate most of the adverse factors involved in handling TV service as a business.

Trade associations play a vital role in the orderly operation of our economic system by fighting for high standards in business morals and technical competence in the industries they represent, and ceaselessly fighting the business vultures whose unrestricted activities could undermine any profession or business.

Membership in a trade association proves a man's recognition and acceptance of his responsibilities. But merely joining is not enough. Active and whole-hearted participation in developing the association's programs and in carrying them out is also necessary.

The basic weakness of most service associations in the past was the lethargy of the members, thus failing to make their associations real, living forces. Men joined these associations with the thought "I'll see what this association can do for me," and then sat back and waited for a lot of good things to happen. When nothing happened they blamed the association and not the real culprits—themselves.

The true spirit that should inspire a man to join a trade association is one in which he will say to himself—"I'll try through my membership in this association to make my industry better and our service to the public the very best that can be given."

### An Association Success Story

An unusual association success story that has occurred in the last few years is that of the National Appliance & Radio-Television Dealers Association (NARDA). Originally organized back in the mid-forties, this dealer association grew modest-

ly for several years. Perhaps the outstanding achievements of the association during its early years were the attraction of high caliber men who became actively interested in the organization and the far-sighted association programs that were initiated at the rate of one a year.

In 1951 they selected a new executive director. To fill this important post they picked a man who had developed an enviable record as a publicist. In the same year they elected a dynamic radio, TV, and appliance dealer as president of the association.

In the succeeding two years during which he served as the organization's president, Mort Farr travelled continuously, talking to groups of TV-appliance dealers in every nook and cranny of the country. In support of his efforts, a strong team of fellow members—officers, directors, and just plain members—worked untiringly in carrying out the basic NARDA programs and in bringing the NARDA story forcefully to the attention of appliance dealers.

Since NARDA numbered among its membership most of the outstandingly successful TV-appliance dealers in the industry, their fellow dealers were able to benefit from the detailed discussions of how they conducted their businesses. Working together as a team they have been able to bring into the open all of the factors that adversely affect the business of retailing radios, television, and appliances and through the power of publicity have been able to force action on the part of some industry factors which, under other conditions, would have been content to stay blind to what was happening.

NARDA members do not look upon their association as a crutch to bear the weight of their individual business management shortcomings. They are rugged individualists who believe sincerely that the success of any individual business hinges entirely on its management's ability and business acumen. The members work through their association to establish and get recognition for rules of fair play in

RADIO & TELEVISION NEWS

# PHOTO FLASH

## 100 WATT-SECOND PORTABLE STROBOLITE OUTFIT

Ideal for outdoor photography by attaching to automobile battery (6/12 or 12/24 VDC) or can be easily converted to 110 VAC operation. Consists of:

**SYLVANIA 200 WATT-SECOND PHOTO-FLASH BULB.** 12,000,000 Lumens. Similar to Sylvania Type R-4320 Bulb. Enclosed in heavy duty PYREX glass covering for rugged service.  
**2.23 MFD @ 2000 VDC INT. G.E. PYRANOL**

**Photo-Flash Type Condensers  
 50 WATT HEAVY DUTY VIBRATOR**

**PLUS**—20 ft. 4 cond. 16 AWG CORD w/ignition coil, trigger housing in hand held lamp ass'y. Adaptable with any type reflector. 2000 V xfmr. —relays—fuses—tubes and misc. parts. **BRAND-NEW** in original carton, with manual. Wt. approx. 50 lbs. **A COMPLETE UNIT at only. . . . . 29<sup>95</sup>**

### SPARES FOR ABOVE

- 200 WATT-SECOND PHOTO FLASH BULB. . . \$7.95
- 23 MFD @ 2000 VDC PHOTO-FLASH COND. . . \$7.95
- 6/12 or 12/24 V HEAVY DUTY VIBRATOR . . . \$3.95
- 20 FT. CORD with ignition coil and trigger housing . . . \$5.95

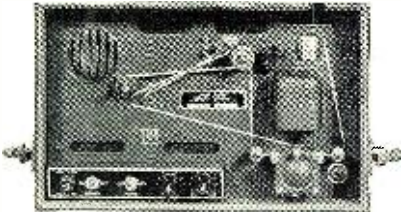

**TG-34 CODE KEYS**—115/230 V 60 cycle. Reproduces code signals automatically on paper tape or can use hand key. Has self-contained speaker. Compact in carrying case—w/tubes and manual. Sh. Wt. 45 lbs. **BRAND-NEW** in original carton **\$24.95.** **USED . . . . . 14<sup>95</sup>**

**McELROY CODE PRACTICE TAPE SET**—15 reels on 16 mm metal reels in heavy wooden slotted case—used with any code unit using inked tape. **BRAND-NEW . . . . . \$12.95**

**McELROY INKED DOUBLE TRACK TAPE SET**—15 reels in metal carrying case w/handle. **\$16.95**

**INDIVIDUAL TAPES** for the following lessons—#1, #2, #6, #8, #11, #14—**NEW** in metal containers. . . . . ea. **\$1.25**

**VIBRATOR POWER SUPPLY PE-157**—Operates from 2 v wet cell. Output: 1.4 v at 500 ma and 125 v @ 50 ma or 1.4 v @ 350 ma and 60v @ 15 ma. Case 6 x 6 x 11 1/2". Contains 4" speaker—vibrator—xfmrs.—diagram—etc. Like New w/cable and plug. Batt. not incl. . . . . **\$14.95**

25% with Order. Bal. Incl. Postage C.O.D.  
 Michigan Residents Add 3% Sales Tax

**AARON ELECTRONIC SALES**  
 6025 MT. ELLIOTT DETROIT 11, MICHIGAN

# TELEVISION

**PREPARE FOR A GOOD JOB!**  
 BROADCAST ENGINEER  
 COMMERCIAL OPERATOR (CODE)  
 RADIO SERVICING

## Television Servicing

(Approved for Veterans)  
 SEND FOR FREE LITERATURE  
**BALTIMORE TECHNICAL INSTITUTE**  
 1425 EUTAW PLACE, BALT. 17, MD.

POPULAR ELECTRONICS  
**Popular Electronics**  
 See Page 91

## TVI Troubleshooting (Continued from page 57)

Such attenuators are commercially available and are either adjustable or fixed in value. Try several values for the fixed-type units until the desired results are obtained. In case some stations that are not causing trouble are weakened too much by the use of the fixed-type attenuators, it might be necessary to provide a switching arrangement.

Earlier in this series it was pointed out that in the absence of modulation, FM and similarly modulated interference reverted back to an unmodulated type of TVI. Thus it follows, that by carefully observing the way in which the pattern changes and by listening to an FM receiver or switching to other channels, a correlation will be obtained between the TVI and its source.

When encountering interferences that you have decided are due to a heterodyning of two separate sources of signals, the solution lies in attenuating only one of them. Since the interference effect is due to the combination of the two signals, reduction or eliminating of one will suffice. The use of traps, filters, and stubs should allow you to eliminate any interference effects encountered which are due to mixed modulation.

### Burst Interference

Fig. 6 illustrates a form of diathermy interference that can be a source of annoyance once it is encountered. Since the 27.22-mc. band is the most popular for diathermy equipment, the problem involves TV sets using the 25-mc. i.f. The cure for this TVI involves complete shielding of the set, as well as filters in the power lines and the antenna input.

**Barkhausen effect:** This effect is usually caused by the horizontal output tube, either a 6BQ6, 6BG6, or 6CD6. Changing the tube will usually eliminate the TVI. However, in some cases, it may be necessary to use an eliminator consisting of a magnet attached to a holder which can be placed over the envelope of the output tube to eliminate the effect. Such an eliminator is commercially available.

**Electric light bulb interference:** This effect, which is quite interesting, is illustrated in Fig. 4. The light bulb which most frequently causes this trouble is the old-type bulb which has a clear glass and a very long filament wire. Many of these are still in use, and they can interfere with TV up to about 100 feet. The effect is usually seen on channels 2, 3, or 4. The author experienced a similar difficulty from a modern light bulb located in a TV lamp on top of the TV receiver. In the event the reader encounters this effect, it is suggested that he investigate such light sources as porch lights, garage, cellar, and attic lights.



## Where High Humidity — High Temperature

are encountered, specify Sarkes Tarzian "Centre-Kooled" rectifier construction. Heavy bakelite core eliminates rectifier-to-chassis shorting. (Ask for information on the conversion Plug-In chassis.) **New replacement guide available at your distributor's.**

**Sarkes  
 Tarzian**

**"Centre-Kooled"  
 SELENIUM RECTIFIERS**

Dept. R4, 415 N. College,  
 Bloomington, Ind.

In Canada: 700 Weston Road, Toronto 9

\*\*\*\*\*  
**Cathode Ray  
 TUBE REJUVENATOR**  
 Fits all makes of picture tubes. Completely automatic. Easy to install, no tools needed. For C. parallel circuits. Your Old Picture Tubes Are Still Useful. List price—\$3.95.  
**TERRIFIC SAVING! 99c**  
**BRAND NEW** each

**TUBES 60% TO 90% OFF LIST! TUBES**

OC3/	6J6	.55	471A	1.19
VR105	6K8	.65	532A	1.19
OD3/	6L6GA	1.05	717A	.99
VR150	6L6M	1.20	722A	.99
1B22	6N7	.70	801A	.19
1A7	6SA7	.49	826	.39
1L4	6SJ7	.54	832A	6.95
2B22	6SK7	.54	836	5.35
2C26	6SL7	.59	837	.29
2C26A	6SN7	.55	841	.29
2D21	6SS7	.75	843	.17
2X2	6SU7	2.49	864	.19
3B22	6Y6	.70	931A	4.75
3D6	7C4	.39	1626	.19
5R4GY	12A6	.55	1633	1.35
5U4	12AH7	1.20	2050	1.35
6AG5	12AR7	.85	2050W	2.35
6AJ5	12C8	.59	5654	1.85
6AK5	12H6	.55	5670	3.25
6AK5W	12L8	.29	5726	1.25
6AL5	12SG7	.75	5749	1.25
6AL5W	12SH7	.59	5751	1.50
6AQ5	22L4	.54	8314	1.70
6AS6	15R	.39	6096/CT	1.75
6BA6	28D7	1.50	7193	.19
6BE6	39/44	.29	9002	.69
6BQ6	114B	.29	9003	1.15
6C4	215A	.09	E1148	.49
6D4	221A	.29	RK34	.99
6H4	316A	.29	VR92	.14
6J4	388A	.59	VT127	.15

**MICROPHONE SUPER-SALE**

- T-44 MIKE—magnetic type consisting of Mike Unit MC-253, Cord CO-287, Plug PL-179 and Jack JK-26 ..... \$1.29
- T-45 MIKE—Carbon Lip Mike ..... 1.95
- T-17 MIKE—Carbon—BRAND NEW ..... 9.75
- TS-13 HANDSET—BRAND NEW ..... 7.95
- T-12—Western Electric Carbon Hand Mike with Cord & PL-68 Plug, BRAND NEW ..... 3.95

**SAVE! SAVE! SAVE!  
 SCR-522 RECEIVERS**

less oscillator assembly, frequency shifter and tubes. Contains all Coils, Transformers, Resistors, Condensers and other valuable parts ..... **\$5.95**  
 SPECIAL! 2 for \$10.00 each

**BC-221 Frequency Meter**  
 Real Value! QUANTITY IS LIMITED—so first come, first served. They are just like new, with original calibration charts. Range 125-20,000 KC with crystal check points in all ranges. Complete with crystal and tubes. **\$139.50**  
 Standard with AC power supply ..... \$159.50  
 MODULATED TYPE with AC Power Supply ..... \$179.50  
 MODULATED TYPE with AC Power Supply ..... \$199.50  
 Limited quantity of BRAND NEW MODULATED FREQ. METERS ..... \$210.00  
 These Frequency Meters are factory treated, checked for frequency alignment and GUARANTEED.

**HEADSETS**

- HS-23 high impedance. BRAND NEW with ear pads. .... \$4.65
- HS-33 low impedance. BRAND NEW with ear pads, cord and PL34 plug ..... 5.65
- HS-33, used ..... 1.89
- CD-307A Cords, 6 ft. NEW ..... \$1.49
- HS-16 high impedance—used ..... .98

**SCR-274N COMMAND and ARC-5 EQUIPMENT**

RECEIVERS		USED	EXCELLENT	NEW
BC-453—190 to 550 KC.			\$24.95	\$49.95
BC-454—3 to 6 MC			14.95	24.95
BC-455—6 to 9 MC			12.95	18.95
1.5 to 3				29.95
TRANSMITTERS				
A-958—2.1 to 3 MC				24.95
BC-457—4 to 5.3 MC			8.95	12.95
BC-458—5.3 to 7 MC				12.95
EC-459—7 to 9.1 MC				24.95
RT-15 ARC 5—50 to 800 KC				24.95
ADDITIONAL EQUIPMENT				
AC-456 Modulator				6.25
BC-450 Control Box (3 Receiver)				1.95
BC-451 Control Box (Transmitter)				1.79
BC-442 Relay Unit (ANT)				5.49
Flexible Shafting with gear to fit receivers				1.95
3 Receiver Rack				1.79
Shock Mount Receiver Rack				2.29
2 Transmitter Rack				1.25
Single Transmitter Rack				2.39
DM-33 Dynamotor for Command Set				3.49
				3.95

**MINIMUM ORDER \$2.00**  
 Immediate delivery—send 25% deposit on C.O.D. orders. If sending full remittance, allow for postage and save C.O.D. charges. All shipments F.O.B., N.Y.C. warehouse. (N.Y.C. residents add sales tax.)

**PLATT ELECTRONICS CORP.**  
 Dept. A, 489 Broome St., N. Y. 13, N. Y.  
 PHONES: WO 4-0827 and WO 4-0828  
 \*\*\*\*\*

continuous duty. It uses a felted cone and a 3.2 ohm voice coil which is specially treated to provide high resistance to moisture absorption.  
 At the present time the "Fabulous Four" is being offered to manufacturers exclusively.

a custom-made speaker, the "Cate-noid."  
 The new unit is a true horn, flaring

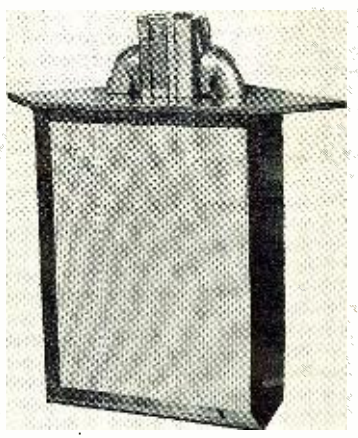

**AMPLIFIER KITS**

Four new amplifier kits have been introduced by *Triad Transformer Corporation*, 4055 Redwood Ave., Venice, California.

The kits cover the range from 10 watts to 40 watts with the HF-12 delivering 10 watts output, HF-18 "Williamson" type all-triode amplifier delivering 16.5 watts, and the HF-40 auditorium amplifier delivering 40-55 watts. A preamp, featuring a complete record equalizer and new tone control, is also available in kit form as the HF-3.

The kits include all necessary transformers, chokes, sectional chassis, and complete instructions for assembly. A catalogue, TR-54, covering these kits is available on request.

out from the speaker to a mouth fifteen feet across. By folding the horn and utilizing the corner of the room the enclosure has been reduced to a compact size.

**"TREASURE CHEST" UNITS**

The addition of two new "Treasure Chest" furniture models to the "Du-ette" line of compact, two-way speaker systems has been announced by *Jensen Manufacturing Company* of Chicago.

The horn is currently available in blonde birch, walnut, and dark mahogany finishes.

The new models measure 23 1/4" long, 11" high, and 11" deep and weigh 21 pounds. They are available in blonde oak and mahogany finishes. Wrought-iron legs are available as an accessory.

**STROBOSCOPIC DISC**

*Rek-O-Kut Company*, 38-01 Queens Blvd., Long Island City 1, N. Y., is now offering a new stroboscopic disc for checking turntable speeds.

**PREAMP-TONE CONTROL**

*H. A. Hartley Co., Inc.*, 521 E. 162nd St., Bronx 51, N. Y. has introduced a new preamplifier and tone control unit in which the operation of the bass and treble controls has no noticeable effect on the volume level. This feature is

Printed in two colors, each pattern band is alternately red and black. This feature simplifies the location of the correct band pattern being checked. The disc is designed for all record speeds at both 50 and 60 cycles. Complete instructions are furnished on the card.

It is available without charge by writing Avery Yudin at the company.

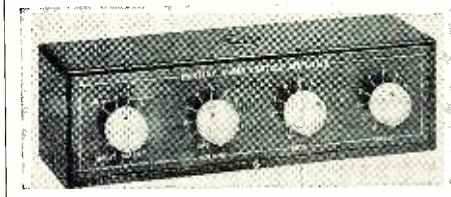

**PRE-RECORDED TAPE**

*Minnesota Mining and Manufacturing Company* of St. Paul has just released a tape recording of the "Desert Suite" from the score of Walt Disney's "The Living Desert."

said to eliminate the need for readjusting the volume control after every modification in tone response.

Release copies of this recording are available for tape recorders operating at 3 3/4, 7 1/2, and 15 ips. The recording is being handled on a nation-wide basis by music stores, photo shops, appliance and hi-fi dealers. —50—

The bass and treble controls are independent of each other, are continuously variable, and permit up to 36 db boost at 40 cycles, 13 db boost and 16 db attenuation at 10,000 cycles. With controls at level positions, the response is flat from 20 to 50,000 cycles. Distortion content is less than .1%.

**DIXIE AUDIO FESTIVAL**

**THE Dixie Audio Festival** will be held in Atlanta, Georgia, at the Henry Grady Hotel, August 27, 28, and 29.

The audio control amplifier is housed in a metal cabinet suitable for panel mounting or remote control applications. The cabinet measures 11"x3"x3".

The Festival will be a showing of high quality phonograph, radio, and tape recording equipment by representatives of various manufacturers. The products of some fifty firms will be shown and demonstrated.

**CORNER HORN**

*Lee Laboratory of Electronic Engineering, Inc.*, 413 L Street, N. W., Washington 1, D. C. is now marketing

Friday, August 27, will be reserved for business meetings between distributors, dealers, and manufacturers. The show will be open to the public on Saturday and Sunday from 1 to 10 p.m.  
 Further details on this event are obtainable from the Dixie Audio Festival Association, 1145 Peachtree St., N.E., Atlanta, Georgia. —30—

**SAFER**  
...and less expensive

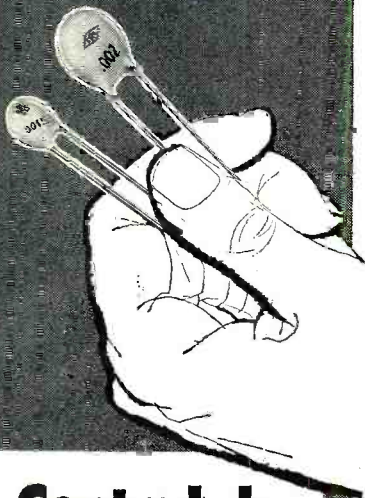

**Centralab**  
Type DD 1000-VDCW  
Ceramic  
Disc Capacitors

Now a complete line of  
"standard" disc capacitors —  
but look at these advantages

- There's no danger of an overload blowing out a Centralab DD Disc. Rated 1000 VDCW, every one is 100% tested before shipping — at twice rated working voltage. (2000 VDC)
- Tolerances are stated honestly. You can install Centralab DD Discs with complete confidence.
- You can't beat Centralab DD Discs for size or price. They're the smallest possible size—and cost only 12¢ net.
- Double coating of Durez provides dependable insulation. Centralab DD Discs operate efficiently up to + 85° C.

Play safe — use Centralab 1000-VDCW DD Discs regularly, even when you replace discs under 1000 VDCW. Stock up at your Centralab distributor.

Send coupon for new Centralab Catalog No. 29 for full details on this and many new Centralab developments.

\*Trademark

**Centralab**

D-3554

Tear out coupon and mail today!

CENTRALAB, A Division of Globe-Union Inc.  
910-H E. Keefe Avenue, Milwaukee 1, Wis.

Send me new  
Centralab Catalog No. 29.

Name.....

Company.....

Address.....

City.....Zone.....State.....

August, 1954

modern cabinet which is available in blonde or cherry mahogany finishes.

**TAPE SPLICER**

Alonge Products, Inc., 163 W. 23rd Street, New York 11, N. Y. has introduced a non-magnetic tape splicer which is so designed and constructed that anyone can make a precision splice in a few seconds.

The principal feature of this new instrument is a cutting arm with three

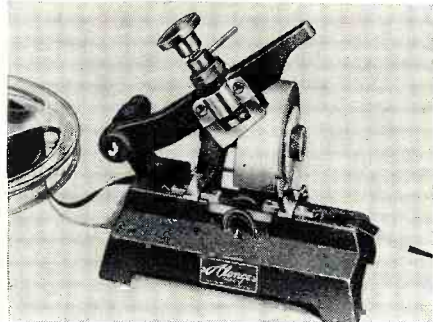

knives. The center knife is directional and can be pivoted and set to cut recording tape at a perfect 90, 67½, or 45 degrees. Two pressure pads, made of non-magnetic spring bronze, hold the recording tape firmly in place while the two side knives cut the splicing tape to the exact width of the recording tape. Two float springs provide static neutralization.

Over-all size of the new unit is 4½"x3½"x3¾". Shipping weight is one pound.

**3-SPEAKER SOUND SYSTEM**

Perfection Electric Company, 2635 S. Wabash Ave., Chicago, Ill. is in production on a compact, 3-speaker unit consisting of one 8" woofer and two 3½" tweeters. The design of the speakers and their placement are said to assure greater high-frequency sound distribution.

The system incorporates a built-in frequency dividing network. The cabinet which houses the system is finished on all four sides so that it can be used on its side or placed on either end in bookshelves, on a table, or on the floor. It is currently available in natural wood, mahogany, or fawn oak finishes.

The system has an impedance of 4 to 8 ohms. Full technical details will be supplied by the company on request.

**SMALL SPEAKER**

The Tube Division of Radio Corporation of America, Harrison, N. J. is now offering a compact, four-inch speaker for use in radios, TV receivers, and other sound equipment.

Measuring only one and a fraction inch in depth and 4½" in maximum diameter, the speaker is built around a high-efficiency type magnet structure that appreciably reduces the magnet materials normally required for the design of a top-quality speaker having comparable power-handling capabilities.

The speaker is rated at three watts

**"COLOR TV**  
**TRAINING SERIES"**  
now appearing in  
**PF INDEX**

the Monthly REPORTER for  
the Electronic Service Industry

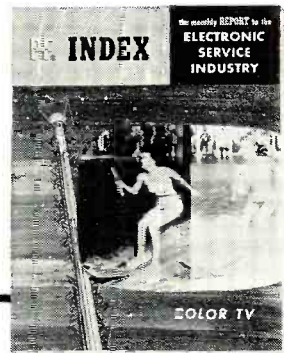

brings you a complete  
education in COLOR TV  
based on practical  
experience with actual  
receivers, and first-  
hand data developed  
exclusively by the  
editorial staff of  
PF INDEX . . . appearing  
month after month. You  
won't want to miss a  
single issue . . . so get

**PF INDEX**

AT YOUR PARTS DISTRIBUTOR

**get it each month**

**only 25¢**

# HARVEY

for HAM GEAR  
In Stock for Immediate Delivery

## Introducing the NEW RADIO SPECIALTY 3 ELEMENT-20 METER ROTARY SHORTBEAM

A new, pre-tuned, efficient 20-meter miniature beam. Lightweight and durably constructed to withstand all weather conditions. Gives top performance.

- Elements: 16 feet from lip to tip.
- Boom: 16 feet.
- Front-to-Back Ratio better than 20db.
- Designed for 52 ohm coax.
- SWR 1:1 at 14,250 kc - 1.3:1 at 14,200 and 14,300 kc.
- Director Spacing: .1 wavelength.
- Reflector Spacing: .15 wavelength.
- Turns with TV rotator.
- 61ST Aluminum used throughout.

Complete and ready for one-man installation ..... **\$59.50**

## New Factory-Wired JOHNSON VIKING II-CD TRANSMITTER



Specifically designed to meet Civilian Defense requirements. This transmitter has been certified to FCDA and is listed by that agency as Certified Radio Equipment.

The II-CD is basically the standard Viking II with the following modifications: Cadmium plated cabinet . . . Modulation limiting system . . . Push-to-talk circuit . . . Continuous coverage from 1.75mc to 4mc. The complete ranges are: 1.75mc to 4mc, 5.2mc to 8mc, 9.8mc to 15mc, 15mc to 21.8mc, and 21mc to 30mc.

Viking II-CD Transmitter No. 240-102-15, complete with tubes less crystals, key and microphone ..... **\$398.00**  
Low Pass Filter ..... 13.50  
"Matchbox" Antenna Coupler ..... 49.85

**Generous Trade-In Allowances  
On Your Present Equipment**

**Anywhere in the world —**

order by mail direct from Harvey. Enclose estimated shipping charge. Excess will be refunded.

NOTE: Prices Net, F.O.B., N.Y.C.  
Subject to change without notice.



# Harvey

RADIO COMPANY, INC.

103 W. 43rd St., N.Y. 36, N.Y. • JU 2-1500

# NEW EQUIPMENT FOR THE AUDIO TECHNICIAN

## AUTOMATIC FM BOOSTER

*Electro-Voice, Inc.*, Buchanan, Michigan is in production on a new automatic FM booster, the Model 3005-FM.

The new unit increases signal strength over 10 times (20 db) and extends the useful range of FM reception. The company's all-electronic



broadband circuit amplifies the signal uniformly, at the antenna, over the entire FM band. It automatically adds gain to any channel selected on the FM receiver.

An integral thermal relay is provided so that the booster may be operated by the receiver "on-off" control without circuit modifications. A "hi-lo" gain switch permits limiting the gain when signals are extra strong.

Bulletin 202, describing the booster in detail, is available on request.

## MAGNECORD RECORDERS

*Magnecord, Inc.*, 225 W. Ohio St., Chicago 10, Illinois has entered the hi-fi consumer market with the introduction of two portable magnetic tape recorder-playback machines in the moderate price class.

The two portable units are said to be able to perform all of the major functions usually found only in higher priced machines. Ease of operation and durability are major features of the new 35 pound portables. The basic difference between the two units, the M-30 and the M-33, is in sound amplification. The M-33 has a built-in amplifier.

Both machines will record or play back 30 minutes of full-range audible sound. Extension reels make it possible to double this time. The units are easily detachable from carrying cases for installation in standard or custom-built cabinets.

## MASCO AMPLIFIER

*Mark Simpson Manufacturing Company*, Long Island City 3, N. Y. has added the Model CM-8 amplifier to its Masco line.

The 8-watt unit has a harmonic distortion of less than 1% at 8 watts. Frequency response is 20-20,000 cps ±

1 db. The controls include a three-position selector switch (radio, phono, "a.c.-off"), bass and treble tone controls, magnetic-crystal input selector slide switch, and volume control.

The unit features inputs for magnetic phono, crystal phono, and a radio tuner. It also includes an auxiliary a.c. socket. The front panel is removable for custom installations.

## ASTATIC CARTRIDGE

*The Astatic Corporation*, Conneaut, Ohio is now offering its Model 51-1-J "Con-Am" (constant amplitude) pickup cartridge to the public.

The new unit features an extremely simple, direct mechanical drive system with low mass of moving parts which reduces needle talk. In addition the cartridge is said to eliminate hum pickup from magnetic fields. Since the cartridge contains no magnets it can be used over a steel turntable without affecting needle pressure.

Response is 30 to 15,000 cps on the RCA 12-5-51V test record. Output is .70 volt nominal on the RCA 12-5-31V record at 1000 cps.

## THE "COMPANION"

*University Loudspeakers, Inc.*, 80 S. Kensico Ave., White Plains, N. Y. is now offering a new, compact, three-way speaker system which has been tradenamed the "Companion."

Designed as a three-way tonally-balanced system employing combination woofer-mid-range and tweeter reproducers together with an inductance-capacitance type dividing network, the unit is housed within a specially engineered, balanced, double-port bass chamber.

The system incorporates a "Diffusi-



cone-8" and a Model 4401 tweeter system with an electrical crossover network employed to provide electrical separation of the low and middle frequencies from the high frequencies.

The "Companion" is housed in a

**RADIO & TELEVISION NEWS**



## NATIONAL "S" METER

2" Sq., Illuminated Scale, calibrated in DB, 0-1 Ma movement. **\$2.95** EA.

2 for \$5.50

### MINIATURE METER

0-500 Microamps, 1 3/8" scale, Bakelite case. An accurate tiny meter ideal for GP meters, SWR bridges, etc. **\$3.95** EA.

3 for \$9.95

### PLATE TRANSFORMER BARGAIN

Made by Chicago Trans. Co. 3000-0-3000 Volts RMS, @ 300 Ma. Primary 115V., 60 Cy. Type FS. Full case. Pri. tapped to reduce Voltage to 2500 V. RMS. BRAND NEW BOXED IN ORIGINAL CASES. A TERRIFIC VALUE AT.....\$29.95 ea.

### MOBILE DYNAMOTORS

Made by Pioneer. Input 6 VDC. Output 400 V. @ 175 Ma. Mounting bracket attached. Removed from equipment. All checked and guaranteed. This is your chance to get a small rugged Dynamotor at only.....Ea. **\$12.95**

### WESTON METERS

0-150 VAC Rectifier type.....	Model 301	\$7.95
0-100 V.D.C. (1000 ohms/v).....	"	5.95
0-10 Volts DC (1000 ohms/v).....	"	5.95
0-1 Ma (KV Scale).....	"	5.95
0-50 Ma DC.....	"	5.95
0-150 Ma DC.....	"	5.95
0-1.5 Mills DC.....	"	5.95
0-200 Microamps (Spec. Scale).....	Model 731	7.95
0-1 Ma (0-100 Scale).....	"	6.95

### PANEL METERS

GOV'T SURPLUS, G.E., WESTINGHOUSE, WESTERN ELECTRIC, SIMPSON, ETC.

<b>2" METERS</b>		<b>3" METERS</b>	
100-0-100 Microamp \$5.95	0-500 Microamps .. \$5.95	0-80 ma DC..... 3.49	0-50 Mill. .... 4.50
0-15 ma DC..... 3.49	0-50 Mill. .... 4.50	0-200 Microamps .. \$6.95	0-150 Volts AC..... 6.95
0-400 Microamps .. \$6.95	0-150 Volts AC..... 6.95	0-500 Microamps .. 5.95	0-20 Amp RF..... 6.95
0-200 Milliamp .. 4.50	0-750 Volts DC..... 5.95	0-250 Milliamp .. 4.50	0-15 Volts DC..... 4.95

MANY OTHER METERS IN STOCK. PLEASE WRITE YOUR REQUIREMENTS.

### WESTON FREQUENCY METER

Model 814. 350 to 450 cycles, 100 to 125 Volts. Regular Price \$100.00.

Our Price, **\$29.95** EA. Brand New .....

### OIL CONDENSERS

4 MFD-600VDC \$ .95	10 MFD-2000VDC \$6.95
10 MFD-600VDC 1.50	12 MFD-2000VDC 7.95
2 MFD-1000VDC .95	12 MFD-2500VDC 3.95
3 MFD-1000VDC 1.25	4 MFD-2500VDC 5.95
12 MFD-1000VDC 2.95	2 MFD-3000VDC 4.95
15 MFD-1000VDC 3.50	4 MFD-3000VDC 5.95
3 MFD-1500VDC 2.65	5 MFD-4000VDC 1.50
5 MFD-1500VDC 2.85	1 MFD-4000VDC 2.75
6 MFD-1500VDC 2.95	4 MFD-4000VDC 12.95
10 MFD-1500VDC 3.75	15 MFD-5000VDC 49.50
15 MFD-1500VDC 4.50	1 MFD-7500VDC 1.75
2 MFD-2000VDC 2.25	3 MFD-8000VDC 24.95
3 MFD-2000VDC 2.95	3 MFD-20KV 49.95
4 MFD-2000VDC 3.85	.00025 MFD-25KV 5.50
6 MFD-2000VDC 4.95	24 MFD-240VAC 4.95
	5 MFD-60VAC 2.95

### G. E. RELAY CONTROL

(Ideal for Model Controls, Etc.)

Contains a sigma midget 8,000 ohm, relay (trips at less than 2 MA), high impedance choke, bimetal strip, neon pilot and many useful parts. The sensitive relay alone is worth much more than the total. **\$1.25** Each 10 for **\$9.90** low price of.....

### R.F. AMMETER

2 1/2" General Electric 0-4 amps RF, Internal Thermo.....Ea. **\$3.75**

2 for \$6.95

### WIRE WOUND RESISTORS

Stock too long to list. We can supply most sizes, so order what you need.

10 Watts. From 1 Ohm to 70K Ohms.. Ea. \$ .15
20 Watts. From 4 Ohms to 50K Ohms.. Ea. .20
25 Watts. From 1 Ohm to 100K Ohms.. Ea. .30
50 Watts. From 5 Ohms to 100K Ohms.. Ea. .40
100 Watts. From 50 Ohms to 100K Ohms.. Ea. .50

### EIMAC VACUUM

<b>CONDENSERS</b>	<b>SOLA CONSTANT VOLT TRANSFORMERS</b>
12 MMF 32KVDC. \$10.95	Input 95-135 Volts
50 MMF 32KVDC. 12.95	Output 115V Regulated
	250 VA .....\$33.65

### READ 'N' SAVE BARGAINS

2" NATIONAL "S" Meter, 0-1 Ma movement, calibrated in DB. **\$2.95**

Non-ind resistors. 350, 100 watt..... .55

6 Henry 100 ma chokes..... .25

Heinemann ckt brkr, 5.5 amp, 110 V..... .95

Var. ceramic trimmer 7 to 45 mmf..... .25

Grile 500 mmf ceramic..... .10 for

15V AC relay SPST 15 Amp contacts..... 1.75

220V AC relay SPST 15 Amp contacts..... 1.75

.01 mmf. 1000 VDC Micacs..... .5 for

.0004 2500 VDC Micacs..... .5 for

.04 600 V Micacs..... .5 for

100,000 ohm, 100 Watt resist..... .45

Flt. Trans. 115V. 60 cy Sec. 10V..... 1.75

Flt. Trans 115V. 60 cy Sec. 6.3V @ 7A..... 1.95

Min. Order \$3.00-25% with Order—F.O.B. New York.

## PEAK ELECTRONICS CO.

66 West Broadway, New York 7, N. Y.  
Phone WORTH 2-5439

## Tracing the Waveform

(Continued from page 61)

design makes the usual disturbance tests in these sections inconclusive. Troubleshooting weak or no sound sometimes takes unnecessary time. Thus one section of the TV receiver where a new approach is needed, is in the audio i.f. amplifiers and the detector circuits. This has been made possible by the standardization of TV receiver production along intercarrier design.

A study of intercarrier theory shows that as a result of frequency conversion at the video detector involving the video i.f. signal, a vertical sync pulse is present as an AM component in the 4.5 mc. intercarrier audio i.f. signal. Fig. 5 shows waveforms of probe-demodulated signals taken at the ratio detector input of a typical TV receiver. Their similarity to the video signal is obvious.

Such being the case, it is then possible to signal trace the intercarrier audio amplifier circuit up to the detector input with demodulator probe in much the same way as it is done in the video i.f. amplifier. Furthermore, certain problems characteristic of audio i.f. and discriminator circuits can now be serviced more systematically.

A frequent source of trouble is the tuned circuit condenser sandwiched into the base of the audio i.f. transformers. This condenser tends to break contact with its respective coil, thus detuning the circuit. The complaint, then, is weak or no sound. Often the weak sound is accompanied by a buzz.

The defective stage is not readily localized since the tube operating conditions (other than frequency) have not been changed. A ready way of handling this problem is to make a pass through all the tuned circuits of the audio i.f. system with the demodulator probe. A marked loss of amplitude will indicate the defective circuit. Where the condition is intermittent, the demodulator probe may be left connected in a strategic position to monitor the signal.

Don't overlook the fact that the discriminator secondary is "hot" at both ends. The author almost overlooked an intermittent discriminator transformer in a *Spartan* chassis 26SD160 because he monitored it only on one side of the secondary. When C<sub>1</sub> (see Fig. 5) opened, the signal amplitude at one side of the transformer secondary fell to zero, while the signal at the other side was affected only to a minor degree.

It should be clear that signal tracing is admirably suited for servicing obscure troubles in the r.f. and i.f. circuits. The usual methods still prevail for ordinary troubles. The tube puller and his predecessor, the screwdriver mechanic, are still with us. Their methods suffice for many complaints. But when a "dog" is brought into the shop and the going gets rough, if necessary, don't hesitate to reach for the demodulator probe. You won't regret it. —30—

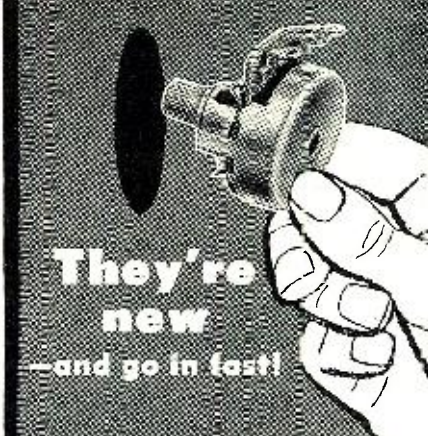

**They're new —and go in fast!**

## Centralab Snap-Tite\* Replacement Controls

### Speed servicing of "hidden" or rear-end TV volume controls



Two fingers are all you need to install a Snap-Tite. Just push it into the chassis mounting hole — it snaps into place.

You need no tools — no nuts, lock-washers, or other hardware.



Six spring clips grip panel for positive, non-twisting mounting.

Shaft is molded, high strength polystyrene, fingertip knurled and slotted for screw-driver adjustment. Extends 1/2" from face of mounting surface



Snap-Tite replaces any "short-shaft" standard control — and, at 45¢ net, costs you about 35¢ less!

You have less stock to carry — ten values replace 75% of current rear-end TV controls.

Order a supply of Centralab Snap-Tite Replacement Controls today from your Centralab distributor

Send coupon for new Centralab Catalog No. 29 describing this and other new Centralab developments.

\*Trademark

# Centralab

E-3454

TEAR OUT COUPON AND MAIL TODAY!

CENTRALAB, A Division of Globe-Union Inc.  
910-H E. Keefe Avenue, Milwaukee 1, Wis.

Send me new Centralab Catalog No. 29

Name.....  
Company.....  
Address.....  
City..... Zone..... State.....

**NOW!**



# COLOR TV COVERAGE IN PHOTOFACT!

**FIRST COLOR TV FOLDER**

the **RCA Model CT-100**

**OVER 40 FACT-PACKED PAGES**

It's a terrific **FIRST**—complete data based on actual analysis of the production model...full schematics, block diagrams, parts lists, tube placement, alignment, wave forms, set-up adjustments—*everything* you want to know about this actual color set—information you want and need to get out in front on Color TV!

**here's how to get it!**

**1** Included with Photofact Folder Set No. 252—out Sept. 1st. You get it in *addition* to over 100 pages of regular Photofact TV-Radio coverage. Get the Color TV Folder at the regular price of the complete Set...Only \$1.75!

**2** You can buy the Color TV Folder separately if you wish. Available from your distributor for only \$1.00!

**GET IT EITHER WAY FROM  
YOUR PARTS DISTRIBUTOR**

**RESERVE YOUR  
COLOR TV FOLDER  
TODAY!**

serves as an indicator which permits the operator to adjust the gain in the system to the characteristic sound level of the subject.

The system for discrimination between the sound pulses produced within the artery and other noise signals is based on the fact that the sounds within the artery are accompanied by corresponding slight increases in pressure within the arm band. The coincidence circuits reject all sound pulses that do not coincide with the necessary pressure pulses. As a further protection, these circuits prevent actuation of the relay system by any sound pulse that is not followed by a similar pulse within one-half of a second.

The blood pressure measurement system has been used on many different humans for periods ranging from an hour to as long as 21 hours. Generally, it was said, the patients were not upset by the apparatus. Operators have found the equipment simple to adjust and anesthetists have called the instrument a blessing, for it tells them in simple, numerical form, in continuous fashion, the exact condition of the patient during surgery.

**THE WAVE OF PERMIT** cancellations and realignment of applications continued to stall grants. As of this writing, all those applicants listed directly below received authorizations to proceed. . . . . L. W.

## NEW TV GRANTS SINCE FREEZE LIFT

Continuing the listing of constructive permits granted by FCC since lifting of freeze. Additional stations will be carried next month.

STATE	CITY	CALL	CHANNEL	FREQUENCY (mc.)	POWER* (Video)
Maine	Bangor	WTWO	2	52-60	1.4
Michigan	Flint	.....	12	204-210	316
New York	New York City	WNYC-TV	31	572-578	251
Oklahoma	Ardmore	KVSO-TV	12	204-210	27.5
West Virginia	Oak Hill	.....	4	66-72	49
Wisconsin	Wausau	.....	7	174-180	100.5
Texas	San Antonio	KCOR-TV	41	632-638	18.6

### NEW CALL LETTER ASSIGNMENTS

Illinois	Chicago	WOPT	44	650-656
Wisconsin	Green Bay	WFRV-TV	5	76-82

\*ERP = (effective radiated power, kw.) . . = Call letters to be announced

## NEW TV STATIONS ON THE AIR

(As of July 25, 1954)

The following new stations bring the lists published in previous issues up to date.

STATE, CITY	STATION	CHANNEL	FREQUENCY RANGE (IN MC.)	VIDEO WAVELENGTH (IN FT.)	VIDEO POWER* (IN KW.)
Alabama	Decatur	WMSL-TV	23	524-530	21
California	San Francisco	KQED†	9	186-192	30
Indiana	Indianapolis	WISH-TV	8	180-186	316
	Terre Haute	WTHI-TV	10	192-198	316
Michigan	Traverse City	WPBN-TV	7	174-180	51
Montana	Missoula	KGVO-TV	13	210-216	60
North Dakota	Valley City	KXJB-TV	4	66-72	100
Ohio	Cincinnati	WCET†	48	674-680	19
Texas	Corpus Christi	KVDO-TV	22	518-524	21
Wisconsin	La Crosse	WKBT	8	180-186	100
Canada	Winnipeg	CBWT	4	66-72	56.2

KOY-TV, channel 10, Phoenix, Arizona, has gone off the air; WECT-TV, channel 18, Elmira, New York, has been temporarily suspended.

The frequency of the video carrier = 1.25 + channel lower freq. limit. Total number of TV stations now on the air in U.S.: 391 (133 of which are u.h.f.).

†Educational.

\*From Station CP application.

the pressure within the arm band to increase. As soon as the pressure in the band exceeds the diastolic value (heart expansion) the microphone begins to pick up sound within the artery. This sound reaches a maximum and decreases, disappearing after the pressure in the band exceeds the systolic point (heart's contraction). By means of a system of amplifiers and relays, the pulses picked up in the microphone actuate two solenoid valves in the air system which open to connect the system to the proper pressure-indicating gauges at the diastolic and systolic points. The valves close almost immediately after opening so that the contracting and expanding pressures, now converted by a transducer to electrical signals, remain registered on indicating meters until a new measurement cycle begins.

The amplifier and relay circuit were said to be arranged in such a way that when the microphone receives the initial sound from the artery, the first valve opens, permitting the adjacent gauge to register the expansion pressure. Since it is not possible to determine the point at which sound disappears until that point has been passed, the pressure is therefore carried beyond the contracting point and allowed to decrease slowly until the contracting pressure is reached again.

The microphone-amplifier combination selects sound pulses of the required amplitude and frequency content, and converts them into electrical pulses of uniform amplitude and duration to actuate the relay and control circuits. Because the sound originating in the artery is considerably attenuated by the time it emerges from the tissues, the mike-amplifier circuit must be quite sensitive to low-amplitude pulses. At the same time it must minimize unwanted signals originating from microphone frictional noises and random sounds in the immediate vicinity. By improvement of the microphone, by shaping the amplifier pass-band characteristics to the restricted band of signals, and by development of special coincidence and verification circuits, it was found possible to construct a sensing device which sharply outlines the end points and is virtually undisturbed by spurious signals.

A crystal microphone with a good response at the lower audio frequencies was incorporated into a standard stethoscope chest piece. The mike is thoroughly shielded to keep electrical noise out of the amplifier input. The output of the mike is applied to a three-stage conventional RC-coupled amplifier having a gain of approximately 80 decibels. This is followed by a low-pass filter.

The output of the filter is introduced into a pulse-stretching and equalizing circuit in the form of a monostable multivibrator. A neon tube connected to the plate of the normally-nonconducting triode of the multivibrator flashes each time a pulse triggers the multivibrator. This neon tube, located on the instrument panel,

# N.J.R.T. TUBES 70% to 90% OFF LIST

## GUARANTEE

ALL NJRT TUBES ARE BRAND NEW AND FULLY GUARANTEED FOR ONE YEAR

Type	Price	Type	Price	Type	Price	Type	Price	Type	Price
1A7GT	.45	6AL5	.39	6BZ7	.95	6W4CT	.45	12V6GT	.50
1B3GT	.67	6AQ5	.39	6C4	.39	6W6GT	.45	12X4	.35
1H5GT	.38	6AQ6	.36	6CB6	.45	6X4	.39	19BC6G	1.15
1L4	.50	6AQ7	.68	6CD6G	1.15	6X5GT	.35	19T8	.75
1N5GT	.62	6AR5	.45	6F6	.45	7E6	.40	25BQ6GT	.75
1R5	.48	6A55	.50	6H6	.53	7X6	.58	25L6GT	.45
1S5	.40	6AT6	.39	6J5	.40	7L7	.77	25W4GT	.45
1T4	.48	6AU4GT	.70	6J6	.50	12AL5	.40	35A5	.49
1U4	.48	6AU5	.82	6K6GT	.39	12AT6	.35	35B5	.38
1U5	.40	6AU6	.45	6L6	.62	12A7	.65	35C5	.38
1X2	.65	6AV6	.39	6R7	.49	12AUG	.38	35L6GT	.45
3A4	.45	6AX4GT	.59	6S4	.39	12AUV	.55	35W4	.45
3Q4	.48	6BA6	.40	6S8GT	.51	12AV6	.50	3SZ5GT	.45
3Q5GT	.48	6BA7	.57	6SA7GT	.41	12AV7	.60	45	.53
3S4	.48	6BC5	.49	6SB7Y	.76	12AX4GT	.55	50B5	.41
3V4	.50	6BD6	.45	6SC7	.59	12AX7	.55	50C5	.41
5U4G	.55	6BE6	.39	6SD7GT	.39	12BA6	.40	50L6GT	.59
5Y3GT	.39	6BF5	.55	6SK7GT	.39	12BA7	.57	70L7GT	1.07
5Y4G	.39	6BG6G	1.20	6SL7GT	.49	12BE6	.41	76	.42
6AB4	.42	6BH6	.45	6SN7GT	.55	12BH7	.65	81	1.25
6AF4	.92	6BJ6	.41	6SQ7GT	.37	12BY7	.65	117L7GT	1.19
6AF6	.75	6BK7	.89	6T8	.75	12BZ7	.65	117P7GT	1.39
6AG5	.49	6BL7GT	.65	6U7	.56	12SL7GT	.49	117Z3	.39
6AH4	.67	6BQ6GT	.77	6U8	.59	12SN7GT	.50	117Z3	.39
6AK5	.59	6BQ7A	.92	6V6GT	.45	12SR7met	.55	807	1.25

T.V. PIX TUBE BRIGHTENER

**\$1.39**

HI-PO TV RECTIFIER TUBES LAST LONGER

Makes Picture brighter, larger

HI-PO 567 TO REPLACE 5U4G..... **\$1.39** | HI-PO 6S78 TO REPLACE 6SN7GT..... **\$1.95**



## NEW JERSEY TELEVISION SUPPLY CO.

Sole Distributor of NJRT Tubes

906B WESTFIELD AVE., ELIZABETH, N. J. EL. 5-3900

## Mobile Antennas

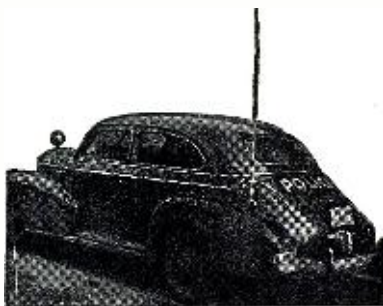

Engineered by Premax

## Increase Signal Strength

Premax Center Loaded Antennas for mobile installations offer a most economical rig that will materially increase signal strength. Can be used for 10 to 75 meters by shorting out. Ask your radio jobber or write direct.

**PREMAX PRODUCTS**  
DIVISION CHISHOLM-RYDER CO., INC.

5423 Highland Ave.

Niagara Falls, N. Y.

PEE-WEE "HIDE-A-WAY" ANTENNA

**79¢**

no bigger than a half dollar.....

**FREE FIVE 1L4 TUBES INDIVIDUALLY CARTONED LIST \$11.25 WITH EVERY ORDER OF \$25.00 OR MORE.**

Many 7 volt types not listed. All tubes individually boxed. For orders under \$10 add \$1 handling charge. Tubes offered subject to prior sale. Prices subject to change. All orders shipped F.O.B. 25% deposit on c.o.d. shipments.

SEND FOR FREE TUBE LISTING.

Tremendous Opportunities in  
**COIN TV**  
and **COMMERCIAL TV**

**TRANSVISION**

offers

**SPECIALLY DESIGNED TV SETS**

with important Patented Features for use in

**Hotels, Motels, Hospitals, and Public Locations**

Also:

**Master Amplified TV Antenna Systems**

Get details now

TRANSVISION, INC.  
NEW ROCHELLE, N. Y.

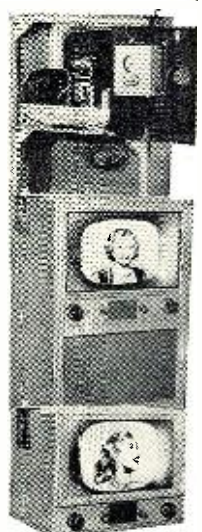

MAIL THIS COUPON TODAY

TRANSVISION, INC., NEW ROCHELLE, N. Y.  
Dept. RNB

Rush full details on COIN OPERATED TV.

Name \_\_\_\_\_

Address \_\_\_\_\_

City \_\_\_\_\_ State \_\_\_\_\_

## Control frequency drift

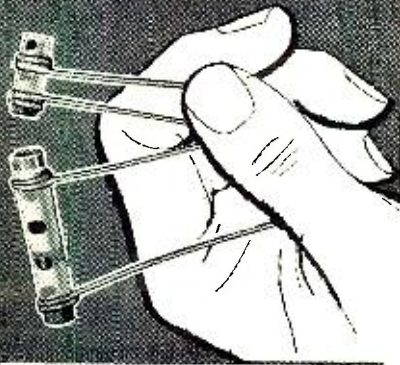

...with these two new  
**Centralab**  
 Temperature-Compensating  
 Tubular  
 Ceramic Capacitors

- (1) N-330 for intermediate temperature rise.
- (2) N-1500 for higher temperature rise.

Part of the industry's most complete, most flexible line of TC tubulars. Let you get additional TC values without combining two or more standard capacitors.

Manufactured to extremely close capacity tolerances.

Meet JAN specifications for military use. Color coded in compliance with RETMA and JAN specs.

Special lacquer insulation keeps lag factor to minimum, when temperature variation reacts on capacitance. Operate at temperatures up to + 85° C.

Packaged one per envelope with complete data, five envelopes per carton.

**NOW ALL T.C. CAPACITORS ONE UNIFORM PRICE**

Use Centralab N-330 and N-1500 TC Tubulars as replacements in existing sets — or in new sets where drift is a problem. Stock up at your Centralab distributor.

Write for new Centralab Catalog No. 29 for details on these and other new Centralab products.

# Centralab

D-3654

Tear out coupon and mail today!  
 CENTRALAB, A Division of Globe-Union Inc.  
 910 E. Keefe Avenue, Milwaukee 1, Wis.

Send me new  
 Centralab Catalog No. 29.

Name.....  
 Company.....  
 Address.....  
 City..... Zone..... State.....

against the engineers who helped to set up the present allocation plan. He didn't feel that we have all the answers now for an immediate change-over to the ultra-highs.

FCC Headman Hyde expressed the same views during the Senate investigation. "There is no magic solution to the problem," he told the probers.

Defending intermixture in the same market, Hyde said: "Technically it is the most efficient way of allocating the scarce and precious frequency space to maximize the number of assignments."

Commenting on the action pending to sanction satellites and boosters which might cover shadowed areas, Chairman Hyde told the committee that petitions for such services were being studied carefully. Such signal amplification techniques were not prescribed originally, he explained, because the Commission was primarily concerned with the basic allocation chart; it was not concerned with intermediate conditions.

V.H.F. BROADCASTERS were deeply disturbed by the demands for moving over to the upper channels and also the sharp criticism speared in their direction by what they called... "paper operators" and "arm-chair colonels"; those who had no broadcast experience and were simply opportunists.

AS THE SENATORIAL group grappled with the volumes of briefs submitted by every segment of industry, other members of the Senate were asked to consider two bills (one of which would amend the Communications Act, and offer relief to the u.h.f. situation). One bill, submitted by Senator Bricker, would give the commission power to regulate the networks, where it was said the bottleneck now obtains. The other, proposed by Senator Johnson, would eliminate the 10% excise tax on u.h.f. sets, combos, and allied components.

A SPECTACULAR DEVELOPMENT in the electronic art was unveiled recently at the Material Testing Laboratory of the Bureau of Standards in Washington, when an instrument which automatically detects changes in the physiological condition of a patient on the operating table was shown. Describing and demonstrating the device, known as the physiological monitor, Dr. A. V. Astin, NBC director, and Dr. George M. Lyon, assistant chief medical director for Veterans Administration research and education, said that for the first time it has become possible to measure changes in a patient's blood pressure, heartbeat, and respiration as they occur and indicate this information on a panel for interpretation by surgeon or anesthetist.

In the instrument, a microphone is located at the point of observation over the brachial (upper arm) artery. Every three minutes a valve of an air supply automatically opens, allowing

## New 4-Speed Magnemite



### for Unmatched Versatility in Field Recording!

Designed for nature sounds, music, street sounds, interviews, conferences, courtroom reporting, missionary work and field reports. All of these may be recorded on a single 4-speed portable, battery-operated spring-wound tape recorder. Features quick speed change with automatic equalization.

Model 610 EM meets both primary and secondary NARTB standards and operates at tape speeds of 15, 7½, 3¾, 1⅛ ips. Records and plays back frequencies up to 15,000 cycles. Model 610 DM operates at tape speeds of 7½, 3¾, 1⅛, ⅛ ips.

These tiny recorders weigh only 17 lbs. with self-contained batteries that last 100 operating hours and include built-in monitoring and headphone playback facilities. Designed for extreme simplicity of operation. Meets the most grueling field tests. May be operated anywhere. Measures only 7 x 10 x 11 inches.

Write for complete technical information and direct factory prices to Dept. RT

## AMPLIFIER CORP. of AMERICA

398 Broadway, N. Y. 13, N. Y.

\*U.S. Reg. U.S. Pat. Off.

### Columbia's 4★ Specials!

#### ★★★ Assorted Resistors—New!

Long pig-tails. American made—not Japanese.  
 Kit of 1,000 ..... \$7.50  
 Kit of 500 ..... 4.25  
 Kit of 100 ..... .98  
 Kit of 50 ..... .65

#### Oil-Filled Condensers

All Brand New!  
 8 MFD @ 600 VDC. \$ .89  
 2 for ..... 1.75  
 8 MFD @ 1,000 VDC..... 1.89  
 2 for ..... 3.50  
 10 MFD @ 600 VDC..... 1.49  
 2 for ..... 2.79  
 8 x 8 MFD @ 600 VDC ..... .95

#### ★★★ New Sigma Relays

DPDT. Hermetically sealed octal base. No better values!  
 15,000 OHM. Each. \$2.99  
 2 for only..... 5.00  
 5,000 OHM.  
 Polarized. Ea... 1.99  
 3 for..... 5.00

#### SCR-518 UHF Electronic Absolute Altimeter

Terrific for conversion to 420 MC and citizen's bands. Consists of transmitter, receiver, indicator, power supply, control boxes, cables with plugs, mounts, etc. Complete less tubes. BRAND NEW. Never before priced so low.  
**ONLY ..... \$19.95!**

#### ★★★ Western Electric Handset

With P-1 button. Like new. Special this month only. Each. .... \$2.95

#### ★★★ AUGUST SPECIAL! Command 40 meter 6-9MC RECEIVER with tubes .... \$3.95

New 7-Ft. Collapsible Antenna. Motor driven with base. .... \$1.29

#### T-17 MIKES—\$2.95

Used. Each.....

#### ★★★ ARB Receiver

Freq. 195-9050 Kc. Covers Beacon, Marine, Broadcast, 80, 75, and 40 Meters. Loop input or single wire. Motor driven band switching. Can be used as complete remote control. Excellent condition... **\$27.50**

#### 2 Meter or 220 Band Variable Transmitter

Freq. 95-210 MC. 50 W. output R.F. contains 2-832, 2-518, 2-6C4, 1-6X5, 1-6V6, 3-6AC7, 1-831 photoelectric cell. 2-24 V. motor blowers, etc. Summer giveaway. Like new..... **\$17.95**

#### Free Crystal Catalogue Sheet

A raft of frequencies and holders for ham, novice and commercial use. SEND FOR IT!

**WANTED! BUYERS WHO MEAN BIZ!**  
 Get on our mailing list to receive FREE copies of our famous Best Buy Bulletins!

## COLUMBIA ELECTRONICS

2251 W. Washington Blvd. Los Angeles 18, Cal.  
 All orders F.O.B. Los Angeles • 25% deposit required  
 • DEALER INQUIRIES INVITED • Min. order \$3.00

**Spot Radio News**  
(Continued from page 20)

that during the first four months of this year, factory inventories were 35% v.h.f.-u.h.f. sets, but only 22% of the sales were for these models; thus production is still ahead of sales.

In response to the question—why all-out u.h.f. sets are not being made—McDaniel said that the answer is purely one of economics. In his opinion, whenever a manufacturer comes to the conclusion that the market for the high-band sets is big enough to afford an advantage to one who markets a u.h.f.-only chassis, such a model will be made and sold. As yet, no one has made that decision, and presumably the reason is that the cost saving is too small in terms of the present market. (One manufacturer noted that an ultra-high set capable of tuning in all of the channels with maximum efficiency could cost up to \$175 more than current combo types.)

Replying to the complaint that sensitivity is lacking in presently-available models, RETMA's chief said that sets now being made are of a quality as high as can reasonably be expected in the present state of the art. To explain this statement, he offered a report on receivers and converters recently completed by a lab in the east. Averages of sensitivity for channels 2 to 6 were disclosed as 91.5 decibels; for channels 7 to 13, 86 decibels, and for the u.h.f. band (channels 14 to 83), 80 decibels. To offset the loss in sensitivity indicated, radiated power would have to be quadrupled. Or, he added, a more sensitive chassis might be made, but at an increase in price; a move that is not justifiable at the present time.

IN CHICAGO, at the annual meeting of the broadcasters, Madame Commissioner Hennock added her support for an exodus to the high bands. She felt that the step should be taken now, but five or ten years could be allowed for completion of the transition.

She said that she was firmly convinced that only the move into the u.h.f. band . . . could save the "patient." In her opinion, it is urgent that we set our sights on this goal and hold it there. The Commission's hope to achieve a competitive nationwide service through the opening of the higher bands, applying the methods that it was felt would bring TV quickly to everyone, has boomeranged, Miss Hennock declared. "It has become painfully apparent that to continue on the course we embarked on when the freeze was lifted, will result in a TV service to the same 12 v.h.f. channels that have been considered inadequate for a nationwide service," Madame Commissioner continued.

Commissioner George Sterling bluntly challenged his colleague's view, saying that it represented an indictment

August, 1954

**8MM 8MM 8MM**

# MOVIES

ON

# APPROVAL

**FREE CLUB MEMBERSHIP**



If you want to receive your films on approval—with the right to screen them in your own home before you decide whether or not you want to buy them—join our club—MEMBERSHIP IS FREE!

**A**- ADULT films—for sophisticated grown-ups.  
**B**- FAMILY pictures—movies for the entire family.  
**C**- CHILDREN'S movies—comedies for kids.

Most entertaining 8MM VARIETY FILMS for home movie shows. Mail coupon today and we'll send you a 50-ft. 8MM FILM—POSTPAID—ON APPROVAL. (Return film and 25c within 5 days without obligation, if it's not worth more than \$1.50.)

When ordering be sure to specify type of films desired.

**BONICA NEWSREEL CLUB, Dept. RT-1**  
 6516 Selma Ave., Hollywood 28, California

Enclosed find \$1.50, Send me One 8mm Movie.  
 Enclosed find \$4.99, Send me Four 8mm Movies.

I PREFER  A,  B,  C FILMS

Please enroll me as a member of your MOVIE CLUB and send me a reel approximately every month postpaid—ON APPROVAL. If I like the reels I will send my remittance within 5 days after I receive it—otherwise I will return within 5 days (enclosing 25c) without obligation. I may cancel my membership at any time.

NAME.....Age.....  
 ADDRESS.....Zone.....  
 CITY.....STATE.....

**MAIL**  
**Coupon**

**RADIO and TELEVISION ELECTRONICS**

 in all Technical Phases  
 New Classes (Day and Evening) Start 1st of Dec., Mar., June, Sept.  
 Free Placement Service for Graduates  
 For Free Catalog write Dept. RN  
**RCA INSTITUTES, INC.**  
 A Service of Radio Corporation of America  
 350 WEST 4TH ST., NEW YORK 14, N. Y.

**\*Pat. Pending**  
**ONLY \$4.95**  
 Ppd. or C.O.D. + Chgs.

**THE NEW TV DYNATRACER**

- TRACES TV SIGNALS AND VOLTAGES
- LOCATES DEFECTIVE COMPONENTS
- REQUIRES NO ADDITIONAL EQUIPMENT

Ideal for trouble-shooting television sets in home or shop. Out-performs more expensive testers and pays for itself on the very first repair.

**A "Must" for Every TV Technician**

The "DYNATRACER" is a self-powered quality test instrument that traces TV signals through any Video, Sound, Sync, AFC, Horizontal or Vertical Sweep Circuit—isolates trouble to a stage or component. Traces voltages (50/500 V. AC/DC). Also locates open, shorted, intermittent or leaky (up to 20 MEGOHMS) condensers, resistors, coils, XFormers, etc.

Complete with Instruction Manual and Repair Guide

**FREE 10 DAY MONEY-BACK GUARANTEE**

With each new order we'll include a unique "TV High Voltage Indicator" useful in your testing work.

Cut out advertisement, attach name and address with \$5.00 bill, check or money order and mail to

**Century ELECTRONICS CO.**  
 211-04 99th Ave., Dept. 216, Queens Village, N. Y.

**SAVE UP TO 85% ON GOV'T SURPLUS!**

**GOV'T SURPLUS E.E.B SIGNAL CORPS FIELD TELEPHONE**

A private phone or intercom system. Easy to operate. Use any place that portable, 2-way communication is desired. Gives clear reception up to 15 miles. Operates on two standard batteries. Several phones may be used on the same line. Set contains a ringing generator, leather carrying case and phone. Each set is reconditioned & checked-out.

Complete circuit - Set of 2 **\$29.50**

Pay by Money Order or Check. P.O.'s accepted from D&B firms. 50% deposit with C.O.D.'s. Prices F.O.B. Los Angeles.

**WORLD'S MOST AMAZING BARGAIN CATALOG**

1954 EDITION—OVER 320 PGS

**SAVE UP TO 85% ON WAR SURPLUS**

Packed with SENSATIONAL VALUES in WAR SURPLUS, FACTORY CLOSE-OUTS and GENERAL MERCHANDISE!

Fully illustrated. Packed with thousands of Bargains in Hand & Power Tools, Radio Speakers, Ear Phones, Electronics, Gadgets, Electric Motors & Blowers, all types of Hydraulic Equipment, Outdoor & Sports Equip., Cameras, Precision Instruments, Microscopes, plus many, many more.

**Only 50c** To cover the cost of Handling and Mailing. REFUNDED with your first order.

**PALLEY SUPPLY CO.** 2263 E. VERNON AVE., /DEPT. TV-8  
 Los Angeles 58, California

# 3 SHURE CRYSTAL PICKUP CARTRIDGES replace the 192

cartridges you are most likely to encounter in your service work!



**Lowest investment for broadest coverage!** The RK-54 is beyond all doubt the most practical Replacement Kit on the market! Proof? Simply this—you get the broadest coverage at the lowest investment—only \$22.55 list! Think of it—3 Crystal Cartridges replace 192 of those specific Cartridges most likely to be in need of replacement! Two of the Cartridges consistently have been “best sellers” in the Shure line—as established by actual sales to Servicemen! The Cartridges are: Model W22AB, 3-Speed, 2-Needle Cartridge—Model W26B, All-Purpose, Single-Needle Cartridge—Model W78, 73 RPM, Dual-Volt, Dual-Weight Cartridge. Model W78 is the new, versatile Cartridge that replaces 149 other Cartridges. This Cartridge alone will become a sensation overnight! Order a Replacement Kit from your Distributor today—once you have worked with this practical kit you will find that these three Cartridges are dependable replacements—will make your service work faster, easier and more profitable!



**TRANSPARENT PLASTIC BOX IS FREE!**

This Handy Box is 5" long, 3½" wide, 1¼" deep.



*The Mark of Quality*

the majority of contacts are with local stations (while in motion) a simple but effective radiator is required.

The 2-meter “J” theoretically shows some advantage over less-efficient antennas, but must be mounted far enough away from the car body to maintain its electrical characteristics. If operated too close to the car’s mass of metal, the “J” may be difficult to tune, as its matching section might be affected by proximity to the car body. Installation of a mobile “J” then becomes cumbersome and, in some cases, unsightly.

The 19” quarter-wave ground-plane mounted atop the car roof has proved its worth as a good compromise antenna. Initial installation may be somewhat difficult, but the “whisker’s” performance more than makes up for the trouble! The antenna is small, unobtrusive, and requires no further thought after installation. For most mobile applications, this one’s hard to beat, and has been used exclusively with the “Two-In-The-Hand” transmitter. Several “record” contacts have been made with the “whisker,” proving its value as an effective radiator.

(To be continued)

## Heavy-Duty Amplifier

(Continued from page 49)

mum surge potential during warm-up is approximately 780 volts. The condenser with the can above chassis potential has a fiber insulating sleeve for shock protection.

The response is down 1 db at 8 cycles and 25 kc., no low- or high-frequency peaks are present and the hum or noise level measures less than .001 volt on the 16 ohm output tap with the input unterminated. A signal level of approximately 1 volt r.m.s. will drive the amplifier to full output.

The model of the amplifier using four output tubes was assembled on a 10" x 13" x 2" steel chassis which allows ample space between components. The sockets, terminal strips, and electrical parts are placed in such a way that very little hookup wire is used; most of the resistors and condensers terminate directly at tube sockets or junction terminals. The total weight of the model amplifier is 23 lbs. including tubes.

The goal in an amplifier design is the simplest assembly possible composed of complementary parts of similar quality all working at a comparable margin of safety to produce the required result. The amplifier described uses a minimum of components, operating within their ratings in a compact, economical assembly to produce a high level of audio power with no critical adjustments or selective assembly.

Those who require an amplifier providing from 20 to 30 watts output will find this particular unit one answer to the problem of obtaining these powers.



## CORY INTERLOCKS

Type B986, Safety Type, with Lock and Key (as shown) Contacts rated 20 Amp. Dspt. Play Safe at the Low Price of..... \$2.85  
Type “C”—Same as Above, but with Double Lock and 2 Keys. Both Locks Must be Operated Before Switch Operates..... \$3.95

## THIS MONTH'S SPECIALS

**SPEAKER-TWEETER** Used on Beachmaster Amplifier. Has 2" Voice Coil and Diaphragm. Response to 20,000 Cycles. Will Handle up to 50 Watts. Complete with Spare Cone. 8 Ohms..... \$9.95  
**VIBROPACK, PE-104:** Input 12VDC/0.58 Amp. Out: 2X4.3V/50MA, 2X45VDC/0.5MA. 2X85VDC/5MA. New. Complete with Spare Vibrator. Well-Shielded and Portable..... \$4.75

## MOBILES! C.D. MEN! CAP!!

**PE-101 DYNAMOTOR**—Converts Easily to Supply Unit Delivering

12 VOLT INPUT 6 V INPUT  
610 V @ 150 MA OR 300 V @ 90 MA  
325 V @ 125 MA 160 V @ 110 MA  
BRAND NEW WITH CONVERSION DATA \$3.75

## DYNAMOTORS

TYPE	INPUT		OUTPUT		Price
	VOLTS	AMPS	VOLTS	AMPS	
35X-059	19	3.8	405	.095	4.35
POSX-15	14	2.8	220	.08	8.95
DA-7A	28	27	1100	.400	15.00
DM33A	28	7	540	.250	3.95
BD AR 93	28	3.75	375	.150	7.50
23350	27	1.75	285	.075	3.95
B-19 Pack	12	9.4	275	.110	6.95
DA-3A*	28	10	500	.050	6.95
			300	.260	
			150	.010	
			14.5	5	
PE 73 CM	28	19	-1000	.350	22.50
BD 69:	14	2.8	220	.08	8.95
DAG-33A	18	3.2	450	.06	4.49
DM 25:	12	2.3	250	.0	6.95

\*Less Filter \*Replacement for PE 94.  
†Used, Excellent.  
PE 94-C, Brand New..... 6.95  
Send M.O. or Check, Shipping Chgs. C.O.D.  
**COMMUNICATIONS EQUIPMENT CO.**  
131 Liberty St. Dept. N-8 New York City 7, N. Y.

## LOWEST PRICE EVER! DUE TO GIANT B-A SPECIAL PURCHASE!

**BATTERY-OPERATED TELEPHONE HANDSETS**

YOU GET } FOR ONLY \$2.88  
2 - PHONES }  
2 - BATTERIES }  
50 FT. WIRE }

**COMPLETE! READY-TO-USE**

Provides at an unbelievably low cost, a dependable 2-way phone system, powered by self contained flashlight batteries and operated over 2-conductor wire for distances up to 1 mile with fine speech reception equal to that of ordinary telephone. Simple-to-operate, push-button switch automatically connects battery. Break-resistant telephone-black polystyrene phones with instant connectors for easy hook-up to 50 ft. of 2-conductor telephone wire included. Shpg. wt. 2 lbs. No. 20A948..... \$2.88  
Complete Per Pair.....

## BURSTEIN-APPLEBEE CO.

1012-14 McGee St., Kansas City 6, Mo.

Send me..... 20A948 S..... enclosed

Name .....

Address.....

City..... State.....

Include postage for parcel post shipments.

RADIO & TELEVISION NEWS

of tremendous get-up-and-go when the time for high speed arrives!

### 12-Volt Operation

Should you wish to "go mobile" in an MG or later model car having the new 12-volt battery system, refer to Fig. 9.

Because each tube draws a different value of filament current, it is necessary to "strap" the filaments as illustrated, in order that each 6-volt side of the series circuit will draw the same total current.

By pairing the 2E26 with the 6X8, and adding 63 ohms in parallel with them, the current flow through the combination totals 1.3 amperes, the same amount flowing through the paralleled filaments of the 5763 and 1635.

Of course the 12AU7 and 12AX7 draw identical currents, and are connected for 12-volt operation as shown in the schematic.

As with the 6-volt connection, one side of the filament line is grounded, whether positive or negative depending upon which side of the car battery is grounded.

The main advantage of the newer 12-volt systems is that of less current drain upon the car battery. Even though the present family car may utilize a 6-volt system, it may be wise to add a second battery to the car, in series with the regular system, to provide a lower-current modernized power source for the 2-meter mobile station.

### The Mobile Antenna

Several antennas have been used with the 2-meter mobile, including the "J," quarter-wave "whisker," and a collapsible 4-element beam.

When you get the urge to park atop a hill and listen for the weak ones, the obvious choice of antenna will be a small beam, such as is carried disassembled in the trunk of the car.

That maneuver really pays off in both louder DX signals from the receiver and approximately doubled signal strength reports for the transmitter.

For most mobile operation, wherein

Fig. 9. Method of wiring transmitter filaments for use with late model cars having 12-volt systems. Total current drain is 1.65 amps, 3.2 amps for the 6-volt system.

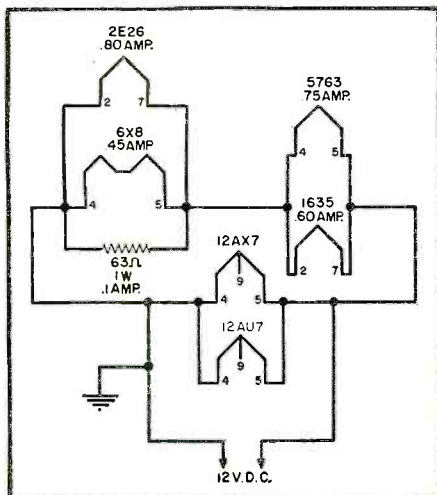

## Pay Only 10% Cash Down 18 Months to Pay on Major Equipment



LEO I. MEYERSON  
W6GFO

Now it is easier than ever to buy from WRL. Pay as little as 10% down and the balance in 18 months. No red tape — we handle our own financing. We will give you a generous trade-in allowance on your present equipment. We have over 600 reconditioned used items — with new factory guarantee. Send for free list. You will profit most when you deal with WRL — THE WORLD'S MOST PERSONALIZED RADIO SUPPLY HOUSE and THE WORLD'S LARGEST DISTRIBUTOR OF AMATEUR RADIO TRANSMITTING EQUIPMENT.

### HALLICRAFTERS S-40B \$119.95



**\$9.54** Per Month  
(12 months)

**\$12.00 CASH DOWN**

Communication receiver with built in speaker covering 540-Kc to 44 Mc in four bands. One RF stage, 2 IF stages.

### HALLICRAFTERS SX-71 \$249.95



**\$13.63** PER MONTH  
(18 Months) **Cash Down \$25.**

Double Conversion sharp selectivity, plus built-in NBFM at moderate cost. 11 tubes plus voltage regulator and rectifier. Low down payment.

### HALLICRAFTERS RECEIVERS AVAILABLE FOR IMMEDIATE SHIPMENT

MODEL NUMBER	12 MONTHLY PAYMENTS	DOWN PAYMENT	CASH PRICE	MODEL NUMBER	18 MONTHLY PAYMENTS	DOWN PAYMENT	CASH PRICE
S-38C	\$3.97	\$ 5.00	\$ 49.95	S-76	\$10.90	\$20.00	\$199.95
S-53A	\$7.95	\$10.00	\$ 99.95	SX-62	\$19.07	\$35.00	\$349.95
S-72 Port	\$8.74	\$11.00	\$109.95	SX-71	\$13.62	\$25.00	\$249.95
S-77A	\$9.54	\$12.00	\$119.95	HT-20XMTR	\$24.50	\$44.95	\$449.50

**SEND TODAY**

## FREE 1954 CATALOG

Get your BIG NEW 1954 WRL CATALOG, offering the greatest selection of radio and television equipment, parts and supplies for the Novice, Experimenters, Hams and Professionals.

WRITE FOR DETAILED EQUIPMENT SPECIFICATION SHEETS



WRITE - WIRE - PHONE 2-0277 COUNCIL BLUFFS, IOWA

WORLD RADIO LABORATORIES  
3415-27 W. Broadway  
Council Bluffs, Iowa

R-8

Please send me:

- 3' x 4' U.S. Radio Map 25c  
 New Catalog  
 Used Equipment List
- WRL XMTR Info  
 SX-71 Info  
 S-40B Info  
 NEW LOG BOOK 25c

Name .....

Address .....

City .....

State .....

### MORE JOBS than graduates

Demand for our engineering graduates exceeds supply. Effective placement. Study in this world-famed college established 1884. Quarters start Sept., Jan., March, June. Approved for Korean Vets.

### Bach. Sci. degree in 27 months

Complete Radio Eng. courses . . . TV, UHF and FM. Also Mech., Civil, Elec., Chem., Aero. and Adm. Eng.; Bus. Adm., Acct. Small classes. Well-equipped labs. Modest costs. Prep. courses. Write Jean McCarthy, Director of Admissions for Catalog and Campus View Book.



**TRI-STATE COLLEGE**

1684 College Avenue, Angola, Indiana

## MEN! THIS IS IT!

Nothing like these "Q.T." Cartoon Booklets, ever!  
**REAL COLLECTOR'S ITEMS!**



1. Maggie and Diggs
2. Teets and Jasper
3. Tillie the Soiler
4. Lord Pushbottom & Emma
5. Villain & Little Nell and others.

**ACT NOW!**

**FREE** CATALOG OF TITILLATING NOVELTIES WITH ORDER

ALL VEST POCKET SIZE — 10 FOR \$1.00  
Box 8516, Dept. 826  
Hollywood 46, Calif.

**Q.T. SALES**

# Become an ELECTRICAL ENGINEER



## Major in Electronics or Power BS Degree in 36 months

Prepare now for a career as an electrical engineer or engineering technician — and take advantage of the many opportunities in these expanding fields.

You can save a year by optional year 'round study. Previous military, academic, or practical training may be evaluated for advanced credit.

## Enter Radio and Television — courses 12 to 18 months

You can be a radio technician in 12 months. In an additional 6-months you can become a radio-television technician with Associate in Applied Science degree. Color television instruction is included in this program.

These technician courses may form the first third of the program leading to a degree in Electrical Engineering. Twenty-one subjects in electronics, electronic engineering and electronic design are included in these courses.

Courses also offered: radio-television service (12 mos.); electrical service (6 mos.); general preparatory (3 mos.).

Terms — September, January, April, July

Faculty of specialists. 50,000 former students—annual enrollment from 48 states, 23 foreign countries. Non-profit institution. 51st year. Courses approved for veterans. Residence courses only.

MS-6A



## MILWAUKEE SCHOOL OF ENGINEERING

MILWAUKEE SCHOOL OF ENGINEERING  
Dept. RT-854, 1025 N. Milwaukee Street  
Milwaukee 1, Wisconsin

Send FREE illustrated booklets  
 Career in Electrical Engineering,  
 Career in Radio-Television.

I am interested in..... (name of course)

Name..... Age.....

Address.....

City.....Zone.....State.....

If veteran, indicate date of discharge.....

cord, terminating in a standard *Amphenol* (or equivalent) 2-way plug, in conjunction with the 2-way receptacle visible on the front panel of the transmitter.

Should the carbon mike be preferable, you're "in" with a standard push-to-talk F-1 button or equivalent, access to the input being made with the standard "ring-tip-sleeve" plug and jack.

### The Power Supply

As illustrated, the "Little Monster" operates at 25 watts input to the final. A 300 volt, 200 ma. dual *Vibrapak* under the car's front seat powers the preamp, driver, and all r.f. stages.

A smaller 350 volt, 60 ma. *Vibrapak* supplies plate potential to the 1635. The entire rig may be operated with a single power pack, but for best results, that supply had better be capable of at least 300 ma., plus darned good regulation!

Remember that a class "B" system puts the modulator plate current on an electrical pogo-stick; the current jumps from a static 10 ma. up to 65 ma. on peaks. If you steal that varying current from the r.f. power supply, each audio variation lowers the r.f. stages' potential, resulting in constantly changing grid drive, varying modulation impedance and possible "downward" modulation.

Considering the jumping-jack modulator plate current, use of an extra supply for the modulator pays off with better audio, steadier carrier, and increased over-all efficiency.

### Design Modifications

Supposing you like the general ideas covered in the foregoing, but wish to construct a rig which operates at less power input? The "Two-In-The-Hand" rig may be run at 8 to 10 watts input by holding down the 2E26's screen-grid voltage.

If  $R_{n1}$ , the screen-dropping resistor, is increased from 10,000 to 35,000 ohms, the off-resonance plate current of the 2E26 will be limited to a maximum of about 60 ma., while the resonant-dip current will drop to the vicinity of 20 ma.

When any values in the screen-grid circuit are changed, the neutralizing capacity,  $C_n$ , must be modified. It was found that higher values of screen resistance necessitated use of lesser values of  $C_n$ . Should you run the rig at reduced power, a suggested value of  $C_n$  would be a 4 to 30 or 5 to 20  $\mu\text{fd}$ . ceramic trimmer.

When operating the transmitter at inputs of 8 to 10 watts, a single power supply may be used, as variations in efficiency of both amplifier and modulator will not be noticed by the guy in East Decalomania.

To go one step further, a lower-power transmitter using another 5763, rather than the 2E26, makes an effective rig. However, the 2E26, when running at reduced power, compares with a high-powered automobile driven at low-speed. It runs fine, but is capable

## STOP VOLUME CONTROL NOISE!



New 6 oz.  
Spray Can

Net to Servicemen **\$2.25**

## CONTAINS AMAZING NEW PERMA-FILM

- ★ CLEANS! . . . dirt and oxidation immediately on contact.
- ★ LUBRICATES! . . . one drop eliminates scratch, hum and noise.
- ★ PROTECTS! . . . assures continued top performance.



2 oz. bottle. Net to Servicemen **\$1.00**

Available in 8 oz. bottles and quart cans. Nearest distributor—or write

**ELECTRONIC CHEMICAL CORP.**  
813 Communipaw Ave., Jersey City 4, N. J.

## AUDELS TV-RADIO SERVICE LIBRARY

HERE IS LATE INFORMATION IN A HANDY FORM FOR RADIO AND TELEVISION REPAIRMEN, SERVICEMEN AND STUDENTS



2 VOLS \$6 COMPLETE \$1 A MONTH PAY ONLY \$1 MO.

AUDELS T.V.-RADIO SERVICE LIBRARY—Highly Endorsed—1001 Facts—Over 1552 Pages—625 Illustrations, Diagrams of Parts. Presents Important Subjects of Modern Radio, Television, Industrial Electronics, F.M., Public Address Systems, Auto, Marine & Aircraft Radio, Phonograph Pick-Ups, etc.

### IT PAYS TO KNOW!

The Basic Principles—Construction—Installation—Operation—Repairs—Trouble Shooting. Shows How to get Sharp, Clear T.V. Pictures. Install Aerials—How to Test. Explains Color Systems, Methods of Conversion, Terms, etc. Includes Ultra High Frequency (U.H.F.)—Valuable for Quick Ready Reference & Home Study. Tells How to Solve T.V. & Radio Troubles—Answers Your Questions.

Get this Information for Yourself.  
7 DAY TEST—ASK TO SEE IT!

## MAIL ORDER

AUDELS, Publishers, 49 W. 23 St., N.Y. 10, N.Y.  
Mail AUDELS T.V. RADIO SERVICE LIBRARY 2 Vols. \$6 on 7 days free trial, if O. K. I will remit \$1 in 7 days and \$1 monthly until \$6 is paid. Otherwise I will return them.

Name.....

Address.....

Occupation.....

Employed by.....RN



## "Two-in-the Hand"

(Continued from page 34)

back" a bit at this kind of power, but there's nothing physically smaller to fit the job!

Three impedance ratios are available at the secondary: 3000, 3750, and 4500 ohms.

When the 2E26 draws 80 ma. at 300 volts, its  $Z_m = 300 \text{ v./}.080 \text{ amp.}$ , or 3750 ohms, which tap is used for precise impedance matching between modulator and final.

The Thordarson T20D76 driver transformer fits the miniature application nicely; it's visible in Fig. 2, mounted on an aluminum shield partition between the r.f. and audio sections beneath the chassis. Made to drive a class "B" 6N7, it fits the rig both mechanically and electrically, receiving plenty of audio voltage from the driver stage, a parallel-connected 12AU7.

You'll note that we cheated a bit by mounting the 12AU7 beneath the chassis. (Where else?! To bottom-mount the 9-pin socket, remove its metal top and solder a #6-32 machine screw into the center lug. This provides a single screw mounting for the entire assembly.

If you like good audio quality with lots of punch, proceed to the crystal mike preamplifier, a 12AX7 mounted beside the 1635 atop the chassis.

Components forming the preamplifier stage solder directly to the 12AX7 socket pins, and are not visible in the photograph beneath the 12AU7. Using the smallest parts available, such as 1/2-watt resistors and tiny disc-type condensers, you'll have less trouble than you'd expect in constructing similar miniature equipment.

Two 8  $\mu\text{fd.}$ , 450 volt electrolytic condensers,  $C_{17}$ ,  $C_{22}$ , in conjunction with  $R_{16}$  and  $R_{23}$ , provide audio decoupling between preamp and driver stages. With a high gain system, you'd better use 'em, or in-phase audio voltages between stages sneak back through the "B+" line, making loud and frightening motorboating noises!

Want to use a carbon mike? This makes the job much easier—forget about the bottom-mounted 12AU7 and its associated components. Replace the 12AX7 with a 12AT7 and revise the schematic as shown in Fig. 6; this eliminates a microphone transformer, using half of the 12AT7 as a grounded-grid, cathode-driven input stage, the opposite half as the driver stage for the class "B" modulator. No mike transformer and no batteries result in a neat installation, and look at the space (!) you'll save!

In either case, there remains the matter of "press-to-talk." If you like a crystal mike, see Fig. 7, showing a *Microswitch* tied down to the D-104 unit. When pressed, the *Microswitch* completes the ground-return circuit for the antenna changeover and power-control relays. A 2-conductor shielded cable substitutes for the regular mike

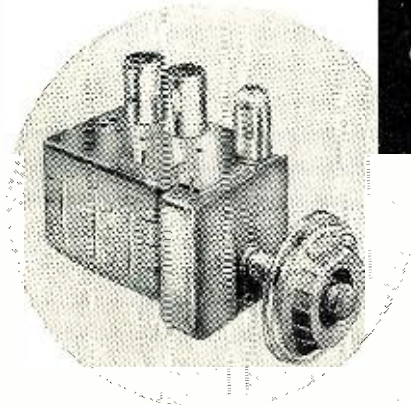

- A compact, combination tuner (the world's smallest) for covering the entire UHF-VHF bands.
- Straight line electrical sequence of compartmented circuits.
- Simple, coaxial tuning.
- Stage shielded.
- **OVERALL PERFORMANCE MAKES ANY SET A BETTER SET.**



Write for folder covering complete description and performance data.

**SARKES TARZIAN, Inc.**  
Tuner Division  
Bloomington, Indiana

### RADIO ENGINEERING DEGREE IN 27 MONTHS

Radio engineering is a big field. There's room for you in it—if you're good. Get first-class training at Indiana Tech. Intensive, specialized course, including strong basis in mathematics and electrical engineering, advanced radio theory and design, television, electronics, Modern laboratories. Low rate. Also B.S. DEGREE IN 27 MONTHS in Aeronautical, Chemical, Civil, Electrical and Mechanical Engineering. G.I. Government approved. Enter September, December, March, June. You can earn part of your expenses right here in Fort Wayne while you are studying.

#### INDIANA TECHNICAL COLLEGE

984 E. Washington Blvd., Fort Wayne 2, Indiana  
Please send me free information on B.S. Engineering Degree in 27 months as checked.

Radio-Television  Aeronautical  
 Civil  Mechanical  Electrical

Name .....  
Address .....

### TREMENDOUS SAVINGS ON PRECISION RESISTORS

Wilkor, 1%, carbonfilm, HiStability, Low temperature co-efficiency, Jan. specs., new, packed in individual sleeves.

1/2 Watt, Type CPSE .06 each  
Ohms, 1200, 1500, 2200, 2700, 3300, 4700, 5100, 6800, 12000, 15000, 18000, 20000, 24000, 39000, 47000, 56000, 62000, 68000, 82000, 100000, 130000, 150000, 180000, 220000, 240000, 270000, 330000, 470000, 510000, 560000, 1 meg.

1 Watt, Type CPI .08 each  
Ohms, 100, 2500, 3300, 5100, 75000, 100000, 2.2 meg.

2 Watt, Type CPI .10 each  
Ohms, 51, 330, 1800.

Minimum order \$5  
FOB Rochester, N. Y. Open acct. to rated firms.

**R. C. CAGAN SALES**  
P.O. BOX 1152 • ROCHESTER 3, N. Y.  
Warehouse, 1045 Mt. Read Blvd.

# For "Wire-Wounds"...

Make Sure . . .

Make It Mallory

Take a look at Mallory's complete line, any time you've got a service job that calls for any kind of wire-wound resistors. There's a big selection of fixed and adjustable vitreous enamel resistors, controls and power rheostats, from which you can choose the exact type needed for just about any replacement.

Only the best in materials and manufacturing methods go into these resistors. They're made to give maximum heat dissipation . . . to take overloads in stride . . . to keep stable values throughout their long service life. All types are conservatively rated, and are available in a wide choice of values.

You can depend on Mallory wire-wound resistors for the same precision-built quality that has made Mallory components . . . capacitors, vibrators and controls . . . the leading choice of servicemen everywhere.

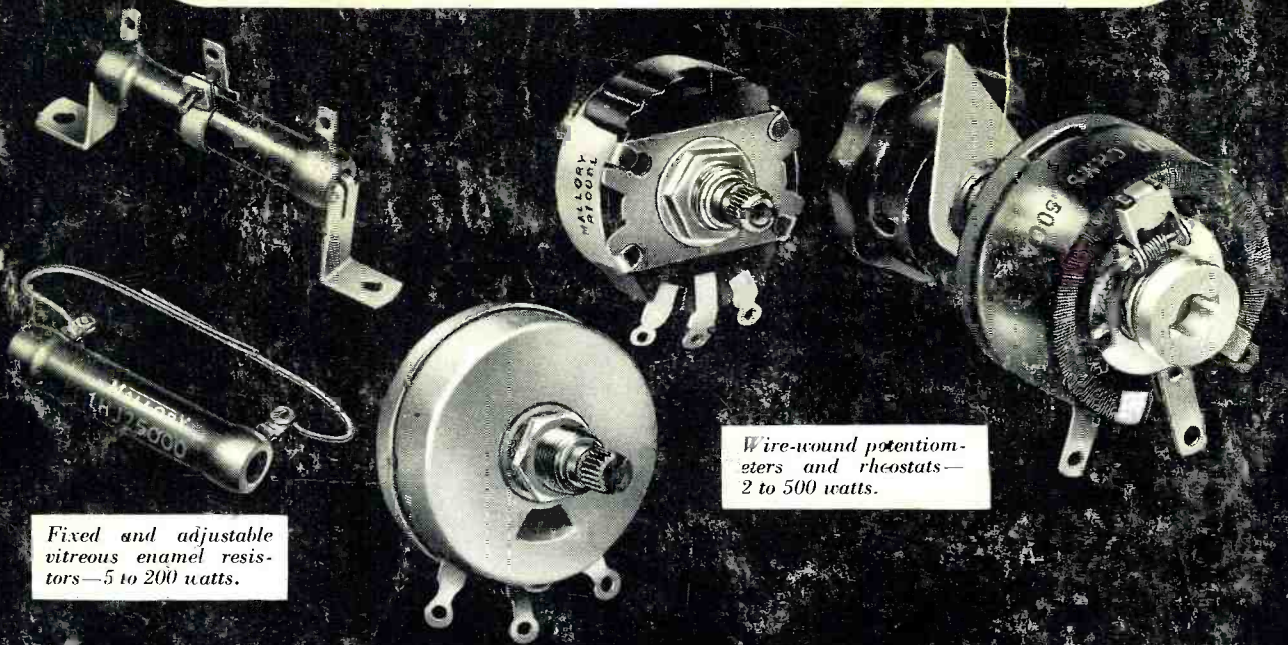

Fixed and adjustable vitreous enamel resistors—5 to 200 watts.

Wire-wound potentiometers and rheostats—2 to 500 watts.

PR MALLORY & CO. Inc.  
**MALLORY**

CAPACITORS • CONTROLS • VIBRATORS • SWITCHES • RESISTORS  
RECTIFIERS • POWER SUPPLIES • CONVERTERS • MERCURY BATTERIES  
**APPROVED PRECISION PRODUCTS**

P. R. MALLORY & CO. Inc., INDIANAPOLIS 6, INDIANA