

# **RADIO & TELEVISION NEWS**

**JULY  
1953**

**IN THIS ISSUE**

**DIRECT-COUPLED  
INSTRUMENT AMPLIFIER**

**A MULTIRANGE  
SENSITIVE CONTROL**

**PULSE DURATION MODULATION**

**PHASE ANGLE  
MEASUREMENTS AT A.F.**

**MEASURING ATTENUATION  
WITH THE SLOTTED LINE**

**THE DAGE  
INDUSTRIAL TV CAMERA**

**KNOW YOUR 1953 RCA  
TV RECEIVER**

**A "MINIMUM" MOBILE FOR  
10-METER CD**

**EW SPEAKER ENCLOSURE**

**RADAR PROTECTS  
FISHING FLEETS**

**(See Page 35)**

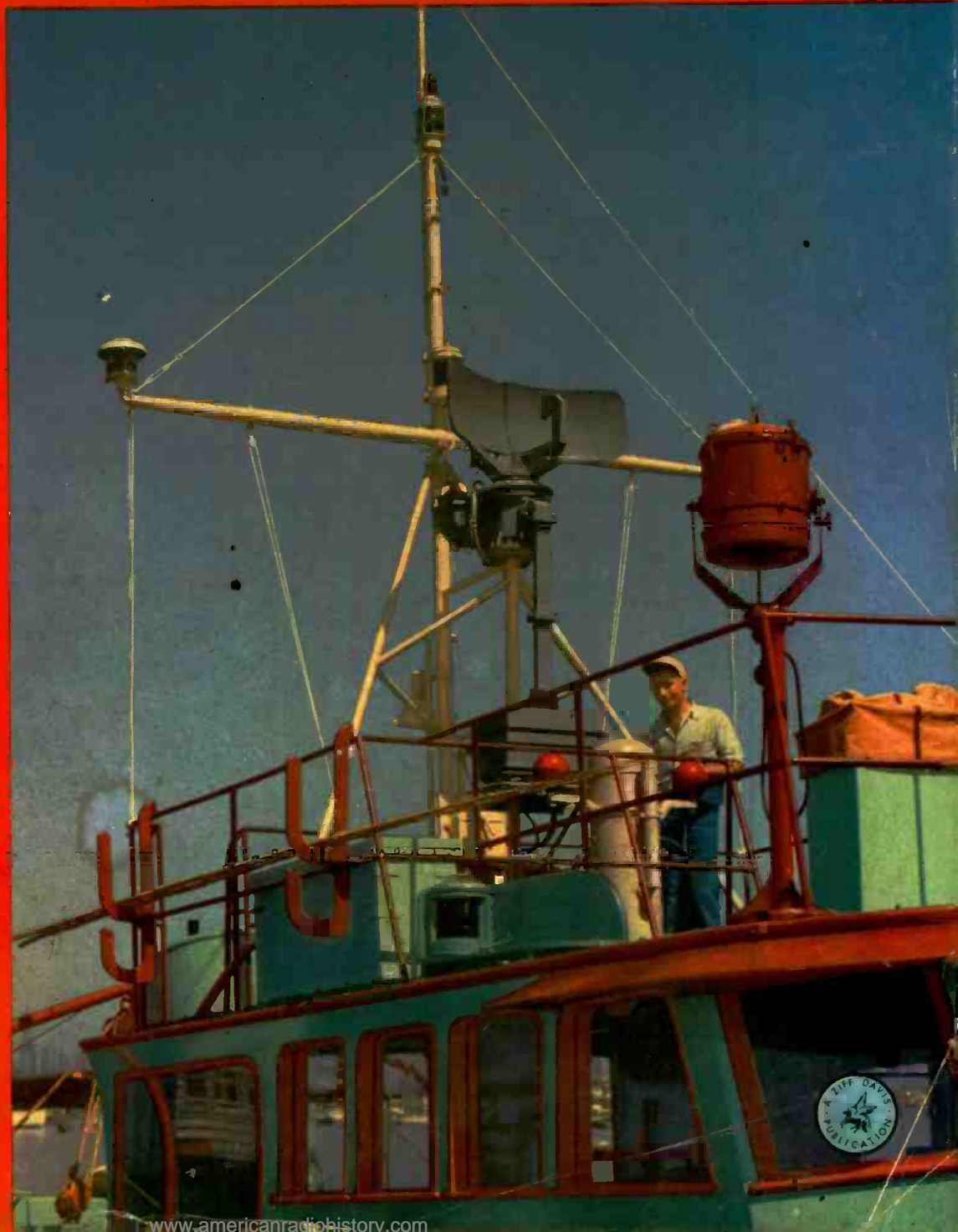





# Partners

... for extra profit

EVERY successful service call automatically results in *extra profit . . . in dollars and cents . . . and in increased "customer confidence."* You can insure *both* kinds of profit by coupling your good name in partnership with another . . . *RCA.*

Wherever you go, the familiar RCA emblem serves as your silent partner, helping you to sell your service and build repeat business. And the superior quality of RCA Receiving Tubes and Kinescopes protects your profit by cutting those costly call-backs caused by premature tube failures.

Helping you to safeguard your reputation is a vital, everyday service of RCA Tubes. And that protection is yours at no extra cost.



## "Sign up" for Success

Identify yourself with RCA! Ask your *RCA Tube Distributor* today how *you* can qualify for a Dealer Identification Plaque displaying your name. He'll give you full details on the big RCA Sales Promotion Program.

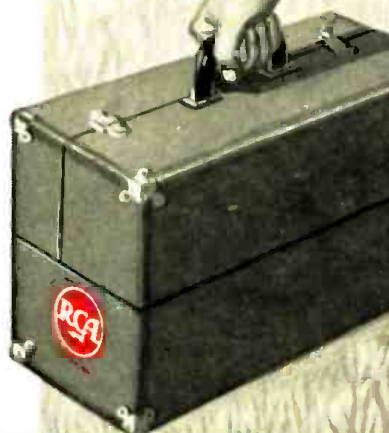

**RADIO CORPORATION of AMERICA**  
ELECTRON TUBES

HARRISON, N. J.



# YOU PRACTICE COMMUNICATIONS with Kits I Send You

## Build This Transmitter

As part of my Communications Course I send you parts to build the low power Broadcasting Transmitter shown at the right. Use it to get practical experience putting a station "on the air," perform procedures required of Broadcast Station operators. You build many other pieces of equipment with kits I send. I train you for your FCC Commercial Operator's License.



# YOU PRACTICE SERVICING with Kits I Send You

## Build This Tester

You build this Multitester from parts I send. use it to earn extra money in your spare time fixing neighbors' Radios. I also send you speaker, tubes, chassis, transformer, loop antenna, everything you need to build a modern Radio and other equipment. You get practical experience working with circuits common to both Radio and Television. All equipment is yours to keep. See and read about it in my FREE 64-page book. Just cut out and mail coupon below!



J. E. Smith has trained more men for Radio-TV than any other man.

# I Will Train You at Home to be a RADIO-TELEVISION Technician

## TELEVISION

### Today's Good Job Maker



TV now reaches from coast-to-coast. Over 15 million TV sets are now in use; 108 TV stations are operating and 1800 new TV stations have been authorized. This means more jobs, good pay jobs with bright futures. Now is the time to get ready for success in TV. Find out what Radio-Television offers you. Mail coupon now for my 2 Books FREE!

## America's Fast Growing Industry Offers You Good Pay, Success

Do you want a good pay job, a bright future, security? Then get into the fast growing RADIO-TELEVISION industry. Hundreds I've trained are successful RADIO-TELEVISION TECHNICIANS. Most had no previous experience, many no more than grammar school education. Keep your job while training at home. Learn RADIO-TELEVISION principles from easy-to-understand lessons. Get practical experience on actual equipment you build with parts I send you.

### Make Extra Money in Spare Time While Training

The day you enroll I start sending you SPECIAL BOOKLETS that show you how to service neighbors' Radios in spare time while training. Use MULTITESTER you build to help service sets, get practical experience working on circuits common to both Radio and Television. Find out how you can realize your ambition to be successful in the prosperous RADIO-TELEVISION industry. Even without Television, the industry is bigger than ever before. 105 million home and auto Radios, over 2900 Radio Stations, expanding Aviation and Police Radio. Micro-Wave Relay, FM and Television are making opportunities for Servicing and Communications Technicians.

### Mail Coupon — Find Out What Radio-TV Offers You

Send for my FREE DOUBLE OFFER. Cut out and mail coupon below. Send in envelope or paste on postal. You will get actual Servicing Lesson to prove it's practical to learn at home. You'll also receive my 64-page Book, "How to Be a Success in Radio-Television." Read what my graduates are doing, earning, see photos of equipment you practice with at home. J. E. Smith, President, Dept. 3GE National Radio Institute, Washington 9, D. C.

## I TRAINED THESE MEN



### Has Growing Business

"I am becoming an expert Teletician as well as Radiotician. Without your practical course I feel this would have been impossible. My business continues to grow." —Philip G. Brogan, Louisville, Ky.

### Good Job with Station

"I am Broadcast Engineer at WLPN. Another technician and I have opened a Radio-TV service shop in our spare time. Big TV sales here. As a result we have more work than we can handle." —J. H. Bangley, Jr., Suffolk, Va.

### Praises NRI as Best Course

"I was a high school student when I enrolled. My friends began to bring their Radios to me. I realized a profit of \$300 by the time I completed the course." —John Hopper, Nitro, West Va.

## NRI Training Leads to Good Jobs Like These



Broadcasting: Chief Technician, Chief Operator, Power Monitor, Recording Operator, Remote Control Operator, Servicing: Home and Auto Radios, P.A. Systems, Television Receivers, Electronic Controls, FM Radios, In Radio Plants: Design Assistant, Transmitter Design Technician, Tester, Serviceman, Service Manager, Ship and Harbor Radio: Chief Operator, Assistant Operator, Radiotelephone Operator, Government Radio: Operator in Army, Navy, Marine Corps, Coast Guard; Forestry Service Dispatcher, Airways Radio Operator, Aviation Radio: Transmitter Technician, Receiver Technician, Airport Transmitter Operator, Television: Pick-up Operator, Voice Transmitter Operator, Television Technician, Remote Control Operator, Service and Maintenance Technician.

AVAILABLE to all qualified **VETERANS** UNDER G.I. BILLS

Tested Way to Better Pay

## Good for Both—FREE

MR. J. E. SMITH, President, Dept. 3GE National Radio Institute, Washington 9, D. C.

Mail me Sample Lesson and 64-page Book, FREE. (No salesmen will call. Please write plainly.)

Name ..... Age .....

Address .....

City ..... Zone ..... State .....

**VETS** write in date of discharge .....



RADIO & TELEVISION NEWS is published monthly by the Ziff-Davis Publishing Company at 64 E. Lake St., Chicago 3, Ill. Entered as second-class matter, July 21, 1948, at the Post office, Chicago, Ill., under the act of March 3, 1879. Authorized by Post Office Department, Ottawa, Canada, as second-class matter. SUBSCRIPTION RATES: Radio & Television News—one year, U. S. and Possessions, Pan-American countries, and Canada \$4.00; all other foreign countries \$5.00. Radio-Electronic Engineering Edition—one year, U. S. and Possessions, Pan-American countries, and Canada \$6.00; all other foreign countries \$7.00. Postmaster—Please return undelivered copies under form 3589 to 64 E. Lake St., Chicago 3, Ill.



Editor and Asst. Publisher  
**OLIVER READ, D.Sc., WIETI**

Managing Editor  
**WM. A. STOCKLIN, B.S.**

Technical Editor  
**H. S. RENNE, M.S.**

Service Editor  
**CHARLES TEPFER**

Amateur Radio Editor  
**N. ROSA, WINOA**

Assistant Editors  
**P. B. HOEFER**  
**M. C. MAGNA**

Television Consultant  
**WALTER H. BUCHSBAUM**

Short-Wave Editor  
**KENNETH R. BOORD**

Staff Artist  
**FRANK SAYLES**

Draftsmen  
**A. A. GANS, W2TSP**  
**J. A. GOLANEK**

Advertising Manager  
**I. L. OSTEN**  
Midwest Adv. Manager  
**JOHN A. RONAN, JR.**

Western Adv. Manager  
**JOHN E. PAYNE**

# RADIO & TELEVISION NEWS

Reg. U.S. Pat. Off.

Radio News Trademark Reg. U. S. Pat. Office • Television News Trademark Reg. U. S. Pat. Office.

First in  
radio-television-electronics

Average Paid Circulation over 200,000

## CONTENTS

## JULY, 1953

The Dage Industrial TV Camera.....	Harold E. Ennes	31
Radar Protects Fishing Fleets.....	Ray Frank, W9JU	35
Coaxial Speaker Dividing Networks.....	Lloyd C. Goss	36
TV Interference Signals.....	Robert B. Gary	38
125-Watt Audio System with Clipping.....	Robert F. Lewis, W8MQU	39
Ferri-Loopstick Crystal Receiver.....	Joseph D. Amorose	42
EW Speaker Enclosure.....	Jac Holzman	43
Transistor Physics Simplified (Part I).....	S. P. Gentile & P. J. Barotta	44
The Monimeter.....	Lloyd V. Broderson, W6CLV	47
Know Your 1953 RCA TV Receiver.....		48
A "Minimum" Mobile for 10-Meter CD.....	Richard G. Finkbeiner, W8AQK	52
Faster TV Servicing Through Circuit Tracing.....	Milton S. Kiver	54
The Oscilloscope as an A.C.-D.C. Voltmeter.....	Walter H. Buchsbaum	57
A Low Distortion Audio Signal Generator.....	George Ellis Jones, Jr.	58
What's the Q-L-C.....	Warren Philbrook	61
Mac's Radio Service Shop.....	John T. Frye	62
TV Parts Replacement Guide.....		63
A Transistor "Electric Organ".....	Louis E. Garner, Jr.	64
New TV Grants Since Freeze Lift.....		75
New TV Stations on the Air.....		75
Service Hints on RCA TV Sets.....		118
Transistor Receiver.....	M. E. Quisenberry	122
Radio-TV Service Industry News.....		130

### DEPARTMENTS

For the Record.....	The Editor	8	Short-Wave.....	K. R. Boord	66
Within the Industry.....		16	What's New in Radio.....		80
Spot Radio News.....		24	Manufacturers' Literature.....		94
Technical Books.....		103			



COVER PHOTO: The radar installation on the fishing boat "White Star", a Pacific Coast vessel operated by the Van Camp Canneries of California. (Ektachrome by P. J. Samerjan)

### ZIFF-DAVIS PUBLISHING COMPANY

Chairman of the Board and Publisher  
**WILLIAM B. ZIFF**

President  
**B. G. DAVIS**

Secretary-Treasurer  
**G. E. CARNEY**

Vice-Presidents  
**H. J. MORGANROTH**

Production Director

**LYNN PHILLIPS, JR.**

Advertising Director

**H. G. STRONG**

Circulation Director

### BRANCH OFFICES

CHICAGO (1)

64 E. Lake St., AN 3-5200

LOS ANGELES (14)

Staller Center, 900 Wilshire Blvd., Mich. 9856



COPYRIGHT 1953  
(All Rights Reserved)  
ZIFF-DAVIS PUBLISHING COMPANY  
Editorial and Executive Offices  
366 Madison Ave., New York 17, N. Y.  
VOLUME 50 • NUMBER 1



Member  
Audit Bureau of  
Circulations

SUBSCRIPTION SERVICE: All communications concerning subscriptions should be addressed to Circulation Dept., 64 E. Lake St., Chicago 1, Ill. Subscribers should allow at least four weeks for change of address.

CONTRIBUTIONS: Contributors are advised to retain a copy of their manuscripts and illustrations. Contributions should be mailed to the New York Editorial Office and must be accompanied by return postage. Contributions will be handled with reasonable care, but this magazine assumes no responsibility for their safety. Any copy accepted is subject to whatever adaptations and revisions are necessary to meet the requirements of this publication. Payment covers all author's, contributor's, and contestant's rights, title, and interest in and to the material accepted and will be made at our current rates upon acceptance. All photos and drawings will be considered as part of the material purchased.

RADIO & TELEVISION NEWS



**NOW...from D.T.I.'s MILLION DOLLAR TRAINING CENTER**

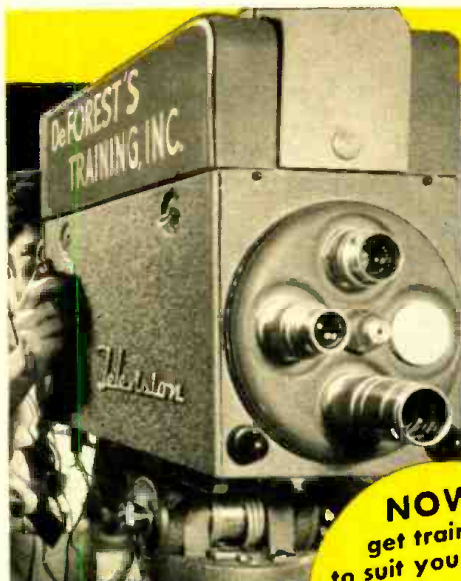

# Learn to master **TELEVISION**

**RADIO - ELECTRONICS**

by getting **EVERYTHING YOU NEED!**

**NOW—  
get training  
to suit your NEEDS**

**TAKE YOUR  
CHOICE**

America's amazing multi-billion dollar Television field now offers you a chance of a lifetime to get started toward a grand job or your own business. With TV station limit now raised from over 100 to 2053, Television is headed for almost every community. Mail coupon today. See how you may prepare to cash in on the coming TV BOOM.

Come to  
**D.T.I.'s**  
great **CHICAGO**  
**LABORATORIES**  
...one of the Nation's **FINEST!**

Now, in the heart of the nation's TV Center, you can get all of your preparation in D.T.I.'s big, modern, wonderfully equipped training laboratories. Loads of commercial equipment and ample, well qualified instructors help you get a thorough, practical preparation in the **SHORTEST POSSIBLE TIME**. Part time student Employment assistance can help you pay your way while in training.

### EMPLOYMENT SERVICE

As soon as you complete either the Chicago Laboratory or Home Training, you'll find D.T.I.'s grand Employment Service ready to help you start earning real money. Get full facts. Mail coupon today.

**MILITARY SERVICE:** If subject to military service, the training information we have for you should prove very helpful. Mail coupon today.

**89 WAYS  
TO  
EARN  
MONEY  
IN TELEVISION  
RADIO ELECTRONICS**

**ACT NOW! MAIL COUPON TODAY**  
Get this publication **FREE!**

**DeFOREST'S TRAINING INC. RN-7-J**  
2533 N. ASHLAND AVE., CHICAGO 14, ILL.

I would like your Opportunity News Bulletin showing "89 Ways to Earn Money In Television-Radio-Electronics"; also, complete facts about the training opportunity made possible by your organization.

Name \_\_\_\_\_ Age \_\_\_\_\_  
Address \_\_\_\_\_ Apt. \_\_\_\_\_  
City \_\_\_\_\_ Zone \_\_\_\_\_ State \_\_\_\_\_

Get **ALL** of your training  
**AT HOME!**...including setting  
up your own **HOME LABORATORY**



ABOVE: You build and keep this big 5 INCH commercial-type oscilloscope — one of the most useful test units used in TV today.



See how you may now get one of today's most complete, effective combinations of major home training aids—including (1) well illustrated lessons, (2) the wonderful aid of HOME TRAINING MOVIES and (3) 21 big shipments of electronic parts for setting up your own HOME LABORATORY. You work over 400 construction and test procedures to get the practical experience you need. This includes building and keeping a 5 INCH "SCOPE", jewel bearing MULTI-METER and a big 21 INCH TV SET. (D.T.I. offers another home training in Television-Radio-Electronics, but without the TV set.) Mail coupon today for exciting facts.



**Use 16 mm. MOVIES** Only D.T.I. provides you with the loan of visual training movies at home to help you master important basic points faster... easier... better!

"ONE OF AMERICA'S FOREMOST  
TELEVISION TRAINING CENTERS"  
— Established 1931 —



**DeFOREST'S TRAINING, INC.**  
AFFILIATED WITH  
**DEVRY Technical INSTITUTE**  
GO 14, ILLINOIS





## Birthplace of the Transistor

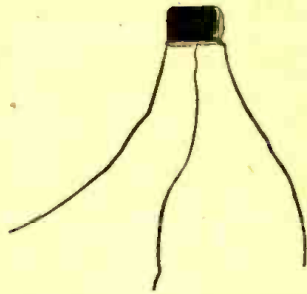

Bell Telephone Laboratories at Murray Hill, N. J. Other laboratories are in New York City and at Whippany and Holmdel, N. J.

The *Transistor*, that revolutionary new electronics device, is a product of *telephone* research. It was conceived, invented and developed at Bell Telephone Laboratories by men in search of ways to improve telephone service. It was announced just five years ago.

The *Transistor* can do most of the things that vacuum tubes can do—and others, too—but it is not a vacuum tube. It works on entirely new physical principles. Rugged, simple and tiny, the Transistor uses incredibly small amounts of power—and then only when actually operating.

*Transistors* promise smaller and cheaper electronic equipment and the spread of electronics where other equipment has not been able to do the job as economically. They are already at work in the Bell System, generating the signals that carry dialed numbers between cities, and selecting the best route for calls through complex switching systems. Engineers see many other possibilities: for example, as voice amplifiers in telephone sets to aid the hard of hearing, and as switches.

Recognizing the tremendous possibilities of the *Transistor* in every phase of the electronics industry, the Bell System has made the invention available to 40 other companies. Thus, again, basic research to improve telephony contributes importantly to many other fields of technology as well.

### TRANSISTOR SUMMARY

Basically, a *Transistor* is a tiny wafer of germanium with three electrodes, over-all about the size of a coffee bean.

It can amplify signals 100,000 times on much less power than a pocket flashlight requires. This opens the door to its use in smaller telephone exchanges where vacuum tube equipment would be too costly to operate.

Unlike a vacuum tube, the *Transistor* has no vacuum and no filament to keep hot. It operates instantly, without "warm-up" delay. The Transistor can also be used as an electric eye and to count electrical pulses.



## BELL TELEPHONE LABORATORIES

Improving telephone service for America  
provides careers for creative men in scientific and technical fields.

RADIO & TELEVISION NEWS



# Unmatched Selectivity— Even at Twice the Money!

## Hallicrafters Model S-76

- ★ Dual Conversion — no images!
- ★ Automatic Noise Limiter!
- ★ Giant "S" Meter — 4" Scale!
- ★ Temperature Compensation!



The medium priced receiver that made the industry adjust its sights! Unmatched selectivity, even from receivers that cost twice as much. Just check the selectivity curves against other sets — see what Hallicrafters unmatched design experience can mean to you.

Model S-76 is a 4-band, dual conversion superheterodyne circuit, covering 538 kc to 32.0 mc. Bands: 538 to 1580 kc, 1720 kc to 4.9 mc, 4.6 mc to 13.0 mc, 12 mc to 32.0 mc. Two 3 gang tuning condensers are used, the first for main tuning and the second gang for fine tuning and electrical band spread. 1 r-f, 2 conversion, 2 i-f stages. 5 position selectivity. Phono input jack. 3 watts audio output. Only **\$17950**



**TVI Suppressed 100 Watter—  
Model HT-20**—Continuous coverage from 1.7 mc to 31 mc. Full band switching. Choice of 10 crystals. Shielded, filtered r-f compartment plus built-in, low-pass 52 (ohm) coaxial line output filter reduces to more than 90 d.b. all responses over 40 mc. Only **\$449.50**

**The Finest Buy in SW!—The S-38C**  
—Best performance per dollar, you'll find, the S-38C is the outstanding low priced set on the market. 540 kc to 32 mc in 4 bands. Maximum sensitivity per tube — far out-performs ordinary broadcast sets. Built-in speaker. 115 V AC or DC. 4 tubes plus rectifier. **\$49.50**

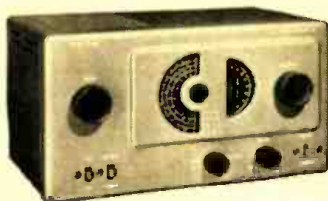

SELECTIVITY CURVES  
S-76

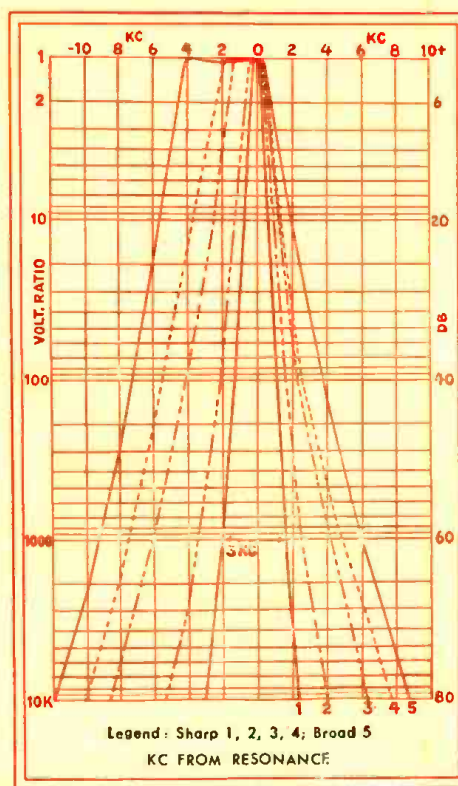

# hallicrafters

Chicago 24, Illinois

Hallicrafters, Ltd., 51 Camden St., Toronto, Canada

*World's Leading Exclusive Manufacturer of  
Communications Equipment, High Fidelity,  
Radio and Television*



**E-V ADDS THE MAGIC TOUCH  
TO TV RECEPTION**

**NEW  
all channel UHF  
TV CONVERTER**



**MODEL 3300**

Truly the ultimate in a UHF TV Converter. Engineered and built by Electro-Voice, the E-V 3300 combines the finest in design, construction and performance. It is thoroughly field proved.



**Adds all UHF Channels to VHF Sets**

Non-slip micrometer type tuning system\* provides smooth, accurate, continuous tuning of all UHF channels 14-83. No band switches, strips or coils. New high-efficiency low-loss circuit. Operates with either separate UHF and VHF antennas or on all-channel (2-83) antenna. Adequate shielding. One control turns Converter and TV set "on" or "off" and switches to correct antenna. Utilizes channels 5 or 6 of VHF TV set as Intermediate Frequency. Does not affect VHF reception.

Installation is simple—connect to antenna input of VHF TV set and just plug in. For 105-125 volts, 50-60 cycles AC. Housed in small, attractive dark brown cabinet, 7 $\frac{3}{4}$ " x 5 $\frac{1}{4}$ " x 6 $\frac{1}{4}$ ". Completely self-contained, ready for installation.

**MODEL 3300. List Price, \$39.50**

\*Patent Applied For

Send for Bulletin  
No. 188

**Electro-Voice**

**ELECTRO-VOICE, INC.**  
410 CARROLL STREET • BUCHANAN, MICH.  
Export: 13 E. 40th St., New York 16, U.S.A. Cables: Arlab

*For the* **RECORD.**

BY THE EDITOR

**SUMMERTIME REVENUE**

**T**HE hot weather that lies ahead of us and the extra daylight hours will keep many TV viewers out-of-doors and away from their sets to enjoy the nice weather. The aggressive service technician will take advantage of the summer months to survey his customers for antenna replacements.

It is a fact—not fancy, that a great proportion of TV antenna installations in fringe areas, especially those made two to four years ago are out-moded and inferior compared with late designs.

We observed, during a recent trip, that many antenna systems in fringe areas and in damp climates are still using flat twin-lead.

Many of these leads are lying flat on the roofing with an accumulated film of soot (carbon) and the leads draped over the metal gutter, en route to the receiver. It is commonplace to find pipe masts improperly guyed with uneven stress at the point of connection. Many guy wires are staggered on the pipe and easy prey to a high wind.

Stand-off insulators are rusted and are discoloring the dwelling and many installations are still without the essential lightning arrester.

It is amazing that these conditions do exist. It is even more amazing that dealers and technicians are so completely blind to the opportunities that are theirs in tapping the replacement market for newer and more efficient antennas and accessories.

Every home owner is familiar with the effects of corrosion on his lawn mower, power tools, the kids' bicycles, and on his plumbing. It is not difficult to explain the necessity for replacing his outside antenna and hardware with new and more efficient arrays.

We have talked with many technicians and have found many to be timid and hesitant about approaching a customer on the subject of antenna replacement. An auto service manager never hesitates to recommend a new spark plug or new tires to a customer if he feels he can justify a sale.

In many instances, he will be doing a customer a real favor and will help to prevent accidents caused by the toppling of poorly guyed masts and towers. He will replace all stand-offs with new parts which he will protect with one of the several sprays now on the market. He will replace all the old flat twin lead with the more efficient tubular types and he will install an approved lightning arrester,

properly grounded and correctly located.

The summertime is ideal for an intensive campaign to check on all the antenna installations that have been in service over two years—especially near salt water. If the installation is one of your own, your approach should be one which implies that you wish to make your customary "periodic" inspection because of the damage such installations can incur due to weather. You should have no difficulty in obtaining permission to make such an inspection. Your report to the homeowner should be complete and carefully worked out. His confidence in your judgement and television "know-how" will probably mean a green light for any work that you may recommend. In some instances only guys, certain hardware accessories, or arresters will need replacing—in other cases the entire installation will have to be renewed.

On "cold" calls on customers for whom you have not done work previously take time to sell yourself and your service before requesting permission to make an inspection of their antenna systems. Most home owners are "damage" conscious and will accept suggestions that will make their property less hazardous if they are approached correctly.

There is no reason why you can't glean many leads from your older service record cards or those that have been in the inactive file for some time. The damage a falling antenna can cause is no small matter and may even endanger life—so the average householder will welcome your suggestion to "take a look before it is too late."

Don't forget to take a look at "John Doe's" antenna too while you are in his neighborhood. Even though he's a new customer and even though his antenna was erected recently and is in good condition, he will long remember your thoughtfulness for two minutes of your time spent in re-checking the recently installed array.

There is still plenty of room in the service field to employ more common sense to the erection of antennas.

Multi-element antennas are still being strapped to old chimneys that have weakened through the years. Many are incapable of supporting the additional weight and stress of an antenna and represent a real hazard to the dwelling and its occupants.

These hazards should be eliminated and there is no better time than now. . . . . O.R.



**big values  
new releases**

# in ALLIED'S latest Catalog & Supplement!

**FREE: SEND FOR BOTH**

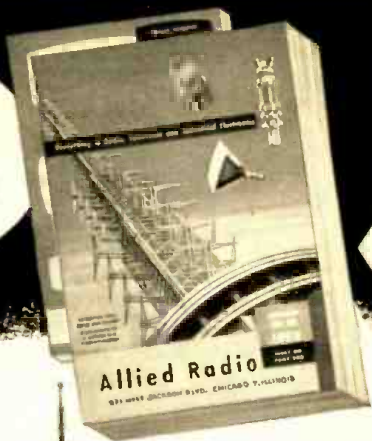

### KNIGHT PORTABLE RADIO KIT

Build this powerful 3-way superhet portable for AC, DC or battery operation. Tunes 535-1650 kc broadcast band; has built-in antenna, PM speaker, printed audio circuit, handsome carrying case. Easy to assemble from illustrated manual. High-quality kit includes all parts, tubes and case (less batteries). Shpg. wt., 6 lbs.  
83-730. Only... \$18.75  
Battery Kit... \$3.64

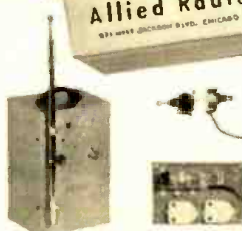

### PHILMORE RADIO CONTROL KIT

Build your own remote-control transmitter and receiver. Operates model airplanes, boats, autos, etc. Crystal-controlled transmitter for 27.255 mc (requires easily obtained FCC operating permit). High-gain super-regenerative receiver. Easy to build. Complete with all parts, telescoping antenna, crystal and cabinet (less batteries). 4 1/2 lbs.  
83-034. Only... \$41.47  
Complete Set of Batteries... \$7.15



### KNIGHT SELF-CHARGING PORTABLE

Deluxe superhet portable for AC, DC or battery operation. With battery "Rejuvenator" circuit which extends normal "B" battery life 2 to 4 times! Covers full broadcast band; has tuned RF amp, loop antenna, AVC, 5" PM speaker. Attractive carrying case, 10 x 12 1/2 x 4 3/4". Complete with tubes, less batteries. 9 lbs.  
6K-718. Only... \$35.75  
80-652. Battery Kit... \$4.36



### WELLER SOLDERING GUNS

Squeeze the trigger—you're ready to solder in 5 seconds. Latest heavy-duty, instant-heat gun; with 2 spotlights that light up working area. Air-cooled transformer. 3 lbs.  
46-642. Single-heat, only... \$9.75  
46-641. Dual-heat, only... \$11.71



### PET 1/4" DRILL VALUE

Precision gear-type chuck drill with pistol grip. Instant-release lock-type trigger switch built into grip. Forced ventilation; runs cool. Speed: no-load, 1600 rpm; full-load, 900 rpm. Capacity: 1/4" in steel, 1/2" in hardwood. 6-ft. cord. For 110-120 v. AC or DC. 4 lbs.  
46-280. Only... \$17.21

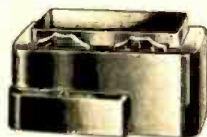

### TV BOOSTER BARGAIN

Famous Standard Coil printed circuit TV booster at less than half original price. Provides uniform gain on all 12 VHF channels. Easy to tune; use with indoor antenna in primary areas, with outdoor antenna in near-fringe areas. Improves reception markedly. For 110-120 v., 60 cy. AC. Shpg. wt., 4 lbs.  
97-233. While they last, Only... \$9.95



### ELECTRO-VOICE UHF CONVERTER

New! Micrometer tuning for smooth, continuous reception of all UHF channels. Just connect to antenna input of any VHF TV set and plug in. Operates with all-channel antenna or separate VHF and UHF types. Single-knob, easy control. Uses VHF channels 5 or 6 as IF. 300 ohms input and output imp. Complete with tubes. For 110-120 v., 60 cy. AC. 5 lbs.  
98-097. Only... \$33.96

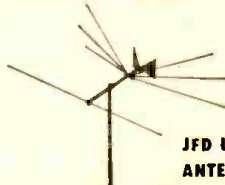

### JFD UHF-VHF ANTENNA

Wonderfully efficient; uses conical element and reflector for VHF and "bow-tie" for UHF. Equipped with printed circuit antenna coupler for excellent signal transfer into single transmission line. Easy to install. (Less mast and 300-ohm twin line.) Shpg. wt., 6 lbs.  
98-368. Only... \$11.20

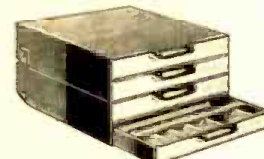

### EQUIPO "LITTLE GEM" CABINET

New! Drawer cabinet for small parts. Contains 4 drawers, with dividers for 48 compartments (dividers adjustable on 1 1/2" centers). Each drawer 1 1/2" h, 11" w, 11" d. Cabinet overall, 6 1/2 x 11 x 11". Olive green baked enamel finish. Shpg. wt., 20 lbs.  
86-066. Only... \$17.80



### TRAV-ELECTRIC SENIOR CONVERTER

Ultra-compact 60 cycle converter for changing 6 volts DC to 110 volts AC. Capacity: 30 watts continuous, 40-45 watts intermittent. Simply plugs into auto cigarette lighter. Permits mobile use of broadcast and SW radios, recorders, dictating machines, fluorescent lamps, etc. Fully filtered. Only 2 1/2 x 2 1/2 x 3 1/2". 3 1/2 lbs.  
80-272. Only... \$10.63



### TV CASTER BASE

Easy to install under any TV console—permits quick and easy rolling to any desired location. Rolls smoothly in any direction. Steel frame is adjustable to 30" wide, 27" deep to fit practically any console. No tools required for installation. Shpg. wt., 11 1/2 lbs.  
98-989. Only... \$5.95

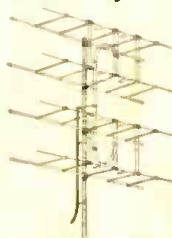

### FINNEY 400A UHF-VHF ANTENNA

New! Double conical antenna featuring 32 driven elements for high gain and directivity, with superior signal-to-noise ratio. Superh for fringe-area reception—good for VHF up to 150 miles or more. Rugged; corrosion-proof; pre-assembled, lightweight. Requires 10-ft. mast and 300-ohm twinline. 14 lbs.  
97-104. Only... \$32.34



### TAP-A-LINE

New type electrical line outlet, powering as many as 8 separate appliances from any wall outlet. Plastic cased; 12" long, 1" square. With 6-ft. cord and plug. Rated 1000 watts, 1 1/2 lbs.  
52-636. Only... \$1.47



### KNIGHT VT VOLT-OHM-MILLIAMMETER KIT

Terrific Value! Response to 2.5 mc. Bridge-type circuit; 1% resistors. Input res.: DC, 20 megs; AC, 1.5 megs. 4 1/2" meter. Ranges: AC p-to-p volts, 0-8-28-84-280-840-2800; AC rms & DC volts, 0-3-10-30-100-300-1000; DC ma. 0-3-10-30-100-300-1000; res. 0-1000-10K-100K ohms & 0-1-10-1000 megs; cap., .005-.5, .05-.5, .5-50, 5-500, 50-5000 mfd. With tubes, leads, case, instructions. For 110-120 v. DC or 60 cy. AC.  
83-120. Only... \$24.95  
83-121. Hi-V Probe; extends DC range to 30 KV \$6.95  
83-122. Hi-Frequency Probe for AC range to 200mc \$5.95

**FREE  
Catalog and  
Supplement**

ALLIED RADIO CORP., Dept. I-G-3  
833 W. Jackson Blvd., Chicago 7, Ill.

Send FREE ALLIED Catalog and Supplement

Enter order for \_\_\_\_\_

\_\_\_\_\_ \$ \_\_\_\_\_ enclosed.

Name \_\_\_\_\_

Address \_\_\_\_\_

City \_\_\_\_\_

Zone \_\_\_\_\_ State \_\_\_\_\_

**ALLIED RADIO**



# YOU CAN GET

## All-New Service Aids from Westinghouse Tube Distributors

Many offered at no cost with RELIATRON TUBE purchases

**1** Create confidence in your shop with bright new signs like these:



Indoor Lighted Sign



Giant Outdoor Illuminated Sign  
Your store name in big letters!



Personalized Window Display  
It never stops moving.



Modern Clock Sign



4-Foot Wall Banner



5-Foot Lighted Window Sign



Brilliant Counter or Window Sign

**2** Attract new customers, build repeat business with lasting reminders like these:



Set Polishing Cloth

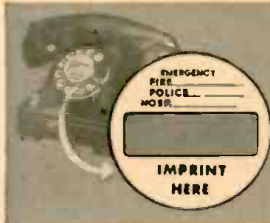

Plastic Phone Dial Reminder



Service Stickers



Lizard Billfold Give-Away



Hard-Hitting Postals — stamped and imprinted.

**3** Be business-like, save time with tested service aids like these:



De Luxe Tube Caddy

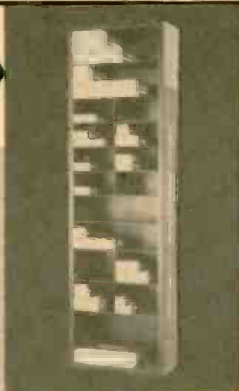

Pilfer-Proof Tube Cabinet



Reversible Service Jacket



Swiss Calendar Watch



TV Tool Set

**SERVICE DEALERS:** You can now get these sales builders — and many more — from your nearest Westinghouse RELIATRON Tube Distributor. Call or visit him soon. If you don't know where to find him, write Dept. G-207 at the address below. We will send you his name and address and a catalog of the complete new Westinghouse line of sales aids and business builders.

YOU CAN BE SURE...IF IT'S  
**Westinghouse**

**RELIATRON TUBES**  
TM

WESTINGHOUSE ELECTRIC CORPORATION, ELECTRONIC TUBE DIVISION, ELMIRA, N. Y.

ET-95027



# WALSCO

## HAS THE ONLY UHF ANTENNAS WITH AMAZING

# X-77

## INSULATOR

Hollow, unbreakable X-77  
Insulator used exclusively on  
Walsco Corner Reflector and  
Reflecto-Fan.

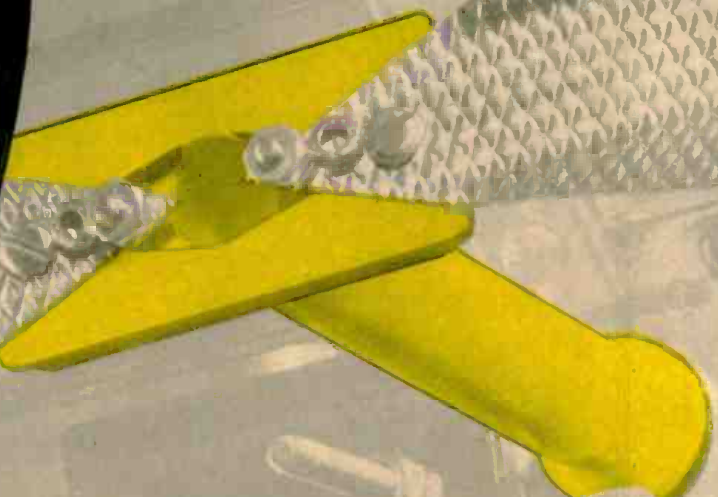

X-77 insulator makes Walsco the most efficient, all-band UHF antennas in America. Nothing compares with it!

X-77 is hollow, allowing lead-in wire to pass through the center. Wire is kept completely out of field pattern. It eliminates broken wires caused by strain of wire on antenna terminals.

X-77 can't break . . . ever! It's 5 times stronger than polystyrene. Silicone treated to shed dust and moisture . . . not affected by extreme heat, cold or wind.

X-77 is non-hygroscopic. Outstanding insulating qualities will last indefinitely.

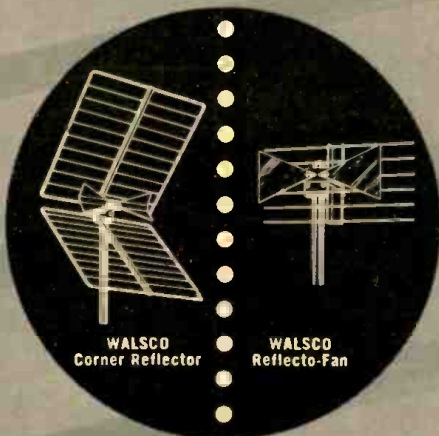

Largest in demand everywhere

Catalog No.	Description	Avg. Gain (db)	List Price
Reflecto-Fan 4400	Single Bay	7.0	\$ 6.75
*4402	Dual Stack	11.0	14.25
*4404	4 Bay Stack	14.5	35.00
Corner Reflector 4450	Single Bay	11.2	14.50
*4452	Dual Stack	16.4	32.00

### WALSCO

Walter L. Schott Co.  
Los Angeles 18, Calif.  
Chicago 6, Ill.

\* Supplied with complete stacking kit.  
Must not included in prices.

Overseas Representative: Ad Auriemo, Inc., 89 Broad St., New York 4, N.Y.



*The Best -  
by Popular Acclaim*

The most  
**Powerful  
TV ROTOR**  
on the market

# TR-2

Power When and Where You  
Need It . . . To Turn ANY TV  
Antenna Array Under All  
Weather Conditions -

Complete rotor with "COMPASS  
CONTROL" cabinet having illu-  
minated "perfect pattern" dial  
(uses 8 wire cable) . . . \$49.95



THE **RADIART** CORPORATION  
CLEVELAND 13, OHIO



**CORNELL-DUBILIER**  
SOUTH PLAINFIELD, NEW JERSEY



# Sweeping the Country!

**BUY DIRECT  
AND SAVE**

**'PRE-FAB'**

# COLLINS TUNERS and RECEIVERS

**AUDIO PRODUCTS CO.**

Collins Audio Products Co. is in no way affiliated with Collins Radio Co.

Two ALL NEW Complete Kits for  
Every High-Fidelity Need

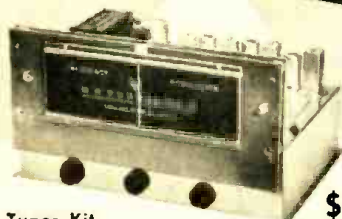

FM Tuner Kit

**\$55**

The FM-11 tuner is available in kit form with the IF Amplifier mounted in the chassis, wired and tested by us. You mount the completed RF Tuning Unit and power supply, then after some simple wiring, it's all set to operate. 11 tubes: 6J6 RF amp, 6AG5 converter, 6C4 oscillator, 6BA6 1st IF, (2) 6AU6 2nd and 3rd IF, (2) 6AU6 limiters, 6AL5 discriminator, 6AL7-GT double tuning eye, 5Y3-GT rectifier. Sensitivity 6 to 10 microvolts, less than 1/2 of 1% distortion, 20 to 20,000 cycle response with 2DB variation. Chassis dimensions: 12 1/2" wide, 8" deep, 7" high. Illustrated manual supplied. Shipping weight 14 lbs.

Each Collins Tuner Kit is complete with punched chassis, tubes, power transformer, power supply components, hardware, dial assembly, tuning eye, knobs, wire, etc., as well as the completed sub-assemblies: FM tuning units, AM tuning units, IF amplifiers, etc., where applicable. Since all these sub-assemblies are wired, tested and aligned at the factory, Collins Pre-Fab Kits are easily assembled even without technical knowledge. The end result is a fine, high quality, high fidelity instrument at often less than half the cost—because you helped make it and bought it direct from the factory. Bring your present reproducing system up to date with a new Collins Tuner.

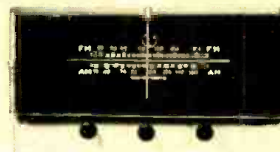

FM/AM Tuner Kit

**\$77<sup>50</sup>**

The original 15 tube deluxe FM/AM pre-fab kit redesigned on a smaller chassis. The tuner now measures 14" wide by 12" deep by 7 1/2" high. This attractive new front and dial assembly opens up new applications where space is at a premium. Kit includes everything necessary to put it into operation—punched chassis, tubes, wired and aligned components, power supply, hardware, etc. Kit comprises FMF-3 tuning unit, IF-6 amplifier, AM-4 AM tuning unit, magic eye assembly and complete instructions. All tubes included. Shipping weight 19 lbs.

## Selected Basic Components For Special Applications

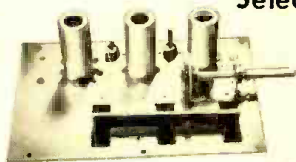

FMF-3 Tuning Unit

**\$15<sup>25</sup>**

The best for FM. The most sensitive and most selective type of "front end" on the market. 6 to 10 microvolts sensitivity. Image ratio 500 to 1. 6J6 tuned RF stage, 6AG5 converter, 6C4 oscillator. Permeability tuned, stable and drift-free. Chassis plate measures 6 1/2" x 4 1/2". In combination with the IF-6 amplifier, the highest order of sensitivity on FM can be attained. Tubes included as well as schematic and instructions. Draws 30 ma. Shipping weight FMF-3: 2 1/2 lbs. Dial available @ \$3.85



IF-6 Amplifier

**\$19<sup>75</sup>**

A remarkable value! 6 tubes are used in the IF amplifier: 6BA6 1st IF, (2) 6AU6 2nd and 3rd IF's, (2) 6AU6 limiters and 6AL5 discriminator. High gain, wide-band response (200 KC) for highest fidelity. 20 to 20,000 cycles. Distortion less than 1/2 of 1%. Draws 40 ma @ 220 volts. Chassis plate dimensions: 11-5/16" x 2 1/2" Shipping weight: 3 lbs.



AM-4 Tuning Unit

**\$24<sup>50</sup>**

Tops in AM superhet performance! A 3-gang tuning condenser gives 3 tuned stages with high sensitivity and selectivity. Assembly is completely wired, tested and aligned ready for immediate use. Frequency coverage 540 KC to 1650 KC at a sensitivity of 5 microvolts. Tubes 6BA6 RF amplifier; 6BE5 converter; 6BA6 IF amplifier and 6AT6 detector. Draws 30 ma @ 220 volts. Mounts on a chassis plate measuring 4" x 7 3/8". Shipping weight 2 1/2 lbs. Dial available at \$3.85.

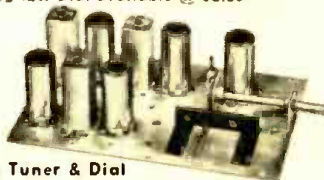

RD-1C Tuner & Dial

**\$28<sup>50</sup>**

The COLLINS RD-1C FM tuner chassis is unique in the field. A whole, compact FM tuner and dial that fits in the palm of your hand. Convert AM sets to FM/AM receivers for only a few dollars! Unlimited applications where space is at a premium. Use in conjunction with your phonograph amplifier. Full frequency response to 20,000 cycles. Sensitivity 20 microvolts, permeability tuned. Tuning unit and IF amplifier on the same chassis plate. Draws 40 ma @ 100 volts. Tubes: 6AG5 converter, 6C4 oscillator, (2) 6AU6 IF amplifiers, 6AL5 in new ratio detector circuit Shipping weight tuner and dial 5 lbs

**MAIL  
COUPON  
TODAY**

To: Collins Audio Products Co. Inc.  
P.O. Box 368, Westfield, N. J.  
Tel. WEstfield 2-4390

- FM Tuner Kit    FM/AM Tuner Kit    Slide Rule Dial Assembly  
 FMF-3 Tuning Unit    IF-6 Amplifier    RD-1C Tuner and Dial  
 AM-4 Tuning Unit

NAME .....

ADDRESS .....

CITY..... STATE .....

Amount for Kit \$..... See weights, add shipping cost \$.....

Total amount enclosed \$..... Check  Money Order

**WHEN YOU THINK OF TUNERS, THINK OF COLLINS AUDIO PRODUCTS**



# RUGGED

*Fiberglas* HELPS MAKE

VEE-D-X **UHF** ANTENNAS

**THE WORLD'S STRONGEST**

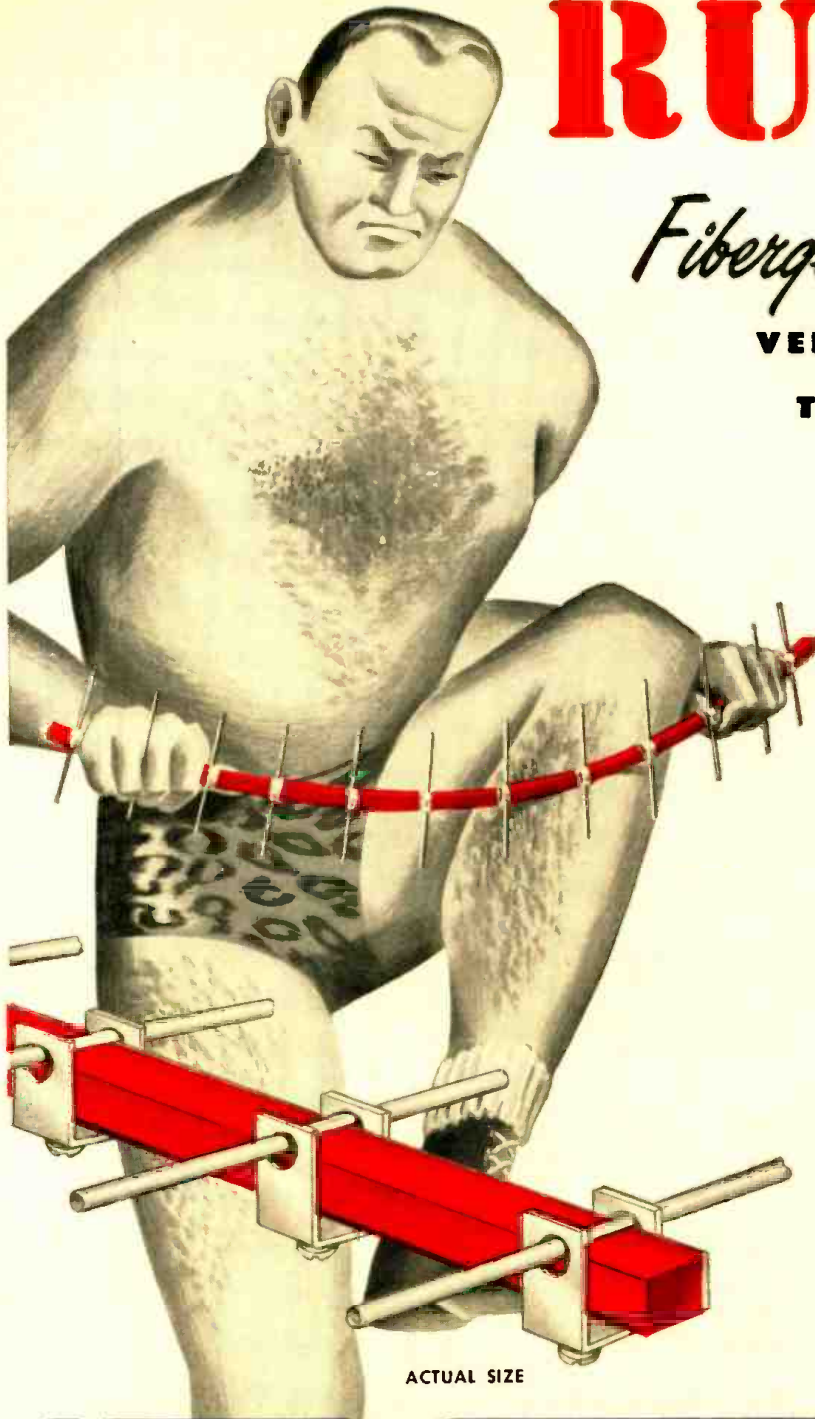

ACTUAL SIZE

The sensationally strong Fiberglas boom used in the construction of VEE-D-X UHF antennas has the highest strength ratio to weight of any material known, and its bright red color makes it easy to identify as a genuine VEE-D-X antenna.

**TV SERVICE MEN EVERYWHERE VOTE VEE-D-X UHF ANTENNAS FIRST FOR CONSTRUCTION — PERFORMANCE — EASE OF INSTALLATION.**

Besides the rugged Fiberglas boom, VEE-D-X UHF antennas are designed with strong, yet light weight solid aluminum elements (to prevent ice loading) and (a VEE-D-X exclusive) Flex-Clamp on the Bow-Tie and Corner Reflector, for positive vise-like grip and ease of installation.

And every VEE-D-X UHF antenna is engineered for powerful performance in all areas! No wonder TV service men are saying, "These VEE-D-X UHF antennas are Power-FULL in both performance and construction."



THE WORLD'S FINEST UHF ANTENNAS

*LaPointe* **ELECTRONICS INC.**  
ROCKVILLE, CONNECTICUT

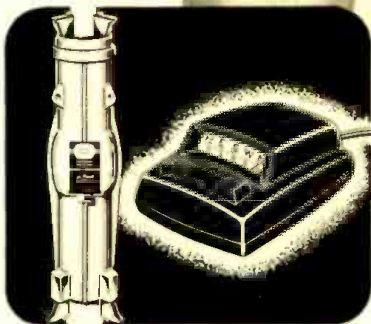

### ROTATOR

Finest in design, construction and performance. Produced in collaboration with three world famous manufacturers. Designed to perform with pin-point accuracy. Beautifully styled control console operates with convenient downward pressure. Choice of two colors.

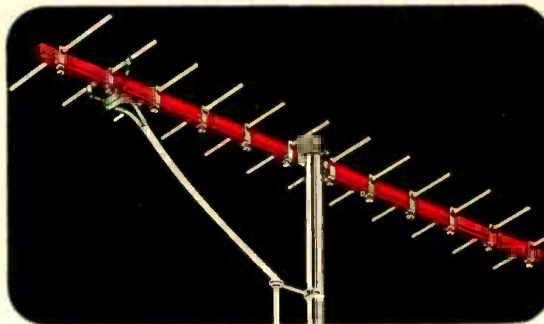

### LONG LONG JOHN

This 12-element yagi is engineered for grand slam power in fringe areas. It is the highest gain single channel antenna ever developed. Rugged Fiberglas boom construction. Strong, light in weight and factory pre-assembled construction for ease of installation. Model LLJ-U.

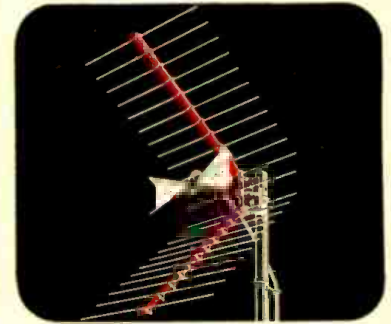

### CORNER REFLECTOR

This is the power-full all-channel VEE-D-X antenna that minimizes probing. Also the answer for UHF fringe and areas where noise or reflection problems exist. Rugged Fiberglas boom construction. Ready for installation in less than 30 seconds. Model COR-U.

**RADIO & TELEVISION NEWS**





Leonard C. Lane,  
B.S., M.A.  
President of Radio-Television  
Training Association,  
Exec. Dir. of Pierce School  
of Radio and Television

# AMAZING NEW TRAINING PLAN

## NOW... YOU CAN BECOME A **LICENSED\* TV TECHNICIAN** LICENSED TV MEN MAKE MORE MONEY

**AT NO EXTRA COST!  
YOU GET A ROUND TRIP TO  
NEW YORK CITY**

FROM ANYWHERE IN THE U.S. OR CANADA—I pay your way to New York and return, PLUS 2 FREE weeks, 50 hours of advanced instruction and shop training at the **PIERCE SCHOOL OF RADIO & TELEVISION**. You use modern electronics equipment, including student-operated TV and Radio stations. You go behind the scenes of New York's big Radio-TV centers, to study first hand. And I give you all this **AT NO EXTRA COST!** (Applies to complete Radio-TV course only.)

Only RTTA makes this amazing offer.

**EXTRA FEATURES THAT MEAN MORE MONEY FOR YOU!**

Thousands of new job opportunities will be available for you right in your own state, now that the government has lifted restrictions on new TV stations. My simple, successful methods can **PREPARE YOU NOW** to take your place in America's booming TELEVISION and Electronics industries... help you get the success and happiness that you always wanted out of life. You learn the practical, easy way by using actual parts and equipment in the 15 big Radio-TV kits I send you, including a **COMPLETE TV RECEIVER**... yours to build and keep.

My Advanced Training Prepares You For Better Jobs Then, after you finish your training for a position as a full-fledged TV Technician—where you can write your own ticket and choose from dozens of fascinating careers—I don't stop there! I continue to train you—**AT NO EXTRA COST!**—to qualify for even better pay in the **BETTER JOBS** that demand FCC licenses, with my...

**FREE\* FCC COACHING COURSE**  
PREPARES YOU AT HOME FOR YOUR  
FCC LICENSE  
THE BEST JOBS IN TV AND RADIO  
REQUIRE AN FCC LICENSE  
Given to every student at **NO EXTRA COST** after  
TV Theory and Practice is completed.

**SET-UP YOUR OWN HOME LABORATORY  
WITH THE 15 BIG TELEVISION-RADIO  
KITS WE SEND YOU (At No Extra Cost)**

**YOU BUILD  
AND KEEP  
ALL THESE  
UNITS**



—INCLUDING BIG SCREEN TV RECEIVER,

- plus Super-Het Radio Receiver, R.F. Signal Generator, Combination Voltmeter-Ammeter-Ohmmeter, C-W Telephone Receiver, AC-DC Power Supply, Everything Furnished Including All Tubes, and Big TV Tube

TAKES UP TO  
**21** in.  
PICTURE TUBE

**NOW!** Advanced FM-TV Training  
For Men Who Know Radio  
Prepares You For Higher Pay Jobs  
In A Few Months  
COMPLETE theory and practical training course... complete with kits including large screen TV receiver.  
FCC License Coaching Course Included FREE.

# ATTENTION! VETERANS!

MY SCHOOLS FULLY APPROVED TO TRAIN VETERANS UNDER NEW G.I. BILL! If discharged after June 27, 1950—CHECK COUPON BELOW! Also approved for RESIDENT TRAINING in New York City... qualifies you for full subsistence allowance up to \$160 per month.



**I GET MY GRADUATES GOOD PAYING JOBS**

**As Merchant Ship Radio Officer, I receive \$867. for 40-day trip. Your training helped me get this fine position.**  
—Stanley Nawrocki

**I now hold a fine airlines position at LaGuardia Field, New York City, thanks to your excellent training.**  
—Joseph Rosenberg

**Your excellent instruction helped me get my present job as an airport radio mechanic for American Airlines.**  
—Eugene E. Baako

**Thanks to your training, I qualified for a good job as a Receiver Tester at Federal Telephone and Radio.**  
—Paul Frank Seier

Many others working at NBC, RCA, CBS, Dumont, Philco, Emerson, Admiral and other leading firms.



**BOTH  
FREE  
New  
Illustrated  
Book plus  
Sample  
Lesson**

**NO SALESMAN WILL CALL!**

Mr. Leonard C. Lane, President  
RADIO-TELEVISION TRAINING ASSN.  
1629 Broadway, Radio City Station  
New York 19, N. Y. Dept. T-7

Dear Mr. Lane:  
Mail me your **NEW** FREE BOOK and **SAMPLE LESSON** that will show me how I can make **BIG MONEY** in TELEVISION. I understand I am under no obligation and no salesman will call.

Name \_\_\_\_\_ Age \_\_\_\_\_  
Address \_\_\_\_\_  
City \_\_\_\_\_ Zone \_\_\_\_\_ State \_\_\_\_\_

I am interested in:  Radio-TV  Advanced FM-TV  
**VETERANS:** If qualified under new G.I. bill, check here  Resident Study

**RADIO-TELEVISION TRAINING ASSOCIATION**  
1629 Broadway, Radio City Station, New York City 19, N. Y.  
Approved as a Correspondence School under the laws of the State of New York



# Within the INDUSTRY



We rest our case  
on evidence  
you can hear



Words can't prove the performance of this superb High Fidelity Tuner. Neither can witnesses. When it's time for

a decision, your judgement of the CRAFTSMEN 10 is based on one thing: evidence you hear with your own ears. Listen—and the conclusive evidence of incomparable sensitivity and flexibility will turn your trial into a lifetime of distinctly better listening.

the  
**craftsmen 10**  
high fidelity  
FM-AM tuner

- Two cathode followers furnish both audio output and detector output for remote installations.
- Built-in pre-amplifier, compensated for variable reluctance pick-ups.
- Automatic Frequency Control entirely eliminates drift, simplifies tuning.
- 5 microvolts sensitivity on both FM and AM.
- 10 kc filter on AM eliminates inter-station squeal.
- Bass and treble tone controls for boost, cut, or 20-20,000 cycle flat response.

JUDGE  
THE C-500 TOO!  
Williamson all-  
triode circuit—  
99.99% distor-  
tion-free!



high fidelity by craftsmen  
means distinctly better listening

For information, write to:

The radio CRAFTSMEN, Inc.  
Dept. R-7, 4401 N. Ravenswood Ave.,  
Chicago 40, Ill.

**LOUIS L. ACKERMAN** has been appointed director of purchasing for *Warwick Manufacturing Corporation*, Chicago radio and television firm.

He was formerly assistant director of purchasing for *Capehart-Farnsworth Corporation* of Ft. Wayne, Indiana and director of purchasing for *Arvin Industries, Inc.*

In his new position Mr. Ackerman will have charge of purchasing for the company's Chicago plant and its recently-acquired plant in Zion, Illinois.



**JERRY KIRSCHBAUM**, vice-president of *Precision Apparatus Corp.*, has been named president of the Sales Managers Club, Eastern Group.

Serving with Mr. Kirschbaum are Bob Ferree, distributor sales manager of *International Resistance Corp.* as vice-president; and Walter Jablon, vice-president of *Bogen Sound Systems* as secretary-treasurer.

B. L. Cahn, vice-president of *Insuline Corporation of America*, was elected director to the executive board of the Show Corporation for a two year term while Vin Uhlrich, renewal tube sales manager for *National Union Radio Corp.*, continues his directorship for another year.

The Sales Managers Club is one of the sponsors of the annual Parts Show held in Chicago.

**ROBERT B. BEETHAM** is the new works manager of the Hicksville plant of *Ampere Electronic Corporation*.

For the past five years, Mr. Beetham was associated with the *Airborne Instrument Laboratory*, where he held the position of executive assistant to the vice-president in charge of research and engineering.

Prior to this period, he was affiliated with the *Collins Radio Company* for a period of fourteen years in an engineering capacity and later as assistant to the president.



**OXFORD ELECTRIC CORPORATION** of Chicago has acquired two new firms, **RADIONIC CONTROLS, INC.** and **WILDER MFG. CO.** both located near Carbondale, Ill. They will be operated as subsidiaries of the parent firm . . . **GEN-**

**ERAL ELECROSONICS, INC.** of New York City and New Rochelle has merged with **SEGAL LOCK AND HARDWARE CO., INC.** of New York . . . **COMMERCIAL PRODUCTS** has been recently established in Toledo, Ohio to manufacture antenna mounting equipment and parts. Principals of the new firm include Glenn W. Braun and associates . . . **AEROVOX CORPORATION** of New Bedford, Mass. has acquired the **CINEMA ENGINEERING CO.** of Burbank, California and will operate the new subsidiary as a division of the corporation . . . **BARTH MANUFACTURING CO.** of Milldale, Conn. has been sold and reorganized under the name of **BARTH ENGINEERING AND MANUFACTURING CO.** The new concern is headed by Charles Russell of West Hartford. Supplementing present manufacturing operations, the new concern plans to emphasize engineering development and production of electronic, electromechanical, and electrohydraulic control equipment . . . **HYTRON RADIO & ELECTRONICS CO.** has officially changed its name to **CBS-HYTRON**. The firm is the radio and television tube manufacturing division of **CBS**, as well as producers of the corporation's line of germanium diodes and transistors.

**H. WARD ZIMMER** has been elected president of *Sylvania Electric Products Inc.* while Don G. Mitchell, former president, has been elevated to the post of chairman of the board.

Mr. Mitchell, who has been president of the firm since 1946, succeeds as chairman, Max. F. Balcom, a member of the *Sylvania* organization and predecessor companies for 35 years. Although Mr. Balcom is retiring from the chairmanship, he will continue to serve the company as a director and in a consultative and advisory capacity.

The new president has been executive vice-president since 1950 and for three years prior to that time was vice-president in charge of operations.

**QUAM-NICHOLS COMPANY** is currently moving into its new block-long factory and executive offices at the intersection of Marquette Road and Prairie Avenue on Chicago's South Side. The new plant will give the speaker manufacturer an estimated 75,000 square feet of production space . . . **WESTCHESTER ELECTRONIC SUPPLY CO., INC.** has leased an entire building at 600-610





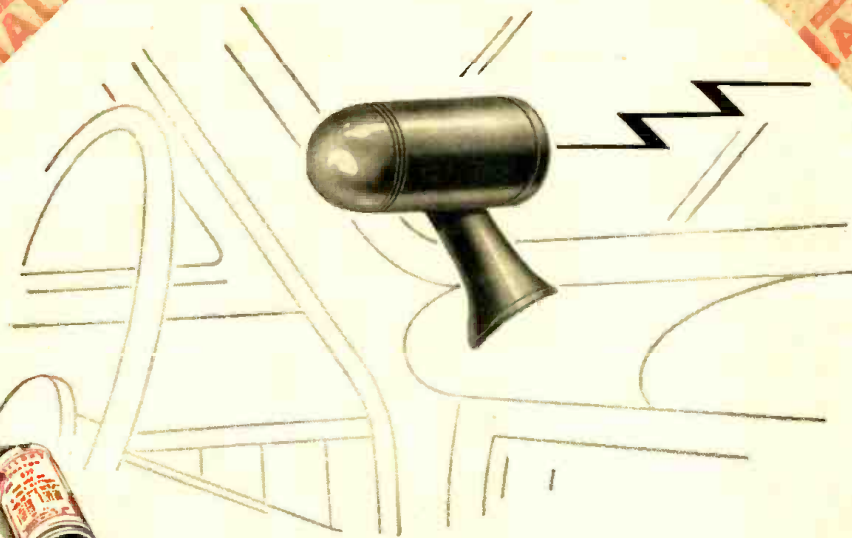

a big, new replacement market for  
**Mallory Vibrators... ELECTRONIC HEADLIGHT DIMMERS**

**THE MARKET** Already, over a hundred thousand new automobiles are equipped with automatic, electronic headlight dimmers. By the end of the year this figure will be multiplied several times . . . and the first of them are beginning to need service.

**THE OPPORTUNITY** This can be big business for you . . . business that may grow even larger than automobile radio service. But, if you are to get full benefit of this new market, automotive shops must be told that these are *electronic devices . . . devices that should be serviced by qualified radio service men*. Explain it, now, to every car dealer and shop for which you do service work.

**THE PRECISION PARTS** Automatic headlight dimmers depend on a vibrator power supply unit. When it is time for vibrator replacement, you can be sure the job is right if you use Mallory. As in the case of automobile radios, Mallory worked closely with the manufacturer and played an important part in this new development by supplying the first original equipment vibrators. With just three Mallory Vibrators you can service any unit now on the market.

P. R. MALLORY & CO., Inc.  
**MALLORY**

CAPACITORS • CONTROLS • VIBRATORS • SWITCHES • RESISTORS  
RECTIFIERS • POWER SUPPLIES • FILTERS • MERCURY BATTERIES

**APPROVED PRECISION PRODUCTS**

**P. R. MALLORY & CO., Inc., INDIANAPOLIS 6, INDIANA**

*Depend on Mallory  
for  
Approved Precision Quality*



Facts listed are published through the courtesy of Mr. Anthony Todaro, part owner of a thriving radio and TV shop in Monessen, Pa. . . . Monessen Radio and Television. Mr. Todaro's growing business is based upon a policy of "the best" in material and service.

When reputations rely upon quality... **PERMA-TUBE** stands the test!

**HERE'S THE PERMA-TUBE RECORD AT \*MONESSEN RADIO AND TELEVISION**

- 1** 1800 installations without a single antenna mast failure.
- 2** Not a single claim for rusted, bent, twisted, or broken masts since PERMA-TUBE was adopted in 1949.
- 3** PERMA-TUBE installations show no wear after 41 months (average antenna life 27 months).
- 4** Storm that flattened 100 antennas failed to buckle PERMA-TUBE masts.
- 5** PERMA-TUBE supports shop's fine reputation for high-quality work.

Here's why PERMA-TUBE backs up quality service

- 1** PERMA-TUBE IS STURDY . . . it's made of special, high-strength, J&L steel.
- 2** PERMA-TUBE IS CORROSION-PROOF . . . it's treated with vinsynite—then coated inside and outside with a metallic vinyl resin base.
- 3** PERMA-TUBE IS EASILY INSTALLED . . . it's the only mast with both ends of the joint machine fitted.

Here's proof of how Perma-tube resists corrosion

Section of ordinary conduit tubing used for TV masts after 96 hours in a salt spray test (A.S.T.M. Designation B-117-49T) to accelerate corrosion. Extensive rust inside the mast has reduced strength—caused rusty water to drain onto the owner's home.

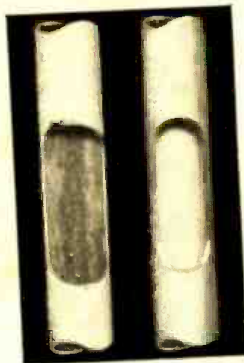

Section of PERMA-TUBE after 500 hours salt spray test shows no evidence of corrosion. Strength has been retained and the chance of rust streaks on owner's home is eliminated. Note sturdier wall thickness of PERMA-TUBE sample.

PERMA-TUBE IS AVAILABLE IN STANDARD LENGTHS . . . DIAMETERS . . . WALL THICKNESSES. FOR COMPLETE INFORMATION MAIL THIS COUPON



Jones & Laughlin Steel Corporation  
495 Gateway Center, Pittsburgh 30, Pa.

Without charge, please send me:  Name of nearest distributor  Complete information on PERMA-TUBE

Name \_\_\_\_\_  
Company \_\_\_\_\_  
Address \_\_\_\_\_

Mamaroneck Ave. in White Plains, N. Y. The two-story brick structure provides over 12,000 square feet of space for conducting the company's distributor business . . . **FEDERAL ELECTRIC PRODUCTS COMPANY** of Newark, N. J. is now completing a new factory in Los Angeles. The plant has 45,000 square feet of floor space and 80,000 additional square feet for parking and future expansion . . . **ARROW ELECTRONICS** has opened a new store at 215 Front Street in Hempstead, L. I. The new outlet, the company's fourth, will stock a complete line of parts and equipment for service technicians, hams, high-fidelity fans, experimenters, hobbyists, engineers, and industrial purchasers . . . **JERSEY SPECIALTY COMPANY** has recently completed a new plant on Burgess Place, Mountain View, N. J. . . . **SENTINEL RADIO CORP.** has opened a factory-owned branch to handle distribution of the company's radio and TV sets in the Greater Chicago area. The branch is located at 1234 W. Washington Blvd. in Chicago . . . Production is underway at the new **INTERNATIONAL RESISTANCE COMPANY** plant in Asheville, N. C. The newly-built, \$200,000 plant will employ approximately 500 persons when operating at full strength . . . **SUN RADIO AND ELECTRONICS CO., INC.** opened its new "electronic supermarket" at 650 Avenue of the Americas in New York with an elaborate open house attended by civic and industry leaders. The headquarters provides 20,000 square feet of sales space all on one floor.

**STEVE VAN ROEKEL** has been appointed general sales manager of the *Stephens Manufacturing Corporation* of Culver City, California.



He comes to his new post from Omaha, Nebraska where he owned and operated the *Midwest Sound Company*, sound equipment distributors. The new executive is an expert in electronics, having had 25 years of experience in the field.

Mr. Van Roekel studied electrical engineering at the University of Colorado and served for three years with the Army Signal Corps during World War II as a specialist in airborne radar.

**RAYMOND C. COSGROVE**, formerly executive vice-president of *Avco Manufacturing Corp.*, has been named management consultant of *National Company*, Malden, Mass. . . . **D. W. GUNN** has been appointed to the newly-created post of assistant-general sales manager of radio tube and TV picture tubes sales for *Sylvania Electric Products Inc.* . . . **NARDA** has appointed **CARL F. GUINEY** to the post of insurance director for the trade association. He will be in charge of the organization. (Continued on page 76)



# RADIO-ELECTRONIC *Engineering* SECTION

**RADIO &  
TELEVISION  
NEWS**

Reg. U.S. Pat. Off.

TELEVISION • RADAR • ELECTRONICS • RESEARCH • COMMUNICATIONS • MICROWAVES

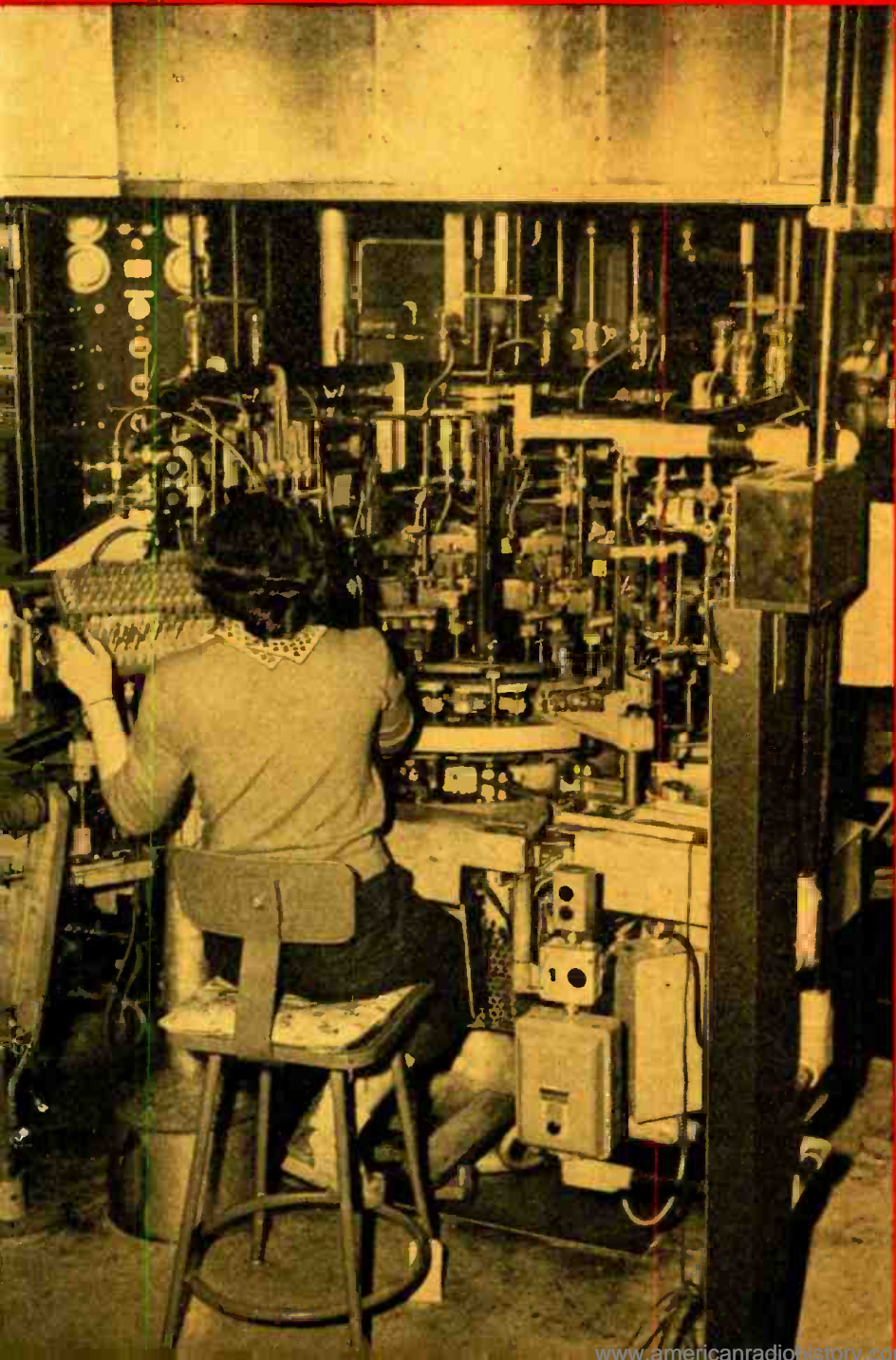

**JULY, 1953**

DIRECT-COUPLED  
INSTRUMENT AMPLIFIER  
3

A MULTIRANGE SENSITIVE CONTROL  
6

PULSE DURATION MODULATION  
8

PHASE ANGLE MEASUREMENTS AT A.F.  
12

ELECTRONIC FLOWMETER  
14

OSCILLOSCOPE VOLTAGE CALIBRATOR  
15

MEASURING ATTENUATION  
WITH THE SLOTTED LINE  
18

URSI-IRE MEETING  
32

**DEPARTMENTS**

NEWS BRIEFS ..... 20

NEW PRODUCTS ..... 22

TECHNICAL BOOKS ..... 23

LOOKING AT TUBES ..... 24

NEW LITERATURE ..... 26

PERSONALS ..... 28

CALENDAR ..... 30



Copyright, 1953, by Ziff-Davis Publishing Company  
RADIO-ELECTRONIC ENGINEERING is published each month as a special section in a limited number of copies of RADIO & TELEVISION NEWS, by the Ziff-Davis Publishing Company, 366 Madison Avenue, New York 17, N. Y.

Edited by H. S. RENNE  
and the Radio & Television News Staff

Modern cathode-coating, grid-winding spot-welding, and sealing-exhausting equipment is operated chiefly by women at the new Bath, N. Y., tube manufacturing plant of Westinghouse Electric Corp. Similar functions are performed at the nearby Elmira, N. Y., factory.



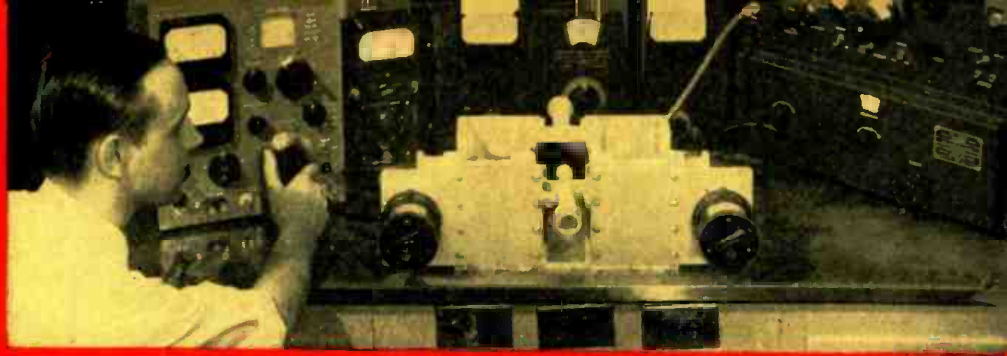

# for SPECIALIZED FILTERS

Decades of experience in the design and production of specialized filters have resulted in UTC being a first source for difficult filters. Fifteen years ago UTC was already the largest user of permalloy dust toroids in the world (exclusive of the telephone system). Present designs include a wide variety of core materials, structures, and winding methods to provide maximum performance in electrical requirements and stability. Illustrated below are a few of the thousands of special-filter designs in present production.

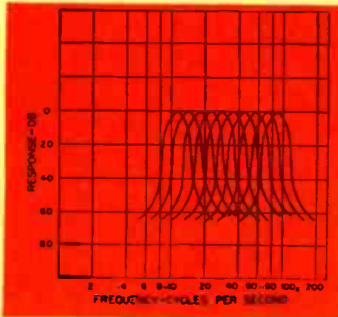

These low frequency band pass filters are held to 1 DB tolerance at the 3 DB crossover ... 600 ohm ... 4 filters per 7½" rack panel.

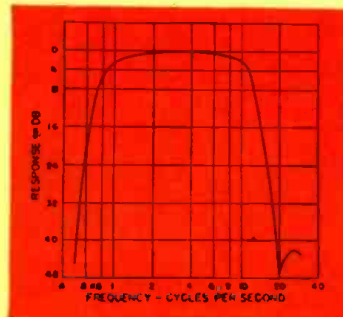

This ultra low frequency filter has a band pass range of one cycle to 10 cycles ... 50,000 ohms ... 700 cubic inches.

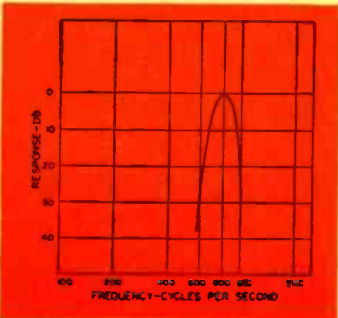
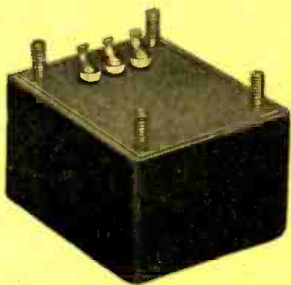

This 600 ohm miniaturized 1 KC band pass filter is housed in a case only 1" x 1¾" x 2½".

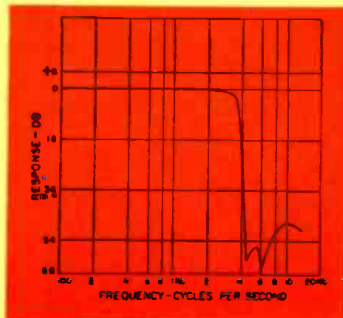

This 600 ohm miniaturized low pass filter is housed in a case only 1" x 1¾" x 2½".

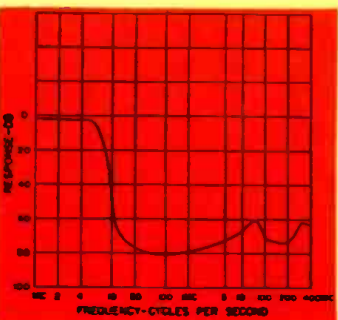
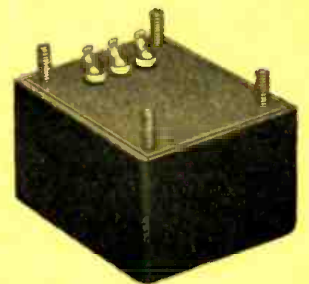

This power line filter provides correct output voltages from sources of 50 to 400 cycles ... noise attenuation is from 14 KC to 400 MC ... 29 cubic inches.

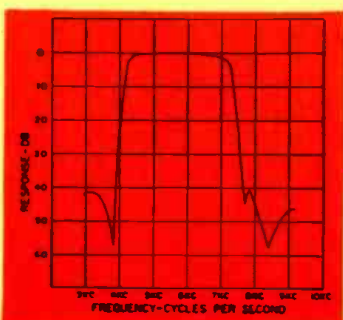

This band pass filter is designed for sharp cut-off at both ends of the range ... 10,000 ohms ... case dimensions 1½" x 2½" x 3¼".



*United Transformer Co.*

150 VARICK STREET

NEW YORK 13, N. Y.

EXPORT DIVISION: 13 EAST 40th STREET, NEW YORK 16, N. Y.

CABLES: "ARLAB"



# DIRECT-COUPLED

# INSTRUMENT

# AMPLIFIER

By

GEOFFREY H. GREY

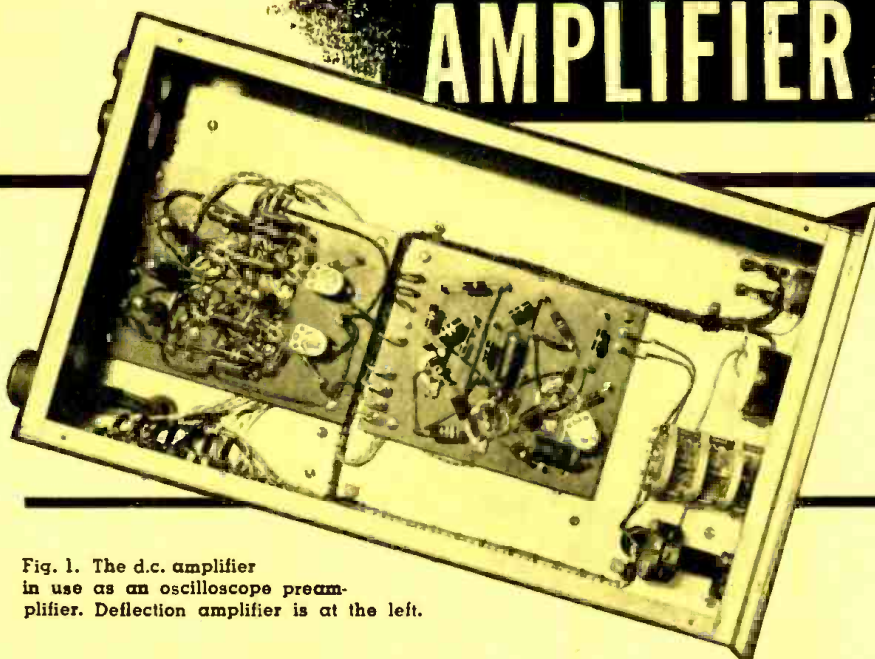

Fig. 1. The d.c. amplifier in use as an oscilloscope preamplifier. Deflection amplifier is at the left.

A DIRECT-COUPLED amplifier with a voltage gain of 200 and a frequency response to 500 kc. has a number of possible uses. It may serve as the voltage amplifier (as distinct from the output or deflection amplifier) in oscilloscopes, in both a.c. and d.c. vacuum-tube voltmeters, and as an ordinary audio amplifier. More specialized applications of this type of circuit are to be found in analog computers and in the field of dynamic measurements on mechanical structures.

A successful device of this type, intended primarily for the oscilloscope application, is pictured in Figs. 3 and 4. This amplifier is believed to be typical of many commercial circuits in current use, and there is nothing bizarre about it. As to its use in oscilloscopes, the desirability—in a general purpose laboratory instrument—of having response to d.c. is hardly controversial. Any good commercial oscilloscope now has this feature whenever the proposed uses in any way justify its inclusion.

Less common is the use of identical horizontal and vertical amplifiers. It is highly desirable to have the X and Y axis performances as alike as possible, for if the X and Y amplifiers are carefully aligned and are stabilized by substantial amounts of inverse feedback, it is possible to place some faith in methods of measurement involving Lissajous and similar figures. It is then possible to make accurate measurements of relative phase shifts at comparatively high frequencies, bordering on the high frequency limits of the oscilloscope amplifiers themselves. This is important when one is attempting to design and construct stable feedback amplifiers.

In a general-purpose oscilloscope of the author's design, the plans called for a sensitivity in both X and Y axis channels of about 28 millivolts per inch for d.c. signals, and the equivalent 10 millivolts r.m.s. per inch for a.c., to be obtained by feedback amplifiers as alike as possible. The first amplifier in each channel was to supply most of the required voltage gain of 200, while the second—or deflection amplifier—was to

have a fairly low voltage gain (15) and the necessary high output voltage capability for driving the plates of the cathode-ray tube. The preamplifier section of both vertical and horizontal amplifiers is the subject of this article.

In arriving at the proper configuration for the preamplifier, the following factors were considered:

1. Drift, due to random changes in emission and to line voltage fluctuations
2. The simplicity and flexibility of the type of feedback divider whereby the adding of the input and feedback voltages occurs at the input grid rather than at a cathode
3. The provision of about 40 db of feedback in the midband, and the maintenance of as much of the original feedback to as high a frequency as possible consistent with good transient response and absolute stability against oscillations
4. Minimization of the number of stages and components
5. Availability of a "spare" grid at the input stage, so that there would be a place to insert a correcting voltage if a servo-type stabilizer to correct for d.c. errors were to be added later (This is an expensive and troublesome modification, but it is capable of virtually removing drift as a problem.)

6. Operation on + and -300 volt regulated power supplies, without intermediate supplies (These  $\pm 300$  volt supplies appear to be standard in a great deal of instrument work, notably in large installations such as computers, and the author confines himself to their use wherever possible. In this particular amplifier, any intermediate voltages for the screens of pentodes, which in a d.c. amplifier have to be regulated, were to be obtained from local regulators of the simplest type. If one has a number of screens at the same potential, for example, it pays to put in a common supply to regulate all of them.)
7. Avoidance of d.c. heater supplies (Regulation of the heater of the input tube by some simple means such as a current-regulator tube was not ruled out, however.)
8. Input impedance to be 2 megohms shunted by a small capacitance, and output impedance to be of the order of a few hundred ohms

The drift requirement led immediately to the use of some form of cathode compensation, and the desire for a spare grid indicated that the cathode-coupled or differential amplifier would be the most suitable of the many circuits available. This type of amplifier stage is most useful in that one may

*A stable amplifier with a gain of 200 and a frequency response that is essentially flat from d.c. to 500 kc.*



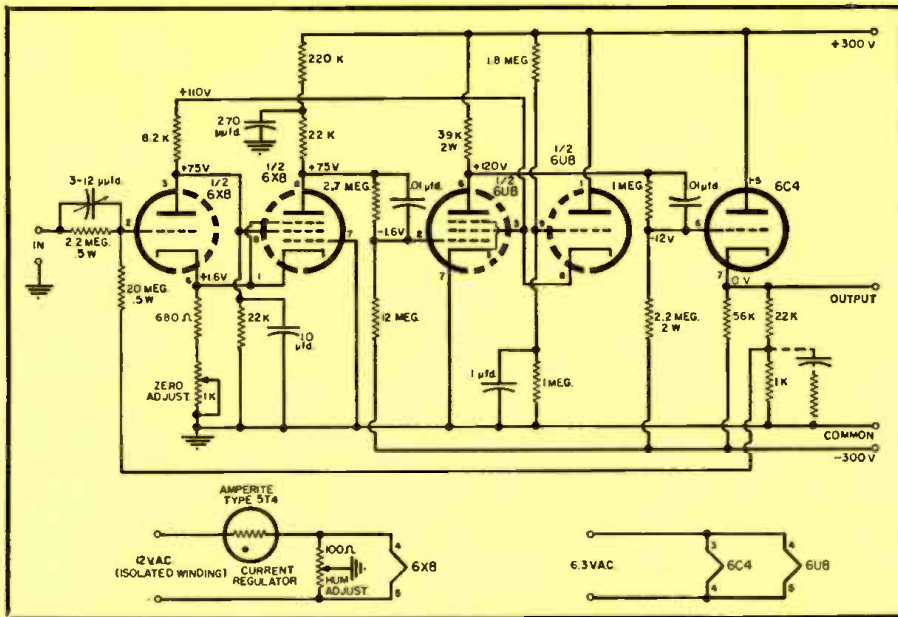

Fig. 2. Complete circuit diagram and parts values for the d.c. amplifier. The heater system for the amplifier is shown at the bottom of the diagram.

use either of the control grids (see Fig. 2) as the input grid, the other grid being grounded or used for inserting feedback voltages. There is a choice of either positive or negative voltage gain, so that negative feedback may be used around the whole amplifier regardless of whether the total number of stages is even or odd. Use of an extra stage of gain just to make the over-all gain come out with the desired sign is therefore unnecessary, and the remainder of the amplifier may be designed without such restrictions. In this case, the first stage was set for positive gain (+200) and the second and last stage had—as usual—a negative gain, so that the over-all gain was negative.

There was something of a conflict regarding the choice of a tube for the input stage. It was desirable to use pentodes in this particular design, for the gain was to be obtained with as few stages as possible, while at the same time it was important to use a dual tube, preferably with a cathode sleeve common to both sections in the manner of the 6J6. The new triode-pentode 6X8 has such a symmetrical structure, with a pentode on one side of the cathode and a triode on the other. Use of this tube offers both high gain and a chance for drift reduction. Since it is not built for low-level service, it cannot be expected to give good results so far as hum and microphonics are concerned, although with reasonably low space currents it would seem to be as good as most tubes in matters of grid content. Selection of tubes is always possible, of course, if one has a large stock at one's disposal, but in this case shock-mounting was resorted to and the grid current was minimized to a reasonable degree by choice of opera-

ting conditions. Hum was not troublesome.

Having chosen the tube and the configuration, it was necessary to allow the bandwidth, gain, grid current, and noise considerations to determine the circuit constants. Past experience in the design of d.c. amplifiers indicated that about a milliampere of plate current and grid biases of about -1.6 volts were most suitable for circuits of this general nature. When the 6X8 has about 75 volts on the triode plate and pentode screen, it will draw roughly 900 microamperes per side for a grid bias (the same on both sides) of the required value. With both triode plate and pentode screen at the same potential of +75 volts above the cathode, and with both sides drawing about equal cathode currents, it was hoped that drift would be minimized. (The triode plate and pentode screen influence their respective cathode currents to about the same degree, for equal grid biases, due to the well-known pentode property of disregarding plate potential once it is above a certain minimum.) About all that can be said at this time, since the more elaborate tests have not yet been performed, is that after a five-minute warmup the drift is very noticeably less than that which has previously been experienced with twin-triode input stages. The drift is not excessive for oscilloscope uses unless a really accurate d.c. measurement must be made.

The triode plate and pentode screen were run from a divider at about +75 volts. Using a similar potential for the pentode plate, the plate load turned out to be about 250K. This proved to be adequately high from the gain standpoint and low enough to get the band-

width desired without having to use too much or too many stages later on.

The voltage divider for the triode plate and pentode screen was made to draw 3.5 ma., the screen taking about 0.2 ma. under quiescent conditions. This point was then bypassed with a 1- $\mu$ f. capacitor, chiefly because past work had shown that noise and hum might be reduced if this were done. The divider is regenerative in action, and there is no loss in gain due to its regulation. In some cases, the gain was observed to go up when this junction was bypassed. (Any change in triode plate potential constitutes an equal change in pentode screen potential, and decreases in gain due to losses in the triode half are made up by increased gain in the pentode half.)

Remaining gain requirements were met by use of another triode-pentode—a 6U8, the pentode section supplying a voltage gain of about 100 and the triode serving as a simple regulator of the cathode-follower variety for the screen of the pentode. Power supply economy held the pentode plate current to about 4.5 ma., which was also felt to be the maximum for a reasonably long life. The 39K load resistor allows a good bandwidth, and the comparatively high plate current and low screen voltage gives a transconductance sufficient to yield the desired gain. With the grid bias again around -1.6 volts, the screen voltage was found to be +110 volts. It was convenient to run the first stage screen divider from the same cathode follower that supplied the screen of the second tube. Duplication of screen divider currents is wasteful, and the slight amount of regeneration which might exist as a result of the common divider is not enough to be a problem. It may be beneficial in raising the effective over-all negative feedback.

Coupling between stages is accomplished by the method most commonly followed in d.c. amplifiers—a resistive divider is returned to a source of -300 volts, with the upper resistor being bypassed for a.c. above a few cycles a second. Some designers prefer to use very small values of capacitance for this bypassing, thus putting a slight rise in the high frequency response of the amplifier to compensate for falling off elsewhere. This seems to be of dubious merit, in most cases, since it does not increase the internal gain of the amplifier except insofar as one loses gain in the midband in order to realize an apparent slight increase at the high end, and it complicates the matter of controlling the response at the high end so that often one does not know what particular value should be used for bypassing.

The output tube is a 6C4 cathode fol-



lower, operated across the whole 600 volts of the supply, with about 5 ma. of plate current. Following it is a resistive divider (22K and 1K) to attenuate the feedback voltage before it goes to the main feedback divider (20M and 2.2M). This double division means that when the input proper is connected to a source with output impedance low compared to 2.2M, the effective feedback voltage at the input grid is approximately  $1/23 \times 2.2/20$ , or about  $1/200$  of the output voltage of the amplifier. Thus the over-all gain is the inverse of this, or 200. The double division is an expedient made necessary by the fact that if one attempted to attain a voltage gain of 200 over-all with only a single division of the feedback voltage, using a 2.2M-input resistor, then the feedback resistor would become 440M in place of the present 20M. The highest value considered by the author to be practical for such purposes is 100M, and this was also the highest value within reach at the time of design. It is, furthermore, rather optimistic to expect to get 500 kc. response when one is using resistors of values greater than 100M without extraordinary precautions.

Capacitance across the 20M resistor, inevitable even though small, makes it necessary to shunt the 2.2M input resistor with a trimming capacitor (3-12  $\mu\text{fd.}$ ). It may also, in some cases, be necessary to compensate the 22K and 1K divider in similar fashion. This is accomplished by putting a suitable pot, say 10K, and perhaps a 500- $\mu\text{fd.}$  capacitor in series across the 1K resistor, then adjusting the pot (and—if necessary for best results—changing to another value of capacitance) for best transient response. A 10-kc. square wave is about right. This compensating circuit is shown dotted in Fig. 2.

As the geometry of the actual ampli-

fier makes such a great difference, it is difficult to predict every part value in advance, and the photographs of a model that works have been provided with the idea of showing one geometrical arrangement which has been carefully worked out.

In matters of construction, as the photographs show, the author strongly believes in liberal use of bakelite boards and in the use of turrets. This type of construction is usually only found in fairly expensive instruments, although it is becoming more common in the middle brackets, so to speak. There is a considerable advantage to the use of this technique in that replacement of the small parts is very easy, and—if the hollow-top type of turret (or terminal lug, as it is often called) is used—there is no twisting of resistor leads. By putting holes in the boards for tube sockets, using hole-saws rather than fly-cutters, and putting the hollow end or main body of the turret on the same side of the board as the tube pins, one is able to indulge in just about as much point-to-point technique as could be desired. At the same time, one has a very handsome and sturdily-built subassembly, with parts that can all be easily replaced. Contrary to past tradition, incidentally, the ends of the resistor leads which go to the tube sockets are not twisted around the pins. Provided that a good solder joint is made, using 60-40 solder, it is not necessary to go in for much twisting and mangling of the leads. After all, the very stout AN series of connectors, which are about as rugged as most people would normally need, merely use solder cups, without twisting or wrapping of leads; and in the far less onerous service which tube socket pins undergo, it would seem that merely pushing the leads into the holes and getting a good solder joint would suffice.

The partial bypassing of the first pentode plate to ground, whereby the plate load is tapped at about the 10% point and a 270- $\mu\text{fd.}$  capacitor hung from there to ground, is done for reasons of high frequency stability. If both stages are allowed to roll off at once at the high end, they will—together with the cathode follower stage—reach the 180° point well before the amplifier has run out of feedback, and oscillations will occur. The network at the first plate merely insures that the plate-to-ground capacitance will appear across the 22K resistor, rather than across the whole 242K, in the region where the other parts of the amplifier are letting down. The 270- $\mu\text{fd.}$  effectively bypasses the main part of the 242K resistance in this region.

With no slope in the useful band greater than 6 db per octave, there is no chance of oscillation; and since the slope is so conservative, the high frequency response is very clean and free from peaks and dips, peculiar phase shifts, and so on. One cannot expect good transient response unless one controls the internal gain out to well beyond the useful band. The parts values are felt to be quite conservative, and the amplifier will not oscillate even for large departures from normal in gain of the individual stages, heater voltage, and component values. Power dissipated in tubes and components was in all cases held to low levels, well below ratings, and the life of each part should be long. No portion of the amplifier is working very hard.

The power supply is rather important. Two good electronic regulators are required, one for +300 volts at 15 ma. and the other for -300 volts at 5 ma. For the less critical d.c. applications, a VR tube system would suffice; and for uses involving a.c. amplifica-

(Continued on page 25)

Fig. 3. Bottom view of the instrument amplifier.

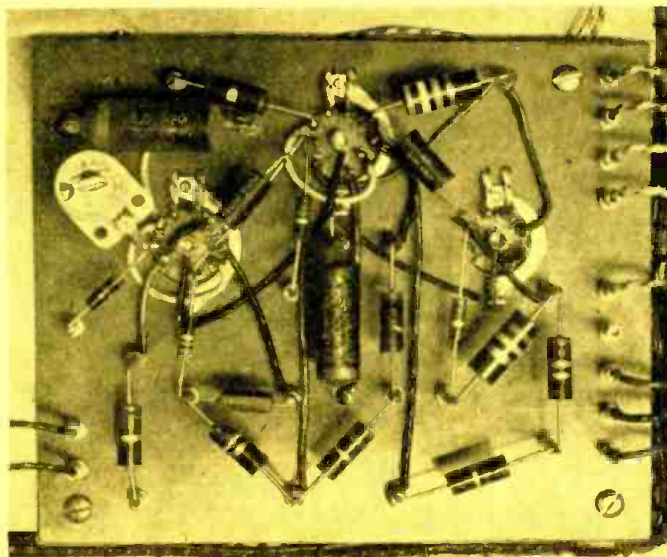
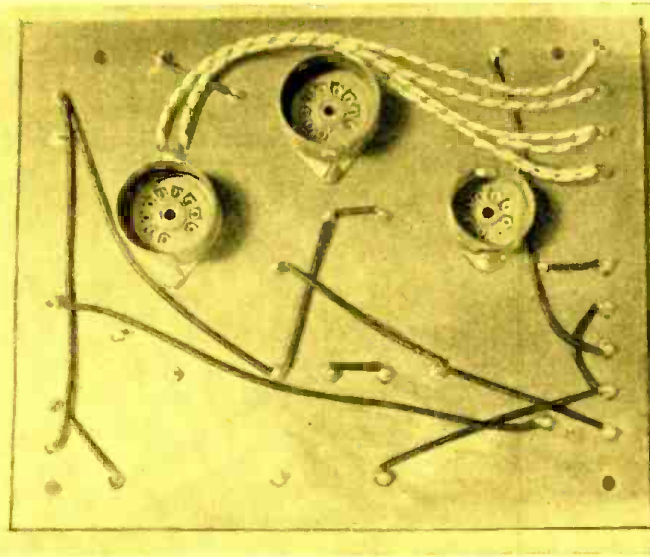
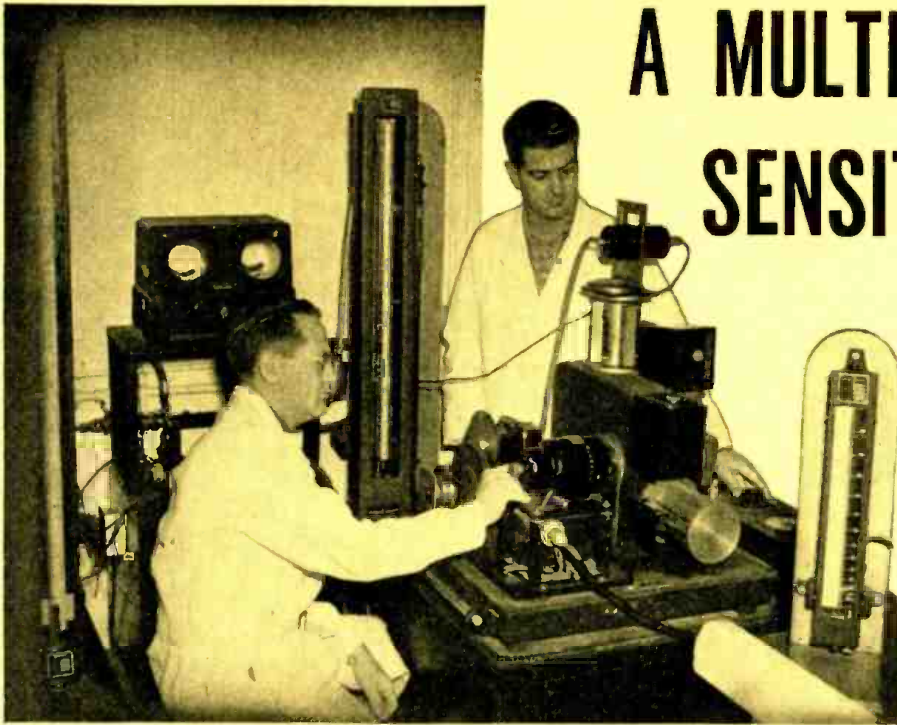

Fig. 4. Top view, showing the heater wiring.





# A MULTIRANGE SENSITIVE CONTROL



The control being given a vibration shake-down test by the authors.

By

**WINSTON ALDERSON and DOUGLAS ERICKSON**

Development Laboratories, Ryan Aeronautical Company

*A sensitive photocell-actuated control for use with instruments utilizing a low torque shaft.*

IN THE Development Laboratories of the Ryan Aeronautical Company, a new multirange sensitive control has been designed which is expected to have wide usefulness in industrial and commercial fields. Invented by the authors, this device is completely positive in operation, is practically unaffected by vibration and temperature change and, most important, will respond to the smallest measurable changes in conditions without detracting from the sensitivity or accuracy of monitoring instruments.

Basically, the device is a sensitive control actuated by a low torque instrument that controls the light source for a photoelectric cell. The cell is connected to a vacuum tube amplifier and a sensitive relay which can transmit a signal to various electrical or electronic apparatus.

The principal objective of the development was to produce a multirange sensitive control of this class which could be operated by various instruments such as sensitive altimeters, air speed indicators, tachometers, pressure gauges and other similar instruments utilizing a low torque shaft. Because of the inherent characteristics of such

instruments, one of the prime requisites of the control was that it should not impair the accuracy or sensitivity of the instrument to which it would be coupled by inducing inertia into the system. Another important consideration, influencing its application to aircraft installations, was that the control be capable of withstanding vibration and temperature change without loss of accuracy or function as well as being suitable for use over a wide range of measurement and with a variety of instruments.

Typical aviation uses for such a sensitive control would be the automatic control of speed, altitude and direction of aircraft in flight. Coupled with a

standard air speed indicator, this control is capable of maintaining the speed of an aircraft within five miles per hour without supervision. Because it is compact, lightweight, and can be attached directly to standard instruments, it is very well adapted for use with light planes, uninhabited or pilotless aircraft and missiles. Used with standard altimeters or tachometers, the device will automatically control plane altitude or engine speed within narrow limits and with positive action.

In addition to the basic functions which the control can perform, it may be harnessed to many other electrical devices to accomplish almost any task which should be performed under conditions that are measured by low torque instruments. For instance, it can automatically raise or lower aircraft landing gear and open and close engine cowl flaps at specified temperatures and speeds.

Because there is no mechanical linkage between the control and the instrument, this device is especially adaptable for use with instruments designed to indicate very slight changes in conditions, such as pressure gauges. It will respond to a pressure change of only one-tenth of an inch of water, or about the pressure of a normal exhalation of breath, without affecting the accuracy of the measuring instrument.

The unit consists of two tiny electric lamps, placed adjacent to each other, two photoelectric cells, a vacuum tube amplifier and two sensitive relays. The entire control apparatus is contained within a compact, cylindrical metal case measuring 4" in length and 3" in diameter.

Within the control body, the elements are separated by a metal partition in which two small, circular openings have been cut. These openings are light-emitting windows for the purpose of allowing light from the electric lamps to impinge upon the photoelectric cells. The small electric lamps are located on one side of the partition and the photoelectric cells are situated on the other side in such a way that the lamps, light windows and cells are in direct lines of sight.

When the control is attached to an instrument, a single modification is

Fig. 1. Sketch of the control unit.

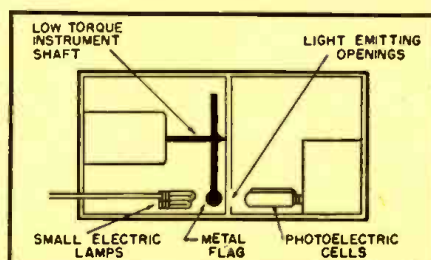



made in the instrument: the rotating pointer is removed and a small, counter-balanced metal flag is substituted. This flag is designed so that it can pass between the light sources and the light-emitting windows to obscure the light which is directed to the photoelectric cells. (See Fig. 1.)

To illustrate the operation of the control, a hypothetical case will be assumed in which the speed of a pilotless missile is to be automatically maintained within a range of 400 to 425 miles per hour. (It might be interesting to note that the control is capable of maintaining this velocity between much closer limits.) The control body is attached to an air speed indicator and the flag is located between stops set at 400 and 425 mph. The control's relays are connected to throttle regulators which will influence the plane's velocity.

To engage the control, the lamps are switched on. If the speed of the missile is below 400 mph, the light from one of the lamps will pass through the window and impinge upon one of the photo-cells. This cell reacts by generating a small current which is amplified by the vacuum tube, and the resultant signal actuates a relay to increase the speed of the missile. This condition (shown in Fig. 2A) obtains as long as the speed of the missile is below 405 mph. When the velocity goes above this speed, the pointer flag rotates and obscures the light from both lamps so that neither cell is activated (Fig. 2B). If the missile speed increases to 425 mph, the pointer flag rotates further, allowing the light from the other lamp to strike the other cell, thereby causing this cell to transmit a signal which operates to reduce the plane's speed (Fig. 2C). When the speed falls to 420 mph, the flag again covers both light-emitting windows and no signals are sent to the missile's speed-governing apparatus (Fig. 2D). Consequently, there is a null area of 20 mph in which the control does not operate. Once the flag enters this null area, the missile speed must either rise to 425 mph or drop to 400 mph before a signal is generated. In either case, the signal continues over a 5-mph margin before ceasing. This relieves the control of constant performance and gives better stability to the missile's flight. By simply varying the size of the flag, it is possible to alter the differential of the device. To change the range, it is necessary merely to rotate the control with respect to the instrument.

It is also possible to use the control to cause a single event to occur with positive reliability and without intermittent response from oscillating instruments. In this application, the control is used with two lamps, one photocell

and a single light-emitting window (Fig. 3B).

One of the two lamps is switched on and the instrument is set in operation (position 1, Fig. 3A). The light from this lamp passes through the window and strikes the cell, causing it to transmit the required signal. This condition obtains until the instrument's pointer flag rotates to a position in front of both lamps and directly in front of the window. At this point (position 2), the light is cut off from the lamp and the cell reacts. The relay then signals the servomechanism, switches on the adjacent lamp and extinguishes the original lamp. As the pointer flag rotates in the opposite direction, it uncovers the window and allows the light from the burning lamp to strike the photocell (position 3). Immediately, the original sequence is again set up in which the cell reacts to transmit the original signal and the relay extinguishes the second lamp and switches on the original lamp.

In this application, the control will operate within a predetermined differential with positive action. Oscillation of the instrument's flag will not cause intermittency of response from the control. By varying the distance between the lamps and the size of the flag, extremely sensitive perception of this differential can be realized.

With the control utilizing two photo-cells, it is possible to achieve amazingly accurate altitude control of flying aircraft by means of a simple modification. Tests have shown that a fast-flying aircraft can be held to within ten feet of a specified altitude under normal

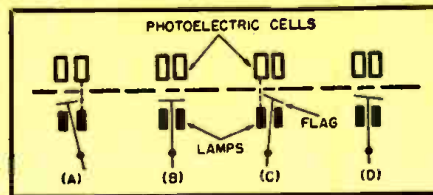

Fig. 2. Operational sequence of the control when dual photocells are used.

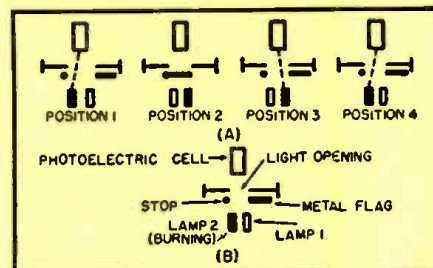

Fig. 3. Operational sequence of the control used with a single photocell.

atmospheric conditions by means of this arrangement.

The Ryan Development Laboratories have tested the control for reliability under conditions of vibration and temperature change. Over a temperature of 189°F., the accuracy of the device was affected less than 1%. In vibration tests, with 55 cycles at .030" amplitude, the control was accurate within a margin of 2%.

Other advantages of the control are its ruggedness, simplicity and low cost of fabrication. It does not require a high voltage power source but will operate on standard 24-volt d.c. current.



The control as applied to an aircraft tachometer (left) and an air speed indicator.





# PULSE DURATION MODULATION

By **HENRY T. PERETKO**  
Princeton University\*

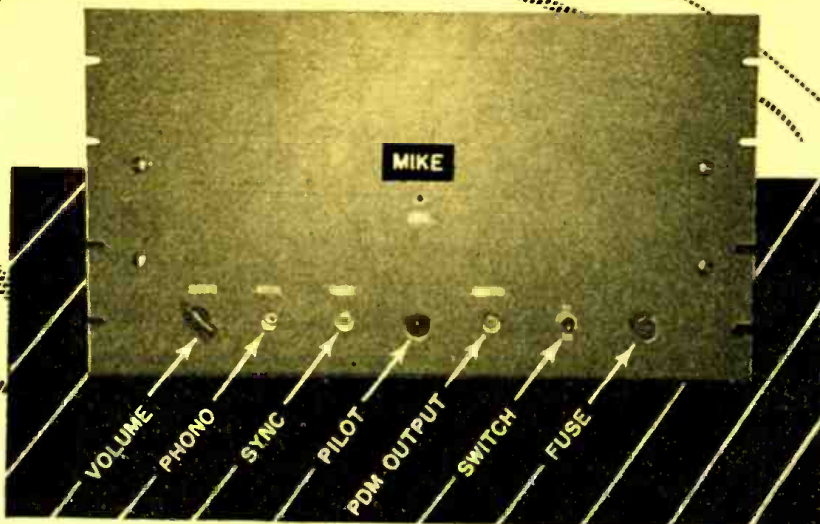

Front view of experimental PDM unit arranged for rack mounting.

*PDM characteristics are discussed, and details are given on an experimental modulator and demodulator.*

**T**HERE ARE many methods of modulation which come under the general heading of pulse modulation, some of which have shown great promise—and thus have been used extensively—and others which are in the developmental stage. It is generally accepted that the three major types of pulse sampling are:

1. Pulse amplitude modulation, or PAM, where the amplitude of the pulse is varied
2. Pulse code modulation, or PCM, where the signal amplitude range is divided into discrete levels and a group of pulses represents each signal level (The number of omissions and the particular pulses omitted in each group contain the information concerning the amplitude of the signal for that single group sample.)
3. Pulse time modulation, or PTM, where the time of the occurrence of some particular characteristic of the sampling pulse is varied

Under the heading of PTM there is:

- (a) Pulse position modulation, or PPM, where the time position of the pulse is varied
- (b) Pulse frequency modulation, or PFM, where the recurrence frequency of the pulse is varied (Note that PFM is not suitable for time-division multiplexing.)
- (c) Pulse duration modulation, or PDM, where the time of the pulse is varied

The last type is also referred to as pulse width modulation, or PWM, and pulse length modulation, or PLM. Moreover, it is evident that either edge or both edges of the sampling pulse

may be varied, giving three other subdivisions under PDM.

The character of the pulse modulation to be treated in detail here is such that the leading edges of the sampling pulses are equally spaced, having a time displacement equal to the repetition or recurrence time. The trailing edges, on the other hand, have a time displacement from their respective leading edges which is proportional to the amplitude of the modulating signal at the exact instant of the trailing edge. See Fig. 4.

## Experimental System

Simple RC differentiation of the stabilized symmetrical plate-coupled multivibrator output and positive clipping with an efficient germanium diode yield negative triggers of relatively short time duration which have a fixed time displacement of 100 microseconds. These triggers are used to drive the linearized cathode-coupled gate, which is the heart of the pulse width modulator used in the experimental system under discussion. A block diagram of the system is shown in Fig. 1.

By merely using RC coupling, since the grid is never driven positive, the

audio signal from the audio preamplifier is injected into the biased grid of the gate, yielding output plate pulses with fixed leading edges and modulated trailing edges. A cathode follower stage is used as a buffer and then the final inverted output is obtained from the shaper amplifier.

Most of the quantitative testing of the experimental unit was done by means of a *General Radio* wave analyzer, which acted as a highly tuned filter demodulator and yielded information on frequency content. Figure 3, however, shows the system which was used to monitor the demodulated output, for both phonograph and microphone, thus noting the quality of reproduction the system offered. The low-pass filter demodulator is shown in Fig. 2. It is this simplicity of demodulation that is inherent in PDM but lacking in PPM because of the extremely small amplitude of the audio component in the PPM frequency spectrum.

The 10-kc. rejection indicated in Fig. 2 is quite necessary since the repetition rate is 10 kc., making the 10-kc. term much larger in amplitude than the signal term itself. For example, if the ratio of the operating pulse width  $\tau_0$  to the repetition period  $T$  is .159, and the depth of modulation  $m$  is 10%, then the ratio of the amplitudes of the 10-kc. carrier term  $f_c$  to the modulating signal term  $f_m$  is 20:1. If  $\tau_0/T$  is .159 and  $m$  is 100%, the ratio is 2:1.

As will be shown later, the audio component may readily be recovered by using the low-pass filter demodulator, since there is no inherent harmonic distortion. However, the lower primary sideband terms result in distortion which limits the usable bandwidth, generally, to slightly less than one-third the recurrence frequency. If, then,

Fig. 1. Block diagram of experimental system suitable for pulse code modulation.

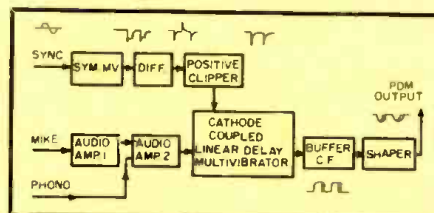

\*This article is based on the author's Master's thesis, submitted to Princeton University on February 6, 1953.



these lower sidebands could be removed separately at the receiver prior to low-pass filter demodulation, the bandwidth of the signal might be raised to its theoretically maximum value of  $f_r/2$  and be completely free of any inherent distortion. To achieve this, it would be necessary to convert the PWM wave train at the receiver to a PAM wave train (whose only sidebands are a pair of primary sidebands, as with AM) prior to low-pass filter demodulation. Though some slight tube distortion might occur due to the conversion, this technique would result in a communication system with no inherent distortion but with the noise-cleaning characteristics of an ordinary PDM system—which would usually include a slicer for this purpose.

### Spectral Analysis

One perfectly general approach to the problem of spectral analysis of a pulse-duration modulated wave train is to express the pulse train as a continuous function of frequency by means of the Laplace transform or the Fourier integral, but the final result is a complicated expression which is difficult to expand—since the actual system yields a line spectrum solution. Another method of attack is to generalize the expression as a function of time obtained by making a Fourier series analysis of a pulse train that is periodic after a few pulses; but this, too, becomes quite involved as it is very difficult to extract the separate frequency components that will exist. Moreover, the expression is too unwieldy to handle cases where the pulse train is almost periodic due to  $f_r/f_m$  not being integrally related.

Since the solution is known to be a line spectrum or a discontinuous function of frequency, it seems logical to use the trigonometric form of the Fourier series. The method of analysis to be employed, then, is simply to express the  $f(t)$  of one pulse by means of the Fourier series and then, in the limits of integration for  $A_n$  and  $B_n$ , to insert for  $\tau$  its value as a function of time, assuming a simple sinusoidal modulation of:

$$\tau(t) = \tau_0(1 + m \sin \omega_m t) \text{ } \mu\text{sec.}$$

- where:  $\tau_0$  = operating width or unmodulated pulse width in microseconds
- $T$  =  $1/f_r$  the repetition period in microseconds
- $A$  = amplitude of the pulse in volts
- $\omega_m$  = the modulating angular frequency
- $m$  = % modulation of the operating width,  $\tau_0$

Completion of this analysis leads to the frequency spectrum of Fig. 5. The predominant components are:

1. D.C. term d.c.  $E_{d.c.}$
2. Modulating frequency term  $f_m$   $E_m$
3. Repetition frequency term  $f_r$   $E_r$
4. Lower primary sidebands  $f_r - kf_m$   $E_{l.b.}$
5. Upper primary sidebands  $f_r + kf_m$   $E_{u.b.}$
6. Harmonics of repetition frequency term and its sideband terms  $nf_r \pm kf_m$

where:  $n$  = order of harmonics of  $f_r$   
 $k$  = order of harmonics of  $f_m$   
 $n$  and  $k = 1, 2, 3, \dots$

Of course, for the mathematical analysis, linear modulation and rectangular pulses of constant amplitude are assumed. Any discrepancies that arise due to these assumptions will be discussed later. The amplitudes of the components are:

$$E_{d.c.} = \frac{A \tau_0}{T} \text{ d.c. volts}$$

$$E_m = \frac{A_m \tau_0}{\sqrt{2} T} \text{ r.m.s. volts}$$

$$E_{r,n} = \frac{A}{\sqrt{2} \pi n} \text{ r.m.s. volts}$$

$$E_{l.b.,n} = \frac{A}{\sqrt{2} \pi n} J_k \left( \frac{2\pi m n \tau_0}{T} \right) \text{ r.m.s. volts}$$

and for  $n = 1$ , where  $\delta = \frac{2\pi m \tau_0}{T}$

$$S_k = \left| \frac{E_{l.b.}}{E_m} \right| = \left| \frac{J_k(\delta)}{\delta/2} \right|$$

See Fig. 6 for a plot of  $S_k$  vs.  $\delta$ .

It is interesting to note that the spectral analysis of a PDM wave train with variable leading edges results in exactly the same expression as that which was obtained when the trailing edges were considered variable. The proof of this is very simple and perhaps intuitive. The only difference is that the

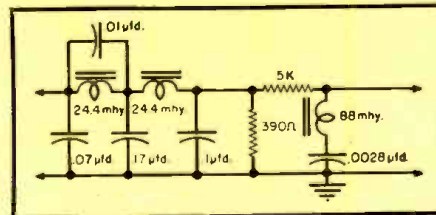

Fig. 2. The low-pass PDM filter demodulator with 10-kc. rejection.



Fig. 3. Block diagram of monitor.

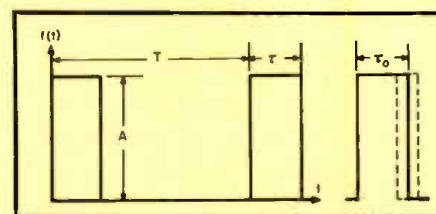

Fig. 4. Typical PDM wave train with various characteristics identified.

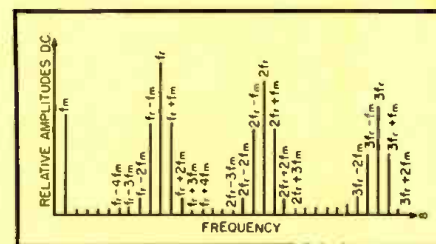
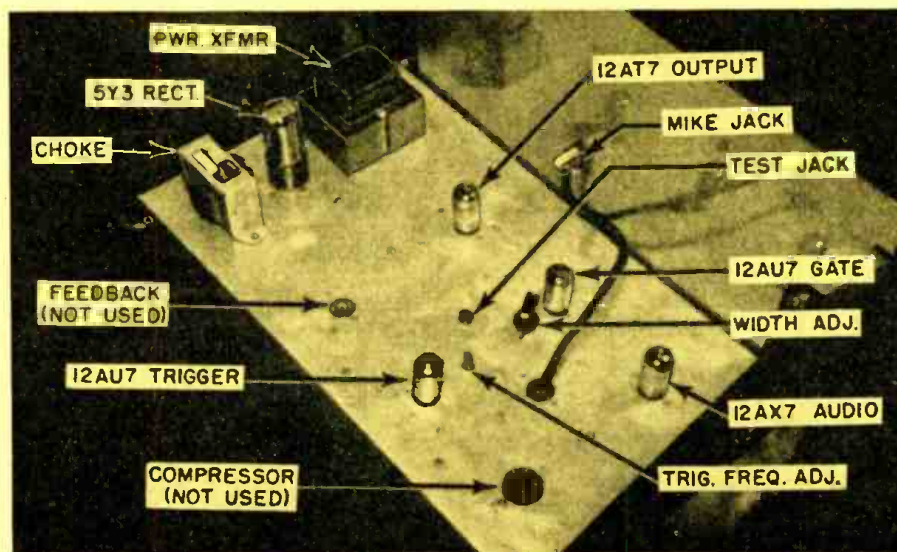

Fig. 5. A few of many spectral lines which may appear with PDM.

limits of integration go from  $(T-\tau)$  to  $T$  rather than 0 to  $\tau$ ; and since  $T$  is fixed,  $C_n$  is still the same.

Spectral analysis of a PDM wave train with both edges variable yields a

Top view of the experimental chassis with various components identified.





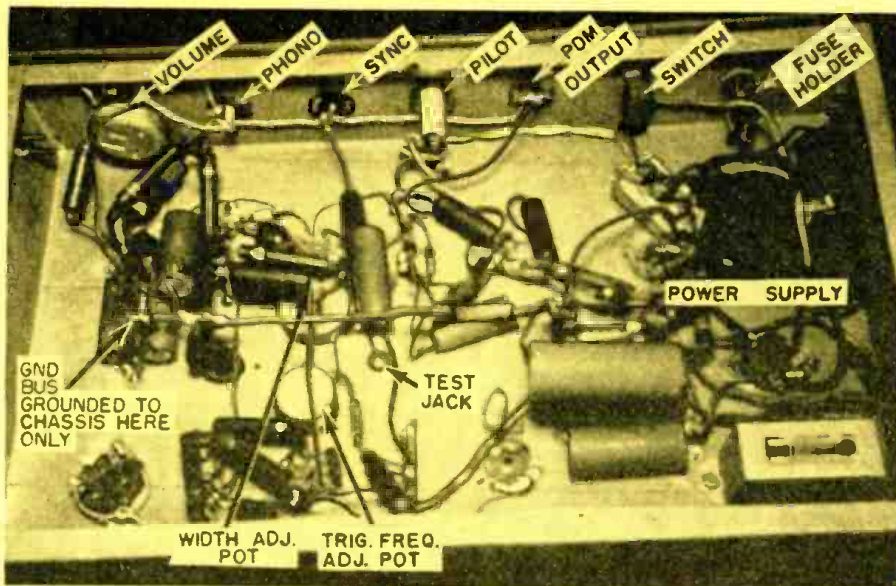

Bottom view of the experimental chassis with various components identified.

separate spectrum for each side of the pulse; if the same modulating signal is fed out of phase, resulting in the pulse spreading out from the center at the same time, two times the single spectrum will be obtained.

### Step Curves

The theoretical sideband distortion step curves (Fig. 7) represent the inherent total distortion the system will have as the upper cutoff frequency of the modulating amplifier is increased. The steps up to 2 kc. are not shown, since the magnitude of  $S_1$  is quite negligible under 50% modulation. At 2.5 kc.,  $S_2$  suddenly enters the signal band and a jump in total distortion

$$(S_T = \sqrt{(S_1)^2 + (S_2)^2 + \dots})$$

appears, whose magnitude varies with the value of  $m$ . At  $3\frac{1}{2}$  kc., another integral submultiple of the repetition frequency,  $S_3$ , is included and another

Fig. 6. Plot of the primary lower sideband amplitudes relative to the modulating signal for pulse duration modulation for  $f_m = 1000$  cps.

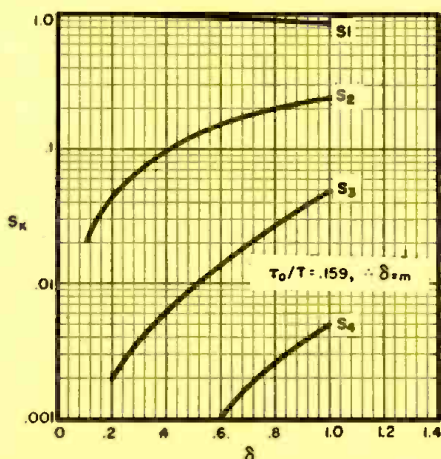

jump appears. In order to avoid the inclusion of  $S_3$ , then, a frequency of 3.2 kc. was selected as the maximum signal frequency to enter the linear delay multivibrator.

Figure 10 shows the cathode-coupled linear delay multivibrator circuit. For a typical medium-mu triode like the 12AU7, the time duration  $\tau$  of the output plate pulse is:

$$\tau = R_o C \ln \left\{ \frac{E_{bb} - E_{k2} + I_{b1} R_{L1}}{E_{bb} + E_{c0} - I_{b1} R_k} \right\} \mu\text{sec.}$$

where the only variable is:

$$I_{b1} = \frac{E_{bb} + \mu E_{o1}}{(\mu + 1)R_k + R_{L1} + r_p} \text{ ma.}$$

or  $\tau = A + BE_{o1} \mu\text{sec.}$ , indicating a linear relation between  $\tau$  and  $E_{o1}$ . The resulting d.c. linearity curves are shown in Fig. 8. The experimental d.c. linearity curve exhibits a saturation effect at low widths since the trigger width is not negligible and limits the minimum modulated pulse width. In Fig. 9, the effect of varying  $E_{o1}$  on the various multivibrator waveforms can be seen.

### Limited Bandwidth Distortion

The theoretical spectral analysis was based upon a pure PDM wave train having perfectly rectangular pulses. The fact that the output pulses were rounded did not pose a particularly serious distortion problem, for this modulator has a bandwidth-repetition frequency ratio of

$$BW/f_r = \frac{70 \text{ kc}}{10 \text{ kc}} = 7$$

which is an adequate high-frequency response and results in negligible distortion<sup>1</sup>.

Generally, a slicer would be used in the receiver, and thus the bandwidth would be effectively increased again due

to the resquaring of the pulses. This would almost completely suppress limited bandwidth distortion and at the same time suppress the major portion of noise picked up between the transmitter and receiver.

The limitation of the band with regard to low frequency response<sup>1</sup> produces phase shift in the signal frequency term, but this phase shift is negligible for PDM.

Bandwidth distortion would not be a problem in PPM since the amplitude of the signal term is quite small (and not constant)<sup>2</sup>, and recovery of the signal is not attempted solely by means of a low-pass filter but rather with a bandpass filter tuned to the carrier frequency, and with a discriminator, as in FM. Another method of demodulating a PPM wave train, however, does involve conversion to PWM, and then low-pass filter demodulation.

### Design Features of System

In this experimental system, the audio cutoff frequencies of the input audio amplifier were selected to reduce the amount of lower sideband distortion entering the signal band. The upper cutoff frequency  $f_c$  was adjusted to 3200 cps by shunting a capacitor from plate to ground. This was done to avoid the inclusion of  $S_2$ , the second lower primary sideband term, into the signal band. As shown in the step curves of Fig. 7, this keeps the distortion down very low. The lower cutoff frequency  $f_l$  was adjusted to 142 cps, which does not disturb the articulation much but helps greatly in reducing over-modulation caused by strong bass tones of short duration.

Only 10% or 20% modulation is advised in order to satisfy a maximum allowable total distortion of less than 1%. This is on the safe side, but it allows for possible intermodulation distortion which might bring the total

Fig. 7. Step curves of % distortion within signal band vs. upper cutoff frequency of modulating amplifier.

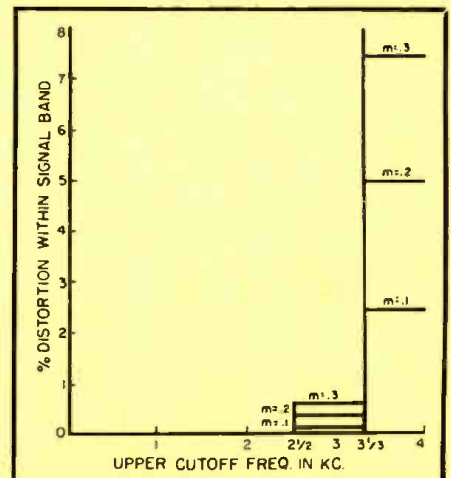



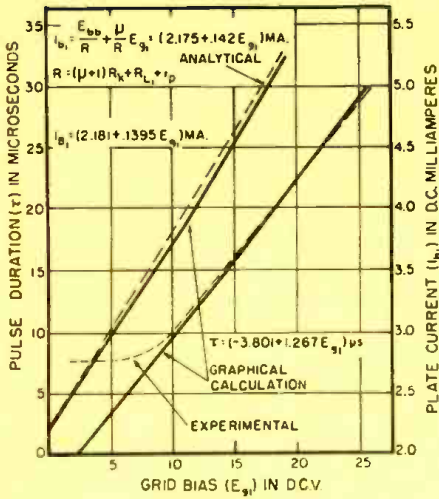

Fig. 8. D.C. linearity characteristic of the cathode-coupled delay multivibrator.

distortion up to 5%—considered as being still satisfactory for general broadcasting.

A repetition frequency of 10 kc. was selected to give an adequate signal bandwidth. In telephone work, 8 kc. is generally used; but this would force  $f_s$  down to about 2700 cps. Actual  $f_s$  is adjusted according to the fidelity desired.

The operating pulse width  $\tau_o$  was selected for best linearity since a small percentage of modulation is used.  $\tau_o$  is made about 15 or 20 microseconds to allow for three other channels for further multiplexing.

The shaper cutoff frequency  $f_s$  was adjusted for 70 kc. so that  $f_s/f_m = 7$ , which is high enough to result in negligible limited bandwidth distortion and yet requires a smaller bandwidth in transmission.

Trigger pulse width is generally made very small, but to avoid a complicated circuit, the width was made smaller than the minimum excursion of the modulated pulse for  $m = 30\%$ , thus preventing saturation and the occurrence of amplitude modulation.

The symmetrical plate-coupled multivibrator was designed to yield a stable trigger source of rapid switchover and rise time.

The delay multivibrator was linearized by experimentally determining suitable values for  $R_{L1}$  and  $R_k$ . Theoretically,  $R_{L1} = .855 R_k$  for minimum harmonic distortion. To avoid stray pickup, leads were kept short and off the chassis, and shielded leads were used for the input jacks. To avoid ground loops, a solid copper ground bus was used which was only grounded once to the chassis at the earliest stage of the modulator—the mike preamplifier stage.

Since the d.c. load current is essentially constant at about half full load, it was not necessary to use a regulated

supply. Adequate filtering (a ripple voltage of approximately 15 mv.) and customary precautions were used to minimize the introduction of hum into the modulated output.

Separate phonograph and microphone inputs permit isolated mixing with sufficient gain (32.3-db phono gain and 67-db mike gain at maximum output) on either input to give 100% modulation.

### Advantages and Disadvantages

The main advantages of PDM may be summarized as follows:

1. It is the easiest to demodulate in comparison to all other systems.
  2. Time-division multiplexing is available for multiple-channel telephone and telemetering applications, to mention but a few. This is true also for other pulse systems (except PFM) but not for AM and FM, which must resort to frequency-allocation multiplexing.
  3. Noise cleaning is achieved by using a slicer prior to demodulation.
  4. Theoretically distortionless reception may be had if sliced PDM is converted to PAM, and then demodulated, thus eliminating lower side-band distortion.
  5. PDM utilizes transmitter energy more effectively due to the sampling process than continuous-duty AM and FM systems.
  6. There exists simplicity of circuitry and components compared to PCM and PPM as opposite extremes of complexity.
  7. There are no quantizing noise considerations as in PCM.
  8. PDM can be sliced and reamplified at each repeater station to keep the S/N ratio above a given minimum threshold level more readily than
- (Continued on page 27)

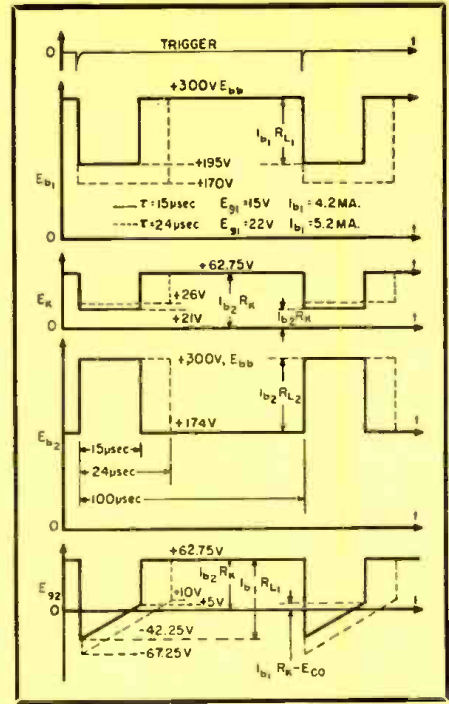

Fig. 9. Calculated waveforms in the delay multivibrator circuit.

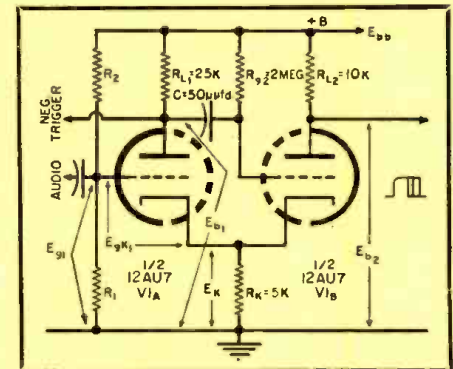
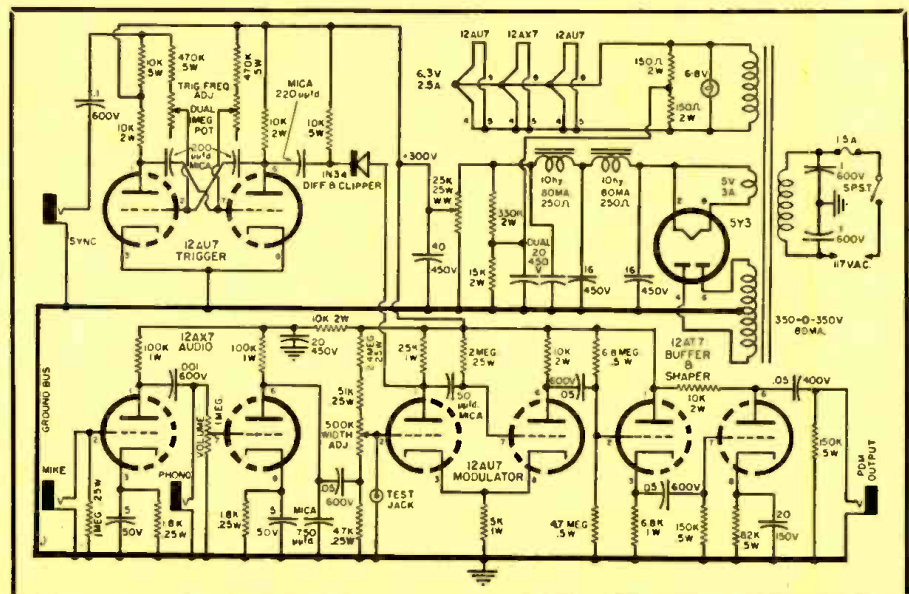

Fig. 10. The cathode-coupled linear delay multivibrator as used in PDM

Circuit diagram and parts values for the experimental PDM system





# PHASE ANGLE MEASUREMENTS AT A.F.

By **ROBERT C. MOSES**

**R**ECENT advances in the field of servomechanisms and the increasing application of specialized communications techniques have brought about renewed interest in the problem of how to determine accurately the phase angle between two a.c. voltages in the audio and ultrasonic frequency ranges. While many excellent phase-meters are obtainable commercially, the need frequently arises for a simple and precise method of phase difference measurement where such equipment is not readily available. This article describes one such technique capable of satisfying the above requirements and well adapted to routine laboratory application.

Phase angle measurements which require visual analysis of circular or elliptical oscilloscope patterns are at best only approximate, because of the difficulty of accurately evaluating the respective ordinate dimensions at phase angles differing appreciably from 0° to 180°. Errors resulting from parallax, astigmatism, and screen curvature frequently render measurement to better than ± 10° very difficult. It is, however, relatively simple to determine precise 0° or 180° phase relationships, since the corresponding patterns converge to straight lines which become superimposed when the exact in-phase or out-of-phase condition obtains. This forms the basis of a simple phase measurement technique in which the accuracy obtained may be substantially better than 2° over a frequency range of 20 cps to 100 kc. The essential elements of this measurement are shown in block diagram form in Fig. 1.

Figure 1 resembles the conventional oscilloscope phase-comparison method, except for the incorporation of a precision phase-shifting element between the signal source and the device under test. The function of the precision phase shifter is to provide a constant-amplitude output voltage, the phase angle of which—with respect to its input—is accurately determinable and capable of continuous variation over a range of 0° to 175°. This is accomplished by means of calibrated variable resistance and capacitance elements of known accuracy. By introducing an appropriate compensating phase shift between the signal source and the device under test, such that the over-all phase angle is returned to zero, the

*Accuracies of 2% at frequencies of 20 cps to 100 kc. are realized with this simple measurement technique.*

equivalent phase shift through the latter may be evaluated to a degree of accuracy dependent only upon the calibration accuracy of the phase-shifting network. Using standard components of known value, measurements to better than 2% up to 100 kc. may be readily obtained.

Because the precision variable phase shifter constitutes the "heart" of the measurement technique, a brief description and analysis of this element may be in order.

Referring to Fig. 2A, if a series resistance-capacitance network is fed from a constant voltage source  $E_A$  and an output  $E_o$  taken across the resistance element of the network, the phase angle between input and output voltages may be expressed by:

$$\phi = -\tan^{-1} \frac{1}{\omega CR} \quad (1)$$

and their relative amplitudes by:

$$\frac{E_o}{E_A} = \frac{\omega CR}{(\omega^2 C^2 R^2 + 1)^{1/2}} \quad (2)$$

The corresponding vector diagram is shown in Fig. 2B.

The maximum theoretical phase shift which such a simple network can produce is 90°, and under these conditions, the attenuation through it is infinite. Practical phase shifters of this type are therefore limited to values of  $\phi$  of less than 80°, and have insertion losses of as much as 15 to 20 db at phase angles approaching the theo-

retical maximum. Because the attenuation increases with the phase shift,  $E_o$  does not remain constant with variations in the network values. This, together with the restricted range of phase shift obtainable, imposes serious limitations upon the use of a series RC network of this type for the application at hand.

If the source  $E_A$  is split into two 180° components of equal amplitude, and the output voltage  $E_o$  taken between the electrical center of the source and the junction of  $R$  and  $C$  as in Fig. 2C, it can be shown that the resulting phase angle  $\alpha$  between  $E_o$  and one component of  $E_A$  will be exactly twice the angle  $\phi$  as defined above, while that between  $E_o$  and the other component of  $E_A$  will be 180° - 2 $\phi$ . It can be shown further that the output voltage  $E_o$  will remain constant regardless of the discreet values assigned to  $\omega$ ,  $R$ , and  $C$ , provided only that the components of  $E_A$  remain equal and in 180° phase relationship. This will be made clear by reference to the vector representation of Fig. 2D. The locus of the intersection of the quadrature vectors  $E_R$  and  $E_C$  describes a semicircle about the midpoint of the vector  $E_A$  as the impedances  $R$  and  $C$  are varied. It follows, therefore, that a vector  $E_o$  connecting the midpoint of  $E_A$  with any point along this locus will be of constant magnitude  $E_A/2$ , and will make a varying angle with the vector  $E_A$ . The corresponding phase and amplitude relations may be expressed by:

$$\alpha = 2\phi = 2 \left[ -\tan^{-1} \frac{1}{\omega CR} \right] \quad (3)$$

$$E_o = 0.5E_A \quad (4)$$

$E_o$  being constant for zero source and infinite load impedances.

In practice, Eq. 4 holds to a close approximation if the source impedance is very much lower than the equivalent impedance of the RC network and the load impedance exceeds about five times the latter.

A practical phase shifter based upon

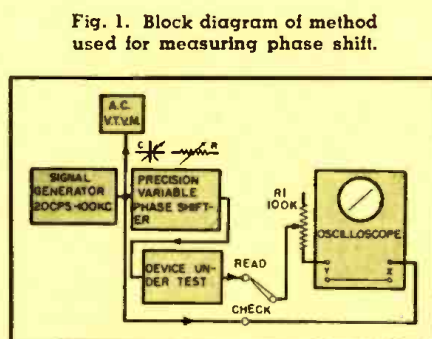

Fig. 1. Block diagram of method used for measuring phase shift.



the above principles may be made to provide up to 175° of phase shift with less than 10% change in output voltage over a frequency range of 20 cps to 100 kc. However, in order for Eq. 3 to be completely valid, it is essential that the two components of  $E_A$  maintain an exact 180° phase relationship and equal amplitude over the entire band of interest. Furthermore, it is important that the source impedance remain constant with frequency and be low with respect to the minimum impedance of the RC network, and also that any loading on the latter be minimized.

A schematic diagram of the variable phase shifter is shown in Fig. 3. The two components of the source  $E_A$  are derived from a balanced phase-splitting triode, one section of a type 12AY7. The effective over-all impedance of the source is of the order of 2000 ohms. The electrical center of the source is at a.c. ground potential by virtue of a constant-voltage plate supply having an equivalent impedance of about 3 ohms. Such a supply may consist of batteries or an electronic regulator, and is absolutely essential in order to maintain accurate balance and correct phase relationship between the two components of  $E_A$ . For the same reason, the plate and cathode load resistors of the phase splitter are matched to 1%, and the former is shunted by a small trimmer capacitor to equalize the interelectrode and stray circuit capacitances. The exact value of this trimmer may be determined by adjusting for equal plate and cathode output voltages at the highest frequency of interest; values of the order of 4-5  $\mu\text{fd.}$  are typical for the average tube and circuit configuration. The phase-shifting network operates into a cathode follower comprising the other half of the 12AY7. The cathode follower presents an effective load impedance of over 5 megohms to the phase-shifting network, and simultaneously isolates the latter from the device under measurement.

The phase-shifting elements  $R$  and  $C$  are calibrated to 1% and together provide an effective variation in RC product of over 10,000 to 1. If available, capacitor decades and nonreactive resistor decades of appropriate accuracy will be found extremely convenient. Table 1 gives a number of RC product values together with the corresponding phase angle in degrees for several commonly used frequencies. These figures were derived from Eq. 3, and will be found sufficiently accurate for most practical purposes. In selecting specific RC combinations for a given frequency, it is recommended that the resistance  $R$  be kept between the limits of 5000 ohms and 1 megohm where possible.

It is important that the oscilloscope used for determination of the 0° "null" point have X and Y deflection amplifiers

which themselves contribute a minimum amount of phase shift over the frequency range of interest. A scope of the wide-band variety is recommended. Alternatively, corrective measures may be incorporated whereby the reference phase is returned to zero at each frequency prior to making a measurement. These measures are provided by means of a variable resistor  $R_1$  in series with the Y-axis input (Fig. 1). (In some scopes,  $R_1$  may have to be placed in the X signal channel.) A switching system facilitates phase correction of the scope by impressing the same signal on both sets of deflection plates simultaneously. In operation, the switch is first set to "check" and the scope adjusted for zero phase shift if necessary by variation of  $R_1$  and the gain controls. The switch is then set to "read", and the phase-shifter variables  $R$  and  $C$  are adjusted to return the phase angle pattern to zero. The net phase shift through the device under measurement may then be evaluated from Eq. 3 or Table 1 for specific values of  $\omega$ ,  $C$ , and  $R$ . This procedure is repeated for as many frequencies as may be desired. For best measurement accuracy, the input to the phase shifter should not exceed 1 volt r.m.s. and overloading anywhere in the system as evidenced by curvature of the straight line pattern should be avoided. Interpolation between adjacent values of  $R$  or  $C$  can be effected by small changes in  $\omega$ ; however, it should be ascertained that any phase shift in the indicating instrument remains constant between the frequencies involved.

In a few cases, ambiguity as to whether an unknown phase shift is in the leading or lagging direction with  
(Continued on page 21)

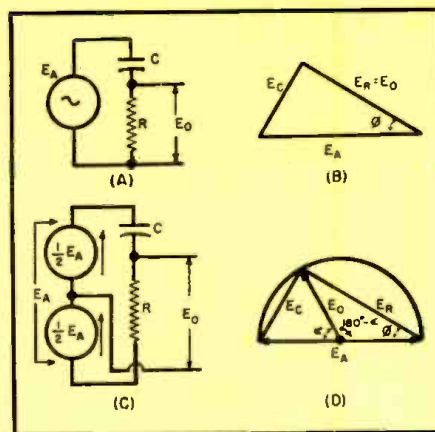
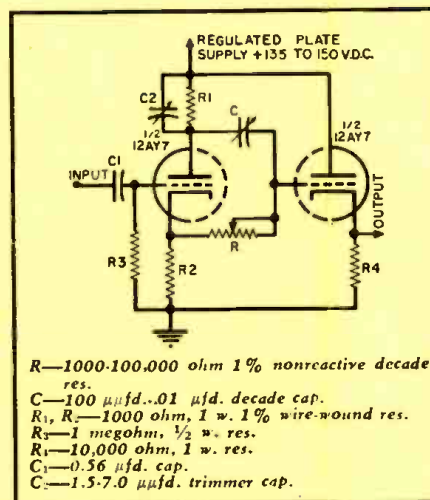

Fig. 2. (A) Conventional phase shifter and (B) vector diagram. (C) Basic principles of the new phase shifter, and (D) vector diagram showing relationships.



$R$ —1000-100,000 ohm 1% nonreactive decade res.  
 $C$ —100  $\mu\text{fd.}$ -.01  $\mu\text{fd.}$  decade cap.  
 $R_1, R_2$ —1000 ohm, 1% 1% wire-wound res.  
 $R_3$ —1 megohm, 1/2 w. res.  
 $R_4$ —10,000 ohm, 1 w. res.  
 $C_1$ —0.56  $\mu\text{fd.}$  cap.  
 $C_2$ —1.5-7.0  $\mu\text{fd.}$  trimmer cap.

Fig. 3. Circuit diagram and parts list of the precision variable phase shifter.



Table 1. Tabulation of RC product values. Values above heavy line are expressed in kilohms-microfarads, below heavy line in ohms-microfarads. Values of R should be kept between 5000 ohms and 1 megohm where possible.

Frequency cps	Phase Angle; degrees lag					
	30°	45°	60°	90°	120°	150°
30	19.82	12.81	9.18	5.31	3.08	1.42
50	11.88	7.69	5.52	3.18	1.83	854.0
100	5.95	3.84	2.76	1.59	919.9	427.0
200	2.97	1.92	1.38	795.6	459.8	213.5
400	1.48	962.5	690.0	397.8	229.9	116.8
700	849.5	550.0	394.1	227.4	131.2	60.95
1K	594.7	384.5	275.9	159.2	91.99	42.70
2K	297.2	192.3	137.9	79.56	45.98	21.35
5K	118.8	76.88	55.18	31.83	18.34	8.54
10K	59.47	38.45	27.59	15.92	9.20	4.27
15K	39.59	25.61	18.38	10.61	6.12	2.84
20K	29.72	19.23	13.79	7.96	4.60	2.14
50K	11.88	7.69	5.52	3.18	1.84	0.85
100K	5.95	3.84	2.76	1.59	0.92	0.42



# ELECTRONIC FLOWMETER

By

**HENRY P. KALMUS**

National Bureau of Standards

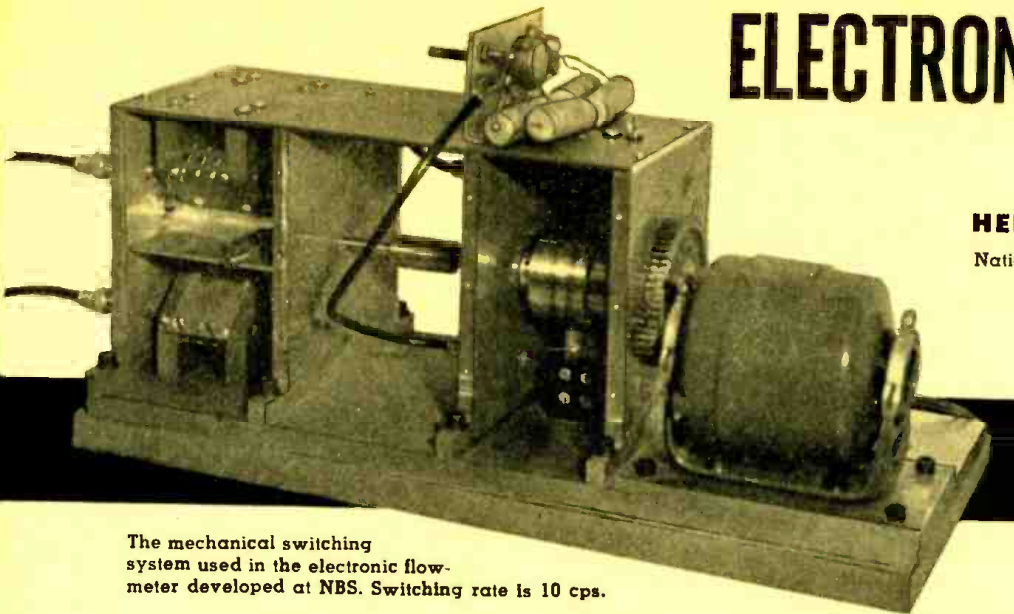

The mechanical switching system used in the electronic flowmeter developed at NBS. Switching rate is 10 cps.

*A wide range of velocities of both gas and liquid flow can be accurately measured with this meter.*

**A** NEW type of electronic flowmeter, capable of measuring the air currents in a still room or the rapid flow of fluids in pipes, has recently been developed at the National Bureau of Standards. This device utilizes the change in velocity of sound waves as a measure of fluid flow. It has a very fast response and does not obstruct the fluid currents in making a measurement. In addition, the signal-to-noise ratio is sufficiently high to permit the measurement of extremely small velocities.

Most of the present methods for measuring the velocity of flowing liquids depend on mechanical devices that usually introduce discontinuities in the

fluid and have inherent inertia which prevents faithful reproduction of fast velocity changes. One type of flowmeter utilizes the principle of the homopolar machine; but this method cannot be used for gases, and the instrument is—at present—restricted to the measurement of conductive fluids. Another method makes use of the resistance change in hot wires placed in the path of fluid flow; however, besides presenting an obstruction to the flow, the hot wire is not generally applicable to fluids that would change chemically or physically as a result of the heat from the wires.

In the newly developed flowmeter, a

sound wave is transmitted over a fixed distance through the flowing fluids, and the phase of the received wave is compared with that of the transmitted wave. The sound energy is imparted to and taken from the fluid through the walls of the containing vessel. No part of the measuring system need come in direct contact with the medium under study. This characteristic of the system makes the unit applicable to the measurement of blood flow in the aorta and to the detection of the flow of chemicals in a closed system, e.g., the coolant in a chain reactor. Minor modifications will permit the measurement of the flow of such fluids as gas or oil in a metal pipe, or a determination of the relative velocity of a ship to that of the water through which it is moving.

In instances other than those involving extremely high velocities, e.g., in wind tunnels, a simple system utilizing merely a stationary device to transmit energy into the medium and another stationary unit to receive it would be impractical because changes in distance or propagation velocity would produce errors far greater than the variations due to flow. For this reason, the transmitter and receiver of the flowmeter are exchanged periodically without varying their locations. This is accomplished by using identical magnetostrictive or piezoelectric exciters—such as barium titanate crystals—as transmitter and receiver, and by switching their connections alternately to the receiving and transmitting channel. Thus, the phase-meter displays two phase shifts alternately, one a function of the sound velocity plus the fluid flow and the other a function of the sound velocity minus the fluid flow. The difference between the two phase shifts is a measure of the velocity of the fluid. The switching can be made to operate faster than the inherent variations occurring in either the transmitter or the receiver, or even the medium. Hence, the variations will occur at a minimum of one complete transmitter-receiver switching cycle, and the phase difference will remain unaffected.

In the first experimental model of the NBS flowmeter, a mechanical switch-  
*(Continued on page 27)*

Typical crystal arrangement of the flowmeter (top) and circuit diagram (bottom).

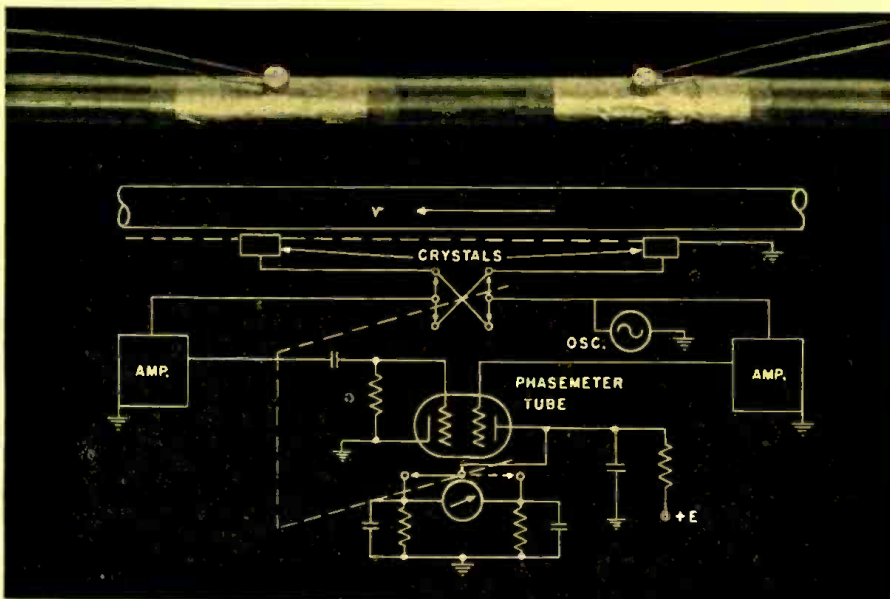



# OSCILLOSCOPE VOLTAGE CALIBRATOR



Front view of the oscilloscope voltage calibrator. Note the "calibrating frequency" switch which makes this instrument unique.

By **ALVIN B. KAUFMAN**

Research Engineer, Northrop Aircraft Co.

*This unit can provide a square-wave calibrating voltage at frequencies of from 1 to 20,000 cps.*

WITH the advent of oscilloscope voltage calibrators, the measurement of the voltage amplitude of observed oscillograph patterns has been vastly simplified. However, in the opinion of the author, the commercial units which are available on the market are not completely satisfactory either in price or in performance. For this reason, a simplified calibrator has been designed which has certain desirable circuitry not available in any of the commercial units and yet is inexpensive in design components.

A prerequisite in the design of an oscilloscope voltage calibrator, not met by all manufacturers, is that its referenced output should remain accurate over a wide range of a.c. line voltage variation. The circuitry described here meets this requirement. With this calibrator, the line voltage may vary from 90 to 135 volts without any visible shift of the calibrating pattern on the oscilloscope. The calibrator's over-all accuracy is  $\pm 4\%$ ; this accuracy may be increased to  $\pm 1\%$  by a minor mathematical or engraving process which will be discussed in greater detail further on in this article.

All commercial calibrators are designed to produce a square wave at line frequency. Thus, ignoring any tilt of the pattern due to poor low frequency response in the oscilloscope, the peak-to-peak value of the pattern—at 60 cps—is used to determine the signal level. Where the frequency of the signal to be calibrated is considerably above the line frequency, the oscilloscope gain may have fallen off, and the low frequency calibration may not be accurate unless a scope-frequency correction factor is employed. Furthermore, there is always the nuisance of juggling sweep frequency dials down from the test frequency to line frequency in order to secure a locked pattern.

This simplified calibrator has provisions for the injection of a signal frequency voltage, between 1 cps and 20

kc., which sets the output frequency of the calibrator. A frequency calibrating signal voltage level between approximately 6 and 120 volts r.m.s. is required. The load on the signal source is 1 megohm and may in general be secured from some section of the circuit under test, with negligible shunting or loading effect. At low levels of external calibrating frequency signal voltage, the zero center (or average reference line) may shift, but the peak-to-peak amplitude will remain a constant over the whole range of calibrating voltage input noted.

The circuitry as shown in Fig. 2 is relatively straightforward, and relies in part on the constant-current characteristics of a pentode with fixed screen excitation. There are, however, a few

points of more than casual interest concerning the design of the calibrator. Basically, the circuit consists of a pentode which is driven alternately between cutoff and plate current saturation. It is apparent from Fig. 1, a family of plate current curves, that for a fixed bias the plate current of the tube is substantially independent of plate voltage variation (if over 50-100 volts), and that a plate load resistor would develop an output voltage independent of everything except screen voltage. Heater voltage variation does not have an appreciable effect on peak-to-peak amplitude as such variation causes only minor changes in the plate current saturation and cutoff points.

In practice, several changes had to be made in the original paper work design. The plate current curves are almost—but not quite—flat, and this caused the output to vary about 5% with change of plate voltage over the specified a.c. line voltage range. Thus, it was necessary to regulate both the plate and screen voltage. Almost all voltage regulation systems employ a gaseous regulator tube either for direct control or as reference control for a vacuum tube system. As the current drawn by the pentode clipper is only a few milliamperes, there was no need for a complicated voltage regulator, a VR tube being directly applicable. It is the use of this VR tube, however, which limits the high frequency output of the calibrator. The VR tube must regulate and hold the voltage across itself by changing the current it draws. It is

Fig. 1. Average plate characteristics for a typical pentode—type 6CB6.

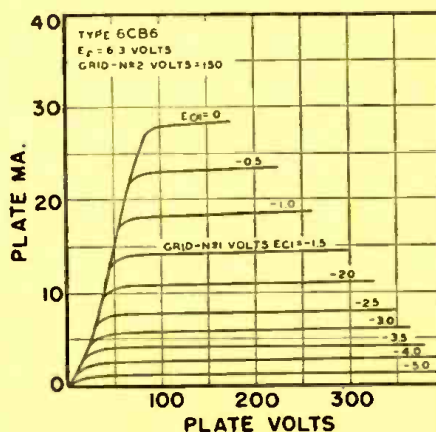







# ENGINEERS:

**DOES YOUR  
PRESENT JOB  
GIVE YOU**

**ALL THESE**

**RCA**

**CAREER**

**ADVANTAGES?**

**POSITIONS NOW OPEN FOR  
SENIOR DEVELOPMENT  
AND DESIGN ENGINEERS:**

- ✓ ELECTRONIC . . .
- ✓ COMMUNICATIONS . . .
- ✓ MECHANICAL . . .
- ✓ COMPUTER . . .
- ✓ ELECTRON TUBE . . .

**PERSONAL INTERVIEWS ARRANGED  
IN YOUR CITY.** A copy of our booklet  
"Challenge and Opportunity," describing the role of the  
engineer in RCA, will be mailed upon request. Please  
send a complete resume of your education and  
experience to:

**MR. ROBERT E. McQUISTON, Manager**  
Specialized Employment Division, Dept. 204G  
Radio Corporation of America  
30 Rockefeller Plaza  
New York 20, N.Y.

## CHECK SHEET

- | Yes                      | No                       |                                                                                   |
|--------------------------|--------------------------|-----------------------------------------------------------------------------------|
| <input type="checkbox"/> | <input type="checkbox"/> | PROFESSIONAL RECOGNITION AND PRESTIGE?                                            |
| <input type="checkbox"/> | <input type="checkbox"/> | ADVANCEMENT IN STATUS?                                                            |
| <input type="checkbox"/> | <input type="checkbox"/> | SECURITY AND STABILITY?                                                           |
| <input type="checkbox"/> | <input type="checkbox"/> | CHALLENGE AND OPPORTUNITY?                                                        |
| <input type="checkbox"/> | <input type="checkbox"/> | HIGH SALARY SCALE AND OPPORTUNITIES<br>FOR PROMOTION?                             |
| <input type="checkbox"/> | <input type="checkbox"/> | EXCELLENT SUBURBAN HOUSING AT<br>REASONABLE COST?                                 |
| <input type="checkbox"/> | <input type="checkbox"/> | FACILITIES FOR PROFESSIONAL<br>ADVANCEMENT?                                       |
| <input type="checkbox"/> | <input type="checkbox"/> | UNEXCELLED TECHNICAL AND LABORATORY<br>FACILITIES?                                |
| <input type="checkbox"/> | <input type="checkbox"/> | ASSOCIATION WITH TOP SCIENTISTS?                                                  |
| <input type="checkbox"/> | <input type="checkbox"/> | TUITION REFUND PLAN FOR ADVANCED STUDY?                                           |
| <input type="checkbox"/> | <input type="checkbox"/> | MILITARY OR COMMERCIAL OPPORTUNITY?                                               |
| <input type="checkbox"/> | <input type="checkbox"/> | MODERATE COST OF LIVING?                                                          |
| <input type="checkbox"/> | <input type="checkbox"/> | MODERN RETIREMENT PLAN?                                                           |
| <input type="checkbox"/> | <input type="checkbox"/> | COMPANY-PAID LIFE INSURANCE?                                                      |
| <input type="checkbox"/> | <input type="checkbox"/> | COMPANY-PAID LIBERAL HOSPITAL, SURGICAL<br>AND DISABILITY PLAN (FAMILY BENEFITS)? |
| <input type="checkbox"/> | <input type="checkbox"/> | LIBERAL VACATION PLAN?                                                            |
| <input type="checkbox"/> | <input type="checkbox"/> | LIBERAL HOLIDAY SCHEDULE?                                                         |
| <input type="checkbox"/> | <input type="checkbox"/> | PROFESSIONAL STATUS AND UTILIZATION OF<br>YOUR EDUCATION AND EXPERIENCE?          |



**RADIO CORPORATION of AMERICA**



# MEASURING ATTENUATION WITH THE SLOTTED LINE



Test setup for measuring attenuation with the slotted line.

By

**A. V. DONNELLY**

College of Engineering, State U. of Iowa

*The VSWR of a test section with the far end shorted is used to determine the attenuation of the section.*

THE determination of attenuation is probably one of the most often required measurements in the microwave region. Calibration of attenuators, determination of directional coupler characteristics, and standardization of power-measuring equipment are only a few of the techniques that directly or indirectly require attenuation determinations. Certain standard procedures are usually followed, most of them being based upon two general methods: (1) the power differential method and (2) the substitution method.

One of the most direct procedures is that of measuring the power input to a test section and determining the power output. The attenuation loss in decibels will then be equal to  $10 \log P_{out}/P_{in}$ . In the substitution method, a calibrated variable attenuator is substituted for the test section and varied until the same loss in power is noted. The insertion loss of the variable attenuator is then equal to the attenuation of the test section. Both of these methods have the disadvantage of requiring either two identical power me-

ters or one single meter with extremely good stability.

A method of determining attenuation is hereby proposed which not only eliminates the need for a power meter or a standard variable attenuator but also results in an experimental procedure quickly performed with a minimum of equipment. The only equipment required is a microwave signal source, a standing-wave indicator, and a means of shorting the test section at its receiving end.

The experimental procedure required to obtain the necessary data is extremely simple and is identical to that encountered in standing-wave and impedance determinations. Figure 1 shows the block diagram of the equipment layout.

After the frequency of the oscillator has been adjusted to the desired value, the voltage standing-wave ratio (VSWR) is measured by means of the slotted line and standing-wave indicator. This value is then inserted in the equation:

$$\text{attenuation loss (db)} = 10 \log \frac{\text{VSWR} + 1}{\text{VSWR} - 1}$$

from which the required attenuation in db is directly obtained.

The above expression is based upon the relationship that exists between the reflection coefficient ( $K$ ) and the voltage standing-wave ratio (VSWR) as:

$$\text{VSWR} = \frac{1 - K}{1 + K}$$

where:

$$K = \frac{Z_R - Z_0}{Z_R + Z_0}$$

In this latter equation,  $Z_R$  is the load impedance and  $Z_0$  the characteristic impedance of the line.

Table 1 (at the left) shows the attenuation loss directly in db for a given VSWR. Casual observation might indicate that the method has its limitations with respect to the range of attenuation that can be determined. However, a more thorough examination will indicate that the useful range in which the VSWR can be determined satisfactorily is very close to the useful range of attenuation encountered in actual practice.

If there is some doubt as to the quality of the short that is being used, the exact attenuation involved in this unit alone can be determined by placing it directly on the end of the slotted line. This value can then be subtracted from the value determined with the test section in place. The shorting plugs that are commercially available generally do not have much more than 0.1 db loss, which can often be neglected unless precision work is being performed.

(Continued on page 21)

Table 1. Attenuation loss in db for various standing-wave ratios.

VSWR	db	VSWR	db	VSWR	db	VSWR	db	VSWR	db	VSWR	db
1.001	33.01	1.085	13.89	1.31	8.72	1.56	6.60	1.81	5.40	2.5	3.68
1.002	30.01	1.090	13.65	1.32	8.60	1.57	6.54	1.82	5.36	2.6	3.52
1.003	28.25	1.095	13.43	1.33	8.49	1.58	6.48	1.83	5.325	2.7	3.375
1.004	27.00	1.10	13.22	1.34	8.37	1.59	6.42	1.84	5.285	2.8	3.24
1.005	26.03			1.35	8.27	1.60	6.36	1.85	5.255	2.9	3.125
1.006	25.24	1.11	12.83	1.36	8.17	1.61	6.315	1.86	5.22	3.0	3.01
1.007	24.58	1.12	12.47	1.37	8.07	1.62	6.26	1.87	5.18	3.1	2.90
1.008	24.00	1.13	12.14	1.38	7.97	1.63	6.20	1.88	5.145	3.2	2.805
1.009	23.48	1.14	11.84	1.39	7.87	1.64	6.16	1.89	5.12	3.3	2.715
1.010	23.03	1.15	11.56	1.40	7.78	1.65	6.105	1.90	5.085	3.4	2.635
		1.16	11.30	1.41	7.68	1.66	6.055	1.91	5.05	3.5	2.55
1.015	21.27	1.17	11.06	1.42	7.60	1.67	6.005	1.92	5.015	3.6	2.48
1.020	20.02	1.18	10.83	1.43	7.52	1.68	5.95	1.93	4.98	3.7	2.40
1.025	19.08	1.19	10.62	1.44	7.44	1.69	5.905	1.94	4.955	3.8	2.34
1.030	18.30	1.20	10.41	1.45	7.35	1.70	5.86	1.95	4.92	3.9	2.28
1.035	17.64	1.21	10.21	1.46	7.28	1.71	5.82	1.96	4.89	4.0	2.215
1.040	17.07	1.22	10.04	1.47	7.21	1.72	5.775	1.97	4.855		
1.045	16.56	1.23	9.86	1.48	7.13	1.73	5.725	1.98	4.825	5.0	1.76
1.050	16.13	1.24	9.70	1.49	7.06	1.74	5.68	1.99	4.80	6.0	1.46
1.055	15.73	1.25	9.54	1.50	6.99	1.75	5.64	2.00	4.77	7.0	1.25
1.060	15.36	1.26	9.39	1.51	6.92	1.76	5.60			8.0	1.09
1.065	15.02	1.27	9.24	1.52	6.86	1.77	5.56	2.1	4.50	9.0	0.965
1.070	14.70	1.28	9.10	1.53	6.80	1.78	5.52	2.2	4.255	10.0	0.87
1.075	14.42	1.29	8.97	1.54	6.72	1.79	5.475	2.3	4.045	15.0	0.58
1.080	14.15	1.30	8.84	1.55	6.66	1.80	5.44	2.4	3.855	20.0	0.43





# RAYTHEON MICROWAVE EQUIPMENT



2000 MC  
AUDIO-VIDEO

## Magnalink

MTR-50

Specifically designed for multi-hop intercity television program relaying, studio-transmitter link or long distance remote pick-up service. A high power CW magnetron provides 7 to 10 times more power for extended range and maximum fade protection. Audio channel subcarrier equipment available for simultaneous audio relaying.



**SYSTEM**

Range up to 100 miles  
Carrier Frequency: 1990-2110 mc  
Video Frequency Response:  $\pm 2$  db to 6 mc

**TRANSMITTER**

Type: QK-174C FM Magnetron  
RF Power Output (to antenna cable): 50 watts  
Frequency Deviation:  $\pm 2.5$  mc  
RF Output Impedance: 51.5 ohms  
Center Frequency Stability: .05 percent  
Video Input (peak to peak) .3 volt minimum, 1 v nominal

Video Input Impedance: 75 ohms nominal.  
Adjustable from 50 to 110 ohms  
Primary Power Requirements: 117 volts  $\pm 5$  percent, 50-60 cycles, 1100 watts  
Panel Space: (Standard 19" rack) 49"  
Weight (crated less antenna) 475 lbs.

**RECEIVER**

Type: Single Superheterodyne  
RF Input Impedance 51.5 ohms  
RF Signal Input (minimum) 73 micro-micro watts  
Local Oscillator: Type 2K-28 reflex klystron  
IF center frequency: 130 mc

IF Bandwidth 17 mc  
Video Output (2 channels): 2 volts peak to peak (adj.)  
Video Output Impedance: 75 ohms  
Primary Power Requirements: 117 volts  $\pm 5$  percent, 50-60 cycles, 400 watts

**ANTENNA DATA**

Reflector Dia.	Gain (DB)	Beamwidth (3DB)
4'	26	8.75°
6'	29.4	5.8°
8'	31.5	4.4°
10'	33.9	3.5°



7000 MC  
AUDIO-VIDEO

## Microlink

KTR-100

Provides in unbelievably light and compact form complete equipment for multiplex wide band video and high quality audio transmission and reception. Highly portable yet ideally adapted for permanent installation with installation, control and servicing features never before available.



Range up to 25 miles  
Carrier Frequency Range 6875-7125  
IF Frequency 130 mc  
Transmitter Power Output 0.1 W min.

**ANTENNA DATA**

Reflector Dia.	Gain (DB)	Beamwidth (3DB)
2'	28	5.0°
4'	34	2.5°
6'	38	1.7°

**MAXIMUM FREQUENCY DEVIATION**  
7.6 mc peak to peak video plus 2.4 mc peak to peak subcarrier or 10 mc peak to peak video only

**VIDEO CHANNEL**

Overall frequency response 6 cycles to 6 mc  $\pm 2$  db  
Video input impedance 40-170 ohms  
Video input level for 10 mc peak to peak deviation is .4V peak to peak input  
Video output impedance 75 ohms  
(2 independently controlled outputs)

Video output level  $\frac{1}{2}$  to 2.5 V peak to peak for both outputs with video gain control

**TRANSMITTER RF MONITOR**

Frequency response 6 cycles to 1 mc  
Level: .5 V p to p for 12 mc deviation  
Polarity: Normally black negative  
Impedance: 50 ohms  
Outputs: One output at RF head, one output at Transmitter control

**AUDIO CHANNEL**

Overall Frequency response 20 cycles to 8000 cycles  $\pm 1$  db  
Input impedance 500/600, 333, 200/500, 125, 50 ohms balanced or unbalanced  
Input level — 10 dbm  
Output impedance 500/600 balanced or unbalanced  
Output level maximum +10 dbm  
Distortion 1.5 percent (approx.)  
Signal to total noise 50 db below swing  $\pm 50$  kc

**POWER SUPPLY**

95-140 V 50-60 cycles single phase  
Transmitter 190 W continuous plus 130 W intermittent  
Receiver 180 W continuous plus 100 W intermittent  
One special voltage stabilizer transformer required for frequency other than 60 cycles.

**PHYSICAL DIMENSIONS**

RF head — Receiver and Transmitter 14" x 23" x 11"  
Weight: approx. 38 lbs.  
Control unit — Receiver and Transmitter 21" x 16" x 9"  
Weight: approx. 43 lbs.  
Tripod weight 24 lbs.  
Tilt head 30 lbs.  
4' dish 22 lbs.  
RF Feed 3 lbs.  
Reflector Bracket Assembly 11 lbs.  
Hi Hat 2 1/2 lbs.

Circuit design and packaging by specialists



Light and convenient units with standardized connections



# RAYTHEON MANUFACTURING COMPANY

Equipment Sales Division  
Dept. 6270 RE, Waltham 54, Massachusetts

## EXCELLENCE IN ELECTRONICS



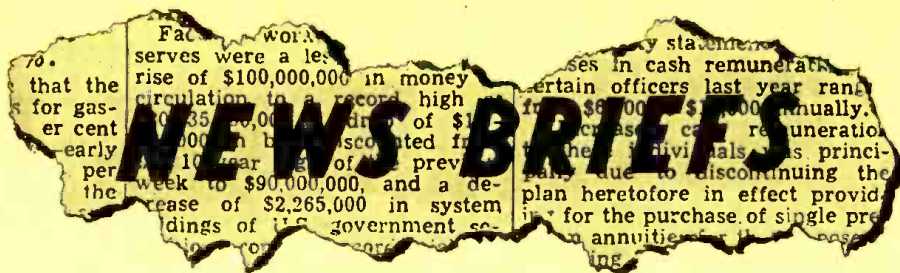

### TELEVISION MICROSCOPE

Scientists and others who tire of squinting with one eye into the tiny eyepiece of a microscope should be interested in this new British instrument



which throws a clear, highly magnified image onto a television screen. Called the "Cintel" Flying-Spot microscope, it was developed by Professor J. Z. Young, of University College, London.

### PRINTED CIRCUITS

At a meeting of the ASME in April, Mr. Norman A. Skow, director of research and development of the *Synthane Corporation*, Oaks, Pa., discussed the advantages of printed circuits, the materials used in their fabrication, and methods of assembly. Serving as a conducting medium in electronic assemblies, such circuits replace to a large extent the internal maze of wires normally found in conventionally assembled equipment.

Practical because of their simplicity and uniformity, printed circuits are particularly adaptable to complex commutators and switching networks where subminiaturization is required. Elimination of manual wiring speeds assembly, Mr. Skow pointed out, and as mechanical reproduction reduces the probability of error, inspection time is automatically shortened while assemblies become more uniform and reliable.

### HEATER REGULATIONS

After June 30, the operation of any industrial heating equipment which does not comply with all of the requirements of Part 18 of the Federal Communications Commission's Rules and Regulations Governing the Industrial, Scientific and Medical Services will constitute a violation of law. Part 18 may be purchased from the Superintendent of Documents, Government Printing

Office, Washington 25, D. C., for five cents a copy.

Among other things, the requirements specify that industrial heating equipment must be operated with sufficient shielding and filtering to prevent interference to authorized radio communication services, and that radiation outside of the I.S.M. bands from such heaters shall not exceed 10 microvolts per meter at a distance of one mile or more from the equipment.

### IRE APPOINTMENT

The Institute of Radio Engineers named Dr. William L. Everitt to serve on the committee of scientists formed at the request of Secretary of Commerce Sinclair Weeks to evaluate the present functions and operations of the National Bureau of Standards in relation to the present national needs. Dr. Everitt, a renowned radio authority and dean of the College of Engineering at the University of Illinois, is a fellow, director and former president of the IRE.

### VIBRATION CALIBRATOR

A resonance-type vibration calibrator has been constructed at the National Bureau of Standards which combines unusual simplicity and economy of construction with pure waveform and high sensitivity. The calibrator consists essentially of a system of mechanically resonant beams (two parallel metal plates separated by a combination

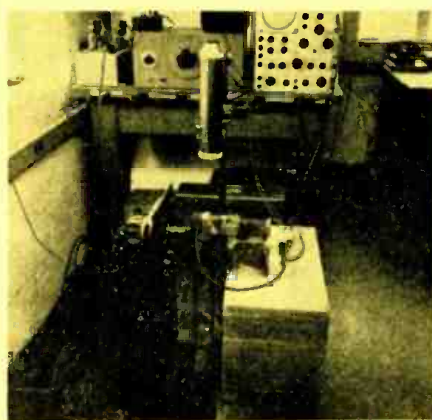

clamping block and calibration table) excited by an ordinary 8" loudspeaker; the transducer being calibrated is fastened rigidly to the mechanical system,

and the amplitude of vibration is observed optically with reference to a fixed point in space.

This device has been used to calibrate moving-coil type velocity gages over a frequency range of 10-250 cps, at displacement amplitudes of as little as 50 microinches. It can calibrate sensitive transducers at low levels of acceleration, of the order of 0.05 to 5 gravities.

### ELECTRONIC TUBE PLANTS

Production of electronic tubes is well under way in the two new manufacturing plants of the newly formed *Westinghouse Electronic Tube Division*. Large cathode-ray television picture tubes and many types of power tubes are now being manufactured at the Elmira, N. Y., plant, headquarters for the division, while small receiving tubes



are being produced at the Bath, N. Y., plant.

Shown in the photograph is one stage in the production of metal-cone cathode-ray tubes at Elmira. As each tube rotates from position to position in the large rotary sealing machine, the metal and glass parts are preheated, joined and annealed.

### PERKIN MOVES

The *Perkin Engineering Corporation* has moved into a 10,000 square foot plant at 345 Kansas Street, El Segundo, Calif. The new plant is fully equipped with modern machinery and facilities for the company's production of standard and military lines of laboratory and airborne d.c. power supplies and associated electronic equipment.

### LOW-LEVEL SOUNDING SYSTEM

Atmospheric temperature and humidity gradients can be measured with increased accuracy, at heights up to 2000 feet, by means of a low-level sounding system developed by the National Bureau of Standards for the Navy Bureau of Ships.

The NBS system is an improved form of "wiredsonde"; airborne instruments are carried aloft by a balloon or kite and are connected to a lightweight 3-conductor electrical cable that is



reeled out from the ground. The airborne unit consists of a gravity motor (left), an electromechanical altimeter (center, removed from housing), and the elements for sensing humidity and

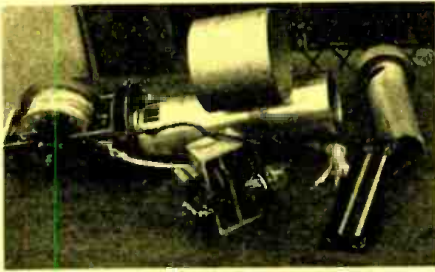

temperature (right, on rectangular mounting).

A detailed description of the system may be found in "National Bureau of Standards Mobile Low-Level Sounding System," which appeared in the NBS Journal of Research, January, 1953 (RP 2381).

#### MOLDITE EXPANDS

Through the acquisition of *Ferricore, Inc.*, of Yonkers, N. Y., the *National Moldite Company* has added ferrite cores to its regular line of magnetic iron cores and molded coil forms. The purchase was made by the *National Moldite Company*, which is located at Hillside, N. J., as part of an expansion program to round out the *Moldite* line of precision electronic components.

#### Measuring Attenuation

(Continued from page 18)

The accuracy of this method of measuring attenuation does not depend upon the stability or calibration of a power meter. In addition, the method provides a means of determining the loss in a system for which it might be extremely difficult or inconvenient

Fig. 1. Block diagram of the test setup for measuring attenuation. The loss may be determined from Table 1 after the standing-wave ratio of the test section with far end shorted has been measured at the desired frequency.

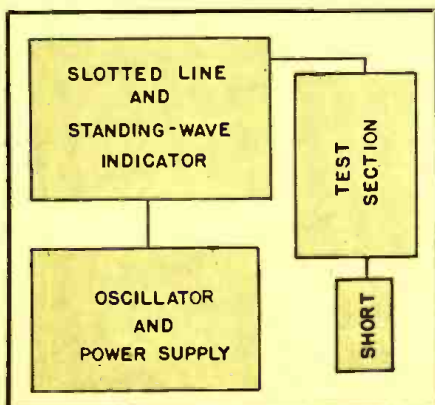

to use either the power differential or the substitution method.

One example of the latter advantage is in the determination of the attenuation of an antenna feeder system where the output and input are separated by more than 100 feet of plumbing. Obviously, the conventional methods would prove to be extremely awkward in such a case. With the slotted-line method, all that is required is to short the receiving end of the system, determine the VSWR from the sending end, and look on the chart for the required loss. The results may be easily, quickly and accurately determined in this manner.

#### Phase Angle Measurements

(Continued from page 13)

respect to the input voltage may occur. The variable phase shifter produces a leading phase angle at all settings. Hence, if the phase pattern approaches and goes through zero without reversing slope as the *RC* product is varied, the unknown angle represents a phase lag. If, however, a decrease in *RC* product produces an apparent increase in phase angle, accompanied by an abrupt reversal in pattern slope, it is an indication that the over-all phase has gone through 180° in the leading direction.

In this case, the unknown phase angle is calculated by subtracting the result as obtained from Eq. 3 from 180°. A small leading unknown phase angle will, under these conditions, require a correspondingly small *RC* product (large introduced phase angle) for a null pattern of opposite slope, and the reversal in slope will occur somewhere within the range of the *RC* network variables. In the majority of instances, the direction of an unknown phase shift will be apparent from inspection of the characteristics of the device under test or from data already taken.

Operationally, this technique of phase measurement may not be entirely suitable for production applications or the like, since a calculation is required for each frequency, and compensation of the indicating instrument is generally necessary. Such refinements as the substitution of a phase discriminator and differential amplifier for the oscilloscope, and direct calibration of the *R* and *C* elements with appropriate phase angle and frequency scales, would facilitate operation at the expense of added complexity. It is felt, however, that for occasional measurements of this type, the method as outlined combines extreme simplicity with excellent stability and accuracy.

## PRECISION PAPER TUBES

any shape... length...  
ID or OD... to meet  
your specific requirements

### SEND FOR ARBOR LIST

Free to you upon request... lists over 1500 sizes... all promptly available. A free sample is also yours for the asking... just send your specifications. Precision Paper Tubes are spiral-wound of finest dielectric kraft or fish paper, phenol impregnated, cellulose acetate or combinations.

Write US TODAY!



## PRECISION PAPER TUBE CO.

2063 W. Charleston St., Chicago 47, Ill. Plant No. 2: 79 Chapel St. Hartford, Conn.  
Also Mfrs. of Precision Bobbins





# NEW PRODUCTS

## DECIMAL SCALER

The Berkeley Scientific Division of Beckman Instruments, Inc., 2200 Wright Avenue, Richmond, Calif., has announced the Model 2105 decimal scaler for use in radioactivity measurement. A wide selection of preset counts is pro-



vided for convenient automatic operation, and there is a wide selection of scaling factors for the operation of an external register, a printing device, or a counting rate computer. New design features in the r.f. high voltage supply lead to increased reliability and improved regulation.

Model 2105 is a direct-reading instrument which utilizes two plug-in decimal counting units and a four-digit mechanical register. High voltage is variable from 300 to 2500 volts, and standard  $\frac{1}{4}$ -volt input sensitivity is provided.

## LEAKAGE TESTER

Whether components or complete assemblies will exhibit satisfactory leakage performance at voltages at or in excess of normal operating potential can be determined with the Cinetech high-potential leakage tester. It is being made available to the industrial field by



Cinetech Company, Inc., 106 West End Ave., New York 23, N. Y.

This device will indicate satisfactory performance when connected to an equivalent resistance of 100,000 to 110,000 ohms at one of three available

voltage ranges, namely, 300, 1000 and 1500 volts, a.c. It will reject instantly, without destructive effects to the equipment under test, when the equivalent resistance of the tested material is less than 100,000 ohms with high voltage applied.

## RESINITE TUBING

Resinite tubing, developed by the Precision Paper Tube Company, is said to provide greatly increased wall strength, improved dielectric and other electrical properties, and high chemical and moisture resistance. Tubes are available in all shapes, widths and lengths. Inner diameters range from .125" to 3", with wall thicknesses from .006" to .100".

These tubes can be supplied threaded inside or outside, slotted, punched, or

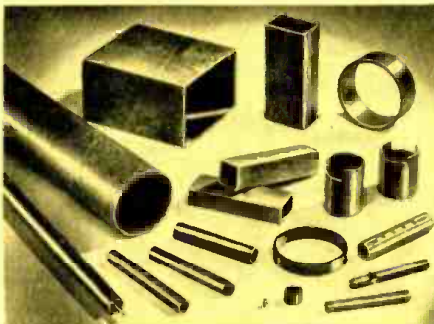

embossed. Threaded coil forms incorporate a special three-row design to afford axial pressure in excess of 25 lb. Torque can be controlled to  $\pm 1$  inch-ounce.

For further information, write to Precision Paper Tube Co., Dept. H., 2035 W. Charleston Street, Chicago 47, Ill.

## SENSITIVE INVERTER

In combination with a suitable 60-cps voltage-sensitive device, the Ballantine sensitive inverter Model 700 makes possible: (1) accurate measurement of d.c. potentials as low as 10 microvolts, and (2) detection of d.c. potentials as low as 1 microvolt, while presenting to the source a resistance of not less than 10 megohms.

Announced by Ballantine Laboratories, Inc., Boonton, N. J., this unit inverts d.c. potentials to a.c. voltages directly proportional in magnitude to the d.c. input voltages and phase-sensitive to the d.c. polarity. It features a built-in calibrator which minimizes

the errors caused by a companion instrument or by the departure of line frequency and voltage from nominal values.

## ANALOG COMPUTER

The Research & Control Instruments Division of North American Philips Company, Inc., 750 South Fulton Ave., Mount Vernon, N. Y., has announced a computer for recording random count-



ing rates on a linear chart with a constant computed statistical accuracy.

This instrument makes use of Ohm's law ( $IR = E$ ) as the analog to the basic counting equation ( $nT = N$ ;  $n$  = counting rate,  $T$  = time interval,  $N$  = total number of counts). A slide-wire resistor is driven by a synchronous motor so that resistance ( $R$ ) in the circuit is proportional to time ( $T$ ). With fixed battery voltage ( $E$ ), the current recorded is proportional to  $n$ .

The Norelco computer must be used with a scaling circuit adjusted for fixed count operation. The range of the instrument is controlled by the choice of scale factor ( $N = \text{scale factor} \times 100$ ) and the speed with which the slidewire is driven.

## CHAIN AMPLIFIER

Designed specifically for television distribution system requirements, the SKL Model 212A-TV chain amplifier has a bandwidth of 40 to 225 mc.; up to 12 v.h.f. television channels can be am-



plified simultaneously with high fidelity. The unit has a gain of 21 db, and a new manual gain control is provided—with a range of 5.5 db—to permit the adjustment of signal levels in the system.

Use of a parallel tube circuit gives the Model 212A-TV chain amplifier high operating reliability. Tube failure results in a loss of 1.6 db gain, not in a loss of the entire picture. Untuned circuit design eliminates loss of picture resolution due to inadequate bandwidth and frequency drift.



For further information, write to *Spencer-Kennedy Laboratories, Inc.*, 186 Massachusetts Ave., Cambridge 39, Mass.

#### PRECISION "MAGIC TEE"

The availability of a new precision X-band hybrid junction has been announced by the *General Precision Laboratory*, 63 Bedford Road, Pleasantville, N. Y. Using a new type of construction, the unit assures isolation of -50 db or better as well as low VSWR over a broad frequency range. In addition to its function as a "magic tee," it can be employed as a highly accurate power divider in the configuration of a shunt or series tee by blocking the appropriate arms.

This component is of precision-machined rather than brazed wave guide fabrication, permitting the holding of close mechanical tolerances with improved performance factors.

#### SCALING UNIT

To speed counting procedures in radioisotope laboratories, the *Nuclear Instrument & Chemical Corporation*, 229 West Erie Street, Chicago 10, Ill., has developed a scaling unit which features an electrically reset timer and register. It is available with either a 500-5000 volt or 500-2500 volt variable power supply.

Slope-mounted in its cabinet, the Model 182 is designed for precision



counting with new simplified controls. It has a wide sensitivity range and linear amplification from 1 millivolt to 1 volt. Resolution time is 2 microseconds, and the amplifier circuit has a rise time of less than 0.2 microsecond.

#### MICROWAVE TV LINKS

Two television microwave links have been announced by the *Raytheon Manufacturing Company*, Waltham 54, Mass. Respectively the most portable and the most powerful TV microwave equipment, they are the first such devices to handle pictures and sound simultaneously on the same wave band.

The KTR-100 "Microlink" is a compact, lightweight relay which operates in the frequency range of 6875 to 7125 mc., with a power output of 0.1 watt.

It includes a completely new a.f.c. and limiter, a special cable compensating switch, accurately controlled trans-



mitter frequency, built-in voltage regulator, and provisions for frequency and modulation monitoring. The transmitting unit is shown in the photograph.

The MTR-50 "Magnalink" is a much larger link, capable of transmitting wideband intelligence over distances of 100 miles. It operates in the 2000-mc. frequency range and is powered by a 50-watt magnetron. By virtue of normal gain factors through a 10-ft. parabola, the 50-watt tube output is multiplied, resulting in an ERP of 50,000 watts.

#### BALUN

Accurate measurements of balanced impedances in the 50-1000 mc. frequency range can be made with the help of the Type 874-UB balun. Announced by the *General Radio Company*, 275 Massachusetts Avenue, Cambridge 39, Mass., the balun is a tunable semi-artificial half-wave line. It acts as a transformer and makes it possible to connect a balanced impedance to an unbalanced coaxial system, such as is used on high frequency measuring instruments. The balun has two advantages over a conventional transformer for this purpose—it can be tuned over a wide frequency range and has very low losses.

#### ELECTRONIC RESISTANCE ANALYZER

Precision measurements of resistors may be made with the electronic resistance analyzer now being produced by *The Kuljian Corporation*. It can be used by resistor manufacturers in selecting resistors to within specified limits. Having high accuracy and a wide range, it is particularly adapted to the selection and measurement of resistances used in analog computers.

Available in either a rack or bench model, this instrument is designed for 115-volt a.c. operation. A precision of balance of 0.02% can be realized over almost the entire range. Range and accuracy tolerances, as well as adding  
(Continued on page 28)

## TECHNICAL BOOKS

"ELEMENTS OF THE THEORY OF FUNCTIONS" by Konrad Knopp. Translated by Frederick Bagemihl. Published by *Dover Publications, Inc.*, 1780 Broadway, New York 19, N. Y. 140 pages. Paper Edition, \$1.25; Cloth Edition, \$2.25.

In the "Elements of the Theory of Functions," only those topics are treated which are simplest yet most important for the further development of the theory. The foundations of real analysis and the elements of analytic geometry, knowledge of which is necessary for a proper understanding of the book, are covered in Chapter 1.

After an introduction to the system of complex numbers and operations performed on them, the concept of sets of numbers, the limit concept, and closely related matters—in particular, the theory of infinite series—are extended to complex quantities. Then, the notion of function and its most important properties is carried over to the case in which independent and dependent variables are complex; when combined with the limit concept, this yields the foundations of a differential calculus for functions of a complex variable. Finally, the elementary functions are dealt with in greater detail.

"THE THEORY OF ELECTRONS and Its Applications to the Phenomena of Light and Radiant Heat" by H. A. Lorentz. Second Edition. Published by *Dover Publications, Inc.*, 1780 Broadway, New York 19, N. Y. 343 pages. Paper Edition, \$1.70; Cloth, \$3.50.

This book is composed largely of a series of lectures which was delivered at Columbia University in 1906 on the theory of electrons and its more important applications in the domain of light and radiant heat. For many years the original edition has been out of print and almost impossible to obtain. In the new edition, the text has been left nearly unchanged except for a small number of alterations and additions in the footnotes and the appendix.

Emphasis is on the general ideas and hypotheses of a physical nature involved, with such mathematical calculations as are used being given in the hundred-odd page appendix. The following topics are covered in detail: general principles applying to the theory of free electrons; emission and absorption of heat; theory of the Zeeman-effect; propagation of light in a body composed of molecules—and the inverse Zeeman-effect; and optical phenomena in moving bodies.





By **WILFRID B. WHALLEY**

Adjunct Professor of Electrical Engineering  
Brooklyn Polytechnic Institute

### *Reproducing tubes for monochrome television.*

**T**HE VAST growth of television, for entertainment and industrial purposes, has required the design and manufacture of millions of picture-reproducing tubes. All picture tubes—or *kinescopes*, as they are often called—represent one large section of the general group known as cathode-ray tubes.

#### **Cathode-Ray Tube Development**

“Cathode ray” was the name given at the end of the last century to the phenomenon which occurred when a heated metallic or semiconductor surface was placed in a high voltage positive electric field, and light was produced from a glass surface at the positive potential.

First use of this phenomenon was made at the beginning of the century when a small filament was sealed in the small end of a chemical flask, the gas pressure reduced to a moderate vacuum, and a high positive voltage applied to the large end. Electrons emitted by the filament were accelerated toward the large end or face, and produced an illuminated spot due to bombardment of the crystal structure of the glass. It was found that the diameter of the spot depended upon the gas pressure, a suitable pressure producing a minimum-size or “best focused” spot. These earliest devices made use of “gas focusing” of the electrons, and produced a beam of moderate diameter.

Next, it was found that the presence of an electric or magnetic field perpendicular to the axis of the tube would move the spot over the face. For the electric field, the movement was toward the positive potential, similar to the acceleration of electrons toward a positive terminal. In a magnetic field, the spot was found to move at right angles to the field, in the same way that a conductor carrying electricity will move in a magnetic field.

By applying a.c. voltages between pairs of electrodes or “plates” in or near the neck of the tube, it was possible to produce patterns corresponding to the waveform of the a.c. voltage.

From these experiments have come the cathode-ray tubes used for oscilloscopes and for television kinescopes.

#### **Picture Tubes**

Since the first experimental devices were developed, major improvements have been made in focusing the electrons, providing good vacua, using suitable coatings on the glass for higher light output, and reducing the adverse effects of ion bombardment. Present focusing is by means of suitable structures known as electron guns, where the focusing is always dependent—in whole or in part—upon electric fields; a magnetic lens may also be employed. As electrons move above a certain critical velocity through a gas, any collision with an atom or a molecule can produce gas ions. The negatively ionized particles will move toward the screen and the positively charged particles toward the cathode, since the cathode (or the control grid) is the most negative point in the tube. The ion bombardment decreases the light output of the screen by affecting the crystal structure. It also damages the cathode, in severe cases removing the coating and making a hole in the surface of the cathode. Hence, much emphasis has been placed upon removing as many of the gas molecules as possible.

As even the best vacuum pumps, in high speed production, leave sufficient gas to produce ion spots on the phosphor, either an ion trap is used with the gun, or an aluminum film is placed over the surface of the phosphor.

#### **Ion Traps**

The ion trap uses the principle of separation of particles of different masses—the same principle that is used in the mass spectrometer. When a charged particle is accelerated in an electric field, and passes through a magnetic field, it moves in a circular path. The radius of curvature depends upon three quantities: the mass, the velocity (due to the electric field), and the strength of the magnetic field. Since electrons have an effective mass very

much below that of gas atoms and molecules, a suitably shaped electron gun placed in a magnetic field of the correct strength will remove the ions from the electron stream.

#### **Aluminum Film**

It has been found that thin films of certain metals will pass electrons, but will absorb ions. The most useful metal for this purpose is aluminum. Since aluminum is a low-cost metal which can be evaporated in a vacuum at a moderate temperature, it is increasingly used in coating the back or inner surface of the fluorescent screen. Many tubes operate without ion “burn” with a straight electron gun, due to the protection by the aluminum film. Of course, the aluminum film provides other advantages: increased light output is obtained since light is reflected forward which would otherwise be directed back into the tube and be lost inside the envelope; and the fluorescent screen is maintained at the applied potential. The aluminum film also increases the small area contrast of the picture.

#### **Present Kinescopes**

Present-day tubes can be divided into two groups—those which are electrically focused, and those which use magnetic focus. Both types have certain advantages. With electrostatic focus guns of the correct aperture and cylinder design, good focus is obtained without an extra magnetic field. Also, the tube will stay in focus with changes in high voltage, such as those due to a.c. line voltage changes.

The magnetically focused tubes will maintain good spot size at the center of the picture for higher beam currents and correspondingly higher peak brightness, due to the more stable and generally larger magnetic-type lens.

#### **“Sticking” Potential**

All fluorescent screens in nonaluminized tubes tend to operate at a potential where the secondary electron emission is unity. This is due to the low conductivity of typical phosphors and the correspondingly high resistance to the positive voltage source. As the electrons in the beam penetrate the crystal structure, secondary electrons are released; if the secondary emission ratio were more than unity, the potential of the phosphor would tend to shift to an equilibrium point for the correct one-to-one ratio.

As the phosphor becomes older, the potential tends to shift downwards, reducing the light output from the tube. With an aluminum film in contact with the phosphor, the crystals are held at the applied high voltage, giving a light output corresponding to the electron velocity.



## Direct-Coupled Amplifier

(Continued from page 5)

tion only, with a coupling capacitor at the output, regulation may not be necessary at all. In multichannel work, of course, the power supplies must be regulated, if only to minimize cross-channel interference.

If stability against line voltage changes is required in the heater supply, the 6X8 may be run from a 12-volt transformer in series with an *Amperite* type 5T4 current regulator (not to be confused with the rectifier of the same designation). In view of the generation of odd harmonics by the nonlinear ballast tube, it is wise—if use of the 5T4 is desired—to connect the potentiometer for hum balancing on the 6X8 side of the 5T4, as shown in Fig. 2, using a completely isolated winding for the 12 volts. In this way, the grounded center arm will move between the two terminals of the heaters themselves, and a balance adjustment for the harmonics as well as for the 60-cps fundamental will occur.

By use of the above techniques, the hum may be made as low as 2 mv. at the output (10 microvolts referred to the input), which is just about twice the noise figure. With film resistors in place of the carbon ones now used, it might be possible to reduce the noise. However, an amplifier of this bandwidth and input resistance is liable to have somewhat more noise than a person who habitually deals with audio amplifiers or similar equipment might expect.

After the amplifier was adjusted for best response to a 10-kc. square wave, its response was noted to be down 1 db at 240 kc. and 3 db at 520 kc., there being a rise of about 0.2 db in the vicinity of 400 kc. The 10-kc. square wave, after passing through the amplifier, has about 5% overshoot and a rise time of a little under a microsecond.

Maximum output was over  $\pm 10$  volts d.c., and the equivalent at a.c., up to at least 200 kc. In order to get a larger swing than this, especially at the higher frequencies, it would have been necessary to raise the power consumption substantially, which was not allowable. This is, after all, a fairly low-level device, being intended to amplify a signal of perhaps 50 mv. up to the 10-volt level (full scale).

A.C. applications of this circuit are plentiful. With or without an input transformer, it would serve as an excellent audio amplifier, although as it stands its main use would be in medium level work. If it were to be used as a preamplifier, the 6X8 could be removed and two 5879's substituted since drift would no longer be a factor. The input resistor could be reduced to perhaps 100K, leaving the 20M the same and

removing the 22K and 1 K divider, with the 20M resistor hung directly between output cathode and input grid. The low-hum, low-microphonic features of the 5879's would prove beneficial while the gain of the pentode would be retained (although the 5879 has only about half the gain of the "hotter" pentodes, gain being sacrificed for wide spacing and reliability, rigidity, etc). This change should be possible without affecting parts values very much; although the cathode resistor will be different, changing the "Zero" pot will suffice. An amplifier using 5879's in this way was the ancestor of this design, and has worked well for over a year as an experimental oscillograph galvanometer driver.

For any application involving accurate measurement of a d.c. signal, however, the drift of this amplifier would be excessive. Some stabilizer would be necessary, such as the RCA drift compensator which is used in almost all modern d.c. amplifiers of good quality. For less critical applications, as in the oscilloscope described, and for all a.c. applications where the d.c. type of amplifier is used merely to avoid trouble in stabilizing the amplifier under feedback, such a stabilizer would not be needed.

In the amplification of a.c. signals, a d.c. amplifier has considerable merit: there is no problem of stabilizing the amplifier against "motorboating" at the low end, when feedback is used; and after one has put coupling capacitors at the input and output, the low-frequency response is solely determined by the input and output time constants, which may in nearly all cases be accurately known and allowed for and which are usually very stable. Transient performance at the low end is far superior to that of the conventional multistage a.c. feedback amplifier.

Other uses of this circuit might be found in vacuum-tube voltmeters. It could be made into a combination a.c. and d.c. meter (provided that rectification was added) if the drift were acceptable, since it has a fairly good bandwidth and response down to d.c. It might prove useful as an integrating amplifier; its simplicity allows networks to be connected from input to output without much instability, while its gain of 20,000 before feedback is good enough for many purposes. As the nucleus for a carrier amplifier, either for a relatively high (5-10 kc.) carrier frequency or for larger amounts of feedback at a lower carrier frequency, it would seem to offer some possibilities also.

### BIBLIOGRAPHY:

Goldberg, E. A., "Stabilization of Wide Band D. C. Amplifiers," *RCA Review*, June, 1950.



# WHEN YOU ORDER WELLS COMPONENTS...

## HERE'S WHAT YOU GET

- ☐ IMMEDIATE DELIVERY FROM STOCK  
(in any quantity)
- ☐ FINEST QUALITY OF FAMOUS BRANDS
- ☐ GENERALLY LOWER PRICES
- ☐ RETURN PRIVILEGE FOR FULL  
CREDIT IF NOT SUITED TO YOUR  
REQUIREMENTS

The valuable service Wells provides to the industry is being used by many of our greatest manufacturers as a matter of course.

Our vast stock (the world's largest) may contain just the components you need to fill urgent orders — at a substantial savings in time and cost.

ADEL CLAMPS • ANTENNAS, Insulators, Mast Sections • BINDING POSTS • BLOWERS • CABLE ASSEMBLIES • CHOKES • COILS • CONDENSERS Oil Filled, Bathub, Hearing Aid, Transmitting Micras, Silver Micras, Ceramic, Variable, Trimmer • CRYSTALS • FILTERS • FUSES & MOUNTINGS • GENERATORS • GROUND RODS • HEADSETS • I.F. COILS • JACKS • JACK BOXES • KEYS, Telegraph KNOBS • LAMPS • LORD MOUNTS • LUGS MOTORS & BRUSHES • PLUGS • RECTIFIERS Selenium, Copper Oxide, Meter, Diode • RESISTORS—All Types • SELSYNS • SOCKETS • SWITCHES Aircraft, Micro, Switchettes, Taggle • TIMERS • TUBING—Flexible • TUNING SHAFTS • TRANSFORMERS All Types • VIBRATORS • WALKIE TALKIES

### DYNAMOTORS

OVER 100,000  
NEW DYNAMOTORS  
IN STOCK!

DM 32A — DM 53A — PE 86 — PE 101C  
DM 33A — D 101 — PE 94, etc.  
Large quantities of brushes for all types of dynamotors and motors.

Write us for quotations. Advise us your requirements.

A complete Signal Corps stock number listing of items in our stock. Write for listing No. SG-200. (For government agencies and contractors only.)

Manufacturers and distributors—write for new Condenser Catalog C-10 now available.

Write, Wire, Phone Your Requirements  
all phones: SEEley 8-4143

# WELLS SALES, INC.

833 W. Chicago Ave., Dept. R, Chicago 22, Illinois



# NEW LITERATURE

## TUBE CHARACTERISTIC CURVES

Here is a conductance curve design book which provides both static and dynamic data on the operating characteristics of 17 popular receiving tubes. Inclusion of dynamic data in addition to static permits the direct determination of both small and large signal operating characteristics of a circuit being designed.

Brief application notes and the basic equations for the most commonly used circuits are included in this book, which is available for \$1 per copy from *Kann-Ellert Electronics, Inc.*, 9 S. Howard Street, Baltimore 1, Md.

## ELECTRICAL INSULATION MATERIAL

Helpful information on the features and uses of fibre and plastic for electrical insulation is incorporated in two catalogs which may be obtained by writing to the Publications Department, *Insulation Manufacturers Corporation*, 565 West Washington Boulevard, Chicago 6, Ill.

Imcor reinforced plastics are described in an 8-page catalog while Phenolite laminated plastics, National vulcanized fibre, and Peerless fishpaper products are covered in a 32-page catalog. Both contain complete descriptions, tabular data, and other information on grades, properties, and fabricating techniques for sheets, rods, tubes, and fabricated or molded parts.

## DICTIONARY OF CARRIER TERMS

Definitions of 150 terms commonly found in telephone and telegraph carrier equipment literature are given in the new *Lenkurt Bulletin EB-101*, entitled "A Dictionary of Carrier Terms." The 16-page booklet also includes a general discussion of carrier equipment theory.

Copies of this publication are available from *Lenkurt Electric Co.*, 1115 County Road, San Carlos, Calif.

## HERMETICALLY SEALED RELAYS

General-purpose hermetically sealed relays for electronic applications are described in a four-page bulletin available from the *General Electric Company*, Schenectady 5, N. Y.

Designated as GEA-5729A, the two-color publication uses photographs, specification charts, and dimensional diagrams in discussing the application, performance, and features of these re-

lays—which are designed to meet or better military specifications.

## PRINTED CIRCUITRY

The first complete description of the *Technograph* process of printed circuits is now available in a new book which covers the processes and uses of printed circuits. The entire subject is treated at sufficient length to indoctrinate anyone interested in the future development of many electronic products through printed circuitry.

This hard-covered, 48-page book may be obtained at \$1 a copy from Dept. T, *Technograph Printed Electronics*, 191 Main Street, Tarrytown, N. Y.

## LIQUID-LEVEL CONTROL

A single-thyratron electronic liquid-level control operating without radio frequency from a single capacitive-type probe is described in Form LL-4-453. This four-page folder, published by *Thermo Instruments Co.*, 1166 El Camino Real, Belmont, Calif., illustrates the control and the probe, and contains alternative schematic arrangements for installation. Specifications are included.

## MAGNETIC IRON POWDERS

Complete technical data on various magnetic iron powders, including photomicrographs, frequency vs.  $Q$  charts, and permeability rating graphs, are available from *Magnetic Powders, Inc.* These data are contained in an eight-page illustrated catalog, No. 354, which covers annealed carbonyl iron powders, hydrogen reduced iron powders, and magnetites. Write to Mr. C. C. Neighbors, *Magnetic Powders, Inc.*, 1047 Fairview Avenue, Johnsonburg, Pa., for your copy.

## MAGNETIC AMPLIFIER CIRCUITS

Three Government research reports describe new magnetic amplifier circuits which make possible better computers and automatic control systems. These reports are available in mimeographed form from the Office of Technical Services, U. S. Department of Commerce, Washington 25, D. C., at 50 cents each. Orders should be accompanied by check or money order payable to the Treasurer of the United States.

The amplifier control circuits and their characteristics are described in

PB 105747, entitled "On the Control of Magnetic Amplifiers." PB 111033, "The Single-Core Magnetic Amplifier as a Computer Element," shows how the new circuits can provide more dependable elements in basic functional components of computers. How the circuits can be used to provide anticipatory correction mechanisms is covered in PB 111022, "Lead Networks Utilizing a Saturable Core Memory."

## NBS REPORT

The National Bureau of Standards has published a ten-page report entitled "Machining of Powdered Iron Materials and Ferromagnetic Ferrites." It contains special techniques for the following materials: polyirons, ferrites and ground ferrites suspended in binders. Altogether, 28 individual materials are discussed.

This report (PB 108118) is available from the Library of Congress Publication Board Project, Washington 25, D. C., in microfilm or photostat form for \$1.25. A limited supply is also available from the Microwave Laboratory, National Bureau of Standards, Washington 25, D. C.

## MICROWAVE COMPONENTS

"Microwave Components" is a concise, well-illustrated bulletin featuring the use of *Crowley* polyiron—a permeable dielectric material—for microwave components. The bulletin also covers various kinds of terminations, stock blank sizes, and machining procedures, and includes drawings of typical polyiron fabrications. It is available to engineers and manufacturing executives from *Henry L. Crowley & Co., Inc.*, 1 Central Ave., West Orange, N. J.

## PRINTED CIRCUIT HANDBOOK

*Method Manufacturing Corporation* has announced the publication of a printed circuit handbook entitled "Utilization of Prefabricated Wiring." This 32-page booklet provides comprehensive and detailed engineering information on the practical application of printed wiring techniques to electronic equipment. It will be sent to anyone requesting a copy on a business letterhead by *Method Manufacturing Corporation*, 2021 W. Churchill St., Chicago 47, Ill.

## WIRES AND CABLES

Copies of a 76-page booklet entitled "U. S. Electrical Wires and Cables for the Chemical and Petroleum Industries," may be obtained from the Electrical Wire and Cable Department of the *United States Rubber Company*, 1230 Avenue of the Americas, New York 20, N. Y.



Divided into four main sections—insulation compounds, jacket compounds, construction, and technical data—the booklet follows the successful pattern of *U. S. Rubber's* earlier book on the coal mining industry. The compound sections have been expanded to include butyl insulation, heat- and moisture-resistant insulations, thermoplastic types, the general-purpose neoprene jacket, and the polyvinyl chloride type jacket.

#### METALLIC RECTIFIER UNITS

The complete line of *G-E* metallic rectifier power conversion units is covered in an eight-page bulletin available from the *General Electric Company*, Schenectady 5, N. Y.

Designated as GEA-5658B, this publication lists the design features and advantages of the *G-E* line, and gives performance data, circuits, dimensions and ratings. A guide is also provided as an aid for preparing contract specifications which entail *G-E* d.c. power supplies and excitors.

#### Electronic Flowmeter

(Continued from page 14)

ing system operating at a 10-cps rate is employed. Switching is achieved by a commutator which is inserted between the crystals on one side and a 100-kc. oscillator and receiver on the other. The oscillator is connected to an amplifier containing carefully designed limiters that produce a square-wave voltage to be injected on one grid of a multigrid phasemeter tube. The receiver-amplifier also furnishes a limited signal to the other grid of the phasemeter tube.

This phasemeter tube is bypassed by a capacitor so that fluctuations at the sound wave frequency are removed and fluctuations at the switching rate may be applied to a synchronized rectifier. The rectifier is actuated in synchronism with the commutator, but its active period is shorter, so that harmful tran-

sients occurring during the crystal transition are suppressed.

A simple commutator, one that would merely switch the crystals alternately to the receiving and transmitting channels, is unsuitable because of the capacitive cross-coupling between the two channels. In order for the transmitted and received pulses to be absolutely representative of the separation between the crystals and the velocity of the fluid, there must be a minimum of coupling between the two channels. By very careful design of the commutator, the leakage capacitance can be reduced to about  $5 \times 10^{-6}$   $\mu\text{fd.}$  and much of the fringe effects and ground currents is eliminated.

The rotor of the commutator is made in the form of a sandwich, consisting of two pieces of insulating material fastened to a grounded conductive shield. Two conductive segments or sectors are mounted on the insulating material but have no connection to the shield. The shield is brought out to the maximum diameter of the rotor, thereby reducing the fringe effects between the sectors. Four rows of carbon brushes are arranged so that the crystals are connected to either the receiver or oscillator for all positions of the rotor. Capacitive coupling between the sectors is reduced by maintaining a clearance of less than 0.015" between the sector shield and the rotor. Similarly, close-fitting shields are provided at the ends of the rotor to assist in reducing fringe effects.

The output of the phasemeter is applied to an electronic high-impedance voltmeter (which can be calibrated directly in terms of velocity) through the rectifier-switch geared to the commutator drive. Fast velocity changes can be observed on the screen of a cathode-ray oscilloscope connected to the plate of the phasemeter tube. Thus, if the plate voltage is made visible, the difference between the voltages developed "upstream" and "downstream" can be used directly to estimate the flow velocity instantaneously.

The commutation operation can be modified by the use of an electronic switch. By using vacuum tubes, the switching frequency can be increased to 1000 cycles, for example, and the time of response can be correspondingly shortened. Four pentode amplifiers are placed between the crystals on one side and the oscillator and receiver on the other. The screen-grid supply is derived from a square-wave generator with a frequency equal to the switching rate (1000 cps). When the screen voltage is positive, the pentode acts as a normal amplifier; when the potential becomes negative, the electron stream in the tube is blocked and good shielding is provided. The amplifiers are so arranged that one pair operates at a time during each half of the switching cycle.

Further modifications in the flowmeter are being considered; one in particular is concerned with flow in metal pipes. A pulsed and gated phase comparison system will be used for this purpose to eliminate the effects of the direct transmission of the sound through the wall of the pipe.

#### Pulse Duration Modulation

(Continued from page 11)

AM and PAM, where slicing is not available.

The primary disadvantages of PDM are:

1. In comparison with FM and AM, PDM requires a greater bandwidth which is traded for an improved signal-to-noise ratio.
2. It does not utilize transmitter energy as effectively as all the other pulse systems which maintain constant narrow pulses.

#### REFERENCES:

1. Libois, L. J., "Application of Pulse Modulation to the Transmission of a Carrier Telephone System Channel Groups." *L'onde Electrique (Paris)*, April-May, 1952.
2. Fitch, E., "The Spectrum of Modulated Pulses." *Jour. I.E.E. (London)*, 1947, Vol. 94, Part IIIA, pp. 556-64.
3. Lozier, J. C., "Spectrum Analysis of Pulse Modulated Waves." *Bell System Tech. Jour.*, April, 1947, Vol. 26, pp. 360-387.

## PLANS INTO PLASTICS

**PRECISION MACHINING  
OF ALL THE PLASTICS**  
including

POLYSTYRENE	COPOLYMER 1422
BUTYRATE	TEFLON
NYLON	KEL-F

**PLASTIC FABRICATING**

Printloid is equipped for the complete production of a wide variety of consumer and industrial items in any quantity. We work with any plastic material in sheets, rods and tubes. Die-cutting, deep drawing, stamping, forming, finishing, and assembling in our own plant.

**PLASTIC PRINTING**  
LETTERPRESS . . . SILK SCREEN  
HOT STAMPING  
for Containers, Displays, Dials,  
Charts, Machined Parts, Etc.

*Ask for brochure illustrating various  
plastic products fabricated to specification by Printloid.*

## PRINTLOID, INC.

95 Mercer St., N. Y. 12, N. Y.

Oscilloscope patterns for instantaneous flow velocities obtained with flowmeter.

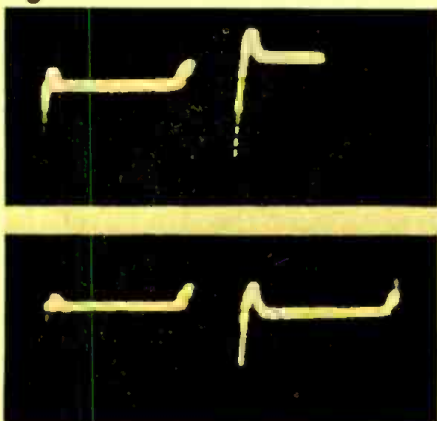



# Personals



**ALTON D. ANDERSON** has been named assistant chief engineer of *Cook Research Laboratories*, a division of *Cook Electric Company*, Chicago, Ill. Since 1950, Mr. Anderson has been director of the Systems Development Section; now he will coordinate the activities of the various technical sections of the *Laboratories* and assist in the direction of over-all technical programs. Prior to 1950, Mr. Anderson was associated with the Naval Ordnance Laboratory.



**DR. SEYMOUR B. COHN**, an authority on microwave components, has joined the staff of Stanford Research Institute to head the Microwave Group in the Aircraft Radiation Systems Laboratory; he was formerly a research engineer at *Sperry Gyroscope Company*. During the war years, Dr. Cohn worked as a special research associate in the Radio Research Laboratory at Harvard University. He holds the 1942 Lamphier Award from Yale University.



**JOHN A. DOREMUS**, well known for his work in the communications field—and more specifically for his contribution to transistor development, has been appointed director of engineering of the *Allen D. Cardwell Mfg. Corp.*, Plainville, Conn. He will be responsible for the company's engineering research as well as engineering supervision of government projects. Mr. Doremus was formerly chief engineer of the Carrier & Control Division, *Motorola, Inc.*



**KENNETH A. HOAGLAND**, formerly assistant engineering manager of the Cathode-Ray Tube Division of *Allen B. Du Mont Laboratories, Inc.*, has now been named chief engineer of this division. One of the outstanding cathode-ray tube experts in the field, Mr. Hoagland has been with the *Du Mont* organization for 12 years. He is credited with the development of the *Du Mont* "Bent Gun" used in cathode-ray tubes and with the "Selfocus" picture tube.



**GEORGE J. ROGERS** has joined the Electronics Division of the National Bureau of Standards. As a member of the Engineering Electronics Section, he will be engaged in the development of miniaturized equipment. Before joining NBS, Mr. Rogers was an electronics engineer with the *Engineer Research and Development Laboratories*, Ft. Belvoir, Va., where he assisted in the development of electronic mine-detecting equipment for metallic and non-metallic mines.



**MARVIN G. WHITNEY** has been appointed assistant to the president of *Hoffman Radio Corp.*, Los Angeles, Calif., with a current assignment on television engineering, quality control and product design. A graduate of Rensselaer Polytechnic Institute, he was with *Radio Corporation of America* for 13 years in various product and plant manager capacities, first at Camden, N. J., and more recently at the new *RCA* engineering plant at Moorestown, N. J.

## New Products

(Continued from page 21)

tional information, may be secured from the Electronics Division of *The Kuljian Corporation*, 1200 N. Broad Street, Philadelphia 21, Pa.

### PRECISION RANGE CALIBRATOR

Measurements within 10 feet for ranges up to 10,000 yards are possible with the Model 531 precision range calibrator just announced by the *Bristol Engineering Corp.*, Lincoln Avenue and



Pond Street, Bristol, Pa. Designed for both laboratory and field use, the Model 531 may be used for radar development and test work, computer measurements, and time base measurements on cathode-ray tube displays.

The basic circuit consists of an accurate range mark generator, a continuously variable delayed pulse and a built-in coincidence and calibrating circuit. By calibrating the variable pulse to a marker close to the desired range, great accuracy can be obtained with a minimum of complexity.

### SIGNAL GENERATOR

A new signal generator, Model 618B, has been designed by *Hewlett-Packard Company* for faster and more accurate measurements of radio relay, radar, TV carrier systems, and similar applica-

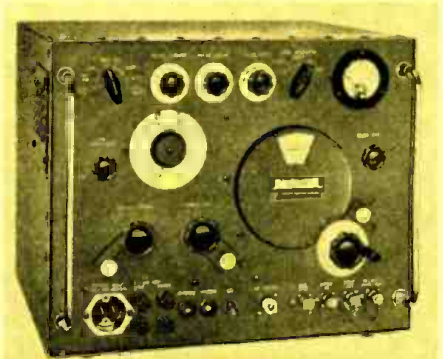

tions involving superhigh frequencies. It is equipped with a reflex klystron oscillator for frequency generation and covers a range of 3800 to 7600 mc.

Model 618B has wide pulsing capabilities; it may be internally or externally pulse modulated. The repetition rate is continuously variable from 40 to 4000



pulses per second, and pulse width is variable from 0.5 to 10 microseconds. For further information, write to *Hewlett-Packard Company*, 395 Page Mill Road, Palo Alto, Calif.

#### CRYSTAL DETECTOR

Another new product has been added to the expanding line of specialized microwave components being developed by *General Precision Laboratory*, Pleasantville, N. Y.—a tunable crystal detector is now available in RG-52/U or RG-68/U wave guide.

This unit, for use in the range from 8500 to 9500 mc., utilizes two screws for

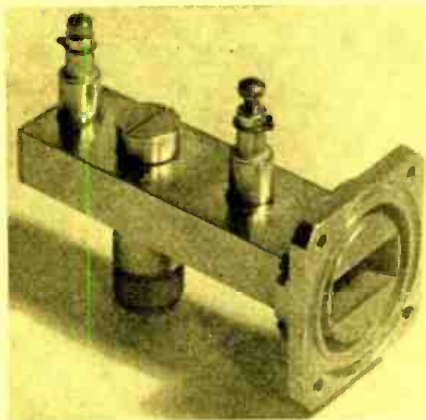

adjusting to optimum VSWR. Its simplicity of design and ease of operation represent an advance over earlier crystal detector designs.

#### CARBON FILM RESISTORS

Production of two high-stability carbon film resistors has begun at the *Chase Resistor Company*. One type of unit is sealed in a glass envelope, evacuated, baked at high temperature under vacuum, and finally sealed in helium of spectroscopic purity. This unit is stable to .01% under all environmental conditions, and has a long-time drift of .01% per year or less. It can be supplied in networks with ratios and temperature coefficients held to very close tolerances.

A less expensive unit is made by solder-sealing the resistor in a ceramic tube with metallized ends. The stability of this unit is less than that of the glass-helium sealed resistor, but much better than that of a varnished resistor, particularly under conditions of high humidity and temperature.

Free literature and sample card for physical dimensions are available upon request on company stationery from *Chase Resistor Co.*, 9 River Street, Morristown, N. J.

#### NULL DETECTOR

Primarily intended for use as a balance indicator for a.c. bridges, the

Type 1212-A unit null detector is also useful as a sensitive wide-frequency-range voltage indicator. Its frequency characteristic is flat within about 1 db from 50 cycles to 500 kc., and it is satisfactory as an indicator at frequencies from 20 cycles to 5 mc.

Type 1212-A is one of the building-block instruments in the unit line being manufactured by *General Radio Company*, 275 Massachusetts Ave., Cambridge 39, Mass. An approximately logarithmic relationship between meter

reading and input voltage gives an on-scale range of about 120 db. The full-scale deflection is about 100 volts, while a signal of less than 40 microvolts deflects the meter by 1% of full scale.

#### MINIATURIZED BALANCE PANEL

Constructed entirely of miniaturized components, the Model BP-2 15-channel balance panel is designed specifically for use in flight test instrumentation and other applications where multiple

#### A "LOUDSPEAKER" CLUTCH

**A FAST-ACTING CLUTCH** that works on the same moving-coil principle as the electrodynamic loudspeaker of an ordinary radio receiver has been developed by the National Bureau of Standards. The new clutch is activated by applying direct current to a coil located in a constant magnetic field. The force resulting from the interaction of the coil current and the magnetic field moves the coil and causes the clutch output disc to be pressed against the rotating input members. In an experimental model constructed at NBS, full output-shaft torque—10 ounce-inches maximum—was attained in less than a third of a millisecond after application of the actuating voltage. Developed by Jacob Rabinow, head of the NBS Electromechanical Ordnance Division, the NBS "loudspeaker" clutch offers advantages for certain instrumentation and computer applications calling for fast response. Possible uses include rapid starting and stopping of magnetic wire or tape recording media in high speed electronic computers, like the Bureau's SEAC, and high speed switching in telephone dial systems.

In the NBS experimental model, the magnets and coils rotate with the clutch input shaft. Although a permanent magnet could be used, an electromagnet was chosen; the clutch can thus be easily cleaned of any accumulated magnetic particles when the magnetizing current is shut off. Two pairs of slip rings transmit the magnetizing and actuating currents to the rotating assembly. A thin

flexible diaphragm is fastened to the actuating coil. When the voltage is applied, the coil jumps forward and presses the clutch output disc between the rotating diaphragm and a backing disc which is also rotating. Vent holes in the output disc, diaphragm, and case assist cooling and avoid compression or rarefaction of air by the diaphragm.

Compensating coils are attached to the pole faces of the electromagnet, close to the actuating coils. All of the coils are connected in series so that the current is the same in all windings, but the direction of current flow in the compensating coils is opposite to that in the actuating coils. This arrangement cancels out the inductance of the actuating coils to the extent that the coupling between coils approaches unity, and thus minimizes the time required for current to rise in the coils after the actuating voltage is applied.

The principle of the NBS loudspeaker clutch is expected to find application in specialized equipment where light loads must be accelerated at an extremely rapid rate. A similar principle has already been used at the Bureau to advance frames of photographic film rapidly at random intervals of time. Although the actuating mechanism rotates in the experimental clutch model described, an alternative design has been drawn up in which the actuating means are stationary and operate the clutching means through thrust bearings.

Partially disassembled model of the "loudspeaker" type clutch. This clutch is actuated by applying voltage to a "voice coil" mounted in a magnetic field.

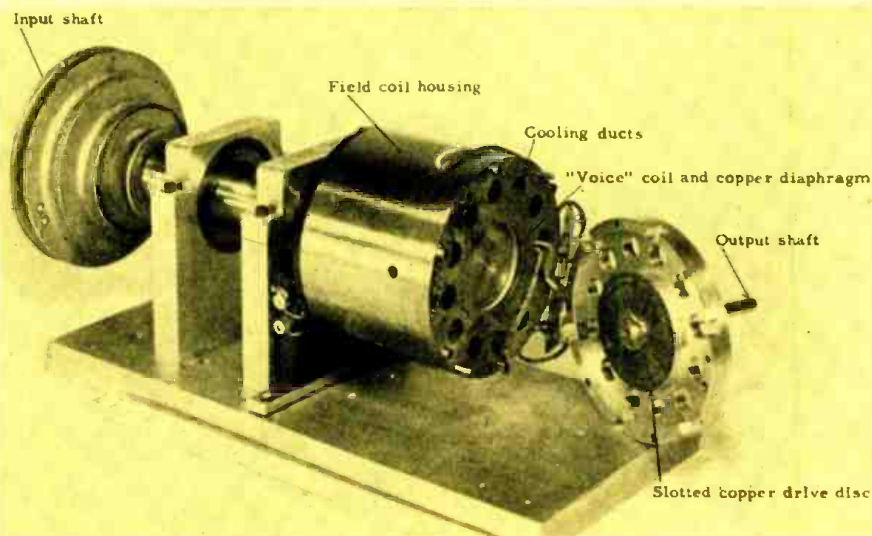



channel data recording is required and where the weight and size of the instrumentation must be kept to a minimum. Applications include electrical balancing of circuits involving strain gauges,



accelerometers, position pickups, and any sensing devices that operate in electrical bridge circuits.

Just announced by the *American Helicopter Co., Inc.*, 1800 Rosecrans Ave., Manhattan Beach, Calif., the unit incorporates miniature 10-turn balancing potentiometers which have a linearity of  $\pm 0.5\%$ . Precision, wire-wound resistors used for calibration—having an accuracy of  $\pm 0.1\%$ —are included.

#### DELAY CABLE

A high-impedance cable designed to delay signals (both sine waves and pulses) for periods from a fraction of one microsecond to several microseconds is being manufactured by *Columbia Technical Corporation*, 5 East 57th Street, New York 22, N. Y. Its primary application is in electronic circuits where minimum attenuation and signal distortion are required as well as fast rise time.

Type HH-2000 has a time delay of 0.11 microsecond per foot, and a nominal characteristic impedance of 2200 ohms. The attenuation for a delay of one microsecond is practically zero up

to 3 mc., 0.5 db at 5 mc., and 2.5 db at 10 mc. The bandwidth for a one-microsecond delay is more than 0-10 mc., and correspondingly larger for smaller time delays. Compared to the commonly used RG-65/U cable, HH-2000 requires about two-thirds less cable length for a given delay.

#### RELAYS

Small, lightweight, 400-cycle a.c. relays, designed to withstand better than 10G vibration in aircraft equipment, have been developed by *Potter and Brumfield*. They are available in either

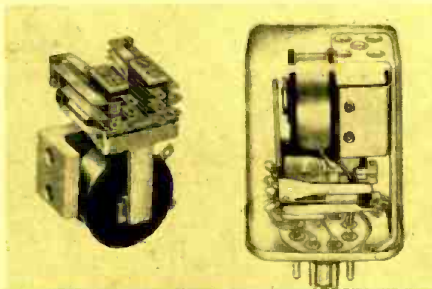

open (shown at left in photograph) or hermetically sealed types.

Both types are furnished with two Form C fine silver contacts rated up to 5 amperes at 115 volts a.c., or 28 volts d.c., noninductive load. Contact pressure is 15 grams or higher at approximately 2 volt-amperes input per pole. Coils are wound on molded bakelite bobbins with a minimum breakdown of 500 volts r.m.s. between all current-carrying elements and ground.

The AF Series relays can be supplied with plug-in or solder terminals and glass-insulated headers. For further details, write to *Potter and Brumfield*, Princeton, Indiana.

#### ELECTRONIC COUNTER

Completely contained in a small, bench-size unit, Model 522B is a new all-purpose precision counter which provides frequency, period and time interval measurements over a broad range. Operating and application details are available from *Hewlett-*



*Packard Company*, 395 Page Mill Road, Palo Alto, Calif.

Model 522B measures rate of occurrences from .00001 to 100,000 per second

and time from 10 microseconds to 27.8 hours. Counting is available over periods of 1/1000, 1/100, 1/10, 1 and 10 seconds or multiples thereof. Time of display can be varied to any duration, counts are automatically reset, and action is repetitive. Results are shown in cycles per second, kilocycles, seconds or milliseconds, and are displayed instantly and automatically in direct-reading form.

#### SQUARE PULSE GENERATOR

*Electrical and Physical Instrument Corporation*, 42-19 27th Street, Long Island City, New York, has announced the Model 200 square pulse generator. It incorporates a new method of pulse shaping which provides square pulses of 0.001  $\mu$ sec. rise time with a comparable delay time, and a pulse width that can be varied from 0.001  $\mu$ sec. to sev-



eral microseconds. The maximum pulse amplitude is 100 volts into low impedance cables for a pulsed power output of 200 watts.

The Model 200 provides two simultaneous pulse outputs, each of which can be individually attenuated and delayed. Output amplitude can be attenuated 84 db in 1-db steps by means of front panel attenuator switches to cover the range of 100 volts to 0.006

#### TECHNICAL PAPERS WANTED

CONTINUED growth and the acceptance accorded this publication shows the need for expanding our editorial coverage. Engineers are requested to submit papers on the following subjects: microwaves, color TV, transistors, industrial electronics, communications, instrumentation, and circuitry. If acceptable, such papers will be paid for at our current rates upon acceptance.

Address all inquiries to H. S. Renne, RADIO-ELECTRONIC ENGINEERING, 366 Madison Avenue, New York 17, N. Y. Telephone MUrray Hill 7-8080.

## CALENDAR of Coming Events

**AUGUST 19-21**—Western Electronic Show and Convention, Civic Auditorium, San Francisco, Calif.

**SEPTEMBER 1-3**—International Sight and Sound Exposition, Palmer House, Chicago, Ill.

**SEPTEMBER 21-25**—Eighth National Instrument Exhibit, Hotel Sherman, Chicago, Ill.

**SEPTEMBER 28-30**—National Electronics Conference, Hotel Sherman, Chicago, Ill.

**OCTOBER 26-28**—IRE-RTMA Radio Fall Meeting, Toronto, Ontario.



volts. A polarity switch allows selection of positive or negative pulses.

### BANDPASS FILTER

Model 310-A, announced by the *Krohn-Hite Instrument Company*, is an adjustable bandpass filter with unity pass gain and 24 db/octave slopes outside the passband. A peaking factor is used to



reduce the attenuation at the cutoff frequencies. Both high and low cutoff frequencies are independently adjustable from 20 cps to 200 kc., providing maximum flexibility of adjustment of both the band center frequency and the bandwidth.

This filter is especially useful in the audio and ultrasonic frequency range for noise measurements, harmonic and frequency analysis, and for psychoacoustics and electromedical research. A descriptive pamphlet is available on request from the *Krohn-Hite Instrument Company*, 580 Massachusetts Avenue, Cambridge 39, Mass.

### OMNIRANGE TEST SET

The ILS signal generator Model AEC-200 is a new portable unit which provides simulated omniphase, ILS, and tone ILS signals for laboratory or ramp testing of airborne v.h.f. and naviga-



tion radio gear. Designed and manufactured by *American Electroneering Corporation*, 5025-29 Jefferson Blvd., Los Angeles, Calif., the set checks omnibearings continuously variable from 0°

### Photo Credits

PAGE	CREDIT
1...	Westinghouse Electric Corp.
6, 7...	Ryan Aeronautical Corp.
14, 29...	Nat. Bureau of Standards

to 360°, and assures accuracy to 1°. In addition, it will check left-center-right, and up-center-down on a 90-150 localizer and glide slope. A self-contained, regulated dual power supply utilizes either 105-130 volts a.c. at 60 cycles, or 22-30 volts d.c. at 5 amperes.



### Oscilloscope Calibrator

(Continued from page 16)

the potentiometer the first division between "Off" and 10 is 50°—to take care of the potentiometer switch on-off action—and that the first division starts at 10 to take into account the "end" resistance with the switch just on. The succeeding angular divisions are all 30° (making a total of 270° between 10 and 100).

In calibrating the calibrator, one should start out by setting the potentiometer shaft at clockwise rotation and locking the knob at 100 on the dial. The calibrator may then be connected to any oscilloscope and set for line frequency calibration. An a.c. signal of known r.m.s. value is applied to the oscilloscope through the calibrator by placing the calibrator multiplier on

"Signal" position. The scope vertical gain should be adjusted to give a selected number of squares (or amplitude) on the scope screen. The a.c. voltage multiplied by 2.82 gives its peak-to-peak value, which is then set on the calibrator's dials. The calibration adjustment of the calibrator should be set to give the same amplitude on the oscilloscope as the previous signal produced.

The aluminum box used to house the calibrator has a 6" x 9" panel which is large enough for all the controls required. A 2" x 4" x 8" chassis offers more than adequate mounting room for all the components. The wiring diagram indicates that the signal and output leads should be shielded. Preferably, one of the new *General Electric* 400-volt germanium power rectifiers should be used to minimize voltage drop, improve the power supply voltage regulation, and thus take some of the load off the VR tube. Otherwise, all other constructional details are largely a matter of personal taste.

### REFERENCE:

1. Kaufman, Alvin B., "Potentiometer Loading Errors," *Radio-Electronic Engineering*, September, 1952.

### RAPID COMPONENT TESTING

By JAMES R. FORD

**BY** utilizing the fluidity and conductivity of mercury, it is possible to provide a very rapid method of testing large numbers of a given component in the same circuit.

Multiterminated transformers and relays are examples of components with which a technique of this type can profitably be used. In particular, it was found to be an extremely efficient method of testing batches of blocking oscillator transformers.

This particular application required that contact be made to six leads; therefore, a block of good dielectric material with feedthrough contacts at the bottom of six counterbored holes was used as the mercury container. The holes were drilled so that they would be in alignment with the terminals of the transformer. The block was then placed in the circuit in such a manner as to maintain critical lead spacing and routing from unit to unit, as well as to add minimum stray capacity to the circuit.

Final mounting of the unit containing the "mercury block" is such that the holes are approximately vertical. Mercury can be easily applied to the proper depth in each hole by the use of a very small-bore eye dropper. The unit is then ready for transformers to be quickly placed in the circuit and taken out again.

Obviously, a technique of this type is warranted only when there are a large number of leads per component and/or a large number of components to be tested rapidly.

Greater flexibility of unit position can be attained by pressure-mounting the components, using a simple clip-on method. This can be accomplished

without greatly affecting replaceability, but it rather drastically complicates the "mercury block" design.

Although the conductivity of mercury is approximately 1/54th that of copper, it is not difficult to keep the mercury resistance plus contact resistance to less than 0.05 ohms; therefore, in general, the relatively low conductivity is not too serious a limitation.

Amalgamation of other metals by mercury is purported to be a consideration with the use of mercury. However, no degrading effect has been noted thus far by the author.

Sketch of the mercury block.

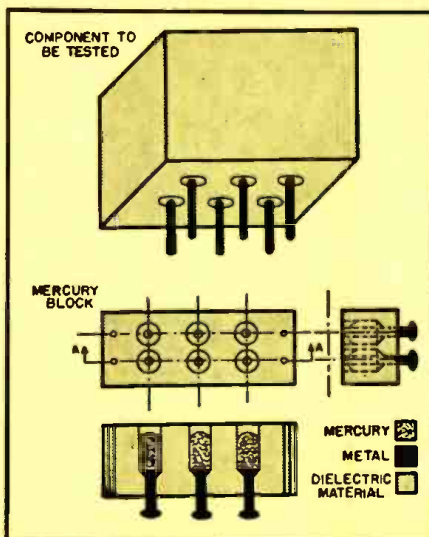



# URSI-IRE MEETING

Joint meeting of USA National Committee of URSI and  
IRE Professional Group on Antennas and Propagation.

THE International Scientific Radio Union is one of several world scientific unions organized in 1919 under a general organization now called the International Council of Scientific Unions. It is commonly designated as the URSI from its French name, Union Radio Scientifique Internationale.

The USA National Committee of the URSI usually holds two meetings a year jointly with the Professional Group on Antennas and Propagation of the IRE. The latest meeting was held in Washington, D. C., April 27-30, at which approximately 85 papers were presented. Not intended to be a complete review of all of these papers, the following report will serve to outline a few highlights of the meeting.

## Lightning

The subject of lightning was discussed quite extensively, with emphasis on radio interference caused by lightning. Various phases of the work being done were reported on by: A. W. Sullivan, J. D. Wells and W. J. Kessler, of the University of Florida; M. M. Newman and J. R. Anderson, of the Lightning and Transients Institute; and S. E. Reynolds, of the New Mexico Institute of Mining and Technology.

A program for coordinated lightning measurements is under way in Florida, New Mexico and Minnesota. Each laboratory composes an apex of a triangulation system for directional and waveshape propagation measurements. Equipment for synchronizing measurements accurately at the various locations was described, and the problems inherent in such widely spaced measurements were analyzed. Characteristics to be studied include: polarity distribution of interfering impulses; typical duration, rates of rise, and peak values of impulses; average duration of static bursts; and representative number of bursts per minute with reference to storm intensity and distance.

An artificial lightning generator was demonstrated. This generator consists of a multiplicity of condensers arranged to simulate the natural discharge path of lightning. Long discharge channels can thus be established at a relatively low starting voltage, permitting a more intensive study of sferics (atmospheric noise) at close range. In the demonstration, a 20,000-

volt flash was caused to travel a distance of about two feet.

## Noise Measurements

Measurements were made at the University of Florida on the effect of atmospheric noise on the reception of speech to determine the per cent of message error under various degrees of noise intensity. The relationship between the  $S/N$  ratio and per cent of message error was found to be practically identical for the five  $S/N$  ratios employed. It was also found that message errors in the presence of noise depend upon message complexity as well as  $S/N$  ratio.

A new type of noise-measuring instrument called the "Stochastimeter" was described. With this instrument, it is possible to make direct measurements of the average value of the noise envelope, the probability distribution, and the average number of noise pulses that exceed any given amplitude level. From these direct measurements, it is possible to calculate the average width of the noise pulses at any amplitude level and the average time between pulses at any amplitude level.

Another type of noise meter was also presented. This meter, developed at the University of Florida, may be termed a wide-range panoramic noise meter. It was designed specifically for the rapid indication of  $S/N$  ratios over a frequency range of 1-25 mc. and a dynamic range of 110 db. The full range may be recorded on a continuous paper strip, or smaller segments up to 200 kc. in width can be displayed oscillographically to permit detailed observation and study of any segment in the 1-25 mc. range.

## Miscellaneous

Several papers presented at the meeting dealt with measurements of various kinds. Some of these will be reviewed briefly.

David M. Kerns, of the National Bureau of Standards, presented a paper which was prepared jointly with Alan C. Macpheson entitled "A New SWR Measurement Technique." Precision of the order of .03% has been attained, although the technique at the present time applies only to sliding loads and yields only the magnitude of the SWR. In the technique, an H-plane junction

provided with a transformer in its side arm is utilized. The r.f. source and detector are connected to the symmetrical arms of the junction. The transformer is adjusted for no reflection, looking into the side arm. Observation of detector response vs. load position yields the SWR pattern.

C. Wellard, of the *International Resistance Company*, discussed a new method for determining resistor performance in the 2-400 mc. band. A resonant cavity is employed along with conventional, commercially available equipment, and the resistance variation and susceptance variation principles are employed. Accuracy is within 5%. Tables have been compiled which make the determination of a.c. resistance rapid. Resistors of conventional design up to 2-watt ratings may be measured.

William F. Gabriel, Naval Research Laboratory, described a broadband, low power, automatic impedance recorder of good accuracy which has been developed for the X-band. An r.f. impedance circuit utilizing broadband wave guide components extracts the amplitude and phase information which operates electromechanical servos in the amplifier-recorder unit. Any incident r.f. power level between 20 and 250 mw. may be used.

H. A. Finke, of the *Polytechnic Research and Development Company*, analyzed various methods of measuring power at microwave frequencies. The bolometer method was analyzed, and errors associated with its use were discussed. A bolometer was described which has a VSWR of less than 1.5 from 500 to 10,000 mc., with a power efficiency of 97.5% at 5000 mc.

A radio-frequency permeameter was discussed by Peter H. Haas, of NBS. With this equipment, measurement is made by inserting a toroidal core into the short-circuited secondary of a transformer whose primary is attached to an r.f. bridge or  $Q$  meter. A device similar to this unit is currently being manufactured by the *National Electronic Laboratories, Inc.*, Washington, D. C.

A dummy load with a high power rating was described by Dr. H. Brueckmann, of the Signal Corps Electronics Laboratory. This load consists of stainless steel wire wound in a helix of uniform diameter and pitch, supported by a coaxial ceramic form, and shielded by a metal tube. The helix acts as a uniform transmission line similar to a delay line, and has relatively high attenuation. Cooling by air can be easily achieved, and an experimental model was described which was rated at 40 kw. from 3 to 30 mc. Input impedance was 600 ohms balanced to ground. Compactness and low weight are features of the unit.



# Centralab Controls —

always within reach . . . always right!

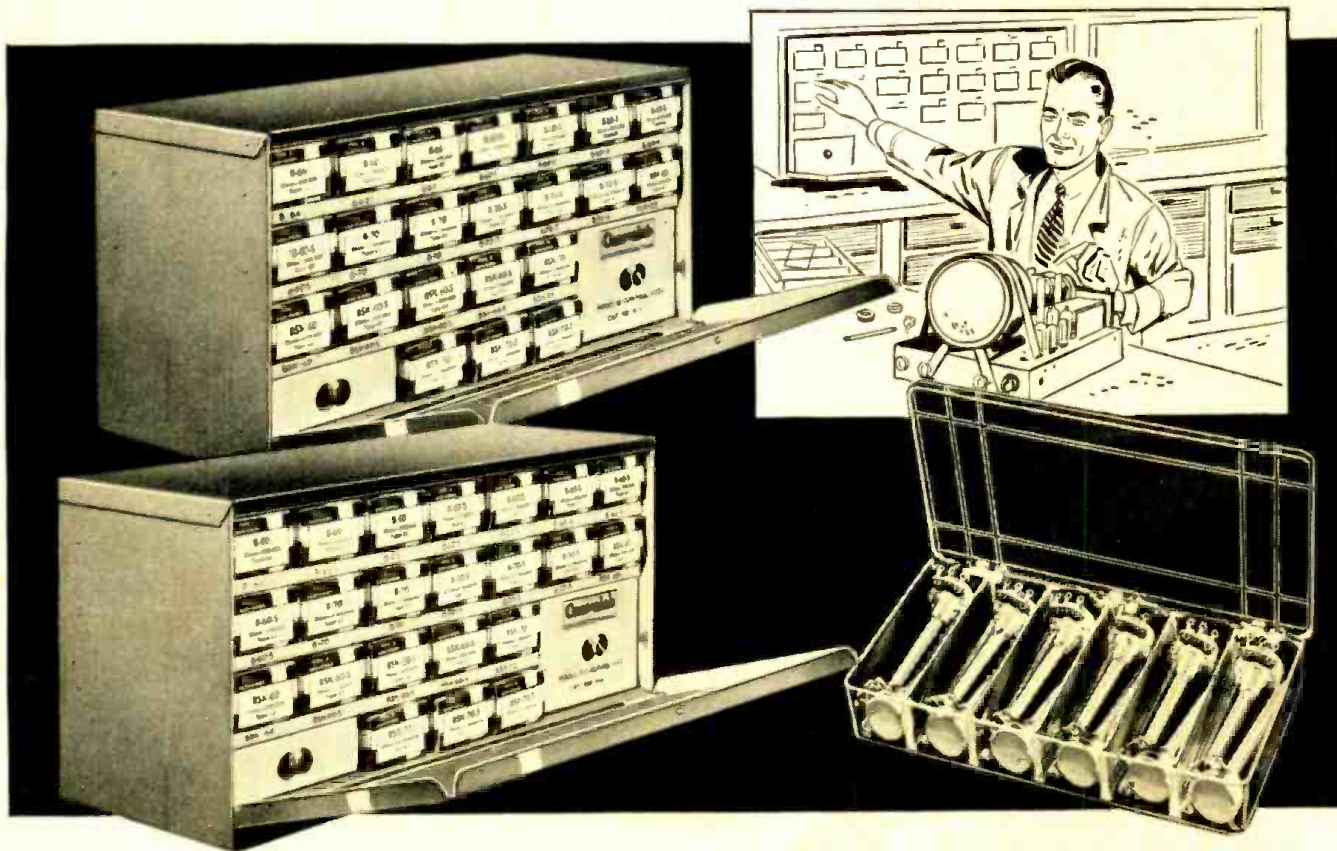

## These handy Blue Shaft\* Kits help take "parts hunting" out of repair service

If you're like thousands of other busy Service Engineers, you can't afford to sacrifice profit time — hunting for repair parts. The smart, sure way to faster service is to have your Centralab controls on hand when you need 'em — in these handy Blue Shaft Control Kits. Assortments contain values you use every day, in plain or switch types. Switches are factory attached and tested for immediate installation. Included are *exact* service replacements for popular radio and TV sets.

Three kit deals are available: B-A Kit contains 22 controls (8 types) in 1/2 and 1 megohm. All units C2 (audio) taper. Newest, revised Kit B-B has 22 controls (15 different types), plus 4 "Fastatch"\* type KB line switches. Ten handy Plasti-Pak Kits of 12 controls each also save time. You pay for parts only — no charge for containers.

You can count on your Centralab Distributor for exact Blue Shaft replacements to keep kits well stocked. So see him soon — he'll be glad to supply the kits you need.

\*Trade Mark

# Centralab

A Division of Globe-Union Inc.

Milwaukee 1, Wisconsin

In Canada, 635 Queen Street East, Toronto, Ontario

## FAST MOVERS . . . NO "SLEEPERS"

**Kit Deal B-A** — 22 controls. 1/2 meg and 1 meg. B types have standard 3" shafts, full-length fluted mill. BSK types have 2 1/8" split-knur shafts. In handy metal cabinet.

PLAIN TYPE				SWITCH TYPE			
3	B-60	1/2 meg.	C2	5	B-60-S	1/2 meg.	C2
2	B-70	1 meg.	C2	3	B-70-S	1 meg.	C2
2	BSK-60	1/2 meg.	C2	3	BSK-60-S	1/2 meg.	C2
2	BSK-70	1 meg.	C2	2	BSK-70-S	1 meg.	C2

Plus one metal cabinet

**Kit Deal B-B (Revised)** — 22 controls and 4 "Fastatch" switches. All have standard 3" shafts, full-length fluted mill. In handy metal cabinet.

PLAIN TYPE				SWITCH TYPE				"FASTATCH" SWITCHES		
1	B-5	1,000	C1	2	B-83	2.5 megs.	C1			
1	B-10	5,000	C1	1	B-84	3 megs.	C1			
1	B-26	25,000	C1	1	B-87	5 megs.	C1			
2	B-31	50,000	C1	3	B-60-S	1/2 meg.	C1	2	KB-1	SPST
2	B-40	100,000	C1	1	BSK-60-S	1/2 meg.	C2	1	KB-2	DPST
1	B-59	500,000	C1	2	B-70-S	1 meg.	C2	1	KB-3	SPDT
2	B-69	1 meg.	C1	1	BT-80-S	2 megs.				
1	B-75	2 megs.	C1		T-600K		C13			

Plus one metal cabinet

**Handy Plasti-Paks** — 12 controls. 10 individual kits, also B type. Plain and switch type. C2 (audio) taper. Split-knur shafts. In useful plastic containers.

CENTRALAB, A Division of Globe-Union Inc.  
910-G E. Keefe Ave., Milwaukee 1, Wisconsin

Please send me complete details on Centralab Radio-TV Kits as found in the new 32-page Catalog No. 28.

Name.....

Firm.....

Address.....

City..... Zone..... State.....



# R<sub>x</sub> for UHF's fringe areas!

## CHANNEL MASTER'S all-UHF TWIN CORNER REFLECTOR

*the most sensitive fringe area antenna ever developed for UHF!*

- Two dipoles—actually two antennas in one.
- Provides twice the gain of any standard-type UHF Corner Reflector.
- Instantly installed in just three steps.
- Furnishes far better picture quality — at far greater distances.
- Eliminates UHF's TWIN TERRORS. Features vibration-proof construction; and "free-space" terminals.



model no. 406

up to  
**16 DB gain!**

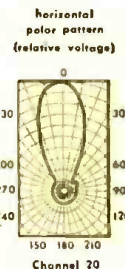
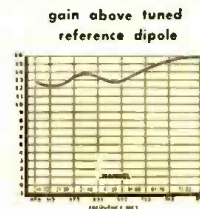

practically  
no  
assembly  
necessary

## CHANNEL MASTER'S 10-ELEMENT DELTA-WELD YAGI

*custom-designed for your specific area!*

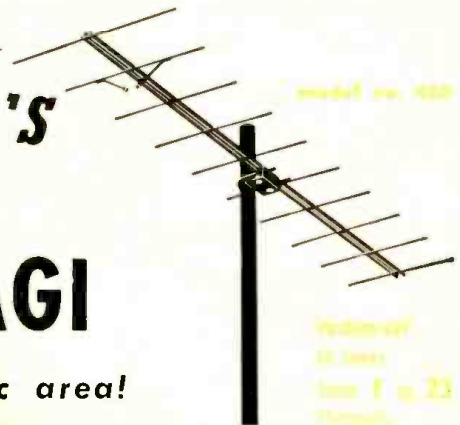

**CHANNEL MASTER  
engineering  
pays off on UHF!**

- Elements permanently WELDED IN POSITION on crossarm.
- Custom construction — designed for almost any UHF area.
- Delta-matched dipole for excellent impedance match.
- Brilliant performance. Average gain: over 11 DB, single bay; over 14 DB, stacked. Even higher on some models.
- Eliminates UHF's TWIN TERRORS.



**CHANNEL MASTER CORP.**  
ELLENVILLE, N. Y.

Write for complete technical literature.



# At Last! a YAGI for the ENTIRE LOW BAND!

## CHANNEL MASTER'S Newest futuramic

Completely covers every low band channel-2 through 6

**Now** the extraordinary high gain of a Yagi . . .  
the razor-sharp directivity of a Yagi . . .  
*Not on just one channel — but clear across the entire Low Band!*

Designed for service TODAY and TOMORROW in these 3 booming VHF markets:

**Areas in which present VHF stations are changing channels (on the Low Band).**

The Futuramic Yagi provides better reception than conventional Yagis on the present channels — and when the shift occurs this superior reception will continue on the new channel WITHOUT INTERRUPTION. And you can make your change-over installations NOW.

**Areas in which a new VHF station is being added to the present one (on the Low Band).**

The great number of single channel Yagis now in use will not bring in the new channel. If an additional Yagi is installed it will have to be tied into the present installation with separate leads and a switching system. However, one Futuramic will do the job of BOTH antennas — at lower cost — with better results on BOTH channels.

**Areas served at present by two or more VHF stations on the Low Band.**

You no longer have to compromise between conventional broad band antennas, and separate Yagis for each channel. The Futuramic gives you the full advantages of both. It combines highest gain and sharpest directivity with simple, economical installation.

horizontal polar pattern (relative voltage)

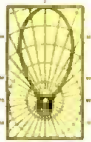

gain above tuned reference dipole

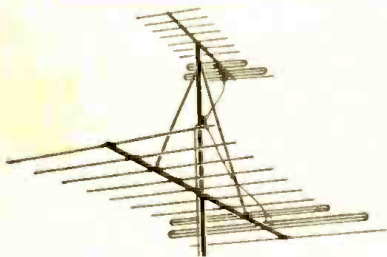
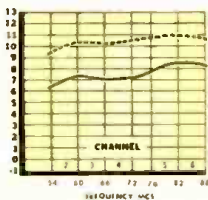

A high-low Futuramic combination is the most sensitive array ever designed for all-channel VHF reception. Just combine models 1173 and 1126.

Now — 6 great Futuramic models, designed for every reception area:

model no.	channels covered	list price
1173	7 — 13	\$20 <sup>83</sup>
1124	2, 3, and 4	\$40 <sup>97</sup>
1125	2, 3, 4, and 5	
1136	3, 4, 5, and 6	
1146	4, 5, and 6	
1126	2, 3, 4, 5, and 6	



CHANNEL MASTER CORP. FLEETVILLE, N. C.





# Concord Radio presents the world's most powerful TV antenna!



**22 Db gain**  
over tuned dipole!

motorless all-direction  
**ALL CHANNEL**  
UHF - VHF - FM  
reception

- Guaranteed 10 times more powerful than stacked 10 element Yagis.
- Receives channel 2-83 from all directions without a rotor.
- Broadband UHF-VHF and FM, motorless all direction reception.
- All aluminum flip-out assembly.

The only TV antenna that instantly beams the television set directly to the signal without a rotor. This antenna brings strong UHF & VHF signals from all directions to weak signal areas instantly . . . with a flick of the nine position switch located near the television set.

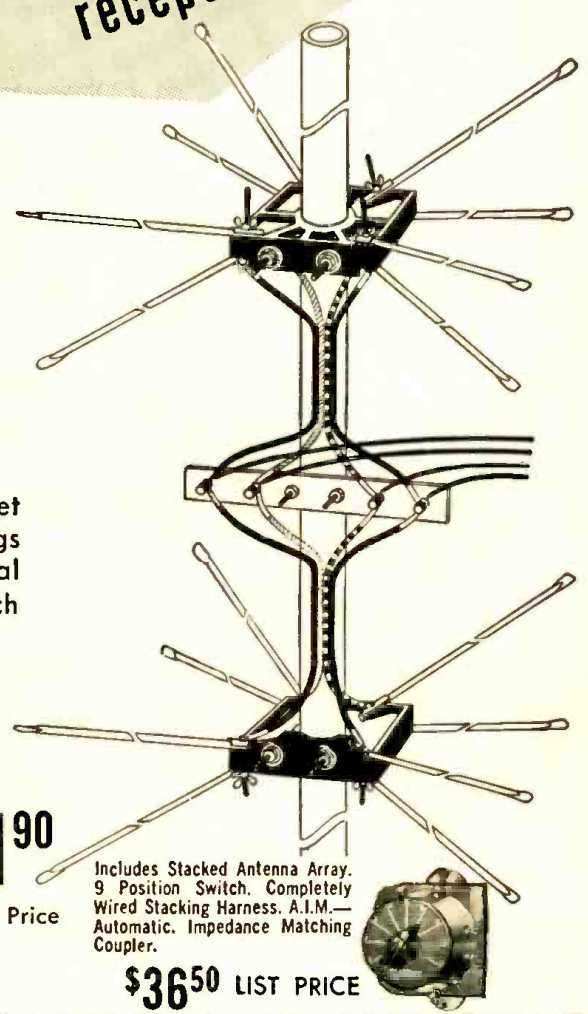

**\$21<sup>90</sup>**  
Dealer Price

Includes Stacked Antenna Array.  
9 Position Switch. Completely  
Wired Stacking Harness. A.I.M.—  
Automatic Impedance Matching  
Coupler.

**\$36<sup>50</sup>** LIST PRICE

**FOUR CONDUCTOR AIR-DIELECTRIC Tubular Matched Impedance TRANSMISSION LINE**

Approximately 300 ohms between every two of the four conductors.



Improves Both UHF and VHF Performance of any ALL-CHANNEL Antenna!

100 Ft.....	\$ 8.90
150 Ft.....	\$13.90
200 Ft.....	\$17.50

Minimum quantity 100 ft.

**MONEY BACK GUARANTEE** To out-perform all other antennas (using rotor motors) on both UHF and VHF, including stacked ten element Yagis, stacked corner and bow-tie reflectors, four bay conicals, etc.

**Concord Radio**  
53 Vesey Street, New York 7, N. Y. Dlgby 9-1132

**CONCORD RADIO** 53 Vesey Street, New York 7, N. Y.

Please send me.....amount at \$36.50 list price.  
Please send me.....amount at \$21.90 dealer net.

Please send me.....feet of 4 conductor tubular at .....

Name \_\_\_\_\_  
Address \_\_\_\_\_  
City \_\_\_\_\_ State \_\_\_\_\_

Check Enclosed  Money Order Enclosed  
 C.O.D. enclosed please find 25% of total purchase price . . . check . . . Money Order.  
 Please put my name on your "Special Bargain" mailing list.

( ) Enclosed find \$\_\_\_\_\_in full. Send prepaid.



# ADVANCE! Raise your earning power—learn RADIO-TELEVISION-ELECTRONICS by SHOP-METHOD HOME TRAINING

## GOOD JOBS AWAIT THE TRAINED RADIO-TV TECHNICIAN

There is a place for you in the great Radio-Television-Electronics industry when you are trained as National Schools will train you at home!

Trained technicians are in growing demand at good pay—in manufacturing, broadcasting, television, communications, radar, research laboratories, home Radio-TV service, and other branches of the field. National Schools Master Shop-Method Home Training, with newly added lessons and equipment, trains you in your spare time, right in your own home, for these fascinating opportunities. OUR METHOD IS PROVED BY THE SUCCESS OF NATIONAL SCHOOLS TRAINED MEN, ALL OVER THE WORLD, SINCE 1905.

## EARN WHILE YOU LEARN

Many National students pay for all or part of their training with spare time earnings. We'll show you how you can do the same! Early in your training, you receive "Spare-time Work" Lessons which will enable you to earn extra money servicing neighbors' and friends' Radio and Television receivers, appliances, etc.



Signal Generator

Audio Oscillator

T. R. F. Receiver

## National Schools Training is All-Embracing

National Schools prepares you for your choice of many job opportunities. Thousands of home, portable, and auto radios are being sold daily—more than ever before. Television is sweeping the country, too. Co-axial cables are now bringing Television to more cities, towns, and farms every day! National Schools' complete training program qualifies you in all fields. Read this partial list of opportunities for trained technicians:

- Business of Your Own • Broadcasting
- Radio Manufacturing, Sales, Service • Telecasting
- Television Manufacturing, Sales, Service
- Laboratories: Installation, Maintenance of Electronic Equipment
- Electrolysis, Call Systems
- Garages: Auto Radio Sales, Service
- Sound Systems and Telephone Companies, Engineering Firms
- Theatre Sound Systems, Police Radio
- And scores of other good jobs in many related fields.

## TELEVISION TRAINING

You get a complete series of up-to-the-minute lessons covering all phases of repairing, servicing and construction. The same lesson texts used by resident students in our modern and complete Television broadcast studios, laboratories and classrooms!



## MASTER ALL PHASES!

Get Master Shop-Method Home Training from an Established Practical Resident School with its own Training — almost 50 Years of Successful Experience in Training Ambitious Men.

We Bring National Schools To You!



You also receive this Multitester

Superheterodyne Receiver

## LEARN BY DOING

You receive and keep all the modern equipment shown above, including tubes and valuable, professional quality Multitester. No extra charges.

## FREE! RADIO-TV BOOK AND SAMPLE LESSON!

Send today for National Schools' new, illustrated Book of Opportunity in Radio-Television-

Electronics, and an actual Sample Lesson. No cost—no obligation. Use the coupon now—we'll answer by return airmail.

APPROVED FOR VETERANS AND NON-VETERANS  
Check coupon below

Both Resident and Home Study Courses Offered!

## NATIONAL SCHOOLS

LOS ANGELES 37, CALIFORNIA • ESTABLISHED 1905  
IN CANADA: 193 E. HASTINGS STREET, VANCOUVER, B.C.

## FIND OUT NOW—MAIL COUPON TODAY!

NATIONAL SCHOOLS, Dept. RH-73  
4000 South Figueroa Street  
Los Angeles 37, California

Mail in envelope or paste on postal card.

Send FREE Radio-TV Electronics book and FREE sample lesson. I understand no salesman will call on me.

NAME \_\_\_\_\_ AGE \_\_\_\_\_

ADDRESS \_\_\_\_\_

CITY \_\_\_\_\_ ZONE \_\_\_\_\_ STATE \_\_\_\_\_

Check here if released from service less than 4 years ago.

Check here if interested in Resident Training at Los Angeles.





For sound trucks • parades  
carnivals • resorts • busses  
outdoor meetings

## ECONOMICAL MOBILE AMPLIFIERS

by  
*Newcomb*



MODEL E-25MP

Newcomb mobile amplifiers are carefully built for the rugged conditions of mobile use and to deliver consistently the top quality performance you expect from any Newcomb amplifier. Dollar for dollar they give you more good service, more convenient operational features and more all around, long-time satisfaction.

MODEL E-25MP delivers 25 watts from either 6 volt battery or 117 A.C. It has a standby switch, separate power and phono switches and inputs for 2 mikes and 1 phono. Heavy duty plugs. 2000 volt hermetically sealed buffer condenser. Phase correction capacitor for phono mo'or.

MODEL E-25M is the same amplifier without phono top.

MODEL E-10M is a rugged, low cost, 10 watt unit also for either battery or A.C. power. Has standby switch, inputs for 1 mike, 1 phono. Special mounting simplifies installation and removal.



E-10M

*Send for full  
information  
today!*

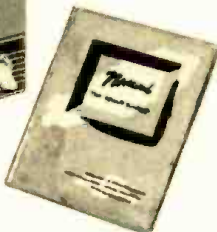

# NEWCOMB

## AUDIO PRODUCTS CO.

Dept. F, 6824 Lexington Ave., Hollywood 38, Calif.

# Spot Radio News

\* Presenting latest information on the Radio Industry.

By RADIO & TELEVISION NEWS'  
WASHINGTON EDITOR

THE CONGRESSIONAL CRUSADE for color TV, sparked three years ago by the volatile Senator from the West, Edwin C. Johnson, and refired a few months ago through bristling letters to his colleagues demanding a probe to learn, unequivocally, why we still have no panchromatic sets, reached a new beachhead a few weeks ago, and with historic results. During a 48-hour trek to Princeton, N. J., and New York City, members of the House Commerce Committee witnessed impressive demonstrations of compatible NTSC color. With their chairman, Rep. Charles A. Wolverton, the group (which included Reps. John W. Heselton, William L. Springer, Joseph P. O'Hara, Joseph L. Carrigg, J. P. Priest, Homer Thornberry, Herbert B. Warburton, John B. Williams, J. A. Younger, Carl Hinshaw, S. B. Derounian, D. L. Rogers, A. G. Klein, and W. T. Cranahan), saw the best color pictures ever shown, and they were excited over the results. So enthusiastic was the committee's headman that he urged that NTSC color be approved quickly so that sets . . . "can become available this Christmas."

In the tests at Princeton, three tri-color sets were on view. Two used sixteen-inch tubes providing 9 by 12-inch pictures, and another had a twenty-one inch picture tube which produced 12 by 16-inch pictures. The program, a 20-minute production, originated in the Colonial Theatre, in New York City, was fed to the Empire State transmitters and micro-waved to Princeton, 45 miles away.

Field-sequential also received a viewing at the CBS studios in New York City, with indifferent results. The Congressmen also saw a slide-show on *Chromatic* tubes, which did not seem to impress them too much. It was felt that the pictures were, in the main, too bright and blurred. This defect, it was said, can be overcome. Commenting on a development now under way to modify the tube, a company spokesman declared that the new tubes would offer improved results and on larger screens; a 28-inch rectangular type with a short neck was now in the tooling stage.

The successful show at Princeton also brought huzzahs from Senator Johnson. In a note to David Sarnoff, which disclosed that a professional

staff member of the Senate Interstate and Foreign Commerce Committee had witnessed a special demonstration of color two weeks prior to the test held for the House Committee, the Senator praised Mr. Sarnoff for his vision in the development of color. "I am convinced that under your leadership and driving force, compatible color television will become a reality, in spite of all obstacles," said the Senator. "Many will throw rocks at you," he added, "because of your determination and strong militant effort to give color television to the people now. Do not let them dismay you."

Emphasizing that the fight for compatible color was just and in the public interest, the Senator pointed out that he will continue to offer every assistance at his command . . . "so that this great advancement in the art of communications becomes available to the people."

"Your efforts in devising a compatible color TV system will long be remembered as a magnificent achievement of science," the Senator's letter declared. "For reasons best known to themselves, there may be those who may desire to drag their feet at this point," the former committee chairman warned. "Please do not allow them to slow you down. You are on the right track. Please keep up the steam."

Even *Columbia*, who earlier had testified that they had given up the fight for field sequential, indicated that compatible color as demonstrated offered interesting possibilities and now would like to conduct special NTSC tests over its New York City facilities. Special permission to telecast compatible color signals was granted by the Commission shortly after *CBS* submitted its request.

Notwithstanding the rousing reception from Congressmen, industry interest in color remained calm. Most felt that color was still in the lab stage. Speaking at a dinner in New York City, the prexy of *Admiral* bluntly declared that industry . . . "has to have the right color picture tube and the right tube simply doesn't exist at present . . ." He pointed out that there are in labs color receivers which produce excellent results, but the color tube is still the problem child. Satisfactory types that are available, he added, are . . . "ex-



# FREE

**TELLS HOW -**

**WE GUARANTEE  
TO TRAIN AND COACH YOU AT HOME  
IN SPARE TIME UNTIL YOU GET**

**YOUR FCC  
LICENSE**

If you have had any practical experience—Amateur, Army, Navy, radio repair, or experimenting.

Here is your guarantee

If you fail to pass your Commercial License Exam after completing our course, we guarantee to continue your training without additional cost of any kind, until you successfully obtain your Commercial license, provided you first sit for this examination within 90 days after completing your course.

**TELLS HOW -**

**OUR AMAZINGLY EFFECTIVE JOB-FINDING SERVICE HELPS CIRE STUDENTS GET BETTER JOBS. HERE ARE JUST A FEW RECENT EXAMPLES OF JOB-FINDING RESULTS:**

**GETS CIVIL SERVICE JOB**

"Thanks to your course I obtained my 2nd phone license, and am now employed by Civil Service at Great Lakes Naval Training Station as an Equipment Specialist."  
Kenneth R. Leiser, Fair Oaks, Mtd. Del., McHenry, Ill.

**GETS STATE POLICE JOB**

"I have obtained my 1st class ticket (thanks to your school) and since receiving same I have held good jobs at all times. I am now Chief Radio Operator with the Kentucky State Police."  
Edwin Healy, 264 E. 3rd St., London, Ky.

**GETS BROADCAST JOB**

"I wish to thank your Job-Finding Service for the help in securing for me the position of transmitter operator here at WCAE, in Pittsburgh."  
Walter Koschik, 1442 Ridge Ave., N. Braddock, Pa.

**GETS AIRLINES JOB**

"Due to your Job-Finding Service, I have been getting many offers from all over the country, and I have taken a job with Capital Airlines in Chicago, as a Radio Mechanic."  
Harry Clare, 4537 S. Drexel Blvd., Chicago, Ill.

**HERE'S PROOF FCC LICENSES ARE OFTEN SECURED IN A FEW HOURS OF STUDY WITH OUR COACHING AT HOME IN SPARE TIME:**

Name and Address	License	Lessons
Lee Worthy, 2210 1/2 Wilshire St., Bakersfield, Cal.	2nd Phone	16
Clifford E. Vogt, Box 1016 Dania, Fla.	1st Phone	20
Francis X. Foerch, 38 Beucler Pl., Bergenfield, N. J.	1st Phone	38
S/Sgt. Ben H. Davis, 317 North Roosevelt, Lebanon, Ill.	1st Phone	28
Albert Schoell, 110 West 11th St., Escondido, Cal.	2nd Phone	23

CARL E. SMITH, E.E. Consulting Engineer, President

**CLEVELAND INSTITUTE OF RADIO ELECTRONICS**

Desk RN-54, 4900 Euclid Bldg., Cleveland 3, Ohio

MONEY MAKING  
**FCC**  
Commercial-Radio Operator  
**LICENSE**  
INFORMATION

**TV Engineering**

INCLUDED IN OUR  
TRAINING AND  
COACHING

**TELLS HOW -**

**EMPLOYERS MAKE JOB OFFERS LIKE THESE TO OUR GRADUATES EVERY MONTH!**

Letter from nationally-known Airlines. "We would also appreciate if you would place the following additional advertisement in your bulletin—Wanted—Superintendent of Communications . . . Salary \$666.66 per month."

Letter from nationally known airplane manufacturer. "We need men with electronic training or experience in radar maintenance to perform operational check-out of radar and other electronics systems . . . starting salary . . . amounting to \$329.33 per month."

Letter from nationally-known Airlines. "We are contemplating placing . . . an Airline Ground Radio Engineer." Starting salary \$385 per month.

These are just a few of the examples of the job offers that come to our office periodically. Some licensed radioman filled each of these jobs; it might have been you!

Ours is the only home study course which supplies FCC-type examinations with all lessons and final tests.

**ACT  
NOW!**

**Get  
ALL 3  
FREE**

Your FCC ticket is Recognized in All Radio Fields as Proof of Your Technical Ability.

**MAIL COUPON NOW!**



Cleveland Institute of Radio Electronics  
Desk RN-54—4900 Euclid Bldg., Cleveland 3, Ohio  
(address to Desk No. to avoid delay)

**B** I want to know how I can get my FCC Ticket in a minimum of time. Send me your FREE booklet, "How to Pass FCC License Examinations" (does not cover exams for Amateur License), as well as a sample FCC-type exam and the amazing new booklet, "Money-Making FCC License information."

Be sure to tell me about your Television Engineering Course.

Name .....

Address .....

City ..... Zone ..... State .....

Paste on 2 cent postcard or send air mail.



# UHF

OR

# VHF

## television...



**INLINE Antenna** for maximum broadband VHF gain over all channels.

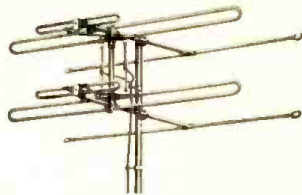

**Stacked INLINE VHF Antenna** for fringe signal areas.

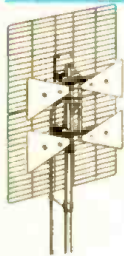

**Two BO-TYs** stacked for increased gain and reduced vertical response.

**BO-TY Antenna** for all-channel UHF reception.

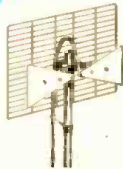

**STACKED-V** for VHF, UHF, or VHF-UHF reception.

**CORNER REFLECTOR** for increased gain over UHF channels.



**RHOMBIC** for any UHF channels where narrow lobe and high gains are needed.

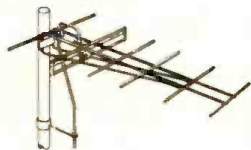

**YAGI** for maximum gain over specific UHF channels.

For the finest picture your set can produce use a Quality AMPHENOL Antenna best suited to the problems of your location. Consult your AMPHENOL Distributor or Dealer about the specific problems of your particular location.

**AMPHENOL**

AMERICAN PHENOLIC CORPORATION  
chicago 50, illinois

tremely complex and require very critical adjustments. There are a dozen interdependent adjustments necessary to bring the three colors into registration. That makes thousands of combinations of adjustments possible, only one of which is correct."

Criticizing the over-zealous probes of Congress, the Mid-western setmaker declared: "Scientific progress cannot be produced or hastened by either Congressional mandate or wishful thinking . . . The one sure way to kill color would be to release it before it is technically ready for everyday trouble-free service in the home. I fervently hope that the industry will not make that mistake."

Another pessimistic view was offered by Dr. Allen B. Du Mont, during a stockholders' meeting. Discussing color, he reported that it would be a long time before a commercially practical system would be approved. The engineers of his company, he added, were still not satisfied that the NTSC system was right for the public. The cost of the picture tube was still too high, he warned, and the system too complex. In his opinion, 3-D TV offered more immediate possibilities than color, and at more attractive prices.

Some of the rather dim comments stemmed from recent field tests during which representative color receivers were checked. During one such study of over a dozen sets, only one provided satisfactory results. Most models suffered from color drift, lack of resolution and brightness, and subject matter was only a fixed slide, showing a closeup of a girl, transmitted over a closed circuit, as well as *via air*.

The unsatisfactory results have not quelled the interest of NTSC members who are certain that all of the problems will be ironed out and practicable models will exist soon. Continuing tests are being held, they said, and daily substantial progress is being recorded. When the system is submitted to the Commission for approval this summer, it was noted, most of bugs will have been eliminated from basic designs, and refinements will then be the order of the day.

LOS ANGELES, playing host to the annual convention of the National Association of Radio-Television Broadcasters, also welcomed five members of the Commission, who traveled three thousand miles to address the group. In the contingent were the new chairman, Rosel Herschel Hyde, ex-Chairman Paul A. Walker, and Commissioners George E. Sterling, Robert T. Bartley, and Frieda Hennock.

In his first public appearance as the FCC's headman, Hyde told NARTB members that the Commission certainly will consider compatible color, when the proposal is submitted, but such consideration will not be rushed. The problem will be taken up in . . . "regular order, in an orderly way, and of course in an objective manner." He viewed the establishment or modification of standards as a serious business; unless exhaustive field testing proves the practical feasibility of a system, he added, the Commission cannot consider a change or the issuance of completely new standards.

The first comprehensive report on the Conelrad plan, designed to avert homing of enemy bombers on broadcast frequencies, was presented by Commissioner Sterling, who noted that over 1000 stations have joined the C plan. He hoped that more would become C members, because . . . "More stations mean greater navigational deception and assure wider dissemination of information to the public. Under the C plan, all stations, AM, FM, and TV, must have radio equipment to receive the radio alert message when broadcast from key stations; such gear includes a monitor receiver tuned to the key station in any given area. At present, C members participate in tests during experimental hours late at night using the special 640 and 1240-kc. cluster-sequential type of intermittent transmission. Some time in the future, Sterling said, he hoped that it might be possible to conduct a drill, which would involve direct public participation during regular broadcast hours. Such a drill, he pointed out, would have a . . . "tremendous impact on industry and public." However, he warned that the cost would be high, probably \$3-million an hour.

(Continued on page 89)



"TV SERVICE  
IS PROFITABLE FOR US...\*

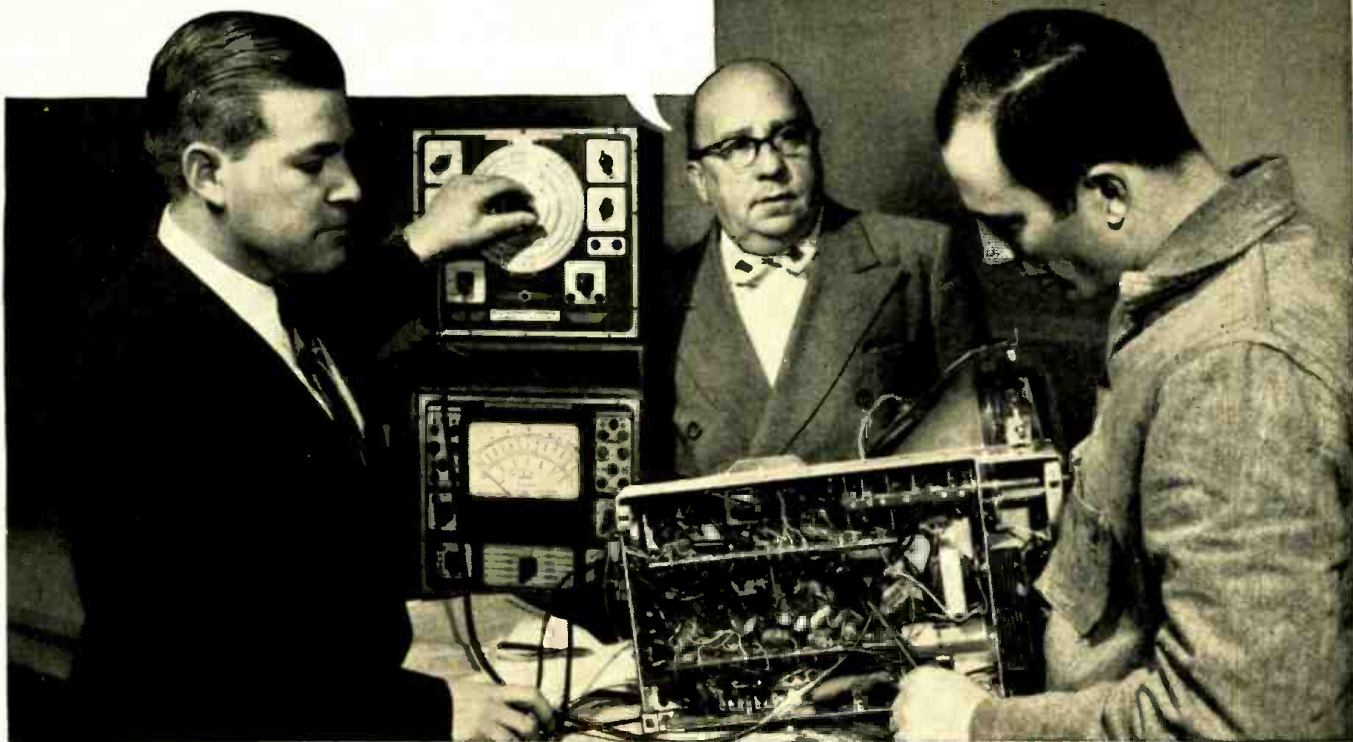

*\*and our customers," says Jack Dow, President, Jack Dow's Music Mart, Inc., with stores in Long Island, New York, communities.*

## G. E. WILL SHOW YOU HOW YOUR TV SERVICE DEPARTMENT CAN OPERATE AT A PROFIT

General Electric Field Engineers are holding Clinics throughout the country — Open to all TV Servicemen — Without Charge

● Top G-E dealers like Jack Dow report that an efficient service department is a very important factor in building a successful television business. You'll find it well worth your while to sit in on one of the G-E Field Clinics now being held. G-E engineers demonstrate quick, simple ways to diagnose and correct TV troubles—with particular empha-

sis on UHF. They will show you how to install and adjust the various kinds of UHF antennas and tuners—and answer your questions on any phase of TV service.

*Get in touch with the service manager at your G-E TV distributor now. Tell him to sign you up for the next clinic in your area.*

General Electric Company, Radio and Television Department, Electronics Park, Syracuse, New York

*You can put your confidence in—*

**GENERAL**  **ELECTRIC**



# Been Surprised Lately?



Get ready for the bang-up bargain opportunity of your life when you take advantage of a "Surprise" Trade-In Allowance on your used (factory-built) test and communication equipment at Walter Ashe. Here, higher trades are the rule, not the exception! Our stocks are complete. Deliveries are prompt. Get your trade-in deal working today. Wire, write, phone or use the convenient coupon.



**HALLCRAFTERS SX-71**  
Less Speaker. Net \$224.50



**NEW HAMMARLUND HQ-140-X Communications**  
Receiver. Less Speaker. Net \$264.50



**NATIONAL NC-183-D**  
Less Speaker. \$369.50



**HALLCRAFTERS S-76**  
Less Speaker. Net \$179.50



**ELMAC Model A-54** Wired for 10, 11, 20, 40  
and 75 meters. Net \$143.00  
Model A-54H. For crystal or dynamic mike.  
Net \$153.00



**NATIONAL HRO-60T**  
Less Speaker. Net \$483.50

**Phone Chestnut 1125**  
All prices f.o.b. St. Louis

**Walter Ashe**  
**RADIO CO.**  
1125 PINE ST. • ST. LOUIS 1, MO.

## FREE CATALOG!

R-53-7

WALTER ASHE RADIO COMPANY  
1125 Pine Street, St. Louis 1, Missouri

Rush "Surprise" Trade-in Offer on my \_\_\_\_\_

for \_\_\_\_\_ (show make and model number of new equipment desired)

Send new 1953 Catalog.

Name \_\_\_\_\_

Address \_\_\_\_\_

City \_\_\_\_\_ Zone \_\_\_\_\_ State \_\_\_\_\_

Send  
for  
your  
copy  
today



# PICKERING

## PROFESSIONAL AUDIO EQUIPMENT

BALANCED COMPONENTS / MAXIMIZE PLAYBACK PERFORMANCE

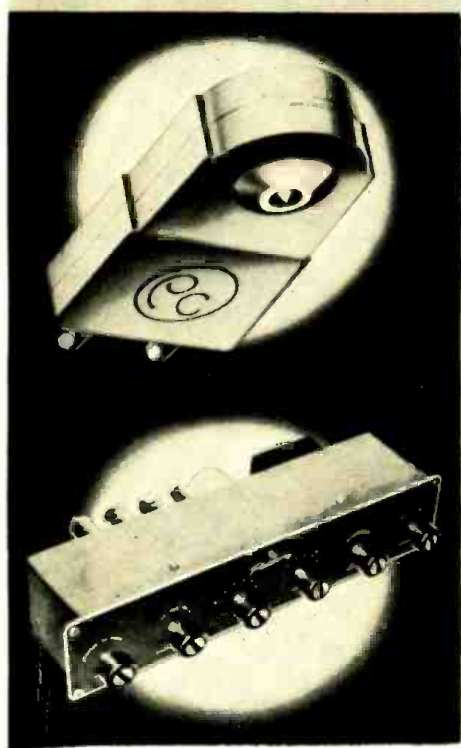

### PICKERING CARTRIDGES . . .

are the choice of audio engineers throughout the world. They are universally acclaimed because of their high output, wide range performance and low distortion. They are used wherever a fine cartridge is required in radio stations, recording studios and for purposes of quality control by leading record manufacturers.

### MODEL 410 AUDIO INPUT SYSTEM . . .

is designed to provide a complete audio control center. Model 410 may be used in any high quality playback system. Three input channels are provided—one for magnetic cartridges and 2 "flat" channels for other audio circuits. A 3-position equalizer network is built into the magnetic cartridge channel and provides accurate equalization for LP, AES and 78 rpm recording characteristics. Separate bass and treble controls are also provided. These are of the step-type and permit bass and treble adjustments in 2 db increments. The tone control circuits are intended to compensate for record characteristics and for listener-environment acoustical conditions. They are not intended to compensate for amplifier and/or loudspeaker deficiencies. Model 410 is intended for use with the highest quality professional type playback equipment. The output of the Model 410 is fed from a cathode-follower circuit and will work into any high quality audio or line amplifier having a high impedance input. It may also be used with a transformer for the purpose of feeding a 500 ohm line. Because of its flexibility, low noise and low distortion level, it is ideally suited for bridging and monitoring purposes and for critical listening applications.

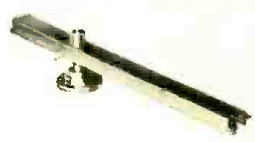

### THE MODEL 190 ARM . . .

is designed primarily for use with microgroove records. Its design has been recognized by leading audio engineers as that which incorporates all of the desirable tracking characteristics. Analysis has shown that for maximum performance with LP records the vertical mass of the moving arm element must be held to a minimum and further, that the arm must be counterbalanced about the vertical axis. This permits minimum stylus or tracking force and provides maximum record life. The Model 190 Arm embodies these all important features necessary for proper microgroove record playback.



### MODEL 230H EQUALIZER-PREAMPLIFIER . . .

is unique in its accuracy of equalization and frequency response. The intermodulation distortion is .2 per cent at normal output level. It is intended for use with high quality amplifiers having gain and tone controls. When used with the Pickering Model 132E Record Compensator the 230H is ideal for radio station and recording studio use and for applications requiring accurate low noise and distortion free playback.



### MODEL 132E RECORD COMPENSATOR . . .

is designed to be used in conjunction with a magnetic cartridge preamplifier such as the Pickering 230H or any preamplifier which provides 6 db per octave bass boost. Six playback positions are incorporated:

- 1—European 78 rpm Records
- 2—Victor 45 rpm and Decca 78 rpm Records
- 3—No high frequency roll-off, 500 cycle turnover
- 4—All Capitol Records, new Victor 33 1/3, Audio Engineering Society Curve
- 5—Columbia, London and most LP Records
- 6—To remove the hiss from old noisy records

Precision elements are used in its construction to give accurate compensation. The 132E is inherently a low distortion R-C device.

## PICKERING PROFESSIONAL AUDIO EQUIPMENT

*"For those who can hear the difference"*

...Demonstrated and sold by Leading Radio Parts Distributors everywhere.  
For the one nearest you and for detailed literature, write Dept. C-2



**PICKERING and company incorporated • Oceanside, L.I., New York**





320K SIG. GEN. KIT \$19.95 WIRED \$29.95



145K SIG. TRACER KIT \$19.95 WIRED \$28.95



950K R-C BRIDGE & R-C-L COMP. KIT \$19.95 WIRED \$29.95



360K SWEEP GEN. KIT \$34.95 WIRED \$49.95



New 214K VTVM KIT \$34.95 WIRED \$54.95

OVER 1/4 MILLION

**EICO** INSTRUMENTS

in use the world over!

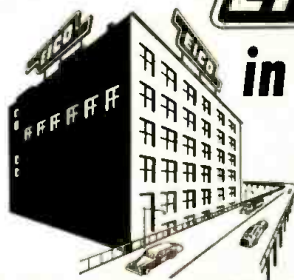

**EICO** new modern facilities for research, development and production—your greater assurance of . . .

**LABORATORY PRECISION AT LOWEST COST**



New 377K SINE & SQUARE WAVE AUDIO GEN. KIT \$31.95 WIRED \$49.95



1040K BATTERY ELIM. KIT \$25.95 WIRED \$34.95



1171K RES. DECADE BOX KIT \$19.95 WIRED \$24.95



625K TUBE TESTER KIT \$34.95 WIRED \$49.95



CRA PIX TUBE ADAPTOR for Tube Tester \$4.50



New 565K MULTIMETER KIT \$24.95 WIRED \$29.95 20,000  $\Omega/v$ ; 31 ranges



315K DELUXE SIG. GEN. KIT \$39.95 WIRED \$59.95



HIGH VOLTAGE PROBE \$6.95



221K VTVM KIT \$25.95 WIRED \$49.95



470K KIT \$79.95 WIRED \$129.50



425K 5" PUSH-PULL SCOPE KIT \$44.95 WIRED \$79.95



**NEW!**

MODEL 495-K SCOPE VOLTAGE CALIBRATOR KIT \$12.95 WIRED \$17.95

**You Build EICO Kits in One Evening, but . . . They last a Lifetime! and You SAVE OVER 50%**

YOU be the judge. See the famous EICO line TODAY — in stock at your local jobber — and SAVE!

Write NOW for FREE newest Catalog 7-R.

America's greatest instrument values bear the name—



ELECTRONIC INSTRUMENT CO., Inc., 84 Withers Street, Brooklyn 11, N. Y.

Prices 5% higher on West Coast. Specifications and prices subject to change without notice.



# THE DAGE INDUSTRIAL TV CAMERA

By **HAROLD E. ENNES**  
Staff Eng., Indianapolis Broad., Inc.

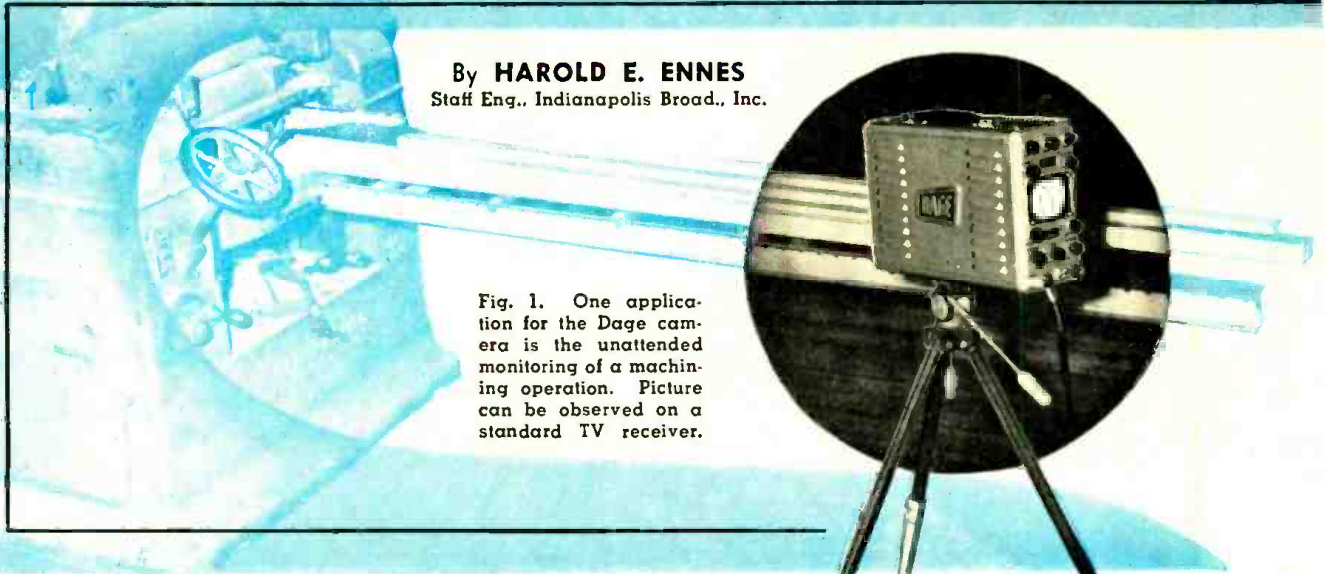

Fig. 1. One application for the Dage camera is the unattended monitoring of a machining operation. Picture can be observed on a standard TV receiver.

*Its compact size, well-designed circuit, and the fact that it can be used with an unmodified, standard TV receiver has captured industry-wide attention. Here is data on how it is built and how it can be used.*

**T**HE inevitable expansion in use of electronic devices in industry is opening another doorway to opportunity. The new field of industrial or general "closed-circuit" television systems is on the verge of vast national enlargement, comparable only to the billions soon to be circulating in TV broadcast transmitters and receivers. The application of electronic "eyes" provides unlimited extension to the arms of industry, science, research, education, and business. A large share of the responsibility for proper servicing and maintenance of such systems will be charged to the independent television service industry.

A recent development in this field is already resulting in the national interest needed to spark large scale activity in closed circuit TV systems. This development is the *Dage* ITV Camera (manufactured by *Dage Electronics Corp.*, Beech Grove, Indiana) technically described in this article. The low price and relative simplicity of setup and use are factors contributing to an assured broad utilization.

Fig. 1 shows the *Dage* camera in unattended operation allowing remote observation of functions. In the simplest installation, the a.c. cord is plugged into a 117-volt outlet and a single interconnecting 73-ohm cable is run from the camera output to the antenna terminals of any standard TV receiver. A simple matching transformer is used for 300-ohm input re-

ceivers. The picture from the camera is received on one of the television channels (2 through 6) and is selected and tuned in exactly the same way as a standard broadcast station is tuned. Any number of cameras at different locations can be fed into a single receiver, or a number of receivers at different viewing points can be connected to one or more cameras, as shown in Fig. 2. No modification of any kind is necessary in the receiver, making practical the pur-

chase of inexpensive receivers where desirable.

The camera is a completely self-contained transmission system with only 17 tubes including the Vidicon pickup tube, video amplifiers, sync generator, regulated power supply, kinescope camera monitor, and composite modulated r.f. output. The unit is 9 $\frac{1}{2}$ " high, 4 $\frac{1}{2}$ " wide, 14" in length, and weighs only 18 pounds.

The miniature size of the *Dage* camera is achieved, in part, by use of

Fig. 2. How a number of cameras at different locations can be fed into a single receiver or how a number of receivers at different viewing points can be connected to one or more cameras. No receiver modifications are required in this TV setup.

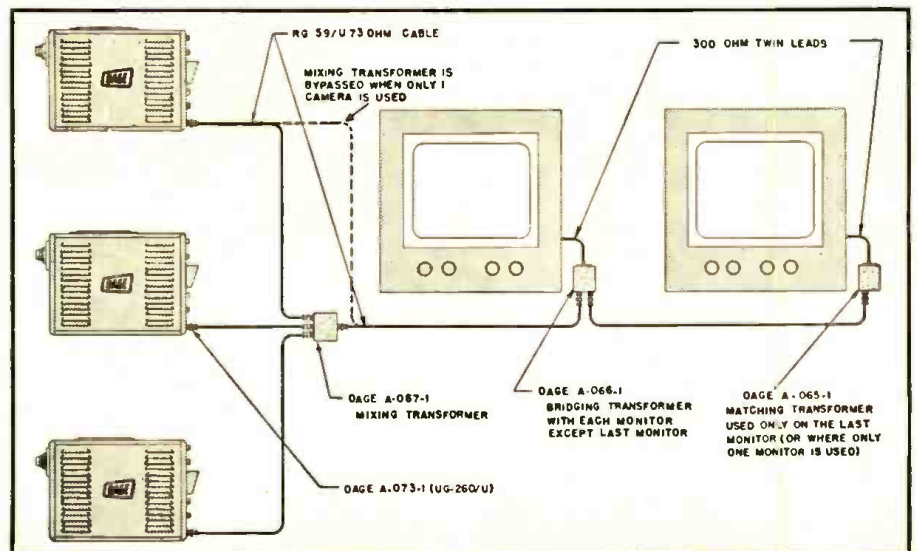



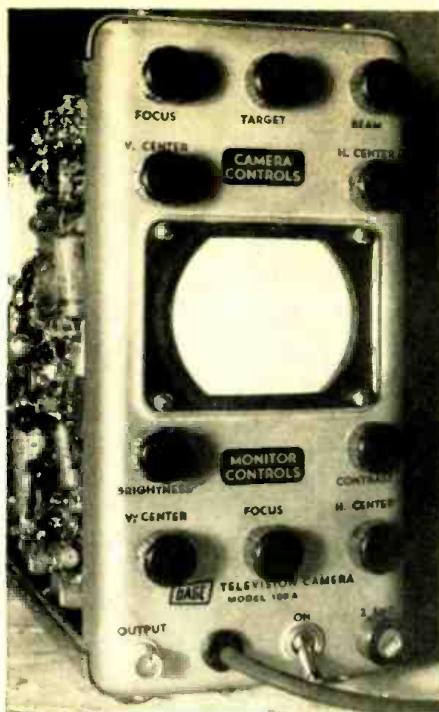

Fig. 3. Rear panel view of the Dage camera showing various camera and monitor controls.

the newly-developed RCA Vidicon pickup tube, type 6198. This pickup tube is only  $6\frac{1}{4}$  inches long by 1 inch in diameter. Familiarity with operational characteristics is important to an understanding of camera operation. Since this tube has not been widely publicized in technical details, a very brief review follows of pertinent points. Fig. 4 is an exaggerated "functional" drawing to illustrate basic operation.

The scanning beam is supplied by a conventional electron gun with a 6.3 volt heater used to heat a thermionic cathode placed at ground potential. Four grids are used with the following functions: *Grid #1* (control grid) Picture cut-off value from -45 to -100 volts. *Grid #2* (accelerator grid) Ordinarily operated at a fixed positive voltage in the vicinity of 275 to 300 volts. *Grid #3* (focusing electrode) Current in the external focusing coil

provides a uniform magnetic field through which the scanning beam is swept by the deflection coil saw-tooth currents. *Grid #3* potential between plus 200 and plus 300 volts provides an electrostatic field in conjunction with the magnetic field to focus the electron beam at the photoconductive target. Current through the external focusing coil is fixed in the *Dage* camera, and *grid #3* voltage is made variable to allow optimum electrical focus. *Grid #4* (decelerator electrode) This is a fine mesh screen adjacent to the photoconductive layer and attached to *grid #3*. This electrode is therefore maintained at the same operating potential as *grid 3*. The physical configuration provides a uniform field on the beam side of the target so that the beam strikes the photoconductive layer perpendicularly, irrespective of the angle from which approach is made. Decelerating action results from the fact that the signal electrode is operated at a much lower voltage of plus 20 to 30 volts. A low-velocity scanning beam results similar to that in the broadcast type image orthicon; but here the similarity ends.

The light-sensitive element may be visualized as being comprised of two separate elements electrically; (1) a transparent conductive film coating on the inner surface of the glass faceplate, and; (2) a thin layer of photoconductive substance on the scanned side. This is obviously highly exaggerated in the drawing. A metal ring around the front end of the tube serves as the signal lead connection, to which the load resistor is connected in series with the "B plus" supply. The scanning beam is in series with the complete signal circuit. The resistance of the photoconductive layer is dependent upon the amount of light striking it through the lens, being very high under no-light conditions, and less in ratio to the increase in light. One plate of the electrically separate plates is charged to the plus voltage on the signal electrode, while the other plate is charged down to cathode potential by the scanning beam. The remaining beam electrons

are turned back in the form of a return beam under the influence of the positive grids, but is not used in the Vidicon.

Under no-light conditions when the photoconductive element exhibits the characteristics of an insulator, very little current flows through the complete signal path. What little current does flow is termed the "dark current" which is a limiting factor in maximum signal electrode voltage. When light reaches the tube, the transparent conducting film on the inner surface of the glass faceplate begins conduction by an amount dependent upon the light intensity at that particular point, causing the corresponding point on the gun side to rise slightly toward the plus potential of the target supply. Thus the beam current increases at the points of the positive potential pattern created on the gun side of the target in accordance with the light distribution in the focused image. It is noted that the signal current through the load resistor increases for light portions and decreases for dark portions of the image, resulting in a positive black signal at the grid of the first pre-amplifier tube.

The scanning area of the Vidicon is only  $\frac{1}{2}$ " wide by  $\frac{3}{8}$ " in height. A 3" lens therefore is a "telephoto" type lens for a Vidicon tube, covering a field of 10 by 13.3 feet at a distance of 80 feet. A 1" lens is the general purpose type and a  $\frac{1}{2}$ " lens is used for "wide angle" applications.

The spectral response under incandescent lighting is approximately the same as the human eye. Response may also be obtained in the infrared and ultraviolet regions. Only 50 to 100 foot-candles of incident illumination is required with a  $\frac{1}{2}$ " or 1" lens (*f*1.5), and a readable picture can be obtained from the *Dage* camera with 10 foot-candles of light.

#### Camera and Monitor Controls

External controls for the camera and built-in monitor are shown in Fig. 3. Fig. 5 shows the interior layout. The monitor uses a 3" kinescope (3RP1) with P1 phosphor. This serves as an excellent "range finder" for lens and camera adjustments where the monitoring receivers may be out of visual range of the camera setup.

The group of "Camera Controls" perform the following functions:

**Focus**—Varies voltage on *grid 3* (focusing grid) of Vidicon. (See block diagram, Fig. 6). In practice the lens focusing collar is adjusted for proper distance to obtain sharp optical focus, then the "Focus" control is adjusted for maximum resolution of picture detail. A resolving power of 350 lines is possible in this camera.

**Target**—Adjusts voltage on photoconductive target of Vidicon. See Fig. 6. Variation of this control affects the quality of the picture in relation to amount of light on the transmitted scene. For a given operating

Fig. 4. "Functional" diagram which illustrates basic operation of the Vidicon tube.

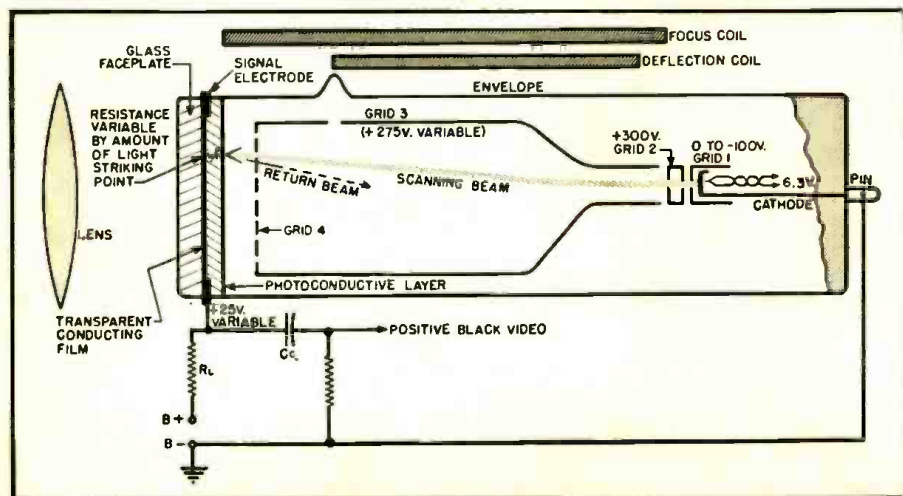



voltage the sensitivity and dark current both tend to gradually change throughout the life of the tube, making mandatory an adjustable voltage to compensate for these changes. Under low light level conditions, the control may be operated toward full clockwise position (maximum voltage) for increased sensitivity. There is, however, a limiting value of target voltage beyond which the non-uniformity of the dark-current background in the picture reaches intolerable proportions. With sufficient light, the picture is improved by reducing the "Target" control setting.

**Beam**—Adjusts the negative potential of grid 1 (control grid) in the Vidicon. At a fully counterclockwise position (maximum negative voltage) the beam is cut off and no picture appears. As the control is adjusted clockwise, fixing amount of beam current by decreasing negative grid potential, the picture is observed to "wipe clean" with the brightest areas coming in last. The low-lights or dark portions of the scene appear first since the beam is sufficient to resolve the darker (less positive) areas, but insufficient to discharge the brighter portions (more positive) areas. The "Beam" control is left just clockwise of the point where there is enough beam current to resolve all highlights, since further rotation causes loss of resolution by the well-known spreading of an electron beam with too much beam current.

**V. Center**—A control in the camera vertical output stage  $V_{10}$  which adjusts the magnitude of d.c. in the vertical deflection coil of the Vidicon. This centers the sweep vertically.

**H. Center**—A control in the camera horizontal output stage  $V_{12}$  which adjusts the amount of d.c. in the horizontal deflection coil for the Vidicon. This centers the sweep horizontally.

The camera "Monitor Controls" are self-explanatory with the exception of the "Contrast" control. This control is actually in the cathode of the second video amplifier stage ( $V_2$ ) and determines the gain of the video amplifier. As such, it affects the contrast of the picture on the viewing receivers as well as the camera monitor. The gain is variable over a range of approximately 10 db. It is often found desirable in practice to set this control about  $\frac{1}{4}$  to  $\frac{1}{2}$  open, and vary the contrast over a fine range by the "Target" control described previously. The "Contrast" control, however, provides a more flexible adjustment for meeting the requirements of different viewing receivers.

### Video Amplifiers

As indicated in Fig. 6, four 6CB6 video amplifier stages are employed. Essentially uniform response to over 4 mc. is achieved by the use of combination series-shunt peaking circuits in all stages except the "high-peaker" stage  $V_3$ . Input stages between the pickup tube and first video amplifier are notably lacking in high-frequency

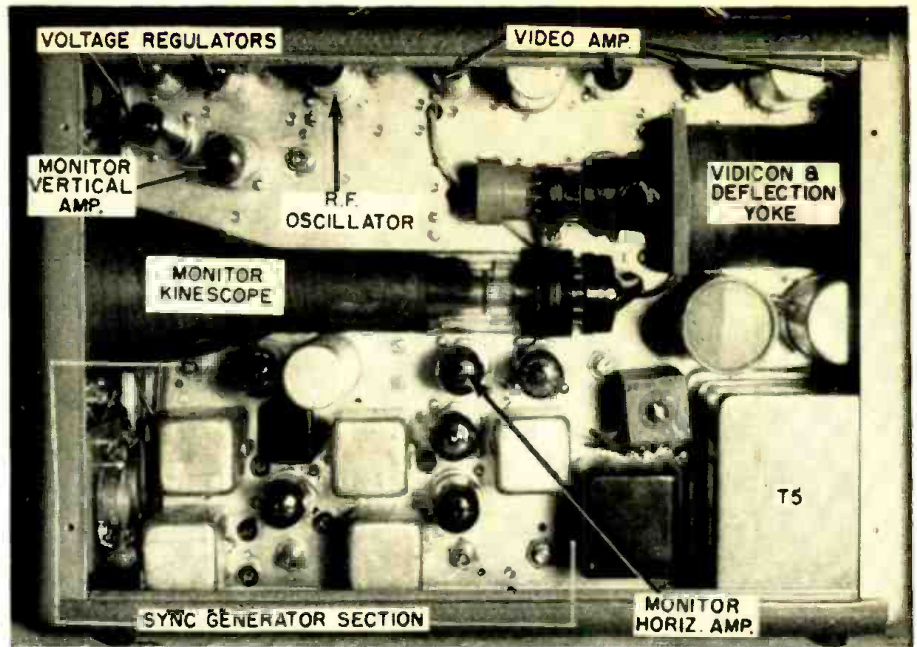

Fig. 5. Internal view of camera showing layout of chassis on the tube side of unit.

response due to the inherently large shunt capacitances of such circuits. It is the purpose of the "high-peaker,"  $V_3$ , in the Dage camera to compensate for this deficiency by a deliberate boosting of the high-end of the response curve in this stage. This is accomplished by using a very low value of plate load resistor (120 ohms) in series with an inductance. This arrangement provides an essentially inductive load at the higher frequencies in the desired passband, resulting in the necessary high-frequency boost for a flat overall response curve.

The "Contrast" control mentioned before is a 1000 ohm variable potentiometer in the cathode of this stage, allowing a 10 db variation of stage

gain. This control may actually be left in the minimum gain position and still provide sufficient contrast in most applications, with judicious setting of "Target" and "Beam" controls.

As noted from Fig. 6, the Vidicon grid #2 (accelerator grid) pin 5, is operated at a fixed plus potential of approximately 275 volts from the low voltage filter supply. The "Focus" control  $R_3$ , resistor  $R_2$  and "Target" control  $R_1$ , form a voltage divider from pin 5 to ground. This provides the proper range of voltage adjustments for "Focus" and "Target" electrodes. The signal current variations through coupling resistor  $R_7$  provide the signal voltage for the following first video amplifier stage through coupling con-

Fig. 6. Block diagram of the camera. An RCA type 6198 Vidicon pickup tube is employed.

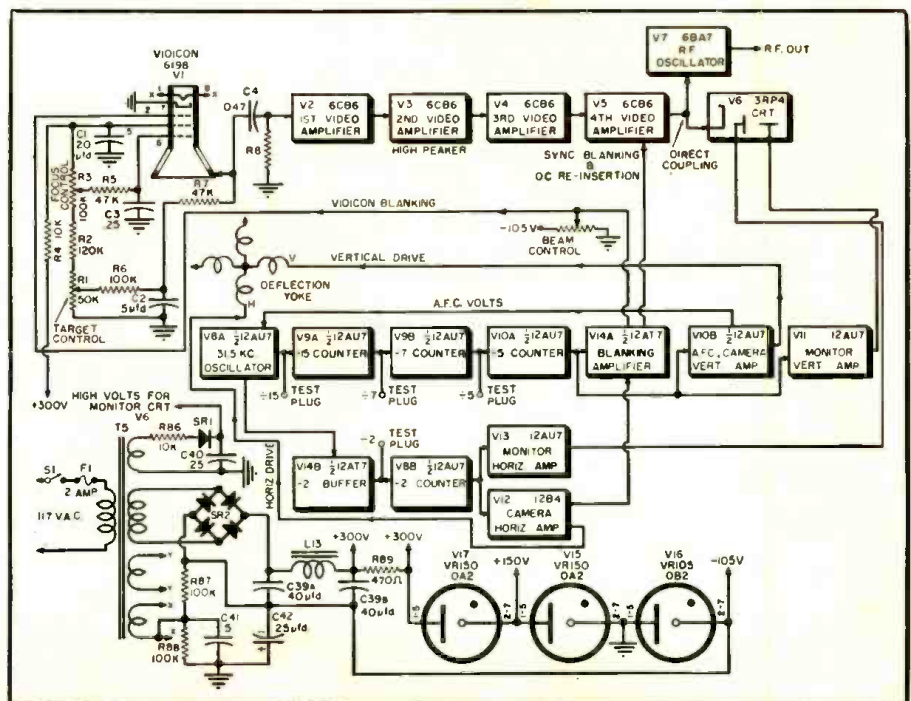





Fig. 7. "Divided by 2" counter pulses on scope when connected to "Test Plug  $\div 2$ ." Every second pulse triggers  $\div 2$  oscillator.

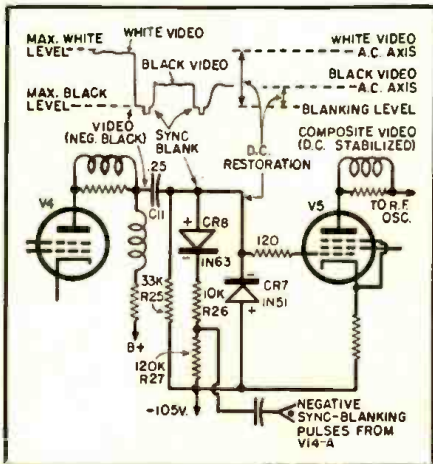

Fig. 8. The sync blanking and d.c. insertion circuit used in the Dage TV camera.

condenser  $C_1$ . Condensers  $C_1$ ,  $C_2$ , and  $C_3$  provide adequate bypass of hum and stray field pickup and isolation from the common impedance of the power supply.

### Blanking and Insertion

An important factor in the excellent results obtainable from this TV system is the simplified but effective method of injecting the sync-blanking pulses and re-inserting the d.c. component. The importance of proper d.c.

Fig. 9. Rectified composite signal at the camera output (line frequency). See text.

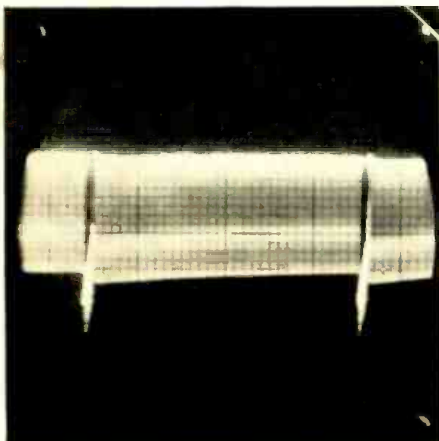

insertion is emphasized by the fact that small shifts in black level have a noticeably adverse effect on dark tone rendition in the image. Sync-blanking insertion and d.c. re-insertion are combined in this camera by the use of two germanium crystal diodes in the circuit illustrated in Fig. 8.  $CR_6$  serves to inject sync-blanking pulses and  $CR_7$  inserts the d.c. component necessary to hold the blanking at a predetermined level irrespective of whether the video signal is in white or black regions at the moment of injection.

The picture signal is black negative polarity at the output of  $V_1$ , coupled to the grid of  $V_2$  through  $C_{11}$  and grid return  $R_{25}$ . This return is made to a negative potential of 105 volts. During the active line scan (no sync-blanking pulses received) the  $V_2$  grid is biased through  $R_{25}$ . At the end of each line, large negative sync-blanking pulses at 15,750 pps are injected at the junction of  $R_{25}$ - $R_{27}$ . At the end of each field, the longer duration 60 pps sync-blanking pulses are injected. During these large negative excursions,  $CR_6$  is driven into conduction inserting the pulses on the video signal.

Insofar as these control pulses are concerned,  $CR_6$  and  $CR_7$  are in series. The larger negative potential existing on the grid during the pulse injection drives  $CR_7$  into conduction at the same instant. Thus the sync-blanking is continually referred to a constant bias reference, and the equilibrium charge on coupling condenser  $C_{11}$  appears as d.c. across diode  $CR_7$  which holds the grid of  $V_2$  at a constant level compared to blanking pulse amplitude. To this d.c. component is added the video a.c. component and constant background brightness relative to scenic content is restored. The direction of bias change is such that it compensates for the shift in the composite video waveform, as illustrated at the top of Fig. 8.

### R.F. Oscillator Output

The composite, d.c. stabilized output of  $V_2$  is black positive and is conductively coupled to the r.f. oscillator

Fig. 10. The rectified composite signal at the camera output (field frequency).

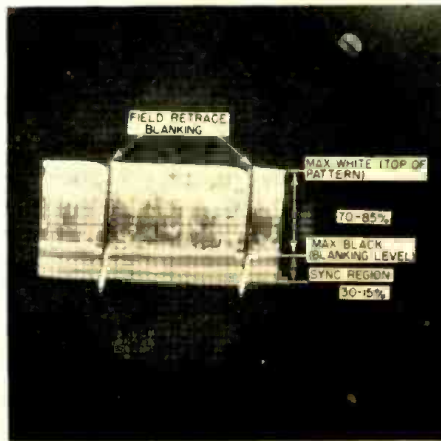

$V_3$  to retain the d.c. component. This stage is a miniature 6BA7 pentagrid converter used in a modified Hartley oscillator circuit to supply a double-sideband, amplitude-modulated video signal. It is tuned to any of the standard TV channels (2 through 6) by means of a slug adjustment in the Hartley coil, and provides a highly stabilized output.

Although the plate of  $V_3$  is conductively coupled to the third grid of the oscillator  $V_1$ , this grid is returned to a point of negative potential and the effective voltage is about plus 5 volts. Grids 2 and 4 and the plate of  $V_1$  operate at the relatively low positive potential of 82 volts.

Since the polarity of the applied composite video is positive, the amplitude of the r.f. carrier increases in the black sync-blanking region, and decreases with picture brightness, resulting in the standard negative modulation. Some beneficial limiting action occurs in  $V_1$  on sync-blank peaks since the added positive potential on grid 3 and relatively low plate voltage causes the tube to be driven into the beginning of plate current saturation. This aids in holding the sync levels at the same height for successive peaks for efficient receiver sync control.

### The Sync Generator

Both line frequency pulses (15,750 pps) and field pulses (60 pps) are derived from a common master oscillator operating at 31,500 cycles. This permits effective use of a line-lock stabilizing circuit which compares favorably in stability characteristics with commercial type broadcast equipment.

Blocking oscillators are used for the master oscillator and all divider circuits. The blocking type has an inherently greater stability than multivibrators when required to obtain greater frequency division than 2. The vertical sync-blanking is derived from the 15, 7, 5 chain of dividers. (The term "sync-blanking" is used since one pulse serves both purposes as shown in Figs. 9 and 10). A pulse from the grid side of the master oscillator is fed through a buffer stage to a single  $\div 2$  counter for the horizontal sync-blanking. Equalizing pulses are not used in this system, greatly simplifying the circuit and maintenance requirements. Since the system is a closed circuit and the control pulses fed to the viewing receiver utilize the same driving pulses that scan the Vidicon pickup tube, ordinary transmission vagaries are precluded and no difficulty is experienced in the field with pairing of lines in a properly adjusted receiver.

The sync generator adjustment is straightforward and simple. The initial adjustment of the 31,500 cycle master oscillator is made by connecting one lead of a pair of headphones in series with a germanium diode to "Test Plug  $\div 2$ ," and the other lead to

(Continued on page 125)



# RADAR PROTECTS FISHING FLEETS

By  
RAY FRANK, W9JU

*Commercial fishing fleets are aided and protected by an impressive array of modern electronic indicating devices.*

**O**NE OF THE hazards of small-boat navigation has always been the inability of the pilot to determine his exact position or detect dangerous obstacles in fog or darkness.

Direction finders are very useful in determining location, but do require continuous plotting on charts to fix the exact position at any given time. Navigation by readings on the sun or stars also has this same limitation.

Many fatal accidents could be prevented if all boats were equipped with the "seeing eye" known as radar, as this device has none of the aforementioned limitations. At any time the surrounding area is under surveillance, with the result that the danger of collision with unseen objects is greatly reduced.

Radar has been in widespread use for military purposes for several years and many special types have been developed for specific applications.

The unit pictured on the cover and in the accompanying photographs is typical of small-boat installations. The radar unit itself is a "Ranger Radar" manufactured by the *Electric Service Company* of Seattle, Washington. This equipment is installed on the boat "White Star," one of the fleet of fishing boats operated by the *Van Camp Canneries* of Terminal Island, California. This company is the processor of the well-known "Chicken of the Sea" brand of tuna.

The boat is a regular working craft of 113 tons and has an over-all length of 104 feet. The boat, which has a cruising range of over 2500 miles, is used for both business and pleasure by Gilbert C. Van Camp, Jr.

The radar antenna shown on this month's cover inset rotates constantly when the unit is in use, affording 360 degree coverage of the surrounding area. Rotation is at a speed of four revolutions-per-minute and, due to the persistence of the viewing screen, any objects scanned by the beam will remain illuminated on the screen until again scanned.

As the antenna rotates, a picture of the surrounding area is formed on the viewing screen of the receiver. The boat always appears in the center of the screen, with surrounding objects

Close-up of the radar antenna installed on the "White Star" showing wave guide.

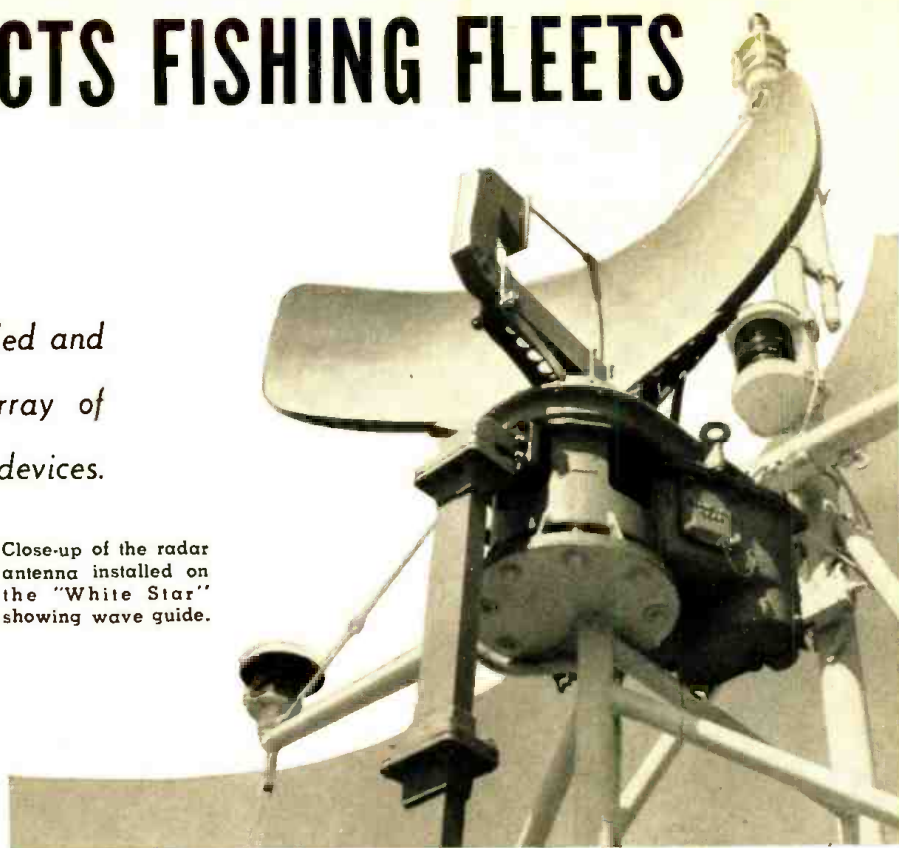

appearing as dots or spots in their exact relation to the boat.

The bezel surrounding the screen is calibrated in degrees so that the relative bearing to the boat may be read directly. The vertical line in the center of the viewing screen may be rotated to allow the operator to determine the exact bearing of any object on the screen. The screen is so positioned that the heading of the boat always appears at the top.

The screen of the unit is calibrated in three ranges. These are 4 miles, 20 miles, and 80 miles. At close quarters such as in harbors, along the coast, or during darkness or fog, the

four-mile range is used. When attempting to locate other boats of the fleet, or under clear sailing conditions, either the twenty- or eighty-mile range is used.

The two longer ranges are particularly useful when one of the boats of the fleet locates a school of fish. Other radar-equipped boats of the fleet can readily locate the lucky boat if the approximate direction is known. Thus, the entire fleet can quickly converge on the spot, greatly increasing the catch.

The peak power developed by the radar unit is great enough to allow  
(Continued on page 123)

Some of the electronic gear installed in the wheelhouse of the "White Star." From left to right are: The Fisher-fone "Captain" transmitter, radar unit, Bludworth direction finder above wheel, and RCA direction finder below.

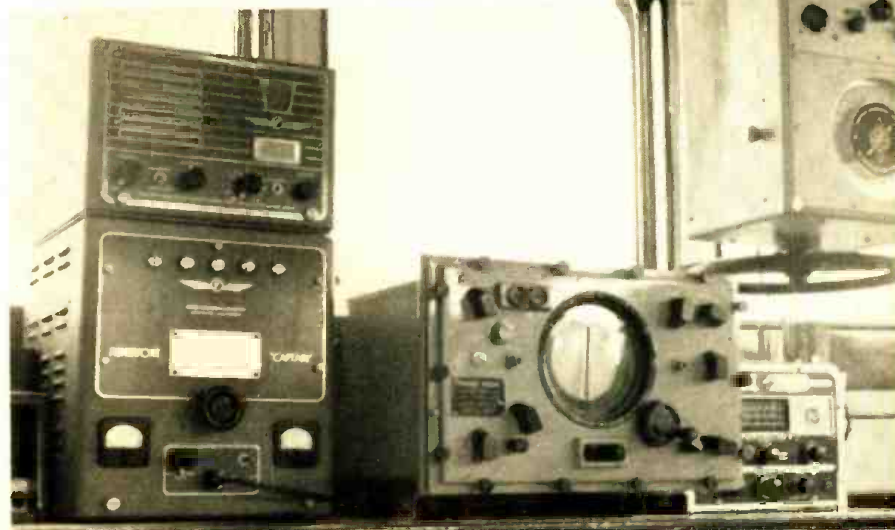



# COAXIAL SPEAKER

## DIVIDING

## NETWORKS

By LLOYD C. GOSS

*The selection of a suitable dividing network depends on several factors, including both price and quality desired*

THE audio enthusiast who wants a high-quality, high-fidelity audio system invariably uses coaxial speaker arrangements. These arrangements consist of two speakers, one for high notes (the tweeter) and the other for reproducing the lows (the woofer). A necessary evil for such a system is the dividing network.

Frequency-dividing networks channel the high frequencies to the tweeter and the low frequencies to the woofer. The frequency at which the network divides between lows and highs is called the crossover frequency. If we consider a network with a crossover frequency of 1000 cps connected to an amplifier producing a 500 cps and a 2000 cps signal, the network directs the 500 cps signal to the woofer and the 2000 cps signal to the tweeter.

Stopbands and passbands also enter into filter terminology. The low frequency stopbands and passbands occur respectively above and below the crossover frequency. High frequency stopbands and passbands are below and above the crossover frequency.

Attenuation, the ratio of power delivered to a load without the network ( $P_1$ ) to the power delivered to the load with the network, ( $P_2$ ) is measured in db (decibels) according to:  $db = 10 \log_{10} (P_1/P_2)$ . We want zero attenuation in the passbands and high attenuation in the stopbands. Typical attenuation curves displayed in Fig. 3 illustrate how the networks shift the amplifier output from one speaker to the other at the cut-off frequency.

Usually the impedance of the high-frequency and low-frequency speakers are the same. This leads to the

problem of matching both speakers to the output impedance of the audio amplifier. The amplifier can be resolved into an equivalent generator and series impedance with Thevenin's Theorem. Fig. 1A illustrates this transformation. The generator has an e.m.f. of  $E_o$  volts equal to the open circuit voltage of the amplifier, while  $R_o$  equals the amplifier output impedance. Now, the maximum power

Fig. 1. (A) Amplifier and its equivalent circuit as a generator and output impedance. (B) Series and parallel quarter-section constant resistance networks. (C) Series half-section network, and (D) Parallel half-section network. Calculations are also given.

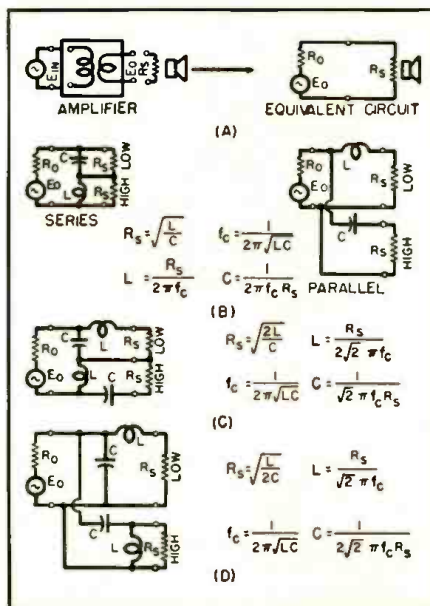

transfer theorem states that maximum power is delivered to a load from a generator when the impedance of the load equals the impedance of the generator. Applied here, the impedance of the speaker must match that of the amplifier at all frequencies. Networks which do this consist of pure reactances. The characteristic impedance of such a network is the impedance seen looking into the network when the network is terminated by its characteristic impedance.

Frequency dividing networks of this type divide into two groups: (1) constant resistance networks and (2) filter networks. The constant resistance network actually has a characteristic impedance independent of frequency while the characteristic impedance of the filter network remains constant only over a portion of the passband.

### Constant Resistance Networks

The constant resistance network derives its name from the fact that when terminated by constant resistance speakers, it presents a constant resistance to the amplifier at all frequencies. These networks also divide into two groups: (1) quarter-section networks, and (2) half-section networks. Schematics of these networks appear in Figs. 1B, 1C, and 1D.

**1 Quarter-section Networks:** Schematics of the quarter-section networks appear in Fig. 1B. The parallel and series networks have identical values of circuit elements and attenuation characteristics. The crossover frequency occurs at series resonance or when the reactance of the inductor equals that of the condenser. Equating these values gives a crossover frequency of  $f_c = 1/2\pi\sqrt{LC}$ . These networks have the unique feature of presenting the amplifier with a constant resistance ( $R_n = \sqrt{L/C}$ ) over the audio range. This advantage enables the output transformer to deliver constant power to the speaker system at all frequencies.

The attenuation curves of Fig. 3 show how the network shifts the amplifier output from one speaker to the other at the crossover frequency. A figure of merit for attenuation in dividing networks is the attenuation in db-per-octave relative to the crossover frequency. This network has an attenuation of 6 db/octave. The equations for calculating  $L$  and  $C$  also appear with the circuit diagram in Fig. 1B. It should be noted that in all the formulas presented in this article,  $L$  is in henrys,  $C$  is in farads, and  $f$  is in cps.

**2 Half-section Networks:** Schematics of the series and parallel half-section networks appear in Figs. 1C and 1D respectively. These networks also present a constant resistance to the amplifier over the audio range. Their attenuation characteristics are superior to the quarter-section type as seen by the curve of Fig. 3. This circuit has a figure of merit of 12 db/octave. The improved attenuation was



expected since the half-section used four elements instead of two.

Again, the crossover frequency occurs at series resonance;  $f_c = 1/2\pi\sqrt{LC}$ . Between the series and parallel networks, a factor of two exist in values of the circuit elements. In the series network, we find the reactances half of those in the parallel network. The equations for calculating the circuit elements appear with the diagram in Figs. 1C and 1D. Selection of either the series or parallel network depends on the crossover frequency desired, the circuit elements on hand, or the price of condensers and inductors.

### Filter Networks

Filter networks differ from constant resistance networks in their impedance characteristics. A filter network is primarily designed to operate between impedances which match the characteristic impedance of the filter. Fig. 4 shows how the characteristic impedance ( $Z_0$ ) of symmetrical "pi" and "T" circuits vary with frequency. When terminated at each end by the characteristic impedance, these filters have zero attenuation in the passband and high attenuation in the stopband. Under these ideal conditions, the nature of the characteristic impedance determines the attenuation. In the passband the characteristic impedance is resistive while at the crossover frequency it becomes reactive. Since a reactive impedance cannot absorb power ( $P = I^2R$ ), the attenuation increases at a rapid rate outside the passband.

Since we cannot match the terminating impedances ideally with transformers and speakers, impedance mismatch losses occur. These losses cause attenuation in the passband and retard attenuation in the stopband. The resulting attenuation curves of Fig. 3 show that the attenuation properties are superior to those of the constant resistance filter.

The cut-off frequencies no longer

occur at the natural series resonance frequency of the reactive elements. For a high pass filter  $f_c = 1/4\pi\sqrt{LC}$ , and for a low pass filter  $f_c = 1/\pi\sqrt{LC}$ . These frequencies occur when the characteristic impedance changes from resistive to reactive.

Formulas for calculation of the circuit elements appear with the circuit diagram of each filter. Again, a choice between a "T" or "pi" network rests on individual preferences and economic considerations. See Fig. 2.

### Design Considerations

Three factors affect the economic considerations of designing a dividing network: (1) crossover frequency, (2) attenuation desired, and (3) quality of parts.

A high crossover frequency lowers the size of the inductors and condensers since the crossover frequency occurs in the denominator of every circuit element equation. Selection of the crossover frequency should stem from the speakers used. Usually 400 cps to 500 cps give optimum performance, but this low range demands large condensers and inductors.

The crossover frequency also has an effect on the quality of parts. The networks were designed assuming the condensers and inductors to be pure reactances. At the crossover frequency, inductors should have a  $Q$  of 20 or better to preserve their attenuation characteristics. Since  $Q = 2\pi fL/R_L$ , doubling the crossover frequency doubles the " $Q$ " of the coil. Also air-core coils must be used because saturation of an iron core changes the inductance with variations in coil current. The resistance due to dielectric losses in condensers can be neglected, but it should be kept in mind that only paper and oil-filled condensers can be used. The electrolytic types are not suitable.

The attenuation curves of Fig. 3 show that for every two elements we get 6 db/octave attenuation. The cost then varies directly as the attenuation de-

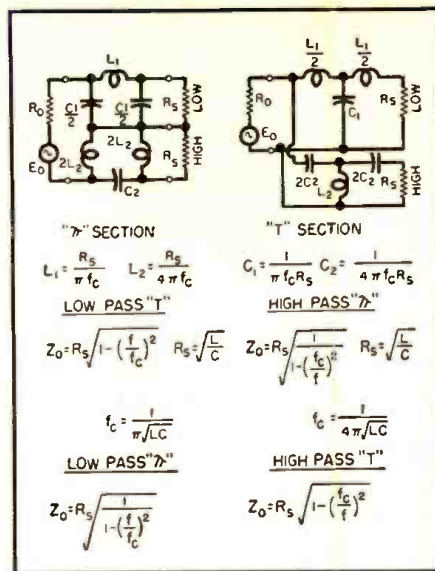

Fig. 2. "Pi" and "T" filter networks.

sired. The constant resistance networks have the advantage of reflecting the speaker resistance to the amplifier at all frequencies. In most cases though, the impedance of the speaker varies with frequency. This is especially true in the low-frequency unit where impedance measurements show an increase of two to three times the normal value, around 100 cps.

The greater attenuation of a "pi" or "T" filter has the disadvantage of an impedance mismatch in the crossover frequency region. In actual circuits this mismatch does not seem to affect the listening quality.

The selection of one of the three basic networks depends upon your desire for quality and your pocketbook.

### BIBLIOGRAPHY

- Brings, G. A.: "Loud Speakers," Yorkshire, Wharfedale Wireless, 1948.
- Hillard, John K.: "Loud Speaker Dividing Networks," Electronics, January 1941.
- Jackson, L. C.: "Wave Filters," Third Edition, London, Methuen & Company, Ltd., 1950.
- Ryder, John D.: "Networks, Lines, and Fields," Prentice-Hall, Inc. 1949.

Fig. 3. Attenuation curves for quarter-, half-, and filter-sections.

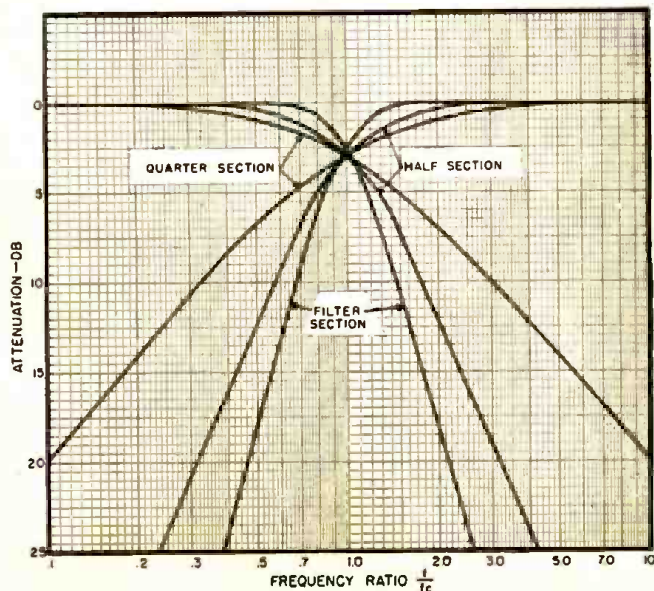
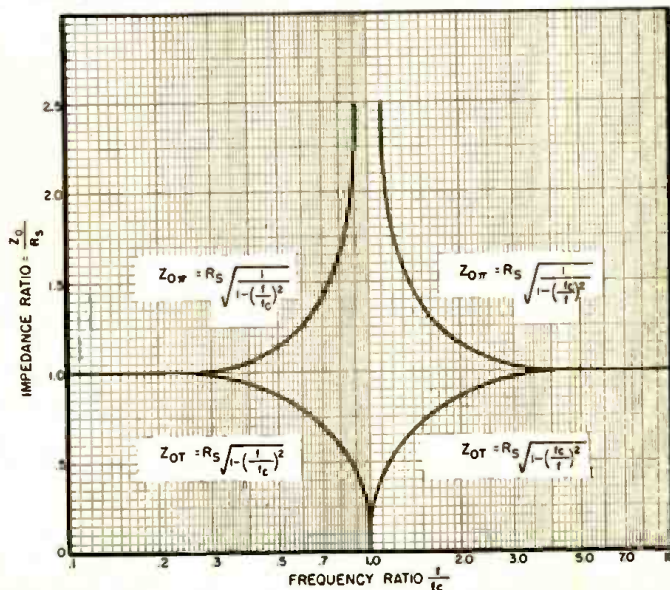

Fig. 4. Variation of characteristic impedance of "pi" and "T" nets.





# TV INTERFERENCE SIGNALS

By

**ROBERT B. GARY**

*A summary of possible TV interference sources and how to eliminate causes.*

**I**NTERFERENCE signals may enter the TV receiver through one or several of the following points: antenna, lead-in, i.f. section, 2nd detector, video amplifier, or a.c. line. The frequency and strength of the interference will determine, to a great extent, where it appears. Signals much higher than the i.f. frequency will usually enter through the r.f. and antenna section while broadcast radio interference is likely to be picked up in the 2nd detector and video amplifier.

The measures taken to eliminate any particular interference will depend on where the signal enters. If interference comes at several points, several different steps are required. Basically the interference is removed either by shielding or blocking it with a resonant circuit. Shielding is necessary where certain parts act as antennas, sometimes the entire TV chassis. Copper screening is a very effective shield, provided it is properly grounded and traps are used on all leads going through the shield.

The a.c. filters for TV sets are standard items and are quite effective if located close to the TV chassis. Filters for the antenna terminals come in a great variety of types and their specifications depend on the type of interference. Most widely used are high-pass filters which cut out all signals below 54 mc. Special FM interference filters and other narrow-band (Continued on page 88)

Fig. 1. Design data for constructing a high-pass 300-ohm filter and a 300-ohm tuned stub as used in a narrow-band wave trap.

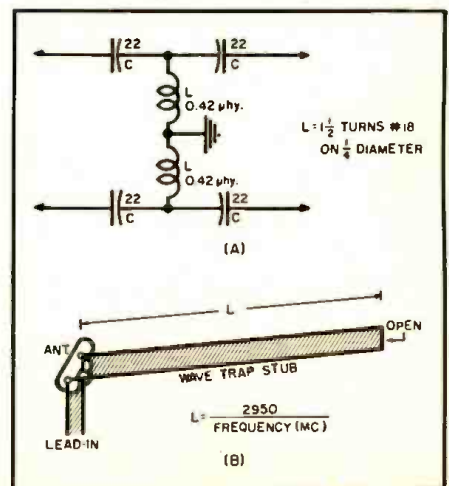

FROM (mc.)	TO (mc.)	SERVICE	HARMONIC	ENTERS AT	REMEDY
.535	1.605	BC	—	2nd det., video, a.c.	Shielding, line filter
1.605	1.8	Aircraft, police	—	2nd det., video, a.c.	Shielding, line filter
1.8	2	Amateur, loran	—	2nd det., video, a.c.	Shielding, line filter
2.065	2.105	Maritime	10	I.F.	High-pass filter, shielding
3.2	3.4	Short-wave	7-8	I.F. 2nd det., video, a.c.	High-pass filter Shielding, line filter
3.5	4	Amateur	6-7	I.F. 2nd det., video, a.c.	High-pass filter Shielding, line filter
4.75	4.85	Short-wave	5	I.F.	High-pass filter, i.f. shields
7	7.3	Amateur	3	I.F., antenna	High-pass filter, i.f. shields
11	11.975	Short-wave	2	I.F., antenna	High-pass filter, i.f. shields
14	14.35	Amateur	3 4	I.F., 41 mc., antenna Antenna, Channel 2	High-pass filter, i.f. shields Modify antenna and lead-in
15.1	15.45	Short-wave	3	I.F., 41 mc., antenna	High-pass filter, i.f. shields
17.7	17.9	Short-wave	3	Antenna, Channel 2	Modify antenna and lead-in
21	21.45	Amateur	—	I.F., antenna, a.c.	High-pass filter, shielding, line filter
21.45	21.75	Short-wave	—	I.F., antenna	High-pass filter, i.f. shields
21.85	22	Aircraft	—	Antenna	High-pass filter
22	22.72	Maritime	—	I.F. (rarely), antenna	High-pass filter
23.2	23.35	Aircraft	—	Antenna	High-pass filter
25.6	26.1	Short-wave	—	I.F., antenna	High-pass filter, i.f. shields
27.185	27.455	Industrial, medical	2 —	Antenna, Channel 2 I.F., antenna, a.c.	Modify antenna High-pass filter, shielding, line filter
28	29.7	Amateur	2	Antenna, Channel 2	Modify antenna and lead-in
29.7	42	Gov't, fire, petroleum, etc.	2 —	Antenna, Channels 2-6 I.F., 41 mc.	Modify antenna and lead-in High-pass filter, shielding
42	44	Police, highway	—	I.F., 41 mc., antenna, a.c.	High-pass filter, shielding, line filter
44	50	Short-wave	—	I.F., 41 mc., antenna, a.c.	High-pass filter, shielding, line filter
54	72	TV	Osc. radiation	Antenna	Modify antenna and lead-in, re-align and shield offender
76	88	TV	Osc. radiation	Antenna	Modify antenna and lead-in, re-align and shield offender
88	108	FM	2 Image	Antenna, Channels 7-13 Antenna, Channels 2-3	Modify antenna and lead-in Wave trap
108	132	Aircraft	Image	Antenna, Channels 3-6	Wave trap
148	174	Gov't, railroad, police	Image 3	Antenna, Channels 7-13* Antenna, Channels 14-22	Wave trap Modify antenna and lead-in
174	216	TV	Osc. radiation	Antenna	Modify antenna and lead-in, re-align and shield offender
216	220	Gov't	3	Antenna, Channels 43-46	Modify antenna and lead-in
220	225	Amateur	Image 3	Antenna, Channel 7 Antenna, Channels 46-49	Wave trap Modify antenna and lead-in
225	470	Aircraft, military	Image 2	Antenna, Channels 14-28* Antenna, Channels 14-83	Modify antenna and lead-in
470	890	U.h.f. TV	Osc. radiation	Antenna, Channels 14-83	Modify antenna and lead-in, re-align and shield offender

\*Where oscillator operates below incoming signal.





The r.f. section of the author's 250-watt transmitter was described in *RADIO & TELEVISION NEWS* for June, 1952. The modulator occupies the center section of the rack. The speech amplifier is below.

# 125-WATT AUDIO SYSTEM WITH CLIPPING

By **ROBERT F. LEWIS, W8MQU**

*More effective use of the phone transmitter, with higher average modulation percentage is had in this audio unit for the author's 250-watt transmitter, described earlier.*

*Multi-impedance output permits use with any transmitter.*

**A** SHORT paragraph at the end of the article entitled "A 250-Watt TVI-Proof Transmitter" which appeared in the June, 1952, issue of *RADIO & TELEVISION NEWS*, made mention of the speech amplifier and modulator which are being used with the rig. Since that time a number of readers have sought additional information on the audio system; therefore it was decided to publish a complete description.

The feature which seemed to command the greatest interest was the speech amplifier, incorporating a low-level clipper-filter system. In view of this fact, it would not be amiss to give brief consideration to the theory and reasons for the use of a clipper.

For years amateurs have tried various methods to increase the effectiveness of their phone transmitters. They have experimented with many systems, such as supermodulation, volume compression, extended positive peak modulation, clipping, and others. Basically the aim of each system is to get as much audio power as possible into the carrier and yet remain within the limits of 100 per-cent modulation.

Probably one of the simplest and most economical methods of increasing average audio power is low-level clipping. The very nature of the complicated speech waveform makes the use of clipping practical. Unlike a sine wave, which is of uniform amplitude, the speech wave consists of perhaps 75 per-cent low-amplitude energy with occasional peaks to several times the average value. Observation of speech on an oscilloscope

will quickly bear out this fact. It is unlawful to exceed 100 per-cent amplitude modulation of a transmitter carrier; therefore it is obvious that if all peaks are kept within those limits the average audio level will be low.

The main objection to overmodulation, especially in the negative direction, is that audio harmonic generation becomes excessive, resulting in adjacent-channel interference, commonly known as "splatter." Clipping is actually taking place when overmodulation occurs, but it is impossible to remove the high harmonic content at this stage of the game. However, if clipping is moved back into the audio system, then it becomes a simple matter to filter out the objectionable audio harmonics. This is done by passing the clipped signal through a low-pass filter having a cut-off frequency of around 3500 cycles.

Clipping and filtering can be accomplished in the output of the modulator itself. However, large amounts of reserve power are required to do the job at this point. It is much more economical to insert clipping in the speech amplifier, where only additional voltage amplification is required. As much as 20 db of clipping can be used, but the character of one's voice is lost at such drastic levels. A figure of 10 db or less, however, does not noticeably impair the quality, but it does give added punch to the signal.

There are several considerations to be observed in the design of a clipper amplifier. Inasmuch as the clipper-filter system tends to make the signal "bassy," it is necessary to compensate for this by reducing the low-frequency

response in that portion of the amplifier preceding the clipper. In order to keep the phase distortion from nullifying the gain obtained by clipping, all stages following the clipper-filter should have very good bass response. Additional amplification is also required to compensate for the loss in signal level which results from clipping. It then follows that the plate supply should be well filtered to prevent hum due to the high gain of the amplifier.

Going from the theoretical to the practical design of a transmitter audio system, we first inspect the circuit of the speech amplifier to be described (see Fig. 1). The tube line-up consists of 6SJ7 and 6J5 voltage amplifiers, 6SN7 clipper stage, half of a 6SN7 functioning as a voltage amplifier, and a pair of 6L6's as power amplifiers. In the original design, both sections of the 6SN7 voltage amplifier were utilized. This system provided too much gain, however, and one section of the tube was eliminated from the circuit. A single 6J5 in this position would serve equally well.

The input to the clipper is controlled by a potentiometer,  $R_5$ , while the output level may be fixed by  $R_{13}$ . By adjusting  $R_5$ , the degree of clipping may be set. Transmitter modulation percentage is determined by the setting of  $R_{13}$ . If the operator desires to eliminate the clipper from the circuit he can do so by throwing  $S_2$  so as to bypass the 6SN7 clipper and its associated filter system, the latter consisting of  $CH_1$ ,  $C_{11}$ , and  $C_{12}$  in a low-pass circuit having a cut-off frequency of about 3500 cycles.



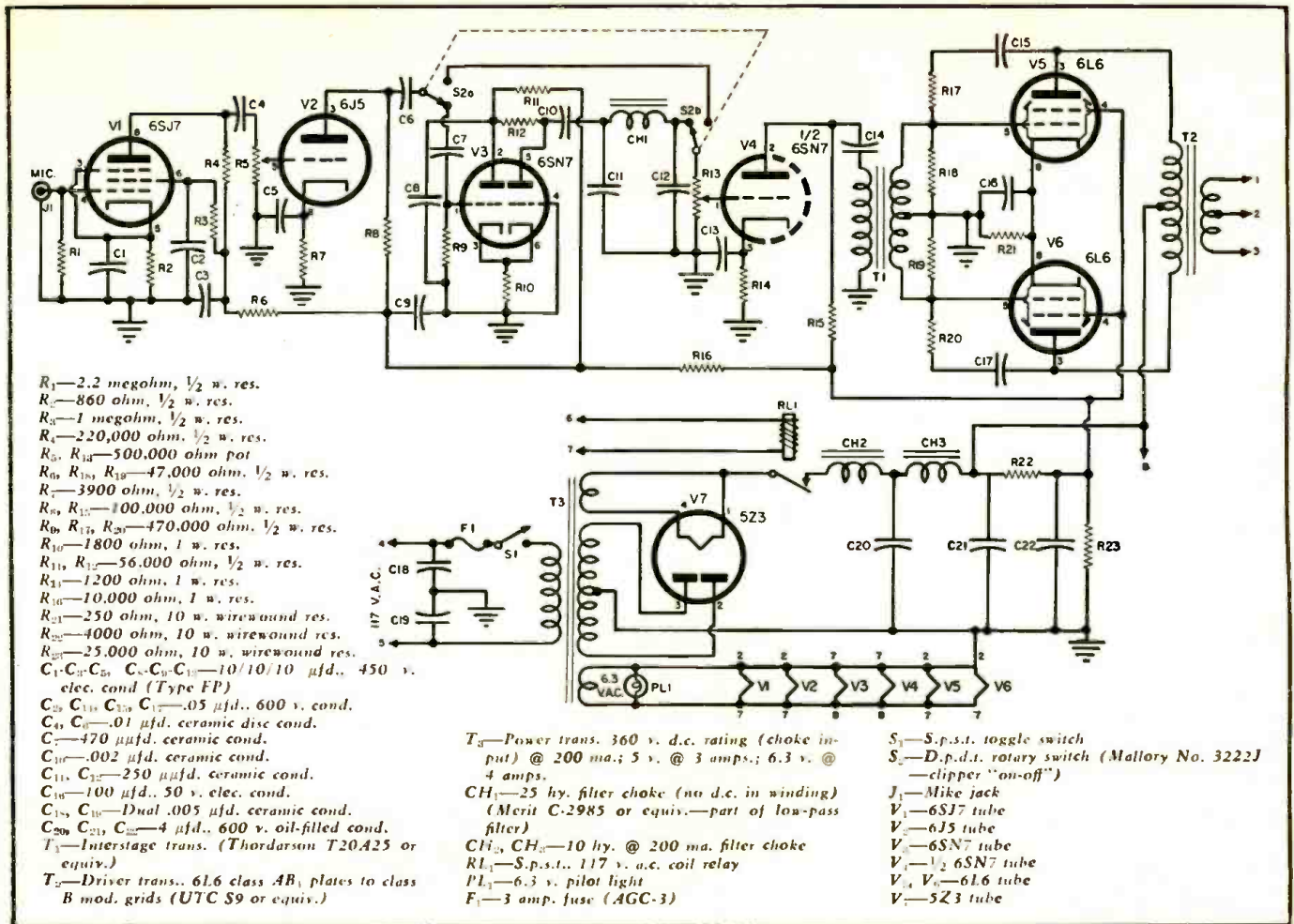

Fig. 1. Schematic of the speech clipper-amplifier which drives the 811 modulator section (Fig. 2). Switch S<sub>1</sub> disconnects the clipper-filter section for "straight" operation. A 6J5 may be used for V<sub>2</sub>. Terminal numbers refer to barrier strip screws.

It will be noted that inverse feedback is utilized in the 6L6 stage. This is a "must" when using the 6L6, or any other tube having high plate resistance, as a driver for class B modulators. By using inverse feedback, the performance of the 6L6 can equal that of a triode, such as the 2A3.

As was mentioned earlier, the low-frequency response of stages preceding the clipper should be poor, to compensate for loss of highs in the clipper-filter system. This is accomplished by the use of a small coupling condenser, 470  $\mu$ fd., at C<sub>7</sub>. Following the clipper, however, the bass response is aided by the use of a large coupling condenser, .05  $\mu$ fd., at C<sub>11</sub>, and a large 6L6 cathode bypass condenser, plus inverse feedback.

For circuit details of the modulator which is used with the 250-watt transmitter, refer to Fig. 2. A pair of 811's is used as a class B amplifier, operating at a plate voltage of about 900 and with zero bias voltage on the grids. The 900-volt plate supply is an integral part of the modulator system and supplies only the 811's. Rectifying is done by a pair of Taylor 866 Jr.'s, while the filter consists of a single choke and two 2- $\mu$ fd. oil-filled condensers. This seemingly small amount of filtering is adequate for a push-pull class B modulator stage, as the

static current drawn by the 811's is low, and any small amount of ripple in the plate current is phased out in the modulation transformer primary winding.

Audio power from the speech amplifier output transformer is applied to terminals 7 and 9 of the modulator, while terminal No. 8 serves as a grid return and is connected to the tap of the driver transformer secondary. Terminals 3 and 4 supply the modulator power supply with 117 v., 60-cycle current. Operation of S<sub>1</sub> applies voltage to the 811 and rectifier filaments. Plate voltage is not available until S<sub>2</sub> and RL<sub>1</sub> are both closed. RL<sub>1</sub> being actuated by a remotely operated send-receive switch.

A special feature of the modulator stage is the use of a relay, RL<sub>1</sub>, to short out the modulation transformer secondary when keying the r.f. section of the transmitter. If this precaution were not taken, it is conceivable that surges of final amplifier plate current could develop voltages in the modulation transformer which could break down its insulation. The relay used for this purpose is a Guardian Model R-100-B, having normally-closed contacts, a 117-volt a.c. coil, and high-voltage insulation. The coil is connected across the primary winding of the high-voltage transformer, T<sub>1</sub>.

When the modulator is in operation, RL<sub>1</sub> is actuated, opening the contacts and placing the secondary of the modulation transformer in the circuit. If the operator desires to go to c.w. it is only necessary to throw S<sub>2</sub> to the "off" position, simultaneously removing modulator plate voltage and shorting the modulation transformer secondary. All filaments are thus left on for instant return to phone operation.

The modulation transformer in this case is capable of handling 125 watts of audio power and will match any r.f. load to any class B modulator plates. Terminations are made in the writer's rig to match a load of 5000 ohms (813 final) to an 811 plate-to-plate load of 6000 ohms. The r.f. load is calculated by dividing the final plate voltage (1250) by the total 813 plate and screen current (about 250 ma.).

For mechanical details of the audio system refer to the top view of the speech amplifier. The tube line-up, starting at the top center of the photograph, is as follows: 6SJ7, 6J5 voltage amplifiers, 6SN7 clipper, 6SN7 voltage amplifier (in back of clipper tube), and 6L6 driver tubes. Directly behind the 6SJ7 stage is a type FP can containing C<sub>1</sub>, C<sub>2</sub>, and C<sub>3</sub>, while the can behind the 6J5 stage houses C<sub>4</sub>, C<sub>5</sub>,



and  $C_{13}$ . Between the 6SN7 and 6L6 tubes is the interstage transformer,  $T_1$ . The driver transformer is shown next to the 6L6 stage.

Power supply components are lined up across the rear of the chassis, with the power transformer at the lower center of the photograph, followed by the 5Z3 rectifier and two filter chokes. Directly in front of the filter chokes are the three filter condensers,  $C_{20}$ ,  $C_{21}$ , and  $C_{22}$ , which are all 4  $\mu$ f., 600 v., oil-filled units. Located on the rear of the chassis are terminals for audio output and supply voltage, plus a fuse holder. Audio output is taken from terminals 1, 2, and 3, while a.c. primary connections are made to terminals 4 and 5. In the writer's model, a remote-control relay is used, and 117 volts a.c. is supplied to the relay coil through terminals Nos. 6 and 7. Terminal 8 provides a source of approximately 360 volts which is used to power a 6L6 amplifier in the radio-frequency section of the rig.

The under-chassis view shows the location of small components and the routing of the wiring harness. The audio choke,  $CH_1$  (Fig. 2), which forms a part of the low-pass filter, can be seen near the center of the chassis.

Before inspecting the front panel view, let us observe the location of parts on the modulator chassis. Located at the approximate center are the 811 modulator tubes, while directly to the left of the tubes is the modulation transformer. At the rear of the chassis, from the right hand side of the photograph, are the high-voltage stage transformer,  $T_1$ , rectifier tubes, filter choke,  $CH_1$ , and the two filter condensers,  $C_1$  and  $C_2$ .

At the rear of the modulator chassis are terminals for output power and supply voltages. High-voltage feed-through insulators are used for the

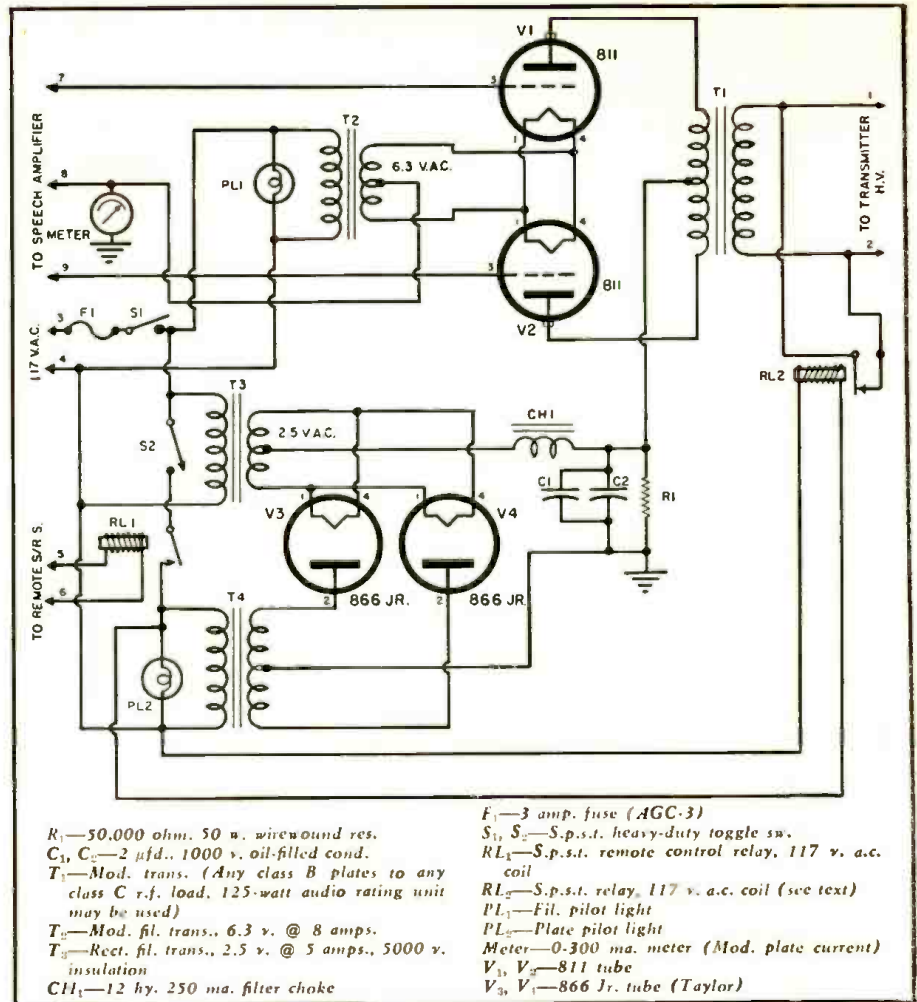

Fig. 2. Schematic of the modulator used in the author's 250-watt transmitter. Any modulator with similar drive requirements could be used instead. This one has some added operating conveniences and safety provisions, as discussed in the text. As it has a multi-impedance output transformer it may be used with other transmitters.

audio output terminals, No's. 1 and 2. Additional terminations. Primary supply (Continued on page 128)

A top-rear view of the modulator. Filament transformers are under the chassis as are the relays and  $R_1$ . The 811 sockets are mounted below chassis on spacers to allow top clearance. Ceramic feedthroughs at left are for audio output (see text).



Top view of the speech amplifier-clipper. Placement of parts is straightforward, the layout almost following the circuit diagram. The clipper-circuit tube is small glass tube near the front panel, in center. The chassis is heavy aluminum.





# FERRI-LOOPSTICK CRYSTAL RECEIVER

By JOSEPH D. AMOROSE ● ● ● ● ●

*Details on a selective, high-sensitivity crystal receiver employing the recently developed ferro-magnetic coil units.*

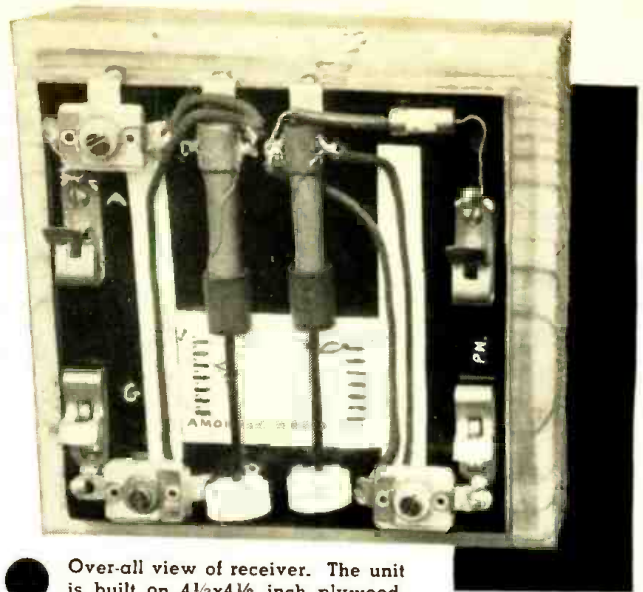

Over-all view of receiver. The unit is built on 4½x4½ inch plywood.

**B**ELIEVE it or not—over two million crystal radios are still in use,” runs a recently published report of a radio owners’ survey.

Revealed, too, were numerous good reasons for owning such a receiver. Many kept one as an “emergency” receiver to maintain constant contact with the radio station’s vital source of information during power failures, storms, disasters, etc. Others had them for the children to listen to—“it keeps them quiet after they go to bed.” Still others like crystal radios because they could listen without disturbing others in the room. A considerable number revealed they made a hobby of radio: they enjoyed trying out new arrangements and hookups. That there are many good reasons for owning such a receiver should be established beyond question.

Interest in crystal radio rose sharply when the war-developed germanium 1N34 diode became available to the public. This fixed-type crystal proved a real boon to the weary members of the “whisker-wiggling” fraternity. No longer was it necessary to search for “loud” spots—the 1N34 stayed “hot.” It was stable, needed no re-adjusting, and it lasted for long periods. Best of all, it was relatively inexpensive. This put it within reach of many.

Yet, crystal receivers always had one serious drawback: selectivity was poor. Unless complicated circuits were used, tuning was “broad as a barn.” When good selectivity was achieved, it invariably came at the expense of volume. This reduced much of the pleasure of listening.

Now, happily, a recent radio advance has come to the aid of the serious crystal set enthusiast, who all these years has been looking for real improvement. Referred to is the new Hi-“Q”, *Ferri-Loopstick* coil. Although intended primarily as an efficient replacement for the old form of loop antenna, these inductances are a “natural” for use in crystal receivers.

They can be used in any part of a crystal circuit where the conventional type coils were formerly employed. Their high “Q” feature permits a degree of selectivity that was hitherto undreamed of. Tuning is sharper, sensitivity is higher. Employed in a standard crystal circuit, these coils, plus a few inexpensive components, can produce a degree of volume and sharpness of tuning that is beautiful to behold. Stations tune in with a sweet, selective “swish.” No hash, no jumble of sounds, no annoying crosstalk is experienced. The tone is crisp, sharp, and clear. It leaves nothing to be desired.

For the hobbyist and constructor interested in trying out this new development, he will find the receiver described well worth his time. Parts required are few and inexpensive. A boy can put them together in 40 minutes. Essential components consist of three trimmers, two *Ferri-Loopsticks*, 1N34 diode, and four *Fahnestock* clips, all to be mounted on a 4½ inch square piece of ¾ inch thick plywood.

A glance at the circuit will show it is a straightforward, two circuit hookup, familiar to most old-timers. The coils should be mounted first. Best coupling is secured by spacing the coil brackets exactly ½ inch apart. (Closer coupling will give higher volume at the expense of selectivity, however). The enameled wire that comes attached to the coil can be used as one lead; another lead is soldered to the

other side of the coil. A match stem should be cemented to each coil’s core to facilitate sliding of the core. Two toothpaste tube caps can be attached to the match stems to permit easier tuning. These two cores do all of the tuning. Leads should be kept as short as possible. Solder all connections carefully. A 100 ft. antenna, erected as high as possible, should be hooked to “antenna,” and a short ground to the nearest cold-water pipe should be attached to “ground.”

After the set is completed, pull out both coil cores so that they are nearly all the way out—this position corresponds to the high-frequency end of the radio dial. Select a station transmitting on about 1500 kc. and adjust all three trimmers for maximum volume, moving the cores in and out slightly, until an optimum setting is achieved. This is the only adjustment required. Thereafter, all remaining stations up to 550 kc. are tuned in by sliding both cores inward, at the same time. If the trimmer adjustments have been correctly made, both circuits will track properly, and the cores will be equidistant in the coils on each station’s setting.

A chart should be placed under the match stems for easy logging. For a pointer, wind a piece of black enameled wire around a matchstick, for example. With a log, stations can be tuned in very quickly; settings won’t vary.

**NOTE:** Tuning of the cores is very sharp and must be done very slowly, otherwise the station will be passed by unheard. Most of the stations in the BC band can be tuned in with the cores traveling less than one inch. From this, the very high degree of selectivity becomes evident. Mounting the set on a 5-inch square wooden block will add weight to the set and permit much easier and more accurate tuning.

In Richmond, Va., this set receives  
(Continued on page 88)

Circuit diagram of crystal receiver. Only six components are required in construction.

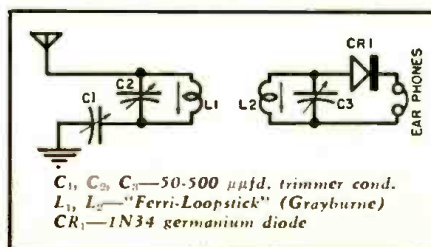





# EW

## SPEAKER ENCLOSURE

Over-all view of the EW speaker cabinet.

By

**JAC HOLZMAN**

G & H Wood Products Co. (Cabinart)

**T**HE author's need for a "portable" speaker enclosure for "on location" recording work dictated the design of this EW speaker enclosure to be described herein. It is now being manufactured commercially by G & H Wood Products Co. (Cabinart), of 75 N. 11th St., Brooklyn 11, N. Y.

Three criteria were set up covering the design of this enclosure: 1. small size, 2. smooth response, and 3. high efficiency. In order to increase the length of the air column in a bass-reflex type cabinet, it was decided to insert a length of board (A) at an angle of 20 degrees to normal. This increased the air column by a half without increasing the over-all dimensions of the enclosure.

This idea is not new but the length of (A) creates two matched chambers within the enclosure and aids in boosting the low-end response of bass-shy 8-inch speakers.

Sound reflects from hard surfaces at an angle of 90 degrees. Most standard reflex enclosures are lined with cotton or Celotex to absorb high-frequency radiation that ordinarily reflects uncontrolled inside the speaker cabinet. Fins (B) and (C) block the right angles at the corners, thereby eliminating the need for sound damping substances. In this way the sound efficiency is increased as the entire back wave can be used.

Tuning the port was the next consideration. The standard formula for determining port size proved useless since lengthening the air column had, in effect, created a "volume" that could not be conveniently measured with a ruler once this baffle had been constructed. An evening spent with an a.f. generator and the v.t.v.m. solved this problem.

(Continued on page 86)

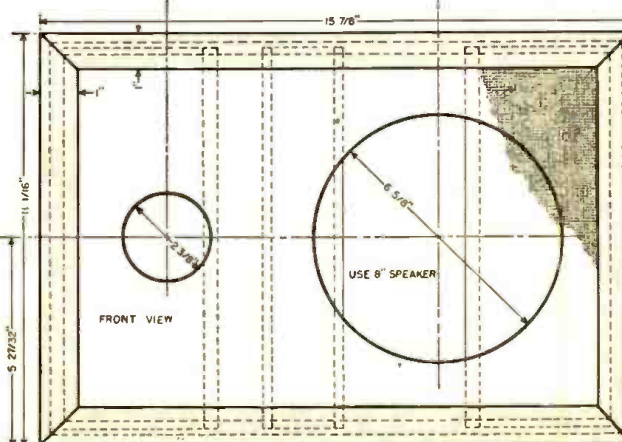
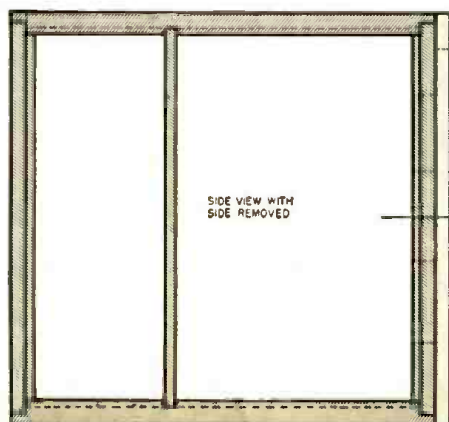
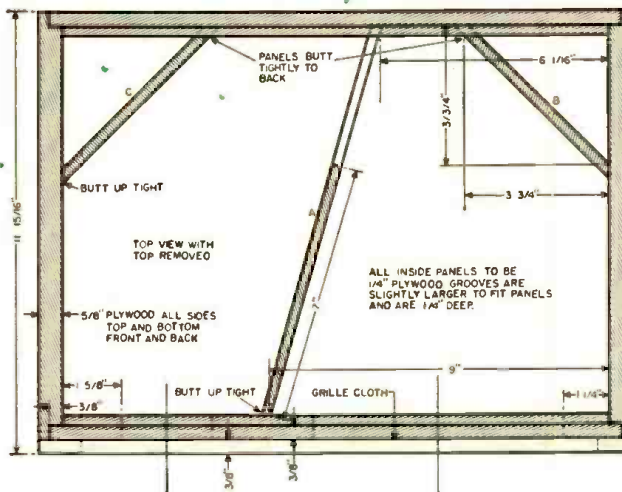
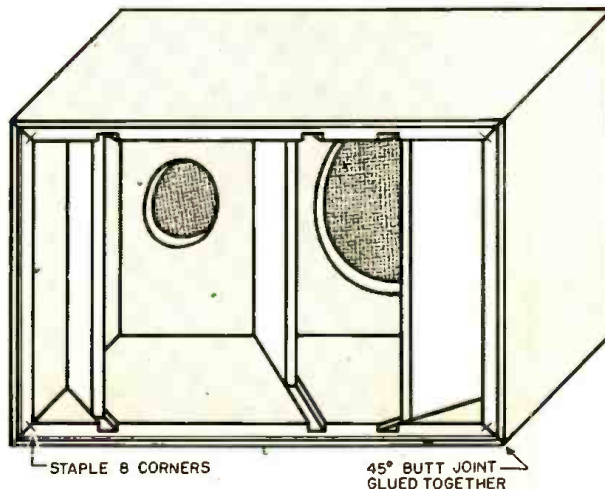



# TRANSISTOR PHYSICS

# Simplified

By **S. P. GENTILE**

Sig. Corps Pub. Agency  
Fort Monmouth, N. J.

By

& **P. J. BAROTTA**

Dir., Hudson Tech. Inst.  
Union City, N. J.

**T**HE transistor is at present emerging from the laboratory and being applied as a practical engineering device for amplification and generation of electric signals, and for a multitude of other applications in which the vacuum tube normally was used. It is to be expected at this stage of development of the transistor, that very little material which is understood easily by the average engineer and technician is available on its theory of operation. A great deal of material is available to the physicist and the advanced engineer (see bibliography), which does not serve the need of the average technician and engineer. The writers have sensed this need, and have prepared these articles specifically for those who wish a non-mathematical presentation of the transistor.

The following paragraphs discuss first the theory of operation of the junction transistors and then the theory of operation of point-contact transistors. This is done deliberately, because the theory of the junction transistor is more easily understood, and an understanding of its operation facilitates the presentation by the writers, and comprehension by the reader, of the theory of the point-contact transistor.

## Atomic Structures

The basic building blocks of matter are *electrons*, *protons*, and *neutrons*. Electrons possess a negative charge. Protons possess an equivalent positive charge and are 1835 times heavier than the electron. The neutron possesses no charge and has the same mass as the proton. A specific configuration of electrons, protons, and neutrons produce the next largest building block which is the *atom*. The atom consists of a nucleus of protons and neutrons around which the lighter electrons rotate. Since there are as many electrons (negative charge) outside the nucleus as there are protons (positive charge) inside the nucleus, the atom is electrically neutral. The atom of one chemical element differs

from the atom of another chemical element only in the number of electrons, neutrons, and protons that they possess. For transistor physics the atoms of only a few elements of the more than ninety known elements are of interest. These are germanium, silicon, antimony, arsenic, aluminum, and gallium. A more detailed study of atoms than that presented in the previous paragraphs, indicates that a large portion of the electrons around the nucleus are tightly bound to the nucleus and do not enter into chemical reactions or transistor physics. The tightly bound electrons and the nucleus form an inert *core* possessing a net positive charge around which the remainder of the electrons rotate. Transistor physics is concerned with the net charge on the core and the electrons surrounding the nucleus. For that reason the germanium atom, which has 32 protons in its nucleus and 28 tightly bound electrons around it, is represented by a circle containing a net charge of +4 (the core) and four electrons (the dashes) as indicated in Fig. 1A. The net charge on the core of the silicon atom is also four, and is therefore represented in the same manner as germanium. Sili-

Fig. 1. Atomic structures. (A) germanium or silicon. (B) antimony or arsenic (donors), and (C) aluminum or gallium (acceptors).

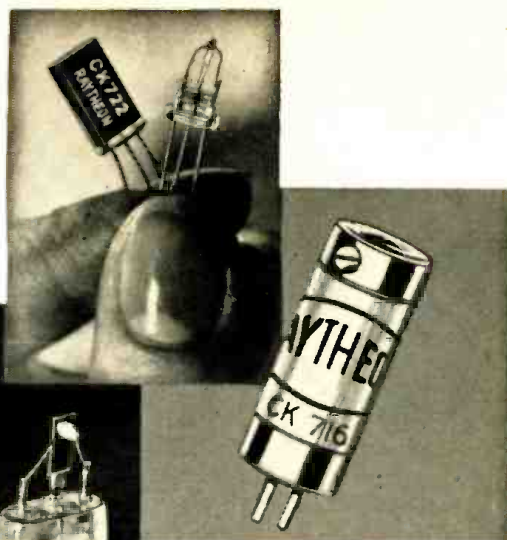
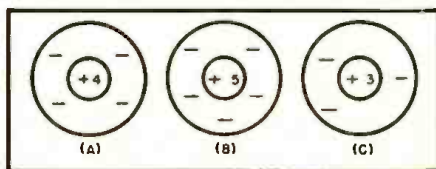

Three typical junction transistors. (Left) RCA's developmental unit before and after embedding in plastic. (Center) Raytheon's CK722. (Right) Raytheon's CK716 point-contact transistor.

## Part I. An easy-to-understand explanation of how and why transistors operate, their characteristics, and limitations.

con is mentioned here only to indicate that transistors can be made of silicon as well as germanium. However, the great bulk of experimental investigation has centered on the latter, and this discussion is concerned chiefly with germanium crystals. Pure germanium is of no use for producing transistors. The phenomena of rectification and amplification of current by germanium is made possible because of the presence of impurities in the crystals.

One type of impurity of importance in the germanium crystals is known as a *donor*. The reason for the choice of this name will become apparent. Antimony or arsenic becomes a donor when it joins the crystal structure of germanium. The net charge on the core of the antimony or arsenic atom is +5 and five electrons surround the core. This is shown in Fig. 1B.

Another type of impurity of importance in the germanium atom is known as an *acceptor*. The reason for the choice of this name also will become apparent as we progress through this article. Aluminum or gallium becomes an acceptor when it joins the crystal structure of germanium. The net charge on the core of aluminum or gallium is +3 and three electrons surround the core. This is shown in Fig. 1C.

## Crystal Structures

A schematic representation of a pure germanium crystal is shown in Fig. 2A. Note that each atom has four neighbors which are equidistant from each other. Between the cores of the atoms and each of their neighbors are



two electrons (shaded area). These form *electron-pair bonds* which come into existence when two or more atoms approach each other. Electrons are in constant motion around the core, and electron-pair bonds are formed when the movements of two electrons, one from each atom, are co-ordinated. This co-ordination attracts the cores towards each other. However, the positive charges on the cores cause them to repel each other until a perfect balance of attraction and repulsion is obtained. The latter condition is known as the condition of equilibrium.

Pure germanium crystals, as described, have no application in the field of transistors. In this form they are good insulators, having a high dielectric constant of 16. The presence of a donor in a germanium crystal is of great importance in transistor physics. When a donor atom (antimony or arsenic) joins the crystal structure of germanium, it must lose one of its electrons which surround the core due to the fact that only four electrons can form electron-pair bonds with the electrons of adjacent germanium atoms. The one electron which cannot form an electron-pair bond becomes an *excess electron* which is free to move through the wide spaces between the cores, as shown in Fig. 2B. As a matter of fact, the excess electron can move through the crystal as though it were in a vacuum.

If a battery were placed across the crystal, the electron would accelerate towards the positive terminal of the battery and enter the positive terminal.

Simultaneously an electron would emerge from the negative terminal to enter the crystal. Thus a continuous conduction of electrons would be maintained through the crystal. The cores of the donor and the germanium remain stationary at all times.

Germanium crystals which contain donor impurities are known as *n*-type germanium. It is obvious that the *n* stems from the fact that conduction through the crystal is mainly a conduction of *negative* charges, namely excess electrons from the donor atoms. At this point in the discussion, it is

felt that a definition of the term *donor* can be fully appreciated: a donor is an element, which, when it joins the crystal structure of germanium, gives off an excess electron.

The presence of an acceptor in germanium crystals is also of great importance in transistor physics. When an acceptor atom (aluminum or gallium) joins the crystal structure of germanium, it must do so by accepting an electron from one of its neighbors in order to complete four electron-pair bonds with its neighbors. In accepting an electron from one of its neighbors, it leaves a *hole* in another electron-pair bond, as shown in Fig. 2C. Obviously the hole will have the equivalent charge of an electron, but it will be positive.

Experiment has shown that the hole is free to move throughout the structure. Conduction of current can take place through a germanium crystal containing an acceptor just as readily as it can through a germanium crystal containing a donor. However, the conduction mechanism is different. If a battery were placed across the crystal, a hole, as shown in Fig. 2C, would accelerate toward the negative terminal. An electron from this terminal would enter the crystal and fill the hole. Simultaneously, an electron from an electron-pair bond in the crystal and near the positive terminal of the battery would leave the crystal and enter the battery. In so doing, a hole is created in the crystal, and the action is repeated. Continuous current flow through the crystal thus can be maintained.

Germanium crystals which contain acceptor impurities are known as *p*-type germanium. It is obvious that the *p* stems from the fact that conduction through the crystal is mainly a conduction of *positive* charges (holes). At this point, then, a definition of *holes* and *acceptors* is apropos. A *hole* is an incomplete group of electrons whose general properties approximate those of an electron, but differs from an electron in that it bears a positive charge. An *acceptor* is an element which, when it joins the crystal structure of germanium, produces a hole.

Fig. 2. (A) Representation of electron-paired bonds in germanium. (B) Presence of a donor in a germanium crystal. (C) Presence of an acceptor in a germanium crystal. Refer to text for an explanation of these phenomena.

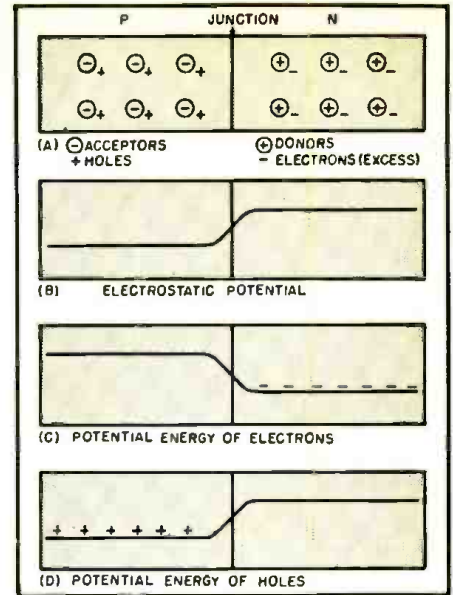
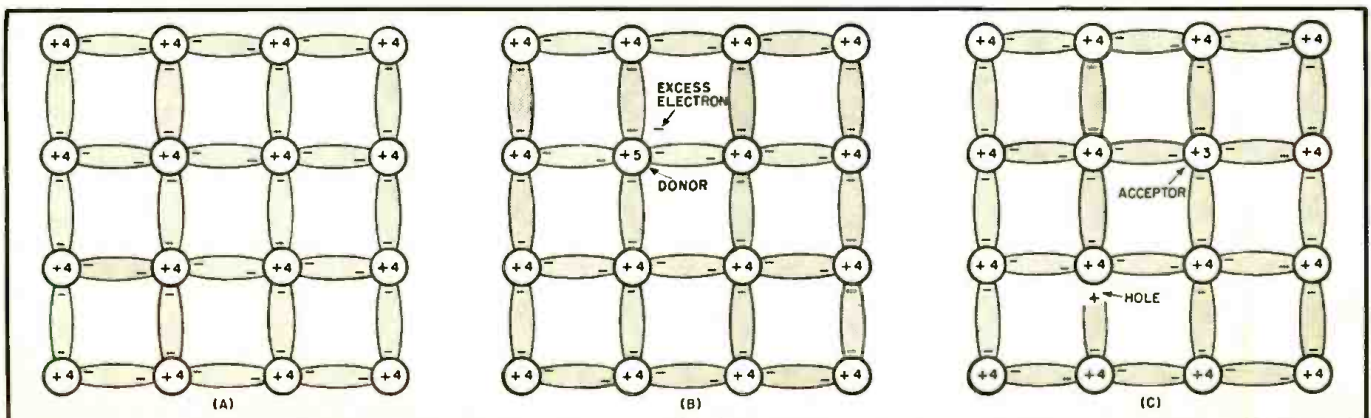

Fig. 3. The "p-n" junction under equilibrium conditions. See text for details.

### P-N Junctions

The radio-television technician and engineer have been aware of the fact that germanium diodes have been used for rectification for a very long time. No doubt, they have serviced or designed equipment using these diodes as second detectors and a.v.c. (automatic volume control) circuits; but they probably never knew exactly what conduction mechanism was involved to cause the rectification. In this section, the writers will attempt to explain how rectification takes place in a germanium diode, not because this article is interested in germanium diodes as such, but because the theory involved is essential to an understanding of current multiplication in transistors.

It has been pointed out that pure germanium crystals are good insulators. It has also been mentioned that *p*-type germanium or *n*-type germanium are relatively good conductors, and can conduct current equally well in either direction. Rectification with a germanium crystal (that is, high conductivity in one direction and high resistance in the other direction) oc-



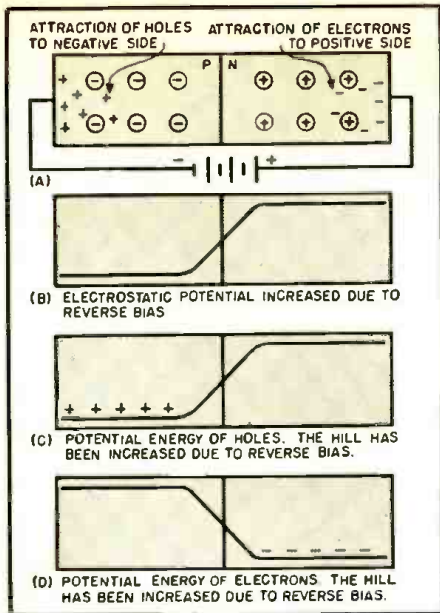
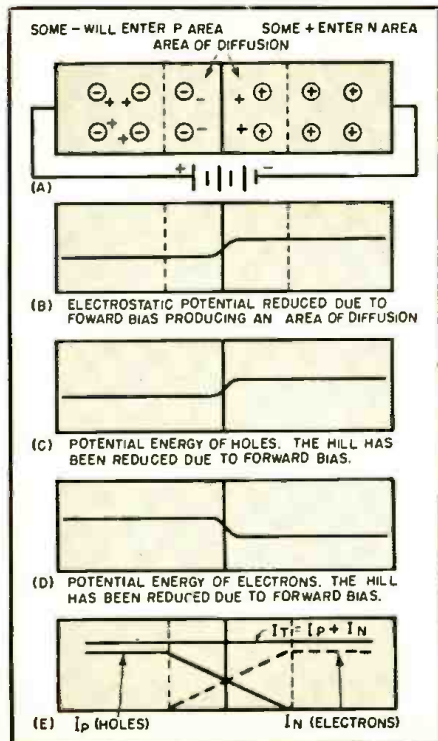

Fig. 4. The "p-n" junction with reverse bias applied under various conditions.

occurs when the p-type germanium and the n-type germanium are placed side by side. The plane at which the two types of germanium meet is called a p-n junction. The phenomenon which occurs at the junctions is of major importance. Fig. 3A illustrates a p-n type junction in a state of equilibrium. The holes concentrate to the left of the p-type germanium and the (excess) electrons concentrate to the right of the n-type germanium. This is caused by the electrostatic potential distribution produced by the acceptor and donor atoms as indicated in Fig. 3B. The electrons remain in the region of highest electrostatic

Fig. 5. The "p-n" junction with forward bias applied. See Fig. 4. shown above.



potential, and the holes remain in the region of lowest electrostatic potential. When the electron is in the region of highest electrostatic potential, its potential energy is at a *minimum*, as shown in Fig. 3C. Since *potential energy* means the ability to do work, and since the electron cannot move to do work after it reaches the point of highest electrostatic potential, it is obvious that it is in a region of low potential energy. It is important to comprehend this statement because transistor physics is explained most readily in conjunction with potential energy diagrams. What has been said of the electron is also true of the hole. When the hole is in a region of lowest electrostatic potential (that is, when the hole is in a region of low negative potential), its potential energy is at a minimum (see Fig. 3D). Holes and electrons will flow into regions of low potential energy only. A low potential energy region for electrons is a high potential energy region for holes, and *vice versa*.

If a battery were connected across a p-n germanium crystal with the polarity indicated as in Fig. 4A, there would be no conduction of current through the crystal. This method of connection, with the positive terminal of the battery to the n-type germanium, and the negative terminal of the battery to the p-type germanium, is known as the *reverse bias* connection. It is obvious that the positive terminal of the battery will attract the electrons and cause them to concentrate still further to the right than under equilibrium conditions. The negative terminal of the battery will attract the holes and cause them to concentrate still further to the left than under equilibrium conditions. As a result, there will be no flow of electrons to the left and no flow of holes to the right. The difference in electrostatic potential between the two types of germanium has been increased as indicated in Fig. 4B. The potential

Fig. 6. An "n-p-n" type junction transistor under conditions of equilibrium.

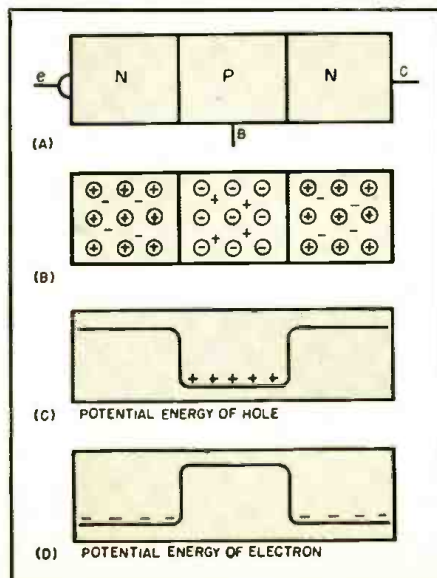

energy hill for the holes has been increased; they will not flow up the steep hill, as shown in Fig. 4C. The same can be said for the potential energy hill of electrons (see Fig. 4D).

If a battery were connected across a p-n germanium crystal with the polarity indicated in Fig. 5A, a current would flow, the magnitude of which depends on the strength of the applied voltage. This method of connection, with the positive terminal of the battery connected to the p-type germanium, and the negative terminal of the battery connected to the n-type germanium, is known as the *forward bias* connection. The positive terminal of the battery repels the holes and causes them to flow towards the n-type germanium. The negative terminal of the battery repels the electrons and causes them to flow towards the p-type germanium. In a small region on either side of the p-n junction, electrons and holes combine. For each hole that combines with an electron from the n-type germanium, an electron from an electron-pair bond in the crystal and near the positive terminal of the battery, leaves the crystal and enters the positive terminal of the battery. Thus, a new hole is created which flows towards the n-type germanium. For each electron that combines with a hole, an electron enters the crystal from the negative terminal of the battery. The current flow in the p-region is substantially a flow of holes, and the current flow in the n-region is substantially a flow of electrons. Fig. 5E shows graphically the currents that flow throughout the crystal. The total current  $I_T$  is constant.  $I_p$  (current by holes) is a solid line, and  $I_n$  (current by electrons) is a dashed line.

Fig. 5B shows that the electrostatic potential between the p-type germanium and the n-type germanium is reduced greatly by the application of a forward bias. Figs. 5C and 5D show that the potential energy hills for holes and electrons are reduced substantially, so that holes can climb the small hill to move into the n-type germanium and electrons can move into the p-type germanium.

By applying the theory just presented, one can understand the phenomenon of rectification in germanium crystals. When the applied voltage produces a forward bias, the crystal acts as a low resistance. When the applied voltage produces a reverse bias, the crystal acts as a very high resistance.

### Junction Transistors

An n-p-n junction transistor is formed by placing a narrow strip of p-type germanium between two relatively long strips of n-type germanium, as shown in Fig. 6A, which is not drawn to scale, to simplify representation. Separate low-resistance contacts are made to each strip. The n-type germanium on the left is called

(Continued on page 100)



# THE MONIMETER

By

LLOYD V. BRODERSON

W6CLV

WHILE monitors and frequency meters are customarily referred to as separate instruments, it is possible to combine the two without sacrificing the merits of either. Herein is described such a unit—the “Monimeter.”

Functioning as a heterodyne frequency meter, it is sufficiently accurate to insure “in-band” operation. Fundamental operation on 3.5 and 7.0 mc. is obtained with a tapped grid coil and a single plate winding. Grid inductance is reduced by the simple expedient of shorting out turns. Unlike harmonic operation, in which the signal strength invariably decreases as the higher frequencies are approached, the “Monimeter’s” signal is of equal intensity on both channels.

As a monitor, operating on these two popular bands, it will enable the transmitting amateur to conform with FCC regulations governing type A-1 transmissions. A veritable “tattle-tale,” it will quickly show up objectionable keying characteristics and undesirable emissions.

Lightweight, compact, and relatively inexpensive, the unit occupies but little space. With normal usage its self-contained dry batteries will be found most economical.

## Circuit

The circuit of Fig. 2 is standard with the exception of the omission of the usual grid condenser and resistor. These components become unnecessary when working in close proximity to a transmitter or receiver and have purposely been omitted.

The extremely low filament and plate current rating of the type 1G4GT tube strongly recommends its use as a regenerative detector. Satisfactory operation is obtained with midget-size “A” and “B” batteries.

$C_1$  and  $C_2$  are bandspread and band-set condensers respectively. Manipulation of these two capacitances allows one to “spot” the band at any desired dial division.  $S_1$ , when closed, permits fundamental operation on 7.0 mc. With  $S_1$  open the grid circuit is resonant on 3.5 mc.

Inasmuch as most components are at ground potential, wiring is greatly simplified and capacity effects minimized.

## Construction

A 6" x 6" x 6" steel utility cabinet houses the entire unit. These cases

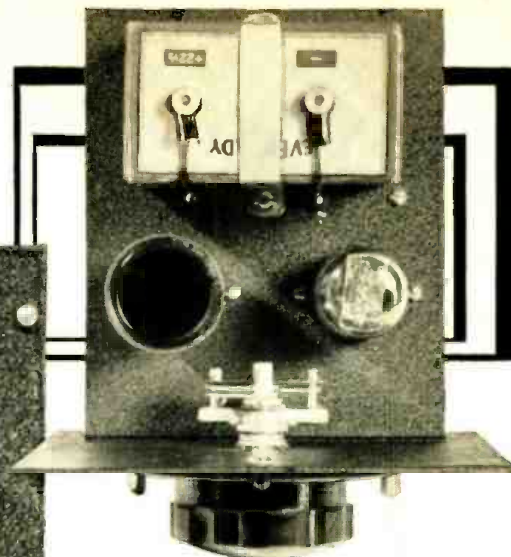
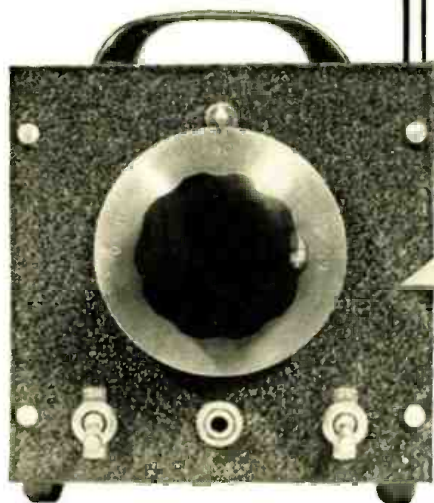

Fig. 1. The “Monimeter.” Left, front-panel view, showing bandswitch, phone jack, and filament switch across bottom. Right, top-of-chassis view. The unit is completely self-contained in a 6"x6"x6" utility box.

*The functions of a frequency meter and monitor can easily be combined in one unit. This one is extremely simple and yet highly effective. Construction is with simple tools.*

are available in gray or black crackle finish, with attached chassis and front and rear panels removable. The original self-tapping screws were replaced with 8-32 machine screws to provide a more rigid assembly.

Centered on the front panel is the main tuning condenser dial and dial indicator. The lower left portion of the panel carries the band change switch while the lower right portion is occupied by the on-off “A” battery toggle switch. Between the two is positioned a closed-circuit jack.

The photographs clearly depict con-

structional details. Much time and patience will be saved by closely following the circuit of Fig. 2. Inasmuch as no less than seven grounded leads are terminated at some point on the front panel or chassis, it will facilitate wiring if these grounded points are prepared in advance.

All wiring is of #18 solid pushback excepting those leads to the “A” battery plug which are flexible. Lock washers are used generously to insure mechanical stability.

The under chassis view shows the  
(Continued on page 115)

Fig. 2. Circuit diagram, parts list, and coil diagram for the “Monimeter.” Only one coil form (standard 1 1/4") is needed for 80 and 40 meters. Note the absence of the usual grid condenser and resistor. No antenna is needed for this type of monitor.

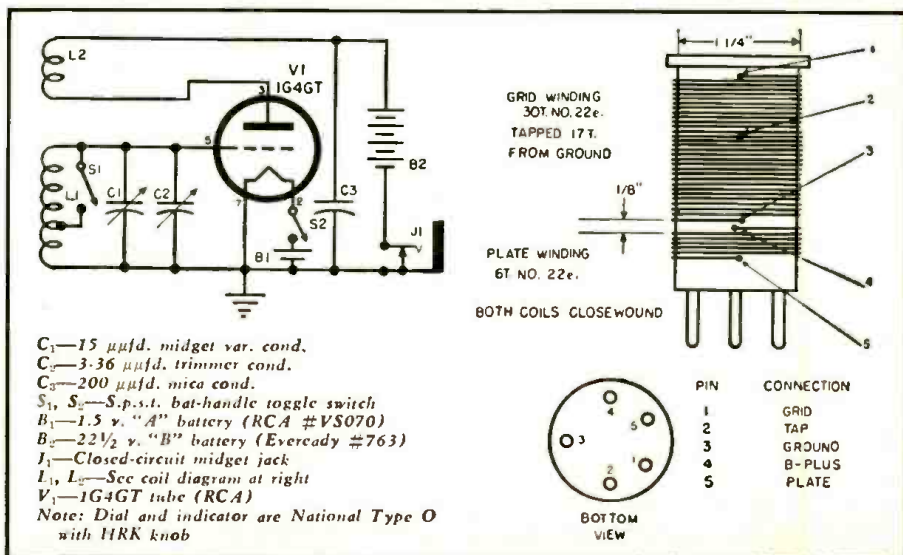



# KNOW YOUR 1953 RCA TV RECEIVER\*

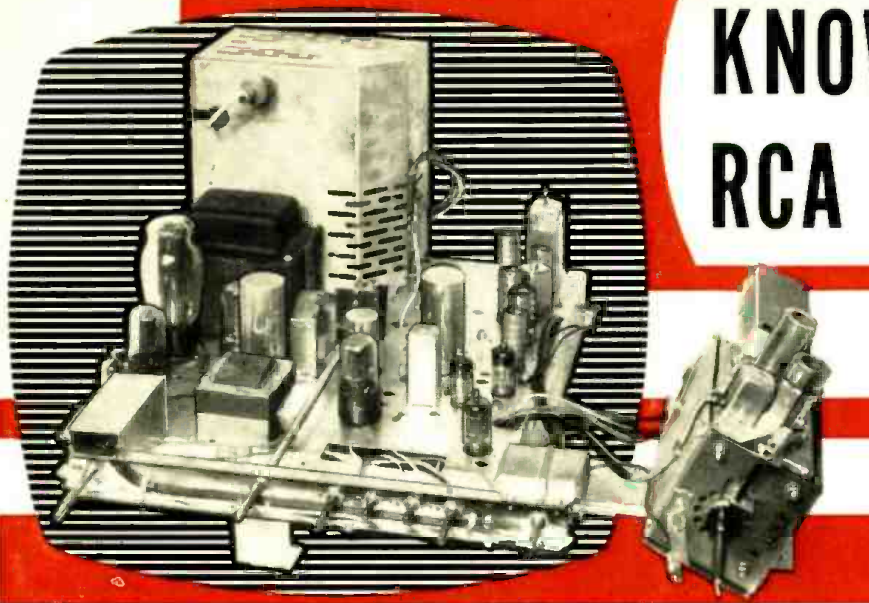

Fig. 1. The RCA Victor KCS-82 chassis shown with the KRK-11 v.h.f. tuner on the right. This chassis, with a KRK-12 tuner, receives both u.h.f. and v.h.f.

*For better, faster servicing; the complete schematic diagram, circuit explanation, and RCA alignment data.*

**O**F THE many design features of the new RCA Victor television chassis, the most significant are the relocation of front-panel controls and the addition of a u.h.f.-v.h.f. tuner in "U" model receivers. To illustrate the new locations of the controls, the KCS-82 chassis with a KRK-11 tuner is shown in Fig. 1. This chassis, as with other current RCA Victor chassis, will be used with either a v.h.f. tuner (KRK-22) or a combination u.h.f.-v.h.f. tuner (KRK-12). The receiver models which use KRK-12 have a "U" suffix added to the model number. Thus, Model 21T303 is a 21-inch receiver which includes the KCS-82 chassis with the KRK-22 (v.h.f.) tuner. Model 21T303U is a 21-inch receiver which includes the same chassis but with the KRK-12 (u.h.f.-v.h.f.) tuner. In early production models, the KRK-11, an r.f. tuner similar to the KRK-22, is used with the KCS-82 chassis.

The location of controls at the chassis front places the Fine Tuning and Channel Selector at their familiar positions on the right-hand side of the chassis. The "On-Off"/Volume and Brightness controls are relocated at the left-hand side. These four controls are the main tuning controls that are visible to the television operator.

Midway between the main controls, a group of auxiliary tuning controls and service adjustments are mounted behind a hinged cover on the receiver cabinet. When the cover is flipped

downward, the concealed controls become accessible for adjustment.

The auxiliary tuning controls consist of the Picture Control, TV-Tone-Phono switch, Horizontal Hold, and Vertical Hold. The position of these controls is shown in Fig. 4. The first two are equipped with knobs for ease of turning. The two hold controls are provided with knurled-end shafts.

Two service adjustments, Height and Vertical Linearity, are also included with the concealed front-panel controls to permit the service technician to make these adjustments conveniently. To discourage unnecessary adjustments, each control has a short shaft with a slotted-end. Other service adjustments are located on the chassis rear apron (See Fig. 3). These include the a.g.c., width, as well as the horizontal linearity, drive, locking range, and frequency adjustments.

## KRK-12 U.H.F.-V.H.F. Tuner

To fulfill its function of sixteen-channel u.h.f. and v.h.f. coverage, the KRK-12 tuner uses a rotary drum into which tuned u.h.f. and v.h.f. inserts are placed. As it leaves the factory, the KRK-12 is equipped with twelve v.h.f. inserts and four blank inserts. The twelve v.h.f. inserts cover Channels 2 through 13. The four blank inserts can be exchanged (at RCA Victor distributors) for four inserts in the u.h.f. band which provide

u.h.f. coverage in a particular area. If desired, any combination of sixteen u.h.f. and/or v.h.f. inserts may be used in the KRK-12.

On each insert are mounted tuned circuits which are connected into the r.f., mixer, and oscillator stages of the KRK-12 so as to function on a selected u.h.f. or v.h.f. channel. In the r.f. circuit, the antenna coil has a 300-ohm input for either u.h.f. or v.h.f. operation. An additional 72-ohm antenna input is provided for u.h.f. operation. When the 72-ohm input is used, the 300-ohm link coupling coil ( $L_{10}$  and  $L_{11}$  in Fig. 6) has to be removed from the u.h.f. inserts that are used. This prevents antenna coupling from two sources into the u.h.f. circuits.

Two 43.5 mc. i.f. traps are located in the antenna circuit common to both u.h.f. and v.h.f. These are identified as  $L_1-C_1$  and  $L_2-C_2$  on the KRK-12 tuner diagram, Fig. 6. A tunable FM trap (not shown on the diagram) is mounted along the 300-ohm antenna input lead. The trap consists of a  $\frac{4}{8}$  inch length of 300-ohm line with one end shorted and the other end terminated with a 5-70  $\mu$ fd. trimmer condenser.

From the antenna coil the signal is coupled, for u.h.f. operation, through a triple-tuned circuit (which includes the antenna coil) to the mixer stage. For v.h.f. operation, the signal is fed through the r.f. amplifier stage  $V_1$ , and then to the mixer stage.  $V_1$  uses a type 6BQ7A tube connected in a driven grounded-grid amplifier circuit. An additional 43.5 mc. i.f. trap ( $L_7-C_6$ ) is located in this stage.

The mixer stage is used alternately for u.h.f. or v.h.f. operation. A silicon crystal diode performs the mixing action of the r.f. and oscillator signals. The mixer tank circuit for u.h.f. operation is the output coil and condenser of the triple-tuned circuit ( $L_5-C_5$ , for example, in Fig. 6); for v.h.f. operation it is the secondary coil and condenser of the r.f. amplifier plate transformer ( $L_{21}-C_{21}$ , for example). (Symbol numbers used here are for illustration only because of the variation of numbers with the different inserts). Oscillator voltage is not injected directly into the mixer tank circuit for u.h.f. operation but is coupled into the mixer stage through an inductance placed close to the os-

\*Prepared by the Commercial Service Section, RCA Service Company, Inc.



illator tank circuit. The inductance is connected between the ground end of the mixer tank and the chassis ground of the tuner. The amount of inductance is made variable so that the u.h.f. oscillator injection voltage can be adjusted to its correct level. This adjustment is accessible on top of the chassis (See Fig. 4) between the oscillator tube and the crystal mixer. For correct u.h.f. mixer operation, the crystal mixer current should be between 0.3 and 3.0 ma. This can be measured at the test point  $TP_1$  as a voltage drop across  $R_{m1}$ , a 100-ohm, crystal biasing resistor.  $TP_1$  is located adjacent to the u.h.f. oscillator injection adjustment on top of the chassis.

Going to v.h.f. mixer operation now, the oscillator injection voltage to the mixer is capacitively coupled on Channels 2 through 6 and is inductively coupled on Channels 7 through 13. The correct level of injection voltage (and consequently, crystal mixer current) can be measured at  $TP_1$  as is done for u.h.f. operation. If a reading of between 0.03 volt and 0.3 volt is not obtained, and it is known that the tuned circuits are properly aligned, the crystal mixer and oscillator tube should be first suspected to be at fault. If not, then other circuit components should be checked until normal circuit operation is established and the correct reading is obtained.

The oscillator stage uses a type 6AF4 tube in a modified Colpitts circuit. The oscillator output is taken at the fundamental frequency for all channels, 2 through 83. Oscillator voltage is developed in the tank circuit formed by  $C_{12}$ ,  $C_{13}$ , the fine tuning control and tuning components located on each insert. The values and tolerances of these components should be carefully noted when replacement is required. Tube and wiring capacities also are significant in this circuit.

To maintain stable oscillation over this wide range of frequencies, the oscillator plate voltage is held to the limits of 85 to 115 volts by a voltage control tube,  $V_4$ . This tube is wired in series with the oscillator plate supply and acts as a variable resistance which changes value in proportion to the current flow. The conduction through  $V_4$  and, consequently, the oscillator plate voltage can be set within limits by a potentiometer in the grid circuit of  $V_4$ . To make this adjustment, a 0-50 ma. meter is inserted in series with the cathode of  $V_4$ . The channel selector switch is placed at a position between channels to stop oscillation in the oscillator stage. Contacts 12 and 13 on the under side of the chassis may have to be jumpered to insure a nonoscillatory state. These contacts are accessible when an empty insert compartment on the drum lies under the contacts. A finger can then be placed over contacts

12 and 13 as a jumper. If the current rises, keep the jumper in place. Adjust the potentiometer  $R_6$  for a 28 ma. reading.

The last circuit to be considered in the KRK-12 tuner is the i.f. amplifier. A 43.5 mc. i.f. signal, developed in the mixer stage, is coupled through a wide-band transformer  $T_1$  to the driven grounded-grid amplifier  $V_5$ , a type 6BQ7A. The output of the amplifier is coupled through  $T_2$ , a link coupling transformer, to the i.f. section on the main receiver chassis.

### The KRK-22 R.F. Tuner

The KRK-22 (see Fig. 5), like the KRK-11, is a v.h.f. tuner which covers Channels 2 through 13 by means of switching inductances. Electrically, both tuners are quite similar. An elevator transformer, along with i.f. and FM traps, is located in a separate compartment at the rear of the tuner chassis. The r.f. amplifier circuit used is the driven grounded-grid type using a type 6BQ7A. An a.g.c. voltage is applied to this stage to prevent overload of the first i.f. amplifier on strong input signals.

Oscillator and mixer circuits are built around a type 6X8 triode-pentode tube. The pentode section provides increased conversion gain and pre-  
(Continued on page 51)

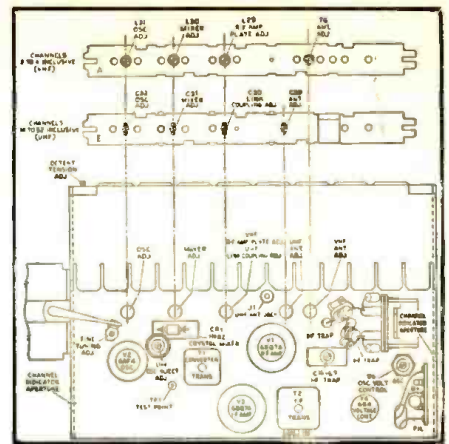

Fig. 2. Top view of the KRK-12 u.h.f. tuner showing the adjustment points and two typical strip inserts.

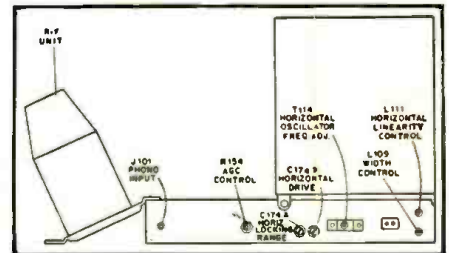
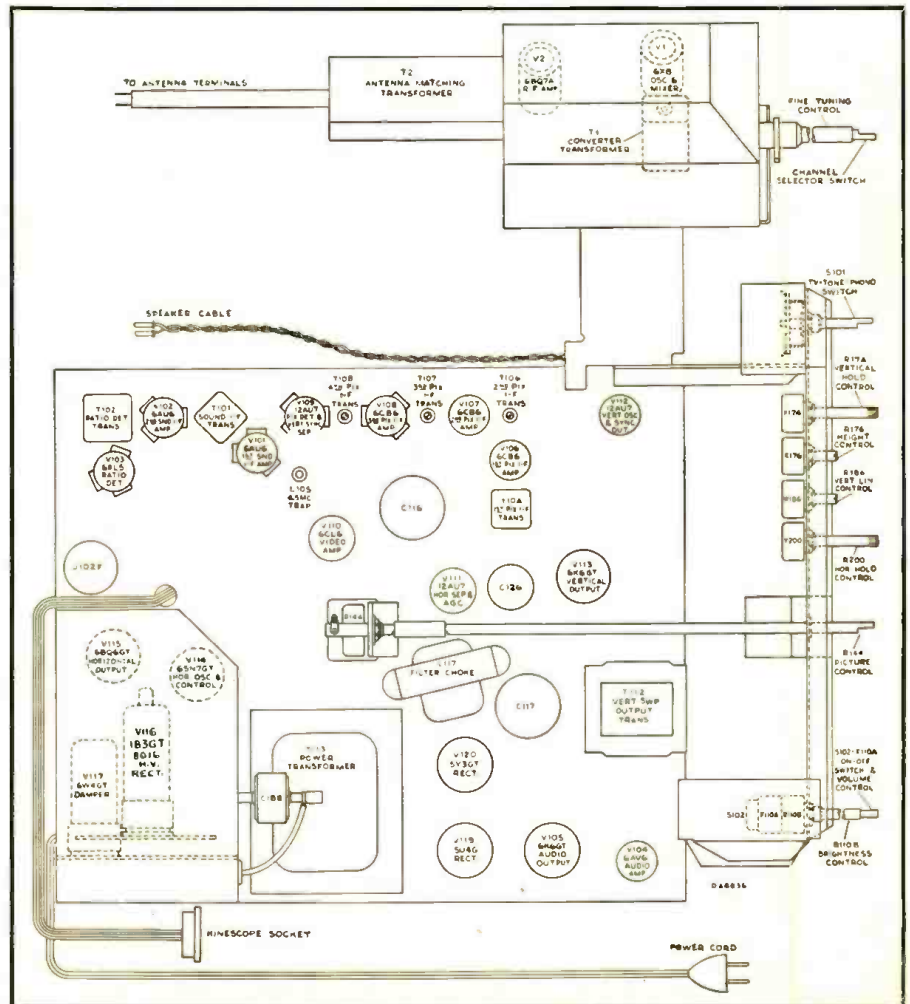

Fig. 3. Rear view of the KCS-82 chassis showing the various rear apron controls.

Fig. 4. Top view of the RCA KCS-82 chassis with the KRK-11 (v.h.f.) tuner.









vents local oscillator feedthrough to the i.f. stages. The local oscillator uses the triode section in a modified Colpitts circuit. The i.f. output of the KRK-22 places the picture carrier at 45.75 mc. and the sound carrier at 41.25 mc.

**I.F. and Video Amplifiers**  
 Three stages  $V_{106}$ ,  $V_{107}$ , and  $V_{108}$ , are used for picture i.f. amplification (See Fig. 5). In early production models 6CB6's were used in all three stages. In later production models  $V_{106}$  and  $V_{107}$  were changed to 6CF6's. Inter-

stage coupling is effected with stagger-tuned bifilar transformers,  $T_{106}$ ,  $T_{107}$ , and  $T_{108}$ , which provide almost unity coupling between stages. A high gain is obtained in these stages which improves the noise immunity of the  
 (Continued on page 111)

Table 1. Alignment data for the video and sound i.f. circuits of the RCA KCS-82 chassis.

VIDEO I. F. ALIGNMENT						
STEP	SIGNAL GENERATOR FREQUENCY	CONNECT TO	OUTPUT INDICATOR	CONNECT TO	ADJUST	REMARKS
1			V.T.V.M.	Junction of $R_{147}$ and $R_{148}$	Bias to -5 volts	Use 7.5 volt battery with 1000 ohm potentiometer across it. Connect positive battery terminal to chassis, potentiometer arm to $R_{147}$ - $R_{148}$ .
2	44.5 mc. no sweep	Terminals A and B of $T_{101}$	V.T.V.M.	$R_{138}$ and $L_{105}$ junction and to ground	$T_{108}$ for maximum reading	Reduce input signal, if necessary, to produce 3 volts of d.c. at $R_{128}$ and $L_{105}$
3	45.5 mc. no sweep	Terminals A and B of $T_{104}$	V.T.V.M.	$R_{138}$ and $L_{105}$ junction and to ground	$T_{107}$ for maximum reading	
4	43.0 mc. no sweep	Terminals A and B of $T_{104}$	V.T.V.M.	$R_{138}$ and $L_{105}$ junction and to ground	$T_{106}$ for maximum reading	
5	47.25 mc. no sweep	Terminals A and B of $T_{104}$	V.T.V.M.	$R_{138}$ and $L_{105}$ junction and to ground	$T_{101}$ (top) for minimum reading	
6	For Models 21-T-303U to 21-T-324U inclusive, follow steps above; except, connect signal generator to front terminal of the crystal mixer in series with a 1500 $\mu\mu$ fd. ceramic condenser, also turn a.g.c. fully clockwise.					
7	43.5 mc. center freq. 5 mc. deviation	$TP_2$ in series with a 1500 $\mu\mu$ fd. ceramic condenser	Oscilloscope through diode probe	Pin 5 of $V_{106}$ and ground	$T_1$ (top) and $T_{104}$ (bottom) for maximum, with 45.75 mc. at 70% of maximum response	Use shortest leads possible.
8	Same as above	Same as above	Same as above	Same as above	$C_{119}$ until 42.5 mc. is at 70% response	After adjusting $C_{119}$ remove load resistors.
9	Same as above	Same as above	Oscilloscope	Pin 2 of $V_{110}$	Retouch $T_{106}$ , $T_{107}$ , and $T_{108}$ to obtain curve below	Adjust sweep generator to give 3 volts peak-to-peak on oscilloscope. Couple a signal generator loosely to the grid of the first picture i.f. amplifier. Adjust the output of the signal generator to produce small markers.
For Models 21-T-303U to 21-T-324U inclusive, follow steps above; except, connect sweep generator to front terminal of the crystal mixer, also preset the channel selector to Channel 5.						
SOUND CIRCUIT ALIGNMENT						
10	4.5 mc.	Pin 1, $V_{101}$	V.T.V.M.	Pin 2, $V_{103}$	$T_{102}$ (top) for maximum reading (d.c.)	Adjust signal level on generator for 6 volts when peaked.
11	4.5 mc.	Pin 1, $V_{101}$	V.T.V.M.	Junction of $R_{106}$ and $C_{108}$	$T_{102}$ (bottom) for zero reading (d.c.)	
12	Repeat steps 10 and 11					
13	4.5 mc.	Pin 1, $V_{101}$	V.T.V.M.	Pin 2, $V_{103}$	$T_{101}$ (top) for maximum reading (d.c.)	
4.5 MC. TRAP ADJUSTMENT						
14	4.5 mc. in series with a 1000-ohm resistor (modulate 30% with 400 cycles)	Pin 2, $V_{109}$	Oscilloscope through crystal probe	Pin 6, $V_{110}$	$L_{105}$ for minimum	Set generator output at .5 volt. Short 3rd picture i.f. grid to ground (pin 1, $V_{108}$ ) to prevent noise from masking output indication.



# A "MINIMUM" MOBILE FOR 10-METER CD

By  
**RICHARD G. FINKBEINER**  
W8AQK



**T**EN-METER mobile amateur stations form the nucleus of most Civilian Defense networks and in this day and age it is the duty of as many amateurs as possible to take part in CD drills. Many are not participating because of the unusually high cost of equipment and the extensive work required for construction and installation. The purpose of this article is to describe the design of a simple 10-meter mobile station that will enable more amateurs to take part in Civilian Defense activities.

Shown in the photos is a transmitter that requires a minimum of parts for construction and is small enough to fit behind the dash or in the glove compartment of an automobile. A broadcast receiver, Gonset converter, and 100-inch side-cowl mounted antenna complete the station. Power for the transmitter is

The 10-meter mobile CD transmitter is powered by the receiver supply and uses the receiving antenna. The input of two watts is adequate for local fixed-to-mobile work, saves battery.

*A minimum of cost and complexity are featured in a mobile ten-meter transmitter designed for local CD network use.*

taken from the vibrator supply in the receiver, and the available two-watt final plate input power gives performance on a par with that obtainable from higher-powered rigs. Note that no trunk space, dynamotor, separate antenna, or dash-to-trunk wiring are required. In addition, the battery drain is equal to that of the receiver, a highly desirable feature during emergency operation over a long period of time.

Fig. 1 shows the transmitter circuit. The r.f. portion of the transmitter uses one half of a 7F7 dual triode as a crystal-controlled oscillator operating on twenty meters.  $L_1$ , the oscillator plate coil, is 20 turns of No. 22 enamel wire closewound on a  $\frac{5}{8}$ " diameter polystyrene form  $1\frac{1}{4}$ " long. Following the oscillator is a 6V6GT power amplifier doubling to ten meters.  $L_2$ , the tank coil primary, is 6 turns of No. 20 wire spaced to  $\frac{1}{4}$ "

Fig. 1. Circuit diagram, showing use of ordinary receiving tubes.  $J_2$  is insulated from chassis as the "B-minus" connection was not grounded in power supply (see Fig. 2). If a supply with no bias tap is used, pin 8 of  $P_1$  can be grounded directly.

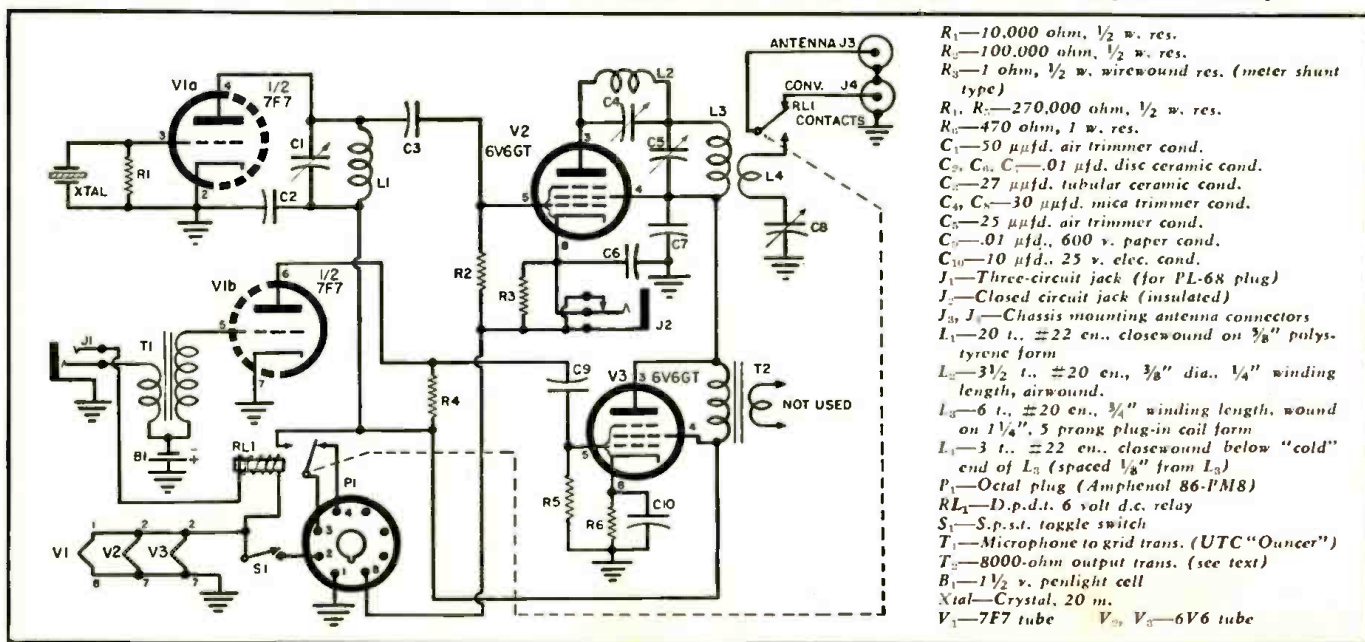



on a 1¼" plug-in coil form. The link  $L_1$  is 3 turns of No. 22 wire close-wound next to the "cold" end of the primary.  $L_1$  and  $C_1$  form a series-resonant circuit to tune out the link reactance at the operating frequency and permit greater output because the internal impedance of the link is theoretically zero under these conditions. All traces of TVI are eliminated by a simple but effective trap,  $L_2$  and  $C_2$ , in the 6V6GT plate lead.  $L_2$  is 3½ turns of No. 20 enameled wire, ⅜" in diameter and ¼" long.

The other section of the 7F7 is used as the first audio stage in the modulator. A T-17 microphone is coupled to the grid by a UTC "Ouncer" microphone-to-grid transformer. Both microphone current and bias for the 7F7 are furnished by a penlight cell which will last its shelf life as only 5 ma. are consumed by the microphone while transmitting. This circuit keeps vibrator "hash" out of the audio circuits, a difficulty often encountered when trying to use the 6-volt receiver supply for microphone current. It also makes a simple bias source for the 7F7 and eliminates the usual cathode resistor and bypass condenser.

Next in line is a 6V6GT Heising modulator, which uses the primary of a replacement type output transformer as an audio choke. Any 5000- to 10,000-ohm plate-to-voice-coil transformer will work, although the original was an 8000-ohm unit with a 5-watt power rating.

Both octal and loctal tubes were used in the original model simply because they were available in the "junk box". As direct substitutes for the 7F7, a 6SL7 octal or 12AX7 miniature type may be used. Also, a 7C5 loctal or 6AQ5 miniature can be substituted for the 6V6GT's.

Two power sockets are added to the receiver as shown in Fig. 2A, the partial schematic of a typical auto radio power supply. A three-prong Jones socket supplies 6 volts and "B" voltage from the second filter section to the converter, while the octal socket carries power to the transmitter. Point "X" is broken so that the transmitter relay may be connected to transfer "B" voltage between the receiver and transmitter. Wire the 6 volt lead to the "hot" heater pin of any tube in the receiver except the rectifier; otherwise vibrator "hash" will get into the converter via the heater wiring.

The cathode and grid returns of the 6V6GT doubler-final stage are connected to the "B-minus" lead in the receiver power supply so that the highest possible "B" voltage will be available. A voltage of 120 to 150 volts (from standstill to maximum generator charge) was available from the Motorola model 251 receiver used in the original installation. Many receivers do not have a bias tap in the power supply and the "B-minus" connection is grounded. In such a

(Continued on page 121)

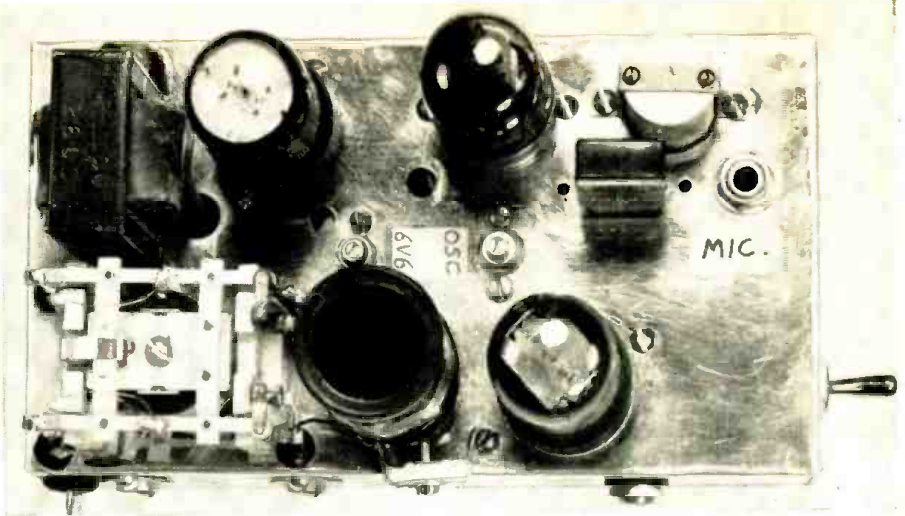

Top view, showing relay and modulator choke at left. The 6V6's may be replaced by 7C5's or 6AQ5's, and the 7F7 oscillator-speech amplifier by a 12AX7 or 6SL7 tube.

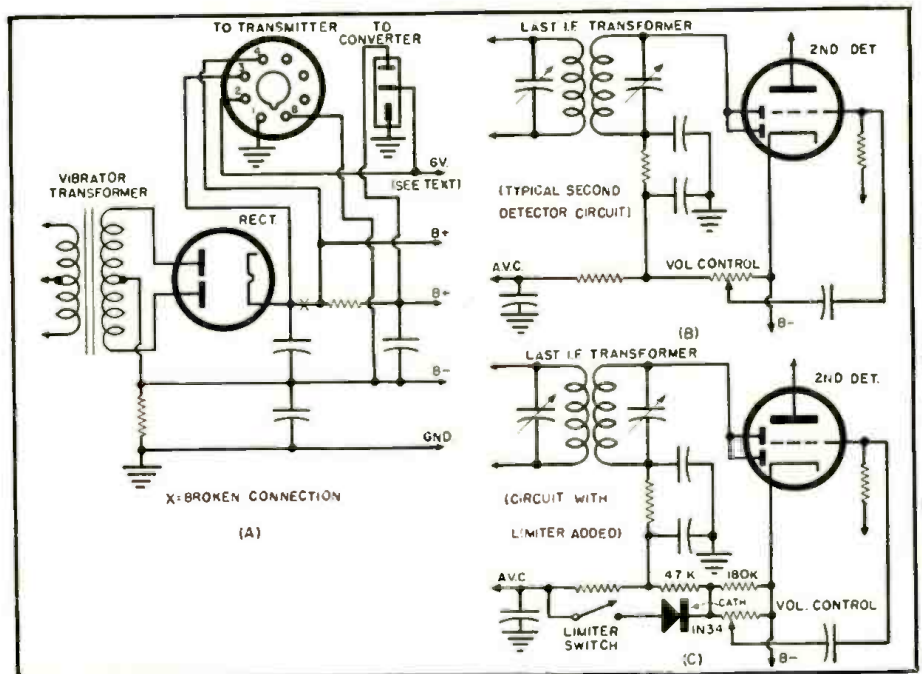
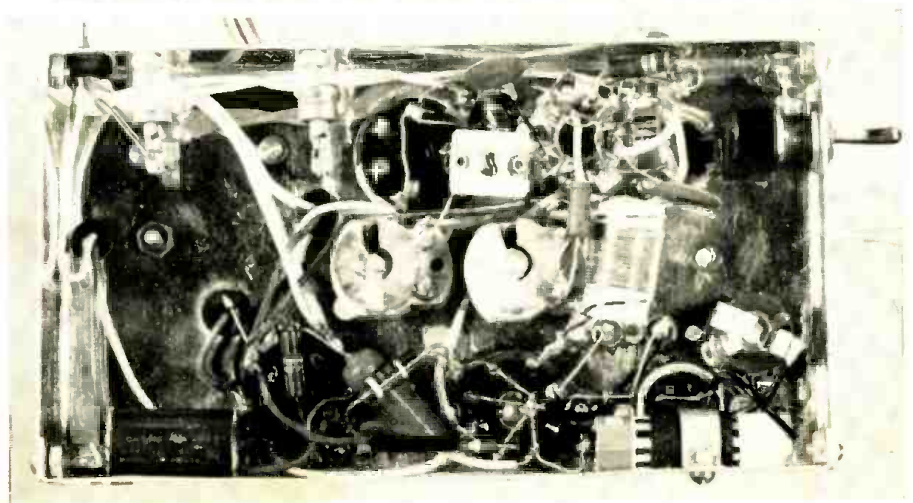

Fig. 2. Modifications of the receiver. (A) An octal socket and 3-prong connector are added to the power supply. Broken connection (X) permits switching power from receiver to transmitter through relay. (B) and (C) show addition of noise limiter.

Bottom view. The TVI-trap L.C. is visible at top center. C. is adjusted through a small hole in bottom plate. The "penlight" cell for microphone is at lower right.





# FASTER TV SERVICING

## THROUGH CIRCUIT TRACING

By MILTON S. KIVER

Pres., Television Communications Institute

*Cut down service time and increase your profits by using these recommended techniques for locating receiver faults.*

ONE of the greatest difficulties that faces many technicians is the tracing of specific circuits through the complex maze of lines that one finds on a television schematic diagram.

You are given a defective television set to service and by examining the symptoms, you form an idea of where the trouble lies. But you're not sure. So the first thing you want to do is see what sort of a signal the suspected stage is receiving from a previous section. But this means tracing back through the circuit and if you are weak on circuit tracing you can easily take half an hour to do a 5-minute job. In your own shop, this means less money. If you are working for someone else, the impression you convey is not favorable. Neither prospect is desirable.

Now, how do you become proficient in circuit tracing? First, by learning as much as you can about the operation of the various circuits in a television receiver. Second, by becoming familiar with the place each stage has in the over-all television schematic. Third, by practicing circuit tracing every chance you get.

In the present article, little can be done to help anyone overcome deficiencies in the first two categories. In every issue of this magazine the reader will find numerous circuit explanations and he is strongly urged to read them. To acquaint yourself with the position and operation of the various stages in a television receiver, reference may be made to any of the textbooks on the market, such as the author's "Television Simplified".

Where we can be of service, however, is with regard to the third point, namely, helping you trace your way through a television schematic. In the allotted space of one article it is impossible to consider every aspect of a television receiver. So, we shall concentrate on the "B+" lines that power the various sections of a television receiver.

The d.c. power supply is the common denominator for the entire television receiver. There is hardly a

circuit in the set to which it does not supply power and what befalls the power supply will affect every stage of the receiver. By the same token, it is entirely possible for a defect in one stage to be reflected, in some way, in one or more of the other stages. Thus, a shorted condenser in one section of a set can so load down the power supply that it renders the entire receiver inoperative.

Now to get down to brass tacks with an actual service problem. A Zenith Model K2229E television receiver was brought into the shop with the complaint of very weak sound and no picture or raster. The combination of weak sound and missing raster immediately suggested a defective "B+" and subsequent measurements bore this out because the "B+" voltage on a number of tubes was low.

The problem then was straightforward: Something was placing so much of a load on the power supply that the voltage was being lowered. The culprit could be a tube, a condenser, or a resistor. (There might be other unusual circumstances but in servicing, like poker, you play percentages first if you want to win.)

The ferreting out of the defective component in a situation like this can be rugged, as any technician who has been faced with a similar problem can tell you. In essence, you are looking for one component out of several hundred and this could easily take half the night unless you know what you are doing.

As a first step, let us take out the schematic diagram of the set and study it for a minute. See Fig. 1. The power supply is transformer coupled to the a.c. line and, as is usual in such instances, the tube heaters are wired in parallel. This means we can remove one tube without affecting any of the others as far as heater power is concerned. The d.c. voltages supplied by the 5U4G rectifier are +250 volts and +150 volts. As far as we can tell, these are the only two d.c. voltages utilized in this receiver. However, it is entirely possible that subsequent voltage divider networks

elsewhere in the receiver do produce other values of d.c. voltages which are used by a number of stages. This is a common practice and therefore is a definite possibility that must be considered.

The next step in tracking down the defect is to determine in which of the lines radiating from the power supply it exists. Let us consider the 150-volt line first. This starts at point *J* and travels to the right and then up until it reaches point *K*. At this point one line travels off to the right, eventually supplying voltage to the screen and plate of  $V_{11}$ , the 6BE6 sync clipper. Of interest, too, along this path is the bridging of the brightness control from the 150 volts to ground.

Disconnect this line at point *K* and see if the voltages in the rest of the set return to normal. Here it did not, so we knew that the trouble, whatever it was, did not exist in this branch of the "B+" network and the wire was resoldered to its terminal.

Returning to point *K*, the 150-volt line moves straight up to point *L* and to the right. See Fig. 1. Here we find:  $V_3$  (6CB6) 3rd video i.f.;  $V_{04}$  (1/2 6U8) screen grid of 1st video amplifier;  $V_{AB}$  (1/2 6U8) sound amplifier;  $V_7$  (6BN6) screen grid of audio detector; and the fringe-lock potentiometer.

Disconnect this line and again see whether the "B+" voltages in the rest of the set return to normal. Still no luck here so the trouble must lie elsewhere.

We have now completed tracking the +150 volt line. The next step would be to return to the power supply and see what success we have with the 250-volt line. This line starts at point *A* just beyond filter choke  $T_3$ . At point *A* the line branches off in several directions and these are best considered one at a time. Moving from *A* to the right we reach point *B*. From point *B*, follow the line down to point *C* and thence to the right. At point *D* we see that the 250 volts feed the screen grid of  $V_{15}$ , the 6BQ6GT horizontal output amplifier. Beyond point *D*, the 250-volt line enters the damper circuit where it is combined with the boost "B+" to provide an increased voltage of 430 volts here. This boosted "B+" then takes care of the plate of the 6BQ6GT and several other stages, as we shall see presently.

(Continued on page 56)



Fig. 1. Schematic of Zenith's Chassis 19K23. See text for explanation of circuit tracing this and similar TV sets.

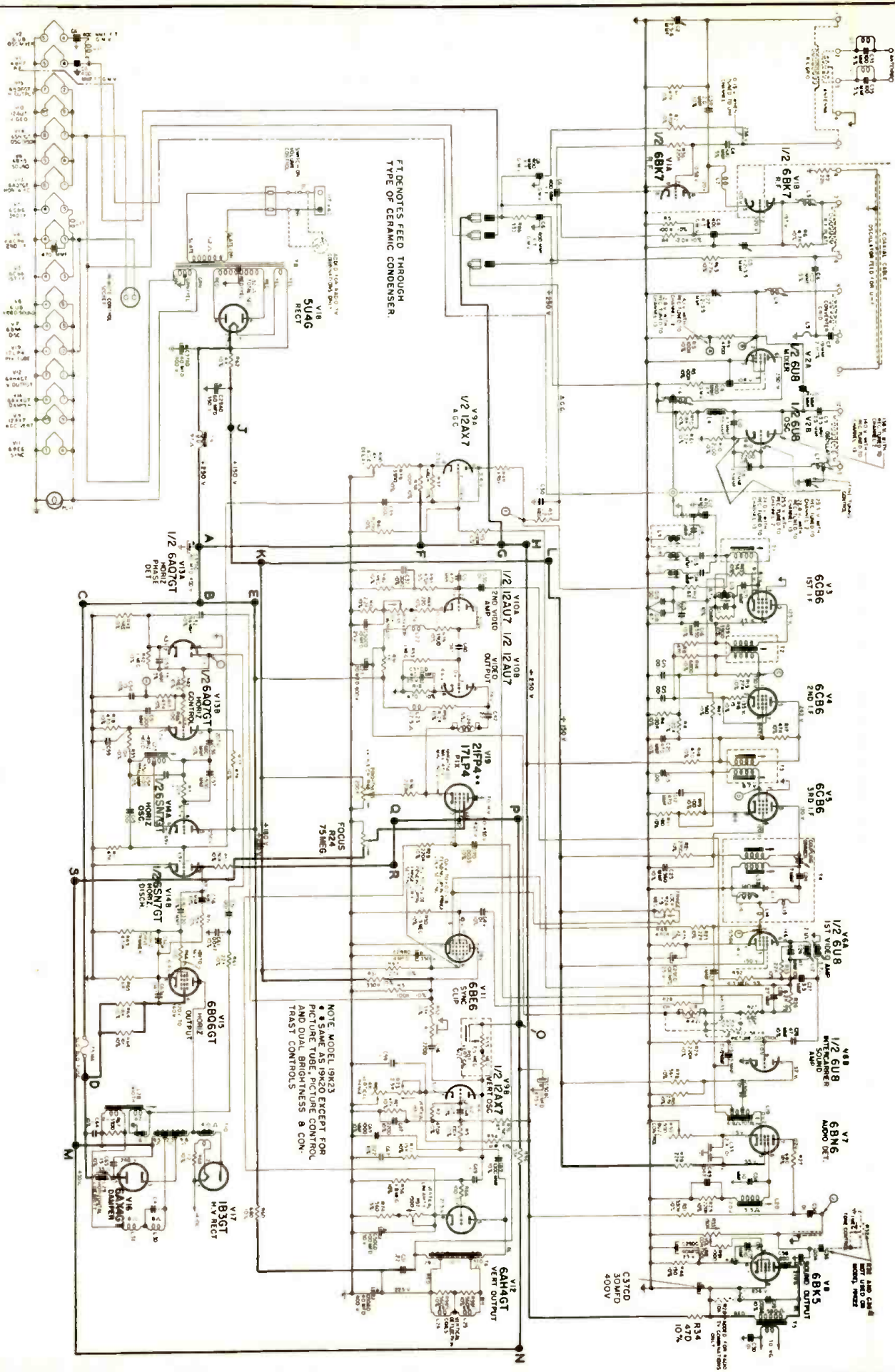



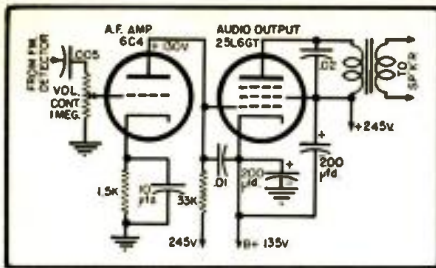

Fig. 2. Schematic of the Hallicrafters audio amplifier circuit showing how the 25L6GT control grid gets its correct bias.

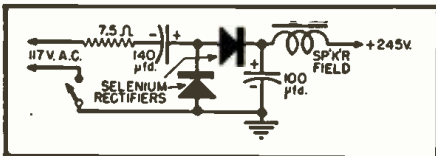

Fig. 3. Power supply of the Hallicrafters Model 1010P receiver. The filaments of the various tubes are series-parallel connected and are not shown on this schematic.

Following the procedure outlined previously the line leading from B to C to D was disconnected and again the voltage in other sections of the set was tested with no change in conditions. In other words, the trouble still persisted.

Returning to point B, let us move on to E and thence to the right. Here we find the following stages connected into the 250-volt line (in the order in which they tap off of the line):  $V_{10A}$  (1/2 12AU7) 2nd video amplifier;  $V_{10B}$  (1/2 12AU7) video output;  $V_{13B}$  (1/2 6AQ7GT) horizontal control tube;  $V_{11A}$  (1/2 6SN7GT) horizontal oscillator; and  $V_{12}$  (6AH4GT) vertical output.

Nothing was achieved in this branch either (by the same disconnecting technique) so we returned to point A again and followed the 250-volt line upward to points F, G, and the circuits into which they connect. At point F the line connects into the cathode of the a.g.c. tube and from here through a series circuit to ground. At G the line branches off to the left where it supplies voltage to all the stages (r.f. amplifier, mixer, and oscillator) of the tuner.

Beyond G to H and off to the right we find the following stages connecting into the 250-volt line:  $V_1$  (6CB6) 2nd video i.f. (and  $V_3$  through  $V_4$ . These two tubes are in series);  $V_{9B}$  (1/2 12AX7) grid and cathode of ver-

tical oscillator;  $V_5$  (6BN6) plate of audio detector; and  $V_6$  (6BK5) sound output.

In the line which branches off to the right at point H we strike pay dirt because disconnecting this line brings the rest of the set voltages back to normal. Somewhere along here, then, must lie our source of trouble and it turns out to be  $C_{517D}$ , a 30- $\mu$ fd. filter condenser. This is evidently leaky, drawing an excessive current through  $R_{21}$ . The latter resistor is charred and had the set been kept on much longer it would undoubtedly have burned out.

As stated previously, the procedure for isolating this particular trouble was straightforward but the technician had to be capable of tracing the "B+" voltage distribution through the receiver. This was done here in some detail to show how it would be carried out. (Some men may be able to figure out a somewhat faster way of tracking down this defect. The longer route was taken purposely to demonstrate all the steps.)

Mention was made previously of the boosted 430 volts and it might pay us to examine this section of Fig. 1 because boost "B+" circuits always prove confusing. In the Zenith set, the boost "B+" can be considered as starting at point M. This is located just below the damper tube. One line from point M goes to the right and up to point N, and then to the left, where we find the plate of  $V_{9B}$ , the vertical oscillator, tied in at point O. Beyond O, there is point P and from here to the first anode of the picture tube.

Also tied into the same line, via Q and R, is the plate of  $V_{13B}$ , the horizontal discharge tube.

To complete the distribution of the boosted "B+" voltage, return to point M and then move to the left. This will take you to point S and up to the focus potentiometer,  $R_{21}$ . The focus electrode of the picture tube feeds off the center terminal of this control.

To some technicians the Zenith diagram might seem to present a fairly complex arrangement and yet in comparison to other sets which he will encounter, this is a comparatively simple distribution system. The paths of the various voltages were clearly defined and could be followed without too much difficulty. Just remember to start at the d.c. supply and to follow

each branch out to its end. Then return, and do the same for each subsequent branch. Do not, at any time, go through any condensers or other components which break the d.c. path required for the transmission of this voltage. Resistors, of course, serve only to decrease the voltage. They do not ordinarily stop it.

Of increasing interest in recent television receivers has been the use of tubes in series-parallel arrangements across the power supply. The power supply in Fig. 3 is taken from one such receiver (a Hallicrafters Model 1010P) and its output voltage is seen to possess a single value, namely +245 volts. However, if you were to examine the remainder of the receiver schematic carefully (not shown here), you would find that a number of tubes tap into a +135-volt line. The question is, where did that 135-volt line come from?

The answer is to be found in the manner in which the various tubes are connected across the power supply. Some stages are powered by the 245-volts directly and, of course, there is no difficulty here. But if we examine the +135-volt line, we see that it is obtained from the cathode of the audio output tube, a 25L6GT. What happens is that 245 volts is applied to the plate circuit of the 25L6GT. Of this, 110 volts is dropped across the tube, leaving 135 volts at the cathode. It is this 135 volts which is then applied to a number of other stages in the receiver. Thus, the 25L6GT audio amplifier is in series with the parallel combination (here) of nine stages. See Fig. 4. All of the series current passes through the audio amplifier tube, but this tube is ordinarily designed to handle such large currents. The remaining tubes in the bottom half of this string are in parallel with each other and they merely divide up the series current as they need it.

One consequence of this type of arrangement is the fact that since the cathode of the audio amplifier is positive (here by 135 volts), the control grid of this tube must also be made positive, although by a somewhat smaller value. The grid of the 25L6GT connects directly to the plate of the preceding 6C4 audio amplifier, receiving through this connection a positive voltage of 130 volts. See Fig. 2. Thus, the grid is 5 volts negative with respect to the cathode, providing the tube with its necessary bias.

It is interesting to note that using tubes in the manner shown in Fig. 4 leads to many defect indications which differ from those obtained in a more conventionally designed receiver. Thus, a failure of the audio amplifier tube to conduct will remove sound and picture and raster from the set. The raster disappears because the screen grid of the horizontal output tube connects into the 135-volt line.

In the ordinary receiver, disappearance of sound, video, and raster could mean only one thing—trouble in the

(Continued on page 68)

Fig. 4. The arrangement in the Hallicrafters Model 1010P receiver by which tubes are employed in a voltage divider network. See Fig. 3 for additional information.

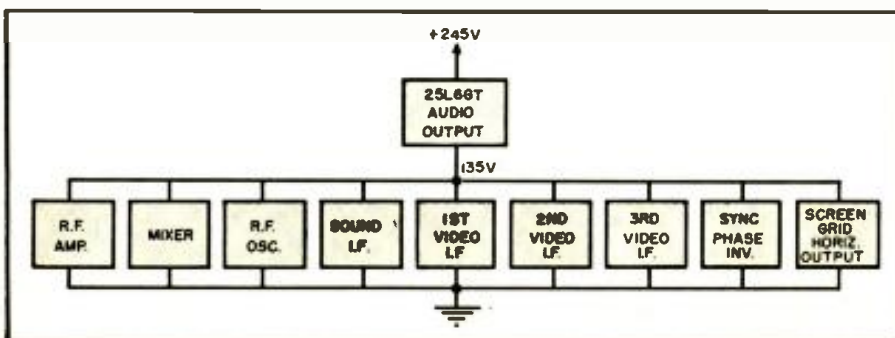



THE oscilloscope can be a very useful, all around instrument in TV servicing, if its capabilities are fully exploited. Most technicians use it to align television r.f. and i.f. stages, in conjunction with a sweep frequency generator, or else they use it to trace signals through various stages. While these are more or less standard applications for the oscilloscope, there are some other useful ways in which the large investment in the scope can be made to pay. For example it is possible to use an oscilloscope as a voltmeter to measure a.c. or d.c.

### D.C. Voltage Measurement

With no signal applied to the vertical scope terminals the horizontal line produced by the horizontal scope sweep depends for its position on the setting of the vertical centering control. If a sudden voltage is applied to the vertical input terminals, the line jumps up or down, depending on the polarity of the input voltage. Try this by connecting the negative terminal of a battery, any voltage you happen to have handy, to the scope ground and then touch the positive terminal to the "high" side of the vertical input terminals. If the line moves off the screen, reduce the vertical scope gain. If the line moves very little, increase the vertical gain. You will observe that after reaching a certain height the line will move back again to its original position. Some oscilloscopes have a switch permitting connection of a d.c. amplifier or a direct connection to the vertical deflection plates and in these scopes the line will not return to the base, but remain at the d.c. height. To use the scope as a voltmeter it is very helpful if a grid printed on transparent plastic is placed in front of the CR tube. This grid can then be used as a reference in checking the location of the base line. A red or black grease pencil or crayon is often used to mark the amplitude of a signal on the scope screen. The system for measuring d.c. voltage on the scope makes use of the same phenomenon as observed with the battery experiment. A d.c. voltage will deflect the electron beam in direct relation to its amplitude. If 1 volt moves the beam two grid divisions, 10 volts will move it 20 divisions. All that is needed now is a reference or calibration voltage and then, by comparison, we can measure d.c. voltages directly.

Because most scopes use a series condenser in the input circuit, the d.c. voltage applied is not in its entirety coupled to the scope amplifier and the only effect on the CRT is the motion of the line up and down as the condenser is charged and then discharges through the grid resistor. In d.c. voltage measurements it is therefore necessary to observe how far from the base the line travels during the charge. For calibrating purposes it is best to touch the battery voltage in the same polarity as the voltage to be measured. If a grid bias is measured, for exam-

# THE OSCILLOSCOPE AS AN A.C.-D.C. VOLTMETER

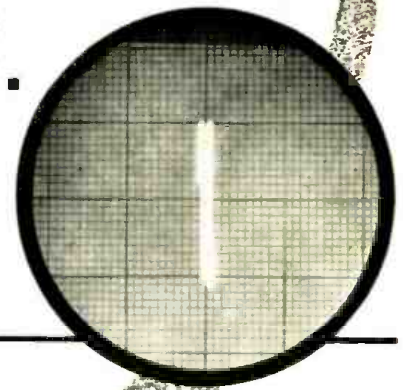

Fig. 1. Scope pattern obtained when horizontal scope gain is reduced to give only narrow vertical strip.

By

**WALTER H. BUCHSBAUM**  
Television Consultant  
RADIO & TELEVISION NEWS

*Increase the usefulness of your scope by calibrating it to operate as a peak-reading, high-impedance v.t.v.m.*

R.M.S.	PEAK-TO-PEAK
.35	1
3.54	10
6.3	17.8
100	282
110	310
117	330
125	352

Fig. 2. Most commonly used peak-to-peak voltages and their equivalent r.m.s. values.

ple, connect the negative battery terminal to the "high" side and the positive to ground. For positive voltages, reverse the connections. Whenever possible the battery voltage should be of the same order of magnitude as the voltage to be measured. Errors may result when a 1.5 volt battery is used to calibrate a scope for measuring 500 volts. In such cases the vertical scope attenuator switch can be used to change scales, but this is not always accurate.

To perform a typical measurement like checking the cathode bias voltage of the horizontal output amplifier, the scope is first calibrated. Using a 3-volt battery we adjust the vertical gain control until the connection of the battery raises the line by six grid divisions. Now we know that 1 volt will deflect the line two divisions.

Fig. 3. Peak-to-peak vs. r.m.s. values.

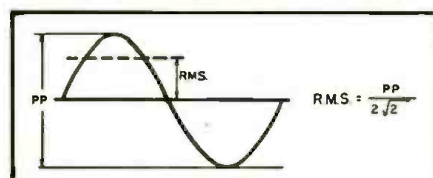

When we connect the vertical scope terminals to the cathode and ground in the TV set we find that the line jumps up to 19 divisions from its base position. This means that the voltage at the cathode is 9.5 volts. In a similar manner any voltage up to about 600 volts can be measured with the scope. The 600-volt limit applies to most scopes and is based on the voltage rating of the input condenser and the limits of the vertical scope attenuator.

### A.C. Measurements

Most a.c. voltmeters are only good for measuring the r.m.s. voltages of sine waves, although some have peak reading scales, also limited to sine wave signals. To measure the peak value of any other a.c. signal, the simplest instrument is the scope.

Actually the scope can be used to measure all a.c. voltages, peak or r.m.s., with greater accuracy than most reasonably priced voltmeters. The principle used in a.c. measurements is the same as in d.c., but here the input condenser of the scope is no longer an obstacle to the signal so that more accurate and readable measurements result. By connecting the signal under test to the vertical scope terminals, its amplitude, as well as wave-shape, can be observed and measured clearly.

The source for calibrating the scope for a.c. is often built into the scope and available at a test jack on the front panel. While the voltage varies with different scopes, most service equipment uses 6.3 volts as the test signal. 6.3 volts is the r.m.s. value  
(Continued on page 88)



# A LOW DISTORTION

# AUDIO SIGNAL GENERATOR

By  
**GEORGE ELLIS JONES, JR.**

Dept. of Chemical Engineering  
University of Pittsburgh

The author's low-distortion signal generator. Circuit improvements, described in the text, provide better performance than is usually found in home-built gear.

*A distortion figure of less than one-tenth of one per-cent and an output flat within  $\pm 1$  db in this generator assure accurate checking of critical amplifier characteristics.*

**A**LTHOUGH a number of Wien bridge type audio signal generators have been described in the literature, the majority have one serious weakness. They produce too much distortion to be used successfully for making harmonic distortion analysis on good audio amplifiers. If the amplifier under test produces, say, 1% distortion and the signal generator's output itself contains 1% distortion, analysis of the amplifier's performance is practically impossible. The amplifier output might, under these circumstances, contain anything from zero to two per-cent distortion. The exact value would depend upon whether the two distortions interacted to cancel or to augment each other. These deficiencies in these typical generators prompted this author to develop a better-than-average Wien bridge oscillator subject, however, to the practical limitation that it could be built from commonly available circuit components.

This signal generator covers a range from 11 cycles-per-second to 120,000 cycles-per-second in four overlapping ranges. Its output is flat within  $\pm 1$  db, being one-tenth of a watt into a 600-ohm load from a 600-ohm source. This maximum level amounts to +20 db or 7.74 volts r.m.s. From 70 to 50,000 cps the distortion is less than one-tenth of one per-cent. Hum and noise are 20 db further down.

A simplified diagram of this oscillator is shown in Fig. 1. The amplifier, indicated by the triangular symbol, yields 180° of phase shift so that the grid of  $V_1$  is driven by a regenerative feedback loop while the drive at the cathode is degenerative. This regenerative loop, produced by the Wein bridge, is frequency-selective. Through it a maximum transmission ratio of 1:3 exists at a frequency,  $f_0$ , given by the equation:

$$f_0 = 1/2\pi RC$$

where:  $R_{w1} = R_{w2} = R$   
and  $C_{w1} = C_{w2} = C$

Fig. 1. Simplified diagram of the oscillator circuit. Function of phase-shift amplifier (triangle) is explained in the text.

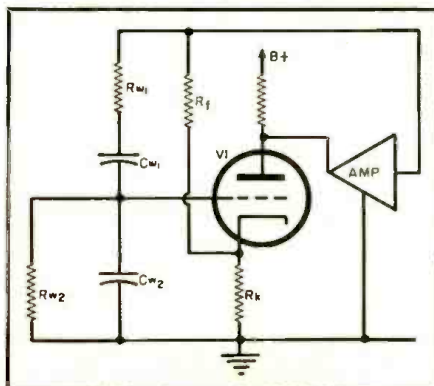

At frequencies other than  $f_0$  the transmission will be less.

If the gain from the grid of  $V_1$  with respect to the output equals or exceeds three, the unit will oscillate at a frequency determined by  $f_0$ . If the gain is greater than three, the amplitude of the output will build up until the amplifier circuits are overdriven into a region of grossly non-linear operation. This produces, on the average over a cycle, an effective gain of about three and an extremely poor output waveform.

To prevent this distortion, amplitude limiting in the region of linear operation is provided by the negative feedback loop. The negative feedback factor (essentially the ratio of  $R_k$  to  $R_f$ ) is dependent on the output-signal amplitude. The cathode resistor,  $R_k$ , is an incandescent lamp bulb. As it gets warmer when the power it dissipates increases, its resistance increases. The power dissipated in this cathode resistor consists of two parts, one from the quiescent current of  $V_1$  and the other from the current flow produced by the output voltage signal impressed across  $R_f$  in series with  $R_k$ . Any increase in output signal level causes  $R_k$  to warm up, increasing its resistance, and thereby increasing the amount of negative feedback. The effective gain from the grid of  $V_1$  to the amplifier output is therefore reduced. In a comparable manner a reduction in output signal level will produce an increase in effective gain. The key to this see-saw situation is the proper adjustment of  $R_f$ . This feedback resistor is set so that an output signal level will be maintained, not by driving the amplifier into non-linear operation, but rather by the compensating effects of the resistance variation in  $R_k$ . Any tendency for the output signal level to change will be reduced by the attendant changes in  $R_k$ . This negative feedback loop therefore holds the output level substan-



tially constant despite: (a) tube deterioration; (b) supply voltage variation; (c) change of amplifier gain with frequency, and; (d) mis-tracking of the Wien bridge elements as the bridge is tuned from one frequency to another.

Unfortunately the impedance presented by the negative feedback loop to the amplifier is rather low (about 3000 to 4000 ohms) and the voltage with which it must be driven is rather high (about 20 volts r.m.s.). The low impedance is mandatory because the total impedance of the feedback loop must be about three times the resistance of the cathode bias resistor,  $R_k$ . Using less signal to drive the feedback loop results in drift in the oscillator output level. The development of 20 volts across 3000 ohms does not sound like much of a problem, unless you want to do it with a single ended-stage and end up with less than one-tenth of one per-cent distortion. However, given enough gain inside the feedback loop, the degenerative feedback loop will assume the extra responsibility of cleaning up the amplifier output stage. Since a regenerative feedback loop is also involved, the distortion reduction produced by the negative feedback is not so great as might be expected. This can be demonstrated mathematically.

For the fundamental frequency,  $f_0$ , the distortion reduction is zero; and for the second harmonic it is less than half of what might have been expected. It is this loss of feedback near the fundamental that causes poor generators to lock in on various harmonics of the power supply frequency.

At low frequencies yet another difficulty arises. The lamp,  $R_k$ , itself produces distortion. The power dissipated in the lamp varies over a cycle of output voltage. The lamp can and does warm up and cool down during the time of a low-frequency cycle. This varies the amount of feedback and distorts the output signal. During a positive half-cycle the lamp increases in resistance, the feedback factor goes up, the effective gain comes down, and the waveform is compressed. On the negative half of the cycle the waveform is expanded. This disfigurement is essentially second harmonic distortion, generated in a feedback loop component as a variation in the amount of feedback.

The isolating amplifier used to separate the oscillator proper from the generator output in most units is an additional source of hum, noise, and distortion. By eliminating this buffer the unwanted signals it produces are also eliminated. Unfortunately using the oscillator output stage for the generator output point places an additional load on that stage and increases its distortion product.

Typical Wien bridge oscillators em-

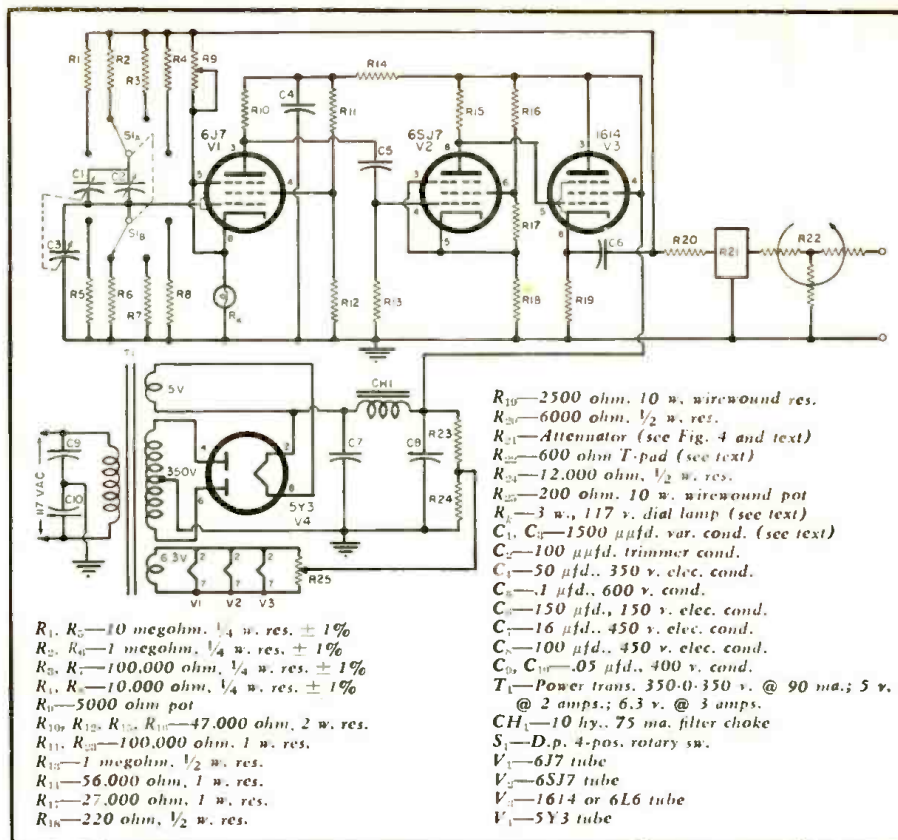

Fig. 2. Circuit diagram of the audio generator.  $R_k$  is a 117-volt, 3-watt pilot lamp (see text). Circuit of  $R_{21}$ , the stepped attenuator, is in Fig. 4. Note the use of a cathode follower driven by a voltage gain pentode, instead of the usual power tube.

ploy either a power pentode or a beam tetrode for the amplifier section. This generator uses instead a voltage-gain pentode driving a cathode follower. The cathode follower is a triode-connected beam power tube. The amplifier section has a gain of about 35 instead of the more typical figure of

two or three found in the usual generator. Feedback inherent in the cathode follower yields an amplifier section with greater gain and less distortion even before the application of over-all negative feedback.

The actual schematic diagram of the generator is shown in Fig. 2. A

Top view of the low-distortion audio signal generator, showing roomy parts layout.

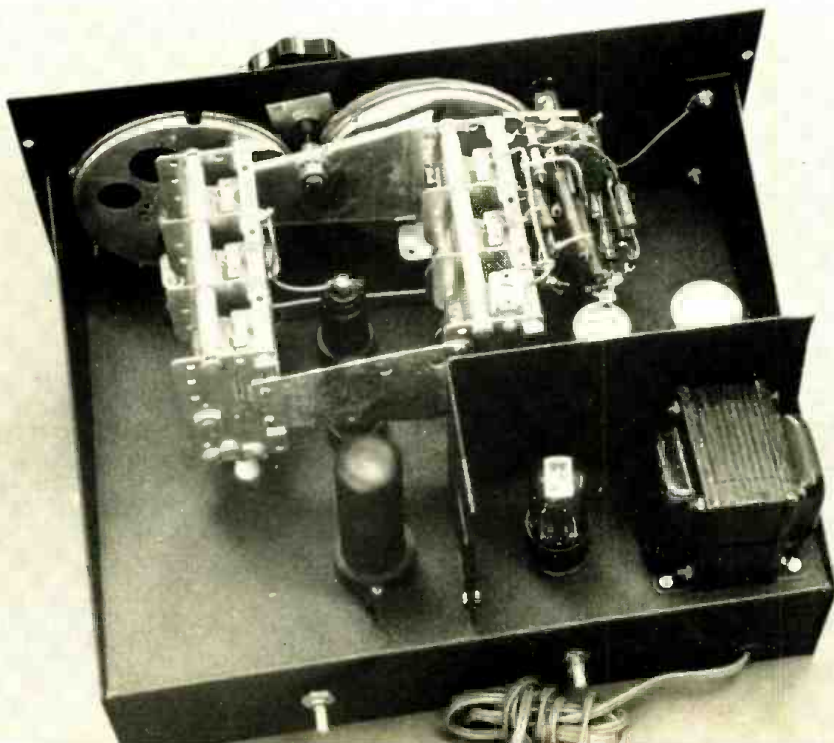



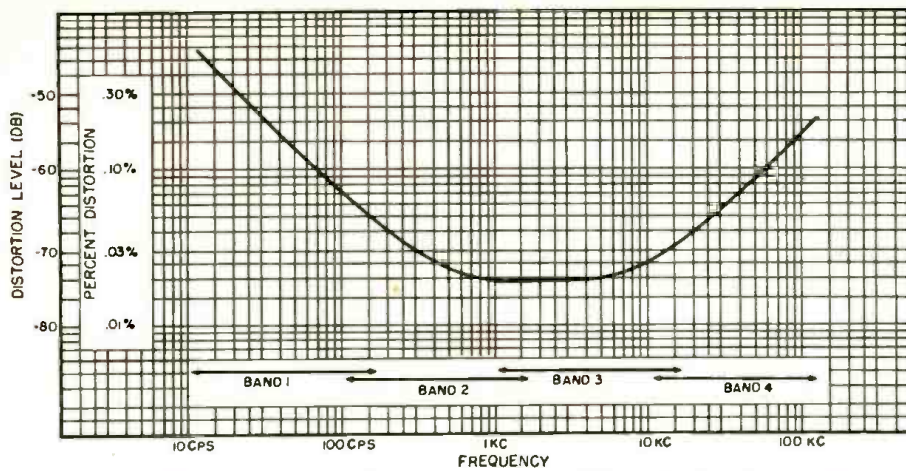

Fig. 3. Harmonic distortion and noise measurement of the audio signal generator. The measurements are valid for all levels including maximum output of 0.1 watt into a 600-ohm load. Residual distortion is 0.02%: rise at ends is discussed in text.

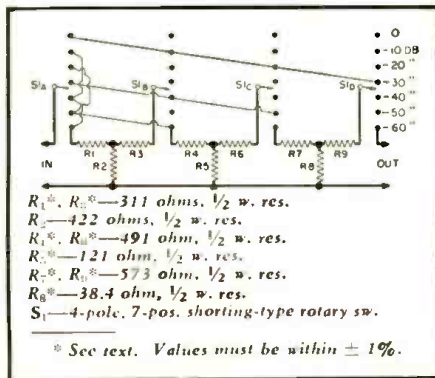

Fig. 4. Circuit of attenuator,  $R_{21}$ , Fig. 2.

6J7 tube was used for  $V_1$  because of the grid cap construction. The amplifier section consists of a 6SJ7 and a 1614 (or 6L6). A group of 600-ohm  $T$ -pads, isolated from the 1614 cathode by a 600-ohm resistor, is connected to the output terminals through a continuously variable 600-ohm  $T$ -pad. Three fixed pads of 10, 20, and 30 db attenuation are used. Resistance values to the nearest ohm are indicated both in the parts list and in Fig. 4 which shows the fixed attenuator wiring in schematic detail. The author constructed his own pads using a variety

of  $\frac{1}{2}$  watt composition resistors. These resistors were selected to give the desired attenuation and approximately the desired impedance. From experience it is recommended that a decade attenuator be purchased unless solving puzzles with a resistance bridge is appealing.

The tuning condensers were constructed by bolting together two three-gang 500- $\mu$ fd.-per-section tuning condensers with brackets of sheet aluminum (see photographs). Since the rotors are thereby electrically connected they must be wired to the grid of  $V_1$ . The entire assembly is mounted on ceramic stand-off insulators to insulate it from the chassis. On each condenser shaft a large dial wheel is mounted. These wheels are interconnected and driven by a dial cable, several turns of which wrap around a  $\frac{1}{4}$ " insulated shaft. This control shaft revolves in two panel bearings, one in the front panel and the other in the aluminum bracket holding the condenser frames. This construction may be seen in the photographs. An indicating dial was devised by mounting a circle cut from a sheet of polar co-ordinate graph paper on one of the dial wheels.

With two pentodes and the cathode

follower a gain of about 380 exists before negative feedback is applied. Reducing this gain to three means that a maximum of 42 db of feedback has been applied. If values of coupling or filtering condensers are to be changed, it is recommended that a regulated power supply be installed. Otherwise you may have to contend with low frequency oscillations of a few cycles-per-minute.

The distortion data on the author's unit is presented in Fig. 3. The inevitable rise in low frequency distortion is apparent, a 3 db rise in distortion having occurred around 300 cps. The lamp-bulb distortion might seem to be creeping in at an unduly high frequency. However, even at 100 cps this effect contributes only 0.06% to a total distortion of 0.075%. Had the residual distortion in the amplifier been around one-tenth of one per-cent, the lamp distortion would just be starting to show up around 100 cycles. As it is, the residual distortion (to be attributed to the amplifier sections) is around 0.02%. This indicates the wisdom of having used the pentode and the cathode follower instead of just a pentode. The rise in distortion at higher frequencies indicates a loss of gain due to shunt capacitances. As the gain goes down the ability of the feedback loop to control distortion deteriorates. In addition, these shunt capacitances change the operating curves for the tubes so that they produce more distortion for a given output. However, a distortion figure of less than one-tenth of one per-cent at 50,000 cycles seems adequate, especially since most commercial harmonic distortion meters will read a little less than 0.10% distortion and will make such measurements only below 15,000 cycles.

After several months of continual use, the equipment has proved to be very satisfactory. The relatively undistorted output is an obvious asset. That this distortion (including hum and noise) is still a very small fraction of the output even at very low output levels has proved of equal importance.

—30—

A close-up view, showing method of mounting and ganging the tuning condenser. See text for details on condenser changes.

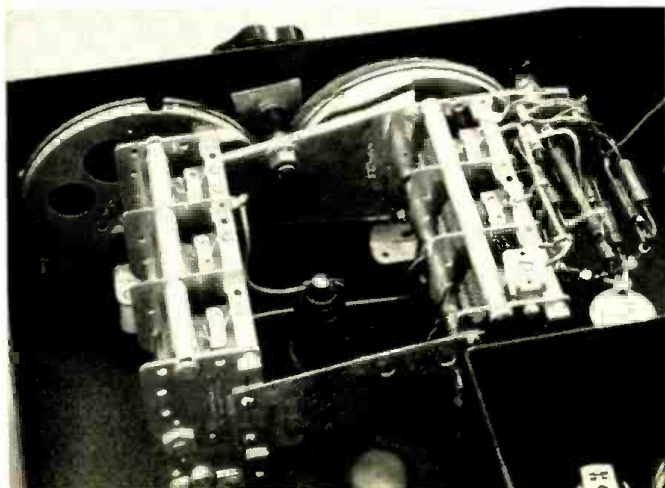

Under-chassis view, showing parts placement, condenser shock mounts, and attenuator assembly. All wiring is point-to-point.

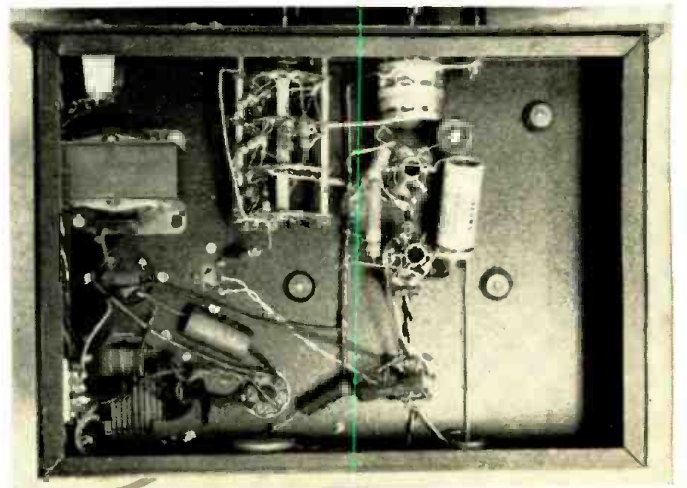







# MAC'S RADIO SERVICE SHOP

By JOHN T. FRYE

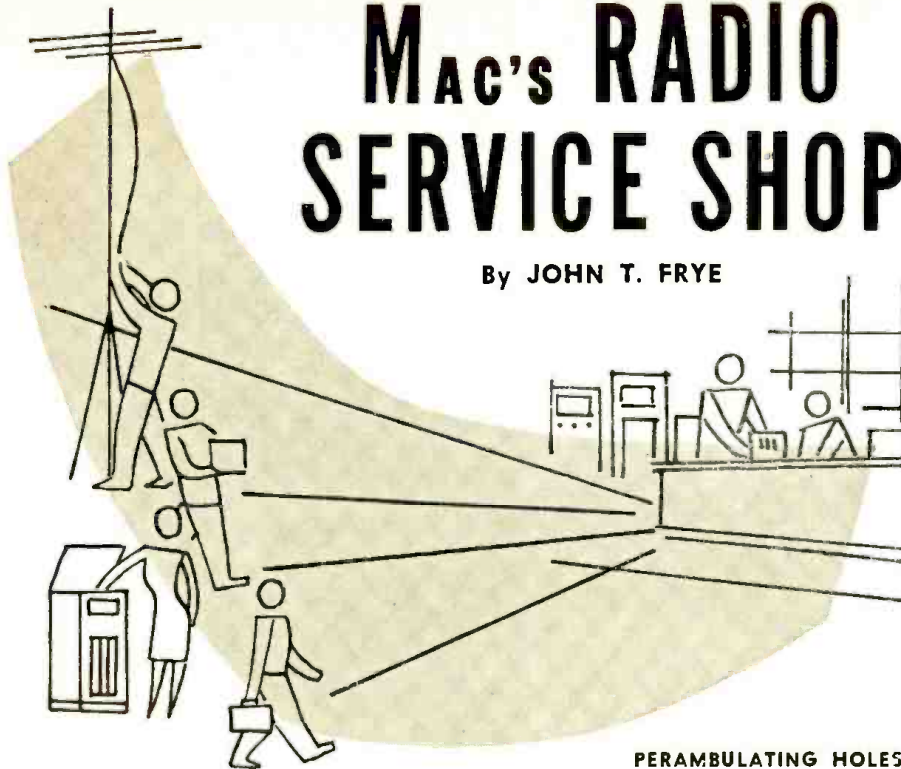

PERAMBULATING HOLES

"HEY, Mac," Barney addressed his boss, "How're you doing with your transistor experiments?"

"I'm learning about as fast as you could expect for an old dog," Mac said as he glanced up from the width coil he was installing. "The hard thing for me is to quit thinking about them as tube substitutes. I keep wanting to use transistors in straight tube circuits instead of working out new circuits designed for their peculiar characteristics. But why do you ask?"

"Well, I've been reading a few articles on them myself, but one thing has me stymied: I simply can't get this business of 'hole conduction' through my head."

"For a man already equipped with a hole in the head that ought to be easy," Mac murmured.

"Never mind the cracks, Wise Guy," Barney exclaimed. "In my book a hole is a large chunk of nothing, and how 'nothing' can conduct 'something'—even though that 'something' is only electrical current—throws me. When I think about it for a while I get that same too-many-rides-on-the-merry-go-round feeling I always have when I try to picture limitless space. Do you suppose you could straighten me out on this hole-conduction thing?"

"I can try," Mac said. "You know that an atom consists of a positive nucleus and a number of electrons circling around that nucleus. Normally the total negative charges of these electrons just balance the positive charge of the nucleus and so produce a net neutral charge on the atom. The electrons occupy various orbits or 'shells' at different distances from the nucleus. Those in the outermost shell are called valence electrons, and they can be thought of as sort of combining

hooks that permit fastening the atoms together in a stable structure.

"For example, each pure germanium atom has four valence electrons, and each of these 'pairs' with a similar valence electron in an adjoining atom to constitute a lattice that fits together as neatly and completely as do the similar squares of a checker board.

"Suppose now we introduce into this geometrical paradise an impurity atom that has five valence electrons. When this five-sided stranger tries to fit in with our four-sided germanium atoms, it doesn't quite come off. Four of the valence electrons of the impurity atoms can tie in with valence electrons of four germanium atoms, but that leaves a single spare electron kicking around loose like a lone stag at a high school dance. The only way this unattached electron can pair with another valence electron is by first casting loose that electron's partner to go wandering around. It is kind of like the game of Pussy-wants-a-corner. Since there is one more player than there are corners, one player always lacks a place to stay. When we add several five-valence-electrons atoms to pure germanium, we create a number of these unattached electrons in the mixture. The presence of these extra negatively-charged electrons gives the material a predominantly negative charge, and we call it *n*—for negative—type germanium."

"But what's all that got to do with holes," Barney interrupted impatiently.

"Keep your shirt on; I'm coming to that," Mac admonished. "Suppose we inject an impurity atom with only three valence electrons into our pure germanium. This three-sided atom

will not fit into our four-sided germanium atom structure any better than did the other type of impurity. Each of the three valence electrons of the injected atoms can combine with a valence electron from a neighboring atom to form a pair, but there will be a fourth neighbor that will have no electron with which to pair; in other words that particular locality will be one electron short.

"Remember that in our pure germanium the positive and negative charges were balanced. Now, at the spot where the electron shortage exists, there will be a positively-charged 'hole,' for a positive charge always results when we remove negatively-charged electrons—in fact, you can define a positive charge as a deficiency of electrons."

"Okay, so you've created a hole; now let's see you make it move," Barney challenged.

Mac arranged a row of ten ceramic condensers on the bench about an inch apart. Then he removed the second from the left.

"Let's pretend this gap from which I took the condenser represents a hole in the germanium," he said. "Look what happens when I slide #3 condenser over into the place of the missing #2: the gap has moved one space to the right. If #4 condenser is slid to the left our gap moves again to the right. We can keep right on sliding condensers to the left into the gap, and the gap will continue to move to the right until it reaches the end of the line. Be sure and note that the gap moved only when a condenser moved; yet each condenser moved only about an inch while the gap moved from one end of the line to the other.

"That's exactly how the positively-charged hole moves through the germanium. A valence electron from an adjoining atom is attracted into the hole and fills it, but in doing this it leaves a hole at the place from where it came. For all practical purposes, the hole jumps from where this moving electron is to where it was. Another electron plugs this new hole and creates another hole at its former resting place. In this fashion, skipping from atom to atom, our hole moves through the germanium. Except for the fact that its charge is positive instead of negative, we can treat it exactly as we do an electron. It will seek a negative electrode just as an electron seeks a positive electrode. Material containing a large number of three-valence-electrons atoms is predominantly positive and is called *p*—for positive—type germanium."

"You know," Barney grudgingly admitted, "I think I'm beginning to understand how this hole business works. Now why don't you go on and brief me on the whole subject of how transistors tick?"

"Oh no you don't!" Mac said firmly. "As Confucius really said, 'When I have presented one corner of a subject, and the pupil cannot of himself



make out the other three, I do not repeat the lesson.' You said the thing that puzzled you was the idea of holes and how they moved about. Now that is cleared up, you can go back and reread those magazine articles on transistor theory and possibly get more sense out of them. Anyway, I'm on to your little game. You are trying to keep me talking so I won't notice how long you have been on that little set. What's the matter with it?"

"That's what I'm trying to find out," Barney said tartly. "The little cuss has got what you might call confusing symptoms. It has no pep on weak stations; yet it overloads on strong stations. When I noticed the overloading I checked the a.v.c. voltage and found a very funny thing: On weak stations or even on no station at all, the voltage on the a.v.c. bus is two or three volts high; yet when I tune in the local station, this voltage only goes up a few more volts. The resistors in the a.v.c. system are all normal in value; I unsoldered the condensers and checked them for leakage without finding any; and I've tried substituting all new tubes. You got any bright ideas?"

"As the French say, 'When in doubt, *cherchez la diagram*,'" Mac remarked as he slid a service manual from the shelf and flipped it open. He studied the diagram of the little set intently for a few minutes, compared the pictured view of the bottom of the receiver with the set itself, and then shut the book.

"Put the vacuum tube voltmeter on the a.v.c. bus again," he told Barney.

The boy clipped the meter to "B-minus" and the a.v.c. lead and obtained a reading of around six volts even when no station was tuned in. When the local station was being received, this value rose to only eight or nine volts and the reception became distorted. While watching the meter, Mac reached over and placed his finger on the stator of the oscillator tuning condenser. Immediately the meter needle fell back to a reading of about one volt. When the finger was removed, the pointer jumped back up to the original high value.

"What does that tell you?" Mac asked Barney.

"Only that when you kill the oscillator the a.v.c. voltage returns to normal. Do you suppose that the oscillator is somehow feeding through to the diode detector and is being rectified and is causing that high a.v.c. voltage?"

"Hardly seems likely." Mac demurred. "And that still would not explain the fact that you cannot develop enough voltage on a strong station. Take the noise-locating probe of the signal tracer and check this little mica condenser right here."

Barney switched the signal tracer to the "Noise" position, which placed a voltage of about two hundred volts

(Continued on page 117)

# TV PARTS REPLACEMENT GUIDE

## TV POWER TRANSFORMERS

Concluding the list of power transformers used in TV sets and their replacements available from most distributors.

All data was furnished by the parts manufacturers listed.

RECEIVER MFR. Part No.	CHICAGO Part No.	HALLDORSON Part No.	MERIT Part No.	TRIAD Part No.	THORDARSON Part No.
<b>PHILCO</b>					
32-8303	TP-405†	P9711†	P-3053	R-37BC	T-26R00
32-8364-1	TP-350				
32-8376	TP-450	P9725	P-3054	R-40BC	T-26R19
32-8381			P-3079		
32-8391	TP-450†	P9725	P-3054	R-40BC	
32-8411-1	TP-355†	P9711	P-3169	R-35A	T-26R19
32-8417	TP-450†	P9727		R-40BC	
32-8423-2		P9713	P-3059	R-37BC	T-26R00
32-8429			P-3055	R-50BC	
32-8452			P-3076		T-26R21
32-8468		F5905		F-51X & 52X	
32-8469	TP-319	P9737	P-3055	R-50BC	
32-8481		P9737	P-3053	R-50BC	
32-8488		P9737	P-3053		
<b>RCA</b>					
7874			P-3063		
37048	PH-145	P9317		R-18B	T-26R23
71415	TP-365	P9731	P-3061	R-31BC	T-26R00
71772	TP-392	P9713	P-3059	R-35BC	T-26R19
71975	PH-70B†	P9713	P2951†	R-11B	T5-24R04
72177	PH-200	P9705	P-3063	R-20B	T-26R23
73567	TP-383	P9709	P-3063	R-33BC	T-26R19
73601	PH-70	P9215	P-2952	R-5B & F-16X	
74046	TP-392	P9711	P-3063	R-35BC	T-26R19
74143	TP-383	P9719	P-3053	R-37BC	T-26R00
74586	TP-370	P9711	P-3063	R-38BC	T-26R00
74874	TP-356	P9731	P-3063	R-38BC	T-26R00
74949	TP-360	P9731	P-3063	R-35BC	T-26R19
74981	TP-356	P9711	P-3078	F-51X & R-35BC	T-26R00
75084	TP-356	P9731	P-3053	F-16X & R-37BC	T-26R00
75207	TP-280		P-3079		
75508	TP-360, 368	P9705	P-3059	R-38BC, 33BC	T-26R19
75566		P9305	P-3051		
76429	TP-280		P-3079		
76495	TP-356	P9737		R-37BC & F-51X	T-26R00
91975		P9311			
940762-1		P9713	P-3063		
<b>RAYTHEON</b>					
B-12D-19250				F-50X	
C-12A-17822	TP-355	P9711	P-3059	R-20BC	T-26R23
C-12A-18399	TP-360	P9711	P-3059	R-35BC	T-26R19
C-12A-18839	TP-360	P9711	P-3059	R-35BC	T-26R19
C-12A-19942	TP-356X	P9711	P-3059	R-37BC	T-26R00
12A-18839		P9711	P-3059		T-26R21
<b>SENTINEL</b>					
22E30	TP-410*	P9707		R-20B	T-26R23
22E43	TP-405 & FO-615		P-3078	R-38B	T-26R00
22E53				R-36B & F-52X	
22E56				R-33B & F-52X	T-26R00
<b>SILVERTONE</b>					
52C-185		P9702	P-3169	R-42A	TV-24R98
A-1098		P9717		R-35B	T-26R19
A-10109	TP-360	P9705†	P-3069	R-47B5	T-26R19
M-52C199	TP-370†	P9708	P-3169	R-38A	T-26R00
N-22397	TP-225		P-3070	R-39B	T-26R21
N-23837	TP-315	P9715		R-39A	T-26R21
N-23840	FO-610†	F5516	P-2948	F-21A	T-21F12
R-65432	PH-70*	P9213	P-3048	R-37B	
R-65463	TP-395	P9719†	P-3059	R-37B	
R-66191	PH-70*	P9213		R-5B	
R-67304		P9213	P-3059	R-5B	
R-70190	TP-395	P9719	P-3053	R-36B	
TR-21			P-3148	R-8A	
TTR-105	TP-355	P9713	P-3063	R-35B	T-26R19
TTR-170D		P9731		R-38B	T-26R00
TTR-182D	TP-405 & FO-615	P9731	P-3078	R-38B	T-26R00
TTR-188D	TP-360†	P9711	P-3059	R-35B	T-26R19
W-508060	TP-375	P9717	P-3067	R-35B	T-26R19
W-508702		P9717	P-3067	R-40B	
W-509380	TP-370*	P9705	P-3055		

\* Add series resistor. † Drill new mounting holes. † Use universal mounting brackets. † Use resistor in rectifier plate lead. (Continued on page 70)



# A TRANSISTOR "ELECTRIC ORGAN"

By  
LOUIS E. GARNER, JR.

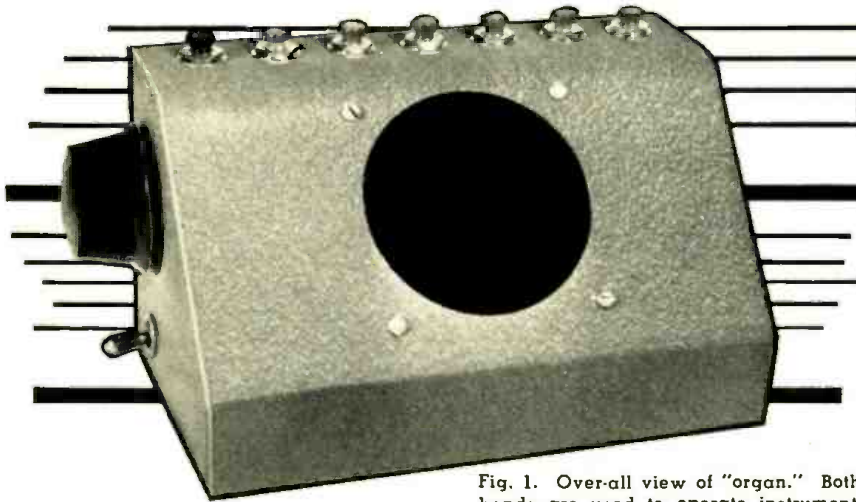

Fig. 1. Over-all view of "organ." Both hands are used to operate instrument.

*An interesting project for the experimenter, this battery operated unit requires few parts for its construction.*

**A**LTHOUGH the device shown in Fig. 1 is not an "organ" in the truest sense of the word, it is capable of producing tunes when operated by a person of moderate skill. In fact, the operator need not be a skilled musician. The average person, with a little practice, can "pick out" tunes, playing one note at a time.

As a toy, the "electric organ" shown is of real value. The author has several times turned his model over to his children, who enjoy playing with it in preference to their more conventional toy pianos, toy xylophones, toy guitars, and other toy musical "instruments." But the value of the device as a toy is not limited to its appeal to children. Although the output is obtained through a loudspeaker, the volume is not so high as to prove distracting to the parents. The children can "make music" to their little hearts' content while the parents, in an adjoining room, can watch television, listen to the radio, or even read, without distraction.

Another real advantage of the "electric organ" shown is its independence from the power line, and the fact that there is relatively no danger of electric shock. Nor is the design such that the battery used has to be replaced every day or so. With average use, the battery should last its normal "shelf life."

These desirable characteristics, for a toy, have all been made possible by utilizing a Raytheon junction transistor in a simple oscillator circuit. As can be seen by reference to the schematic diagram, Fig. 2, relatively few other parts are required for the operation of the unit.

Referring to the schematic diagram, Fig. 2, a type CK722 transistor is con-

nected as a modified grounded-emitter "Hartley" oscillator. The emitter is connected through push-button switch  $S_1$  to the positive terminal of a small hearing-aid type battery, and the collector is connected through one-half of the transformer ( $T_1$ ) primary winding to the negative terminal of the battery.

The necessary feedback signal for operation is obtained from the other half of the transformer primary winding, which is connected through coupling condenser  $C_1$  to the base of the transistor.

Resistors  $R_2$  to  $R_4$  serve as "base return" resistors, with the desired resistance selected by depressing the proper push-button ( $S_2$  to  $S_4$ ). If toggle switch  $S_5$  is thrown, the "base return" resistor becomes  $R_1$  and  $R_2$  in series. Since  $R_1$  is variable, the total resistance value can be adjusted from the value of  $R_2$  to the sum of  $R_2$  and  $R_1$  or from 8200 ohms to more than 2 megohms.

The 3" PM loudspeaker is connected to the proper taps on the secondary winding of  $T_1$ . Transformer  $T_1$  thus serves both as an "oscillator coil" and as an "output transformer."

In operation, one of the resistor switches,  $S_1$  to  $S_4$ , and the power switch,  $S_5$ , are thrown simultaneously. Battery current can then flow over two paths.

Part of the current flows through the "base return" resistor and the base-emitter of the transistor, establishing the bias current for the transistor. The amount of bias current obtained depends on the battery voltage and the total impedance of the resistor plus the internal base-emitter impedance of the transistor. Since the external resistor generally has a

greater value than the internal impedance of the transistor base-emitter circuit, the base current, for practical purposes, can be said to depend primarily on the size of the "base return" resistor.

Current also flows over the path including half of the transformer primary winding and the collector-emitter circuit of the transistor. This is the collector current and its value depends primarily on the amount of base current flow (as well as on the battery voltage).

Any changes in collector current induce an a.c. voltage in the primary of transformer  $T_1$ . This voltage is coupled through condenser  $C_1$  to the base of the transistor, adding an a.c. component to the d.c. base current, and causing corresponding changes in collector current. Thus, the basic conditions for oscillation are set up—positive feedback from output to input circuit, coupled with stage gain.

The frequency of operation depends on the transistor characteristics, on the transformer used, on the value of coupling condenser  $C_1$ , and on the size of the "base return" resistor. Varying any of these factors permits the frequency to be changed. In practice, it has been found easiest to vary the size of the "base return" resistor, hence a selection of resistors ( $R_1$  to  $R_4$ ) with corresponding switches ( $S_2$  to  $S_4$ ).

Where a continuously variable resistor is used ( $R_1$ ), the frequency can be easily varied over wide ranges. In the model shown, the output frequency can be varied continuously from about 20 cps to about 10 kc. simply by adjusting  $R_1$ .

The frequency of operation bears an inverse relationship to the size of the "base return" resistor, that is, as the resistor value is reduced, the frequency of operation increases.

At the same time, the base current (and hence the collector current) increases. Thus, at high frequencies the battery current drain is several times greater than at lower frequencies. It is this characteristic that makes it necessary to provide a fixed resistor ( $R_2$ ) in series with the continuously variable control. Thus,  $R_2$ , although limiting the maximum frequency of operation when the variable control is used, also limits the maximum base and collector current and thus serves to protect the transistor from damage.

Since oscillation is obtained by means of "brute force" feedback rather than by employing a tuned cir-



cuit, the signal obtained is not a sine wave. Rather, it is extremely rich in harmonics. The exact waveform obtained varies with frequency, and also with the characteristics of the transistor and transformer used.

### Construction Hints

Because of the simplicity of the circuit, duplication of the model should not prove at all difficult for the average technician. The only real care that must be exercised is when installing the transistor. If the transistor is soldered directly into the circuit (instead of a socket being used), especial care must be taken that the transistor leads are not overheated.

Circuit layout, lead length, and lead arrangement all are completely non-critical. It is suggested, however, that standard good wiring practice be followed.

The author's model has been assembled in a standard ICA sloping front cabinet, and easily obtained push-button switches used for the various "keys." A different color push-button (black) was used for the "power" key ( $S_1$ ) than for the "tone" keys ( $S_2$  to  $S_6$ —red push-buttons were used here). Six notes were provided, plus a continuously variable control ( $R_1$ ).

The prospective builder may use any arrangement of keys and case which he feels is desirable. An ingenious technician should have no difficulty in modifying the keys of a toy piano to serve as switches for the "electric organ," assembling the rest of the components within the case of the piano. If space permits, the loudspeaker could be mounted within the toy piano case, otherwise it could be mounted separately (a sloping panel meter case makes an excellent "baffle" for a 2" or 3" speaker).

If preferred, a 5", 6", 8" or larger speaker may be used in place of the 3" speaker used by the author.

The transformer used by the author is of the "universal replacement" type with a multi-tapped secondary winding. If the builder uses a similar transformer, he should experiment with loudspeaker connections to the different taps, choosing the pair giving the best results.

Although only six "keys" (and hence six notes) are provided in the model shown, any number of keys may be used, simply by adding more switches and different value resistors. Thus, if a child's toy piano is used as the basic unit, a different note can be supplied by every key on the board.

Since the frequency (tone) of the note obtained as each key is depressed depends not only on the size of the "base return" resistor ( $R_1$  to  $R_6$ ) but also on the individual characteristics of the transistor and transformer used, there is no simple way of determining the size of these resistors in advance. Rather, they are determined experimentally after the unit is wired and tested.

Two methods may be employed for choosing these resistors. If the com-

pleted unit is to be used primarily as a toy, the resistor values may be chosen arbitrarily without regard to the notes obtained. This method was used in the author's model. A series of resistors having values of 150,000, 170,000, 190,000, 210,000, and 260,000 ohms were used.

On the other hand, if the builder intends to use the completed unit to play actual tunes, each key should be adjusted to give the desired musical note. This can be done either by using a potentiometer to determine the proper resistor value, later permanently installing a fixed resistor, or by using a rheostat for each resistor. The second method is the more flexible as it permits readjustment at any time, but is also the more expensive, requiring a separate potentiometer for each note to be sounded.

(Note: For the frequency of various musical notes, refer to "Fun with a Home-Built Electronic Organ," by Jim Kirk, RADIO & TELEVISION NEWS, March 1953.)

The continuously variable control was included in the author's model more as a novelty than for any serious purpose. However, it does permit unusual tonal effects to be obtained, and may be either retained or omitted, as desired by the builder. Some builders may even wish to provide several such controls.

### Operation

In the author's model a separate power switch, as such, has not been provided. Rather, the power switch ( $S_1$ ) becomes one of the "playing keys."

To sound a particular note, the desired "tone key" ( $S_2$  to  $S_6$ ) and the "power key" ( $S_1$ ) are depressed simultaneously. They are held down long enough to sound the desired interval (quarter note, half note, full note, etc.) and then released together.

Either one finger of each hand may be used, in approved "hunt and peck" typewriter style, or the fingers of both hands may be employed to cover all the operating "keys." The latter tech-

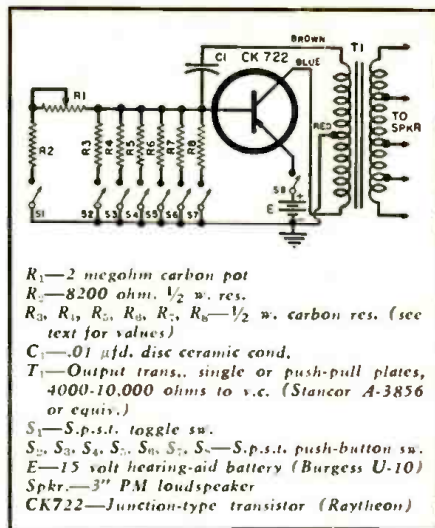

Fig. 2. Schematic of transistor "organ."

nique requires considerably more practice to be used successfully than the former.

To use the continuously variable control, the toggle switch ( $S_1$ ) is thrown. One note at a time may be sounded by rotating the knob (on the side of the case in the author's model) to the desired position, then depressing and releasing the "power key." If a continually changing note is desired, the "power key" is held down while the control knob is rotated back and forth. Quite eerie effects can be obtained by doing this.

Since depressing more than one "tone key" at a time essentially connects two or more resistors in parallel, considerable change in resistance, and hence in the frequency of the note sounded, results. This enables the operator to achieve unusual tonal effects by depressing two, three, or more of the "tone keys" simultaneously. Other effects may be obtained by using the continuously variable control in conjunction with the individual "tone keys" (by throwing toggle switch  $S_1$  and then depressing a "tone key" and the "power key" simultaneously).

-30-

Fig. 3. Internal view of unit. The "organ" is housed in a standard instrument cabinet.

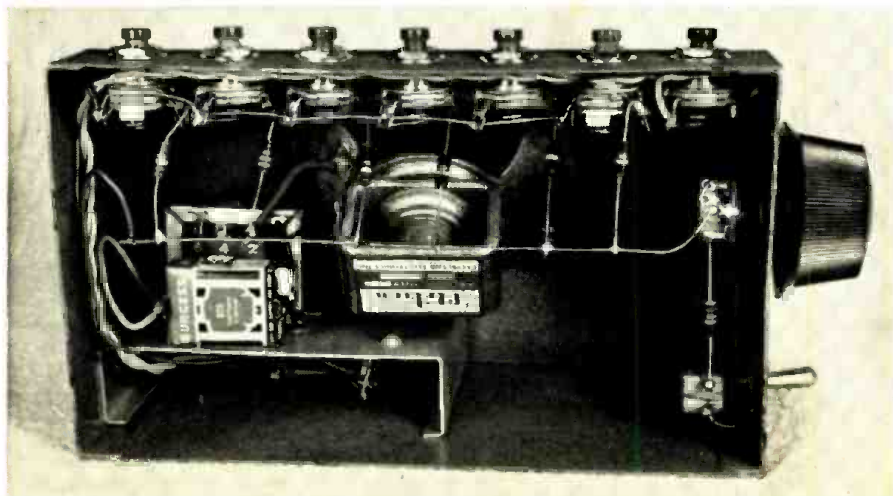





# International SHORT-WAVE

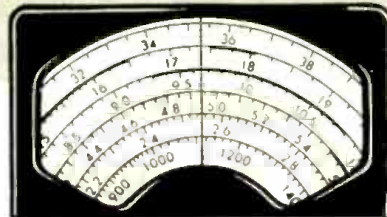

Compiled by KENNETH R. BOORD

**T**HE INTERNATIONAL SHORT-WAVE CLUB, London, is now carrying on its second short-wave station popularity contest. Until July 31, all short-wave listeners throughout the world—whether members of ISWC or not—are invited to write down names of their three favorite short-wave broadcasters; in as few words as possible, explain why the No. 1 choice is the favored station; then mail this vote to Arthur E. Bear, Secy., ISWC, 100, Adams Garden Estate, London, S.E. 16, England. Suitable prizes will be awarded for best explanations, and results will be announced in the August bulletin of ISWC.

### Club Notes

**England**—Headquarters for the International Short-Wave League is 86, Barringer Road, London N. 10, England; editor is J. Eric Alban, G3JEA, 85, Inverness Terrace, London, W. 2, England. (*Monitor*) W. A. Winchester, 4, Woodgate Road, Eastbourne, Sussex, England, head of the ISWL Correspondence Bureau, would be glad to hear from anyone interested in corresponding with persons in other countries (list choice of countries); an IRC should be enclosed, along with

This attractive Listening Post of veteran DX-er J. W. (Jack) Sherman, Tampa, Florida, is built around a National HRO. Sherman has an ingenious system of antenna masts and towers, all built so they can be lowered to the ground and anchored safely in about five minutes to avoid hurricane damage to his rather elaborate installation.



a self-addressed envelope for reply.

**Japan**—The Japan DX Radio Club, Box 7, Nerima, Tokyo, Japan, publishes an Overseas Edition of its bulletin (in *English*); welcomes members from throughout the world. (Ishikawa, Japan)

**USA**—The annual outing of the United 49'ers Radio Society will be July 18 at the farm of Jim Pickering, Highstown, New Jersey.

### Around the World

**Albania**—Radio Tirana, 7.850, 6.560, now has news 2345-2400, 1415-1430. (Pearce, England)

**Anglo-Egyptian Sudan**—Radio Omdurman, listed 524 kc., 6.437, 7.600, gives schedule as Arabic daily 2315-2345, 1130-1430; Fri. only 0300-0430, 0900-1000; Sun. only 0300-0400; in *English* on Fri. 1230-1300, Sun. and Wed. 1115-1130. (Hardwick, N. Z.)

**Angola**—Radio Clube de Huilla, 10.048, noted 1335 with talk in Portuguese;

(Note: Unless otherwise indicated, all time is expressed in American EST; add 5 hours for GMT. "News" refers to newscasts in the English language. In order to avoid confusion, the 24 hour clock has been used in designating the times of broadcasts. The hours from midnight until noon are shown as 0000 to 1200 while from 1 p.m. to midnight are shown as 1300 to 2400.) The symbol "V" following a listed frequency indicates "varying." The station may operate either above or below the frequency given. "A" means frequency is approximate.

often has severe CWQRM. (Pearce, England) Closing 1600 with "A Portuguesa;" measured 10.046. (Earnhardt, N. C.) Luanda, 11.862A, was noted recently on *extended* schedule to 1830 closedown. (Niblack, Ind.) Mercier, France, says CR6RO, Silva Porto, is still using 7.582 to 1530 closedown; best around 1415. (*Nattugglan*, Sweden)

**Argentina**—LRA, 9.69, signs on now 2030 instead of 2100; Spanish. (Balbi, Calif.) Noted at good level in *English* 1800 over 15.345. (Jacobson, Ill., others)

**Australia**—By this time, *Radio Australia* should have moved from 11.840 to 11.810 for the North American East Coast "morning" beam 0700-0845, with Sunday DX session 0830.

**Azores**—Ponta Delgada's 11.090 outlet is on *summer* schedule of 1400-1500. (Ferguson, N. C.) Heard on 4.865 at 1530 with news in Portuguese.

**Bechuanaland**—Mafeking's 5.900 outlet is strong in South Africa 1400-1500. (Sarkady)

**Belgian Congo**—OTM2, 9.380, Leopoldville, noted closing 1600 at excellent level in N. J. (Scheiner) OTM4, 6.295, noted with *English* announcement 2327, good level, some QRM. (Dadson, Mich.)

**Belgium**—ORU, 6.000, signs on 1300 with multilingual calls including *English*; this service runs 1300-1600 for Northern Europe. (Pearce, England) Heard over 11.850 at good level 1400. (Scheiner, N. J.) Noted on 17.860 with news 0515. (Sanderson, Australia.) ORU heard over 9.767 to North America 2000-2205 (some days to 2230) parallel OTC, 9.655, Leopoldville, Belgian Congo. (Matherly, Ohio, others)

**Canada**—CJCN, 6.010, Sydney, N.S., has news 1830, frequent commercials. (Niblack, Ind.) CHNX, 6.130, Halifax, N.S., noted 2230-2313 sign-off. (Hamilton, Mo.)

**Cape Verde Islands**—CR4AA, near 7.400, noted signing on with "A Portuguesa" 1500; news in Portuguese 1545; off 1658 with "A Portuguesa." (Pearce, England)

**Ceylon**—Colombo, 9.57, relays VOA currently 0830-1200 to India-Pakistan; heard well in Britain. (O'Sullivan) *Radio Ceylon*, 3.320, noted 0630 with musical program, commercials. (Sanderson, Australia) Good level on 11.975 at 1030 relaying VOA. (Jacobson, Ill.; Fuller, R. I., others)

(Continued on page 104)



# HERE'S A WINNING CARD...



## The **RAYTHEON** Bonded Electronic Technician's Identification Card

is mighty important to customers. It instantly identifies the bearer as an expert technician representing a reputable company — lends reassurance to the apprehensive set owner.

But this is only one of the ways the *Raytheon Bonded Electronic Technician Program* helps you. The cash-protection of the Raytheon Bond (backed by

Continental Casualty Company), the Raytheon "Code of Ethics" and the sound, sensible business methods the code suggests all help to create customer confidence and good will. That means more business now, and more business in the future from a steadily increasing backlog of satisfied customers.

This potent weapon in the war against consumer mistrust is yours *without cost* if you can qualify for it. It is Raytheon's investment in *your* future. Call your Raytheon Tube Distributor today, and ask him if you can become a *Raytheon Bonded Electronic Technician*.



RIGHT... FOR SOUND AND SIGHT



**RAYTHEON MANUFACTURING COMPANY**

Receiving Tube Division  
Newton, Mass., Chicago, Ill., Atlanta, Ga., Los Angeles, Calif.

*Excellence in Electronics*

RAYTHEON MAKES ALL THESE: RECEIVING AND PICTURE TUBES • RELIABLE SUBMINIATURE AND MINIATURE TUBES • GERMANIUM DIODES AND TRANSISTORS • NUCLEONIC TUBES • MICROWAVE TUBES









**TRAIN FASTER—TRAIN BETTER—TRAIN EASIER  
 IN 10 MONTHS—OR LESS—FOR  
**RADIO-TELEVISION****

Our 21st Year Training Men for Greater Incomes and Security in Radio-Television

**I SEND YOU  
 18 BIG KITS**

of Radio Television parts and equipment. Much of your training will be actual construction and experimentation . . . the kind of truly PRACTICAL instruction that prepares you for your Radio-Television career.



Frank L. Sprayberry  
 President  
 Sprayberry Academy  
 of Radio

**NEW! NO OBLIGATION PLAN**

**You Have No Monthly Payment Contract to Sign  
 Pay For Your Training as You Earn and Learn**

You can get into Radio-Television, today's fastest growing big money opportunity field, in *months* instead of years! My completely new "package unit" training plan prepares you in as little as 10 months or even less! *No monthly payment contract to sign—thus NO RISK to you!*

This is America's finest, most complete, practical training—gets you ready to handle any practical job in the booming Radio-Television industry. Start your own profitable Radio-Television shop . . . or accept a good paying job. I have trained hundreds of successful Radio-Television technicians during the past 21 years—and stand ready to train you, even if you have no previous experience! Mail coupon and get all the facts—FREE!



**Valuable Equipment Included  
 With Training**

The new Sprayberry "package" plan includes many big kits of genuine, professional Radio-Television equipment. You perform over 300 demonstrations, experiments and construction projects. You build a powerful 6-tube 2-band radio set, multi-range test meter, signal generator, signal tracer, many other projects. All equipment and lessons are *yours to keep* . . . you have practically everything you need to set up your own profitable Radio-Television service shop.

**Earn Extra Money While You Learn!**

All your 10 months of training is **IN YOUR HOME** in spare hours. Keep on with your present job and income while learning. With each training "package" unit, you receive extra plans and "Business Builder" ideas for spare time Radio-Television jobs. New television stations everywhere, open vast new opportunities for trained Radio-Television Technicians—and those in training. If you expect to be in the armed forces later, there is no better preparation than practical Sprayberry Radio-Television training.

**YOU BUILD** the Television set and the powerful superhet radio receiver shown above. **IN ADDITION** to the other test units shown here (many are not shown because of lack of space). All equipment I send you is **YOURS TO KEEP.**

Approved for Veterans under the G. I. Bill

**SPRAYBERRY ACADEMY OF RADIO 111 NORTH CANAL ST.  
 Dept. 25-Y, Chicago 6, Ill.**

**MAIL COUPON  
 TODAY!  
 NO OBLIGATION**

I invite you to get all the facts—  
**FREE TO YOU 3 BIG  
 RADIO-TELEVISION BOOKS**

I want you to have ALL the facts about my new 10-MONTH Radio-Television Training—without cost! Rush coupon for my three big Radio-Television books: "How to Make Money in Radio-Television." PLUS my new illustrated Television Bulletin PLUS an actual sample Sprayberry Lesson—ALL FREE. No obligation and no salesman will call. Mail coupon NOW!

**SPRAYBERRY ACADEMY OF RADIO, Dept. 2 -Y  
 111 North Canal St., Chicago 6, Ill.**

Please rush to me all information on your 10-MONTH Radio-Television Training Plan. I understand this does not obligate me and that no salesman will call upon me. Be sure to include 3 books FREE.

Name..... Age.....

Address.....

City..... Zone..... State.....





to the

**E. E. or**

**PHYSICS GRADUATE**

with an interest  
or experience in

**RADAR or**

**ELECTRONICS**

*Hughes Research and Development Laboratories, one of the nation's large electronic organizations, are now creating a number of new openings in an important phase of operations.*

*Here is what one of these positions offers you*

**OUR COMPANY**

located in Southern California, is presently engaged in the development of advanced radar devices, electronic computers and guided missiles.

**THESE NEW POSITIONS**

are for men who will serve as technical advisors to the companies and government agencies purchasing Hughes equipment.

**YOU WILL BE TRAINED**

(at full pay) in our Laboratories for several months until you are thoroughly familiar with the equipment that you will later help the Services to understand and properly employ.

**AFTER TRAINING**

you may (1) remain with the Laboratories in Southern California in an instruction or administrative capacity, (2) become the Hughes representative at a company where our equipment is being installed, or (3) be the Hughes representative at a military base in this country—or overseas (single men only). Adequate traveling allowances are given, and married men keep their families with them at all times.

**YOUR FUTURE**

in the expanding electronics field will be enhanced by the all-around experience gained. As the employment of commercial electronic systems increases, you will find this training in the most advanced techniques extremely valuable.

*How to apply*

*If you are under 35 years of age and have an E.E. or Physics degree and an interest or experience in radar or electronics,*

write

**to HUGHES**

**RESEARCH AND DEVELOPMENT LABORATORIES**

*Scientific and Engineering Staff*

*Culver City, Los Angeles County, California*

Assurance is required that the relocation of the applicant will not cause the disruption of an urgent military project.

# TV PARTS REPLACEMENT GUIDE

## TV POWER TRANSFORMERS

(Continued from page 63)

RECEIVER MFR. Part No.	CHICAGO Part No.	HALLDORSON Part No.	MERIT Part No.	TRIAD Part No.	THORDARSON Part No.
<b>SPARTON</b>					
AB44014-1		P9731	P-3053	R-33B & F-16X	T-26R00
AB44015-1	TP-360	P9711	P-3059	R-35B	T-26R19
AB44017-1	PV-200* & FO-615	P9708	P-3169 †	R-16A & F-51X	
AB44018-1	TP-450	P9725	P-3067	R-40B	
AB44019-1;		P9727	P-3054		
020-1					
AB44021-1		P9727	P-3067	R-40B	
AB44027-1	TP-360	P9711	P-3059		
<b>STEWART-WARNER</b>					
508060	TP-375*	P9717		R-35B	T-26R19
508702	TP-450*	P9717	P-3054	R-35B	T-26R19
509380	TP-370*	P9705	P-3053	R-39B	T-26R19
509679				R-35B	T-26R19
520487	TP-356	P9711			
709679				R-40B & F-50X	
<b>STROMBERG-CARLSON</b>					
161414				R-40A	T-26R00
161417		P9728	P-3174	R-50A	
161419	TP-395*	P9709	P-3059	R-38B	T-26R00
161421		P9728		R-50B & F-13X	
161423				R-36B	
161424			P-3053	F-16X	T-21F10
161425	FO-63	F5512	P-2946	F-51X	
161427			P-3053	R-50B	
161429	TP-356*				
Models 317RPM, 317TM			P-3055	R-50B	
<b>TELE-TONE</b>					
TTR-105	TP-355	P9713	P-3059	R-35B	T-26R19
TTR-170-D		P9731		R-33A	T-26R19
TTR-174-D	FO-615 & FO-610			F-21A & F-13X	T-21F12
TTR-182-D	TP-405 & FO-615	P9737	P-3078	R-38B	T-26R00
TTR-188-D	TP-360 †	P9711	P-3059	R-35B	T-26R19
TTR-193-D	TP-405*	P9739	P-3055	R-39B	T-26R21
TTR-222D	FO-615	F5511	P-3074	F-52X	T-21F60
<b>TRAV-LER</b>					
TV-TR1	TP-360 †	P9708	P-3169	R-33A	
TV-TR-9		P9730	P-3169	R-38A	T-26R00
<b>TRUETONE</b>					
C12A-18839	TP-360*	P9711	P-3070	R-35B	T-26R19
52C170	TP-410	P9713	P-3169	R-35A	T-26R19
52C196		P9733	P-3169	R-42A	TV-24R98
53X286	PH-120B	P9317		R-14B	TS-24R05
53X290	PH-70*	P9315		R-10B	
53X291		P9207		R-6B	
53X297		P9711	P-3063	R-35B	T-26R19
53X298	TP-355	P9713	P-3059	R-20B	T-26R23
53X302	TP-360	P9719	P-3059	R-37B	R-26R00
53X308	TP-392	P9731	P-3053	R-33B	T-26R19
53X313	TP-392	P9731	P-3053		
53X318	TP-360	P9709	P-3059	R-33B	T-26R19
<b>WESTINGHOUSE</b>					
V-5936		P9723	P-3066	R-50B	T-26R00
V-6131	PV-120	P9208		R-12B	TS-24R05
V-6481	FO-615	F5511		F-52X	T-21F60
V-6481-2	FO-615 †	F5529 †	P-3074	F-52X	T-21F60
V-6481-3	FO-615 †	F5529 †	P-3074	F-52X	T-21F60
V-6505	PV-70A †	P9305	P-2951 †	R-7B	
V-6851	PH-70B	P9307	P-2951	R-7B	
V-6988	TP-365*	P9721	P-3061	R-31B	T-26R00
V-9395	TP-225	P9723	P-3066		
V-9595-1	TP-365* & FO-615	P9723	P-3066	R-39B	T-26R21
V-9723	TP-356	P9723	P-3066	R-39B	T-26R21
V-9780		P9723	P-3066	R-39B	T-26R21
V-9899	TP-365* †	P9723	P-3066	R-39BC	
V-9958	TP-365* †	P9723	P-3066	R-38B	T-26R00
V-9958-2	PH-200	P9723	P-3066	R-39B	
<b>ZENITH</b>					
95-1124	TP-390	P9728	P-3174		
95-956	PV-200 †	P9318		R-20A	T-26R23
95-1115	TP-390	P9728			
95-1168	TP-390	P9725	P-3169	R-50B	
95-1169		P9725	P-3169	R-50B	
95-1171				F-21A & F-13X	T-21F12 & 21F08
95-1242	TP-358			R-35A*	T-26R19
95-1245	TP-362	P9728	P-3169	R-14A	
95-1253	PV-120A	P9314		R-40A	
95-1260	TP-358			R-40B	
95-1277	TP-324				

\* Add series resistor. † Drill new mounting holes. ‡ Use universal mounting brackets. § Use resistor in rectifier plate lead.



# BUILD YOUR OWN Heathkits

- TEST INSTRUMENTS
- AMPLIFIERS
- RECEIVERS, etc.

- 1 Save by ordering direct from manufacturer.
- 2 All high quality standard band components
- 3 Increased knowledge through actual construction
- 4 Sound engineering insures excellent performance
- 5 Kit construction is fascinating and enjoyable

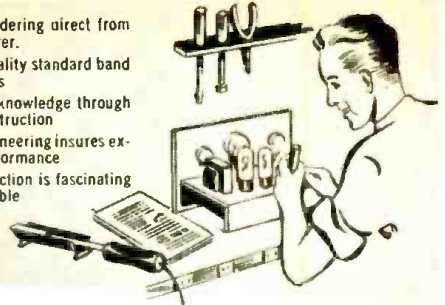

**\$43<sup>50</sup>**  
Shipping  
Wt. 26 lbs.

## Heathkit MODEL O-8 OSCILLOSCOPE KIT

The outstanding new 1953 model O-8 Heathkit Oscilloscope features the finest performance ever offered in this extremely popular kit instrument. Primarily intended as a general purpose oscilloscope for the faithful reproduction of actual wave forms and other electrical phenomena, it's vastly improved band width, good 100 KC square wave reproduction, three step vertical input attenuator, .025 volts per inch vertical sensitivity, etc., admirably qualify this instrument for TV and radio servicing, laboratory use, ham application and all general electronic development work. Improved vertical band width is obtained through the use of shunt peaking chokes with proper cathode compensation in the push-pull output stage. For additional flexibility of operation, provisions have been made for direct connections to the deflection plates, a Z axis input and a spot shape control for really fine focusing.

This beautiful kit is complete with all 10 tubes, including a 5" cathode ray tube, calibrated graph screen and flexible test leads. All necessary construction components, such as hardware, chassis, transformer, etc., and a detailed step by step construction manual, greatly simplify the assembly of this instrument.

## Heathkit VOLTAGE CALIBRATOR KIT

The use of a Voltage Calibrator will greatly increase oscilloscope usefulness. Provides a convenient method of making peak to peak voltage measurements by establishing a relationship between the unknown wave shape and the Voltage Calibrator. Voltage ranges .01-100 volts peak to peak. The Voltage Calibrator features direct reading scales and a regulated power supply system.



MODEL VC-2  
**\$11<sup>50</sup>**  
Shipping Wt. 4 lbs.

## Heathkit ELECTRONIC SWITCH KIT

The Heathkit Electronic Switch Kit will further extend scope usefulness by permitting simultaneous observation of two individually controlled traces. Continuously variable switching rates 10 cps to 2,000 cps in three ranges. Will also serve as a square wave generator over the range of switching frequencies.

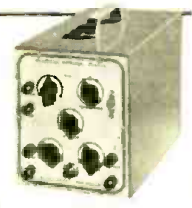

MODEL S-2  
**\$19<sup>50</sup>**  
Shipping Wt. 11 lbs.

## Heathkit VACUUM TUBE VOLTMETER KIT

The beautiful new 1953 Heathkit Model V-6 VTVM, the world's most popular kit instrument, now offers many outstanding new features in addition to retaining all of the refinements developed and proven through the production of over 70,000 VTVM kits. The Heathkit VTVM now features extended voltage ranges with 50% greater coverage on the DC range. New 1 1/2 volt low scale provides well over 2 1/2 inches of scale length per volt permitting faster measurements with greater accuracy. AC and DC ranges are 0-1.5-5-15-50-150-500-1500 volts (1,000 volts maximum on AC). Ohmmeter ranges are X1, X10, X100, X1,000, X10K, X100K X1 meg. Measures .1 ohm to 1,000 megohms. Other features are oh scale, center scale zero adjust and polarity reversal switch. High 11 megohm input resistance virtually eliminates circuit loading.

The low anti-inflation price of this tremendously popular kit includes all tubes, necessary constructional material, test leads and the construction manual.

MODEL V-6  
**\$24<sup>50</sup>**  
Shipping  
Wt. 6 lbs.

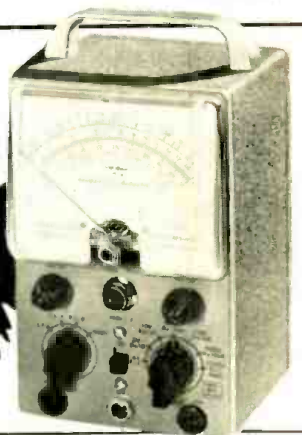

## Heathkit AC VACUUM TUBE VOLTMETER KIT

MODEL AV-2  
**\$29<sup>50</sup>**  
Shipping  
Wt. 5 lbs.

A new amplifier type AC VTVM that makes possible those sensitive measurements so essential in laboratory or audio work. Ten voltage ranges covering from .01 RMS full scale to 300 volts RMS full scale. Input impedance 1 megohm with frequency response 20-50,000 cycles. Ten DB ranges from -52 to +52 DB. Four diodes in meter bridge circuit for maximum linearity.



## Heathkit HANDITESTER KIT

MODEL M-1  
**\$13<sup>50</sup>**  
Shipping  
Wt. 3 lbs.

The ever popular Handitester is now supplied with a Simpson 400 microampere meter movement. Provides AC and DC voltage ranges 0-10-30-300-1,000-5,000 volts. Ohmmeter ranges 0-3,000 and 0-300,000 ohms. DC current measurements 0-10 and 0-100 milliamperes. A completely self contained portable instrument.

**HEATH COMPANY • Benton Harbor 15, Mich.**



# HEATHKITS for the ENGINEER

## Heathkit VISUAL AURAL SIGNAL TRACER KIT



MODEL T-3  
**\$22<sup>50</sup>**  
 Shipping  
 Wt. 10 lbs.

Designed especially for service applications in AM-SW-FM-TV repair work. RF and audio two channel input. More than adequate sensitivity—new noise locator circuit—calibrated wattmeter—substitution speaker—visual signal indication. Can be used with scope and VTVM, checks phono cartridges, phono mechanisms, microphones, tuners, etc. Let the Heathkit Visual Aural Signal Tracer help you.

## Heathkit RESISTANCE SUBSTITUTION BOX KIT



Choice of 36 switch selected resistance values 15 ohms to 10 megohms. All standard RTMA 1 watt 10% resistors. Buy several for those lab and service applications.

MODEL RS-1  
 Ship. Wt. **\$5<sup>50</sup>**  
 2 lbs.

## Heathkit AMATEUR TRANSMITTER KIT



MODEL AT-1  
**\$29<sup>50</sup>**  
 Shipping Wt. 15 lbs.

Here is the long awaited Heathkit entry into the amateur radio field. The Heathkit AT-1 Transmitter kit is a well designed basic transmitter incorporating many desirable features and providing maximum overall performance.

Convenient hand switching eliminates the bother and annoyance of plug in coils. It is merely necessary to switch to the desired frequency and plug in your favorite crystal or VFO. This transmitter features a self-contained power supply mounted on the same chassis and cabinet enclosed to minimize TVI. AC line by-passed to reduce radiation.

The coils supplied with the Heathkit AT-1 are pre-wound and adjusted for the necessary frequency coverage of 80-40-20-10 meters. The entire kit is supplied complete with all tubes, coils, punched and formed chassis and cabinet, as well as all constructional material required. A detailed assembly and operation manual is also furnished.

## Heathkit CONDENSER CHECKER KIT



An instrument designed solely for its particular job. Not a "sideline" of a multiple function instrument. Measures value and quality of unknown condensers and resistors. Capacity range .00001 mfd to 1,000 mfd. Resistance range 100 ohms to 5 megohms. Sensitive electron beam indicator—five polarizing test voltages—safety spring return leakage test switch. An amazingly accurate instrument at this low price.

MODEL C-3  
**\$19<sup>50</sup>** Shipping  
 Wt. 8 lbs.

## Heathkit SIGNAL GENERATOR KIT



MODEL SG-7  
**\$19<sup>50</sup>**  
 Ship. Wt. 8 lbs.

A service "must" is a reliable source of modulated (400 cycles) or unmodulated RF output. Frequency range 150 KC to 150 MC. Step attenuated and variable output—internal or external modulation. High output level and performance with low cost.

## Heathkit GRID DIP METER KIT



World's largest selling Grid Dip Meter. Five pre-wound coils—frequency coverage 2-250 mc. Simplified construction and operation.

MODEL GD-1A  
**\$19<sup>50</sup>**  
 Ship. Wt. 4 lbs.

## Heathkit TUBE CHECKER KIT

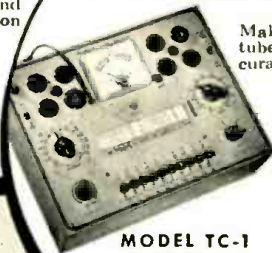

MODEL TC-1  
**\$29<sup>50</sup>**  
 Shipping Wt. 12 lbs.

Make those all important tube tests quickly and accurately. Checks all tube types encountered in radio and TV work. Simplified setup and switching system provides fast checks for shorts, opens, individual elements and over-all quality. Portable cabinet available at slight additional cost. TV picture tube adapter also available. See order blank.

Revised Roll Chart .50

## Heathkit SQUARE WAVE GENERATOR KIT



MODEL SQ-1  
**\$29<sup>50</sup>** Ship. Wt. 12 lbs.

True square wave output with frequency range 10 cycles to 100 KC. High variable output voltage level 0-20 volts at 600 ohms output impedance. Provisions for external synchronization. The ideal instrument for TV service work and wide band amplifier circuit development.

## Heathkit LABORATORY REGULATED POWER SUPPLY KIT



MODEL PS-2  
**\$29<sup>50</sup>**  
 Ship. Wt. 17 lbs.

A regulated variable 160-450 volt DC output power supply for the lab or service shop. Accurate voltage and current measurements with large Simpson meter. AC supply 6.3 volts at 4 amperes—standby switch eliminates warmup time. Low hum content—5 tube circuit. AC and DC output voltages isolated from panel for maximum operational flexibility.

## Heathkit VIBRATOR TESTER KIT



MODEL VT-1  
**\$14<sup>50</sup>**  
 Shipping Wt. 6 lbs.

Checks for starting and quality of interrupter and self rectifier type vibrators. Five sockets—checks hundreds of types. Operates from continuously variable type battery eliminator.

**HEATH COMPANY • Benton Harbor 15, Mich.**



# SERVICEMAN · AMATEUR · STUDENT

## Heathkit IMPEDANCE BRIDGE KIT

Provides choice of Wheatstone, Capacitance Comparison, Maxwell or Hay bridge circuits. Measurement of resistance-capacitance-inductance-dissipation factor-storage factor. 1% precision silver mica capacitance standard. 1/2% precision resistors.

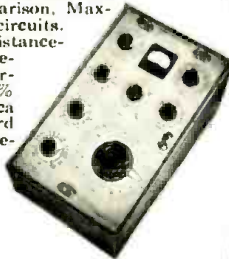

MODEL IB-1B  
**\$6950**  
Shipping Wt. 15 lbs.

## Heathkit DECADE RESISTANCE KIT



MODEL DR-1  
**\$1950**

Ship. Wt.  
4 lbs.

Individual switch selection of twenty 1% precision resistors in 1 ohm steps from 1 to 99,999 ohms. Sturdy ceramic wafer switches featuring silver plated contacts and smooth positive detent action.

## Heathkit Q METER KIT

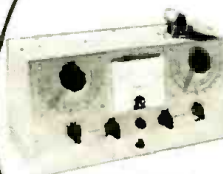

MODEL QM-1  
**\$3950** Ship. Wt.  
14 lbs.

A typical Heathkit invasion of the laboratory instrument field. Here is the first successful low priced Q meter ever offered in kit form. Oscillator supplies RF in the range of 150 KC to 18 mc. Reads Q directly on calibrated meter scales. Measures Q of condensers, RF resistance and distributed capacity of coils. Calibrate capacitor with range of 40 mmf to 450 mmf with vernier  $\pm 3$  mmf. All measurements made at the operating frequency.

## Heathkit INTERMODULATION ANALYZER KIT

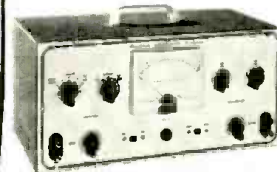

MODEL IM-1  
Shipping Wt. 17 lbs. **\$3950**

Intermodulation distortion analysis is one of the most satisfactory methods of checking audio equipment. The IM-1 features two self contained high frequency generators (3,000 and 7,000 cycles) a 60 cycle low frequency source, intermodulation section, AC VTVM, and power supply all in one complete unit. Direct reading IM percentages on 3 calibrated scales 30% —10%—3%.

## Heathkit AUDIO OSCILLATOR KIT

MODEL AO-1  
**\$2450**

Ship. Wt.  
11 lbs.



Features sine or square wave coverage from 20-20,000 cycles in 3 ranges. Variable 10 volt output level at 600 ohms impedance. Thermistor controlled linearity—precision multiplier resistors—distortion less than .6%. An outstanding instrument value at this amazing low price.

## Heathkit AUDIO FREQUENCY METER KIT



MODEL AF-1  
**\$3450**

Ship. Wt. 12 lbs.

Indicates audio frequency on large 4 1/2" Simpson meter. Ranges 10 cycles to 100 kc at input voltage level of 3-300 volts RMS. The input wave shape is not at all critical. Useful in production line testing—indicating square wave frequency—determining generator output. Operation entirely electronic, no vibrating reeds.

## Heathkit BAR GENERATOR KIT



MODEL BG-1  
**\$1450**

Ship. Wt. 6 lbs.

The Heathkit BG-1 Bar Generator represents another welcome addition to the fast growing line of popular Heathkits. The station transmitted test pattern is rapidly disappearing and the Bar Generator is the logical answer to the TV serviceman's problem in obtaining quick accurate adjustment information.

The Bar Generator produces a series of horizontal or vertical bars on the TV screen. These bars are equally spaced and will quickly indicate picture linearity of the receiver under test. Since picture linearity is independent of transmitting frequency, it is unnecessary to provide coverage throughout the VHF range, thereby holding down instrument cost.

The Heathkit Bar generator is simple to use and is extremely portable, providing a quick means of checking the television receiver either in your workshop or in the customer's home.

## Heathkit DECADE CONDENSER KIT

Switch selected 1% silver mica precision condensers providing capacity range of 100 mmf. to 0.111 mfd. in steps of 100 mmf.

MODEL DC-1  
**\$1650**

Shipping Wt. 4 lbs.



## Heathkit AUDIO GENERATOR KIT

A new extended range 18 cycles —1 megacycle audio instrument at a remarkably low price. Five continuously variable output ranges—600 ohm output impedance—low distortion figure, less than .4% from 100 cps through audible range.



MODEL AG-B  
**\$2950**

Ship. Wt. 11 lbs.

## Heathkit TELEVISION SWEEP GENERATOR KIT

Frequency coverage 10-90 mc and 150-230 mc. Variable sweep width 0-12 mc, built in absorption type marker, step and continuously variable output and blanking circuit.

MODEL TS-2  
Ship. Wt. 20 lbs. **\$3950**



## Heathkit BATTERY ELIMINATOR KIT

A variable 0-8 volt DC supply source rated at 10 amperes continuously and up to 15 amperes intermittently. Voltmeter, ammeter, automatic overload relay, fuse protection—heavy duty Mallory 17 disc rectifier.

MODEL BE-3  
Ship. Wt. 17 lbs. **\$2450**



## WRITE FOR *Free* CATALOG

New 32 page 1953 Catalog lists all kits, specifications, schematics and latest price information.

# HEATH COMPANY · Benton Harbor 15, Mich.

## Heathkit SUPERHETERODYNE RECEIVER KITS



Broadcast Model BR-1 5 Tube-Broadcast Band 550 to 1600 KC coverage. Shipping Weight 11 lbs.  
**\$19.50**

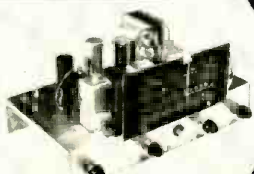

Three Band Model AR-1 6 Tube all wave circuit 3 Ranges, continuous coverage 550 KC. to over 20 MC. Shipping Weight 11 lbs.  
**\$23.50**

## NEW HEATHKIT WILLIAMSON TYPE AMPLIFIER KIT

The ideal amplifier for custom high fidelity audio installations. Tops in performance, value, and flexibility of operation. Either Altec Lansing Peerless or Acrosound output transformers available. First Williamson type amplifier supplied with a matching preamplifier.

### PRICES OF VARIOUS COMBINATIONS

W-2 Amplifier Kit (Incl. Main Amplifier with Peerless Output Transformer, Power Supply and WA-P1 Preamplifier Kit) Shipping Weight 37 lbs. Shipped express only	<b>\$69.50</b>
W-2M Amplifier Kit (Incl. Main Amplifier with Peerless Output Transformer and Power Supply) Shipping Weight 29 lbs. Shipped express only	<b>\$49.75</b>
W-3 Amplifier Kit (Incl. Main Amplifier with Acrosound Output Transformer, Power Supply and WA-P1 Preamplifier Kit) Shipping Weight 37 lbs. Shipped express only	<b>\$69.50</b>
W-3M Amplifier Kit (Incl. Main Amplifier with Acrosound Output Transformer and Power Supply) Shipping Weight 29 lbs. Shipped express only	<b>\$49.75</b>
WA-P1 Preamplifier Kit only. Shipping Weight 6 lbs. Shipped express or parcel post	<b>\$19.75</b>

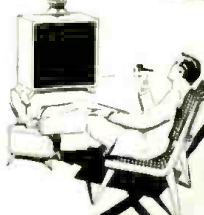
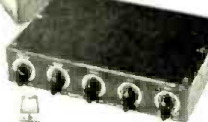

## Heathkit ECONOMY 6 WATT AMPLIFIER KIT

MODEL A-7  
**\$14.50**



Dual inputs—separate bass and treble tone controls—output impedances 4-8-15 ohms.

Ship. Wt. 10 LBS.

A-7A Amplifier with pre-amplifier stage for low level inputs... **\$16.50**

## Heathkit HIGH FIDELITY 20 WATT AMPLIFIER KIT

MODEL A-8  
**\$33.50**

Shipping Wt. 16 lbs.



A high fidelity full 20 watt general purpose amplifier. Dual inputs and separate tone controls for maximum flexibility. Peerless output transformer 4, 8 and 16 ohms.

A-8A with additional preamplifier stage for low level cartridge, microphone, etc. **\$35.50**

## Heathkit FM TUNER KIT

MODEL FM-2

**\$22.50**

Shipping Wt. 9 lbs.

Sensitive transformer operated 8 tube circuit. Frequency coverage 88-108 mc. Pre-assembled and tuned "front end." Vernier tuning with slide rule type dial.

# HEATH COMPANY • Benton Harbor 15, Mich.

## ORDER BLANK



MAIL YOUR ORDER TODAY TO THE  
**HEATH COMPANY**  
BENTON HARBOR 15,  
MICHIGAN

From \_\_\_\_\_

SHIP VIA

- Parcel Post  
 Express  
 Freight  
 Best Way

(PLEASE PRINT)

QUANTITY	ITEM	PRICE	QUANTITY	ITEM	PRICE
	Heathkit Oscilloscope Kit—Model O-8 (26 lbs.)	\$43.50		Heathkit Square Wave Generator—Model SQ-1 (12 lbs.)	29.50
	Heathkit Amateur Transmitter Kit—Model AT-1 (15 lbs.)	29.50		Heathkit AC VTVM Kit—Model AV-2 (5 lbs.)	29.50
	Heathkit Bar Generator Kit—Model BG-1 (6 lbs.)	14.50		Heathkit Intermodulation Analyzer Kit—Model IM-1 (17 lbs.)	39.50
	Heathkit Voltage Calibrator Kit Model VC-2 (4 lbs.)	11.50		Heathkit Regulated Power Supply Kit—Model PS-2 (17 lbs.)	29.50
	Heathkit Electronic Switch Kit—Model S-2 (11 lbs.)	19.50		Heathkit Handitester Kit—Model M-1 (3 lbs.)	13.50
	Heathkit TV Alignment Generator Kit—Model TS-2 (20 lbs.)	39.50		Heathkit Decade Resistance Kit—Model DR-1 (4 lbs.)	19.50
	Heathkit Q Meter Kit—Model QM-1 (14 lbs.)	39.50		Heathkit Decade Condenser Kit—Model DC-1 (4 lbs.)	16.50
	Heathkit Grid Dip Meter Kit—Model GD-1A (4 lbs.)	19.50		Heathkit Impedance Bridge Kit—Model IB-1B (15 lbs.)	69.50
	Heathkit VTVM Kit—Model V-6 (6 lbs.)	24.50		Heathkit Resistance Substitution Box Kit—Model RS-1 (2 lbs.)	5.50
	Heathkit Visual-Aural Signal Tracer Kit—Model T-3 (10 lbs.)	22.50		Heathkit F.M. Tuner Kit—Model FM-2 (9 lbs.)	22.50
	Heathkit Condenser Checker Kit—Model C-3 (8 lbs.)	19.50		Heathkit Broadcast Receiver Kit—Model BR-1 (11 lbs.)	19.50
	Heathkit RF Signal Generator Kit—Model SG-7 (8 lbs.)	19.50		Heathkit Three Band Receiver Kit—Model AR-1 (11 lbs.)	23.50
	Heathkit Tube Checker Kit—Model TC-1 (12 lbs.)	29.50		Heathkit Amplifier Kit—Model A-7 (10 lbs.)	14.50
	Heathkit Portable Tube Checker Kit—Model TC-1P (15 lbs.)	34.50		Heathkit Amplifier Kit—Model A-7A (10 lbs.)	16.50
	Heathkit Portable Tube Checker Cab. only No. 365 (8 lbs.)	7.50		Heathkit Amplifier Kit—Model A-8 (16 lbs.)	33.50
	Heathkit TV Tube Adapter No. 355 (1 lb.)	4.50		Heathkit Amplifier Kit—Model A-8A (16 lbs.)	35.50
	Heathkit Battery Eliminator Kit—Model BE-3 (17 lbs.)	24.50		Williamson Type Amplifier Kit (Type: )	
	Heathkit Vibrator Tester Kit—Model VT-1 (6 lbs.)	14.50		Shipped express only	
	Heathkit Audio Generator Kit—Model AG-8 (11 lbs.)	29.50		WA-P1 Preamplifier Kit (6 lbs.) (Shipped exp. or p.p.)	
	Heathkit Audio Oscillator Kit—Model AO-1 (11 lbs.)	24.50			
	Heathkit Audio Frequency Meter Kit—Model AF-1 (12 lbs.)	34.50			

Enclosed find ( ) check ( ) money order for Please ship C.O.D. ( ) postage enclosed for \_\_\_\_\_ pounds.

On Express orders do not include transportation charges—they will be collected by the express agency at time of delivery.

ON PARCEL POST ORDERS include postage for weight shown. . . . . ORDERS FROM CANADA must include full remittance for merchandise.



# NEW TV GRANTS SINCE FREEZE LIFT

Continuing the listing of construction permits granted by FCC since lifting of freeze. Additional stations will be carried next month.

STATE	CITY	CALL**	CHANNEL	FREQUENCY (mc.)	POWER* (Video)
California	Fresno	.....	47	668-674	210
	San Francisco	.....	32	578-584	81
Indiana	Waterloo	.....	15	476-482	20.5
Iowa	Cedar Rapids	WMT-TV	2	54-60	54
Kentucky	Richmond	.....	60	746-752	81
Michigan	Cadillac	.....	13	210-216	290
Minnesota	Minneapolis	WTCN	11	198-204	316
	St. Paul	WMIN-TV	11	198-204	316
Missouri	Cape Girardeau	.....	18	494-500	11
Montana	Great Falls	KMON-TV	3	60-66	1.7
New Hampshire	Kene	.....	45	656-662	23
New York	Albany	WROW-TV	41	632-638	200
Oklahoma	Miami	.....	58	734-740	1.75
Rhode Island	Providence	.....	16	482-488	210
South Carolina	Greenwood	WCRS-TV	21	512-518	93
Texas	Abilene	KBRC-TV	9	186-192	17.4
West Virginia	Wheeling	.....	7	174-180	316

## REVISED CALL LETTER LISTING

(Since the publication of the listings in April, May, and June, the following final TV call letters have been assigned to new stations by the Commission.)

STATE	CITY	CALL	CHANNEL	FREQUENCY
Arizona	Yuma	KIVA	11	198-204
California	Monterey	KMBY-TV	8	180-186
	Salinas	KSBW-TV	8	180-186
Colorado	Grand Junction	KFXJ-TV	5	76-82
Florida	Panama City	WJDM	7	174-180
Idaho	Idaho Falls	KID-TV	3	60-66
	Pocatello	KISJ	6	82-88
Illinois	Bloomington	WBLN	15	476-482
	Champaign	WCIA	3	60-66
" "	Harrisburg	WISL-TV	22	518-524
	Springfield	WICS	20	506-512
Indiana	Indianapolis	WNES	67	788-794
	Indianapolis	WJRE	26	542-548
Kansas	Wichita	KEDD	16	482-488
Massachusetts	North Adams	WMGT	74	830-836
	Northampton	WNOH	36	602-608
Michigan	Benton Harbor	WHFB-TV	42	638-644
Minnesota	Austin	KMMT	6	82-88
Montana	Butte	KXLF-TV	6	82-88
New Jersey	Atlantic City	WOCN	52	698-704
New Mexico	Santa Fe	KTVK	2	54-60
New York	Elmira	WECT	18	494-500
North Carolina	Charlotte	WAYS-TV	36	602-608
	Durham	WCIG-TV	46	662-668
North Dakota	Minot	KNDK	10	192-198
Oklahoma	Oklahoma City	KTVO	25	536-542
	Tulsa	KCEB	23	524-530
Oregon	Eugene	KTVF	20	506-512
	Medford	KBES-TV	5	76-82
" "	Salem	KPIC	24	530-536
	Dallas	KDTX	23	524-530
Texas	Houston	KTVP	23	524-530
Utah	Salt Lake City	KUTV	2	54-60
West Virginia	Wheeling	WLTV	51	692-698

\*ERP = (effective radiated power, kw.). \*\*Call letters without TV suffix from application files and subject to change; except where included in calls such as KKTU or WTVT. . . = Call letters to be announced

# NEW TV STATIONS ON THE AIR

(As of June 25, 1953)

STATE, CITY	STATION	CHANNEL	FREQUENCY RANGE (IN MC.)	VIDEO WAVELENGTH (IN FT.)	VIDEO POWER* (IN KW.)
Arkansas	Fort Smith	KFSA-TV	22	518-524	265
California	Bakersfield	KFAY-TV	29	560-566	20.5
	Fresno	KMJ-TV	24	530-536	33
Georgia	Rome	WROM-TV	9	186-192	32
Idaho	Nampa	KFXD-TV	6	82-88	.5
Michigan	Battle Creek	WBKZ-TV	64	770-776	23.5
Pennsylvania	Scranton	WGBI-TV	22	518-524	290
	Scranton	WTVU	73	824-830	17.6
Wisconsin	Madison	WKOW-TV	27	548-554	85

\*From Station CP application. The frequency of the video carrier = 1.25 + channel lower freq. limit. Total number of television stations now on the air: 196 (44 of which are u.h.f.)



## be an expert on AUTO RADIO SERVICING!

Get the only authoritative compilation of its kind—complete Auto Radio Service Data coverage of all important models since 1946—in 3 great PHOTOFACT Manuals! All data complete, accurate, uniform—based on lab analysis of the actual auto radios covered. Helps you service any model quicker, easier—for greater profits. Get the complete Library!



### VOL. 1. AUTO RADIO SERVICE MANUAL

Covers over 100 models made from 1946 to 1949 by 24 manufacturers. Each receiver is completely covered in uniform format; includes schematics, chassis photo views, replacement parts data, service hints, etc. All data based on actual lab analysis. 396 pages, 8½ x 11".

ORDER AR-1. Only \$4.95



### VOL. 2. AUTO RADIO SERVICE MANUAL

Covers 60 different chassis (40 models) used in 1948, 1949 and 1950 auto radio receivers. Authoritative, complete service data that makes your work quicker, easier and more profitable. 288 pages, 8½ x 11".

ORDER AR-2. Only \$3.00



### VOL. 3. AUTO RADIO SERVICE MANUAL

Covers 47 different chassis (80 models) used in 1950, 1951 and 1952 auto radio receivers. Absolutely the most complete, accurate and easy-to-use data available—uniform and practically presented to

make you an expert on the repair of any auto radio. 288 pages, 8½ x 11".

ORDER AR-3. Only \$3.00



### SPECIAL OFFER!

All 3 Volumes, Yours for Only \$9.95  
Save on the Complete Library—see your PHOTOFACT Distributor

## HOWARD W. SAMS & CO., INC.

Order from your Parts Jobber today, or write direct to HOWARD W. SAMS & CO., Inc. 2203 E. 46th Street, Indianapolis 5, Ind.

My (check) (money order) for \$... encl. Send:

AR-1 \$4.95  AR-2 \$3.00  AR-3 \$3.00  
 Complete 3-Volume Library \$9.95

Name .....

Address .....

City..... State.....

**IMPOSSIBLE  
BUT TRUE!**

**SINGLE CHANNEL  
5 ELEMENT DELTA-MATCH  
YAGIS**

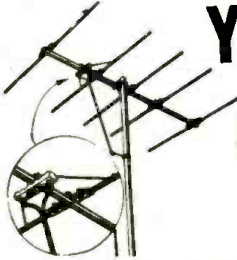

**ONLY  
\$200**  
each  
LOTS OF 5

We know it's hard to believe, and we hardly believe it ourselves — but here it is, so make the most of it! These beautifully fabricated Yagis usually sell for 3 to 5 times our price!

Delta-Match principle insures flat response over entire channel bandwidth, providing maximum fidelity in both picture and audio portion of TV signal. These Yagis available for channels 2, 3, 4, 5 and 6, together with detailed instructions for cutting to channels 7, 8, 9, 10, 11, 12 or 13. Sorry, no less than 5 antennas of one channel. SPECIFY CHANNEL WHEN ORDERING.

Free with each order of 5 antennas 1 all-purpose hack-saw with blade and complete instructions for simple conversion of lower frequency Yagis to high frequency Yagis.

Stock No. YDM5—Packages of 5 Yagis.  
Wt. 40 lbs. Net \$10.00

**Concord Radio**  
55 Vesey Street, New York 7, N. Y.  
Phone DLgby 9-1132

**Spectacular  
KIT VALUES!**



**1,000 RESISTORS**

½ watt, 1 watt, 2 watt, 5 watt. All new, 5 and 10% tolerance. Well assorted, popular values. Sensationally low priced!  
1000 resistors..... **\$7.95**

**15 "FP" CONDENSERS**

Single, double, triple section, 10 to 80 Mfd. 25 to 450 Volts. Sturdy plastic utility box. Wt. 3½ lbs. No. FPK15—Kit of 15 condensers. **\$3.98**



**Condenser Treasure Chest**



Surprise value! 75 paper, by-pass, mica, electrolytic, "FP," oil-filled, ceramic, TV and bathtub condensers. Plastic Utility box. Wt. 10 lbs. No. CTC75—Kit of 75 condensers. **\$7.95**

**15 MICA CONDENSERS**

Popular sizes, receiving type mica. 600 to 1000 volts test. Silver mica included. In plastic utility box. Wt. 1½ lbs. No. MCK15—15 Micas..... **\$ .98**  
Same as above, 75 Micas..... **\$3.50**



**25 CERAMICONS**



Fresh, new, popular assortment, worth twice the price! In sturdy plastic utility box, wt. 1 lb. No. CCK25—25 Ceramicons. **\$1.49**

Minimum order \$5. 25% Deposit with C.D.D. orders. F.O.B., N. Y. C.

**CONCORD RADIO**,  
55 Vesey St., New York 7, N. Y. Dept. N-7.  
Please include my name on your special bargain mailing list. Free of charge.

NAME.....  
ADDRESS.....  
CITY..... ZONE..... STATE.....

**NOW—Real HI-FI  
LOW COST  
TAPE RECORDING  
EQUIPMENT**

PT-3M  
DUAL-TRACK  
DUAL-SPEED  
3.75 & 7.5 i.p.s.  
TAPE  
MECHANISM  
**\$59.75**



PRE-7 PRE-AMP  
**\$39.75**



This high quality, low cost tape recording combination by Pentron is ideal for all custom installation work. Can be mounted on slides, or built into present phono drawer. Easily built into your present system — or design your new system around this great pair. Frequency response 50 to 11,500 at 7.5 i.p.s. Immediate delivery — from stock!

PMC—Portable Carrying Case with both units above, complete..... **\$114.50**

ARROW ELECTRONICS  
**AudioCenter**  
BEAUTY IN SOUND  
65 CORTLANDT ST., NEW YORK 7, N. Y., DIGBY 9-4714

**COMPARISON PROVES  
EICO OFFERS  
GREATEST V-O-M values!**



GET the MOST for your money — Before you buy, see chart below!  
World-renowned **EICO**  
VOLT-OHM-MILLIAMMETERS

\* #536 KIT \$12.90. Wired \$14.90  
#526 KIT (with 1% multipliers)  
only \$13.90. Wired \$16.90

VERIFY AT YOUR DEALER'S	EICO	Co. A	Co. B	Co. C	Co. D
\$12.90 up (KIT)	YES	No	No	No	No
31 ranges?	YES	No	No	No	No
Full-size 3-inch meter?	YES	Yes	Yes	Yes	No
400 ua sensitivity?	YES	Yes	Yes	Yes	No
Zero to 1 v. range on both AC and DC?	YES	No	No	No	No
5000 v. range on both AC and DC?	YES	Yes	No	Yes	No
AC/DC sens. 1000 n/v.?	YES	Yes	Yes	Yes	No
DC and AC Current Ranges?	YES	No	No	No	No
In KIT and Wired Form?	YES	Wired Only	Wired Only	Wired Only	Wired Only
Lowest cost in the industry?	YES * See Above	No	No	No	No

Write for FREE Catalog MR-7 & name of local dealer. Prices 5% higher on West Coast.

**ELECTRONIC INSTRUMENT CO., Inc.**  
84 WITHERS STREET, BROOKLYN 11, N. Y.

**Within the Industry**  
(Continued from page 18)

tion's group insurance plan . . . **WALTER M. JONAS** is the new vice-president in charge of production for *Radio City Products Company* of Pennsylvania. He was formerly production manager for the firm . . . **JOSEPH L. BALDWIN** is the new editor-in-chief of *Philco Corporation's* official dealer publication "Hi-Hat Club News" . . . **JOHN J. MUCHER**, prominent manufacturer and chairman of the board of *Clarostat Mfg. Co., Inc.*, died recently at the age of 70. He and his two brothers founded the firm in 1921 . . . **WILLIAM M. ALLISON** has been appointed as technical advisor to *Sprague Electric Co.* He has been with the firm for 20 years . . . **V. E. WOLLANG** is the new manager of distributor and export sales for *Oxford Electric Corporation* . . . **EDWARD J. GATELY, JR.** has been named project engineer for *Weathers Industries*. He was formerly associated with *Clifton Precision Products* and is connected with *Gately Development Laboratories* . . . **JOHN STEVENS** is the new director of manufacturing and production head of all television activities in the TV Division of *Hoffman Radio Corp.* He will be in charge of the company's three television plants . . . **HERBERT J. ALLEMANG** has been appointed vice-president in charge of planning for *Philco Corporation*. He will be responsible for the long-range planning of manufacturing facilities, organization, and operations of the company . . . **CHARLES E. BALZ** has been named sales manager of *Burgess Battery Company's* United States Battery Division. He has been assistant sales manager for the past two years and for the previous ten years advertising and promotion manager . . . **LAWRENCE E. PRISCAL** is the new director of purchases for *Sentinel Radio Corporation*. He has been with the firm for 21 years, the last several years as managing director of the service department.

**BENJAMIN J. KATZ**, who formerly headed his own advertising agency, has been named director of the newly-organized promotion and public relations department of the *Jerrold Electronics Corporation* of Philadelphia.



Mr. Katz was recently released from the Air Force where he served as public information officer for the Pacific Northwest Radar Command. Prior to his recall in April 1951, Mr. Katz spent nine years in Philadelphia advertising circles, interrupted during World War II by service with the Air Corps.

In his new post, he will be in charge of advertising, sales promotion, publicity, and public relations for the master television antenna systems manufacturer.



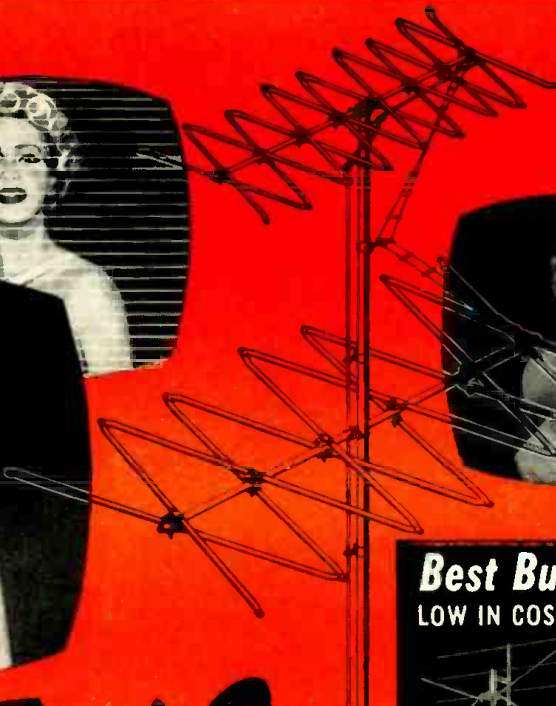

# The Picture Tells the Story

TV Antennas exist for one reason — to provide a clear, strong, sharp picture!

TRIO ZIG-ZAG\* TV Antennas perform so well in this all important respect that they are America's most wanted.

Yes, a picture — the TV picture — tells the TRIO story more eloquently than anything else! Where all other antenna designs fail, high gain TRIO ZIG-ZAG TV Antennas consistently lock in sharp, clear pictures — from Maine to Texas, in city or country!

TRIO TV antennas look different, work different — provide a magnificent DIFFERENCE in picture quality!

\*Patent Pending



**Also in the Picture**  
 The TRIO Rotator and Direction Indicator are the most dependable ever built. Developed after \$50,000 research. Fully guaranteed for a FULL two years!

New insulating sleeve, with longer leakage path and elimination of slit, does away with assembly errors — elements cannot short out. For maximum strength, new steel, electro-plated element clamps have been introduced.

## Best Buy in UHF Antennas LOW IN COST — HIGH IN PERFORMANCE

### NEW TRIO UHF BOW-TIE with reflector

Sturdy, broadband antennas of uniformly high gain that have been thoroughly field tested. Phasing strips installed, pre-assembled — a jiffy to attach reflector screen. Available in one, two and four bay models. Usual high-quality TRIO construction.

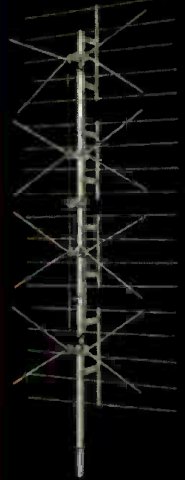

Model UBT-4  
 Supplied With  
 4 Foot Mast

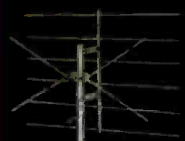

Model UBT-1  
 Supplied With  
 2 Foot Mast

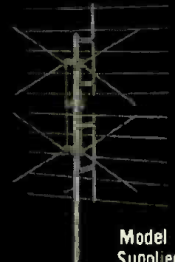

Model UBT-2  
 Supplied With  
 3 Foot Mast

## NEW TRIO UHF MULTI-CHANNEL YAGI ANTENNAS

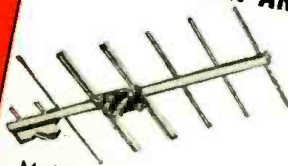

Broadband yagis developed by TRIO now successfully applied to UHF. Four models cover all UHF channels, rarely any one area.

- Model 6-UBY 14-26 for Channels 14-26
- Model 6-UBY 27-42 for Channels 27-42
- Model 6-UBY 43-60 for Channels 43-60
- Model 6-UBY 61-83 for Channels 61-83

These high gain six element yagis have sharper directivity, thereby eliminating ghosts. Thoroughly field tested. Entire antenna mounted in front field of reflector or antenna elements. Mast clamp supplied. Completely assembled.

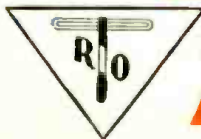

# TRIO MANUFACTURING CO.

GRIGGSVILLE, ILLINOIS



# AMERICA'S FINEST 28 WATT—50 WATT AND 10 WATT P.A. VALUES

**\$69.95 BUYS A 28 WATT \$150.00 LIST VALUE PORTABLE P.A. SYSTEM**  
(Illustration B)

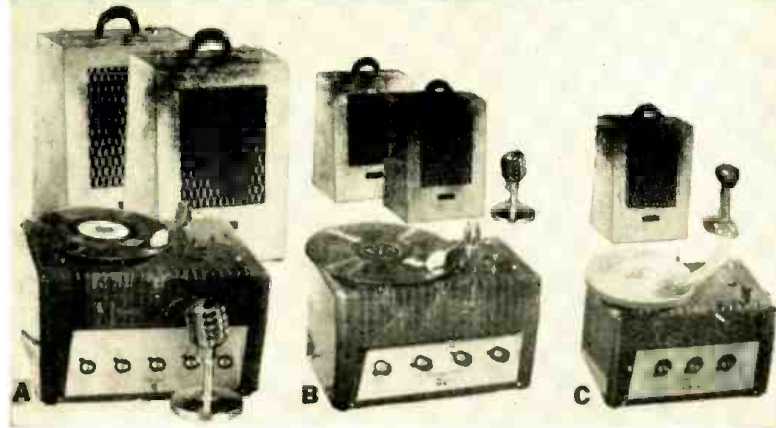

**3-SPEED PHONO TOP—TWO 12-INCH SPEAKERS**  
**7-TUBES PUSH PULL 6L6'S HEAVY LEATHERETTE COVERED PLYWOOD PORTABLE CASES**  
**CRYSTAL MIKE \$8.95 EXTRA**

**STOCK No. AP-28X.** Portable 28 watt public address system. You get a 7-tube heavy duty push-pull 6L6 amplifier with inputs for 2 mikes either crystal or dynamic with separate mixing volume controls. One phono input. Fully variable tone control high fidelity, wide range frequency response. The heavy duty output transformer has taps for 4, 8, 16, 25, 50 and 500 ohm speaker connections. Two heavy duty 12 inch Alnico V P.M. speakers, each with 25 feet of speaker cable. Each speaker is mounted in separate carrying cases. Each case has a snap on back and is large enough to give each speaker handling. Each case is 21" x 14" x 13 inches. One is used to carry the amplifier. A 3-speed phono motor and pick-up is mounted in the top of the amplifier to play 33 1/3, 45 and 78 RPM records.

This portable P.A. system will put out 30 watts all day long and 28 to 30 watts peak audio. McGee offers you this \$150.00 list portable P.A. system at a terrific saving.

**STOCK No. AP-28X complete portable PA system with 3-speed phono and speakers as pictured (less mike) ship. wt. 71 lbs. \$69.95.** Electro Voice model P10 \$28.50 list crystal mike with 20 feet of cable and 15" stand \$8.95 extra. Floor type mike stand instead of desk stand \$4.95 extra.

**50-WATT PORTABLE P.A. ON SALE \$99.95**  
**3-SPEED PHONO TOP—TWO 12" SPEAKERS**  
(Illustration A)

10-tube portable 50-watt public address system. 4-61.6G (push-pull parallel) output tubes. Inputs for 2 microphones, either crystal or dynamic, with separate mixing volume controls. Twin bass and treble tone controls. High fidelity wide range output transformer with taps at 4, 8, 16, 25, 50 and 500 ohms. Complete with 2 super heavy duty 12" PM speakers and 25 ft. cables mounted in separate leatherette-covered carrying cases. 21"x21"x13". The amplifier fits in one of the cases for carrying. This amplifier will put out 40 watts all day long and 50 to 60 watts peak with ease. 3-speed turntable and pickup arm to play all records 33 1/3, 45 and 78 RPM is mounted in the top of the amplifier. Stock No. AP-50X. 50 watt portable P.A. system similar to the 28-watt model pictured above, less microphone. Sale price, \$99.95. Shipping weight, 100 lbs. Shipped via Express or Truck only. Regular \$45.00 list Electro-Voice 610 dynamic microphone with 20 ft. cable and desk stand, \$11.95 extra. For floor stand instead of desk stand, add \$4.95.

**10-WATT PORTABLE P.A. ON SALE \$42.95**  
**3-SPEED PHONO TOP—10" ALNICO PM SPEAKER**  
(Illustration C)

5-tube portable 10-watt (14-watt peak) public address system. (Push-pull 7C5) U. L. approved amplifier with wide range response. Inputs for microphone and phono, with separate mixing type volume controls. Tone control. 10" Alnico V PM speaker is housed in a leatherette case 21"x14"x13" which holds the amplifier for carrying. 3-speed turntable and pickup arm to play all records 33 1/3, 45 and 78 RPM is mounted in the top of the amplifier. List value, \$90.00. Stock No. AP-10X. 10-watt portable P.A. system has only one case and one 10" speaker, less microphone. Sale price, \$42.95. Shipping weight 41 lbs. Shipped via Express or Truck only. Crystal microphone with non-removable desk stand, \$3.95 extra when ordered with the AP-10X portable P.A. system.

**BRUSH CRYSTAL EAR PHONE With Control \$5.49**

Simply clip on to the speaker voice coil of any radio or TV set or to an audio amplifier. No soldering necessary. Listen in privately to your favorite programs. The tiny Brush crystal ear phone fits your ear just like a regular hearing aid ear piece. A small remote control box enables using 30 ft. from the radio or TV set. Has its own separate volume control and small matching transformer built-in to operate the crystal ear phone. Ideal for hospitals, homes, hundreds of other uses. 10 times more comfortable to wear than conventional earphones. Stock No. BR-500 includes Brush crystal ear piece, remote control box, 30 ft. of cable and instructions. Sale price, \$5.49 complete. Brush crystal earphone with 36" cord. Stock No. BR-51, \$2.95. You connect it like any crystal earphone, diagram furnished. Necessary kit includes volume control with push plus coupling capacity and instructions, 99c extra.

**INDIVIDUALLY CARTONED ELECTRONIC RADIO & TV TUBES**

McGee offers you a wide selection of good quality TV and Radio tube types. Individually cartoned. Our private brand. These are not set mfg's, cuts, but a carefully inspected fine line of tubes with a full 6 months guarantee. Types listed are in stock in good quantity at this time. Thousands sold. Order 50 tubes and take 15% off the listed prices.

02A	.....	\$0.59	6AT6	.....	.49	6K7GT	.....	.59	7Y4	.....	.69	12S17GT	.....	.59
1A7GT	.....	.59	6AU6	.....	.49	6L6G	.....	1.09	12AT6	.....	.69	12S18GT	.....	.69
1B3GT	.....	.79	6AV6	.....	.49	6B4	.....	.59	12A8GT	.....	.69	12S17GT	.....	.79
1H5GT	.....	.59	6AX4GT	.....	.69	6SA7GT	.....	.59	12AT6	.....	.49	1986GG	.....	1.79
1L4	.....	.59	6BA6	.....	.69	6AW7GT	.....	.59	12AT7	.....	.69	2580GGT	.....	.99
15A	.....	.59	6BF6	.....	.69	6SF6GT	.....	.59	12AV6	.....	.69	3217GT	.....	.79
155	.....	.59	6BC5	.....	.59	6SK7GT	.....	.39	12AU7	.....	.69	35B5	.....	.59
174	.....	.59	6BD6	.....	.49	6SL7GT	.....	.69	12AV6	.....	.59	35L6GT	.....	.59
18A	.....	.59	6BU4	.....	.49	6SW7GT	.....	.59	12AV7	.....	.59	35L6GT	.....	.59
1U5	.....	.59	6BF6	.....	.59	6SU7GT	.....	.69	12AX4GT	.....	.59	35W4	.....	.39
30A	.....	.59	6BG6G	.....	1.29	678	.....	.79	12AX7	.....	.69	35L6GT	.....	.59
35GT	.....	.69	6BH6	.....	.59	68A6	.....	.59	12BA6	.....	.59	35L6GT	.....	.59
35A	.....	.59	6BJ6	.....	.59	6V6GT	.....	.59	12BE6	.....	.59	47	.....	.49
354C	.....	.49	6BK7	.....	.99	6W4GT	.....	.59	12BD6	.....	.59	50B5	.....	.59
6A84	.....	.49	6BQ6GT	.....	.39	6X4	.....	.39	12CA6	.....	.59	50C5	.....	.59
6A84	.....	.69	6C4	.....	.39	6X5GT	.....	.49	12K8GT	.....	.59	50L5GT	.....	.59
6AK5	.....	.89	6CB6	.....	.59	7A7	.....	.69	12Q7GT	.....	.59	50L5GT	.....	.59
6AL5	.....	.49	6CD6G	.....	1.49	7B7	.....	.79	12RF7	.....	.59	50L5GT	.....	.59
6AQ5	.....	.49	6HE6T	.....	.59	7H7	.....	.79	12SJ7M	.....	.59	11723	.....	.39

**3 STATION INTERCOM MASTER \$16.95**  
**SUB STATION \$3.95**

3-station intercom master housed in chrome plated metal cabinet 7 1/2" x 8" x 5" sloping front. Full 3-tube amplifier for 110 volt AC-DC operation. Press-to-talk switch is on top of the cabinet and volume control with off-on switch and station selector switch are on either side. May be used with from one to 3 sub-stations. (See matching cabinet chrome plated sub-station P.M.A-5.) Master is quiet at all times except when press-to-talk switch is pressed at the master or call-back switch is pressed at the sub. Uses 3-wire intercom cable. 3-station intercom master MIM-A3, shipping weight 10 lbs. Sale price, \$16.95 each, sub-stations extra. 3-wire plastic intercom cable, 100 ft. for \$1.95, 500 ft. for \$8.95.

**1000 INTERCOM SUB-STATIONS TO SELL AT \$3.95 EACH**

Chrome plated, with call back switch for a 3-wire intercom master. Size 7 1/2" x 6" x 5" sloping front. 5" Alnico V PM spkr. Intercom dealers buy at less than present production costs. Limited quantity. Stock No. PA-A3, ship. weight 8 lbs. Sale price, \$3.95 each or 3 for \$10.00. Special 3-wire plastic intercom cable, 100 ft. \$1.95, 500 ft. for \$8.95. Brown leatherette covered intercom sub-station with call back switch for use with 3-wire intercom masters. 5" square and 2 1/2" deep. Has new plastic grill cloth. Alnico V PM speaker. A true McGee value. Stock No. NE-5, ship. weight, 1 1/2 lbs. Sale price \$3.95 each or 3 for \$10.00. 3-wire plastic intercom cable, 100 ft. for \$1.95, 500 ft. for \$8.95.

**ESPEY 12-TUBE FM-AM CHASSIS, \$59.95**

**\* BUILT-IN PRE-AMP FOR G. E. VARIABLE RELUCTANCE PICK-UP**  
**\* WIDE RANGE AUDIO**  
**\* WHY NOT ORDER WITH A COAXIAL SPEAKER AND A RECORD CHANGER? SEE OUR SPECIAL OFFERING**

McGee's new 1953 model 12-tube FM-AM chassis. Latest design with phono inputs for all types of record players, crystal or G.E. variable reluctance. Receives standard broadcast 550 to 1700 kc and FM 88 to 108 mc. Wide range audio response (push-pull 6V6 output) and bass boost tone control. Loop antenna for broadcast and 300 ohm line type FM antenna may be supplied in cabinet. Attractive lighted slide rule dial. Chassis size, 13 1/2" x 9" high and 9" deep. Complete with tubes: 6BE6, 6BA6, 6BA6, 12AT7, 6X4, 6SQ7, 6XQ7, 6N7, 12AT7, 2-6V6GT and 3-6K7 rectifier cartridges. Stock No. 7C, less shipping. Price of chassis, \$59.95, less speaker. Output matches voice coil of our 12" or 15" coaxial speakers.

**ESPEY DEAL (1), \$99.95**  
Espey 7-C chassis complete with 12" coaxial PM speaker CU-14Y and VM-950 G.E. 3-speed changer equipped with a G.E. turn-about variable reluctance cartridge. A better home music system than ordinarily available. Espey Deal #1. Sale price \$99.95. With 15" speaker P-15CS, stock No. P-15CS instead of CU-14Y, \$10.00 extra.

**ESPEY DEAL (2), \$118.95**  
Espey 7-C chassis complete with 12" coaxial PM speaker CU-14Y and the English Garrard 3-speed changer equipped with a G.E. variable reluctance turnabout cartridge. Our best home music system. Espey Deal #2. Sale price \$118.95. With 15" coaxial PM speaker P-15CS instead of CU-14Y, \$10.00 extra.

**50-WATT BOOSTER AMPLIFIER**

**50-WATT BOOSTER AMP. \$39.95**  
**2-Mike Pre-Amp \$12.95 Extra.**  
**Not a Kit, but a Manufactured Amp.**

50-watt booster amplifier with push-pull parallel 6L6 output tubes. Connect to your present amplifier as a booster or use with the PH-2X Pre-amp to the use of 2 mikes and gives 50 watts of audio. Booster has a 6.3 volt heater. 6L6 output transformer, matches speaker with 4-8-16 ohm voice coil. Also 60 ohm and 200 ohm line. Booster has a 225 mill power supply with 5U3 rectifier. Price includes tubes: 4 6B6, 7N7 and 5U3. The two variable controls are for mixing volume control and bass control. Size 8 x 6 1/2 x 1 1/2". Stock No. PA-55N. Shipping weight 20 lbs. Sale price \$39.95 ea.

**2-MIKE PRE-AMP.**

Pre-amplifier plugs in directly to the PA-55N Booster amplifier. It enables use of 2 Crystal or Dynamic Mikes plus one low level input. Furnished with 4 foot cables and plugs for remote control of the 55 watt Booster Amplifier. Small chassis size 5 x 3 1/4 x 4 1/4". Stock No. PH-2X. With tubes 7F7 and 7N7. Net price \$12.95 ea.

**McGEE'S \$62.50 LIST 15" COAXIAL SPEAKER, \$23.95**  
**New 1953 Model—21 Oz. Alnico V Magnet—5" Tweeter**

This is the finest 15" coaxial PM speaker value that we have ever offered. New 1953 production, of a famous manufacturer of fine speakers. The 15" speaker has a 2 1/2" oz. Alnico V magnet with one piece free floating, of one piece construction. Will reproduce low frequencies down to 20 cps. The 5" tweeter is coaxially suspended and has a rigid cone to reproduce only the high frequencies. It will respond up to 17,500 cps. The high-pass filter is concealed under the top cover, leaving only two wires to connect both the tweeter and woofer to any 8 ohm output transformer of a radio or high fidelity music lover's amplifier. Stock No. P-15CS, shipping weight 13 lbs. Net price \$23.95.

**12" JENSEN PM, \$15.95**

Another McGee Scoop! Jensen Concert 12", 1 1/2" oz. Alnico V magnet PM speaker. 8 ohm voice coil. Will take 25 watt audio. You save dollars on this speaker. Just 100 to sell. Shipping weight 8 lbs. Stock No. P-12P. Sale price \$15.95; 2 for \$30.00.

**G.I. 3-SPEED CHANGER WITH G.E. \$22.95**  
**VARIABLE RELUCTANCE TURN-ABOUT CARTRIDGE**

Another tremendous McGee Scoop! Brand new General Instrument 3-speed automatic record changers. Complete with RFX-050 G.E. variable reluctance cartridge with turn-about stylus. Plays all 3 speeds automatically: 7 1/2", 10" or 12" records. Has 12" x 12" record tray. Base size, 12" x 12 1/2". Shipping weight 14 lbs. Stock No. 700-GE. Scoop price, \$22.95.

G.I. 3-speed changer same as above, but with Webster Hip-over twin needle cartridge. Stock No. GI-700. Sale price, \$21.95 each.

**McGEE RADIO COMPANY**  
1422 GRAND AVE., KANSAS CITY, MISSOURI  
TELEPHONE VICTOR 9045. WRITE FOR FLYER  
Prices F.O.B. K.C. Send 25¢ Deposit with Order, Balance Sent C.O.D. With Parcel Post Orders, Include Postage



# TELEVISION BOOSTERS AND CONVERSION KITS ON SALE AT MCGEE

## GENUINE STANDARD COIL T.V. BOOSTER Not Surplus. But Right From the Factory

**\$10.95**

Latest Model B-51 Standard Coil Television Booster. McGee makes another lucky purchase and as usual, passes the saving on to you. The famous Model B-51, 12 Channel Standard Coil TV booster, which lists for \$23.00, is offered to you for only \$10.95 each. Brand new, factory cartoned and fully guaranteed by McGee. This top quality single stage booster utilizes printed high frequency circuits for improved performance on all channels. Uses 6AK7 tube. Average gain, 6 to 7 volts on low channels and 5 or 6 on high channels. No distorting of picture or sound. Has extremely low noise factor. Continuous one-knob tuning and channel selector control switch for on-on and by-passing 300 ohm lead-in set. Modern design, dark brown plastic cabinet. 8 x 1 1/4 x 1 1/4. Made for 110 volt, 60 cycle AC operation. Shipping weight 5 lbs. Model B-51. Sale price, \$10.95 each, or buy 2 for only \$20.00.



## FRINGE AREA TV RECEPTION IS BETTER WITH OUR McMURDO SILVER TV BOOSTER \$10.95—TWO FOR \$20.00



Read the article on pages 52 and 53 of the December "Radio & TV News." You will see how a booster like the McMURDO Silver Super Sonic was used for fringe area TV reception. We can't guarantee this unusual reception, but we will guarantee this booster to be a sensational value. Contains 200 variable inductance TV tuner from channel 2 including the FM band through channel 13. Self-powered for 110 volts AC operation. Incorporates a 6J6 tube. Input for 300 ohm TV line and 300 ohm output to TV set. Single knob tuning. Attractive plastic case. McMURDO Silver Super Sonic TV-M booster. Stock No. GB-61. Shipping weight 5 lbs. Sale price, \$10.95 each or two for \$20.00.

## 20 INCH CONVERSION KIT \$29.95

YOU GET—

- 20HP4—20" PICTURE TUBE
- 20-INCH PLASTIC MASK
- 14 K.V. FLYBACK AND 70° YOKE



Our 20" conversion kit includes a 6-month guaranteed 20HP4, 20" rectangular blackface picture tube, plus a 14,000 volt G.E. built high voltage flyback transformer, plus a matched 70° cosine yoke, plus a 20" rectangular gold trimmed plexiglas mask and suggested diagram. The picture tube is the latest electro-static focus type that requires no focus coil. Shipped via express or truck only. Ship. weight, 10 lbs. Stock No. 20-TP, net price, \$29.95. Price with Raytheon or GE 1 year guarantee picture tube, \$10.00 extra.

## 14-Inch Conversion Kit WITH G.E. TUBE \$25.95

14-inch conversion kit: You get a 14-inch black face, 1 year guarantee G.E. 14CP4 picture tube, a 70° detection yoke with matching 14,000 volt G.E. flyback and a 14" plexiglas gold trim safety mask, plus conversion instructions. Stock No. 14CC-G. Sale price, \$25.95.

## 17-INCH CONVERSION KIT \$25.95 You Get—17BP4A 17" Picture Tube 17-Inch Plastic Mask 14 K.V. Flyback and 70° Yoke

17-inch conversion kit with a 17BP4A, 17" rectangular blackface electro-nigrel focus picture tube with 6 months' guarantee. Plus a matched 70° cosine yoke, a G.E. built 14,000 volt flyback and a 17" rectangular gold trimmed plexiglas mask and safety shield, suggested diagram furnished. Shipping weight, 30 lbs., via Express or Truck only. Stock No. 17-AM, 17" conversion kit. Sale price, \$25.95. Kit Price with GE or Raytheon 1 year guarantee picture tube, \$5.00 extra.

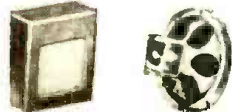

## SPEAKER AND BAFFLE SALE

### 8" SPEAKER AND BAFFLE \$4.95

Stock No. 818. Tan leatherette covered, plywood slant type wall baffle, plus an 8" Oxford, 2.15 ohm, Alnico 5 magnet PM speaker. A real hot McGee special for only \$4.95 each, or \$4.70 each in lots of 3 or more.

### 12" SPEAKER AND BAFFLE \$7.95

Stock No. CA-12. Tan leatherette covered plywood slant type wall baffle, plus a 12" Quan, 4.63 ohm, Alnico V magnet PM speaker. (Popular Adjustamec model.) A terrific McGee value for only \$7.95 each, or \$7.50 each in lots of 3 or more.

## 10" SPEAKER AND BAFFLE \$6.95

Stock No. CA-10. Tan leatherette covered plywood slant type wall baffle, plus a 10" Permaton, 3.16 ohm, Alnico V PM speaker. Only a few hundred to sell at \$6.50 each, or \$6.25 each in lots of 3 or more.



## RCA 201E1 T.V. TUNER \$7.95

Terrific buy on this RCA tuner. We have a limited quantity of the famous original 201E1, 13 channel completely wired and tested TV front end tuners. Ready to connect to your TV video I.F. strip. Offered at a sacrifice. Price was \$44.00. Now only \$7.95 each, with tubes. Each tuner in good condition but has been repaired. Stock No. RCA-12P. TV front end tuner. Converter coil type for accurate sound as used in the famous 630 chassis. Complete with 3-6J6 tubes. \$7.95. Specify shaft length desired, either 2" or 4".

### RCA 201E-1 T.V. TUNER

Same as pictured above only new—with 2 7/8" shaft. Stock No. 2201. Sale Price, \$11.95.



## 3-TUBE SARKES-TARZIAN T.V. TUNER \$9.95

This popular Sarkes-Tarzian Type 3 tuner is widely used. 13 channel rotary type switch with individually tuned coils. Price is complete with diagram and three tubes: 6C4 osc., 6H6 I.F. and 6AG5 mixer. Regular factory cost is twice our price. Each tuner is wired ready to hook up to a video and sound I.F. strip. May be used with either inter-carrier or separate sound I.F. circuits. Has built-in converter as used in the famous 630 chassis. Complete with 3-6J6 tubes. \$7.95. Specify shaft length, either 2" or 4".

## STANDARD COIL SUPER CASCADE TUNER \$19.95 UHF STRIPS \$7.50 EXTRA

The Cascade Circuit of the Standard Tuner offers a new development of this famous TV front end assembly which affords a 2-to-1 improvement in gain and a 35% to 50% reduction of noise over the pentode tuner. Other advances include: easy conversion to UHF reception by interchange of channel inductors; increased sensitivity for TV sets in fringe areas; elimination of booster use; and a high profit item for the serviceman as a replacement unit sale. Brand new factory TV-2000 TV tuner, compl. with tubes 6BK7 or 6BQ7 and a 6J6. Shaft length 3/4". Scoop UHF (specify channel) strips supplied in pairs for above cascade tuner, \$9.40 per set. UHF strips for other models of the Standard Coil tuners specify channel and series; either F, G, K, Q, R, H or M as printed on the tuner. \$7.50 per set.



## UHF TELEVISION CONVERTER \$34.95

Sutco UHF television converter with built-in booster. Continuously variable for channels 14 thru 83. Built-in wide band VHF booster for channels 2 thru 13. Self powered for 110 volt, 60 cycle AC operation. Selector switch gives choice of VHF or UHF antenna. VHF antenna may be fed thru the broad band booster or direct to the TV set. Stock No. 21A, shipping weight 7 lbs. Net price \$34.95.



## REGENCY RC-600 \$37.46

Carefully engineered and of highest quality construction. Features extreme stability, air dielectric in the tuning element. Image rejection of VHF stations down 50 to 60 db. Converts all sets and is highly recommended for those having split sound and video. Tubes are 6AF1 oscillator, crystal diode mixer, 6BK7 dual triode IF amplifier and selenium rectifier. Front panel change-over switch for UHF or VHF. Input and output impedances 300 ohms. For 110 volt 60 cycle AC operation. Shipping weight 8 lbs. Stock No. RC-600. Price \$37.46 each.

## CAPEHART CABINET FOR 100 SET—ONLY \$99.95

Beautiful, finest quality walnut combination radio-phonograph cabinet, 42" high, 12" wide and 22" deep. Made for Capehart's finest combination, setting for \$200.00. Has highly polished matched walnut panels. Made of 3/4" material. Top 1 1/2" solid stock. This cabinet weighs approximately 17 1/2 lbs. The changer, radio and speaker grill all have hinged doors. Radio compartment on right hand side is 14" high and 11 1/2" wide. Made to mount chassis vertically. Changer compartment is 14" high by 26 1/2" wide. Large enough to hold any record changer or recorder mechanism. Front 10" of top over the changer compartment is hinged to fold back for easy access to the changer. Both radio and changer compartments come with uncut blank panels. Speaker grille cut for a 12" speaker and the speaker compartment is completely enclosed. Shipping weight, 27 1/2 lbs. Stock No. K-275W Capehart combination cabinet. Net price, \$99.95. Walnut.

## COMPLETE RADIO, TELEVISION AND AMPLIFIER KITS AT MCGEE

### 3-WAY PORTABLE KIT

**\$15.95**

New 1952 Model 3-way personal portable radio kit. Operates on 110 Volts AC-100 or 67 1/2 V. leatherette covered case size, 5 1/2 x 5 1/2 x 8 1/2". Receives broadcast 550 to 1620 KC. A conventional 2-gang superhet circuit with 450 KC iron core IF's. Incorporates the new super gain stick loop antenna. All plated chassis. Lab. approved circuit matched parts. Price includes all parts, tubes, diagram, Alnico V PM speaker. A factory check type PN-37 ship. plus weight 7 lbs. The complete kit, less batteries, \$15.95. 67 1/2 V. B. \$1.59; 110 V. A. \$3c extra.

### Build Your Own Phono-Mike Broadcaster \$7.95

Kit Model DE-6R. With this simple kit, you can build a 3-tube phono oscillator that also has a mike input. Will broadcast over any radio within your home (about 75 feet) from 1000 to 1500 kc. Inputs for crystal mike or crystal phono pickup. Fader control fades from mike to record. Ideal for a home P.A. system, baby listener and home entertainment. A complete kit of parts including tubes. Kit Model DE-6R. Net price, \$7.95. DE-6RWT. wired and tested. Net price, \$9.95. Crystal mike and desk stand, \$4.95 extra. Concealed microphone unit, only 1" in diameter and 1/2" thick. Specially hidden mike when ordering. Stock No. T-001. Net, \$3.95 extra.

### 8-Tube Hi-Fi Amplifier Kit \$29.95

A complete kit including tubes: 3-7E5, 2-12AX7, 2-triode 6V6 rectifier, diagram and photos. Inputs for radio tuner and any kind of phono pickup crystal or G.E. variable reluctance, and either crystal or dynamic mike. Output matches 8 ohm voice coil. Twin electronic bass and treble tone controls with fanle selector switch for either juice box quality with heavy bass response or brilliant symphonic range. Response 18 to 20,000 cps. 8 tube all triode amplifier complete with tubes. Shipping weight 25 lbs. Model 723. Net \$29.95.

### 10-Watt Hi-Fi Amplifier Kit \$14.95

A complete kit of parts to build an AC transformer operated television chassis for use with a 1 1/2" x 7" or 20" rectangular picture tube. The 12 channel Sarkes-Tarzian type 3 tuner is wired, as is the 4 tube video I.F. strip. Chassis is of the conventional design. Do not buy this unless you understand television. It is difficult to wire. We furnish schematic. Kit model WH-20. Ship. wt. 40 lbs. less all tubes. Net \$59.95. Cascade tuner \$10.00 extra. Model BK-110 kit, less speaker, shipping weight 18 lbs. Net \$29.95.

### 10-TUBE RADIO KIT \$29.95

10 tube broadcast radio chassis. 12 channel, complete with tubes: 2-6X4, 2-6AT7, 3-6SN7, 1-6B17, 2-6V6 plus 5Y3 rectifier, diagram and instructions. 3 gang superhet with 8" slide rule dial. Chassis size, 12 1/2" x 10" x 8 1/2" high. Features push-pull 6V6 high fidelity audio. Output matches 3 to 8 ohm voice coil or crystal phono pickup and crystal mike. Heavy duty power transformer. Model BK-110 kit, less speaker, shipping weight 18 lbs. Net \$29.95.

### 6-TUBE 2-BAND KIT \$14.95

Popular with schools and colleges for training. 6 tube AC-DC 2 band radio kit with plastic cabinet. Receives broadcast and 6 to 18 mc shortwave. Full range speaker with 5" speaker and slide rule dial. A complete kit with tubes: 12SK7, 12K8, 12SK7, 12SQ7, 50L6 and 6X25, diagram and instructions. Factory quality. Cabinet size 12" x 8", slide. Shipping weight 12 lbs. Model ME-2. Net \$14.95.

### 5-TUBE AC-DC KIT \$12.95

Model RS-5. A 5 tube AC-DC straight through kit, housed in the same cabinet as ME-2 above. Complete with tubes. Shipping weight 10 lbs. Net \$12.95.

### AC POWERED BROADCAST TUNER KIT \$12.95

A self-powered, 3-gang superhet tuner kit with R.F. stage. This complete kit is furnished with a diagram, photos and tubes: 6BA6 R.F., 6BD6 oscillator, R.F., 6BA6 I.F. detector, 6AL5 diode, AVC, plus rectifier. Comes to you with audio amplifier. Ideal for use with our S-2020 or 7x3 amplifier kits. Chassis size, 9 1/2 x 4 1/2" high. Shipping weight, 7 lbs. Broadcast tuner kit Model BT-88X. Net price, \$12.95.

**McGEE RADIO COMPANY**

Prices F.O.B. K.C. Send 25% deposit with Order, Balance Sent C.O.D. With Parcel Post Orders, include Postage

TELEPHONE VICTOR 9045. WRITE FOR FLYER 1422 GRAND AVE., KANSAS CITY, MISSOURI



For additional information on any of the items described herein, readers are asked to write direct to the manufacturer. By mentioning RADIO & TELEVISION NEWS, the page and the issue number, delay will be avoided.

**FM-AM TUNER**

*Fisher Radio Corporation*, 41 E. 47th Street, New York, N. Y. has recently introduced an AM-FM tuner which has been designated as the Model 50-R.

The new unit incorporates a two-band superheterodyne with completely independent r.f. channels for FM



and AM. The FM section comprises a dual-triode, cascode, tuned r.f. stage for maximum signal-to-noise ratio and two i.f. stages followed by two cascaded limiters. These are combined with a *Foster-Seeley* discriminator to produce an *Armstrong* system.

Hum level, with the volume control at zero, is more than 100 db below two volts output and more than 90 db with volume control full on. The cathode-follower output permits output leads up to 200 feet in length.

The circuit uses fourteen tubes including the tuning eye and rectifier. The tuner is completely shielded, is housed in an etched aluminum chassis, and measures 14 3/4" wide, 8 1/2" high, and 9 1/4" deep. It weighs 17 pounds.

**"KLIPSCH" ENCLOSURE**

*G & H Wood Products* has been licensed by *Klipsch & Associates* to manufacture and distribute a *Klipsch*-designed loudspeaker enclosure.

The units to be manufactured will be made under the *Klipsch* "Rebel 1V" patent and will be marketed through parts distributors in both assembled and kit form.

The new line will be advertised and promoted as the *Klipsch* "Rebel 1V" by *Cabinart*, the high-fidelity trademark of *G & H*.

**ACOUSTICAL TILE**

*Tropicraft*, 14 Sherwood Place, San Francisco 3, California is now marketing an acoustical tile which has been designed with appearance as well as performance in mind.

Known as "Tropi-Tile", the new product is made from fibrous glass

surfaced with "Woven-Wood". The tile is available in ten textures and a variety of "House and Garden" colors as well as special decorator-colors-to-order.

The company invites inquiries regarding this new product and its applications.

**TOWER ACCESSORIES**

*Alproco, Inc.* of Mineral Wells, Texas is currently offering two base units for use with television receiving towers.

The B1-WS base, for use with the company's standard or commercial 6-foot aluminum tower sections, fits peak or flat-top roofs and is made of heavy galvanized steel with flat feet that pivot to any angle. The base weighs 17 pounds.

The second unit, the MB-1R, is a universal base which permits roof mounting with or without fastening to the roof. Designed for difficult installations, the base is hinged, can be tilted at any angle, and can be mounted side, hip, or flat. Of sturdy construction, the unit weighs 7 pounds.

**MARKER INJECTOR**

A bypass marker injector to provide uniform markers at any point on vis-



ual response curves, in traps, or along the base line of a curve has been announced by *Scala Radio Co.* of 2814 19th Street, San Francisco 10.

The SMI-53 "Super Marker Injector" has been designed to operate with any service sweep generator, scope, or marker generator. This unit is designed for application at video, i.f., and r.f. frequencies through 200 mc. When used with a low capacitance probe, the wide-band amplifier permits effective signal tracing in i.f. circuits. Thus, the instrument is suited to troubleshooting as well as alignment of TV receivers. It provides localization of dead or weak stages, and relative gain measurements.

The unit comes complete with an instruction manual and two coaxial test leads. A data sheet on the instrument is available from the company.

**CAMERA CHAIN**

*Standard Electronics Corporation* of 285 Emmett St., Newark 5, N. J. has introduced a new television camera chain, the SE-TE 468.

The new television camera provides operational characteristics and features which result in greater camera

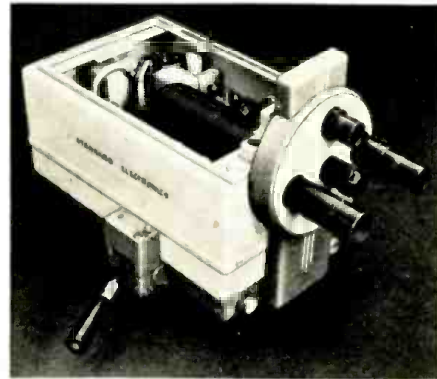

versatility and lower initial and operating costs, according to the company.

The new unit can be used for live, film, field work, stills, and test patterns. Stills and test patterns will not burn in. The pickup tube used in the camera is said to be 50 per-cent cheaper than other commonly used studio pickup tubes.

The camera features a single control for lens position and focus; full 8 mc. bandwidth; good depth-of-focus control; electronic view finder; four-lens turret using inexpensive, small diameter lenses; tally lights; and inter-communication.

The company will supply complete information on request.

**AUDIO EQUIPMENT**

*Radio Craftsmen, Inc.*, 4401 N. Ravenswood Ave., Chicago 40, Illinois is introducing two new pieces of audio gear to the trade.

The *Craftsmen-500* has been designed primarily to be used as a separate audio power unit and can be conveniently installed in built-in locations. Its specifications include power output of 15 watts maximum; frequency response of  $\pm .1$  db, 20 cps

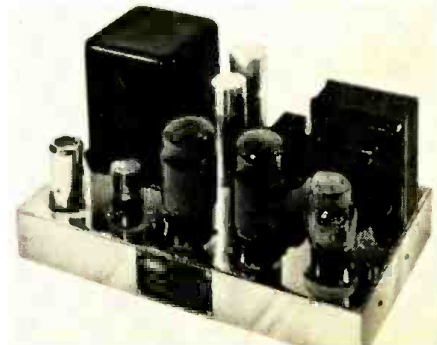

to 20,000 cps and  $\pm 2$  db, 5 cps to 100,000 cps; power response 12.5 watts



# How to make PICTURE-TUBE SUBSTITUTIONS EASILY



New CBS-Hytron Substitution Chart for Television Picture Tubes helps you pick logical substitutions easily, quickly. It's a cinch to use this complete, up-to-date Chart. An Index of types leads you to proper Substitution Group listing all readily interchangeable types. You pick an available type . . . with the least number of necessary service adjustments. That's it. No other references required. You save time . . . money. You need this indispensable CBS-Hytron TV Substitution Chart. Get it from your CBS-Hytron distributor. Or write direct today.

## WHAT'S IN IT

1. General Introduction outlines scope and purpose.
2. Introductory Notes give details on tabulation.
3. Typical Substitution shows how to use Chart.
4. Index indicates Substitution Group for each type.
5. Substitution Groups narrow choice to logical substitutions.
6. Basing and Outline Drawings give basing and dimensional data.

## FEATURES

- All necessary data given for all electromagnetically deflected types, regardless of make.
- Directly interchangeable types indicated.
- Other popular substitutes and required service changes high-lighted and explained.
- Substitution, not conversion, emphasized.

## GOT THESE HELPFUL GUIDES?

All are complete. Include all types, regardless of make. Give all pertinent data. Are free. Get yours today.



Miniature Guide includes 250 types, 111 basing diagrams. Indicates similar larger prototypes.



Crystal Diode Guide describes 92 types, 19 basing diagrams. Indicates typical application for each type.



TV Picture-Tube Guide lists 164 types, 19 basing diagrams for all magnetically deflected picture tubes.

## New . . . Free DECAL

Not just an identification. But a colorful decal that sells for you! *Sells* your magic ability to recapture new-set sparkle. Let this decal pull customers to you. Get it today from your CBS-Hytron distributor.

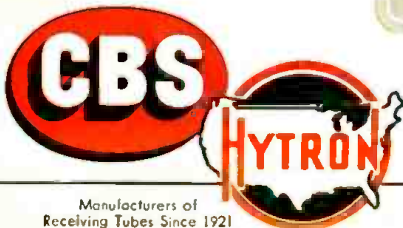

Manufacturers of Receiving Tubes Since 1921



CBS-HYTRON Main Office: Danvers, Massachusetts

A Division of Columbia Broadcasting System, Inc.

## NOW 3

## CBS-HYTRON TEST ADAPTERS



7-Pin Mini., \$1.45 Net

8-Pin Octal, \$2.25 Net

9-Pin Mini., \$1.75 Net

**BY POPULAR DEMAND.** You can now buy CBS-Hytron Test Adapters in all three popular sizes: 7-pin miniature, 8-pin octal, 9-pin miniature.

You can now test *all* sockets dynamically . . . "topside." Without wrestling with heavy chassis. Without disturbing wiring or parts. Just plug tubes into Test Adapters and Adapters into sockets. Presto, socket connections are topside . . . ready for your test prod. You check voltage, resistance, gain, intermittents, oscillation. Trace signals, etc. All the e-a-s-y topside way. Order *all three* Test Adapters from your CBS-Hytron distributor today.



**YOU SAVE**  
On These Audio Specials

**AT NEWARK**

**1 NEWARK LOW-COST AMPLIFIER**

Compact 8-watt amplifier using 2-6V6 or 6K6 push-pull output tubes. Employs 6SN7 as Audio Driver and Phase Inverter; 5Y3GT is rectifier. Response, 50 to 12,000 cycles. Has continuously variable tone and volume controls. Outlet for AC phono motor plug on back. Output impedance, 8 ohms. Chassis size, 6x8 1/2 x 5 3/8". 7 lbs. **81F000. NET 21.50**

**2 NEWARK COAXIAL SPEAKERS**

Outstanding high-fidelity values! These low-cost speakers provide good high frequency response and bass reproduction. All have high-frequency tweeter unit and crossover network. Av. wt., 8 lbs.

**83F994. 8" Speaker.** Rated 6 watts. Has 2.15 oz. Alnico V magnet. Imped., 6 ohms. **NET 8.95**

**83F995. 12" Speaker.** Rated 12 watts. Has 10 oz. Alnico V Magnet. Imped., 8 ohms. **NET 12.95**

**83F996. 15" Speaker.** Rated 14 watts. Has 10 oz. Alnico V magnet. Imped., 8 ohms. **NET 19.95**

**3 BRUSH BA-116 MIKE-PRICE REDUCED!**

Originally sold for \$8.61! Now available, while quantities last, at the low, low price of \$5.95. This rugged microphone is ideal for tape recording, PA, or Amateur use. Response, 50 to 6,000 cycles. Output level, -53 db. High impedance. Shock-mounted, crystal cartridge. Has 3/8"-27 thread Brown. Wt., 1 1/2 lbs. **54F350. Special 5.95**

Order from Dept. R-7

Send for Catalog

223 W. Madison St.

**NEWARK**  
ELECTRIC COMPANY

Chicago 6, Ill.

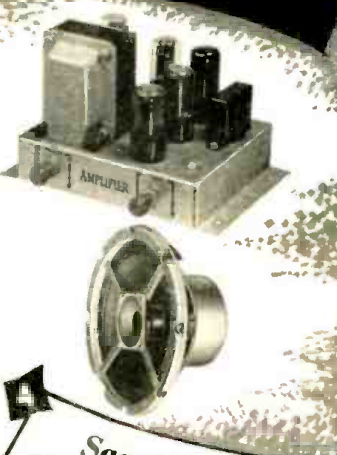

Save! Low Price!  
**WESTERN ELECTRIC**  
MODEL 134-B-3 HEARING AID  
Regularly \$185.00 Now **24.50**

Brand new units, packed in original case. Complete with receiver, cord, battery cord less ear plug and batteries. Wt., 1 lb.  
**54G501. Special 24.50**  
**BATTERIES FOR ABOVE**  
49F124. Burgess 8R... 23  
49F176. B'gess XX22. 1.35



± 1 db, 10 cps to 50,000 cps; phase shift ± 15 degrees, 20 cps to 20,000 cps; total harmonic distortion less than .1% at 10 watts at mid-frequencies; power consumption is 105-125 volts, 60 cycles, 125 watts. Overall dimensions are 8" x 13 1/2" x 7 1/2".

The second unit is the "800", a compact phono equalizing and tone compressing system on a single chassis. Five front panel control knobs provide complete and flexible control of an entire custom high fidelity music system.

**"Q" TESTER**

Lako Manufacturing Co., 506 E. Townsend St., Milwaukee, Wisconsin has developed a test instrument for television servicing, the Model 400-A "Q" Tester.

With this instrument it is possible



to test deflection yokes, width coils, and horizontal transformers without removing them from the set. The unit drives the test part at proper waveform and frequency and measures the output voltage. Since the output is a function of the "Q", a single shorted turn will result in almost negligible output as compared with a good part.

The company will supply full details on request.

**PERMOFLUX ADAPTER**

Permoflux Corporation, 4900 W. Grand Ave., Chicago 39, Ill. has announced the availability of a new adapter which permits any of the company's binaural headsets to be used for conventional monaural service.

The input end of the adapter has a jack to receive the PL-68 type

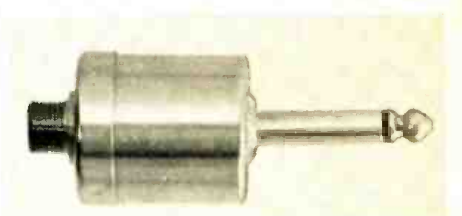

three-circuit plug of the binaural headset. The output end is a standard two-circuit PL-55 type plug which can be plugged into any conventional headset jack.

**RADIO & TELEVISION NEWS**

**ROUND, SQUARE, KEY and "D" OPENINGS QUICKLY MADE with Greenlee Radio Chassis Punches**

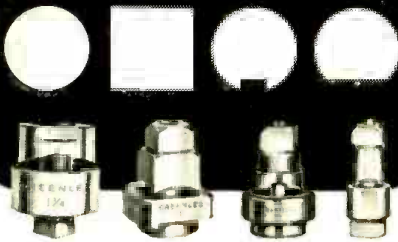

Save hours of hard, tedious work... cut accurate holes in chassis for sockets, plugs, controls, meters, panel lights, etc. with GREENLEE Punches. In 1-1/2 minutes or less make a smooth hole in metal, bakelite or hard rubber up to 1/16" thick. Easy to operate... simply turn with ordinary wrench. Wide range of sizes. Write for details. Greenlee Tool Co., 1887 Columbia Avenue, Rockford, Ill.



(Advertisement)



"Quick, Watson, the JENSEN!"



# ASSURED ELECTRICAL ACCURACY BASED ON MANUFACTURERS' PROCUREMENT PRINTS

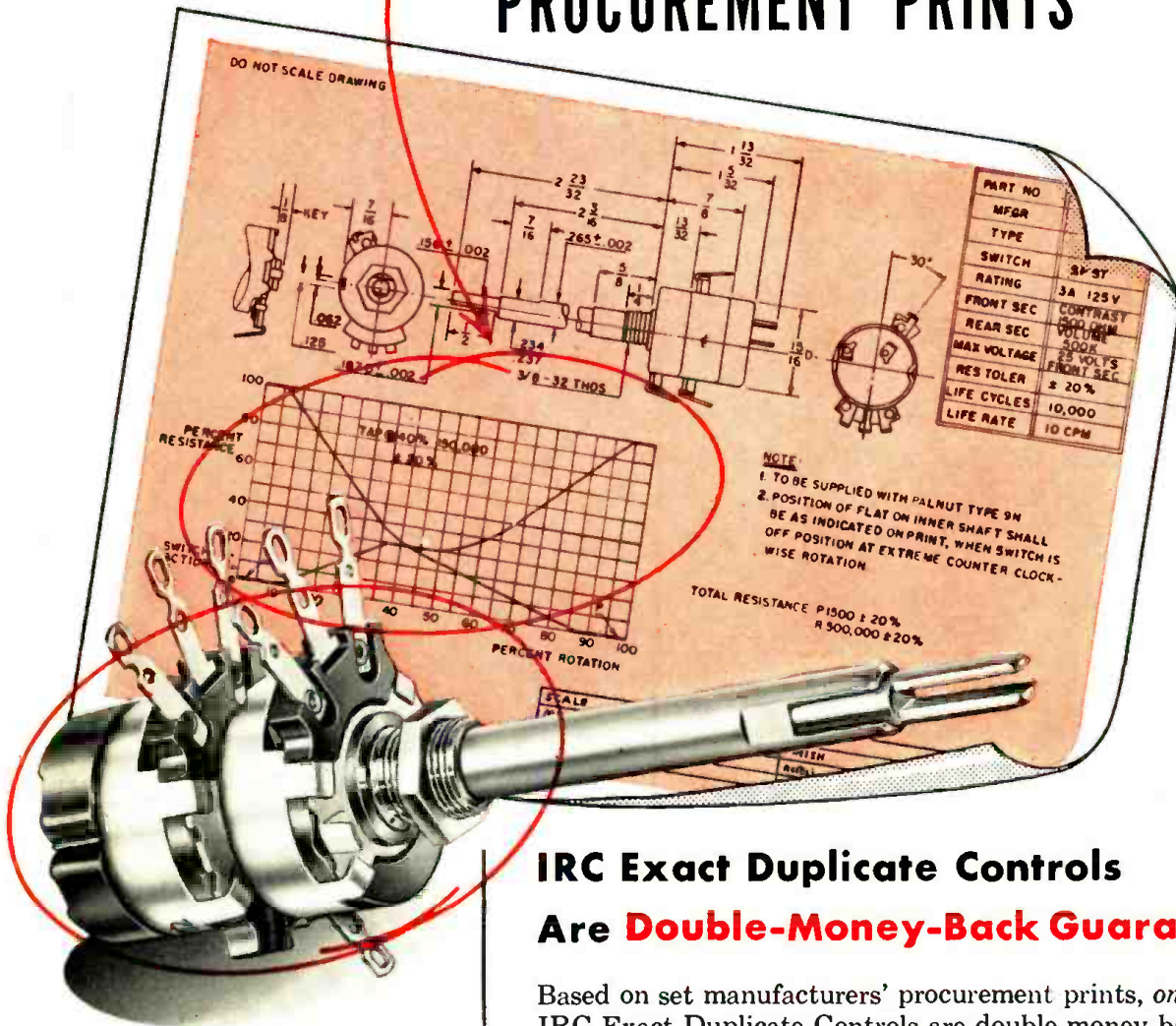

**ONLY IRC GUARANTEES  
ACCURATE ELECTRICAL OPERATION  
AND SATISFACTORY MECHANICAL FIT  
OR DOUBLE-YOUR-MONEY-BACK**

Electrical specifications of this typical manufacturer's procurement print are exactly duplicated by IRC's QJ-412 control (shown). CONCENTRIKIT assembly includes PI-206 and R1-223 shafts with B17-109 and B13-133X Base Elements and 76-1 Switch.



Wherever the Circuit Says ~~~

## IRC Exact Duplicate Controls Are **Double-Money-Back Guaranteed**

Based on set manufacturers' procurement prints, *only* IRC Exact Duplicate Controls are double-money-back guaranteed for accurate electrical operation. This firm guarantee applies to both IRC factory-assembled Exact Duplicates *and* universal CONCENTRIKIT equivalents.

Set manufacturers' electrical specifications are closely followed.

Resistance values are carefully selected to match.

Tapers are watched carefully; IRC doesn't arbitrarily substitute tapers to obtain wide coverage.

For exact duplicate controls of guaranteed accuracy, specify IRC. Most Service Technicians do.

## INTERNATIONAL RESISTANCE CO.

415 N. Broad Street, Philadelphia 8, Pa.

In Canada: International Resistance Co., Ltd., Toronto, Licensee



# BECOME AN ELECTRICAL ENGINEER



**Bachelor of Science Degree  
in 36 months.**

**Major in Electronics or Power.**  
Now, prepare for a career in  
these rapidly expanding fields.

This school will prepare you to become an engineer, technician or service man. Previous military, academic or practical training may be evaluated for advanced credit.

## Enter Both Radio and Television

In 12 months you can attain the *Radio-Technician's* certificate. An added 6 months course qualifies you for the *Radio-TV Technician's* certificate and the Degree of "Associate in Applied Science." The Technician's course is the first third of the program leading to a Bachelor of Science Degree in Electrical Engineering with a major in Electronics.

Also offered: 12-month Radio-TV service course; 12-month Electronics or Electro Technician Courses; 6-month Electrical Service Course and 3-month refresher and general preparatory classes.

## Terms Open April, July, Oct., Jan.

Famous for its Concentric Curriculum. Faculty of specialists. 50,000 former students. Annual enrolment from 48 states and 23 overseas countries. Non-profit. 50th year. Courses approved for Veterans.



## MILWAUKEE SCHOOL OF ENGINEERING

MILWAUKEE SCHOOL OF ENGINEERING  
Dept RH753, 1025 N. Milwaukee  
Milwaukee 1, Wisconsin

Send:  Free 160-page Catalog describing Electrical Engineering Courses;  Booklet on Careers in Radio-TV.

I am interested in.....  
name of course

Name.....Age.....

Address.....

City.....Zone.....State.....

If veteran, indicate date of discharge.....

The adapter, Model BMA-1, was developed in response to requests from users of binaural headsets for a method of adapting their phones to standard service.

### "DYNATRACER"

Century Electronics Co. of 8509 21st Ave., Brooklyn, N. Y. is currently offering a new test unit to the service fraternity.

The "Dynatracer" is a portable self-powered instrument designed to trace



or inject signals through video, sound, sync, a.f.c., vertical, or horizontal sweep circuits.

With a flick of a switch, it will also trace voltages and locate open, shorted, or intermittent components.

The new unit comes complete with operating instructions.

### ANTENNA ROTATOR

LaPoint Electronics Inc. of Rockville, Conn. has released its new "Vee-D-X" antenna rotator to the trade.

The rotating unit features a unique gear train, positive antenna stop, special weather-resistant finish, easy line connection, and the ability to support over 200 pounds. The control console



is decorator-styled and is available in heather green or cordovan mahogany. A unique control lever incorporates both compass and numerical reference points. The special control circuit requires no screwdriver adjustment.

### MICAMOLD CONDENSERS

Micamold Radio Corporation, 1087 Flushing Ave., Brooklyn 37, N.Y. is now in production on a line of hermetically-sealed, metal encased "Ambirite" condensers.

The new units are designed to provide long and satisfactory operation in ambient temperatures up to 150 degrees C. They can be supplied with single and dual sections in standard capacitance values and voltage ratings in various case sizes.

The ability of these condensers to operate throughout the temperature range of -55 degrees C to +150 degrees C is attributed to the "Ambirite" dielectric. Capacitance change with temperature is small.

An engineering bulletin on these new units is available from the company on request.

### BATTERY SOLDERING IRON

Hexacon Electric Co., 119 W. Clay Avenue, Roselle Park, N. J. has announced a soldering iron which can be connected to either 6 or 12 volts.

The new unit will generate any degree of heat required for soldering light or heavy work. A switch button controls heat. The iron will melt solder in 20 seconds.

The iron comes equipped with a nickel-chromium heating element, a 12 foot abrasion- and oil-resistant rubber heater cord, battery clips, and a non-breakable plastic handle. The over-all length is 12½ inches.

### GEIGER COUNTER

The Radiac Co., Inc., 489 Fifth Avenue, New York 17, N. Y. has released a newly-engineered, ultra-sensi-



tive Model 105-D "Prospectoscope" for radioactive mineral prospecting.

The Model 105-D can be used for prospecting from low flying aircraft, from a moving vehicle, or on foot, and also for probing drill holes to depths of 50 feet.

The unit is equipped with a 26" Geiger tube. It can be removed from the instrument and fitted to the 50 foot coaxial cable provided. It also features a standard-size beta-gamma Geiger probe, which is interchangeable with the giant-sized tube. An accurate meter having five ranges gives the prospector a broad selection of instrument sensitivities. A built-in speaker gives an aural indication of radioactivity.

### VIBRATOR LINE

A new line of series drive vibrators specifically designed for long, dependable service in communications equipment has been introduced by James Vibrapower Company, 4036 N. Rockwell St., Chicago 18, Ill.

Series drive has been incorporated in all of the company's replacement models where the original communications equipment has been designed to accommodate such an assembly. The mechanism gives steady, low-voltage starting throughout the extended life of the component.

The design, in addition, separates starting and driving functions from main vibrator contacts, insuring



# BUY TEST EQUIPMENT ON THIS RADICALLY NEW TIME PAYMENT PLAN

**NO INTEREST!! - NO CARRYING CHARGES!!**

USE CONVENIENT TIME PAYMENT ORDER BLANK BELOW

Superior's New  
Model 770

## VOLT-OHM MILLIAMMETER

**Sensitivity—1000 ohms per volt**

Uses latest design 2% accurate 1 Mil. D'Arsonval type meter. • Same zero adjustment holds for both resistance ranges. It is not necessary to readjust when switching from one resistance range to another. This is an important time-saving feature never before included in a V.O.M. in this price range. • Housed in round-cornered, molded case. • Beautiful black etched panel. Depressed letters filled with permanent white. Insures long-life work with constant use.

- SPECIFICATIONS:**
- 6 A.C. VOLTAGE RANGES: 0-15/30/150/300/1500/3000 Volts.
  - 6 D.C. VOLTAGE RANGES: 0-7.5/15/75/150/750/1500 Volts.
  - 4 D.C. CURRENT RANGES: 0-1.5/15/150 MA. 0-1.5 Amps.
  - 2 RESISTANCE RANGES: 0-500 Ohms. 0-1 Megohm.

**\$14.90 NET** The Model 770 comes complete with self-contained batteries, test leads and all operating instructions.



Model 770 is an accurate pocket-size V.O.M. Measures only 3/16" x 5/16" x 2 1/4".

Superior's New  
Model TV-11

## TUBE TESTER



Operates on 105-130 Volt 60 Cycles A.C. Hand-rubbed oak cabinet complete with portable cover

**\$47.50 NET**

• Uses the new self-cleaning Lever Action Switches for individual element testing. Because all elements are numbered according to pin number in the IMA base numbering system, the user can instantly identify which element is under test. Tubes having tapped filaments and tubes with filaments terminating in more than one pin are truly tested with the Model TV-11 as any of the pins may be placed in the neutral position when necessary. • Uses no combination type sockets. Instead individual sockets are used for each type of tube. Thus it is impossible to damage a tube by inserting it in the wrong socket. • Free-moving built-in roll chart provides complete data for all tubes. • Phono Jack on front panel for plugging in either phones or external amplifier detects microphonic tubes or noise due to faulty elements and loose external connections.

Superior's New  
Model 670-A

## SUPER-METER

A COMBINATION VOLT-OHM MILLIAMMETER PLUS CAPACITY REACTANCE INDUCTANCE AND DECIBEL MEASUREMENTS

- SPECIFICATIONS:**
- D.C. VOLTS: 0 to 7.5/15/75/150/750/1500/7,500 Volts.
  - A.C. VOLTS: 0 to 15/30/150/300/1,500/3,000 Volts.
  - OUTPUT VOLTS: 0 to 15/30/150/300/1,500/3,000 Volts.
  - D.C. CURRENT: 0 to 1.5/15/150 Ma. 0 to 1.5/15 Amperes
  - RESISTANCE: 0 to 1,000/100,000 Ohms 0 to 10 Megohms
  - CAPACITY: .001 to 1 Mfd. 1 to 50 Mfd. (Quality test for electrolytics)
  - REACTANCE: 50 to 2,500 Ohms. 2,500 Ohms to 2.5 Megohms
  - INDUCTANCE: .15 to 7 Henries 7 to 7,000 Henries
  - DECIBELS: -6 to +18 +14 to +38 +31 to +58

**\$28.40 NET**

**ADDED FEATURE:** The Model 670-A includes a special GOOD-BAD scale for checking the quality of electrolytic condensers at a test potential of 150 Volts.



Comes housed in rugged, crackle-finished steel cabinet complete with test leads and operating instructions. Size 6 1/4" x 9 1/2" x 4 1/2".

Superior's New

## TV BAR GENERATOR

THROWS AN ACTUAL BAR PATTERN ON ANY TV RECEIVER SCREEN!!



TV Bar Generator comes complete with shielded leads and detailed operating instructions

**\$39.95 NET**

**CONNECTS DIRECT TO ANTENNA POST  
NO CONNECTION INSIDE RECEIVER**

**Features.**—Can be used when no stations are on the air. • Provides linear patterns to adjust vertical and horizontal linearity • Provides vertical and horizontal sweep signals • Provides signal for testing video amplifiers.

Superior's Model 660-A—A NEW A.C. OPERATED

## SIGNAL GENERATOR

Provides Complete Coverage for A.M.—F.M. and TV Alignment



• Tubes used: 1-6BE6 as R. F. Oscillator, mixer and amplifier. 1-6BE6 as Audio Oscillator. 1-6H6 as Power Rectifier. The Model 660-A comes complete with coaxial cable test lead and instructions

**\$42.95 NET**

• Generates Radio Frequencies from 100 Kilocycles to 60 Megacycles on fundamentals and from 60 Megacycles to 220 Megacycles on powerful harmonics. • Accuracy and stability are assured by the use of permeability trimmed III-Q coils. • R. F. available separately or modulated by the internal audio oscillator. • Built in 400 cycle sine wave audio oscillator used to modulate the R. F. signal also available separately for audio testing of receivers, amplifiers, hard of hearing aids, etc. • R. F. Oscillator Circuit: A high transconductance heptode is used as an R. F. oscillator, mixer and amplifier. Modulation is effected by electron coupling in the mixer section thus isolating the oscillator from load changes and affording high stability. • A. F. Oscillator Circuit: A high transconductance heptode connected as a high- $\mu$  triode is used as an audio oscillator in a high-C Colpitts Circuit. The output (over 1 Volt) is nearly pure sine wave. • Attenuator: A 5 step ladder type of attenuator is used.

### NEW TIME PAYMENT PLAN ORDER BLANK

MOSS ELECTRONIC DISTRIBUTING CO., INC.  
Dept. B-63, 38 Murray Street, New York 7, N. Y.

Please send me the units checked below. I am enclosing the down payment with order and agree to pay the monthly balance as shown. It is understood there will be no carrying interest or any other charges, provided I send my monthly payments when due. It is further understood that should I fail to make payment when due, the full unpaid balance shall become immediately due and payable.

- MODEL 770 ..... Total Price \$14.90  
\$2.90 down payment. Balance \$2.00 monthly for 6 months.
- MODEL TV-11 ..... Total Price \$47.50  
\$11.50 down payment. Balance \$6.00 monthly for 6 months.
- MODEL 670-A ..... Total Price \$28.40  
\$7.40 down payment. Balance \$3.50 monthly for 6 months.
- TELEVISION BAR GENERATOR ..... Total Price \$39.95  
\$9.95 down payment. Balance \$5.00 monthly for 6 months.
- MODEL 660-A ..... Total Price \$42.95  
\$12.95 down payment. Balance \$5.00 monthly for 6 months.
- I enclose \$..... as down payment.
- Ship C.O.D. for the down payment.

Signature.....

Name.....

Address.....

City..... Zone..... State.....



WORLD'S LARGEST MANUFACTURER  
OF CUSTOM BUILT TELEVISION

# MATTISON

SILVER ROCKET 630 CHASSIS

• with TUNEABLE •

BUILT-IN BOOSTER

for Better DX Reception

Featuring NEW CASCADE TUNER  
made for UHF interchangeable  
tuning strips and 70° COSINE YOKE

Tube  
Complement:  
28 tubes  
3 rectifiers  
1 CRT

32

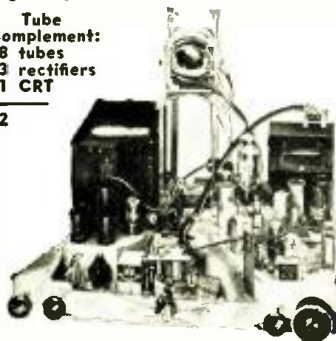

## All Channel Booster

• Broad band single knob control pre-amplifier built in to eliminate long leads which may cause regeneration and attenuation of signal.

• ONLY THE MATTISON 630 CHASSIS HAS AN ALL CHANNEL TUNEABLE BUILT-IN BOOSTER THAT INCREASES SIGNAL STRENGTH UP TO 10 TIMES. THE SILVER ROCKET WILL OUT-PERFORM ANY CHASSIS MADE AND IS PRICED RIGHT TO SELL FAST WITH AN EXTRAORDINARY MARGIN OF PROFIT FOR YOU. WRITE FOR CONFIDENTIAL PRICE SCHEDULE.

ALL CABINETS MADE IN MATTISON'S OWN CABINET FACTORY!

ANNOUNCING  
the New  
AMBASSADOR  
for 1953

The only open face console made in every expensive decorator finish . . . on guaranteed genuine mahogany, walnut, oak and other rare woods!



The AMBASSADOR 17" and 21"  
Best Looking . . . Best Value. Too!

Full size console for eye level television. Available in every expensive decorator finish. Featuring removable safety glass. Dimensions height 42 inches, width 26 inches, depth 23 inches.

DEALERS! SERVICE DEALERS! Here is your opportunity to become the "important" TV Dealer in your area for THE FINEST CUSTOM-BUILT LINE OF TV RECEIVERS. FREE!! Write for Mattison's merchandising portfolio explaining the "UNASSEMBLED PLAN" and "\$1,000,000 FLOOR PLAN."



Manufactured with integrity

When you buy from Mattison you need only one source of supply! You can buy a Mattison Chassis, a Mattison Cabinet or a complete Mattison TV Set!

**Mattison Television & Radio Corp.**

10 West 181st St., Dept. RN, N.Y. 53, N.Y.

greater dependability and additional hours of service.

A complete data sheet on these new models and other of the company's communications vibrators is available on request.

### RECORDING REELS

A new 7" plastic reel for use in magnetic recording with diagonal "V" slots for faster threading and a larger hub for more constant tape speed has



been introduced by Minnesota Mining and Manufacturing Co., 900 Fauquier St., St. Paul 6, Minn.

Designed to reduce errors in program timing, it is the first large-hub reel to accept all standard recording tapes, irrespective of thickness, without danger of tape spillage.

Two threading slots are provided on each side of the reel, including a unique "V" slot that reduces threading time by nearly one-third. More even winding of the tape on the reel is provided by reduced inside width of the reel and use of tapered flanges, thus minimizing the possibility of nicked edges and tape breakage.

### JUNCTION TRANSISTORS

Radio Receptor Co., Inc. of 251 West 19th St., New York 11, N. Y. has added three types of "p-n-p" junction transistors to its line of germanium products.

The new units are sealed in a thin plastic sheet only .120" x .343" x .375". Leads may be soldered in or clipped to plug into a standard transistor or hearing aid socket. The asym-

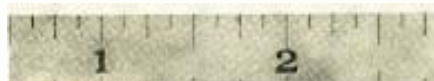

metrical lead spacing insures proper polarity and fits the standard subminiature socket.

Good performance is obtainable with as little as .5 ma. at 1.5 volt of col-

lector voltage. Under these conditions the high gain type RR 20 has a current amplification of 40 and a power gain of 36 db. The general purpose type RR 14 and the economy type RR 21 have current amplification of 25. The latter two types have cut-off currents of only 10 microamperes and a noise figure of 22 db (1000 cps).

### INSULATOR GROMMET

JFD Manufacturing Co., Inc. of 6101 16th Ave., Brooklyn 4, N. Y. is in production on a universal insulator grommet for all television downloads.

This polyethylene insert for stand-off insulators will accommodate tubular and ribbon lead as well as oval, rectangular, and coaxial type transmission lines, thus facilitating the handling of lead-ins for both u.h.f. and v.h.f. installations.

### SUBMINIATURE RESISTOR

Electra Manufacturing Co. of 2537 Madison, Kansas City, Mo. is currently offering a tiny deposited-carbon 1/2 watt resistor which has been especially designed for miniature work.

This "transistor" resistor is only 3/32 inch long and 5/64 inch in diameter. It is available in a range of resistances from 4 ohms to 250,000 ohms. It is rated at a maximum of 250 volts. Tolerances are ±1%, ±5%, and ±10%.

Additional details are included in the company's bulletin E-4 which is available on request.

### EW Speaker Enclosure

(Continued from page 43)

All of the preliminary design and testing work had been carried out using an 8-inch Wharfedale speaker. The problem now was whether or not the enclosure would perform equally well using other makes of 8-inch speakers. Several were tried, among them Altec, Permoflux, Jensen, and University units. The result of these tests seemed to indicate that any good 8-inch speaker could be used in this system.

The next problem seemed to be one of production. The positioning and size of fins (B) and (C) was such that to bolt the speaker securely in place was virtually impossible. The commercial version has solved this problem by slotting the sides (or top and bottom if the unit is used horizontally) of the cabinet so the fins can slide in and out, thus making the speaker readily accessible. The back panel of the cabinet is secured in place by means of wood screws.

The mechanical details of the cabinet, as given on page 43, show how comparatively simple this enclosure is in construction and belie its "big enclosure" performance. All-in-all, this unit has done a man-sized job on "location" recording and has performed well in the author's home.



This name  
 spells Quality  
 and Profits



**U**NEATABLE quality is built into every Sylvania product. Even beyond that, Sylvania quality goes back to its essential metals, chemicals, and materials.

**Sylvania quality is fundamental**

Sylvania grinds and formulates its own phosphors, and applies them by improved methods which assure maximum uniformity and fine picture-tube performance. Sylvania draws its own high-quality tungsten filaments and winds and tests its own coils.

Naturally, this far-reaching quality control results in an enviable nation-wide reputation. Today 7 of the top 10 television set makers use Sylvania Picture Tubes and Receiving Tubes. Naturally, too, Sylvania quality pays off in fewer call-backs, more satisfied customers . . . and *more profits for you.*

You'll find your friendly Sylvania Distributor a mighty high quality man to do business with, too. Call him today!

July, 1953



Be sure to install Sylvania Picture Tubes and Receiving Tubes in all the sets you service. Your customers know about Sylvania's fine quality and they'll appreciate your selection of Sylvania products for their sets.

# SYLVANIA

Sylvania Electric Products Inc., 1740 Broadway, New York 19, N. Y.



**LIGHTING • RADIO**

**ELECTRONICS • TELEVISION**

In Canada: Sylvania Electric (Canada) Ltd., University Tower Bldg., St. Catherine St., Montreal, P. Q.



# THESE BOOKS HELP YOU EARN MORE IN TV SERVICING

## "How to Understand and Use TV Test Instruments"



Provides basic explanations of how each test instrument operates. Covers: VT Voltmeters, AM Signal Generators, Sweep Signal Generators, Oscilloscopes, Video Signal Generators, Field Intensity Meters, Voltage Calibrators. Describes each in detail; explains functions; tells proper use in actual servicing; shows how to avoid improper indications. Helps you get the most from your instruments; saves you time, helps you earn more. 148 pages, 8 1/2 x 11".

ORDER TN-1. Only.....\$3.00

## "TV Servicing Short-Cuts"

Describes a series of actual TV service case histories, giving step-by-step explanations of how the service technician localized and tracked down each problem. Shows how these frequently recurring troubles can be tracked down and solved in any set. Explains how to apply proper time-saving servicing techniques — gives you the successful experience of experts, to make your service work easier, quicker, more profitable. 100 pages, 5 1/2 x 8 1/2".

ORDER TK-1. Only.....\$1.50



## "Servicing TV in the Customer's Home"



Saves you time, work and chassis-hauling on outside TV service calls. Shows you how to make successful repairs on the spot using these methods: employing VTVM and capacitor probe to trace down trouble; "tube-pulling" to diagnose trouble by observing audio and picture effects; performance tests through analysis of test pattern; adjustment techniques developed for field servicing. Saves time, avoids chassis removal. 96 pages, 5 1/2 x 8 1/2".

ORDER TC-1. Only.....\$1.50

## "Television Tube Location Guides"

VOL 3. Shows tube positions and functions in hundreds of important TV sets. Helps save servicing time. Often, looking at the picture or listening to the sound, provides the clue to the trouble. Frequently, a tube failure is the cause. This guide, with its clear, accurate tube placement and function diagrams, makes trouble diagnosis and tube replacement quick and easy, without removing chassis. 192 pages. All new diagrams continuing coverage from Vol. 2.

ORDER TGL-3. Only.....\$2.00

VOL 2. Over 200 pages of tube placement diagrams not included in Vols. 1 and 3.

ORDER TGL-2. Only.....\$2.00

VOL 1. Over 200 pages of diagrams not in Vols. 2 and 3. ORDER TGL-1. Only.....\$1.50



## "Photofact Television Course"



A full, easy-to-understand explanation of TV principles, operation and practice. Covers Cathode Beam Formations and Control, Beam Deflection Systems, Beam Mod. and Synchron.; analyzes CR tubes, camera tubes, voltage supplies, saw-tooth generators, sync. circuits, control functions, antenna circuits, RF input tuning, IF systems, AGC, DC restoration, etc.; with full bibliography and glossary. 208 pages, 8 1/2 x 11".

ORDER TV-1. Only.....\$3.00

## HOWARD W. SAMS & CO., INC.

Order from your Parts Jobber today, or write direct to Howard W. Sams & Co., Inc. 2203 East 46th Street, Indianapolis 5, Ind.

My (check) (money order) for \$..... enclosed. Send the following books:

- TN-1     TK-1     TC-1  
 TGL-3    TGL-2    TGL-1    TV-1

Name.....

Address.....

City..... Zone..... State.....

## "Ferri-Loopstick" Receiver

(Continued from page 42)

5 of the 6 locals with ease and perfect clarity. Tried out in Baltimore, by M. M. Schuman, another old-timer who built the set described, this receiver tuned in 7 of the 8 locals there, clearly and consistently. Such reception, obviously, must be considered unusual, particularly in view of the few parts used.

No miracle is promised, however. The writer, who has spent some 30 years testing and building all types of crystal radios, merely feels that here is not a sensation, but a receiver that is just a little bit different, a little bit better than the sets the serious constructor has been accustomed to.

Of one thing the author feels certain, the hobbyist or experimenter who builds this set will find his time and effort well compensated, in the pleasure and entertainment this receiver will provide. Try building this when you have a free evening.

-30-

## TV Interference

(Continued from page 38)

filters are used to trap out individual interference frequencies.

Some interfering signals, like oscillator radiation from other TV sets, occur at the same frequencies as the desired signal. Rotating the antenna, shielded lead-in cable, and finally, realignment of the offending receiver are the only remedies here.

For the reader's convenience design data is given in Fig. 1 for a high-pass, 300-ohm filter, and for a 300-ohm tuned stub used as a narrow-band wave trap. Stub length is in inches.

-30-

## FIRST AID

FROM A. E. Hutchins, radio officer aboard the SS Fullerton Hills, comes an interesting story regarding an unusual application for Matthew Mandl's "Demagnetizer" which appeared in the January issue of this magazine.

He reports that on a recent trip in mid-Mediterranean one of the able-bodied seamen got a steel splinter in his eye and suffered two days before Mr. Hutchins heard about it. The Pharmacist's Mate had been unable to dislodge the splinter and it had just about been decided that the man would have to be put ashore for hospitalization.

Mr. Hutchins remembered the "Demagnetizer" he had built and suggested that it might be strong enough to pull out the steel particle. They agreed that nothing could be lost by trying so they brought the man to the radio shack. Mr. Hutchins applied the magnet as close as possible and turned on the current. At once the seaman reported that the splinter was out. After the man's eye was rinsed out he returned to duty.

Our thanks to Mr. Hutchins for passing on this story.

-30-

## Scope as Voltmeter

(Continued from page 57)

of this voltage, but on the scope the peak-to-peak voltages are measured. The peak-to-peak voltages of any sine wave are related to the r.m.s. value as shown in Fig. 3. From this we see that 6.3 volts r.m.s. is equivalent to 17.8 volts peak-to-peak. When the 6.3-volt test point or some 6.3-volt filament point in the receiver is used as the calibrating voltage, the vertical amplitude should be adjusted until the signal covers 17 to 18 divisions. The most accurate system is to reduce the horizontal scope gain until only a narrow vertical strip is obtained as in Fig. 1. This makes it quite easy to center the signal vertically and adjust its amplitude until it covers just the right number of divisions. In Fig. 1, a 0.35-volt r.m.s. (1-volt peak-to-peak) signal was used and adjusted to cover 20 divisions. As shown, the signal is slightly larger than 20 divisions and further adjustments of the vertical gain control are needed. When an a.c. voltage is now measured, the calibration with the 1-volt signal is accurate down to 0.25 volt and up to about 2 volts. Although the height of the screen is more than 40 divisions, the edges no longer represent linear deflection and should not be used. If the signal is larger than 2 volts, the 6.3-volt r.m.s. calibration can be used or else the 1-volt signal can be adjusted to cover 5 or 10 divisions. In the latter case voltages up to 8 or 4 volts, respectively, can be measured. The main thing in making scope voltage measurements is to adjust the calibrating voltage for convenient interpretation. Making 1 volt equal to 1, 2, 5, or 10 divisions helps to avoid errors in reading the measured voltage. For the reader's convenience Fig. 2 lists the most frequently used calibrating voltages by r.m.s. and peak-to-peak value.

There is one limitation on a.c. measurements that should be mentioned and that concerns frequency. Many service-type scopes have a linear frequency response in the vertical section up to 500 kc., others go up to 2 or 3 mc. For a.c. voltage readings only the linear portion can be used and frequencies at which the amplifier gain drops 1 or more db cannot be measured by using a 60 cps calibrating signal.

## TRANSISTOR CONTEST

RAYTHEON is sponsoring a transistor application contest which offers a total of \$10,000 in prizes to the lucky winners.

The contestant is required to build a piece of equipment using one or more of the company's CK722 transistors. He then submits a photograph, a completed entry blank, and a 500 to 1000 word article describing the equipment, to the company.

Full details and official entry blanks are available from all Raytheon tube distributors.

-30-



**Spot Radio News**  
(Continued from page 26)

When and if a drill is held, listeners will hear the following message: "We interrupt our normal program to cooperate in security and civil defense measures as requested by the United States Government . . . This is a Conelrad radio alert. Normal broadcasting will now be discontinued for an indefinite period . . . Civil defense information will be broadcast in most areas at 640 or 1240 on your regular radio receiver."

When stations are alerted, they will be obliged to discontinue the normal program, cut the transmitter carrier or sound carrier on TV, for approximately five seconds, then return carrier to the air for approximately five seconds, and cut carrier again for another five seconds. This step will be followed by returning the carrier to the air and broadcasting a 1000-cycle steady-state tone for 15 seconds; the announcement then follows.

Eastern, central, and western zones have been assigned to the C plan. In the east, A. Prose Walker is in charge, serving as FCC liaison officer, Eastern Air Defense Force, at Stewart Air Force Base, Newburgh, New York. Ernest C. Thelemann has been given the central zone base. He is also an FCC liaison officer, representing the Central Air Defense Force, P.O. Box 528, Kansas City, Missouri. On the West Coast, Robert D. Linx is in charge at the Hamilton Air Force Base, Hamilton, California.

THE WHITE HOUSE was also represented at the broadcast conclave, in the form of a special letter from the President to NARTB prexy. Harold E. Fellows. Said the President: "Our nation's vast broadcasting system, developed over a period of only three decades, testifies again to the extraordinary achievements that are possible in a free and competitive economy. Today, radio reaches into ninety-eight per-cent of the homes of America. Television may soon match that record . . . This vast coverage imposes an impressive responsibility upon those operating our broadcasting stations and directing network activities . . . To inform the people fully, fairly, and freely, to hearten their spirit with healthy entertainment, to encourage in every possible way aspiration toward a better state for all mankind—these are the high purposes to which you are dedicated . . . I am confident that the nation's broadcasters will continue to meet this extraordinary responsibility."

ONE OF THE HIGHLIGHTS of the Pacific-coast meeting was the appearance of Madame Commissioner Frieda Hennoek pleading for more funds for the Commission so that more hearing examiners can be retained to process more station authorizations. Declar-



MODEL 50-R

**IT'S  
HERE!  
IT'S THE  
BEST!**

# FISHER

## FM-AM TUNER

■ We haven't the space here to give you *all* the details on the new FISHER 50-R. However, we *can* tell you *there is no other like it*, anywhere, and at any price! **FEATURES IN BRIEF:** Armstrong system, dual limiters, two IF stages, cascode RF stage, full limiting even on only 1 microvolt signal. Sensitivity, 1.5 microvolts for 20 db of quieting, AFC on switch and adjustable for locality. *Adjustable selectivity on AM.* Separate AM and FM front ends, fully shock-mounted. Response uniform, 20 to 20,000 cycles. Distortion less than 0.04% for 1 volt output. Hum level more than 100 db below two volts output. Cathode follower output. Fully shielded; bottom cover, Aluminum chassis. 12 tubes plus tuning eye and rectifier. Self-powered. **\$159.50**

*"Of the very best!"* —HIGH FIDELITY  
MAGAZINE

# FISHER

## PREAMPLIFIER EQUALIZER

■ "Either of these two units is of the very best," says *High Fidelity Magazine* of the FISHER 50-C Master Audio Control and 50-A Amplifier. The 50-C can be used with *any* amplifier. Intermodulation distortion is virtually unmeasurable. Complete phono equalization, loudness control, 5 inputs, 5 input level controls, cathode follower outputs. Self-powered.

Chassis, \$89.50  
With cabinet, \$97.50



# FISHER

## 50-WATT AMPLIFIER

■ THE FISHER Laboratory Standard Amplifier Model 50-A is, beyond a shadow of a doubt, *the world's finest all-triode amplifier*—and yet moderately priced. **FEATURES:** High output—less than 1% harmonic distortion at 50 watts (.08% at 10 watts.) Intermodulation distortion below 2% at 50 watts. Uniform response within .1 db, 20-20,000 cycles; 1 db, 5 to 100,000 cycles. Hum and noise more than 96 db below full output. Quality components and beautiful workmanship throughout. **\$159.50**

Write for illustrated brochure

**FISHER RADIO CORPORATION**  
39 EAST 47th STREET • NEW YORK

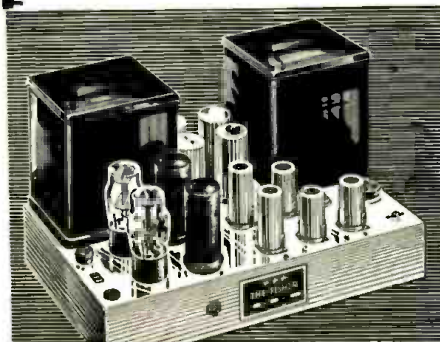



# MOST POWERFUL FRINGE AREA CHASSIS

## THE NEW 1953 CO-CHANNEL "630 FA-2\*"

With Genuine Armstrong FM Sound System

The CHASSIS That Television Engineers and Servicemen Are Buying for Themselves . . .

### CHECK THESE EXCLUSIVE FEATURES

- 10 WATT push-pull audio output. Frequency range from 40 to 12,000 cycles • Standard Coil Cascade Tuner prevents radiation • Retrace Blanking Circuit allows you to raise the brightness without the annoying vertical retrace lines • Heavy duty front focus control • Automatic gain control potentiometer allows you to adjust the threshold sensitivity as low as 4 microvolts & still keep the full 4MC band width • Improved sync amplifier • Improved automatic brightness control • Set aligned for 21.9 MC. New Ham hand will not interfere • Improved fused high voltage power supply gives full 14.5 KV unner load. Will handle all picture tubes up to 24 inch with full sweep • Improved video amplifier has a gain of 40 • All moulded plastic condensers give long life & trouble-free operation • Easily adapted to new UHF stations in 2 minutes by just changing a strip in the tuner • Extra heavy duty power transformer with large safety factor • 6CB6 tubes in Video IF to give full gain • Extra filtering in power supply for hum & ripple-free operation • Phono Connection & switch on chassis allows you to play your phonograph or tuner through the built-in 10 watt hi-fidelity amplifier • Extra heavy duty focus coil, which runs cool • Full focus cosine yoke.

Send for New FREE TV Parts & Hi-Fi Catalog

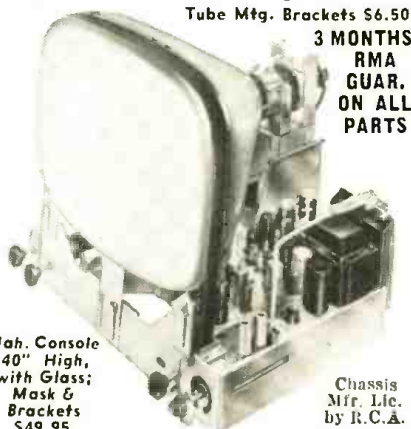

Mah. Console 40" High, with Glass; Mask & Brackets \$49.95

Tube Mtg. Brackets \$6.50  
3 MONTHS RMA GUAR. ON ALL PARTS

Chassis Mfr. Lic. by R.C.A.

### THE ONLY CHASSIS WITH PUSH-PULL AUDIO OUTPUT AT

# \$169<sup>95</sup>

Less C.R. Tube and Brackets

Complete with 12" ROLA Hi-Fi Speaker (Fed. Tax Incl.)

Detailed Service Manual & Schematic—\$1

### TV PICTURE TUBE SALE

Standard Brands • Factory New GUARANTEED 1 FULL YEAR

- 16" Tube. \$19.95
- 17" Tube. \$27.95
- Ring and Sleeve for 24" . . . \$7.50
- 20" Tube. \$34.95
- 21" Tube. \$39.95
- 24" Tube. \$79.95

All merchandise is brand new, factory fresh & fully guaranteed. Mail & phone orders filled upon receipt of certified check or money order for \$25 as deposit on TV chassis. 20% on other items. Balance C.O.D., F.O.B. N.Y. Prices & specifications subject to change without notice. No Fed. taxes to pay. Prices lower than DFS SHOWROOM: 171 Washington St., N.Y. 7. N.Y. Granmercy 7-9245 MAIL ORDER DEPT.: 400 Lafayette St., N.Y. 3

### TV GOLD PLASTIC MASKS

- 16" and 17" . . . \$ 4.95
- 20" and 21" . . . \$ 7.95
- 24" . . . \$14.95

OVER 100 BARGAIN-PRICED CABINETS FOR TV & AUDIO INSTALLATIONS. Send for FREE folder and price list. Full line table models, consoles, consolettes and TV-Radio-Phono combinations. Many styles, Mahogany, blonde, etc.

## AIREX RADIO CORP.

# ARKAY

world's finest radio kits

Write for free Brochure

RADIO KITS, INC., 120 Cedar St., N. Y. 6

### GET INTO TV SERVICING

Send for free 24-page illustrated booklet which tells you how to become a successful TV technician. America's leading TV service school offers you a specialized training program that unites non-essential math & design theory. You concentrate on radio & TV servicing only. You get professional training & experience right in our fully-equipped shops & laboratories. Send for this booklet today. Write Dept. R-73. No obligation—no salesman will call. Approved for Veterans

### WESTERN TELEVISION INSTITUTE

341 W. 18th St. Los Angeles 15, Calif.

# PAY LESS FOR TUBES

INDIVIDUALLY BOXED • FULLY TESTED • EACH TUBE GUARANTEED FOR SIX MONTHS

Type	Price	Type	Price	Type	Price	Type	Price
1B3GT	\$ .69	6A55	\$ .50	6K6GT	\$ .41	12A27	\$ .70
1M5GT	.46	6AT6	.38	6L6C	.80	12BA6	.45
1L4	.57	6AU6	.43	6L6CA	.80	12BE6	.47
1N5GT	.57	6AV6	.38	6S4	.46	12BH7	.63
1R5	.56	6B4G	.96	6SA7GT	.52	12BZ7	.75
1S5	.47	6BA6	.45	6S7GT	.47	12SA7GT	.52
1T4	.59	6BC5	.53	6SK7GT	.50	12SK7GT	.50
1T5GT	.71	6BD5GT	.89	6SL7GT	.62	12SL7GT	.61
1X2	.67	6BE6	.47	6SN7GT	.54	12SN7GT	.54
3Q5GT	.65	6BF5	.60	6SQ7GT	.42	12SQ7GT	.44
3S4	.55	6BG6	1.34	6T8	.78	19B6G	1.39
3V4	.56	6BH6	.57	6U8	.85	19C8	.94
5V4C	.43	6BJ6	.48	6V6GT	.46	19T8	.79
5V4G	.73	6BK7	1.10	6W4GT	.45	25B0G	.89
5Y3G	.34	6BL7	.83	6W6GT	.57	25L6GT	.48
5Y3GT	.30	6B06	.89	6X4	.34	25Z6GT	.42
6AB4	.46	6BQ7	1.10	6X5GT	.33	35A5	.48
6AF4	1.40	6BZ7	1.10	6Y6G	.59	35B5	.47
6AG5	.54	6C4	.34	7N7	.52	35C5	.47
6AK5	.95	6CB6	.53	12AT6	.38	35L6GT	.47
6AK6	.63	6CD6	1.85	12AT7	.68	35W4	.31
6ALS	.40	6CD6	1.85	12AUG	.43	35Z5GT	.30
6AN4	1.30	6F6GT	.45	12AU7	.55	50B5	.47
6AQ5	.46	6H6GT	.49	12AV6	.38	50C5	.47
6AQ6	.42	6J5GT	.40	12AV7	.80	50L6	.47
6AR5	.38	6J6	.62	12AX7	.61	117Z3	.39
						117Z6	.68

Each tube is performance-proven. 25% deposit must accompany all orders. Balance C.O.D. All Prices F.O.B., N.Y.C. If remittance is made with order, you can deduct 25% \$1.00 handling charge for orders under \$10.00. Subject to Prior Sale. Importer inquiries invited.

# PHILLIPS TUBE COMPANY

2281 Nostrand Ave. BROOKLYN 10, N. Y. Cloverdale 3-8010-1-2

ing that the Commission is . . . "second only to the atomic Commission in importance to the country's welfare . . ." she wondered why Congress insisted on slicing their budget, taking millions off the appropriation request. The extra \$300,000 received from Congress was a mere trickle, she added, because it represented but a small return of the moneys deleted from the budget request. "Our budget was less last year than in 1946 when we had no television stations to speak of," Madame Commissioner reminded her listeners. "We need more of everything at the Commission," she emphasized. "Not only examiners, but engineers and lawyers, too."

Earlier, in a letter to all Senators, a demand for more FCC dollars was also made by Senator Johnson. He pointed out that billions of dollars of new business can be created for the nation's dealers, wholesalers, and manufacturers by allotting more money to the Commission, so that they could get more stations on the air. Not only do TV and radio people profit from new stations, he added, but countless others who either supply the radio-TV industry or sponsor programs and thus stimulate sales of other merchandise. The Senator noted that it would not cost the Government any more to have more new TV station applications processed this year and next, than it would to have such processing parceled out over a five or ten-year period.

According to the Senator, at least \$8-billion more new business would result in a relatively short period of time, if more station construction authorizations were cleared, thus hastening broadcast operation.

SENATOR GEORGE A. SMATHERS also joined the drive for accelerated processing. But he claimed that speedier hearings would solve the problem. Too much time, he said, is spent in examinations. Hundreds of competing applications are still in the files, the Senator declared. This was inexcusable, he pointed out. So determined was the Senator to get action, that he introduced a resolution asking the Senate Commerce Committee to investigate this condition and determine just what must be done to get those contested cases out of the files. In his opinion the real need for stations is . . . "in areas where we find several applicants competing for the right to televise over the two or three channels which have been authorized in that area." It has been well established, he said, that there are many single-station applicants who have no intention of building a television station, and only intend to . . . "hold on to a license until he can dispose of it at a profit, or until the population in that area is sufficient to justify his erecting a television station."

BROADCASTERS' and TELECASTERS' income in 1952 rose sharply according to preliminary estimates released by the

# START ON THE ROAD TO SUCCESS

## Study the RCA TV Servicing Course in your spare time

ARE YOU SATISFIED with the position you now hold? Do you feel you're worth more money? Are you pleased with yourself, your work, your associates . . . and your future? What does the next year hold for you . . . and the year after that?

Are you content merely to plod along through the best years of your life . . . or do you want to get into more pleasant work . . . hold a well-paid job . . . perhaps establish your own business?



If you are looking for a REAL opportunity . . . If you want to GROW with a GROWING INDUSTRY . . . If you want to grasp the success that should be yours, *then we say to you, study TV Servicing.*

Everyone knows that Television is the fastest growing industry today. Opportunities are going begging for men who have the training and ability to grasp them. Now *is the time to start on the road to success in TV Servicing.*

### Study at Home in your spare time

The RCA Institutes Home Study Course in TV Servicing is easy to learn. You progress rapidly, step by step, as you learn the procedure of servicing and trouble-shooting TV receivers and installing TV antennas. Hundreds of pictures and diagrams help you understand the how-it-works information and the how-to-do-techniques.

### A Service of Radio Corporation of America

The RCA Institutes TV Servicing course was written and planned by instructors with years of specialized experience in training men. You get up-to-the-minute information, too, because you study right at the source of the latest developments in Television. Your lessons are carefully examined and accurately graded by competent teachers who are interested in helping YOU to succeed.

RCA Institutes is licensed by the University of the State of New York . . . an affiliate member of the American Society for Engineering Education . . . approved by leading Radio-Television Service Organizations.

### It costs so little to gain so much

RCA Institutes makes it easy for you to take advantage of the big opportunities in TV Servicing. The cost of the TV Servicing Home Study Course has been cut to a minimum. You pay for the course on a pay-as-you-learn unit lesson basis. *No other home study course in TV Servicing offers so much for so little cost to you.*

RCA Institutes conducts a resident school in New York City offering day and evening courses in Radio and TV Servicing, Radio Code and Radio Operating, Radio Broadcasting, Advanced Technology. *Write for free catalog on resident courses.*



**RCA INSTITUTES, INC.**  
A SERVICE OF RADIO CORPORATION OF AMERICA  
350 WEST FOURTH STREET, NEW YORK 14, N. Y.

**SEND FOR FREE BOOKLET**—Mail the coupon—today. Get complete information on the RCA INSTITUTES Home Study Course in Television Servicing. Booklet gives you a general outline of the course by units. See how this practical home study course trains you quickly, easily. Mail coupon in envelope or paste on postal card.



### MAIL COUPON NOW!

RCA INSTITUTES, INC., Home Study Dept. RN753  
350 West Fourth Street, New York 14, N. Y.

Without obligation on my part, please send me copy of booklet "RCA INSTITUTES Home Study Course in TELEVISION SERVICING." (No salesman will call.)

Name \_\_\_\_\_  
(please print)

Address \_\_\_\_\_

City \_\_\_\_\_ Zone \_\_\_\_\_ State \_\_\_\_\_



# RADIO Surplus Buys

## CRYSTALS

in FT 241-A Holders - 1/2" Pin SPC. Marked 54th OR 72nd Harmonic MC Freq. Listed below by fundamental frequency with fractions omitted.

500 KC Crystals **\$1.95**  
 1000 KC Crystals **\$3.95**  
 200 KC Crystals **\$1.00**

370	407	444	476	509
372	408	445	477	511
374	409	446	479	512
375	411	447	480	513
376	412	448	481	514
377	413	450	483	515
379	414	451	484	516
380	415	452	485	518
381	416	453	486	519
383	418	454	487	520
384	419	455	488	522
385	420	456	490	523
386	422	457	491	525
387	423	458	492	526
388	424	459	493	527
390	425	461	494	529
391	426	462	495	530
392	427	463	496	531
393	429	464	497	533
394	430	465	498	534
395	431	466	501	536
396	433	468	502	537
397	434	469	503	538
398	435	470	504	540
400	436	472	505	
401	437	473	506	
402	438	474	507	
403	440	475	508	
404	441			
405	442			
406	443			

10 for \$8.00, Postpaid

### FOLLOWING CRYSTALS AVAILABLE IN FT 243 HOLDERS 1/2" PIN SPACING

4165	5127.5	6875
4240	5205	6975
4280	5285	7350
4310	5335	7450
4330	5485	7750
4335	5587	7875
4350	5660	7950
4370	5730	8273.3
4440	5852.5	8350
4445	5875	8450
4540	6073.3	
4635	6140	
4710	6350	
4880	6525	
4980	6550	
4995	6700	
5035	6825	

**\$1.00**  
EACH

11 for \$10.00, Postpaid

PLEASE ENCLOSE FULL AMOUNT WITH ORDER  
 QUANTITIES AVAILABLE  
 WRITE FOR YOUR REQUIREMENTS

**C & H SALES CO.**

BOX 356-MT EAST PASADENA STA. • PASADENA 8, CALIF.

Commission. Revenues of the AM-FM broadcast industry in '52 amounted to \$173.1 million or about 5 per-cent above '51. While seven networks (four nationwide and three regional, and including 25 owned and operated stations) estimated total revenues of \$101 million, or 3 per-cent below '51, more than 2300 other radio stations estimated total revenues of \$372.1 million, an increase of 7.4 per-cent above '51.

In the 63 TV markets (i.e., those with operating TV stations prior to '52), 108 TV stations reported as much total revenue from TV operations as did 529 AM licensees from AM station operation. More than three out of every five broadcast advertising dollars spent in Los Angeles, Columbus, and Cleveland were spent on TV in those markets.

The total revenues from the TV industry were estimated at \$336.3 million for '52; approximately 43 per-cent above the '51 volume of \$235.7 million.

Networks (including their 15 owned and operated stations) reported revenues of \$191.9 million, expenses of \$182.9 million and income of \$9 million. The '52 network TV revenues were almost 50 per-cent above '51. However, as a result of a proportionately greater increase in expenses (56 per-cent) network income was reported at \$2 million below the '51 figure of \$11 million.

Ninety-three TV stations (excluding 15 network owned and operated stations) estimated total revenues of \$143.7 million or about 33 per-cent above '51. With station expenses increasing at a slower rate (28 per-cent) the income of these stations rose to \$45.6 million or 51 per-cent above '51. Fourteen stations, authorized in '52 since the freeze lift, esti-

mated total revenues of \$700,000, expenses of \$800,000 and a loss of \$100,000. Of the 14 stations, only three were in operation more than two months during '52.

ALTHOUGH hampered by a lack of hearing examiners, many approvals for new construction appeared on the late Spring docket. At this writing, post-thaw authorizations have risen to nearly 360, with a majority of the grants made to the high-band stations.

Once again, as the table on page 75 illustrates, many new areas appear on the new-station timetable. Among these newcomers are Miami, Oklahoma, and Keene, New Hampshire.

IN REPORTING on the communication facilities designed for the Olympic Games of '52 at Helsinki, a few months ago, it was noted that about 150 commentators from about 30 countries were expected to attend, and accordingly an extensive array of mikes, amplifiers and associated gear would be required. It has now been learned that 41 countries were represented with 147 commentators, together with 21 observers and technicians. To meet the demands of these announcers and associates, 34 microphone positions had to be set up, each position providing facilities for a commentator, assistant, and an interpreter. To assure constant uninterrupted contact, a set of round-the-clock circuits were placed in operation; Helsinki was permanently connected during the sixteen-day period of the games over eleven trunk circuits to Stockholm, Oslo, Copenhagen, Berlin (2 circuits), Hamburg, Stuttgart, Cologne, Brussels, London, and Hilversum. Scandinavian broadcasting stations handled most of the long-distance s.w. transmissions. . . . L.W.

Regency

UHF

the quarter million dollar converter

**CONVERTER  
 MODEL RC-600**

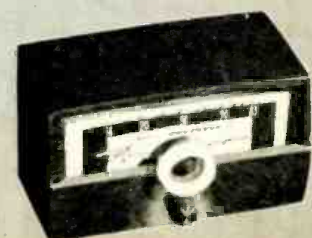

**\$49.95 list**

# Where do you want to go in **TV-ELECTRONICS** and how soon will you get there?



Free CREI booklet lists opportunities  
and gives you a plan for grasping them!

**D**O YOU HAVE a career time-table? Do you know how much you should or could be earning two years from now? Five years? Many men are plodders without a plan. They wander through life never doing what they want to do, never receiving enough pay, never achieving true career satisfaction. Because they never knew ahead of time where they should or could be at a given date, they never planned ahead. When an opening arises, somebody else is promoted. When January 1st rolls around, they're just where they were a year before. Their *error*, failure to plan, can be the lesson which shows you the *secret* of future success. In this expanding, bustling TV-Electronics world, there is a whole lifetime of happiness and high earnings waiting for you, if you name your goals, and take steps to reach them. Thousands of ambitious young men have found success in TV-Electronics through the aid of the CREI booklet, "Your Future in the New World of Electronics." The newest edition tells of electronics' golden opportunities. Almost 200 TV stations are now on the air. 2,000 more are on the way. There are over 21,000,000 TV sets and over 100 million radios in use.

This is the era of Communication: aeronautical, marine, police and fire, industrial, land transportation communications; this is the era of defense orders and a manufacturing industry which last year alone sold billions of dollars worth of electronic equipment, and is expected to do no less than 10 billion dollars worth excluding military orders. All these developments mean positions: in development, research, design, production, testing, inspection, manufacture, broadcasting, telecasting and servicing. Who will get these positions? You—if you have a career time-table; if you can foresee your future in electronics; if you are willing to advance your knowledge; if you spend 2 minutes to write for your copy of "Your Future In the New World of Electronics," and follow the plan it describes.

This is the booklet that shows you how CREI home study leads the way to greater earnings. However, being an accredited technical school, CREI promises you no short-cuts. You must translate your willingness to learn into salable technical knowledge via study. CREI knows what it means to grow along with a booming industry. This year CREI is celebrating its 26th Anniversary, having started in 1927 in the early days of radio. Since then CREI has provided thousands of professional radiomen with technical educations. During World War II, CREI trained thousands for the Armed Services. Leading firms use CREI courses for group training in electronics at company expense; among them are United Air Lines, Cana-

dian Broadcasting Corporation, Trans-Canada Airlines, Sears Roebuck & Co., Bendix Products Division, All-American Cables and Radio, Inc., RCA-Victor Division and Machlett Laboratories. CREI courses, prepared by recognized experts, are constantly revised to keep them up-to-date. Student work is under the personal supervision of a CREI Staff Instructor who knows and teaches what industry needs.

You choose your own hours when you study at home. Upon completion you join the many CREI graduates who have found their diplomas keys-to-success in Radio, TV and Electronics. CREI alumni hold many top positions in America's leading firms.

At your service is the CREI Placement Bureau which helps find positions for students and graduates. Although CREI does not guarantee jobs, the bureau now has many more requests for personnel than can be filled. Talk to men in the field and check up on CREI's high standing in electronics instruction. Determine for yourself right now that your earnings are going to rise with your knowledge—and that you will rise with this booming industry. All this CREI offers you, provided you sincerely want to learn. Fill out the coupon and mail it today. We'll promptly send you your free copy of "Your Future in the New World of Electronics." The rest—your future—is up to you.

CREI resident instruction (day or night) is offered in Washington, D. C. New classes start once a month. **VETERANS:** If you were discharged after June 27, 1950—check the coupon for full information about the new G.I. Bill of Rights.

## MAIL COUPON FOR FREE BOOKLET

**CAPITOL RADIO ENGINEERING INSTITUTE**  
Dept. 117 3224 16th St., N.W., Washington 10, D. C.

Send booklet "Your Future in the New World of Electronics" and course outline.

CHECK FIELD OF GREATEST INTEREST }  TV, FM & Advanced AM Servicing  Aeronautical Radio Engineering  
 Practical Television Engineering  Practical Radio Engineering (AM, FM, TV)

Name .....  
 Street .....  
 City ..... Zone ..... State .....  
 Check  Residence School  Veteran



# MANUFACTURERS' LITERATURE

Readers are asked to write directly to the manufacturer for the literature. By mentioning RADIO & TELEVISION NEWS, the issue and page, and enclosing the proper amount, when indicated, delay will be prevented.

## SENSITROL RELAY

WESTON SENSITROL, coil sensitivity only 10 microamps! Built like meter. At 10ma. needle swings over into permanent magnet which grips it to close contacts rated 1 ampere. Perfectly damped. Contacts will not close contacts. Built-in reset relay. Catches contacts when 12 to 24 volts AC or DC is momentarily applied to reset leads. The Sensitrol works directly from photoelectric, thermocouples, or any source of minute current. No electronic amplifier needed! A \$60.00 precision device for only **\$12.95**

## SENSITIVE POLARIZED RELAY

This is the device that the services use to replace relays. Now offered to the public for the first time! SP/DT, both contacts normally open. The PURSITY of an applied 1/2 VDC, 5 MA current determines which contact closes. Use for micro-positioning, remote control, model control, etc. Our free data sheet shows you just how to use it. In metal box with two other heavier duty relays. NEW, slightly dirty. **\$6.95** (Shipping weight, 4 lbs.)

## SUPER SENSITIVE RELAY BK-7-B

Single pole, double throw. Coil 4000 ohms. Sensitivity accurately adjustable on calibrated scale. At 5 on scale sensitivity is 12 milliwatts (1.2 milliwatt, 2 volts) and from 5 to 40 on scale the sensitivity decreases linearly to 1/3 ma (1/3 milliwatt, 6 volts). Thousands of uses: telemetric, color-operated or capacity operated or thermocouple operated circuits, sequencer circuits, etc. Fully encased. 1 1/2" x 3 3/4" x 1 1/2" deep. Weight, 1 1/2" x 2 1/4" x 1 1/2" overall. Contact door and screwdriver adjustable stationary contacts. Brand New, Only \$1.95 each, 10 for \$17.50 (Shipping Weight, each, 1 lb.)

## A SENSITIVE RELAY!

Closes at 4 to 5 ma. (Extra set of SP/ST contacts for additional sequence, close at 6.5 ma.) Coil 6000 ohms. Sensitivity easily altered by bonding limit arm or changing spring. Only 1 1/2" x 2 1/4" x 1 1/2" overall. Dozens of applications, and offered at a "stock up" price. Removed from clean equipment. **ONLY 98c each, 3 for \$2.75** Boxed, reconditioned, like new. **\$1.69**

## PRECISION CALIBRATING CRYSTAL

200 KC. Same as used in late model Collins Autotune Xmitters. In FT-241-A holder (1/2" pin spacing). Use in Pierce untuned oscillator circuits to get check points very close together all the way up the spectrum. BRAND NEW **\$2.95**

## 12 CHANNEL T-V TUNER

Complete front end, famous make "Silvor Circle." Furnished with original factory instructions, less tubes. Dozens of uses: receivers, converters, etc. The TV bargain of the year for builders, amateurs, students. These are factory rejected for minor \$5.00 damage. **ONLY \$1.95 each, 3 for \$5.00** (Shipping Weight, each, 3 lbs.)

## OIL FILLED FILTER CONDENSERS

(All famous makes)

10 mfd. 600 vdc. 3"x1 3/4"x5 5/8" OA ht. BRAND NEW **\$2.75**  
6-6 mfd. 600 vdc. 2 1/2"x2 1/2"x4 1/4" hich. bolt mounting, ups under. BRAND NEW **2.85**  
8-8 mfd. 600 vdc. 2 1/4"x2 1/4"x4 1/4" hich. bolt mounting, ups under. BRAND NEW **2.95**

## 2" PM SPEAKERS, heavy magnets.

BRAND NEW **\$1.25**

12 VOLT RECEIVER DYNAMOTORS. Deliver 250 vdc. 60 ma. Shipping wt. 4 lbs. EXCELLENT USED **\$7.95**

274N PLUG. 7-prong male plug to fit back of command rears, and extra. This is the same plug as used in the racks. NEW, each 21c; five for **\$1.00**  
Local Control Adapter Parts for 274N or ARC-5 revr. Exact pot, each, knob, etched plate, and instruction data. Ready to mount. **\$1.29**  
SPINE TUNING KNOB. **.79c**

## 0-1 DC MILLIAMMETER

A hard-to-get meter at a hard-to-get price. These are unused 2 1/2" aviation type meters, which we have modified for general use, including new white scale plate with large, easy to read calibration. **ONLY \$4.50**

PE-101-C DYNAMOTOR. Brand new. (Shipping weight, 13 lbs.) **\$4.95**

OUTPUT TRANSFORMER. 5000 ohms input to TWO outputs. 300 ohms or 3.5 ohms. Use as input for 12A6, 6V6, etc., or to match speaker or headset. NEW, potted, shielded. **.79c**

ANTENNA MAST SECTIONS, MS-49, 50, 51, 52, 39c  
New, original packing. Each

## CRYSTAL MICROPHONE GIVEAWAY!

Sensitive hearing aid capsule sealed in neat, compact, flat container with tinned terminals. Crisp, clear, high-level output. Ideal for implants, ties, truck-aways. Individually tested and guaranteed. **ONLY 98c**

## CERAMIC COIL FORM ASSORTMENT

Contains 12 BRAND NEW ceramic coil forms, 98c  
various diameters and spacings. **ONLY .98c** (Shipping wt. 10 lbs.)

## BROADCAST BAND & AERO

MN-26-C Remote Controlled navigational direction finder and communications receiver. Manual DF in any one of three freq. bands, 150 to 1500 KC. 24 V. Self-contained dynamotor supply. Complete installation, including receiver, control box, loop, azimuth control, Left-Right Indicator, plugs, loop transmission line, and flex. shafts. **\$69.50**  
BRAND NEW, ORIG. PACK. (Shipping Wt. 75 lbs. Express Collect.)

## HI-FI HEADSET

Uses annular grooved plastic fibre cones with voice coils as in speakers, and padded chromite ear muffs to obtain spacing for correct acoustical load. Gives finest music reproduction, flat far beyond upper and lower limits of auditory perception. Pair in series has measured impedance of 600 ohms at 1000 cycles, obtained with built-in high quality transformer. Checked out with frequency standard ear pads. **\$7.95** (Shipping weight, 3 lbs.)

6 V VIBRATOR KIT. Vibrator plus non-sine transformer, two outputs: 700 VCT, 145 ma for plates; 15 V for bias. Can deliver 320 V at 130 ma. (Shipping wt. 6 lbs.) **NEW \$2.89**

## EASY MONEY!

We're still buying surplus gear. Tell us what you've got, its condition and your price. If we like it you'll get our check quick.

## G. L. ELECTRONICS

905 S. Vermont Ave., Los Angeles 6, Calif.  
All Prices F.O.B. Los Angeles Calif. Buyers Add Sales Tax  
GET ON OUR MAILING LIST

## FREE REPRINT

The Mellon Institute, 4400 Fifth Avenue, Pittsburgh 13, Pa. is making available without charge copies of an article "Electronics in Industrial Research" by Axel H. Peterson.

This article by Dr. Peterson, who is head of the department of instrumentation at the Institute, originally appeared in the magazine "Industrial Laboratories."

## NEW "VARIACS"

General Radio Company, 275 Massachusetts Ave., Cambridge 39, Mass. has recently issued a 12-page catalogue describing its "V-line Variac" autotransformers.

These new units incorporate the "Duratrak" construction, a silver alloy coating applied to the brush tracks to prevent contact surface deterioration even when operating at fixed brush settings.

The catalogue explains the operation of these new autotransformers and describes the various units currently available.

## "SHORT-FORM CATALOGUE"

Tektronix, Inc., P. O. Box 831, Portland 7, Oregon has issued a "Short-Form Catalogue" which pictures and briefly describes its line of test instruments for laboratory and service work.

Included are seven oscilloscopes, two square-wave generators, one amplifier, two preamplifiers, one time-mark generator, and a series-waveform generator.

A listing of the company's representatives and branch offices is also included.

## COMPONENT DEVELOPMENTS

Aerovox Corporation of New Bedford, Mass. is currently offering a new bulletin which deals with recent electronic component developments, particularly high-temperature metallized-paper condensers and other of the company's products.

The Advertising Department of the company will forward a copy of this 6-page bulletin which also describes resistors, high-voltage plate assemblies and ceramic condensers as well as the company's printed-wiring development.

## NEW AMPLIFIER DATA

A new revised edition of the company's "Williamson Amplifier" instruction sheet has been issued by Standard Transformer Corporation of 3580 Elston Ave., Chicago 18, Ill. Complete with performance curves,

schematic, parts list, chassis layout, and diagrams, the sheet has been revised and reissued in response to a heavy demand for this material.

Three Stancor transformers are used in the circuit and two completely punched and finished chassis are available from distributors to make construction of the amplifier as easy as possible.

## SPRAGUE CATALOGUE

Sprague Products Co., 51 Marshall St., North Adams, Mass. has issued a comprehensive catalogue describing and listing its ceramic condensers.

Covering more than 375 ratings in 11 different voltages from 300 to 20,000 volts d.c., ranging in size and style from the company's subminiature units to its molded plastic condensers, the listing includes all of Sprague's greatly enlarged ceramic line.

Designated as Catalogue C-650, this listing includes all the ceramic condensers a service technician might possibly need. Copies of this publication are available from all of the company's distributors or from the company direct.

## RECTIFIER DATA

The Electronic Rectifier Co. of Rochester, N. Y. is issuing a one-page catalogue sheet which lists and describes twelve of the company's 127 products.

By using an almost telegraphic style of copy, these twelve items are described in sufficient detail to give a prospective buyer a good idea of the type of rectifiers and battery chargers available.

## IRC DIODE DATA

International Rectifier Corporation, 1521 E. Grand Ave., El Segundo, California has issued a bulletin, GD-1, which describes in detail the characteristics and advantages of its new line of germanium diodes.

The company is now in a position to produce germanium diodes in any quantities desired. Any of the standard units listed in the bulletin may be shipped from stock. Larger production quantities can be scheduled to meet requirements.

## ATTENUATION FILTERS

Cornell-Dubilier Electric Corp., South Plainfield, N. J. has issued a 12-page catalogue with descriptions, illustrations, and technical data on a portion of their wide line of "Quietone" filters.

More than 135 different types of the company's feedthrough, pi, and universal filters are listed in the new bulletin. It includes filters for r.f. attenuation in virtually every type of electronic and electrical equipment.

Besides complete, detailed, electrical characteristics, the descriptions include outline drawings, physical characteristics, circuit diagrams, photographs, and charts.

A copy of Bulletin No. NB-148 is available from your C-D distributor or factory representative or from the company direct.

#### REPLACEMENT PARTS

*Merit Coil and Transformer Corp.* of Chicago has announced the availability of a new and revised edition of its "TV Repl Guide".

This year's edition, which has been expanded to 40 pages, features the addition of helpful i.f.-r.f. coil and width-linearity coil listings. The new No. 406 also contains information on new flybacks, yokes, and power transformers manufactured by the company.

#### "GOLD BONDED" DIODES

*Transitron Electronic Corp.*, 403-407 Main Street, Melrose 76, Mass. has issued a 4-page bulletin giving complete technical specification on its new line of "Gold Bonded" diodes.

Included in the publication is information on the Types 1N48, 1N51, 1N58, 1N63, 1N69, 1N70, 1N81, T1, T2, T3, T4, and T5. Performance curves and other characteristics are included along with a large cut-away drawing showing the construction of the diodes.

A copy of Bulletin #TE-1300 is available on request.

#### "HUSKY" RELAYS

*Price Electric Corporation*, Frederick, Maryland is currently offering copies of a 4-page bulletin describing its line of "Husky" relays.

Included are photographs and specifications on subminiature, balanced armature, high-shock, hermetically-sealed, high-current, etc. relays. All of the relays described were exhibited at the recent IRE show.

Copies of this bulletin are available without charge. Please specify "the IRE bulletin" when making your request.

#### RCA TUBE BOOKLET

The *RCA Victor Division of Radio Corporation of America*, Harrison, N. J. has issued an up-to-date "Who's Who" of RCA electronic tubes which describes 495 different receiving types and kinescopes having their chief application in radio and television receivers.

The new booklet, Form No. 1275-F, was designed to provide service dealers with an up-to-date catalogue of RCA receiving tube information and to serve as a guide in the selection of most suitable tubes for given applications.

A copy of "RCA Receiving Tubes July, 1953



MODEL RP-1

**\$59<sup>50</sup>**

SHIPPING  
WT. 30 LBS.

Shipped  
Express  
Only

A new concept  
of recorded music

## THE HEATHKIT Dual RECORD PLAYER KIT

- Dual matched speakers for room filled perimeter sound
- Plays all record sizes, all speeds
- Newly developed ceramic cartridge
- Automatic shut off for changer and amplifier

Here is a *new* introduction to quality record reproduction. A simple to operate compact table top model with none of the specialized custom installation problems usually associated with high fidelity systems. Two matched speakers mounted in an acoustically correct enclosure reproduce *all* of the music on the record. Reproduction with the unique sensation of being in a halo of glorious sound.

The world famous VM Tri-O-Matic record changer plays all three record sizes at all three speeds. Automatic shut off for both changer and

amplifier after the last record is played. A wide range ceramic cartridge features an ingenious "turn-under" twin sapphire stylus for LP or 78 records without turning the cartridge. Simplified easy to assemble four tube amplifier featuring compensated volume control and separate tone control. Proxilyn impregnated fabric covered cabinet supplied completely assembled. You build only the amplifier from simple step-by-step instructions. No specialized tools or knowledge required.

The Heathkit Dual Kit includes cabinet, VM player, speakers, tubes, and all circuit components required for amplifier construction. If a kit project has ever tempted you, here is the perfect introduction to an interesting and exciting pastime. Build the Heathkit Dual and enjoy unusually realistic room filling reproduction of fine recorded music.

#### OTHER *Famous* HEATHKIT AMPLIFIERS

#### THE HEATHKIT 6 WATT AMPLIFIER KIT

Model A-7B

**\$14<sup>50</sup>**

Ship. Wt. 10 lbs.

The Heathkit Model A-7B Amplifier features separate bass and treble tone controls — two compensated inputs — three output impedances 4, 8, and 16 ohms — frequency response  $\pm 1\frac{1}{2}$  db from 20 to 20,000 cycles — push pull beam power output at full 6 watts.

Heathkit Model A-7C with preamplifier stage..... **\$16.50**

#### HEATHKIT *High* FIDELITY AMPLIFIER KIT

**\$35<sup>50</sup>**

Model A-9A  
Ship. Wt. 17 lbs.

A 20 watt high fidelity amplifier especially designed for custom installations. Low hum and noise level 9 pin miniature dual triodes in pre-amplifier and tone control circuits. Four switch selected inputs. Frequency response  $\pm 1$  db 20 to 20,000 cycles. Output impedances of 4, 8, and 16 ohms.

#### Write For Free CATALOG

New 32 page 1953 Catalog lists all kits, specifications, schematics and latest price information.

## HEATH COMPANY

BENTON HARBOR 15  
MICHIGAN

YOU SAVE BY ORDERING DIRECT FROM FACTORY



## National Electronics GREATEST Special Purchase BARGAIN

Tremendous Savings While They Last

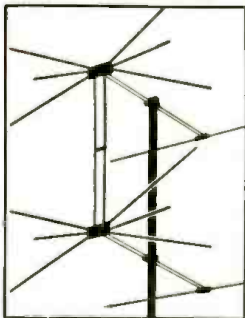

**2 BAY  
16 ELEMENT  
CONICAL  
ARRAY  
INCLUDING  
HIGH BAND  
ADAPTERS**

**\$ 4.65** Each  
IN LOTS OF THREE  
Single Lots **\$4.95**

Never before has National Electronics had a BARGAIN like this. We made a special purchase in order to get these sensational prices. And this array has everything. This conical 2-bay 16-element array provides ultra-fine fringe reception. Includes sixteen 7/8-inch aluminum type fringe receivers. Includes sixteen 7/8-inch aluminum type aluminum elements, including bonded adapters for greater gain on the high channels and is complete with one pair of stacking bars to each array. These are packed in cartons of three 16-element arrays per carton, with the rods, at **\$13.95** per carton. When purchased in single 16-element arrays, separately boxed—your cost is, **\$ 4.95** each. 3 Two-Bay Arrays per carton without Tie Rods **12.50** carton. 4 Bay Ultra-Fringe Stacking Assembly for Above—Model 4B **1.95** set.

### SAVE WITH ROCKET 35-FT. MAST KITS

Economy mast kit contains 3-10' seamless TITANIUM COATED 1 1/2" O.D. masts, one 5' mast, 300 feet of 3/20 galvanized steel guy wire, and everything else needed including guy rings, mast connectors, insulators, cable clamps, guy hooks, and solved mounting base. 35-foot Mast **\$15.95** Kit. 25-foot Mast **\$11.95** Kit.

### LOWEST PRICES ON ANTENNA ACCESSORIES

Mast Steel (unplated) 3/4" crimped 1 1/4" O.D.	\$1.05
Mast Steel (unplated) 1 1/4" O.D.	1.95
Mast Connectors for 1 1/4" O.D. Mast	.59
Chimney Mount Complete with Straps	1.19
Fork Roof Saddle (will take up to 1 1/2" O.D.)	1.59
Lighting Arrestor—TV	.69
Galvanized Steel Guy Wire—#20	34cft.
Rocket 1-wire Lead—7/28 strands	2cft.
UHF Low loss tubular 300 ohm twin lead—100' roll	4.95
Open Wire for long lead-ins—500' reel	19.90
Mast Stand-off Insulators—3"	.10
Screw Type Stand-off Insulators—3"	.03

ALL PRICES F.O.B. CLEVELAND, OHIO. Do not remit more than simple purchase price. Pay shipping charges on receipt of goods. 3% deposit on all C.O.D. orders. Please. Money-back Guarantee. Prices Subject to Change Without Notice.

## Sensational Reception on ALL UHF AND VHF CHANNELS

Covers channels 2 thru 83. Sensational broad band performance makes it a favorite in many areas where there is more than one transmitter. High gain suitable for fringe usage. Service man's array includes eight 3/8" aluminum elements, two 3/8" Aluminum Cross Arms, Universal Mast Clamp. Model All-38 **\$6.95** Ea. Lots of 6 **\$6.50** Ea. Matched Stacking Bars, Per Pair **.90** Ea.



### ROCKET BROAD BAND YAGIS

• SENSATIONAL GAIN  
• SENSATIONAL PICTURE IN FRINGE AND ULTRA FRINGE AREAS  
Switch to Yagi Broad Band Hi-Gain Antennas! These new Yagis give you Yagi reception on the 5 low-band and 7 hi-band channels—no restriction to one single channel. A two-bay array will outperform even a 16 or 12-element single channel Yagi. Price is sensationally low. Complete service man's array includes 1 double reflector, 2 folded dipoles, 3 directors, Universal mast clamp. Easy-to-assemble quick rig construction. Model RB24 Ch. 2 thru 6 **\$10.95** Ea. Model RB713 Ch. 7 thru 13 **5.95** Ea. Matched stacking bars **1.25** Pr.



### Fringe Master MOTORLESS DIRECTRONIC

Clear 5 Sharp Pictures — All Channels in All Directions.  
• NO GHOSTS • NO INTERFERENCE  
• ELECTRONICALLY BEAMED  
• NO MOTORS NEEDED  
With new transmitters coming on the air, only the Motorless Directronic offers "round the compass" reception without motors. The Model AX-500 18-element stacked array provides sparkling reception in city or fringe—in all directions. Service man's kit provides 18-element aluminum elements, 6-position Directronic Beam Selector, 1 set matched stacking bars, 75' TIE-X Cable, Universal U-Clamp. Complete Kit **\$16.95**

### HI-GAIN SINGLE CHANNEL YAGIS

5 element—Ch. 2, 3, 4... **\$7.95** Ch. 5 or 6... **\$6.95** Ch. 7-13... **\$3.95**

### CATALOG AVAILABLE

## National Electronics OF CLEVELAND

THE HOUSE OF TV VALUES  
107 Delco Building Cleveland 3, Ohio

for AM, FM, and Television Broadcast" is available from the company's tube distributors.

### TRANSVISION TV KITS

The Educational Dept. of Transvision, Inc., New Rochelle, New York has issued an 8-page catalogue listing the various build-it-yourself television kits now available from the company.

Emphasis has been placed on "packages" than can be assembled by those with no special technical training. The kits are broken down into "stages" which can be built and then assembled into a complete receiver.

A copy of catalogue No. K153 is available from the company on request.

### RELAY DATA

Potter & Brunfield of Princeton, Indiana has released its Catalogue #122 describing a line of relays, contactors, and shaded pole motors.

Included are relays and contactors for every electrical and electronic application—power, multiple contact, multiple leaf, latching, plate circuit, impulse, space saver, telephone, miniature, shockproof, etc. Also shown are enclosures for sealing individual relays or multiple groups hermetically, and octal, solder-terminal, and miniature plug-in connections.

Copies of this 24-page catalogue are available without charge.

### WIRE CATALOGUE

United States Wire & Cable Corp., Progress & Monroe Streets, Union, N. J. has issued a new catalogue which lists and illustrates wires and cables used in communications, electronics, television, etc.

This 24-page catalogue, No. PM-3, is lithographed in two colors for added legibility and contains many valuable reference tables, diagrams, and charts. Each class of wire or cable is described in detail as to construction, chemical, and physical properties as well as typical uses.

Make your request on your company letterhead for a free copy of this catalogue.

### CARTRIDGE REPLACEMENTS

The new Shure phonograph cartridge replacement manual, #66, is now available without charge at all Shure Brothers, Inc. distributors.

The new publication has been designed to aid service technicians and distributors in selecting the correct cartridge replacement for over 1900 phonographs, radio-phonographs, and radio-TV-phono combinations manufactured from 1938 through 1952.

The manual also includes technical data on the company's line of magnetic tape and wire recording heads. This information includes typical operating data, descriptions, and a numerical listing.

### REPRINTS AVAILABLE

A novel method of placing and orienting u.h.f. antennas for maximum TV picture signal is described in a

## AMPERITE Studio Microphones at P.A. Prices

Ideal for BROADCASTING RECORDING PUBLIC ADDRESS

"The ultimate in microphone quality," says Evan Rushing, sound engineer of the Hotel New Yorker.

• Shout right into the new Amperite Microphone—stand 2 feet away—reproduction is always perfect.

• Not affected by any climatic conditions.  
• Guaranteed to withstand severe "knocking around."



Models  
RBLG—200 ohms  
RBHG—Hi-imp.  
List \$42.00



"Kontak" Mikes  
Model SKM, list \$12.00  
Model KKH, list \$18.00

Special Offer: Write for Special Introductory Offer, and 4-page illustrated folder

## AMPERITE Company, Inc.

561 BROADWAY • NEW YORK 12, N. Y.

Canada: Atlas Radio Corp., Ltd., 560 King St. W., Toronto

## ELECTRON TUBE TECHNICIANS

We now have several openings for technicians to work in the fabrication and processing of advanced type electron tube research models.

To qualify for one of these openings you should be experienced in experimental work for research and development in vacuum tubes, which includes the fields of mechanics, electronics, chemistry and high-vacuum techniques.

ADDRESS RESUME OF TRAINING AND EXPERIENCE TO

## HUGHES

RESEARCH AND DEVELOPMENT LABORATORIES

Technical Personnel Department

CULVER CITY, LOS ANGELES COUNTY, CALIFORNIA







# New Portable Battery-Operated Spring-Motor Tape Recorder



## The Magnemite\*

For all field recording without AC power! Smaller and lighter than a portable type-writer, the Magnemite® actually makes field recordings that can be played on any studio console equipment. Completely self-powered, the Magnemite® goes away with bulky and cumbersome generators, storage batteries and rechargers.

Just check these unusual features:

- Noiseless and vibrationless governor-controlled spring-motor assures constant tape speed.
- 100 operating hours per set of inexpensive flashlight-type dry cell batteries.
- Earphone monitoring while recording, and earphone playback for immediate quality check.
- Operates in any position, and is unaffected by movement or vibration during operation.
- Warning indicator tells when to rewind, and shows when amplifier is on.
- Broadcast models weigh 15 pounds. Slow-speed models weigh only 10 pounds.
- Requires no more desk space than a letter-head, measuring only 11 x 8½ x 5½ inches.

There's a choice of 5 different models for any recording need. High fidelity units, meeting primary and secondary NARTB standards, which record and play back frequencies up to 15,000 cycles, are available for broadcast stations, critical music lovers, and scientific research. For investigation, missionaries, reporters, and general dictation while traveling, there are units which play up to 2 hours per reel of tape.



**AMPLIFIER CORP.  
of AMERICA**

398 Broadway, N. Y. 13, N. Y.

\*Trade Mark Reg.

free reprint being offered by *United Technical Laboratories*, Morristown, N. J.

Designated as *UTL Bulletin #2*, the publication is a reprint of John T. Frye's article "The Versatile Crystal Probe" which originally appeared in the April 1951 issue of this magazine.

The article explains how a single service technician can check the entire roof and obtain maximum picture signal strength. The method described recognizes that, at u.h.f., a difference of as little as three feet in antenna placement, and five to ten degrees in orientation, can make a great difference in the strength of the received picture. —30—

### The "Q-L-C" (Continued from page 61)

will serve to check the component.

#### Principle of Operation

The "Q" meter basically is a variable frequency oscillator which feeds an r.f. voltage to a parallel resonant circuit consisting of the inductance to be measured and a variable calibrated condenser. A meter circuit is placed across this resonant circuit.

The oscillator is adjusted to the frequency at which the coil is normally used, and a constant current is passed to the parallel resonant circuit. The variable condenser is set to a value which makes the circuit resonant, as indicated by a maximum reading on the meter. To find the "Q" of the coil from this resonant circuit, we use the relation that the "Q" of a parallel resonant circuit is proportional to the voltage across it at resonance. If the current to the resonant circuit is a constant, the meter, which reads the voltage drop across the resonant circuit, may be calibrated directly in "Q."

Reference to the circuit of the *Heath "Q" meter*, Fig. 1, shows that

the signal is obtained from the generator section (12AT7) tube, and the resonant circuit comprises the "Resonance" condenser and vernier, the injection padder condenser (5000  $\mu$ fd. "Special"), and the coil under test (shown dotted).

In application, and when it is desired to indicate resonance, a v.t.v.m. circuit, consisting of the 6AL5 and 12AU7, is connected directly across the terminals of the "Resonance" condenser. The 680-ohm resistor in the cathode circuit of the second half of the 12AT7 feeds some of the output of the generator to the meter to calibrate the latter for the constant current output. Because the injection padder is much larger in capacitance than the "Resonance" condenser, practically all of the voltage across the coil will also appear across the "Resonance" condenser where it is conveniently measured by the v.t.v.m.

To measure capacitance with the "Q" meter, merely insert an inductance across the coil terminals and find the resonance point for the circuit with the unknown condenser—and then without it (at the same frequency). The difference in capacity settings is the value of the unknown condenser.

In order to insure a constant injection current, the output from the generator is fed through a small trimmer condenser in series with the large injection padder. A simple adjustment of the trimmer, during calibration of the instrument, fixes this current accurately.

It is essential that a constant plate voltage be applied to the circuitry. Rectified plate voltage, using a conventional rectifier circuit, is stabilized by a VR-150 voltage-control tube.

The instrument described is one which has gained considerable appeal among aggressive service technicians. It represents, we think, a logical service tool for the radio-television service technician and engineer. —30—

Rear view of the Heath Model QM-1 showing the subchassis construction.

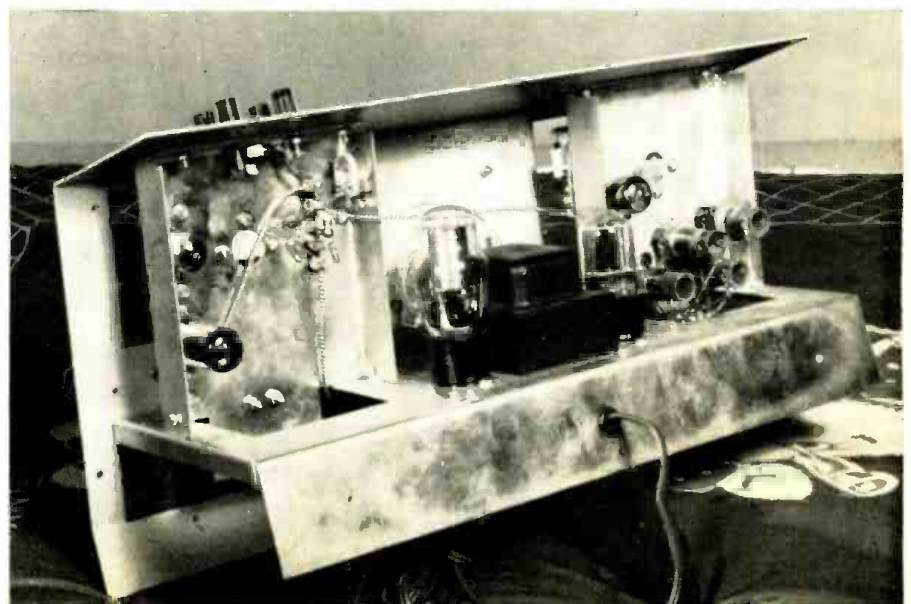



# MAIL YOUR ORDER TODAY—OLSON WILL RUSH IT RIGHT AWAY!

## TRUE HIGH-FIDELITY AT NEW LOW COST!

### Revolutionary Audio-Tone High-Fidelity Loudspeaker

Olson worked shoulder to shoulder with electronic experts to develop the New Audio-Tone High-Fidelity Loudspeaker—our goal being to give you a powerful yet compact quality speaker system for true High-Fidelity sound reproduction at lowest possible cost. Audio-Tone incorporates the now famous principle of employing the corner of a room as an extended bass and high range reproducer. Vibration and distortion-free Audio-Tone now makes it possible for you to enjoy the full tonal range and fine reception found only in the much more expensive space-consuming cabinet loudspeakers. You'll be thrilled by the full, rich, resonant tones you never knew existed when you attach the Audio-Tone to your present AM or FM Radios, Tuners, TV, or Record Player. Special wafer-type Fibro-pad baffle traps and removes all the undesirable tones exhibiting from the back of the speaker. Audio-Tone's compact size, high power output, attractive and attractive enclosure also make it an ideal installation for clubs, schools, offices, auditoriums, factories, etc. Easy to assemble, a boy can do it in 20 minutes. Audio-Tone comes complete with 6" x 9" Low Frequency Reproducer and a 4" High Frequency Reproducer. Tweeter with 24" Alnico 5 Magnets, Maroon Leatherette Enclosure, Hand-some Plastic-Weave Grille, Look-at-Wire, Cross-over Condenser, Mounting Hardware and Full Instructions. Corner Size—18" High, 20" Wide, 10" Deep. Shpg. wt. 11 lbs.

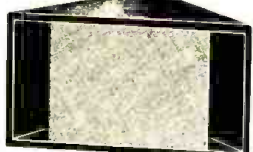

Stock No. S-201 Complete, Ready to Assemble... **\$19.95**

## Sets a record! But Gently

### 3-SPEED GENERAL INSTRUMENT AUTOMATIC RECORD CHANGER

#### WITH GENUINE ASTATIC "TURNOVER" CARTRIDGE

Changes All Sizes—7, 10, 12" All Speeds—33 1/3, 45, 78 RPM

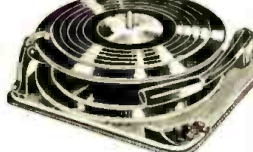

### HI-FI DELUXE MODEL Stock No. RA-113

Equipped with "Turnover" cartridge and dual needle. One side for 24" and 45 RPM discs and the other side for 78 RPM discs. Both sides equipped with precision metal long-lasting tips. Regular retail price \$32.50. Shpg. wt. 15 lbs.

Single, each \$22.99 Ea., Lots of **\$21.99**

This General Instrument Record Changer has turned out to be Olson's ALL TIME BEST SELLER. For Good Reasons. First it performs like the Best. It is the smoothest running changer on the market today. Records slip gently down the spindle—no chance of damaging these valuable records. Simple to operate because it is precision-built by craftsmen who have had years of experience. Thus insuring years of trouble-free performance. Changer may be connected to any Radio, TV or Amplifier. Clever "touch-matic" allows you to reject a record at will. Genuine Astatic "Turnover" Cartridge is included at this fabulous low cost. Of course they're Brand New, in original factory-sealed cartons, and guaranteed 100% by Olson and the manufacturer. Operates on 115 Volts AC, 60 Cycle. Base size 12" x 12 1/2" x 5 1/4" above plate and 3 1/2" below.

## 6-TUBE CUSTOM AUTO RADIOS

Here's your chance to save plenty on these nationally famous CUSTOM AUTO RADIOS. Simple to install—no cables, no brackets, no holes to drill. Install in 3 to 4 minutes. Custom-built to fit in dash of each model car listed. Six tubes including rectifier—2 being dual-purpose—thus you really get 8-tube performance. Dynamic speaker with powerful Alnico 5 permanent magnet. Easy vision slide-rule dial. Beautifully harmonized finish. Shpg. wt. 16 lbs.



**\$41.97**

STK. NO.	MAKE OF CAR	YEAR MODEL
RA-300	Chevrolet	1949-1950
RA-351	Chevrolet	1951-52
RA-142	Chevrolet	1953
RA-200	Dodge	1949-1950
RA-251	Dodge	1951-52
RA-124	Dodge	1953
RA-100	Ford	1949-1950
RA-151	Ford	1951
RA-152	Ford	1952

CHOICE OF ANY MODEL

STK. NO.	MAKE OF CAR	YEAR MODEL
RA-144	Ford	1953
RA-451	Hudson	'48-49-50-51-52
RA-751	Henry J.	1951-52
RA-143	Mercury	1952-53
RA-200	Plymouth	1949-1950
RA-651	Plymouth	1951-52
RA-125	Plymouth	1953
RA-551	Studebaker	1950-1951-1952

### NEW TOP COWL AUTO ANTENNA "LIGHTS-UP"

Req. \$5.95. Single, Ea. \$1.89 **\$1.59** Stock No. AU-25

Olson is first with the brightest, brightest auto antenna ever designed. Dress up your car with this amazing Glo-Tenna that lights up at night. Made of chrome-plated brass. Latest air-flow conductor plastic. Extends to 37 1/2". Top cow-l model complete with low loss polyethylene lead-in, built and connecting wire and full instructions. The manufacturer, a leader in auto antennas, requested that we put your attention to his name. Shpg. wt. 2 lbs.

### Rear Deck Auto Speaker Outfit

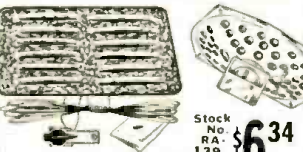

Now you can have a rear deck extension speaker outfit in any car for less than half the regular price! Complete matched set—nothing more to buy. Three-way control switch permits operation of front, rear or both speakers at once. You get: Aluminum neutral mesh grille; Heavy-duty 8" x 9" speaker; 3-way switch; All screws, wire and instructions. Shpg. wt. 4 lbs.

Stock No. 139 **\$6.34**



### PERMEABILITY TUNED AM FRONT END

BRAND NEW! PARTS ALONE WORTH \$4.50. Used in standard broadcast receivers in place of variable condenser and associated parts. Sets condenser—includes antenna, tuned circuit and oscillator coils, dual trimmers. Designed for linear dial calibration through approximately 340° rotation by means of concentric cam and lever drive. Connects directly to mixer grid and r-f grid to make complete receiver. Mounted on plate 3 1/4" x 5 3/4". Instructions included. Shpg. wt. 1 lb.

3 for \$5.50 **\$1.89 EACH**

Stock No. L-46

## COMPLETE TV ANTENNA

A complete stacked array. Made by a famous manufacturer whose name and brand is on every factory sealed carton. Look what you get: 2 Six-element conical arrays; 1 flat top; 2 Five-foot mast sections; 60 ft. 3/8" dia. 1/2" dia. Standoff insulators; 1 mounting base; 1 guy ring; 1 clamp; hardware. Elements are highest quality aluminum. Reg. list price is \$31.95. Shpg. wt. 15 lbs. Express only.

Stock No. AU-24 **\$12.99** Complete Set

## ONLY WILCOX-GAY Recordio TAPE RECORDER

with PREST-O-MATIC push-button keyboard

gives Maximum performance for Lowest cost!

DUAL SPEED—Records at 1 1/2" and 3 1/4" Per second

STOCK NO. AMP-17

**\$99.50**

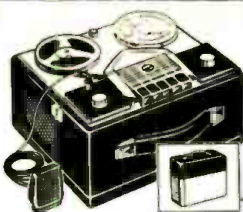

Records for 2 hours on half of a 7" reel plus another 2 hours on other half at 1 1/2" per second; and at the 3 1/4" per second speed you can record 2 full hours on each half of a seven-inch reel, 80-6000 CPS.

This is the famous Deluxe Wilcox-Gay Recorder that retails all over the country for \$179.95. Naturally they are all brand new, in factory sealed cartons and Guaranteed 100% by Wilcox-Gay and Olson.

How can we sell this outstanding value for such an amazing low price? The answer is simple... our main purpose in this business is to offer the highest quality for lowest cost... and the Recordio is a perfect example.

Record those treasured "Family Highlights"... or your favorite music, broadcasts, friends or parties. Use it in your business for dictation, meetings, speeches, etc. Portable Recordio is also a valuable aid in Schools, Churches, and Clubs.

Remember... It's completely Automatic—the finger-tip controls are so simple even a child can operate it. And we're offering the finest controls we've ever featured at LESS than Dealer's Cost.

INSTANTANEOUS RECORDING OR PLAYBACK, 2-SPEAKER, RECORDS, PLAYS BACK, FRANGES, LOOK AT THESE QUALITY-PACKED FEATURES: Five "Prest-o-matic" Controls allow instant choice of all operating functions... high speed forward and reverse record, stop, play-back, handles up to 7" reels. Neon Indicator shows Normal and Overload levels. Full Range Variable Tone Control allows maximum brilliance to a deep, rich bass tone. Volume Control has and treble compensated for best reproduction. WEATHERPROOF, READY TO OPERATE. Included: COMPLETELY CONTROLLED Reluctance Microphone. Radio, Phone, TV Input Jack permits recording from radio, phone or TV speaker voice and by means of patch cord. External Speaker Jack for external speakers automatically disconnects internal 5" x 7" elliptical P.M. Speaker. 4 Tubes: 6AR7, 6AQ5, 6AV6, 6X4 Rectifier. 7 ft. Cord. Handsome Removable Cover. Operating Instructions. Size: 12" x 14" x 9" AC U.L. Approved. 110-120 Volt 60 Cycle

## BRAND NEW PLASTIC BASE RECORDING TAPE

600 FT. REEL 1200 FT. REEL

STOCK NO. X-275 \$1.29 each  
X-276 \$1.49 each  
Lots of 10 \$12.99

Get the buy of your life. Save up to 64% on high quality RECORDING TAPE. A large manufacturer had to sell his inventory and he unloaded the whole deal. Olson now offers you this high grade fully guaranteed recording tape at prices which defy competition. Standard 1 1/2" wide, 600 and 1200 ft. lengths. Frequency response 50 to 8000 cps. Plastic Reel included with each. Shpg. wt. ea. 1 lb.

## PHONO SLIDES

STOCK NO. X-326

3 Pair for \$119 PAIR \$3.00

Used to mount changers in cabinets. Heavy-duty metal bearing action. Capacity 30 lbs. 1 1/2" long. Reg. List Price \$4.00. Shpg. wt. 2 lbs.

## CRYSTAL MIKES

Astatic high output crystal mic for PA systems and recorders. Equipped with handle base and 7' shielded cable. Shpg. wt. 5 lbs.

STOCK NO. M-67, \$5.95 each  
M-66, same as M-67, but built into handle \$6.95

## 12" CO-AXIAL SPEAKER

Our new 1953 Model. Guaranteed to outperform any speaker in its price class. Equipped with two "high concentration" Alnico 5 magnets and a high frequency diffuser. The 12" section delivers the bass while the inner 3" tweeter speaker section delivers the treble tones. Together they give you "living tone". This speaker is unconditionally guaranteed to satisfy even the most critical user or Olson promises to refund your money. Only two wires to connect to any radio or amplifier. Voice coil impedance 8 ohms. Frequency response 30 to 17,500 cps. Shpg. wt. 10 lbs.

**\$12.95** Stock No. S-168

## 10 WATT HI-FI PUSH-PULL AMPLIFIER

Built-in Pre-Amplifier • G-E Cartridge Input • Treble and Bass Boost • All-Aluminum Chassis • Push-Pull Output • Multiple Speaker Impedances Tubes Bombshell Value! It's unbelievable. A full 10 watt Hi-Fi Amplifier completely assembled and ready to play. Built-in PHASE AMP for G-E and similar types of magnetic pickups. 4 Inputs: 1 crystal phono, 1 magnetic phono, 1 radio mike, 4 Controls: 1 Bass, 1 Treble, 1 Volume, 1 Phono-radio Switch. Output Impedances: 4, 8, 16 ohms. Peak Power output 17 watts. Order this amplifier today and see what brilliant, realistic tone it will deliver. Supply is limited. Everyone in factory sealed carton. You couldn't buy the parts alone for this price. Remember this speaker is unconditionally guaranteed to satisfy even the most critical user or Olson promises to refund your money. Only two wires to connect to any radio or amplifier. Voice coil impedance 8 ohms. Frequency response 30 to 20,000 cps at less than 1/2% of distortion. 5 Tubes: 1-6SL7, 1-6BC7, 2-6V6, 1-5Y5. Complete with tubes. Size 12" x 6 1/2" x 1 1/2". Can be used with any phono or speaker but you should take advantage of the Combination Deal offered below.

**\$32.95** Stock No. RA-102



## COMBINATION DEAL!

Both for Only **\$39.95** WITH TUBES Completely wired. Not a kit.

## 10 WATT HI-FI PUSH-PULL AMPLIFIER COMPLETE WITH 12" CO-AXIAL SPEAKER

Stock No. AS-67

This is the best matched Amplifier-Speaker Deal in America Today. You get the 10 Watt Hi-Fi Amplifier, as described above, PLUS the 12" Co-Axial Speaker—also as described above. Can be built into any cabinet or housing, giving you a complete amplifier system you will be proud to own and show to your friends. Look at our Amazing Low Price—and Order Today. Shpg. wt. 25 lbs.

## PRICES SLASHED TO BITS ON OLSON RESISTOR KITS GIANT "SUPER-ASSORTMENT" KIT—232 RESISTORS

Olson Offers you a Price-Busting Assortment of Brand New, Fully Guaranteed Most-Popular Resistors At the Lowest Price in Our History. Without a doubt this is The Highest Resistor Bargain to be found in America Today. Every Kit is chock full of Popular Values—sizes you need and use every day in TV and Radio Servicing. Invaluable to hams and experimenters. Many leading brands of resistors are included such as IBC, Clarostat, Central and other top-notchers. KIT CONTAINS: 200—1/2 Watt Resistors, 20—1 and 2 Watt Resistors, 12—5 to 25 Watt Wirewounds. A total of 232 Assorted Popular Resistors worth at least \$23.50. Every Kit is unconditionally guaranteed to please or you get your money back. Every Resistor is RMA Color Coded or stamped with value. Tolerances are 5%, 10% and 20%. This amazing offer will not be repeated when our stock is gone. Shpg. wt. 2 lbs.

**\$3.95** Stock No. AS-64

## OLSON'S BIG NEW BARGAIN CATALOG FREE!

Get Olson's LOWER-than-wholesale prices from this famous book. STANDARD BRANDS—FRESH STOCK. IMMEDIATE DELIVERY. Catalog is two colors—10 full pages of unbelievable bargains each mailing. Simply note on your order or write today for your free copy from: OLSON RADIO WAREHOUSE, 275-C EAST MARKET ST., AKRON 8, OHIO.

## OLSON STORES TO SERVE YOU IN:

CLEVELAND, OHIO 2020 Euclid Avenue  
CHICAGO, ILLINOIS 623 W. Randolph Street

PLEASE: MINIMUM ORDER \$3.00

275-C EAST MARKET ST., AKRON 8, OHIO



# POSITIVE CURES

## for TV TROUBLES!



### TV MANUFACTURERS' RECEIVER TROUBLE CURES

A brand new series of practical books. Gives you exact directions for correcting TV receiver performance "bugs". Each cure is official, factory-authorized, direct from the receiver's manufacturer. It is positive! Listings by manufacturer and model or chassis number. Helps correct the most difficult faults—picture jitter, hum, instability, buzz, tearing, etc.

#### 1 VOLUME 1

Covers 12 prominent brands — ADMIRAL, AIR-KING, ANDREA, ARVIN, BELMONT-RAYTHEON, BENDIX, CALBEST, CAPEHART-FARNSWORTH, CBS-COLUMBIA, CERTIFIED, CROSLEY, DUMONT. Over 120 pages (5¼ x 8¼"), illus. .... \$1.80

#### 2 VOLUME 2

Covers — EMERSON, FADA, FIRESTONE, FREED, GAMBLE, SKOGMO, GENERAL ELECTRIC, HALL-CRAFTERS, HOFFMAN, INDUSTRIAL, INTERNATIONAL, JACKSON. Over 120 pages (5¼ x 8¼"), illus. .... \$1.80

#### 3 VOLUME 3

Covers — KAYE-HALBERT, KENT, MAGNAVOX, MAJESTIC, MECK, MERCURY, MIDWEST, MONTGOMERY WARD, MOTOROLA, MUNTZ, NATIONAL, NORTH AMERICAN PHILIPS, OLYMPIC, PACIFIC-MERCURY, PACKARD-BELL, PHILCO. Over 120 pages (5½ x 8½"), illus. .... \$1.80

#### VOLUMES 4 and 5

Coming soon! Covers prominent manufacturers not included in the first three volumes.

**One service job will more than pay the cost of this series of books!**

#### NEWEST RIDER BOOKS

##### HOW TO USE METERS

by J. F. Rider

##### OBTAINING AND INTERPRETING TEST SCOPE TRACES

by J. F. Rider

Buy these books now at your jobber or book store... or, if not available from these sources:

**JOHN F. RIDER PUBLISHER, INC.**  
Dept. RN7 480 Canal Street, New York 13, N. Y.

## Transistor Physics (Continued from page 46)

the emitter and the *n*-type on the right is called the collector. The *p*-type at the center is called the base. The connections to the crystals are designated *e*, *c*, and *b* respectively. Fig. 6B shows a schematic representation of the distribution of donors, acceptors, holes, and electrons, with no external potentials applied (equilibrium conditions). Fig. 6C is the potential energy diagram for holes. As expected, the holes are concentrated in the region of lowest potential energy for them, and they will not climb the potential energy hills to the left or right. Fig. 6D is the potential energy for electrons. They are concentrated in the region of lowest potential energy for them. They will not climb the potential energy hills to enter the *p*-type germanium. The result is that there is no current flow of holes or electrons under equilibrium conditions. For transistor applications the *n-p-n* transistor is biased normally as indicated in Fig. 7A. The *p-n* junction between the emitter and base is biased in the forward direction. The *p-n* junction between the base and the collector is biased in the reverse direction. The potential energy diagram for electrons when no signal is applied is shown in Fig. 7B. (In *n-p-n* transistors the major current carriers are electrons, and for that reason the potential energy diagram for holes is not presented). The application of forward bias between the emitter and the base substantially reduces the potential energy hill at the left *p-n* junction. As a result some electrons will climb this hill and enter the *p*-type germanium. Since the base strip is relatively thin, most of the electrons which enter it will not combine with holes, but will pass through the strips and easily go down the potential energy hill which favors the entrance

Fig. 7. An "n-p-n" structure under operating conditions. See text for discussion.

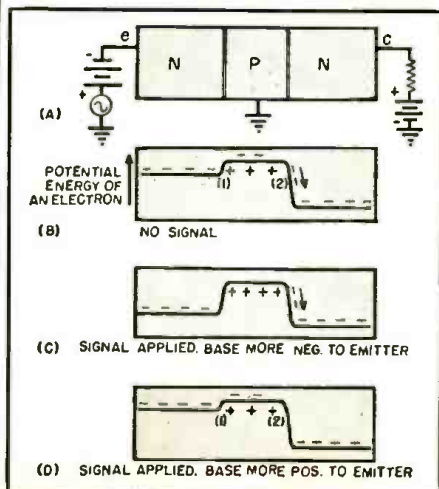

## THE Case WITH A 1,000 APPLICATIONS

This all-purpose case is ideal for housing meters, controls and switches of all types. Made of heavy molded block plastic with matching phenolic panel. Easy to drill and saw. Available in two sizes; 5-1/4" x 6-7/8" x 2-5/16" and 3-3/4" x 6-1/4" x 2"

Ask your Distributor for Waldom's Plastic Case.

### WALDOM ELECTRONICS INC.

911 Larrabee St., Chicago 10, Ill.

#### HI-GAIN TUNER-BOOSTER

LESS TUBES WITH DIAL

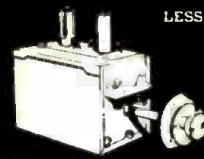

**\$4.75**

COMPLETE WITH TUBES

**\$6.00**

Solve poor T.V. reception with a Hi-Gain Booster. Banish weak fringe areas, reduce snow. This unit comes to you as a highly serviceable High-Gain Tuner. Uses 6J6 Tubes in very efficient Hi-Q Circuit. Has 8 tuned circuits using pure silver inductances and individual compensation providing high gain on all channels. Built in 5:1 Vernier Drive. This is a complete departure from ordinary tuners.

All necessary parts and instructions are included to convert this unit in a few minutes to one of the highest gain boosters on the market regardless of price.

#### 100 ASSORTED RESISTORS

Carbon insulated. New in current RMA Values 5%, 10% and 20% in ½, 1 and 2 watt

**\$1.00**

Shipments sent postpaid when full payment is enclosed with order. 25% deposit on C.O.D. shipments. Open account privileges to rated firms. Send for our new bulletin listing many T.V. Components at terrific price reductions.

FRANK W. DE GRAY AND ASSOCIATES  
11842 WEST JEFFERSON BOULEVARD  
CULVER CITY, CALIFORNIA

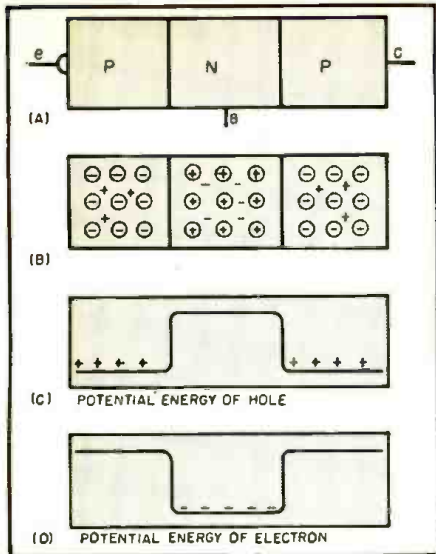

Fig. 8. A "p-n-p" structure under conditions of equilibrium. Refer to Fig. 6.

of electrons from the base strip to the *n*-type germanium of the collector is produced by the reverse bias between the collector and the base.

If a signal is applied which makes the base more negative with respect to the emitter (opposes forward bias), the potential energy diagram will change to that shown in Fig. 7C. The potential energy hill between the emitter and the base is increased, and as a result fewer electrons will climb the hill to enter the *p*-type germanium. However, those that do enter the *p*-type germanium will not recombine with holes but will easily fall to the collector region of low potential energy.

If a signal is applied which makes the base more positive with respect to the emitter (aids forward bias), the potential energy changes to that of Fig. 7D. The potential energy hill between the emitter and the base is decreased and as a result more electrons (compared to the number which flow when no signal is applied) will flow into the *p*-type region. Most of these electrons will not combine with holes but will flow easily to the low potential energy level of the *n*-type germanium on the right.

The operation of the *n-p-n* junction transistor can be compared to the operation of a triode vacuum tube. The emitter is equivalent to the cathode, the base to the grid, and the collector to the plate. Practically all the electrons which emerge from the emitter (cathode) go to the collector (plate). The base (grid) current is extremely small, consisting only of a small number of electrons equal to the recombination number of holes and electrons in the *p*-type region. It is interesting to note that two types of current are involved in the vacuum tube and two types of current are involved in the transistor. The thermionic electrons (those boiled off the cathode) of the tube are equivalent to the excess electrons from the emitter. The small conduction current of electrons (those

**ATR**

for A.C. current  
**ANYWHERE!**



STANDARD and HEAVY DUTY  
**INVERTERS**

For Inverting D. C. to A. C. ... Specially Designed for operating A. C. Radios, Television Sets, Amplifiers, Address Systems, and Radio Test Equipment from D. C. Voltages in Vehicles, Ships, Trains, Planes and in D. C. Districts.

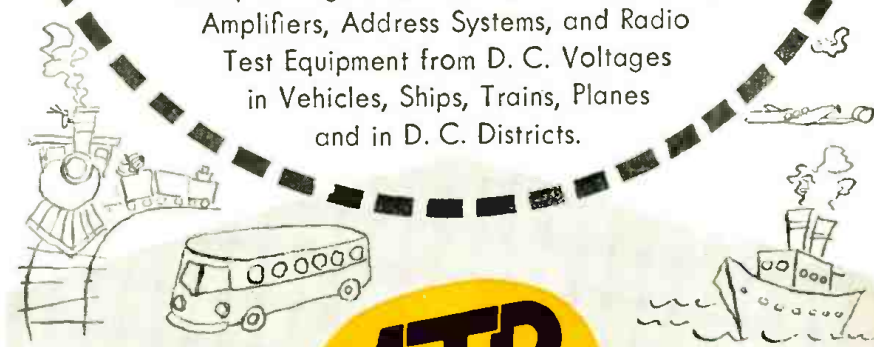

See your jobber  
or write factory



- ✓ NEW MODELS
- ✓ NEW DESIGNS
- ✓ NEW LITERATURE

"A" Battery Eliminators, DC-AC Inverters, Auto Radio Vibrators  
**AMERICAN TELEVISION & RADIO Co.**  
Quality Products Since 1931  
SAINT PAUL 1, MINNESOTA—U. S. A.



Let MILTON S. KIVER Help You Prepare For U.H.F.-TV And...

# TELEVISION SERVICING

Easy to TRAIN AT HOME This Practical Way!

Men with the right training in Television Servicing are in big demand... pull down big pay. T.C.I. TRAINS YOU RIGHT with easy-to-follow technical training designed by servicemen, for servicemen! You learn practical, professional type Television Servicing without leaving your present job. Included are money-making extras such as set conversion, master antenna installation, U.H.F.-TV and field servicing short cuts. You can start earning Television money after the first few lessons. You learn to test, trouble shoot and repair all types of TV sets the proven, practical way!

## HERE'S HOW YOU GET EXPERIENCE!

You train on your own large screen modern television receiver, furnished as part of your course. This set is yours to keep! As an optional feature you can get two weeks of actual field experience out on service jobs and on the repair bench for Chicago's largest independent servicing organization. You learn Television Servicing by actually doing Television Servicing... you get the practical know-how you need to qualify for BIG MONEY in this fast-growing field! Age is no barrier, Many TCI students are over 40!

**VETERANS!**  
T.C.I. is approved for G.I. training under Public Law 550. Check coupon.

**ACT NOW!** Mail coupon for FREE Catalog and SAMPLE LESSON. Write TODAY!

**TELEVISION COMMUNICATIONS INSTITUTE**  
205 W. Wacker Dr., Dept. I-AM Chicago 6, Ill.

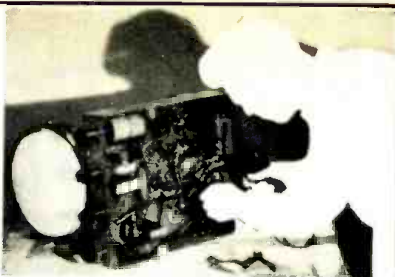

**YOU GET** and keep modern large screen Television receiver.

**YOU DO** actual testing, servicing, trouble shooting and repairing

**TV BROADCASTING COURSE READY NOW!**

Train at home for these big pay studio jobs! Video engineers, cameramen, microwave engineers, etc. Easy non-mathematical training covers all phases. Write!

## MAIL NOW FOR FREE BOOKLET

MILTON S. KIVER, President  
TELEVISION COMMUNICATIONS INSTITUTE  
205 W. Wacker Dr., Dept. I-AM, Chicago 6, Ill.

Itush full facts on the course checked below. I am not obligated. Salesman will not call.

TV Servicing  TV Broadcasting  Veterans: check here

Name.....

Address.....

City..... Zone..... State.....

BEGINNERS check here for information on Pre-Tel Radio Course.

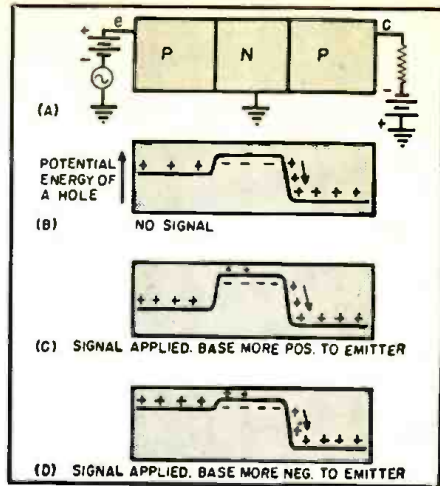

Fig. 9. A "p-n-p" structure under operating conditions. See text for full details.

which flow in and out of the grid to control plate current) is equivalent to the small current of holes in the base region (which increase or decrease to control collector current).

A *p-n-p* junction transistor is formed by placing a narrow strip of *n*-type germanium between two relatively long strips of *p*-type germanium, as shown in Fig. 8A. Low-resistance contacts are made to each strip, and are designated *e*, *b*, and *c*, which stand for emitter, base, and collector, respectively. Figs. 8C and 8D are equivalent to Figs. 6D and 6C respectively, except that in the *p-n-p* transistor the hole plays the role that the electron played in the *n-p-n* transistor. Figs. 9A, 9B, 9C, and 9D, are also equivalent to Figs. 7A, 7B, 7C, and 7D. Note that in order to bias the *p-n* junction between the emitter and the base of the *p-n-p* type transistor in the forward direction, the emitter must be made positive with respect to the base. To bias the collector in the reverse direction (Fig. 9A), the collector must be made negative with respect to the base. It is obvious that the explanation of the operation of the *p-n-p* transistor (where the hole is the major current carrier) is the excess electron.

(Concluded next month)

## HAM CLUB MEETINGS

**T**HE Cleveland Area Council of Amateur Radio Clubs is holding a basket picnic on Sunday, July 26th from 1300 until dark. The affair will be held at Round-up Lake Park, on Route 82, about 30 miles from downtown Cleveland.

Registration is \$1.00 and further details are available from Warren Sladky, W/ABGTZ.

**AUGUST 8 and 9** have been set by A.W.I.M.U. and C.A.R.S. as the dates of the combined hamfest. The event will be held at Big Springs, Idaho, 20 miles south of the west entrance to Yellowstone Park. Registration fee is \$1.00 per licensee or family. Cabins, camp grounds, and commercial power are available.

Reservations for cabins should be made with the hotels. For a list of such accommodations and additional details, write W700Y, Secretary, Harlowtown, Montana.

## STAY ON THE AIR WHEN POWER FAILS...with an ONAN Electric Plant



Model 10EL, 10KW A.C.

**AUTOMATIC START & STOP**

When storms, floods, or fires interrupt electricity and force you off the air, you lose listeners and income. Guard against loss, assure vital public service during emergencies by installing an Onan Electric Plant. Onan Standby Electric plants serve many network and private stations. Automatic models to 35,000 watts.



PORTABLE ELECTRIC PLANTS FOR MOBILE RADIO USES

Supply A.C. power for broadcasting at scene of events. Light in weight. Can be carried by hand or in trunk of car. A.C. models: 400 to 3,000 watts.

Write for FREE Folder



**D. W. ONAN & SONS INC.**  
7897 University Avenue  
Minneapolis 14, Minnesota

**The Leader**  
Model A

**Perma-Power Battery Eliminator**  
for 1 1/2, 2 and 6 Volt Radios

mfd. by

**Perma-Power COMPANY**

Chicago 25, Illinois

Manufacturers of Electronic Equipment Since 1928



## Technical BOOKS

**"TELEVISION RECEIVER DESIGN I"**  
by A. G. W. Uitjens. Published by *Philips Technical Library*, Eindhoven, Holland. Available in the U.S. from *Elsevier Press, Inc.*, 402 Lovett Blvd., Houston 6, Texas. 177 pages. Price \$4.50.

This first book in the new *Philips* series of technical treatises covers the design of the i.f. stages in a television receiver.

The text material is divided into seven main sections covering the gain and bandwidth with two-terminal coupling networks; the response curve of the complete amplifier; distortion; gain, bandwidth, and distortion with four-terminal coupling networks; noise; feedback; and practical considerations based on the theory.

While the author's style is thoroughly readable, the treatment of the subject matter is at an engineering level and a working knowledge of television circuitry and a comprehensive understanding of mathematics are prerequisite.

This volume deals with the application of the pentode in the i.f. section of a superheterodyne television receiver and h.f. amplification in a t.r.f. television receiver.

The second volume of this series will cover flywheel synchronization of saw-tooth generators.

**"VADE-MECUM"** edited by P. H. Brans. Published by *P. H. Brans, Ltd.*, Antwerp. Available in the U.S. from *Editors and Engineers, Ltd.*, Box 689A, Santa Barbara, California. 304 pages. 10th Edition (1953) Paper bound.

This volume is a supplement to the 9th Edition ("Radio Tubes") and an introductory section to the 11th Edition which will cover television tubes. The three volumes (or editions), taken together, will provide the user with a complete listing of tubes for all purposes.

The text material is divided into four tables which list the original tube and its potential substitute; original tubes and their near equivalents; special and unusual tubes and their equivalent tube families; and military tube designations for all countries.

As with all of the "Vade-Mecum" editions, the instructions for using the tables are given in several languages, including English, French, German, Dutch, Italian, Spanish, etc.

Engineers, experimenters, or hams whose work involves the use of equipment or tubes from other countries will find this publication of great assistance.

**"TV MANUFACTURERS' RECEIVER TROUBLE CURES"** edited by Milton S. Snitzer. Published by *John F. Rider Publisher, Inc.*, New York. 110 pages. Price \$1.80. Paper bound. Volume 2.

This is the second of the series of handbooks covering suggested receiver changes as made by the manufacturers of the TV sets in question.

Volume 2 covers receivers manufactured by *Emerson, Fada, Firestone, Freed, Gumble-Skagmo, General Electric, Hallicrafters, Hoffman, Industrial TV, International TV, and Jackson*. Subsequent books will cover additional sets.

As with the first volume, the service notes are presented in concise form with partial schematics or pictorial diagrams being included where required.

\* \* \*

**"HEARING AIDS, THEIR USE, CARE AND REPAIR"** by Matthew Mandl. Published by *The Macmillan Company*, New York. 155 pages. Price \$3.50.

Although this text is addressed primarily to the wearers of a hearing aid, the material incorporated is also of interest to service technicians who repair and service such electronic devices.

The author describes typical hearing aids now in use, outlines the problems and adaptation techniques for the new user, describes the various methods of wearing the device, care of the hearing aid, battery care and storage, the making of minor repairs, the electronic repair factors, servicing procedures and typical troubles, and future trends in the development of hearing aids.

The material on servicing includes a listing of the test equipment required, servicing materials needed, replacement parts to be stocked, servicing precautions, testing methods, continuity and resistance measurement, signal tracing, and listening tests. The various tube types used in hearing aids are also discussed.

The technician who handles this type of service work will want a copy of this book for reference.

\* \* \*

**"PIX-O-FIX TV TROUBLEFINDER GUIDE"** by Alfred A. Ghirardi & R. G. Middleton. Published by *Rinehart Books, Inc.*, New York. Price \$1.00.

This handy and compact guide carries 24 TV trouble-pictures on a revolving wheel. By matching the picture on the receiver screen with the picture in the guide a corresponding key number can be obtained which is the clue to the next step.

With the proper key number the user can then refer to the corresponding pull-out card which lists the possible causes and remedies for this condition.

Most of the common television receiver faults have been included in the guide so that the service technician will find the bulk of his troubleshooting problems covered in this compact form.

The price of the book "Sound Reproduction" reviewed in the June issue should have been \$3.85 not \$6.75 as quoted.



*American's*

25th year of leadership

in the design and manufacture of quality microphones. Pioneers of the attractive "full-vision" design of quality microphones to be heard but not seen. Enjoy perfect performance... plus... full vision for both artist and audience.



*American*

MICROPHONE CO.

370 S. FAIR OAKS AVE., PASADENA 1, CALIF.



# "In music, listening quality is everything..."

1 It is the No. 1 MUST. Without it everything else becomes meaningless. The AUDAX CHROMATIC has that quality to a degree not equalled by any other pickup" . . . so says the violinist, David Sanger, of amplifier fame (*Toscanini's NBC Symphony*).

2 Be it diamond or sapphire, every stylus has a limited life-span; the diamond lasts the longest. Obviously, then, replaceability of the stylus—at home, is of the greatest importance.

**ONLY AUDAX PROVIDES REPLACEABILITY—AT HOME—OF EITHER STYLUS, INDEPENDENTLY OF THE OTHER.**

3 The revolutionary new records are so true to the original that almost any pick-up is bound to give some results . . . but it takes a reproducer of the highest order, one sensitized to the nth degree . . . a CHROMATIC POLYPHASE—to bring out every subtle shading, every nuance so essential to the real music of which these discs are capable.

But . . . only YOU can decide what sounds best to you. Therefore. See and Hear the Audax CHROMATIC and—You be the judge . . . yet Audax costs no more than ordinary pickups.

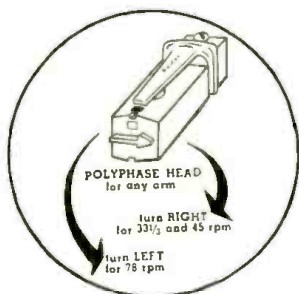

One single magnetic unit plays all home records.

Available with the new Compass-Pivoted Audax arms and to fit the high quality record changers.

\* #81 in 1953 ELECTRONIC PHONO FACTS now obtainable from your dealer

**AUDAX COMPANY**  
500 Fifth Avenue, New York 36  
Creators of Fine Audio-Electronic apparatus for over 25 years

"The Standard by Which Others Are Judged and Valued"

## International Short-Wave (Continued from page 66)

**Chile**—CE960, 9.593 Santiago, opens 0645 with identification signal, chimes, and rooster crowing; program begins 0650. (West, Va.) Noted in Britain 2030 with chimes and call "Radio La Americana." CE1190, 11.939A, Valparaiso, heard with music and Spanish announcement 1845, fair level. (Catch)

**China**—Radio Peking noted on 10.200 at good level in *English* 0400; heard on *measured* 9.0298 at 0535, fair level; picked up on 6.200 around 0430 in *English* (some days parallel with 6.100, others not). (Ballou, Calif.) Heard in Chinese 2000 on 15.06AV and 11.685AV, weak to fair. (Balbi, Calif., others)

**Colombia**—Brown, Colo., reports HJKH testing on 5.070 recently with *English* identification around 2200.

**Costa Rica**—"La Voz de America en Costa Rica" recently has been on 6.166 from 6.172; announces 6.165; is QRM'd from 2015 by Berne, Switzerland. (Stark, Texas)

**Denmark**—OZF, 9.52, noted 2112-2130 closing in *English*, good level; announces *English* for North America 2030-2130, 2200-2300. (Roberts, Conn.)

**Dominican Republic**—H19T, *Broadcasting Tropical*, Puerto Plata, has returned to 6.190 after a sojourn to 6.215A. (Niblack, Ind., others)

**Dutch New Guinea**—Radio Hollandia, 7.126, noted in Sweden around 0515-0530. (*Nattugglan*, Sweden, and others)

**Egypt**—Cairo, 11.815, noted signing on 1320 with march, then news in French; 1330 news in *English*, 1340 Greek, 1350 Italian. (Pearce, England) Noted opening on 9.75 parallel 6.085A at 2300 with bells striking, then setting-up exercises (*Arabic*). (Bellington, N. Y.) SUX, 7.852A, noted closing *Arabic* session 1700; fair level in N.C. (Earnhardt)

**Ethiopia**—Radio Addis Ababa, 15.06A, noted 1310 with popular music; news 1330; should close 1430. (Pearce, England)

**France**—Excellent signal noted from Paris, 17.85, at 0945; off 1000. (Bishop, Ohio)

**French Equatorial Africa**—Brazzaville, 11.97, 9.44, noted with *English Lesson* prepared by *Radiodiffusion Francaise*, Paris, at 1345. (Pearce, England) News noted on these channels 1745. (Gerran, N.Y.)

**French Guiana**—Radio Cayenne, 6.198A, seems to close now 1815 although schedule is listed 1730-1830. (Stark, Texas)

**French Morocco**—Mercier, France, reports Radio Maroc, 7.215, Rabat, closing 0900. (*Nattugglan*, Sweden)

**Germany**—The (West) German Overseas Service, 6.270, noted 2100 with German and *English* announcements; asked for reports to Radio Cologne, Germany. (Bellington, N.Y.)

**Greece**—Radio Athens, 11.718, is



17" Table  
**\$122.68**

Pl. \$12.27 Fed.  
Excise Tax

20" Table  
**\$134.50**

Pl. \$13.45 Fed.  
Excise Tax

Check these luxury features:  
Ultra sensitivity, dynamic range control, UHF adaptability, Duo power supply, Acoustical Sound system . . . all in a beautiful Mahogany finish cabinet.

20" Console  
**\$149.95**

Pl. \$15.00 Fed.  
Excise Tax

21" Console  
**\$164.95**

Pl. \$16.50 Fed.  
Excise Tax

### ALSO AVAILABLE TV CHASSIS

All sets have full 1-yr. factory picture tube warranty, and standard 90-day RTMA parts warranty. Mail and Phone Orders Filled. \$25 deposit, balance C.O.D., Shipping Charges Additional.

**STEPHEN SALES CORP.**

45 Crosby St., N. Y. 12, N. Y. Phone: WO 4-R233

Dealer Inquiries Invited

## AUDELS TV-RADIO SERVICE LIBRARY

HERE IS LATE INFORMATION IN A HANDY FORM FOR RADIO & TELEVISION REPAIRMEN, SERVICEMEN & STUDENTS



**2 VOLS. \$6 COMPLETE \$1 MO. PAY ONLY 1 MO.**

IT PAYS TO KNOW!

AUDELS T.V.-RADIO SERVICE LIBRARY presents the important subjects of Modern Radio, Television, Industrial Electronics, F.M. Public Address Systems, Auto, Marine & Aircraft Radio, Phonograph Pick-Ups, etc. Covers Basic Principles—Construction—Installation—Operation—Repairs—Trouble Shooting. Shows How to get Sharp, Clear T.V. Pictures. Install Aerials—How to Test. Explains Color Systems & Methods of Conversion. 1001 Facts—Over 1260 Pages—625 Illustrations—Parts & Diagrams—Valuable for Quick Ready Reference & Home Study. Tells How to Solve T.V. & Radio Troubles—Answers T.V. & Radio Questions.

Get this information for Yourself.  
**7 DAY TEST—ASK TO SEE IT!**

**MAIL ORDER**

AUDEL Publishers, 49 W. 23 St., N.Y. 10  
Mail AUDELS T.V. RADIO SERVICE LIBRARY 2 Vols. \$6 on 7 days free trial. If O.K. I will remit \$1 in 7 days and \$1 monthly until \$6 is paid. Otherwise I will return them.

Name \_\_\_\_\_  
Address \_\_\_\_\_  
Occupation \_\_\_\_\_ RN  
Employed by \_\_\_\_\_

RADIO & TELEVISION NEWS



widely reported with *English* 1245-1255. Is beamed then to England. (Hibbard, Mass., others) Central Forces Radio Station, 7.420. Athens, noted signing on 1030 (Sun. 1000) with march-anthem (sung); closing 1820 after call in Greek by woman; also noted as early as 0155 tune-in and still going 0425 tune-out. Kozani, 7.950A, noted 1740 with light music, closing 1800 after call, with anthem (sung). (Pearce, England)

*Guadeloupe* — Basse-Terre, 9.435A, still noted 1745-2000; some days is also heard around 0600-0630 sign-off. (West, Va., others)

*Guatemala* — TGNB, 9.668, noted running to 2348 closedown on a recent Wed. (Ballou, Calif.) TGWA, 9.76, noted 2330 at excellent strength in Mass. (Golden) Heard a recent Mon. with *English* on 15.17 at 1815-1825 (may also be Wed., Fri.). (Ni-black, Ind.)

*Haiti*—4VRW, 10.065A, is still strong in Britain from 1600 onwards. (Pearce) 4V2S, Port-au-Prince, noted recently on 5.845 instead of 5.945 with recordings from 1600 tune-in. (Saylor, Va.)

*Hong-Kong* — ZBW3, 9.525, noted 0300 with news. (Sanderson, Australia)

*Hungary* — *Radio Budapest*, 9.833, noted 1630 relaying *Radio Moscow*: with own *English* transmission 1730-1745 closing. (Roberts, Conn.) Good on this channel in *English* 2030. (Ballou, Calif.)

*India*—AIR, 11.85, noted with news 1930; into Tamil 1940. (Roberts, Conn.) VUM2, 4.920. Madras, heard in England by Fairs 1050 in Home Service relay of Indian music. (URDNC)

*Indo-China (Vietnam)* — *Radio France-Asie*, 9.745AV, Saigon, noted closing French transmission 1030; reopening for Europe with "La Marseillaise" 1035, followed by news in French; *English* 1100-1130 closedown; announces next *English* for 1830 on 7.230. (Pearce, England) *Radio France-Asie*, 11.925, noted 1000 with recordings, announcements in both *English*, French; good level. (Ballou, Calif.) Heard with news on this channel 2100. "Voice of Vietnam," 7.288, heard with news in Vietnamese at 0615. (Sanderson, Australia) On 9.620 at 0520, fair level in Calif. (Ballou)

*Israel*—*Kol-Israel*, 9.010A, is now on summer schedule—has "Voice of Zion" session (*English*) 1515-1600 closedown; news also 1415. 4XB44, *Galei-Zahal* (Israeli Forces Station), 6.725, Tel Aviv, noted 1345 with light music; call by woman 1400, then closed with bugle sounding "Lights Out;" this is summer closedown. (Pearce, England)

*Italy*—Rome, 9.63, noted with *English* from around 1230; signing off 1040 on 21.560; back 1045 to South Africa in *English*. (Bishop, Ohio) Heard to North America on 9.57, 11.905A at 1900-2200; news 1920, 2145. (Jim Smith, Mich.)

*Ivory Coast*—*Radio Abidjan* has new schedule for 7.215, 600 watts. of 0145-0230, 0715-0800, 1330-1600 in French,

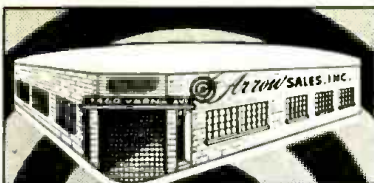

## FOLLOW ARROW FOR BIGGEST STOCK AT LOWEST PRICES

- RADAR—TRANSMITTERS
- RECEIVERS—TUBES—PARTS

**234-258 MC RECEIVER**  
11-tube UHF tunable receiver with schematic. Like new.  
**\$17.95**  
Rack .....\$3.50  
Control Box.. 1.50

**RADAR TEST EQUIPMENT**  
TS-3. TS-12. TS-13. TS-15. TS-33. TS-34. TS-35. TS-36. TS-45A/M3.  
FOLLOW ARROW TO GET HIGHEST PRICES FOR YOUR NEW AND USED RADAR GEAR! What have you to sell? WRITE TODAY!

**Monthly Specials!**  
RT-34/APS-13 420 MC. TRANSCIVER with 5 stages of 30 MC. IF amplifier strip. Less tubes & R.F. section. With dynamotor.. **\$6.95**  
BC-604 30 W. FM TRANSMITTER. For 20-27 MC. band. Ideal for 10-11 meters. Complete with tubes, temperature controlled crystal oven and technical manual with all instructions for BC-603 and BC-604. Less dynamotor and crystals. Excel. cond. ....\$12.95

**AN/APS-3**  
Airborne radar set. Now complete..P.U.R.  
**AN/APR-4**  
Receiver & tuning unit.....P.U.R.  
**AN/APS-4**  
Airborne radar. New.  
Complete .....P.U.R.  
**AN/APS-6**  
Airborne radar set. New.  
Complete .....P.U.R.

**INTERPHONE AMPLIFIER**  
BC-709-B  
A 2 position single stage audio amplifier. Uses 1 tube and operates from self-contained batteries. With Instruction Manual and Schematic. **\$3.95**  
NEW (less batteries).....

**SCR-625 FAMOUS MINE DETECTOR**  
For prospectors, miners, oil companies, plumbers, etc. New. **\$59.50**  
WHILE THEY LAST!

**ARC-4 TRANSCIVER**  
140-144 MC. Complete with control box, tubes, 12/24 VDC dynamotor with schematic. This is a special reduction for this month only. **\$32.50**  
Like new  
MT 101 ARC-4. Rack.....\$6.00

**COMMAND EQUIPMENT (SCR-274N)**

	Used	New		Used	New
BC-442 ANTENNA RELAY. Less cond. with cond.	\$1.95	\$ 3.95	BC-453 With tubes	\$19.95	
BC-451 TRANSMITTER CONTROL BOX	1.50	5 3.95	MC-211 90° ANGLE COUPLING UNIT.		\$0.95
BC-450 3-RECEIVER REMOTE CONTROL BOX	2.95	2.95	FT-234 MOUNTING RACK for single transmitter	2.95	3.50
MC-215 MECHANICAL DRIVE SHAFT. Per length		2.95	FT-226 MOUNTING RACK for 2 Command Xmttrs.		3.95
BC-496 2-POSITION RECEIVER CONTROL BOX		2.95	FT-221 MOUNTING PLATE for FT-220		1.50
BC-455 0-9 MC RECEIVER. With tubes	9.95	14.95	FT-220 MOUNTING RACK for 3 receivers		2.25
BC-454 (3-6 MC) With tubes	9.95	9.95	FT-225 MOUNTING PLATE for BC-456		2.25
			BC-456 MODULATOR. For SCR-274		4.50
			Complete set of 4 tubes for transmitter		1.25

**C.A.P. SPECIAL COMBO**  
**BC-624 VHF RECEIVER**  
Freq. range 100-156 MC. Less tubes & crystals, with conversion dope. Used, good cond. .... **\$19.95**  
**BC-625 VHF TRANSMITTER**  
Freq. range 100-156 MC. Less tubes & crystals, with conversion dope. Used, good condition. **\$12.95**  
**BOTH TRANSMITTER & RECEIVER. \$29.95**  
Per set .....

**Miscellaneous Specials!**  
HS-18 HEADSET. 8,000 ohms. New.....\$2.45  
HS-23 HEADSET. High Imp. New..... 4.95  
HS-30 HEADSET. Featherweight type. Low Imp. NEW.....\$2.49 USED..... 1.49  
HS-33 HEADSET. Low Imp. New..... 6.95  
HS-38 HEADSET. USED, excel. cond..... 1.49  
NEW..... 3.50  
T-26 CHEST TYPE MIKE. New..... 2.75  
T-32 DESK STAND MIKE. New..... 5.95  
LIP MIKE. Nav. type. New..... .98

**SURPRISE PACKAGE!**  
20 lbs. of good, useable radio parts.....\$2.95

PE-125 POWER SUPPLY: Operates on 12 or 24 v. battery. NEW.....\$17.95  
CD-307 EXTENSION CORD. For HS-23-33. NEW..... .95  
Used..... .45  
RS-38 MIKE. NEW..... 1.75  
Used..... .95  
BC-605 INTERPHONE AMPLIFIER. With dual mike input circuit. NEW..... 5.95  
TELEPHONE REPEATER AMPLIFIERS:  
EE-9B, New, with tubes..... 17.95  
EE-9D, New..... 12.95  
FL-B RANGE FILTER..... 1.95

TUBES!	TUBES!	TUBES!	TUBES!	TUBES!
16JPA .....\$19.95	304TH .....\$8.95	5CP .....\$4.95	3FP7 .....\$2.25	9003 .....\$1.65
16AP4 .....\$4.95	304TL .....\$8.95	5BP4 .....\$4.95	4AP10 .....\$1.49	9001 .....\$1.65
16DP3 .....\$19.95	840-B .....\$2.75	5PP7 .....\$2.25	21D .....\$.69	9003 .....\$1.65

MP-22 MOBILE ANTENNA. MOUNTING RACK. Comp. with hardware. New. Per Pair \$4.95. Ea. \$2.95  
TU-17 TUNING UNIT. (2-3 MC.) For BC-223 New. Used..... 2.95  
1-70 "S" TUNING METER. NEW..... 2.50  
WOBULATOR. See p. 41 Dec. 23 RADIO NEWS 5.95  
BC-1023 75 MC. MARKER BEACON RECEIVER. Complete with tubes, mtz. rack. NEW..... 10.95  
TU-25 TUNING UNIT. (3.5-5.2 MC.) For BC-223 Xmtz. Used..... 2.95

**TUBES! NEW! ORIGINAL BOXES!**  
Limited Quantities Available  
250TL.....Ea. \$11.50      250TH.....Ea. \$14.50

\$5.00 MINIMUM ORDER ACCEPTED. All items subject to prior sale. All shipments F.O.B. warehouse. Calif. residents add tax with remittance. 20% deposit required. Please specify shipping instructions with order. EQUIPMENT WANTED! Highest prices paid for all types of Electronic Gear!

**ARROW SALES, INC.**  
Cable Address: ARROWSALES PO Box 5-1810  
Mailing Address: P. O. Box 3878-R, N. Hollywood, Calif.  
Office-Warehouse: 7460 Varma Ave., N. Hollywood, Calif.





24 HOUR DELIVERY FROM STOCK!

# RELAYS

Our stock of more than a million relays — in over a thousand different types — is the world's largest. Don't delay your production for want of large or small quantities of relays of any type.

Telephone, wire or write for quotations.



NEW AND MORE COMPREHENSIVE

## 1953 RELAY SALES CATALOG

NOW READY

Be sure to send for your copy



Telephone

SEeley 8-4146



833 W. CHICAGO AVE. DEPT. 8, CHICAGO 22, ILL.

Baoule, Ebrie, Dioula; plans new studios and other improvements soon. (Scheiner, N. J.)

**Japan**—Radio Japan, JOA2, 7.180, noted 0600 with news. (Sanderson, Australia) As soon as funds are available, Radio Japan will add transmissions for Europe, Brazil. (Scheiner, N. J., others)

**Kuwait** — "Huna Kuwait," 5.000, noted 1345 in Arabic to closedown after call 1430; no anthem at close. (Pearce, England) Scheduled 0000-0200, 1130-1400 daily; hopes to increase power from 1 kw. to 5 kw. with the installation of new equipment soon; reports to The Broadcasting Officer, Radio Station, Security Department, Kuwait, Arabia, are requested. (Radio Amateur, London)

**Madagascar** — Radio Tananarive, 9.515, noted signing on in French 2230. (Riggle, Ohio)

**Malaya**—BFEB, Singapore, noted closing 1145 on 11.955; closing 0900A on 17.755; heard on 15.435 opening 0915. (Pearce, England) Heard earlier opening on 15.435 at 0400. (Balbi, Calif.) Final closedown noted 1145. (Bishop, Ohio) The Forces Broadcasting Station, 5.010, Singapore, is on the air daily 0700-0900 with English identification at start and close; uses 7.5 kw. and signals are beamed "up the Malayan peninsula;" plans to include a British (English) session within the next few months. (Radio Australia) At present heard with Swahili, Gurkah, Hindustani. (Sanderson, Australia)

**Mauritius**—V3USE, 15.075, Forest Side, is heard in Sweden with French musical program after 1105 but soon fades out. (Radioklubben Universal, Sweden)

**Mozambique**—CR7BJ, 9.776A, Lourenco Marques, noted from 2300 (Sun. from 0000) with English session, many commercials, frequent time checks. (Ferguson, N.C., others) Noted on 3.49A at 1100-1200, good signal; on 4.92A at 1100. (Sarkady, South Africa)

**New Zealand**—Wellington noted on ZL9, 11.810, parallel ZL3, 11.78, around 2300. (Balbi, Ballou, Calif.)

**Nicaragua**—Granada, 7.850A, fine level from 1730-2200 sign-off; all-Spanish: CWQRM heavy at times. (Saylor, Va.)

**Northern Rhodesia**—Lusaka, 4.826, noted with BBC news relay 1300, closing 1402 with "God Save the Queen." (Pearce, England) Heard over the 3.914 outlet around 1115 parallel 7.22. (Sarkady, South Africa)

**Norway**—Radio Norway, LLR, 7.240, heard Sun. with English ("Norway This Week") 0900-0920. (Pearce, England)

**Pakistan**—Radio Pakistan noted to Indonesia 0600-0715 on 15.270, 17.770; all-native except talk in English 0645; news 0200, 0330, 0730 on 17.710; 1015 on 11.885. (Pearce, England) APD1, 15.335, Dacca, heard 2115 with news; Karachi, 17.835, noted 0515 with English talk, music. (Sanderson, Australia) Dacca, 15.335, heard with English

as early as 2030. (Ferguson, N.C.) Noted closing 2100 in English on 11.885 to Southeast Asia, announcing 15.335 in parallel. (Niblack, Ind.)

**Panama**—HP5J, 9.607, Panama City, noted 1930 with request program of popular songs, announcements in English; strong level in Ind. (Niblack)

**Paraguay**—ZPA1, 6.275, Asuncion, noted around 2020-2045 with announcements in Spanish; fair level. (Ferguson, N.C.) ZPA5, 11.950, Encarnacion, has news in Spanish 1650A. (O'Sullivan, England)

**Philippines**—Dumaguete, noted 0635 with religious session in English; news 0700; announced DYH4. (Ballou, Calif.) DUH2, 6.170, Manila, heard signing off 1000 at good level; DYH2, 6.140, Cebu City, noted 0945 with fine level. (URDXC) DZ17, 6.080, is a new frequency; DZH4, 6.000, was formerly short-wave outlet of medium-wave DZMB, now relayed by DZ17; DZH4, 6.000, now relays medium-wave DZRH as does DZR2, 9.640; DZ17 operates 1658-1100 daily; news 1730-2345, 0600. (Radio Australia)

**Portugal** — Lishon, 15.125, noted often now 1400-1500 parallel 11.996A. With verification, Radio Renascenca, Lisbon, listed 6.154, 500 watts, 1430-1900. (Pearce, England) Lisbon noted from 1600 on 11.964A at excellent level but with some QRM from Brazzaville, 11.970, Fr. Eq. Africa. (Scheiner, N.J.) Heard opening 1900 on 5.973A. (Niblack, Ind., others) Good on 15.125 in Portuguese 0600. (Morrison, R. I.)

**Portuguese India**—Radio Goa, 9.610, is often heard in Sweden 1030 with religious programs in English. (Fennell, Sweden)

**Rhodes**—VOA relays via "The Courier" are scheduled currently on 6.015, 1300-1715 to Near East, and 1730-2245 to Caucasian USSR; on 7.200, 1030-1715, 1730-2245 to Caucasian USSR; on 11.805, 0830-1015 to USSR.

**Roumania**—Radio Bucharest noted with news, commentary, music from 1500; strong on 12.032, fair on 9.252, 6.218; ends English 1545. (Pearce, England)

**Saudi Arabia**—Djeddah noted near 7.310 signing on 1118 with march-anthem after interval signal; all-Arabic to 1213 closedown (no anthem). (Pearce, England) Noted here around 2300, evidently moved from 7.210A. (Bellington, N.Y.)

**South Africa**—Johannesburg, 4.945, noted at good level 2315-0000 with request musical session. (URDXC) Heard on 4.897A opening 2345 in Afrikaans, good level. (Cox, Dela.) Johannesburg, 9.870, heard closing 1505 after newscast. (Monitor, England)

**Southern Rhodesia**—Salisbury, 6.000A, is good level in South Africa 1100. (Sarkady)

**Spain**—Radio Mediterraneo, 6.995A, Valencia, noted 1000 with popular music, call in Spanish; off 1010. (Pearce, England) Malaga, 7.017, noted 1615 with news in Spanish, music. (Sanderson, Australia) Madrid, 9.363, has English for Europe 1515-1545; for North America 1800-1840,

**BUSINESS REPLY CARD**

No Postage Necessary if Mailed in U. S. A.

3c Postage will be Paid by

*Radio-Electronic Engineering*

EDITION OF RADIO & TELEVISION NEWS

366 MADISON AVENUE  
NEW YORK 17, NEW YORK

**FIRST CLASS**

Permit No. 37110

Sec. 349, P. L. & R.

NEW YORK, N. Y.

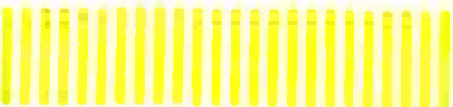



Enter A Subscription For:

**RADIO-ELECTRONIC**  
*Engineering*

EDITION OF  
RADIO & TELEVISION NEWS



NAME \_\_\_\_\_

ADDRESS \_\_\_\_\_

CITY \_\_\_\_\_ ZONE \_\_\_\_\_

STATE \_\_\_\_\_

POSITION \_\_\_\_\_

COMPANY \_\_\_\_\_

7-53

I'll pay when Billed

Remittance enclosed

Canada, Mexico, South  
America same as U. S. A.  
For all other countries add  
\$1.00 for each year.

3 years \$10<sup>00</sup>

2 years \$9<sup>00</sup>

1 year \$6<sup>00</sup>

# Communications Receivers



Contains All Components

**COMPLETE KIT**—This kit is complete with every part necessary to assemble into a finished receiver, including tubes and cabinet. Chassis is punched and marked. Mount the parts, wire it, align it and you have a fine receiver of commercial appearance, that can't be beat for 3 or 4 times the price. Parts layout, schematic diagram and alignment instructions are supplied.

## FEATURES:

- 2 Watt P.P. Audio
- Amplified AVC
- Voltage Regulated Oscillator Supply
- Noise Limiter
- Beat Oscillator
- Air Tuned R.F. Trimmers
- 2 Stage Permanently Tuned 455 KC I.F. Plus Crystal Filter
- Phone Jack—Built-in Stand-by Relay
- Operates on 105 to 125 Volts AC or DC Power Source
- Frequency Range 200 KC to 400 KC and 490 KC to 19 MC in Six Bands
- 40:1 Geared Ratio Dial Drive
- 11 Tubes Plus Selenium Rectifier
- 65G7 RF AMP.
- 65B7Y Mixer
- 2-65G7 I.F.
- 6M6 2nd Det & N. L.
- 65F7 AVC AMP.
- 65L7 BFO & 1st Audio
- 65L7 Phase Inverter
- P.P. 25L6GT Audio
- VR-75 Voltage Regulator
- Full Vision Calibrated Dial
- Cabinet 19 1/2" long x 10 1/2" high x 12 1/2" deep
- Finished in fine grain black wrinkle
- Front Panel silk screened to identify each control
- Shipping weight 45 lbs.
- Shipped Express Only.

## FRONT PANEL CONTROLS

- Tuning
- R.F. Gain
- Audio Gain
- BFO-AVC Switch
- BFO Pitch
- Power On-Off
- Stand-by
- Noise Limiter On-Off and Control
- Antenna Trimmer
- Crystal Filter On-Off
- Crystal Phasing
- Selectivity
- Band Change Switch
- Calibrated Dial Face

**Special**  
**\$59.50**  
KIT  
PRICE  
EACH

Wired and Tested  
**\$89.50**

## TERRIFIC KIT BARGAINS

### SURPRISE KIT!

Minimum of 5 lbs. of usable, new radio—TV—electronic parts. Complete satisfaction guaranteed or 100% of purchase price refunded. . . . . **\$1.99**

Paper tubular condenser kit of 100 new values from .0001 to .1 mfd. \$15.00 value for only . . . . . **\$5.95**

50 assorted mics in popular values from 10 to 10,000 mmfd. \$7.50 value for only . . . . . **\$2.95**

15 assorted single, double and triple section PP condensers worth \$15.00 for only . . . . . **\$3.95**

25 assorted volume controls \$10.00 value for just . . . . . **\$2.95**

15 assorted popular size 5 and 10 watt resistors for . . . . . **\$2.95**

### PHONO AMPLIFIER

A 3 tube phono amplifier complete with tubes and output transformer. Made especially for Boulevard. Uses 50L6-35Z5-12SQ7. A super buy. . . . . **\$6.95** ea.

### COPPER OXIDE RECTIFIERS

Bradley Labs (CX3E Series) Dual Bridge Rectifiers. Current and Temperature Characteristics Balanced to Better than 1% from -40°C to 70°C. 10.5 Volts Input. Max. D.C. Center Leg Current 15 M.A. Used as Balanced Modulators and Bridges. . . . . **\$2.00**

### WELLER GUNS

- WS-100—Single Head—100 Watt . . . . . **8.77**
- WS-200—Single Head—200 Watt . . . . . **9.75**
- Wp-135—Dual Head—100/135 Watt . . . . . **10.73**
- Wp-250—Dual Head—200/250 Watt . . . . . **11.71**

## SPECIAL "HI-FI" VALUES

### NEW MEISSNER GOLDEN MATCHED HI-FI SYSTEM

AM-FM Tuner—Webster 3 speed changer. GE triple play magnetic pick up. 10 watt Hi-Fi amplifier with built in pre-amp. Electro-voice 12" Co-Ax speaker complete with all plugs and mounting board. Ready to play . . . . . **\$199.95**

BRITISH 10" ELAC HI-FI SPEAKER 5 WATT—8 OHM VOICE COIL . . . . . **\$9.95** Ea.

NEW GARRARD MODEL RC80 3-SPEED AUTOMATIC RECORD CHANGER . . . . . **\$41.46**

Hi-Fi Craftsmen—A-84—15 Watt Amplifier . . . . . **\$99.50**

Hi-Fi Craftsmen—ST-83—AM-FM Tuner . . . . . **\$129.95**

McIntosh—A-116—30 Watt Amplifier . . . . . **\$139.50**

Craftsmen—C-500—15 Watt Amplifier . . . . . **\$99.50**

Craftsmen—C-10—AM-FM Tuner . . . . . **\$131.50**

Pickering Long Play Cartridge for 33 1/3 RPM with Diamond Needle . . . . . **\$36.00**

GE Diamond Replacement Needle . . . . . **\$16.17**

Jensen H-222 12" Co-Axial Speaker . . . . . **\$46.75**

Jensen G-610 15" Tri-Axial Speaker . . . . . **\$224.91**

3 Speed Phonograph with Leatherette carrying case 2 tube amplifier . . . . . **\$21.95**

*Boulevard Special!*  
V-M Model 950  
RECORD CHANGER

Tri-A-matic, 3 speed, flip-over dual needle crystal cartridge. List **\$46.50**  
Your Cost, Only. . . . . **\$28.95**

## TUBE KITS BEST BRANDS AT BEST PRICES

- 3V4, 1T4, 1R5, 1S5 . . . . . **\$2.19**
- 304, 1T4, 1R5, 1S5. List Value \$8.00. Tube Kit only . . . . . **\$1.98**
- 354, 1T4, 1S5, 1R5. List Value \$7.80. 4-Tube Kit . . . . . **\$1.98**
- 1U4, 354, 1S5, 1R5. List Value \$7.80. All Four Tubes for . . . . . **\$1.98**
- 117Z3, 1U5, 354, 1R5, 1T4. AC-DC Portable Kit. All for . . . . . **\$2.49**
- 12AT6, 12BA6, 12BE6, 35W4, 50B5, 5 Tubes for . . . . . **\$2.59**
- 50L6GT, 35Z5GT, 12SQ7GT, 12SK7G, 12SA7G. 5 Tubes for . . . . . **\$3.22**

### RECEIVING TUBE SPECIALS

- Manufacturer's Surplus—Boxed—Fully Guaranteed
- 6SN7GT . . . . . 88c 12AT6 . . . . . 60c
  - 6AU6 . . . . . 65c 12BA6 . . . . . 69c
  - 6RQ7 . . . . . 60c 12BE6 . . . . . 69c
  - 6X6GT . . . . . 60c 35Z5 . . . . . 54c
  - 6S4 . . . . . 54c 50B5 . . . . . 69c
  - 6AL5 . . . . . 59c 50C5 . . . . . 69c

We Carry a Full Line of CBS-Hytron and National Union Receiving and Picture Tubes at Regular Discounts.

### TEST EQUIPMENT

- Eico Latest—Model 470—7" Push-Pull Scope Kit . . . . . **\$9.50**
- Factory Wired . . . . . **129.50**
- Preline 7" Scope Kit Model 300K . . . . . **94.95**
- Factory Wired Model 300W . . . . . **199.50**
- EMC—Model 204 Tube Checker . . . . . **55.90**
- EMC—Model 205 Tube Checker . . . . . **47.50**
- EMC—Model 206 Tube Checker. 581.83

## PHILMORE KITS at Lowest Prices!

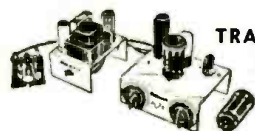

Novice  
TRANSMITTER and  
POWER SUPPLY  
KIT  
Including Key!

25 watt input, 2 band operation. 3.7 MC to 3.75 MC and 26.96 to 27.23 MC; has crystal oscillator, tuned output amplifier. Easy to assemble . . . includes pictorial diagrams, tuning condensers, tubes, power supply, receivers, instruments, etc. . . . . **\$29.40**

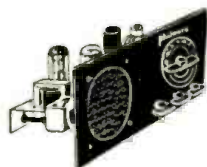

### 2-tube AC-DC RADIO KIT

Includes simple instructions and diagrams, complete less tubes, headset, wire and solder. 115V AC . . . . . **\$7.35**  
or DC . . . . . **\$7.35**  
Set of tubes: 35Z5 and 12SJ7 . . . . . **\$1.51**

### 3-TUBE AC-DC RADIO KIT

2 band including short wave . . . Easy to assemble; with good 4" PM Speaker. 550-1700 KC on broad-cast band; 6-18MC on short wave. 115V AC or DC. Complete with speaker. . . . . **\$11.76**  
Set of tubes: 35Z5, 50L6, 12SJ7 . . . . . **\$2.39**

## TV ANTENNA SPECIAL!

Here's a real bargain in a quality all band in-line antenna complete with 5 ft. mast for only. . . . . **\$5.95** ea.

TERM: 25% Deposit with order. Balance C.O.D. Include postage with parcel post orders. All prices F.O.B. Chicago and subject to change without notice. All merchandise subject to prior sale.

### ONE-BAND MODEL

RADIO KIT \$19.11  
550 to 1800KC.

### TWO-BAND MODEL

RADIO KIT \$22.34  
550 to 1600KC and 5.5 to 16MC.

5 TUBE SUPER HET RADIO KITS AS ABOVE AT THESE LOW, LOW PRICES. Simple pictorial diagrams make these kits really easy to assemble. Supplied with chassis, colorful cabinet. All necessary parts ready to assemble. 115V AC or DC. Size: 8 1/2" x 5 1/2" x 5 1/2".

ORDER YOUR KITS TODAY

## RADIO CRAFTSMEN

Model 202

### HIGH FIDELITY TV CHASSIS

202 Chassis, only . . . . . **\$252.50**  
Tube mounting kit . . . . . **21.40**  
21PP4A (standard brand warranted tube) . . . . . **40.00**

BUY all 3 above and save \$15.00 on tube. . . . . complete **\$298.90**

## TV PICTURE BRITENER

For correcting soft, dark or weak picture tubes. ONLY . . . . . **\$1.95** EA.

### BAT HANDLE TOGGLE SWITCHES

Rakelite insulation and silver-plated lug terminals on all units. SPST type rated at 3 amps, 250 volts. All others 3 amps, 125 volts. Underwriters Laboratories Approved. Shank 15/32" dia., 15/32" long. With mounting nuts.

Stock No.	Mfrs. Type	Poles	NET EACH	Lots of 100 EACH
R125	20994-IH	SPST	51c	46c
R126	21350-FH	NPST	56c	50c
R127	20992-CX	DPST	76c	69c
R128	20995-FR	DPST	88c	79c

**BOULEVARD ELECTRONICS, INC.**

808-10 W. JACKSON BOULEVARD • CHICAGO 7, ILLINOIS

DE 2-4458

RADIO AND TELEVISION SUPPLIES



# NOW! BECOME EXPERT AT RADIO- TELEVISION IN 4 EASY STEPS!

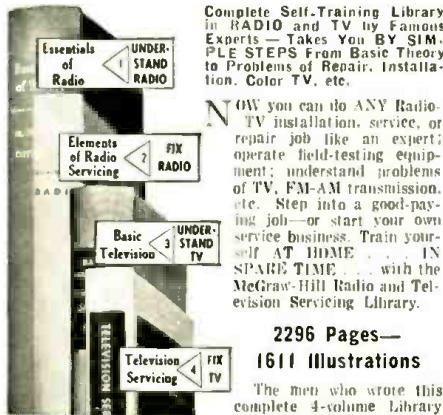

Complete Self-Training Library in RADIO and TV by Famous Experts — Takes You BY SIM-  
PLE STEPS From Basic Theory to Problems of Repair, Installation, Color TV, etc.

Now you can do ANY Radio-TV installation, service, or repair job like an expert! operate field-testing equipment; understand problems of TV, FM-AM transmission, etc. Step into a good-paying job—or start your own service business. Train yourself AT HOME IN SPARE TIME... with the McGraw-Hill Radio and Television Servicing Library.

2296 Pages—  
1611 Illustrations

The men who wrote this complete 4-volume Library are among the outstanding radio and TV instructors in America today. Every detail is clearly explained in over TWO THOUSAND PAGES of step-by-step instruction and over SIXTEEN HUNDRED "how-to-do-it" illustrations, cross-section diagrams, etc. The review questions and answers "nail down" everything you learn. At-a-glance "trouble-shooting" charts show how to diagnose instantly any radio or TV breakdown... and how to repair it expertly and quickly. The Library will pay for itself many times over. It gives all you need to know for FM and TV in the FCC's 1st-class license exam; gives an experienced technician more confidence and skill.

### SEND NO MONEY

Mail coupon below to examine complete four-volume Library FREE for 10 days. No obligation. Or you may examine individual books FREE for 10 days by checking the proper boxes in coupon.

### PARTIAL CONTENTS ESSENTIALS OF RADIO.

800 pages, 433 illus. Circuit Analysis • Vacuum Tubes • Circuits: Detector • Amplifier • Tube Oscillator • Power Supply • Transmuting, Receiving • Etc.

**ELEMENTS OF RADIO SERVICING.** 475 pages, 375 illus. Multimeters • AC Power Supply • Speakers • Antennas • Auto Radio • Push-Pull Output Stage

**BASIC TELEVISION.** 592 pages, 415 illus. Scanning • Synchronizing • Video Signal • Brightness Control • DC Interpolation • Picture • FM Alignment • Picture Tubes • VHF and UHF transmission • Reception

**TELEVISION SERVICING.** 429 pages, 388 illus. Antennas • Transmission Lines • Test-pattern and Picture Analysis • Localizing Interference Troubles • Interference Remedies • Deflection Circuits  
**AND MUCH MORE!**

### FREE 10-DAY TRIAL COUPON

McGraw-Hill Book Co., Inc., Dept. RTN-7  
327 West 41st St., New York 18, N. Y.

Send me for 10 day free examination the Radio and TV Servicing Library, 4 Vols. (Regular retail price is \$26.75; Special Course Price only \$21.95 in easy installments.) If not satisfied with Course, I will return it, pay nothing. Otherwise, I'll send \$1.95 plus delivery then and only \$1.00 in monthly installments. If you wish to examine any of these books individually, check below the ones you wish us to send you for 10 Days' FREE EXAMINATION:

- |                                                      |                                                              |
|------------------------------------------------------|--------------------------------------------------------------|
| <input type="checkbox"/> Essentials of Radio, \$7.50 | <input type="checkbox"/> Elements of Radio Servicing, \$5.25 |
| <input type="checkbox"/> Basic Television, \$7.50    | <input type="checkbox"/> Television Servicing, \$6.50        |

For any book I keep, I'll send \$2.00 plus delivery in 10 days, balance in easy monthly installments.

Name \_\_\_\_\_  
Address \_\_\_\_\_  
City \_\_\_\_\_ Zone \_\_\_\_\_ State \_\_\_\_\_  
Position \_\_\_\_\_

Company \_\_\_\_\_ RTN-7  
 WE PAY FOR DELIVERY if you send first payment of \$1.95 when ordering Library or full price when ordering individual books (prices above). Same return privilege. (Offer applies to U.S.A. only.)

2205-2245. (Carroll, Me.) "La Voz de la Falange," 7.380, noted in Sweden at 1500. (England)

Surinam—Paramaribo, 5.752, 15.404A, noted with news in Dutch by man 1815. (Cox, Dela.)

Sweden—Radio Sweden, 11.880, strong level 2300 with news. (Ballou, Calif.) Heard with news to Far East 1800-1815 on 9.535; same channel 1930-2000 in English to Canada, USA. (Parsons, Pa.)

Syria—Damascus, 11.913A, noted with English for Western Europe 1630-1730 closedown. (Parsons, Pa.)

Taiwan—Taipeh, 7.130, noted 0550, fair level with deep fading. (Ballou, Calif.) Noted on BED26, 10.080, at 1700 with Chinese news, music; BED24, 9.820A, at 0445 with Chinese news; BED6, 11.735, at 2345 with news, music, then Chinese session from 0000. (Sanderson, Australia)

Thailand—Bangkok, 7.103A, noted 0555 at good level in native session. (Ballou, Calif.)

Station sent schedule as Overseas Service (omni-directional) 0500-0625, news 0515, in Malay 0600, on HSK5, 6.240, 1 kw.; HSK7, 11.910, 500 watts, and HSK8, 15.640, 250 watts; Home Service 1900-2000, 0630-1020, 827 kc., 10 kw.; 7.140 (actually 7.105A), no power mentioned; 6.240, 11.910, 15.640. (Scheiner, N. J.)

Trinidad—Radio Trinidad lists current schedule on 3.275, 790 kc. at 0500-2200; on 6.085 at 0500-1700; no mention of 9.625. (Pearce, England; Johnson, Ohio) Evident move from 9.625 to 6.085 not confirmed at press time.

Turkey—TAT, 9.515, fine level in English to North America daily 1815-1900. (Richmond, N.Y.; England, N.H., others)

### Press Time Flashes

The monthly DX session, "This Radio Age," from Radio New Zealand is currently aired the first Tue. of each month 0430 over ZL7, 6.080, ZL8, 9.620. (Radio Australia)

The Central Forces Radio Station, Athens, Greece, lately has returned to its old channel of 6.33 from 7.420; noted 1255. (Pearce, England) 4VEH, Cap Haitien, Haiti, has a new 10 kw. transmitter under construction for use in the 49- and 60-m. bands. (West, Va.) Port Moresby, Brit. New Guinea, has ceased use of VLT7, 7.280, VLT9, 9.520, and all its sessions are now aired over a new outlet, VLT6, 6.130. (Ballou, Calif.; Radio Australia, others) A station with news in French on 7.410A at 1800 seems to announce as "Radio Hirondelle," may be Hanoi, Indo-China (Vietnam); usually has dance music (recordings) from 1815. (Pearce, England)

The German Bundespresident, Dr. Theodor Heuss, inaugurated the new (West) German Short-Wave Service recently over the 20 kw. transmitters at Norden-Osterloog; five daily 3-hour transmissions are now presented—original broadcast 1300-1600 to Africa, 11.795; tape recording rebroadcasts 1700-2000 to South America, 11.795; 2030-2330 to North America,

# CRYSTALS

## FOR ALL PURPOSES

LOW FREQ.—FT 241A for SSB, Iatice filter, 1/2" spc. 54th or 72nd harm channels listed by fund. Fractions omitted.	SCR. 522 1/2" sp.	BC-610 2 banana plus 1/2" spc.
374 395 418 487 511 400 464	5910	2030 2435
375 396 419 488 514 440 466	6370	2045 2442
377 397 420 490 515 441 468	6450	2105 2532
379 398 422 491 516 442 470	6470	2125 2545
380 401 423 492 518 446 472	6497	2145 2557
381 403 424 493 519 447 474	6522	2155 2562
383 404 425 494 520 450 475	6547	2220 2615
384 405 426 495 522 452 476	6610	2258 2637
385 407 427 496 525 461 477	7350	2280 3250
386 408 431 497 526 462 479	7580	2282 3322
387 409 433 498 530 463 480	7810	2290 3510
388 411 435 503 531	99c ea.	2300 3520
390 412 436 504 533	10 for \$1.29	2305 3550
391 413 438 506 537	10 for \$1.29	2320 3580
392 414 439 507 538	10 for \$1.29	2360 3945
393 415 444 508	99c each	2390 3995
394 416 445 509	10 for \$1.29 ea.	2415

49c each, 10 for \$4.50

FT-1/2" spc.

4190 6175 7773 1015 5725 5840 6306 6475 6640 7506 7706
5030 6206 7806 2045 5740 5850 6325 6506 6673 7540 7973
5485 6773 7840 3735 5760 5873 6340 6540 6706 7573 8240
6040 6873 7873 5305 5773 5906 6373 6573 6740 7606 8250
6073 6906 7906 5677 5800 5940 6406 6573 7440 7840 8273
6140 7740 7940 5706 5806 5973 6450 6600 7506 7650
5825 6273 6473 6606 7673

49c ea.

10 for \$4.50

99c each

10 for \$9.00

### Special Purchase! FM Radio Chassis

BB-108 MC—Complete with 6 tubes, built-in antenna and speaker. Product of famous radio and TV maker whose name we promised not to mention... **\$16.95**  
Maroon plastic cabinet for above \$5.95.

### TWO-STATION INTERCOM SYSTEM

Consists of master and remote station, 20-ft. of 3 wire cable, 115 V operation, AC or DC. Extra wire .05 per ft. **\$16.97**

### TV CHASSIS NOT A KIT

Complete with picture tube and speaker. 20 tubes. Standard coil high gain cascade front end.

20-INCH: **\$157** | 17-INCH: **\$143**

# Sun

PARTS DISTRIBUTORS, LTD.

520 TENTH ST., N.W. - WASHINGTON, D.C.

Please mention  
**RADIO & TELEVISION NEWS**  
when answering  
Advertisements

### RADIO ENGINEERING DEGREE IN 27 MONTHS

Radio engineering is a big field. There's room for you in it—if you're good. Get first-class training at Indiana Tech. Intensive specialized course, including strong basis in mathematics and electrical engineering, advanced radio theory and design, television, electronics, Modern Laboratories. Low rate. Also B.S. DEGREE IN 27 MONTHS in Aeronautical, Chemical, Civil, Electrical and Mechanical Engineering. U.S. Government approved. Enter September, December, March, June. You can earn part of your expenses right here in Fort Wayne while you are studying.

### INDIANA TECHNICAL COLLEGE

963 E. Washington Blvd., Fort Wayne 2, Indiana  
Please send me free information on B.S. Engineering Degree in 27 months as checked.

Radio-Television  Aeronautical  
 Civil  Mechanical  Electrical

Name \_\_\_\_\_  
Address \_\_\_\_\_



7.290, 6.270; 0530-0830 to Far East, 15.275; 0930-1230 to Near East, 11.795. All broadcasts in German, the first 10 minutes being news followed by 5 minutes of commercial news; remainder is musical entertainment and talk features. Reports are requested to Deutsche Welle, Koeln, Fankhaus N.W.D.R., Cologne, Germany.

*Radio Free Asia* has ceased its short-wave transmission from San Francisco, Calif., relayed by Manila, Guam, will concentrate on use of m.w. stations in Far East and on other more direct means of communicating with Asian peoples. (Winch, Calif., others)

According to officials of *Radio Thailand*, Bangkok, by this time, should have a new 50 kw. station on the air, HSK9, with three separate programs for overseas listeners; the existing omni-directional broadcast 0500-0625 is to be continued, with addition of news and program in Chinese (Kuoyu dialect); two additional transmissions are to be beamed to North America, Europe, at times that had not yet been decided at press time; another 10 kw. m.w. station is due for service in 1954. Watch for the new 50 kw.-er on 6.24, 7.105, 11.910, or 15.630 around 0500-0625. (Scheiner, N. J.)

According to announcement, *Radio Peking's* former 0400 *English* session is now on *summer* schedule at 0300; other *English* periods (1730, 0830) remain unchanged.

Budapest, Hungary, has moved to *summer* channel 11.91 from 6.248A; noted 1845 relaying Moscow over the 11.91 outlet. (Bellington, N.Y.) Noted with *English* 1930 to North America, announcing similar broadcasts for 1715, 2300 on 11.91, 7.22, 9.833. (Johnson, N.H.) Cushen, N.Z., says Suva, Fiji, is being heard now on two channels in parallel—5.975, 6.100—around 0030 and later.

*Marconi's Wireless Telegraph Co., Ltd.*, England, says the 9 new short-wave transmitters being built for SABC, South Africa, will be 20 kw. and will cover all of South Africa; will be located at Paradys, near Bloemfontein, and frequency changing will be controlled centrally. SABC officials say they hope to have one of these  
(Continued on page 110)

## Custom-Styled for Hi-fidelity



Dimensions: 35½" H., 23½" W., 18" D.

Finishes: Blond Birch, Cordovan Mahogany or Birch.

Baffle Area: 6½ cubic feet.



**MODEL 28**  
Equipment Cabinet  
**72.00**  
net



**MODEL 27**  
Speaker Cabinet  
**48.00**  
net

Designed for the audiophile, these handsome cabinets will accommodate any combination of high fidelity components. Panels are replaceable for future changes of equipment. The loudspeaker cabinet is acoustically correct, tuned for the average 12" or 15" loudspeaker, pre-cut as requested. Construction is of select birch, with a fine lacquer finish hand-rubbed to a high gloss. All joints are glued and screwed, and lock-joint miters are used throughout, affording utmost rigidity.

Sold through leading radio parts distributors. Write for free catalog RN-7.

**G & H WOOD PRODUCTS COMPANY 75 N.11th ST. BKLYN. 11, N. Y.**  
Pioneers in radio furniture for high fidelity equipment.

# Compare... prove EMC superiority



### model 102

(1000 ohms per volt meter) • 3" SQUARE METER • 3 AC CURRENT RANGES (0-30/150/600 ma.) • Same zero adjustment for both resistance ranges 0-1000 ohms, 0-1 megohms) • 5 DC & 5 AC Voltage Ranges to 3,000 volts • Also 4 DC Current Ranges ..... **\$14.90**

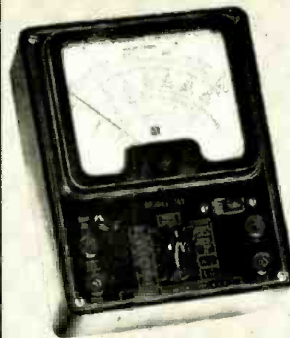

### model 103

(1000 ohms per volt meter) • 4½" SQUARE METER • 3 AC CURRENT RANGES (0-30/150/600 ma.) • Same zero adjustment for both resistance ranges (0-1000 ohms, 0-1 megohms) • Same Ranges as Model 102 • Also 5 DB Ranges ..... **\$18.75**  
Model 103-S with plastic carrying strap..... **\$19.25**



### model 104

(20,000 ohms per volt meter) • 4½" SQUARE METER (50 microamperes-Alnico magnet) • Includes carrying strap • 5 DC Voltage Ranges at 20,000 ohms volt to 3,000 V., 5 AC Voltage Ranges to 3,000 V. • 3 Resistance Ranges to 20 megs • Also 3 AC & DC Current Ranges • 5 DB Ranges ..... **\$26.95**  
HVT 30,000 Volt Probe for Model 104 ..... **\$7.95**

— See them at your Jobbers —

# EMC

Write Dept. RN-7 for Free Complete Catalogue of these and other instruments.

**ELECTRONIC MEASUREMENTS CORPORATION**  
280 LAFAYETTE STREET • NEW YORK 12, N. Y.

EXPORT DEPARTMENT 136 LIBERTY STREET, N. Y. C. 6, N. Y.



# Sarkes Tarzian

Centre-Cooled

PATENTS NO. 2618692 & 2620384

## SELENIUM RECTIFIERS

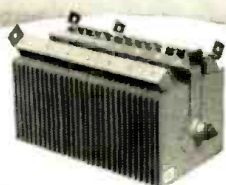

### Power Type

Available over a range that includes a few volts and milliamperes of current to hundreds of volts and thousands of amperes. Fourteen cell sizes provide widest available range of selection.

### Radio Type

Versatile low-cost rectifiers that have found application in all types of electronic equipment as well as radio and television receivers. A complete line is available.



### Embedments



A recent "first" in the industry, Sarkes Tarzian embedments offer the advantages of hermetically sealed rectifiers at a fraction of the size, weight and cost.

### Diodes

Currently available in two sizes, (1/8" and 5/16" housings) Sarkes Tarzian diodes are designed for use as limiters, bias voltage, low current relay voltage and many other very low current applications.



### High Voltage

This popular line of tubular rectifiers offers the design engineer a compact—long lived high voltage—low current source of DC power.

Please write, wire or phone for complete information on all types of Sarkes Tarzian Selenium Rectifiers.



**Sarkes Tarzian, Inc.** RECTIFIER DIVISION  
Dept. R-5, 415 N. College Ave., Bloomington, Ind.

new transmitters on the air by the end of 1954, all in use by middle of 1955. (Scheiner, N. J.)

Burma plans three new 50 kw. short-wave transmitters to be completed in 1955, and an overseas service then for neighboring countries. (Scheiner, N. J.) By this time, *Radio Luxembourg* plans to have a new 50 kw. transmitter on the air to beam French sessions on 6.090 with omnidirection antenna 0040-0930, 1045-1800; current schedule on 15.350 is 0600-0800 in Flemish, and 1300-1800 on 6.090 in *English*. (Scheiner) *WRH* says *Radio Tirana*, Albania, is now broadcasting a special program on 9.700 for Albanians in USA on Sun. 1930-2000; not confirmed at press time.

More recently, the 0730-0740 news from *Radio Pakistan* has been noted on 17.770 instead of on (former) 17.710. (Pearce, England) *Radio Peeking* lists revised schedule of 1600-1700 on 6.100, 10.260, 11.690; 1700-1730 on 6.100; 1730-1800 *English* on 11.690, 15.060; 1800-2100 on 11.690, 15.060; 0300-0330 on 6.100, 10.260; 0400-0430 *English* on 6.100, 7.500, 9.040, 10.260, 11.690, 15.060, 15.170; 0430-0700 on 11.690, 15.060; 0700-0730 on 6.100, 7.500, 9.040, 10.260, 11.690, 15.060, 15.170; 0730-1030 on 11.690, 15.060 (*English* 0830-0900A). Wrote that will increase transmitter power in near future. (Scheiner, N. J.) Chania, Greece, is now on 8.970, relays *Radio Athens* 0600. (Bluman, Israel, via *WRH*) More recently, Damascus, 11.913A, Syria, has had news 1645 (rather than 1715). (Pearce, England) CBFW, 6.090, Canada, has ceased operations due to opening of new BCB stations in the Western Provinces. (NNRC)

SBC, Berne, Switzerland, is now on summer schedule; changes include 0945-1130 to India-Pakistan (*English*) on 11.865, 17.784 (replacing 9.665); 1145-1330 to Middle East (*English*) on 11.865, 15.120 (replacing 9.665); 0600-0830 European program beamed to Africa on 17.784 (replacing 21.520); all other programs are unchanged. (*WRH*)

*English* newscasts from AIR, Delhi, India, are now 1930-1940, 11.850, 9.630; 2310-2320, 17.705, 15.130; 0235-0245, 17.740, 15.380; 0830-0840, 15.380, 11.850; 1045-1055, 15.290, 11.780.

"Voice of Free China," Taipeh, Taiwan, is scheduled 2300-2400 *English* to USA, 11.735, 15.235; 2300-0030 dictation news (Chinese) to China. South Seas, 670 kc., 6.095, 7.130 (from 0000 also on 11.735); 1400-1600 European program, 11.800 (*English* 1420, French 1450); 1730-2300 Chinese, Cantonese, Mandarin to Asia, 670 kc., 7.130, 11.735. (Hardwick, N.Z.) Martin, R.I., recently noted NBA, 7.820, Balboa, Canal Zone, with sports for Puerto Rico evenings (*EST*).

#### Acknowledgment

Thanks for FB reports; keep them coming to 948 Stewartstown Road, Morgantown, West Virginia, USA. Good DX-ing this summer!—K.R.B.

## for dependable sound INDUSTRY relies on ATLAS



DR Double-Reentrant Projectors

#### DEPENDABLE QUALITY:

The latest electro-acoustic research and engineering—and over 20 years of manufacturing know-how—are behind every ATLAS product.

#### DEPENDABLE SERVICE:

Coast-to-coast and around the world today—in every Industrial, Marine, Railroad, Military, Educational, Civic, U.S. and Foreign Government application—under every kind of climate and noise condition—ATLAS sound equipment is famous for highest efficiency and durability. That's the proof of ATLAS performance dependability.

#### DEPENDABLE DELIVERY:

Yes, ATLAS gives our Government highest priority. And yes, we too feel the pinch of material shortages. But our customers will continue to get our usual dependable delivery—because we believe in equitable and dependable distribution to all ATLAS users.

#### DEPENDABLE PROFITS:

Completeness of line, excellence of product, dependable delivery, right prices—that's the ATLAS combination that means high, steady Industrial Sound profits for You!



Paging & Talk-Back Speakers



ALNICO-V-PLUS Driver Units



Dual Speakers



FULL-GRIP, VELVET-ACTION Mike Stands



# ATLAS SOUND CORP.

1446-39th Street, Brooklyn 18, N. Y.  
In Canada: Atlas Radio Corp., Ltd., Toronto, Ont.

## EASY TO LEARN CODE

It is easy to learn or increase speed with an Instructograph Code Teacher. Affords the quickest and most practical method yet developed. For beginners or advanced students. Available tapes from beginner's alphabet to typical messages on all subjects. Speed range 5 to 40 WPM. Always ready—no QTM.



#### ENDORSED BY THOUSANDS!

The Instructograph Code Teacher literally takes the place of an operator-instructor and enables anyone to learn and master code without further assistance. Thousands of successful operators have "acquired the code" with the Instructograph System. Write today for convenient rental and purchase plans.

## INSTRUCTOGRAPH COMPANY

4711 SHERIDAN ROAD, CHICAGO 40, ILLINOIS

RADIO & TELEVISION NEWS



1953 RCA Receivers  
(Continued from page 51)

i.f. system. The alignment of  $T_{106}$ ,  $T_{107}$ , and  $T_{108}$  is simple because each transformer is peaked for maximum response at one specific frequency. The over-all i.f. response, including the response of the input i.f. transformer  $T_{101}$ , should be flat with 42.50 mc. and 45.75 mc. falling at the 70% points on the response curve. A 47.25 mc. tunable trap is located across the primary of  $T_{101}$  to attenuate the adjacent channel sound carrier.

A diode formed by the grid and cathode of  $V_{106.1}$  is used to detect the video signal from the i.f. signal. Both the sound and video signal appear across the diode load components,  $R_{103}$  and  $L_{101}$ . The 4.5 mc. sound signal developed across  $L_{101}$  is coupled to the sound circuits. A 4.5 m.c. parallel-tuned trap,  $L_{102}$  and  $C_{127}$ , prevents sound from entering the video amplifier stage.

The diode formed by the plate and cathode of  $V_{106.4}$  is prevented from interacting with the picture detection by holding the plate negative with respect to the cathode. This is done by coupling negative voltages from the a.g.c. bus and the horizontal drive circuit. These voltages are filtered by the components  $C_{124}$ ,  $R_{127}$ , and  $R_{128}$ .

A frequency compensated video amplifier  $V_{110}$  is used following the picture detector.  $V_{110}$  employs a 6CL6 in a directly-coupled pentode circuit. The picture or contrast control is part of the plate load. RC networks across the control provide a varying degree of compensation as the control setting is changed.  $L_{107}$ - $R_{116}$  and  $C_{121}$ - $R_{122}$  give additional compensation acting in series with the signal lead to the cathode of the kinescope.

#### Sync Separator and Output Stages

The horizontal sync separator,  $V_{112.2}$ , and the vertical sync separator,  $V_{109.12}$ , remove sync voltages from the composite video signal to operate the sweep circuits. Each separator stage uses one-half of a 12AU7.  $V_{112.2}$  is biased almost to cut-off by  $R_{109}$  in its cathode circuit.  $R_{109}$  and  $C_{117}$  form an RC network of short time constant. As a result,  $V_{112.2}$  can approach cut-off rapidly and the plate signal will contain the horizontal pulses and only the leading edge of the vertical pulses.

When the composite video signal is applied to the grid of  $V_{109.12}$ , the grid draws current on both the horizontal and vertical sync pulses. As a result, the grid develops voltage across  $C_{121}$  which biases  $V_{109.12}$  to a point near cut-off. The video signal lies beyond cut-off and is not passed by the tube; only the sync pulses are developed in the plate circuit. The vertical pulses across  $R_{106}$  are coupled through  $R_{123}$  to the vertical sync output stage,  $V_{112.4}$ .

The bias on  $V_{112.4}$  varies with changes of plate voltage on the first and second picture i.f. amplifiers resulting

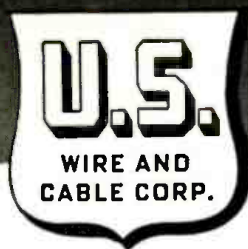

# "Rotaxial" Cables

for

## COMMUNITY TV SYSTEMS



Several of the largest and most successful Community TV Antenna Systems in the country, specify U. S. Cables.

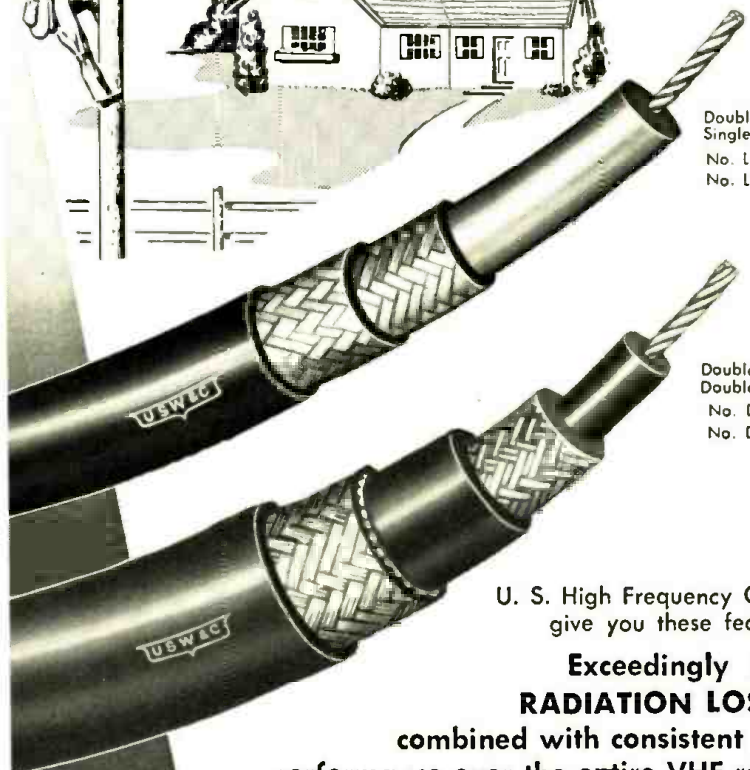

Double Braid, Single Jacket  
No. LR 5900  
No. LR 1100

Double Braid, Double Jacket  
No. DSDJ-59  
No. DSDJ-11

U. S. High Frequency Cables give you these features:

**Exceedingly LOW RADIATION LOSSES,** combined with consistent peak performance over the entire VHF range.

**LONG LIFE** and maximum efficiency, regardless of weather conditions, are inherent in these cables.

*New Catalog:* Write for your copy today.

## UNITED STATES WIRE & CABLE CORP.

PROGRESS AND MONROE STREETS • UNION, NEW JERSEY

Representatives in Principal Cities







tical hold control,  $R_{171}$ , acts as a frequency control for the oscillator.  $R_{171}$  is connected into the grid return of the vertical sweep output tube,  $V_{113}$ , so that momentary collapse of the picture is prevented when  $R_{171}$  is adjusted rapidly. When a rapid adjustment is made and an increased driving voltage is impressed on  $V_{113}$ , a counteracting voltage is coupled to the grid of  $V_{113}$  from the hold control.

A network formed by  $R_{151}$ ,  $R_{152}$ ,  $R_{153}$  and  $C_{105}$  introduces feedback in the sweep output stage to improve linearity and to reduce vertical bounce caused by a.c. line fluctuations. The linearity control,  $R_{156}$ , is in the cathode circuit of  $V_{113}$  and varying the setting of this control varies the bias (and operating point) on  $V_{113}$ .

The horizontal sweep and oscillator control circuit is a slightly modified "synchroguide" circuit. Additional drive from the horizontal oscillator has been provided by the addition of  $R_{205}$  which allows a portion of the saw-tooth voltage to appear on the oscillator grid. The range of the horizontal hold control has been extended by increasing the size of the control from 50,000 ohms to 75,000 ohms.

#### A.G.C. Circuit

The a.g.c. circuit used to develop r.f. and i.f. bias voltage is the familiar keyed type circuit. The keying pulses are taken from terminal 4 on the high-voltage transformer and are applied to the plate of the a.g.c. amplifier  $V_{114}$ . As a result,  $V_{114}$  conducts during horizontal retrace time and negative voltage is developed in the plate circuit. This voltage is used to control the gain of the r.f. amplifier and first two i.f. amplifier stages. The amount of bias voltage produced is controlled by the conduction through  $V_{114}$  which, in turn, is determined by the amplitude of the horizontal sync pulses applied to the grid. Sync pulses for this function are taken from the a.g.c. potentiometer which is located in the cathode circuit of the horizontal sync separator.

A delay of the r.f. a.g.c. voltage is introduced by  $R_{121}$  and  $C_{125}$ . The positive voltage fed to the r.f. a.g.c. bus through  $R_{121}$  is overcome by the negative a.g.c. voltage only after the r.f. signal input has reached a level of approximately 500 microvolts. This delay is applied because less snow will develop on weak signal inputs when no a.g.c. voltage is applied to the r.f. amplifier stage. To prevent the r.f. amplifier grid from going positive with the voltage introduced through the delay network, the diode sections of  $V_{101}$  are tied to the r.f. a.g.c. bus.

#### Sound Circuits

The sound signal developed across  $L_{101}$  in the picture detector stage is coupled through two stages of sound i.f. amplification,  $V_{101}$ , and  $V_{102}$ . Inter-stage coupling of these pentode circuits is effected by a single-tuned transformer,  $T_{101}$ , which is peaked at 4.5 mc. A ratio detector stage,  $V_{103}$

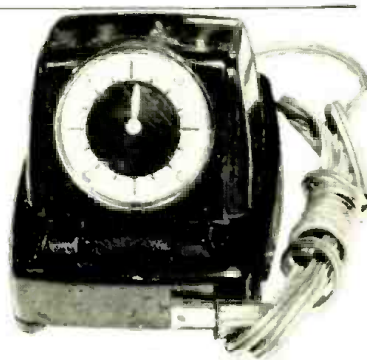
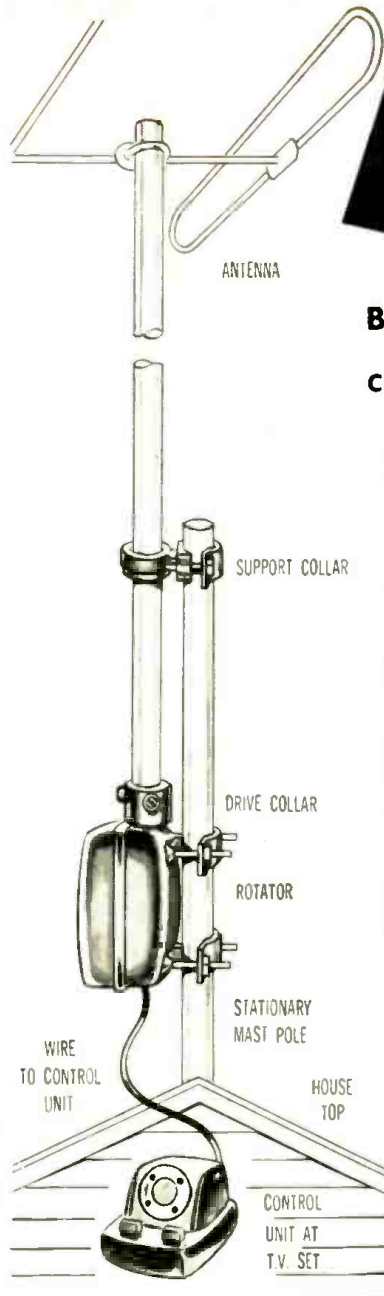

Control Unit

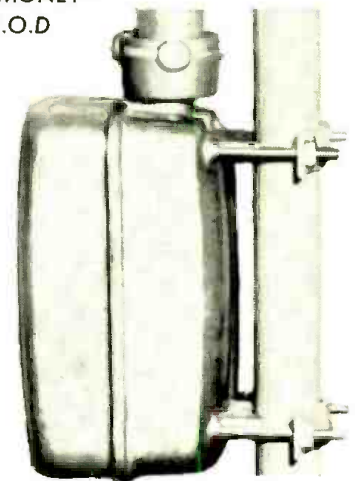

Rotator and Bearings

# LOOK

## BIGGEST BARGAIN IN T.V. TODAY

### CHECK THESE OUTSTANDING FEATURES

1. High starting torque—no slipping.
2. 370-degree rotation—get all T.V. signals
3. Surplus power—large or small antennas.
4. Outboard bearings—relieves wind load.
5. Sturdy compact construction—7 pounds.
6. Water-proof aluminum cover.
7. Finger-tip control unit—handsome finish.
8. Thirty feet 3 circuit weather proof lead wire.
9. Signal light indicates end of 370° rotation.
10. Easily installed—complete instructions—trouble free operation. Nationally advertised.

**COMPLETE OUTFIT—Rotator, Bearings, Control unit and wiring at GIVE-AWAY price.**

**Limited Supply—Order Today!**

First come—first served! This is the CHANCE of a LIFE-TIME close out. You must HURRY! Get your order in the mail today. Send no money. 10 days FREE TRIAL.

WAS \$39.95—NOW **\$16<sup>95</sup>**  
 GUARANTEED  
 10 DAY FREE TRIAL

SEND NO MONEY—  
 WE SHIP C.O.D.

**ORDER TODAY • DIRECT FROM  
 K. W. SALES CO.  
 BOX 1212, TIPTON, INDIANA**



# HERE IT IS!



Complete, up-to-date listings, illustrations, and descriptions of ERIE Electronic components are contained in the new ERIE CATALOG D-53.

This catalog assembles all the new items introduced since publication of our last catalog together with the long-time standard numbers.

Ask for it at your Distributors, or write Dept. B for your copy.



ERIE RESISTOR CORPORATION . . . ELECTRONICS DIVISION  
Main Offices ERIE, PA.  
Sales Offices: Cliffside, N. J. • Philadelphia, Pa. • Buffalo, N. Y. • Chicago, Ill.  
Detroit, Mich. • Cincinnati, Ohio • Los Angeles, Calif.  
Factories: ERIE, PA. • LONDON, ENGLAND • TORONTO, CANADA

(a type 6AL5), follows the sound i.f. amplifiers.

A six-position function switch,  $S_{101}$ , is connected into the output of  $V_{103}$  and provides three positions of tone for both television and phonograph operation. In the phonograph position, the kinescope is disabled by removing the heater and first anode voltages. Further sound amplification is provided by  $V_{101}$  and  $V_{105}$ .

To facilitate the servicing of the KCS-82 chassis the schematic diagram (Fig. 5) includes d.c. voltage readings at tube pins and other points in the circuit. The voltage measurements are made with a v.t.v.m. with zero signal input to the receiver.

### Alignment Procedure

Refer to Table 1, steps 1 through 9, for the alignment procedure for the video i.f. stages.

Steps 1 through 6 are to be followed preliminary to alignment with a sweep generator. When using the sweep generator, keep the leads as short as possible. There should not be more than one inch of unshielded lead at the end of the sweep cable. Connect the sweep ground lead to the r.f. unit outer shield. Complete the procedure below, and then go to step 7 in Table 1.

- Set the channel selector switch to Channel 4.
- Clip 330-ohm resistors across terminals "A" and "B" of  $T_{107}$  and  $T_{108}$ .
- Preset condenser  $C_{110}$  to minimum capacity.
- Insert a -5 volt bias at the junction of  $R_{117}$  and  $R_{118}$ . Set the a.g.c. control fully clockwise.
- Connect a 180-ohm composition resistor from pin 5 of  $V_{106}$  to terminal "A" of  $T_{106}$ .
- Couple a signal generator loosely to the oscilloscope diode probe to obtain markers.

30

there must be a reason that more

**QUIETROLE**  
TRADE MARK REG. U.S. PAT. OFF.  
is being SOLD!\*

More Servicemen are finding that only QUIETROLE, the original, non-conductive, non-inflammable Lubri-Cleaner will assure positive quietness to noisy TV and radio controls and switches. It does so much, yet, costs so little.

Carried by leading jobbers everywhere!

manufactured by

**QUIETROLE COMPANY**  
Spartanburg, South Carolina

**!!POWERFUL ALNICO MAGNETS!!** . . . "U" TYPE for Wire or Tape Erase: Sskr. or Phones—49c

BAR MAGNET (3/4x3/8x1/4) . . . pol. . . ea. 39c 12/4.00  
ROUND BAR (1 1/4x5/80.D.) . . . pol. . . ea. 69c 6/3.50  
ALNICO "CHIP" MAGNETS . . . sm. irreg. shapes. Approx. 90 pins/oz. . . 15c oz. \$1.50 lb.

ALNICO MAGNET KIT . . . Powerful Bar, Block, etc. . . Kit of 10 asstd. . . . . 1.98  
(WRITE FOR LATEST "ALNICO" SUPPLEMENT)

**AC-DC BLOWER** (Deleco)—approx. 25 CFM, 5-100 RPM, 27-30V. Bakelite housed firm (4 1/2x6") . . . . . **7.95**

**MOULDED BAKELITE CONDENSERS** (Micanoid)  
100 asstd. 20mmf.-2mf. 200-600V—50asstd.—1.98

**CARBON RESISTORS** . . . 1/3-2W. 100 asstd. . . . 1.98

**ELECTROLYTICS**, Inc. multi-sect: 150-450V—8asstd. 1.98

**RADIO HARDWARE TREASURE** . . . FULL L.H. CAN of: Nuts, Screws, Washers, Lugs, etc. . . 89c 3 lbs/2.49

**POTENTIOMETERS**, V.W. & carb. to Integ—6 asstd. 1.49

**ROTARY SELECTOR SWITCHES**, incl. multi-deck, 1/2" shafts. Kit of 6 asstd. . . . . 1.75

**EXPERIMENTAL TUBES** for Test. Research. Fil. tested. Kit of 40 asstd. revq. types . . . . 1.98

---

**!!SUPER \$\$\$ SAVINGS!!** . . . with the New "JUMBO RADIO-ELECTRONICS PARTS KIT" . . . . .  
A "GOLD-MINE" of inventory odds & ends!  
**CONTROLS, SWITCHES, RESISTORS, CONDENSERS, SOCKETS, WIRE, COILS & MUCH MORE** (shppg. wt. 20 lbs.) . . . . . **\$3.95**

**HI-FI CRYSTAL HAND MIKE**—hi-imped., mounted bakelite case. 5 1/2 ft. cable . . . . . 3.95

**HEADPHONES**—sensitive Alnico powered. Low-imped. Adj. forks. 3 ft. lined cord. . . . . 2.29

**T-30 THROAT MIKE**—neckband+plug. . . . . 10/6.50

**EXT. CORD & SWITCH** for T-30. Less Pl. 68. 40c 10/4.50

**6V. FIL. TRANSFORMER** (2 1/2x3 1/4), 4 amps. . . . 1.75

**115V. AC ELECTROMAGNET**—6 oz. built. Cont. duty. 1" O.D. 3/8" . . . . . ea. 98c 6/5.00

**6V. AC-DC PLUNGER SOLENOID** 1 1/2" O.D. X 1 1/2" travel . . . . . ea. 98c 6/5.00

**G-E PLATE RELAY** (C12791-B100P30) SPDT. 10K ohm coil. 5ma. . . . . ea. \$1.29 10/10.00

**18V. DYNAMOTOR** (Pioneer Gen-2 Motor SR2669). 450VDC, 50ma. Less end caps. . . . 3.95

**1N21 CRYSTAL DIODES** . . . . . ea. 69c 10/6.50

**PL54 JK26 CONNECTORS** . . . . . set 39c 10/3.50

**32 P.E. MAGNET WIRE**—12 oz. spool . . . . . 98

**21CET MAGNET WIRE**—50 ft. . . . . 1.29 100ft/1.98

**"KINKLESS" SUPER FLEXIBLE BRAID WIRE** (32/40) WITH STANDS CDMT. BENDING & TWISTING. Cotton core; outside silk braid—20ft/98c 100ft/3.75

---

**"DIRECT FACTORY SPEAKER REPAIRS SINCE 1927"**  
Min. order \$3.00. 20% deposit req. on all C.O.D.'s. Please add sufficient postage—excess refunded.

**LEOTONE RADIO CORP.**  
67 Day Street  
New York 7, N. Y.

**ANSWERS TO QUIZ**  
(Page 68)

- 270 volts.
- First, there is a +135-volt line. This is obtained by a voltage-divider arrangement consisting of resistors (as distinguished from tubes). Second, there is a boost "B+" line. The value of this voltage is not given directly on the diagram but it can be approximated by noting that pin No. 10 of the picture tube has a voltage of +415 volts. The boost "B+" value is higher than this, possibly on the order of 450 to 470 volts.
- A. 270-volt line; B. 270-volt line; C. 135-volt line; D. Boost "B+" line; E. 270-volt line; and F. No "B+" line, of course, since the ratio detector requires no "B+."
- Horizontal sweep oscillator, vertical sweep oscillator, and picture tube.
- No.

**EDITOR'S NOTE:** Our sole purpose in presenting this quiz in conjunction with a feature article is to help you in your service work. Whether or not we will continue this feature will depend on how you, the readers, react. Will you drop us a line and let us know what you think of this idea?

**The Monimeter**  
(Continued from page 47)

method by which a small tubular "A" battery may be easily mounted. An ordinary hose clamp is centered just forward of the lower front edge of the "B" battery. Tightening the adjustable clamp screw holds the battery firmly in place.

The 22.5 volt "B" battery is held in position by a thin metal strip, 1/2" wide, placed at the center of the battery. Both "B" leads are guided to their terminating points on the underside of the chassis through small rubber grommets.

Note that bandset condenser,  $C_2$ , is mounted across the coil socket prongs with its adjusting screw facing outward. A 1/2" hole is drilled through the bottom plate opposite the screw slot and lined with a snug fitting rubber grommet. By laying the cabinet on its side,  $C_2$  may be varied with an insulated rod. This eliminates the usual procedure of removing the front panel-chassis assembly each time an adjustment becomes necessary.

A 3 1/2" chrome-finished carrying handle centered on the top of the cabinet and four rubber cushioning feet fastened to the bottom corners complete the unit's outward appearance.

**Coil Data**

Both windings are of #22 plain enameled wire, closewound, with 1/8" spacing between grid and plate coils. A 5-prong, 1 1/4" diameter coil form 2 1/2" long provides ample winding space.

$L_2$  has 6 turns wound on the lower part of the coil form.  $L_1$ , occupying the upper portion of the form, consists of 30 turns, tapped at the 17th turn from the grounded end for 7.0 mc. fundamental operation. This tap may be made easily by slightly spacing the 17th turn from the 16th and 18th, drilling a small hole in the coil form directly under the tapping point, soldering a lead to the tapping point, and terminating it at the proper prong.

No "pruning" of grid turns should be necessary if these specifications are followed. Inasmuch as bandset condenser  $C_2$  compensates for discrepancies in inductance by adding or subtracting capacity, the usual "cut and try" method is eliminated.

It is well to remember both coils must be wound in the same direction for oscillation to occur. The coil specifications of Fig. 2 should be followed closely, making certain all five coil leads are properly terminated.

**Calibration**

Perhaps the simplest method of calibration is to employ a receiver whose calibration is known to be accurate for the 3.5 mc. channel.

With the "Monimeter" turned on (Continued on page 116)

Don't Miss a One of the Exciting New

Developments in Electronics.

Keep Up Your Subscription to

**RADIO & TELEVISION NEWS**

Circulation Dept., 64 East Lake Street, Chicago 1, Ill.

**FIRST CHANGER**  
*Custom Engineered*

**for HIGH FIDELITY!**

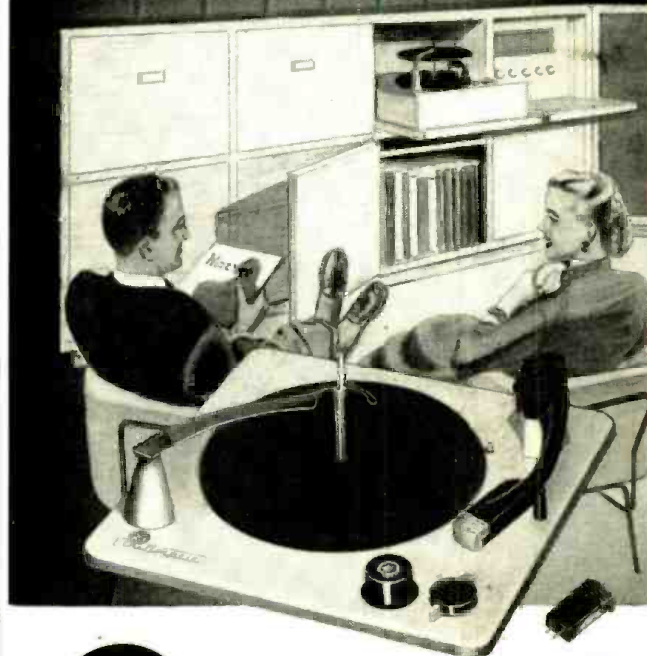

V-M 935HF Record Changer \$59.95  
"all the music is all you hear"

*triomatic*<sup>®</sup>  
**935HF HIGH FIDELITY  
RECORD CHANGER**

**Featuring:**

- Exclusive laminated turntable with precision-formed concentricity is mounted on new 3-ball thrust bearing!
- Exclusive 4-pole, 4-coil motor!
- Resonance-free aluminum die cast tone arm and two precision cast plug-in heads (less cartridges)!
- Gentle tri-o-matic spindle eliminates groove gripping record holders. Records are gently lowered to spindle shelf and flat, air-cushion dropped, silently to the turntable!
- V-M 45 Spindle included! (permits automatic play of up to 14 large center-hole records).
- Muting switch assures silent change cycle.

\*Slightly higher in West.

Send for complete details on this superb instrument. PLEASE MAIL COUPON for your copy of, "Bring Concert Halls Within Your Walls."

V-M Corporation, Benton Harbor 4, Mich.  
Please send illustrated folder, "Bring Concert Halls Within Your Walls," describing the V-M 935HF record changer.

Name.....  
Address.....  
City..... State.....



*Music Lovers*  
and  
*Professionals*  
RECOGNIZE THE  
INIMITABLE

MODEL 12A  
10 WATT



MODEL 10C4  
30 WATT

*Naturalness*  
IN SOUND  
REPRODUCTION



MODEL 7  
SELF-POWERED PRE-AMP

AFFORDED ONLY

BY

**BROOK**

HIGH QUALITY  
AUDIO AMPLIFIERS

Write today for complete technical data;  
also name of nearest dealer. Dept. RH-3

**BROOK ELECTRONICS, INC.**

*First in the High-Quality Audio Field Since 1934*  
34 DeHART PLACE, ELIZABETH, N. J.

and  $S_1$  in an open position, the dial may be set at the 90-division mark. The receiver dial is then set at 3500 kc.  $C_2$  is adjusted until the signal heard in the receiver is exactly zero beat with 3500 kc. A series of readings should be taken every 50 kc. ending with 4000 kc. The 4000 kc. reading will occur at approximately the 10-degree division mark on the "Monimeter" dial. Readings at 50 kc. intervals over the range 3500-4000 kc. represent 11 reference points. A calibration curve may now be drawn and intermediate frequencies determined by interpolation.

#### Operation

If the circuit and coil data of Fig. 2 have been carefully followed, no difficulty will be encountered. One should make sure that the front and rear panels are fastened securely and coil and tube remain firmly seated in their respective sockets.

$S_1$  in an open position allows fundamental 3.5 mc. operation by utilizing all grid coil turns.  $S_1$ , closed, furnishes fundamental operation on 7.0 mc. by shorting out approximately 56% of the coil turns. The ratio of capacity ( $C_1$ ) to inductance ( $L_1$ ) will determine the percentage of bandspread possible.  $C_2$  is a major factor in "spotting" the desired channel at any pre-set dial division.

With coil specifications as outlined and an extra stator plate added to  $C_1$ , a 90-degree dial spread is obtained over the 3500-4000 kc. range. Approximately 40 dial divisions cover the 7000-7300 kc. band.

All frequency measurements should be made with  $S_1$  open. Thus, the 3.5 mc. range is checked using the fundamental while 7.0 mc. readings employ the second harmonic.

Although specifically designed to cover only these two ranges, it is

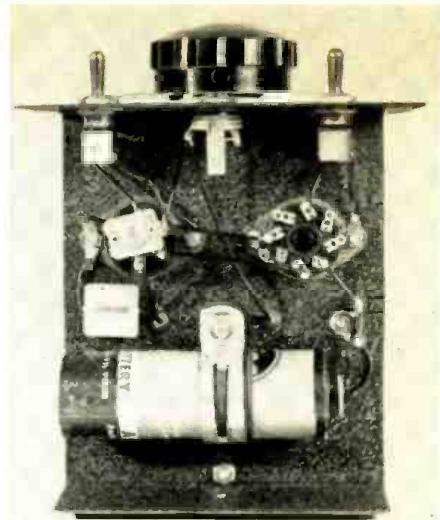

Fig. 3. Under-chassis view of "Monimeter." A glance shows the small investment in time and money for this operating convenience.

possible to check the 14-mc. and 28-mc. spectrum by employing harmonics of a higher order.

#### Conclusion

With stabilized, self-excited oscillators daily replacing or augmenting crystal-controlled units, a combination monitor-frequency meter will be found indispensable.

Properly constructed and calibrated, accurate frequency measurements may be made and one's signal critically examined. Familiarity with the "Monimeter" will suggest uses other than routine monitoring and frequency spotting.

As an additional construction incentive it would be well to remember that this station accessory never becomes obsolete. It will be found equally valuable whether one boasts a transmitted power input of a kilowatt or the smallest fraction thereof. —30—

TV set shipments to dealers by states for period 1946-1952 as reported by RTMA.

STATE	TOTAL	STATE	TOTAL
Alabama	156,268	Nebraska	139,479
Arizona	49,948	Nevada	581
Arkansas	36,893	New Hampshire	63,570
California	2,097,472	New Jersey	1,282,586
Colorado	100,571	New Mexico	20,406
Connecticut	445,902	New York	3,505,155
Delaware	77,200	North Carolina	255,067
District of Columbia	251,054	North Dakota	1380
Florida	200,495	Ohio	1,855,765
Georgia	279,827	Oklahoma	195,962
Idaho	2315	Oregon	46,872
Illinois	1,621,753	Pennsylvania	2,098,227
Indiana	582,977	Rhode Island	178,126
Iowa	247,251	South Carolina	59,907
Kansas	86,395	South Dakota	3673
Kentucky	242,375	Tennessee	194,736
Louisiana	141,818	Texas	607,640
Maine	22,769	Utah	89,691
Maryland	466,881	Vermont	13,787
Massachusetts	1,061,436	Virginia	305,390
Michigan	1,121,839	Washington	220,367
Minnesota	301,055	West Virginia	126,768
Mississippi	39,669	Wisconsin	359,147
Missouri	549,597	Wyoming	3065
Montana	1156		
		GRAND TOTAL 21,812,263	

**Mac's Service Shop**  
(Continued from page 63)

d.c. across the probes, and checked the condenser. Instantly a roaring grinding sound issued from the tracer speaker, indicating that the condenser was permitting surges of current to pass through it.

"Oh don't look so smug!" Barney exclaimed as he reached for the diagonal cutters. "How can this little condenser in the oscillator section cause that a.v.c. trouble?"

"If you would do more service manual thumbing and less test prod fumbling, as I keep trying to get you to do, you would know," Mac replied. "In this set the grid-leak of the oscillator section of the mixer tube returns to "B-minus" in the usual way, but the r.f. from the grid goes through that defective mica condenser and then through an oscillator coil winding to the a.v.c. bus. Now do you begin to see?"

"I think so," Barney said slowly. "The voltage developed on the oscillator grid across the grid-leak is fed through the partially-shortened condenser to the a.v.c. bus and so keeps the voltage there jacked up above normal, and that cuts down on the sensitivity of the set. On the other hand, when a strong station is being received, the high a.v.c. voltage that would normally be developed is shorted out partially through the low resistance path of the leaky condenser and the oscillator grid-leak. That allows the tubes to overload with the strong signal and produces the distortion. Check?"

"Check and double check!" Mac congratulated. "That's precisely the way it works. I'm beginning to believe there is hope for you after all."

"Gee, thanks!" Barney remarked wryly.

**SERVICE ACTIVITIES**

**T**HE Pennsylvania State Federation (FRSAP) at its April meeting went on record as endorsing the proposed Pennsylvania Licensing Bills HB-838 and HB-839 as a step toward correcting the ills in the servicing industry.

The group, representing affiliated chapters in Philadelphia, Chester, York, Williamsport, Pittsburgh, Altoona, Hollidaysburg, Scranton, Wilkes-Barre, and Harrisburg, also passed a resolution "condemning RTMA and NEDA for alleged opposition to the will of organized radio-TV technicians and service dealers in Pennsylvania."

**T**HE National Electronic Technician and Service Dealers Assn. (NETSDA) elected a new slate of officers at its three-day Eastern Conference held in Paterson, N. J.

Steps were taken to obtain a charter of incorporation for the national group.

Newly elected officers include: Roger K. Haines, president; David Van Nest, vice-president; John Wheaton, corresponding secretary; O. Capitelli, recording secretary; T. L. Clarkson, treasurer; Milan J. Krupa, sergeant-at-arms. Offices and headquarters are at 165 E. Broadway, New York.

-30-

**AT LAST! A Way to Check Flyback & Yoke Accurately... FAST!**



**NEW Lako "Q"-Tester**

only \$69.50

Model 400-A

**MONEY-BACK GUARANTEE**

Test flybacks, yokes, width coils, and linearity coils right in the set! And do it in minutes instead of hours! This sensational new Lako "Q"-Tester is today's greatest development in TV servicing . . . detects one shorted turn in a thousand . . . saves hours of wasted labor. Just one quick test shows comparative rating, tells whether part is good or bad. Ready to use, 110 v A.C., complete instructions included, 90-day factory warranty.

**ORDER NOW . . . MONEY-BACK GUARANTEE!** Full purchase price refunded if you are not fully satisfied within 10 days!

CLIP HERE . . . write name, address in margin . . . enclose check . . . mail to:

*Lako*

**LAKO COMPANY**  
ELECTRONICS DIVISION  
316 EAST TOWNSEND ST.  
MILWAUKEE 12, WISCONSIN

**SCHEMATICS—CONVERSIONS FOR SURPLUS GEAR**

**NEW LIST! MANY ADDITIONS!**

Send stamped, self addressed envelope for List C. Add 25c for chart explaining AN nomenclature.

R. E. BOX 1220  
GOODHEART BEVERLY HILLS, CAL.

**ANOTHER OUTSTANDING JOBBER RADIO PRODUCTS SALES CO.**

1237 - 16th St.  
Denver 2, Colorado

HAS THE SENSATIONAL NEW **EICO** 470-K 7" SCOPE KIT IN STOCK!

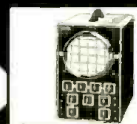

\$79.95



**GIFT...**

from America's most advanced Hi-Fi studios . . . Come in or write for your copy of "Sound Advice" by Irving Greene, 124 pages of vital Hi-Fi data . . . It's FREE!

**ASCO SOUND CORPORATION**  
115 WEST 45th STREET, NEW YORK 36



Let me show you how EASY it is to  
**LEARN TV**  
 the practical way --



ASSEMBLE A  
**TRANSVISION  
 TV KIT**

Pay as You Wire \$ **39**  
 Down Payment.

I WILL HELP YOU to start learning TV the practical way — by assembling a TRANSVISION TV KIT in EASY STAGES. For only \$39 you get PACKAGE #1 (standard first pkg. for all of our kits). This package gives you the BASIC CHASSIS and over 450 TV COMPONENTS with complete Instructions, Drawings, Photos, Service Booklet, and a year's subscription to my "TV and Electronics Notes". When ready, you order the next stage (pkg. #2), etc. Low prices make your complete kit a terrific buy!



**FREE CATALOG**

Shows 6 Great TV Kits:

EXCLUSIVE: Only Transvision TV Kits are adaptable to UNF. Ideal for FRINGE AREAS. No Previous Technical Knowledge required. Write now!

TRANSVISION, INC., Dept. RN7  
 NEW ROCHELLE, N. Y.

MAIL THIS COUPON TODAY

Mr. D. Gnessin, Educational Director  
 TRANSVISION, INC., NEW ROCHELLE, N. Y. Dept. RN7

I'm enclosing \$ \_\_\_\_\_ deposit. Send standard kit PACKAGE #1, with all Instruction Material. Balance C.O.D.

Send FREE copy of your new TV Kit Catalog.

Name \_\_\_\_\_  
 Address \_\_\_\_\_  
 City \_\_\_\_\_ State \_\_\_\_\_

Tremendous  
 Opportunities in  
**COIN TV**  
 and **COMMERCIAL TV**

TRANSVISION offers the only specially designed line of Coin-Operated and Commercial TV with the **PREVIEWER\* ATTACHMENT** (Pat. Pend.)

This field offers rich rewards to enterprising servicemen or dealers — on part time or full time basis.

\*The Electronic Previewer is a patented device which makes coin operation really pay off in a big way. Boosts revenue by "sampling" — by giving a short preview of TV programs to prospective customers. Works like magic in enticing sales.

Get details now.  
 TRANSVISION, INC.  
 NEW ROCHELLE, N. Y.



MAIL THIS COUPON TODAY

TRANSVISION, INC., NEW ROCHELLE, N. Y. Dept. RN7

Rush full details on COIN OPERATED TV.

Name \_\_\_\_\_  
 Address \_\_\_\_\_  
 City \_\_\_\_\_ State \_\_\_\_\_

# SERVICE HINTS ON RCA TV SETS

## 630TS SERIES

Foldover at right-hand side of picture.

This may be caused by a reduction in bias on the grid of the 6BG6 horizontal output tube. The grid resistor ( $R_{200}$ ) should be in the vicinity of 470,000 ohms. Replace if defective.

## 7T103 SERIES

Loss of sync and intermittent loss of high voltage.

This may be caused by a shorted or open damper tube ( $V_{113}$ , 6W4) heater winding in the power transformer. To check, use a 6-volt filament transformer instead of the damper tube winding. If this cures the trouble, remove the power transformer ( $T_{100}$ , RCA stock part #75508) and replace it.

## 9T57, 9T77, & 9T79 SERIES

Narrow vertical bars on left-hand side of raster.

This may result from internal corona or arcing within condenser  $C_{108}$  (4.7  $\mu$ fd.) in the plate circuit of  $V_{111}$  (the 6BG6 horizontal sweep output tube). See accompanying diagram. (This interfer-

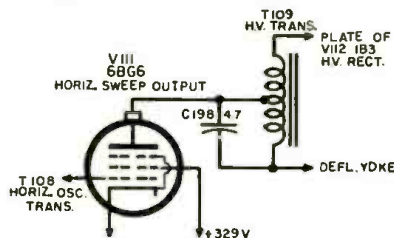

ence is similar to that caused by Barkhausen oscillations, and the normal preventative steps for such oscillations should be tried first, i.e., placing a magnet over the 6BG6, adjusting the drive, replacing the 6BG6, etc. If these are not effective, replace condenser  $C_{108}$ .)

## 17T153 SERIES

Vertical roll.

When the vertical hold control needs to be reset during the initial warm-up period and is operated

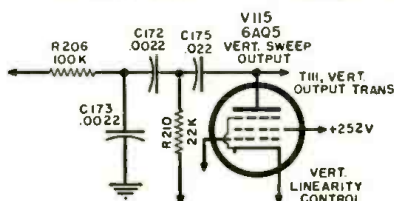

at the extreme clockwise position of its rotation, it indicates that condenser  $C_{112}$  (see diagram) has changed value with time and tem-

perature. This condenser should measure .0022  $\mu$ fd. If faulty, replace it with a 1000 v. oil-impregnated tubular paper condenser.

## 17T153 & 21T176 SERIES

Snowy picture.

Improper r.f. and i.f. bias may cause snow in the picture in medium field strength areas. This may be accompanied at times by extremely dark picture with strong signals.

The cause of improper bias may be leaky condensers in the a.g.c. circuit. To correct this, do the following:

1. Check electrolytic condensers  $C_{121}$  (2  $\mu$ fd.) and  $C_{118}$  (2  $\mu$ fd.).
2. When replacing either of these condensers, make certain that you observe the proper polarity since these are electrolytics.

## 21T159, 21T165, 21T176, 21T177, 21T178, & 21T179

Foldover or white bar in center of raster.

This may be due to low screen voltage on 6CD6, the horizontal sweep output tube ( $V_{111}$ ). Check the screen resistors  $R_{255}$  (8200 ohms) and  $R_{205}$  (8200 ohms). These may be open; replace if necessary.

Low brilliance and small picture.

This may be caused by a partially shorted width control coil. Check coil  $L_{100}$ , and replace with RCA stock part #76484 if defective.

Poor interlace.

This may be caused by coupling between the vertical and horizontal sweep circuits due to incorrect lead dress. To correct this, do the following:

1. Dress the red lead from the yoke socket to the high-voltage transformer under the lance on the side of the high-voltage cage.
2. Connect condenser  $C_{118}$  (.047  $\mu$ fd.) from pin 2 of  $V_{111}$  (6SN7 horizontal sweep oscillator) to ground, instead of from the nearby terminal board to ground.

## CHASSIS KCS68

Vertical sync instability.

This may be caused by reflected signals which reach the receiver out-of-phase with the direct signal from the TV station. The following changes are recommended in the sync separator stage to increase the vertical sync stability. See diagram. These changes will make the receiver slightly more sensitive to noise on weak signals.

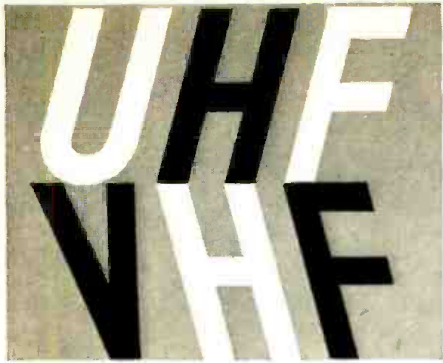

double purpose for double sales!

**JFD Lightning Arrester AT103**

protects UHF and VHF signals

For use with UHF or VHF tubular twin lead, the AT103 is the perfect tie-in for every antenna sale. And the exclusive JFD strain-relief lips that prevent contact washers from ripping the twin lead apart give you yet another sales-making feature. Write for bulletin #139. \*No. AT103 \$2.25, list.

\*Complete with stainless steel strap and aluminum ground wire.

JFD Manufacturing Co., Inc., Brooklyn 4, N. Y.

World's largest manufacturer of television antennas and accessories

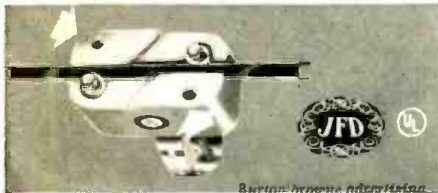

**New Guaranteed TUBES Standard Brands**

0A2	\$1.00	5BP1	4.50	801A	.39
0A3 VR75	1.10	5CP1	4.95	804	10.95
0B2	1.40	5C22	37.50	805	3.25
0C3 VR105	1.00	5D21	18.50	807	1.65
0D3 VR150	.90	5FP1	1.95	807W	9.95
1A3	1.00	5R42V	1.40	809	2.95
1B23	8.95	6ALS	1.75	811	2.90
1B24	9.50	6ANS	2.90	813	11.95
1B27	12.50	6AS6	2.30	814	2.95
1N21B	2.50	6BL6	99.50	828	9.95
1N22	1.25	6BM6	99.50	829	8.95
1N23	1.25	6F4	4.50	829B	9.95
1N23A	2.25	6I4	5.95	830	4.75
1N23B	3.25	6K4	3.50	832A	9.95
1N3A	1.75			836	3.45
1N3B	1.50			837	1.45
1N58A	1.25			849	29.50
1N63	2.15			851	39.50
1N69	4.85			852	19.95
2A515	4.25			860	4.50
2C39	19.95			861	19.95
2C40	7.25			864	1.50
2C42	19.95			872A	3.25
2C43	12.50			884	1.40
2C44	1.15			871A	5.50
2C46	19.95			994	.33
2C51	4.50	15E	1.75	955	.49
2C52	4.95	15R	.89	958A	2.69
2D21	4.95	FG17	3.95	958B	2.45
2D21W	2.49	FG32	12.95	1005	.69
2E22	1.95	FG95	22.00	1618	.90
2K22	7.25	FG104	24.50	1619	1.45
2K25	28.50	VT-127A	2.95	1625	.39
2K26	69.50	100TH	9.50	1626	.39
2K28	110.00	304TL	7.95	5635	8.95
2K29	23.95	250TH	16.50	5637	1.40
2K39	110.00	307A/RK75	4.25	5638	1.10
2K41	110.00	304TL	7.95	5639	8.95
2K45	110.00	310A	4.95	5644	4.25
2K48	99.50	3508	3.95	5645	8.95
3A4	299.50	393A	8.95	5646	8.95
3A5	1.25	394A	3.95	5651	2.75
3B23	4.95	417A	8.50	5654	2.00
3B24	4.75	446A	1.19	5670	4.30
3B24W	7.50	703A	4.50	5672	1.20
3B26	3.50	705A	1.50	5676	1.65
3B28	7.50	707B	14.95	5686	4.25
3BP1	4.95	715B	8.95	5687	4.25
3C22	72.50			5694	2.60
3C23	9.95			5702	3.50
3C24	1.50			5704	2.45
3C33	9.95			5718	8.95
3C45	14.95			5719	8.95
3CP1	3.95			5726	2.00
3E29	11.95			5744	1.95
3FP7	1.95			5749	2.25
3GP1	3.95			5814	2.50
3HP7	3.95			5844	4.50
3K23	299.50			8012	1.95
3K30	299.50			8015	4.95
4R24	6.95			8025A	4.95
4C35	22.00			9001	1.25
4-65A	17.50			9002	2.98
4-125A	25.00			9003	1.50
4X150A	22.50			9032	1.50
4X500A	85.00			9033	1.50
				9034	1.50
				9035	1.50
				9036	1.50
				9037	1.50
				9038	1.50
				9039	1.50
				9040	1.50
				9041	1.50
				9042	1.50
				9043	1.50
				9044	1.50
				9045	1.50
				9046	1.50
				9047	1.50
				9048	1.50
				9049	1.50
				9050	1.50
				9051	1.50
				9052	1.50
				9053	1.50
				9054	1.50
				9055	1.50
				9056	1.50
				9057	1.50
				9058	1.50
				9059	1.50
				9060	1.50
				9061	1.50
				9062	1.50
				9063	1.50
				9064	1.50
				9065	1.50
				9066	1.50
				9067	1.50
				9068	1.50
				9069	1.50
				9070	1.50
				9071	1.50
				9072	1.50
				9073	1.50
				9074	1.50
				9075	1.50
				9076	1.50
				9077	1.50
				9078	1.50
				9079	1.50
				9080	1.50
				9081	1.50
				9082	1.50
				9083	1.50
				9084	1.50
				9085	1.50
				9086	1.50
				9087	1.50
				9088	1.50
				9089	1.50
				9090	1.50
				9091	1.50
				9092	1.50
				9093	1.50
				9094	1.50
				9095	1.50
				9096	1.50
				9097	1.50
				9098	1.50
				9099	1.50
				9100	1.50

**WE PAY HIGHEST PRICES FOR YOUR SURPLUS!**

**Vacuum Capacitors**  
50-15 \$5.95  
50-32 \$12.50  
12-32 10.00  
100-20 14.50

**Jsh ELECTRONICS**  
Dept. R-23  
7552 Melrose Ave.  
Los Angeles 46, California

1. Change resistor  $R_{115}$  (220,000 ohms) to 1 meg.,  $\frac{1}{2}$  w.,  $\pm 10\%$ .
2. Change resistor  $R_{116}$  (8.2 meg.) to 3.9 meg.,  $\frac{1}{2}$  w.,  $\pm 10\%$ .

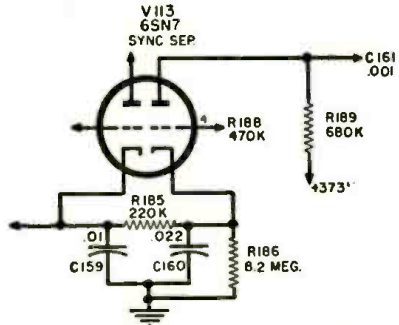

3. Change resistor  $R_{110}$  (680,000 ohms) to 22,000 ohms,  $\frac{1}{2}$  w.,  $\pm 10\%$ .
4. Change condenser  $C_{110}$  (.022  $\mu$ f.) to .056  $\mu$ f., 400 v.
5. Add a 100- $\mu$ f. condenser from pin 4 of  $V_{113}$  (6SN7 sync separator) to ground.

**ALL SETS**

**Erratic station tuning.**  
When TV station tuning varies, depending on the direction of approach of the channel selector switch, it indicates that there is variation in inductance during the switch operation. This may be the result of loose wafer switch contacts which cause the compression and expansion of the coils mounted on the switch when tuning. The loose contacts may result from excessive heat, applied during soldering, melting the wax on the wafer and loosening the switch terminals on which the inductances are mounted. When repairing r.f. units, care should be exercised not to overheat the oscillator switch wafer as this will cause the damage described. Repair by replacing the wafer.

**ALL SETS**

**High-voltage arc at picture tube.**  
This condition may occur in humid weather when there is a collection of dust and moisture around the bell of metal cone picture tubes. The following procedure will eliminate this trouble:

1. Remove the entire coating on the glass bell using methanol or acetone.
2. Wash the glass bell thoroughly with a good detergent.
3. Dry the glass bell thoroughly.
4. Apply a good coating of Johnson's "Car-Plate." Allow to dry, then wipe off the white residue.

**ALL SETS USING 17CP4, 17QP4, & 21AP4 PICTURE TUBES**

**Poor focus.**  
Poor focus in these sets may be due to magnetization of parts of the picture tube electron gun. To demagnetize these tubes, connect an electromagnetic focus coil to

Now... **INSURE BEST RECEPTION**  
with the  
**FINEST TV CHASSIS EVER DESIGNED**  
**TRANSVISION**  
**630 De Luxe**  
TYPE  
TV CHASSIS  
with High-Fidelity Sound  
Mfr. licensed under RCA patents

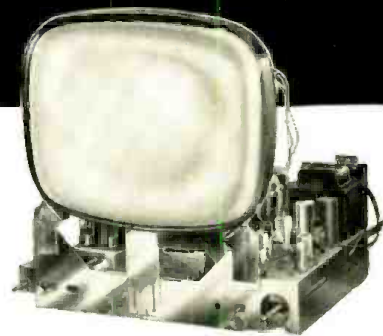

Embodies the latest and finest improvements, notably:

- Super Fringe Area Circuit
- Redesigned for Peak UHF Performance
- Hi-Fidelity Push-Pull Audio (40-13,000 Cycles)
- 12" Hi-Fidelity Speaker

**\$139**  
net  
Plus 10% Fed. Tax  
**CRT EXTRA**

In this space we can mention only a few of the other great features of this De Luxe Chassis: 31 tubes (28 tubes, 3 rectifier tubes plus CRT in a kee... 32 tubes)... Only Sprague "Black Beauty" Molded Condensers used throughout... Allen Bradley and IRC RESISTORS... Handles up to 24" picture tube... Layout of most efficient type for ease of servicing... Carries standard RMA Guarantee... The choice of those who want the finest in chassis.

**CABINETS:** For details on Transvision's famous beautiful line of TV cabinets, write for information on Agent's Program.

**1 YEAR GUARANTEE ON CRTs**

17" Rectangular Glass CRT	net \$22.25
20" Rectangular Glass CRT	net \$31.95
21" Rectangular Glass CRT	net \$36.95

Order direct from factory:  
**TRANSVISION INC., New Rochelle, N. Y.**

FREE: Sample copy of "TV and Electronics Notes." Or send 50c for year's subscription.

**MONEY-BACK GUARANTEE:**

10-DAY TRIAL: Buy and try the Transvision 630 Type De Luxe Chassis for 10 days. Then, if you wish, you may return it. Your purchase price less 10% (our cost of handling and re-packing) will be promptly refunded.

Ask for  
**FREE**  
Circuit and  
Technical  
Data

**TRANSVISION, INC.**  
DEPT. RN-630 NEW ROCHELLE, N. Y.

( ) Send me 630 Circuit and Technical Data.  
( ) Enclosed find \$\_\_\_\_\_ deposit. Balance C.O.D. Ship \_\_\_\_\_ chassis. \_\_\_\_\_ CRTs.  
( ) Enclosed find \$\_\_\_\_\_ in full. I accept your 10 Day Trial terms.

Name \_\_\_\_\_  
Address \_\_\_\_\_  
City \_\_\_\_\_ State \_\_\_\_\_



## PE-101C DYNAMOTOR

6 or 12 Volt



(Reprints of original CQ conversion articles — Oct. and Dec., 1952 issues, furnished.)

• This is the Dynamotor the Hams have been talking about! Easily adapted to supply 625 V. @ 150 MA. and 325 V. 125 MA. at 12 Volts—or 300 V. 90 MA. and 160 V. 110 MA. at 6 Volts. (Illustration shows modified.) NEW: \$1.95

### TELEPHONE WIRE

3 Conductor, copper & steel, 525 ft. ....\$1.75

## ANTENNA EQUIPMENT

### MAST BASES—INSULATED:

MP-132 BASE—Illustrated at left—1" heavy coil spring, 2" insulator. Overall length: 11½". Weight: 2¾ lbs. Price .....\$3.95

MP-S-33 BASE—Insulated type with heavy coil spring and 5" dia. insulator. Requires 2" hole for mounting. Weight: 9 lbs. ....\$5.95

### MAST SECTIONS FOR ABOVE BASES

Tubular steel, copper coated, painted, in 3 ft. sections, screw-in type, MS-53 can be used to make any length with MS-52-51-50-49 for taper. Any section. ....50c Each Larger Diameter Section: MS-54 .....\$1.25

## DYNAMOTORS

DYNAMOTOR and BLOWER: 9 Volts DC input; output 450 Volts 60 MA. 4500 RPM. At 6 Volts DC input; output 260 Volts 65 MA. 3000 RPM. Price .....\$4.95

INPUT:	OUTPUT:	STOCK No.:	PRICE:
12 V. DC.	220 V. 70 MA.	DM-24	\$ 6.95
14 V. DC.	330 V. 135 MA.	DM-330	7.95
14 V. DC.	500 V. 500 MA.	PE-59	14.95
12 V. DC.	250 V. 50 MA.	DM-25	8.95
12 or 24 V. DC.	500 V. 50 MA.	USA /0515	3.95

TRANSFORMERS—110 V. 60 CYCLE PRIMARIES:  
5 Volt CT-25A—10,000 V. Ins. OPEN FRAME—6" x 5" x 3½" .....\$7.95  
6.3 V. 1 Amp. ....1.25 24 V. 1 Amp. ....1.95  
24 V. ½ Amp. ....1.50 24 V. 6.5 Amp. ....5.95  
G-24—or 30 Volt 8 Amp .....5.95

Address Dept. RN • Minimum Order \$5.00 • Prices F.O.B., Lima, O. • 25% Deposit on C.O.D. Orders

# FAIR RADIO SALES

132 SOUTH MAIN ST.  
LIMA, OHIO

# RADIO ANTENNA

## Center Loaded

The Original Designed  
by Premax for

# MOBILE RIGS

The Antenna that gives better signal and reception, enabling you to cover greater distances.

Available for 10 to 75 meters, with special coils for C.A.P., Airport, Civil Defense and Marine.

Send today for Bulletin and prices of Premax Mobile Antennas and Mountings.

## PREMAX PRODUCTS

DIVISION CHISHOLM-RYDER CO., INC.

5304 HIGHLAND AVE., NIAGARA FALLS, N. Y.

## RECEIVER AND TRANSMITTER

RECEIVER BC-229 or 429—TRF Receiver with 3 Plug-in Coils to cover Freq. Range 201 to 398, 2500—4700, 4150—7700 KC. With 6 Tubes: 1/37—1/38—3/39. Power Supply required. 6 or 12 Volt & 250 Volts. Size: 16"x8"x7". Schematic included. ....\$8.95

TRANSMITTER BC-230—Voice modulated Trans. with 5 Plug-in Coils to cover Freq. Range 2500 to 7700 KC. With 4 Tubes: 2/109—2/35 & RF Meter 0-1.5 Amps. Power Supply required. 6 or 12 Volt & 350 Volts. Size: 13"x8"x7". Schematic included. ....\$8.95

SPECIAL BUY—BOTH RECEIVER AND TRANSMITTER .....\$15.00

## BLOWERS—115 VAC 60 CYCLE



SINGLE TYPE: (Illustrated at left) 100 CFM, 2½" intake, 2" outlet. Complete size: 5" x 6". Order No. IC839 .....\$8.95

DUAL TYPE: 100 CFM, 4" intake, 2" Dis. Each Side. Complete size: 8" x 6". Order No. IC880 .....\$13.95

COMPACT TYPE: 108 CFM. Motor built inside squirrel case. 4½" intake; 3¾" x 3" Dis. Complete size: 4¼" W x 8¾" H x 8¼" D. Order No. 2C067 .....\$11.50

FLANGE TYPE: 140 CFM, 3½" intake; 2½" Dis. Complete size: 7½" W x 7¼" H x 6¾" D. Order No. IC807 .....\$13.95

FLANGE TWIN: 275 CFM, 4½" intake; 3¾" x 3" Dis. Complete size: 11¾" W x 8¾" H x 8-1/16" D. Order No. 2C069 .....\$21.95

## POWER SUPPLIES

VIBRATOR TYPE—6 Volt DC input; output 230 Volt DC 50 MA.—not filtered—w/Tube. Ideal for Command Receiver operation as receiver is filtered internally. Size: 4½" x 4¼" x 3½" .....\$5.95

## BATTERY SWITCHING UNIT and METER

Used to switch load from one battery to another—or 6 to 12 Volts. Contains Weston 2" Meter—0-15 Volt DC Scale for reading battery voltage. 20 Amp DPDT Switch and Indicator. Case size: 4" x 8¼" x 2¾" NEW: \$2.95

117 volts a.c. and pass the coil slowly over the neck of the picture tube past the electron gun, and then slowly withdraw it. If such a coil is not available, any electromagnetic coil capable of withstanding 117 volts a.c. may be used.

## UNUSUAL TV TROUBLE

By RICHARD BLITZER

Tele-Video Associates

THE television technician can usually determine, by observing sound, picture, and raster, just what circuit is to blame for faulty receiver operation. However, every now and then a difficulty arises which results in very peculiar symptoms being exhibited in seemingly independent circuits. Here is one that the writer encountered recently.

The symptom: Sound perfectly normal, picture present but out of sync horizontally and vertically. This particular set was a Crosley Model 9-407, but the circuit, as shown in Fig. 1, is common to many other sets.

All suspected tubes associated with the sync section were replaced without success. An oscilloscope showed good video signal at the plate of the video amplifier, as indicated on the schematic diagram, and also at the cathode of the d.c. restorer tube (D.C.R. on the diagram). No sync pulses were observed at the plate of the D.C.R. tube. An ohmmeter indicated that R<sub>1</sub> was normal and C<sub>1</sub> not shorted.

A d.c. voltmeter showed that the cathode of the d.c. restorer tube was +50 volts. Condensers C<sub>2</sub> and C<sub>3</sub> were checked on the ohmmeter but exhibited no symptoms of shorts or leakages. As an additional check, the voltage on the cathode of the d.c. restorer tube was measured while C<sub>2</sub> and C<sub>3</sub> were disconnected. The cathode still had +50 volts on it.

The only source of the positive voltage to the d.c. restorer cathode was the grid of the picture tube. With the CRT's base plug disconnected, the ohmmeter read 500,000 ohms between base pins 2 and 11, the grid and cathode.

This leakage between the grid and cathode of the picture tube allowed the positive d.c. voltage of the brightness control to reach the d.c. restorer cathode. The d.c. restorer stage was thus biased with a positive cathode and could not conduct. As a result, no sync pulses were permitted to leave the d.c. restorer stage and reach the horizontal and vertical circuits.

Replacing the picture tube cured the trouble completely.

Fig. 1. Partial schematic of Crosley 9-407.

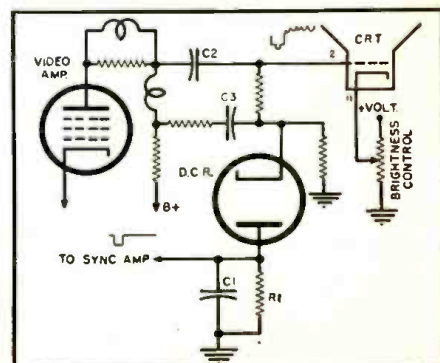

# !!WANTED!!

In order to supply government and industrial requirements, we are paying top dollar for all types of radio and electronic surplus. We specialize in test equipment and complete radios, such as:

APA, APN, APQ, APR, APS, APT, ARB, ARC, ARN, ART, ATC, BC, DY, I, IE, LM, MG, PE, PU, SCR, TCS, TN, TS, and many others.

WE ESPECIALLY NEED: APA10, APN9, APR4, APS4, ARC1, ARC3, ART13, ATC, BC221, BC342, BC348, BC611, BC721, DY12, DY17, I100, LM10 to LM18, MG149F, MG149H, PUI4, R5/ARN7, R5A/ARN7, SCR718C, TCS, TN16, TN17, TN18, TN19, TN54, TS3, TS13/AP, TS33, TS35, TS45, TS75, TS76, TS102, TS147/UP, TS148/UP, TS173, TS174, TS175, TS250, TS251, TS323, (ICT, IF, IG, 5CT, 5DG, 5F, 5G, 6DG, 6G 115V. 60 c.p.s. Selsyns), and all types of Hewlett Packard, General Radio Co., Measurements Corp., Boonton Radio, Ferris, Leeds & Northrup, and other test equipment.

Please state accurate description, condition, and your lowest price. Explain modifications, if any. We pay freight charges.

PURCHASING AGENTS, ENGINEERS, EXPORTERS, INDUSTRIAL BUYERS, DEALERS, AND INDIVIDUALS, Please send us your requirements.

New Catalog Now Available

# PHOTOCON SALES

417 N. Foothill Blvd.  
Pasadena 8, California

SYcamore 2-4131  
RYan 1-6751



**10-Meter Mobile for CD**  
(Continued from page 53)

case pin 8 of the power plug can be grounded. The metering jack,  $J_2$ , which is insulated from the chassis in this transmitter, might not have to be insulated with some other power-supply arrangement.

The shape and size of the chassis base are determined mainly by the size of the larger components and the available space in the car. The chassis shown measures 4" x 7½" x 1½" and was home-made from a piece of scrap aluminum. No dust cover was made because the unit was mounted at the back of the glove compartment.

The initial adjustments and tests are made with an a.c.-operated, 150-volt power supply. Connect the transmitter power plug to the power supply as follows: pins 1 and 8 to ground, pin 2 to 6.3 volts (with the other side of the 6.3-volt output grounded), and pin 3 to "B-plus." Wedge the relay contacts shut with toothpicks (as they will not close on a.c.) and turn on the power. Connect a v.t.v.m. in series with an r.f. choke to the grid of the 6V6GT doubler-final and tune the oscillator trimmer,  $C_1$ , for a maximum indication, which should be about -45 volts. Then, for maximum dependability, shift  $C_1$  slightly toward the high-frequency side of resonance. Next, plug a 0-1 ma. meter into  $J_2$  and adjust  $C_2$  for a minimum indication which will be approximately 20 ma. (Full scale deflection on the meter is 50 ma. with shunt  $R_1$  in place.) A 150-ma. pilot lamp is next connected to the antenna jack and  $C_3$  adjusted for maximum brilliance. Change the setting of  $C_3$  slightly to compensate for any changes in reflected impedance.

The TVI trap is adjusted by tuning a nearby TV set to a channel most susceptible to interference, usually Channel 2, and adjusting  $C_4$  for minimum interference. This adjustment is critical and should be made carefully. If a bottom plate is used it should be in place and the adjustment made through a small hole drilled in it.

After installation in the car it will be necessary to touch up the adjustments of  $C_2$  and  $C_3$  with the aid of a field-strength meter.

Noise limiters are essential in mobile communications and Figs. 2B and 2C show the "before" and "after" circuits of a typical second detector circuit to which a shunt type noise limiter has been added. The clipping level is automatically adjusted by the a.v.c. voltage to the strength of the incoming signal. In this installation the s.p.s.t. limiter switch was mounted on the bottom of the receiver case by a bracket. If it is necessary to extend the switch beyond the receiver be sure to use shielded leads.

The complete receiver modification involves very few parts and very little



**NEW-** THE *World Master* NATIONAL NC-SS

**WORLD-BEATING RECEIVER AT A WORLD-BEATING PRICE!**

For shortwave listeners and amateurs, here's a receiver that tops them all for value! Compare these features: ① Calibrated bandspread for 80, 40, 20, 15 and 10 meter bands (large 6" indirectly-lighted lucite scales), ② Advanced A.C. superhet circuit uses 8 high gain miniature tubes plus rectifier, ③ covers 540 kcs. to 40 mcs. in 4 bands, ④ tuned R.F.

stage, ⑤ two I.F. stages, ⑥ 2 high-fidelity audio stages with phono input and 2-position tone control, ⑦ built-in speaker, ⑧ antenna trimmer, ⑨ separate high frequency oscillator ⑩ Sensitivity control, ⑪ series valve noise limiter, ⑫ delayed A.V.C. ⑬ headphone jack, ⑭ standby-receive switch . . . And all this for only \$119.95

for radio's crowning achievements



**National**

National Company, Inc., Malden, Mass.



**SAVE \$\$—HOT SUMMER BUYS—SAVE \$\$**

- HERE'S ANSWER TO LOW ANGLE PROBLEM  
20-40 METER GROUND PLANE ANTENNAS ARE PRACTICAL USING OUR LIGHTWEIGHT MOLYB-GENIUM STEEL WHIPS. COPPER PLATED with baked paint finish, threaded tapered sections, standard 3/8 stud on bottom.  
Five 16-ft. elements suitable for 20 meter ground plane, complete kit . . . \$22.50  
32-Foot VERTICAL WHIP . . . . . 5.75
- FOR MOBILEERS  
LIGHTWEIGHT SECTIONAL WHIPS, easily demountable to prevent pilferage. fits std. car mounts.  
8-footer, \$3.75 12-footer, \$4.95 16-footer, \$ 6.95  
CENTER LOADING COILS FOR ALL TYPES . . . 3.50
- GRAND NEW DYNAMOTORS  
6 VOLT INPUT, 180V/225 ma. output . . . . \$ 9.95  
6 VOLT INPUT, 350V/150 ma. output . . . . 9.95  
6 VOLT INPUT, 500V/175 ma. output . . . . 14.95  
12/24 VOLT INPUT, 350V/225 ma. output . . 11.95  
12/24 VOLT INPUT, 625V/175 ma. output . . 12.95  
12 VOLT INPUT VIBRATOR-PAC, for operation in new model cars w/12 volt bat. del. 250V/40 ma. . . . . 7.95
- 6 VOLT INPUT, 250V/50 ma. output, PM field requires low battery current . . . . 6.95
- PE 101-C DYNAMOTORS, brand new in original cartons, operates on 6, 12, 24 volt input, special . . . . . 4.45  
DITTO, with outtown embelish. . . . . 4.95  
DITTO, CONVERTED, ready to install . . . . 7.95
- COMPACT 50 AMPERE CONTACTORS, for 6-12-24 volt operation, efficient remote control . . . . . 3.45
- EVEREADY #467, 67½V. B battery for portables, outdated but good as new, stock up at spec. . . . . 1.95

**Best TV Buy You've Ever Seen!**

TRULY LIFE SIZE PICTURE • AUTOMATIC BEAM SUPPRESSOR • FLAT VIEWING SCREEN • FULL FOCUS • BUILT-IN ANTENNA • HIGH-FIDELITY SOUND SYSTEM • AUTOMATIC GAIN CONTROL • NEW IMPROVED PROTELGRAM (ADVANCED SCHMIDT) BIG-PICTURE SYSTEM DEVELOPED BY PHILIPS, WORLD FAMOUS ELECTRONICS LEADER • 23 TUBES PLUS 1 GERMANIUM DIODE • STANDARD TOP QUALITY COMPONENTS, INCLUDING "STANDARD COIL" TUNER • FULL SIZE CONSOLE—40½" HIGH, 25" WIDE, 21" DEEP • SHIPPING WT.: 124 LBS.

**GUARANTEED BRAND NEW!**

SHIPPED IN ORIGINAL FACTORY SEALED CONTAINER, **\$179.50**  
Our Price, Only . . . . . Complete  
Original List Price . . . . . \$399.95

LINK & BOSCH MOBILE POLICE RECEIVERS, 5 tubes (RF stage) used tunable 2-3 mc. adj. switch control, w/6 volt power supply, 250V/100 ma. IDEAL Ham, C. D. MAHS & MACHINE services. Makes hot recvr w/RF converter, used operating cond. With new 5" PM apr. . . \$12.95

**ELECTRONIC SPECIALTY SUPPLY CO.**  
58 Walker Street, New York 13, New York



# HARVEY

The House  
of Audio



## THE ORIGINAL WILLIAMSON HR-15 AMPLIFIER KIT



The famous, original Williamson HR-15... still acclaimed the leader... in kit form, with the original Partridge output Transformer. Assemble this kit, and in 3 hours or less, enjoy the finest sound you ever heard. Operates from a tuner, phono-preamp, crystal pick-up, or other signal source. Absolute gain is 70.8 db with 20 db of feedback. Frequency response:  $\pm .5$  db, from 10 to 100,000 cps. Output impedances to match all speakers from 1.7 to 109 ohms. Kit is complete with 5 tubes (1-5V4, 2-6SN7, and 2-5881 (or 807 if requested), 2-Punched Chassis, 2-Resistor Mounting Strips, Sockets, Partridge WWFB Output Transformer, Assembly Instructions, and All Other Necessary Parts for Amplifier and Power Supply. \$76.50

HR-15 as above, but with Partridge CFB Output Transformers (hermetically sealed) \$90.00

PARTRIDGE OUTPUT TRANSFORMERS available separately. WWFB \$26.00 CFB \$40.00

NOTE: HR-15 and Kits may be had with British KT-66 Output tubes for \$3.00 additional.



## PARTRIDGE Audio Output Transformers

Famous in England for their use in the original design of the Williamson Amplifier, Partridge Output Transformers are now made available in this country in four different primary impedances for other amplifier applications. These transformers are built to the very highest standards and are intended for equipment reproducing the full audio bands with the lowest possible distortion. All Model CFB transformers are hermetically sealed and will withstand climatic extremes. Power rating is 60 watts from 30 to 30,000 cps with less than 1% distortion without negative feedback.

Secondary windings furnish outputs to match the following loads: .95, 3.8, 8.5, 15.2, etc., to 60 ohms. Dimensions: 5 1/2" x 5" x 5" high. Weight: 10 lbs. Each \$40.00

Specify Primary Impedance desired:  
4000, 5000, 10,000 or 12,000 ohms.



## ELDICO TR-75-TV TRANSMITTER KIT

This is an ideal unit for the novice. Very simple to assemble. New, revised circuit

to aid in the elimination of TVI. Uses 6L6 oscillator — 807 amplifier combination. Pi-network output. Husky power supply delivers 600 volts to the 807. Complete... including a punched chassis and shielded cabinet.

Unbelievably low priced at \$64.95  
MD-40 modulator kit for above \$49.95  
MD-40P as above but with power supply \$59.95

Visit the Harvey AUDIOTorium  
See, hear, and compare sound equipment from the largest selection available anywhere.

NOTE: Prices Net, F.O.B., N.Y.C.  
Subject to change without notice.



**Harvey**  
RADIO COMPANY, INC.

103 W. 43rd St., N. Y. 36, N. Y. • JU 2-1500

work, as evidenced from Fig. 2. An octal socket and three-prong Jones socket (S-303-AB) to match the connector on the converter are all that is needed for the power supply. There will be no difficulty involved in mounting the 1N34 diode and the 47,000-ohm and 180,000-ohm resistors for the

noise limiter circuit in most sets. Experience with this station has shown that an efficient mobile setup is possible with only a "glove-compartmentfull", instead of a "trunkfull", of equipment. Try it, and see for yourself.

-30-

# TRANSISTOR RECEIVER

By M. E. QUISENBERRY

Instrument Research Division  
National Advisory Committee on Aeronautics, Langley Laboratories

An interesting toy for the youngsters that will fascinate adults as well—a wristwatch "Dick Tracy"—type radio set.

IN ORDER to provide my young daughter and her friends with a small, sturdy, "Dick Tracy" type receiver, the unit described herewith was designed and constructed. As is usually the case with such projects "for the kids," the neighborhood fathers are monopolizing it pretty completely.

This subminiature receiver is molded in a block of clear plastic which is only about half as high as a cigarette lighter. Two standard miniature Ray-O-Vac penlight flashlight batteries fit into the clip on top and the earset lead and short antenna wire come out of the side.

Tuning is by means of the knob soldered to the adjusting screw of a standard padder condenser. It is turned off by inserting a small piece of plastic under one of the battery clips.

By clipping the antenna wire to any convenient "aerial" normally found around the home (radiator, metal frame of a floor lamp, clothesline, etc.) normal phone volume and adequate selectivity on local stations are obtained. To reduce volume on the more powerful local stations, the receiver is tuned off-frequency slightly.

The antenna feeds directly into a high "Q" Vari-Loopstick antenna coil which has the mounting base cut off and the slug cut down to work into the small space. The brass screw to

adjust the inductance of the coil is brought out the side below the tuning condenser as a range adjustment. The padder tuning condenser parallel-tunes this coil. The tuning condenser will tune the receiver from 1500 kc. down to about 750 kc. To tune below this point, turn the range adjustment screw in four or five turns. A pickup loop of from 30 to 50 turns is wound on the Loopstick form as near to the coil as possible and is fed into a 1N34 crystal detector. Over-coupling will lower the "Q" of the tuned Loopstick circuit. Too loose coupling will reduce sensitivity.

The signal from the detector circuit is capacity-coupled to the junction transistor audio amplifier through a small .25  $\mu$ fd. condenser. If space is available the value of the .25  $\mu$ fd. condenser should be increased to 2  $\mu$ fd. or more. The junction transistor is connected as a grounded-emitter circuit giving a relatively high input impedance. The value of  $R_2$  is chosen to give about 1 ma. in the collector circuit.

The entire unit can be fitted into the cardboard box in which ordinary "22" cartridges are packed or molded in Paraplex plastic, obtainable from chemical supply houses. The receiver can then be equipped with a strap and worn as a wrist-watch set if desired.

-30-

Circuit diagram of transistor receiver.

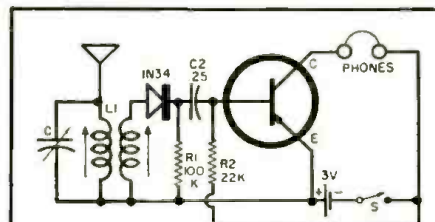

- $R_1$ —100,000 ohm, 1/4 w. res.
- $R_2$ —Approx. 22,000 ohm, 1/4 w. res.
- $C_1$ —100-525  $\mu$ fd. mica padder cond.
- $C_2$ —.25  $\mu$ fd., 200 v. cond. (see text)
- $S_1$ —See text
- $L_1$ —Modified "Vari-Loopstick" (see text)
- 1—1N34 crystal diode ("Detector")
- 1—Junction transistor (Raytheon CK-722)
- 2—Miniature penlight cells (Ray-O-Vac #716)
- 1—2000 ohm earphone

The plastic-encased miniature radio set.



## Radars Protects Fleet (Continued from page 35)

consistent operation over the maximum range under the most adverse conditions. Operation is on an approximate frequency of 3000 mc. The antenna is fed by a wave guide which may be seen in the photographs. This wave guide is fitted with a rotating joint at the antenna end.

Operation of the equipment requires relatively little training which makes it applicable for widespread use. Complexity in equipment for use by unskilled personnel would defeat its purpose.

A great many other electronic navigation safeguards are provided on a well-equipped boat such as this one. In this particular boat a 100-watt radiotelephone is provided for communication with other boats of the fleet, the Coast Guard, and shore stations. This equipment may be seen to the left of the radar unit in the photographs, with the transmitter on the bottom, and the receiver mounted on top.

The equipment is a *Fisherfone* "Captain" manufactured by the *Fisher Research Laboratories* of Palo Alto, California. The transmitter may be preset to any of five channels, with instant channel selection by means of a switch. A pilot light indicates which channel is in use.

The receiver may be preset to ten crystal-controlled channels or may be manually tuned for general coverage of the marine band. Push-to-talk operation is provided so that this equipment is almost as simple to use as an ordinary telephone. A restricted radiotelephone permit, which may be obtained by passing a very simple non-technical examination, is all that is required of the operator of this equipment.

A switch on the receiver selects either the built-in speaker or the receiver portion of the handset. In this manner conversations may be kept semi-private if desired.

A reserve 50-watt, four-channel radiotelephone transmitter-receiver, not shown in the photographs, is also provided for emergency use in case the main equipment fails. This equipment is manufactured by the *National Company* of Malden, Massachusetts.

To the right of the radar unit, and partially concealed by it, is a direction-finder receiver manufactured by *RCA*. This receiver, in conjunction with the loop antenna mounted on top of the wheelhouse, may be used to take bearings from radio stations and, by triangulation, the exact position of the boat may be plotted.

The large case mounted above this direction-finder, with the handwheel projecting below, is another direction-finder manufactured by *Bludworth*. As this unit is capable of tuning only to radio beacon stations, it is seldom used. It was installed by the U. S.



## SPECIAL BUYS!

### WHILE THEY LAST

300 ft. of 15 ohm coaxial cable.....\$9.95  
Attenuator—one cavity type..... 7.95



### BROADCAST BAND & AERO

Ideal for Use in Boats, etc.

MN-26-C Remote Controlled Navigational Direction Finder and communications receiver. Manual DF in any one of three freq. bands, 150 to 1500 KC. 24 V. Self contained dynamotor supply. Complete installation, including receiver, control box, loop, azimuth control, left-light indicator, plugs, loop transmission line and flex. shafts. .... \$89.50  
LIKE NEW..... \$69.50  
MN-26-Y 150 to 325 KC. 125 to 640 KC. 304 to 7 megacycles, compd. installation..... \$69.50  
Receiver alone..... 35.95  
MN-26-C alone, like new..... 39.50  
MN-26-C or MN-26-Y as is, less tubes..... 13.95  
With tubes, Used good..... 24.95  
MN-20-5 Loop, Brand New..... 6.95  
MN-52 Crank drive, New..... 2.50

### SCR-274N COMMAND and ARC-5 EQUIPMENT

	AS IS	E.C. USED (With tubes)	NEW
BC-450 Control Box (3 Receiver).....	\$1.95	\$3.95	\$3.95
BC-456 Modulator.....	\$2.95	4.95	
BC-451 Control Box (Transmitter).....	1.95	3.95	
BC-442 Relay Unit ANT With Condenser.....	3.95		
Without Condenser.....	1.29	2.95	
Flexible Shafting with Gear to all receivers.....		2.45	
3 Receiver Rack.....		2.29	2.98
2 Transmitter Rack.....		2.39	3.97
Single Transmitter Rack.....		2.25	2.95
DM-32 Dynamotor for Command Set.....		3.25	9.95
DM-33 Dynamotor for Command Set.....		2.95	3.95
Shock MTR. for 3 Receiver Rack, 2 Trans. Racks, Modulator or Ant. Relay Unit.....	1.95	2.45	

### WANTED!

All TS, APR, APS, ARC, ARN, ART, SCR, R89 and BC equipment—write today! Quote lowest prices in your first letter

RT 34 APS 13 Transceiver used as a full warning radar on 415 MC. Containing a 300KC IF Strip and various other parts, these units have been stripped of RF sections and all tubes, but are an excellent buy if only for parts and IF Strip..... ONLY \$4.95  
BC 624 receiver (SCIT 522), less tubes..... used \$4.95  
100-150MC..... used \$14.95

### HAND SETS

TS9, excellent condition..... \$4.95  
TS13, excellent condition..... 5.95  
TS Type, exe. less cord..... 2.95

BC457 TRANSMITTER—1 to 5.3 mc and BC458 TRANSMITTER—3 to 7 mc and BC455 RECEIVER—3 to 9 mc (as is, less tubes and crystals)..... ONLY \$4.95 each  
All three units..... \$10.95

### "MONTHLY SPECIAL"

TRANSCIVER—140-144 mc. 2 meter, used, excellent condition, less dynamotor, less tubes..... only \$17.95

Shipments F.O.B. warehouse. 20% Deposit on orders. Minimum order \$5.00. Illinois residents, add regular sales tax to remittance. Prices subject to change without notice.

### MIKES and HEADSETS

MS-33 Low Impedance Headset..... exc. \$2.95 new \$5.95  
MS-23 Headset..... used 2.95 new 4.95  
CD-307 Ext. cord for MS 23-33..... like new .79  
Throat Mike—T 30..... like new .98  
Lip Mike—Navy Type..... like new .38  
CW 49505 High Impedance headset complete with headband..... Used 98c  
MB-7 Headband..... used, exc. \$1.29  
MS-18 Headset..... used 1.29 new \$1.98  
MS-38 Headset..... exc. 1.85 new 2.29  
MS-30, miniature headset..... used 1.49 new 2.49

### WOBUlator

### BUILD TV-FM-AM SWEEP GENERATOR

You can build "Versatile Sweep Frequency Generator" with APN-3 magnetic unit..... \$ 6.95  
BC-1206 Beam Receiver 260-400KC..... 9.95  
MN-26LB Receiver exc..... 59.50  
RCA Sound Powered Phones..... brand new, 12.95 two for 24.95  
TS3 AP..... S-Band Power Frequency Meter 195.00  
TS-18/AP Test Set..... 69.50  
APR-2 Radar Search Receiver, 87-1000MC..... 195.00  
APR-4 Radar Search Receiver, 38-1000MC..... 399.00  
TS100 Oscilloscope..... 175.00  
IE 10A-SCR522 Test Unit..... 295.00  
MG-153 Inverter..... Used 69.50  
I-222 Signal Generator..... Used, exc. 125.00  
R-11B-AP13..... Like new 350.00  
AN/AP15 Transmitter..... Like new 189.50

### DYNAMOTORS

The best dynamotor for conversion to 6v. Multiple windings! After conversion you get choice of 190 or 350 v. at 50 MA or 250 v. at 100 MA. Complete dope sheet furnished. \$465  
BRAND NEW (See "CQ" Aug. Issue)..... \$465

### Surprise Package!

SURPRISE PACKAGE. 15 lbs. of assorted good radio parts..... \$1.95  
A real value at..... \$1.95

### MISCELLANEOUS EQUIPMENT

FL 8 used, exc..... \$1.19 BC 347 each..... used 95c  
BC 906 each..... 3.95  
RT ARR-1—Receiver, easily converted to 220 mc. (See Radio & Television News—Jan. '49.) Brand new, complete with Tubes..... \$4.95

RT7 APN1 TRANSCIVER UNIT—Used as an altimeter. It may be converted for signaling control circuits, etc. Complete with 14 tubes and dynamotor they are in good used condition at the amazingly low price of..... \$29.95  
Used, less tubes, as is..... 4.95

### YE-4B

General Electric Delay Line Unit 1000 ohms + or - 10% band pass 0-2 mc. 4 micro-second delay time. Brand new..... 1.98

### SELSYN TRANSMITTER

Autodyn Transmitter Assembly for matching to I-82 Indicator. Used, excellent condition..... ONLY \$10.95. Complete with Indicator..... \$19.95

RL-42 Reversible Motor with antenna reel and clutch, used..... \$ 2.95  
BC-433 RADIO COMPASS RECEIVER 200 to 1700 KC. med. excellent condition, with tubes..... 39.95  
used, exc. less tubes..... 24.95  
used, as is, less tubes and covers exc. for parts..... 8.95  
orders. Minimum order \$5.00. Illinois residents, Prices subject to change without notice.

## R W ELECTRONICS

Dept. N, 1712-14 S. Michigan Ave., Chicago 16, Ill.

PHONE: HARRISON 7-9374

### TRAIN FOR A SUPERVISORY POSITION IN ELECTRONICS

Thorough 2-year course covers electrical circuits and machinery, basic electronics and industrial electronics. Franklin Technical Institute graduates are in demand as junior engineers for research and test work, sales engineering, supervisory work on production lines and drafting room design work. Other engineering and technical courses. Coed. Day, evening, 45th year. Write for catalog.

FRANKLIN TECHNICAL INSTITUTE  
46 Berkeley Street Boston 16, Mass.

The Standard Records for:

- MUSICAL DEMONSTRATIONS
- ENGINEERING TESTS

Send for complete catalog

**COOK LABORATORIES**  
ROUTE 2 STAMFORD, CONN.

**BARGAIN HUNTING?**

**RADIO SERVICEMEN!**

Write for SENSATIONAL CATALOG

**HENSHAW RADIO SUPPLY**  
3619 TROOST KANSAS CITY, MO.



# PERFORMANCE



*Guaranteed*

**TO LAST  
A LIFETIME!**

**UNIVERSITY COBREFLEX-2  
WIDE-ANGLE TRUMPET**

Lifetime Performance has been built into each Cobreflex-2. Nothing yet produced compares in construction and design efficiency. Once installed, the Cobreflex-2 can be forgotten. The Cobreflex-2 is Breakdown-Proof... truly performance guaranteed to last a lifetime.

**Compared! Tested! Proven Superior!**

Write for  
technical  
literature



When used with University Driver Units  
Meets Any of the Following:  
Frequency Response  
Power Capacity  
Impedance Requirement  
Mounting  
Application

Model T-30 Driver Unit Cont. Power: 20 Watts over 250 CFS Response: 250-15,000 CFS Impedance: 8 Ohms	Model SA.HF Driver Unit Cont. Power: 25 Watts Response: 90-10,000 CFS Impedance: 16 Ohms	Model MA.75 Driver Unit Cont. Power: 25 Watts Response: 90-4000 CFS Impedance: 16 Ohms	Model PA.30 Driver Unit Cont. Power: 30 Watts Response: 80-10,000 CFS Impedance: 16/165/250/300 1000/2000 ohms Power Tap: 170V 30/20/165/2.5 Watts	Model SA.30 Driver Unit Cont. Power: 30 Watts Response: 90-10,000 CFS Impedance: 16/45/165/250 500/1000/2000 ohms Power Tap: 170V 30/20/165/2.5 Watts

UNIVERSITY LOUDSPEAKERS • INC. 80 SOUTH KENSICO AVENUE, WHITE PLAINS, N. Y.

Army during World War II when they leased the boat.

The loop antenna of the *Bludworth* direction-finder is also used with the RCA direction-finder, avoiding duplication of antennas. The antenna is rotated by means of the handwheel projecting below the *Bludworth* unit. Bearings of the received stations are indicated directly on the dial of the *Bludworth* direction-finder.

Additional electronic equipment includes two fathometers to indicate depth of water. Both units are manufactured by *Submarine Signal Company*. One unit has a calibrated range of 400 feet, while the other has a range of 1000 fathoms.

Fathometers operate on a principle similar to radar, with a supersonic signal being transmitted instead of the microwave signal. This signal is sent out by a special transducer, mounted under the boat. When this supersonic wave strikes an object, it is reflected and picked up by a special underwater microphone. The received signal is amplified and fed to an indicator. The indicator shows the elapsed time between the transmitted and received signal, and is calibrated directly in feet or fathoms.

In harbor navigation the 400-foot unit is particularly useful to indicate submerged reefs or other obstacles. For deep-sea navigation, the 1000-fathom unit is used.

The 400-foot unit has another application in that it can be used to give an indication of large schools of fish. Large schools of fish will show on the indicator dial as a false bottom. By skillful interpretation of the readings it is frequently possible to locate good fishing grounds.

The art of deep-sea fishing is as old as man himself, but adoption of electronic techniques has done much to raise this from a catch-as-catch-can status to one of science. Further developments in this field will undoubtedly do much to reduce the element of chance. In addition, the safety of those who man these fleets has been greatly increased by the electronic developments of the past few years.

## Windsor TUBES

RADIO & TV RECEIVING

TESTED and  
GUARANTEED  
for **PEAK**  
PERFORMANCE

TO MERIT your confidence—to insure your satisfaction—every tube we ship has been tested in a radio or TV set for **PEAK PERFORMANCE**.

Each tube is attractively packaged in individual carton—and, EACH WINDSOR Tube carries full RTMA GUARANTEE!

Type	Price	Type	Price	Type	Price
1B3GT	\$0.63	6BH6	\$0.57	12AT6	\$0.48
1R5	.56	6BQ6GT	.89	12AT7	.68
1S5	.47	6BQ7	.84	12AU7	.53
1T4	.56	6C4	.37	12AV7	.79
1U4	.55	6CB6	.53	12AX7	.61
1U5	.46	6CD6G	1.85	12BA6	.45
1X2A	.67	6J5GT	.40	12BE6	.47
3V4	.56	6J6	.62	12BH7	.63
5R4GY	.91	6K6GT	.41	12SA7GT	.52
5U4G	.40	6S4	.46	12SK7GT	.50
6AB4	.46	6SH7GT	.47	12SQ7GT	.42
6AG5	.54	6SK7GT	.50	25BQ6GT	.89
6AK5	.95	6SL7GT	.62	25L6GT	.48
6AL5	.40	6SN7GT	.54	35B5	.48
6AQ5	.46	6SQ7GT	.42	35C5	.48
6AU6	.43	6T8	.77	35Z5GT	.30
6BA6	.45	6V6GT	.46	50B5	.47
6BC5	.53	6W4GT	.45	50C5	.47
6BE6	.46	6W6GT	.57	50L6GT	.47
6B66G	1.34	6X4	.34	117Z3GT	.39
		6X5GT	.33		

WRITE FOR ADDITIONAL TUBE TYPES AND PRICES. We also stock Special Purpose and Transmitting Tubes at similar savings! 25% Deposit with Order. All merchandise F.O.B., N.Y.C. For orders less than \$10, add \$1 handling cost. Deduct 2% if full remittance accompanies order. All merchandise subject to prior sale and price change without notice. Dept. N-7.

**Windsor ELECTRONIC TUBE CO.**  
1515-N SHEEPSHEAD BAY ROAD, BROOKLYN 35, N. Y.

## MERIT POWER TRANSFORMERS

115 Volt 60 cycle Primary

120V/50MA/6.3V-1.5 AMP (P-3045)	\$2.73
150V/25MA/6.3V-5 AMP (P-3046)	1.76
480VCT/50MA/6.3V-2.5 AMP (P-3047)	3.23
480VCT/40MA/5V-2 AMP/6.3VCT-2 AMP (P-2949)	3.53
520VCT/70MA/5V-2 AMP/6.3V-3 AMP (P-3051)	4.53
700VCT/90MA/5V-3 AMP/2.5VCT-12.5 AMP (P-2952)	5.88
650VCT/40MA/5V-2 AMP/6.3VCT-2 AMP (P-2950)	3.67
700VCT/90MA/5V-3 AMP/6.3VCT-3.5 AMP (P-2953)	4.70
700VCT/120MA/5V-3 AMP/6.3VCT-4.7 AMP (P-2953)	5.44
750VCT/150MA/5V-3 AMP/6.3VCT-5 AMP (P-2954)	7.05
800VCT/200MA/5V-3 AMP/6.3VCT-5 AMP (P-2955)	8.23
870VCT/250MA/5V-3 AMP/2.5V-10 AMP/6.3VCT-3 AMP/6.3 or 5V-3 AMP 80 VOLT BIAS TAP (P-2956)	10.29
700VCT/225MA/5V-3 AMP/6.3V-10 AMP/6.3V-2.7 AMP (P-3070)	12.49
724VCT/295MA/5V-6 AMP/12.6VCT-5 AMP/5I-2 AMP (P-3061)	10.12
700VCT/200MA/5V-2 AMP/5V-3 AMP/6.3V-6 AMP/6.3V-7 AMP (P-3165)	10.58
800VCT/300MA/5V-3 AMP/5V-6 AMP/12.6VCT-10 AMP (P-3166)	12.64
1750V/2MA/2.5V-2 AMP/6.3V-.9 AMP/6.3 or 2.5V-2 AMP (P-3170)	6.17
2500V/5MA/2.5V-2 AMP/6.3V-3 AMP/6.3 or 2.5V-3 AMP (P-3171)	8.23
5/8" Half Shell Mount. "TV Replacement" Upright Mount	

## HYTRON TEST ADAPTERS

7 pin miniature	\$1.42
8 pin octal	2.30
9 pin miniature	1.70

## HYTRON TOOLS AND AIDS

Tube Lifter	.14
Soldering aid	.48
Pruning tweezers	.34
Tube puller	.73
7 & 9 pin straighteners	.54

## HYTRON POINT CONTACT TRANSISTORS

PT-2S	12.40
PT-2A	12.40
T-2 socket	.30

## SPECIALS

No. 14 enamel 100 ft. coil	.95
No. 12 enamel 100 ft. coil	1.25
No. 10 enamel 100 ft. coil	2.45
NE-40 3 watt neons	.38
2 1/2 watt argons	.19
NE-2 neons with leads	.08
100-1/2 watt resistors (asst'd)	1.00
25W-150 OHM wire wd rheostat	.58
6VDC to 110 VAC—40 watt supply	9.95

All prices F.O.B. our warehouse New York

**LEEDS RADIO CO.**

75 Vesey St. Dept. A New York City 7



"This is our most exciting model!"



# STAN-BURN E-P-A-R-K-E

## CATHODE RAY TUBE SPECIALS One Year Guarantee

G. E.		STAN-BURN	
5TP4	\$44.95	10BP4A	\$11.00
7JP4	17.10	12LP4A	14.20
10BP4A	19.25	14CP4	17.00
10FP4A	24.00	15DP4	19.50
12KP4A	27.10	16AP4	21.60
12LP4A	21.70	16FP4	19.60
12UP4B	28.25	16GP4	21.60
14CP4	24.50	16EP4A	22.60
16AP4A	30.95	16DP/HP4	19.60
16DP4A	28.20	16DP/HP4A	20.60
16GP4	31.25	16KP4	18.50
16KP4, 16RP4	28.20	16LP4	20.60
17BP4A	23.90	16LP4A	21.60
17CP4	23.90	17BP4	18.50
19AP4A	39.45	17CP4	21.60
20CP4	24.75	19AP4	23.90
20LP4	37.50	19AP4A	25.90
21EP4A	37.35	20CP4	29.50
24AP4A	78.50	21EP4	32.50

## ANTENNAE SPECIALS

RED DOUBLE "V" Antenna	1.11	12 or more
RMS EVA 100 DOUBLE "V" Antenna	\$2.29	\$2.09
10 Element Conical 3/4"	2.49	2.39
Folded Hi Straight Low Quick Rig 1/2" elements	3.55	2.55
WINDUP CONICALS	4.25	3.25
5 FOOT SWEDGED MASTS	.79	.69
10 FOOT PLAIN	1.39	1.29
NEPCO MASTS	1.69	1.49
42 Mtl.		\$ 9.95 M Ft.
55 Mtl.		11.95 M Ft.
72 OHM COAXIAL		38.00 M Ft.
12" Heavy Slug Speaker		Special \$3.98

CHASSIS 630 REGAL with Cascade Tuner. \$149.50  
OPEN FACE CABINET 42.00

WIRE RECORDERS IN STOCK  
PENTRON - Model 973C - 2-speed Tape Recorder

RADIO CRAFTSMAN  
Model C400 - Hi-Fi Amplifier Net 42.90  
Model C10 - All-FM Tuner Net 131.50  
Model C500 - Williamson Amplifier Net 99.50  
We also carry MASCO - BOGEN - PILOT, etc. Amplifiers, Pre-Amps, FM Tuners and WEBSTER Tape Recorders.

6x9 PM Speaker	3.98	630 Vert. output potted	1.29
7" PM Speaker	3.98	630 Vert. Blocking	.89
27J1 G.E. Flyback	1.98	OSC XForms	19.95
70" Yoke	1.98	Cascade Tuners	17.95
630 Vert. output upright	1.98	Standard Tuners	21.25 mc. 14.95

AUTHORIZED DISTRIBUTORS for General Electric, Kenrad, Tung-Sol, National Union, De Wald, Regal, Automatic and General Motors.

Automatic Custom-Built Radios for Plymouth, Ford, Chevrolet and many others, always in stock. We carry a Complete line of HI-FIDELITY and sound equipment. Send us your requests. We also carry a complete line of popular makes of Radio Tubes at 50-10% discount. Also many other special purpose and transmitting tubes, and all electronic parts and equipment at lowest prices. Send us a list of your requirements for prompt quotations. Terms: 20% with order. Balance C.O.D. All prices F.O.B. NEW YORK Warehouse. Minimum order \$5.00. Write for our latest price list and Hi-Fi catalog to Dept. RN-7.

**STAN-BURN RADIO and ELECTRONICS CO.**  
(C.B.S. THEATRE BLDG.)  
1697 BROADWAY • NEW YORK 19, N.Y.

Please Mention  
**RADIO & TELEVISION NEWS**  
When Answering Advertisements

**110V. AC POWER SUPPLY FOR ANY 274-N RECEIVER**

Just plug it into the rear of your 274-N RECEIVER - any model. Complete kit and black metal case, with ALL parts and diagrams. Simple and easy to build in a jiffy. Delivers 24 volts plus B voltage. No wiring changes to be made. Designed especially for the 274-N receiver. Only \$8.95.

Filament trans. for 274N receivers. Pri. 110V, 60 cy. AC. Sec. 24V @ .6A. An excellent buy at \$1.95 ea.

**SPLINED TUNING KNOB FOR 274N RECEIVERS**

An exclusive O-R item manufactured for us. Fits BC-453, BC-454 and other 274N receivers. This is a really hard-to-obtain item. Only .89c ea.

**OFFENBACH-REIMUS**  
1564 Market Street, San Francisco, Calif.

## Dage TV Camera (Continued from page 34)

the high-side of an audio oscillator adjusted to 15,750 cps. In this way the audio oscillator beats with the second harmonic provided by the 31,500 cycle master oscillator and a zero beat may be obtained from the use of the germanium diode. Listening to the phones, the operator varies the 31,500 cycle "Adjust" control (screwdriver-adjust chassis control) in the grid circuit of the master oscillator for zero beat. Although a number of tones may be heard, depending upon how far out of range the 15,750 cycle "Adjust" control in the ÷2 circuit happens to be, variation of the master oscillator control allows the operator to distinguish the second harmonic beat from the others. After this zero beat is obtained, the 15,750 cycle "Adjust" control is varied for zero beat with the remaining tone. An oscilloscope connected to "Test Plug ÷2" will now show the pattern illustrated in Fig. 7. This indicates that every second pulse is syncing the ÷2 counter whose free-running frequency is close to 15,750 cycles.

Germanium diodes are employed in the interstage coupling networks of each vertical divider chain to bring the firing time into synchronism and for effective stage isolation to prevent interaction. Each divider is accurately adjusted by connecting the oscilloscope to the "Test Plugs" for that particular divider as noted in Fig. 6. Fig. 11 shows the pattern obtained at "Test Plug ÷15" indicating that every 15th pulse synchronizes the oscillator when the 2100-cycle "Adjust" control (31,500 ÷ 15) is properly adjusted. The same procedure is carried out through the remaining ÷7 and ÷5 counters. Tube  $V_{10A}$  is the final countdown for the vertical pulses, supplying 60 pps to the blanking amplifier  $V_{10A}$ , the camera vertical pulse amplifier  $V_{10B}$  and monitor vertical amplifier  $V_{11}$ .

The blanking amplifier  $V_{10A}$  receives the vertical pulses on the grid, while

Fig. 11. "Divided by 15" counter pulses on scope when connected to "Test Plug ÷ 15". Every 15th pulse triggers ÷ 15 oscillator.

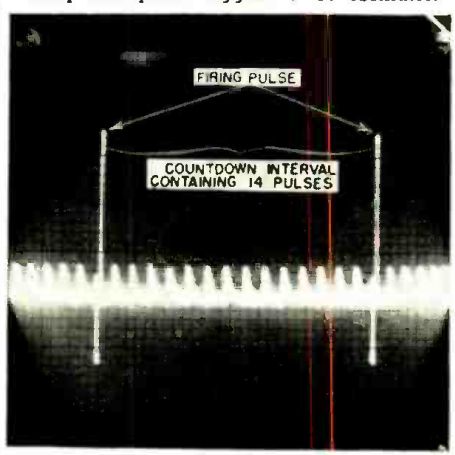

**4 for 53 NEW**

**Trav-Electric CONVERTERS**

CHANGE 6 OR 12 VOLT D.C. TO 110 VOLT A.C. 60 CYCLE  
Just plug into Cigar Lighter on Dash.



**Trav-Electric Super**  
Model 6-71160  
60 cycle  
60-75 Watts  
**\$37.95 LIST**

Size 4" x 5" x 6" Operates

- Wire Recorders
- Amplifiers
- Soldering Iron
- Dictating Machines
- Turntables
- Small Electric Drill



**Trav-Electric Master**  
Model 6-51160  
60 cycle  
40-50 Watts  
**\$24.95 LIST**

Size 4" x 5" x 6" Operates

- Curling Irons
- Radios
- Turntables
- Small Dictating Machines
- Test Equipment, etc.
- Portable Phonographs
- Electric Shavers, etc.



**Trav-Electric Senior**  
Model 6-11160  
60 cycle  
35-40 Watts  
**\$15.95 LIST**



**Trav-Electric Midget**  
Model 6-11160  
60 cycle  
10-15 Watts  
**\$10.95 LIST**

Size 2" x 2" x 3 1/2" Operates Test Equipment, All Electric Shavers

**Fully Guaranteed**  
See Your Jobber or Dealer  
**TERADO COMPANY**  
MFRS. OF PRECISION EQUIPMENT  
1068 RAYMOND AVE. • ST. PAUL 14, MINN.  
In Canada write: Atlas Radio Corp., Ltd.  
560 King St. West, Toronto 28, Ont.  
Export Sales Division: Scheel International, Inc.,  
4237 N. Lincoln Ave., Chicago 18, Ill., U. S. A.  
Cable Address—Harscheel



# SELECTED SURPLUS

**NON-INDUCTIVE RESISTORS** **59¢**  
Ohmite, 250 Ohm, 100 Watt. Special, 5 for \$2.50

**SOLA CONSTANT VOLT. TRANSF.**  
Pri. 95-125 volts, 60 cy. Sec. Regulated at 115 volts. 30 VA. \$ 9.95  
120 VA. \$22.50

**OIL CONDENSER SALE**

2 MFD-2500 VDC \$2.95	3.75 mfd 660VAC. \$2.45
4 MFD-2500 VDC. 5.95	.1 mfd 7500VDC. 1.75
2 MFD-3000 VDC. 3.95	.1 12KV DC. 2.95
3 MFD-4000 VDC. 5.95	.01x.01 12KV DC. 2.95
1 MFD-5000 VDC. 2.95	5 mfd 660 VAC. 2.95

**6 HY, 400 MA FILTER CHOKE**  
Made by Acme. Only 30 Ohms DC Res. **\$2.50**  
ALL BRAND NEW.  
Priced at a fraction of cost. 3 for \$6.50

**0-150 MICROAMP METER**  
G.E. 2" flush Bakelite case. Scale 0-150 Microamps. BRAND NEW. A Terrific Value. **\$4.95**

**G.E. PLATE TRANSFORMER**  
Pri. 120 V., 60 cy. Sec. 1140 Volts Ct. @ 1 amp. Ideal for Bridge Rect. Fully Cased, Herm. Sealed. In original cartons. ONLY. **\$16.95**

**MOBILE DYNAMOTORS**  
MADE BY PIONEER AND EICOR  
6 Volts Input, 425 Volts at 375 MA Output. 6 3/4" Long, 4" Diameter. Weight 10 lbs. List Price Approx. \$70.00. **\$24.95**  
BRAND NEW, ONLY.

**CARTER SUPER DYNAMOTOR**  
12 Volts Input, 400 V. Output @ 200 MA Continuous or 375 MA Intermittent duty. Model B420. Designed for Police, Aircraft and Marine Use. Small, rugged and efficient. **\$24.95**  
BRAND NEW, ONLY.

**G. E. RELAY CONTROL**  
(Ideal for Model Controls, Etc.)  
Contains a sigma midgeet 8,000 ohm. relay (trips at less than 2 MA), high impedance choke, bi-metal strip, neon pilot and many useful parts. The sensitive relay alone is worth much more than the total **\$1.25** Each 10 for **\$9.90**

**Panel Meters**  
NEW GOV'T SURPLUS STANDARD BRANDS  
2" METERS  
0-10 MA AC. \$2.95  
3" METERS  
0-50 Microamps. \$8.95  
0-100 Microamps. 7.95  
0-200 Microamps. 6.95  
0-400 Microamps. 5.95  
0-500 Microamps. 5.95  
0-10 Milliamps. 4.50  
0-150 Milliamper. 4.50  
0-200 Milliamper. 4.50  
0-300 Milliamper. 4.50  
0-500 Milliamper. 4.50  
0-1000 Milliamper. 4.50  
0-50 Volt DC (1 MA) 4.95  
0-150 V. DC (1 MA) 4.50  
0-1.5 Volts AC. 4.95  
0-3 Volts AC. 4.95  
0-150 Volts AC. 7.50  
0-15 kv DC w/ multiplier 9.95  
4" METERS  
0-200 Microamps. \$8.95

**METER BUY OF THE YEAR!**  
2" Simpson Meters  
Round bakelite case. Brand new, original cartons. **\$3.95**  
0-1 MA DC. **\$3.95**  
0-300 Volts DC, 1000 Ohms/v (1 MA) **\$3.95**  
DB Meter -10 to +20 **\$3.95**  
ANY 3 METERS. **\$11.50**

**WIRE WOUND RESISTORS**  
Stock too long to list. We can supply most sizes, so order what you need.  
5 Watts. From 1 Ohm to 40K Ohms. Ea. \$ .09  
10 Watts. From 1 Ohm to 70K Ohms. Ea. .15  
20 Watts. From 4 Ohms to 50K Ohms. Ea. .20  
25 Watts. From 1 Ohm to 100K Ohms. Ea. .30  
50 Watts. From 5 Ohms to 100K Ohms. Ea. .40  
100 Watts. From 50 Ohms to 100K Ohms. Ea. .50  
**ADJUSTABLE SLIDER, WIRE WOUND**  
10 Watts from 1 Ohm to 10K. \$ .25  
25 Watts from 20 Ohms to 2.5K. \$ .35

**VACUUM CONDENSERS**  
50 mmf. 32 KV, Eimac. \$9.95  
50 mmf. 20 KV, Jennings. 7.95

**1 MEGOHM, 1% W.W. PRECISION RESISTORS, SHALLCROSS, ONLY. 97¢ ea.; 10 for \$8.95**

**BAKELITE CASED MICAS**

MFD	VDC	Price	MFD	VDC	Price	MFD	VDC	Price
.001	600	\$ .28	.01	1 KV	\$ .45	.02	2 KV	\$ .90
.002	600	.23	.002	1200	.35	.005	2500	.55
.01	600	.26	.024	1500	.65	.002	2500	.45
.02	600	.26	.033	1500	.75	.004	2500	.50

Mfn. Order \$3.00-25% with Order  
**PEAK ELECTRONICS CO.**  
66 West Broadway, New York 7, N. Y.  
Phone WOrth 2-5439

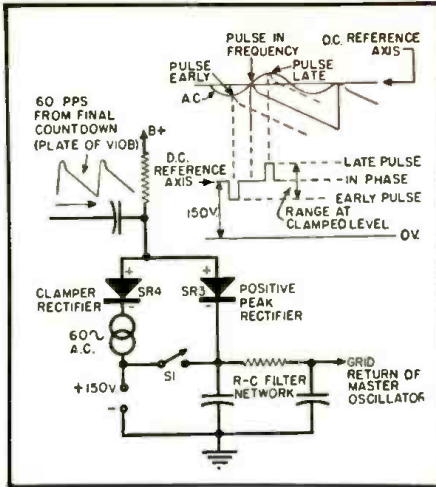

Fig. 12. The clamping-comparison line lock.

horizontal pulses are injected on its cathode from the  $V_{12}$  stage. In this manner the composite sync-blanking pulses of negative polarity appear at the plate and are injected into the grid of  $V_5$  as described for Fig. 8. Fig. 9 shows the rectified composite output signal displayed at line frequency, and Fig. 10 illustrates the field frequency.

Horizontal and vertical size and linearity controls for Vidicon sweep are incorporated as screwdriver-adjustable chassis controls. The amplitude of vertical sweep ("Camera Height Control") is determined by the setting of a potentiometer in the grid excitation branch of  $V_{10B}$ . A separate potentiometer across the resistors which determine the bias on the  $V_{10B}$  grid serves to adjust the tube transfer-curve characteristics and is the sweep "Vertical Linearity Control". The two adjustments are obviously interdependent in action. The camera "Width Control" is an adjustable condenser between the  $\pm 2$  counter output ( $V_{5B}$ ) and the camera horizontal output stage  $V_{12}$ .

The master oscillator can be locked in operation by the 60 cycle a.c. power line frequency by means of a unique clamping-comparison circuit. Two selenium diode rectifiers are used as indicated in the simplified schematic of Fig. 12. The action is based upon the fact that the blocking time of the oscillator is dependent not only upon the RC time constant of its grid circuit, but also upon a static grid potential which determines the extent to which the grid condenser may charge during the "on" time. Pulses from the final vertical countdown (60 pps) are combined with a fixed d.c. potential upon which is superimposed a 60 cycle a.c. line voltage, and the resultant clamped voltage is used to vary this static grid potential and automatically correct the master oscillator frequency.

The fixed reference d.c. potential is applied at the cathode of  $SR_1$  in series with the a.c. filament winding Y-Y (Fig. 6). The anodes of  $SR_2$  and  $SR_3$  are parallel connected across a d.c. potential and pulses from the

# SUMMER CLEARANCE PRICES SLASHED

**T.V. TUBES—ROCK BOTTOM PRICES**  
In lots of 6 each No. only

6B66	89c	6C86	39c	6AQ5	38c
19B6	89c	6AK5	6c	6C6	\$1.05
12AX7	47c	6BQ6	57c	654	49c

Tube Special—Broken Keys—Electrically Perfect  
12AG... 29c; 4 for \$1.00 12K8... 49c; 7 for \$3.00  
Tube Sale—2A7-55-27-85-91-56. No Mixed Ass't. 6 of Any Type \$2.25

Heavy Duty Shielded P.P. Input Trans. \$1.00  
M.D. Silver Contact Trans. Keys. 1.00  
Bat Handle S.P.S.T. or D.P.S.T. Toggle Switch. 25c  
Isolantite Octal Panel Clamp Sockets. 3c ea.  
100 Assorted Resistors. \$1.95  
1 Mfd., 1,000V Oil Filled Cond. 75c  
2 Gang Var. Cond. 456 K.C. with Osc. Section. 234 in. Pulley on 3/8" Shaft. 49c  
Westinghouse Kuprox Rectifier 0.04 Amp. 28 Volts. Reg. \$11.00 ea. Special. \$1.95  
**BRAND NEW 10" PHONO RECORDS—Ass't.**  
Jazz—Popular, Rhythmic—Blue. Please specify.  
12 for \$1.79 or 24 for \$3.00  
Slide Pole—10 Pos. 2 Gang Switch. 29c  
Grind your own Crystals. Pure Brazilian Quartz. Various sizes and thicknesses. 1/4 lb. pkg. \$1.00  
4 Tube Drilled Chassis. 4 1/2"x6 1/2"x1 1/4". 29c each  
Signal Corps Phones—2 M. Ohms (8 M. Ohms Imp.) \$1.25  
2 Ft. Ext. Cord (and Plug) 40c

**TUBE TUBULAR ELECTROLYTICS**  
20-20 MFD. 150 V. 49c 30-30 MFD. 150 V. 57c  
40-40 MFD. 150 V. 59c

Low-Loss Short Wave Lock Type Air Trimmer Variable Condensers  
5 Pl., 20Mmfd. .14c  
7 Pl., 25-30 Mmfd. .15c  
8 Pl., 30-35 Mmfd. .16c  
14 Pl., 56 Mmfd. .24c

1,000 OHM WIRE WOUND POTENTIOMETER. 15c  
30 HY. FILTER CHOKE SHIELDED. 3 for \$1.25  
PIEZEO CRYSTAL HOLDERS. 12 for \$1.00—\$6.00 per C

RCA Band Switches—3 Gang, 3 Pos. 3 band, 30c 6 Gang, 4 Pos. 4-5 band, 40c  
Trimmer-Padder Asst.—all isolantite—singles, dual, triples—100 ass't. \$2.25

ATTENTION: Prospectors, Explorers for Hidden Treasures! Construct a U.S. Army Type of Metallic Mine Detector Amplifier. Amplifier unit only (less tubes and batteries) with cables, headphone cord, and Jack. Army wiring diagram. Type AN/PR-1. \$1.95

Philco push button Rotary Switch Double Pole. 35c  
8 or 9 Gang Push Button Switch. 49c

DRILLED CHASSIS FOR 5-6 tubes 5"x10"x1 1/4". 25c  
PHONE JACKS—OPEN & CLOSED AUTO. 38c  
156-1 RAT 10 VERNIER DIALS—4 in., 3/8 in. Hub. 35c

SALE—PHONO RECORD ALBUMS—12—3 comp.—15c; 10—3 comp.—15c; 4 comp.—20c; 12 comp.—69c  
VULCAN HEAVY DUTY 100 WATT SOLDERING IRON. Built for U.S.N.—Brand New—Equip. sells for \$8.50. OUR PRICE \$2.99

MINIMUM ORDER \$3.00—NO C.O.D.  
SHIPMENTS—PLEASE INCLUDE POSTAGE  
NEWARK SURPLUS MATERIALS CO.  
324 Plane Street, Dept. JY, NEWARK 1, N. J.

## SAY YOU SAW IT IN RADIO & TELEVISION NEWS

### COMPLETE TV AERIAL KIT

Consisting of:  
● Hi-low antenna  
● 7-ft. heavy duty mast  
● 75 ft. 300 ohm wire  
● 50 ft. guywire  
● Sturdy swivel base  
● 6 stand-off insulators

Special Priced **475** Boxed

### STRAIGHT LOW TV AERIAL AR27

Only **175**

Servicemen's array - pre-assembled. Lab-band array only, with mast clamps for mast up to 1 1/4".

10% CASH WITH ORDERS

**ALMO RADIO CO.**  
509 ARCH ST. & 6205 MARKET ST.  
Philadelphia, Pa.  
6th & ORANGE STS. • Wilmington, Del.  
4401 VENTNOR AVE. • Atlantic City, N. J.  
1133 HADDON AVE. • Camden, N. J.  
317 Park Heights Avenue • Salisbury, Md.



final countdown (hence dependent upon master oscillator frequency) are injected at this point. With the "Line-Lock" switch  $S_1$  closed (unlocked position) the static grid potential is fixed by the d.c. potential of 150 volts. The comparison function is shorted out in this position of the switch. With  $S_1$  open (line-lock position) the cathode of  $SR_1$  is varied above and below the d.c. reference potential at the 60 cps line rate. Injection of the 60 pps from the final countdown to the anodes results in a clamped value at  $SR_1$  dependent upon the relative frequency with the 60 cycle variation.  $SR_1$  serves as the positive peak rectifier for the clamped pulse. If the master oscillator and all frequency dividers are exactly adjusted, the 60 pps coincide with the 60 cycle variations, and the voltage is clamped at the d.c. reference potential. (See waveforms, Fig. 12.) If the 60 pps from the final counter are early or late (too high or too low in frequency) the clamped level falls in the negative direction or rises in the positive direction. The level change is filtered to pure d.c. correction at the output of the filter network to which the master oscillator grid is returned. The direction of change is such that the cut-off period is shortened if the frequency was too low, or lengthened if the frequency was too high.

The author wishes to thank George Fathauer, inventor of this system and president of the *Dage Electronics Corp.*, for supplying the technical data on the camera and permission to publish this article.

-30-

## WIRELESS OPS OF "OLD"

FOR some time we have been considering a column dedicated to "Old Time Wireless Operators"—not "Radio Operators" for that appellation is too modern. We believe that we may have something along that line in the near future as our mail has brought us a reminder that 1952 was the 40th anniversary of the sinking of the "S.S. Titanic" in the North Atlantic and the subsequent employment of a large number of wireless operators for our American passenger ships.

It was in 1912 that our radio men put on long pants and became an integral part of American shipping. What has become of these men? Through this column we are going to try and find out what goes with the "Old Timers."

Our compliments to all "Old Timers" of 1912 and thereabouts and we would certainly appreciate your writing us as to when and where you first became a "commercial" operator, either ashore or afloat and by whom you were employed. We would also like to know how long you continued as a commercial radio operator and what you are doing now. A recent picture of yourself would also add interest to the column as would career highlights.

We feel that your story will be of interest to our readers, so you old brass pounders get busy and write us, in care of this column, and watch for its early appearance.

-30-

SEE LEO FIRST FOR . . .

# hallicrafters

I can SAVE you money... Liberal Trade-ins



LEO I. MEYERSON  
WØGFO

JUST ARRIVED! THE NEW 100 WATT HT-20 XMTR—\$449.50



**\$179.50**  
**S-76 RECEIVER**

Extra selectivity with double superheterodyne circuit. One RF, two conversion and 3 IF stages. Range 550-1550 Kc, 1.7-34 Mc in four bands. 8 tubes plus voltage regulator and rectifier. Complete with tubes, less speaker.



**\$224.50**  
**SX-71 RECEIVER**

Double Conversion sharp selectivity, plus built-in NBFM at moderate cost. 11 tubes plus voltage regulator and rectifier. Low down payment.

NAME YOUR TERMS • LOW DOWN PAYMENTS • PERSONALIZED SERVICE

HALLICRAFTERS RECEIVERS AVAILABLE FOR IMMEDIATE SHIPMENT

S-81	\$49.50	S-40B	\$119.95	ST-83	\$129.95
S-82	\$49.50	S-53A	\$ 89.95	S-78A	\$ 89.50
A-84	\$99.50	S-72L	\$119.95	SX-62	\$299.50
S-38C	\$49.50	S-77A	\$119.95	S-72 Portable	\$109.95
R-46 Speaker	\$19.95	SX-73	\$975.00		

Famous WRL RADIO REFERENCE MAP 25c



CU on 10-20 & 75 Meters

NEW LOG BOOK 25c

For mobile or fixed station. Spiral binding. Full column log listing all FCC required info. Will accommodate 1,325 stations. "Q" signals, phonetic alphabet, amateur international prefixes.

PHONE 7795

WRITE—WIRE

**World Radio**  
LABORATORIES INCORPORATED  
COUNCIL BLUFFS, IOWA

IT'S NEW! IT'S FREE!

WRL 1953 CATALOG

Send for your copy today. Contains everything new in radio and television. Jam-packed with bargains. Lea I. Meyerson, WØGFO

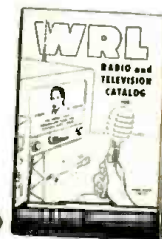

Send For FREE Copy

WORLD RADIO LABORATORIES  
744 West Broadway  
Council Bluffs, Iowa

R-7

Please send me:

- Radio Map 25c  SX-71 Info  
 New Catalog  S-76 Info  
 Used Equipment List  New Log Book 25c

Name .....

Address .....

City .....

State .....

## SPEAKER RECONING

Complete line Cones, Spiders, Rings and Voice Coils. Custom Built Voice Coils. Low prices. Write for Parts List and Reconing information.

WESTERN ELECTRONICS CO.

3164 West Colfax Denver 4, Colo.

## ON-THE-SPOT BATTERY RECORDER

WALKIE-RECORDALL 1/2 lb. miniature BATTERY RECORDER-PLAYBACK  
Continuous, permanent, accurate. Indexed recording at only 5c per hr. Instantaneous, permanent playback. Picks up sound up to 60 ft. Records conferences, lectures, dictation, 2-way phone & sales talks, while walking, riding or flying. Records in closed briefcase with "hidden mike"! Write for Detailed Literature.

MILES REPRODUCER CO., INC.

812 BROADWAY Dep'TRN-7, NEW YORK 3, N. Y.

## GET INTO ELECTRONICS



You can enter this uncrowded, interesting field. Defense expansion, new developments demand trained specialists. Study all phases radio & electronics theory and practice: TV; FM; broadcasting; servicing; aviation, marine, police radio. 18-month course. Graduates in demand by major companies. U.S. or equivalent required. Begin Jan. March, June, Sept. Campus life. Write for catalog.

VALPARAISO TECHNICAL INSTITUTE  
Dept. RD Valparaiso, Indiana



Here's the new **SHURE**  
**SLIM-X**  
 All-Purpose Crystal  
**MICROPHONE**



MODEL 777  
 List Price \$18.95  
 MODEL 777s  
 (with switch)  
 List Price \$20.95  
 (Price includes  
 cradle  
 for mounting  
 on stand)

Its Versatility and  
 "Hand-a-Bility" make it  
 an ideal low-cost  
 all-purpose microphone

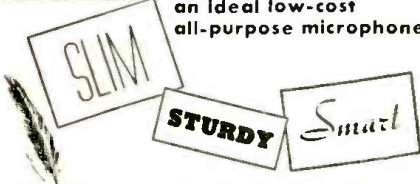

**LIGHT!** The new "777" Slim-X Microphones are rugged little microphones weighing only 6 ounces! They are designed for good-quality voice and music reproduction. Their versatility and "hand-a-bility" make them ideal for use by lecturers, announcers, instructors, and Hams; for audience participation shows; carnivals; panel and quiz shows; and use with home-recorders. When mounted on either cradle or swivel, the "777" can be removed in a flash (no tools necessary)—simply by lifting it out of the holder. This makes it an ideal "walk-around" hand-held microphone.

**TECHNICAL INFORMATION:** Smooth frequency response—60 to 10,000 c.p.s.; special-sealed crystal element—for long operating life; high impedance; 7 single-conductor cable, disconnect type. Dimensions: (Microphone only) Length, 4½"; Diameter 1". Finish: Rich satin chrome overall.

**NOTE:** Lavalier cord for suspension of Microphone around neck is available. (optional).

**ACCESSORIES FOR "777"**

**MODEL 538 STAND** is a heavy die-cast base. Includes metal screw machine stud for connecting microphone adaptor to stand base.

List Price: \$3.00

**MODEL A25 SWIVEL ADAPTOR** features a long-life, high-quality swivel connector. Is lined with a long-life nylon sleeve—for noise-free and scratch-free insertion and removal of microphone.

List Price: \$5.00



**SHURE BROTHERS, Inc.**

MICROPHONES and ACOUSTIC DEVICES  
 225 W. Huron St., Chicago 10, Ill., Cable: SHUREMICRO

**125-Watt Audio System**

(Continued from page 41)

voltage is connected to terminals 3 and 4. The remote control relay coil is supplied through terminals 5 and 6, while terminals 7, 8, and 9 receive audio voltage from the speech amplifier section. Also mounted on the rear of the modulator chassis is a bayonet-type fuse holder.

No under-chassis view is shown of the modulator, as the only parts located there are the filament transformers and relays, and these parts can be mounted in any convenient location.

For front panel views we turn to the photograph showing the complete transmitter. Three units make up the entire rig, with the r.f. section (see RADIO & TELEVISION NEWS, June, 1952), at the top. Below the r.f. section is the modulator panel, and at the bottom is the speech amplifier unit.

Looking first at the modulator panel we find the 811 plate current meter at the center. Below, near the bottom of the panel, are the filament switch, filament pilot light, plate pilot light, and plate switch.

Components mounted on the speech amplifier panel are: Input control,  $R_1$ , output control,  $R_2$ , and a dummy knob was used to balance the front panel layout. Below the knobs are located the microphone connector, clipper "in-out" switch, a.c. switch, and pilot light.

Aluminum was used for all foundation components. All chassis are 12 x 17 x 3 inches in size and all panels are 8¾ x 19 inches. Chassis-mounting brackets were used to strengthen the units. These were cut and bent

from 16-gauge sheet aluminum at a local sheet-metal shop.

The chassis were left bare, but the fronts of all panels were given a coat of "Cadet Gray" auto enamel, following a primer coat of zinc chromate. The finishes were sprayed on, followed by a half-hour period of baking under heat lamps. Heat should not be applied, however, until the enamel has become set at room temperature. Needless to say, all panel drilling was completed before the paint job was undertaken.

Construction of the audio units followed normal procedure, with all major components being mounted before wiring was begun. All 60-cycle a.c., high-level audio, and d.c. wiring of any appreciable length was laced into cables which follow around in the corners of the chassis. Low-level audio leads were shielded, while all small parts such as resistors and condensers were either connected between socket terminals or mounted on lug strips. The type of octal sockets used in the speech amplifier have soldering lugs as an integral part of their mounting plates. All ground connections for any given tube were made to the lugs on that tube's respective socket.

Sockets for the 811 modulator tubes were mounted with spacers about 1½ inches below the surface of the chassis due to the height of the tubes. This permitted the vertical mounting of the 811's even with the 8¾-inch panel.

After completion of the modulator and speech amplifier, each unit was checked through with an ohmmeter as a precaution against errors. Then the two sections were mounted in a standard 26¼-inch rack cabinet, along with the 250-watt 813 r.f. section described in the previous article. Interstage wiring was laced into a cable which

Bottom view of the clipper-filter speech amplifier system. The small choke near center is in the clipper-filter circuit. Terminal strips were used liberally for precise wiring. The "professional" dress is easily achieved in this large chassis.

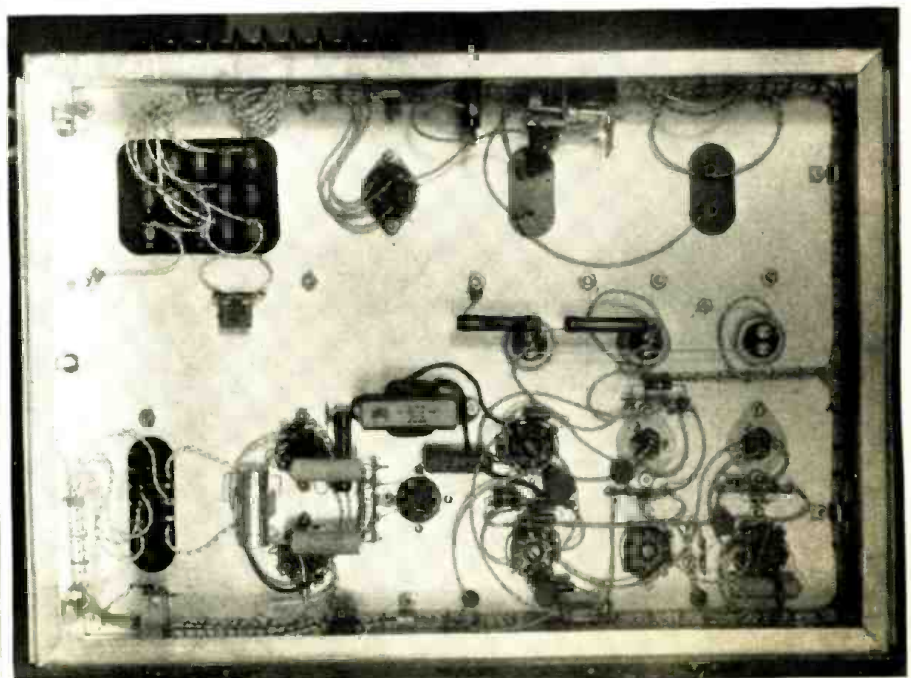



was run down the side of the cabinet and secured to the wall at several points by cable clamps.

Testing and adjustment of the clipper controls were made with the r.f. section delivering full power to a dummy load and with an oscilloscope connected to give an r.f. envelope pattern. The output control of the clipper was set to a point somewhat below the 100 per-cent modulation point. Then, while speaking into the microphone, the input control,  $R_{in}$ , was advanced until audio peaks reached a point where they no longer increased in amplitude. This was the point where clipping was beginning. Advancing the input control beyond this setting did not increase the peak amplitude, but did bring up lower-level passages. With clipping taking place, the output control,  $R_{out}$ , was advanced until the oscilloscope indicated 100 per-cent modulation, as evidenced by peaks nearly reaching the zero-level line. Under normal conditions the output control setting does not have to be changed. The degree of clipping, however, can be adjusted by changing the position of  $R_{in}$ . In the writer's rig, normal settings for 100 per-cent modulation and about 10 db of clipping showed both input and output controls at about 11 o'clock. Input control settings in other cases, however, may vary widely, depending upon the type of microphone used, the level of one's voice, and the distance the operator speaks from the microphone.

### SERVICE BENCH NOTE

By R. A. HUNHOLZ

RAYTHEON MODEL C2002A

There was no sound or picture on this set and the customer complained that the set blew  $\frac{1}{4}$  amp. fuses so he had put in a 6/10 amp. "Slo-Blo" unit which immediately blew out.

We pulled out the two 6BQ6's, and the 6W4, inserted a  $\frac{1}{4}$  amp. fuse and turned on the set. The sound was restored. The conclusion was that the current requirement of the set was too high due to a short in the high-voltage branch. Resistance readings taken throughout this section revealed no shorts. A d.c. ammeter, on the 1 amp. scale, was connected to the bridge fuse mounting. An a.c. ammeter was used in the primary of the power transformer. The power plug was inserted carefully in the a.c. outlet.

The set's current consumption rose to normal on the ammeter in the primary circuit and then as it came up to operating temperature rose alarmingly. The d.c. ammeter reading also increased beyond normal and short-circuit frying noises were heard in the high-voltage cage. The a.c. plug was pulled to prevent power transformer burnout.

Brief connection was again made and white arcing was seen inside the horizontal linearity coil. This coil was removed and upon being disassembled arcing was found on the iron core and burn-through on the coil form was discovered. None of this damage was visible on the outside of the coil. The iron core is at ground potential and the coil winding carries boost voltage and high-frequency a.c. for d.c. high-voltage generation.

Replace the horizontal linearity coil to correct this fault.

-30-

# MONEY MAKERS!

## FOR MOBILE-RADIO SERVICE ENGINEERS!

Provide for future expansion in this profitable field, with Lampkin frequency- and modulation-measuring equipment.



### For Any Number of Frequencies, AM or FM. The Type 105-B MFM.

The Type 105-B Micrometer Frequency Meter, or MFM, measures center-frequency on any number of nearby transmitters, AM or FM, 0.1 MC. to 175 MC. Performs as signal generator for mobile receivers. 20 MC. up. Meets FCC requirements for mobile services, with accuracy guaranteed better than 0.0025%. Can be checked against WWV. Price \$220.00 net.



### The Type 205 FM Modulation Meter for Multiple Mobile Frequencies.

Instantly tunable anywhere, 25 MC. to 200 MC., the Type 205 measures maximum FM deviation due to modulation, as required by the FCC. Indicates 0-25 KC. deviation. Simple to use, easy to carry. No charts or tables. Price \$240.00 net.

Send name and address for literature

Name .....

Address .....

City ..... State .....

**LAMPKIN LABORATORIES, INC.**  
MFM DIVISION  
BRADENTON, FLORIDA



## Editors and Engineers PUBLICATIONS

### BETTER TV RECEPTION

New 2nd Edition.

IT COVERS ALL YOU WANT TO KNOW ABOUT

fringe and low-signal areas

BETTER TV RECEPTION has become the standard guide for the installation technique and a popular text for TV enthusiasts.

Book No. E&E-TR2

**\$2.50 per copy\***  
(paperbound) at our store



Radiotelephone License Manual. Typical study questions with concise answers for any commercial U.S.A. radiotelephone operators license. Order Book No. E&E-RL1 ..... \$3.75\*

Antenna Manual. A practical, comprehensive book on antennas, for everyone interested in transmission and reception. Over 300 pages. Order Book No. E&E-AM1 ..... \$3.50\*

Radio Handbook. Giant 13th Edition. A one-volume library of radio information with extensive, simplified theory. Detailed how-to-build-it data on dozens of items of practical radio equipment. 734 pages. Order Book No. E&E-RH13 ..... \$6.00\*

Surplus Radio Conversion Manual. Volume 1. Practical conversions. Write for list of contents. Order Book No. E&E-SM1 ..... \$2.50\*

Surplus Radio Conversion Manual. Volume 2. Companion to Volume 1. Order Book No. E&E-SM2. \$2.50\*

\*Plus any tax.

### BUY FROM YOUR DISTRIBUTOR

ADD 10% ON DIRECT MAIL ORDERS TO EDITORS AND ENGINEERS, LTD., BOX 680A, SANTA BARBARA, CALIF. Bookstore order from BAKER & TAYLOR, Hillsdale, N. J.

LEARN

# Television-Radio Electricity

REFRIGERATION-ELECTRONICS  
IN THE GREAT SHOPS OF COYNE

## TRAIN QUICKLY! OLDEST, BEST EQUIPPED SCHOOL of ITS KIND in U.S.

Come to the Great Shops of Coyne in Chicago. Get practical training in opportunity fields—TELEVISION-RADIO—ELECTRICITY—ELECTRONICS—vital in Defense Program. Prepare now for a better job in industry or better service rating.

### Approved for Veterans

Finance Plan—Enroll now, pay most of tuition later. If you need part-time work to help out with living expenses while at Coyne, we'll help you get it. Special tuition plan for men of Draft Age.

**FREE BOOK** Clip coupon for Big Free Illustrated Book. No salesman will call. Act NOW.

B. W. Cooke, President  
**COYNE** A TECHNICAL TRADE INSTITUTE CHARTERED NOT FOR PROFIT Established 1899 500 S. Paulina, Chicago

ELECTRICITY ★ TELEVISION RADIO ★ REFRIGERATION ★ ELECTRONICS

B. W. COOKE, Pres.  
COYNE School  
500 S. Paulina St., Chicago 12, Ill. Dept. B3-85H

Send FREE BOOK and full details on:

TELEVISION-RADIO  ELECTRICITY

NAME .....

ADDRESS .....

CITY ..... STATE .....



**TUBES BRAND NEW! TUBES**

1R22	69c	30/44	29c	824	39c
1H23	\$3.75	100R	49c	841	27c
2K22	49c	11B	29c	843	19c
2C26	09c	215A	09c	844	19c
2C26A	09c	221A	29c	1R26	19c
3H22	\$1.19	310A	29c	7103	19c
3H6	39c	388A	59c	0002	69c
7C4	39c	471A	\$1.19	E1148	49c
10Y	39c	232A	\$1.19	1R34	99c
12KBY	39c	732A	99c	VR92	14c
15R	39c	801A	19c	VT127	15c

**HEADSETS**

HS-23	High Impedance. BRAND NEW with ear pads.	\$5.95
HS-31	Low Impedance. BRAND NEW with ear pads, cord and PL54 plug.	6.45
HS-33	BRAND NEW—Western Electric.	7.25
HS-307A	Cord. 6 ft. BRAND NEW.	\$1.49
HS-14	High Impedance. Includes two receiving units.	3.95
HS-16	High Impedance—used.	.98



**SCR-274N COMMAND and ARC-5 EQUIPMENT**

RECEIVERS	USED	EXCELLENT USED	NEW
BC-453—190 to 550 KC	\$29.95		\$49.95
BC-454—3 to 6 MC			24.95
BC-455—6 to 9 MC 1.5 to 3.	\$13.95		19.95

TRANSMITTERS	USED	EXCELLENT USED	NEW
A-958—2.1 to 3 MC			29.95
BC-457—4 to 5.3 MC	14.95		29.95
BC-458—5.3 to 7 MC	14.95		34.95
ARCS T-19—3 to 4 MC	24.95		24.95
BC-459—7 to 9.1 MC			29.95
T-15 ARC 5—500 to 800 KC			29.95

**ADDITIONAL EQUIPMENT**

BC-456 Modulator		1.49	1.95	7.29
BC-450 Control Box (3 Receiver)		1.29	1.79	2.75
BC-451 Control Box (Transmitter)				2.39
BC-442 Relay Unit (AMT)				5.69
Plugs: PL-147, 148, 151, 152, 153, 154, 156—EACH			1.25	
Flexible Shuffling with gear to fit receivers				2.69
3 Receiver Rack	1.79	2.29		2.98
2 Transmitter Rack	1.69	2.39		3.97
Single Transmitter Rack				3.97
DM-33 Dynamotor for Command Set		2.95		3.95
Mounts for Above Racks		1.95		

**ARMY TEST UNIT 1-236**

Meter is contained in a metal box 5 1/2" long x 3 3/4" wide x 3 1/4" deep. Comes complete with test leads and instruction book. Can be used for testing between AC and DC measuring resistance of circuits, checking fuses and testing capacitors.

**SPECIAL \$4.19**

**FIELD TELEPHONES**

Army surplus, completely reconditioned and electrically tested, using 2 flashlight cells and a pair of interconnecting wires. GUARANTEED.

New \$28.95. LIKE NEW \$22.95

**20 POUNDS OF ASSORTED RADIO PARTS**

A TERRIFIC BUY AT ONLY... \$2.79

**TURBO AMPLIFIER**

4 tube Amplifier used by U. S. Air Force. 115 V. Input at 400 cycles. Without tubes—EXCELLENT.

**\$119**

**ARC-5/R-28 2 MTR RCVR \$25.95**

Here is the 2-meter superhet you have been looking for! Absolutely one of the BEST available today! Tubes from 100 to 150 Mes. in four crystal channels. (Easily converted to continuous tuning.) Tube group is as follows:

717A—R.F., 717A—Mixer, 2-12SH7—1st and 2nd I.F. 16.9 Mc.  
 12SL7—Det., AVC Spulch, 12SL7—1st audio-spulch amplifier.  
 12A6—2nd audio, 12SH7—R.F. Osc.—4th Harmonic Gen.  
 717A—Trip, 12th Harmonic Gen. 717A—Dblr.—12th Harmonic

Excellent, used \$25.95

BE SURE TO VISIT PLATT'S BRANCH STORE at 159 GREENWICH ST., N.Y.C. (just off Cortlandt St.). You'll find many bargains that space does not allow us to list here.

**MINIMUM ORDER \$2.00**

Immediate Delivery—Send 25% deposit on C.O.D. orders. All shipments F.O.B., N.Y.C. (N.Y.C. residents add sales tax to your remittance.)

**PLATT ELECTRONICS CORP.**

Dept. A. 489 Broome St., N. Y. 13, N. Y.  
 PHONES: WO 4-0827 and WO 4-0828  
 BRANCH STORE: 159 Greenwich St., N. Y. C.

# RADIO-TV Service Industry News

**AS REPORTED BY THE TELEVISION TECHNICIANS LECTURE BUREAU**

THE recent convention sponsored by the Television Service Engineers of Greater Kansas City, Inc., and billed as the national convention of the Television, Radio and Electronics Servicing Industry under the auspices of NATESA, was presented with a professional touch that was a credit to the officers of TSE who managed it. Perhaps the most significant feature of this service convention was that the service businessmen who attended it paid a \$10.00 registration fee. This bespeaks of a recognition of individual responsibility on the part of businessmen in service that is somewhat new to the activity of servicing. It adds a dignity to the business of servicing that men engaged in it are willing and able to "pay their own freight" in financing programs that are of vital interest to them.

True, those who attended the Kansas City convention got a swell package of information and entertainment for their ten dollar registration fee. They heard a series of intensely interesting and informative talks given by men who know service industry problems; they were treated to a dinner, a luncheon, and a banquet topped off by an excellent floor show; and they

were able to examine a wide range of the latest products of service interest in the exhibition hall.

It was a *service managed* show. TSE had the whole-hearted support and cooperation of all local electronic parts distributors and most of the manufacturers' representatives who operate out of Kansas City. All arrangements for the affair were handled by a professional public relations expert.

Service business and technical talks were given by John Thompson, *General Electric Company*; Lee Allen, *American Phenolic Corp.*; Frank Mansfield, *Sylvania Electric Products Inc.*; Lloyd Austin, *Simpson Electric Co.*; Harold Rieth, *Regency* division of *I.D.E.A. Inc.*; Robert Artman of the *Empire Coil Co.*; Larry Kearney, *La Pointe Electronics Inc.*; and Chet Jur, *Merit Coil & Transformer Corp.*

Al Saunders, nationally known lecturer on TV servicing and director of the *Saunders Radio & Electronic School* of Boston, Mass., delivered two major talks. At the banquet he spoke on "Service Progress Through Cooperation" and on the last day of the convention he discussed "Service Education." L. B. Calamaras, executive

The main auditorium of the Deming Hotel in Terre Haute, Ind., was filled to capacity by TV technicians from Indiana and Illinois who came to hear Edward M. Noll present his TTLB lecture on u.h.f. television. Sponsored by Archer & Evinger, parts distributing firm of Terre Haute, the lecture attracted technicians from towns in a radius of 150 miles.





vice-president of the National Electronic Distributors Association spoke on "Service Licensing."

Frank Moch, president of NATESA, presented association awards to John Thompson of the *General Electric Company*, Neal Hunter of *Sprague Products Company* and Frank Mansfield of *Sylvania Electric Products Inc.*, for their companies' public relations programs on behalf of the independent service industry.

Television Service Engineers of Greater Kansas City comprises twenty-eight member firms who operate in that metropolitan trade area. Present officers are Albert A. Richards, president; J. B. McDowell, vice-president; Ray Crawford, secretary; Robert Hester, treasurer; and M. D. Thompson, sergeant-at-arms.

### Predictions—and a Credo

David Sarnoff, chairman of the board of *Radio Corporation of America*, painted a glowing picture of the future of TV and radio, of u.h.f., of color TV, and the electronics field in general in his keynote address at the NARTB convention in Los Angeles.

Of u.h.f., he said, "Developments now under way will enlarge the coverage and improve the quality of the u.h.f. signal. New antenna systems will increase efficiency of u.h.f. transmission and control the broadcast energy so that the signal can be directed into valleys within the coverage pattern. There is no doubt that operations in u.h.f.—'the band of the future'—will fill a place of growing significance in television."

On the subject of color television, Mr. Sarnoff pointed to the recent highly successful demonstrations of compatible color television as proof that it was technically ready for submission to the FCC for review and decision. He predicted that perhaps a half million color television receivers could be produced within three years after the Commission establishes commercial compatible color television standards.

Woven into the fabric of Mr. Sarnoff's address was a moral challenge to all industry elements to fulfill all responsibilities of service to the public.

"Radio was built on the basis of service to the American people. Television must be based on the same solid foundation. For all its drama and potential for profit, television should be no place for get-rich-quick Wallingfords, more interested in what they can take than what they can give.

"Sure, they may ride high for a time, but they will have no staying power. Sooner or later, the public will intervene, and they will lose out to broadcasters who have shouldered the responsibilities on which continuing opportunities for profit are founded.

"Television, like radio, should be a profession, with all that term best implies in integrity, dignity, and above all dedication to a tradition of pub-

**NOW...PROFESSIONAL QUALITY SOUND REPRODUCTION  
RIGHT IN YOUR OWN HOME!**

THE AMAZING NEW  
**FAIRCHILD**  
SERIES 215  
**DIAMOND  
CARTRIDGE**



Replace any modern pickup with this new cartridge, and enjoy recorded music as never before! *High compliance*—freedom of stylus to yield to rapid lateral deflections—provides these exciting improvements:

- New shades of tone color from fine recordings!
- New clear timbre in high volume piano chords!
- Rich low-frequency tones never previously heard!
- Arm resonance, "needle talk," rendered inaudible!
- Stylus wear greatly reduced, record quality preserved!
- And above all—TRACKING DISTORTION ELIMINATED!

High compliance, low-mass stylus assembly and smooth linearity of extended range are exclusive features of the new Fairchild 215.

First to achieve near-perfect lateral compliance for optimum Hi-Fi performance...

With finest diamond stylus for 33, 45 or 78 rpm records

Now Only  
**\$37.50**

ORDER FROM YOUR AUDIO DEALER—or write direct to:

**FAIRCHILD RECORDING EQUIPMENT**  
8th Ave. & 154th St., Whitestone, N. Y.  
Manufacturers of the World's Finest Professional Sound Equipment

**SELLS ON DEMONSTRATION**  
**THE New DuKANE**  
**Tru-Fidelity**  
**TAPE RECORDER**



THE FINEST IN  
**TRU-FIDELITY**  
**RECORDING**

SELLS  
READILY  
AT  
**\$299.50**

(SLIGHTLY HIGHER  
WEST OF ROCKIES)

**DEALERSHIP AVAILABLE NOW!**  
**MAIL COUPON FOR INFORMATION TODAY!**

at our risk!

Dept. RN-73, RINEHART BOOKS, Inc.,  
Technical Division,  
232 Madison Ave., New York 16, N. Y.

Send MODERN OSCILLOSCOPES AND THEIR USES for 10-day FREE EXAMINATION. If I decide to keep the book, I will then remit \$6.00 plus a few cents postage in full payment. If not, I will return book postpaid and owe you nothing.

NAME.....

ADDRESS.....

CITY..... ZONE... STATE.....

OUTSIDE U.S.A.—Price \$6.50 cash with order. Money back if book is returned in 10 days.

DUKANE CORP. Dept. RTN-73 St. Charles, Ill.

Send details on the new DuKane Tru-Fidelity Tape Recorder.

I am interested in a dealership.

Name.....

Address.....

City..... State.....

ESTABLISHED AS "OPERADIO" 1922

**NOW! YOU'LL  
REALLY  
KNOW HOW  
TO USE  
OSCILLOSCOPES!**



Here, at last, is a practical book that makes it easy for you to learn to use the oscilloscope FULLY on all types of AM, FM and TV service work—and dozens of other applications. MODERN OSCILLOSCOPES AND THEIR USES, by Jacob H. Ruitter, Jr., of Allen B. DuMont Labs contains 326 fact-jammed pages of just the help you need—written so you can easily understand it. The book shows exactly how the 'scope works; how to use it on all service jobs from trouble-shooting to re-aligning; how to make connections; how to adjust circuit components; how to set controls and how to analyze patterns. 370 illustrations including pattern photos make things doubly clear.

When, where, why and exactly how to use your 'scope.

How to interpret patterns.

How to handle tough jobs in less time.



## TELEPHONES



DESK TYPE PHONE, IDEAL FOR PRIVATE-INTERCOM, AMATEUR MIKE, ETC. USES HI-QUALITY CARBON TRANSMITTER. POWERFUL MAGNETIC RECEIVER. A GREAT, ONCE-IN-A-LIFETIME VALUE. AS SHOWN. RINGER BOXES FOR ABOVE. WOOD CASE. RINGER BOXES FOR ABOVE. METAL CASE. **\$3.50**

## DYNAMOTORS

TYPE	INPUT VOLTS	AMPS	VOLTS OUTPUT	AMPS OUTPUT	PRICE
PE 86	28	1.25	250	.060	\$4.25
OM 416	14	6.2	330	.170	6.75
OM 33A	28	7	540	.250	3.95
BO AR 93	28	3.25	375	.150	7.50
23350	27	1.75	285	.075	3.95
B-19 Pack	12	9.4	275	.110	8.95
			500	.050	
OA-3A*	28	10	300	.260	6.95
			150	.010	
			14.5	.060	
5053	28	14	250	.350	3.95
PE 73 CM**	28	19	1000	.350	
337	14	8	425	.160	7.95

\* Replacement for PE 94.  
\*\* Price sent on request.

## INVERTERS

PE-218-H: Input: 25/28 vdc. 92 amp. Output: 115 v. 350/500 cy 1500 volt-ampers. New. \$44.50  
PE-206: Input: 28 vdc. 38 amps. Output: 80 v 800 cy. 500 volt-amps. Dim: 13"x5 1/2"x10 1/2". New. \$22.50

**VIBROPACK**, WALLORY TYPE G-556. IN-225. 250/275/300 VDC @ 100 MA. Brand New with 2 spare vibrators. \$12.50

**VIBRATOR**, TR 1210. FOR USE IN INDUSTRIAL INVERTERS. DELIVERING 115 VAC @ 100 WATTS FROM 12 VDC. \$1.65

## MOBILES! C. D. MEN! CAP!!

IDEAL DYNAMOTOR - CONVERTS EASILY TO SUPPLY UNIT DELIVERING  
12 VOLT INPUT 6 VOLT INPUT  
610 V @ 150 MA OR 300V @ 90 MA  
325V @ 125 MA OR 160V @ 110 MA  
BRAND NEW WITH CONVERSION DATA. **\$3.75**

## BAND PASS FILTERS

INPUT IMPEDANCE: 2000 OHMS. OUTPUT: TO GRID. AVAILABLE IN FOLLOWING RANGES:

CHANNEL	F <sub>1</sub>	F <sub>1</sub> *	F <sub>2</sub> *
5	1155	830	1620
7	2270	1620	3180
8	3180	2270	4450
9	4450	3180	6230
10	6230	4450	8720

\* F<sub>1</sub>: Center Freq. in CPS; F<sub>1</sub> and F<sub>2</sub> are lower and upper limits (CPS) respectively, at -20 dB points. Size 1 3/4" diam. x 4" L. Price, \$4.95 Each

## JAN/UG CONNECTORS

UG 9 U	\$0.85	UG 58 U	\$0.70
UG 10 U	.95	UG 89 U	1.05
UG 21 U	.80	UG 102 U	.75
UG 22B U	1.25	UG 188 U	1.15
UG 22 U	1.20	UG 254 U	2.50
UG 27 U	1.20	UG 261 U	1.10
UG 27A U	2.25	D-166366	.75

## GN 35 Hand Generators

BRAND NEW, IN ORIGINAL CARTONS. WILL DELIVER 8 V @ 2.5A AND 325-365 V @ 100 MA OR 10 V 1.25A AND 380-420 V @ 70 MA. LESS HAND CRANKS. A GREAT VALUE. **\$17.50**

## H.V. FILAMENT XFMR

NO. FT-38A-  
PRIMARY: 115V 60 CY. 1 PH.  
SEC. 2 WDGs. 2.5V AT 7 AMPS  
EACH. AND WDC. 6.3V @ 2.5A  
TESTED AT 7500 VDC BETWEEN ALL POINTS  
HERM. SEALED. SIZE: 5 1/2" H x 3 1/2" L  
D x 4 W. HAS 4 STUDS. 1/2" L ON 2 3/8 x 3" CENTERS.  
AS SHOWN. **\$2.79**

## SELENIUM RECTIFIERS\*

Current (Continuous)	18/14 Volts	36/28 Volts	54/42 Volts	130/100 Volts
1 Amp.	\$1.25	\$2.10	\$3.60	\$7.50
2 Amps.	2.20	3.60	6.50	10.50
2 1/2 Amps.	...	...	...	13.00
4 Amps.	3.75	...	8.75	...
5 Amps.	4.95	7.95	12.95	27.00
6 Amps.	5.50	9.00	14.00	33.00
10 Amps.	6.75	12.00	20.00	40.00
12 Amps.	8.50	16.00	25.50	50.00
20 Amps.	13.25	24.00	36.00	90.00
24 Amps.	16.00	31.00	39.50	98.00
30 Amps.	18.50	36.00	* FULL-WAVE	
36 Amps.	25.50	45.00	BRIDGE TYPES	

Send M. O. or Check. Shipping Chgs. C.O.D.  
**COMMUNICATIONS EQUIPMENT CO.**  
131 Liberty St. Dept. N-7, New York City 7, N. Y.

lic usefulness. It should provide careers upon which young Americans can enter with the same proud sense of fulfilling a vital public function that they have in entering science, medicine, law, or journalism. That inner awareness of mission applies not only to stations and networks but to TV performers, production people, administrators, salesmen, and technicians."

In concluding his address Mr. Sarroff epitomized over-all industry responsibility in preserving the elements of our way of life:

"In the final checkup, the amazing history of our industry, its record of consistent growth and success, are end products of the American system of free economy. They represent not merely triumphs of electronics but triumphs of America. It is the magic of freedom that gives full play to all the energies and talents in our economy; that strikes a fruitful balance between competition and cooperation; that blends the motive power of self-interest and public interest to enrich the life of the individual citizen and the vitality of the nation as a whole.

"The price of that freedom has ever been restraint and self-discipline, as well as a strong sense of personal and group responsibility. Nowhere is the payment of this price more essential than in an industry like ours, using public channels and concerned with the needs, the well-being, the happiness, and moral health of the entire population."

## Good Business Sense

Harry B. Price, Jr., of Norfolk, Va., has built one of the country's foremost television and appliance retail businesses. As president of *Prices, Inc.*, operating three stores in Norfolk, he has built an organization that consistently produces more than a million dollars worth of business a year from hard selling and fair dealing. As an active and hard-working vice-president in the National Appliance & Radio-TV Dealers Association, he has helped hundreds of fellow appliance dealers through his frank discussions of the business policies that have been responsible for the signal success of his organization.

Since the elements of success are the same in the operation of a radio-TV servicing business as in television and appliance retailing, service executives are finding it profitable to study Mr. Price's business operating observations. In a recent letter to the Appliance Dealer's Association of Greater Cincinnati he asked them a forthright question—"What kind of a dealer are you?"

"Dealers have a great decision," he said in his letter. "You must make up your mind as to what kind of a dealer you want to be. You must decide whether you will strive to be a positive contributing influence in this industry or whether you will be content in remaining or becoming a 'parasite.'"

### CRYSTALS!

### LOWEST PRICES!

ONLY 79¢ EA.

ACT NOW

In FT 241-A Holders—15 in. Pin SPC. These are designated 5th or 72nd Harmonic MC freq. Listed by fundamental freq. with fractions omitted.

372	394	414	436	458	476	497
374	395	415	437	457	479	501
375	396	416	438	458	480	502
376	397	418	440	461	481	503
377	398	419	441	461	483	504
378	400	420	442	462	484	505
380	401	422	443	463	485	506
381	402	423	444	464	486	507
383	403	424	445	465	487	508
384	404	425	446	465	488	509
385	405	426	447	468	490	511
386	406	427	448	469	491	512
387	407	429	450	470	492	513
388	408	430	451	472	493	514
390	409	431	452	473	494	515
391	411	433	453	474	495	516
392	412	434	454	475	496	

5 CRYSTALS, 20 for \$4.50. 20 for \$6.50. Assorted ONLY \$2.75  
10 for \$4.50. 20 for \$6.50. Assorted ONLY \$2.75  
COMPLETE SET!!!!!! 80 crystals covering above basic freq. including a 500 Kc. crystal. All for \$16.50

**SPECIAL** 500 Kc. Crystal ..... \$1.25  
1000 Kc. Crystal ..... 2.25  
All above crystals sent postpaid. Also available in complete sets for SCR-608, SCR-528, SCR-62R, and TRC. Foreign, wholesale, and dealer inquiries invited. Write for LARGE QUANTITY DISCOUNTS.

ARC-5 OR 274-N TRANSMITTERS	
2-1.3 mcs. Brand new.....	\$19.95
4-5.3 mcs. With tubes.....	6.95
5-3.7 mcs. With tubes.....	6.95
7-9.1 With tubes.....	14.50
ARC-5 OR 274-N RECEIVERS	
Equipped with tuning knobs	
10-55 kc. ....	\$19.95
1.5-3 mcs. Brand new.....	24.50
3-6 mcs. Less tubes.....	6.95
3-6 mcs. With tubes.....	10.95
6-9.1 mcs. With tubes. Used.....	10.95
New.....	22.50
6-9.1 mcs. Used. Less tubes.....	8.95
MD-7 ARC-5 PLATE MODULATOR. Excel. cond. ....	14.95
BC-450 274-N Modulator. Less dynamotor. Excel. cond. ....	3.95
12 V. COMMAND RECEIVER DYNAMOTOR. New.....	12.95
Plus All Accessories Needed for Above.	

**AIRCRAFT, HAMS & MARINE MEN!**  
SCR-183 12 V. RECEIVER & TRANSMITTER! Covers aircraft, marine and ham bands! Complete with coils, control boxes, tuning head, flex cable, rack and shock mount! Individual parts sold. \$25.95. This month slash-price special! **\$15.95**

### MARINE EQUIPMENT

**COLUMBIA'S NEWEST HI-POWERED 1953 MARINE TRANSMITTER.** Puts out max. power allowed by F.C.C. Contains all latest improvements & meets newest F.C.C. specs. Specify whether 12 or 24 V. frequency desired, and positive or negative ground. Full 10-day, unconditional guarantee. Pre-tuned, ready to install. **\$349.50**

**BC-223 25 W. TRANSMITTER & ARB RECEIVER.** For 24 V. inst. Receiver covers beacon, standard, and best marine frequencies and amateur bands. This combo makes the finest LOW-COST marine installation on the market. Complete, checked out, ready to go. The whole deal ONLY **\$185.00**

Write in for conversion info for 12 V. inst. **DU-1 LOOP MAKES AIR RECEIVER!** One of the best radin compass units made. With conversion done. Used only **\$22.50**

**JEFFERSON-TRAVIS MARINE 5 W. RADIO-TELEPHONE.** Made by Emerson Radio Corp. 2-channel, crystal controlled receiver & transmitter. F.B. for small boats with 6 V. system or sail boat. Will run 48 hrs. on standard 6V. car battery. Complete with tubes, instructions, but less crystals and battery. NEW **\$79.50**

Above unit with 110 V. charger for 6V. bat. (new) NEW **\$89.50**

**CRYSTALS FOR ABOVE.** Specify freq. and set of 4 needed. Per Set. **\$22.50**

Send for our NEW, FREE CATALOGUE!  
At same time tell us what new or used radio gear you have to sell. We pay TOP \$\$\$!  
All orders F.O.B. Los Angeles. 25% deposit required. All items subject to prior sale.  
**COLUMBIA ELECTRONIC SALES**  
522 South San Pedro St. Los Angeles 13, Calif.

## Unlimited Opportunities in RADIO ENGINEERING

### DEGREE IN 27 MONTHS

Complete Radio Engineering course, including Telev., U.I.F.P. and F.M. Bachelor of Science Degree also in Mech., Civil, Elect., Chem., and Aero. Eng.; Bus. Adm., Acct. Extensive campus, modern buildings, well equipped labs. Low cost. Prep courses. Personalized, practical instruction. Founded 1884. Placement service. Growing shortage of engineers. Prepare now for unlimited opportunities ahead. Approved for Korean vets. Enter September, January, March, June. Write for catalog.

**TRI-STATE COLLEGE**

1673 College Avenue. ANGOLA, INDIANA

### RADIO & TELEVISION NEWS



"You must decide whether this business is worth the long pull, justifying sound policies of operation, with the knowledge that all good things demand some sacrifices and that the ultimate rewards and the satisfaction of accomplishment make the struggle worthwhile. Or you can decide to take what the immediate offers and forget about tomorrow or next year. That attitude makes you a parasite.

"Webster's dictionary defines a parasite as, 'A useless person doing no work but living in comfort at the expense of others.' That describes too many dealers today who are getting what volume they enjoy through the process of selling merchandise at a price. Sometimes at a price of only \$10.00 above cost, on the premise that any sale is better than no sale. They are living off a market created by the money, sweat, and heartaches of many organizations and individuals that preceded them. They work little and contribute nothing. They represent a serious threat to our way of life.

"Look around you at the monuments to sound operation and constructive thinking," his letter continued. "Successful retailers in all lines are those who have built a reputation for fair values, the same treatment of all customers, and good service after the sale was made. *Develop a philosophy of operation or a creed.* Make your store a good place in which to spend money. Make your organization a good place in which to work. Make your group an asset to the community. Build stature through fair dealing and profits through intelligent operation. Be fair with suppliers—then you will be in a position to demand equitable and intelligent treatment from them.

"The recent failures of dealers who have seemingly done a satisfactory volume of business should be a warning. I list some of the reasons for insolvency:

1. Inadequate capital for size of business.
2. Unintelligent buying.
3. Failure to recognize the break-even point and adjust overhead when volume drops.
4. Failure to develop loyal, competent employees.
5. Failure to build joint respect and cooperation with suppliers.
6. Carrying too many lines.
7. Lack of planning and a complete misunderstanding of, or ability to, promote and advertise.
8. Indifference and just plain laziness.
9. Not getting the profit on sales—either giving it away in discount or too large trade-in allowance.
10. Too much investment in trade-ins.

"Take the matter of planning. If you don't plan how do you know how much to spend for advertising, for example? How do you develop a budget? How do you establish your break-even point?

## ORDER BY MAIL FROM

### GET YOURS FREE!

#### COMPLETE '53 SPECTRUM FCC FREQUENCY ALLOCATIONS

- COMPLETE ALLOCATIONS OF ENTIRE BAND, 100 KC TO 100,000 MEGS.
- EASY TO READ COLOR CHART
- A MUST FOR ENGINEERS, HAMS, SERVICEMEN AND EXPERIMENTORS

**FREE!** At Wholesale Radio Parts Co. Inc.

BY MAIL: enclose 10 cents to cover postage and handling cost.



Immediate Delivery!

### PRECISE 300 K 7" SCOPE KIT

Sensitivity—Less than 10 mv.

Has true electronic sweep magnifier. Astigmatism control. Push-pull vertical from input thru output push-pull horizontal. Internal blanking and Z modulation with blanking amplifier. Driven and non-driven sweeps. Over 2 MC flat response. (3 db.) IC amplifiers. Cathode follower input on vert. and horiz. Internal calibrator. Horiz. and vert. stepping attenuator. NEW 7 tube highest sensitivity. COMPLETE WITH ALL TUBES, HARDWARE AND STEP-BY-STEP CONSTRUCTION BOOK.



MODEL 300 K  
**\$9495**

#### More Famous PRECISE Kits!

630K RF-AM TV & MAPPER GENERATOR KIT	\$33.95
(630KA pre-assembled head \$28.95) (100W) wired	
635K UNIVERSAL AF SINE, SQUARE & PULSE GENERATOR KIT	\$32.50
(635A wired)	\$32.50
610K RF SIGNAL GENERATOR KIT	\$23.95
(610A pre-assembled head \$28.95) (100W) wired	\$39.95
907K VTVM KIT WITH 7 1/2" METER	\$38.98
(907 wired)	\$57.98

#### Check Pix Tube Circuits on-the-Spot



### New! RMS PIX-EYE

\$597

Eliminates time, labor and danger of unnecessary removal of picture tube. Makes instant checks of brightness control, video, contrast control, low voltage and filament voltage circuits.

### NEW PT-150 TAPEMASTER PORTABLE DUAL SPEED TAPE RECORDER

Self-Contained Speaker & Amplifier in 1 Unit!



Features—Freq. Resp.: 50-8000 cps. 3 db. at 7.5 and 50-5000 at 3.75 db. a sec. forward and rewind speed (20:1 ratio). Dual speed: 7.5 & 15.75 in. per sec. (dual track). 1/2" width tape—manual reversal. Inputs for radio, phono and mike. Equalization high and low compensation for record and play. Hi-fidelity for portable use or custom installation. Complete with microphone, speed dial, tape and 7" empty takeup reel.

**\$124.50**

**FREE!** Write for new value-packed "FYI" bulletin #107. Write for our big audio guide, "Hi-fidelity Magic."

## WHOLESALE RADIO PARTS CO., Inc.

311 W. BALTIMORE ST., BALTIMORE 1, MD.

## "WHOLESALE RADIO"

### Equal to \$100 TV Aerial Systems 360° SUPER DIRECTRONIC

Electronically Rotates  
in All Directions

Exclusive Snyder Engineering and Design cuts cost to **\$4495**

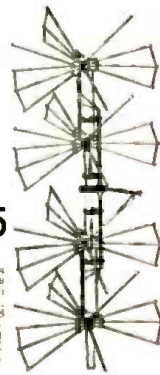

Especially for ultra-fringe areas where signals arrive from more than one direction. Extra high gain over any other broadband aerial. No motors or electric power. 48 elements. COMPLETE WITH POSITION DIRECTRONIC BEAM SELECTOR, 150' TETRAPOLAR TRILIN CABLE, UNIVERSAL U CLAMPS. Order Snyder Model AX-548.

Model AX524—Same Directronic operation as AX-548. 2 bay, 24 elements. Complete with 6' pos. aw. 100 ft. tubular cable, 3 matched stacking bars, 6 U clamps. **\$24.95**

**RESISTOR & CONDENSER BARGAINS**  
100 ASS'T RESISTORS, 1/2-1.2 W. .... \$1.95  
50 ASS'T MICA COND. 5mmf to .001 mf. .... 1.95

Why Waste Time Waiting for Test Pattern

### RMS TV BAR GENERATOR

Makes Actual Bars on Any TV Screen

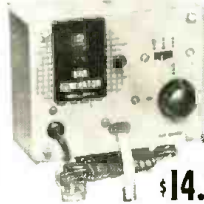

\$14.95

Make accurate, on-the-spot linearity adjustments. No chassis removal necessary. Operates directly into ant. terminals. Adjust number of horiz. & vert. bars. Complete unit. Order RMS BAR-1.

**PIC TUBE BRIGHTENER** \$149  
Gives new life to old pic. tubes. For use in parallel filament circuit. Model 95

### SUTCO UHF CONVERTER & VHF BOOSTER IN 1 UNIT

Enables any TV now being made to receive UHF and also boost VHF in fringe area. Has own power supply, a crystal mixer, a 6AF4 and a 6J6. Booster has 75-300 ohm input and output. Operates on 110-125 V AC. Terminals for UHF & VHF antennas. Model 21A. **\$35.70**



### SPECIAL! PRICES SMASHED!

Westinghouse Gamma Counter Tubes  
Was \$50. Alpha, Beta and Gamma Counter tubes. Self-quenching. #5979 B5-1 **\$895**

Was \$35. Gamma Counter tubes. Self-quenching. #5980 B5-2 **\$495**

### AC-DC MUSIC AMPLIFIER

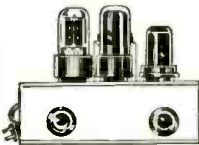

Volume and tone control.  
1.5 w. output.

See your jobber.

MICHEL MFG. CO.  
227 N. Water St.  
Milwaukee 2, Wis.



### RCA INSTITUTES, INC.

A service of Radio Corporation of America  
350 West 4th St., New York 14, N. Y.

OFFERS COURSES IN  
ALL TECHNICAL PHASES OF  
RADIO, TELEVISION, ELECTRONICS

Approved for Veterans  
Write Dept. RN-53 for Catalog

### BRAND NEW • FULLY GUARANTEED SENSITIVE MICROAMMETER



WESTON 301  
Original  
Weston  
Boxes  
0-20 Micro-  
amps DC

3 1/2" Round Flush Mount Bakelite Mfd. for Test Set #582—No. KS9490 **\$9.95** FOB NY

Rated Accounts 10 Days. Others 25% with Order. Balance COD

GREENWICH  
Sales Company  
59 Cortland St.,  
N. Y. 7  
Duby 9-3813

MFRS QUANTITY AVAILABLE  
Spot Delivery  
"An" Inspected & Approved



# 1 = 4

with

# R C P

## MODEL 324

Because the Radio City Products Model 324 "DO-ALL" Tube and Battery Tester packs into one instrument the performance of four.



... Sufficient Facilities to Test

- 1. All TV and Radio Tubes**  
Sockets for all standard 4.5, 6.7, octal, loctal, miniature and subminiature are provided. Tests transmitting, hearing aid, ballast, pilot light, gaseous rectifiers and tuning indicator types. All readings are indicated on a large easily read meter.
- 2. Cathode Ray Tubes**  
Checks all magnetic deflection types right in the set or cartou. Will locate and isolate all shorts or leaks.
- 3. Batteries**  
Tests popular portable battery types under load. Indicates true condition of battery under check.
- 4. All This and a Reactivator Too**  
Gives extra life to otherwise dim or bad picture tubes.

Adds a professional note to any service bench or store counter. Available in both counter and portable models, complete with CR Tube Adapter Cable.  
Two Styles To Meet Your Service Needs—  
Model 324C—Counter model with open style metal case. Size: 13 3/4" x 12 3/4" x 4". Weight: 10 lbs. Price: \$69.95  
Model 324P—Combination portable—counter model. Smart looking, hand-rubbed carrying case with slip-hinge cover—includes battery test leads. Size: 16 1/2" x 14 1/2" x 5". Weight: 12 lbs. Price: \$79.50

Remember You Can Do More With A "DO-ALL"  
See It at Your Parts Distributor  
Write Dept. RN-7 for RCP '53 Catalogue.

**RADIO CITY PRODUCTS CO., INC.**  
152 West 25th Street  New York 1, N. Y.

"There is a better day coming and the ones of us who operate our businesses intelligently—make a profit—justify our existence through service to our customers... will benefit from a growing market and profit possibilities. We will have to earn our rightful place in the market I envision by loving our work, believing in our industry, and working hard. We can join together in NARDA for the exchange of know-how, techniques and ideas, and hasten to relieve the practices that will and must go."

### Summer Service Slumps

This is the time of the year when service businesses that have been managed on a day-to-day basis really begin to feel the pinch of less money from reduced volume of business. Service operators who were too busy during the Fall and Winter months to think of long-range promotions and ways and means of cushioning the sag in business that normally occurs at this time of the year, are starting to worry about how they are going to weather the summer months.

Last year, of course, interest in what was happening at the political conventions boomed the service business during the period when normally it is at its lowest ebb. It has been heartening to observe how many service executives, seasoned by experience in previous slumps, took advantage of the succeeding eight months of good business to provide for fill-in volume during this summer when they knew business would be off. None of these organizations will have big, unpaid accounts with their parts jobbers to sweat out during the Summer in the hope that the early Fall business will take them off the hook.

Many organizations have promotional programs already underway for radio and record player service. Summertime is relaxation time during which the average person drifts away from his normal living routine. Many will take a "vacation" from television and go back to radio and record listening. In radio days they took a vacation from normal radio listening because that was their main entertainment medium during the winter months. Now that television is the basic entertainment medium in TV homes, radio and record listening will provide the summertime change that most people seek.

Other organizations have prepared to handle low-voltage house wiring, or air conditioner installation and maintenance, or electronically operated garage doors as a fill-in for the normal seasonal slump in television servicing. But whatever vehicle these organizations selected to cushion the normal drop in volume, *planning* for it was started months and months ago.

### Service Business Management

All set manufacturers are vitally interested in the development of strong, technically qualified, intelli-

gently managed independent service organizations in every city, town, and village across the country. Many of them are spending substantial amounts of money to determine what it takes to operate an electronic service business profitably and are passing the results of their findings along to the service industry.

Russ Hanson of *Motorola*, for instance, advises service operators to plan technicians' time so the business will average \$50 per-day-per-skilled technician. He also cautions not to let payrolls exceed 40% of gross sales. He urges service executives to work on the basis of monthly budgets with real cost records and to keep records of service requests, jobs completed, payroll and productivity of each man, backlog of work, and how long each job was in the shop and why.

In their conversations with successful service business executives in all sections of the country your editors have found that in the top businesses, management *knows* volume, productivity, costs, and gross profit either daily or weekly. Most of them have programs all planned to jack up volume when business drops.

### Management Planning

Dan Creato, vice-president of the *RCA Service Company*, recently outlined the basics for successful service business management in a talk given before the Allied Technicians Association of West Collingswood, N. J.

"Television servicing can be highly profitable," he said, "but only if efficient technical service is combined with good business management."

"The palmy days of 1946 are over. The desperate shortage of trained technicians has improved. People no longer find it necessary to pick just any kind of television service. They have been conditioned to demand and expect the best.

"When I say that people demand and expect the best, I say it without regard to the size of the servicing organization. And when I say that an efficient operation is essential, I mean it for the small shop as well as for the larger service business. The customer expects the same good service from both. And each can go broke just as easily as the other without an efficient operation."

Mr. Creato pointed out the vital necessity for *planning*—"a man doesn't get far unless he knows where he is going"—and outlined the elements of good service business planning. He stressed the necessity for setting up an operating budget and detailed the elements that must be included in this basic blueprint of service management.

In discussing technician training he pointed out that no technician can be expert in servicing all makes of sets. He said, "If a service organization establishes a policy of servicing all makes of sets, it must be prepared to accept the responsibility of training its technical personnel in the basic

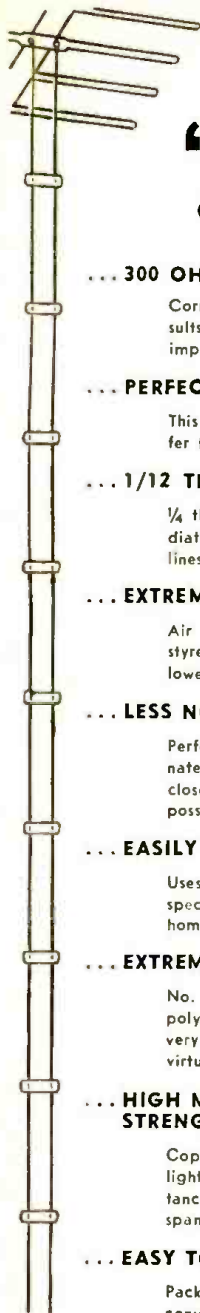

FOR VHF UHF TV INSTALLATIONS

LOW LOSS 300 OHM

**"LL300"**

OPEN WIRE LINE  
PATENT APPLIED FOR

... 300 OHMS IMPEDANCE

Correct size wire and spacing results in 300 ohms characteristic impedance.

... PERFECT IMPEDANCE MATCH

This means maximum signal transfer from the antenna to set.

... 1/12 THE RADIATION LOSS

1/4 the spacing means 1/12 the radiation loss of 450 ohm open wire lines.

... EXTREMELY LOW LOSS

Air dielectric plus clear polystyrene spacers results in the lowest possible loss of signal.

... LESS NOISE PICKUP

Perfect impedance match eliminates standing waves—this plus close spacing results in the lowest possible noise pickup.

... EASILY INSTALLED

Uses conventional stand-offs—no special hardware needed. Enters home through 1/2" hole.

... EXTREMELY LONG LIFE

No. 18 copperweld conductors, polystyrene spacers combined with very low wind resistance means virtually indefinite life.

... HIGH MECHANICAL STRENGTH

Copperweld construction plus light weight and low wind resistance make 200' unsupported spans possible.

... EASY TO USE SPOOLS

Packaged on 100, 150, 200, 250' convenient, easy to use spools.

All the above features mean: **BETTER RECEPTION—LONG LIFE—EASE OF INSTALLATION PLUS LOW COST** when you use LL-300 OPEN WIRE. Order through your Jobbers or write for free circular.

R. J. BUCHAN CO. BRICELYN 1, MINN.

Read  
**RADIO & TELEVISION NEWS**  
Every Month

**CODE SENDING RECEIVING SPEED**

HIGH SPEED WITHOUT NERVOUS TENSION

REVEALING BOOK shows how "crack" operators develop high speed and proficiency. Learn code for Amateur or Commercial Radiotelegraph License, or improve your sending and receiving.

with the Candler System which develops radiotelegraph experts and code champions. **FREE BOOK!**

CANDLER SYSTEM CO. Denver, Colo. Box 928, Dept. 244.

July, 1953

'know how' governing the proper operations and maintenance of these receivers, and also recognize the fact that labor time will be high on those brands not serviced daily by the technicians."

Mr. C reato placed particular emphasis on customer relations. He stressed that good "customer relations" begin at the time a service call is received at the office and must be carried through by the actions and attitude of the technician who handles the call.

In concluding he said, "this business of television servicing will grow even bigger in the years to come. Those people who give good service and operate on a sound business basis will be a part of that growth. Those people who give poor service or operate inefficiently will fail. We must set high goals and we must meet them. We must price for profits. We must make fair and reasonable charges. We must not over-charge but we must never dabble in cut-rate service. Each of us must conduct our service business so people will say:

"That is a dependable service organization. Their service will cost some money but it is worth it." -30-

**HAMBOREE**

**T**HE Egyptian Radio Club, Inc. of Granite City, Illinois, is sponsoring its annual "Hamboree" on the Fourth of July.

The picnic and auction will run from 9 a.m. to 9 p.m. with refreshments continuously available.

To locate the picnic grounds hams should follow signs to the club located near the Illinois approach to the "Chain of Rocks" bridge on Route 66 north of Granite City, Illinois.

Additional details on this event are available from the Club secretary W. F. Guenneug, Box 1300, R.R. 1, 700 S. Chouteau Slough Road, Granite City, Illinois. The club station is W9ATU. -30-

**HONORS FOR TWO**

**J**ACK PERMUTH and Sam Bialek of Clarostat were honored by the company at a cocktail party and banquet held during the Radio Pacts Show in Chicago.

Both men received 25-year pins, gold watches, and scrolls as tokens of appreciation for their services to the firm. -30-

**PHOTO CREDITS**

Page	Credit
31, 32, 33, 34, 125	Dage Electronics Corp.
35	P. J. Samerjan
43	Sound Workshop
44 (left), 48, 49, 50, 112	Radio Corporation of America
44 (center & right)	Raytheon Manufacturing Co.
55	Zenith Radio Corporation
61, 98	The Heath Company

THE  
*Original*  
WRENCH  
WITH THE  
SCREWDRIVER ACTION!

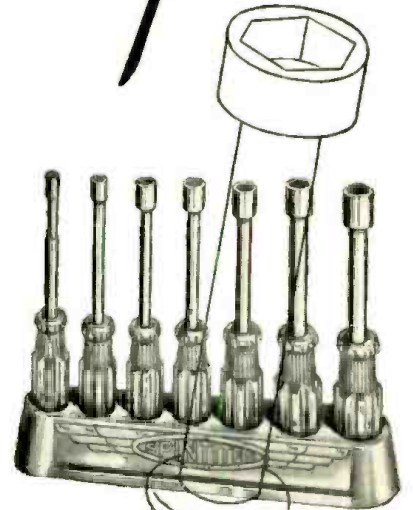

**SPINTITE**  
REG. U. S. PAT. OFFICE

120 STYLES and SIZES

for

- ASSEMBLY WORK
- REPAIR WORK
- RADIO
- TELEVISION
- INDUSTRIAL
- AIRCRAFT



**STEVENS WALDEN, Inc.**  
WORCESTER 4, MASS.



# BUILD 15 RADIOS AT HOME ONLY

With the New Improved 1953 Progressive Radio "EDU-KIT" **\$19<sup>95</sup>**

NOW INCLUDES  
SIGNAL TRACER  
and  
CODE OSCILLATOR

- FREE TOOLS WITH KIT
- ABSOLUTELY NO KNOWLEDGE OF RADIO NECESSARY
- NO ADDITIONAL PARTS NEEDED
- EXCELLENT BACKGROUND FOR TELEVISION
- 10-DAY MONEY-BACK GUARANTEE



## WHAT THE PROGRESSIVE RADIO "EDU-KIT" OFFERS YOU

The "Edu-Kit" offers you a Home Radio Technician Course at a rock-bottom price. You will learn how to identify Radio Symbols and Diagrams; how to build radios, using regular radio schematics; how to wire and solder in a professional manner. You will learn how to operate Receivers, Transmitters, and Audio Amplifiers. You will learn how to service and trouble-shoot radios. You will learn code. You will receive training for F.C.C. license. In brief, you will receive a basic education in Radio exactly like the kind you would expect to receive in a Radio Course costing several hundred dollars.

### THE KIT FOR EVERYONE

It is not necessary that you have even the slightest background in science or radio. The "Edu-Kit" is used by young and old; by radio schools and clubs; by the Veterans' Administration for Vocational Guidance and Training. No instructor is required. Instructions are complete, simple and clear. You cannot make a mistake.

### PROGRESSIVE TEACHING METHOD

The "Edu-Kit" uses the principle of "Learn by Doing." Therefore you will build radios, perform jobs, and conduct experiments to illustrate the principles which you learn. You begin by learning the function and theory of each of the radio parts. Then you build a simple radio. Gradually, in a progressive manner, you will find yourself constructing more advanced multi-tube radio sets, and doing work like a professional Radio Technician. The "Edu-Kit" Instruction Books are exceedingly clear in its explanations, photographs and diagrams.

### The Progressive Radio "EDU-KIT" Is Complete

You will receive every part necessary to build fifteen different radio sets. Our kits contain tubes, tube sockets, chassis, variable condensers, electrolytic condensers, mica condensers, paper condensers, resistors, line cords, selenium rectifiers, tie strips, coils, hardware, tubing, hook-up wire, solder, etc. Tools are included, as well as an Electrical and Radio Tester. Complete, easy-to-follow instructions are provided. In addition, the "Edu-Kit" now contains lessons for servicing with the Progressive Signal Tracer, F.C.C. instructions, quizzes. The "Edu-Kit" is a complete radio course, down to the smallest detail.

### TROUBLE-SHOOTING LESSONS

Trouble-shooting and servicing are included. You will be taught to recognize and repair troubles. You will build and learn to operate a professional Signal Tracer. You receive an Electrical and Radio Tester, and learn to use it for radio repairs. While you are learning in this practical way, you will be able to do many a repair job for your neighbors and friends, and charge fees which will far exceed the cost of the "Edu-Kit." Our Consultation Service will help you with any technical problems which you may have.

### FREE EXTRAS IN 1953

- Electrical and Radio Tester
- Electric Soldering Iron
- Book on Television
- Radio Trouble-Shooting Guide
- Membership in Radio-Television Club
- Consultation Service
- Quizzes
- Training for F.C.C. License

Send me the "Edu-Kit" with Money-back Guarantee—include All FREE extras.

- Check or M.O. enclosed—postage prepaid  
 C.O.D. (U. S. Only)—I will pay postage  
 Send further information

Outside U.S.A.—cash orders only; send international M.O. or check on U.S. bank. Postage Prepaid. "Edu-Kit" for 210-250 V. AC/DC \$22.45.

NAME \_\_\_\_\_

ADDRESS \_\_\_\_\_

**PROGRESSIVE ELECTRONICS CO.**

497 Union Ave., Dept. RN-20, Brooklyn 11, N.Y.

# INDEX OF Advertisers

JULY 1953

[While every precaution is taken to insure accuracy, we cannot guarantee against the possibility of an occasional change or omission in the preparation of this index.]

ADVERTISER	PAGE	ADVERTISER	PAGE
Airex Radio Corp.	90	McGee Radio Company	78/79
Allied Radio Corp.	9	McGraw Hill Book Co., Inc.	108
Almo Radio Company	56	Mallory & Company, P. R.	17, 4th cover
American Microphone Co.	103	Mattison Television & Radio Corp.	86
American Phenolic Corporation	26	Michel Mfg. Co.	133
American Television & Radio Co.	101	Miles Reproducer Co., Inc.	127
Amperite Company	96	Milwaukee School of Engineering	84
Amplifier Corp. of America	98	Moss Electronic Distributing Co., Inc.	85
Arday Radio Kits	90	National Company	121
Arrow Electronics	110	National Electronics of Cleveland	96
Arrow Sales	76	National Radio Institute	3
Asco Sound Corporation	117	National Schools	23
Ashe Radio Company, Walter	28	Newark Electric Company	82
Atlas Sound Corp.	110	Newark Surplus Materials Co.	126
Audak Company, Inc.	104	Newcomb Audio Products Co.	24
Audel, Publishers	104	Offenbach & Reimus	125
Bell Telephone Laboratories	6	Olson Radio Warehouse	99
Boulevard Electronics, Inc.	103	Onan & Sons, D. W.	102
Brook Electronics, Inc.	116	Peak Electronics Co.	126
Buehan Company, R. J.	135	Perma-Power Company	102
C & H Sales Co.	92	Phillips Tube Company, Incorporated	90
Candler System Co.	135	Photocon Sales	120
Capitol Commodities Co., Inc.	112	Pickering & Company	29
Capitol Radio Engineering Institute	93	Platt Electronics Corp.	130
C B S Hytron	81	Premax Products	120
Centralab	19	Premier T.V. Radio Supply	97
Century Electronics Co.	137	Progressive Electronics	136
Channel Master Corporation	20 & 21	Quietrole Company	114
Cleveland Institute of Radio Electronics	25	RCA Institutes, Inc.	91, 133
Collins Audio Products Co., Inc.	13	R. W. Electronics	123
Columbia Electronic Sales	132	Radiart Corporation	12
Commissioned Electronics Co.	137	Radio City Products, Inc.	134
Communication Equipment Co.	132	Radio Corporation of America	2nd cover
Concord Radio	22, 76	Radio Craftsmen, Inc.	16
Cook Labs, Inc.	123	Radio Engineering Company	136
Coyne Electrical School	129	Radio-Television Training Association	15
DeCray & Associates, Frank W.	100	Rad-Tel Tube Co.	137
DeForest's Training, Inc.	5	Raytheon Mfg. Company	67
Du Kane Corporation	131	Regency	92
Editors & Engineers Limited	129	Relay Sales	106
Electronic Instrument Co., Inc.	30, 76	Rider Publisher, Inc., John F.	100
Electronic Measurements Corp.	109	Rinehart Books, Inc.	131
Electronic Specialty Supply Co.	121	Sams & Company, Howard W.	75, 88
Electro Voice	8	Sarkes Tarzian, Inc.	110
Erle Resistor Corporation	114	Schott Company, Walter L.	11
Fairchild Recording Equipment	131	Shure Brothers	128
Fair Radio Sales	120	South River Metal Products Co., Inc.	68
Federal Telephone & Radio Corporation	3rd cover	Sprayberry Academy of Radio	69
Fisher Radio	89	Stan Burn Radio & Electronics	125
Franklin Technical Institute	123	Stephan Sales Corp.	104
G & H Wood Products	109	Steve-Et Electronics Corp.	68
G. L. Electronics	94	Stevens Walden, Inc.	135
General Electric Company	27	Sun Parts Distributors, Ltd.	108
Goodheart, R. E.	117	Sylvania Electric Products, Inc.	87
Greenlee Tool Co.	82	TAB	138
Greenwich Sales Company	133	Television Communications Institute	102
Hallcrafters	7	Terado Company	125
Harvey Radio Company	122	Transvision, Inc.	118, 119
Heath Company	71/74, 95	Trlo Manufacturing Co.	77
Henshaw Radio Supply	123	Tri-State College	119
Hughes Research & Development Laboratories	70, 96	United States Wire & Cable Corporation	111
Illinois Research Laboratories	68	University Loudspeakers, Inc.	124
Indiana Technical College	129	V-M Corporation	115
Instructograph Company	110	Valparaiso Technical Institute	127
International Resistance Co.	83	Waldom Electronics, Inc.	100
J F D Mfg. Co.	119	Western Electronics Co.	127
J S H Sales Co.	119	Western Television Institute	90
Jensen Industries, Inc.	82	Westinghouse Electric Corporation	10
Jones & Laughlin Steel Corporation	18	Wholesale Radio Parts Co., Inc.	133
K. W. Sales Company	113	Winsor Electronic Tube Co.	125
Lako Company	121	World Radio Laboratories	127
Lampkin Laboratories	129		
LaPointe Electronics, Inc.	14		
Leeds Radio Co.	124		
Leotone Radio Corp.	114		

## NEW IDEAS WANTED. NEW ELECTRONIC ACCESSORY ITEMS TO MANUFACTURE AND MARKET

Sales and Service Organization Available . . . What Have You to Offer in Facsimile • Industrial Television • Telephone • Radio

Note . . . We Have a Special, Immediate Need of Facsimile Equipment for Intra-office and Plant Use.

We Need . . . Selective Radio Signal Transmitter and Selective Radio Signal Receivers to Locate Doctors in Hospitals.

Receiver Weight Should Be 5-10 Ounces

**RADIO ENGINEERING COMPANY**

Inquirer Building, Philadelphia 30, Pennsylvania



# Classified

Rate 50c per word. Minimum 10 words

## RADIO ENGINEERING

COMPLETE radio, electronics theory & practice; television; broadcasting; servicing; aviation, marine, police radio. 12 or 18 months. Catalog. Valparaiso Technical Institute, Dept. N, Valparaiso, Ind.

### FOR SALE

SELL used television receivers. Large market. Prices start at \$10 and up. Buy direct from us. Send forty cents for price lists and descriptions. Ace Television, Kalamazoo, Michigan.

TAPE Recorders, Tapes, Accessories. Unusual Values. Dressner, 621-R East 20th St., New York City 2, N. Y.

TUBES and equipment bought, sold, and exchanged. For action and a fair deal, write B. N. Gensler, W2LNI, 136 Liberty, New York 6, N. Y.

ALL types of Antennas for Amateur and TV, Aluminum Tubing. Willard Radcliff, Fostoria, Ohio.

ROOSTERS, \$7.95. Standard Coil B-51 in original factory sealed cartons. Pacific Television Enterprises, 915 Dairy Ave., Corcoran, Calif.

NEW RCA 3A1A original cartons, \$8.75 each. Tubes, surplus—bought, sold. Free list. Write, Mark, Box 14, New York City 72.

DIAGRAMS—Radio 75c; record changers, recorders \$1.25. Television with service data \$2.00. Where model unknown, give part numbers. Kramer's Radio Service, Dept. J53, 36 Columbus Ave., New York 23, N. Y.

ISOLATION transformer 35w 117v see 117 or 135 plus 6.3v 15a 2 1/4 x 2 1/2 x 3. \$2.45 includes postage 3 lbs. Bulletin available. Empire Electronics Company, 409a Avenue L, Brooklyn 30, N. Y.

TV-FM antennas. All types including UHF. Mounts, accessories. Lowest prices. Wholesale Supply Co., Dept. H, Lunenburg, Mass.

BATHTUB condensers, nationally famous, 1ufd 600v, 30c, 10,000 ohm potentiometers, nationally famous, 15c, 7 for \$1.00. Radio Surplus 5&10, 41 W. Main, Branford, Conn.

### WANTED

AN/APR-4, other "APR," "ARR," "TS," "IE," ARC-1, ARC-3, ART-13, everything surplus; Tubes, Manuals, Laboratory equipment. Describe, price in first letter. For Sale: Reconditioned Watthour Meters, four for \$10.00. Engineering Associates, 434 Patterson Rd., Dayton 9, Ohio.

WILL buy all Art-13/type T-17A, \$200.00. Art-13/type T-47, \$150.00. BC-348 unmodified, \$75.00. BC-348 modified, \$55.00. APN-9, \$200.00. ARC-3 complete, \$750.00. R77 Receivers, \$100.00. ARC-1, \$600.00. BC-312, \$65.00. BC-312, \$60.00. Ship via Express C.O.D., subject to inspection to: H. Finnegan, 49 Washington Ave., Little Ferry, N. J.

### CORRESPONDENCE COURSES

USED correspondence Courses and Books sold and rented. Money back guarantee. Catalog free. (Courses bought.) Lee Mountain, Pisgah, Alabama.

RAILROAD and Radio Telegraph Home-Study Courses. One dollar per lesson. Complete Course 36 lessons. Bell Communication School, 10 Parker Ave., San Francisco 18, Calif.

### PATENT ATTORNEYS

ATTENTION: Inventors of Electronic, Electrical, Audio, Automobile Products. Will buy or pay royalties on any manufacturable ideas if inventions are possible money makers. We manufacture. Please write Box 535, Radio & Television News, 64 E. Lake St., Chicago 1, Illinois. Advise arrangement for discussion.

A SERVICE for selling inventions. Patent Engr. Dev. Co., 617 Pioneer Amer. Bldg., Houston, Texas.

### MISCELLANEOUS

SPEAKERS repaired, wholesale prices, guaranteed workmanship. Amprite Speaker Service, 70 Vesey St., New York City 7.

RICHES, Security, Happiness, Yours to achieve. Booklet, \$1.00. W. A. Horn, P. O. Box 763, San Francisco, Calif.

TEST Equipment repaired and Calibrated by factory staff. All makes. Solar, Simpson, Triplett, Heath, etc. Immediate service. Douglas Instrument Laboratory, 176 Norfolk Ave., Boston 19, Mass.

RECONDITIONED Televisions, \$30.00 up. WIAPL, 1420 South Randolph, Arlington, Texas.



# 70% to 90% off list! TOP TUBE BUYS

All Tubes Individually Boxed! Check this list for Rigidly-Tested, Full One-Year Guaranteed Tubes.

Type	Price	Type	Price	Type	Price	Type	Price	Type	Price
1A5GT	.30	5V4	.73	6BL7	.59	6W6GT	.44	19T8	.79
1A6G	.30	5W4	.50	6B06GT	.59	6X4	.37	19V8	.89
1A7GT	.47	5X4	.40	6BQ7	.95	6X5GT	.37	24A	.63
1AB5	.30	5Y3G	.32	6BZ7	.95	6X8	.61	25AV5	.83
1B3	.65	5Y3GT	.32	6C4	.37	6Y6G	.48	25B06GT	.62
1B5	.30	5Y4G	.35	6C5GT	.39	7A4	.47	25L6GT	.39
1B7GT	.30	5Z3	.46	6C6	.58	7AF7	.53	25W4	.56
1C5GT	.43	6A7	.59	6C8C	.24	7B4	.44	25Z5	.40
1E7	.29	6A8	.62	6CB6	.44	7C6	.40	25Z6GT	.37
1G4GT	.24	6AB4	.44	6CD6G	1.11	7E6	.30	26	.45
1G6	.30	6AC5	.43	6D6	.45	7X7	.70	27	.39
1H4C	.30	6AJ5	.90	6E5	.48	12A8	.61	32L7	.89
1H5GT	.40	6AK5	.75	6F5GT	.39	12AL5	.37	32L7	.89
1H6	.24	6AL5	.38	6F6	.37	12AT6	.37	35B5	.40
1J6	.24	6AQ5	.39	6F8C	.24	12A77	.56	35C5	.39
1L4	.46	6AQ6	.37	6G6C	.52	12A8V	.38	35L6GT	.41
1LC5	.51	6AR5	.37	6H6GT	.41	12AU7	.43	35W4	.37
1N5	.46	6A55	.50	6J5GT	.37	12AV6	.39	35Z5GT	.37
1P5	.57	6AT6	.37	6J6	.52	12AV7	.59	36	.60
1Q5	.58	6AU6	.38	6J7C	.43	12AX4	.48	41	.42
1R5	.45	6AV5	.83	6J8	.30	12AX7	.48	42	.42
1S5	.39	6AV6	.37	6K5	.47	12AZ7	.69	43	.55
1T4	.45	6AX4	.53	6K6GT	.37	12BA6	.38	45	.55
1T5	.53	6AX6G	.24	6K7	.44	12BA7	.60	45Z5	.49
1U4	.45	6B4C	.64	6L5	.24	12BD6	.45	50B5	.39
1U5	.39	6BA6	.39	6L6	.64	12BE6	.39	50C5	.39
1V	.60	6BA7	.57	6Q7	.45	12BF6	.39	50C6	.59
1X2	.63	6BC5	.44	6S4	.38	12BH7	.63	50L6GT	.41
2A3	.70	6BC7	.34	6S8	.53	12BY7	.65	50Y7	.50
2A4G	.24	6BD5GT	.59	6SA7GT	.43	12C8	.34	53	.24
2X2	1.50	6BD6	.45	6SD7GT	.41	12F5GT	.34	56	.24
3A4	.45	6BE6	.39	6SF5GT	.46	12J5GT	.42	57	.58
3E5	.46	6BF5	.41	6SG7GT	.41	12J7GT	.34	58	.60
3Q4	.48	6BF6	.37	6SH7	.73	12K7GT	.34	70L7GT	1.09
3O5GT	.49	6BG6G	1.25	6SJ7GT	.41	12L8	.70	75	.41
3S4	.46	6BH6	.46	6SK7GT	.41	12SA7GT	.44	76	.44
3V4	.47	6BJ6	.39	6SL7GT	.48	12SF5	.50	77	.57
5U4G	.45	6BK7	.59	6SN7GT	.52	12SG7GT	.52	78	.47
				6S7GT	.37	12SJ7	.44	80	.35
				6SR7GT	.45	12SL7GT	.48	83	.68
				6S57	.42	12SL7GT	.47	85	.59
				6T8	.56	12SN7GT	.52	117L7	.37
				6U4	.60	12S07	.44	117Z3	.37
				6U5	.44	12SR7	.49	807	.99
				6U6	.63	14J7	.30	1274	.99
				6U8	.61	14W7	.30	1274	.99
				6V6GT	.39	19BG6G	.95	2050	1.85
				6W4GT	.44	19C8	.70	6113	1.00

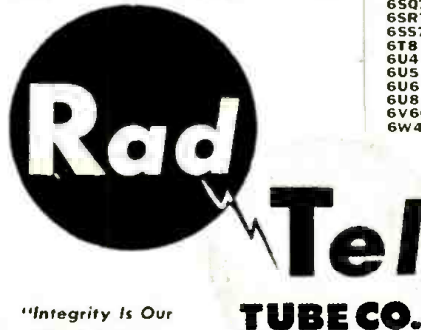

"Integrity Is Our Chief Asset"  
Phone: Essex 5-2947

TERMS: A 25% deposit must accompany all orders—balance C.O.D. All shipments F.O.B. Irvington warehouse. Orders under \$10—\$1.00 Handling Charge. Subject to prior sale.

Don't Delay . . . Order Today!

115 COIT STREET  
Dept. RN-7  
IRVINGTON 11, N. J.

### RECORDING TAPE (PLASTIC BASE)

40% OFF

WASHINGTON, D. C.: WHERE ELSE WOULD THERE BE MORE REO ^ TAPE?

\* 1200 ft. blastic tape with blastic reel included. Each reel individually boxed. Choice of nationally famous top quality brands such as: RECEVES (SPN-12) 3.20; WEICOM (2008) 3.20; OJBO (1251) 3.23; SCOTCH (111-A) 3.25; URSHI. Professional Grade (211) RPA) 3.30. (List Price on above tapes are 5.50 ea.)

• 10% additional discount to Club Members of: A. TAPE-RESPONSE INTERNATIONAL, 3488-22nd St., San Francisco, Calif. (Fred Goetz, Secretary)

B. VOICES-RESPONSE CLUB, 1814 N. Mango Ave., Chicago, Illinois (John Schirmer, Secretary)

New empty blastic reels in boxes for easy labeling 3"—10c; 4"—22c; 5"—24c; 7"—30c each. EMPTY BOXES, 3"—3c; 4"—5c; 5"—5c; 7"—10c.

• We carry new recorders, recording blanks, tape, tape recorders, etc., at large savings. PLEASE INCLUDE SUFFICIENT POSTAGE.

COMMISSIONED ELECTRONICS CO.  
2503 Champlain Street, N.W., Washington, 9, D.C.

### THE NEW DYNATRACER\*

Designed To  
DOUBLE YOUR PROFITS  
CHECK SETS IN THE HOME  
Makes TV servicing easier,  
faster and more accurate at  
LOW COST.

Trace signals and voltages—  
Locate defective components  
instantly.

REQUIRES NO  
ADDITIONAL EQUIPMENT  
"DYNATRACER" is a portable self-  
powered quality instrument that is  
used under actual operating condi-  
tions. "DYNATRACER" is designed  
to trace signals through any video,  
sound, sync, AFC, vertical or hori-  
zontal sweep circuit and instantly  
isolate trouble to a stage or com-  
ponent.

ADDED FEATURE:—

With a flick of the switch, the  
"DYNATRACER" will also trace voltages and in-  
stantly locate open, shorted or intermittent condens-  
ers, resistors, coils, speakers, transformers, etc.  
Complete instructions and Trouble-Shooting Methods  
Enclosed. Satisfaction guaranteed.  
Century instruments are quality engineered for ac-  
curate and efficient servicing.

CENTURY ELECTRONICS CO.  
8509-21st Ave., Dept. 202, Brooklyn 14, N. Y.



\$4.95

P.P.O. OR C.O.D.  
PLUS POSTAGE  
WITH CHARGES







Presenting *Federal's* TV-1185

...**"PIPELINE"** of the air!



with the all-weather "silver" pigmentation that lets you  
**INSTALL IT** and **FORGET IT!**

FEDERAL'S TV-1185 — newest sensation of the top-quality twin-leads — is virtually a "pipeline" for better-than-ever TV reception... VHF or UHF!

Insulated with the revolutionary Federal-developed "silver" polyethylene, TV-1185 is amazingly *tough* and *efficient*. It repels sunlight... fights heat... resists moisture and salt spray and other destructive deposits. Dirt and dust *tumble* off its fine, smooth, tubular surface!

TV-1185 keeps the energy field inside the weather-proof "silver" polyethylene sheath... providing *low loss*... *more constant impedance*... a better TV picture regardless of area or length of lead!

There's nothing finer for VHF or UHF than Federal's "pipeline" twin-lead... *because nothing but the finest has gone into its design and production!*

For complete details see your Federal distributor or write to Dept. D-559.

**OUTSTANDING FEATURES  
OF FEDERAL'S  
TV-1185**

- Exceptionally low loss
- Holds impedance values
- Copperweld conductors—7/#28
- Leads in Weatherometer tests
- Flexible in low temperatures
- Minimizes deterioration due to sunlight.
- Top performer in any area
- Attenuation- db/100 ft.

10 mc— 0.50	400 mc— 2.6
50 " — 0.95	500 " — 3.0
100 " — 1.25	1000 " — 4.5
200 " — 1.7	

• **SO EASY TO INSTALL:**

Expose required length of wire by stripping off polyethylene. To tight-seal, heat end of tube with match or other flame and crimp together with pliers. Sealing assures quality performance under all atmospheric conditions.

*Federal*  
*Telephone and Radio Corporation*



SELENIUM-INTELIN DIVISION, 100 KINGSLAND ROAD, CLIFTON, NEW JERSEY

In Canada: Federal Electric Manufacturing Company, Ltd., Montreal, P.Q.  
Export Distributors: International Standard Electric Corp., 67 Broad St., N. Y.



Depend on Mallory  
for  
Approved Precision Quality

# GET A BIGGER SHARE

of the NEW UHF market  
with the Mallory UHF Converter



The new UHF market is a big one . . . and the Mallory UHF Converter is ready to help you make the most of it. Thousands of sets will need converting when UHF television goes on the air in your area . . . and the Mallory Converter can be your fastest moving item.

- The Mallory Converter adds *all* existing UHF channels to *any* TV set . . . without sacrificing reception of existing VHF channels.
- Mallory precision quality insures high quality picture definition . . . easy tuning.
- Your customers have nothing more to buy, no further adjustments to make . . . even if they move to another broadcast area.

*Ask* YOUR MALLORY DISTRIBUTOR

for complete details of the Mallory Converter. It has been a "best seller" in areas where UHF is already on the air. It can be your answer to a bigger share in the new UHF market.

### Installation is fast and EASY

All you need to do is connect the antenna lead and power lines from the Converter to the set. It can be done in your customers' homes in a matter of minutes.

P. R. MALLORY & CO. Inc.  
**MALLORY**

CAPACITORS • CONTROLS • VIBRATORS • SWITCHES • RESISTORS  
RECTIFIERS • POWER SUPPLIES • FILTERS • MERCURY BATTERIES

**APPROVED PRECISION PRODUCTS**

P. R. MALLORY & CO. Inc., INDIANAPOLIS 6, INDIANA