

RADIO & TELEVISION NEWS

ANC

APRIL
1952
35¢
Canada 40¢

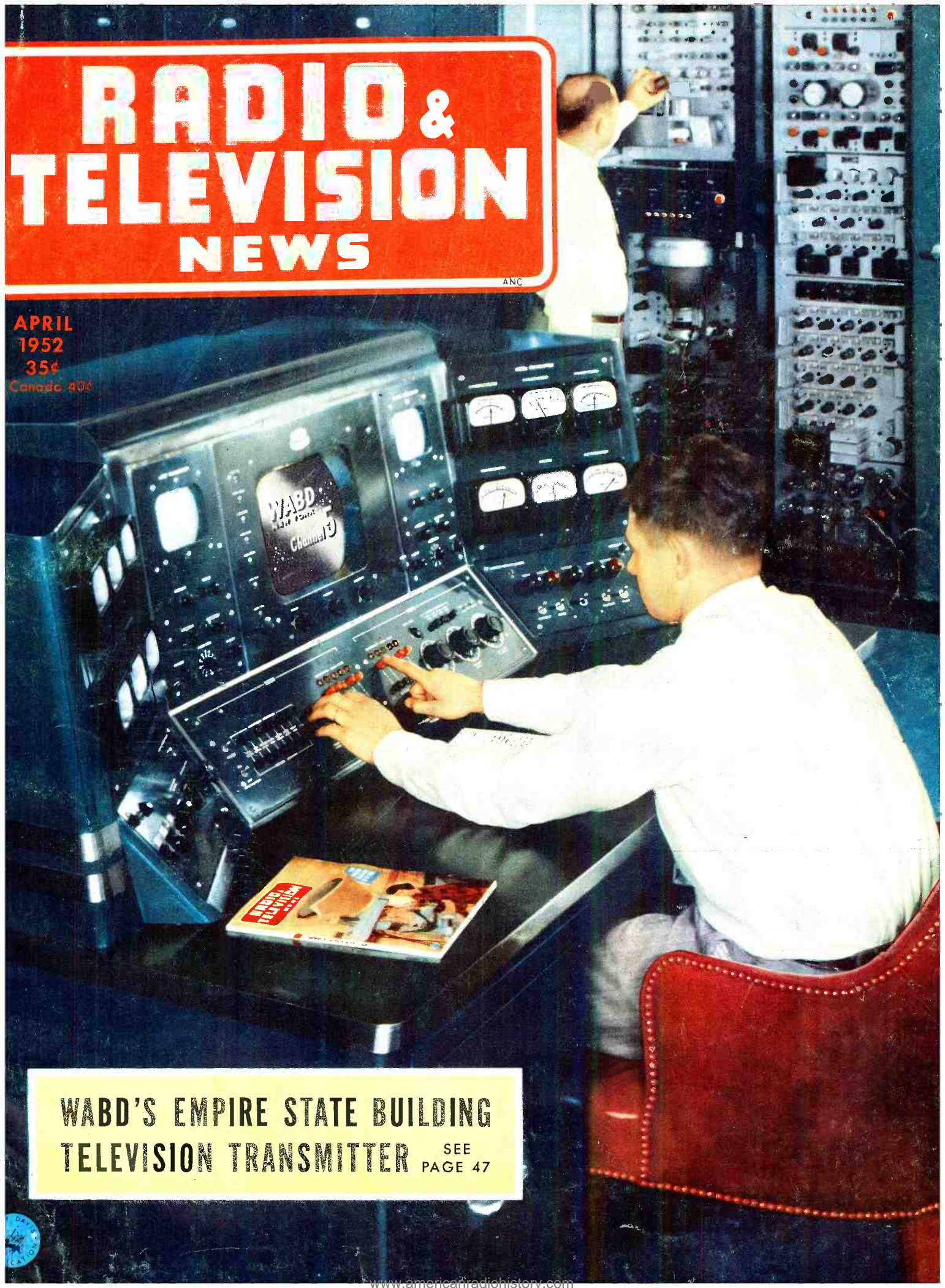

WABD'S EMPIRE STATE BUILDING
TELEVISION TRANSMITTER SEE
PAGE 47

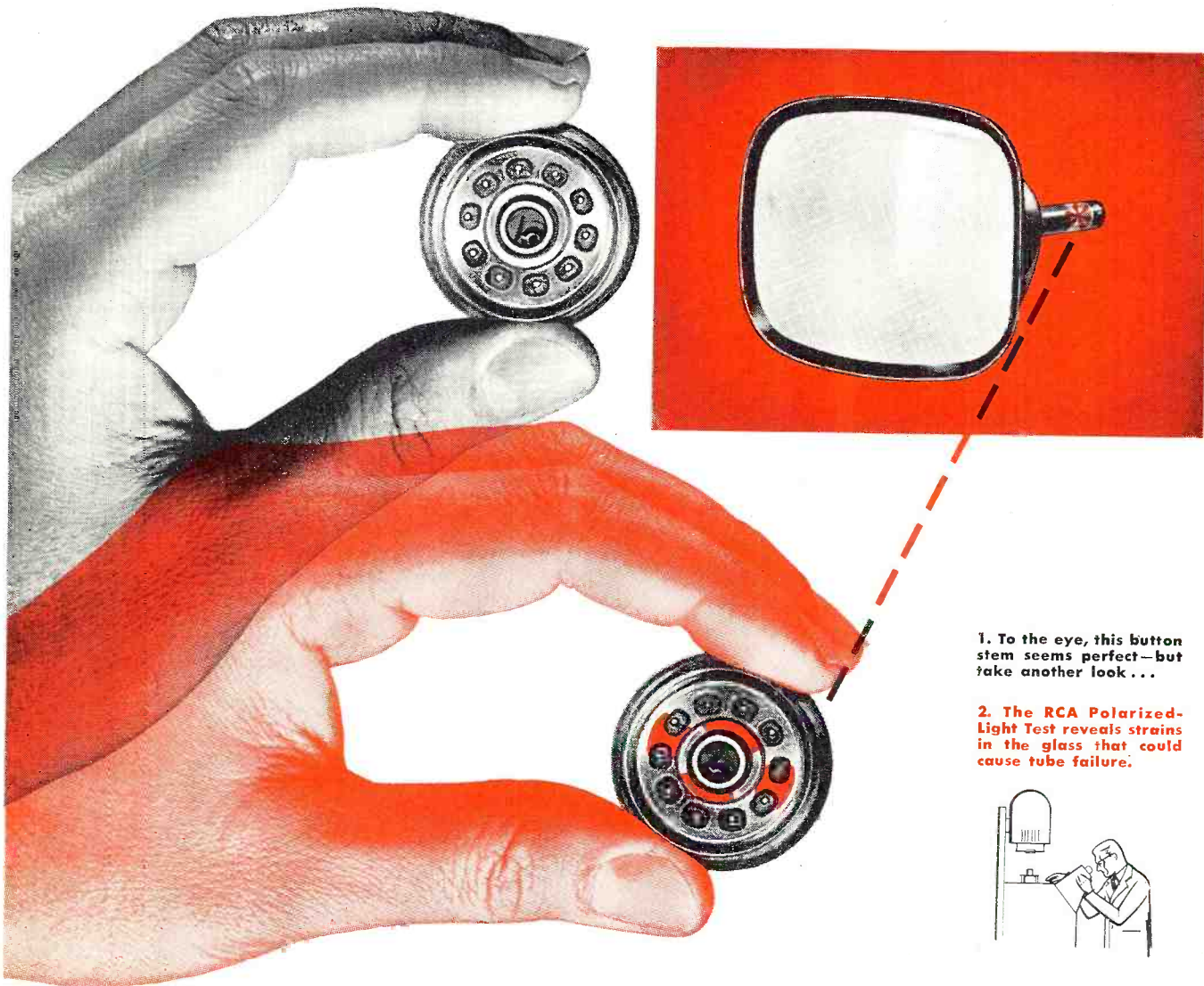

1. To the eye, this button stem seems perfect—but take another look...

2. The RCA Polarized-Light Test reveals strains in the glass that could cause tube failure.

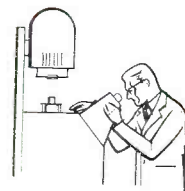

A DOUBLE-TAKE to safeguard your reputation

AT FREQUENT INTERVALS throughout the day, RCA production inspectors pick finished button stems hot off the griddles of the sealing machines, and subject them to an ingenious "polarized-light test." Reason? Even slight variations in sealing temperature can, and do, set up strains in the areas of glass-to-glass and glass-to-metal seals that could result in fractures. The Polarimeter... especially designed for RCA... reveals these otherwise invisible strains, and prevents im-

perfect assemblies from reaching the final production line.

By taking a second look, RCA virtually licks a possible fracture before it occurs... not only on button stems, but also neck-to-flare seals and the face-plate section adjacent to the rim seal of metal-shell picture tubes.

This constant vigilance and *quality control* at *all* stages of manufacture assure that RCA standards will be met on the final assembly line. In this way, RCA closely guards its own reputation

for quality... and yours as well.

In RCA picture tubes, the difference is *top-quality control*. That's why, dollar for dollar, RCA picture tubes have no equal.

With RCA Receiving Tubes, as well as RCA Kinescopes, **TOP-QUALITY CONTROL** makes the difference.



RADIO CORPORATION of AMERICA
ELECTRON TUBES
HARRISON, N. J.



I Will Show You How to LEARN RADIO-TELEVISION SERVICING OR COMMUNICATIONS by Practicing in Spare Time



YOU PRACTICE RADIO SERVICING

You build the modern Radio shown below as part of my Servicing Course. I send you speaker, tubes, chassis, transformer, loop antenna, everything you see pictured and EVERYTHING you need to build this modern Radio Receiver. Use it to make many tests, get practical experience.



YOU PRACTICE RADIO COMMUNICATIONS

I send you all the parts to build Transmitter shown below as part of my new Communications Course. Conduct actual procedure of Broadcast Operators, practice interesting experiments, learn how to actually put a transmitter on the air.

EXTRA PAY IN ARMY, NAVY, AIR FORCE
Knowing Radio, TV, Electronics can help you get extra rank, extra prestige, more interesting duty at pay up to several times a private's base pay. You are also prepared for good Radio-TV jobs upon leaving service. Mail coupon TODAY.

NEW

I TRAINED THESE MEN

"After graduating, worked for servicing shop. Now Chief Engineer of three Police Radio Stations."—S. W. DINWIDDIE, Jacksonville, Illinois.



"While learning, made \$5 to \$10 a week in spare time. Now have a profitable spare time shop."—L. ARNOLD, Pontiac, Mich.



"I accepted a position as Radio and Television Technician. . . was promoted to manager of Television Service and Installation."—L. HAUGER, San Bruno, California.



"Have my own shop. Am authorized serviceman for five manufacturers and do servicing for 7 dealers."—P. MILLER, Maumee, O.



"Four years ago, a bookkeeper on a hand-to-mouth salary, am now a Radio Engineer ABC network."—N. H. WARD, Ridgefield Park, New Jersey.



"When I enrolled, had no idea it would be so easy to learn. Have equipped my shop out of spare time earnings. I am clearing about \$40 to \$60 a month."—J. D. KNIGHT, Denison, Tex.



I Will Train You at Home with MANY KITS OF PARTS I SEND

Do you want good pay, a job with a bright future and security? Would you like a profitable shop of your own? The fast growing, prosperous RADIO-TELEVISION industry is making these opportunities for you. Radio alone is bigger than ever. 90 million home and auto Radios, 3100 Broadcasting Stations, expanding use of Aviation and Police Radio, Micro-Wave Relay, Two-Way Radio for buses, taxis, etc., are making opportunities for Servicing and Communications Technicians and FCC-Licensed Operators.

Many Soon Make \$10 A Week Extra in Spare Time Keep your job while training at home. Hundreds I've trained are successful RADIO-TELEVISION TECHNICIANS. Learn Radio-Television principles from illustrated lessons. Get PRACTICAL EXPERIENCE experimenting with circuits common to Radio and Television. Many students make \$5, \$10 a week extra fixing neighbors' Radios in spare time. Special Booklets start teaching you the day you enroll.

Television is TODAY'S Good Job Maker
In 1946 only 6,000 TV sets sold. In 1950 over 5,000,000. By 1954, 25,000,000 TV sets will be in use, according to estimates. Over 100 TV Stations are operating in 35 states. Authorities predict there will be 1,000 TV Stations. This means new jobs, more jobs, good pay for qualified men.

Send Now for 2 Books FREE—Mail Coupon
Send for my FREE DOUBLE OFFER. Get actual Servicing lesson. Also get my 64-page book, "How to Be a Success in Radio-Television." Read what my graduates are doing, earning. Send coupon in envelope or paste on postal. J. E. SMITH, President, Dept. 2DE, National Radio Institute, Washington 9, D. C. OUR 39TH YEAR.

NOW! Advanced Television Practice
New, special TV kits furnished to build high-definition SCOPE . . . RF OSCILLATOR with flyback power supply . . . complete TV set . . . many other units. You see pulse, trapezoidal, saw-tooth wave forms. Get valuable PRACTICAL EXPERIENCE locating and correcting TV troubles. Mail coupon for facts, pictures and prices!

A TESTED WAY TO BETTER PAY...MAIL COUPON NOW

Good for Both—FREE

MR. J. E. SMITH, President, Dept. 2DE
National Radio Institute, Washington 9, D. C.
Mail me FREE Lesson and 64-page book.
(No salesman will call. Please write plainly.)

NAME.....AGE.....
ADDRESS.....
CITY.....ZONE.....STATE.....
Approved for Training Under G. I. Bill

The ABC's of SERVICING
How to Be a Success in RADIO-TELEVISION

Editor
OLIVER READ, D.Sc., D.Litt.

Managing Editor
WM. A. STOCKLIN, B.S.

Technical Editor
H. S. RENNE, M.S.

Associate Editor
HAROLD BECKER

Midwest Editor
RAY FRANK, W9JU

Assistant Editor
P. B. HOEFER

Television Consultant
WALTER H. BUCHSBAUM

Short-Wave Editor
KENNETH R. BOORD

Staff Artist
FRANK SAYLES

Chief Draftsman
B. L. NEWMAN, W9ROB

Advertising Manager
L. L. OSTEN

Midwest Adv. Manager
JOHN A. RONAN, JR.

Western Adv. Manager
JOHN E. PAYNE

Color Art Editor
HERMAN E. BOLLIN

First in
radio-television-electronics
Average Paid Circulation over 200,000



Reg. U.S. Pat. Off.

Radio News Trademark Reg. U. S. Pat. Office • Television News Trademark Reg. U.S. Pat. Office.

CONTENTS

APRIL, 1952

Interpreting That TV Pattern (Part I).....	Ken Kleidon	35
The Junction Transistor.....	H. S. Renne	38
Magnetic Tape Duplication.....	Leon A. Wortman	40
Novel Test Meter.....	Phil Weiss and Ed. Clark	42
A Single-Sideband Transmitter Adapter.....	John F. Clemens, W9ERN	43
WABD's TV Transmitter.....	Scott Helt	47
TV Antenna Couplers for Multi-Set Operation.....	Walter H. Buchsbaum	48
Adapters to Speed Up Your Service.....	Jack Darr	50
A Mobile 75-Meter V.F.O.	W. O. Crusinberry, W9DVV	52
Microwave Klystron Oscillators (Part I).....	Joseph Racker & Lawrence Perenic	54
Stacking Four Z-Matched Yagis.....	Harry Greenberg & Harold Harris	57
An Adapter for NBFM Reception.....	E. Fernandez De Castro	58
Servicing Noise-Rejection Circuits.....	P. F. Rhodes	60
Mac's Radio Service Shop.....	John T. Frye	64
A High-Quality Auditorium Amplifier.....	Lloyd B. Hust	65
Crystal Diodes in Modern Electronics (Part 7).....	David T. Armstrong	70
Vacuum Tubes as Variable Resistance Circuit Elements.....	Wayne B. Denny	72
Audio Simplified (Part 8).....	David Fidelman	74
Phono-Equalizer Chart.....	Charles P. Boegli	94
A Remote-Control for Your TV Set.....	Irving Gottlieb, W6HDM	100
Crispening and Resolution Improvement in TV Receivers.....	Edward M. Noll	106
Radio-TV Service Industry News.....		126
Improved FM Sensitivity.....	James A. Mitchell	148

DEPARTMENTS

For the Record.....	The Editor	8	What's New in Radio.....	96
Spot Radio News.....		16	Manufacturers' Literature	132
Within the Industry.....		26	Reel Review	135
Short-Wave.....	K. R. Boord	69	New TV Products.....	154
Technical Books		159		



COVER PHOTO: The master control console at WABD's new television studio in the Empire State Bldg., New York. WABD is one of five stations using the Empire State TV tower. (Kodachrome by Ed Padykula)

Chairman of the Board and Publisher
WILLIAM B. ZIFF

President
B. G. DAVIS

Secretary-Treasurer
G. E. CARNEY

Vice-Presidents
M. H. FROELICH

H. J. MORGANROTH
Production Director

LYNN PHILLIPS, JR.
Advertising Director

H. G. STRONG
Circulation Director

LOUIS ZARA

BRANCH OFFICES
CHICAGO (1)
185 N. Wabash, AN 3-5200
LOS ANGELES (14)
815 S. Hill St., TUCKER 9213



VOLUME 47 • NUMBER 4



Member
Audit Bureau of
Circulations

Editorial and Executive Offices, 366 Madison Ave., New York 17, N. Y.

RADIO & TELEVISION NEWS is published monthly by the Ziff-Davis Publishing Company at 185 N. Wabash Ave., Chicago 1, Illinois. Entered as second-class matter July 21, 1948, at the Post Office, Chicago, Ill., under the act of March 3, 1879. Entered as second-class matter at the Post Office Department, Ottawa, Canada. Postmaster—Please return undelivered copies under form 3589 to 64 E. Lake St., Chicago 1, Ill.

SUBSCRIPTION RATES: RADIO & TELEVISION NEWS—in U.S., Canada, Mexico, South and Central America, and U.S. Possessions, \$4.00 for twelve issues; in British Empire, \$5.00; all other foreign countries, \$5.00 for twelve issues. **RADIO-ELECTRONIC ENGINEERING EDITION**—in U.S., Canada, Mexico, South and Central America, and U.S. Possessions, \$6.00 for twelve issues; in British Empire, \$7.00; in all other foreign countries, \$7.00 for twelve issues. **SUBSCRIPTION SERVICE:** All communications concerning subscriptions should be addressed to Circulation Dept., 64 E. Lake St., Chicago 1, Ill. Subscribers should allow at least two weeks for change of address.

CONTRIBUTIONS: Contributors are advised to retain a copy of their manuscripts and illustrations. Contributions should be mailed to the New York Editorial Office and must be accompanied by return postage. Contributions will be handled with reasonable care, but this magazine assumes no responsibility for their safety. Any copy accepted is subject to whatever adaptations and revisions are necessary to meet the requirements of this publication. Payment covers all author's, contributor's, and contentant's rights, title, and interest in and to the material accepted and will be made at our current rates upon acceptance. All photos and drawings will be considered as part of the material purchased.

Copyright 1952 by Ziff-Davis Publishing Company. All rights reserved.

RADIO & TELEVISION NEWS

**NOW... GET EVERYTHING YOU
NEED TO LEARN AND MASTER**

TELEVISION

RADIO-ELECTRONICS AT HOME!

Use REAL commercial-type equipment to get practical experience

Your future deserves and needs every advantage you can give it! That's why you owe it to yourself to find out about one of the most COMPLETE, practical and effective ways now available to prepare AT HOME for America's billion dollar opportunity field of TELEVISION-RADIO-ELECTRONICS. See how you may get and keep the same type of basic training equipment used in one of the nation's finest training laboratories... how you may get real STARTING HELP toward a good job or your own business in Television-Radio-Electronics. Mail the coupon today for complete facts — including 89 ways to earn money in this thrilling, newer field.

D.T.I., ALONE, INCLUDES BOTH MOVIES and HOME LABORATORY

In addition to easy-to-read lessons, you get the use of HOME MOVIES — an outstanding training advantage — plus 16 big shipments of Electronic parts. Perform over 300 fascinating experiments for practical experience. Build and keep real commercial-type test equipment shown at right

Get BOTH of these information packed publications FREE!

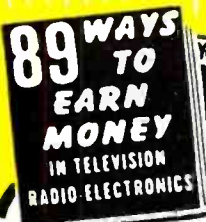

MODERN LABORATORIES

If you prefer, get all your preparation in our new Chicago Training Laboratories—one of the finest of its kind. Ample instructors, modern equipment. Write for details!

MILITARY SERVICE!

If you're subject to military service, the information we have for you should prove very helpful. Mail coupon today.

ACT NOW! MAIL COUPON TODAY!

DE FOREST'S TRAINING, INC. Dept. RN-4-1
2533 N. Ashland Ave., Chicago 14, Ill.

Without obligation, I would like your Opportunity News Bulletin showing "89 Ways to Earn Money in Television-Radio-Electronics"; also, the folder showing how I may prepare to get started in this thrilling field.

Name.....Age.....
Address.....Apt.....
City.....Zone.....State.....



17 INCH TUBE

ABOVE: Build and keep a real 17 INCH commercial TV receiver. Optional after completing regular training at moderate added cost.

Here's the REAL THING!

SET UP YOUR OWN HOME LABORATORY



R-F Signal Generator



Oscilloscope

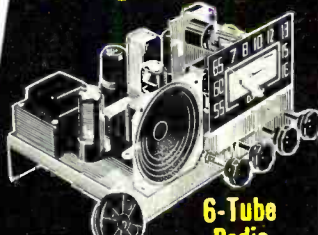

6-Tube Radio

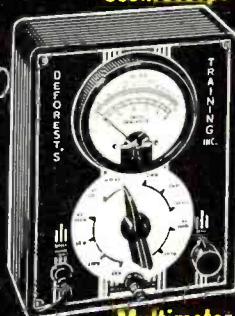

Multimeter

"ONE OF AMERICA'S FOREMOST TELEVISION TRAINING CENTERS"

De FOREST'S TRAINING, INC.

CHICAGO 14, ILLINOIS

A De VRY INSTITUTION



Airex ... WHERE MERCHANDISE IS TOPS...
PRICES ARE LOW...VALUES THE GREATEST

NO FREE MERCHANDISE • OUR PRICES ARE LOW • QUALITY SUPREME

NOW—THE FINEST "630" TV CHASSIS EVER—WITH THE AMAZING CASCODE TUNER

Reception up to 200 miles • 4 microvolt sensitivity

This wonderful new Super DX handles all tubes from 10" to 24" . . . will bring in better reception up to 200 miles without the use of boosters and will work where other sets have failed. The NEW STANDARD COIL CASCODE tuner gives you greater sensitivity with less snow. This tuner utilizes the newly developed 6BK7 tube with the gold-plated grid . . . is fully shielded against radiation and has a newly designed converter circuit. Has new improved Mark flyback with keyed AGC for better picture control; 15 KV output; 3-stage sync separator; 5-hour minimum heat run at factory. Moulded plastic condensers; syncro lock; improved new Ferrite core width coil, for greater range of width. Armstrong FM sound system; improved linearity control. Factory wired, aligned and tested before shipment. Phono connection and switch on chassis. Complete with RCA Hi-Fi 12" Speaker. DIRECTLY ADAPTABLE FOR COLOR AND UHF STATIONS.

\$149⁹⁵
 Complete with 12" RCA Hi-Fi Speaker. Fed. Tax Included Less Picture Tube

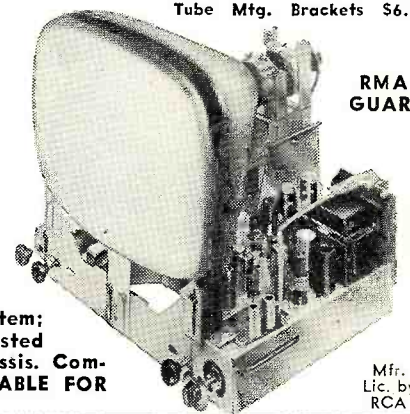

Tube Mtg. Brackets \$6.50

RMA GUAR.

Mfr. Lic. by RCA

SENSATIONAL SPECIAL OFFER OF THE AIREX SUPER DX COMPLETE TV SETS . . . THE FINEST SET VALUE IN ITS PRICE CLASS

These outstanding sets were specially designed to meet our rigid specifications to assure you many pleasant hours of trouble free TV at an unequalled price. The mfr. is licensed by RCA. RMA guarantee. All you have to do is plug in and play.

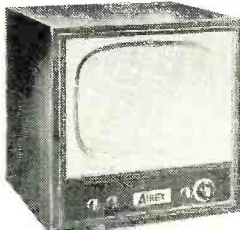

17"—\$154.95
 20"—\$179.95

24" TV CONSOLE
 1 Year Warrantee on Tubes and Parts **\$299⁹⁵**

Check These Features

- Has standard coil Cascode tuner that brings in reception up to 200 miles • 20 tubes • Large HI-FI speaker • Hand rubbed, satin finished genuine mahogany cabinet • AGC • Moulded plastic condensers • Black, glareless picture tube, guaranteed for 6 months • Adaptable for UHF and color • Synchronized FM audio system • 5 hour heat run at factory • Factory wired, aligned and tested • Mounted in cabinet.



17"—\$174.95
 20"—\$199.95

Price Smashing Values in TV Cabinets for "630" Chassis

Beautiful, richly finished, hand rubbed mahogany cabinets to suit every taste. They are designed to house the "630" chassis, 12" speaker and up to 20" TV tube. The combination cabinets will hold up to a 20" TV tube, radio and Webster record changer, with ample record space.

All cabinets are equipped with mask and mounting brackets. The perfect chassis deserves a perfect cabinet. It will be a focal point of beauty in your home. Other models in stock. When ordering chassis and cabinet, no tube mounting brackets needed. Send for FREE circular.

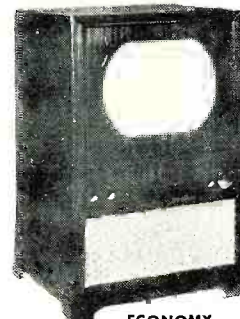

ECONOMY

38x22 1/2 x 22 1/2—16" and 17" tube . . . \$49.95
 41x25x23—16" to 20" . . . 59.95
 45x28x25—24" tube . . . 74.95
 Blonde \$10 Additional

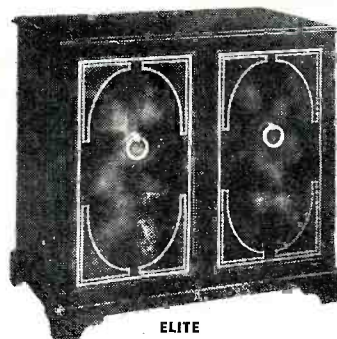

ELITE

Combination—39x40x23 1/2. Red antique gen. leather. Gold leaf hand tooling . . . \$149.95
 In limed oak, gold colored leather 159.95



STRATFORD

40x28 1/2 x 23 1/2. Genuine crotch Mahogany doors . . . \$89.95

All merchandise is brand new, factory fresh & fully guaranteed. Mail & phone orders filled upon receipt of certified check or money order for \$25 as deposit on TV chassis, 20% on other items. Balance C.O.D., F.O.B. N. Y. Prices subject to change without notice. No Fed. taxes to pay. Prices lower than OPS Regs.

AIREX RADIO CORP. 171 Washington St., N.Y.C. 7, N.Y.
 Phone Worth 2-4029

TV TUBE EXTRA

Standard Brands BLACK-GLARELESS
 Factory New—1st Quality
 Guaranteed 1 Year

- 14" Rectangular \$26.95 17" Rectangular \$32.95
- 16" Rectangular 29.95 20" Rectangular 39.95
- 16" Round . . . 33.50 24" Round Metal 69.95
- Ring and sleeve for 24" . . . \$7.50
- TV MASKS
- 16"x17", \$4.95; 20", \$7.95; 24", \$14.95

TV ANTENNA BARGAINS

Following antennas can be used with our sets and are perfect for fringe area use. Complete with 10 ft. mast, 100 ft. wire, insulators, mounting brackets & lightning arrestors.

- Stacked Conical . . . \$19.95
- Stacked Double Vee . . . 19.95
- Single Conical . . . 15.95
- Single Double Vee . . . 15.95

PORTABLE PHONO—33 1/3 RPM

Brand new, 2 tube amplifier. Tone control. Single speed. External jack for extra speaker. Cases slightly imperfect. . . . **\$13⁹⁵**

AIR KING 6-TUBE CHASSIS

Superhet, AC-DC for custom installation. Complete with loop antenna, all tubes and extra RF stage. Ready to play. Reg. \$25. **\$11⁹⁵**
 MATCHING PLASTIC CABINET . \$3.95

Airex Special 5-Watt Amplifier

3 Tubes, Phono Mike Input. Separate Bass & Treble Control. . . . **\$19⁹⁵**

- 2-Tube Phono Amplifier . . . \$5.95
- 3-Tube Phono Amplifier . . . \$6.95

All Complete with Tubes

300 OHM TV LEAD-IN WIRE
 14 Strands Each Leg. Heavy Duty.
 100 Ft., \$2—1,000 Ft., \$17.95

"NOW YOU CAN FIX YOUR OWN TV SET!"
 Simplified book. Fix over 1,000 models listed by 39 manufacturers. **\$1⁰⁰**

SPECIAL BARGAINS

- Approved 10-Watt Amplifier . . . \$ 34.50
- Espy FM-AM Radio, 12 Tubes . . . 69.95
- Webster Webcor "210" Tape Recorder . . . 149.50
- RCA Hi-Fi speaker . . . 4.95
- Standard Coil Cascode Tuner . . . 24.95
- Super Sonic Booster, MDL107 . . . 14.95
- Regency Booster, MDL DB410 . . . 19.11
- Resistor Assortment 1/2 to 2 Watt . . . 100—\$2.49; 1,000 22.00

COMPLETE LINE 630 PARTS
 RADIO TUBES 40% TO 60% OFF LIST

SEND POSTCARD TO BE PUT ON FREE MAILING LIST

GUARANTEED tops for SELECTIVITY.



*Men!
Look this one over
for Real Engineering!*

500 Cycles at
6 DB with Rounded
Top; Sharpest Selectivity
Position

3 KC at 60 DB

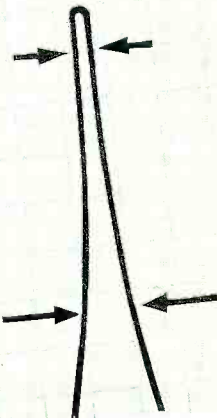

hallicrafters

NEW S-76 \$169⁵⁰

**DUAL CONVERSION 50 kc 2nd I-F
GIVES GREATER SELECTIVITY THAN
ANY OTHER RADIO ON THE MARKET
COSTING EVEN TWICE AS MUCH!**

HERE'S PROOF! — The actual selectivity curve shown above is the reason veteran "Hams" all over the world are buying the new S-76. It's the Radio Man's choice for **MAXIMUM SELECTIVITY . . . THE BEST VALUE** in the history of radio!

New running mate to the already famous SX-71 double conversion receiver. More usable selectivity than the best crystal. **GIANT 4-IN "S" METER** calibrated in microvolts and "S" units. Four bands 538—1580 kc, 1720 kc to 32 Mc. Calibrated electrical bandspread, 5 position selectivity, average sensitivity 2 microvolts with ½ watt output. 9 tubes plus regulator and rectifier . . .

hallicrafters

"The Radio Man's Radio"

WORLD'S LEADING MANUFACTURERS OF PRECISION
RADIO & TELEVISION • CHICAGO 24, ILLINOIS

JFD CORSAIR

yagis



"zero-in"

the show!

JFD all-aluminum "Corsair" Yagi antennas really "zero-in" the show... reaching far out on exact channel wavelength to bring in the strongest signal for the sharpest picture... and they're fast and easy to install—just swing the Quik-Rig elements into position and tighten the wing nuts.

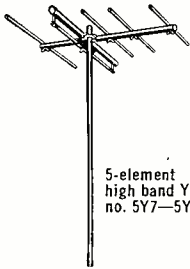

5-element high band Yagi no. 5Y7—5Y13

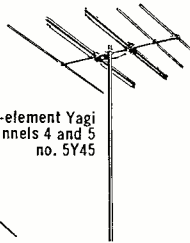

5-element Yagi for channels 4 and 5 no. 5Y45

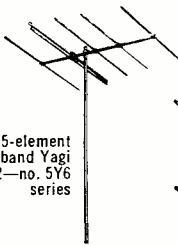

5-element low band Yagi no. 5Y2—no. 5Y6 series

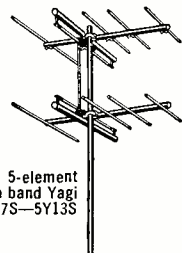

5-element stacked high band Yagi no. 5Y7S—5Y13S



for free data sheet #59

write JFD Mfg. Co.
Brooklyn 4, N.Y.
BEnsonhurst 6-9200

world's largest manufacturer
of TV antennas & accessories

For the RECORD.

BY THE EDITOR

THE AMAZING TRANSISTOR

FEW developments of recent years have served to stir the imagination as has the "junction transistor," announced by *Bell Laboratories* last year and described more fully on page 38. If this new device lives up to its advance notices, and there is every reason to believe that it will, it may well revolutionize the entire electronics industry.

This device removes many of the major objections to the more widespread use of vacuum tubes. It requires no heater power and only a very small amount of plate power, thus tremendously reducing the heat developed in equipment in which it is used, and also greatly simplifying power supply problems. It is practically indestructible, being capable of withstanding shocks and vibration that would completely destroy ordinary or even specially constructed vacuum tubes. There is no heater to burn out, no grid to short out, no cathode to fail; its life is practically unlimited. A life of 70,000 hours minimum has been suggested, and there is good reason to believe that such performance can be achieved and even exceeded.

There are other attributes of this amazing device which make it equal to or superior to conventional tubes, such as power gains of 50 db (100,000 times), and mutual conductances on the order of 30,000 micromhos per milliamper of current. Input and output impedances may be varied widely merely by altering connections. Plate circuit efficiency approaches very closely the theoretical limit of 50% for Class A and 100% for Class C operation, reducing the plate circuit power requirements well below those required for conventional tubes.

It would be well to insert a word of caution at this point. The junction transistor has some characteristics which limit its field of application, at least in the present state of development. For example, the maximum gain can be realized only at frequencies up to a few kilocycles, although useful gain as high as a megacycle or more has been achieved. Transistors are essentially low-power devices. One unit, having a cross-sectional area of about one square centimeter, has been built which is capable of producing an output of two watts, but conventional units are rated much lower. Another disadvantage which is being rapidly overcome is the difficulty encountered in mass-producing these items.

In spite of these disadvantages, the junction transistor is one of the most exciting developments to emerge from

the research laboratories of this country in recent years. The characteristics of extreme ruggedness, long life, small size (about half the size of a pea), small power requirements, and high gain will permit the junction transistor to be used where heretofore conventional tubes were not even considered. Also, it is reasonable to believe that these units will replace vacuum tubes completely in many pieces of complex electronic equipment, such as electronic computers, and that they will be utilized in such applications as industrial electronic controls, controls in aircraft, and innumerable other locations where ruggedness, small size and reliability are paramount virtues.

One can foresee many military uses for this device, particularly in the field of proximity fuses and guided missiles. If the frequency response can be improved, and there is every reason to believe that it will be, its field of usefulness will be tremendously increased. Even in the present stage of development, it can be used along with the point-contact type of transistors, which have a frequency response up to 75 megacycles, and are now in mass production.

The junction transistor operates very satisfactorily at extremely low power levels. For example, Mr. R. L. Wallace at *Bell Laboratories* built an audio oscillator which operated satisfactorily with a power input of only 0.08 microwatt, provided by a power supply of 55 millivolts at 1.5 microamperes! Useful amplification is possible with input powers in this order of magnitude. It is thus conceivable that an amplifier or other electronic device could be built using this transistor which would last indefinitely, completely unattended, if powered by the new atomic battery recently announced, or some other long-life source of power.

Junction transistors are not available commercially at this time, and the point-contact type are available in only limited quantities. However, a great deal of effort is being spent in readying these devices for commercial applications, and it should not be too many months before small quantities will be available for experimental purposes, with full-scale production following very shortly.

It is highly improbable that the transistor will eventually replace the vacuum tube. It will, however, serve as a means of obtaining ultra compact and highly stable electronic devices for the home, for industry, and the military. O.R.

RADIO & TELEVISION NEWS

GET THIS

ALLIED

Best Buy in Hi-Fi

New Pilot AF-605 Hi-Fi AM-FM Tuner

at a sensationally low price

only \$42⁹⁵

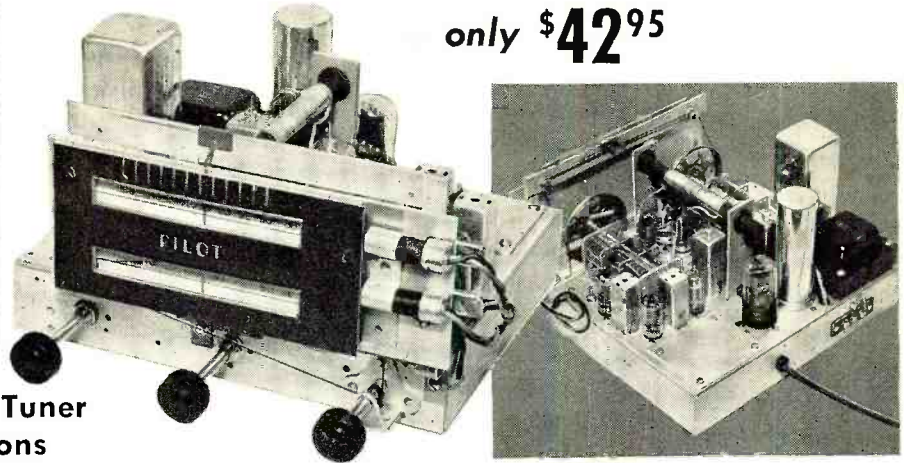

Lowest Cost High-Quality Tuner Ideal for Custom Installations

The new Pilot AF-605 Tuner provides splendid reception of standard AM broadcasts and the 88-108 mc FM band. Features flat response within 2 db from 20-15,000 cps, with low distortion and high signal-handling ability. Has relatively low output impedance to minimize high frequency attenuation in output cable. Includes inputs for phono and TV, controlled by band switch. With slide-rule dial (each band separately illuminated); separate 3-gang tuning condensers for AM and FM; provision for outside AM and FM antennas; self-contained power supply.

FM Features: Tuned RF stage for maximum sensitivity and selectivity; built-in line; antenna temper-

ature-compensated oscillator; ratio detector with 225 kc wide linear response; IF response 200 kc wide at 6 db points; 300 ohm balanced input to antenna coil with electro-static shield.

AM Features: Tuned RF stage; built-in high efficiency new "ceramic loop stick" iron-core antenna; IF wave trap; IF response 7.5 kc wide at 6 db points; separate diode for AVC voltage.

Pilot AF-605 Tuner Complete. Chassis size, 11 1/2x6x9". For 110-120 volt, 50-60 cycle A.C. Complete with 9 miniature type tubes and rectifier. Shpg. wt., 8 1/2 lbs. 97-944. *ALLIED'S* low price only \$42.95

Best Buy IN A CUSTOM Hi-Fi AM-FM- Phono System

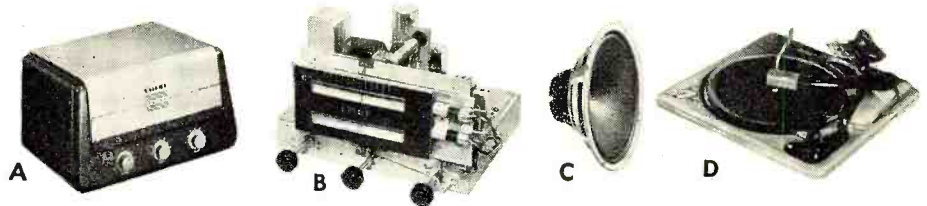
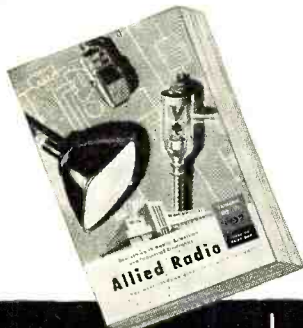

a complete top quality AM-FM-Phono System at low cost

Here's the special value **ALLIED** complete home entertainment system that provides superb reproduction from records as well as AM-FM broadcasts. The system includes (A) the famous **KNIGHT** 20-Watt High-Fidelity Amplifier with response ± 1 db, 20-20,000 cps—unconditionally guaranteed for one full year; (B) the Pilot AF-605 FM-AM Tuner described above; (C) the General Electric S1201D 12" High-Fidelity Speaker with 14.5 oz. Alnico V magnet; (D) the Webster-Chicago 106-27 Three-Speed Automatic Record Changer with plug-in heads and 2 General Electric variable reluctance cartridges (one for standard

records, one for LP records). The system is supplied complete, with all necessary cables and leads for interconnecting the components, plus all tubes, hardware and complete installation and operating instructions. Cables are equipped with plugs, ready to connect—no soldering required. Shpg. wt., 66 lbs. Here is a complete High-Fidelity system, unsurpassed for value, providing wide-range reproduction from records and AM-FM radio.

93-422. Complete AM-FM-Phono System. *ALLIED'S* low price... \$169.50
\$25.43 down, \$12.73 monthly for 12 months

FREE 212-PAGE ALLIED CATALOG

Send today for **ALLIED'S** authoritative, complete 1952 catalog, listing full selections of tubes, parts, test instruments, audio equipment, industrial components—everything in Electronics at lowest prices. Look to **ALLIED** for speedy delivery, expert personal help and complete satisfaction. Get your **FREE** 212-page **ALLIED** catalog now.

ALLIED RADIO CORP., Dept. 1-D-2
833 W. Jackson Blvd., Chicago 7, Illinois

- Ship the Pilot AF-605 AM-FM Tuner (\$42.95)
- Ship the complete AM-FM Phono System (\$169.50)
- \$..... enclosed. Full Payment Down Payment
- Send **FREE** 1952 **ALLIED** 212-Page Catalog

Name

Address

City Zone State

Electrons probe the future

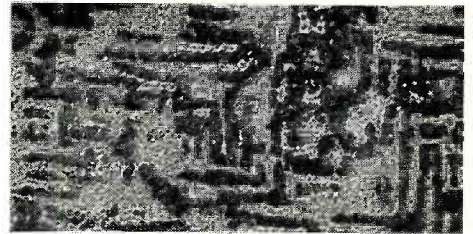

1 Electron micrograph of an alloy of aluminum, nickel, cobalt and iron. Magnification 20,000 diameters.

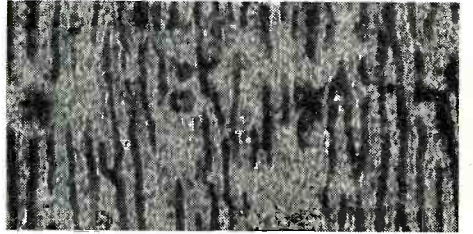

2 Cooled from high temperature in a magnetic field, the alloy becomes a powerful, permanent magnet. Note changed structure. Black bars reveal formation of precipitate parallel to the applied field. Each bar is a permanent magnet.

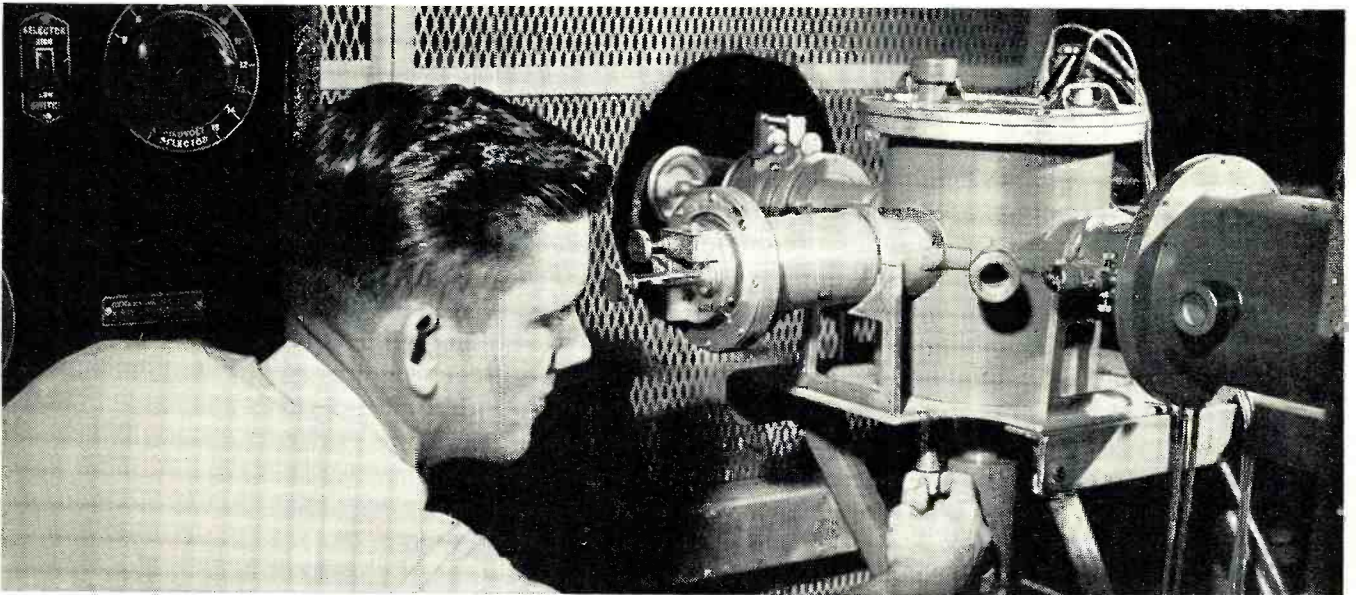

3 A Bell scientist adjusts electron diffraction camera. Electrons are projected on the specimen at glancing angles. They rebound in patterns which tell the arrangement of the atoms . . . help show how telephone materials can be improved.

IN 1927, Bell Laboratories physicists demonstrated that moving electrons behave like light waves, and thus launched the new science of electron optics.

Now, through the electron beams of the electron microscope and electron diffraction camera, scientists learn crucial details about the properties of metals far beyond the reach of optical microscopes or chemical analysis.

At the Laboratories, electron beams have revealed the minute formations which produce the vigor of the permanent magnets used in telephone ringers and magnetron tubes for radar. The same techniques help show what makes an alloy hard, a cathode emit more electrons and how germanium must be processed to make good Transistors.

This is the kind of research which digs deep *inside* materials to discover how they can be made better for your telephone system . . . and for the many devices which the Laboratories are now developing for national defense.

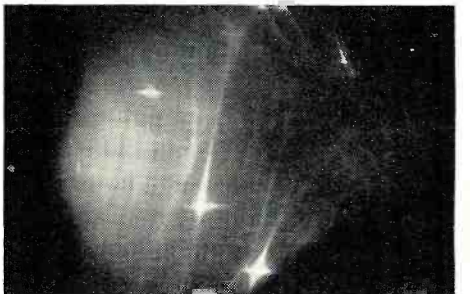

4 Diffraction pattern of polished germanium reveals minute impurities which would degrade the performance of a Transistor.

BELL TELEPHONE LABORATORIES



Improving telephone service for America provides careers for creative men in scientific and technical fields.

RADIO & TELEVISION NEWS

TRAIN

for Security! Good-Paying Jobs!

MAKE THE MONEY YOU'VE ALWAYS DREAMED OF!



LEARN RADIO -TELEVISION AND ELECTRONICS BY EASY SHOP METHOD TRAINING AT HOME!

You get all the parts—even tubes!— for this modern Superheterodyne Receiver. You learn to build it step by step. And you keep it! Get all the facts. Mail coupon now.

Let **NATIONAL SCHOOLS**—a resident-training school for nearly 50 years—train you at home for today's unlimited opportunities in Radio-Television-Electronics. National Schools is one of the largest schools of its kind. It is located in Los Angeles—the center of Radio and TV world! It has four large buildings of modern shops and labs. Its faculty is considered tops in the business.



You learn from lessons prepared by experienced instructors and engineers. Men who are successful Radio and Television technicians. Men who have trained 1000's of men like YOU!

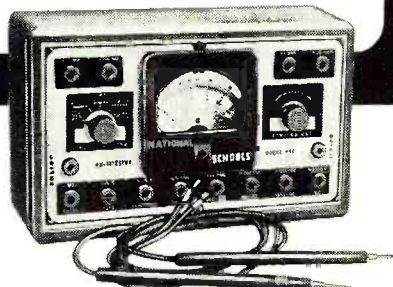

Only National Schools Gives You This Professional Multi-Tester!

You get this amazing, new testing instrument—factory-made and tested—complete—ready to use! Simple to operate. Accurate and dependable. An instrument every Radio-TV man needs. Light enough to carry around—so you can use it at home or on service calls. You'll be proud to own this valuable equipment.

Here are only a Few of the Good-Paying Jobs You Can Choose

Radio Station Engineer, District Service Manager, Aircraft Radio Inspector, Own Your Own Repair Shop, Inspector Technician, Service Specialist, Special Government Jobs, Complete TV Service, Sound Truck Operator. Many more!

National Schools graduates have secure, good-paying jobs like these! So don't wait—mail the coupon today. Now—while you're thinking about it!

Attention! Men Going into Service Soon!

National Schools' course quickly prepares you for many important jobs in the Armed Services. With National Schools Training you have an opportunity to get into special service classifications—with higher pay and grade—immediately!

FREE SERVICE FOR GRADUATES

National Schools uses its great influence and prestige to help you find your place in the field of your choice. Don't put it off! Start yourself toward a skilled trade! Get the big pay you've always wanted!

NATIONAL SCHOOLS
LOS ANGELES 37, CALIFORNIA • ESTABLISHED 1905
In Canada: 193 Hastings St., Vancouver 4, B.C.

MAIL THIS COUPON TODAY—WITHOUT FAIL!

NATIONAL SCHOOLS, Dept. HR-42
4000 South Figueroa Street
Los Angeles 37, California

Mail in envelope
or paste on
penny post card.

Mail me FREE the book mentioned in this ad. Also a free sample lesson. I understand no salesman will call on me.

NAME _____ AGE _____

ADDRESS _____

CITY _____ ZONE _____ STATE _____

Check here if you were released from the Service less than 4 years ago.

You Train At Home—In Your Spare Time

National Schools Shop Method Home Training gives you basic and advanced instruction in all phases of Radio-TV-Electronics. And remember—your training is based on resident school training principles. You learn fast from hundreds of diagrams and pictures. All instructions are written by experienced technicians who work in Radio and TV every day. All instructions have been developed and tested in National Schools' own labs and studios, which are equipped with the latest RCA equipment. No wonder this National Schools course is so up-to-date, practical, interesting. And so easy to learn! And no wonder it is held in such high regard by leaders of American industry! Approved for eligible Veterans.

We Teach You How To Make Welcome Extra Money—While You Learn!

Many National Schools students—men like you—make plenty of extra dollars each week in spare time! Fixing neighbors' radios, appliances—and other ways we teach you. You start learning and earning from the day you enroll. From the very first lesson!

WE SEND YOU LOTS OF PARTS LIKE THIS!

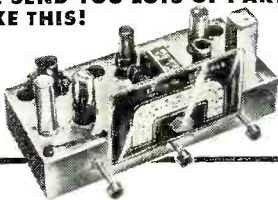

With National Schools Shop Method Home Training, you get basic principles and plenty of practical training. You learn by doing. No wonder you learn so fast! We send you many parts—all of professional, modern quality. You do lots of practical experiments. You advance day by day, step by step. Until you can even build the modern Superheterodyne Receiver you see above—plus other important testing units. The free book tells you all about it. The free sample lesson shows how easy the training is. Use the coupon. Send today — without fail!

**DON'T PUT IT OFF!
GET THE BIG SALARY YOU HAVE ALWAYS WANTED!**

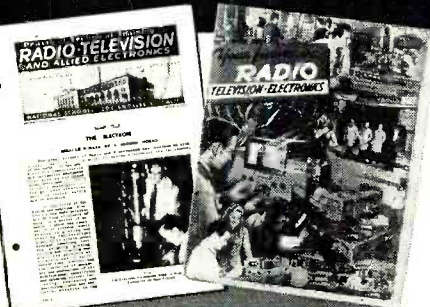

FREE BOOK TELLS YOU HOW!

Page after page—in color—tells you everything you want to know. Mail the coupon. Get this valuable book today. And if you hurry—YOU GET A FREE SAMPLE LESSON, TOO! Shows how easy National Schools Home Training is. Mail the coupon today.

Today's Shortage of Trained Technicians Creates Chance of a Lifetime For You!

Think of it! With guided missiles, radar, and other electronic devices so important to national defense! With big, new developments in TV. With over 90,000,000 home and auto radios, over 12,000,000 TV sets. With more than 3100 radio stations...over 100 TV stations—and more building every day...yes, imagine the great opportunity you have today!

YOU are wanted in Radio-Television-Electronics! America's fastest-growing field. High-pay jobs—the kind you've always wanted—are waiting for YOU!

Job Security! Big Money! For YOU! in Today's Expanding Industries!

Trained Radio and Television technicians really make important money these days. Thousands of National Schools graduates—men just like you—are earning good money all over the country. Why not you? And—National Schools graduates get the personal satisfaction of being highly-skilled technicians. Men people respect. Men who enjoy their work—rather than having to drag along in just any old job.

National Schools Has Trained 1000's of Successful Men! Why Not YOU?

In almost every state—and many foreign countries—National Schools graduates are filling big jobs with famous companies. Or running their own successful businesses. What are YOU waiting for? National Schools training is complete training. So when you graduate you can take advantage of today's big opportunities in Radio-Television-Electronics—fast.

SAVE TUBES- WITH G.E.'S NEW



TUBESAVER

Says Al Mirus of Mirus TV Service Shop (left), 6579 Glenway Ave., Cincinnati, O.: "Our G-E Tubesavers do just what the name says. That's why we have one at every bench. A Tubesaver holds up to 52 tubes in their proper sequence, gripping the tubes so tightly they can't fall out. Built-in pin-straighteners help, too. The best and most practical device we've seen!"

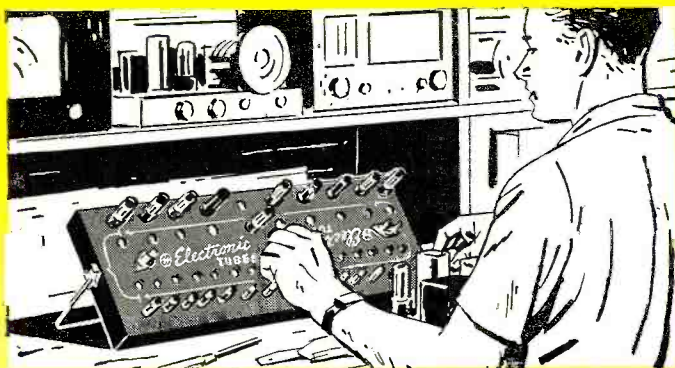

← **NO MORE WORRY ABOUT PUTTING TUBES BACK IN THE WRONG SOCKETS!...** The systematic layout of the G-E Tubesaver keeps tubes in their exact order. Moreover, they stay that way because rubber inserts keep them from dropping out—even if you tip the Tubesaver sharply! With its convenient handle design, the Tubesaver can be laid flat on the bench, angled, or hung on the wall nearby.

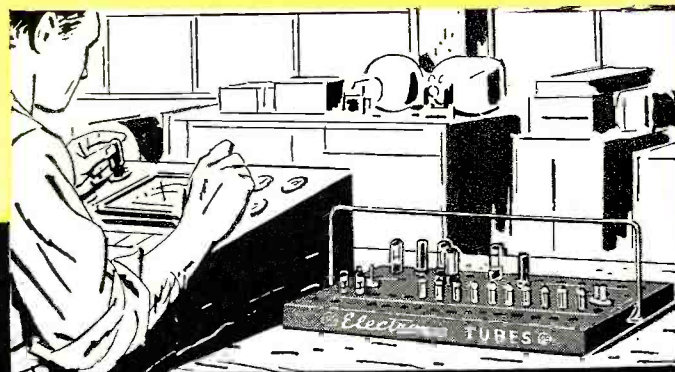

NOW YOU CAN TEST TUBES FAST AND ACCURATELY!... Place tubes in the inner holes of the G-E Tubesaver. Test them one-by-one. Put the good tubes in the outer set of holes, and return rejects to the inner set. Interruptions are no handicap—the Tubesaver keeps tubes correctly arranged till you resume work. In their proper order you now show the full tube complement of the receiver —

← which tubes are usable, which not!

**SEE YOUR G-E
TUBE DISTRIBUTOR
FOR FULL DETAILS!**

SAVE TIME- SERVICE AIDS!

PICTURE-TUBE CARRIER

Here's a practical aid that enables you to carry a cartoned picture tube safely and easily with one hand, leaving the other free for service equipment. Heavy canvas straps—quickly adjusted—hold the tube carton firmly. Rounded leather grip fits snugly in the hand. Blue and yellow colors are attractive. Save extra steps with this new convenience!



DROP-CLOTH

Use this handy G-E drop-cloth to cover fine rugs or cabinets. It's durably woven, with a soft texture that won't harm the most delicate surface. A plastic top coating takes hard wear, resists hot solder, can be wiped clean in a jiffy. Customers will appreciate your protecting their furnishings from dust, grime, and stray particles of metal!

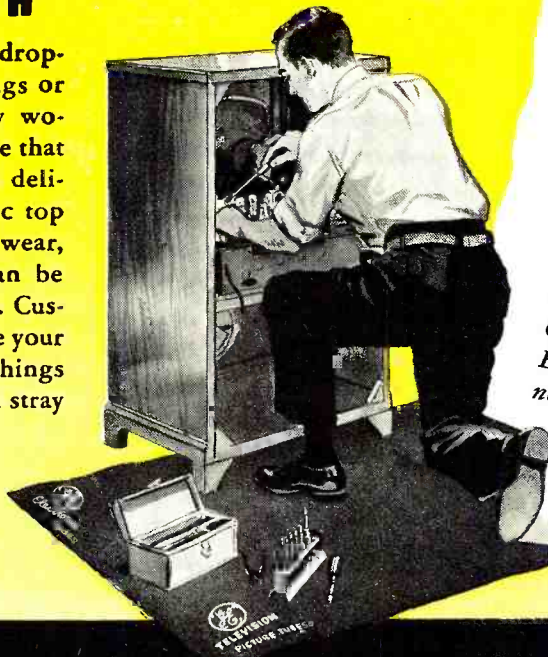

MAKE MORE CALLS PER DAY

... with these G-E-tube service aids! They cut time and costs, build customer goodwill. Your General Electric tube distributor will be glad to help you obtain them. Phone or write him today!
*General Electric Company,
Electronics Division, Schenectady 5, New York.*

161-1A1

You can put your confidence in—

GENERAL  ELECTRIC

Here's your Opportunity

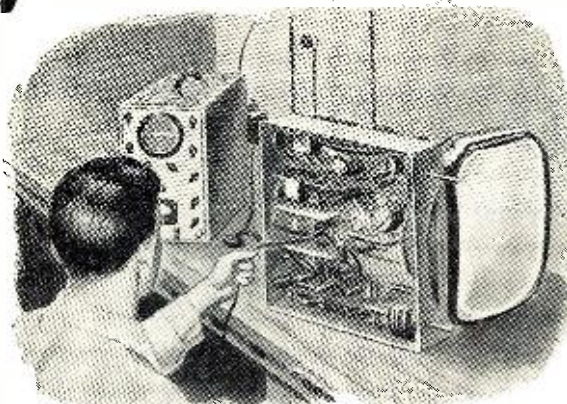

to prepare for a good job or a business of your own in TV SERVICING

There are today more good jobs open in TV Servicing than there are trained and experienced men to fill them. Yes, thousands of opportunities exist now for good-pay jobs offering employment security for years and years to come. Thousands of TV Servicing jobs are going begging. Do you want one of them?

Experts agree, that because of the critical shortage of trained and experienced TV Servicemen, and the tremendous future growth of the industry, no vocational field today offers more opportunities than TV Servicing.

The Big New Industry with a Great Future

Television is just in the beginning stages of its big industrial boom. Look at these amazing facts:

- Within a few years over 1000 TV stations will be telecasting compared with 108 TV stations now on the air.
- Nearly one-half of all families living within the present TV areas do not yet own TV receivers.
- The new trans-continental video network plus better and more interesting programs plus larger viewing screens and color TV will increase the installation of new receivers, will induce present owners of 12-inch and smaller size viewing screens to buy newer model receivers.
- The power increases of many existing stations and improved reception range of current receivers will result in receivers being installed and serviced in the fringe areas of present stations.
- Under the FCC proposal, over 70 per cent of all communities will be served by UHF channels exclusively. This means TV servicemen must know UHF receivers before the new UHF stations in their area are opened.

- No one yet knows how great the industrial TV market will be.

RCA Institutes Home Study Course prepares you for a Career in TV Servicing

The addition of the RCA Institutes TV Service Training to your present radio-electronics experience will qualify you to step out and grasp the golden opportunities that now exist in television—America's fastest growing industry.

Learn at home—in your spare time—while you study the practical *how-to-do-it* techniques with *how-it-works* information. Easy-to-read and easy-to-understand lessons under the supervision of RCA engineers and experienced instructors quickly train you to qualify for the many good jobs now waiting for trained TV servicemen. Don't pass up this lifetime opportunity for financial security and a bright future in TV. Learn TV Servicing from RCA—pioneers and leaders in radio, television and electronic developments.

RCA Institutes conducts a resident school in New York City offering day and evening courses in Radio and TV Servicing, Radio Code and Radio Operating, Radio Broadcasting, Advanced Technology. Write for free catalog on resident courses.

Send for FREE BOOKLET

Mail the coupon—today. Get complete information on the RCA INSTITUTES Home Study Course in Television Servicing. Booklet gives you a general outline of the course by units. See how this practical home study course trains you quickly, easily. Mail coupon in envelope or paste on postal card.



MAIL COUPON NOW!

RCA INSTITUTES, INC., Home Study Department RN-45
350 West Fourth Street, New York 14, N. Y.

Without obligation on my part, please send me copy of booklet "RCA INSTITUTES Home Study Course in TELEVISION SERVICING." (No salesman will call.)

Name _____ (Please print)
Address _____
City _____ Zone _____ State _____



RCA INSTITUTES, INC.
A SERVICE OF RADIO CORPORATION OF AMERICA
350 WEST FOURTH STREET, NEW YORK 14, N. Y.

PRESENTING COLLINS AM-FM "PRE-FAB" TUNERS

NOW you can
build a Collins
AM-FM tuner from
the Pre-Fab units
shown below!

COMPLETE VERSATILITY is the byword in this new tuner design. Through the addition of the AM circuit, the Collins tuner will meet all requirements for home music systems and installations where a fine tuner is required.

ECONOMY: The very finest in tuner design is offered you at exceptionally low prices. Collins quality is your assurance of a fine product that will work to your complete satisfaction. You cannot duplicate this tuner in its completed form at twice the price!

**3 Ways to purchase
COLLINS Tuner . . .**

1. As an AM tuner kit
2. As an FM tuner kit
3. As an AM-FM tuner kit

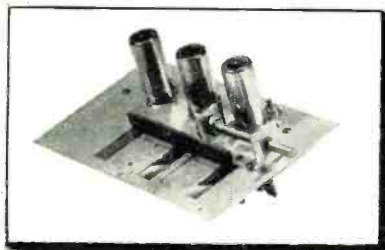

FM Tuning Unit **\$15.25**

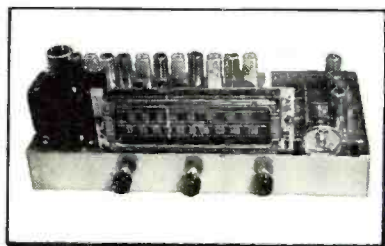

The Collins FM-AM Pre-Fab Tuner Kit As It Looks
After You Assemble It (Total Kit Cost **\$69.00**)



AM Tuning Unit
(Includes IF and
Audio Amplifier) **\$19.25**



FM IF Amplifier **\$19.75**

Tuning Eye Kit
Available At

\$2.85

UC-2 Universal Chassis Kit **\$14.75**



ALL PRE-FAB UNITS ARE ASSEMBLED, WIRED, TESTED, AND ALIGNED AT FACTORY. PRICES SHOWN INCLUDE TUBES.

The FM tuning unit employs a 6J6 dual triode RF amplifier; 6AG5 converter, and 6C4 oscillator. Permeability tuned, stable, and drift-free. High sensitivity of between 6 and 10 microvolts. Dimensions: 7 1/4" x 4 1/2". The IF amplifier for FM uses 6 tubes! 6BA6, (4) 6AU6, and 6AL5 discriminator. High gain, wide band response for highest fidelity reception. Frequency response of FM section, plus or minus 2 DB, 20 to 20,000 cycles. Distortion less than 1/2 of 1%. Dimensions: 11 1/16" x 2 1/2".

The AM tuning unit utilizes a super-het circuit employing three tubes: 6BE6 converter, 6BA6 IF amplifier, and 6AT6 detector. Extremely high sensitivity and selectivity is accomplished through the use of new, high gain iron-core transformers. Careful alignment provides widest response available from this type of circuit. If builder desires, triode amplifier section of 6AT6 tube may be used as first audio stage.

Chassis Kit includes all necessary parts. Nothing else to buy! Instruction Manual included with detailed, step-by-step procedure, pictures and schematic diagrams. Chassis measures 8" x 17" x 2 1/2". Overall, the tuner, when assembled, measures 8" x 17" x 6".

**MAIL ORDER COUPON
TODAY!**

TO: COLLINS AUDIO PRODUCTS CO. INC.
P.O. Box 368, Westfield, N.J.

Enclosed Find Check Money Order For

AM Tuning Unit

FM Tuning Unit

FM IF Amplifier

UC-2 Chassis Kit

M-1 Tuning Eye Kit

NAME _____

ADDRESS _____

CITY _____ STATE _____

Six quality features of all Tung-Sol Picture Tubes mean better TV receiver operation

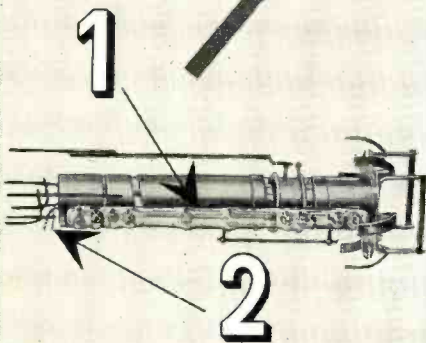

1. Glass bead type assembly is stronger, both mechanically and electrically—gives greater protection against leakages and arcing.

2. Double cathode tab provides double protection against failure in the cathode circuit.

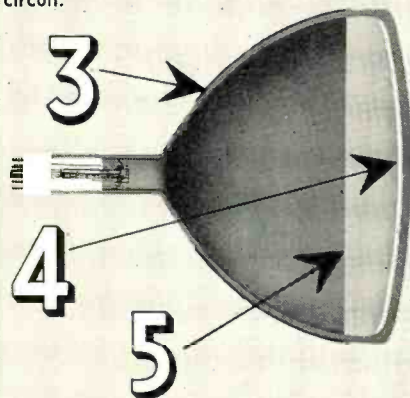

3. Low resistance of outside conductive coating minimizes radiation of horizontal oscillator sweep frequency.

4. Fortified screen composition resists burning (X pattern).

5. Rigid control of internal conductive coating materially improves service reliability.

6 Tung-Sol Picture Tubes can be used with single or double field ion trap designs.

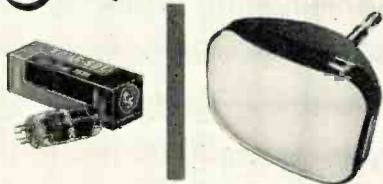

TUNG-SOL
RADIO, TV TUBES, DIAL LAMPS

TUNG-SOL ELECTRIC INC., Newark 4, N. J.
Sales Offices: Atlanta • Chicago • Culver City (Calif.)
Dallas • Denver • Detroit • Newark

Tung-Sol makes All-Glass Sealed Beam Lamps, Miniature Lamps, Signal Flashers, Picture Tubes, Radio, TV and Special Purpose Electron Tubes.

Spot Radio News

★ Presenting latest information on the Radio Industry.

By RADIO & TELEVISION NEWS'

WASHINGTON EDITOR

FCC's annual report to Congress, always a widely-read document, in its newest version, should become one of the most popular publications on Washington bookshelves. For in this edition, the seventeenth (fiscal year ending June 30, 1951), there appears a wealth of valuable information that countless persons in government and industry will find constantly useful throughout the year. Not only does the text disclose, in detail, developments in television and general broadcasting, but also advancements made in common-carrier services, which are described as being of equal concern to the public, since they help to protect life and property, aid commerce and industry, and provide employment, and other individual benefits.

Reviewing the progress achieved in aeronautical radio, the report states that expansion in this art has been extremely rapid. In 1938, the records show that there were less than 1500 aeronautical stations of all kinds. At the close of the fiscal year of '51, there were more than 34,000 authorized aircraft and ground stations, an increase due in part to the large growth of voluntary installations of communications equipment aboard private aircraft. Describing the assorted types of stations using radio communications, the Commission noted that there are many of a rather specialized nature in this category. There are, for instance, the airdrome control stations, which provide communications between the control tower and aircraft or aeronautical mobile utility stations for the purpose of controlling aircraft within the control area of an airport, as well as both aircraft and vehicular traffic on any portion of the landing area. This control is extremely important, in that it provides a means of directing arriving and departing traffic so as to maintain safe separation of planes to avoid collision. Also assured is an efficient flow of air traffic into and out of the airport. To date, there are fifty-six stations of this type operating throughout the country.

Mobile utility stations represent another special type of aviation communication service now in use. Over one-hundred are now used aboard crash, fire, and maintenance cars, operating in airdromes to provide contact with control towers. This service affords safety insurance for those in the

planes, on the field, and in nearby communities.

Navigational type facilities were also described as vital in the aircraft-communication program, and thus far the Commission has authorized more than one-hundred-fifty stations for this purpose. Many types of aids are employed: radio beacons, radio direction finders, radio ranges, localizers, glide paths, marker beacons, ground-control approach, instrument landing, radar and distance measuring stations. The service is normally operated by the CAA. However, because of the use of off-airways-route operation by air carriers, it has become necessary for the carriers to establish and operate additional navigation facilities.

Flying-school stations were also found to be key users of radio facilities. According to the Commission's review, eighteen licenses were granted for this purpose to those who operate ground-air schools and require communications for flight instructions to students or pilots. Not only is this contact necessary for instruction, but for the promotion of safety of life and property. Flight testing stations were also noted as an active user of radio facilities, with over one-hundred such stations approved last year.

One of the largest users of radio, according to the Commission, is the public service stations, which provide communication between individuals aboard aircraft in flight and persons on the ground. Nearly five-hundred and fifty licenses have been released for this purpose.

During '51, a new type of station was also inaugurated; aeronautical advisory. It was authorized to meet an increasing demand for advisory air-ground communication at the smaller airdromes, many of them in remote locations not served by regular aeronautical control or communication facilities. Analyzing the services provided by these new stations, the annual review declares that they permit contact between an airport operator and private aircraft enabling pilots to ascertain the condition of the runways, type of fuel available, wind conditions, weather, and other information required for plane operation.

Railroad radio service was also reported to have really spread its wings. As of '51, the railroads had in excess of six-hundred authorizations covering

RADIO & TELEVISION NEWS

Want To Double Your Pay?



How To Pass **FCC** **COMMERCIAL** **RADIO OPERATOR** **LICENSE** **EXAMINATIONS**

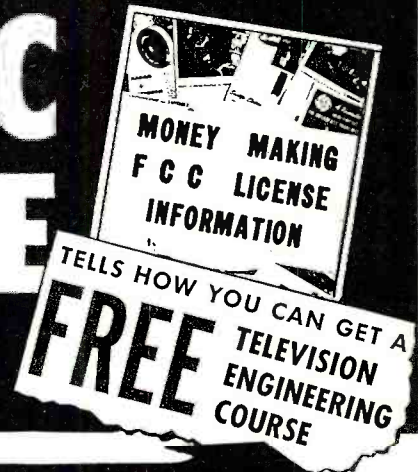

GET THIS AMAZING NEW BOOKLET FREE!

TELLS HOW —

WE GUARANTEE
TO TRAIN AND COACH YOU AT HOME
IN SPARE TIME UNTIL YOU GET
YOUR FCC LICENSE

If you have had any practical experience—Amateur, Army, Navy, radio repair, or experimenting.

TELLS HOW —

Employers make
JOB OFFERS Like These
to Our Graduates Every Month!

Letter, October 11, 1951, from Chief Engineer, Broadcast Station, North Carolina. "Need men with radiotelephone 1st class licenses, no experience necessary. Will learn more than at average station for we are equipped with Diesel Electric power, transmitting and studio equipment."

Telegram, October 2, 1951, from Chief Engineer, Broadcast Station, Wyoming. "Please send latest list available first class operators. Have November 10th opening for two combo men."

Letter, October 8, 1951, from Chief Engineer, Broadcast Station, Texas. "Please send list of latest licensed graduates."

These are just a few examples of the job offers that come to our office periodically. Some licensed radioman filled each of these jobs . . . it might have been you!

HERE'S PROOF FCC LICENSES ARE OFTEN SECURED IN A FEW HOURS OF STUDY WITH OUR COACHING AT HOME IN SPARE TIME

Name and Address	License	Lessons
Leo Worthy, 2210 1/2 Wilshire St., Bakersfield, Calif.	2nd Phone	16
Clifford E. Vogt, Box 1016, Dania, Fla.	1st Phone	20
Francis X. Foerch, 38 Beueler Pl., Bergenfield, N. J.	1st Phone	38
S/Sgt. Ben H. Davis, 317 North Roosevelt, Lebanon, Ill.	1st Phone	28
Albert Schoell, 110 West 11th St., Escondido, Calif.	2nd Phone	23

CLEVELAND INSTITUTE OF RADIO ELECTRONICS
Desk RN-40, 4900 Euclid Bldg., Cleveland 3, Ohio

April, 1952

TELLS HOW —

Our Amazingly Effective
JOB-FINDING SERVICE
Helps CIRE Students Get Better Jobs

Here are a few recent examples of Job-Finding results:

GETS CIVIL SERVICE JOB

"Thanks to your course I obtained my 2nd phone license, and am now employed by Civil Service at Great Lakes Naval Training Station as an Equipment Specialist."
Kenneth R. Leiser, Fair Oaks, Mtd. Del., McHenry, Ill.

GETS STATE POLICE JOB

"I have obtained my 1st class ticket (thanks to your school) and since receiving same I have held good jobs at all times. I am now Chief Radio Operator with the Kentucky State Police."
Edwin P. Healy, 264 E. 3rd St., London, Ky.

GETS BROADCAST JOB

"I wish to thank your Job-Finding Service for the help in securing for me the position of transmitter operator here at WCAE, in Pittsburgh."
Walter Koschik, 1442 Ridge Ave., N. Braddock, Pa.

GETS AIRLINES JOB

"Due to your Job-Finding Service, I have been getting many offers from all over the country, and I have taken a job with Capital Airlines in Chicago, as a Radio Mechanic."
Harry Clare, 4537 S. Drexel Blvd., Chicago, Ill.

OURS IS THE ONLY HOME STUDY COURSE WHICH SUPPLIES FCC-TYPE EXAMINATIONS WITH ALL LESSONS AND FINAL TESTS.

Your FCC Ticket is recognized in all radio fields as proof of your technical ability.



MAIL COUPON NOW

CLEVELAND INSTITUTE OF RADIO ELECTRONICS
Desk RN-40—4900 Euclid Bldg.
Cleveland 3, Ohio
(Address to Desk No. to avoid delay.)

I want to know how I can get my FCC ticket in a minimum of time. Send me your **FREE** booklet, "How to Pass FCC License Examinations" (does not cover exams. for Amateur License), as well as a simple FCC-type exam and the amazing new booklet, "Money-Making FCC License Information."

Tell me how I can get your Free Television Course.

Name

Address

City..... Zone..... State.....

Paste on penny postcard or send air mail.



You headphone users have always known just what you want—flat response, high sensitivity, low distortion, rugged construction, lightweight, comfortable design. Now for the first time, all of these features are combined in a single headphone designed around the exclusive BIMORPH CRYSTAL* drive element. These outstanding, new headphones result from Brush pioneering and experience in acoustics and electronics.

- Exceptionally flat frequency response
- Exceptional bass response
- Low distortion
- Lightweight—designed for comfortable wear
- Sensitivity is approximately 6.3 dynes/cm²/volt at 1000 cps.
- Exclusive METALSEAL CRYSTAL* for protection against high humidity
- Impedance of 100,000 ohms at 1000 cps.
- No transformer required
- Multiple installations are readily made

Available from your local radio parts jobber in three styles: Double headset, Single headset and Lorgnette style.



Brush Microphones—Superior Brush crystal microphones are available in five models. See them at your dealer.

* Trade Mark Registered

THE **Brush**
DEVELOPMENT COMPANY
3405 Perkins Avenue • Cleveland 14, Ohio



Piezoelectric Crystals & Ceramics
Magnetic Recording Equipment
Acoustic Devices
Ultrasonics
Industrial & Research Instruments

nearly four-hundred land stations and 5300 mobile units. Approximately fifty per-cent of the class 1 roads were said to employ such facilities for communication on and with trains en route and communication within yard and terminal areas. Forty-one frequencies in the 152-162 megacycle band have been allocated for the rail contacts.

In ham radio, one of the greatest spurts in interest was noted by the ether patrolmen. At the end of the fiscal year, there were approximately 90,500 amateur licenses and 88,700 operator licenses outstanding. The number of stations was said to be higher because many operators are licensees of more than one station, either as trustee-licensees of stations used by clubs or by military units, or as owners of personal stations at more than one address. There are, of course, many hams who do not have station licenses due principally to their being in the Armed Forces, or inability to locate a station at a permanent address.

Striking tribute to the talents of the hams appears within the Commission's report, in an extensive review of their achievements, not only during '51 but in other years. Commenting on the ability of the hams, the Commissioners said: "Through the exercise of their skills in designing, developing, constructing, and experimenting with radio equipment, and developing communication techniques, as well as by providing scientific observation services and emergency communication service in times of disaster or local emergency, and the handling of personal messages between members of the Armed Forces and their families at home, the amateurs have demonstrated that the privileges granted them have been well justified." Continuing, in a summarization of the national value of the amateur radio service, the report declares that the service . . . "constitutes a reserve of self-trained radio technicians and operators upon which the country can draw in times of war and other national need, and its special networks, equipment of its stations, and other amateur activities have proved extremely valuable in the national defense program. . . . In the planning for the defense of the civilian population in case of armed attack, the Federal Civil Defense Administration is encouraging the integration of amateur radio stations, operators, and networks into the local civil defense organizations to provide civil defense communication."

The value of the hams in times of emergency is also extolled in the report. One of the most outstanding examples of public service by the hams was cited as having occurred during the early part of '51, when severe storms blanketed a large portion of Texas for a period of over 170 hours, completely disrupting communication and power lines within that area. It was pointed out that . . . "communications handled by the amateurs in the area, using emergency power in many

(Continued on page 90)

RADIO & TELEVISION NEWS

Better Fringe Area Reception



with the

EXTRA POWER

you get with

VEE-D-X

JC YAGI The single channel workhorse
Outperforms and outsells all others. The pioneer pre-assembled Yagi. Provides powerful signal at lowest cost with minimum installation time.

JC — Low Channels \$17.60 List
JC — High Channels 9.57 List
JH — Low Channels 2.30 List
JH — High Channels 1.45 List

NEW LONG JOHN

8 Element Yagi

Gives equal gain to a double-stacked 5 element Yagi Array at lower cost.

A new 8 element Yagi that provides 41% more gain than the best 5 element Yagi, or equal gain to a double-stacked 5 element Yagi array — yet is lower in cost, is easier to install, and provides better roof-top appearance. Famous VEE-D-X pre-assembled construction. The ideal antenna for fringe area operation.

Ch. 2 or 3	...\$29.85 list
Ch. 4 or 5	...\$26.15 list
Ch. 6\$23.65 list

\$12.50 (Less Mast)
List For Ch. 7-13

Stacked Arrays
Ideal for sharper, clearer pictures in difficult reception areas.

THE SUPER
Highest gain and most powerful all-channel television antenna ever manufactured. A four-bay, full wave, 32 element stacked array of extra heavy construction. Sharp beam angle minimizes ghosts, noise, and co-channel interference. \$129.50 List

ROCKET BOOSTER
(Patent Pending)
Powerful new single channel mast-mounted booster. Amplifies signal at antenna height where most favorable signal-to-noise ratio exists. \$34.95 List

OUTBOARD BOOSTER
Out of sight . . . out of the way . . . this single channel booster delivers 18 db gain with full 5 megacycle band width. Eliminates bothersome tuning. Just install it and forget it. \$19.95 List

RW-200 ARRESTER
Positive protection against lightning. The full sized arrester that costs no more than a midget. Only \$1.25

KEEP UP-TO-DATE on the latest TV antenna developments!

FREE . . . this completely new catalog

VEE-D-X

MAKERS OF THE WORLD'S MOST POWERFUL ANTENNA SYSTEMS

THE LaPOINTE-PLASCOMOLO CORPORATION
Windsor Locks, Connecticut

Gentlemen:

Rush information on following

Send me your new FREE catalog.

Name

Street

City Zone State

This Amazing MAGNA-TIP SCREW DRIVER!

4 Screw Drivers in 1

Yours
FREE!

...with every 100 Sylvania
Receiving Tubes or 4 Picture Tubes
purchased between April 1st and May 15th

"SAVES HOURS
IN RADIO
AND TV WORK!"

It's the greatest time-saving tool you ever saw! Just slip the right-sized bit in place and a permanent Alnico magnet charges the bit...holds both your bit and screw in place for fast, easy, one-hand operation.

Lifetime quality

Made of fine tool steel, this slim-shaft driver is 8½ inches long. Equipped with 2 Phillips and 2 slotted bits, (3 bits in handle compartment and one in shank). And the shank itself is a power driver for ¼-inch hex-head screws.

You get it FREE when you buy 4 Sylvania TV Picture Tubes or 100 Sylvania receiving tubes. But, better hurry! Offer closes May 15th. Your Sylvania Distributor is the man to see ... TODAY!

"NEVER LOSES
ITS MAGNETIC
GRIP!"

 SYLVANIA 

What you can do now
to speed your
**SUCCESS IN RADIO-
 TELEVISION-
 ELECTRONICS**

Send for this FREE CREI Booklet and see



THERE is a vacancy coming up. It means a boost in pay, prestige and security. Can you fill it?

The answer is "No," if you postpone your preparation for success. The answer is "Yes," if opportunity finds you ready. "Ready" means "TRAINED." And your training must start now, if you expect to be big enough for a bigger job. You ask "What can I do *now*?" You will find many valuable suggestions in a free booklet, "Your Future in the New World of Electronics." Not only does it picture fabulous opportunities . . . it tells you what to do to grow with an industry desperately seeking trained men. Expansion is phenomenal: In the defense build-up alone, more than \$7 billion in electronics contracts have been awarded. In 1951, the top manufacturers alone sold about \$3 billion in equipment. It is estimated that by 1961 the radio-electronics industry will do no less than \$10 billion per year, excluding defense orders.

Growing civilian markets include radio-equipped police cars, fire-equipment, taxis, planes, ships—in increasing numbers. There are industrial radio network installations, medical applications, and countless others.

There are 109 TV stations now on the air. The FCC's chairman predict 1500 stations within 5 years, and 2500 stations by 1961. Already it is estimated there are 15,690,394 TV sets and over 100,000,000 radios in operation. How these figures will increase in the next few years, the most daring experts are reluctant to predict. This much is certain: Limitless numbers of positions must be filled—in development, research, design, production, testing, inspection, manufacture, broadcasting, telecasting, and servicing. To fill these posts, trained men are needed—men who somewhere along the line are alert enough to improve their knowledge and skills.

"Your Future in the New World of Electronics" shows how CREI Home Study leads to greater earnings, by helping get you ready for the openings described above.

CREI promises no short cuts. In an accredited technical school such as this, *you must study* to transform

your ambition and energy into knowledge that pays off. Since its founding in 1927, CREI has provided thousands of professional radio men with technical educations. During World War II CREI trained thousands more for the Armed Services. Leading firms choose CREI courses for group training in electronics at company expense; among them are United Air Lines, Canadian Broadcasting Corporation, Trans Canada Airlines, Bendix Products Division, All American Cables and Radio, Inc., RCA Victor Division, Mochlett Laboratories, Canadian Marconi and Heppner Mfg. CREI's practical courses are prepared by recognized experts. You get up-to-date material; your work is under the personal supervision of a CREI staff instructor, who knows and teaches you what industry needs. Training is accomplished on your own time, during hours chosen by you. As a graduate, you'll find your CREI diploma the key to success in Radio, TV and Electronics.

At your service is the CREI Placement Bureau, which finds positions for advanced students and graduates. Although CREI does not guarantee jobs, requests for personnel far exceed current supply. CREI alumni hold top positions in America's leading firms.

Now is the time to decide—to act. When opportunity knocks, knowledge must be "at home." You supply the willingness to learn. We supply the technical training. This combination of ambition and knowledge is unbeatable in the new Age of Electronics. Fill out the coupon and mail it now. We'll promptly send you your free copy of "Your Future in the New World of Electronics."

CREI Resident Instruction (day or night) is offered in Washington, D.C. Here work is done with the latest equipment, in ideal surroundings, under close personal supervision. New classes start once a month. For a CREI Residence School catalog, check the last line of the coupon below.

MAIL COUPON FOR FREE BOOKLET

CAPITOL RADIO ENGINEERING INSTITUTE

Dept. 114D, 16th & Park Rd., N.W., Washington 10, D. C.
 Send booklet "Your Future in the New World of Electronics" and course outline.
 CHECK TV, FM & Advanced AM Servicing Aeronautical Radio
 FIELD OF Practical Television Engineering Engineering
 GREATEST Broadcast Radio Engineering (AM, FM, TV)
 INTEREST Practical Radio Engineering

Name

Street

City Zone State

If residence school in Wash., D. C., preferred, check here

A 4 Bay array of Channel Master Z-Match Yagis, installed on the Super Mount, produces

OVER **15** DB gain
on the LOW BAND.

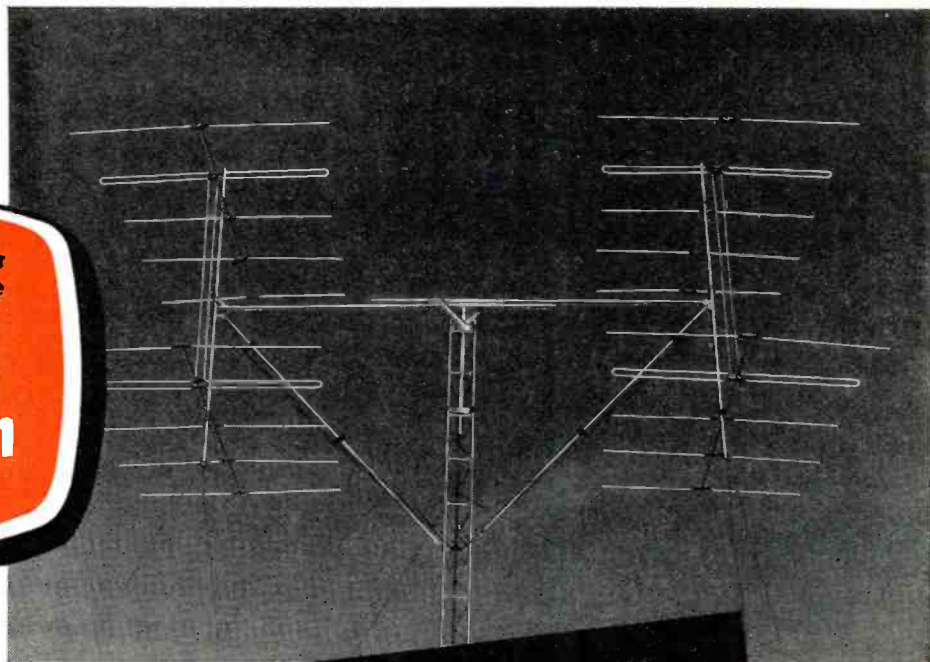

new **super mount** by CHANNEL MASTER
model no. 9100

for the most **SENSITIVE**
stacking arrangement
you've ever seen!

Versatile—yes! And efficient, too! *Full wave spacing* on the Super Mount improves the performance of any antennas, and provides higher gain than any other practical stacking arrangement yet devised. A 4 Bay Low Band Z-Match Yagi array, installed on the Super Mount, and using Channel Master's new Z-4 Matching Harness, provides gains of over 15 DB, the highest ever achieved in a practical TV antenna installation. Easily assembled.

Eliminate mismatch and watch gain zoom skyward!

It's a well-known fact. The mismatch created by stacking ordinary Yagis causes a noticeable loss of gain. Now—Channel Master has developed the Z-4 Matching Harness, which extends the impedance-matching principles of the exclusive Z-Match Yagi system. This Harness perfectly matches 4 Z-Match Yagis to 300 ohm line. Such an array provides over 15 DB gain on the Low Band, and over 16 DB gain on the High Band—providing the strongest and clearest fringe pictures you've ever seen.

Remember—antenna gain is pure gain—free of noise and snow!



Write for complete technical literature and name of your authorized distributor.

\$52⁷⁸
list price

the right way...
the **ONLY** way...
to install:

4 Low Band Yagis
for 1 channel

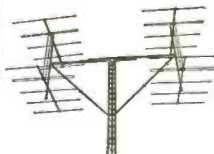

2 pair of Yagis for 2
different channels

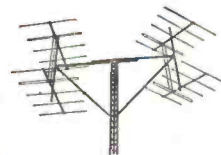

Any combination of
Broad-Band and Yagi
antennas on one mount

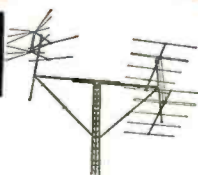

Unlimited stacking arrangements are made possible by the Super Mount.

CHANNEL MASTER CORP. ELLENVILLE, N. Y.
RADIO & TELEVISION NEWS

HE CUT HIS TV SERVICE COSTS IN HALF — AND TRIPLED HIS VOLUME IN 6 MONTHS!



"COMPARE THESE BILLS..."

● In York, Pennsylvania, a tough TV reception area, Leon Bernstein's Peak Television Service has tripled its business volume in the past 6 months. While doing this, reports Bernstein, "we have not added to our personnel and we've cut shop costs by 50%. The answer is in the efficient General Electric test equipment we bought last May. More than any other factor, it has helped build our reputation for fast, accurate repair work."

Repair bills tell the story. Using ordinary TV test equipment, a typical sync repair job added up to 3 man hours in the shop and \$12.25 billed to the customer. An identical repair job done with the reliable General Electric Scope, Marker and Sweep was finished in 1½ hours!

Have you checked your shop costs lately? The G-E Tube and Parts distributor in your area may have the answer to a better profit story for you. Call him today, and ask to see a demonstration of what these instruments can do for your operation.

PHONE 42305
OFFICE COPY
PEAK TELEVISION SERVICE INC.
584 YALE STREET
YORK, PENNA.
DEALER: *George Brown*
NAME: *George Brown*
ADDRESS: *1120 York Ave*
Mar. 1952
REMARKS & REPAIRS —

QUAN.	CHANGE	PAID OUT	WAGE FEED	DESCRIPTION	PRICE	REC'D. ON ACCT.
				<i>Poor picture quality and bad synchronization</i>		
				<i>Double shooting replaced 5000 ohm resistor in second Video I.F. Stage — 1 1/2 hrs.</i>		
				<i>Check and realignment of Video I.F. Section — 1 1/2 hrs.</i>		
					6.00	
					6.25	
					TOTAL \$ 12.25	

Rec'd By: _____
THIS IS YOUR INVOICE - PLEASE PAY SERVICEMAN
TERMS: NET C
9012250

With ordinary test equipment, repair of this one sync job required 3 hours.

PHONE 42305
OFFICE COPY
PEAK TELEVISION SERVICE INC.
584 YALE STREET
YORK, PENNA.
DEALER: *Ken Lewis & Sons*
NAME: *Tom Johnson*
ADDRESS: *43rd Berwyn Ave*
Mar. 1952
REMARKS & REPAIRS —

QUAN.	CHANGE	PAID OUT	WAGE FEED	DESCRIPTION	PRICE	REC'D. ON ACCT.
				<i>Poor picture quality and bad synchronization</i>		
				<i>Double shooting replaced 5000 ohm resistor in second Video I.F. Stage — 1 hour</i>		
				<i>Check and realignment of Video I.F. Section — 1/2 hour</i>		
					4.25	
					2.00	
					TOTAL \$ 6.25	

Rec'd By: _____
THIS IS YOUR INVOICE - PLEASE PAY SERVICEMAN
TERMS: NET C
9012250

Video realignment is greatly simplified when G-E test equipment is used.

TV TEST EQUIPMENT THAT COVERS BOTH VHF AND UHF

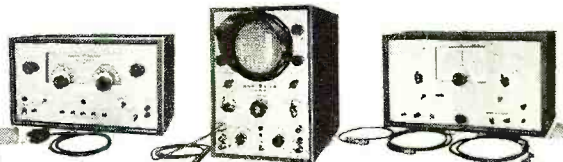

General Electric Company, Section 942
Electronics Park, Syracuse, N. Y.

Please send me latest bulletins on General Electric Television Test Equipment.

NAME _____
COMPANY OR TITLE _____
ADDRESS _____
CITY _____ STATE _____

You can put your confidence in —

GENERAL  ELECTRIC

Here's why it saves you Centralab switches —

*You'll get the switch you want...when you want it...at one source!
Your nearby Centralab distributor offers the most complete line of
switches, kits and parts available to the industry!*

"If it's available at all — my Centralab distributor will have it."

That's what more and more servicemen are saying. And that's why the trend to Centralab is growing every day. Today's servicemen know that Centralab carries the most complete line of switches and switch parts available to the industry.

If you need standard or special-purpose switches for AM, FM or TV repair, intercom installations, P. A. systems or medium-duty power applications — your

Centralab distributor has them in stock. Single- and multi-pole. Rotary or lever action (phenolic or steatite). Shorting or non-shorting contacts.

If you are building your own switches for test gear, etc. — you'll find switch parts, indexes, kits in Centralab's standard or "DD" line that meet your requirements. And that goes for highly rated switches for custom installations or high fidelity power supply, too.

When you need switches or switch parts, make your choice Centralab — the most complete line available.

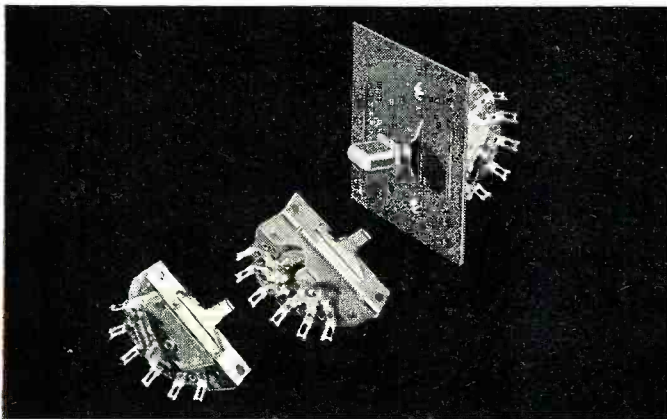

LEVER ACTION SWITCHES—for speech input equipment for line and program switching—monitoring, transceivers, band change, P. A. and intercoms, model railroad systems and industrial test equipment. Available in positive, spring return or combination. Coil spring index has minimum life of 150,000 switching cycles.

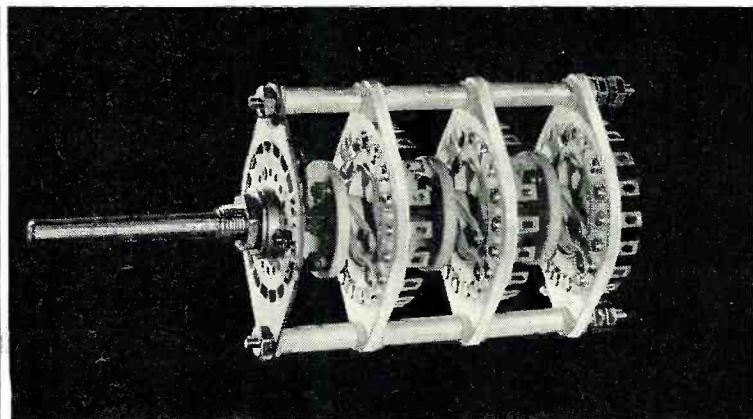

MEDIUM DUTY ROTARY SWITCH — for medium high power and excellent accuracy in transmitter, industrial control and balancing, laboratory testing, power supply converter and many other special applications. Rated at 750 watts (7½ amps, 60-cycle, 115 volts AC). 1, 2 or 3 poles...18 contact sections...up to 20 sections per shaft.

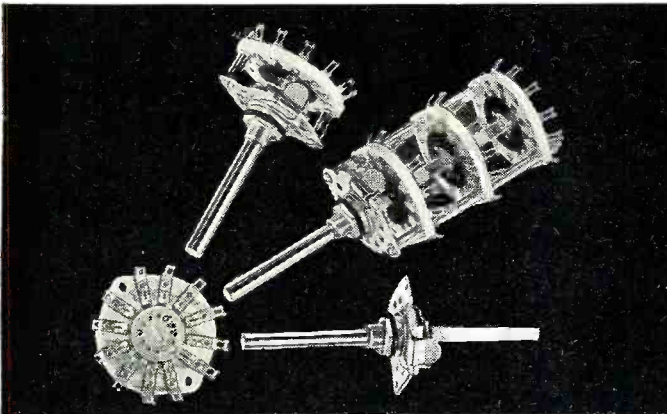

ROTARY SELECTOR SWITCHES — for use in fast, positive band switching in critical radio frequency circuit applications — in the oscillator, buffer or final amplifier stages of transmitters with input up to 75 watts and plate voltages up to 850 v.d.c. Also amateur rigs, test equipment and low current switching. Steatite or phenolic insulation.

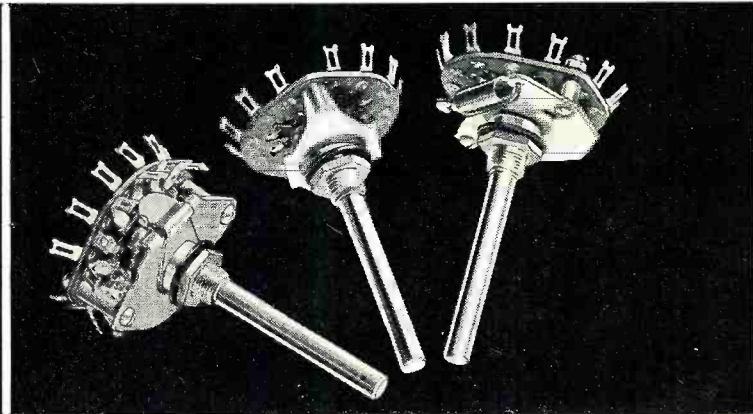

ROTARY ACTION FLAT SWITCHES—for program switching — monitoring, transceivers, band change, P. A. and intercoms. Phenolic insulation. Cadmium plated metal parts. A 4-pole, 2-position, non-shorting type with positive leaf spring index. Can be used a SPST, SPDT, DPST, DPDT, 3PST, 3PDT, 4PST or 4PDT.

It costs me and money to buy



SMALL GENERAL PURPOSE SWITCHES—on-off and step control switches for radio, P. A. channel selectors, wave band, meter reversing, meter selector, intercom talk-listen,

momentary line or remote speaker return and dual auto radio speaker control. Clips and contacts heavily silver plated. Phenolic insulation. SPST, SPDT, DPST, DPDT, etc.



414-419 ROTARY SWITCH KITS—give you a convenient, easily available source of stock sections, indexes and hardware for assembling practically any standard or special switching arrangement desired. Contain Centralab "DD" Index and Section construction. Attractive steel cabinet, fits standard steel shelving. 17" x 11⁵/₁₆" x 12³/₄".



1500 SELECTOR SWITCH KIT — ideal convenience for labs, design and service engineers, industrial electronic maintenance departments, hams and experimenters. 33 standard rotary switch phenolic sections, 16 index assemblies and adequate supply of flat shafts, spacers, nuts, bolts, lockwashers and knobs. 8" x 8" x 7".

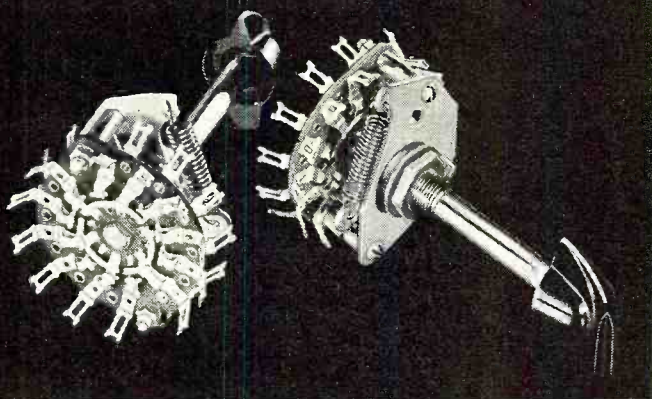

INTERCOM SWITCHES — for public address and intercom talk-listen systems. Six pole, 3 position. Available in two types — spring return from both sides to center and spring return one side, positive opposite side. For long, hard use in industrial test equipment. They are Centralab De luxe, "DD", style.

Centralab

A Division of Globe-Union Inc.
910 E. KEEFE AVE., MILWAUKEE

Get the whole story of Centralab switches for electronic and industrial uses. Write for Centralab Catalog.



MERIT

TV full-line Components For
Improvement, Replacement, Conversion



SELL IMPROVED RECEPTION

MERIT "TV" Kit #1000 for edge to edge focus—contains MDF-70 Cosine Yoke, HVO-7 Universal Flyback and MWC-1 Width Linearity Control. Keep a Kit handy—you'll get plus-business and a reputation for "know-how."



MDF-70... original of the "cosine" series—low horz. high vert inductance. Used by such famous sets as

Radio Craftsman. Cosine Yokes will improve 10,000,000 sets now in use!

MERIT...HQ for TV Service Aids

MERIT's 1952 Catalog #5211 now available... introducing MERIT IF-RF Coils, includes Coil & Transformer data, listings. Other MERIT service aids: TV Repl Guide #404, Sept. '51 issue—covers 3000 models, chassis of 82 mfrs; Cross Ref Data on IF-RF Coils, Form #14. Write: Merit Coil and Transformer Corporation, 4425 North Clark Street, Chicago 40.

These three MERIT extras help you:

- Exclusive: Tape-marked with specs and hook-up data
- Full technical data packed with every item
- Listed in Howard Sams Photo-facts



* Merit is meeting the TV improvement, replacement and conversion demand with a line as complete as our advance information warrant!



BERTON BROWNE ADVERTISING

Within the INDUSTRY

JOHN H. BOSE, an engineer associated with Edwin H. Armstrong, has been elected president of the Radio Club of America for 1952.

Other officers elected to serve during the coming year include: Vice-President Ralph R. Batcher, engineer for the Radio-Television Manufacturers Association; Corresponding Secretary Frank H. Shepard, Jr., president of *Shepard Laboratories*; Recording Secretary Frank A. Gunther, vice-president of *Radio Engineering Laboratories, Inc.*; and Treasurer Joseph Stantley, president of *Continental Sales Company*.

The following men were elected to serve on the board of directors: Ernest V. Amy, Edwin H. Armstrong, George E. Burghard, Alan Hazeltine, Harry W. Houck, Jerry Minter, and Harry Sadenwater.

* * *

LAWRENCE R. COHEN has been named sales manager for Army Equipment for the Electronics Division of *General Electric Company*. He will handle the division's sales to all branches of the Department of the Army.



George C. Trotter received a similar appointment as sales manager for Air Force equipment. Both men will headquarter at Electronics Park in Syracuse.

Mr. Cohen is a graduate of Brooklyn College and served with the U.S. Signal Corps from 1943 to 1946. Serving principally at the Signal Corps center at Fort Monmouth, he also attended radar schools at Harvard and MIT. He has been with *G-E* since 1946.

Mr. Trotter attended Harvard and served as a Lieutenant (jg) in the electronics group of the Navy's Bureau of Aeronautics from 1942 to 1945. He has been associated with *G-E* since 1948.

* * *

ELECTRICAL REACTANCE CORPORATION has been formally merged with *Aerovox Corporation* and will henceforth operate as the "Hi-Q" Division of *Aerovox*, Olean, New York.

In the fall of 1949, the *Aerovox Corporation* purchased all of the outstanding common stock of the *Electrical Reactance Corporation* and the present merger of the two companies into one is being made in the interests of closer cooperation with the parent company and increased efficiency.

Charles E. Krampf will continue as vice-president of the *Aerovox Corporation* and will be directly responsible for the operation of the new division. Tom Conway, general manager of the

merged company, will continue as general manager of the new division.

* * *

KING P. RAY is the new field sales manager for *Stewart-Warner Electric*, the radio and television division of *Stewart-Warner Corporation*.



In his new position, Mr. Ray will be responsible for the general marketing problems and field work at the distributor level under the expansion program of the company's television and radio division. The position of field sales manager is a newly-created one. He will make his headquarters in the general offices of the company in Chicago.

Prior to joining the company, he served as assistant to the vice-president of *Daystrom Corp.* of Chicago.

* * *

DR. ALAN HAZELTINE has been named president of the Alexander C. Humphreys Foundation.

The Foundation was organized a year ago to honor and perpetuate the memory of the late Dr. Alexander C. Humphreys, utilities executive and second president of Stevens Institute of Technology, who introduced courses which constituted the first approach to management engineering made by any engineering college.

The first goal of the Foundation will be to raise funds to fully endow professorships in Economics of Engineering.

Dr. Hazeltine is a graduate of Stevens, taught electrical engineering at the college from 1907 to 1925, and physics and mathematics from 1933 until 1944. He is famous for his invention of the neutrodyne radio receiver and as a consultant in radio-electronics.

* * *

HANS U. HJERMSTAD is the newly-elected vice-president in charge of engineering for *Sola Electric Company* of Chicago.



He has been in charge of engineering development for the company since 1948 as assistant to the president. He will continue to head *Sola's* engineering department and engineering laboratory which develops new product designs and applications in industry for the company's transformer products.

Prior to his association with *Sola*, Mr. Hjermsstad was affiliated with *Federal Electric Company* as vice-

“When we think of V-R tubes, we think of **CBS-HYTRON**”

**TUBES ARE KNOWN
BY THE COMPANY THEY KEEP**

It's automatic with scores of top-flight manufacturers. They turn to CBS-Hytron for the miniature OA2, OB2 and standard OC3, OD3.

That's only natural. They know CBS-Hytron has the know-how... know-how gained from making over 15,000,000 voltage regulators. They know CBS-Hytron supplies these apparently simple tubes to either JAN or commercial specifications. (In fact, CBS-Hytron's factory tests of VR tubes are much tougher than JAN.) And they know CBS-Hytron... top producer of VR tubes... can be depended upon for prompt delivery.

Follow the leaders yourself. Buy the best. Order your gaseous voltage regulators from CBS-Hytron.



Write for Complete Free Data on
CBS-HYTRON voltage-regulator tubes



MAIN OFFICE: Salem, Massachusetts

Reads like the blue book of electronics...
this list of famous companies who from long experience buy the best in voltage-regulator tubes... CBS-Hytron.

Admiral Corporation • Airborne Instruments Lab., Inc. • Aircraft Armaments, Inc. • Aircraft Radio Corp. • Aircsearch Mfg. Co. • Applied Physics Corp. Applied Research Laboratories • Arma Corporation A.R.F. Products, Inc. • Atomic Instrument Co. Audio Products Corp. • Ballantine Laboratories, Inc. • Arnold O. Beckman, Inc. • Bell Aircraft Corp. • Bell Telephone Laboratories, Inc. • Bellaire Electronics, Inc. • Bendix Aviation Corp. • Berkeley Scientific Corp. • Bill Jack Scientific Instrument Co. • Bright Radio Laboratories • The Brinnell Co. Browning Laboratories, Inc. • J. H. Bunnell & Co. Cambridge Instrument Co., Inc. • The Allen D. Cardwell Mfg. Corp. • CBS-Columbia, Inc. • CBS Television • Collins Radio Co. • Connecticut Telephone & Electric Corp. • Consolidated Vultee Aircraft Corp. • Cornell-Dubilier Electric Corp. • Crosley Division, Avco Mfg. Corp. • DDD Manufacturing Co. • Douglas Aircraft Co., Inc. • Allen B. DuMont Laboratories, Inc. • Edo Corporation • Eicor, Inc. • Electro-Physical Laboratories, Inc. • Electrotechnic Corp. • El-Tronics, Inc. • Fada Radio and Electric Co., Inc. • Fairchild Guided Missiles Div., Fairchild Engine and Airplane Corp. • Federal Manufacturing and Engineering Corp. • Federal Telecommunication Laboratories, Inc. • Federal Telephone and Radio Corp. • Ford Instrument Co., Div. of Sperry Corp. • Gaveco Laboratories, Inc. • General Communication Co. General Precision Laboratory, Inc. • General Radio Co. • Gilfillan Bros., Inc. • Gonset Company • The Gray Mfg. Co. • The Hallcrafters Co. • The Hammarlund Mfg. Co., Inc. • Harvey-Wells Electronics, Inc. • Hazeltine Electronics Corp. • Hewlett-Packard Co. • Hickok Electrical Instrument Co. • Hoffman Radio Corp. • Hubbell & Miller Co. • Industrial Control Co. • Industrial Development Engineering Associates, Inc. • Jack & Heintz, Inc. Jackson Electrical Instrument Co. • Kepco Laboratories, Inc. • Lavoie Laboratories, Inc. • Lear, Incorporated • Lewyt Corporation • Link Radio Corp. • Loral Electronics Corp. • Lyman Electronic Corp. • Lyseo Mfg. Co., Inc. • P. R. Mallory & Co., Inc. • The Glenn L. Martin Co. • The W. L. Maxson Corp. • McDonnell Aircraft Corp. • McElroy Manufacturing Corp. • Melpar, Inc. • Midwest Engineering Development Co., Inc. • Minshall-Estey Organ, Inc. • Motorola, Inc. • National Company, Inc. National Electrical Machine Shops, Inc. • National Research Corp. • National Research Council, Canada • New London Instrument Co. • Nuclear Measurements Corp. • Nutone, Inc. • Photobell Co. Pilot Radio Corp. • Portable Electric Tools, Inc. Precision Apparatus Co., Inc. • Press Wireless Mfg. Co., Inc. • Radiation, Inc. • Radio Development & Research Corp. • Radio Engineering Laboratories, Inc. • Rauland-Borg Corp. • Raymond Rosen Engineering Products, Inc. • Raytheon Mfg. Co. Reed Research, Inc. • Sanborn Company • Sangamo Electric Co. • Schuttig & Company, Inc. • Sentinel Radio Corp. • Servomechanisms, Inc. • Setchell Carlson, Inc. • Shallcross Mfg. Co. • F. W. Sickles Div., General Instrument Corp. • Sierra Electronic Corp. • A. F. Smuckler & Co., Inc. • Sonar Radio Corp. • Spencer-Kennedy Laboratories, Inc. • The Stamford Electronics Co. • Fred Stein Laboratories • The Superior Electric Co. • The Technical Materiel Corp. • Telechrome, Inc. • Tel-Instrument Co., Inc. • Times Facsimile Corp. • Tracerlab, Inc. • Trad Television Corp. • Transducer Corp. • United Scientific Laboratories, Inc. • Varo Mfg. Co., Inc. Wells-Gardner & Co. • Western Electric Co. • Western Sound & Electric Labs., Inc. • Westinghouse Electric Corp. • Weston Electrical Instrument Corp. • Weston Laboratories • Wilcox Electric Co., Inc. • Witeco Mfg. Co.

In addition to many other prominent manufacturers, the U. S. Army, Navy, Air Force, Coast Guard, AEC, CAA, FCC, National Bureau of Standards, government development laboratories and other government agencies, well-known research laboratories and universities, foreign countries, and the nation's leading electronic parts distributors.

THE LATEST AND THE GREATEST
ADVANCEMENTS IN PICKUP CARTRIDGES
ARE
Astatic

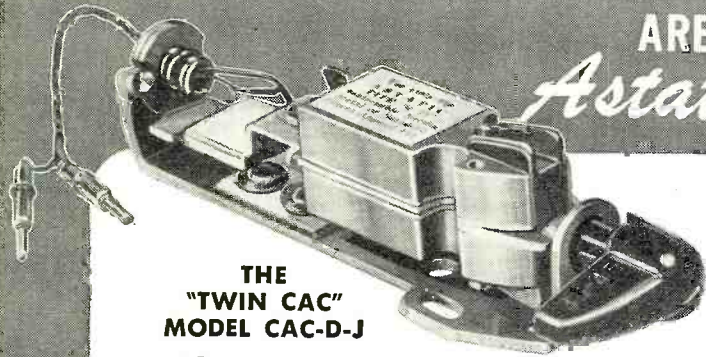

THE
"TWIN CAC"
MODEL CAC-D-J

FITS MOST of the popular changers. The first turnover design to remove all obstacles preventing true perfection of reproduction. Combines two complete CAC cartridge assemblies, back to back, on a common plate. Output and response characteristics of each side established independently of the other. Needles are also, of course, entirely independent of each other, free of interaction. Unique but simple switching device in turnover mechanism connects only the cartridge or side being used to amplifier phonograph input. Furnished complete with turnover bracket and knob assembly, with standard 1/2" mounting holes. Wiring terminating in pin connectors, graduated for two dimensions now standard on lead wire connectors. Easily installed without soldering. Equipped with Type Q (3-mil) and Type Q-33 (1-mil), sapphire-tipped needles.

LIST PRICE \$10.50 CODE ASXDJ

ONE OF THE THREE NEW ASTATIC TURNOVER PICKUPS EQUIPPED WITH THE TWIN CAC CARTRIDGE IS A SPECIAL MODEL, THE 9-D. LISTING AT ONLY \$11.50, IT IS DESIGNED FOR REPLACEMENT ON V-M MODELS 920, 950, 955, 970, 971, 975, 980 AND 985. REPLACE THE ENTIRE TONE ARM—EASILY, QUICKLY, WITH ONLY A SCREWDRIVER—FOR THE THRILLING NEW PERFECTION OF REPRODUCTION WHICH THE TWIN CAC CARTRIDGE MAKES POSSIBLE.

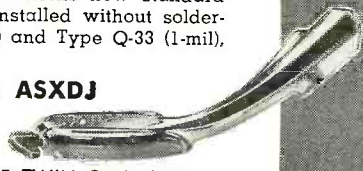

THE MODEL L-12-U

LEAVE condenser harness on for low output (1.2 volts) . . . or slip it off for high output (4.0 volts) . . . and you can replace most standard 78 RPM cartridges with this single model. Reproduction guaranteed to better or equal the previous unit. Needle chuck limiting feature restricts motion of the chuck both radially and lengthwise, prevents dislocation of chuck, and protects against crystal breakage from rough handling and when changing needle. Furnished with complete installation instructions and listing of cartridges the L-12-U replaces.

LIST PRICE \$4.95 CODE ASWSF

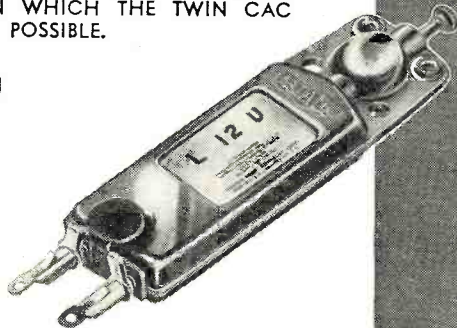

WRITE FOR COMPLETE DETAILS ON ANY
ASTATIC PRODUCTS MENTIONED ABOVE



EXPORT DEPARTMENT: 401 Broadway, New York 13, N. Y.
Cable Address: ASTATIC, New York

president in charge of research, engineering, and manufacturing.

FEDERAL TELEPHONE AND RADIO CORPORATION has established a mobile radio communications department for the design, manufacture, sale, and servicing of a complete line of vehicular and railroad mobile radio equipment. The new department will operate at *Federal's* newly-acquired plant in Passaic, New Jersey . . . **LION MANUFACTURING CORPORATION**, well-known Chicago manufacturer of electrical devices, will unveil its line of television receivers at the Parts Show in Chicago during May and officially enter the market during the Chicago Furniture Market held in July . . . **SYLVANIA ELECTRIC PRODUCTS INC.** has purchased the cabinet plant of **BLAIR PARK FURNITURE MFG. COMPANY** at High Point, N. C. The 55,000 square foot plant will operate as part of the parent company's Radio & Television Division . . . **BECKMAN & WHITLEY INC.**, San Carlos, California instrument-engineering organization, has established a new guided missile products division . . . **LOU F. WAELTERMAN** has established a new manufacturers' representative firm which has headquarters at 8543 McKenzie Road, St. Louis 23, Missouri.

IRVING G. ROSENBERG has been named director of operations, responsible for



Allen B. Du Mont Laboratories, Inc.'s television receiver and cathode-ray tube divisions.

Mr. Rosenberg has been manager of *Du Mont's* cathode-ray tube division since 1946 and actively supervised its growth and expansion. He has been with the company since 1942, starting in production control.

He will make his headquarters at the company's East Paterson, N. J. plant.

STANDARD COIL PRODUCTS CO. INC. and *General Instrument Corporation* have agreed to an exchange of stock at the rate of five shares of *General Instrument* for four shares of *Standard Coil*.

Standard Coil plans to operate *General Instrument* as a wholly-owned subsidiary. The parent company has plants in Chicago; Los Angeles; Bangor, Michigan; and through another subsidiary, *Kollsman Instrument Corporation*, in Queens, N. Y.

General Instrument has plants in Elizabeth, New Jersey; Chicopee, Mass.; and Joliet, Illinois.

KEPCO LABORATORIES, INC. will house its production, research, and development facilities in an ultra-modern plant, now nearing completion in Flushing, New York . . . **TUNG-SOL SALES CORPORATION** has moved from

Los Angeles to 857 Washington Boulevard
(Continued on page 120)

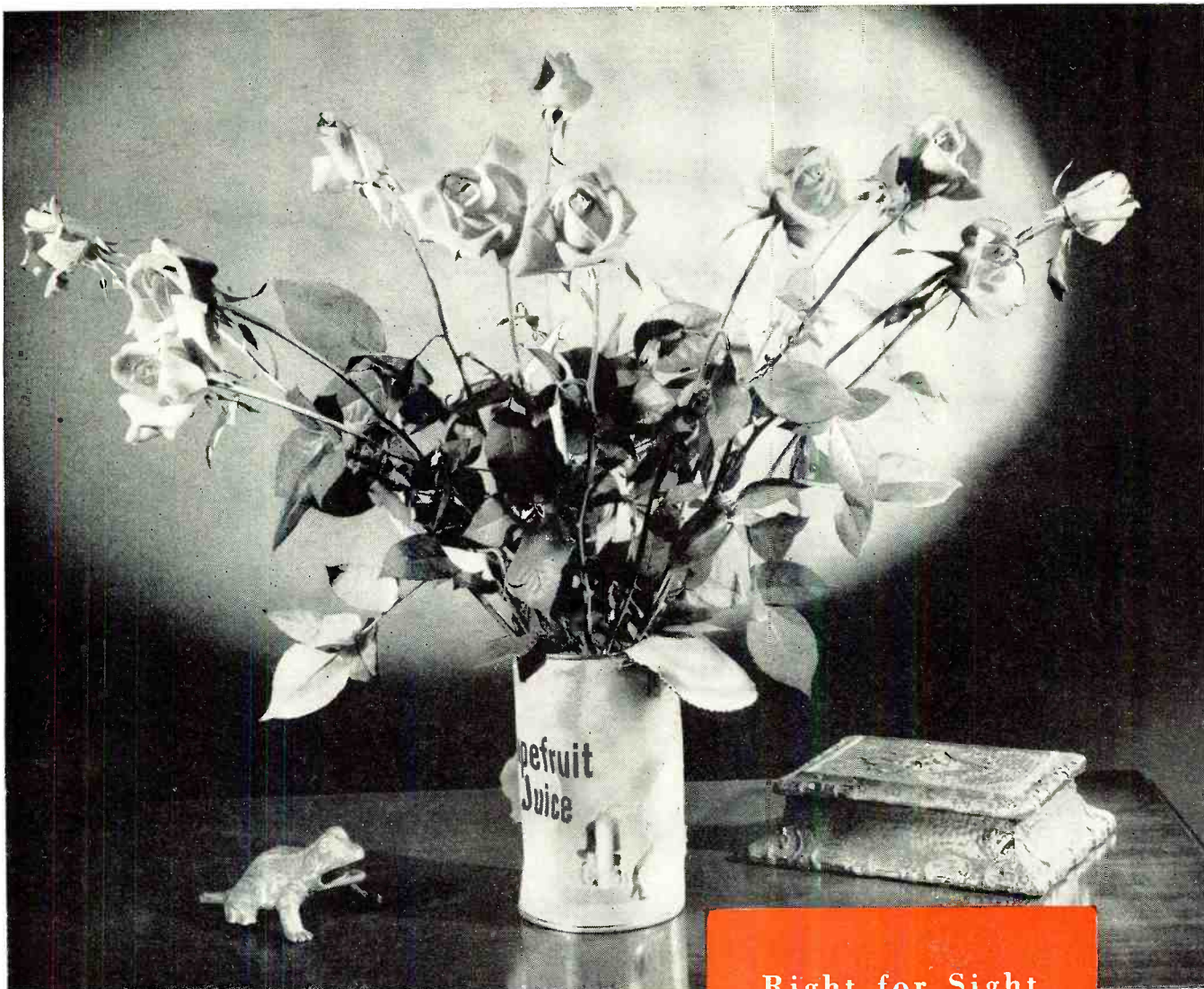

Right for Sight



RAYTHEON PICTURE
TUBES

Makeshift Replacements Reduce Picture Quality

Replacements with
Raytheon Television Tubes
assure picture quality

Don't forget! Raytheon Picture Tubes with Corona Inhibitor
give constant picture clarity whatever the weather.



Excellence in Electronics

RECEIVING AND PICTURE TUBES • RELIABLE SUBMINIATURE AND MINIATURE TUBES • GERMANIUM DIODES AND TRANSISTORS • RADIAC TUBES • MICROWAVE TUBES

RAYTHEON MANUFACTURING COMPANY

Receiving Tube Division

Newton, Mass., Chicago, Ill., Atlanta, Ga., Los Angeles, Calif.



RARE GEMS BY TRABERT & HOFFER, INC. — MAUBOUSSIN

BURTON BROWNE ADVERTISING



1.



2.

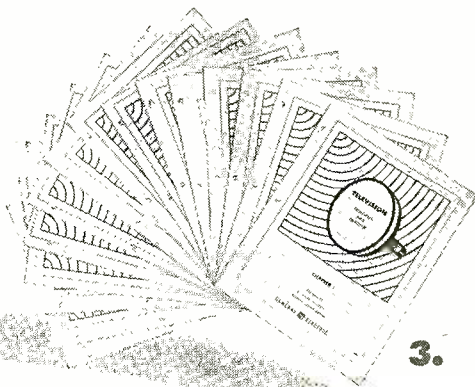

3.

6 PRACTICAL AIDS TO MAKE YOUR SERVICE JOB EASIER!

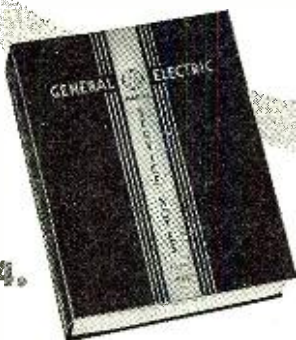

4.



5.

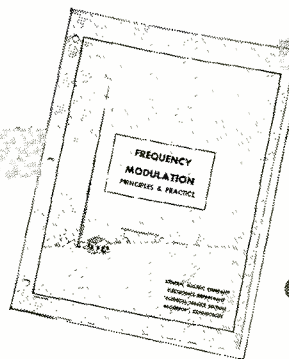

6.

1. Radio and TV Service Manuals

Four separate volumes of service notes on AM home and portable receivers, FM and TV receivers, and radio-phonos. The books contain complete service manuals on G-E radio and TV sets for the years 1946 through 1952. Also schematics, parts lists, alignment procedures, electrical and mechanical specs, etc.

2. G-E TV Receiver Service Guide

Brand new—80 pages packed with information on all G-E television receivers built since 1945—102 models! Contains schematic diagrams, replacement parts list, tube and component layouts, picture tube assembly adjustments, cabling of combination receivers, R-F tuner units, and top and bottom chassis views.

3. TV Principles and Practice

A complete course in itself—for the trained serviceman. Each chapter is a separate booklet of standard office file size. Fifteen in all, they cover practical applications of TV receivers of the post-war period, together with a detailed description of modern test equipment; TV antennas and trouble shooting techniques.

4. Bound Volume 1939-1942

Here are all the individual manuals for G-E portable and home receivers manufactured during the years from '39 to '42 inclusive. AM home and portable receivers, FM sets, TV receivers and radio-phono combinations. Schematic diagrams, electrical and mechanical specs, parts lists, etc.—all in one binder.

5. TV and Radio Parts Catalog and Price List

Lists the parts of every G-E radio and TV receiver manufactured since October, 1945. In this book you will find all the information you need about any part—catalog number, description, sets in which it is used, and price. Practical, hard cover, loose-leaf pages.

6. FM Principles and Practice

Special effort has been made in this booklet to acquaint the serviceman with the important differences between AM and FM. Circuit descriptions are particularly complete. Useful information on antenna theory, plus pointers on how to choose antenna location and how to calculate antenna length.

HOW TO GET THEM—Your General Electric receiver distributor is the man to call. He will see to it that you get the aids you need to make your servicing more profitable. Why not ask him today? *General Electric Company, Receiver Department, Syracuse, New York.*

You can put your confidence in—

GENERAL  ELECTRIC

GET YOUR NEW Hallicrafters

COMMUNICATION RECEIVER HERE and



Save Money With a "Surprise" Trade-In Allowance on Your Used Test and Communication Equipment

For super dooper savings on Hallicrafters Receivers get a Walter Ashe "SURPRISE" Trade-In offer on your used (factory-built) Test Instruments or Communication Equipment. Walter will give you an extra-liberal allowance that will put the Hallicrafters model of your choice within easy reach! So don't delay! Get your trade-in deal working today. Wire, write, phone or use the handy coupon below.

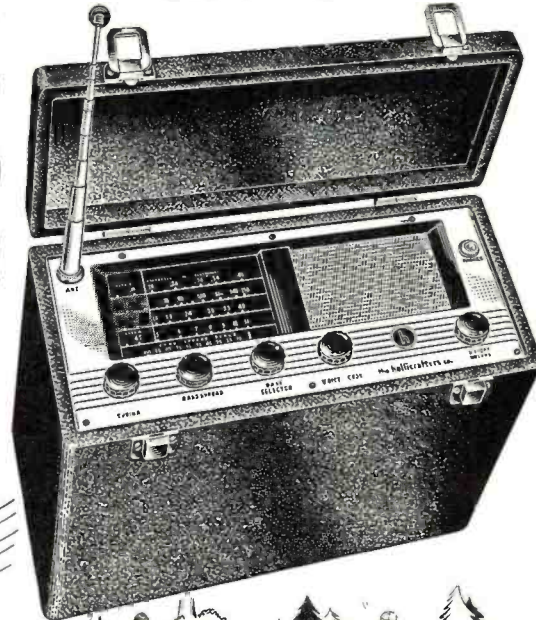

Wherever You May Roam... on Land or Sea



HALLICRAFTERS SX-71—Shpg. wt. 33 lbs. Only \$199.50 (Less speaker). R-46 speaker, 19 lbs. Only \$19.95

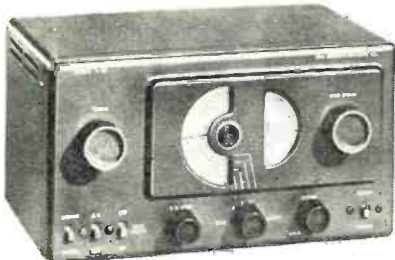

HALLICRAFTERS S-38B—Shpg. wt. 14 lbs. . . Only \$49.50

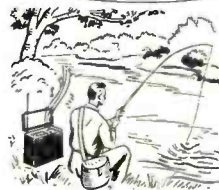

Keep The Home Ties With The S-72, Long-Range Portable

Soldier, sailor, marine, businessman, diplomat, world traveler, explorer—wherever you are . . . no matter where you go . . . you'll always be just "around the corner" from home with this extra-sensitive, portable broadcast-short wave radio. Plenty of sensitivity for far-distant stations, even where ordinary receiving sets fail. Can be used on 110-120 volt AC or DC, or self-contained batteries. Covers 540KC. To 30MC.

Shpg. wt. 16 lbs.
Only \$109.95 (less battery)

Battery Pack for S-72
(Shpg. wt. 8½ lbs.) \$4.17

FREE CATALOG!

New 164 page catalog. Features all the latest and best in ham gear, radio equipment and electronic supplies for industry, schools, home and workshop.

All prices F. O. B. St. Louis • Phone Chestnut 1125

Walter Ashe
RADIO CO.
1125 PINE ST. • ST. LOUIS 1 . MO.

Walter Ashe Radio Co. 1125 Pine St., St. Louis 1, Mo. RN-4-52
 O. K. Walter, Rush "Surprise" Trade-in-offer on my _____
 for _____ (show make and model No. of new equipment desired)
 Rush Free Copy of your new Catalog.
 NAME _____ ADDRESS _____
 CITY _____ Zone _____ STATE _____



Learn RAD TELEVISION

**-New Package Unit Plan- PAY AS YOU LEARN
NO MONTHLY PAYMENT CONTRACT TO SIGN!**



**I Send You
18 BIG
KITS
OF RADIO-
TELEVISION
EQUIPMENT**

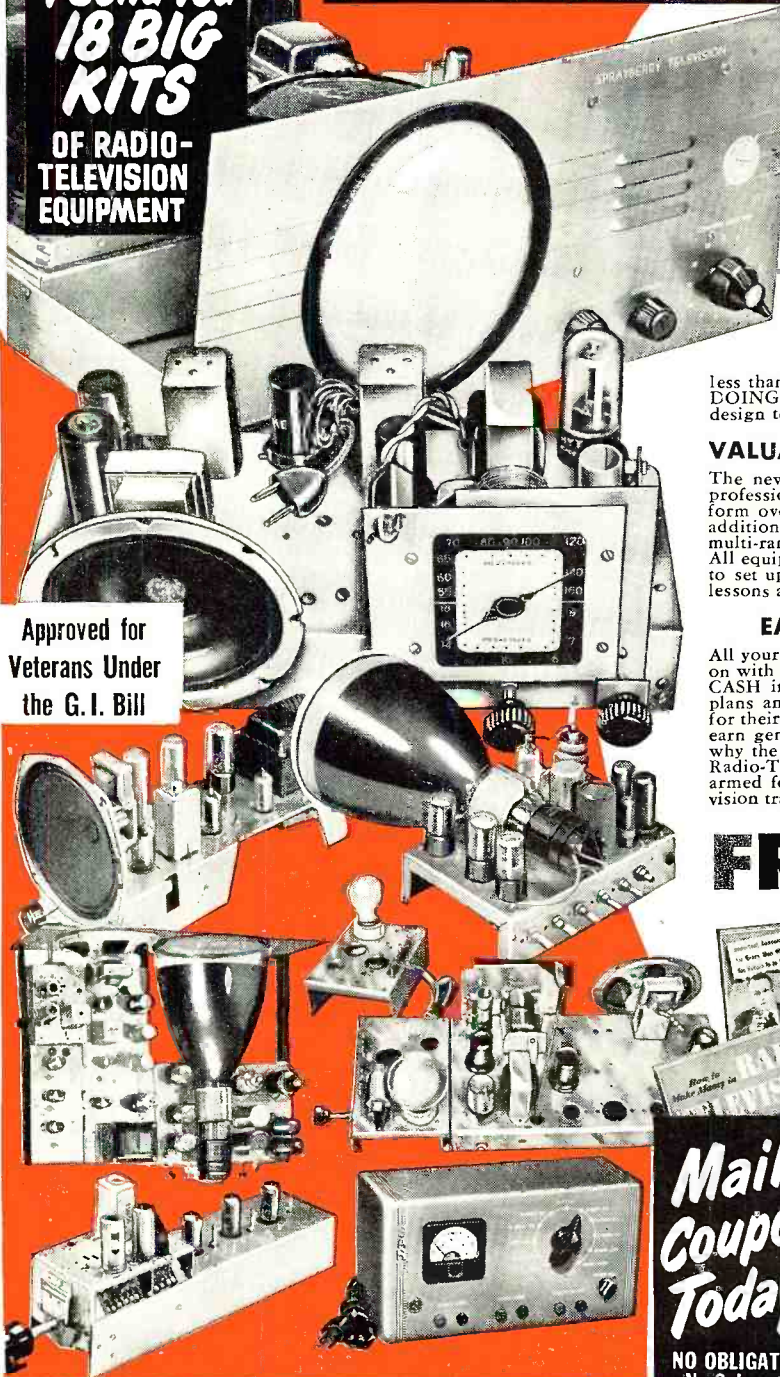

**Approved for
Veterans Under
the G. I. Bill**

**IF YOU ARE
EXPERIENCED IN RADIO**

Men already in Radio who seek a short intensive 100% TELEVISION Training with FULL EQUIPMENT INCLUDED are invited to check and mail the coupon at the right.

**TRAIN IN 10 MONTHS OR LESS
At Home in Your Spare Time**

Now . . . be ready for Radio-Television's big pay opportunities in a few short MONTHS! Frank L. Sprayberry's completely new "Package" training unit plan prepares you in just 10 MONTHS . . . or even less! Equally important, there is NO monthly payment contract to sign . . . thus NO RISK to you! This is America's finest, most complete, practical training—gets you ready to handle any practical job in the booming Radio-Television industry. In just 10 months you may start your own profitable Radio-Television shop . . . or accept a good paying job in this fascinating expanding field at work you've always wanted to do. Mr. Sprayberry has trained hundreds of successful Radio-Television technicians—and stands ready to train you in less than one year, even if you have no previous experience. You learn by DOING . . . actually working with your hands with equipment of special design to illustrate basic theory instead of relying on books alone.

VALUABLE EQUIPMENT INCLUDED WITH TRAINING

The new Sprayberry "package" plan includes many big kits of genuine, professional Radio-Television equipment. While training you actually perform over 300 demonstrations, experiments and construction projects. In addition, you build a powerful 6-tube standard and short wave radio set, a multi-range test meter, a signal generator, signal tracer, many other projects. All equipment is yours to keep . . . you have practically everything you need to set up your own service shop. The interesting Sprayberry book-bound lessons and other training materials . . . all are yours to keep.

EARN EXTRA MONEY WHILE YOU LEARN!

All your 10 months of training is AT YOUR HOME in spare hours. Keep on with your present job and income while learning . . . and earn EXTRA CASH in addition. With each training "package" unit, you receive extra plans and ideas for spare time Radio-Television jobs. Many students pay for their entire training this way. You get priceless practical experience and earn generous service fees from grateful customers. Just one more reason why the Sprayberry new 10 MONTH-OR-LESS training plan is the best Radio-Television training in America today. If you expect to be in the armed forces later, there is no better preparation than good Radio-Television training.

FREE 3 BIG RADIO TELEVISION BOOKS



I want you to have ALL the facts about my new 10-MONTH Radio-Television Training—without cost! Act now! Rush the coupon for my three big Radio-Television books: "How to Make Money in Radio-Television," PLUS my new illustrated Television Bulletin PLUS an actual sample Sprayberry Lesson—all FREE with my compliments. No obligation and no salesman will call on you. Send the coupon in an envelope or paste on back of post card. I will rush all three books at once!

SPRAYBERRY ACADEMY OF RADIO
Dept. 25-H, 111 North Canal St., Chicago 6, Ill.

**Mail
Coupon
Today!**
NO OBLIGATION
No Salesman
Will Call

SPRAYBERRY ACADEMY OF RADIO, Dept. 25-H
111 North Canal St., Chicago 6, Ill.

Please rush to me all information on your 10-MONTH Radio-Television Training Plan. I understand this does not obligate me and that no salesman will call upon me.

Name..... Age.....

Address.....

City..... Zone..... State.....

Please check Below About Your Experience

Are You Experienced? No Experience

Now in **MASS PRODUCTION...**

**PYRAMID ULTRA-COMPACT
metallized
paper capacitors**

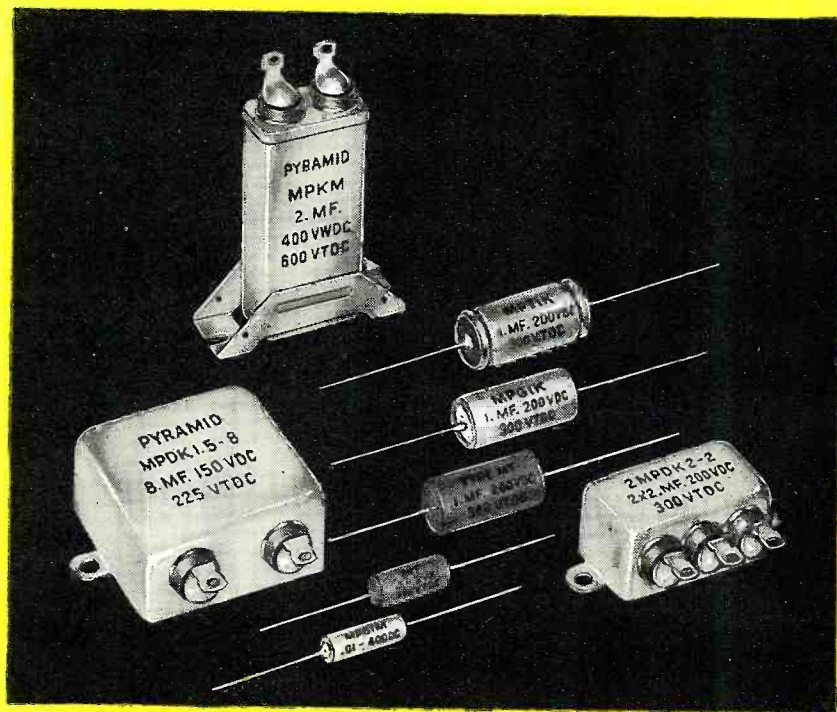

PYRAMID Series M CAPACITORS use a specially-prepared metallized paper, providing all-important savings in size and weight. . . . Pyramid now produces large quantities of these capacitors in a wide variety of cardboard or hermetically sealed metal containers.

Your letterhead inquiries are invited



PYRAMID ELECTRIC COMPANY • 1445 HUDSON BLVD., North Bergen, N. J.

INTERPRETING

that TV PATTERN

By
KEN KLEIDON
Belmont Radio Corp.

WITH the rapid changes and new circuits being introduced in the growing television industry, the TV technician is compelled to develop new and modern servicing techniques to keep pace. A troubleshooting procedure, based on the picture tube as a source of information, has been developed by C. W. Hoshour, director of service, *Belmont Radio Corporation*, and presented in recent lectures to technicians throughout the country.

It is a known fact that a good radio technician can shoot trouble in a radio receiver by simply using his ears. He can translate into circuitry, what he hears and usually put his finger on the trouble. By the same token, a TV technician can use his eyes to ferret out service faults. The picture tube is an important and readily available piece of test equipment and it furnishes a great deal of servicing information. If the TV technician knows in what way the various circuits contribute to a normal television picture, he can, by viewing the face of the picture tube, determine what particular circuit is causing a certain trouble. The ability of a technician to interpret what he sees on the face of the picture tube will provide him with a quick, easy, and modern method of television troubleshooting.

The test patterns reproduced in this and the articles to follow are actual photographs of the picture tube of an operating television receiver. The various conditions were simulated in the receiver to give the desired results. Only a few were touched by the artist's brush as the desired conditions could not be set up at the time. The test pattern used is the *RCA "Indian-Head"* superimposed on a pattern consisting of 24 dots horizontally and 14 dots ver-

Fig. 1. Normal picture. It is clear, steady, with proper contrast between black, white, and various shades of grey, is properly centered and focused, and has excellent definition.

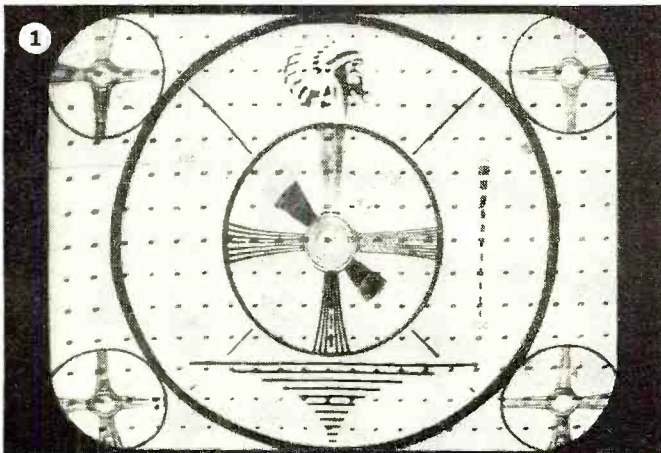

tically obtained from a composite video and r.f. generator at *Belmont Radio*.

Fig. 1 is the average television picture that can be seen on any normally operating receiver in a local signal area. Obtaining a good television picture depends on the following factors; station transmission limitations, receiver design and adjustments, signal strength, and antenna installation. The station transmission curbs greatly limit the over-all quality of a television picture. Present FCC standards limit the system in bandwidth and resolution and provide a picture which is equivalent to 16 mm film. A 16 mm film has approximately 250,000 picture elements whereas the standard 35 mm movie film has approximately 1,000,000 elements. Thus picture quality is limited because of present transmission standards and "movie quality" should not be expected.

Receiver design and adjustments also play an important role in obtaining a good picture. A receiver should have a tuner with ample gain and a high signal-to-noise ratio, i.f.

Fig. 2. An example of ghosts or multiple images. The image at the far left is the original unreflected signal while the various displaced images to the right are reflected pictures.

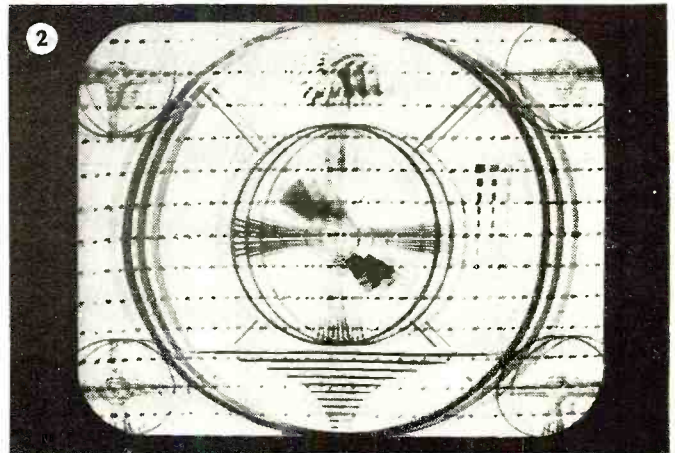

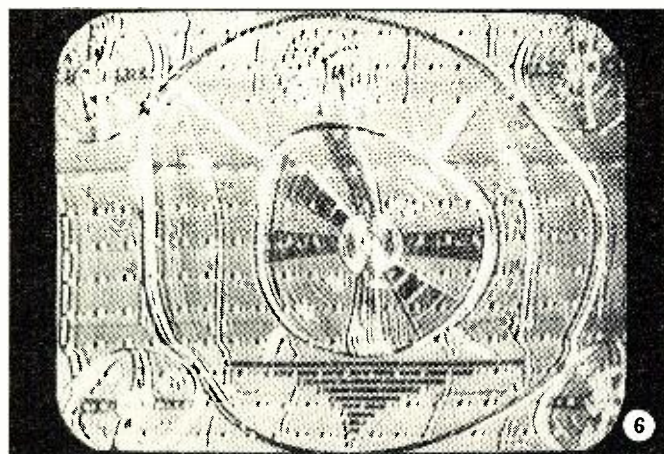
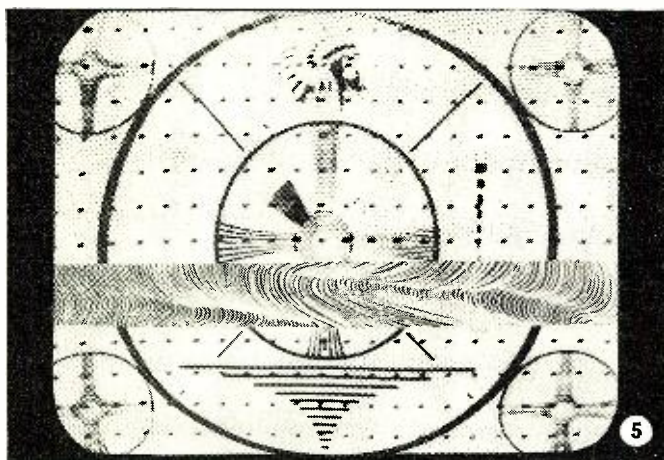
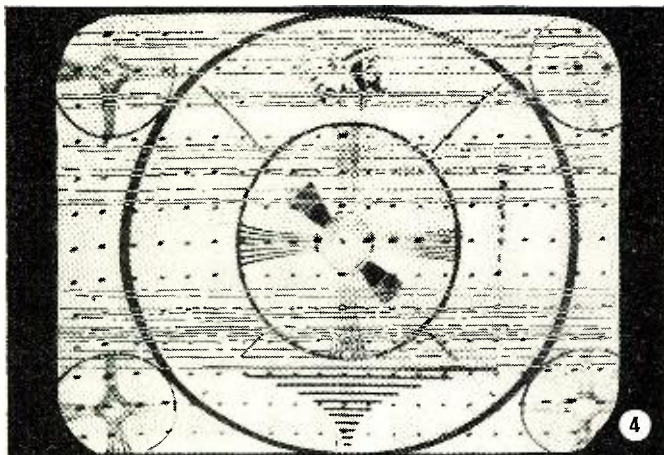
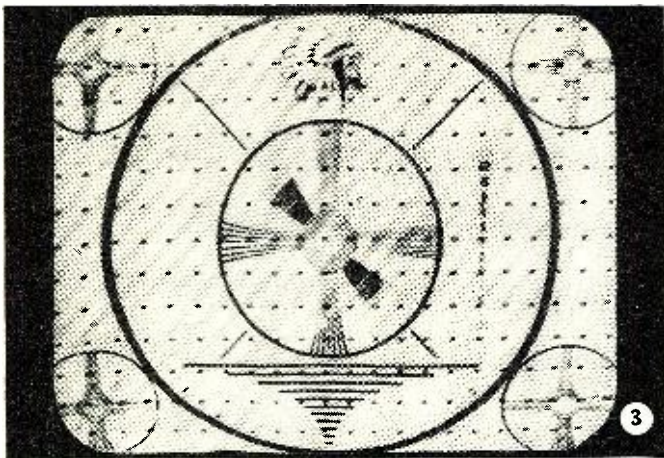

and video amplifiers of sufficient gain and bandpass to obtain all the reproducible frequencies, a good a.g.c. system to prevent overloading in strong signal areas and fading in weaker signal locations, and good sync circuits in order to avoid poor synchronization. Receiver adjustments to fill the screen and give reasonable linearity, r.f. and i.f. alignment, centering, focus, and proper contrast are also important and must be made in order to obtain a good picture.

Signal strength will depend mainly upon the distance from the TV station, station transmitting power, and the surrounding terrain. Buildings, mountains, or hills may reduce the signal strength and produce objectionable ghosts. As a general rule, picture quality will improve with increased signal strength.

Antenna installations will vary with the signal strength available. In low signal areas much more attention must be given to the installation. Such points as height, orientation, length and matching of transmission line, and gain of the antenna must be considered to obtain a good television picture.

There are four basic types of outside interference which are detrimental to a good picture. Their effect on the picture is easily discernible but in many cases the interference can be minimized or eliminated. Many articles have been written on these various types of interference, therefore, only the more important points will be covered in this series. These four types of interference are quite common but since they cause considerable trouble for the technician, they are worthy of consideration.

Ghosts or multiple images are transmitted signals which are reflected from buildings, mountains, or other objects in the vicinity and reach the antenna at different time intervals. The signal time delay causes displaced images, as shown in Fig. 2. Fig. 2 represents the original and three reflected signals. The image at the far left is the original unreflected signal. The sync has stabilized on the first ghost reflection and it has greater signal strength. Thus, it appears that there is one forward and two trailing ghosts.

There is no set or standard procedure for eliminating ghosts. There are many solutions that have proved successful in various locations. However, the same solution may not always produce the desired results. The trial and error method often proves to be the best procedure. In an area where ghosts are present, orienting or rotating the antenna may produce a stronger unreflected signal and decrease the strength of the objectionable signal causing the ghosts. In some cases, pointing the antenna toward the source of reflection rather than the station may produce favorable results. Other suggested remedies include installing a more directional type antenna, using separate channel antennas, installing an antenna rotor, matching the antenna to the receiver, connecting a shorted quarter-wave tuned stub, or eliminating standing waves by obtaining the correct transmission line length.

One other solution may be to relocate or move the antenna. In some cases, moving the antenna only a few feet completely eliminated all traces of ghosts. The distance and direction the antenna should be moved are usually best determined by trial and error. The distance the antenna should be moved can also be determined mathematically. This is accomplished by using the ratio of ghost displacement as related to picture width. The picture

Fig. 3. An example of r.f. interference. Narrow, evenly-spaced bars appear diagonally between a vertical or horizontal position. Bars may be wavy or bent and vary widely in number.

Fig. 4. Ignition interference causes sporadic black and white streaks in the horizontal direction. They move vertically and at random with no particular pattern discernible on the screen.

Fig. 5. Diathermy interference produces a herringbone pattern which tears part of the picture in a horizontal plane. This is generally synced vertically and may also move vertically.

Fig. 6. Mistuning, faulty antenna installation in fringe areas, or overloading causes white following black portions of picture to appear as ghosts with poor over-all definition. May be accompanied by poor sync and horizontal pulling of raster.

Fig. 7. Normal fringe reception characterized by lack of contrast accompanied by snow and, in some cases, susceptibility to r.f. interference. Good horizontal and vertical sync stability is difficult to obtain under such fringe area conditions.

Fig. 8. Ghosts and weak signal conditions are apt to cause snow, poor contrast, poor sync stability, and horizontal displacement.

Fig. 9. An example of 60-cycle hum. The light and dark shading of the picture in the horizontal plane usually exists only when a picture signal or carrier is present at the r.f. input.

Fig. 10. Sound bars. Intermittent light and dark shadings of picture in horizontal plane may or may not move vertically.

width corresponds to approximately $9\frac{1}{2}$ miles of the delayed distance traveled by the reflected signal. Displacement of the ghosts, illustrated in Fig. 2, as related to picture width shows an approximate delay of $\frac{1}{4}$ mile. Knowing the additional distance traveled may assist in determining the reflecting source.

A case of r.f. interference is usually caused by a strong signal whose frequency is higher than the station's received video carrier. The strong signal may be radiated and picked up from high powered radio equipment in the vicinity, local oscillator in a nearby receiver, or radio from ham equipment. The interfering signal beats with the video carrier thus producing a "difference" frequency falling within the video range. The higher the interfering signal is above the video carrier the narrower and more numerous the diagonal lines. An interfering signal approximately 3 megacycles above the video carrier is illustrated in Fig. 3. This type of interference may not affect every station and may vary from station to station in different locations. One point of interest to remember concerning r.f. interference is that the amount of picture interference is governed by both the signal strength of the station and the strength of the interfering signal. The stronger the station signal the less will be the effect of the interfering signal.

Such r.f. interference may also be caused by radiation from video detectors (similar to heterodyne "tweet" in broadcast receivers) and sound discriminators or r.f. high voltage power supplies in older type receivers. Keeping the antenna transmission line away from these portions of the receiver may help reduce the interference. In apartment buildings where local oscillator radiation is offending, the use of a master antenna system completely eliminates this problem. Not much can be done to eliminate r.f. interference unless corrective measures are taken at the source of interference. Means of reducing or eliminating this type of interference include the installation of a more directional, higher gain antenna, the use of wave traps and tuned stubs, or shielding the transmission line to reduce pick-up.

Ignition type interference, characterized by black or white streaks running across the picture (Fig. 4), is generally due to breaking contact-type electrical equipment such as the ignition systems of trucks and cars, cash registers, electric razors, vacuum cleaners, or adding machines. This interference can be picked up by the antenna or transmission line or can come in through the power line. A power line filter installed between the receiver and wall outlet will usually eliminate the power line as a source of interference. Other possible remedies are to relocate the antenna so that it is as far away from street traffic as possible, twist the transmission line approximately one turn per foot, or install shielded transmission line. Another condition which simulates ignition interference may be due to corona or arcing in the high voltage supply.

Diathermy interference, Fig. 5, is generally caused by radiation from x-ray equipment, commercial r.f. heating units, ultraviolet and fluorescent lights, brush motors, and other 60-cycle operated equipment. This type of interference is best reduced or eliminated by installing some type of corrective measures at the source. Since this is not always possible, other methods, such as installing a booster, high pass filters, or tunable stubs must be tried. The last mentioned suggestion has proved successful in various instances.

(Continued on page 150)

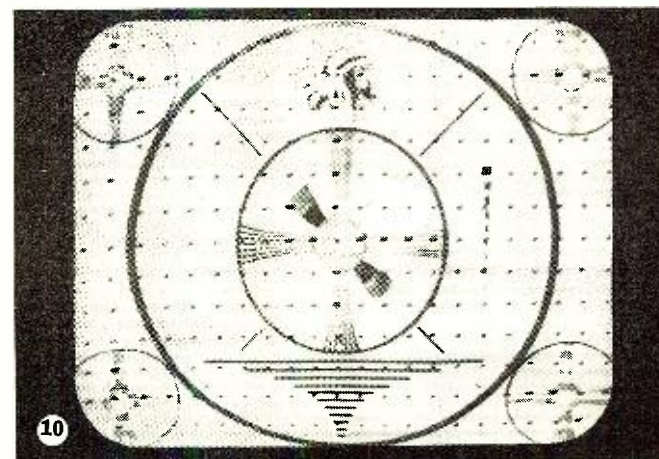
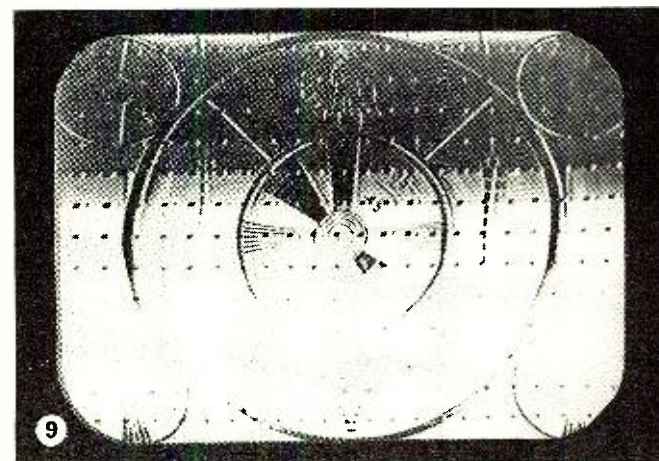
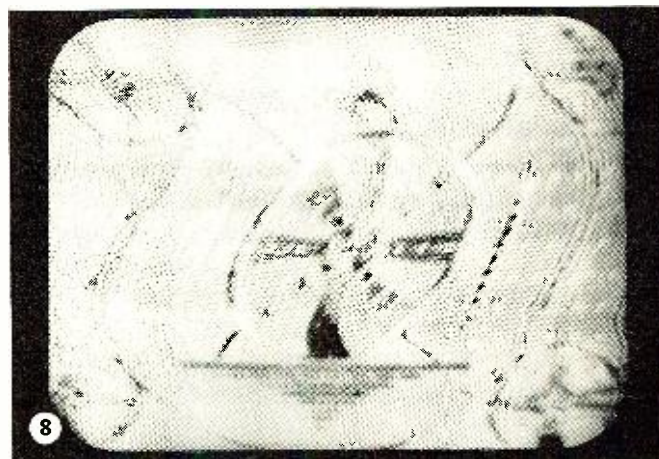
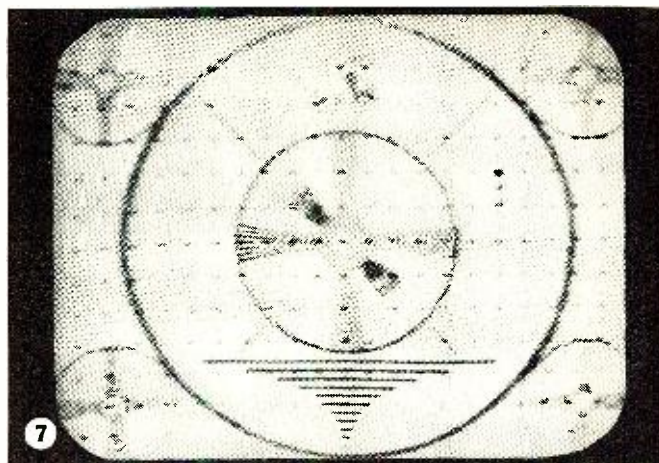

THE JUNCTION TRANSISTOR

By
H. S. RENNE

Technical Editor
RADIO & TELEVISION NEWS



Comparative size of the new junction transistor and a standard miniature type 6AK5, which is $\frac{3}{4}$ " in dia.

Details on Bell Laboratories' newly-developed unit and a discussion of some potential uses.

▼ HERE was a tremendous amount of excitement among electronic engineers when the first point-contact transistor was announced by *Bell Telephone Laboratories* some four years ago. This initial enthusiasm, however, was soon replaced by a great deal of hard work at the laboratories where efforts were made to iron out the "bugs" existing in the original design, and to ready the device for mass production. These goals have now been reached and reliable, uniform point-contact transistors are in limited production.

The original interest in transistors was given a new stimulus last July with the announcement of the *junction transistor*. Based on theoretical work at *Bell Laboratories* by Dr. William Shockley, this new device possessed qualities which seemed to indicate that in many respects it would prove to be superior to the point-contact type of transistor. Intensive research and development work is now in progress all over the country to determine its limitations and capabilities and to prepare it for mass production.

Transistors are constructed of a metal called *germanium*, which is classed as a semi-conductor. Conduction of electricity through germanium can take place either by a flow of electrons or by a flow of so-called "holes" which are, in effect, an absence of electrons. The result is similar to what would occur if an electron were replaced by a positive charge. The type of con-

duction is determined by very slight amounts of impurities in the germanium. If these impurities are such that conduction takes place by means of electrons, the germanium is of the "N" type. If conduction is by means of "holes," the germanium is known as the "P" type.

The basic construction of the junction transistor is shown in Fig. 1. It consists essentially of a very thin wafer of "P" type germanium cut from a single crystal and placed between two tiny bars of "N" type germanium, also cut from a single crystal. Because of this construction, the junction transistor is often referred to as the "NPN" transistor.

This new device has many characteristics which entitle it to be called the first serious rival to the vacuum tube. Its amplifying properties are in many respects superior to conventional tubes, and it is far more rugged with respect to shock and vibration than any known tube. It is much smaller (about half the size of a pea), and has an expected

Fig. 1. Basic construction of the junction transistor. Two types of germanium are used.

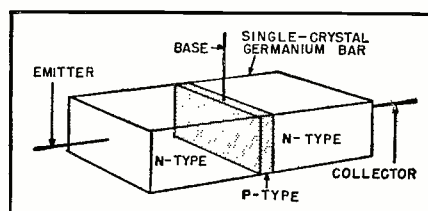

service life greatly exceeding that of conventional tubes.

Fig. 3 shows the form of presentation which has been adopted for the junction transistor. The base is the center or "P" type section of germanium; the collector and emitter are the "N" type sections.

Power amplifications as high as 50 db (100,000 times) have been achieved with specific units, and it is reasonable to assume that this figure can be approached or even exceeded in production units. The actual power output rating of the transistor itself is rather small, depending primarily on the cross-sectional area of the germanium at the junction. Most of the experimental units use a germanium rod about a sixty-fourth of an inch in diameter, and have an output rating on the order of 50 milliwatts, heat dissipation within the unit being the limiting factor. One transistor has been assembled with a cross-sectional area of a square centimeter which has a rating of two watts, and still higher-powered units are possible.

A variety of input and output impedances may be achieved by connecting the transistor in different ways. Fig. 2 shows the three possible connections, together with a corresponding practical circuit for each.

The arrangement in Fig. 2A is called the grounded-base circuit, characterized by a low input impedance and a high output impedance. Typical values would be from about 50 to 250 ohms for the former, and from 1.5 to 13.5 megohms for the latter. These values depend to quite a large extent on the construction of the transistor, as well as the amount and kinds of impurities present in the germanium. Power gains of 40 to 50 db can readily be achieved with this arrangement when impedances are matched, and appreciable gains can be obtained with a load resistance of only a few thousand ohms. One advantage of the latter arrangement is that the gain is almost completely independent of those transistor properties which vary from unit to unit. When amplifier stages of this type are cascaded, a matching transformer should be used.

The second type of connection, illus-

RADIO & TELEVISION NEWS

trated in Fig. 2B, is known as the grounded-emitter circuit. This is the most desirable circuit for many applications. Input impedance is higher and output impedance much lower than for the grounded-base arrangement, typical values being 250 to 1500 ohms for the input impedance, and 250,000 ohms to 1.5 megohms for the output impedance. Maximum available gain is over 50 db. In the practical circuit of Fig. 2B, the base will float at a certain potential. If a different potential is desired, various arrangements for biasing may be used. A two-stage amplifier utilizing this circuit and having a power gain of about 90 db is shown in Fig. 4. This amplifier is pictured at the right of Fig. 5.

The power gain available from the grounded-collector stage, shown in Fig. 2C, is rather low, about 15 to 20 db, but the circuit has certain other advantages which make it desirable. Input impedance is high although varying widely with the load resistance. Output impedance likewise depends upon input loading, but in general is quite low. Thus, this circuit arrangement takes on the characteristics of a cathode follower, and if the source impedance is on the order of a few thousand ohms, the output impedance may be 25 ohms or less. Audio enthusiasts would undoubtedly like to use this device to drive a voice coil direct, without using an output transformer!

The junction transistor is especially suited for use at very low power levels. Its efficiency is exceptionally high, closely approaching the theoretical maximum of 50% for Class A and 100% for Class C amplification. Thus, the input battery power required can be extremely small. For example, an audio oscillator (shown at left, Fig. 5) has been built which operates satisfactorily with an input power of only 0.08 microwatt, consisting of 50 millivolts at 1.5 microamperes! To demonstrate the small power required, Mr. R. L. Wallace, of Bell Laboratories, powered this oscillator with the output of a photovoltaic cell exposed to room illumination. In another experiment, he formed a battery by wrapping a dime in a piece of paper which he had previously moistened by chewing on it. The moist paper became one electrode of the battery, and the dime the other. In both cases, the output was sufficient to be audible from an ordinary telephone.

Mr. Wallace also performed some interesting calculations to show that this device could really be called a "flea-power" device. Assuming a dog flea weighing one milligram and jumping to a height of 50 centimeters, both of which are reasonable figures, he calculated that the flea, in making one such jump every minute, would use approximately the same amount of energy as the minimum required to keep the oscillator functioning! It is logical to assume, therefore, that satisfactory amplifiers can be built which would operate on comparably small amounts of input power.

It should not be supposed from the previous discussion that this transistor is a cure-all for everything. There are disadvantages which may or may not be overcome in future development work. One is the problem of frequency response. Maximum gain of the junction transistor is attained at frequencies on the order of a few kilocycles, with the gain falling off rapidly as the frequency increases. (Usable gains up to one megacycle and more have been realized, however.) One factor affecting frequency response is the transit time of the electrons and "holes" through the "P" layer. Making this layer thinner should increase the frequency response, but it would also increase the capacity between the two "N" electrodes. A thickness of about a thousandth of an inch has been used for this "P" layer.

Another problem is that of the mass production of these items. The amount of impurities in the germanium must be controlled very carefully, as variations of as little as one part in one hundred million can change the properties of the transistor. Also, there is the mechanical problem of fastening leads to such small pieces of germanium. How this is done on present samples has not been revealed. The units must be made to have uniform characteristics in production, so that a transistor in a piece of equipment may be replaced by another transistor without re-engineering the whole circuit. Samples which have been tested have been found to be very temperature-sensitive, although operation is completely satisfactory over normal temperature ranges.

These problems are gradually being overcome and it is expected that production samples on a limited basis will be available not too many months hence.

Here is a device which most certainly will give the vacuum tube a run for its money—if not completely replace it—in the majority of applications. It has
(Continued on page 166)

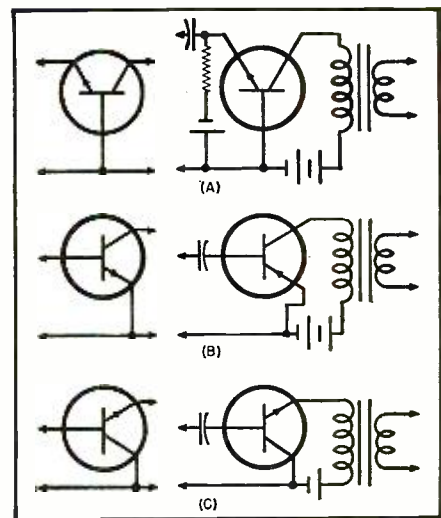

Fig. 2. How the input and output impedances may be varied by connecting the junction transistor different ways. In each case, the connection is shown along with a corresponding practical circuit. (A) Grounded-base circuit. (B) Grounded-emitter circuit. (C) Grounded-collector hookup. See article for a complete description of their possible applications.

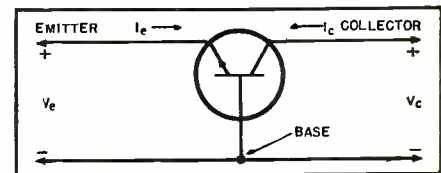

Fig. 3. Symbol which has been adopted to designate the junction transistor.

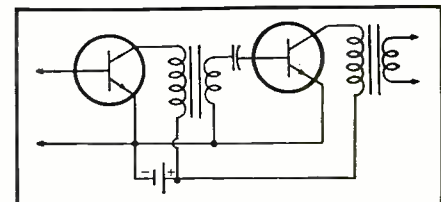
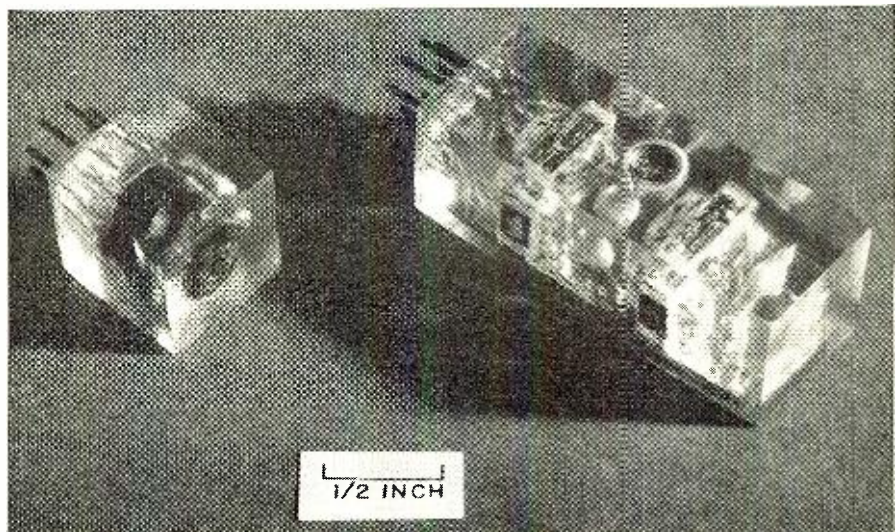
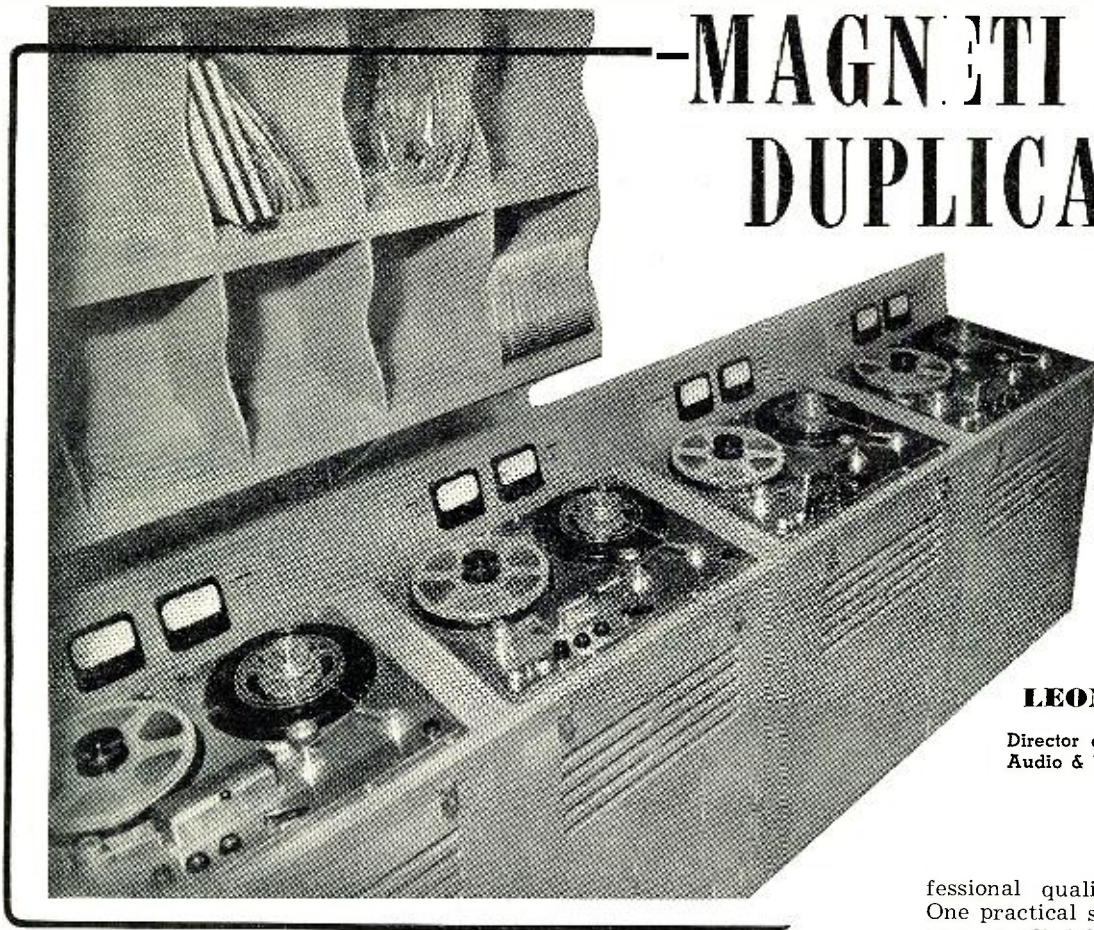

Fig. 4. A grounded-emitter type circuit used as a two-stage amplifier which has a power gain of approximately 90 db.

Fig. 5. (Left) Audio oscillator which operates with an input power of .08 microwatt and (Right) a two-stage audio amplifier which was built using the circuit of Fig. 4.



MAGNETIC TAPE DUPLICATION



Partial view of bank of five tape duplicator machines. Two vu meters, mounted at back of each unit, monitor the outputs of dual-track twin playback amplifiers. Toggle-type tension adjusting switches are left and right of meters.

By
LEON A. WORTMAN

Director of Adv. & Sales Promotion
Audio & Video Products Corporation

Here is one approach to the duplication of high quality pre-recorded music. Information on other companies' methods will be given in later issues.

BY THEIR very nature, original tape recordings cannot be processed to produce a large quantity of duplicates in the same way that original disc recordings are handled. That is, one cannot make a mold or matrix from a length of magnetic tape for pressing purposes. Thus, in modern recording and mass duplication techniques, the advent of magnetic tape recording and its popular acceptance by professional and non-professional users has brought about a unique problem: how to make a mass number of copies of an original tape recording that are faithful in reproduction, yet can be accomplished rapidly and economically.

The *Minnesota Mining & Manufacturing Company* has been coping with the problems of mass duplication of tapes for many years. To my knowledge, they have evolved two distinct techniques. One is a "printing" process in which a virgin tape and the original tape are rolled in close contact together at a high speed through a magnetic field. This usually results in a modified duplication of the original, not entirely a facsimile, and not completely satisfactory from the distortion standpoint. The other technique is one

of re-recording from the original tape to a multiple number of reels driven from the same capstan (a long shaft) and passing across individual recording heads. This has proved to be more satisfactory than the first. However, for some reasons with which I am not familiar, the results were still not entirely satisfactory facsimile copies of the original tape.

This leaves private industry very much on its own with respect to developing completely satisfactory techniques of tape duplication. Since the majority of the customers for a tape copying service are professional broadcasters and true high fidelity enthusiasts, nothing less than an exact facsimile of the original sound is acceptable. Thus, any organization which becomes involved in the manufacture of a catalogue of "tape records," at present, finds itself completely on its own, without a backlog of experience from which to draw. That was the position of *A-V Tape Libraries, Inc.* a year ago when it was created for the purpose of manufacturing and merchandising a catalogue of music, pre-recorded on magnetic tape.

They had the same problem to surmount as do the others: how to do pro-

fessional quality duplication work? One practical solution to the problem was supplied by the engineering departments of *Ampex* and *Audio & Video Products Corporation*.

Ampex had recently developed a new recorder which would faithfully record and play back signals as high as 100,000 cycles-per-second. This is the special-purpose equipment which is now used extensively by military and scientific research specialists in telemetry and data recording. This meant that, operating at a multiple speed, the entire audio spectrum could be rapidly re-recorded from one tape to the other without attenuating either the bass or treble ends, and done rapidly enough to maintain the factor of economy. As a matter of fact, aside from the cost of the original equipment and virgin magnetic tape stock, the entire cost of duplication is labor alone, since no "processing" is involved.

Referring to the block diagram, Fig. 1, an *Ampex* tape transport mechanism is used for the playing of the original tape. However, the standard magnetic head housing was modified for this installation. It contains no erase or record heads, but it does contain two separate playback heads. These two heads are staggered vertically so that both tracks of a dual-track tape can be played back simultaneously. The electronics chassis contains dual playback amplifiers, one for each track. Of course it does not contain an erase-bias oscillator or any record circuitry. When it is necessary to erase tape, a *Cinema Degausser* (tank erase) Type 9205 is employed.

The output of each playback chan-

RADIO & TELEVISION NEWS

nel terminates at line level in the audio rack which can be seen in the photographs. Separate gain controls are provided for each playback channel to insure a matched balance between the two levels. Across the output terminals of these gain controls are meter multipliers and vu meters for gain-setting. The outputs of these playback gain controls terminate in Channel Busses #1 and #2, across which are bridge-multiplied the inputs to the duplicators.

At the moment, there are five master tape duplicators. Like the original tape player, modified tape transport mechanisms are used. No erase head is provided, but bias current is generated for the two separate record heads which are staggered vertically, in the same way that the heads are staggered for simultaneous dual-track playback in the master machine. The head housing also contains a dual-track playback head for monitoring purposes. The electronics chassis contains dual record amplifiers which are fed independently to each of the two staggered heads. Dual playback head amplifiers are also contained on the electronics chassis. Thus, dual-track tapes are rapidly produced by simultaneously recording both tracks, resulting in an important reduction in labor-time costs on this score by as much as one-half.

The vu meter panels are mounted above and to the rear of each of the five tape duplicators. Connected to the outputs of the duplicator playback amplifiers, they permit continuous visual monitoring of the operation of the individual duplicator channels. An audio power amplifier, mounted in the rack,

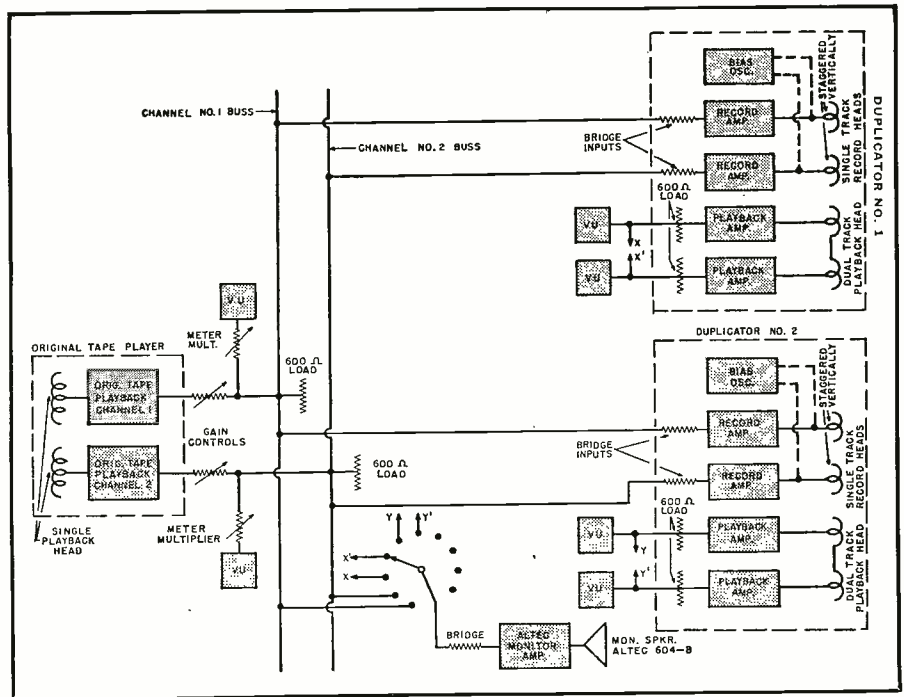

Block diagram of the Audio & Video tape duplicating set-up used for the mass duplication of the A-V Tape Libraries' music catalogue. Only two of the machines are shown.

is connected for bridging and, through a rotary selector-switch, can be placed across either of the two channel busses or across any of the ten duplicator playback channels. Because of the accelerated tape speeds involved, the audio monitor functions as an indicator of the existence or non-existence of signal and as a check on over-all level changes. An experienced operator can actually detect changes in frequency response in addition to level changes.

By carefully auditioning the original tape at the correct speed and on standard *Ampex* Model 200 and 300 equipment, the quality of the original recording is predetermined. Frequent spot-checking by actually playing every fifth duplicated tape that each machine produces permits close quality control of the finished product.

An additional operating feature is the specially installed "tension selec-
(Continued on page 134)

Audio rack and remote control panel. The two vu meters in the audio rack monitor the outputs of the dual-track playback channels of the original tape player. Patching facilities are provided. The key switches of the remote control panel enable the single or multiple operation of any or all units.

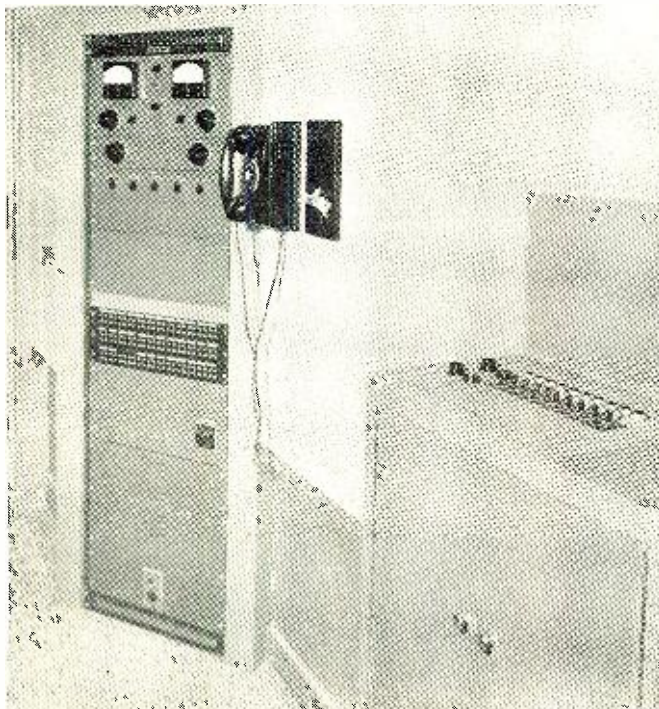

Another view of duplicating machine bank. The original tape player machine is on the left. Original tapes are usually recorded at 15 or 30 inches-per-second. However, industrial or sales training tapes are frequently supplied at 3¾ or 7½ inch speeds. These are also handled by this particular set-up.



Novel Test Meter

By
PHIL WEISS
and
ED. CLARK

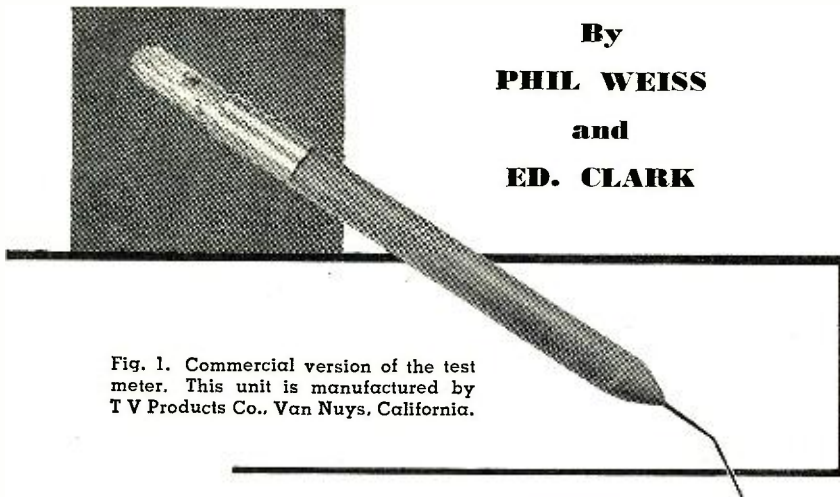

Fig. 1. Commercial version of the test meter. This unit is manufactured by TV Products Co., Van Nuys, California.

Details on a simple instrument which will permit d.c. voltage checks to be made on home TV calls.

THE meter that a technician uses to check a TV set in the customer's home is quite different from the one he would use in his shop. In a shop instrument the important characteristics are: accuracy, stability, high impedance, and good frequency response. In a field instrument the most important characteristics are: ruggedness, convenience, compact size, and light weight.

On a house service call the meter is seldom used except to check the d.c. voltage at a few power points, and at the plate and screen of a few tubes. Here the accuracy of the meter is quite unimportant when working on an unfamiliar chassis, with no circuit diagram, and only a general idea of what the correct voltages should be. For this type of work the technician requires a simple, rugged meter small enough to fit in the tool box. If greater accuracy is required, he may also keep a v.t.v.m. out in the car, to be used on rare occasions. For years the author carried the common volt-ohm-milliammeter in his tool box. The standard one-mil movement was too insensitive for many applications, particularly for use with a standard high voltage probe. The special high voltage probe built for this meter was too bulky and loaded the circuit excessively (1 mil at 20,000 volts is 20 watts). The meter leads were always tangled, with broken clips and the insulation burned from brushing against hot tubes and drawing high voltage arcs.

The instrument was too big to fit inside most TV cabinets, where it was too dark to read it anyway, so it was usually set on top of the cabinet, a hazardous location at best. As a result of its many falls from cabinets the glass was broken and the plastic

case cracked. The pointer was banged out of shape, the switch was erratic, and the knob was always falling off. The meter was costly to replace, and too big and heavy to carry around in a crowded tool box.

The "flash-meter" shown in Fig. 1 is the size of a fountain pen. The parts cost 50 cents. It uses no lead wires. The tip is applied to the point of measurement and the ground-return is through the user's body. The body resistance is negligible compared to the high impedance of the meter. One finger is held against the metal band on the instrument, and another finger, of either hand, touches the chassis. The neon glow lamp indicates the d.c. voltage by flashing at the rate of one flash per second per hundred volts. With a little practice, voltages can be read within 25%, or about as close as on the meter with the old bent pointer, through the cracked glass in a dark room.

The current flow is too slight to be noticed even by the most squeamish, but a ground wire may be used if desired. The flash-meter is especially handy in sets where the chassis is not grounded. The ground finger is placed on the chassis as if it were ground, since the leakage resistance to the chassis is usually much less than that of the instrument.

Fig. 2. Circuit diagram of test unit. The resistor should be as large as possible.

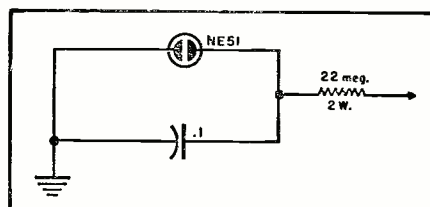

The circuit is shown in Fig. 2. The resistor is the highest standard value obtainable, and is safe to use up to 3000 volts. It provides a higher input impedance than most v.t.v.m.'s. The condenser is used to store up enough energy to cause a visible flash, and is chosen to give a convenient rate of flash. Higher values of resistance or capacity would result in a proportionally slower rate. Flashes up to 10 or 15 per second can be evaluated by waving the neon lamp back and forth slightly. The lamp itself is an NE51, and is easily replaceable if broken.

Unfortunately, the neon lamp will not flash below 75 volts. Lower voltages can be measured indirectly by placing the ground return finger at some convenient point at about 150 volts and measuring down from there. Again for the squeamish, a ground wire may be used. Another less convenient, but safer, method to measure below 75 volts, is to hold a tiny 67½ volt battery in series with the ground finger, thus extending the range of the flash-meter down to 7½ volts. The drain on the battery is very small.

Voltages around 10,000 volts can be measured with the aid of a standard high voltage probe. With a 560 megohm probe, the lamp flashes four times per second at 10,000 volts. A cheap high voltage probe can be made by assembling four 22 megohm resistors in series inside a bakelite tube. This gives a flash rate of 20 per second at 10,000 volts. If desired, the condenser can be reduced in value five times, which makes the instrument more useful at high voltages, but rather tedious to use at low voltage, since it would flash only once every 5 seconds at 100 volts. This makes the instrument quite accurate, if a watch is used to time the flashes, but of course it is not intended to replace the v.t.v.m.

To sum up the advantages and disadvantages of the flash-meter as compared with any other device which can fit in the tool box: The flash-meter measures 6"x½"x½" and weighs just 2 ounces. It requires no leads and needs no switching. The impedance is 22 megohms and the unit may be used with a high-voltage probe. It is practically unbreakable and is almost burn-out proof. Accuracy of 25 per cent is possible with this gadget and the unit will measure d.c. voltages from 75 to 1000 volts. It costs approximately 50c for parts.

By contrast, a 1 ma. meter measures 6"x3"x3" and weighs approximately 20 ounces. Both leads and switching are needed. The impedance is 1000 ohms-per-volt and the meter is nearly useless at high voltages. It is a relatively fragile instrument but will measure both a.c. and d.c. volts from 0 to 1000 in addition to reading ohms and milliamperes. Accuracy is about 10 percent and the parts required cost about \$13.50.

From this comparison it is easy to see that this handy little meter has many advantages in TV servicing.

A Single-Sideband TRANSMITTER ADAPTER

By
JOHN F. CLEMENS
W9ERN

NEW horizon in amateur radio communication is opening with the advent of practical single-sideband transmission. This type of radio phone has been used for years by commercial stations and the theoretical nature of the system has intrigued engineers with its terrific possibilities in savings of both radio spectrum and power. Only within the past few years have amateurs demonstrated that single-sideband communication is practical for the average amateur and many experimentally-minded hams are enjoying its many benefits on the air today. Anyone who has never heard this type of phone should listen near the high frequency end of the 75 meter band any evening. Of course, the uninitiated will be somewhat at a loss to understand the voices they hear, but a little experimenting with the receiver adjustment will reveal the secret of tuning in the signal. Briefly, the receiver is used in about the same way one would use it to receive a c.w. signal: a.v.c. off, b.f.o. on, audio gain full on, and r.f. gain reduced. The problem then is just a matter of tuning the receiver to the frequency where the b.f.o. would zero-beat the carrier of the transmitting station. Of course, the fact that the transmitting station is not radiating a carrier is somewhat of a complication, but slow and careful tuning will quickly make the voice understandable and very fine tuning will produce excellent quality. It is impossible to distinguish between single-sideband and conventional AM with a properly adjusted receiver, except that the single-sideband station will show little or no selective fading, and will usually be readable through considerably more interference since the receiver may be adjusted for greater selectivity without impairing reception.

Two methods of single-sideband generation are in use among amateurs today. Both methods have some points

in common. Of course, the received signal is the same irrespective of the system used to produce it and the requirements in the transmitter stages which amplify the signal to the desired power level are also the same. The two systems are called the "filter" system and the "phasing" system.

It is well known that in an amplitude modulated signal, three component waves make up the output signal which is transmitted to the receiver. These components are the carrier, which remains unchanged in frequency or amplitude during modulation, and the two sidebands. The frequency of the sidebands is determined by the modulation frequency, one being the sum of the carrier and modulation frequency, and the other being the difference between the carrier and the modulation frequency. The amplitude of the sidebands varies from zero, when there is no modulation, up to one-half the carrier amplitude at 100% modulation. Since these component waves are distinct, it is possible to transmit either of the sidebands, or both of them, without transmitting the carrier. In the filter method of generating the single-sideband signal, the modulated signal is merely passed through a very selective filter which will pass only the range of frequencies which the desired sideband will have with modulating frequencies over the voice range. This requires a filter

about 3 kc. wide with very great attenuation at the frequencies of the carrier and the unwanted sideband.

The phasing system makes use of other principles, namely, balancing out unwanted components by generating, simultaneously, components equal in amplitude but of opposite phase. All these signals are combined in a common tank circuit, where the unwanted components combine in opposite phase and hence add up to zero, while the desired sideband components add in-phase to produce the output signal. The necessary phase relationships for this balancing procedure are obtained automatically in the following arrangement:

Two separate transmitters are driven from the same source of r.f., at the carrier frequency. The r.f. driving power for one of these transmitters is passed through a network which shifts the phase of the voltage by 90 degrees, while the other transmitter receives its driving voltage directly from the r.f. source. Therefore, the two transmitters are being driven by voltages 90 degrees apart in phase.

An audio signal is used to modulate each transmitter independently by conventional circuits. Audio voltages for the two transmitters are again derived from the same source, but the audio signal is passed through a network of resistors and condensers which has two pairs of output terminals, and due to

Front view of the unit. The adapter produces one watt of single sideband output on either 75 or 20 meters when driven by a c.w. input signal in the 4 mc. band. Toggle switch permits operator to select either upper or lower sideband output.



Used between the low-cost exciter unit and the 150-watt r.f. amplifier described in the February and March issues, this adapter permits single-sideband phone transmission on two bands. A voice-operated relay circuit is also included.

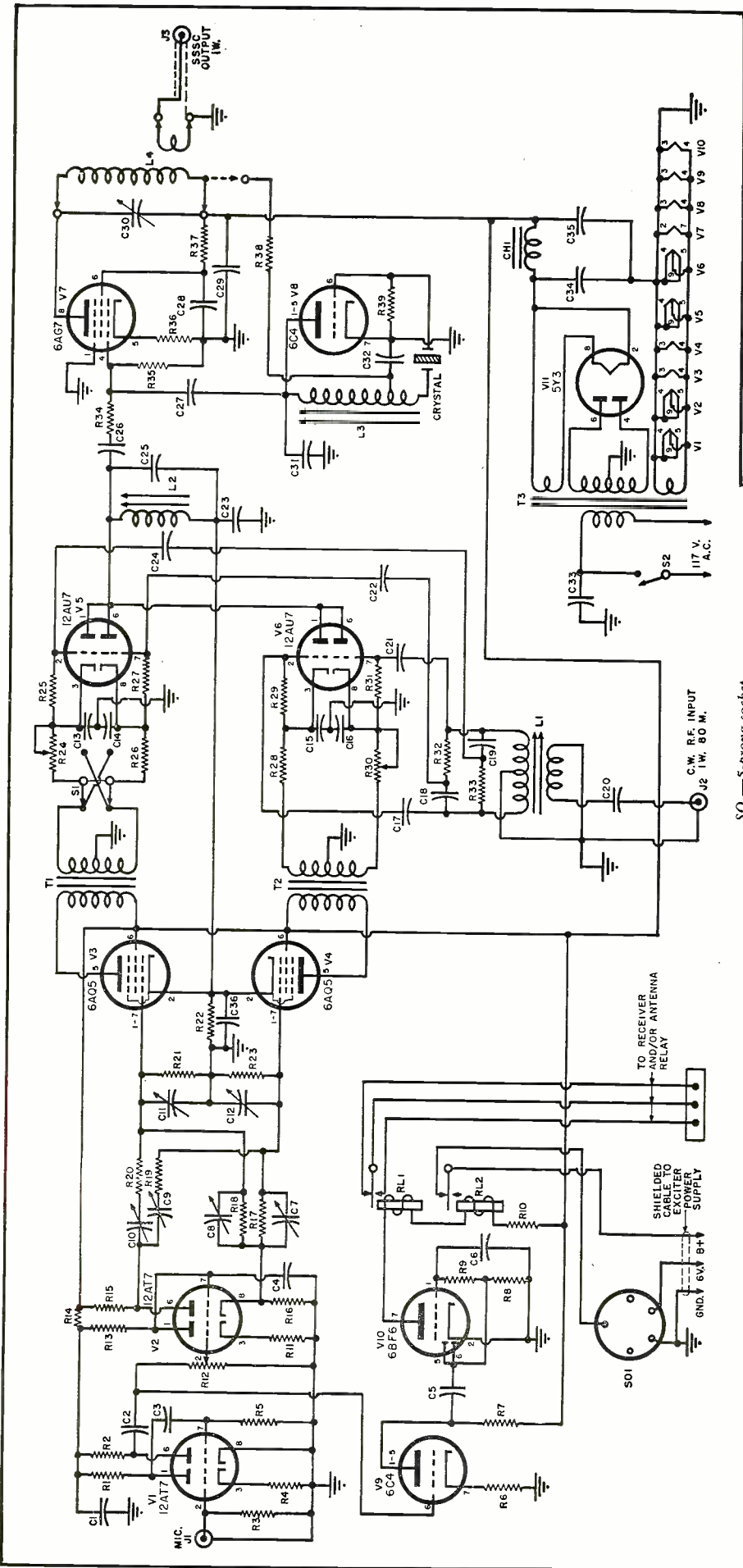

Schematic diagram of the single-sideband transmitter adapter. This unit is designed to be used with the low-cost exciter unit and the 150-watt universal r.f. amplifier previously described by author.

the special design of this network, the output voltage at one pair of terminals always lags the output voltage across the other pair of terminals by one quarter of an audio cycle, or 90 degrees. When the output of the two separate transmitters is combined by connecting them to a common tank circuit, one of the sidebands is balanced out while the other is reinforced. Meanwhile, the carrier output of each transmitter has been prevented from reaching this tank circuit by resorting to an older and better-known circuit, the balanced modulator. Each modulated stage in each of the transmitters is a balanced modulator so that no car-

- S01—5-prong socket
 - Xtal—See text
 - L1*—Pri. 25 t. #30 Formvar on 3/8" form with slugs; cover with layer of Scotch tape and over sec. 20 t. #30 Formvar, center-tapped, over primary (Cambridge Thermionic Type LS-3 form)
 - L2*—45 t. #30 wire on 3/8" form with slug (Cambridge Thermionic Type LS-3 form)
 - L3*—36 inches of #30 wire tapped 12 inches from start end, wound on 3/8" form with slug (Cambridge Thermionic Type LS-3 form)
 - L4*—80 m.—53 t. #22 wire on 1" Millen form with 3 t. link
 - 20 m.—11 t. #18 wire on 1" Millen form with 2 t. link and jumper
 - V1, V3—12AT7 tube
 - V4, V6—6A05 tube
 - V5, V7—12AU7 tube
 - V8—6AC7 tube
 - V9—6C4 tube
 - V10—6BF6 tube
 - V11—5Y3 tube
- *The Cambridge Type LS-3 forms are available from Allied Radio Corporation, 833 West Jackson Boulevard, Chicago 7, Illinois, or from your local parts distributor.

- C4, C17, C18, C19, C21, C22, C23, C24, C25, C26, C27, C28, C29, C30, C31, C32, C33, C34, C35, C36, C37, C38, C39—100 µfd. ceramic cond.
- C35, C36, C37, C38, C39—0.1 µfd. ceramic cond.
- C7—89.5 µfd. padder cond.
- C8—407 µfd. padder cond.
- C9—525 µfd. padder cond.
- C10—2420 µfd. padder cond.
- C11—806 µfd. padder cond.
- C12—176 µfd. padder cond.
- C13—250 µfd. ceramic cond.
- C14, C15, C16, C18, C19, C20, C21, C22, C23, C24, C25, C26, C27, C28, C29, C30, C31, C32, C33, C34, C35, C36, C37, C38, C39—5000 µfd. ceramic cond.
- C20—100 µfd. var. cond.
- C21—25 µfd. 50 v. elec. cond.
- C22—25 µfd. 50 v. elec. cond.
- T1—Mod. trans. (Merit A-3008 or equiv.)
- T3—Power trans. 350-0-350 v. c.t. @ 120 ma.; 5 v. @ 2 amp.; 6.3 v. @ 3 amp.
- RL1, RL2—1000 ohm sensitive relay, 10 ma. d.c. operating current
- CH—10 Ry., 120 ma. filter choke
- J1, J2, J3—Coax receptacle
- S01—D.p.d.t. sw.
- S02—3-p.s.t. toggle sw.
- R1, R2, R3—470,000 ohm, 1/2 w. res.
- R4—1 megohm, 1/2 w. res.
- R5—2200 ohm, 1/2 w. res.
- R6—4.7 megohm, 1/2 w. res.
- R7, R8, R9, R10, R11, R12, R13, R14, R15, R16, R17, R18, R19, R20, R21, R22, R23, R24, R25, R26, R27, R28, R29, R30, R31, R32, R33, R34, R35, R36, R37, R38, R39—47,000 ohm, 1/2 w. res.
- R10—10 megohm, 1/2 w. res.
- R11—100,000 ohm, 1/2 w. res.
- R12—5600 ohm, 2 w. res.
- R13—2700 ohm, 1/2 w. res.
- R14—1 megohm volume control
- R15—1.2 megohm, 1/2 w. res.
- R16—220,000 ohm, 1/2 w. res.
- R17, R18, R19, R20—560,000 ohm, 1/2 w. res.
- R21—400 ohm, 10 w. pot.
- R22—1000 ohm, 10 w. pot.
- R23—470 ohm, 1/2 w. res.
- R24—390 ohm, 1/2 w. res.
- R25—270 ohm, 1/2 w. res.
- R26—270 ohm, 1/2 w. res.
- R27—27,000 ohm, 1/2 w. res.
- R28—100 ohm, 1/2 w. res.
- R29—10,000 ohm, 1 w. res.
- R30—8 µfd. 450 v. elec. cond.
- C1, C2, C3, C4, C5, C6, C7, C8, C9, C10, C11, C12, C13, C14, C15, C16, C17, C18, C19, C20, C21, C22, C23, C24, C25, C26, C27, C28, C29, C30, C31, C32, C33, C34, C35, C36, C37, C38, C39—1000 µfd. ceramic cond.

rier output appears in the individual transmitter outputs or the combined output of the two. This, in brief, is the mechanism of the phasing method of generating single-sideband signals. Reference to the bibliography will explain this system in greater detail.

The principal benefits derived from single-sideband and suppressed carrier transmission are savings in power and frequency spectrum. It is a little difficult to give exact figures on the amount of power SSSC will save unless a specific example is given. For the purposes of this analysis it is desirable to speak, at the outset, of transmitter power output rather than input. Assume a conventional AM rig which has a rated output of 100 watts. This is the power in the carrier wave. At 100% modulation, each of the two sidebands will contribute 25 watts to the output circuit, so that the average power output at full modulation is 150 watts.

A single sideband will give equal coverage and "loudness" in the same receiver if its output is 50 watts. But since the spectrum of the transmitter is less than half as great as in the case of the AM transmitter, there is no reason why the receiver should not be used with greater selectivity. If the selectivity of the receiver is doubled, the signal-to-noise ratio will be improved to the point where a single-sideband transmitter with an output of only 25 watts will give the same signal-to-noise ratio as the original 100 watt AM rig. Essentially, then, a single-sideband transmitter rated at 25 watts will compete successfully with an AM transmitter having an output of 100 watts.

To obtain a carrier output of 100 watts will require an input to the AM transmitter of approximately 300 watts, assuming the use of grid bias or some similar form of efficiency modulation. (Plate modulation would give better efficiency in the r.f. power stage but additional power requirements in the audio power-generating stages would have to be charged against the over-all AM transmitter, resulting in about the same, or even slightly less, total transmitter efficiency.)

The linear amplifier in the single-sideband transmitter will, theoretically, be capable of an efficiency of 78%, but to be on the safe side we will assume that the actual efficiency obtained is only 50%. Therefore, an input of 50 watts to the single-sideband transmitter will be required.

It can be seen from this comparison that a much smaller single-sideband transmitter competes equally with a large AM transmitter with a practical ratio of about six-to-one. An additional benefit is derived from the fact that the linear amplifier in the single-sideband transmitter is operating at full input only with full modulation and it is possible that during periods of no modulation the power input may be close to zero. In the AM transmitter the input with no modulation is still

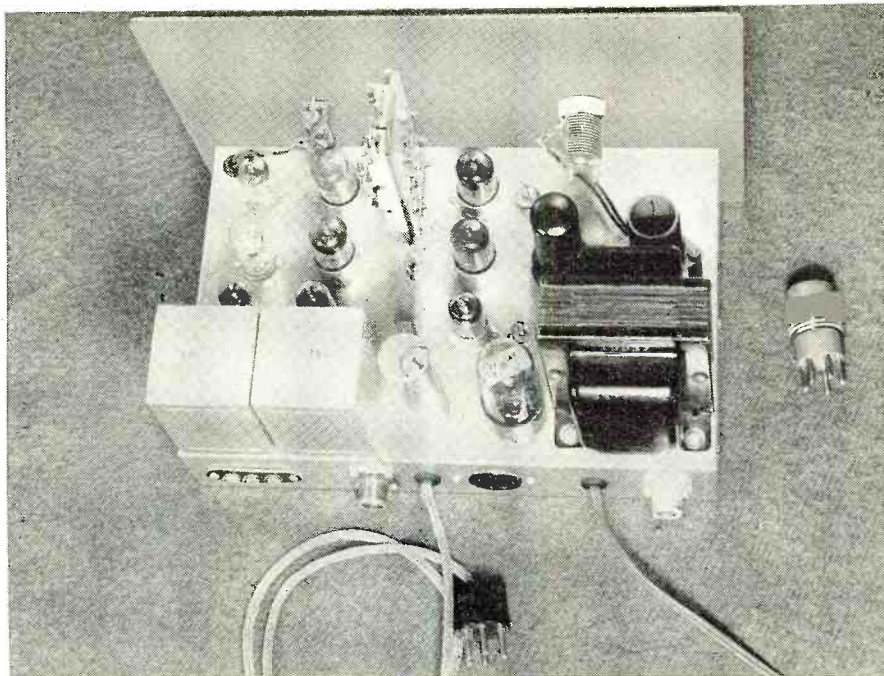

Rear view of adapter. The chassis measures 11x7x2 inches. The voice-operated relay contacts connect to the terminal strip for control of the external circuits.

300 watts. This means that the tube capacity in the AM transmitter must be very much greater than in the single-sideband transmitter. For instance, a single 807 should be limited to an input of about 45 watts in the type of AM rig we have used as an example, while the same tube is rated to deliver an *output* of 60 watts under the conditions of operation suitable for single-sideband suppressed carrier transmission.

The transmitter adapter pictured is designed to be inserted in series with the 50 ohm coax cable between the low-cost exciter and the 150-watt universal r.f. amplifier described by the

author in the February and March, 1952 issues of this magazine, although it may be used with other equipment. It converts the one watt c.w. output of the exciter to a single-sideband signal having a peak power output of about one watt. Either upper or lower sideband is available with the flip of the toggle switch on the front panel. The phasing system is used. The unit is completely self-powered and auxiliary circuits are included to give voice-operated-relay control of the transmitter. The 80-meter signal of the v.f.o. is used to give v.f.o. operation over the entire phone band and by plugging in a 20-meter coil into the

Underchassis view. The general placement of parts may be seen in this photograph. The balancing controls and gain control are mounted on front panel of unit.

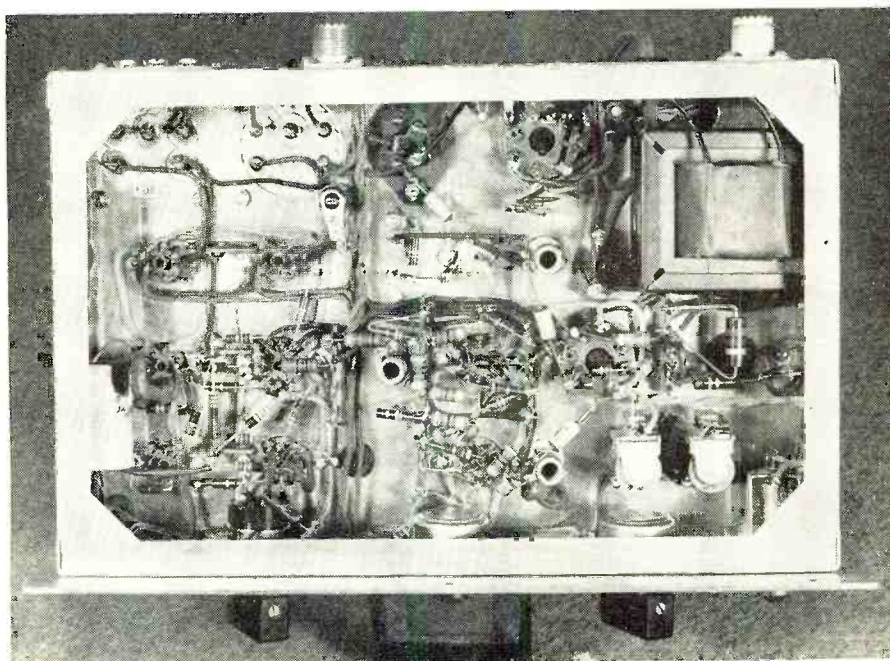

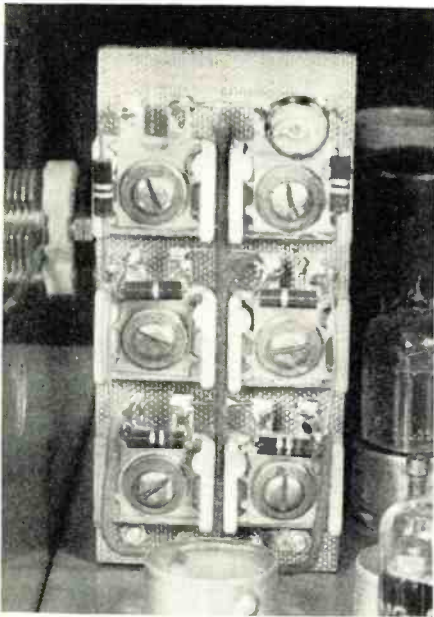

The audio phase shift network is composed of broadcast-type adjustable mica padders and $\frac{1}{2}$ watt resistors, assembled on an insulating panel. A 1000 $\mu\mu\text{fd}$. silver mica condenser parallels the padder to obtain large capacity required of condenser C_{10} .

adapter, the same v.f.o. is used to cover the 20-meter phone band where the output is also one watt.

The simpler parts of the adapter circuit will be covered before analyzing the single-sideband generating system itself. First, a standard power supply delivers an output of 300 volts of well-filtered d.c. Hum can be ruinous to the quality of the SSSC transmitter in the low power stages, so adequate filter condensers should be used.

The 6C4 is used as a separate audio amplifier to drive the voice-operated relay circuit. This amplifier is connected

to the output of the second microphone amplifier stage before the gain control so that settings of the gain control do not affect the relay operation. The 6C4 output is rectified by the diode plates of the 6BF6 and the resulting d.c. is applied as a bias voltage to the triode section. The relay windings are in the plate circuit of the triode section and the relays are held in by the plate current of the tube in the absence of audio signals. Since the coupling condenser, C_5 , is charged through the low plate resistance of the 6C4, the bias appears on the grid of the 6BF6 almost instantly when an audio signal is introduced, causing the relays to be de-energized. R_6 and C_6 comprise an audio filter which prevents the audio voltage from reaching the 6BF6 grid, which would cause the relays to chatter, but the time constant of the combination is too short to cause any appreciable lag in actuating the relays. The bias voltage must bleed off the grid through R_7 , and since it is of much higher resistance than the 6C4 plate resistance, there is a delay of a fraction of a second after cessation of the audio signal before the relays are re-energized. Thus, the relays close immediately when the operator starts talking and open a fraction of a second after he stops, but the lag is sufficient to hold the circuits closed during normal talking. By "closing" in this case, is meant, of course, closing the external circuits, i.e., the v.f.o. plate supply and the antenna relay or receiver muting circuits which may be used.

The microphone input stage employs cathode bias to allow the use of a low-resistance dynamic mike. The second half of the 12AT7 uses contact potential bias to get more gain by avoiding cathode degeneration. There is plenty of audio gain for even low output

mikes. The second 12AT7 is a direct-coupled phase inverter, with its balanced output direct coupled to the phase shift network. C_7 is used to limit the high frequency response of the audio circuits to the range of frequencies over which the audio phase shift network is effective.

The audio phase shift network itself is built of standard value resistors (10% tolerance) and adjustable padder condensers. The padder condensers are of the same type but plates and mica may be pilfered from the low capacity units and added to the high capacity units. These condensers are best set to the desired value on a capacity bridge before being installed. The capacity values should be matched within about 5%. Once adjusted, the network needs no further attention. It should provide two outputs (at the grids of the two 6AQ5's) 90 degrees apart in phase and equal in amplitude, over a range of approximately 140 to 4000 cycles. The RC product of each element in the network is exactly equal to the value originally specified by Dome¹ but the values of the resistors have been increased ten times, while the capacities have all been reduced by a factor of ten. This results in a network of smaller components, while presenting load impedances to the associated tubes which are of conventional order. It should be noted that there is a d.c. path through the network from the 12AT7 cathode to each of the 6AQ5 grids, so that a portion of the cathode voltage appears at the 6AQ5 grids. This positive bias is compensated for by an unusually large value of cathode bias resistor (R_{c2}) in the 6AQ5 stage so that the normal operating bias of the 6AQ5's is negative.

Approximately one watt of audio power is obtained from the secondary of each of the 6AQ5 output transformers, T_1 and T_2 . Although the transformers shown are surplus SCR-522 modulation transformers run backwards, any small modulation transformer of about one-to-one ratio is satisfactory. Impedance matching considerations are not critical.

The radio frequency driving power is coupled into L_1 through a 50 ohm coax cable from the exciter. The primary effective inductance is resonant with C_{20} at the input frequency and the primary-to-secondary ratio of L_1 has been adjusted so that the resistive component presented to the input cable is 50 ohms. The input coax cable is therefore terminated in its characteristic impedance, the most efficient and desirable condition possible. The slug tuning L_1 is adjusted for maximum r.f. drive which corresponds to the matched condition. The turns ratio for L_1 was actually determined experimentally by means of bridge measurements on the input coax and if this coil is duplicated closely, a good impedance match is assured.

One of the balanced modulators receives its excitation voltage directly
(Continued on page 152)

Under chassis view of the r.f. circuits. The crystal oscillator and balanced modulator tank circuits both feed the 6AG7 grid. The r.f. phase shift condensers and resistors are assembled on the tie strip between the balanced modulator tubes and L_1 .

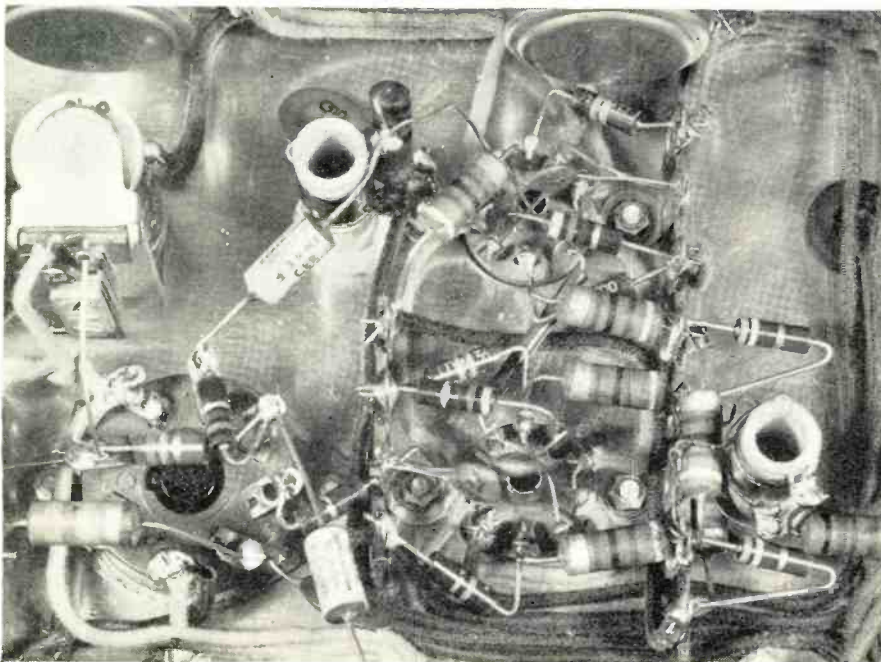

WABD's TV TRANSMITTER

By **SCOTT HELT**

Research Dept., Allen B. Du Mont Laboratories, Inc.

THIS month's cover shows a portion of the new *Du Mont* WABD transmitter installation on the 82nd floor of the Empire State Building in New York City. The transmitting antenna is installed atop the 102nd floor of the building—a common steel tower being employed to support the transmitting antennas of WABD and several other metropolitan area television stations.

In the *Du Mont* transmitter installation the equipment is arranged in a "U" in order to bypass a large cross-section supporting column located in the center of the room. Despite this arrangement, it was necessary to locate the equipment in such a way that the operating engineer could have a clear view of all front panels and indicating instruments.

When the engineer is seated at the control console, thirteen racks of video and audio equipment, auxiliary to the transmitter, are installed to his right. The *Du Mont* 5 kilowatt (visual) and 2.5 kilowatt (aural) "Oak" type transmitter is installed to his left while the five transmitter cubicles, or cabinets, are mounted in the wall facing the thirteen racks of auxiliary equipment across the room. Thus the large cross-section column does not interfere with the station operation because of the carefully planned layout.

Metal duct piping and an exhaust system remove the warm air from the 5 kw. transmitter cubicles and equipment racks in order to keep the equipment at a safe operating temperature. The transmitter is air-cooled throughout so the warm air radiated by the tubes must be exhausted.

The transmitter console, behind which the operating engineer is seated, contains all of the controls and meters required for normal and convenient operation of the transmitter. The console has provision for placing the transmitter into or out of operation, and for checking its performance under regular operation—particularly with reference to the quality of the incoming and transmitted signals. In addition, equipment has been incorporated

Du Mont 5 kw. "Oak" transmitter installed at Station WABD, Empire State Bldg., New York.



WABD's new transmitter installation in the Empire State Building has many unique operating features.

which will permit tracking down and eliminating operating faults and difficulties which may develop during the course of a transmission. All of the essential meters necessary to the operation of both the visual and aural portions of the transmitter are duplicated at the console so that the operator may read them without leaving his position.

A line waveform monitor at the console displays the video waveform on a small cathode-ray tube screen, the horizontal sweep being linear and precisely synchronized at half the line frequency of the video signal, *i.e.*, 7875 cycles-per-second. The horizontal scanning rate is, of course, 15,750 cycles-per-second under American television standards.

The frame waveform monitor, similar to the line waveform monitor, has a sweep frequency equal to half the field frequency of the video signal, or 30 cycles-per-second. The field rate in television is 60 cps.

Thus, the electronic information in the picture, at either the horizontal or vertical frequency, may be viewed by the operator on either one of the two small monitoring cathode-ray tube screens.

A larger picture monitor, which is capable of high resolution and is located at the center of the console panel, permits the operating engineer to continuously monitor the picture being transmitted.

Suitable gain and level controls and

indicators are provided at the console for handling both the visual and the aural levels required for proper signal transmission.

Also visible in the cover photograph is the "Monochrome Scanner" which is housed in one of the auxiliary racks to the right of the console. This new unit replaces the monoscope camera chain which was formerly used to transmit the station's test pattern exclusively.

The *Du Mont* TA 150-B "Monochrome Scanner" not only provides a means for transmitting the station test pattern but may also be used to transmit regular 2" x 2" slides of the type used for advertising messages. These "spot" announcements in slide form may be inserted at any point in the program by merely pushing a button which controls the scanner. As many as 25 slides may be inserted in the magazine of the scanner at one time and the slides can be changed at the rate of one every .2 second, at the push of the button.

This scanner unit is actually a complete signal source for the television station and it is only necessary to provide horizontal and vertical drive and blanking from a standard sync generator to place this equipment in operation.

This equipment eliminates the necessity for "firing" up a whole camera chain just to transmit a test pattern or "spot" announcements on slides.

-30-

TV ANTENNA COUPLERS for Multi-Set Operation

By

WALTER H. BUCHSBAUM

Author, "Television Servicing"

***Eliminate unnecessary antenna installations by
using a single array to feed several TV sets.***

THE problem of operating several TV receivers from a single antenna comes up frequently in TV service work. When a second TV receiver is sold it is quite a sales point to add that the present antenna will do the job for both sets. In the service shop itself it is important to have several antenna connections available and it is not always practical to clutter up the roof with four or five antennas, especially if the space is small and the antennas interfere with each other. In apartment houses the antenna situation is often the main reason why landlords discourage TV sets and sometimes prohibit roof antennas entirely. Thus, use of a single antenna for several TV receivers is a very desirable feature and knowing how to make such installations is bound to mean more money for the technician.

Many different devices are sold to the service trade for the purpose of permitting multiple installations, but not all of them will work in each particular instance. In many cases a simple home-made or inexpensive commercial unit will do a good job while in the other instances an elaborate, well engineered system may be needed.

Requirements

The three main requirements of any system of multiple TV installations are: enough signal, correct impedance match, and sufficient isolation to avoid oscillator radiation. RTMA standard measurements for receiver sensitivity use two indications; the number of microvolts input which will produce one volt of signal at the detector above noise, and the number of microvolts required to produce 20 volts peak-to-peak at the kinescope. A fairly sensitive receiver will require about 150 microvolts for 1 volt at the second de-

detector and half that much for a 20 volt signal at the picture tube. If a 500 microvolt signal is supplied, any properly aligned receiver will give very adequate pictures. In fringe areas good reception is often obtained with 50 or 100 microvolts, but for our purposes let us assume that 500 microvolts is the minimum signal any good TV installation should supply. Most antennas within a 20 mile radius from a station will produce anywhere from 500,000 to 10,000 microvolts, much more than the minimum needs. To determine just how strong a signal a particular antenna is delivering it is best to use a calibrated field strength meter, but a rough indication may be obtained by measuring the a.g.c. bias of the TV set. If the bias for the i.f. tubes ranges from 4 to 6 volts, the signal is well over 10,000 microvolts in the average set. Readings and receiver sensitivities will vary, but whenever the bias reaches over 3 or 4 volts the signal is much stronger than needed. Since the signal must be divided up in multiple installations, the signal strength at the antenna is an important consideration and will determine just how elaborate and expensive the installation will be.

Assuming that the antenna picks up a clean signal of sufficient strength, the impedance matching of the antenna to the transmission line and of the line to the receiver are the next important steps. A mismatch at either end of the line can result in reflections or "standing waves" which means a loss in signal at the receiver plus the appearance of a reflection or "ghost" on the screen. In the average installation some mismatch usually exists, but it is so slight that it is not objectionable. For example, the antenna impedance at the feed points is rarely exactly 300 ohms,

while the standard 300 ohm twin-lead does have that value as its characteristic impedance. The nominal 300 ohm input of most TV receivers can vary anywhere from 50 to 500 ohms and some laboratory measurements by the author show just such a variation in identical tuner models. To verify this, try grasping the twin-lead of any installation on a high-band station and slide your hand up and down the line. Usually some variation in contrast will be observed during this procedure. This, by the way, is the simplest check for reflections or standing waves on a twin-lead transmission line. The importance of impedance matching cannot be exaggerated, especially when more than one receiver is connected to a single antenna. We shall refer to this again when actual installations are described.

Interference from sources outside the antenna and its transmission line can be eliminated by using suitable filters as long as the interfering signal is not the same frequency as the incoming TV signal. In the latter instance a remedy may be quite complex or impossible. A particular type of such interference is radiation from another TV receiver. Assume that your set is tuned to Channel 5 and your neighbor's set to Channel 2. The picture carrier from Channel 5 has a frequency of 77.25 mc. and the local oscillator in your neighbor's set operates at approximately 80 mc. This 80 mc. signal will be received together with Channel 5 and produce a 2.75 mc. interference on your screen. This will appear as a weaving grid, superimposed on the picture from Channel 5. Varying the fine tuning control may have some effect on the grain of the interfering pattern, but the only sure way to eliminate it is to reduce the amount of radiated signal your antenna receives. There are many other combinations of TV channels that will show interference between two receivers due to oscillator radiation and a lot depends on the i.f. frequencies which determine the oscillator frequency. One solution to the problem is the adoption of 40 mc. i.f. amplifiers

RADIO & TELEVISION NEWS

which would place oscillator frequencies so far apart that there could be no interference within one TV band. Another solution lies in better shielding and decoupling in the design of TV tuners to minimize the radiated signal. Both of these solutions, however, are beyond the scope of the service technician and other means must be found to overcome this problem which becomes most acute when several receivers are connected to a common antenna.

Two Receivers On One Antenna

The simplest instance of multiple TV installations is the home having two receivers which are to be fed from a single antenna delivering a fairly strong signal. Assume that with a single receiver connected to the antenna, the weakest station will produce an a.g.c. bias of 4 volts. This corresponds to at least 10,000 microvolts at the transmission line terminals. Since we know that most receivers will give excellent pictures with 500 microvolts, considerable losses can be tolerated in coupling both TV sets to the single antenna.

Fig. 1 shows the circuit for such an installation using resistor matching pads and isolating condensers. The purpose of C_1 is to avoid a.c. short circuits in case either or both receiver chassis are "hot" or grounded to the power line. The two H-type matching pads help to reduce oscillator radiation interference from one receiver to the other. It is true that they also result in a loss of signal, but we are only using these pads because more than enough signal is available. If each of these pads were designed so that $\frac{1}{10}$ of the input voltage appears at the output, the 10,000 microvolt signal would be reduced to 1000 microvolts for each receiver. This is quite sufficient for excellent pictures. The oscillator radiation from one set to the other, however, would be reduced not ten, but a hundred times. The first pad would reduce it ten times, and the second pad would reduce the remainder again ten times, or a total attenuation of 100 times. We can see now how the use of resistor matching pads helps eliminate oscillator radiation interference.

In order to maintain the proper impedance match between the transmission line and both receivers, the resistor network must be balanced and have the correct input and output impedance. In the circuit of Fig. 2, Z_{line} is the characteristic impedance of the transmission line, such as 300 ohms for the standard TV twin-lead or 72 ohms for some types of coaxial cable. The Z at the other end of the H-pad is the input impedance of the receiver. When the receiver is connected to the pad the impedance looking in at Z_{line} should be exactly the same as the characteristic impedance of the transmission line. Therefore, a resistor of the same value as the receiver impedance must be connected across these terminals to maintain correct termination of the transmission line when one receiver is

not connected to the distribution system.

The table of Fig. 2 gives some actual values for H-pads used in multiple TV installations. Matching receivers to a line having the same impedance, as in the first four examples of the table, permits fairly low losses and low attenuation. Voltage ratios of 9:1 and 16:1 are shown here, resulting in attenuation of 19 and 24 db respectively. It should be kept in mind that the reduction in oscillator radiation will be twice the attenuation, or 38 and 48 db. In the case of matching a 300 ohm line to a 72 ohm receiver the minimum losses exceed the 9:1 or 19 db figure and therefore only the 16:1 or 24 db examples are given. The values of resistors shown in this table are chosen for their closeness to standard components. In order to avoid resonant circuits the wirewound type of resistor should not be used for these pads, but only $\frac{1}{2}$ watt carbon composition types employed. The actual construction of an H-pad as described here is quite simple, but a few rules must be observed. Unless 5% tolerance resistors are used it is advisable to measure a number of resistors with a correctly calibrated ohmmeter and select those closest to the prescribed values. If possible both R_1 resistors should measure the same, even if the value is slightly different from the desired one. The same applies to the two R_2 resistors. This is recommended to avoid unbalancing the input to the receiver. To maintain the correct impedance and keep stray capacities at a minimum, the smallest resistor, not over $\frac{1}{2}$ inch long, should be used. Keep all leads very short, preferably less than $\frac{1}{8}$ inch. Soldering such short leads tends to heat up the resistor excessively and special care should be taken to make a good solder connection without applying too much heat to the resistors. Many technicians mount an H-pad on a small piece of bakelite or polystyrene to keep all parts in place, while others use a layer of polystyrene or Scotch tape to add some rigidity and insulation. Under no circumstances should such a pad be taped up with ordinary electrician's or any paper based tape, since this might reduce the impedance and result in mismatch.

In a multiple installation using resistor pads, the best location for the

Fig. 1. Circuit for coupling two receivers by means of resistor matching pads and isolating condensers of suitable size.

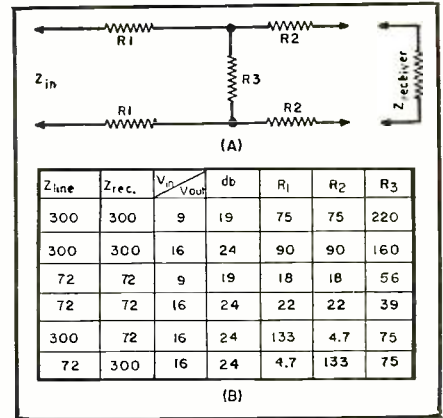
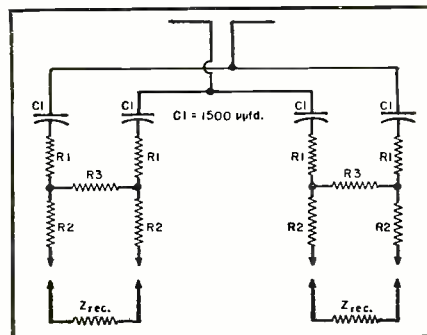

Fig. 2. (A) Network for matching two receivers of different characteristic impedances. (B) Table of values for H-pads as used in multiple television installations.

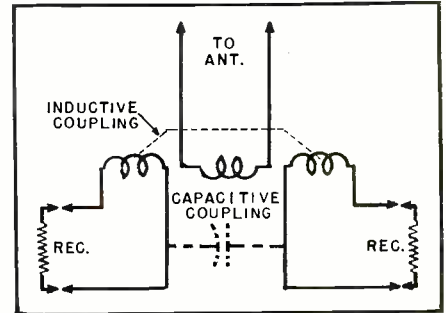

Fig. 3. Commercial-type coupler used to connect two to four sets to one antenna.

pad is near the receiver antenna terminal. Remember that an unused pad must be terminated with an additional resistor of the same value as the receiver's input impedance. Actual experience shows that up to ten receivers can be operated from a single antenna giving 10,000 microvolts of signal or more provided that the distance between receivers is not less than 10 and not more than 50 feet. If sets are too close, radiation through the air will undo the work of the attenuator pads. At distances beyond 50 feet the losses due to the long transmission line will become large enough to seriously reduce the useful signal.

Commercial Antenna Couplers

Several TV accessory manufacturers offer coupling devices that permit two or four TV sets to be operated from one antenna without the use of resistor pads. One type of circuit found in these units is shown in Fig. 3. This is effectively a simple r.f. transformer with the primary connected to the antenna and two secondaries for the two TV receivers. The actual appearance of this device is more like that of the elevator transformer input circuit used in many TV tuners to permit either a 300 or 72 ohm input. An effort is made to minimize the capacitive and inductive coupling between the two windings going to the receivers to reduce oscillator radiation. Nevertheless there is considerable coupling between the two sets and oscillator radiation may

(Continued on page 86)

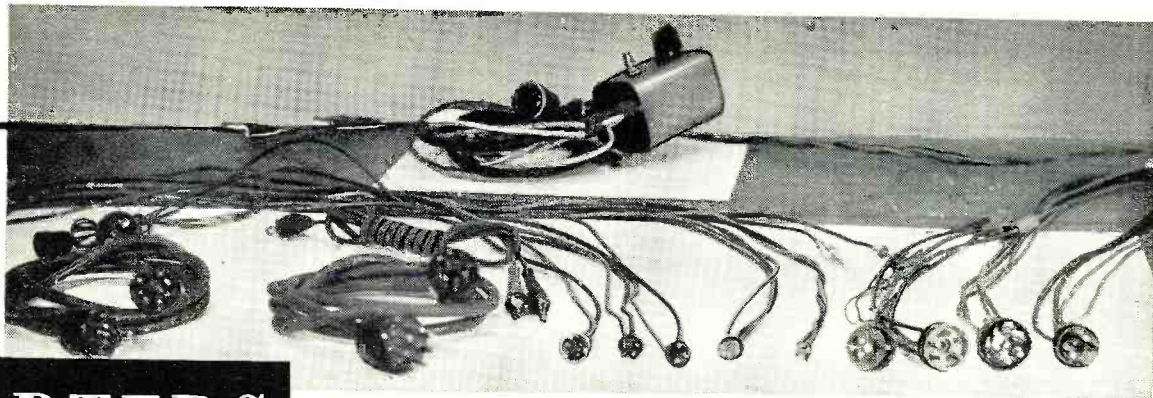

ADAPTERS

The different types of speaker-connection adapters, used with bench speaker. Unit in background is used for bench-testing of Motorola two-way FM receivers. Box contains volume control, switch, and squelch control. The large units in the left foreground are used to test Wurlitzer and Rock-Ola juke box amplifiers.

To Speed Up Your Service

By JACK DARR

TIME saved is money earned, in anybody's shop. Your service bench itself can be a tool—an actual test-instrument—with a few simple additions. A test speaker, a few resistors and switches, an old choke or field coil, a small panel with a d.c. ammeter and binding-posts, together with an easily-built set of adapter harnesses and test leads, can earn several dollars each month and make your work a lot easier.

Testing radio or TV chassis without pulling the speaker; testing p.a. systems or juke-box amplifiers under load; checking auto radios without removing the speaker from the car; testing two-way FM radio equipment without pull-

Many tedious service procedures can be expedited by adopting these unique technician-tested aids.

ing the control heads; locating distortion, rattles, noisy transformers, or field coils; all of these procedures and more can be done easily with a gadget like this. The one described was set up to fit our requirements. Yours can be different, if you have different equipment to work on. The whole thing can be built out of junk-box parts, if desired, for a small outlay of cash. Ours is built into a panel of the bench. It could be built into a small box, if it would be more convenient.

Fig. 1A is the schematic of the bench-speaker assembly and its connections. The speaker is a salvaged 8-inch PM unit which has been re-coned. T_1 is a 10,000 ohm, center-tapped, output transformer, also salvaged. R_1 is a 16-ohm, 25-watt resistor, for testing p.a. and juke-box amplifiers. R_2 is a 10,000 ohm, 50-watt resistor, tapped at 5000 ohms, which is used as a substitute field on juke boxes. SO_1 is a heavy-duty octal socket, used with adapter cables for juke box testing. Extensions are run from the voice-coil field and output-transformer wires to the ends of the bench, to eliminate moving the chassis or having to use excessively long wires. These are connected in parallel with the jacks on the main panel. Only one set may be connected at a time, of course. S_1 is used to disconnect the voice coil from the transformer, if necessary. L_1 is an old 1000-ohm speaker with a bad voice coil, however, a choke could be used here instead. S_2 is the "VC Resistor" switch, used with R_1 for p.a. system tests. Pin jacks are also connected to this resistor for use if needed.

Now, let's put it to work. Although there are a lot of different speaker plugs in use, from the tiny RCA phonotype plug up to a heavy-duty, 6-pin unit on p.a. systems, there is just barely enough standardization to let us get by without having to build a warehouse to hold them all. A standard 4-, 5-, 6-, and 7-pin, male, the 4-, 5-, and 6-pin "recessed male" type and similar female types, a plug such as used on 1.4-90 v. battery packs, a

Bench power panel used to test an auto radio. Ammeter on right measures drain of set, meter on left measures charging current into battery. Switch in the center controls battery charger. Note extension jacks at right of photo. These are connected in parallel with jacks on main test speaker panel. A similar test set at the other end of the bench, increases usefulness of the set.

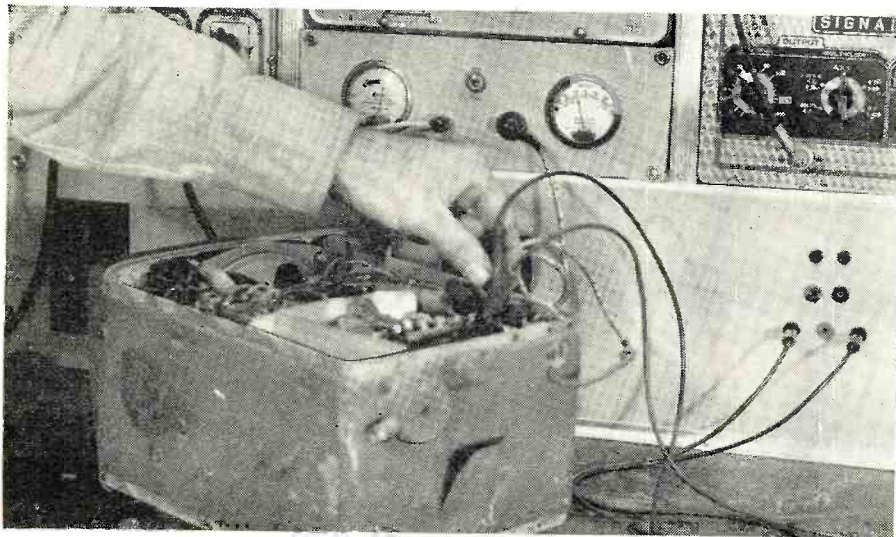

standard 1.4-volt "A" battery plug, and about a half-dozen special plugs for the non-standard sets, will take care of over 90% of the sets encountered. If you have quite a few of one particular model, it'll be worth-while to order a speaker plug from the manufacturer or your distributor. *Philco, Stromberg-Carlson, RCA*, and many others have these special plugs, which can be purchased for only a few cents each.

In addition to the plugs, you'll need two pairs of test leads, 36 inches long, with pin tips on one end, and insulated alligator clips on the other. With these, any non-standard plug can be jumpered and connections made to the proper places inside the chassis. We use standard pin-jacks for the speaker connections and banana jacks for the field. One pair of test leads, 36 inches long, will suffice here. With these three pairs of leads, any set can be connected for testing, even if you don't have the correct plug.

A new adapter can be made up in about five minutes, if you have the plug and a schematic of the set with which it is to be used. For hooking up adapters to work with a center-tapped output transformer, for instance, it's handy to color code them; use a red wire for the "B-plus," and black for the plates. This is the reason we used different jacks for the field; they can be hooked up quite a bit faster if you do not have to trace them out each time.

Automobile radios may be serviced faster by using adapters for the connecting leads. Many of the speaker adapters just mentioned can be used on both auto and home radios. The "hot" leads will require special adapters. Get one of each type fuse holder and put them on about an 18-inch length of at least #6 flexible wire. A heavy battery-clip is used for the ground connection. The battery connections on the panel are brought out to two binding posts. Heavy spade lugs are used on the ends of each lead.

Bench speaker unit. Left-hand vertical connections are used for dummy load resistor. Octal socket in center is used with speaker and load resistor for juke box and p.a. system tests.

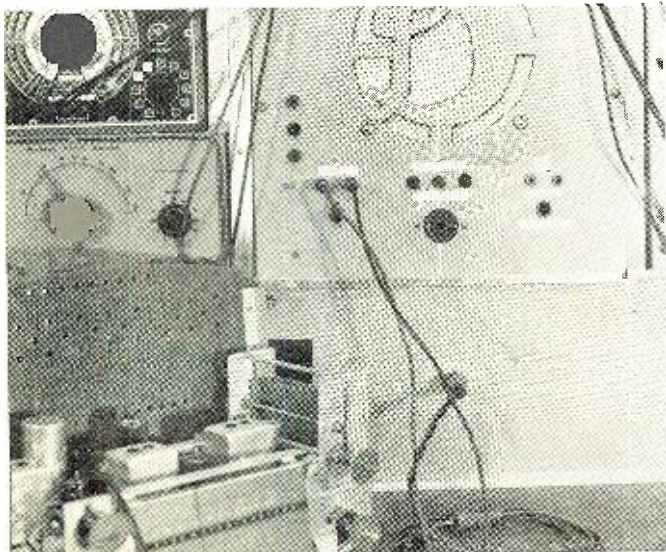

Fig. 1. (A) Schematic of test speaker and accessory panel. S₂ is used to select voice coil of speaker or load resistor for amplifier testing only. (B) The auto radio test panel. The 30-0-30 ammeter was salvaged from a "defunct" Delco plant. The "battery booster" is a 4-ampere trickle charger. The switch is in the primary of the booster. (C) The adapter cable used to connect juke box amplifier to test speaker panel. This cable fits most Rock-Ola amplifiers. Cables can be made up to fit any amplifier. P₁ is an Amphenol male octal shell-plug while P₂ is a standard Amphenol male, five-prong plug.

An ammeter is hooked in series with one of the battery wires in the panel (See Fig. 1B). Some of these will require a fuse in order to make the connection. Bridge the fuse with a piece of wire soldered to the caps. With the ammeter in the circuit you don't need a fuse for protection as any overload will show up instantly and it is annoying to have the fuse blow in the middle of a job.

Mobile two-way radio equipment can also be serviced quickly with this same equipment, using a special adapter. Receivers and transmitters use a remote control head with the volume and squelch controls, switches, pilot lights, microphone plugs, etc. mounted in it. We built a dummy head, using two standard volume controls, a switch, and two plugs. The cabling is simple as we omitted pilot lights, etc., and used only the essential wires. Using this, a receiver can be connected for test in about one minute. The transmitter could also be hooked up in a similar manner but thus far we haven't found it necessary. If we do, we'll hook up the necessary set of plugs and a harness.

Juke boxes, p.a. systems, and musical instrument amplifiers can be tested for power output by using the heavy-duty load resistor and measuring the voltage developed across it. As we do quite a bit of juke box work, we made up the special adapter cable shown in

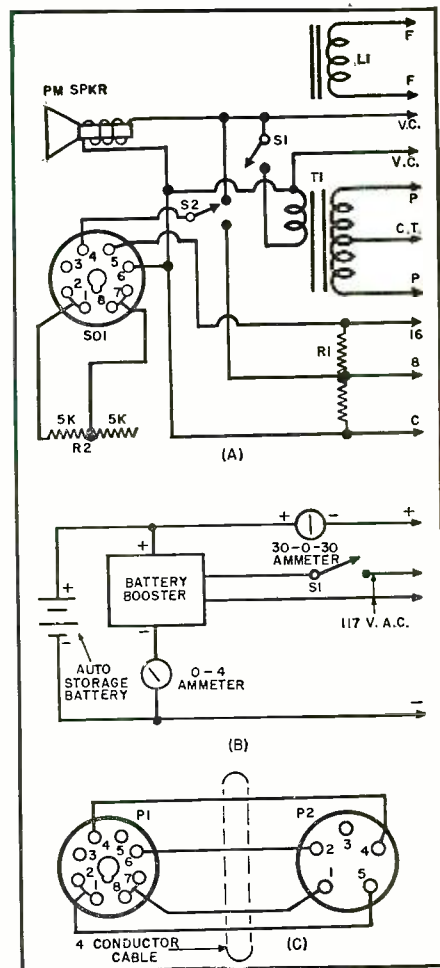
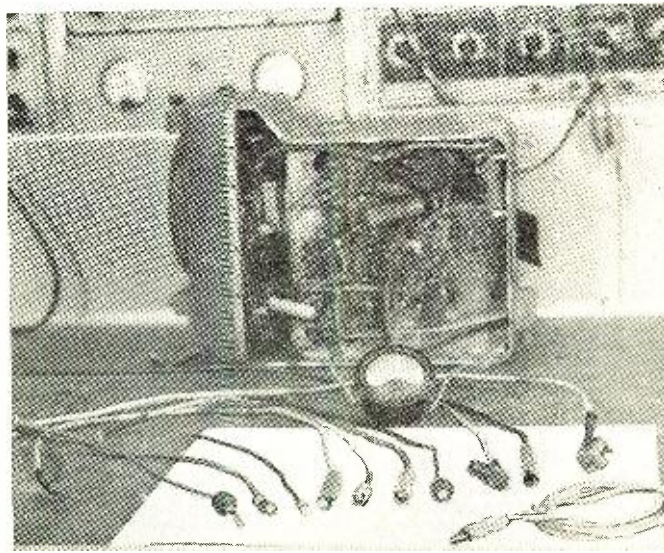

Fig. 1C. This cable and plug assembly fits most *Rock-Ola* juke boxes. Any other make could be connected in the same way. A word of caution here; don't connect the full output of p.a. systems, etc. across this kind of speaker, and then wonder why the voice-coil smokes! If you want to hear it, add a small condenser from the resistor to the speaker, or turn the gain down. (Continued on page 116)

Adapters used to connect auto radios to bench power panel for testing. Ground clip is at right. Meter is portable, with home-made shunt, for testing in cars. Connectors replace set's fuse.



A MOBILE 75-METER V.F.O.

By
W. O. CRUSINBERRY,
W9DVV

Instructor, De Forest's Training, Inc.

IT ONLY takes two or three days of operation on 75 meters for one to realize the futility of trying to operate with crystal control alone. This is especially true in mobile operation due to the relatively low power that most of us must use. Therefore the v.f.o. described in this article was constructed for installation in the author's car, and designed for front panel mounting so that the bulky components of the final and the modulator could remain in the trunk compartment. The unit has been quite successful in this installation and has proven very stable even under severe mechanical vibration and the varying voltage conditions present in most mobile power supplies.

The unit was built with the idea in mind that it would be used with an existing crystal-controlled transmitter and the original oscillator could be retained in the event that one desired crystal control facilities in addition to the v.f.o. Therefore this v.f.o. can be readily adapted to most of the conventional mobile transmitters without the necessity of altering or rebuilding the existing crystal oscillator or driver stages. The circuit also includes facilities for energizing the v.f.o. alone so that one may QSY with the final off.

Circuit

A 6AK6 was chosen for the oscillator tube itself and the conventional Clapp circuit is used. Bench tests indicated slightly better frequency stability with the Clapp, under varying supply voltage conditions, than with the Hartley circuit.

The main tuning condenser is C_1 , and zero temperature coefficient condensers are used at C_2 and C_3 . The bandset condenser is C_4 , and with the values shown in Fig. 2 the 75-meter band, from 3.85 to 4.0 megacycles, is spread out over almost the full 180 degrees of the tuning condenser rotation.

The buffer stage also utilizes the 6AK6 and is straightforward in design. The plate tank circuit of this stage uses a slug-tuned coil which is broad enough in its inherent tuning characteristics so that, if it is tuned to resonance near the middle of the band at 3.9 megacycles, it will not require re-tuning over the desired frequency range of operation. Shunt feed is used in the plate circuit and therefore one end of the coil may be at chassis ground for simplicity in mounting.

The output of the buffer is link

Rear view of the 75-meter v.f.o. showing the "Velvet Vernier" mechanism from a surplus tuning unit. The chassis measures 5" x 6" and fits a 6" x 6" box.

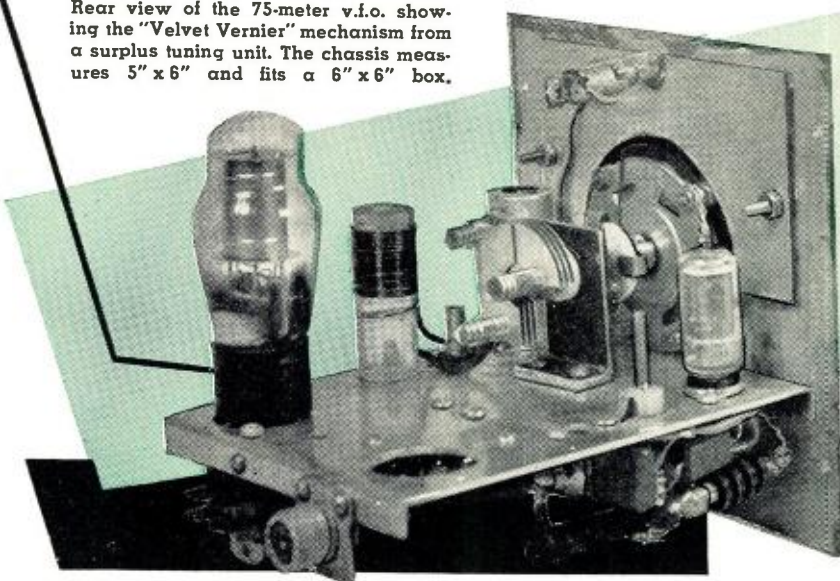

Construction details on a compact unit which has been designed for front-panel mounting in a car.

coupled to the final which, in the author's installation, is nine feet away in the trunk compartment. RG59U coax, coupled with a four-turn link around the cold end of L_2 , is used for this run of nine feet.

It was found expedient to use a voltage regulator tube for stabilization of the oscillator voltage in the v.f.o.

There will often be a variation of as much as 50 volts in most mobile power supplies between full battery charge and the run-down condition that exists after operating a couple of hours. The 8 to 10 mils that the voltage regulator draws in extra current is well repaid in frequency stability.

The v.f.o. was constructed, in our

case, on an old chassis that at one time was a mobile converter. The chassis size is 5 by 6 inches and mounts in a standard 6-inch square utility box. However, as can be seen from the photographs, there is a great deal of space left on the chassis. It would therefore be possible to use a smaller size, say 4 by 5, which would result in a much more compact finished unit. A miniature VR tube is available which would allow the use of a smaller cabinet.

Mechanical stability is far and above the most important consideration in the mounting of the oscillator components. Bear in mind that a v.f.o. used in a car is going to be subjected to much more severe mechanical vibration than one used in the shack. The parts, especially tuning components, must be mounted firmly on the chassis so that there will be absolutely no movement between the parts and the chassis. All bolts should be tightened firmly and lock washers used wherever possible.

Reference to the photographs will show that the model uses a "Velvet Vernier" mechanism from a surplus tuning unit. This vernier has a knob-to-condenser-shaft reduction ratio of 2.5 to 1; however, any comparable vernier will do. The dial itself was fabricated with a scale drawn in India ink and a pointer attached to the condenser shaft. The dial face is separated from the front panel by about 1/8 inch, which allows the light from a pilot bulb, mounted inside the cabinet, to shine on the face.

The switch on the left of the front panel applies filament voltage to the

Fig. 1. Method for connecting S_2 (Fig. 2).

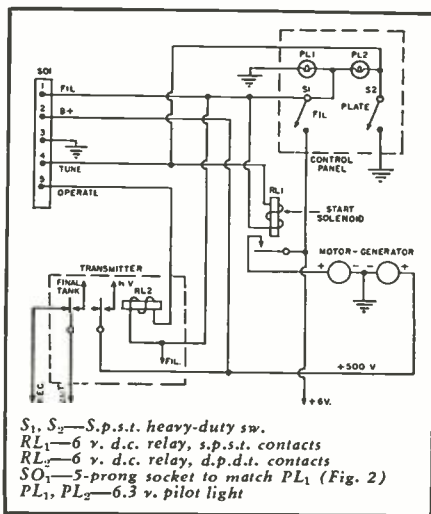

unit, and the switch on the right is a "Tune-Operate" switch. This allows application of supply voltage to the v.f.o. alone for the purpose of tuning to a desired frequency with the final off.

Fig. 1 is a diagram showing how the "Tune-Operate" switch (S_2 , Fig. 2) on the v.f.o. is wired into the regular mobile transmitter and control panel circuits. As can be seen, if the "Tune-Operate" switch is in the "Tune" position, it opens the circuit to the main "B+" and antenna relay RL_2 in the transmitter. If the regular plate switch on the control panel is now actuated, it will start the dynamotor and high voltage will be applied only to the v.f.o. Since RL_2 does not energize, there will be no plate voltage applied to the final and the antenna will remain connected to the receiver. After the desired frequency is set, by the dial calibrations or by "zero beating" in the receiver, the transmitter final can be energized by turning the "Tune-Operate" switch to "Operate." Variations, of course, can be made at the discretion of the individual to make the control circuit applicable to his own installation.

Coupling to the Transmitter

As mentioned previously, it is likely that no changes will be required in the transmitter circuit in order to drive it with the v.f.o. The right hand portion of the diagram of Fig. 2 (set off by dotted lines) shows the circuit of the buffer plate tank in this installation. The coax from the v.f.o. is simply link coupled, with about four turns, to the r.f. ground end of the buffer tank coil in the transmitter. If the transmitter has a tuned grid circuit in the final the link should be coupled to it instead of the buffer. When using the v.f.o. with a crystal-controlled transmitter, be sure to remove the crystal from its socket. In the event that enough drive

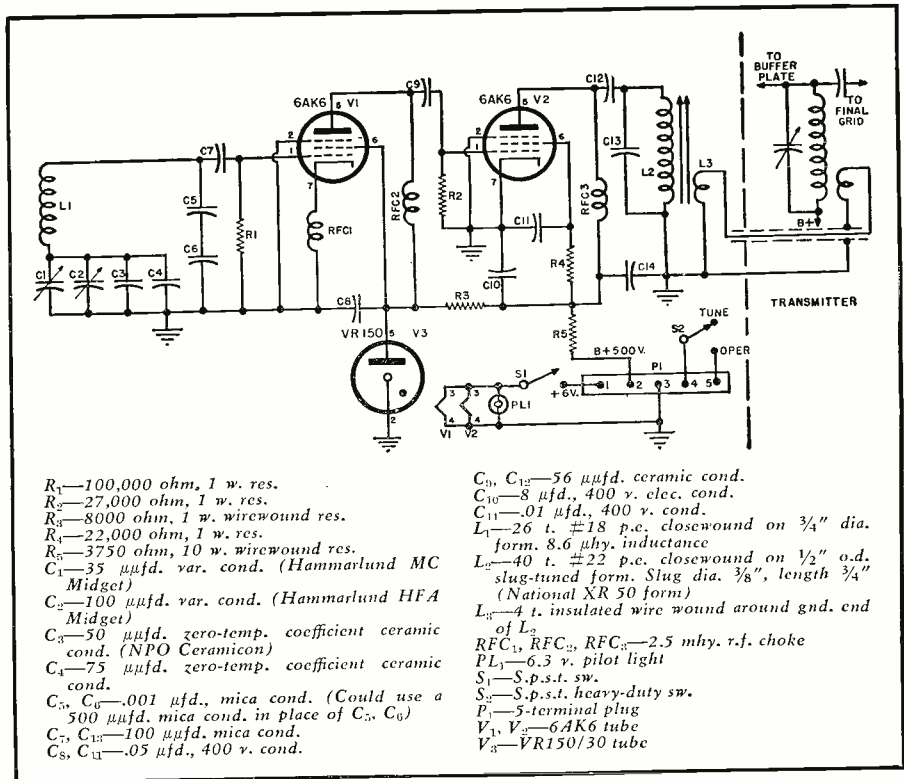

Fig. 2. Circuit diagram of v.f.o. and method of coupling it to the transmitter.

is not available from the v.f.o., such as might be the case with a triode final, the unit could be coupled to the grid circuit of the buffer stage of the transmitter to provide an additional stage of amplification. In order to reduce the total current consumption of the transmitter, the tubes which are not used, when coupled to the v.f.o., should be removed from their sockets. A coax connector is used at the transmitter end of the coax to facilitate changing back to crystal control. To do this the coax is simply disconnected and the tubes and crystal replaced in the transmitter.

Alignment and calibration of the v.f.o. are relatively easy. Any receiver of reasonable accuracy can be used, and if it is first checked against the 5 megacycle WWV signal it will suffice for use in calibrating the v.f.o.

It is suggested, however, that after calibration the operator respect the band edge limits to the extent of 10 or 15 kilocycles. A grid dip oscillator should also provide an excellent means of calibrating the unit by beating in a receiver.

Before the calibration process can begin the v.f.o. must be placed in its
(Continued on page 104)

Under chassis view of the compact, mobile 75-meter v.f.o.

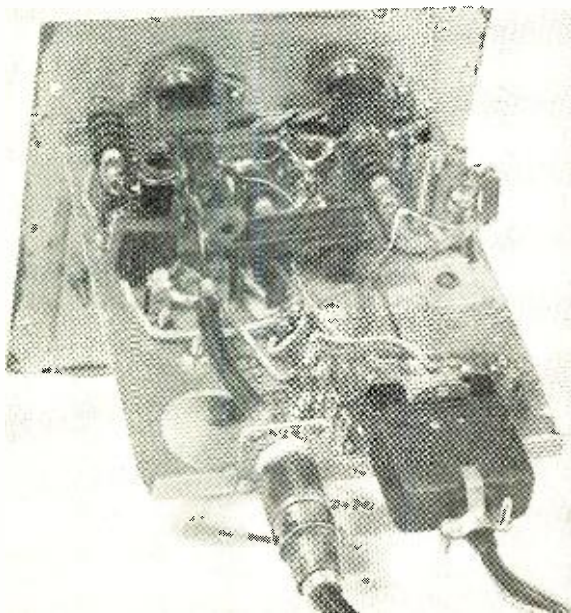

Front panel view of unit showing the simplified controls.

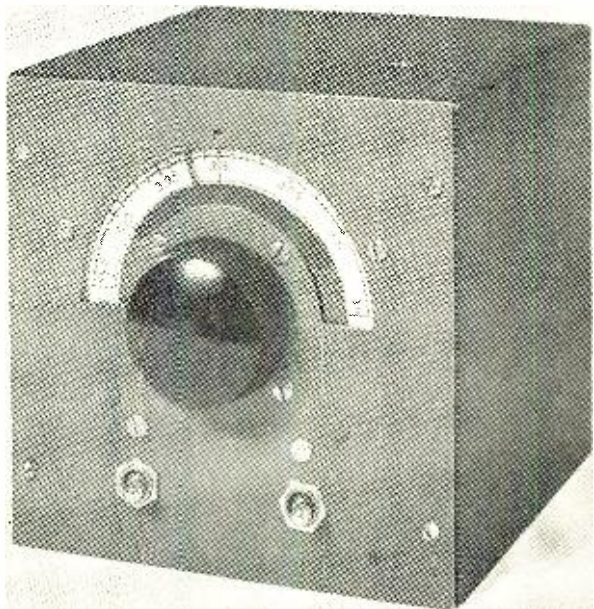

MICROWAVE KLYSTRON OSCILLATORS

By
JOSEPH RACKER*
and
LAWRENCE PERENIC†

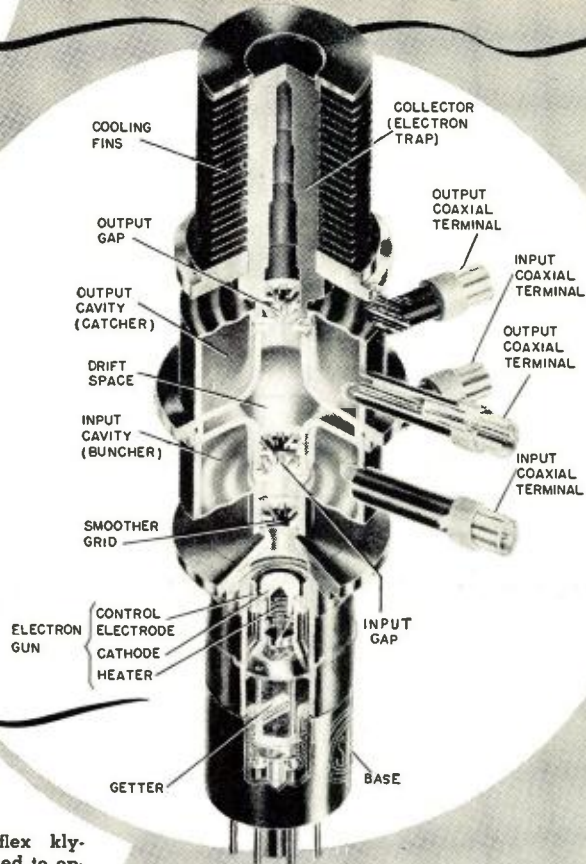

Sylvania's reflex klystron is designed to operate at wavelengths between 6-7 cm.

Part 1. Practical operating data on klystrons as used in present-day communications equipment.

MICROWAVE frequencies are being used to an ever-increasing degree in commercial television and communications links, amateur transmission, and a long list of governmental and industrial electronic devices such as radar, instrument landing, guided missiles, and air traffic control. Consequently, the field of microwave techniques offers an excellent opportunity to technicians and engineers, as well as providing interesting equipment for ham operation.

Fig. 5 is a block diagram of a typical transmitter and receiver operating at microwave frequencies. As seen in this diagram, all stages except the microwave oscillator in the transmitter and input circuit and local oscillator in the receiver, operate at conventional frequencies. This illustrates a very important fact, namely, a thorough understanding of microwave oscillators and their associated circuits provides the reader with a very substantial basis for servicing and building many microwave systems. In other words, generally speaking, a microwave transmitter is no more than a conventional type transmitter which uses a microwave oscillator. A microwave receiver is a standard superheterodyne circuit using a microwave local oscillator and input circuit.

There are a number of methods of generating energy at microwave frequencies including lighthouse oscillators, magnetrons, traveling wave tubes, and klystrons. The klystron oscillator, which is the subject matter of this article, is by far the most com-

monly used oscillator, particularly in commercial equipment.

For reasons that need not be discussed in this article, it is extremely difficult and inefficient to generate microwave energy using conventional techniques and tubes. Of the microwave oscillators listed, only the lighthouse tube uses standard oscillator circuits. This type of oscillator, however, has an upper frequency of about 4000 mc. All of the other oscillators, sometimes called transit time oscillators, employ new and different techniques of oscillation.

Since entirely new techniques are involved, the authors have divided this article into two parts. The first part describes the basic theory of klystron

operation so that a reader who has never had any previous microwave experience can understand how it works. The second part covers the practical aspects of the klystron oscillator, namely, its construction, characteristic curves, methods of tuning, modulation, and servicing. Needless to say, the reader cannot absorb the material presented in the second part unless he understands the theory outlined in the first part.

Conservation of Energy Law

A very familiar universal law—conservation of energy—which is rarely used in electronic theory becomes very important in klystron and other transit time oscillator operation. They are called transit time oscillators because the energy required to sustain oscillations is obtained from the electron stream while it is *in transit* between cathode, or electron gun, to plate, or collector. In order to understand how this energy is transferred, the conservation of energy law must be applied to the electron flow.

Consider the flow of an electron that leaves the cathode of the diode, shown in Fig. 1, and travels toward the plate. When the plate is positive with respect to the cathode, the electron is accelerated toward the plate. Whenever any mass, including an electron, is acceler-

Fig. 1. Electron flow in a diode tube.

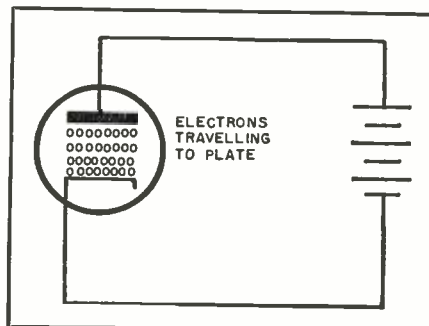

* Radar Consultant.
† Chief Electronic Engr., Bogart Manufacturing Corp.

ated it picks up energy. From the law of conservation of energy it is known that this energy must come from some other element in the system.

Actually, in this case, the energy comes from the battery. This is most easily seen at the instant that the electron actually reaches the plate. At this time the electron would normally neutralize a positive charge and the plate potential would decrease. However, the battery has been expending energy and drawing an electron away from the plate, as the transit electron approaches it, so that when the electron actually reaches the plate there is no net change in charge and the plate potential remains constant. The most important fact, however, is that when an electron is accelerated, it gains energy, and this energy comes from some element in the system.

Similarly, if the plate potential is negative, the electron is retarded, or slowed down, by the plate. When an electron is retarded, it is giving up energy. Thus when it approaches the plate it repels an electron on the plate toward the battery. This, in effect, means that energy is being returned to the battery.

Now let us apply this law of conservation of energy to an electron flowing in an electric field such as can exist in the cavity described in a later paragraph. If the electron is accelerated by the field it is gaining energy which must come from the field and make it weaker. Hence an electron that is accelerated by the field causes the field strength to decrease. Conversely, an electron that is retarded by the field, loses energy to, and increases the field strength. In this article, the direction of the electric field will be depicted by an arrow and the magnitude of the field by length of arrow. An electron flowing in the direction of the field is accelerated by it (some texts use the reverse convention), while an electron flowing against the field is retarded by it.

Flow in Cavity Resonator

At microwave frequencies a special type of tuned circuit, known as a cavity resonator, or simply a cavity, is required. The cavity is a hollow metallic box which can be rectangular, cylindrical, spherical, or a number of other shapes. Several common types of cavities are shown in Fig. 2. The cavity is usually about one-half wavelength long (wavelength as measured in the cavity), although it can also be any multiple number of half wavelengths long.

In any tuned circuit, such as the conventional LC tank at conventional frequencies, there is a continuous exchange of energy from magnetic to electric field, and *vice versa*. For example, in the LC circuit the energy stored in the magnetic field around the coil is transferred into the electric field, building up in the condenser, as the current in the circuit declines. During the next half cycle, as the condenser discharges, the condenser electric field

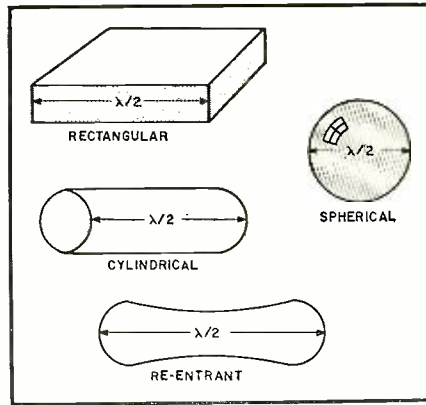

Fig. 2. Several common types of cavities.

energy is transferred into the magnetic field which is being generated around the coil.

In a cavity this continuous exchange of energy takes place in the air within the cavity. In a one-half wavelength rectangular cavity, for example, the electric field exists sinusoidally along the length of the cavity as shown in Fig. 3. The field is always maximum at the center and reduces to zero at the ends. The magnetic field in the cavity also has a sinusoidal variation, being maximum at the ends and becoming zero at the center. In Fig. 3, three instantaneous values of the electric field distribution are shown. In Fig. 3A, the electric field is at its maximum intensity. In Fig. 3B, which occurs a short time later, the entire field is declining (and beginning to build up the magnetic field). In Fig. 3C, the field has undergone a half-cycle of operation (since 3A) and is at its maximum negative value.

Just as in any tank circuit, the intensity of the electric field during each successive cycle would decrease slightly, due to small energy loss—equivalent to resistive loss—unless some method of replenishing this energy is available. This can be done by use of an electron stream. Assume that, as shown in Fig. 4, a small slot is inserted at the center of a rectangular cavity

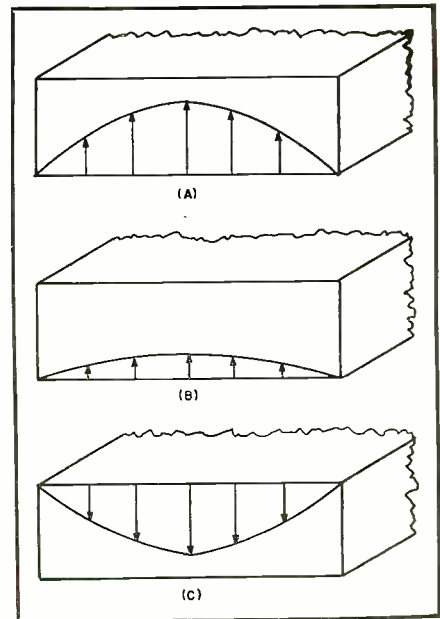

Fig. 3. Electric fields in rectangular guide.

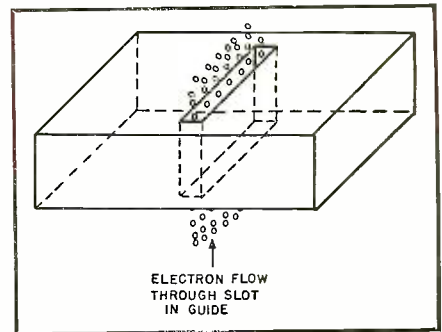
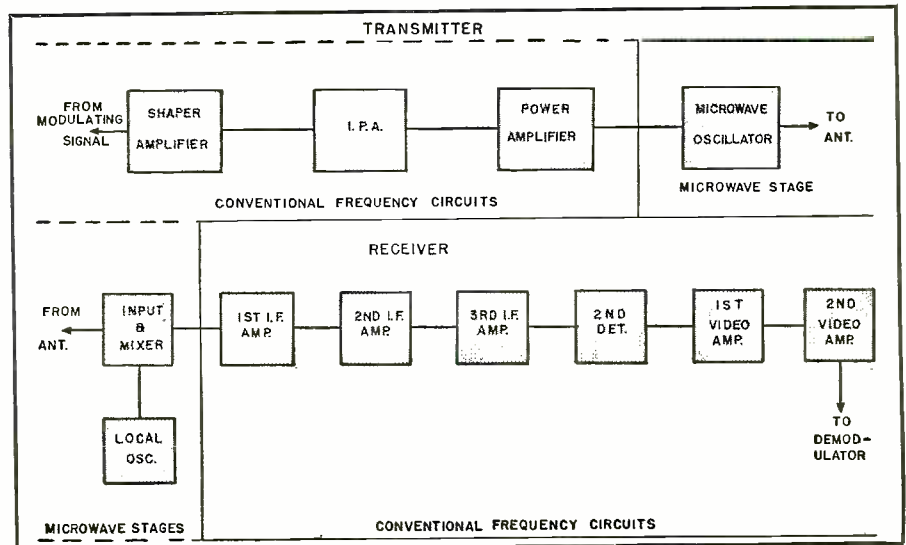

Fig. 4. Electron stream flowing through the slot in a rectangular wave guide.

and an electron stream is directed through this slot. When the electric field of the cavity is so directed (positive half-cycle) that it accelerates the electrons, energy is transferred from the field to the electrons and the field intensity diminishes and oscillations are damped out. However, if the field is so directed (negative half-cycle) that

Fig. 5. Block diagram of a conventional microwave transmitter and receiver.



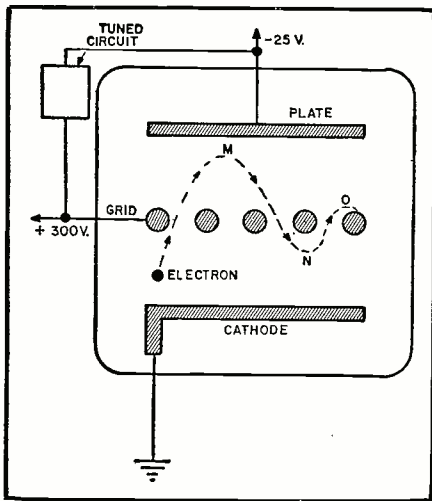

Fig. 6. The electron motion in a positive-grid (Barkhausen-Kurz) type oscillator having constant electrode potentials.

it retards the electron flow, then energy is transferred from electrons to field, and oscillations are sustained. This is the basic principle of klystron operation.

Velocity Modulation

In the foregoing example, if the electron stream were passed through the cavity with uniform intensity, it would increase the field during one half-cycle and decrease it during the next half-cycle and there would be no net exchange of energy. However, if we could arrange the electron stream so that the density of electron flow during the field negative half-cycle is much greater than the density during the positive half-cycle, then there would

Fig. 7. Basic representation of klystron.

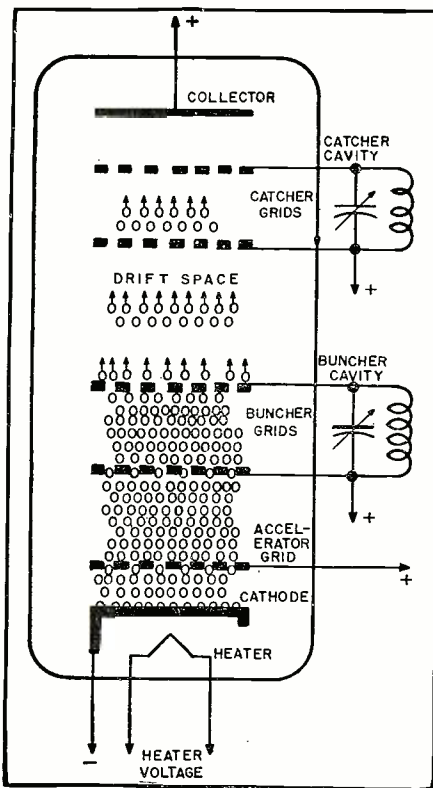

be a net exchange of energy from electron stream to the field. The process by which the electron beam is "bunched" in this manner is known as bunching or "velocity modulation."

The velocity modulation action is best understood by considering the operation of the simplest type of velocity modulation oscillator called the positive grid, Barkhausen-Kurz, or retarding field oscillator. In this type of oscillator, shown in Fig. 6, the grid is operated at a positive potential with respect to cathode and plate, and the plate is negative with respect to the cathode.

The operation of this circuit will be considered first under d.c. conditions and then with an a.c. voltage applied to the grid. In addition, although the complete action involves many electrons, it will be simpler to first investigate the behaviour of a single electron. Then, later, the reasoning thus obtained will be extended to entire groups of electrons.

Consider the flow of an electron leaving the cathode of the tube shown in Fig. 6 with the tank circuit shorted out (no a.c. voltage on grid). As an electron leaves the cathode it is accelerated toward the grid by its high positive potential. By the time the electron reaches the grid its velocity is high and it may either hit the grid, delivering its energy in the form of heat, or—more likely—it will pass through the space between grid wires into the region between grid and plate. In the grid-plate region the electric field is in the opposite direction because the plate is negative with respect to the grid. This field tends to slow down the electron and for this reason the oscillator is sometimes called the "retarding field" oscillator.

If the plate voltage is sufficiently negative, the electron will come to rest at some point in space between the grid and plate. The attraction of the grid then causes the electron to reverse direction and move back toward the grid. The electron then swings back and forth past the grid (path *M, N, O*) until it eventually hits one of the grid wires. The phenomenon is very closely parallel to that of the oscillation of a damped pendulum (damped because electron loses some energy during each cycle).

If no other elements were introduced

in the circuit many individual electron oscillations would occur in the space between plate and cathode, causing equivalent energy oscillations in the grid circuit. The exact phase and amplitude of these oscillations between any two electrons would depend upon the time at which the electrons were emitted and the space charge at that time. It is obvious that under these conditions no useful oscillator energy can be supplied to the grid circuit, since the electron oscillations are random and cancel each other.

Now assume that an a.c. voltage is superimposed upon the grid (tank circuit no longer short circuited). The frequency of this signal is so high that by the time the electron travels from cathode to the grid, the voltage has changed one-half of a cycle, for example from maximum positive to maximum negative, or from zero to zero, and so on. This is shown in Fig. 8 where (A) plots the a.c. voltage and (B) the oscillatory (no energy loss) electron path. Let us define the velocity, v_0 , as the velocity of the electron at any point in the cathode-plate space with grid potential at the d.c. value shown in Fig. 6.

Consider the relative velocities of the electrons leaving the cathode during grid a.c. potential of *A, B, and C* shown in Fig. 8A. An electron leaving during time *A*, travels at a velocity less than v_0 in the cathode-grid plane because during this time the grid is always at a negative a.c. potential. It loses more velocity between grid and plate since during this time the grid is positive. Thus, its over-all velocity is less than v_0 .

An electron leaving the cathode with grid potential at *B* will travel at about v_0 , since during both its cathode-grid and grid-plate paths the grid is positive half the time and negative half the time. Finally, an electron emitted at time *C* will travel at a velocity greater than v_0 , since the grid is positive (a.c.) when it is in the grid-cathode plane and negative in the grid-plate plane. It is readily seen that the electrons emitted at time *C* tend to catch up with electrons emitted at time *A* so that electrons will tend to oscillate in bunches instead of completely at random. Now useful oscillatory energy can be supplied to the grid circuit.

Klystron Operation

Basically, the klystron, as shown in Fig. 7, consists of an electron gun, "buncher" and "catcher" grids, and a collector. The electron gun is similar to those found in cathode-ray tubes and functions to provide a steady stream of electrons. The buncher and catcher grids are part of the cavity resonators, slotted in the center using the same principles shown in Fig. 4. The electron stream is velocity modulated by the buncher grids and converted to microwave energy in the catcher grids. Electrons passing through the catcher grids are removed from

(Continued on page 122)

Fig. 8. Graph of (A) grid a.c. voltage and (B) electron position in space leaving cathode when the time base is equal to zero.

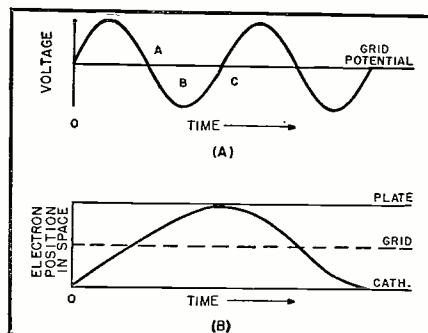
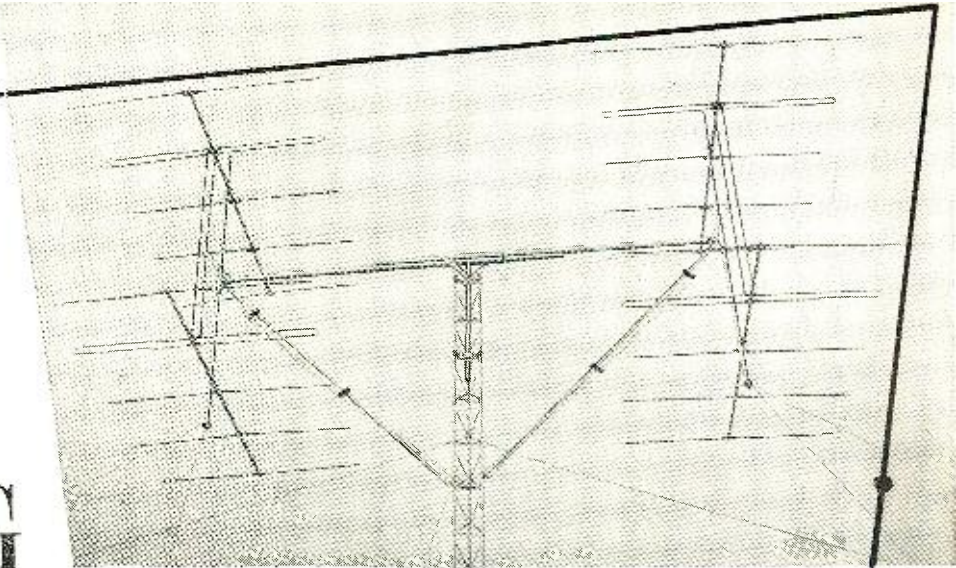

Fig. 1. The new Channel Master "Supermount" antenna stacked horizontally. The unit features adjustable structure.



STACKING

FOUR Z-MATCHED YAGIS

By HARRY GREENBERG* and HAROLD HARRIS†

A new mechanical and electrical system incorporating a simple mounting arrangement and a new impedance matching harness.

A PRACTICAL system for stacking four yagis by extending the principle of impedance matching which led to the development of the "Z-Match" yagi system has been developed by Channel Master Laboratories. The resulting gains of over 14 db are the highest yet attained in a practical television antenna.

The problem was of a dual nature because the mechanical problems were as formidable as the electrical ones. For instance, if four-bay, half-wave vertical stacking were attempted on Channel 2, the antenna array would require about 25 feet of unguyed mast. On the other hand, on the high band, the length of masting required for four bays is about 10 feet, which is a practical dimension. Therefore, a separate mechanical approach was required on each band, although the electrical problem of phasing and matching was the same. On the low band, the four-bay array was constructed by arranging two stacked yagis side by side. This arrangement was made practical by a new adjustable structure made of heavy welded tubing (Fig. 1). This large mounting framework was trade named the "Supermount."

The adjustable cross boom of the "Supermount" provided for full-wave horizontal spacing between the two stacked arrays. Since full-wave spacing was utilized, the distance between

the two stacked arrays ran up to 17 feet on Channel 2. The entire structure was supported at the center. This meant that tremendous twisting torques were developed under brisk winds. This torsion was excessive on most commercial television towers because horizontal stacking narrows the directivity of the antenna and makes it more sensitive to twisting. The twisting problem was solved by guying the array at its outer extremities under each stacked yagi. Guying at these points also kept the guy wires

out of the field of the antenna. These guy wires, in turn, created a large downward thrust on the extended booms and this, in turn, was offset by diagonal braces.

Since all of these operations had to be accomplished while assembling the entire array from the top of a tower, the entire structure was designed in two parts so that the spacing between stacked arrays could be adjusted for each channel and so that the diagonal brace could be pivoted to fasten with

(Continued on page 102)

Fig. 2. Operating principle of the four Z-matched yagi antennas.

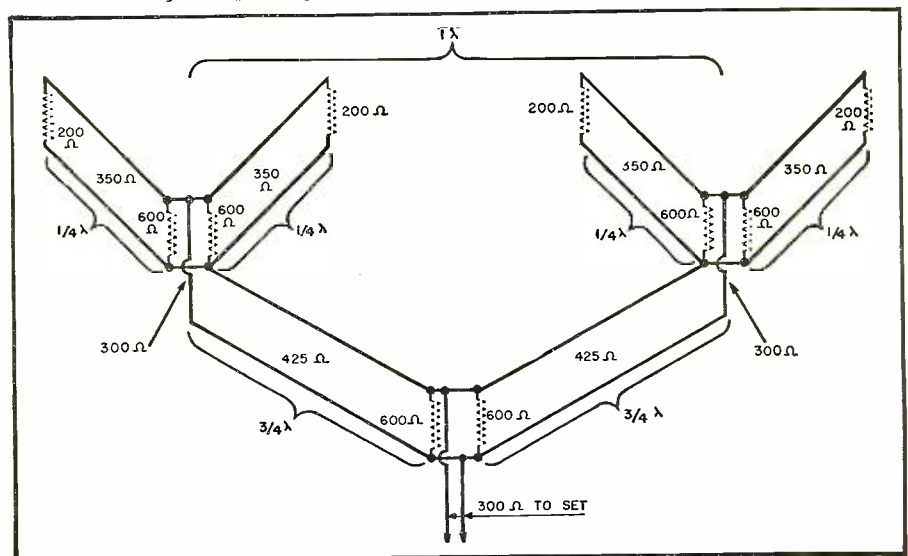

* Chief Electronic Engineer, Channel Master Corp.
 † Vice-president, Sales & Engineering, Channel Master Corp.

An Adapter for NBFM Reception

By

E. FERNANDEZ DE CASTRO

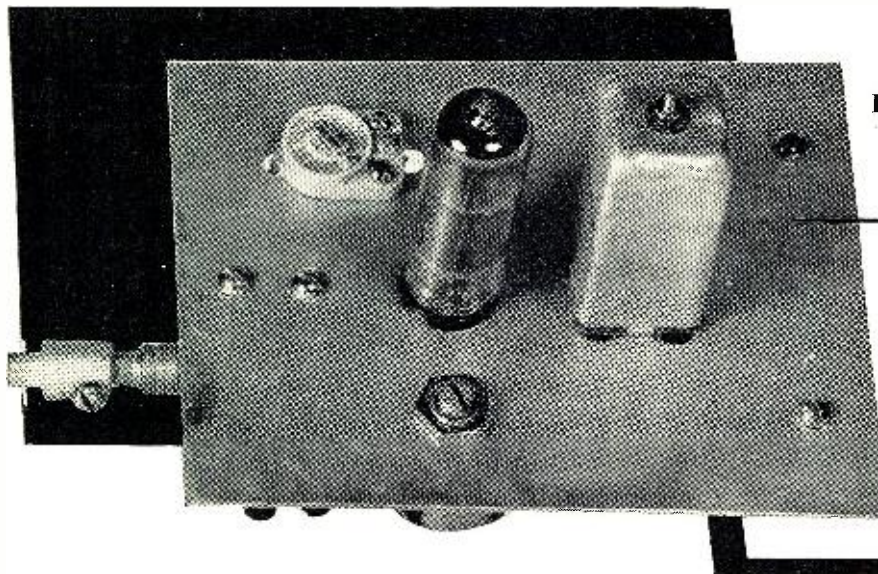

Top view of the small subchassis used to mount the adapter. The screwdriver adjustment is for the cathode potentiometer used for setting the point of best amplitude limiting action of the unit. The ceramic trimmer back of the tube is for compensating the tuning of the last i.f. transformer for differences in the distributed capacities of the wiring. The switch changes operation from AM to FM.

Details on a unique ham application for the recently-introduced 6BN6 gated-beam tube.

ALTHOUGH the advantages of using a suitable FM detecting system in NBFM work are recognized by everyone, most hams still rely on the "off-tuning" method of reception on standard AM sets, thus losing most of the advantages of that type of communication.

Although several types of FM adapters for NBFM work are available at the present time and despite the fact that information on how to build them has often been published, their use is still somewhat restricted because of the difficulty encountered in finding suitable components. Such well-known surplus receivers as the BC-348 and the BC-345 have an i.f. value for which no commercial adapters have been designed nor are suitable discriminator transformers available to build adapters for such receivers.

A solution to this problem can be found in the use of the "gated-beam tube" which is available commercially as the 6BN6. This tube, so-called from the way the electron stream is formed and controlled before reaching the anode, makes possible the construction of a simple adapter for NBFM reception without resorting to special components. In fact, the parts required, with the exception of the tube, are among those usually found in any ham's or experimenter's junk box.

The circuit is simple and straightforward. It has given excellent results with every type of receiver with which it has been used and has proved suitable for all types of FM transmission, whether amateur narrow band or broadcast wide band. The limitation on the highest signal deviation that can be received is determined by

the selectivity of the i.f. channel of the receiver with which it is being used and not by the adapter itself which is easily adjustable to any desired bandwidth.

The advantages of this unit include the saving of time and money and the elimination of hard-to-get parts. The only resonant circuit required in the assembly can be obtained from a discarded i.f. transformer winding or the secondary of an r.f. coil—a distinct advantage in the case of receivers using an i.f. other than 455 kc.

How It Works

It is a well-known fact that an FM detector operates by providing an audio voltage proportional to the frequency deviation of the carrier—not its amplitude. In fact, amplitude variations of the signal are removed before the detection process by means of one or more limiter stages.

The gated-beam tube takes care of both of these functions, amplitude limiting and frequency detection. In its construction electron optic techniques, together with a special arrangement of the electrodes, have been used to obtain an operational characteristic that is quite different from that exhibited by the usual type of tubes.

Frequency detection with the 6BN6 is provided by off-phase operation of its two grids while an efficient limiting action is obtained by the unusually sharp cut-off characteristics of its curve.

Fig. 1B is a simplified schematic of the electrode arrangement in the 6BN6. From this diagram it is easy to see that in many respects this tube resembles the familiar cathode-ray tube. This similarity can be explained by the fact

that in the gated-beam tube the electron stream must be accurately formed and focused on the different control elements in order to obtain its unique performance characteristics.

There are two control grids which influence the plate current flow. The normal control grid is located next to the cathode while the second grid, called the "gating" or "quadrature grid", is near the anode of the tube in the position normally occupied by the suppressor grid of pentode tubes.

The control action of the grids is very steep, resembling the "all-or-nothing" action of the grid in gas-filled tubes. A signal of 1½ volts swings the plate current from cut-off to saturation. This "on-off" action, as the "gate" closes or opens fully, is what gives the tube its name.

Although the principle of operation of the 6BN6 tube as a limiter-discriminator has been covered fairly thoroughly in recent technical literature, it might be well to review briefly its operational behavior.

Electrons emitted from the cathode are formed into a narrow beam by the focusing electrode and directed toward the first control grid. The accelerator electrode around the first grid not only serves to speed the electron beam on its way toward the anode but also acts as a collector for those electrons not passing through the grid, in order to avoid the formation of a space charge which would tend to lower the emission capabilities of the cathode.

The electron lens further shapes the beam and directs it, through the screen grid, toward the aperture in the shield that encloses the anode and the gating grid. The accelerator electrode is tied internally to the screen grid of the tube while the focusing electrode (beam deflector plates), the electron lens, and the anode shielding are all tied internally to the cathode—the

common connection for which is brought to pin 1 at the tube base. The shape and spacing of all these electrodes contributes to the shielding of one grid from the other, thus making their control action independent and sharp.

Fig. 1A is a practical circuit for a combined limiter-discriminator for NBFM reception which the author built for use with a *National NC-57* receiver.

The signals to be detected are applied to the first control grid, pin 2, through a suitable coupling circuit. Operational bias is provided by the voltage drop in the cathode resistors, one of which is adjustable in order to provide optimum operational conditions for the limiter. The second control grid, pin 6, is returned to ground through a parallel resonant circuit tuned to the operating frequency of the i.f. channel of the receiver. Normal operating voltages are provided for the plate and screen grid of the tube through suitable voltage dropping resistors.

When the signal is impressed on the first grid, the electron beam is modulated in a series of groups or bunches of electrons as the grid potential varies from cut-off to saturation with each positive cycle of the r.f. signal. As the control action of the grid is very steep, all of these pulses will have practically the same amplitude, the maximum value being determined by the plate current saturation and not by the signal amplitude. Limiting of the signals is thus obtained.

The pulses or bunches of electrons are like cyclic variations of the density of the electron's beam and this varying electrostatic charge induces a pulsed current in the gating-grid circuit that flows to ground through the tuned circuit connected at that point. The phase and magnitude of the voltage developed at that grid will be dependent on the resonant characteristics of the circuit and the relation between its resonant frequency and that of the impressed current.

As the frequency of the input signal varies, the phase relationship between the voltages at the control and the gating grid will also vary. As both grids have the same controlling action over the plate current flow, the latter will be in the form of pulses of constant frequency but varying width. The pulses of varying duration are integrated by the plate's RC network, the results being a current whose amplitude changes in accordance with the frequency deviation of the signal impressed on the first grid.

The tuned circuit which is connected from the gating grid (pin 6) to ground is the key to the successful operation of the circuit and every effort must be made to obtain a "high-Q" unit for this part since the audio voltage obtained at the output of the circuit will be controlled, to a great extent, by the resonant characteristics of this circuit. We used a winding from a 455 kc., permeability-tuned transformer shunted

by a 25 μfd . ceramic condenser and obtained excellent results. If the adapter is to be used with a receiver that, like the BC-348, has a higher value of i.f. (910 kc.), the winding from a permeability-tuned broadcast band r.f. coil can be used, shunted by a 50 or 75 μfd . ceramic condenser.

Precautions should be taken to insure adequate shielding between components of the limiter grid and those of the quadrature grid circuit since any coupling external to the tube will unbalance the phase relationship between grids. Best results will be obtained if the gating-grid tuned circuit is shielded and its leads are kept well separated from the limiter grid connections.

Since space requirements for this adapter are modest, the unit can be built into the receiver permanently and a switch can be used to change from normal AM reception to NBFM operation.

In the author's case, it was found necessary to add a small trimmer condenser (a 1.5 to 7 μfd . ceramic unit) from the plate of the receiver's second detector to ground in order to equalize the tuning of the last i.f. transformer in both positions of the switch since the input capacity of the adapter was found to be slightly higher than that of the second detector of the set.

The RC network in the plate circuit acts as an integrator circuit for the plate current pulses and, at the same time, serves as a de-emphasis network. The values given in the schematic were found suitable for NBFM reception with a 455 kc. i.f. channel. Other values of capacitance may be more suitable for other values of i.f. or modulation index.

Adjustments

Once the circuit is built and all connections are checked against the wiring (Continued on page 119)

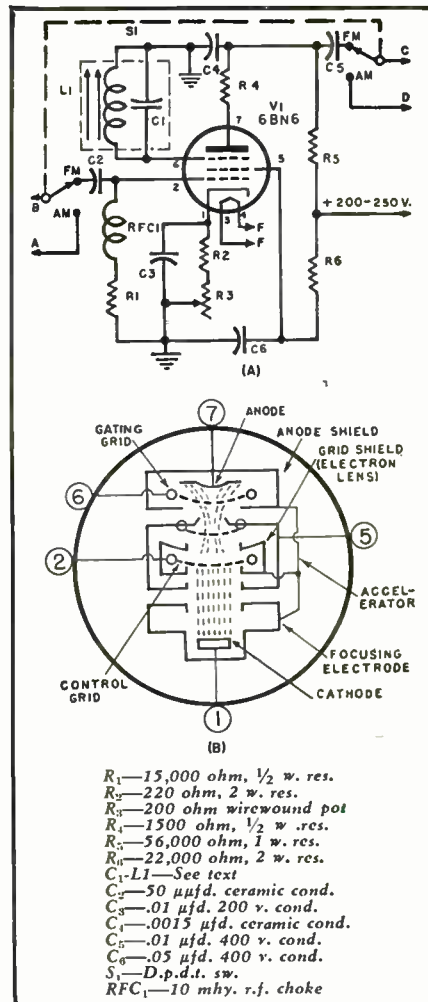
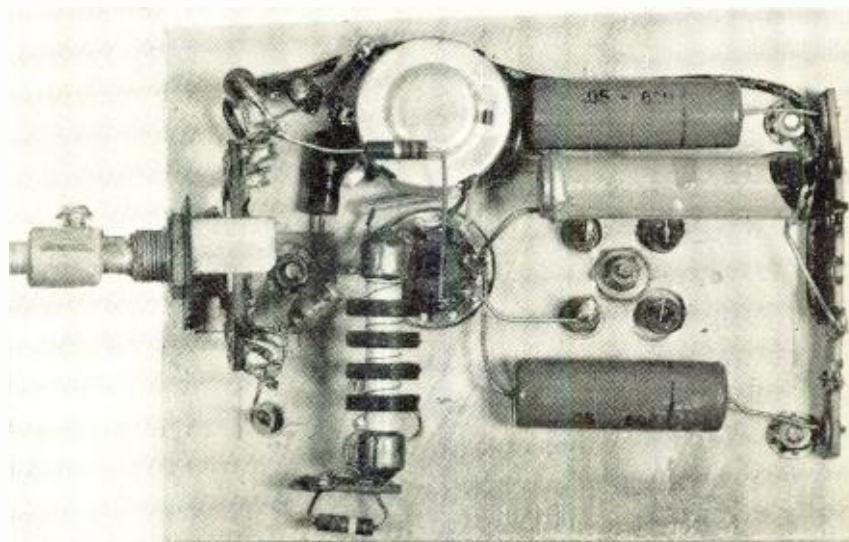

Fig. 1. (A) Schematic of the NBFM adapter. Lead A of the changeover switch connects to the second detector tube in the set. Lead B connects to the secondary of the last i.f. transformer. C is connected to the high side of the volume control, and D to the set's second detector. (B) The arrangement of elements in the 6BN6 tube.

Bottom view of the adapter subchassis. The changeover switch has an extension shaft in order to permit the adapter to be operated from the front panel of the receiver. The terminal strip at the right is used as a tie-point for all the connections which are needed to obtain the necessary adapter voltages from the receiver.



SERVICING NOISE-REJECTION CIRCUITS

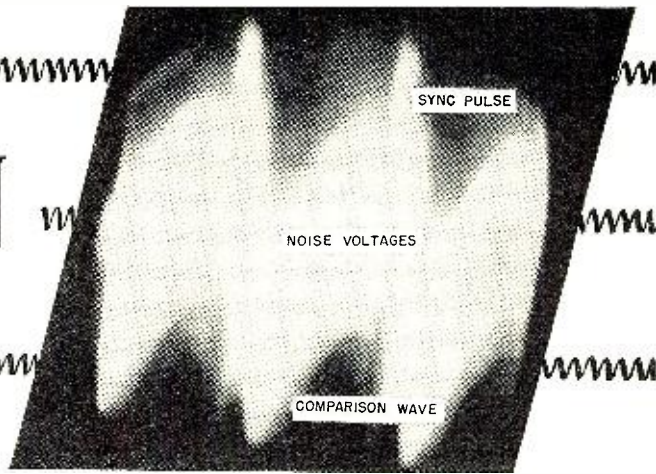

Fig. 1. A properly operating sync amplifier clips the noise pulses to the same height as the sync pulses. Sync is regularly recurrent, noise has a random distribution pattern.

By
P. F. RHODES

Down-to-earth, "how to fix it" instructions covering one important servicing problem.

FIELD experience indicates that the noise-rejection circuits of modern TV receivers are customarily neglected in checking out a set. This is an unfortunate situation, because it is only a matter of luck if the picture is stable under conditions of high local noise level, or normal noise level with a weak signal due to a poor antenna, or to a distant transmitter.

Because noise-rejection tests and adjustments are neglected, it is frequently claimed that receiver A holds sync much better than receiver B under conditions of fringe reception. Next week, another B receiver is discovered to hold sync even better than receiver A. Sometimes the puzzle is resolved by shrugging it off with the comment, "Sometimes you get a good chassis from the factory, and sometimes you get a lemon."

Ridiculous comments of this kind point up the need for better understanding of noise-rejection circuits, and more information concerning the tests which should be made.

Horizontal A.F.C. Circuits

Forerunners of present-day TV receivers utilized differentiators which

triggered the horizontal oscillator directly. These early receivers operated very well in areas of high signal-to-noise ratio. However, it was soon discovered that the picture would tear annoyingly in response to any burst of noise. We can recall the completely unsatisfactory performance of these receivers in weak-signal areas where noise pulses competed continuously with horizontal sync pulses for control of the picture.

Today, every TV receiver is provided with horizontal automatic-frequency-control circuits designed to immunize the horizontal oscillator against false triggering due to noise pulses. Some of these circuits are very clever in conception, and are a tribute to the ingenuity of electronic design engineers.

Three basic principles are used to

"sort out" the horizontal sync pulses, and reject noise pulses. The most popular principle employed at present is the averaging-out process, which will be analyzed in detail. The second principle in use operates by means of a noise gate. The third principle is that of the electrical flywheel. One form of the flywheel is sometimes combined with a gate circuit.

Operation of A.F.C. Circuits

Averaging-out circuits take advantage of the fact that sync pulses are regularly recurrent, while noise pulses have a random distribution in time. The sync pulses are added to a comparison wave, as shown in Fig. 2. The comparison wave is obtained from the horizontal oscillator or from the sweep circuit. Most frequently, the comparison wave is a saw-tooth obtained by integrating the voltage waveform from the sweep circuit.

The important considerations are shown in Fig. 2. The conduction of diodes D_1 and D_2 is determined by the peak-to-peak voltages between plate and cathode of each tube. If the horizontal oscillator tends to change frequency, the result is that the sync pulse rides up higher on one saw-tooth, but rides down lower on the other saw-tooth, as shown. As a result, one diode conducts more current, while the other diode conducts less. The combined outputs of the diodes is then no longer zero, but there is a residual positive or negative output voltage which is filtered and applied to the grid of the oscillator. The oscillator responds to this control voltage by returning to its initial frequency.

More important, however, than this mechanism of frequency control is the ability of the circuit to average out noise pulses. A photograph of noise in a phase detector is shown in Fig. 1. (The photo shows noise superimposed

Fig. 2. As the horizontal oscillator tends to drift in frequency, the sync pulses ride up one saw-tooth and down the other, changing the relative voltages V_1 and V_2 .

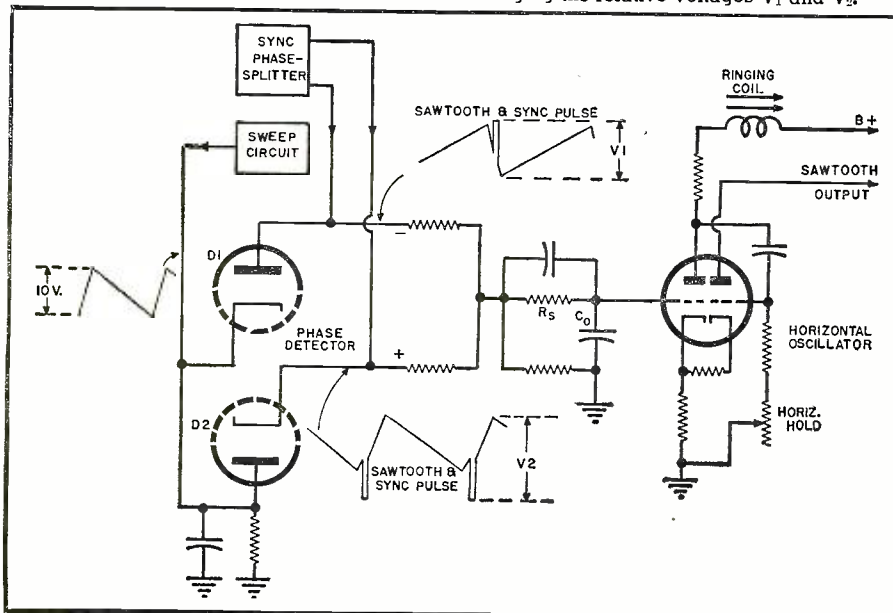

upon a sine wave, which is sometimes used instead of a saw-tooth — circuit action is the same.) It should be observed that the noise is distributed uniformly and at random over the comparison wave. As a result, the two diodes of the phase detector conduct about equally due to noise. *Most of the noise is averaged out at this point.* Of course, we are assuming that the phase detector is truly balanced, with a matched pair of diodes, proper lead dress to avoid unbalanced feedthrough, and similar ideal working factors.

Because noise is random in character, it approaches uniformity in distribution, but does not quite attain uniformity. As a result, there will be a small fluctuation of output from the phase detector due to lack of complete uniformity of the noise. Two circuit actions are utilized to minimize this residual fluctuation. Quite frequently, clipping facilities are provided both in the video amplifier and in the sync amplifier, which operate to clip noise pulses to a common level, provided the noise pulses are higher than the sync pulses. This clipping action contributes to greater uniformity of noise at high levels.

In addition, a delay filter is provided between the output of the phase detector and the input of the horizontal oscillator, as shown in Fig. 2. This delay filter not only smooths out the irregular output of the phase detector to provide a d.c. control voltage, but it also presents a time delay between the application of an input voltage and the appearance of an output voltage. That is, it takes time to charge up the output condenser C_o through the series resistor R_s .

This time delay smooths out fluctuations due to noise, because these fluctuations vary from positive to negative in a random manner; several cycles of operation must go by at the input to the delay filter before an appreciable change occurs at the output. In this manner, final minimization of noise is accomplished.

Tests for Noise Rejection

One important test for noise rejection is made by inserting a sufficient number of attenuator pads in series with the antenna line to make the horizontal sync become jittery (on the verge of losing sync). If the receiver is correctly adjusted, the picture should be so weak at this point that it no longer has entertainment value.

If the noise-rejection circuits are operating correctly, only the horizontal-hold control and the ringing coil (if used) will require adjustment to obtain satisfactory noise rejection. The horizontal-hold control determines the natural period of the horizontal oscillator, which is normally set as near 15,750 cycles as possible. However, if frequency drift occurs during warm-up, the oscillator should be adjusted after a short warm-up period.

The ringing coil can be adjusted in the same manner for maximum noise immunity. The action of the ringing

coil is shown in Fig. 3. During the forward trace, the negative blocking voltage on the grid of the oscillator decays exponentially, and approaches the cut-off voltage level asymptotically. As illustrated, any slight disturbance in the grid circuit can easily cause false early triggering.

However, if we superpose a suitable sine wave upon the exponential, the decay curve no longer approaches the cut-off level asymptotically, but now intersects the cut-off level at an appreciable angle. As shown, grid disturbances have less tendency to cause false early triggering. It might be mentioned in passing that this discussion of the ringing coil operation is a good approach to the concept of a noise gate.

After the horizontal-hold control and the ringing coil have been adjusted, it may be found that the noise-rejection action of the circuit is unsatisfactory: the picture may tear up before it loses

its entertainment value. In such cases, it is well to try several different diodes in the phase detector, to find a pair that are most nearly balanced.

If the sync lock is still not tight enough after tubes have been selected, the best procedure is to check the waveforms through the sync-control circuits with an oscilloscope. Not only should the waveforms be correct on both 15.75 kc. sweep, and on 60 cps sweep, but the peak-to-peak voltage of each waveform should check within 20% of the value specified in the receiver service manual. Note in this regard that the line voltage to the receiver must be set at the design-center value of 117 volts. Unfortunately, complete waveform information is not always available, and in such cases the service engineer must rely entirely upon his own ingenuity and experience in circuit analysis.

Incorrect waveforms and incorrect

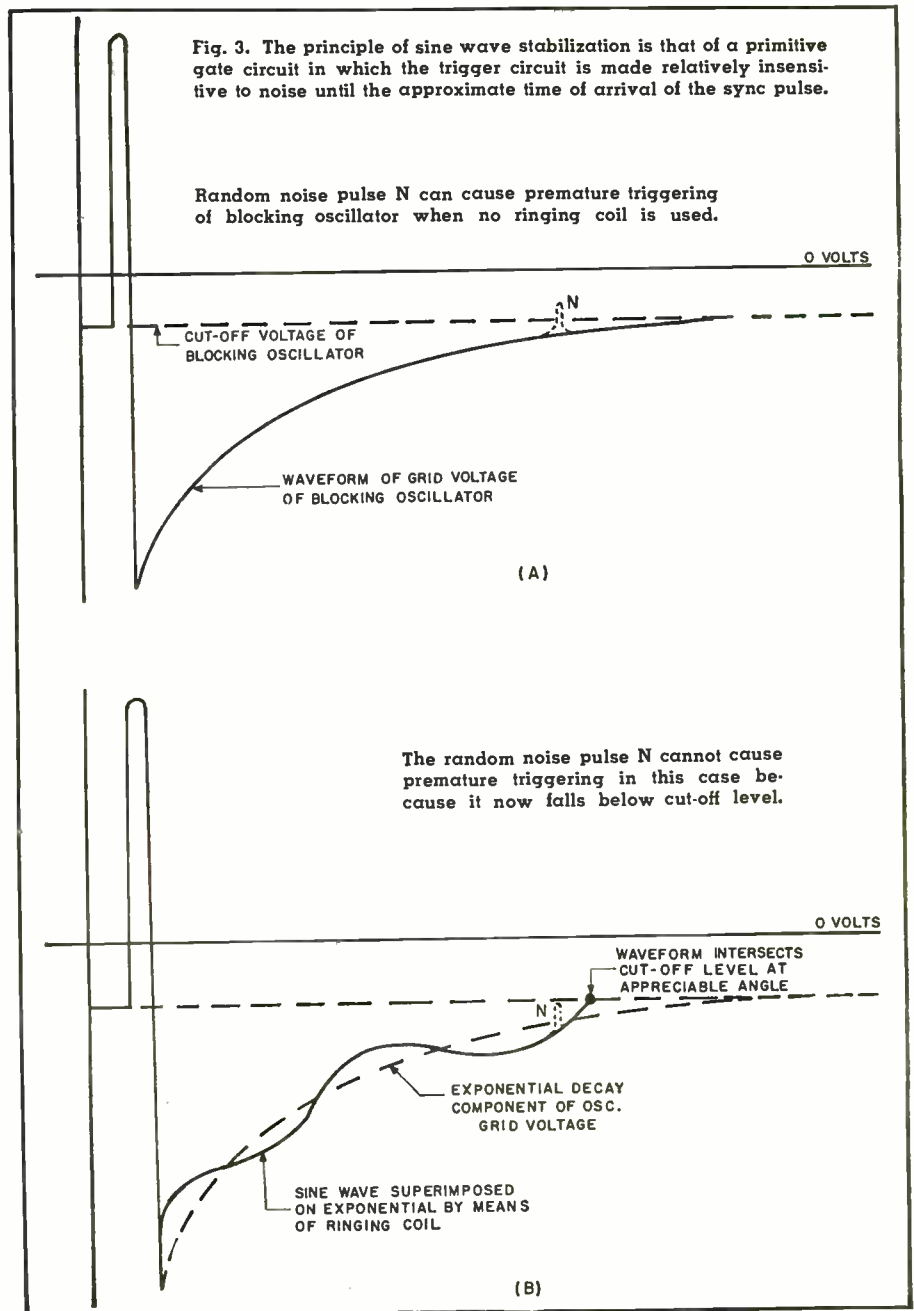

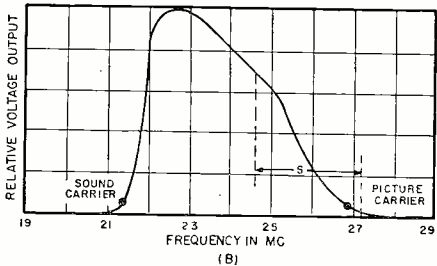
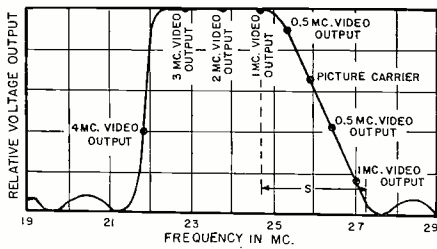

Fig. 4. (A) Sync pulses obtained from this type of receiver response will be adequate. If picture carrier is dropped to the 26.5 mc. point, the pulses will be greatly attenuated. Sync pulses are developed largely on portion of response curve marked "S". (B) Inter-carrier response curve, with picture carrier too low on curve. Reduced response at sync pulse frequencies "S", with the resulting unstable sync action.

peak-to-peak voltages usually result from open or partially open condensers, as defective resistors are almost always caught in the routine d.c. voltage check. Of course, there are a few resistors which do not carry d.c. current, and these will be picked up in the scope check. Resistance measurements in TV circuits are complicated by branch circuits and by electrolytic condensers which frequently have to be disconnected before the measurement can be made.

The possibility of improper lead dress must be kept in mind, as "feedthrough" can easily ruin the best noise rejection circuit. Such feedthrough is best discovered by inspection of the scope waveforms. Lead dress is usually OK when the receiver leaves the factory,

but may have been disturbed during prior service operations. When evidence of feedthrough is seen on the scope, do not re-arrange the lead dress at random, but carefully study the circuit diagram to determine where the trouble could occur, and then proceed according to plan.

If feedthrough fails to account for waveform contamination, the service engineer should next look for common impedances. In most cases, common impedances are due to electrolytic condensers which bypass two or more circuits; as the bypass capacitance decreases with aging of the condenser, more cross-talk occurs between the circuits.

The possibility of defective soldered joints must not be overlooked as a cause of waveform contamination. Just as a high-reactance bypass condenser can produce cross-talk in common circuit paths, so can a high-resistance connection lead to circuit interaction. Such high-resistance connections can be effectively checked on the low-ohms range of a service ohmmeter.

It is evident that efficient and effective servicing of noise-rejection circuits requires diagnosis of receiver operation at low signal levels, analysis of circuit action via waveform inspection and voltage measurement, and, last but not least important, bringing to the problem all the technical know-how and ingenuity which the service engineer can command.

Use of Instruments

Although this article is primarily concerned with the noise-rejecting circuits of TV receivers, it is perhaps well to point out that proper use of instruments is just as important as competency in circuit analysis. The diagnosis of a circuit fault frequently fails due to misapplication of service instruments. The following points are of major importance:

1. The circuit under test must not be excessively loaded by the test in-

strument. Know what the input impedance of your instrument is at the highest frequency under test; look at the circuit diagram to determine the approximate impedance at the test point. To be safe, the instrument should have an input impedance at least 10 times that of the circuit under test.

2. If the input impedance of the instrument is unacceptably low, either use a higher-impedance instrument or connect a suitable high-impedance probe between the instrument and the circuit under test. Make certain that the probe is suitably compensated against frequency and phase distortion.

3. Peak-to-peak probes are satisfactory for use with a vacuum-tube voltmeter, provided the impedance of the sync circuit is sufficiently low, and provided the waveform is not a narrow pulse. If in doubt, check the peak-to-peak reading on the voltmeter against the reading on a calibrated wide-band scope. Remember that a voltmeter always reads the highest voltage present, whether it is that of the desired waveform or not. Your scope distinguishes between these components.

We have shown that a practical test of a noise-rejection circuit can be made by inserting a sufficient number of attenuating pads in series with the antenna until the picture either "broke sync" or lost its entertainment value. If the noise-rejection circuits are operating properly, the picture will become too washed-out and too dim for satisfactory viewing, before it breaks sync lock.

We determined that inadequate noise rejection can result from unbalanced diodes in the phase detector, misadjustment of the horizontal-hold control (which places an added burden on the a.f.c. circuit), warm-up drift of the horizontal-oscillator frequency, open or partially-open condensers in the a.f.c. circuits (these do not usually show up on a d.c.-voltage check), and improper feedthrough of various wave-

Fig. 5. Normal sync pulse obtained from a receiver aligned to a 2 megacycle bandwidth to permit good video reception in the fringe areas.

Fig. 6. Pulse ghosts as seen on the screen of a receiver operating in a difficult location and caused by multipath transmission. The use of a highly directional antenna frequently improves reception in this case.

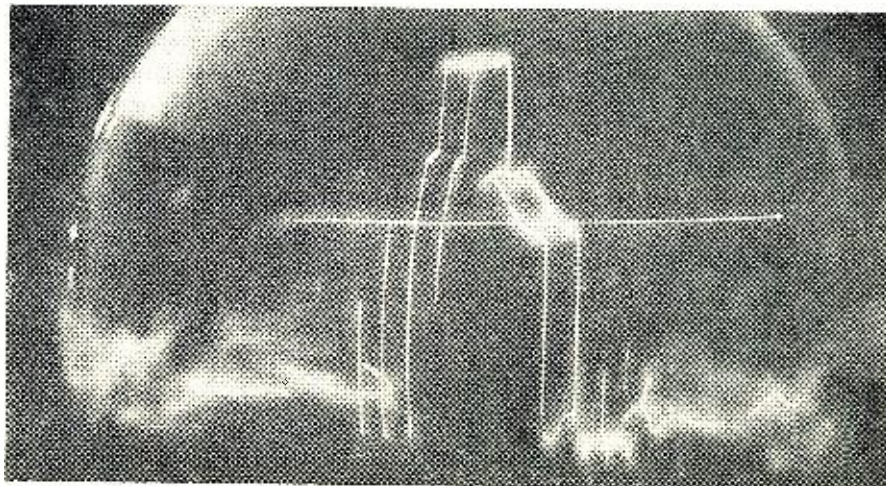
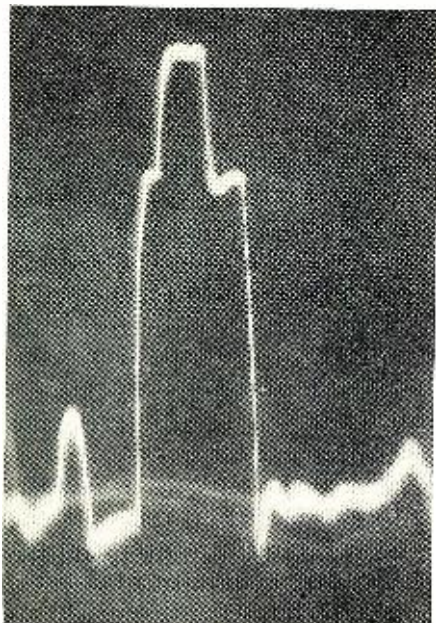

forms due to incorrect lead dress or to failing electrolytic condensers which act as a common bypass for two or more circuits.

Vertical Sync Noise Rejection

It is well to observe that the vertical sync circuits are inherently immune to noise because of the long time-constant of the integrator. Noise pulses are relatively narrow, and are rejected by the integrator accordingly.

This is not to say that the vertical sweep oscillator cannot develop sensitivity to noise, and "roll" the picture annoyingly, especially at lower signal levels. This fault can usually be traced to an open condenser in the integrator. Such a condenser cannot be checked satisfactorily with a voltmeter, but shows up definitely on a scope check as distortion of the waveform. The scope also shows the noise pulses coming through the defective integrator, providing the required attenuator pads are used in the antenna line to increase the signal-to-noise ratio.

Faults Due to Alignment

As shown in Fig. 4A, the main body of the sync pulses is developed by the sideband frequencies in the neighborhood of the picture carrier. Misalignment of the receiver can, accordingly, attenuate and distort the sync pulses, as shown in Fig. 4B. If the waveform check indicates that the sync system is not receiving pulses with sufficient peak-to-peak voltage, it is well to make a sweep-alignment check of the overall high-frequency response of the circuits from the antenna posts to the second detector.

It sometimes happens that peak-to-peak voltage specifications are not available for the receiver. In such cases, the service engineer must endeavor to locate the data for some other receiver which uses the same type of sync system, or, he will perhaps be forced to fall back on his own knowledge of circuit operation. Cases like this really test the mettle of the service engineer.

Faults Due to Pulse Ghosts

Failure of a receiver to hold sync, even under relatively high signal-to-noise conditions, has occasionally been observed due to faults in transmission. One of these faults is pulse ghosts, as shown in Figs. 5 and 6. It should be understood that these ghosts can arise from reflection on coaxial cable links, and mismatches in transmission equipment, as well as from the more familiar multipath transmission situation.

Depending upon the number and spacing of the pulse ghosts, as well as upon the type of sync circuits used, mild or severe loss of sync control may result. There is little or nothing that can be done to remedy the situation in the horizontal a.f.c. circuits. However, it is sometimes possible to stabilize the vertical sync by using the power-line voltage for synchronization.

To phase the power-line voltage suitably for vertical sync use, a phasing network as shown in Fig. 7 is usually

required. Although this method provides tight vertical sync lock under all conditions, it should be noted that the method fails if the transmitter and receiver do not operate from the same public utility. The frequency and phase relations of different utilities are constantly shifting. As a result, the picture will roll continuously at the difference between the two power-line frequencies.

Noise Gates

If horizontal sync pulses are injected directly into the grid circuit of a blocking oscillator, stable sync action takes place. However, if noise pulses are also present, these cause severe picture tearing. To avoid this difficulty, noise gates are used which minimize the time during which false triggering can occur. In addition, the gate is followed by a delay filter, which operates as a flywheel and further reduces the possibility of false triggering. In some receivers, additional stabilization is provided by a ringing circuit.

A basic gate circuit is shown in Fig. 8. The frequency of the blocking oscillator is controlled, as in other noise-rejection circuits, by the d.c. voltage bias from the control tube. The pulsed output from the control tube must be filtered, as shown, to develop this d.c. bias voltage.

The control tube is cut off during most of the forward trace, so that any noise pulses which may be present will be unable to affect the output of the control tube. When the time approaches the arrival of the sync pulse, the comparison waveform is nearing its positive peak value; addition of the sync pulse to the comparison wave is now able to bring the control tube out of cut-off, and produce plate-current flow. Noise pulses can also get through the gate at this time.

It is apparent from the diagram that the relative phasing of the sync pulse and the saw-tooth comparison wave determines the width of the control pulse; if the circuit is in proper adjustment, the width of this control pulse is always less than the width of the sync pulse. Consequently, as the horizontal oscillator tends to drift, the

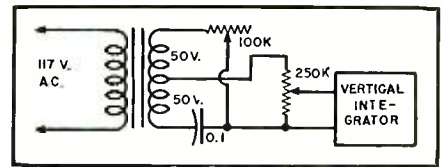

Fig. 7. A phased power line voltage can often be used to stabilize the vertical sync action. Disconnect integrator from the sync separator and energize integrator from a phasable network. Note that the primary terminals must be reversed in some cases.

control pulse width varies accordingly, which changes the plate-current flow through the control tube.

Not quite all noise pulses are rejected by the gate circuit, because the time of threshold must slightly precede the arrival of the sync pulse in any practical circuit. A saw-tooth or a parabolic comparison waveform is utilized in such systems, so that the grid of the control tube rises rapidly to threshold, thereby minimizing the number of noise pulses which are effective in causing plate-current flow. Noise rejection is maximized, not only by use of an optimum waveform, but also by proper adjustment of cut-off voltage applied to the grid of the control tube.

The noise that gets through the gate has the effect of widening the control pulse in a somewhat random manner. However, when circuit adjustments are properly made, the resulting tendency for the horizontal oscillator to increase in frequency will not exceed the lock-in range. The random variation in width of the control pulse is averaged out in the delay filter, so that there is no noticeable horizontal shift of the picture.

As in other noise-rejection circuits, the more obscure causes of instability are often traced to faulty condensers which are not caught in a d.c.-volts or resistance check. Likewise, improper lead dress can cause feedthrough to the horizontal oscillator circuit. A scope check at the grid of the oscillator should show no trace of noise pulses, although the receiver is operating at maximum gain, with no station signal.

A ringing coil is used by some re-
(Continued on page 162)

Fig. 8. Immunity to noise depends chiefly on the proper threshold at grid of control tube. The cut-off level is usually adjusted by means of the plate supply voltage. A ringing coil, if used in the circuit, should be inserted at point "R."

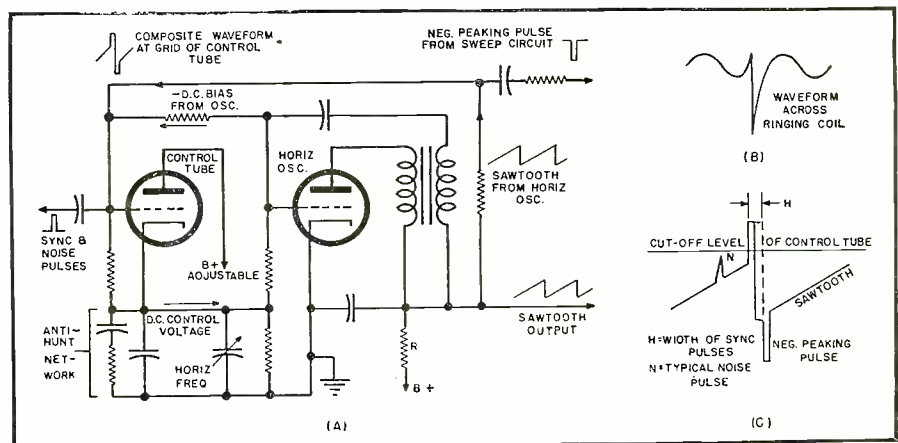

Mac's RADIO SERVICE SHOP

By JOHN T. FRYE

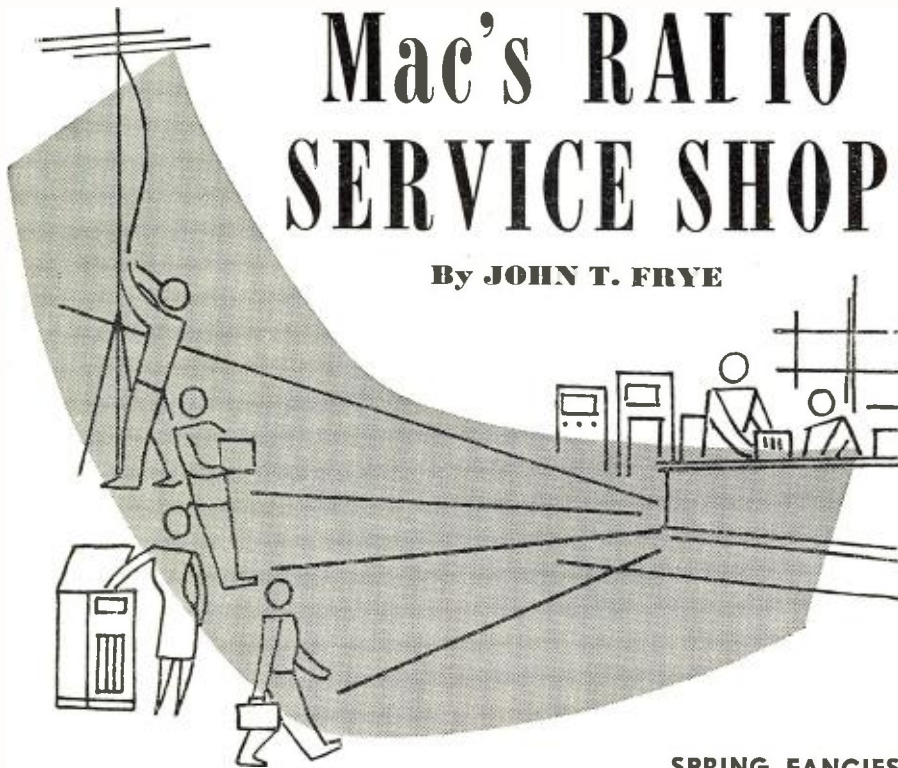

SPRING FANCIES

dim view of the average person's ability to follow instructions. Look what happens when most people try to take the tubes out of their little a.c.-d.c. sets and put them back the way they were, even when they have a tube diagram to help them."

"You've got a point there," Mac agreed; "but leaving the danger angle entirely out of it, how much help do you think these books would really be to the average owner of a TV set."

"Why they would be a wonderful help," Barney said with a straight face. "They promise to show you how you can repair anything from a shorted picture tube to a set that won't stay in sync in from a few seconds on the comparatively simple jobs to up to five whole minutes on the really tough ones. Just think of that! Why it often takes poor old inefficient me, who never read one of those books, almost five whole minutes to get the back off some of the receivers that use a whole handful of woodscrews to hold it on."

"Guess we'd better buy some of those books and read 'em," Mac suggested wryly.

"We certainly should," Barney blandly agreed. "The fellow who has one of these books needs only a screwdriver to make all of his repairs. There you have gone and wasted better than a thousand dollars on your scopes, sweep generators, vacuum tube voltmeters, bar generators, tube testers, and service manuals. After we have studied these books, we can sell all of that expensive and unnecessary equipment and buy ourselves a nice new screwdriver apiece and really settle down to turning out the TV sets. Since, at the outside, we shall have to spend only five minutes on a set, we'll really make money fast. As it is, we often waste three or four hours running down a tough intermittent or doing a complete job of realignment. Come to think of it, we can let Matilda here read the books, too, and then she can fix sets just as well as you can, for experience is entirely unnecessary, and all of those years that you have spent studying and working on electronic equipment have just been wasted."

"Tsk, tsk! What a pity!" Mac exclaimed with a broad grin. "Better had we get one of these books at once."

"I'm not sure a technician can buy them," Barney said darkly. "The writers of these books do not trust radio and television technicians. In fact, they encourage the set owner to buy the book so that he can avoid being 'soaked' by independent repairmen. I think I'll use that line in advertising my own book. 'Don't let the doctor gouge you for performing a simple operation.' I'll argue; 'buy this book and take out your own appendix. No experience necessary.'"

Miss Perkins looked desperately from Mac's faintly-smiling face to the dead-serious one of Barney. "Mac, how can you stand there and encourage the boy in such a mad idea as writing a book like that?" she de-

(Continued on page 164)

MAC and his office girl, Miss Perkins, stood side by side looking out of the window of the service shop at the ambling figure of Barney coming back to work after his lunch hour. As the youth walked slowly along, his red hair flaming brightly in the April sunshine, his freckled face bore a look of dreamy introspection.

"Ah me," Mac sighed; "what wouldn't I give to be young again in the spring-time!"

"Yes," Miss Perkins said with an echoing sigh. "All you need is a look at that rapt expression on his face to know how true are those words about in the spring a young man's fancy lightly turns to thoughts of love."

Barney floated through the door and gradually allowed his eyes to focus on the faces of the other two. Then he spoke in a voice of quiet awe:

"I have just been the recipient of a beautiful thought!"

"Blonde, brunette, or redhead?" Mac inquired solicitously.

"Whatever are you babbling about?" Barney asked with a puzzled frown. "I mean I've just figured out how I'm going to make my first million dollars."

"Thoughts of love," Mac quoted mockingly out of the corner of his mouth to Miss Perkins. "And pray tell us," he continued to Barney, "just how you are going to harvest all this lettuce."

"It's a lead-pipe cinch," Barney answered confidently. "I'm going to write a book entitled 'How to Remove Your Own Appendix, or That of a Friend or Member of Your Family, Using Only a Discarded Razor Blade.'"

"Hm-m-m-m," Mac said slowly; "I

see you like a short snappy title anyway. Where did you get your inspiration for this future best-seller?"

"At the lunch room magazine rack this noon. I was leafing through several of the magazines that try to give popular explanations of various scientific and mechanical achievements, and I ran across quite a few ads for books that promised to tell the television set owner just how he could repair his own television set. Right then I decided that if you could tell a guy who didn't know from nothing about radio or television how he could locate and repair any one of the thousand and one things that can get wrong with a TV set, telling him how to perform a single operation like an appendectomy ought to be duck soup."

"But," Miss Perkins objected, "if the TV instructions are a flop, all the guy will have is a botched-up set; but if your surgical instructions go wrong, he will have a candidate for a harp. That's too dangerous."

"How safe do you think it is to encourage an untrained person to go prowling around in a TV chassis carrying various lethal potentials up to 15,000 volts and better?" Barney demanded. "For years radio magazines have been warning technicians, who are already familiar with high voltage circuits, to be extremely careful to avoid shock in work on television sets; but these books blandly egg the set owner on into wading right into his receiver. Some of them try to protect themselves by saying there is no danger when instructions are followed, but any technician who has had any experience with the ability of untrained people to follow directions in dealing with electronic equipment takes a very

A High-Quality AUDITORIUM AMPLIFIER

Amplifier and power supply are built on separate chassis.

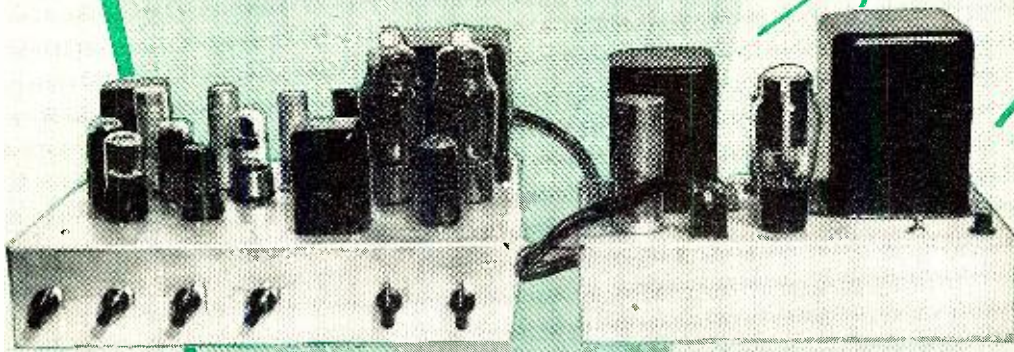

By
**LLOYD B.
HUST**

**Construction data on a p.a. unit which features
two mike inputs, radio input, and master mixer.**

THE great degree of refinement of the audio art which has been attained in the past few years has resulted in a number of so-called "high fidelity" amplifiers. Many of these amplifiers meet the specifications while others are high fidelity in name only. Each designer has his own pet likes and dislikes, and we hear much about the relative merits of pentode tubes *versus* triodes; strict class A operation as opposed to class AB₁ or AB₂; the merits of feedback in an amplifier; flat amplifiers or compensated circuits and so on, *ad infinitum*. However, in spite of the confusion which often arises from such discussions, one can be sure that the real test of an amplifier of any design, be it a unit of high or low power, a circuit of the "old standby" type, or one with all the latest frills, is its performance under actual working conditions. Laboratory tests and mathematical theory notwithstanding, the real test of an amplifier is how it *sounds* to the listener in actual operation. A few pains taken in the building of any amplifier, along with the use of high quality components in its construction will usually insure good results, and one does not have to be an engineer to build a really *good* audio system, provided that he takes advantage of the technical information made available to the experimenter by the audio engineer.

The builder should first consider the application of the equipment he plans to build, and that can be a guide in his planning. If moderate power is all that is needed, class A operation of triodes will usually give superb results. On the other hand, higher power requirements will usually necessitate the use

of class AB₁ or class AB₂ design. It should be remembered that triode output tubes are characterized by their low power sensitivity and low plate power efficiency, but when used as class A amplifiers, by their low distortion. On the other hand, pentodes and beam power tetrodes are characterized by their high power sensitivity and plate power efficiency, but they usually have somewhat higher distortion than triodes. If the designer keeps these facts in mind he can build an amplifier of optimum performance in the application for which it is intended.

Since the amplifier described in this article was to be used in an auditorium of moderate size, it was felt that the use of triodes as output tubes would be desirable, providing that sufficient power could be obtained from them. After some experimentation, 807's were chosen as the output tubes. Although these tubes are tetrodes, they can be operated as triodes by connecting the screen grids to the plates. These tubes were chosen instead of 2A3's or 6B4's for two reasons. One reason is that the indirectly heated cathode of the 807, as opposed to the directly heated cathode of the other types, gives less residual hum. The other reason is the greater plate dissipation rating of the 807's. The lower hum level of tubes of the indirectly heated cathode type is especially important if modern high-efficiency speakers are to be used, and the high plate dissipation rating makes it possible to operate these tubes as class A₂ amplifiers, thereby realizing

power output in the neighborhood of 30 watts from two of these tubes. Since there are not many amplifiers which operate in this class, a word regarding them is in order here. A class A amplifier is considered to be one in which plate current flows in the output tubes during 360 degrees of the signal current cycle. It is generally concluded that at no time during the cycle will grid current flow. A class A₂ amplifier conforms to these specifications except that grid current flows during a portion of the cycle. However, at no time is plate current cut off. In order to fulfill these conditions, it is necessary to operate the tubes at lower bias voltages than are used for class A or AB₁ service, and this lower bias, allowing greater no-signal plate current, calls for tubes with relatively high plate dissipation ratings. The May, 1951 issue of the *Radio-Electronic Engineering Edition of RADIO & TELEVISION NEWS* gives typical operating conditions for a pair of these tubes operated as class A₂ triodes.¹

The amplifier, after considerable experimental work, was finished with the following features: Two microphone inputs, one high impedance and one low impedance; an input for a radio tuner or crystal phono pickup; electronic mixing with a separate control for each channel and a master mixer control. The low impedance input will take input impedances of 50, 150, 250 and 600 ohms, which makes it suitable as an input for any type of low impedance microphone as well as practically any type of line. It is also suitable for low impedance phono pickups or low impedance magnetic tape heads. The *Chicago* BI-7 input transformer used in this channel is of high quality, having a frequency response which is flat within a fraction of a decibel from below 50 to well over 20,000 cycles. This transformer also has 70 db hum

¹ Sterling, Howard T.: "Tube Applications in Amplifier Design," *Radio-Electronic Engineering Edition of Radio & Television News*, May 1951, page 14A.

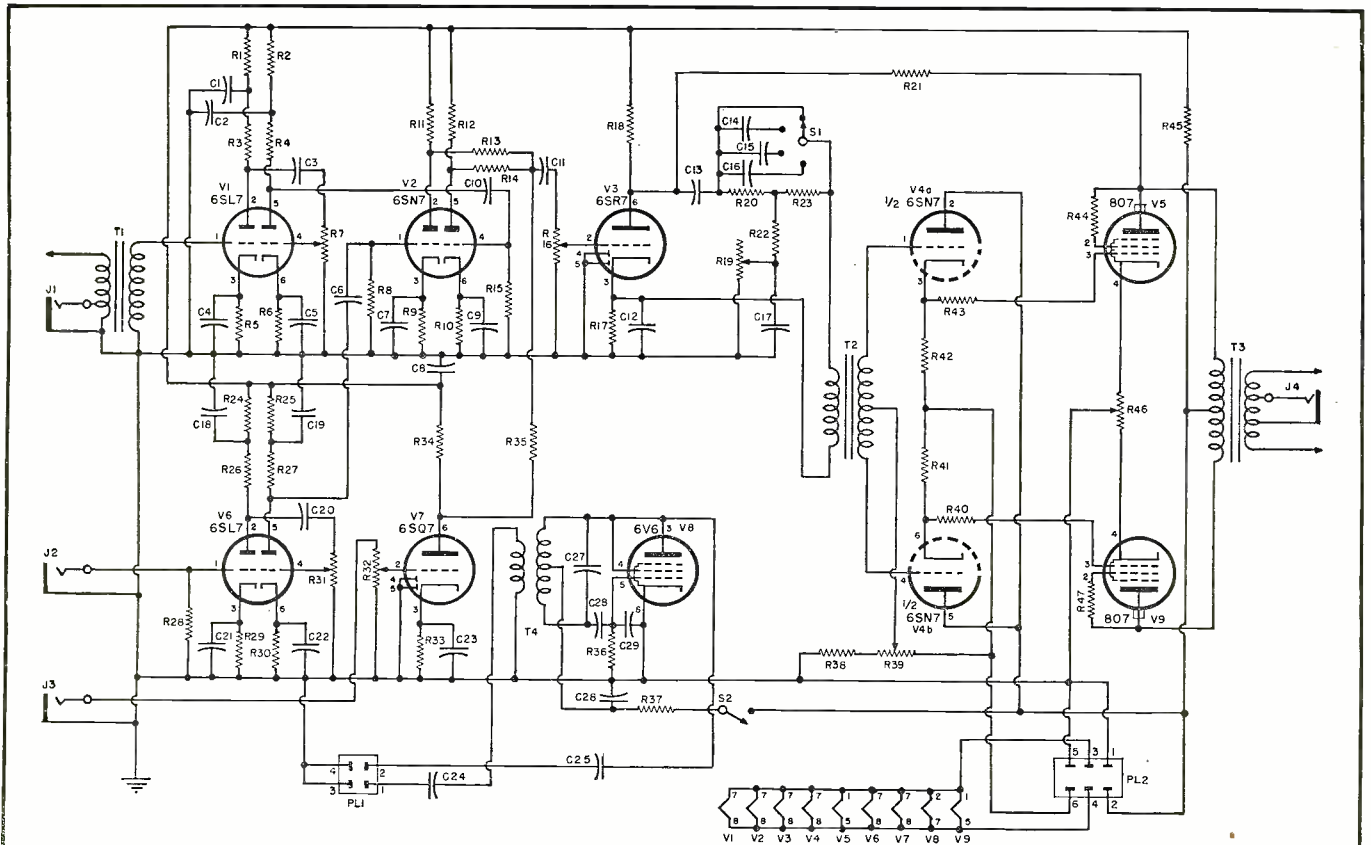

- R₁, R₂, R₂₁, R₂₂—39,000 ohm, 1/2 w. res.
- R₃, R₄, R₁₁, R₁₂, R₂₀, R₂₁, R₂₆, R₂₇, R₃₄—100,000 ohm, 1/2 w. res.
- R₅, R₉, R₉, R₁₀, R₂₀, R₃₀, R₃₃—2200 ohm, 1/2 w. res.
- R₇, R₁₈, R₁₉, R₃₁, R₃₂—500,000 ohm pot with regular audio vol. control taper
- R₆, R₁₂, R₃₅, R₃₆—470,000 ohm, 1/2 w. res.
- R₁₃, R₁₄, R₃₇—1 megohm, 1/2 w. res.
- R₁₇—1500 ohm, 1/2 w. res.
- R₁₈—33,000 ohm, 1/2 w. res.
- R₂₀—22,000 ohm, 1/2 w. res.
- R₃₀—33,000 ohm, 1/2 w. res.
- R₃₇—15,000 ohm, 2 w. res.
- R₃₈—6800 ohm, 2 w. res. (in author's model res. is variable)
- R₃₉—10,000 ohm wirewound pot
- R₄₀, R₄₁—470 ohm, 1/2 w. res.
- R₁₁, R₁₁—22,000 ohm, 2 w. res.
- R₄₄, R₄₄—1000 ohm, 1/2 w. res.

- R₁₅—15,000 ohm, 1 w. res.
- R₁₆—50 ohm wirewound pot
- C₁, C₂—10/10 μfd., 450 v. elec. cond.
- C₃, C₆, C₁₀, C₁₁, C₃₀—1 μfd., 600 v. cond.
- C₄, C₅, C₇, C₉, C₁₂, C₂₁, C₂₂, C₂₈—25 μfd., 25 v. elec. cond.
- C₈, C₂₀—10/10 μfd., 450 v. elec. cond
- C₁₃—5 μfd., 600 v. cond.
- C₁₄, C₂₇, C₂₉—500 μfd. mica cond.
- C₁₅—250 μfd. mica cond.
- C₁₆, C₂₅—100 μfd. mica cond.
- C₁₇—0.004 μfd., 600 v. cond.
- C₁₈, C₁₉—10/10 μfd., 450 v. elec. cond.
- C₂₄—0.005 μfd., 600 v. cond.
- C₂₆—0.1 μfd., 600 v. cond.
- J₁, J₂, J₃, J₄—Single circuit jack
- PL₁—4-prong socket (Jones)
- PL₂—6-prong socket (Jones)
- S₁—S.p. 4-pos. sw.

- S₂—S.p.s.t. sw. (in author's model, S₂ is ganged with S₁ and is closed in position 1, open in all others)
- T₁—Input trans. 50/150/250/600 ohm pri. to 50,000 ohm c.t. sec. (Chicago BN-7 or equiv.)
- T₂—Input trans. Single 10,000 ohm plate to 50,000 ohm c.t. sec. (Chicago B1-8 or equiv.)
- T₃—Output trans. Push-pull, 5000 or 3000 ohm c.t. pri. to 600/16/8 ohm c.t. sec. (Chicago BO-9 or equiv.)
- T₄—Osc. coil (Webster-Chicago 65P024 or equiv.)
- V₁, V₆—6SL7 tube
- V₂, V₃—6SN7 tube
- V₄—6SR7 tube
- V₅, V₈—807 tube
- V₇—6SQ7 tube
- V₈—6V6GT tube

Circuit diagram and parts list covering the auditorium amplifier. 807's are used, connected as triodes.

reduction, due to its excellent shielded construction, which makes it ideally suited to this type of application.

The high impedance channel was designed for use with standard high impedance type microphones, but it has sufficient gain to be used with a high impedance tape recording head if desired. The mixing action of this channel with the low impedance channel and with the phono channel is very smooth and operates without a trace of interaction between channels.

The phono channel has sufficient gain for use with any of the many types of crystal phono pickups, and it is especially suited to operate from a radio tuner, either AM or FM. The master mixer control which follows these three channels makes it possible to increase or decrease the volume of the amplifier without disturbing the relative volume levels of the various channels. This feature makes for easy volume adjustment, even though all channels are in use simultaneously.

As seen in the photographs, the am-

plifier and power supply are built on separate chassis, the amplifier chassis measuring 14" x 10" x 3", while the power supply chassis dimensions are 7" x 12" x 3". The two units are connected by a cable with a 6-prong Jones plug on each end. The power supply and amplifier are supplied with corresponding plugs to make power supply connection or disconnection extremely simple. This two-unit type of construction has several advantages of which perhaps the greatest, is that of hum reduction because of the degree of isolation of the power transformer and the amplifier proper. Another value of a separate power supply is apparent to the builder who does considerable experimental work—one power supply can perform for several experimental jobs.

The two high gain channels of the amplifier each utilize the two sections of a 6SL7 tube connected in cascade. The volume control for each channel is in the second stage. The output from the second section of each 6SL7

is fed into a section of a 6SN7, the output of which is fed to the master mixer control. The output of the 6SQ7 phono amplifier is also fed to this control. R₁₃, R₁₄, and R₃₅ are 1 megohm resistors which are used to isolate the plates of the tubes feeding this control. The master mixer control, R₁₆, controls the signal fed to the grid of the 6SR7 tube, from whence the signal is fed, either directly or through the equalizing circuit, to the 6SN7 driver tube.

Several hum prevention measures are used in the construction of this unit. The center tap of the filament winding of the power transformer is grounded. In the model shown, this proved adequate as far as heater-to-cathode hum is concerned, but in some models it may be necessary to use a 20 ohm potentiometer across the 6.3 volt winding and ground the center. In this way, a precise balancing-out of hum can be achieved. Only one connection is made to the chassis proper—at the socket of the tube V₁. All other grounds are made to a ground bus which is

made of No. 12 wire mounted on insulated tie posts. This bus can be seen in the photograph of the under chassis view. It is grounded to the chassis as indicated before. All jacks, condenser mounts, etc., are insulated from the chassis to eliminate any possibility of ground loops. There are two or three relatively long grid leads in the amplifier, and these are shielded, but the shielding is not allowed to touch the chassis, and one end only is grounded to the ground bus. Some of these precautions may seem needless to the uninitiated, but they pay off in the hum-free operation of the amplifier. It should be said in the discussion of hum precautions that at first, d.c. operation of preamplifier tubes was contemplated, but it was found that in addition to the measures taken as mentioned above, the twisting of all a.c. leads, and dressing them close to the chassis, made the use of d.c. on the heaters unnecessary.

It is the opinion of the author that any really up-to-date amplifier should have provision for magnetic tape recording and playback, and accordingly, this unit is provided with an ultrasonic oscillator to adapt it to this purpose. The oscillator tube is a 6V6GT connected as a triode, and it supplies ultrasonic voltages for both high and low impedance recording heads, as well as erase heads. When the waveform of this voltage was checked on an oscilloscope, a good sine wave, necessary in distortionless recording, was observed. The output of the oscillator is fed to a 4-prong Jones socket through condensers C_{21} and C_{22} . Since the sizes of these condensers vary somewhat according to the recording heads used, their values may have to be adjusted to suit the particular head used. The values shown work nicely with the Shure Model 815 head, the connection from the plate of the oscillator tube going to the high impedance winding of the head, and the connection from the secondary of the oscillator coil furnishing the voltage for the erase section of the head.

For the oscillator circuit a Webster-Chicago oscillator coil (65P024) is used. Other oscillator coils designed for magnetic tape or wire recorders can be used, but the values of the other components in the oscillator circuit may have to be changed to suit the characteristics of the particular coil used. In most cases the maker of the oscillator coil furnishes the necessary data with the coil. The oscillator operates best with 250 to 275 volts on the plate of the tube and some adjustment in the size of R_{27} may be necessary to assure the correct voltage here. This resistor aids in keeping the high frequency oscillations of the 6V6 out of the power supply as well as performing its function as dropping resistor in the plate circuit of the oscillator.

The original design and tests of the amplifier were made by striving for a flat response. However, to make the unit suitable for magnetic recording and for other applications in which equalization is required, a number of

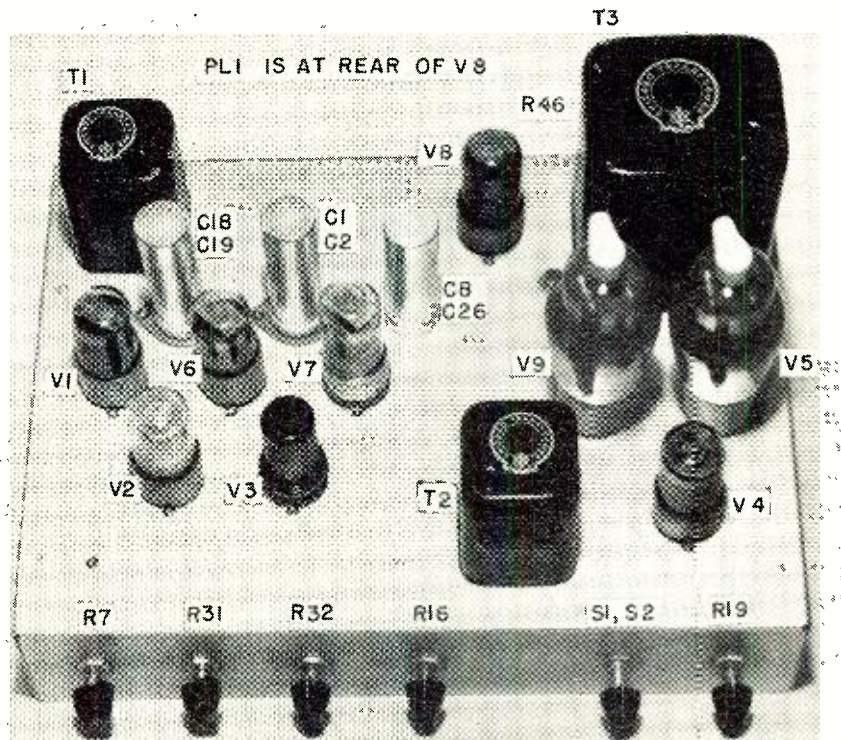

Top view of the amplifier chassis. Careful parts layout facilitates servicing.

equalizing circuits are arranged so that they can be switched into the circuit. The equalizing portion of the amplifier consists of R_{19} , R_{20} , R_{22} , and R_{23} ; C_{14} , C_{15} , C_{16} , and C_{17} along with S_1 . S_1 switches in a bridged-"T" equalizing network which gives some attenuation of the middle frequencies, which, in effect, gives high and low boost to the signal. Switch position 1 gives the greatest attenuation with positions 2 and 3 giving lesser degrees, while position 4 short circuits the equalizing network and, in effect, removes it from the circuit. The action of R_{19} is to give variable attenuation to the bass portion of the signal in the first three positions of the switch. In the fourth position, R_{19}

has no effect. R_{19} should be placed in the treble position—all resistance out of the circuit—for magnetic recording, and it should be placed in the bass position—maximum resistance in the circuit—for playback of magnetic recordings. The switch S_2 removes the plate voltage from the oscillator tube when the oscillator is not desired. In the author's model, this switch (S_2) is one section of S_1 and is closed in positions 1 and 2 of S_1 . However, it is recommended that a separate switch be used for this purpose so that the oscillator can be cut in or out regardless of the position of the equalizing switch.

It is obvious that if the builder is not interested in the adaptation of this am-

Power supply circuit and parts list. This unit is mounted on separate chassis.

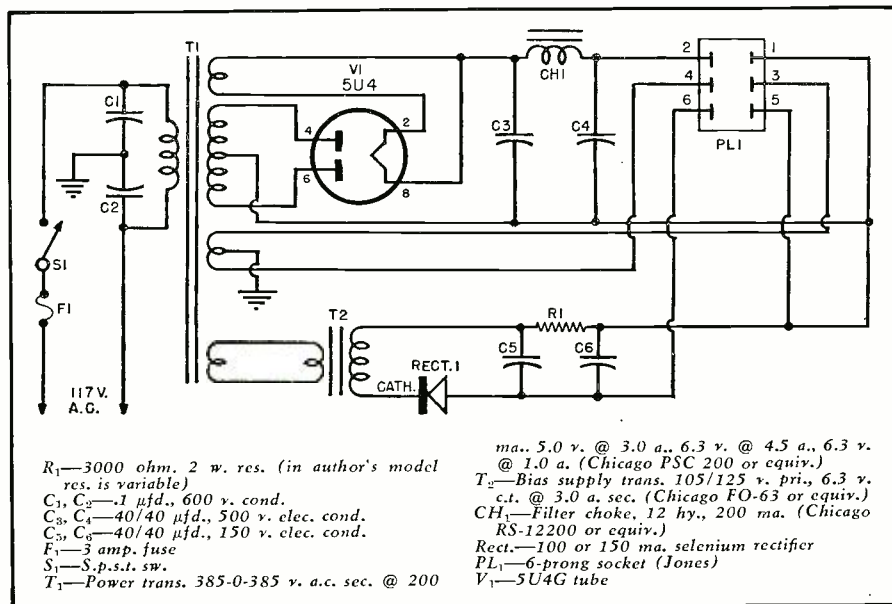

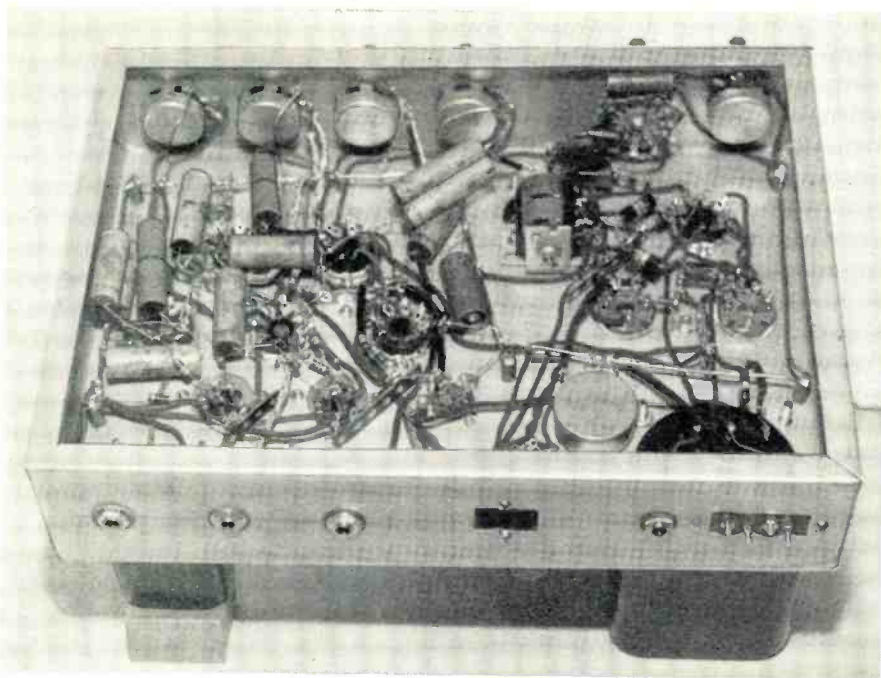

Bottom view of the amplifier. Easily-obtainable parts have been used throughout.

plifier to magnetic recording, the oscillator and equalizing circuits can be eliminated and a somewhat simpler amplifier will result. However, the addition of these circuits does not introduce any great problems and they will be of use in many installations. Either high or low impedance magnetic recording heads can be used. If a high impedance head is used, the audio voltage can be taken from the plate of one of the output tubes, while a low impedance head can take its audio signal directly from an appropriate tap on the output transformer.

Some discussion of the output stage and associated driver is in order as the operation of the output stage is not conventional. In order to operate the output tubes class A₂, the following operating conditions prevail: Plate voltage, 400; grid voltage —35; driving

voltage 50; plate-to-plate load 3000 ohms; zero signal plate current (both tubes) 140 ma., max.; and signal plate current 215 ma. Maximum signal instantaneous grid current is 20 milliamperes.

Since grid current flows during part of the cycle, it is necessary to design the driver stage so that distortion will not result. One consideration is that the driver stage must be capable of supplying some power to the grids of the output tubes. The use of a driver transformer of proper design could provide this, but since the windings of the transformer would have to carry considerable current, the frequency response would suffer. A cathode follower driver tube is capable of supplying considerable power to the driven stage, and it has several other advantages, not the least of which is a practically

Under chassis view of the power supply. This unit measures 7x12x3 inches.

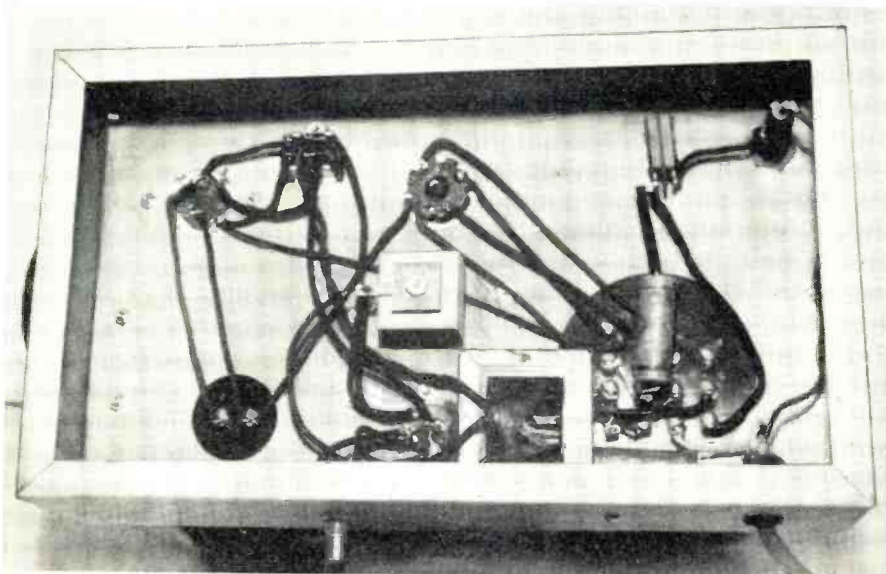

flat response. For this reason, a 6SN7 tube operated as a cathode follower was used as the driver. The circuit selected is one which has been used successfully in other high-quality amplifiers, and it can be considered tried and true. Fixed bias is used on the driver stage as well as on the output stage, the voltage drop through the cathode resistors of the driver bringing the output stage bias to the right value. R_{25} is the bias control, and it should be adjusted so that the voltage at each grid of the 807's is 35. This can be done if the total bias voltage supply is in the neighborhood of 105 volts. The use of the recommended values of resistors R_{25} and R_{26} will insure this condition.

A phase inverter could be used to supply the signal to the driver stage, but since practically every type of phase inverter has some fault, a high quality transformer was chosen to supply the driver grids. The *Chicago* BI-8 input transformer was selected because of its wide range flat response. Since this transformer must not be used with direct current in the primary if this wide range response is to be maintained, it is coupled to the plate of the previous tube by the use of a .5 μ fd. condenser. This arrangement insures that a balanced voltage, exactly 180 degrees out-of-phase, is supplied to the two grids of the cathode follower. The plate voltage of the tube feeding this transformer is supplied through a 33,000 ohm plate load resistor.

The power supply of this amplifier is built on a separate chassis which can be mounted above or below or to one side of the amplifier proper. The *Chicago* PSC-200 power transformer and RS-12200 choke are used as companion units for the plate supply, while the bias supply is provided by a small filament transformer—the *Chicago* FO-63. This transformer is connected “backwards” to supply the necessary bias voltage. That is, its 6.3 volt winding is connected to the extra filament winding on the power transformer so that the original primary delivers in the neighborhood of 120 volts. This is connected through a 100 or 150 ma. selenium rectifier to a filter system consisting of a 40-40 μ fd., 150 volt filter condenser and a 3000 ohm, 2 watt resistor. This combination will give the correct bias voltage for the output and driver stages. The author considered using a voltage regulator tube with this bias supply, but experiments with the amplifier under load indicated that it was not necessary. The use of a selenium rectifier in the bias supply has the advantage that there is no “warm up” period for the bias supply, and bias is supplied to the tubes before the plate voltage, which is a protective feature.

The filter condensers of the plate supply are 500 volt condensers with 40 μ fd. in each section. This high voltage rating is necessary because of the possibility of high surge voltages. These condensers, in conjunction with the RS-12200 choke, supply well filtered volt-

(Continued on page 149)



International SHORT-WAVE

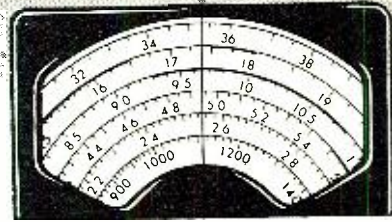

Compiled by **KENNETH R. BOORD**

AT THE time this was compiled, the Broadcasting Corporation of Japan, Tokyo, had just resumed (test) operations of its Overseas Services in Japanese and *English*. A letter received from the station's officials pointed out:

"The Broadcasting Corporation of Japan has resumed operation of its international broadcasts in both *English* and Japanese languages. The purpose of this international broadcast is to tell the world the actual condition of Japan and how the country is being rehabilitated with the kind help and cooperation of friendly nations; and how the people are willing to do what they can for the promotion of a better understanding among the nations of the world. Listeners overseas are, therefore, cordially requested to send their reports of reception of our station, giving us at the same time their candid opinions as to the kind of programs they want to be sent on the air. All mail should be addressed to International Broadcasting Section, Nippon Hoso Kyokai (The Broadcasting Corporation of Japan), Tokyo, Japan."

General format for the various beams includes opening announcement; news in *English*; commentary in *English*; music; news in Japanese; commentary in Japanese; closing announcement; closedown.

Schedules were listed: *Transmission 1*—To North America 0000-0100, JOB, 6.069; *Transmission 2*—To North China 0600-0700, JOB, 6.069, and JOA, 7.180; *Transmission 3*—To Central China 0700-0800, JOB and JOA; *Transmission 4*—To Philippines and Indonesia 0900-1000, JOB-2, 11.705, and JOA-2, 9.675; *Transmission 5*—To India 1030-1130, JOB-2 and JOA-2.

The test transmissions have been widely heard throughout the United States. It is reported by overseas sources that the International Service is being beamed from two 50 kw. transmitters—one at Yamata and one at Nazaki.

Our best wishes go to the Broadcasting Corporation of Japan for the future expansion of its International Service.

* * *

Radio Club Notes

England—The first postwar meeting of the World Friendship Society of Radio Amateurs was held recently in London. It was decided that an annual meeting of the group will be held here-

after. The Mullard Organization presented a display of its cathode-ray tubes, radio tubes, and the projection system of TV developed by Mullard. A high point of interest was the presentation of a book-token to Miss Barbara Jordan, a member of a School Radio Club at the Guilford Girls' School in Nottingham. The book-token was given as a mark of the Society's esteem for Barbara's achievement in passing the G.P.O. c.w. test at 12 w.p.m. at 14 years of age. She is thus the youngest girl in the British Isles to have achieved this distinction, officials of the club point out. Barbara is now authorized to operate the School Club Station, G3FYN, and to operate at station G2ATM (operated by Stan Read, the science teacher at the Guilford Girls' School), under supervision. Young people anywhere in the world who are interested in the activities of WFSRA's Junior Section, should get in touch with Bob Kenny, G3AAU, at 30, Churchbury Road, Enfield, Middlesex, England.

(Note: Unless otherwise indicated, all time is expressed in American EST; add 5 hours for GCT. "News" refers to newscasts in the English language. In order to avoid confusion, the 24 hour clock has been used in designating the times of broadcasts. The hours from midnight until noon are shown as 0000 to 1200 while from 1 p.m. to midnight are shown as 1300 to 2400.) The symbol "V" following a listed frequency indicates "varying." The station may operate either above or below the frequency given. "A" means frequency is approximate.

This young SWL is Ronald Guentzler, Cleveland, Ohio. Equipment shown includes a Zenith 10-S-155; preselector and converter for Zenith unit (preselector operates 7-18 mc. and converter covers 200-540 kc.). Hallicrafters S-41-G, BC-454-B, and BC-455-B.



Norway—A new short-wave listeners' club is Arctic Listeners Club, Tromso, Norway, according to *Nattugglan*, Sweden.

USA—Anyone wishing information about the United Shortwave Listeners of the World should write direct to the club's editor, Steve Brookner, 85 Glenham Street, Providence 7, Rhode Island. President of this organization is Hal Buchert; treasurer is Pat Crandell.

* * *

This Month's Schedules

(NOTE: By the time you read this, some short-wave stations may have gone on Summer Time Schedules; in such cases, you may find broadcasts are now one hour earlier than listed herein.—KRB)

Afghanistan — Peter Ridgeway, South Africa, flashes that *Radio Kabul*, 9.975, now has its daily *English* session 1110-1120; opens with flute-like instrument around 1105; closes with one request number at 1120, except Sundays when extends the request period to 1200A.

Albania — *Radio Tirana*, 7.852A, noted signing off 1629 with march; weak level. (Robbins, Ind.) Has news 1615. (Ridgeway, South Africa)

Algeria—GDX-aren, Sweden, lists
(Continued on page 112)

CRYSTAL DIODES In Modern Electronics

By
DAVID T. ARMSTRONG

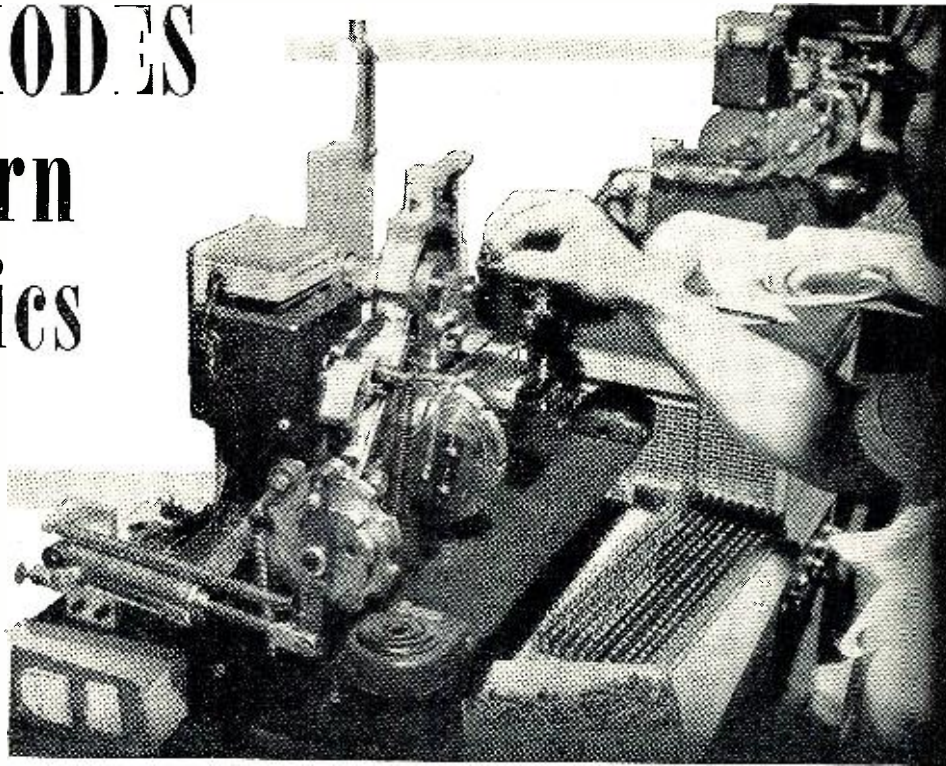

Whisker and pellet assemblies are mounted in plastic cases on this specially-designed high-speed assembly machine. The whisker point is welded to the germanium pellet and very accurate pressure maintained between these two parts. Following this, and on same machine, the units are electrically formed by high current pulses.

Part 7. How germanium diodes can be used in TV circuits to perform the sync stripping function.

PREVIOUSLY before the control impulses in the composite video signal can be used for synchronizing purposes they must be stripped from the remainder of the video and blanking information. This is essential to prevent these other signals from interfering with the sync circuits. Sync stripping may be performed in several ways; by using a diode in the form of a detector, by using a triode operating with low plate voltage and high grid resistance, and by using a pentode with low plate voltage and grid bias. We are concerned here only with the use of a diode sync stripper because this is the only method strictly applicable to germanium crystal diodes.

The point at which the composite video signal is taken for application to the clipper circuit is generally the output of the video amplifier. By permitting the composite video signal to come through the video amplifier before applying it to the clipper, there is less need for amplification of the sync pulse after the clipper action. Further, where noise limiting is employed in the video amplifier, and this is generally true, more stabilized and less distorted signal is available for sync. It is possible to amplify the signal after the clipper action; this is done in some receivers, but it does add to the cost of the completed product.

Basic Crystal Diode Circuit

The composite signal furnished to the stripper circuit may be obtained from the video detector or from any stage of the video amplifier. It is common to take it from the output of the video amplifier because a high amplitude signal with good signal-to-noise ratio is available there. Generally, the sync will be good when the contrast control is correctly adjusted for proper picture presentation.

Let us assume we have a source of positive-going composite video signal.

Fig. 1A illustrates a basic diode circuit used for stripping; note that this is in the form of a detector circuit. The time constant of R_1-C_1 is sufficiently large so that only the sync pulses cause diode current to flow. The direct current develops sufficient bias voltage across R_1 to prevent stripping any video information from the composite video signal below the blanking level.

The pulse current flows through R_2 and the stripped pulse voltage may be taken off across this resistor. This stripper should be driven from some constant source because any change in

the input voltage may result in a change in the voltage across C_1 . The long time constant of R_1-C_1 may cause loss of the sync pulse until the clipping level adjusts to the proper voltage value.

Before we proceed further with the analysis of the use of a germanium diode for this type circuit to see how it would fit in, the reader is warned that a pentode cascade circuit is superior in all respects to a cascade germanium crystal circuit. But there are some advantages in using the germanium diode which make it quite worth while to consider.

To obtain reliable synchronization over the wide range of signals at the sync input and to produce clear-cut separation of all video components below the separation level, regardless of amplitude or phase of the video signal, usually requires three vacuum tubes. It requires three germanium diodes to provide comparable performance. Hence, the chief virtue of the germanium diode sync separator is the saving in tubes and components, plus space economy.

Circuit simplification is the order of the day; any reduction in the number of tubes on a chassis makes possible the designer's dream of smaller and more compact television receivers. The use of a diode high level separator connected by suitable coupling methods to the plate of the last video amplifier

Fig. 1. (A) Basic biased diode clipper. The time constant of R_1-C_1 should be large. Either a tube type diode or a crystal type diode may be used in this circuit. (B) Basic diode type clipper. The time constant of R_1-C_1 should be long compared to time of the line scan. It is frequently 200 to 300 microseconds. Either a tube or crystal diode is used as the detector element.

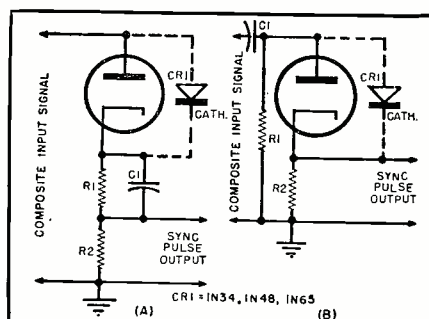

stage is one method of reducing the number of tubes on a chassis.

Sync Separation

There are several methods of separating the sync signals from the composite video signal. Fundamentally, this is generally accomplished by applying the composite video signal to a diode, triode, or pentode, so biased that no signal flows through the tube except for that part of the entire signal above the blanking level. This means that a clipper diode will be operated with a negative bias of sufficient value that current will flow through the diode only during the time that the signal is above the blanking level. This is illustrated in Fig. 1B, which shows another type of biased diode clipper arrangement, in addition to that shown in Fig. 1A.

In this circuit the positive-going input signals permit current to flow only for a portion of the input signal; therefore the plate current consists only of sync pulses free from the actual picture information. The biased diode methods of sync separation shown in Figs. 1A, 1B are the simplest clipper circuits. The diode conducts when the input signal is positive and the time constant of R_1-C_1 is sufficiently great to keep the diode from conducting except during the peaks above the blanking pedestal. The diode current drawn charges the condenser to the peak value of the input signal and establishes a bias across condenser C_1 . This bias is sufficient to keep the diode from conducting except during the peak excursions of the composite video input signal. The excursion of the signal from the video intelligence level to the peak sync level is the essential line timing operation which synchronizes the horizontal oscillator in the receiver.

When the diode does conduct a voltage appears across R_2 proportional to the sync pulses. The values of R_1 and C_1 are chosen to prevent diode current from flowing except during the interval when the signal is in excess of the blanking level. In general this is a satisfactory signal clipper, but the output sync signal is relatively small because a diode contributes no amplification to the clipped sync pulse.

One disadvantage of the tube type diode clipper circuit is that some video signal may be coupled to the output circuit by virtue of the cathode-plate capacitance of the tube, usually 3 to 4 $\mu\text{fd.}$, for the 6H6 and 6AL5 type tubes. This is one instance in which a germanium diode crystal has a decided advantage. On the other hand since a diode conducts only during the peaks of the sync pulses it acts as a clamper (a clamping circuit is one in which the amplitude of a waveform is maintained at a certain potential level) and the peak of each recurring sync pulse is lined up at the same level.

In the clipper diode circuit shown in Fig. 1B the time constant of C_1 and R_1 maintains a high average bias between the plate and the cathode. The condenser C_1 is charged to the peak value

of the input signal during the peak excursions of the input signal. If the time constant is of the proper value, a high average bias will be maintained between the plate and the cathode and the only time during which current will flow through R_2 is during the time that the input signal is above the 75% blanking level.

Combination Circuits

In some instances it is possible to combine the functions of sync separator and d.c. restorer in a single crystal diode component. Fig. 2 presents such a circuit for the consideration of those interested in simplification. Another crystal may be added to this circuit to perform the function of clipper, as shown in Fig. 3.

The germanium diode CR_1 is the sync separator-d.c. restorer diode. The one megohm resistor is the normal diode load resistor and the 0.05 $\mu\text{fd.}$ condenser the coupling condenser. The resistor in series with the anode of the germanium crystal and the CRT bias is the impedance across which the sync signals are developed. The operation of this circuit depends largely upon the value selected for resistor R_1 . Sync pulse output, video leakage, and reinserted d.c. are affected by the size of this component. Values from 4700 to 10,000 may be used depending upon how much video leakage can be tolerated, how much departure from ideal d.c. restoration is permissible, and how much sync pulse amplitude is required.

The circuit action for this diode circuit is as follows: The composite video signal at the cathode of the crystal CR_1 causes rectification and this sets up a voltage across the 1 megohm load resistor, approximating the blanking level. During the line scanning interval the 0.05 $\mu\text{fd.}$ condenser discharges partially through the 1 megohm resistor to maintain the blanking level. At the end of the line scan the condenser recharges rapidly during the sync pulse, and a pulse of current (corresponding to the sync pulse) flows through the resistor in series with the anode of the germanium crystal and the CRT bias. It is the voltage corresponding to this current pulse which may be used as the sync signal.

Zero diode capacitance would be a

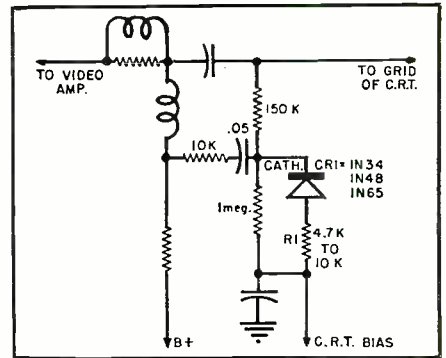

Fig. 2. Combination sync separator and d.c. restorer. This circuit is especially suitable for compact, moderately-priced sets.

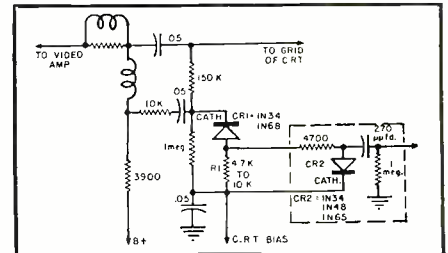

Fig. 3. Combination sync separator, d.c. restorer, and clipper diode circuit. Clipper diode is shown in the dotted line section.

gift from the gods at this point, because the small (nominally 2 $\mu\text{fd.}$) capacitance of the germanium diode permits a vestige of the video signal to appear at the sync pulse output whenever the video modulation frequency exceeds 0.5 mc. The clipper diode, CR_2 of Fig. 3, in conjunction with the 4700 ohm resistor is a shunt limiter of the type discussed earlier in this series, under AM and a.v.c. This shunt type limiter helps remove jitter resulting from video leakage that appears on the sync pulse base line.

The combination sync separator-d.c. restorer circuit shown in Fig. 2 is undesirable without the limiter shown in Fig. 3 because this helps eliminate sync variability and unevenness. The circuit may be improved by the use of a limiting sync amplifier circuit, as an adjunct to this germanium diode circuit; this is shown in Fig. 4.

Variability in blanking level appears (Continued on page 117)

Fig. 4. Germanium diode sync separator and sync clipper with sync auxiliary circuit. This is an idealized version of the circuits shown in Figs. 2 and 3 as it eliminates the defects of those circuits and introduces no new circuit faults.

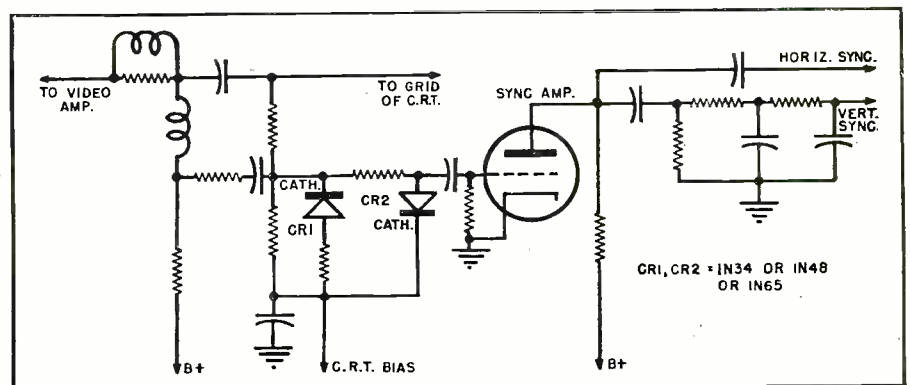

VACUUM TUBES

as Variable Resistance Circuit Elements

By

WAYNE B. DENNY

Physics Dept., Grinnell College

How vacuum tubes can be used as volume or tone controls in place of ordinary variable resistances. Article also covers v.t. applications in expander and compressor circuitry.

THE use of vacuum tube circuits to simulate variable capacitances and variable inductances is common practice in many branches of electronics. Variable reactance tube circuits find application in frequency modulation systems, automatic frequency control systems, the Scott type of dynamic noise suppressor, and elsewhere. In these applications the effective plate-to-cathode reactance depends upon the grid-to-cathode voltage. But a.c. circuits contain resistance as well as inductance and capacitance. The dynamic plate-to-cathode resistance of vacuum tubes can be used as a

circuit element and this resistance is easily varied between rather wide limits by the application of suitable grid-to-cathode voltages. Minimum values of R_p are normally obtained with zero potential difference between grid and cathode. Maximum values of R_p occur when the negative grid voltage approaches cut-off, in which case R_p approaches infinity. This is clearly seen by inspection of the plate characteristics for triodes. (See Fig. 2.) The value of R_p at any point is the reciprocal of the slope of the constant grid voltage line through that point. The plate resistance is defined as

$$R_p = \frac{\delta V_p}{\delta I_p} = \frac{\Delta V_p}{\Delta I_p}, E_c = \text{constant}$$

It will be noted that for the usual triode, R_p has its minimum values in the upper left-hand portions of the characteristics while the maximum

values occur nearer the bottom and toward the right.

The criteria for proper use of the plate resistance of a vacuum tube as a variable circuit element are: (1) R_p should change smoothly from minimum to maximum with increasing values of negative grid potential; and (2) R_p should be independent of normally expected plate voltage fluctuations. The first criterion requires no comment. The second requires that the constant grid voltage lines should be straight (though not parallel) in that region of the characteristics over which operation is normally expected. This criterion cannot be completely satisfied because the constant grid voltage lines approximate a three-halves power law. Thus the linearity requirements are similar to those assumed for the so-called "small signal analysis" of vacuum tube circuits generally. For large signals the variation of R_p with variations in plate voltage may or may not be detrimental depending upon the application.

Applications

In Fig. 1A variations of e_c are used to control the gain of a voltage amplifier. In this circuit R_2 and the plate resistance R_p of V_2 comprise a voltage divider connected between the plate of V_1 and ground. If R_2 is large compared to R_1 and the plate resistance of V_1 , the effective load-line for V_2 is the line R_2 of Fig. 2. Strictly speaking, this is the load-line only when the signal voltage is zero. When a signal is impressed the operating point fluctuates along one of the constant grid voltage lines. It is more correct, therefore, to speak of the *effective load region*. In Fig. 2 the effective load region is bounded by the dotted lines parallel to and equidistant from the no-signal load-line, R_2 . The positions of the intercepts of these two dotted lines correspond to a signal voltage at the plate of V_1 whose peak value is ΔV_p . If e_c is variable between zero and cut-off, maximum attenuation occurs when e_c is zero.

$$\frac{e_{out}}{e_{in}} = \frac{(\text{gain of } V_1) \times R_{p \text{ min}}}{R_2 + R_{p \text{ min}}}$$

Minimum attenuation occurs when the operating point is shifted to cut-off. With a finite load resistance connected across the output of the circuit the minimum attenuation is never zero; the larger the load resistance the less

Fig. 1.

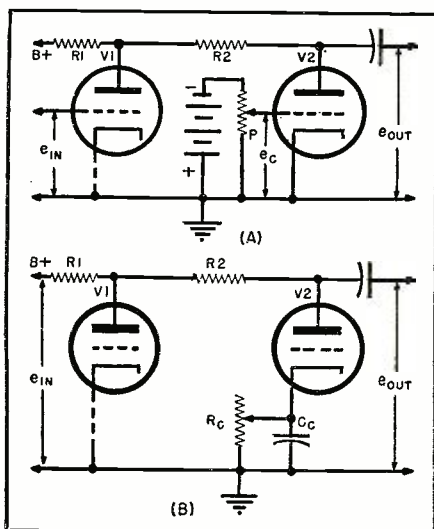

Fig. 2.

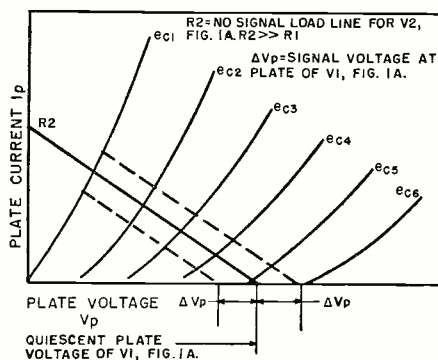
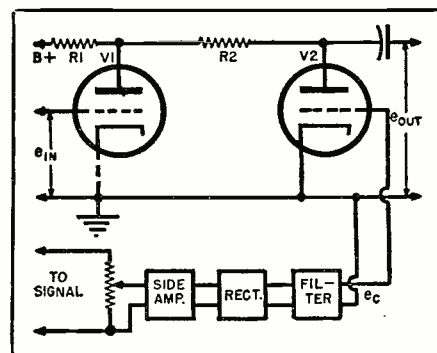

Fig. 3.



is the minimum attenuation. This circuit is useful because potentiometer P can be located at a remote point: no signal currents are carried by P . A more practical circuit is shown in Fig. 1B. Here the grid voltage for V_2 is developed across the variable cathode resistance R_c . The function of C_c is three-fold: (1) it places the cathode of V_2 at ground potential for a.c.; (2) it helps to satisfy the second criterion by making the grid voltage independent of the instantaneous plate potential; and (3) it removes signal currents from R_c which is required when this control is remotely located.

One disadvantage of this circuit is its inability to reduce the output voltage to zero. However, it is suitable when gain reductions on the order of 20 to 25 db are sufficient. One obvious application for custom audio installations is a remote volume control located near the telephone or a favorite listening position. In this and similar applications the circuit is definitely superior to the use of a variable- μ tube with remotely located variable cathode resistor. The latter arrangement, although employed in some commercial equipment, contributes a high order of distortion unless the signal voltages are very small. This occurs because of the curvature of the variable- μ characteristic. By comparison, the resistance tube attenuator is practically distortion-free provided the second criterion is satisfied as it will be for signal voltages less than 10 volts or so.

Volume Expansion and Compression. When the control voltage e_c is derived from the signal to be amplified there results an extremely efficient volume expander or compressor. As shown in Fig. 3, the signal voltage is amplified by the side amplifier, rectified, filtered, and then the control voltage is fed to the grid of the variable resistance tube. For expansion the signal is picked off ahead of the resistance tube: for compression the signal is picked off behind the resistance tube to avoid possible inversion of the dynamic relations of the signal.

If the time constants of the filters of Fig. 3 are short, the control voltage, after amplification by the resistance tube, will appear in the expanded or compressed signal. This amplified control may exceed the desired signal with consequent overloading of subsequent amplifier stages. The circuit of Fig. 4 avoids this possibility by the use of a push-pull arrangement. The push-pull cathode followers are practical proof against overloading caused by extraneous control voltages at the plates of the resistance tubes. Further, the cathode followers isolate the primary of the transformer from the variable generator resistance offered by the resistance tubes. All control voltages cancel in the transformer. The writer has built several expander-compressors using this arrangement. The time constant can be as short as a few milliseconds without transient distortion.

Dynamic Noise Suppression. In the circuit of Fig. 5 the variable resistance

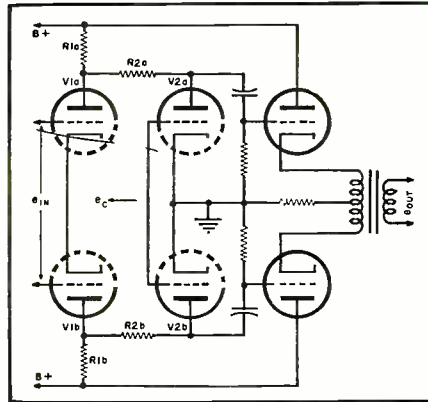

Fig. 4.

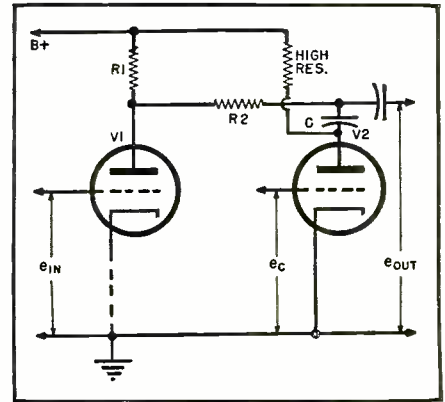

Fig. 5.

tube and C comprise a low-pass type of tone control. When the grid voltage of the control is zero the plate resistance is low and high frequency roll-off results. With the resistance tube biased to cut-off, the plate resistance approaches infinity and the frequency response is flat. Here again, the control can be picked off from the signal and high frequency noise suppression results. However, the control voltage should be derived mainly from the higher frequency portions of the signal. This is accomplished by insertion of a suitable high-pass filter in the side amplifier circuit. It should be mentioned that the type of noise suppression obtained with this circuit is *vertical*, not *horizontal*. The rate of attenuation obtained with this arrangement is always less than 6 db per octave.

Fig. 6 shows a low frequency noise suppression circuit which is suitable for variable-reluctance phonograph cartridges. The usual low frequency compensation is provided by R_1 , R_2 and C_1 . The resistance tube is shunted across C_1 . When its plate resistance is low, C_1 is effectively short circuited. This removes the low frequency compensation with the over-all result that low frequency roll-off occurs. Once more the control voltage e_c is derived in the same manner as in the previous circuit except that a low-pass filter is inserted in the side amplifier. If several values of C_1 are used to provide different turnover frequencies the amount of low frequency noise suppression increases as the turnover frequency increases. Since the amount of low frequency noise and rumble also increases with the turnover frequency this characteristic is a distinct advantage; maximum noise suppression occurs under the conditions where it is most needed. Experimental curves for this circuit are shown in Fig. 8.

For those who prefer the selective feedback method of low frequency compensation the circuit of Fig. 7 is offered. Here the circuit is conventional except that the feedback condenser is shunted by a resistance tube. When the grid voltage of this tube approaches cut-off the operation of the circuit is entirely normal. When, however, the plate resistance is lowered, the feedback condenser is shorted out

(Continued on page 147)

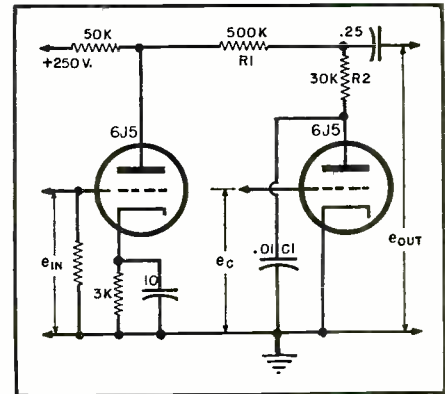

Fig. 6.

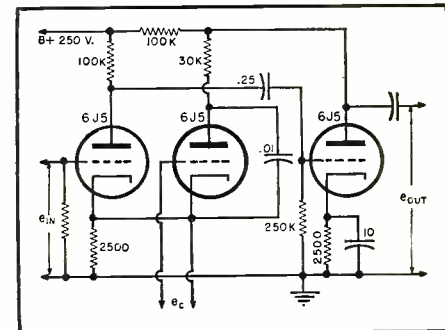
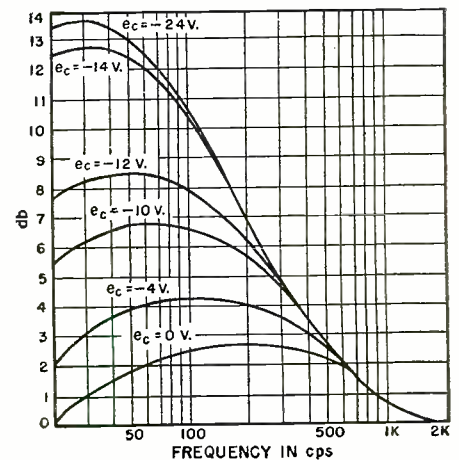

Fig. 7.



Fig. 8.



(Left) Brociner dual-horn corner reproducer. (Right) RCA 15" duo-cone loudspeaker mounted in a bass reflex cabinet whose response is shown in graph, Fig. 5.



G & H Wood Products Co.'s folded-horn corner enclosure kit, shown assembled.

By
DAVID FIDELMAN

Part 8. A discussion of the power amplifier, its role as the final stage of amplification, in the electronic channel of reproduction.

THE power amplifier is the final stage of amplification in the electronic channel of the recording or reproducing system, and its function is to supply driving power to the output electromechanical transducer. The transducer, which converts this electrical energy into the appropriate mechanical motion, may be either a recording head or a loudspeaker. The output signal of the power amplifier must be free from distortion, and must satisfy power and output impedance.

Since electromagnetically-operated transducers, such as recording heads and loudspeakers, are generally very low impedance devices, the power amplifier must feed into a load impedance on the order of 2 to 15 ohms. The output impedance of the amplifier appears in the electromechanical equivalent circuit of the loudspeaker and affects the transient response, therefore it should be less than one-half the load impedance for best mechanical transient response.

The output power requirements for sound reproduction are determined by the specific application—particularly upon the size of the room in which the

sound is being reproduced. The power required for rooms of different sizes can be determined from the curve of Fig. 1, which shows approximately the required amplifier power for reproduction of music when a standard cone loudspeaker is used. Generally it is desirable to have more power available than is shown in this curve, since the sharp transients which are often present in speech and music may require greater power if they are to be reproduced without distortion. In an average-sized room in the home, an amplifier and loudspeaker capable of handling 8 to 10 watts of electrical power will have an adequate reserve.

Design of Power Amplifiers

The power amplifier consists of a single amplifier stage using a tube or tubes that will supply the necessary output power and a transformer to match the relatively high plate impedance of the tube to the low impedance of the load. However, it is not simple to obtain the required power from the tubes and pass it through the output transformer to the load, while still maintaining the required distortion

and frequency characteristics. For this reason, most of the difficulties in the reproducer circuits center about the power amplifier, and a wide variety of solutions has been attempted.

For a number of reasons, high-quality power amplifiers should be push-pull rather than single-ended:

1. Push-pull amplifiers have less distortion, because even-harmonic distortions are cancelled leaving only the odd-harmonic distortion.

2. Since the effects of the plate currents of the two tubes cancel one another in the transformer core, there is no d.c. saturation of a well-balanced output transformer, and the low frequency response is better.

3. The effects of power supply hum are greatly reduced, since this hum is cancelled out in the transformer.

4. The push-pull stage does not tend to cause motorboating in the amplifier. These advantages are so important that a push-pull circuit using two smaller tubes is definitely preferable to a single larger tube capable of de-

livering the same total power output.

There is considerable question whether it is preferable to use triodes or beam-power tetrodes in audio power amplifiers. It is generally agreed, however, that best results are obtained from push-pull amplifiers with overall negative feedback from output to input, including the output transformer in the feedback loop. The use of negative feedback in this application has the following advantages:

(a) The linearity of the output/input amplitude response curve is considerably improved, resulting in a decrease in harmonic distortion and intermodulation;

(b) The frequency response is improved, becoming flatter over a wider range of frequencies;

(c) The output impedance is reduced, thus improving the transient response of the loudspeaker;

(d) The effects of changes in tube characteristics, of random changes of the parameters of the amplifier, and of power supply voltage changes are reduced.

Other circuits in use at the present time make use of triodes without negative feedback and of beam-power tetrodes with feedback. Triode amplifiers have an advantage in that their distortion components contain a smaller distribution among the higher-order harmonics than beam-power tetrodes, therefore have a less unpleasant type of intermodulation distortion. However, beam-power tubes with feedback give better results than triodes without feedback, although not as good as triodes with feedback, and in general give better power efficiency and require lower drive voltages.

The choice of tubes for the specific amplifier being designed depends upon the power required, as determined from the curve of Fig. 1. Basic information concerning the operation of the various power tubes—such as power output, plate load impedance, grid bias voltage, plate voltage, etc., are given in the receiving tube handbook, and can be used as a guide in the selection of tubes. However, the final design of the power stage must be done with the use of the plate-current characteristics.

In designing the push-pull amplifier from the plate-current characteristic curves which are given for the tubes, a composite set of curves must be constructed and used instead of those given for the single tube. The reason this is necessary is that the steady-state current in each tube has no effect on the audio output signal because of the transformer coupling, and it is only the dynamic difference in the plate currents of the two tubes which appears in the secondary winding of the transformer. The composite curves are constructed essentially by subtracting the currents through the two tubes to approximate the effect of the transformer. This is done by placing the plate voltage-current curves of the individual tubes back-to-back, with the common operating voltage superim-

posed, and then averaging the plate current for grid-potential curves corresponding to the same applied signal, as shown in Fig. 2.

The precise manner in which the composite curves are constructed may best be understood by a more detailed study of Fig. 2, which illustrates this procedure for a push-pull 2A3 amplifier. Two sets of curves are redrawn from the tube handbook, and each set of curves is taken to represent one of the tubes. Assuming a plate voltage of 300 volts, place the two sets of curves back-to-back with the 300 points coinciding as shown. Then, assuming some value of grid bias voltage (for example, -60 volts as shown), draw a line which represents the difference in the currents of the two tubes. Next, draw similar plate-current-difference lines for the various other values of grid voltage. (It should be noted that the curve for -70 volts for one tube is matched with -50 volts for the other tube, since the signal voltages on the two grids are opposite in phase, and the voltage on one increases while the voltage on the other decreases.) These lines will be practically straight, and represent the current-voltage curves taking into account the transformer and the push-pull method of operation of the circuit.

The load line is then drawn over the composite characteristics in the same manner as for an ordinary set of tube characteristics. The load line in Fig. 2 intersects the zero-current axis at 300 volts (which was initially selected by superimposing the two sets of curves at this voltage), which is the quiescent or zero-signal operating point. When extended, the load line intersects the zero-voltage axis at 400 milliamperes, therefore its resistance is 750 ohms. Multiplying by 4 gives the total plate-to-plate load resistance, which is thus 3000 ohms in this case. When signals are applied to the grids, the values of the plate currents of the tubes lie along this line. Desirable operating conditions for the two 2A3 tubes in a push-pull amplifier are therefore: Plate voltage, 300 volts; Grid bias voltage, -60 volts; and Load resistance

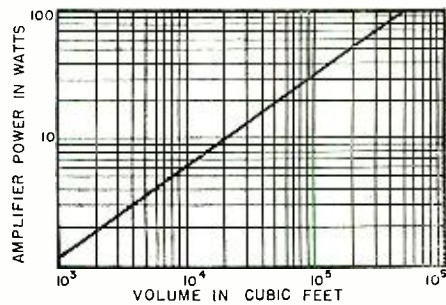

Fig. 1. Approximate amplifier power requirements for rooms of various dimensions.

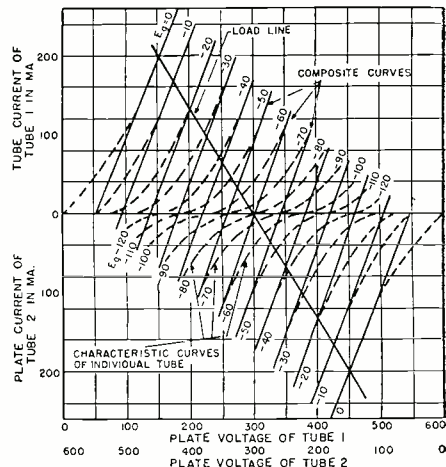
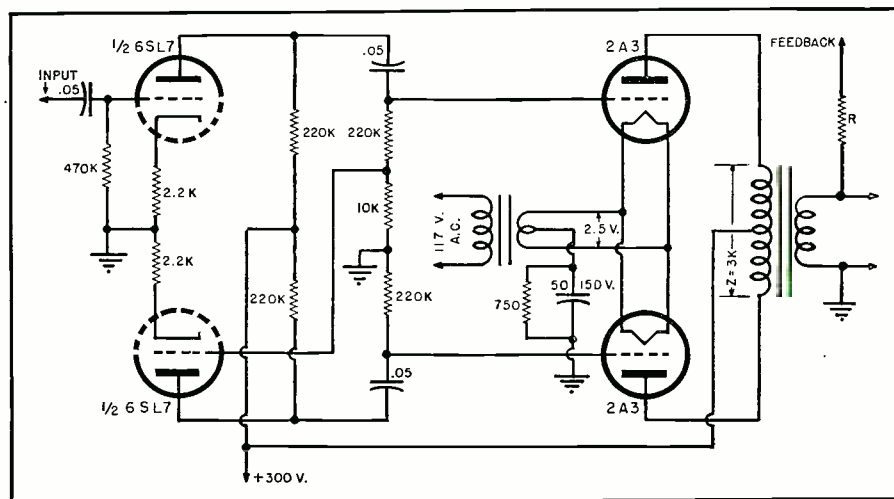

Fig. 2. Construction of the composite curves used in designing a push-pull amplifier.

(plate-to-plate), 3000 ohms. However, the composite curves represent the signal currents through the plate load, and not the actual tube currents. Each tube will still draw 40 ma. of plate current for zero signal. The total plate current for each value of grid voltage is found by adding the two plate currents, instead of subtracting them as for the composite curves, and the average plate current is found by averaging the sum of the two plate currents for a complete signal cycle.

This method of graphical construction for the push-pull power amplifier is the basis for the data given in the tube handbooks, and whenever such in-

Fig. 3. A basic push-pull amplifier designed from the composite curves of Fig. 2.



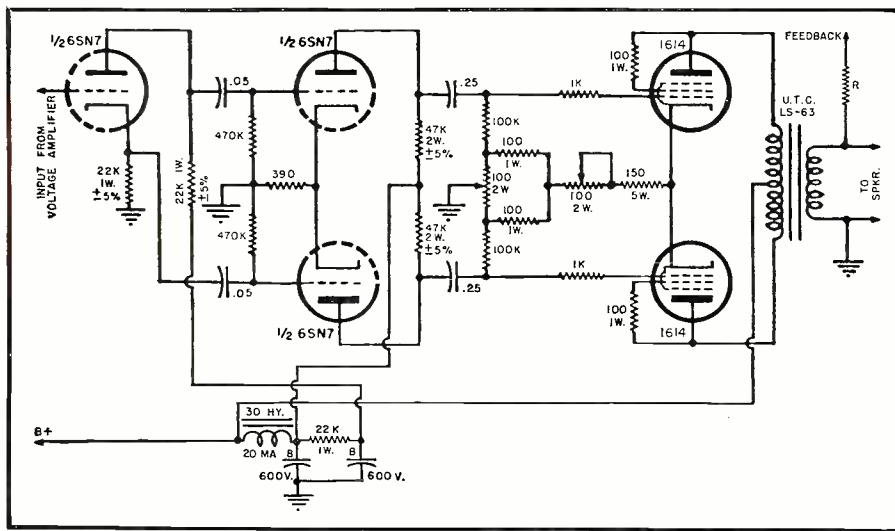
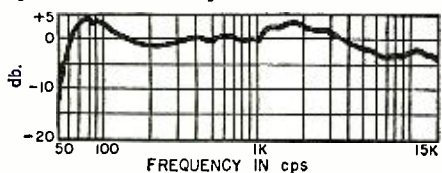

Fig. 4. A modified schematic of the Williamson power amplifier circuit.

formation is given it can be assumed to be the same values as would be obtained by an independent calculation of this type. It forms the basis of the various types of push-pull amplifiers which are in general use at the present time. The schematic diagram of a basic push-pull power amplifier circuit based upon these design principles is shown in Fig. 3. The driver stage is a typical phase-inverter amplifier circuit which has already been described in an earlier article in this series. The input signal from the voltage amplifier is amplified by the first triode and drives one of the push-pull tubes, while the second triode section amplifies a small part of this drive voltage with a 180-degree phase reversal to drive the second push-pull grid with the proper voltage and phase. The power amplifier consists of two 2A3's in the circuit designed from the curves in Fig. 2, with +300 volts on the plates, -60 volts grid bias, and a 3000 ohm plate-to-plate output transformer matched to the loudspeaker impedance. (The feedback connection which is indicated will go to an appropriate point in the voltage amplifier.) The grid drive signal voltage required by each 2A3 for full output is approximately 40 volts rms, and is easily obtained from the 6SL7 driver tubes. The amplifier, as shown, is capable of delivering 10 watts into the loudspeaker, and will give quite good results in the average home sound reproducing system. This circuit is shown using triodes, but it can also be designed for pentodes or beam-power tetrodes such as the 6L6 and 6V6.

Another power amplifier circuit which has recently been designed in England and has achieved wide popu-

Fig. 5. Frequency response of a high-quality speaker mounted in good bass-reflex cabinet.



larity because of its excellent performance is the *Williamson amplifier*. The schematic circuit diagram of the power amplifier section is shown in Fig. 4. The input signal from the voltage amplifier is applied to a cathode-follower phase inverter, which supplies the two equal signals, opposite in phase, required by the push-pull amplifier. These signals, however, do not drive the power amplifier directly, but are instead amplified in a push-pull driver stage that supplies the signal voltage for the power amplifier grids. The power tubes are connected as triodes and feedback is taken from the secondary of the output transformer to an appropriate point in the voltage amplifier. In this circuit, the output transformer is extremely important, and should very closely meet the original specifications for satisfactory performance. Too low a primary inductance in the transformer tends to produce instability at the low frequencies, while variations in the leakage inductance and capacities between the windings will affect the high frequency response. At the present time a number of manufacturers are producing transformers for use with this circuit, and it is also possible to purchase commercial kits which contain all the components necessary for construction of this amplifier. Commercially constructed amplifiers based upon this design are also available, and indication of the performance of this circuit may be obtained from the following typical specifications: Frequency response, ± 0.1 db 20-20,000 cps; Frequency response, ± 2 db 5-100,000 cps; Harmonic distortion, less than 0.1% at 10 watts output at mid-frequencies; Intermodulation, less than 0.5% at 10 watts output. These characteristics are extremely good, and are in fact considerably better than what are considered to be the minimum requirements for good reproduction.

Loudspeakers

In designing and setting up any sound reproduction system, it should always be kept in mind that the quality of the

reproduced sound can be no better than that produced by the worst component in the system. Generally this "worst component in the system" is the loudspeaker. When it is considered that the loudspeaker is required to reproduce the same sound which is produced by all the instruments of a large orchestra, from the upper limit of audibility down to the lowest notes which can be produced by the pipe organ, the difficult task which it is called upon to accomplish becomes more clearly evident. The improvement in the quality of reproduction which has taken place has resulted largely from the improvement in loudspeaker design and manufacture.

The loudspeaker must be of comparable quality to the rest of the system, and should meet the same requirements as the rest of the system. That is, when an electrical signal of the proper characteristics is applied to the input terminals, the output sound should be free of frequency, amplitude, transient, and other distortions at all rated input power levels. Ideally, the distortions introduced by the loudspeaker should be within the limits specified for the rest of the system, but in practice there are no speakers available at the present time which meet these requirements. (However, this does not mean that the quality of the rest of the system should be made worse, since this would only further lower the over-all quality of the system.) It is, in fact, difficult even to measure the characteristics of loudspeakers, since such a measurement requires a sound-standard microphone and must be done in a room with no resonances and whose walls do not reflect any sound to interfere with the measurement. The information which is supplied by the manufacturer must be accepted by the experimenter who hasn't extensive testing facilities, and this information is generally quite reliable.

The frequency response curve of a typical high-quality commercial loudspeaker is shown in Fig. 5. This response illustrates some of the important factors which should be found in a good loudspeaker:

(a) The response should be reasonably flat over a frequency range of 50-10,000 cps.

(b) The frequency response curve should be fairly smooth, with as few sharp peaks and dips as possible, since these discontinuities in the response represent mechanical resonances which result in bad transient response.

(c) The power rating of the speaker or speakers used should correspond to the rest of the system and to the requirements of the listening room, so that there will be no distortion at high sound levels.

Even these requirements can only be a guide in the selection of appropriate loudspeakers for sound reproduction systems, since the loudspeaker is a complex electromechanical system whose properties in relation to the ear

(Continued on page 108)

OUTSTANDING VALUES NOW AVAILABLE

RPC SUPER CHIEF ANTENNA KIT

The finest in all-around reception.

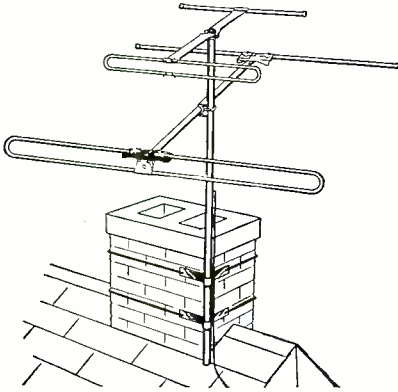

Separate high band and low band antennas. Constructed of high tensile aluminum. Complete with:

- 60 ft. 300 ohm line.
- 5 ft. 1 1/4" rustproof steel mast.
- Double strength chimney mount.
- 2—mast std. off.
- 1—7" std. off.
- 3—3 1/2" std. off.
- 1—RCA lightning arrestor.

COMPARE THIS PRICE! \$7.95

REDUCE YOUR TV RECEPTION TROUBLE



THE TURRET BOOSTER

- Fully concealed within set.
- Comes on when receiver is turned on.
- No wiring necessary—simple as removing a tube.
- Improves reception—increases video output at least 15%.

Just the thing for fringe area boost or in local areas where antennas are not allowed. PRICE.....**\$9.95**

(Special discount to dealers)

SUPER SALE ITEM ELECTRIC SOLDERING GUN



Best Made. 250 watt capacity. Heats in less than five seconds. Operates on 60 cy. 120V, AC. Trigger switch. No current or time wasted. **Lightweight.** Gives perfect balance and soldering ease. **Built-in Spotlight.** Compare this gun to any other on the market.

\$9⁹⁹

Complete with nickel and brass tip.
Extra tips..... **15c**

AMAZING VALUE 3-Way Portable TRAV-LER AC—DC—Battery



- Superhet circuit.
 - Tubes 1S5, 3S4, 1R5, 1U4 and Selenium Rectifier.
 - Alnico V PM Speaker.
 - Attractive airplane dial, luggage type case.
 - Small size. 5 1/4" H x 8 3/8" W x 4 3/4" D.
- Exceptional reception and tone. Nowhere else at this price! **\$17.59**
Batteries, 1—67 1/2V, 2—1 1/2V flashlite cells. **\$1.85**

STANDARD MANUFACTURED VIBRATORS

These fine vibrators, the ultimate in precision vibrator construction, will replace 95% of all auto vibrators.

- Standard 4 prong.....**\$1.19 ea.**
10 for.....**\$11.00**
- Offset 4 prong—
Delco type.....**\$1.29 ea.**
10 for.....**\$12.00**
- Buick type 5 prong.....**\$2.59 ea.**
10 for.....**\$23.00**

CUSTOM BUILT AUTO RADIOS

Easily installed. Fine, top quality. Ready to place in your car. Designed for each specific car.

All sets—6 tube. 3 gang; super heterodyne. Extra sensitive circuit. Low battery drain. Beautiful finish and dial. These models now available:

- | | |
|--------------------|--------------------|
| 1951—Ford | 1948-49-50-51— |
| 1949-50—Ford | Hudson |
| 1950-51—Stude- | 1951—Chev- |
| baker | rolet |
| 1951—Henry J | 1949-50—Chev- |
| 1951—Plymouth | rolet |
| (with grill plate) | 1949-50—Dodge, |
| | Plymouth |
| | (with grill panel) |

List Price, **\$59.95**

YOUR PRICE.....\$41.95

AUTO ANTENNAS



TOP COWL: 3 section staff, 58" extension. Bakelite insulator, chrome trim. Single hole mount. Simple installation. Complete with lead. **\$1.89** each. Case of 25.....**\$1.79** each

SIDE COWL: 3 section staff, 63" extension. Complete with tenite insulators. Static ball and tip shielded. Low loss lead.

\$1.69 each. Case of 25 **\$1.59** each

INDOOR TELEVISION ANTENNA



Now TV reception without the outdoor antenna. Effective range 20 to 25 miles from station. Excellent reception. Easily installed—takes 5 seconds. Easily orientated. Heavy base—will not tilt. Attractive. Friction clutch-type action on the rods. Complete with lead in.....each **\$1.55**
Case lots of 25.....each **1.45**

Radio Parts Company, 614 RANDOLPH ST., CHICAGO 6, ILL.

Features OF THE NEW 1952



PROOF OF THE NEW O-7 OSCILLOSCOPE'S OUTSTANDING PERFORMANCE

Below are actual, unretouched photographs showing the outstanding frequency response characteristics of the NEW 1952 HEATHKIT OSCILLOSCOPE, MODEL O-7. To the left is a 10 KC square wave — to the right is a 4 MC sine wave as they actually appear on the screen. Two highly severe tests to make on any scope (only the best of scopes will show traces like these) — and the O-7 really comes through.

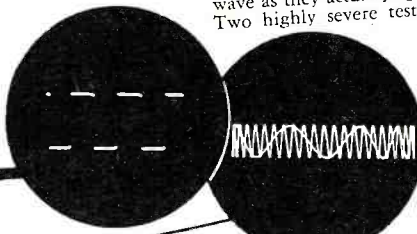

COMPANION VACUUM TUBE VOLTMETERS

Here are the two NEW 1952 VACUUM TUBE VOLTMETER COMPANION PIECES. Matched instruments of new design to open up the whole field of DC, AC, and resistance measurements for you. The new greatly reduced size combines style, beauty, and compactness — The V-5 and AV-1 have the new panel and cabinet construction as shown on the right. A tremendous pair of voltmeters. Small in size but virtual giants in the range of measurements they make.



NEW STYLE AND BEAUTY

Style that's modern, yet functional — that's the trend of today — and Heathkits are right up to the minute. Note the cut showing the new V-5 and AV-1 cabinet and panel construction. The front panel and rear cover slide right over the recessed flange of the case thereby eliminating sharp edges and pointed corners. The voltmeter kits aren't "shelf" or "mounted" instruments — they're moved about on the bench a lot and thus the new compact size and specially designed cabinets — Another 1952 Heathkit feature.

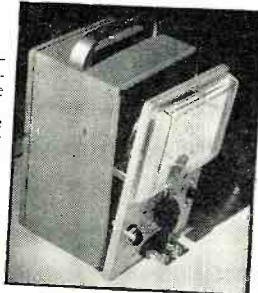

A STATEMENT FROM SIMPSON ELECTRIC CO.

In choosing Simpson Meters for their Heathkit VTVM, the Heath Co. has set a new high standard of kit meter quality. The same high quality of material, workmanship and design that has given Simpson the reputation for building "Instruments That Stay Accurate" is found in the Heathkit Meter Movement.

SIGNED
SIMPSON ELECTRIC CO.

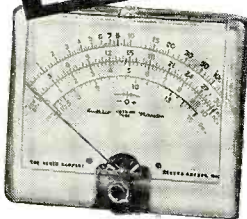

A STATEMENT FROM CHICAGO TRANSFORMER

It is indeed gratifying to note the outstanding sales records you are building with your Heathkits.

This sales success is readily understandable, since we are cognizant of the high quality standards you have established for your component suppliers.

We at Chicago Transformer are proud that our product has contributed to the recognized quality and increasing popularity of Heathkits.

CHICAGO TRANSFORMER DIVISION
Essex Wire Corporation

L. S. RACINE
Vice-President and Sales Manager



HEATHKIT PRECISION RESISTORS

Where exact resistance values are required for instrument accuracy, the Heath Co. has spared no effort in supplying the finest resistors available. Precision resistors as manufactured by Continental Carbon Inc., and Wilcor Corp., meet the rigorous JAN (Joint Army-Navy) specifications and are small in size, extremely non-inductive, highly stable, have a low temperature coefficient, and can be held to great accuracy. You'll find quality components in Heathkits.

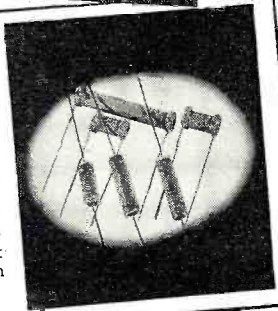

COLLEGES USE HEATHKITS

Colleges and Universities throughout the country are using Heathkits in their electrical engineering, radio, and physics laboratories — Heathkits are the answer to good test equipment at low cost, plus being rugged, dependable, and accurate. Trade schools are having their students build Heathkits to obtain a first hand working knowledge of test equipment and to get the practical experience gained by construction. Heathkits fill school needs.



YOU SAVE BY ORDERING DIRECT FROM MANUFACTURER—USE ORDER BLANK ON LAST PAGE

EXPORT AGENT
ROCKE INTERNATIONAL CORP.
12 E. 40TH ST.
NEW YORK CITY (16)
CABLE: ARLAB-N.Y.

The HEATH COMPANY

... BENTON HARBOR 15, MICHIGAN

New LABORATORY LINE HEATHKITS

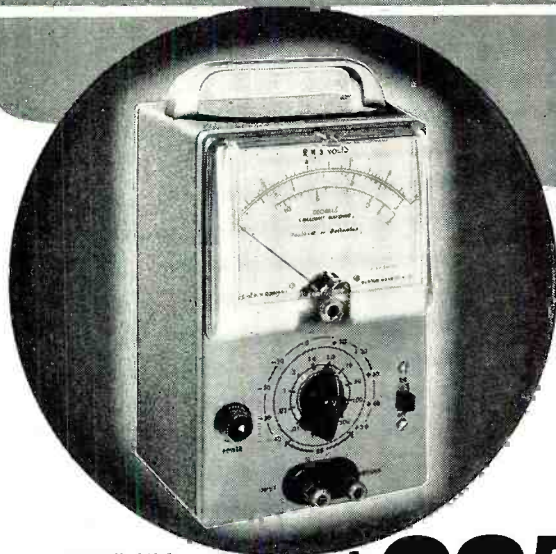

MODEL AV-1
Shipping weight 5 lbs.

NEW *Heathkit* A.C. VACUUM TUBE VOLTMETER KIT

Now — as a Heathkit — at a price anyone can afford, an AC VTVM.

A new kit to make possible those sensitive AC measurements required by audio enthusiasts, laboratories, and experimentors. Here is the kit that the audio men have been looking for. Its tremendous range of coverage makes possible measurements of audio amplifier frequency response — gain or loss of audio stages — characteristics of audio filters and attenuators — hum investigation — and literally a multitude of others. Ten ranges consisting of full scale .01, .03, .1, .3, 1, 3, 10, 30, 100, 300 volts RMS assure easy and more accurate readings. Ten ranges on DB provide for measurements from -52 to +52 DB. Frequency response within 1 DB from 20 cycles to 50 KC.

The ingenious circuitry incorporates precision multiplier resistors for accuracy, two amplifier stages using miniature tubes, a unique bridge rectifier meter circuit, quality Simpson meter with 200 microampere movement, and a clean layout of parts for easy wiring. A high degree of inverse feedback provides for stability and linearity.

Simple operation is accomplished by the use of only one control, a range switch which changes the voltage ranges in multiples of 1 and 3, and DB ranges in steps of 10.

The instrument is extremely compact, cabinet size — 4 1/8" deep x 4-11/16" wide x 7 3/8" high, and the newly designed cabinet makes this the companion piece to the VTVM. For audio work, this kit is a natural.

\$29⁵⁰

NEW *Heathkit* AUDIO FREQUENCY METER KIT

MODEL AF-1
Shipping weight 12 lbs.

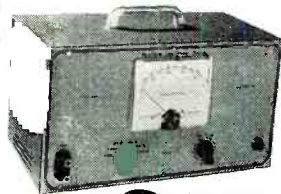

\$34⁵⁰

A NEW Heathkit Audio Frequency Meter — the ideal instrument for determining frequencies from 20 cycles to 100 KC. Set the selector switch to the proper range — feed the signal into the input terminals — and read the frequency from the meter — completely simple to operate, and yet dependable results.

Quality Simpson 200 microampere meter has two plainly marked scales (0-100 0-300). These scales, read in conjunction with the seven position selector switch, give full scale readings of 100, 300, 1000, 3000, 10,000, 30,000, and 100,000 cycles. Convenient ranges for fast and easy readings.

For greatest accuracy, the 1-3-10 ratio of ranges is maintained and each range has individual calibrating control.

Input impedance is high (1 megohm) for negligible circuit loading. A signal and a change in signal voltage between 2 and 300V can be fed directly into the instrument reading. In addition, input wave shape is not critical (the unit will read the frequency of either sine wave or square wave input).

The tube complement consists of a 6SJ7 amplifier and clipper, 6V6 amplifier and clipper, 6HG meter pulse rectifier, 6X5 power supply rectifier, and OD3/VR150 voltage regulator.

Construction is simple, and quality components are used throughout.

NEW *Heathkit* INTERMODULATION ANALYZER KIT

Intermodulation testing of audio equipment is rapidly being accepted by more and more engineers and audio experts as the best way to determine the characteristics of audio amplifiers, recording systems, networks, etc. — shows up those undesirable characteristics which contribute to listening fatigue when all other methods fail.

The Heathkit Intermodulation Analyzer supplies a choice of two high frequencies (3000 cycles and a higher frequency) and one low frequency (60 cycles). Both 1:1 or 4:1 ratios of low to high frequencies can be set up for IM testing, and the ratios are easily set by means of a panel control and the instrument's own VTVM. An output level control supplies the mixed signal at the desired level with an output impedance of two thousand ohms. The Analyzer section has input level control and proper filter circuits feeding the instrument's VTVM to read intermodulation directly on full scale ranges of 30%, 10% and 3%. Built-in power supply furnishes all necessary voltages for operating the instrument.

You won't want to be without this new and efficient means of testing



MODEL IM-1
Shipping wt. 18 lbs.

\$39⁵⁰

NEW *Heathkit* SQUARE WAVE GENERATOR KIT

The new Heathkit Square Wave Generator Kit with its 100 KC square wave opens an entirely new field of audio testing. Square wave testing over this wide range will quickly show high and low frequency response characteristics of circuits — permit easy adjustment of high frequency compensating networks used in video amplifiers — identify ringing in circuits — demonstrate transformer characteristics, etc.

The circuitry consists of a multivibrator stage, a clipping and squaring stage, and a cathode follower output stage. The power supply is transformer operated and utilizes a full wave rectifier tube with 2 sections of LC filtering.

As a multivibrator cannot be accurately calibrated, a provision is provided to allow the instrument to be accurately synchronized with an accurate external source when extreme accuracy is required.

The low impedance output is continuously variable between 0 and 25 volts and operation is simple. You'll really appreciate the wide range of this instrument, 10 cycles to 100 kilocycles — continuously variable. Kit is complete with all parts and instruction manual, and is easy to build.



MODEL SQ-1
Shipping wt. 14 lbs.

\$29⁵⁰

YOU SAVE BY ORDERING DIRECT FROM MANUFACTURER—USE ORDER BLANK ON LAST PAGE

REPORT AGENT
ROCKE INTERNATIONAL CORP.
15 E. 40th ST.
NEW YORK CITY (16)
C/RE, AREA-N.Y.

The **HEATH COMPANY**

... BENTON HARBOR 15, MICHIGAN

THE *New* 1952 Heathkit OSCILLOSCOPE KIT

MODEL O-7
SHIPPING WEIGHT 24 LBS.

\$43⁵⁰

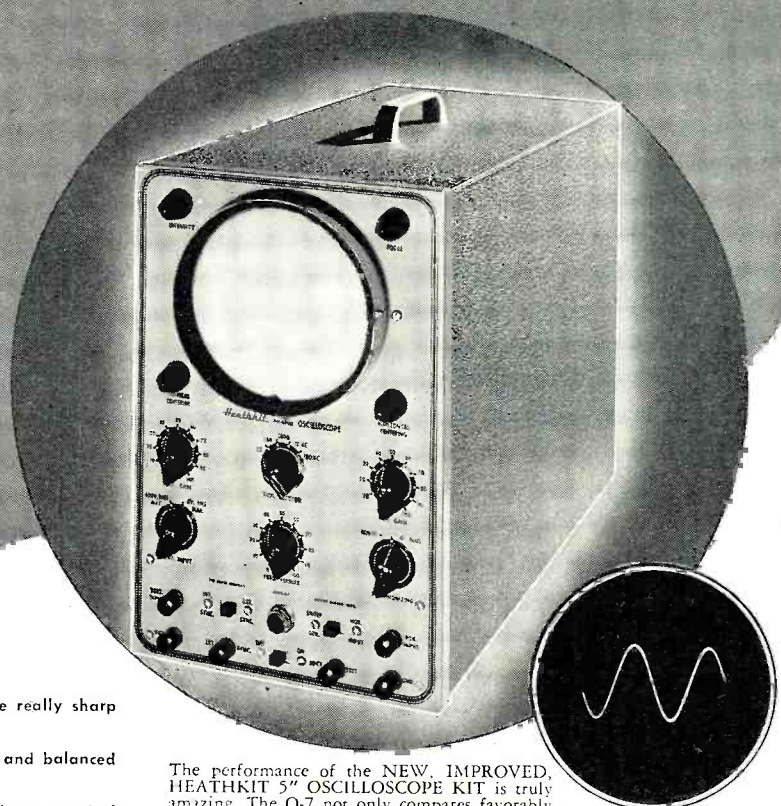

Features

- New "spot shape" control for spot adjustment — to give really sharp focusing.
- A total of ten tubes including CR tube and five miniatures.
- Cascaded vertical amplifiers followed by phase splitter and balanced push-pull deflection amplifiers.
- Greatly reduced retrace time.
- Step attenuated — frequency compensated — cathode follower vertical input.
- Low impedance vertical gain control for minimum distortion.
- New mounting of phase splitter and deflection amplifier tubes near CR tube base.
- Greatly simplified wiring layout.
- Increased frequency response — useful to 5 Mc.
- Tremendous sensitivity .03V RMS per inch Vertical — .6V RMS per inch Horizontal.
- Dual control in vernier sweep frequency circuit — smoother acting.
- Positive or negative peak internal synchronization.

The performance of the NEW, IMPROVED, HEATHKIT 5" OSCILLOSCOPE KIT is truly amazing. The O-7 not only compares favorably with equipment costing 4 and 5 times as much, but in many cases literally surpasses the really expensive equipment. The new, and carefully engineered circuit incorporates the best in electronic design — and a multitude of excellent features all contribute to the outstanding performance of the new scope.

The VERTICAL CHANNEL has a step attenuated, frequency compensated vertical input which feeds a cathode follower stage — this accomplishes improved frequency response, presents a high impedance input, and places the vertical gain control in a low impedance circuit for minimum distortion. Following the cathode follower stage is a twin triode — cascaded amplifiers to contribute to the scope's extremely high sensitivity. Next comes a phase splitter stage which properly drives the push-pull, hi-gain, deflection amplifiers (whose plates are directly coupled to the vertical deflection plates). This fine tube lineup and circuitry give a sensitivity of .03V per inch RMS vertical and useful frequency response to 5 Mc.

The HORIZONTAL CHANNEL consists of a triode phase splitter with a dual potentiometer (horizontal gain control) in its plate and cathode circuits for smooth, proper driving of the push-pull horizontal deflection amplifiers. As in the vertical channel, horizontal deflection amplifier plates are direct coupled to the CR tube horizontal deflection plates (for improved frequency response).

The WIDE-RANGE SWEEP GENERATOR circuit incorporates a twin triode multivibrator stage for producing a good saw-tooth sweep frequency (with faster retrace time). Has both coarse and vernier sweep frequency controls.

And the scope has internal synchronization which operates on either positive or negative peaks of the input signal — both high and low voltage rectifiers — Z axis modulation (intensity modulation) — new spot shape (astigmatism) control for spot adjustment — provisions for external synchronization — vertical centering and horizontal centering controls, wide range focus control — and an intensity control for giving plenty of trace brilliance.

The Model O-7 EVEN HAS GREAT NEW MECHANICAL FEATURES — A special extra-wide CR tube mounting bracket is provided so that the vertical cascade amplifier, vertical phase splitter, vertical deflection amplifier, and horizontal deflection amplifier can mount near the base of the CR tube. This permits close connection between the above stages and to the deflection plates; distributed wiring capacity is greatly reduced, thereby affording increased high frequency response.

The power transformer is specially designed so as to keep its electrostatic and electromagnetic fields to a minimum — also has an internal shield with external ground lead. You'll like the complete instructions showing all details for easily building the kit — includes pictorials, step-by-step construction procedure, numerous sketches, schematic, circuit description. All necessary components included — transformer, cabinet, all tubes (including CR tube), completely punched and formed chassis — nothing else to buy.

NEW INEXPENSIVE Heathkit ELECTRONIC SWITCH KIT

The companion piece to a scope — Feed two different signals into the switch, connect its output to a scope, and you can observe both signals — each as an individual trace. Gain of each input is easily set (gain A and gain B controls), the switching frequency is simple to adjust (coarse and fine frequency controls) and the traces can be superimposed for comparison or separated for individual study (position control).

Use the switch to see distortion, phase shift, clipping due to improper bias, both the input and output traces of an amplifier — as a square wave generator over limited range.

The kit is complete; all tubes, switches, cabinet, power transformer — and all other parts, plus a clear detailed construction manual.

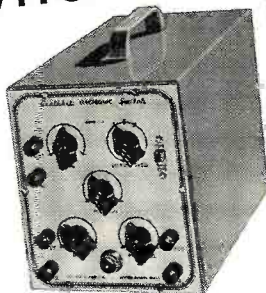

Model S-2
Shipping Wt. 11 lbs.

Only
\$19⁵⁰

YOU SAVE BY ORDERING DIRECT FROM MANUFACTURER—USE ORDER BLANK ON LAST PAGE

EXPORT AGENT
ROCKE INTERNATIONAL CORP.
13 E. 40th ST.
NEW YORK CITY (16)
CABLE: ARLAB-N.Y.

The HEATH COMPANY

... BENTON HARBOR 15, MICHIGAN

THE *New* 1952

Heathkit VTVM KIT

MODEL V-5
SHIPPING WT. 5 LBS.

\$24.50

Features

- New styling, — formed case for beauty.
- New truly compact size. Cabinet 4 1/8" deep by 4-11/16" wide by 7 3/8" high.
- Quality 200 microamp meter.
- New ohms battery holding clamp and spring clip — assurance of good electrical contact.
- Highest quality precision resistors in multiplier circuit.
- Calibrates on both AC and DC for maximum accuracy.
- Terrific coverage — reads from 1/2V to 1000V AC, 1/2V to 1000V DC, and .1 to over 1 billion ohms resistance.
- Large, clearly marked meter scales indicate ohms, AC Volts, DC Volts, and DB — has zero set mark for FM alignment.
- New styling presents attractive and professional appearance.

A real beauty — you'll have only highest praise for this NEW MODEL VACUUM TUBE VOLTMETER. Truly a beautiful little instrument — and it's more compact than any of our previous models. Note the new rounded edges on the front panel and rear cover. The size is greatly reduced to occupy a minimum of space on your workbench — yet the meter remains the same large size with plainly marked scales.

A set of specially designed control mounting brackets permit calibration to be performed with greatest ease — also makes for ease in wiring. New battery mounting clamp holds ohms battery tightly into place, and base spring clip insures a good connection to the ohms string of resistors.

The circuitry employs two vacuum tubes — A duo diode operating when AC voltage measurements are taken, and a twin triode in the circuit at all times. The cathode balancing circuit of the twin triode assures sensitive measurements, and yet offers complete protection to the meter movement. Makes the meter burn-out proof in a properly constructed instrument.

Quality components are used throughout — 1% precision resistors in the multiplier circuit — conservatively rated power transformer — Simpson meter movement — excellent positive detent, smooth acting switches — sturdy cabinet, etc.

And you can make a tremendous range of measurements — 1/2V to 1000V AC, 1/2V to 1000V DC, .1 to over 1 billion ohms, and DB. Has mid-scale zero level marking for quick FM alignment. DB scale in red for easy identification — all other scales a sharp, crisp black for for easy reading.

A four position selector switch allows operator to rapidly set the instrument for type or reading desired — positions include ACV, DC-V, DC-V, and Ohms. DC- position allows negative voltage to be rapidly taken. Zero adjust and ohms adjust controls are conveniently located on front panel.

Enjoy the numerous advantages of using a VTVM. Its high input impedance doesn't "load" circuits under test — therefore, assures more accurate and dependable readings in high impedance circuits such as resistance coupled amplifiers, AVC circuits, etc. Note the 30,000 VDC probe kit and the RF probe kit — available at low extra cost and specially designed for use with this instrument. With these two probes, you can make DC voltage measurements up to 30,000V, or make RF measurements — added usefulness to an already highly useful instrument.

The instruction manual is absolutely complete — contains a host of figures, pictorials, schematic, detailed step-by-step instructions, and circuit description. These clear, detailed instructions make assembly a cinch.

And every part is included — meter, all controls, pilot light, switches, test leads, cabinet, instruction manual, etc.



Heathkit 30,000V DC PROBE KIT

A new 30,000 V DC Probe Kit to handle high voltages with safety. For TV service work and all other high voltage applications. Sleek looking — and guard — jet black handle. Red body with connector, cable, and PL55 type plug. Plugs into Heathkit VTVM so that 300V scale is conveniently multiplied by 100. Can be used with any standard 11 megohm VTVM.

\$550

No. 336 High Voltage Probe Kit
Shipping Wt. 2 lbs.



Heathkit RF PROBE KIT

This RF Probe Kit comes complete with probe housing, crystal diode detector, connector, lead and plug and all other parts plus clear assembly instructions. Extends range of Heathkit VTVM to 250 Mc. ± 10%. Works on any 11 megohm input VTVM. Specify No. 309 RF Probe Kit.

\$550

Ship. Wt. 1 lb.

YOU SAVE BY ORDERING DIRECT FROM MANUFACTURER—USE ORDER BLANK ON LAST PAGE

EXPORT AGENT
ROCKE INTERNATIONAL CORP.
13 E. 40th ST.
NEW YORK CITY (16)
CABLE: ARLAB-N.Y.

The HEATH COMPANY

... BENTON HARBOR 15, MICHIGAN

Heathkit SIGNAL GENERATOR KIT

Model SG-6
Shipping Wt. 7 lbs.

The new Heathkit Signal Generator Kit has dozens of improvements. Covers the extended range of 160 Kc to 50 megacycles on fundamentals and up to 150 megacycles on useful calibrated harmonics; makes this Heathkit ideal as a marker oscillator for TV. Output level can be conveniently set by means of both step attenuator and continuously variable output controls. Instrument has new miniature HF tubes to easily handle the high frequencies covered.

Uses 6C4 master oscillator and 6C4 sine wave audio oscillator. The kit is transformer operated and a husky selenium rectifier is used in the power supply. All coils are precision wound and checked for calibration making only one adjustment necessary for all bands.

New sine wave audio oscillator provides internal modulation and is also available for external audio testing. Switch provided allows the oscillator to be modulated by an external audio oscillator for fidelity testing of receivers. Comes complete, all tubes, cabinet, test leads, every part. The instruction manual has step-by-step instructions and pictorials. It's easy and fun to build a Heathkit Model SG-6 Signal Generator.



Heathkit CONDENSER CHECKER KIT

Only
\$19.50

Model C-2
Shipping Wt. 6 lbs.



Checks all types of condensers — paper — mica — ceramic — electrolytic. All condenser scales are direct reading and require no charts or multipliers. Covers range of .00001 MFD to 1000 MFD. A Condenser Checker that anyone can read. A leakage test and polarizing voltage for 20 to 500 V provided. Measures power factor of electrolytics between 0% and 50% and reads resistance from 100 ohms to 5 megohms. The magic eye indicator makes testing easy.

The kit is 110V 60 cycle transformer operated and comes complete with rectifier tube, magic eye tube, cabinet, calibrated panel and all other parts. Has clear detailed instructions for assembly and use.

NEW Heathkit SIGNAL TRACER AND UNIVERSAL TEST SPEAKER KIT

\$19.50

Model T-2
Shipping Wt. 7 lbs.

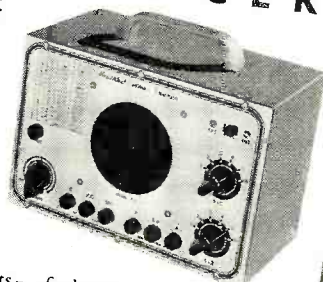

The popular Heathkit Signal Tracer has now been combined with a universal test speaker at no increase in price. The same high quality tracer follows signal from antenna to speaker — locates intermittents — finds defective parts quicker — saves valuable service time — gives greater income per service hour. Works equally well on broadcast, FM, or TV receivers. The test speaker has an assortment of switching ranges to match either push-pull or single output impedances. Also tests microphones, pickups and PA systems. Comes complete: cabinet, 110V 60 cycle power transformer, tubes, test probe, all necessary parts, and detailed instructions for assembly and use.



Model TC-1
Shipping Wt. 12 lbs.

\$29.50

Heathkit TUBE CHECKER KIT

The Tube Checker is a MUST for radio repair men. Often customers want to SEE tubes checked, and a checker like this builds customer confidence. In your repairing, you will have a multitude of tubes to check — quickly. The Heathkit tube checker will serve all these functions — it's good looking (with a polished birch cabinet and an attractive two color panel) — checks 4, 5, 6, 7 prong Octals, Loctals, 7 prong miniatures, 9 prong miniatures, pilot lights, and the Hytron 5 prong types. AND IT'S FAST TO OPERATE — the gear driven, free-running roll chart lists hundreds of tubes, and the smooth acting, simplified switching arrangement gives really rapid set-ups.

The testing arrangement is designed so that you will be able to test new tubes of the future — without even waiting for factory data — protection against obsolescence.

You can give tubes a thorough testing — checks for opens, shorts, each element individually, emission, and for filament continuity. A large BAD-?-GOOD meter scale is in three colors for easy reading and also has a "line-set" mark.

You'll find this tube checker kit a good investment — and it's only \$29.50.

YOU SAVE BY ORDERING DIRECT FROM MANUFACTURER—USE ORDER BLANK ON LAST PAGE

EXPORT AGENT
ROCKE INTERNATIONAL CORP.
13 E. 40th ST.
NEW YORK CITY (16)
CABLE, ARCADIA, N.Y.

The **HEATH COMPANY**

... BENTON HARBOR 15, MICHIGAN

NEW 1952 *Heathkit*
**BATTERY ELIMINATOR
 KIT**



Model BE-3
 Shipping Wt. 17 lbs.

- Can be used as battery charger.
- Continuously variable output 0 - 8 Volts — not switch type.
- Heavy duty Mallory 17 disk type magnesium copper sulfide rectifier.
- Automatic overload relay for maximum protection. Self-resetting type.
- Ideal for battery, aircraft and marine radios.
- Dual Volt and Ammeters read both voltage and amperage continually — no switching.

The new Heathkit Model BE-2 incorporates the best. Continuously variable output control is of the variable transformer type with smooth wiper type contacts. There are no switches or steps and voltage between 0 and 8 Volts is available at 10 Amperes continuous and 15 Amperes intermittent. Maximum safety from overloads and shorts provided by automatic overload relay which resets itself when overload is removed.

The new rectifier is a 17 plate Mallory magnesium copper sulfide type. This is the most rugged type available for long trouble-free use. Output is continuously metered by both a 0 - 10 Volt Voltmeter and a 0 - 15 Amp Ammeter. Shorted vibrators indicated instantly by ammeter. Equip now for all types of service — aircraft — marine — auto and battery radios — this inexpensive instrument vastly increases service possibilities — better be ready when the customer walks in.

NEW *Heathkit*
**SINE AND SQUARE WAVE
 AUDIO GENERATOR KIT**

Designed with versatility, usefulness, and dependability in mind, the AG-7 gives you the two most needed wave shapes right at your fingertips — the sine wave and the square wave.

The range switch and plainly calibrated frequency scale give rapid and easy frequency selection, and the output control permits setting the output to any desired level.

A high-low impedance switch sets the instrument for either high or low impedance output — on high to connect a high impedance load, and on low to work into a low impedance transformer with negligible DC resistance.

Coverage is from 20 to 20,000 cycles, and distortion is at a minimum — you can really trust the output wave shape.

Six tubes, quality 4 gang tuning condenser, power transformer, metal cased filter condenser, 1% precision resistors in the frequency determining circuit, and all other parts come with the kit — plus, a complete construction manual — A tremendous kit, and the price is truly low.

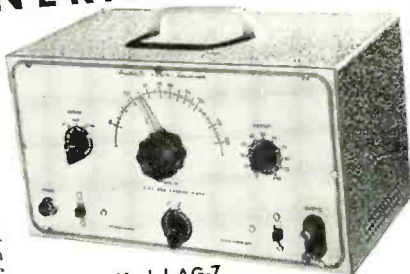

Model AG-7
 Shipping Wt. 15 lbs.

\$34.50

THE NEW *Heathkit*
HANDITESTER KIT

A precision portable volt-ohm milliammeter. Uses only high quality parts — All precision 1% resistors, three deck switch for trouble-free mounting of parts, specially designed battery mounting bracket, smooth acting ohm adjust control, beautiful molded bakelite case, 400 micro-amp meter movement, etc.

DC and AC voltage ranges 10 - 30 - 300 - 1000 - 5000V. Ohms range 0 - 3000 and 0 - 300,000. Range Milliampers 0 - 10 Ma, 0 - 100 Ma. Easily assembled from complete instructions and pictorial diagrams.



\$13.50

Model M-1
 Shipping Wt. 3 lbs.

NEW *Heathkit*
T.V. ALIGNMENT GENERATOR KIT

Here is an excellent TV Alignment Generator designed to do TV service work quickly, easily, and properly. The Model TS-2 when used in conjunction with an oscilloscope provides a means of correctly aligning television receivers.

The instrument provides a frequency modulated signal covering, in two bands, the range of 10 to 90 Mc. and 150 to 230 Mc. — ALL ALLOCATED TV CHANNELS AS WELL AS IF FREQUENCIES ARE COVERED.

An absorption type frequency marker covers from 20 to 75 Mc. in two ranges — therefore, you have a simple, convenient means of frequency checking of IF's, independent of oscillator calibration.

Sweep width is controlled from the front panel and covers a sweep deviation of 0-12 Mc. — all the sweep you could possibly need or want.

And still other excellent features are: Horizontal sweep voltage available at the front panel (and controlled with a phasing control) — both step and continuously variable attenuation for setting the output signal to the desired level — a convenient instrument stand-by position — vernier drive of both oscillator and marker tuning condensers — and blanking for establishing a single trace with base reference level. Make your work easier, save time, and repair with confidence — order your Heathkit TV Alignment Generator now!

Model TS-2
 Shipping Wt. 20 lbs.

\$39.50



YOU SAVE BY ORDERING DIRECT FROM MANUFACTURER — USE ORDER BLANK ON LAST PAGE

EXPORT AGENT
 ROCKE INTERNATIONAL CORP.
 13 E. 40th ST.
 NEW YORK CITY (16)
 CABLE: AREA-N.Y.

The **HEATH COMPANY**

... BENTON HARBOR 15, MICHIGAN



Model 1B-1B
Shipping Wt. 15 lbs.

\$69⁵⁰

Heathkit IMPEDANCE BRIDGE KIT

This Impedance Bridge Kit is really a favorite with schools, industrial laboratories, and serious experimenters. An invaluable instrument for those doing electrical measurements work. Reads resistance from .01 Ohms to 10 meg., capacitance from .00001 to 100 MFD, inductance from 10 microhenries to 100 henries, dissipation factor from .002 to 1, and storage factor from 1 to 1000. And you don't have to worry about selecting the proper bridge circuit for the various measurements—the instrument automatically makes the correct circuit when you set up for taking the measurement you want. Bridge utilizes Wheatstone, Hay, Maxwell, and capacitance comparison circuits for the wide range and types of measurements possible. And it's self powered—has internal battery and 1000 cycle hummer. No external generator required—has provisions for external generator if measurements at other than 1000 cycles are desired. Kit utilizes only highest quality parts, General Radio main calibrated control. Mallory ceramic switches, excellent 200 microamp zero center galvanometer, laboratory type binding posts with standard 3/4 inch centers, 1% precision ceramic-body type multiplier resistors, beautiful birch cabinet and ready calibrated panel. (Headphones not included.)

Take the guesswork out of electrical measurements—order your Heathkit Impedance Bridge kit today—you'll like it.

Heathkit LABORATORY RESISTANCE DECADE KIT



\$19⁵⁰

Shipping Wt. 4 lbs.

An indispensable piece of laboratory equipment—the Heathkit Resistance Decade Kit gives you resistance settings from 1 to 99,999 ohms IN ONE OHM STEPS. For greatest accuracy, 1% precision ceramic-body type resistors and highest quality ceramic wafer switches are used.

Designed to match the Impedance Bridge above, the Resistance Decade Kit has a beautiful birch cabinet and attractive panel. It's easy to build, and comes complete with all parts and construction manual.

Heathkit LABORATORY POWER SUPPLY KITS

Limits:

No load.....	Variable	150-400V DC
25 MA.....	Variable	30-310V DC
50 MA.....	Variable	25-250V DC

Higher loads: Voltage drops off proportionally

Every experimenter needs a good power supply for electronic setups of all kinds. This unit has been expressly designed to act as a source. Voltage control allows selection of HV output desired (continuously variable within limits outlined), and a Volts-Ma switch provides choice of output metering. A large plainly marked and direct reading meter scale indicates either DC voltage output in Volts or DC current output in Ma. (Range of meter 0-500V D.C., 0-200 Ma. D.C.). Instrument has convenient stand-by position and pilot light.



\$29⁵⁰

Model PS-1.....Ship. Wt. 20 lbs.

Comes with power transformer, filament transformer, meter, 5Y3 rectifier, two 1619 control tubes, completely punched and formed chassis, panel, cabinet, detailed construction manual, and all other parts to make the kit complete

Heathkit ECONOMY... 6 WATT AMPLIFIER KIT



MODEL A-7
Shipping Wt. 8 lbs.

\$14⁵⁰

- Choice of 4-8-15 ohm output impedances.
- Response flat $\pm 1\frac{1}{2}$ db from 20—20,000 cycles.
- 6 watts output.
- Good fidelity at low cost.
- Output tubes working in push pull.
- Volume, bass, and treble controls.
- Two separate inputs.

The purpose of this kit is to provide to the kit builder a low cost amplifier with excellent fidelity. The circuit consists of four tubes with following functions: a 12SL7, one section working as an amplifier and one as a phase splitter, two 12A6 output tubes working in push pull, and a 5Y3 rectifier in a full wave rectifier circuit.

The unit operates from a husky power transformer, and has good output transformer with a choice of 4—8—15 ohm output impedances. (Speaker not included).

The kit provides excellent listening pleasure and the price is really low. Compare it with all others. You won't find a better buy.

MODEL A-7: For tuner and crystal phono inputs. Has two position selector switch for convenient switching to type of input desired.

Model A-7-A: Has a 12SH7 preamplifier stage with special compensation network for operation with reluctance phono input. Shipping Wt. 8 lbs.....**\$16.50**

Heathkit HIGH FIDELITY 20 WATT AMPLIFIER KIT

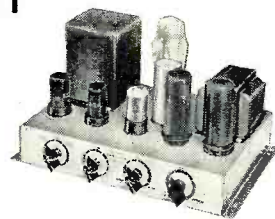

MODEL A-8
Shipping Wt. 18 lbs.

\$33⁵⁰

The A8 (or A-8A) is a high quality amplifier for those who want high fidelity output at moderate cost. Frequency response within ± 1 db from 20—20,000 cycles. Distortion at 3db below maximum power output (at 1,000 cycles) is only .8%. Kit has a Chicago power transformer in drawn steel case and a Peerless output transformer with output impedances of 4—8—16 ohms. Bass and treble controls permit listener to select output with tonal qualities of his own liking.

The tube lineup is composed of a 6SJ7 voltage amplifier, a 6SN7 amplifier and phase splitter, two 6L6's in push-pull output and a 5U4G rectifier. All parts furnished (speaker not included) and the construction manual makes assembly easy.

MODEL A-8: For tuner and crystal phono inputs. Has two position selector switch for convenient switching to type of input desired.

MODEL A-8A: Features an added 6SJ7 stage (preamplifier) for operating from variable reluctance cartridge phono pickup, mike input, and either tuner or standard crystal phono pickup. A three position selector switch provides flexible switching. Shipping Wt. 18 lbs.....**\$35.50**

YOU SAVE BY ORDERING DIRECT FROM MANUFACTURER—USE ORDER BLANK ON LAST PAGE

EXPORT AGENT
ROCKE INTERNATIONAL CORP.
13 E. 40th ST.
NEW YORK CITY (16)
CABLE: ARLAB-N.Y.

The HEATH COMPANY

... BENTON HARBOR 15, MICHIGAN

Heathkit RECEIVER & TUNER KITS for AM and FM



\$19.50

Model BR-1 Broadcast Model Kit covers 550 to 1600 Kc. Shipping Wt. 10 lbs.

Model AR-1 3 Band Receiver Kit covers 550 Kc. to over 20 Mc. continuous. Extremely high sensitivity. Shipping Wt. 10 lbs.

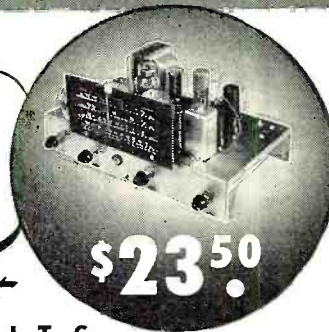

\$23.50

TWO HIGH QUALITY Heathkit SUPERHETERODYNE RECEIVER KITS

Two excellent Heathkits. Ideal for schools, replacement of worn out receivers, amateur and custom installations.

Both are transformer operated quality units. The best of materials used throughout — six inch calibrated slide rule dial — quality power output transformers — dual iron core shielded. I.F. coils — metal cased filter condenser. The chassis has phono input jacks, 110 Volt output for phono motor and there is a phono-radio switch on panel. A large metal panel simplifying installation in used console cabinets is included. Comes complete with tubes and instruction manual incorporating pictorials and step-by-step instructions (less speaker and cabinet). The three band model has simple coil turret which is assembled separately for ease of construction.

TRUE FM FROM Heathkit FM TUNER KIT

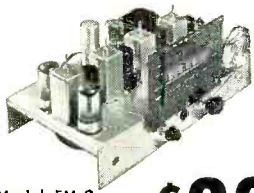

Model FM-2
Ship. Wt. 9 lbs.

\$22.50

The Heathkit FM Tuner Model FM-2 was designed for best tonal reproduction. The circuit incorporates the most desirable FM features — true FM.

Utilizes 8 tubes: 7E5 Oscillator, 6SH7 mixer, two 6SH7 IF amplifiers, 6SH7 limiter, two 7C4 diodes as discriminator, and 6X5 rectifier.

The instrument is transformer operated making it safe for connection to any type receiver or amplifier. Has ready wound and adjusted RF coils, and 2 stages of 10.7 Mc IF (including limiter). A calibrated six inch slide rule dial has vernier drive for easy tuning. All parts and complete construction manual furnished.



MAIL TO THE
HEATH COMPANY
BENTON HARBOR 15,
MICHIGAN

ORDER BLANK

From _____

SHIP VIA

- Parcel Post
- Express
- Freight
- Best Way

Quantity	Item	Price	Quantity	Item	Price
	Heathkit Oscilloscope Kit — Model O-7			Heathkit H.V. Probe Kit — No. 336	
	Heathkit VTVM Kit — Model V-5			Heathkit R.F. Signal Gen. Kit — Model SG-6	
	Heathkit FM Tuner Kit — FM-2			Heathkit Condenser Checker Kit — Model C-2	
	Heathkit Broadcast Receiver Kit — Model BR-1			Heathkit Handitester Kit — Model M-1	
	Heathkit Three Band Receiver Kit—Model AR-1			Heathkit Power Supply Kit — Model PS-1	
	Heathkit Amplifier Kit — Model A-7 (or A-7-A)			Heathkit Resistance Decade Kit — Model RD-1	
	Heathkit Amplifier Kit — Model A-8 (or A-8A)			Heathkit Impedance Bridge Kit — Model IB-1B	
	Heathkit Tube Checker Kit — Model TC-1			Heathkit A.C. VTVM-KIT — Model AV-1	
	Heathkit Audio Generator Kit — Model AG-7			Heathkit Intermodul. Analyzer Kit—Model IM-1	
	Heathkit Battery Eliminator Kit — Model BE-2			Heathkit Audio Freq. Meter Kit — Model AF-1	
	Heathkit Electronic Switch Kit — Model S-2			Heathkit Square Wave Gen. Kit — Model SQ-1	
	Heathkit T.V. Alignment Gen. Kit — TS-2				
	Heathkit Signal Tracer Kit — Model T-2				
	Heathkit R.F. Probe Kit — No. 309				

On Parcel Post Orders, include postage for weight shown and insurance. (We insure all shipments.)

On Express Orders, do not include transportation charges — they will be collected by the Express Agency at time of delivery.

Enclosed find Check Money Order for _____

Please ship C.O.D. Postage enclosed for _____ lbs.

ALL PRICES SUBJECT TO CHANGE WITHOUT NOTICE

EXPORT AGENT
ROCKE INTERNATIONAL CORP.
13 E. 40th ST.
NEW YORK CITY (16)
CABLE: ARLAB-N.Y.

The **HEATH COMPANY**

... BENTON HARBOR 15, MICHIGAN

RADIOTELEPHONE LICENSE MANUAL

Now, in one convenient volume, all the information necessary to obtain your radiotelephone license. Contains four elements:

- ELEMENT I:
Questions on Basic Law
- ELEMENT II:
Basic Operating Practice
- ELEMENT III:
Basic Radiotelephone
- ELEMENT IV:
Advanced Radiotelephone

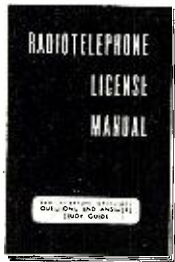

\$3.75 per copy
(plus any tax)

RADIO HANDBOOK

13TH EDITION



THE
ONE-VOLUME
REFERENCE
LIBRARY FOR
PRACTICAL
RADIOMEN,
TECHNICIANS
AND ADVANCED
AMATEURS!

734 PAGES!

How to design, construct and operate standard types of radio transmitting and receiving equipment, at standard frequencies

and in the v-h-f range. Profusely illustrated and indexed, with a multitude of new ideas for improved operation. THE LARGEST "RADIO HANDBOOK" EVER PUBLISHED.

\$6.00 per copy
(plus any tax)

WORLD'S RADIO TUBES

BRAN'S "VADE-MECUM"

The most complete listing of transmitting and receiving tubes available. More than 15,000 tubes from 253 manufacturers. Characteristic tube data of United States, British, French, Czech, German, Russian, Australian, Hungarian, Swedish, Japanese, Danish, Dutch, Spanish, Belgian, Argentine and all other available types. New 1952 edition available in 16 languages.



\$5.00 per copy
(plus any tax)

BUY FROM YOUR DISTRIBUTOR

ADD 10% ON DIRECT MAIL ORDERS TO

EDITORS AND ENGINEERS, LTD.
BOX 689A, SANTA BARBARA, CALIF.

Bookstores order from BAKER & TAYLOR, Hillside, N.J.

TV Antenna Couplers

(Continued from page 49)

appear when this type of coupler is used. The great advantage of this circuit over the resistor pad is the fact that it will work well on fairly weak signals. The transformer losses are quite small and for all practical purposes a 1000 microvolt signal will produce almost 500 microvolts at each receiver, sufficient for good pictures. In the case of resistive pads a 1000 microvolt signal would hardly be usable. Oscillator radiation interference is present only when the two receivers are tuned to two different channels where the oscillator frequency of one falls within the r.f. channel of the other. As long as this condition is avoided, the transformer-type coupling unit shown in Fig. 3 can be recommended, especially for near-fringe areas. Although the bandwidth of this transformer is quite broad, some difference will be observed on different channels. One such commercial unit, using this circuit, is shown at the right in the photo, page 48. In installing such a device the two transmission lines going to the receivers should be kept separate. Under no circumstances should they be mounted alongside each other on a molding or wall. The JFD "TelePlex" unit, page 48, has the additional feature of a built-in lightning arrester which serves as protection for both TV sets. In order for this arrester to be effective, however, a good ground must also be provided.

Another type of commercial antenna coupling unit was described in detail in the article "Built-in Home TV System" appearing in the January 1952 issue of this magazine. In that unit the equivalent of transmission line circuits were used to get four isolated signals from a single antenna. The great advantage of this particular circuit lies in its low signal loss and it is, therefore, especially useful in weak signal areas. See page 48 (left). In a showroom where all receivers are close together and can be tuned to such channels as to avoid interference between sets, the Brach coupling is quite suitable. One drawback with this circuit is the fact that since all four receivers are effectively in series, oscillator radiation is often present.

There are several other antenna coupling units on the market and their principle of operation is usually based either on the transformer circuit shown in Fig. 3 or on transmission line theory.

Distribution Amplifiers

We have dealt with the problem of operating several receivers from a single antenna by assuming that a fairly strong signal is available. As we have shown, the solution to this problem is not too complex or expensive, but once the signal drops below about 1000 microvolts and more than two or four receivers must be fed, the installation becomes quite expensive.

If the signal strength varies between 50 and 500 microvolts at the antenna and two or three receivers are used, a booster can be used in conjunction with either resistive pads or one of the commercial coil-type couplers. In a location where only one station is received, possibly in both TV bands, a special broadband booster is required. The best solution in this instance would be to use one of the new weatherproof types that is permanently installed at the antenna. A transmission line is brought to a convenient spot near the first receiver and then the line is coupled to the different television receivers. The only function of the booster in this application is to provide sufficient signal strength to permit some attenuation. Before such an installation is made it will be helpful to know the gain of the booster over the channels being used and the amount of signal present at the antenna.

Where the signal is considerably less than 200 microvolts or a large number of receivers are to be operated, a specially engineered distribution amplifier and network is indicated. Page 48 (center) is the DAB 1 M distribution amplifier manufactured by *Blonder-Tongue Labs*. This unit is typical of many similar amplifiers such as the "Tacoplex" apartment house TV system, the "Intravideo," and many other multiple installation systems. Basically it consists of an amplifier section for each received channel. The signal can be obtained either from a common antenna or from individual antennas aimed at one particular station. Each signal is amplified according to its need and fed to a cathode follower. The output signals from the various cathode followers are carried by regular transmission lines to the different receivers. Since the signal leaving the amplifier is quite strong, it is possible to use resistor pads at each receiver to reduce oscillator radiation between sets. Another feature of such an amplifier is that although different stations are received at different signal strengths, the amount of amplification can be regulated so that signal strengths are all equal when they reach the receivers.

As we mentioned before, the cost of such an installation is quite high. A complete system for a 100 family apartment house may cost up to \$10,000. A really large distribution system requires considerable engineering and involves test equipment and procedures not normally within the reach of the average service technician. But for some of the smaller installations where four to ten receivers are used it is possible and quite profitable for the technician to obtain a commercial distribution amplifier and do the entire job. Before embarking on any elaborate installation it will be wise to check local regulations on house wiring, fire ordinances, etc. Manufacturers' literature and detailed instructions should be followed closely with special consideration being given to local conditions. A detailed analysis should be made of the number and locations of

Simpson model 480 genescope

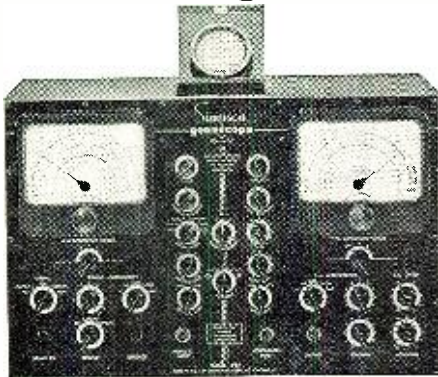

DON ANDERSON
HOFFMAN

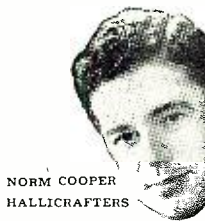

NORM COOPER
HALLCRAFTERS



FRANK SMOLEK
ZENITH



MAX SCHINKE
ADMIRAL



FLOYD MAKSTEIN
EMERSON

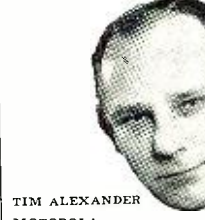

TIM ALEXANDER
MOTOROLA

RECOMMENDED

by service managers of leading manufacturers

These leading service managers agree the Simpson Model 480 Genescope is THE instrument for accurate testing and alignment of TV and FM receivers.

It provides ALL the necessary signal sources and includes the famous Simpson high sensitivity oscilloscope completely equipped with a high frequency crystal probe for signal tracing. Also available without the oscilloscope as Simpson Model 479 TV-FM Signal Generator.

For complete specifications see your Parts Distributor or write SIMPSON ELECTRIC COMPANY, 5200 W. KINZIE ST., CHICAGO 44.

BURTON BROWNE ADVERTISING

receivers, total signal required, length of lines, number and types of antennas, and the amplification necessary for each station. Be sure to list all these items, together with the impedance of the antenna and the different receivers, before deciding on a specific amplifier. All these factors are the cornerstone of a successful multiple TV installation and no amount of modification and adjustment later can make up for careful and exact planning. -30-

DIODES IN FM DETECTORS

By ARTHUR TRAUFFER

AFTER reading the series of articles "Crystal Diodes in Modern Electronics" currently running in RADIO & TELEVISION NEWS, experimenters and service technicians will want to try replacing tubes with germanium diodes in FM detectors and a.f.c. circuits.

In sets using a 6H6 in a Foster-Sceley discriminator, ratio detector, or a.f.c. circuit, quick and simple changeover to germanium crystals can be accomplished without disturbing any of the set wiring. See the photograph and the diagram of Fig. 1. Simply remove the base of an old 6H6 or other octal tube and mount the crystal diodes in the base as shown. The wire leads on the crystals are soldered into the tube base prongs. To use, simply pull out the 6H6 and plug in the crystals.

The writer uses a pair of 1N34's but it's best to use a 1N35 which consists of a pair of carefully matched 1N34's.

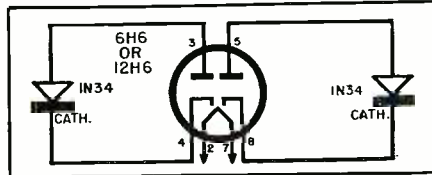

Fig. 1. Diagram showing how germanium diodes can be connected to the base of a 6H6, 6H6GT, or 12H6 octal tube.

This kink does not apply to the 6AL5 which has a non-removable base or to sets having tube heaters series-wired.

As explained by Mr. Armstrong in his series, better circuit balance is sometimes obtained by shunting a resistor across each crystal diode. In this case, simply parallel-mount the resistors, reaming the bottom openings in the tube base prongs, if necessary, to accommodate the extra lead. -30-

How converted socket looks when the germanium crystal diode is in place.



INDISPENSABLE! PHOTOFACT BOOKS



Photofact Television Course. Covers TV principles, operation and practice. 216 pages; profusely illustrated; 8 1/2 x 11". Order **TV-1**.....Only **\$3.00**

Television Antennas. New 2nd edition. Describes all TV antenna types; tells how to select, install, solve troubles. Saves time; helps you earn more. 200 pages; illustrated. Order **TAG-1**.....Only **\$2.00**

Television Tube Location Guide. Volume 2. Accurate diagrams show position and function of all tubes in hundreds of TV sets; helps you diagnose trouble without removing chassis. 224 pages; pocket-size. Order **TGL-2**. Only **\$2.00**

Television Tube Location Guide. Vol. 1. Over 200 pages of TV receiver tube position diagrams on hundreds of models. Order **TGL-1**.....Only **\$1.50**

Making Money in TV Servicing. Tested proved methods of operating a profitable TV service business. Covers all important phases. Authoritative, valuable guide to success. Over 130 pages. Order **MM-1**.....Only **\$1.25**

Servicing TV in the Customer's Home. Shows how to diagnose trouble using capacitor probe and VTVM. Short-cut methods help save time, earn more on outside service calls. Order **TC-1**.....Only **\$1.50**

1949-1950 Record Changer Manual. Vol. 3. Covers 44 models made in 1949, including multi-speed changers and wire and tape recorders. Original data based on actual analysis of equipment. 286 pages; 8 1/2 x 11"; paper-bound. Order **CM-3**.....Only **\$3.00**

1948-1949 Changer Manual. Vol. 2. Covers 45 models made in 1948-49. Paper bound. Order **CM-2**. Only **\$4.95**

1947-1948 Changer Manual. Vol. 1. Covers 40 post-war models up to 1948. Order **CM-1**.....Only **\$3.95**

Recording & Reproduction of Sound. 2nd Edition. New, completely revised and vastly enlarged edition of the outstanding original volume. The most authoritative treatment of all phases of recording and amplification ever written. Over 800 pages. 6 x 9". Order **RR-2**. Only **\$7.95**



Audio Amplifiers. Vol. 3. Clear, uniform, accurate data on 50 important audio amplifiers, plus full coverage of 22 FM and AM tuners, produced during 1950. 362 pages, 8 1/2 x 11". Order **AA-3**.....Only **\$3.95**

Audio Amplifiers. Vol. 2. A complete analysis of 104 well-known audio amplifiers and 12 tuners made 1949-50. 368 pages, 8 1/2 x 11". Order **AA-2**.....Only **\$3.95**

Audio Amplifiers. Vol. 1. 102 amplifiers and FM tuners made through 1948. 352 p. Order **AA-1**.....Only **\$3.95**

Auto Radio Manual. Complete service data on more than 100 post-war auto radio models. Covers over 24 mfrs. 350 pages, 8 1/2 x 11". Order **AR-1**.....Only **\$4.95**

Communications Receiver Manual. Complete analysis of 50 popular communications models. 246 pages, 8 1/2 x 11". Order **CR-1**.....Only **\$3.00**

Radio Receiver Tube Placement Guide. Accurate diagrams show where to replace each tube in 5500 radio models, covering 1938-1947 receivers. 192 pages, pocket-size. Order **TP-1**.....Only **\$1.25**

Dial Cord Stringing Guide. Vol. 2. Covers receivers made from 1947 through 1949. Shows you the one right way to string a dial cord in thousands of models. Pocket-size. Order **DC-2**.....Only **\$1.00**

Dial Cord Guide. Vol. 1. Covers sets produced 1938 through 1946. Order **DC-1**.....Only **\$1.00**

Order from your Parts Jobber or write direct to
HOWARD W. SAMS & CO., INC., 2201 E. 46th St., Indianapolis 5, Indiana

HOWARD W. SAMS & CO., INC.

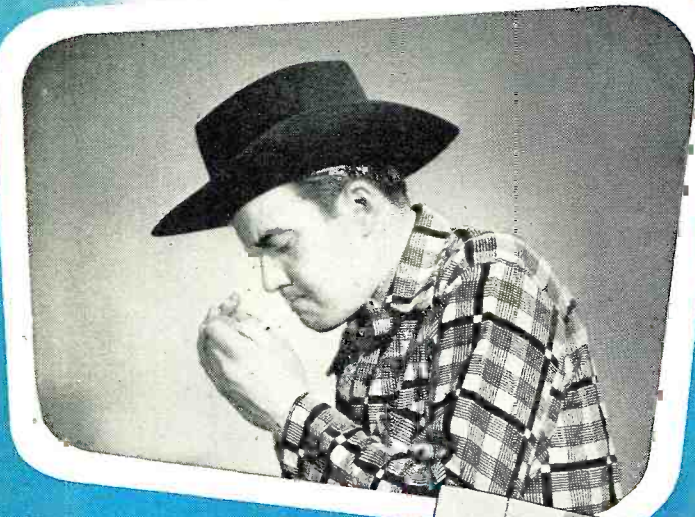
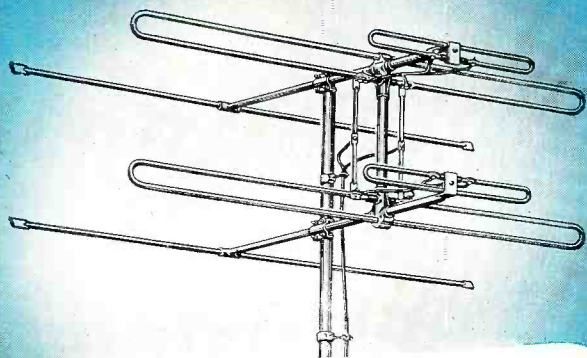

AMPHENOL

this 
Book



... contains information never before available in a concise, readable form. It presents a complete discussion of the factors and conditions which affect television reception and the reasons for good TV pictures. The one single factor which contributes the most to Better TV Picture Quality is the television antenna. The best and most expensive TV set can present a picture no better than that received by the antenna.

This book gives a detailed discussion, complete with illustrations and graphs, of the various types of antennas, their characteristics and performance under given conditions. In addition, the book contains information on the problem of coordinating the antenna with the location.

Your Authorized Amphenol Distributor has a free copy of this book waiting for you—ask for yours today!

AMERICAN PHENOLIC CORPORATION

1830 SOUTH 54th AVENUE • CHICAGO 50, ILLINOIS

AMPHENOL

Spot Radio News

(Continued from page 18)

cases and on an entirely voluntary basis, related to the dispatching of trains and other utilities, the relaying of orders for emergency food supplies, the reporting of hourly weather observations, the bridging of gaps in commercial telegraph facilities for handling emergency and death messages and the relaying of personal messages regarding the health and safety of individuals . . ."

THE SPRAWLING GROWTH of radio, emphasized throughout the report and in a letter of transmittal to Congress, was described as having placed an unusual burden on the Commission's staff, seriously affecting its operation. According to Wayne C. Coy, the manpower problem has become extremely acute and additional funds are urgently needed to recruit help. He hoped, therefore, that the increase in the budget, indicated in President Truman's message, would be allowed. Specifically, about a twenty-four percent increase or about \$2 million more will be needed, noted the former FCC chairman. Senator Edwin Johnson revealed an intense interest in the Commission's problem and indicated that he will argue for more funds so that the FCC can do a . . . "bigger job."

THE FREEZE LIFT, which should be officially an item of the past when this column appears in print, is expected to inaugurate an exciting era for telecasters and viewers.

One of the features of the lift will be the allocations for eventually over 1500 new stations on the ultra-high band, or Channels 14 to 83. This new projected home for TVcasters has prompted many to make enthusiastic predictions on television's future. In one such forecasting mood, Zenith's Vice-President H. C. Bonfig said, during an address in Kansas City, Missouri: "Crystal gazing is always a rash venture, but on the basis of what we know about u.h.f. and what we know about the ability of engineers to discover new advantages in new frequencies, I make the prediction that the stations on the u.h.f. channels are going to render as good or better all-round service than the v.h.f. stations now in operation."

In Washington, during a consulting engineering seminar, a striking interest was also exhibited in the potentialities of the higher bands. So keen was this ultra-high interest that the manufacturer who sponsored the meeting decided to announce the possibilities of the new channels in page ads in the metropolitan dailies. And during the sessions, it was disclosed that three types of converters would be available during the early fall for high-band pickup: single- and two-station, and all-channel converters, with prices ranging from about \$10 to \$50. It was also said that all new receivers would be able to accommodate the converters or combination very-high/ultra-high 16-station tuner heads that will be produced soon, too. Consultants and industry specialists at the meeting also predicted that there would be a supply of transmitters and auxiliary gear available for the new stations scheduled to operate on the low or new high bands. It was believed that as many as 22 new v.h.f. stations may go on the air before the year is out and perhaps a few on the higher bands. Next year should see at least 60 u.h.f. stations operating.

COLOR IN TV, which with the issuance of the Wilson order curbing set production, returned quietly to conservative labs and sombre meeting rooms, roared back to the headlines shortly after the New Year holidays, when NPA called a meeting to reappraise the clamp ruling.

The return visit of industry to a color conclave was, in part, inspired by an exchange of correspondence between Defense Chief Charles Wilson and Senator Edwin Johnson, who had felt that the original desist order was . . . "an unwarranted crippling blow aimed directly and specifically at color television." In the Senator's opinion . . . "Every conceivable legal maneuver and technical roadblock has been used in the past years to delay the availability of color television to the public . . ." and the curb ruling pro-

vided the halt result that he and others were interested in avoiding. Declaring that the order was an attempt to regulate the end product, the fiery Senator asked Wilson: "What difference is there to the defense effort once you have made the allocation of the materials, as to whether or not the materials are used for black and white or color?"

Roaring statements sparked the recall meeting. In a specially-prepared ten-page document, RCA's Board Chairman David Sarnoff accused CBS of failure to bring color to the public at moderate prices, as forecast at Commission hearings. He noted that Columbia had promised that color sets would be available at about \$300, but instead they offered sets . . . "with a ten-inch picture tube . . . at a price of more than \$600 for the set including installation, warranty and taxes." Adding that this increase had been made in a market in which prices on black and white sets were dropping rapidly, Mr. Sarnoff said that even . . . "CBS cut prices on its own . . . sets by 20 per-cent." The statement then noted that the adapters promised by CBS were never put on the market. And, declared Mr. Sarnoff . . . "Instead of converters selling for at \$110 to \$150 as . . . promised . . . CBS announced in July of '51 that it intended to put slave converters on the market which would sell for about \$250. These converters, likewise, never reached the market."

Charging too that the sequential proponents also failed in their broadcast promises, he noted that . . . "CBS never broadcast even half of its promised regular schedule of 20 hours of color a week by September 25, the end of the three-month period."

Discussing the CBS request for a quarter-of-a-million fractional horsepower motors for '52, which were to be used to turn the wheels in the mechanical color sets, Mr. Sarnoff indicated that it was generally known that these motors . . . "have been in short supply as a result of defense work." In any event, the board chairman added . . . "Even according to the optimistic prediction of CBS' manufacturing subsidiary prexy . . . CBS only intended to turn out color television sets at the rate of 80,000 a year. . . . And it is doubtful whether . . . CBS could have reached this figure during '52, even if it were allotted all the material it asked for. . . . It is obvious that CBS made an unreasonable request, which it was expected, NPA would be obliged to deny."

In reply, CBS Prexy Frank Stanton described the contributions his company had made to color which . . . "cannot be obscured by unprincipled attacks." In the interest of the public, he added, if . . . "anyone thinks that new color television standards should be adopted . . . let him take these issues before the FCC . . . where they can be resolved by testimony under oath and by actual demonstration of performance."

April, 1952

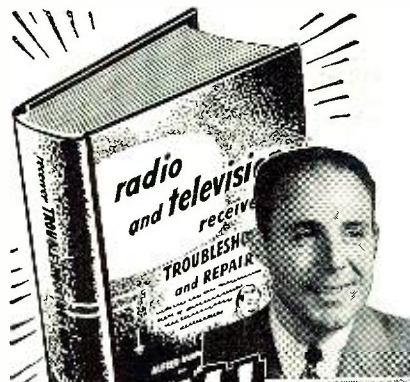

NOW! **GHIRARDI'S Complete**
Radio-TV Service Training Course
Helps you lick the toughest service problems!
Paves your way to the big-money jobs!

22 COURSES IN ONE!

Here is what this big book covers:

- 1—Receiver Components and Their Troubles; 2—How to Develop a Systematic Troubleshooting Procedure; 3—Basic Methods: Preliminary Questions and Checks; 4—Static Tests; 5—Dynamic Testing; 6—Practical Direct-Approach Troubleshooting; 7—Special Problems in AC/DC and 3-Way Portables; 8—Special Battery Set Problems; 9—Servicing Communications Receivers; 10—Troubleshooting Television Receivers; 11—Taking Performance Data; 12—Re-aligning AM Receivers; 13—Re-aligning FM; 14—Re-aligning TV; 15—Replacing Defective Resistors; 16—Replacement and Repair of R-F and I-F Inductors and Transformers; 17—Power, A-F and Deflection-Frequency Inductors and Transformers; 18—Defective Capacitors; 19—Servicing Tuning-Drive Mechanisms, Station-Selector and Band Switches; 20—Testing, Replacing and Repairing Loudspeakers; 21—Servicing Record-Playing Equipment; 22—Servicing Home Recorders.



**MONEY-SAVING
COMBINATION**

Make your service library complete—save money in the bargain. Get the above great new Ghirardi book PLUS the new Ghirardi **RADIO AND TELEVISION RECEIVER CIRCUITRY AND OPERATION** (issued only a few months ago) at the special price of only \$12.00 for the two. (Regular price for the two books is \$12.75.)

Ghirardi's **RECEIVER CIRCUITRY & OPERATION** brings you complete, easy training on the basic circuits and operating principles of all radios, TV sets, record players, etc. Makes you far less dependent on service manuals, mfrs.' data—helps you go right to the seat of troubles in 1/2 the usual time!

**SEE COMBINATION OFFER
IN COUPON**

RADIO and TELEVISION RECEIVER TROUBLE- SHOOTING and REPAIR

by A. A. Ghirardi and J. R. Johnson
820 pages, 417 illustrations, 6 x 9, price \$6.75

The complete know-how of service procedure by the most modern time-saving professional methods.

BRAND NEW! . . . JUST OFF PRESS

Here's the big book you've been waiting for . . . the new Ghirardi guide to modern Radio-TV servicing by professional methods . . . a book that can help give your earning power a big boost by teaching you to work faster, more efficiently on every receiver service job!

RADIO AND TV RECEIVER TROUBLESHOOTING AND REPAIR starts with a full analysis of radio-TV components and why they fail. Next you learn how to work by the most modern service methods—from quick analyses to static tests of electrical characteristics to dynamic signal tracing and signal injection. Special problems in ac/dc, battery sets and others are clearly explained.

MAKES TV TROUBLES EASY TO REPAIR

A big TV service section is arranged so that you can find answers to specific problems in a jiffy. Complete chapters greatly simplify alignment procedure for each type of receiver. Six chapters cover every phase of component replacement, testing, tuning problems, speaker troubles, etc. Over 400 illustrations make things doubly easy to understand—including dozens of unique step-by-step charts that explain complicated details of the work almost at a glance.

Nowhere else will you find servicing explained so clearly or in such handy form for either home study or on-the-job reference. Read this great book for 10 full days at our risk. MAIL COUPON TODAY!

FLASH! SHOULD SERVICEMEN BE LICENSED?

No matter how any of us may feel about it, the fact remains that many cities and states are now preparing laws requiring servicemen to undergo rigid licensing tests. Let these two Ghirardi books help prepare you today for any such test you might have to pass!

10-DAY EXAMINATION

Dept. RN-42, Rinehart Books, Inc., Technical Division,
232 Madison Ave., New York 16, N. Y.

Send the new Ghirardi **RADIO & TELEVISION RECEIVER TROUBLESHOOTING & REPAIR** for 10-day examination. If I like book, I will then promptly send \$6.75 in full payment. If not, I will return book postpaid in good condition and owe you nothing.

RADIO-TV SERVICE COMBINATION OFFER—Send above book PLUS **RADIO & TV RECEIVER CIRCUITRY AND OPERATION** on same examination basis. Special price for both books only \$12.00 (to be paid in 10 days, or books returned).

Name _____

Address _____

City, Zone, State _____

Employer's name & address _____

Prices outside U.S.A., cash only—\$7.25 for **RADIO AND TV RECEIVER TROUBLESHOOTING & REPAIR** or \$12.00 for **COMBINATION OFFER**. Money back if you return books within 10 days.

CHOICE OF T-V ENGINEERS

the new **GONSET**

RADARRAY

Used extensively by leading T-V stations and engineers.

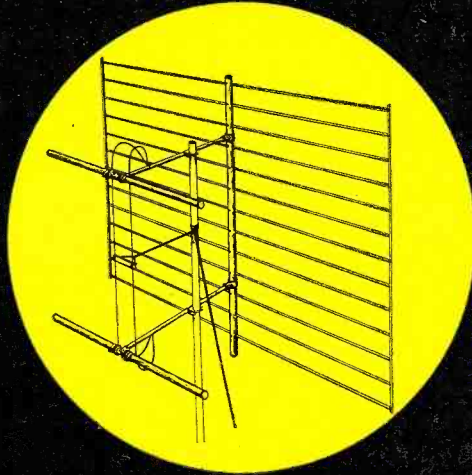

The favorite West Coast Antenna now available nationally. The exceptionally high gain and front to back ratio on **ALL 12 CHANNELS** makes the **GONSET RADARRAY** the number one choice for difficult installations. For the ultimate in television reception the new **GONSET RADARRAY** is the answer. No side lobes. Ruggedly constructed yet light enough to be used on a rotator.

Another engineering achievement by the originators of prefabricated open-wire line for T-V.



GONSET CO. RN
801 S. Main St., Burbank, Calif.
Please send RADARRAY ENGINEERING BROCHURE.
Name _____
Address _____
City _____ Zone _____ State _____

Appearing on behalf of *Chromatic Television Labs*, a *Paramount Picture* subsidiary interested in the *Lawrence* tube, Barney Balaban, *Paramount* prexy, said that the curb order . . . "penalizes efforts made to advance the electronic art under a system of free competition . . . and needlessly frustrates progress in TV."

While no decision had been made by NPA, as this column was being prepared, it was believed that the curb order would be tempered to permit the processing of theater and commercial color-system equipment, provided that this can be done with allotted materials. The ruling may also be rewritten to permit the manufacture of home color sets, if such sets can be made with components now available for general black and white chassis production. There was doubt that permission to make color sets would interest anyone, since materials are too short even for normal black and white model manufacture. However, the theater angle may appeal to many, for it might be possible to produce a few of the larger screen equipments with available parts and material; this should interest movie exhibitors and provide a means of evaluating the audience-building possibilities of such projection.

BROADCASTING on the sight-and-sound, and sound fronts, will this year, a presidential-election year, strike a new high in listener interest. Commenting on this, former FCC Chairman Wayne Coy noted, during an address in Cleveland: "During the last campaign, TV had an impact when there were only 1-million sets in use. Imagine what the impact will be in this fateful year of 1952 when there are 16-million sets in use and perhaps 60 per-cent of the American families looking in—seeing and hearing and understanding more about what goes on in the conventions than most of the spectators right in the hall. . . . It is already apparent that the expenditures for political time during this year will break all records. . . . In bringing listeners and viewers a well-rounded presentation of the convention activities and of the campaigns, radio stations—both aural and visual—will perform one of their most valuable services."

Declaring that during this year, more than ever before, the public will really begin to deeply appreciate the advantages offered by TV, the Commission's former chief said that television . . . "will bring to the fore the historic significance of two precious freedoms which are the common heritage of all of the American people; the freedom to look and the freedom to listen. . . . Only through the full exercise of these freedoms can the American people have in their broadcasting system the truly democratic instrument of information that their democratic society requires." Truly, an illuminating assessment of the power of television. . . . L.W.

EASY MONEY!!
If you don't get our postcards telling the cash we'll pay for that surplus gear you bought when the buying was good, then **YOU ARE LOSING MONEY!** So send us your name and address **NOW** and **GET ON OUR MAILING LIST!**
G. L. ELECTRONICS
905 S. VERMONT AVE., LOS ANGELES 6

EASY TO LEARN CODE

It is easy to learn or increase speed with an Instructograph Code Teacher. Affords the quickest and most practical method yet developed. For beginners or advanced students. Available tapes from beginner's alphabet to typical messages on all subjects. Speed range 5 to 40 WPM. Always ready—no QRM.

ENDORSED BY THOUSANDS!

The Instructograph Code Teacher literally takes the place of an operator-instructor and enables anyone to learn and master code without further assistance. Thousands of successful operators have "acquired the code" with the Instructograph System. Write today for convenient rental and purchase plans.

INSTRUCTOGRAPH COMPANY
4711 SHERIDAN ROAD, CHICAGO 40, ILLINOIS

BUY TEST EQUIPMENT ON THIS RADICALLY NEW TIME PAYMENT PLAN

NO INTEREST!! - NO CARRYING CHARGES!!

USE CONVENIENT TIME PAYMENT ORDER BLANK BELOW

Superior's New

JUNIOR SUPER-METER

MOST COMPLETE AND COMPACT MULTI-SERVICE INSTRUMENT EVER DESIGNED

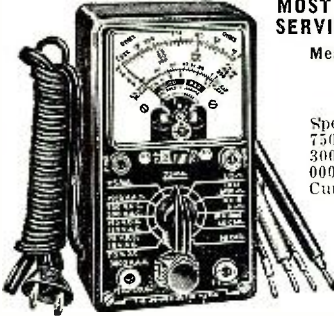

Measures: * Voltage * Decibels
* Capacity * Resistance
* Current * Inductance
* Reactance

Specifications: D.C. Volts: 0-7.5/75/150/750/1500 Volts. A.C. Volts: 0.15/150/300/1500/3000 Volts. Resistance: 0-10-100/100,000 ohms. 0-10 Megohms. D.C. Current: 0-7.5/75 Ma. 0-7.5 amps. Capacity: .001 Mfd.—2 Mfd. 1 Mfd.—20 Mfd. Electrolytic Leakage: Reads quality of electrolytics at 150 Volt test potential. Decibels: -10 Db to +18 Db. +10 Db. to +38 Db. +38 Db. to +58 Db. Reactance: 15 ohms—25 K ohms 15 K ohms—2.5 Megohms. Inductance: .5 Henry—50 Henries 30 Henries—10 K Henries. Plus Good-Bad scale for checking the quality of electrolytic condensers.

Handsome round cornered molded bakelite case 3 1/8" x 5 7/8" x 2 1/4" complete with all test leads and instructions

\$2140 NET

Superior's New Model TV-11

TUBE TESTER

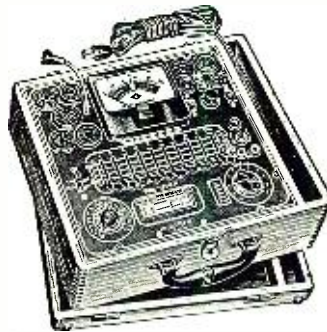

• Uses the new self-cleaning Lever Action Switches for individual element testing. Because all elements are numbered according to pin number in the RMA base numbering system, the user can instantly identify which element is under test. Tubes having tapped filaments and tubes with filaments terminating in more than one pin are truly tested with the Model TV-11 as any of the pins may be placed in the neutral position when necessary. • Uses no combination type sockets. Instead individual sockets are used for each type of tube. Thus it is impossible to damage a tube by inserting it in the wrong socket. • Free-moving built-in roll chart provides complete data for all tubes. • Phono jack on front panel for plugging in ether phones or external amplifier detects microphonic tubes or noise due to faulty elements and loose external connections.

Operates on 105-130 Volt 60 Cycles A.C. Hand-rubbed oak cabinet complete with portable cover

\$4750 NET

Superior's New Model CA-12

SIGNAL TRACER



The well known Model CA-12 is the only signal tracer in the low price range including both meter and speaker!!!

SPECIFICATIONS: • Comparative Intensity of the signal is read directly on the meter—quality of the signal is heard in the speaker. • Simple to Operate—only one connecting cable—no tuning controls. • Highly Sensitive—uses an improved vacuum-tube voltmeter circuit. • Tube and Resistor Capacity Network are built into the detector probe. • Built-In High Gain Amplifier—Alnico V Speaker.

Completely Portable—weighs 8 pounds—measures 5 1/2" x 6 1/2" x 9".

Model CA-12 comes complete with all leads and operating instructions

\$3395 NET

Superior's New

TV BAR GENERATOR

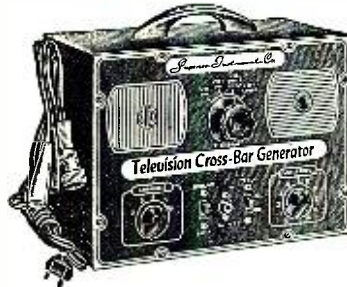

Throws an Actual Bar Pattern on Any TV Receiver Screen!!!

Two Simple Steps:

1. Connect Bar Generator to Antenna Post of any TV Receiver.
2. Plug Line Cord into A.C. Outlet and Throw Switch.

RESULT: A stable never-shifting vertical or horizontal pattern projected on the screen of the TV receiver under test.

TV Bar Generator comes complete with shielded leads and detailed operating instructions. Only

\$3995 NET

Power Supply: 105-125 Volt 60 Cycles. Power Consumption: 20 Watts. Channels: 2-5 on panel, 7-12 by harmonics. Horizontal lines: 4 to 12 (Variable). Vertical lines: 12 (Fixed). Vertical sweep output: 60 cycles. Horizontal sweep output: 15-750 Cycles.

Superior's New Model 660—AN AC OPERATED

SIGNAL GENERATOR

Provides Complete Coverage for A.M.-F.M. and TV Alignment

• Generates Radio Frequencies from 100 Kilocycles to 60 Megacycles on fundamentals and from 60 Megacycles to 240 Megacycles on powerful harmonics. • Accuracy and stability assured by use of permeability trimmed IF-Q coils. • A.F. available or modulated by the internal audio oscillator. • Built in 400 Cycle sine wave audio oscillator used to modulate the R.F. signal also available separately for audio testing of receivers, amplifiers, etc. • Oscillator Circuit: Uses a miniature high frequency type of acorn triode in a Hartley circuit to insure a high degree of stability. By using the same type of triode as a buffer amplifier, complete and positive isolation between the R.F. oscillator and the attenuator is attained. • Attenuator: a 3 step ladder type of attenuator is used. Each step of the attenuator is controlled by a separate attenuator control thus providing intermediate level steps. • Tubes used: 955, as R.F. Oscillator, 955 as Modulated Buffer Amplifier.



68N7 as Audio Oscillator and Power Rectifier.

The Model 660 comes complete with coaxial cable test lead and instructions

\$4295 NET

NEW TIME PAYMENT PLAN ORDER BLANK

MOSS ELECTRONIC DISTRIBUTING CO., INC. Dept. B-24, 38 Murray Street, New York 7, N. Y.

Please send me the units checked below. I am enclosing the down payment with order and agree to pay the monthly balance as shown. It is understood there will be no carrying interest or any other charges, provided I send my monthly payments when due. It is further understood that should I fail to make payment when due, the full unpaid balance shall become immediately due and payable.

- JUNIOR SUPER METER Total Price \$21.40
\$5.40 down payment. Balance \$4.00 monthly for 4 months.
- MODEL TV-11 Total Price \$47.50
\$11.50 down payment. Balance \$6.00 monthly for 6 months.
- MODEL CA-12 Total Price \$33.95
\$9.95 down payment. Balance \$4.00 monthly for 6 months.
- TELEVISION BAR GENERATOR Total Price \$39.95
\$9.95 down payment. Balance \$5.00 monthly for 6 months.
- MODEL 660 Total Price \$42.95
\$12.95 down payment. Balance \$5.00 monthly for 6 months.
- I enclose \$..... as down payment.
- Ship C.O.D. for the down payment.

Signature

Name

Address

City Zone..... State.....



HEAR YE! PROCLAMATION!

The most sensational offer-to-buy ever made! We've got \$53,361.22 to spend! We want to buy ALL TYPES of new and used RADIO GEAR...

IT'S BEEN FUN BUYING YER STUFF—BUT

remember we're in the business of selling it, too! We purchased rafts of gear all over the country...

MARINE GEAR—SUPER SPECIALS!

COLUMBIA MARINER: 100 W. 4-channel x-tal control. The best darn 100 W. marine xmtr on land or sea!

BC-223 TRANSMITTER: 25 W. 12 or 24 V. Complete with power supply, tubes and cables.

ARB RADIO-COMPASS RECEIVER: Covers 190-9,000 kcs. This set is dynamite for beacon, standard broadcast, marine and amateur use.

DU-1 DIRECTION FINDING LOOP: Swell for use with ARB Receiver. Excel. cond. PLUS FREE SCHEMATIC. ONLY \$27.50

5 W. MARINE RADIO TELEPHONE

Jefferson-Travis Emerson Radio Corp. Freq. 2-3 mcs. 2-channel, x-tal control. Complete with mike, speaker, 110 V. charging unit...

MN26-C RADIO COMPASS: Complete with tubes, loop, flex cables, plugs and control box. Excel. cond. \$89.95

MOBILE EQUIPMENT

ARC-4 VHF TRANSCEIVER: Freq. range: 140-144 mcs. Fine for 2-meter, novice, CAP. 12 or 24 V. input.

SCR-522 VHF TRANSMITTER & RECEIVER: Freq. range: 100-156 mcs. Xtal controlled, SUPER FOR ALL VHF WORK.

AIRCRAFT EQUIPMENT

Wild Blue Yonder Boys—Check These!

ARN-7 MN-26-C SCR-269 ARR-5 ARR-7 HS-33 Headset VHF ARC-5 MN24C Loop (CAA)

TUBES

Table listing tube types and prices: 2AP1 \$10.95, 6J7 \$0.75, 813 \$9.95, 5BP4 4.95, 6K7 1.10, 829B 9.95, 6AC7 1.50, 6L6M 2.50, 832A 9.95, 6AG7 1.25, 6X5 .75, 1625 .59

ARC-5 OR 274-N TRANSMITTERS

2.1-3 mcs. New \$19.95
3-4 mcs. Used, excel. cond. 14.95
4-5 mcs. Used, good cond. 6.95
5.3-7 mcs. 5.50
5-B-1 12.50

ARC-5 OR 274-N RECEIVERS

.35-1.3 mcs. Brand new \$49.50
1.5-3 mcs. Brand new 24.50
6-9.1 mcs. Brand new 11.95

28 V. RECEIVER DYNAMOTOR 1.50
RACK FOR DUAL TRANSMITTER (274-N) 2.95
TRIPLE RECEIVER RACK 5.00
BC-442-A ANTENNA RELAY with 50 mmfd. condenser. Excel. cond. 3.95

FILAMENT TRANSFORMER: 9, 10, 11, 12 and 13 V. @ 3 amps. Terrific for Command conversion and H.O. Model Work. AND BRAND NEW, TOO! Only \$1.89

JUST SIGNED NEW LEASE! Yep, good old Columbia Electronics Sales just signed new long term lease and will continue to maintain our buying warehouse at same address.

All orders F.O.B. Los Angeles, 25% deposit required. All items subject to prior sale.

COLUMBIA ELECTRONIC SALES
522 South San Pedro Street
LOS ANGELES 13, CALIFORNIA

PHONO-EQUALIZER CHART

By CHARLES P. BOEGLI

INASMUCH as new data has become available since the publication of the author's article, "An Improved Equalizer-Preamp" in the April 1951 issue, it is now possible to revise the equalizer design chart which accompanied the original article.

The new information includes the establishment of a standard playback curve by the Audio Engineering Society and the publication of recording characteristics by RCA Victor. Of particular note is the fact that the new RCA Victor recording curve, which is the same for all speeds, is identical to the AES curve.

It should also be noted that London FFRR 33 1/3 rpm records follow the NAB characteristic, the previous table was in error on these discs. The 78 rpm FFRR records, both Decca and London, follow the previously published curve.

The final addition to the chart is an equalizer for a flat characteristic with a 350 cps bass turnover. This frequency

lies midway between 250 and 500 cps and the new equalizer will be found acceptable in most cases. The other two, the 250 and 500, are included in the table for those who wish them, but there would be little point in including all three in any amplifier.

One worthwhile improvement has been incorporated into the construction of the preamp by several builders. It consists in mounting the equalizers on a three-gang rotary switch with the gangs properly spaced to avoid over-crowding.

The potting of the equalizers, if desired, may be carried out not only with hard microcrystalline wax but also with any other suitable compound such as ceresine wax or a commercial potting compound.

Equalizers of the type described can be used not only in the small preamplifier which was the subject of the previous article, but also following a triode stage in any amplifier.

The assistance of T. B. Couch of New Rochelle, N. Y. and Willis Cox of Cincinnati, Ohio in providing helpful information on response curves and construction data is hereby acknowledged with gratitude.

REVISED EQUALIZER CHART

Table with 4 columns: EQUALIZER CHARACTERISTIC, EQUALIZER DESIGN, GOOD COMPENSATION FOR, ACCEPTABLE COMPENSATION FOR. Rows include (A) Flat 250 cps turnover, (B) Flat 500 cps turnover, (C) Flat 350 cps turnover, (D) AES 400 cps bass turnover, (E) NAB 500 cps bass turnover, (F) 400 cps bass turnover, (G) 300 cps bass turnover, (H) 500 cps bass turnover.

Over a Million RELAYS!

This list represents only a small part of more than a million relays in our stock — one of the world's largest. All relays are standard make, brand new in original packing, and fully guaranteed by Relay Sales. Send us your relay requirements. We can make immediate delivery at substantial savings in cost to you.

IMMEDIATE DELIVERY!

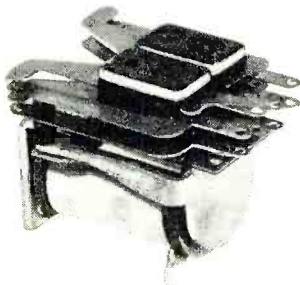
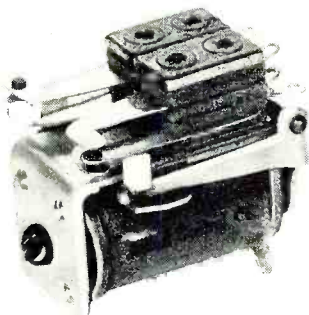
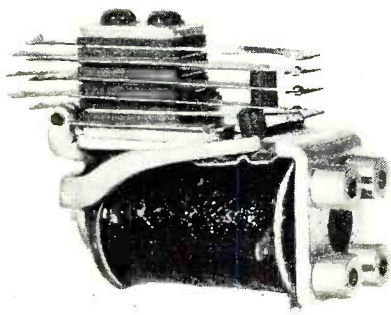

Midget Relays						
STK. NO.	VOLTAGE	OHMS	CONTACTS	MFG. & NO.	UNIT PRICE	
R-416	4 VDC.	9	1C @ 1.5 AMP.	ADVANCE 1603S	\$1.65	
R-378	6 VDC.	100	1A @ 1.5 AMP.	ADVANCE 1601S	1.50	
R-850	12 VDC.	450	1A @ 1.5 AMP.	ADVANCE 1601	1.50	
R-379	19/27 VDC.	250	2A @ 1.5 AMP.	ADVANCE 1605	1.65	
R-694	24 VDC.	300	1A @ 5 AMP.	ADVANCE 1601A	1.50	
R-935	28 VDC.	1000	1C @ 1.5 AMP.	ADVANCE 1603S	1.65	
R-572	24 VDC.	256	1C	AIRCRAFT RADIO CORP.	1.25	
R-857	24 VDC.	260	1 MAKE BEFORE MAKE	AIRCRAFT RADIO CORP. 9453	1.75	
R-912	4/5 VDC.	20	3A-1C CERAMIC	ALLIED TXK50	1.45	
R-291	6 VDC.	5	1A	ALLIED .73A71	1.25	
R-921	6.7 VDC.	18	1A Dbl. Brk. @ 10 amp.	ALLIED CRX-11	1.45	
R-738	12 VDC.	60	3A	ALLIED TX3A	1.20	
R-922	12 VDC.	75	1A Dbl. Brk. @ 10 amp.	ALLIED CRX-13	1.45	
R-144	12 VDC.	228	1A	ALLIED D-283486	1.45	
R-696	24 VDC.	230	1A @ 8 AMP.	ALLIED 55837	2.00	
R-145	18/24 VDC.	250	2A CERAMIC	ALLIED 7252	1.45	
R-723	24 VDC.	280	1C	ALLIED 7251	1.50	
R-298	21 VDC.	300	1A	ALLIED CB-5	1.25	
R-296	21 VDC.	300	1A	ALLIED CA-5	1.25	
R-586	21 VDC.	300	1A & 1C	ALLIED 73A-69	1.25	
R-142	24 VDC.	400	2C	ALLIED 73A50	1.50	
R-785	24 VDC.	200	2C @ 10 AMPS.	AUTO. ELECT. ZH-37169-1	2.00	
R-375	24 VDC.	200	2A heavy duty	AUTO. ELECT. H-87063-1	1.75	
R-373	12/20 VDC.	225	1A split	AUTO. ELECT. SQA	2.50	
R-370	12 VDC.	75	1C	AUTO. ELECT. MANKATO R-25	2.30	
R-607	24 VAC.	INT.	1A	AUTO. ELECT. MANKATO R-45-D	1.20	
R-606	24 VAC.	INT.	1A & 1B	AUTO. ELECT. MANKATO R-45-F	1.20	
R-605	24 VAC.	INT.	3A	AUTO. ELECT. MANKATO R-45-G	1.20	
R-374	24 VDC.	300	2A heavy duty	BETTS & BETTS RAC-15AS	1.75	
R-728	6 VDC.	30	1A	CLAREA-26690	1.25	
R-149	6/8 VDC.	45	1B	CLAREA-20545	1.50	
R-732	12 VDC.	120	1A	CLAREA-25454	1.45	
R-281	12 VDC.	126	2A	CLAREA-13415	1.25	
R-347	18/24 VDC.	300	1A	CLAREA-19469	1.10	
R-376	24 VDC.	300	1A	CLAREK	1.25	
R-818	18/24 VDC.	300	1B	CLAREA-8058	1.30	
R-133	24 VDC.	300	NONE	CLAREA-20388	.75	
R-348	18/24 VDC.	300	2A	CLAREA-16734	1.15	
R-138	24 VDC.	300	4A	CLAREA-16280	1.45	
R-349	18/24 VDC.	300	1C	CLAREB-16947	1.25	
R-377	24 VDC.	300	1C	CLAREB-22441	1.45	
R-132	24 VDC.	300	2C	CLAREA-16265	1.55	
R-731	24 VDC.	300	2C	CLAREA-16734	1.95	
R-492	24 VDC.	300	4C 1A	CLAREA-22717	1.55	
R-626	24 VDC.	400	1A @ 5 AMPS.	CLAREA-12408	2.00	
R-786	60 VDC.	1300	2C	CLAREK	1.95	
R-415	60/85 VDC.	1800	2A	COOK418	1.75	
R-371	2 VDC.	30	1C Ceramic	COOK55340	1.45	
R-755	24 VDC.	300	1A	E-Z ELECTRIC	1.50	
R-150	6 VDC.	30	1A	G. E.55526	2.50	
R-893	14 VDC.	150	1A, 1C	G. E.55531	2.50	
R-895	14 VDC.	150	2A, 1B, 1C	G. E.55589	2.50	
R-896	24 VDC.	260	2A	GUARDIAN36761	1.50	
R-959	24 VDC.	747	2C	LEACHP-501424	1.20	
R-693	2/6 VDC.	125	1C @ 3 AMP	LEACHP-3	1.25	
R-947	12/24 VDC.	320	1C @ 3 AMP.	LEACHP-3	1.35	
R-692	6/24 VDC.	1280	1C @ 3 AMP.	PAUL HENRY 1010	1.45	
R-856	18/24 VDC.	300	1B	PRICE BROS.	1.45	
R-913	6 VDC.	20	3A, 1C CERAMIC	PRICE BROS.	2.00	
R-915	12 VDC.	70	1A Dbl. Brk. @ 10 amp.	PRICE BROS.	1.85	
R-148	12 VDC.	100	2C & 1B	POTT. & BRUM.	1.00	
R-222	12 VDC.	100	2A	RSM	1.45	
R-834	6 VDC.	20	3A, 1C			

OTHER RELAY TYPES IN STOCK

- Keying Relays
- Voltage Regulators
- Rotary Relays
- Differential Relays
- Contactors
- Sealed Relays
- telephone Relays
- Special Relays



Manufacturers and Distributors:
Write for the new Relay Sales Catalog.

Telephone
Seeley 8-4146

833 W. CHICAGO AVE., DEPT. 8, CHICAGO 22, ILL.

COYNE BOOKS

SHOP-TESTED TECHNICAL BOOKS
ON RADIO, TV AND ELECTRONICS

Distributed by
HOWARD W. SAMS & CO., INC., Indianapolis 5, Ind.



APPLIED PRACTICAL RADIO-TELEVISION

Brand new! Over 1500 pages on the latest in Radio and TV—EVEN COLOR TV and UHF. Over 5,000 subjects, 1,000 illustrations. Shows how to install, align, balance *all* Radio and TV sets... how to use test instruments for TV service... latest data on adaptors, converters, much more. Get this 5-Volume Library now.

No. CTB-11—Vol. 1... \$3.25
No. CTB-12—Vol. 2... 3.25
No. CTB-13—Vol. 3... 3.25
No. CTB-14—Vol. 4... 3.25
No. CTB-15—Vol. 5... 4.25

**5 VOLUME SET
COMPLETE
No. CTB-50 \$15.00**



CYCLOPAEDIA OF TELEVISION Complete, Up-to-Date Reference Manual

Fact-packed reference book that covers every phase of Television, including COLOR TV and UHF. Gives you complete understanding of how TV receivers work, how to repair and keep them operating properly. Special complete section on *picture pattern servicing* (dozens of actual photos). 750 pages, over 450 photos, diagrams, charts, drawings, test patterns. In quick reference alphabetical order. **\$5.95** Order your copy now. No. CTB-1.....

PRACTICAL TELEVISION SERVICING, TROUBLE-SHOOTING MANUAL

SHOWS YOU HOW TO align, service, install, adjust and tune every part of the audio and video sections. Helps you handle all problems. Covers sweep oscillators, frequency control, FM, amplifiers, tuners, etc. Latest data on COLOR TV and UHF! 18 big chapters, 300 illustrations (many in 4 colors)—1500 TV facts. Complete, practical, up-to-date. **\$4.25** No. CTB-4.....



ELECTRONICS

You will find this book a "gold mine" of easy-to-follow "on-the-job" electronic data. Starts right at the beginning—explains in simple language all the basic principles of electronics. Fully illustrated with helpful photographs, diagrams, and tables. Endorsed by leading manufacturers, union officials and educators. 400 pages. **\$3.75** No. CTB-2.....

MODERN RADIO INSTRUMENTS AND TESTING METHODS

This up-to-the-minute book tells all about modern radio and electrical testing equipment and how to use it. Packed with money-making shortcuts on trouble-shooting, servicing, construction and other jobs. Over 350 pages, 220 photos and diagrams. Covers Multipliers, Resistors, Ohmmeters, Oscilloscopes and many other subjects. All data has been pre-tested and checked in the Coyne radio shops. **\$3.25** No. CTB-3.....



RADIOMAN'S HANDBOOK

Here is a remarkable radio "answer" book. 3,000 facts packed into 350 pages give you complete instructions to speed trouble-shooting. Illustrated with hundreds of charts, diagrams, tables, circuits and shortcuts. Fully indexed. No. CTB-5 **\$2.75**



Order from your Parts Jobber today, or write direct to Howard W. Sams & Co., Inc., 2201 E. 46th St., Indianapolis 5, Ind.

\$..... enclosed (no C.O.D.'S please). Send the following Coyne Books:

- CTB-11 CTB-14 CTB-1 CTB-4
 CTB-12 CTB-15 CTB-2 CTB-5
 CTB-13 CTB-50 CTB-3

Name.....

Address.....

City..... Zone..... State.....

WHAT'S *New in Radio*

For additional information on any of the items described herein, readers are asked to write direct to the manufacturer. By mentioning RADIO & TELEVISION NEWS, the page, and the issue number, delay will be avoided.

NEW RHEOSTAT

Tru-Ohm Products, 2800 Milwaukee Avenue, Chicago 18, Illinois, has developed a new rheostat which provides smooth variation of resistance under the most adverse conditions and insures

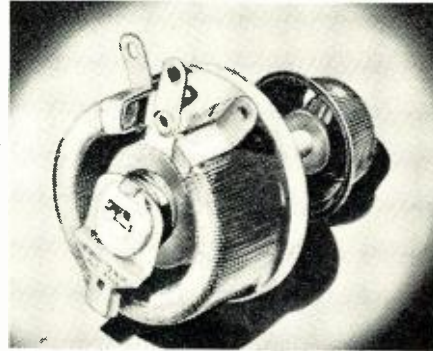

dependable service by virtue of its all ceramic-metal construction.

An extra deep core, on which resistance wire is toroidally wound, means a more conservative power rating. The rheostat is available in either uniformly or taper wound models with a standard tolerance of 10 per-cent.

WILLIAMSON-TYPE AMPLIFIER

The Heath Company, Benton Harbor, Michigan, has added a Williamson-type amplifier and matching preamplifier to its extensive line of kits.

The amplifier and power supply kit (WA-A1) uses two 6SN7GT's, two 807's, and one 5V4G. It has a frequency response within 1 db from 10 cycles to 100 kc. Intermodulation distortion at a 5 watt output is .5% using 60 and 3000 cycles. The output impedance is 4, 8, or 16 ohms, and the input voltage for a 5 watt output is 1.2 volts across 470,000 ohms. Power requirements are for 105-125 volts, 50 or 60 cycles, 120 watts. The amplifier and power supply



chassis each measure 7" high, 5½" wide, and 11" long.

The matching preamplifier unit (WA-P1) uses one 12AY7 or 12AX7 and one 12AU7. There are three switch-selected inputs, i.e., two low gain for crystal pickup and tuner and one high

gain for magnetic pickup. It features a switch-selected turnover for 78 rpm and LP on the high gain channel. The bass and treble tone controls will boost or cut a maximum of 15 db at 20 cycles and 20 kc. respectively. Power requirements are 220 volts d.c. at 6 ma. and 6.3 volts at 600 ma. Dimensions, less shafts and knobs, are 2¼" high, 10¼" wide, and 7¼" deep.

RANDOM-NOISE GENERATOR

General Radio Company, 275 Massachusetts Avenue, Cambridge 39, Massachusetts, has developed a new "random-noise generator," the Type 1390-A.

A gas-discharge tube operated in a magnetic field is the noise source. Two stages of amplification and suitable filters make it possible to have an open-circuit output voltage of one volt on the three frequency ranges, extending from 30 cycles to 20 kc., 500 kc., or 5 mc. The normal, or Gaussian distribution of amplitudes is very good with only moderate clipping on the 500 kc. and 5 mc. ranges.

A panel output control and voltmeter



is provided on the generator and, where relatively low levels are required, an external Type 700-P1 voltage divider can be used.

PRINTED CIRCUITS

Stupakoff Ceramic and Manufacturing Company, Latrobe, Pa., has announced the development of a series of printed electrical circuits for various applications.

A number of standard circuits is currently available, some of them incorporating as many as six separate resistors and condensers in a permanent circuit. Special circuits can be made to meet individual requirements.

A four-page booklet, Bulletin 1151, describes these new units in some detail and is available on request.

CHASSIS LINE

Minute Man Products, Inc., 430 E. 102nd Street, New York 29, New York, is currently offering its new line of standard chassis, relay rack panels, mounting brackets, and bottom plates through radio jobbers.

Featuring complete flexibility, sturdy

RADIO & TELEVISION NEWS

diness, and availability, these metal products meet the requirements of amateurs, research organizations, and engineering departments.

Each chassis comes complete with a speedy template guide, a 16 x 22 inch simulated blueprint containing full scale drawings of holes most generally used in chassis and electronic circuits. This guide can be used as a reference or as an actual template aid.

SERVICE TOOL

W & M Sales and Engineering Co., 1211 N. Market Street, Wichita, Kansas, is in production on a unique tool which is especially well suited for radio and television servicing.

The tool consists of a lighted screwdriver with five slender, detachable blades designed particularly for radio and television applications. The whole unit is compact and small enough to permit its use in crowded chassis. The light, which is an integral part of the handle, provides sufficient light for working inside cabinets or on large chassis.

The product is being marketed by the company itself and additional details and prices are available on request.

TWO-SPEED DRIVES

Transradio Ltd., 138A, Cromwell Road, London S.W.7, England, is in production on a new two-speed precision drive unit which has been trade-named the "Microdual."

This unit is designed to provide absolute accuracy in the control of angular movements for variable condensers, inductances, wavemeters, etc. The "Microdual" provides exact angular movements from 0 to 180 degrees without backlash from a single control knob. A coarse searching speed and fine setting control are available over the entire range.

A data sheet, D1, containing com-

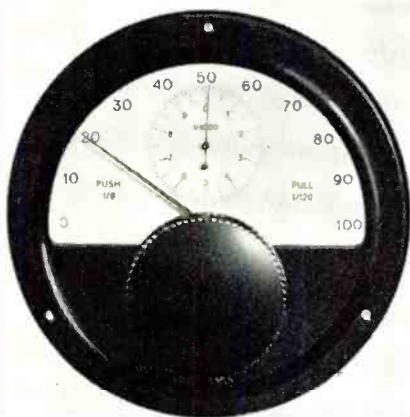

plete information on this new unit is available from the company on request.

CORNER HORN ENCLOSURE

Electro-Voice Inc., Buchanan, Michigan, has introduced a new Klipsch-licensed, moderately-priced folded corner horn enclosure designed to accommodate the company's 15" coaxial speakers and for 800 cps separate 2-way and 3-way speaker systems.

TV DIRECT FROM THIS GREAT FACTORY TO YOU

BRINGS YOU

Finest Quality at Lowest Prices



TRANSVISION

TV KITS, WIRED CHASSIS, and SETS
CABINETS, COMPONENTS, INSTRUMENTS, and ACCESSORIES

SENSATIONAL OFFER

on Top Quality TV Picture Tubes:

• FREE—VALUABLE PREMIUMS:

With every Transvision tube you buy, you get a Merchandise Premium Coupon of real value. Write for list.

• TRADE-IN ALLOWANCE on old tubes:

Make from \$2.50 to \$5.00 glass allowance on each "dud."

• FULL 2 YR. GUARANTEE:

Only Transvision gives you a Guarantee for 24 months.

COMPARE: Get the full details on the Transvision tube deal today.

FREE BOOKLET: "INSIDE CRT, or What You Should Know About Picture Tubes." Written by CRT experts, illustrated. It will MAKE MONEY FOR YOU. WRITE FOR IT NOW.



TRANSVISION Picture Tube PRICES

Type	Your Cost if no old tube is traded in—DEALER PRICE—	Allowance for old tube	Your FINAL COST, if old tube is turned in. DEALER NET—
10BP4	\$17.95	\$2.50	\$15.45
12JP4	17.95	2.50	15.45
12LP4	19.95	3.00	16.95
14RP4	19.95	3.00	16.95
16DP4	27.95	4.00	23.95
17BP4	25.95	4.00	21.95
19AP4	37.00	5.00	32.00
20CP4	35.95	5.00	30.95
24AP4	69.95		

So IMPORTANT is this great instrument, that on Jan. 28 the N. Y. TIMES devoted a feature article (copy on request) to the TRANSVISION

TESTER-REACTIVATOR

FOR PICTURE TUBES

Tests Picture Tubes and Renews Brightness of Your Dim Picture Tubes. Without removing picture tube from set, measure Cathode emission . . . locate shorts between elements . . . locate high resistance shorts or leakage as high as 3 megohms. Then, REACTIVATE dim picture tubes if there's no mechanical break in tube. 110V-60 cycles; weighs 3 lbs.

\$19⁹⁵ net

Fully Guaranteed.



FIELD STRENGTH METER AT NEW LOW PRICE

Improve TV installations; save half the work with the Transvision Field Strength Meter. **\$59** net Model FSM-1, complete with tubes. . .



BEAUTIFUL TV CONSOLES

Ideal for Custom-Building or Conversion. Factory prices start from \$49. Send for Cabinet Catalog now.

MULTI-SET CONNECTORS

feed up to 5 TV Sets from 1 Antenna
Prices: Multi-Set Conn. for 2 sets. . . \$4.95 list*
For 3 or 4 sets. 7.95 list*

*Dealers, write for discounts

Want to Make More Money in TV?

Write for the Transvision Factory Agent Plan

and Complete Illustrated Literature



FREE: EXTRA INCOME EVERY MONTH from hints in "TV and Electronics Notes." Request sample copy. addressograph plate and mailing for FREE Subscription. Monthly issues are gold mines of info on New Products, Sales, Service, Conversion, etc. WRITE DEPT. RN4 TODAY!

TRANSVISION, INC. NEW ROCHELLE, N. Y.

HICKOK

NEW TELEVISION Videometer



MODEL 650

**WILL REBROADCAST
TELEVISION PICTURE
ON ANY CHANNEL**

The HICKOK Model 650 Videometer is the first instrument of its kind to accurately and rapidly solve your servicing problems with the necessary tests to visually identify trouble in any section of a TV receiver.

FEATURES:

- An all-purpose video generator. Provides an electronically accurate bar or dot pattern on the screen of any TV receiver— independent of station operation.
- Can be used as a TV transmitter to simultaneously transfer a picture to any number of TV receivers—on any desired channel.
- RF output, directly calibrated in microvolts for sensitivity measurements.
- Substitute Video Amplifier with gain of 0 to 10.
- Crystal controlled timer for greater accuracy.
- Fast, accurate, the ideal instrument for all area servicing.
- Increases TV maintenance profits—allows you to trouble shoot many more installations per day.
- Built only by HICKOK. Contains highest quality components throughout for lasting accuracy and dependability.

Write for the new, complete Hickok Test Instrument Catalog today.

THE HICKOK ELECTRICAL INSTRUMENT CO.
10524 Dupont Avenue • Cleveland 8, Ohio

Employing the walls of the room as an extension of the exponential air load on the driver, the unit is flat within ± 5 db down to 30 cps. An adaptable baffle board arrangement permits

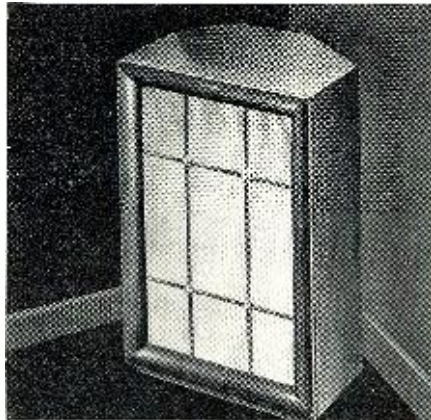

mounting the 15" coaxial speaker or the 2- or 3-way systems without modification.

The new "Royal" enclosure measures 37" high, 20½" deep, and 22¾" wide. It weighs 69 pounds. The unit is currently available in either mahogany or blonde finish.

Bulletin 183 includes complete details on the new "Royal" unit and is available on request.

NULL INDICATOR

Marion Electrical Instrument Company of Manchester, New Hampshire, has recently introduced a new "ruggedized," hermetically-sealed null indicator which is currently available in two models.

Mounting requirements and physical dimensions of these new units conform to JAN-1-6 standards. Although center-point sensitivity is high (1 μ a. per mm or higher), the meter's shaded pole face and shielded core construction are said to give sharply logarithmic attenuation as deflection departs from the null point, and to provide ample overload protection. Stated maximum safe current is ten times actual rated full scale value.

The Models HS2 (2½" size) and the HS3 (3½" size) are available in numerous current sensitivity styles and internal resistance characteristics.

50-WATT RHEOSTAT

Hardwick, Hindle, Inc., Newark 5, New Jersey, is in production on a completely redesigned 50-watt rheostat, the H-50.

Features of this new unit include a toroidal ceramic form wound with resistance wire which is coated and bonded to a refractory base by means of the company's new high-temperature vitreous enamel. The unique design of the contact arm permits the use of a "bus bar" type brush which affords a minimum of resistance between the resistive element and collector ring. The self-adjusting feature provides positive smooth electrical control.

The terminals of the H-50 are made of strong, corrosion-resistant alloy.

The units are designed to comply with current standards of JAN-R-22, RTMA, NEMA, and are listed by *Underwriters' Laboratories, Inc.*

A data sheet on the H-50 is now available on request.

SIGNAL GENERATORS

Decade Instrument Company of Caldwell, New Jersey, has introduced a new signal generator which incorporates several interesting features.

These new generators have been developed for the range from 10 kc. to 100 mc. Known as "Decalators," they consist of a series of decade-switching oscillators. The units feature direct readings for 9000 separate steps of frequency; high frequency accuracy without the use of charts or dial; frequency settings which are obtainable with simple decade-switching; excellent short term stability, plus or minus 2 cycles on all frequencies; high accuracy, plus or minus .05%, at maximum frequency.

The Model #10-100 with a frequency range of 10 kc. to 100 kc. is currently available and other models will be forthcoming shortly.

H.V. POWER SUPPLY

North American Philips Company, Inc., 750 S. Fulton Avenue, Mt. Vernon, New York, has introduced a new low-cost, regulated high-voltage d.c. power supply unit for use with cathode-ray and Geiger counter tubes.

This miniaturized unit is light in weight, operates at temperatures from minus 30 degrees C to 80 degrees C

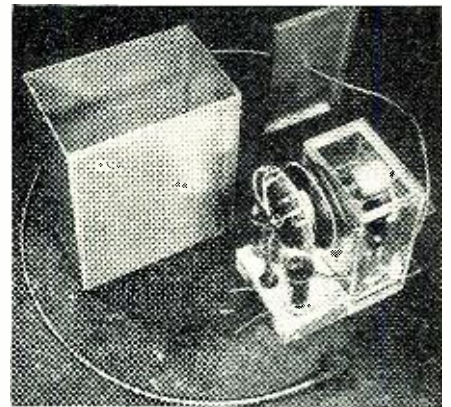

and can be adapted for many applications, particularly airborne and radar equipment.

Input is 315 volts d.c. at 50 ma. Output is 18 kv. d.c. at 150 μ a. maximum. Taps may be provided at lower voltages to supply intermediate accelerating anodes. The a.c. ripple averages 1%. The unit is built to withstand 21 kv. at 50% humidity.

Dimensions of the power supply unit are 6" wide, 5¼" high, and 3½" deep. It weighs 2½ pounds. Volume is approximately 110 cubic inches.

POWER OUTPUT METER

Daven Company, 191 Central Avenue, Newark, New Jersey, is currently offering a new, 50-watt output power meter, the Type OP-961, to the trade.

The new meter has been especially
(Continued on page 138)

RADIO & TELEVISION NEWS

Lowest Prices Largest Stock

TUBES and PARTS

All TUBES are guaranteed for one year . . . individually boxed.
10% DISCOUNT on orders of 100 tubes or more, all brands.
Us this Order Blank!

Double "V"
TV Antenna Kit

300 ohm line, insulators,
guy wire, hardware, full
size antenna with double
length 9 ft. mast

\$795
Complete Kit

Quantity		Quantity	
0Z4		6AB7	\$1.15
0Z4G	59c	6AC5GT	1.31
1A5GT	.65	6AC7	
1A7	.99	6AG5	1.19
1B3GT	.95	6AG7	1.44
1B5		6AH6	
1C7G	29c	6AK5	1.40
1E7		6AK6	1.08
1H6		6AL5	72c
1H5GT	.65	6AQ5	
1H6G	1.15	6AQ6	.81
1J5GT	.95	6AR5	.74
1L4	.29	6AT6	.54
1LA4		6A55	.90
1LA6	1.19	6AU5GT	1.45
1LC5		6AU6	59c
1LC6		6AV6	
1LD5	.95	6B4G	1.44
1LE3	1.19	6B5	
1LH4	1.19	6B6G	.79
1LN5	1.19	6B8GT	1.15
1N5GT	.72	6BA6	.65
1P5GT		6BA7	.87
1Q5GT	95c	6BC5	.72
1R5		6BC7	.79
1S5	72c	6BD5GT	1.15
1T4		6BE6	.65
1U4		6BF5	.99
1U5	.65	6BF6	.59
1X2A	.95	6BG6G	1.73
2A3	1.15	6BH6	72c
2A5	.79	6BJ6	
3LF4	1.19	6BN6	1.44
3Q4	.79	6BQ6	.85
3Q5GT	1.08	6BQ7	1.58
3S4		6C4	
3V4	72c	6C5GT	59c
5T4	1.40	6C6	.79
5U4G	.59	6C8G	1.15
5V4G	.87	6CB6	.72
5W4		6CD6G	1.69
5W4GT	59c	6D6	.79
5X4G	.65	6D8G	1.15
5Y3GT	.45	6E5	.79
5Y4G	.54	6F5GT	59c
5X4G	81c	6F6GT	
5Z3		6F8G	1.15
6A3	1.15	6G6G	.95
6A7	1.21	6H6	.59
6A8GT	.99	6H6GT	.65

Quantity		Quantity	
6J5GT	\$.54	7A6	
6J6	1.04	7A7	
6J7G	.79	7A8	81c
6J8G	1.15	7B4	
6K5GT	.87	7B5	.81
6K6GT	.59	7B6	.81
6K7GT	.79	7B7	.81
6K8GT	.87	7B8	.81
6L5G	.95	7C4	1.44
6L7	.87	7C5	
6N6G	1.40	7C6	81c
6N7GT		7C7	
6P5GT	1.08	7E6	.99
6Q7GT	.65	7E7	1.19
6R7GT	.95	7F7	.99
6S4	.65	7F8	1.76
6S7GT	1.15	7G7	1.19
6S8GT	.95	7H7	.90
6SA7GT	.72	7J7	1.19
6SC7		7K7	
6SD7GT	99c	7L7	
6SF5	.59	7N7	99c
6SF5GT	.65	7Q7	
6SF7	.72	7R7	
6SH7GT	.79	7S7	1.19
6SJ7		7V7	1.19
6SJ7GT	81c	7W7	
6SK7GT	.58	7X6	.99
6SL7GT	.87	7X7	1.19
6SN7GT	.79	7Y4	
6SQ7	.54	7Z4	81c
6SQ7GT	.59	12A7	1.15
6SR7GT	.65	12A8	.79
6SS7	.72	12AH7	1.45
6T7G		12AT6	.54
6T8	1.15	12AT7	1.04
6U5	1.10	12AUG	.72
6U6GT		12AU7	.65
6U7G	79c	12AV6	.54
6V6GT	.59	12AV7	1.15
6W4GT	.65	12AW6	.95
6X4	.54	12AX7	.87
6X5GT	.68	12BA6	.65
6Y6G	.87	12BA7	.87
7A4	.90		
7A5	.99		

Quantity		Quantity	
12BE6	\$.65	35B5	72c
12BF6	.59	35C5	.59
12BH7	1.08	35L6	.45
12C8	1.15	35W4	99c
12F5GT	65c	35Y4	54c
12H6	.54	35Z3	.95
12J5GT	.79	35Z4	.79
12K7GT	.65	35Z5	
12Q7GT	.72	35Z6G	
12SA7GT	.79	35/51	
12SC7	.79	41	72c
12SF5GT	72c	42	
12SF7		43	
12SH7GT	.79	45	
16S17GT	.81	45Z5	.59
12SK7GT	.72	46	1.04
12SL7GT	.87	47	
12SN7GT	.99	50A5	1.21
12SQ7	.54	50B5	72c
12SQ7GT	.59	50C5	1.04
12SR7GT	.79	50C6G	.59
12Z3	.95	50L6	.79
14A7		50X6	.59
14AF7	99c	50Y6	.59
14B6		70L7	1.40
14B8		71A	.87
14C5	1.19	75	1.10
14C7	1.08	77	
14F7	.99	80	.61
14F8	1.44	83	1.45
19B6G	2.15	85	.79
19T8	1.04	117L7	1.40
20	1.40	117N7	.54
24A	.79	117P7	1.08
25AC5GT	1.04	117Z3	.54
25BQ6GT	1.15	117Z6	1.08
25L6GT	.59	807	1.55
25W4GT	.72	813	8.95
25X5	1.04	1294	29c
25Z6GT	.79	1299	.45
32L7GT	1.15	1629	.29
35A5	.99	2050	2.00
		2051	1.15
		7193	.87
		VT51	29c
		VT52	

TUBE SPECIALS!

- | | | | |
|-------|---------|--------|------------|
| 6AU6 | ea. 59c | 6SK7GT | ea. 58c |
| 6V6GT | ea. 59c | 6BQ6GT | ea. 85c |
| 12AU7 | ea. 65c | 6CD6G | ea. \$1.69 |

TUBE KITS

BEST BRANDS at BEST PRICES

- | | |
|--|--------|
| 3Q4, 1T4, 1R5, 1S5.
List Value \$8.00. Tube Kit only | \$2.39 |
| 354, 1T4, 1S5, 1R5.
List Value \$7.80. 4 Tube Kit | \$2.39 |
| 1U4, 354, 1S5, 1R5. List Value \$7.80.
All Four Tubes for | \$2.39 |
| 3V4, 1R5, 1S5, 1T4.
List Value \$7.20. All for | \$2.39 |
| 117Z3, 1U5, 3V4, 1R5, 1T4.
AC-DC Portable Kit. All for | \$2.89 |
| 12AT6, 12BA6, 12BE6, 35W4, 50B5.
5 Tubes for | \$2.95 |
| 50L6GT, 35Z5GT, 12SQ7GT,
12SK7G, 12SA7G. 5-Tubes for | \$3.22 |

TV PICTURE TUBES

- Six month guarantee
- | | | | |
|--------|---------|--------|---------|
| 10BP4 | \$13.95 | 16GP4 | \$29.95 |
| 12LP4 | \$16.95 | 16JP4 | \$29.95 |
| 12LP4A | \$16.95 | 16RP4 | \$23.95 |
| 14PB4 | \$22.95 | 16TP4 | \$23.95 |
| 7JP4 | \$15.95 | 17BP4A | \$24.95 |
| 16AP4 | \$29.95 | 19AP4A | \$39.95 |



P. M. SPEAKERS

12" Coaxial PM Speakers \$12.95 ea.

High fidelity with high pass filter attached. 20 watt; 40-17500 cps. response; 8 ohm VC.

Very best quality—NATIONAL BRANDS Individually Packed

- | | | | |
|----|---------------|-----|------------|
| 3" | \$1.26 ea. | 8" | \$3.23 ea. |
| 4" | 1.36 | 10" | 5.10 |
| 5" | 1.59 | 12" | 6.54 |
| 6" | Special Price | | \$1.59 ea. |

RESISTOR KITS

Insulated 1/2, 1 and 2 watt assortment of most used values, best brands. 100 for 50 asst.—\$2.95

\$4.95

TWIN LEAD

300 ohm twin lead 55 Web virgin polyethylene, in either clear or brown, the finest available.

1000 ft. \$1850 | 100 ft. \$195

Get our special sales bulletins . . . write TODAY!

6 FOOT LINE CORD

UL apprvd. cord and plug—10 for \$1.95
TV Tubular Capacitor .05 mfd, 600V-
VDC
Only

79c ea.

TUBULAR ELECTROLYTIC FILTERS

40-20 mfd., 150 V—with 20 mfd., 15V . 20c ea.
TUBULAR MOLDED—8 mfd., 450V . 16c ea.

TV INLINE FOLDED DIPOLE ANTENNA

At this price we cannot mention manufacturer's name, complete with mast, ind. boxed. \$7.98 each

TERMS: 20% DEPOSIT with order, balance C. O. D. \$1.00 handling charge for orders less than \$5.00. All shipments F. O. B. Chicago. Our parts and tubes are warranted to be 100% replacements for the prototypes in the listings above. Prices are subject to revision without notice. SATISFACTION GUARANTEED. Illinois residents add 2% sales tax. ORDER TODAY!

Premier RADIO TUBE CO.

551 W. Randolph St. Chicago 6, Illinois
ANDover 3-1590

A REMOTE-CONTROL For Your TV Set

By
IRVING GOTTLIEB, WGHDM

A remotely positioned "front end" that can be used for audio volume control, station selection; and contrast adjustment.

THE arm-chair control of a television receiver may be accomplished by means of the arrangement diagrammed in Fig. 1. The principle of operation involves the substitution of a remotely-situated "front end" for that of the receiver. Station selection, audio volume control, and contrast can be adjusted from the actual viewing position. The system is intended to be used with conventional type TV receiver circuits, but will work well with intercarrier type video sets.

The i.f. output energy from the remote tuner is fed to the television receiver by means of shielded coaxial cable and is coupled by dropping a three-turn loop over the first i.f. transformer (the front end output transformer or coil). The oscillator tube or the mixer tube of the TV receiver is removed. The audio volume control of the receiver is set to a position corresponding to slightly greater volume than will normally be desired and the remote unit is ready for an initial trial. A few words are in order regarding the audio volume control on the remote tuner, since this is the feature which distinguishes this system from others.

The sound i.f. energy is attenuated by means of a tunable series wave trap, connected in parallel with the remote front end output coil. This series LC circuit must have a high "Q," otherwise two adverse effects will be evi-

dent. First, if the "Q" is not great enough the range of control of the audio volume will be restricted. Second, distortion of the picture will result as the wave trap "bites" into the video i.f. spectrum. From the author's experience, it is fairly certain that practical considerations rule out the possibility that the "Q" will be excessive. Of course the ideal trap for this purpose would have a rectangular rejection curve. Actually, it will be found that any single layer coil with a geometric configuration similar to those commonly used for television i.f. coils will be suitable, providing it can be made to resonate with approximately 10 μmf . capacity. If the resonating capacity is much higher than this, it will generally be found that the "Q" is too low. On the other hand, attempting to resonate with much less than 10 μmf . makes the initial adjustment quite tricky and may result in a restricted range of control. The distributed capacitance of the coil may cause an undesired and stray capacitance resonance in the video i.f. band.

The series wave trap coil, L_1 , resonates at 21.25 mc. with capacitance comparable to that associated with wiring and stray capacitance. Because of this, the author has not included specifications for the home-winding of this coil but suggests instead that the situation be handled as follows.

Since the RCA Model 630TS is one

of the most popular TV sets and since replacement parts for this receiver are almost universally available, the author would like to suggest that the sound i.f. transformers used in the second sound i.f. stages of this receiver be used for L_1 . These transformers are designated T_{111} and T_{112} on the RCA schematics but carry the common stock number of 201K1.

To install such a unit in the remote tuner, merely remove the primary and secondary condensers of the i.f. transformer, insert the primary in the circuit position designated L_1 and disregard the secondary.

This works out well because the permeable slug can be used to compensate for the effects of stray capacitances which might otherwise shift resonance outside the range of the variable condenser "volume control." This slug introduces no deleterious effects in the form of undesired shunt resonances as appeared to be the case when a home-made coil was used in conjunction with a slug.

Once the experimenter achieves success with the wave trap, the only other "gremlin" likely to interfere with smooth operation is the possibility of i.f. frequency resonances in the LC circuits consisting of the two pickup loops and the inherent capacitance of the coaxial cable. Trouble of this nature can be eliminated by shunting capacity across either or both pickup loops. The need for such capacitance and the value thereof will depend mainly on the type and length of coaxial cable used.

The contrast control provides only vernier action for receivers employing a.g.c. but has sufficient control for receivers lacking a.g.c. so that manual compensation of signal strength, and therefore picture contrast, is provided right at the remote tuner. This is a necessity for such receivers because in changing channels the picture quality is usually affected. This remote tuner accomplishes this by controlling the gain of the r.f. stage.

When used with intercarrier sets, the volume of the sound is controlled not by the series wave trap but by detuning the station selector in such a way that the sound i.f. system in the intercarrier receiver is deprived of signal energy. This can be accomplished without greatly affecting the video i.f. channel. If a non-continuous tuner is used, the vernier tuning element will perform this function.

The power supply incorporated in the remote tuner may be of any type capable of delivering about 50 ma. at 100 to 150 volts. An added refinement, involving the use of a VR tube to maintain the output voltage constant, is worth considering, especially in areas where line voltage fluctuates considerably.

All-in-all, this device is inexpensive to build, simple to install, and contributes much to the pleasure to be derived from TV viewing. Give it a try—you'll enjoy the results.

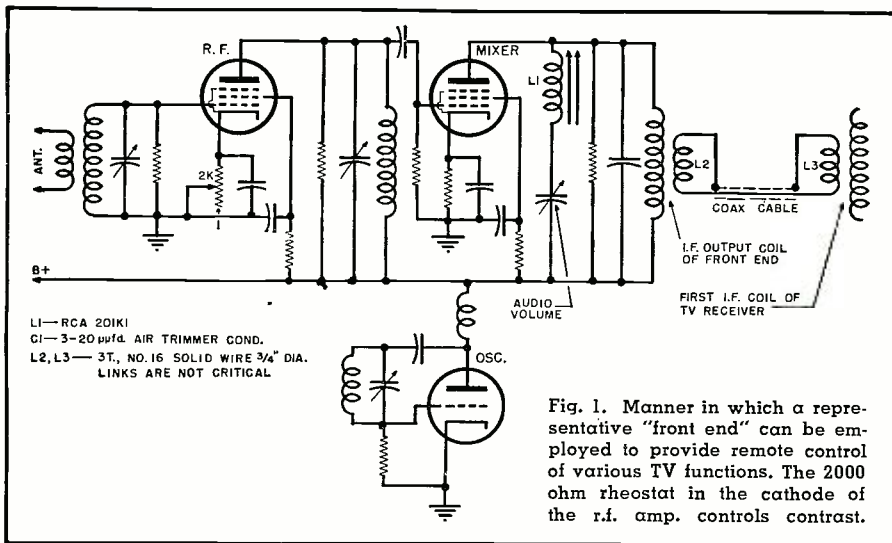
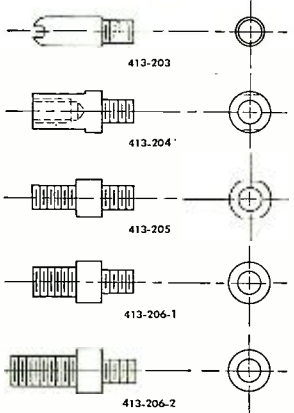

Fig. 1. Manner in which a representative "front end" can be employed to provide remote control of various TV functions. The 2000 ohm rheostat in the cathode of the r.f. amp. controls contrast.



**solves a basic problem
for the service man**

**the ERIE
413 "UNIVERSAL"
HV FILTER
CERAMICON for TV**



• You stock one body type of Ceramicon. An assortment of terminals such as illustrated at the left enables you to replace any one of a multitude of terminal combinations as found in receivers of different manufacturers. With a fraction of the inventory otherwise required you are able to service practically any receiver on the market rated at 20 KV or lower . . . quickly and profitably.

Order through your jobber.

Electronics Division
ERIE RESISTOR CORP., ERIE, PA.
LONDON, ENGLAND . . . TORONTO, CANADA
Cliffside, N. J. • Philadelphia, Pa. • Buffalo, N. Y. • Chicago, Ill.
Detroit, Mich. • Cincinnati, Ohio • Los Angeles, Calif.

LEARN
**Television-Radio
Electricity**
REFRIGERATION-ELECTRONICS
IN THE GREAT SHOPS OF **COYNE**

**TRAIN QUICKLY! OLDEST, BEST
EQUIPPED SCHOOL of ITS KIND in U.S.**
Young and Older Men . . .

Come to the Great Shops of Coyne in Chicago. Get practical trainings in TELEVISION-RADIO or ELECTRICITY—vital in Defense Program. Prepare now for a better job or better service rating.

START NOW—PAY LATER
You can finance most of your tuition, pay for it later in easy monthly payments. Special plan for men of Draft Age. Part time employment service available.

FREE BOOK Clip coupon for Big Free Illustrated Book. Indicate below course that interests you. No salesman will call. Act NOW.

COYNE SCHOOL
ELECTRICITY ★ TELEVISION
RADIO ★ REFRIGERATION ★ ELECTRONICS

B. W. COOKE, Pres.
COYNE School
500 S. Paulina St., Chicago 12, Ill. Dept. 42-85H
Send FREE BOOK and full details on:
 TELEVISION-RADIO ELECTRICITY

NAME

ADDRESS

CITY

STATE

Leotone

CABINET DRAW SLIDES . . . silent, ball-bearing
13" (9" ext.)—\$2.10 pr.; 15" (11")—\$2.25;
18 1/2" (12 1/2")—\$2.39; Heavy-duty, all-steel
16 1/2" (12 1/2") ext. \$3.25
NEW "JUMBO RADIO PARTS KIT" . . . 17 FULL
LBS. of: COILS, RESISTORS, CONDENSERS,
SOCKETS, WIRE, SWITCHES, ETC. 3.95

50 W . . . 32
OHM RHEO-
STAT (IRC)
1/4" shaft
1/4" shaft \$1.79

50W-15 OHM
RHEOSTAT
(IRC) 1/2"
shaft \$1.49

60 CYCLE SYNCHRONOUS MOTOR . . . 110V.
Part of Watt-Hour Meter CHOCK-FULL of
Matched Gears, Worms, Dials, etc. ONLY. \$ 1.98
12 1/2 FT. WHIP ANTENNA . . . 4 screw sects. . . 1.98
W-110B FIELD WIRE . . . New 1/2 Mile rolls
(60 lbs.) 7.95
1 Mile on orig. steel reel (160 lbs.) . . . 18.50
SOUND POWER TANK PHONES (B19-MKII) . . .
NEW, Pair 2.49
HS-33 HEADSET leather band . . . 2.49
ANB-H-1 PHONE UNITS . . . lo-impedance . . ea. .98
PORTABLE METAL UTILITY BOX . . . 10x10x4"
6 1/2" web strap. Hinged, snap-lock lid.69
115VAC RELAY ACTION . . . 2" lever arm.
1x1 1/2x2 1/2"98
220V/110V STEP-DOWN BALLAST . . . 60 watt. . 1.39
#13 SCE MAGNET WIRE . . . 50 ft. coil . . . 1.29
#30 P.E. MAGNET WIRE . . . 400 ft. coil 23c; 5/8"
#28 SCE MAGNET WIRE . . . 600 ft. coil 29c; 1/2"
#20 PUSH-BACK WIRE . . . Red, Yel., Blue or
Blk. 100 ft.89

HEARING AID PARTS . . . MIDGET
OUTPUTS (3/4x1/2). 50B5, 55B5
to V.C. ea. 49c; 6/\$2.49
MIDGET AUDIO CHOKES (3/4x3/4)
4500 ohms D.C. 2.49
HEARING AID AMPLIFIER (2 tube)
MAKE A REAL VEST POCKET
RADIO, adding simple circuit.
1 1/2"x2"x5". WITH SCHEMATIC
FOR 2 OR 3 TUBE SET. Less
tubes, case 2.49
HEARING AID TUBES, set of 2 for
above 2.98
HEARING AID BONE CONDUCTION
RECEIVER (1 1/2"x3/4"x1 1/2"). Ex-
cel. MUSICAL CONTACT MIKE.
DIRECTPHONE. MIN. SPKR.
Lo-imped. 2.49

HIFIDELITY CRYSTAL HAND MIKE . . . Hi-imp.
rod. Molded bakelite; shield cable. . . \$3.95
EXPERIMENTAL TUBES . . . for Test, Research,
etc. P.I. tested. Kit of 40 asstd. rev. types 1.98
"POLYSTYRENE" . . . 12" leads . . . R.O.D. 1/2"
10c; 3/8"—20c; 1/2"—36c; 5/8"—55c; 3/4"—79c;
1.29
TUBING (O.D.): 1/2"—10c; 3/8"—12c; 1/2"
17c; 5/8"—23c; 3/4"—27c; 1"—36c; 1 1/2"—
VARIABLE CONDENSERS . . . four 250 mmf.
sects. 1/4" shaft; 7/16"x2 3/4" ea. \$1.25; 3/7 2.98
SUPERHET or TRF VARIABLES . . . 2 gang.69

"ALNICO MAGNET SPECIALS" . . . Set of
TWO 2 1/2" O.D. BAR MAGNETS, 4 1/2" &
1 1/2" boxed \$2.29
FLAT BAR MAGNET . . . 1 1/2"x1"x5/16"79
ROUND BAR MAGNET . . . 4"x1/2" O.D. . . . 1.65
"U" MAGNET . . . 1 1/2"x3/4"x5/8" ea. \$1.10; 5.50
ALNICO "CHIP" MAGNETS . . . small irreg.
shapes. Approx. 90 pcs. per oz. 15c oz. . . 1.50
ALNICO MAGNET KIT . . . Powerful Bar,
Block, "U", Rod, etc. Kit of 10 assorted. 1.98
Min. Order \$3.00. Only 20% deposit req. on all
C.O.D.'s. Full remittance with foreign orders. Please
add sufficient postage—excess refunded.

EOTONE RADIO CORP.
67 Dey Street
New York 7, N.Y.

Z-Matched Yagis
(Continued from page 57)

a universal clamp at any point of the tower. The cross booms are held in a section of tubing of larger diameter so that the first yagi of each pair can be put on, the connecting rods attached, and then swung into the upper position by rotating the boom. Then the lower yagi is put on. The identical process is repeated for the other pair of yagis. Before discussing the electrical considerations in phasing and matching four yagis, it is interesting to note that the "Supermount" can be used for mounting stacked yagis of two different channels even though they require separate orientation.

In the article, "The Yagi Antenna" published in RADIO & TELEVISION NEWS, October 1951, the problem of matching a two-bay yagi to 300 ohm line was discussed. A system, subsequently named the "Z-Match" system, was described. In this system, the single yagi uses a three-conductor fold and by wider spaced elements is designed to accurately match 300 ohm line. The impedance is dropped to 200 ohms by taking out the center bar in the folded dipole. The center bars from the two yagis are then used as the linear matching transformers and they step the 200 ohm impedance up to 600 ohms. The two 600 ohm impedances in parallel total 300 ohms and match the line accurately. It is two arrays of this description which are to be stacked in four bays. From the following, it will be evident that an accurate two-bay impedance of 300 ohms is necessary.

In the case of the high-band yagi, the four arrays were stacked vertically

Fig. 3. The "Supermount" antenna stacked vertically. Because the unit is adjustable, several arrangements are possible.

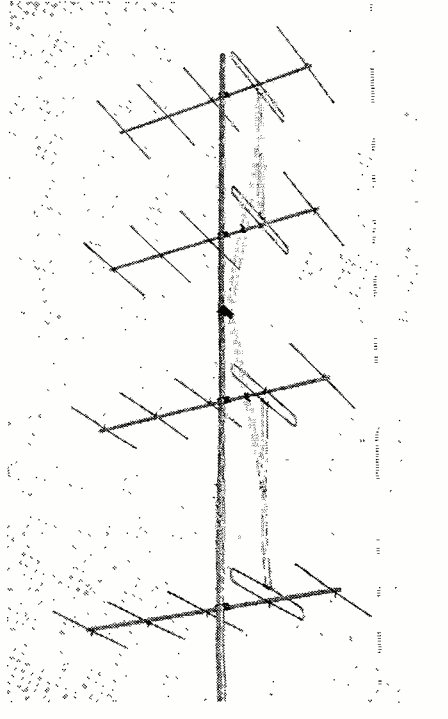

with half-wave spacing between each bay (Fig. 3). On the low band, the two half-wave stacked arrays were spaced a full wave apart. Since these dimensions made the use of a quarter-wave transformer impossible, and since half wavelengths of line do not transform impedances, two $\frac{3}{4}$ wavelengths of line were used. This length has the same impedance transforming properties as a quarter-wave line. That is, the matching impedance is equal to the square root of the input impedance multiplied by the output impedance or $Z_m = \sqrt{Z_i \times Z_o}$. Therefore, the problem resolved itself into the following considerations. We knew that in order for the feed point of the entire four-bay array to match 300 ohm line, each two-bay antenna had to present an impedance of 600 ohms. These two 600 ohm impedances in parallel equalled 300 ohms which was the required impedance. We also knew that each two bay "Z-Match" array had an impedance of 300 ohms. The problem then was to transform the 300 impedance of each two-bay yagi to 600 ohms through the $\frac{3}{4}$ wave transformer. Substituting in the formula $Z_m = \sqrt{Z_i \times Z_o}$ we get the following: $Z_m = \sqrt{300 \times 600}$ or $Z_m = 425$ ohms. In other words, a $\frac{3}{4}$ wave line having a characteristic impedance of 425 ohms will tie the two stacked yagis into one four-bay array with all impedances matched to 300 ohms.

The entire system is shown schematically (Fig. 2). Electrically, the system is the same whether the stacking is vertical or horizontal. Special 425 ohm harnesses were developed for each band. On the high band, a self-supporting open-wire system was used. On the low band, a special wide-spaced 425 ohm ribbon type transmission line was developed because ordinary open-wire line was difficult to support on the boom structure.

-30-

NEW MICROWAVE CHANNELS

THE Long Lines Department of American Telephone and Telegraph Company has filed application with the FCC for authority to provide additional channels for television service between Chicago, Omaha, and San Francisco. The additional channels will operate over the transcontinental microwave radio-relay system that now carries both telephone and television circuits.

At present there are two channels for television, one in each direction, between Chicago and San Francisco and an additional westbound channel in the Chicago-Omaha section.

Of the three new channels, one will be placed in service late this year and will operate from Chicago to San Francisco. The other two channels will be placed in service in 1953, adding one channel from San Francisco to Chicago and one from Omaha to San Francisco. Upon completion of this project there will be five channels available for full-time TV service, three westbound and two eastbound.

The network now has 24,000 miles of channels, 14,000 miles carried by radio-relay, the balance by coaxial cable. -30-

The BEST BUY in Recorders!

Complete PUSH-BUTTON CONTROL



CUT TAPE COSTS IN HALF
OUT PERFORMS EVERYTHING IN ITS PRICE CLASS
HIGHEST QUALITY & RESPONSE
EVER BUILT INTO A PORTABLE

15,000 cps at 15 & 7½ inches per second

AMPELEX

AMPEX ELECTRIC CORPORATION
Redwood City, California

Advanced Series 400-A

Write for Bulletin A-211

AX-72

Newcomb Packs More Quality Features In New Low Cost "E" Series Amplifiers

No other low-priced amplifiers offer so much quality as is found in the Newcomb "E" Series 10, 17, 25 and 50 watt models which include phonographs, mobile and portable assemblies



Low cost has been achieved through simplification of design stressing all essential requirements but avoiding frills. There has been no sacrifice in quality of materials or craftsmanship in the making of these fine utility amplifiers.

MODEL E-25, illustrated, is unquestionably the standout 25-30 watt amplifier in the low-priced field, designed to fill the majority of everyday needs.

It has inputs for two high impedance microphones and a phonograph, with provision for easy conversion of mike inputs to low impedance. New individual bass and treble tone controls offer wide range of adjustment for varying conditions and feature bass emphasis for phonograph without emphasizing voice bass. Finest molded type coupling condensers give protection from heat and moisture. Etched metal panel is lighted for night use, operating knobs are large and skirted for easy handling.

SPECIFICATIONS

Power output: 25 watts design center rating, 30 watts maximum, at less than 5% distortion. Frequency response: ± 2 db, 40 to 15,000 cycles. Inputs (3): 2 mike (2 meg.) gain 117 db, and 1 phono ($\frac{1}{2}$ meg.) gain 77 db. Output impedances: 4, 8, 16, 500 ohms. Tubes (6): 1-6SJ7, 1-6SC7, 1-6J5, 2-6L6G, 1-5Z4. Power consumption: 90 watts at 117 volts, 60 cycles A.C. Shipping weight: 19 lbs.

Check catalog wanted
and mail coupon

NEWCOMB AUDIO PRODUCTS CO.
Dept. F, 6824 Lexington Ave., Hollywood 38, Calif.

LOW COST E SERIES
DELUXE H SERIES
CUSTOM K SERIES

Name _____

Address _____

Firm _____

104

Mobile V.F.O. (Continued from page 53)

cabinet. A hole must be made in the cabinet, on the top or bottom, so that the bandset condenser C_2 can be adjusted by means of a screwdriver or alignment tool.

The main tuning condenser C_1 should first be set to the high frequency end, or minimum capacity, and the padder C_2 then adjusted to a value which results in oscillation at a frequency of about 4.05 megacycles. Setting the tuning condenser C_1 to maximum capacity will then change the frequency to approximately 3.75 megacycles if the values of L and C shown in the schematic are used. This gives a bandspread of over three quarters of the dial to the 75 meter phone band from 3.85 to 4.0 megacycles.

With the v.f.o. connected to the stage to be driven in the transmitter, and the tuning condenser C_1 set at 3.9 megacycles, the slug in L_2 should be adjusted for maximum grid current in the final, or the stage being driven. The tank circuit in the transmitter, to which the link is coupled, should also be tuned for maximum grid current in the driven stage. A definite peak will be found indicating that the circuits are tuned to resonance. If this value of grid current, at the peak, is greater or less than the rated grid current of the tube, the link coupling to the stage can be increased or decreased accordingly. If a different coil form or a slug of different permeability is used for L_2 , it may be necessary to change the value of C_{13} or the number of turns on the coil in order to reach resonance. A grid dip oscillator will again find use here in determining the resonant frequency of the L_2 - C_{13} combination.

The v.f.o. drives the final directly in this installation as can be seen from Fig. 2. The final is a 6BQ6 and it is driven to 3.5 milliamperes of grid current over nine feet of coax. The unit has also been used successfully to drive

2E26 and 807 finals to rated grid current.

It is to be understood, of course, that the characteristics of the final, the antenna coupling circuits, and the type of antenna used will all determine the amount that the transmitter frequency can be changed without the necessity of retuning the final. In our case it was not possible to QSY the entire 150 kilocycles of the 75 meter band without retuning due to the rather sharp tuning characteristics of the antenna in use. However, the range available without serious loss of signal strength at the receiving end is great enough to warrant the use of the v.f.o. rather than crystal control. The ideal arrangement would, of course, be an installation in which the entire transmitter is located on the front panel of the automobile. Retuning could then be accomplished from the driver's seat in case it was necessary after changing frequency.

Tests with several stations, while in motion, brought forth no reports of frequency instability even while driving over streetcar tracks and rough roads. All-in-all, the v.f.o. has proven to be a worthwhile addition to the mobile rig.

-30-

FREE HAM TRAINING

THE Delco Radio Club of Delaware County, Pa. has approved a plan for sponsoring a beginner's class to teach code, theory, and practical application of radio knowledge. Emphasis will be placed on license requirements.

The club has made available its club house at Front Street and Providence Road in Media, Pa. for these training sessions and will provide the necessary materials for carrying out the program. There is no charge of any kind for this training.

Classes will meet each Tuesday evening at 8 p.m. and complete details on the program are available from the club's secretary, Ralph R. Garrick, 2525 Olcott Ave., Ardmore, Pa. Ardmore 4987-W.

-30-

Andrew L. Lawson, JA2CL, who operates the oldest amateur radio station in Japan, is one of the most popular civilians at FEAMCOM. His popularity stems from his hobby of reuniting servicemen with their families in the States through ham contacts. Pfc. Samuel R. Estabrooks (right) talks to his family in Hawaii as Mr. Lawson supervises.



RADIO & TELEVISION NEWS

LEARN Practical RADIO AT HOME



COMPLETE ONLY . . .

\$19⁹⁵

BUILD 15 RADIOS

ABSOLUTELY NO PREVIOUS TRAINING NEEDED
EXCELLENT BACKGROUND FOR TELEVISION

10-DAY MONEY-BACK GUARANTEE

WHAT THE 1952 PROGRESSIVE RADIO "EDU-KIT" OFFERS YOU:

This is a practical home radio course. You learn theory, construction, operation, trouble shooting, code. You build RECEIVERS, TRANSMITTERS, AMPLIFIERS, CODE OSCILLATOR, SIGNAL TRACER.

You start with a simple radio circuit, and gradually advance to more complex circuits. No previous background is required. No instructor is needed. All parts and instructions are included and every single step is clearly explained.

All parts are guaranteed, individually packaged, identified, and explained. There is nothing extra to buy. You receive all parts, tools and instructions at once. You keep everything; there is absolutely nothing you return to us.

You can easily pay for the kit in a short time by repairing radios. Use the tester and signal tracer for servicing. The signal tracer alone is worth more than the price of the entire kit.

USED BY RADIO SCHOOLS AND GOVERNMENT AGENCIES!

The Progressive Radio "Edu-Kit" includes tubes, paper condensers, mica condensers, electrolytic condensers, variable condensers, selenium rectifiers, chassis, hardware, tie strips, tube sockets, solder, wire, soldering iron, tubing, coils, instruction book, radio trouble-shooting guide, radio tester, television trouble-shooting manual, etc.; in brief, everything you need in a practical radio course.

Order your "Edu-Kit" today, or send for further information.
Postage prepaid on Cash orders—C.O.D. orders accepted in U.S.A.

PROGRESSIVE ELECTRONICS CO.

497 UNION AVE. -- DEPT. RN-4 -- BROOKLYN, NEW YORK

FREE RADIO TESTER & SOLDERING IRON

GET A WELL-PAYING JOB



GO INTO A PROFITABLE BUSINESS AND PLAN FOR A FUTURE



40 New Crystal Diode Circuits for Radio-TV Servicemen, Hams

This book belongs in the file of every Radio and TV Serviceman and Ham. Shows 40 new, tested ways of using Sylvania Crystal Diodes. Contains a special chapter on Radio and TV service devices, including instructions for making an Antenna Orientation Meter, a Tuned Crystal-Type Signal Tracer, and numerous other

helpful circuits. Other chapters give circuits for hams and experimenters. Detailed directions and easy-to-follow diagrams. We know this little book can save you a lot of time . . . and money, too. For your copy just send a quarter with your request to: Sylvania Electric Products Inc., Dept. E-3004, Emporium, Pa.

THIS BOOK IS LOADED WITH NEW IDEAS... TIME SAVERS



Only **25¢** Postpaid

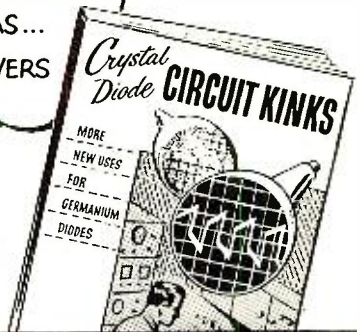

RADIO TUBES; TELEVISION PICTURE TUBES; ELECTRONIC PRODUCTS; ELECTRONIC TEST EQUIPMENT; FLUORESCENT TUBES, FIXTURES, SIGN TUBING, WIRING DEVICES; LIGHT BULBS; PHOTOLAMPS; TELEVISION SETS

SYLVANIA

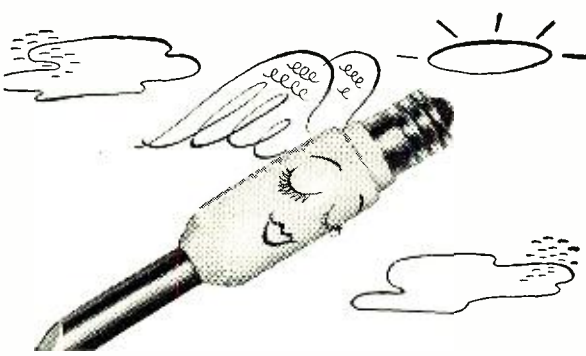

For a Heavenly Soldering Job, Insist on Ungar's little Angels

Need we say more?

No. 537-S 1/4" PENCIL TIPS, 20 Watts

For Light Duty Work. Recommended for small meters and instruments, small joints and hard-to-reach points on radio and TV, printed circuits, delicate electronic assemblies, aircraft instrument repair, hearing aid assembly and repair.

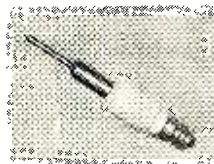

Write for Catalog No. 400

Ungar ELECTRIC TOOLS, INC., Los Angeles 54, Calif.



KIT OF 100 RESISTORS

Consists of popular 1/2 and 1 watt resistor values. Made by leading manufacturers—\$2.99 All Standard Brands!

COMPLETELY NEW 630 TV CHASSIS 30 TUBE with NEW CASCODE TUNER

Reception Up to 200 Miles, 4 Microvolt Sensitivity

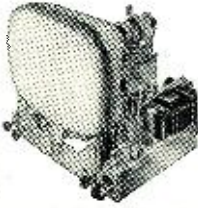

The new standard coil Cascode Tuner gives better sensitivity and definition. Fully shielded against radiation, and has the latest converter circuit. Keyed AGC, 15 KV output, all latest components for greater stability. Complete with RCA 12" speaker. Standard RMA guarantee. Factory aligned, ready-to-play, less CR tube. Federal taxes included \$149.95

UNIVERSAL MOUNTING BRACKETS\$6.50

BUILD YOUR OWN 630!

New Life-Size Set of Instructions Everything at a Glance on

4 GIANT 25" x 38" CHARTS

Each step broken down, indispensable for building, converting, modernizing or even troubleshooting any 630 TV receiver. \$2.49

630 SUPER DELUXE 31-TUBE TV KIT

Operates all 16" to 24" picture tubes. Complete with all tubes, hardware, new life-size builder's instructions. (Less CR Tube and Wire.) \$119.49

10 MFD-600V OIL CONDENSERS

Rated at 220v AC, these Sprague and C-D condensers will operate safely at voltages up to 1000 volts. Each 99¢

Write for Quantity Prices

Mounting BracketsEach 15¢

POWER TRANSFORMERS

STANCOR: Pri. 110v, 125v, 50-60 cy. Sec. 900v c.t. @ 325 mils; 6.3v @ 4.5 amps; 6.3v @ 4.5 amps; 5v @ 6 amps, upright mt. \$10.95

RCA: Pri. 115v, 50-60 cy. Sec. 750v c.t. @ 225 mils; 6.3v @ 8 amps; 6.3v @ 1.2 amps; 5v @ 3 amps. Half-shell mtg. \$6.95

PHILCO: Pri. 115v, 50-60 cy. Sec. 650v c.t. @ 150 mils; 6.3v @ 4.5 amps; 6.3v @ .3 amps; 5v @ 3 amps. Half-shell mtg. \$3.95

PRECISION: Pri. 115v, 50-60 cy. Sec. 650v c.t. @ 80 mils; 6.3v @ 3 amps; 5v @ 3 amps. Upright mtg. Ship. Wt. 4 1/2 lbs. \$3.69

FILAMENT TRANSFORMERS

ALL PRIMARIES 115 VOLTS

6.3v c.t. @ 1.2 amps. Channel mt.	\$1.24
6.3v c.t. @ 3 amps. Channel mt.	1.85
6.3v c.t. @ 5 amps. Cased	2.95
2.5v c.t. @ 3 amps. Channel mt.	.90
7.5v c.t. @ 10 amps. Channel mt.	1.55
6.3v @ 6 amps. Oil 12.6v @ 3 amps	2.69

FILTER CHOKES

Hv. @ Ma.	Ohms DC	Mounting	Price
16 @ 85	200	Channel mt.	\$0.89
10 @ 60	300	Cased	.69
2.5 @ 25	60	Channel	1.19
5 @ 15	75	Channel	1.29
10 @ 15	200	Cased	1.39
10 @ 100	180	Channel	1.89
10 @ 200	100	Channel	1.87
10 @ 250	70	Cased	2.35
12 @ 700	85	Cased	9.95

STEP-UP STEP-DOWN TRANSFORMERS

Pri. 115 to 230—230 to 115. 150w	\$4.25
250w	\$5.25
500w	7.95

All Upright Mounting

TERMS: 20% cash with order, balance C.O.D. unless rated. Prices F.O.B. our warehouse in N. Y. C. Minimum order \$3. NOTE: Due to conditions beyond our control, prices are subject to change.

Phone WOrth 4-3270

ACORN ELECTRONICS CORP.

76 Vesey St., Dept. N-4, New York 7, N. Y.

Crispensing and Resolution Improvement in TV Receivers

By EDWARD M. NOLL

For both monochrome and color, "crispensing" will help to accentuate small area contrast.

"CRISPENSING" is a term used to identify the new CBS technique for improving the apparent resolution in a TV picture. However, in these days of intercarrier i.f. systems, network transmission, large picture tubes, and limited resolution, crispensing has its application in monochrome receivers as well as in the color field. Crispensing, by accentuating small area contrast, helps to recapture some of the brightness definition that is lost by the poor high frequency

response of the television receiver.

Where the highs are deficient, the sharp transitions in brightness cannot be followed with fidelity. As the scanning beam at the camera tube scans a (assumed) black bar (See Fig. 1) in a televised scene, there is a sharp transition from white to black and a similarly abrupt return to white as the bar is passed. The resulting signal formed for each line as the beam scans the bar from left to right is similar to the squared pulse of waveform A in Fig. 1.

During the transfer of this signal from the camera tube to the picture tube a degeneration of highs causes an integration of the pulse, resulting in a waveform of the type shown in Fig. 1B. This type of signal, when applied to the grid of a picture tube, causes a gradual change from white to black at the edge of the bar and a slow smear-like transition back to white at the end of the bar. Because of this the edges of the bar do not stand out clear and crisp in the picture.

It is the function of a crispensing cir-

Fig. 1. Waveform improvement by "crispensing." (A) Pulse representation of single line of video. (B) Result of poor high frequency response. (C) Crispensing spikes. (D) Effective resultant with crispensing.

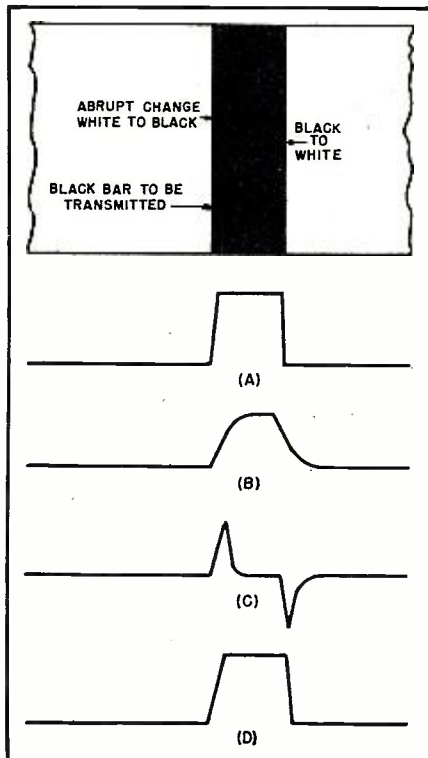
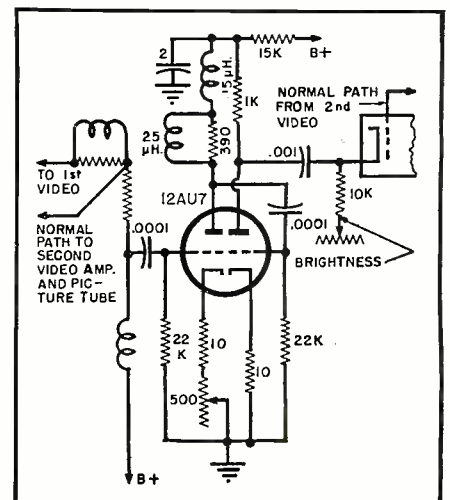

Fig. 2. Schematic of "crispensing" circuit.



cuit to recover some of the original sharp change in brightness at the leading and trailing edges of the bar. A crispening circuit can be added to the video amplifier of practically any receiver, as shown in Fig. 2. In this system, the normal video signal path from the video detector to the grid of the picture tube is not interrupted. Instead an alternate path is provided through the crispening circuit to the cathode of the picture tube.

A crispening circuit of the type shown consists of a two-stage differentiation-amplification system which is made up of short time-constant RC coupling circuits and peaking coils. The differentiators emphasize the high frequency portions of the video signal which are present in all fast transitions of brightness. They really form spikes that follow edge changes of the original information more faithfully than the video signal passing over the normal video amplifier path. Spike high frequency changes are shown in the waveform of Fig. 1C.

The normal video signal is applied to the grid of the picture tube while the spikes formed by the crispening system are applied to the cathode of the picture tube. These spikes are of such a polarity as to reinforce the original slowed-down changes present in the video signal applied to the grid. The combined influence of these two separate signals is similar to the waveform of Fig. 1D which shows how the leading and trailing edges follow the original changes more closely than the signal of the waveform shown in Fig. 1B.

This basic circuit can be installed in monochrome receivers having a limited frequency response. In installing such a system it is important to remove excitation for the crispening circuit at a point which will provide spikes of a proper polarity to reinforce the changes being applied to the grid of the picture tube, i.e., the cathode and grid signals must be of opposite polarity. A control in the cathode circuit permits spike amplitude regulation and is adjusted for best picture appearance without overshoot (intense white following the black). If the gain is not adequate, as could be the case when a single-stage video amplifier is used in the receiver, an additional crispening stage can be used or experimental increases made in the value of the plate load resistor.

There are more elaborate versions of crispening systems that have higher ratios of resolution improvement. In fact, apparent resolution of specific types of information (sharp transitions that are a part of the extended information in televised scenes) can be more than double the high frequency limit of the bandwidth. It certainly provides a convenient means of improving small area contrast. It is of particular benefit in a field sequential color television system that must sacrifice response in favor of a higher field rate.

-30-

Alprodco

ALUMINUM TOWERS

TV • FM • AM

BROADCASTING
AND
RECEIVING

The Height of
Perfection

ALPRODCO AIRCRAFT ALUMINUM TOWERS

- Lower Cost per Installation
- Easy to Install
- Light Weight
- Strong
- Long Lasting
- Attractive

Alprodco Towers are sold
through local parts distributors.

Write for literature and
full details.

ADDRESS DEPT. B

Alprodco, Inc.

KEMPTON, INDIANA
MINERAL WELLS, TEXAS
DUBLIN, GEORGIA



Now! HERE'S EVERYTHING YOU WANT TO KNOW TO

Pass FCC Radio Exam

FOR COMMERCIAL OPERATORS

IT'S GREAT TO HAVE AN FCC LICENSE WITH SO MANY BIG PAY JOBS OPEN!

2218 ANSWERS to FCC Study Guide Questions—Covers the Requirements Needed to Pass Commercial Radio

Operator's Examination in ANY Class

HERE'S the tested way to prepare for commercial radio operator's exams. Get your FCC License in ANY class. Prepare for big jobs and big money. This brand-new, revised, and enlarged book ANSWERS 2218 questions in the FCC Study Guide. Used successfully by thousands of beginners to prepare for basic exams—helps experienced operators get better ratings, top jobs!

Brand New, 10th Edition—668 Pages, 131 Illustrations

668 pages crammed with NEW FCC examination requirements. Answers latest technical and legal questions. 69 questions and answers cover the NEW Element 8 on ship radar. NEW and revised list of important originals, standard abbreviations, changes in use of International Morse Code.

A gold-mine of reference data on radio communication, apparatus, circuits, regulations, etc. Includes 46 special problems given in new FCC guide on antenna systems, loran, radar. PLUS easy-to-follow diagrams for all questions where diagrams are required.

PARTIAL CONTENTS

- Basic Law • Operating Practice • Basic and Advanced Radiotelephone • Radiotelegraph • Aircraft Radiotelegraph • Ship Radar Techniques • International Morse Code —PLUS 185 ANSWERS for new and revised questions listed in current FCC Study Guide • NEW Information on Television Antenna Systems, Radar, Loran, Aircraft Radio Telegraph, Marine Operational Procedure — and much more!

SEND NO MONEY—EXAMINE FREE

Just mail coupon below to get the new, supplemented 10th Edition "Radio Operating Questions and Answers" on 10 DAYS' FREE TRIAL. If not satisfied that it will help you pass FCC Radio Exams—just return it, owe nothing. Otherwise, send only \$6.50, plus a few cents delivery, as full payment. Mail coupon TODAY.

**McGraw-Hill Book Co., Inc., Dept. RTN-4-52
327 West 41st St., New York 18, N. Y.**

Send me "Radio Operating Questions and Answers" for 10 days' FREE EXAMINATION. If fully satisfied I will send you \$6.50 plus delivery as full payment. Or I will return book postpaid in ten days and owe nothing.

Name

Address RTN-4-52

City State

Employed by

SAVE DELIVERY COST—Check here if enclosing \$6.50 WITH coupon. Then WE prepay postage. Money back if you return book.

Audio Simplified

(Continued from page 76)

are not yet completely understood. The loudspeaker particularly, of all the components of the sound reproducing system, should be chosen by a listening test because the ear is the best judge of the over-all integration of the many complex factors which are involved in loudspeaker design.

The actual details of the loudspeaker design and construction are not of as much interest to the audio experimenter as the actual performance of the various designs. The basic loudspeaker is the simple cone loudspeaker in which the paper cone is caused to vibrate by the current in a small coil mounted between the poles of a magnet. The construction of this type of loudspeaker is shown in Fig. 6. Other types of loudspeakers are essentially variations of this basic design.

The single-cone loudspeaker can be used alone for good sound reproduction, but in many cases variations of the single-cone loudspeaker are used to give better reproduction. A simple and effective method of obtaining a wide frequency range is to use two loudspeakers—a large-cone speaker with good low-frequency and poor high-frequency response for reproduction of the lows, and a small-cone speaker with good high-frequency and poor low-frequency response for reproduction of the highs. Most of the best loudspeaker systems use this method in one form or another to obtain good frequency response. Two types of dual loudspeakers are illustrated in Fig. 7. The type illustrated in A consists of two separate speakers which may be mounted separately with the high-

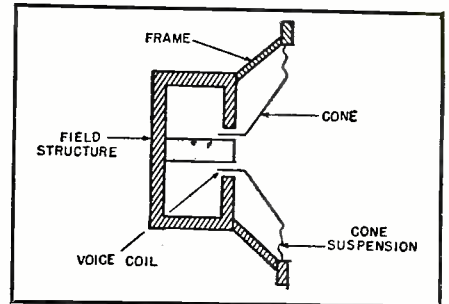

Fig. 6. Construction of a dynamic speaker.

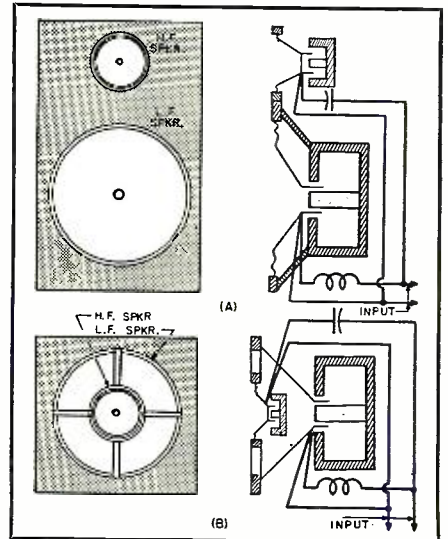

Fig. 7. Use of separate high- and low-frequency speakers to obtain wide frequency range. (A) Two separate speakers mounted separately. (B) Coaxial structure with the high-frequency unit mounted in the center of the low-frequency loudspeaker.

frequency unit (sometimes called the "tweeter") physically separated from the low-frequency unit (which is some-

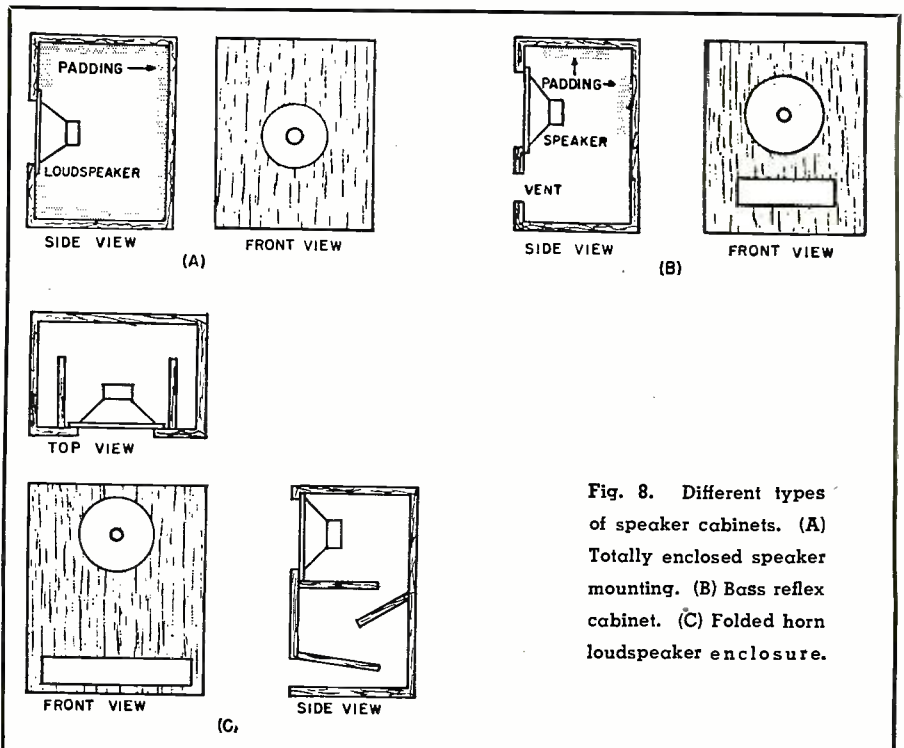

Fig. 8. Different types of speaker cabinets. (A) Totally enclosed speaker mounting. (B) Bass reflex cabinet. (C) Folded horn loudspeaker enclosure.

HI-FI FANS *Order the Famous* PERMOFLUX Royal Eight" SPEAKER

For Test TODAY!
10 DAY TRIAL
MONEY BACK GUARANTEE!

High Fidelity Fans the country over acclaim the clean, brilliant life-like musical reproduction of the Permoflux Royal Eight" . . . the 8" Speaker proved comparable to any 12"! Combined with the new Permoflux Corner Baffle . . . either singly or arranged in Multiple Speaker Units . . . the Royal Eight" re-creates original programs with even superior sensitivity and fidelity . . . every instrument in full range tonal balance. Here's Big Speaker Performance in a small easy-to-install frame at a sensible price.

IMPORTANT: This sensational offer available from Distributors displaying a Blow-up of this ad or upon writing to the PERMOFLUX CORPORATION, Chicago 39, Illinois.

Royal Blue Line Catalog J-207 available upon request.

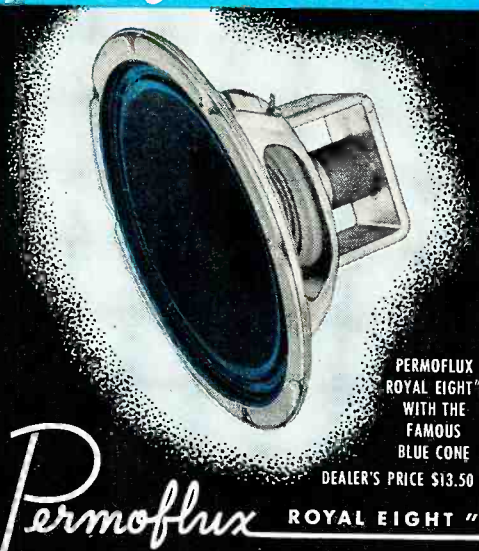

PERMOFLUX ROYAL EIGHT" WITH THE FAMOUS BLUE CONE

DEALER'S PRICE \$13.50

Permoflux ROYAL EIGHT"

PERMOFLUX CORPORATION
CHICAGO 39, ILLINOIS
GLENDALE 5, CALIFORNIA
Canadian Licensee—Campbell Mfg. Company,
Toronto, Canada

PERMOFLUX CORPORATION
4918 W. Grand Ave., Chicago 39, Ill.

Please send _____ Permoflux Royal Eight" (8T-8-1) FOR 10 DAY TRIAL

Check Money order enclosed

Your Name _____

Address _____

City _____ Zone _____ State _____

times called the "woofer"), or B the two speakers may be mounted in a single coaxial structure with the tweeter at the center of the woofer. When two loudspeakers are used in this manner, the frequency below which the low-frequency speaker receives the electrical signal and above which the high-frequency speaker receives the signal is called the "crossover frequency." The "crossover network" for separating these frequencies which in the simplest case consists merely of a capacity in series with the tweeter and an inductance in series with the woofer, permits signals of the correct frequency to energize the proper loudspeaker.

The other commonly used method of obtaining good loudspeaker frequency response is by use of the "duocone" principle in a single loudspeaker. A double cone is used, so that whereas the entire cone moves at low frequencies, at high frequencies only the center section moves. This type of loudspeaker gives the same type of performance as the dual coaxial unit, but has a much simpler construction and all the sound originates in the one loudspeaker. Extremely good results have been obtained with the use of loudspeakers of this type.

Loudspeaker Baffles

Loudspeakers are designed for a wide frequency response, with a large cone for good low-frequency reproduction and a small cone for good high-frequency reproduction. However, the size of the loudspeaker cone alone will not insure adequate low-frequency reproduction, and for good performance, the loudspeaker must be mounted in a proper type of cabinet.

If the loudspeaker is mounted alone in free air, the sound from the back of the cone is 180° out-of-phase with the sound from the front. At low frequencies where the wavelength of the sound is much greater than the dimensions of the loudspeaker, the sounds from the two sides of the cone tend to cancel each other. To reduce this effect, it is necessary to mount the loudspeaker in a *baffle* which prevents this interference. Many different types of baffles have been developed to give better low-frequency reproduction from a loudspeaker, at the same time being reasonably economical and not requiring an excessive amount of space.

The simplest type of baffle is obtained by mounting the loudspeaker in a very large plane surface or wall, so that the sound from the back has to travel a great distance to reach the front, and cancellation will take place only at very low frequencies which are normally not heard. For good reproduction of frequencies down to 50 cps, the baffle should be approximately 8 feet square, with the loudspeaker mounted off the center. When loudspeaker response curves are given by the manufacturer, they are generally measured in a large baffle of this type. This method of loudspeaker baffling is quite popular for built-in home reproduction systems, where the speakers



**MANUFACTURERS!
EXPORTERS!
PURCHASING AGENTS!
•HONESTY•INTEGRITY
•QUALITY OF
PRODUCT**

- Radio and Receiving Tubes
- Transmitting & Special Purpose Tubes
- Radio and Electronics Parts and Equipment
- All Types of Electrical Wire, Magnet Wire, and Cable

*Write — Wire — Phone
For Your Special Needs*

We are also bonafide General Purchasing Agents.
CAN WE HELP YOU?
References: Dun & Bradstreet.

Electronic Expeditors

225 N. Wabash Ave., Dept. R, Chicago 1, Ill.
Phone ANdover 3-0841



BRANCH OFFICES

9015 Wilshire Blvd., Beverly Hills, Cal., CR 4-6237
507 Fifth Ave., New York 17, New York, MU 7-0084

TEVCO

SINGLE REFLECTOR CONICALS

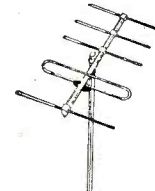
1259—Single Bay	3/8" elements. 3.19
1256—Single Bay	1/2" elements. 3.89
1254—Double Bay	3/8" elements. 6.68
1258—Double Bay	1/2" elements. 7.89
1257—Four Bay	3/8" elements. 14.89
1253—Four Bay	1/2" elements. 17.19

FIVE ELEMENT YAGI BEAMS

2002 to 2006—any to channel.	8.69
2007 to 2013—any hi channel.	3.19
1236—Single Bay Twin-V.	3.76
1237—Double Bay Twin-V.	7.49
1231—Four Bay Conical.	16.99
1230—Double Bay Conical.	7.89
1243—Swift Rig Folded Hi Folded Low.	3.89
1240—Single section conical—lots of 6.	1.69
1244—Swift Rig Folded Hi Straight Low.	3.49
2113—Deluxe Indoor Antenna.	1.99
1860—Chimney Mount.	Dozen Lots 1.19
1905—3 1/2" Mast Snap-On Standoff.	Per 100 3.60
1873—3 1/2" Mast Standoff Insulator.	Per 100 5.50
1872—4" Nail-In Insulator.	Lots of 50 .02
1870—3 1/2" Wood Screw-Eye Insulator.	Lots of 50 .02
1229—Single Bay Conical.	3.75
1861—5 Ft. 1 1/4" Diam. Galv. Steel Mast.	.82

Send for quantity prices and complete list

TELEVISION SUPPLY CO.
Box 13 Greenpoint Station Brooklyn, N. Y.

are often mounted in a wall or a closet. It has, however, the disadvantage that it requires a considerable amount of space or a convenient wall.

The most common type of mounting for loudspeakers in commercial radio receivers and sound reproducers is the conventional open-back cabinet which also contains the receiver-amplifier chassis and the phonograph mechanism. This baffle is objectionable acoustically, because the enclosure behind the loudspeaker acts as an open-ended resonant tube and accentuates the response at its resonant frequency. This resonance generally occurs somewhere in the frequency range between 100 and 200 cps, and results in the "boomy" quality which is so characteristic of most commercial radio receivers. These faults are not present in properly designed cabinets. Good results are obtained by mounting the loudspeaker either in a back-enclosed cabinet, in a bass-reflex cabinet, or in a folded-horn cabinet.

The back-enclosed cabinet is a simple baffle consisting of a rigid box which completely encloses the back of the speaker, and padded on the inside with sound absorbent material. Thus the sound from the back of the cone is completely absorbed. The effect of the cabinet volume coupled to the speaker is to raise its resonant frequency, therefore the volume should be as large as is conveniently possible, and this type of cabinet is most suitable for loudspeakers whose resonant frequency is quite low.

At low frequencies, the coupling between the loudspeaker and the air depends upon the size of the cone. If the cone is made large enough for effective low-frequency response the high-frequency response is reduced, and considerable expense is involved in purchasing the large low-frequency unit and an additional high-frequency unit. The bass-reflex cabinet is a simple and effective method of increasing the coupling to the air by acting as an acoustic phase inverter, and adds the sound from the back of the cone in-phase with the sound from the front at low frequencies. It consists of a closed cabinet with an opening through which the volume is coupled to the air and has the same effect as a resonant LC circuit. Best results are obtained when this resonant frequency is the same as that of the loudspeaker, and when the area of the opening is approximately that of the cone. The bass-reflex cabinet is widely used in high-quality sound reproducing systems, and has given excellent results with speakers ranging in size from 8-inch to the large 18-inch woofers used in theaters and auditoriums.

The folded-horn type of cabinet has become widely used in home reproducing systems where the best low-frequency reproduction is desired. In this type of cabinet the sound is radiated from the front of the speaker cone at high frequencies, and through a horn coupled to the back of the cone at low frequencies. When the cabinet is

flyweight or heavyweight

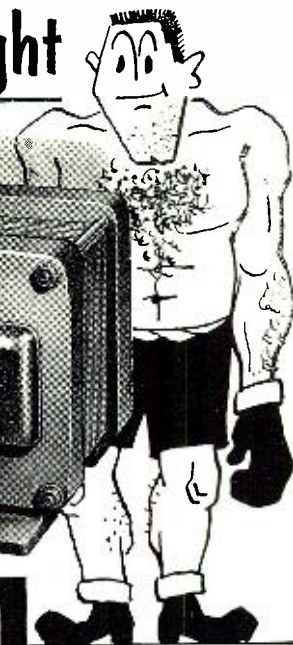
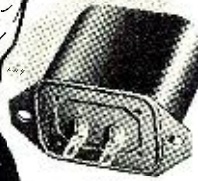

CHICAGO

builds the world's toughest transformers in a complete range for every need

From "flyweight" High Q Chokes to "heavyweight" Modulation bruisers, CHICAGO "Sealed-in-Steel" transformers are *really rugged*. Talk about "torture"—these units can "take it," and deliver complete dependability and continuous service under the most adverse conditions. Your electronic parts distributor can supply the *complete* range of CHICAGO *New Equipment* units for every modern circuit requirement: Power, Bias, Filament, Filter, Audio, MIL-T-27, Stepdown, etc.—all in exclusive "Sealed-in-Steel" construction.

THERE'S NOTHING TOUGHER THAN THE "SEALED-IN-STEEL" NEW EQUIPMENT LINE

CHICAGO's one-piece drawn-steel cases are the strongest, toughest, best-looking transformer construction available. The one-piece seamless design (in a choice of 3 mountings) enclosing an electronically perfect unit, provides the best possible electrostatic and magnetic shielding, with complete protection against adverse atmospheric conditions. Whether your transformers must pass the most rigid MIL-T-27 specs. or are intended simply for average applications—*play safe*—choose CHICAGO "Sealed-in-Steel" transformers.

FREE "NEW EQUIPMENT" CATALOG



You'll want the full details on CHICAGO's *New Equipment Line*—covering the full range of "Sealed-in-Steel" transformers designed for every modern circuit application. Write for your Free copy of this important catalog today, or get it from your electronic parts distributor.

Available in 3 Versatile Constructions

H-TYPE

Hermetic sealing meets all MIL-T-27 specs. Steel base cover is deep-seal soldered into case. Terminals hermetically sealed. Ceramic bushings. Stud-mounted unit.



S-TYPE

Steel base cover fitted with phenolic terminal board. Convenient numbered solder lug terminals. Flange-mounted.



C-TYPE

With 10" color-coded leads brought out through fibre board base cover. Lead ends are stripped and tinned for easy soldering. Flange-mounted.



CHICAGO TRANSFORMER

DIVISION OF ESSEX WIRE CORPORATION

3501 ADDISON STREET • CHICAGO 18, ILLINOIS



TRADE MARK REG.

Ore.) HJDW, 5.055, Medellin, noted 1900 with station call; fair level in England. (Catch) HJEF, 4.768, Cali, "Radiodifusora del Occidente," is a new one noted evenings (EST); also new is H. FU, 4.797, Armenia, "La Voz del Comercio," also heard well evenings (EST). (Legges, N. Y., via URDXC)

Costa Rica—TIRH, 11.972, San Jose, is good level some days around 1300-1500. (Saylor, Va.)

Cuba—COCW is currently on measured 6.314V; noted 1928 with music. (Oskay, N. J.) *Radio Salas*, COBZ, 9.030, Havana, noted with call 2000. (Sams, Ore.)

Curacao—PJC2, 5.014, Willemstad, noted after 1910 with popular recordings and commercial announcements in English. (Catch, England)

Cyprus—The Near East Arab Broadcasting Station, Limassol, is now scheduled 2255-0130 on 6.135, 6.170, 6.790, 9.550; 0300-1000 on 6.170, 6.790, 9.650, 11.720; 1000-1400 on 6.135, 6.790, 9.650. All programs are in Arabic with news 2:00, 0045, 0100, 0630, 1030, 1115, 1330; dictation speed news 0100 and 1115 (except on 6.790 which carries the General Program). (WRH Bulletin) The 6.170 outlet noted around 0000 in Arabic at fair to poor level; the 6.790 outlet was poor 0025 with Arabic music. (Kary, Pa.)

Czechoslovakia—Prague, now announcing as "The Voice of Peace," noted on 11.840 in English 0715-0745; announced 15.320 in parallel but was not audible in 19-m. band. Announced further English broadcasts daily 1400 and 1600 in the 25- and 48-m. bands. Noted in English 1400 on 6.170, 11.875. (Pearce, England) Heard on 15.320 at C730 announcing as "The Voice of Peace." (Fried, Mich.) At 1400 in English on 11.875. (Bellington, N. Y.)

Denmark—OZF, 9.52, Copenhagen, noted 2130 signing off English for North America; weak in Iowa. (Lund)

Dominican Republic—HI8Z, 5.023, Santiago, moved here from 5.030. (Legges, N. Y., via URDXC)

Dutch New Guinea—Radio Hollandia has moved back to its former 7.170 spot. (Cushen, N. Z.)

Ecuador—HC2CA, Salinas, was noted recently on a new channel of 6.902 at 2100. (Machwart, Mich.)

Egypt—Radio Cairo has settled down on 9.715 (from 9.555). (WRH Bulletin; others). Noted more recently opening 1400 with news; usually closes around 1600; several monitors report this one with news also 1430. In verifying for Bellington, N. Y., listed frequency of 9.715 at 1345-1700, power 6 kw.

El Salvador—YSUA, 6.100.3, San Salvador, noted 2005 with music. (Oskay, N. J.)

Ethiopia—Radio Addis Ababa, ETAA, 15.047A, noted Saturdays and Sundays around 1235-1303 sign-off; good signal in Louisiana. (Locke)

Finland—Helsinki, 15.190, noted with news 0715-0724; announces 9.55 and 17.800 in parallel and that repeat broadcast at 2200 (for USA) is on these three outlets. (Pearce, England)

France—Sanderson, Australia, re-

SERVICEMAN'S DIARY... by Ben Grim

MY HUSBAND TOOK THE SET APART LAST NIGHT, TO MAKE THINGS EASY FOR YOU. HE SAYS THE TROUBLE ISN'T SERIOUS AND YOU CAN FIX IT IN A FEW MINUTES WITH THE RIGHT TOOLS.

IF YOU ASK ME, EVEN A MAGICIAN COULDN'T FIX THAT SET IN LESS THAN A WEEK NOW THAT HER OLD MAN WORKED ON IT!

I TOLD HER HUSBAND I THOUGHT THE ONLY TROUBLE WAS THAT THE BABY HAD PULLED THE AERIAL WIRE LOOSE BUT HE WOULDN'T LISTEN TO ME.



AMERICA'S NO. 1 CAPACITOR FAVORITE

Over 200 million Sprague Black Beauty Telecap molded paper tubular capacitors in use today tell their own story of unsurpassed quality! And they cost no more!

These sturdy molded tubulars are the only capacitors in radio-television parts history that have been imitated but not duplicated. Only Sprague Telecaps are made by the exclusive dry assembly process... and that's why they're unmatched for dependable performance!



TELECAP® MOLDED TUBULARS

Sprague's Famous
"Black Beauties"

SPRAGUE

SPRAGUE PRODUCTS COMPANY

(Distributors' Division of Sprague Electric Co.)

51 Marshall Street
North Adams, Massachusetts

free

send for it

212-PAGE

ALLIED Catalog



the only complete up-to-date catalog for Everything in Radio, Television & Industrial Electronics

Send for the Buying Guide that's used daily by thousands of service technicians, engineers, Amateurs, sound men, builders and experimenters. Make your selections from the world's largest stocks of quality equipment—at lowest money-saving prices. Get every buying advantage at ALLIED—speedy delivery, expert personal help, and complete satisfaction on every order. Make ALLIED your single, dependable source for electronic supplies.

SEND FOR FREE CATALOG

ALLIED RADIO

ALLIED RADIO CORP., Dept. 1-DA-2
833 W. Jackson Blvd., Chicago 7, Ill.

Send FREE 212-Page ALLIED Catalog

Name _____

Address _____

City _____

Zone _____ State _____

ports Paris on 21.740 with French program of news and music 0615.

Paris, 5.97, heard 1642-1645 with French lesson; signed off 1645 in Portuguese. Noted on 7.24 at 0845-0900; at 0900 identified in *English* and announced *English* service for Sat. and Sun. 0800-0900 on that channel. (Rodger, Scotland) Paris noted on 9.560 and 9.680 at high level around 2000; signed off 2030; no *English*. (Niblack, Ind.) Paris, 9.755, is noted around 1300 with a United Nations broadcast. (Leary, Ind.)

French Equatorial Africa—Radio Brazzaville, 11.970, noted with news 1745-1800. (Ripton, N. Y.) Is also parallel on 9.440 at that time. Heard by Guterman, N. J., with news around 1545-1600, then in French.

Heard on 9.440 with program of French news and music 0045. (Sanderson, Australia.) The 11.970 outlet noted with news 1200-1215. (Bishop, Ohio)

An outlet of this country on 15.596A was recently heard with news in French 1400 and signing off with "La Marseillaise" 1500. (Kary, Pa.) May be *Radio Chad*.

French Morocco—Radio Maroc, 6.006, Rabat, noted 0200-0330 fade-out with all-Arabic session. (Saylor, Va.)

French West Africa—Radio Dakar is reported on 9.71 afternoons, parallel with 11.896A, to closedown 1800. (Bellington, N. Y.; others)

Germany—RIAS, 6.005, Berlin, noted leaving the air 0245 and re-opening 0400. (Bellington, N. Y.) AFN, 5.470, logged 1505 with popular program of "Twenty Questions"; Leipzig, 9.728A, heard at good strength with dance music around 1730. (O'Sullivan, England)

Gold Coast—Accra, 4.915, noted 1245 with Gold Coast News; 1255 racing results; 1258 weather forecast; 1300 signed off with "God Save the Queen," after announcing would re-open next day in the 49-meter band. (Pearce, England) However, a *WRH Bulletin* lists current schedules as 0528-0700 on 6.049 and 1013 (Sat. from 1043) to 1330 on 4.915.

Greece—Radio Athens, 7.300, comes in with fair to good signal in its North American beam 2000-2100. (Van Gilder, Mass.; others) Noted ending *English* news 2050. (Hord, Ind.)

Larissa, 6.745, noted at poor to fair level with bad QRM when tuned 0050. (Kary, Pa.) *Radio Jannina* is now on 6.230; Athens (Forces Station) has moved from 6.340 to 6.275; *Radio Macedonia* has changed its channel to 8.010. (*WRH Bulletin*)

Guatemala—The English program from TGWA, 9.758, on Mon., Wed., Fri. at 1900-1930 is called "The Belize Program" and is directed to listeners in British Honduras. (Bellington, N. Y.) TGNA, 9.668, still noted well 2200-2230 in *English*. (Hoffman, N. Y.) The 11.850 channel is parallel; has Mail Bag on Wednesdays 2230-2300.

TGNA is still eager to receive reports—especially from USA—on its new 11.850 outlet. (Boice, Conn.)

Haiti—The French program of VOA at 1230-1300 to Europe is rebroadcast

at 1700 from *Radio Citadelle*, 6.300, Cap-Haitien. (*WRH Bulletin*) 4VRW, 9.950A, Port-au-Prince, noted 1545-1600; announced in both French and *English*; program was mostly in French. (Niblack, Ind.) 4VM, 6.012, Port-au-Prince, noted 2131 with *English* identification, then anthem; closed 2132. (Machwart, Mich.)

Holland—PCJ, 21.480, Hilversum, noted with news 0545; PHI, 11.730, heard with Dutch news 2230; PCJ, 15.220, heard with news program 0530. (Sanderson, Australia) Noted on 9.59 with news around 1510. (Rodger, Scotland)

Honduras—Radio Monserrat, 6.675A, Tegucigalpa, noted with call 2130. (Sams, Ore.) San Pedro Sula, 6.351, noted closing one night at 2333; identifies in *English* frequently. (Machwart, Mich.)

India—AIR, 5.960, noted with news in Hindustani 0830. (Sanderson, Australia) Delhi, 11.85, heard often at 1830 sign-on; leaves air 2000 but returns 2030; news at 1930, 2130. (Niblack, Ind.) Pearce, England, notes the 5.960 channel 1430 with slow news in Arabic, and signing off 1455 after call of "Huna Delhi."

Indo-China—Radio France-Asie, 9.754A, Saigon, noted 1000-1032 when signed off with "La Marseillaise;" another day closed 1000. (Pearce, England) By now may have moved from 11.830 to (proposed) 11.925 to escape QRM. (Cushen, N. Z.) Saylor, Va., reports *Radio Hue*, 7.205, at good level around 0200-0300 some days with all-French program.

Iran—GDX-aren, Sweden, lists *Radio Tabriz* on 6.090 at 0900-1230 sign-off; *English* 1215-1230. Ridgeway, South Africa, reports ECQ, 9.68, Teheran, with news 1500; Russian 1515 when is always jammed.

Ireland—A letter from Radio Eireann states is on the air daily with news at 1330 and 1710 using a 1.5 kw. transmitter; that frequencies are 9.595, 15.120, or 17.840, depending on the season of the year. However, in recent

COMMISSIONS AVAILABLE

INDUSTRIAL management men, as well as electrical, industrial, aeronautical engineers working in the field of production control or material procurement, now have the chance to step directly into the ranks of commissioned officers in the Air Force, according to a recent announcement by Lt. Col. Charles D. Morat, Jr., Director of Military Personnel Procurement of the First Air Force Mitchel Air Force Base, N. Y.

The Air Force will now commission men who have a master's degree in these production fields or a bachelor's degree plus one year of business experience. Openings are for lieutenants and captains as well as for older men with wider experience in these fields.

Inquiries addressed to the director will bring full details on this new program.

MAY



brings to you in its
RADIO-ELECTRONIC ENGINEERING Edition
(available by subscription only)

The status of Microwaves Present and Future

- Economic Analysis
- Applications
- Communications Systems
- Tubes—Antennas—Wave Guides
- Test Equipment
- Directory of Manufacturers
- Listing of Existing Links

You won't want to miss this Special Microwave Issue
of RADIO-ELECTRONIC ENGINEERING.

It will be an authoritative and important
reference manual that you will read and reread
for its significance and timeliness in microwave operations.

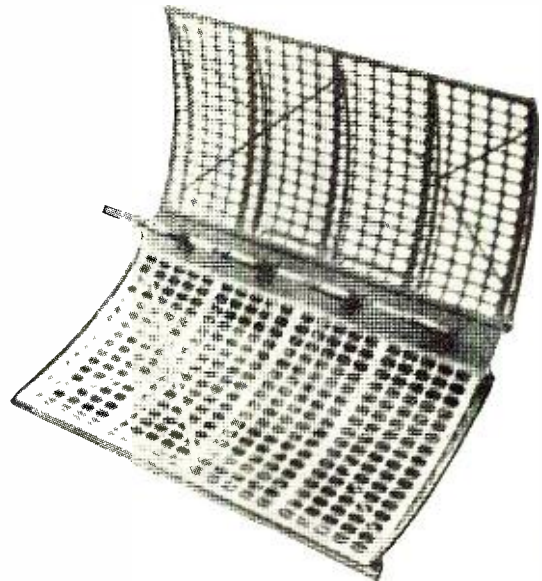

Subscribe to RADIO-ELECTRONIC ENGINEERING—It's the magazine within
a magazine—In addition to all RADIO & TELEVISION NEWS content, you
get at least 5 EXTRA articles per month on important technical advances in
television—radar—research—communications—microwaves.

Stay alert to every vital technical development in all phases of electronics.
Start your RADIO-ELECTRONIC ENGINEERING subscription with the Special
Microwave Issue. Use the RADIO-ELECTRONIC ENGINEERING subscription
card facing this page!

Publishers also of: PHOTOGRAPHY • PHOTOGRAPHY ANNUAL • MODERN BRIDE • FLYING • FICTION GROUP
• ZIFF-DAVIS COMICS

NEW GRA BURNE TUB & TOOL CARRIER

HOT

with Detachable Mirror
for Observing Pix Tube

You made it the Champ!

We interviewed hundreds of Servicemen like yourself to tell us the features you want in a professional carrier. Model CP embodies all your practical suggestions. That's why Servicemen say it's today's truly unbeatable carrier value!

Other Grayburne Tube Carriers available:

Model CL: for the "long haul". Holds 200-225 tubes. \$13.50 net.

Model CJ: for the "short haul". Holds 60-70 tubes. \$9.95 net.

SERVICEMEN: For name of your nearest Grayburne distributor, write to us NOW!



GRAYBURNE CORPORATION, 103 Lafayette St., New York 13, N. Y.

FROM
THIS BOTTLE



**FLOWS THE
MAGIC LIQUID**

QUIETROLE
TRADE MARK REG. U.S. PAT. OFF.

The product that gave to the serviceman the first and most reliable weapon for quieting noisy TV and Radio controls, switches and other moving parts **WITHOUT** removal from chassis.

BUY FROM YOUR DISTRIBUTOR
Mfd. By

QUIETROLE COMPANY
Spartanburg South Carolina

NEW! MOSLEY ROOF-THRU



**The Leak-Proof Roof Entrance
for
TV and FM Transmission Line
and Rotator Control Cable**

Here's the new ROOF-THRU, another MOSLEY product for BETTER TV PICTURES Through More Efficient Installation. ROOF-THRU provides the easiest and most practical method of bringing in lead-in for concealed-in-wall installations using MOSLEY Flush Mounted Sockets.

Why the ROOF-THRU Way Is Best:

- Permits shorter lead-in line resulting in less loss of signal energy—less interference pick-up!
- Copper flashing and plastic bushing provides perfect seal against leaks!
- Prolongs life of transmission line by keeping it out of weather!
- Eliminates unsightly wires on outside of house!
- Long lasting—weather can't hurt ROOF-THRU!
- Easy to install on new or old buildings!

Cat. No. 624 MOSLEY ROOF-THRU.
List Price.....\$5.84

See the ROOF-THRU and MOSLEY Flush Sockets at your jobber.

MOSLEY ELECTRONICS
2125 Lackland Road, Overland, Missouri

Adapters for Servicing (Continued from page 51)

16 mm sound projectors may also be tested with the proper plugs. Jones and Cannon plugs seem to be popular on this equipment, and you may have just what you need around the shop. Even "professional" theater sound equipment may be hooked up to this gadget.

Record-changer adapters, to connect phono motors, pickups, electrical "rejects," etc., can also be made. The special motor plugs may be connected to a short length of cord and a plug and used to adjust these units. Changers using special plugs are easily checked with this setup.

Many quick tests may be made with this system. To check a speaker for opens, hook up two leads to the voice coil jacks and touch them across the suspected speaker. Similarly, with output transformer primaries, hook up the bench speaker transformer and touch it from plate to screen of the output tube. Distortion and rattles suspected of originating in the set's speaker may be traced by substituting the bench speaker. Frying noises, caused by electrolysis of winding, field, or output transformer, may be traced down by connecting the substitute in place of the suspected unit. Use the substitute field to replace an open filter choke, so that you can operate a set long enough to find other possible defects and make a complete estimate on the job. If you think it is worthwhile, install a set of resistors and a tap switch, as a resistor substitute. Filter condensers might be added too.

Once you have the basic unit installed, you'll find new uses for it every day. A few feet of test lead wire, a pair of tips, and a plug are all you need to make up an adapter for any set. The ones suggested in this article are more or less standard and will fit about 90% of all sets. Here's a helpful hint on keeping the adapters straight. Get several of the L-shaped screw-hooks, cup-hooks, etc., and screw them into a convenient wall. Hang up to three adapters on each. Put the most frequently used ones at your end of the bench, the others at the other end. On an average, these gadgets will save you from five to fifteen minutes on every job and, at today's prices, that's really worth-while!

EMERGENCY NET MEET

THE Western Pennsylvania Emergency Network, comprised of hams who have volunteered to serve as a communications link during war or some other period of national distress, will hold its annual hamfest April 20th.

Over 1000 persons are expected to attend this gathering which will feature a variety of competitive events.

Full details on this event are available from John Duggan, W3OBO, chairman of the hamfest, 1400 Creedmoor Ave., Pittsburgh 26, Pa.

Crystal Diodes

(Continued from page 71)

as a slow variation of background illumination; this combined with the shift in the direction of white results in visible retrace lines to such an extent that this circuit is not recommended except where compactness and low price are more important than generally acceptable picture quality.

The defects of the circuits of Figs. 2 and 3 may be overcome by the use of separate crystals for sync separation and d.c. reinsertion, plus a few additional components. This improved cascade type germanium diode separator is shown in Fig. 5. These refinements permit a larger sync pulse output and better separation because the circuit may be optimized as a sync separator. The d.c. restorer diode is shown in this circuit as a design feature only; it plays no part in the sync separating function. It is necessary to provide individual long time-constant biasing networks and the clipper circuit should be directly coupled to the video amplifier output.

The peak conduction of germanium diode CR_2 during the sync pulse interval produces a d.c. component. This charges the condenser in the biasing network, and this d.c. component cuts the diode off in the time between pulses.

The biasing network condenser loses a small portion of its charge during the line scanning interval, but this charge is replenished during the successive pulse intervals. The resulting diode current through the added series resistor produces a voltage pulse which corresponds to the desired sync pulse. It is this pulse which appears at the cathode of CR_2 with all the video com-

Fig. 5. Cascade separator with d.c. reinsertion. R_1 is the video amplifier plate load resistor and should be approximately 3300 to 3800 ohms. C_1 and C_2 should be 1 μ fd. electrolytics. The value of these units will affect the sync pulse amplitude and the video leakage. They may be as small as 5000 μ fd. in which case the leakage will approximate 5% at 40 volt peak signal. The ratio of output voltage to input voltage is .80 for a cascade pentode type circuit and approximately .65 for this cascade-type germanium diode circuit.

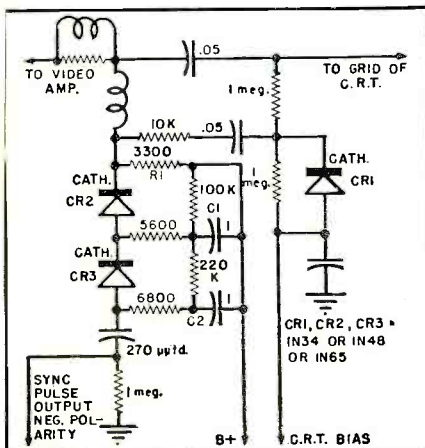

April, 1952

FOR A FAST BUCK

in a slow market

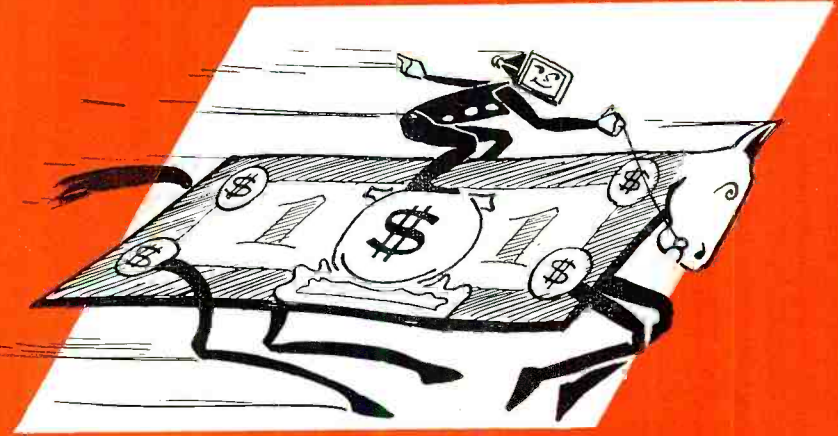

push

Teletowers

When "They're Not Buying Sets,"
Plug Auxiliary Equipment.

**Prompt Delivery...
Competitive Prices!**

If set sales lag, keep volume up by pushing Teletowers! More Teletowers are sold than towers of any other make. Teletowers "get the jump" by introducing improved product features.

Among Teletowers "firsts" are (1) Fixed pole providing mount adaptable to all antenna rotors. (2) Top plate with guy holes for easy guying. (3) Straight TXT section that eliminates bending under heavy stack load. (4) Roof mount adjustable to greater range of heights. (5) Built-in base that permits raising of tower on severest slope after base is fastened to roof. (6) Durable, exclusive Telecote finish. (7) Rigidity that resists wind of super-hurricane strength.

Sell Teletowers to customers who are now out of the set market! Mail Coupon Today.

CANADIAN REPRESENTATIVE:
Atlas Radio Corp., Ltd., 560 King St., W. Toronto, Canada

Penn Boiler & Burner Mfg. Corp.
Dept. N., Lancaster, Penna.

Please send me free, profit-building information on Teletowers.

Name

Address

PENN

Teletowers
Lift towers
Penna-Mast
Hardware

PENN BOILER & BURNER MFG. CORP., LANCASTER, PA.

AT LAST! TV RECEPTION UP TO 200 MILES

ON ACTUAL FIELD TESTS WITH
NEW DX630 CHASSIS
USING THE CASCODE TUNER

will operate in fringe areas or in localities remote from TV broadcast stations up to 200 miles.

- HAS 4 MICROVOLT SENSITIVITY—10 times any other TV receiver. Will pick up distant stations without use of boosters or special antenna arrays—and with less noise. Will operate any tube including 24", greater brilliance, improved keyed AGC circuit, (eliminating flickering and fading).
- Uses the best materials with a high factor of safety to insure trouble-free operation, STD.
- RTMA GUARANTEE free replacement of defective parts or tubes for 90 days. Completely factory wired chassis ready to operate with 12" P.M. Speaker.

Price including excise tax..... \$147.50

TELEVISION PICTURE TUBES

Standard Brands

ONE YEAR GUARANTEE

12 1/2" (Black or White).....	\$22.50	Glass 16" Round (Black).....	\$28.50
Glass 14" Rectangular (Blk.).....	\$23.50	Glass 16" Rectangular (Blk.).....	\$27.25
17" Rectangular (Blk.).....	\$25.95		
19" Round (Blk.).....	\$39.95		
20" Rectangular (Blk.).....	\$28.35		
21" Rectangular (Blk.).....	\$42.95		
24" Metal.....	\$67.25		

Write for Pictures of our Large Selection of T.V. Cabinets

SPECIAL!!

6 TUBE AC-DC KIT

At last! A low-priced kit designed for high sensitivity, excellent selectivity and good tone quality. Uses 25L6, 25Z6, 6SQ7, 6SA7, 6SK7, 6SK7 in an easily constructed circuit. The 6-Tube Kit is shipped with all parts, including punched chassis, resistors, condensers, coil, sockets, PM Speaker, hardware, etc.

And at a closeout price of only X182 less tubes and cabinet..... **\$6.95**

X183 Extra for matched set of six tubes for kit..... **\$3.25**

5-TUBE AC-DC SUPERHET KIT

Five tube superheterodyne kit, A.C.-D.C. contains all components required to construct this latest design, highly sensitive superheterodyne broadcast receiver complete with black bakelite cabinet (excludes wire and solder) Price \$7.95.

Extra for a kit of 5 tubes (12AT6, 12BA6, 12BE6, 35WA, 50C5). Price \$3.25.

NEW REGENCY BOOSTER

YOUR MONEY RETURNED IN FULL—

If the New Regency Television Booster fails to improve your television enjoyment! Bring your picture out of the snow and reduce interference!

- Push-Pull Neutralized triode design assures high gain without adding snow.
- No external impedance matching devices required.
- Inductive tuning assures same high-gain wide-band operation on all channels.
- Single knob tuning control.
- Underwriters approved with 90 day RMA guarantee.

LOWEST Price—ONLY **\$19.11**

A SCIENTIFICALLY DESIGNED PHONO SCRATCH FILTER

Resonated at approximately 4500 cycles effectively reducing objectionable needle scratch without altering the brilliancy of reproduction. Contains a HI-Q SERIES resonated circuit. Tested by means of an audio oscillator and an oscilloscope to give 22 db attenuation with very low signal loss.

EASY TO ATTACH

Just two wires to clip on. Compact Price..... **\$1.98**

All Merchandise Subject to Prior Sale. All Prices Subject to Change without Notice.

WRITE FOR COMPLETE CATALOG N-4

EDLIE ELECTRONICS INC.

154 Greenwich St. New York 6, New York

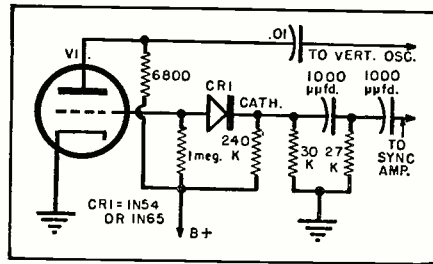

Fig. 6. Vertical pulse separator with an amplifier, an inverter, and a limiter.

ponents stripped off; hence, only the sync pulse remains.

To improve the pulse stripping action over the wide range of video signals the germanium diode CR_2 is connected in series with CR_1 . CR_2 has its separate biasing network. Since the clipping level of the second crystal is determined by the partially separated sync pulse output of CR_1 the combined action of the two crystal diodes is cumulative. The final sync pulse output is relatively free from video components at all the usable signal amplitudes; the separation is quite sharp.

It may be of interest to mention that the crystal diodes operate with fixed d.c. bias obtained partially from the plate load resistor of the video amplifier output pentode. By reducing the dynamic resistance of the crystal diodes during conduction this biasing action makes available a sync pulse of fairly large amplitude. Another advantage in using crystal diodes in this type cascade circuit is the low capacitance of the crystals which makes it possible to load the video output circuit with the sync clipper, without necessitating any changes in the high frequency compensation network.

Vertical Pulse Separator

The function served by the circuit in Fig. 6 is to provide six large-amplitude, steep-fronted positive pulses for vertical synchronization. The circuit is so designed that these pulses coincide in time occurrence with the serrations in the vertical sync section of the standard RTMA synchronizing signal.

The trigger pulses of the vertical deflection circuit have sharp rising wavefronts and are of relatively large amplitude. Hence, this circuit will provide stable vertical sync without critical adjustments or components.

The conventional vertical sync integrator is replaced in this circuit with a two-stage differentiating network with a specially selected time constant. The differentiator is supplied with mixed horizontal, vertical, and equalizing pulses, all in positive polarity. The swing of the inverse voltage at the trailing edge of the broad vertical sync pulses is approximately three times the amplitude of the swing of the inverse voltage at the trailing edges of the horizontal pulses.

The biased series-connected germanium diode crystal clips off the horizontal components, and the vertical pulses which remain are of negative polarity; these are amplified, inverted,

and squared in the triode pulse amplifier stage. The germanium diode clipper element provides excellent pulse discrimination because it has less capacitance than the interelectrode capacitance of the best tube type diodes now available.

This is an important point because any capacitance in shunt with the clipper diode is likely to bypass the high frequency components of the horizontal pulse amplifier. This would impair sharp pulse separation, cause faulty interlacing, and sometimes produce crosstalk between vertical and horizontal sync signals.

The next and concluding section of this series on germanium crystal diodes will deal with a.f.c., the horizontal phase comparator, and a.g.c. circuits.

(Concluded next month)

TECHNICIANS ORGANIZE

A NEW technicians' group, which is an outgrowth of the old Radio Technicians' Association, San Fernando Valley Chapter, has been recently organized under the name "Society of Radio and Television Technicians Inc."

The Society received its charter and organization papers from the state of California in January and has already inaugurated an impressive program for its members.

Dinner meetings are held twice monthly and the programs are designed especially for the practicing technician. Except for a short business session at the beginning of each meeting, the entire evening is devoted to technical matters.

Technicians, jobbers and their salesmen, and apprentices in the San Fernando Valley who are interested in joining such a group should contact Dell Davis, chairman of the public relations committee of the Society, at 1745 W. Glenoaks, Glendale 1, California.

-30-

HAM CONVENTION

THE Oregon Amateur Radio Association will hold its annual convention at the Osburn Hotel in Eugene, Oregon, Saturday and Sunday, April 26th and 27th.

All radio amateurs and their XYL's are cordially invited to attend. The registration fee for licensed hams is \$6.50 and for all non-hams \$2.50. Only licensed hams will be permitted to participate in the drawings for prizes.

The program will include a demonstration of screen grid modulation by John Reinhartz using his portable 1 kw. Eimac transmitter, a hidden transmitter hunt, a "swapfest" for unused radio gear, a demonstration of electronic control of ship models, and the prize drawings.

Hams may register by mail by addressing their checks or money order to "Wink" Wintler, W7KL, Eugene, Oregon.

A large turnout is expected for this event and persons living in the vicinity of Eugene are urged to make their reservations early to insure accommodations at the convention.

-30-

NBFM Adapter

(Continued from page 59)

ing diagram, the adapter may be wired into the set. Plate and filament voltages may be obtained from the receiver's power supply as the current requirements are low. The input signal is taken from the same point as the second detector connection.

The adjustment procedure is as follows. With the changeover switch in the AM position, tune in an NBFM signal, centering the carrier, i.e., the point of minimum audio between the two sideband tuning points. Next switch off the a.v.c. of the receiver and switch on the adapter. Tune the gating-grid circuit for maximum audio output and minimum distortion and then retune the secondary of the last i.f. transformer for maximum audio and minimum background noise.

Next tune in a weak AM signal and reduce the r.f. gain control until the modulation is audible even though distorted. Proceed to the adjustment of the cathode bias for optimum limiting action, that is, maximum output on the AM signal. Once these adjustments are made, the adapter is ready for operation. Finally, peak the compensating condenser that peaks the last i.f. transformer with the switch in the normal or AM position. The adapter is now ready to go.

Those who like to experiment can try out this type of circuit using one of the standard heptode mixer tubes (6SA7, 6BE6, or 6SB7Y) instead of the 6BN6. With heptodes, the oscillator grid (pin 2) is used as the signal or 1 miter grid and the normal signal grid (pin 6) as the gating or quadrature grid. To insure efficient operation, the oscillator grid (pin 2) should be returned directly to the cathode through a 100,000 ohm resistor and the gating grid returned to ground by means of the tuned circuit. Operational bias can be fixed by means of a 330 ohm cathode resistor, suitably bypassed to ground. The limiting action with the heptodes is less noticeable than with the gated-beam tube, but in all other respects the former will operate adequately in the adapter. —30—

SOCKET PUNCHES

By L. H. TRENT

WHY do extra work when using a socket punch? Here is an idea that will save your nerves and possibly some skinned knuckles.

Drill a normal pilot hole and thread the punch parts through the metal. Tighten the punch drive screw by hand until the punch is seated firmly at the correct place on the chassis. Tighten the screw about two turns with a pliers. Then use a woodworking brace to drive the screw in the punch.

The chuck of a carpenter's brace has square jaws, while a hand or motor drill is equipped with a triple jaw and cannot be used. A few drops of heavy oil on the driving screw will cut the friction. —30—

Just Published



EXACTLY what you want in servicing instruction

- detailed, illustrated trouble-shooting procedures
- for every flaw or failure you're likely to encounter in any TV receiver
- completely and clearly indexed for quick reference

Whatever the trouble, in picture or sound, you'll be able to put your finger on it quickly and accurately with the aid of this book. More important, you'll KNOW HOW TO FIX IT, without guesswork or trial and error, and with full assurance that the trouble is REALLY CORRECTED.

A complete master index, in clear, convenient tabular form, lists over 100 trouble symptoms—all the various hums, sound distortions, streaks and bars on picture, focus defects and all others that you're likely to find—with the probable causes of each and the page on which full servicing instruction for that particular fault is given.

You won't have to thumb through batches of manufacturers' notes, never sure that you have the right directions for the latest improvements or changes. Here are the instructions you need for correcting trouble in each circuit in any set, and the CLEAR UNDERSTANDING of each circuit you need in order to BE SURE that the adjustments you make will achieve the desired results.

300 illus.
A handy 421-page,
fact-packed guide

You'll find

Handy lists of troubles that may occur in each section of the TV receiver and the exact procedures for correcting each.

Large clear block diagrams of typical commercial circuits for tuners, focus control systems, R-F voltage supply, sync separator systems and all other basic TV receiver circuits.

New original photographs showing actual symptoms of trouble on TV screens to aid identification.

Full explanation of unusual, hard-to-find troubles and how to fix them, as well as all ordinary defects.

Complete instruction on the use of testing equipment, and oscilloscope patterns to facilitate the checking of test results.

Ways of improving overall performance; how to improve gain, reduce ghost reception, minimize interference.

Special servicing instruction for color TV and for VHF and UHF receivers.

Are these top-ranking aids on your working reference shelf?

and much more



Fischer's RADIO & TV MATHEMATICS

"An extremely useful reference," wrote *Radio News* about this unique book. Here are step-by-step solutions, showing what formulas to use and what numerical values to substitute, for HUNDREDS of typical radio and TV servicing, construction, and operational problems, arranged under radio topics for quick reference.

Noll & Mandl's TELEVISION & FM ANTENNA GUIDE

A basic course on antenna theory combined with a complete handbook on antennas and their installation. Shows how to pick the right antenna for the site, determine the best position for it, install transmission line for maximum efficiency and all other practical details for getting the most out of the antenna system.

Noll's TV FOR RADIOMEN

Explains very clearly and fully all basic principles of television reception, the essentials of TV transmission, and the construction and operation of each part of modern TV receiving systems; and gives step-by-step instruction in installation, adjustment, alignment, and basic trouble-shooting procedures. A basic book for anyone in television servicing, noted for clarity and completeness. Here are all the fundamental why's and how's by a man known throughout the country as a leading authority on the technical aspects of television.

See them ON APPROVAL

Look them over. If you're not entirely satisfied you may return the books without further obligation.

The Macmillan Co., 60 Fifth Ave., New York 11

<input type="checkbox"/>	Mandl's TV Servicing	\$5.50	Please send me the books checked at left. I will either remit in full or return the books in 10 days.
<input type="checkbox"/>	TV for Radiomen	\$7.75	Signed
<input type="checkbox"/>	Radio & TV Math.	\$6.75	Address
<input type="checkbox"/>	TV & FM Antenna Guide	\$6.25

MATTISON

**SILVER ROCKET
630 CHASSIS with
• TUNEABLE •**

**BUILT-IN BOOSTER
for Better DX Reception**

Featuring **NEW CASCODE TUNER,
70° COSINE YOKE and
VARIABLE AGC CONTROL**

Tube
Complement:
28 tubes
3 rectifiers
1 CRT

32

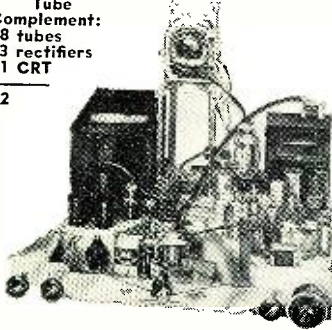

All Channel Booster

• Broad band single knob control pre-amplifier built in to eliminate long leads which may cause regeneration and attenuation of signal.

• **ONLY THE MATTISON 630 CHASSIS HAS AN ALL CHANNEL TUNEABLE BUILT-IN BOOSTER THAT INCREASES SIGNAL STRENGTH UP TO 10 TIMES. THE SILVER ROCKET WILL OUT-PERFORM ANY CHASSIS MADE AND IS PRICED RIGHT TO SELL FAST WITH AN EXTRAORDINARY MARGIN OF PROFIT FOR YOU. WRITE FOR CONFIDENTIAL PRICE SCHEDULE.**

• Mattison features a complete line of cabinets MADE IN MATTISON'S OWN CABINET FACTORY. 36 breathtaking designs that blend perfectly in any setting, traditional or modern.

DEALERS! SERVICE-DEALERS!

Here is YOUR opportunity to become the "important" TV Dealer in your area for THE FINEST CUSTOM-BUILT LINE OF TELEVISION RECEIVERS.

FREE! Write for MATTISON'S merchandising portfolio explaining:

**"THE MATTISON
UNASSEMBLED PLAN"**

and

**"THE MATTISON
\$1,000,000 FLOOR PLAN"**

FREE TO ALL!!!

Write for consumer guide titled
**"WHAT TO LOOK FOR
WHEN PURCHASING A TV RECEIVER"**



Manufactured with integrity

When you buy from Mattison you need only one source of supply! You can buy a Mattison Chassis, a Mattison Cabinet or a complete Mattison TV Set!

Mattison Television & Radio Corp.

893 Broadway, Dept. R, N. Y. 3, N. Y.

Within the Industry (Continued from page 28)

ward, Culver City, California. Increased warehouse space enables the Division to carry larger stocks and the modern facilities provide for more rapid service . . . **P. R. MALLORY & CO.** is undergoing a half-million dollar expansion program in which 62,000 square feet of manufacturing space will be added to facilitate production of components for the Armed Forces . . . **SIERRA ELECTRONIC MANUFACTURING COMPANY** has just completed a 10,000 square ft. addition to its plant at 1050 Brittan Avenue, San Carlos, California . . . **HOFFMAN RADIO CORPORATION** has added 38,000 square feet of floor space to its No. 5 plant at 6200 South Avalon Boulevard, Los Angeles, California . . . **MAGNA ELECTRONICS COMPANY** recently moved from Los Angeles to 9810 Anza Boulevard, Inglewood, California . . . **VARIAN ASSOCIATES**, 99 Varian Street, San Carlos, California, is planning to erect a new million dollar research laboratory in South Palo Alto . . . Retaining its Los Angeles factory at 6809 Victoria Avenue, **INTERNATIONAL RECTIFIER COMPANY** has just opened a new plant and administrative offices at 1521 E. Grand Ave., El Segundo . . . **AIRTRON, INC.** has completed its transfer of administrative quarters to enlarged suites at 20 E. Elizabeth Ave., Linden, N. J. Acquisition of space brings the company's occupancy up to 100,000 square feet in Linden . . . **SPRAGUE ELECTRIC COMPANY** has established engineering offices at 11325 Washington Boulevard, Culver City, California to better serve the growing electronics and aircraft industries of Southern California . . . **GENERAL ELECTRIC COMPANY'S** pioneer venture in educational and industrial research cooperation is revealed in their plans for the new *General Electric Advanced Electronics Center* at Cornell University, Ithaca, New York . . . **CLIPPARD INSTRUMENT LABORATORY, INC.** is moving to a new 21,000 square ft. plant now under construction at 7350-7390 Colerain Avenue, between Mt. Airy and Groesbeck, Ohio, to keep pace with the increased demand for electronic equipment.

THE 1952 PARTS SHOW which will be held in Chicago at the Conrad Hilton Hotel May 19 through 22, has set up a detailed and explicit list of qualifications for attendance with three days set aside for distributors who handle a full and comprehensive line of component parts and equipment, and a fourth day for industrial buyers, industrial engineers, government agencies, and those who fit into special categories in the electronic distribution field.

"Special guests," as such, will be entirely eliminated and all persons attending will know well in advance of the Show on which days they may be admitted. Press badges will be lim-

ited to working editorial members of the press. Advertising executives will be admitted under the auspices of the member-exhibitor companies they serve.

The Parts Show is not open to the public.

* * *

NARDA, the national trade association of appliance and radio-TV dealers, has announced that local organizations of retail appliance and radio-television dealers will receive specially compiled reports for their exclusive use on the costs-of-doing-business in their areas as a part of the nation-wide annual survey conducted by the trade group.

The association points out that there will be no charge or obligation for these special studies but it is necessary that at least 20 dealers in each area participate in order to get an adequate sampling of that territory. This is the first time in the five years that the surveys have been made that individualized studies will be conducted.

Local groups who wish to participate in this survey are asked to contact NARDA headquarters, 1437 Merchandise Mart, Chicago so that questionnaires may be forwarded without delay.

* * *

J. J. SAMUELS has been named general sales manager of *Fidelity Tube Corporation* of East Newark, New Jersey.



He was formerly associated with *Sheldon Electric Company* as director of sales and a member of the board of directors. He has a

diversified background in the television and electronics industry, having been connected with *RCA*, *Bendix Radio*, and *Tele-Tone* before joining *Sheldon*, and subsequently, *Fidelity*.

* * *

STEVEN E. LASEWICZ has been appointed production manager of *The LaPointe-Plascomold Corporation*, Windsor Locks, Conn. . . . **STANLEY W. CHURCH**, mayor of New Rochelle, New York, has been elected vice-president in charge of public relations and a director of *Sightmaster Corp.* . . . **WILLIAM E. FARRAGHER**, account executive of *Arthur Towell, Inc.*, has been named assistant advertising manager of *Magnecord, Inc.* of Chicago . . .

ABE KALINSKY, designer and production consultant in the transformer field, has been appointed general manager in charge of production for *Heldor Manufacturing Company* of Bloomfield, New Jersey . . . **W. S. ALLEN** has been named general manager of the Electrical Division of *Olin Industries, Inc.* He will be responsible for the operation, production, sales, research, development, and quality control of the division's products manufactured in the company's New Haven, Conn. and Covington, Tenn. plants . . . **ARTHUR M. WENGEL**, electronics research engineer for the *Ray-*

O-Vac Battery Company of Madison, Wisconsin, died of a heart attack recently. He had been on the company's staff since 1932 . . . **ROBERT R. PORTER** has been named vice-president and sales manager of the *Sperry Corporation*. He was formerly president of the company's *Ford Instrument Company Division* . . . *Erie Resistor Corporation* has named **BYRON B. MINNIUM** to the post of vice-president and general manager of the Electronics Division and **GORDON GROTH** vice-president and general manager of the company's Plastics Division . . . **RICHARD F. DOOLEY**, vice-president of *Admiral Corporation*, has retired after serving the company since its founding in 1934. He will continue as a director and consultant for the company . . . **WILLIAM H. HAPPE, JR.** is the new works manager of the Electronics Division, *Curtiss-Wright Corporation* of Carlstadt, New Jersey . . . **CHARLES H. WIRTH** is the new engineering representative for the *Audio & Video Products Corporation* . . . **PAUL GAYNOR** is the new vice-president in charge of merchandising for *CBS-Columbia Inc.* He will be responsible for the company's merchandising, sales promotion, advertising, and publicity activities . . . **JAMES W. KELSO**, former United Nations artist-designer, has joined *Packard-Bell Company* as chief cabinet designer.

JOSEPH G. DeVICO has been appointed to the new position of director of advertising and sales promotion by *Majestic Radio & Television*, Division of *The Wilcox-Gay Corporation*. He formerly served as advertising manager of the *Majestic* division.

In his new position, he will direct advertising and sales promotion for the company's line of radios and television receivers and supervise promotion activities for *Wilcox-Gay* "Recordio" equipment.

Mr. DeVico has been with the present organization for six years, having joined the company when it was known as *Garod Electronics Corporation* in October 1945. —30—

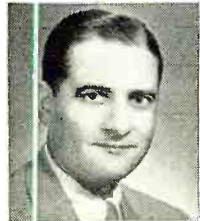

1947

1952

A Record of Performance!

PROVING YOU'RE

Always Right With Earl White

FROM a modest beginning March 15, 1947, Radcom Engineering Co. has steadfastly adhered to a policy that has been dominated by a dependable brand of service that makes us rightfully proud of a record of performance. This business requires a highly-specialized know-how and a trained ability to provide a service to our ever-widening clientele in this country and abroad. To these people in the trade we owe a huge debt of gratitude for the confidence and trust they have placed in our ability to deliver the goods. We pledge to redouble our efforts in the years ahead to merit your future confidence, patronage and trust. Thanks a million!



Earl White

SPECIALIZING IN U.S. SIGNAL CORPS, AIR FORCE & NAVY RADIO AND COMMUNICATIONS EQUIPMENT WITH COMPLETE RE-WORKING FACILITIES.

Always Right With Earl White

RADCOM Engineering Co.

8 LIVINGSTON ST.

NEWARK 3, N. J.

GIANT TV SALE

Save on Chassis, Tubes, Cabinets, Accessories, etc.

NEW—THE SENSATIONAL 630-DX CHASSIS

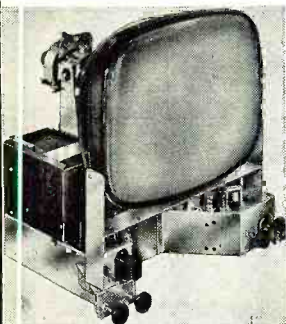

Amazing Low Price!
1952 Model—30-Tubes—
For 16" to 24" Picture
Tubes.

FINEST CHASSIS AVAILABLE At Any Price! For long range and best reception up to 200 miles without a complicated booster or antenna, this new, advanced 630-DX Chassis gives 3-times normal reception. Special extra-high gain standard coil tuner offers greater sensitivity, top performance on any channel; aligned & tested for 5 hours; molded condensers; 4 microvolts sensitivity; FM sound system; horizontal & linear lock and is directly adaptable for color and UHF. This is the very best Chassis buy—order NOW at this low-low price! You can't beat it!

RMA Guaranteed—Factory Wired Complete, ready to play including 12" speaker, hardware and knobs: **\$149.50** (Incl. Fed. Tax—less CRT)

Special Price—Limited time only **ORDER NOW and SAVE!** FREE! With any chassis, a copy of the famous "TV Trouble Shooting Method," locates all troubles in a jiffy. Complete with illustrations and hundreds of rapid checks. Get yours NOW—FREE!

TV TUBE ACCESSORIES—ANTENNAS

Each Specially Priced!

Universal Mounting Bracket	\$5.95	Famous Conical "Fan-Tenna"	\$6.19 ea. \$5.59
Sleeve & Ring for 16" Metal	3.85	Finest antenna made at any price. Completely pre-assembled. All seamless aluminum doweled elements & cross-arm. Regular list: \$12.43. Save more than half!	
Sleeve & Ring for 19" "	4.04	lots of 6	
Sleeve & Ring for 24" "	7.95		

LUXURIOUS, NEW TV CABINETS

For 630 Chassis, 17" 19", & 20" Picture Tubes

Model 100
Reduced to **\$39.50**



Save 45%!
Custom Styled



Model 200
Now only **\$49.50**

Blonde finish add \$10

Every beautiful cabinet, in richly finished, hand-rubbed mahogany will stand out in any room. Made special to house the 630 chassis, they will carry a 17", 19" or 20" picture tube. Every cabinet is custom styled, made by craftsmen and guaranteed perfect. Includes safety glass, mask and mounting brackets. Order Now and Save 45%!

All Prices Reduced! CRYSTAL CLEAR LUCITE MASKS

Franted in Rich Gold Leaf Finish

RO—Round Tubes	
RE—Rect. Tubes	
14" RE 14 1/2" X 13 1/4"	\$1.49
16" RE 12 1/2" X 15 1/2"	5.79
16" RO 13 1/4" X 17"	5.89
17" RE 13 1/2" X 17"	5.89
19" RO 15 1/2" X 20"	7.69
20" RE 16 1/2" X 20 1/2"	7.69
24" RO 21 1/2" X 25"	13.95

TV PICTURE TUBES

6-Months Guarantee—non pro-rata
Black Face—Brand New—Standard Brands—
Sealed Cartons

10BP4 Round-Glass	\$24.95	16HP4 Round-Glass	\$33.95
12LP4 Round-Glass	24.95	17BP4 Rect.-Glass	29.95
14BP4 Rect.-Glass	24.95	19AP4A Round-Metal	37.95
16GP4 Round-Metal	31.95	20CP4 Rect.-Glass	37.95
21" Rect. Cylindrical face	39.95	24AP4 Round-Metal	69.95

NOW! Write for FREE Catalog including new complete line of tubes, parts, accessories for radio & TV, plus test instruments.

MINIMUM ORDER: \$5.00. 25% deposit with order, balance C.O.D. Include postage with order. All merchandise subject to prior sale. F.O.B. New York City. Prices subject to change without notice.



THE ROSE COMPANY

98 Park Place

Dept. R-4, New York 7, N. Y.

Cortlandt 7-6195

IT'S NEW



The MAGNEMITE*

Designed by A. C. Shaney, internationally-known leader in tape recorder development, and built by Amplifier Corp. of America, leaders and pioneers in magnetic recorders since 1936 — the Magnemite* is also a leader in its field — the first completely portable tape recorder, powered by self-contained dry batteries! Measuring only 11½ x 8½ x 5½ inches, and weighing only 9¾ lbs., the Magnemite* represents ease and convenience in remote recording.

Your Net Price **\$189.50**
Complete with batteries, microphone, and earphones.

*Trade Mark Reg. Order today, or write for additional literature to:

AMPLIFIER CORP. of AMERICA · 398 Broadway · New York 13, N. Y.

THE 10-POUND PORTABLE BATTERY-OPERATED MIDGET TAPE RECORDER

New DRY BATTERIES

The Magnemite* uses inexpensive dry batteries that last 100 operating hours. No wet cells that require re-charging or special handling.

New SPRING MOTOR

The governor-controlled constant speed motor runs 15 minutes per winding.

New 2-HOUR RECORDING

This extended playing time is obtained because of 1⅞ in. per sec. tape speed, and the use of two sound tracks on standard 5 in. tape reels.

New SENSITIVITY

Crystal-clear recordings can be made from any distance up to 100 ft. away from the microphone.

Klystron Oscillators

(Continued from page 56)

the circuit by the collector. The entire assembly is enclosed in a vacuum tube.

The electron gun directs a constant intensity stream of electrons through the buncher grids. The electric field, due to the cavity action between these grids, is varying sinusoidally. Accordingly, some electrons are accelerated, some maintain the same velocity, and others are retarded as they pass through these grids.

The electrons emerge from the buncher having various velocities, but the electron stream still has an essentially uniform density. The electrons then flow through a field-free "drift space." It is assumed, for simplicity, that in this region there are no d.c. or r.f. fields, and that any space-charge effects are negligible.

In this drift space, the electrons that were speeded up by the buncher begin to catch up with the slower moving electrons ahead of them. In a similar manner, the electrons which were slowed down by the buncher lag behind more and more until they are overtaken by electrons that left the buncher at a later time. This bunching process, similar to that occurring in the positive grid oscillator, eventually results in the breaking up of the electron beam into groups, or bunches, of electrons. These bunches of electrons are separated by regions in which there are comparatively few electrons.

The electrode arrangement thus far described is useless in the sense that no output signal has been obtained. In principle, an ordinary plate might be installed at the end of the drift space and be used to collect the signal from the electron beam. The voltage of the plate would rise and fall as it was struck by the bunches of electrons. Unfortunately this method of signal collection is not practical because the frequencies at which velocity modulated tubes operate are so high that stray capacity of the external load circuit would short circuit this energy.

Therefore another cavity is used to absorb this energy. This cavity, known as the catcher, is placed at the point in the drift space where maximum bunching occurs. The field of this cavity is so phased that it always is negative with respect to the bunched electrons. Hence energy from the bunched electrons is transferred to the catcher cavity and oscillations are sustained. The field is positive across these catcher grids during the time that there is a region of relatively few electrons and, therefore, little loss of energy occurs during this part of the cycle.

Proper phasing between catcher and buncher grids is effected by feeding back some of the catcher cavity energy into the buncher cavity. The remainder of the oscillator energy is coupled through a coaxial cable to the desired load.

After passing the catcher grids, the

RADIO Surplus Buys

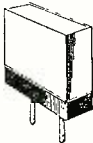

CRYSTALS

... in FT 241-A Holders—1/2" Pin SPC. Marked in 54th OR 72nd Harmonic MC Freq. Listed below by fundamental frequency with fractions omitted.
500 KC Crystals only. Limited Quantity. **\$1.95**

372	411	487	400	462
374	412	488	440	463
375	413	490	491	464
377	414	491	442	464
379	416	492	444	466
381	418	493	446	468
383	420	494	448	470
384	422	495	450	472
385	423	496	451	474
387	424	497	452	475
388	425	498	453	476
390	427	502	455	477
391	429	504	456	479
392	431	507	457	480
394	433	509	459	501
396	435	511	461	505
398	437	512	461	505
401	438	514	461	505
403	481	516	461	505
405	483	523	461	505
407	484			
409	485			

49c ea. or 10 for \$4.50; 99c ea. or 10 for \$9.00

TUNER FROM NAVY "BN" EQUIPMENT

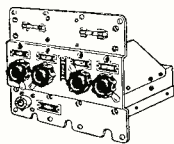

Simply modified into 2-meter converter for car or communications receiver. Uses 1-6J6, 1-6SH7, 1-9006, 1-6J5 (Not furnished).

Slug is tuned from 157 to 187 Megacycles. Includes schematic diagram for "BN" equipment.
Now—A New LOW Price..... **\$4.95**

SENSITIVE ALTIMETERS



Pioneer, Kollsman, and Bendix Sensitive Altimeters. Range 0-35,000 ft., calibrated in 100's of feet. Barometric setting adjustment. No hook-up required. . . . mounts easily in auto or aircraft.
Used. Good..... Each **\$12.95**
Postpaid

ALTIMETER, AIRCRAFT



U. S. Navy surplus Altimeters, range 0-10,000 feet. Adjusts to sea level setting of terrain. Simply installed, requires no hook-up . . . for auto or aircraft installation.
BRAND NEW..... Each **\$7.95**
Postpaid

ALL EQUIPMENT F.O.B. PASADENA UNLESS OTHERWISE SPECIFIED. PLEASE ENCLOSE FULL AMOUNT WITH ORDER

C & H SALES CO.

BOX 356—M T, East Pasadena Station, Pasadena 8, Calif.

KAAR RADIOPAK

THE MOBILE RADIOTELEPHONE

KAAR ENGINEERING CO.
PALO ALTO - CALIFORNIA

EVERY RADIOMAN

Can Use These

SERVICE HINTS!

Valuable Manual Yours—FREE!

Every page of "How to Simplify Radio Repairs" is packed with on-the-bench, practical ideas. Contains photos, charts, diagrams—no fluff—no vague theory. In plain every-day language it gives you priceless suggestions—new servicing ideas. You'll use and benefit from the experience of experts. Partial list of contents: How to Localize Trouble; How to Service Amplifiers; How to Test for Distortion; How to Test Audio Circuits; How to Test Speakers; How to Find Faults in Oscillators; How to Test Radio Parts—and it's all yours—FREE! No obligation.

SEND COUPON OR PENNY POSTCARD FOR YOUR FREE COPY TODAY!

FEILER ENGINEERING CO., Dept. 4H2
8026 N. Monticello Ave., Skokie, Ill.
(Suburb of Chicago)
Please RUSH my FREE copy of "How to Simplify Radio Repairs."

Name

Address

City..... Zone..... State.....

electrons are moving at a greatly reduced velocity and are finally removed from the tube by a positive collector plate. The collector plate potential must be positive enough to attract all the electrons, but not so positive that electrons will strike at a high velocity and cause secondary emission. It is obvious that any random electron flow detracts from the over-all efficiency and stability of the system. Hence, the importance of effective removal of electrons after they have passed catcher grid.

In the second article on this subject, some of the practical aspects of klystron operation will be considered.

(Concluded next month)

SWITCH IMPROVEMENTS

ONE of the serious shortcomings of the electronic switch described by James G. Arnold in the article "An Inexpensive Electronic Switch" (July, 1951 issue of RADIO & TELEVISION NEWS) is the difficulty of exactly superimposing the two waves.

Robert Cortner of Honolulu, Hawaii has overcome this difficulty by a simple circuit arrangement and an addition to the switch. The grounded ends of R_5 and R_{10} in the original design (Fig. 3, page 33) are returned to ground through 10,000 ohm resistors (R_{14} and R_{15} in diagram below). A 1.5 volt penlite cell furnishes the bias, while the 250,000 ohm resistor R_{13} allows the two signals to be balanced.

This circuit does not permit the gain of the two amplifiers to be reduced to zero but this is not objectionable except on signals of extremely high level. Signals of this magnitude are rarely encountered in this type of work.

-30-

Circuit changes for electronic switch.

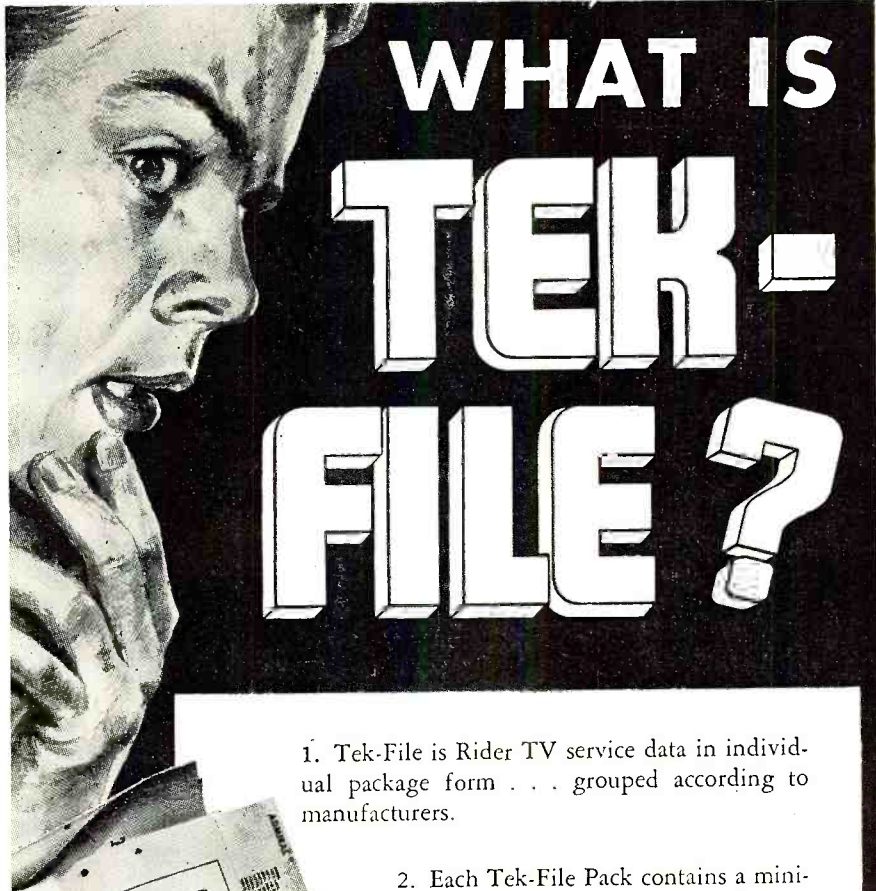
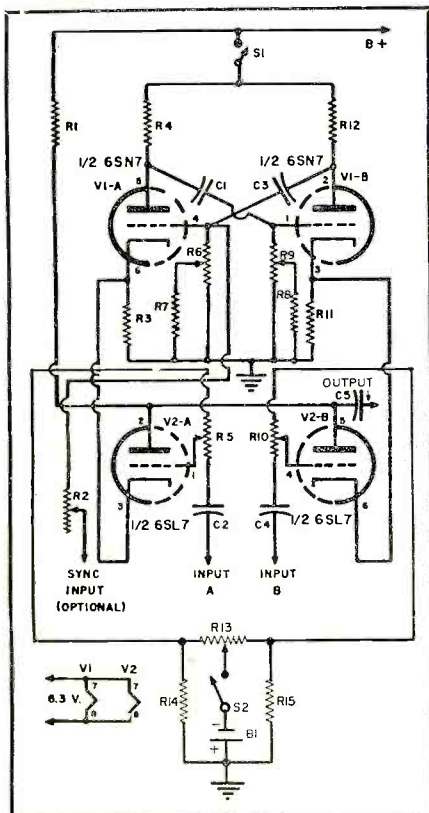

WHAT IS TEK-FILE?

1. Tek-File is Rider TV service data in individual package form . . . grouped according to manufacturers.

2. Each Tek-File Pack contains a minimum of 128 pages (8½ x 11") separated into file folders for fast, easy reference; perfect for house calls.

3. New Tek-File packs are available every month . . . so far, a total of 48 packs have been issued.

4. All Tek-File data is the official, complete factory-issued data direct from the manufacturer . . . not edited, abridged or prepared by an independent laboratory.

5. Tek-File makes servicing easy. Each pack contains all the manufacturer's data you need . . . and it's guaranteed to match the set! Schematics chassis views, troubleshooting test patterns, parts lists, circuit changes . . . it's all there!

6. Check these Tek-File extras: Free index covering all Tek-File packs at your jobber. Free coupon in each pack; 15 gives you permanent binder for Tek-File shelf use. Free Tek-File Handies containing the manufacturer's cures for troubles.

Remember, all this for only \$2.00!
Buy it from your jobber . . . today!

IT'S
FACTORY
AUTHORIZED!



JOHN F. RIDER

PUBLISHER, INC.
480 Canal St., N.Y. 13, N.Y.



IRC ANNOUNCES A BRAND NEW LINE

UNIVERSAL REPLACEMENTS FOR CONCENTRIC DUALS

- Two new, low-priced, 4-piece CONCENTRIKITS—simplified and improved.
- Less-than-a-minute assembly of Exact Duplicate Controls—in home or shop—without special tools.
- Complete line of Exact Duplicate Shafts—no filing, slotting, cutting, hammering or soldering needed.
- Expanded line of IRC Base Elements—for assembly of both carbon and wire wound concentric dual controls.
- Cover 416 Manufacturers' Concentric Dual Parts Numbers—used in over 5,000 TV models.

Features

COVER MORE REPLACEMENTS AT LOWER STOCK COST

It's a fact! With a small stock of these new IRC CONCENTRIKITS, Exact Duplicate Shafts and Base Elements, you can cover most all concentric dual replacements. That means less money tied-up in inventories—and less stock lost through obsolescence. And it means faster servicing—and time saved because you can schedule your trips to your IRC Distributor.

GREATER STOCKING AND SERVICING CONVENIENCE THAN EVER

Cover Major TV Sets at Fractional Cost with New IRC DEALER ASSORTMENTS

IRC CONCENTRIPAKS

You can get IRC's new CONCENTRIKITS now in low-cost, easy-to-stock CONCENTRIPAKS... handy assortments which include Base Elements, Exact Duplicate Replacement Shafts and Switches to suit specific brands of TV sets. Price is only a fraction of cost of factory-assembled controls.

CONCENTRIPAK for Philco—KC-1. Replaces any of 13 Philco concentric dual controls—plus 11 others. Costs only \$10.20.

CONCENTRIPAK for RCA—KC-2. Replaces any of 14 RCA concentric dual controls—plus 36 listings among 15 other makes. Costs only \$7.44.

CONCENTRIPAK for Admiral—KC-3. Replaces any of 14 Admiral concentric duals plus controls for Packard Bell, Sparton, Stromberg-Carlson. Costs only \$7.80.

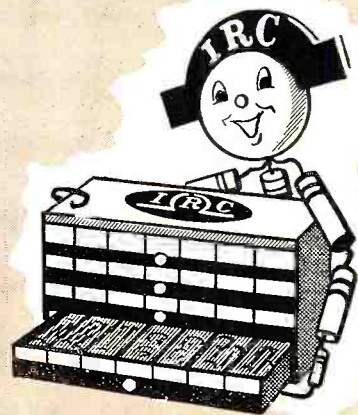

IRC DEALER ASSORTMENT #14

Wide-coverage, low-cost dealer stock of CONCENTRIKIT parts. Provides coverage of 240 concentric dual listings (equivalent of 149 different concentric duals). Supplies replacement coverage among 59 trade names, including RCA, Emerson, Admiral, Philco, Crosley, G.E. and many other widely sold makes.

MAKE IRC YOUR ONE STOP SOURCE OF ALL CONCENTRIC

OF CONCENTRIC DUAL REPLACEMENTS



PLUS FACTORY-ASSEMBLED EXACT DUPLICATES FOR TV CONCENTRIC DUALS

- Double-Your-Money-Back Guarantee of satisfactory mechanical fit and electrical operation.
- Full line includes 295 factory-assembled Exact Duplicate Controls covering 416 Manufacturers' Concentric Dual Parts Numbers—used in over 5,000 TV models.
- Includes both carbon and wire wound types.
- Designed and manufactured to accurate specifications—under rigid quality control. No need to reverse connections or alter in any way.
- Each carton stamped with Manufacturer's Part Number and IRC Stock Number. Frequently avoids re-checking listings for control identification.

Features

Here's the complete Exact-Duplicate TV coverage you've been wanting—all from one dependable source. A full line of 295 Exact Duplicate Concentric Dual Controls to suit almost every TV model—from the largest set producer to the smallest—and many more. AND built to accurate specifications—to fit without reverse connections or alterations. Double your money back, if any of these Factory-Assembled Exact Duplicate Concentric Dual Controls fails to give satisfactory mechanical fit or electrical operation.

Get the full story of IRC's new, improved CONCENTRIKITS and FACTORY-ASSEMBLED EXACT DUPLICATE REPLACEMENT CONTROLS. Mail the coupon for Catalog Bulletin DC1C. It contains stock numbers, prices, TV models covered, and parts numbers.



INTERNATIONAL RESISTANCE CO.

401 N. Broad Street, Philadelphia 8, Pa.

In Canada: International Resistance Company, Ltd., Toronto, Licensee.

Wherever the Circuit Says

INTERNATIONAL RESISTANCE COMPANY
415 N. Broad Street, Philadelphia 8, Pa.

Please send me full details of:—

- IRC's new, improved CONCENTRIKITS, with Exact Duplicate Replacement Shafts, Base Elements and Switches.
- IRC's 295 new Factory-Assembled Exact Duplicate Replacement Controls.

NAME

COMPANY

ADDRESS

CITY STATE

DUAL REPLACEMENT CONTROLS

ATR

Makes
it easy
to DEMONSTRATE
AND TEST
D.C. APPARATUS
FROM A.C. LINES



"A" BATTERY ELIMINATORS

For DEMONSTRATING AND TESTING
AUTO RADIOS

New Models . . . Designed for testing D.C.
Electrical Apparatus on Regular A.C. Lines.
Equipped with Full-Wave Dry Disc Type
Rectifier, Assuring Noise-less, Interfer-
ence-Free Operation and Extreme
Long Life and Reliability.

✓ NEW MODELS
✓ NEW DESIGNS
✓ NEW LITERATURE

"A" Battery Eliminators, DC-AC Inverters
Auto Radio Vibrators

See your jobber or write factory

AMERICAN TELEVISION & RADIO CO.
Quality Products Since 1931
SAINT PAUL 1, MINNESOTA-U.S.A.

RADIO-TV Service Industry News

AS REPORTED BY THE
TELEVISION TECHNICIANS LECTURE BUREAU

WHEN authorized, u.h.f. television will present a host of new problems to the forces of the television installation and servicing industry. With from 2000 to 2500 telecasting stations possible in the new channels numbered 14 to 83, which cover the 470 to 890 mc. band, plus the stations that will be operating in the present v.h.f. band, television programs will be available in practically every city and hamlet across the country.

The first stations to be built will be located in present non-television areas. By the time these stations are ready to go on the air most of the receiver manufacturers will probably introduce their v.h.f.-u.h.f. combination sets with the circuits for receiving u.h.f. included in the receiver design. Quite obviously, the receivers that do not employ the continuous type of tuner will be equipped with the proper coils to receive the channels allocated to the area where the receiver is installed. Although receiver manufacturers have not divulged their circuit designs for u.h.f.-v.h.f. combinations, it is reasonable to anticipate many innovations in circuitry as field experience indicates the circuit combinations that are the most successful.

The immediate problem that will develop when u.h.f. is introduced into new areas is that of determining the

best type of antenna to meet the peculiar needs of each newly-opened television area. *Radio Corporation of America* has been conducting exhaustive studies on u.h.f. reception since 1946 and its experiences provide a good practical basis for commercial u.h.f. installations.

The *RCA* studies began in July 1946, when experimental transmissions and tests were conducted in New York at 288 mc., 510 mc., and 910 mc. In September, 1948, equipment was made available and tested in Washington, D.C., at 504-510 mc.

After the Washington tests, the *RCA* u.h.f. project was moved to Stratford, near Bridgeport, Connecticut. Tests were made at this location at 530 mc., and are being continued at 850 mc. These studies include checks of transmitting and receiver antenna characteristics, receiver installation problems, effects of terrain and foliage, effects of weather, ground propagation, u.h.f. receiver converters, transmission lines, and many other factors.

It is interesting to note that the studies of indoor antennas of the built-in or cabinet types indicated that they were generally less satisfactory for fringe area use than outdoor antennas. A person moving or standing near the indoor antenna may cause a momentary deleterious effect on picture

Edward M. Noll of the Television Technicians Lecture Bureau explains the most important features of test instruments in television servicing in his lecture on "Test Instrument Applications." His lecture includes the demonstration of the alignment of a u.h.f. converter using presently-available service test units.



quality. Venetian blinds, awnings, and similar objects were also reported to affect the signal received with indoor antennas.

Light antenna types have been thoroughly checked in the course of the RCA u.h.f. experiments. These included the fan dipole, two-stacked fan dipole, the stacked "V", the rhombic, the parabolic reflector, the corner reflector, the helix, and the six-element yagi.

In reporting on these tests the RCA Service Company stated that "Every installation site was thoroughly surveyed for optimum results before a u.h.f. antenna was installed. Often it was found that the fan dipole antenna did not produce sufficient pick-up. In such cases, the stacked "V" was substituted. If this proved inadequate, a corner reflector antenna was tried. If improvement was insufficient with substitution of antennas, the height of the antenna was increased. Where signals were received by reflection, the best position of the antenna was found to be critical as to orientation and height. A distance of a few inches horizontally or even vertically made a great difference in the picture quality.

"Where u.h.f. and v.h.f. antennas are installed, it is best to survey first for the u.h.f. channel, since it is more critical as to location. In many installations, the u.h.f. antenna may be mounted on the v.h.f. supporting mast. However, separate masts are sometimes needed."

The RCA u.h.f. experiments seem to indicate that changes may have to be made in the method now employed by many television installation and service contractors in handling receiver installations for u.h.f. reception. Many service contractors follow the plan of checking and aligning each receiver before it is delivered to the purchaser for installation. The installation crew handle all installation work up to the receiver input. Their installation reports include information on receiver performance after the installation is completed but the installation men do not make any adjustments on the set. A receiver technician follows up to make any necessary adjustments on the equipment.

During the early days of u.h.f., at least, it is probable that a member of the installation crew will have to be a fully competent TV technician, so that receiver adjustments can be made where necessary at the time of selecting antenna position, route of lead-in, etc.

Service Companies for U.H.F.

The metropolitan areas in which the majority of the present 107 v.h.f. stations are located will have their own peculiar problems with u.h.f. In some of the larger cities, for instance, the suburban districts will be in the fringe area of their local u.h.f. telecasting stations when the transmitting antenna is located in the center of the city. Reception problems due to signal block-outs from line-of-sight obstructions and reflections will be severe.

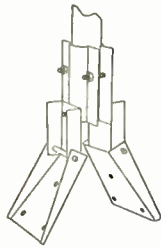

Television Accessories:

Universal flat and peak roof mount made of heavy gauge steel, aluminum finish. Adjustable flaps provide a easy means for mounting on any peak regardless of roof pitch. Swivel mast holder takes up to 1 1/2" pipe and can be raised easily. **PRICES: Each: \$1.69.**
Box of 12: \$17.50

GUY CLAMPS up to 1 1/2" Pipe.....	Each	Box of 12
GUY RINGS—1 1/2" Pipe.....	25c	\$2.40
	15c	1.49

TURNBUCKLES:

Dia.	Total L.	Open L.	Closed L.	Ea.	Doz.
#14	1/4"	2 3/8"	7 1/2"	5 1/2"	\$1.65
#15	5/16"	2 3/8"	7 1/2"	6 1/2"	2.16
HOOKS: #187 5/8" x 5" Galvanized; 6c Each;					Box of 24 \$1.30
AIRCRAFT CABLE: 1/8" x 7 x 7 strands, Weather-proofed, 47 Foot Lengths only at..... 75c Ea.					
GUY CABLE CLAMPS: 3/8" 10c Ea. Box of 25..... \$2.25					

TRANSFORMERS AND CHOKES

TRANSFORMERS—110 V. 60 CYCLE PRIMARIES:	
Sec. 6.3 Volt 1 Amp.....	\$1.25
Sec. 24 Volt 1/2 Amp.....	1.50
Sec. 24 Volt 1 Amp.....	1.95
Sec. Two 12 V. 4 A. windings—Gives 12 V. 8 A. or 24 V. 4 A. 5.95	

CHOKES:

II-115	8 Henries 500 MA Filter, 5000 V. Ins....	\$ 10.95
II-121	13 Hy. 250 MA Filter, 1500 V. Ins....	4.95
II-412	4-12 Hy. Swinging, 300MA, 2500V. Ins....	4.95

CORDS—CABLES

CD-501	Cord f/GN-45 Generator.....	\$2.00
CD-318	Cord w/PL-58 & SW-141 & JK-48F f/Throat or Lip Mic.....	.89
CD-307	Cord—4.5 Ft. w/PL-55 & JK-26.....	.89
CD-604	Cord w/C-410 Trans. & PL-54 Plug.....	.89
BC-375	or 191 Cable w/PL-64, 61, or 59 each end.....	2.50
CD-365	Cord for LP-21 Loop.....	2.00
MC-215	Tuning Shaft for 274N.....	2.00

ANTENNA EQUIPMENT

MAST BASE—INSULATED

MP-132 BASE—as illustrated at left. 1" heavy coil spring, 2" insulator. Overall length: 11 1/2". Weight: 2 1/2 lbs. Price..... **\$3.95**

MAST SECTIONS FOR ABOVE BASE



BASE—Tubular steel, copper coated, painted, in 3 foot sections, screw-in type. AIS-53 can be used to make any length. With MS-52-51-50-49 for taper. Price for any section..... **50c Ea.**

AN-104A	Antenna—100-156 MC.....	\$2.00
AN-117	Whip Steel—6 Ft. Length.....	1.50
AN-109A	Whip Steel, 5 Ft. w/Base.....	1.50
AN-37/ARN-5	Ram's Horn, 110 MC.—USE4.....	5.95
LP-21-A	Loop for ADF equip.—Used, tested.....	9.95
AT-37/APT	Stub—113-150 MC.....	6.95
AT-42/APT-3	or APT-1 Stub—113-150 MC.....	6.95
AN-97/ARQ-8	Spike with coaxial lead in base.....	4.95
AS-61/ARN-5	Half-Wave Dipole—335 MC.....	3.95

MOUNTINGS AND CLAMPS:

FT-154	for BC-348 Receiver.....	\$2.50
PT-470	Mounting and Clamp.....	1.00
MC-476	Maple Ball for above—f/Fairlead.....	1.00
MC-396	Wood Clamp for Fairlead.....	.75
M-235	Bobbin & 250 Ft. W-100 Antenna Wire.....	3.50
WT-7	Weight for Trailing Antenna.....	1.50

TUNING UNITS COILS

TU-7-8-9-10-26	for BC-191-375.....Used:	\$3.95
LP Transformers f/274N—85 KC—1415 or 500 KC.....	Ea.	1.50

AUTOSYN TRANSMITTER:

Autosyn Transmitter from LP-21A Loops, used with I-81 or I-82 indicators. Operates from 26 Volt 400 cycle. With calibrated Dial and Correction Pointer. MC-507..... **\$6.95** MC-217..... **\$5.95**

GEAR TRAIN MOTOR

Ball bearings, low inertia reversible type, 588 RPM. Extra large gear, 3/4 RPM operates 26 Volt 400 cycle or 12 Volt 60 cycle. Removed from LP-21 Loops. Type—10047-2-A..... **\$4.95**

MISCELLANEOUS

Leg and Seat Assy. for Hand Generator.....	\$ 3.50
BC-230 Transmitter, with Tubes.....	4.95
T-20 AHC-5/BC-135. Freq.—4 to 5.3 MC.	New: 14.95
R-1/ARR-1 Rec. f/conversion to 220 MC.....	4.95

CONTROL BOXES:

	NEW:	USED:
C-57/ART-13—f/ART-13 Trans.....	\$ 6.95	\$4.95
MR-9C/Control Box f/IRA-10 Rec. w/Mic.....	12.95	3.95
BC-434 for ADF.....	3.95	1.95
BC-732 for Localizer.....	3.00	
BC-646 Control Box f/BC-645.....	3.95	
BC-461 Reel Control Box w/Counter.....	2.95	

Address Dept. RN • Minimum Order \$5.00 • Prices F.O.B., Lima, O. • 25% Deposit on C.O.D. Orders

BC-223 TRANSMITTER



30 Watt transmitter with Crystal or MO control on four pre-selected channels. CW, MCW cover frequency range 2000-5200 KC. by use of plug-in coils. Complete with tubes and choice of one Tuning Unit (listed below). Less Mtg.—Prices:
NEW: \$32.50

USED **\$26.50**
(Gov't. Reconditioned)

CABLE—Trans. to Power Supply.....	\$2.00
TUNING UNITS: TU-17—2000-3000 KC.; TU-18—3000-4500 KC.; TU-25—3500-5250 KC.....	\$3.50 EACH
Spare VIBRATOR & TUBE KIT f/PE-125BX.....	\$ 5.95
PE-125BX POWER SUPPLY f/BC-223—12/24 Volt input; output 475 Volts 150 MA.....	NW: 14.95
SPARE TUBE KIT in metal box, f/BC-223.....	5.95
OPERATING MANUAL for BC-223AX.....	2.50
SHOCK MOUNTING for PE-125.....	1.50
PT-173 MOUNTING for BC-223.....	2.50
BC-223 TRANSMITTER—Incomplete for parts. No front panel or meters. Price—As is.....	\$4.95

AERIAL WIRE

Aerial Wire—Phosphorus
Bronze #16
Stranded, 200 lb. test, Weather-proof, 150 feet on Reel. RL-3 with Clips..... **\$1.50**

WIRE—HEAVY DUTY RUBBER COVERED

2/2 #16—20 Ft. Length..... **\$1.25**
2/2 #12—10 Ft. Length..... **1.00**
1/2 #6—Shielded, 15 Ft..... **1.50**
1/2 #6—Shielded, 7 1/2 Ft..... **.75**
1/2 #2—Shielded, 8 Ft..... **1.00**
1/2 #8—Cotton covered—Per Foot..... **.06**
1/2 #14—Shielded, Rubber Covered, 50 Ft. Length..... **\$2.75**
Or Per Foot, at..... **.06**

BLOWERS:

115 Volt 60 cycle BLOWER (pictured), approx. 100 CFM Dis. 2 1/4" intake; 2" outlet. Quiet running. Motor size e: 2 1/2" x3 1/4". NEW—not Gov't surplus. Order No. RN-520. **\$7.99**



DUAL BLOWER—Same as RN-520 above, except has blower assembly on each side of motor. Order No. RN-800..... **\$12.95**

POWER SUPPLIES:

VIBRATOR TYPE—6 Volt DC input; output 230 Volt DC 50 MA. filtered w/tube. Size: 6 1/2" x4" x5 1/2"	Price.....	\$6.95
VIBRATOR TYPE—6 Volt DC input; output 230 Volt DC 50 MA.—not filtered—w/tube. Ideal for command receiver operation as receiver is filtered internally. Size: 4 1/2" x4 1/4" x3 1/4"	Price.....	\$4.95
PE-157 POWER SUPPLY—2 Volt Vibrator Supply, operates from 115-54, 2 Volt Battery mounted in Case. Output voltage 1.4 V. 1/2 Amp 125 V. 50 MA. Less Battery, Speaker, & External Power Cord—with Vibrator.....		\$4.95
BB-54 2 Volt Dry Battery.....		2.95

METERS:

0-150 Volt, 400 cycle, 2 1/2" Rd.....	\$3.95
0-5 Amp. AC, 3" Rd., 0-75A Scale.....	3.95
0-5 Milliamp DC, 2 1/2" Sq., 0-5 Scale.....	3.95
0-1 Milliamp DC, 2 1/2" Rd., 0-150 Scale.....	3.95
0-500 Microamp, 2 1/2" Rd., 0-15 & 0-600 DC Volt Scale.....	3.95
TUNING METER 1-700 Hz Reverse Scale, Weston #606 for Compass Control Boxes.....	3.95

PLUGS AND CONNECTORS:

PL-112 Plug for LP-21 Loop.....	\$1.25
PL-P-103 Plug for BC-348.....	1.50
MC-211 Rightangle Adapter for Comm. Sets.....	.50
M-359 Rightangle Coaxial Connector.....	.25

DYNAMOTORS:

DYNAMOTOR AND BLOWER 9 Volts DC input, output 450 Volts 60 MA., 4500 RPM. At 6 Volts DC input, output 260 Volts 65 MA., 3000 RPM. Price..... **\$4.95**



INPUT:	OUTPUT:	STOCK NO.:	PRICE:
14 V. DC	600 V. 300 MA.	RD-86	\$9.95
12 V. DC	220 V. 70 MA.	DM-24	6.95
12 V. DC	220 V. 100 MA.	DM-18	4.95
12 or 24 V. DC	440 V. 200 MA. &	D-104	9.95
	220 V. 100 MA.	DM-375	8.95
14 V. DC	375 V. 150 MA.	DM-330	7.95
14 V. DC	330 V. 135 MA.	BE-59	14.95
14 V. DC	500 V. 500 MA.	USA/90516	3.95
12 or 24 V. DC	275 V. 110 MA.	DM-33; 5055; DM-416;	
	PE-101, etc.		

FAIR RADIO SALES 132 SOUTH MAIN ST. LIMA, OHIO

USE PHOTOFAC

the world's best Radio and TV Service Data ...



WE'LL PROVE YOU'LL SAVE TIME and EARN MORE WITH PHOTOFAC

FREE Service Technicians: We'll send you any Photofact Folder listed in the "PF INDEX and Technical Digest." If you haven't an Index, get a free copy from your local Photofact distributor or write for it today. To obtain Free Folder, be sure to state Photofact Set and Folder Number as shown in the Index.

NOW—learn for yourself how PHOTOFAC makes your Radio and TV work quicker, easier, more profitable! Just get and use an actual PHOTOFAC Folder. Discover why over 35,000 successful service technicians count on this invaluable data daily. No other service gives you PHOTOFAC'S completeness, accuracy, uniformity and lowest cost. PHOTOFAC is the only Radio-TV service data prepared from laboratory analysis on the actual equipment. Get your FREE Folder now. Examine, use, compare. See why you can't afford to be without PHOTOFAC!

NOTE: Our FREE Folder offer is limited to Service Technicians only. Attach coupon below to your letterhead and mention your jobber's name. Experimenters and others may obtain the Photofact Folder by remitting amount shown below.

HOWARD W. SAMS & CO., INC.

HOWARD W. SAMS & CO., INC.
2201 E. 46th St., Indianapolis 5, Ind.

I am a Service Technician. Send me Free Folder No. which appears in Photofact Set No. (as listed in the PF Index).

I am an Experimenter. Enclosed \$..... Send me Folder No. which appears in Photofact Set No. (TV—\$1.00. AM/FM—50c. Record Changer. or Communication Receiver—75c)

Name.....

Address.....

City.....Zone.....State.....

EASY PAY PLAN!

PAY AS YOU EARN! Ask your distributor about this amazing plan. Only \$18.39 puts the entire profit-boosting Photofact library in your shop now!

However, television installation and service contractors now operating successfully in the metropolitan areas will be able to adjust their operational procedures to handle the individual requirements of their u.h.f. installations.

The new service business opportunities that will stem from the expansion of u.h.f. telecasting will occur in the hundreds of medium and small-sized cities and towns that have u.h.f. channel allocations. These service businesses will probably follow a pattern of operation similar to the successful installation and service contract operations in present v.h.f. fringe areas. In fringe areas, of course, an outdoor antenna is necessary with every receiver installation. In most cases, the cost of the antenna system represents a substantial part of the total sale and in some installations it will equal the cost of the receiver. The personnel, facilities, and "know how" for making successful installations is a prime requisite for the fringe area service contractor with the result that his installation department has a larger staff than his receiver adjustment and servicing department.

Managers of successful service businesses in fringe areas now frown upon expanding their activities beyond a proven profitable radius from their headquarters. Distances vary in different parts of the country but, on an average, television service businessmen have found it inadvisable to handle installation and service contracts over twenty miles from their shops.

Many service businessmen feel that u.h.f. will usher in an era of small branch operations in which service contractors will establish sub-depots in the u.h.f. areas adjacent to their operating headquarters. It is felt that the activities of installation crews working out of a centrally-located shop can be profitably applied over a much larger area than the time of technicians who will handle the subsequent receiver service calls that will be required. The elements of time and distance are not so important on installations since these can be scheduled for the most economical routing of the crews. But time and distance are vitally important on receiver service calls since there is no way of pre-determining when and where they will be required. The opinion that servicing depots may be the answer to adequate, efficient television service in small u.h.f. localities is based upon the facilities they would provide for prompt service by competent technicians backed by all of the know-how, planning, equipment, and stocks of a large central operation.

However, experienced service businessmen will move cautiously in expanding their operations. They have learned from costly experience that it is easier to expand than it is to contract a service business. They have learned that the first consideration is whether the firm is financially sound enough to finance an expansion pro-

LOW FREQUENCY CRYSTALS

FT-241A (Brown) Holders, Channel spacing, 1.388 kcs. All frequencies in kilocycles.	89c ea.
375 440.277 430.555 458.333 486.111 513.889	513.889
376.388 404.166 431.944 459.722 487.500 515.278	515.278
377.777 405.555 433.333 461.111 488.888 516.666	516.666
379.166 407.000 434.666 462.500 490.278 518.055	518.055
380.555 408.333 436.111 463.878 491.666 519.444	519.444
381.944 409.722 437.5 465.277 493.055 520.833	520.833
383.333 411.111 438.888 466.666 494.444 522.222	522.222
384.722 412.5 440.277 468.055 495.833 523.611	523.611
386.111 413.888 441.666 469.444 497.222 525.000	525.000
387.5 415.277 443.222 470.833 498.611 526.388	526.388
388.888 416.666 444.444 472.222 500.000 527.777	527.777
390.277 418.055 445.833 473.611 501.388 529.166	529.166
391.666 419.444 447.222 475.000 502.777 530.555	530.555
393.055 420.833 448.611 476.388 504.166 531.944	531.944
394.444 422.222 450.000 477.777 505.555 533.333	533.333
395.833 423.611 451.388 479.166 506.944 534.722	534.722
397.222 425.000 452.777 480.555 508.333 536.111	536.111
398.611 426.388 454.166 481.944 509.722 537.5	537.5
400.000 427.777 455.555 483.333 511.111 538.888	538.888
401.388 429.166 456.944 484.722 512.5 540.277	540.277

Power Supply for Any 274-N Receiver

Just plug it into the rear of your 274-N RECEIVER, any model. Complete kit and black metal case, with ALL parts and diagrams. Simple and easy to build in a jiffy. Delivers 24 volts plus B voltage. No wiring changes to be made. Designed especially for the 274-N receiver. All necessary parts for conversion of rest of receiver also included. ONLY \$8.95.



CONDENSER TESTER

• One of our best sellers! Useful, versatile laboratory item, in kit form. Simple, and easy to build in less than an hour. Checks condenser leakage and continuity up to 8 megs. Will test any paper, electrolytic, mica or oil capacitor from 50 mmf. to 50 mfd. Self-contained power supply and neon bulb indicator with socket and bezel. Drilled metal cabinet. Complete instructions and diagrams included with each kit. Only \$5.00.



NOVICE 500V POWER SUPPLY KIT

Here is all the makin's for a sweet little power supply suitable for 807's. Includes: Power transformer, 2—4mfd, 600V oil filled condensers, 1—10 henry choke, 1—5U4 rectifier, 1—socket, 1—chassis, line cord, power switch and terminal board. Supply output voltage is 500 volts at 200 ma. Only \$16.95 kit



LOOK! NO HANDS!

This mike leaves both hands free for mobile QSO's. Fastens to operator by simple snap strap. Adjustable. Double action sw. operates push-to-talk or holds on. Only \$2.00 ea. POSTPAID in U.S.A. and CANADA.

NEW PHONE PATCH

Now redesigned into more compact and convenient housing, the π 6000S phone patch retains all of its excellent characteristics. Provides you with exactly what you need to patch your phone into transmitter or receiver. Features include hi-impedance input suitable for xtl mike and both hi and low impedance inputs to insure proper match to your particular receiver. Unit is complete "Sure-fire" ready to go to work for you. Only \$4.95 ea.

TRANSFORMERS-CHOKES:

920-0-920 or 740-0-740 AC @ 200 ma. Pri. 115V, 60 cycle, AC. Upright shielded case. Excellent for 807's. Only \$10.80 ea.

5V, 25A. Pri. 115V, 60 cy. AC. A real rugged job excellent for 304TL—4-250A etc. Limited quantity. Only \$4.50 ea.

10H, 200 ma choke. Hermetically-sealed steel case. Also has hum-bucking tap. A beautiful item only \$1.98.

Power Transf. 350-0-350 @ 70 ma. 5V @ 3A. 6.3 @ 3A. Pri. 110V, 60 cy, AC. Upright mtg. \$3.25 ea.

Power transf. Pri. 115V, AC, 60 cy. Sec. 520-0-520 @ 200 ma. \$5.25 ea.

350-0-350 @ 300 ma. 6.3 @ 4A. 6.3 @ 8A. 5V @ 3A. Pri. 115V, 60 cy. AC. \$7.95 ea.

450-0-450 @ 200 ma. Pri. 115V, 60 cy. AC. 5V @ 3A. 6.3 @ 5 amp. In shielded case. Only \$8.90 ea.

350-0-350 @ 350 ma. 6.3 @ 10A. 5V @ 6A. Pri. 115V, 60 cycle. Only \$8.95 ea.

Minimum order \$2.00. All items subject to prior sale. All prices subject to change without notice. 20% deposit must accompany all orders, balance C.O.D.

OFFENBACH & REIMUS CO.

1564 MARKET ST.
SAN FRANCISCO, CALIF.

gram, and second, what the enlarged operation will produce in the way of stable income.

Most radio service operators who entered the television installation and service business in the early days of TV grabbed all of the business they could get and expanded their activities far beyond their basic resources to finance them. Those who survived the subsequent recessions in installations and in annual contract business learned early that two of the most important elements in the continuing success of a service business were accurate records of all transactions and a monthly profit and loss statement prepared by a qualified accountant. This helps them to avoid the experience of the radio service operator who jumped into the television installation field in the early days, hired a couple of men, accepted all of the business he could get, and worked day and night to corral as much of the "easy money" in television as he could. At the end of a few months, when his cash in the bank did not measure up to the volume of business he was doing, he asked an accountant to look over his books and tell him what was wrong. He found that he had done approximately ten-thousand dollars' worth of business, but that it had cost him eleven-thousand dollars to handle it.

Price Cutting

Last summer, when television installation and service business was at rock bottom, some service contractors and dealers resorted to price cutting in an effort to get business. However, service businessmen who manage their businesses on the basis of accurate "cost of doing business" records did not resort to price cutting because it was obvious that the lower prices would force them to operate at a loss. Of course, the larger the volume of business that was brought as the result of cut prices meant an increasingly larger loss.

While it was hard sledding for these service businessmen who maintained the prices they had to get in order to do business at a profit to weather the summer slump, the benefits they received when business picked up more than offset their summertime losses.

Those contractors and dealers who cut prices found that once they cut their prices it was impossible to restore them to profitable levels after business picked up. In order to minimize their losses at the reduced prices, they had to cut corners wherever possible on installation and service. These practices showed up in a higher average of customer complaints and repeat calls.

On the other hand, the service businesses that maintained their prices gave excellent service and as business moved to higher levels, they were able to capture the cream of the installation and service business in their areas.

Service Association Activities

At their recent election, the Associated Radio-Television Service Dealers

April, 1952

TURNER

products are performance-proved!

- ★ Attractive Design
- ★ Quality Construction
- ★ Competitive Price



★The Turner TV Booster
Low-noise-level Cascode circuit produces a good picture under receiving conditions that nullify the efforts of many other leading boosters



★The 50D "Aristocrat"
World's Finest Dynamic microphone . . . for TV, FM, AM, recording and public address. Use the Aristocrat wherever performance of the very highest quality is demanded.

★The Model 33
The most popular general purpose microphone on the market. Accurate pick-up and faithful reproduction with either the 33X Crystal or 33D Dynamic.



Model 22X-22D



Model 34X



Model 25X-25D



Model 20X



Model 99D-999D-U9S



Model 9X-9D



Model 60X

See the sparkling NEW additions to the famous Turner line at the 1952 Radio Parts Show, May 19-23, Hilton Hotel, Chicago.



THE TURNER COMPANY 933 17th St., N. E. Cedar Rapids, Iowa

IN CANADA:
Canadian Marconi Co., Ltd.
Toronto, Ont., and Branches

EXPORT:
Ad. Auriema, Inc.
89 Broad Street, New York 4

Crystals licensed under patents of the Brush Development Company

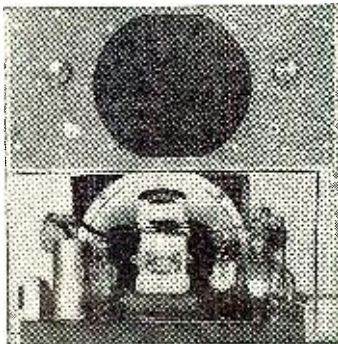

Bargain #1, Front and Rear Views

HIGH QUALITY AUDIO AMPLIFIERS

Bargain #1—3-Tube A-C/D-C Phono. Amplifier (panel type, as shown in two views at left). Reconditioned Army surplus. GUARANTEED. Has 8" Jensen Speaker! Separate motor off-on switch. Phono. & Earphone Jacks, Tone & Vol. controls. Size 4 1/2" x 5 3/8" x 4" deep! Ready to use, w/Tubes . . . Only \$8.45 ea! Phono. Amplifier, same type as above except with separate 5" voice coil. Overall: 4" x 8 1/2" x 4 1/2" high. Complete w/3 Tubes, 6SL7GT, 6V6GT, 6X5GT. Very Special \$18.95!

Bargain #2—5-watt A-C Microphone & Phono. Amplifier. Chassis type, attractive enamel finish. Has many uses! Jacks & separate Gain Controls for Mic. & Phono. Tone Control is compensated type, for improved bass at low level! Output matches 3.2 ohm speaker on 3 ft. cord. Overall: 4" x 8 1/2" x 4 1/2" high. Complete w/3 Tubes, 6SL7GT, 6V6GT, 6X5GT. Very Special \$18.95!

Bargain #3—3-Tube A-C/DC Phono. Amplifier ("tuck-away" L-shape chassis type). Tone & Vol. controls. Connects to any standard 50L6 output transformer. Overall: 5" x 2" x 3" deep, plus 3/4" shaft-and-bushing length. Less Tubes. Only \$3.50! Set of Tubes for above, 12SQ7, 50L6, 35Z5. Special \$2.00 set!

Minimum order \$3.50; subject to prior sale; F.O.B. N.Y.C.; 20% with order, balance C.O.D. Prompt shipment.

NATIONAL ELECTRONICS DISTRIBUTORS
168 Washington St., New York 6, New York
CORtlantd 7-2327

THE MOST COMPLETE LINE OF TV CABINETS IN THE COUNTRY

River Edge... superb quality by skilled craftsmen. All cabinets are custom made, all with hand-rubbed finishes... table models, open face consoles, combinations, with bars, sliding doors, swivel bases, and many other fine features.



A typical example is the M-111 shown, which will accommodate up to 24" tube with or without record drawer, made of solid mahogany and mahogany veneers. A complete line of conversion cabinets available with adaptable masks made to fit all name brand chassis. River Edge Industries defies all competition with complete price range retailing from \$40 to \$400.

W 36" x D 25" x 41"

Write for catalog
New territories open for Representatives, Distributors and Jobbers.

RIVER EDGE INDUSTRIES

River Edge, New Jersey, ORadell 8-0900
N. Y. Showroom: 192 Lexington Ave., CHickering 4-2120

STAN-BURN E. D. ARKIE

ANTENNAE SPECIALS

DOUBLE V 3/8" Dowel.....	1-11	Or More
DOUBLE V 3/8" Dowel.....	\$2.98	\$2.20
DOUBLE V 1/2" Dowel.....	3.45	2.40
DOUBLE V 1/2" Dowel.....	3.95	2.95
10 Element Conical 3/8".....	3.55	2.55
Folded Hi Straight Low Quick Rig 1/2" elements.....	4.25	3.25
WINDOW CONICALS.....	4.95	3.75

MASTS

5 FOOT SWEGGED.....	.79	.69
10 FOOT PLAIN.....	1.39	1.29

TV WIRE

55 MH. 300 OHM.....	\$15.95 M Ft.
72 OHM COAXIAL.....	\$2.50 M Ft.

CATHODE RAY TUBE SPECIALS

10BP4 ZETKA \$14.95	16TP4A DUMONT \$26.00
10BP4 N. U. 19.95	17BP4A FEDERAL 23.00
10BP4A N. U. 19.95	17BP4A DUMONT 26.00
12LP4 ZETKA 19.95	19AP4 SHELTON 29.95
12LP4A THOMAS 19.95	19AP4 G.E. 39.95
16AP4 ZETKA 26.00	19BP4A THOMAS 39.95
16AP4A G.E. 38.00	20CP4A DUMONT 39.95
16DP4A THOMAS 28.80	20CP4A SHELTON 37.00
16GP4A RAULAND 33.00	21EP4A DUMONT 42.95
16GP4 ZETKA 26.00	24AP4A SHELTON 63.00
16JP4A THOMAS 28.80	24AP4A G.E. 76.00
16RP4A GE & NU 26.00	

CHASSIS C70 REGAL with Cascade Tuner. \$139.50
211 T3 FLY BACK (Similar to RCA)..... 1.98
OPEN FACE CABINET..... 39.00

TRANSFORMERS

Nationally Advertised

RCA type for 16" to 24" X032.....	\$3.85
G.E. type for 16" to 24" X045.....	3.85

These are very special prices while they last!

DEFLECTION YOKES

COSINE FERRITE TDD YOKE 70°.....	\$4.20
----------------------------------	--------

SPECIALS

GI 3 speed Changer-Model 700P33-45.....	\$19.50
VM 3 speed Changer-Model 407-31.....	22.50

AUDIO DEVICES, DISCS AND TAPE IN STOCK

12" Heavy Slug Speaker.....Special \$4.98
500 MMFD Barrel Type-20,000 KV Screw end..... 1.19
Plain end.....Special while they last 75c

WIRE RECORDERS IN STOCK

PENTRON-Model 9T3C-2 speed Tape Recorder.....	\$116.68
Net. GAY-Model 2A10.....	89.97
4 Prong Vibrators each.....	\$1.25
Lots of 12 or more.....	1.19

Standard TV Tuners.....\$18.95
Cascade Guaranteed Tuners (with tubes)
SPECIAL! While they last..... 21.95

AUTHORIZED DISTRIBUTORS for: General Electric, Kenrad, Tung-Sol, National Union, Jewel, De Wald, Regal, Automatic and Setchel Carlson.

We carry a complete line of popular makes of Radio and TV tubes, at 50% discount. Also many other special purpose and transmitting types, and all electronic parts and equipment at lowest prices. Send us a list of your requirements for prompt quotations.
Terms: 20% with order. Balance C.O.D. All prices FOB, NEW YORK Warehouse. (Minimum order \$5.00. Write for our latest price list to Dept. RN4

STAN-BURN RADIO and ELECTRONICS CO.

(C.B.S. THEATRE BLDG.)
1697 BROADWAY • NEW YORK 19, N.Y.

Unlimited Opportunities in RADIO ENGINEERING

DEGREE IN 27 MONTHS

Complete Radio Engineering course, including Telev., U.I.F. and P.M. Bachelor of Science Degree also in Mech., Civil, Elect., Chem., and Aero. Eng.; Bus. Adm., Acct. Extensive campus, modern buildings, well equipped labs. Low cost. Prep courses. Personalized, practical instruction. Founded 1884. Placement service. Growing shortage of engineers. Prepare now for unlimited opportunities ahead. **Enter September, January, March, June. Write for catalog.**



TRI-STATE COLLEGE

1642 College Ave. ANGOLA, INDIANA

TWIN-TRAX TAPE RECORDERS



...give you more

MORE MODELS
the most complete variety of recorders for professional, semi-professional and experimenter use.

MORE FEATURES
for better quality, smoother performance and easier operation.

MORE VALUE
because our direct sales policy saves you dealer markups.

Send today for our catalog 5109 which lists complete technical specifications and performance ratings for all recorder models and accessories. *Trademark Reg.

AMPLIFIER CORP. OF AMERICA

398 Broadway New York 13, N. Y.

of Columbus, Ohio, selected Fred Colton as president, Sam Oppenheimer, vice-president; George Dykes, secretary, and Fred Oberle, treasurer.

ARTSD, which celebrated its eighth birthday early this year, is one of the industry's most interesting and successful associations. It was probably the first service management association to be organized. Its membership is restricted to executives of the service dealers and TV contractor organizations whose business practices measure up to the Association's standards.

The Association works closely with local parts and set distributors. Four times each year they hold a dinner and business meeting with local distributors and through the exchange of ideas that such meetings encourage, the combined groups have been able to keep Columbus comparatively free from television service racketeers.

ARTSD cooperates wholeheartedly with the local Better Business Bureau and local newspapers have helped to publicize the organization and what it stands for in promoting efficient, dependable radio-television service.

Typical of the publicity that the Association has received from the local papers is the following extract from a column which appeared in the *Columbus Dispatch*:

"There are unscrupulous television and radio repairmen operating in Columbus at present. Not many but there doesn't need to be many to give the entire trade a black eye.

"They are careful operators, too, who function in such a way that the Better Business Bureau has heretofore not been able to blacklist them officially, nor can the police bring charges against them because, even in the most blatant cases of crooked practice, solid, brickwall evidence cannot be obtained.

"(The Better Business Bureau this week has released in its bulletin 'libel-proof' evidence against one or two organizations and plans to increase its efforts at publicizing unfair practices in the trade.)

"There is another way to stop these dishonest repair and service men. Some reputable service dealers in Central Ohio are formed into an organization known as the Associated Radio-Television Service Dealers to assure the public of a square deal. The organization began its ninth year last Wednesday night with a banquet at Grandview Inn, pledged to put the disreputable repairmen out of business.

"The TV set repair abuse has not been as vicious in this territory as in some of the larger cities but it has been bad enough. The only method that will root it out is organization, the members feel, and the Better Business Bureau wholeheartedly approves."

In addition to their activities on management problems in the operation of their service businesses, ARTSD committees provide four technical meetings per year for their members and members' employees. The Asso-

ciation cooperates wholeheartedly in all distributor-sponsored lectures and technical meetings.

The Master Television Servicemen's Association recently organized in Cincinnati, Ohio, now numbers more than fifty members. This group is developing an aggressive program of activities to provide their members with the outstanding lectures and training programs on TV installation and servicing. B. H. Sparks, service manager for Ohio Appliances, has been acting as industry liaison man for the new Association. -30-

CONVENTION TV

In view of the importance and growing interest in the forthcoming national political conventions, the Long Lines Dept. of American Telephone and Telegraph Company is making every effort to expedite extension of network television facilities to provide service to Miami, New Orleans, Houston, Dallas, Ft. Worth, and Oklahoma City by July.

Originally scheduled for the "last half" of 1952, the network additions are being rushed to meet the earlier date. It was emphasized, however, that priority of construction and possible material shortages make it impracticable to assure the advanced dates.

The job involves the equipping of existing cables and providing new microwave facilities. -30-

TV SALES IN MEXICO

By EMIL ZUBRYN

MEXICO has had television a comparatively short time, but already abuses in sale of receiving apparatus are widespread. Television receivers are selling in the country at triple their worth and, on occasion, even five times the nominal retail value. This situation has been revealed by a study of import statistics covering television sets brought into the country in 1950.

The official Bureau of Statistics, according to tabulated data, shows that 6617 sets were imported in that year, with a value of 7,239,426 pesos (\$837,358). This is to say that each set cost importers 1094 pesos (\$126.47). However, the price to the Mexican public was fixed at 3500 pesos (\$404.71). These figures apply to standard table model television receivers.

Cabinet, floor-model receivers show an even greater disparity in prices to the public. Of this type the Bureau figures show that 3595 sets were imported with a total value of 4,467,617 pesos (\$515,972). A breakdown of per-set cost shows that the average cost to importers was 1242 pesos (\$143.56). The price to the public for the cabinet receivers varied between 7000 and 10,000 pesos (from \$809.20 to \$1,156.00).

These figures graphically reveal why television has not as yet "caught on" in Mexico. Statistics for 1951 are lacking but a spot survey of retail stores shows that sets are still selling at prices far beyond the average public's reach. Due to public resistance prices have fallen off somewhat but table models still range around 3000 pesos while cabinet sets hover around the 7000 pesos and up mark. -30-

April, 1952

SEE LEO FIRST FOR . . .

hallicrafters

1 can SAVE you money . . . Liberal Trade-ins

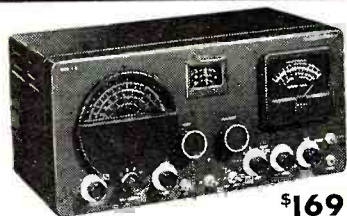

\$169.50

New S-76 RECEIVER

Extra selectivity with double superheterodyne circuit. One RF, two conversion and 3 IF stages. Range 550-1550 Kc, 1.7-34 Mc in four bands. 8 tubes plus voltage regulator and rectifier. Complete with tubes, less speaker.

R-46 SPEAKER \$19.95



\$199.50

SX-71 RECEIVER

Double Conversion sharp selectivity, plus built-in NBFM at moderate cost. 11 tubes plus voltage regulator and rectifier. Low down payment.

R-46 Speaker \$19.95

NAME YOUR TERMS • LOW DOWN PAYMENTS • PERSONALIZED SERVICE

HALLICRAFTERS RECEIVERS AVAILABLE FOR IMMEDIATE SHIPMENT

S-38B	\$49.50	S-72 Portable	\$109.95
S-40B	\$99.95	SX-62	\$289.50
S-81	\$49.50	S-78A	\$89.50
S-82	\$49.50	S-76	\$169.50
		R-46 Speaker	\$19.95

Famous WRL RADIO REFERENCE MAP 25c



CU on 10-20 & 75 Meters

NEW LOG BOOK 25c

For mobile or fixed station. Spiral binding. Full column log listing all FCC required info. Will accommodate 1,525 stations. "Q" signals, phonetic alphabet, amateur international prefixes.

PHONE 7795

WRITE—WIRE



JUST OFF THE PRESS!

WRL 1952 CATALOG

Send for your copy today. Contains everything new in radio and television. Jam-packed with bargains. Leo I. Meyerson, WØGFO



FREE

WORLD RADIO LABORATORIES R-4
744 West Broadway
Council Bluffs, Iowa

Please send me:

- Radio Map SR-75 Info
 New Catalog SX-71 Info
 Used Equipment List New Log Book

Name

Address

City State

WALKIE TALKIES \$4.99

Complete Set of 2

POCKET SIZE



—ELECTRONIC VOICE POWERED
No tubes, batteries, adjustments, license or permit needed.
Guaranteed to work anywhere up to 1/4 mile with extra wire. Swell for garage to house, etc. Your own private, talk-listen phone. Not war surplus. Brand new. Solid Aluminum Case. Two complete units with wires—READY TO USE! SEND ONLY \$1.00 deposit and pay postman \$3.99 C.O.D. or send \$4.99 for PP delivery. Limited supply. MIDWAY COMPANY, Dept. WRT-4, KEARNEY, NEBRASKA.

ON-THE SPOT BATTERY RECORDER

WALKIE-RECORDALL 8 lb. miniature BATTERY RECORDER-PLAYBACK
Continuous, permanent, accurate, indexed recording at only 5c per hr. Instantaneous permanent playback. Picks up sound up to 60 ft. Records conferences, lectures, dictation, 2-way phone & sales talks; while walking, riding or flying. Records in closed briefcase with "hidden mike"! Write for Detailed Literature.

MILES REPRODUCER CO., INC.

812 BROADWAY Dep't RN-5 NEW YORK 3, N. Y.

No Experience Needed To

PRINT YOUR OWN POST CARDS

The GEM STENCIL DUPLICATOR saves money . . . gets results quickly! Hundreds of uses for every type of business and organization. We ship the GEM complete with all supplies. Guide Board for accurate printing and 60-page Book of Ideas at the special low price of only \$8.50 (a \$15.00 value)



Our 21st Year

FREE TRIAL OFFER

Use the GEM FREE at our expense! SEND NO MONEY. Write and complete GEM outfit will be sent you postpaid. After ten days, send us only \$8.50 or return the GEM. You must be satisfied! WRITE TODAY.

BOND EQUIPMENT CO. Dept. 52
6633 Enright • St. Louis 5, Mo.

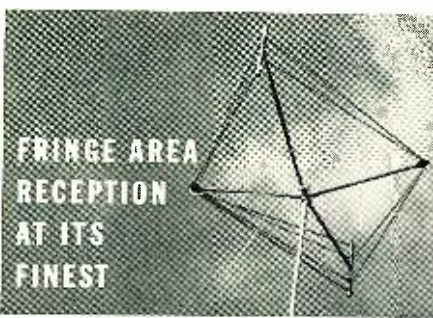

WITH THE RHOMBIC
Phillips
DX-er

Actually proven in field tests to have higher gain in fringe areas than any other antenna in use today.

- NON-RESONANT... 14DB GAIN
- COMPLETE COVERAGE... CHANNELS 2-13
- REDUCES OR ENTIRELY ELIMINATES GHOSTS
- SHARP DIRECTIVITY... LOBE WIDTH 20°
- PRE-ASSEMBLED · WIND RESISTANT

Pat. Pend.

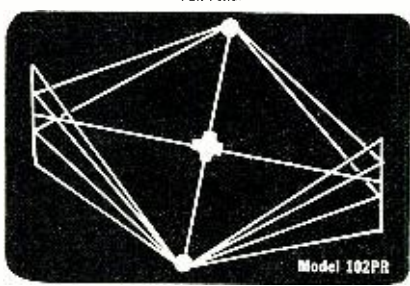

For High and Low Bands (2-13)

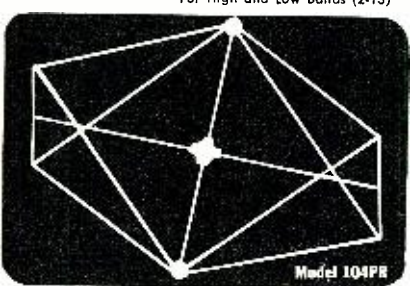

High Band Only (7-13)

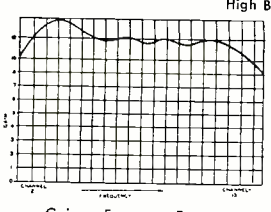

Gain vs. Frequency Response

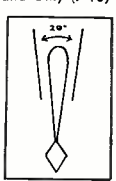

Response Pattern

Write Today for Technical Literature on this Outstanding Rhombic Antenna.

Roger-Phillips
 RESEARCH LABORATORIES
 717-RM NO. LAKE AVE., PASADENA 6, CALIF.

Manufacturers' Literature

Readers are asked to write directly to the manufacturer for the literature. By mentioning RADIO & TELEVISION NEWS, the issue and page, and enclosing the proper amount, when indicated, delay will be prevented.

"TECHNILOG"

University Loudspeakers, Inc., 80 S. Kensico Avenue, White Plains, New York, has issued a new general catalogue which will be of special interest to p.a. men and high fidelity enthusiasts.

Designated the "Technilog," this new 28-page publication carries both product and application data in simple and easy-to-use form. Curves, charts, typical circuitry, and practical discussions on such subjects as overload protection of loudspeakers, impedance matching, speaker baffles, phasing, reverberation, etc., have been included.

Copies of this new catalogue are available now at radio parts distributors or from the manufacturer direct.

TEST PROD PRODUCTS

United Technical Laboratories, Morristown, New Jersey, is offering a copy of its new two-color illustrated folder describing eleven "Klipzon" test prod products used by experimental and product development laboratories and radio and TV service technicians.

Each product description includes a brief text, illustration, and unit prices. The listings include high frequency crystal probes, streamlined test prods and leads, heavy duty test prods and leads, a.f. and r.f. shielded leads, mini-prod connectors, test prod handles, heavy duty test prod handles, mini-prod adapters, heavy duty adapters, longie adapter, and laboratory test leads.

The folder slips into a #10 envelope as a stuffer for distributor mailings to radio-TV service technicians and other users of test equipment.

"PALNUT" FASTENERS

The Palnut Company, 61 Cordier Street, Irvington, New Jersey, has issued a new four-page folder covering its line of fasteners for radio and television coils and shield cans.

Included in the new publication are illustrations of the fasteners, data on thread engagement, gripping points and supporting arms, specifications in tabular form, assembly instructions, and mechanical drawings.

Copies of this folder are available without charge on request.

INSULATION PRODUCTS

Complete descriptive information and technical data on the company's electrical insulation products have been included in a new 24-page catalogue recently issued by *Insulation Manufacturers Corporation* of 565 W. Washington Blvd., Chicago 6, Illinois.

The catalogue incorporates six bulletins, four completely new, on the various "Inmanco" products. Included are No. 499 which describes methods, materials, and applications for fabricated insulators; No. 499A which discusses the requirements, styles, and materials for ready-to-use motor slot insulators; No. 489 which gives information on the features of dispenser packaged cuffed motor slot paper; No. 443 which provides data on vulcanized washers; No. 280 on standard and special sizes and styles of hard maple wood motor slot wedges; and No. 441 which discusses the advantages and sizes of space-saving, curve-formed fiber motor slot wedges.

Copies of the individual bulletins or the complete catalogue containing all of the bulletins is available from the company's Publications Dept.

MILITARY-TYPE RESISTORS

Chicago Telephone Supply Corporation, Elkhart, Indiana, has issued a data sheet describing performance characteristics of its Types 95, 90, and miniaturized 65 military-type resistors.

Data on these high temperature, high stability, composition variables includes wattage and voltage ratings, humidity characteristics, leakage resistance, temperature coefficient, rotational life, and voltage coefficient as well as schematic drawings.

Copies of Data Sheet No. 155 are available without charge from the company.

BOOSTER BROCHURE

JFD Manufacturing Company, Inc., 6101 16th Avenue, Brooklyn 4, N. Y., is currently offering copies of a four-page brochure describing its line of "Tuck-Away" boosters.

The booklet is illustrated and carries complete data on the VB and SW models, including performance characteristics and specifications.

Copies of the "Tuck-Away" brochure may be obtained without charge from the advertising department of the company.

MINIATURE COMPONENTS

Southwestern Industrial Electronics Co., 2831 Post Oak Road, P.O. Box 13058, Houston 19, Texas, has issued a compact data sheet covering its new line of miniature transformers and reactors.

The data sheet carries complete details on these new hermetically-sealed, low frequency transformers and reactors. Information is provided on input, output, and interstage transformers,

and four types of reactors. The units themselves weigh 3 ounces and measure $\frac{1}{16}$ " x $1\frac{1}{8}$ " x $1\frac{1}{8}$ " and are available in standard ($\pm 5\%$) or special ($\pm 1\%$) tolerances.

A written request to the company will bring a copy of this new data sheet without delay.

BIMETAL THERMOSTATS

Stevens Manufacturing Company, Inc., 69 South Walnut Street, Mansfield, Ohio, has just issued a bulletin describing its new neoprene-protected bimetal thermostats.

Hermetically-sealed MH disc type and CH strip type units are described along with information on suggested applications. The bulletin illustrates the operating principles involved and includes detailed dimensional drawings of the styles available for use where contamination is a problem. Ratings and construction data are tabulated for both types.

Copies of Bulletin L-4609 are available on request.

NEW ASA STANDARD

The American Standards Association, 70 E. 45th Street, New York 17, New York, has issued a new standard covering shunt and series condenser units for use on a.c. power transmission and distribution systems, at nominal frequencies of 60 cycles and below, for modifying the performance of the system at normal frequencies.

The new standard does not include high frequency units used in communication services and also excludes condensers used in connection with instrumentation.

Copies of the "American Standard for Capacitor Units" C55.1-1951 are available, at 40 cents each, from the ASA.

TUBE TESTER DATA

The Hickok Electrical Instrument Company, 10514 Dupont Avenue, Cleveland 8, Ohio, has issued a new four-page folder which illustrates and describes ten of its most recent dynamic mutual conductance tube tester models.

In addition to providing performance data on the various models, the booklet explains the principle of this type of tube testing.

At the same time the company has announced the availability of a new tube roll chart for Hickok tube testers, dated January 1, 1952. This chart includes all the new tubes on which data was available at the time of printing.

The roll chart is \$1.00 while the folder (Form TT5) is free. Write direct to the company for either or both of these items.

MILITARY CONDENSERS

A new catalogue on military-grade paper dielectric condensers, made in accordance with the requirements of military specification JAN-C-25, has just been released by the Sprague Electric Company, North Adams, Massachusetts.

Sam's Surplus Sells For Less

COMMAND AND/OR ARCS TRANSMITTERS and RECEIVERS

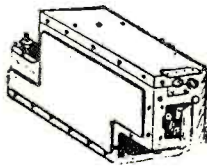

3-6 MC Receiver.
Used \$ 6.95
New 17.95

6-9.1 Receiver.
Used \$ 6.95
New 12.95

Triple Receiver
Rack\$1.95

V.H.F. ARC5 Transmitter or Receiver, Complete w/tubes
Used \$24.95
New

2.1-3 MC Transmitter with tubes 14.95
4-5.3 MC Transmitter with tubes 6.95
5-3.7 MC Transmitter with tubes 6.95
7-9.1 MC Transmitter with tubes 9.95 \$19.95
3-4 MC Transmitter with tubes 18.95
28V Receiver Command Dynamotors \$0.97

MODULATORS
BC-456 with Tubes, less dyn..... 2.95
MD-7/ARC5 Plate Modulator..... 8.95
MD-7 Modulator Dynamotor, 28V 2.95
BC-433 Receiver—with tubes.....\$24.95
MN-26C Compass Receiver..... 24.95 \$39.50
MN-26Y Compass Receiver..... 24.95 39.50
BC-357 Marker Beacon Rec. W.O. Tube 5.95



BC-223 Transmitter. 30 watt. Ideal for Ship-to-Shore or Ham Rig. Crystal or MO control on four pre-selected channels. 2000 to 5250 KC. Use of 3 plug-in coils. Five tubes: 2-801, and 3-36, and TU 17-18-25 tuning units.

Transmitter—\$39.95. Tubes—5.75. Tuning Units—\$2.25. Amp Meter. No. 60.0-60. New—1.29.

CIVIL AIR DEFENSE or 2 METERS
ARC-4. W/tubes. Good, used.....\$29.95
522 Trans.-Receiver. W/tubes. Good, used 69.50
Modulation Transformer. BC-375. New..... 2.49
BC-375 Trans. 100 Watt Voice, CW, MCW, freq. range 200 kc to 12 mc, uses Plug-in Tuning Units listed complete with tubes,
less Tuning Units..... \$29.95

Tuning Units for BC-375 or 191 Trans:
TU- 7 4500- 6200 kc\$2.49
TU- 8 6200- 7700 kc 2.49
TU- 9 7700-10000 2.49
TU- 10 10000-12500 2.49
TU- 22 & TU-26 200-500 kc..... each 4.50
FT-151 Shock Mounting for BC-375 or 191..... 2.95
BC-306 Antenna Loading..... 1.95
GP-7 Navy Transmitter: 100 watt master os. Can use on any freq. from 350-9050 kc. by using proper plug-in. With 1 tuning unit.....\$13.33

LOOP ANTENNAS
DU-1 2 tube amplifier. New \$25.95
MM-20-ENew 7.95
LP-21 ANew 16.95
Rotatable Loop Unit—Type MN-20E. 8" diameter—used with MN-26 Compass and RA 10 DB. By Bendix. Only\$7.95
FL8 Filters—A's, B's, C'sNew 1.95
FL5 FiltersNew .95
Hand Keys—J-38New 1.19

TSC Transmitter & Receiver with 12V Power Supply and Cables. Good—used.....\$179.50
Heineman Circuit 115 V., 20 amp. 1.39
Breakers 115 V., 5 amp. .97
Prop Pitch Transformer, only..... new 6.95
RT-7PN-1 Transceiver w/o tubes. Used 9.95

Cash with order. Prices subject to change without notice. California orders please include 3 1/2% Sales Tax. Please include approximate postage—Excess will be refunded. What Have You in Surplus? Submit 1306 BOND STREET, at PICO

ESEGE SALES COMPANY INC. LOS ANGELES 15, CALIFORNIA

"S" METER



"S" METER

"S" METER—SAM'S SPECIAL. Illuminated face (supplied with miniature lamp). Full scale reading of 5 ma. A standard value for most "S" Meter Circuits. Dia. across face— $2\frac{3}{8}$ ". Black bakelite face. Reverse-set pointer..... New \$2.49
Vibrators—Mallory. For use on 12 V battery.....New \$0.97

TRANSFORMERS

12V 24V 2am 110V primary.....\$2.95
ARC-4 2 Meter Transceiver, tubes, good, used \$29.95
BC-434 Control.....Used—\$1.95 New 2.95
Code Tapes for TG-10 15 rolls. New..... 7.95
BC-906 Absorption Type Freq. Meter Range 150-225 mc. 0.500 DC Microm. Used \$11.50
Field Phones E-E 8's.....Used \$19.95 pr. New \$34.50 pr.
Relay. SP-ST. Leach 6 V or 12 V..... New 1.49

CRYSTALS—CR IA/AR DYNAMOTORS

8150.000—8036.25—8001.43 \$1.19 ea. 3 for \$2.95
PE103 New Case \$29.95
PE-103 New, Less Base..... 19.95
DM-32A Input 28V. Output 250 DC. .06 amps. Used 1.95
PE-73 29V @ 20 amps. output 1000V @ .350 amps. New 8.95

PE-77 14V @ 40 amps output 1000V @ .350 ampsNew 19.95
SPEC. 27V @ 400V 7.50 mil 750V 350 mil.....New 12.95
PE-94 or SCR—522 24V. Used—\$5.95 New 14.95
PE-94 Dynamotor only 4.95
DM-34 12V @ 2.8 amps. Output 220V @ 160 ampsNew 9.95
SPEC. 9V @ 450V output @ 80 ma. New 5.95
SPEC. 12V @ 320V output @ 80 ma. New 4.95
SPEC. 6V @ 250V output @ 80 ma. New 6.95
SPEC. 12V @ 440V output @ 200 ma. New 12.95
ARC-1 DY-9/ARC-1Used 11.50
14 Volt Input—425 Volt Output at 163 miles. Starting Filter and Relays in base. Like New 3.95
RL-42B Antenna Reel Ass. Less wire. New 9.95

OIL CONDENSERS

Standard Makes—New
2 mfd 600V \$0.49
4 mfd 600V 1.39
1 mfd 1000V .69
3 mfd 4000V 7.95
.5 mfd 2500V 1.49
10 mfd 600V 2.95
2 mfd 2500V 3.95
2 mfd 5000V \$ 8.95 2 mfd 7500V 29.59
T-30 Throat Mikes.....Used—3 for \$0.50
CD-307 Head Set Extension Cord..... 1.19

HEAD SETS

HS-30New \$1.95
HS-23.....Used—\$1.95; New 2.95
Matching Transformer for HS-3069

RG-7U Coax Cable, 97.5 ohms.....foot .08
MIKE CHEST SET "F-1" button..... New .99

DECK INSULATORS

Bowl & Flange type. Heavy galv. metal flange— $10\frac{1}{2}$ " dia. Porc. bowl set in rubber gaskets. Top bell— $7\frac{3}{8}$ " dia. Brass feed thro rod l insul. dist. between top bell and flange— $6\frac{1}{2}$ ". New \$2.95

MAKE THIS YOUR HOME FOR IMPORTANT WORK UNDER IDEAL CONDITIONS

- TEST & INSPECTION ENGINEERS • FIELD ENGINEERS
- ELECTRONIC ENGINEERS • LAB. TECHNICIANS
- TV RECEIVER DESIGN ENGINEERS

NEEDED TO WORK ON: YOU BENEFIT FROM high wages, a modern, air-conditioned plant, paid vacations and holidays, group insurance and a good chance for advancement. Housing immediately available in the beautiful suburban and country areas that surround the Bendix Radio plant.

Write, Phone or Wire Mr. E. O. COLE, Dept. O

Bendix Radio

DIVISION OF BENDIX AVIATION CORPORATION
BALTIMORE 4, MARYLAND



Cash in on TV Service Profits!

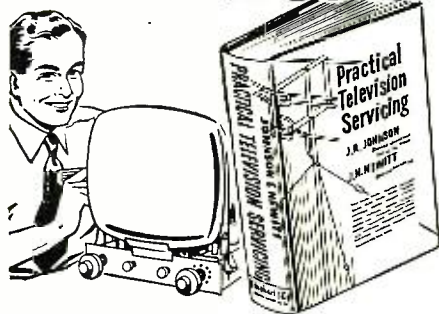

PRACTICAL TELEVISION SERVICING

By J. R. Johnson and J. H. Newitt
375 Pages, 230 Illustrations, \$4.00

Good training for television service doesn't need to cost you a lot of money! This great book at only \$4.00 is a complete guide that tells you step by step just what to do, what mistakes to avoid, what tools, parts and equipment to use—in short, how to handle every phase of television receiver servicing promptly, efficiently and profitably.

LEARN FAST! ... LEARN RIGHT!

The authors of PRACTICAL TELEVISION SERVICING actually operated a TV service shop to get the specific, how-to-do-it information they now pass along to you in easily understood form. In addition to a clear explanation of how television work differs from radio, they show exactly how to perform all operations in trouble-shooting, diagnosing and remedying television troubles. You don't bother with needless theory. They show you exactly how to do the work!

Dozens of actual TV servicing case histories, service hints and common TV receiver troubles make the book literally worth its weight in gold.

Subjects include: TV System Fundamentals; R-F, I-F and Detector Sections; Video Amplifiers; Cathode Ray Tubes; Synchronizing and Sweep Circuits; Power Supplies; Antenna & Wave Propagation; TV Receiver Installation; Test Equipment and Alignment; Wiring and Repair Techniques; Color Television; Receiver Layout Diagrams—and dozens more. In addition there are countless tips on such things as getting better fringe area reception; improving picture linearity; checking video response with a square wave; getting signals over a mountain and numerous others.

Read PRACTICAL TELEVISION SERVICING on our 10-day examination offer! Send coupon today!

READ IT 10 DAYS • at Our Risk!

Dept. RN-42, RINEHART BOOKS, Inc.,
Technical Division,
232 Madison Avenue, New York 16, N. Y.

Send PRACTICAL TELEVISION SERVICING for 10-DAY FREE EXAMINATION. If book is O.K. I will then promptly remit \$4.00 in full payment. If not, I will return book postpaid in good condition and owe you nothing.

Name

Address

City, Zone, State.....

Employers' Name & Address.....

Price outside U. S. A., \$4.50—cash only.
Money back in 10 days if you return book.

The new Catalogue 21 is intended to serve as a reference guide for engineering and purchasing agents in specifying and buying condensers to meet the stringent performance requirements for various branches and agencies of the Department of Defense.

This 24-page booklet is available on business letterhead request only.

SOLDERLESS CONNECTORS

Complete specifications for solderless cable connectors have been included in the new catalogue sheet prepared by *The Workshop Associates*, Division of *The Gabriel Company*.

Included are dimensions and electrical characteristics on the company's Models W-50, W-60, W-80, and W-100 for RG-8/U, RG-11/U, and RG-59/U cable.

Copies of Form WA 54-164 may be obtained from the company at 135 Crescent Road, Needham, Massachusetts, or from radio parts distributors.

EDUCATIONAL BOOKLET

In answer to many inquiries from people outside the electronic industry as to the function of electronic parts wholesalers, the National Electronic Distributors Association has prepared a four-page brochure outlining the basic structure and functions of electronic parts distributors.

Covered in the pamphlet are sources of supply, material handled, customers served, type of employees, services rendered, the status of the electronic parts distributor, and his function in wartime.

Copies of the publication have been mailed out to manufacturers doing business through distributors and to manufacturers' representatives who sell for the suppliers and to distributors.

Individual copies of the brochure may be obtained by writing NEDA at 221 N. La Salle Street, Chicago 1, Illinois.

HEATH CATALOGUE

The Heath Company of Benton Harbor, Michigan, has just published a new catalogue covering its line of "Heath-kit" test equipment and amplifiers.

This new 16-page catalogue includes schematics, inside photographs, application data, and circuit descriptions of the instruments. Among the units pictured and described are the company's probe kits, scope kit, voltmeter kits, audio and signal generators, electronic switches, condenser and tube checkers, signal tracers, impedance bridge kits, etc., in addition to receiver, tuner, and amplifier kits.

The company will supply copies of this 1952 catalogue to those making their requests direct to the firm.

"NEW PRODUCTS AND SERVICES"

The New York Journal of Commerce, 63 Park Row, New York 15, New York, has announced the availability of the 1952 edition of "New Products and Services," an 80-page compilation of time and money-saving innovations.

All of the year's most successful creations, ranging from electronic devices to self-watering flower pots, are described and cross-indexed in this illustrated booklet. Television is prominent among the items described. In addition to new models, the booklet describes a viewing aid based on the science of optics, a highlight control that produces an unusual three-dimensional appearance, and a variety of "custom built" sets incorporating unique features. There is also an explanation of the "telejector" which makes it possible to screen TV spots and shows in the office, and a description of a television set-on-wheels which can be installed in a private car and operated by means of a control panel mounted on the arm rest of the rear seat.

Copies of the publication "New Products and Services" are available from the paper at a cost of 50 cents each. Payment must accompany your order.

-30-

Tape Duplication

(Continued from page 41)

tor," enabling the accommodation of both NARTB and RTMA reels. The duplicating equipment is so planned that it can service other diversified professional accounts in addition to *A-V Tape Libraries*. For example, broadcast stations may require copies wound on 10½" NARTB reels, while industrial sales-training programs may be required on 5" to 7" RTMA reels in order that they can be played on "home" type tape machines. Because of the difference between the inner diameters of reels, tensions of the take-up and supply sides of the tape transport become a factor in maintaining a constant linear speed of the tape over its full length of running time. Further, it may be necessary to have a 10½" reel on the supply side and a 5" or 7" reel on the take-up side. Rather than compromise the finished product, separate toggle-type tension adjusting switches for the supply and take-up motors were installed in the circuitry and mounted on the vu meter panels situated just above each duplicator.

Another operating idea that has been incorporated is the remote control panel which is mounted in a horizontal position on the table to the right of the relay rack. It consists of a bank of key switches which actuate a group of relays which enable the operator to start and stop all of the equipment at one time, or to "lift" any of the duplicators individually without affecting the motions or levels of the others.

As magnetic tape comes into greater usage and novel applications are found for this fascinating medium, the demand for mass facsimile copying of original tape recordings increases. The demand for *Audio-Video's* unique service has been increasing steadily since its installation a year ago—a strong indication of the trend in the industry.

-30-



A-V Tape Library

THE A-V *Tape Libraries*, 730 Fifth Avenue, New York, New York, now lists 26 available program reels in its current brochure. The firm will add at least two new reels each month. Many of the programs offer up to two complete symphonic works. The series is available in three basic forms: Single-track (Part 1 and 2, or both) at 7.5 inches-per-second (ips); Double-track (includes both parts) at 7.5 ips; and Double-track (includes both parts) at 3.75 ips. All programs are recorded on Scotch #111 plastic tape on 7" reels. Outstanding is the A-V "Concert Hall" series of complete programs. These are re-recorded from tape masters (see page 40) on Ampex recorders. They provide music of high quality for the home or for FM broadcast. We have received several of the A-V tapes for review. They were reproduced (this month) through a typical hi-fi music system comprising a Magne-corder PT63JA, Craftsmen C500 amplifier, and Altec 604B speaker system. Single-track, 7.5 inch-per-second tape (A-V's coding "A") was used. Data on these tapes appears in later paragraphs.

Tape Recording Industries (Magnetic Libraries)

We have received word from Dale Perry of *Tape Recording Industries*, Lansing, Michigan, that they are now perfecting their process for the duplication of music on multiple tape machines. The masters are recorded in the studios of "Potte Parisien" in the Champs Elysees, Paris and Magellan Studio which is also used by *Pathe Marconi* for the recording of well-known discs in France. Various combinations are used to cater to all types of musical interpretation. The con-

The neat carton used by A-V Tape Libraries to house its pre-recorded reels. The box is printed in black, yellow ochre, and ivory and provides a handy means of keeping the tapes in order and from damage.

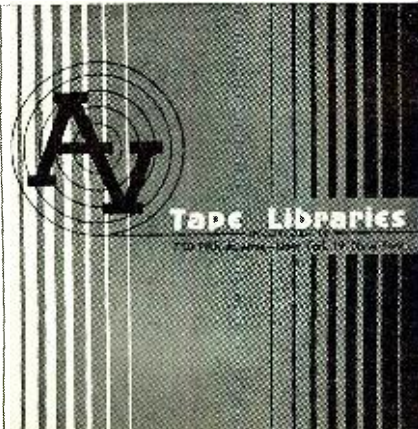

NEW

Automatic Radio

CUSTOM-BUILT AUTO RADIOS

RECORD SMASHING VALUES!

1949-1950-1951-1952

CUSTOM-BUILT AUTO RADIOS

LIST PRICE—\$59.95

Ford, Chevrolet, Plymouth, Dodge, Henry J, Hudson, Stude-baker. Each radio is a six tube superheterodyne six volt battery operation—three gang tuning condenser and tuned RF stage PM speaker Alnico No. 5, wt. 10 lbs.—easy installation.

ATTRACTIVE DISCOUNTS TO DEALERS

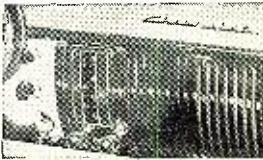

AUTO RADIO SHORT WAVE CONVERTER

• Tunes 63 Meters Through 17 Motors • Band Spread Tuning • Use with any Car Radio • Powerful and Sensitive • Size 7" x 2 3/4" x 3 3/4" • Easy to Install

\$24.95

TUBES Prices Slashed

2C34\$0.85	6AL466
2X2/87995	6AQ577
3C24 1.95	6AR579
7C4 1/203A75	6AT659
10Y340	6AU669
15R85	6AV675
30 SPEC55	6AV769
39/44C40	6BA669
45 SPEC35	6BE673
WE 203A 8.80	6BJ699
51B465	6BQ779
WL531 4.95	6J5GT63
713A 1.00	6J6 1.29
801A45	6J785
803 4.45	6J798
82695	6SD7GT90
841A 4.95	6SN7GT79
86485	6U5G95
CK100585	6V6GT68
CK1007 1.20	6W4GT66
162635	6X5GT70
1629 1.15	7C685
2051 1.45	7C885
719330	12AU675
8011 1.70	12BA679
900695	12BE689
C8B 9.75	12AV675
CEQ72 1.30	12BA879
CK70 4.25	12BE889
CRP-72 1.30	12SQ785
E-114835	12SQ785
HY-61625	25Z575
RKR-72 35	35W490
RK-7365	35W490
5HP4 4.95	50B596
5HP7 1.95	50C589
116685	50LGT85
1130T85	50LGT85
5U4G57	90 1.15
5W490	9585

RELAYS

12VDC DPST Allied Box 32 \$1.25
24VDC DPDT Allied B6D38 1.45
24VDC 3 PDT 8 AMP 1.25
24VDC Solenoid Operates 2 1.75
Switches 1.25
40VDC DPST-SPDT 1000 Ohm 1.25
110VAC DPST 1AMP Contacts 3.25
St. Dunns CNA-1070 3.95
110VAC DPDT 25 AMP Con- 3.95
tacts 3.95
115VAC DPST St. Dunns 3.25
CNA-2997 3.25
220VDC DPDT ST Dunn 3.95
230VAC DPDT GE 4.00
12HG11A2 4.00

TERMS: Minimum order \$5.00—Mail orders promptly filled—All prices F.O.B. Boston, Mass. Send M.O. or check. Shipping charges sent C.O.D. 25% deposit required with all C.O.D. orders.

Prices Subject to Change without Notice
SEND FOR OUR CATALOGUE
Inquiries from Dealers, Schools
and Industrial Firms Invited

TWIN CHART RECORDER

Estelrine Angus Twin Chart Graph Recorder Model AWT-N. Scale 2.5-0, 2.5 MA DC. Feed Hourly 3/4", 1 1/2", 3"-6"-12". Minute 3/4"-1 1/2"-3"-6". Synchronous Clock and Chronograph Pens on each unit. Complete. Brand New.

HI-VOLTAGE FILTER CHOKES

4 HY 4.5 AMP DC 3 OHMS 1230 RMS to ground GE 69G31 New.
2 1/2 HY 4 AMP 5 OHM 20,000 Test. New.
1 HY 3.2 AMP DC 3.5 OHM GE 69G45B New.
1 1/2 HY-3 HY 2 AMP DC 34,000 VDC GE Y3464A. New.

CAPACITORS

	BATH TUB	EA.	TEN	
4 MFD	600 VDC	.95	.45	
2 MFD	400 VDC	.60	.60	
.25 MFD	600 VDC	.40	.35	
5 MFD	600 VDC	.40	.35	
2X1 MFD	600 VDC	.65	.65	
OIL-FILLED AND GE PYRANOL				
1 MFD	600 VDC	.85	.80	
2 MFD	600 VDC	.95	.95	
4 MFD	600 VDC	1.40	1.40	
5 MFD	600 VDC	1.65	1.60	
1 1/2 MFD	600 VDC	2.50	2.35	
2	1000 VDC	1.65	1.60	
.5 MFD	2000 VDC	2.00	1.90	
.25 MFD	3000 VDC	2.85	2.80	
1 MFD	7500 VDC	12.50	12.00	
1 MFD	12000 VDC	14.95	14.90	
1.008MFD	15000 VDC	12.50	11.75	
.045 MFD	16000 VDC	12.95	12.50	
PAPER				
8-8 MFD	600 VDC	2.25	2.15	
3X8 MFD	Tobe, Ferrite	600 VDC	2.55	2.40
8-8-4 MFD	650 VDC	2.45	2.25	
ELECTROLYTIC				
2500 MFD	3 VDC	.40	.40	
500 MFD	12 VDC	.90	.85	
25 MFD	25 VDC	.40	.35	
40 MFD	35 VDC	.60	.55	
50 MFD	50 VDC	.60	.55	
1000 MFD	25 VDC	1.25	1.15	
1500 MFD	50 VDC	1.50	1.45	
60-160MFD	150 VDC	1.50	1.25	

RADAR TEST EQUIPMENT

10 CM Echo Box Frequency Range 2890MC-3170 MCS Direct Reading Micrometer Head Ring Prediction Scale plus 9% to minus 9% type "N" Input. Resonance Indicator Meter. With 10CM Directional Coupler, Accessories and Spares. Brand New.

LINEAR POTENTIOMETERS WW

Ohms	Watts	EA.	TEN
500	2	\$0.45	\$0.40
1000	2	.50	.45
3000	2	.55	.50
10,000	2	.55	.50
5000	3	.50	.45
7500 Dual	3	.85	.80
10,000	3	.85	.80
25,000	3	.65	.60
50,000	4	.90	.85
15	25	.95	.90
50	25	.95	.90
25	25	.95	.90
50	25	.95	.90
100	25	.95	.90
200	25	1.20	1.10
500	25	1.20	1.10
1000	25	1.30	1.25
3000	25	1.40	1.35
15,000	25	1.70	1.60
20,000	25	2.00	1.95
150/Switch	50 AN 3155-50	2.15	2.00
200 W/Switch	50	2.15	2.00
800	50	2.65	2.50
10,000	50	2.95	2.75
15	60	2.95	2.75
15	75	2.95	2.75

HI ALTITUDE PRESSURE SWITCH

Calibrated for Altitudes of 10,000-20,000-30,000 Ft. normally open. New\$6.00

EQUIPMENT SPECIALS

BC-224 Receiver. Used \$79.00
BC-733 Glide Path Rec. New
BC-AG-229 Rec w/tubes. Used 4.95
BC-AI-429 Rec w/tubes. Used 4.95
BC-709 Interphone Amplifier New 4.00
BC-325 Transmitter. New
R5/ARN-7 Compass Rec. New
RC-433 Compass Rec. Used 34.50
Walrus-Talkies. Crystal Controlled 2.3-4.6 MC. New.
TBL-13 X-Miter with Spares.
MN-26V Compass Rec. New. 39.95

COMET ELECTRONIC SALES CO.

22 Washington St. • BEacon 2-7863 • Brighton 35, Mass.

Advance with ELECTRONIC CITY

You need firm grasp of fundamentals to keep pace with these complex, fast-growing fields. In thorough 2-year course learn electricity, electronics, physics, mathematics, drafting, etc. Other engineering and technical courses. Coed. Day, evening, 44th year. Write for Catalog.

FRANKLIN TECHNICAL INSTITUTE
46 Berkeley Street Boston 16, Mass.

RADIO and TELEVISION ELECTRONICS

RCA

Thorough training for men and women in all Technical phases
Enroll NOW for New Classes (Day & Eve.) which start 1st of Mar., June, Sept. & Dec.

Free Placement Service For Graduates
For Free Catalog write Dept. RN-52
RCA INSTITUTES, INC.
A Service of Radio Corporation of America
350 West 4th St., New York 14, N. Y.

Enjoy the best!

GARRARD

Outplays the rest!

GARRARD

World's Finest 3-speed Record Changer with Automatic stop. Quiet motor. Heavy turntable. Prevents disturbing resonance, wows, rumble.

GARRARD SALES CORP., Dept. 4N
164 DUANE ST., N. Y. 13

Gentlemen:

I am interested in learning what to look for when purchasing a 3-speed record changer. Please send me, without obligation, your FACT SHEET.

NAME _____
ADDRESS _____
CITY _____ ZONE _____ STATE _____

Can be used with your present set

Now you can
believe everything
you hear!



the
CRAFTSMEN 500
ULTRA FIDELITY
audio amplifier

Even we were amazed when we tested this remarkable amplifier. Never before, in our experience (or yours) has such remarkable performance been recorded. The C-500 is 99.99+ % distortion-free. We had to think of a new word to describe it. The word is ULTRA-FIDELITY. Hear the "500" and you'll know why.

C500 Amplifier Features

- **FAMOUS WILLIAMSON** all-triode circuit.
- **FREQ. RESPONSE:** ± 0.1 db., 20 cps to 20,000 cps; ± 2 db., 5 cps to 100,000 cps.
- **POWER RESPONSE:** 12 watts ± 2 db., 10 cps to 50,000 cps.
- **TOTAL H DISTORTION:** Less than 0.1% at 10 watts, at mid-freqs.
*0.01% at av. listening level below 1 watt.
- **TUBE COMPLEMENT:** (2) 6SN-7GTA; (2) KT66 power output; 5V4G rectifier.

Sold by leading radio parts distributors everywhere or write to

THE RADIO
craftsmen INC.
Dept. R-4, 4401 N. Ravenswood Ave.
Chicago 40, Ill.

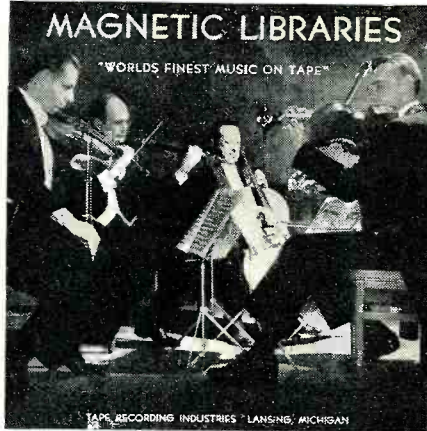

Reproduction of the reel box cover used by Magnetic Libraries to house its various pre-recorded magnetic tape selections.

ductors are favorite broadcasters on the Continent and include such well-known personalities as Guy Luypaerts, Tito Fuggi, Adolphe Sibert (who has broadcast through Radio Miami), Jack Dieval (known in the U.S.A. as the "French Romantic Pianist"), etc.

The recording medium consists of special equipment built for this purpose with a frequency response of ± 1 db from 30 to 12,000 cycles. Both standard speeds of 7.5 and 15 ips are employed. Most of *Magnetic Tape Libraries'* tape masters are recorded with a single microphone pickup. This is the popular "Neumann Electrostatic" type.

We are informed that on the Continent they are using special duplicating machines which run off twenty copies at a time at high speed for 3.75 or 7.5 ips. Copies are made on French *Pyral* or on *Scotch* magnetic tape. These tapes are sold or hired on the Continent with a special exchange service for factories, stores, restaurants, etc. and each program is timed to run for approximately 30 minutes. Many of these masters will be shipped to the U.S. for duplication and these will be available in the very near future.

Berlant Associates (Concertape)

Another pioneer in the field of pre-recorded magnetic tapes is *Concertone*. In a letter received from *Berlant Associates*, 4917 West Jefferson Boulevard, Los Angeles, California, comes the report:

"We sent a questionnaire to a selected group of several hundred *Concertone* customers comprising a representative cross-section of professional, semi-professional, and amateur users. Of these about 65% replied and of the replies those interested in pre-recorded tape outnumbered the non-interested by eight-to-one. Most of those who had no interest were recording studios and other professionals who were in the business of recording tape themselves.

"We found that there was no agreement about the desired tape speed, reel sizes, or between single or dual track recording. The only approach to unanimity was in the preference for plastic tape over paper tape.

For Top Value!
IT'S ALWAYS
NEWARK

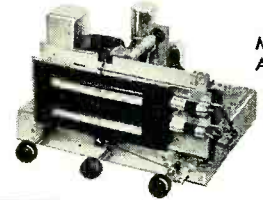

Model
AF-605

**SPECIAL BUY! PILOT HI-FI
ONLY \$42.95 FM-AM TUNER**

A deluxe high-fidelity FM-AM tuner chassis at a sensationally low price. Bandswitch has 4 positions: AM, FM, Phono and TV. Circuit has one stage audio amplifier with flat response, ± 2 db, 20 to 15,000 cps; has negative feedback for low distortion and high signal-handling capacity. Separate 3-gang tuning condensers and tuned RF stages are used on both FM and AM for increased sensitivity and selectivity. FM section has temperature-compensated oscillator for minimum drift; AM section has IF wave trap for rejection of signals in the IF passband. Sensitivity: FM, 20 microvolts for .3 volt audio output with quieting; AM, 3 microvolts for .3 volt output. Circuit uses: 6-6BA6, 1-6BE6, 1-6AL5, 1-6AT6. Rectifier is 6X5GT. Self-contained power supply. Has built-in FM and AM antennas, plus provision for external antennas. Chassis size, 11 1/2 x 6 x 9" deep. For 110-120 volts, 60 cycles AC. 8 1/2 lbs.
81R300. SPECIAL PRICE.....42.95

**NEW LOW
PRICE**



GI

3-SPEED CHANGER

Brand new 3-speed record changers—at less than manufacturer's cost! Made by General Instrument, these units automatically play all 3 sizes of records—7", 10" and 12" at 33 1/3, 45 and 78 rpm. Tone arm uses crystal cartridge with single .002" needle to play both standard and microgroove records. Size, 12 3/4" wide x 12" deep x 5-7/16" high. Requires 4-1/16" above and 3/16" below. 12 lbs.
81R000. SPECIAL PRICE.....17.88

**BARGAINS
IN TOP-QUALITY
TRANSFORMERS**



Hi-Fi Output Transformers

Fig. A. 50-watt super high-fidelity output transformer for the Williamson circuit. Matches push-pull parallel or push-pull 6L6, 6V6, 807, and other tubes to 4, 8, 16 ohm voice coil; also 60 and 250 ohm line. Range: 30 to 50,000 cps. 4000 ohms primary, P to P. Case, 4 1/2 x 3 7/8" dia. 7 lbs.
54R101. SPECIAL PRICE.....2.45

High-Voltage Power Transformer

Fig. B. Save on this smashing value! Has primary of either 110 or 220 volts AC. Two secondary windings: 70-0-70 volts at 50 ma for bias, and 1250-0-1250 volts at 350 ma. Size, 6 1/8 x 7 1/2 x 8 1/8". Wt., 36 lbs.
54R104. SPECIAL PRICE.....8.95

Send for **NEWARK'S**
FREE CATALOG 51

NEWARK
ELECTRIC COMPANY

323 W. Madison St., Chicago 5, Ill.



"Because of the large segments who wanted 15 inches-per-second and/or 7.5 inches-per-second, 10½ inch reels and/or 7 inch reels, single track and dual track (all of these in various combinations), we have decided that our *Concertape* be issued in a variety of forms from single track recording on 10½ inch reels at 15 ips, for those who want the utmost in fidelity and frequency response, to dual track recordings on 7 inch reels at 7.5 inches-per-second for those who want tape economy combined with excellent reproduction.

"Because electronic dubbing must necessarily be done in small batches, the way the Scots make whiskey, it will be possible to supply recordings in the combinations of tape speed, reel sizes, and type of track that the various types of customers desire. The recording specifications also will be determined to some extent by the character of the music and its length. The longer the material, for example, the greater would be the need for larger reels, lower speed, and dual tracks."

We are anxiously looking forward to the opportunity of reviewing *Concertapes* as soon as they become available.

Tape Review

A-V (AUDIO-VIDEO) #1003

Part 1. Overture to Romeo and Juliet (Tchaikovsky)—Piano Concerto #2 in C Minor (Rachmaninoff)

Austrian State Symphony Orchestra, Kurt Woss, conductor, Felicitas Karrer, soloist.

Part 2. Piano Concerto #2 in C Minor (Rachmaninoff) Concluded—Etudes, Opus 25, Nos. 1, 2, and 3. (Chopin)

Austrian State Symphony Orchestra, Kurt Woss, conductor; Alexander Jenner, soloist.

A-V (AUDIO-VIDEO) #1005

Part 1. Symphony No. 4 in E Minor, Opus 98 (Brahms)

Austrian Symphony Orchestra, Kurt Woss, conductor.

Part 2. Symphony No. 4 in E Minor (Brahms) Concluded—Symphony No. 88 in G Major (Haydn)

Salsburg Mozarteum Orchestra, Paul Walter, conductor.

A-V (AUDIO-VIDEO) #1009

Part 1. Piano Concerto in A Minor, Opus 16 (Grieg)

Austrian Symphony Orchestra, Kurt Woss, conductor; Felicitas Karrer, soloist.

Part 2. Symphony No. 6 in C Major (Schubert)

Austrian Symphony Orchestra, Kurt Woss, conductor.

A-V (AUDIO-VIDEO) #1011

Part 1. Overture to Egmont (Beethoven)

Austrian Symphony Orchestra, Hans Wolf, conductor.

Part 2. Emperor Concerto for Piano & Orchestra in E Flat Major, Opus 73 (Beethoven)

Felicitas Karrer, soloist.

These tapes are all from A-V's "Concert Hall" series and provide one hour of program material. The tape masters were recorded under ideal conditions. Copies were made using the techniques described on page 40 of this issue. All are well suited for broadcast purposes and, in addition, are compatible with the finest home music systems.

A-V (AUDIO-VIDEO) #102

The Best Things in Life Are Free—Amargura—'I'm Confessin'—If I Had You—As Time Goes By—Come to the Mardi-Gras—Till the



NEW GOODLINE AIRLEAD has everything you want!

- Sharp, clean, "snow-free" pictures.
- Correct impedance for "ghost-free" reception. Nominal 300 ohms.
- Lower in cost than other leadlines purported to accomplish same results.
- Correct spacing for minimum radiation loss—Less than 1% of operating wave length.
- Fully insulated—approved by safety experts.
- Pure, unadulterated polyethylene insulation—specially treated by our chemists for extreme weather.
- High-efficiency conductors: Flexible, stranded—to insure long life.
- Easily installed—with standard insulators.
- Packaged in convenient lengths: 100', 250', 500', 1,000', 2,500'.
- AT YOUR DEALERS, or Write For Free Samples and Literature.

*Patent Pending *Trade Mark U.S. and Foreign Patents Pending
EXCLUSIVE LICENSEE AND SOLE MANUFACTURER

Don Good, INC.

1014 FAIR OAKS AVENUE
SOUTH PASADENA, CALIFORNIA

OTHER OUTSTANDING GOODLINE PRODUCTS:

VARIABLE TELETRAPS—2: Highly effective for eliminating interference from FM STATIONS, and DIATHERMY and AMATEUR SIGNALS within its tuning range.

HI-PASS FILTER: Eliminates or greatly reduces interference picked up by I. F. AMPLIFIER or TV RECEIVER—interference arising from strong, local low-frequency fields: X-Ray, Diathermy Equipment, Neon Lights, Etc., Etc.

PEN-OSCIL-LITE

Extremely convenient test oscillator for all radio servicing; alignment ● Small as a pen ● Self powered ● Range from 700 cycles audio to over 600 megacycles u.h.f. ● Output from zero to 125 v. ● Low in cost ● Used by Signal Corps ● Write for information.

GENERAL TEST EQUIPMENT
38 Argyle Buffalo 22, N. Y.

RADIO-TV-ELECTRICAL TESTER All-around Trouble Shooter

Will test Radio-TV tubes, ignition coils, condensers (all types), spark plugs, trons, transformers, speakers, etc., for opens, shorts, leaks, into megohms. Sensitivity compares with VTVM. Tests 70-750 volts AC or DC. Tests mica, paper, oil, ceramic, air and electrolytic condensers for shorts, opens, leaks, and you can tell approximate capacity after few tests. CHECKS INDUCTANCE, TOO.
For all Engineers, Experts, and Beginners. Only \$495 plus 25c postage
NO DANGER, NO SHOCKS, NO PLUG IN and will not harm anything you test.
3-day money back guarantee.
HOWARD SALES CO., Dept. RN-4
539 Atlantic Avenue Brooklyn 17, New York



RADIO ENGINEERING TELEVISION ELECTRONICS

Thorough training in all phases of radio and electronics, open to high school and junior college graduates. Old established school specializing in Radio training exclusively. Modern laboratories and courses. Enrollments limited. Approved veteran training.

VALPARAISO TECHNICAL INSTITUTE
Dept. RD Valparaiso, Ind.

SPINTITE

REG. U. S. PAT. OFFICE

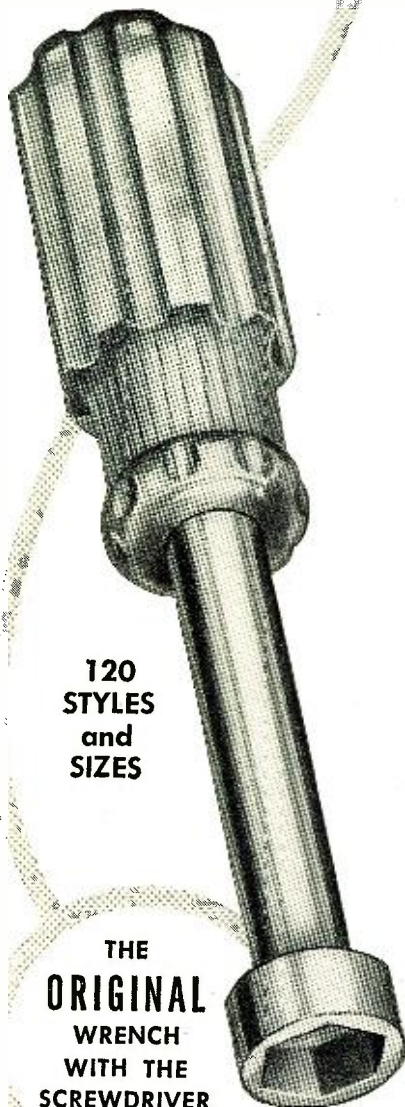

120
STYLES
and
SIZES

THE
ORIGINAL
WRENCH
WITH THE
SCREWDRIVER
ACTION

for

- ASSEMBLY WORK
- REPAIR WORK
- RADIO
- TELEVISION
- INDUSTRIAL
- AIRCRAFT



STEVENS WALDEN, Inc.
WORCESTER 4, MASS.

End of Time—Almost Like Being in Love—
I'll Never Be the Same—Baia—Give Me the
Simple Life

A-V (AUDIO-VIDEO) #103

Why Was I Born—Should I Tell You I Love
You—Tomorrow is Forever—Dream—You're
Mine—Holiday for Strings—Malaguena—
Guilty—Two Loves Have I—Pavanne

Numbers 102 and 103 provide excel-
lent material for dinner music. These
tapes, which provide one-half hour of
music, are superbly recorded and cer-
tainly come under the heading of "easy
listening."

A-V (AUDIO-VIDEO) #602

Kiss Me Again—I'm Falling in Love With
Someone—Moonbeams—A Kiss in the Dark—
Sweetheart—Among My Souvenirs—Rose In
the Bud—Remember—I'll See You Again—
Lady of the Evening—Summertime

Number 602 bears the title "Organ
Reveries." Apparently there was a
lack of bass on the original recording
and an attempt was made to equalize
for the deficiency in dubbing. There
is an over-abundance of bass on the
tape submitted for review. Otherwise,
an excellent tape. This is a half-hour
program.

MAGNETIC LIBRARIES TAPE

1. Stories (Tales) From The Vienna Woods
2. Annen Polka (Strauss) 3. The Gypsy Baron
—Potpourri
- Orchestra of the Bremen Opera and Orchestra
of the German Tape Productions.
1. Eine Kleine Nachtmusik 2. Notturmo No. 3
3. Theme & Variations from the Trout Quintet
Members of the Bremen Philharmonic, Walter
Bohle, pianist.

While excellent tapes, these could be
improved by careful editing of the se-
lections. There is a distinguishable
"thump" during the silent part be-
tween the selections. Frequency re-
sponse is excellent. Both tapes well
performed.

In future appearances of this column,
we will report on how the big-name
recording companies are reacting to
this new medium of home entertain-
ment. We will also attempt to report
on what the industry is learning about
this new medium and on new and
unusual applications of magnetic re-
cording and, for the professional and
amateur inventors, we will try to tip
you off as to what needs inventing.

We invite other producers of pre-
recorded tape libraries to participate
in this review. All submitted tapes
must be single-track at 7.5 ips.

-30-

REEL REVIEW

A New Feature for RADIO & TELEVISION NEWS' Readers

If present plans materialize RADIO & TELEVI-
SION NEWS will bring you each month a com-
plete listing and review of all the new tape
recordings.

Obviously, if an insufficient number of tape re-
cordings are released, it will be impossible to
run this feature on a monthly basis.

What's New in Radio

(Continued from page 98)

designed to read power or impedance
accurately at all impedances over the
audio frequency range. This unit indi-
cates a maximum power output of 50

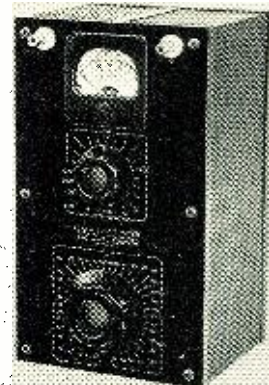

watts. It is capable of measuring that
power accurately, determining the
characteristic impedance or effect of
load variation on the system, and other
applications involving the measure-
ment of power and impedance.

With an impedance adjustable over
a range of 40 steps from 2.5 ohms to
20,000 ohms, the instrument will mea-
sure 50 watts in steps of .1 milliwatt.
It is also calibrated to measure deci-
bels from -10 db to +47 db.

REGULATED POWER SUPPLY

Kepeco Laboratories, Inc., 149-14 41st
Avenue, Flushing 55, New York, has
released a new standard voltage-regu-
lated power supply, the Model 3100.

The new unit features a low voltage
regulated power supply with excellent
regulation, high stability, low ripple
content, and low output impedance.

The d.c. output voltage is contin-
uously variable from 0-3 volts and de-
livers from 0-100 ma. In the range 0-3
volts the output voltage variation is
less than 5 millivolts for both line fluc-
tuations from 105-125 volts and load
variations from 0-100 ma.

The supply is designed for relay rack
mounting or bench use. It is 19" wide,
7" high, and 11" deep.

MINIATURE RESISTORS

Dale Products, Inc. of Columbus,
Nebraska, has announced the avail-
ability of a new line of miniature
power resistors in two, five, and ten
watt sizes.

These "Dalohm" resistors offer com-
pletely welded construction from ter-
minal to terminal for trouble-free per-
formance. A special silicone material
seals the resistance element, making it
impervious to moisture.

Standard tolerance is one per-cent
but tolerances as high as .05 per-cent
can be furnished if required. The tem-
perature coefficient of these units is
practically flat. The resistance shift is
less than .00002 per-cent per degree C.

New illustrated price sheets are
available on request.

-30-

International Short-wave

(Continued from page 114)

years only the 1330 period has been reported as "heard" and this on (only) 17.840. (Ferguson, N. C.; Saylor, Va., others)

Israel—Tel Aviv, 6.830, heard with weak level 0035; music. (Kary, Pa.) Tel Aviv's "claimed" 9.000 channel was recently *measured* 9.0075V; noted 1625 in *English*; previous measurements were 9.0096 and 9.0125. (Oskay, N. J.)

Italy—Rome, 15.315, noted with Italian news and musical program 0700; on 21.500 with *English* news and program details 0515. (Sanderson, Australia) Heard 0545 signing on for Far East on 11.91, 17.800, and 15.400; started with news; music 0600. (Pearce, England) Rome noted on 3.910 with music 1628; good signal in Britain. (O'Sullivan) Heard on 7.110 with Arabic to about 1610, then in Italian; news in Arabic 1545-1600. (Kary, Pa.)

Jamaica—Radio Jamaica, 3.360, still noted signing off 2300A with "God Save the Queen"; fair level in Calif. (Baker) Noted around 2000 with local programs and commercials. (Van Gilder, Mass.) The 4.950 outlet usually is a good signal in USA with news 0730. (Tschopp, Texas; others)

Japan—AFRS, Tokyo, noted on 4.860 at 0730-0830 and later; identifies on half-hour; local time is given after identification. (Tschopp, Texas) NHK's JK12, 9.655, noted 1740 in Japanese; time pips and "NHK" identification at 1800. (Pearce, England)

Kenya—When this was compiled, the Forces Broadcasting Service, East African Command, McKinnon Road Depot, was being heard on 7.265A relaying the BBC news at 2300; has recordings of popular music from 2315A; weak to fair level with QRM from VOA, Tangier Relay Base, on 7.270. (Stark, Texas; Bellington, N. Y., others) Usually identifies twice between end of BBC news at 2315A and start of recorded session. Ridgeway, South Africa, lists this one heard 2200-2400.

Nairobi, 4.855, noted with recordings 1445; closed 1458 with "God Save the Queen." (Pearce, England)

Lebanon—Beirut verified with QSL card; gave frequencies as 836 kc. and 8.036 at 0000-0115; 0515-0800; 1000-1600; *English* for 1000-1100; French 1200-1515. (Oskay, N. J.) Noted by Pearce, England, opening *English* session 1000.

Liberia—ELBC, Monrovia, appears to be on approximately 6.027 now (listed 6.025); noted as early as 1700 to closing with *English* announcement at 1845; has bad QRM from around 1815 when PCJ puts carrier on the air slightly lower. (Kary, Pa.)

Luxembourg—Radio Luxembourg is scheduled daily 0600-0830 on 15.350; 1300-1900 on 6.090. (Radio Australia)

Madagascar—Radio Tananarive is now using three outlets for its French sessions—9.515, 6.17, and 3.320 (*new*). (WRH Bulletin) Heard on 9.515 at

ARROW "The Home of Values!"

COMMAND (SCR 274 N) EQUIPMENT

	Used	New
BC-453, with tubes	\$19.95	
less tubes	14.95	
BC-454, less tubes	7.95	
BC-455, 6-9 mc receiver, with tubes	9.95	\$14.95
less tubes	7.95	
BC-457, 4-513 mc transmitter, less tubes	5.95	
BC-458, less tubes	5.95	
BC-459, less tubes	12.95	
T-23 ARC 5, 100-156 mc xmt.		49.50
BC-496, 2 position Rec. Control Box		1.95
MC-215 Mechanical Drive Shaft, per length		2.45
BC-450 3 Receiver Remote Control		2.95
BC-451 Transmitter Control Box		1.50
BC-442 Antenna Relay, complete		3.95
3 Receiver Rack		1.95

VIBRATORS

2 Volt—7 Prong Synchronous	69c	10 for \$6.00
6 Volt—4 Prong Non-synchronous	98c	10 for 9.00

MISCELLANEOUS SPECIALS!

	Used	New
BC 442 Less Condenser	\$1.49	\$1.95
APS 13 UHF Antenna, Pair		.98
I-97 Bias Meter	3.95	4.95
RL 42 Antenna Gearbox Motor and Reel	4.95	7.50
Circuit Breaker 40 Amps		.59
I 82 F Five Inch 360 degree compass indicator and Selsyn receiver		6.95
A-81-2 Transmitters Selsyn for I82 indicator		4.95
(both I82F & Trans. Selsyn for \$11.00)		
PE-101 Dynamotor		2.75
Model 507, Thermal-converter Weston Type D, range 12 amp		.59
BC-1023 Marker Beacon Receiver, complete with tubes, shock mount and instruction manual		9.95
RC43, kit of plugs, insulators, etc. for BC-1023, new		1.75
BC-924 27-38 MC. FM Transmitter, complete with tubes	19.95	
BC-584 27-38 MC. FM Transmitter, less dynamotor	19.95	
ARB Control Box		1.95
BC 1206 Receiver, new		7.95
BC-375, transmitter only		19.95
110 volt, 60 cycle blower		7.95
A27 Phantom antenna		1.95
PE 206 Inverter		4.95
Scott Hi-Fi output transformer		1.49
PE-218 Inverter		19.95
SCR-522, transceiver, less tubes	39.50	
BC-709, battery operated, lt. wt. inter-phone amplifier, complete with tube, shock mount and manual, brand new ea.		\$3.95
BC 625 Transmitter (SCR522), less tubes, used		\$19.95
PE 120 Vibrator Power Supply for BC 620-659, used, less vibrator	4.95	
TU6 Tuning Unit (BC375), used	2.95	
TU25 Tuning Unit (BC375), used	2.45	

SCR 625 Famous Army Mine-Detector

For Prospectors, Miners, Oil Companies, Plumbers, etc.

This unit is being offered now at a considerable reduction in price. Recently advertised at \$79.50 it is now available in the same brand new wrappings in suitcase style carrying case (less batteries) at

\$59.50 WHILE THEY LAST! Used, like new, \$39.50

ARROW SALES, Inc.

Dept. N, 1712-14 S. Michigan Ave., Chicago 16, Ill.
PHONE: Harrison 7-9374

MIKES and HEADSETS

HS 23 High Impedance Headset	new	\$4.95
HS-33 Low Impedance Headset		5.95
CD-307 Ext. cord for HS 23-33	like new	.95
T-32 Desk Stand microphone	Good	
used cond.		2.95
Throat Mike—T 30—New		.98
Lip Mike—Navy Type—New		.98
Extension Cord and Switch Assembly for lip and throat Mikes—New		.98
CW 49505 High impedance headset, complete with leather headband and rubber cushions.		98c
Used		
RS-38, Microphone		\$4.95
TS 10 sound powered HAND SET	new	\$9.95 ea.
used		\$5.95 ea.
HS-38	new	\$2.29
HS-30, miniature headset	new	2.49
used		1.49

WOBUlator

See page 43—December "Radio News"
\$5.95 ea.

CONDENSERS. 19c each.		6 for \$1.00
1 mfd.—800 VDC	1 mfd.—400 VDC	
.1 mfd.—1200 VDC	1-2.4 mfd.—400 VDC	
1 mfd.—1200 VDC	1-1—2000 VDC	
39c each.	3 for \$1.00	
.25 mfd.—1500 VDC	1 mfd.—1000 VDC	
2 mfd.—220VAC		

MONTHLY SPECIAL

RT28/APG4 Transceiver—Originally designed for the release of bombs, contains wobulator (see pg. 43, Dec. "Radio News"), plus entire circuit, less tubes and dynamotor. This unit is very similar to the RT7/APN1.
AN EXCELLENT BUY. \$8.95

SCR 508 EQUIPMENT

BC 603 Receiver L/dyn.	\$24.95	Exc. Used
BC 604 Transmitter L/dyn.	12.95	Exc. Used
BC 605 Amplifier L/dyn.	6.95	New
EC 606 Control Box.	.95	Exc. Used
FT 237 Mounting.	9.95	Exc. Used
MP 48 Mast Base.	2.95	Exc. Used
TM 11-600 Tech Manual.	1.95	
Crystals. Set of 80.	19.95	

CJP-20 ABX Power unit, (ASB7) new with tubes. used with tubes. \$4.95 / 3.95

CATHODE RAY TUBES

3FP7 - - \$1.95	4AP10 - - \$.95
5FP7 - - 1.95	5CP1 - - 3.95
5BP4 - - \$3.95	
16JP4 - \$19.95	16DP4 - \$19.95
90 DAY GUARANTEE	

Tubes—304TH	\$8.95
304TL	8.95
830B	2.95
9001	1.39
9002	.98
9003	1.49

Write for complete bargain tube list.

I. D. 6B/APN4

LORAN INDICATOR SCOPE

less tubes, like new ONLY **\$29.95**

R9/APN4, complete with tubes, like new \$17.95

Shipments FOB warehouse. 20% Deposit on orders. Minimum order \$5.00. Illinois residents, add regular sales tax to remittance. Prices subject to change without notice.

* **WE NEED YOUR** *
* **WANTED** *
* Surplus *
* Electronic Equipment *
* **WE PAY TOP \$\$\$ FOR:** *
* Radio Receivers * An Connectors *
* Transmitters * Clamps *
* ARC-1 * Plugs *
* ARC-3 * Cords *
* ART-13 * Relays *
* Control Boxes * Telephone Materials *
* Indicators * WE BUY ANYTHING!! *
* **WRITE, WIRE TODAY!** *
* **TELL US WHAT YOU HAVE** *
* **TALLEN COMPANY, INC.** *
* **Dept. RN, 159 Carlton Ave.** *
* **Brooklyn 5, N. Y.** *

RADIO ENGINEERING DEGREE IN **27 MONTHS**
Radio engineering is a big field. There's room for you in it—if you're good. Get first-class training at Indiana Tech. Intensive specialized course, including strong basis in mathematics and electrical engineering, advanced radio theory and design (inc. TV and Electronics). Modern laboratory. Low tuition. Also 27-month courses in Aeronautical, Chemical, Civil, Electrical and Mechanical Engineering. Approved for G.I.'s. Enter June, September, December, March. You can earn part of your expenses right here in Fort Wayne while you are studying.
INDIANA TECHNICAL COLLEGE
942 E. Washington Blvd. Fort Wayne 2, Indiana
Please send me free information on B.S. Engineering Degree in 27 months as checked.
 Radio-Television Aeronautical
 Civil Mechanical Electrical
Name
Address

SAVE MORE!

G.E. PYRANOL, 330 V., 60 Cyc., 1.75 MU-F.	\$ 1.39
C.D. 173346 CAPACITOR (Paper), 250 MFD., 250	1.19
BC-937 B VOLTAGE REGULATOR, Good. Used.	7.95
BC-451 ARC 5 CONTROL BOX, Good.	8.95
BC-442 ARC 5 ANTENNA RELAY, less con- denser.	1.55
BC-442 ARC 5 ANTENNA RELAY WITH CON- denser.	2.75
BC-AR 408 CONTROL BOX	1.25
BC-AE 231 CONTROL BOX	1.15
RE-ARR1 CONTROL BOX	1.49
C-237/APG7 CONTROL BOX	1.49
C-237/APG15 CONTROL BOX	2.97
J 141/APG15 CONTROL BOX	2.85
BE-73 SWITCH BOX, brand new	15.00
BC-1153 INDICATOR UNIT with c/r tubes & cables.	N.85
WL 130 C WIRE, twisted pair (plastic), ap- prox. 3,000 feet per can	6.95
BC-1153 INDICATOR with CRT Tube and Cables	N.85
BE-73 SWITCH BOX, Brand New	12.95
AS-69/APT ANTENNA ASSEMBLY, Brand New.	5.97

GRAB BAG!!

Parts taken from equipment. Consists of High Voltage Transformers, Oil Filled Capacitors, Bathtubs, Resistors, Terminal Boards, Sockets, Knobs, Relays, Controls, Coils, etc., etc.

WE LEAVE THE QUANTITY UP TO YOU!!

ONLY **17c** PER POUND THERE'S NO BETTER BUY ANYWHERE

DYNAMOTORS

	Good—Used—Tested!	
DM-18	\$ 4.50	PE-119A
DM-20	4.50	PE-118 A
DM-22	2.95	PE-115 A
DM-23	3.50	D-104 Dual 12 V.
PE-24	4.95	Input, Output 225 and 440 V. Brand New
PE-218 INVERTER	11.95	

50 BY-PASS CONDENSERS, TUBULARS, Popu- lar Sizes, 400 to 600 Volts. . . ONLY \$2.95
HOOK-UP WIRE ASSORTMENT, Cut Lengths to 12", Stripped Ends. . . 2 Lbs. . .99

POTENTIOMETER KIT

15 types—Carbon and W.W. S.D. and Shaft Types. Includes 1/2 and 1 meg. W/Switches. \$2.65

RESISTOR KITS—100 ASSORTED

Over 50 values in each kit. 5 and 10% tolerances.
1/2 to 2 watt . . . \$2.95 per kit
5 and 10 watt . . . 3.95 per kit
20 and 50 watt . . . 5.95 per kit

TERMS—Send 25% deposit with order, balance C.O.D. Shipped F.O.B., N.Y.C. (N.Y.C. residents add 3% sales tax.)

CIRCLE SALES CORP.
113 GREEN ST., N.Y. 12, N.Y. - WOrth 4-1541-2

JOBBERS! REPS!

Are you receiving the Radio & Television News Sales Planner every month?

This profit planning service is available without cost to all authorized distributors, jobbers, and representatives.

For complete details, please write on your own letter-head to:



SALES PLANNER
366 Madison Ave.
New York City 17, N.Y.

1120 with news in French by man and woman, interspersed with short pieces of music; call 1130, then popular and light musical items; still audible 1340 with drama in French. (Pearce, Eng-land)

Malaya—Radio Malaya, 7.200, noted with news and musical program 0615. (Sanderson, Australia) Kuala Lumpur, 6.025, heard closing 1030 after dance music session. (Ridgeway, South Africa)

BFEBS, 9.69, Singapore, closes 1000; BBC news is relayed 1100 over the 11.955 and 15.300 outlets. (Ridgeway, South Africa) Noted on 7.120 at 1041; fine level in Calif. (Winch)

Mexico—XESC, 15.205A, strong after- noons (EST); XEXE, 11.900, at good volume 0900 and around 1800 announc- ing "La Voz de Mexico"; XEHH, 11.880, very strong mornings, also good after- noons and evenings, often causes in- terference to LRS, Argentina, same channel. (Niblack, Ind.)

Monaco—Radio Monte Carlo, 9.785, noted 1100-1200, mostly music with French announcements; good signal for the time of day. (Baker, Calif.) Noted Fridays on 6.035 ending "Back to the Bible" (English) at 1805; left air 1810. (Catch, England; others)

Mozambique—The 19 m. outlet of Lourenco Marques was noted recently on 15.265A with a surprisingly good, steady signal, comparatively free from interference, at 1200 when had news in Portuguese followed by commercial advertisements and what seemed to be stock market quotations to around 1215. (Kary, Pa.) Sent QSL card con- firming CR7BG, 15.270, 10 kw. At last check seemed close 15.29. CR7BU, 4.925V, noted 1450 with popular music and (English) commercials; CR7BV, 4.82V, heard 1450 with light music; off with "A Portuguesa" at 1500. (Pearce, England)

CR7BU, 4.9262, noted 1650 with American recordings and English an- nouncements; signed off 1702; an- nounced as parallel in the 30-meter band; woman made final announce- ment in Portuguese before station left the air. (Oskay, N. J.) When this was compiled, Lourenco Marques' 31-m. outlet used for English sessions was being alternated between approxi- mately 9.740 and 9.770; when noted afternoons (EST) to 1600A sign-off on 9.770A was in clear with fine level; when on 9.740A was weak and almost buried by OTC2, Belgian Congo. (Boice, Conn.; Hord, Ind.; others)

The 31-m. outlet used for Portu- guese programs from 0000 is still wan- dering around; more recently was heard on 9.820A at strong level and with no QRM. (Bellington, N. Y.)

New Caledonia—Radio Noumea, 6.035, noted from 0200 sign-on (with "La Marseillaise") to 0245 with music; good strength in Calif. (Baker) Usu- ally has QRM from VOA from around 0230. (Oestreich, Washington State)

New Zealand—ZL4, 9.540, noted with weak level 0530 with news to 0545 sign- off; at end of newscast gave preview of next day's programs. (Kary, Pa.)

Nicaragua—A Spanish-speaking sta- tion noted on 6.055 at 1920 is believed to be YNOW which is no longer heard on 6.833. Nicaraguan stations are in the process of moving to new channels. (Oskay, N. J.) Tschopp, Texas, also re- ports YNOW on 6.055, noted 2345-2400 when signed off with march.

The Latin American heard on 6.47A evenings is *Radio Mundial*; heard so announced in Spanish at 2200 recently. (Bellington, N. Y.)

Northern Rhodesia—GDX-aren, Sweden, lists ZQP, 7.220, to 1230 sign- off.

Norway—LLP, 21.670, heard with Norwegian news and music 0600; LKV, 15.170, heard with English and Nor- wegian program 0600. (Sanderson, Australia)

Pakistan—Radio Pakistan, 11.885, noted with Arabic news and music 2045; on 15.335 with news for local lis- teners 2245, and on same channel with news for native listeners at 0630. (Sanderson, Australia) Sent QSL card by airmail; confirmed Lahore (heard on 4.805) relaying Karachi 11.674; Dac- ca, 15.620, relaying Karachi on 7.0966; Karachi, 11.674 and 9.484. Schedule for news in English was given as 2130-2145 on 7.0966, 15.335; 0200-0210 on 15.620; 0330-0340 on 9.645, 15.620; 0730-0740 on 7.0966 and 15.620; 1015-1030 on 6.235 and 11.674; and General Overseas Service (English at slow speed) at 1210-1230 on 6.235, 9.484. (Pearce, Eng-land) News at 2130 heard on 7.096A. (Lane, Wyo.)

Panama—HO50 is back on 5.9955; noted 0715 with music. (Oskay, N. J.) The Dawn Bible Students Association, East Rutherford, N. J., lists a contract for English Bible Study broadcasts with station HP6J, Panama, on 9.790 at 1815 on Sundays, says Oskay, N. J. Heard?

Panama—ZPA1, 6.275, Asuncion, fair at 1932-2000 and later. (Lane, Wyo.)

Peru—OAX4R, Radio Nacional del Peru, logged on 15.150A with fair to good signal 0345 in Spanish. (Saylor, Va.) Radio Nacional del Peru, 5.8864, heard with fine level mornings; noted signing on 0555 with series of trumpet melodies, then march selection 0600. (Oskay, N. J.) Recently found parallel on 5.8864 and 9.560A around 2317 with Latin American music. (Bellington, N. Y.) OAX4, 15.105, Radio El Sol, Lima, noted with English program 2200-2330. (Ferguson, N. C.)

Philippines—DZH9, 11.855, Manila, heard irregularly after 0100, fair sig- nal in Calif. (Balbi) This outlet noted in Australia 0500 with news; and on 15.300 at 2200. (Sanderson) Lane, Wyoming, reports the 25-m. outlet is actually 11.854, noted 1020-1200 sign- off.

The short-wave outlet of "Voice of Davao" which was reported off the air some time ago is still heard by Wada, Japan, on its old channel of 7.280. (WRH Bulletin)

Poland—Warsaw noted on 6.115 with English for North America at 2315 and 0030. (Fried, Mich.)

Portugal—"Aquí Lisboa Emissora Católica Portuguesa," or "Radio Renascença," logged on 6.154 with gong and call 1732; orchestral selections; at 1800 had call, then classical music; another day at 1800 had sacred music by choir. (Pearce, England)

Lisbon, 15.130, noted from tuning 1105 with powerful signal; went off suddenly at 1125. (Bishop, Ohio) Heard on 11.995, with 11.960A in parallel, at 1430. (Kary, Pa.) *Radio Free Europe*, 9.605, noted 1600 with Hungarian session. (Oskay, N. J.)

Portuguese Guinea—Bissau, 5.838A, noted with news of Portugal at 1720, followed by news of the world (also in Portuguese) to 1730; signed off 1800 with "A Portuguesa." (Kary, Pa.)

Roumania—*Radio Bucharest* noted with news 1400 on 9.252 at fair level; good level then on 6.210. (Pearce, England) Ridgeway, South Africa, reports Bucharest was heard recently on 7.250 as early as 1130; *English* at 1530.

Sao Tome—*Radio Clube de Sao Tome*, 4.8075, CR5SC, noted 1450 tune-in; gong, call at 1500, followed by varied recordings to 1600 when closed with "A Portuguesa." (Pearce, England)

Saudi-Arabia — Djeddah, 5.987A, noted recently signing on 2330 in Arabic. (Kary, Pa.) Sign-on varies. Noted by Lane, Wyo., on 11.950 at 1200-1300.

South Africa—SABC, 5.892A, Cape Town, still noted signing on weekdays 2345 with setting-up exercises. Reported by Kary, Pa., at 0000 with news in Afrikaans. Pearce, England, reports "SABC Calling Africa" on 11.937 in *English* 1200; announced would run to 1500 closedown. Asked for reports to SABC, Johannesburg; at 1200 had news, weather, sports.

Southern Rhodesia — Salisbury, 7.285A, noted 1030-1045 with children's program (*English*) recently; good level in Calif. (Baker) Noted on Saturdays as early as 1030; at times with relays from BBC; usually fades out between 1130-1230. (Rosenauer, Calif.) Noted on 3.320 when tuned 1445, had dance music; closed 1500 with "God Save the Queen." (Pearce, England)

Spain—Malaga, 7.022 has French on Wednesdays 1600-1620. (Radio Sweden) This one noted in England closing 1800 with two clock chimes, Spanish announcement, and Spanish National Anthem. (Catch) FET-1, 7.008V, measured at 1550 when had music; previous measurement was 7.0038. (Oskay, N. J.) Madrid, 9.368A, noted 1815 with *English* for North America; fair level in Chicago. (Favre) *Radio S.E.U.*, EDV10, now is on about 7.088, heard to after 1800. (Pearce, England)

Surinam—According to a verification from the station, Paramaribo uses 5.757 at 0810-1040, 1540-2040, and Sundays 0640-1140, 1440-2100; also on 15.405 from 1710. (Radio Sweden) The 15.405 outlet noted on a Sunday 1000-1030 sign-off carrying a religious program in Dutch and *English*. (Kary, Pa.)

"Wholesale" Brings You Red-Hot Values In TELEVISION

ANTENNAS · ACCESSORIES · PARTS

Snyder's Amazing New

360° MOTORLESS TV AERIAL

Same Clear Pix As Motor Rotating Aerial Systems Costing Triple This Price

FOR FRINGE AREA Only \$18.95

COMPLETE with three 3 1/2 ft. masts 75 ft. 3 conductor cable. Beam selector sw., guys rings and mtg. base.

Electronically beams in complete 360° rotation to give clear picture on all channels. You choose direction with Directronic selector switch mounted on or near TV set. Complete double-stacked arrays with 18 hi-tensil double-alloy aluminum elements.

Model AY-599 same as above less masts \$16.95

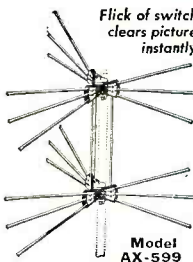

Model AX-599

TV ANTENNA ACCESSORIES

- STEEL EXTENSION POLES. Weather treated
10 ft. long, 1 1/4" di. \$2.19
5 ft. long, 1 1/4" di. Crimped end 1.35
3 1/2 ft. long, 1 1/4" di. Crimped end 1.19
CHIMNEY MOUNT BRACKETS
CM-100 Complete with strap pr. 1.59
HEAVY DUTY MAST BRACKETS WB-2 pr. 1.75
Adj. to 18" from wall 3.75
ANTENNA SWIVEL BASE, Aluminum
FS-1 1/2" O.D. mast section39
300 OHM TWIN LEAD per ft., 3c; 100 ft. 25.00
52-70; 1000 ft.25.00
DOUBLE THROW KNIFE SWITCH .45
ANTENNA WALL MOUNTS (with Hardware)
PAM-1 For poles 1" - 1 1/2" di. 6" from mast to wall 1.15
PAM-4 For poles 1" - 1 1/2" di. Up to 12 1/2" from wall 1.80
PAM-6 For poles 3/4" - 1 1/2" di. Adj. 1" to 16" from wall 3.45

Snyder's Powerful 5 Element

YAGI TELEVISION ARRAYS

For Fringe & Ultra Fringe

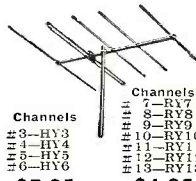

Highly directional and closely tuned to each channel. Cuts interference and noise to a minimum. Five elements; one folded dipole, three directors and one reflector. Individual array for each channel. Specify channel desired.

Channels 7-RY7, 8-RY8, 9-RY9, 10-RY10, 11-RY11, 12-RY12, 13-RY13
\$7.95 \$4.95
TIE RODS for stacking 2 Yagi Arrays \$85c
Specify Hi or Lo band. pair

Lowest Price Conical Array! Can Be Stacked for Fringe Areas 8 Interchangeable Elements

Covers complete TV-FM band. Hi-tensil 3/8" aluminum alloy elements. Includes mast clamp for use with poles up to 1 1/2" di. Can be used with any type lead-in 72 to 300 ohms. Less Mast. \$4.95
Model XA-14 \$42.50 in lots of 10

CONICAL TIE RODS with hardware pr. 85c
4 BAY TIE RODS for stacking 2 double stacked conicals, with hardware \$1.95

SAVE \$14.00! BRAND NEW G.E. FRONT END

COMPLETE WITH TUBES Reg. \$27

Pre-aligned RF head end unit. Brand new GE replacement for GE models 810-814-820-830-835-840. **12.95**

SALE! Replacement Speakers Alnico 5 PM

- Square: 4" \$1.69
Round: 4" 1.89
5" 2.10
6" 2.10
8" 4.10
10" 4.10
12" 5.39
Oval: 4 x 6 2.35
5 x 7 2.95
6 x 9 3.29

Universal Non-Sync Vibrator 6 V. 4 Prong

- Replaces Radio Shack 530A, 530I, 5326P, 5342M, Delco 7239124, Mallory 853-44-294, Philco -83-0026, 82-0025, 413367, Motorola 33-33-48A3332, 48K11026, Tru-tone 19A25, Zenith 190-27-12, Zenith 190-27-6, Zenith 190-27-7
1 1/2" di. x 27/8" \$1.59

TV TRANSFORMERS

- 57T011 VERT. OUTPUT TRANSFORMER
Replacement for 204T2. 19,000 ohms pri. imp. Turns ratio 10:1. Mtg. center 1 1/8" x 1 3/4" \$2.95
43T011 VERT. OUTPUT TRANSFORMER \$1.79
Same as above. Mtg. center 2 1/8" x 1 3/4"
16TB11 VERT. BLOCKING OSC. TRANSFORMER
Replacement for 208T2. Mtg. center 1 1/8" x 1 3/4" \$1.49
21TB11 VERT. BLOCKING OSC. TRANSFORMER
Same as above. Mtg. center 2" \$1.19

Address Orders to Dept. RN-4
WRITE FOR FREE FLYER

WHOLESALE RADIO PARTS Co., Inc.

311 W. Baltimore St. BALTIMORE 1, MD.

ROOF MOUNTS

- PEAK ROOF MOUNT
PRA-148 for peak roofs. Flat roofs. Side walls. Masts 3/4" to 1 1/2". \$2.69
BASE MOUNT
PRA-136 for sloping or flat roofs. Side walls. Masts 3/4" to 1 1/2". \$1.79
Universal Base Mount PRA-138 \$2.39
Guy Wire Ring & Collar GRA-140 .95
Crown Fit Peak Roof Mount PRA-150 .395

- ANT. SW. COUPLERS
TC-374—enables 2 sets to be connected to 1 ant. set. \$2.10
TS-587—enables 3 ants. to be connected to one set. \$2.10
TS-551—enables 2 ants. to be connected to one set. \$1.55

LEARN TELEVISION

ELECTRONICS and RADIO
Engineering Laboratory and Classroom
Training. Day and Evening Classes.
Write for Illustrated Catalog
ELECTRONICS INSTITUTE, Inc.
21 HENRY, DETROIT 1, MICH.

SCHEMATICS—CONVERSIONS FOR SURPLUS GEAR

NEW LIST! MANY ADDITIONS!
Send stamped, self addressed envelope for List B. Add 25c for chart explaining AN nomenclature.
R. E. BOX 1220
GOODHEART BEVERLY HILLS, CAL.

MARK THESE VALUES! TOP STANDARD BRANDS ONLY—100% GUARANTEED

RCA-GE-SYLVANIA-HYTRON-PHILCO-KENRAD-NUTUNG-SOL-WESTINGHOUSE-WESTERN ELECTRIC

1B3GT 89c **6AG5 79c** **5U4 59c** **6J6 89c** **12A7T 99c**

024 59 6AG7 51.16
1L4 79 6AK5 1.29
1R5 79 6AL559
1S5 79 6AL659
1X2A 1.09 6BA667
5V4G 1.09 6BA667 6BG6 1.89 6H674
5Y3 46 6BC578 6C8678 6N798
6AB4 79 6BD677 6C06 2.25 6S1779
1000 Kc. CRYSTALS—Laboratory Precision 1.35
Cut. New. Uncased. Each
Write for Your Free Bargain List Now!

128E6 S 84 3525 S 54
12BH7 1.07 50A5 1.09
12SA7 79 50L667
12SX7 72 95725
12SO7 64 958A59
All Amer. Kit. \$3.19
Fiducial subject to change
25% Dep. Bal. COB, N.Y.C.
Phone: TYrone 3-5151

MARK electronics 1888 Randall Ave. New York 72, N. Y.

TUBE DEAL?

Get a dozen FREE with every order at 70% OFF LIST

MINIMUM ORDER: 100 ASSORTED TYPES

Every Type in Stock • Guaranteed • Brand New

Terms: 25% with order, balance C.O.D. All merchandise subject to prior sale, F.O.B. New York City

TeleVision Materials Corp.
125 Cedar St., New York 6, N. Y. • COrtlandt 7-4307

EBCO Mfrs. of PICTURE TUBES and ELECTRONIC EQUIPMENT

Sold only thru Radio Parts Jobbers

17" Rectangular C.R.T.net **\$21.95**

20" Rectangular C.R.T.net **\$32.95**

Prices include tax
EIGHTEEN MONTHS GUARANTEE!

"EBCO" Dual-Purpose CHECKER-REACTIVATOR
for TV Picture Tubes

A MONEY MAKER FOR SERVICEMEN:

Check picture tubes for shorts, cathode emission, leakage, etc., without removing tube from TV set. Also PUT NEW LIFE into weak tubes with the REACTIVATING power of this instrument. Lightweight, portable; 110V-60 cycles. Factory-guaranteed. ASK YOUR JOBBER.



Model 10 net **\$19.95**

FIELD STRENGTH METER
Want better antenna orientation? Better TV performance? Want to save time and money? Then use the NEW "EBCO" FIELD STRENGTH METER. Measures field strength from 50 to 50,000 microvolts at the 300 ohm input terminals. Many other great features. net **\$64.95**

2-SET CONNECTORS
Two-set Connector for TV.Net \$2.95
Four-set Connector, operates 3 or 4 sets from 1 antenna.Net 4.95

ASK YOUR JOBBER!

ELECTRONIC BEAM CORP.
923 Old Nepperhan Ave.
YONKERS, N. Y.
Phone: YONkers 3-3514

Communication Problems Solved

with ARMY FIELD

TELEPHONES and TELEPHONE WIRE

All-purpose—all-weather

This is genuine W110B Army Field Wire on original steel reels. Insulated. 2-conductor, copper-steel strands. Excellent for all types of communication. Used extensively by telephone companies, industry, engineering projects, ranches, public address systems.

EEB FIELD TELEPHONES
Factory reconditioned LIKE NEW; per pr. . . \$38.50 Guaranteed.

GRADE 1—Unused, excellent condition.
Mile reels (wt. 160 lbs.)..... **\$22.50**
Half-mile reels (wt. 80 lbs.)..... **12.50**
500 ft. reels (wt. approx. 18 lbs.)..... **4.95**

W-130—Lightweight Assault Wire—2 Conductor. Excellent inter-com wire. Unused, excellent condition. 10,500 ft. reels. Approx. 3,300 ft. reels..... **57.50
19.50**

Send for FREE FOLDER

All prices F.O.B., Sacramento. No C.O.D. (Calif. residents add 3% for sales tax.) Prices subject to change without notice. Send check or money order.

LORIS SALES, P. O. Box 1896 M-4, Sacramento, Calif.

"WE'RE TEARING OUR HAIR OUT . . ."



to buy desperately needed equipment such as ART-13, BC-348, BC-224, BC-342, BC-312, ARC-1, BC-788, I-152, T-17MICS, BC-221, R5/ARN-7 or components. In fact, we'll buy any parts or accessories no matter how small. For speedy, efficient service and a real honest deal, phone, wire or write:

V & H RADIO & ELECTRONICS SUPPLY CO.
2033 W. Venice Blvd., Los Angeles 6, Calif.
Telephone: REpublic 3-1127

Sweden — Radio Sweden, 11.880, noted at good level in North America in English 0700-0715, then in Swedish to 0745 closedown. (Guentzler, Ohio; others) SBP, 11.705, noted with church services, then musical program 0530. (Sanderson, Australia) Noted parallel at 1945 in English on 6.065 and 6.095. (Oskay, N. J.) And parallel on 9.535 and 9.620 with English 2300-2315. (Bellington, N. Y.) Noted by Mast, N. Y., on 6.065 at good level around 1430.

Switzerland — HEI3, 7.210, Berne, noted with fair signal in North American beam around 2100 through much CWQRM. (Lund, Iowa)

Taiwan — BEC32, 9.780, has clear signal in Australia 0530 with Chinese session. BEC26, 10.080A, good signal with Chinese news and music 0630; BEC36, 7.334, noted with National Anthem and Chinese news and music 0700. (Sanderson, Australia) Taipei, 7.133, heard at good level recently 0650 to as late as 0815; announced calls of BED2, BED7, and BED6; mostly in Chinese dialects. (Kary, Pa.) "The Voice of Free China," 11.800, Taipei, noted with English 1420-1440. (GDX-aren, Sweden)

Tangiers — Radio Africa, 7.130A, noted 1310-1435 with dance music; announcements by woman in Spanish and by man in French. (Rodger, Scotland) Noted by Pearce, England, at 1025.

Pan-American Radio, 7.300, heard 1730 with popular recordings; announcements in French by woman; at 1801 had sign-off announcements in French, Spanish, English. (Catch, England)

Thailand — Bangkok, 15.910, noted 0630 with announcement in English, then news in Thai; on 6.240 with Western music and news in Thai 0645. (Sanderson, Australia)

Trans-Jordan — Hashemite-Jordan Broadcasting Station, Jerusalem, broadcasts on 44.3 and 42.5 meters at 0000-0100 in Arabic; 0600-0630 in English; 0630-0730 in Arabic; 0930-1030 in English, and 1030-1430 in Arabic, according to verification. Ramallah is listed on 7.110. (Radio Sweden)

Trinidad — Radio Trinidad's new outlet on approximately 3.270 normally signs off 2200 but on some occasions runs longer with special broadcasts. (Golden, Mass., others) Some weeks ago carried relay of cricket games from Radio Australia until around 0230. Relays BBC news 2100. Mudryj, Mich., notes Radio Trinidad on 9.625 at 0545 with news, according to the United 49'ers Radio Society.

Turkey — TAP, 9.465, noted with news 1615; TAV, 17.830, with news and music 0730. (Sanderson, Australia) TAT, 9.515, still noted at good level 1815-1900 with English session for North America. (Hord, Ind.) TAQ, 15.195, noted at good level 1030-1045 in Persian. (Ridgeway, South Africa)

Uruguay — Montevideo, 11.835, excellent around 1830; all-Spanish programs. (Niblack, Ind.)

USI (Indonesia) — Radio Andir, 11.940, noted with musical program,

Dutch announcements 0600. (Sanderson, Australia) Current schedules of Djakarta include to Australia-New Zealand 0600-0700 over YDC, 15.150; to Malaya 0600-0700, YDB2, 4.910; to India 0930-1030, YDC, 15.150; to West Coast USA, YDE, 11.770 at 0930-1030; to Malaya 0930-1030, YDB2, 4.910; to Europe 1400-1500, YDF7, 11.770; to New Zealand 1400-1500, YDC, 15.150; Dutch program to Holland 1300-1400, YDF7, 11.770, and YDC, 15.150. (ISWC, London) YDE, 11.77, and YDB3, 7.27, noted 0600 with *English* talk. (Balbi, Calif.)

USSR—When this was compiled, *Radio Moscow* was noted with good signal on 11.825 with the *English* program for North America 0800-0830; several other channels parallel.

A Soviet outlet has been logged on measured 4.3956 at 0640 with oriental-type music and man announcer in foreign language; bad CWQRM; identified with Moscow chimes 0630. Moscow, 4.947, noted 1635 with news in progress; CWQRM. (Oskay, N. J.) *Radio Tashkent*, 6.825, noted signing on in *English* for India-Pakistan at 1115; had news, commentary; at 1130 announced *English* sessions are 1000 and 1115 daily in this service. (Pearce, England)

Vatican—HVJ, 5.9674, noted 1525 with man in European language; identified 1545 with bells of St. Peter's; Hungarian program followed at 1545. (Oskay, N. J.) Noted on 9.646 with news 1000; in Polish 1015 when was jammed. (Lane, Wyo.)

Venezuela—YVKB, 4.890, Caracas, noted 2230-2300; YVKF, 4.880, tuned 1745 when had news in *English*; identified as "Ondas Populares" at 1800. YVLK, 4.972, Caracas, heard 1915-1935 with all-Spanish program. (Tschopp, Texas) YVKO, 6.170, noted in Spanish 1903. (Bellington, N. Y.)

Yugoslavia—*Radio Yugoslavia*, Belgrade, is noted on 6.100 to 1800. (Bellington, N. Y.) Sent schedule for this channel as 2330-0100, 0845-1200, 1400-1800; *English* at 1145-1200, 1400-1415; French 1415-1430, 1700-1715. (Pearce, England)

Press Time Flashes

According to a letter from the Director, Emisora de Radiodifusora, Spanish Guinea, some weeks ago Santa Isabel, 7.200, was to have increased its power to 750 watts; schedule was to be 0130-0230, 0700-0900, 1300-1500 daily; all-Spanish except 1300-1330 when was to carry Portuguese for Sao Tome, Principe, and Angola. (Oskay, N. J.) Has not yet been reported as heard.

The station engineer of 2AP, 3.410, 6.030, Apia, Western Samoa, has notified Fox, New Zealand, that (proposed) tests will not take place now. (Radio Australia) De Leon, Mexico, reports TGNA, Guatemala, on announced 5.942 with fair level 2000-0000; Tegucigalpa, Honduras, on announced 6.075 with good level 1930-2030.

Radio Wien, 9.665, Vienna, Austria,

April, 1952



"CONICAL-V-BEAMS"

*REGISTERED TRADE MARK

NOW! Improved "CLOVER-V-BEAM"

features PRACTICAL E-Z RIG DESIGN

Offers high sensitivity reception on roof, window or in attic

Weights only 24 ounces—

Minimizes wind, ice and weathering

Supplied completely assembled—installs easily and quickly

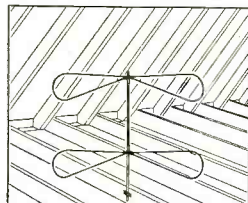
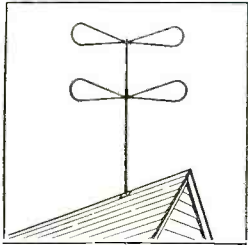
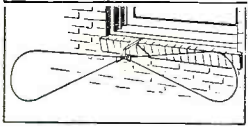
HIGH SENSITIVITY! Offers exceptionally high gain and high signal to noise ratio over the entire TV and FM bands. Low vertical angle results from 1/2 wave stacking—minimizes ghosts, airplane flutter and interference originating above or below. "Conical-V-Beam" dipoles provide 2 to 1 front to back ratio.

E-Z RIG SAVES TIME! Array comes compactly folded, completely preassembled and is speedily rigged by simply tightening two nuts. Servicemen acclaim its super-practical design and ease of installation in both indoor and outdoor applications.

ECONOMY PRICED! Growing demand for the improved "Clover-V-Beam" makes it possible to offer this service-free antenna at a new low price of \$4.75 list. For illustrated data sheet and suggestions for unusual applications, call or write the Telrex Engineering Department.

"CONICAL-V-BEAMS" are covered by Patent No. 23,346
CANADIAN and FOREIGN PATENTS PENDING

telrex inc.

AMERICA'S
OUTSTANDING
TELEVISION
BEAM

Originators and
Manufacturers of
"CONICAL-V-BEAMS"
—INSIST on
the original!

CONICAL-V-BEAMS

ASBURY PARK 7, N. J.

Master

ACCEPTED!

COAXIAL TYPE

Mounts

APPROVED!



Sold at all Leading Distributors or write:

Master Mobile Mounts, Inc.

1306 Bond Street • Los Angeles, California

SELL Jensen

PHONO NEEDLES

For Any Type

Record Player

Please send me **FREE** Jenselector. Picks the proper replacement needle.

Name _____

Address _____

City _____ State _____

Jensen Industries, Inc., 336 S. Wood St., Chicago 12

Special Purchase FM Radio Chassis

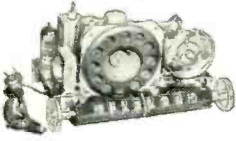

88-108 MC

Complete with 6 tubes. Built-in Antenna and Speaker. Product of Famous Radio & TV Manufacturer whose name we promised not to mention.

Regularly \$29.95

Brand New

\$16.95

TUBE LINEUP
 1-128A7 1-125B
 2-128A6 1-35W4
 1-35B5

May also be used as an FM Tuner by picking signal off detector.

NOW AVAILABLE: Cabinets for above—Maroon plastic—may be bought separately **\$5.95**

SPECIAL PURCHASE!

GENERAL INSTRUMENTS 3-SPEED



AUTOMATIC RECORD CHANGER
 REGULARLY \$34.95

BRAND NEW

\$19.97

With all-purpose cartridge and needle. Plays 33 1/3, 45, and 78 RPM records automatically.

NOTE: Do not send money for postage on above items. We ship best way—charges collect.

LOW FREQ. XTALS-FT 241A

For SSB, lattice filter, etc. 1/2" spc. 54th or 72nd harmonic channels listed by fundamentals. Fractions omitted.

372	404	436	506	400	462	5910	2030	2442
374	405	437	507	440	463	6370	2045	2532
375	407	438	508	441	464	6450	2105	2845
377	408	481	509	442	466	6470	2125	2557
379	409	483	511	444	468	6497	2145	3202
380	411	484	512	446	469	6522	2155	3215
381	412	485	514	447	470	6547	2220	3237
383	413	487	515	448	472	6510	2258	3250
384	414	488	516	450	474	7350	2280	3322
385	415	490	518	451	475	7480	2282	3510
386	416	491	519	452	476	7580	2290	3520
387	418	492	520	455	477	7810	2300	3550
388	419	493	522	457	479	7930	2305	3570
390	420	494	525	459	480		2320	3580
391	422	495	526	461			2360	3945
392	423	496	530				2390	3955
393	424	497	531				2415	3995
394	425	498	533				2435	
395	426	503	537					
396	427	504	538					
397	429							
398	431							
401	433							
402	434							
403	435							

SCR 522

Xtals
 1/2" pins
 1/2" spc.

400	462	5910
440	463	6370
441	464	6450
442	466	6470
444	468	6497
446	469	6522
447	470	6547
448	472	6510
450	474	7350
451	475	7480
452	476	7580
455	477	7810
457	479	7930

99c ea.
 10 for
\$9.00

SPECIAL
 210 Kc xtals
 without holders
69c Each
 3 for **\$2.00**

BC-610

Xtals
 2 banana
 plugs
 3/4" spc.

2030	2442
2045	2532
2105	2845
2125	2557
2145	3202
2155	3215
2220	3237
2258	3250
2280	3322
2282	3510
2290	3520
2300	3550
2305	3570
2320	3580
2360	3945
2390	3955
2415	3995
2435	

\$1.29 each

HAM XTALS-FT 243 HOLDERS—1/2" pin spc.

4190	6773	7840	1015	5773	6273	6540	7440	7650
5030	6873	7873	1129	5800	6306	6573	7473	7673
5185	6906	7906	2045	5806	6325	6575	7506	7706
6340	6973	7940	3735	5825	6340	6600	7540	8240
6073	7740	7973	5305	5840	6373	6606	7573	8340
6106	7773	8273	5677	5850	6406	6625	7606	8400
6125	7806	8306	5706	5873	6440	6640	7640	
6140			5725	5875	6450	6673		
6173			5740	5906	6473	6706		
6175			5750	5940	6475	6740		
6206			5760	5973	6506	6740		

Add 20c for each 10 xtals or less for postage and handling.

JUST ARRIVED!

New Philmore Novice XMTR Kit

Approx. 35-40 watts input. Uses plug in coils for all band C. W. operation. 6V6 OSC. 6L6 AMP. 80 RECT. on 2 chassis. Complete with punched chassis, tubes, coils for 80 meters, all parts, antenna, key, step-by-step instructions, lens crystal. Write for further description and price.

TERMS: All items F. O. B., Washington, D. C. All orders \$30.00 or less, cash with order. Above \$30.00, 25 per cent with order, balance C. O. D. Foreign orders cash with orders, plus exchange rate.

SUN RADIO
 OF WASHINGTON, D. C.
 938 F STREET, N. W. WASH. 4. D. C.

is audible in Sweden 0600 with program in German; sent nice QSL card; power is only 0.3 kw. (Lundin) OTC, 9.767, Leopoldville, Belgian Congo, announces *English* for North America now is at 2100-2315. (Stark, Texas)

4VEH, Haiti, informs Hord, Indiana, that it is out of QSL cards and doesn't know when will have more.

Radio Jornal do Comercio, Recife, Brazil, was noted recently (Sunday) around 0630 on 11.825; may be using that channel during the 0355-1100 session. ZPA5, Encarnacion, Paraguay, heard at strong level 1010 and again 1520 on 11.945. (Serrano, Brazil)

"Date With Baghdad" is the title of a series of *English* programs especially arranged by the Iraqi Broadcasting Station for listeners in Europe daily 1413-1500 on 11.724; includes news, cultural and spiritual aspects of life in Iraq; also classical and popular music; opens 1413 with song of the Bulbul (nightingale of Iraq). (*WRH Bulletin*)

Radio Mundial, 6.465, Nicaragua, is back on the air; is listed YNZZ, Managua, at 400 watts; noted to past 2300 and on by 0700. (Stark, Texas) HVJ, 15.095, Vatican, noted with fair level in French 0930-0945, then in German to 1000. (Kary, Pa.) H12A, 9.68, Dominican Republic, heard with strong signal around 1750; news in Spanish 1755-1800 when announced "La Voz de Releccion." Lisbon was recently logged at 1515 on 11.96, 11.995, and 12.025; badly QRM'd on latter channel; heard 1635 parallel on 9.74, 11.96. (Bellington, N. Y.)

OXI, Godthaab, Greenland, sent QSL card giving current frequency as 7.094 at 1630-1845. (Pearce, England) Noted on approximately this channel signing off 1900 with the Danish National Anthem; suffers badly from CWQRM. (Robbins, Ind.)

When this was compiled, *Radio Free Europe* was being widely heard on many channels; often heard around 1730 parallel on 7.105, 7.285, 7.300, and 9.605, and with a separate program on 7.190A. At various times lately has

been found on 5.97, 5.985, 6.02, 6.095, 7.105, 7.14, 7.190A, 7.285, 7.300, and 9.605. Most of *Radio Free Europe's* transmitters are listed in Germany, but at least the 9.605 channel is a relay from Lisbon, Portugal. (Bellington, N. Y.; others)

A *WRH Bulletin* says the VOA program in Korean at 0630-0700 and 1730-1800 is relayed in Korea by Pusan on 2.510 and 7.935 and by Taegu on 4.777; that a VOA program at 0845-0900 is repeated by these stations at 2130-2145, and that a roving transmitter ship relays all VOA programs in Korean.

A flash from *Radio Sweden* says *Radio Africa*, Tangiers, now on 7.125A, will soon radiate on 6.020 with 25 kw.

Patterson, Ga., says he recently heard *Radio Algerie* at 1740-1800 sign-off on approximately 7.210; man and woman announcers; left air after playing "La Marseillaise;" had bad CWQRM. Stark, Texas, reports *Radio Nacional del Peru*, 9.562A, coming through before 1900 and heard usually to at least 2300; at times has bad heterodyne.

Galei-Zahal, 4XB44, Israel Forces Broadcasting Service, Army P.O. 162, Israel, sent QSL card listing 6.725 as frequency; schedule of 1130-1500. (Pearce, England)

O'Sullivan, England, reports Madrid, Spain, heard on 4.470 at 1650 with tangos, good level. Pearce, England, recently heard a station on 9.610 at 1035 with "Bringing Christ to the Nations" (*English*) which he believes is *Radio Goa*, Pt. India; unintelligible after 1058 due to sign-on of a station on the high-frequency side (VOA Relay, Tangiers) and one on the lower side (*Radio Free Europe's* relay from Portugal). Heard another day 1010 in Portuguese; at 1115 in native dialect. He reports *Radio Pakistan*, 15.620, Dacca, with *English* 0200-0210; Pakistan with news on 5.990 parallel 11.674 at 1015-1030; news at dictation speed 1210-1230 on 9.484. 6.235; also at 1430-1515 on 7.010 and 6.235 with test broadcast to Turkey, then to 1600 to the

Among those attending the first postwar meeting of the World Friendship Society of Radio Amateurs in London were: Albert Eagle, WFSRA member; a representative of the Mullard Organization; A. H. Bird, G6AQ, the general secretary of WFSRA; and John Beavan, G3GBL, secretary of the society's "Bedfast Club."



United Kingdom; had varied Western and Pakistani recordings; announced in English about every 15 minutes. Pearce reports FET-1, *Radio Falange de Valladolid*, Spain, on 7.006 at 1500 signing on with long selection of Spanish music; call by woman, "Viva Franco! Arriba Espana!" Then news in Spanish.

Radio Juventud, Cadiz, Spain, noted on 7.200 to 1800 closedown; sent nice QSL card. (Robbins, Ind.)

Current schedules for newscasts from AIR's Home News Service are 2130-2145 on 3.250, 5.990, 7.170, 9.630, 11.850, 15.290 (Delhi), 6.150 (Bombay), 6.010, 7.210 (Calcutta), 4.920, 6.085 (Madras), and 6.065 (Mysore); at 0300-0310 on 7.290, 9.630, 15.290, 17.740, 17.760, 21.700 (Delhi), 9.550 (Bombay), 7.210 (Calcutta), 7.260 (Madras), and 6.065 (Mysore); at 0730-0740 on 7.170, 9.590, 15.380, 17.760 (Delhi), 6.150 (Bombay), 6.010 (Calcutta), 6.085 (Madras), and 6.065 (Mysore); at 1030-1045 on 3.250, 3.435, 4.940, 5.960, 9.590, 11.940 (Delhi), 4.840 (Bombay), 3.350 (Calcutta), 4.920, 6.085 (Madras), and 6.065 (Mysore). (*WRH Bulletin*)

Allocated channels for stations in Pakistan include Dacca (7.5 kw.), 3.460, 4.807, 5.035, 6.120, 7.140, 7.263, 7.655, 7.668, 9.614, 11.890, 15.270, 15.335, 17.835. Karachi (two transmitters of 50 kw. each), 3.450, 4.935, 5.980, 5.990, 6.075, 6.235, 7.010, 7.096, 7.263, 9.484, 9.645, 9.755, 11.570, 11.580, 11.650, 11.674, 11.726, 11.770, 11.810, 11.845, 11.885, 11.914, 15.270, 15.335, 15.620, 17.770, 17.835. Lahore (0.3 kw., to be increased to 10 kw.), 3.355, 4.785, 6.075, 6.138, 7.270, 7.284, 11.800, 11.840. (*WRH Bulletin*)

Radio Sweden's weekly DX session are being aired in the Home Service on 11.705 on Fridays at 1015 and on 6.065 at the end of the Home Service around 1730 (Fridays), and on 6.065 on Saturdays at the end of the "morning" transmission at 0215. At the time this was written, did not seem to be radiated in the Overseas Service over the new 100 kw. transmitters at Horby. Sweden's Home Service is broadcast throughout the "day" by one of the old 12 kw. transmitters at Motala on 7.270. The official schedule for the new 100 kw. transmitters in the *English* language periods of the International Service is to Eastern North America 1900-2000, 6.065; 0700-0615, 11.880. To Western North America 2300-2315, 9.535; 1600-1615, 9.535. To South America 1900-2000, 6.095; 0600-0615, 21.580; 1800-1815, 6.095. To Far East 0800-0815, 9.535; 1800-1815, 9.535. To South Asia 2300-2315, 9.620; 0900-0915, 9.535; 0945-1030, 9.535. To Middle East 2200-2215, 9.535; 1200-1215, 9.535. To Africa 0000-0030, 9.535; 1300-1315, 9.535. In most cases, Swedish is used for 30 minutes at the end of these *English* periods. The European Service is on 6.095 in Swedish 1400-1430; German 1430-1500; *English* 1500-1530, and French 1530-1545. The Swedish Home Service is relayed 0000-0400 on 6.065; 0400-1200, 11.705; 1200-2245, 6.065. Wants



80% to 90%
off list!

Dependable performance and economical service are two outstanding features overshadowing even these sensationally low-priced, high quality, fully guaranteed tubes. Every tube must pass rigid tests in our plant. You can compare RAD-TEL tube performance and quality with any standard tube anywhere.

Check this list for Fully Guaranteed Tubes

Type	Price	Type	Price	Type	Price	Type	Price	Type	Price
1A6	.59	5A24	.39	6B17	.59	6T8	.56	14J7	.55
1A7GT	.47	5U4G	.40	6BN7	.79	6U5	.44	14W7	.55
1A85	.59	5V4G	.54	6BQ6GT	.59	6U8	.59	19B6G6	.59
1B3	.49	5Y3GT	.32	6C4	.37	6V6GT	.39	19T8	.79
1B5	.59	5Y3G	.32	6C5GT	.39	6W4GT	.44	25BQ6GT	.62
1B7GT	.59	5Y4G	.35	6C86	.44	6W6GT	.44	25L6GT	.39
1C5GT	.43	5Z3	.39	6CD6G	1.11	6X4	.37	25Z5	.40
1G6	.55	6A3	.59	6E5	.48	6X5GT	.37	25Z6GT	.37
1H4	.46	6AB4	.44	6F5GT	.39	6Y6G	.48	32L7	.85
1H5GT	.40	6AC7	.59	6F6G	.39	7E6	.43	35B5	.40
1L4	.46	6AG5	.43	6F6GT	.37	7X6	.39	35C5	.39
1L6	.43	6AJ5	.90	6G6G	.52	7Z4	.37	35L6GT	.41
1LC5	.51	6AK5	.75	6H6GT	.41	12A8GT	.46	35W4	.37
1LC6	.48	6AL5	.38	6J5GT	.37	12A15	.37	35Z5GT	.37
1LN5	.51	6AQ5	.39	6J6	.52	12AT6	.37	36	.49
1N5	.46	6AQ6	.37	6J7G	.43	12AT7	.56	41	.42
1P5	.57	6AR5	.37	6J8G	.63	12AU6	.38	42	.42
1R5	.45	6AT6	.37	6K6GT	.37	12AU7	.43	43	.55
1S5	.39	6AU6	.38	6K7G	.44	12AV6	.39	45	.55
1T4	.45	6AV6	.37	6K7GT	.44	12AV7	.59	50B5	.39
1T5	.53	6B4G	.64	6L6G	.64	12AX4	.48	50C5	.39
1U4	.45	6B5	.64	6L6GA	.64	12AX7	.48	50C6	.59
1U5	.39	6BA6	.39	6S4	.38	12BA6	.38	50L6GT	.41
2A3	.59	6BC5	.44	6S8	.53	12BA7	.46	50X6	.53
3A4	.45	6BD5GT	.59	6SA7GT	.43	12BE6	.39	50Y7	.50
3E5	.46	6BE6	.39	6SD7GT	.41	12K7GT	.46	70L7GT	1.09
3Q4	.48	6BE5	.41	6SG7GT	.41	12Q7G	.39	76	.44
3Q5GT	.49	6BF6	.37	6SJ7GT	.41	12SA7GT	.44	80	.35
3S4	.46	6BG6G	.94	6SK7GT	.41	12SK7GT	.48	117L7	.89
3V4	.47	6BH6	.46	6SL7GT	.48	12SL7GT	.47	117Z3	.37
5AX4	.37	6BJ6	.39	6SN7GT	.52	12SN7GT	.52	807	.99
				6SQ7GT	.37	12S9T	.44	1274	.99
				6SR7	.37	12SR7	.49	1276	.99



PICTURE TUBES . . .

- 14BP4... 14.50
- 16RP4... 19.50
- 17BP4... 19.50

TERMS

A 25% deposit must accompany all orders— balance C. O. D. All shipments FOB Newark warehouse. Orders under \$5—\$50 Handling Charge. Subject to prior sale.

32 BEECHER STREET
NEWARK, NEW JERSEY

LOOKING for a can to put it in??

ALUMINUM & ZINC IF etc. CANS AVAILABLE

*17 x 2 3/4".....	\$0.06	*2 3/4 x 2 1/2".....	\$0.09
*1 7/16 x 1 1/2 x 2 3/4".....	.09	*1 3/4 x 2 5/8".....	.07
*1 7/16 x 1 1/2 x 2 3/4".....	.06	*2 2 3/4 x 3 5/8".....	.10
*2 1/2 x 2 1/2 x 3 3/4".....	.12	*7/8 x 7/8 x 1 5/8".....	.06
*1 1/2 dia. x 1.....	.06	*1 dia. x 4 3/4".....	.12
*2 1/8 dia. x 3 1/4".....	.08	*2 1/8 x 2 1/2 x 3 3/4".....	.20

RELAY SPECIALS

Type	Coil	Contacts	Features	PRICE
Sigma 4F	8000	SPDT	1 ma plate	\$2.95
Sigma 5	65 (2)	SPDT	2-24 VDC	\$4.45
Leach 1077BF	100	DPDT	ANTENNA TYPE	1.55
Clare Type C	400	DPSI	make-11V	1.25
Clare Type C	3500	DPDT	8 ma plate	.75
ALLIED FLD	42	SPNO	6 VDC MINI.	3.25
Allied BN	200	4PDT	10 AMP. CONT.	2.15
Allied Bc	14	3PDT	6 VDC 10 A CONT.	2.45
Rotary Relay, 14 y operation/remote model trains, etc.				1.35
Klixon Type BR Thermal Relay, 110/220 VAC				1.85
1 RPM 110 V 60 cy Instrument Motor, Hi Gear Ratio				.89
F W E Mini Selenium rect. 12 ma 115 vac in				1.45
G.E. THYRITE voltage regulator 3rd harmonic generator.				.29
3-40 ms at 21-23 volts, pk. of 5				1.15
TERMINAL STRIP, 6 term, hi volt, barrier				1.45
FILTER CHOKE, 4 hy, 160 ma, 60 ohm cased				5.45
PP INPUT TRANSFORMER, pri:2 8K-16K, sec:2 1.00K 30-				2.35
300 cy 10B, envd, Federal, suitable servo				2.95
FILAMENT TRANSFORMER, 115V pri, 6.3/12A				.85
AUTO TRANSFORMER, 115/68/83 volt at 1 1/2 A				3.95
W. Variable type D-1021319				1.75
KWH METER, 5 amp 115 volt AC, used cond.				1.75
TUBE SPECIAL, 7 yne 3D21A, 6000 available				1.45
LINE FILTER NF 4-1, 100 amp, 24 VDC				
SELENIUM RECT. F.W.B 90 VAC in 150 ma				

OIL CAPACITORS

4 MF/600 VDC TLAD type	\$1.35	4 MF/600 VDC TJ type	\$1.65
6 MF/600 VDC TJ type	2.55	10 MF/600 VDC TJ type	4.75
15 MF/600 VDC TJ type	8.50	20 MF/600 VDC TJ type	9.75

SPECIAL NOISE SUPPRESSION CAPACITORS

CA-442	CA-443	CA-481	CA-209	CA-275	CA-177A	CA-166
--------	--------	--------	--------	--------	---------	--------

Willard 6 volt 46 amp bat.

ELECTRONIC SPECIALTY SUPPLY CO.
56 C Lispenard Street New York 13, N. Y.

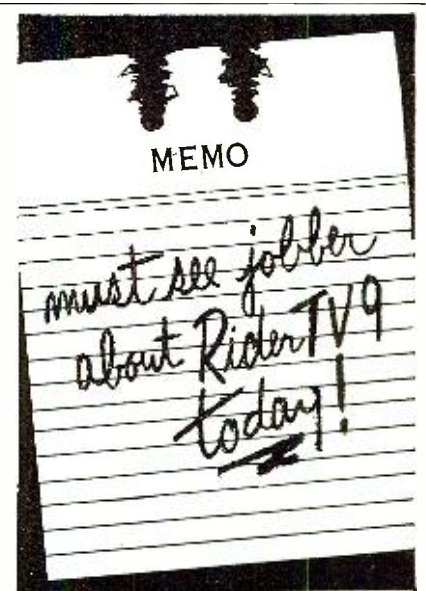

PLATT ELECTRONICS

PRE-AMPLIFIER MODEL K-1
 The K-1 is used to amplify output level for microphones and phonographs. Operates on 24-28 VDC. can be converted to 110 AC. Comes complete with PL 55 plug and 2 foot 119-B cord, 2 terminal blocks and instruction book.
BRAND NEW.....SPECIAL! \$3.95

SCR-27N
COMMAND and ARC-5 Equipment
RECEIVERS

	USED	NEW
BC-433-190 to 550 KC.....	\$22.95	\$42.50
BC-434-3 to 6 MC.....	11.95	18.95
BC-435-6 to 9 MC.....	11.95	18.95

TRANSMITTERS

BC-457-4 to 5.3 MC.....	12.95	21.95
BC-458-3.3 to 7 MC.....	12.95	21.95
BC-696-3 to 4 MC.....	20.95	39.95
UC-459-7 to 9.1 MC.....	16.95	27.50

ADDITIONAL EQUIPMENT

BC-456 Modulator.....	.95	6.95
BC-450 Control Box (3 Receiver).....	1.49	2.95
BC-451 Control Box (Transmitter).....	1.29	2.49
BC-442 Relay Unit (ANT).....	2.95	3.95
Plugs: PL-147, 148, 151, 152, 153, 154, 156—EACH.....	1.25	
Flexible Shafting with gear to fit Receivers.....		1.69
3 Receiver Rack.....	2.25	
2 Transmitter Rack.....	1.69	

BC-221 Frequency Meter
 Real Value! QUANTITY IS LIMITED—so first come, first served. They are just like new, with original calibration charts. Range 125-20,000 KC with crystal check points in all ranges. Complete with crystal and tubes.....
\$139.50

TIME CLOCKS
 12 and 24 hour cycle timing. Unlimited uses. Needs minor repairs. AN EXCELLENT BUY! HOW CAN YOU GO WRONG!
ONLY \$9.95

20 POUNDS ASSORTED RADIO PARTS
 A TERRIFIC BUY AT ONLY.....
\$2.79

HEADSETS

HS-33 low impedance with cord and plug, used, fine condition.....	\$3.29
HS-23 high impedance, BRAND NEW with ear pads.....	4.25
HS-33 low impedance, BRAND NEW with ear pads, cord and PL54 plug.....	4.95
HS-30 with ear plugs, low impedance, used, good condition.....	1.69
CD-307A Cords, 8 NEW.....	.89
H-16/U high impedance. Includes two receiving units.....	\$3.95

VHF Excellently Reconditioned Guaranteed
SCR-522
AIRBORNE COMMAND EQUIPMENT
 Frequency Range 100 to 156 mcs. in 4 channels receiver and transmitter. Crystal controlled. Complete equipment. Consists of trans/rec, control box BC-602, dynamotor PE-94, AN104A antenna, plugs, etc. Power input with PE-94 is 28 v.
 Electrically Tested—Complete as Shown. Only **\$129.50**
 BRAND NEW—PRICES ON REQUEST

NOW! Fill Your Battery Only Twice a Year
 with Automatic Battery Filler
 Made by leading Detroit Auto Mfr. Doubles battery life over ordinary care, prevents battery breakdowns. Fits all cars, instantly installed.
ONLY \$1.95 COMPLETE

DUAL PURPOSE EMERGENCY UNIT
 • Fire Extinguisher
 • Tire Inflator
 Made by leading Detroit Auto Mfr. Especially recommended for oil, gas and electrical fires. Guaranteed by mfr. against defects.
 Order two—one for your home; one for your car in case of flats or fires.
ONLY 2.29 each

MINIMUM ORDER \$2.00
 Immediate Delivery—Send 25% deposit on C.O.D. orders. All shipments F.O.B. N.Y.C. (N.Y.C. residents add sales tax to your remittance.)

PLATT ELECTRONICS CORP.
 Dept. A, 489 Broome St., N. Y. 13, N. Y.
 PHONES: WO 4-0827 and WO 4-0828

reports to Radio Sweden, Stockholm 7, Sweden.

The International Red Cross, Geneva, Switzerland, has been testing recently at various hours over 7.210. Will make further tests during the year; wants reception reports.

Paris is using 7.103 for Finnish programs 1215. (Radio Sweden)

AIR, 5.990, noted with European Service (*English*) daily 1400-1515. (Hansson, Sweden) *Radio Alerta*, Valencia, Spain, is now audible on 7.500 to 1800 sign-off. (Radio Sweden)

Damascus, Syria, recently sent this schedule—on 11.915, 20 kw., to Western Europe, 1530-1630 French, 1630-1730 French; 17.865 20 kw., to India-Pakistan, 0945-1045 in *English* and Arabic; 7.145, 20 kw., 0200-0930 Arabic, *English*, and French; 6.165, 20 kw., 2330-0200, 0630-0800, 1000-1700, (Kelting, N. Y.) The 7.145 outlet should have *English* 0500-0600. (Leinbach, N. Y.)
 YNWW, *Radio Sport*, 7.849, Nicara-

gua, heard 2045-2300 sign-off. (Krejny, Ohio)

The monthly DX sessions from Berne, Switzerland, are scheduled for the first Tuesday and Wednesday of each month as follows—Tuesday—To United Kingdom and Ireland, 1405, 9.665, 6.055; to North America 2050 and 2235 on 6.165, 7.210, 9.535, 9.665, 11.865. Wednesday—To Eastern Australia and New Zealand 0235, 11.865; to Western Australia and Far East 0420, 15.305, 17.784; to Southeast Asia and Japan 0805 on 11.865, 15.305, 17.784; to India and Pakistan 1005, 11.865, 9.665; to South Africa, 1005, 15.305; Middle East 1205, 11.865, 9.665.

Acknowledgement

Thanks for the fine reports, fellows! They will be welcomed from anyone, anywhere in the world—to Kenneth R. Boord, 948 Stewartstown Road, Morgantown, West Virginia, U.S.A. . KRB.

LIGHTWEIGHT CORD FOR PHONES

By ARTHUR TRAUFFER

MANY thousands of the war-surplus earphones, shown in the photograph, have been sold, but the writer never met anybody that likes the heavy cable and split-connector that comes with it. Designed for rugged armed-forces use, the heavy stiff cable is a nuisance when these fine phones are used for test work, crystal sets, or any application where weak signals must be heard. Every little bump or jar on the cable is carried to the phone and sounds like somebody is hitting the phone with a hammer! And the writer has actually had a pair of these phones slide off a table by the sheer weight of the cable hanging over the edge!

To do away with all this, you can easily replace the cable with a lightweight soft and flexible cord, as follows: Obtain a standard cord for a single earphone. These are from four to six feet long, have copper tinsel inner con-

ductors, and pins on both ends, or pins on one end and spade-lugs on the other. Referring to the drawing, cut the old cord at "A," loosen the set-screw and pull out cord at "B," and pull the cable out of cable-clamp "C." Now pull the new cord through the clamp and connect the same as the old cable was connected. At point "A" you will have to make a twisted splice; wrap the splice with fine wire, and tape tightly. You cannot solder the splice without melting the copper tinsel conductor.

At point "B," break the two small prongs off of the spade-lug and insert the tip of the cord into the hole in the phone and tighten the set-screw. Now mash the cable-clamp with a pair of pliers to hold the new, smaller diameter cord securely. You will be pleased with the convenience of the new soft lightweight cord.

—30—

Method for changing the earphone cord.

Surplus earphones with lightweight cord.

Variable Resistances

(Continued from page 73)

and the response is flat. Experimental curves for this circuit are shown in Fig. 9. The control voltage can be introduced between ground and the grid of the control tube when dynamic action is desired. The characteristics of this circuit are seen to be similar to those of Fig. 8 except that the circuit of Fig. 7 offers the additional advantages of inverse feedback.

So far the writer has used resistance tubes only in circuits operating at low (audio) frequencies. Resistance tubes appear to offer no particular advantages when used in connection with high frequency amplifiers, particularly with those employing tuned circuits. It seems probable that the tube capacitances of the resistance tube would introduce undesirable effects in such applications. However, in low frequency circuits where little distortion can be tolerated the use of resistance tubes as attenuators is simple and effective.

The applications cited are by no means exhaustive but are described merely to indicate some of the possibilities. Technicians in fields other than audio will appreciate the application of resistance tubes to their own special problems.

Pentodes as Resistance Tubes. All circuits described herein have used triodes as the variable resistance elements. The question naturally arises: Why not use pentodes? Inspection of pentode characteristics shows that the plate resistance is very small at low values of grid and plate voltages. However, as the plate potential increases from very small values to medium values, the changes in plate resistance are rather abrupt. The consequent curvature of the grid voltage lines in this region makes it difficult to satisfy the second criterion mentioned earlier. Furthermore, the screen current is very high at low plate voltages and the screen dissipation is likely to be excessive. Also, the relative simplicity of triode circuits seems to dictate their use in all but very special applications.

-30-

Fig. 9.

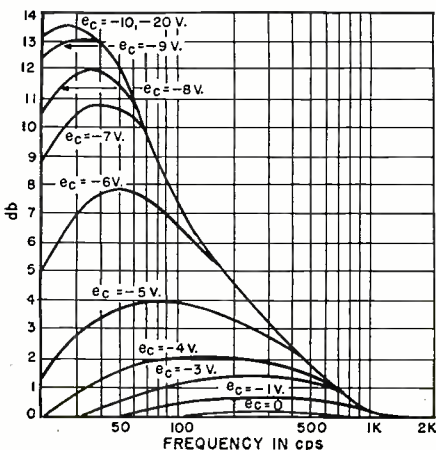

B SS REFLEX

KITS

EQUIPMENT CABINETS

by **Cabinart**

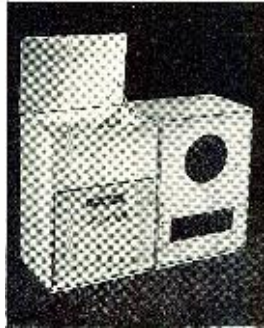

DIMENSIONS
33½" high
23" wide
16" deep

LUMBER
¾" thick
Fir Ply

Equipment cabinet accommodates any WEBSTER, GARRARD or REK-O-KUT changer, and any combination of standard tuners or amplifiers. Tuner compartment inside dimensions: 20" high x 21¾" wide x 15¼" deep. Bass reflex cabinet volume: 6 cu. ft.

ASSEMBLED CABINETS

(Sanded smooth, ready for finishing)

MODEL 70 (Equipment cabinet) . . . 36.00*

MODEL 7115 (12" speaker cabinet) . . . 24.00*

MODEL 7112 (15" speaker cabinet) . . . 24.00*

CABINET KITS (Ready for assembly)

MODEL 80 (Equipment kit) 27.00*

MODEL 8112 (12" speaker kit) . . . 18.00*

MODEL 8115 (15" speaker kit) . . . 18.00*

Speaker Cabinets also furnished in a smaller size for 8" or 12" Speaker. Dimensions: 30" high x 18½" wide x 12" deep.

MODEL 758
Assembled
8" speaker
18.00*

MODEL 7512
Assembled
12" speaker
18.00*

MODEL 858
8" speaker kit
15.00*

MODEL 8512
12" speaker kit
15.00*

All kits include:

- Lumber Cut to Size
- Baffle Pre-cut for 12" or 15" Speaker
- Saran Plastic AcoustiCloth
- Hardware • Plastic Wood
- Sandpaper • Glue
- Kimsul Acoustic Insulation
- Assembly Instructions
- Finishing Instructions

ALSO AVAILABLE

KITS FOR CORNER FOLDED HORN ENCLOSURES

MODEL 61 12" Speaker 19.95*
MODEL 63 15" Speaker 23.95*

*Sold only through radio parts distributors. Net prices, slightly higher West and South.

G & H WOOD PRODUCTS COMPANY - 75 NORTH 11th STREET - BROOKLYN 11, NEW YORK

TRIO the TROUBLE PROOF TV ROTATOR

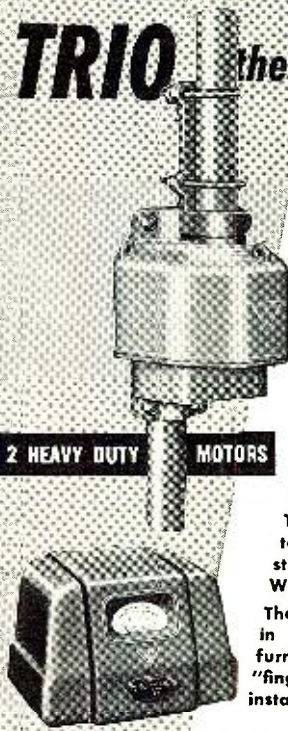

For years of dependable, unflinching service—in good weather and bad—you can't beat the new TRIO Model TR-2M TV ROTATOR and DIRECTION INDICATOR.

Sturdy and completely weatherproof, the TRIO ROTATOR will support the heaviest TV arrays—even in 80 MPH winds! Its sound design and construction has been proven by three years of extensive field testing under every extreme of weather. The TRIO ROTATOR will not freeze up!

Two 24 volt motors are used—one for each direction of rotation. Thus, each motor operates just 50% of the time—cannot burn out! Positive electrical stops at both ends of 360° turn eliminates lead damage.

The TRIO ROTATOR is precision built to extremely close tolerances. Housing is die-cast aluminum for greater strength, lighter weight and perfect alignment of parts. Will fit any mast, 1" to 2" diameter.

The smartly styled TRIO DIRECTION INDICATOR is housed in a sturdy plastic cabinet that harmonizes with any furniture style. Easy operation is assured by the new "finger-tip" control and the easy-to-read dial that clearly, instantly indicates exact antenna position.

See the new TRIO ROTATOR at your jobber today!
It's tops for TV—ideal for ham arrays too!



Trio MANUFACTURING COMPANY
GRIGGSVILLE, ILLINOIS

SAVE 54%

Hi Fi AM/FM TUNER

ACTUAL VALUE \$89.95

Special at Radio Shack **\$42.95**



- ★ Hi-Fidelity
- ★ 10 tubes
- ★ AC operation

Use with any amplifier or TV set



Never such a bargain in FM history.

Brand new PILOT tuner with \$130-tuner features:

(1) separate FM and AM 3-gang tuning condensers; (2) tuned RF stage on both FM and AM; (3) built-in FM and AM antennas for local reception; (4) terminals for outside antenna; (5) temperature-compensated oscillator; (6) high-Q RF coils; (7) iron-core IF's; (8) AVC; (9) advanced AM superhet and FM ratio detector circuits; (10) 4-position switch for AM/FM/phono/TV-audio or recorder; (11) selective FM/AM pilot lights; (12) miniature tubes thru-out; (13) built-in dual-filtered AC power supply; (14) compact size — only 1 1/4 X 5 7/8 X 10 1/2" over-all. 15 lbs.

For only \$42.95 you get this \$89.95 Pilot tuner complete with tubes, knobs, brown-and-bronze escutcheon, and built-in mounting brackets!

ORDER NOW — PROMPT SHIPMENT WHILE THEY LAST

BARGAIN ACCESSORIES, TOO!



\$5.70

DUAL-STYLUS CARTRIDGE

variable-reluctance type, two sapphire styli for LP and 78's, brand new, guaranteed. Reg. price \$8.20.



\$11.95

6-POSITION EQUALIZER

matches above GE pickup to all recording curves for best reproduction. Buy 'em both for only \$16.95!

SPECIAL "PACKAGE DEAL"

FM/AM tuner, GE dual cartridge, GE pre-amp, equalizer, Garrard 3-speed changer, and 12" co-axial PM speaker with built-in cross-over network . . . and FREE 2-year subscription to "High Fidelity" magazine. Value \$183.50. Yours for only \$124.50. Speaker alone.....\$14.95

FREE! 192-page Catalog 52-R. Write now for yours!

RADIO SHACK CORPORATION

167 Washington St., Boston 8, Mass.

Improved FM Sensitivity

By JAMES A. MITCHELL

A few simple tube changes help to boost the FM gain of a well-known high fidelity tuner unit.

THE Meissner AM-FM tuner, Model 9-1091A is a popular high fidelity tuner with good FM and excellent AM sensitivity. As used in my audio set-up it performed well but there were several FM stations 75 to 200 miles distant which did not come in with sufficient strength for good listening. This was largely due to the mountainous terrain in my East Tennessee location. Several good music programs were carried on some of them so I set out to increase my signal gain.

Consideration was given to yagi antennas and FM boosters but the need for antenna rotation and separate tuning discouraged those approaches. Several suggestions have appeared in print to increase the gain of TV sets by replacing the 6AG5's with higher transconductance tubes like the 6BC5. This approach offers a very convenient solution and was successfully tried.

The 9-1091A has a full Armstrong circuit with a tube line-up as follows: r.f. amplifier, 6AG5; oscillator, 6C4; converter, 6AG5; i.f. amplifiers, 3—6AG5's; limiters, 2—9001's; and detector, 6AL5. Thus there are five 6AG5's in the circuit. Higher gain replacements are the 6BC5 and the 6CB6. The 6BC5 has a higher transconductance than the 6AG5 and has identical pin connections. The 6CB6 has still higher transconductance but a connection must be made from the No. 7 to the No. 2 pin, since the suppressor grid is not connected to the cathode internally in this tube as in the other two. The increase in transconductance is from 5000 for the 6AG5 to 6200 for the 6CB6 under identical circuit values. Thus it would seem that an increase in gain on the order of 20% might be obtained by substituting a 6CB6 for a 6AG5. Since there are five 6AG5's in series the total increase in gain by replacing them all with 6CB6's could be 1.2⁵ or 2.5.

The circuit diagram showed that a connection between the 7 and 2 pin already existed in the r.f. amplifier, so I slipped in a 6CB6. A slight readjustment of the input and r.f. amplifier alignment condensers was necessary for maximum gain. The interelectrode capacitances of these tubes is just enough different to require a slight adjustment. The meter showed the input to the limiters to be up 20%. I settled for putting a 6BC5 in the converter position so that I would not have to get into the tuning unit at all. The signal was now up nearly 40% and two of distant stations were limiting satisfactorily. The slight alignment adjustments could be made easily by watching the tuning eye.

After about a month of improved reception the urge to change the i.f. tubes possessed me and so I soldered short leads across the 2 and 7 pins and put the 6CB6's in place. Again it was thrown out of alignment and this time it took a little professional assistance with an oscillator to get it properly tuned. The gain was a little more than doubled by this change, however, and I was not only getting the original borderline stations with good quieting but several new ones appeared on the dial. The over-all increase in signal gain was estimated at 2 to 3 times. No tendency toward oscillation or instability was ever noted, although the gain of the already hot three-stage i.f. amplifiers was doubled. Background noise between stations was definitely increased but the limiting was so improved by the extra signal strength that critical listening is now enjoyable on many stations not previously picked up.

These changes have been incorporated in another Meissner of the same model in town with similar improvement in results. These tube substitutions are recommended if a two- to threefold increase in gain will improve FM reception and may as well be put into effect as tube failures occur.

—30—

ROCHESTER HAMFEST

THE Rochester Amateur Radio Association will hold its annual hamfest on Saturday, May 10th at the Elk's Club in Rochester, New York.

Technical talks are scheduled for the afternoon and a special program has been planned for the entertainment of the ladies. Dinner will be followed by entertainment and a talk.

For reservations write the Rochester Amateur Radio Association, P. O. Box 1388, Rochester 3, New York.

—30—

SPEAKER SHIM

By HARRY J. MILLER

CONSIDERABLE success in centering voice coils of small speakers is possible by using narrow strips, cut from snapshot negatives, as speaker shims.

These negative strips are thin enough to be practical and at the same time they have sufficient stiffness to permit easy insertion.

When a speaker, which has a gap larger than the thickness of the negative film, is to be re-centered, make the strip slightly wider and its springiness will compensate for the extra space. In this case, the width of each shim used, generally three, should be the same.

—30—

RADIO & TELEVISION NEWS

Auditorium Amplifier

(Continued from page 68)

age, but additional filtering is supplied by the decoupling condensers mounted on the amplifier chassis. The Chicago PSC 200 transformer is rated at 385-0-385 volts at 200 milliamperes, but with the filter system as shown, voltage tests indicated that the full 400 volts of d.c. were available at the plates of the output tubes under full load. The power supply is entirely capable of supplying the requirements of this amplifier as indicated by the fact that after several hours of operation, the power transformer becomes only slightly warm. In fact, it is the coolest running unit with which the author has had experience.

The output transformer is the Chicago BO-9, connected to match a 3000 ohm plate-to-plate load to speaker and line. A jack is supplied for an 8 ohm speaker and a terminal strip is provided for the other output impedances. In order to further reduce the already low output impedance of the amplifier, inverse feedback is used from the plate of one of the output tubes to the plate of the 6SR7. Care must be taken to supply the feedback from the plate of the output tube which is in-phase with the plate of the 6SR7. This can be done by experiment, the out-of-phase tube connection resulting in a squeal or howl. The feedback voltage is delivered by a 100,000 ohm, 1/2 watt resistor connected directly between the two plates. No reactances are included so that no frequency discrimination will result because of this feedback.

The adjustments necessary for the correct operation of the amplifier are few and simple. The bias voltage must be adjusted by manipulating R_{10} until the voltage from grid to ground of each output tube measures -35 . Then the plate current of each tube must be balanced by adjusting R_{16} . The best way to make this adjustment is to cut a milliammeter into each plate circuit and adjust R_{16} until each tube draws the same plate current. An alternate method is to place a voltmeter between the center tap of the primary of the output transformer and the plate of an output tube and to note the voltage. Then the voltage between this tap and the other plate should be noted. R_{16} must then be adjusted until these two voltages are the same. The author used a vacuum tube voltmeter in making these adjustments with excellent results.

The results obtained with the finished amplifier are very gratifying. Music and speech are reproduced with an exceptional clean-cut quality. Furthermore, extended listening tests brought about no listener fatigue—the quality sounded as good after several hours of listening as at first—a good test for any amplifier. Hum is practically non-existent at low listening levels, and is so far below the signal level at high volumes that it is impossible to discern it.

-30-

NOW!

The Sensational New WEATHERS One-Gram Capacitance Pick-Up

(Cartridge Form)



AT LONG LAST! — REALISM without noise
20 TO 20,000 CYCLES

Can Only Be Compared With 15" Tape For Highest Quality!

Will Improve and Replace Any Modern Phonograph Pickup

- ✓ One gram stylus pressure with ideal tone arm
- ✓ Two grams pressure on modern Webster changers
- ✓ Very low pressures with other players, including RCA 45 changer
- ✓ Will operate properly with most good quality tone arms

Constant Amplitude Response, 20 to 20,000 cps. 1 volt into 1/2 megohm at 1000 cps.
AES Response Equalization from separate output connection, for LP records.

Replaceable 1-mil sapphire stylus (choice of 1-mil or 3-mil sapphire stylus on request).
Records last thousands of plays. One sapphire plays thousands of records.

WEATHERS CARTRIDGE
AT A NEW LOW PRICE

WEATHERS power supply, complete with power cord, for 117 volts, 60 cps. net \$14.50

Complete with ultra-flexible cable, oscillator unit, tube, installation hardware and instructions. net

\$37.50

Oscillator requires 6.3 volts ac at 0.3 amp, and 250 volts dc at 2ma. Available from most amplifiers.

Check or Money Order. No. C.O.D.'s Please
Shipments postpaid in U.S.

WEATHERS INDUSTRIES
510 RICHEY AVE., W. COLLINGSWOOD 6, N. J.

Let MILTON S. KIVER Help You Prepare For U.H.F.-TV And...

TELEVISION SERVICING

Easy to TRAIN AT HOME This Practical Way!

Men with the right training in Television Servicing are in big demand . . . pull down big pay. T.C.I. TRAINS YOU RIGHT with easy-to-follow technical training designed by servicemen, for servicemen! You learn practical, professional type Television Servicing without leaving your present job. Included are money-making extras such as set conversion, master antenna installation, U.H.F.-TV and field servicing short cuts. You can start earning Television money after the first few lessons. You learn to test, trouble shoot and repair all types of TV sets the proven, practical way!

HERE'S HOW YOU GET EXPERIENCE!

You train on your own large screen modern television receiver, furnished as part of your course. This set is yours to keep! As an optional feature you can get two weeks of actual field experience out on service jobs and on the repair bench for Chicago's largest independent servicing organization. You learn Television Servicing by actually doing Television Servicing . . . you get the practical know-how you need to qualify for BIG MONEY in this fast-growing field! Age is no barrier. Many TCI students are over 40!

ACT NOW! Fill out and mail coupon for FREE Catalog and SAMPLE LESSON. Write TODAY!

TELEVISION COMMUNICATIONS INSTITUTE
205 W. Wacker Dr., Dept. TV Chicago 6, Ill.

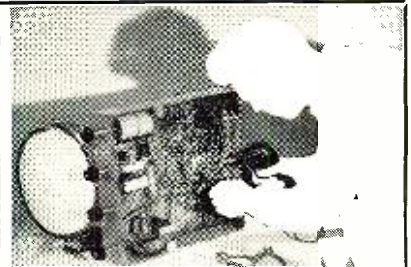

YOU GET and keep modern large screen Television receiver.

YOU DO actual testing, servicing, trouble shooting and repairing

TV BROADCASTING COURSE READY NOW!
Train at home for these big pay studio jobs! Video engineers, cameramen, microwave engineers, etc. Easy non-mathematical training covers all phases. Write!

MAIL NOW FOR FREE BOOKLET

MILTON S. KIVER, President
TELEVISION COMMUNICATIONS INSTITUTE
205 W. Wacker Dr., Dept. 1-V, Chicago 6, Ill.

Rush full facts on the course checked below. I am not obligated. Salesman will not call.

() TV Servicing () TV Broadcasting

Name Age

Address

City Zone State

() BEGINNERS check here for information on Pre-Tel Radio Course.

DUAL POWER SUPPLY

A completely wired, Dual Power Supply, delivers 600 volts DC at 200 ma and 250 volts at 75 ma. Both sections filtered with high grade capacitors and chokes. 1.5 volts—60 cycles primary fused and by-passed. Mounted on chassis shelf, 8" wide, 15" long. Has two extra filament windings of 6.3 volts at 5 amps, and 12.6 volts at 2.5 amps. Output brought out in cable with provisions for external AC and HV switch. Ideal for low power transmitters and modulators. Complete, busless 50KV and 6X5GT rectifiers. Terrific value at.....\$14.95

Power Transformer Bargains

115 Volt, 60 Cy. Primary
800 Volts CT @ 250 MA., 6.3V @ 4A, 6.3V @ 4A, 6.3V @ 2A, 5V @ 2A. Fully Cased. BRAND NEW, Wt. 14 Lbs. Only **\$7.89** ea.

750 volts CT @ 200, MA 6.3V @ 10 amps, 5V @ 3A. Fully cased, removed from TV equipment. Guaranteed. each **\$3.75**

SCOPE TRANSFORMER BARGAIN
2500 V @ 3 ma, 2.5 V @ 2 A, 6.3 V @ 6 amp. Removed from TV equipment. Guaranteed. Terrific value @..... **\$1.89**

SENSITIVE RELAY

D'Arsonval moving coil type, mounted in meter case. Adj. 700 microamps to 1 ma. Made by Triplet. ea. **\$5.75**

6 VOLT DC RELAY

Small Size. Ideal for Mobile Use, SPDT

\$0.99

PANEL METERS

NEW GOV'T SURPLUS STANDARD BRANDS
*Special Scale

2" METERS

0-100 MA. \$2.45
0-10 MA. AC 2.95
0-2 AMP RF 2.95
0-4 AMP RF 2.95
0-50 AMP AC 2.95
0-30 AMP DC 2.95

3" METERS

0-1 MA 4.95
0-2 MA 4.50
0-2.5 AMP RF 5.95
0-500 MA 5.95
0-100 VDC (1 MA) 5.95
0-200 VDC (1 MA) 5.95
0-250 VDC (1 MA) 5.95
0-750 VDC (1 MA) 5.95
0-150 VAC 6.95

FILTER CHOKES

6 Hy 90 MA. \$0.79
10 Hy 175 MA. 2.25
10 Hy 250 MA. 2.75
10 Hy 350 MA. 3.95
6 Hy 500 MA. 4.95
6 Hy 400 MA (Rusty) 2.95

PIGTAIL MICAS

MMF: 5, 20, 50, 60, 100, 250, 300, 400, 500, 750, 800, 1000, 2000, 3000, 4000, 5000, 6000, 10000. \$0.09 ea.

Silver Mica Capacitors
MMF: 10, 50, 60, 340, 750, 780, 1000. \$0.12 ea.

FILAMENT TRANSFORMER

6.3 Volts at 10 Amps plus 2.5 Volts CT at 12 Amps. 3500 Volt Insulation. Primary 115 Volt 60 Cy. Fully shielded. \$2.99 ea.

BAKELITE CASED MICAS

MFD	VDC	Price	MFD	VDC	Price	MFD	VDC	Price
.001	600	\$.18	.024	1500	\$.65	.001	5 KV	\$1.60
.002	600	.24	.032	1500	.75	.002	5 KV	1.60
.01	600	.26	.02	2 KV	.90	.002	5 KV	1.60
.02	600	.26	.005	2500	.55	.003	5 KV	1.90
.01	1 KV	.45	.004	2500	.50	.001	6 KV	2.50
.002	1200	.35	.0001	5 KV	.70	.002	6 KV	2.90

WIRE WOUND RESISTORS

5 watt ohms: 25-50-84-200-2500 \$0.09 ea.
10 watt ohms: 25-40-1325-2K-4K15 ea.
20 watt ohms: 150-300-750-1K-1.5K, 2.5K-7K-10K-20K20 ea.
30 watt ohms: 100-2500-5300-18K22 ea.
100 watt ohms: 100-3750-1500-2K, 10K, 15K, 20K, 100K59 ea.

POWER SUPPLY KIT

1-UTC Power Transformer 700 VCT @ 60 ma, 5V @ 2A, 6.3V @ 1-2A.
2-UTC 60 ma chokes. Transformer and chokes fully cased. Transf. and 2 Chokes. SPECIAL \$3.95

ADJUSTABLE SLIDER RESISTORS

20 Watt: 1, 5 Ohms \$0.25
50 Watt: 500 Ohms35
75 Watt: 20, 150, 200 Ohms39
100 Watt: 50, 375069

PEAK ELECTRONICS CO.

188 WASHINGTON ST., NEW YORK 7, N. Y.

Phone COrtlandt 7-6443-4

Interpreting TV Patterns

(Continued from page 37)

Outside interferences (excluding ghosts) when caused by radiation of electrical equipment will affect the picture only when such equipment is in operation. Time and effort are required to track down the appliance or equipment causing the interference. When the source has been determined it is possible to minimize the trouble by connecting a large condenser across the contacts, or by installing a booster at the receiver or detuning the i.f.'s.

Since the market for television receivers has almost reached the saturation point in metropolitan areas, TV distributors and dealers are now emphasizing sales in the suburbs and in nearby communities. Technicians will have to face the problem of poor reception in these fringe areas. The cause of pictures like those shown in Figs. 6, 7, and 8, is weak signal strength. Technicians have often modified receivers in order to increase gain and improve the over-all picture quality. These design changes are commendable only insofar as they produce the desired results. The best method is to increase the signal strength at the antenna terminals of the receiver. Since an antenna installation must often be a compromise because of the cost involved, receiver modifications such as substituting higher gain r.f. or i.f. tubes, removing or decreasing a.g.c. to the r.f. or i.f. stages, and realignment to decrease bandwidth and increase gain may be tried to obtain a more favorable picture. Before receiver modifications are attempted, the customer should be advised that while the changes will produce a better picture in the present location, if the receiver

is moved to a stronger signal area or if at a later date the signal strength is increased, the receiver may not perform satisfactorily because of the modifications.

Fig. 6 illustrates the results of a faulty antenna installation and station interference in fringe reception areas. In local signal areas this condition may be due to lack of care when tuning in a station, generally tuning to the low frequency side of the signal rather than the high frequency side. This may also be the result of overloading caused by a loss of a.g.c., gassy i.f. tubes, or a defective video amplifier stage. This condition may also be caused by a low-voltage filter condenser which produces 120-cycle hum.

The normal fringe reception test pattern of Fig. 7 is the pattern which may be expected on the screen of a receiver operating in a low signal area, a condition existing in fringe areas. In local signal areas this condition may be caused by a weak or dead r.f. tube in the tuner, i.f. tubes, or associated components.

Ghosts combined with a weak signal condition (Fig. 8) can generally be found in receivers which are operating on inside or built-in antennas in apartment buildings where an outside antenna is not permitted. This condition is also prevalent in cases where antennas are installed in valleys or are located between high buildings resulting in almost complete shielding of the antenna from the signal source. This condition may also be caused by a broken or shorted transmission line. Possible solutions to improve reception include installing an outside antenna where possible, increasing the height of the antenna, re-orienting or relocating the antenna, installing a booster, or performing receiver modifications to increase gain.

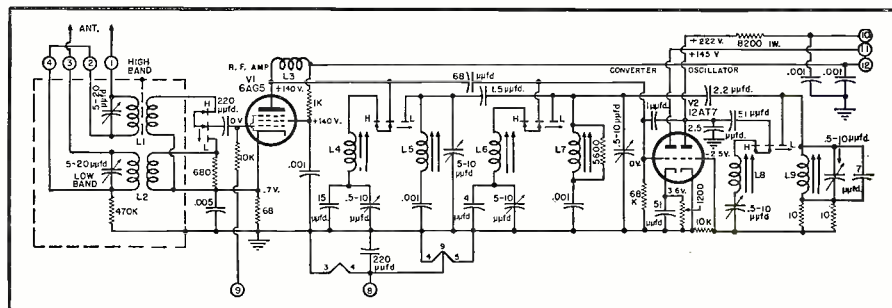
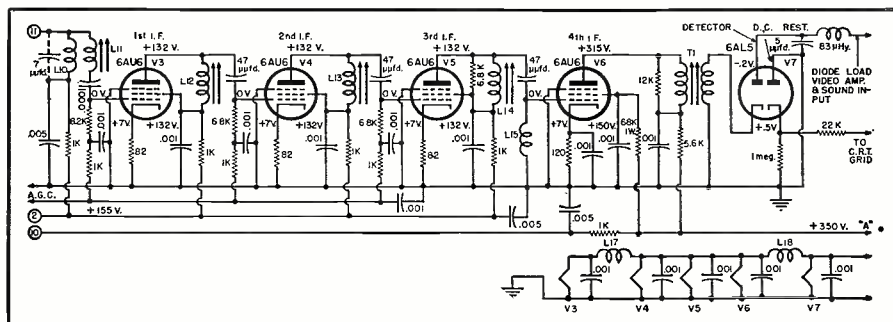

Fig. 11. Schematic of the tuner used in a current Raytheon television receiver.

Fig. 12. The video i.f. amplifier incorporated in a recent Raytheon video set.



A 60-cycle hum is generally due to a short or leakage between the cathode and filament in the i.f. or video amplifier tubes (See Fig. 9). The hum will be noticeable only when receiving a picture (raster will appear normal) if an i.f. tube is at fault or may be present at all times if a filament-to-cathode leakage exists in the video amplifier stage. This condition is also possible when one-half of the low voltage power transformer secondary is inoperative or when one-half of the low voltage rectifier is defective, causing a condition similar to that produced by a poorly filtered half-wave supply. Radiation from a 60-cycle sweep generator being operated near the receiver should not be overlooked as a possible source of the trouble. Substitution of i.f. or video amplifier tubes is a quick solution. One other method is to short the cathode of each defective tube to ground. Start with the higher gain tubes first and test only those tubes that are above ground with respect to 60 cycles. A short or leakage between cathode and filament will immediately show up.

Another common annoyance to the TV viewer is sound bars (Fig. 10). Sound bars may be caused by mistuning of the receiver, microphonic station camera equipment, a microphonic vertical oscillator tube, or microphonic a.g.c. controlled r.f. and i.f. tubes. A microphonic vertical oscillator will cause compression and expansion of the scanning lines which results in light and dark shadings. (A microphonic horizontal oscillator tube will produce a sideward displacement.) Brilliance modulations which show up as light and dark shadings are caused by microphonic r.f. or i.f. tubes which will not respond to vibration without signal. One simple method of determining which section of the receiver is at fault is to tune to an off channel and jar the cabinet. If the sound bars are no longer present an r.f. or i.f. tube is microphonic. If, however, the sound bars remain, the vertical oscillator tube is at fault. Once the troublesome section is found, tap the tubes until the microphonic tube is located. Replacement, obviously will cure the trouble.

In Part 2 of this series the video amplifier, a.g.c. system, sync, and vertical deflection circuits will be analyzed, using the picture tube as the source of information.

(To be continued)

NEW OFFICERS NAMED

THE Florida Association—R & TTC—has elected the following officers to serve one-year terms.

President Steven Petruff will have Shan Desjardines as his vice-president. Thomas M. Middleton as secretary, and A. Ed Stevens as treasurer. Board members include: John Gilbert, Samuel Kessler, C. E. Lawrence, John J. Petruff, Chas. Pierce, Clem Ryan, and Orville E. Smith.

The association voted to affiliate with NETSDA.

SAVE! QUALITY TRANSFORMERS-UP TO 75% OFF!

Copper is critical—Transformer steel is scarce—prices on quality products are higher—deliveries are uncertain—**BUT...**
Harrison comes thru again!

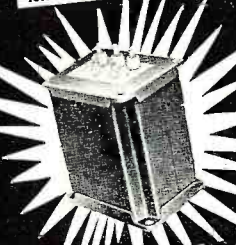

with a sensational offering of the high quality line of one of the larger and better known transformer manufacturers!

Designed for consistently dependable service in Industrial and Amateur applications. Steel cased, mounting, universal.

Every one is brand new—in original boxes—factory sealed—guaranteed perfect.

We have this tremendous stock here—ready for immediate shipment. Call now—your better offer—NOW—at these unbelievably low prices—it won't be around for long!

HARRISON
NEW YORK 7, N.Y.
225 GREENWICH STREET
(10 West Broadway, at Barclay St.)
Barclay 7-7777

DRIVER TRANSFORMERS To Couple Driver Plate to Amplifier Grids									
Type No.	Driver Tube	Output Tube	Turn Ratio Pri. Sec.	Class	Pri. Imp.	Sec. Imp.	Watts	Max. Wgt.	YOUR PRICE
A-4020	6X5, 30, 49, 1H4	Single 1J6, 19	2.5:1	A	10	600	1.45		
A-4021	6V6, 42, 2A5	PP2A, 616	1.7:1, 1.5:1, 1.3:1	A	35	1.25	2.95		
A-4022	6V6, 42, 2A5	Single 6A3, 6X7	2:1, 4:1, 3:1	A	10	1.25	2.45		
A-4023	6V6, 42, 2A5	PP2A, 616	1.7:1, 1.5:1, 1.3:1	A	15	9.25	1.50		
A-4024	4K, 6Y6, 29	PP2A, 616	2.2:1	A	30	8.75	3.25		
A-4025	616, 2A5, 47, 42	PP2A, 616	1.4:1	A	40	10.50	1.55		
A-4026	616, 2A5, 47, 42	Class B Grids 15	1:1, 1.25, 1.5, 1.75	A	15	15.50	6.95		
A-4047	Line to Grid	Watt capacity Class B Grids 30	1.5, 1.25, 1.3	B	17.50	6.95			

MODULATION TRANSFORMERS Compound Filled Cases—For Specific Applications									
Type No.	Output Tubes	Ohms Impedance	Watts	Max. Wgt.	YOUR PRICE				
A-4011	PP2A, 6A3, 616, 616	6000Ω T 5000-2000 10000	25	12.25	4.40				
A-4014	PP2A, 6X7, RK-41, HY56, HV01, RK24	3000Ω T 6000-2000 1500-10000	60	19.25	7.95				
XP-3310	PP2A, 607, RK41	15000Ω T 6000Ω T 1500-10000	175	22.00	6.95				
A-4426	Line or Carbon Mike to Grid	600Ω T 150 6000	60	13.25	3.55				

HEAVY DUTY OUTPUT To Couple to 4-8-15-25-50 Ohm Line or VC									
Type No.	Tube	Class	Impedance	Max. Watts	YOUR PRICE				
A-4027	Single 616, 2A5, 6A3, 6Y6	A	2000	13	2.75				
A-4028	PP2A, 616	A	4000 C.T.	13	3.25				
A-4029	PP2A, 616	A	4000 C.T.	34	5.40				
A-4031	PP2A, 6Y6, PP2A3	A	9000 C.T.	30	4.45				
A-4032	PP2A, 2A5, 7C5	B	10600 C.T.	25	4.50				
A-4033	PP2A, 2A5, 7C5	A	3300 C.T.	55	6.75				
A-4034	PP2A, 2A5, 7C5	A	2000	2	4.45				

CHOKES									
Type No.	Inductance Henries	Current Rating M.A.	DC Res. Ohms	Volts	YOUR PRICE				
C-4087	4-16	150	210	3000	8.25				
C-4088	4-16	200	140	3000	10.50				
C-4089	4-16	250	125	3000	13.00				
C-4090	3-14	300	300	3000	14.25				
C-4091	3-14	350	200	3000	16.50				
C-4092	10	200	140	3000	16.50				
C-4093	10	250	125	3000	18.75				

FLATE TRANSFORMERS									
Type No.	Sec. Hms	Sec. DC Volts	Sec. DC M.A.	Sec. DC Volts	YOUR PRICE				
P-4067	1450-1450	1000	300	45.50	18.85				
P-2863**	1175-1175	1000	300		.89				
P-1931	350-350	1000	70	7.25	2.15				

FILAMENT TRANSFORMERS 115 Volts, 50 Cycles Primary									
Type No.	Sec. Volts	Sec. Amps	Insulation	YOUR PRICE					
4049	2.5 c.f.	10	1000V	11.25					
P-4051	2.5 c.f.	25	3500V	17.50					
P-5222	2.5 c.f.	10	2500	1.75					

UNIVERSAL MODULATION TRANSFORMER									
Type No.	Impedance	Pri. M.A. Side	Sec. Impedance	Max. Sec. Volts	Watts	YOUR PRICE			
A-4004	2000-20000	1.50	2000-20000	50 100	15	12.00			
A-4005	2000-20000	1.50	2000-20000	150 300	60	16.00			

New WILLIAMSON TYPE

Heathkit AMPLIFIER KIT

AMPLIFIER Features

- First Williamson Type Amplifier supplied with matching preamplifier
- Uses Altec Lansing Peerless output transformer.
- Practically distortionless—Harmonic and intermodulation distortion both less than 1/2 of 1% at 5 watts output.
- Frequency response ±1 db from 10 cycles to 100 kc.
- Output impedance 4, 8, or 16 ohms.

The new Heathkit Williamson Type Amplifier kit is the best obtainable in amplifiers today—the choice of the really discerning listener. You can hear the difference and measurements actually bear out the superb performance. Frequency response ±1 db from 10 cycles to 100 kc allow you to hear the highs and lows with equal crispness and clarity. Harmonic and intermodulation distortion both less than 1/2 of 1% at 5 watts output eliminate the harsh and unpleasant qualities which contribute to listening fatigue.

The circuit is similar to the one published in Audio Engineering Magazine for November, 1949, and is considered by engineers throughout the audio field as one of the best ever developed. The Main Amplifier (which may be purchased separately) consists of a voltage amplifier and phase splitter using a 6SN7, a driver stage using a 6SN7, and a push-pull output stage using a pair of 807 tubes. The output transformer is manufactured by the Peerless Division of Altec Lansing and is built to their highest standards. Output impedances of 4, 8, and 16 ohms are available. The power supply uses a separate chassis with husky Chicago Transformer power transformer and choke, and 700V Mallory filters for long hum-free operation. A 5V4G rectifier is used.

The main amplifier and power supply are each on a chassis measuring 7" high by 5 1/2" wide by 11" long.

PREAMPLIFIER AND TONE CONTROL UNIT KIT

The preamplifier kit consists of a 12AX7 (or 12AT7) dual triode first amplifier stage with a turn-over control for LP or 7R record types, and a 12AU7 amplifier stage with individual bass and treble tone controls which each provide up to 15db of boost or attenuation. A switch on panel selects either magnetic, crystal, or tuner inputs. Preamplifier also is well suited to custom installations—it will operate in either vertical or horizontal position, and special notched shafts of the controls and switches allow a variety of shaft lengths to be selected. Dimensions: 2 1/4" high by 10 1/4" wide by 7 1/4" deep.

WA-A1 Amplifier kit—Combination 1—(Main Amplifier and Power Supply) complete with WA-P1 Preamplifier kit. Total Ship. Wgt., 34 lbs. (Shipped Express only) **\$69.50**

WA-A1 Amplifier kit only—Combination 4—(Main Amplifier and Power Supply). Less WA-P1 Preamplifier. Total Ship. Wgt., 29 lbs. (Shipped Express only)..... **\$49.75**

WA-P1 Preamplifier Kit only. (less power supply) (Tubes included). Total Ship. Wgt., 7 lbs. (Shipped Express or Parcel Post)..... **\$19.75**

WRITE FOR Free CATALOG

The HEATH COMPANY

BENTON HARBOR 15, MICHIGAN

YOU SAVE BY ORDERING DIRECT

NEW a "must" book
for every
TV Service Technician

"Servicing TV
in the
Customer's Home"



**SAVES TIME
SAVES WORK
Earns More
for You
on Outside
Service Calls**

shows how
to diagnose trouble using
capacitor probe and VTVM

Here's the book you've been asking for—practical, proved help to make your outside TV servicing really effective and profitable. Saves time, work and chassis hauling... shows you how to make successful repairs on the spot. You learn the following: 1. A simple, effective method for tracing down trouble, using your VTVM and a simple capacitor probe. 2. Methods for finding your way around a strange circuit—shows you how to "pull tubes" and diagnose trouble by observing audio and picture effects. 3. How to judge TV set performance by analysis of the test pattern. 4. Methods for making adjustments in the field. You'll want this essential, profit-building book. Handy pocket size; sturdy cover. **\$1.50**

ORDER TC-1. Only Pays for itself on the very first job.

HOWARD W. SAMS & CO., INC.

Order from your Parts
Jobber, or write direct to
HOWARD W. SAMS & CO.,
2201 E. 46th St., Indianapolis 5, Ind.

**ORDER
TODAY**

Send... copy(ies) of "SERVICING TV IN THE
CUSTOMER'S HOME," \$1.50 per copy.

(Check) (money order) for \$.....enclosed

Name.....

Address.....

City.....State.....

An SSSC Adapter
(Continued from page 46)

from the balanced secondary of L_1 . The second balanced modulator receives its excitation from the secondary of L_1 via a balanced 90 degree phase shift network made up of C_{13} , R_{32} , C_{34} , and R_{33} . Each of the condensers has a reactance at 4 mc. equal to 390 ohms, the resistance of each resistor. The 90 degree phase shift between the two excitation voltages is not affected by the tuning of L_1 , but rather is dependent on the resistance-to-reactance ratio of the two pairs of resistors and condensers. This type of phase shift network is much more broadband than a tuned type so that the phase shift is close to 90 degrees over the entire phone band.

12AU7's are used as the two balanced modulators with a potentiometer in one cathode lead of each as a fine balancing control to balance the circuit electrically against a fixed resistor in the mirror cathode lead. These two pots are on the front panel of the unit and the balancing adjustment may be accurately made by watching the receiver S-meter and setting the two controls for minimum signal from the transmitter adapter.

Audio voltages are applied to the cathode circuits of the balanced modulators to avoid the requirement of four r.f. chokes to feed the plates separately. This is plate modulation rather than cathode modulation because the grid leak resistors are returned to the modulation transformer secondaries rather than to ground, but the modulation is introduced in the "B—" lead rather than in the "B+" lead as is more commonly done.

The four plates of the balanced modulators are simply connected in parallel and to the common tank circuit comprised of L_2 and C_{25} , where the single-sideband signal appears. Since no carrier is being generated, it is not necessary to apply "B+" to the modulator plates, but a small amount of d.c. is helpful to aid in setting the balance controls. For this reason, the "cold" end of L_2 is returned to the cathodes of the 6AQ5's which are at a suitable potential.

The single-sideband signal is applied to the grid of the class A 6AG7 output amplifier to be amplified to the one-watt level. This stage is operated with cathode degeneration to improve its stability.

If 20-meter operation is desired, it is only necessary to plug in the 20-meter output coil. This coil has a jumper wire to one of the unused pins which applies plate voltage to the harmonic crystal oscillator. The crystal oscillator generates a comparatively large output which is also impressed on the grid of the 6AG7. This results in grid current in the 6AG7 and the tube operates as a linear mixer, generating the beat signal between the 10 mc. crystal oscillator output and the 4 mc. single-sideband to produce a 14

**Sensational TV
BARGAINS!**

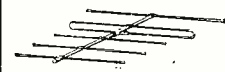

**Rocket
YAGI**

5 ELEMENT TV ANTENNA

Excellent Pictures in Fringe Areas

HIGH GAIN. Clearer, sharper, steadier pictures. **PERFECT PICTURES IN FRINGE AREAS.** Minimum interference from ghosts and noise due to a directive pattern. Five elements include one folded dipole, three directors, and one reflector. Supplied less mast. **MATCHES 300 OHMS IMPEDANCE.** Molded insulator provides additional strength. Exclusive design mast clamp prevents antenna turning or coming under any conditions. **STURDY. TROUBLE-FREE CONSTRUCTION.** No return calls. No broken elements. Stands the test of severest weather. Elements of extra heavy aluminum-clamped top and bottom. **QUICK RIG.** Completely pre-assembled. Just swing elements into line and tighten wing nuts. Simple and quick and easy. Available for any channel, high or low band.

Channels 2 and 3 **\$7.95** each
Channels 4, 5, and 6 **\$6.95** each
Channels 7 to 13 **\$3.95** each

EACH CHANNEL requires a DIFFERENT Yagi. When Ordering specify exact channel number desired.

SOLD ONLY BY MAIL BY NATIONAL ELECTRONICS

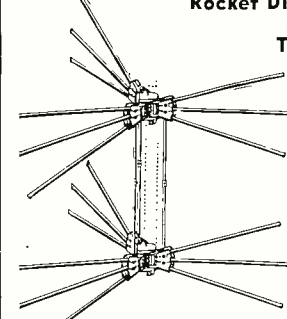

**Rocket DIRECTRONIC
MOTORLESS
TV ANTENNA**

**360°
Electrically
Switched Beam**

- No Motors
- No Roof Orientation
- No Electric Power
- No Ghosts

The Directronic 8 element, 360° antenna is the finest for ultraring or metropolitan reception. The Hi-PAC molded insulator is a masterpiece of extreme tensile strength not affected by weather or temperature, either mechanically or electrically. Included in the AX-599 "Serviceemen's Array"

- 18 hi-tensile aluminum alloy elements
- 1 set of connecting stubs (3)
- Universal U Clamps for masts to 1 1/2"
- Directronic Beam Selector
- 75 feet of Tri-X Cable
- 1 stacked array per carton
- AX-56 Directronic, 6 element Single.....\$ 9.50
- AX-566 Directronic, 12 element Stacked..... 14.25
- AX-59 Directronic, 9 element Single..... 10.35

All above antenna prices include Tri-X Cable and Switch.

SOLD ONLY BY MAIL BY NATIONAL ELECTRONICS

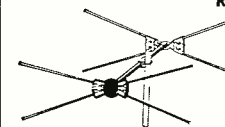

**Rocket ALL CHANNEL
CONICALS**

This sturdy, all-aluminum constructed TV antenna is designed for broad-band reception on all TV channels, plus FM. High Gain, 4 to 1 front to rear ratio. All channels 2-13. Uni Directional. Maximum signal to noise ratio. For use with 72-130-300 ohm lines. Low incepton angle. Complete with all hardware—less mast.

- Single Bay.....\$3.75 each
- Stacked Array with 2 Bays.....\$2.20 each

SOLD ONLY BY MAIL BY NATIONAL ELECTRONICS

- 4 Conductor #20 Solid Motor Wire..... 1 3/4c ft.
- 1 1/4" O.D. (Ducted) 5' crimped..... \$1.05
- Mast Steel (Ducted) 10'..... \$1.95
- Mast Steel (Zinc plated) 10'..... \$1.59
- Mast Connectors for 1 1/4" O.D. Mast—10" long..... 49c
- Tri-X 3 Conductor Lead-in..... 3c ft.
- Peak Roof Saddles (Will take up to 1 1/2" O.D.)..... \$1.49
- Twin Lead 300 Ohm—#70 Mil—Solid..... 2c ft.
- Twin Lead 300 Ohm—#65 Mil—10/28 Stranded..... 2 1/2c ft.
- Double Stacking Assembly for stacking..... \$1.70 set
- Aluminum Guy Line 7/18—Stranded—300 ft. coil..... \$4.95
- Arrestors (TV Lightning)..... \$1.20 each
- Chimney Mount—Complete with Straps..... \$1.19
- Coax—72 Ohm..... 6 1/2c ft.
- Guy Wire—Galvanized—4 strand #20..... 1/2c ft.
- Guy Wire—Galvanized—9 strand #20..... 1/2c ft.
- Guy Wire—Galvanized—11 strand #20..... 1 1/2c ft.
- Boosters—Anchor—101-75..... \$26.97
- Stand-off Screw Insulators—3" for 300 Ohm..... \$2.75 c
- Stand-off Screw Insulators—1" for 300 Ohm..... \$5.50 c
- Strip Clamp Stand-off Insulators—3"..... \$8.50 c

PRICES SUBJECT TO CHANGE WITHOUT NOTICE ALL PRICES F.O.B. CLEVELAND, OHIO
Do not remit more than complete purchase price. Pay shipping charges on receipt of goods. 25% Deposit on C.O.D. orders, please. Money Back guarantee

National Electronics
OF CLEVELAND
THE HOUSE OF TV VALUES
104 Delco Building • Cleveland 3, Ohio

mc. single-sideband output signal. Ten mc. rocks are rare and expensive, yet it is highly desirable to use a crystal oscillator for reasons of stability and doubling or tripling to 10 mc. from a lower frequency crystal is not desirable because of the likelihood of passing spurious harmonics through to the output tank. For this reason, a harmonic crystal oscillator was used. In this type of oscillator, the crystal oscillates on the third harmonic of its normal frequency, so that it is possible to use a crystal of approximately one-third the desired output frequency. Although 10 mc. has been used throughout the above discussion for the sake of round numbers, the actual frequency should be closer to 10.3 mc. so that when heterodyning the range of 3900-4000 kc., the output will cover the 20-meter phone band. A suitable crystal would therefore have a fundamental frequency of about 3433 kc. and such crystals are readily obtainable on the surplus market.

A word may be said about the voice-operated relay system using a pair of sensitive relays. By judicious adjustment it is possible to make one relay close a trifle ahead of the other so that the receiver can be silenced before the transmitter is turned on, and two independent circuits may be operated. Double-pole relays of the sensitive type are rather unusual.

The single-sideband adapter has given excellent results on the air in conjunction with its associated amplifier, and has even worked over surprising distances with its one watt peak output coupled directly into the antenna.

REFERENCE

1. Dome, R.B.: "Wideband Phase Shifting Networks," *Electronics*, December, 1946.

BIBLIOGRAPHY

Goodman: "What is Single-Sideband Telephony?" *QST*, January, 1948.

Norgaard: "What About Single-Sideband?" *QST*, May, 1948.

Norgaard: "A New Approach to Single-Sideband" *QST*, June, 1948.

Rust: "Single Sideband for the Average Ham" *QST*, August, 1949.

Nippe: "Audio Phase-Shift Networks" *QST*, January, 1950.

-30-

"OLD TIMERS' NITE"

THE Delaware Valley Radio Association has scheduled its 8th Annual "Old Timers' Nite Round-up" and banquet for Saturday, April 19th.

The affair will be held in the Grand Ballroom of the Hotel Stacy-Trent, W. State Street at Willow in downtown Trenton, N. J.

Guest speakers will include radio personalities, some of them famous in wireless history. W2ZI's now-famous collection of old time wireless gear will be on display.

Prizes will be awarded to operators who can produce "vintage" commercial and ham tickets. A special award will also be presented to the "Grand OM" whose radio experience dates back to the earliest days of wireless.

Tickets to this STAG affair are available from Ed G. Raser, W2ZI, general chairman of the event.

-30-

April, 1952



KLIPZON

The
VERSATILE
CRYSTAL PROBE

Bring your VTVM and VOM up-to-date by using KLIPZON TYPE V or C CRYSTAL PROBE.

Get VHF performance from your regular instruments.

Well-known SELF-HOLDING POINT gives added convenience in testing.

There are many testing advantages with KLIPZON PROBES
Here are some of the things you can do!

- Measures VHF up to 200 M.C., with minimum loading and de-tuning; allows you to check gain per stage throughout receiver.
- Check the operation of oscillator tube by holding probe nearby.
- Gives a rough check of Q for quick determination of coil merit.
- Makes "one man" antenna directional orientation easy; no phoning or shouting.
- Use with ordinary low frequency oscilloscope, to SEE audio or Video Modulation, of VHF signal.
- Use regular oscilloscope for stage-by-stage alignment of TV receiver.

Write for folder #21 which fully describes these tests and others.

Ask to see KLIPZON PROBES and other products at your regular distributor.

UNITED TECHNICAL LABORATORIES
MORRISTOWN, N. J.

ENGINEERS and MANUFACTURERS
ELECTRONIC SPECIALTIES

VIS-U-ALL TUBE and TOOL CASE

© TRADE MARK REGISTERED

Holds 107 Tubes
and All Tools for
TV Home Service

Only 16 x 13 1/2 x 7 1/2 in...
closed. Weighs only 7 1/2
lbs. (21 lbs. when full)

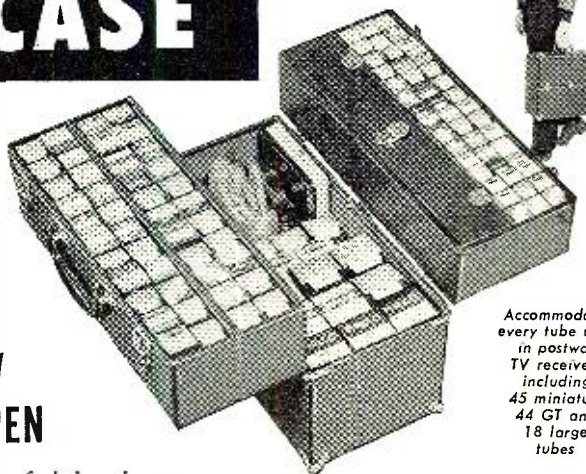

EVERYTHING IN FULL VIEW WHEN CASE OPEN

No hidden tubes. Easy to find the tubes you want, when you want them. Saves time. Holds tubes snugly and protects them against breakage. Tool compartment, 15 1/2 by 3 by 2 1/2 inches in size, accommodates all tools ordinarily needed for home service calls. Case is made of strong plywood with durable leatherette covering. Sturdy clasp fasteners and convenient luggage-type handle. Handiest case you ever saw, and a real boon to busy service men. Order yours now! If not satisfied, return within ten days and your money will be refunded.

Accommodates
every tube used
in postwar
TV receivers
including
45 miniature
44 GT and
18 large
tubes

NET PRICE

\$14.95

Case Only

Send check or money
order. We will ship
day order is received.

TELEVISION ENGINEERS, INC.

1539 W. Harrison Street • Chicago 7, Illinois

© Copyright, January 1, 1952

153

Successful TV Service Men MUST Be Good Business Men

In operating a TV Service Shop, the technician finds himself called upon to be a business man—in charge of a complex, major operation. For this reason, SERVICE MANAGEMENT MAGAZINE places great emphasis on the vitally essential *business* fundamentals—including the knack of getting along with the public.

TV Service Demands Sound Management

To survive, to thrive, to make money, the TV Service Man needs a grasp of salesmanship, advertising, financing, accounting, stock purchasing. He must know how to hire and train the right kind of personnel. He must watch collections, carefully maintain his credit-rating. He should know how to apportion his available capital, how to get along with his banker.

Realizing that business skill is as important as technical talent, SERVICE MANAGEMENT MAGAZINE includes valuable articles monthly on business procedures.

Why not send for a sample copy? Or, better still, send \$3.00 for a full year's subscription. Use the convenient coupon—*now*.

SERVICE MANAGEMENT

The Business Magazine of the
Radio-Electronics Industry

161 Luckie St. Atlanta, Georgia

Service Management, 161 Luckie St.
Atlanta, Georgia

Enclosed find \$3.00 for which enter a
year's subscription.

Name

Address

City..... State.....

NEW TV PRODUCTS on the Market.....

NEW TUBE FOR TV

The Tube Department of the *General Electric Company*, Syracuse, New York, has announced the availability of a new tube which has been designed to reduce vertical distortion on television receivers which are operated from a low "B plus" supply voltage.

The new tube, type number 6BX7-GT, is a twin triode designed for the vertical output stage of television receivers as a combined vertical deflection amplifier and vertical oscillator.

It is designed to provide better linearity and more sweep at a lower driving voltage. Because it will operate at a lower voltage, use of the tube will also result in a saving of transformer copper.

Among typical operating characteristics for each section are a cut-off voltage of 40 volts with 250 volts on the plate and 80 ma. plate current at zero bias with 100 volts on the plate. The new tube has a maximum plate supply voltage rating of 500 volts as a vertical deflection amplifier.

"FRETLINE"

Fretco Television Company, 1041 Forbes Street, Pittsburgh 19, Pa., has made a new improvement on its open wire transmission line.

"Fretline" is now being manufactured with a newly-designed insulator made of clear, prime virgin polystyrene. Because all coloring matter has been eliminated from this insulator, the line shows less loss and improper impedance than other types, according to the company.

The wire used in the new "Fretline"

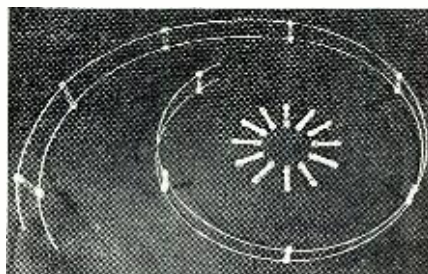

is hard drawn with precision tolerance and will hold its shape even after extensive exposure to salt spray.

A data sheet covering this new product is available from the company on request.

IGNITION FILTER

Telematic Industries, Inc., 1 Jorammon Street, Brooklyn, New York, has added a new ignition filter to its line of TV service accessories.

The WT-28 filter is designed to eliminate or reduce ignition interfer-

ence from TV receivers. This unit is an antenna feeder filter tuned to ignition frequency peaks and consists of a resonant shunt inductance and a series line capacitance which offer extremely high attenuation to ignition interference.

The unit is housed in a compact shielded case which can be installed at the antenna terminals of the receiver.

THERMO RELAY

A new automatic thermo relay is currently being offered by *B-T Manu-*

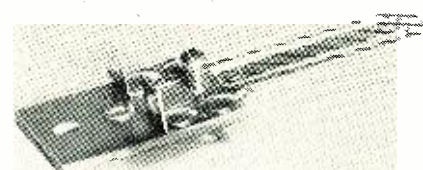

facturing Corporation, 38 N. Second Avenue, Mt. Vernon, New York.

Designated as Model TR-2, this unit will control equipment drawing up to .5 amp at 117 volts and a wide range of actuating currents. The time delay is adjustable from 1/10th to 4 seconds. The construction is rugged and simple and the unit uses contacts of fine silver. Over-all length is 2 3/8".

This unit has many applications in television and electronics where auxiliary switching and/or time delay are to be accomplished inexpensively.

"SPACELINE"

Clearbeam TV Antennas and Accessories, Burbank, California, is now marketing a new and improved type of TV twin-lead which is said to eliminate at least 50 per-cent of the signal loss.

"Spaceline" is made of a tough 20-gauge copper wire and pure 55 mil polyethylene. In this line, by eliminating a substantial portion of the polyethylene and substituting air for insulation, *Clearbeam* engineers have cut TV signal loss by at least half.

The new lead-in is now available at jobbers in 1000 foot spools.

NEW INDOOR ANTENNA

Snyder Manufacturing Company of 2218 W. Ontario Street, Philadelphia, Pa., is now in production on its new indoor "Directronic" TV antenna system.

The new unit embodies the electronic principles and operation of the company's outdoor "Directronic" introduced last year. The indoor "Directronic" is an all-channel antenna offering a combination of elements for picture clarity on each channel and full 360 degree orientation without the use

of motors or electric power. A "beam selector," mounted on or near the television set, gives remote control of element combinations.

Instead of rigid elements, this new unit has flexible tape elements which adhere in a horizontal position to any ceiling. The antenna has been designed to be concealed in closets or attics or sealed to the ceiling of a room.

GUY WIRE TIGHTENER

Universal Metal Products Company, 1211 Palmwood Avenue, Toledo 7, Ohio, is currently introducing a new antenna guy wire tightener and lock which has been trademarked "Universal Guy Lock."

This new item is now available in two models—the Model GL 2 has the mounting screw permanently attached to the chassis while the Model GL 1 is without a screw but has a mounting hole large enough to accommodate any size mounting bolt.

The units replace any size turn-buckle and mounting screw. They are positive locking and provide unlimited take-up and easy equalizing adjustments. The guy wire is easily attached to the shaft and the unit has a rust-resistant plate chromate finish.

A data sheet on the new units is available on request.

PREAMP COUPLER

JFD Manufacturing Co., Inc., 6101 16th Avenue, Brooklyn 4, New York, has developed a "Hide-Away" preamp coupler which will permit the operation of up to 13 receivers from a single antenna without loss of signal strength.

Catalogued as the EC-4, four sets may be operated from each of these units. Video signals are boosted by two r.f. amplifier stages using 6BQ7 tubes.

The "Hide-Away" will be marketed



both for multi-receiver homes and for restaurants, motels, and small hotels where the larger television distribution systems would be economically impractical.

The company will supply complete details on the EC-4 on request.

DISTRIBUTION UNIT

Blonder-Tongue Laboratories, Inc. of 38 North Second Street, Mt. Vernon, New York, is in production on a two-outlet distribution amplifier, the Model DA2-1-M.

Featuring two isolated TV set out-



SARKIS TARZIAN TUNERS. Uses 1-6C4, 2-6AG5. Good condition. As is, less tubes **2.98 ea.**

FILTER CHOKES

Stock No.	Description	Price Ea.
647	5.6 Henries, .085A, 900V. ins.	50.89
794	5.0 Henries, .090A, 900V. ins.	50.89
8350	10.0 Henries, .225A, 500V. ins.	4.98

TANK CIRCUIT, 150-200 Mc. Uses 2-822's. In Metal Shield Box, complete w/tubes... **\$7.95 ea.**

TRANSFORMERS, 117 V., 50/60 C. Primaries

Stock No.	Description	Price
1159	Sec = 1-650 V.C.T. @ .150A; Sec = 2-6.3V @ 2.1A; Sec = 3-7V @ 3A Jefferson.	\$4.95
1160	Sec = 1-430 V.C.T. @ .100A; Sec = 2-6.3V @ 1.2A; Sec = 3-5V @ 3A Jefferson.	5.95
8398	Sec = 1-6.3V @ 10.0A; Sec = 2-6.3V @ 1.5A; Sec = 3-7V @ 3A.C.T. sec = 860V @ 141 A.C.T. Westinghouse, Tuffnell Insulated.	7.95
1158	Sec. 4000V @ .025A Jefferson.	8.95
1157	Sec = 1 4V @ 16.0A; Sec = 2.5V @ 1.75A Jefferson.	5.75

AUDIO OUTPUT TRANSFORMERS

900 V. Insulation 60 ma primaries. Secondaries match 3.2 ohms nominal.

Stock No.	Primary Impedance	Price Ea.
987	2,000 ohms	\$0.49
775	2,400 ohms; with bucking winding	.59
247	2,500 ohms	.49
178	2,500 ohms; with bucking winding	.59
656	5,000 ohms	.49
576	6,000 ohms	.49
868	8,000 ohms	.49
430	1,100 ohms; with bucking winding	.59

AMP "Champ" Hand Tool

Shears bolts and machine screws! **\$3.95 Each**
Cuts and strips wire!
Crimps solderless terminals! postpaid in U.S.A.

EVERYTHING you buy from KEY is fully guaranteed. If you are not satisfied you may return your purchase for credit or refund as you prefer. NO questions asked. All merchandise offered subject to prior sale. Minimum order \$2.00. All prices are FOB Baltimore, Maryland. Shipment will be made by Railway Express Collect unless otherwise specified. Include 25% with all COD orders. The prices shown in this ad supersede all previously published prices.

OIL-FILLED CAPACITORS

Capacity	Voltage	Price ea.
0.1 mfd	1,000 V.D.C.	\$0.19
2.0 mfd	1,000 V.D.C.	1.49
3.5 mfd	250 V.A.C.	.69
4 mfd	3,000 V.D.C.	5.95
6 mfd	1,000 V.D.C.	3.29
7 mfd	250 V.A.C.	1.39
7 mfd	600 V.D.C.	2.69
8 mfd	1,000 V.D.C.	3.69
8 mfd	350 V.A.C.	2.75
10 mfd	1,000 V.D.C.	3.89
12 mfd	600 V.D.C.	3.50
16 mfd	350 V.A.C.	3.98

PAPER CAPACITORS, TYPE TTR

Capacity	Voltage	Price Ea.
.002 mfd.	.005 mfd., .01 mfd., 100 for 3.85	
1.0 mfd	400 V.D.C., C-D RM14100	.39
2.0 mfd	400 V.D.C., C-D RM14200	.49
4.0 mfd	400 V.D.C., C-D RM14300	.89

FP CAPACITOR

40/30/10/10 mfd. @ 500/350/350/300 V.D.C.W.V. \$1.00 each.

MICA CAPACITOR

Aerovox type 1460 .006 mfd. 500 V.D.C.W.V. 10 for \$1.00, postpaid in U.S.A.

ATTENTION INDUSTRIAL USERS!!!!

We have large stocks of the following items:
Ambienol Connectors
Allen Bradley Potentiometers
T & B "Sta-Kon" Terminals
Tube Sockets
High-vacuum and Gas-filled Condensers
Compression Type Trimmer Capacitors
Magnet Wire
AMP Terminals
Burndy Hyluss
Fiberglass Yarn
We invite your inquiries. We will reply the same day your query is received.
Write, wire, or phone—Phone No. Wilkens 6300.

Key Electronics Division

1801 N. LONGWOOD ST. BALTIMORE 16, MARYLAND

TELLS HOW TO SOLVE TV TROUBLES AND ANSWERS TV QUESTIONS

AUDELS TELEVISION SERVICE MANUAL covers T.V. information at your finger ends. Shows good receiver adjustment and How to Get Sharp, Clear Pictures, How to Install Aerials—Avoid Blurs, Smears, Interference and How to Test. Explains Color Systems and Methods of Conversion. IT PAYS TO KNOW! Over 380 PAGES & 225 ILLUSTRATIONS explaining operating principles of Modern Television Receivers.

Just Out!
1001 FACTS 19 CHAPTERS
Placement of Television Receivers—Receiver Controls; Test Patterns & Adjustments—Television Interference—Interference Traps—Television Antennas & Transmission Lines—Master Antenna Systems—Antenna Installation Procedure—Television Broadcasting—Television Receiver Fundamentals—Circuit Description of Typical Receiver—Television Picture Tubes—Projection Type Receivers—Television Testing Instruments—Television Servicing—Trouble Shooting—Television Terms.

Shooting—Color Television—**7 DAYS FREE TRIAL**
GET THIS PRACTICAL ASSISTANCE FOR YOURSELF
MAIL COUPON TODAY—

AUDEL, Publishers, 49 W. 23rd St., N.Y.
Mail me postpaid for 7 days examination
AUDEL TELEVISION SERVICE MANUAL (Price \$2).
If O.K. I will mail you \$2, otherwise I will return book.

Name _____
Address _____
Employed by _____ TV

South River NEWS

6" WALL BRACKET Model WB-6

Designed for average wall installation on homes with small eave overhang. Constructed of heavy gauge steel, riveted for extra strength. Has hot-dip galvanized finish which prevents rust-staining of walls. Special "U" bolt fits all size masts up to 1 1/2" O.D. and prevents mast from turning in high winds. With hardware.

South River Antenna Mounting Accessories are carried by every leading TV Parts Jobber from coast to coast.

New catalog mailed to all Dealers and Service Men. Write, if you haven't received yours!

SOUTH RIVER METAL PRODUCTS CO., INC.

SOUTH RIVER, N. J.

PIONEER AND OUTSTANDING PRODUCER OF FINEST LINE OF ANTENNA MOUNTS

Become an Electrical Engineer



MAJOR IN ELECTRONICS



- B. S. Degree in 36 Months
- Radio-Television Technician Certificate in 18 Months

Experts predict that by 1954 there will be at least two positions for every engineering and technical graduate. This College offers a tested plan that permits you to enter these vast employment opportunities at an early date. First—you save a valuable year through optional year-round study. Second—you can receive advanced credit for prior training gained in the armed forces, other schools or field experience.

ENTER BOTH RADIO AND TELEVISION THROUGH THIS PLAN

12 months or one-third of the B.S. degree course (Electronics major) — also brings you the Radio Technician's certificate. An added 6-month course qualifies you for the Radio-TV Technician's Certificate.

The Famous "UNIT CHASSIS SYSTEM"



of teaching was developed here. It "breaks down" the TV set by stages. You learn every component of all types and makes—and are prepared for future design changes, including the advent of color.

SPECIAL! Television Clinics

Ambitious Radio and TV Servicemen can enroll now in special one-month spring or summer clinics — to handle latest field service problems. Write for full details.

Over 48,000 former students from all states and 23 overseas countries. Faculty of trained specialists. Modern laboratories and equipment. Nonprofit technical institute and college 49th year.

MILWAUKEE

SCHOOL OF ENGINEERING

• FOUNDED 1903 •

Terms open April, July, October, January

FREE — Write for "Occupational Guidance Bulletin," "Your Career" booklet, and Catalog.

Milwaukee School of Engineering
Dept. RN-452, 1025 N. Milwaukee
Milwaukee, Wisconsin

Without obligation send Catalog for Electrical Engineering, B. S. Degree, major in Electronics; Power; "Your Career"; Occupational Guidance Bulletin on: Radio-TV; Electrical Power; Welding; Heating, Refrigeration Air Conditioning. TV Service Clinic.

Name _____ Age _____
Address _____
City _____ Zone _____ State _____
If veteran, indicate date of discharge _____

lets and a through-line output, it can be used in master antenna systems of any size or as a complete system for the two-set home. Providing full electronic isolation and amplifying all

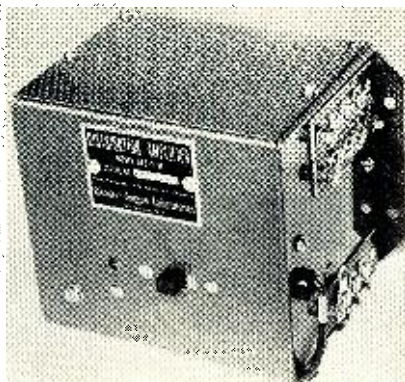

channels simultaneously to each TV set, these units may be used in a series by interconnecting them with 75 ohm line. Simple screw terminals provide for speedy, economical installation.

Employing two 6BC5 tubes, the new unit amplifies all channels without loss to each TV set output and, in addition, has correct impedance matching at each terminal for 75 and 300 ohm lines. Maximum input and output signal voltages are .5 on 75 ohms and 1 volt on 300 ohms.

DUO-CHANNEL YAGI

Channel Master Corp., Napanoch Road, Ellenville, New York, has recently introduced a new two-channel yagi antenna, the "Z-Match" dual yagi, Model 645.

Covering both Channels 4 and 5, this antenna provides a perfect match to 300 ohm line, in both single and stacked arrays. Performance has been improved by new element and reflector lengths, and a single bay gives over 8 db measured gain on each channel. Stacking provides 100% additional gain. Four stacked Model 645's furnish actual gain of over 14 db on each channel, according to the company.

A unique phasing harness keeps the gain flat on both Channels 4 and 5. The antennas have a front-to-back ratio of over 20 db. Complete literature, with technical details, gain curves, and 4-bay stacking information is available on request.

GLARE FILTER

T.V. Development Corp. of 204 McDonald Avenue, Brooklyn 23, N. Y., has recently introduced a television glare filter which has been trademarked the "Vision-ease."

The new filter comes in either blue or smoke and is scientifically designed to protect eyes from fatiguing glare. According to the company it increases definition and contrast under any lighting condition.

Filters are easily attached to any television receiver by means of the double-face adhesive supplied with each unit. They come in an assortment of sizes to accommodate tubes from 10

FRINGE AREA & DX PROBLEM SOLVED with NEW DAVIS SUPER-VISION ANTENNA

"THE ONLY TV ANTENNA SOLD WITH A MONEY-BACK GUARANTEE"

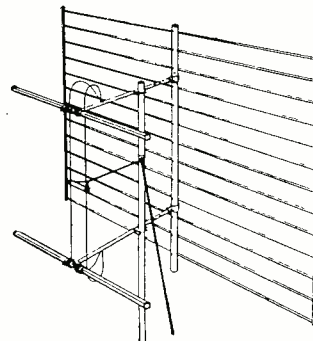

10 OUTSTANDING FEATURES:

1. EXCELLENT FOR FRINGE AREA and DX RECEIVING—and broad band receiving with high gain on all channels—2 through 13.
2. CLEARER PICTURES UP TO 125 MILES OR MORE—from the station.
3. GHOST PROBLEMS REDUCED or eliminated due to excellent pattern.
4. PROVIDES 10 DB OR MORE GAIN ON HIGH CHANNELS where gain is needed most.
5. EXCELLENT FRONT TO BACK RATIO on all channels. Eliminates co-channel interference.
6. MINIMIZES INTERFERENCE: Airplane Flutter—Diathermy and Ignition—F.M.—Neon Signs—X-Ray—Industrial—Etc.
7. ELIMINATES DOUBLE STACKED ARRAYS, and out-performs 2 bay yagis on low band and 4 bay yagis on high channels.
8. ONLY ONE TRANSMISSION LINE NECESSARY.
9. NO WORRY OVER POSSIBLE CHANNEL CHANGES on either high or low channels.
10. CAN BE TIPPED WITHOUT TILTING MAST to take advantage of horizontal wave lengths.

AT YOUR JOBBERS, OR WRITE TO:

DAVIS ELECTRONICS 1-5
3047 W. Olympic Blvd., Los Angeles 6, California
SIRS: RUSH INFORMATION TO ME AS CHECKED BELOW:

- Send Free Technical Data on new SUPER-VISION ANTENNA.
 Send Name and Address of NEAREST JOBBER.

Name _____
Street _____
City _____ State _____

WE'LL PAY TOP DOLLAR for Your RADIO & AIRCRAFT EQUIPMENT

We want to buy your parts or equipment—and we'll prove our bid will be "tops"! Just send us the dope on your equipment, its type and condition—and your asking price. You'll get the fastest, most profitable action you've seen in many a day!

CANDEE-AIRCO, Dept. "R"
3306 Burbank Blvd. Burbank, California

WILL BUY ALL

ART13/T47A \$220.00; ART13/T47 \$150.00; BC348's (not B's or C's) \$65.00; ARC-3 complete \$750.00; R77 Receivers only \$400.00; ARC-1's \$600.00; BC312's \$65.00; BC342's \$60.00. SHIP VIA EXPRESS C.O.D. "SUBJECT TO INSPECTION"—to

H. FINNEGAN
49-57 Washington Ave., Little Ferry, New Jersey

through 21 inches. Each filter is individually boxed.

Copies of the data sheet covering these various filter models are available on request.

PIVOTING TV TOWER

Tel-a-Ray Enterprises, Inc., Box 332, Henderson, Kentucky, has developed a new television tower that pivots in the middle and swings over to the ground for servicing.

The new "Swing-Over Tower" is of steel angle and welded construction and guaranteed against weather damage. It is available in two models—a 50 foot unit for mounting in concrete in the ground (without guy wires) and a 24 foot house-top model.

Both models incorporate the exclusive "swing-over" feature that permits the top of the tower to be lowered to the ground or roof. Field tests show that one man can raise or lower the tower in three minutes.

GROUND RESISTANCE TESTER

Borden Engineering Co., New Providence, New Jersey, has developed a new lightweight, low cost ground resistance tester which has been designed especially for radio and television installation and service technicians.

Known as the "Type Z Groundometer," this new unit measures the resistance to earth of ground rods, water pipes, etc. It is direct reading over three ranges, 10, 100, and 1000 ohms full scale. The instrument comes complete with 10" duplex reference probes on which are wound the three test leads of proper length for the correct spacings.

Complete instructions for the installation and grounding of radio and TV antenna masts is included in Bulletin #180 which accompanies the unit.

TEST INSTRUMENT

The Electronics Division of *General Electric Company*, Syracuse, New York, has recently introduced a new combination sweep and marker generator designed primarily for factory use.

The Model ST-11A is a TV channel sweep combining sweep signal and

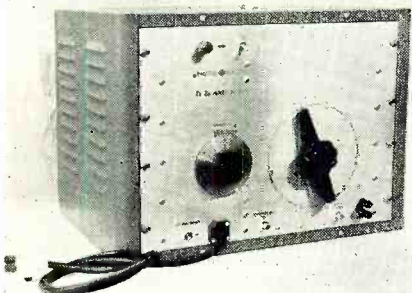

markers for r.f. alignment of television head-ends and over-all systems. Its rugged and simple design, incorporating only two controls, make it ideal for factory use.

It features single-knob selection of sweep and from one to five marker fre-

WHAT TO BUY and WHAT TO DO with HOME TAPE RECORDERS

explained for everyone in

High Fidelity

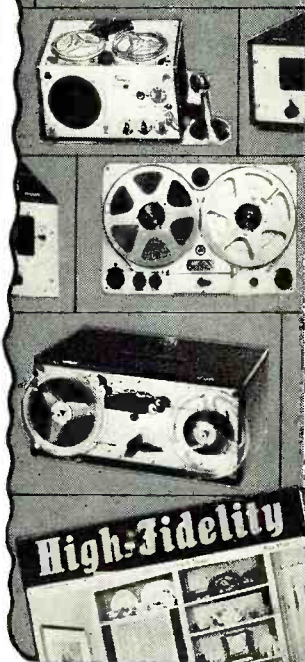

Before you decide what to buy, consult HIGH-FIDELITY. If you choose and use your equipment correctly, you can get professional-quality recording and reproduction, even with very little experience. This is the magazine that shows you how to do it.

HIGH-FIDELITY, the big Magazine of Information, is filled with articles and advertisements showing the latest improvements in recorders, microphones, amplifiers, and speakers for home and professional use.

In non-technical language, with elaborate illustrations, HIGH-FIDELITY covers the selection, installation, and use of tape recorders for all purposes—even some you may not know about. See for yourself. Use the coupon to order a subscription to this fascinating magazine.

HIGH-FIDELITY is devoted to hi-fi reproduction from tape, records, and radio. It is a large-size magazine, handsomely illustrated, and printed on fine paper. Published quarterly by Milton B. Sleeper

Mail Coupon Today!

Mr. Charles Fowler, Editor, High Fidelity Magazine
13 Audio Building, Great Barrington, Mass.

Please enter my subscription to High Fidelity Magazine:
 \$6.00 for three years (SAVE \$6) \$3.00 for one year (SAVE \$1)

Name _____

Address _____

Add 50¢ per year for Canada, \$1.00 foreign countries

CRONAME TV CONVERSION KIT

Be Proud of Your Big Tube Conversion or Custom Installation

3 Professional Quality Components

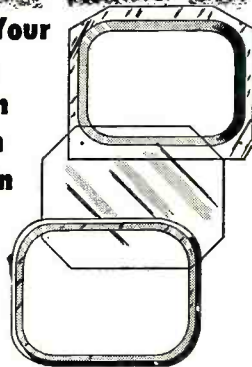

1. Metal Mask Tailored for Perfect Fit.
2. Heavy 1/4" Tempered Safety Glass.
3. Beautiful Gold Finished Metal Escutcheon.

All Popular Sizes: 14", 16", 17" and 20"

Easy Installation Instructions Included

Order CRONAME TV CONVERSION KITS; CRONAME TUNING DIALS, KNOBS and ACCESSORIES from Your Parts Jobber.

Send for New CRONAME Catalog.

WALDOM

ELECTRONICS, INC.

911 N. Larrabee St., Chicago 10, Ill.
Mfrs. of Replacement Speaker Cone Assemblies

ROUND, SQUARE, KEY and "D" OPENINGS QUICKLY MADE with Greenlee Radio Chassis Punches

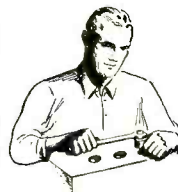

Save hours of hard, tedious work . . . cut accurate holes in chassis for sockets, plugs, controls, meters, panel lights, etc. with GREENLEE Punches. In 1-1/2 minutes or less make a smooth hole in metal, bakelite or hard rubber up to 1/16" thick. Easy to operate . . . simply turn with ordinary wrench. Wide range of sizes. Write for details. Greenlee Tool Co., 1884 Columbia Avenue, Rockford, Ill.

TOOLS FOR CRAFTSMEN
GREENLEE

NEW! 2ND EDITION of the only complete reference on AUDIO!

"The Recording & Reproduction of SOUND"

by OLIVER READ



Completely revised and vastly enlarged new edition

OVER
800
PAGES

A "Must" for
Sound Engineers, Hi-Fi
Enthusiasts, P. A.
Men, Broadcasting
Stations, Recording
Studios, Students

largest selling
book in its field

CONTENTS:

A Partial List of Authoritative Chapters:
Behavior of Sound Waves; Basic Recording Methods; Lateral Disc Recording; Microgroove Recording; The Decibel; Phono Reproducers; Stylus; Microphones; Loudspeakers and Enclosures; Dividing Networks and Filters; Attenuators and Mixers; Home Music Systems; P.A. Systems; Amplifiers; AM and FM Tuners—PLUS HUNDREDS OF OTHER SUBJECTS

Now you can have all the *right* answers to any subject in the field of Audio. Learn how to select and get the most out of recording equipment. Tells you how to select the proper amplifier for given applications, how to test amplifier performance, how to eliminate hum. Explains microphone, speaker and pickup principles and selection factors. Shows how to utilize inverse feed-back, expanders and compressors. Covers hundreds of subjects—a vast wealth of reliable information found in no other single volume. If you work in the field of Audio, this book belongs in your library. Order your copy today!

6" x 9" **ONLY \$7.95**
Hard Covers
800 pages 700 illustrations

**ORDER
TODAY**

Order from your Parts
Jobber, or write direct to
HOWARD W. SAMS & CO., INC.
2201 E. 46th St., Indianapolis 5, Ind.

My (check) (money order) for \$.....
is enclosed.

Send copy(ies) of *The Recording &
Reproduction of Sound (RR-2)*. \$7.95 per copy.

Name.....

Address.....

City..... State.....

quencies simultaneously. A continuously variable condenser-type attenuator has a range in excess of 100 db. Output is ¼ volt at 300 ohms balanced or 72 ohms unbalanced.

NEW YAGI ANTENNA

LaPointe-Plascomold Corp., Windsor Locks, Conn., has introduced a new antenna in its "Vee-D-X" line, the "Long John."

The new unit is an 8-element yagi which is said to provide up to 41 percent gain over 5-element yagis. The antenna has been designed to be used with the company's "Rocket" booster to provide improved fringe area reception. The booster is a single-channel, mast-mounted model that boosts the signal before line loss occurs and before line noise is picked up.

In combination, these new units are said to help eliminate snow and flop-over, both of which have been major obstacles to fringe area selling.

TV LENSES

Ercona Camera Corp., 527 Fifth Ave., New York 17, N. Y. has announced the availability of a new line of Zeiss lenses for TV cameras.

At present the lenses are only being produced with RCA mounts but *Du Mont*, *G-E*, and *General Precision* mounts will be available shortly.

The line includes focal lengths from 1 to 14 inches. The company will supply full details on request. —50—

To keep Africans living in the remote villages of the Gold Coast's Northern Territories informed of events in the country, experiments are being carried out with a loudspeaker system called the Rediffusion Kiosk. The Kiosk is a strongly-built, modern-looking structure standing six feet high and built of reinforced concrete with slatted wooden front. Inside is a battery-operated short-wave receiver with a specially made speaker horn, designed to provide good audibility to a crowd of up to 50 persons. The Kiosk is switched on by a voluntary attendant for a few hours during the best listening times and is normally tuned to Accra, Gold Coast stations.

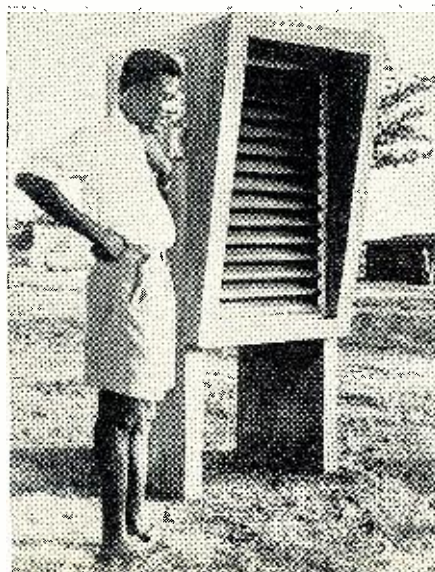

for dependable sound, INDUSTRY relies on ATLAS



DR Double-Reentrant Projectors



Paging & Talk-Back Speakers



ALNICO-V-PLUS Driver Units



Dual Speakers

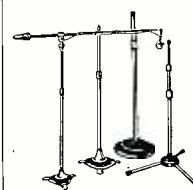

FULL-GRIP, VELVET-ACTION Mike Stands

DEPENDABLE QUALITY:

The latest electro-acoustic research and engineering—over 20 years of manufacturing know-how—are behind every ATLAS product.

DEPENDABLE SERVICE:

Coast-to-coast and around the world today—in every Industrial, Marine, Railroad, Military, Educational, Civic, U.S. and Foreign Government application—under every kind of climate and noise condition—ATLAS sound equipment is famous for highest efficiency and durability. That's the proof of ATLAS performance dependability.

DEPENDABLE DELIVERY:

Yes, ATLAS gives our Government highest priority. And yes, we too feel the pinch of material shortages. But our customers will continue to get our usual dependable delivery—because we believe in equitable and dependable distribution to all ATLAS users.

DEPENDABLE PROFITS:

Completeness of line, excellence of product, dependable delivery, right prices—that's the ATLAS combination that means high, steady Industrial Sound profits for You!

JUDGE for yourself, COMPARE ATLAS at your local Jobber today. See why ATLAS is the preferred line for utmost dependability. Write NOW for FREE, latest Catalog 551.



ATLAS SOUND CORP.

1446-39th Street, Brooklyn 18, N. Y.

In Canada: Atlas Radio Corp., Ltd., Toronto, Ont.

LEARN CODE NOW!!!

BE A RADIOMAN . . . Code ability recognized by all Service Branches. Here is an Electronic Code Trainer complete with Army Key-Tube-Phone-Variable Note. Simply plug in A.C. or D.C. and use. Instructions and simplified code training course included. Factory Guaranteed . . . Complete as advertised. Nothing else to buy. We pay postage. Send \$5.95. Check. Money Order. For Group Training, Deluxe model with 5" Speaker, \$7.75. Additional Keys, for either unit, each \$1.00.

GREENWICH SALES CO. 57 CORTLANDT ST. NEW YORK 7, N. Y.

QUALITY · SERVICE · DEPENDABILITY
DUMONT PERFECTLY CENTERED
COMPLETELY MOLDED **CAPACITORS**
Sold and Preferred Everywhere
DUMONT Electric Corp.
308 Dyckman Street, New York 34, N. Y.

RADIO & TELEVISION NEWS

Technical BOOKS

"THE RECORDING AND REPRODUCTION OF SOUND" by Oliver Read, Editor of RADIO & TELEVISION NEWS and RADIO-ELECTRONIC ENGINEERING. Published by Howard W. Sams & Co., Inc., Indianapolis 5, Ind. 790 pages, 700 illustrations. \$7.95. Second Edition.

The first edition of this book was a best-seller in its field, and justifiably earned the title of the "Audioman's Bible." This second edition has been vastly expanded and revised to provide even greater coverage of the field, and to add much new information, bringing the reader up-to-date on all recent significant developments in audio. It is written in a free and easy style with a minimum of mathematics, making the material readable and easy to understand.

In addition to discussing basic concepts on all aspects of audio, the volume presents a wealth of practical information on magnetic and disc recording and reproduction, microphones, amplifiers, tone control and equalizer circuits, complete music and p.a. systems, loudspeakers and enclosures, acoustics, and audio measurements. Every conceivable facet of the audio field is covered for both hobbyist and engineer.

The last chapter presents the NARTB recording and reproducing standards, and the appendix gives much valuable information in the form of mathematical tables, formulas, charts, nomographs, color codes, and a bibliography on magnetic recording.

Here is a volume which every audio hobbyist and engineer should have on his bookshelf.

* * *

"MOST-OFTEN-NEEDED 1952 TELEVISION SERVICING INFORMATION" compiled by M. N. Beitman. Published by *Supreme Publications*, Chicago. 192 pages. Price \$3.00. Volume TV-6. Paper bound.

This newest edition of a familiar servicing handbook contains circuit diagrams and essential service data on the current receivers of thirty television manufacturers.

As was the case with previous editions, this manual carries special service notes, television alignment procedure data, various adjustment and alignment details, and a complete schematic diagram of the receiver in question.

* * *

"RADIO AND TELEVISION TV RECEIVER TROUBLESHOOTING AND REPAIR" by Alfred A. Ghirardi and J. Richard Johnson. Published by *Rinehart Books, Inc.*, New York. 795 pages. Price \$6.75.

This encyclopedic work for the technician contains all of the information required to identify, locate, and repair defects in radio and television receivers. While the authors have assumed

April, 1952

Superior's *new* TELEVISION BAR GENERATOR



THROWS AN ACTUAL BAR PATTERN ON ANY TV RECEIVER SCREEN!!

TWO SIMPLE STEPS
1. Connect Bar Generator to Antenna Post of Any TV Receiver.

2. Plug Line Cord into A.C. Outlet and Throw Switch.

RESULTS—A stable never-shifting vertical or horizontal pattern projected on the screen of the TV receiver under test.

AT YOUR RADIO PARTS JOBBER

DEALERS NET PRICE only **39⁹⁵**



Manufactured and Guaranteed by **SUPERIOR INSTRUMENTS CO.**
227 Fulton Street • New York 7, N. Y.

Write Dept. RN-4 for catalog of complete line.



HEY, MAC!

ONLY **\$2.95**

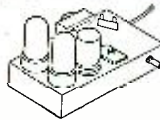

3-TUBE AC-DC PHONO AMPLIFIER KIT

Easy to build with our big pictorial and schematic diagrams. Plays with excellent fidelity and volume. Complete with pre-punched chassis, parts and hardware. Shipped less 12507, 5016 and 3525 tubes and small amount of wire and solder required. Operates on 110-120 volts AC or DC. A big buy for little money!

Kit of 3 tubes for amplifier..... \$2.46
5" Alnico PM Speaker..... \$2.15

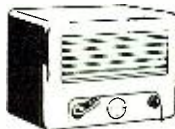

VOCATRON PORTABLE WIRELESS INTERCOM

No special wiring or installation required. Operates on any 105-125 volt AC or DC lighting circuit over distances up to 1/2 mile! Extra units may be added for multiple station system. Neat plastic cabinets measure only 6 3/4" x 4 3/4" x 5 1/4". Complete with tubes, ready for instant use. Per pair..... \$79.50
Extra Vocatron Intercom Unit..... \$9.75

High-Gain Conical Antenna

\$3.75 each
in lots of 10
\$4.25 singly

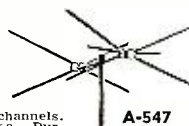

High-gain conical for all channels. Excellent directional response. Durable aluminum with unbreakable molded polystyrene insulators and many other exclusive features. Elements may be stacked.
300-ohm Twin Lead.....\$2.50 per 100. \$19.95 per 1000
5-ft. Aluminum Mast.....\$1.03 singly
93c each in lots of 10

STAR ELECTRONIC DISTRIBUTORS, INC.

Dept. RN-4 - 7736 S. Halsted, Chicago 20, Ill.

FIRST AID FOR TV SETS!

H. G. CISIN'S "TV DOCTOR"
Shows you how to fix many TV set troubles.

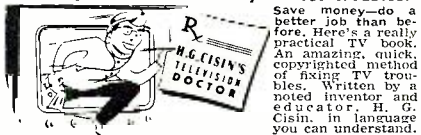

Makes TV Servicing Easier!
Tubes Cause a Large Percentage of TV Troubles! TV DOCTOR helps locate bad tubes.

WITHOUT EXPERIENCE — PICTURES AND TEXT SHOW WAYS OF FIXING MANY TV FAULTS WITHOUT INSTRUMENTS.

Shows short cuts and time savers learned from years of service experience. Lists over 123 trouble conditions. Method applies to all TV sets from oldest to newest.

It money-making, fact-crammed, detailed, illustrated chapters: Practical ways to combat interference and ghosts, how to appraise TV sets, valuable information on antennas, lead-ins, color, practical — not theoretical — pointers on TV sets, ion traps, tubes used in TV, addresses of manufacturers — a veritable encyclopedia.

Only \$1 — you'll say it's worth hundreds. 5-day Money Back Guarantee

FREE SPECIAL OFFER

Get a new, full-size, profusely illustrated, \$1 book—"TV TROUBLE PICTURE GUIDE INCLUDING TV TERMS SIMPLY EXPLAINED" as a FREE GIFT, by ordering the "TV DOCTOR" and H. G. Cisin's famous "TV TROUBLE SHOOTING METHOD" which trains you to be a TV Diagnostician, selling for \$1. Think of it— all 3 TV books postpaid for only \$2 — you save \$1.

\$1 Post-paid

H. G. CISIN, Consulting Engineer (Dept. N-6)
200 Clinton Street, Brooklyn 2, N. Y.

Enclosed find \$2, full payment for "TV DOCTOR" & "TV TROUBLE SHOOTING METHOD" PLUS my FREE copy of "TV TROUBLE PICTURE GUIDE." Rush all three books postpaid.
 Enclosed find \$1, full payment for "TV DOCTOR." Rush copy postpaid.

Name.....
Address.....
City..... Zone..... State.....

HARVEY

is First with the Finest at Most Reasonable Prices!

WILLIAMSON HR-15 AMPLIFIER KIT

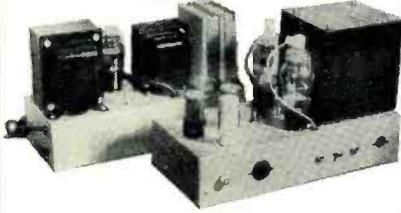

The famous Williamson HR-15 amplifier circuit... now available with the original Partridge transformers built to Williamson's specifications. Build this kit in 3 hours or less, and enjoy sound of a quality you never heard before. The HR-15 is a 2-Chassis power amplifier for use with tuners or other front ends having own volume and tone controls. All American triodes, 2-6SN7GT, 2-807 or 6BG6G in PP output, 5V4G rectifier. Response ± 5 db, 10-100,000 cycles. Output impedances 1.7 to 109 ohms in 8 steps. Absolute gain 70.8 db, 20 db. of feedback around 4 stages and the output transformers. Kit is Complete with Tubes, Punched Chassis, Pre-wired Resistor Board, Sockets, Genuine Partridge Output Transformer, and All Necessary Parts.....\$76.50

As Above, with CFB Transformer.....\$90.00
PARTRIDGE Output Transformers available separately WWFB, as used in above kit.....\$26.50
CFB Transformer, Hermetically sealed.....\$40.00

HR-15T A Williamson Kit with all TRIAD TRANSFORMERS... including power transformer, chokes and specially designed output transformer which is completely sealed in tar. ± 2 db. 10-100,000 cps. Harmonic Distortion less than .1% - 10 watts output. Output impedances 4-8-16 ohms\$69.50
Both HR-15 and HR-15T Kits available with KT-66 tubes for \$3.00 extra.

★ ★ ★ ★ ★

NEW MORROW CONVERTER



An asset to any shack... Easy to read... Easy to operate... Sturdy construction for long, trouble-free service.

Full width dial with 1% calibration accuracy—Built-in automatic noise limiter—1 micro-volt sensitivity on all bands—Three gang tuning condenser with a ratio of 20 to 1—Separate isolated coils for each band and stage—Tuned preselector, mixer and oscillator—Single point tuning, no images or birdies—Antenna trimmer on front panel—Drift free, pre-calibrated oscillator—AVC on preselector, no strong signal blocking—I.F. amplifier with 4 tuned circuits, output frequency 1525 Kc.—Grey hammer tone finish—Complete with mounting hardware and instruction book.

Model 2BR for 10-75 meters, net\$54.95
Model 2BRLN for 10-75 meters, net\$49.95
Model 3BR for 10-20-75 meters, net\$64.95
Model 3BRLN for 10-20-75 meters, net\$59.95
The LN series converters are identical to the standard 2BR and 3BR converters, less the noise limiters.

NOTE: In view of the rapidly changing market conditions, all prices shown are subject to change without notice and are net, F.O.B., N.Y.C.

Telephone **hrc** Luxembourg 2-1500

HARVEY

RADIO COMPANY, INC.
103 West 43rd St., New York 18, N. Y.

that the technician using this text has a basic knowledge of electricity, electronics, and receiver circuitry, they have provided all of the other specialized data required in receiver servicing.

A clearcut and practical approach to the problems of servicing characterizes this text. The style is clear and simple and the language is straightforward and nonmathematical. Step-by-step procedures have been favored in the text material in order to assist the technician in tracking down the service fault. Approximately 400 illustrations have been used to amplify the reading material.

The first chapter of the text is devoted to a description of the various components that go into a modern receiver and an analysis of the circuit faults that can be attributed to a breakdown of these parts. The balance of the book covers troubleshooting methods and the various servicing techniques employed in repairing radios, television sets, record players, loudspeakers, and home recorders.

Each chapter concludes with a summary of the material covered and a list of review questions by means of which the student can check his grasp of the subject matter.

Technicians will find this a useful and up-to-date companion to their copies of the author's "Modern Radio Servicing," which originally appeared some ten years ago.

"HOW TO PASS RADIO LICENSE EXAMINATIONS" by Charles E. Drew. Published by John Wiley & Sons, Inc., New York. 367 pages. Price \$4.50. Paper bound. Third Edition.

This is an up-to-date handbook for those persons preparing for any of the FCC radio operator's licenses with the exception of the examinations in aircraft radio-telegraph and ship radar techniques.

This book covers elements 1 through 6 in question-and-answer form with the answers being given in the same concise form as required in the examination. The elements covered include basic law, basic operating practice, basic radiotelephone, advanced radiotelephone, radiotelegraph operating practice, and advance radiotelegraph.

In addition, the text includes four appendices which carry data on the FCC and its rules governing commercial radio operators, extracts from radio laws, "Q" code and abbreviations, and miscellaneous but pertinent data.

This book is not intended to supplant regular textbooks on the subjects covered but is a supplementary work dealing specifically with those subjects upon which the FCC examinations are based.

"TELEVISION FACTBOOK No. 14" compiled by Television Digest Staff. Published by Television Digest, Washington, D. C. 112 pages. Price \$5.00.

This new edition is the 14th in "Television Digest's" semi-annual se-

Model 200 AM & FM SIGNAL GENERATOR

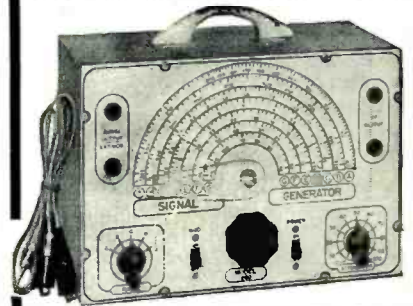

Specifications: • R. F. FREQUENCY RANGES: 100 Kilocycles to 150 Megacycles. • MODULATING FREQUENCY: 400 Cycles. May be used for modulating the R.F. signal. Also available separately. • ATTENUATION: The constant impedance attenuator is isolated from the oscillating circuit by the buffer tube. Output impedance of this model is only 100 ohms. This low impedance reduces losses in the output cable. • OSCILLATORY CIRCUIT: Hartley oscillator with cathode follower buffer tube. Frequency stability is assured by modulating the buffer tube. • ACCURACY: Use of high-Q permeability tuned coils adjusted against 1/10th of 1% standards assures an accuracy of 1% on all ranges from 100 Kilocycles to 10 Megacycles and an accuracy of 2% on the higher frequencies. • The Model 200 Operates on 110 Volts A.C. Comes complete with output cable and operating instructions.

\$2.85 NET
Sold on Money-Back-If-Not-Satisfied Guarantee.

INTRODUCTORY SPECIAL ON STANDARD BRAND TUBES

5Y3 \$.50
6J6 1.00
6W460

Write for free catalogue of complete line of test equipment and tubes.

GENERAL ELECTRONIC DISTRIBUTING CO.
Dept. RN-4, 98 Park Place, New York 7, N. Y.

PHOTOCON SALES

1062 N. Allen Ave. Sycamore 4-7156
Pasadena 7, Calif. RYan 1-8271

WRITE FOR OUR WINTER SURPLUS SALES CATALOGUE

WE WILL BUY YOUR NEW OR CLEAN USED ELECTRONIC SURPLUS: ARC-1, ARC-3, BC-224, BC-348, BC-312, BC-342, ATC, ART-13, APS-13, BC-221, LM's, TS-12, TS-13, TS-23, TS-34, TS-35, IE-19A, I-222, SCR-522, TS-100, or any BC, I, IE, TS, APR.

WRITE FOR PRICES:

APR4, TS34/AP, TS13/AP, TS148/UP, ARC-1, ART13, APA11, TS184, TS251, etc.

DuMont 208B 5" Oscillograph EXCELLENT \$225.00
804CS Federal Radio Signal Generator 8-330 mc. EXCELLENT 400.00
APN-1 Altimeter Indicator 0-1 mshunt, 250° dial. NEW 2.95
LM & BC-221 Frequency Meter with cal. book, crystal, and tubes. EXCELLENT 99.50
SCR-625 Mine Detector. NEW 69.50
USED 39.50
AN/APN4B Complete EXCELLENT 150.00
PE-218 Inverter 400N. NEW 29.50
Weston Model 545 Tachometer Meter NEW 17.50
HS-33 600 ohm Headsets. USED 3.50
NEW 5.95
400 cycle Inverters—G.E. 5D21N3A Input 24V. DC. Output 115V. AC. 400 cycles 485 V.A. NEW 24.50
DuMont 241 Oscillograph. EXCELLENT 300.00
G.E. Oscillograph CR05Y. EXCELLENT 225.00
Drafting Machine single scale 16" Fulcrum less scale. Enc. 35.00
CRT-3 Two-Channel Gibson Girl. NEW 75.00
DuMont 224 Oscillograph less front cover EXCELLENT 125.00
TS173/UP Freq. 90-180Mc Freq. Meter EXCELLENT COND. 600.00
Genescope—Superior 480. NEW 340.00
196A Signal Generator. LIKE NEW 375.00

NOTE: One of the largest and most complete electronic surplus stocks in the country. We have thousands of tubes, capacitors, plugs, accessories, transmitters-receivers, test equipment, etc. Send us your requirements.

TERMS: Prices F.O.B. Pasadena, California. 25% on all C.O.D. orders. Californians add 3% Sales Tax. Prices subject to change without notice.

RADIO & TELEVISION NEWS

ries. This compact and comprehensive handbook includes data on personnel and facilities of all networks and of the 109 TV stations already licensed, along with a complete listing of actual and projected TV stations in Canada, Mexico, Cuba, and South America.

A tabulation of the 479 applications for new TV stations pending before the FCC is also given. TV-radio production figures, sets-in-use, and market data on TV and other areas of the United States have been included along with a 34 x 24 inch wall map in color showing present TV areas and actual and projected coaxial-microwave network routes used for television transmissions.

In addition, the editors have reproduced the full text of the "Code of Television Practices" and have listed television program sources, and the national sales representatives of TV stations.

Complete directories of TV receiver manufacturers, the FCC, Congressional Committees handling TV-radio matters, consulting engineers, attorneys specializing in TV-radio, the NPA Electronics Division, etc., complete this fact-filled handbook.

* * *

"PRINCIPLES OF RADIO" by Keith Henney and Glen A. Richardson. Published by John Wiley & Sons, Inc., New York. 641 pages. Price \$5.50. Sixth Edition.

This is a completely revised and rewritten version of the Fifth Edition which appeared in 1945. In the seven years that have elapsed since the previous edition made its appearance many changes have taken place in the radio field and it is in the interest of covering these vital points that this newest edition has been prepared by the authors.

Like the earlier versions, this book has been written so simply that the student studying alone can understand the material without recourse to other texts. This edition includes chapters on fundamentals, d.c. circuits, electrical meters and measurements, magnetism and electromagnetism, inductance, capacitance, properties of a.c. circuits, resonance, properties of coils and condensers, vacuum tubes, the tube as an amplifier, rectifiers and power supplies, audio amplifiers, detection of AM signals, AM receiver systems, oscillators, AM transmitters, transmission lines, antennas and electromagnetic radiation, FM and detection, u.h.f. phenomena, electronic instruments, transients and wave shaping circuits, television, and radar equipment.

The new text features a large number of practical problems and has many of the circuit problems worked out in detail to assist the student in checking his grasp of the subject matter involved.

As a one-volume "library" on the subject of radio, this book would be hard to beat.

-30-

April, 1952

ENGINEERS • HAMS • STUDENTS SERVICEMEN • HOBBYISTS

Get this Advanced Thyatron Circuit
110 V, 60 cycle AC

REMOTE CONTROL

at this SENSATIONALLY low price

Here's your chance to own a genuine Thyatron Electronic Remote Control at Sensationally low cost!

PRECISION THYATRAN CIRCUITRY

These completely wired, Thyatron precision thermostatic remote controls can be modified by you, easily and quickly, for remote control of hundreds of such devices as: Model Trains, Planes, Boats, Cars; turn radio and TV sets on-off; open and close garage doors from within car; control appliances; machinery, power tools; Burglar, Fire, Temperature and Rain Alarm Systems; Poultry Brooder Controls, and many, many more amazing controls your own ingenuity and inventiveness can dream up. Complete schematic diagram supplied. Each control unit contains a highly sensitive relay, a 110V, 60 cycle filament transformer, many condensers and resistors, (some

1% precisions) and a host of other valuable parts easily worth several times our low cost for the wired, tested unit.

SUPPLY LIMITED ORDER NOW!

Remote Control Unit, Less Cabinet and Tubes **2.88**

Kit of 3 Tubes for above, consisting of 1-6SN7GT, 1-6SL7GT and a genuine GE Thyatron GL-5662 (Net \$3.30). All 3 tubes when ordered with Remote Control Unit, all for **3.95**

Bakelite Cabinet for Remote Control Unit, size 5 3/4" x 5" x 3 1/4". Sturdy, handsome. Special **1.00**

Order all three, The Remote Control Unit, Kit of Tubes, and Cabinet and save! All Three Items Above, Special **7.50**

No C.O.D. Postpaid in U.S.A. only.

Send Check or Money Order to Dept. RT.



only **\$288**

(Less Cabinet and Tube Kit)
Shipped Postpaid in U.S.A. Only

POPULAR REMOTE CONTROL USES

- ON-OFF For Radio or TV, Transmitters
- Model Trains, Planes, Boats, Cars, Trucks
- Open and Close Garage Doors From Inside Car
- Control Appliances, Machinery, Power Tools
- Alarm Systems — Burglar, Fire, Temperature, Rain
- Poultry Brooder Controls
- And Many, Many More

MANUEL KLEIN CO.

(The House of Integrity)

94 Chambers Street, New York 7, N. Y.
REctor 2-6460

FOR THE "GOLDEN EAR" CROWD

THE PFAN-TONE STRAIN-SENSITIVE PICKUP

Here's why this truly faithful reproducer appeals to people gifted with the "Golden Ear" . . . why the PFAN-TONE STRAIN-SENSITIVE PICKUP brings out the brilliance of great voices and orchestras . . . the latent music on your records that other pickups leave untouched.

- The PFAN-TONE STRAIN-SENSITIVE PICKUP is an amplitude transducer with a CONSTANT RESISTANCE of about 250,000 ohms.
- Signal output is at a practically CONSTANT IMPEDANCE LEVEL.
- Excellent Transient Response.
- NO DISTORTION, phase shift or evidence of intermodulation is audible.
- LINEAR RESPONSE, free from peaks or resonances.

Cartridges are available for both standard and micro-groove, and can be had with Famous PFANSTIEHL M47B Precious Metal Alloy or diamond tipped styli.

A special preamplifier is necessary to provide the correct D.C. voltage for the pickup element and to provide the first stages of signal gain. Four styles are ready, or, if you prefer, you can build your own from the circuit in the literature.

Ask your radio supply man, or write today for complete FREE INFORMATION.

PFANSTIEHL
CHEMICAL COMPANY

101 Lake View Avenue, Waukegan, Illinois

BUYING ANTENNAS?

Buy by This Mark —
The Seal of Quality Products
and Sound Business Practices



C. & M. MANUFACTURING CO.
Eastondale, Mass.

CAMBURN, INC.
Woodside, L. I., N. Y.
CHANNEL MASTER CORP.
Ellenville, N. Y.

THE FINNEY CO.
Cleveland 3, Ohio
HY-LITE ANTENNAE, INC.
New York 51, N. Y.

JFD MANUFACTURING CO., INC.
Brooklyn 4, N. Y.

RADELCO MANUFACTURING CO.
Cleveland 25, Ohio

THE RADIART CORPORATION
Cleveland 2, Ohio

RADIO MERCHANDISE SALES, INC.
New York 59, N. Y.

WALTER L. SCHOTT COMPANY
Los Angeles 18, California

SNYDER MANUFACTURING CO.
Philadelphia 40, Penna.

T-V PRODUCTS CO.
Brooklyn 5, N. Y.

WARD PRODUCTS CORP.
Division of The Gabriel Co.
Cleveland, Ohio

THE WORKSHOP ASSOCIATES
Division of The Gabriel Co.
Needham Heights 94, Mass.

NOW YOU'LL Really Know How to Use 'Scopes!



Don't let the oscilloscope "stump" you! Learn to use it fully on all sorts of jobs—and watch your efficiency soar!

MODERN OSCILLOSCOPES AND THEIR USES

BY JACOB H. RUTER, JR.
of Allen B. DuMont Laboratories, Inc.
326 pages, 370 illustrations, \$6.00

Here at last is a book that makes it easy for you to become expert in the many uses of the greatest, most versatile service instrument of all—the oscilloscope! It contains no involved mathematics. First, the author explains oscilloscopes fully—then gets right down to earth in telling exactly how to use them on AM, FM and TV service work . . . from locating receiver troubles to aligning and adjusting the most complicated circuits.

HOW THEY WORK

Expert knowledge of oscilloscopes helps you work faster, far more accurately and more profitably on all sorts of service and laboratory jobs. Basic subjects covered include: 1—Introduction to Oscilloscopes; 2—History of the Oscillograph; 3—Development of the Cathode Ray Tube; 4—Principles of Cathode Ray Tube Operation; 5—Details of the Modern Cathode Ray Tube; 6—The General-Purpose Oscilloscope; 7—Power-Supply Circuits; 8—Amplifiers, Attenuators and Positioning Circuits; 9—Time-Base Circuits.

HOW TO USE THEM ON THE JOB

Each operation is carefully explained including the making of connections, adjustment of circuit components, setting the oscilloscope controls and analyzing patterns. About 400 illustrations including dozens of pattern photos make things doubly clear. Here are the specific how-to-do-it subjects covered: 10—Operation; 11—Interpretation of Basic Patterns; 12—Auxiliary Equipment; 13—Typical Applications in Electronics; 14—Servicing A-M Receivers; 15—Servicing F-M Receivers; 16—Television Receiver Servicing; 17—Use of the Radio Transmitter; 18—Using the Oscilloscope in Teaching; 19—Additional Industrial Uses; 20—Photographing Cathode Ray Tube Patterns; (a) Glossary.

Send coupon today!

READ IT 10 DAYS . . . at our risk!

Dept. RN-42, RINEHART BOOKS, Inc.,
Technical Division,
232 Madison Ave., New York 16, N. Y.

Send MODERN OSCILLOSCOPES AND THEIR USES for 10-DAY FREE EXAMINATION. If book is satisfactory, I will then send you \$6.00 promptly in full payment. If not, I will return book postpaid in good condition and owe you nothing.

Name

Address

City, Zone, State

Employers' Name and Address

Price outside U. S. A. \$6.50, cash only.
Money back if you return book within 10 days.

Rejection Circuits

(Continued from page 63)

ceiver manufacturers, as suggested in Fig. 8, to immunize the blocking oscillator against minor circuit disturbances such as power supply variations and thermal noise in the resistors and tubes. The operation of a ringing coil was explained earlier in this article. To adjust the ringing coil, a scope should be used. The usual pattern to be sought when a gated control tube is used is shown in Fig. 8B.

Origin of Noise

Noise which arrives at the horizontal a.f.c. circuits has two possible origins. A portion of the noise is received with the signal at the antenna (or may be picked up by the down-lead), and the remainder of the noise is generated in the r.f. tuner. You can distinguish between the two sources of noise by disconnecting the antenna lead and comparing the amount of snow in this raster with the amount observed before disconnection. If the receiver noise is excessive, try changing the r.f. and mixer tubes. Overheated load resistors in the r.f. and mixer stages will contribute more noise than cooling-running resistors.

If the down-lead contributes excessive noise, as determined by disconnecting the lead from the antenna and testing the contribution of the lead as above, try using shielded cable from the antenna to the receiver.

Boosters provide a better signal-to-noise ratio when installed at the antenna, other things being equal, because once a signal has been allowed to fall to the noise level, no amount of amplification can recover the signal.

The amount of noise which gets through an amplifier is directly proportional to the bandwidth. If the signal-to-noise ratio is low, realign the receiver for one-half normal bandwidth and shift the center frequency of the picture amplifier to place the picture carrier near the top of the response curve. Do not try to compensate the i.f. curve deficiencies by adjustment of the r.f. and mixer circuits, as this will lower the signal-to-noise ratio; it is important to obtain uniform band response in both the r.f. and i.f. circuits.

Contributing Factors

Wide fluctuations of line voltage, often encountered in rural areas, contribute to unstable synchronization. Accompanying symptoms of line-voltage variation are changing focus, changing picture width, and some variation in brightness. The sync can be stabilized in such cases by use of a line regulating transformer.

Occasionally power lines are excessively noisy, causing loss of sync. Attention should be given to antenna placement, power-line filtering, lead-in shielding, and, if possible, suppression of the man-made noise at its source.

RARE SURPLUS

ARC-5 COMMAND TRANSMITTERS

Brand new with tubes and xtals.

T-155 Mc. to .8 Mc. . . . \$19.95

T-168 Mc. to 1.3 Mc. . . . 21.50

T-19 . . . 3.0 Mc. to 4.0 Mc. . . . 22.95

D.C. GEN. TYPE P-1—Westinghouse

24 V. D.C. @ 200 Amps., speed range 2500 to 4500 R.P.M. This unit is rumored to deliver full voltage at about 1800 R.P.M. Spline shaft. NEW, in original crates! . . . \$37.50

AIRCRAFT TRSMTR.—Bndx. # TA-12C

4 individual V.F. Osc. channels for preset frequencies between 2 and 18 Mc. 100 watt rating wired for 24 V. Less tubes, power supply and modulator. Used—exc. cond. . . \$19.95

TUNING UNITS—for GP-6 & 7,

TCE-1, etc.

D-3000—4525 Kc. E-4525—6500 Kc. F-6200

—9050 Kc. Ideal for 100 watt transmitter

final, exciter, etc. . . . \$39.5 ea.

A terrific value!

CABLES & CORDS

Coax Cable—RG/8U—NEW, with PL-259 on

one end and Navy connector on opposite end.

50 ft. coil \$4.75

52 Ohm 1/2" O.D. coax cable. Unmarked. (Min.

order 25 ft.). NEW . . . \$1/2 ea. ft.

Line Cords—Rubber covered. U.L. 6 ft. Heavy

Duty. 2—#16 A.W.G. cond. Ideal for test

equip. or appliance use. NEW . . . 45c ea.

Line Cord—Rubber covered and shielded with

rect. bakelite plug. Ideal for motor operating

equip #18 cond. NEW . . . 49c ea.

Heavy Duty Rubber Covered Extension Cords—

2 and 3 wires. 25, 50 and 100 ft. lengths.

Prices on request.

3 Cond. #18AWG Shielded. Rubber Outer

Jacket. 1/2" O.D. (24 1/2 ft. coil). NEW \$1.49

6 Cond. #18AWG Rubber Jacket. 3/8" O.D.

(25 1/2 ft. coil). NEW . . . \$1.95

OUR COMPLETE

CATALOG IS READY!

SEND FOR YOUR COPY NOW!

Material subject to prior sale. 25% dep. with all orders. Bal. C.O.D. Orders received less postage, shipped express. Minimum order \$3.00.

FOREST SALES CO. Inc.

702 Madison St., Euclid 6-1664
OAK PARK, ILL.

GROMMES

THE G SERIES



A complete line of P. A. and commercial amplifiers.

New TV CLARIFIER

Actually has
FOUR TIMES
the interference
"Suck"
of previous
model.



See your Jobber or
WRITE FOR CATALOG

Precision Electronics, Inc.
641-643 MILWAUKEE AVE.
CHICAGO 22, ILLINOIS

RADIO & TELEVISION NEWS

Noise is occasionally generated in the receiver itself, due to minute corona discharges in the high-voltage system, or to defective connections with fluctuating contact resistance.

Some sync systems require neutralization to avoid instability, or actual oscillation, termed "squegging." Such neutralization may consist of a critical spacing between a pair of condensers and their leads. It should be observed that nearly all noise-rejection systems involve feedback control, and that suitable means are taken in the design and/or adjustment of the circuit to avoid over-control or regeneration.

Flywheel Noise Rejector

The one type of noise rejector which does not utilize feedback control principles makes use of an electrical flywheel. If the sync pulses are developed across a plate load which consists of a properly tuned ringing coil, the tuned coil will generate a sine wave voltage across its terminals. The frequency of this voltage is independent of the presence of random noise voltages, provided the "Q" of the coil is high. This sine-wave voltage is, therefore, utilized as a trigger voltage for the horizontal oscillator, which is thereby effectively immunized against noise.

The efficiency of noise rejection obtained in this system is directly proportional to the "Q" of the ringing coil. If greater noise rejection is desired, the value of the shunt resistor across the coil can be increased. However, a higher "Q" results in greater phase shift of the ringing voltage if the frequency (phase) of the transmitted sync is not quite constant, and the result is a noticeable change in horizontal centering of the picture.

A compromise must thus be made between the desired degree of noise rejection, stability of the transmitted sync, and tolerable drift of the picture. This can be determined only by experiment.

-30-

AUDIO FAIR IN CHICAGO

THE 1952 Audio Fair in Chicago will be held at the Conrad Hilton Hotel in Chicago May 23rd and 24th.

To give manufacturers and distributors an opportunity to reach the huge high fidelity market in the Midwest, the Audio Fair in Chicago, counterpart of the Audio Fair held annually in New York, will follow the 1952 Electronic Parts Show.

The Fair will be held on the fifth, sixth, and seventh floors of the Conrad Hilton. Manufacturers who participate in the Parts Show early in the week may remain in their fifth and sixth floor display rooms for the Audio Fair at a reduced participation fee. Manufacturers and distributors who are not exhibiting at the Parts Show may reserve display rooms on the seventh floor of the hotel for the Audio Fair.

Unlike the parts show, the Audio Fair will be open to service technicians, sound specialists, and to the general public.

-30-

April, 1952



"Centre-Kooled"

SELENIUM RECTIFIERS



THE SELENIUM RECTIFIER "BIBLE"

Most complete book of its kind ever published . . . 80 pages of valuable information about Selenium Rectifiers . . . 48 pages of Radio and Television circuit diagrams . . . 20 pages on Power Rectifiers . . . 3 pages on High Voltage Rectifiers . . . a 7 page cross index replacement guide. Send 50c for your copy or see your distributor.

Sarkes Tarzian, Inc., RECTIFIER DIVISION
Dept. R-2, 415 N. College Ave.
Bloomington, Ind.



SPRING SALE

PRICES SLASHED

Don't Buy Tubes until you get our prices.

Westinghouse Kuprox Rectifier 0.64 Amp. 28 Volts. Reg. \$11.00 ea. Special **\$1.95**

12 BRAND NEW 10" PHONO RECORDS—Ass't Jazz—Popular. Please specify **\$1.79**

Single Pole—10 Pos. 2 Gang Switch **29c**

2 piece, 5 pole Male and Female separable Amphenol plugs. Both with Flex. shielded cables. Approx. 7 ft. long. 35c pair **3 pr. for \$1.00**

Grind your own Crystals. Pure Brazilian Quartz. Various sizes and thicknesses. 1/2 lb. pkg. **\$1.00**

4 Tube Drifted Chassis. 4 1/2" x 6 1/2" x 1 1/2". 29c each

4 inch P.M. SPEAKER **\$1.50**

3 in. 450 ohm Dynamic Speaker **\$1.35**

Signal Corps Phones—2 M. Ohms (3 M. Ohms Imp.) **\$1.25**

2 Ft. Ext. Cord (and Plug) **40c**

TOBE TUBULAR ELECTROLYTICS

20-20 MFD. 150 V. **49c** 30-30 MFD. 150 V. **57c**

40-40 MFD. 150 V. **59c**

<p>Low-Loss Short Wave Lock Type Air Trimmer Variable Condensers</p> <p>5 Pl.—20Mmfd. 14c</p> <p>7 Pl.—25-30 Mmfd. 15c</p> <p>8 Pl.—30-33 Mmfd. 16c</p> <p>14 Pl.—56 Mmfd. 24c</p>	<p>3 GANG T.R.F. VARIABLE CONDENSERS 000365 Con. 65c</p> <p>D.P.D.T. SLIDE TOGGLE SWITCH 15c</p>
---	--

1,000 OHM WIRE WOUND POTENTIOMETER. 15c

30 HV-FILTER CHOKE SHIELDED. 3 for \$1.25

CARTER WIRE WOUND C.T. VARIABLE 20 OHM RESISTORS .85c per doz.

PIEZO CRYSTAL HOLDERS. 12 for \$1.00—\$6.00 per C.

RCA Band Switches—3 gang, 3 pos. 3 band. 30c 6 gang, 4 pos. 4-5 band. 40c

Trimmer-Padder Ass't.—all isolantite—singles, duals, triples—100 ass't. pieces. **\$2.25**

Patco push button Rotary Switch Double Pole. **35c**

ATTENTION! Prospectors, Explorers for Hidden Treasures! Construct a U.S. Army Type of Metallic Mine Detector Amplifier. Amplifier unit only (less tubes and batteries) with cables, headphone cord, and jack. Army wiring diagram. Type AN/PES-1. **\$1.95**

RCA Ass't Mica By-Pass Cond. .001, 100 for **.95c 8 or 9 Gang Push Button Switch. **49c****

DRILLED CHASSIS FOR 5-6 tubes 5" x 10" x 1 1/2". **25c**

PHONE JACKS—OPEN & CLOSED AUTO. **18c**

BY SPEAKER VOL. CONTROL—60 OHMS. **15c**

SALE—PHONO RECORD ALBUMS—12"—3 comp. **15c 10"—3 comp. **15c**; 4 comp. **20c**; 12 comp. **69c****

VULCAN HEAVY DUTY 100 WATT SOLDERING IRON. Built for U.S.N.—Brand New—Empty, sells for \$8.50. **OUR PRICE \$2.99**

AMERTRON AUDIO OUTPUT XFORMER—Pri. 10,000 @ 15 MA; Sec. 300, 6-1 Ratio. **\$1.49**

MINIMUM ORDER \$3.00—NO C.O.D. SHIPMENTS—PLEASE INCLUDE POSTAGE

NEWARK SURPLUS MATERIALS CO.
Dept. AP

324 Plane Street NEWARK 1, N. J.

SELLS ON DEMONSTRATION

DUKANE

MAGNETIC TAPE RECORDER



THE FINEST IN HIGH FIDELITY RECORDING

at LOW COST!

DEALERSHIPS AVAILABLE NOW!

MAIL COUPON FOR INFORMATION TODAY!

DUKANE CORP. Dept. RTN-42, St. Charles, Ill.

Please send information on the Dukane Magnetic Tape Recorder.

I am interested in a dealership.

Name _____

Address _____

City _____ State _____

ESTABLISHED AS "OPERADIO" 1922

SINGLE OR STACKED

POWERFUL ALL CHANNEL PERFORMANCE
PLUS HIGH GAIN IN FRINGE AREAS

WITH THE SENSATIONAL NEW
ROGER-PHILLIPS
FIVE ELEMENT ALL CHANNEL
YAGI

- ALL CHANNEL COVERAGE
- HIGH FRONT TO BACK RATIO
- REDUCES CO-CHANNEL INTERFERENCE
- COSTS LESS THAN DOUBLE STACKED ARRAYS
- RUGGED CONSTRUCTION...EASIER TO INSTALL
- PROVIDES EQUAL GAIN ON ALL CHANNELS
- PERFECT MATCH FOR 300 OHM LINE
- PRE-ASSEMBLED...LIGHT WEIGHT

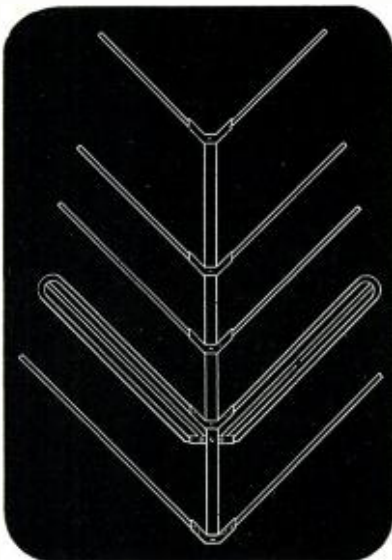

Model AC-5

(1/4 Wave Stacking Bars Built-in...Ready for Use)

Write Today for Technical Literature

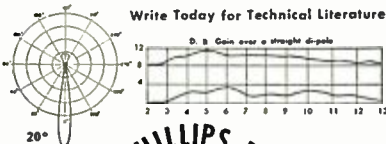

717-RA NO. LAKE AVE., PASADENA 6, CALIF.

Mac's Service Shop

(Continued from page 64)

manded. "Why he scarcely knows enough about surgery to cut his own fingernails. You know he would never be allowed to publish the book. It would be murder!"

Barney strode slowly and deliberately over to the wall calendar and with a circling thumb and forefinger ringed the date: April 1st. "April Fool, Matilda!" he shouted as his face broke into a delighted grin.

"You mean there are no books like that about television?" she asked with a suddenly rose complexion.

"No, I mean I was just joshing about writing a book myself. I was not kidding about the fix-it-yourself books on television."

"I've seen some of those books myself," Mac broke in; "and the better ones are not really too awful. They do not encourage the set-owner to take the back off the set at all. About all they do is tell how the size and linearity controls can be used to correct minor picture defects and to give some pointers on orienting the antenna to get rid of ghosts, etc. When more than this is required, they recommend that a technician be called.

"On the other hand a few books are appearing that attack technicians as being crooks and gougers and blatantly assure the set-owner that he can repair practically anything that goes wrong with the set without the use of instruments. That, of course, is a deliberate misrepresentation. The fact that a money-back guarantee is given with some of these books does not change this fact in the least. That money-back business is an old dodge that takes advantage of the fact that not one person in a hundred will bother to return a low-cost item for a refund even though he is not satisfied with it."

"I don't imagine you are much concerned with the business that the sale of these books will take away from technicians, are you?" Barney wanted to know.

"Not at all," Mac replied quickly. "As you know, after the guy has fouled his set up but good, he will call us; and then we shall follow our established policy of upping the tariff sharply for working on a set that shows definite evidence of having been tampered with. As I have explained to you before, we do not do this with any idea of 'punishing' the owner for trying to do his own repair work. It is simply to pay us for the extra time experience has shown will be necessary to repair and thoroughly check a receiver when a natural set failure has been aggravated and complicated by untrained tinkering."

"Well," Barney said as he started for the service room, "since I have decided not to write that book, perhaps I had better start doing a little work for that million."

"That's not a bad idea," Mac agreed

There is Nothing
for us to Add...



...when BROOK AMPLIFIER owners tell the story so much better.

"...absolutely transcendent"
"It is excellent---better than I had anticipated."
"In years of building amplifiers, trying out almost every quality unit on the market, I still have you to file my card on the merit; I still in performance and pure enjoyment---consistent enjoyment to the BROOK."
"I still think there is nothing quite like the BROOK."
"May we suggest that you assemble your home music system around

THE **BROOK**
ALL TRIODE HIGH QUALITY
AUDIO AMPLIFIER

Write for detailed information, free booklet, *Better Listening*, and name of dealer in your locality. Dept. RD-2

BROOK ELECTRONICS, INC.
34 DeHART PLACE, ELIZABETH 2, N.J.

Accurate Component Tester

Build \$100 Instrument Yourself—From Junk Box!

Build a bridge for accurate measurements of resistance capacity, inductance. Startling new circuit reduces testing time; gives accurate precision measurements; indicates direct values or % of deviation of selected standards. Booklet with complete plans—simple, easy text, many tables, diagrams, make it a snap for amateur, engineer—only \$1.00, postpaid! Guaranteed, money back in 7 days if not "tickled pink." Write today.

TECHNOLOGICAL DEVELOPMENTS
475-B Fifth Avenue, New York 17, N. Y.

COUPON-OF-THE-MONTH

- TUBES—STD. BRAND 35Z5 or 12SQ7...2 for \$0.99
- VOL. CONTROLS—STD. BR. .5 Meg. W. SW3 for .99
- CONDENSERS—40-40 Mfd. 150V...2 for .99
- CONDENSERS—40-20 Mfd. 150V FP...2 for .99
- LOOP ANTENNA—HI GAIN (5"-8")...2 for .99
- SAPPHIRE PHONO NEEDLES (List \$2.50)...2 for .99
- OSC. COILS 455 KC (for 12SA7)...4 for .99
- RESISTOR KIT—50 Ass'd, 1/2 to 2 Watt...99
- BYPASS COND. KIT—18 Ass'd...99
- DIAL CORD KIT—100 ft. Ass'd. & 6 Springs...99
- GRILLE CLOTH—6 Ass'd, 6"x6" & 10 Knobs...99
- COMBINATION KIT—All above Items—Only... 10.00

WITH THIS COUPON—ORDER AT ONCE
Write for Monthly Coupons and Bulletin
RADIO DISTRIBUTING CO., Pasadena 18, Cal.

Amaze Yourself and Your Friends!
By Adding Pipe-Organ-Type Bass

to your present Amp. and Spkr.
without muffling highs & middle
REVOLUTIONARY CIRCUIT INVENTION
only 4-resistors & 4-condensers

No. A25 Schematic & Data \$2.00

DULL'S ELECTRICAL TRANSLATIONS
702 N. Bancroft Wilmington, Del.

RADIO & TELEVISION NEWS

as he followed him; "but if you really do want to make a lot of money, I can give you an idea to be thinking about."

"I'm all ears; let's have it."

"Well, you start thinking of a good use to which you can put these TV towers after the necessity for them has gone. As more and more TV stations come on the air and fringe areas cease to be fringe areas, these towers are going to start coming down. Then a man will be able to pick them up, I figure, just for dismantling them. Now if you can think of a really practical use to which you can put these light, sturdy, long-lasting sections of tower, you will really be in business. About all I have come up with so far are rose trellises and grape arbors; but I am sure that a sharp character like yourself, with an imagination equal to that of Baron Munchausen, will be able to do much better than that."

"Um-m-m-m," Barney said as he pulled thoughtfully at an ear lobe, "I believe you've really got yourself an idea there. For a while, of course, a guy could dismantle the towers in an area where a new TV station started up and resell them in other fringe areas, but the sections are so bulky and hard to transport that such a plan would not be very practical. I guess I'll have to dream up a really super on-the-spot conversion for them."

"I'll be eagerly awaiting to hear about that," Mac promised as he switched on the bench lights and picked up his solder gun.

-30-

D.C. POWER SUPPLY

By NATHAN GREEN

FOR the small radio shop or the experimenter with limited funds there is always the problem of purchasing expensive test equipment which may be used very infrequently. Some shops, for example, handle very few auto radios and yet need a convenient source of d.c. power. We have found it convenient to employ an automobile generator run by an electric motor through a pulley-V-belt arrangement. The generator was obtained from an automobile "graveyard" for \$3.00. The motor is the one used to run the shop grinder; it is mounted on a motor rail so it is easily moved from grinder to generator. The generator (from a Chevy of 1934 vintage) is operated at a speed of approximately 1000 rpm by the 1/4 hp. motor. At this speed the no-load voltage is about 7.5 volts which drops to 6 volts when an auto radio is being tested. To change the voltage any large amount it is necessary to change the pulley size, but small adjustments can be made by changing the position of the generator's third brush. The setup is completed with an ammeter obtained from the same auto "graveyard." The output of the generator shows up on the oscilloscope as a most peculiarly shaped pulsating current, but so far we have never felt the need of filtering. The mechanical noise is somewhat reduced by mounting the whole assembly on sponge rubber feet.

For special purposes a no-load voltage of about 18 volts may be obtained by turning the armature at 1600 rpm.

-30-

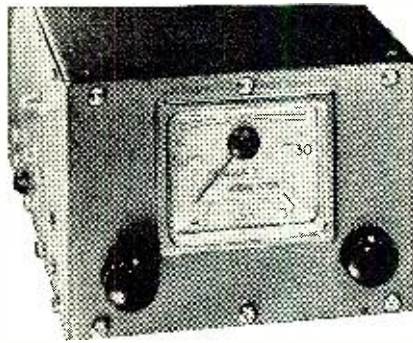

Model M-51

for emergency communications

USED BY HUNDREDS OF MUNICIPALITIES FROM BOSTON, MASS., TO ALHAMBRA, CAL.

POLIC-ALARM

MONITORADIO

5 Models For All Systems

6 VOLT MOBILE

M-51

Tuneable 30-50 MC

M-101

Tuneable 152-163 MC

115 VOLT AC-DC

PR-31

Tuneable 30-50 MC

PR-8

Tuneable 152-163 MC

AIRCRAFT

AR-1

AM Tuneable 108-132 MC

115 Volt AC-DC

Says S. L. Grant, City Manager, Winchester, Virginia . . .

"I think you have a receiver that is well built, and I see no reason why it should not be in demand by all public works departments that have a transmitter available."



Users of FM 2-Way Radio Communications equipment throughout the entire nation, find Polic-Alarm and Monitoradio a welcome innovation to low-cost mobile communications radio .

For Complete Information: See Your Jobber—Or Write Us Today

RADIO APPARATUS CORPORATION

55 N. NEW JERSEY ST., INDIANAPOLIS 4, IND., PHONE: ATLANTIC 1624

It's... KESTER FLUX-CORE SOLDER



IN DEMAND

IN DEMAND and used by the manufacturers of original equipment . . . Best for you, what could be better . . . Kester Rosin-Core, "Resin-Five" and "Specialized" Solders!

KESTER SOLDER COMPANY
4235 Wrightwood Ave., Chicago 39
Newark 5, N. J. • Brantford, Can.



SELENIUM RECTIFIERS—FULL-WAVE BRIDGE TYPES

Current (Continuous)	18/14 Volts	36/28 Volts	54/42 Volts	130/100 Volts
2 Amps.	\$2.20	\$3.60	\$6.50	\$10.50
4 Amps.	3.75	6.75	8.75
6 Amps.	5.50	9.00	14.00	36.00
10 Amps.	6.75	12.00	20.00	45.00
12 Amps.	8.50	16.00	25.50	52.50
20 Amps.	13.25	24.00	36.00
24 Amps.	16.00	31.00	48.00
30 Amps.	18.50	36.00
36 Amps.	25.50	45.00

All our Rectifiers are new & Guaranteed one year. We manufacture special types of rectifiers and rectifier supplies to your specs . . . FAST DELIVERY.

Weston Micro-Ammeters

0-100 Micro-Amps Range with blank scale. Brand New, in original Weston cartons. Special \$5.95

New, Selenium Rectifier Transformers

PR1: 115 V. 60 cycle in. 4 Amps. \$ 8.75
SEC: 0, 12, 18, 24, and 12 Amps. 16.75
36 Volts. 24 Amps. 35.75

QUALITY, TESTED TUBES

NEW & GUARANTEED, in Stock Now!
Many Others Not Listed (XMTG, etc.)
—Write for Low, Low Prices.

DA2\$1.00	6AK550.95	12SJ750.75
OB21.10	6AN52.95	12SL7GT75
OZ465	6AQ690	12SR775
1A7GT1.00	6AR575	GE 21175
1B3GT85	6B6H98	304-TL8.95
1AE41.10	6BK71.40	304-TL8.95
1N2180	6BQ6GT70	8071.65
1N21-B3.50	6C455	8139.25
1N231.45	6C6G70	GE 872-A4.50
1N23-A2.50	6F695	95545
1N23-B3.75	6F798	90065.25
1N341.95	6F8-G98	161675
1X2-A90	6H675	16241.40
2B775	6J595	162640
2E243.25	6K775	162930
2E263.25	6K775	162930
3A48.85	6L798	20511.25
3AP110.75	6R880	20511.25
3BP16.75	6S7W98	5608-A2.95
3BP1110.00	6SG770	591075
3D630	6SH770	900444
3O5GT1.00	6SJ7GT75	90051.50
SFP71.95	6V6GT1.60	VR-1051.25
5U4G1.45	6V61.25	VR-15090
5V4G1.05	6X5GT45	VR-15095
5X485	12A675		
5Y395	12C885		
6AB798	12BD61.25		
6AC765	12SF570		
6AJ51.65	12SH795		

BARRY ELECTRONICS CORP.

136 Liberty Street, N. Y. 6, N. Y. REctor 2-2563
Terms: 25% with order, balance C.O.D.—Send a few cents for postage—All merchandise guaranteed, F.O.B. N.Y.C. Remember, you can order tubes not listed at same savings.

SO IMPORTANT — it was
 Featured in Special Article
 in

The New York Times

Jan. 28, 1952

FREE copy
 of article on request

**UNIT REACTIVATES
 TV PICTURE TUBES**

Small Electronic Device Tests
 Sets at Home and May Add
 Year or More of Use

By T. R. KENNEDY Jr.
 A small electronic device that
 can be applied to home television
 receivers to test and reactivate the
 picture tube without removing the
 picture tube from the set, resulting in
 increased brightness in many and con-
 siderably longer useful life, has
 been placed on the market for the
 first time by a New York manu-
 facturer.

In some cases, it was said, the
 picture tube may be made almost
 as good as new and given as much
 as a year's useful life before re-
 placement is necessary.
 The instrument is small and
 compact. It weighs three pounds
 or less, costs little and is simple to
 operate. Picture tubes, some-
 times new and never in a receiver,
 have shown remarkable improve-
 ment in brilliance and definition
 after a few minutes of operation
 here in the last few days.

Although the principle of its op-
 eration is not new—cathode-ray
 tube manufacturers have used it
 for years in the initial making of
 picture tubes—its incorporation
 in a small unit
 re-acti-
 vates
 in pic-
 ture
 tube
 mad-
 by and
 rain i-
 use i-
 be ca-
 it i-

"The almost immediate urgency
 need for such an instrument, which
 also soon may be produced in kit
 form for home assembly, is ap-
 parent. Eight to ten million TV
 sets estimate, have now been in
 use for three to four years or
 more, and "probably are in need of
 test and reactivation to "renew
 their brightness." Unfortunately,
 loss of brightness, it was pointed
 out, seldom can be detected short
 of comparing the old tubes with
 new ones in lately produced sets.

Furthermore, picture tubes in
 their original cartons in stores may
 have lost some of their brightness,
 which has been described as a
 "kind of aging process" to which
 all large cathode-ray tubes and
 all large electronic tubes are
 subject. Such similar devices are
 used today, cost from \$25 to \$65,
 and are used to reactivate picture
 tubes from their cartons, and tubes
 in TV sets without removing the
 tube from the receiver.

The instrument is a standard pic-
 ture-tube socket to the tube,
 which is attached to the new in-
 strument, turning a switch on the
 side of a small neon bulb as a
 check on the tube is indicated
 directly on a dial of the tester,
 which is plugged into an AC home
 electric outlet. The receiver, mean-
 while, is not turned on.

In some cases the test and re-
 activation "accomplished in less
 than
 ven two
 min-
 utes."



**TRANSVISION CR TUBE
 TESTER - REACTIVATOR**

performs 2 vital functions:

- Tests Picture Tubes
- Renews Brightness of Many Dim Picture Tubes

It's a TESTER:

Without removing picture tube from set, you apply this precise instrument to:

- Measure Cathode emission
- Locate shorts between elements
- Locate high resistance shorts or leakage as high as 3 megohms

It's a REACTIVATOR

for dim CR Picture Tubes

Revives dim TV Picture Tubes, without removal of tubes from sets. Works on a great many tubes with low light output, if there's no mechanical defect in tube. 110 V—60 cycles. Portable, weighs only 3 lbs. One or two applications pays for instrument.

SATISFACTION GUARANTEED
 or money refunded if you return
 the instrument in 10 days in good
 condition.

\$19⁹⁵
 NET

TRANSVISION, INC.

DEPT. RN4 NEW ROCHELLE, N. Y.

() Send me CR Tube Tester-Reactivator(s).
 () Enclosed find \$ deposit. Balance C.O.D.
 () Enclosed find \$ in full. Send prepaid.

Name _____
 Address _____
 City _____ State _____

Junction Transistor

(Continued from page 39)

practically no heat loss, making it useful in applications where very large numbers are required, such as electronic computers of various kinds. It is extremely rugged, reliable, and has an almost indefinite life. A typical value of transconductance is 33,000 micromhos per milliampere, and of amplification factor, 39,000. Since the output impedance of a cathode follower is 1/G_m, an output impedance of 5 ohms is possible with a current of 5 ma. The G_m is inversely proportional to the absolute temperature, so that fantastically large values can be achieved by supercooling. Its noise figure is better than some vacuum tubes, being as low as 10 db and less on some of the units which have been tested.

These characteristics are certainly sufficient to justify the excitement and anticipation brought about by the announcement that such a device had been developed. Lest anyone be misled, it would be well to emphasize that this device is not commercially available at the present time, but commercial production is definitely planned for the near future.

WALKER HEADS FCC

PAUL A. WALKER has been named to the post of chairman of the FCC, succeeding Wayne Coy who resigned recently to accept a position in private industry.

Mr. Walker has served as vice-chairman of the Commission since 1945 and a member of the Commission since its inception in 1934.

PHOTO CREDITS

Pages	Credit
35, 36, 37	Belmont Radio Corporation
38, 39	Bell Telephone Laboratories
40, 41, 135	Audio & Video Products Corporation
42	T V Products Co.
47	Allen B. Du Mont Laboratories, Inc.
48 (left)	Brach Manufacturing Corp.
48 (center)	Blonder-Tongue Labs., Inc.
48 (right)	ED Manufacturing Co., Inc.
54	Sylvania Electric Products, Inc.
57, 102	Channel Master Corp.
70	General Electric Company
74 (left)	Brocner Electronics Laboratory
74 (center)	Radio Corporation of America
104	J. S. Air Force Photo
106	U. S. Air Force Photo
136	Taite Recording Industries
144	World Friendship Society of Radio Amateurs
158	British Information Services

ERRATA

In Fig. 2, page 39 of the February 1952 issue ("A High-Quality Audio Amplifier") resistor R₁ should be omitted from the circuit entirely. The B plus lead should connect to pin 8 of V₅. CH₁ should be 25 h₀₀. 20 ma. rating. Use the smallest available size. For C₁, C₂, C₁₀, C₁₁, a 500 v. rating is adequate.

The parts list accompanying Fig. 3, page 51 of the February issue ("A High Gain Signal Tracer-Amplifier") contains an error. T₂ should be a 300-0-300 volt unit instead of the 150-0-150 volt unit specified.

In the January issue, the coil table on page 41 ("A Vacuum Tube Keyed Transmitter") doesn't specify the winding length for L₂ when used on 80 meters. This figure should be 1 inch.

TUBES AT LOWEST PRICES

1A7	.79	6C4	.48	12AT7	.95
183	.85	6CB6	.55	12AUG	.65
1L	.90	6GW	.85	12AU7	.69
1L6	.95	6J5M	.65	12AV7	.85
1LN5	.90	6J6	.95	12AX7	.65
1R5	.59	6K6	.95	12BK7	.70
1S5	.80	6N6	1.50	12BR7	.80
1T4	.75	6N7	1.10	12BE6	.55
1U5	.55	6E7M	.95	12BF7	.70
3Q4	.70	6SA7M/GT.	.75	12CF5M	.70
3V4	.65	6SQ7GT	.70	12CK7	.75
5Y3	.35	6SH7M/GT.	.70	12DQ7	.75
5Z2	.65	6SJ7M/GT.	.80	12DN7	.85
6AB4	.65	6SN7GT	.65	12E6GT	.75
6AC7	.90	6EL7	.65	14BE	.95
6AG5	.80	6SN7	.65	19T9	.95
6AL5	.48	6SQ7GT	.65	25Z6GT	.59
6AQ5	.65	6Y8	.95	25W4	.70
6AV6	.48	6V6GT	.55	35L6	.55
6AV8	.58	6W4	.49	35W4	.45
6AV6	.65	6X4	.40	35Z5	.48
6AB5 GNS	.90	6X5	.40	50B5	.55
6BC5	.65	6V6	.70	50C5	.55
6BE6	.60	7AD7	1.20	50L6	.55
6BF5	.75	12A6	.60	59	.90
6BF6	.70	12AT6	.45	89Y	.75

IMMEDIATE DELIVERY!

Write for quotations, many other types available. 20% Deposit with order, balance C.O.D. All tubes subject to prior sale. Prices subject to change without notice.

WRITE, WIRE, CALL—TODAY!

We Buy Anything in Electronics—

large or small quantities!

NAT ADELMAN

168 Washington St. New York 6, N. Y.
 CO. 7-6091

BRAND NEW TUB S

0R2	\$.50	6AV6	\$.55	6SJ7	.79
1A3	.75	6BA6	1.30	6SK7	.79
1B3GT	.95	6BA6	.70	6SG7GT	.89
1G5	.65	6BE6	.70	6SN7GT	.89
1H4G	.89	6BC6G	1.75	6SR7	.79
1L5	.65	6SL7GT	1.20	6TL7	.79
1R4	.69	6C5	.79	6ST7	1.10
1S5GT	.79			6T8	1.00
1V	.99			6V6GT	.69
1X2A	.95			6W6GT	1.30
2A4G	1.50			6Y6	.79
2C40	1.50			7C5	.79
3AHGT	1.59			7H7	.79
3C23	.79			7K4	.79
3R4	.75			12A6	.69
3S4	.75	6CB6	\$1.39	12AH7GT	1.10
4C7	1.60	6CD6	2.40	12AT7	1.15
5B1	1.98	6F8G	.99	12AU	.99
5T4	1.10	6G6	1.10	6AV6	.69
5V4GT	.52	6G6	1.10	12BA6	.79
5Z3	.69	6H8	.79	12CB	.79
6A3	1.49	6K7	.69	12JC7	.59
6AB7	1.29	6K8	.79	12K8	.79
6AC7	.99	6KB6	.99	12L7	.79
6AG5	.99	6L6G	1.25	12SC7	.89
6AC7	1.39	6L7	1.10	12SH7	.79
6AK5	1.45	6M4	.99	12SF7	.89
6AG6	1.09	6N7	.99	12SK7	.89
6AL5	.49	6SQ7GT	1.20	12L7GT	.89
6AN5	4.95	6SH7M/GT	.70	12SN7GT	.79
6AG6	4.95			12STGT	.89
6AR5	.79			12T7GT	.89
6AR6	.75			50L6G	.65
6AS5	2.95	50-15	\$ 5.95	50T9	32.00
6AT6	.55	50-30	12.50	73A/B	16.50
6AUG	.65	50-32	12.50	813	8.50
				12.50	

**YOUR
 SURPLUS
 WANTED!**
 We Pay
 Highest
 Prices!

Complete Line of Transmitting & Receiving Tubes.
 Send Cash With Order and Save C.O.D. Charges!
J. S. H. SALES CO.
 Dept. R-11, 7552 Melrose Ave., Los Angeles 46, Calif.

RADIOS 1, 2 & 3 band Electric and/or battery
TELEVISION AC/DC Operation
TEST INSTRUMENTS Write for FREE Catalog
ARKAY—Radio Kits, Inc.
 120 Cedar St., New York 6, N. Y.

LEARN CODE
 No matter how difficult it has been for you to learn code before, I guarantee that you will memorize the Morse International Code in two hours or return method within 5 days and I will refund your money. Get in on the fun of "easy license" civilian radio. Send one dollar for complete method. **NOTHING ELSE TO BUY!**
OTTO LUTHER, NEW PRESTON, CONN.

SENDING SPEED
CODE RECEIVING
HIGH SPEED WITHOUT NERVOUS TENSION
 REVEALING BOOK shows how "crack" operators develop high speed and proficiency. Learn code for Amateur or Commercial Radiotelegraph License, or improve your sending and receiving. I with the Candier System which develops radio-telegraph experts and code champions.
CANDLER SYSTEM CO. FREE BOOK
 Box 928, Dept. 2-D, Denver, Colo.

RADIO & TELEVISION NEWS

Classified

Rate 50c per word. Minimum 10 words

RADIO ENGINEERING

COMPLETE radio, electronics theory & practice: television; broadcasting; servicing; aviation, marine, police radio. 12 or 18 months. Catalog. Valparaiso Technical Institute, Dept. N, Valparaiso, Ind.

SALE

B.C. 348 110 volts, almost unused. Make offer. A. C. Woodrich, 35 Highland Pl., Wellsville, N. Y.

HEARING Aids. Zeniths, Western Electrics. Reconditioned. Make miniature transmitters or receivers. Complete with ear piece and cords. \$16.00 each. Gloria Davis, 2135 Caten Ave., Brooklyn, New York.

HEARING aids, used. Zeniths, less accessories, \$7. One-piece Nationals, \$10. One-piece overhauled, with accessories, \$20.00. Shelby Instrument, 321 W. 7th St., Long Beach, Calif.

TUBES, surplus, bought-sold. Free list. Betz, 73 Caroline Ave., Yonkers, N. Y.

DIAGRAMS Radio. Record Changers. Recorders, 75c; Television with Service Data, \$1.25 up. State manufacturer and model number. Kramer's Radio Service, Dept. N8, 36 Columbus Ave., New York 23, N. Y.

RECORD changer parts for leading makes. We ship everywhere. Friend's Wholesale Distributors, 106 N. 6th St., Philadelphia 6, Pa.

VITA-DRIVE is an excellent cleaner for slipping rubber phono drives and belts. 75c for 1 oz. bottle. Write for circular. Friend's Wholesale Distributors, 106 N. 6th St., Philadelphia 6, Pa.

POCKET Drafting Machine. Solves trig and impedance problems. \$3.00 postpaid. Triculator, 643 W. 109th Pl., Los Angeles 44, Calif.

TV and FM Antennas. Yagi, Conical, Bow-Tie. Mounts, accessories. Lowest prices. Wholesale Supply Co., Dept. H, Lunenburg, Mass.

BACK Copies Ire Proc., Jan. '43 thru 1951, \$50.00; Electronics, Jan. '45 to present, \$40.00; QST, Nov. '42 thru 1949 ex. Mar. '43 & May '49, \$25.00, express prepaid. Box 522, Radio & Television News, 185 N. Wabash, Chicago 1, Ill.

WANTED

WILL buy all ART13/T47A, \$220.00; ART13/T47, \$150.00; BC348's (not B's or C's), \$65.00; R77 receivers only \$400.00; complete ARC-3 unit, \$750.00; BC312's, \$65.00; BC342's, \$60.00; ARC-1 complete, \$600.00. Ship via express C.O.D. Subject to inspection, to H. Finnegan, 49-57 Washington Ave., Little Ferry, N. J.

AN/APR-4, other "APR-," "ARR-," "TS-," "IE-," ARC-1, ARC-3, ART-13, everything surplus; Tubes, Manuals, Laboratory equipment. Describe, price in first letter. Littell, Farhills Box 26, Dayton 9, Ohio.

WANTED. New, complete EE-108 sound powered field telephone sets. Wire prices and quantity, collect. Coastal Corp., 447 Calvert Ave., Alexandria, Virginia.

CORRESPONDENCE COURSE

USED Correspondence Courses and Books sold and rented. Money back guarantee. Catalog free. (Courses bought.) Lee Mountain, Pisgah, Ala.

RADIO Servicing Course shows latest short cut methods. Lessons easy to follow. Only \$3.00, postpaid in U.S.A. Buyers Syndicate, 30 Taylor St., Springfield, Mass.

BE a Broadcast Engineer. FCC license preparation. \$25 complete. W. R. Moody, Consulting Electronics Engineer, 5705 Carters Lane, Riverdale, Md.

MISCELLANEOUS

REPAIR your own radios, tells how. \$1.00 postpaid. Information free. Slaters Radio Service, Corsicana, Texas.

SPEAKERS repaired, wholesale prices, guaranteed workmanship. Amprite Speaker Service, 70 Vesey St., New York City 7.

LOWEST Prices. We shop for your TV, radio needs. Smallest part to complete units. Details. TV Shopper's Service, Box 521, Radio & Television News, 185 N. Wabash, Chicago 1, Ill.

"SUBSTITUTE" beats tube shortage. 900 direct-interchangeable tubes listed. Chart, 50c. Alexander, 780 E. 214th St., New York City.

SPRING SALE

BRAND NEW STANDARD BRAND TUBES

Individually Boxed and Guaranteed

0Z4 ... \$5.59	6AU5 ... 1.59	6SA776	12BE679
1A798	6AU676	6SK779	12SA777
1B3 ... 1.02	6AV667	6SL7 ... 1.19	12SK777
1H589	6AB669	6SN789	12SN7 ... 1.09
1N587	6BA7 ... 1.16	6SQ772	12SQ768
1R582	6BC586	6T8 ... 1.19	14A7 ... 1.03
1S579	6BE682	6V6GT86	14B6 ... 1.03
1T483	6BG6 ... 1.76	6W466	19T8 ... 1.34
1U578	6BH686	6W689	25BQ6 ... 1.49
1X2A96	6BN6 ... 1.32	6X474	25L685
3Q489	6BQ6 ... 1.44	6X574	25W488
3Q5 ... 1.02	6C476	7C589	35L686
5U465	6CB686	7F793	35W458
5V4 ... 1.10	6CD6 ... 2.49	7N799	35Y486
5Y347	6F688	7Z484	35Z557
6AB7 ... 1.39	6H676	12AT665	50A596
6AC7 ... 1.21	6J559	12AT7 ... 1.09	50B586
6AG586	6J6 ... 1.09	12AU689	50C586
6AH6 ... 1.49	6J781	12AU796	50L672
6AK5 ... 1.49	6K666	12AV679	117Z378
6AL568	6K774	12AV7 ... 1.24	
6AQ572	6L6GA ... 1.69	12AX799	
6AT668	6S476	12BA679	

Above only partial list of tubes on sale. Send for complete list.

FREE—New Big Catalog Just Off the Press!!

STEVE-EL ELECTRONICS CORP.

VISIT OUR NEW STORE

Dept. N-4 61 Reade St., New York 7, N. Y. COrlandt 7-0086

Concertone

MAGNETIC TAPE RECORDERS



NETWORK RECORDER NWR-1

"just like being there"

THE ONLY low cost high fidelity tape recorders delivering professional performance. Professional users' net prices begin at

\$345.00

Write for Bulletin #102
Manufactured By

Berlant Associates

4917 W. Jefferson Boulevard
Los Angeles 16, California

630 CHASSIS



World's Finest TV RECEIVER

New and improved Super Famous "630" T.V. Chassis, 30 tubes (including 3 rectifiers, manufactured under license by the Radio Corporation of America.

Standard R.M.A. Guarantee! FREE replacement on all defective tubes and parts. FEATURES: • Full channel coverage. • Discriminator-type FM sound system. • Improved picture brilliance. • AFC horizontal hold. • 3-stage sync separator and clipper. • Automatic brightness control. • 4 Mc band width. • Highest quality parts used. All standard tubes. • For all Cathode Ray tube sizes and types. 16", 17", 19", 20", 24" Tubes.

With Hi-Gain standard coil tuner and R.C.A. Hi-Fi 12" Speaker, knobs and hardware. Less Cathode Ray Tube..... **\$141.50**

630 JDX Chassis—Extra power for fringe areas. Can be operated without booster or complicated antenna. Less Cathode Ray Tube..... **\$151.50**

Available with DuMont Input Tuner FM Radio, less Cathode Ray Tube..... **148.50**

Chassis Mounting Brackets when ordered with chassis..... **4.95**

YOU CAN BUY

PICTURE TUBES

(magnetic deflection types only)

WITH A ONE YEAR GUARANTEE

for

\$ 1.30 PER INCH

Tubes smaller than 12" @ \$15.60 minimum.
Add \$1.50 per tube for all metal tubes.

Send us your dud picture tubes. We will return them completely factory rebuilt with all scratches removed, new gun, coatings and screen and guarantee them for 1 year. Broken neck tubes must have at least 2" of neck. Send them prepaid, packed securely and insured. Include full payment with order and we will ship in 48 hours. Otherwise allow 1 week C. O. D. All shipments collect.

EXAMPLE: 16" TUBE X \$1.30 = \$20.80
if metal tube add 1.50

PACKING? Send a \$2.00 deposit and we'll send you a shipping carton. Deposit will apply to order. Be sure to include tube type and size. DEALERS: Save money—don't hang on to duds—turn them into new stock.

All prices subject to change without notice

VACTRON

398 ASHFORD AVE., DOBBS FERRY, N. Y. 167

DOW SURPLUS

TELECHRON SYNCHRONOUS MOTOR
Type C2M 115V-60 cycle Model 822 M-6—
RPM—Removed from new Surplus.....\$3.95

MISCELLANEOUS ITEMS—ALL NEW
Rubber Grommets—100 asst. \$0.89
BC 457—Xmitters 4 to 5 mc new..... 9.95
BC 461 control box with counter..... 1.49 ea.
744C mike and plug..... .95 ea.
Hookup Wire approx. 400 ft. 2 to 4 ft.
lengths and longer..... .98
APC condensers, all sizes..... 49 ea.
1000-ft. W-130 twisted Telephone wire..... .95
50 Watt-Tube Sockets—new..... 1.00
Antenna Insulators—10 for..... 1.00
3 Asst. 24V Relays..... 1.89
FILAMENT TRANSFORMERS—110V-60 cycle
input, output 9V to 13V in 1V steps—out-
put, rated 3 amps..... 1.89
G.E. Solenoids—14V DC—25 ohms—Mycalex
arm, many applications—new..... .49

GP7 TUNING UNITS, A TO F, for ECO, \$3.95 ea.

PANEL METERS		RHEOSTATS	
STANDARD BRANDS	Watts	Ohm	ea.
◆ SPECIAL SCALE	25	5	\$0.98
5Q—SQUARE CASE	25	15	.98
3" METERS			
0-8V AC WES.	\$2.95	25	.98
0-130V AC	4.95	100	.98
0-150V AC	5.95	145	.98
0-15V AC	3.95	250	.98
0-15V DC	3.95	370	.98
0-2V DC	3.95	500	1.49
1-1 Mill DC SQ.	6.95	1000	1.95
100-0-100 DC Mill.	3.95	25	5000
0-800 Mill DC SQ.	4.95	100	2.50
Freq. 350 to 450	1.00	100	2.50
115V	12.95	150	500
		150	5000
		150	3.95

2" METERS

0-1 RF Amp.	55.95		
0-8 RF Amp.	3.95		
0-3 DC Mill.	3.95	2½ MH—100 mill.	2.9c
0-150 Micro Amp.	7.95	2½ MH—500 mill.	5.9c
F Tuning D.C.	1.95	2½ MH—1000 mill.	5.9c

BUY YOUR TUBES HERE
OIL CONDENSERS

SURPLUS		SPRAGUE #4884	
13-4	Ballast \$0.19		
801A	\$0.39 4/	Four 8 mfd Sections in	
843	39 4/	One Can. 600V—oil-	
1825	39 4/	per feet for am-	
1826	39 4/	plifiers.....\$4.95	
18615	39 4/		
RK73	59 4/		
658A	59 4/		
65N7GT	59 4/		
6S17	59 4/		
6ALS	79 4/		
11B5	41		
41	59 4/		
RKR73	179 4/		
8AK5	119 4/		
2051	69 4/		
837	149 4/		
15E	149 4/		
3MP7	195 4/		
SFP	195 4/		
1816	195 4/		
807	1.50		
6C4	1.69		
8012	1.19		
RK39	2.75		
803	3.95		
660	3.95		
531	3.95		
2J21A	4.95		
5B1	4.95		
5B4	3.95		
304TL	6.95		
3B1	3.95		
250R	6.95		
804	8.75		
4E27/257	11.95		
861	19.95		
849	19.95		

NEON INDICATORS

NE 2	10c ea.
NE 30	29c ea.
NE 48	37c ea.

EDWARDS BUZZERS

#1892—115 V-60 cycle	
.05 amp.....	\$0.98
#15—size 0-12V DC	
works on 6V less cover.	
Fine for Code Practices	
Sets. Ea.69c
10 for.....	\$4.95

FUSES		KEYS	
Amp.	Type	Each	10 for
1/2	8AG	\$0.03	\$0.25
1	8AG	.03	.25
1	3AG	.03	.25
3/16	3AG	.03	.25
1/2	3AG	.03	.25
2	3AG	.02	.25
2	3AG	.02	.25
4	3AG	.02	.25
10	3AG	.02	.25
15	3AG	.02	.25
20	3AG	.02	.25
1	4AG	.05	.40
4	4AG	.05	.40
10	4AG	.05	.40
15	4AG	.05	.40
20	4AG	.05	.40
35	4AG	.05	.40
40	4AG	.05	.40
70	4AG	.05	.40
20	5AG	.05	.40
40	5AG	.05	.40
50	5AG	.05	.40
70	5AG	.05	.40

VARIABLE CONDENSERS—ALL NEW

Dual 35 mmd per Section. Miniature.....	\$1.49
Dual-100 mmd per Section.....	1.49
3 Gang 365 per Section.....	.98
4 Gang 147 mmd per Section.....	1.25
8 Gang 365 per Section.....	2.95

5M ohm 20W.....	\$0.15	JK 26 and PL 54	\$0.10
5M ohm 50W.....	.69	3 AG fuse post.	\$0.25
5M ohm 25W.....	.15	4 AG fuse post.	.25
10M ohm 10W.....	.15	8 AG type HJM	.20
10M ohm 150W.....	.79	807 Tube Sockets	.49
25M ohm 2W, 3 for	10	Acorn Sockets	.21
55M ohm 2W, 3 for	10	MG153F	\$149.50

30 ft. hook-up wire, Plastic Cover.....	\$0.10
Luminous Paint Kit For Dusting, Painting or	
Mixing. Glows in the Dark.....	.79
6 ft. AC line cords.....	ea. .15
Single Hole mtd. Push Button Switch.....	1.19
TS11 Hand Sets.....	6.95
Toggle B9A Sw-SPDT—center off.....	3/ 1.00
Toggle B18 SPDT.....	3 for 1.00
Toggle B11 SPDT Momentary.....	1.00
Micro Switch BZ-RQ41 SPDT.....	.79
Resistor Kit.....	100/ 2.89
A62 Phantom Antenna for 10 Meters, new.....	.75
35 FOOT STEEL ANTENNA MAST KIT. Five	
feet sections—new.....	12.95
Soldering Paste 1/2 lb. can.....	.10

Write us for your meter wants. Over 3,000 in
stock. Write for Our 16-Page Bulletin.
DOW RADIO, INC.
1759 E. Colorado St. Pasadena 4, Calif.
PHONE: SYcamore 3-1196
\$1.50 min. order. 25% deposit with orders.
Send full remittance to save C.O.D. charges.
All merchandise fully guaranteed. Subject to prior sale.

APRIL 1952
INDEX OF Advertisers

While every precaution is taken to insure accuracy, we cannot guarantee against the possibility of an occasional change or omission in the preparation of this index.

NAME	PAGE
Acorn Electronics Corporation.....	106
Adelman, Nat.....	166
Airex Radio Corporation.....	6
Allied Radio Corporation.....	9, 114, 169
Aluminum Products Corp.....	107
American Phenolic Corp.....	90
American Television & Radio Co.....	126
Amplex Electric Corporation.....	103
Amplifier Corporation of America.....	122, 130
Antenna Manufacturers Assn., The.....	161
Arday Radio Kits, Inc.....	166
Arrow Sales, Inc.....	139
Ashe Radio Co., Walter.....	32
Astatic Corporation.....	28
Atlas Sound Corporation.....	158
Audel & Company, Theo.....	155
Barry Electronics.....	165
Bell Telephone Laboratories, Inc.....	10
Bendix Radio.....	133
Berlant Associates.....	167
Blonder-Tongue Labs.....	109
Bond Equipment Company.....	131
Brook Electronics, Inc.....	164
Brush Development Company.....	18
Buchan, Richard J.....	168
C & H Sales.....	122
Candle-Airco.....	156
Candler System Co.....	166
Capitol Radio Engineering Inst.....	21
Centralab, Inc.....	24, 25
Channel Master Corporation.....	22
Chicago Transformer Company.....	111
Circle Sales Corporation.....	140
Cisin, H. G.....	159
Clearview Television, Inc.....	168
Cleveland Institute of Radio Electronics.....	17
Collins Audio Products Co., Inc.....	15
Columbia Electronic Sales.....	94
Comet Electronic Sales Co.....	135
Commercial Surplus Sales Company.....	168
Communication Equipment Company.....	109
Coyne Electrical School.....	102
Davis Electronics.....	156
DeCray & Assoc., Frank W.....	168
DeForest's Training Inc.....	5
Dow Radio Inc.....	168
DuKane.....	163
Dull's Electrical Translations.....	164
Dumont Electric Corporation.....	158
Editors & Engineers, Ltd.....	86
Eddie Electronics, Inc.....	118
Electronic Beam Corporation.....	142
Electronics Institute, Inc.....	141
Electronic Expeditors, Inc.....	110
Electronic Instrument Co., Inc.....	3rd Cover
Electronic Specialty Supply.....	145
Ernie Resistor Corporation.....	102
Esege Sales.....	133
Fair Radio Sales.....	127
Feller Engineering Company.....	122
Finnegan, H.....	156
Forest Sales.....	162
Franklin Technical Institute.....	135
G & H Wood Products.....	147
G. L. Electronics.....	92, 112
Garrard Sales.....	135
General Electric Company.....	12, 13, 23, 31
General Electronic Dist. Corp.....	160
General Test Equipment.....	137
Gonset Company.....	92
Good, Inc., Don.....	137
Goodheart, R. E.....	141
Grayburn Corporation.....	116
Greenlee Tool Company.....	157
Greenwich Sales Company.....	158
Hallcrafters Company, The.....	7
Harrison Radio.....	151
Harvey Radio Company, Inc.....	160
Heath Company.....	78 thru 85, 151
Hickok Electrical Instrument Co.....	98
High-Fidelity Magazine.....	157
Howard Sales.....	137
Hytron Radio & Electronics Co.....	27
Indiana Technical College.....	139
Instructograph Company.....	92
International Resistance Company.....	124, 125
J. F. D. Manufacturing Company.....	8
J S H Sales Company.....	166
Jensen Industries, Inc.....	143
Jersey Specialty Company.....	109
Kaar Engineering Company.....	122
Kester Solder Company.....	165
Key Electronics Division.....	155
Klein, Manuel.....	161

Unused ELECTRONIC COMPONENTS

- 39 pieces BC-957-A RADAR INDICATOR
- 22 pieces TA-12B TRANSMITTER
- 24 pieces RA-10-DB RECEIVER
- 32 pieces BC-605-D INTERPHONE AMPLIFIER

PLUS
Large stock of AN connectors in most sizes... big assortment electronic components; plugs, resistors, condensers, potentiometers and other parts.

★
Available for inspection at our Baltimore warehouse
★
COMMERCIAL SURPLUS SALES CO.
4101 Curtis Avenue
Baltimore 26, Maryland
TELEPHONE: CURTIS 3300

RESISTOR KIT \$3.00
100 Assorted Insulated 1/2, 1 and 2W Standard RMA Values (Not Surplus). Kit Contains 20 Values in 5%, 10%, 20% Tolerances.

MINIATURE TUBE SOCKETS
7 pin wafer type, 25 for \$1.00

FOCUS POTS 10K W.W. 4 WATT
THREE FOR \$1.00

WRITE FOR CATALOGUE
POSTAGE PAID CASH WITH ORDER
FRANK W. DE GRAY AND ASSOCIATES
P. O. BOX 1276 CULVER CITY

RHOMBIC TV ANTENNAS
Power Gains of 100 and More for consistent extreme fringe area reception.
BUILD YOUR OWN—USE OUR RHOMBIC TV ANTENNA BOOK
• Complete Simplified Building instructions and drawings for 24 sizes.
• Use and Design of open wire lines.
• Information on Stacked Rhombics.
\$1.50 Richard J. Buchan
Postpaid WOTIF Brieclyn, Minn.

THIS AD MAY BE SMALL—BUT IT CAN MEAN B-I-G MONEY TO YOU!
I want to buy BC-348, BC-342, BC-312, ARC-1, BC-788, I-152, T-17MICS, ART-13, BC-221 or any parts thereof, no matter how small. In fact, I'll buy anything. I'm not kidding! Let me prove it!
Wire or write: **ROBERT SANETT**
4668 Dockweiler, Los Angeles, Calif.
Telephone: York 4637

ATTENTION SERVICE MEN
7" Test record and speed indicator with large hole to test mechanical operation of 45 R.P.M. Changers—made of unbreakable vinyl—takes less than 15 seconds for complete playing cycle—a boon to technicians who do any changer work—75¢ each. C.O.D.
CLEAR-VIEW TELEVISION, INC.
5542-44 Ridge Ave. Philadelphia 28, Pa.

NAME	PAGE
LaPointe Plasmacoid Corporation	19
Leotone Radio Company	102
Loris Sides	112
Luther, Otto	166
MacMillan Company	119
McGee Radio Company	88, 89
McGraw-Hill Book Company	108
Mallory & Co., P.R.	4th Cover
Mark Electronics	141
Master Mobile Mounts, Inc.	143
Mattison Television Company	120
Merit Coil & Transformer Corp.	26
Midway Company	131
Miles Reproducer Company, Inc.	131
Milwaukee School of Engineering	156
Mosley Electronics	116
Moss Electronics	93
National Electronics of Cleveland	152
National Electronics Distributors	129
National Radio Institute	3
National Schools	11
Newark Electric Company	136
Newark Surplus Materials	163
Newcomb Audio Products	104
New England Television Corp.	169
Niehols Radio & Television	169
Offenbach & Reimus Company	128
Peak Electronics Company	150
Penn Boiler & Burner Mfg. Corp.	117
Permoflux Company	110
Pfanstiehl Chemical Company	161
Photon Sales	160
Pickering and Company, Inc.	169
Platt Electronics Corp.	116
Premier Radio Tube Company	99
Precision Electronics	162
Progressive Electronics Company	105
Pyramid Electric Company	34
Quietrole Company	116
RCA Institutes, Inc.	14, 135
Radcom Engineering Company	121
Radio Apparatus Corporation	165
Rad-Tel Tube Company	145
Radio Corporation of America, Second Cover	
Radio Craftsmen, Inc.	136
Radio Distributing Company	164
Radio Ham Shack, Inc.	101
Radio News	115
Radio Parts Company	77
Radio Shack Corporation of Boston	148
Raytheon Manufacturing Company	29
Regency	30
Relay Sales	95
Rider, Publishers Inc., John F.	123, 145
Rinehart Books	91, 134, 162
River Edge Industries	130
Roger-Phillips Research Labs.	132, 161
Rose Company, The	121
Sams & Company, Howard W.	87, 96, 128, 152, 158
Sauett, Robert	160
Sarkes-Tarzian, Inc.	163
Service Management	154
Simpson Electric Company	87
South River Metal Products	155
Sprague Products Company	143
Sprayberry Academy of Radio	33
Stan-Burn Radio & Electronics	130
Star Electronics Distr., Inc.	159
Steve-El Electronics	167
Stevens-Waldon, Inc.	138
Sun Radio of Washington, D. C.	144
Superior Instruments Co.	159
Sylvania Electric Products	20, 105
Tab	170
Tallen Company	139
Technological Developments	161
Television Communications Institute	149
Television Engineers, Inc.	153
Television Materials Corporation	142
Television Supply Company	110
Telrex Inc.	143
Transvision, Inc.	97, 166
Trio Manufacturing Company	147
Tri-State College	130
Tung-Sol Electric Inc.	16
Turner Company	129
Ungar Electric Tool Company, Inc.	105
United Technical Laboratories	153
V & H Radio & Electronics	142
Vactron	167
Valparaiso Technical Institute	137
Waldom Electronics, Inc.	157
Weathers Industries	149
Wholesale Radio Parts Co., Inc.	141
World Radio Laboratories, Inc.	131

**REACTIVATE
PICTURE TUBES**
BUILD REACTIVATOR & CRT TESTER FOR
\$3.00—SEND \$1.00 FOR FULL DETAILS
NICHOLS TELEVISION LABORATORIES
236 Madison Ave., Perth Amboy, N. J.

THE 3 Bs... BEETHOVEN, BRAHMS AND BACH

they're different
they're improved
they're better than ever!

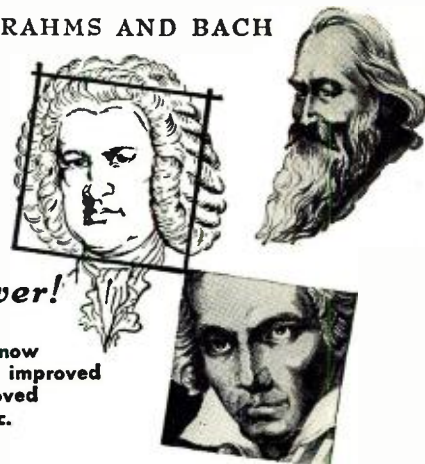

Yes, Bach, Beethoven and Brahms are now better than ever—we don't mean we've improved their music, but we do mean we've improved the reproduction of their recorded music.



It's the new, improved Pickering Cartridges that give credence to this claim. Yes, Pickering Cartridges are different. They're improved. They're better than ever. Pickering patented Cartridges with Dynamic Coupling* are superior in every way, by providing: HIGHER FREQUENCY RESPONSE • NEGLIGIBLE INTERMODULATION DISTORTION • BETTER TRACKING CHARACTERISTICS

*DYNAMIC COUPLING ASSURES constant stylus contact with the record grooves over the entire audio spectrum (20-20,000 cps) • full frequency response • full transient response • no resonances • no mistracking • no grinding of groove walls

PICKERING and company, incorporated



Pickering High Fidelity Components are available through leading Radio Parts distributors everywhere; detailed literature sent upon request. Address Department C

Oceanside, L. I., New York



SENSATIONAL VALUE!

630 SUPER 30 TUBE CHASSIS
Mfr. Licensed under R. C. A. Patents

Complete with
2 1/2" first quality
tube
AND
Beautiful hand-
rubbed Mahog-
any Console
Cabinet.
COMPLETE PRICE
\$259.95



slightly higher
with full doors

the latest 1952 model with all the newest electronic improvements...

- peak sensitivity for fringe areas
- synchrolock tuning
- keyed A G C
- 15,000 volts under load
- 12-inch RCA speaker
- can be adapted to color & UHF
- high quality parts

A set—NOT A KIT

Completely wired, Factory Engineered, aligned and tested. RMA Guaranteed

1 YEAR GUARANTEE ON TUBE

A half-hour to mount; ready for operation. Saves up to \$150.

Compare this anywhere for high quality—low price!

Write Dept. F for further information. Phone and mail orders filled on receipt of money order for 25% as deposit... the balance C.O.D., f.o.b. N. Y.

NEW ENGLAND TELEVISION CORP.
75 CHURCH STREET NEW YORK, N. Y.



Low Cost Powerful P.A.!

COMPLETE • READY TO USE

Tops for powerful indoor-outdoor use; ideal for electioneering. Easy portability. Covers 4,000 persons indoors, up to 25,000 sq. ft. outdoors. Full 30 watts usable output; 2 high-imp. mike inputs, 1 phono input, each with separate volume control; tone control; fidelity ±2 db from 40-20,000 cps. Complete system includes: 30 watt amplifier and tubes, Electro-Voice "Cardax" unidirectional mike with adjustable floor stand and 20' cable; 2 General Electric 12" PM speakers, each with 30' cable; portable carrying case holds all. 16 1/2 x 12 1/2 x 23". For 110-130 v., 60 cy. A.C. Shpg. wt., 75 lbs. Complete, less only phono top.

93-372. Complete 30 Watt System. Only \$119.75
93-340. 3-Speed Phono Top for above. Only \$16.95
Available on Easy Terms—write for details

FREE See the 212-Page ALLIED Catalog for other Sound Systems, ranging from 8 to 80 watts. Write for Free copy of Radio's leading Buying Guide today.

ALLIED RADIO

833 W. Jackson Blvd., Dept. 1-DD-2 Chicago 7, Ill.

EICO

TEST INSTRUMENTS

guards



Majestic

HIGH STANDARDS OF
TELEVISION PRODUCTION QUALITY

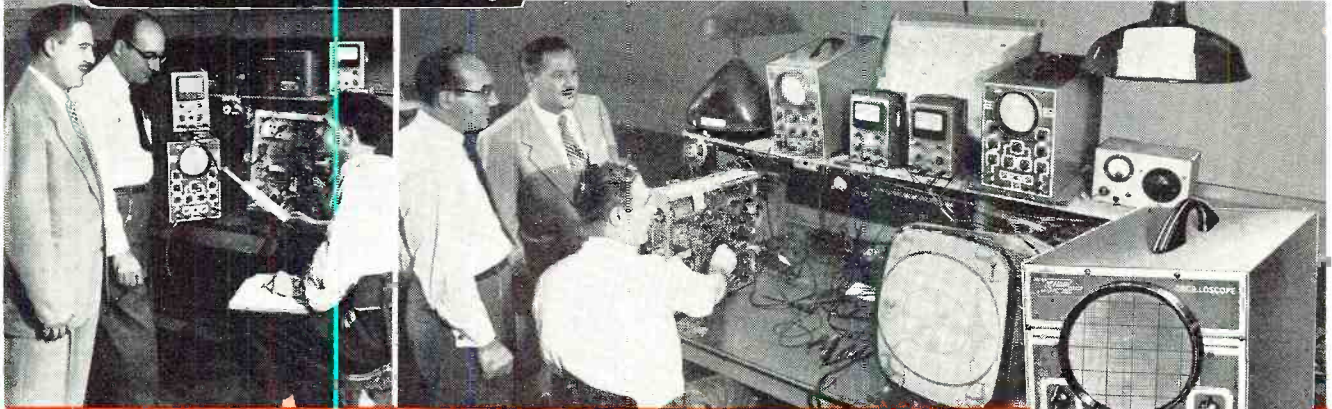

In the Majestic design laboratories, Frank J. Diel and assistant Paul Smith, discuss with Harry R. Ashley, some important prototype-circuit measurements just taken with the 425K Oscilloscope, #221 VTVM and #HVP-1 HV Probe.

Frank J. Diel, Majestic's Chief Engineer, and Harry R. Ashley, President of EICO, inspecting the use of the EICO Model 425 5" Push-Pull Oscilloscope, Model 221 Vacuum Tube Voltmeter and Model HVP-1 High Voltage Probe at the important Final Test Position on the Majestic Television production lines.

KITS - Wired Instruments

For Laboratory Precision at Lowest Cost—
the Leaders Look to **EICO!**

Why does The Majestic TV Division of The Wilcox-Gay Corp., another one of America's leading TV manufacturers, specify EICO Test Instruments on both its production lines and in its design laboratories?

BECAUSE—like Emerson, Tele-King, Tele-Tone, CBS-Columbia, and many another famous TV manufacturer coast to coast, Majestic knows that

ONLY **EICO** TEST EQUIPMENT DELIVERS ALL 10 **EICONOMICAL** FEATURES

1. Laboratory Precision
2. Lowest Cost
3. Lifetime Dependability
4. Speedy Operation
5. Rugged Construction
6. Quality Components
7. Latest Engineering
8. Super-Simplified Assembly and Use Instructions
9. Laboratory-Styled Appearance
10. Exclusive EICO Make-Good Guarantee

Before You buy any higher-priced equipment, be sure You look at the **EICO** line—in **Wired** as well as **Kit form!** Each **EICO** product is jam-packed with unbelievable value. **YOU** be the judge—compare, see **EICO** instruments today—in stock at your local jobber—and **SAVE!** Write **NOW** for **FREE** newest Catalog 4-R.

FOLLOW THE LEADERS... INSIST ON EICO!



NEW 555K MULTIMETER
KIT \$29.95. WIRED \$34.95
20,000 ohms/volt



NEW 950K R-C BRIDGE & R-C COMP. KIT \$19.95
WIRED \$29.95



320K SIG. GEN. KIT \$19.95. WIRED \$29.95

NEW 322K SIG. GEN.
KIT \$23.95. WIRED \$34.95



NEW 1040K BATTERY ELIM.
KIT \$25.95. WIRED \$29.95



511K VOM
KIT \$14.95
WIRED \$17.95



NEW 526K MULTI METER
KIT \$13.90 WIRED \$16.90
1000 ohms/volt

NEW 1171K RES. DECADE BOX
KIT \$19.95 WIRED \$24.95



NEW 625K TUBE TESTER KIT \$34.95
WIRED \$49.95



145K SIG. TRACER KIT
\$19.95
WIRED \$28.95



NEW 315K DELUXE SIG. GEN. KIT \$39.95
WIRED \$59.95



360K SWEEP GEN. KIT \$34.95
WIRED \$49.95

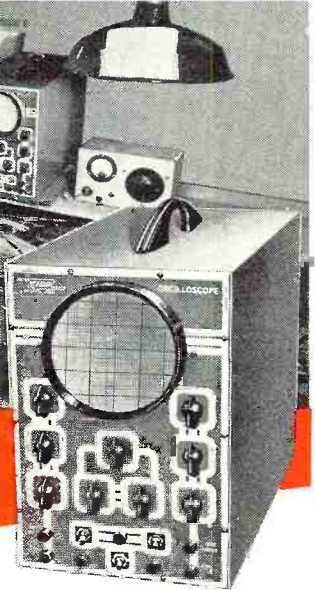

NEW 425K 5" PUSH-PULL SCOPE KIT \$44.95. WIRED \$79.95



NEW 221K VTVM KIT \$25.95 WIRED \$49.95



HIGH VOLTAGE PROBE \$6.95

EICO

ELECTRONIC INSTRUMENT CO., Inc.
84 WITHERS STREET, BROOKLYN 11, NEW YORK

©1951

Prices 5% higher on West Coast. Due to unstable conditions, prices and specifications are subject to change without notice.



Why pick 'em blind?

Buying capacitors by rating without also specifying brand is like buying neckties blindfolded. You just don't know what you're getting. When it comes to capacitors, don't buy blind . . . don't trust to luck . . .

Make Sure! Make it Mallory!

When you use Mallory capacitors for all your service work, you do yourself and your customers a real favor. Mallory capacitors give long, trouble-free performance.



TV and radio set manufacturers accept Mallory FP's as *the* standard of capacitor quality. Operating continuously, even at temperatures as high as 185° F. (85° C.), Mallory FP's give longer, more dependable performance . . . handle higher ripple current.



Mallory Plascaps® give outstanding performance because they are completely engineered to eliminate premature shorts . . . unsoldered leads . . . off-center cartridges. And they are priced right.

You can count on Mallory FP's and Plascaps because they are backed by 25 years of capacitor research and on-the-job experience. Mallory produced the first dry electrolytic capacitors . . . pioneered developments that give you capacitors which are smaller . . . more uniform . . . more resistant to heat. And they cost no more. Don't trust to luck when you order capacitors. Always specify Mallory.

Depend on your Mallory Distributor for quality products at competitive prices.

P. R. MALLORY & CO. INC.

MALLORY

CAPACITORS • CONTROLS • VIBRATORS • SWITCHES • RESISTORS
• RECTIFIERS • VIBRAPACK* POWER SUPPLIES • FILTERS

*Reg. U.S. Pat. Off.

APPROVED PRECISION PRODUCTS

P. R. MALLORY & CO., Inc., INDIANAPOLIS 6, INDIANA