

# RADIO NEWS

AUGUST  
1942  
25c  
In Canada 30c

W. E. Engineer Checking Signal Corps Set



**SIGNAL CORPS MAINTENANCE**  
★ EMERGENCY PORTABLE  
★ ELECTRONICS IN INDUSTRY

# DAVEGA

AMATEUR DIVISION, 63 Cortlandt St., N. Y., N. Y.  
World's Largest Radio Dealer



## Echophone Model EC-3

Now you can buy all these communications features at moderate prices. Echophone, Model EC-3: Crystal filter (four position variable selectivity). Calibrated bandspread, automatic noise limiter. Preselection on all bands. Two stage IF amplifier. Flywheel tuning. Separate 6" PM speaker housed in matching cabinet. CW monitor. 10 tubes. 3 bands. Covers from 550 to 2100 kc.—2.1 to 8.1 mc.—7.9 to 30 mc. Electrical bandspread. Operates on 115 volts AC/DC. Echophone (Model EC-3) \$59.50.

*Immediate Delivery!*

### World's Largest Stock of Recording Accessories

Recording Discs—  
10" Aluminum Seconds Lightweight—Dozen \$3.00  
12" Aluminum Seconds Lightweight—Dozen \$4.20  
10" Steel Seconds Heavyweight—Dozen \$3.25  
12" Steel Seconds Heavyweight—Dozen \$4.80  
Federal 6" Steel—Dozen \$1.00  
Federal 8" Steel—Dozen \$1.50  
Stellite Recording Needles—79c  
Steel Recording Needles—15c  
No order of less than \$5.00 accepted.

## Echophone E. C. 1



6 Tubes  
ELECTRICAL  
BAND SPREAD  
10-550 METERS  
IMMEDIATE DELIVERY

**\$24<sup>50</sup>**

## ★ SPECIAL ★ *Extreme Value!*

Leach Recording Panel  
Aluminum turntables  
Tangent geared Cutting Arm  
78 R.P.M.  
Split phase Capacity G E Motor  
Less Cutting Head  
Fits any standard cutting head

**\$19<sup>95</sup>**  
A. C.-60 Cycles

## ECHOPHONE EC-2

The communications buy of the year! 8 tubes. 3 bands. Tunes—from 550 kc. to 30 mc. Five-inch PM dynamic speaker. Pre-selection on all bands. Calibrated bandspread scale on 80/40/20/10 meter amateur bands. Automatic noise limiter. Electrical bandspread. Operates on 115 volts AC/DC.



**\$42<sup>50</sup>**

## ★ SPECIAL ★

Presto Model 16X Recorder  
16" Turntable; 2 Speed  
Hi Fidelity Cutting Head  
4 Stage Amplifier  
Lathe Type Cutter mechanism  
Frequency Range 50-7000 Cycles  
Special \$425.00

AMATEUR DIVISION  
63 CORTLANDT STREET  
NEW YORK, N. Y.

# DAVEGA



**J. E. SMITH, President  
NATIONAL RADIO INSTITUTE  
Established 27 Years.**

He has directed the training of more men for the Radio Industry than any other man in America.



**BROADCASTING** and other type Radio Stations employ Radio Technicians and Operators with average pay among the country's highest paid industries.



**RADIO REPAIRING**, a booming business right now, with no new sets being made, pays many \$30, \$40, \$50 a week for full time—\$5, \$10 extra a week for spare time work.



**LOUD SPEAKER SYSTEMS**, a growing field, require many trained Technicians, offer good opportunities for the future.

### I Trained These Men



**Chief Operator Broadcasting Station**  
"Before I completed your lessons, I obtained my Radio Broadcast Operator's license and immediately joined Station WABC where I am now Chief Operator." **HOLLIS F. HAYES**, 327 Madison St., Lapeer, Mich.

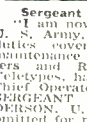

**Sergeant in Signal Corps**  
"I am now a Sergeant in the U. S. Army, Signal Corps. My duties cover Radio operating, maintenance of Army Transmitters and Receivers, operating Teletypes, handling duties of the Chief Operator in his absence." **SERGEANT RICHARD W. ANDERSON**, U. S. Army (Address omitted for military reasons).



**\$10 a Week in Spare Time**  
"I repaired some radio sets when I was on my tenth lesson. I really don't see how you can give so much for such a small amount of money. I made \$600 in a year and a half, and I have made an average of \$10 a week—just spare time." **JOHN JERRY**, 1729 Penn St., Denver, Colorado.

# I will send you a Lesson Free to show how I train you at home in spare time for Good Jobs in Radio

Here is a quick way to better pay. Radio offers you the opportunity to make \$5, \$10 a week extra in spare time a few months from now and to prepare for good full time wartime or peacetime Radio jobs paying up to \$50 a week. **MAIL THE COUPON**. Get my Sample Lesson **FREE**. Examine it, read it—see how easy it is to understand. See how I train you at home in spare time to be a Radio Technician.

**Why Many Radio Technicians I Trained at Home Make \$30, \$40, \$50 a Week**

The Radio Repair Business is booming now because manufacturers have stopped making new home and auto sets and the country's 57,400,000 sets are getting older, requiring more repairs, new tubes, parts. This is opening new opportunities for full time and part time Radio Technicians to get good jobs or to open their own Radio repair businesses. Radio Technicians and Operators hold good jobs in the country's 882 Broadcasting Stations and in Aviation, Commercial, Marine and Government Radio. Loud Speaker Systems give good jobs to many. The Government is calling for Civilian Radio Operators and Technicians. Government orders for millions of dollars worth of Radio equipment offer opportunities in Radio Factories. Men with Radio Training are in line for extra rank and pay in the Army and Navy. Many Radio developments such as Television and Frequency Modulation, held back by the war, will make Radio a live-wire field for the future.

**My 50-50 Method Gives You Both Training and Experience**

My Course is thorough and practical. I give you basic training in Radio Theory and Practice which enables you to understand the operation and design of practically every type of Radio apparatus. You understand your work—know what to do—instead of merely relying on your mechanical ability to fix a few common Radio faults and make a few adjustments. That's why many men who have been in Radio before they enrolled report that my Course helped them make more money, win success. I train you, too, for Television—a mighty important branch of Radio for the future.

**Beginners Quickly Learn to Earn \$5, \$10 a Week Extra in Spare Time**

Due to the boom in the Radio repair business, practically every neighborhood offers opportunities for a good part time Radio Technician to make extra money fixing Radio sets. I give you special training to show you how to start cashing in on these opportunities early. You get 6 Big Kits of Radio Parts and instructions for conducting experiments and building test equipment to help you do better, faster Radio repair work. My 50-50 method—half working with Radio parts I send you, half studying my Lesson Texts—makes learning Radio at home interesting, fascinating, gives you valuable practical experience.

**Find Out What Radio Offers You—Mail Coupon**

Get my **FREE** Lesson and 64-page Book, "Rich Rewards in Radio," at once. See what Radio offers you as a skilled Radio Technician or Operator—both **TODAY** and **FOR THE FUTURE**. Learn how practical—how easy to understand—how thorough my Course really is. Read letters from more than 100 men I have trained so you can see what they are doing, earning. Mail the Coupon **NOW**—in an envelope or paste it on a penny postcard.

**J. E. SMITH  
President, Dept. 2HR  
National Radio Institute  
Washington, D. C.**

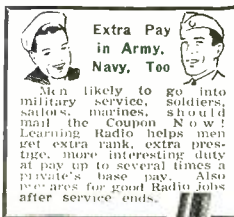

**Extra Pay in Army, Navy, Too**

Men likely to go into military service, soldiers, sailors, marines, should mail the Coupon **NOW!** Learning Radio helps men get extra rank, extra prestige, more interesting duty at pay up to several times a private's base pay. Also prepares for good Radio jobs after service ends.



**THIS FREE BOOK HAS HELPED HUNDREDS OF MEN MAKE MORE MONEY**

**TRAINING MEN FOR VITAL RADIO JOBS**

### SAMPLE LESSON FREE

Get my Sample Lesson "How Radio Programs are Sent from the Studio to Your Home." It traces a Radio program from the studio microphone to your loud speaker. 32 diagrams, pictures and photographs explain every step clearly. You learn the appearance and use of Radio parts. Learn to read simple diagrams, become acquainted with coils, condensers, resistors, power supplies, sound, modulation, R. F. and A. F. circuits. See for yourself how complete, how practical my Lesson Texts are. **MAIL THE COUPON—NOW.**

## Good for Both 64 PAGE BOOK Free SAMPLE LESSON Free

**J. E. SMITH, President, National Radio Institute Dept. 2HR, Washington, D. C.**

Without obligating me, mail your Sample Lesson and 64-page Book **FREE**. I am particularly interested in the branch of Radio checked below. (No salesman will call. Write plainly.)

- |  |  |
|--|--|
| <input type="checkbox"/> Radio Service Business of My Own  | <input type="checkbox"/> Aviation Radio Stations                           |
| <input type="checkbox"/> Service Technician for Radio Stores and Factories   | <input type="checkbox"/> Operating Broadcasting Army, Navy, Radio Stations |
| <input type="checkbox"/> Spare Time Radio Servicing  | <input type="checkbox"/> Operating Police Radio Stations                   |
| <input type="checkbox"/> Auto Radio Technician (if you have not decided which branch you prefer—mail coupon for facts to help you decide.) | <input type="checkbox"/> Operating Ship and Harbor Radio                   |

Are.....

Name .....

Address .....

City..... State..... 2HR





Trade-Mark Registered

VOLUME 28

NUMBER 2

The Technical Magazine devoted to Radio in War, including articles for the Serviceman, Dealer, Recordist, Experimenter and Amateur

# Contents for August, 1942

## FEATURES

<b>Signal Corps Maintenance</b> .....	Lewis Winner	<b>7</b>
<b>Civilian Schools Teach Radio Ops</b> .....	Pvt. P. R. Howland	<b>10</b>
<b>Field Strength Meter for Induction Control</b> .....		
.....	Milton T. Putnam and Stephen F. Bushman	<b>14</b>
<b>Silent Air Raid Wardens</b> .....	Ted Healy	<b>17</b>
<b>Sensitive VTVM for AC, DC, and RF</b> .....	Rufus P. Turner	<b>18</b>
<b>Centralized Sound in a Naval Station</b> .....	Sidney Harman	<b>20</b>
<b>FM for Ships at Sea</b> .....	Seldon Summers	<b>23</b>
<b>Emergency Portable for Existing Channels</b> ...	Oliver Read, W9ETI	<b>24</b>
<b>Electronics in Industry</b> .....	S. R. Winters	<b>26</b>
<b>Power Transformer Design</b> .....	William A. Stocklin	<b>28</b>
<b>Non-Metal Shieldings</b> .....	B. H. Porter	<b>33</b>

## INDUSTRY

<b>Spot Radio News in Defense and Industry</b> .....	Lewis Winner	<b>39</b>
--	--------------	-----------

## DEPARTMENTS

<b>Aviation Radio Course, Part 4</b> .....	Paul W. Karrol	<b>30</b>
<b>Practical Radio Course, Part 6</b> .....	Alfred A. Ghirardi	<b>36</b>
<b>Book Review</b> .....	<b>32</b>	<b>QRD? de Gy</b> ..... <b>32</b>
<b>Mrs. Literature</b> ...	<b>38</b>	<b>What's New in Radio</b> <b>38</b>

Copyright 1942  
ZIFF-DAVIS PUBLISHING COMPANY  
Member of the Audit Bureau of Circulations

★ ★ ★ ★ ★

W. B. ZIFF  
Publisher

B. G. DAVIS  
Editor

C. R. TIGHE  
Ass't to the Publisher

### Editorial

OLIVER READ, W9ETI      R. B. FRANK, W9JU  
Managing Editor      Tech Ed (on leave)

WILLIAM A. STOCKLIN      HERMAN R. BOLLIN  
Associate Editor      Art Director

### Advertising

S. L. CAHN      J. M. ECKERT  
Advertising Manager      Central Adv. Mgr.

### Circulation

H. G. STRONG  
Circulation Manager

★ ★ ★ ★ ★

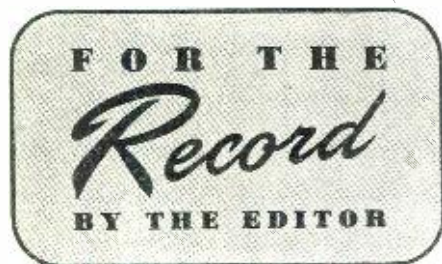

REQUESTS are still pouring into this office for entry blanks for the National Competition for Radio Inventions. So far, a great many radio men have returned their entries and the number is increasing daily. One of the most interesting aspects of the subjects presented is that many of the most valuable contributions are simply *practical ideas*. Some of these are extremely simple in design and show that a great deal of thought has been given by the applicant. It is amazing to learn that we have been overlooking many valuable short cuts that could have been applied to the design, construction and operation of various radio apparatus.

There is still time for those of you who have not already entered your  
(Continued on page 56)

RADIO NEWS is published monthly by the Ziff-Davis Publishing Company at 540 N. Michigan Ave., Chicago, Ill. New York Office, 270 Madison Ave. Washington Bureau, Occidental Hotel, Lt. Col. Harold E. Hartney, Mgr. Subscription Rates: in U. S. \$2.50 per year, single copies 25 cents; in South and Central America and U. S. Possessions, \$2.50 per year; in Canada \$3.00 per year, single copies 30 cents; in British Empire, \$3.50 per year; all other foreign countries \$6.00 per year. Subscribers should allow at least 2 weeks for change of address. All communications about subscriptions should be addressed to: Director of Circulation, 540 N. Michigan Ave., Chicago, Ill. Entered as second class matter March 9, 1938, at the Post Office, Chicago, Illinois, under the Act of March 3, 1879. Entered as second class matter at the Post Office Department, Ottawa, Canada. Contributors should retain a copy of contributions. All submitted material must contain return postage. Contributions will be handled with reasonable care, but this magazine assumes no responsibility for their safety. Accepted material is subject to whatever adaptations, and revisions, including "by-line" changes, necessary to meet requirements. Payment covers all authors, contributors or contestants rights, title, and interest in and to the material accepted and will be made at our current rates upon acceptance. All photos and drawings will be considered as part of material purchased.

IT'S NOT TOO LATE  
 TO WIN GENEROUS CASH AWARDS!  
**INVENT**... *for National Defense*

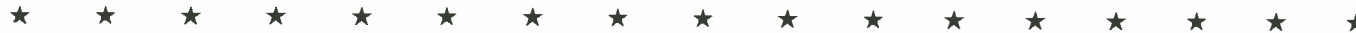

Through the  
**NATIONAL COMPETITION FOR RADIO INVENTIONS**

*Sponsored by*



WIN ONE OF THE VALUABLE PRIZES



**CASH PRIZES TOTAL \$600.00**

- 1st Prize - - - - - \$300.00
- 2nd Prize - - - - - \$125.00
- 3rd Prize - - - - - \$75.00
- 4th through 13th Prizes (\$10.00 each) - \$100.00



WHETHER PRIZE-WINNERS OR NOT, all entries of value to our nation in wartime will be submitted to the National Inventors Council of the U.S. Department of Commerce with the judges' recommendation.

**ANYONE CAN ENTER**  
 providing he is a citizen of the United States or of a friendly nation. *No models are necessary!* You needn't be an expert writer. Just send in your ideas, accompanied by an official entry blank!

**FILL IN AND MAIL THIS COUPON TODAY!**

National Competition for Radio Inventions  
 RADIO NEWS  
 540 North Michigan Avenue  
 Chicago, Illinois

Please send me official entry blank and full details of the National Competition for Radio Inventions. I want to do my part to help us win the war.

My name is.....  
(Please print or write plainly)

Address.....

City & State.....

**YOUR COUNTRY URGENTLY NEEDS TRAINED RADIO TECHNICIANS**



**I'LL TRAIN YOU QUICKLY FOR  
GOOD RADIO JOBS  
... CIVILIAN OR MILITARY!**

**I GIVE YOU FULL RADIO EQUIPMENT  
to do Practice-Giving Experiments!**

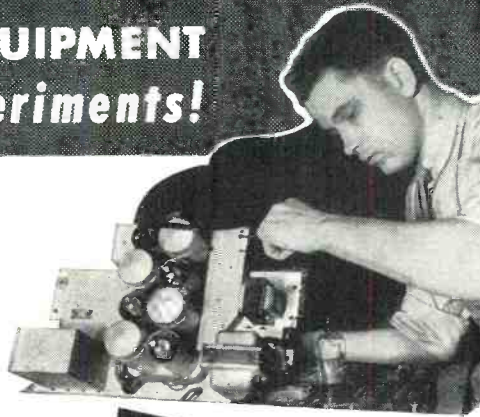

**IF YOU REMAIN A  
CIVILIAN OR ENTER  
MILITARY SERVICE ...  
Radio Training Will  
Enhance Your Future!**  
• READ THESE LETTERS •

**"Grossed Between \$150 and \$200"**  
"Since finishing your training I've started in the Radio repair business. I have about all the work I can take care of. I have grossed between \$150 and \$200 in the last few months in my spare time. I think your course is 'tops'." W. Francis Waseka, Fountain City, Wisconsin

**"Salary Has Increased"**  
"Since I have finished your radio training I had to enlarge my laboratory with some new equipment, as I have all the radio repair that I can handle. My salary has increased to 50 to 75 dollars a week. I install transmitter equipment and public addressing systems. Money can not buy the training that I received through your academy. To all young men that are interested in radio training the Sprayberry Training is the only training. You can not go wrong for I am the one that knows." Asa Smith, Post Box 528, Ft. Leavenworth, Kansas.

**You Learn Easily in Spare Time  
... at Home or at Camp!**

The Sprayberry Course is specially designed for easy understanding. Many practical features are included to help you make fast progress. Beginners need have no fear of "getting lost." The course starts right at the beginning of Radio . . . unfolds each step in a simplified, logical style. You quickly develop a thorough-going knowledge of Radio Set Repair and Installation Work, Mobile Radio (Auto-Tank), Signal Tracing, Aviation Radio, Electronics, Television, Frequency Modulation, etc.

**Training Prepares You for a Business of Your Own ... or Good Radio Jobs at Excellent Pay**

Right now . . . more than ever before, Radio offers amazing opportunities for trained men. Curtailment of new Radio set production insures an ever-increasing volume of civilian Radio Service work . . . to keep the nation's home Radio receivers in good working order. Sprayberry training will give you quick, easy access to a profitable business of your own. Or you can choose an interesting, well-paying Radio job in one of the nation's Radio factories at work on Radio and electrical equipment for planes, tanks, ships, etc. These and many more are the civilian opportunities open to you. Should you enter the armed forces, your Radio training will qualify you for a higher rating—better pay and interesting work. Bear in mind, too, if you enter the Service after you start your Sprayberry course you can easily continue your studies at camp as countless fellows are now doing.

**No Previous Experience Needed**

It makes no difference what your education has been. I can fit you quickly for a good-paying radio job. Your success is my full responsibility. I make it easy for you to grasp Radio principles and remember them. Moreover, your training need not interfere with your present work.

**EASY TO START**

You can get complete details about my course by writing for my new, valuable FREE CATALOG. Mail coupon. No obligation.



**YOU GET A DUAL PURPOSE  
RADIO SET FOR EXPERI-  
MENTS AND SET TESTING**

(1) I supply you with Radio Parts which you use to gain pre-experience in Repair Work. (2) Most important . . . these same parts are used as a Modern Signal Generator and for Signal Tracing, Electric Eye Tube, etc., write for details.

**EARN WHILE YOU LEARN**

Along with your Training, you will receive my BUSINESS BUILDERS which will show you how to put your knowledge to profitable use in handling money-making Radio Service jobs shortly after you begin Training.

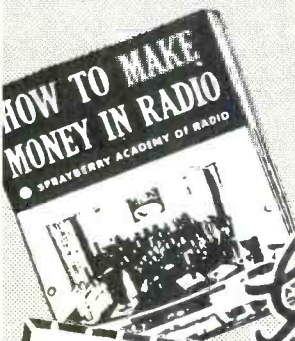

**Get FREE BOOK**

**SPRAYBERRY ACADEMY OF RADIO**  
F. L. Sprayberry, Pres.  
525-H University Place, N. W.  
Washington, D. C.

Please send me FREE copy of "HOW TO MAKE MONEY IN RADIO".  
Name .....  
Address ..... Age .....  
City ..... State .....  
Tear off this coupon, mail in envelope or paste on penny postcard.



**REMEMBER** THE SPRAYBERRY COURSE IS SOLD UNDER MONEY-BACK AGREEMENT

**O**RGANIZING a Maintenance system to provide sufficiently trained personnel, spare parts and repair shops with which to maintain the quarter of a million radio sets and other *Signal Corps* equipment, to be in the possession of the Army by June 30, 1942, has been the job of the *Maintenance Division of the Office of the Chief Signal Officer*.

Satisfactory progress is being made for the provision of necessary men and equipment. The recent establishment of fifteen schools throughout the country for the training of maintenance personnel is greatly facilitating this part of the program. It is expected ultimately to train approximately ten thousand (10,000) radio mechanics in these schools.

There are at present 51 operating repair shops and nineteen new shops under organization. Power tools, hand tools, and other equipment needed for those shops are being supplied. Spare parts for the repair of radios, Aircraft Warning equipment and other electrical communications devices are being shipped to the various shops.

It would be well to explain that the maintenance of *Signal Corps* equipment is done in five echelons. Of these, three are army personnel and two civilian personnel.

The first three echelons, consisting of enlisted troops, are sent into actual combat zones. It is the responsibility of these troops to inspect and maintain all field equipment. Equipment

too badly damaged is returned to "behind-the-lines" repair shops where civilians perform the necessary work to restore it to usefulness.

The fourth echelon consists of repair shops located in the zone of the interior with stationary crews. These shops are manned by civilian personnel.

Personnel in the various *Corps Area* shops are civilians. In these shops, all major repair work is done by civilian mechanics, thereby releasing the regular army maintenance troops for

advanced combat duty and field service.

The fifth echelon consists of shops similar to those in *Corps Areas*, but are part of the larger depots such as those maintained in Philadelphia, Chicago, San Francisco, and the general base at Lexington, Ky. The Philadelphia depot shop alone has more than 400 civilian employees.

Actual servicing and repair work, as well as periodic inspection of equipment, for the most part, is done by civilian personnel as noncombatants.

# SIGNAL CORPS MAINTENANCE

by LEWIS WINNER

***The demand for radio mechanics is on the increase. It is now estimated that schools will train at least 10,000 of these men***

Battalion communication officer preparing his portable radio. Note spare generator in rear.





Officer hands dispatch to motorcycle messenger. Note tied-down antenna.



Students attending this laboratory learn theory of both AC and DC.

Here is a shore party walkie-talkie in operation in the field.



New radio developments of the *Signal Corps*, which include receiving and sending sets for tanks, scout cars and aircraft, demand highly skilled and trained technicians and mechanics for maintenance. The "walkie-talkie" radio, a compact sending and receiving set which can be carried with ease by one man (foot soldier), is one of the most important contributions to efficient army communications.

Such sets go with combat troops under any and all conditions, enabling a commander to direct isolated units toward a common objective. Naturally, this human "radio station" must be practically self-reliant, in that he must be sufficiently well-trained and informed to quickly service or repair minor failures that occur in the field. At "behind-the-lines" bases or depots, this work, as well as major repairs is done by civilian personnel.

The *Signal Corps* also supplies special radio equipment for the *Air Force*, including radio compasses and beacons, switchboards, telegraph, radio sets, field telephones, and other communications equipment. Division Signal companies operate communications facilities and make minor repairs on Signal equipment for all units of the division.

To touch on just one phase of radio maintenance alone, such components and adjuncts as antennae, headsets, microphones, receivers, transmitters, tuners, tubes, batteries, coils, capacitors, power and electrical units—all these must be inspected and serviced by experts in radio engineering and electronics. Special testing devices are required for practically every piece of equipment. Instruction manuals, with schematic drawings listing all tools required and the necessary procedure for detection and correction of most frequent ills or likely failures, are furnished to members of maintenance staffs.

Aircraft Warning equipment is under continuous inspection by mobile repair units. Mobile repair units are actually motorized repair trucks, built and equipped in such a manner that they may be used for dual purpose of preventive as well as corrective service. All necessary tools, materials, instruments, gauges, accessories, parts and even complete exchange units are carried in this vehicle.

All large depots and *Corps Areas* are allotted repair trucks in numbers sufficient to properly service the territory. One trained radio engineer and two trained radio mechanics are assigned to each mobile repair unit. Whether or not these men are army or civilian personnel depends on the zone of their activities; civilians are never sent into combat areas.

In addition to this mobile equipment, *Corps Areas* are provided with at least one or more repair shops in addition to tools, testing equipment, stocks of spare parts, and directions for inspection services. Specialized training at the Aircraft Warning School is given to all personnel of



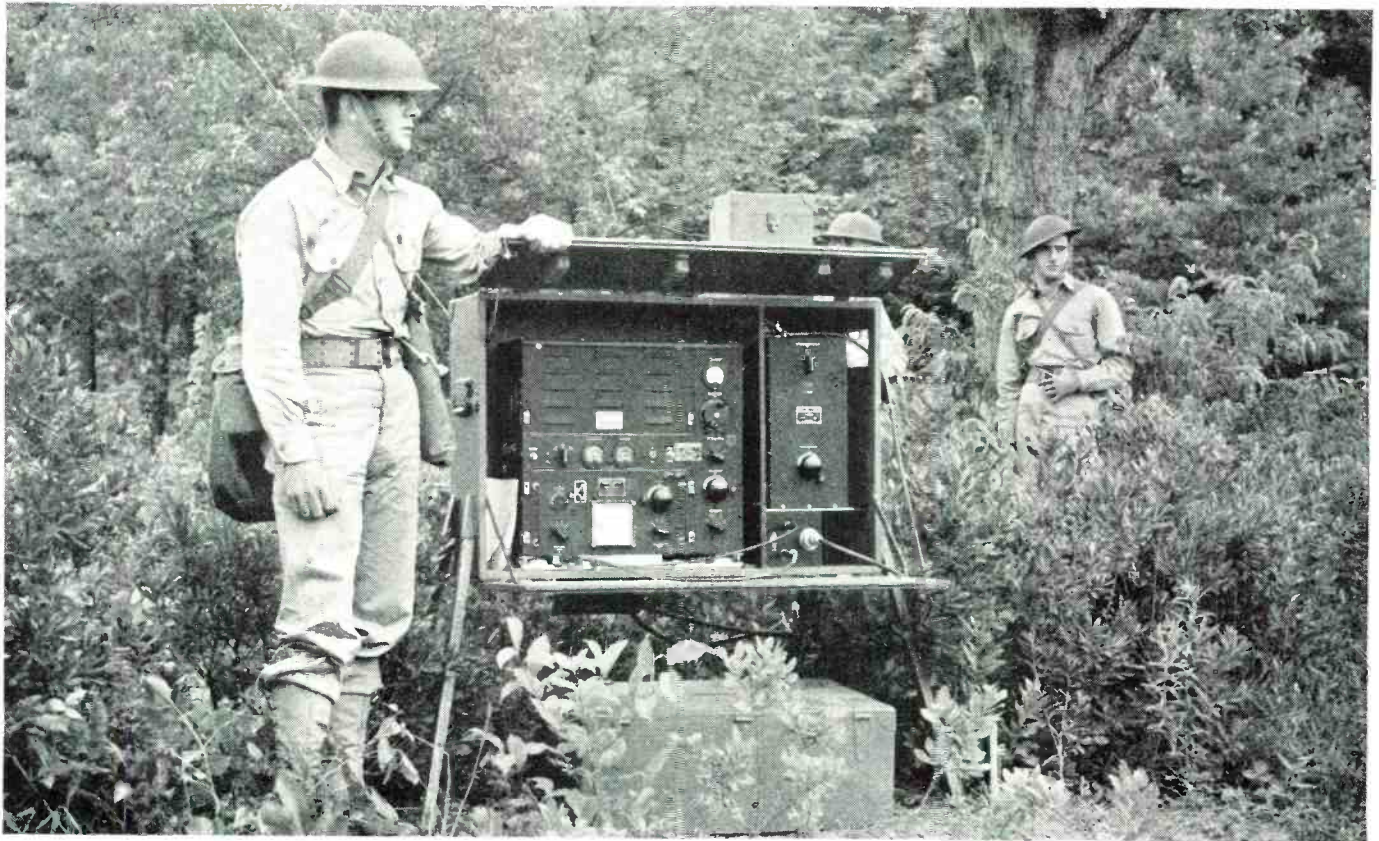

This elaborate field set is housed in a sturdy wood case. Legs are detachable.

*Corps Area* depots assigned to this activity. Here men are trained to establish and conduct an adequate routine inspection and repair service so that detectors will be operative at all times.

In anticipation of the tremendously increased maintenance problem pertaining to *Signal Corps* equipment, an approved requirements program of radio mechanics, to be hired at the rate

of one thousand per month, was started February 1, 1942. These employees will be sent to *Maintenance Division* schools resulting in the formation of a pool which will serve overseas needs, as well as the Continental United States.

Young men qualified and desirous of overseas duty should make application to their nearest *Corps Area Depot Signal* office or write to *Civilian Person-*

*nel Division, Office of the Chief Signal Officer, Washington, D. C., requesting a copy of Form 375. Full particulars may be obtained from this office. No hiring will be done in Washington, D. C., unless men have first been interviewed by their local field office and sent especially for further consultation.*

-30-

An enemy plane is spotted. Operator gives information to headquarters over "walkie-talkie."



# Civilian Schools Teach Radio Ops.

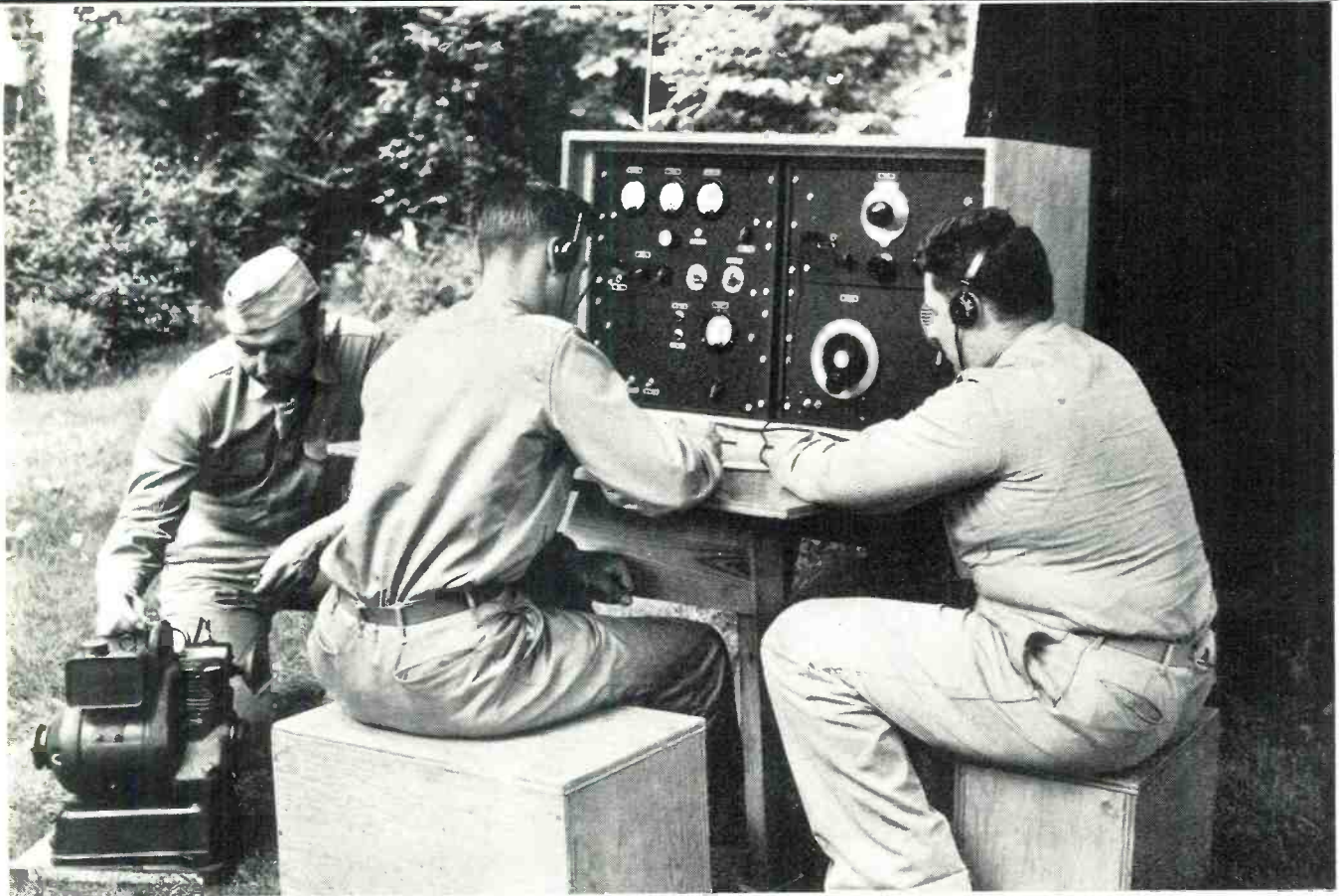

Operators and mechanics apply their knowledge in solving practical field problems.

by Pvt. P. R. HOWLAND

***Radio operators are being turned out by the hundreds in but twelve weeks' time. They can copy on typewriters at 18 wpm***

**D**ESPITE the fact that the U. S. Army has had well established radio schools for training technicians and radio operators for a number of years past, the present emergency has necessitated the training of a quota which these schools were unable to fill, even though running well over their intended capacities.

New schools had to be established quickly; schools which would train competent men in the shortest possible time. But how was this to be accomplished? Would it be possible for the commercial radio schools to train Army operators and technicians? They possessed the needed instructors and some of the equipment necessary. Their knowledge of commercial radio theory and operation would certainly

serve as a stepping stone to Army procedure instruction. Why not give the idea a trial?

With this thought in mind, several commercial schools were approached by the U. S. Army Signal Corps, among which was the *Midland Radio and Television School* of Kansas City, Missouri. Educational contracts were awarded and the intensive training courses were embarked upon.

The training administered by the school proved to be so successful that their contract was greatly expanded. The entire facilities are now being used to train a major portion of the civilian trained Army radio men which have been contracted for by the Army. Under the direction of Captain T. D. Mitchell, the staff is giving instruc-

tion to approximately one thousand men in their Military Radio School which occupies five floors of the Keystone Building.

In addition, the *Signal Corps* stipulated that a complete new military school be established in Athens, Georgia, to serve the various *Signal Corps* organizations and *Service Arms* throughout the southeastern United States.

The purpose of this article is to portray the functioning of this unique Army-civilian school which is known as *The Fourth Corps Area Signal School*. This school has literally been built from the ground up in an unbelievably short time. The initial class of one hundred men started on March 9, 1942. The entire school under the command of Major Chas. E. Dunn is now running at full speed. Mr. C. L. Foster, who was transferred from the Kansas City School, is now civilian director.

Instructors have been transferred to Athens, Georgia, from Kansas City. There is now a staff of sixteen competent civilian instructors, experts in a broad scope of related radio and operating subjects.

Six hundred men are now undertak-

ing the intensive twelve weeks course with an additional one hundred men being enrolled every two weeks. The problem of quartering this sudden influx of men has been effectively solved by partially leasing three Athens' hotels, the Y. M. C. A., and the Costa Building which has been converted into a dormitory. The *University of Georgia*, located near the school, is providing the meals for the radio students at the cafeteria.

Through the cooperative efforts of the various civilian agencies concerned, these perplexing problems of feeding, quartering, and training have been dealt with most efficiently. Their work has contributed immeasurably to our Victory effort.

#### **Selection of Students**

Men selected to take the prescribed course of studies come from various arms of the service throughout the southeastern United States. A great majority are drawn from strategic *Signal Corps* training fields in Florida. Others are from camps in Louisiana, Mississippi, and adjoining states.

Selection is based on the grade received in the *U. S. Army Signal Corps* Code Aptitude Test as well as general radio background and ability. Selection takes place at the home organization of the individuals chosen.

The training at the Athens School is divided in two major divisions. One consists of the Operator's Course and the other consists of the Mechanic's Course. The two courses run concurrently, each student specializing in one or the other.

The six hundred men of the present enrollment are divided into Companies A, B, C, D, E, and F. Each company consists of one hundred men. Fifty men from each company are trained as operators and the other fifty undergo training as maintenance men.

The actual methods of instruction have been left largely to the discretion of the school. However, general Army methods are pursued.

#### **The Operator's Course**

The Operator's Course comprises twelve weeks of full time training with the object of graduating an experienced operator capable of copying code on the "mill" at eighteen words per minute, or better. In addition, the operator must be thoroughly familiar with the fundamentals of radio theory, radio construction, Army net procedure, and practical field operation.

This twelve weeks' period is subdivided in six sections, each consisting of two weeks. Every two weeks the schedule is altered without disrupting the various training phases of the other students to allow for the new enrollees. New students are roughly classified as experienced in code or inexperienced. Those in the novice class are taught the code sounds by voice until they are sufficiently familiar with the combinations to copy from a code sending machine. The initial speed is six words per minute using a commercial tape composed of five letter code groups. Code practice



This large laboratory is used for training the radio mechanics.



Touch typing is mastered and later combined with code reception.

Advanced operators simulating net procedure with transceivers.



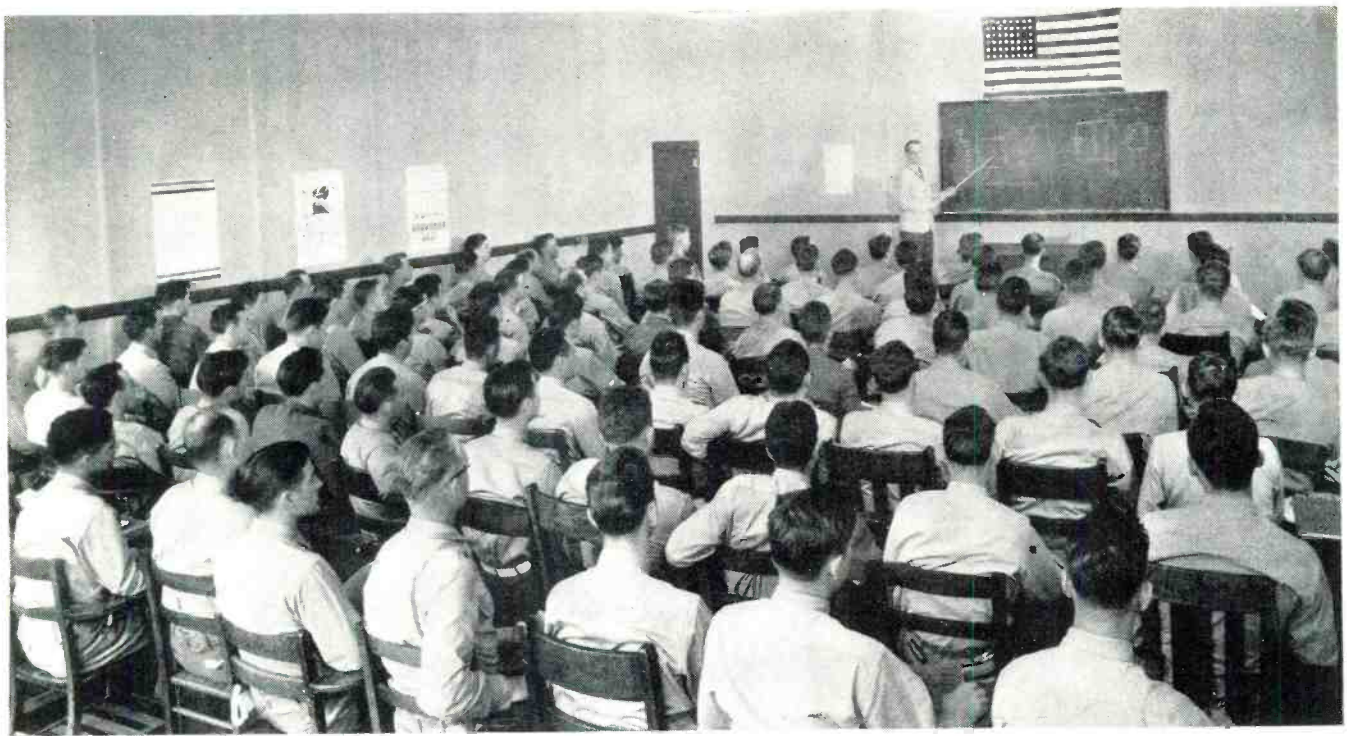

One of the many classrooms at the school. These students are receiving instruction in radio theory.



All mechanics are required to undergo extensive laboratory training.

Operators copying code at various speeds in one of the classrooms.

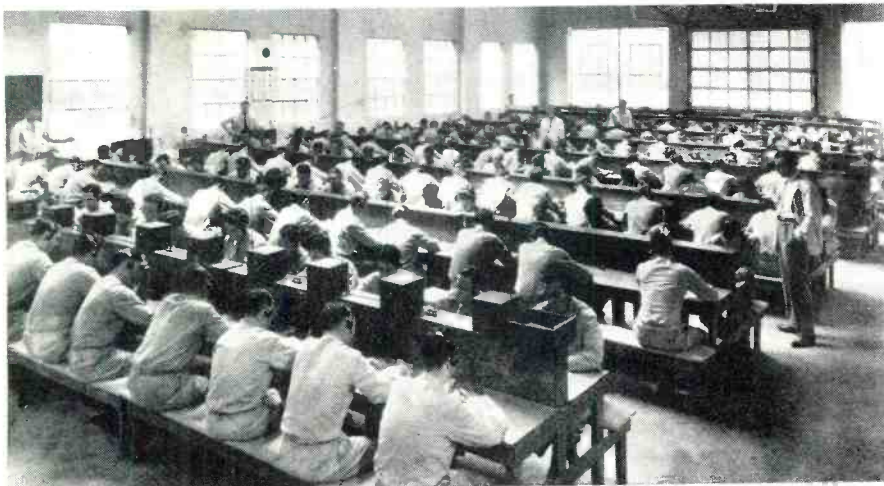

tables, each with an individual sending machine, are arranged so as to allow the student to graduate from one speed to the next higher level in the following order:

- Table No. 1 6 w.p.m.
- Table No. 2 10 w.p.m.
- Table No. 3 14 w.p.m.
- Table No. 4 18 w.p.m.
- Table No. 5 20 w.p.m.
- Table No. 6 25 w.p.m.

Thus an accurate check can be made on each student's progress.

Those students already familiar with code are placed on the faster tables according to their ability. Typical call-ups, message headings, and message texts are sent on the advanced tables to acquaint the student with receiving the message forms that are studied in net procedure classes. This serves a two-fold purpose, as can be seen.

Touch typing is taught throughout the course. As soon as the student is proficient enough in his typing to master a speed of thirty words per minute he is instructed in copying code directly on the "mill." This phase of training is generally reached in the seventh or eighth week.

Code sending is begun in the third week. The sending work includes both elementary practice and actual transmitting work with other students. This serves as a personal check on the quality of their own code and their progress in speed. During net procedure classes the instructors listen to all transmissions of each individual through monitoring earphones. Mistakes in either sending or procedure can thus readily be corrected by him through this synoptic view of the simulated net.

One hour a day is devoted to radio theory during the first ten weeks of the course. Three hours a day are given over to radio theory in a combined class of operators and maintenance men during the last two weeks. The theory classes are based on Midland's specially prepared text. This text follows a comprehensive, step by step instruction format. Practical laboratory work supplements the theoretical instruction during the seventh week. Each student is at that time required to construct a CW transceiver. The student then utilizes this set in net procedure operation.

During actual combat the operators are not required to serve as maintenance men on their own equipment. This is the duty of the mechanic. However, should circumstances deem it necessary, the operators can service as well as operate their own sets in view of the training received.

#### **The Mechanic's Course**

The Radio Mechanic's Course of the Signal School has as its prime objective the training of a man who can build, set up, and maintain a radio in operation over extended periods and under the most extenuating circumstances. This object is achieved through a comprehensive study of theory, practical laboratory work, and field operation.

This twelve weeks' instruction period is divided as follows:

1. Fundamental Electricity and Vacuum Tubes, 6 weeks.
  2. Radio Transmitter Theory, 4 weeks.
  3. Field Radio Equipment, 2 weeks.
- Each course is subdivided into a theory section and a laboratory section.

#### **Fundamental Electricity and Vacuum Tubes**

During this first six weeks a set of twenty-two lessons are covered. A partial list of the subjects includes Ohm's law, alternating current, meters, advanced alternating current, a.f. amplifiers, r.f. amplifiers, oscillation and regeneration, multi-element tubes, and superhet receivers. In the laboratory the student constructs vibrator power supplies and 110 volt a.c. power supplies. Characteristic curves are plotted on vacuum tubes and various detector circuits are built. Many other important experiments are conducted. Section one is consummated by having each student construct a five tube superhet receiver. A delayed AVC (Automatic Volume Control) stage and a BFO (Beat Frequency Oscillator) stage are then added. A seven-tube communications receiver is the final result.

#### **Radio Transmitter Theory**

The Radio Transmitter portion is composed of ten lessons. Crystal controlled oscillators, modulation, antennae, and motor generators are a few of the phases included in the detailed classroom study. Laboratory work includes the construction of numerous types of oscillators among which are the following: Hartley Oscillator, Col-

(Continued on page 44)

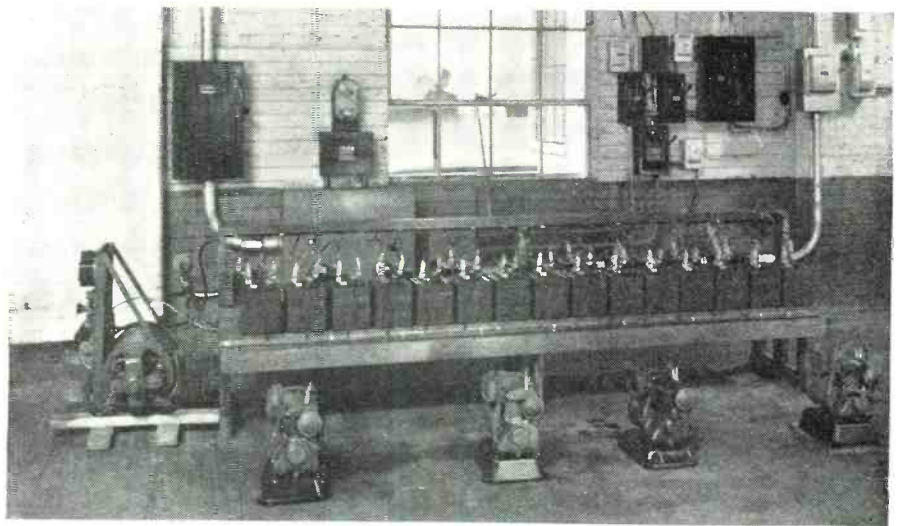

This assortment includes a good supply of motorgenerators and batteries.



This is the main entrance to the Midland school, Fourth Corps Area.

Portable field set in operation to study approved net procedures.

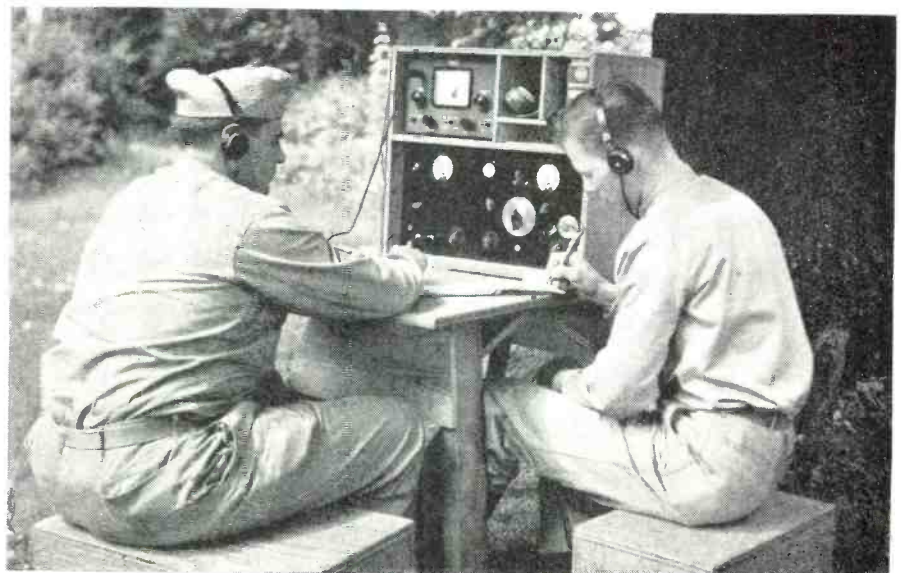

# FIELD STRENGTH METER FOR INDUCTION CONTROL

by **MILTON T. PUTNAM** and **STEPHEN F. BUSHMAN**  
Broadcast Engineer Development Engineer

*This home-built portable meter permits adjustments on low-frequency equipment to be made with good accuracy.*

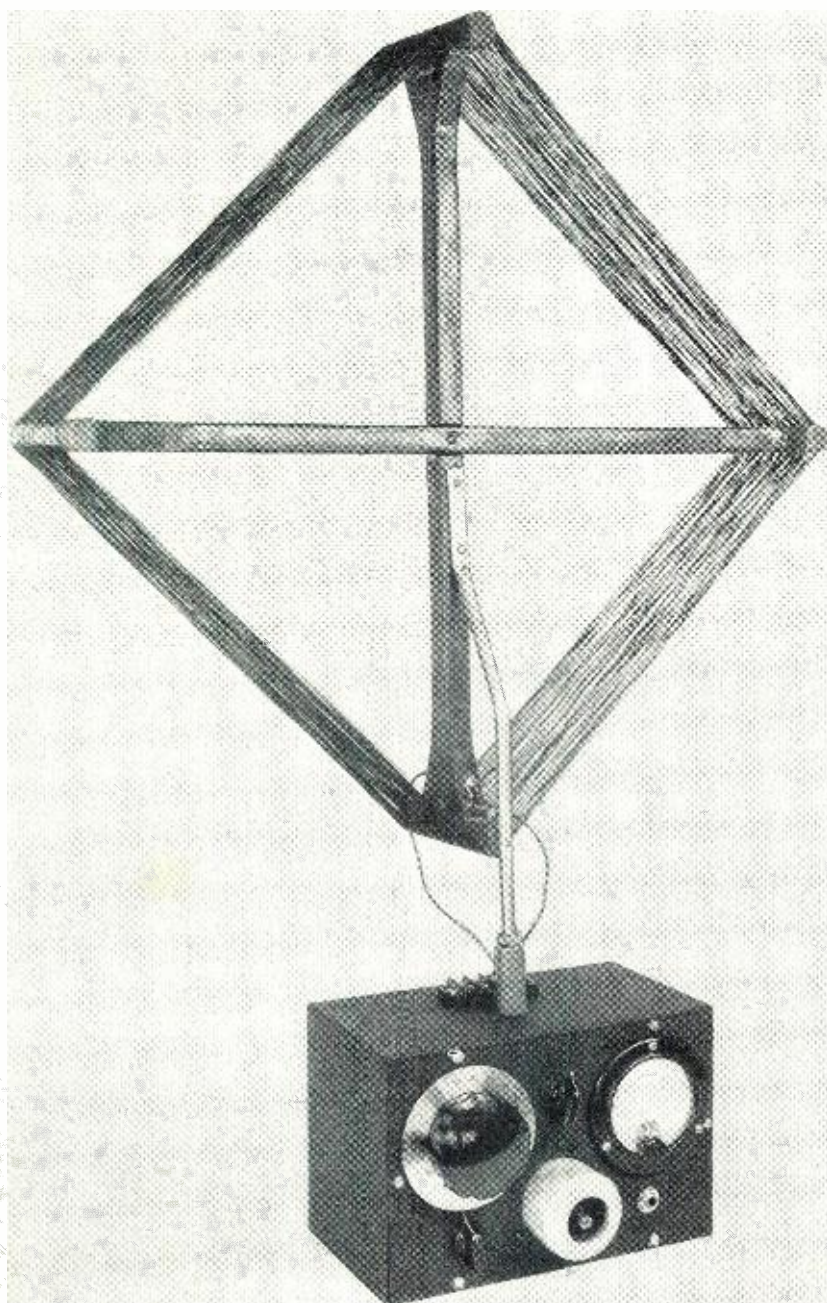

**T**HE field strength meter described in this article was designed and built to satisfy the need for a simple and portable device for checking the strength and quality of the output of low frequency transmitters and oscillators.

As anyone knows who has ever built an induction field transmitter, a phonograph oscillator or any one of a wide variety of low frequency, low powered radio control devices, it is not an easy matter to determine if the field strength produced is actually within the prescribed limits. Fifteen microvolts per meter at a distance of  $\lambda/2\pi$  from the signal source is not a very great field strength but since that is the limit set by the *Federal Communications Commission* for unlicensed transmission, it is important to know how to determine it.

It is possible to calculate the theoretical field strength on the basis of a known r.f. current in a simple antenna such as a loop, but there are several reasons why other means of determining the field strength may be desired. The signal may not emanate entirely from the loop, if one is used, since other parts of the transmitter may be radiating and inducing a field. Then, too, it may be desirable to use a random piece of wire for the antenna, from which it would be very difficult to calculate the field strength. These and a number of other reasons may dictate a means of actually measuring the strength of the field.

It became evident early in this investigation that it was not going to be practical to design an instrument which could be simply and easily built for portable use and which would at the same time have a sensitivity of 15 microvolts per meter at frequencies as low as 50 k.c. The primary limitation or sensitivity is the pickup antenna, since this would have to be physically fairly small in order to be portable, and the voltage induced in any antenna for a given field strength is pro-

Left: Hair combs are used to space wires.

portional to frequency. This means that a loop which would have, as an example, 20 microvolts induced in it at 1,000 k.c., would have only one microvolt induced in it at 50 k.c., if placed in a field of equal strength. Consequently greater amplification would be required, which would in turn require a more elaborate and sizable amplifier.

Since it was intended to make the field strength meter so that it could be exactly duplicated by the home constructor without elaborate equipment, it was decided to use only two tuned circuits and two tubes. The sensitivity obtainable with such an arrangement falls well short of  $15 \mu\text{v}/\text{m}$ , so the possibility of measuring intensity at a point close to the antenna and predicting from that measurement what the strength at a greater distance would be was investigated. The result of the investigation was the chart of Allowable Field Strengths at Various Distances (Figure 1), which is based upon the theoretical distribution of field strength in the vicinity of an antenna, such that the total field strength at a distance of  $\lambda/2\pi$  will be  $15 \mu\text{v}/\text{m}$ . Having this data at hand, it is only necessary to know the sensitivity of the field strength meter, take the measurements at a convenient point and compare them with Figure 1 to determine if the intensity is within the required limits.

As can be seen from the photographs, the field strength meter itself is very compact and light in weight, so that it can be easily carried about. It is built in a 4"x5"x9" steel cabinet, which is just large enough to house the two 45 volt B batteries, the two 1.5 volt dry cells, the meter, the two gang variable condenser, the tubes and associated parts. The loop must, of necessity, be large, in order to be effective at low frequencies. Its dimensions are 15"x15" and the 140 turns are spaced over a width of 4 1/2" to minimize distributed capacity.

The FS meter tunes from 47.5 to 158 k.c. with the loop shown. The loop and



Coils plug in the shield can. Basic instrument is a 0-1 DC milliammeter.

the coil of the only other tuned circuit are made so that they can be plugged in. With the loop and the coil shown, the instrument tunes from 47.5 to 158 k.c. in two steps obtainable by switching in suitable capacities. The meter has been calibrated for sensitivity in this frequency range only, but other frequencies can be had with other inductances. Referring to Figure 2, the sensitivity ranges from approximately 400 to 1400  $\mu\text{v}/\text{m}$ , which is as good as the sensitivity of many portable receivers in the broadcast band.

The first stage of the FS meter is a conventional r.f. amplifier, using a 1N5GT pentode. The loop serves also as the grid coil. A large r.f. choke serves as the untuned plate inductance. One section of the two-gang

condenser tunes the loop, while the other tunes the detector grid coil.

The second tube, also a 1N5GT, is a grid leak detector. This form of detector was chosen because of its high sensitivity to weak signals. The use of a 10 megohm resistor for the grid leak helps both the sensitivity and the selectivity, the former because it enables a large negative voltage to be built up on the grid and the latter because it limits the current flow in the grid circuit, and thus limits the extent to which the tuned circuit is "loaded."

A 0-1 ma. d.c. meter reads plate current in the detector circuit. It serves as the indicator of the field strength. The greater the field strength, the greater will be the signal reaching the detector grid circuit. When a sufficient signal is impressed on the grid,

Fig. 1.

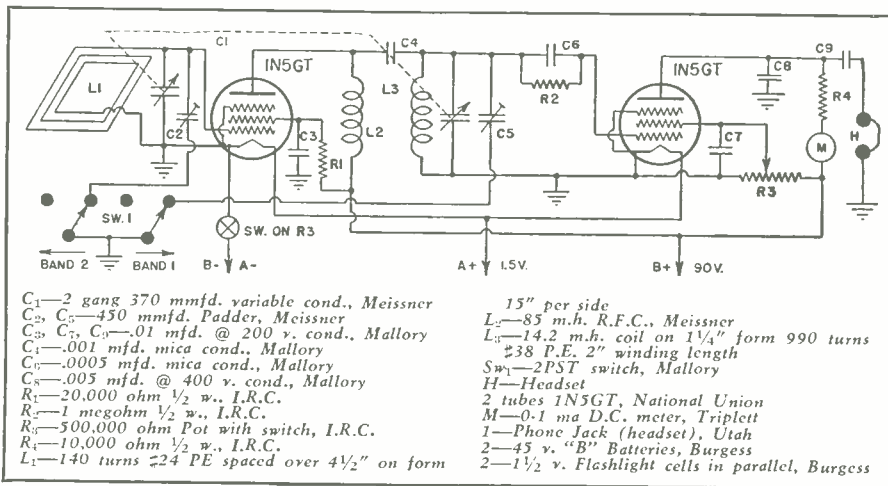
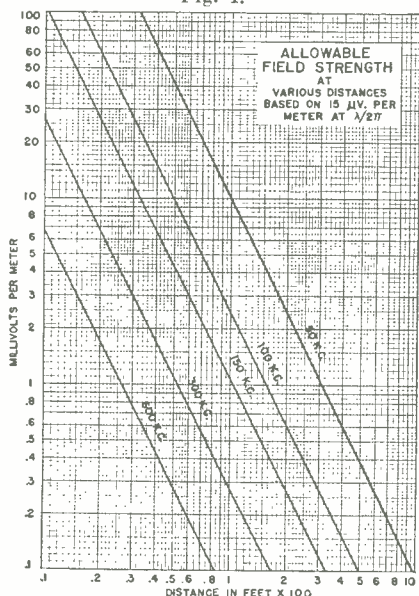

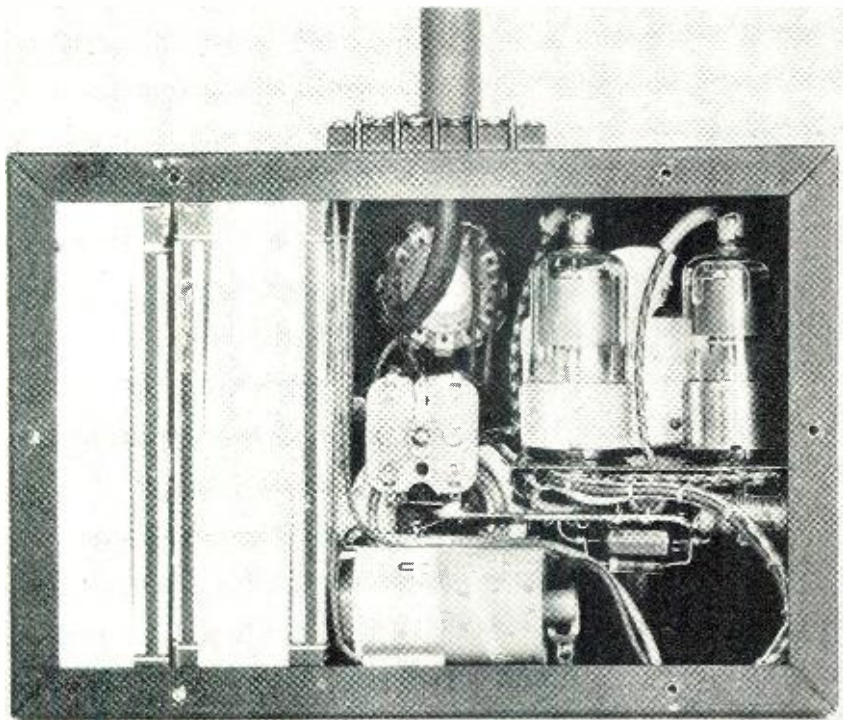

The B batteries fit snugly into the metal case. Cells are held by clips.

grid current will flow in such a direction as to make the grid more negative.

When the grid voltage changes in a negative direction, the plate current is correspondingly reduced and the needle of the 0-1 ma. dips.

To enable the meter to be set at full scale for a reference point, a potentiometer is placed in the screen circuit. Adjustment of the potentiometer causes the screen voltage to be varied, which in turn controls the plate current.

Audio voltage is developed across the plate loading resistor if the signal is modulated. This voltage is coupled to the phone jack for use in monitoring.

Most of the parts mentioned can be seen in the photographs. The shield, visible in the lower central part of the front panel, holds the detector grid coil. On the rear of the shield can is mounted a 4-prong socket for the plug-in coil and two padder condensers for tuning the loop and detector coil on the lowest frequency band. The rotary switch which puts them in or out of the circuit is mounted on the top center of the panel. A little shelf, approximately  $3\frac{1}{2}'' \times 4\frac{1}{2}''$ , holds the tube sockets and associated parts.

The screen potentiometer used for adjusting the meter is at the lower left on the panel. The filament on-off switch is mounted on this potentiometer.

The loop is wound on a wooden frame with round

dowels at the extremities. The dowels are slotted to receive and hold the turns of wire.

The support for the loop is a hollow cylindrical steel piece  $\frac{3}{4}'' \times 1\frac{3}{4}''$ , which makes a good bearing for the  $\frac{3}{8}''$  brass rod support of the loop. The loop is supported so that there is approximately 4" clearance above the cabinet. This spacing is important to maintain the Q of the loop. A terminal block is placed on top of the cabinet to make connection with the loop.

A description of the method of calibrating the FS meter is given at the end of the article, for the benefit of those who have access to the necessary test equipment and who wish to calibrate their own meter. However, it should be possible to duplicate this

device quite closely by following the directions in this article and since the number of parts is small and the adjustments at a minimum, the sensitivity achieved should be sufficiently close to that of the original so that the user can follow the calibration curves shown in this article. The accuracy obtained will of course not be perfect, but should be sufficient to allow the user to operate with something approaching maximum field strength and still keep within the law.

The procedure in determining field strength is very simple. It consists of rotating the loop so that the plane of the loop passes through the source, turning on the filaments, allowing a minute or two for the parts to reach operating temperature, adjusting detector plate current to 1 ma. without signal, and then tuning for the signal. The plate current will decrease (depending upon signal strength). The resultant meter reading is then referred to the chart of field strength vs. meter readings, using the curve nearest the operating frequency and interpolating for maximum accuracy.

The field strength determined should then be referred to the chart of allowable field strengths at various distances, Figure 1 to determine if operation is within allowable limits.

It is to be remembered that there is no assurance that the field strength will positively be  $15 \mu\text{v}/\text{m}$  at  $\lambda/2\pi$  if it is at the allowable level at a closer point. The curves of allowable field strength are calculated from theoretical data which usually holds true, but which can be altered by unusual local condition. Consequently it is advisable to take the readings as far from the antenna as possible and to check field strength in *all directions* from the antenna, rather than in one direction only.

As has been frequently pointed out, there are two components of a radiated field. One component, called the "radiation field," decreases proportionately with distance. If effects of ground and ionosphere absorption and reflection can be ignored.

The other component, called the "induction field," decreases in intensity as the square of the distance. Close to the antenna, that is, up to about  $1/50$  wavelength the induction field strength is considerably greater than the radiation field strength but as the distance increases, the radiation field increases in importance. At  $\lambda/2\pi$  the fields are equal, generally, and beyond that, the induction field rapidly diminishes to insignificance. It is within this area (radius of  $\lambda/2\pi$ ) that the induction field plays its outstanding role.

The two fields are not in time phase as one of them reaches its maximum

(Continued on page 54)

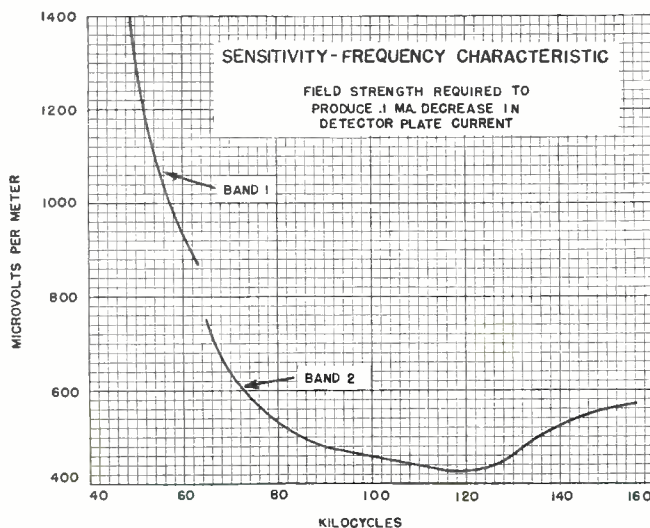
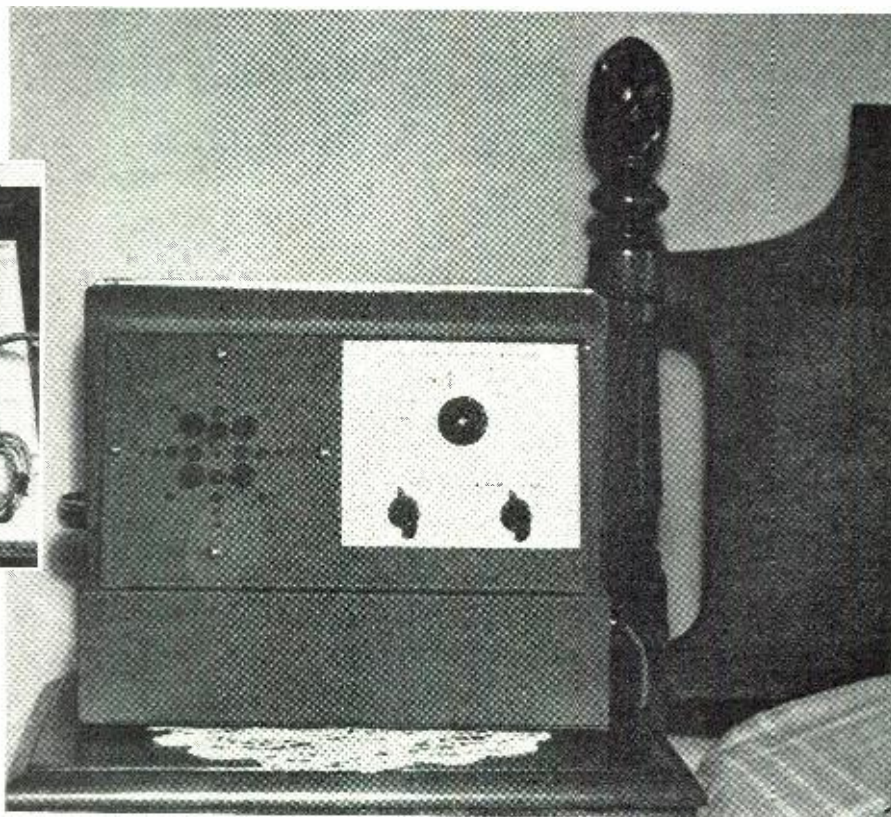

Fig. 2.



Below: National Union alarm installed in a Zenith all-wave portable. Makes an efficient alarm for wardens that move from place-to-place on duty.



**T**HE Silent Air Raid Warden was conceived in December, 1941, and taken from an old idea used by this writer to remote control his amateur station W2BSD back in 1929. No claims are made for its originality since it represents no more than one of the many electronic circuits, but its simplicity and application make it worthy of consideration.

Before going into the construction details of the Silent Air Raid Warden, a word or two about national home defense. Our national and local organizations have tried to plan for any eventuality, but every nation, city and hamlet is now a target for a surprise attack. It is impossible to know in advance when, where and how (if ever), and under what conditions we here in this country will be attacked by our enemies. It is, therefore, unwise to have one set of plans for all possible emergencies.

Realizing this, it can readily be seen that it would not be advisable to have all plans for dealing with our aggressors, known publicly. There is, however, one fairly proven probability that in the event of an enemy attack, all broadcast stations in the vicinity will go off the air. Another method that might be used is that all stations throughout the nation will shut down, later returning to the air synchronized on one frequency. This method would permit the *Interceptor Command* to direct our armed forces, instruct the civilian population without giving away any one position, and upset the enemies' direction finding equipment, causing them to become confused—a very effective weapon that can work both ways. In all probability the Broadcast stations will first leave the air, then return to the air, using one of the many methods, as directed by the *Interceptor Command*.

The Silent Air Raid Warden was designed originally for the thousands of families living in residential areas out of the hearing range of the local siren,

# Silent Air Raid Wardens

by **TED HEALY**

*Here is a simple and inexpensive home-made alarm which can be built by experimenters.*

especially if one is in a sound sleep. In this country Radio will keep the public well informed, but if you live in an outlying residential neighborhood and are in a sound sleep, much precious time may be lost before you are aware of an oncoming attack. It is here that the Silent Air Raid War-

den serves a public need, WHILE IT SLEEPS.

### Construction Details

The Silent Air Raid Warden is little more than a five or six tube portable or midget radio, with a few added parts and slight changes in the wiring.

*(Continued on page 49)*

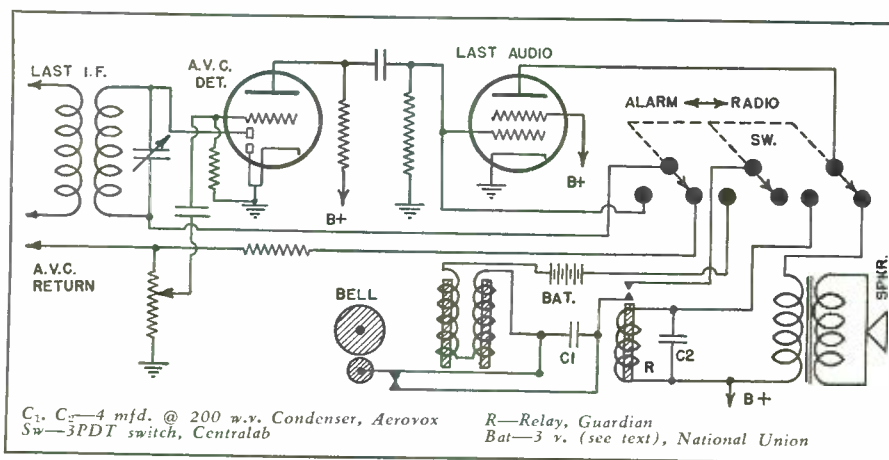

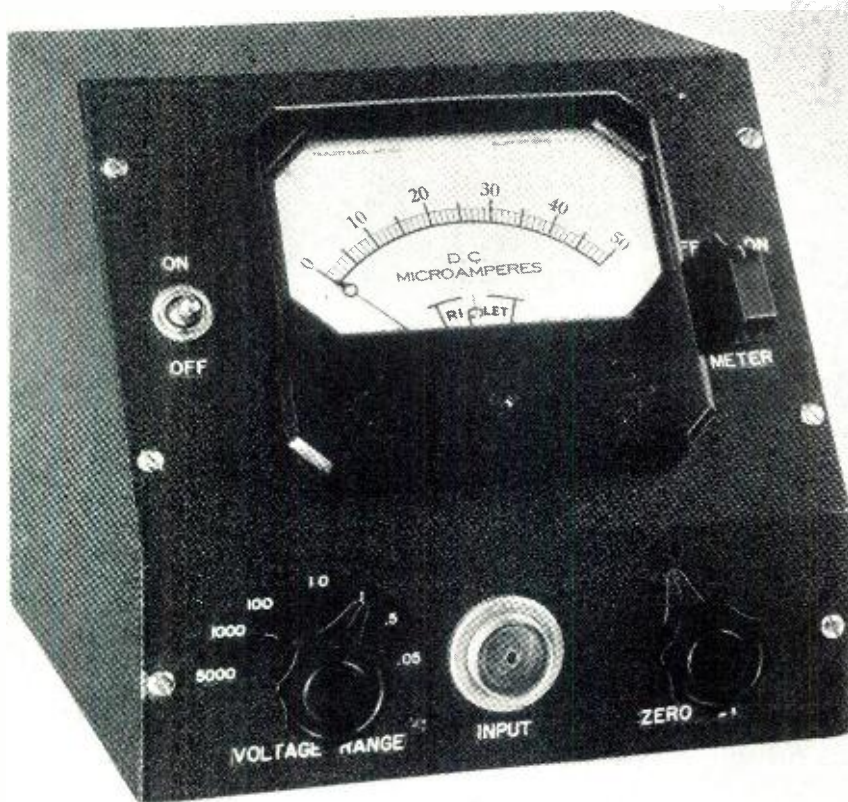

All lettering is made on glazed paper. Strips are held with rubber cement.

# SENSITIVE VTVM for AC, DC, and RF.

by **RUFUS P. TURNER**

Consulting Engineer, RADIO NEWS

***This instrument is capable of measuring low or high values. Seven ranges permit accurate readings. Meter is a 0-50 Microammeter.***

**A** WIDE-RANGE electronic voltmeter is a versatile tool in any phase of radio work. The usefulness of such an instrument is directly proportional to its low-range sensitivity and its high-voltage possibilities.

The vacuum-tube voltmeter described in this article has seven ranges, the full-scale limits of which extend from 50 millivolts to 5,000 volts—complete coverage of 100,000 to 1. The input resistance is constant at 20 megohms for all voltage ranges, and the meter is usable directly for all d.c. measurements, or with an external rectifier probe for a.c. and r.f.

By judicious choice of tube and circuit arrangement, the linear scale of a d.c. microammeter may be utilized directly, although the builder may if he desires make a special multi-range scale to replace the one supplied by the manufacturer.

There is a minimum of adjustments—the voltage range switch and zero-set—and the circuit is simple. This meter offers no outstanding constructional difficulties and may be undertaken by any careful radio workman.

Figure 1 shows the circuit diagram of the instrument. It will be seen that the basis of the arrangement is the

fixed-bias d.c. amplifier employing a 7C6 triode section. This particular tube was chosen because at the rated plate voltage and with one volt of bias, its transconductance is 1,000 micromhos. Operating in this manner, a 1-volt d.c. potential applied to the triode grid will cause a plate-current deflection of 1 milliamperere. Higher voltages may then be measured conveniently with the same arrangement by means of a suitable grid-circuit voltage divider. A further advantage is the linearity of the deflection which permits the use of the standard current meter scale, and the calibration of any convenient point along that scale.

The sensitivity of the circuit is increased by reducing the size of the plate current meter. Thus, by employing a 0—50 d.c. microammeter, rather than the common 0—1 milliammeter, a full-scale deflection of 0.05 volt may be obtained and all higher voltages measured through the grid-circuit voltage divider.

Plate voltage to the 7C6 is regulated at 255 by means of the VR105 and VR150 gaseous tubes in series. Adequate filtration is obtained through the regulator current-limiting resistor, R12, and the filter condenser, C3.

Fixed bias is supplied to the grid of the triode by a 1-volt *Mallory* grid bias cell, BC, connected directly in the grid lead. Several other common methods of bias supply were tested during our developmental work but were discarded in favor of the bias cell because of their tendency to introduce a ripple voltage into the grid circuit or to reduce the effective plate-cathode voltage.

The wirewound variable resistor, R11, is the zero-set control by means of which the instrument is initially zeroed. It will be seen that this control is one arm of a d.c. bridge circuit in the plate section of the layout. The 7C6 plate resistance forms the "missing" arm, and the purpose of the bridge is to balance out the no-signal plate current which is slightly in excess of 1 milliamperere. The resistances, R8 and R9, have been chosen such that the current passing through them is approximately five times the triode plate current. The combined resistances of R10 and R11 at zero balance have been chosen to be equal approximately to ten times the meter resistance. Both of these expedients insure maximum sensitivity with the microammeter shown.

During the initial warm-up period, a current many times higher than the full-scale deflection of the microammeter will flow through the latter and probably damage it if left in the circuit. Consequently, a switch, S2, is provided for the purpose of cutting the meter out of the circuit until the 7C6 cathode has had time to come up to operating temperature.

The capacitors, C1 and C2, by-pass the grid and plate circuits against a.c. or r.f. components, while C4 and C5 are common line by-pass units.



Easier reading of the meter is afforded by using a metal cabinet that is constructed with the panel at an angle. Panel mounts last.

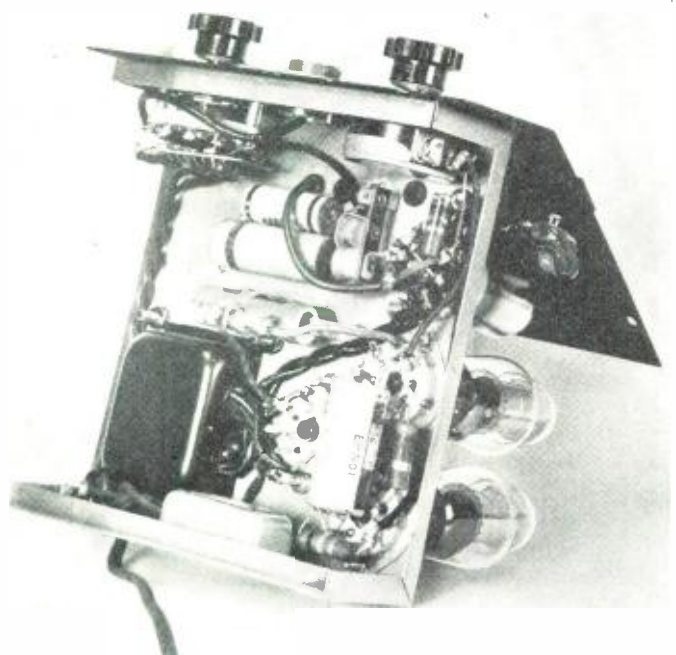

The power transformer is of the closed-shell type. This is very desirable to reduce the stray A.C. fields from sensitive circuits.

The input voltage divider is composed of the resistors R1-R2-R3-R4-R5-R6-R7, a series string which presents a total input resistance of 20 megohms to the voltage source under test. Various points along this string are selected by means of a good-grade ceramic rotary switch, S1.

D.c. input to the instrument is through the coaxial units marked A and B in the diagram. The coaxial line is a low-loss affair insulated with polystyrene beads. The test point of this coaxial probe is inserted into the output pin jack of the external a.c. probe for a.c. measurements. The meter circuit will then read peak values of the rectified a.c.

It was originally intended to employ the 7C6 diodes as internal a.c. rectifiers and to make a.c. measurements as well as d.c. through the coaxial probe. However, the introduction of the diodes into the circuit proved not entirely satisfactory. Appreciable frequency error entered the picture, and the contact potential of the internal diodes necessitated an additional zero-set circuit which hardly seemed worth sacrificing the advantages of an external a.c. probe. The diodes are consequently tied to the cathode at the socket, as shown in the diagram.

The instrument is self-powered and regulated by miniature components such as may be found in any experimenter's junk box or on any enterprising service stock shelf.

The entire circuit is simple and straightforward and does not possess undue complication.

Figure 2 shows the circuit of the a.c. and r.f. probe employed by the writer. This is a miniature unit quite similar to the external probe designed by *General Radio* for their 726-A v.t. voltmeter. A 955 acorn-type tube is connected as a shunt-type diode rectifier to

deliver a d.c. voltage equal very nearly to the a.c. peak value to the d.c. amplifier circuit.

1 and 2 are the probe terminals through which the unknown alternating voltage is applied to the diode circuit, and the leads 3, 4, 5, 6, and 7 pass through a cable for socket connection into the instrument proper. When it is desired to isolate the probe completely from the amplifier circuit ex-

cept to apply the rectified a.c. to the grid, batteries may be used to heat the 955 and the coaxial probe point is inserted into the pin jack shown in Figure 2.

The lead number 3 connects through the socket and plug to the top of R<sub>1</sub> in the input voltage divider. 4 and 5 are shorted by a socket-terminal jumper to connect the bucking battery, (Continued on page 48)

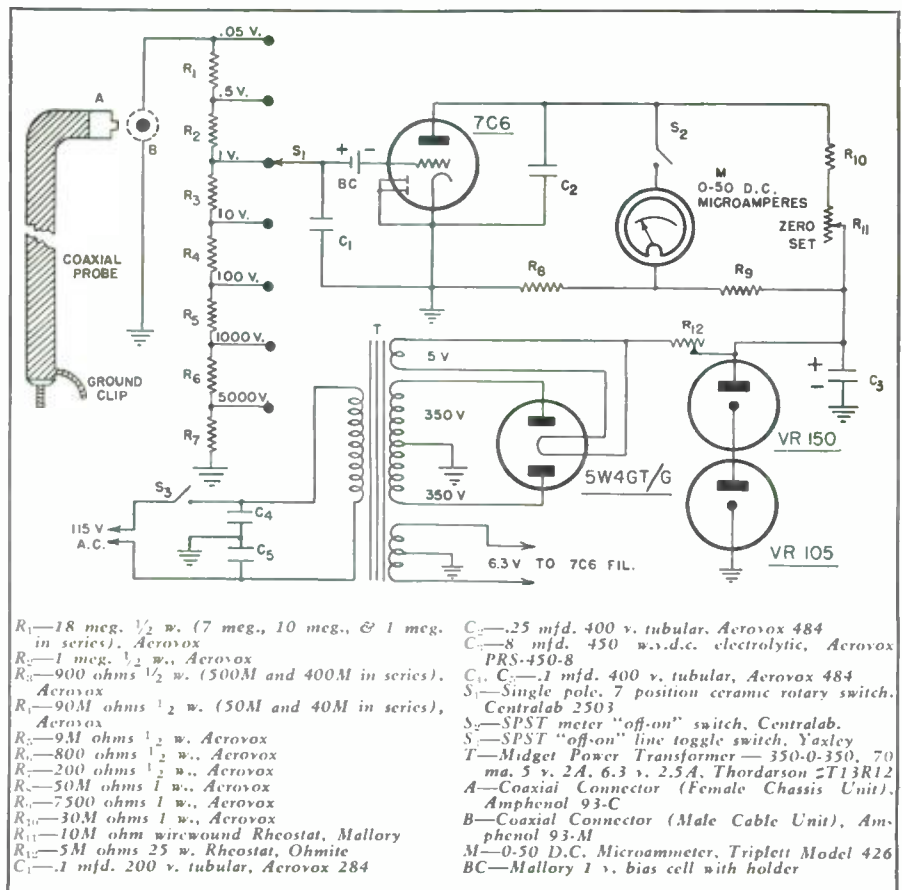

# CENTRALIZED SOUND IN A NAVAL STATION

by **SIDNEY HARMAN**

Sound Engineer, The David Bogen Co.

*The author presents a complete design of a large installation now in operation. The article gives many valuable hints to the radio serviceman.*

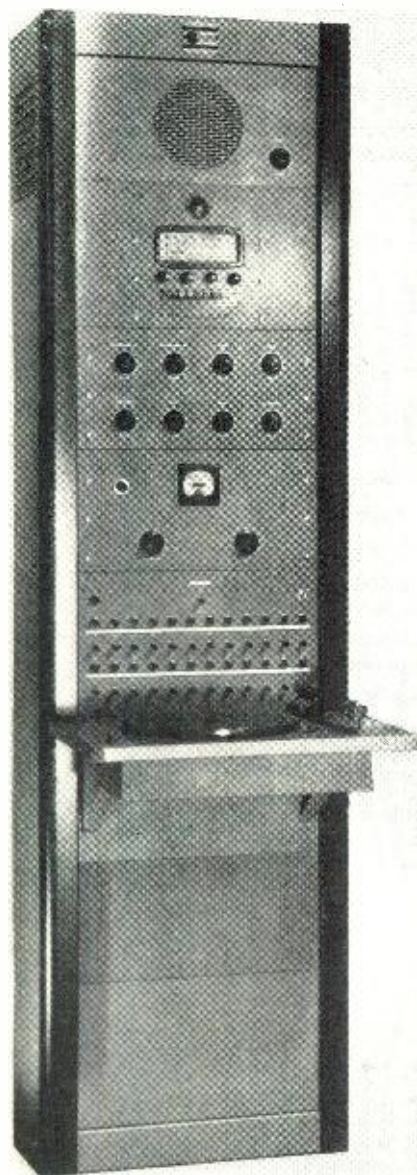

The Central control panel of the elaborate sound system.

**I**N the first of this series of articles, the various functions of the new Centralized Sound Equipment were discussed. It is the intention of this and all successive articles, to take one specific and typical system and to paint its complete picture—to describe its origin, its purpose, its operation.

Sound serves no more worthwhile function than expediting the flow of work, whether that work be the preparation for an attack, the production of arms, or the training of the men who really "Fly 'Em."

The location of the Naval Air Training Station which we shall discuss must for obvious reasons be withheld. Suffice it to say that it is one of the largest, newest and most completely equipped training stations in the United States. Over 1,200 men are in constant training to fly the Navy's PBV, TBD and F4U ships. These are the men who have blazed the story of American freedom at Midway and in the Coral Sea. These are the men on whose shoulders, the burden of the new war at sea has fallen. And in the training of these "flying fools," sound plays a vital role.

The training area consists of seven separate airfields, the administration center, 12 cadet barracks, each housing 100 cadets, the Parade Grounds, Athletic Field, Dining Halls and the entertainment area (Ballroom, Canteen, Bowling Hall, Tennis Courts and Swimming Pool). The system to be described covers the complete station with the exception of the airfields and the administration center. It operates in the essential living and training area and provides means for tying this area into the administration center.

Figure 1 shows the ground layout for the area to be covered. It will be noted that there are twelve barracks, arranged in two parallel sides of six each. For convenient reference, these have been marked No. 1, No. 2, No. 3, No. 4, etc. The other locations are easily identified and require no explanation.

Each barrack is approximately 300 feet by 100 feet and houses 100 cadets. The dining halls are approximately 200 feet squared, seating over 1,000 men each. The ballroom is 300 feet by 150 feet. There are four complete bowling alleys, six tennis courts and a pool 125 feet by 75 feet. The parade ground is, conservatively, 1,500 feet by 350 feet and the athletic field extends over two miles of property.

It was desired to establish a system which would provide for the issuance of orders from the office of the Commandant, in Regimental Headquarters, to each barracks (in charge of a Battalion Commander) individually or to all barracks simultaneously. The system was to operate in such manner that each battalion commander could issue paging calls, announcements and orders of the day to his own barracks and that any call or program originating at the Parade Grounds, Athletic Field or Ballroom could be distributed to other selected areas in the station or to all areas simultaneously.

Telephone lines bring special messages from Washington and vital defense areas into the training station, and it was required that these special messages be transmitted to every point in the system (again selectively, in groups, or all at one time).

It was recognized that many radio programs (presidential broadcasts, news and entertainment, etc.) were of vital interest to the men in training and a tuner was therefore to be included on the Control rack.

For much the same purpose and also to provide martial music for the parade area, a dual speed 16" turntable

*The author of this article, a brilliant sound engineer, is fast becoming an outstanding authority in this very latest field. Special study is required in order to be able to tackle the many problems that must be solved in installations of such magnitude. His analysis of the subject removes many of the problems that confront most men who attempt to install elaborate units like the system described in this exclusive text.*

was incorporated in the Central Control rack. The motor employed was of variable speed so that marching records might be adjusted to the desired tempo.

The Central Control rack (shown in Figure 2) therefore includes a three-band tuner, a 16" dual-speed turntable, the 24 selector switches for the remote boosters (Seventeen are now in use, the additional seven switches are for contemplated expansion of the system), the mixer panel on which are mounted controls for the (1) Central Microphone, (2) Tuner, (3) Phonograph, (4) for the outputs from the Parade Grounds, (5) Athletic Field, (8) Ballroom, and (6) and (7) two special remote telephone lines. On the output meter panel, are mounted master gain and tone controls for the line amplifiers. A monitor speaker, equipped with its own volume control, is mounted on the top panel.

Operation of the system is described in relation to the functional schematic in Figure 3 and reference to that schematic will simplify the analysis. The eight inputs to the mixer pre-amplifier are fed into the line amplifier which feeds out at zero level on a 30 ohm line to the various remote boost-

ers. The diagrams show each of the selective switches in "On" position and it will be noted that a 6 volt indicating pilot light is operated at each switch position. These are all green pilots, and are lit, of course, when the related switch is thrown. The emergency switch throws the output of the line amplifier into the zero level inputs of all the boosters.

The system is operated at zero level throughout, employing standard telephone lines. Thus, if the Commandant at Regimental Headquarters desires to issue an order to Barrack No. 7, he turns up the control of the microphone at the mixer panel, and throws switch No. 7 which causes the related pilot light. Zero level is fed over the telephone line into Booster Amplifier No. 7, and 20 watts of power are then evenly distributed among the 16 eight-inch PM speakers in Barrack No. 7 (8 on each of two floors).

Should the Battalion Commander at Barrack No. 7, who is also Battalion Commander of Barrack No. 8, wish to issue orders to his own barracks, he throws the switch (at switch box) closing his microphone circuit and feeding zero level tapped off Booster Type A into the input of Booster Type B, thereby driving the speakers in Bar-

racks No. 7 and No. 8 with 20 watts to each group of 16 eight-inch speakers. The Grounds Layout, Figure 1, shows the location of the speakers and also of the remote booster amplifier in each of the barracks.

Four twelve-inch Permanent-Magnet cone type speakers, mounted in metal radial baffles are provided in each of the dining halls. The survey disclosed that approximately 30 watts of audio power would be required to adequately cover each of the dining halls, and a special zero level 30 watt booster amplifier was therefore employed. It will be noted from the functional schematic that the power is evenly distributed among the four speakers which are loading a 500 ohm line from the output of the remote booster.

The parade grounds, covering the area between the two rows of barracks is a vital section of the station, and had to be equipped in such manner that parades, drills, and other exercises could be conducted with complete sound coverage. Eighty watts of audio power driving three highly efficient 4½' reflexed trumpets was determined as necessary to adequately accomplish this function, and the *Bogen* E80 booster which is driven to

Fig. 3.

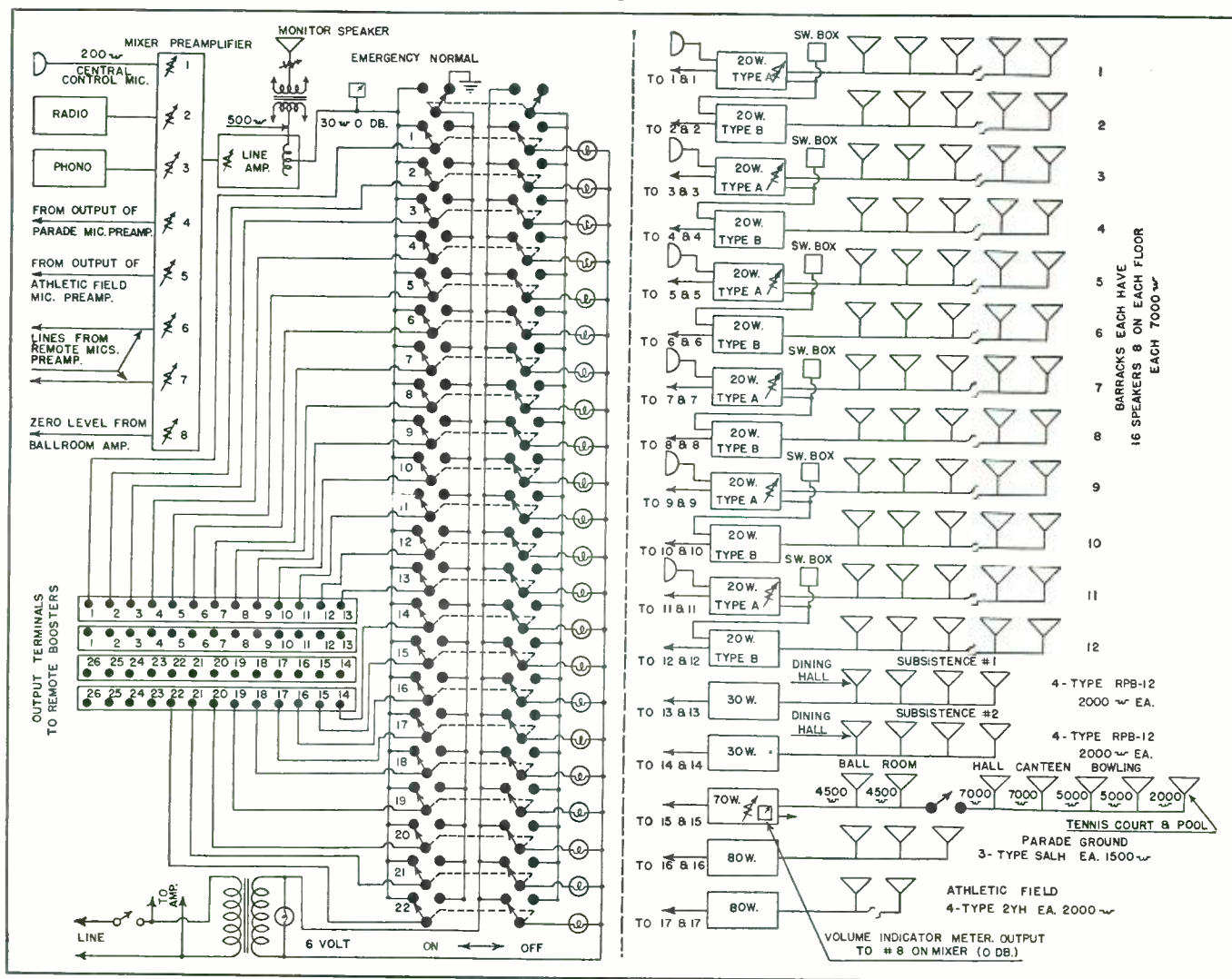

full output by zero level input was selected. The three *Bogen-University* SALH trumpets employ transformers tapped at 1,500 ohms to properly match the 500 ohm output line of the E80, and to distribute the power equally. These three trumpets are mounted in a cluster in front of Barracks No. 7, and the 80 watt amplifier is mounted in a small rack which also houses a pre-amplifier, the function of which is discussed later in the article. This rack is located inside Barracks No. 7.

The spacious athletic field is equipped with two Bull Projectors of the reflex type. A special dual acoustic mechanism couples two 25 watt driver units to each projector and a total of 80 watts is divided among the four horns. These units are so extremely efficient that announcements are readily heard two miles from "homeplate." The E80 booster at the Athletic Field is also mounted in a rack containing a pre-amplifier, and this rack is located in Barracks No. 1.

The Ballroom was provided with a special 70 watt amplifier, equipped with a zero level input and with separate local microphone and phonograph inputs. A switch at the ballroom amplifier permits the speakers for the hall, canteen, bowling alleys and tennis courts to be cut in or out. Thus, when a special program is in progress in the Ballroom, the other locations fed by the E75 amplifier are thrown into the circuit, and when a play or dance is taking place, these other speakers are cut off. Approximately ten watts are required in each of the two 12" cone speakers in the ballroom; 5 watts in each of the two cone type speakers in the hall and canteen; 7 watts in the two metal reflex trumpets in the bowling alleys and 20 watts is required for the 4 1/2' reflex trumpet covering the tennis courts and pool. Reference to the functional schematic will show how these varying power levels are obtained by the use of transformers of different secondary values at the various speakers, to load the 500 ohm output of the amplifier.

The output of the special E75 amplifier is also tapped for zero level and an output meter is built in to indicate this level. The zero level output is fed over a telephone line into the input of the mixer pre-amplifier as shown in the functional schematic, so that the operator of the master control, by turning up Control No. 8 on the mixer, and depressing the appropriate selector switches, can distribute a program taking place in the ballroom to any or all of the barracks and other locations in the system.

We mentioned, earlier in the article that the Parade Grounds and Athletic Field were equipped with zero level pre-amplifiers in addition to the 80 watt boosters. The outputs of these pre-amplifiers are fed into their respective inputs at the mixer pre-amplifier in the Central Control and can then be distributed throughout the system. As a matter of fact, an address at the Parade Grounds is delivered to the Parade Grounds speakers in the very manner outlined above.

The microphone is fed into the pre-amplifier and the zero level output of the preamplifier is fed into input No. 4 of the Central Control. Switch No. 16 is then depressed and the zero level output of the line amplifier is fed over the telephone line into the input of the 80 watt booster. The trumpets are then driven by the booster output.

It can then be seen that any program originating at the Ballroom, Parade Grounds or Athletic Field can be distributed to any part or to the whole of the station.

It will be remembered that there is one Battalion Commander in charge of each of two barracks, and a special zero level 20 watt booster amplifier is located in each of the barracks. These boosters are of two types—Type A and Type B. One type A booster is located in each of the odd numbered barracks (the Battalion Headquarters) and one type B booster is placed in each of the even numbered barracks—see Figure 3. The A type booster has two inputs; one for microphone level and the other for zero level.

The output of Type A feeds its own group of speakers and is also tapped for zero level, to drive Type B booster. Type B has two zero level inputs—one for the output of the A booster and the other for the output of the line amplifier in the central control rack. The output of the B booster drives the speakers in the even numbered barracks. With this arrangement two functions are possible: (1) The Battalion Commander can initiate a program to each of the two barracks under his supervision by using the local microphone at the A type amplifier, or (2) A call or program initiated at the central control can be fed into the zero level inputs of Type A and B boosters by depressing the appropriate switches, and each of the two boosters then drives its own group of speakers.

We spoke earlier in the article of the two telephone lines coming into the Administration Building from points outside the station. These direct Washington calls are then brought into the Central Control rack at Regimental Headquarters into inputs No. 6 and No. 7 on the mixer pre-amplifier and can then be distributed to any or all of the remote booster amplifiers.

It will be seen from the above description that the Centralized System in operation at the Naval Training Station is quite complex, yet it must be pointed out that it is essentially a compromise solution to a problem which might well have been solved in an even more elaborate, more expensive manner.

It was pointed out, at the offset, that a specific appropriation had been allocated for the system, and it was therefore necessary to design it so that all requisite functions would be fulfilled at a cost held within the established limit. The matter of cost is often a prime factor in the design of centralized equipment, and many ingenious devices and developments can be traced to the necessity for accomplishing complex functions with a minimum of equipment. In this system, for example, a limited number of telephone lines was made available, and it became necessary, therefore, to design it so that all necessary operations could be achieved with them.

The system could have been designed so that the filament supply at the remote boosters would always be on and the plate supply would be relay-controlled from the master control in Regimental Headquarters. This is the familiar standby position which throws on the plate supply only when the system is in operation.

Precedence might also have been given to the master control, so that any call originating at the master would take priority over the local microphone programs at the barracks, by opening the local microphone circuit. In order to achieve these two conditions, however, relays and two extra lines to each booster would have been necessary. This would have meant the practical duplication of the

(Continued on page 55)

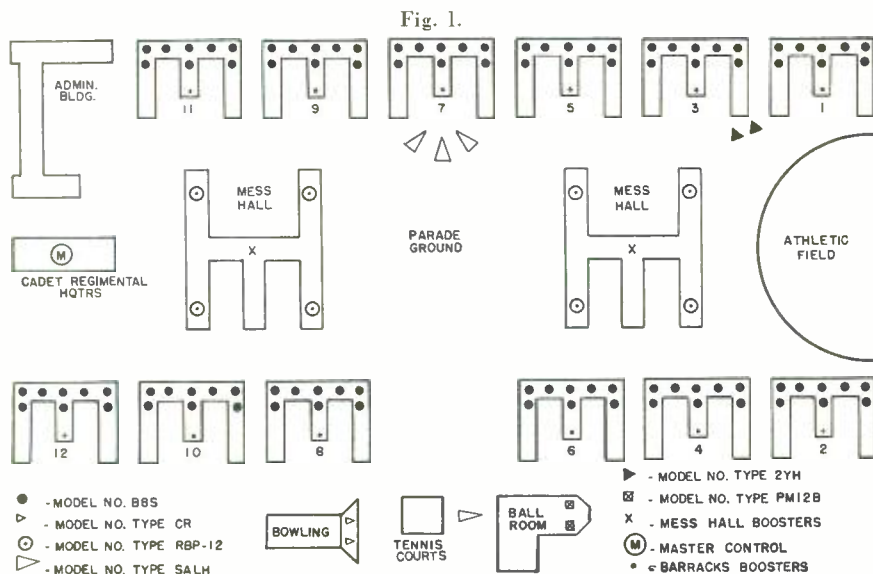

# FM FOR SHIPS AT SEA



This photo was taken during an experiment with FM transmission on one of our navy vessels.

**W**ITH the great United States fleet on the prowl in the Atlantic and Pacific oceans, communication facilities of ships are subjected to microscopic examination. Frequency-modulation radio transmission presents a peculiar problem for ships at sea. Such receivers of the broad-band modulation type favor the reception of signals of larger intensity. That is, of two received signals, one twice as strong as the other, the receiver will receive the stronger to the almost total exclusion of the other.

During engagements, or maneuvers, if two vessels of the fleet are close together and are communicating by frequency modulation, it would be impossible for either ship to receive orders from the flagship, or commanding vessel, if, as is the usual condition, all ships are using similar radio

by **SELDON SUMMERS**

*Flagships may now transmit signals to fleet to break all transmissions and to receive orders.*

equipment, operating at the same power and frequency. This, of course, is due to the fact that the commanding vessel, which may be lying at a greater distance from either communicating ship, finds itself unable to break through. This condition might very well father disaster during times when minutes tick out the destinies of Nations.

A frequency modulation system, or staticless radio has been perfected recently by Hans Roder of the General Electric Company, Schenectady, New York, which allows signals to be

transmitted to a vessel while it is receiving other signals from another ship or transmitting station of far greater signal intensity.

The transmitter comprises an oscillator, which generates a carrier-wave frequency modulated by the modulator, amplified by a power amplifier, and radiated by the antenna. The frequency modulator is equipped with voice communication signal with currents having frequencies from zero to four kilocycles which are supplied over a circuit and switch, in left-hand  
*(Continued on page 46)*



Checking frequency of the portable against crystal-controlled standard.



Ready for service. Note rugged rod mounts.

# EMERGENCY PORTABLE FOR EXISTING CHANNELS

by **OLIVER READ**  
Managing Editor, RADIO NEWS

*This compact transmitter-receiver features crystal control and utilizes standard parts and tube types.*

**I**NDEPENDENT manufacturers of radio equipment have been largely responsible for the great strides taken in recent months in the development of simplified transmitting and receiving sets. No longer is there any place for so-called "gingerbread" within the makeup of these modern units. Simplicity is the keynote and the engineer has responded by cutting down wherever possible on the number of component parts and by general simplification of the circuit designs with the result that not only is efficiency stepped up and the maintenance problem reduced, but the equipment, particularly portables, is greatly reduced in weight. Following this trend, the design of the portable transmitter-receiver, herein described, finds ready application for all short-range com-

munications problems and follows only those circuits which had been found from past experience to be able to "deliver" where more elaborate equipment might fail.

This transmitter-receiver was originally designed for marine use; e.g., a ship-to-barge or barge-to-barge. Later, due to the present war emergency, it was discovered that here was an ideal set-up for short distance communication that can be used on existing channels, both civilian and military.

There is nothing new or sensational with the circuit employed, but it bespeaks careful study and analysis in the selection of every component going into its construction. For example, standard parts and tubes are used throughout which automatically simplifies the problem of obtaining suit-

able replacements if and when required. The use of up-to-date and easily obtained receiving type tubes means that practically every town will be a potential source for tube replacements and it will not be necessary to resort back to the original maker or to one of the larger radio parts jobbers for an emergency replacement.

### **Circuit Design**

The transmitter section consists of a 1LN5 local pentode in a conventional *Pierce* circuit. Note that the crystal X-1 connects directly across the plate and control grid of the tube. A variable plate coil L4 is adjusted to the crystal frequency by adding or removing turns from the inductance. No condenser is used for tuning purpose across L4, there being enough distrib-



uted capacity in the inductance so that no additional capacity need be used. The r.f. output fed through C16 is sufficient to drive the 1LB4 amplifier tube to full output. Resistor R11 is used as a conventional grid resistor and the amount of grid voltage will depend entirely upon the excitation from the oscillator stage. The 1LB4 is also a receiving type pentode. Its plate circuit is tuned by condenser C14, the value of which will be governed by the operating frequency of the transmitter. For lower frequencies, around 3 mc., a capacity of approximately 100 mmfd. is required. No specifications for the coils will be given, as this will depend entirely upon the frequency employed. Coupling to the antennae which is a collapsible type fish pole is provided by inductance L3.

The entire loading for proper plate current of the 1LB4 will depend upon the number of turns and the amount of coupling between the antenna and plate windings of L3. Once adjusted, proper loading will be had as long as the antenna is extended to the same height each time the set is placed into operation.

The modulator tube is a 1LB4 and, in this combination, it serves both as a modulator and as an audio amplifier for sending and receiving respectively. A 4-pole, two-position lever type switch makes the necessary circuit change, so that in its normal position, the receiver will be in operation and the speaker will be connected in customary manner. In send position, the speaker becomes a dynamic microphone and its output is fed into the primary of the audio transformer T3

and its output fed into the control grid of the 1LH4 (triode section) of this diode-triode. The signal is again fed back through C11 into the control grid of the 1LB4 modulator and is of sufficient amplitude to drive this tube to full output.

The transformer T4 is so designed that it may serve either as an output

transformer or as a center-tapped modulator choke when the switch is placed in the send position. Note that both the screen and the plate of the 1LB4 r.f. amplifier are modulated. This makes for better linearity and the usual screen dropping resistor may be eliminated due to the low voltage

(Continued on page 52)



The complete assembly includes the single A, and 2 B batteries.

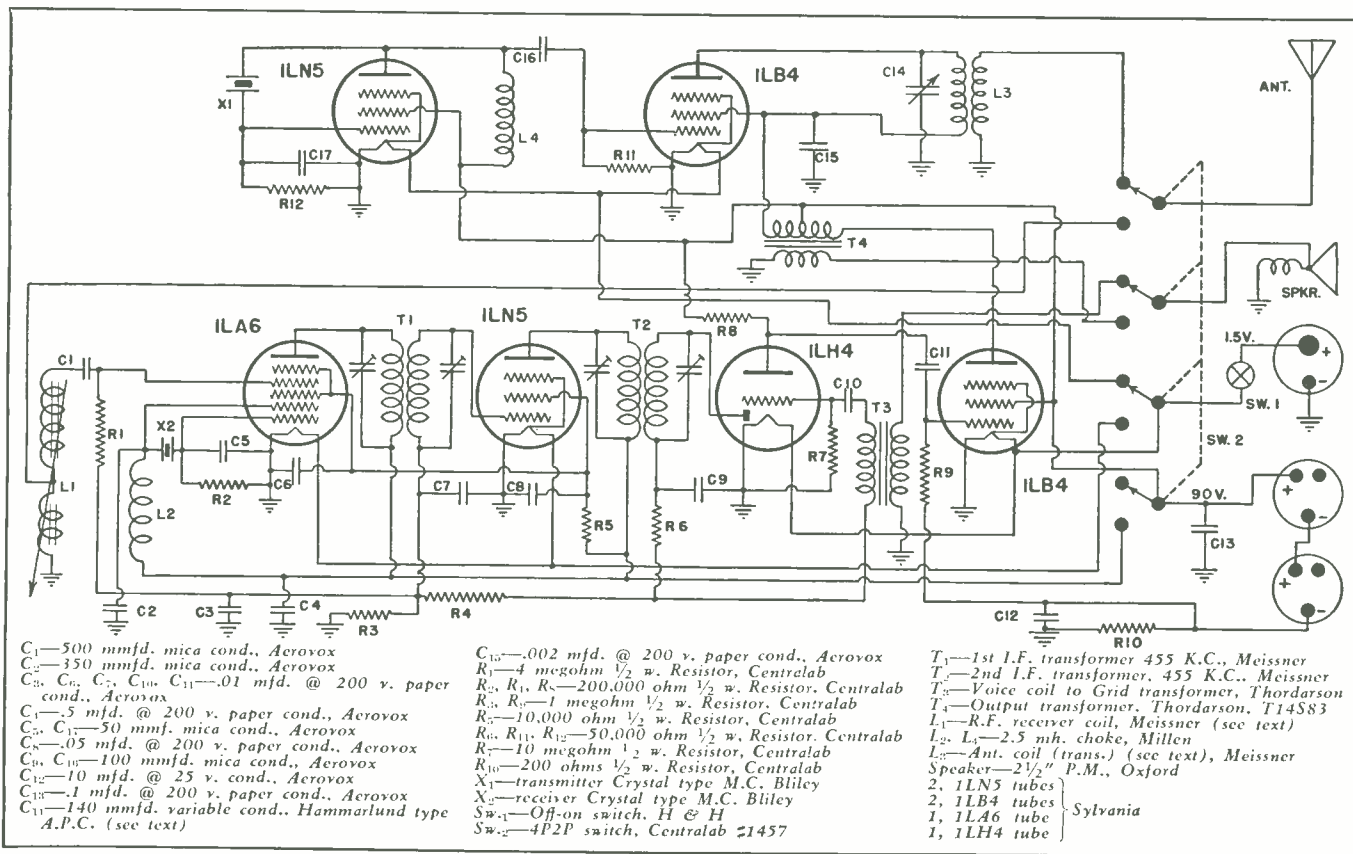



These kitchen-to-dining room doors open automatically.

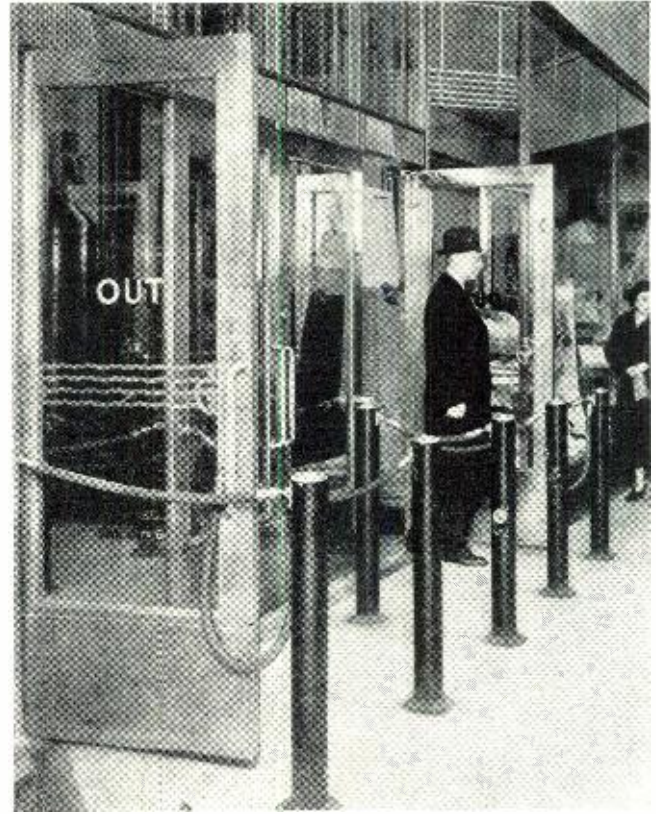

Department store doors controlled by photo cell unit.

# ELECTRONICS IN INDUSTRY

by **S. R. WINTERS**

Washington, D. C.

***This is the first in a series of articles which will prove extremely helpful to radio servicemen.***

**T**HE science of electronics is "electrifying" a nation. Though the smallest unit of matter, the electron, is performing an elephant's job as an industrial robot. Literally and figuratively, the electron tube—with a stream of electrons flowing across space in a vacuum or gas-filled bulb—is forming thousands of electrical bridges for as many different industrial applications. The phototube—in its uncanny function when occupying the path of a beam of light which, either interrupted or established, stops or starts a flow of electrons—is lending itself to such an astonishing number of uses as to be comparable to the fecundity of Kansas grasshoppers.

The electronic products of the *General Electric Company* alone, total close to one thousand—with no limit in sight. Then, too, the variety of uses of the phototube, first cousin of the radio tube, is such, as to defy def-

inition and render impotent the proverbial "57" varieties by comparative description. Moreover, the future of electronics is so challenging as to write the prophetic phrase, "Coming? The Age of Electrons." Charles E. Wilson, president of the General Electric Company, has said: "Perhaps we should call electronics the fire of the future. Like fire, it can be a savage foe or a powerful servant. Like fire, it is almost universal in its potential applications to our lives. Fire was a gift to the barbarians which men have shaped to their uses. Electronics has been no gift. The men of science learned its secrets and earned its blessings during decades of unremitting toil, patience, trial and error, and brain work. To most people, electronics is radio, with all of its entertainment, communication and service. But the electronic tube, so innocent and so mysterious to a layman's eyes,

will touch you, in the years to come, wherever and however you live—your sight, hearing, and taste, the food you eat, the healing of your body, the safety of your home, and the tremendous progress of your business, whatever it may be."

Today, electronic products are being employed for opening doors, leveling elevators, limiting motions, bringing out exactness in registering in printing presses, straightening cloth in textile machinery, controlling punching presses, timing welding operations to give exact welding performance, counting, calculating, controlling lighting and illumination levels, detecting metals, locating defects and pinholes in metals, as smoke indicators, and in a score of measuring instruments for measuring sound and vibration, color, light, frequency, speed, thickness, pressure, temperature, turbidity; as relays and telemeters, as power recti-



G.E. blackout photoelectric eye focused on streetlight.



Lights in this classroom are turned on by photo-units.

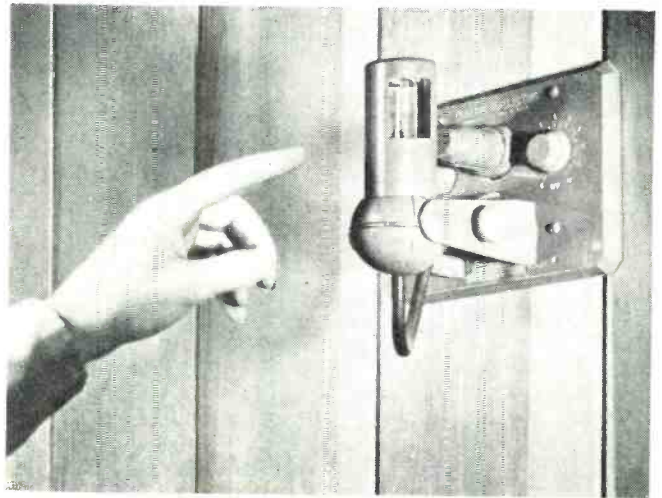

This is the control unit mounted on classroom corner.

fiers, for examining large metal structures for flaws, and in the field of medicine for diagnosis and healing to alleviate pain and suffering. Amplifying the descriptive suggestion of the therapeutic value of the electron tube, it is used to supply high-frequency power for the so-called "fever machines" in hospitals and sanatoriums, where artificial temperatures are generated as therapeutic agents in the treatment of certain diseases.

As recent as March of this year, the photoelectric tube played such a novel role, that it challenged the imagination to such heights as to compare the "age of electrons" to the transition of radio from the crystal set to the power amplifier or with the first television broadcast. Actually, the "electronic gavel" was introduced at a banquet in New York City and instead of the toastmaster pounding a wooden mallet repeatedly, the diners were quieted by the mere passing of a human hand back and forth through an invisible beam of light focused on a photoelectric tube. The latter, in turn, caused a "knocker" to function and produce a pounding noise similar to that of the conventional gavel. No wide stretch of the imagination is required to envision the day when a chain of nation-wide banquets of a college or commercial organization may be called to order by the "electronic gavel." Similarly, the august Senate or House of Representatives of the Congress, may be brought to strict attention by the speaker passing his hand to and fro through this invisible beam of light. Thus, the pounding wooden gavel of an autocratic late Speaker Joe Cannon, or a shrewdly politically-minded Speaker Jack Garner, may soon be among the limbo of forgotten things.

About seventeen or eighteen years ago, this writer recalls an off-duty hobby of a member of the Radio Laboratory of the *Bureau of Standards*, toying with a photoelectric tube in opening his automobile garage. Then the idea was regarded as so fantastic that it never reached the daylight of print. Today doors may be opened and elevators leveled by use of the science of electronics, with such unflinching accuracy as to render these

*(Continued on page 51)*

An outdoor-type photoelectric relay for show windows.



# POWER TRANSFORMER DESIGN

by **WILLIAM A. STOCKLIN**

Associate Editor, RADIO NEWS

***Transformers are becoming hard to get. The serviceman can construct satisfactory substitutes—even by using wire which is removed from obsolete or discarded parts of all kinds.***

**A**NY device may be called a transformer if it transfers electric power from one circuit to another by means of magnetic induction.

Transformers in general may be broken down into two fields: Radio Frequency (r.f.), Transformers and Audio Frequency (a.f.), Transformers or Air Core and Iron Core transformers respectively. Air Core transformers may be classified as a particular group of transformers that are operating at any frequency above the audio range. That is, at Radio Frequency while Iron Core transformers which include power, output, audio transformers, etc., are those that operate within the audio frequency range and only occasionally in the r.f. range.

The first impression one would have when mentioning power transformers is that they are heavily constructed, with large cores and heavy windings; that they are usually enclosed in metal cases with either air or water cooling facilities provided to carry away the heat developed by the various losses such as eddy currents, hysteresis, etc. But let us not forget the power transformers utilized in our every day radio receivers. For obvious reasons we will confine this article to only those power transformers used in our modern radio receivers and other low wattage units that may be used in many phases of home gadgeteering.

Priorities are affecting each and every one of us. Parts are difficult to obtain and special designed parts are impossible to be had. Therefore, it is our intention from the following simple basic design theory that every average radio technician be able to construct a power transformer to his own designs. *Even though raw materials may not be had one can salvage the wire and laminations from any obsolete or unused transformer.*

In order to cover completely the various terms and set standards involved in power transformer designs as used by every transformer manufacturer we will break the transformer down into its various components, as follows:

The coil proper consists of layers of

copper wire interlaced with some insulating material such as plain kraft paper or glassine paper. This paper is used for two reasons: One, as a dielectric to insulate the wire between layers and second, to permit ease of winding, so that the various layers of copper wire are more intact and wound easier when interlaced with some form of paper. The thickness of this paper is determined by the size of wire and the voltage potential between two consecutive layers. The voltage potential between layers is directly dependent on the number of turns. Therefore, the potential between layers of fine wire (where there are more turns per layer) is considerably larger than if a heavy wire were used. Inasmuch as glassine paper has a potential gradient of approximately 600 volts per one mill (.001) thickness, which is a sufficient safety factor for any simple power transformer we will only consider the proper paper to be used for simplicity of winding, bearing in mind that the less paper we use the more copper wire may be wound on a given core.

It has been found from practical experience to use the following thicknesses of glassine paper given in inches

for the corresponding wire sizes.

No. 41 to No. 38 incl. . . . .00075

No. 37 to No. 34 incl. . . . .001

No. 33 to No. 31 incl. . . . .0015

No. 30 to No. 28 incl. . . . .002

For wire sizes larger than No. 28 where a paper heavier than .002 should be used it has been found that ordinary kraft paper is advisable, for economical reasons and that the dielectric strength of this type of paper at a thickness of .003" or over is sufficient for the voltage potential involved, therefore, the following sizes of kraft paper are used:

No. 28 to No. 25 incl. . . . .003

No. 24 to No. 19 incl. . . . .004

No. 18 and larger. . . . .006

The insulation used between various separate windings of the transformer should be sufficient to withstand a potential of 1500 volts which has been set as a standard breakdown voltage between all windings, and windings to the iron core. This has been found to be approximately 2 layers of .005 Fish-paper. The tube on which the coil is wound should be mechanically strong to prevent the tube from crumbling, approximately 5 layers of .008" gummed kraft paper. This, of course, varies with the size of the core, the larger the core the stronger the tube.

The wire used to make up the coil is annealed copper, single enamel coated. The single coat of enamel is sufficient insulation to prevent shorting of consecutive turns. Copper wire is used for the simple reason that it is economical and its resistance is relatively low to allow an efficient design.

Any current-carrying wire has a resistance loss which is emitted in the form of heat. Therefore, the size of wire should be chosen with care so that the I<sup>2</sup>R loss is kept to a minimum for maximum transformer efficiency. Advantage is therefore taken of the circular mill (C.M.) area of various sizes of wire as listed in any wire table. The circular mill area is a factor derived from the square of the diameter of the wire taken in mills. For example, number 20 wire has a diameter of .03196 inches or 31.96 mills,  $31.96^2 = 1,022$  C.M. Now assume that a current of 1 amp. is flowing in the



"Wouldn't it have been much easier to just lower the mike?"

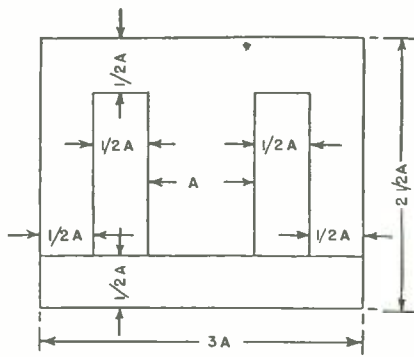

Fig. 2.

wire and if the wire were a No. 20 would be operating that wire at 1,022 C.M. per amp. If the wire were half the size in C.M. (No. 23 wire 509 C.M.), it would be operating at 509 C.M. per ampere.

The radio industry up to the present has been a very competitive field. As a result of the public demand for lower priced receivers the radio industry had to use all of its ingenuity in designing power transformers so that the maximum quality may be obtained at the least cost.

Bearing this in mind in determining the correct wire size, it is considered reasonably good operating efficiency to operate the wire at a minimum of 600 C.M. per ampere, while the ideal operating point would be approximately 1,000 C.M. per ampere.

Figure No. 1 is a wire table in a convenient form to determine readily the circular mills per ampere for any given wire size at a particular current value. For an example No. 30 wire with a current of .142 amperes would be operating at 700 C.M. per ampere.

#### Laminations

The core is made up of consecutive sheets of laminations. They consist of a silicon steel, specially processed for use in transformers. A standard lamination is shown in Figure 2 with the various dimensions based on the center-leg. The size of the center-leg determines the lamination number such as a 1" lamination will have a 1" center-leg, while a .75" lamination will have a  $\frac{3}{4}$ " center-leg. There are other laminations that are not considered standard but are used extensively such as the .90" lamination which has a center-leg of .93" and a window opening of .56".

There are many different grades of laminations, the most widely used types are transformer C grade and the dynamo grade. Transformer C grade has been the most popular but recently the trend has been towards the dynamo grade which is the least costly of the two but the total no-load wattage loss is somewhat greater, .72 and 1.01 watts per lb. respectively, assuming a 26 gauge lamination and operating at a flux density of 64,000 lines per square inch.

The cores in all the iron-core transformers are made up of thin sheets of laminations so that the eddy current losses may be reduced to a minimum.

In a closed-core transformer with a solid core, Figure 3a, the core can be considered as a single turn secondary which would have a low voltage induced in it by the rapidly varying magnetic field through it. This produces circular currents (so called eddy currents) flowing as shown in Figure 3a in a plane at right angles to the direction of the main field and in such a direction as always to be opposed to the main magnetic field through the core. These currents would be very large when a solid core is used due to its low resistance.

By constructing the core of numerous laminations, each one insulated from the other by a coat of insulating varnish or enamel or by taking advantage of the present methods of processing the laminations, utilizing the normal surface oxide as an insulator, the eddy currents are reduced considerably. Since the resistance of these paths is very much greater as shown in Figure 3b, by decreasing the thickness of the laminations, the eddy currents losses can be reduced to any desired value, but there is a limit, since if the material is made too thin the space occupied by the insulating material becomes excessive.

For this reason and also that the cost of assembling the numerous laminations increases it has been found that the most practical thickness (gauge) of laminations used vary between 24 and 29 gauge, No. 24 gauge is approximately .025 inches thick, while the 29 gauge lamination is .014 inches

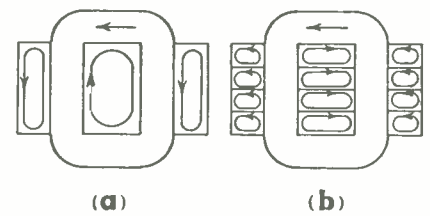

Fig. 3.

thick. It has been found that by utilizing the normal surface oxide, and a 26 gauge lamination, and then impregnating the entire laminated core and coil in varnish or a suitable wax compound (which when properly executed forms an insulating film over the oxide coating) that the eddy currents are reduced to a point giving a fairly efficient transformer design. It may be advisable to mention at this point that a stack of laminations measuring 1" includes the interlayer insulation and therefore a stacking factor of 90% is used in determining the flux density of the transformer.

The reversal of a magnetic field in a magnetic core to a similar field strength in a reverse direction, followed by a second reversal as to establish the original direction of magnetization, constitutes a complete magnetic cycle. The completion of a magnetic cycle requires a definite input known as the hysteresis loss. Also the normal surface oxide is somewhat magnetic and at the higher flux densities carries an appreciable flux which leaks from the core material proper,

(Continued on page 61)

Fig. 1.  
WIRE TABLE

No. Gauge	Area C. M.	Diam. in.	C.M. Per Amp.				
			600	700	810	900	1000
11	8234	.0926	13.70	11.75	10.20	9.15	8.23
12	6530	.0827	10.90	9.40	8.08	7.25	6.53
13	5178	.0737	8.60	7.40	6.40	5.74	5.18
14	4107	.0658	6.80	5.90	5.00	4.57	4.11
15	3257	.0587	5.40	4.60	4.00	3.62	3.26
16	2583	.0524	4.30	3.70	3.20	2.87	2.58
17	2048	.0468	3.40	2.90	2.50	2.28	2.05
18	1624	.0417	2.70	2.30	2.00	1.81	1.62
19	1288	.0373	2.10	1.80	1.60	1.43	1.29
20	1022	.0333	1.70	1.50	1.25	1.13	1.02
21	810	.0297	1.35	1.20	1.00	.90	.81
22	642	.0265	1.07	.91	.80	.71	.64
23	509	.0237	.85	.72	.63	.56	.50
24	404	.0212	.67	.57	.50	.44	.40
25	320	.0189	.53	.45	.40	.35	.32
26	254	.0169	.42	.36	.31	.28	.25
27	201	.0152	.33	.28	.25	.22	.20
28	159	.0135	.26	.22	.20	.17	.15
29	127	.0121	.21	.18	.16	.14	.12
30	100	.0108	.16	.14	.12	.11	.10
31	80	.0096	.13	.10	.10	.089	.080
32	63	.0086	.10	.09	.080	.070	.063
33	50	.0077	.083	.071	.062	.056	.050
34	40	.0068	.067	.057	.050	.044	.040
35	31	.0061	.052	.044	.040	.034	.031
36	25	.0055	.042	.036	.031	.028	.025
37	20	.0049	.033	.029	.025	.022	.020
38	16	.0044	.027	.023	.020	.018	.016
39	12	.0039	.020	.017	.015	.013	.012
40	10	.0034	.016	.014	.012	.011	.010
41	8	.0031	.013	.011	.010	.009	.008

# AVIATION RADIO COURSE

by PAUL W. KARROL

## Part 4. The development of antennae for aircraft has increased the effective range in all services.

**A**N aircraft radio installation is only as efficient as its antenna systems. No matter how well designed the receiver, transmitter, and associated equipment may be, if the antenna systems are haphazardly installed, slovenly maintained and generally inferior, very little will be gained by employing the best equipment obtainable.

The antenna systems on modern aircraft entail many detailed considerations both from the design and installation standpoints. The aviation radio technician must know without doubt antennae theory, the types of antennae available for aircraft, how they are employed, installed and maintained.

The purpose of this lesson is twofold. First, it will acquaint the uninitiated with aircraft antennae; and second, it will give all essential pointers on choosing proper antennae and how to install and maintain them.

There are many and various designs of aircraft radio equipment on the market and likewise many different types of antenna systems are employed. No two antenna installations are alike unless connected to the same type of equipment installed in the same type of aircraft and made exactly the same way with the same materials. By applying generalized considerations, many problems encountered can usually be solved satisfactorily, but in the long run, detailed information is usually always needed to cope with a particular situation. Therefore, as much detailed consideration as deemed necessary will be given.

There are now eight types of air-

craft antennae. These are: the belly T; the vertical mast; the V; the wing tip to wing tip; the T; the loop; and the multi-frequency and trailing wire antennae.

The belly T antenna is installed directly underneath the belly of the aircraft and consists of a single conductor suspended between two insulators, with the leadin being connected to its center. The directional qualities often exhibited by the topside T

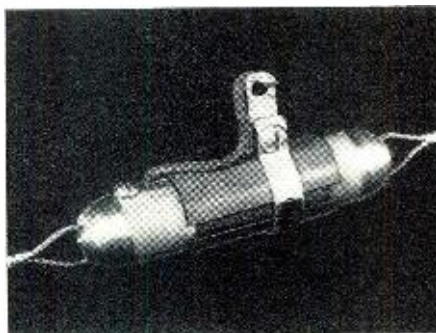

Variable antenna loading coil.

can be partially eliminated by suspending it in the manner just described and is often used as the receiving antenna connected to the radio range receiver. The belly T is not as susceptible to icing as are the antennae mounted on the topside of the aircraft.

The vertical mast antenna is seldom used as a transmitting antenna but is confined to reception. However, now that ultra-high frequency radio aids are coming into greater prominence, we find that it is occupying the lime-

light. It is used mainly for the reception of radio range signals, is very non-directive and is sometimes used as a supporting mast for the wing tip to wing tip antenna, an insulator being installed on its top for this purpose. The length of this antenna varies but is usually about seven to eight feet in length. The covering on the antenna proper is the mast which is usually constructed of light but durable wood. It is hollow and houses the wire which forms the antenna proper which is suspended between a base and top insulator. In some cases no individual leadin is used to connect the greater portion of the antenna to the receiving apparatus; this being accomplished by allowing enough wire to form the antenna and the leadin when the mast is installed. Because the vertical mast antenna is nothing more than a whip or fish-pole type antenna, it differing in that it is covered (weather shielded), it is sometimes called a "straight pole vertical."

The installation of the vertical mast antenna is relatively simple because provisions are usually made by the manufacturer for fastening it directly to the fuselage of the aircraft by means of a drilled base plate, screws provided with lock nuts being utilized to effect installation.

A very common error is to mount this antenna near other antennae which inevitably results in less pickup and undesirable reflective effects. If at all possible, this antenna should be under-belly mounted if its length is commensurate with the height of the plane (from belly to ground) with wheels (landing gear) extended.

An antenna which is often used on

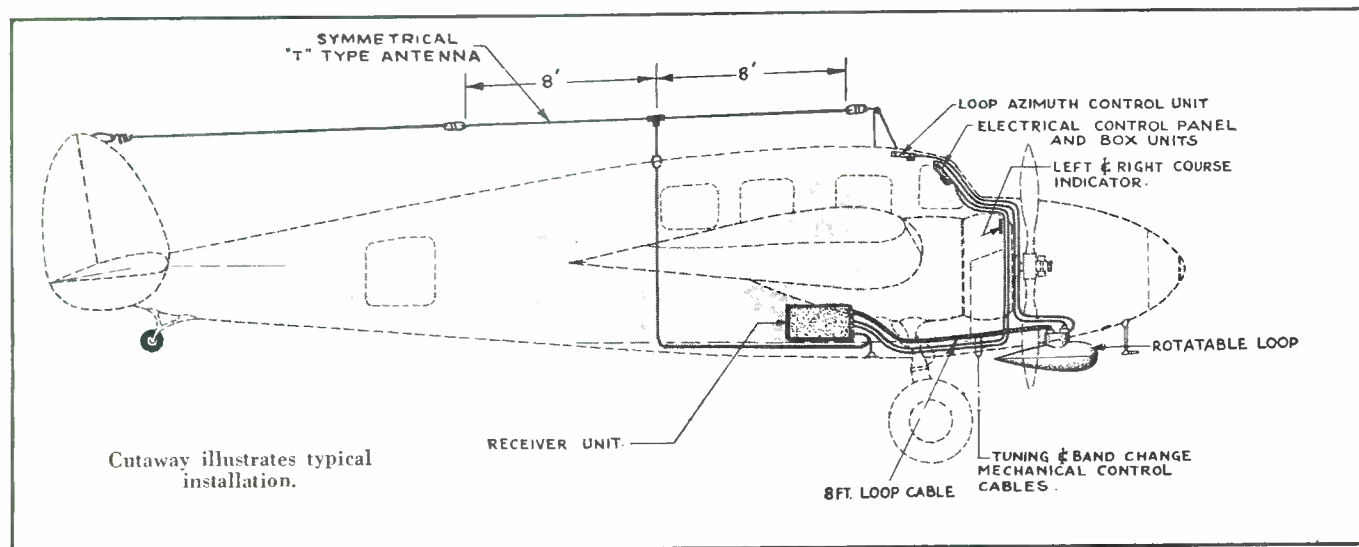

small as well as large aircraft for both transmitting and receiving is the V antenna. It is sometimes called the "flat-top" and sometimes referred to as the "split V," and is suspended between one wing tip to the rudder to the other wing tip by means of insulators attached to shock cord or spring and pulley assemblies. Where it is desired to use the V for both transmitting and receiving (and when no antenna relay is employed) an insulator is inserted between the two running leads from each wing about five feet from the rudder lead-thru insulator; appropriate lead-in wires being connected to each side of the V; one for transmitting and one for receiving. This practice is utilized more on smaller aircraft where mounting space is rather limited.

The wing tip to wing tip antenna takes inherent advantage of all possible installation space. One end of the antenna is fastened from one wing tip to the other wing tip; suspended in the middle of its run by means of a mast mounted on the aircraft. This antenna seems to be one of the most efficient of the lot but it does have some pronounced directional characteristics which are sometimes objectionable. However, it is recommended to those who must utilize equipment operating on the lower frequency bands necessitating longer antennae.

The T type antenna (topside T) is fastened from rudder to either wing tip or to a sub-mast located in the center of the fuselage or near wing junctures. It is used quite extensively on small as well as large aircraft for both receiving and transmitting; but mostly the former. It is very directive if mounted close to the aircraft and due to metal mass reflection will exhibit marked "wave front" characteristics.

The loop antenna is used for direction finding, homing compasses, etc. It consists of an insulated ring upon which is wound a number of turns of wire depending upon the type of receiver employed. It may have two or more bank windings. Where it is mounted on small aircraft for compass work (homing) it is usually static, that is, it cannot be rotated. On larger aircraft it may be operated manually through 360° and be equipped with a direct reading azimuth scale. Most present day loops are shielded with a streamlined housing which is highly desirable not only from an aerodynamic standpoint but also from an electrical standpoint. It is usually mounted as near as possible to the fore-part of the ship underneath its belly (nose) and sometimes it will be found on top the aircraft. The policy of installation of course is dictated by the particular design of the aircraft and the manner in which the equipment it serves is installed and located.

When a sense antenna (antenna used for determining correct azimuth) is used in conjunction with the loop it is usually mounted near the loop and is usually from three to six feet

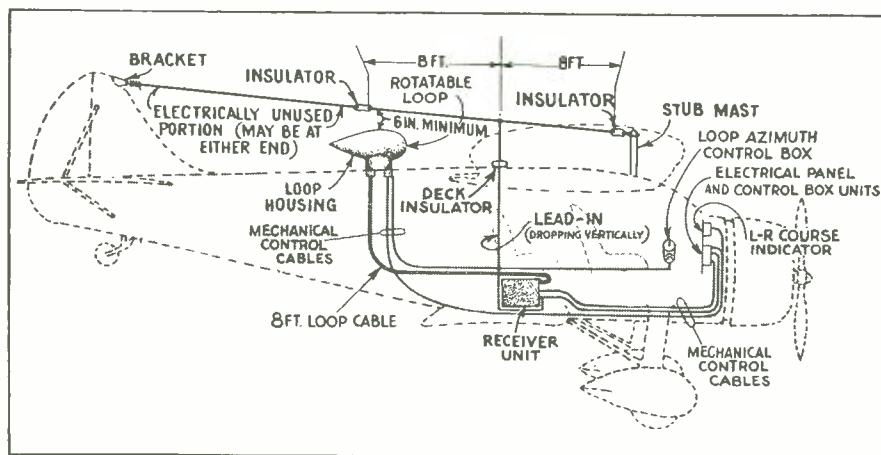

This installation includes directional loop.

long. It may be either a vertical or a T antenna.

The multi-frequency antenna is an antenna designed to take care of a wide range of frequencies; it usually being installed in the same manner as the wing tip to wing tip antenna, the insulator and tuning element being used to attach the antenna to end-supports.

Trailing wire or "variable frequency" antennae have been used with much success. The antenna consists of either a manually or electrically operated reel upon which is wound as high as 400 feet of wire. Attached to this reel is a fairlead which allows the wire to leave the aircraft. After the plane leaves the ground the correct amount of wire (according to frequency-wavelength) is reeled out behind or beneath the aircraft. A weight keeps the wire near the horizontal or vertical position. Connection to the receiver is established by

means of a rotatable ring or by utilizing a metallic reel insulated from its mounting by means of isolantite insulation material. The trailing wire reel is always mounted as near the operator and receiver as possible. However, where an electrically operated reel is employed it may be mounted near the tail of the aircraft and the lead-in from the reel brought to the receiver and/or transmitter on suspension insulators.

When long distance communication is desired and it is imperative that an antenna cut to frequency be employed, the trailing wire antenna offers all that is desired. It is not too susceptible to ice formation if not too heavily weighted.

Antennae installed on aircraft are capacitive elements using the aircraft frame and structure as a counterpoise and in the case of all-metal aircraft the entire plane.

(Continued on page 62)

This is the RCA antenna coupling system widely used on aircraft.

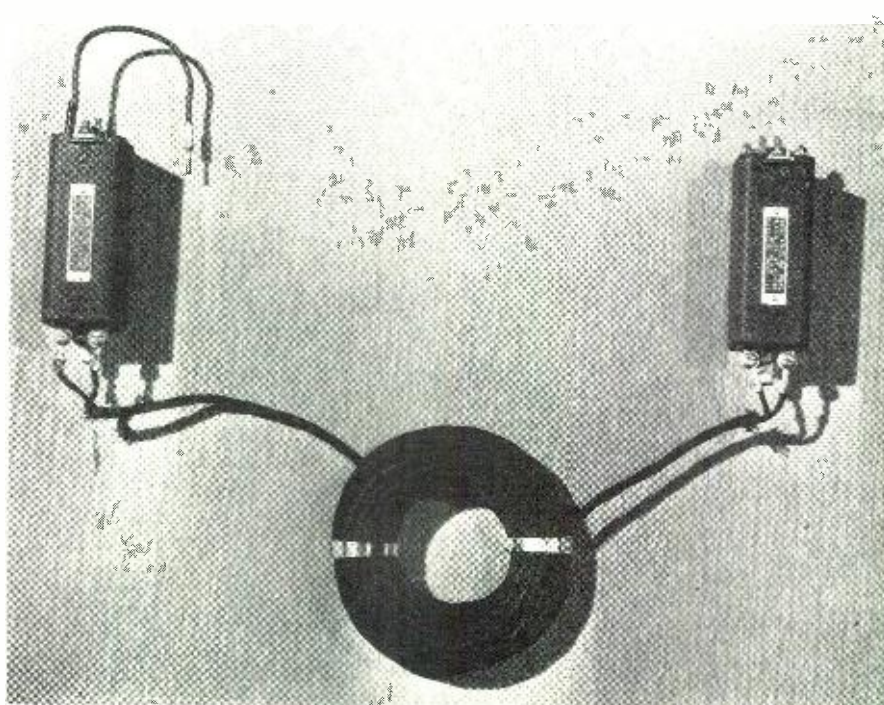

"BASIC RADIO," by J. Barton Hoag, Lt. Comm. U.S.C.G., etc. Published by D. Van Nostrand Company, Inc., 250 Fourth Avenue, New York City. Price, \$3.25. 379 pages.

Electron tubes and circuits, with their wide ramification in radio and line communications, in industrial production and in research work are so numerous and complex as to bewilder the beginner. He needs a guide which will present the important items in orderly sequence from the simple to the complex.

Many special tubes and circuits have been tested and discarded during the past thirty years. Others have proven their merit and remain with us today. These are the ones to study. This book attempts to select the important and the tested, basic tubes and circuits and to present both a simple explanation of how they work and where they are applied, together with sufficient numerical constants and other details to make them readily understandable.

The book is designed for the student with only a limited background of physics and mathematics. The more involved material is presented graphically; the few simple widely used equations are explained in detail.

This excellently prepared text book should find wide application in our many military and civilian schools, as it detours many of the non-essentials which are included in many of the older methods of study.

"RADIO PROGRAMS INTENDED FOR CLASSROOM USE," by Carroll Atkinson, Ph.D., published by Meador Publishing Company, Boston, Mass., 128 pages, price \$1.50. A number of books have been published with the intention of helping classroom teachers utilize radio as an educational tool. Many of these have fallen into the error of providing information about the programs that were currently available at the time the particular volume was published. This volume is a frank appraisal of radio programs intended for classroom use and attempts to avoid error by recording the efforts, both successful and otherwise, that to date have been made to provide this type of educational service.

This volume is only one of a group of several. The others include, "Broadcasting to the Classroom by Universities and Colleges," "Public School Broadcasting to the Classroom," "Radio Extension Courses," "Radio Network Contributions" and "American Universities." All of these books, written by Carroll Atkinson, sell at \$1.50 each and cover many important subjects which confront our instructors today. They all make interesting reading and are a valuable

*(Continued on page 55)*

# QRD? de GY



by **JERRY COLBY**

**A**LL the wise guys settin' 'round Buzzer Rooms and saying, "'Tisn't so" can throw their slide rules outta the nearest window becuz it's an established poetical fact. Yessir, in the spring a young man's fancy turns to serious calculations and Brother Karl, beg pahdon Suh, Lieutenant Karl Baarslag, USN, up and did it t'other day when he said "I do" to the question by a Sky Pilot "Do you take this woman to be your lawful wedded wife?" Just goes to prove what an education will do for a man. Before he passed his fifty-umph exams to wear two gold stripes on his shoulders he kept himself busy writing books, fighting for recognition of radiops and, incidentally, earning a living pounding brass on the briny. The Navy must have given him a few hours off duty so to keep himself busy he gets married. He has our heartiest congrats and we know that he'll make his marriage a success in every way, inasmuch as Brother Baarslag has made a success of everything he's tackled, including the ROU.

**A**ND speaking of the ROU, we quote Brother Fred Howe of the New York Office. "Dear GY: Are you the man who is holding back all the radio operators? Someone seems to have run away with them or else is deliberately holding them back. In case you are not the person who is doing this, kindly use your column to determine who is back of this dark and mysterious plot. Hi, hi. In other words, if you happen to see anyone out your way who has a port or starboard list and wears spectacles, and at the same time appears to look like a sea-going radio officer, kindly call the police and deport him to this neck of the woods. We can use him. In my vain endeavors to find Radio Officers to sail the ships, I am about to run "ads" in the Police Gazette, Christian Science Monitor and the New Masses. Do you know of any chicken farm magazines? In my sea-going days almost everyone aboard ship made dire threats of starting a

chicken farm. If they did this nefarious thing and carried it out to a successful conclusion this may be the answer to my International Witch Hunt for men to man the vessels of our Merchant Marine. If all of these men who told me they were intending to start a chicken farm, did so, it seems to me that Egg Foo Young should be much cheaper than it is. As for eggs themselves, both old and young, the New York grocers don't seem to know that the last war ended more than 23 years ago. Using my powers of deduction, a la Sherlock Holmes, this would indicate to any good detective that chicken farms are just as scarce as chickens' teeth, and that the men who threatened to leave the ships and start laying eggs never did so. Eggs are so high here that some people believe they're made out of rubber. I must be on the wrong clue.

Not only am I worried about the scarcity of radiops but I can't sleep nights for fear of how my ledgers will appear next year. They say we can't have any more rubber. What will a man do when he makes a mistake? Did this ever bother your busy mind? There are many mistakes, however, which cannot be erased by means of rubber. Think of the big mistake I made when I took up radio! If I had all the rubber in Java it wouldn't do

*(Continued on page 53)*





# NON-METAL SHIELDINGS

by **B. H. PORTER**

Acheson Colloids Corporation

*American ingenuity is solving many problems presented by shortages of material. Here is a satisfactory substitute for radio shielding.*

**R**ESTRICTIONS, on the use of metal, arising out of priorities and, in some instances, actual supply shortages force radio amateurs to devise substitutes. The illustrations depict some of the new wrinkles which have been found useful as a result of the situation. Detailed instructions for duplicating them follow:

## **Vacuum Tubes and Grounding Methods**

When metal radio tubes and metal shields for glass tubes are unavailable, convenient shielding of the latter type is effected by painting or spraying the exterior surfaces of the glass with a fairly concentrated dispersion of colloidal graphite in water. After the carrier evaporates, a homogeneous and tenacious film of electrically conductive graphite remains, provided the glass has first been rendered grease free. Simple mixtures of dry graphite powder and water, incidentally, will not produce this result. The graphite must be of the colloidal variety, that is, specially processed until the particles become so minute that indefinite suspension in water is possible. Chromic acid (1 part potassium dichromate to 10 parts of concentrated sulphuric acid) is an effective glass wash when followed by thorough water-rinsing and air-drying.

Permanent grounding connection to the graphite coating is readily made

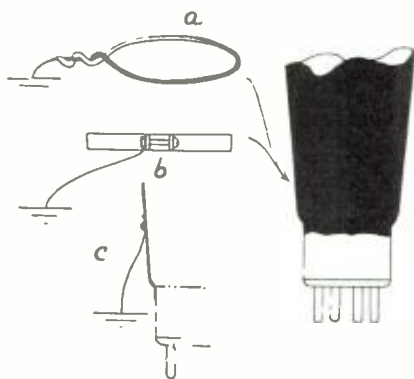

Fig. 1.

by arranging a loop of copper wire (1a) or a metal band clamp (1b) about the tube before the coating is formed. Care should be taken to seal the edges between the connection and glass with ample quantities of the graphite dispersion. Should the tube coating be applied first, it may be advisable to cover completely the loop or band surfaces before affixing the parts, and then apply a third film overlapping the coated connection and the graphited glass. Positive electrical contact is insured in this manner.

Film grounding may also be accomplished by the "cat's whisker" method (1c)—wherein a single, small-gauge copper wire is bent spring fashion to touch the side of the coated glass tube and cemented onto glass with a globule of concentrated colloidal graphite in water. A spot of varnish or shellac,

applied over the dried mass, will further strengthen the connection against vibration and disruption. A light polishing of the dry films, moreover, with a soft cloth tends to decrease their electrical resistance.

Whenever non-treated tubes normally generate excessive heat, or those bearing a continuous graphite film exhibit this effect, the tube surfaces are best coated lattice or screen fashion, leaving a portion of the glass untouched. In most cases, the good heat-radiating quality of graphite, superior to that of most metals, can be relied upon to dissipate filament heat. In any case, the graphite bands, if used, should be continuous and well overlapped at the intersections. A fine camel's hair brush will satisfactorily accomplish this.

The grounding of such coatings is made by any one of the three methods described above provided areas immediately adjacent to and directly under the connection are solidly or continuously coated. It is feasible in either procedure (Fig. 1 or Fig. 2) to continue the graphite coating wholly or in a single narrow strip down over the insulating base walls to touch a conveniently formed ground lead on the top of the baseboard or chassis. Tubes equipped with an external grid top obviously are coated, in either method, only to within a half inch of the metal.

(Fig. 3) Ordinary cardboard mailing tubes, or other suitable non-conductive forms of sufficient diameter to allow for heat radiation within, may be employed as vacuum tube shields. Electrical conductivity is imparted to

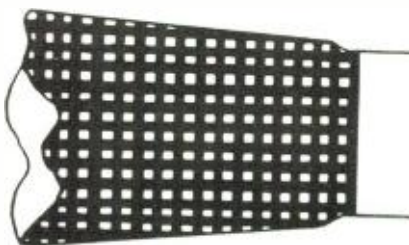

Fig. 2.

fibrous forms, like mailing tubes, by applying liberal quantities of graphite solution made up of 1 part concentrated colloidal graphite and 10 parts of water. After several such coats have been applied, or when the porous material is well saturated, a final overall surface film composed of the 1 part colloidal graphite to 2 parts water mixture is formed. Should the fibrous shape possess a hard, glazed or not too porous surface, the 1-to-2 graphite dispersion can be applied at once as in the case of glass.

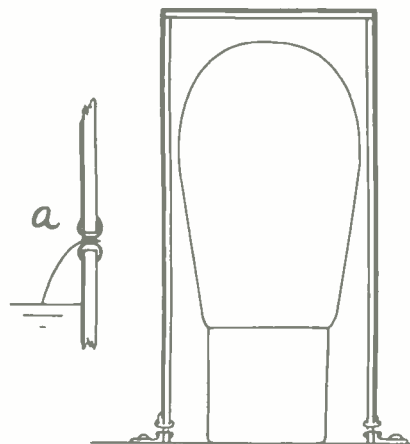

Fig. 3.

Ordinary metal eyelets (3a), inserted on the walls and having a wire lead soldered in place, before graphite treatment is made, constitute a good ground connection. The wire loop, clamp-band, "cat's whisker" and base form of contact, already mentioned, may likewise be employed. The eyelets, incidentally, make good fasteners for angle strips supporting the shield.

## **Shielding of Tubing**

(Fig. 4) Glass and rubber tubing, coated with a fairly concentrated dispersion of colloidal graphite and carrying appropriate conductors, constitute useful substitutes for metal-shielded power feeds and other leads requiring similar protection. Pre-

(Continued on page 44)



This young lady is standing in front of one of the latest GE FM transmitters. Note indicator pilot lamp.



Regulations require that the operator take readings at regular intervals and to record these on the log.

## THE WEAKER SEX?

*Marjorie E. Allen holds amateur radio ticket W2NRC as well as 2nd class commercial telephone and 2nd class radio telegraph licenses. She is a graduate of the American Radio Institute.*

Marjorie's job includes announcing in addition to her other duties. Note transcription turntable.



"Riding gain" at the control console is another task for this young lady. Note cardioid microphone.





Coils for Signal Corps equipment must pass the most rigid tests.



Connecting leads to minute sockets requires steady nerves and hands.

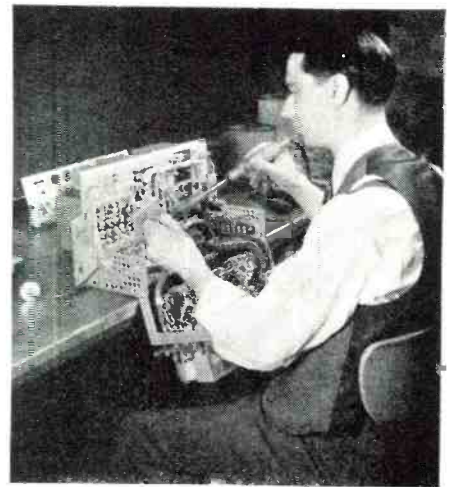

Wiring cable to tight spots is a job for an expert wire craftsman.



Counterboring case for equipment for fighter and bomber aircraft.

# W. E. RADIO GOES TO WAR

*This graphic story shows the important part that the manufacturers are playing in supplying radio units to Uncle Sam.*

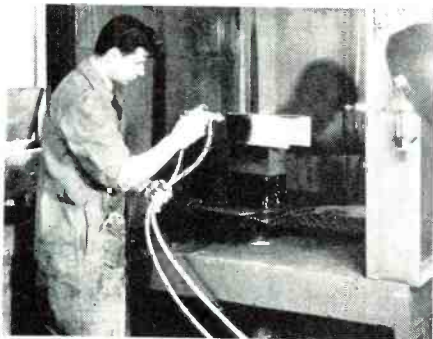

Spraying on a protective coating of wrinkle enamel on SC radio set.

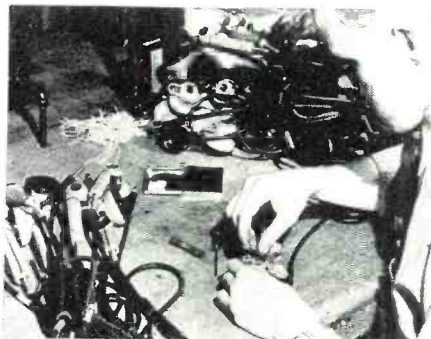

A special "bomber mike" receives final check before being shipped.

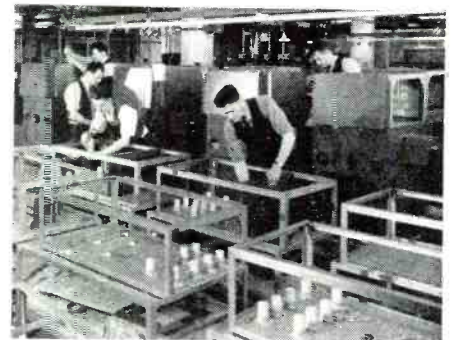

Assembly of frames for support of Signal Corps transmitting units.

Operator checks microphones to see that they are in perfect condition.



Checking gears for condenser to be used on aircraft radio equipment.



Industrial workers emulate army efficiency at this huge factory.

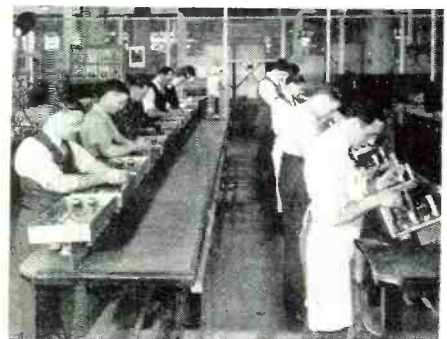

# PRACTICAL RADIO COURSE

by ALFRED A. GHIRARDI

## Part 6. The radio student should master these subjects.

### Magnetism Produced by Current

CONTINUING last month's lesson concerning one of the most interesting and important relations between electricity and magnetism—the production of magnetism by electric currents—we see that every conductor of electricity has a magnetic field. When the conductor is coiled into the form of a helix, the magnetic

The magnetic flux around a coil is greatly increased by insertion of an iron core, the extent of the increase depending upon the composition of the iron used.

If the direction of current flow through a wire is known, the direction of the resulting magnetic field may be determined by grasping the wire with the right hand so that the extended

the direction indicated by the arrows, the electrons in it tend to pile up at one end, that is, a voltage is generated. This action is called *electromagnetic induction*. The portion of the wire actually cutting across the magnetic field is often called the *inductor*, as distinguished from the rest of the conductor which really does not induce e.m.f. since it is not cutting across any lines of force.

No current flows in the conductor in Fig. 2 (a) because the circuit is *open*—only an electromotive force or voltage is induced. If the circuit is now completed, as shown at Fig. 2 (b), an electric current flows through the wire every time an e.m.f. is induced in the inductor by moving it up or down across the field. (The same voltage and current would be produced if the process were reversed, that is, if the inductor were kept stationary and the magnetic field moved across it.) In fact, in many cases of electromagnetic induction encountered in radio work (as, for example, in transformers, etc.) the inductor is stationary and the magnetic field moves rapidly.

From the above, three laws of electromagnetic induction can be formed:

1. The stronger the magnetic field, the greater is the voltage (and current) induced.
2. The faster the motion of the wire, across the field, the greater will be the voltage (and current) induced.
3. The greater the number of inductors cutting across the magnetic field, the greater is the voltage (and current) induced.

By using a sensitive current-indicating instrument in the arrangement shown at (b), these laws can be very simply and convincingly demonstrated.

For the first, use a weak magnet, then a strong one (or two magnets placed side by side with their "like" poles together), and compare the deflection of the current-indicating instrument caused by each.

For the second, move the inductor up and down in the magnetic field, first slowly, then faster and faster, comparing the instrument deflection.

For the third, move first the single inductor A-B up and down in the magnetic field, at a definite rate of speed, noting the deflection of the current indicator. Now, double the wire, forming two inductors, A-B and C-D, as shown at (c), and move these up and down in the field at the single inductor speed rate. Twice as much e.m.f. is produced as indicated. Actually, the same e.m.f. is induced now in each inductor, but since they are in series

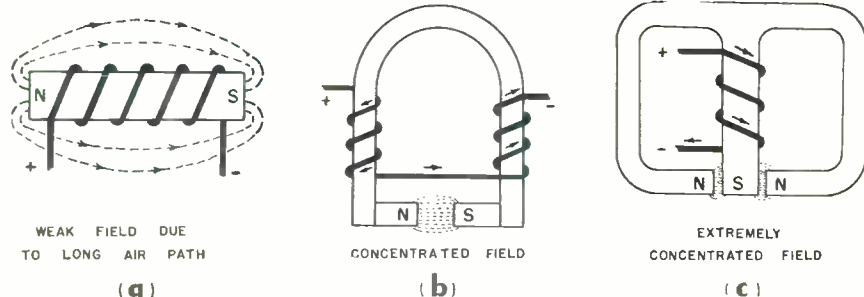

Fig. 1.

field is concentrated, passing through the helix and looping around the outside. The strength of the field depends on the strength of the current (amperes) flowing in the wire, and the number of turns of wire in the helix.

It is much stronger if a core of iron (or other permeable magnetic material) is placed within the coil, because highly permeable magnetic materials are naturally the easiest in which to establish magnetism.

In Figure 1 are shown various forms and shapes of cores.

A still more effective form employed where extreme concentration of the magnetic energy is required is shown in cross-section at (c). Here the iron shell of the assembly constitutes the path for the external magnetic flux, while the center core provides the internal path. The entire energy is thus concentrated across a sometimes extremely short gap. This is the type of magnet assembly employed in electrodynamic loud-speakers and it is in this narrow gap that the movable voice coil is suspended.

The strength of the magnetic field around a conductor varies directly with the amount of current flowing. This is true whether this conductor is a straight wire or wire wound into the form of a coil. In the latter case the strength of the magnetic field will also vary directly as the number of turns in the coil. The magnetizing power of a coil is given in terms of "ampere turns," a figure equal to the product of the current flow in amperes multiplied by the number of turns in the coil.

thumb points in the direction in which the current is flowing. The fingers will then point in the direction of the magnetic lines of force around the wire. This is commonly known as the "Right Hand Rule for Electromagnets."

If the direction of current flow through the turns of a coil is known, then the *north* pole of the coil will be indicated by the extended thumb of the right hand when this hand grasps the coil with the fingers pointing in the direction in which current flows in the individual turns. This is known as the "Right Hand Rule for Coils." Fig. 1 (a) is a simple solenoid coil with a straight iron core. Its external field, extending along the outside of the entire coil length is rather diffused and relatively weak. In (b) this core is bent into a "U" shape and half the coil is placed on each leg. The distance between the poles, or the "magnetic gap," as it is often called is thus made much shorter and the resulting magnetic force becomes more highly concentrated.

### Electromagnetic Induction

The second important relation between electricity and magnetism is the fact that an electric voltage (e.m.f.) is generated in a conductor if it is moved properly across a magnetic field. This phenomenon is illustrated in Fig. 2 (a): a magnetic field is established in the air gap between the north and south poles of a horseshoe-shaped permanent magnet. The conductor A-B is placed crosswise in the field. If the conductor is moved downward in

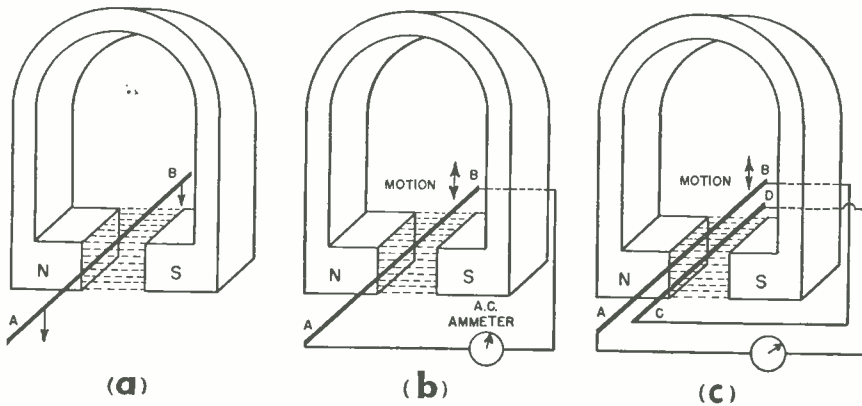

Fig. 2.

with each other, the two e.m.f.'s are additive. The total e.m.f. at any instant is therefore the sum of both.

The current induced by electromagnetic induction flows through the conductor and, like any other current, creates its own magnetic field around the conductor. In fact, the direction of the induced e.m.f. and current is always such that the magnetic field produced by the induced current tends to oppose the motion (or cause) producing the current. This is known as Lenz's Law of electromagnetic induction. Stated simply, it means that whenever electricity is generated by electromagnetic induction, an equivalent amount of mechanical power must be consumed to overcome the magnetic opposition set up by the induced current. Electrical energy is therefore not created in the process; mechanical energy is simply converted into an equivalent amount of electrical energy. This will be discussed later.

The direction of the induced current can always be found by Fleming's right hand rule: "Imagine holding your right hand in the magnetic field, with the thumb, forefinger and middle finger extended at right angles to each other, the forefinger pointing in the direction of the lines of force, and the thumb pointing in the direction of motion. Then the middle finger will point in the direction of the induced e.m.f. ('positive' to 'negative')." This is illustrated in Fig. 3.

Application of Fleming's rule to Fig. 3 reveals that the arrangement illustrated there constitutes a simple generator of alternating voltage and current for when the inductor is moved upward through the field, the induced voltage and current are in the direction indicated, and when it is moved downward, they are in the opposite direction. Hence the induced voltage and current reverse in direction for each complete up-and-down movement of the inductor.

The phenomenon of electromagnetic induction is utilized in many important radio equipment components. Among them are dynamos, motor-generators and converters; power, output, audio, intermediate-frequency and r.f. transformers; loop antennae, etc.

#### Generators

A generator creating electric pressure by the phenomenon of electric

conductors cutting through a magnetic field, is shown in the simplified diagram of Fig. 4. If the strong magnetic field is established between the north and south poles by a permanent magnet structure, the generator is termed a *magneto*; if the field is established by an electromagnet to

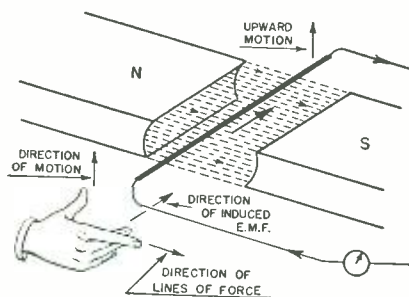

Fig. 3.

which a unidirectional exciting current is fed, the generator is termed a dynamo.

A loop of wire A (Fig. 4) is arranged so that it can be rotated about the axis X-X; the ends of this loop are fastened to rotating slip rings S-S, against which stationary brushes B-B press lightly. The electrical circuit of which this rotating loop is a part, is completed through the external circuit, which may be any electrical device to which current is supplied by the generator.

When the loop is forcibly rotated by the application of external mechanical power, an e.m.f. is generated in the inductors D and E, causing current to flow through the electrical circuit comprised of the loop, the brushes and

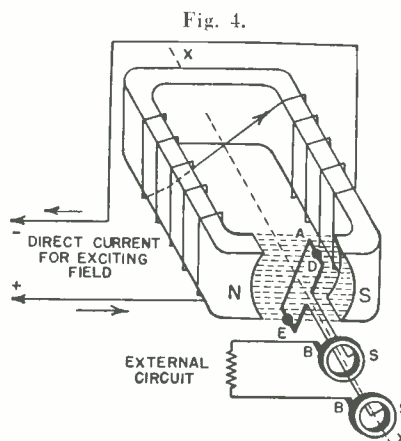

Fig. 4.

the external circuit. Fig. 5 is a series of diagrams, simplified for clarity, the magnetic field in which the loop rotates is merely indicated. The loop of wire is assumed to be rotating with uniform speed in the direction of the curved arrows.

If only the inductor, marked with a dot, is considered, the generated voltage will be zero at the *start* position, because the conductor is moving parallel to the magnetic field and is therefore not cutting across any lines of force. Gradually, as it revolves, it begins to cut more and more across the field (thereby generating voltage), until a quarter of a revolution later, at the  $\frac{1}{4}$  cycle position (see illustration), when it is cutting squarely across the field, maximum voltage is generated. It reduces again as the loop revolves to the  $\frac{1}{2}$  cycle position, where it is again zero. Then the voltage will be generated in the *opposite* direction (because it now begins to cut the lines of force in the opposite direction), and will rise to maximum when the  $\frac{3}{4}$  cycle position is reached, decrease to zero when the loop returns to the original position.

As the inductor thus sweeps by a pair of north and south magnetic poles, a complete cycle of voltage is generated. first in one direction, then in the other. The other inductor (unmarked in the illustrations), forming the opposite side of the loop, always has a voltage induced in it as it passes under the magnetic pole of opposite polarity. Since the voltages induced in these two inductors are in series, always at any instant in additive direction with respect to each other, the voltage across the entire loop (that which appears at the brushes) is equal to their sum at any given instant.

Fig. 6 illustrates graphically the variations in magnitude and changes in direction of the induced voltage. The curved lines represent the voltage at any instant by its vertical distance above or below the horizontal axis line. At *start*, the voltage is zero (when both inductors are moving parallel to the lines of force). As the inductors begin to cut across the lines of force, the voltage rises to a positive maximum; as the inductors pass under the poles at the  $\frac{1}{2}$  cycle position, the voltage falls to zero, reverses, and increases to a negative maximum as the inductors pass under the opposite poles; the voltage finally decreases to zero as the loop completes the cycle and starts another. The current in this circuit rises and falls with the voltage; it flows alternately, first one way, then the other. Directly from this action comes the term *alternating current*.

The generator illustrated in Fig. 4 and Fig. 5 is classified as a two-pole, single phase, revolving-armature, alternating-current generator. The rotating loop of wire is the *armature*; those two sides in which the voltage is generated, are the *inductors*. The magnetic field coils of wire energizing

(Continued on page 59)

# Manufacturer's Literature

Our readers are asked to write directly to the manufacturer for this literature. By mentioning RADIO NEWS and the issue and page, we are sure the reader will get fine service. Enclose the proper sum requested when it is indicated. This will prevent delay.

## Aerovox 1942 Catalog

This new printing of the *Aerovox* condenser, resistor and test instrument catalog includes all of the changes and additions brought forth by present production limitation. Every type of condenser used for the construction or servicing of transmitters, receivers and for industrial application is included. *Aerovox* engineers have rallied to the call and have improved upon many existing types, have simplified designs and have eliminated those condensers which are of the obsolete types.

Copies may be obtained from the *Aerovox Corporation*, New Bedford, Mass.

## Technical Manual on G-E Receiving Tubes

A 24-page technical manual on *G-E* radio receiving tubes, prepared to assist those who work or experiment with radio tubes and circuits, has been released by the Renewal Tube Sales Section of the *General Electric Radio Television and Electronics Department*, Bridgeport, Conn. The manual can be obtained by radio servicemen, radio technicians, experimenters, radio amateurs and others technically interested in radio tubes by writing the *G-E Department* at Bridgeport, Conn. The price is 25c.

## Long Live Your Microphone!

Is the title of an interesting new 4-color 16-page booklet, prepared and published by *Shure Brothers*, designers and manufacturers of microphone and acoustic devices. This unusual booklet tells the story and picture "how to get the best service from your microphone."

There are helpful hints on the use and care of Crystal, Dynamic and Carbon Microphones . . . practical pointers on feedback, output, cables, response and other valuable information.

It is the first booklet of its kind ever published and is an important contribution to the War Conservation Plan. All the material and data are based on actual statistics from the *Shure Service Department* making it a practical guide for microphone users.

A copy may be obtained free of charge simply by writing for Bulletin 173G to *Shure Brothers*, 215 W. Huron Street, Chicago, Illinois.

(Continued on page 50)

# ★ WHAT'S NEW IN RADIO ★

## New Dynamotors for Communication Systems

A new line of dynamotors for communication and other service in aircraft, tanks, and mobile field equipment has been announced by the *General Electric Company*.

Dynamotors perform an important task in communication work by raising battery voltage to radio transmitter or receiver voltages. Aircraft, tanks, jeeps, etc., obtain their electrical power from generators driven by the main engines of the unit. A floating battery usually is in the circuit. The voltage of this power supply is too low for satisfactory radio operation, so dynamotors are employed as the most effective means of obtaining necessary higher voltages.

The new line of *General Electric* dynamotors comprises five types, ranging from 25 to 600 watts in output, and from 3 to 31 pounds in weight. Formex wire insulation, light weight, and reliability under rigorous conditions are features. Each unit is designed for high output from a small frame size.

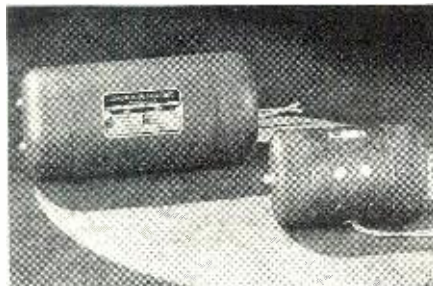

Objectionable alternating-current ripple is kept at a value which requires a minimum of filter to provide satisfactory operation of the communication equipment. The dynamotor commutators are carefully cut and undercut so that commutation will meet rigid standards.

The end caps are formed aluminum or steel covers which fasten to the end shields to keep dust and dirt out. End shields are of high-pressure cast aluminum or steel. Cartridge-type brush mechanisms are used, and brush holders are anchored in the castings. Capacitors are supplied across the brushes when needed for suppression of radio interference, and brush springs are shunted with copper pig-tails.

Other features are: spiraled armature punchings to reduce noise and eliminate locking effect; carefully selected ball bearings with provision for lubrication and cleaning; and a stator formed from stainless-steel tubing. *General Electric Co.*, Schenectady, New York.

## Littelfuse Indicator Light

This light goes on *only* when the circuit is broken.

This is the time, trouble, and money saving service rendered to remote control by an indicator manufactured by *Littelfuse Incorporated*, 4757 Ravenswood Ave., Chicago, Ill. It is listed as *Littelfuse Panel Mounting*, No. 1414.

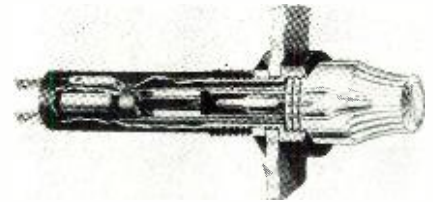

The value and dependability of this indicator is evidenced by its wide use in railway signaling equipment and aircraft applications. But it is equally applicable to any circuits, circuit breakers, line switches, etc.

When installed at any convenient or desirable point in connection with remote motor control it works instantly, with a plainly visible signal to show "on" or "off." When the circuit breaker opens the light goes on.

It can be had for 24 or 48 volt filament bulb, with which no resistor is used. Otherwise it uses a built-in 200,000 ohm protective resistor, in series with a neon lamp. The resistor prevents the lamp from blowing out, as ordinary lamps do, on unexpected high voltages. In the *Littelfuse* installation the lamp glows on currents as low as 100 microamperes.

The *Littelfuse Indicator*, or Panel Mounting No. 1414, has a black bakelite body, and transparent molded cap. It is made for panels up to 5/16" thick and 1/2" diameter mounting hole. Overall length 2" below panel, 7/8" above panel. The rating is 90 to 250 volts. Regularly furnished without lamp.

Complete information on applications of the *Littelfuse Indicator* may be obtained by addressing the manufacturer.

## Jacks, Plugs, and "Throw-Aways" in American Molded Products Line

American Molded Products Company of 1751 North Honore St., Chicago, Ill.,

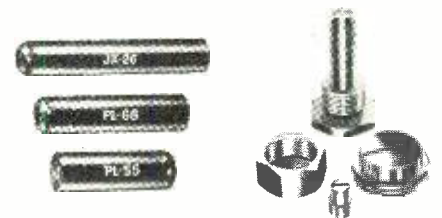

is in production of molded plastic plugs and jacks from stock molds for immediate delivery. Stock molds are now available for Jk-26, Jk-48, PI-54, PI-55, and PI-68.

These are for standard units and (Continued on page 65)



# Spot Radio News

**I N D E F E N S E A N D I N D U S T R Y**

*Presenting latest information on the Radio situation.*

by **LEWIS WINNER**

RADIO NEWS WASHINGTON CORRESPONDENT

ODD AS IT SEEMS, NO SHORTAGE of replacement parts in Canada appears likely for some time at least, and as yet, no restrictions have been placed on the manufacture of such parts, revealed Supplies Controller A. H. Williamson in a recent statement before the Province of Quebec Radio Trades Association. The message went on further to say that . . . "if at all possible, we do not want to see anyone deprived of the use of their radio set, and it will be the patriotic duty of every radio serviceman to keep the present sets in operating condition as long as possible. Replacement parts are only a very small percentage of any manufacturer's ordinary output and most manufacturers and supply houses have a considerable stock of replacement parts on hand."

Unfortunately we cannot reveal such a . . . "no-shortage . . . no restriction" . . . status here. Of course, as we have said before, it must be remembered that the Canadian market is relatively small, and comparatively speaking we probably have an equivalent supply of parts available. For it is true that there are dealers who have a supply of parts and may continue to receive more and more through the aid of the Production Requirements Plan, the PD-1X plan and other material ruling relaxations that may be applied soon. But restrictions must, of necessity, prevail. To a degree, it all depends on the copper situation, which to date, hasn't been too promising. Many are puzzled by the shortage of this popular metal, realizing that practically all of the ore is mined here in the Americas. But it must be remembered that pre-war restriction production schedules, price pegging and other requirements of our pre-war-economic structure, made it impossible to provide the flow of copper we need now. Our military demands now are almost twice of that last year, when a shortage already existed. And the anticipated shortage this year for essential civilian and military needs is well over four times that of last year. It isn't hard to see why so much copper is needed, when we recall that battleships use millions of pounds of copper, bombers require miles and miles of wire and shells, of which millions and millions are being made, use casings in which copper is predominant.

There are some indications that before the fall, the emergency inventory pools created, will be sufficiently large

to permit a monthly allotment of sizable proportions for vital needs, thus permitting a truly consistent program of manufacture of parts and tubes.

**A RULING THAT WILL DEFINITELY SPOT** the location of every transmitter in the country is now in effect. For the Federal Communications Commission has ordered every one in possession of a radio transmitter, who does not hold a station license, to apply for registration. Previously the Defense Communications Board had issued an order in which it determined that the national security and defense and the successful conduct of the war demand that the Government have knowledge of all persons who possess equipment that will transmit. For each transmitter, a separate application had to be filled out and sent to Washington.

**JAMMING OF BROADCASTS IS NOT** so prevalent now on the propaganda-news-war front, James L. Fly, chairman of the FCC, revealed recently while testifying at a Congressional hearing on proposed changes in the communications act. The popular nuisance of jamming was now practically a thing of the past, by mutual agreement among the warring nations, he said. This was so, he pointed out, because such interference led to a situation whereby all broadcasts might be made worthless. The world powers had not reached a binding agreement on this phase of transmission, but rather an unspoken understanding. The few times this interference practice has been employed recently have been during broadcasts of claims and counter-claims, where the nations have been reluctant to provide admissions of losses. But even this practice is rapidly disappearing, because of the realization that jamming of counter propaganda broadcasts is just as disastrous to either groups of listeners, for the net result is that little of intelligence is heard by anyone.

**ANOTHER RAID ON ENEMY-OWNED PATENTS** was recently made by Leo T. Crowley the Alien Property Custodian. The patents seized included hundreds owned by Telefunken and relating to radio and television equipment, as well as those of Siemens covering similar apparatus and aircraft instruments, as well.

In view of the unprecedented interest in patents and inventions, prompted by the present emergency, Washing-

ton has conceived of a variety of new forms of patent legislation designed to adjust the real or imaginary ills of the patent system. Some of the proposals are really designed to aid the inventor, and some, well, they have evidently worked out with two tongues in the cheek. Take, for instance, the bill of Senator O'Mahoney, known as S.2303, on which hearings are now being held by the Senate Committee on Patents, headed by Senator Bone. This bill was supposedly offered as an emergency measure with a view to facilitating the Government's use of patented inventions, even though there are sufficient laws on the books. This proposed law goes beyond the present emergency requirements, since it would actually permit Government confiscation of patents. In addition, the proposed legislation would permit indiscriminate license to use any patented invention regardless of whether or not used in war work, such licenses to extend for the term of the patent. In addition, there is nothing in the law that provides for an adequate basis for evaluation of the patent or compensation of the owner. This drastic legislation is certainly unnecessary and is certainly of no aid to either the Government or the individual. It is the perfect way to provoke a death sentence on the inventive genius of America . . . a talent on which this Nation has been built.

**LONG CONSIDERED AN ESSENTIAL, STANDARDIZATION** is at last receiving its due recognition. For now, this important work of industry, is proceeding at a rate never reached before, said R. E. Zimmerman, president of the American Standards Association at the last annual meeting in New York.

"This entire defense effort," said Mr. Zimmerman, "has been seriously hampered by the diversity of specifications and requirements for products, acutely so in the case of strategic materials.

"What a boon it would have been to the industries of this country, if at the beginning of the defense effort we had had 5000 good seasoned American standards, instead of five hundred. Many a manufacturer who today facing a shut-down as a result of the defense effort through a lack of scarce materials would have been able to carry his full part in production had we had a full complement of American standards to which our manufacturers, big and little, were accustomed to working."

The OPA has asked the Standards Association to undertake several projects, which includes commonly used household appliances as refrigerators. Although radio has not been included, it is hoped it will be. The purpose of these particular jobs is to assure the public of the quality of these products in the face of shrinking supplies of raw materials and to conserve production space needed for war orders.

During the past year, twice as many standards as in any year have been adopted, and it is hoped that this will be redoubled this year.

**TELEVISION RELAYING SYSTEMS** are continuing to prove their unusual value. Recently, air-raid warden programs originating in the television studios of WNBT in New York, were picked up by the GE television relay station in the Helderberg Mountains and relayed to television station WRGB which rebroadcast them for the Schenectady county wardens. With this new relay system, over 2000 air raid wardens can attend lessons, after which they listen to lectures and have question and answer periods. The Schenectady county civilian defense officials have established seven official posts throughout the county. Programs are received by television receivers loaned by General Electric.

**AMONG THE MANY QUESTIONS ON PRIORITIES** asked in Washington, five have been found to be the most frequent. They are: (a)—“Once you have obtained a preference rating for materials, how do you go about getting your requested supplies?” . . . (b)—“In applying for priority assistance, is it necessary to specify a definite delivery date on the application form?” . . . (c)—“Does the fact that the WPB is going into an allocation system mean that there will be no more priority ratings?” . . . (d)—“What is a blanket rating?” . . . (e)—“What are project ratings?” And here are the answers, in respective order: (a)—By endorsing a purchase order for these supplies, and stating on the face of it a prescribed certification of the preference rating that entitles you to them. You extend this purchase order to your suppliers, who in turn, can extend it to sub-suppliers . . . (b)—Priorities regulation No. 1 as amended requires every applicant for priority assistance to specify in his application the latest date on which such items requested can be delivered to him to meet his contract obligations or production schedules. All applications specifying immediately, or at once, will be returned to the applicant. Place and exact delivery date must be filled in . . . (c)—Priority ratings will remain to supplement and implement the allocation system . . . (d)—A limited blanket rating or P order covers certain vital industries important to defense, assigning a rating or ratings for all the materials required to produce a specified product, within the limits of the order . . . (e)—Project

ratings are preference ratings for material going into essential construction; plant expansion to fill war orders, for example, or defense housing for war workers. No building project will qualify for this unless it is important to the war effort, or vital to the public health and safety.

**A MODIFICATION OF INVENTORY** restrictions in radio and wire communications industries now allows material for specific Army, Navy and other war projects to be stocked without interference with normal operating inventories. This relaxation was prompted because the previous inventory restrictions included in orders P-129 and P-130, forced operators to acquire large inventories of material for specific projects authorized by the Director of Industry Operators. The restrictions prevented these operators from acquiring normal inventory for current operations.

Order P-129 makes an A-3 rating available to an operator or his supplier for deliveries of materials essential for maintenance and repair and protection of service in connection with radio and wire communication operations. The new interpretation also states that operators must include in their inventories of materials all items of salvaged material and supplies, whether held for re-use or for sale as junk. Such items must be counted in inventories until they have been physically incorporated into maintenance, repair, operating construction or other projects.

**LONG AN ESCAPEE OF CRITICAL** control rulings, quartz crystals have finally been caught in the Order net. A ruling now in effect, provides that, except by specific authorization, quartz crystals may be used only for (a)—products for use in implements of war, produced for the Army, Navy, or other Government agencies or Lend-Lease; (b)—oscillators and filters for use in radio systems operated by Federal agencies or commercial airlines, or (c)—telephone resonators. All purchasers must certify to the manufacturer of crystals that the products will only be used for these purposes. Holders of 25 pounds or more of quartz crystals, or ten pieces in manufactured form not incorporated in a mounting, as of May 18th, had to report to the WPB. Consumers must also report on form PD-484 monthly, by the 20th of the month. And sales of more than 10 pounds of quartz crystals must be reported within ten days after the transaction on form PD-485.

Fortunately, there is a bright side to this dismal ruling, in that since most of the precious crystals are found in the Western hemisphere, improved shipping and production facilities to be expected soon will afford an early relaxation of the ruling.

**AGAIN THE NUMBERS 44** appear in a fateful WPB ruling, that apply to a division of radio. The new ruling,

L-144, prohibits the sale and delivery of laboratory equipment to university and other private laboratories engaged in research work unrelated to the production of materials, or in other research not directly connected with the war effort, unless the particular use is approved. Fortunately the greatest percentage of radio developmental work is concentrated on the war effort. Thus the ruling affects but a small percentage of such activity, which is also probably related to the war effort, and thus admissible for a rating which will secure the necessary instruments.

The ruling contains some “ease” sections, such as the one providing for the handling of requests for equipment not specifically permitted. In addition the order permits any laboratory or other user to obtain repair parts and operating supplies for maintenance of existing equipment and activities.

The need for instruments which may be necessary and appropriate in the public interest, will be determined by E. R. Schaeffer, chief of the Safety and Technical Equipment Branch who will act for the director of industry operations.

To obtain the necessary amounts of critical materials, manufacturers should fill out the PD-25A applications under the PRP program. Distributors, wholesalers and jobbers requiring priority assistance should file PD-1X forms with the Distributors Branch of the the WPB.

**THE ARMY WAR SHOW** in which Signal Corps activities are a featured attraction, was wildly acclaimed on its first stop in Baltimore. In a driving rainstorm, 30,000 sat to watch this tremendous spectacle. The show which is on tour of the major cities of the East, South and West, made its second stop in Philadelphia, where for six nights, hundreds of thousands gathered to see the most exciting military show of all time. Full page advertisements announced its appearance, some of the advertisements being headed . . . **WAR COMES TO PHILADELPHIA.** From the demonstrations put on during the show, it certainly looked like war had come to Philadelphia, at least at Franklin Field, where the show was held. Fifty freight cars, twenty-five passenger cars, one hundred and fifty road trucks and a task force of 1,500 are involved in this dramatic presentation. The Signal Corps demonstrations include pole setting, wire throwing, two-way radio, walkie-talkie. In addition, there are demonstrations of light machine guns, heavy machine guns, tanks, searchlights, motorcycles, jeeps, ground and air force units, and many others. The entire proceeds of the affairs go to the Army Emergency Relief. Watch for this amazing two-hour action show!

**THE ELECTRIC LIGHT BULB** critical material curtailment reveals a paradoxical situation that the radio industry would welcome. For although the use of critical materials in the manu-



facture of electric bulbs will be curtailed, the production of the light bulbs themselves will not be curtailed. Actually the new ruling, known as limitation order L-28, permits a greater production than in 1940. For during the three-month period beginning July 1, and for each three-month period thereafter, manufacturers will be permitted to produce bases for incandescent and fluorescent lamps at a rate of 125% of his production in 1940. In addition, he may exceed even that rate of production in one three-month period, if he will reduce his production during the succeeding three months accordingly. All this is possible because effective substitutions are being made. The base, formerly of solid brass, will now be made of steel, plated with brass. Lamp leads, formerly made of a 50-50 combination of nickel and copper, will be made of iron wire plated with nickel and copper. Filament supports, formerly made of nickel and molybdenum, will be made of iron wire plated with nickel. The filament itself will be made of tungsten, since no satisfactory substitute has been found. We are quite fortunate in this respect, though, for we have in California, Colorado and Nevada a source of tungsten concentrates that is being mined most successfully. Idaho and Utah are now looming on the horizon as potentially good producers of tungsten, too. Probably the greatest agency responsible for the rapidly increasing discovery of tungsten ore is the fluorescent lamp. This is a comparatively new prospecting element which causes minerals to glow or fluoresce brilliantly, each with a distinctive color, as, for instance, scheelite or calcium tungstate, a bright yellow-orange light. In addition to indicating the presence of tungsten in new places, the fluorescent light has been of great assistance in pointing the way for additional production at marginal operations, as well as helping to select tungsten in ores containing other fluorescent minerals as molybdenum, zinc and calcite.

Plating processes used in the new substitution processes will require only about a tenth as much of the critical metals as was used before. Since many of these substitutes and materials are radio-tube essentials too, and since these alternate methods have been adopted by the tube industry months ago, there is every possibility that some similar relaxation action will be allowed in radio tube manufacture.

**THE MAN POWER MOBILIZATION PROGRAM** affecting everyone, and particularly those in technical service, such as radio engineers, servicemen, operators, etc., is soon to fall into full swing. The commission controlling this program, known as the WMC will mobilize manpower for duty on benches or laboratories, in much the same way the Selective Service System marshals those for combat service. The United States Employment Service with 1,500

offices will register applicants and place them in jobs. This does not mean that a labor draft will exist. It is, instead, a voluntary movement to place every man and woman in the job for which he or she is best suited and most needed.

According to present statistics, 20,000,000 will be required in war production services by 1944. Seven to eight million are expected to come from suspended or converted peacetime industries, 400,000 to 600,000 from the farm, 400,000 from professional ranks, 1,500,000 from the unemployed and 2,000,000 from the home . . . housewives, youths and retired workers.

Although it is true that the military services require manpower too, it is also important that industry maintains its share of essential production. For instance, says Washington, a college student majoring in chemistry or electrical engineering, need not resign from school and look for a job, or join the services. It is best that he finish the courses, for he'll be more valuable as a technician later on. In addition, he can obtain suitable military training while at school. And, says Washington, if you are a specialist, making dies, or engaged in research work in a war plant, you should remain at your work, instead of joining the services.

If you would like to get a war job, and have no training in industry, you should enroll in any one of the 2,400 vocational schools, 10,000 public school shops or 200 technical colleges and universities. Thus far, 3,750,000 persons have been trained (or are receiving training) in the past two years. In addition many green workers are trained on the job after they are hired in war plants.

In its surveys, the WMC will cover the manpower status of the broadcast industry, too, to learn the exact conditions that have to be ironed out. Those considered extremely essential to the stations or allied units, will be allowed to remain at their present posts. Information with these "essential-manpower" data will be sent to the local selective service boards so that they may act properly on deferments. The FCC and Selective units will be consulted by the WMC, before, of course, making final deferment decisions that will be directed to the local boards.

**A NEW VICTORY SYMBOL . . . V-7 . . .** was recently born in a General Electric war plant. The symbol covers seven points for victory. They are (1)—Understand your job . . . (2)—Do it right the first time . . . (3)—Conserve materials . . . (4)—Catch mistakes quickly . . . (5)—Keep a clean shop . . . (6)—Keep fit . . . (7)—Buy War Bonds.

**IN THE BROADCAST INDUSTRY**, pooling of parts has become a practice among many stations. The DCB made recommendations to the WPB that such practice be given official sanction and thus adopted by all stations. While

thus far, no official rulings have been made, it is expected that such rulings will be adopted soon. In the meanwhile stations in many localities are voluntarily following the DCB suggestions . . . exchanging scarce components . . . and keeping things humming . . . without burdening already burdened manufacturers with orders for parts that would delay the war production.

Some service shops have adopted similar practices, and before long many more will. It is, of course, nothing new to many shops to lend a hand to their neighbor with a part or two, out of stock. But it is something new to have to make it a habit, and unfortunately, in some instances, it may have to be just that . . . although not deliberately so.

To be most effective, this exchange practice would have to be inter-city and inter-state, requiring centralized inventory control. Thus service shops or dealers would pool their shortage problems and forward them to one of many depots where such parts would be available. The individual units would also supply inventories of their parts so as to provide a source of replacements.

**THE SHORTAGE OF SHELLAC HAS PROMPTED** a wave of "record-saving" campaigns throughout the nation. As we pointed out some months ago, records have high scrap value in that the shellac in them can be used as an effective binder.

The campaigns are being waged in cities from coast-to-coast. For instance, in Los Angeles, the Broadway Department Store bought about 1,500 pounds of records in four weeks. They pay 2 cents for each small record brought in, and 3 cents for the larger kind. In Baltimore, the price for the twelve-inch discs is four cents, and as many as available can be brought, whether or not new records are to be bought. In Bridgeport, the Columbia Recording Corporation are fostering "record nights." Old records will be accepted at the box office toward the purchase of tickets, each record being worth two-and-a-half cents. In other words, four records would be good for the purchase of a ten cent ticket. An experimental "record-night" in Akron, Ohio, brought in 45,000 records in a month. Tokens are used in Marshall Field's in Chicago. Three tokens are given for each record. These tokens are applied against the purchase of new records. In addition, Field's also pays for the scrap value of the record. In Knoxville, Tennessee, stores are offering six cents a pound for all old records, except laminated and old Edison records. Sears, Roebuck in Montgomery, Alabama, offers five cents for three old records of standard material, broken records being accepted if all the pieces are available. Other stores are offering ten cent War stamps to anyone bringing in four old records of standard material.

**THE RECENT DIATHERMY RULINGS**, ordering licensing of all equipment and consequent control of the transmitting activities of these units, seem to be working very effectively. Thus far, several instances of both signal interference with Government operations and simple illegal traffic, have been uncovered. In addition, it has uncovered other forms of transmission that interferes with radio operations of the Government. For instance, an X-ray machine owned by Dr. W. L. Smith of Monroe, Louisiana, was found to be offering interference to air-force operations. Thus the DCB ordered the operation of this X-ray unit to be stopped.

**A NEW METHOD OF PACKAGING** radio tubes, which is said to save as much as 50% in packing materials that are strategically important to the war effort has been developed by the RCA Manufacturing Company. This new development was demonstrated in New York City recently by the inventor, Charles I. Elliott, whose contributions to the packing and shipping practices of the industry have been known for years. The method of packing now proposed is said to outmode practices that have been in use for over 30 years.

**SILVER AND ITS ALLOYS** are playing new and important roles in radio, particularly with the restrictions on copper now in force. Silver is particularly adaptable because in contact work, for instance, it resists corrosion, its electrical resistance is low and its contact resistance can be kept within required limits. The oxide which forms on most metals increase contact resistance greatly. But with silver, corrosion is chiefly, if not entirely, in the form of a very thin sulfide film which has relatively low resistance. Visually the difference may not be apparent, but electrically, it is an important feature.

**WARTIME LITERATURE AND SERVICE PLANS** are on the march, with General Electric the latest to join in. Their latest effort, a 16 page booklet, entitled . . . A Captain in the Kitchen . . . contains data on how to keep a variety of electrical appliances at peak efficiency. Radio is, of course, given a section, with emphasis on many factors of interest to every serviceman. Particular care is taken in these data to avoid scaring consumers into being so meticulous about the equipment that it ceases to be a convenience. Instead, the use and care information offered, has been designed to help eliminate, by customer education, unnecessary service calls and to encourage service calls in place of amateur tinkering when service calls are advisable.

**IN VIEW OF THE URGENT NEED** of the Navy for men experienced in receiving and sending code, station WFIL, Philadelphia has established a class of code. Studio facilities will be

available, in addition to typewriters, telegraph keys, equipment for automatic tape transmission and receiving. Navy supervisors under the command of Lieutenant Commander Samuel Townsend, Communications officer of the fourth Naval district will supervise. Admission to classes will be predicated on the ability of the applicant to pass a preliminary physical examination at the Navy Recruiting Office and his willingness to enlist in the Navy, when he has acquired a speed of 15 to 20 words a minute.

The classes are expected to require approximately eight weeks of training, on the basis of two classes per week.

Additional wartime schooling is being put into effect by the University of Texas physics department. Dr. M. Y. Colby, department chairman has announced that the urgent need for trained radio technicians and other physicists in military service, civil service and war industry has caused the department to set up a new schedule of course eliminating all of the frills. In this streamlined course, 75 semester hours will be covered.

**TIRE FRICTION STATIC IN AUTO RADIOS** has been a complex subject that has defied countless. Accordingly it is truly news to announce that a report recently made offers the first practical explanation of this peculiar problem. The report prepared by J. W. Liska and E. E. Hanson of the Firestone Tire and Rubber Journal reveals that types of pavement and weather conditions are contributing factors controlling the amount of static.

Concrete pavement causes less static trouble than asphalt, while static increases on either type pavement if the surface is hot and dry. For this reason, there may be less static present during the early morning driving than later in the day. Grease film in the front wheel bearings was also identified as a cause of increasing static. Tires with low electric resistivity and small coil springs placed between the front wheel and the front axle eliminate much of the static annoyance, tests revealed.

Results also indicated that when the wheels were connected electrically through the brake bands to the frame of the car, the static discharges diminished considerably. After the brakes were released, if the car still had sufficient speed, the static discharge would build up to annoying proportions. The explanation, according to the report, is that charge separation occurs in the tire-pavement contact area by the similar frictional process. This is possible because the tire tread and usually the road are poor electrical conductors. However, a tire is not a perfect insulator. Thus the charges on the tread leak over through the tire side walls to the wheels. A leakage occurs from the wheel to the pavement contact area. Thus, says the report, if we assume that the car moves at a constant velocity over a uniform pavement, an equilibrium will event-

ually be reached between the charge leakages from the treads to the wheels and from the wheels to the pavement contact areas. However, since the pavement surfaces usually do not possess uniform electrical properties, the rate of charge generation at the tire treads of a moving car will fluctuate over wide limits and the equilibrium voltage is interrupted.

The report goes on to say that since the rear wheels are connected electrically to the frame of the car, they possess a much larger capacitance than the front wheels which are partly insulated from the frame by grease films in the bearings. It is, therefore, likely that large enough differences of potential often exist across the grease films in the front wheel bearings to cause electrical breakdown. Another cause of radio static, continues the report, is the charging of the car by induction. The negatively charged treads repel electrons from the fenders and other nearby regions to the more remote parts of the car, and, in general, lower its potential with respect to the ground. Whenever a fluctuation in the tread potential occurs, momentary electrical displacement currents also occur in the car. Any insulation between various parts of the car, such as the grease film in the front wheel bearings, will therefore be conducive to spark-over. This process probably is responsible for the major part of tire static interference with radio reception. If the axle and the wheel are maintained at the same potential by small coil springs placed in compression between the metal hub of the front wheel and the front axle, the greatest part of the static trouble is eliminated. What little remains is not troublesome and can probably be ascribed to a similar mechanism between other fairly well insulated parts.

Distance tests revealed that over as small a distance as 0.5 mile on a uniform pavement fluctuations in the car potential as large as 1,000 or 2,000 volts were often recorded.

**SLOGANS HAVE ALWAYS BEEN DYNAMIC AIDS** to production. And thus industry has asked for and received slogans that are sure to make that V spear out and spread its wings. Here are a few of the recent ones that are particularly effective . . . T.N.T. (Today Not Tomorrow . . . Western Electric) . . . Speed The Wheels To Beat The Heels (American Steel and Wire) . . . If It's Nip and Tuck Make It The Nip That Gets Tuck (DuPont) . . . Production Quotas Must Be Beat To Knock The Axis Off Its Feet (Globe-Union).

**METHODS FOR MORE AND BETTER** war production conceived by individual workman will hereafter prompt citation awards from the WPB. Individuals will receive either of three awards. One is the Award of Individual Production Merit. The second is the Certificate of Individual Production  
(Continued on page 58)

**JUST ONE**

*of* **THE HUNDREDS  
OF MIDLAND  
TRAINED MEN**

*"Keeping 'em flying"*

Now that the Government has taken control of the Airlines, the importance of the fascinating jobs so ably handled by Midland-trained Airline Radio Operators and Radio Maintenance men employed by practically all Airlines operating in and from the United States has increased many times over. Today they are well-paid Civilian Soldiers of the Airways . . . And when we win this war, they will be in on the ground floor of the tremendous expansion the Air Transport Industry will enjoy.

### DEMAND EXCEEDS SUPPLY

Ever since the inception of Midland Airline Radio training, the demand for our students and graduates has far exceeded the supply. Today, the demand is more than ten times greater than the supply. Students are reserved far in advance and go on the job before they graduate, **DIRECTLY FROM SCHOOL**. Airlines look to Midland for radio personnel because our training is thorough, in tune with the times, supervised by instructors released to us by major Airlines, and directed by a 9-Airline Advisory Board.

### TWO CIVILIAN TRAINING PLANS

Midland offers qualified men two proven training plans. You may secure all of your training in our modern communications and maintenance school in Kansas City, Missouri. Or, if you prefer, you may take part of your training at home and then come to Kansas City for intensive, advanced training. Should you enroll for the last mentioned plan, you have the privilege of transferring to resident school, receiving full credit for all tuition payments. Liberal terms granted to worthy men who want to do their part now . . . men who want a good job and a future when the axis has been given the "ax". It is not necessary for you to enlist to become a Midland student.

### ARMY DIVISION

As contractors to the U. S. Army Signal Corps, Midland operates two army radio schools . . . one in Kansas City, Missouri, and the other in Athens, Georgia. The Army students are selected and sent to us by the Signal Corps for training in specialized military communications work. Every Midland civilian student is proud of the part their school is taking in helping to bring **VICTORY** to the United Nations.



Midland Graduate Eldon Beazley, Senior Operator, Braniff Airways, Dallas, Texas, station.

**MIDLAND** welcomes strict investigation. We want you to find out all about our unusual employment record and our high standing in the Air Transport and Radio Industries. This is time for **ACTION** . . . not just "thinking". Take your first step in discovering the true merits of Midland training. Clip the coupon, fill it out, then . . .

## MAIL IT TODAY!

Mr. Norm Souther, Vice President  
Midland Radio & Television Schools, Inc.,  
Civilian Department  
Power & Light Bldg., Kansas City, Mo.

Please send me without obligation your profusely illustrated, 58-page catalogue and training outline "RADIO . . . the Voice of the Airlines", which fully describes your civilian Airline Radio training and the opportunities you offer qualified men.

NAME \_\_\_\_\_ AGE \_\_\_\_\_

ST. OR RFD. \_\_\_\_\_

CITY \_\_\_\_\_ STATE \_\_\_\_\_

CD-8

## Civilian Schools

(Continued from page 13)

pitts Oscillator, Tuned Grid-Tuned Plate Oscillator, Electron Coupled Oscillator, and Crystal Oscillator. These circuits are constructed during the ninth week. In the tenth week a complete transmitter is constructed consisting of a crystal-controlled oscillator, tetrode buffer and triode power amplifier. The Class C power amplifier is plate modulated with a type 801 triode, operating class A. The single AF stage preceding the modulator may be operated either as an AF oscillator for oscilloscope observations

of the modulated wave, or as an AF amplifier for a carbon microphone.

### Field Radio Equipment

Three hours of lectures from the *Signal Corps Instruction Manuals* on popular Field Sets plus five hours of field and laboratory work each day make up the ninth week. Communications receivers are aligned and Field Sets SCR 245, SCR 288, SCR 193, and SCR 195 are studied. Major emphasis is placed on practical application of radio knowledge. This statement sums up the Mechanic's Course.

During the last week of training the operators and mechanics work together in the field under conditions as nearly as possible like those encountered in typical Army net operation.

Army type equipment, which has been constructed by expert radio men in Midland's laboratories to Army specifications, is used by these field classes.

Here the men are welded into a communications unit which will serve to link the ever expanding divisions of our fighting forces in their march to Victory. And when the last din of battle fades, these men will still possess a knowledge which will profit them in their later civilian life.

-30-

## Non-Metal Shielding

(Continued from page 33)

cleansed glass tubing, preferably warmed, is coated by painting on a 1-to-2 "Aquadag" solution. Film contact may be made by the clamp and loop methods or with a lead heat-embedded in the glass itself (4a).

The flexibility of rubber tubing is, in no way, decreased by the application of graphite films to the grease-free surfaces. Actually the colloidal particles tend to fill the pores of the rubber and produce homogeneous surfaces. More than one coat may be necessary, depending on the porosity of the surface. Grounding can be accomplished with a metal eyelet, well surrounded with sealed graphite covering and complete with soldered lead, inserted in the tube walls (4b).

Should one find it advisable to splice or join a glass and rubber tube, proper electrical connection is assured by coating both the exterior and interior (up to the length of splice) with aqueous colloidal graphite before joining the parts (4c). Additional application over the joint is always advisable. One might remember, too, that films of nitrocellulose varnish afford protection in instances where their use may be helpful. Likewise, a thorough drying with heat or even baking of coated parts, whenever this can be safely done without injury to the base materials, assures the complete exclusion of water and affects the film in such a way as to discourage absorption of moisture from the air.

### Shield Partitions and Flat Surfaces

The method outlined in the treatment of fibrous shields for vacuum tubes (as in Fig. 3) is also useful for preparing shield partitions or planes

# "WHATEVER IT IS," SAID PILEZER TWIGG, "I DON'T WANT ANY"

Blithely ignoring the "No Admittance" sign over the door, the young man with the sample case barged into the back room of the Acme Radio Emporium where Serviceman Pilezer Twigg was busy on an ailing radio.

"If you're selling something," warned Pilezer grimly, "don't bother me. I'm busy."

"My dear sir," said the man with the sample case, "I'm not selling something. I'm practically giving it away."

"Whatever it is," snorted Pilezer, "I still don't want any."

"How can you say that when you don't even know what it is? Look!"

Pilezer couldn't help but look. Thrust just in front of his nose was a gadget that looked like a cross between a widget and a hoozit.

"We call it the Little Marvel," continued the salesman glibly, "and to call it a marvel is putting it mildly. It's a combination mousetrap, shaving mug, can opener, tooth brush, shoe brush and clothes wringer, etc. Also, it will rock the baby, let the cat out and mix cakes. We absolutely guarantee that just one Little Marvel will do at least 10% of all the work around the house. Think what a dozen will do!"

"Even if it was good," growled Pilezer, "I still wouldn't want it."

"But, my dear man, you are passing up the opportunity of a lifetime."

Suddenly, the young man with the sample case found himself flat on his back with Pilezer encased on his chest.

"Listen," said Pilezer grimly, "I told you I didn't want any. Understand?"

"Uh-huh."

"Besides," continued Pilezer, "you should talk to me about handy devices. Did you ever hear of



the famous Sprague Atoms?"

"Nuh-no."

"Well, they're midget dry electrolytic condensers. Your Little Marvel is a piker beside them. They'll do more jobs than you can shake a stick at—and do 'em right. For instance, that radio on the bench calls for a three-section replacement condenser that you can't get today from the factory. How am I going to get that set fixed up and delivered this afternoon? Would your Little Marvel do it?"

"Nuh-no."

"Well, Sprague Atoms will. I can take two 8 mfd. 350 V. Atoms and a 25 mfd. 25 V. Atom, strap 'em together and the job will be done. The Atoms will actually be smaller. They'll cost less and do the job better."

"But that's only the beginning," Pilezer went on. "With only a small stock of Atoms I can handle just about every condenser replacement job I ever get. Atoms are made in just about all capacities, all voltages, singles and duals. They're easier to install, cheaper, small enough to fit in anywhere, big enough to last longer and perform better than most old-style condensers that they replace. They're moisture-proof. They'll stand a whale of a surge voltage. They have exceptionally low power factor. They'll even stand up on a lot of jobs where only wet electrolytics were formerly used. Would your Little Marvel do all of that?"

"Gosh," gasped the salesman. "Not being in the radio business, I don't know what I'd do with them, but if Atoms are that good, maybe I ought to have some, anyway. How about selling me one—or maybe even a dozen?"

"Now you're talking," said Pilezer, allowing him to get to his feet. "Those are the first really sensible words you've spoken today."

# SPRAGUE PRODUCTS CO.

North Adams, Mass.

GOOD CONDENSERS — EXPERTLY ENGINEERED — COMPETENTLY PRODUCED

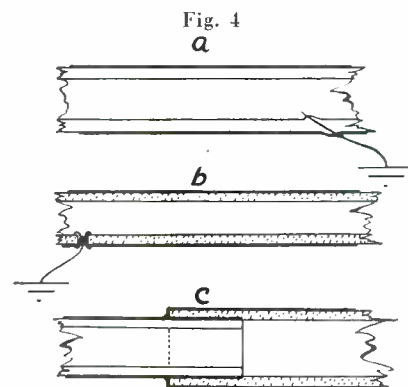

used in separating and shielding stages and components. As flat, fibrous surfaces of comparatively large size may curl during the impregnation treatment, slow or heat drying under pressure will minimize this and assure a flat surface for the final coat. Sheets of glass, bakelite, plastic, wood veneer are simply painted with a concentrated graphite dispersion. Metal eyelets or "cat's whisker" contacts are conveniently employed for the electrical connection to thin supports.

In the same way wood, glass, plastic materials used for enclosing a radio set or similar equipment can be painted on the inside for shielding purposes. As metal becomes increasingly unavailable for chassis structures or baseboards, this technique may be utilized in commercial receivers.

#### **Preparation of Graphite Mixture**

Practical suggestions for forming films and several precautions to be observed during the process have been given throughout this article. The final consideration on the subject of non-metal shielding is the preparation of the graphite mixture itself. It was pointed out in the beginning that only *colloidal* graphite, that is, liquid-suspendable graphite of minute particle size, could be used with any degree of success. This material, as purchased commercially, is a heavy black paste which requires care in diluting if the best results are to be obtained. Distilled water, for example, is the best diluent. Moreover, it should be added slowly to the paste while thorough and pro-

longed stirring is carried on. Any gel-like residues that fail to go into solution are eliminated by straining the dispersion through silk, cambric or other closely woven cloth. Masses so separated may then be further worked with a small amount of water before being returned to the original

solution, which is now ready for application.

-30-

Have YOU Entered the Inventors' Contest?

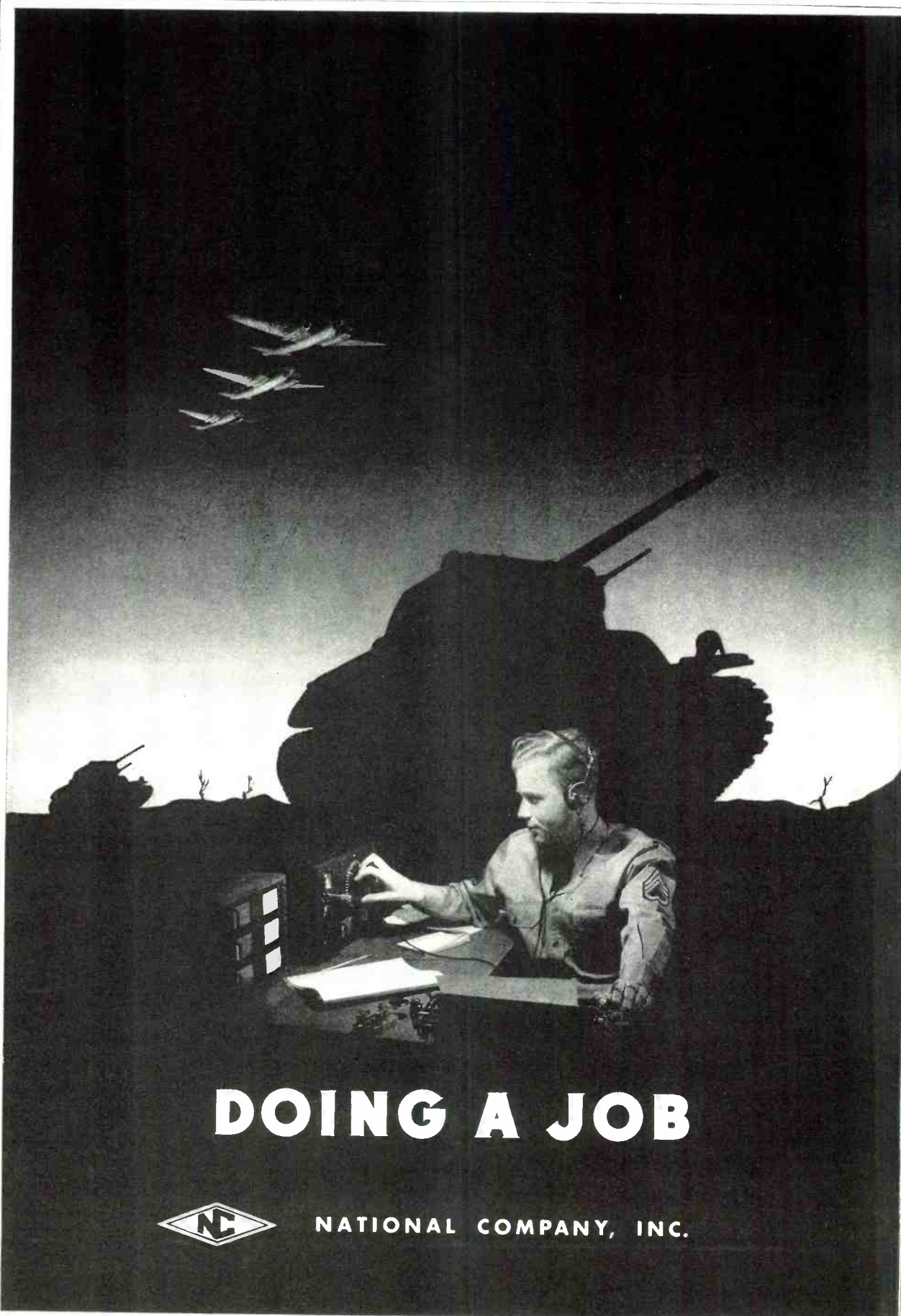

# DOING A JOB



NATIONAL COMPANY, INC.

**FM for Ships**  
(Continued from page 23)

position, to the input circuit of the modulator. By operating the switch to right-hand position, the modulator can be supplied with currents of different and much higher frequency, as, for example, forty kilocycles. These higher "calling currents" are used to attract the attention of the operator of the called vessel, even though, at the time, it is in communication with another vessel, before actual transmission of messages and orders.

The frequency modulator, when

supplied with currents of the normal audio-signal frequency, such as voice currents, shifts the frequency of the carrier wave by plus and minus 25 kilocycles, for example, for 100 percent modulation. When supplied with the calling current of 40 kilocycles, the frequency of the carrier wave shifts by plus or minus 65 kilocycles. The power amplifier and antenna are designed to transmit the carrier wave when so modulated.

The receiver is the ordinary f.m. receiver with antenna, radio frequency amplifier, converter, local superheterodyne oscillator, intermediate-frequency amplifier, amplitude limiter, frequency - amplitude con-

verter, output audio-frequency amplifier, and loud speaker. The carrier wave received on the antenna is amplified and converted to intermediate frequency by the converter.

The intermediate frequency amplifier is arranged to transmit the intermediate frequency plus frequencies within a band of 25 kilocycles, above or below the intermediate frequency. These currents are supplied to the limiter which removes any amplitude modulation, so that all currents in the output of the limiter are of equal amplitude.

During normal audio-frequency communication, these currents vary in frequency from 25 kilocycles below the intermediate to 25 kilocycles above, and are supplied to the amplitude converter where they are converted to currents of varying amplitude—the output currents being linearly proportional to the frequency of currents at the input of the converter. During normal communication, the output currents include voice frequency, which is amplified by the audio amplifier and sent on to the loud speaker.

A filter is connected to the output of the frequency-amplitude converter, which is designed to pass the calling currents of 40 kilocycles and to include currents of audio frequency. Currents of the 40-kilocycle frequency passing through the filter are amplified and rectified. The rectified currents are utilized to operate a relay which, when energized, causes a lamp to light before the operators of two communicating ships, which tells him that the flagship is breaking through to give orders.

Before the transmission of normal signals, the radio man of the flagship operates a switch to the right for a short time and, thus, transmits a carrier wave modulated by the 40-kilocycle calling current. This produces a frequency shift of the carrier of 40 kilocycles. When these currents are received by vessels, even though they are in communication with another ship, transmitters are shut down immediately to let orders from the commanding ship come through, or to permit their reception by the other ship.

The normal f.m. receiver is capable of adequate reception of currents of calling frequency without modification if the channel is connected to filter out the 40-kilocycle currents and amplifies and detects them after reproduction by the frequency-amplitude converter. This is possible even though the intermediate-frequency amplifier is designed for the transmission of the 50-kilocycle band extending from 25 kilocycles below the intermediate-frequency to 25 kilocycles above.

In the intermediate-frequency channel, during the calling period, the nearest side band to the carrier is removed 40 kilocycles from the carrier. Also, these circuits are designed only for transmission of the band extending to 25 kilocycles above and below



**Triplet**  
ELECTRICAL  
INSTRUMENTS

"Portables"  
Speed-Up  
War Production  
Testing

Triplet Portables speed up electrical testing with the dependable accuracy that is a vital part of war production.

And whether your particular interest lies in laboratory service, production line testing, experimental work, field service, or plant maintenance, you will find your need provided for, with exacting and lasting accuracy in the expanded line of Triplet Portables.

In the drive of production-line testing, Triplet Portables supply the full-scale accuracy, the consistent performance, the hair-trigger answers that result from the Triplet method of safe-guarding quality, by making every essential part in the Triplet plant.

If you, like the writer of the letter quoted below, want to back up our armed forces with time-saving production practices, write for complete details on other Triplet Portables, panel electrical measuring and test equipment.

Excerpt from  
letter of a prominent  
manufacturer (original  
in our files):

"With the Ohm Meter we have on order we can do in . . . seconds, what now takes a couple of hours."



**Model 625**

Models 625 D.C. and 635 A.C. Portables are unequalled for today's rush in production testing or the rigid requirements of laboratory checking. These highly attractive molded case instruments have long 4.58" hand calibrated mirror scales. The hinged cover closes when instrument is not in use, for added protection. Black molded case for D.C. instruments; A.C. is red. Size is 6" x 5 1/2" x 2 1/2". Has detachable leather strap handle.



**Model 425**

Another new Portable combining attractive symmetrical case proportions, a long readable scale, and requiring a minimum of bench space when in use. A real beauty in design for those preferring something different. Case and base are molded; base size 5" x 4 3/8". Model 425 D.C. (3.12" hand calibrated mirror scale); Model 435 A.C. (2.88" hand calibrated mirror scale.)

**THE TRIPLET ELECTRICAL INSTRUMENT CO.**  
BLUFFTON, OHIO

the carrier. Thus, it would appear that satisfactory reception of the calling currents would be impossible.

However, if two ships were communicating, assuming that the signal produced by the first ship is unmodulated, this unmodulated carrier would produce a voltage at the input of the limiter of the receiver. Then the flag-ship desires to break in. It is assumed that this signal is frequency modulated and produces a voltage at the receiver of the second vessel. These signals are received and transmitted through the radio-frequency amplifier; converter, and intermediate frequency amplifier, all of which possess selectivity and tend to reduce transmission of the side-band frequencies, which, of course, are necessary to the reproduction of the signal. The calling frequency is very high, compared to the normal signal. The shift in carrier frequency produced by it is also high, compared to the shift in carrier frequency produced by the normal signal.

Currents of the first pair of side bands are attenuated a certain number of times in the part of the receiver prior to the limiter. The second pair of side bands are small—being further removed from the carrier—and are highly attenuated. The effect, therefore, is negligible. This is also true of side bands of higher order.

If calling currents are of such high frequency that side bands lie removed from the carrier further than frequencies which the receiver is designed to receive, such current may be received with suitable intensity even against a carrier from another station of ten times greater intensity. This results from the high frequency of the calling current, and the high shift in frequency of the carrier. Calls are best transmitted through the narrow band circuits of the receiver in the presence of the normal signal, if it be a wide band call, and if the frequency band be traversed at a high-frequency rate. —30—

**A** REVOLUTIONARY new principle of packing radio tubes which, if utilized by the tube industry, will result in major contributions to the war effort in shipping space, material, handling and warehousing savings, has been developed by the manufacturers of RCA radio tubes.

By adopting the new method, RCA alone is saving some 120 tons of packing material a year, and is able to ship approximately twice as many tubes in a box-car or truck, thus halving the

need for critical shipping space. The new method supplants packing, handling, storing and shipping practices which have been common for many years.

To extend the value of the new packing principle more quickly, RCA has granted patent rights to the new type cartons to other tube manufacturers. In addition, other tube manufacturers have been shown factory routines that have been developed to make the most efficient use of the new process. —30—

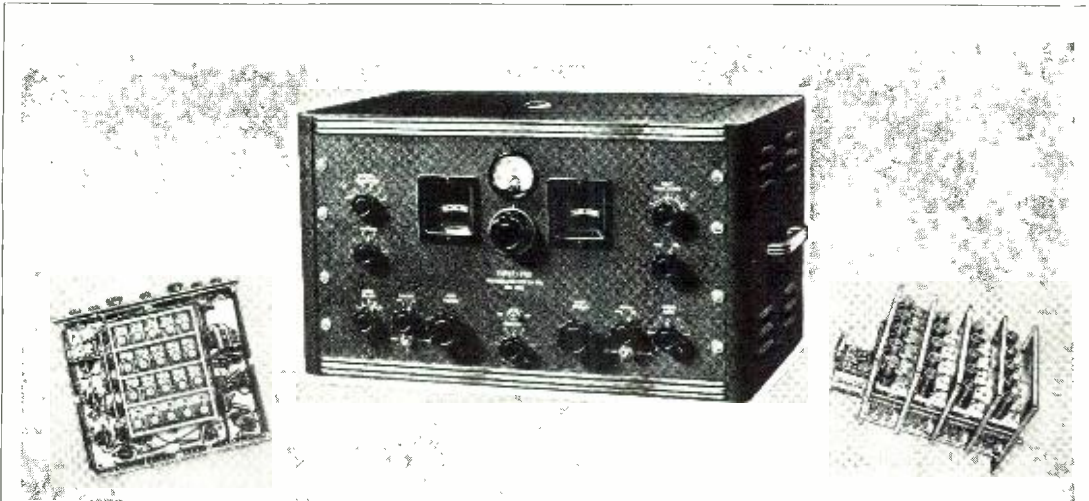

# Equal to any EMERGENCY!

**I**N Alaska, Antarctic, Far East, everywhere, you will find "Super-Pro" receivers. Many provide the sole means of communication with the outside world. The sound design of the "Super-Pro" and its record of dependable performance is your guarantee of satisfaction. Engineers who choose receivers for such service just can't be wrong. Their choice of a "Super-Pro" is acknowledgment of its superiority. Take a tip from the experts and make your next receiver a "Super-Pro." It is economical too. You don't have to trade every year when you own a "Super-Pro."

Send coupon or call at your nearest dealer's for 16-page booklet containing complete technical information on the "Super-Pro" Series 200. The "Super-Pro" is available in several ranges, taking in frequencies as low as 100 kc.

Export Office:  
100 Varick St., N. Y. C.

"Super Pro"

SERIES - 200

---

HAMMARLUND MFG. CO. RN-8  
460 W. 34th St., New York City  
Please send "Super-Pro" Booklet

Name .....

Address .....

City ..... State .....



## HAMMARLUND

## VTVM

(Continued from page 19)

the purpose of which is to buck out the steady contact-potential current due to diode emission.  $R_6$  is an ultra-midget 1000-ohm potentiometer built into the probe unit. The resistor following the diode plate is a filter component and its value may have to be chosen with care with respect to the resistance of the  $R_1$ - $R_7$  string. By making this resistor somewhat larger than the value recommended, the v.t. voltmeter may be made to read convenient RMS rather than peak values.

It is not recommended that a.c. or

r.f. voltages higher than 200 be measured with the measuring head shown. The reader is not restricted to the type of a.c. probe shown in Figure 2. He may please his own fancy in this regard. Rider's *Vacuum Tube Voltmeters* gives working designs for several such probes of different circuit arrangement.

### Mechanical and Electrical Construction

The instrument occupies small quarters, as may be seen from the photographs. It is built on a 7" x 6" x 2" Bud C-1584 chassis and is housed in a sloping panel Bud 1584 wrinkle-finish cabinet. The range switch occupies

the lower left corner of the front panel, the coaxial input unit is mounted in the lower center, and the zero-adjusting potentiometer in the lower right.

The meter, a *Triplet Model 426*, is mounted in the center of the sloping panel, and on each side of it is mounted a single switch—one the a.c. line switch and the other the meter on-off switch.

The voltage divider resistors,  $R_1$  to  $R_7$ , are mounted on a small, thin bakelite panel which is fastened directly to the Isolantite voltage range switch,  $S_1$ , with which it is associated.

Rectifier and voltage regulator tubes are mounted close to the transformer which occupies the right rear corner of

# YOU CAN'T WORK ANY HARDER BUT-YOU CAN WORK MORE EFFICIENTLY!



Today servicemen are not only over-loaded with work, they're worrying how they're going to keep up with the rush.

Now, there's a limit to the amount of night work you can do—But, there's no limit to the increased production you can get from greater efficiency.

Save precious hours—reach for your Rider Manuals on every job. Stop wasting time "guessing out" servicing information that your Rider Manuals can place right at your fingertips.—And, you'll need all thirteen Rider Manuals.

### RIDER MANUALS

Volumes XIII to VII.....\$11.00 each  
Volumes VI to III..... 8.25 each  
Abridged Volumes I to V.....\$12.50  
Automatic Record Changers and Recorders. 6.00

### A-C CALCULATION CHARTS

A modern, streamlined engineering aid that greatly reduces the time heretofore required for alternating current engineering calculations. Two to five times as fast as a slide rule—and more fool-proof. 146 charts—all direct reading—printed in 2 colors—operative over a frequency range of from 10 cycles to 1000 megacycles.

160 Pages—9½ x 12 inches—\$7.50

### FOR EARLY PUBLICATION

Inside the Vacuum Tube—complete elementary explanation of fundamentals of vacuum tubes.

### OTHER RIDER BOOKS YOU NEED

The Cathode Ray Tube at Work.....\$3.00  
Frequency Modulation..... 1.50  
Servicing by Signal Tracing..... 3.00  
Meter at Work..... 1.50  
Oscillator at Work..... 2.00  
Vacuum Tube Voltmeters..... 2.00  
AFC Systems..... 1.25  
HOUR-A-DAY-WITH-RIDER SERIES—on "Alternating Currents in Radio Receivers"—on "Resonance & Alignment"—on "Automatic Volume Control"—on "D-C Voltage Distribution." 90c each

## JOHN F. RIDER PUBLISHER, Inc.

404 Fourth Avenue New York City  
EXPORT DIVISION: Rocke-International Elec. Corp.  
100 Varick Street, New York City Cable: ARLAB

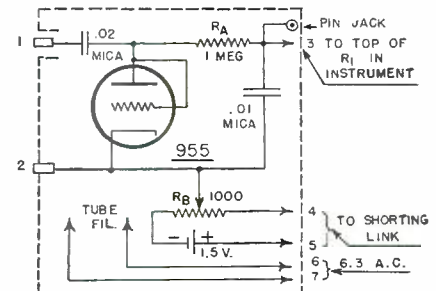

Fig. 2.

the small chassis, and the voltmeter tube, 7C6, is mounted toward the front and along the right hand edge of the chassis.

The bias cell holder is mounted as close as physically possible to the 7C6 loctal socket, and its negative lug is soldered directly to the grid terminal of the socket. The holder is so mounted that the cell is held with its face vertical, in accordance with the manufacturer's recommendations.

All wiring, particularly that in the 7C6 grid circuit, must be kept as short as possible and be made in a direct fashion. Power leads may conveniently be cabled.

The line cord passes out through the rear of the chassis and cabinet through rubber grommets and is secured by a double-lug terminal strip mounted close to the transformer.

Leads from the meter and switches pass through the chassis top through midget rubber grommets lining holes drilled close to meter and switch positions.

### Adjustment and Calibration

After the power supply circuit has been wired, the voltage regulators should be adjusted. This is accomplished by disconnecting the lead from  $C_2$  to the junction of  $R_8$  and  $R_{11}$  and setting the clip on  $R_{12}$  so that 30 milliamperes pass through the VR tubes in this no-load condition. The clip is tightened, the B-plus lead replaced, and the power unit regulator is fully adjusted.

After the wiring is completed and carefully inspected, the switch  $S_2$  is opened, removing the delicate microammeter from the circuit, and the line



YOU NEED RIDER MANUALS  
TO "CARRY ON"



switch  $S_2$  thrown to the on position. After allowing two minutes or so for the 7C6 cathode to come up to operating temperature, the meter switch is closed and the control  $R_{11}$  manipulated to bring the pointer of the meter to zero. The instrument is then allowed to run undisturbed for another ten to fifteen minutes to stabilize, whereupon it will be necessary again to set the meter to zero by means of the potentiometer.

With the range switch,  $S_1$  in the 1-volt position, one volt d.c. is then applied through the coaxial line, the positive terminal being connected to the inner conductor of the line and the negative terminal to the ground clip. This one volt must be determined very accurately by means of a good-grade d.c. voltmeter and might be obtained from a standard 1.5-volt dry cell through a small volume-control type of potentiometer. Upon application of this voltage, the microammeter should be deflected exactly full-scale. If it is not, the chances are that some of the resistors in the input voltage divider are off value or that the 7C6 is considerably off rated transconductance. Various units in the input voltage divider may be replaced to correct inaccuracies traced to this source, and several 7C6 tubes may be tested in the instrument for best results.

It will be well to mention at this point that the resistors used in the input voltage divider must be carefully hand picked in order to insure accuracy of voltage readings. In fact, the accuracy of the instrument depends upon the efficiency of this divider. It is not absolutely imperative that the resistors be exactly of the values indicated if they are all off value by the same proportion.

Individual d.c. voltages may be applied to the various ranges, selecting each with the switch  $S_1$  and noting the meter deflection.

After the d.c. calibration has been completed, it will not generally be necessary to make a separate a.c. calibration, as the instrument will indicate the peak value of alternating voltages applied to the measuring head (Figure 2). However, a check may be made to ascertain that the a.c. attachment is functioning properly. The measuring head (a.c. probe) is connected to the instrument, a known alternating voltage applied to the probe input terminals, and the meter deflection noted. The latter should be the peak value of the applied voltage (1.41 X the measured value as indicated by a common a.c. voltmeter of good accuracy). If the deflection does not attain this value, or if it is desired to have the meter read RMS values, the diode filter resistor ( $R_4$  in Figure 2) may be either increased or decreased to obtain the desired reading.

Before placing the a.c. probe into operation, the diode contact potential must be bucked out by means of the potentiometer  $R_{10}$  (Figure 2) to prevent a steady deflection of the meter (and

consequent error). This is done best by setting the meter to zero with the probe disconnected. After stabilization has been reached, the probe is connected, without a.c. input, and the potentiometer  $R_{10}$  adjusted to correct any change of the meter reading. The instrument is then ready for a.c. measurements. —30—

### Silent Warden (Continued from page 17)

Upon close examination of the diagram, it will reveal that the a.v.c. voltage is lifted from the R.F. and I.F. stages and applied to the grid of the last audio stage (follow bottom wire

of last I.F. coil to switch). The voltage developed in the a.v.c. circuit when the set is tuned to the average local broadcast station, is sufficient to bias the last audio stage to cut-off, permitting little or no current to flow in the plate circuit.

In this plate circuit, and by means of the SW, the speaker is replaced by a 1 to 10 ma. relay (contacts open when unenergized), which controls the bell alarm circuit. When the set is pretuned to a local station, and the SW is thrown to the alarm position, no current flows through the relay and the set is silent. But, should the pretuned station leave the air, the a.v.c. voltage will fall off, causing current to flow through the relay, thereby

## THE NEW TUBE TESTER MODEL 1240

Instantaneous snap switches reduce actual testing time to absolute minimum. Tests all tubes 1.4 to 117 volts. Sockets for all tubes — No adapters.

### SPECIFICATIONS:

- ★ Tests all tubes, 1.4 to 117 volts, including 4, 5, 6, 7, 7L, octals, loctals, Bantam, Jr., Peanut, single ended, floating filament, Mercury Vapor Rectifiers, the new S series, in fact every tube designed to date.
- ★ Spare socket included on front panel for any future tubes.
- ★ Tests by the well-established emission method for tube quality, directly read on the GOOD ? BAD scale of the meter.
- ★ Jewel protected neon.
- ★ Tests shorts and leakages up to 2 megohms in all tubes.
- ★ Tests leakages and shorts in all elements AGAINST all elements in all tubes.
- ★ Tests BOTH plates in rectifiers.
- ★ Tests individual sections such as diodes, triodes, pentodes, etc., in multi-purpose tubes.
- ★ Latest type voltage regulator.
- ★ Features an attractive etched steel panel.
- ★ Works on 90 to 125 volts 60 cycles A.C.

Model 1240 comes complete with instructions and tabular data for every known type of receiving tube. Shipping weight 12 pounds. Size 6" x 7½" x 10¾". Our Net Price. **\$14<sup>85</sup>**

COMPLETE WITH PORTABLE COVER

## MODEL 1230 SIGNAL GENERATOR

WITH FIVE STEPS OF SINE-WAVE AUDIO

### SPECIFICATIONS:

1. Combination R.F. and A.F. Signal Generator, R.F.—100 K.C. to 90 Megacycles, A.F.—200 to 7500 cycles: Sine-Wave, — WITH OUTPUT OF OVER 1 VOLT. All direct reading, all by front panel switch manipulation.
2. R.F. and A.F. output independently obtainable, alone or with A.F. (any frequency) modulating R.F.
3. Latest design full-range attenuator used for controlling either the pure or modulated R.F.
4. Accuracy is within 1% on I.F. and broadcast bands: 2% on higher frequencies.
5. Giant dial etched directly on front panel, using a new mechanically perfected drive for perfect vernier control.
6. Operates on 90 to 130 V. A.C. or D.C. (any frequency).

The Model 1230 comes complete with tubes, shielded cables, molded carrying handle and instructions. Size 14" x 6" x 11". Shipping weight 15 pounds. Only **\$14<sup>85</sup>**

**SUPERIOR INSTRUMENTS CO.** 227 Fulton St., Dept. RN-8  
NEW YORK, N. Y.

Streamlining

# SYLVANIA SERVICEMAN SERVICE

by  
FRANK FAX



A lot of fellows tell me that replacing worn-out parts is a ticklish problem these days.

Duplicating tubes is particularly tough. Very often the entire circuit or the wiring set-up of the chassis has to be changed.

That's why the new Sylvania Base Chart should be just what the doctor ordered. Like earlier editions, it provides a complete cross-index of all Sylvania tube types and bases.

But more than that — this handy and popular guide can now be used in three different ways: as a wall chart, a pocket booklet, or in the service kit.

You can get the Base Chart right away by writing to me, Frank Fax, Dept. N-8, Hygrade Sylvania, Emporium, Pa. Remember, it's free.

There's no charge, either, for many of the invaluable sales helps on the list below. And the others are available at cost price. Select the ones you need and write for them now.

1. Window displays, dummy tube cartons, timely window streamers, etc. (From your Sylvania jobber only)
2. Counter displays
3. Electric clock signs
4. Electric window signs
5. Outdoor metal signs
6. Window cards
7. Personalized postal cards featuring timely topics
8. Imprinted match books
9. Imprinted tube stickers
10. Business cards
11. Doorknob hangers
12. Newspaper mats
13. Store stationery
14. Billheads
15. Service hints booklets
16. Technical manual
17. Tube base charts
18. Price cards
19. Sylvania News
20. Characteristics sheets
21. Interchangeable tube charts
22. Tube complement books
23. Floor model cabinet
24. Large and small service carrying kits
25. Customer card index files
26. Service garments
27. 3-in-1 business forms
28. Job record cards (with customer receipt)
29. "Radio Alert" Post-cards
30. Radio Caretaking Hints to the Housewife

# SYLVANIA

RADIO TUBE DIVISION  
HYGRADE SYLVANIA CORPORATION

closing the bell ringing circuit.

A good 1 to 10 ma. relay with adjustable spring tension should be used. C2 is important, as it by-passes the audio frequencies and keeps the relay from chattering. The bell is nothing more than a common a.c./d.c. doorbell and can be purchased for about fifty cents. C1 across the contacts of the bell is again important. The 3-volt battery used for ringing the bell, can be replaced with either a bell transformer or a voltage dropping resistor in the a.c. line. If the set is d.c. operated, only a voltage dropping resistor can be used, but do not use the voltage that supplies the filaments of the tubes, as this will cause the set to become erratic when in the alarm position.

Battery operated sets are impractical from the standpoint of cost of operation, but any reasonably good five or six tube a.c./d.c. set, with a.v.c. and preferably one that uses an outside aerial, can be easily converted by a serviceman or amateur. If the cabinet of the set is too small to house the additional equipment, the bell, switch, battery and relay can be mounted in an external box, and connected to the set by means of a six wire cable.

Before retiring, the set is turned on to the Radio position. Your favorite local Broadcast station that maintains a 24-hour a day schedule is tuned to in the usual manner. Upon retiring, the switch is thrown to the Alarm position. The set is now silent, but alert, and will remain so, as long as the broadcast station stays on the air. Should an air raid be attempted during the night, the *Interceptor Command* will notify all broadcast stations in that area to leave the air. This is usually preceded by a blast of tone and a short announcement. As soon as the station's carrier is taken off the air, the Silent Air Raid Warden will set off its alarm, very much in the same manner as a pre-set alarm clock. A quick check of conditions should be made by throwing the alarm-radio switch to the radio position. If all the local stations in your area are found to be off the air, you can be sure that necessary precautions should be taken.

With slight changes to meet the individual requirements, the bell ringing circuit can be made to control any kind of electrical or mechanical equipment.

-50-

## Mfrs. Literature (Continued from page 38)

### Ohmite Catalog No. 18

This catalog has been published with the aim of being as helpful as possible to the users of rheostats and resistors, and we feel sure you will find it a valuable source of information. Many types of controls, switches, miscellaneous items are illustrated to serve every purpose.

Catalog is completely up to date and

may be obtained by writing to the *Ohmite Manufacturing Company*, 4835 Flournoy Street, Chicago, Illinois.

### Emby Photo-Electric Cells

This catalog illustrates and describes the many cells manufactured by the *Emby Products Company* and gives full electrical characteristics and other valuable information to help in the selection of the proper cell for a given application. These are of the barrier layer, self-generating type. Light striking upon the cell generates current sufficient to operate relays and meters directly without the use of auxiliary power supply.

Copies may be had by writing to the *Emby Products Company*, 1800 W. Pico Blvd., Los Angeles, Calif.

### Insuline Catalog

This latest printing shows the complete line of I.C.A. quality metal products. Many types are illustrated and serve as foundation units for all types of transmitting broadcast receiving and amateur equipment. Several metal specialties are shown, including metal trim plates and chrome ventilating louvres. Also included are many commonly used small radio parts, including dials, plugs, jacks, sockets, test leads, chokes and utilizing tools.

Address your request to the *Insuline Corporation of America*, 30-30 Northern Blvd., Long Island City, N. Y.

### Gray Keger TG-10 Bulletin

This catalog illustrates the new TG-10 automatic code sender. It is finding application in various code establishments and schools and is used to transmit code with extreme accuracy to the student. In teaching student radio-operators the National Morse Code, one of the most difficult problems has been to provide proper practice signals. This unit will solve this problem and will fully answer rigid and comprehensive requirements for equipment of this type. It provides an easily controlled source of practice material for large groups of students.

The bulletin gives full specifications and other information may be obtained from the *Gray Manufacturing Company*, 16 Arbor Street, Hartford, Conn.

### Polymet Condenser Catalog

Far-sighted servicemen and jobbers realize that now, more than ever, they must jealously guard their standing in the field. Every effort must be made to build and maintain customer satisfaction by supplying items of proven merit.

Condensers account for a great percentage of the parts business and the manufacturers of *Polymet* electrolytic and by-pass condensers are helping jobbers and servicemen to protect that important segment. Members of the trade, including manufacturers of fluorescent lighting equipment are invited to send for a copy of the latest catalog and price sheet, now available from the *Polymet Condenser Company*, 699 E. 135th St., Bronx, New York.

-50-

## Electronics

(Continued from page 27)

mechanically-controlled actions, common procedure. Closing and opening doors by use of the "electric eye" has been, furthermore, lifted from the realm of a hobby of scientific pastime. The Brown and Williamson Tobacco Company of Louisville, Kentucky, lately installed photoelectric controls on doors in its shipping and receiving departments. This concern, taking into account substantial savings on heating bills, as well as operating costs, estimates savings of 40 or more dollars a day. In this tobacco manufacturing plant, the shipping and receiving departments function 24 hours a day. Six master doors must be opened and closed as heavy loads of leaf tobacco come in, shipments of cigarettes and smoking tobacco go out. Until the "magic eye" radio tubes came to the rescue, these huge doors were operated manually. This meant a dissipation of time in opening and shutting them, plus precious moments lost in signaling for the doors to come ajar. The costs of heating these rooms were high; the doors opening to the outer air moved sluggishly in opening and closing—sometimes they stood ajar because there just wasn't sufficient time to close them. Consequently, employees were exposed frequently to variable weather conditions. Now the "magic eye" operates with the precision of a yardmaster closing the switch of a railroad track.

It might be apropos to mention here the fact that Hollywood, with its eyes ever searching for the startling and dramatic, has also employed the "electric eye" in building up the final climax in the recent motion picture, "They Drive by Night." Here the heroine murders her unwanted husband by locking him in a carbon-monoxide-filled garage, and then drives cautiously out through electronically controlled gates. At the last trial, she is finally forced into a confession and goes mad when she is once more confronted with the "electric eye" used in opening the gateway which leads from the courtroom to the corridors of prison cells, and she subconsciously recalls the last time she encountered the same "accusing" eye. Thus we find the possibility of using electronics even in the science of criminology as combined with the art of motion pictures.

The Lighthouse Service of the United States Department of Commerce was perhaps the first government (or commercial) agency to seize upon the utility value of the "electric eye" when, more than 15 years ago, the signals of a lighthouse were turned on and off automatically. This marked the beginning of the "manless" lighthouse; a combination of the electron tube, radio equipment, and relays—all acting in unison to control the beacon lights for the benefit of mariners.

Now, in World War II, a photoelectric control has been contrived especially for turning off display window lights, illuminated signs, or protective lighting, during "blackouts." This so-called "light watchman" is a photoelectric relay which is actuated by the nearest city-street light. When the latter flashes dark at the onset of a "black-out," the "electric eye" relay turns off the lights in the show window, sign, or protective lighting arrangement. When the street light flashes on again, the controlled lights are again energized. This photoelectric relay is quite directional, subject only to the control of the street light at which it is aimed. A momentary delay prevents false operation of the relay by the flickering of the street lights. It is so designed that if either of the two electron tubes fails, or if the sensitive relay coil is open-circuited, the photoelectric relay is de-energized, and the lights are turned off. The relay of this robot or "light watchman" will not influence the normal functioning of time switches, if the latter are employed to turn on the lights at dusk and turn them off at a predetermined time.

The "electric eye" as an automatic servant in controlling the functioning of a lighting system has invaded the classrooms of a new school—the Crow Island School in Winnetka, Illinois. Here, to guarantee adequate illumination for the eyes of pupils, the inside corners of the classroom have predetermined lighting levels, and a photoelectric relay turning on a row of 100-watt lamps overhead when the corner-classroom lights are inadequate. Conversely, when the natural light returns to a value above a certain level, the overhead electric lights are turned off automatically. This unique lighting effect dovetails with the central theme around which this new schoolhouse orientates—namely, about the child's individual development, intellectually, physically, and emotionally.

A more complex example of the control mechanism inherent in an electron tube is that of a "register" installed on a rotogravure press of the *Philadelphia Inquirer*. Precise control of four colors is kept at press speeds of about 1,000 feet a minute. Two photoelectric devices are employed for each color unit. One watches practically invisible yellow register marks, one-hundredth of an inch in width, on the margin of the paper-carrying web; the other watches a disc fixed on the printing cylinder, and applies corrections automatically. As soon as any variations appear, a small motor geared to the cylinder-driving mechanism scientifically shifts the position of the cylinder with respect to the preceding impression, with the result that the colors are in register with a precision of five-thousandths of an inch. For practical purposes, such an infinitesimal tolerance is accuracy itself.

-30-

## QUALIFY at home—quickly

for your pick of 200,000 RADIO JOBS  
in the U. S. Armed Forces, Aviation,  
Industry, Broadcasting and Police Radio

**NOW! The exact training  
you need—simplified for  
rapid self-instruction**

## FUNDAMENTALS OF RADIO

The Complete A-B-C of Basic Radio  
in One, Easy-to-Master Handbook

### BY SIX DISTINGUISHED RADIO EXPERTS

W. L. EVERITT, Editor, Director of Operational Research Section, Signal Corps, U. S. Army; L. C. SMEBY, Signal Corps, U. S. Army; W. CARL OSTERBROCK, U. of Cincinnati; F. H. PUMPHREY, Signal Corps, U. S. Army; P. H. NELSON, Ohio State; E. C. JORDAN, Ohio State.

If you want to prepare yourself for radio work in advance of induction or enlistment in the military services, or if you want to get into radio broadcasting, or in the radio industry itself as a radio technician, here is the book that will give you the basic training you need. FUNDAMENTALS OF RADIO trains you in the entire field of basic radio communications, from the simplest circuits right through FM transmission. No previous experience is necessary. Written not for engineers, but for student technicians who must know how to maintain and operate all types of radio apparatus, and have only a limited time in which to master the basic training.

### Your Instructors—"Tops" In Their Fields

Each author combines practical experience with teaching ability. Each not only knows what it takes to qualify you for radio opportunities, but how to pass his knowledge on to you. Your instructors are experts whose associations include the Signal Corps of the U. S. Army, NAB, IRE, Rutgers, Ohio State, etc. Moreover, FUNDAMENTALS OF RADIO follows the instruction outline recommended by the National Association of Broadcasters.

### Complete Training for Today's Needs

(A Partial Glimpse of the Contents)

Concise Review of Radio Mathematics—A.C. and D.C. Circuits—Electronic Principles—Rectified Power Supplies—Sound and Its Electrical Transmission—Audio Amplifiers—Vacuum-Tube Instruments—Electro-magnetic Waves Transmission of Signals by Radio—Radio Frequency Amplifiers and Detectors—Amplitude Modulation—Radio Transmitters and Receivers—Frequency Modulation—Radio Wave Propagation—Radio Antennas.

### Don't Postpone Opportunity

FUNDAMENTALS OF RADIO gives the usable information that qualifies you as a radio technician, as well as the foundation for more advanced study and promotion. Without obligation, read and study FUNDAMENTALS OF RADIO for five days. Mail coupon NOW! (400 pages—Handbook style) Price \$5

### MONEY-BACK GUARANTEE

PRENTICE-HALL, Inc.  
Dept. FR-2, 70 Fifth Ave., N. Y. C.  
Please rush copy of FUNDAMENTALS OF RADIO. I enclose \$5, plus 10c postage. If, within 5 days, I decide not to keep this book, I am free to return it for refund of the purchase price.

Name .....

Address .....

City & State .....

SEND C. O. D., plus few cents postage charges. (Same refund guarantee.)

# BARGAINS IN RADIO PARTS!

*Guaranteed All New  
and 100% Perfect...  
in Original Packages*

**RECORDING DISCS!** . . . thousands of acetate coated discs . . . amazingly good quality at lowest price for quick sale . . . minimum background noise—coated on 2 sides—non-inflammable . . . With Labels.

6 1/2" in lots of 10 . . . **57c** In lots of 100 . . . **\$5.50**  
8 " in lots of 10 . . . **77c** In lots of 100 . . . **7.50**  
10" in lots of 10 . . . **97c** In lots of 100 . . . **9.50**



**P. M. SPEAKERS!**—All new—thousands in original cartons. 4" and 5", good heavy construction. V. C. impedance 3-4 ohms. (Less transformers) 4" at **89c** each. 5" at **\$1.10** each.



**ASTATIC CRYSTAL PICK-UPS!**—high grade, low pressure pick-up. Statuary brown finish with single hole mounting bracket. Mounting center 7". Plays up to 12" records . . . your new low price **\$2.95 each**

**AUTO CONTROL HEADS,** with cables, will fit most cars and sets. Complete. . . . **\$1.89**

**COILS**—2 band AC-DC coils, high gain. Per set **49c**

**PUSHBACK WIRE** in assorted lengths. Per lb. **60c**

**SERVICEMEN'S SPECIAL!**—10 lbs. Radio Parts Kit. An assortment of controls, switches, coils, variables, resistors, condensers, etc., all perfect and brand new! . . . **only \$2.95**

**FREE!** Servicemen write today for free catalog listing thousands of parts bargains . . . hardware and replacement parts.

**WE SAVE YOU MONEY! . . .  
DROP A POST CARD TODAY**

## RANDOLPH RADIO

609 W. RANDOLPH ST., CHICAGO, ILL.

"Millions of Parts for Millions of Radios!"

## Emergency Portable

(Continued from page 25)

employed. Tuning of the r.f. amplifier is best done by inserting (temporarily) a 0-50 ma. meter in series with the lead between T4 and the screen of the 1LB4 r.f. amplifier. The no-load plate current will depend upon the actual plate voltage applied. The secondary of L3 should be adjusted until there is an approximate 20% increase of plate current as indicated by the milliammeter. After this adjustment has been made, this meter may be removed.

Further checking may be done with a small neon lamp held against the fish pole antenna. When the transmitter is on, there should be a faint glow and when speaking into the set, the glow should increase in intensity with modulation. Should the brilliancy diminish, it will indicate that the coupling of L3 has been made improperly.

### Receiver

The receiver employed utilizes a crystal-controlled oscillator used in conjunction with a standard superhet circuit and is designed to employ regular receiving type tubes. The coil in the oscillator portion (L2) is designed to resonate at the frequency of the crystal X-2. This may be a random-wound coil of small diameter or a

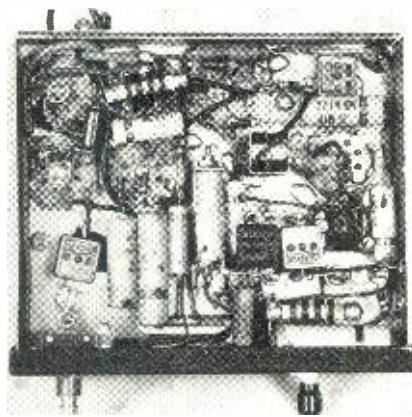

Underside view of portable.

manufacturer's type honeycomb coil. The control grid of the 1LA6 is used as the r.f. stage of the superhet. An iron core inductance is used and the antenna is connected to the center tap of the inductance where sufficient coupling will result. The a.v.c. return lead is at the low potential end of R1, directly from the control grid of the 1LA6.

The i.f. amplifier operates at a conventional frequency of 455 kc. although this frequency is not critical. The i.f. amplifier tube is a 1LN5 r.f. pentode and provides sufficient gain to amplify even weak signals. The 2nd I.F. transformer (T2) feeds directly to the diode of the second detector-audio amplifier tube 1LH4. In the receive position, as well as in that of the send position, the triode section functions in customary manner.

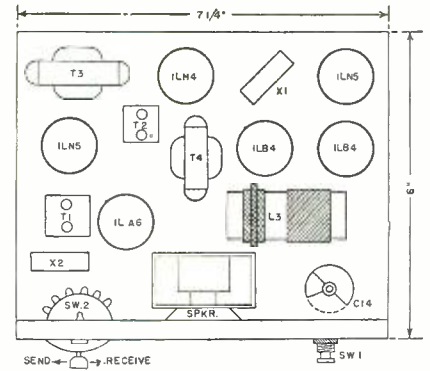

Layout of parts.

Automatic volume control was found to be essential, as there are many applications of this type of equipment, for it is used admirably as a "walkie-talkie" and where its use will require operation over all types of terrain. The use of a.v.c. will prevent fading of signals.

In actual tests between two portables of this type, reliable communication was had at a frequency of approximately 2 mc. over a distance of 5 1/2 miles. At a distance of 1 mile, signals of S3, R6-7 were recorded. Considering the use of very low plate and filament potentials, results were even better than those contemplated.

A distinct advantage for the circuit used in this portable transmitter-receiver is in the matter of conversion to higher power. It is only necessary to change the two 1LB4's over to 7C5's and to supply these two tubes with 6-volt potential. This may best be done by supplying a 6-volt airplane type "A" battery. It is also possible to change the receiver tubes over to those employing 6-volt filaments and by so doing, realize the greater gain afforded by the use of these tubes. The transmitter is capable of approximately ten times greater power output when 6-volt tubes are used. It is also recommended that in such cases, the plate voltage be doubled.

The illustrations show clearly the layout used for the set. The transmitter portion is kept over to one side so that all connecting leads may be kept as short as possible. The two crystals, one for the transmitter, the other for the receiver, are clearly shown. The coil L3 mounted next to the speaker is the modulated amplifier inductance.

### Conclusion

The entire chassis and its associated batteries are mounted into a compact wood case reinforced on all corners and supplied with substantial hardware and with a heavy duty carrying handle. In addition, a canvas strap is furnished so that the entire unit may be carried over the operator's shoulder in true "walkie-talkie" fashion. Wide experience with many types of antennae, have shown the necessity for providing sturdy mountings and by using heavy insulators and clamps. The illustrations show the application of this assembly. There is little danger of damaging the insulating material, due

to the protection afforded by the large clamps.

One of the outstanding features is that no special gadgets are required for the support of special microphones and the service life of the batteries is greatly extended by eliminating unnecessary change-over relays which actually draw as much, if not more, battery current than do the entire tubes under normal conditions. An interlock switch turns the equipment off automatically when the cover is closed, thus preventing undue wear from the batteries which would take place if the set were allowed to remain in operation when not required.

-30-

**QRD? de Gy**  
(Continued from page 32)

me any good at all. The Japs knew they made a big mistake when they picked on MacArthur, so they hurried over to Singapore and Java. Well, it didn't do them any good. They've got to go to Australia to get some wool to pull over the eyes of their subjects. War is surely Hell!

**I**N our endeavors to run to earth the cause for the present scarcity of radio operators, the matter of current wages was brought to our attention. This may be a contributing cause. One of our members who made a round-the-world voyage got paid off with so much money that he quit his job. This was several months ago. A few days ago this poor man came into our office and inquired as to how was shipping. We offered him his choice of 24 jobs. After a long discussion in which a vivid description of each vessel and its contemplated run was given, all of which was said to have been much more interesting than any lecture he had ever heard in a Chinatown Bus, the man finally admitted that he was down to his last thousand dollars and would surely be in for a job very shortly . . . surely by the end of September. Our steno says that I haven't looked sane since the man left. After picturing the beauties of Icelandic crags, the rosy-cheeked strawberries of Archangel, the cool refreshing breezes of the Persian Gulf, and the romance of a voyage along the Spanish Main with beautiful streamlined subs rolling at ease off picturesque Cape Hatteras, under the shadows of Morgan's ancient hideouts, Morro Castle and quaint Point Jupiter, the man didn't bite. He walked away saying that he thought I was full of baloney. What a stubborn people!

Well, GY, I guess that is enough foolishness for this time. I never believed the government and private industry would need so many radio operators. If it keeps up this war will be won by the members of CTU, exclusively. The men get off their ships and new ones are sent to take their

places. Then they get off, ad infinitum. The higher the wages, the greater the scarcity. Wages in the maritime industry have risen so rapidly that we can't keep an accurate record of the jumps. Men are getting so they don't try to compute their wages any more. Most of them say that they usually receive several hundred dollars more than they anticipated. They merely take it, wondering all the while where they'll put it. Some quit their jobs believing the company paid them too much.

CTU's new base wage scale is \$175 per month. If the men perform clerical work, add another \$25 or \$35 and to this add the new bonus, overtime, port bonus, traveling "expense," hush money, beer money, and what have you. And the wages are way beyond the ability of anyone less than an Einstein to compute. As for duties, these are mostly of an "executive" nature. No weather reports, no press, no music, no bearings, no messages. If a Radio Officer is, perchance, caught working, or attempting to work, either directly or indirectly, by subterfuge or otherwise, he is investigated by the FBI, Naval Intelligence and the Anti-saloon League as to probable clues to fifth column proclivities. He is given the Royal Suite, two towels per week, soap and matches. If he gets his feet wet he speaks over the radio, is given hot coffee by the Coastguard and the Newspapers refer to the incident by saying, "The Radio Officer and the Captain were among the survivors." "A good time was had by all for about 56 hours in a lifeboat." REMEMBER PEARL HARBOR!

**B**ROTHER C. B. BOLVIN from way-down Akron PD notices that Fred Reed after nine years of parking the carcass in the chair here at WPDO up 'n' went to Uncle Sam's FCC for a job. Located at Lexington, Kaintuck, at present, and reports he is well pleased with the new assignment. Also Don Dayton left a Chief's billet at WAKR to take a Civil Service appointment in Washington, D. C. Paul Nurches whose recent moves have kept four secretaries busy logging them, also accepted a civil service appointment, Wright Field his latest spot. Paul's moves in the past year have been from WADC to Goodyear Airship, Akron, thence to Goodyear, Miami, to Eastern Airlines, Miami, to Wright Field, Dayton. What a globe trotter, eh. What's that something about a rollin' stone. . .

**A**ND yet there are many radiops who have been writing in inquiring where jobs are to be found. Which goes to prove that a billet is a billet even if it's on a tanker. So if you want to help Uncle Sammy and, incidentally, want to see some action on the high seas, get in touch with Brother Howe who'll steer you right into a soft spot. So with 73 . . . ge . . . GY.

-30-

**BUY WAR SAVINGS BONDS & STAMPS**

Victory  
is in the air  
WITH  
**POLYMET**

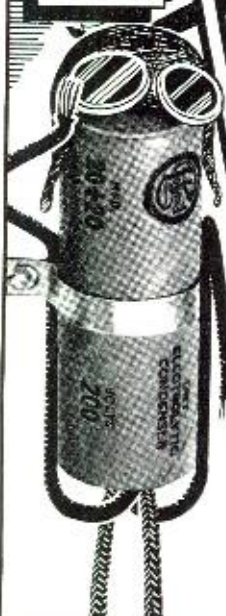

We are now supplying the Army and Navy contractors with POLYMET Condensers. Uncle Sam comes first with us. However, expansion of our facilities enables us to fill regular requirements with very little delay.

**POLYMET CONDENSER CO.**  
699 E. 135th St.  
NEW YORK, N. Y.



MR. RADIOMAN —  
Do You Want a  
**BETTER JOB**  
in Radio?

● **A BETTER JOB with increased pay is within the grasp of every radioman who has the ambition and courage to start training now for greater efficiency today and security tomorrow.**

You realize, of course, the tremendous opportunities that exist in radio today. You must be aware of the unprecedented demand for highly qualified, technically trained radiomen. But, only the BETTER jobs are open to such men!

- If you now hold a commonplace job in radio . . .
- If you hold a temporary job today and long for a permanent job for the future . . .
- If you have the ambition and desire to hold a position of responsibility with higher pay . . .

. . . then a CREI home-study course in Practical Radio Engineering will help you to acquire the necessary technical knowledge and ability which is demanded by the better, higher-paying positions in technical radio.

**Write for Details**  
about CREI Home Study Courses

If you are a professional radioman and want to make more money—let us prove to you we have something you need to qualify for the BETTER career-job opportunities that can be yours. To help us intelligently answer your inquiry—please state briefly your education, radio experience and present position.

Free Booklet Sent



CAPITOL RADIO  
ENGINEERING INSTITUTE

Dept. RN-8, 3224-16TH ST., N. W., WASH., D. C.

**Field Strength**  
(Continued from page 16)

a quarter of a cycle before the other. Since the total field strength is to be  $15 \mu\text{v}/\text{meter}$  at the point where the fields are ordinarily equal, and since the fields are  $90^\circ$  out of phase, each field may be  $15 \times 0.707 = 10.6 \mu\text{v}/\text{meter}$  at this point. The radiation field then increases linearly with distance toward the antenna.

As mentioned previously, the FS meter was calibrated with the aid of instruments not ordinarily available to the private experimenter. The  $Q$  ( $= 2\pi f L/R$ ) of the loop tuned circuit was measured on a  $Q$  meter, and the sensitivity of the instrument was determined with a signal generator with calibrated output. However, it is possible to calibrate the instrument with only the calibrated signal gener-

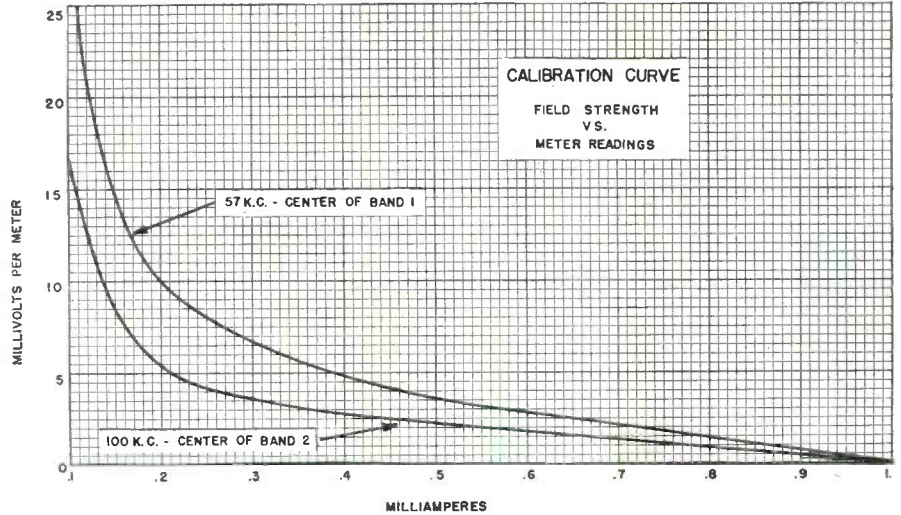

Fig. 3.

ator, or with an uncalibrated signal generator and a vacuum tube voltmeter. The  $Q$  could be determined

with the aid of the generator and tube voltmeter, but it should be possible to construct a loop from the directions in this article which has practically the same  $Q$  as used with this FS meter, and thus eliminate that effort. The loop in question has an effective  $Q$ , when used in conjunction with the large capacity mica padding condensers, which varies nearly linearly from approximately 130 at 50 kc. to 46 at 150 kc.

The calibration procedure is then as follows:

1. Apply the calibrated signal generator directly to the grid of the first tube. Determine the voltage input required to produce a given decrease in detector plate current (0.1 ma. is chosen for the sensitivity frequency curve).

2. Divide this voltage,  $E$ , by the  $Q$  of the tuned loop circuit for the equivalent induced voltage ( $e$ ) of the loop. The value of  $Q$  can be taken from this article if the loop is a close reproduction of the one described.

3. Divide  $e$  by the effective height,  $h_e$ , of the loop to get field strength  $\epsilon$ .

The mathematical statement of the foregoing is as follows:

$$e = \frac{E}{Q},$$
 where  $e$  and  $E$  are in the same units.

$$h_e = \frac{2\pi N A f}{3} \times 10^{-9} \text{ meters,}$$
 where  $f$  is in kc. and  $(A)$  area of loop in sq. cm.

$$\epsilon = \frac{e}{h_e} \mu\text{v}/\text{m},$$
 if  $e$  is in microvolts and  $h_e$  is in meters.

The effective height of the loop used was

$$h_e = \frac{2\pi \times 140 \times 15^2 \times 2.54^2 \times 10^{-9} f}{3}$$
 meters.

$$\therefore h_e = 4.25 \times 10^{-4} f \text{ meters.}$$
 This can be changed to the working formula

$$\epsilon = 2360 \frac{e}{f} \mu\text{v}/\text{m},$$
 where  $e$  is expressed in microvolts and  $f$  in kilocycles.

**For Replacements**

**Centralab MIDGET RADIOHM**

● These are the days when the service man is king . . . and when the SERVICE DEPARTMENT is fast becoming the most important part of your organization. Keep up your good name and reputation by using CENTRALAB parts wherever possible . . . The MIDGET Radiohm, small in size, fits well in crowded chassis as solder lugs do not project far beyond the control radius of  $17/32"$ . Available single, dual or triple, plain or tapped, with or without switch.

**CENTRALAB, A Division of Globe-Union Inc., Milwaukee, Wis.**

"The large control efficiency is due to the long straight path of the famous wall type resistor. You get certain, smooth, flawless attenuation. ALWAYS SPECIFY CENTRALAB".  
OLD MAN CENTRALAB

**Sound Systems**  
(Continued from page 22)

wiring now in use, and in this particular case, the cost would have been prohibitive. The solution then was to design the amplifiers for 24 hour operation so that they could be on all day, and to operate the system in such manner that the Barracks Commander would simply turn off his local microphone when a call from the control master was being issued.

The system described in this article is only one of a number of custom engineered systems in use at the Training Station and a subsequent article will deal with the special high powered intercommunication equipment soon to be placed in operation.

Future articles will also treat of more complex systems in which relay control of plate supply and precedence functions are incorporated.

-30-

**Book Review**  
(Continued from page 32)

addition to the vocational radio laboratory.

"WIRELESS AND HOW IT WORKS," published by *Longmans Green & Co.*, London, New York, Toronto. 56 pages. Price, 40c. This little book is intended to help all those who want a clear picture of wireless, its urgencies and the way in which it works. No detailed descriptions of sets or mathematical formulae are included; for them the student must go to the recognized text books. However, this simple introduction with its many diagrams will be of help to all those who are turning to the study of wireless so that they may play their part in the battle of freedom.

"SPRAGUE MANUAL OF RADIO INTERFERENCE ELIMINATION," prepared and published by *Sprague Products Company*, North Adams, Mass. Price, 25c. Even the finest of radio broadcasts or the performance of the most costly radio receiver may be ruined—and very often is—by a factor over which neither the broadcaster or manufacturer has any control. This factor is man made interference—electrical disturbances created by all manner of lighting equipment, appliances, motors, signs, etc., and transmitted by one means or another to the radio set, from which they blast forth as noise. Hence the *Sprague Interference Manual* is presented.

It brings, we believe, the most complete, most practical and by all odds, most genuinely helpful data available to the radio and electrical professions; as it has been prepared to analyze and show how all types of interference may be stopped or greatly reduced.

-30-



The bomber must be built and the crew must be trained.

In war plants and in training stations throughout America, **BOGEN CENTRALIZED SOUND SYSTEMS** are helping to build the ships and train the men — expediting production, locating vital men instantly, issuing orders and automatic signals and alarms.

May we tell you how?

DAVID BOGEN CO., INC.  
663 BROADWAY,  
NEW YORK CITY



**RADIO**  
CATALOG NO 58  
164 PAGES  
SETS-PARTS  
SUPPLIES  
FLUORESCENT  
*Burstein Applebee Co.*

**BIG FREE CATALOG**  
EVERYTHING IN RADIO  
Sets, parts, supplies, public address systems, amateur equipment, testers, kits and fluorescent lighting at lowest prices. Huge stocks, bought months ago — ready for shipment the same day your order is received. The Defense Program is making big demands on our industry but because of our advance buying we are able to fill your orders promptly and efficiently.

**BURSTEIN-APPLEBEE COMPANY**  
1012-14 McGEE STREET, KANSAS CITY, MISSOURI

**RADIO OPERATORS' LICENSE MANUAL**

1942 EDITION



The most complete and authentic question and answer manual on commercial radio operator license examinations. 1297 questions and answers, 230 pages of vital information for radio operator license candidates.

\$3.00 Postpaid or write for descriptive circular.

**WAYNE MILLER**  
222 North Wells St. CHICAGO



Official Photographs U. S. Marine Corps.

Not so long ago American industry was putting up a heroic defense . . . a defense against time.

Today that picture has changed. Production "ahead of schedule" of vital equipment is making it possible for our boys to take the offensive. Thordarson is proud of the part it is playing in producing transformers so vital to our armed forces in launching a "Terrific Offense."



**THORDARSON**

ELECTRIC MFG. COMPANY  
500 WEST HURON STREET, CHICAGO, ILL.

*Transformer Specialists Since 1895*

## SAVE MONEY ON—

**CABINETS, RECORDERS, CHANGERS, and RADIO PARTS**



**OXFORD TYPE PD.** A beautiful hand-rubbed, piano-finished cabinet. Made of five-eighths stock. Rose Mahogany and Walnut. A real piece of furniture 33" high, 32" long, 17" deep. Phono compartment 31 x 15 x 6"..... **\$26<sup>95</sup>**



**"LAKE SPECIAL" CHANGER-RECORDER**  
Magnetic cutting head, crystal pickup. 1 3/4 ounce needle pressure. 14" wide, 14" long, 5" high above board, 3" depth below board. 78 RPM. Records on discs up to 10" in diameter. Plays all records. Self-starting dynamically balanced induction motor. Enables you to build a combination recorder and record-changer in a single unit. This month, only..... **\$24<sup>95</sup>**



**1942 "Velvet Action" Record Changer**  
Plays 10 1/2" or 12 10" records. 14" by 14" by 5" high. Crystal pickup. Reject switch—automatic or manual change—two point record suspension. 115 volt, 60 cycle. Only 7 seconds to change records. Easy to install..... **\$16<sup>95</sup>**



**Deluxe Changer**  
Ideal for small cabinets. Only 12" x 13" x 4 1/2" high. Plays 10 1/2" or 12 10" records. Crystal pickup, offset record suspension, reject switch, smooth action..... **\$12<sup>95</sup>**

### Victory Special . . . . . V

**NATIONALLY-KNOWN, HEAVY DUTY MOTOR.** Silent, dependable, induction type, self-starting motor; 9" turntable, 78 RPM. Enclosed gears. For 110 v. 60 c. \$11.50 list. **\$4<sup>65</sup>**  
Now only.....

**New Bargain Bulletin Arouses Nation!** Gigantic money saving values help Servicemen, Jobbers, Radio Dealers and Sound Men. Everyone can save money and help "Keep 'Em Listening". Everybody can improve their business this easy, money saving way. A new cabinet or a new combination radio and phonograph will help make any home a better place to live in. We also save you money on all radio parts. SEND NOW FOR NEW FREE BULLETIN.

**LAKE RADIO SALES CO.**  
615 W. Randolph St. Chicago

## For the Record

(Continued from page 4)

ideas or inventions in this contest to do so and we urge you to send for your application blanks so that you may be assigned an entry number in order that this form will be available at the time you are ready to send in your idea, manuscript or blue-prints. You don't have to be a professional writer to cash in on this opportunity. In fact, several of the ideas are simply penciled out on ordinary writing paper and in many cases, these do not exceed more than 50 or 100 words together with an illustration of your idea. In time, we'll publish prize winning articles and ideas for you readers, just as soon as we can do so without jeopardizing the entrants' rights or reveal these ideas to our enemies.

One thing is certain, when the contest closes, we will have a cross-sectional view that will enable Uncle Sam to apply these ideas into the design of many types of military equipment.

Keep up the good work, fellows, and get your request in for entry blanks without delay.

### Diathermy Machines

**T**HE recent orders by the *Federal Communications Commission*, stating that all diathermy machines must be registered no doubt will be of great aid to the radio servicemen. The interference created by these innocent transmitters has been a continuous source of headache to thousands of radio listeners and amateurs. Little has been done to eliminate this interference. The official order, no doubt, will in time help to clean up the situation, at least we hope so! Operation of any type of radio equipment simply cannot be tolerated in wartime and amateurs and servicemen can cooperate with the F.C.C. by reminding owners of diathermy equipment that they must register or suffer the consequences.

Which reminds us—we spoke of the golden opportunity for the entire radio industry to raise its standards of radio receivers, as a result of this present war emergency. We hope that after the final shot—when we return to our normal way of living—that we will no longer see the cut-rate competition on radio receivers. Many of these manufacturers who are responsible will be eliminated and those companies which have directed their efforts in the right direction no doubt will be rewarded and will be able to turn out better receivers which would sell at fair retail prices.

### Post War Radio

**W**E predict an entire new conception of amateur radio "after the duration." Much of the new equipment now being turned out features new circuits and technique which will find everyday application for amateur radio transmitters and receivers when

the war is over. In fact, we are sure that most contacts will be carried out on ultra-high-frequencies. Television, without a doubt, will play an important part in the new radio to come and even the amateur radio operator will be able to include television at his station at reasonable cost for the equipment.

The amateurs at present are doing their bit in the services of our Armed Forces and in our production plants. We have had occasion to talk to many of them of late. In every case, they are looking forward to a reinstatement to their bands and we feel they will be justified in demanding a return to their hobby.

Many amateurs are still available on the home front to serve in the new emergency setup. Complete details of the latest rulings will be found in "Spot Radio News." Don't fail to read this latest report by Lewis Winner in this issue.

### Electronics and the Serviceman

**M**ANUFACTURERS of electronic equipment have not as yet realized that much of their potential business, after the war is won, will be contracted for by our radio servicemen. We have received several reports from our writers stating that they had encountered much difficulty in getting the manufacturer of a certain gadget to remove the "hush-hush" about his product. There seems to be a lack of cooperation or understanding or both between the manufacturer of electronic equipment and the serviceman. To correct the fault, both the manufacturer and servicemen must see "eye to eye." Some items of electronic equipment are so simple in application that they are merely package goods and can be handled like any over-the-counter sale.

However, the larger part of electronics is in industry where a thorough understanding of scope, function, installation problems, and maintenance are needed.

Manufacturers and their engineering salesmen are now required to perform many tasks in supervising installations and maintenance. They need to be relieved of these duties and the serviceman needs the business he can gain by being an installation supervisor and maintenance man.

Some manufacturers of electronic equipment try to make a secret of the working principles of their products and some of them will not furnish wiring diagrams even to their own salesmen and field engineers.

Manufacturers of photocells publish wiring diagrams and manufacturers of equipment have been known to declare that any equipment made according to the diagrams will fail to work. One maker even has trick phototubes made for his equipment so that no standard tube can be used for replacements.

What is behind this smoke screen? The answer seems to be that a substantial number of servicemen who



lacked business acumen have spoiled things for the serviceman who is content to be in the service field and wants to build it up.

When a serviceman is called upon to care for a radio he doesn't say, "Mister Customer, you paid more for this radio than the cost of the parts. You should have let me make your radio for you. You have been gypped."

Yet that is exactly what many spoilers among the servicemen have done in the electronic field.

The manufacturer of electronic devices, like the radio manufacturer, is not selling parts. He is selling performance. What is more, failure to perform in the electronic field may damage manufacturing equipment or ruin production schedules to the tune of a hundred times the cost of the electronic device. To be sure, the difference between the cost of parts and the cost of the product is greater in the electronic field but manufacturing expenses are many times higher.

The serviceman who has business acumen will realize these factors:

Electronic sales have not yet reached the point where mass production is possible.

Each industrial sale requires engineering knowledge and experience.

The user may lose a great deal of money through improper installation, wrong equipment or failure of the device to perform.

The sales engineer must make expensive trips and surveys in many cases where he has to recommend that the industrialist stick to his present method instead of using electronic devices.

An industrialist must buy a product that has the backing of a reputable manufacturer with an engineering staff, who is willing and able to assume responsibility.

Radios are guaranteed for 90 days but electronic devices are guaranteed for a period of from one to five years.

Manufacturers of electronic devices must often design and build special housings and special supporting devices to meet the needs of individual installations.

One case where the serviceman was at fault is typical of many. An industrialist called him in to service an electronic device and the serviceman asked, "How much did you pay for this?" Upon being told, he said, "That is several times the cost of the parts; you have been gypped." Then he talked the industrialist into letting him make a new one. It did not work. He first succeeded in giving the electronic manufacturer a "black eye" and then failed himself; with the consequence that the industrialist is "soured" on all electronic equipment.

A serviceman who will work up a good reputation as an installation man or an installation supervisor and a maintenance specialist will develop a profitable business, but when he attempts to sell home-made electronic equipment, he ruins his own reputation and mars the progress of those who in-

vest in manufacturing plants and employ engineers and production experts.

### Training Opportunities

**A**LMOST daily, we learn of some new college, university, or vocational school announcing the opening of a new course to train radio operators, maintenance men, and for specialized technical jobs. One of these is a science-packed, war emergency program to turn out physicists for Uncle Sam in twenty months time and to be opened by the *University of Texas Physics Department* this summer.

There is urgent need for trained radio technicians and other physicists in military service, civil service jobs, and in war industries. This has caused authorities to set up a new schedule of courses eliminating all "frills" and getting down to hard bed-rock in the shortest time possible. The 75 semester hours of work embraced in the program—about 25 courses—are all in fields of physics, mathematics and chemistry.

Another radio technician course was recently opened by the *Marquette University*, Milwaukee, Wisconsin. The budget of this class is to turn out radio technicians for the *Signal Corps* and the *Army and Navy*. The government can use at least 100,000 enlisted men and 6,000 officers in radio and many technicians in this line of endeavor are also wanted in civilian life. The college makes no charge for this course, except that the student must furnish text books and supplies.

The above cases are typical of the great opportunities now offered to radio minded students and hundreds of men, yes, even women, are taking advantage and are going at their studies with a determination that will some day qualify them as future post-war radio servicemen and servicewomen and industrial technicians.

### Equipment for Radio Instruction

**T**HE terrific demand upon manufacturers of all types of test equipment has made it most difficult for many schools to obtain items vitally needed for proper instruction of the students. A search made recently revealed that in most of our universities could be found hundreds and hundreds of valuable instruments and meters, which, upon further investigation, were found to be used only an hour or two per week at the most. Many of these were in the Physics Departments and it seems to us that the various professors could do a great service to their country by releasing such little-used equipment to those schools which so sadly lack these important items. Many radio schools are now operating 24 hours a day. They are doing their parts to train men for Uncle Sam and are entitled to fullest cooperation from those able to furnish them equipment, even though it be on a loan basis.

Remember—we are at war. No radio equipment can remain idle. It is one of our first lines of offense and defense.

## FASTER, BETTER TESTS with RCP VOLT-OHM-MILLIAMETER

Speed, accuracy and economy feature RCP's 3-in-1 Multitester—the Volt-Ohm-Milliameter you need for wartime servicing. Save precious time, save costly errors and—above all—save money. This popular instrument has *everything* required for fast, accurate work, without needless, price-boosting frills and gadgets. Just check a few of its features!

RCP MODEL NO.

**423**

Complete,  
ready to operate  
only **\$23<sup>50</sup>**



- ★ Three-inch, 2% accurate meter with sensitivity of 2,500 ohms per volt.
- ★ Uniform AC-DC voltmeter sensitivity of 1,000 ohms per volt.
- ★ High ohmmeter range 10 megohms. Center to full scale ratio 125. Low ohm scale reads 5 ohms at center and each of first ten divisions read 0.1 ohms.
- ★ Each shunt and multiplier individually calibrated to tolerance of plus or minus 2%.
- ★ Multipliers individually matched in pairs for overall accuracy within 1%.
- ★ Suppressor type copper oxide rectifier for AC measurements.
- ★ Completely self-contained with necessary batteries in hardwood walnut finish case. (Portable model in walnut carrying case at \$25.95 equipped with complete set of test leads.)

**Radio City Products Company**  
INC.  
127 WEST 26th STREET NEW YORK CITY

## RECORD CHANGERS



**DELUXE MODEL NO. 175.** Plays twelve 10" or ten 12" records. Crystal pick-up with permanent needle. Newly designed dependable smooth operation. Reject switch. Automatic or manual control. Easy to install. 14" x 14" x 5" high. 60 C. 115 V.  
Your Price..... **\$19<sup>95</sup>**

### OTHER SPECIALS

**MODEL 165** Detrola standard automatic changer. Net..... **\$16.50**  
**MODEL 240** Record player-recorder. Two speed (78 and 33 1/3 R.P.M.). Net..... **\$24.95**  
**MODEL 280** Automatic changer-recorder Precision built. Net..... **\$44.95**  
**MODEL 385** Chassis, complete with 8 tubes, 10" speaker, push-buttons, F.M., Foreign and Standard bands. Net..... **\$64.95**

**CABINETS**—Complete assortment 1942 uncut console and custom built combination cabinets of modern and period design. Available in walnut, maple, mahogany, or blonde finish.

Complete line of radios and equipment in stock. Write us today for special circular.

**MUTUAL RADIO PRODUCTS CO.**  
771 ARTHINGTON ST., CHICAGO, ILL.

We have a large stock of

**HALLICRAFTERS**

**HAMMARLUND**

**RME**

**HOWARD**

RECEIVERS, transmitters and all radio supplies of all sorts at lowest wholesale prices. Order from us for immediate delivery. We specialize in Government and other priority orders and solicit such buyers, as well as civilian and all other customers.

- YOU get 10-day trial
- YOU get best trade-in

We also have a store at 2335 Westwood Blvd., West Los Angeles, Calif. Write, phone, telegraph us anytime about any radio supplies. It will pay you to deal with us. Your inquiries invited.

WE ALSO PAY CASH IMMEDIATELY for used communications receivers and transmitters. Write, telephone, or telegraph description.

**HENRY RADIO SHOP**

Butler, Missouri

"World's Largest Distributors of Communications Receivers"

## AMPLIFIERS

12 to 30 WATT



Rebuilt  
All Like New

20 WATT PUSH-PULL 6L6 AMPLIFIER. MODEL No. 103-A. Input for one crystal or dynamic microphone. Input for crystal or high-impedance magnetic phono pickup. Full-range tone control. Frequency response 30 to 10,000 CPS. Output impedance 8 or 16 ohms. Supplies field current for one or two 2500 ohm speaker fields. Uses 1-6SE5, 1-76, 1-6A6, 2-6L6's, and 1-5Z3. Less tubes and speaker, only **\$16<sup>95</sup>**

25% deposit required on all C.O.D. orders.

Write today for free Bargain List of New and Rebuilt Amplifiers and Parts.

**PEERLESS RADIO AND SOUND CORP.**

17 S. Desplaines St., Chicago, Ill.

New Handy **UNIVERSAL REPLACEMENT** Capacitor



Write for Catalog

**SOLAR MFG. CORP., Bayonne, N. J.**

### Female Operators

LAST month, we told you about the ever increasing entrance of the fairer sex into various phases of military and civilian radio. We received recently a group of photos which show just one example of how women can fit into the war picture. Congratulations, gals! We need many more for industry and communications like the gal illustrated on page 34 of this issue.

### A Reminder

MANY letters and phone calls have been received from readers desiring to obtain civilian radio jobs. Apparently they lack a bit of information as to where they should go to make application. The *Civil Service Commission* has plenty of jobs for those who can qualify. Full particulars may be obtained from any *U.S. Post Office* and much time can be saved by getting those forms which cover the jobs in which they are interested.

### Vacation

THIS year, we shall combine our vacation with a visit to several of our radio training centers. So far, we have called upon many of these and in each case, have learned a great deal about the part that radio is playing in our military setup. Will have much to tell you when we return. 73—O. R.

—30—

### Spot Radio News

(Continued from page 42)

tion Merit, and the third and highest will be the Citation of Individual Production Merit. This citation will be signed by Donald Nelson. From the extent of unusual individual developments produced in scores of radio plants, it appears as if the radio divisions of our war effort will keep Donald Nelson mighty busy as a citation signer.

AN ENGRASSING FILM, SHOWING HOW 75,000,000 pounds of junk metal, exclusive of much iron and steel, was salvaged for re-use in communication equipment, by the Bell System was recently shown in New York City. The film entitled . . . Mines Above Ground . . . depicted the methods used in Western Electric plants to collect, sort and refine scrap accumulated from manufacturing operations. Telephone equipment no longer useful was shown being dismantled, the reparable parts being put aside for re-use and the remaining pieces being sent to the furnaces to begin life over again. Many of the spectacular scenes were made in the plant of the Nassaus Smelting and Refining Company in New York, a subsidiary of Western Electric. Here giant electric and oil-fired furnaces melt down old telephones and turn them into strong brass, bronze and other alloys to be forged into tools of war.

TECHNICAL BOOKS ARE PROBABLY the most welcome tool of student and engineer today. And recently there have appeared some exceedingly useful volumes as . . . *Fundamentals of Vacuum Tubes (2d edition)* by Austin V. Eastman, Associate Professor of Electrical Engineering at University of Washington (McGraw-Hill Book Co., \$4.50) . . . *Gaseous Conductors* by James D. Cobine, Assistant Professor of Electrical Engineering at Harvard University (McGraw-Hill Book Co., \$5.50) . . . *The Superhet Manual* edited by F. J. Camm, Editor of *Practical Wireless* (Chemical Publishing Company, \$2.50) . . . *An Introduction to the Operational Calculus* by Walter J. Seeley, chairman of the Department of Electrical Engineering, Duke University (International Textbook Company, \$2.00) . . . *Acoustic Design Charts* by Frank Massa, B.S., M.Sc., in charge of the Acoustic division of Brush Development (The Blakiston Company, \$4.00).

Each of these books contains data that should prove helpful in the classroom, laboratory or workshop. Some are advanced . . . and some are rudimentary. In Eastman's book, although an effective engineering analysis of vacuum tube laws and applications is presented, a simple knowledge of calculus is all that is necessary to an understanding of the mathematical sections of the book. Seeley's book on Calculus affords a new and effective interpretation and analysis that is suitable for both undergraduates as well as the practicing engineer. Frank Massa's book on *Acoustic Design Charts* should be in every library. There are 107 full page plates, with over 750 curves. Acoustic theory has been converted into practical data of quantitative value that can be used without complex computations and interpretations.

### Personals

Roy J. Faulkner, former president of the Auburn Automobile Company, has been appointed vice-president of General Broadcasting System and its affiliates. . . . Quite a few changes have taken place in the CBS offices in view of the war. Harry C. Bucher, vice-president in charge of Washington operations, has been called to active duty in the Navy as a Lieutenant Commander, attached to the Office of the Director of Naval Communications. Succeeding Mr. Bucher is Earl H. Gammons, who has been with CBS for thirteen years as manager of WCCO, Minneapolis. Gilson Gray, a commercial editor at CBS, was also called by the Navy to become a Lieutenant Commander. . . . Otto Sorg Schairer, vice president of RCA in charge of the RCA laboratories, was recently awarded an honorary degree of Doctor of Engineering by the University of Michigan. . . . The chief engineer of WSM, Jack DeWitt, has gone back to his alma mater, Bell Laboratories, to develop equipment for the Government. Walter E.

Bearden, also of WSM, has left to work with the Columbia University branch of the National Research Council. . . . Chairman James Lawrence Fly of the Federal Communications Commission was nominated for reappointment as a FCC member, for a term of seven years by President Roosevelt. Fly, who also serves as chairman of the Defense Communications Commission, is expected to receive his confirmation from the House. . . . Robert M. Morris, pioneer NBC engineer, is now in Washington as a Chief Radio Engineer in the U. S. Army Signal Corps. Morris produced the famous orthacoustic recording. . . . V. H. Fraenkel has been placed in charge of the co-ordination of commercial engineering at GE, replacing G. F. Metcalf, who has gone to the Signal Corps as a Lieutenant Colonel.

-30-

### Practical Radio

(Continued from page 37)

it and the iron core comprise the *field* of the generator.

If the voltage goes through 60 complete cycles in one second, it is a *60-cycle voltage*. The current made to flow in the external circuit by this

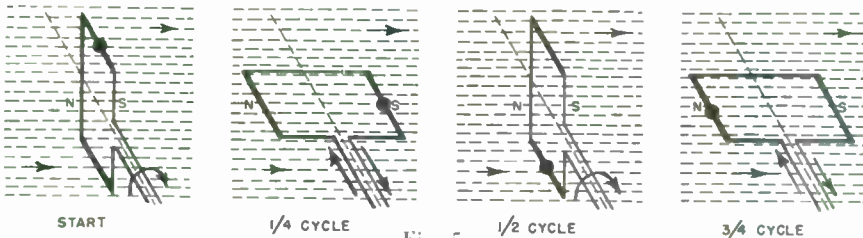

Fig. 5.

voltage is a *60-cycle current*.

Large alternating current generators are usually built with the magnetic field structure as the rotating element and the armature as the stationary element; several structural and electrical advantages are obtained thereby. The fundamental electrical actions taking place in such generators are, however, basically similar to those described here.

#### Direct Current Generator

In a direct current generator, the voltage is generated in exactly the same manner as in the single phase alternating-current generator just described. Fig. 7 shows diagrammatically a direct-current generator corresponding to the single phase alternator of Fig. 4. Their only difference is the fact that instead of the continuous slip rings in the alternator, the d.c. generator uses a mechanical device called a *commutator*. It reverses the connections from the external circuit to the revolving conductors in the armature at just the instant the current induced in the latter is reversing. The commutator, therefore, is actually a revolving reversing-switch. Each end of the loop of wire is connected to one

segment of the commutator which rotates with it (each segment being insulated from the others). The stationary sliding contacts or brushes are so placed that the current always flows from the loop *into* one, and *from* the other again into the loop, regardless of which relative direction the current in the loop itself flows. In this way, the brushes or terminals are designated by the terms *positive* and *negative*, simply to distinguish the direction in which the current is assumed to flow.

#### Structure of Commercial Generators

Modern, commercial d.c. generators are no more than improved versions of the simple generator illustrated in Fig. 7. The generator unit illustrated has a split-ring commutator. In small machines, the field structure contains two or four poles energized by suitably connected electromagnet windings placed on each. To furnish a good magnetic path between the poles, thereby creating a very intense magnetic field with minimum field exciting current, the armature coils are wound on a core of soft iron or steel stampings, in which are punched slots to receive the armature conductors.

The space between the field poles is thus almost entirely occupied by iron,

not air. Instead of only a single-turn armature coil, many turns of wire are wound on it to take advantage of the fact that the induced e.m.f. is proportional to the total number of inductors cutting the magnetic field. All are suitably spaced and connected so the individual e.m.f.'s induced in them add together. By so constructing the armature, generators supplying appreciable total output voltage may be designed even though the physical size of the machine, speed and induced voltage in each inductor are moderate. The commutator is made up of copper segments, insulated from each other and from the armature shaft. The leads from the armature coils are soldered into slits or risers at the segment ends. The brushes, which carry the current from the commutator to the external circuit, are usually made of small blocks of graphite carbon. A small coiled spring at the end of each brush serves to press the brush lightly against the revolving commutator so that good electrical contact is made.

#### Mechanical Energy to Drive Generator

Since the induced current flowing through the armature coils produces

Make Good Money in  
**RADIO**  
Learn Easily In Spare Time

War has opened tremendous opportunities for men with knowledge of radio. Thousands needed! Train yourself in spare time with . . .

**GHIRARDI'S PRACTICAL RADIO PHYSICS COURSE**  
Will give you basic training in  
**RADIO-SOUND-TELEVISION** All made easy as A-B-C

Here is radio's leading home-study training course all in one complete inexpensive volume. Contains all essential foundation electrical and radio knowledge to prepare you for any type of radio work. Clear, concise explanations easily understood even by beginners with no previous technical knowledge of higher "math."

**Extra Pay in Army and Navy**  
Promotion is fast for men with radio knowledge. Begin training at once in spare time for more interesting duty, extra pay, higher rank. Use **Ghirardi's famous RADIO PHYSICS COURSE**, the very same book that the Army, Navy, Marine Corps and Coast Guard men and schools use. Sam Sampisi (U. S. Naval Training School) writes: "This book . . . is the very best in our work in the Navy; for promotion, I recommend it to all my fellow radiomen."

**5 DAYS' EXAMINATION**  
Take 5 days to look through this big 36 volumes-in-one book, 972 pp., 508 illustrations, and 856 Self-review questions make every point clear and easy to understand. If not convinced it is the most clear and complete book on radio, return it and money will be refunded.

**OTHER GHIRARDI RADIO BOOK**  
Modern Radio Servicing, the famous 1300-page "Bible" of trained servicemen, teaches you practical radio repair work—how to use test instruments, troubleshoot and how to repair all makes of receivers. WHAT to do and HOW to do it! 708 illus. \$5 Postpaid.

**Radio Troubleshooter's Handbook**, revised and enlarged, speeds up radio-repair work by providing 710 big pages of vital servicing data for all home and auto radio receivers. Most frequently used Reference Data Handbook in Service Shops. Complete \$5.

**New "Replacement Battery" Wall Chart**  
Gives "Type" Numbers of all the "Comparable" and "Replacement" A, B, and A-B Batteries (of 23 battery manufacturers) for 1250 models of 100 makes of portable battery-operated radio receivers. This big 17"x22" wall chart is yours for only 10c. Send for our today.

**MAIL COUPON NOW!**  
**RADIO & TECHNICAL PUBLISHING CO.**  
Dept. RN842, 45 Astor Place, New York, N. Y.  
Please rush the following Ghirardi Radio Books to me on 5-Day Money-Back Trial:  
 Radio Physics Course \$5.00  
 Modern Radio Servicing \$5.00  
 Radio Troubleshooter's Handbook \$5.00  
 Special Money-Saving Combination Modern Radio Servicing and Handbook Only \$9.50  
 Enclosed is 10c for "Replac. Batt." Wall Chart.  
NAME.....  
ADDRESS.....  
CITY..... STATE.....  
See Your Distributor or Mail This Coupon Now.

**INVENTORS**  
PROTECT your idea with a Patent  
Secure "Patent Guide" and "Record of Invention" form—Free. No charge for preliminary information. Write today!  
**CLARENCE A. O'BRIEN and HARVEY B. JACOBSON**  
Registered Patent Attorneys  
2106-H Adams Building, Washington, D. C.

**RADIO ENGINEERING DEGREE IN 27 MONTHS**  
Intensive, specialized course, including strong basis in mathematics and electrical engineering, advanced Radio Theory and Design, Modern Laboratory, Law tuition, Self-help opportunities. Also 27-month courses in Aeronautical, Chemical, Civil, Electrical and Mechanical Engineering, Participation in Civilian Pilot Training Program. Enter September 8, December, March, June. Catalog.  
**INDIANA TECHNICAL COLLEGE**  
782 E. Washington Blvd., Fort Wayne, Ind.

**RADIO TECHNOLOGY**  
**RCA** Institutes offer an intensive course of high standard embracing all phases of Radio and Television. Practical training with modern equipment at New York and Chicago schools. Also specialized courses in Aviation Communications, Radio Servicing and Commercial Operating. For Free Catalog Write Dept. RN-42.  
**RCA INSTITUTES, Inc.**  
A Radio Corporation of America Service  
75 Varick St., New York

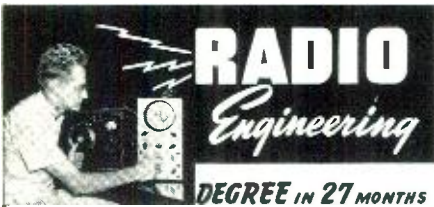

★ Complete Radio Engineering course in 27 months. Bachelor of Science degree. Radio (television, talking pictures and the vast electronic field) offers unusual opportunities. Defense needs call for the engineer. Demand exceeds the supply. Courses also in Civil, Electrical, Mechanical, Chemical, Aeronautical Engineering; Business Administration, Accounting and Secretarial Science. Tuition, living costs low. Distinguished for technical 2¼ year courses. Special preparatory department for those who lack required high school work. Enter September, January, March, June. Cosmopolitan student body. 59th year. Write for catalog.

1682 College Ave. Angola, Ind.

**TRI-STATE COLLEGE**

**NOW—A REALLY HIGH-POWERED—Radio Engineering Library**

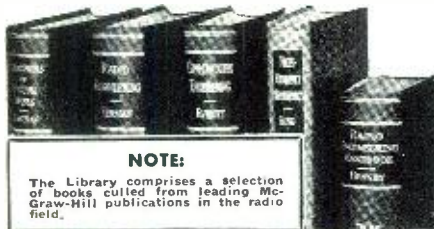

**NOTE:**

The Library comprises a selection of books culled from leading McGraw-Hill publications in the radio field.

- especially selected by radio specialists of McGraw-Hill publications
- to give most complete, dependable coverage of facts needed by all whose fields are grounded on radio fundamentals
- available at a special price and terms

THESE books cover circuit phenomena, tube theory, networks, measurements, and other subjects—give specialized treatments of all fields of practical design and application. They are books of recognized position in the literature—books you will refer to and be referred to often. If you are a practical designer, researcher or engineer in any field based on radio, you want these books for the help they give in hundreds of problems throughout the whole field of radio engineering.

**5 VOLUMES, 3319 PAGES, 2289 ILLUSTRATIONS**

1. Eastman's FUNDAMENTALS OF VACUUM TUBES
2. Terman's RADIO ENGINEERING
3. Everitt's COMMUNICATION ENGINEERING
4. Hund's HIGH FREQUENCY MEASUREMENTS
5. Henney's RADIO ENGINEERING HANDBOOK

10 days' examination. Easy terms. Special price under this offer less than books bought separately. Add these standard works to your library now; pay small monthly installments, while you use the books.

**10 DAYS' FREE EXAMINATION—SEND COUPON**

McGraw-Hill Book Co., 330 W. 42nd Street, N. Y. C.

Send me Radio Engineering Library, 5 vols., for 10 days' examination on approval. In 10 days I will send \$3.00 plus few cents postage, and \$3.00 monthly till \$24.00 is paid, or return books postpaid. (We pay postage on orders accompanied by remittance of first installment.)

Name .....

Address .....

City and State .....

Position .....

Company ..... RN. 8-42

its own magnetic field tending to oppose the motion of the inductors (Lenz's Law), the armature of a generator must always be supplied with mechanical energy from some source if it is to drive the inductors effectively against the opposing forces set up within. Generators are frequently used for charging storage batteries, and as the source of filament, plate and screen voltages for operating radio equipment if suitable power supply lines are not readily accessible.

For example, aircraft, police and emergency radio transmitters and receivers, military field radio equipment, mobile sound amplifier equipment, etc., must be operated under condi-

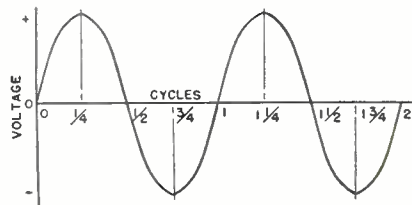

Fig. 6.

tions where ordinary power supply lines are not available. The proper operating voltages for at least part of the circuits of such equipment are usually obtained from suitable generators. When generators supply electrical power for such applications, the mechanical energy needed to drive the generator armature is commonly supplied by a wind-driven propeller, a small gasoline engine, hand power, or an electric motor element operated from a convenient source of electric power different in value or character from that which the generator produces.

Generators are often built in combination with electric motor elements in various ways when it is necessary to: (a) convert available d.c. to a.c. of the required same, or different, voltage; (b) convert available a.c. to d.c. of a required different voltage. In such machines, the electric motor element is of a required voltage. In such machines, the electric motor element is designed especially to operate from the available power supply line in order to furnish the mechanical energy required to drive the inductors of the generator element.

If the radio equipment requires a d.c. power supply but only an a.c.

power line is available, a rotary converter may be used to convert from one type of current to the other. Such a machine contains a single magnetic field structure in which an armature rotates. This armature is provided with a single winding which is connected both to a set of slip rings and a commutator. The a.c. supply is connected to the slip rings so that the machine operates as an alternating current motor so far as the a.c. side is concerned. At the same time, d.c. is taken from the commutator and brushes, so this side of the machine is acting as a d.c. generator.

The machine, however, may take power from a d.c. supply, operating as a d.c. motor, and deliver a.c. from the slip rings. When operated in this manner, it is said to be an inverted rotary converter. Such machines are often used for operating a.c. radio equipment, sound amplifiers, recorders, etc., from d.c. power lines.

When it is necessary to operate d.c. equipment from an available d.c. power supply of different voltage (usually a lower voltage) a dynamotor is usually employed to boost the voltage to the required value. A dynamotor contains a single magnetic field structure in combination with a single armature which has two independent electrical windings, two commutators and two sets of brushes.

One commutator connects to the low-voltage "motor" winding, and the other connects to the higher voltage "generator" winding. Machines of this type are used widely for supplying the high voltages required for the plate and grid circuits of mobile radio equipment (such as that used in aircraft, tanks, police cars, sound trucks, etc.)

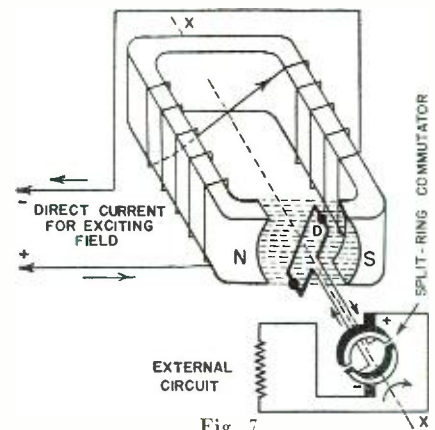

A motor generator is a machine consisting of a complete electric motor mechanically coupled to a complete generator. The motor is simply the driving unit for the generator, and is electrically isolated from it. Motor generators may be constructed to perform almost any desired current conversion function, i.e., convert d.c. to a.c., convert a.c. to d.c., convert d.c. to d.c. of different voltages, convert a.c. to a.c. of different voltage (although this is usually accomplished more efficiently and cheaply by a transformer), etc. However, since a motor gener-



ator contains two complete housings and field structures, two armatures, two sets of bearings, and a heavy mounting bed, it is heavier, more bulky and more expensive than a dynamotor or converter of equal electrical rating, since the latter has only a single field structure and armature. Because of this additional size and weight, motor generators are seldom used in mobile radio applications where these factors are important. Dynamotors or converters are employed instead.

(To be continued)

### Transformer Design

(Continued from page 29)

resulting in a hysteresis loss in the scale.

One of the prominent properties of any magnetic material is that the magnetic field of the iron lags behind those of the current (magnetizing force). If the current is slowly increased (Figure 4), then the magnetic flux in the iron also increases from 0 to A where saturation is reached. If the current is now gradually decreased, the iron loses some of its magnetic lines of force, but when the current reaches zero, the iron still has some lines of force (OC) left in it as residual magnetism. Therefore, additional current is necessary in the opposite direction to permit the magnetic force to attain zero value (DE). This additional force is considered the hysteresis characteristic of the material. Hysteresis losses are greater for dynamo grade than for regular transformer C grade, .913 to .633 watts per pound at 64,000 lines per square inch, respectively.

The practice of annealing laminations is highly recommended, although costly, for the purpose of reducing core losses.

Both hysteresis and eddy current losses are reduced by annealing *after stamping*. Removal of punching strains by the final annealing of the stampings results in reduced hysteresis losses and in improved permeability.

Edge burrs are reduced by annealing laminations after stamping, which lowers the inter-lamination eddy current losses. Mechanically, annealed laminations can be held to a much closer flatness tolerance, giving a denser core stack, permitting the core material to function completely free from strain, and making possible a rigid final assembly free from hum and vibration. The hysteresis and eddy currents just mentioned make up the main portion of the core losses and are lost in the form of heat. These losses and the I<sup>2</sup>R coil losses make up the losses which will determine the temperature rise of the transformer. It has been found that a 55° C rise above room temperature (ambient temp.) is about the maximum permitted for safe design and therefore it has been set as a standard for the radio industry.

The size of the core is an important factor in transformer design and should be computed with great care. It is this core that permits a low reluctance path for the magnetic lines of force which in turn should produce a highly magnetic field. The strength of the magnetic field at any point is expressed for convenience, in lines of force per square inch, at a given point. This is termed the flux density, symbolized as "B". The hysteresis and eddy current losses vary proportionately with the flux density, that is, the number of lines of force per square inch at which the transformer is operating. As the flux density increases, the core losses increase quite readily, therefore, it has been found most practical to operate the transformer at a maximum flux density of 90,000 lines per square inch and for a well designed unit somewhere in the neighborhood of 60,000 lines per square inch. These values will vary with different grades of lamination and, therefore, may only be taken as average.

To determine the flux density at

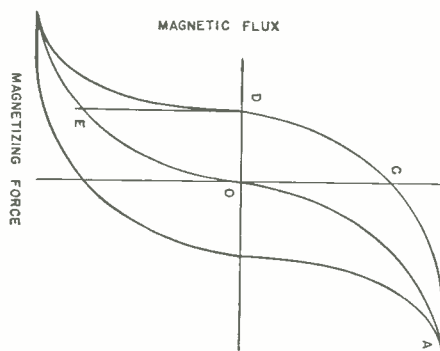

Fig. 4.

which a particular transformer is operating, we will use the following formula:

$$B'' \text{ max.} = \frac{E \text{ effec.} \times 10^7}{4.44 f N A'' K}$$

kilo lines per sq. inch.

B'' max. = kilo lines per sq. inch of core area.

E effec. = R.M.S. Primary Voltage.

N = Number of Primary turns.

f = frequency in cycles per second.

A = Cross-section of the magnetic path (center-leg) in square inches.

K = Stacking factor assumed at 90% (Design theory).

Transformers are used as a convenient means of increasing or decreasing the voltage to the desired value by transferring electrical energy from one circuit to another or simply to be used as an isolating transformer inasmuch as the various windings are not directly connected.

Whether the transformer raises or lowers the voltage depends entirely upon the ratio of the number of turns in the secondary to the number of turns in the primary.

It is apparent that since the coil and the magnetic circuit are stationary, the e.m.f. is induced in the secondary by the change in magnitude and direction of the magnetic flux as a result

**RACKS · CHASSIS · CABINETS**

**PAR-METAL**

**for ELECTRONIC APPARATUS**

ENGINEERS, CONTRACTORS: Send specifications for estimates, or request Catalogue No. 41

**PAR-METAL PRODUCTS CORP.**  
32-62 49th ST., LONG ISLAND CITY, N. Y.  
Export Dept.: 100 Varick St., New York, N. Y.

**IT'S ALLIED FOR EVERYTHING IN RADIO!**

Equipment for

**War Industry**

**Armed Forces**

**Home Front**

RADIO plays a big part in our march to Victory—and ALLIED plays a big part in Radio.

American War Industry counts on ALLIED for its Radio and Electronic equipment used in research and production operations.

ALLIED is at the service of our Armed Forces, supplying thousands of radio items for active use and instruction applications.

And on the Home Front, ALLIED helps keep American radios at top efficiency.

Your ALLIED Catalog is the key to Everything in Radio—Radio Receivers; Test Equipment; Tools; PA Systems; Tubes; Books; over 15,000 Radio and Electronic Parts for service replacement work, for industrial application, for war use. And all this is backed by Radio's most complete stocks and speediest service. It will pay you to keep your ALLIED Catalog handy for Everything in Radio!

### ALLIED RADIO CORP.

833 W. Jackson Blvd., Dept. 1-H-42  
Chicago, Illinois

Send me your FREE 1942 Radio Supply Catalog.

Name: .....

Address: .....

City: ..... State: .....

**READ CODE LIKE AN EXPERT**  
**SEND CODE**  
**Learn Quickly at Home—Get Real Speed**

It's easy, fascinating, to become a good op. with the NEW ALL ELECTRIC MASTER TELEPLEX CODE TEACHER to help you. Only instrument ever produced which records your sending in visible dots and dashes—then sends back to you at any speed you desire. Also sends practice work, recorded by an expert. That is why so many schools teaching code prefer Master Teleplex, why thousands agree this method is surest and quickest—has taught more ops in the past few years than all other methods.

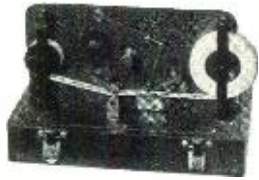

There are NO PERFORATIONS — NO INK. Far superior to anything ever developed — a marvel of simplicity.

**FREE BOOK**

We furnish Complete Course, 100 days of a Master Teleplex, give you personal instruction with a MONEY-BACK GUARANTEE. Low cost. Send today for booklet FREE. No obligation.

**TELEPLEX CO., 107 HUDSON ST. JERSEY CITY, N. J.**

**MODERN PARTS for MODERN CIRCUITS**  
 THAT HAVE BEEN  
*"Designed for Application"*  
 CATALOG UPON REQUEST

**JAMES MILLEN MFG. CO. INC.**  
 150 EXCHANGE ST. MALDEN, MASS.

**It's FREE! It's NEW!**  
**LAFAYETTE RADIO CATALOG**  
 New AM-FM Sets, Combinations, Portables, P.A. Systems and thousands of Standard Radio Parts, Books, Tools, etc. Every radio serviceman, industrial users—defense plants, etc., should have a copy of this big reference work. It's a veritable encyclopedia of all that's new in radio, electronics, etc.

**125 PAGES OF BARGAINS**  
 Write today for your copy. Get in on these super "buys" while they last. Camera fans—ask for camera catalog. Hurry! A post card will do.

**LAFAYETTE RADIO** Dept. RNS  
 901 W. JACKSON BLVD., CHICAGO  
 265 PEACHTREE ST., ATLANTA

**COMMERCIAL RADIO INSTITUTE**  
 A radio training center for over twenty years. Well equipped. Excellent faculty. Practical RESIDENT COURSES in Radio Telegraphy, Broadcast, Servicing, Industrial, Television, Aeronautical, Drafting, Mathematics and Studio Technique. Placement Bureau. Day and Evening Fall Classes Now Forming for October 5. Catalog upon request.  
 Dept. C, 38 W. Biddle St., Baltimore, Md.

**GOOD JOBS in RADIO**  
 for young men age 17 to 20

As older men leave for the Army, RADIO calls for recent high school graduates. Prepare now for jobs in Radio Engineering, Broadcasting, Marine, Aviation, Police Radio, Servicing, Radio Manufacturing. Our streamlined courses give excellent preparation for Army and Navy Service. Expenses low. Write for free catalog.

**THE DODGE TELEGRAPH & RADIO INSTITUTE**  
 410 Monroe St., Valparaiso, Indiana

of an a.c. voltage being applied to the primary winding.

A transformer will also operate of course if a pulsating or changing direct current is sent through the primary as is the case in the performance of an output transformer.

As the primary winding is wound on the iron core, its magnetomotive force when applying an A.C. potential to the primary produces an alternating flux in the core, this flux which is linked with the secondary windings induces an e.m.f. potential in the secondary windings at the same frequency but in the opposite direction, that is, the primary and secondary voltages are 180° out of phase. Because of this induced e.m.f. the secondary winding is capable of delivering current and energy.

We will first assume that the secondary winding is not connected and therefore no current is flowing in it. With the primary then applied to the line potential we will have a current flowing in the primary. This current consists of lost energy and is as a result of the core losses in the lamination, nominally the hysteresis and eddy currents and the primary I<sup>2</sup>R loss. This current flow is known as the no-load magnetizing current which may be converted into watts and referred to as the core losses. This wattage is usually in the vicinity of 1 to 7 watts depending of course on the type and design of the transformer.

In a conservatively designed transformer where the core losses are low and the resistance drop of all windings are also held to a minimum the voltage induced in the secondary are directly proportional to the turns ratio, that is:

$$\frac{E_{pri.}}{N_{pri.}} = \frac{E_{sec.}}{N_{sec.}}$$

However in the design of power transformers where the cost is held to a minimum the losses must be considered. The effective primary voltage is therefore the applied e.m.f. minus the I R drop of the primary and the available secondary voltage would be that voltage induced in the secondary minus the I R drop of the winding. Therefore we may revise the previous equation to the following:

$$\frac{E_{pri.} \text{ applied} - I R_{pri.}}{N_{pri.}} = \frac{E_{sec.} \text{ available} + I R_{sec.}}{N_{sec.}}$$

This formula is only rarely used in practical radio design, inasmuch as the current in each winding warrants considerable calculation. It has been found more convenient to take advantage of past experience and roughly estimate these losses, in determining the proper turns ratio.

(To be continued)

**Aviation Radio**  
 (Continued from page 31)

Most aviation radio manufacturers incorporate antenna tuning units in their transmitters (and sometimes receivers) which adequately take care of specific antenna characteristics. If an antenna is too long mechanically it can be shortened electrically by employing the correct amount of capacitance in series with it; and if too short can be "loaded" by inserting the correct amount of series inductance. By utilizing the correct amount of both capacitance and inductance by means of tap or rotary switches, a combination will be found whereby the power amplifier stage of the transmitter is matched properly to the antenna. In other words, the antenna will be resonated to the power amplifier and maximum radiation will result.

When it is desired to increase the length of an aircraft antenna it would be wise to keep it as far away from the airplane structure as possible. That is, the increase in length should always be in a direction away from the main body of the metal mass. Absorption losses in aircraft antennae are often very high (especially at ultra-high frequencies) and for this reason the antennae should be installed so that main portions are away from

**Camera Fans!**  
**WIN A \$500 WAR BOND**  
 OR ONE OF THE OTHER 308 PRIZES!

Enter the big 1942 Popular Photography Picture Contest... Think of it! \$3,500 in prizes! 309 separate awards! Yes, this spectacular contest is open to all and costs nothing to enter. You've got just as good an opportunity to win as anyone. So don't delay. Get in this new picture contest now, make your camera pay dividends.

**FOR COMPLETE DETAILS SEE THE AUGUST ISSUE**

**POPULAR Photography**

**NOW ON SALE AT ALL NEWSSTANDS AND CAMERA STORES**

the plane, suspended on either masts or sub-masts to effect a clearing. The vertical antenna seems to be the "out" as far as absorption losses are concerned.

The dielectric losses and conductor losses should be a small influence upon the effective radiation resistance of the aircraft antenna; impedance should be the influencing factor. So when designing the antenna, the many factors which influence efficiency should be duly taken into consideration.

If an antenna cut to approximately  $\frac{1}{4}$  wavelength is used (V, T, antennae) the right amount of operating capacitance and approximately the correct amount of antenna resistance is usually realized when the present frequencies now used by aircraft for transmitting purposes are taken into consideration.

In figuring the length of an antenna for  $\frac{1}{2}$  wavelength operation all that is necessary is to multiply the number of meters by 1.64. If your transmitter must transmit on a frequency of 3,105 kilocycles we first find the wavelength, which is approximately 96 meters; multiply 96 by 1.64 and we get approximately 157.5 feet. A quarter wave would be  $\frac{1}{2}$  of 157.5 or 78.75 feet. If the transmitter to which the antenna is to be connected employs an antenna tuning unit, figuring length to the exact foot is not necessary. On an aircraft the size of an Aeronca or Taylorcraft, one would find it a very difficult job to install an antenna 78.75 feet long! It can be seen readily then that some provision must be made to tune the antenna. A quarter wavelength antenna to operate on 6,210 kilocycles would still occupy a large amount of space on any modern private aircraft. Therefore, after figuring out the amount of space you have for the installation of the antenna, a compromise must be drawn between specific length and allowable length. Where it is found that sufficient space is not available for installing the conventional type of antenna it is possible to install both a V type and an underbelly antenna both connected together. However, the addition of a loading coil is recommended when a circumstance of this kind presents itself.

The question has often been asked, "Why isn't it possible to use the entire aircraft structure as an antenna for the radio installation? It's 'insulated' when it is in flight."

It has been done in the case of all-metal aircraft with some little success. Remembering that the aircraft structure forms a part of the electrical system, and also serves as a "ground" for the installed radio equipment should deter anyone from trying this system. Then someone says, "Well, we've got grounded antenna systems. Why won't it work?"

It will work but not as effectively as a "free" antenna that has been designed specifically for transmitting and receiving.

Common antennae (used for both transmitting and receiving) are employed to a very large extent. An antenna relay which switches the common antenna between both receiver and transmitter must be used. When the transmitter is operating one contact of the relay automatically shorts out the receiver input. In some relays one contact shorts out the input of the receiver and at the same time removes the high voltage and applies it to the transmitter. One will usually find separate relays performing each task however.

The adjustment of the antenna relay is no simple matter if one has not had experience with this type of equipment. In no case should a novice attempt adjustment. When contacts are pitted, dirty and worn, they should be cleaned with either crocus cloth or a very light sandpaper (No. 000). Never use a file or emery cloth! Arm adjusting wrenches should be provided for proper spacing of contacts and for the proper adjustment of spring tension.

The type of wire used for the construction of aircraft antennae is very important. Soft drawn copper wire, or stranded wire often used for the home antenna system should never be used. Flexible stranded wire having a cloth core may be used with success for trailing wire antennae, however the type of wire recommended is copper-clad (coated) steel wire. The copper coating affords good electrical conductivity and the steel gives the needed strength. When using this type of wire it must be remembered that even the slightest nick will impair its efficiency. Under no circumstances use pliers to make connections to insulators both lead-in and strain. Pliers must only be used for cutting; and then a sharp pair of diagonal pliers should be used in order to cut the wire as close to the connection as possible.

There are three ways that are utilized in making antenna ties (lead-in to antenna proper and insulators). These are: the double bend tie; the loop tie; and the cross or T tie.

The double bend tie consists of running the antenna through the insulator leaving about  $1\frac{1}{2}$  feet of wire extended through the hole. This wire is bent back toward the insulator hole groove and wound in neat spirals for about  $\frac{1}{2}$  inch. Then doubled back and the end of the tie-in wire re-inserted in the insulator hole and wound back on the first spirals. One drop of solder is used to cinch the spirals together; then a coating of weather-proof varnish or glyptal is applied to the spirals.

Loop ties are made by pulling the antenna through the strain insulator and a second piece of wire about  $1\frac{1}{2}$  foot long is cut and also run through the hole. A bight is taken at the insulator proper and with the second piece of wire, two tight spirals are made. The loose ends are then clipped off and with the end of the antenna wire proper another spiral is made

4 STANDARD TYPES  
of Amperite Regulators replace over 400  
types of AC-DC Ballast Tubes now in use.  
Amperites are real REGULATORS... have  
patented Automatic Starting Resistor which  
prevents initial surge and saves pilot lights  
... Ask Your Jobber.

**AMPERITE**

THE *Simplest*  
WAY TO REPLACE  
**BALLASTS**

WRITE FOR REPLACEMENT CHART  
AMPERITE Co. 541 BROADWAY, NEW YORK, N. Y.

**FIX ANY RADIO**  
Amazing New Invention

*Simplified Radio Servicing by Comparison Method*

Learn to repair radios in minutes instead of hours. Revolutionary, different **Comparison** technique permits you to do expert work almost immediately. Most repairs can be made without test equipment or with only volt-ohmmeter. Simple point-to-point, cross-reference, circuit suggestions locate faults quickly and easily.

**FOR BEGINNERS OR EXPERTS**

Find any radio fault with ease. Follow the comparison tests given on 16 large trouble-shooting blue-prints, 112 text pages, Over 1,000 practical repair hints. Hundreds of simplified tests using a 5c resistor and a filter condenser. Covers every radio set—new and old. Introductory material for beginners and to serve as a review for experienced radio men. Also several chapters on test equipment. Presented in manual form, 8 $\frac{1}{2}$  x 11 inches. Entire plan is stark new and will change servicing methods. Protected by U. S. Copyright.

**SATISFACTION GUARANTEED**

Take advantage of our "no-risk" trial. Send coupon today. Use this time-saving, money-making radio servicing method for 15 days without any obligations. See how much time you will save every day on every radio job. Learn new short-cuts in radio servicing. Then decide to keep **Comparison Method Manual** or return it and receive a cash refund. You cannot lose—but you owe yourself a chance to look at this plan.

**NEW 1942 EDITION**

The training will more than pay for itself on the first radio job. Examine and use this unique plan for 15 days at our risk. Send coupon right now—use the plan this week.

Developed by M. N. Beitman, radio engineer, teacher, author, & serviceman.

**TRIAL ORDER COUPON**

SUPREME PUBLICATIONS, 328 Jefferson St., Chicago, Ill.

Ship the new manual, "Simplified Radio Servicing by Comparison Method," for examination. I am enclosing \$1.50, full price, send postpaid. I must be satisfied or you will refund my money.

NAME: .....

ADDRESS: .....

## THIS IS YOUR CHANCE!★

You may never have another chance to step into a real paying position where opportunity is unlimited. . . . **RADIO CODE OPERATORS** are wanted right now! . . . The Army, Navy and our Merchant Marine needs trained operators—you can train for one of these positions now!—right in your own home by the Candler System. Thousands of code operators have been trained by the Candler System during the past quarter of a century. Today you, too, can learn by using this easy, practical system. Courses for beginners and operators wishing maximum code proficiency. It's up to you—if you want a real future send a post card or letter today—no salesman will call.

### Get a FREE Book

Write today and get the free **BOOK OF FACTS**. Tells you all the facts about being a Radio Code Operator—your copy is waiting for you—send for it today! There's no obligation.

## CANDLER SYSTEM CO.

Box 928  
Dept. N-8 Denver, Colorado

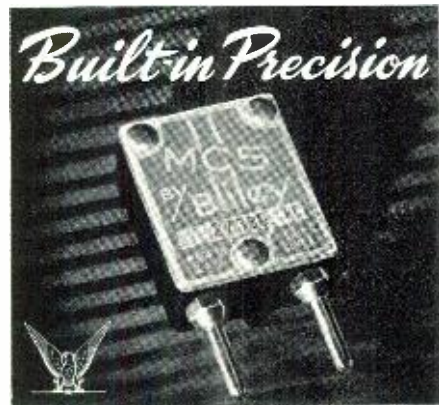

Accuracy and dependability are built into every Bliley Crystal Unit. Specify **BLILEY** for assured performance.

**BLILEY ELECTRIC CO. Erie, Pa.**

## NEW CATALOG

### OF SOUND AMPLIFYING SYSTEMS

AUDIOGRAPH Sound Systems represent the latest in Public Address equipment—a complete line plus pre-tested accessories.

### NEW LOWER PRICES

Outstanding quality and performance at prices that help you meet any competition.

WRITE FOR YOUR FREE COPY

## AUDIOGRAPH THE FIRST NAME IN SOUND

John Meck Industries—Liberty at Pennsylvania Ave., Plymouth, Ind.

**LES** Correspondence Courses In  
**RADIO and ELECTRICAL ENGINEERING**

**ELECTRICAL ENGINEERING** Get good grasp of wide electrical field. Prepare yourself at Low Cost, for secure future. Modern course. So simplified anyone can understand quickly.

**RADIO ENGINEERING** Extra fine course in radio, public address, photo-electric work. Train you to be super-service man, real vacuum-tube technician. Experimental kit furnished. Diploma on completion.

Send postcard or letter for Free Copy of school catalogs, full details, all about deferred payment plan, etc. **SEND NOW!**

**WRITE** **LOW \$25** Either AS **25** Courses

**LINCOLN ENGINEERING SCHOOL** Box 931-R44, LINCOLN, Nebr.

just ahead of the first two. A drop of solder is used between the second and third spirals to effect good connection. Varnish is used as before.

The cross or T tie is used for connecting leadins to antennae proper. The length of the leadin is measured to the foot and 1½ feet of wire is left on each end; that is, the total length of the leadin should be the length it must run plus 3 feet. One end of the wire is started on the antenna proper first by running a spiral to the left for about six turns (all spirals on all ties should be six turns) then doubled back and wound on the right; doubled back again on the antenna proper using six more turns. No solder being used for this connection.

After the leadin has been connected to the leadin insulator, flexible wire should be used to connect the inside connection of the insulator to the receiver-transmitter or antenna relay. Enough slack should be left in the wire to cope with vibration both at the relay and the insulator connection. Connection to the receiver is effected by using the same size of wire as connects the outside antenna to the leadin insulator. If bare wire is to be used for the lead-through connection, isolantite beads should be strung on the wire to provide proper insulation.

When stringing the antenna it must be remembered that a certain amount of slack should be left in the antenna to cope with the undesirable effects of vibration. One will seldom see a good antenna installation where the antenna has been tightened excessively.

If shock cord is used for providing the necessary play in the antenna, care should be taken to make connections as tight as possible without fully taxing the cord. When spring and pulley assemblies are used to provide the necessary elasticity these should not be tightened to the point where vibration of the antenna will cause undue wearing of the pulley.

Leadins should be run as direct to the receiver as is possible and sufficient slack should be left in this element also in order that the drag caused by slip-stream action will not weaken its connection to the antenna proper.

If it is necessary to run the leadin for some distance to the receiver, relay, etc., suspension insulators should be utilized wherever possible. Particular care should be taken to see that transmitter output leads to the antenna are carefully insulated. Where co-axial cable is used for the leads (and this is recommended whenever possible) suspension insulators need not be used as often as when "straight conductors" are employed. Usually, three insulators are all that need be used in suspending co-axial, viz., at the transmitter proper; in the center of the cable; and where it leaves the aircraft for connection to the antenna.

Choosing the proper size of strain insulator is not difficult but the choice

## Classified

Rate 15c per word. Minimum, 10 words

### CORRESPONDENCE COURSES

RADIO Communications courses qualifying for all Federal licenses. Home study and resident courses. American Radio Institute, 1123 Broadway, New York, N. Y.

USED Correspondence Courses and Educational Books sold or rented. Inexpensive. Money-back guarantee. Write for Free Catalog listing 4000 bargains. (Courses Bought.) Lee Mountain, Pisgah, Alabama.

CORRESPONDENCE Courses and educational books, slightly used. Sold. Rented. Exchanged. All subjects. Satisfaction guaranteed. Cash paid for used courses. Complete details and bargain catalog free. Write Nelson Company, 500 Sherman, Dept. H-237, Chicago.

### MISCELLANEOUS FOR SALE

USED Riders Manuals. Roxy Radio Repair Service, Mitchell, S. Dak.

### PATENT ATTORNEYS

INVENTORS—Before disclosing your invention to any one send for Form "Evidence of Conception"; "Schedule of Government and Attorneys' Fees" and instructions. Sent free. Lancaster, Allwine & Rommel, 414 Bowen Building, Washington, D. C.

### RADIO ENGINEERING

RADIO Engineering, broadcasting, aviation and police radio, servicing, marine and Morse telegraphy taught thoroughly. All expenses low. Catalog free. Dodge Institute, Elm St., Valparaiso, Ind.

EMERGENCY  
FM-AM SYSTEMS  
Coming Next Month  
RADIO NEWS



## THE TRUTH ABOUT BILLY MITCHELL!

Vitriolic prophet of air-war as we know it today, stormy petrel of the post World War era, Gen. Billy Mitchell stands as one of the enigmas of military aviation. . . . His brilliant career, his outspoken frankness and his many mistakes are all revealed for you in "The Billy Mitchell Case," by Congressman Melvin J. Maas, another exclusive article in **FLYING** magazine. Read about this remarkable precursor of modern military aviation, condemned and commended by friends and enemies alike, in the

AUGUST ISSUE

# FLYING

NOW ON SALE AT ALL NEWSSTANDS

"Nearly everyone in aviation reads **FLYING**!"



must be exact. Consulting the manufacturer's catalogs will nearly always give the information the technician actually needs. A common suspension scale calibrated in pounds will give the amount of static pull on the in-

ulator if inserted between one end of the antenna and insulator. Allowing 45% for added pull due to vibration and aerodynamic drag (wind resistance) should be sufficient for all calculations, including icing.

Depending upon the type of wire used for antenna construction, age and corrosion will usually weaken any wire used; the time extending from 75 to 100 hours in hot and humid climates to 100 to 250 hours in moderate climate. In cold weather copper wire will tend to become brittle and if iced will break rather quickly. Therefore it is necessary that the exact amount of tension be placed on the antenna proper on initial installation.

Antenna for UHF is a subject in itself and should be considered separately. At ultra high frequencies antenna length must be exact, coupling methods must be standard; adequate insulation must be utilized; and each antenna must have been designed with a particular service requirement in mind. We will cover UHF antennae in another part, both aircraft and ground.

(To be continued)

### What's New in Radio

(Continued from page 38)

meet the most exacting requirements. Numbers are perfectly stamped and filled.

#### G. E. Sensitive D-C Relay for Aircraft Service

A new sensitive direct-current relay for aircraft service has been announced by the industrial control division of the *General Electric Company*. The relay, designated CR2791-C100C, is specially designed for use in vacuum tube output circuits where the power available is so small as to require operation on extremely low currents.

A sealed aluminum cover protects the relay from dust and against damage from rough handling. The relay is small and light in weight, weighing only 3 1/4 ounces, and is designed to meet all Air Corps requirements set up for devices of this type.

It has a maximum continuous current rating of 2 amperes at 32 volts, and a maximum make or break rating of 10 amperes. The coil is rated at 32 milliwatts minimum and 1 watt maximum. Maximum coil resistance is 3000 ohms. The contacts provide single-pole, double-throw operation.—*General Electric Co.*, Schenectady, New York.

#### Solar High Voltage Filter Capacitors

Type XJ capacitors provide a wide range of capacities in d.c. voltage ratings from 6000 to 25000.

Liberal design and rigidly controlled production processes have been combined to produce a unit which is mechanically rugged and electrically dependable.

## FOR VICTORY



**BUY UNITED STATES SAVINGS BONDS AND STAMPS**

ON SALE AT YOUR POST OFFICE OR BANK

### AMERICA ON GUARD!

Above is a reproduction of the Treasury Department's War Savings Poster, showing an exact duplication of the original "Minute Man" statue by famed sculptor Daniel Chester French. War Bonds and Stamps, on sale at your bank or post office, are a vital part of America's victory preparations.



## F-M vs A-M for EMERGENCIES!

Here are the FACTS, carefully weighed and interpreted, about the use of F-M in emergencies, to maintain communication with hard-to-reach areas, and to eliminate "dead" spots for portable apparatus. . . . Read how F-M in UHF channels may revolutionize emergency radio setups, how already utilities have F-M-equipped radio patrols, like the one shown above, touring key properties guarding against sabotage. . . . Don't miss "Emergency F-M/A-M Systems" in the

SEPTEMBER ISSUE



ON SALE AT NEWSSTANDS EVERYWHERE AUGUST 25th

ONLY A FEW LEFT!

ORDER YOUR

**GENUINE WEBSTER TODAY!**  
**RECORDER-PLAYBACK**



JUST \$28.95 COMPLETE

Plays records up to 12" dia. Cuts records up to 10" dia. outside-in at 110 lines per inch. 78 RPM induction type motor employs an internal rim-drive to the turntable. Assembly includes 10" turntable, motor, cutting mechanism, crystal cutting head, 1 1/2 ounce low-pressure crystal pickup, with full instructions for connecting to any set or amplifier. Complete unit with case and As-tatic microphone. Wt. 25 lbs. Size 16"x13"x9". For 110V. 60 cycles.

NOTE: Prices for separate units are:

Webster Recording Unit only	\$19.95
Case	4.95
Microphone	4.45
Cutting Transformer	.75

Positively no C.O.D. shipments made, unless order is accompanied by a deposit of at least 25%. All prices F.O.B. Chicago

Write TODAY for NEW Free Bargain List of Other Specials

### ARROW RADIO CO.

902 W. Jackson Blvd.

Chicago, Illinois

**BOOST Service Profits**  
**LOWEST PRICES....**  
**FASTER DELIVERY at**  
**RADOLEK**

Radolek stocks replacement parts to repair any radio — every type of tube, transformer, speaker, condenser, volume control, resistor, auto radio accessories — everything you need at rock bottom prices. And too, Radolek understands service problems — gets your order to you in double quick time. Order from Radolek for complete satisfaction!



**RADOLEK REPAIR SERVICE**  
 Let Radolek repair your damaged or burned out transformers, coils, speakers, test apparatus, etc. Guaranteed equal to new. Write for prices.

**FREE! BIG NEW RADIO SERVICE GUIDE!**  
 Buying from Radolek means Greater Values, Better Service and More Profits. Send today for the Big FREE Radolek Service Guide.

**SEND TODAY! PASTE ON A POST CARD**

**RADOLEK CO., Dept. B-69**  
 601 W. Randolph St., Chicago, Ill.  
 Please send the Big FREE Radio Service Guide

Name .....  
 Address .....  
 DEALER  SERVICEMAN  SOUND ENG.

**SAVE AT RADOLEK**



● These super-sealed Aerovox paper tubulars are just as good as they look. Beneath that colorful yellow-black-red label jacket you'll find an extra-generously-waxed cartridge for maximum protection against moisture penetration. Likewise extra-generously-waxed ends, neatly milled, with pigtail leads that won't work loose. In all climes, from frigid Arctic to torrid tropics, these paper tubulars are establishing new performance records. Why take less?

**PAPER TUBULAR  
CONDENSERS**

Type 484—400 v. D.C.W.  
          .01 to 1.0 mfd.

Type 684—600 v. D.C.W.  
          .001 to .5 mfd.

Type 1084—1000 v. D.C.W.  
          .001 to .1 mfd.

Type 1684—1600 v. D.C.W.  
          .004 to .05 mfd.

● **Ask Our Jobber . . .**

He'll gladly take care of your essential condenser requirements with these paper tubulars and other types. Ask for latest catalog—or write us direct.



Containers are heavy gauge steel, welded oil tight and hot tinned. The wet process porcelain insulators are amply proportioned to withstand potentials far in excess of the rated voltage of the capacitor. Case and terminals are bonded together by gasket material carefully treated to insure an oil tight joint under extreme temperature conditions.

The long vacuum drying and impregnating process is performed after the completed stack is permanently assembled in the case. This eliminates the possibility of short life due to breakdown of air trapped in the windings. The vacuum treated mineral oil impregnant assures low leakage current and negligible capacity change over a wide range of operating temperature.—Solar Mfg. Corp., Bayonne, N. J.

● **"Kum-Kleen"**

Due to the conservation of all types of metal, many industries have found it necessary to use a substitute for name plates, metal tags, identification, patent number and instructions tags.

A new product has been developed under the trade name of "Kum-Kleen"

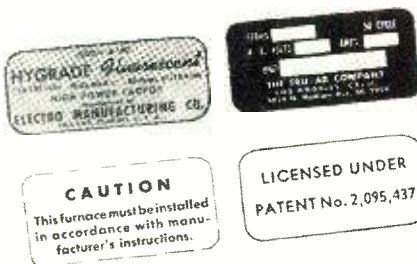

which is being widely used as a substitute. This product adheres permanently to any smooth surface including metals, glass, plastics, enamel, varnish, wood and is applied without moistening, will adhere even when exposed to high temperatures or changing climatic conditions.

They are particularly advantageous at this time as they eliminate the necessity of drilling, tapping and riveting in application, yet have the permanent quality of metal tags.

They are being manufactured by Avery Adhesives, 451 East Third Street, Los Angeles, California.

● **New Battery Replacement Chart for Service Men and Dealers**

The Radio & Technical Publishing Co. is offering to radio dealers and service men a handy new wall chart which instantly shows the replacement and other electrically comparable batteries for more than 1250 models of portable radio receivers. Included in the chart are batteries of 23 leading makes, and receiver models of 100 makes. Prepared by Alfred A. Ghirardi, it is believed that this is one of the most complete and accurate battery replacement charts available today.

Printed in U. S. A.

**PHOTO CREDITS**

Page Numbers	Credits
Cover . . . . .	Western Electric Co.
7, 8, 9 . . . . .	U. S. Army Signal Corps
10, 11, 12, 13 . . . . .	William Dunn
14, 15, 16, 17 . . . . .	Piper Studios
18, 19 . . . . .	Piper Studios
20 . . . . .	The David Bogen Co.
24, 25 . . . . .	Piper Studios
26, 27 . . . . .	General Electric Co.
30 . . . . .	Air Associates, Inc.
31 . . . . .	RCA Mfg. Co.
35 . . . . .	Western Electric Co.

**Index to Advertisers**

COMPANY	PAGE No.
Aerovox Corp. . . . .	66
Allied Radio Corp. . . . .	61
Amperite Co. . . . .	63
Arrow Radio Co. . . . .	65
Bliley Electric Co. . . . .	64
David Bogen Co. . . . .	55
Burstein-Appelbee Co. . . . .	55
Candler System Co. . . . .	64
Capital Radio Eng. Inst. . . . .	53
Centralab . . . . .	54
Classified . . . . .	64
Commercial Radio Inst. . . . .	62
Davega . . . . .	Second Cover
Dodge Institute . . . . .	62
Hallcrafters Co. . . . .	Back Cover
Hammarlund Mfg. Co., Inc. . . . .	47
Bob Henry . . . . .	58
Hygrade Sylvania Corp. . . . .	50
Indiana Technical College . . . . .	59
Inventors' Contest . . . . .	5
Lafayette Radio Corp. . . . .	62
Lake Radio Sales Co. . . . .	56
Lincoln Eng. Schools . . . . .	64
P. R. Mallory & Co., Inc. . . . .	Third Cover
McGraw-Hill Book Co. . . . .	60
John Meek Industries . . . . .	64
Midland Radio Schools . . . . .	43
Wayne Miller . . . . .	55
James Millen Mfg. Co., Inc. . . . .	62
Mutual Radio Products Co. . . . .	57
National Company, Inc. . . . .	45
National Radio Institute . . . . .	3
O'Brien and Jacobson . . . . .	59
Par Metal Products Corp. . . . .	61
Peerless Radio & Sound Corp. . . . .	58
Polymet Condenser Co. . . . .	53
Prentice-Hall, Inc. . . . .	51
R. C. A. Institute, Inc. . . . .	59
Radio & Tech. Publ. Co. . . . .	59
Radio City Products . . . . .	57
Radolek Co. . . . .	65
Randolph Radio . . . . .	52
John F. Rider Publ. Co. . . . .	48
Solar Mfg. Co. . . . .	58
Sprague Products Co. . . . .	44
Sprayberry Academy of Radio . . . . .	6
Superior Instruments Co. . . . .	49
Supreme Publications . . . . .	63
Teleplex Co. . . . .	62
Thordarson Electric Mfg. Co. . . . .	55
Triplet Electrical Instrument Co. . . . .	46
Tri-State College . . . . .	60

# STORMY!



..but there's a silver lining

"War is hell", said General Sherman...and he didn't have to put up with today's shortages of essential materials. It's tough on manufacturers, tough on distributors, and tough on radio servicemen. Getting the right replacement for that balky set...Wow! What a job it can be!

Yes, sir, it's a tough situation. But it is all in today's work —and you can count on Mallory to help in every way possible. Here are three ways we're helping right now:

**1. Standardized Parts:** Many years ago, Mallory began developing standardized and interchangeable radio parts. Universal replacement condensers, for instance, make mighty useful...and practical...substitutes when the exact design used in an old receiver isn't to be had for love nor money. Nowadays, you can be glad that Mallory had the foresight to standardize the design of many components...because standardization saves you time and enables you to get along with a minimum inventory.

**2. Practical Books and Booklets:** Sure, you have to use ingenuity to make repairs on that stubborn old receiver. It helps when you have reference books right on the shelf above your workbench. The latest "MYE", the Mallory Radio Service Encyclopedia, belongs on that shelf because it's full of useful information...is just what you need to make the best of a tough servicing situation. Booklets on specific products available on request...see your Mallory Distributor.

**3. Information Free:** It's yours for the asking...the help of Mallory radio engineers on your specific problems. Just write a letter or post card to our Application Engineering Section, Wholesale Division.

**P. R. MALLORY & CO., Inc.**  
**INDIANAPOLIS      INDIANA**

Cable — PELMALLO

P. R. MALLORY & CO. Inc.

# MALLORY

Approved Precision Products

MALLORY

SRN-72-J70616-DMR-63 24  
FRANK G WIEBEL JR  
244 HAGER ST  
HAGERSTOWN MARYLAND

*the Commandos*  
could tell you about  
**hallicrafters**  
communications equipment!

