

# RADIO NEWS

AUGUST  
1941  
25c  
In Canada 30c

radio  
*Trade*  
news  
EDITION

*Special*  
SOUND  
ISSUE



# Skyrider

**FOR 1942**

**A THIRTEEN TUBE, SIX BAND COMMUNICATIONS RECEIVER**

Features of the Skyrider 32 • Two stages preselection • Calibrated bandspread inertia controlled • Micrometer scale tuning inertia controlled • Tone and AC on-off • Beat frequency oscillator • AF gain-RF gain • Crystal phasing • Adjustable noise limiter • Send-receive switch-AVC-BFO switch • 80/40/20/10 meter amateur bands calibrated • Wide angle "S" meter • Push-pull high fidelity, audio output • 6-step wide range variable selectivity.



See Your Hallicrafter Distributor for Full Details

**the hallicrafters co.**

CHICAGO, U. S. A.

**Used by 33 Governments  
Sold in 89 Countries**



by THE EDITOR

“NECESSITY is the mother of invention”—so the saying goes. This certainly applies to the Radio Industry in general. We find a constant change being made in the design of conventional equipment, such as the present-day receiver. It will not be surprising if we see a radical departure from conventional designs in the very near future.

Aluminum has already been discarded and in its stead we find substitute metals being developed and used as replacements and in fabrication of new parts. Steel is being used for variable condensers and several manufacturers are substituting paper type capacitors in place of the electrolytics.

No doubt, we shall see some improvements in set design as the engineers must now put forth their greatest effort in order to cope with the present situation brought about by National Defense. In the past, too much attention has been paid to “ginger-bread” and non-essentials, and it has been necessary for certain companies to dream up new features for standard circuits in order to compete with the more progressive circuit designs of the largest companies.

This brings up the question: “What will radio receivers look like a year from now?” We are quite certain that they will not resemble, at least in appearance, present-day models. We anticipate a change in push-button tuning methods and, also, predict that practically all coils used in tuned circuits will feature permeability tuning. This will eliminate the small variable condensers which, up to now, have made use of aluminum plates in their construction. American engineers have long led the pace in the design of radio equipment, and their initiative is certain to meet all problems that might confront them.

\* \* \*

THIS month brings two new outstanding authors to the columns of RADIO NEWS. Each has contributed an article of interest to the Sound man. They are: Mr. P. J. Faber, of *Montgomery Ward*, and Mr. Ralph T. Glover, of *Jensen Radio Mfg. Co.* Mr. Faber's article gives some valuable pointers on the selection of sound equipment; while Mr. Glover's article shows the advantages of using the proper type of loud speaker to meet conditions found in different types of sound installations.

\* \* \*

WE learn from informed sources that more and more of the manufacturers will curtail their 1942 production of radio receivers. This will result in the increased need of servicing on existing sets. Here the serviceman will step into his own. We believe that this business of keeping the

(Continued on page 57)



# RADIO NEWS



Trade-Mark Registered

Including Articles on POPULAR TELEVISION

The Magazine for the radio amateur  
experimenter, serviceman & dealer

Vol. 26, No. 2

## Contents for August, 1941

### FEATURES

- British Radio Combats Blitz** . . . . . Samuel C. Milbourne 6  
A description of the British Radiolocator's operating technique.
- **A Universal P. A. Amplifier** . . . . . Raymond B. Frank, W9JU 8  
An up-to-date universal amplifier for medium sized sound jobs.
- **Build This Simple Inter-Comm.** . . . . . James Fulleylove 11  
Very inexpensive to build is this inter-office communicator.
- Loudspeakers for Music & Voice Reproduction** . . . . .  
Ralph T. Glover 12  
An analysis of representative speakers and how they are used.
- As I See It!** . . . . . John F. Rider 15  
The author's viewpoint on present day issues gives sound advice.
- How to Select a Sound System** . . . . . Peter J. Faber 16  
A most complete guide for the wide-awake p.a. or serviceman.
- Build Your Own Recording Studio, Part VI.** . . . . . Oliver Read, W9ETI 20  
Concluding the present series of articles for the recordist.
- Sane Sound Ideas** . . . . . R. C. Jones 23  
Novel and practical arrangement for the soundman who likes flexibility.
- Field Day at Grand Island** . . . . . Rowland J. Long, W9NLP 24  
Illustrated story of an expedition recently made by three radio-hams.
- **Converting the Sky Buddy** . . . . . Lloyd V. Broderson, W6CLV 34  
Few parts are needed to add a transmitter to this popular receiver.
- **For the Technician: Inter-office Communications System** . . . . .  
H. I. Glunz 37  
A technical analysis for the design of a special inter-comm. system.

Cover Picture: Audio pattern as viewed on oscilloscope screen showing variable amplitudes.

### DEPARTMENTS

- |                                  |  |  |
|----------------------------------|--|--|
| What's New in Radio . . . . . 30 | Manufacturer's Literature 38               | The Video Reporter . . . . . 39            |
| Hamchatter . . . . . 28          | Aviation Radio . . . . . 26                | Ring the Bell . . . . . 33                 |
| QRD? . . . . . 36                | Washington Communi-<br>cation . . . . . 10 | Radio Physics Course . . . . . 60          |
| Bench Notes . . . . . 27         | Police Radio . . . . . 22                  | Serviceman's Experi-<br>ences . . . . . 19 |

Copyright 1941,  
ZIFF-DAVIS PUBLISHING COMPANY  
Member of the Audit Bureau of Circulations

RADIO NEWS is published monthly by the Ziff-Davis Publishing Company at 608 S. Dearborn St., Chicago, Ill., William B. Ziff, Publisher; B. G. Davis, Editor; Oliver Read, W9ETI, Technical Editor; Raymond Frank, W9JU, Laboratory Technician; A. H. Erickson, W9TDI, Draftsman; Herman R. Bollin, Art Director; S. L. Cahn, Advertising Manager, New York Office, 270 Madison Ave. Subscription \$2.50 per year, single copies, 25 cents; foreign postage \$1.00 per year additional, Canada 50c additional. Subscribers should allow at least 2 weeks for change of address. All communications about subscriptions should be addressed to: Director of Circulation, 608 S. Dearborn St., Chicago, Ill. Entered as second class matter March 9, 1938, at the Post Office, Chicago, Illinois, under the Act of March 3, 1879. Entered as second class matter at the Post Office Department, Ottawa, Canada. Contributors should retain a copy of contributions. All submitted material must contain return postage. Contributions will be handled with reasonable care, but this magazine assumes no responsibility for their safety. Accepted material is subject to whatever adaptations, and revisions, including "by-line" changes, necessary to meet requirements. Payment will be made at our current rates upon acceptance and, unless otherwise specified by contributor, all photographs and drawings will be considered as constituting a part of the manuscript in making payment.

# DAVEGA

AMATEUR DIVISION, 63 Cortlandt St., N. Y., N. Y.  
World's Largest Radio Dealer

## THE NEW 1942 SKYRIDER 32



Engineered by Hallicrafters to produce superior communications performance, the new Sky rider 32 is a 13 tube, 6 band receiver covering everything on the air from 500 kc. to 40 mc. Two stages of preselection. Calibrated bandspread inertia controlled. Micrometer scale tuning inertia controlled. Tone and AC on-off. Beat frequency oscillator. AF gain—RF gain. Crystal phasing. Adjustable noise limiter. Send-receive switch—AVC-BFO switch.

80/40/20/10 meter amateur bands calibrated. Wide angle "S" meter. Push-pull high fidelity audio output. 6-step wide range variable selectivity. \$149.50.



### ECHOPHONE Model EC-2

The communications buy of the year! Eight tubes. Three bands. Tunes from 550 kc. to 30 mc. Five inch PM dynamic speaker. Pre-selection on all bands. Calibrated bandspread scale on 80/40/20/10 meter amateur bands. Automatic noise limiter. Electrical bandspread. Operates on 115 volts AC/DC. Now you can have all these amazing features at the remarkably low price of \$29.95.

### ECHOPHONE Model EC-3

Check all these communications features, then look at the incredibly low price! Crystal filter (four position variable selectivity). Calibrated bandspread. Automatic noise limiter. Preselection on all bands. 2 stage IF amplifier. Fly-wheel tuning. Separate 6 in. PM speaker. CW monitor. 10 tubes. 3 bands. Covers 550 kc. to 30 mc. Electrical bandspread. Operates on 115 volts AC/DC. Priced at only \$49.95.



BUY FROM THE WORLD'S LARGEST RADIO DEALER

AMATEUR DIVISION  
63 CORTLANDT STREET  
NEW YORK, N. Y.

# DAVEGA

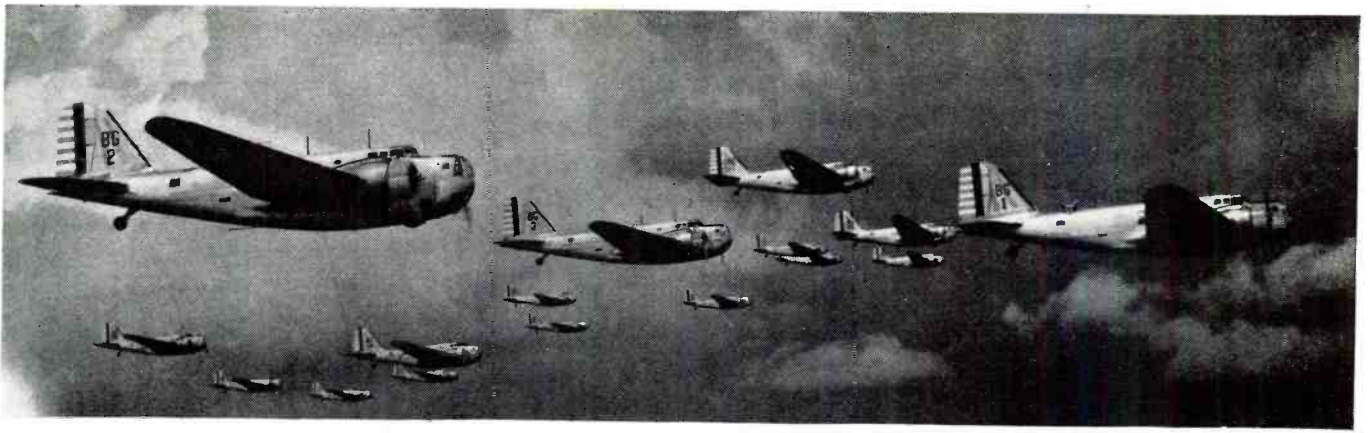

# *The September* **U. S. ARMY** **AIR FORCES** *Issue*



FLYING AND POPULAR AVIATION'S Giant September Issue . . . a 284-page, all-out, all-inclusive issue on the United States Army Air Forces . . . is a must for all radiomen. Here is the most informative and comprehensive report on American military aviation and military radio operations ever published. Tells the story of this vital branch of the Service clearly and thoroughly . . . including the important role that radio is now playing in military aviation communication and navigation. The complete story . . . from the first feeble experiment with military airplanes thirty years ago until the huge Army air arm of today . . . detailing and outlining each unit of the Air Forces and how it functions. Replete with color, gravure and pull-out sections, this brilliant, authoritative and truly inspiring record of the United States Army Air Forces will be a document you will want to read and re-read . . . to treasure and refer to—not for weeks, not for months, but for years. Reserve your volume now!

*The* most  
informative  
and beautiful  
issue in the  
history of  
Aviation . . .

**FLYING**  
AND POPULAR AVIATION

ON SALE AT ALL NEWSSTANDS AUGUST 8th—50¢ A COPY



August, 1941

5

# BRITISH

by  
**SAMUEL C.  
MILBOURNE**

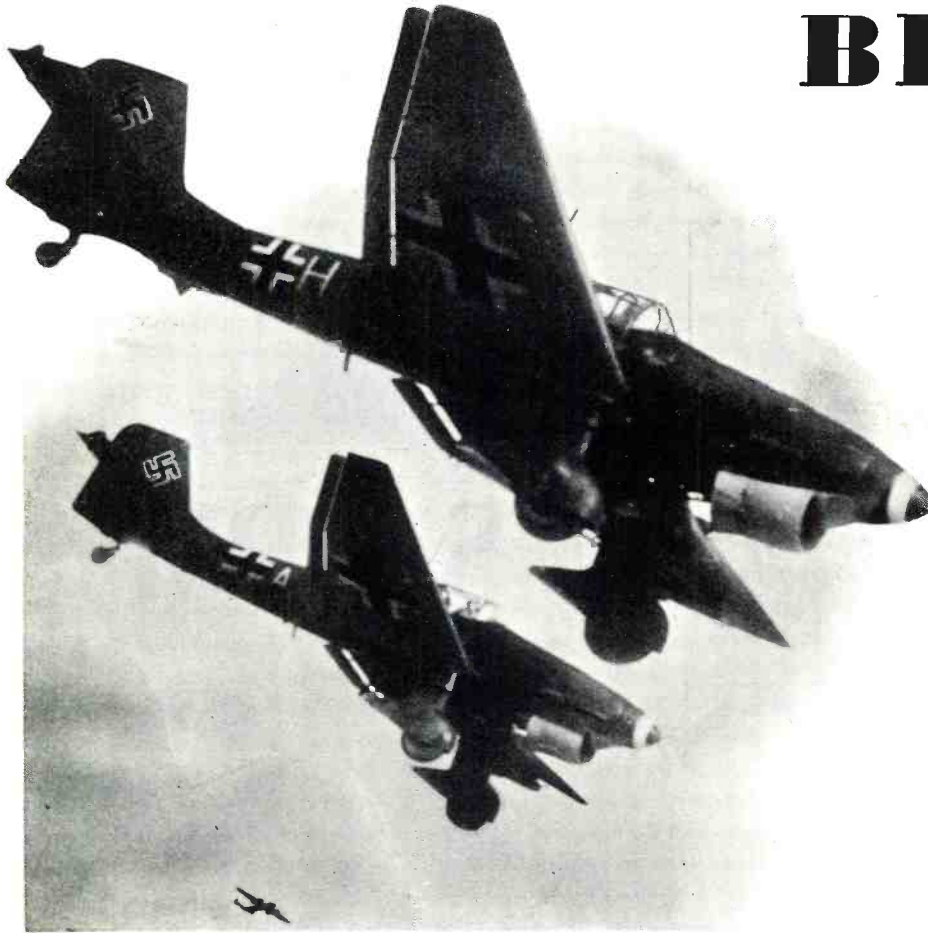

Enemy bombers approach the English coast and encounter the radio beams that are in operation at all times.

**Here is the complete story of radio's latest contribution to the defense of the Democracies as told to the author by a member of the Royal Air Force who is, at present, in this country.**

Artist's conception showing fixed and mobile stations.

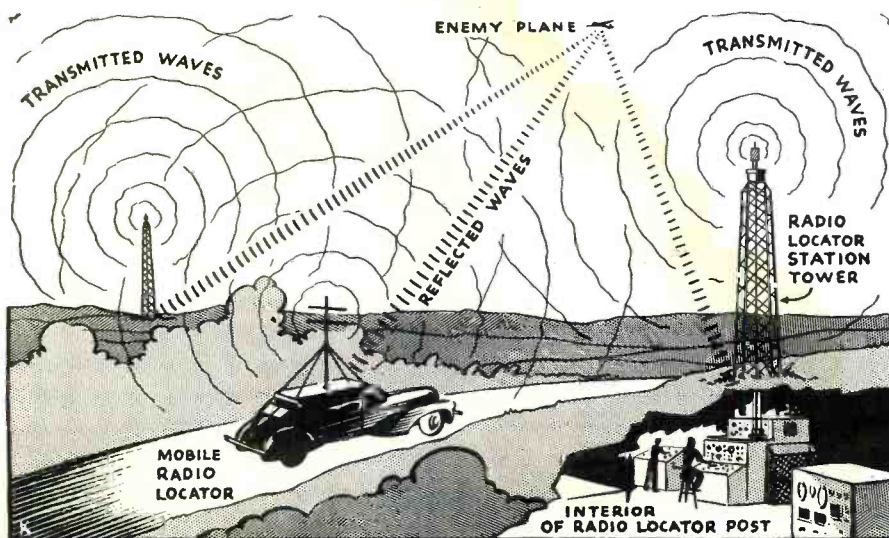

**T**HE fog hangs low along the English coast, obscuring visibility like a closely-shut door.

Inside underground rooms all over the country sit tense men and women operators. They keep an alert watch for the change in readings of the indicating instruments before them which might at any moment announce the pending arrival of a flying visit from "Jerry," as the British fighting man calls the Germans, and some unwanted "Bundles for Britain."

Above these underground radio listening posts, and dotting the countryside, tower tall masts which are crowned by objects resembling ordinary ultra-short wave antennas.

Suddenly an alarm bell rings. Instantly, a procedure is set in motion which will not augur well for the visitors. There is no hubbub—no shouts — no great excitement, but quickly and quietly the operators adjust the controls and constantly watch the resulting indications on the panel instruments.

"Position 24—Block S," one observer reports into a phone connected to R.A.F. headquarters. "They're heading northeast and making for Birmingham."

"Right!" another added. "Position 23—Block T. Speed 300. Altitude 10,050."

At R.A.F. headquarters, the report of the imminent arrival of enemy bombers over a part of Britain results in immediate flight orders. In a matter of seconds from the time the original alarm impulse arrived, British fighter planes are roaring off into the fog to meet the enemy intruder. Changes in the position of "Jerry" are constantly being relayed to the R.A.F. fighter planes, and soon there is a furious air fight in progress. A series of blasts rock the countryside as the German bombers prematurely dump their load of death and streak back across the Channel like frightened rabbits.

Some time later, a report is received at Radiolocator headquarters that the bombing attempt has been repulsed, three of the enemy have been brought down and the balance chased back without their having a chance to drop a death-dealing load on a single target. Thus, another victory is chalked up for the fighter pilots of the R.A.F. and the new Radiolocator system.

Previous to the perfection of this radio "lifesaver," British planes had to keep a ceaseless patrol up and down the English coast. Likely as

# RADIO *Combats Blitz*



Combat planes thunder to meet the approaching enemy bombers.

not, bad visibility or darkness would allow whole batches of enemy aircraft to slip through the flying cordon. When this happened, bombs fell on some hapless section of England, bringing death and misery to many.

In technical terms, how does the Radiolocator operate? That's what the Editors of RADIO NEWS commissioned me to find out for our readers, but I soon learned that there would be no schematic diagrams given out on *this* system. I was advised, good-naturedly, by responsible authorities that the amount of technical information available for public release was "very limited"—the fact was that it was exactly zero! After all, you can't blame the British for being close-mouthed about it. Remember, in modern warfare, *what's sauce for the goose is applesauce for the gander*. If the British were to show their whole bag of tricks on the Radiolocator, the enemy might be able to devise counter-measures.

Don't think that I am merely trying to be melodramatic when I state that *this very article will be minutely studied by German agents with the hope that in it somewhere can be found a clue to the mystery of the Radiolocator!* That is merely counter-espionage routine. That is why a secret must remain a secret—even from RADIO NEWS readers.

This much I did find out.

First, the system is essentially that of radio-signal transmission, reception and detection. The system is composed of hundreds of ultra-short wave transmitters and receivers which cover the countryside. These transmitters broadcast a constant "barage" of radio "feeler" waves which cover the country like a gigantic invisible tent. When an object such as

an enemy airplane passes into this radio-tented area, the "feeler" waves are reflected from the enemy plane and these feeble, minute signals are picked up by Radiolocator stations. By applying the principles of radio-direction-finding, and other basic radio principles, the position in the sky of the unwelcome intruder is plotted very accurately, and this information is used by defense fighter planes and anti-aircraft batteries with telling effect.

Thus, we might easily compare the operation of the Radiolocator to an *Absolute Altimeter* operating in reverse. The original altimeters used in airplanes measured all altitudes in feet above sea level. The Absolute Altimeter measures the actual dis-



Civilian Technical Corps emblem.

tance of the plane above the ground by timing the echo of a short-wave signal.

With the *Radiolocator*, a sharply-focused microwave is projected into space and "scans" a certain section of the sky like a searchlight. When the wave strikes an enemy aircraft, it is deflected back to earth. This "rebound" wave is picked up by the sensitive Radiolocator receiving device and the results used to calculate the position in space of the plane.

The Radiolocator is vastly superior to the old sound detectors which were, in effect, "mechanical ears." Its superiority is due chiefly to the fact that

sound waves travel through the air at a comparatively slow speed as compared to radio waves. (Sound travels 741 miles per hour at 32 degrees F. and radio's speed is at the rate of 186,000 miles per second.) As planes now travel 300 to 400 miles per hour—some faster—the

old sound detectors resulted in a large margin of error because the *apparent* location was always considerably behind the *actual* location of the enemy plane. With Radiolocation, there is a different situation. As the reception of the signal is almost instantaneous, there is no error from this source, and complicated instruments are used to plot with amazing accuracy the position in the sky of the enemy plane.

One point not clearly understood by many is that the British are using *more than one type* of Radiolocator. They have small mobile units which have a limited range, but which can be concentrated quickly in any given area when desired. These units are mounted in trucks in a manner similar to the equipment used in the original Radiolocator experiments. Other units are permanent, astoundingly intricate, electrical and mechanical installations which resemble a combination of the Radio City control room, Mount Whitney Observatory and a Ham's dream of Heaven. However, it can also be stated that much of the equipment and circuits follow recognizable lines, that is, an experienced serviceman or

(Continued on page 40)



The Inventor

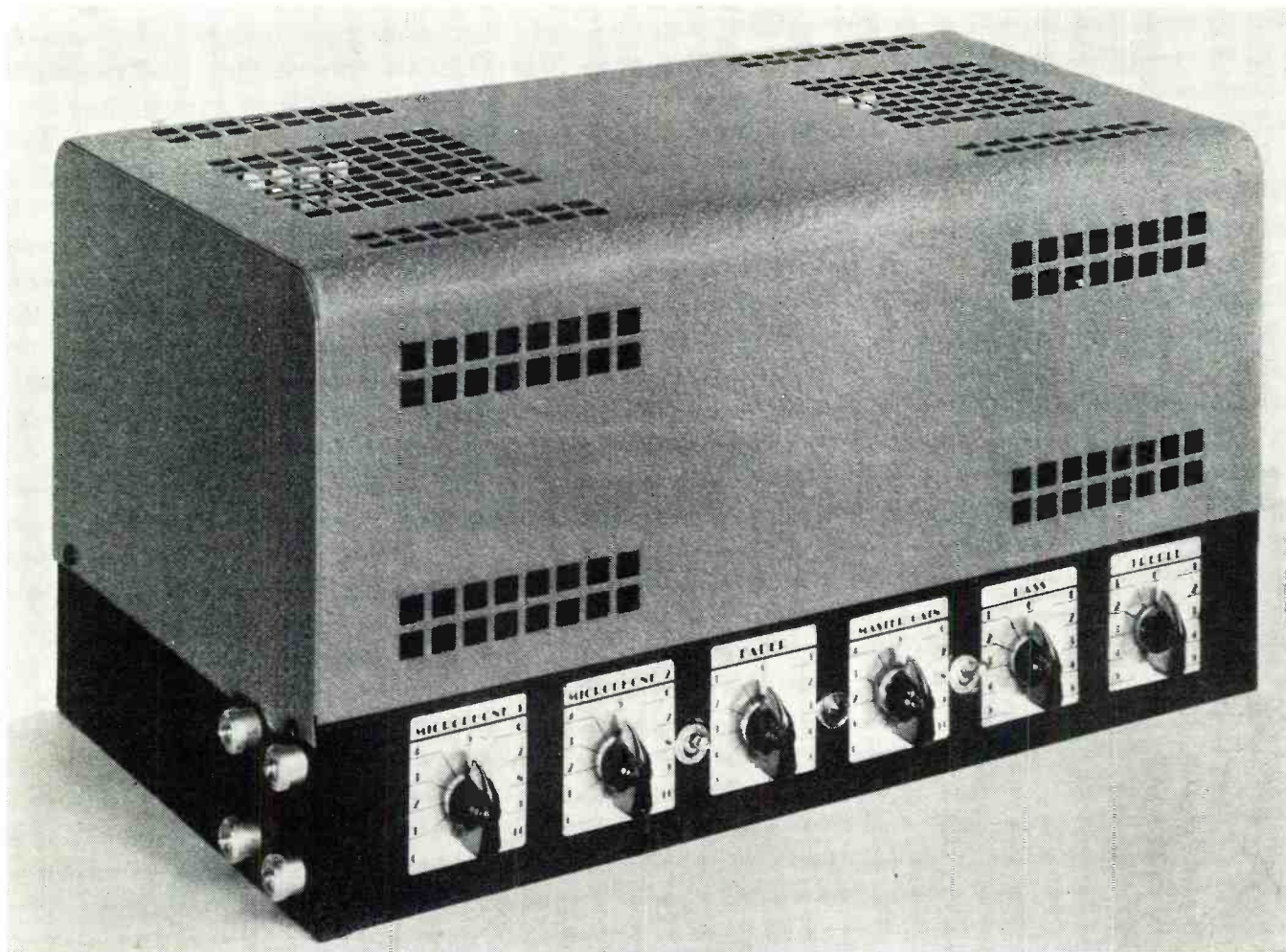

Front view of amplifier shows the four input connectors mounted on the side of the chassis.

# A Universal P. A. Amplifier

by **RAYMOND B. FRANK, W9JU**

*This flexible public address amplifier will find application for any small installation where two loudspeakers are used.*

**I**N the past, the need has been felt several times for an amplifier that could be used away from power lines and still not require a gasoline driven generator or other bulky or expensive equipment to furnish the necessary power. The most common and readily available source of supply is a regular 6 v. storage battery. It is difficult to imagine any condition under which this source of power is not available. In addition, the need for a respectable power output was felt so that the unit could be used on a sound truck or at picnics or out-door gatherings and still insure adequate coverage. Good quality and sufficient input channels to meet any

requirements were necessary. Due to the great variation in acoustic properties of different locations, it was necessary to incorporate tone compensating controls of the attenuate-accentuate type.

Analysis of the above requirements resulted in the amplifier to be described. Due to the universal power requirements, a vibrator type supply was adopted rather than a dynamotor.

The tube line-up finally decided on was *RCA 6SJ7*, as amplifier for each microphone channel; *RCA 6C5* tone control tube; *RCA 6N7* self-balancing phase inverter, and push-pull *RCA 6A5G*'s as output tubes. *RCA 6X5*'s with elements connected in parallel

were used as rectifiers. A *Turner* push-pull vibrator was selected to handle the power requirements on battery, due to its freedom from hash.

The triode output tubes were selected in preference to the various beam and pentode types available due to their freedom from distortion on peaks, and greater tolerance in place of plate load. The latter feature is important when using an amplifier with speakers as the impedance of the voice coils varies considerably with frequency.

## **Layout and Construction**

The unit was constructed on a *Bud* 10x17x3 black crackle finish chassis with a slate gray grille cover and



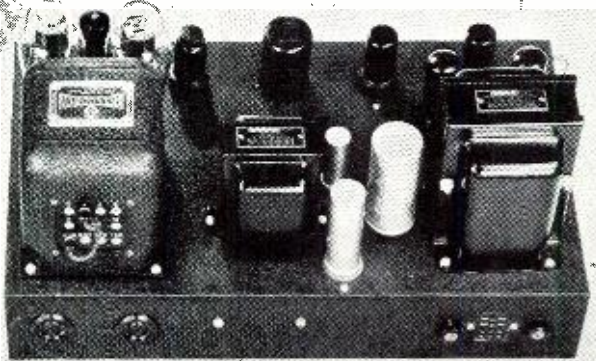

Rear view of amplifier showing variable taps on output transformer. Note the two fuse receptacles.

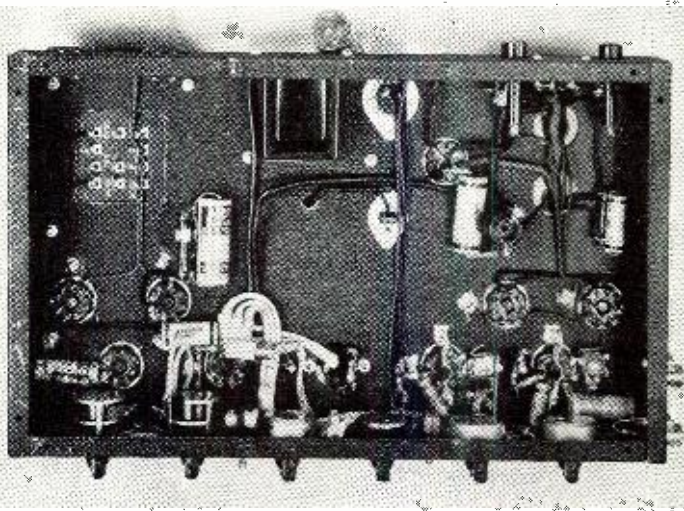

Underside of the chassis. Wiring is kept to a minimum and all hot leads are carefully shielded.

black crackle bottom plate. *Amphenol* self-shorting microphone connectors were mounted on the left-hand drop of the chassis to accommodate the dual microphone and phono channels. The controls, from left to right, are: first microphone gain, second microphone gain, a.c. switch, fader for the two phono inputs, pilot light, master gain, plate switch, bass tone control, treble tone control.

In the front view of the chassis can be seen the two 6SJ7 tubes, while slightly to the rear of them are mounted the 6X5G's used for the recti-

fiers. The tone control choke is mounted in the center of the chassis near the front edge. To the right are mounted the 6C5 tone control tube and the 6N7 phase-inverter. The 6A5G output tubes are mounted between the 6N7 and the output transformer. The *Thordarson* universal power transformer is mounted in the left rear corner of the chassis, while a vibrator is mounted next to it in order to keep the heavy current-carrying leads as short as possible.

The first filter choke, CH3, is mounted between the vibrator and

output transformer. Miniature can type electrolytics were used in the filter circuit, C15 and C16 being in a common can. In the rear view of the chassis the two 4-prong sockets used for speaker connections can be seen near the left edge of the chassis along the rear drop.

Near the right edge are mounted the two fuse holders while between them is mounted a *Jones* 10-contact female chassis connector. This connector is so wired that switching from a.c. to battery is automatically taken care of when the proper plug is in-

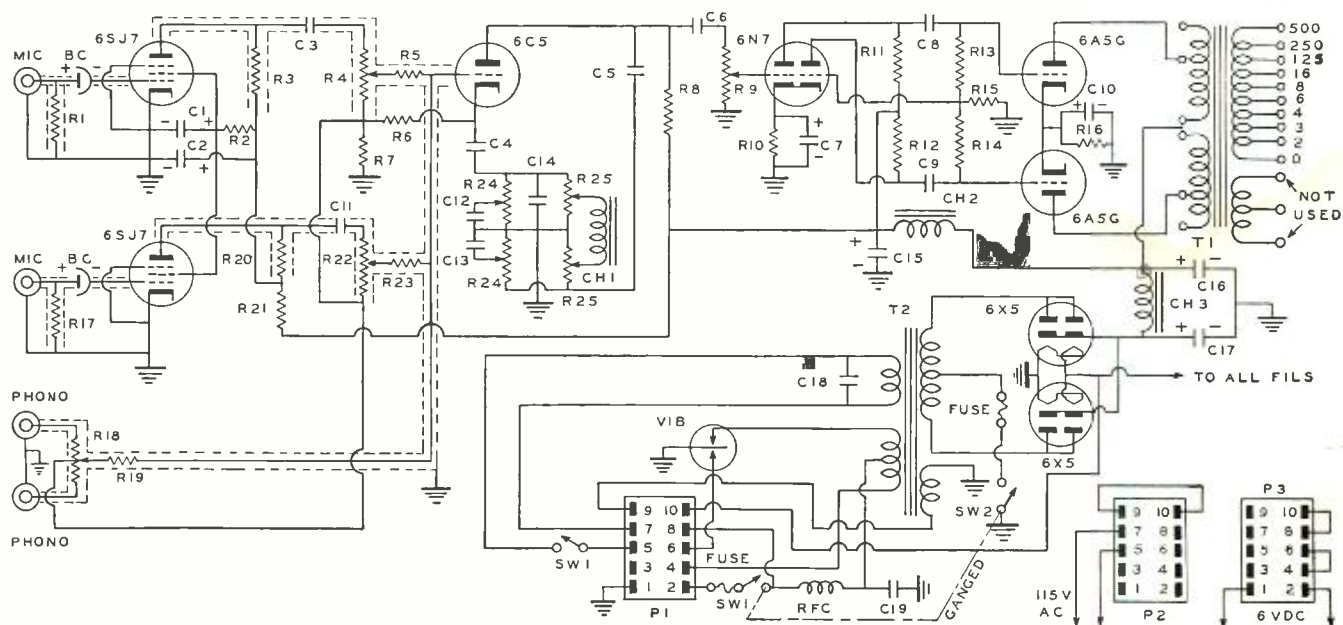

Plenty of taps are provided at the output transformer for accurate speaker match.

- R<sub>1</sub>, R<sub>11</sub>—2 meg., 1/2 w., IRC
- R<sub>2</sub>, R<sub>3</sub>, R<sub>4</sub>, R<sub>10</sub>, R<sub>22</sub>—1 meg., 1/2 w., IRC
- R<sub>5</sub>, R<sub>12</sub>, R<sub>13</sub>, R<sub>14</sub>, R<sub>20</sub>—250,000 ohms, 1/2 w.
- R<sub>6</sub>, R<sub>23</sub>—2 meg. pot., Mallory
- R<sub>7</sub>—20,000 ohms, 1/2 w., IRC
- R<sub>8</sub>—25,000 ohms, 1/2 w., IRC
- R<sub>9</sub>—1 meg. pot., Mallory
- R<sub>10</sub>—3,000 ohms, 1/2 w., IRC
- R<sub>11</sub>—100,000 ohms, 1/2 w., IRC
- R<sub>12</sub>—750 ohms, 10 w., Ohmite
- R<sub>13</sub>—2 meg. CT fader pot., Mallory
- R<sub>14</sub>—50,000 ohms, 1/2 w., IRC
- R<sub>15</sub>, R<sub>24</sub>—Dual tone control pots., Thordarson
- R<sub>16</sub>—8 mfd., 450 v. electro., Aerovox
- C<sub>1</sub>, C<sub>2</sub>, C<sub>3</sub>, C<sub>4</sub>, C<sub>5</sub>, C<sub>6</sub>—0.1 mfd., 400 v. paper, Aerovox

- C<sub>11</sub>—0.1 mfd., 400 v. paper, Aerovox
- C<sub>12</sub>—1.0 mfd., 200 v. paper, Aerovox
- C<sub>13</sub>—1 mfd., 400 v. paper, Aerovox
- C<sub>7</sub>—25 mfd., 25 v. elec., Aerovox
- C<sub>10</sub>—25 mfd., 50 v. electro., Aerovox
- C<sub>12</sub>—0.03 mfd., 400 v. paper, Aerovox
- C<sub>14</sub>—0.0015 mfd. postage stamp mica, Aerovox
- C<sub>15</sub>, C<sub>16</sub>—20 mfd., 450 v. electro., midget can type, Aerovox
- C<sub>17</sub>—10 mfd., 450 v. electro., midget can type, Aerovox
- C<sub>18</sub>—0.06 mfd., 600 v. paper, Aerovox
- C<sub>19</sub>—5 mfd., 200 v. paper, Aerovox
- T<sub>1</sub>—output transformer, 5000 ohms to spkr. or line, Thordarson T15590

- T<sub>2</sub>—Universal vibrator transformer, Thordarson T14R40
- CH<sub>1</sub>—Bass boost choke, Thordarson T14C70
- CH<sub>2</sub>—15 ma. filter choke, Thordarson T68C08
- CH<sub>3</sub>—filter choke, Thordarson T17C00B
- SW<sub>1</sub>—SPST Toggle, H & H
- SW<sub>2</sub>—DPST Toggle, heavy duty, H & H
- RFC—See text
- P<sub>1</sub>—10 contact chassis connector, Jones
- P<sub>2</sub>, P<sub>3</sub>—10 contact plugs, Jones
- VIB—4 prong push pull vibrator, Turner No. 6C1
- Chassis & Grill, 10x17x3, Bud F1012
- Bottom plate 10x17 Bud
- Sockets & Microphone connectors, Amphenol
- Tubes—RCA

serted. The bottom view of the chassis shows the location of the various components clearly and no difficulty should be experienced by the constructor in following the layout from the photographs. The vibrator choke, RFC, is mounted close to the transformer leads in order to suppress any hash at its source. This choke is wound in two layers on a  $\frac{5}{8}$ " bakelite form, each layer consisting of 20 turns of No. 14 P.E. wire. *Millen* socket shields are used to isolate the grid and plate circuits of the 6SJ7 tubes and prevent self-oscillation.

The fuse in the center tap of the power transformer, T2, is for the protection of the rectifier tubes in the event of failure of the filter condensers, while the fuse in the vibrator lead protects the battery and vibrator in case of a sticky vibrator.

#### Wiring

Wiring is simple and straightforward. The first step is to wire the vibrator circuit using No. 12 stranded wire for this purpose, to keep the voltage drop as low as possible. Care should be taken to keep these leads as far as possible from the high-gain stages in order to eliminate any tendency towards hash pickup. Leads from the microphone connectors to the bias cells and phono fader should be shielded as well as plate leads in the 6SJ7 stages. Coupling condensers in the plate circuits of the 6SJ7 tubes should be wrapped in scotch tape and then shielded by means of flexible braid. Leads to both tone controls should be well shielded. By-pass condensers and resistors are placed so as to afford the shortest possible leads.



All controls arranged symmetrically.

In wiring the output transformer, T1, the 5000 ohm taps are used and the tertiary winding is left unused. Both speaker sockets are wired in parallel and the transformer terminals marked "Line" are connected to them. A jumper is connected between the two plugs furnished with the transformer and by plugging in the various terminals output impedances of two, three, four, six, eight, sixteen, one twenty-five, two fifty and five hundred ohms are available. These impedances will take care of any combination of speakers it is desired to use.

#### Testing

After the wiring of the amplifier has been completed, cables should be made  
(Continued on page 49)

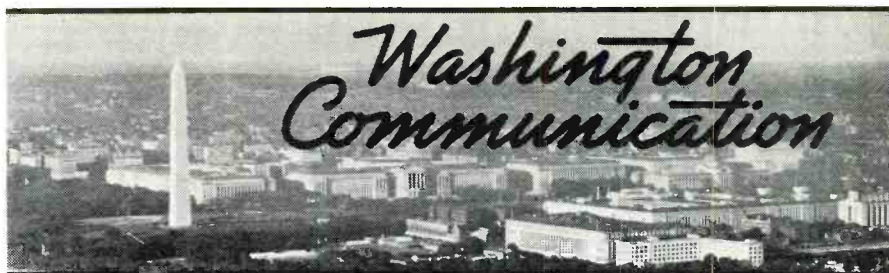

by ALFRED TOOMBS

Special Washington Correspondent for RADIO NEWS

### Radio-Control Valuable Defense Aid

**T**HE British announcement that they were using a secret new radio device to locate approaching German planes was the first tip-off to the general public that the belligerents had succeeded in adapting radio to any war purpose other than the exchange of insults. The radio locator attracted wide interest, but to those who have been following the course of research in military aviation the British device was old stuff. In America, we have gone far beyond this locator and in the development of other radio weapons.

Radio devices are the most closely guarded of all the Army's closely guarded secrets. Under lock, cover and twenty-four hour guard are weapons and radio developments which are fantastic and revolutionary. The radio locator which the English told the world about is just one of these.

This locator device has been used by the English to detect the approach of German planes, to estimate their altitude, rate of speed and to follow their course. It may be described as an absolute altimeter in reverse. It sends short waves out like beams of searchlights and when these waves hit an airplane they bounce back to the detectors. The echoes are timed and the direction from which they came is plotted. These are infinitely better than acoustic detectors in use in Europe at the start of the war because sound travels only 1,087 feet per second while radio waves move along at 186,000 miles per second.

As early as 1929, the United States had developed the first version of this radio locator. During subsequent years, improvements were made and at the outbreak of the war, we had the device almost in its present form. The English first hit on the idea around 1934 and after the start of the war, made some improvements which made it valuable. It was, however, the revelations made to the English by American military radio experts that enabled the development of the present device. It is merely an adaptation of the American plane locator. The development of the appropriate wave generating tubes and sensitive devices for their reception is the real achievement in the sound locator.

The United States has adapted this device for its very secret anti-aircraft apparatus. The Army is said to have developed it to such a point that the radio-motivated device will locate a plane, estimate its altitude, rate of speed and direction of flight, then rapidly adjust the fuse of the shell for these reckonings and fire the gun. The Nazis are known to have anti-aircraft guns which operate on this same echo principle and which are effective up to about 24,000 feet.

Many radio devices which the Army has developed are so secret that not even a general mention of them may be made in print. There is no secret, however, about the fact that both the Army and the Navy have developed amazing airplanes and boats which are operated by radio remote control.

The dream of pilot-less airplanes has been persistent in military aviation. Some years ago, our military men built planes that could be flown by radio and since have perfected these to a degree greater than anyone dreams. The Army has been carrying on advanced experiments at Selfridge Field, Detroit, with radio controlled planes, which are flown by an operator who stays on the ground. Radio controlled planes can also

be directed from other ships in the air and for bombing purposes this represents the ideal arrangement. One plane, carrying a crew of operators, could go over enemy territory with a group of bombers. The control plane could fly at altitudes where it would be safe from ground fire, sending the radio planes in at lower levels and directing the release of bombs with remarkable accuracy. The development of radio controlled planes has been given impetus by the advances made in television. For by using television, it will become possible for the operators—either on the ground or in other planes—to see just what they would if they were in the radio ship. American radio wizards are working feverishly on these problems now.

The Army has developed a radio-controlled speedboat for harbor defenses, which is operated by the same principle as radio-controlled boats which the Navy has long been using. This ship, which has been tested recently at Fortress Monroe, Va., moves along at about 35-miles an hour and can be started, stopped, speeded up and steered in any direction from shore or air. It is equipped with a secret gyroscopic device which enables it to hold any desired course.

Note: *Reginald Denny*, the movie actor, has established himself as an authority on radio-controlled planes. He is now making a number of small planes of this type for the Government to be used for target practice. They are equipped with parachutes, so they may be floated to earth without being destroyed.

The possibilities of radio in warfare are little known and it is vitally important for this country to keep ahead in the research field if we are to stay abreast of other nations. The *Signal Corps* will spend \$12,000,000 on radio research—much of it at Fort Monmouth, N. J.—this year and virtually the entire research facilities of the great *General Electric, R.C.A., Westinghouse* and *Bell Telephone* companies, not to mention the laboratories of hundreds of other organizations, are being turned over to *Signal Corps* assignments.

In addition, a number of good ideas are being cleared through the *National Inventors Council*, the group which was set up at the beginning of the emergency to sift through all the ideas submitted to the Government for military inventions. The council is divided into twelve sub-committees—of which two, the *Signal and Communications* committee and the *Geometrical and Optical Instruments* Committee, handle radio inventions. Dr. W. D. Coolidge, director of research for *General Electric*, heads the radio committee and he states that a number of new radio ideas have turned up. Dr. Coolidge is hoping for some good ideas on remote control and locating devices, scrambling devices for voice communication, infra-red and other secret signalling devices, code systems, automatic telegraph keys, etc. The council gets about 100 inventions a day—of which ten are in the radio field. All suggestions are investigated and, if worthy, are tried out at Fort Monmouth.

As service men and others in radio know only too well, many of the ablest men in the field are now in Army service. They are being given every chance to show their talents—with the formation of special companies of repairmen, special courses and research assignments, and the training of officer

(Continued on page 53)

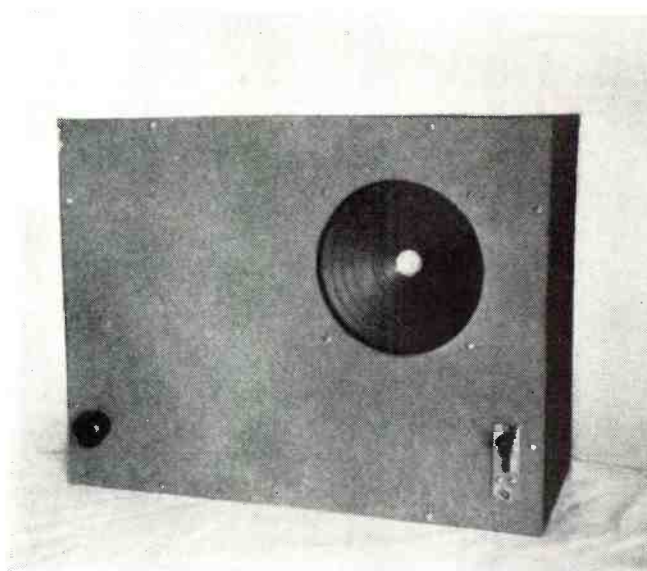

Almost any box will be suitable for the completed unit.

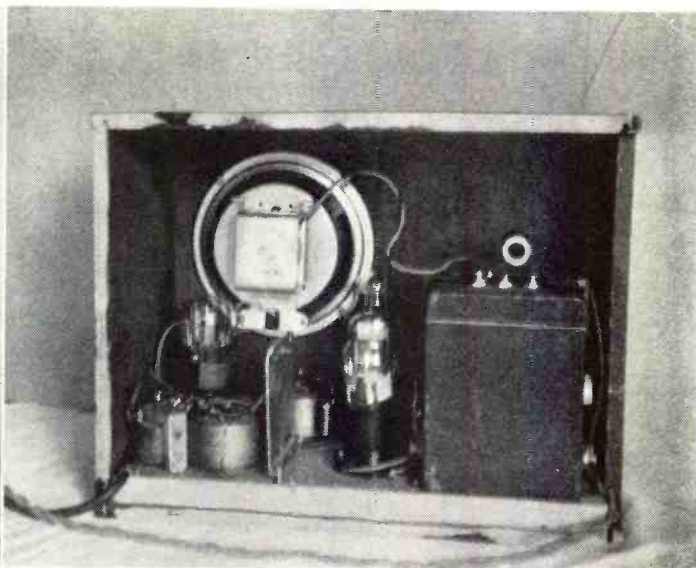

Back view showing how the speaker and parts are mounted.

# Build this SIMPLE INTER-COMM.

by **JAMES FULLEYLOVE**  
Port Washington, New York

*Here is an easily-built inter-office communicator that may be constructed from parts found in most experimenter's and servicemen's spare parts boxes.*

**E**VERY radio ham or experimenter who, like the writer, has his shack located in the attic or other remote part of house, has probably, at some time or other, contemplated the desirability of installing some system of communication between that point and the more highly civilized part of his home.

One of the chief problems, of course, is that of running the cable between points; but assuming that this difficulty has been overcome, there is still the question of what kind of device to attach to the ends of the wire. A common telephone is quite serviceable; but for real convenience, ease of operation, and intelligibility, there is nothing like the recently-popularized, amplified, inter-communication system. At any rate, this was the opinion of the writer which spurred him to designing the little outfit to be described herewith.

The circuit shown is the result of considerable experimentation and was finally adopted by reason of its simplicity and all-around workability. It consists essentially of a two-stage amplifier, located at the master sta-

tion, and two small dynamic speakers, one at each end of the line. Operation consists simply of switching these two speakers, which serve as both loud-speaker and microphone, to opposite

ends of the amplifier; one being connected to the input and the other to the output for talking one way, and vice-versa for talking the other way.

(Continued on page 60)

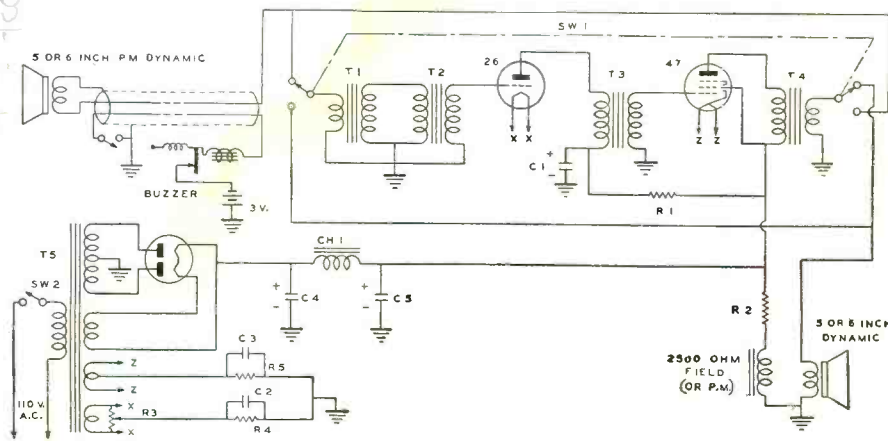

$R_1$ —10,000 ohms, 1 w., Aerovox  
 $R_2$ —4,000 ohms, 10 w., Aerovox  
 $R_3$ —50 ohms pot., Mallory  
 $R_4$ —2,000 ohms, 1 w., Aerovox  
 $R_5$ —450 ohms, 10 w., Aerovox  
 $C_1, C_2, C_3$ —8 mfd., 450 v. Electro., Mallory  
 $C_4, C_5$ —1 mfd., 200 v. paper, Mallory

$T_1, T_4$ —Spkr. to voice coil transformers  
 $T_2, T_3$ — $3\frac{1}{2}$  to 1 interstage audio transformers  
 $T_5$ —350-0-350 @ 40 ma.—5.0 v. @ 2.0 A—2.5 v. @ 1.75 A—1.5 v. @ 1.0 A  
 $Ch_1$ —15 hy @ 40 MA filter choke  
 $Sw_1$ —DPDT low capacity switch  
 $SW_2$ —SPST toggle H & H

# Loudspeakers for Speech and Music Reproduction



Fig. 4 illustrates the reflex, or folded projector that is capable of handling power outputs up to 25 watts. Covers wide distribution angle.

by

**RALPH T. GLOVER**

Jensen Radio Manufacturing Co.,  
Chicago, Ill.

*Special speakers for the reproduction of voice and music are analyzed by an expert in the sound field.*

listening conditions are essential when differences are small, for the *memory* of the ear is almost invariably poor, and the location of the reproducers in the room and other details of the test may importantly influence the results.

The ear is moderately critical of *balance* in music reproduction, although it is rather easily misled in this respect. For example, a system reproducing the mid range of frequencies will sound "thin" if the high frequency range is extended without corresponding extension of the low frequency range. One indication of what is meant by balanced response is given in Fig. 1, in which three different response curves are shown, differing in the total frequency range covered, but properly proportioned in the low and high frequency regions. It should be emphasized that the element of balance is most important in music reproduction; unbalance in the direction of emphasis on the high frequency range is desirable in high efficiency speech reproduction where we are more concerned with "punch" and "carrying power" than with fidelity.

Fig. 2 shows how the impression of balance can be created by over-emphasis as contrasted with actual frequency range extension. Response curve 2 would be "bright" and give the impression of adequate high frequency range to the untrained listener, although it would lack the character and realism of response curve 1 due to its deficiency in the shaded region. Similar considerations apply to the low frequency region. Under some conditions, response curve 2 may actually be preferable to curve 1; for example, in amplitude-modulated radio

**P**ARADOXICALLY, the ear is both extremely tolerant and highly critical. Just as the artist can convey the essential meaning of an idea by a rough sketch entirely lacking in fine detail, so can the sound engineer effectively transmit a spoken message whose meaning is unmistakable but which has no more resemblance to the original speaker's voice than the rough sketch bears to the original object which the artist was illustrating. And just as the artist forcefully concentrates attention on the important *essentials* in his sketch, so can the sound engineer gain attention and enhance the *meaning* of the spoken message by comparable suppression of detail. When this principle is properly applied, the ear tolerates this distortion because the mind is more interested in the *meaning* of the message than in faithful resemblance

to the original in quality. These considerations are of course highly important in the design of the most effective paging, announcing, inter-communications and "P.A." installations.

The critical side of the ear is displayed in a number of ways. When two nearly identical sound reproducers are carefully compared in laboratory listening tests, there is practically always a decided preference for one reproducer or the other, although response curves may show measured differences of the order of only 1 db between them! In a practical sense, either reproducer would perhaps be suitable for its intended purpose, but under laboratory conditions permitting instant change-over from one to the other, the preference for one or the other will almost always be evident. It should be noted that direct comparisons under carefully controlled

reception and reproduction of lateral phonograph records, the impression of "brightness" may be retained and the effects of noise and distortion minimized by shortening the high frequency range in a manner similar to that of response curve 2.

### Speech Reproduction

Accurate, high-fidelity reproduction of speech is one of the most difficult problems in sound reproduction, and requires a system free from distortion and capable of reproducing a frequency range almost as wide as that required for high fidelity music. The same loud speaker systems used for high quality music reproduction are generally quite suitable for high quality voice reproduction. Except in voice training, where it is important for the student to hear his voice reproduced exactly as others hear it and other similar applications, it is not only unnecessary but usually highly undesirable to handle speech on a high-fidelity basis.

There are a number of reasons why it is not only permissible but desirable to limit response in voice reinforcement applications. Exhaustive studies of speech and hearing by telephone engineers established long ago that most of the power in the voice lies in the region below about 300 cps., and that the intelligibility or "understandability" is hardly affected if this entire low frequency region is completely eliminated. It is thus the high frequency components which carry the intelligence of speech, yet contain relatively little energy. If the low frequency components are reduced in the system, then more power can be delivered to the same reproducer in the all-important high frequency region than would otherwise be possible.

The ear is highly sensitive in the middle high frequency region and this aids in increasing the effectiveness of speech reproduction when the low frequencies are suppressed. Moreover, in indoor applications, particularly in gymnasiums, airplane hangars, factories, and other places with hard walls where low frequency sound absorption is practically nil, suppression of the low frequencies greatly aids intelligibility by reducing the apparent reverberation. Since radiation of the higher frequencies is rather directional with most reproducers, they can be directed in many cases toward the audience where considerable high frequency absorption can take place before the first reflection. Microphone feedback is reduced also by this type of handling of the response characteristic.

Attenuating the low frequency components gives the voice a crisp, clear quality that is quite unnatural though highly effective. It lends what is popularly called "punch" or "carrying power" to the reproduction, and compels the attention of the listener.

There are many ways of introducing low frequency attenuation into the reproducing system. It can be accomplished by means of (1) a high-

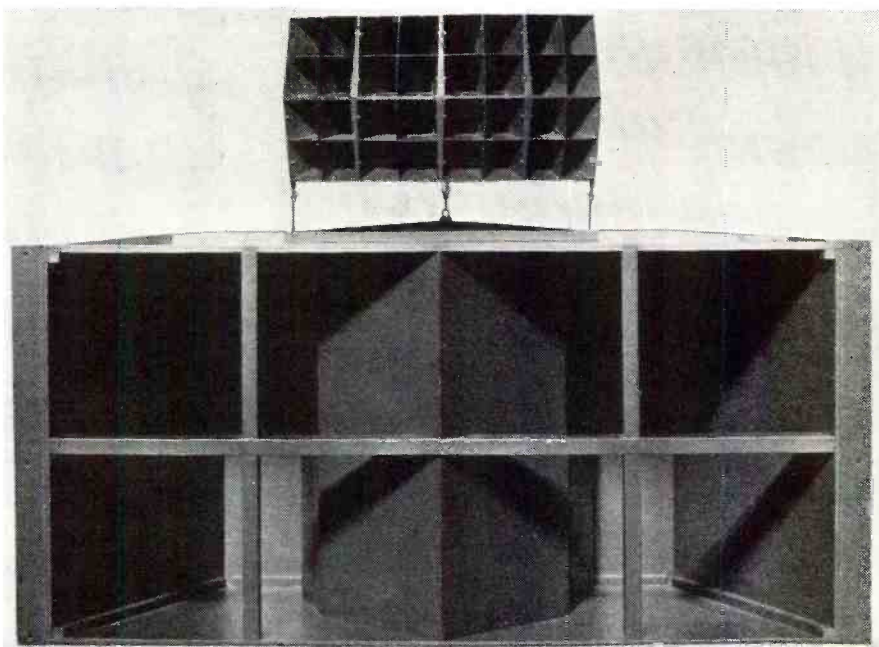

Specially-designed speaker projector system for large theatres which require a wide frequency range to compensate for acoustic conditions.

pass filter installed at amplifier input or output; (2) modification of an inter-stage coupling network between voltage amplifier tubes (3) proper design of the loudspeaker itself (4) a combination of the foregoing methods.

There are definite advantages in using a sound reproducer designed especially for use on speech. In the first place, the speaker can be designed for suitable suppression of the low frequencies to the general advantage of the efficiency in the desired portion of the frequency range. This frequently brings with it the accompanying advantage of wider angle distribution of sound, since in the absence of low frequency requirements, the radiator (or virtual source at the mouth, if a horn is used) may be made smaller and hence less directional. Furthermore, the response curve can be adjusted in the design process so as to place the correct emphasis on the proper portion of the middle high frequency region. The extreme highs can also be eliminated to advantage for they are not needed for high efficiency speech reproduction and contribute mainly noise and distortion products.

When the loud speaker is designed to suppress the low frequencies, it is desirable to attenuate the electrical input at the low frequencies to avoid distortion products. If the amplifier is to be used close to its rating, it is well to introduce the low frequency "roll-off" before the final power stage. This is easily done by reducing the value of one or more coupling condensers between voltage amplifier stages. If the amplifier is to be used for music reproduction also, a switching arrangement can be provided to alter the coupling values to suit the service. Fig. 3 shows the usual range of desirable low frequency reduction in the amplifying equipment. The desired characteris-

tics can be obtained by adjusting coupling values with the aid of an audio oscillator and output voltmeter to check the resulting electrical response curve.

Direct radiator (or cone type) loudspeakers are quite satisfactory for speech reproduction at moderate levels if properly designed. Both reflexed and conventional horns are often used to increase efficiency over a portion of the frequency range. Complete projectors may be designed in this manner so that they have better low frequency response than can be obtained with a compression type driven unit and horn combination, and such projectors are indicated when emphasis is on music reproduction.

Where speech reinforcement at medium to high levels is the main requirement, the compression type driver unit and properly designed horn is the logical choice because of the relatively high efficiency of this type of projector. A reflexed or folded projector utilizing a metal alloy annular diaphragm unit is illustrated in Fig. 4. A loudness efficiency at least four times that of some direct radiator type projectors is realized, thus permitting the use of a smaller power amplifier or the production of higher intensity sound with the same amplifier. Reflex construction is employed to give long acoustic length without excessive overall dimensions, and to reduce exposure to weather through the mechanical baffling effect of the reversed reflex sections. Power rating is 25 watts maximum on normal speech or music input.

Coverage angles rather than power requirements often determine the number of projectors required for a given installation. With all projectors, there is a progressive loss of high frequency response, apparent loudness

and intelligibility as the listening position is moved away from the axis. The larger the mouth or bell diameter, the greater are these effects and the smaller the allowable coverage angle becomes. The useful total angle which the projector will cover depends upon the extent to which these effects can be tolerated. Allowing 3 db maximum allowable loss at 1,000 cps., the projector illustrated, having a bell diameter of 20 3/4", will cover a total angle of 54 degrees. To cover an angle of 100 degrees, two such projectors should be used.

### Music Reproduction

The problems in music reproduction are divisible into three general categories by class of service: (1) low fidelity, (2) medium fidelity and (3)

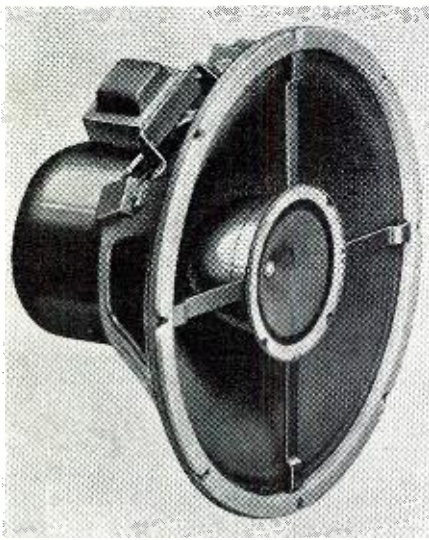

Coaxial speaker which is capable of wide frequency range. Fig. 7.

extended-range high-fidelity. In this article, we concern ourselves briefly with extended-range high-fidelity reproduction only. Such reproducers involve very special considerations in design and in general must be operated from an audio frequency electrical system in which distortion is held to very low values.

Reproducers which can be classified as extended-range high-fidelity devices have been and are manufactured with a single direct-radiator type loud speaker. There is no doubt, however, that the very best results are obtained when the frequency range is subdivided with low and high-frequency speakers handling their respective portions of the frequency range.

Electrical networks are used to confine the energy delivered to each speaker to that portion of the frequency spectrum which it is designed to reproduce. A schematic diagram of such a system is shown in Fig. 5.

When considerable power must be handled and a large area served, the reproducing system generally comprises a low frequency channel consisting of heavy duty low frequency cone type speakers, feeding a folded horn to increase efficiency, and a high frequency channel which employs a multicellular horn fed by one or more compression type driver units. The multicellular horn provides the proper load for the driver units and properly projects the high frequency sound over the required area. Such systems are used in large indoor installations, such as in theaters and large stadia and in outdoor applications which involve the coverage of large crowds. A typical system of this type is illustrated in Fig. 6.

When high fidelity extended-range sound is to be reproduced at levels not exceeding that required for a large room or very small hall, a more simple and less expensive two-way system can be used. One such system has the low and high frequency speakers mounted in an integral coaxial assembly, illustrated in Fig. 7. Because the condition of moderate power handling capacity has been imposed, the high channel consists of a specially designed direct-radiator type speaker of relatively small size. The low frequency speaker (a 15-inch unit as illustrated) can then be designed for best possible reproduction of the frequency range below that handled by the high frequency unit.

The question is frequently asked if the ordinary small speaker will serve as a "tweeter." The answer is that no conventionally designed speaker has the extended high frequency response which is obtainable in a unit designed especially for this purpose. Separate high frequency speakers and dividing networks are now available for those who wish to construct their own two-way systems, or who may wish to add a tweeter to an existing medium fidelity speaker of the twelve or fifteen-inch class. In factory-built coaxial speakers, the dividing network is commonly mounted on the housing of the low frequency speaker.

To obtain maximum extension of response into the low frequency region—an especially important point in extended range systems because of the

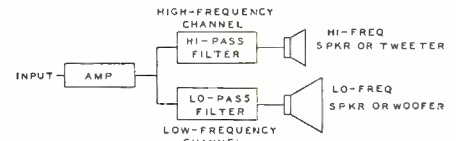

FIG. 5—BLOCK DIAGRAM OF BASIC TWO-CHANNEL HIGH-FIDELITY REPRODUCING SYSTEM

Fig. 5. Basic circuit networks show how the extended speakers operate.

necessity for proper balance between "high" and "low," it is absolutely essential that the low frequency speaker be mounted in an enclosure with the proper acoustic characteristics. Most suitable for the purpose is a bass reflex enclosure which utilizes the back-side radiation to increase the total output at the low frequency end of the spectrum.

As mentioned previously, distortion in the electrical system will be objectionably apparent in an acoustical system maintaining good efficiency to 12,000 cycles and with an appreciable contribution to the total output in the 15,000 cycle region. With FM broadcast and high quality transcription records, such a system can be operated without electrical frequency limitation with excellent results. With AM broadcast and ordinary lateral record input, it will usually be found necessary to "roll-off" the high frequency response by means of a suitable tone control for most pleasing results.

An innovation in relatively inexpensive extended range reproducers is the provision of an auxiliary control which makes it possible to adjust the response in accordance with the quality of the program material. Thus on distortion-free sources, the full frequency range can be utilized, while the amount of high frequency contribution to the output is subject to instant reduction for relatively low quality input. Two such high frequency controls are employed, the first a "roll-off" control as illustrated in Fig. 8, which is incorporated in the high channel of coaxial units employing a two channel network, the other an adjustable resistance network which is inserted in the high frequency speaker circuit of less expensive units employing a bridging network. Both systems are quite satisfactory.

—30—

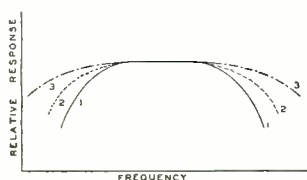

FIG. 1—RESPONSE CURVES 1, 2, 3, ARE BALANCED FOR HIGH AND LOW-FREQUENCY RESPONSE.

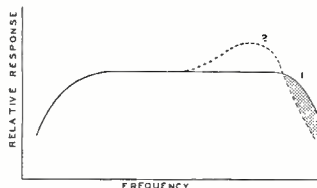

FIG. 2—BALANCED RESPONSE (1) COMPARED WITH APPARENT BALANCE BY OVER-EMPHASIS (2).

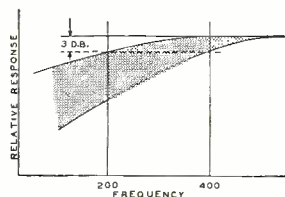

FIG. 3—SUGGESTED RANGE OF ELECTRICAL LOW FREQUENCY ATTENUATION FOR NORMAL SPEECH REPRODUCING SYSTEMS.

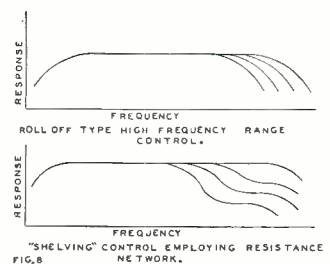
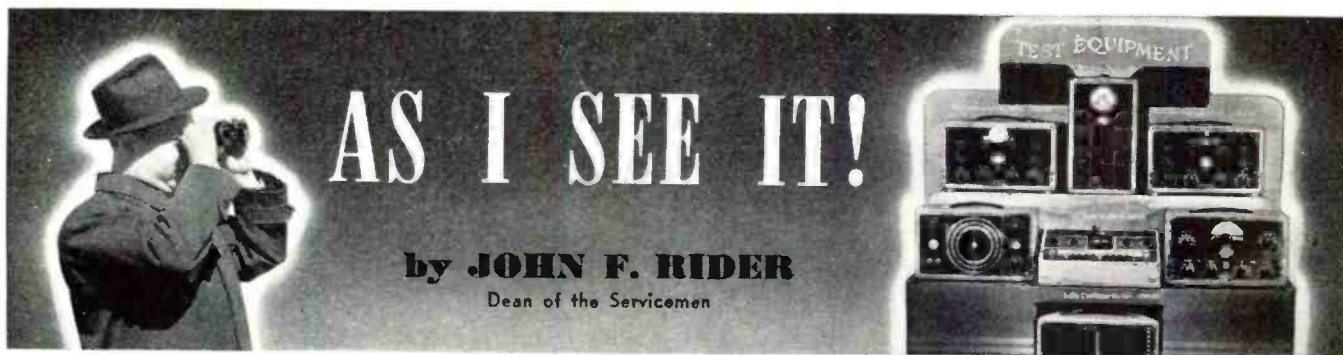

FIG. 8—"SHELVING" CONTROL EMPLOYING RESISTANCE NETWORK.

Figures 1-2-3-8 illustrate the effects mentioned in the text. Note the effect of roll-off characteristic on Fig. 8.



# AS I SEE IT!

by **JOHN F. RIDER**

Dean of the Servicemen

**W** *Back to Improvising* **HEREVER** we go we hear people talking about the impending shortage of replacement parts. That there will be such a shortage is a well-established fact; so for the present we will forget that phase of the subject and speak about one of the resultant consequences.

What we have in mind is that it looks as if the serviceman is destined to be put on his own for a while and in a very peculiar way at that. Today is 1941 but as I see it, we will be doing things like we did back in the twenties. Radio receivers know nothing about war or part shortages. Neither does electricity—so that as long as receivers are placed in operation, just so long will they become defective on occasion and require repair. And repair there must be, for radio is no longer just a medium of entertainment and education—it now is a vital link between the public and the government. The more serious the situation—the more imperative is it that this link be maintained intact.

But how will millions of receivers be kept in repair if it will be difficult to get parts? That's the serviceman's headache and to some extent also the government's. From rumors floating around, the government intends doing its share by removing the replacement branch of the radio industry from its present ranking of 29th on a classification list of 30, and stepping it ahead a few notches. This will in a way, if it does come to pass, alleviate the tenseness of the situation as far as the serviceman is concerned—but it will be far from being cleared up.

To put it bluntly, the radio serviceman will have to *improvise* during his repair work. What else is there to do—if replacement parts are not available in required quantities? To improvise is more easily said than done, for such work is just as close to design as it is to service—if not more so. And for the past twenty years the subject of design has not been something which was discussed so freely in the servicing field. Instead of talking about it, every effort was made to forget that phase of radio. For example, as the fates would have it, that part of the radio receiver which seems destined to be most difficult to procure—the output transformer—is a weak link. Replacement of such parts of

the radio system are quite commonplace and this is not strange in view of the fact that with the exception of the power transformer, most of the power is handled in the output transformer.

If such transformers are not available, Joe Serviceman must improvise a coupling system between the output tube, or tubes as the case may be, and the loud speaker. If by chance the output system is tied back to what is ahead of it in the audio-amplifier by means of an inverse feedback arrangement, the choice of constants and components for this output coupling system, will not be the simplest.

Whether or not the public will be willing to accept reduced quality of output or a reduction of output signal level simply because the existence of a national emergency creates such a condition when exact replacement parts are not available and an inferior equivalent system must be installed by the serviceman, is an unknown quantity. Frankly, we doubt that they would accept anything less than that to which they have become accustomed, particularly when all indications point to higher service charges—a condition which servicemen will not be able to control. In view of the inevitable increase of living costs and the fact that whatever parts will be purchased will no doubt cost more than heretofore, it will be necessary to charge more for service than heretofore.

But there is no use worrying about service charges—when a far more important worry is present to give the servicing industry moments of anguish. To improvise in r.f., i.f., and a.f. systems—to replace transformers with

resistance-capacity combinations—to try to step up gain at one point so as to compensate for inevitable loss at another—is not an operation which can be sloughed off like the unnecessary singleton deuce of clubs.

The serviceman who does the work will have to know more than the page number in the jobbers' catalogue where required replacement parts were listed before—the jobber's 'phone number so that he can call an organization and ask that the truck deliver the needed part on its next trip—but also how the original part, no longer available, was used by the manufacturer when he made the receiver. In other words, the "why" of receiver operation is really coming to the fore in radio servicing. This is the same as saying that design construction will come to the front in radio servicing and without such knowledge it seems pretty clear that it will be difficult to improvise the equivalent of what was originally used so as to replace the original, which no longer can be obtained.

Trying to rebuild punctured or bent contact condensers, damaged transformers, wire wound resistors is out of the question, because the serviceman does not possess the apparatus required for such work. Only one choice exists: to improvise the closest possible equivalent of the original. To attempt to list all of the places in the radio receiver where operation of this character may become necessary, judging by what the conditions are in the parts business, is an unnecessary waste of space. You can gather your own ideas of what the future looks like by reconciling shortages in such

(Continued on page 64)





Left: Dance orchestras are one of the most lucrative income sources.

Chime sound installations offer a real service to the community folk.

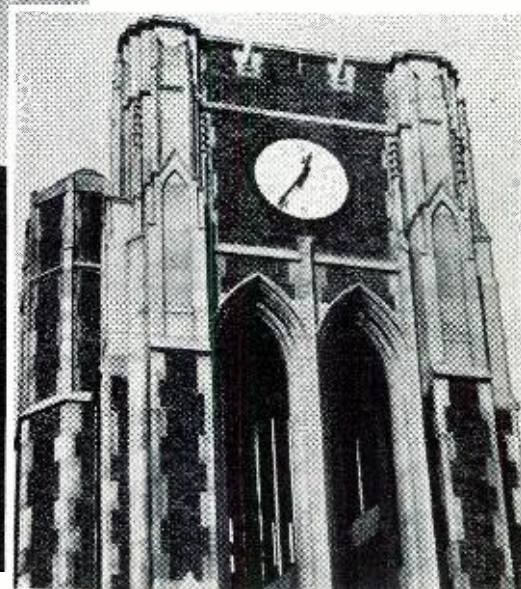

# *How to Select* **A SOUND SYSTEM**

by **P. J. FABER**

Montgomery Ward & Co., Chicago.

**S**ELECTING the correct sound system does not require technical knowledge nor a full understanding of the exact operation of the "inside" of an amplifier. The important thing to keep in mind is that "all must hear." Using that as a yard-stick, the selection becomes a simple one. Many amplifiers are purchased with no thought in mind as to future requirements or additions to the sound equipment such as extra speakers and extra microphones. This should be kept in mind when making the selection. *Ample reserve power should always be allowed for* these additions since the initial cost of the amplifier for a few extra watts is spending one's money wisely. The actual extra cost of operation is so small that it can hardly be measured and still it is simple to adjust a *large* amplifier to be a *small* amplifier by means of the volume controls.

In determining the size of the amplifier, these three rules should be kept in mind.

1. Noise level.

2. Area to be covered in square feet.

3. Acoustics—(location, indoor or outdoor or both).

The most baffling problem for the average purchaser of sound equipment is noise level. While it affects everyone of us every day, few understand what is meant by *noise level*, mostly because the term "noise level" is a misnomer and secondly the human ear is automatic and adjusts itself to its surrounding condition without us using any special effort to do so. For example, on a busy day, the telephone in your office sometimes can hardly be heard but on a quiet day the telephone appears to ring with a tremendous volume.

The telephone ring is the same from day to day and its volume doesn't change but the surrounding noises do. Another good example is that we can carry on a conversation in an empty building at normal voice volume and it can be heard all over the building but in a noisy area we must talk louder in order to be heard. This "resistance" is called "noise level." Your

public address system must always be capable of enough power to overcome this noise level at all times in order to be efficient and this is the purpose of a public address system.

To the preceding paragraph, we will indicate the size of public address system most desirable for various applications. The size mentioned in the preceding paragraph is for average work and does not take into consideration those special cases in which a special study must be made of the adverse conditions encountered.

## **Orchestra**

In selecting a sound system for an orchestra, the first thing to determine is to whether it is to be portable or not. Most orchestras should have no less than a 25-watt amplifier. Many of the better orchestras employ a 40 watt unit. Weight, however, is an important factor and must be taken into consideration. For this reason, the orchestra should always select a sound system that is packaged in a number of sections rather than in one large package as it is easier to store in a car



Right: Carnivals served by portables.  
Projection speakers should be used.

Below: Stadia need plenty of power.  
Clearly projected voice is important.

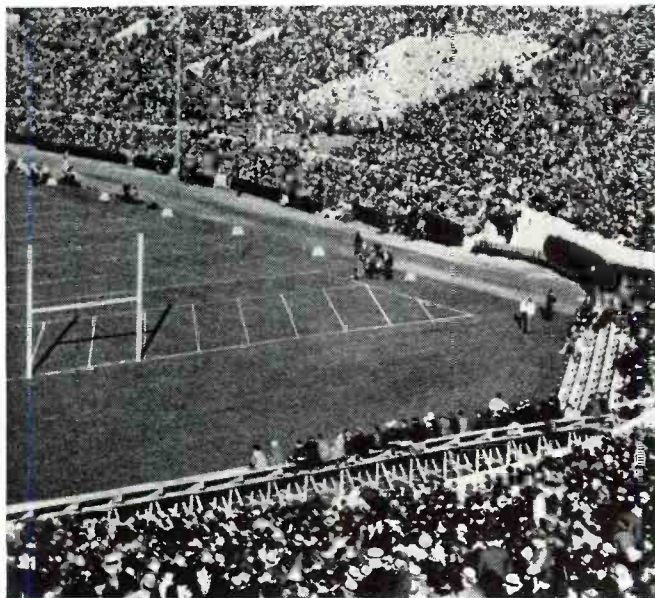

***The author tells how to analyze the many sources of revenue that are present to the wide-awake sound man and shows what equipment is needed for best results.***



and it is easier to carry as the weight is distributed in several carrying cases rather than in one.

As to the type of amplifier, that is, the microphone inputs and speaker outputs. Every orchestra should be equipped with at least two microphones. By using two microphones, they need not be crowded together in order to pick up each instrument with a recognizable volume. Also, most orchestras have a soloist or special instrument which is to be a solo and requires an individual microphone. For general orchestra pick-up, there are many types of microphones that can be used satisfactorily. The ribbon, dynamic or crystal, operate very efficiently for general pick-up. For the soloist's microphone, or a microphone that is handled frequently, adjusted up or down and moved from place to place during the performance, the dynamic is preferred over the ribbon type. All of the microphones available today in the nationally advertised brands are honestly rated and honestly priced. There are many grades of



Above: Roller rinks are noisy. They need a large amplifier. Below: Mortuaries require a record player with a selection of religious discs.

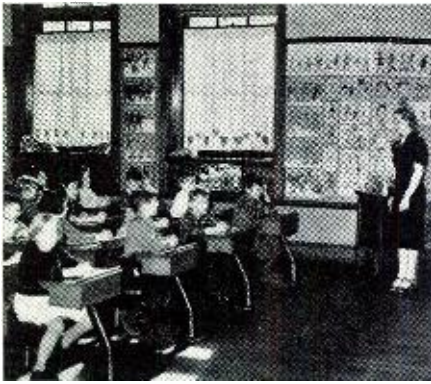

Public schools need sound in each classroom for efficiency.



A typical church with tower. May be served with inexpensive units.



Gyms require a high-power output to offset the noise level.

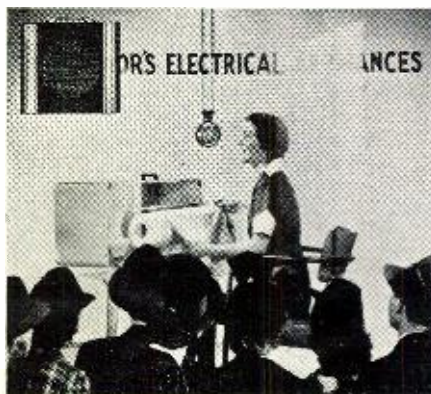

Store window selling needs only a small amplifier and speaker.

each type but because of the great improvement made in microphones for the past several years, good results will be obtained from most any of them.

For those orchestras wanting the finest microphone, such as the anti-feed back or anti-howl microphone, most of the better microphone manufacturers have such a model available.

Since orchestras are asked to play in all different types of buildings, many of which have poor acoustics, an amplifier should be selected in which speakers can be added at any time. Buildings with high ceilings do not require the speakers that low, long ceilings do. Since most orchestras use portable systems, speakers can be bought in split cases in which two speakers are in every case. To connect each speaker is a simple matter. The better amplifiers are equipped with speaker matching or impedance matching devices. These devices, in some instances, are marked as to the number of speakers attached to the amplifier and it is only necessary to turn the speaker selector switch to the number of speakers used and this automatically makes it the correct electrical connection.

A common error that many orchestras make in placing their speakers, is that they are confronted with dead spots in some halls and to overcome these dead spots, they place the speaker in that point in the hall. These dead spots usually occur in the back or back center of the hall. Under no condition should speakers ever be placed in that position. The speaker should always be placed *as near the orchestra as possible*. If this cannot be done, the speaker should be placed from the dead spot the exact equal distance the orchestra is from the dead spot. The reason for this is that the sound travelling from the speaker is exactly the same speed as that travelling from the orchestra. If the speaker is placed in the dead spot or back of the hall, the orchestra will be heard twice and this is commonly termed "double talk," and this spoils the tone quality and "Timing" of the orchestra, and is very confusing to the dancers on the floor.

#### **Fraternal Organizations**

Most of the fraternal organizations today realize the importance of public address systems for their entertainments, picnics and parades. The most desirable amplifier for this purpose is the combination 6 volt and a.c. amplifier commonly known as the "mobile" system. These amplifiers are rated from 10 to 40 watts and operate well from 6 volt storage battery or from 115-volt a.c. Most of the fraternal organizations run dances for their members from time to time and for this reason, the mobile system should be equipped with phonograph as well as conventional microphone. These mobile systems can also be had with automatic record changer.

Since these amplifiers are often used for outdoor entertainments, such as

picnics, parades, etc., a hand microphone is strongly recommended rather than the microphone and stand. In the parades, the microphone can be suspended from the ceiling of the car directly in front of the operator and both hands are left free for operation of the amplifier or driving of the car.

For the average *Legion Posts, Elks Club, Knights of Columbus, etc.*, a 25 watt to 35 watt amplifier is recommended since most of these organizations have fairly large crowds at their dances and have high noise level. Guard against selecting too small an amplifier. The initial cost between the large and small amplifier is insignificant compared to results.

Speakers for these amplifiers should be of the permanent magnet type and never less than two speakers should be operated at any one time. Since these systems will be used for general entertainment work and outdoor work, it is recommended that these organizations provide themselves with two sets of speakers, one in a diagonal carrying case and another set in projectors or horn baffles that can be mounted on a car or can also be mounted in their meeting halls.

The speakers and projectors are especially valuable in those lodge halls over store buildings where the hall is a long, narrow affair and where difficulty is encountered in getting the sound through the back end of the hall. Projectors will perform much better than speakers in flat carrying cases because of their rifle or nozzle action.

#### **Chime Systems for Churches**

The church installations vary as to types probably more than any other type of installation. Some churches wish to replace their bells with chimes. For these installations, a large amount of power is required. Other churches want only speech re-inforcement on the inside of the church for church services. An installation of this kind requires very little power. Other churches again will want a combination of both and still others wish to have "hard of hearing service" in conjunction to either system.

The ministry is becoming very conscious of the importance of public address systems in their churches. In some of the larger churches, the minister must talk extremely loud to be heard in the back of the church. Anyone who has had the experience of carrying on a discussion in a loud strenuous tone, over a period of time, realizes it is probably one of the most tiresome accomplishments. With a public address system, with the speakers placed correctly, an ordinary speech voice can be heard plainly in any part of the church.

In a church installation for speech re-inforcement, the important point to remember is that the public address system should be so installed and so adjusted that the audience is not conscious of the installation. Under no condition should the public address

(Continued on page 42)



# SERVICEMAN'S EXPERIENCES

by LEE SHELDON

I WAS looking out the front window one afternoon about two weeks ago when a big new car pulled up in front of the shop. An important-looking man jumped out and strode toward the door. I recognized him as Jim Turner, a local politician and real estate dealer.

"Hey, Al!" I shouted to my partner, and the three of us met in the front of the store.

"Is this *Salutary Sales & Service*?" he asked. "Frankie sent me here. I want an auto radio, and I want it quick. How long does it take to install one?"

Frankie was the mechanic from a nearby garage; he had told us, the week before, about Turner's new car.

"Give us two hours," Al replied. "It'll cost you forty dollars."

"Right!" Turner agreed. "Call a cab for me—I'll leave the bus here."

Just like that.

After he'd left, Al and I both started to work on the installation. It was sure a beautiful car—a '41 *Dernier Cri*, reeking with accessories—and we were especially careful to scratch it as little as possible. We noticed a strange thing as we connected the "A" lead: the storage battery was even newer than the car—so new it wasn't dusty, and of a make that didn't come with that model bus.

We had finished and were about to take the car for a trial spin just as Turner showed up.

"Sorry," he said, "but I've got to take the thing earlier than I expected. Through with it?"

We walked into the shop with him.

"About the money," he said, pulling out his wallet, "I have about twenty-five dollars cash to spare, so I'll pay you the rest when I get back. I'm leaving for Wisconsin on a vacation. Never mind the receipt. So long!"

I turned to Al in surprise.

"How's happen you let him pull a stunt like that?" I demanded.

"Why not?" Al said. "I wouldn't let many others get away with it, but everyone knows Turner by reputation—he wouldn't waste time trying to rook shopkeepers out of \$15 balances."

"It's been done," I cautioned. "Big shot or no big shot, \$15 is \$15!"

"Perhaps you'd rather have him go down the street to *Redoubtable Radio Repairs*," Al taunted.

"I'll bet *they* wouldn't let him get away without signing for credit," I pointed out.

"Therein lies the difference between our two establishments," Al said. "Turner knows a lot of people, gets around fast, and talks to everybody. We must make him realize his good will is important to us!"

"Well," I said, dubiously, "I hope he remembers us."

He remembered us, all right!

He drove up fast in his car the following Tuesday, pulled something heavy off the back seat, kicked our door open, and dumped his auto radio on the counter. Boy, was he boiling!

"Take your damned set back," he shouted. "You ruined the first vacation I've had in ten years! Give me my twenty-five bucks back, and let me out of here quick!"

Al looked at the set. "Hook it up," he told me. Then, to Turner, he replied: "Sorry, but I can't refund your money. As a matter of fact, you still owe us fifteen dollars. If there's something wrong with the set, we'll gladly fix it—but a sale's a sale!"

I have never seen a man who appeared as highly combustible as Turner at that moment. If the set hadn't begun to play, he'd probably have exploded. Instead, the noise was a distraction, because he seemed astonished to hear the thing worked. He bit the end from a cigar, took a deep breath, and said:

"You two guys got me into a terrible jam. I took my wife up into Wisconsin after I left you Saturday. About nine p.m., we parked in the country to admire the sunset and listen to the music. Suddenly, the set began to sputter, and the car began to burn. I shut off the radio and raised the hood. A big cloud of dark, evil-smelling smoke came out. I threw dirt all over

the motor and under the instrument panel. My wife ran down the road and started screaming.

"I had to walk two miles to get a 'phone, and it took me a lot of arguing to get a tow truck out. We were pulled into the nearest town—14 miles—and we found a mechanic willing to work for double time. He worked continuously until Monday noon. I had to pay for new wiring, cleaning the dirt from the motor, a new battery, towing, a labor charge, and for the removal of your radio.

"Our vacation was ruined. My wife, who hasn't missed a Sunday morning church service since I've known her, threatened to leave me. The total cost of your sloppy work, not counting the loss of my vacation and my wife's high regard, comes to \$250.

"However, I don't want to be too tough on you fellows. Simply apologize and give me my \$25 back, and I won't take you to court!"

"I am sorry to hear of your misfortune," Al answered calmly, "and I believe most of it was unnecessary. But you are unfair to blame us. In the first place—"

"Nuts!" Turner shouted. "I have a notarized statement in my pocket, signed by the mechanic, saying the trouble was caused by your defective radio. It's an iron-clad case. Will you, or will you not, return my \$25?"

"I won't," Al declared. "Furthermore, I'd enjoy meeting that mechanic in court—it would be a pleasure to educate him. *He's* the fellow you should be bearing down on!"

Turner was halfway out the door, but stopped to say: "I'll send for him, at my expense. I now consider it a public duty to run gyps like you out of business!" Then he slammed the door, and drove away in second.

"We must make him realize his good will is important to us," I mocked. "What got into you, Al—why didn't you give him his money?"

"If I had," Al replied, putting on his coat, "it would have been the same as a confession of guilt. We've got a job on our hands—to convince him we're not at fault."

"You'll never do it," I said. "Hey—where are you going?"

"Out to find why a brand new car needs three storage batteries the first week it is run," Al said. "Take care of the store."

We had a flurry of business the next morning, and, although I was worried and curious, I didn't get a chance to

(Continued on page 49)



"Radio Research Bureau calling! Are you listening to so-and-so?"



The author's recording console designed for flexibility and ease of operation. Continuous recording requires two tables.

# Build Your Own RECORDING STUDIO

by OLIVER READ

*In this concluding article of the present series the author gives a workable plan for constructing a studio which includes all necessary space needed to carry out a successful recording business.*

**M**ANY readers of this series of articles have expressed their wishes for complete data for the construction of a recording studio. Good recording can be done in the home if care is taken in the selection of equipment and in the manner in which it is used. Previous articles in this series have stated what is necessary in the way of equipment and accessories for the making of high quality discs. *In recording there is no substitute for precision.* This applies not only to the turn-table itself, but to the remaining parts which form an integral part of the complete recording layout.

In order to do recording on a commercial scale, it is necessary that the recordist rent sufficient space so that his studio may be arranged, and one which will be able to handle a considerable number of performers at one time.

The illustration shows a typical well-planned studio layout. It consists of a large studio, which is equipped with the necessary units, such as

piano, organ, and sound effects gadgets. Also, the main control, or operating room, where the recordings are made. And finally, a waiting, or reception room of sufficient area so that several people may be comfortably seated. If the studio is to be located in a town of average size, a large office may be rented and treated acoustically so that it will meet all of the requirements needed for proper recording.

The recording room, or booth, includes at least two turn-tables of the professional type, the necessary amplifier, and possibly a spare, a monitor loud speaker, storage bins for new discs, and storage facilities so that a complete library may be accumulated of dubbings or any other types of entertainment which would prove valuable in days to come. These cabinets should be provided with doors and they should be tight fitting so that all dust may be kept out.

Good lighting is very important in order that the recordist be able to have a clear vision of the procedure when

making cuts. Usually, individual lights are provided, one over each turn-table. In addition, a large overhead light will be required in the control room. This should be of the indirect type so that no glare will be present.

Studio lighting should be done indirectly in order to produce a soft light, free from shadows so that a clear vision may be had by the artists when they are called upon to move about while reading a script.

The walls in the studio must be treated acoustically in order to guard against echoes and reverberations. One of the special sound absorbing materials such as *Celotex* may be used, or the walls may be covered with heavy drapes which extend the full height of the walls. Provision should be made so that these drapes may be closed in front of the windows where a maximum amount of absorption is required. A suitable signalling system should be installed and should include a warning light so that the artist in the studio can be notified when the recording

operations are about ready to proceed.

One important consideration is the design of the window placed in front of the recording console. It is best to use three sheets of glass set in a suitable framework with about two inches of air space between each piece. This is necessary in order that no sound can penetrate from the studio.

A large carpet should be installed in the studio to cover the floor completely. The ceiling may require some treatment, the most inexpensive being to stretch canvas on some framework that is suspended about 6 inches below the ceiling. Some experimenting will have to be done in order to determine just how much treatment will be required for the studio. It will depend greatly upon the area and the number of windows present. So much for the important features that should be included in a recording studio.

Previous articles have covered the general technique of recording and we shall summarize this series with a brief discussion of discs and general points pertaining to making records.

### Discs

The blank record in recording is referred to as the disc. These differ from the ordinary phonograph record in that the coating or surface of the record instead of being hard is rather soft and flexible. Practically all modern recording discs consist of either a paper, cardboard, glass or metal base which is coated with a material similar to automobile lacquer.

It is necessary that this coating be absolutely smooth on the surface and that a uniform thickness be sprayed or flowed onto the base. The amount of this coating varies with records of different manufacturers. The better types have a coating which is at least .008 thick. The average groove cut onto this type of disc measures between .002 inch and .003 so that a sufficient amount of material will still be

left between the bottom of the groove and the base of the disc.

The cheaper discs use either the paper or cardboard base. The lacquer coating is applied on both sides of the base so that it will be possible to make a recording on two sides. They may be purchased in various sizes. The standard diameters are 6", 8", 10", 12", and 16". Ordinarily the paper base type is confined to the small diameter discs, i.e., those up to and including 10" diameter. The larger discs, those up to and including the 16" transcription size, have a metal base, usually of aluminum.

Inexpensive discs are available which are capable of good quality recording. Some of them are capable of being played back for up to 200 playings, while others are limited to but very few before they must be discarded. The coating on various discs differs, some of this material being harder than others. Furthermore, the life of the disc will depend not only upon the quality of the disc but also by the sharpness of the needle and in the application one should use a bit of discretion in selecting a recording disc which is to be used for quality performances. The more one spends for a disc the better will be the fidelity as a rule. The small size paper discs make excellent personal greetings as they may be easily mailed the same as a letter.

There is a vast difference between the home recording blanks and those that are designed for *professional* and semi-professional use. These discs are covered with a high grade lacquer coating and have a mirror smooth surface. They are free from grit or other impurities and are capable of the finest fidelity when cut properly. They are made in all sizes up to and including the 17½" master, transcription disc. Their base is generally made of high grade aluminum or glass. This

base has a very uniform thickness and is carefully polished to a high luster.

The process of manufacture of professional discs is one of great precision. Air conditioning is used throughout the plants that are engaged in making these discs so that dust or any particles from the air will not get into the lacquer.

It is well to point out that the surface material used on instantaneous recording blanks never becomes hard or dry even after being cut. For that reason it is necessary that the cutting stylus be extremely sharp in order that it will not have a tendency to dig into the record. It is for this reason that when playing back the record you cannot use ordinary steel needles. Professional and semi-professional recording discs are rather expensive. One should do his experimenting with a lower priced disc before attempting to use the better types.

In addition to the sizes mentioned before there are what is known as master discs. These are actually a bit larger than the conventional sizes. For example: a 12" master disc actually has an overall diameter of 13½". The extra area is required when duplicates are to be made and these are known as "pressings."

Professional discs usually have a heavier base when used either for transcription or for studio purposes. They may be used only on standard 16" transcription tables. The same quality disc is available in the smaller sizes for the home recordist who is satisfied with nothing but the finest. However, as previously stated, one should gain sufficient experience with inexpensive discs before attempting to make recordings with a more expensive disc.

Before we may proceed to make good recordings it is necessary that the prospective recordist take certain precautions in order to have all of the equipment operating properly. To begin with if one has never used his particular machine he should make certain that the turntable is capable of maintaining a constant speed under varying loads. A good test for this is to place one's finger against the side of the revolving table and to exert a slight pressure against the table. There should be no perceptible drag or slowing down of the table as it revolves. A still better method would be to record a sustained note and to play it back using the above test. If the pitch of the note decreases it will indicate that the table is actually losing speed. However, there is a simpler method which may be used and one which is fairly accurate. In the chapter under accessory items we mentioned the use of a stroboscope. This simple gadget will indicate visually any increase or decrease from the original speed. If the above tests indicate that the table is able to withstand the drag induced by the finger, it will be capable of furnishing the necessary power to offset the drag which will be caused by the cutting

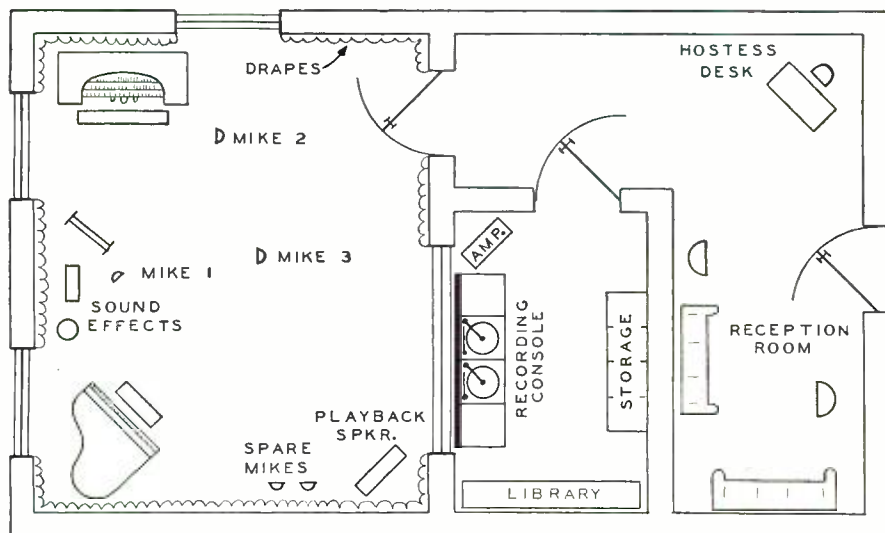

An efficient floor plan for a modern studio. Note absence of frills. Grand piano and organ console placed in far corner to conserve space.

stylus. The next procedure will be that of making a test record. For this purpose an inexpensive blank may be used as a matter of economy.

Before proceeding we must adjust the cutting stylus so that it will present the proper position with reference to the cutting surface. Generally the crystal cutter is designed so that the stylus tip has an included angle of from 88 degrees to 90 degrees and a clearance angle of from 45 degrees to 55 degrees. The tip radius of the cutting stylus is approximately .0015" to .002". The stylus after being placed in the cutting head will be within 4 or 5 degrees from the vertical position. All recording arms proved means for adjusting these angles and in most cases this angle is rather critical. Inasmuch as cutting needles are of a standard length it is important that when they are inserted into the stylus holder they be pushed all the way up into the opening before the set screw is tightened. Failure to observe this precaution will result in a different angle with respect to the recording surface when a new stylus is inserted and where it might not be placed all the way in the needle holder.

The next step is to adjust the depth of cut. As previously mentioned recorders cut with a definite number of lines or grooves per inch. For example at 100 lines per inch the space between groove centers will be .010". If the cutting stylus is adjusted so that it removes a chip which is .002" wide the spacing then becomes .008". If the stylus amplitude of .003" is used there will be a clearance of .005" between each groove.

The uncut portion remaining between grooves is called the land. There must be sufficient land so that the audio peaks that caused the side-to-side etching within the groove will not completely cut through this land. In other words if we cut deeper into the record we will reduce the land and run the risk of overcutting into adjacent grooves.

If more than one hundred lines per inch are cut further precautions must be taken in order to provide sufficient land or spacing between grooves so that the overcutting will not spoil the record. It is for this reason that the home recorders are limited to the cutting of approximately 100 lines per inch.

In professional equipment where a higher precision is used it is possible to cut as high as 200 lines per inch. In this case the amplitude of the cutting stylus must be held within very close limit.

The next test is to examine the chip or thread that is left after cutting a series of grooves. These should be shiny in appearance and should lay flat when drawn across the back of one's hand. If they are kinky and dull in texture we must look for the source of trouble. Usually a dull thread indicates either a dried out disc or a dull

(Continued on page 54)

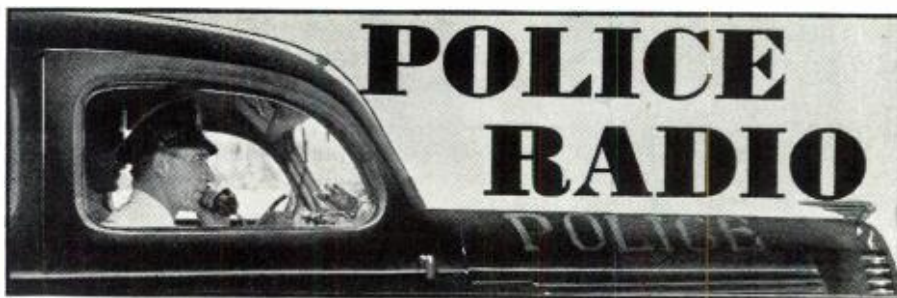

by WILBERT T. PETERSON  
Illinois State Police Dept.

### Personalities

WE take off our hats this month to Perry Bennett, sheriff of Boone County, Illinois. Bennett is a young aggressive man who wanted a police radio system in his department and obtained it, the hard way. He raised the money himself to purchase station house equipment and two two-way mobile units for his car and his chief deputy's car.

Most of the operating duties at the station house transmitter WSKO are performed by Bennett's mother, Mrs. Smith, who also does all of the household duties at the sheriff's home and cooks for the county prisoners.

The station house, located in Belvidere, contains four receivers with which they monitor the two Wisconsin medium high channels, the Illinois State Police, and their own ultra high channel.

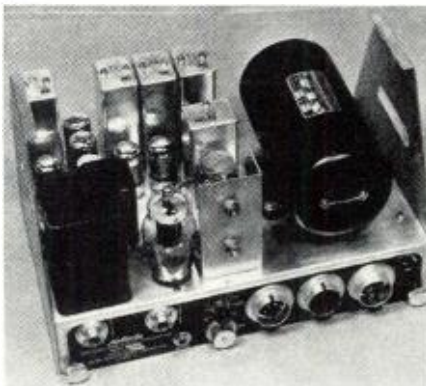

Motorola F-M Transmitter for police.

Boone county is rather small and is composed almost entirely of rural area. Sheriff Bennett has definitely proven that a radio system is just as necessary to a small county as it is to a large one, as the number of road thefts has decreased enormously since the system has been in operation.

Eugene A. Hubbell, W9ERU, chief up at Rockford, Illinois, Police Station WPGD is trying very hard to convince the local authorities that the purchase of a c. w. transmitter would greatly increase their traffic handling capabilities.

The staff at Rockford consists of Hubbell and two other active hams, Milton Carlson, W9FFQ, and William Holmin, W9AIC. These fellows at present copy traffic on the police c. w. net and answer via fone, however, they are very capable of answering by c. w., that is if they had a rig.

Incidentally, Hubbell was the fellow that won the Amateur Radio code speed contest copying 52.2 w.p.m. Imagine being able to copy code at that speed and not being able to answer the boys on the police net!

Jerry Sayer, chief radio man at Janesville, Wisconsin, is one of RCA's greatest boosters. He has an RCA 100-watt station

house rig and has 12 cars equipped with two-way RCA units.

The station is owned by Rock County, however, it also gives service to the Janesville City Police. The transmitter is operated remotely by the county or city dispatcher.

Jerry is the fellow who did the radio operating with the MacGregor expedition in 1937 and 1938 at Reindeer Point in Greenland. Many of the hams worked him there under the call OX2QY. He has been connected with Janesville since 1939.

Another exponent of home-made equipment is Ray Gronier, radio man of Madison, Wisconsin, Police, WASD.

We understood Ray built all of the equipment including about twenty-five cars and two life-saving boats.

The transmitter is a 300-watt Collins job on 2382 kc. The two life-saving boats are located on Lake Menona and Lake Mendota which bound the city. Two-way communication between these ships and WASD is maintained.

Ken Crittenden of the Beloit, Wisconsin, Police really has two jobs with the department. He is a police officer, however, since he holds a commercial fone license, he was placed in charge of the radio system.

Robert Lathrope, engineer of WMPD the Waukesha city and county police radio station, claims he really has a good top-loaded antenna on 2450 kc. The antenna was tuned remotely by using a field strength meter.

Lathrope recently increased his power from 100 to 250 watts and changed over to plate modulation. All of his receivers are brought in by three telephone lines from a remote point.

The Waukesha county and city departments can operate the transmitter from their respective offices.

Speaking of beautiful station layouts, we believe Herb Waering's WPKD at Milwaukee, Wisconsin by far surpasses any police

(Continued on page 65)

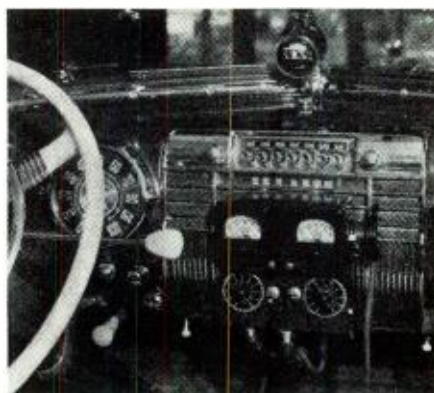

Complete control board in dash unit. All switches are within easy reach.

Right: The complete portable installation is seen ready for action wherever 115 volts a.c. is available.

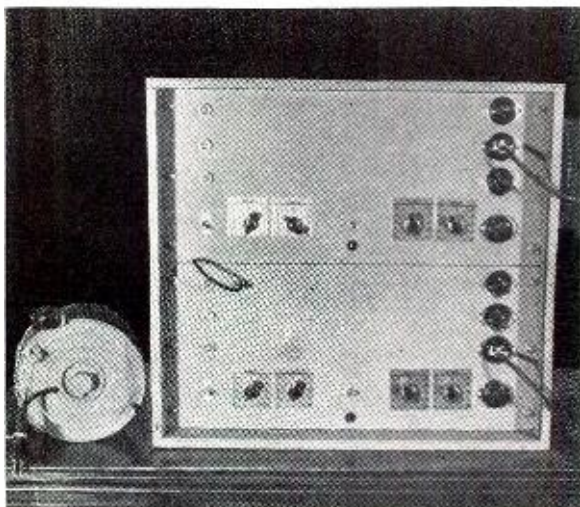

Above: Two commercially-available p.a. amplifiers are mounted into one compact wooden cabinet assembly.

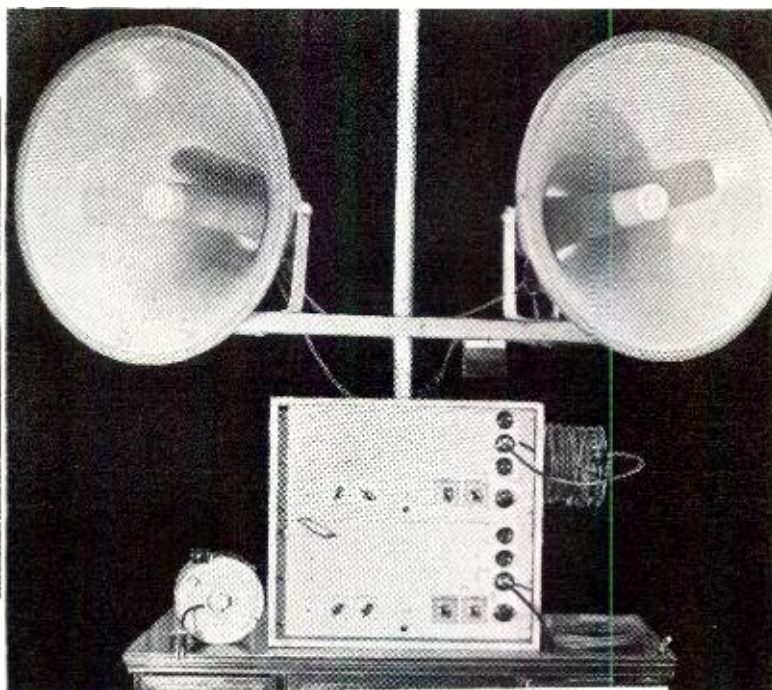

**T**ODAY we live in a national defense-conscious world. This program is the main headline of newspapers, radio and movie newsreels. But I, and other sound men like me have a problem of a different kind of defense. It is the problem of employing our own sound equipment, and adapting it for more efficient use to our own personal sound jobs of public meetings, city and county fairs, etc. In a sense we are defending our efficiency, our reputations and our sound equipment.

In working on sound jobs for the last ten years, there has accumulated a number of faults, I felt, which existed in the rental of sound equipment. It was with these various faults in mind that I set about to construct an amplifier system that was, in a certain sense, my ideal.

The largest bugaboo on a sound job, especially a large job, was that something might happen at any time in the form of a breakdown. And, of course, there have been breakdowns. But, fortunately, they were able to be repaired with no time out. To eliminate this in the amplifier section, I made two *Stancor* 430 amplifier units up to fit in one case rack and panel style. If one amplifier goes bad, the other is right on the job. You can change from one amplifier to the other in only three seconds. This feature should by all means save quite a few gray hairs on those real particular jobs where your reputation is at stake.

On all amplifiers that I have been able to purchase on the open market the input, output and power cords have been scattered all over the amplifier according to the likes of the designer. But for real practicability on a rental job the cords all coming out in front where they are at your fingertips at a second's notice is by far the best. It eliminates that hunting, fum-

## Sane Sound Ideas

by R. C. JONES

Salem, Ohio

*This practical layout was evolved by the author in an attempt to condense existing equipment into a single efficient p.a. unit.*

bling and moving that always accompanies an amplifier with the connections coming out the back and sides. The fact that you can see all the connections and their condition, plus the fact that they are at your fingertips will save a few more gray hairs.

Another feature of this amplifier, which most manufacturers are now using, is the visual output switch which is used on this job right below the output sockets just at your fingertips for quick "changeovers"; and also so that you can readily see at a glance that you are using the correct impedance. It is possible to change voice coil or line impedance with a mere flip

Two speakers mounted for wide coverage.

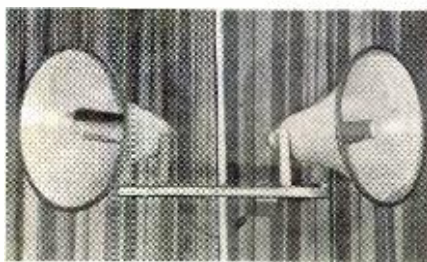

of the switch and still use the same socket and speaker lines. There are many times when it is more convenient just to run voice coil, and some of the speaker equipment is wired in that way. The two filament leads of a four prong socket are used for the output terminals.

Another headache which appears in a rental job is getting the proper power and tone with a single tone control on an amplifier. I have run into quite a few jobs where less bass would enable me to cut through a lot better. And in some cases where music was used, more bass was needed. So *dual controls* are just the thing, and they surely do the job swell! It is possible to match the system to the type of job and acoustics and get far better results.

The power cord has constantly been an item that was always in the way when transporting. Besides, it looks like a hay wire mess. So the cord in this case comes separate with a male and female plug. When carrying, there is no tripping or power cord wrapped around the amplifier job to

(Continued on page 44)

# FIELD DAY AT



The first three photos show W9NLP, W9QEA, and W9ETI carrying the rigs out to the trailer in the morning darkness. Upper right—Rolly and Ollie assemble the 20 meter beam on the ground beneath the shadow of the steel tower.

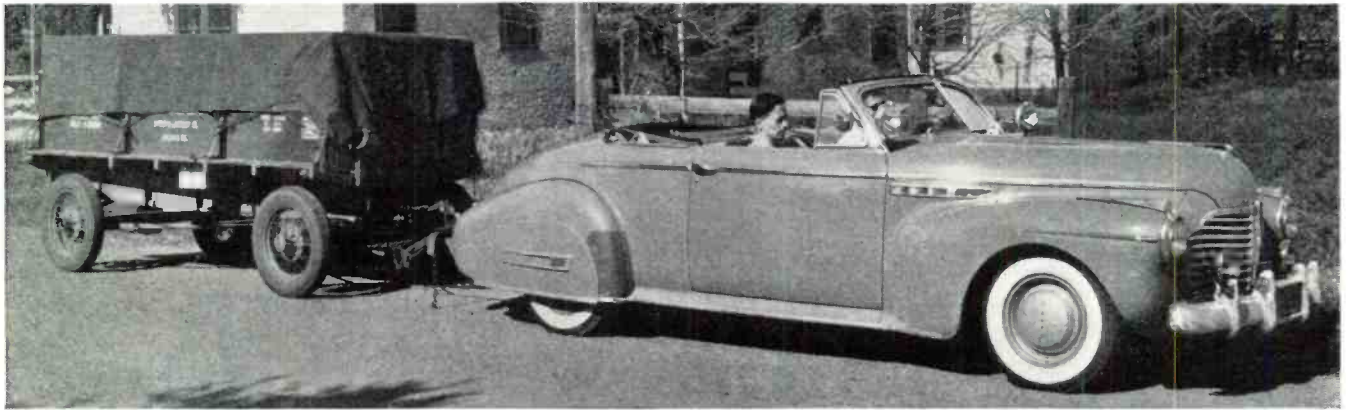

The end of the long pull. W9QEA and W9ETI ride in comfort while W9NLP takes a well-deserved snooze in the trailer. The trip to Grand Island was made in 13 hours, including time out for lunch and other refreshments along the route.



Looking more like a "fixed" beam than a hastily put-together job the signal squirter stands ready to use.

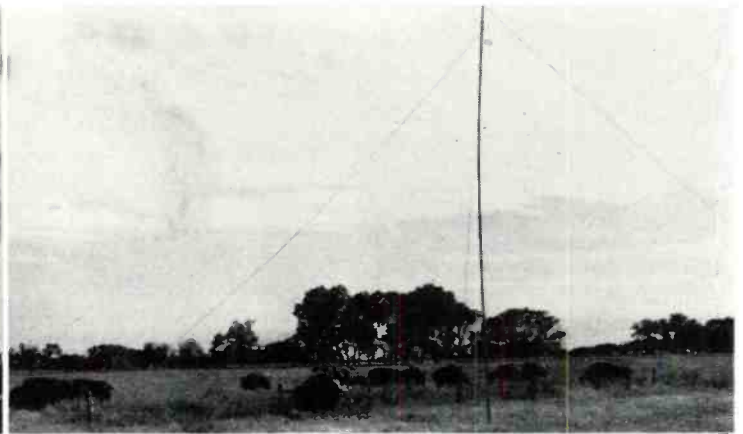

The wooden sky hook was erected when the buffalo were occupied at a safe distance from the pole location.

Aerial view of Shady Bend Camp. Encircled section is where the gang took up quarters. New addition is above.



Ollie, W9ETI, has just contacted another state and is making his log entry. This contact on 40 meter cw.





# GRAND ISLAND



Rolly ties down the last of the guy ropes. Vern, W9OVL, works 40 cw. Note refreshments! W9ETI, W9NLP, and W9QEA pose in front of the trailer. Rolly, W9NLP, talks to an east coast station from the 20 meter phone position.

by **ROWLAND J. LONG, W9NLP**  
Chicago, Ill.

**Modern transportation permits emergency equipment to be moved to remote locations where it can serve National Defense communications.**

**T**HIS is the story of three radio amateurs who participated in the recent ARRL Field Day from a rather unusual angle. It all started as a result of a contact made on the air two nights before the trip got under way with W9OVL, who lives in *Grand Island*, Nebraska. The writer, W9NLP, was visited at his home on that evening by W9QEA, and preparations were being made to get all of the radio equipment in shape for this yearly demonstration of amateur skill in operating emergency power under emergency conditions.

It was while trying out one of the low-powered transmitters that the contact with W9OVL was consummated. The result of this QSO was a decision to pack up and go to *Grand Island* for an emergency set-up. This involved considerable mileage but we felt that we could prove one of two things. First, that on short notice operators could be sent out with equipment on Army trucks, or in cars, to almost any spot in the *United States* and establish communications over a wide area for purposes of *National Defense*. Second, that it might not be possible in some locations to have reliable communication except in certain directions.

Karl Kopetzky, W9QEA, and yours truly, Rolly Long, W9NLP, were joined by Oliver Read, W9ETI, in this venture. A half ton of radio equipment consisting of receivers, transmitters, test equipment, and *Eicor* gasoline generator were loaded onto an 11-foot trailer, easily obtained in most large cities, and the trip was under way.

The 650 mile trek was completed in 13 hours without difficulty. By driving in shifts, a constant high average

of speed was realized. A 1941 *Buick* provided the necessary pulling power for the trailer. We found out one thing, however, and that was that the standard axle ratio furnished on most cars is best for emergency service where a heavy load must be pulled in addition to the weight of the car. Our motor power, W9QEA's blimp, was provided with a high speed gear ratio. The lack of reserve power was felt most when attempting to climb hills, or in passing other automobiles. In spite of this, we were able to make the trip in the time specified, which includes time out for meals and refreshments.

Upon our arrival in *Grand Island*, we found ourselves located at *Shady Bend Tourist Camp*, which is a typical modern auto camp. We were told that an abandoned windmill tower was available if we wished to make use of it. Imagine three hams refusing such an offer! It was decided to erect a 20 meter 2-element beam and to place this on top of the tower. It could also serve to support some of the other antennae used for the other bands. The illustrations show how well this beam was thrown together and when finally set up it took on the appearance of a well-planned installation. The performance of this beam left little to be desired as more than half of the states worked were directly due to the efficiency of the beam. We tied a long rope to one side of the framework and this served to rotate the beam when necessary.

The problem now was to find a suitable mounting for the other ends of the long wire antennae. These consisted of an off-center fed horizontal 160-meter wire, a 40 meter doublet, and a 80-meter doublet. We had taken along several long pieces of 2 x 2's and

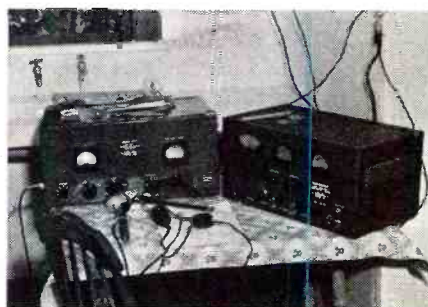

Hallicrafter's HT6 and SX 25 on 20.

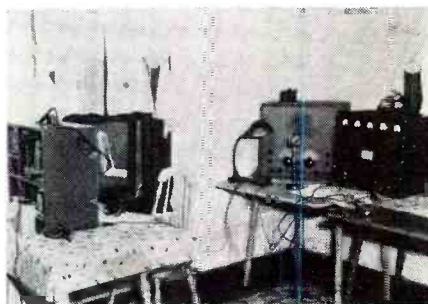

Corner of the improvised ham shack.

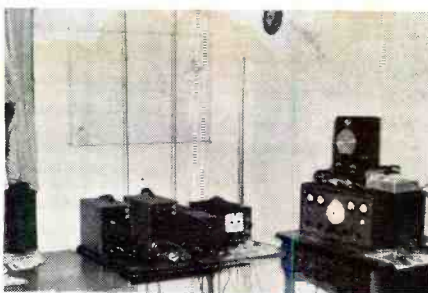

2 1/2 meter rigs handy for locals.

Eicor gasoline plant in operation.



these were spliced together and set up in the adjoining Buffalo pasture. Yes, we said Buffalo! And we do mean Buffalo! It seems, from what we later learned, that we were surrounded by one of the few privately owned buffalo herds in existence. Not knowing how these creatures look upon the erection of antennae in their pasture, we treated them with a great deal of respect! The writer and W9ETI tackled the job when the buffalo were looking the other way.

The equipment was set up in a small cabin, the one nearest the pasture, with the exception of the 20 meter position. This was located in another cabin some 50 feet away. The following units saw service: a *Hallicrafters* HT-6 transmitter with an SX-25 receiver. This combination in conjunction with the beam was responsible for working the first stations. The first contact was with W1JFR, who is located in Massachusetts, followed by other contacts in Connecticut, Illinois, New York, Virginia and Pennsylvania. Yours Truly had the pleasure of making the first contacts and thereafter shifts were maintained to keep the 20 meter position going as long as the band permitted.

Ollie Read, W9ETI, got on with his self-contained portable station and this little ten watter, operating on 160, 80 and 40 meters, added many more states to the log sheet. Later, all three units were going and Karl, W9QEA, joined the fun with his 50 watt rig, and more states were added to the rapidly increasing list.

We were not out for points, but rather to see how many stations could be worked in as many states as possible, in order to make a survey at a later date.

We were joined on Saturday night by Verne M. Painter, W9OVL, who is the same chap contacted before the trip began. 'Tis a small world! Verne had the pleasure of adding new states to our list, particularly on 20 meter phone.

Conditions were very unfavorable on 160, 80 and 10 meters. Static was usually heavy and very few signals were even heard on these bands. Therefore, little attempt was made to communicate on those bands. Nevertheless, the final count showed that we had made 73 contacts and had included a grand total of 6 states worked. We felt that this was highly satisfactory and believed that we could have added several more if we had worked during the full 24 hour period, which we did not do. Ollie and myself elected to go to bed about midnight on Saturday, possibly due in part to the effort put forth in getting up the 20 meter beam. Karl continued to operate for several hours thereafter in search of states which we had not heard during the day.

It was interesting to note that the best reports were had from stations on the two coasts, and the reports

(Continued on page 45)



by CHARLES J. SCHAUERS

### Dynamotor Maintenance

**R**ADIO equipment installed in aircraft which utilize centralized power systems consisting of the usual storage battery, generator, etc., usually employ dynamotors or vibrator packs for supplying the high voltage for plate supply in conjunction with the commonly used low pass filter systems.

A dynamotor is simply a motor and generator armature built on a common shaft and using the same magnets and field windings. This construction permits the housing of the two units in one case and reduces the physical size and weight of the entire unit.

Dynamotors used with aircraft radio equipment have relatively high overload factors, their actual physical size being governed by the amount of output power needed. Due to the rigid requirements of the aviation services, many manufacturers manufacture "flight tested" units. These dynamotors will take an unusual amount of hard usage and are factory tested with every known device with extreme care to insure the purchaser of a power unit that is both reliable and consistent. Tests paralleling actual operating conditions aboard aircraft are made before the unit is placed into service and before a CAA approval certificate is issued, the unit must have passed the "7" tests as prescribed by that governmental agency. That is, these tests must be passed by a unit installed on board an aircraft used for scheduled air transportation.

The initial cost of the various types of dynamotors vary according to the size, but the initial cost of the average dynamotor found in most installations is approximately \$28.00. If the dynamotor is properly installed when first purchased and the manufacturer's instructions carried out after installation as pertains to maintenance, very little trouble will be given by the average unit. However, if the dynamotor is haphazardly serviced after installation and no attention is paid to specific maintenance instructions, then trouble will inevitably develop, with the result that needless "overhaul" bills must be met.

It is well to keep in mind, that the dynamotor you work on is an "electro-mechanical device" and must be given consideration from two angles, viz., the mechanical and the electrical. It should also be remembered that each manufacturer promulgates his own service information for his own equipment; for this reason certain instructions from one manufacturer may not be applicable to a machine of another.



Cutaway view of dynamotor unit.

Dynamotors are not expensive to maintain and give trouble free operation for many hours, but there always comes a time when they "give up the ghost" and refuse to function properly. This is where the *aircraft radio serviceman* steps in.

If a dynamotor stops functioning properly, there are a number of causes that the technician should be familiar with. Worn brushes, pitted-shortened commutators, shorted filter elements, defective bearings, dirty commutators, loose brushes due to holders being out of line, and dirty input and output contact terminals.

Most units make connection to associated units through plug and cable connections; and if for any reason it is found necessary to modify these connections, the manufacturer should be consulted and asked for recommendations concerning requirements. During the past three years, various types of dynamotor units have made their appearances, but the type usually found in the average aircraft installation employs two com-

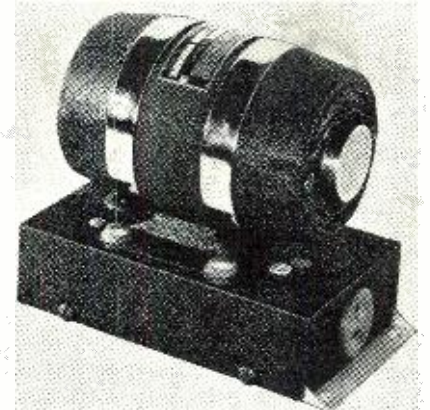

Filter added to a dynamotor.

mutators, viz., a low voltage and a high voltage. Of course, there are some units that employ as many as six commutators, but very few of these are in operation at the present time. One example of a multi-commutator dynamotor is one manufactured by the *Carter Motor Co.*, of Chicago. This genemotor has four separate commutators, one input and three separate outputs and can be made to handle any d.c. input such as 6, 12, 24, volts, etc. The three output commutators can be designed to handle any range of voltages providing the total capacity does not exceed 150 watts.

High voltage commutators have commutator bars smaller and less in width than the low voltage side. The high voltage commutator is always composed of smaller and usually more bars than the low voltage side; the greater number of commutator bars help to reduce the commutator ripple and improve the "wave form" of the output voltages. The reason for the larger low voltage commutators is that the low voltage side of the unit requires more current handling capacity in the conductors than does the high voltage side.

Remember! *Low input voltages* are just as detrimental as *high input voltages* to any dynamotor. For this reason always make certain as to the amount of voltage going

(Continued on page 48)

# BENCH NOTES

by **ROBERT KENDALL**  
Service Manager, Indianapolis, Indiana

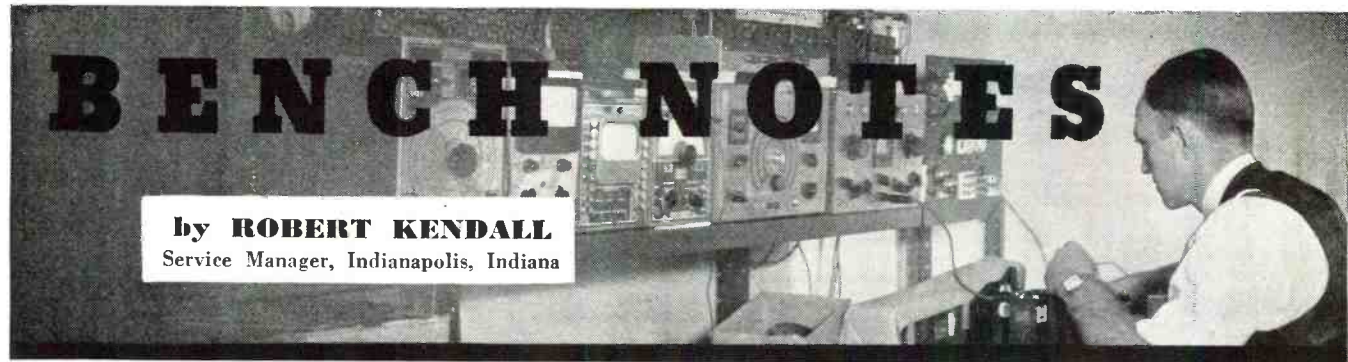

## P.A. and the Radio Man

**I**N these United States at least, practically every able-bodied citizen can and does cherish the ambition to make a noise in the world, and there are many ways of doing this without playing a trumpet in *Phil Harris'* band, or beating the drum in a Tom-show. It has been done by so simple (in more ways than one) expedient as sitting in a tree an hour longer than some other goof in Keokuk, or by flying a plane a little farther than the last fellow, and thereafter setting up as an authority on anything from women's hats to international politics. While as for most of us, we get little further in attracting the attention of our fellows than slamming doors behind us, there is always the man who has something to say whenever he can corral an audience, and for the talkers of this world the modern P.A. system has been developed.

It is apparent from the increasing space allotted each year to public address systems in the wholesalers' catalogs that this business is as yet suffering no decline, and the radio man should be among those best qualified to handle it. While for a time such ambiguous and puzzling technical terms as decibel and V. U. were rampant, much of the mystery has been taken out of the subject and the aver-

age radio man should find that this work may be handled competently with a tenth of the technical knowledge necessary to repair a radio receiver.

The terms DB and VU are of little value to anyone outside the design and research laboratories, and about all the radio man needs to know is the area that a given power output will cover satisfactorily, and how to connect his apparatus together, which are matters on which information may be secured from a dozen sources. As for the supposedly profound mysteries of proper horn placement, over which so much head-shaking and tut-tutting has been done by some already in the business, this is mostly bosh as far as the average job is concerned, and any intelligent man with reasonably good hearing can solve such problems in short order by trial-and-error, without acquiring any gray hair or wrinkles in the process.

In the selection of microphones the budding P.A. man will find a wide range of styles and prices, in the three popular types—dynamic, velocity and crystal, and for ordinary purposes, especially when speech is being amplified, the ones in the lower price ranges are quite satisfactory. The beginner with small capital, who must limit himself to the possession of one microphone at the start, may find that the dynamic type is a little better suited for all-around service; and since acoustic howl from feed-back is the most common "bug" encountered in P.A. work, it would probably be more economical in the long run to get one of the uni-directional type to begin with.

The beginner most often goes astray in the selection of the amplifier, being influenced too much by low costs. The small 6 or 8-watt amplifiers are suitable for outright sale and permanent installation where the requirements are within their range, but are seldom useful for rental purposes, for which amplifiers capable of covering larger areas will be necessary. The smaller crowds that meet in auditoriums that can be covered with a 6-watt amplifier are generally too small to be profitable prospects for a rented system.

In the smaller towns where few large auditoriums are found the P.A. man may be able to get by for a long time with a 15-watt amplifier, but a 25-watt job would of course be much

preferable, and permit the owner to take care of practically all the jobs he would ordinarily find. Either system will handle up to four speakers if necessary, but as might be expected the larger amplifier will cover practically twice as much space. Generally speaking, a 15-watt amplifier will adequately serve indoor areas up to five or six thousand square feet. For outdoor service these figures should be divided by two.

As for the question, "Where can the radio man sell his sound?" the answer to that one is easy—"Almost anyplace where there is going to be a gathering of more than a few dozen people," but as for the problem of actually getting the business that is a different story. It will not be enough to buy a sound system, hang a card in the window announcing the fact, and then wait for the telephone to ring. To be successful in the P.A. field, the sound man must keep informed of scheduled events in his area of trade, and then *hustle out* after the business. Sound can often be sold to organizations that had not previously considered its use, if the salesman has enough ingenuity to show the advantages of using it.

There is undoubtedly money to be made in public address work, but it is doubtful if more than one man out of

(Continued on page 46)



"How come you can hear Puerto Rico but not hear me call from downstairs?"



"The Philharmonic program will not be heard. Instead—we present the—"



Swell rig of w7hph.



28 mc. beam of w8tch.



w9eit and rig.

w8gxc's "Signal Shifter."

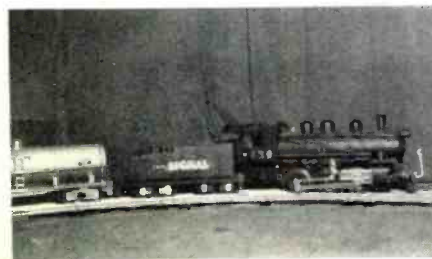

AS we write this stint we are continually interrupted by reports of phenomenal Field Day results attained by various groups who participated this year. From early reports received here it appears that participation this year was at least double that of previous years. Scores of the leading groups this year will probably run in the nature of better than twelve thousand points. The highest score we have heard of so far was that set by an east coast group who operated eleven transmitters and made over eight hundred contacts. Whew! Several of the local groups have reported in excess of four hundred contacts in spite of conditions locally not being favorable for the higher frequency bands.

Results like these indicate the amateurs' interest in emergency type of communication, which in itself is the best possible training for National Defense. From personal experience we know the difficulty of operating under the unfavorable conditions usually encountered on Field Day. Rain, high winds, falling tents, blown filter condensers, etc., together with the strain of striving to beat the other fellow all offer good training so necessary if our Country is to have a strong, well trained reserve of radiomen. It is no mean task to keep several transmitters and receivers operating simultaneously so that interference between positions is at a minimum. Each year sees improvement in operating technique. Over ninety percent of the contacts made by one local group on the forty meter band this year were with other portable stations, which indicates the growing interest in emergency work. All in all it is a healthy condition for Amateur Radio and the country's best interest. Hail Field Day!

Yrs, The HC Editor.

#### From the Mail Bag:

**DEAR ED:** Here's a few lines about the gang here in the 26th Signal Company, Camp Edwards, Mass.

We haven't been on the ham bands as official permission is pending. If and when it is given, beware of a rugged signal signing with the call W1BS as there is a Harvey 100T and a Super Pro raring to heat the ether. Plus a flock of transceivers.

The radio section could well have its own manifests. Headed by Master Sergeant Franklin W. Wiggins, W1GEV, other W1's answering roll call include: CZI, DIP, FPU, FWT, FZX, JHZ, JLY, JWS, KME, LYG, LYP, MKV, and NEG. Having acquired code speed several others are going after tickets.

Speaking of code speed, here are some tips for those registered under the Selective Service Act. If drafted, your ham license will probably result in your assignment to a communications unit. It will be to your own advantage to be able to copy at least 15 WPM of mixed characters. Experience gained in message handling will be a big help, especially if acquired in an Army net. All copy in the army is made by hand printing while the navy ops are required to use the mill. Don't worry about the printing as that can be picked in short order. Your pay as a specialist will be based on ability with a possible high of \$66 per month.

It's true one won't get rich in any man's army but the life is not as dismal as some imagine. You soon get used to rising with old sol, the uniforms are cozy and snappy, lots to eat and not beans by the way, and

plenty of diversions for the hours off duty. If you chance to hear W1BS on—give us a blast and in the meantime best of 73S. Pvt. Francis McAllan, W1FZX.

**FROM** ur 1st District Reporter W1JOM who sez:

W1LZV of Quincy is back on 2½ after taking a try on 10 fone. He is running 24 wts to an RK-34.

W1NBS "nobodies sweetheart" recently pd a visit to W1NBT. They hooked in 2 mikes & u shuda hrd what went on. It wuz on 2½ so its ok.

W1BIL of R. I. is cuming thru on 2½ in Boston fb.

W1NHZ is the call of the local Home Guard Unit. The station wl operate on all bnds frm 160 to 2½ meters on fone & cw. They wl hve one big rig & several port transmitters & transceivers.

When a station questioned the rept tt W1WV gave him he sd tt it must be condx becuz he was using a "Nat. HRO" rcvr. Ats sum compliment.

W1LUD is wrking port on 2½ frm Dorchester.

W1IHN recently pd a visit to W1GWK. W9DYG is wrking fixed prt from 1st call area. Conn. to be exact.

W1GVS is on 10 fone & operating frm all places. Kenmore Sq., the heart of Boston proper. Hows the auto QRM om, hi, hi.

If u hve wrked all 6 ops at K5AT don't forget to ask for the Wrked All Operators crd. The crd is an attractive 5 by 9 crd wid all the ops signatures on it.

W1NGH tt "No Good Ham" of Jamaica Plain is on 2½ fone. He has given up Qsling becuz "lack of returns." Where's sum of tt stuff we usta call in the old days "Ham Spirit," fellas?

W1MLG attends Northeastern University. W1AUU is dwn on 10 fone frm one sissie.

There's one section in Boston with abt 12 2½ meter stations. They call the place Squeaky Rcvr Lane.

W1JDO gives a course over at M.I.T. on "How to becum a Ham." W1AKD recently changed his qth.

W1LNG wrking prt frm Dorch. on 2½ fone.

W1IWK of Springfield or better known arnd Boston by his local call arnd these parts as W1NHV is on 2½, 160 & 75 fone, frm both locations. He attends Northeastern University.

W1BPZ is a piano tuner by trade. He ought to go into cw tuning, frm the sound of a lot of the sigs.

W1HQB is on 75 fone. It is the station of the Parkway Radio Club.

W1LSN of Exeter, N.H., is on 5 meters & has a swell sig.

W1APK has just put a xtal rig dwn on 2½ fone. He is located in Pembroke, N.H. By the way, Basel has recently bn bitten by the moving pic bug. He has a complete 16 mm movie outfit.

W1EGR is gg to Tufts College. He is taking up a Radio Engineering course of the Nat Defense Training Program.

For N.E. hams who have friends at Camp Edwards on the Cape, u'll be interested to know tt there r several stations set up & r active on 160 fone.

W1LNL operating prt on 2½ frm Dorchester.

W1CZC of W. Medford has rebilt his rig frm 80 wts to a 320 watt outfit. Tom is running sum HK-24's in the fnl & doing a swell job modulating wid 46's in class B.

A cupla Sundays ago W1KSF stirred up quite a bit of activity on 2½ fone by gg prt airplane. He started off wrking the sta at abt 6500 ft & ended up at 10,400 ft. Altho Norry wrked quite a big of DX he was wrking under difficulty becuz he had to cut his engine & glide when on the rcve position. The temp was 15 degrees at 7,000 while dwn below it was 70. Credit for the fine wrk done also goes to the co-pilot, Fred, who took over while Norry caught his



w9hwn works Field Day.



w9vsx/9 Field Day Gang.

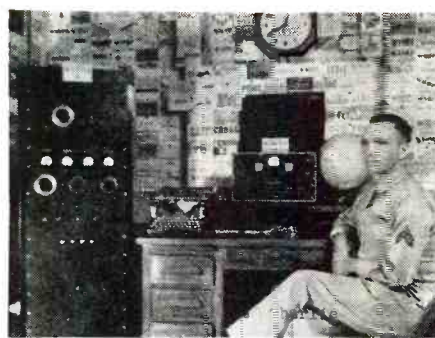

"Charlie" K6saj.

breath. (u know at 7.000 the air is pretty thin.) Sum of the stuff he wrked while over Norwood airport were: W1HCK, R.I. r-9 both ways; LBY, R.I. r-9; LIH, Conn. r-8; FGX & JFX of R.I.; also a 2 way contact into N.Y. r-9 both ways. Other sta wrked were: MUD, GEJ, IWD, MUO, HXC, JQA, APH, JOM, IHY, MBS, LKT, KLK, MKX & many others too numerous to record in this valuable space. Hi, hi.

**W3JGJ** writes as follows:  
W3HQX, W3JGK, and W3JGJ are brothers living in the same house wid separate stations in different parts of their basements.

W3HQX's layout is a 809 final running about 45 watts wid an FB7A for a rcvr. Also he has a vy fb transcvr on two es one half meters.

W3JGK, Ward, went down at the same time as W3JGJ, Roger, es rcvd their tickets the same day.

W3JGK has a 47 osc. running about 19 watts. He, like Perry, is using a FB7A for rcving purposes.

W3JGJ. (Just gud junk) has a T-21 Osc/running abt 25 watts on 40 cw. Rcvr is just a sky buddy (Bles it).

Perry is 20, Ward is 18, es Roger is 16 years old.

Anyone having a practical scheme of how to run two xmtrs at the same time, please send it to either of the above. (QRM AWFUL!)

W3iff, Shorty, recently bought a NC-200 which is wrking very fb. For a rig he is using a 6L6x osc. running abt 35 watts. He will in the future build one of those super rigs.

W3HHR, Butch, has a Signal Shifter pushing a pair of 809's in the final. Rcvr is a Sky Buddy. (Another!)

W3HKJ, Jack, is thinking of building a rig that will surpass anything alive, according to him, es he tore down his past rig es started to build the wonderful one when he got an awful sickness of yl trouble es the rig was immediately dropped es he is slowly putting a condenser in each day. HI! His rcvr is a Howard 430.

W3HZ, Ace, is inactive right now becuz of, yep, you gessed it, FEMALES! but recently he has shown signs of life es is trying to get a rig on two es one half. Gud luck, Ace, HI.

W3HiF, Lenten, also bought a NC-200 es is active on ten fone.

W3HSD, Merlin, the DX hound, who wid 35 watts has wrked more dx than most of the 20 fone KWS, is now active on 40 wid his 35 watts from his T-21 osc. on 7032. Any body knw of ani dx for him to wrk? Any body know of ani dx?

W3ILC, Bill, is hrd on 40 CW wid a newly completed ECO es once in a while he wrks a K6. He has a very fb home made super het for his rcvr, es his rig is in a panel job which any ham wud be proud to own.

W3INK, Walt, is also hrd on 40 CW running his 809 final to 145 watts. His 809 always shows color. W3ILC runs 300 watts to a pair of 809's, so he is just as bad. Walt es Bill supposedly stay up every Friday nite until the band is almost dead, es then they sleep all day Saturday. HI.

W3ISE, Dave, recently joined the ranks of the FTS. He is one ham who really likes to handle messaces. He runs about 30 watts wid his lately completed ECO. Rcvr is also a SKY BUDDY.

**H**ERE'S sum gossip from around these parts by W4HEL.

W4FPD sending out code practice on 160. Speed varies from 5 to 25 wpm. Gus really lays out a fb sig es has a fb fist. Gus is also net-control for the S.C. emergency net on 160.

5 yls from around Charlotte took their exams for their licenses recently. Hpe they

get on 160 . . . hi hi.

W4CIV runs abt 40 watts on 160. Ed really gets out, must be his xyl who calls cq or that fb antenna, which is it Ed?

W4GLZ, yl operator can be hrd just abt ani time talking to Pete, W3FOU. I wonder wat they talk abt all that time, it's not the wx.

We need sum more pictures like that of W4GEX that was in the June issue of RV . . . wow!! by the way Bonnie long time no see, wat smatter?

W4HGB is planning an emergency all band xmtr running abt 25 watts. George's big rig just abt knocks the rcvr off the operating table.

I wonder how W4DST es W3GCD find so muchto talk abt.

Wat's so rare as a station on 160 who hasn't an eco, maybe its a cw signal on 10 meters, by the way 10 has been open for short skip during a few of these summer nites.

K6QUI moved to Charlotte es now has W4HIZ.

W4GCW's 450 watts really knocks a hole in the qrm.

W4HKI is a NYA station in West Columbia, S.C.

W4CJQ is a policeman, better slow down when going thru Gastonia, N.C. Charlie's antenna is 190 ft. high—he has it hooked to a water tank. Wish there was sum water tanks near here.

W4FHE is operating fixed portable in Florence, S.C. gid to cu back on 160 Walter.

**F**ROM W5JPC the following:

W5JKP is a NYA station located at Bonham, Texas. The op is W5JQH.

W5JRX is another of those All-Girl Radio Stations located in Gladewater, Texas. Operation is on 160.

W5IKZ, formerly of Kilgore, is now with KTBC in Austin.

W5IYJ is now the proud possessor of a National NC-200 Receiver.

One of the most regular signals here comes from W5JGX of Harlingen, Texas. Rupert uses a rig composed of a 6L6 osc. and pp 809's in the final. The receiving end is taken care of with a SX-25.

W5JMU is one of Kilgore's recent additions on 40. 600 watts and a Breting 40 is used in this Jr. College Station. They are soon to have another op.

Three of the most active stations on 40 that are located in Waco are operated by Tex. W5JED, Don, W5JHW, and Len, W5JLU.

W5JDQ is a NYA station located in Marshall, Texas, and is operated by JND and JLN.

W5DUX is now back on the air after renewing his Class A ticket. Riley pounds the key on 80 using a Signal Shifter running into a final. He has trouble keeping a Sky Wire up. Maybe sky-hooks would help.

W5JPC claims to have worked Shawnee, Okla., with no plate voltage.

W5CXD is the owner of a code proficiency certificate from the ARRL.

W5FGT recently obtained his 2nd Class Telegraph License from the FCC.

W5IZN went up for his Class A ham ticket several weeks ago.

W5DHH is now in the Signal Corps.

W5Jealous Envious Dames has worked 38 states with 10 watts and a 3 tube homebrew rcvr.

**F**ROM F. E. E., R. I.

Just a line to let you know about the 2½ meter activity in R. I.

W1NDQ, North Providence; W1JVF, Smithfield; W1NBU, Providence; W1LPO, Tiverton; W1HXV, East Providence; W1MSD, Riverside; W1CNJ, Providence; W1FUB, Lakewood; W1HRZ, Edgewood; W1HJB, Providence; W1BFB, East Greenwich; W1JFF, Newport; W1JP, Providence.

(Continued on page 66)



YL W9jw collects calls.

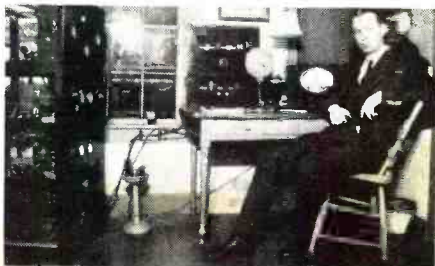

"Russ" W8dec.



W4ekg.



W1lyl.



W1lh op at whdh.

# WHAT'S NEW IN RADIO

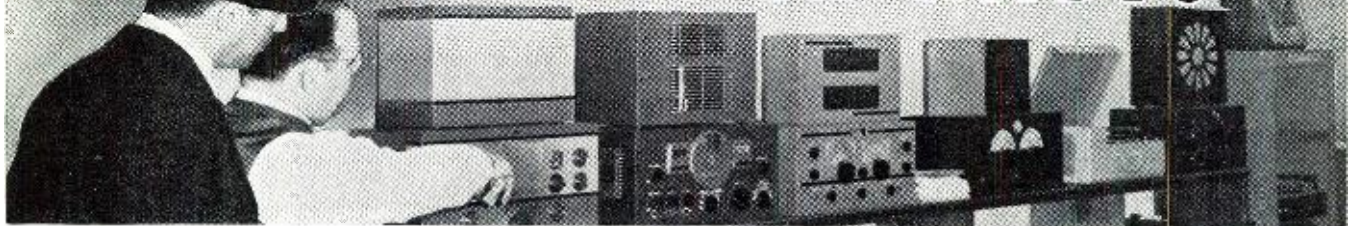

NEW ECHOPHONE RECEIVER OFFERS HAM AND SWL APPEAL. Another *Echophone* "Commercial" receiver makes its bow to the radio world in the form of the Model EC-3. Selling in the lower price brackets of the communications type receiver range it nevertheless presents a surprisingly large number of features of the type found normally only in much more expensive equipment.

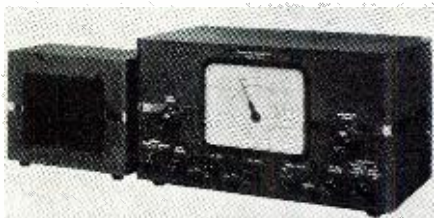

Among these features are a tuned r.f. stage on all bands, continuous coverage from 545 kc. to 30.5 mc., crystal filter, four degrees of selectivity including two in which the crystal filter is in the circuit, crystal phasing control for maximum interfering signal reduction, automatic noise limiter with switch, phone-tip jacks and speaker-phone switch, beat-frequency oscillator with variable pitch control, external PM speaker in matching cabinet, electrical bandspread with calibrations for four ham bands, but usable anywhere in the receiver's tuning range, indirectly illuminated dial scales, and several others.

Especially distinctive are its provisions for operation from both a.c. and d.c., 115-volt lines, and a unique monitor circuit which enables the ham to listen in on his own c.w. transmissions.

Its eight tubes (not counting the ballast tube) are of the most modern and effective types. All connections including headphone tip jacks are at the rear while its twelve controls are all accessibly located on the front panel. The metal cabinet is finished in neat crystal lacquer, including the speaker cabinet.

NEW AIRLINE 100-WATT DELUXE AMPLIFIER. The largest, most powerful amplifier of the entire *Montgomery Ward* line of



amplifiers. Has more than enough output to handle 99% of the largest sound instal-

lations. A unit that is ideally suited to handling stadiums, large auditoriums, athletic events and especially adapted to Church Belfry chime applications.

Featured are the four microphone inputs each with individual gain control on the inclined, illuminated front panel. In addition a split fader controls the volume of either the built-in or an external phono. A Master gain control provides overall gain settings at any volume level without disturbing the individual settings. The large 3-inch front panel level meter is directly calibrated in Watts output (0-100) and db's. It tells the user at a glance the power output of the amplifier for the best results for any type of sound installation. Meter is optional equipment. Fully Variable Bass and Treble controls assure complete compensation for various building acoustics as well as providing for better equalization of some phono records. Inverse feedback circuit provides advanced tone standards.

Like all *Airline* Amplifiers this 100-watt DeLuxe Model can be supplied with or without the built-in phono. The quiet, self-starting 78 r.p.m. motor is a heavy-duty type with cast frame, rubber mounted. The pickup is a latest model Astatic crystal with offset head and convenient pickup rest. Closed needle cup and individual motor off-on switch are included. A long playing precious metal point needle is furnished; this needle gives the user almost complete freedom from needle changes for as many as 2,000 ten-inch records. A knurled knob set screw makes it easily replaceable when the need arises.

An exclusive *Montgomery Ward* patented feature on both the 100- and 75-watt DeLuxe Amplifiers is the external speaker selector included with the unit. It's supplied with these two amplifiers at no extra cost. Its primary advantage lies in the ease with which speakers are connected to the Amplifier proper. It is necessary only to run a single 500-ohm line from the output of the amplifier to the speaker selector terminals. This distance may be up to several hundred feet. When the selector box has been placed at the general speaker location, any number of speakers up to six may be plugged in. A calibrated knob operated switch then is set for the correct impedance to match the number of speakers in use. Compared to the usual built-in selector this external unit has the added advantage of simplifying the speaker wiring. Where the speakers are placed at a considerable distance from the amplifier this results in an increased saving in wire cost to the user.

As standard equipment this *Airline* amplifier is fitted with plug-in electrolytic filter condensers; the kind which up to now were available only for police radio, military and naval communications, etc. Stepping even further, in an effort to provide uninterrupted service, *Airline* engineers have designed a new blow-proof condenser as optional filter equipment. This special permanently installed condenser is guaranteed un-

conditionally against blow-out for 10 years. This feature as well as remote control is available, if desired, on the *Airline* 30-, 50-, 75- and 100-watt DeLuxe Amplifiers. The 75-watt amplifier uses 14 tubes while a total of 16 are incorporated into the 100-watt size which uses six 6L6G's in push-pull parallel. Case appearance and dimensions are the same for both 75- and 100-watt amplifiers. Size: 23 by 13½ by 10 inches high. Operation is from 105- to 125-volt, 60-cycle a.c.

RADIO AND CLOCK MODEL BY SONORA. *Sonora Radio & Television Corp.* of Chicago currently presents a new and distinctive compact table model radio—a 5-tube a.c.-d.c. Superhet, tuning 535-1720 kc. This new

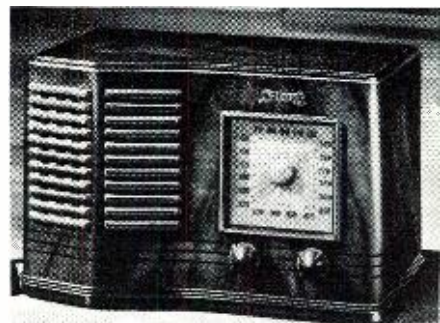

radio has the built-in "Sonorascope" loop which eliminates the need for ground and aerial; Automatic Volume Control; Dynamic Speaker; Square Clock-type Dial with handsome Gemloid face. The cabinet is of an entirely original design, created of rich walnut veneers, hand-rubbed to an expensive-looking piano finish. Style notes are the unusual overlay lattice-type grille and the attractive inlay trim stripes that follow the graceful contour of the cabinet. Size: 9" long, 5½" deep, 5¾" high. Shipping weight, 7 lbs.

NEW MIDGET MOULDED CAPACITORS NOW AVAILABLE. For use in radio receiver and other similar applications requiring mica capacitors of small size and rigid mounting facilities, *Cornell-Dubilier* announces the new Type 8 unit illustrated.

Moulded in brown bakelite, the overall size of these new capacitors is 1⅝" x ⅝", with thickness varying from .25 to .4 inch, depending on the capacity. Insulated mounting holes, entirely independent of the terminal lugs, are moulded in the bakelite.

The standard units are available in capacities from .000001 mfd. to .01 mfd. Those up to .003 mfd. carry d.c. operating voltage ratings of 500; above this value the rating is 300 volts. Lugs are of tinned brass and the capacity and voltage ratings are clearly stamped on each unit.

In addition to the standard unit, the Type 8 is also available in low-loss, yellow bakelite and can be supplied on special order

with any or all of the following characteristics: capacity tolerance as close as plus or minus 2%, temperature aged, with salt-

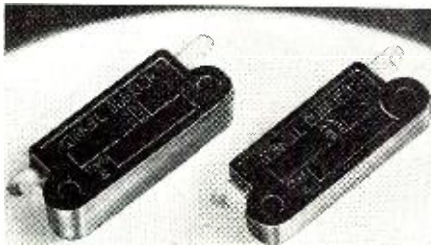

water immersion seal against humidity, and for d.c. operating voltage rating of 800.—*Cornell Dubilier Elect. Corp.*, South Plainfield, N. J.

NEW KNIGHT 6-TUBE A.C.-D.C. SUPERHET. *Allied Radio Corporation*, Chicago, announces a new, low-cost, 6-tube table model radio, Model No. B17100. A 2-band tuning range incorporates a domestic band from 535 to 1650 kc. and a short-wave band from 5.7 to 18.3 mc. Outstanding features include: high-gain "Magna-Beam" loop aerial (also contains provisions for outside aerial, if desired); big Slide-Rule Dial; 5-inch dynamic speaker; full A.V.C., etc. Two watts Beam Power output is fully developed by this superhet. An advanced 1941 circuit, licensed by RCA and Hazeltine, provides the latest tubes as follows: 12SA7GT, 12SK7GT, 2-12SQ7GT, 35L6GT, 35Z5GT. The cabinet, housing the *Knight 6*, is of the newest Continental type design, fashioned from choice walnut veneers, featuring softly rounded contours. Cabinet measures 13" x 6 $\frac{5}{8}$ " x 7 $\frac{1}{2}$ ". Operation is from 110-120 volts, 40-60 cycles a.c., or 110-120 volts, d.c. Model B17100.

A product of *Allied Radio Corporation*, 833 West Jackson Boulevard, Chicago, Illinois.

SYLVANIA PANEL LAMP KIT OFFERS REAL SALES AID. In a handy kit that a serviceman can easily carry with him on every

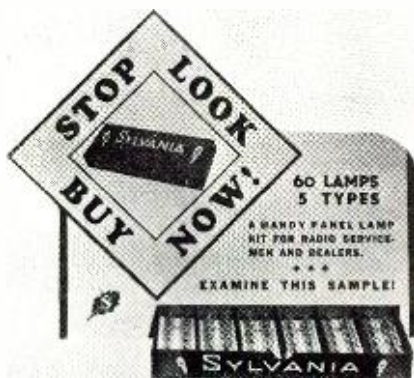

service call, *Sylvania* packs 60 Panel Lamps. These 60 lamps include 5 of the most popular types encountered in regular servicing work. Distribution is through *Sylvania* jobbers. On jobber counters you'll find Panel Lamp Kits being merchandised to the trade with the aid of a counter card that slips over the open kit.

The *Sylvania* Panel Lamp Kit is fast becoming standard equipment with alert servicemen who have a clear eye on extra profit opportunities.—*Hygrade Sylvania Corporation*, 500 Fifth Ave., New York City.

VULCAN ELECTRIC SOLDERING IRON PRODUCTION SET COMPRISES FOUR VULCAN DEVICES. Soldering Iron, Rheostat, Blower, and Supporting Stand to hold the Iron are

all included in this novel set. The stand can be supplied to hold the iron at any height or angle. The rheostat gives perfect heat control. The blower carries away all smoke and flux fumes from the operator, and permits a close, clear view while soldering on small assemblies. The exhaust of the blower may be piped to the outside air



if desired. Any size or style *Vulcan Electric Soldering Iron* may be used.—*Vulcan Electric Co.*, 600 Broad St., Lynn, Mass.

NEW EICOR CONVERTER NOW BEING MANUFACTURED. *Eicor*, Chicago, manufacturers of Dynamotors, Power Plants, Converters, and d.c. Motors, announce a new Converter design. This new unit is more compact, more modern, more convenient for portable or permanent use. It converts direct cur-



rent to alternating current for amplifiers, projectors, phonographs, radio receivers, transmitters, medical equipment, musical instruments, and other applications. Available for 6, 12, 32, 115, 230 volts, or other standard d.c. input—and have standard a.c. output. All-equipped with ball bearings. With or without filter. Built for high efficiency, quiet operation and long life. For full details, write to *Eicor*, 1060 W. Adams St., Chicago, Illinois.

NATIONAL DEFENSE NEEDS SPUR SPRAGUE SIZE REDUCTIONS. The perennial goal of smaller condenser sizes has been given further impetus by the government's request to reduce all non-defense uses of aluminum as much as possible. It will be no surprise to those who know *Sprague* to learn that their engineers have "come through" again. For example, *Sprague* 8 mfd. condensers, previously housed in an aluminum can 1 $\frac{3}{8}$ " in diameter have been reduced to a diameter of 1" . . . an aluminum saving of better than 35%. Users say that the new small sizes live up to specifications and functional characteristics in every respect.

Catalog of these and other *Sprague* units

may be obtained on request to the *Sprague Products Co.*, North Adams, Massachusetts.

NEW MIKE STANDS BY ATLAS. A new departure from the conventional microphone stand adjustment is offered by the "Trigger" principle introduced by *Atlas Sound*. The adjustment mechanism requires only a "touch-of-the-finger" in order to release the locking mechanism and permit vertical adjustment. The new telescoping-tube feature will eliminate "mike murder" and loss of composure on the part of speakers and entertainers, who formerly fussed and struggled with many types of customary twist-lock arrangements in order to adjust microphone height. The "Trigger" allows one-hand control at all times, permitting the microphone user the freedom of his other hand to hold a script or other object. The new "Trigger"

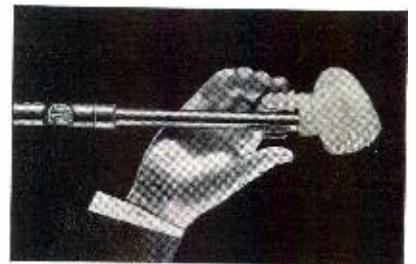

will be available on at least six of the microphone floor stands in the new 1941 line. *Atlas Sound Corporation*, 1449-39th Street, Brooklyn, New York.

LATEST RCA TRANSMITTING TRIODE. The 8005 is a new transmitting triode with a maximum plate dissipation of 85 watts in class C telegraph service. It is particularly useful in diathermy, class B modulator, and r.f. power amplifier service. The 8005 combines high power output with small size,

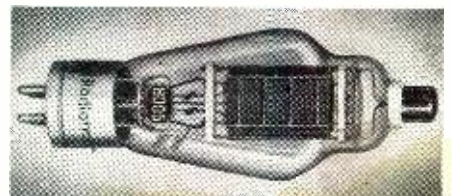

This combination has been made practical by the use of a zirconium-coated molybdenum plate, a ceramic-insert metal base, a plate-cap ceramic insulator, and a hard-glass bulb. A single tube in class C telegraph service (ICAS ratings) may be operated at a plate input of 300 watts with a driving power of only 7.5 watts. Maximum ratings may be used at frequencies as high as 60 megacycles.

Made by *RCA Manufacturing Co., Inc.*, Harrison, N. J.

NEW UNIVERSAL A.C.-D.C. COMMUNICATION RECEIVER. *Howard Radio Company*



announces a new communication receiver, (Continued on page 52)

# NEW TUBES

RCA announces a new series of vacuum tubes—RCA-9001, RCA-9002, and RCA-9003—designed for use by engineers, experimenters, and amateurs working in the ultra-high frequencies. These new types, known as Midget Tubes, are particularly well suited for FM, Television, and other applications requiring high-efficiency, high-gain circuits at unusual frequencies.

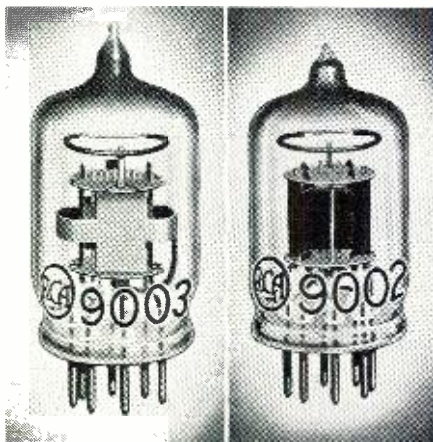

These Midget Tubes combine the bulb and base structure of Miniature Receiving Tubes with electrode structures similar to those employed in unipotential-cathode Acorn Tubes. Each tube has two cathode leads to permit the completion of the plate and screen r.f. circuits with a minimum of circuit inductance common to the grid circuit, and thus to provide increased gain at ultra-high frequencies. This double-lead feature is desirable because the effects of

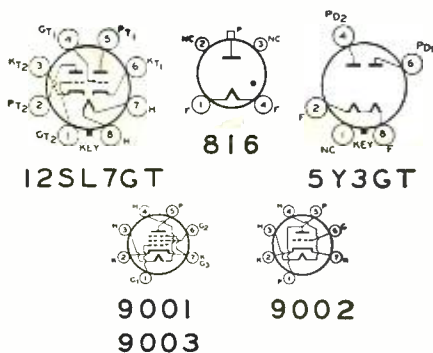

Socket Connection Data.

lead inductances increase rapidly as the operating frequency is increased. The single-ended design of the 9001, 9002, and 9003 has the added advantage of requiring a minimum of mounting space.

RCA-9001 is a sharp cut-off pentode intended for use as an r.f. amplifier or detector. RCA-9002 is a triode with moderately high amplification factor useful as detector, amplifier, and oscillator. In addition to its two cathode leads, the 9002 has two plate leads. The 9003 is a remote cut-off pentode designed for mixer and i.f. or r.f. amplifier applications. The super-control features of the tube make it very effective in reducing cross-modulation and modulation distortion over the entire range of received signals.

(More data on page 56)

# RADIO GADGETS

## Economy Class "B" Coupling

A VERY novel system used at W3CRB is herewith illustrated. It permits accurate match between a class "B" modulator and the final amplifier at a fraction of the cost of the usual Class "B" transformer. Other advantages are that the modulated amplifier may be operated at a considerable distance from the modulator over that normally employed with the usual Class "B" transformer methods. The system is considerably more flexible because it permits radical changes to be made in the tube complement and operating conditions at very little expense.

An ordinary push-pull output transformer (receiving type; tubes to speaker) is used. The voice coil terminals of one transformer connect to the voice coil terminals of the other, forming a line of low impedance. The plate connections for a single output stage are connected in the B+ lead to

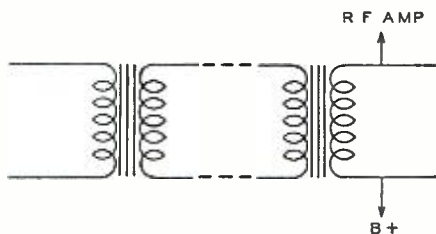

Diagram of the Coupler.

the modulated r.f. amplifier. Obviously, both transformers should have the same impedance for the voice coil winding, although slight differences may be ignored without going into involved mathematical impedance calculations. The line between the two transformers may be of almost any length, which permits the r.f. unit to be operated at some distance from the modulator. There is no reason why p.a. transformers could not be used for higher powered transmitters. Changing either the r.f. amplifier or the modulator necessitates changing only one transformer. Universal output transformers may be used, and need never be changed because of future changes in the layout.

Tubes like the 250, 45, or 71A would use the same transformer as one designed for 6L6's Class "A." Types 42 and 2A5 would use the same transformer required for 6F6's. In all cases, a single output transformer for a 6L6 may be used instead of a single output for the 250. The 250 transformer was specified only because it may be purchased cheaply from surplus stock in the hands of many dealers. For real economy midget

transformer replacements may be purchased for less than a dollar. For better quality, large full size transformers of the better makes will cost from a dollar up. The best buys are from surplus stock of large receiving transformers from mail-order houses or wholesale radio stores, or may be salvaged from sets junked by the radio serviceman, or radio dealer. It will be found that even a tiny midget output transformer will take considerable overload imposed by the r.f. amplifier. An ordinary midget pentode output has been operated at 90 ma. (60 watts input) for periods of over one-half hour at a time without undue heating. This is possible because receiving output transformers are usually conservatively rated inasmuch as they are subjected to long operating periods by the BCL's.

The modulating impedance of the Class "C" amplifier is calculated by dividing the plate voltage by the plate current. Increasing the plate current will lower the impedance, etc.

## Hammer-Scissors Gadget

Many servicemen and experimenters have old volume tone controls, or switches which could be put in service for a longer period of time if the lock washer which fits in the shaft groove could be removed easily so that the shaft and its associated apparatus could be removed in order to make repairs or to clean the unit. It is easy to remove this washer using an ordinary pair of scissors and a hammer.

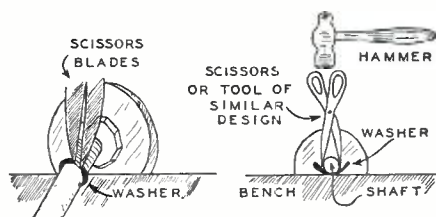

Scissors remove lockwasher.

Place the scissors' points between the two ends of the washer and, after resting the control shaft on a hard surface, use a hammer and tap the handle of the scissors which will force the washer to spread. It may then be removed easily from the shaft.

## Handy Filament Supply

An ordinary midget output transformer of the voice coil type may be used as a filament supply source for small tubes. A transformer designed for Type 45 tubes is shown connected to a 110 v. a.c. line and is used as a filament transformer to supply low voltages. Enough current will be

(Continued on page 56)





# RINGING THE BELL

by

SAMUEL C. MILBOURNE

## Profitable P.A. Prospects

SOME "authorities" are of the opinion that servicemen no longer require a list of types of possible p.a. prospects, because every serviceman is now supposed to be thoroughly familiar with the subject. That is about as sensible as stating that servicemen no longer require new tube booklets because they are thoroughly familiar with all tube types.

Every serviceman who has any intention of selling sound installations is in need of a compact listing of types of prospects for sound systems; and this listing will change from time to time as new uses for speech equipment are evolved, in the same manner as tube listings change by additions and deletions of tube types. To the end that you who do some selling of sound equipment (or who hope to) will have such a reference list, we have compiled a *Master Prospect List for Public Address Rentals and Sales*—52 sources of additional revenue to help you in *Ringling the Bell*.

We make no statement that this listing is 100% complete, because to do so would require more space in *RADIO NEWS* than available, and more time for research work than we could conveniently give to it. However, you can be assured that if you actually use this listing in hunting p.a. system prospects, it will return you real profits. In any rate, it is a very handy guide.



"Message for you! You're wanted for jury duty back in Indiana."

By studying the *Master Prospect List*, you will see that it lists 52 prospect types and locations for various sound installations. The lettered columns refer to the particular uses to which sound equipment can be placed in each location. The code is as follows:

- A—Sound reenforcement—voice.
- B—Sound reenforcement—entertainment.
- C—Sound reenforcement—orchestra.
- D—Sound reenforcement—individual instruments.
- E—Public Address—announcing or announcements.
- F—Public Address—call or page systems.
- G—Public Address—traffic control.
- H—Public Address—loading, unloading, docking.
- I—Public Address—Overflow meetings.
- J—Radio—Centralized or individual.
- K—Recorded music.
- L—Education—instruction.
- M—Recording.
- N—Entertainment—Sound effects.
- O—Entertainment—Supplementing live orchestra.
- P—Advertising or ballyhoo.
- Q—Demonstration.
- R—Alarm System.
- S—Chimes.
- T—Recorded organ music.
- U—Portable P.A. System at burial.

Thus, to determine the uses for a sound system at any of the 52 locations given in the *Master Chart*, you merely run your eye down the list to the proper location and then across the page, noting the columns in which cross-marks appear. Each cross-mark in a column denotes a probable use for sound equipment at the particular location. By referring to the coded list, these uses are found easily.

It will also be noted that sound reenforcement is listed as different from public address installations. This distinction is drawn to accent the difference between (1) locations which require moderate reenforcement of the voice, music, entertainment, etc.; and, (2) locations which require reproduction of these sounds (such as between rooms), or locations which are outdoor and in which the original sound would be lost in accompanying sounds (such as stadiums).

To sell sound equipment, you must first know *whom to sell*. The *Master Prospect List* is a guide in the answer of this important question. You can

make a 3x5 inch card file of actual prospects' names, addresses, etc., using the Master list as your basis, i.e., you can place on these cards the information about all the *manufacturing plants, offices, business clubs, country clubs, etc.*, in your section of the city (or your town), and then send each a letter explaining the various uses to which sound equipment can usually be placed in such cases. Follow this with a personal call on each prospect and an offer of a *Free Sound Survey*. A *Sound Survey* is a careful determination by the sound serviceman—salesman of the needs for sound equipment by the prospect, the types and quantities of sound equipment involved, and an estimate of the complete cost.

Next, it is absolutely essential that you *know your product*. Get all the information available from your sound equipment manufacturer. Study this literature. Talk to the manufacturer's or jobber's sound engineer regarding any problems which might face you. *Become thoroughly and completely sold on the brand of sound equipment you are selling*. Then, with *knowledge and conviction* you can approach your prospect with complete confidence of your ability to handle any job.

Third, you *must* approach the prospect with the idea in mind that you are trying to sell him a service. Keep the angle constantly before you that *you must show the prospect how the installation will help his business*, or you will not make the sale. For purposes of this discussion, you can consider *all* prospects are in business, whether that business be entertainment, religion, politics, recreation, institutional work, education, etc. You must find a *reason* for the prospect's possible purchase of *any* sound equipment. You must convince your prospect that the reason is a valid one. You must then convince him that *your* particular brand of sound equipment and *your* services are superior to any others. That is why it is well worth a serviceman's while to represent a well-known, established manufacturer of sound equipment—customer acceptance is so much easier.

While the chart gives most of the necessary information, the remainder of this article will be devoted to certain of the prospects and their special problems.

## Manufacturing Plants

What was written previously about  
(Continued on page 50)



The converted set takes on a most pleasing appearance. The escutcheon is cut from cardboard.

## Converting the SKY BUDDY

by LLOYD V. BRODERSON, W6CLV

Salinas, Calif.

***There are many communications receivers in daily use that may be changed into a combination transmitter-receiver by adding a few inexpensive parts obtainable in most ham junk boxes.***

**S**INCE its inception a few years ago, an increasing number of newcomers (and not a few old timers) have selected the *Sky Buddy* Model S-19R as their station receiver. This latest model incorporates such improvements as ten meter coverage and provision for d.c. operation.

It is not the purpose of this article to extoll the virtues of any one manufacturer's product; there are several excellent receivers on the market in the same price range as the *Buddy*. The changes made in one model by the author will serve to show how this and other receivers may be altered.

Some pleasing changes have been made in the receiver's outward appearance, such as colored control knobs, nickel plated self-tapping screws, chromium plated handles, a silver disk mounted over the speaker

grill, tip jacks for various voltages, and finally, a *complete low power transmitter* is housed within the receiver itself. In addition, provision has been made for keying the beat-frequency oscillator for use as a code practice unit.

Rather an imposing list of changes—but with a little judicious planning, all of the above may be accomplished at relatively low cost.

The photographs and layout diagrams are self explanatory and show clearly the outward changes that have been made. There are no complicated adjustments; a few hours at the work bench with an ordinary twist drill and the necessary components is all that is required.

The first operation should be the removal of the five black control knobs on the front panel. These may be

dipped in whatever color is desired, preferably vermilion or aluminum. A small can of fast drying enamel will be more than sufficient for the job. An 8-32 bolt is temporarily inserted in each knob as a handhold while being dipped.

The seven black screws are removed from the top cover and replaced with half round nickel plated self-tapping screws.

Four quarter inch holes are drilled in the lower right side of the cabinet to take four phone tip jacks. Two 6.3 volt heater leads are taken off at the socket connections of the 6SQ7 (second detector and first audio tube) and terminated at two of the jacks. The positive high voltage lead runs from one filament terminal of the 80 rectifier tube to the third tip jack. The remaining jack is merely grounded to

the chassis and serves as the negative high voltage terminal.

These connections give us 6.3 volts at 1.7 amps. and approximately 220 volts d.c. at 47 ma. which can be used for testing various equipment.

The five inch diameter disk covering the speaker grill may be cut from a piece of medium weight cardboard and given a coat of aluminum. When dry, two circles are inscribed near its outer circumference and the station's call letters imprinted in the center. The disk is glued to the four bolts holding the speaker; these points are free from crackle enamel and afford a good "bite" for mounting. An alternative would be to visit the local printing shop and have them print the circles and call letters. (Not all of us still retain our mechanical drafting instruments from bygone days.)

A three inch, or larger, chromium plated handle is mounted on each side of the cabinet. These may be procured from most hardware stores—even the local "5 and 10" stores carry quite a selection.

### Transmitter Construction

There is nothing tricky about the transmitting circuit of Fig. 1. It is standard in every respect and practically fool proof. The complete transmitter section is mounted on a presd-wood deck and given a coat of black crackle enamel. The layout diagram shows the placement of each part and the cut-out necessary to clear the 41 audio tube. Small bushings are used to raise the deck one and one quarter inches above the receiver chassis.

The entire unit may be wired before installation, it being necessary only to feed the heater, key and antenna connections through the receiver chassis after the unit has been mounted. If the deck has been positioned correctly, there will be sufficient clearance from the speaker and 41 audio tube.

Referring to Fig. 4 showing the connections made to the receiver's power supply, it will be noted that the positive high voltage lead is made at one of the filament terminals on the 80 rectifier tube socket. The negative high voltage lead can be at any convenient point on the chassis (ground). The two heater leads from the 6L6 tube are connected at the heater terminals of the 41 tube. All of our transmitter power requirements are taken care of by these simple connections.

The center-tap of the transmitter plate coil is connected to the .001 mfd. mica antenna series condenser and thence to the small feedthrough insulator mounted at the rear of the receiver chassis. Finally, a keying lead is run to the open circuit keying jack opposite the feedthrough insulator.

### Coil Data

The transmitter plate coil is designed to cover the 7 mc. band. It consists of 19 turns of No. 20 enameled wire wound on a one and one-half inch diameter form, and spaced to occupy



Plenty of spare room for parts is available in this popular receiver so that no crowding of parts is necessary to add the features specified.

a winding length of approximately one and one-half inches. The antenna connection is made at the center of the coil. To conserve space, a 50 mmfd. variable padder condenser is mounted inside the coil form.

Although designed primarily for the 40 meter band, other frequencies may be covered with appropriate coils and crystals.

### Antenna Coupling

The antenna is capacitively coupled

to the plate coil through the mica condenser, C2. This affords a simple means of terminating an end-fed 7 mc. antenna. Should the builder desire, inductive coupling could also be utilized by adding an antenna winding on the same form that holds the plate winding. The leads would terminate at two additional feedthrough insulators on the rear of the chassis. With these two antenna coupling methods, almost any type of radiator may be

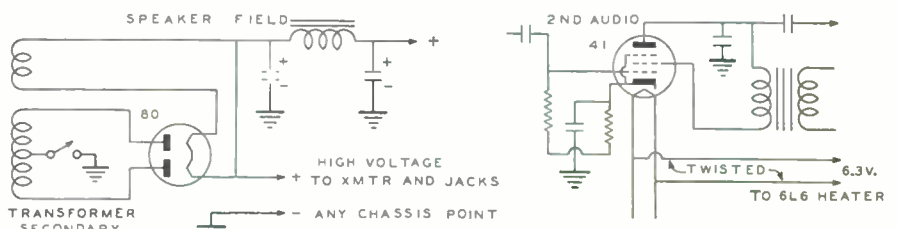

FIG. 4 - PORTIONS OF CIRCUIT DIAGRAM SHOWING POINTS AT WHICH 6.3V. AND 215 V. ARE OBTAINED.

Above: Added connections. Below: B.F.O. and transmitter wiring.

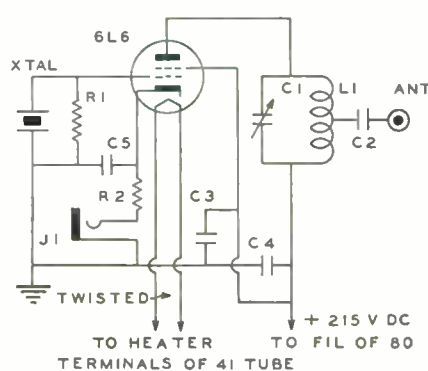

FIG. 1 - TRANSMITTER CIRCUIT.

- R<sub>1</sub>—75,000 ohms, 1 w., IRC
- R<sub>2</sub>—75 ohms, 10 w., Mallory
- C<sub>1</sub>—50 mmf. var., Bud LC1682
- C<sub>2</sub>—.001 mfd. midget mica, C-D
- C<sub>3</sub>—.01 mfd., 400 v. paper C-D
- C<sub>4</sub>—.006 mfd. midget mica, C-D

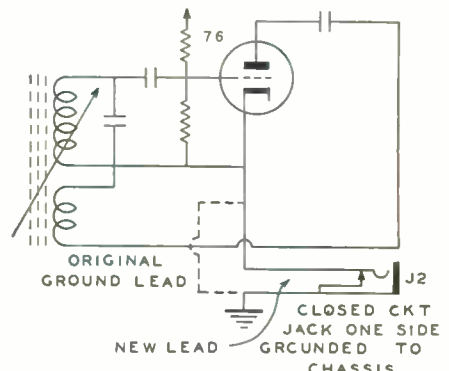

FIG. 2 - B.F.O. CIRCUIT SHOWING KEYING

- C<sub>5</sub>—.00015 mfd. midget mica, C-D
- C<sub>1</sub>—3-30 mmf. coupling cond., Hammarlund Mex
- J<sub>1</sub>—Open circuit jack, Bud
- J<sub>2</sub>—Closed circuit jack, Bud
- 1 1/2" 5-prong coil form, Bud
- Chassis—2 3/4" x 5 3/8" x 1 1/8" Preswood

employed. A midget variable condenser could also be mounted at the rear of the chassis for series or parallel tuning of Zepp feeders should this be found necessary.

It will be noted in Fig. 3 that the radiator used for transmitting also serves for receiving, making "break-in" operation possible. In order to isolate the r.f. from direct contact with the receiver coil windings, a small trimmer condenser (3-30 mmfd.) is inserted in series with the lead from feedthrough insulator to the receiver antenna terminal. This condenser is mounted at the rear of the post marked "A-1." A one-half inch hole may then be drilled in the bottom plate directly over the adjusting screw of the condenser. This obviates the necessity of removing the bottom cover should adjustment be necessary after the unit has been wired and re-assembled. Some de-tuning effect was noted on our model.

### Tuning Data

Tuning this little transmitter is simplicity itself. A neon globe of the one-half or one watt size is touched to the

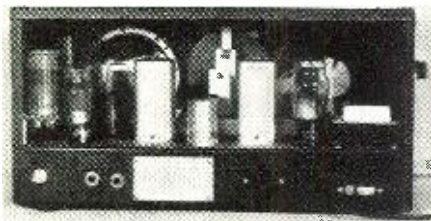

Rear view of changed-over Sky Buddy showing added coil form.

antenna terminal and the midget padding condenser adjusted with an insulated rod until the globe indicates maximum brilliancy. With plate voltage around 200, crystal current will be extremely low. The 6L6 should draw

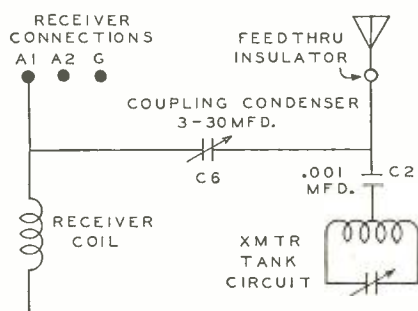

FIG 3—COUPLING CIRCUIT FROM XMTR TANK TO RECEIVER ANT. COIL:

approximately 25 ma. (.025) at which reading an input of five watts is represented.

It should be borne in mind that the receiver's power transformer is designed to deliver approximately 245 volts d.c. at 47 m.a. (.047). Taking into consideration the current drawn by the receiving tubes and the 25 ma. (Continued on page 55)



by JERRY COLBY

ALTHOUGH we have received numerous letters from well-meaning but entirely selfish radiops who feel that the six months law should not have been liberalized, we still feel that the passage of the bill which enables well-qualified radio operators and technicians to man the numerous vessels now being put into commission is doing the national emergency a favor. We hear from all sides that radiops are as scarce as hen's teeth. Yet there are those "dogs in the manger" who would forget the present emergency for some exclusiveness in the dismal and distant future. We have on file letters from radiops who can stand an efficient watch with operating ability and technical efficiency beyond question, yet unable to gain admittance into the holy sanctuary because they lack the six months experience. Perhaps it isn't news to many of our readers, but to those who have not been following this column may we enlighten them that it was this column which advocated and was instrumental in pushing through the six months' experience bill some six years ago. We firmly believe that this practical experience does aid a newcomer to learn the ropes and gain confidence. But we believe that during this national emergency a radiop who is willing to take the chance should have the billet when seasoned veterans are not available so that needed bottoms should not be tied up to rot at some dock.

HERE'S a typical letter from a radiop without the six months' experience . . . "for the past eight years I have been operating on the lightships in the Pacific Northwest District but feel the need of a change as the job is beginning to get stale or I am getting fed up on it, I'm not sure which. Have never thought much before about membership in the unions or very seriously considered commercial jobs as it seemed that this job was good for from here on out and there were some promotions to look forward to. But now that the Coast Guard has absorbed the Lighthouse Service only the enlisted men have anything to look forward to in the line of promotions . . . would not care at all for an overseas run but would prefer something of coastwise or intercoastal nature. Or there may be some other assignments that I am not familiar with that would be acceptable. Having my home in Oregon naturally would want something that would allow me to get home occasionally, even for just a short time. . . ." If this man's past experience isn't sufficient to permit him to stand a capable watch, then ye Ed doesn't know his radioping. And there are many, many more like him.

AND from A. B. Anderson, roving and dynamic delegate of the Radio Officers Union, comes this appeal quote Say, OM, do us a favor will yuh and put out an SOS in your column for license holders desirous of going to sea to get in touch with the ROU immediately, if not sooner. All ports are going daffy trying to dig up men. It's awful. Give it a write up in Capitals and tell them where to write or call: Fred M. Howe, ROU, Rm. 1511, 265 W. 14th St., New York City; Andrew MacDonald, ROU, 14 East Lexington St., Baltimore, Md.; David D. Barry, ROU, Rm. 406, 170 Summer St., Boston, Mass.; Charles Luck, ROU, 349 Barrone St., New Orleans, La.; Andrew B.

Anderson, ROU, Rm. 402, 110 Market St., San Francisco, Calif. . . . And tell them about the high wages, officers status, paid vacations, nice new ships with short wave and inter-mediate equipment, etc. . . . We need First Class ticketmen bad and can also use plenty of Second Class inexperienced men. Do your stuff, OM. Signed A. B. Anderson . . . Unquote. Which ought to make those who would quibble over details realize that mere experience should not overshadow the necessity for shipping much needed cargoes over to the embattled democracies.

ONE of our correspondents writes in thusly quote . . . seems most of my time these days is digging up info for the FBI and NI . . . They sure are going at it hammer and tongs . . . investigating. I believe that the Navy is not going to take over the Merchant Marine radio rooms; I'm pretty sure of this. However, there is no doubt whatever but what they are going to purge all American ships of known or suspected commies. I don't know just when the boom will fall, but I think things are being arranged so that action can be taken very shortly. The commies seem to have gotten wind of what is in store for them as lots of them are deserting their ships and disappearing. Quite a few of them, those who think their political affiliation is unknown, remain and are keeping awfully quiet. They, too, will have to go and you can bet your last buck on that. The FBI and NI aren't fooling. It sure is too bad that there are some radiops who are so darn stupid and can't seem to grasp the fact that "birds of a feather flock together" so that they will be on a spot. Your articles have done quite a bit of good among the old timers, but the youngsters just can't be convinced. I've heard that the FBI goes aboard every ship in Seattle. I am told that the same thing will take place in Frisco, starting next week. San Pedro ships will also get the same treatment. I have been contacted by G2 who want me to give them the names of known or suspected subversives who have gone into Army Service. They, too, are worried. Guess it's all because of how the Nazis took over Europe by infiltration. Well, OM, I guess Uncle Sam is now awake and what happened in Europe is not going to happen here . . . unquote.

BROTHER Anderson of the CTU sez that he was in Seattle for the past five weeks where he lined up enough men in the Alaska SS Co., the Alaska Trans. Co. and the Northland Trans. Co. to file for elections. He is now in Frisco getting things in readiness for NLRB elections in several inter-coastal and off-shore companies. He also states that Arthur H. McKinley, wounded in the last world war with the Canadians, very anti-anti quit the Matson freighter, SS Diamond Head, in Pedro and went to Frisco to take out the CTU controlled SS Alcoa Pilgrim. He was getting \$137.50 on the Diamond Head and will now receive \$185.00 plus a 25 per cent bonus for going to Halifax, N. S. on the Alcoa Pilgrim. Quite a different wage scale. . . . The Maritime Commission is taking forty (40) inter-coastal ships from the West Coast presumably for the Red Sea run. Several of these ships will come from the Amer. Hawaiian Line, a couple from Matson and four (Continued on page 66)

# Design Data for Modern Inter-Comm.

by **H. I. GLUNZ**  
Hicksville, Long Island, N. Y.

**Complete engineering data given that will  
permit accurate design for inter-comm's.**

**S**INCE the advent of two way or inter-office communication systems in the commercial market, there have been few systems which performed in an efficient manner over more than a short period of time.

The system which is designed here is simple in operation and comparatively efficient, consisting of a Hartley shunt fed oscillator, frequency modulation, single stage amplification, diode detection, output transformer to the speaker, and, of course, a power supply. The system is not only comparatively efficient but compact and very mobile.

Figure 1 shows the schematic of the circuit. As all of the other positions are identical, they are represented by blocks with the transmission lines running to their respective positions.

The oscillator design will now be explained in full.

Using a 6N7 tube twin triode, two tube operation can be obtained in one envelope, thereby obtaining a saving in space.

$$P_{hi} = E \times I = 6.3 \times .8 = 5.04 \text{ watts.}$$

$$I_{max} = 100 \text{ mills.}$$

$$I_{max \text{ osc}} = 40 \text{ mills.}$$

$$I_{max} = K \left( E_c + \frac{E_p}{\mu} \right)^{\frac{3}{2}}$$

As the constant K in formula 1 is governed by tube dimensions, then it will be necessary to know the value of K in that we may obtain the maximum emission of the heater without reaching a point of saturation. We now transpose and solve for value of K.

$$K = \frac{I_m}{\left( E_c + \frac{E_p}{\mu} \right)^{\frac{3}{2}}} = \frac{6}{\left( \frac{130}{35} \right)^{\frac{3}{2}}} = \frac{6}{7.3} = .82$$

The next step will be to find the instantaneous value of grid voltage. By reference to formula 1 we can transpose and obtain this value.

$$I_m^2 = K^2 \left( E_c + \frac{E_p}{\mu} \right)^3 \quad \frac{I_m^2}{K^2} = E_c + \frac{E_p}{\mu} = \mu E_c + E_p$$

$$\therefore E_c (1 + \mu) = \mu \left( \frac{I_m}{K} \right)^{\frac{2}{3}}$$

then

$$E_c = \mu \left( \frac{I_m}{K} \right)^{\frac{2}{3}} = \frac{35 \left( \frac{40}{.82} \right)^{\frac{2}{3}}}{1 + \mu} = 13.1 \text{ volts.}$$

There will be a maximum of 13 volts applied to the grid, but to allow a safety factor of 3 volts in order to eliminate any possibility of a breakdown the future calculations will be based on 10 volts on the grid.

The minimum plate voltage will have to be determined in order that the plate is not allowed to go to a negative value with regards to the grid.

$$E_{p \text{ min}} = \mu \left[ \left( \frac{I_m}{K} \right)^{\frac{2}{3}} - E_c \right] = 35 [13.1 - 10] = 105 \text{ volts.}$$

$$\therefore E_{c \text{ max}} = 10 \text{ volts.} \quad E_{p \text{ min}} = 105 \text{ volts.} \quad \theta = 140^\circ$$

We shall now compute the ratio of the d.c. to maximum and the ratio of the a.c. to maximum that will be flowing in the oscillator section of our circuit.

$$\frac{I_{D.C.}}{I_{max}} = .22 = 40 \times .22 = 8.8 \text{ mills D.C.}$$

$$\frac{I_{A.C.}}{I_{max}} = .38 = 40 \times .38 = 15.2 \text{ mills A.C.}$$

Allowing 15% of the total d.c. value for current flowing in grid circuit.

$$I_g = 1.2 \text{ mills.}$$

The grid biasing voltage will now be calculated from the equation.

$$E_{c \text{ bias}} = \frac{E_p}{\mu} + \left( E_{c \text{ max}} + \frac{E_{p \text{ min}}}{\mu} \right) \frac{\cos \left( \frac{\theta}{2} \right)}{1 - \cos \left( \frac{\theta}{2} \right)}$$

$$= \frac{250}{35} + \left( 10 + \frac{105}{35} \right) \frac{\cos \left( \frac{140}{2} \right)}{1 - \cos \left( \frac{140}{2} \right)}$$

$$= \frac{250}{35} + \left( 10 + \frac{105}{35} \right) .5$$

$$E_{c \text{ bias}} = 13.6 \text{ volts.}$$

The grid leak resistor will now be computed.

$$R_g = \frac{13.6 \times 1000}{1.2} = 11,000 \ \Omega$$

And as the plate current will be equal to the direct current flowing in the plate minus the grid current or

$$I_{P \text{ D.C.}} = I_{P \text{ D.C.}} - I_{g \text{ D.C.}} = 8.8 - 1.2 = 7.6 \text{ mills.}$$

$$I_{P \text{ A.C.}} = I_{P \text{ A.C.}} - I_{g \text{ A.C.}} = 15.2 - (1.2 \times 2) = 12.8 \text{ mills.}$$

$$P_{in \text{ D.C.}} = 250 \times 7.6 = 1.9 \text{ watts.}$$

$$P_{A.C.} = \frac{(E_{max} - E_{min}) I_{A.C.}}{2} = \frac{(250 - 105) 12.8}{2} = .92 \text{ watts.}$$

$$\% \text{ Efficiency} = \frac{\text{output}}{\text{input}} \times 100 = \frac{.92}{1.9} \times 100 = 48.5\%$$

The circuit constants will now be given consideration.

$$E_c = E_c + E_{c \text{ max}} = 10 + 13.6 = 23.6 \text{ volts.}$$

The calculation and configuration of the turns in the oscillator coil can be determined by referring to *Bureau of Standards Circular No. 74 Radio Instruments and Measurements*.

Calling  $N_T$  or turns in tank inductance then

$$N_T = N_P + N_c$$

$$\frac{N_c}{N_P} = \frac{23.6}{145} \therefore N_c = N_T \left( \frac{23.6}{145} \right)$$

The tank inductance and value of the grid leak condenser are now made therefore as

$$R_{eq} = Q \omega L$$

$$E = \sqrt{P \omega L Q_{eff}} \therefore E^2 = P \omega L Q_{eff}$$

$$L_{th} = \frac{E^2}{P \omega Q_{eff}} = \frac{145^2 \times 10^6}{21,000 \times 2\pi \times 6.28 \times 10^5 \times 50} = \frac{21,000}{29} = 727 \ \mu\text{h.}$$

(Continued on page 58)

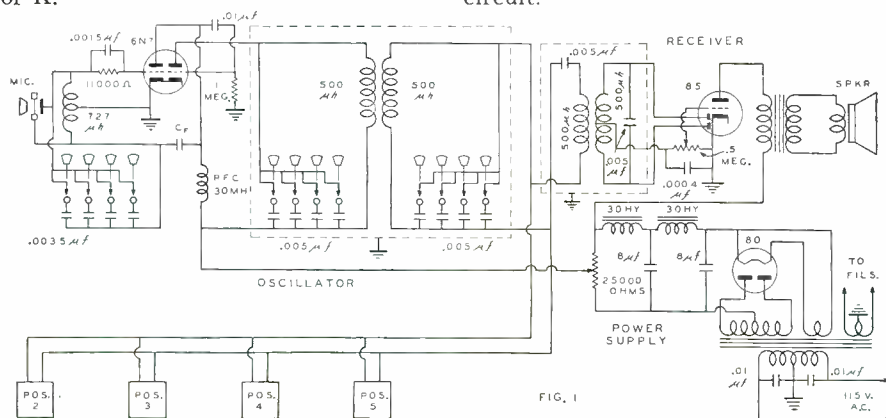

Wiring diagram of the F.M. Intercomm.

**"RADIO ENGINEERING HANDBOOK."** 3rd Edition, by Keith Henney, Editor-in-Chief Member, The Institute of Radio Engineers, author of "Principles of Radio," "Electron Tubes in Industry"; Editor, "Electronics." The book contains 945 pp., including index. Published by McGraw-Hill Book Co., Inc., 330 W. 42nd Street, New York, N. Y. Price, \$5.00. In preparing new material and in revising existing material for the 3rd Edition, the same principles were followed as in the first edition. An endeavor has been made to prepare a comprehensive working manual of the radio science and to compile in a single book concise information on each of the branches of radio engineering. As in earlier editions, there is in this volume a considerable amount of what may be called fundamental background, but the emphasis is on practice rather than on theory.

Each of the sections has been brought up to date. Several have been completely rewritten, notably those on Television, High-Frequency Technique, Loud-Speakers, Acoustics, Detection and Modulation, Facsimile, and Aircraft Radio. In each of these fields, much progress has been made since 1935. The authors of the individual sections have the requisite theoretical background as well as the very necessary practical experience in the field.

The engineer will find in this book many man-hours of effort compiled in the form of tables, in curves, and converted into concise English by the engineers, physicists, and teachers who have aided the editor in preparing this new edition. Copies are available from McGraw-Hill Book Co., New York, New York.

**RCA GUIDE FOR TRANSMITTING TUBES**, published by the *RCA Manufacturing Co., Inc.*, Camden, N. J., U.S.A., price 25c per copy. The *RCA Guide* for Transmitting Tubes is dedicated to the power tube fraternity. It contains technical information on a most extensive line of modern-air-cooled transmitting tubes. In it are described such tubes as *RCA's* new U.H.F. midget types, the new low-cost push-pull beam type, the efficient low-cost half-wave mercury-vapor rectifiers. Complete data supplemented by carefully proven circuits show how *RCA* Transmitting Tubes may be utilized to their best advantage. Outstanding feature of the new *RCA Guide* is its transmitters, designed, constructed and tested specifically for description in this book. They represent a wide range of application and meet modern demands for transmitter simplicity coupled with efficiency, economy, and flexibility. They are designed to do a job. In presenting the *RCA Guide*, the publishers believe that it will be most helpful to engineers, experimenters, and amateurs in the field of radio communication. Copies are available by writing to the *Commercial Engineering Section, RCA Manufacturing Company, Inc.*, Harrison, N. J. Price, 25c.

**MOST OFTEN NEEDED 1939 RADIO DIAGRAMS**, compiled by M. N. Beitman, and published by *Supreme Publications*, 3727 W. 13th Street, Chicago, Illinois. Price, \$1.50. Accurate radio diagrams are needed to repair sets quickly and properly. In this one manual you will find all the popular 1939 diagrams you really need. All sets, which have been sold in large quantities during the 1939 radio season, are included. The most  
(Continued on page 64)

# MANUFACTURERS' LITERATURE

Our readers are asked to write directly to the manufacturer for this literature. By mentioning **RADIO NEWS** and the issue and page, we are sure the reader will get fine service. Enclose the proper sum requested when it is indicated.

**RCA ISSUES NEW GUIDE FOR TRANSMITTING TUBES.** 72-Page Book Describes 69 Tubes, Five Transmitters, 150 Circuits. *RCA's* finest and most complete engineering and amateur guidebook on transmitting tubes is now off the press and is being made available through *RCA* Tube and Equipment Distributors throughout the country.

It contains comprehensive data on 69 air-cooled transmitting tubes, including the new important types 815, 816, 8000, 8001, 8005 and the Midget Tubes 9001, 9002, and 9003. Complete data supplemented by carefully proven circuits show how *RCA* transmitting tubes may be used to the best advantage. The book contains 150 circuits and illustrations and is twice the size of last year's edition.

The outstanding feature of the new Guide is found in the transmitter designs which are shown in great detail. They were designed, constructed and tested specifically for inclusion in the book.

Among the transmitters is included complete constructional information on a plate-modulated *RCA-815* transmitter operating from 2½ to 20 meters, a high-power single-control 813 transmitter, an 809 economy transmitter and others.

All of the equipment described represents a wide range of application and meets modern demands for ready transmitter simplicity coupled with efficiency, economy and flexibility. Price is 25 cents a copy. Copies may be obtained from all *RCA* Tube and Equipment Distributors or direct from *RCA Commercial Engineering Section*, Harrison, N. J., by enclosing the proper remittance.

**NEW JONES CATALOG ILLUSTRATES NEW PRODUCTS.** A new 20-page catalog, known as No. 11, has just been released by *Howard B. Jones*, 2300 Wabansia Avenue, Chicago, Illinois, illustrating and describing their complete line of multi-contact plugs and sockets, terminals, terminal panels, fuse mounts, etc.

It includes their "300," "400" and "500" series plugs and sockets, hundreds of terminal panels for every inter-connecting requirement, barrier strips, bulk terminals; and shows several new items recently added to the line.

A copy of this catalog will be sent free upon request to *Howard B. Jones*, 2300 Wabansia Ave., Chicago, Ill.

**NEW AIRLINE TWO EDITION SOUND CATALOG NOW READY.** "Simplified Sound Systems" is the intriguing title of a new Sound Equipment Catalog just released by *Montgomery Ward & Co.*, Chicago, Ill. It is published in two separate editions. The first directed to the entertainment field, gives helpful information in selecting the proper size amplifier for Orchestras, Skating Rinks, Entertainers, Fairs, Carnivals, Ballrooms, and Banquet Halls.

The second edition also helps the prospective user to choose wisely the equipment best suited to his needs. However, this issue is written to be of the greatest benefit to Churches, Evangelists, Schools, Mortuaries, Auditoriums and Chapels. Chimes-in-the-Steeple Recommendations are also given.

The new lines of *Airline* Amplifiers and associated sound equipment are presented in both editions. Shown and described are the Standard a.c. amplifiers, the new Deluxe a.c. line, the latest group of exclusive Three-Way Sound Systems, the Standard 6 v. d.c.-110 v. a.c. amplifiers and the Deluxe 6 v. d.c.-110 v. a.c. amplifiers. A "package" Church Chime System and School System is also listed. In addition a full line of nationally known recorders and accessories are presented. This is supplemented with many new record players, changers, speakers, microphones, baffles, trumpets, projectors, etc.

A copy of either edition is available by writing to *Montgomery Ward & Co.*, 618 W. Chicago Ave., Chicago, Ill.

**LEAROMATIC NAVIGATOR, A NEW BASIC INSTRUMENT FOR FLYERS DESCRIBED IN LATEST CATALOG.** The *Learmatic Navigator* is a new basic instrument for navigation of aircraft. It ushers in a new era in air safety by supplying the pilot, automatically, with a continuous graphic solution of many navigational problems, including instrument approach and landing. In common with all other *Lear Avia* products, the *Learmatic Navigator* has been designed by pilots for pilots.

A complete description of this new instrument will be found in this new catalog sheet, now ready for distribution. The instrument is conceded by many to be the most important contribution to the art of air navigation developed in the last decade.

Copies may be obtained from *Lear Avia, Inc.*, Dayton, Ohio.

**GENERAL CEMENT RADIO CHEMICALS AND PRODUCTS, CATALOG No. 142.** Many new items are listed in the latest catalog published by the *General Cement Manufacturing Company*. Some of these include service cement in new type bottles, hammer finish kits, new cabinet repair kits, new phonograph needles, phono-stylus set screws, wire strippers, new hardware items, new switches, dial cables, new radio knobs and knob pullers. Many of the regular items have been improved to make them more practical and salable to the customers. Due to existing conditions, say the manufacturer, we can't say how long we will be able to supply all of the merchandise, but we will do all that we can to insure giving prompt service. Many other items are contained in the catalog, which includes 36 pages. Copies are available from the *General Cement Mfg. Co.*, Rockford, Illinois, U.S.A.

**JANETTE ROTARY CONVERTERS—DYNAMOTORS, BULLETIN 13-25.** This new bulletin supersedes No. 13-25 published in January, 1941, and includes a very complete line of Dynamotors and Rotary Converters to meet all requirements. These units are suitable for commercial, domestic, amateur, and military applications. By offering a wide variety of units, the prospective purchaser will find it easy to solve his particular problem. Many improvements have been made in this famous line of converters-dynamotors. Of particular interest is an  
(Continued on page 59)

# The VIDEO REPORTER

by Samuel Kaufman

**W**ELL, it's just as we predicted! The Federal Communications Commission has authorized commercial television and—as we write these lines—holders of experimental licenses are squawking over some of the Government's "musts." Many of the video participants are particularly burned up over the requirement of a minimum telecasting program service of fifteen hours a week and there is such strenuous objection to this provision that some minor revision on the part of the FCC might be forthcoming.

July 1 was the designated starting date for commercial service by stations meeting FCC requirements. And, judging by the many years of experimentation and intensive program development of leading networks and laboratories, it would seem as if the contenders for television supremacy would leap down the track at the word "Go!" But they've been toeing the mark for such a long time that their muscles are stiff and creaky.

When the word "Go!" did come, they found that their reflexes didn't respond and that they required a bit of a rub down.

But instead of a rub down, certain prominent contenders for television leadership

are now worried about being rubbed off the video roster.

The networks are so alarmed over another FCC ruling—the one calling for a new order of the day for radio chains—that they're too scared to do anything about further television expansion.

The two FCC orders—the one regulating network operations and the one sanctioning commercial television—were not connected on the surface. But some observers, reading between the lines, seem to think that the networks won't dare to attempt to snatch too great a claim on video development.

Without taking sides in the battle between the FCC and the networks regarding the latter's status as "a monopoly," it seems apparent that the networks had long taken it for granted that television was "their baby." They had a cock-sure attitude about this and, to an extent, considering their financial investment in video progress, they may have rated a certain leadership. But they seem to have taken too much for granted and, now, standing in the public spot under the Government charge that they are a monopoly, it certainly doesn't seem wise to leap in television with all their resources at this time.

It seems that the FCC charges will have to simmer down before television, insofar as network participation goes, will really go to town!

**C**OMMERCIAL television standards, as of July 1 (the Government's designated starting date) will be 525 lines at 30 frames per second.

The boosting in the number of lines does not worry the potential participants as much as the shift to frequency modulation for the sound portion of their eye-and-ear shows. This means an additional investment to transmitters that were thought to be all ready to go.

It may be significant that there has not been an early start in revamping the old 441-line receivers in use in the New York

area. While it is best to make the necessary adjustments when the new-type transmissions are actually on the air, there is more than a bit of skepticism that considerable delays may be experienced before actual commercial telecasting on the new standards is available.

**T**HE Radio Corporation of America, perhaps feeling that it will be a long, long time before it will realize profits through receiver sales or through television sponsors on its network subsidiary stations, is looking for new means of video income and has launched a powerful campaign for the introduction of television equipment into theatres. That is, the campaign got off to a powerful start. But a few days after the opening gun, the shouting simmered down to a murmur—and an occasional moan.

A full dress show was staged for theatre owners at the *New Yorker Theatre*. The featured event (conveyed over wirelines and not available to home look-and-listeners) was the middleweight championship prize-fight between *Billy Soose* and *Ken Overlin* which originated in *Madison Square Garden* a few blocks away. There were many embellishments, including newsreels, a playlet and other television features.

But, alas, the result—to this observer and many others he queried—seemed flatter than an anemic flounder caught under a steamroller.

From the program-building end, the effort was worth a bit of praise, but the pickup, particularly that of the prize-fight, was a poor job. And it was the fight that was the featured event of the evening.

It is our guess that RCA is off on the wrong track if it is attempting to give priority to theatre television. While this represents a tremendous field for the future, the shortage of "special event" material—and this is the only thing that would pack television equipped theatres—is obvious. And we doubt whether a great number of theatre

(Continued on page 61)



## Here are your KNIGHT "BIG THREE" Value Leaders for Greater P.A. Profits! RENT THEM—INSTALL THEM—EARN MORE WITH THEM!



**1 30 WATT PORTABLE SYSTEM**  
The PA Favorite—packed with deluxe features! Has 3 Input Channels; Inverse Feedback; Bass-Treble Control; Phono Top (optional); Safused Speakers; Speaker Selector; Illuminated Panel; etc. System includes: Knight 30 Watt Amplifier; Shure Crystal Mike and Stand; 2—12" Dynamic Speakers, tubes—all in portable, compact case for convenient use. As illustrated.  
**YOUR PRICE (less phono top and meter) \$57.75**



**2 15-18 WATT MOBILE SYSTEM**  
An "all-out" Value! Works from 6 volts or 110 volts. Has Dual Input; Inverse Feedback; Built-in Phono; Bass-Treble Control; Speaker Selector; Standby Switch; Safused Speakers; Illuminated Panel; etc. System includes: Knight 15-18 Watt Amplifier; Shure Crystal Mike and Stand; 2—12" Speakers in projectors; tubes. Ideal for all indoor-outdoor applications.  
**YOUR PRICE..... \$71.90**



**3 50 WATT CARDIOID SYSTEM**  
A new deluxe idea in Sound! Has everything: 6 Input Channels; Dual Tone Equalizers; Electronic Mixing; Inverse Feedback; Power Driver; Speaker Selector; Safused Speakers; Illuminated Panel; etc. System includes: Knight deluxe 50 Watt Amplifier; Shure Cardioid Mike and Stand; 2—12" Dynamic Speakers; 2—Steel Projectors; tubes, etc.  
**YOUR PRICE (less phono top and meter) \$107.50**

KNIGHT Sound Systems are available to Service-Dealers and Sound Men on attractive Time Payment Terms. Write for full details and 15 Day Trial Offer. You'll be 'way ahead with the new KNIGHT PA!

### ALLIED RADIO CORP.

833 W. Jackson Blvd., Dept. 1-SH-1, Chicago, Ill.

#### GET THE FULL DETAILS

Write today for data covering these "BIG THREE" PA Value Leaders. Ask for our explanatory chart on how to choose the right PA System for any installation. Or submit your PA problems to ALLIED Sound Engineers—competent advice is based on individual problems. No obligation. Address Dept. 1-SH-1.



★ **KILL** the  
**Feedback Fiend**  
 with a Shure  
 ★ **CARDIOID**

It's a  
**Knockout**



You've got feedback licked the moment you hook up a Cardioid. You can notice the difference *at once*—even under the roughest acoustic conditions—indoors or outdoors. You get *more volume without feedback*—you pick up the sound you want without interference from background noise or reverberation—you simplify every installation—because the Cardioid is *dead at rear!* Check these facts—with your Jobber or write us. Replace now with Shure Cardioids. Uniplex Crystal at \$35.50 list Unidyne Dynamic at \$47.00 and \$49.50 list.



*Patented by Shure Brothers, Crystal Microphones licensed under Brush Patents.*

**SEND FOR FREE CATALOG**

SHURE BROTHERS  
 225 W. Huron St., Chicago, Ill.  
 Send me free Catalog 153N.

Name.....  
 Address.....  
 City.....State.....  
 Occupation.....

**British Radio**  
 (Continued from page 7)

ham would find a great deal of the equipment similar to present-day commercial receiver and transmitter circuits.

It doesn't take too much imagination to fill in some of the missing details. Whether frequency-modulated or amplitude-modulated waves are used, whether the frequency of the waves is measured in meters or centimeters, and just how the system can be made to give such accurate results, all are closely guarded military secrets of prime value.

However, it may also be stated that Radiolocators have improved the efficiency of the Observation Corps several times over any previous method, and Radiolocators can be credited with reducing greatly enemy activity over Britain.

The Radiocator system was developed in England by *Robert Alexander Watson Watt*, a Scottish scientist attached to the *Air Ministry*. It was no "flash out of the blue," but was the result of patient laboratory research on the part of *Watt* and a group of distinguished scientists. Actually, the system has been a young man's development, being evolved in an endless series of what we might call "Hamfests." *Watt* is a chubby-faced man with a Puckish grin and a distinctly humorous strain. He has a brilliant mind as is shown by the often intricate and delicate apparatus devised by him and his conferees.

A point of interest to all dyed-in-the-wool radio experimenters is that back in 1935, after the first tests with crude apparatus assured the inventors that planes could be spotted by radio, months were spent in painstakingly building most of the equipment by hand. The finished job didn't look like a modern streamlined version of a Communications receiver, but the fact was that it worked with such range and accuracy that it proved itself immediately.

The important point to grasp in this whole proposition is that the art is an entirely new one—so new that a name had to be coined for it—*Radiolocation*. It is a field which has vast future possibilities, because *Air Chief Marshal Sir Philip Joubert* has made the statement that, when peace comes, the art of Radiolocation will be applied to commercial aviation and will add greatly to the safety of flying. It may also be used on ships to guard against a collision between ships, or against piling up on a treacherous reef. In fact, speaking about its use at sea, *Radiolocators may be the answer to the submarine menace!!*

Thus, we can get a peep into the future and visualize a completely new branch of radio work—Radiolocation. So far, although the United States has a reciprocal agreement with Britain on such devices and thus has full information on the art of Radiolocation,

there is no opportunity at present in this country for radiomen to study and become experienced in this new art.

However, American radiomen have a prime opportunity to learn all about the art of Radiolocation right at the "horse-trough," so-to-speak. The British, as all the newspapers have announced, are looking for thousands of American radio-men and women to manufacture, operate and maintain these devices on the British Isles. These adventuresome souls will be formed into an organization known as the C.T.C. (Civilian Technical Corps) whose headquarters in this country is at 15 Broad Street, New York City.

Most radiomen are already familiar with the general facts about these jobs, but I was interested in learning a little bit more about the actual qualifications for acceptance, the training to be given volunteers, the possible danger involved and, above all, what life in the C.T.C. will be like.

One thing which immediately impressed me favorably was the leeway allowed applicants as to education and experience.

There are only three major qualifications. First, you must be over 18 and under 50. Second, you must be physically fit and of "sound" character, as the British put it. Third, you must have sufficient technical education and experience to be a *good* radio serviceman. That's all. It is emphasized that each applicant will be judged on his or her individual merits. Two years of high school are suggested as a minimum, but even this may be waived if the applicant has the experience to shoot trouble and shoot it in a hurry. It must be remembered that Radiolocators are on 24-hour service and when something goes wrong, it must be fixed at once. Code is not required. You can depend on the British to look at such a problem realistically and not become mired down in a sea of fancy qualifications. Thus, any serviceman or "ham" worth his salt technically could qualify for the C.T.C.

The routine of training a new C.T.C. member will take eight weeks. During that time he will be taught the rudiments of Radiolocation, the circuits and various types of Radiolocators, and he will have free access to all of these devices, an opportunity that many people would almost give their right arm for. After basic training, the volunteers will be split up into smaller groups and given specialized training according to the branch of Radiolocation service in which they will work. From these groups, the new C.T.C. graduates will go to jobs giving actual experience in Radiolocation under war conditions.

Of course, there is always a chance of being the unwilling recipient of a "message of enlightenment" from a stray German bomber, but C.T.C. members will run the same risks as those under which the British civilians—men, women and children—have



# radio *Trade* news

FOR THE DEALER, JOBBER & SERVICEMAN

---

## *The Trade Month in Review*

The outlook in the Sound Industry looks bright--in spite of the fact that Government priorities have curtailed the supply of aluminum and other materials. One of the leading jobbers has already substituted paper filter capacitors for the electrolytics. Others will follow with similar substitutes and sales are expected to reach a new high during the next few months.

Complaints from the jobbers seem to indicate that some re-arranging must be done in the matter of priorities if they are to survive. A recent case tells of one such jobber's order being "grabbed off" the final assembly line when it was scheduled to be shipped to him for sale to the customer. If this continues, the hardship will reach a point where the jobber's business will dwindle, particularly on metal goods, to a low volume, or completely stop. Commercial wants must be met at any cost.

Instantaneous recording discs with glass substituted for aluminum, have become standard. Reports seem to indicate that this problem was solved in record time. The fidelity has appeared to improve, according to several engineers recently interviewed.

Export licenses for radio and electrical products, which went into effect on July 2, 1941, are now required through the Export Control Administration for foreign shipments of radio sets, tubes, and some parts, together with many electrical products containing mica. Included in the new radio items to which government licensing control is extended are receiving sets and tubes therefor, transmitting sets, tubes, and parts, together with mica condensers, transmitters, etc., and rheostats.

The recent recognition by the F.C.C. of the RMA's ability to be a competent and efficient spokesman for the industry should inject a better understanding between the two organizations and will instill a feeling of confidence between them.

Statistics show that the average life of the radio receiver is five years. If that is correct, then one-fifth of the sets in this country stop functioning every year—ten million sets—just about the normal radio production. Each month that the radio business is stopped, due to lack of material, almost a million sets will cease to function and to serve the purpose for which they are intended. Many will say that these sets can be repaired. "With what?" "If the set and parts manufacturers cannot get raw material—where will all the needed parts come from?" Time will tell!

The Priorities Division of O.P.M. has decreed that radio set production must shortly drop to about 30% of the 1940 volume. This will place hundreds of employes in other jobs. Factories turning out luxury goods will be needed for Defense production items. The specialized training of the personnel will be valuable for this effort. Radio can, and will, adjust itself to present and future demands.

The past month has been one of the busiest in Radio's history. No doubt it will continue at a fast pace for a long time to come. The sale of Ham equipment seems to be about normal. Smaller units are being sold—indicating that many amateurs are building portable emergency gear.

August, 1941



Don't pass up the opportunity to sell installations like this one.

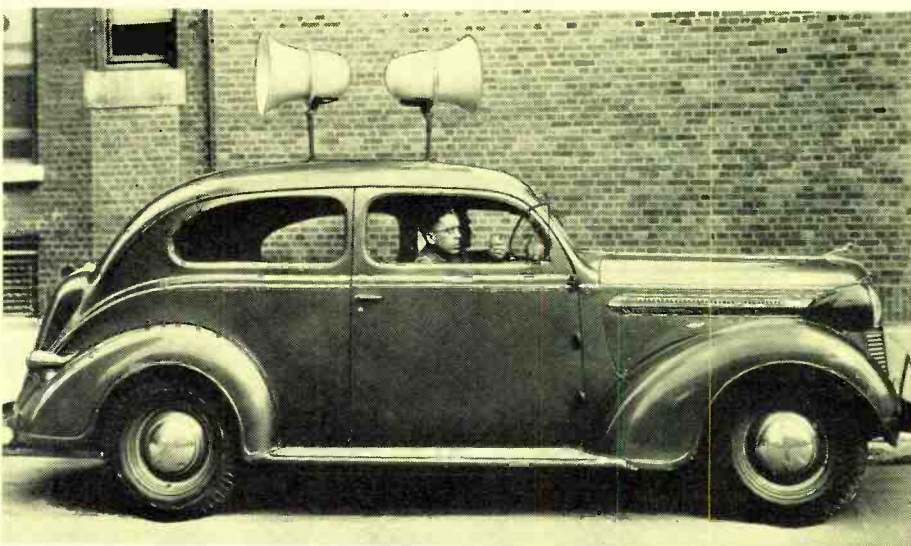

Electioneering campaigns offer a lucrative income source to the soundman. Two projectors are mounted on a sedan, one to cover the front area, and the other to project to the rear.

# Sound Selling For the Serviceman

by RAY HUTMACHER

Utah Radio Products Co., Chicago, Ill.

**T**HE Sound business is at present one of the fastest growing branches of the radio industry. It is definitely no longer in its infancy. Here is a huge lucrative business that for some reason or other has eluded the average serviceman.

Countless thousands of dollars have been spent in experimentation, production and actual field tests over a number of years.

Finally has emerged a business that may well be called *sound* in more ways than one.

Equipment offered the public through the sound dealer today is the finest money can buy. What a few years ago were dreams, today are established facts. Imagine! A speaker that can be heard for ten or fifteen miles! An amplifier with a flat response curve, from 30 to 9500 cycles! A microphone so sensitive that it can pick up a barely audible whisper at a distance of twenty-five feet!

All of these achievements are at the finger tips, today, of the man who really makes up his mind to go after, and get, his share of the sound business.

In this article we shall progress steadily through the different stages of this business, devoting time to each phase that will help you increase, and maintain the increase in your own sound business.

## KNOW YOUR EQUIPMENT

You can teach a parrot to say most anything, but he won't know what he's talking about. We find many sound salesmen today; taught a certain "canned sales

sermon." They are *lost* when confronted with competitive salesmen who really know their merchandise from the ground up.

It is well to pause here, and say a few words about the four most important components in a sound system. Respectively they are: Amplifier, Speakers, Microphone, and Turntable.

The amplifier is the heart of any sound system. It should therefore be selected with great care. The three most important things you need know about an amplifier are: 1. The usable power-output available. 2. Frequency response—the ability to reproduce the tonal range. 3. The degree of accommodation offered for microphones, phonos and speakers. Every well designed amplifier delivers a certain amount of usable power, comparatively free from distortion. It will also deliver a large peak output, which, however, is only usable on occasional passages. Make sure the amplifier you select for a particular installation has the right usable power. There is no universally accepted standard in the industry for rating the wattage output of an amplifier. Therefore, you must rely (unless you have the necessary costly and delicate instruments) upon the honesty and integrity of the maker. With regard to frequency response, for average requirements, a tonal range of 70 to 7500 cycles per second is acceptable. The particular installation will determine the necessary number of mikes, speakers, etc. Make sure the amplifier you figure on will provide for them.

The proper selection of speaker, or speakers, is just as important to a good sound installation as the amplifier itself. Make sure then when selecting them that they are heavy enough to handle the full peak output of the amplifier and that their frequency response is equal to or above that of the amplifier. In general, speakers can be classified as follows: The *cone speaker* which falls into two types—*permanent magnet* (PM), which is energized by a charged magnet and requires no external excitation other than for the voice coil, and the *electro-dynamic* speaker which uses a wire wound coil externally energized either by a line from the amplifier or by 110 volt A.C. by means of a rectifier.

Next in importance is the *diaphragm* type unit. Field energy for these units is provided in the same as was explained for cone type speakers. They differ in this respect. Instead of using a large paper or composition cone for setting in motion the sound waves they use a small metal or composition diaphragm to set in motion the sound which is then induced through a trumpet usually of reflex type which gives a greater exponential length to the baffle. Proper baffling of speakers will be discussed later.

## MICROPHONES, TYPES, USES, ETC.

The most popular types of microphones today are the crystal, dynamic and velocity. Crystal and dynamic types are ideal for picking up sounds from all directions where feedback is not a problem. The dynamic type is somewhat more rugged than the crystal and is better adapted for outdoor and portable use. Crystal microphones are apt to, under highly humid conditions, absorb moisture. Velocity mikes are directional types picking up sound from only front and back and they are therefore suitable for use where feedback is encountered. There are now on the market uni-directional crystal and dynamic mikes which have a sheathing arrangement that covers all of the sensitive pickup area except for areas necessary for directional use.

Phonograph turntables are a very important part of the sound installation and should be given the same consideration as any of the integral parts of the system. Three things are most important. The pickup, motor, and turntable mechanism itself. Most important of all in a pickup, of course, is its ability to reproduce the full response of all non-commercial records now available. It must also have a light needlepoint pressure to prevent unnecessary wear on the record. The turntable motor must be of constant speed, sturdily built so that no overheating will occur. Speed must be 78 or 33 $\frac{1}{3}$  r.p.m. or both. The turntable mechanism should be as simple in operation as possible and still perform its job with a minimum of trouble. Remember, the fewer moving parts the less chance for trouble.

As proper speakers are of such great importance I believe we should return to that subject for more complete detail.

First, baffles are of prime importance. A flat type baffle should be used where the greatest spread of sound is desired. In this group falls the reflex type case, wall baffles and boards. Projector type baffling is suggested for projecting sound great distances in a narrow channel, thus, "aiming your sound." Use of trumpets is indicated where sound is to be projected comparatively long distances in a slightly wider beam. For example, in mortuary installations the bass reflex type reproducer is recommended. In banquet halls, night clubs and school classrooms the wall baffle case or plain flat baffle is most practical. For factory paging, outdoor meetings etc. the projector type will give excellent results. Stadiums, athletic fields, race tracks are citations of the best uses to which trumpets may be put.

There are many points to be brought out, which will enhance, and add to the performance, of any installation. Elimination of low response for speech is very important. In speech systems lows add "boominess" from reflections. Good "middle highs" should be a "must" in every system you sell. They are responsible for the brilliance which is so pleasing to the ear, and which when absent, gives the listener that "off balance" feeling, which is very annoying, especially during long programs. The use of more speakers than is absolutely necessary to make a system just audible will repay you many times, not only in added profits but in customer satisfaction. This will allow operation of the speakers at a lower sound level and prevent blasting. The use of "L" pads on each speaker in multiple applications, will assure the equal distribution of load to each speaker (or variance of load where a system is both indoor and outdoor).

## WHERE TO BUY YOUR SOUND EQUIPMENT

There are countless sound jobbers, the length and breadth of the land, waiting to serve you with whatever merchandise you may be called upon to need for any installation regardless of the difficulties it may present. Choosing the right one, however, is going to be most important to you not only today, but tomorrow and even next year. Your choice should be one, who first has a fair policy with re-

gard to guarantees, replacements, factory service, etc. He can have, and uphold, this policy only if he carries merchandise made by reputable manufacturers, who stand behind their products.

You might say, "Why should I buy systems made by, or made from, parts that are nationally advertised, when I can buy 'no name' merchandise cheaper?" Here's why, systems made from parts, and by manufacturers of national reputation, didn't just happen.

These companies grew by stint of hard work, good engineering and fair dealing. The more demand their advertising creates the more they can produce, the more they produce the more their costs are lowered. These savings are passed on to you through the jobber handling this merchandise. This, added to the fact that you are buying merchandise you know is guaranteed. Your jobber must be aggressive. He must be on his toes at all times keeping abreast of latest developments in the sound field. He knows that you as a sound man are not going to be satisfied with a last year's sound system in view of this year's latest developments.

Last but not least, your sound jobber must carry an ample stock. If you are installing a system, and it's all set up ready to go, except for one cable connector, or a missing plug, or some other such infinitesimal part, you want that part now, not tomorrow or next week.

## SALES APPROACH SELLING TECHNIQUE, ETC.

When you are out to make a sale, remember, one of the first rules in selling; *sell yourself, then your product.* The first minute in any sales interview is the most important. In that first minute you must accomplish these things. You must instill confidence and create interest, that will last through the remainder of your sales interview. Calling on a customer with a clean shaven face, a neatly pressed suit is small effort to exert compared to the self courage and added prestige it will create. Remember that you are not selling a luxury. You are selling a necessity.

That is not a trick sales sentence but an absolute fact. Realize how much more efficient any wholesale firm, for instance, can operate when all departments are immediately available to one another through the use of an intercommunicating system. The needless operations, the steps saved, quicker handling of orders which lead to better customer satisfaction. All of these are steps that will definitely show up as added profits for your sound customer. The initial cost and installation of a call system in the face of these savings and added profits becomes secondary.

It is usually possible to find out enough about a customer's needs *before* calling on him to enable you to take along a temporary set up and give at least a partial demonstration. An actual demonstration is far more valuable than a hypothetical sales story. Get the merchandise in the prospect's hands. If it is the right system for him and *if* your sales story is *convincing* and *ethical* he will be more than reluctant to part with the very sys-

tem he sees will make his business more efficient and increase his profits.

## YOUR SERVICE POLICY

Maintaining a generous but business-like service policy on all sound systems sold by you is highly important. A disgruntled customer is not a very good ad for your business. In order to assure yourself that there will not be unnecessary service calls on any installation make sure you have explained to the customer by actual demonstration *exactly* how to operate the system under *all* conditions that might arise. Then stand back of the merchandise to the fullest extent of your ability.

A burned out tube replaced free of charge even when slightly past the warranty period will, in effect, be inexpensive advertising which will greatly increase customer good-will toward your company, and good-will is good advertising. Especially is this true when this customer starts talking to Mr. So-and-So who runs the bowling alley around the corner and who is in the market for that new system for his cocktail lounge. Make arrangements with your customer for periodic check-ups on his equipment. This will give you an added source of service income and also forestall any over costly over-haul jobs for your customer.

Making a thorough check on all sound equipment in your territory provides an excellent way for you to obtain not only more sound and service business, but will oft-times lead also to many new jobs.

Many sound systems are in operation today that are not worthy of the name. These are a definite hazard to all and it is poor policy to keep on using this antiquated equipment from day to day. Where these systems are discovered it is usually not a hard job to convince the owner that a complete service check up or a new system would be to his advantage. It is just as easy to drive customers away with a system that garbles enunciation and music as it is to attract them with a system which is easy on the ears.

## RENTALS

Here is a source of revenue that will absorb much of the monthly overhead that goes on just the same during rush or slack seasons. Political Gatherings, Social Groups, Patriotic Meetings, Outdoor Meets of all types are ideal prospects for sound rentals. Behind any of these groups the main purpose in mind is to be heard by as many people as possible. Without a modern sound system this becomes practically impossible. When a group or an organization has spent hundreds and often thousands of dollars to assemble an illustrious array of speakers or entertainers they are not apt to hesitate at spending the few dollars necessary to assure clean, clear deliverance of these talents to the assembled audience by renting a sound system.

In the foregoing article we have progressed through the steps necessary to put you on the successful path toward sound selling, remember though that all of the articles written will not be of any use unless the *theories* set forth therein are *practiced*, and enlarged upon by the man in the field.

# WHAT'S NEW IN SOUND

## CENTRALIZED SYSTEM DESIGNED TO INCLUDE FM/AM TUNER

The new *Hallicrafters* Model RSC-2 is a unit which should find wide application in centralized radio systems in hotels, hospitals and industrial plants. Because it provides both FM and AM broadcast reception it will offer special appeal to those institutions where high electrical noise levels have made ordinary radio reception unsatisfactory. In addition, the FM feature provides the finer quality so desirable for distribution in the dining rooms or other public rooms.



The RSC-2 includes three units—an FM/AM tuner, a high fidelity 25-watt amplifier and a monitor speaker, all enclosed in a single rack of the table-mounting type. The tuner provides AM reception throughout the range of 540 to 1650 kc. and FM in the range of 40 to 51 mc. In addition the amplifier provides microphone and phono inputs, thus making these additional types of service available for distribution over the centralized loudspeaker or headphone networks. Wide operating flexibility is afforded by separate bass and treble equalization controls, separate control of volume from each input source, and provision for mixing and fading these sources.

An outstanding feature of this new equipment is its excellent tone quality. The frequency response of the amplifier alone is flat within plus or minus 1½ db. from 30 to 20,000 cycles per second. The response of the tuner alone for FM reception varies less than 1 db. from 30 to about 7,000 c.p.s., is down only 1.8 db. at 10,000 and 4 db. at 15,000 c.p.s.

For existing installations where it is desired to modernize equipment, both the S-31 FM/AM tuner and the S-31A amplifier employed in this combination are available separately.

## "BI-POWER AMPLIFIER"

*Webster-Rauland* presents their new 60 watt "BI-POWER" amplifier. The unit has a newly designed circuit using to best advantage and in a most practical manner, the characteristics of a unique 5 tube power output consisting of 3 rectifier tubes types 83 and 5U4, each performing a separate function in absolute relation to each other and obtaining maximum efficiency from two 6L6G's.



The unit, conservatively rated at 60 watts, incorporates such features as: 4 microphone inputs, 2 phono inputs with dual fader, complete mixing and fading on all 6 inputs, separate bass and treble tone controls, remote mixing of 3 microphones, illuminated panel, and many others.

## 15-WATT SYSTEM ANNOUNCED BY RCA

An all purpose sound system, complete in one compact unit including amplifier, controls and record player, has been announced for use in mobile, portable, or permanent installations by George Ewald, RCA Commercial Sound Division Mgr.



The new system operates from 105-125 volts, 60 cycle electric power, or from a 6-volt storage battery with very low drain. It delivers 15 watts output, making it ideal for such uses as in sound trucks, advertising, amusement parks, sport events, political meetings, parades, fairs, carnivals, sales campaigns and picnics. Light in weight and easily moved by attached carrying handles, the unit measures 16½" long, 12" deep, and 12" high.

The turntable is mounted atop the amplifier case in conjunction with a high quality crystal pickup. Tone and volume controls are at the base of the unit.

## SHURE "HI-LO" CRYSTAL PICKUP

An entirely new low-cost 1 ounce Crystal Pickup with permanent sapphire point needle is announced by *Shure Brothers*, designers and manufacturers of

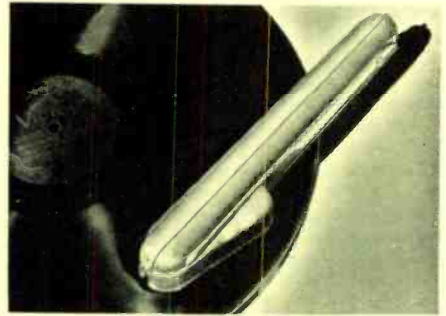

microphones, pickups, cutters. The new "Hi-Lo" high-voltage low-pressure Pickup has the greatest ratio of output voltage to needle point impedance—1.4 volts output at 1000 c.p.s. (Audiotone record) with only 1 ounce needle pressure. This makes possible easy, economical replacement of conventional pickups—improves reproduction—practically eliminates record wear—greatly increases record life. Improved tracking helps reduce surface noise—saves wear on record grooves. The use of a permanent sapphire point needle eliminates the inconvenience of changing needles.

In the *Shure* "Hi-Lo" Pickup, new type cartridge bearing seats provide "pinch" compensation—permit easy up and down motion of moving system to overcome "pinch" effect and follow record grooves correctly. Special design permits extremely accurate production.

## NEW INTERCOM SYSTEM

*Talk-A-Phone Mfg. Co.*, of Chicago, announces a new moderately priced Intercommunication System. Known as the LP-5, this system is of the master selective type. It works with up to a total



of five sub-stations. The Master Station can call any one of the individual sub-stations or all together at one time. Sub-stations can call the master at will. Sub-stations can communicate with the Master Station without operating switch—and persons may speak as far as fifty feet away from the unit and be clearly heard. Includes a special "Silent" feature which permits master to be called, yet excludes noise pickup from sub-stations. Operates from 110 v. AC or DC.

## LAFAYETTE CUSTOM-BUILT SYSTEM

The new Lafayette Custom-Built sound systems offer the sound specialist an excellent opportunity to obtain really custom assembled equipment at stock model



prices. Thus any selected group of stock items such as standard Lafayette amplifiers, radio tuners, record - playing equipment, booster amplifiers, etc., can be assembled by Lafayette in the form of a single, inclosed rack-and-panel unit complete with interconnecting cable-plugs to provide both the appearance and utility of a much higher priced "Custom" job.

As an example of the complete adaptability offered by the special assemblies, the illustration herewith shows a unit made up to provide radio and recorded programs, as well as voice announcements, for distribution over an extensive network of loudspeakers and headphone requiring total power output of up to 150 watts. All panels represent stock equipment with the exception that the input amplifier involved minor changes to adapt it to the special requirements of this particular installation. The equipment, reading from top to bottom, consists of radio tuner and monitor speaker, input amplifier, automatic record player (concealed behind grill), and three 50-75 watt booster amplifiers.

## NEW TURNER MIKE

The Turner Co., Cedar Rapids, Iowa, is announcing a new Dynamic salt-shaker type Microphone, No. 211, which utilizes a new type magnet structure and Acoustic network. Because of these features the new 211 offers outstanding performance characteristics.

Turner No. 211 meets the requirements of extended range set up by the new frequency modulation method of broadcasting. The unique diaphragm structure used in this microphone has resulted in extremely low harmonic and phase distortion, without sacrificing high output level. These units have tilting heads, balanced line output connection and 25 feet of heavy duty cable. The streamlined design is finished in rich satin chrome. Model 211 has a level of -56 DB below 1 volt per bar for hi-impedance units. The 500 ohm model has an output of 2.5 millivolt for 10 bar signal, while the 200 ohm model has an output of 1.6 millivolt for 10 bar signal. The 30-50 ohm model has an output of .25 millivolt for 10 bar signal. The range is 30-10,000 cycles.



## NEW 48 WATT BELL AMPLIFIER

Among a number of units of equipment attracting special comment at the recent Chicago Radio Parts Show was a newly designed, streamlined 48-watt amplifier, shown by the Bell Sound Systems, Inc. of Columbus, Ohio. It was one of a completely new line presented by this company.

Several valuable features are claimed for this popular sized unit. It has individually controlled electronic bass and treble boost, which permits unlimited tone selection. Supplemented by inverse feedback and beam power output tubes, it eliminates feedback difficulties to a remarkable degree. The inverse feedback also stabilizes the amplifier and brings improved wave form to low frequencies.

Three microphone channels and a phono pickup channel have separate volume controls, permitting any combination of volume. A tap type impedance switch is built into the amplifier chassis.

## NEW OPERADIO INTERCOMM

The Operadio Manufacturing Company announce their new Flexifone IC system and new 420-12 unit. The Flexifone system consists of a master posi-



tion and remote speakers. Up to six outlying speaker stations may be used and they may be equipped with a call switch at slight additional cost. The selector switch on the master station is arranged so that the different speaker stations may be called individually or all at once. The master station is equipped with an off-listen-talk switch normally in the listen position. Both the master station and the outlying speaker stations are housed in attractive moulded brown bakelite cases.

## ALLIED UNIVERSAL SYSTEM

The new 30 watt mobile sound system just announced by Allied Radio Corp.

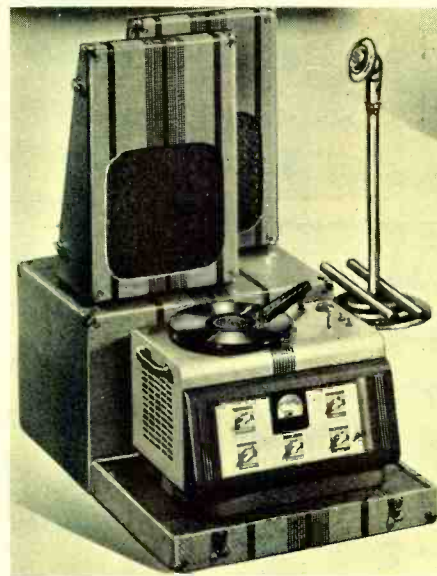

features high output plus universal power requirements. Operation may be from a 6 volt storage battery or 110 volt, 60 cycle AC. with full 30 watt output. The amplifier features four input channels, electronic mixing, built in phono turntable, dual tone controls, speaker selector switch, V. I. meter, plus rugged durability. A two-tone sturdy steel case which will blend with any surroundings is used to house the amplifier. An external phono or radio tuner may be used in conjunction with the built in phono to furnish continuous entertainment. A standby switch is provided to conserve battery power. The speaker selector switch enables any combination of speakers to be matched instantly with no guesswork.

Speakers are mounted in a split carrying case of matching design, and affording easy portability. A dynamic type microphone with a combination floor or desk stand is provided. Speakers are available in different types of mountings to meet varied operating conditions.

## ZENITH SALES INCREASE

Zenith Radio Corporation has received orders from the following companies for automobile radios for 1942 models:

Ford Motor Company, for Ford, Mercury, Lincoln and Lincoln-Zephyr cars.

Nash-Kelvinator Corporation, for Nash cars.

Hudson Motor Company.  
Willys Overland Motors, Inc.

All of the above automobile radios are to be equipped with the new Safety Foot Control auto radio device, introduced by Zenith, which permits the driver of the automobile to keep his eyes on the road and his hands on the wheel while tuning the radio, changing stations, and silencing the receiver when approaching railroad crossings or other dangerous intersections.

# Building Chain Profits

by Eugene Carrington  
Allied Radio Corporation, Chicago, Ill.

**T**HE profit resulting from an initial recording unit sale is but the first link in an endless chain of successive profits which can be brought easily to follow. Add to this the fact that public interest in this relatively new and now inexpensive development is high, and the potential market as yet only barely scratched, and you have, with a properly planned sales program, one of the biggest money making projects ever placed within your reach.

The initial investment required for getting started is small. Practically no stock is needed. Everything you will want is available from radio jobbers and mail order houses whose large stocks are, in a sense, yours to draw on when needed. Equipment thus available runs from basic units, for those who wish to build their own: recording attachments, for plugging into the radio; recording units complete in themselves; and combination radios and recorders, for those who want the most versatile type of installation.

Recording discs range from the very inexpensive paper-base plastic types, available in many grades of quality; to the finest obtainable metal and glass-base acetate variety. Needles likewise range from the low cost steel to the best metal-alloy and sapphire-jewel-tipped professional types.

The market for this equipment is as already stated, practically untouched. The possible uses for recording equipment are nearly endless. Let's look at a few. In the home, recorders can be used for entertainment at parties; for recording favorite orchestras, performers, music and

historical events from the radio; for making records of the children as they grow up; for providing a narrative or sound-effects background for home movies; for sending personal greetings to friends and relatives by mail, etc.

Schools have great need for this equipment as a means of auditioning progress in the teaching of speech, music, dramatics, elocution, languages, etc. The professions offer many opportunities. Particularly among lawyers, preachers, salesmen, public speakers, singers, actors, and the like. All of these as well as others will welcome this inexpensive and most effective way of "hearing themselves as others hear them." Night clubs also are using recorders for dance band practice and are recording patrons' voices with orchestra, for entertainment purposes. These are but a few of the hundreds of applications existent in every community. No doubt you can think of many others right now that have not been mentioned here.

To sell recording successfully, a well planned campaign of some type must be formulated and rigidly followed. The form such a campaign will take, depends entirely on your local trade setup and the amount you can afford to spend for this purpose. It is essential first that a window display and a store demonstration unit be set up. News that you are now a recording equipment sales headquarters can be brought to the attention of your trade through any one or more of the usual channels, such as handbills, envelope stuffers, newspaper ads, door-to-door calls and telephone canvass.

To sharpen interest and promote immediate "word-of-mouth" publicity, you can offer a free recording for those who make purchases in your store, or, with no strings or obligations attached, to a select group of likely prospects. You can also create much interest by recording conversations with customers while in your store (without their knowing you are doing this, of course) and immediately playing the record back, after which the disc should be presented as a gift.

One of your best sales getters as well as an additional source of profit, is to have a portable recorder available for rental purposes. The same machine can be used for free home demonstrations and trial purposes. This has been found by most dealers to be the quickest means to an ultimate sale.

Once a sale has been completed, your big opportunity for additional profits has arrived. The possibilities here are many. To begin with, you are going to profit many times from the sale of needles, recording blanks, and commercial records, which will be bought frequently. These sales can be increased materially if you will take the trouble to inform your users as to what types of needles and records to use for various purposes. Show them that it is not necessary to use expensive

accessories when recording for practice or for fun. Point out the types of needles and discs they should use for best results when wanted.

Another mighty important sales angle is to keep your users informed as to latest developments in needles and discs. It proves that you are wide awake as to what is going on in your profession, and it keeps their interest awake by giving them an opportunity to be first to use the latest. We are all experimenters at heart and the urge to have the new, is always a strong sales producer.

Among your select group of users, it will pay you handsomely to make personal calls periodically, to see how they are getting along. You should do this for several very good reasons. First it will pull out possible complaints resulting from improperly operated equipment and thus give you the opportunity to straighten them out before they become serious. This will insure continued satisfactory interest in their equipment and promote as a result favorable "word-of-mouth" advertising to other prospective customers. This service also often leads ultimately to the sale of better equipment.



This type of unit may be rented out by the dealer for extra cash.



Recording a child's voice is one of the most popular for records.

## TRIPLETT GETS PLAQUE

Triplett had a silver wedding anniversary a couple weeks ago on June the 8th and all of the representatives spent a lot of money going together and presenting them with a very beautiful plaque and a solid silver tea set.

Mr. Triplett has been most active in the company which he heads.

Note the signatures of representatives on the face of the plaque.



## A LONG TRAIL

That leads to all the places where the population is interested in the sale and application of *Sylvania* radio tubes, and it's W. R. Jones, *Hygrade Sylvania Corporation* Director of Commercial Engineering, Emporium, Pa., who hits the trail almost constantly, conducting *Sylvania* Service School classes in all parts of the country and advising radio technicians on *Sylvania* Radio Tube receiver applications.



Mr. Jones for the past six years has averaged 48,695 miles, equal to twice around the world, of travel on company business or a total of 292,170 miles. Between trains and special radio engineering assignments, Mr. Jones lectures to radio servicemen and dealers. Over the past three year period Mr. Jones has spoken 222 hours in 111 *Sylvania* Service School Meetings, an average of two hours speaking time per meeting, and that's not just a lot of talk.

## NEW OFFICE FOR AMPLIFIER CO.

The *Amplifier Co. of America*, of 17 West 20th Street, New York City, announces the opening of their export offices at 36 Pearl Street, under the direction of Mr. R. V. Collins. Mr. J. J. Sloane, former export manager, will now handle all special government defense contracts.



The newest self-charging portable radio is demonstrated to dealers.

## G-E DEALERS SEE NEW LINE

*General Electric's* new line of portable radios, featuring the self-charging storage battery radio, is being introduced to more than 10,000 dealers from coast to coast in a series of meetings sponsored by *G-E's* Retail Development League.

RDL, in its second year, is currently staging the third 1941 meeting for 207 local retail chapters. Another feature of the current meetings in which lively interest is reported in all sections is an

open forum discussion on the 1942 line of refrigerators.

Each retail chapter meeting is conducted by a thoroughly trained program manager representing RDL headquarters in Bridgeport, Conn. In the current meetings the program managers carry with them the complete new line of *G-E* portable radios. The program managers are skilled professional showmen with a thorough knowledge of *General Electric* and its home appliance and radio lines.

## UNIVERSAL GOING STRONG

*Universal Microphone Co.*, Inglewood, Cal., upon the return of James R. Fouch, president and general manager, from an eastern trip late in June, announced that its factory force had been tripled and night shifts would be inaugurated.

The California plant has for some time been in production with 300 aircraft microphones daily for the army with a total of 20,000 instruments called for.

## WESTON APPOINTS SIEVERS AND FARNEMAN

The *Western Electrical Instrument Corporation* has just announced the appointment of Edward S. Sievers as *Weston* representative, located at 567 Subway Terminal Bldg., 417 So. Hill St., Los Angeles, Calif. John D. Farneman will be associated with Mr. Sievers in this territory.

## PLASTIC INSTRUMENT DIALS STAY WHITE

White instrument dials that are not discolored by high temperature, light, chemical fumes, or moisture are being made at the *Westinghouse* Meter Division, Newark, N. J., by means of a recently developed liquid plastic material, which is sprayed on metal much the same as lacquer or paint would be.

## McMURDO SILVER JOINS FADA

Announcement has just been made by J. M. Marks, President of *Fada Radio & Electric Co., Inc.*, Long Island City, N. Y. of the formation of the company's new Special Equipment Division, with *McMurdo Silver* appointed as Vice-President in charge of the new department.

## FM FOR CLEVELAND RAILWAY

Frequency-modulation radio is to play an important part in keeping the *Cleveland Railway Company's* transit system working at highest efficiency. Permission has been granted by the *Federal Communications Commission* for operation of a 250-watt FM transmitting station and ten portable 25-watt two-way car equipments, all of which are being supplied by the *General Electric Company*.

The station will have the call letters W8XXN, and will be located at East Ninth Street and Carnegie Avenue. The ten FM-equipped cars will operate in the different zones of the city, "patrolling" the lines of the company. The two-way equipments permit the inspectors to report in to headquarters on traffic conditions, to learn immediately of traffic complications resulting from fires or other causes, and to reroute the transit vehicles as conditions require.



# DISC and THAT

by Bill Adams

## TEN TOP TUNES WITH WHICH TO STOCK YOUR SHELVES

NAME	ORCHESTRA	NUMBER
"Daddy"	Sammy Kaye	Victor-27391
"Green Eyes"	Xavier Cugat	Victor-26794
"Where You Are"	Dinah Shore	Bluebird-B-11164
"Montevideo"	Harry James	Columbia-35932
"Simpatica"	Dick Jurgens	Okeh-6120
"Kiss the Boys Goodbye"	Bea Wain	Victor-27445
"Sleepy Serenade"	Andrew Sisters	Decca-3821
"Paradise Isle"	Bing Crosby	Decca-3797
"The Reluctant Dragon"	Sammy Kaye	Victor-27449
"Time and Time Again"	Benny Goodman	Columbia-36050

## ALBUM HITS

Cante Flamenco	Columbia-C-59
Schottisches	Decca-A-220
Piano Reveries	Victor-P-64
Jerome Kern Melodies	Decca-A-232
Louis Armstrong Classics	Decca-A-233
Circus	Columbia-C-58
Japanese Folk Music	Decca-A-172

"Floods of Spring," (Donald Dickson) Rachmaninoff Victor-4548  
The Victor concert orchestra under the direction of Nat. W. Finston presents on ten-inch red seal disc, Donald Dickson, baritone, singing in English an outstanding version of this Rachmaninoff piece. It is warm, vital and sung with great feeling.

"Waltz," from Eugen Oniegin (Side "B") Tchaikowsky Decca-25325  
The Royal Opera House Orchestra of Stockholm deliver a most happy event on this Decca recording. Although not a new release, it is by far the finest interpretation to be found anywhere. It is lilting music and Armas Jarnefelt conducts so brilliant a performance, that once hearing you will add this Decca to your library of Tchaikowsky musts. "Polonaise," from Act 3 from the same opera is on side "A".

"Waltzes from Rosenkavalier," Richard Strauss—The Cleveland Orchestra Columbia-11542-D  
Light, brisk and delightfully presented, Arthur Rodzinski conducts a summer special.

"Samson & Delilah," Saint Saens, Marion Anderson, Contralto Victor-18008  
Excerpts from this ever famous opera have been presented time and time again. It seems that most singers and in particular the contralto, must prove proficiency with one or more arias from this Saint Saens masterpiece. "My Heart, At Thy Sweet Voice," ("B") is by far the better known. Side "A" from Act 2, "Love, Come Aid My Weakness," is the more interesting of the two arias, inasmuch as, it possesses a new freshness. Both sides are sung with care and with much finesse.

## FIVE OUTSTANDING CLASSICAL ALBUMS

"Carnival of the Animals," Saint Saens Victor-M-785  
An ideal album of music for young folks. Plays up on the child angle.

"Symphony No. 2 in C Minor," Tchaikowsky Victor-M-790  
A musical event not to be missed. This is the first recording of Tchaikowsky's 2nd Symphony, and the official debut of Eugene Goossens and The Cincinnati Symphony.

"Symphony No. 4 in E Minor," Brahms Columbia-M-452  
Leopold Stokowski and The All-American Youth Orchestra present a new and important recording of Brahms' immortal 4th Symphony.

"Firebird Suite," Stravinsky Columbia-M-446  
The Firebird Suite, of Ballet Russe fame, is again presented by Leopold Stokowski and The All-American Youth Orchestra.

"Valse Nobles Et Sentimentales," Ravel Columbia-X-194  
Robert Casadesus, eminent French pianist, again proves himself master interpreter of Ravel music. On two ten-inch discs.

## Box Score for July, 1941

"The Hut-Sut Song"	10 points
"Aurora"	10 points
"Good Bye Now"	10 points
"Two Hearts That Pass in the Night"	5 points
"Keep Cool, Fool"	5 points
"Music Makers"	10 points
"I Understand"	10 points
"I Only Want a Buddy Not a Sweetheart"	10 points
"Jezebel"	No score
"Do I Worry"	5 points

Total 70 points

Out of a total possible 100 points the box score rates last month's predictions 75% correct. The following basis of scoring is used and only actual record sales in total, as closely as can be ascertained through reliable sources, are used: the first ten top tunes in record sales are given 10 points each. The next five tunes, that is sales listings from eleventh leading to 15th, are allowed 5 points each. Other tunes from 15th position on down are not counted.

## CROSLLEY KEEPS BUSY

An increase in Crosley radios, refrigerators and other major appliances is provided for in the production and distribution program for the coming year, in spite of the fact that a sizable part of the Corporation's facilities are now devoted to production for national defense purposes.

This fact was emphasized by R. C. Cosgrove, vice-president and general manager, and by Robert I. Petrie, vice-president and general sales manager of The Crosley Corporation, at the annual spring sales conference of Crosley zone and district managers held in Cincinnati.

Both Crosley officials pointed out that the company is fortunate in that it has available ample manufacturing space to provide fully for both domestic and government needs.

## EMERSON APPOINTS THREE NEW DISTRIBUTORS

Charles Robbins, Sales Manager of the Emerson Radio and Phonograph Corporation, New York City this week announced the appointment of three well-known distributors for Emerson products:

The Norge Products Co., Inc. of New Orleans, La., G. H. Lehleitner, President; Southern Furniture Sales Co. of Knoxville, Tenn., F. E. Fowler, President and E. L. Fielden, Sales Manager; and Electric Supply Co. of Grand Rapids and Kalamazoo, Mich., J. L. Popkin, President.

The officials of the distributing concerns have all expressed great enthusiasm for the Emerson line and its possibilities in their territories. All of these organizations have been in business for a number of years and are highly regarded in the trade.

"We are happy at the acquisition of these firms to the Emerson distributing family," stated Mr. Robbins, "for we have selected these concerns with an eye towards rendering better service and merchandising assistance to the dealers in those territories.

## NEW JOB FOR FM

The Columbia Broadcasting System is obtaining three 50-watt FM relay transmitters for two circuits, to carry its short-wave programs from its New York City studios to its International short-wave transmitting station at Brentwood, Long Island, approximately forty miles away. One equipment will be used as a standby program circuit. Located near the top of the studio building, the FM transmitters will be remotely controlled from the master studio control room on one of the floors below.

The equipments, being supplied by the General Electric Company, include monitors, monitor loud speakers, and receivers, as well as the transmitters themselves.

Investigations have shown that FM transmission is ideally suited for such an application.



been living since the beginning of the war.

I asked *Squadron Leader Russell*, who has charge of the *C.T.C.* New York office, what life in the *C.T.C.* will be like.

"For anyone who is really interested in radio," this tall, obliging officer replied in a warm, friendly voice, "I cannot imagine a more absorbing life. However, as in every other job, a good deal of *C.T.C.* work will be daily routine.

"But *C.T.C.* Radio mechanics will first be specially trained in the new art of radiolocation, which they cannot learn anywhere else, and thereafter will be in charge of some of the most fascinating equipment imaginable.

"I know many men who went into the radiolocation branch of the *Royal Air Force* without knowing beforehand what kind of work they were going to do. But I have not met one who regretted it. Many have told me that they would not change their jobs for any other. Not only do they feel that they are doing a really worth-while and important war job—in which their technical knowledge is used to the best advantage—but that they also are (as *Lord Beaverbrook* put it) 'working on the frontiers of science.' They are in at the beginning of a new art which, after the war, is most certain to develop into one of the most important branches of the radio industry."

*C.T.C.* members get their food, transportation, lodging, clothing and medical care plus a salary of between \$1100 a year for beginners to \$2,000 a year for Chief Foreman. They get two to three weeks vacation every year with pay, and a month's pay on discharge. They are not subject to British income tax and may send a portion of their salaries home each month if they so desire. They are free of military discipline and combat duty, being subject only to the regulations of the *C.T.C.* and British laws governing civilian workers. *C.T.C.* Radio mechanics will perform much the same technical duties as radio mechanics of the Forces, and they will receive other benefits similar to those of airmen in the *Royal Canadian Air Force*.

Will there be thrills and action in store for a member of the *C.T.C.*? *Squadron Leader Russell* says, "Certainly! But I think that they are likely to be more *technical* than *pyrotechnical*, so to speak."

Will Radiolocators be the answer to the problem of an adequate home defense against enemy invaders? Only time can tell, but in the meantime, all Britains are saying, "Thumbs up!" with renewed hope and a prayer that Radiolocators, war's newest defense weapons, will, with American technical aid, turn the trick.

-30-

"FOR THE RECORD" COLUMN  
HAS FURTHER PARTICULARS  
ON CIVILIAN TECHNICAL CORPS

August, 1941

The **FINEST MICROPHONES**  
for P.A. and RECORDING!



**AMPERITE VELOCITY MICROPHONE WITH PATENTED ACOUSTIC COMPENSATOR**

**New P. G. DYNAMIC WITH NEW SUPERIOR ELIPSOID PICK UP PATTERN!**

**AMPERITE KONTAK MIKES IDEAL FOR AMPLIFYING STRINGED INSTRUMENTS USED WITH ANY AMPLIFIER AND WITH RADIO SETS.**



ASK YOUR JOBBER . . . WRITE FOR FOLDER

**AMPERITE**

561 BROADWAY NEW YORK

## QUALITY PAYS . . . OR WHY MR. VAN DROOL DROPPED HIS SPOON IN THE SOUP

IT happened during the dinner hour at the Van Drool mansion.

Rich Mr. Van Drool was sipping soup in perfect rhythm to the music of his super de luxe radio console. Suddenly came a noise like a firecracker as a midget condenser—which serviceman Wilbert Fixit had installed just the day before—exploded. Mr. Van Drool jumped, dropped his spoon and swore. What made him so mad, he said afterwards, was not that he dropped his spoon in the soup, but that he burned his fingers getting it out.

That experience taught Serviceman Fixit a lesson. No more midget dry electrolytics for him. He'd use big, full-sized replacements and play safe. One day, however, his jobber gave Wilbert a sample Sprague Atom and some literature about it.

"Guaranteed not to explode!" snorted Wilbert as he read the literature. "Phooey!"

But Wilbert was a methodical man. He put the Atom under test. No matter what he did, it wouldn't explode. Although the condenser was only rated at 450 volts, he had to smack it with over 750 volts before it even broke down. Then Wilbert bought a dozen more Sprague Atoms and found they tested equally good.

While he was testing them, Mr. Van Drool's chauffeur dragged one of the

upstairs radios into the shop.

"The boss wants this fixed in an hour," he explained. "And no foolin'. He says it's your last chance to please him."

"Lordy," groaned Wilbert, after examining the set. "A three-section condenser gone bad. It'll take me a week to get one from the factory."

Then he thought of his Sprague Atoms and the ST mounting strap the jobber had supplied with them. He could take two 8 mfd. 350 V. Atoms and a 25 mfd. 25 V. Atom, strap 'em together—and the job would be done. It was the only thing Wilbert could do, so Wilbert did it.

To his surprise the three Atoms when strapped together were actually smaller than the original three-section condenser. Also, his total net cost on the Atoms was only 96c, whereas a duplicate unit would have cost \$1.20.

What's more, the Atoms stayed put. Mr. Van Drool was more than pleased—and that meant Wilbert was pleased, too. Today he uses Atoms for practically all of his replacements, big or little.

"I save 'steen ways by using Atoms," is the way he puts it. "I save money, I save shoe leather, I save time, I save my good disposition—and I save customers. Best of all, Mr. Van Drool will never drop his spoon in the soup again."

Drooly yours,

**SPRAGUE PRODUCTS CO.,**  
North Adams, Mass.

# IT HAD TO COME!

Dealers and servicemen thruout the entire country have proven—with their REPEAT ORDERS—that "Lake Radio" is the house of values. That's why we were forced to move to new and larger quarters.

Our new home will enable us to give you even faster service and greater savings. Everything in radio—from cabinets to condensers, from rheostats to record changers—can now be supplied by "Lake Radio." Here are typical Lake bargains—

## RECORD CHANGER



Plays 10 12" or 12 10" records. 14" by 14" by 5" high. Crystal pickup. Handles warped records. Will not chip or crack records. Reject switch—automatic or manual change—2 point record suspension. 115 V. 60 cycles. Only 7 seconds to change records.

**\$12<sup>95</sup>** F.O.B.

## CONSOLE CABINET



OXFORD TYPE PD. A beautiful hand-rubbed, piano-finished cabinet. Made of five-eighths stock. A real piece of furniture 33" high, 32" long, 17" deep. Phono compartment 31 x 15 x 6. Rose mahogany or walnut.

**\$19<sup>50</sup>**

Other combination console cabinets from \$12.50

New folder lists uncut console, table, phono, and combination cabinets, as well as all radio parts.

Send for this folder TODAY!

**LAKE RADIO SALES CO.**

615 W. Randolph St.

Chicago

## Selecting a Sound System

(Continued from page 18)

system ever be adjusted to where one becomes conscious of the baffles and projectors. The installation should be purely based on speech re-inforcement that does not detract from the minister's voice. To accomplish this, the location of the speakers in the church is of all-importance. Distance from the speakers platform to the audience is of the utmost importance. A standard rule that can be followed is that the speakers be placed on each side of the ministers platform or directly above it. The distance from the back of the church to the loud speaker must be exactly the same as from the speakers platform to the back of the church. The voice from the loud speaker then will reach the audience at the same time the minister's voice reaches the audience and when this is true and when the public address system isn't turned up too loud, it is extremely difficult for the audience to differentiate between the loud speaker and the minister. For the average church, for speech re-inforcement, a high grade amplifier of 15 watts will usually suffice. Two loud speakers are usually sufficient for this type of installation.

### Chime System

On chime systems, several installations can be recommended. Before making one, the following points must be taken into consideration (metropolitan or quiet area). If the church is in a busy, noisy location, it will require more power than a church in a rural section. Some chime installations should be heard only in a close, surrounding area, and other installations require that the speakers be heard for several miles. It depends entirely upon what your customer wishes. In either installation, the speakers should be placed as high as possible.

Churches having towers should use the upper ventilation windows for speaker outlets. Those churches having no towers can place their speakers in the opening of the parapet where the bell is usually located. For short distances or where the chimes are to be heard in the surrounding area, a short projector is usually used in a standard speaker driver unit or aluminum driver unit. Since most towers or parapets have four openings, it is recommended that four speakers be used to obtain 360° coverage. In a large installation, the morning glory type of trumpet should be used, either the aluminum permanent magnet type or the heavy duty horn unit. In placing the trumpets or projectors in a tower, they must be protected against rain and should also be screened against the entry of birds.

When the speakers are installed, in a tower, installation usually can be improved by moving the horns upward or downward. You will find that it is not desirable to have the chimes too loud in the surrounding area and for

this reason, the projector should be used so that it points upwards until a reasonable volume is obtained in the immediate neighborhood of the church.

For a chime system, at least 75 watts of power are required. In most cases, 100 watts is most desirable since the same amplifier that is used for chime can also be used for speech re-inforcement and can be played in the inside of the church the same time they are played on the outside. Also by having excessive power, the hard-of-hearing device can be attached to the same amplifier. Every church has a certain number of hard-of-hearing folks who do appreciate hearing every word of the church service and the addition of the hearing aid feature is a simple one.

### Microphones for Church Installations

The type and placing of microphones in church installations varies as to denomination. For a church installation, a good standard anti-feed back microphone is most desirable. In the Catholic church, at least two microphones are employed—one located at the altar and the other at the pulpit. A third microphone is desirable if placed in the choir loft which is usually located in the back of the church. This microphone should be of the low impedance type because of the long cable lengths required. Most microphone manufacturers list transformers so that a high impedance microphone can be used as a low impedance microphone by turning a selector switch.

In the Methodist or Baptist church, two microphones are sufficient, one at the pulpit directly in front of the speaker and the other located at the choir. By careful observation of the location of the service, it will show you exactly where to place the microphone. For choir work in any one of the denominations, a ribbon or velocity microphone is highly recommended.

On the combination of chime and interior speech re-inforcement, the interior speakers must have separate volume controls at the speakers. The trumpets in the tower are operated at a maximum at all times and for this reason these inside speakers should be so arranged that they have separate volume controls. In an installation of this kind, it is also wise to have separate output transformers with a switch arrangement whereby the tower speakers can be cut off since it is not desirable to have the service go out over the tower. Using a high grade double-pole, double-throw switch on the 500 ohm line with separate output transformers for each line of speakers, is the ideal installation. The hard-of-hearing system in that case is then connected to the interior speaker line but this again should have a separate transformer.

### Chime Records

The purpose of a chime system is to take the place of the costly bell system in the church. The chime system is usually not intended to play vocal or ordinary phonograph records and for this reason a selection of records to be used

on a chime system must be very carefully chosen. Records that may sound good on the ordinary phonograph often times will not reproduce well on a chime system. Special chime records are available in which accurate recordings have been made of very fine chime numbers, such as *University of Chicago Chapel*, *St. Paul Cathedral of New York*, etc. These records are ideal and give perfect reproduction. For best results, chime records should be played individually, that is, manually and not on an automatic record changer. Due to the tremendous power of amplification used on chimes, the slightest slippage or "wow" becomes very noticeable on a system of this kind. Needle scratch must also be carefully checked. A very light weight pick up with an extra good transcription motor and sapphire should be used. Accuracy in the motor and pick up are of the greatest importance.

#### Church Hard of Hearing System

This installation is simple. Single ear pieces with a half-head band and lorgnettes with long handles are available. For the male members of the congregation, the head band is more desirable and for the women the lorgnette. Installations should be so arranged that each outlet, either ear piece or lorgnette, are supplied with an individual volume control. This is necessary. These controls should be of the "T" pad variety. When installing a deaf system, avoid creating a "deaf mutes row." These afflicted people do not like to be herded in one row of pews—the installation can be so arranged that the church member can have this control in his regular pew.

#### Football Fields

Schools and colleges now recognize the fact that their sports and athletic department is one of the most important departments in the institution, financially and for popularity. All schools, regardless of size, have an athletic department and realize the importance of a public address system. Those who attend their sports events, can't enjoy them unless they know "the score." In the average school the athletic field is usually laid out in a typical oval shape. Most of the smaller colleges and high schools have seats only on one side of the field. Larger colleges have seats completely around the field. Both of these fields take a separate type of installation.

For athletic fields having seats on one side, it is most desirable to place the speakers of the trumpet style on the opposite side of the field pointing the speakers towards the crowd. By doing this, a smaller amount of speakers are required for complete coverage.

On the completely surrounded bowl, the speakers should be located on both sides of the field and run parallel with the seats. In selecting the size of the system, remember that most athletic fields are of about the same size and

the number of seats and the "spread" or area is the controlling factor.

Do not hesitate to buy a large amplifier on which extra speakers can always be added. The average school installation requires from 50 to 100 watts either in single unit or booster style amplifier. Most of the standard amplifiers on the market today are equipped so that additional speakers can be added at any time. The cost of the amplifier that has just enough power to get by and one that has reserve power is inconsequential. For best results the speakers should be cabled with lead cable or conduit. The cost of lead cable is not any more than a good rubber cable which must be

removed after each event. Speakers should be so arranged that they can be removed and stored away. As to types of speakers, the morning glory trumpet or the inverted trumpet of the magnet type, is most desirable.

Microphones on athletic installations should be of the low impedance types because of the long cable lengths. In announcing for football and other events, this should be done from top of the grand stand. The microphone and the announcer should be located in a partially sound-proofed enclosure near the top of the grand stand.

The number of speakers required depends entirely upon the area of the size of the amplifier. On the average

## GET RID OF CIGAR BOX CONFUSION!

HAVE THE RESISTOR YOU WANT  
RIGHT AT YOUR FINGER TIPS



## FREE!... THE IRC RESIST-O-CABINET

Here's an end to cigar boxes, tin cans, jars and other unsatisfactory make-shift methods of keeping resistors. The IRC Resist-O-Cabinet is specifically designed to hold resistors systematically and safely without bending of leads. It gives you a compact resistor "department" that puts any wanted resistor right at your finger tips and gives you a visual inventory of your resistor stock in a split second. Best of all . . . it's yours without one penny extra cost . . . with any of three factory-packed IRC Resistor assortments.

IRC Type BT Metallized have won acknowledged leadership in every mechanical and electrical characteristic. They're always dependable—they stay put. 1/2-, 1- and 2-watt sizes in all ranges. Insist on IRC's and be sure to get the FREE Resist-O-Cabinet! Your jobber has yours ready.

**INTERNATIONAL RESISTANCE CO.**

401 North Broad Street

Philadelphia, Pa.



**INSULATED Metallized RESISTORS**

high school installation 75 to 100 watts is most desirable and can easily cover the average high school crowd. Purchasing the amplifier in a single unit with separate output transformers so arranged that a number of output transformers with impedance matching arrangements can be used is advantageous. The amplifier can also be transported from the football field to the gymnasium, serving several purposes.

In a gymnasium, anti-feed back microphones are almost necessary because of the acoustics. Any one of the standard anti-feed back microphones now available handle gymnasium work very nicely.

Speaker location in the gymnasium varies depending upon the acoustics and shape of the building. If trumpets or projectors are used, with an anti-feed back microphone and where the speakers are placed high, they can be located in the center of the gymnasium giving a 360 degree installation. Placing speakers parallel or in line with the microphone in one end of the building often makes an ideal installation. Baffle speakers are not desirable.

#### Circuses, Roller Rinks, Etc.

Due to the extremely high noise level at roller rinks, and circuses, the heavy duty amplifier must be employed. The average roller skating rink needs a 75 watt to 100 watt amplifier together with four or six trumpets or metal projectors. In placing the speakers in

roller rinks, it should be remembered that speakers must be located in the center of the hall or rink and as high above the crowd as possible. Horns should be spread in 360 degree position. Roller rinks are usually equipped with small electric organs and a pickup is made with a dynamic microphone, or, in some cases, the amplifier is directly connected to the organ and used as a booster amplifier. Many installations also use phonograph records, a special variety which are recorded at a slow tempo for skating purposes. For continuous entertainment, the amplifier should be provided with a dual turn table.

Installation for circuses is somewhat similar to roller skating rinks and the noise level is equally as high, and for this reason the average installation requires about a 100 watt amplifier. Most circuses prefer the single unit system in preference to the multiple booster style amplifier because of the multiplicity of parts that must be handled. Speakers employed for circus work are usually the morning glory trumpet style, either with a cone driver unit or magnetic driver unit. These are centrally located directly over the "rink." Most circuses prefer close talking, crystal or dynamic microphones. Where the announcer is located in such a position where feed back might be encountered, the anti-feed back microphone of the low impedance type should be employed.

-50-

### Sane Sound Ideas

(Continued from page 23)

bother with. The amplifier comes in a neat, square box on the job, giving a nice, commercial appearance. The sides of the case have no extruding parts. The handles are cut into the sides of the case which also helps the ventilation problem, besides being easier to carry. The output and power sockets are also mounted in a shell to make a nicer appearance and also to protect them from dust, and to protect the plugs from damage when in use. There is a front cover to fit flush over the front. There is also a waterproof canvas cover to fit over the unit for protection when transporting, and in case of rain on outside jobs.

The two amplifiers are coupled together by a coupling condenser from one driver tube grid to the other, so that the inputs of either amplifier may feed the output of the other amplifier. A number of interesting uses may be made of this arrangement. It is possible to use all the inputs at once, and in this case there would be the choice of four high impedance mikes or two mikes and two phono. units all at the same time. Each amplifier has a rating of thirty watts, and so if you need more power you can just feed the other amplifier and have a total of 60 watts at your command from any or all of the various inputs. Normally,

one amplifier will cover both jobs and the other will be ideal just as an emergency spare. This additional amplifier may also be used at fairs where one amplifier is used for the grandstands and the race horse starter wants another for use in speaking to the horsemen while he is getting the horses started. Also the spare could be used on remote speakers for ballyhoo while the main show is on.

It is possible also to run a different set of speakers off the second amplifier and run them at a higher or lower volume to get a better sound coverage. Speakers may be run at different volume levels at different distances from the stage to get different tonal effects. By looking over your past sound jobs it will be easy to find where you could have used a separate amplifier connected in this manner.

The solution to the problem of finding equipment of this type was to purchase a *Stancor* kit No. 430 which, in itself, is a complete amplifier. You will find that considerable improvement can be obtained by rotating the input transformer to the 6L6 stage. It is very critical. These amplifiers fit into this type amplifier system with the minimum amount of changing. Monitor speakers or meters are mounted separately, but they may be mounted on the panel. The panels are of masonite to help cut down the weight. The cabinet is of 1/2" plywood shel-lacked and lacquered gray. Amplifier units, poles and various equipment are lacquered this special color of gray to distinguish this sound equipment.

There are two holes on each side of the cabinet to hold spools of wire. There is a pipe flange mounted on the inside of the cabinet which is used as a holder for the 1/2" pipe on which the spool revolves. One hundred feet of speaker cable are on each spool with connections on both ends. It only takes a second to run a speaker up to any length you wish and snap it into the amplifier and to the speaker. It not only presents a neat appearance, but also eliminates a lot of headaches in trying to untangle speaker lines. The mike lines can be mounted in the same manner.

Speaker mounting has always been a problem on most any installation. The picture here will show what has been done to eliminate this trouble. An inch and a half electrical thin wall conduit was used for a strong, yet very light, pole to carry the speakers. These are painted gray as they come from the supply house. A 38 inch two-by-four is drilled so that it may be slid up and down this pole. Two bolts pull the two-by-four tight so that it may be anchored at any height. Saw-cuts are made out from the center hole so that the bolts can pinch the pole for a good anchor. Two bolts are mounted near the end to fasten the speakers.

The speakers in this case are *Universities* which are very easily mounted, and, in this case, they may be turned

## New EFFICIENCY

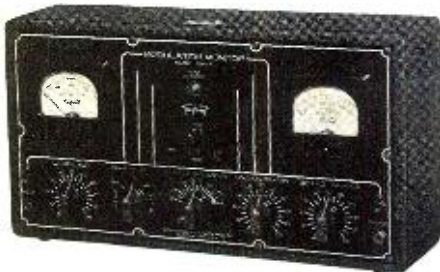

### TRIPLET MODEL 1696-A

You've solved your problem of getting maximum efficiency from your transmitter when you invest in a Model 1696-A Modulation Monitor . . . A new monitor with improved shielding—just the unit for 10-meter bands. Plug it into your AC line—make simple coupling to the transmitter output and the monitor shows:

- Carrier Reference Level • Per Cent of Modulation • Instantaneous Neon Flasher (no inertia) indicates when per cent of modulation has exceeded your predetermined setting. Setting can be from 40 to 120 per cent.
- Helps comply with FCC regulations. Has two RED • DOT Lifetime Guaranteed Triplet instruments. Modernistic metal case, 14 1/2" x 7 3/4" x 4 1/2", with black suede electro enamel finish. . . . Black and white panel.

Model 1696-A . . . Amateur Net Price . . . \$38.34

Also available as a rack panel mounting unit.

FOR MORE INFORMATION

WRITE SECTION 158 HARMON AVENUE

THE TRIPLET ELECTRICAL INSTRUMENT CO.

Bluffton, Ohio

and elevated at any degree to get the best angle for good coverage. Two speakers may be mounted above, and two below so that from one to four speakers may be mounted on this one pole. There is a line transformer for matching the speakers on the wood cross arm. Each speaker has a three foot cord with a male plug for connecting to a line, and also a short cord with a female plug so that another speaker may be connected to it.

By connecting one speaker to another a long bank of speakers may be connected together without a complicated switch box arrangement. The pole must either be planted in a hole or guy wires must be used. Or, if possible, strap it to another pole, tree, or building. I have found no base that would hold this unit at the ten foot height. By getting the speakers mounted ten feet up, and in the clear, they give a lot better sound coverage, and besides, the appearance is certainly tops!

In building a unit of this type it does take a lot of time, but the simplicity, the ease, and the appearance plus the fact that you can insure your customer good sound for the whole job, is well worth the time and trouble. The sound man with this unit will have real pride in installing and hauling this on the job without the usual headache, worries and gray hairs.

-50-

### Field Day at Grand Island

(Continued from page 26)

from these stations indicated good signal strength. We did not find it so easy to work the near-by states and, in fact, much time was spent in listening for stations in adjacent states around Nebraska. We did finally work Kansas, however. The south was well covered and stations in Texas gave indications that we were being well received in that locality. We found that most of the Coast contacts were made on 20 meter phone, while the remaining states were covered mostly on 40 meter c.w. The call W9QEA/portable was adopted for our official call-letters.

Dismantling of the equipment began at 2 o'clock on Sunday afternoon, and shortly thereafter we began the long swing home. The beautiful weather which we had enjoyed on Saturday had passed and we found ourselves in the midst of a heavy steady rain which was encircling the central states. In fact, it rained for 18 hours out of the 19 required to make the journey home.

Driving was continuous throughout the night, and we finally arrived back in Chicago at 10 o'clock Monday morning, where it was still raining.

We considered the trip highly successful from many viewpoints. First, because it showed that amateur operators can take *regular station equipment* of low power and operate from emergency power in the most remote

localities and establish communication with other stations in a very short period of time. We operated from a *Eicor* gasoline driven generator, which gave us excellent regulation for three transmitters, and only required refueling on three occasions. It performed admirably, and this type of unit is easily transported for use in such emergency applications.

Many amateurs are already owners of gasoline plants, and they can do their bit toward the National Defense effort by adopting this method of emergency power for their equipment. This generator was located in an abandoned hut, which we found out in the buffalo pasture.

We believe that *Uncle Sam* will make full use of amateur emergency facilities should the occasion arise where it is needed. By close cooperation and practice, we amateurs will be able to do our part toward the National Defense Effort. Similar activities were carried out by other groups in these United States, and we learned that the results of the contest were most gratifying. We hope to see more of this activity in the near future, and urge all amateurs to participate in these Field Days whenever possible. We should like to see more of them held, both by individuals as well as club groups.

-50-

## MAKE THE MOST OF THIS Unusual Opportunity



This year radio servicemen have the business—plenty of it—and with it the opportunity of making money—big money.

Your only problem today is one of production—getting more sets serviced in less time. You can turn out more jobs each working day by having at your finger tips complete servicing data on the flood of 1-, 2-, 3-, 4-, 5-, even 10-year-old sets that are, and will continue to come, to your bench. Therefore you need all twelve Rider Manuals.

"Wiring diagrams" are not enough. You need the complete, authorized servicing data which can only be found "all in one place" in Rider Manuals. Here you have cash-in-hand information on i-f peaks, operating voltages, alignment frequencies, parts values, voltage ratings of condensers, wattage ratings of resistors, coil resistance data, dial cable adjustments, etc., etc.

#### CLARIFIED SCHEMATICS

As an example of the thoroughness of the Rider Manual service look at Volume XII. This, the latest volume, covers sets

made since May, 1940. In it you will find "Clarified Schematics." Bound right in the volume, this section breaks down over 200 models that had had original schematics so involved that they would heretofore have taken you hours to decipher them. From Rider's "Clarified Schematics," however, you can see at a glance which coils, condensers, resistors and switch contacts are used in the r-f, mixer and oscillator sections of each setting of the wave band switch.

Be sure your production flows through smoothly—keep increasing your profits and lowering your operating costs. Be sure you have complete servicing information—Be sure you have all twelve Rider Manuals.

### An Apology

The advance orders for Volume XII exhausted our first two printings. By the time you read this ad the third printing will be off press and your jobber will be able to supply you immediately with your copy of Rider Manual, Volume XII.

**JOHN F. RIDER, Publisher, Inc.**  
404 FOURTH AVENUE, NEW YORK CITY

Export Division: Rocke-International Elec. Corp., 100 Varick St., New York City. Cable ARLAB



NOW'S THE TIME

TO GET ALL TWELVE  
**RIDER MANUALS!**

Volumes XII to VII—\$10.00 each  
Volumes VI to I—\$7.50 each

Because you can do more jobs in less time, you can pay for the missing volumes you need from the increased profits they will give you. Get them now when you can afford and profit most from them.

## Bench Notes

(Continued from page 27)

ten succeeds in this work, the failure being largely due to the sound man's own lack of initiative. The man who is unable to visualize for himself the opportunities for selling sound in his community had best save his money, as in the end his equipment will set idle in a corner, gathering the usual "white elephant's" quota of dust.

### Ad Nauseam Department

**A**LTHOUGH we are assured in every other breath that they "don't talk about that," it seems to this writer that "my sister and I" unload a lot of doleful reminiscence every evening. We hope we are not being too rude when we venture to express the hope that they will run over and take *Amapola* for a long walk now and then.

### De Gustibus Non Est Disputandum

**T**HE text today, it will be observed, is taken from the Latin, and it may be one of the few practical advantages of possessing a smattering of the classics to be able to drag out these musty tag-lines to lend a learned air to a discourse, and at the same time very useful if writing at space rates. Those who escaped serving time with archaic languages at school may look up the caption in the back of the dic-

tionary, or accept our translation as "Tastes are not to be disputed,"—or, as they say across the bridge in Greater New York, "One man's meat is another man's perzon." No doubt the Greeks had a word for it too, but never having had a yen for the restaurant business, Greek still remains Greek to this writer.

Neither should the truth and wisdom of this ancient maxim be disputed, but it is probably symptomatic of our immaturity as a nation that no other sensible rule for pleasant daily living is so generally ignored, with the result that it is almost impossible to express a preference for any particular brand of commodity without being immediately assailed by the derogatory comments from devotees of other brands. There can hardly be a smoker who has not passed around his favorite cigarettes, only to have them scornfully rejected by others as being largely of equine origin, and unfit for use by any intelligent being.

It is probably a most conservative estimate that enough words and bad manners are employed in arguments over the fancied merits and demerits of 15-cent cigarettes in one month, to supply our political contestants for the next five years, but in the end it is all wasted as each disputant goes his way, without his likes or dislikes being changed in the least, and a lowered opinion of his friends' tastes and judgment.

This is only a natural trait of human nature, and one of the reasons that we regard with no enthusiasm certain exhortations composed by sales-minded writers with firm beliefs in the unlimited power of ballyhoo. It has been some time ago that we read elsewhere such an article, in which the serviceman was taken severely to task and berated soundly for not devoting more time to telling his customers about "the good things they may be missing."

It would seem that radio broadcasting already had an ample number of qualified experts in the tub-thumping end of the business, and as for the average serviceman, harassed by the necessity of keeping up with the field technically, while turning out a sufficient number of jobs per day to keep the bean-pot boiling.

In addition the fact that few technically-minded men have more than a little qualification or inclination to act as unpaid touts for the soap and physic manufacturers, most radio men find that their working day is pretty well occupied by their own immediate affairs, and few will have any spare time to devote to amateur attempts at propaganda, that may end in the futility of all discussions on personal preferences. It may be that we are just a drag on the wheels of Progress, but we have in the past always assumed that the customer called us in as a radio repairman, not as a George Jean Nathan of the radio, as we find that the customer's interest usually lies in the questions of what it is going

to cost to repair his set, and when will he get it back.

Assuming that the average serviceman, who is a day behind his schedule, and perhaps a week behind with his rent, does decide to give some of his time to the cause—a review of tangible results is not apt to be encouraging. He starts off brightly with the first customers along these lines: "Oh, by the way—have you heard the new program, the Tribulations of Tessie Taskett? She's engaged to Elmer, a handsome young embalmer, and there is not just ONE thing she can't tell him but FIVE! She's great—her sobs and sniffles are by far the loudest on the air." This selling talk comes to a dead end, when the customer remarks he is a symphony addict, and it is plain that a very low estimate of the serviceman's I.Q. is forming in his mind. Undismayed, the serviceman tries again with his next customer, meeting with more response—in fact, a little too much. She not only listens to Tessie, but Bessie, Fanny, Maggie and a dozen others as well, and is quite willing to discuss their synthetic troubles the rest of the morning. After forty minutes of this, the serviceman finds that she will not spend \$2.00 for the new 6B5 tube needed, as she can and will buy a new midget receiver for 50c down, which as she figures it is a saving of \$1.50.

Our hero backs out hastily as she begins to quote some of the corny philosophy of that lovable old busybody, Maw Gherkin, and in an effort to make up for time lost by this unprofitable venture, he acquires a \$2.00 ticket for running through a stop-light, and finally arrives an hour late at the home of Mrs. Rychbee, a fair representative of his best class of customers. As the serviceman delves in the works of a 400-dollar combination, he begins a chatty discussion of the "good things she may be missing" to which Mrs. R. merely murmurs "Indeed," with an expression that implies she would be using a lorgnette if she had one, while the temperature begins to slide toward 32°. Nevertheless our hero makes another attempt, at which the lady departs with a barely audible appeal apparently addressed to her Maker, and the serviceman begins to suspect he has made a chump of himself. Mrs. Rychbee, in common with millions of other educated Americans, feels quite capable of selecting her own entertainment, and gratuitous advice along this line may be considered something of an impertinence.

As the service man closes his shop for the day, with the virtuous glow of having done his bit for broadcasting, and a gross income of \$5.10, which is offset by a growing conviction that one-fourth of his day has been wasted in unprofitable talk that at best left half his clients feeling he was a garrulous nit-wit; he may be inclined to repeat the words of Prof. Jerry Colonna:

"You had to open your big mouth."

—30—

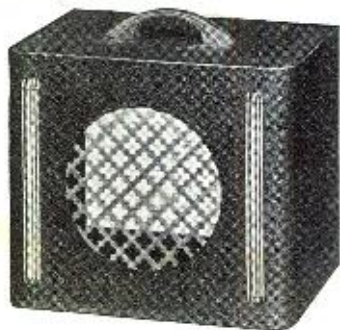

Give Your Equipment  
"Commercial Appearance"  
with BUD Sheet Metal

Write today for your copy of the new No. 241 Catalog. It describes the complete line of BUD Sheet Metal, Condensers, Coils, Plugs, Jacks, etc.



**BUD**  
**BUD RADIO, Inc.**  
CLEVELAND, OHIO

## Hints on Hum

by Willard Moody

**T**HE ways in which a radio transmitter, or transmitters, may be guilty of interference with regular broadcast or short wave reception are numerous, and the remedies available are also numerous in their types and in their applications to the problems involved in getting rid of the interference wherever it exists. The commonest form of interference, in these modern days of superheterodyne receiver usage, is the code signal often received quite strongly because of the fact that the major portion of the receiver amplification is in the intermediate frequency circuit where the signal of the powerful, interfering transmitter is of the identical or very close to the i.f. of the receiver. Most of the cheaper a.c.-d.c. midgets, and even some of the larger models, have no provision whatever for the reduction of this type interference. Some sets have a wave trap installed in the antenna circuit, as a low impedance shunt circuit across the input to the receiver. In all cases, however, where code interference at the i.f. has been encountered, I have found that the most effective remedy is to use a circuit of parallel *L* & *C* in the antenna circuit, and if you want a good wave trap, you had better build it yourself, because many of the regular commercially available traps simply do not do the job.

In some instances, you may run across a case of interference on the regular band by a broadcaster who is putting in a very strong signal in a particular locality. What is necessary here is the attenuation of that powerful signal to the extent that it does not interfere with the other desired stations and yet the attenuation does not proceed so far as to limit the satisfaction from receiving the interfering station without noise when tuned to it, and it is desired to receive it. If the signal is cut down too much, the a.v.c. in the set will bring up the sensitivity and the result will be a lot of static. So use a wave trap of good quality, but simply detune it slightly, to give the desired attenuation of signal.

In certain cases, a wave trap for the elimination of telegraphic signals is of no effect when installed at the input to the set and tuned to the i.f. Probably, then, it is a high frequency signal and an r.f. choke of the small 2.5 mh. type will cure the trouble. Frequently, in the case of amateur interference, the above will suffice, but, sometimes, it is necessary to use a selective filter or wave trap. This r.f. choke should be placed in the antenna lead of the set, two of them being used in the case of a doublet, with a switch to short out the chokes for short wave reception. What often happens is that the oscillator harmonics in a super will beat with the high frequency xmtr and produce an i.f. interfering signal or heterodyne. You can redesign the oscillator or use the above choke. I prefer the choke in the antenna lead.

A rather peculiar case of radio transmitter interference was recently encountered, when it was noticed that the putting in operation of the new

television transmitter atop the Empire State building was, because of its radiation, providing the users of a *Philco Phone*, an inter-office communicator of the wire type, with the sound portion of the television programs. The site of the transmitter is about a half mile from the office building where was located the *Philco Phone*, on the twenty-second floor of the building. Mr. Wood of the Engineering Department of RCA in the Empire State Building, recommended the use of a pair of r.f. chokes in the power leads to the *Philco Phone*, because I had advised him that the interference persisted with the input wires disconnected, whereupon he supposed that the signal was getting in by means of the power line. I tried his suggestion, but it did not work. I also tried the suggestion of Mr. Fitzgerald of the *Philco Service Department*, which was to put a condenser of 250 mmfd. from the grid of the first voltage amplifier to chassis, an idea which made the ultra high frequency signal even more clearly received, so I took off this condenser and, instead, put it across the grid to cathode of the tube, a 6k5 G. This effected some reduction in the signal, but the interference was still there. Next, determined to find the point where the r.f. was being rectified, I took a condenser and shunted out the first grid circuit, then the second. The r.f. disappeared with the second grid circuit short circuited by means of a heavy condenser, but if one which would not adversely affect the operation of the *Philco Phone* were employed, then the interference persisted. Finally, I noticed that the base of the second voltage amplifier tube shield was not making perfect contact. I pressed down on the tube shield, the interference disappeared. The very powerful television sound radio wave was striking the elements of the tube directly, and being rectified in the grid circuit of the second amplifier tube it struck, with the resultant audio being amplified by the output tube, a 25A6.

The puzzling part, of course, was the way in which the r.f. was getting into the *Philco Phone*, and only step by step analysis could possibly have solved the difficulty. With the tube shield cleaned and seated firmly, no further trouble was evidenced in the circuit of the communicator. Incidentally, the frequency of the interfering wave was approximately 45 mc., while the *Philco Phone* operates, normally, on only the audio range!

Similar interference is possible and has happened in many instances where the powerful field of a transmitter was responsible for rectification in the first stage of a high gain public address amplifier or movie sound head. The remedy, of course, is to use combinations of r.f. chokes and condensers in the microphone input lines and in the power line to the amplifier. In the case of high frequency interference, particular attention should be paid to spacing turns on the r.f. chokes to keep the distributed capacity at a minimum, otherwise the interfering signal will simply jump the choke. Direct pickup should be avoided, also, by shielding the chokes and condensers, where possible, although in most cases it will not be necessary to go to such extremes. The power line choke should be located as close to the amplifier as possible, and the same applies to the input circuits.

-30-

## DID YOU KNOW . . .

- . . . That there are 586 Receiver trade names in the Sylvania Tube Complement Book?
- . . . That there are 16,730 Radio Models?
- . . . That there are 100,380 tubes or sockets involved?

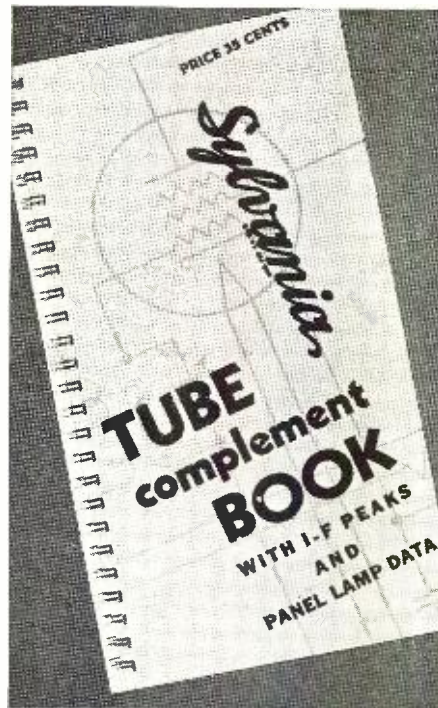

## . . . That the 1941 EDITION SYLVANIA TUBE COMPLEMENT BOOK CONTAINS

The First Collection of Panel Lamp Numbers Ever Compiled?

**W**HERE can you find all this information? In the handy, sturdy Sylvania Tube Complement book . . . the serviceman's standby.

Wire-O bound, the Sylvania Tube Complement book holds 272 pages . . . opens flat, without danger of its falling apart or any of the pages tearing out.

This compilation is the only one of its kind in the industry. It is indispensable to the man who wants to build a sound, steady business on a foundation of satisfied customers. Whether the job calls for knowledge of a 1924 antique or the latest 1941 model you're never in the dark if you have the Sylvania Tube Complement book in your kit.

Write for this book today—enclosing 35c in stamps or coins. And ask, too, for a full list of Sylvania's 125 silent salesmen. Many of these tested selling aids are free . . . others are very fairly priced. And each one of them will help you do a better job, get more trade, make more money.

Sylvania Radio Tube Division

## HYGRADE SYLVANIA CORPORATION

EMPORIUM, PENNSYLVANIA

500 Fifth Ave., New York, Salem, Mass., St. Mary's, Pa., Ipswich, Mass., Towanda, Pa.

Also makers of Hygrade Lamp Bulbs, Hygrade Fluorescent Lamps and Miralume Fluorescent Light Fixtures

## Aviation Radio

(Continued from page 26)

into the unit when the aircraft generator is operating at full charging rate and with just battery input. If possible, always compensate for "average voltage input" either at the generator or at the control panel.

Dynamotors should be mounted so that large air circulation around the unit is affected. Shock absorbers should be used as base mountings and sufficient slack left in the main power cables to cope with vibration. Where a dynamotor is to be operated for lengthy periods without "letups", it would be wise to remove the end bells to allow for greater air circulation to prevent over-heating. If the unit is installed near an air vent, make certain that an air filter is installed in the vent in order to keep dirt, etc., from contaminating the working parts of the dynamotor. Longer life is assured if this is done.

In making the periodic check (time specified by the manufacturer), check for the correct amount of lubrication. In some instances, the working units of the dynamotor (bearings, etc.) are sealed in a lubricant. When a case of this nature is found, the usual routine check of the shaft ends should be made. If the bearings are not "sealed in" check for cleanliness, clean the commutators, and always check the brush tension and fitting to the commutators. Also, examine the leads attached to the brush holders and determine their condition. In cleaning commutators use plug polish if possible, and if none is available use crocus cloth. As a last resort use very fine sandpaper, but never use emery cloth. The reason being that emery cloth contains metal particles which will become imbedded between the commutator segments and short circuit them.

When small cuts are found where the brushes ride the commutator segments, or that part of the commutator is exceedingly bright in color in comparison to the rest of the surface, the brush tension is too tight. The correct color of the commutators should be a chocolate brown. If brushes ride rough and spark, always test the commutator for roundness by swinging the armature between two centers and see that the mica between the segments does not project beyond the copper segments. If the commutator has either of these defects, it should be trued and smoothed on a lathe by an experienced machinist; then if the trouble was due to protruding mica (due to mica being harder

than the copper), the commutators should be undercut. Undercutting is accomplished by scraping the mica with a thin steel blade until it is below the surface of the copper bars.

Undercutting is seldom necessary. However, if the mica is actually too hard to wear evenly with the bar, then undercutting should be resorted to. Defective parts should be replaced and if repairable, repaired. When making continuity tests, lift the brushes from the commutators and check from the brushes. When checking for noise (bench test) a "dynamic" tester should be used. An ordinary type 30 tube with plate and grid tied together in a diode circuit, with the output of the dynamotor (high voltage) connected to the input through a condenser having a capacitance approaching 1 mfd., and a pair of phones connected in the output for indicating the amount of noise present; makes a fine "noise indicator." For a very accurate check on the dynamotor's condition a cathode ray oscilloscope should be used. Insufficient tension will cause sparking, selective commutation, unbalanced circuits in the armature and unstable voltage and consequently introduce noise in the receiver. Too, a noisy carrier may be heard if the condition exists in a dynamotor "feeding" a transmitter.

Sometimes brushes will exhibit "hard spots." These are due to improper mixture of the brush ingredients. When a brush is found where spots are present, it is usually a good policy to replace all brushes in order to obtain equal distribution of the load. The only point of contact on a brush containing a hard spot or spots after some wear are the spots themselves; this inevitably results in glowing, pitting and "under brush" sparking. A brush that does not move freely in its holder creates sparking, glowing, and heat. Brushes that stick in their holders should be replaced and not tampered with. However, when new brushes are installed in the unit it is sometimes necessary to use a small file to "true" the edges of the brush proper so that it will move freely in the holder. If, after a few hours of operation the brushes stick after installation, remove them and examine the holders for proper clearance. This clearance should be between ten to fifteen mils on all sides, and if it is found that sufficient clearance cannot be created by "tooled spreading" then new brush holders should be installed.

When mica extends above the commutator surface brush sparking will be noticeable, and blackening and burning of all the commutator segments will result. "Circle fire" usually accompanies the sparking; this

is due to the short circuiting of the segments by particles of the brushes worn away by the protruding mica. Brush chattering is also caused by high mica and is evidenced by an audible noise some distance away from the unit. This noise compares favorably with that noise made by fan blades when paper is held against them.

Commutators that are dirty do not work properly! When dirt, lint, grease, etc., collects on the commutator it generally works up under the brushes and between the brush and brush holder preventing proper free movement of the brush. This results in sparking due to poor electrical contact and in most cases will cause heating of the brushes and the commutator too. If the motor loses speed, or fails to start, look for dirty commutators. The surface of the commutators should be cleaned with carbon-tet. There are three commutator colors which give a good indication of the following: First, bluish or black color—usually overheating; second, chocolate brown color . . . dynamotor operating normally; third a bright or raw copper color—look for too much brush tension.

Faulty commutation coupled with poor voltage regulation can usually be attributed to a weak field. Where a weak field is present in the motor side, poor speed regulation will be noticed.

When insulation break downs occur, grounding usually results. Finding the ground is a simple matter if a good continuity tester is available.

After brushes are installed (new) the dynamotor should be operated for at least three hours under no-load and for at least one and one-half hours under full load. However, due to the fact that most manufacturers ship extra "pre-ground" brushes with every unit sold, the "grinding" time may be lessened to one hour under no-load and thirty minutes under full load.

In greasing dynamotors, always use the type of grease specified by the manufacturer; and do not feel that just because it was all right to use "type E-3-A" in one dynamotor, that it would be all right for another. It just doesn't work out that way. (So I have found . . . much to my sorrow.) Use just enough lubricant to cover the bearings and *no more!* Excess grease has a tendency under heating conditions to flow into the commutator with the results mentioned above.

A word about power relays used in conjunction with dynamotors: Always check the arm tension when installing a new relay and always make certain that the contact points are dressed down on your periodic inspection. Because the relay found in the average dynamotor is a very sturdy device very little service work is necessary other than the usual inspection and cleaning.

### From the Mailbox

**W.** A. DeLONG of Oblong, Illinois, asks about the length of time the law requires to retain a radio log at: aeronautical stations, aeronautical point-to-point stations, airport stations, and aircraft stations.

According to Section 9.41 of the R.R. of the FCC, all stations in the aviation services except aircraft station must possess operating logs. The logs must contain the following information: hours of operation, frequencies used, stations with which communication was held, signature of operator on duty. It is wise to keep a log of contacts made from aircraft (aircraft log) even though one isn't actually required. Radio logs should be kept for at least one year after completion.

### Hint of the Month

A ¼-watt neon bulb makes a swell visual indicator for "flying the beam" if connected into the remote control box of the receiver or connected directly to the receiver's output terminals. The station is first tuned in aurally, then the volume is adjusted so that a faint glow is perceptible when the "signal break" takes place. With practice it is possible to actually read the station identification signals, but the actual "fadeout" should not be depended upon for station location. This method was thought of after having to wear the phones for two hours . . . got pretty tiresome! —30—

# "Movieland"

**SETS THE PACE WITH THORDARSON AMPLIFIERS**



Out where the movies have made every-one sound conscious, critical buyers of sound equipment specify Thordarson Amplifiers. In beautiful Los Angeles, Thordarson Amplifiers were selected to complete the pleasant effect created by "Wedding Manor." Here, hundreds of couples are married every month in festive atmosphere. The finest in sound reproduction being desired, a Thordarson Tru-Fidelity Studio Amplifier was chosen for recorded voice reproduction, while a 55 Watt Amplifier was installed mainly for reproduction of organ music. A 20 Watt is connected to remote speakers. Sound men are ever discovering new fields. They no longer wait for opportunity to knock at their door, but go out to find it. A Thordarson quality amplifier can convert that dull, dreary restaurant on the corner to a delightful meeting place. Write today for the new Thordarson Amplifier Catalog No. 600-F—it gives complete details on amplifiers from 8 to 55 watts output; also pre-amplifiers and boosters for power installations up to 1000 watts.

## THORDARSON

ELECTRIC MFG. CO.  
500 W. HURON ST., CHICAGO, ILL.

**TRANSFORMER SPECIALISTS SINCE 1895**

Pictures courtesy of Mrs. DuBois Wedding Manor, Los Angeles



## Serviceman's Experiences

(Continued from page 19)

speak to Al. He wasn't worried, though. I was out on deliveries all afternoon, and when I came back at about six, neither Al nor Turner's set was there.

I turned on the lights and stood by. At about eight p.m., Turner's car pulled up in front of the store! Al was in the car, with Turner, and they were talking and listening to a radio! They saw me and motioned for me to come out.

"Jump into the back seat," Turner said, very cordially. "Here—have a cigar. You have a swell partner, fellow. Last night he went to my garage, and he and Frankie repaired my car. Tell him about it, Al, old boy!"

"His trouble was simply a defective cut-out relay," Al explained. "The battery that came with the bus discharged, and Frankie put in a second one just before the radio was installed. Turner was in such a hurry to get away on his vacation, that Frankie didn't have time to check anything else. Up in the woods, the defective relay made contact solidly while the motor was off, and the battery discharged in a hurry. The third battery was necessary only because the mechanic up north wanted to load as many things as he could on the bill. Last night Frankie and I repaired the relay, and replaced the radio."

"Swell," I said, "by the way—where is that broken-down mechanic that's so liberal with his accusations? I'd like to meet him!"

"On his way home," Turner laughed, "and I hope he gets stalled!"

"About your wife," Al said, "might I suggest you explain she missed church last Sunday because of an act of God?"

"It's an idea," Turner said, "but, to tell the truth, I'm sort of glad. After thirteen years this business of hauling her to church every Sunday gets monotonous."

He turned the set up louder.

"Boy, oh, boy!" he said, happily, "just listen to that quality!—makes driving a pleasure. You know," he added, "you fellows must have thought it was very important to get my good will back!"

"Just part of our regular service," Al replied, smiling at me from behind a cloud of cigar smoke.

-30-

## Universal Amplifier

(Continued from page 10)

up for both a.c. and battery, using No. 12 stranded wire for the battery leads. In order to keep the voltage drop in the battery leads as low as possible, these leads should not be over 5 feet in length and should be fitted with heavy duty battery clips. The unit

should first be tried on a.c. After inserting the tubes in their proper sockets, the a.c. cable should be plugged in and SW1 turned on. After the tubes have been allowed to warm up, the plate switch SW2, should be thrown and voltages should then be checked at various points. The plate voltage on the 6A5G's should be approximately 350 volts, while the voltage after the second filter choke will run approximately 300 volts. The voltage drop measured by the cathode resistor R16 should be approximately 60 volts.

Assuming that the voltages are all correct, a speaker should be plugged in the output socket, and the tap in the output transformer set so as to match its impedance. It should be possible to open the gain controls "full-on" with no oscillation or excessive hum. Any hum present will have to be eliminated before proceeding farther. Hum is best cured by first localizing it and then eliminating it by means of shielding or re-location of parts.

If the amplifier is stable and free from hum, a phono-pickup should now be connected to one of the phono inputs and the tone control set to a normal position. Reproduction should sound full and natural, while rotating the tone controls to various positions should afford several variations of tone. After the phono channels are working satisfactorily, the microphone should be connected to one of the inputs and both these channels tested in the same manner as the phono channels.

The battery cable should now be inserted in place of the a.c. cable and, assuming that the cable and plug connections are correct, the amplifier operation should be fully as satisfactory as that on a.c. In the event that hash is present when used on battery, it may be necessary to shield the leads to the plate switch and vibrator as well as the leads to the vibrator winding and transformer. A by-pass condenser of  $\frac{1}{2}$  or 1 mfd. across the battery leads close to the input plug will also aid materially in difficult cases of hash elimination.

### Application

An amplifier of this sort has many and varied uses. Mounted in a sound truck along with a dual phonograph table and suitable speakers and microphones, it will provide an additional source of income for the serviceman, or, during the summer months, it may be rented to groups holding picnics, concerts, or other outdoor events. For indoor use where a.c. is available, it may be used in conjunction with an orchestra for vocals, or to furnish the necessary dance music in itself.

With a suitable transformer to match it to a Class C load, it furnishes an ideal modulator for a low powered transmitter. Speakers used will depend upon the particular application. For outdoor use, probably the most satisfactory all-around type is the trumpet style. Indoors, the wall type is usually best suited.

-30-

Yes, Sir!  
They Used a

# TURNER PUSH-PULL VIBRATOR

in the construction of the 10  
WATT PORTABLE AMPLIFIER

... described in the preceding  
article! Now ...

See

WHY PUSH-PULL  
Offers MORE  
POSITIVE ACTION

With "Stroboscac" — the stroboscopic light, the human eye can see the fastest action as in a slow-moving picture. Actually lets you see the action of a Turner Push-Pull in contrast with an ordinary vibrator.

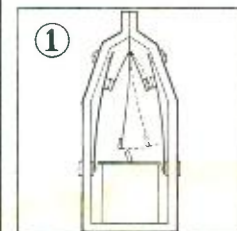
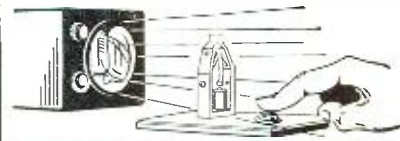

Diagram 1 shows the action of an ordinary vibrator, as seen in front of the Stroboscac. Note the shorter swing of the reed — the unbalanced pressure of contact points.

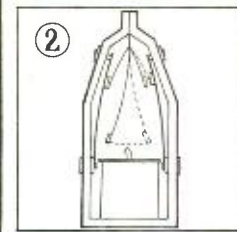

Diagram 2 shows Push-Pull action in front of the Stroboscac. Clearly shows the wider, perfectly balanced swing of the reed, resulting in increased contact pressure and decreased contact resistance.

Compare the wider swing of the reed, the emphasized action of the contact points and the steady, chatter-free operation. No wonder Turner Push-Pull Vibrators give longer, more trouble-free life. Cash in NOW. Write for full information immediately.

FREE 16-page manual for Radio Service Engineers. Gives a wealth of technical information, and explanation of Push-Pull!

THE TURNER CO.

908 17th St. N. E. Cedar Rapids, Iowa

TIME TO TURN TO



## Ringing the Bell

(Continued from page 33)

proving the worth of the sound equipment to the prospect, goes double in this case. Sound equipment in a manufacturing plant must help the business make more profit by (1) cutting down time (2) increasing output.

Many industrial plant managers find that music during working hours reduces fatigue and actually "ups" production. Others use inter-communicators to cut down unnecessary running around the plant.

### Offices

Here's a tip that every serviceman-salesman of sound should be working constantly. National defense requires a speed-up of all production and office procedure. To speed up you must cut down wasted time and wasted motions. What better way is there to do this in a big office than by means of an inter-communicator. Remember, most plants and offices are expanding. If they already have an inter-communicator or other sound equipment, see that it is adequate for the new needs. If not, sell the plant or office on an expanded system.

An idea which has found some favor with business concerns is the use of an instantaneous recorder to keep track of orders and important messages. In this way, the order or the message cannot be garbled. It's all there on a record. Another important use for recorders in offices is the recording of speeches. Often an executive will have an important speech to make before a large group. Such speeches take a lot of time in the prep-

aration and mode of delivery. The use of a recorder will add greatly to the final result, because it will help improve the executive's delivery, remedy speech faults, find weak places in the speech and do all this faster and more efficiently than by any other way.

### Political Campaigns

Politics and political campaigns offer the serviceman-salesman of sound equipment his biggest promise of good business and his biggest threat of bad credit. Before you do any business with a political club, organization, candidate, etc., make up your mind to insist on *cash on the barrel-head*. Also, don't let personal politics or preferences cloud the picture. This is a straight business proposition—you aren't being asked for a recommendation.

Whom to see? For state work, see the *State Central Committee* for each party. For county work, see the *County Central Committee* for each party and for each county that you can handle. For city work, see all the party or candidate managers. Remember that sound trucks are often rented by individuals who contribute the cost of such rentals to their favorite candidate. See the people "in the know" and find out who are likely contributors. Then go out and button-hole them.

For political campaigns, you will need three types of sound apparatus.

(1) 110 volt systems for installation in public auditoriums, political clubs, etc.

(2) 6 volt systems for automobile and truck use.

(3) Small battery-operated systems for street-corner political wind-jammers.

Rental or sale? Most political p.a. work is on a rental basis. However, after the rental is over, you often can convince political clubs in the city that owning their own sound system is a smart investment. Or, you can make the deal on a Rental-Sale plan, a certain amount of the rental to apply to the sale of the equipment if bought within a certain period.

### Schools

Here is a real chance for the sound serviceman-salesman to "do his stuff." Every community has elementary and high schools. Besides these, there are possibly a thousand or more universities, colleges, engineering schools, mining schools, schools of music, etc., who are perfect prospects for sound installations.

In the elementary and high schools, multiple schoolroom installations are a great aid to teaching. Most servicemen realize this, but few servicemen realize the scope of such aid and the number of courses such equipment would benefit.

These include music (from radio and selected phonograph records); dramatics (radio plays, sound-reinforcement in auditorium, instantaneous recordings of rehearsals); public speaking (sound-reinforcement, and instantaneous recordings of student

progress, and for correction of defects in speech); instrumental music (instantaneous recordings of student progress); languages (short-wave broadcasts in foreign language being studied); modern history, current events, etc. (radio programs of national, state and local interest, news programs, special events); physical training (special recordings for mass calisthenics).

Besides these, there are many special radio programs of lectures by experts on subjects pertinent to literature, history, geography, physics, biology, etc. Many schools are building up a library of selected recordings which they use from time to time in various courses throughout the year.

There is the field of p.a. installations in stadiums, athletic fields, etc., as well as the installation of visual educational equipment (talking movies).

Yes, the field for sound installations in educational institutions is big enough to give any serviceman something to "bite into" in the way of prospects for sound equipment.

### Fairs, Carnivals, Circuses, Etc.

Here is an opportunity to cash in on special acts and events. If you have a small truck, you may be able to rent it to ballyhoo the coming of a fair, circus or carnival. Both portable and mobile equipment is needed. A word of caution. If the sound equipment is to be used at a carnival, and the power is to be supplied from the carnival power plant, be sure that the equipment will stand wide variations in line voltage!

Special activities which would be benefited by sound-reinforcement are barkers, contests (hog-calling, band, etc.), races, cattle judging, parades, etc. Here is another tip. Work a deal with the "carni" people to furnish them with a certain amount of p.a. rental equipment in return for a space in the carnival where you can sell recordings. Use the small 6-inch discs and don't forget to use a small p.a. outfit in front of your concession.

### Theater

The many uses for sound-reinforcement and other sound equipment in a theater are too well known to comment on. Bank nights, amateur nights, beauty contests, etc., all require a mike on the stage. However, here is another sales tip. Do a good job of installing such a system and then go after the talkie equipment service work if you are qualified. No equipment is now sold with any service deal. The field is wide open.

### Religious

Here's another spot for a real sound selling job. Sell highest quality sound equipment *only*. Plug hearing-aids, an amplified choir, carillons, sound-reinforcement for the minister or priest, chimes, etc. Here, again, it is wise to see whether some well-to-do member of the congregation can be sold on the idea of contributing a set of chimes, or a sound system in memory of some loved one.



**C**OMplete Radio Engineering Course in 27 months. Bachelor of Science Degree. Prepares you for important positions in National Defense and industry. Radio (television, talking pictures and the vast electronic field) offers unusual opportunities for trained radio engineers. Recognized by the War Department for the training of radio operators. Courses also in Civil, Electrical, Mechanical, Chemical, Aeronautical Engineering, Business Administration and Accounting. Tuition, living costs low. World famous for technical 2 1/4 year courses. Special preparatory department for those who lack required high school work. Students from all parts of the world. 58th year. Enter Sept., Jan., March, June.

Write for catalog.

1681 College Ave. Angola, Ind.

**TRI-STATE COLLEGE**



Don't miss the marine end of sound installations. Voice amplifiers are replacing old-fashioned megaphones and whistles for loading and unloading operations, docking of ships, etc. Visit your docks and see what can be done along this line.

Well, there's the dope on a whale of a lot of sound prospects. If you study it and use the chart, you will benefit in increased sales and easier sales. Here is another chance for you to keep "Ringing the Bell."

-30-

No.	Type	Location	A	B	C	D	E	F	G	H	I	J	K	L	M	N	O	P	Q	R	S	T	U
1	Business	Mfg. Plants					X	X		X	X	X	X							X			
2	Business	Offices						X					X							X			
3	Campaigns	Political	X	X			X			X	X							X					
4	Club	Business	X	X	X		X	X			X	X	X				X						
5	Club	Country	X	X	X		X	X			X	X					X						
6	Club	Fraternal	X	X	X		X	X			X	X	X				X						
7	Club	Political	X	X	X		X			X	X						X	X					
8	Education	Grade School, Public and Private	X					X			X	X	X							X			
9	Education	High School, Public and Private	X					X			X	X	X							X			
10	Education	College	X					X	X		X	X	X							X	X	X	
11	Government	Municipal and County						X	X		X	X	X							X			
12	Government	State						X	X		X	X	X							X			
13	Government	National						X	X		X	X	X							X			
14	Hotel	Commercial	X	X	X		X			X	X	X					X						
15	Hotel	Furnished Apts.						X			X												
16	Hotel	Residential						X			X												
17	Hotel	Resort	X	X	X		X			X	X	X	X			X							
18	Institution	Asylum or Sanitarium						X			X	X	X							X			
19	Institution	Homes for Aged or Poor						X	X		X	X								X	X	X	
20	Institution	Hospital						X			X	X	X										
21	Institution	Orphanage						X	X		X	X	X							X			
22	Institution	Penal						X	X		X	X	X							X			
23	Recreation	Amusement Parks	X	X	X		X			X	X	X	X				X	X					
24	Recreation	Bathing Beaches						X	X		X	X	X				X	X					
25	Recreation	Billiards, Bowling						X	X		X						X						
26	Recreation	Dance Halls	X	X	X		X			X							X	X					
27	Recreation	Dog, Horse and Auto Tracks						X	X		X						X						
28	Recreation	Fairs, Carnivals	X	X	X		X			X			X				X						
29	Recreation	Fields and Stadiums						X	X		X	X											
30	Recreation	Skating Rinks	X				X			X	X						X						
31	Recreation	Swimming Pools						X			X	X					X						
32	Recreation	Theater	X	X	X		X			X						X	X			X			
33	Religion	Cemeteries	X					X			X	X								X	X	X	
34	Religion	Chapel	X					X			X	X								X	X	X	
35	Religion	Church	X					X			X	X								X	X	X	
36	Religion	Undertaker	X					X			X											X	X
37	Restaurant	Cafeteria						X			X	X											
38	Restaurant	Concessioner, Roadside Stand	X					X			X									X			
39	Restaurant	Diner						X			X	X											
40	Restaurant	Dining Room	X	X	X		X			X	X												
41	Restaurant	Road House	X	X	X		X			X										X	X		
42	Restaurant	Soda Fountain, Lunch Room						X			X	X											
43	Restaurant	Tea Room						X			X	X											
44	Store	Auction	X					X			X									X			
45	Store	Department						X	X		X									X	X		
46	Store	Drug						X			X											X	
47	Store	Super-Market						X	X		X									X			
48	Store	Variety (5c to \$1.00)						X	X		X									X	X		
49	Transportation	Airport						X	X		X												
50	Transportation	Bus Station						X	X		X												
51	Transportation	Railroad Station						X	X		X												
52	Transportation	Steamship Dock	X					X	X	X	X												

# Be a Radio Technician



## Learn at Home to Make \$30, \$40, \$50 a Week



Chief Operator Broadcasting Station

"Before I completed your lessons, I obtained my Radio Broadcast Operator's license and immediately joined Station WAMP, where I am now Chief Operator." HOLLIS F. HAYES, 327 Madison St., Lapeer, Michigan.

Radio is a young, growing field with a future offering many good pay spare time and full time job opportunities. And you don't have to leave home to become a Radio Technician. I train you right at home in your spare time.

### Why Many Radio Technicians Get Good Jobs at Good Pay

Radio broadcasting stations employ operators, technicians. Radio manufacturers employ testers, inspectors, servicemen, in good-pay jobs. Radio jobbers, dealers, employ installation and servicemen. Many Radio Technicians open their own Radio sales and repair businesses and make \$30, \$40, \$50 a week. Others hold their regular jobs and make \$5 to \$10 a week fixing Radios in spare time. Automobile Radios, Aviation, Commercial Radio, Loudspeaker Systems, Electronic Devices are other fields offering opportunities for which N.R.I. gives the required knowledge of Radio. Television promises to open good jobs soon.

\$200 a Month in Own Business



"For several years I have been in business for myself making around \$200 a month. Business has steadily increased. I have N.R.I. to thank for my start in this field." ARLIE J. FROEHLER, 300 W. Texas Ave., Goose Creek, Texas.

### Many Make \$5 to \$10 a Week Extra in Spare Time While Learning

The day you enroll, I start sending you Extra Money Job Sheets—start showing you how to do Radio repair jobs. Throughout your course I send plans and directions which have helped many make \$5 to \$10 a week in spare time while learning. I send special Radio equipment to conduct experiments and build circuits. My 50-50 training method makes learning at home interesting, fascinating, practical. YOU ALSO GET A MODERN, PROFESSIONAL, A.L.W.A.V.E. SET SERVICING INSTRUMENT to help you make money fixing Radios while learning and equip you for full time work after you graduate.



\$10 a Week Extra in Spare Time I am doing spare time Radio work, and I am averaging a round \$500 a year. Those extra dollars mean so much—the difference between just barely getting by and living comfortably. — JOHN WASHKO, 97 New Cranberry, Hazleton, Penna.

### Find Out What Radio, Television Offer You — Mail Coupon

Act TODAY! Mail the coupon for my 64-page Book, "Rich Rewards in Radio." It points out Radio's spare time and full time opportunities and those coming in Television; tells about my course in Radio and Television; shows more than 100 letters from men I have trained, telling what they are doing and earning. Read my money back agreement. MAIL COUPON in an envelope, or paste on a penny postcard—NOW!

J. E. SMITH, President Dept. 1HR National Radio Institute Washington, D. C.

**Mail this Now FREE**  
Get 64-page Book

**RICH REWARDS IN RADIO**

Mr. J. E. Smith, President  
Dept. 1HR  
National Radio Institute  
Washington, D. C.

Mail me FREE without obligation, your 64-page book "Rich Rewards in Radio" (No salesman will call. Write plainly.)

Age.....

Name.....

Address.....

City..... State.....

## What's New in Radio

(Continued from page 31)

which can be operated from almost any power current: 105-117, 120-150 and 210-240 volts, alternating or direct current. Uses six latest type tubes giving nine-tube performance. Has three-gang tuning condenser and a stage of tuned radio frequency on all bands. Tunes continuously from 540 kc. to 43 mc. (556 to 7 meters) on four overlapping bands with band spread on all bands. Literature on request from *Howard Radio Co.*, 1735 Belmont Ave., Chicago, U. S. A.

**NEW BARRIER TERMINAL STRIPS BY HOWARD JONES.** The Interconnection of electrical circuits in industrial equipment has required the use of sturdy, compact terminal strips, with maximum metal-to-metal spacing, in order to safely carry the required current.



*Howard B. Jones* designed six barrier strip series to meet these requirements. The body is of heavy-molded Bakelite, with barriers between each set of terminals . . . following around the edge of the strip and terminating with the base. They not only give maximum metal-to-metal spacing, but prevent direct shorts from frayed wires at the terminals.

The new 150 series, comprising three sizes—150, 151 and 152—have been added to the already popular 140 series line. The No. 150 have 10-32 screws, with  $\frac{5}{8}$ " metal-to-metal spacing . . . the No. 150 have 12-32 screws, with  $\frac{3}{4}$ " metal-to-metal spacing . . . and the No. 152 have  $\frac{1}{4}$ "-28 screws, with 1" metal-to-metal spacing. These sizes cover most industrial requirements.

Complete information will be sent free upon request to this publication or direct to *Howard B. Jones*, 2300 Wabansia Avenue, Chicago, Illinois.

## ASSURED STABILITY

WITH

## BLILEY CRYSTAL UNITS

10-20-40-80-160  
METER BANDS

**TYPE B5**—This highly active crystal unit for the 40 meter band has less than 4 cycles/me/°C drift. Price \$4.80.

**TYPE LD2**—An efficient and powerful low drift crystal unit for the 80 or 160 meter band. Price \$4.80.

**TYPE HF2**—Simplifies the construction of 5-10- and 20-meter transmitters. Drift, 20 meters, 20 C/mc/°C. Price, 20 meters, \$5.75.

**TYPE BC3**—A moderately priced mounted crystal with unusual activity and power output. Drift 23 C/mc/°C. Price, 40, 80 or 180 meters, \$3.35.

**BLILEY ELECTRIC CO. • ERIE, PA.**

**KNIGHT 14-TUBE FM-AM CONSOLE.** *Allied Radio Corporation*, Chicago, has introduced as the feature radio of their Spring and Summer line the new *Knight* 14-tube FM-AM Phono-Radio with Changer—a three-way combination for splendid reception of frequency and amplitude modulated broadcasting and reproduction of records.

The *Knight* 14-tube Hi-Fidelity Tuner provides a tuning range of 540-1650 kc. for all standard (a.m.) broadcasts and 40-51 mc. for the FM range. The tube lineup is: 6SK7 as r.f.; 6SA7 as Det.-Osc. (dual purpose); 1852 (6AC7) as i.f.; 1853 (6AB7) as i.f. (4.3 mc.); 6SJ7 as Limiter; 6H6 as Discriminator; 6SK7 as i.f. (455 kc.); 6SR7 as 2nd Det.-AVC-1st Audio; 5U4G as Rectifier. Outstanding features include: r.f. stage; three-gang condenser; AVC; etc.

The specially designed Hi-Fidelity Audio Amplifier is built on a separate chassis and has a frequency response of 50-10,000 cycles. Output is full 20 watts. The following tubes are employed: 6SJ7 as Pre-Amp.; 6SC7 as Mixer-Driver; 2-6L6G as Output Stage; 5U4G as Rect. Inverse Feedback. Bass-Treble control for perfect acoustical balance and special 12-inch concert p.m. Dynamic Speaker result in full-throated and realistic tonal reproduction.

The deluxe Automatic Record Changer plays up to fourteen 10-inch or ten 12-inch records for an hour's entertainment. Has new one-ounce featherweight crystal pickup and lifetime needle which assures longer record life.

The *Knight* 14-tube FM-AM is housed in a beautiful walnut console cabinet measuring 36" high; 36 $\frac{3}{4}$ " wide; 18 $\frac{1}{4}$ " deep. For 110-120 volts, 60 cycles, a.c. operation.

A product of *Allied Radio Corporation*, 833 West Jackson Boulevard, Chicago, Illinois.

**NEW AIRLINE 25-WATT STANDARD AMPLIFIER.** Illustrated is a rugged, dependable, low-cost, 25-watt *Airline* Amplifier, symbolical of the new Standard line of *Montgomery Ward Sound Systems*. The entire group comprises an 8-, 15-, 25-, 35- and 50-watt size for use on 110-volt, 60-cycle a.c. and a 14- and 20-watt mobile type for use on a.c. and 6-volt battery as well. No frills, no useless gadgets to get out of order—but a reliable P.A. System built to stand up under any kind of operating conditions. Six high efficiency tubes are used with Beam power push-pull output.



A New Eye Level Control Panel places all controls where you can see them at a glance. There's no need to stoop when adjusting volume, tone, etc. The control knobs are of an attractive ivory plastic with contrasting escutcheon of bright finished metal. The furniture steel case is finished in a new, easy to clean, smooth hammered, copper-colored finish. Size: 16 $\frac{1}{2}$ " by 12" high overall.

Inverse Feedback produces a full 25 watts of undistorted power free from bothersome hum and also improves the tone. Tubes used: two-6SC7's; one-6N7G; two-6L6G's, and one-5U4 power rectifier. On the back of the chassis are two mike sockets, each with front panel controls.

Front Panel Fuse guards against damage by accidental overload. Also has ruby pilot light. The errorproof Speaker Sockets for one or two 8-ohm speakers assure best tone because speakers are automatically connected properly. Accordingly there is no fuss or bother with "phasing" or re-soldering as may occur when ordinary appliance plugs are used.



The built-in Phono has a constant speed 78 r.p.m., fan-cooled motor; streamlined crystal pickup with long playing needle (good for 2,000 playings), pickup rest and off-on switch. Phono and mike may be used at one time if desired. Operates on 105-125-volt, 60-cycle a.c., or if phono operation is not essential, on both 50- and 60-cycle a.c.



Typical of the entire *Airline* group of Sound Systems, this amplifier can now be obtained either with or without built-in phonograph. In addition an external phono with its own gain control can also be plugged into the amplifier. This means that a continuous musical program can be provided using the built-in phono in connection with an external record player and fading from one to the other.

As with other *Airline* amplifiers a wide selection of speakers, projectors, baffle cases and other accessories is available. Also in many instances a choice of as many as six popular microphones is available at one common price. On the 35- and 50-watt size a simple speaker impedance matching device is built in. This provides the following outputs; 2, 4, 8, 166, 250 and 500 ohms. In addition the usual two-speaker sockets are standard equipment. *Montgomery Ward & Co.*, 618 W. Chicago Avenue, Chicago, Ill.

## Washington Communication

(Continued from page 10)

candidates—and the Army is building the world's best Signal Corps.

From one Army private at Scott Field, Ill., for instance, has come an idea which has been favorably reported to the War Department. Pvt. Joseph R. Crowden, a graduate of Carnegie Tech. was one of the great army of amateur experimenters who decided to join the regular Army. He had been spending most of his money for equipment in civilian life and decided to go into the Air Corps and do his experimenting while taking the technical course offered to radiomen of that service.

He enlisted last January and this spring he reported to Col. W. P. Hayes, *Scott Field* commander, that he had perfected something new for remote controlled planes. His invention, the details of which cannot be discussed, was an improvement over the old type radio relay used in flying planes by radio remote control. A principal feature is that it operates on a single frequency without distortion by static or other outside interference. It has stood up under all tests so far, and apparently the Army is going to adopt it. You know—it's the privates who win the wars.

### British Need Radio Experts

**W**HEN the British Air Attache, Commander G. C. Pirie, put forth his call for American radio technicians to go to England to help man the radio locators and other devices, some alarm was felt in Washington lest the British grab off too many experts in this field, sorely needed now in this country.

But this worry was soon dispelled. The British promised to ship them all back, if we got to the point where we needed every American radioman. And the boats which have left for England since have not exactly been packed with men who answered the call, anyway. After one week of the drive to enlist a technical corps of Americans, the British had found only twenty applicants who were able to pass the examination. Robert Lyle Ames, of Schenectady, a worker in the *General Electric* plant, led all the rest by scoring 99.5 on the test. The first contingent of twenty was sent on its way and the British began collecting the rest of the 15,000 to 30,000 they hope to enlist.

As a matter of fact, if they find that many radio experts in this country who are willing to quit their jobs on American defense orders and go to England, it will surprise everyone. The Department of Labor informs us that there are not more than 22,000 workers in this country—exclusive of the merchant marine and the armed services—who could meet the British qualifications. Every man-jack of these is at work now, the Department believes.

Apparently, the British are hoping to enroll several thousand hams, most of whom would be eminently qualified. Those who are enlisted will be paid from \$24 to \$38 a week, with free room and board. They will be transported to Canada and then sent to England by boat. They will wear uniforms of Canadian blue and will be assigned to duty in various parts of the British Isles, chiefly operating the radio locators. For you guys who consider this war a personal matter between Mr. Hitler and yourselves, here's your chance. You can get further information or enlist at the headquarters of the *Civilian Technical Corps*, 15 Broad Street, New York City.

### Ham Topics

**A**S was forecast here long since: The FCC has put out an order which provides that hams who have gone into military service may have their licenses continued until they return to civilian life by merely writing a letter making a request for renewal and attaching a note from the commanding officer of their outfit, certifying that they are in service.

There's a new call on the air—W3USA, which has been assigned to the net control

station of the Army Amateur Radio System in Washington. For some time, Major David Talley, head of the AARS operations in the War Department, has been trying to get the call letters for his outfit and has at last succeeded. The letters replace the old call, W3CXI.

The AARS is staying on the job this summer and has launched what looks like a red hot competition between its members in various Corps Areas. Each week, there will be a quiz contest on some part of Army procedure and the nine Corps Areas will compete to see which scores highest. Here's the way it works: Questions on Army radio-telegram and radio-telephone procedure will be included in the weekly ZCVA messages transmitted from WLM/W3USA. Army amateurs will send their answers to their net control stations, from which point they will be forwarded to the Corps Area Signal Officer. We'll keep you posted here on the results, as we get them.

The following are the schedules for the ZCVA messages and the contest each Monday: 4 p.m. (EST), W3USA on 7010 kc. and 14280 kc.; 5 p.m. (EST), WLM, on 3497.5 kc. and 6990 kc.; 7 p.m. (EST), WLM on 3497.5 kc. and 6990 kc.; 10 p.m. (EST), WLM on 3497.5 kc. and 6990 kc.

### More Ham Licenses Suspended

**T**HE crack-down we've been warning you hams about has come. The FCC has hauled off and suspended a score of amateurs for contacting foreign stations and the word is getting around that this particular pastime does not pay.

In the haul, the FCC Defense Operations Section netted one strange fish. They picked up a ham station operated from an Army post in contact with a Nazi station. The German had twisted his prefix—a cute little trick which they try habitually—and apparently the American station was not aware of the nationality of the sender, although he must have known it was a foreign station. Army Intelligence is seeking to establish this point, although there is nothing to indicate that anything sinister is involved. However, the dangers growing out of a contact between a ham station in a strategic Army reservation and a station manned by Hitler's minions—no matter how innocent—are quite apparent.

In the cases on which the FCC acted, it was made quite clear that *no* subversive activity was suspected. The suspensions, for 60 days, were handed the following: W1LKO, James L. Waller, Pittsfield, Mass., contacting Brazil; W2DKE, Halscy W. Kline, Schenectady; W2HGG, Edward A. Gruler, Glendale, N. Y.; W2INS, Charles R. Hoffman, Jamaica, N. Y.; W3FUM, James T. Steele, Harrisburg, Pa.; W8SZR, Joe John Simon, Cleveland; W8VAG, William E. Elder, Hamilton, O.; W9QMQ, Clifford L. Highfill, Indianapolis; W9RRV, John T. Tyner, Glenview, Ill.; W9LCE, Eldon F. Davidson, Coffeyville, Kans.; W2MLO, Harvey F. Columbine, East Rockaway, L. I., all for contacting Honduras; W9FOI, Ralph E. Signaigo, Madison, Ill., contacting Cuba; W9GGI, Robert J. Hessler, Western Springs, Ill., for contacting Brazil; W9ZZL, Oliver Ward, Junction City, Kans., contacting Mexico; W3IPJ, John W. Brown, Lansdowne, Pa., contacting Hungary; W5BJF, Claude E. Smith, Tulsa, Okla., contacting Honduras and Mexico; W8EHB, Paul C. Lustig, Pittsburgh, contacting the Dutch East Indies; W9HJ, Harry L. Veatch, Fort Wayne, Ind., contacting Haiti; W2CSW, Kenneth Earl Hyldahl, Perth Amboy, N. J., contacting Brazil.

The FCC is going over the air like a bloodhound every minute of the day. You can't get away with it.

**W**HILE they were at it, the Defense Operations Section pulled in a few more unlicensed stations. In Portland, Ore., they nabbed a 20-year-old youth who had been contacting licensed hams and in Los Angeles, a 26-year-old unlicensed operator was arrested for communicating with licensed operators. Direction finding equipment in a mobile unit turned up an unlicensed station in Sault Ste. Marie, Mich., and in Salida, Colorado, a citizen was arrested for operating unlicensed station "KIDA," over which he

to obtain

**Superior Performance**  
**WITHOUT ADDITIONAL COST**  
**ALWAYS USE**  
*Meissner*  
**PRECISION-BUILT**  
**PRODUCTS**  
**Progressively Engineered**  
for the  
**Serviceman**  
**Radio Amateur**  
**Sound Engineer**  
**and Experimenter**

Write for Free 48-page Catalog

DEPT. N-8

*Meissner* MT. CARMEL, ILLINOIS  
**"PRECISION-BUILT PRODUCTS"**

## GENERAL NOTICE!

Dr. Lee DeForest and  
U. A. Sanabria are  
technically directing the

### AMERICAN TELEVISION LABORATORIES

433 E. Erie Street of  
Chicago, Illinois, and  
Hollywood, California

As part of our program this year we are providing completely free training for technically inclined men to qualify for technical work in Radio Communications and Television. Clip the coupon below today and send for our application form. Experienced Radio men are invited to apply for engineering training without charge.

**GET ALL THE FACTS. MAIL COUPON TODAY!**

American Television Laboratories T10  
433 E. Erie Street, Chicago, Illinois  
Gentlemen: Please send me your application form for FREE training.

Name \_\_\_\_\_  
Street \_\_\_\_\_  
City \_\_\_\_\_ State \_\_\_\_\_

had been playing records with the idea of soliciting advertising business.

For the first time, the FCC used an airplane to track down an unlicensed station. The big range finders of the FCC had picked up the broadcasts of another "Fritz," who defied anyone to locate him and tried to get over the idea he was a pretty dangerous gent. He made the mistake of talking too long to alert hams, however, and while he was chattering on, the FCC was closing in on him in mobile units. When they had trouble spotting the station from automobiles, they packed their direction finding equipment into a borrowed airplane and got bearings on the station. They located it in Haydenville, Mass., and arrested a man who gave his name as Stanley Magdalensky, 35.

The long arm of the FCC is reaching out beyond the borders of this country. For the monitoring stations are patrolling the air waves of South America and are giving the rest of the world a good going over while they're at it, just so they'll know where all the illegal stations are.

The Mexican Government, acting on information furnished by the FCC, closed up an illegal station in Mexico City, which was being run by a couple of American hams. No charges were pressed. The Government of El Salvador confiscated a Nazi station which had been operating in that country, sending direct to Germany and working with a net of other Nazi stations in South America. Other of our Good Neighbors have been furnished with locations on all these vipers in their bosoms and there will be some more closed before long.

### New Mississippi Phone Net

THE Old Mississippi, which said goodby to the fleets of sidewheelers long ago, will say hello by radiotelephone to a new day on August 1. For the FCC has authorized inauguration on that date of a radiophone system on the old Father of Waters. Six frequencies had been assigned for the river's first ship to shore service.

THE commercial broadcasters, now battling it out with the FCC over its order to break up alleged monopolistic practices, showed an increase of 19 per cent in business and of 39 per cent in income last year, it was reported in Washington. Payrolls and employment also went up over the year before. No matter what else comes of the FCC Monopoly Report and the subsequent Senate Hearing, you can bet that the Communications Act, which defines the FCC's powers, will be rewritten as soon as a busy Congress can get around to it. —30—

## Recording Studio Series

(Continued from page 22)

cutting stylus. A thread which is shiny and straight indicates that the stylus is sharp and that the lacquer on the record is fresh. Furthermore after a series of grooves are cut without audio they may be removed from the record and the disc may then be inspected under an ordinary lamp. The reflection of the lamp in the record should be clear and the beam of light undistorted. A cleanly cut recording disc possesses a distinct shine when so observed and this test indicates the condition of the grooves. If the stylus had been dull the walls of the groove instead of being sharply cut would have been "dug out" with the result that reflection from the light would be distorted.

If too much pressure is exerted on the cutting stylus it may actually dig through the coating material and cut into the base of the disc. Obviously this would ruin the point of the cutting stylus. If this occurs the stylus should be discarded and the tension increased to hold the cutting arm away from the surface of the record. Inasmuch as approximately one-quarter of the coating is used when cutting the groove there will, under normal circumstances, be enough left to prevent this occurrence.

The density of the lacquer varies with different lengths of recording discs. The ones having the softest coating will require the most careful depth of cut adjustments.

### How to Record Off the Air

A final test after all adjustments have been made is to make a full recording preferably from a radio tuner and to compare the finished record with the program as it is normally heard. Take for example an orchestra. Listen carefully to the music and study its texture. Then make a record of the next selection and you will be able to determine whether or not you have obtained a correct transcription of the original quality and detail of the orchestra.

Some form of tuner is required and this may either be a separate unit designed for recording purposes or may be the receiver which is an integral part of the conventional home radio combination - recorder. Instructions are always provided for the proper use of this type of equipment. In the case of the semi-professional turntable which requires an external tuner we should select one that is capable of receiving local broadcasts with maximum fidelity. Unlike the conventional receiver which is sensitive to outside stations as well as locals, a recording tuner need only possess enough sensitivity to pick up local programs. Practically all outstanding programs appear on one of the various radio networks. These tuners are designed so that they receive the entire bandwidth of 10 k.c. They are, therefore, capable

of receiving the full range of audio capabilities of the transmitter. This type of tuner will make the highest quality recordings. The station should be accurately tuned in order that maximum fidelity appear through the recording mechanism.

If one cannot locate the reason for obtaining poor quality records we recommend the use of an inexpensive microscope. These may be used for visual examination of the grooves under light. One particular microscope made for the purpose is known as an "Audioscope." By observing the width of the groove with respect to the width of the land we may determine fairly accurately the depth of cut. If these two widths appear to be equal we will have made what is known as a fifty-fifty cut. In fact we may use a forty-sixty cut wherein we have forty per cent as the width of the groove and sixty per cent as the width of the land.

It is also possible to observe the condition of the cutting stylus by placing it in focus with the microscope under a strong light. Any burrs, chips, or other imperfections will immediately become apparent.

We must avoid dropping the cutting arm and stylus onto the turntable or any other object. One need only use caution to avoid this common fault.

If too great a cutting angle is used the cutting stylus may dig into the record. This plowing effect may be eliminated by adjusting the stylus to a more vertical position.

One thing must be avoided and that is that the chip or thread must not tangle around the cutting stylus. If this material were permitted to slide under the stylus the stylus would actually leave the groove and come down to start another groove as the scrap disappeared. This may be remedied by correcting the pitch of the face of the stylus so that the thread is thrown toward the inside or toward the hub of the record.

In no case should the recordist attempt to utilize more cutting surface on the record than the recording mechanism will permit. In other words the stylus must never cut any given groove more than one time. To do so would result in an extra cut and if this procedure were permitted to continue we would soon cut through the material onto the base. To eliminate this condition is a matter of good judgment on the part of the recordist and he should never attempt to cut more than the amount allowed on a record of given size.

Sometimes a recording disc appears which has an uneven surface. They should be carefully examined before use and if one does appear which has an inferior surface it should be rejected. If a bump is encountered it may easily cause the stylus to jump off the record and to return violently and this would cause the stylus to dig in to the soft material. Similarly if we lower the cutting stylus onto the revolving disc with a thud the same fault will occur.

**MODERN PARTS for MODERN CIRCUITS**  
THAT HAVE BEEN  
*"Designed for Application"*  
CATALOG UPON REQUEST

**JAMES MILLEN MFG CO INC.**  
150 EXCHANGE ST. MALDEN, MASS.

**20 TIMES EASIER FOREIGN TUNING!**  
SUPER BAND SPREAD CHASSIS  
9-BANDS (ON 6 DIAL SCALES)  
% + \$50 TRADE-IN  
30 DAYS TRIAL  
COMPLETE

**1942 MIDWEST CHASSIS MODERNIZES YOUR RADIO**  
BREMNER TUBES FROM BOSTON TUNING MAGNA YENMA LOOP AERIAL

**MIDWEST RADIO CORPORATION**  
DEPT. 11-A CINCINNATI, OHIO (USER-AGENTS WANTED)

It is most important that the cutting stylus never be lowered onto the disc unless the table is revolving. Likewise the arm should be lifted from the revolving table before the table is stopped.

### 33-1/3 R.P.M. Recordings

This type of cutting is used on transcription records in order to obtain a fifteen minute playing time per side. Due to the slow velocity of the table there will be a definite loss of high notes as the stylus approaches the inside diameters. Most of these recorders cut from the inside-out and the cutting begins at approximately a 7" diameter. The high notes must be boosted to overcome the slow velocity of the turning record and as the cutter travels in an outward direction this boost is gradually reduced as the velocity to the stylus increases. Remember that the cutting speed is much greater at the outside than at the inside. Furthermore, it is generally advisable to use more volume when cutting first begins. After a diameter of approximately 10" is reached the volume or gain may be reduced to the normal cutting level.

A special instrument termed an "equalizer" is available to fit most professional tables. This is basically a variable tone control and volume control contained in one automatic unit. This is placed on the feed screw carriage in such a manner that the cutter will move the slider on the equalizer and this will be an accurate substitute for manually operated equalizer. The theory on "equalizing" was covered in former articles.

First quality recordings cannot be made on large diameter discs at slow speed when a diameter less than approximately 7" is used. This is because the high frequency impressions etched into the side walls of the groove will be so pinched together that the playback needle will not be able to track. In other words the needle, more than likely, will hit only the high spots and the beauty and quality of these high frequencies will be lost or badly distorted.

### Conclusion

Summarizing recording procedure in general we find that certain basic fundamentals must be applied if we are to obtain first class results.

- Select a recording table that will not vary in speed under load.
- Select an amplifier which has all of the qualifications necessary for faithful reproduction.
- Use as high grade a cutting stylus as your funds will permit.
- Use only playback needles designed for home recording purposes.
- See that proper adjustments are made to the cutter mechanism before attempting to make a record.
- Select recording discs which are absolutely smooth, flat and fresh.
- Observe the volume level as shown on the indicator.
- Make sure that the table is perfectly level in two directions.

i. Lower the stylus gently onto the revolving disc, never abruptly.

j. Avoid jarring of the table when a recording is being made.

k. Use the proper depth of cut.

l. If steel needles are used change them often.

m. Never remove dust from a recording by any other means than to hold the record under a forced stream of cold water or air. Dry the disc with a soft silk cloth. Never use a brush.

n. Place microphones with care.

If the recordist will observe the above precautions he may soon learn to make records properly and these should be comparable to the finest commercial records available. Success in recording depends upon an intelligent application of electrical and mechanical phenomena and in any event a lot depends upon the "common sense" used by the individual. Excellent recordings are being made daily by thousands of users of portable and home recording equipment and the ones turning out the best records invariably are the ones who have given the most thought both before and after cutting their records. In conclusion may we suggest that when each record is finished it be labeled properly and stored in a vertical position rather than in a pile. This applies particularly to the aluminum based recording discs.

We will start a new series in the next issue of RADIO NEWS. Watch for it!

-30-

## Converting the Sky Buddy

(Continued from page 36)

for the 6L6 transmitting tube, this results in a small overload but presents no serious difficulties. However, any attempt to load the 6L6 to more than 25 ma. will result in the transformer becoming excessively warm. From this it is apparent that the transmitter's input is necessarily limited by the drain that can safely be put on the transformer. Should the builder desire, this transformer could be replaced by one of larger rating, thereby raising the transmitter input several times.

To those who have as yet to give "flea power" a trial, many surprising contacts are in store. With the unit described all U.S.A. districts have been worked on 7 mc. as well as stations in U. S. possessions.

Referring to Fig. 2 it will be seen that the 76 BFO cathode to ground connection has been opened and a new lead terminated at a closed-circuit jack on the rear of the chassis. This simple operation provides one with an oscillator circuit which can be keyed and used for various purposes. The newcomer will find it an excellent code practice unit.

In operation, the BFO switch on the front panel is left at the "On" position

and a carrier is tuned in on the broadcast band. A key inserted in the jack makes-and-breaks the cathode to ground connection. The tone may be controlled by varying the pitch control. When the key is removed, the closed circuit jack automatically closes the cathode to ground connection. Many of the boys now joining the Signal Corps have learned the code by using a similar arrangement. It has appeal to the newcomer in radio as well.

### Portable Operation

The *Buddy S-19R* and its new appointments need not necessarily be confined to permanent locations where commercial power is available. It is equally efficient in the role of portable receiver and transmitter. There are no intricate changes to make. Simply remove the shorting plug from the rear of the chassis and make connections to the d.c. voltage supply. In most instances, this will usually be a genemotor or vibrapack powered by a 6 volt storage battery, the battery also providing the necessary heater requirements.

The changes recommended are by no means the ultimate in what may be accomplished. They merely serve to show how a standard communications receiver may be "re-vamped" to duplicate the operation of several units, usually classified as associated equipment.

-30-



Around the World

with HQ-120-X

OWNING an "HQ-120-X" is like taking a world cruise. Stations all over the world can be tuned in with extreme ease. Particularly now with great events happening, everyone is following the news as it is made momentarily. The "HQ-120-X" will bring in foreign stations and up to the minute news on political situations as well as other interesting foreign programs. Automatic volume control maintains even strength of fading signals and a noise limiter does much to eliminate unfavorable man made interference. Try an "HQ-120-X" right in your own home; your local dealer will be glad to arrange a demonstration.

WRITE FOR "HQ" BOOKLET!

HAMMARLUND MFG. CO., Inc. RN-8  
424 W. 33 St., N. Y. City  
Please send 16-page "HQ" booklet

Name .....

Address .....

City .....

State .....

**HAMMARLUND**

Canadian Office: 41 West Av. No., Hamilton, Ont.

## Gadgets

(Continued from page 32)

available so that the unit will supply the filaments of such tubes as a 71A in an efficient manner. The same idea may be used as a substitute for an ordinary doorbell transformer.

### Audio Oscillator Adapter

Here is a very simple gadget that can be made from spare parts and which will appeal to many experi-

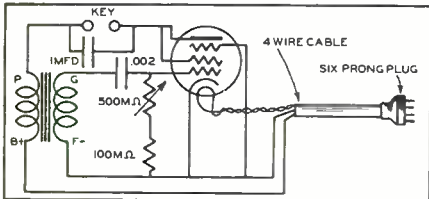

menters and amateurs. The illustration shows the diagram using any popular tube which may be on hand. Operation is simple. Take the power tube out of the radio set and put it in the oscillator socket, then insert a 6-pronged plug into the power tube socket in order to furnish power to the adapter. The number of wires required for this connector will depend upon the tube used. The tone of the oscillator is varied by different settings of the rheostat in the grid circuit. The transformer is an old audio interstage unit, preferably one having a ten-to-one ratio. The cheaper the transformer, the better. If oscillation is not had, either the primary or secondary leads should be reversed.

## EICOR

### POWER PLANT

Model 4AP6

Used by  
W9QEA  
Portable  
on Grand  
Island  
Trek

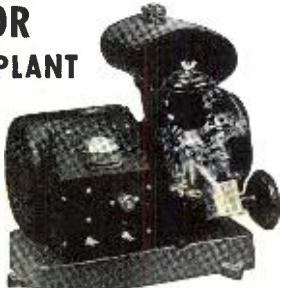

Many Types and Sizes — Write for Bulletin G2  
EICOR, 1076 W. Adams St., Chicago, U. S. A.



## EASY TO LEARN CODE

It is easy to learn or increase speed with an Instructograph Code Teacher. Affords the quickest and most practical method yet developed. Available tapes from beginner's alphabet to typical messages on all subjects. Speed range 5 to 40 WPM. Always ready—no QRM.

**MACHINES FOR RENT OR SALE**  
The Instructograph Code Teacher literally takes the place of an operator-instructor and enables anyone to learn and master code without further assistance. Thousands have used and endorse the Instructograph System. Write today for full particulars and convenient rental and rental plans.



### INSTRUCTOGRAPH COMPANY

Dept. NR, 4701 Sheridan Rd., Chicago, Ill.  
Representatives for Canada  
Radio College of Canada, 54 Bloor St. West., Toronto.

### Emergency Alligator Clip

Here is a handy clip that can be made in a jiffy from an ordinary safety pin. It only takes a small bit of solder and a soldering iron. Take an ordinary safety pin and straighten out

### TAKE OFF HEAD & BEND LOOPS

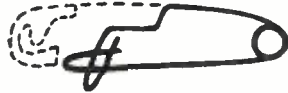

the hook. Form this into the shape shown in the illustration. Solder the hooks as shown. That's all there is to it. It makes an excellent emergency clip and is very much lighter than the regular alligator clips normally used. The hooks may be widened with applications of solder so that they will have a better grip on wire of small sizes. In many cases where a heavy clip actually tears the wire, by using a light weight clip of this type, the trouble may be eliminated.

### Magic Eye Holder from a Tube Shield

An emergency holder for the tuning eyes may be made from an old tube shield found in nearly all experimenters' or servicemen's junk boxes. Two

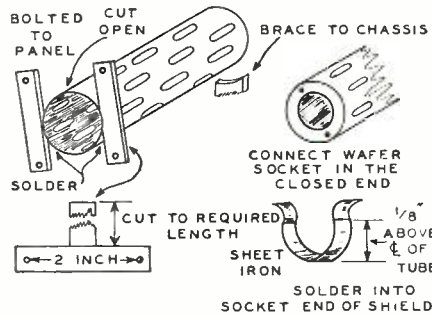

MAGIC-EYE TUBE HOLDER FROM TUBE SHIELD

flat angle pieces on the front of the shield are soldered securely after being cut to proper shape for the particular hardware used. The socket is bolted onto the bottom of the shield and all connections are made before placing the final assembly at the proper position. If a manufacturers' type socket is used, the spring clamp illustrated is soldered into the tube shield in such a position as to catch the base of the tube and still leave enough of the tube protruding from the top of the shield to allow it to be run through a panel cutout. A brace is held vertically under the bottom end of the shield where it will hold the assembly firmly in position. It is connected directly to the chassis below.

### Homemade "B" Tester

To test the plug-in type of "B" batteries, a simple device may be built for rapid test. The cost to construct will be about one dollar which takes a minimum of parts, most of which can be found in any serviceman's junk box.

The parts needed are: one d.c. volt-

meter with a range of 0 to 50; one single-pole-double-throw toggle switch, one three prong plug (like those that are used in the plug-in "B" batteries) and a few feet of good insulated wire.

The negative wire connects directly from the negative post of the meter to the negative prong on the battery plug. The wire from the positive terminal of the meter is connected to the middle terminal on the toggle switch; so that when the switch is reversed it changes the meter circuit from the 22½ to the 45 volt.

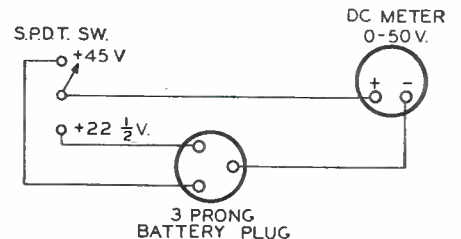

The 22½ volt lead from the battery plug connects to one of the end terminals on the switch and the 45 volt lead connects to the other terminal on the switch. The three wires that connect the battery plug to the meter should be twisted together to form a cable about one foot long. —30—

## New Tubes

(Continued from page 33)

These three new types offer wide possibilities in the exploration and practical use of the ultra-high frequencies. They offer economies not heretofore possible in u-h-f receiving types.

RCA is also making available two new receiving tubes and two new transmitting tubes as follows:

RCA-5Y3-GT/5Y3-G—Full-Wave High-Vacuum Rectifier.

RCA-12SL7-GT—Twin-Triode Amplifier.

RCA-816—Half-Wave Mercury-Vapor Rectifier.

RCA-8005—Transmitting Triode.  
The 5Y3-GT/5Y3-G is a new full-wave, high-vacuum rectifier tube having the same electrical characteristics as the 5Y3-G which it supersedes. The 5Y3-GT/5Y3-G employs GT-construction with T-9 bulb and octal 5-pin base, and is directly useable in sockets intended for the 5Y3-G.

The 12SL7-GT is a new twin-triode amplifier of the high-mu, single-ended type with separate cathode terminals for each triode unit. It is recommended for use in resistance-coupled circuits as a voltage amplifier or phase inverter. This high-mu type has separate cathodes which are brought out to terminals in the base and, therefore, offers much greater flexibility from the circuit designer's standpoint than do other high-mu twin-triodes having only a single cathode connection.

The 816 is a new half-wave, mercury-vapor rectifier designed for transmitting equipment requiring a small-size rectifier handling less power than the RCA-866-A/866. Although the 816 requires less than half the space of the 866-A/866, its design is such as to permit of a peak inverse voltage of 5,000 volts and a peak plate current of 0.5 ampere. Other features of the 816 are its dome-top bulb for mount reinforcement, a top-cap for plate connection, and an edge-wise-wound ribbon filament made of a new alloy material to provide large emission reserve and long life.



## We beg your pardon?

On page 8 of the July issue of RN was illustrated (Picture No. 16) a portable. This was manufactured by Westinghouse Elect. Co., and not by Western Elect. We regret this error and extend our apologies to both Westinghouse and Western Electric Co.

**LEARN RADIO** SERVICING-8 WEEKS  
OPERATING-5 MONTHS

**"LEARN BY DOING"**



Actual shop training on real equipment. You don't need previous experience. Prepare for Radio operator's Government license and for good jobs in Broadcast, Police Radio, Aircraft stations, ships, commercial radio stations, or for good jobs in Service Shops, Radio manufacturers and many other branches of Radio. Greater opportunities in Radio today than ever before.

**EARN WHILE LEARNING**  
If you need part time work to help out with living expenses we will help you get it. Employment service after graduation.

**I'LL FINANCE YOUR TRAINING**  
You don't need to lay out a lot of money for Coyne training for on my "pay after graduation" plan you can get your training first and pay for it in easy monthly payments after your training period is over. Mail the coupon today and I'll send you my big free book and tell you all about my plans to help you—even if you don't have much money to lay out. Don't delay. Send the coupon today and get all the facts with no obligation on your part.

*H.C. Lewis*

**COYNE ELECTRICAL SCHOOL, Radio Division** Pres.  
500 S. Paulina St., Dept. CI-3K, Chicago, Ill.  
Send me all details of "Pay-After-Graduation" Plan and BIG FREE Illustrated Book on RADIO.

NAME \_\_\_\_\_  
ADDRESS \_\_\_\_\_  
CITY \_\_\_\_\_ STATE \_\_\_\_\_

**EVERYTHING IN RADIO**



**BURSTEIN-APPLEBEE COMPANY**  
1012-14 McGEE STREET, KANSAS CITY, MISSOURI

**NEW! 1941 MODEL Pocket Tubes Batteries Radio**

**DURABLE PLASTIC CABINETS**  
Dual Bands—Magictones—Microdial

File your pocket or purse. Wt. 6 ozs. Small cigarette package. Receives standard & some short wave. PATENTED POWER RECTIFIER. No tubes, batteries. Hi-ratio easy tuning slide "MICRODIAL" M.L. OF ILL. SAYS: "MIDGET RADIO WORKS FINE!" ONE YEAR SERVICE GUARANTEE!

Sent complete ready to listen with instructions & tiny phone for use in homes, offices, hotels, in bed, etc. SIMPLE TO OPERATE—NO ELECTRICITY NEEDED!

**SEND NO MONEY!** Pay postman only \$2.99 plus postage charges on arrival or send \$2.99 (Check, M. O. Cash) and you will be sent post-paid. A MOST UNUSUAL VALUE! ORDER NOW! FREE! "MAGICTONES"—ELIMINATES OUTSIDE WIRES!

**MIDGET RADIO CO.** Dept. HG-4 Kearney, Nebr.

## For the Technician

(Continued from page 37)

$$X_c = \frac{10^{12}}{2\pi f c} = C \mu\mu f = \frac{10^{128}}{6.28 \times 10^5 \times 10^{18}} = \frac{1590 \mu\mu f}{C \mu\mu f = .0015 \mu\mu f \quad R_c = 11,000 \Omega}$$

The time constant of the grid leak and condenser will now be calculated to show that there can be no blocking effect.

$$T = RC = 11,000 \times .0015 \times 10^{-6} = \frac{16.50}{10^6} =$$

.00001 second and as frequency is the reciprocal we have that

$$f = \frac{1}{T} = \frac{10^6}{16.5} = 60 \text{ K.C.}$$

The capacity of the tank condenser can be next computed.

$$C_t \mu\mu f = \frac{10^{18}}{4\pi^2 f^2 L} = \frac{10^{18}}{39.4 \times 10^{10} \times 727} = \frac{3500 \mu\mu f}{C_t \mu\mu f = .0035 \mu\mu f}$$

The capacity that will be added to the oscillator when frequency modulation is in operation, allowing a one (1) k.c. swing each side of the resonant peak to insure that there will be no distortion due to this added capacity from the capacity microphone, this capacity will now be computed, then by calling this added capacity  $\Delta C$  we will have a condition as

$$C_1 - C_2 = \Delta C$$

When  $C_1$  is equal to capacity at 100 k.c. and  $C_2$  will be equal to capacity at 99 k.c.

$$C_1 \mu\mu f = \frac{10^{18}}{4\pi^2 f^2 L} = \frac{10^{18}}{39.4 \times .99^2 \times 10^{10} \times 727} = \frac{10^{18}}{2820} = 3562 \mu\mu f = .00356 \mu\mu f$$

The absolute values for  $C_1$  is equal to 3491  $\mu\mu f$  and the capacity added from microphone will be equal to 3562  $\mu\mu f$  or 71  $\mu\mu f$  added which will make no appreciable difference on the carrier frequency. Therefore the value of  $\Delta C$  is equal to 71  $\mu\mu f$ .

Band pass filter design and calculations are next to be computed. As the resonant frequency is to be 100 k.c. therefore our primary and secondary will also be turned to 100 k.c. allowing a 1 k.c. swing each side of the resonant peak the value of K or the coefficient of coupling can now be very easily computed.

$$K = \text{coefficient of coupling} = \frac{\text{width of Pass band}}$$

$$\frac{f. \text{ of tuned circuit}}{\text{width of Pass band}} = 2 \text{ k.c.}$$

$$f. \text{ of tuned circuits} = 100 \text{ k.c.}$$

$$K = \frac{2}{100} = \frac{1}{50} = .02$$

Now as the  $Q_{eff}$  or effective  $Q = \sqrt{Q_p \times Q_s}$ , or if the  $Q_p = Q_s$  the effective  $Q$  is approximately the same.

$$\sqrt{Q_p \times Q_s} = \frac{1.5}{K} = \frac{1.5}{.02} = 75 \text{ Qeff.}$$

Having the effective  $Q$  of the circuit the resistive component of the filter at 100 k.c. will now have to be known.

$$\therefore Q = \frac{\omega L}{R} = \frac{2\pi f L}{R} \quad \text{where } \omega = 6.28 \times 10^4$$

and assuming L to be equal to 500  $\mu\text{hs}$

$$\text{transposing for R then as } Q = \frac{\omega L}{R}$$

$$R = \frac{\omega L}{Q} = \frac{6.28 \times 10^4 \times 500 \times 10^6}{75} = \frac{6.28}{15} = 0.419 \Omega$$

at 100 k.c., then in having the secondary design identical to the primary the characteristics will be the same.

The capacity that will be needed to give the proper voltage output at 100 k.c. or resonance will be

$$C_{\text{band pass}} = \frac{10^{18}}{4\pi^2 f^2 L} = \frac{10^{18}}{39.4 \times 10^{10} \times 500} = \frac{10^{18}}{1.97} = 5090 \mu\mu f.$$

or .005 uf condenser.

At the receiving end of this system we shall employ an 85 or a Duplex Diode Triode and for the same reason that we used a 6 N7 in the oscillator end of the system for simplicity and saving of space.

It will be noticed that in the r.f. section of the receiver, in the primary side of the transformer we are using a series resonant circuit, while in the secondary side parallel resonance is employed.

The reason for this being that in series resonance we have a rise of current, this current being a function of frequency and the field strength being a function of frequency, therefore, the voltage induced into the secondary also being a function of frequency the rectified voltage will vary as the frequency modulation. And as this current is dependent on the frequency and by using a coil having a comparative high Q we can control not only the current but also the selectivity of the tuned circuits, selectivity being dependent upon the slope of the resonant curve.

From the diode section we obtain full wave rectification and by using a potentiometer in the grid circuit for adjustment voltage on grid of amplifying section of tube we can then put the output directly through the audio transformer to a small permanent magnet type of speaker.

This output transformer that is used to match the impedance of the triode section of the 85 tube should have a primary impedance of 2,500  $\Omega$  the secondary impedance being from 6 to 8  $\Omega$ .

The feedback condenser  $C_f$  in the oscillator section of the system should be such that the capacitive reactance should be equal to .1 of the inductive reactance of the plate choke.

The operation of this particular type of inter-office communication system is the essence of simplicity, while in this particular type the design is for five (5) transmitting and receiving positions, of course each receiver and transmitter is assembled into one compact unit.

From now on the oscillator shall be known as a transmitter for reasons

## For the Record

(Continued from page 4)

neighbor's set going becomes more important as the days go by. It is surprising that so many people tolerate inoperative sets when the cause of the breakdown may be due to some slight mishap and the set could be placed into service for a nominal expenditure. The wide-awake serviceman will be quick to stress the importance to the set owner of keeping his equipment in good operating condition.

**S**PEAKING of entering the service, RADIO NEWS draftsman, Al Erickson (W9TDT), has been trying to get into the Air Corps Communications for the past several weeks. Uncle Sam, it seems, has been holding out for four more pounds of flesh. Al tried to gain the necessary weight, but came the torrid spell in ol' Chi and he was taking it off rather than putting it on. Finally, in desperation, he went home to the family farm in Wisconsin where he's just going to bide his time 'til he tips the scales at the correct figure. We hope that by the time you read this he'll be out there turning the generator crank, or some other such work, for the good old U. S. Best of luck to you, Al!

**O**NE question commonly asked nowadays is, "will metal tubes be replaced by the older glass types?" Analysis shows that there will be little advantage in discontinuing those tubes which are sealed in steel envelopes. Modern high-gain circuits require that 80% of the tubes be shielded. In other words, if we return to the glass types, we would still need the metallic slip-over shields, many of which are made of aluminum. Much effort is being put forth in order to secure priority ratings for tube manufacturers so that they will be supplied with the necessary material in order to meet requirements.

**I**N spite of the warnings to the amateurs from Uncle Sam, it seems as if the boys simply will not realize that the National Emergency has placed their status in a rather precarious position by their failure to observe regulations and by continual abuse of privileges given to them in this, the only country where amateur radio as a hobby may still be pursued.

Recently, eighteen more amateur licenses were suspended or revoked as a result of these violations. All of which reminds us that there is still a certain group of radio amateurs who abuse the remaining privileges, particularly on the fone band. Many so-called "Saturday night brawls" are actually transmitted by certain stations where the operator opens his mike in order that all members of the party be heard. This places the amateur in a very awkward position as far as the public is concerned, and it greatly discounts what prestige he may gain in other endeavors, which are legitimate. How about it, fellow hams, must we tolerate this misuse of our hobby?

**T**ECHNICALLY trained radiomen and engineers are at a premium in foreign countries, such as Great Britain. The recent announcement in

the daily papers of the English Radiolocator has aroused considerable interest in the United States, and there is every reason to believe that Uncle Sam will adopt similar measures, both for National Defense purposes as well as to looking ahead to the future where this newest of radio adaptability can serve mankind during times of peace by guiding the pilot safely through the air and by contributing, in general, to the safeguarding of the public.

An opportunity of working at first-hand with one of the most important radio developments in the world today is now open to American radio enthusiasts through membership in the newly organized *Civilian Technical Corps*. Volunteers accepted for the Corps, organization of which was announced June 18 from the British Embassy in Washington, become paid, non-combatant employees whose work consists solely in the servicing and maintenance of the highly technical equipment now in use by the British Army, Navy and Air Forces.

Inquiries concerning the nature of the work abroad are being handled in New York City by the British Consul General, and with the full knowledge and approval of the United States Government and the State Department. A New York office of the corps has been established at 15 Broad Street, New York City, to deal with applications for enrollment. In calling for volunteers, Air Commodore Pirie stressed the fact that while technicians of all kinds are needed, the most pressing demand is for both professional and amateur radio technicians.

**A** VERY excellent description of the Radiolocator is featured this month in RADIO NEWS. While certain information, of necessity, must be withheld, it will, nevertheless, show the reader how the basic system works. This sensational development is operated and maintained by the British Civilian Technical Corps and those accepted are assigned to posts in the United Kingdom, or elsewhere overseas. Free board and living quarters are provided by the British Government. Distinctive clothing, with a special insignia, is also furnished. Salaries range from \$24.12, per week, for basis workers, to \$38.65, per week, for chief foremen. Volunteers who require a course of instruction receive \$21.11 per week, for a period not exceeding one month from the date of enrollment.

Corps members will be given facilities to allot up to 50% of their pay to a wife or child in U. S. currency. Single men with dependents may allot up to 25% of their pay. There are many other benefits offered and information is available from the Civilian Technical Corps, c/o British Consulate General, 25 Broadway, New York City.

Here is a real opportunity for the radio enthusiast to receive highly specialized training while being paid for his time.

**W**E have had the pleasure of talking with several representatives of leading manufacturers of recording equipment and accessories during recent weeks. They believe, as we do, that home recording is still in its infancy and that the public, in general,

does not appreciate the value of this new addition in the field of radio entertainment. Like all good things we enjoy, we get the most out of those that we understand and appreciate.

They tell us that in order to achieve high-quality recordings that we must have the proper tools to do the job. Mass production of home recorders has made it possible for the average wage-earner to purchase a unit that would serve to give some entertainment.

Many buyers of home recorders are bitterly disappointed when they attempt to cut records of their favorite programs, particularly music, because of the short playing time available on such machines. The present series has stressed the importance of using high-grade equipment for proper recording. This has been a step in the right direction! We expect to find that the trend will be towards the purchasing of better units that are capable of longer playing time, and will give more "minutes-per-dollar" to the buyer.

The present series comes to a close in this issue, and we are preparing a new series on the subject which will serve as a "Recording Handbook" for the reader.

**T**HIS hot weather reminds us that with all of the "sea-going" jobs now available, it would be a good idea to sign up for a berth on one of those 50 foot yachts we see out in the harbor. Pounding brass would be much more enjoyable than picking on a typewriter during this heat-wave. "Yes—they've really got somthin there!" O.R.

—30—



**FREE 180 PAGE CATALOG SEND FOR IT NOW!**

**EVERYTHING IN RADIO At Lowest Prices!**

**EVERYONE IN RADIO NEEDS THIS BOOK!**

Serviceman, Dealer, P.A. Man, Amateur or Builder, get your ALLIED Catalog now! It's the most complete Radio Catalog out today—your Guide to real savings on everything in radio

**50 New Sets. Real Radio hits—3-Way Personal Portables, phonoradios, home recorders, autoradios, amateur sets, etc.**

**New P.A. Great New Sound Systems—7 to 75 watts—for Rentals, Orchestras, Schools, Churches, etc. New Ideas—new applications—new low prices—Time Payments—15 Day Trial, etc.**

**Servicemen. New Test Equipment—tools and gadgets—more than 15,000 quality replacement parts. Big Special placement Section, tool Barrain Section, tool Builders. Count on ALLIED for all the new kits and builders' supplies. You can depend on ALLIED as your Radio Supply Headquarters because ALLIED is the 100% Radio House that's always at your service.**

**ALLIED RADIO CORP.**

833 W. Jackson Blvd., Dept. 1-H-1, Chicago, Illinois.

Send me your FREE 1941 Radio Supply Catalog.

Name.....

Address.....

City..... State.....

## FUTURE DRAFTEE?

### Learn Code Now!

- ★ The Army and Navy have an urgent need for the draftee who has an advanced knowledge of code. Untrained draftees require time-costly instruction. Trained operators do not! With time a vital factor, the government wisely places the trained draftee in the more advanced positions in the government's communication divisions.
- ★ **SO BE PREPARED.** Help your Uncle Sam and help yourself by being properly trained for those advanced positions. Be ahead of the other fellow—start learning code now!
- ★ The **CANDLER SYSTEM** is the easy, practical way to prepare yourself right in your own home for the future in the Army, Navy, or Commercial Communications field.

**CLIP THIS COUPON FOR YOUR FREE COPY of the 52-PAGE BOOK of FACTS!**

**CANDLER SYSTEM COMPANY, Dept. S-8, ASHEVILLE, N. C., U. S. A.**  
I am interested in preparing myself for the future so please send me my free copy of the 52-page BOOK OF FACTS.

NAME \_\_\_\_\_ (Please Print)  
STREET \_\_\_\_\_ CITY \_\_\_\_\_ STATE \_\_\_\_\_

# RADIO ENGINEERING,

broadcasting, aviation and police radio, servicing, marine radio telegraphy and telephony, Morse telegraphy and railway accounting taught thoroughly. 48 weeks' Engineering course equivalent to 3 years of college radio work. All expenses low. Catalog free. School established 1874. Dodge's Institute, Oak St., Valparaiso, Ind.

## RADIO COURSES

Start September

- RADIO OPERATING—BROADCASTING
- RADIO SERVICING—a practical course
- RADIO AMATEUR CODE • TELEVISION
- ELECTRONICS—1 yr. day course, 2 yrs. eve. Day and Evening Classes. Booklet Upon Request.

**New York Y. M. C. A. Schools**  
7 W. 63rd St. New York City

## COMMERCIAL RADIO INSTITUTE

A radio training center for over twenty years. Well equipped. Excellent faculty. Practical resident courses in Radio Telegraphy, Broadcast, Servicing, Industrial, Television, Aeronautical, Drafting, Mathematics and Studio Technique. Positions Guaranteed. Fall term October 6. Catalog upon request.  
**Dept. C, 38 West Biddle St., Baltimore, Md.**

## RADIO-TELEVISION

Oldest, largest Radio-Television school in West trains you for good pay job. Complete instruction including Radio Construction and Service, Broadcast Operating, Sound, Talking Pictures, Television, Public Address, etc. Flexible plan to meet specific needs of those with or without jobs. Transportation allowed to L. A. Earn room and board while learning. Request Free Catalog.

**NATIONAL SCHOOLS** Dept. 8-RN  
Los Angeles

## RADIO ENGINEERING DEGREE IN 2 YEARS

Intensive, specialized course, including strong basis in mathematics and electrical engineering, advanced Radio Theory and Design. Modern laboratory. Low tuition. Self-help opportunities. Also 2-year courses in Aeronautical, Chemical, Civil, Electrical and Mechanical Engineering. Participation in Civilian Pilot Training Program. Enter September 2, December, March, June. Catalog.

**INDIANA TECHNICAL COLLEGE**  
781 E. Washington Blvd., Fort Wayne, Ind.

## Correspondence Courses in RADIO and ELECTRICAL ENGINEERING

**ELECTRICAL ENGINEERING** Get good electrical field. Prepare yourself at Low Cost, for secure future. Modern course. So simplified anyone can understand quickly.  
**RADIO ENGINEERING** Extra fine course in radio, public address, photo-electric work. Train you to be super-service man, real vacuum-tube technician. Experimental kits furnished. Diploma on completion.

Either course, only \$25. Deferred payment plan available. Write for free copies of school catalog, student magazines, full details. **SEND NOW!**  
**LOW AS \$25**  
LINCOLN ENGINEERING SCHOOL, Box 931-R-32, LINCOLN, Neb.

systems we see a ray of hope for varicolored television offerings.

The network exponent of color television in New York has announced a tie-in with the Metropolitan Museum of Art in the matter of exhibiting the works of great masters via the iconoscope and its complementary color disk. This is clever promotion as well as good programming—provided that the received images are satisfactory. No one is more fussy about excellent reproduction than an art lover, and television can't afford to kid around with them in matters of distorting great paintings and still expect to keep them reserved for their potential permanent audience. But we do recall that art lovers were none too pleased with black-and-white reproductions of paintings made available over the competitive network's video station several seasons before.

AS late as a full month before the date when commercial television was to have its official birth with the full blessings of the FCC, there was a general lackadaisical air in New York television circles. An acrid note was sounded and it was due to the belief that the FCC was a year too late in sounding the starting bell for commercial television. We came across several participants who claim that *Chairman Fly* and his commission confreres applied the brakes to television a year before when it really could have gotten a foothold. But, now, they say, the unlimited national emergency that has been proclaimed makes it an inopportune time to invest heavily in a new industry that is hampered by material shortages as well as by an overcautious public which knows that London's television screens were darkened as a result of the war. They don't want to buy receivers in volume, it is believed, until they are assured that a television program service is permanent. And the best way they can tell is by observing it in radio shops and department stores for an extensive period before plunking down their own money for home receivers.

TELEVISION studios are working intensively on developing formulas for future programs. What some of the participants may have up their sleeves is still secret, but all disclosed efforts to date failed to reveal any originality. There has been nothing spectacularly creative—nothing to reflect that a great entertainment technique will be developed within the field of television itself. Rather, the program lads have been content to borrow methods of procedure from the movies, the stage and radio.

The easiest way to solve the program problem is to give television fans a little bit of everything, the video directors seem to believe. And they borrow a bit of talent and technique from here and a little bit from there and then they stir it all up with the result of obtaining a none too palatable hash.

The potentialities of television programming are so enormous that the directors of experimental shows seem scared of their shadows. Television can be an original entertainment medium right from the start. It is our view that television will be a bigger entertainment medium than the stage and screen put together. To rely wholly on that dated pair of illusion-creators is a mistake. Instead, the video art can develop its own technique—and it can be a polished, acceptable medium at the very start. The only requirement is that the holders of commercial television licenses will have to open their purse-strings for creative writers, imaginative directors and top-notch talent.

In matters relative to writing, directing and casting programs, broadcasting has been playing up to the stage and screen for many years. And radio has developed a program inferiority complex as a result. So, at the start, television should realize that it is potentially a more powerful and far-reaching medium than plays and movies and should, right from the start, relegate Broadway and Hollywood to a contributory rather than dominating spot. True, stage and screen personalities will be in television demand—but their iconoscope ability is more important than marquee prominence.

AS these lines are being written, the war in Europe shows no signs of abating and television program activities in all foreign nations is at a virtual standstill. When once again the world is at peace, it is apparent that Europe—or what's left of it—will look to the U.S.A. for a pattern for television procedure.

Even with the American industry's slow pace, some television progress is being made from day to day. Television leadership is a thing to be proud of, but the distinction would carry much more significance if there were several contenders for the honors. The stimulus provided by international television competition is a thing that would be warmly welcomed by the entire video industry.

THE possibilities of television's usefulness in wartime are great, and recent seasons demonstrations revealed several possible ways in which the video eye can become a vital military tool.

Television transmitting airplanes can fly over enemy territory and relay scenes of objectives to home bases for long distance shelling activities. And, possibly, the planes can be radio-controlled, thus effecting similar results through a robot pilot with no risking of human lives (except, obviously, on the enemy side).

It is disconcerting to realize that what was once conceived as an out-and-out entertainment medium can be used for such lethal purposes as warfare. But it should be realized that its military application can be especially important to defense measures.

EVERY now and then some American city other than New York does something in the way of television that makes the industry sit up and take notice. However, there is growing evidence that New York will be the video capital of the U.S.A. This has been implied time and time again by the many pioneering technical efforts in the field which used the largest American city as its testing grounds. But more important than that is the rating of the Big Town as a talent center.

We are bound to hear from Hollywood to the effect that the cinema city is the logical contender for talent leadership of the nation when, as, and if nation-wide video networks are placed in operation. But we cannot agree.

True, Hollywood has a load of movie names which may register as well over the kinescope as they do over the theatre screen. But movie names won't be enough to support a bid for leadership. New York has "on call" the cream of the crop in the way of radio, stage, concert and, yes, even movie names. It may seem odd to suggest that New York can compete with Hollywood in the television availability of movie personalities. But it's true! Mind you, we said *availability* and not *quantity*. And what good is quantity if just a very small percentage can be signed when needed for a television show?

Broadcasting experience of many years has shown that there are great difficulties in obtaining talkie stars for Hollywood broadcasts when they were seasonally engaged before the cameras; it's often hard for a star to find time away from the klieg lights for the countless rehearsals as well as the actual broadcast. But, when they're in New York, there's barely a hitch in taking on the mike assignment that won't clash with other activities.

We've even known of movie stars who preferred a special flight to New York (all expenses paid by the sponsor, of course!) to appear on a radio program. And the same will hold true of television.

The video industry has already demonstrated its operating independence of the movie industry. While the movies may not exactly take a back seat in television rating, they apparently will have to be content with one off the center aisle. And it is very likely that a batch of broadcasters who have their eye on television allocations will be a bit disappointed, too, in discovering that telecasting won't be dominated by the present broadcasting fraternity.

It all comes down to this: Television programming calls for such a broad scope of material and expertness of presentation that the video art is on the alert for a few dozen

The same applies to T3; though it is not nearly as sensitive. Do not use the centertap of the 1.5 volt winding on the power transformer. Unless you are very lucky, it will not be in the exact electrical center; and any slight deviation means a loud hum from the 26. Use a potentiometer across the winding. Anything from 10 ohms up to a hundred will do, but one with many turns of wire is preferable as it gives you a finer adjustment.

In an earlier model, 5 mfd. condensers were used to bypass the cathodes; but it was found that a reduction to .1 mfd. produced a marked drop in hum level as well as eliminating a tendency towards boominess. A slight drop in the overall gain was also evidenced by this change, but it was more than compensated for by the increased intelligibility.

As shown in the diagram, a 2500 ohm electrodynamic speaker was used at the master station. The only reason for this was that such a speaker was already on hand, for a permanent magnet unit such as is used at the remote station would be preferable. If you do use a field coil speaker, do not attempt to follow the common practice of using the field as a filter choke in the power supply. Such a connection is all right when the speaker is performing its normal function; but when used as a microphone, it must have well-filtered d.c. in the field. It naturally does not get this when acting as a choke.

Operation of the system is very simple. If you are at the master station and wish to speak to someone at the other end, turn on SW2, throw SW1 to "talk," and say your say. Then flip, to "listen" for the reply. You will have to train the family not to answer until you have stopped speaking and had time to throw the switch, as evidenced by a slight click and silence. If they try to shout you down in the middle of a speech, they simply won't be heard.

On the other hand, if you wish to contact the master station from the remote, you must make use of the push button at that point. This sounds the buzzer at the other end and indicates to the party there that someone wishes to speak with him. He is then at liberty to start up the amplifier and ask, in effect, what all the fuss is about.

An idea of the sensitivity and volume output of this system is given by the fact that, with the writer's installation, a person speaking no less than two feet from the master mike in the attic can carry on a comfortable conversation with someone anywhere on the first floor, the remote speaker being located in the dining room.

In regard to running the connecting cable between stations, the writer found that the easiest and least obtrusive method was to follow the hot water heating pipes. Obviously, this would not be possible in all cases; but where it is, it is no trouble to poke the cable through the same hole in the

floor as the pipe occupies, enlarging it slightly if necessary, and to tie the cable out of sight behind the pipe as it runs down the wall. This should be a particularly handy method for the reader who lives in a family where "unsightly wires" or any slight damage to the house are frowned upon. The cable used, incidentally, is two-wire, shielded.

The model built by the writer was done in breadboard style, as shown in the photographs, and mounted in a homemade cabinet with a quarter inch Masonite front. As junkbox parts were used almost exclusively, the exact cost cannot be given. However, a replica built entirely of new parts should not cost more than around ten dollars.

One more point. Some difficulty may be encountered in securing a power transformer with both 2½ and 1½ volt windings. If so, either a separate filament transformer can be added, or else a higher voltage winding on the main transformer used with a suitable dropping resistor. Do not, however, attempt to use the same winding for both the 26 and 47 filaments; it runs you into complications.

-30-

### Video Reporter

(Continued from page 39)

owners would invest in the costly equipment for just occasional "Standing Room Only" events. Championship prizefights and other headlining sport events don't take place daily.

Furthermore, there's an added wrinkle in how television interests can afford to pay for "television rights" to sporting events. If they think they'll get them free, there's another guess coming. Radio didn't hurt the box-office at sporting events in the past because it whetted the desire to see the contests. But telecasting the events, while promotionally effective, won't have as good results at sporting arena box offices.

TELEVISION, despite its long period of promotion, is still something of a side-show. Of course, the public hasn't had the opportunity to regard it in any other light. But it is still being treated as a sort of "freak" novelty.

The New York headquarters of the radio network that has been selling "television tours" to the public has now combined the video sightseeing trip with its older-established radio studio rubberneck tour. And, at "two shows for the price of one," it is anticipated that summer visitors to New York will flock to the tour in great numbers.

Television may not have yet reached astronomical proportions, but it has gained some star-gazing recognition. An enterprising New York telescope barker stationed on Forty-second Street, between Fifth and Sixth Avenues, is selling glimpses of the television antenna atop the Empire State Building for five cents a look. While his nearby heaven-gazing competitors have the moon and the planets as their headlining features, this fellow is drawing business by aiming his lens at the turnstile-shaped video aerial.

WE couldn't help but feel that the sudden high-pressure hallyhoo for color television was a sort of technicolor red herring designed just to bide time until its various exploiters charted their courses for more active participation in the video art. Now, however, with word reaching us that some laboratories are working on electronic color

## INTRODUCING A NEW TYPE OF MULTI-WAVE TUNER

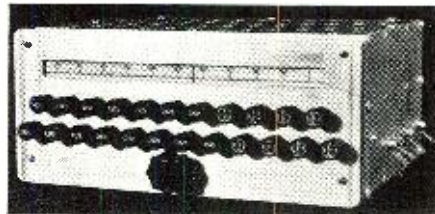

### A COMPLETE FREQUENCY COVERAGE IN 23 STEPS

10 domestic broadcast stations—1700 kc. police band—160 meter amateur band—2400 kc. police band—80 meter amateur band—aircraft—49, 31, 25, 20, 19, 16, 13, 10 meter bands . . . and all this by means of push buttons. Guess work in short wave reception is eliminated in that this precision built product is capable of receiving short wave stations with the same facility as stations in the domestic broadcast band. No external variable condenser gang necessary; no gang switch used: no oscillator padding condensers; tuning is positive and smooth; mounted in dustproof metal cabinet; overall dimensions of tuner proper: 9¼" x 6¾" x 4¼". Model 142 as illustrated above for superheterodyne circuit—465 kc. Wired and tested. Complete with instructions, circuit diagrams, charts and other useful data. Patents applied for.

**\$15.60**

Price  
WE PAY THE POSTAGE

Immediate Delivery Made Upon Receipt of Order

### MICHIGAN RADIO PRODUCTS

LUDINGTON, MICHIGAN

## FIX ANY RADIO

Amazing New Invention

Simplified  
Radio  
Servicing  
by  
Comparison  
Method

Repair radios in minutes instead of hours. Revolutionary different Comparison technique permits you to do expert work immediately. Most repairs can be made without test equipment. Simple, point-to-point, cross-reference, circuit suggestions locate the fault instantly. Covers every radio set—new and old.

Complete  
**\$1**  
Training

### FOR BEGINNERS OR EXPERTS

Find any radio fault with ease. Follow the comparison tests given on 16 large trouble-shooting blue-prints. Over 1,000 practical repair hints. Hundreds of simplified tests using a 5c resistor and a filter condenser. Introductory material included for beginners and will serve as a review for experienced radio men. Also several chapters on test equipment. Presented in manual form, 8½ x 11 inches. Entire plan is stark new and will revolutionize servicing technique. Protected by U. S. Copyright, but may be used by you for speeding up radio service work.



Developed by  
M. N. Beitman,  
radio engineer,  
teacher, author,  
& serviceman.

### SATISFACTION GUARANTEED

Take advantage of our "no-risk" free trial. Use this time-saving, money-making radio servicing method for 10 days without any obligations. See how much time you will save every day on every radio job. Learn new short-cuts in radio servicing. Then decide to keep Comparison Method Manual or return it and receive a complete refund in full. You cannot lose — but you owe yourself a chance to look at this plan.

### NEW 1941 EDITION

The complete simplified training is yours for only \$1.00, full price. It will more than pay for itself on the first radio job. Examine and use this plan for 10 days at our risk. Send free examination coupon right now. Use the plan this week

## 10 DAYS FREE EXAMINATION SUPREME PUBLICATIONS

3727 W. 13th St., CHICAGO, ILL.

You may ship the new manual, "Simplified Radio Servicing by Comparison Method," for free examination. I am enclosing \$1.00, the full price, and 10c for postage. I must be satisfied or you will refund my remittance.

NAME:.....  
ADDRESS:.....

# RADIO made EASY

## LEARN AT HOME - IN SPARE TIME

**36 VOLUMES in 1 Big Book!**

1. Broadcasting System
2. Sound & Speech Music
3. Electron Theory; Electric Current
4. Elec. Units; Ohm's Law
5. Electric Circuits; Batteries
6. Magnetism
7. Electromagnetism
8. Electromagnetic Induction
9. Inductance
10. Capacitance; Condensers
11. A.C. Circuits
12. Filters
13. Measuring Instruments
14. Radio Waves
15. Broadcast Radio
16. Receiving
17. Vacuum Tube Principles
18. V. T. Characteristics
19. Vacuum Tube Construction
20. V. T. Detector and Amplifier Action
21. Radio Frequency Amplification
22. "Superhetero."
23. R.F. Amplifiers; Tuning
24. Audio Amplifiers
25. Loudspeakers
26. Battery Receivers
27. Power-Supply Units
28. Electric Receivers
29. Auto and Aircraft Radio
30. Phonograph; Public Address
31. Short-Waves
32. Photoelectric Cells; Cathode-Ray
33. Television
34. Antennas and Grounds
35. Testing; Servicing
36. Sound Pictures

**Ghirardi's COMPLETE Course will train you QUICKLY**

Here's your **BIG CHANCE** to get a thorough training in basic **RADIO FUNDAMENTALS**—quickly, easily. There are **BIG OPPORTUNITIES** and lots more jobs for men with radio training—in radio factories, in radio service shops—and in all branches of the Army and Navy.

**RADIO, SOUND, TELEVISION —MADE EASY AS A, B, C.**

Ghirardi's famous **RADIO PHYSICS COURSE** is the cheapest, quickest radio training you can find. The whole science of Radio, Sound, & Television in a form completely intelligible even to beginners without any previous radio experience. Clear explanations and 856 self-testing Review Questions make it as easy to understand as a primer. Thousands of successful radio men got their start with this book, and it's used by more radio schools and students than any other radio text in the world! Get this whole 972-page course today for only \$4—and get started on your own radio career!

**Use It 5 Days —OUR RISK!**

Your money back if not fully satisfied. Don't delay—get started now—mail this coupon at once!

972 Pages  
508 Illus.

**Only \$4**

**CLIP OUT — AND MAIL!**

Radio & Tech. Publ. Co. Dept. RN-81, 45 Astor Pl., N. Y.

Enclosed find \$4 (\$4.50 foreign) for my copy of "RADIO PHYSICS COURSE" with your 5-day Money-Back Guarantee.

Name

Address

City  State

Send me free literature.

## RADIO PHYSICS COURSE

by Alfred A. Ghirardi

### Super-Het Beat Action

An actual example of the "beat" action in a superheterodyne receiver will be considered now. Suppose the modulated carrier signal voltage of a broadcasting station transmitting on say 1,000 k.c. is being received. Let us further suppose that this was modulated by a 3,000 cycle sound in the broadcasting station. Let us suppose also that the intermediate-frequency amplifier of this superheterodyne receiver is designed to amplify at a fixed frequency of 175 k.c., permitting of course, a band of frequencies 10 k.c. wide (170 k.c. to 180 k.c.) to pass through it freely, so that the sideband frequencies will not be cut or weakened. Consider simply the carrier frequency. Now the desired signal is separated from those of other stations by the r.f. tuning circuit, and is amplified by the single r.f. stage. From here it goes to the "mixer" circuit where it is combined with a steady a.c. voltage of 1175 k.c. produced by the oscillator tube in the receiver. (The oscillator has been adjusted to generate a voltage of this frequency for this particular case. When receiving stations of other frequencies, the oscillator must generate a different frequency in order to produce the 175 k.c. beats.) The result is, that in the mixer circuit the 1,000 k.c. modulated signal voltage and the 1175 k.c. oscillator voltage combine to produce a resultant voltage having a frequency equal to the average of these, that is 1087.5 k.c. This new resulting voltage makes cyclic variations in amplitude, at a rate of 1175—1000, or 175 k.c. every second (beat frequency). These variations in amplitude are in exact accordance with the modulations of the incoming signal voltage. Now this 1087.5 k.c. resulting voltage is applied to the grid circuit of the first detector tube, this being either of the "grid leak and condenser" type, or the "grid-bias" type. The effect of the detector, is to demodulate the 1087.5 k.c. voltage, removing the 1087.5 k.c. variations by the detector action. The output of the first detector is therefore a current or voltage possessing the 175 k.c. cyclic variations modulated in accordance with the original signal modulations. After passing through the primary of the first coupling transformer, this is an a.c. voltage of 175 k.c. modulated as above. It is then amplified by the intermediate amplifier, and finally fed to the second detector where it is demodulated again, only this time, the 175 k.c. variations are removed and the audio-frequency modulations are left. These are amplified by the audio amplifier and fed to the loud speaker. It is interesting to note that the first detector really performs the function of detection or demodulation, notwithstanding the assertions of some writers to the contrary. It removes the variations of the average frequency resulting from the mixing of the incoming signal frequency and the oscillator frequency, and preserves the beat modulation. The second detector removes intermediate-frequency variations, leaving the original audio-frequency modulations.

## Simple Inter-Comm.

(Continued from page 11)

At first glance, the reader will probably be somewhat surprised at the selection of tubes in the amplifier. There is a good reason for the choice, however. For the sake of compactness, most commercially built, inter-office communicators make use of the a.c.-d.c., transformerless type of construction. This necessitates the use of indirectly heated cathode type tubes, due to the series filament connection. As these tubes are slow heating, it is essential that the amplifier be left running constantly if it is to be ready for service at a moment's notice.

This practice is no doubt quite tolerable in an office where the communicator is in constant use; but in a home installation where the need for service is relatively rare, it is really not satisfactory. It was therefore decided to sacrifice compactness in the amplifier and make use of quick heating, filament type tubes, through the use of a power transformer. With this arrangement, practically no time is needed for warming up (actually about two seconds); and the amplifier need be left running only during actual use.

As the selection of a.c. filament type tubes is limited to less than half a dozen different types, there was not much trouble involved in deciding what kinds to use; and a 26 and 47 were soon singled out as the best combination. When transformer-coupled as shown in the diagram, they provide just the right amount of gain for the dynamic microphones (speaker). The series transformers in the input serve merely to boost the gain in the absence of a proper voice-coil-to-grid transformer, T1 being a plate to v.c. output transformer reversed, and T2 a 3½ to 1 interstage audio, the same as T3.

In order to prevent feedback in the amplifier, several precautions must be observed. First, the talk-listen switch, SW1, must be of a type with low capacity between the elements; for although switching was purposely done in the low impedance voice-coil circuits to minimize the possibility of stray coupling, the amplifier will still howl if too much capacity exists between the input and output circuits.

A Federal Anti-capacity, D.P.D.T. switch was used in the original model and proved quite satisfactory. For the same reason, all leads to the switch should be shielded. Feedback will also result if the output transformer, T4, is located too close to T1 and T2.

Several precautions are also necessary to prevent excessive hum in the output. Obviously, if T1 and 2 are anywhere near the power transformer, they will pick up hum. They must be isolated as much as possible and not screwed down until the position of minimum hum has been found.

## READ AND SEND CODE

### Learn Easily at Home This Quicker Way

No experience needed. Beginners read code quickly, copy accurately. If already an op, speed up your wpm with this approved amazing all Electric Master Teleplex Code Teacher. Only instrument which records your sending in visible dots and dashes on specially prepared paper tape—then sends back your own key work at any speed you wish. Fascinating, foolproof—gets results because you learn by HEARING as well as SEEING. That is why thousands agree this method is surest and quickest. While not designated standard equipment, Teleplex is used at many U. S. Army Posts, Naval Training Stations. We furnish Complete Course, lend you the New All Electric Master Teleplex, and personal instruction with a MONEY-BACK GUARANTEE. Low cost, easy terms. Write today for folder RNS, no obligation.



**TELEPLEX CO., 107 HUDSON ST., JERSEY CITY, N. J.**

## RADIO TECHNOLOGY

**RCA** Institutes offer an intensive course of high standard embracing all phases of Radio and Television. Practical training with modern equipment at New York and Chicago schools. Also specialized courses in Aviation Communications, Radio Servicing and Commercial Operating. For Free Catalog Write Dept. RN-41.

### RCA INSTITUTES, Inc.

A Radio Corporation of America Service  
75 Varick St., New York 1164 Merchandise Mart, Chicago

**SOLAR RED-CAPS**

Smaller Diameter Dry Electrolytics

**SPEED Servicing**

Write for Catalog

**SOLAR MFG. CORP. Bayonne, New Jersey**

which are self-explanatory, as each transmitter is a 100 k.c. type of output and with the addition of padding condensers we can vary the output fre-

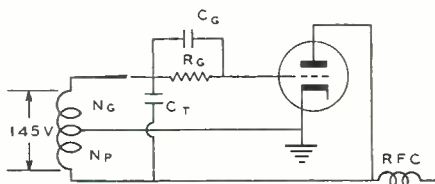

FIG 2

quency from the minimum of 100 k.c. to the maximum of 140 k.c. meaning that while each receiver has one and only one frequency to which it will respond, its own transmitter can and will broadcast over four other frequencies.

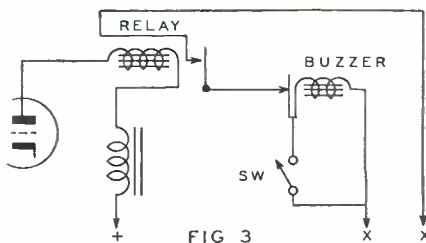

FIG 3

While frequency modulation is one of the most economical as well as non-complex type, that can be used in broadcasting, but due to the wide band spread in commercial broadcasting, this feature will introduce harmonics and consequently distortion, but transmitting over a narrow band 2 k.c. such as this type of system employs frequency modulation is ideal.

In regard to radiation of this system to be picked up by receivers in the immediate neighborhood, the possibility of that factor is very remote. As the fundamental formula for wavelength in meters is

$$\lambda = \frac{300,000,000}{\text{fcy/sec}}$$

and as the line must be a 1/4 or a multiple thereof of the carrier frequency to produce an appreciable radiation if open lines were to be used for transmission the above formula would give critical dimensions at which the line would radiate, but by use of a concentric transmission line of the flexible type this possibility is eliminated. At our highest frequency we would have

$$\lambda = \frac{300,000}{14} = 2143 \text{ meters}$$

$$\therefore 2143 \times \frac{1}{4} = 536 \text{ meters}$$

or a radiating distance of 1742 feet.

Frequency to which each position has, is tabulated below.

Station	1	2	3	4	5
Transmitter Frequency	100-110 120-130	100-110 12-140	100-11- 130-140	100-120 130-140	110-120 130-140
Receiver	140	130	120	110	100

As an additional refinement for those who desire an audible or visible signaling device, a vacuum tube relay

having a low resistance coil is put in the plate circuit of the 85 amplifier to insure a small voltage drop. The external circuit may contain a high frequency buzzer or a light, power being supplied from the power transformer, also having a short circuiting switch to eliminate the buzzer from the circuit when speaking.

## Mfgs. Literature

(Continued from page 38)

original converter built specially for sound apparatus and features are included which make this a "must" for the mobile sound installation. Copies of this new bulletin may be had by writing to the *Janette Mfg. Co.*, 556-558 West Monroe Street, Chicago, Illinois, U.S.A.

ATLAS SOUND CORPORATION CATALOG F-41 IS NOW READY FOR DISTRIBUTION. A very complete line of projectors, trumpets, adapters, horns and speakers, marine speakers, chandelier baffles, transformers, projector units, fixtures, parabolic baffles, various types of enclosures, and communicator boxes, carrying cases, stands, couplings and connectors are included. A new "Morning Glory" projectors have been designed for super efficiency. They are properly reflexed, very compact, and are carefully stormproofed while maintaining a sturdy construction. The dynamic reflex principle offers many acoustical and mechanical advantages over the earlier type exponential trumpets. The folded, or double-re-entrance design allows overall compactness and, yet, retains sufficient acoustic air column length. The ease of mounting is an added advantage over the straight exponential trumpet. Copies of this new catalog may be had from the *Atlas Sound Corporation*, 1443 39th Street, Brooklyn, New York.

GEOPHYSICAL EQUIPMENT AND SUPPLIES, A NEW BULLETIN BY FISHER RESEARCH LABORATORIES. This sheet describes the new super-deluxe M-Scope, industrial model. The manufacturer claims that no finer metal locator has ever been built. The special features include the new 4 1/2 inch M-Scope visual indicator. This new meter assures a sensitivity and accuracy not found in any other metal locator regardless of price or make, says the maker. The power output of the super-deluxe model is twice that of the standard deluxe model and by means of a 5-point switch can be regulated in convenient steps. Copies of this bulletin are available from the *Fisher Research Laboratory*, 1961 University Avenue, Palo Alto, California.

## Personality Note

Sloan Fellowship Award  
Won by RCA Engineer

W. ENDRES BAHLS, who is now in complete charge of development and design work in connection with special radio tubes at the Harrison, New Jersey laboratories of the *RCA Manufacturing Company*, has been awarded an Alfred P. Sloan Foundation Fellowship for a year of advanced study of industrial problems at Massachusetts Institute of Technology.

One of eleven engineers chosen from all U. S. industry to receive the honor, Mr. Bahls will spend one year at the Institute attending the Business and Engineering Administration School. Two years ago Richard T. Orth, now a member of the Manufacturing Administration staff at RCA's Camden headquarters, was similarly honored by the Sloan Foundation.

Purpose of the Fellowship is to permit men actively engaged in industry to study such subjects as finance, accounting, labor relations, economics, law, and marketing, stressing the sociological aspects of modern industry.

Mr. Bahls was born in Lincoln, Nebraska, in 1908. He received his B.S. and E.E. degrees from the University of Nebraska in 1929. From 1929 to 1937 he was employed as research engineer at the *Westinghouse Electric and Manufacturing Company*, Pittsburgh, and also did graduate work in physics at the University of Pittsburgh.

In 1937 he entered the Research and Engineering Department of the *RCA Manufacturing Company* at Harrison, where he took charge of the development and design work connected with special tubes such as gas control tubes and mercury-vapor rectifiers, the position he holds at present. While at M.I.T., he will be on leave of absence from *RCA*. Mr. Bahls is married and has two children.



Compare Lafayette values with any others! You'll see why prominent radio engineers, men who *know*, have made Lafayette their radio headquarters for over twenty years. Follow this 'wise money' to Lafayette for far greater value, prompter service, and complete stocks of the finest in nationally advertised build-your-own radio kits, parts, supplies and rools. There's a brand-new, better-than-ever, Lafayette radio catalog now on the press. Be among the first to get a copy of this valuable FREE book! Fill out the coupon *now*, paste it on a postcard—and mail it TODAY!

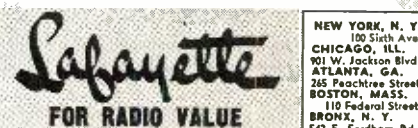

Lafayette Radio  
Dept. 2H1—100 Sixth Ave., New York, N. Y.  
or 901 W. Jackson Blvd., Chicago, Ill.

Please reserve my copy of new FREE Catalog.

Name.....  
Address.....  
City.....State.....

Master Minds. Despite the many ambitious programming efforts made to date—particularly in New York and Hollywood—the surface has hardly been scratched. Program directors have been dabbling in whatever studio and remote control pickups came to mind. Some of the programs have been good, a great many have been mediocre and few flopped so hard that they're still bouncing.

**T**ELEVISION'S scope is encyclopedic. Like radio it can draw on virtually everything known to man for program topics. And, better than radio, it can bring them home visually as well as audibly. And that's where a big problem lies. The field is so gigantic that program directors don't know where to start. And a few apparently don't know where to stop. The important thing is to realize right at the outset that television is a new and independent medium and while it can borrow talent and technique from the stage, screen, radio, concert hall, lecture platform, school room, sports arena and other spots, it *must* develop its very own formulae.

It's our guess that the cultural end of programming will rank side by side with the anticipated comedy, drama and variety offerings.

## New Developments in the Trade

### Amplifier Sets Motor Speed

**I**T IS common practice among radio and sound men to use the 60 cycle power line as a substitute standard frequency source for modulation, measurement and timing purposes. But in the equipment illustrated here this process is exactly reversed. A precision 60 cycle tone generator is utilized to drive a half-kilowatt electric motor through the medium of a high-power audio amplifier system.

The purpose is to provide mechanical driving power of absolutely constant speed. For most purposes a synchronous motor operated directly from commercial power lines provides adequate stability of speed. But such lines are subject to instantaneous and short-period frequency variations and are therefore not capable of precise speed regulation. Mechanical means for speed regulation were also found unsuited to the requirements in this case.

In this apparatus a 60 cycle audio-frequency standard generator capable of maintaining its frequency accurate to one part in 100,000 constitutes the source of excitation. Its output is fed into an amplifier capable of 500 watts of undistorted output and this in turn supplies the driving power for the synchronous motor.

The design of this system is a development of the Research Section at the Propeller Division of the Curtiss-Wright Corporation to meet the requirements of certain critical test applications in the Curtiss-Wright plant. The actual equipment as shown in the accompanying photographs was built by the Transformer Corporation of America, New York City, its engineers also collaborating with Curtiss-Wright engineers in design details.

As a result of this sort of collabora-

tion, making the specialized knowledge of experienced electronic engineers available to industry in the solution of its individual problems, electronic equipment is coming to play an increasingly important role in today's stepped-up industrial program.

### Unique Sound System

**T**HE proceedings in the twenty courtrooms of the Allegheny County Courthouse, at Pittsburgh, Penna., are clearly audible these days, since the installation of individual sound systems in each of the courtrooms by Hamburg Brothers, RCA wholesale distributors in the city.

Each of the twenty units of the system is independent of all the others, and consists of microphones, a 25-watt amplifier, and two high quality loudspeakers. Lapel microphones are provided for the judge and for each of the lawyers. There is a stand microphone for the witness chair. Thus, the words of every participant in the courtroom proceedings are heard easily in every corner of the room.

Also included in each unit is an inter-communicating system on the bench, so that the jurist may communicate with the court stenographer, his chambers, or adjoining offices without leaving the bench. Frequent causes for delays are thus avoided.

### Big Jump in New Sound Business

**S**ALES of RCA sound amplification and re-enforcing equipment and related units showed an increase approaching 50 per cent in the first quarter of 1941 as compared with the same three-month period of 1940, according to George R. Ewald, RCA Commercial Sound Division Manager. The increase brings sound equipment sales volume for the first quarter to the highest point in RCA history.

Mr. Ewald attributed the sales increase, which follows several years of steady gains, to the fact that business men, industrialists, churches, schools, and even the home, have been "sold" on the value of sound as a service.

"The steadily rising tide of our Commercial Sound business is cresting at new heights as the rewards of years of patient salesmanship, advertising, and sales promotion are reaped," Mr. Ewald said. "Businessmen and industrialists are discovering that they can save time and money, and increase efficiency, with a sound system adapted to their individual needs. Greater safety, and a reliable emergency service, are other factors. At a time when the National Defense program is getting into high gear, it all adds up to wider use of the RCA line of coordinated sound equipment."

### New Circuit Perfected

**F**OR the first time in history, it is possible to have standard broadcasts, short-wave and frequency modulation all from a single circuit arrangement with a single dial and a single set of controls.

Such is the latest achievement of the



## HERE IT IS...

the new Hallicrafters SX-32—the communications receiver I know you'll want!

13 tubes. Frequency coverage from 500 kc. to 40 mc. Adjustable noise limiter. Push-Pull high fidelity, audio output. 6 bands. Crystal phasing. Two stages of pre-selection. AVC-BFD switch.

Get the best in short-wave reception! Your outmoded receiver is worth a liberal trade-in allowance from me, so drop me a line here at Butler and get my free estimate! Rock-bottom terms (financed by me to save you money) PLUS my liberal trade-in allowance make any receiver in my stock—the world's largest—with your easy reach.

Drop me a line today!

Bob Henry

W9ARA



**HENRY  
RADIO SHOP**  
BUTLER, MISSOURI

WORLD'S LARGEST DISTRIBUTOR OF AMATEUR RECEIVERS

## Get the Job You Want!

### CREI Technical Training Enables You to Go After—and Get the Jobs That Mean Something in Radio!

Jobs that provide security . . . jobs that will mean something long after "tomorrow" has come and gone . . . must be won and held on *ability!* Now is the time for you to plan your career for the future and not just relax in your job today. You have a "jump" on the other fellow, because your present experience is a valuable asset, if supplemented by CREI modern technical training. It's worth taking time right now to find out how CREI offers you a *planned program* for advancing yourself in radio.

#### THINK THIS OVER: Actual Records Show—

- CREI graduates, as a group, are among the highest paid in radio!
- CREI men are in more than 350 broadcasting stations!
- More than 5,000 radiomen have taken this course of training!
- Employers are increasingly calling upon CREI for personnel replacements and additions.

**WRITE TODAY!** If you are a professional radioman and want to make more money, send for free booklet and factual information. Please state briefly your education, radio experience and present position and whether interested in home study or residence course.



## CAPITOL RADIO ENGINEERING INSTITUTE

Dept. RN-8, 3224 16th St., N. W., Wash., D. C.

Philco laboratories—an achievement incorporated in the 1942 line of radio receivers just introduced.

"The major problem confronting our engineers when they tackled this problem was to solve the question of noise reduction," stated David Grimes, Philco chief engineer. "After long and costly experimentation, we perfected the XXFM balanced detector tube which functions in an entirely new way and serves as the key to the new circuit arrangement."

This achievement was worked out in conjunction with a double channel transformer and a special antenna coupling system—a combination which made possible a simple and practical system of frequency modulation reception, making FM simply another band on the circuit, like all other bands.

As a result of this, instead of a radio that used only part of its tubes for FM and only part of its tubes on the other bands, the exclusive Philco FM system permits using all the tubes on all bands. In other words, a 10-tube FM set of other makes gives only a five-tube performance on either FM

or standard broadcast whereas all tubes are employed at all times on the exclusive Philco FM system, Grimes stated. This guarantees FM reception without sacrifice of tone and performance when the set is tuned in on short wave or standard broadcasts.

Another feature of the FM arrangement exclusive with Philco is a special built-in FM aerial arrangement which operates automatically, switching in instantly when the receiver is set for the FM band. Thus, for the first time in FM history, a practical built-in antenna system is available in place of the unwieldy, expensive aerials usually employed for FM reception.

"We also felt that an important consideration was to improve tone control so that the full benefits of FM would be insured," Grimes pointed out. "In order to do this we equipped all but one of the 1942 models having FM with separate bass and treble controls. This provides for an unlimited variety of tone adjustments."

Utter simplicity of operation is offered in the new models combining all three types of broadcast. FM, standard and short-wave are all operated from a single set of controls and all that is necessary to switch to FM is to push a button. Simplicity of operation is carried even further by creation of a dial which is calibrated to agree with FM station numbers.

"As a result of these various advances, we feel that economical engineering is combined with technical advances which takes care of consumer demand in those cities which already have FM broadcasting and yet anticipates the needs elsewhere without penalizing the purchaser," Grimes stated.

## As I See It!

(Continued from page 15)

materials as copper, zinc, tin, iron, steel, aluminum and nickel. Picture where all of these parts are used in one way or another in the average radio receiver and you have an idea of where in that receiver, you will be called upon to use your own initiative, ingenuity, and knowledge.

Now we don't mean to harp on a fact that many people have shouted for more theory in the past, and that servicemen, on the other hand, have yelled for more part data. That's so much water over the dam. What the serviceman should think about today is the absorption of as much theory as possible. You will find it imperative in the future and very valuable today. In making this statement, we are not deliberately playing the part of an alarmist—but there is no sense in being an ostrich. It just isn't sound to bury your head in the sand because you don't want to see the trouble around you.

Fortunately it is not a hopeless situation. Very few things ever are, if you analyze them with a sound mind and a cool head. There is no doubt about the fact that when the emergency we speak about actually arises, radio magazines and other periodicals will do their share in supplying that information which a serviceman will need in order to be able to carry on his work. But commonsense dictates that it is not wise to depend wholly upon the efforts of others if we realize the importance of the situation represented by the 55,000,000 receivers now in the hands of the public, many of which are more than five years old. It does not take much imagination to visualize the difficulties involved in presenting to the servicing industry all of the information which would be necessary in order that some of those old receivers be kept in repair when original replacement parts or even exact duplicates are not available. This has not been much of a worry in the past simply because each year witnessed replacement of some of the old receivers with new receivers. Such replacement in 1942, and perhaps even at the end of 1941, will be very much less than heretofore.

But why should the serviceman wait for the arrival of the emergency? Why shouldn't you, as a serviceman, get the facts right now by reading through whatever books and magazines give the story of theory? Now is the time we read those articles which you deliberately ignored during the years that have passed.

The serviceman who has a library of radio magazines such as RADIO NEWS, *Radio and Radio Broadcast* which were published between 1922 and 1932 is really fortunate. For it seems as if the industry was more cognizant at that time for the need



**NEW HAND SET—AIRCRAFT TYPE**  
 . . . for mobile, pack transmitters, amateurs, aircraft, 2-way phone systems, etc. Dependable, long life, low price. Black Bakelite case with 6 ft. cord. Microphone and receiver terminated separately. Switch not available. Wt. complete only 7 oz., packed 1 lb. 75 ohms match line impedances; 2,000 ohms match plate circuit of output tube. Either resistance.  
**UNIVERSAL MICROPHONE CO. \$10.00**  
 Ltd., Inglewood, Calif., U.S.A. List

## Classified

Rate 15c per word. Minimum, 10 words.

### CORRESPONDENCE COURSES

**AMATEUR** Radio licenses, training in code and theory. Resident and home study courses. Hundreds of licensed students. American Radio Institute, 1123 Broadway, New York.

**USED** Correspondence Courses and Educational Books sold or rented. Inexpensive. Money-back guarantee. Write for Free Catalog listing 4000 bargains. (Courses Bought.) Lee Mountain, Pisgah, Alabama.

**CORRESPONDENCE** courses and educational books, slightly used. Sold. Rented. Exchanged. All subjects. Satisfaction guaranteed. Cash paid for used courses. Complete details and bargain catalog free. Nelson Company, 500 Sherman, Dept. H-237, Chicago.

### PATENT ATTORNEYS

**PATENTS**—Advice and booklet free. Highest references. Best results. Promptness assured. Watson E. Coleman, Patent Lawyer, 724 9th Street, Washington, D. C.

**INVENTORS**—Before disclosing your invention to any one send for Form "Evidence of Conception"; "Schedule of Government and Attorneys' Fees"; and instructions. Sent free. Lancaster, Allwine & Rommel, 414 Bowen Building, Washington, D. C.

### PHOTO FINISHING

**ROLLS DEVELOPED**, two prints each and two free enlargement coupons, 26c, reprints, 2c each; 100 or more, 1c. Summers Studio, Unionville, Mo.

### RADIO ENGINEERING

**RADIO** Engineering, broadcasting, aviation and police radio, servicing, marine and Morse telegraphy taught thoroughly. All expenses low. Catalog free. Dodge's Institute, Elm St., Valparaiso, Ind.

### RADIO SUPPLIES

**LATEST** Radio Parts Catalog. Anchor Radio, 203 Elm, Ithaca, N. Y.

**AT LAST** Radio Tubes can be rejuvenated. Instructions One Dollar. Warranted. Vance Lind, St. Paul, Nebr.

## Book Review

(Continued from page 38)

often needed diagrams are presented in this one handy manual. This manual should become very popular with the serviceman who strives to keep his establishment on an up-to-date basis. Copies are available from the *Supreme Publications, Chicago*.

**HAMMARLUND SHORT WAVE MANUAL FOR THE AMATEUR AND EXPERIMENTER**, Sixth Edition, 32 pp., price 10c, published by *The Hammarlund Mfg. Co., Inc.*, 424 West 33rd Street, New York City. This new Sixth Edition shows the very latest gear for the short wave amateurs and experimenters. Many of the designs have been brought up to date and of particular interest is "A Transmitter Frequency Controlled Unit, with Three-Band Output," which was designed by George W. Shuart, W2AMN. Features an electron coupled oscillator, a 6SK7 buffer and an 807 final amplifier. Many novel features are included, which make it an outstanding low-power transmitter. Full constructional data is supplied in the manual. Copies are available for 10c to help cover cost of the mailing, from the *Hammarlund Mfg. Co., Inc.*, 424 West 33rd Street, New York City.



of radio theory and presented such facts in these issues. The theory contained therein is just as good today as it ever was—and becoming more important. The *I.R.E. Proceedings* is a technical paper, much heavier in language used by its contributing authors than other papers—but examination shows that there were published during the years of 1922 to 1935 many articles which, while highly technical in spots, did nevertheless contain information which the average serviceman can follow, even if the equations mean nothing.

If you have text books on hand don't use them as paper weights or something to rest a radio chassis upon. Take the time off to read them—you'll be needing what's inside.

Despite varied comments concerning the trials and tribulations of the servicing industry, we cannot help but say that as far as actual servicing procedure is concerned, that which has taken place up to this time, is easy. It may have taken time to locate a fault and the fact that it was a matter of replacement, but it's going to be much tougher in the future to make that replacement. What are you going to do about it?

**WHAT** has happened to all this talk about servicing as a business? Or has it ceased being a commercial enterprise simply because people stopped saying that servicing is a business. Well, whether people talk about it or don't talk about it, the fact remains that the commercial-minded man in the servicing business has a definite edge over the rest. Unless I am completely cockeyed in my ideas, there will be more need for business acumen in years to come than ever before. I have my moments when I wonder why it is that, with all of the evidence which proves the necessity for the application of business principles in the radio servicing field, there is such total disregard and neglect of something which is a cardinal thought in all commerce.

-30-

### Police Radio

(Continued from page 22)

station we have ever seen.

The operating room is a vast affair with a *Western Electric* kilowatt fone rig plus a spare one for emergency use. There is also a motor generator room containing a *Kohler* Emergency power unit.

The room also contains two desks for c. w. and fone operation, a power control panel, frequency monitoring panel, receiver and line amplifier panels, and a new three-band c. w. rack.

This c. w. rack contains a common power supply and three individual transmitters for each band. The frequencies are changed by a rotating switch on the c. w. desk.

### General Electric F.M.

**GENERAL ELECTRIC'S** F.M. equipment is working very well at *Maywood* and *Riverside*, Illinois, claims Larry Dutton, radio engineer for the two towns.

G.E.'s frequency modulation equipment consists of two basic units, a receiver and a 25-watt transmitter. Each can be used for either fixed or mobile service, only the power supply need be changed.

The transmitter is direct crystal controlled, phase modulated, using a dynamotor power supply for mobile use. The receiver is the conventional double conversion superhet, however, it uses one crystal to control both heterodyning frequencies.

Dutton is looking for a flexible car antenna which will give way to overhanging foliage, but will remain rigid while the car is in motion. The insulating cups break if too much strain is placed on the antenna. The new *REL* antenna seems to be the nearest approach in overcoming this difficulty.

### Jensen Speechmaster

**DURING** the radio trade show in Chicago, we saw something very interesting in the *Jensen Mfg.* exhibit in the form of their new "speechmaster" loud speaker.

This reproducer is designed to cut off rather sharply below 500 cycles, thereby allowing the higher frequencies which give intelligibility and crispness to the voice predominate.

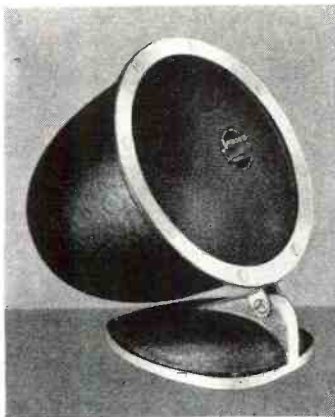

Such a speaker is very useful in police communication work, where man-made static and atmospheric are usually always present. The quality is somewhat like the old magnetic speakers, however, they are capable of handling up to 5 watts power.

*Jensen* also makes a 6-watt reflex and a 25-watt model speechmaster for high level paging and call systems. The 6-watt reflex speechmaster could be used very nicely on traffic control cars or accident prevention squads.

### Reminiscing

**SITTING** back in our chairs, many of us at one time or another have thought to ourselves just what should be done to better our working conditions.

It seems whenever we pass into one of these day dreams, the first thing that comes to our mind is the frequency situation. We fully realize the huge amount of work the *FCC* is undertaking at this time, however, we do hope they will consider our plea for more frequencies as soon as possible. Conditions are getting almost impossible on the c. w. bands during the evening hours. We certainly do believe the police emergency service should be next in line after the *National Defense* situation is brought under control. There should be no reason for one c. w. op to jam another in order to get his emergency traffic through.

The next subject of importance that comes to our mind is the fact that as a general rule, radio-ops are not being paid what they are worth. Police radio operation and maintenance is a highly technical profession, but

## SPRAYBERRY TRAINS YOU for GOOD PAY! STEADY WORK! ADVANCEMENT! in RADIO and TELEVISION



**DON'T WAIT! START NOW!**

You Can Make Money Almost At Once You'll be quickly shown how to get and do neighborhood Radio Service Jobs... for practice and profits. You easily learn Television, Frequency Modulation, Signal Tracing, Mobile Radio (Auto-Tank), Aviation Radio, Electronics, Facsimile Radio, Radio Set Repair and Installation Work. I'll Prepare You Quickly In Spare Time

At Home Or At Camp

SPRAYBERRY Training does not interfere with your present work. You will receive personal coaching service all the way. You'll be fitted to hold down a good paying job in Radio or to have a Radio business of your own.

You Get Professional Test Equipment

Plus Experimental Outfits Includes 146 RADIO PARTS (to build complete Radio Receiver), RADIO TOOLS and a TESTER-ANALYZER. MY EXPERIMENTAL OUTFITS enable you to conduct actual experiments with your own hands.

### NO EXPERIENCE NEEDED

It makes no difference what your education has been, I can fit you to become a real RADIO TECHNICIAN. Your success is my full responsibility.

THE SPRAYBERRY COURSE IS SOLD UNDER MONEY-BACK AGREEMENT

**RUSH COUPON for BIG FREE BOOK**

SPRAYBERRY ACADEMY OF RADIO  
F. L. Sprayberry, President  
425-H University Place, N. W.  
Washington, D. C.

Please rush my FREE copy of "HOW TO MAKE MONEY IN RADIO."

Name..... Age.....

Address.....

City..... State.....

(Mail in envelope or paste coupon on penny postcard)

## PUBLIC ADDRESS HEADQUARTERS



**RADOLEK De Luxe Public Address Systems** offer the most for your money in Styling—Hi-Fidelity Performance—Reserve Power—fast, convenient, easy installation. Offered in 15, 30, 50 and 100 watt sizes— for permanent, portable or mobile use. They feature from 2 to 6 input channels, built-in input and mixing controls, AVC, and the newly developed "feedback" tone control circuit. Wide choice of microphones and speakers. Mail coupon for complete information.

### RADOLEK'S NEW 1941 RADIO PROFIT GUIDE

**FREE!**

Indispensable to every serviceman, dealer and sound engineer. Send for big FREE Radolek Profit Guide now!



**SEND TODAY! PASTE ON A PENNY POST CARD**

RADOLEK CO., Dept. B-57  
601 W. Randolph St., Chicago, Ill.

Please send information on Radolek Public Address equipment—also new 1941 Radio Profit Guide.

Name.....

Address.....

DEALER  SERVICEMAN  EXPERIMENTER



## Reach for a DANDEE!

- If ever there was a condenser that could qualify as a so-called universal or general-utility electrolytic, it's the new PRS 450-8 Aerovox Dandee. Why? Because it's the most compact midget metal-can dry electrolytic on the market... a genuine hermetically-sealed job... full-rated capacity and voltage... colored polarity-indicating ends... spun-over jacket preventing shorts and grounds—in a word, a real good electrolytic to fit in tight places.

For your convenience, these PRS 450-8 Dandees come packed in individual cartons and also in the handy five-to-the-box or ten-to-the-box cartons. Be sure you have a supply of these handy "universals" on hand. And when it comes to those quick servicing jobs, or those new assemblies, just reach for a Dandee!



### Ask for Copy...

Our latest catalog is yours for the asking. Ask your jobber—or write us direct. Also ask about a free subscription to the monthly Research Worker.



just compare the radio man's salary with other professional men such as doctors, lawyers and the like. A survey of salaries for police ops averages somewhere around 150 dollars per month. Frankly, we cannot think of any other type of professional man accepting a salary of this amount.

Wandering back to our police circuit, we wonder how many years will pass before all of the states will be represented in the police radio-telegraph net. Up to the present time, only 25 states are represented by an interzone station. Without a doubt, every police c.w. op dreams of the day when he can get a message to any spot in the U.S.A. We are also thinking of what a great satisfaction such a network would be to the *National Defense* officials, especially if all of the stations were equipped with emergency power equipment.

Another subject that seems rather irritant is the political friction between cities and counties, each wanting a separate radio station of their own. In rural areas, this is absolutely unnecessary as traffic is not heavy enough to warrant individual stations, especially so at this time when our frequencies are very limited. We know of several cases where a county and city station are located in the same city and operating on the same frequency!

This complication would not have arisen had an agreement been made between the city and county to share one transmitter and one or the other operating it remotely. Of course, the situation now is that one station is constantly interfering with the other resulting in further friction between the two departments.

We firmly believe that in rural areas it is possible for many nearby towns to work remotely into one transmitter, thus reducing interference, and conserving our frequencies.

-30-

### QRD? de Gy (Continued from page 36)

or five from *McCormick SS Co.*... *Marsodak SS Co.* and the *Bernstein SS Co.* have both signed agreements with *CTU* for \$175.00 for straight radio plus war bonuses... *CTU* won the *NLRB* election in *Farr Spinning* and operating (ten oil tankers) and negotiations are now under way for an agreement.

THE farflung northwest territory is heard from through the mouthpiece of Seattle which appears to be as busy a spot as any on the *National Defense* map. Vessels are being reconditioned and new up-to-date radio apparatus installed to equip them for the heavy duty just over the horizon. The radiops who can remember the calls *WRH (SS Harvard)* and *WRY (SS Yale)* would have been tear-eyed when the *Yale* hove into *Smith Cove* to be converted into a floating hotel for mechanics and construction workers at the new *Navy Air Bases* being built at *Women's Bay* near *Kodiak, Alaska*. Do you oldtimers remember the sensation created that day in 1911 when the *Yale* and the *Harvard*, the white flyers, went into service between 'Frisco, 'Pedro and 'Diego with a standard speed of 21 knots? Yow-sah! The *Harvard* went to her grave a few miles north of *Point Arguello* on the morning of *May 30, 1931*, after a brilliant career which included, along with the *Yale*, a year of running the *English Channel* as a transport during the previous fracas. The *Yale* still proudly carries the two gold chevrons on her stacks as a reminder to all that if the need arises she can again act as a transport.

THE *American Mail Line* boats, the *President Grant (KDUT)* and the *President Jackson (KDPA)* have had their radio innards dismantled and are now equipped with

the last word in xmtrs. It seems only yesterday that *Globe Wireless* installed their famous *Type MC* xmtrs on this fleet operating out of *Seattle*. We have all copied that pleasing whine of those *ACW* rigs of the *Dollar Line* in the seven seas and every remote corner of the earth. What a punch those big 500 watt *Gamatrons* used to knock out. These are now headed for the junk pile in this era of crystal controlled or electron coupled *MOPA* rigs and *AC Superhet* receivers. The best is none too good.

AND speaking of oldtimers, (*Genial Gil Gilman*, Chief Radiop on the *SS Baranof* of the *Alaska SS Co.* can certainly be rated as one with his twenty-two (22) years of service for this outfit. Many sourdoughs who made the long trek into *Nome* in the spring and out again in the fall with a lot of broken dreams of finding that elusive yellow metal made *Brother Gil* their Father-confessor. He did his bit in '17 with the *Gas Warfare Division* and was seriously injured in action in the *St. Mihiel* sector in '18. For this he received the *Order of the Purple Heart* from the *War Dept.* But *Gil* will tell you that dodging bullets in *France* wasn't half so dangerous as working on the *Alaskan* run. He's been shipwrecked 23 times in several different vessels. Which is some sort of a record, or something, eh.

STATION "NRG," the U. S. Navy's little QTC-QTE xmtr. that has held forth on verdant *Cape Mala* for so long, is being closed. Of no great importance for bearings save during an occasional heavy rain squall, it was an immense help to many of the lads working 600 meters on the *West Coast* of *Panama* when old *NAX* had developed a bad case of *Tin Ears*. Hail and farewell, *NRG*.

NOW that most of the former *Ocean* greyhounds have turned belligerent, or partially so, thereby silencing their radio keys, some temporarily and others permanently, it seems to us that just about the busiest mobile station is *Uncle Sam's SS America "WEDI"*. More power to our rejuvenated *Merchant fleet* flying our own *Stars and Stripes*. And more power to those hundred per cent *American radiops* who have been helping to track down subversive radiops and radio stations. Keep up the good work. So with best 73 . . . . GY.

-30-

### Ham Chatter (Continued from page 29)

dence; *W1BIL*, *Pawtucket*; *W1JER* and *W1MNC*, mobile around *Providence*; *W1LKY*, *Providence*; are all on most every evening from 8 PM on.

*W1JFF* contacted *W2LXQ* on *Fishers Island, N. Y.*, 40 miles or so air line from *Newport, R. I.*

The boys use for sigs *HK24's*—*HY 75's*, *76's*, *P.P. osc.* and *W1JFF* a *6E6* long lines. For receivers *955's*, *76's*, *6J5's*, *HY75's*, *7A4's*, *6C5* fer det. and generally 2 stages of audio.

*W1JFF* uses for ant. 2 half waves in phase vertical 70 ft. high. Lots of the boys use inside (3rd floor) antenna and get out fb.

We are all looking for the fellows down in *Conn.* as *R. I.* to *Conn.* on 5 meters used to be easy.

AND from our reporter *W9LEM*: *W9ABT's* got a new jr. op. Came in with an *R9* plus note. *Stub* has been very busy lately writing up an article with high hopes that it will be printed in "R. N."

*W9JYN*, *Frank* or "Wimpy" from *Watford City, N. Dak.*, was up and called on *LEM*. He's working with *North Dakota State Highway Dept.* and is short of operating time. However he gets on the air on *Sundays* once in a while. *JYN LEM-DAO* all went out to see *ABQ* and *ABT*. Had quite a ham fest. Should have had *ERR* here to make it complete. *Frank* works 160 meters mostly up near 1962 kc.

Had a letter from *W9ERR* who is way down in *New Mex.* and he is having trouble finding a definite *QRA* to get his ticket modified. Hope to be able to have a rag-chew with him over the air soon though. There'll be a chance for some of us guys to get *New Mex.*!

# BUY DIRECT FROM THE MANUFACTURER AND SAVE

WE KNOW OUR PRICES ARE VERY LOW and expect a certain amount of skepticism from servicemen who have never purchased the SUPERIOR way, but seven years of sticking to our way of doing business has convinced us and many thousands of servicemen who have purchased from us that it is a practical and mutually profitable way of doing business. We know that the average income of the Radio Serviceman prohibits his purchasing high-priced equipment, and yet the very nature of his work makes it necessary for him to use accurate, dependable and up-to-date equipment. We know we have solved the problem for him and our continually expanding business proves that servicemen recognize this claim to be true.

BESIDES THE THOUSANDS OF SERVICEMEN AND TECHNICIANS, THE FOLLOWING WELL-KNOWN NAMES ARE LISTED AMONG SUPERIOR INSTRUMENT PURCHASERS: Standard Oil Company of New Jersey; U. S. Dept. of Agriculture; U. S. Dept. of Commerce; U. S. War Department; C.C.C. Camps; National Youth Administration; Goodyear Tire and Rubber Co.; E. I. duPont de Nemours & Co.; University of Nebraska; Leland Stanford Junior University; Westminster College; Oberlin College; University of Michigan; Boston College; Pomona College; Board of Education, Remus, Michigan; Board of Education, City of New York; Board of Vocational Education, State of Illinois; City of Bartow, Florida; Florida State Dept. of Education; Educational Dept., Custer, North Dakota.



## The New Model 1220 POCKET LABORATORY

★ WEIGHS ONLY 28 OUNCES!!  
★ USES a 2% ACCURATE 0-200 MICROAMMETER—ENABLING MEASUREMENTS AT

**5000 OHMS PER VOLT SPECIFICATIONS**

- ★ 6 D.C. Voltage Ranges: 0-3-10-50-250-500-5,000 volts.
- ★ 3 A.C. Voltage Ranges: 0-15-150-1500 volts.
- ★ 4 Resistance Ranges: 0-3000 ohms, with 15 ohm center, direct reading to 0.2 ohm; foregoing base range multiplied by 10, by 100 and by 1,000, to read up to 3 Meg. with self-contained 3 V. flashlight battery.
- ★ D.C. Current Ranges: 0-200 microamperes; 0-2-20-200 Milliampers, using wire-wound shunts.
- ★ 3 Output Meter Ranges: Same as A.C. Voltage Ranges.
- ★ 3 Decibel Ranges: From -2 to +58 D.B., based on .006 watt in 500 ohms.

Model 1220 comes complete with cover, self-contained battery, test leads and instructions. ONLY **\$10<sup>45</sup>**

## THE NEW CHANNEL-ANALYZER

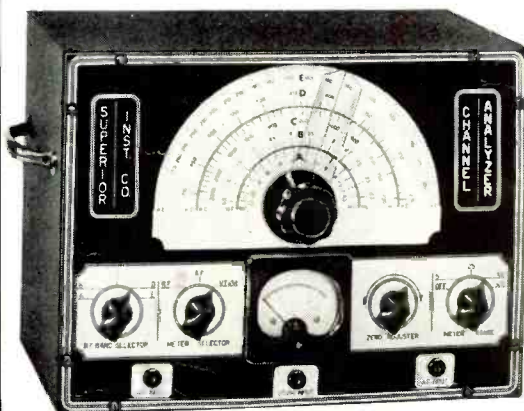

FOLLOWS THE SIGNAL FROM ANTENNA TO SPEAKER OF ANY SET

The well-established and authentic SIGNAL T R A C I N G METHOD of locating the very circuit in which there is trouble, and the very component that causes the trouble, is now for the first time available at a price any radio serviceman can afford.

### THE CHANNEL-ANALYZER WILL

- ★ Follow the signal from antenna to speaker through all stages of any receiver ever made.
- ★ Instantly track down exact cause of intermittent operation.
- ★ Measure both Automatic-Volume-Control and Automatic-Frequency-Control, voltages and circuits without appreciably loading the circuit, using built-in highly sensitive Vacuum-Tube Voltmeter.
- ★ Check exact gain of every individual stage in receiver.
- ★ Track down and locate cause of distortion in R.F., I.F., and A.F. amplifier.
- ★ Check exact operating voltage of each tube.
- ★ Locate leaky condensers and all high-resistance shorts, also show opens.
- ★ Measure exact frequencies, amount of drift and comparative output of oscillators in superhets.
- ★ Track down exact cause of noise.

The Superior Channel-Analyzer comes housed in shielded cabinet and features an attractive etched aluminum panel. Supplied complete with tubes, three specially engineered shielded input cables, each identified as to its purpose. Also full operating instructions. Size 3 1/2" x 10" x 6". Shipping weight 19 pounds. Only... **\$19<sup>75</sup>**

Canadian Distributors; Radio Parts Supply

## The New Model 1240 TUBE TESTER

Instantaneous snap switches reduce actual testing time to absolute minimum. Tests all tubes 1.4 to 117 volts.

Sockets for all tubes—

No adapters.

### SPECIFICATIONS:

- ★ Tests all tubes, 1.4 to 117 volts, including 4, 5, 6, 7, 7L, octals, octodes, Bantam, Jr., Peanut, single ended, floating filament, Mercury Vapor Rectifiers, the new S series, in fact every tube designed to date.
- ★ Spare socket included on front panel for any future tubes.
- ★ Tests by the well-established emission method for tube quality, directly read on the GOOD ? BAD scale of the meter.
- ★ Jewel protected neon.
- ★ Tests shorts and leakages up to 2 megohms in all tubes.
- ★ Tests leakages and shorts in all elements AGAINST all elements in all tubes.
- ★ Tests BOTH plates in rectifiers.
- ★ Tests individual sections such as diodes, triodes, pentodes, etc., in multi-purpose tubes.
- ★ Latest type voltage regulator.
- ★ Features an attractive etched aluminum panel.
- ★ Works on 90 to 125 volts 60 cycles A.C.
- ★ Model 1240 comes complete with instructions and tabular data for every known type of receiving tube. Shipping weight 12 pounds. Size 6" x 7 1/2" x 10 3/4". Our Net Price. **\$11<sup>85</sup>**

PORTABLE COVER \$1.00 ADDITIONAL

## MODEL 1230 SIGNAL GENERATOR

WITH FIVE STEPS OF SINE-WAVE AUDIO



### SPECIFICATIONS:

1. Combination R.F. and A.F. Signal Generator, R.F.—100 K.C. to 90 Mcrcycles, A.F.—200 to 7500 cycles; Sine-Wave.—WITH OUTPUT OF OVER 1 VOLT. All direct reading, all by front panel switch manipulation.
2. R.F. and A.F. output independently obtainable, alone or with A.F. (any frequency) modulating R.F.
3. Latest design full-range attenuator used for controlling either the pure or modulated R.F.
4. Accuracy is within 1% on I.F. and broadcast bands; 2% on higher frequencies.
5. Giant dial etched directly on front panel, using a new mechanically perfected drive for perfect vernier control.
6. Operates on 90 to 130 V. A.C. or D.C. (any frequency).

The Model 1230 comes complete with tubes, shielded cables, molded carrying handle and instructions. Size 14" x 6" x 11". Shipping weight 15 pounds. Only... **\$12<sup>85</sup>**

Company, 962 Bleury St., Montreal, Canada

**SUPERIOR INSTRUMENTS CO.** 136 Liberty St., Dept. RN8  
New York, N. Y.

# Just Out! **MYE**

## THE NEW 4<sup>TH</sup> EDITION



BIGGER *and* BETTER THAN EVER!

MORE THAN 400 PAGES!

NEW FROM COVER TO COVER!

ABSOLUTELY UP-TO-DATE!

ALL I. F. PEAK FREQUENCIES!

CIRCUIT REFERENCES APLENTY!

COMPLETE TUBE COMPLEMENTS!

ORIGINAL PART NUMBERS ON ALL CONDENSERS, VOLUME CONTROLS, AND VIBRATORS!

COVERS ALL OF RIDER'S REFERENCE, INCLUDING VOLUME 12!

Have You Ordered Your Copy?

New-Model Listings Increased by more than 35%

The Answer to Every Service Problem

A Real Time-Saver

See Your Distributor NOW!

Order your copy of this new, 4th edition MYE today! The supply is limited. And once the present printing is exhausted, *there won't be any more!*

So don't delay. Get your Mallory distributor on the phone—NOW—Order your copy today.

Save your old Aluminum parts. It is patriotic to give them to National Defense.



### The Biggest News You've Ever Had On Volume Controls!

New mechanical and electrical precision. Rugged! Easily installed. An A-C switch that snaps on and stays on. Quiet operation. Start using them today!



### This Is Mallory's Year On Replacement Condensers!

More have gone into service in 1941 than in any other year! Use Mallory Replacement Condensers for fast, efficient work and your customers' satisfaction!

P. R. MALLORY & CO., Inc., INDIANAPOLIS, INDIANA

More than ever —INSIST ON

P. R. MALLORY & CO., Inc.  
**MALLORY**  
APPROVED  
PRECISION PRODUCTS

VIBRATORS • VIBRAPACKS • CONDENSERS • VOLUME CONTROLS • ROTARY SWITCHES • SINGLE AND MULTIPLE PUSH BUTTON SWITCHES • RESISTORS • RADIO HARDWARE