

LEADS IN ALL FIELDS

# RADIO NEWS AND SHORT WAVE RADIO

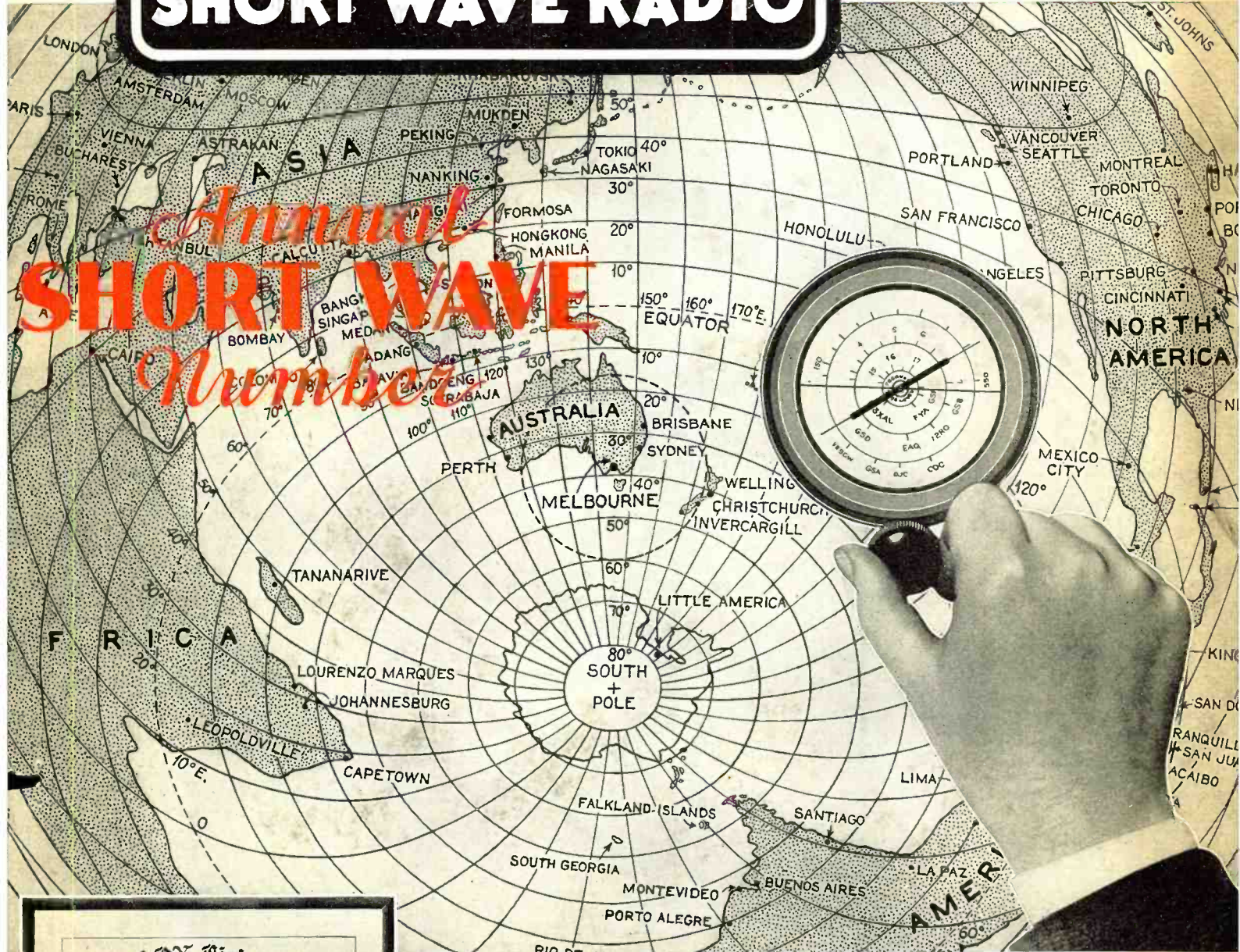

APRIL, 25¢



Annual  
**SHORT WAVE**  
Numbers



## MAKE MONEY IN SERVICE

- A publication devoted to progress in Radio
- |                  |              |              |
|------------------|--------------|--------------|
| Short Waves      | Service Work | Television   |
| DX Reception     | Engineering  | Electronics  |
| Set Building     | Experiments  | Broadcasting |
| Amateur Activity | Measurements | Applications |



# SHORT-WAVE RECEIPT ON IS POSITIVELY BETTER WITH G-E's NEW V-DOUBLET ANTENNA

● Every owner of an all-wave receiver wants his set to perform at maximum efficiency. He wants uniformly good reception — a minimum of noise. All this depends to a large degree on the type of antenna system used.

The new G-E V-Doublet All-wave Antenna System approaches the ideal more closely than any heretofore available.

Notice the unique "V" construction. The "V" provides an efficient transfer of energy from the antenna to the lead-in (transmission line). A special transformer, in turn, provides an efficient transfer of energy from the lead-in to the receiver and at the same time balances out interference picked up by the lead-in.

Below 55 meters, the antenna operates as a V-Doublet and above 55 meters, it is automatically changed to a standard antenna by the special coupling transformer. Therefore man-made interference is minimized, giving clear short-wave reception and, without switching, excellent reception of standard broadcasts as well.

Simple to install—requires only 2 points of suspension over a 50-foot span. Not unsightly in appearance when installed. Any length lead-in of 100 feet or over may be used. This new exclusively General Electric Antenna System is exactly what every all-wave radio owner has been wanting. Mail the coupon for complete details.

Price of antenna kit \$5.95.

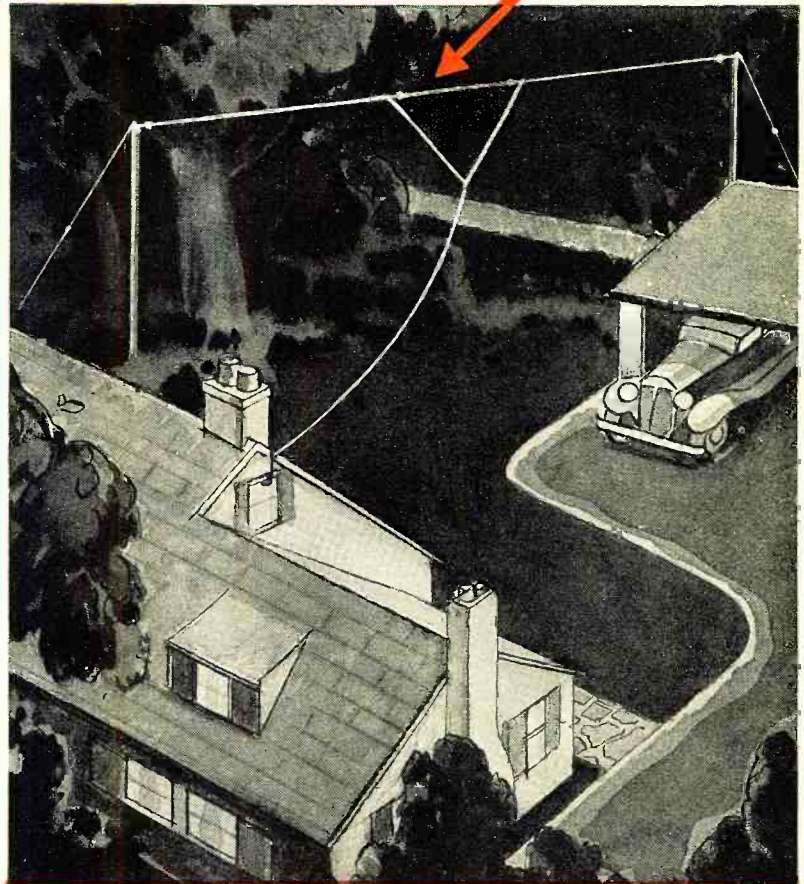

General Electric Company,  
Merchandise Department,  
Bridgeport, Conn.

Attention:  
Sales Promotion Section R-164

I am interested in the New G-E All-wave Antenna System. Without obligation on my part, I would like to have you send me details regarding it.

Name.....

Street address.....

City..... State.....

# GENERAL ELECTRIC

## ALL-WAVE RADIO

MERCHANDISE DEPARTMENT, GENERAL ELECTRIC COMPANY, BRIDGEPORT, CONNECTICUT



# How a "Tip" got Tom a Good Job

**Panel 1:** GEE, THERE'S DJ C. IN BERLIN. THAT'S THE TENTH FOREIGN STATION TONIGHT. RADIO IS SURELY FUN.

**Panel 2:** HELLO, TOM. HOW'S EVERYTHING? OH, NOT SO GOOD BILL, BUT I'M STILL HAVING FUN PLAYING WITH RADIO. HAD DJ LAST NIGHT ON A LITTLE SET I BUILT. IS RADIO STILL YOUR HOBBY TOO?

**Panel 3:** NO, TOM. I'VE BEEN TOO BUSY MAKING GOOD MONEY OUT OF RADIO TO SPEND TIME "PLAYING" WITH IT. GOSH, BILL, YOU'RE SURE LUCKY. I NOTICED YOUR SWELL CLOTHES AND SNAPPY CAR. I THOUGHT YOU HAD INHERITED A MILLION. TELL ME ABOUT IT.

**Panel 4:** I AM LUCKY, TOM, BUT YOU HAD THE SAME CHANGE REMEMBER ABOUT A YEAR AGO I SHOWED YOU A BOOK FROM NATIONAL RADIO INSTITUTE THAT TOLD ABOUT THE OPPORTUNITIES AND BIG FUTURE IN RADIO, AND HOW OTHERS HAD SUCCEEDED THROUGH THEIR HOME TRAINING? REMEMBER, I TRIED TO GET YOU TO ENROLL FOR THEIR COURSE WHEN I DID.

**Panel 5:** WELL, IT WAS THE SMARTEST MOVE I EVER MADE. I'M DOING SWELL. MARY AND I ARE TO BE MARRIED NEXT MONTH, TOM. WHY DON'T YOU SNAP OUT OF IT? DON'T STAY IN THAT DREARY LOW PAY JOB ALL YOUR LIFE. RADIO IS MORE THAN A PLAYTHING. IT'S A BIG BUSINESS. IT'S YOUR OPPORTUNITY. TAKE MY TIP. IT ISN'T TOO LATE. RADIO IS STILL YOUNG AND GROWING.

**Panel 6:** IF BILL SUCCEEDED, I CAN TOO! THEN I CAN MAKE REAL MONEY SERVICING RADIO SETS OR GET A JOB IN A BROADCASTING STATION OR INSTALL AND SERVICE LOUD SPEAKER SYSTEMS OR MAKE GOOD MONEY IN ANY ONE OF THE MANY OTHER NEW AND GROWING BRANCHES OF RADIO. THERE'S NO END OF GOOD JOBS FOR A TRAINED RADIO MAN! YES, SIR, I'M GOING TO SEND FOR THAT FREE BOOK AND GET THE DOPE RIGHT NOW!

**Panel 7:** YOU CERTAINLY KNOW RADIO. MINE NEVER SOUNDED BETTER. N. R. I. TRAINING CERTAINLY PAYS. I JUST STARTED A FEW MONTHS AGO AND I'M MAKING GOOD MONEY ALREADY. THIS SPARE TIME WORK IS SWELL FUN, AND SOON I'LL BE ALL SET FOR A GOOD FULL TIME JOB.

**Panel 8:** THANKS!

OH, TOM IT'S WONDERFUL—TO THINK HOW FAST YOU'VE GONE AHEAD SINCE YOU WENT INTO RADIO. WE NEVER COULD HAVE GOTTEN MARRIED ON WHAT YOU WERE GETTING BEFORE.

OUR WORRIES ARE OVER. I'M MAKING GOOD MONEY NOW, AND THERE'S A BIG FUTURE AHEAD FOR US IN THIS LIVE WIRE RADIO FIELD.

..... I will help you start a spare time or full time **Radio service business Without Capital**



**Many Radio Experts Make \$40, \$60, \$75 a Week**

The world-wide use of Radio sets has made hundreds of opportunities for good spare time or full time Radio businesses. Many of the seventeen million Radio sets are only 25% to 40% efficient. I will show you how to cash in on this condition. I will show you how to install and service all types of receiving sets in spare time. I'll show you how to make enough money while learning Radio to start your own service business. Clip the coupon. Get my free book, "Rich Rewards in Radio." Read how hundreds of N. R. I. men have made good money in spare time or full time businesses.

**HERE'S PROOF THAT N.R.I. MEN MAKE GOOD MONEY**

**"Made \$6,000 in 2 Years"**

"Soon after the depression started, I found myself without a job, but I was well protected with N. R. I. training. I swung right into full time Radio servicing and I have made over \$6,000 in a little over two years."—Wm. Spartivent, Sparty Radio Service, 93 Broadway, Newark, N. J.

**"\$500 a Year in Spare Time"**

"Although doing spare time Radio work only, I have averaged about \$500 a year extra in addition to my regular income. Full time Radio work would net me many times that amount."—Edw. H. Fawcett, Slough Rd., Ladner, B. C., Canada.

**FREE: Radio Servicing Tips**



Let me PROVE that my Course is clear, easy to understand, and fascinating to study. Send the coupon for a free lesson, "Trouble Shooting in D. C., A. C. and Battery Sets." This interesting lesson gives 132 ways to correct common Radio troubles. I am willing to send this book to prove that you, too, can master Radio—just as thousands of other fellows have done. Many of them, without even a grammar school education, and no Radio or technical experience, have become Radio experts and now earn two or three times their former pay. Mail the coupon now.

**Many Make \$5, \$10, \$15 a Week Extra in Spare Time While Learning**

The day you enroll I start sending you Extra Money Job Sheets which quickly show you how to do radio repair jobs common in most every neighborhood. I give you plans and ideas that have made good spare time money—\$200 to \$1000 a year—for hundreds of fellows. My Course is famous as "the Course that pays for itself."

**Get Ready Now for a Business of Your Own and for Jobs Like These**

In just about 15 years, Radio's growth has created over 300,000 jobs. (Thousands more jobs will be opened by new Radio developments. Broadcasting stations use engineers, operators, station managers and pay up to \$5,000 a year. Manufacturers employ testers, inspectors, foremen, engineers, servicemen, buyers, for jobs paying up to \$7,500 a year. Dealers and jobbers employ servicemen, salesmen, buyers, managers, and pay up to \$100 a week. My Free Book tells about these and other opportunities.)

**Television, Short Wave, Loud Speaker Systems Included**

There is opportunity for you in Radio. Its future is certain. Television, short wave, loud speaker systems, ship Radio, police Radio, automobile Radio, aviation Radio—in every branch, developments and improvements are taking place. Here is a real future for thousands of men who really know Radio—men with N. R. I. training. Get the training that opens the door to good pay and success in this growing industry.

**Find Out What Radio Offers You**

I am so sure N. R. I. can train you satisfactorily that I agree in writing to refund every penny of your tuition if you are not satisfied with my Lesson and Instruction Service upon completion. Get my 64-page book of facts. It's free to any ambitious fellow over 15 years of age. It tells you about Radio's opportunities; about my Course; what others are doing and making. Find out what Radio offers you. No obligation. ACT NOW! Mail coupon in an envelope, or paste it on a 1c postcard.

**J. E. SMITH, President**  
**Nat'l Radio Institute, Dept. 5DR**  
**Washington, D. C.**

**MAIL THIS for FREE 64 page book**

Dear Mr. Smith: Without obligation, send me the Reference Book and your free book about spare time and full time Radio opportunities, and how I can train for them at home in spare time. (Please print plainly.)

NAME.....  
 ADDRESS.....  
 CITY.....  
 STATE.....  
 M



Vol. XVI  
No. 10



Edited by LAURENCE M. COCKADAY

S. GORDON TAYLOR  
Managing Editor

WILLIAM C. DORF  
Associate Tech. Editor

JOHN M. BORST  
Technical Editor

SAMUEL KAUFMAN  
Broadcast Editor

EVERETT M. WALKER  
Associate Editor

JOSEPH F. ODENBACH  
Art Editor

April, 1935

## Reading Guide to this Issue—

As a matter of convenience for those having specialized interests in the radio field, the following lists the articles and features in this issue, classified under 14 heads. The numbers correspond with the article numbers in the Table of Contents on this page:

- Amateurs—3, 4, 5, 6, 11, 12, 13, 14, 15, 16, 17, 19, 24, 29.
- Broadcast Fans—5, 6, 7, 12, 13, 14, 16, 19, 21, 22, 23, 25, 27.
- Dealers—1, 2, 5, 6, 7, 8, 10, 13, 14, 16, 17, 19, 25, 26, 28, 29.
- Designers—6, 11, 17, 19, 20, 29.
- DX Fans—3, 5, 6, 11, 12, 13, 14, 16, 19, 21, 22, 23, 25.
- Engineers—11, 17, 19, 20, 22, 23, 29.
- Experimenters—3, 7, 14, 17, 19, 20, 29, 30.
- Manufacturers—1, 2, 19, 29.
- Operators—4, 11, 12, 16, 22, 23, 24, 31.
- Servicemen—1, 2, 3, 6, 11, 13, 14, 16, 19, 25, 26, 28, 29, 30.
- Set Builders—3, 6, 7, 13, 17, 19, 26, 28, 29.
- S. W. Fans—1, 2, 3, 5, 6, 8, 9, 10, 11, 12, 13, 14, 15, 16, 18, 25, 29.
- Students—11, 12, 16, 17, 19, 28, 29, 30, 31.
- Technicians—3, 5, 6, 7, 13, 17, 19, 20, 26, 28, 29, 30.

## Next Month—

For Short-Wave and Broadcast DX Fans: Charts showing Airline Distances of the World and the U. S.; S. W. Time Tables; Pronunciation of the Alphabet in Foreign Languages; Identifying Sound Effects employed by Foreign Stations; and Broadcast Stations of North and South America, excepting the U. S.

For Servicemen and Technicians: A new home-built V. T. voltmeter; Radio in Aviation.

For "Hams": A new preamplifier using "Acorn" tubes; the "Ham" Shack.

For Set Builders: Constructional data on the R. N. Short-Wave Converter and on the Browning 35 All-Wave Receiver.

|    |  |     |
|----|--|-----|
| 1  | The Short Waves.....                             | 597 |
|    | <i>Editorial</i>                                 |     |
| 2  | The Future of Short-Wave Reception (Part 1)..... | 598 |
|    | <i>By Charles A. Morrison</i>                    |     |
| 3  | The "Radio News" S. W. Converter (Part 1).....   | 600 |
|    | <i>By S. Gordon Taylor</i>                       |     |
| 4  | The "Ham" Shack.....                             | 602 |
|    | <i>By Everett M. Walker</i>                      |     |
| 5  | A Modern "Ham" Receiver.....                     | 603 |
| 6  | How to Build the Browning 35 (Part 2).....       | 604 |
|    | <i>By Glenn H. Browning</i>                      |     |
| 7  | Single-Tube A.C.-D.C. Receiver.....              | 606 |
|    | <i>By Richard Feeney</i>                         |     |
| 8  | S. W. Station Identification Chart.....          | 607 |
| 9  | The DX Corner for Short Waves.....               | 608 |
|    | <i>By Laurence M. Cockaday</i>                   |     |
| 10 | World Short-Wave Time Table.....                 | 610 |
|    | <i>Compiled by The Editor</i>                    |     |
| 11 | Wavelength-Frequency Conversion Chart.....       | 613 |
| 12 | World Distance Map (South Africa).....           | 614 |
|    | <i>By John M. Borst</i>                          |     |
| 13 | Testing the "All-Star" Junior.....               | 615 |
|    | <i>By the Editor</i>                             |     |
| 14 | A New Double-Doublet Antenna.....                | 615 |
| 15 | How I Won the Denton Trophy.....                 | 616 |
|    | <i>By H. S. Bradley</i>                          |     |
| 16 | World Time Conversion Chart.....                 | 617 |
|    | <i>By The Technical Editor</i>                   |     |
| 17 | Short-Wave Design Calculations.....              | 618 |
|    | <i>By Ralph R. Batcher</i>                       |     |
| 18 | Capt. Hall's S. W. Page.....                     | 620 |
|    | <i>By Capt. Horace L. Hall</i>                   |     |
| 19 | High-Fidelity (Adjustable).....                  | 621 |
|    | <i>By I. A. Mitchell</i>                         |     |
| 20 | First Aid to Inventors (Part 6).....             | 622 |
|    | <i>By E. E. Free</i>                             |     |
| 21 | The DX Corner for the Broadcast Band.....        | 624 |
|    | <i>By the B. B. Editor</i>                       |     |
| 22 | WOR's New 50-KW Transmitter.....                 | 626 |
|    | <i>By Samuel Kaufman</i>                         |     |
| 23 | KYW's New 10-50 KW Transmitter.....              | 626 |
|    | <i>By John Strong</i>                            |     |
| 24 | U. S. Radio Time Signals.....                    | 627 |
|    | <i>By Robert Hertzberg</i>                       |     |
| 25 | A New 4-Band Superheterodyne.....                | 627 |
| 26 | Profits in Group Hearing Aids.....               | 628 |
|    | <i>By Charles A. and Paul Bottorff</i>           |     |
| 27 | Backstage in Broadcasting.....                   | 630 |
| 28 | The Service Bench.....                           | 632 |
| 29 | The Technical Review.....                        | 634 |
| 30 | Students Radio Physics Course.....               | 636 |
| 31 | QRD? .....                                       | 642 |

Published Monthly by Teck Publications, Inc., Washington and South Avenues, Dunellen, N. J.

Lee Ellmaker  
President and Treas.  
B. Holecpl  
Secretary

H. D. Crippen W. P. Jeffery  
Advertising Management  
Virgil Malcher  
205 W. Wacker Dr., Chicago  
Western Representative

EDITORIAL AND EXECUTIVE OFFICES

461 EIGHTH AVENUE, NEW YORK CITY, N. Y.

Entered as second class matter at the Post Office at Dunellen, N. J., under the act of March 3, 1879. Copyright, 1935, by Teck Publications, Inc., in U. S. and Canada. All rights reserved. Registration of title of this publication as a trade mark applied for in United States Patent Office. Printed in the United States of America. The contents of this magazine must not be reproduced without permission. We cannot be responsible for lost manuscripts, although every care is taken for their safety.

25c a Copy, \$2.50 a year,  
\$3.00 in Canada, \$3.50 in  
Foreign Countries. Sub-  
scribers are notified that  
change of address must reach  
us five weeks in advance of  
the next date of issue.



INDEX TO ADVERTISERS

|   |                    |
|---|--------------------|
| Aerovox Corp.                             | 643                |
| Alden Products Co.                        | 635                |
| Allied Radio Corp.                        | 642, 645           |
| All-Star Headquarters                     | 653                |
| American Transformer Co.                  | 653                |
| Autonator Laboratories, Inc.              | 654                |
| Bell, Inc., J. Matheson                   | 654                |
| Birnback Radio Co., Inc.                  | 650                |
| Blan The Radio Man, Inc.                  | 650                |
| Burstein-Applebee Co.                     | 641, 648           |
| Candler System Co., The                   | 650                |
| Capitol Radio Engineering Inst.           | 642                |
| Capitol Radio Research Laboratories, Inc. | 649                |
| Central Radio Laboratories                | 655                |
| Chicago Radio Apparatus Co.               | 639                |
| Classified Advertisements                 | 654                |
| Clough-Brengle Co.                        | 652                |
| Coast-to-Coast Radio Corp.                | 649                |
| Cornell-Dublier Corp.                     | 654                |
| Cornish Wire Co., Inc.                    | 651                |
| Coyne Electrical School                   | 633, 649           |
| Crowe Name Plate & Mfg. Co.               | 652                |
| Cutting & Sons                            | 648                |
| Deutschmann Corp., Tobe                   | 647, 648           |
| Dodges Institute                          | 635                |
| Electrad, Inc.                            | 641                |
| Electrical Supply Corp.                   | 648                |
| Experimental Radio Labs                   | 635                |
| General Electric Co.                      | Second Cover       |
| Goldentone Radio Mfg. Co.                 | 652                |
| Hallcrafters, Inc.                        | 639                |
| Hammarlund Mfg. Co.                       | 629                |
| Hatry & Young                             | 648                |
| Hetro Electrical Industries               | 656                |
| Hull Mfg. Co.                             | 650                |
| Hygrade-Sylvania Corp.                    | 638                |
| Imperial Radio Crafters                   | 655                |
| Indiana Technical College                 | 643                |
| Instructograph Co.                        | 652                |
| International Correspondence Schools      | 653                |
| Kato Engineering Co.                      | 654                |
| Ken-Rad Corporation, Inc., The            | 655                |
| Kenyon Transformer Co., Inc.              | 631                |
| Lynch, Inc., Arthur H.                    | 656                |
| McGraw-Hill Book Co., Inc.                | 650                |
| M & H Sporting Goods Co.                  | 649                |
| Midwest Radio Corp.                       | Fourth Cover       |
| National Company, Inc.                    | 656                |
| National Radio & Electrical School        | 656                |
| National Radio Institute                  | 593                |
| National Union Radio Corp.                | 644                |
| Newark Electric Co.                       | 648                |
| New York Y.M.C.A. Schools                 | 651                |
| Nutter & Cross, Inc.                      | 648                |
| O'Brien, Clarence A.                      | 654                |
| Pioneer Genemotor Corp.                   | 632                |
| RCA Institutes, Inc.                      | 634                |
| RCA Manufacturing Co.                     | 654                |
| Radio Circular Co., Inc.                  | 653                |
| Radio City Labs                           | 656                |
| Radio City Products Co.                   | 652                |
| Radio Shack, The                          | 648                |
| Radio & Technical Publishing Co.          | 636, 637, 651      |
| Radio Trading Co.                         | 650                |
| Radio Training Association of America     | 654                |
| Raytheon Production Corp.                 | 641, 649, 650, 654 |
| Readrite Meter Works                      | 641                |
| Rider, John F.                            | 632                |
| Rim Radio Mfg. Co.                        | 643                |
| Rivard Mfg. Co.                           | 653                |
| Sager Electrical Supply Co.               | 648                |
| Scott Radio Labs., Inc., E. H.            | 651                |
| Silver, Inc., McMurdo                     | 635                |
| Solar Mfg. Corp.                          | 648                |
| Sound Systems, Inc.                       | 655                |
| Sprague Products Co.                      | 652                |
| Sprayberry, F. L.                         | 652                |
| Supreme Instruments Corp.                 | 596                |
| Teleplex Co.                              | 635                |
| Toledo Sound Equipment Laboratories       | 650                |
| Triplett Electrical Instrument Co.        | 643                |
| Tri-State College                         | 641                |
| Try-Mo Radio Co., Inc.                    | 652                |
| United Radio Service                      | 648                |
| United Transformer Corp.                  | 645                |
| Webster Co., The                          | 640                |
| Weston Electrical Instruments Corp.       | 595                |
| Wholesale Merchandisers, Inc.             | 643                |
| Wholesale Radio Service Co.               | 634, 646           |
| Wright-DeCoster, Inc.                     | 655                |
| Yaxley Mfg. Co., Inc.                     | Third Cover        |

# PROFITABLE SERVICING DEMANDS AN *Accurate* ALL-WAVE OSCILLATOR

*Here it is*

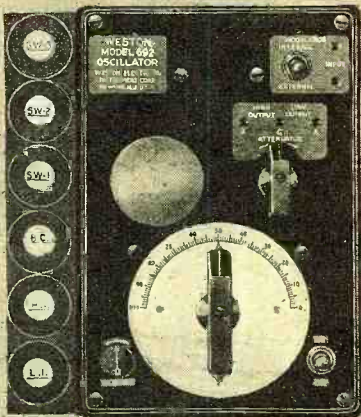

**All-Wave!**  
Complete Receiver Frequency Coverage

**Basic!**  
Frequency Band Depends Only on Plug-In Coil

**Stray Field!**  
Below 1/2 Microvolt at all Frequencies

**Output!**  
1 to 100,000 Microvolts

**Triple Shielded Attenuator**

**Independent Modulation Circuit—Constant Percentage**

**High Impedance Input for External Modulation**

**Individually Designed Coils for Each Band**

**Constant Impedance 200 Ohm Output Circuit!**

Here's the complete solution to your oscillator problem! Weston supplies it in the new Model 692 . . . an oscillator designed to do a precision aligning job on radio receivers.

Model 692 is not limited to the present frequency bands for frequency ranges can be added at any time.

A few of the outstanding features of this all-wave precision oscillator are shown above. Study them carefully . . . and make your own comparisons. Then, send for the descriptive bulletin which contains all the facts on the oscillator you have been waiting for . . . one that will enable you to give complete customer satisfaction on every aligning job. Mail the coupon today . . . Weston Electrical Instrument Corporation, 615 Frelinghuysen Avenue, Newark, N. J.

## WESTON *Radio Instruments*



Weston Electrical Instrument Corporation  
615 Frelinghuysen Avenue  
Newark, New Jersey.

Send for Bulletin on Model 692 All-Wave Oscillator.

Name \_\_\_\_\_  
Address \_\_\_\_\_  
City \_\_\_\_\_ State \_\_\_\_\_



# World Wide Acceptance

**SUPREME TUBE TESTER**  
MODEL 85  
OPERATING DATA

From every country in the world has come demand for the Supreme 85 Neonized Tube Tester. Get it from your Jobber at the Dealers Net Cash Wholesale Price, \$39.95



● **Supreme Instruments Corporation, Greenwood, Miss., U.S.A.** ●  
Export Dept., Associated Exporters Co., 1457 Broadway, New York City



# Radio News

April, 1935

## "More" on the SHORT WAVES

(The Editor—To You)

We recall some predictions and advice made during the last four years on short-wave radio. This annual issue contains still more short-wave information invaluable for anyone interested in this most progressive activity, whether he is a new fan, an expert DX'er, a serviceman, or a dealer

**T**HE Future of World Radio lies in the Short Waves! That has been the Editor's opinion for the last four years, and many early prophecies have now come true. In August, 1931, we published our First Short-Wave Number, including articles on short-wave receiver design, articles on transmitting on the ultra-short waves and a very complete short-wave station list. Our Second Annual Short-Wave Number appeared in August, 1932. In introducing this subject again this year we quote from that month's editorial: *There is not the slightest doubt in the Editor's mind but that short-waves have a more thrilling and newer enjoyment than any other field in radio. . . . Japan, Australia, Africa, Hawaii, Europe—the world's voices in your ears!*

The next Annual S. W. Number occurred in March, 1933. In it was published a wealth of short-wave material answering such questions as: What kind of ap-

paratus was necessary for short-wave reception? What is the best time to listen for distant stations? What stations come in best in the morning? In the afternoon? In the evening? When is the best time to listen for London, Rome, Paris, Australia, Buenos Aires, Caracas, Geneva? What time of day or night is it in a foreign country? What is the airline distance between stations heard and your own location? The Annual Short-Wave Number for 1934 was published in April (as it is this year) being at the very beginning of the best short-wave season. We quote from the editorial of that issue: *It is only a matter of time when every radio set will include facilities for tuning in all bands of the short waves. Why? Because with a short-wave set one is able to listen in, not only to stations in his own city, but to stations located, literally, all over the globe!*

Today, 90 percent of the (Continued on page 637)

### THE SHORT-WAVES AND HUMAN FELLOWSHIP

*Men are learning that human beings have the same love of home and family, the same general hopes and fears, the world over, even if their speech, customs and dress are not ours. The Short-Wave Broadcasts of public events from foreign lands, such as this procession in Rome, are teaching the world that a Human is a Human Anywhere!*





# THE FUTURE OF SHORT-WAVE

From the radio fan's point of short-wave reception craze? Is it a future of radio? This subject is called in this series by the president

**Charles A.**  
*Part*



FROM MUSSOLINI IN ROME—

*Such events as this, showing Il Duce starting the excavation of the Mausoleum of Augustus, are often broadcast by short waves, around the world.*

**T**ODAY world-wide reception on the short waves is an accomplished fact. On a day of average reception conditions with a moderately sensitive all-wave receiver, it is possible for a radio listener to have his choice of the program offerings of many lands. We are accustomed to accepting the marvelous results of modern scientific endeavor in a very prosaic and matter-of-fact manner, so that it is indeed quite easy to lose sight of the fact that world-wide reception—for the average layman—is a thing of only recent growth.

**T**HE Short-wave Dx'er, the Amateur, the experimenter in radio equipment has been receiving foreign short-wave stations for some years now. In fact it is largely through the research and patient experimentation of these groups of radio enthusiasts that the consistency of our present day international short-wave reception has been made possible. It would be a mistake to say that short-wave reception is today in a fully perfected state, as perfection in scientific development

comes only through years of minute research, invention, and the building up of a vast sum of knowledge which satisfactorily explains all the "Whys and Wherefores!" Recent successful ascents into the Stratosphere will do a great deal, we hope, in solving some of the vagaries of the actions of these high-frequency currents that go traveling, and bounding along through the upper stratas, or layers of air, which are better known in radio as the "Appleton," "Kennelly" or "Heaviside" layers. Recent developments in transmitting aerials are doing a great deal towards solving the problem of fading. Electrical interference has been, perhaps, the greatest problem of all. The average person should not hesitate in buying an all-wave receiver because he does not believe that foreign reception is practical, or possible, or because he believes a later model receiver will bring a great improvement. This is false reasoning as in scientific research there will always be some new changes and developments and to put off buying on

this account will be to deprive yourself of one of the greatest developments of all times. Within reasonable limits you will find international, or foreign short-wave reception on an up-to-date receiver surprisingly good and in fact at times unbelievably good. Any one familiar with short wave reception will tell you that at times foreign stations come in as good or better than local stations. I have perhaps heard the short-wave transmissions from Daventry hundreds of times, but nevertheless I never fail to get a new thrill when I hear the announcer say "This is London Calling," or to wait in anticipation on the hour for the first booming strokes of Big Ben chiming from the towers of Parliament. It might be surprising to some people to know that thousands of radio listeners in all parts of the world, daily set their watches and clocks to the tone of the first stroke of Big Ben in London. So I say to those who, as yet, do not know the great fascination of foreign reception—"Do not delay longer in purchasing an all-wave receiver."

Short-wave reception of foreign stations being a comparatively recent development, it is a little risky to even venture a guess as to what the ultimate expansion of short-wave facilities will bring. I firmly believe however that we are just on the threshold of a new "International Unity." This will be

## HEARD AROUND WORLD

*Below is the new Prato-Smeraldo, Italian short-wave transmitter, IZRO, which carries the "American Hour," on Mondays, Wednesdays and Fridays at 6 p.m., E.S.T. At left, the studio of the Moscow radio station during a characteristic "dialogue" broadcast.*

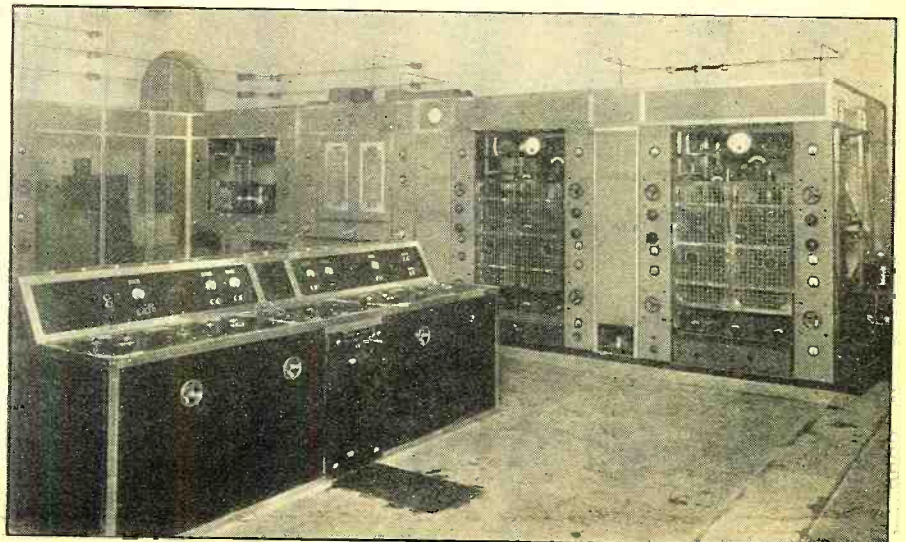
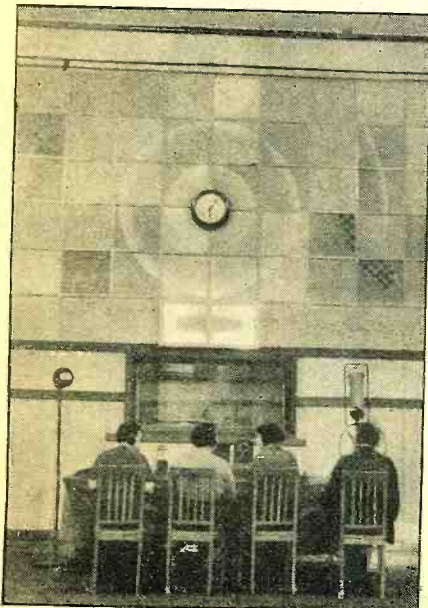



# INTERNATIONAL RECEPTION

view, just what is there to this passing fad or is it really the big discussed frankly and enthusiastically of the International DX'ers Alliance

## Morrison One

brought about by short wave radio more than any one factor. Through the magic of any length, distance is completely annihilated. No longer is it possible for nations to carry on secret intrigues, or to fool the people of their own countries for any length of time, as now before a historical event is even over, it is being carried into the homes of a nation; yes, even into the homes of the whole world through these same willing servants of the ether. Radio has become the strongest weapon of established government, and countless examples might be given of the role that radio has played in the dissemination of political authority. The administration of the National Recovery Act has been carried on to a great extent by radio. President Roosevelt's calm fireside radio messages of reassurance, and good faith have been carried to the homes of the nation and by short waves to the peoples of every civilized country in the world. Daily newscasts in English are a regular feature of the short wave stations of Europe. It is a never ending source of interest to me to read of some topical event of major importance, and then to turn to my radio to see what London has to say about it, to see what Germany has to say about it and to see what the French have to say. Many different angles of the same subject are brought to light, and the same event viewed from these international angles brings a new vividness to the events of

the day. Every world-minded person, and every student of world politics should by all means avail themselves of short-wave facilities as they will find here a medium more satisfactory for first-hand knowledge than anything heretofore known. I firmly believe that the future of international short-wave reception will bring with it Peace among the Nations, as it is quite important to note that as we learn to understand the peoples of other lands, to appreciate their national heritages, to become acquainted with the best things in their music, their culture and their everyday life, we will find fear, distrust and jealousy vanishing. We will learn to have a great admiration for these offerings of great music, oratory, and drama. These people who have heretofore existed, only in the pages of some dusty Atlas, now have become warm living personalities whom we actually hear daily over the short-waves. They in

### A FAVORITE STATION

*The powerful German "D" transmitter that flings its short-wave programs across oceans. At right, Major Andrew Harris, conductor of the huge British band of the Scottish guards, whose programs have often been broadcast by the British Empire "G" short-wave stations.*



—TO MILKING CONTESTS  
IN SWEDEN

*One short-wave world broadcast from Stockholm carried the winner's voice, telling how she won.*

fact become our friends. Friends do not resort to blows to settle a misunderstanding. They sit down and talk things over in a sensible manner and come to some definite conclusion without hard feelings. This is the logical result of understanding and friendship.

I predict that the Empire type of broadcasting systems, of England, of France and of Germany, will eventually be adopted by every large nation! These national broadcasting stations are not alone merely broadcasting stations for the dissemination of music or entertainment, but have become in reality the OFFICIAL VOICE OF THAT NATION! That this is a recognized fact is daily brought to our attention, as when we tune our dials to Daventry, England, we cease to think of it as merely station GSB, GSA, or GSC, on a certain wavelength, but (Continued on page 638)

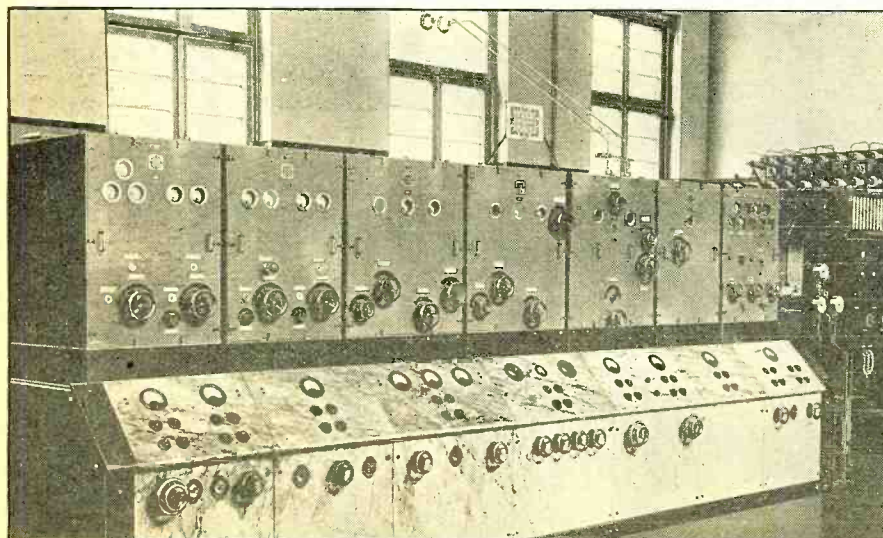



# Build This RADIO SHORT-WAVE

This easy-to-build converter of broadcast receivers too good wave receiver. It also offers profit to the serviceman

S. Gordon

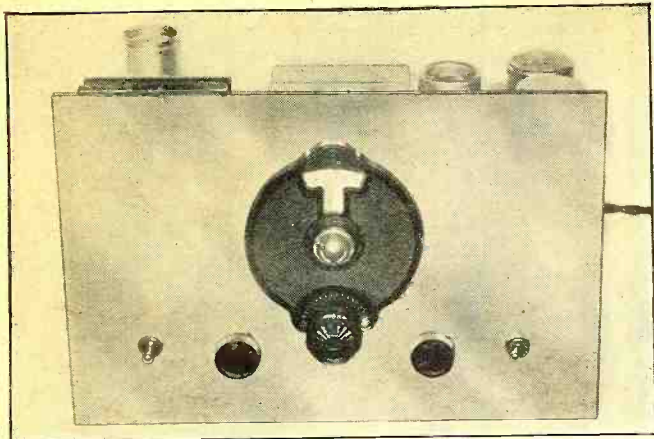

### THE FINISHED JOB

The large, illuminated dial provides single control tuning. The other knobs are small midget trimmers in the r.f. and detector circuits to insure perfect alignment of circuits. The switch at the right switches the antenna from converter to broadcast receiver. At the left is the line switch.

**T**HE converter described in this article is one which has been in process of development for some months. Dale Pollack, of Columbia University; John H. Potts, a design engineer well known to RADIO NEWS readers through his service equipment designs; Hubert L. Shortt, chief engineer of Wholesale Radio Service Co., and the writer have collaborated in the design, and it is felt that this is one case where the old saying, "too many cooks spoil the broth," does not apply.

**B**ROADCAST receivers in general use today vary widely in sensitivity; the best home receivers being rated at 1 microvolt or less, while the midgets may reach as low as 400 microvolts. A short-wave converter, if it is to be generally applicable, should be capable of providing maximum usable short-wave sensitivity when working into a broadcast receiver of this least sensitive type. The question then arises as to just what constitutes maximum usable s.w. sensitivity. Opinions vary on this, but inquiry among a number of test engineers seems to establish 5 microvolts as the value. In some unusual

locations, favored by low noise levels, greater sensitivity than 5 microvolts can sometimes be used, but in the average home the level of noise from atmospheric and man-made interference is such that a signal below 5 microvolts is lost.

The RADIO NEWS Short-Wave Converter was designed to meet or exceed these sensitivity requirements. Actually, when used ahead of a receiver having 400-microvolt sensitivity, it provides overall short-wave sensitivity ranging between 0.4 and 3.6 microvolts. Even with the broadcast receiver sensitivity adjusted to the low value of 1000 microvolts, the converter provides sensitivity better than 5 microvolts over the greater part of its frequency range. This is shown by the solid line of Figure 1, which is a curve made from actual laboratory measurements.

If the broadcast receiver uses 5 or more modern tubes, its sensitivity is likely to be between 20 and 50 microvolts. At the latter value, the converter will result in short-wave sensitivity ranging well below 1 microvolt, which

is more than can ever be used. Such added sensitivity is not in any way objectionable, however. It simply means that only a part of the broadcast receiver sensitivity need be used. If the receiver includes a.v.c., this reduction is taken care of automatically.

The selectivity of the converter-receiver combination is, of course, a good deal better than that of the receiver alone because of the additional tuned signal circuits in the converter. Image-frequency selectivity is unusually good for the same reason, and also because the intermediate frequency (about 540 kc.) to which the broadcast receiver is tuned is considerably higher than that employed in all-wave receivers.

From the viewpoint of the home constructor, band-switching involves numerous problems of wiring, interaction between the coils of the different ranges, etc. Also the use of band-switching very materially increases the cost for parts. For this reason the converter being described provides only a single tuning range. This range, from 5800 to 16,300 kc. (51.7-18.4 meters) is made wide enough to include the most important short-wave broadcast bands—19, 25, 31 and 49 meters. In addition, it includes numerous commercial phone, aviation and amateur bands, and therefore offers about every type of service obtainable on the short-waves.

A built-in power supply, operating from the a.c. line is included, making installation and operation foolproof and simple. In making the installation, the antenna ("L" type or doublet) is per-

### THE CHASSIS LAYOUT

Figure 2 shows the schematic circuit of this 4-tube converter. At the left is a view of the condensed layout of the parts—a layout which makes for short leads and absolute stability in operation. At the extreme right of the next page is the bottom view showing wiring and arrangement of parts under the chassis

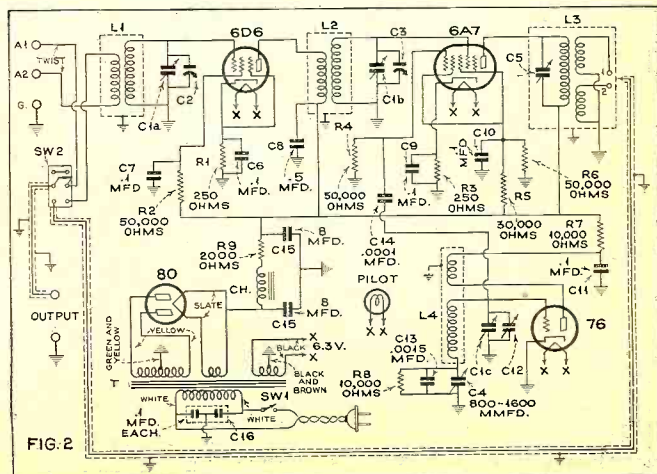
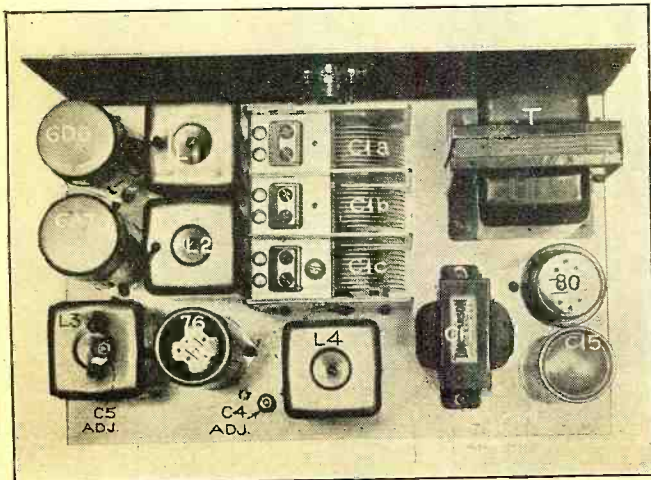



# NEWS CONVERTER

should prove a boon to owners to discard in favor of an all-an excellent opportunity for or custom set builder

Taylor

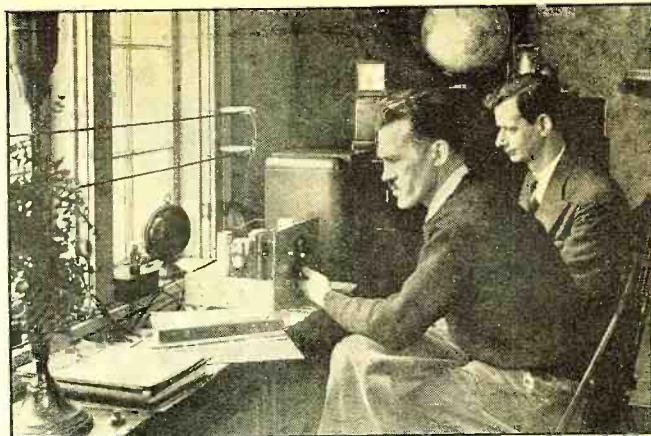

### OPERATING TESTS

*Tests at several listening posts and elsewhere show that the converter provides excellent short-wave reception with broadcast receivers ranging from insensitive t.r.f. jobs of the vintage of 1928 to modern multi-tube supers having a sensitivity rating better than 1 microvolt*

manently connected to the converter, and the shielded converter output wire is permanently connected to the antenna terminal of the broadcast receiver. The power cord is plugged into the a.c. line and the job is finished. The antenna switch on the front panel of the converter provides for changing over the antenna when straight broadcast-band reception is desired, automatically disconnecting the converter input and output circuits. At the left of the panel is the line switch.

There are three controls, the large one is the tuning control. The other two are auxiliary trimmers in the r.f. and detector stages. These trimmers are used instead of those of the compression type usually included on the r.f. and detector tuning condensers and are placed on the front panel to make possible exact alignment at any desired frequency when absolute maximum efficiency is desired. Normally, they need not be used in tuning but instead can be adjusted to resonance at any point in the tuning range of the converter and left that way. All tuning throughout the entire range is then accomplished by means of the single main tuning knob. When operated this way, the sensitivity and selectivity are somewhat reduced, the sensitivity then being as indicated by the broken line of Figure 1.

As will be noted from the schematic circuit, Figure 2, this converter employs 4 tubes—a 6D6 in the tuned r.f. stage,

6A7 modulator, 76 oscillator and 80 rectifier. The r.f. stage is employed to provide the needed gain and image-frequency selectivity. The 6A7 functions as an amplifier at the oscillator frequency and a modulator, but a separate tube is employed for the oscillator. This method has been found to offer certain advantages over the common

### "BLUEPRINTS"

A COMPLETE set of full-size drawings have been prepared on this converter. These include a full-scale picture wiring diagram, full-scale working drawings of panel and chassis, a schematic diagram, etc. These prints are made by a special process to avoid the shrinkage encountered in ordinary prints. As a result they may be used as drilling templates for the direct location of all holes with full assurance of accuracy.

It is expected that these prints will be ready for mailing by March 5.

A set of prints may be obtained by sending 50c to: RADIO NEWS Blueprint Department, 461 Eighth Ave., New York City, asking for RADIO NEWS "Blueprints"—Set No. 4.

one of using the 6A7 as both oscillator and detector, among which are more complete freedom from interaction both in tuning and operation. Moreover, this practice of amplifying the output of the oscillator insures a strong heterodyne component which is desirable, considering that the signal and oscillator voltages each contribute to the amplitude of the i.f. voltage.

Tuning of the r.f., detector and oscillator circuits is accomplished by means of the 3-gang condenser, C1. Alignment is obtained by means of the semi-adjustable padding condenser (C4-C13), the oscillator trimmer C12, which is built into the 3-gang condenser, and the r.f. and detector trimmers C2 and C3. The output transformer, providing inductive coupling to the broadcast receiver, is tuned by a compression type condenser mounted in the same can. This transformer has two output windings, one to match it to broadcast receivers having high-impedance inputs and the other (Continued on page 638)

### SENSITIVITY MEASUREMENTS

Figure 1 shows the overall short-wave sensitivity when using this converter ahead of a broadcast receiver having only 1000 microvolt sensitivity. With an average broadcast receiver (about 100 microvolt sensitivity) the overall sensitivity increases to better than 1 microvolt

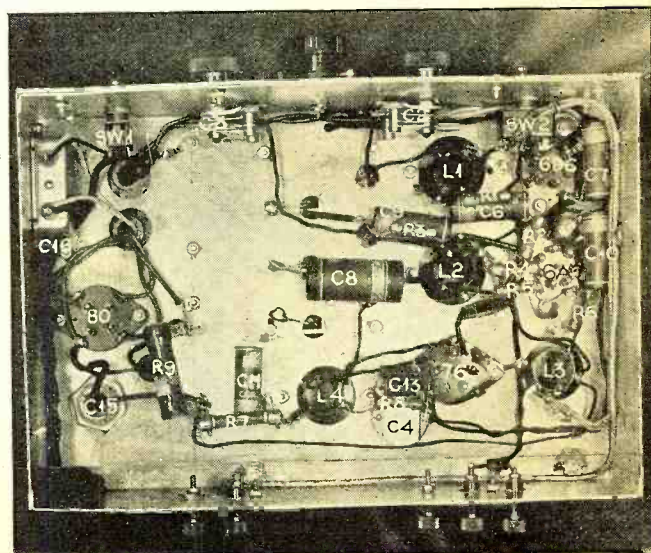
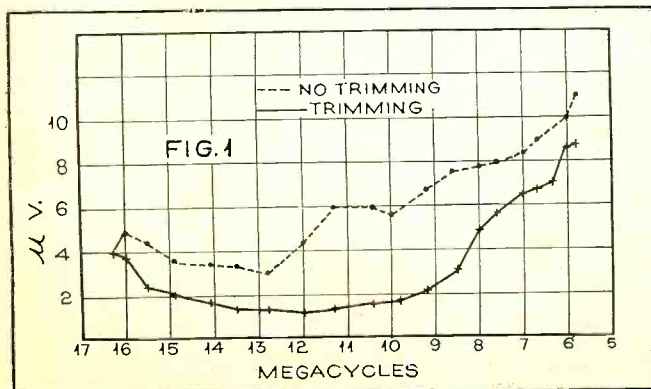



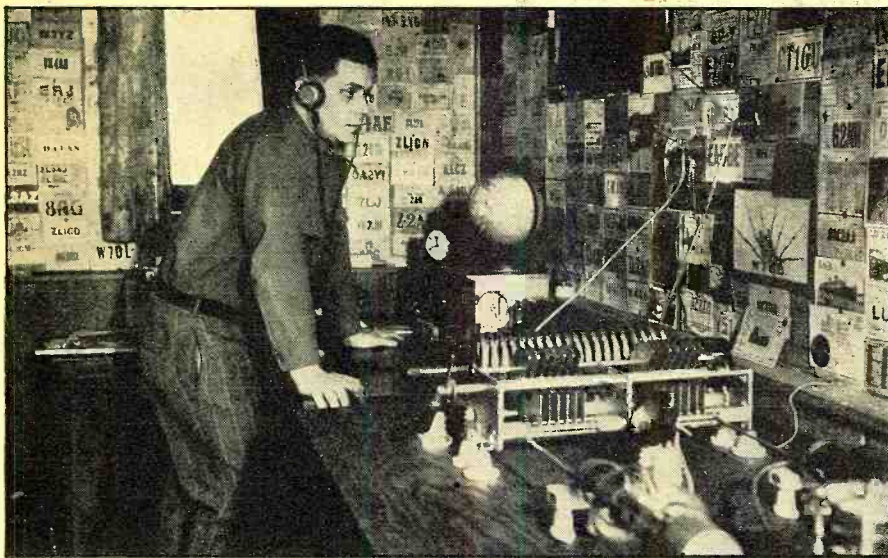

# THE "HAM" SHACK

CQ CQ CQ

FAMOUS SEATTLE AMATEUR  
 This is Ed Stevens and his amateur station at Seattle, Washington. Notice the efficient layout of the transmitter in the foreground and the QSL cards on the wall received from all over the world.

**T**HE amateur's neglect of the 10-meter band is becoming serious. Only a few endowed with the pioneering experimental initiative have attempted to do anything with it, and yet the band holds tremendous possibilities for development. Those who have pioneered on this channel have found it has all the desirable qualifications for local communication, and under certain conditions some extreme DX may be obtained. Recently a group of four Eastern amateurs got together with the idea of discovering for themselves just what may be expected of signals on this channel. The band has many features. It extends from 28,000 to 30,000 kilocycles, making it 2000 kilocycles wide—one of the widest available to the ham. Within this 2000 kilocycles there is a 500-kilocycle 'phone band (from 28,000 to 28,500 kilocycles)—something in itself that breathes of tremendous potentialities.

**T**HERE are to your Editor's knowledge, only a few (probably less than 100) actively engaged in communication on 28,000 kilocycles. When an eastern clan of 10-meter enthusiasts ventured on the channel, there were no other signals to be heard, save a few police stations operating between 7 and 10 meters. Less than seven amateur stations have been heard in the first six months of listening. However, knowledge of the possibilities of the band are not unknown. As far back as 1928, one or two pioneers began experimenting on 10 meters and obtained results that should have encouraged greater activity on the channel. For instance, one station succeeded in communicating across the Atlantic in 1928. But, the chief difficulty has been that other stations have shown little or no interest in the band, with the result the pioneers were left stranded and finally abandoned their work because there was no one to listen to them or to give them reports. It might be mentioned here that ultra-high frequency television is gaining tremendous headway. Not less than four inventors of independent systems are contemplating the operation of television stations this year, and of course, if the visual art should gain sufficient impetus, there will be a spontaneous cry for additional high-frequency channels. This, of course, will endanger the permanence of the 10-meter amateur band unless the

amount of activity thereon is sufficient to warrant its continued allocation. This is another reason why the eastern group began their 10-meter activity.

Operation on 28 megacycles is not much unlike that on 56 megacycles. Only a small antenna is required (about 16 feet 5 inches) and low power will be more than sufficient for communication within reasonable limits. Distance possibilities are very freakish, but, on the other hand, local communication is extremely reliable. It has been found that under normal conditions local signals have about the same signal intensity within the so-called "visual range" or above the horizon, but unlike five meters, they seem to carry much farther than a 5-meter signal. However, the quasi-optical effect is less noticeable. Whereas a 5-meter signal may pass over a valley without being audible in the hollow, a 10-meter signal will follow more faithfully the contours of the earth's surface.

Ten meters is a compromise band between high frequencies and ultra-high-frequencies, tending more in characteristics toward the ultra-high category. One of the most appealing features of the channel is: it is possible to use stable master-oscillator, power-amplifier transmitters and superheterodyne receivers. Signals of this type, when received on a sensitive receiver are extremely sharp, but extremely loud when

tuned to peak resonance. Hundreds of stations could be accommodated on the channel without causing interference to one another.

Manufacturers of typical amateur receiving sets, such as National, Hammarlund and others, are making 10-meter coils for their standard model sets. Some of the newer amateur receivers are designed to tune down to 7 or 8 meters, so that the problem of obtaining a good receiver for 28 megacycles is greatly simplified. In addition, most 56 megacycle receivers also are designed to operate on ten meters by simply changing a coil. Receivers of this type may be used either as super-regenerators or as plain regenerative receivers.

The transmitter problem is a simple one. Those who have 20 meter transmitters merely have to add another doubler to operate on ten. Others will prefer to construct a special transmitter for the band in view of the fact only a small amount of power is necessary.

A typical transmitter constructed by one of the eastern group of 10-meter enthusiasts consists of a single electron-coupled oscillator using a 59-type tube and a 210 tube as a final amplifier. The grid circuit of the oscillator is tuned to one-half of the operating frequency, or twice the wavelength, i.e., between 14,000 and 14,250 kilocycles. The plate circuit of the 59 tube is tuned to the operating frequency in the 28,000 kilocycle band. Such an arrangement gives far more stability than it is possible to obtain by operating the oscillator grid circuit on the operating frequency. The layout of parts closely follows the accompanying schematic wiring diagram. The oscillator is mounted at the right of the baseboard with the grid and plate coils on either side. The amplifier is at the left and also follows the congruent layout. All leads should be made as short as possible, and every component part should be securely fastened.

All tuning condensers used are 50 mmfds. The oscillator-doubler grid coil, L1, has nine turns of 1/8-inch copper tubing 2 inches in diameter. All other coils have four turns of the same material and also are 2 inches in diameter. The copper tubing provides an extremely rigid coil, and may be self-supporting. Spacing between turns is about equal to the diameter of the

(Continued on page 647)

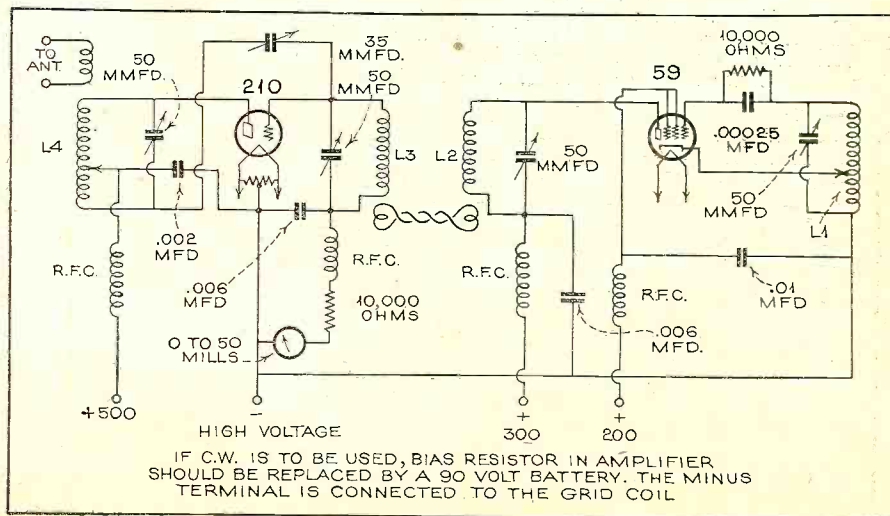



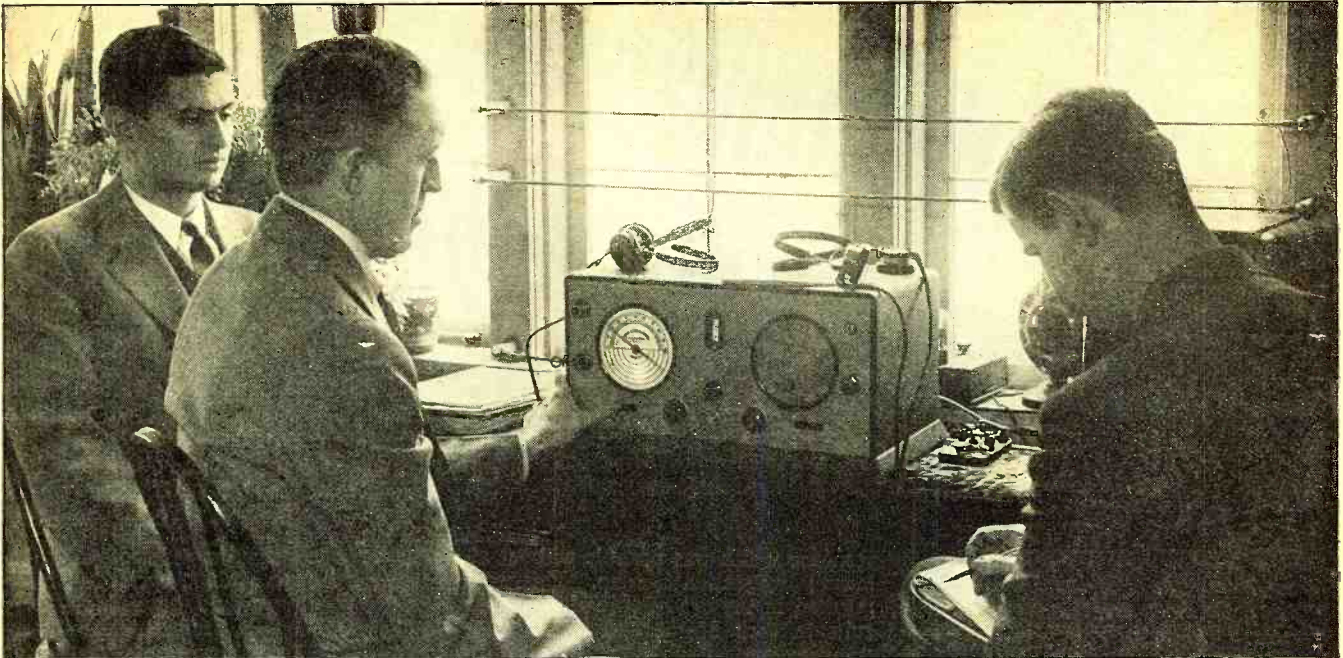

TESTING THE NEW "AMATEUR" RECEIVER AT WESTCHESTER

Scene at the Westchester Listening Post where a number of well-known amateurs and short-wave reception authorities have heard the new set demonstrate its ability to "step-out" and pull in distance stations consistently. The set works exceptionally well also on headphones, which make it ideal for short-wave reception in the "Wee-Sma" hours

# A MODERN RECEIVER FOR SHORT WAVES AND "HAM" COMMUNICATION

*(The Super-Skyrider)*

By the Staff

**D**ISCRIMINATING amateurs and short-wave listeners are always on the lookout for new receivers that will answer the exacting needs of the "semi-professional" operator, especially where utmost selectivity and sensitivity, accuracy of tuning, and maximum freedom from unwanted noise is concerned. Here is a new super-heterodyne, one in which plug-in coils are done away with and where the set is a complete unit, with power pack, amplifiers and loudspeaker, all in a single

commercial type shielded cabinet. The "Super-Skyrider" is a 4-band receiver, tuning from 13 to 210 meters. The bands are arranged for best sensitivity on the amateur communicating wavelengths and on the frequencies used by the principal foreign short-wave

broadcasting stations. A fifth band may be included at the option of the user. Wavelengths on this extra band may be either: the broadcast band, or the 10-meter amateur band. And besides all this, the intermediate frequency is arranged so that a crystal filter may be added for maximum-selectivity, single-signal communication work. The controls for the crystal may be seen at the left-hand end of the front panel. The crystal "plugs-in" inside the cabinet.

The circuit used is that shown in the schematic diagram where a 6D6 tube serves as the initial r.f. amplifier. This is followed by a combination oscillator and first detector circuit utilizing a 6A7 tube. Then come two i.f. stages using 6D6 tubes. These, in turn, are followed by another (Continued on page 639)

### THE CRYSTAL CIRCUIT

At the left is shown the relative size of the holder unit containing the crystal oscillator. The schematic circuit is shown below

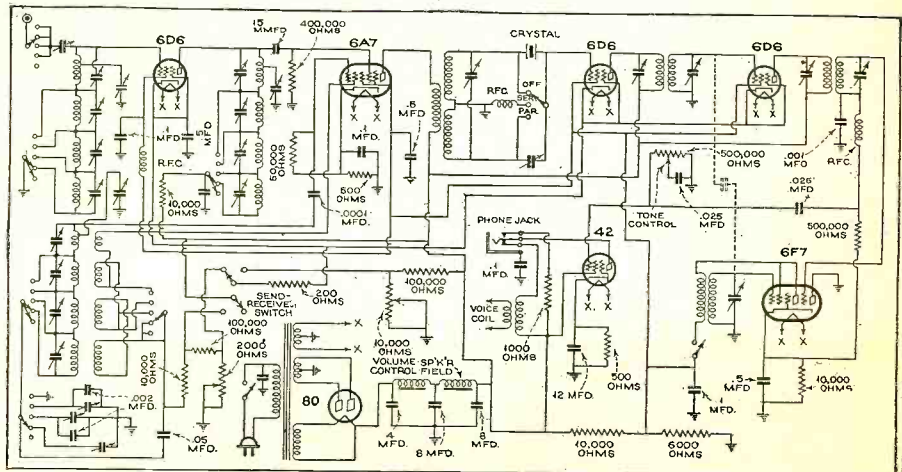



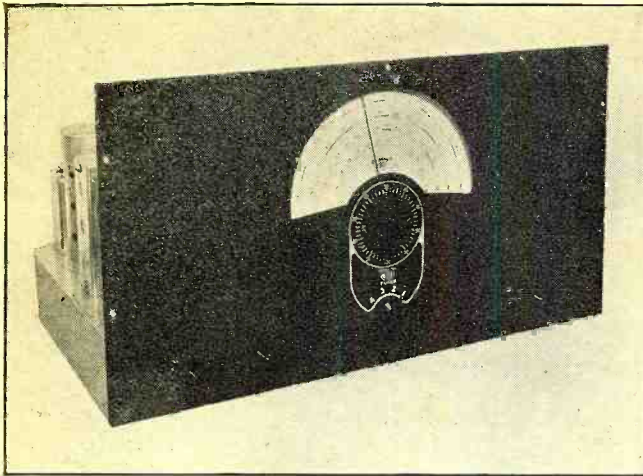

#### THE COMPLETED RECEIVER

*This shows the ship-shape appearance of the final model with its engraved tuning escutcheon in place.*

**I**N the March issue of RADIO NEWS the writer described an all-wave superheterodyne especially designed for the set builder, experimenter, DX enthusiast and amateur. The receiver consists essentially of a tuned-antenna circuit followed by a stage of r.f. amplification on all bands; an electron-coupled oscillator, a double-band pass intermediate stage, an automatic volume control which may be switched on or off at will, and a beat-frequency oscillator for c.w. reception.

**T**HE receiver covers a range of frequencies of from .55 to 22.6 megacycles and, due to the extreme care in design, layout, and selection of parts, has a sensitivity of 1. microvolt or less all over the tuning range. In fact, the sensitivity is greater than can be used even under the most favorable atmospheric conditions. Figure 1 shows sensitivity curves on the four bands. It will be noted that the response is almost uniform on any one band.

A great deal of design study was given the intermediate amplifier for it was desired to have the highest quality

response which was possible without allowing any station overlap. This work resulted in the use of three high-Q circuits in each of the two intermediate transformers. Each of the six inductances which are tuned are in turn made up of a series of three pi windings which results in lowering the distributed capacity of the coils and materially sharpens the individual tuned circuits. The resultant resonance curve for the IF amplifier has already been shown in RADIO NEWS so that it remains to picture the overall selectivity of the receiver which is due to the tuned antenna circuit, r.f., and intermediate amplifiers as a whole. Figure 2 shows such curves taken at 600 and 1000 kilocycles. It will be noted that the "nose" of these curves is very broad but that the sides are relatively steep. This means that the high audio frequencies in the received music which are so necessary for high quality reception are attenuated very little, but that 10 kilo-

cycle selectivity is assured. For example, a note of 2500 cycles in the received music would be reduced only 37% or about 5. decibels while the interference from a station operating on an adjacent channel 10 kilocycles away would be reduced some 99.2 % or about 40 decibels. This broad "nose" tuning curve is actually noticeable in operating the receiver for the micro-vernier tuning control may be rotated several degrees on broadcast without a noticeable change in signal level, however rotating it a fraction of a degree farther entirely tunes out the signal. This may readily be seen to be the case from the selectivity curves. For the operator in tuning the micro-vernier in effect slowly slides the whole tuning curve to the right or the left of the signals carrier which remains stationary and when he reaches the steep portion of the curve the signal decreases very rapidly.

Great care has been taken throughout in the selection of parts, for the completed receiver is no better than each item of its kit of components. The base and panel are drilled and finished so that the assembly of the parts is relatively simple. The two bottom photos show a top and a bottom view of the apparatus mounted on the chassis. It is advisable to mount all of the tube

# The "HOW TO" BROWNING

(By Glenn H. Browning)

In this installment the author and details for his latest creation. He procedure for installing the tuner parts of the circuit. Operating

Part

#### UNDER-CHASSIS VIEW

*This picture shows what the bottom arrangement of parts is like. The diagram at the right, Figure 2, gives over-all selectivity at two frequencies.*

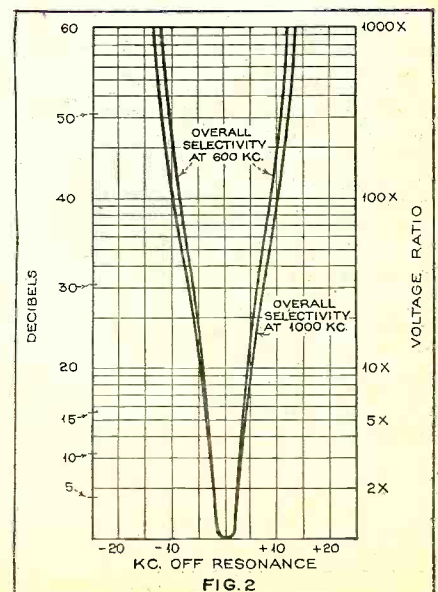
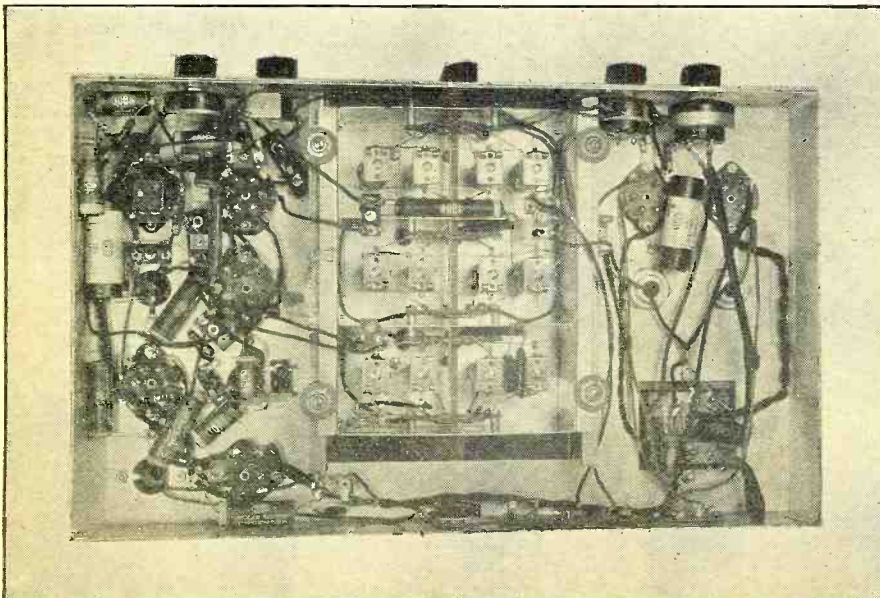



BUILD"

# 35!

designer discusses construction also outlines the best methods of unit and for wiring it to the other hints will follow next month

Two

sockets and shield bases first. The same mounting screws are used for both, the tube socket being held below the chassis and the tube shield base above. It is important to have the tube sockets contacts in the position shown on the diagrams, for care has been taken to make all leads carrying r.f. current as short as possible. The insulating straps should then be fastened in the positions shown on the drawing. The power transformer is mounted as indicated, and, and the filament wiring done. As will be noted the transformer has a 2.5 and a 6.3 filament winding so that either 6.3 or 2.5 volt tubes may be used according to the set builder's desire. The 2.5 and 6.3 volt tubes are identical in their electrical characteristics even to having the same input and output capacitances and fit the same sockets, that is, the 58 equals the 6D6, the 2A7 equals the 6A7, the 2A6 equals the 75, the 56 equals the 76, and the 2A5 equals the 42. The transformer has an electrostatic shield between the primary and secondary windings which helps to eliminate any noise being fed into the set from the lighting circuit and at the same time eliminate a modulation hum sometimes encountered. However, even with this electrostatic shield it was thought advisable to place an .05 mfd. condenser across the primary, for in some cases this further reduces line noise. With this condenser across the lighting circuit, one side of which is usually grounded, a voltage may be obtained between the metal chassis and a ground wire attached to a water pipe or radiator. This is not harmful but a

slight shock will be obtained upon taking hold of the ground wire and the chassis at the same time. Reversing the plug in the 110-volt outlet will eliminate this voltage in practically all cases. The writer simply speaks of this effect and its cause and cure so that the set builder will not think that he has made a mistake in wiring. For those who want to work from picture-wiring diagrams rather than from the schematic (shown on page 539, last month) the designer has prepared a set of 5 "blueprints" which can be obtained along with the kit.

After the filaments are wired the screen grids, power supply, and plus B leads should be connected. These leads should be run along the bottom of the chassis out of the way. The resistors and bypass condensers should then be soldered into place. The placement of these has been worked out so that they mount either on the tube sockets themselves or on the insulating straps provided for that purpose. This placement is shown on the drawings and should be followed. Be sure to follow the wiring diagram in bypassing, for a number of the condensers return to the cathode of the tubes and *not* to ground.

The volume controls and switches on the front of the chassis may be temporarily mounted (This temporary

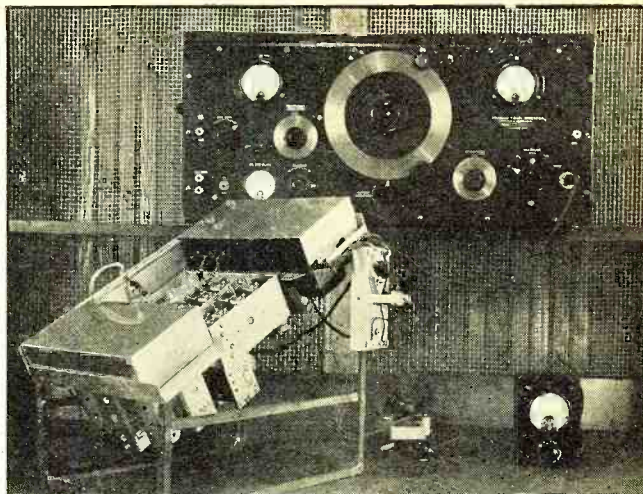

THE "ALIGNMENT" SET-UP

A portion of the shielded room in which the tuner is finally adjusted and aligned by means of an all-wave signal generator and a recording meter for registering signal response.

mounting will have to be removed when the front panel is put on as these controls hold the front panel to the chassis) and wired. The i.f. transformers have been carefully adjusted at the factory to the intermediate frequency of 456 kilocycles and care should be taken *not* to change their adjustments!

The leads are also cut to length and if they are not long enough to reach the proper connections some of the parts must be mounted incorrectly. The last apparatus to mount is the tuner unit which carries the gang of three tuning condensers together with the coil and switch assembly. This is mounted on soft-rubber grommets which should be placed between the main chassis and the tuner. Besides the grommet an insulating washer is furnished which is placed before the metal washer is put in place. The nuts which hold the complete assembly should be just slightly tightened so that the tuner cannot slide around. Under these circumstances the rubber grommets will give a cushion effect which tends to reduce mechanical acoustical feed-back caused by the actual vibration of the condenser plates due to the sound waves from the loudspeaker.

Great care (Continued on page 646)

SENSITIVITY CURVES

Figure 1, at left, gives over-all sensitivity, in microvolts, for the four band-frequencies. The picture, at right, shows the rear view of the fully shielded set.

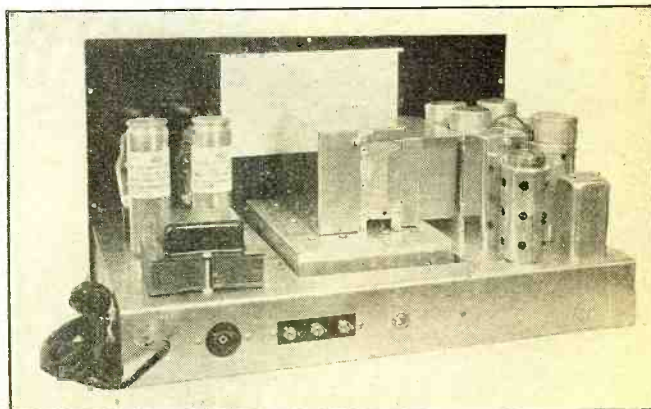
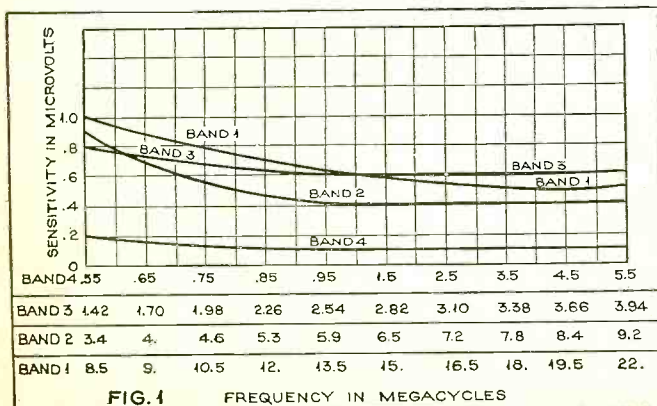



# How to Build a SINGLE-TUBE A.C.-D.C. RECEIVER

Richard Feeney

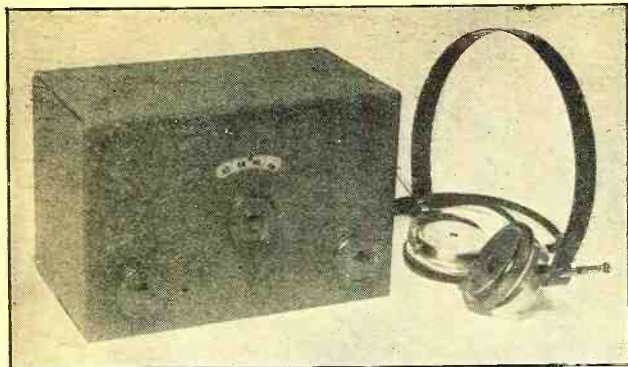

**T**HE tiny single-tube universal set described in this article is probably the simplest complete receiver that the beginner can build. It is made possible by the employment of the new type 12A7 tube, which is a combination pentode and rectifier. Not only will the beginner be attracted to the construction of this small set, but the veteran radio constructor, for it offers a wavelength coverage from 40 to 500 meters, compact design, simplicity of assembly, wiring and operation, and, last, but by no means least, its universal use on either 110 volts direct or alternating-current (50-60 cycles) or batteries.

The overall dimensions are only 6 inches long, by 4 inches high, by 3½ inches deep. A comparison of its size can be gotten from the headphones, which are shown alongside of the receiver in the illustration. Considering its compact size, it is truly a portable universal set, adapted to any type of operation and it makes an ideal traveling set for the hotel room, camp, and many other applications which will suggest themselves.

This little set fits in very nicely for headphone reception in the late hours of the night, when it is not desirable (or advisable??) to disturb the other members of the household who have retired. The circuit consists of a standard regenerative detector employing the pentode section of the 12A7 tube. A conventional grid-leak arrangement is used and it will be noticed that the an-

tenna is capacitively-coupled, through the condenser C1, to the detector circuit. The power-filter system employs a resistance of 25,000 ohms, R3, and two 8 mfd. electrolytic condensers, C5 and C6.

There are three plug-in coils covering a wavelength range from 40 to 500 meters, providing police, airplane and amateur signals and also short-wave programs on the popular 49-meter band, in addition to the regular broadcast programs. For those who desire to wind their own coils, the specifications for the three coils are given at the end of the article.

In assembling and mounting the parts, refer to the picture-wiring diagrams in Figures 2 and 3. The antenna condenser C1 is insulated from its mounting bracket by means of the two insulating washers (one plain and one with a shoulder), which are provided, for this purpose, with the kit of parts.

The following procedure can be employed to advantage in wiring the different parts. Connect one side of the condenser C3 and the resistor R1 to the prong G on the coil socket and the other side of these components is then soldered to the nearest lug on the bakelite mounting disc MD. Now solder to this same lug a flexible insulated wire, approximately 7 inches long. The next step is to bring this lead through the hole provided for it in the center of the chassis and then solder a grid-clip to its free end; this is the control grid connection to the tube. When this job is finished, connect the stator plate terminals of the aerial condenser, C1, and tuning condenser, C2, to the grid prong of the coil socket.

Next solder an insulated lead (about 12 inches long) to the rotor side of the

antenna condenser, C1; this is a flexible lead for connection to the aerial lead-in. Ground the minus F prong of the coil socket to the chassis and the positive F prong to one of the phone terminals. Connect the plate prong of the coil socket to the No. 2 terminal of the 12A7 socket. A word of caution is necessary in connecting the electrolytic filter condensers C5 and C6. At one end of these condensers there is a positive marking (+) and at the other end a minus designation (-); solder both minus connections of these condensers to the chassis and connect one positive side of one condenser to one end of the resistor, R3, and the positive side of the other condenser to the other end of this same resistor, as shown in the diagram.

The connections to the remaining parts are so simple and self-evident in the circuit and picture-wiring diagram that further detailed description is unnecessary.

For battery operation, simply replace the type 12A7 tube with a type 6F7 tube and connect a battery cable to the battery terminal strip as indicated in the schematic wiring diagram in Figure 1. The type 6F7 tube is a heater type which includes a triode and a remote cut-off pentode tube, in a common envelope. It requires 6.3 volts for the heater voltage instead of the 12 volts which was necessary for the 12A7 tube. For this purpose, four 1½-volt dry cells can be connected in series or a 6-volt storage (Continued on page 633)

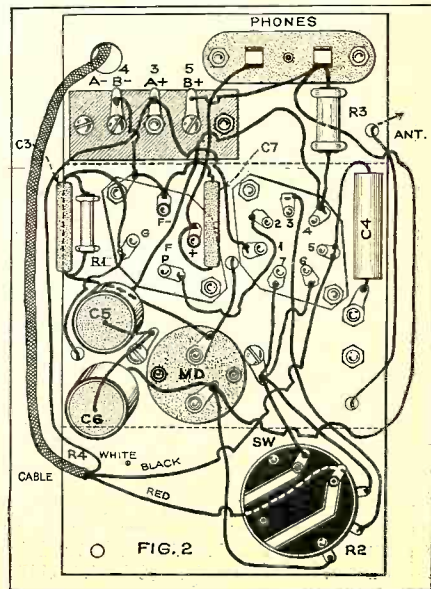
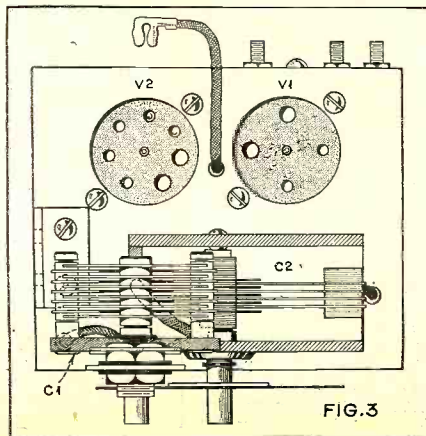
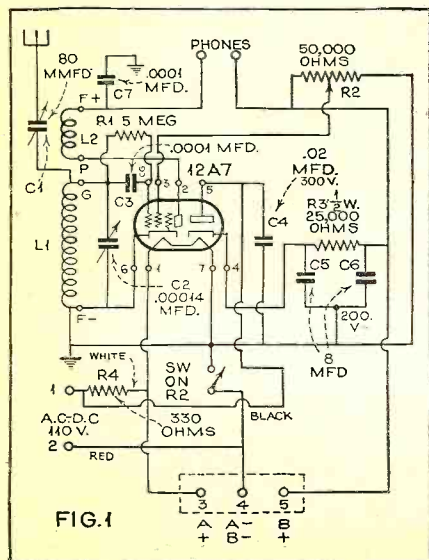



# S. W. STATION IDENTIFICATION CHART

| Call Letters                           | Address   | Name                    | Announcement   | Identifying Signals  |
|--|---|-------------------------|--|--|
| CJRO, CJRX                             | James Richardson & Sons., Ltd., 155 Royal Alexandra Hotel, Winnipeg, Manitoba                 |                         |  | Begins with "O Canada", Strikes 4 gongs  |
| CNR                                    | L'Inspecteur General, Directeur de L'Office des Postes, Rabat, Morocco                        | Radio-Maroc             | "Ici Radio-Rabat dans Maroc"   | Metronome between selections, finishes with "La Marseillaise"  |
| COC                                    | Short Wave Radio Station, COC, P.O. Box 98, Havana, Cuba                                      |                         | "Seh-O-Seh, Habana, Cooba." Sometimes in English   |  |
| COH                                    | Calle B, No. 2, Vedado, Havana, Cuba  |                         | "Estacion de onda Corta Seh-O-acha," Spanish and English   |  |
| CP5, CP6, CP7                          | Compania Radio Boliviana, Calle Socabaya 231, La Paz, Bolivia                                 | Radio Illimani          | "Radio Illimani"   |  |
| CQN                                    | Postmaster General, Macao, Asia   |                         |  |  |
| CR6AA                                  | Caixa Postal 118, Lobito, Angola, Port. W. Africa   |                         |  |  |
| CR7AA                                  | Gremio dos Radiofitos da Colonia de Mozambique, Portuguese, E. Africa                         |                         | "Radio Lorenzo Marques"  |  |
| CT1AA                                  | Av. Duque de Avila, 86 r/c, Lisbon, Portugal  | Radio Colonial          | "CT1AA, Radio Colonial"  | 3 cuckoo calls   |
| CT1CT                                  | Oscar G. Lomelino, Rua Gomes Freire 79, Lisbon, Portugal                                      |                         |  |  |
| CTIGO                                  | Portuguese Radio Club, Parede, Portugal   |                         |  |  |
| DFB                                    | Reichspostzentralamt, Berlin, Germany   |                         |  | Three tone whistle at beginning of transmission: D, C, G.  |
| DJA, DJB, DJC, DJD, DJN, DJQ           | Reichsrundfunkgesellschaft, Haus des Rundfunks, Berlin-Charlottenburg, 9, Germany             |                         | "Dear Friends and listeners in North America," etc., German, English and Spanish spoken  | Chimes—Eight notes of old German song, frequently repeated   |
| EAQ                                    | Station EAQ, Apartado Correos 951, Madrid, Spain  |                         | "Akee Ay-Ah-Coo Madrid, Espana," Big Ben Chimes Announces in Spanish and English   | Ends with "Rachmaninoff's Prelude"   |
| FIQA                                   | Dept. of Mail, Telegraph & Telephone, Tananarive, Madagascar                                  |                         | "Radio Tananarive."  | Opens with "Ramona," ends with "Marseillaise"  |
| FYA                                    | Station Radio-Coloniale, 98 Bis. Boulevard Haussmann, Paris, (8e), France                     | Radio-Coloniale         | "Ici Parea, Radio Coloniale," Does not use call letters  | Chimes of French clock, quarter hours. Ends with "Marseillaise" and "Bon soir Mesdames, Bon soir Mesdemoiselles. Bon soir Messieurs" |
| GSA, GSB, GSC, GSD, GSE, GSF, GSG, GSH | British Broadcasting Corp., Broadcasting House, London, W1, England                           |                         | "This is London calling you"   | Starts and Finishes with Big Ben's gong. Sometimes "God Save the King"   |
| G6RX                                   | Mr. G. A. Struthers Rugby Radio Station, Hillmorton, England                                  |                         |  |  |
| HAS, HAT                               | A. Magyar Kir Posta, Kiserleti Allomas, Gyali-ut 22, Budapest, IX, Hungary                    |                         |  |  |
| HBL-HBP                                | M. G. Gallarati, Information Section, League of Nations, Geneva, Switzerland                  | Radio Nations           | "Radio Nations," Does not use call letters; speaks English, Spanish and French   |  |
| HCJB                                   | Radio Station HCJB, Casilla 691, Quito, Ecuador   | La Voz de los Andes     | "La Voz de los Andes"  | Two tone chime, announces in Spanish and English   |
| HC2ET                                  | Radiodifusora HC2EP, Box 249, Guayaquil, Ecuador  | El Telegrafo            |  |  |
| HC2RL                                  | Dr. Roberto Levi, Box 759, Guayaquil, Ecuador   | Quinta Piedad           | "Hello, America." Announce in English and Spanish  | Ecuadorian Anthem  |
| HHH                                    | San Pedro de Macoris D.R. La Voz de Iguano  | La voz de Iguano        | Spanish and English every half hour: "HHH Santo Domingo, operating on a frequency of 6818 kc"  |  |
| HIZ                                    | Secretaria de Estado, De Trabajo y Comunicaciones, Santo Domingo, Dominican Republic          |                         |  |  |
| HHA                                    | Rafael Western, Box 423, Santiago de los Caballeros, Dominican Republic                       | La Voz del Yaque        | "La Vox del Yaque"   | Plays "Anchors Aweigh" at start and finish of program  |
| HI4D                                   | La Voz de Quisueya, Santo Domingo D.R.  |                         |  |  |
| HJ1ABB                                 | Elias J. Pellet, Box 715, Barranquilla, Colombia  | La Voz de Barranquilla  | "La Voz de Barranquilla, Acha-hota-uno-ah-beh-beh," announces in Spanish and English   | Chimes like NBC  |
| HJ2ABA                                 | Pomplio Sanchez C., Tunja Boyaca, Colombia  | La Voz del Pais         | "La Voz del Pais"  |  |
| HJ3ABD                                 | Colombia Broadcasting, Calle 16, No. 5-40, Bogota, Colombia                                   | Ecos de Calle           | "Acha-Kah-Efeh"  | Gong   |
| HJ4ABE                                 | Cia. Radiodifusora de Medellin, Medellin, Colombia  |                         |  |  |
| HJ4ABN                                 | Mauizales, Colombia   | Ecos del Occidente      | "Ecos del Occidente"   |  |
| HJ5ABC                                 | R. Angulo Radiodifusora HJ5ABC, Cali, Colombia  | La voz de Colombia      |  |  |
| HJ5ABD                                 | Cali, Colombia  |                         | "Achay-jay-sinko-ah-bay-day"   |  |
| HP5B                                   | Estacion Miramar, Box 910, Panama City, Panama  | The Voice of Panama     | "Estacion Miramar", the voice of Panama  |  |
| HVJ                                    | Station HVJ, Vatican City, Italy  | Laudetur Jesus Christus |  | Clock's ticks in studio. Announcer begins with "Pronto, pronto, Radio Vaticano," ends with "Laudetur Jesus Christus"                 |
| I2RO (2RO)                             | Ente Italiano Audizioni Radiofoniche, Via Montello No. 5, Rome, Italy                         | Prato Smeraldo          | "Radio Roma Napoli." Lady announcer, sometimes a whole string of Italian cities; does not use complete call letters. During American hour from Rome a man announcer says "2 R O, Rome" |  |
| JES                                    |   |                         | "Osaki". Announcer speaks English and Japanese, announcer seems to be American   |  |
| JVR                                    | Kemikawa Sending Station, Kemikawa-Cho, Chiba-Ken, Japan                                      |                         |  | 3 gongs—2 gongs, 1 pause, 1 gong, 1 pause then 1 chime   |
| LKJ1                                   | Ministere du Commerce du Royaume de Norvege, Oslo, Norway                                     |                         | "Broadcasting Oslo"  |  |
| LSY                                    | Transradio Internacional, San Martin 329, Buenos Aires, Argentina                             |                         |  | Begins with zylophone notes E, E, G sharp, A   |
| OAX4B                                  | Messrs Grellaut & Co., Apartado 1242, Lima, Peru  |                         |  |  |
| OAX4D                                  | D. U. S. A., All-American Cables, Inc., 835, Lima, Peru                                       | La Voz de Peru          | "Radio D. U. S. A., La Voz de Peru". In Spanish and English  |  |
| OER2                                   | Oesterr. Radioverkehrs, A.G., Johannesgasse 4b, Vienna, Austria                               |                         | "Hallo, Hier Radio Wien"   | Metronome can be heard   |
| ORP, ORK, ORG                          | Regie des Telegraphes et des Telephones. Direction des Radiocommunications, Brussels, Belgium | Belradio                | "Ici Bruxelles I. N. R. emission speciales pour" la Congo par la station de Ruys-selede  | Finishes with "La Brabanconne"   |

To be continued Next Month



## S.W. PIONEERS Official RADIO NEWS Listen- ing Post Observers

LISTED below by States are the Official Radio News Short-Wave Listening Post Observers who are serving conscientiously in logging stations for the DX Corner.

### United States of America

Alabama, J. E. Brooks; Arkansas, Don Pryor, James G. Moore; Arizona, Geo. Pasquale; California, E. G. DeHaven, C. H. Canning, O. I. Noda, E. S. Allen, A. E. Berger, Geo. C. Sholin, Wesley W. Loudon; Colorado, Wm. J. Vette; Connecticut, Phillip Swanson, Geo. A. Smith, H. Kemp; District of Columbia, Douglas S. Catchum; Florida, Geo. H. Fletcher, E. M. Law, James F. Dechert; Georgia, James L. Davis, C. H. Armstrong, Guy R. Bigbee, John McCarley, R. W. Winfree; Idaho, Bernard D. Starr, Lawrence Swenson; Illinois, Phillip Simmons, E. Bergeman, Robert L. Weber, Floyd Waters, Chas. A. Morrison, Larry Eisler; Indiana, Freeman C. Balph, J. R. Flannigan, Henry Spearling; Iowa, J. Harold Lindblom; Kansas, C. W. Bourne, Wm. Schumacher; Kentucky, James T. Spalding, Charles Miller, Wm. A. McAlister, Geo. Krebs; Louisiana, Roy W. Peyton; Maryland, Howard Adams, Jr., James W. Smith, J. F. Fritsch; Massachusetts, Armand A. Boussey, J. Walter Bunnell, Harold K. Miller, Donald Smith, Elmer F. Orne, Arthur Hamilton, Roy Sanders; Michigan, Stewart R. Ruple; Minnesota, E. M. Norris, Dr. G. W. Twomey, M. Mickelson; Mississippi, Dr. J. P. Watson, Mrs. L. R. Ledbetter; Missouri, C. H. Long; Montana, Henry Dobrovainy; Nebraska, P. H. Clute, G. W. Renish, Jr., Harold Hansen; New Hampshire, P. C. Atwood, A. J. Manix; New Jersey, William Dixon, R. H. Schiller, Wm. F. Buhl; New Mexico, G. K. Harrison; New York, Robert F. Kaiser, Wm. Koehnlein, T. J. Knapp, Joseph M. Malast, Capt. Horace L. Hall, S. G. Taylor, John M. Borst, Wm. C. Dorf, R. Wright, I. H. Kattell, H. S. Bradley, Donald E. Bame, Albert J. Leonhardt, Edmore Melanson; Nevada, Don H. Townsend, Jr.; North Carolina, H. O. Murdoch, Jr., W. C. Couch, E. Payson Mallard; Ohio, Oker Radio & Electric Shop, R. W. Evans, C. H. Skatzes, Donald W. Shields, Albert E. Emerson, Samuel J. Emerson, Clarence D. Hall; Oklahoma, H. L. Pribble, Robert Woods; Oregon, Glenn E. Dubbe, Virgil C. Tramp, James Haley, Geo. R. Johnson, Ned Smith; Pennsylvania, Edward C. Lips, K. A. Staars, C. T. Sheaks, George Lilley, John A. Leininger, F. L. Stitzinger, Hen. F. Poln, Chas. Nick, Oliver Amie; Rhode Island, Joseph V. Trzuskowski; South Carolina, Ben F. Goodlett, Edward F. Bahan; South Dakota, Paul J. Mraz; Tennessee, Charles D. Moss, Adrian Smith; Texas, Heinie Johnson, Bryan Scott, John Stewart; Utah, Harold D. Nordeen; Vermont, Joseph M. Kelley, Eddie H. Davenport; Virginia, Gordon L. Rich, G. Hampton Allison, D. W. Parsons; Washington, A. D. Golden, Chas. G. Payne; West Virginia, Kenneth Boord, R. E. Sumner; Wisconsin, Willard M. Hardell, Walter A. Jasiorowski; Wyoming, Dr. F. C. Naegeli.

Applications for Official Observers in the remaining States should be sent in immediately to the DX Corner.

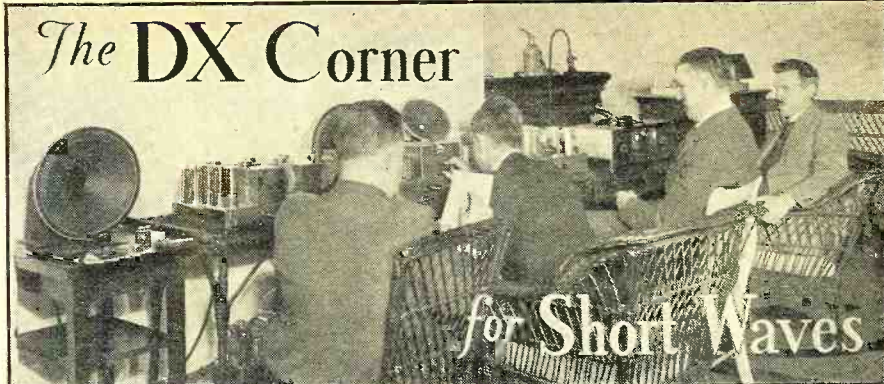

## S. W. TIME SCHEDULE

LAURENCE M. COCKADAY

THE twenty-fifth installment of the DX Corner for Short Waves contains the World Short-Wave Time-Table for 24-hour use all over the world. The list starts at 01 G.M.T. and runs 24 hours through 00 G.M.T., right around the clock! This new Time-Table contains a List of Short-Wave Stations, logged during the last month in the RADIO NEWS Westchester Listening Post (in our Editor's home), as well as at our official RADIO NEWS Short-Wave Listening Posts throughout the world. It provides an hour-to-hour guide to short-wave fans, whether experienced or inexperienced. The new type of Time-Table shows the Call Letters, Station Locations, Wavelength and Frequency in the middle column. The column at the left gives the times of Transmission, in G.M.T. a.m., and the column at the right gives the Times of Transmission, in G.M.T. p.m. The corresponding time in E.S.T. is also given and space has been left for filing in your own Local Time. The time, E.S.T., in the U. S. would be 8 p.m., E.S.T., for 01 G.M.T., as there is a five-hour difference. The time E.S.T. for 13 G.M.T. would, therefore, be 8 a.m., E.S.T. These two features can be seen at the beginning of each outside column in the new Time-Table. The times, C.S.T., for these two corresponding hours would be 7 p.m., C.S.T. and 7 a.m., C.S.T. The times, M.S.T., for the corresponding hours would be 6 p.m., M.S.T., and 6 a.m., M.S.T. The times, P.S.T., for corresponding hours would be 5 p.m. and 5 a.m., P.S.T. In this way American listeners can easily fill in their own Local Times at the top of the columns. Foreign listeners would probably prefer to use G.M.T., anyway, or, if not, can compute the time difference from G.M.T. and fill in their Local Time in each column head. We earnestly request our readers to give us their opinions of the new Time-Table, as we think it is simpler and saves turning over four pages to find out the schedule of a particular station at a particular time of day. At the end of the Time-Table is a List of Symbols, covering the various irregularities of transmission, schedules, etc. Do you want the Time-Table running vertically on the page or horizontally across the page as formerly? We believe our readers will find this new system a superior one when they have become familiar with it.

### OUR GENIAL L. P. O.

This is the smiling countenance of Dr. Max Hausdorff, who maintains an exceptionally fine Listening Post for Short Waves at his home in Switzerland.

### Affiliated DX Clubs

We are hereby placing a standing invitation to reliable DX Clubs to become affiliated with the DX Corner as Associate Members, acting as advisers on short-wave activities, in promoting short-wave popularity and reception efficiency. A list of associate organizations follows: International DX'ers Alliance, President, Charles A. Morrison; Newark News Radio Club, Irving R. Potts, President, A. W. Oppel, Executive Secretary; Society of Wireless Pioneers, M. Mickelson, Vice-President; U. S. Radio DX Club, Geo. E. Deering, Jr., President; the Radio Club Venezolano of Caracas, Venezuela, President, Alberto Lopez; The World-wide Dial Club of Chicago, Illinois, President, Howard A. Olson.

Any DX fan wishing to join any one of these Clubs or Associations may write for information to the Short-Wave DX Editor, and his letter will be sent to the organization in question. Other Clubs who wish to become affiliated should make their application to the Short-Wave DX Editor. Clubs associated with the DX Corner have the privilege of sending in Club Notes for publication in RADIO NEWS.

### Your DX Logs Welcome

Please keep on sending in information on any stations and Best Bets that you hear during the coming month, getting them in to the short-wave DX Editor by the 20th of the month. In this way you share your "Best Catches" with other readers and they, in turn, share with you making for improved general knowledge on short-wave reception. Our Editors are doing the same thing, working with you day and night, to bring you the best and most reliable short-wave information. Your logs are welcome and are sincerely invited.

Also send in photographs or snapshots of yourself in your S.W. Listening Post for publication in a future DX Corner. Let our readers see what you look like! RADIO NEWS will pay you \$1.00 for each accepted photo, to help defray expenses. Have a copy of R. N. show visibly in the picture.

### Listening Post Observers and Other Fans Please Notice

Listed on next page is this month's partial information regarding short-wave stations, heard and reported by our World-Wide Listening Posts. Each item in the listing is credited with the Observer's surname. This will allow our readers to note who obtained the information given. If any of our readers can supply actual Time Schedules, actual Wavelengths, correct Frequencies, or any other Important Information regarding these





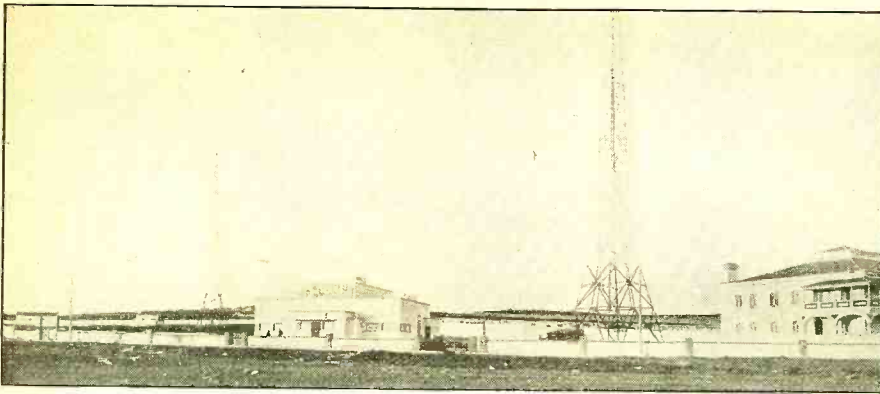

THE NEW PORTUGUESE STATIONS CT1GL AND CT1GO

Here is the home of the new short-wave station, heard on 24 meters and 48 meters, CT1GO, showing the towers of the long-wave station, 291 meters, CT1GL, of the Portuguese Radio Club.

items, the DX Corner Editor and its readers will be glad to get the information. There are some hard stations to pull in in these listings, but we urge our Listening Posts and other readers to try their skill in logging the stations and getting correct information about them. When you are satisfied that you have this information correct, send it in to the editor; or if you have received a "veri" from any of the hard-to-get stations, send in a copy of the "veri" so that the whole short-wave fraternity may benefit. The list follows:

**HP5B**, Panama City, Panama, 49.73 meters, 6030 kc., 8-10:30 p.m., E.S.T., daily, and also 12-1 p.m., E.S.T., daily. (Catchim, Lumsden, Baier, Moore, Anderson, Shumacher, Harris, Adams, S Emerson, L. Miller, C. Miller, Rambo, Porter, Wright, Dickson, Hamilton, Potts, Jasiorowski, Eisler, Meher, Malast, Chambers and J. Clark.)

**CT1AA**, 31.25 meters, now has a program Tuesdays, Thursdays and Saturdays, 5-7 p.m., E.S.T. (Swanson, Skatzes, Catchim, Baadsgaard, Seaman, Adams, Miller, Wright and Winand.)

**ORK**, 29.04 meters, 10330 kc., program is now from 2:45-4:15 p.m., E.S.T. (Winand.)

**I2RO** programs are now as follows: on 30.6 meters, 9780 kc., 2:30-5 p.m., E.S.T. daily; on 49.3 meters, 6085 kc., 6-7:30 p.m., E.S.T., Mondays, Wednesdays and Fridays; there is also now an extra 30.6-meter program on Mondays, Wednesdays and Fridays, from 7:45-9:15 p.m., E.S.T. The address of the station is Ente Italic no Avdizioni Radiofoniche, Rome via Montella 5. (Kaiser, Armstrong, Heilwic, Jasiorowski, Fitzpatrick, Fletcher, Shumacher, Anderson, Melanson, A. Emerson, Coover, Potts, C. Miller, Chambers, Sholin, Malast, Thwaites.)

One listener reports **I2RO** testing on 25.4 meters.

**HJ4ABN**, also reported **HJ4ABB**, **HJ4ABA**, **HJ4ABL**, Manizales, Colombia, 49.15 meters, 6100 kc., reported heard 7:15-8 p.m., E.S.T. (Wright, Swanson, S. Emerson, Rehak, A. Emerson, Hamilton, Skatzes.) (At the Westchester Listening Post we have heard this call as **HJ4ABN** and have heard the station on the air also from 10 p.m. to midnight, E.S.T.)

**YV6RV**, Valencia, Venezuela, 49.75 meters, 6030 kc., 5-7 p.m., E.S.T. (Wright, Malast, Skatzes, A. Emerson.) (At the Westchester Listening Post this station was heard to announce as *La Voz de Carabobo* and heard testing as late as 10 p.m., E.S.T.)

Who has heard **YV5RMO**, 25.6 meters, from 5-8 p.m., E.S.T., and from 2-6 p.m., E.S.T., on Sundays?

**OXL** has been reported on 52 meters on

c.w and also testing on telephone. (Swanson, Melanson.)

**DJE** reported on 16 meters irregularly mornings.

**HAS3** reported now on 19.518 meters Sundays, 13-14. G.M.T. (Armstrong, Baadsgaard, Miller.)

**HAT** reported now on 55.56 meters, Mondays, 01-02, G.M.T. (Donaldson, Miller, Styles, Armstrong, Baadsgaard.)

**VK3ZX**, Caulfield, Victoria, reported Sundays, 4:30-6:30, Eastern Australian Standard Time, on 7000 kc.

**KNRA**, Seth Parker's yacht, reported heard from the Southern Pacific on the 40-meter band. (Catchim.)

**CT1GO** reported on 48 meters on Sundays from 8-11 p.m., E.S.T., and on Wednesdays and Fridays, 7:20-8:15 p.m. Also heard on 24.2 meters.

**TIXGP3**, San Jose de Costa Rica, 51.5 meters, reported on the air 8-11 p.m., E.S.T., irregularly. (Catchim.)

**HJ3ABH**, Bogota, Colombia, 49.92 meters, reported heard daily noon to 1 p.m., and 7:30 to 9:45 p.m., E.S.T. (Catchim.)

**HC2ET**, Guayaquil, Ecuador, reported heard on 65.2 meters, 4600 kc., 9-11 p.m., E.S.T., on Wednesdays and Saturdays. They cannot be mistaken on account of their 10-20 tone chimes. (S. Emerson, L. Miller, C. Miller, Catchim and Schumacher.)

Station "Tripoli," North Africa, reported heard on 31.7 meters. (Catchim.)

**XGBD**, Shanghai, China, reported heard in early morning hours on 31.32 meters. (Schumacher.)

**W8XAL**, Cincinnati, Ohio, gives interesting programs for learning calls of foreign short-wave stations at 11:30 p.m., E.S.T., twice weekly. (Schumacher.)

**CO9CC**, Santiago de Cuba, reported heard on 48.75 meters, 6160 kc., broadcasting after 10 p.m., E.S.T. (Fletcher.)

**PKYDA** are the proper call letters for the popular Java station on 6120 kc., they are reported heard 5-10 a.m., E.S.T., daily. (Rambo and Loudon.)

**JVQ** reported heard on 7450 kc., 5-7 a.m., E.S.T., (Rambo.)

**Moscow**, now on 50 meters and 17.24 meters on Sundays, Mondays, Wednesdays, at 9 p.m., G.M.T. (On Sundays, 3 a.m. to 3 p.m., G.M.T., 25 meters, and at 11 a.m., G.M.T., both 17.24 and 25 meters.)

**H1IA** is now using 50 watts on 6188 kc., being on the air 12-2 p.m., 8-10 p.m., on their local time, which is 20 minutes ahead of E.S.T. (Morse.)

**WSM** is reported soon to be on the air with a short-wave transmitter on 6060 kc. (Skatzes.)

**SUV**, Cairo, has been heard testing with  
(Continued on page 612)

**S.W. PIONEERS**  
Official RADIO NEWS Listening Post Observers

LISTED below by countries are the Official RADIO NEWS Short-Wave Listening Post Observers who are serving conscientiously in logging stations for the DX Corner.

- Alaska, Thomas A. Pugh.
  - Argentina, J. F. Edbrooke.
  - Australia, C. N. H. Richardson, H. Arthur Matthews, A. H. Garth, A. E. Faull.
  - Bermuda, Thursten Clarke.
  - Brazil, W. W. Enete, Louis Rogers Gray.
  - British Guiana, E. S. Christiani, Jr.
  - British West Indies, E. G. Derrick, N. Hood-Daniel, Edela Rosa.
  - Canada, J. T. Atkinson, C. Holmes, Jack Bews, Robert Edkins, W. H. Fraser, Charles E. Roy, Douglas Wood, A. B. Baadsgaard.
  - Canal Zone, Bertram Baker.
  - Canary Islands, Manuel Davin.
  - Central America, R. Wilder Tatum.
  - Chile, Jorge Izquierdo.
  - China, Baron Von Huene.
  - Columbia, J. D. Lowe, Italo Amore.
  - Cuba, Frank H. Kydd, Dr. Evelio Villar.
  - Denmark, Hans W. Priwin.
  - Dutch East Indies, E. M. O. Godee, A. den Breems.
  - Dutch West Indies, R. J. van Ommen.
  - England, N. C. Smith, H. O. Graham, Alan Barber, Donald Burns, Leslie H. Colburn, C. L. Davies, Frederick W. Gunn, R. S. Houghton, W. P. Kempster, R. Lawton, John J. Maling, Norman Nattall, L. H. Plunkett-Cheekman, Harold J. Self, R. Stevens, L. C. Styles, C. L. Wright, John Gordon Hampshire.
  - France, J. C. Meillon, Jr.
  - Germany, Herbert Lennartz.
  - Hawaii, O. F. Sternemann.
  - India, D. R. D. Wadia.
  - Italy, A. Passini, Dr. Guglielmo Tixy.
  - Japan, Masall Satow.
  - Malta, Edgar J. Vassallo.
  - Mexico, Felipe L. Saldana.
  - New Zealand, Dr. G. Campbell Macdiarmid, Kenneth H. Moffatt.
  - Norway, Per Torp.
  - Philippine Islands, Victorino Leonen.
  - Portugal, Jose Fernandes Patrae, Jr.
  - Scotland, Duncan T. Donaldson.
  - South Africa, Mike Kruger, C. McCormick, A. C. Lyell, H. Mallet-Veale.
  - Spain, Jose Ma. Maranges.
  - Switzerland, Dr. Max Hausdorff, Ed. J. deLopez.
  - Turkey, Hermann Freiss.
  - Venezuela, Francisco Fossa Anderson.
- Applications for Official Observers in the remaining countries should be sent in immediately to the DX Corner.

OFFICIAL OBSERVER FOR ITALY  
Meet Mr. A. Passini, Official Radio News Short-Wave Listening Post Observer for the Italian provinces.

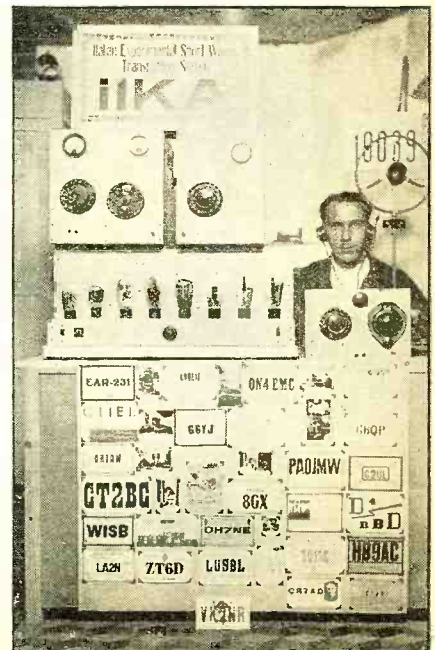







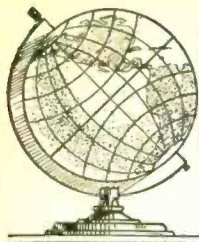

# WORLD SHORT WAVE TIME-TABLE



(Continued from the Previous Page)

Hours of transmission for the World's Short Wave Broadcast Stations

| HOURS OF TRANSMISSION |    |    |    |    |    |    |    |    |    |    |    | FILL IN LOCAL TIME    |          |      |                                   |  |  |  |  |  |  |  |  | HOURS OF TRANSMISSION |    |    |    |    |    |    |    |    |    |    |    |              |  |  |  |  |  |  |  |  |  |  |  |
|-----------------------|----|----|----|----|----|----|----|----|----|----|----|-----------------------|----------|------|-----------------------------------|--|--|--|--|--|--|--|--|-----------------------|----|----|----|----|----|----|----|----|----|----|----|--------------|--|--|--|--|--|--|--|--|--|--|--|
| 8                     | 9  | 10 | 11 | M  | 1  | 2  | 3  | 4  | 5  | 6  | 7  | EASTERN STANDARD TIME |          |      |                                   |  |  |  |  |  |  |  |  | 8                     | 9  | 10 | 11 | N  | 1  | 2  | 3  | 4  | 5  | 6  | 7  |              |  |  |  |  |  |  |  |  |  |  |  |
| 01                    | 02 | 03 | 04 | 05 | 06 | 07 | 08 | 09 | 10 | 11 | 12 | GREENWICH MEAN TIME   |          |      |                                   |  |  |  |  |  |  |  |  | 13                    | 14 | 15 | 16 | 17 | 18 | 19 | 20 | 21 | 22 | 23 | 00 |              |  |  |  |  |  |  |  |  |  |  |  |
| Wave-length Meters    |    |    |    |    |    |    |    |    |    |    |    | Call Letters          |          |      |                                   |  |  |  |  |  |  |  |  | Frequency Kc          |    |    |    |    |    |    |    |    |    |    |    | City Country |  |  |  |  |  |  |  |  |  |  |  |
|                       |    |    |    |    |    |    |    |    |    |    |    | 44.6+                 | TIEP     | 6710 | San Jose, Costa Rica              |  |  |  |  |  |  |  |  |                       |    |    |    |    |    |    |    |    |    |    |    |              |  |  |  |  |  |  |  |  |  |  |  |
|                       |    |    |    |    |    |    |    |    |    |    |    | 45.0+                 | HC2RL    | 6668 | Guayaquil, Ecuador                |  |  |  |  |  |  |  |  |                       |    |    |    |    |    |    |    |    |    |    |    |              |  |  |  |  |  |  |  |  |  |  |  |
|                       |    |    |    |    |    |    |    |    |    |    |    | 45.3                  | PRADO    | 6616 | Riobamba, Ecuador                 |  |  |  |  |  |  |  |  |                       |    |    |    |    |    |    |    |    |    |    |    |              |  |  |  |  |  |  |  |  |  |  |  |
|                       |    |    |    |    |    |    |    |    |    |    |    | 45.3+                 | RW72     | 6611 | Moscow, U. S. S. R.               |  |  |  |  |  |  |  |  |                       |    |    |    |    |    |    |    |    |    |    |    |              |  |  |  |  |  |  |  |  |  |  |  |
|                       |    |    |    |    |    |    |    |    |    |    |    | 46.2                  | HJ5ABD   | 6490 | Cali, Colombia                    |  |  |  |  |  |  |  |  |                       |    |    |    |    |    |    |    |    |    |    |    |              |  |  |  |  |  |  |  |  |  |  |  |
|                       |    |    |    |    |    |    |    |    |    |    |    | 46.2+                 | H14D     | 6482 | San Domingo, D. R.                |  |  |  |  |  |  |  |  |                       |    |    |    |    |    |    |    |    |    |    |    |              |  |  |  |  |  |  |  |  |  |  |  |
|                       |    |    |    |    |    |    |    |    |    |    |    | 46.5+                 | HJ1ABB   | 6447 | Barranquilla, Col.                |  |  |  |  |  |  |  |  |                       |    |    |    |    |    |    |    |    |    |    |    |              |  |  |  |  |  |  |  |  |  |  |  |
|                       |    |    |    |    |    |    |    |    |    |    |    | 46.6                  | W3XL     | 6425 | Bound Brook, N. J.                |  |  |  |  |  |  |  |  |                       |    |    |    |    |    |    |    |    |    |    |    |              |  |  |  |  |  |  |  |  |  |  |  |
|                       |    |    |    |    |    |    |    |    |    |    |    | 47.0                  | YV4RC    | 6375 | Caracas, Venez.                   |  |  |  |  |  |  |  |  |                       |    |    |    |    |    |    |    |    |    |    |    |              |  |  |  |  |  |  |  |  |  |  |  |
|                       |    |    |    |    |    |    |    |    |    |    |    | 47.5                  | H1Z      | 6315 | San Domingo, D. R.                |  |  |  |  |  |  |  |  |                       |    |    |    |    |    |    |    |    |    |    |    |              |  |  |  |  |  |  |  |  |  |  |  |
|                       |    |    |    |    |    |    |    |    |    |    |    | 47.8                  | HJ3ABF   | 6275 | Bogota, Colombia                  |  |  |  |  |  |  |  |  |                       |    |    |    |    |    |    |    |    |    |    |    |              |  |  |  |  |  |  |  |  |  |  |  |
|                       |    |    |    |    |    |    |    |    |    |    |    | 48.1                  | OAX4B    | 6230 | Lima, Peru                        |  |  |  |  |  |  |  |  |                       |    |    |    |    |    |    |    |    |    |    |    |              |  |  |  |  |  |  |  |  |  |  |  |
|                       |    |    |    |    |    |    |    |    |    |    |    | 48.1                  | HJ4ABC   | 6230 | Pereira, Col.                     |  |  |  |  |  |  |  |  |                       |    |    |    |    |    |    |    |    |    |    |    |              |  |  |  |  |  |  |  |  |  |  |  |
|                       |    |    |    |    |    |    |    |    |    |    |    | 48.4                  | CT1GO    | 6198 | Paredo, Portugal                  |  |  |  |  |  |  |  |  |                       |    |    |    |    |    |    |    |    |    |    |    |              |  |  |  |  |  |  |  |  |  |  |  |
|                       |    |    |    |    |    |    |    |    |    |    |    | 48.4                  | H11A     | 6188 | Santiago de Los Caballeros, D. R. |  |  |  |  |  |  |  |  |                       |    |    |    |    |    |    |    |    |    |    |    |              |  |  |  |  |  |  |  |  |  |  |  |
|                       |    |    |    |    |    |    |    |    |    |    |    | 48.7+                 | HJ2ABA   | 6150 | Tunja, Colombia                   |  |  |  |  |  |  |  |  |                       |    |    |    |    |    |    |    |    |    |    |    |              |  |  |  |  |  |  |  |  |  |  |  |
|                       |    |    |    |    |    |    |    |    |    |    |    | 48.7+                 | CJRO     | 6150 | Winnipeg, Manitoba                |  |  |  |  |  |  |  |  |                       |    |    |    |    |    |    |    |    |    |    |    |              |  |  |  |  |  |  |  |  |  |  |  |
|                       |    |    |    |    |    |    |    |    |    |    |    | 48.7                  | YV3RC    | 6150 | Caracas, Venezuela                |  |  |  |  |  |  |  |  |                       |    |    |    |    |    |    |    |    |    |    |    |              |  |  |  |  |  |  |  |  |  |  |  |
|                       |    |    |    |    |    |    |    |    |    |    |    | 48.7                  | VE9CL    | 6150 | Winnipeg, Man.                    |  |  |  |  |  |  |  |  |                       |    |    |    |    |    |    |    |    |    |    |    |              |  |  |  |  |  |  |  |  |  |  |  |
|                       |    |    |    |    |    |    |    |    |    |    |    | 48.7                  | CSL      | 6150 | Lisbon, Portugal                  |  |  |  |  |  |  |  |  |                       |    |    |    |    |    |    |    |    |    |    |    |              |  |  |  |  |  |  |  |  |  |  |  |
|                       |    |    |    |    |    |    |    |    |    |    |    | 48.8+                 | W8XK     | 6140 | Pittsburgh, Pa.                   |  |  |  |  |  |  |  |  |                       |    |    |    |    |    |    |    |    |    |    |    |              |  |  |  |  |  |  |  |  |  |  |  |
|                       |    |    |    |    |    |    |    |    |    |    |    | 48.9+                 | ZGE      | 6130 | Kuala Lumpur, F. M. S.            |  |  |  |  |  |  |  |  |                       |    |    |    |    |    |    |    |    |    |    |    |              |  |  |  |  |  |  |  |  |  |  |  |
|                       |    |    |    |    |    |    |    |    |    |    |    | 48.9+                 | LKJ1     | 6128 | Jeloy, Norway                     |  |  |  |  |  |  |  |  |                       |    |    |    |    |    |    |    |    |    |    |    |              |  |  |  |  |  |  |  |  |  |  |  |
|                       |    |    |    |    |    |    |    |    |    |    |    | 48.9+                 | ZTJ      | 6122 | Johannesburg, Africa              |  |  |  |  |  |  |  |  |                       |    |    |    |    |    |    |    |    |    |    |    |              |  |  |  |  |  |  |  |  |  |  |  |
|                       |    |    |    |    |    |    |    |    |    |    |    | 49.0+                 | W2XE     | 6120 | New York, N. Y.                   |  |  |  |  |  |  |  |  |                       |    |    |    |    |    |    |    |    |    |    |    |              |  |  |  |  |  |  |  |  |  |  |  |
|                       |    |    |    |    |    |    |    |    |    |    |    | 49.0+                 | PKYDA    | 6120 | Bandoeng, Java                    |  |  |  |  |  |  |  |  |                       |    |    |    |    |    |    |    |    |    |    |    |              |  |  |  |  |  |  |  |  |  |  |  |
|                       |    |    |    |    |    |    |    |    |    |    |    | 49.0+                 | PK1WK    | 6116 | Java                              |  |  |  |  |  |  |  |  |                       |    |    |    |    |    |    |    |    |    |    |    |              |  |  |  |  |  |  |  |  |  |  |  |
|                       |    |    |    |    |    |    |    |    |    |    |    | 49.0+                 | YV2RC    | 6112 | Caracas, Ven.                     |  |  |  |  |  |  |  |  |                       |    |    |    |    |    |    |    |    |    |    |    |              |  |  |  |  |  |  |  |  |  |  |  |
|                       |    |    |    |    |    |    |    |    |    |    |    | 49.0+                 | VE9HX    | 6110 | Halifax, N. S.                    |  |  |  |  |  |  |  |  |                       |    |    |    |    |    |    |    |    |    |    |    |              |  |  |  |  |  |  |  |  |  |  |  |
|                       |    |    |    |    |    |    |    |    |    |    |    | 49.0+                 | VUC      | 6109 | Calcutta, India                   |  |  |  |  |  |  |  |  |                       |    |    |    |    |    |    |    |    |    |    |    |              |  |  |  |  |  |  |  |  |  |  |  |
|                       |    |    |    |    |    |    |    |    |    |    |    | 49.1+                 | W3XAL    | 6100 | Bound Brook, N. J.                |  |  |  |  |  |  |  |  |                       |    |    |    |    |    |    |    |    |    |    |    |              |  |  |  |  |  |  |  |  |  |  |  |
|                       |    |    |    |    |    |    |    |    |    |    |    | 49.1+                 | W9XF     | 6100 | Chicago, Ill.                     |  |  |  |  |  |  |  |  |                       |    |    |    |    |    |    |    |    |    |    |    |              |  |  |  |  |  |  |  |  |  |  |  |
|                       |    |    |    |    |    |    |    |    |    |    |    | 49.1+                 | HJ4ABN   | 6100 | Manizales, Col.                   |  |  |  |  |  |  |  |  |                       |    |    |    |    |    |    |    |    |    |    |    |              |  |  |  |  |  |  |  |  |  |  |  |
|                       |    |    |    |    |    |    |    |    |    |    |    | 49.1+                 | VE9GW    | 6090 | Bowmanville, Can.                 |  |  |  |  |  |  |  |  |                       |    |    |    |    |    |    |    |    |    |    |    |              |  |  |  |  |  |  |  |  |  |  |  |
|                       |    |    |    |    |    |    |    |    |    |    |    | 49.2+                 | I2RO     | 6085 | Rome, Italy                       |  |  |  |  |  |  |  |  |                       |    |    |    |    |    |    |    |    |    |    |    |              |  |  |  |  |  |  |  |  |  |  |  |
|                       |    |    |    |    |    |    |    |    |    |    |    | 49.3+                 | CP5      | 6080 | La Paz, Bolivia                   |  |  |  |  |  |  |  |  |                       |    |    |    |    |    |    |    |    |    |    |    |              |  |  |  |  |  |  |  |  |  |  |  |
|                       |    |    |    |    |    |    |    |    |    |    |    | 49.3+                 | W9XAA    | 6080 | Chicago, Ill.                     |  |  |  |  |  |  |  |  |                       |    |    |    |    |    |    |    |    |    |    |    |              |  |  |  |  |  |  |  |  |  |  |  |
|                       |    |    |    |    |    |    |    |    |    |    |    | 49.3+                 | DJM      | 6073 | Zeesen, Germany                   |  |  |  |  |  |  |  |  |                       |    |    |    |    |    |    |    |    |    |    |    |              |  |  |  |  |  |  |  |  |  |  |  |
|                       |    |    |    |    |    |    |    |    |    |    |    | 49.3+                 | CQN      | 6073 | Macao, Asia                       |  |  |  |  |  |  |  |  |                       |    |    |    |    |    |    |    |    |    |    |    |              |  |  |  |  |  |  |  |  |  |  |  |
|                       |    |    |    |    |    |    |    |    |    |    |    | 49.3+                 | OER2     | 6072 | Vienna, Austria                   |  |  |  |  |  |  |  |  |                       |    |    |    |    |    |    |    |    |    |    |    |              |  |  |  |  |  |  |  |  |  |  |  |
|                       |    |    |    |    |    |    |    |    |    |    |    | 49.3+                 | VE9CS    | 6070 | Vancouver, B. C.                  |  |  |  |  |  |  |  |  |                       |    |    |    |    |    |    |    |    |    |    |    |              |  |  |  |  |  |  |  |  |  |  |  |
|                       |    |    |    |    |    |    |    |    |    |    |    | 49.4+                 | VQ7LO    | 6060 | Nairobi, Kenya, Afr.              |  |  |  |  |  |  |  |  |                       |    |    |    |    |    |    |    |    |    |    |    |              |  |  |  |  |  |  |  |  |  |  |  |
|                       |    |    |    |    |    |    |    |    |    |    |    | 49.4+                 | W8XAL    | 6060 | Cincinnati, Ohio                  |  |  |  |  |  |  |  |  |                       |    |    |    |    |    |    |    |    |    |    |    |              |  |  |  |  |  |  |  |  |  |  |  |
|                       |    |    |    |    |    |    |    |    |    |    |    | 49.4+                 | W3XAU    | 6060 | Philadelphia, Pa.                 |  |  |  |  |  |  |  |  |                       |    |    |    |    |    |    |    |    |    |    |    |              |  |  |  |  |  |  |  |  |  |  |  |
|                       |    |    |    |    |    |    |    |    |    |    |    | 49.4+                 | OXY      | 6060 | Skamlebaek, Den.                  |  |  |  |  |  |  |  |  |                       |    |    |    |    |    |    |    |    |    |    |    |              |  |  |  |  |  |  |  |  |  |  |  |
|                       |    |    |    |    |    |    |    |    |    |    |    | 49.5+                 | GSA      | 6050 | Daventry, England                 |  |  |  |  |  |  |  |  |                       |    |    |    |    |    |    |    |    |    |    |    |              |  |  |  |  |  |  |  |  |  |  |  |
|                       |    |    |    |    |    |    |    |    |    |    |    | 49.6+                 | HJ1ABG   | 6042 | Barranquilla, Col.                |  |  |  |  |  |  |  |  |                       |    |    |    |    |    |    |    |    |    |    |    |              |  |  |  |  |  |  |  |  |  |  |  |
|                       |    |    |    |    |    |    |    |    |    |    |    | 49.6+                 | W1XAL    | 6040 | Boston, Mass.                     |  |  |  |  |  |  |  |  |                       |    |    |    |    |    |    |    |    |    |    |    |              |  |  |  |  |  |  |  |  |  |  |  |
|                       |    |    |    |    |    |    |    |    |    |    |    | 49.7+                 | HP5B     | 6030 | Panama City, Pan.                 |  |  |  |  |  |  |  |  |                       |    |    |    |    |    |    |    |    |    |    |    |              |  |  |  |  |  |  |  |  |  |  |  |
|                       |    |    |    |    |    |    |    |    |    |    |    | 49.7+                 | VV6RV    | 6030 | Valencia, Venezuela               |  |  |  |  |  |  |  |  |                       |    |    |    |    |    |    |    |    |    |    |    |              |  |  |  |  |  |  |  |  |  |  |  |
|                       |    |    |    |    |    |    |    |    |    |    |    | 49.8                  | DJC      | 6020 | Zeesen, Germany                   |  |  |  |  |  |  |  |  |                       |    |    |    |    |    |    |    |    |    |    |    |              |  |  |  |  |  |  |  |  |  |  |  |
|                       |    |    |    |    |    |    |    |    |    |    |    | 49.8+                 | ZH1      | 6012 | Singapore, Malaya                 |  |  |  |  |  |  |  |  |                       |    |    |    |    |    |    |    |    |    |    |    |              |  |  |  |  |  |  |  |  |  |  |  |
|                       |    |    |    |    |    |    |    |    |    |    |    | 49.8+                 | COC      | 6010 | Havana, Cuba                      |  |  |  |  |  |  |  |  |                       |    |    |    |    |    |    |    |    |    |    |    |              |  |  |  |  |  |  |  |  |  |  |  |
|                       |    |    |    |    |    |    |    |    |    |    |    | 49.8+                 | XEBT     | 6010 | Mexico City, Mex.                 |  |  |  |  |  |  |  |  |                       |    |    |    |    |    |    |    |    |    |    |    |              |  |  |  |  |  |  |  |  |  |  |  |
|                       |    |    |    |    |    |    |    |    |    |    |    | 49.9+                 | VE9DN    | 6005 | Montreal, Quebec                  |  |  |  |  |  |  |  |  |                       |    |    |    |    |    |    |    |    |    |    |    |              |  |  |  |  |  |  |  |  |  |  |  |
|                       |    |    |    |    |    |    |    |    |    |    |    | 49.9+                 | H1X      | 6000 | San Domingo, D. R.                |  |  |  |  |  |  |  |  |                       |    |    |    |    |    |    |    |    |    |    |    |              |  |  |  |  |  |  |  |  |  |  |  |
|                       |    |    |    |    |    |    |    |    |    |    |    | 49.9+                 | RW39     | 6000 | Moscow, U. S. S. R.               |  |  |  |  |  |  |  |  |                       |    |    |    |    |    |    |    |    |    |    |    |              |  |  |  |  |  |  |  |  |  |  |  |
|                       |    |    |    |    |    |    |    |    |    |    |    | 50.1                  | TGX      | 5984 | Guatemala City                    |  |  |  |  |  |  |  |  |                       |    |    |    |    |    |    |    |    |    |    |    |              |  |  |  |  |  |  |  |  |  |  |  |
|                       |    |    |    |    |    |    |    |    |    |    |    | 50.2+                 | HVJ      | 5969 | Vatican City                      |  |  |  |  |  |  |  |  |                       |    |    |    |    |    |    |    |    |    |    |    |              |  |  |  |  |  |  |  |  |  |  |  |
|                       |    |    |    |    |    |    |    |    |    |    |    | 50.5+                 | HJ1ABJ   | 5940 | Santa Marta, Col.                 |  |  |  |  |  |  |  |  |                       |    |    |    |    |    |    |    |    |    |    |    |              |  |  |  |  |  |  |  |  |  |  |  |
|                       |    |    |    |    |    |    |    |    |    |    |    | 50.6+                 | HJ4ABE   | 5860 | Medellin, Colombia                |  |  |  |  |  |  |  |  |                       |    |    |    |    |    |    |    |    |    |    |    |              |  |  |  |  |  |  |  |  |  |  |  |
|                       |    |    |    |    |    |    |    |    |    |    |    | 51.2+                 | VV3RMO   | 5850 | Maracaibo, Venez.                 |  |  |  |  |  |  |  |  |                       |    |    |    |    |    |    |    |    |    |    |    |              |  |  |  |  |  |  |  |  |  |  |  |
|                       |    |    |    |    |    |    |    |    |    |    |    | 51.4+                 | HJ2ABC   | 5824 | Cucuta, Colombia                  |  |  |  |  |  |  |  |  |                       |    |    |    |    |    |    |    |    |    |    |    |              |  |  |  |  |  |  |  |  |  |  |  |
|                       |    |    |    |    |    |    |    |    |    |    |    | 51.7+                 | T1X      | 5795 | San Jose, Costa Rica              |  |  |  |  |  |  |  |  |                       |    |    |    |    |    |    |    |    |    |    |    |              |  |  |  |  |  |  |  |  |  |  |  |
|                       |    |    |    |    |    |    |    |    |    |    |    | 51.8+                 | OAX4D    | 5780 | Lima, Peru                        |  |  |  |  |  |  |  |  |                       |    |    |    |    |    |    |    |    |    |    |    |              |  |  |  |  |  |  |  |  |  |  |  |
|                       |    |    |    |    |    |    |    |    |    |    |    | 52.0                  | T1GPH    | 5777 | Almatica, San Jose, Costa Rica    |  |  |  |  |  |  |  |  |                       |    |    |    |    |    |    |    |    |    |    |    |              |  |  |  |  |  |  |  |  |  |  |  |
|                       |    |    |    |    |    |    |    |    |    |    |    | 52.7+                 | NQAJ     | 5660 | Shanghai, China                   |  |  |  |  |  |  |  |  |                       |    |    |    |    |    |    |    |    |    |    |    |              |  |  |  |  |  |  |  |  |  |  |  |
|                       |    |    |    |    |    |    |    |    |    |    |    | 52.7                  | FIQA     | 5692 | Tanavarive, Mad.                  |  |  |  |  |  |  |  |  |                       |    |    |    |    |    |    |    |    |    |    |    |              |  |  |  |  |  |  |  |  |  |  |  |
|                       |    |    |    |    |    |    |    |    |    |    |    | 55.5+                 | HAT      | 5400 | Budapest, Hungary                 |  |  |  |  |  |  |  |  |                       |    |    |    |    |    |    |    |    |    |    |    |              |  |  |  |  |  |  |  |  |  |  |  |
|                       |    |    |    |    |    |    |    |    |    |    |    | 64.5+                 | HC2EP    | 4650 | Guayaquil, Ecuador                |  |  |  |  |  |  |  |  |                       |    |    |    |    |    |    |    |    |    |    |    |              |  |  |  |  |  |  |  |  |  |  |  |
|                       |    |    |    |    |    |    |    |    |    |    |    | 69.4                  | G6RX     | 4320 | Rugby, England                    |  |  |  |  |  |  |  |  |                       |    |    |    |    |    |    |    |    |    |    |    |              |  |  |  |  |  |  |  |  |  |  |  |
|                       |    |    |    |    |    |    |    |    |    |    |    | 69.5                  | YNLF     | 4316 | Managua, Nicaragua                |  |  |  |  |  |  |  |  |                       |    |    |    |    |    |    |    |    |    |    |    |              |  |  |  |  |  |  |  |  |  |  |  |
|                       |    |    |    |    |    |    |    |    |    |    |    | 70.2                  | RW15     | 4273 | Khabarovsk, Siberia               |  |  |  |  |  |  |  |  |                       |    |    |    |    |    |    |    |    |    |    |    |              |  |  |  |  |  |  |  |  |  |  |  |
|                       |    |    |    |    |    |    |    |    |    |    |    | 73.0                  | HCJB     | 4107 | Quito, Ecuador                    |  |  |  |  |  |  |  |  |                       |    |    |    |    |    |    |    |    |    |    |    |              |  |  |  |  |  |  |  |  |  |  |  |
|                       |    |    |    |    |    |    |    |    |    |    |    | 74.9+                 | CT2AJ    | 4000 | San Miguel, Azores                |  |  |  |  |  |  |  |  |                       |    |    |    |    |    |    |    |    |    |    |    |              |  |  |  |  |  |  |  |  |  |  |  |
|                       |    |    |    |    |    |    |    |    |    |    |    | 79.9+                 | CT1CT    | 3750 | Lisbon, Portugal                  |  |  |  |  |  |  |  |  |                       |    |    |    |    |    |    |    |    |    |    |    |              |  |  |  |  |  |  |  |  |  |  |  |
|                       |    |    |    |    |    |    |    |    |    |    |    | 81.0+                 | Radio LL | 3700 | Paris, France                     |  |  |  |  |  |  |  |  |                       |    |    |    |    |    |    |    |    |    |    |    |              |  |  |  |  |  |  |  |  |  |  |  |
|                       |    |    |    |    |    |    |    |    |    |    |    | 84.0+                 | CR7AA    | 3543 | Lourenzo Marques, Mozambique      |  |  |  |  |  |  |  |  |                       |    |    |    |    |    |    |    |    |    |    |    |              |  |  |  |  |  |  |  |  |  |  |  |

A—Sunday, Winter only  
 B—Sunday, Monday, Wednesday, Friday  
 C—Monday, Wednesday, Friday  
 D—Daily at hours indicated  
 E—Tuesday, Thursday  
 F—Friday  
 G—Tuesday, Thursday, Saturday  
 H—Wednesday, Friday, Sunday  
 I—Irregularly  
 J—Thursday, Saturday  
 K—Monday, Friday  
 L—Wednesday, Saturday  
 M—Monday  
 N—Monday, Wednesday, Thursday  
 O—Tuesday, Friday, Sunday  
 P—Except Tuesday, Wednesday, Summer only  
 Q—Except Tuesday, Wednesday  
 R—Thursday, Friday, Saturday  
 S—Sunday  
 T—Tuesday  
 TH—Thursday  
 U—Sunday, Summer only  
 V—Wednesday, Sunday  
 W—Wednesday  
 Y—Monday, Wednesday, Saturday  
 Z—Tuesday, Friday  
 AA—Saturday, Sunday  
 AB—Except Monday, Tuesday, Wednesday  
 AC—Monday, Tuesday, Saturday  
 AD—Time at 20 G.M.T.  
 AE—Except Monday, Wednesday, Friday  
 AF—Saturday irregularly  
 AG—Tuesday, Sunday  
 AH—Time at 7:30 G.M.T.  
 AI—Tuesday, Friday, Saturday  
 SA—Saturday  
 SA—Except Saturday, Sunday  
 XF—Except Friday  
 XG—Except Tuesday, Thursday, Saturday  
 XM—Except Monday  
 XS—Except Sunday  
 XSA—Except Saturday  
 XT—Except Tuesday  
 XTH—Except Thursday  
 XW—Except Wednesday  
 XX—Tuesday, Thursday, Friday  
 XY—Except Tuesday, Sunday





### THE HOME OF THE PORTUGUESE RADIO CLUB

*This is the fine modern building of the Radio Club (at Lisbon), with 6000 members, that owns stations CT1GL and CT1GO.*

London around 10 p.m., E.S.T. (Ricker.)

Who is Radio National Experimenter? 10280 kc., heard 4-6 p.m., E.S.T. (Miller.)

COC, Havana, Cuba, conducts special DX programs at 11:30 p.m. to past midnight Saturday nights. (Moore and Miller.)

HI4B, Santo Domingo, D. R., 48.18 meters, about 6225 kc., heard early in the evening irregularly. This station is not to be confused with HI4D. (A. Emerson.)

VUB and ZGE reception has been actually verified by the stations for our L.P.O. Baadsgaard at Ponoka, Canada. (FBOM, Editor.)

JVT still is reported the best Japanese station heard on 6750 kc., 5-7 a.m., E.S.T. (B. Baker, Loudon, Haley.)

KKH, Honolulu, reported heard on 7520 kc., 11 p.m., E.S.T. (Rambo, Loudon.)

PEF, Batavia, Java, reported heard on about 6100 kc., 7-9 a.m., Sundays. (Schumacher.)

VE9GW has changed its frequency to 6090 kc. (Brumgard, Jasiorkowski, Kalmbach.)

JZG, Nazaki, Japan, 6330 kc., reported heard 5-7:30 a.m., E.S.T., irregularly, sending programs to JIC at Taihoku, Formosa, who also transmits on 5980 kc., relaying Formosa programs up to about 8 a.m., E.S.T. (Sholin.) Lester Lio reports JIC on 5890 kc. almost every Sunday morning from 13-13:25, G.M.T. He also gives the town as Taiwan.

HI4D, Santo Domingo, D. R., reported heard 5-7:40 p.m., E.S.T., except Sunday. (Schumacher.)

HJ1ABJ, Santa Marta, Colombia, reported heard on 50.55 meters, 5.94 mc., 6:30-9 p.m., C.S.T. (Jasiorkowski.)

VLK are the call letters for VK2ME when working on 28.51 meters or other special frequencies. (Dixon, Boillotal.)

HIX, Santo Domingo, D. R., reported heard on 51.7 meters, Tuesdays and Saturdays, from 8 p.m. on. (Dixon.)

HJ3ABH, Bogota, Colombia, reported on 50.17 meters, 5.94 mc., heard from 6:30-9 p.m., C.S.T. (Jasiorkowski.)

RIM, Tashkent, Siberia, reported heard on 19.68 meters talking to RKI on 19.84 meters, mornings after 7 a.m., E.S.T. (Dixon.)

A fine time-zone map in colors 28 inches by 48 inches can be obtained by writing to the Hydrographic office of the Navy Department, Washington, D. C. (Boillotal.)

HJ4ABC, Pereira, Colombia, reported heard on 48.15 meters, 6.23 mc., Mondays 7:30-8:30 p.m., E.S.T. (Jasiorkowski.)

What station on 64 meters announces as

"La Prensa y el Telegrafo"? (Schumacher.)

HCK, Quito, Ecuador, reported heard on 51.9 meters, 5780 kc., 7-10 p.m., E.S.T. (Jasiorkowski.)

Who has heard the new Portuguese transmitter, CSL at Lisbon, on 48.78 meters, 6150 kc., from 23 to 00, G.M.T.? (Mascarenhas, N. C. Smith, Houton, Hillburn.)

Who has heard YV5RMO on 25 meters at 11:30 a.m.? (B. Baker.)

What station in Barbados has call letters with a V and transmits on about 7070, 7120 kc., and thanks listeners for letters as well as playing phonograph records? (T. Clarke.)

DJM, Zeelson, Germany, reported heard on 49.38 meters. (Lyell.)

VPD, Suva Radio, at Suva, Fiji Islands, 13075 kc., reported heard Mondays to Fridays inclusive, 12-13 G.M.T., and Saturdays from 05:30-06:30 G.M.T. (Matthews.)

### THAT ELUSIVE HP5B

*Views of the new station at Panama City, which transmits on 49 meters, 6030 kc., broadcasting from the Miramar Club.*

Courtesy R. Baker

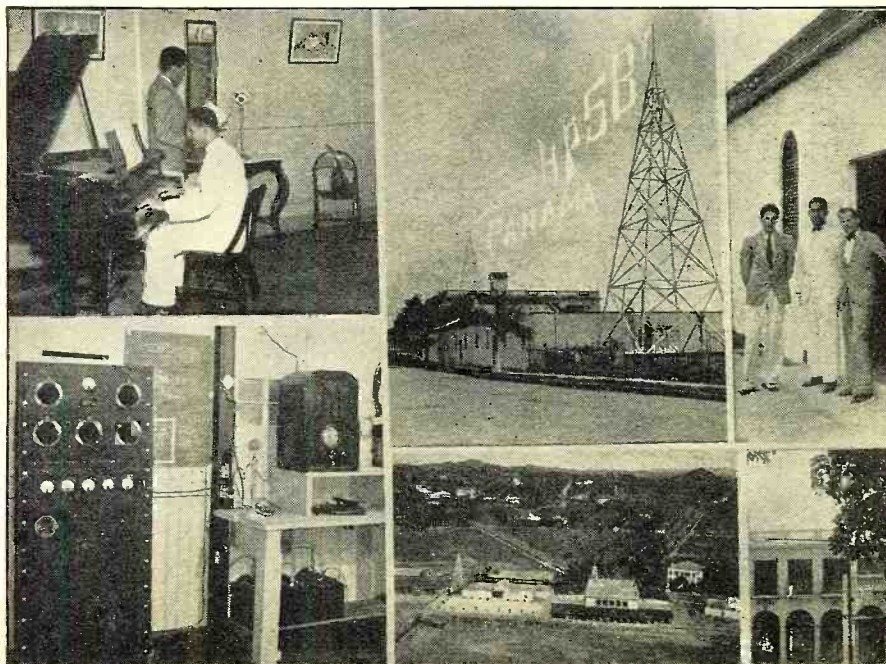

FYB, Paris, reported heard 2-2:30 p.m., E.S.T., playing records as well as time signals. (Fritsch.)

Another listener reports CT1GO, Parede, Portugal, 48.4 meters, daily except Tuesday, 12:30-13:30 G.M.T., and on Sundays 16:30-18 G.M.T. He also reports them on 24.8 meters Tues., Thurs., Friday, 18-19:15 G.M.T., and Sundays 15-16:30 G.M.T.

LKJ1, Oslo, Norway, 31:45 meters, 9540 kc., and on 48.98 meters, 6128 kc., 15-23 G.M.T. (Styles.)

FIQA, correct wavelength reported as 52.7 meters, 5692 kc., heard daily except Sunday, 8-8:45 G.M.T., 15-16 G.M.T., and 19:30 to 20 G.M.T. On Saturdays it is also heard from 17:30 to 19 G.M.T.

DJQ, 19.63 meters heard broadcasting to East Asia.

TIGPH, "Almatica" San Jose de Costa Rica, reported heard on 5.777 kc. (A. Emerson.)

OAX4B, Lima, Peru, 48 meters, reported on 6230 kc., broadcasting Wednesday and Saturday, 7-9 p.m., E.S.T. (Schumacher, Malast, Dixon, Jasiorkowski and Neighbour.)

OAX4D, 51.9 meters, 5780 kc., relays OAX4C on Wed. and Sat., 9-11:30 p.m., E.S.T. (Schumacher, Skatzes, Tramp.)

OA4R, Lima, Peru, an amateur broadcaster, is reported on 42 meters, transmitting from 4-5 p.m., E.S.T., irregularly and from 7-10 p.m., E.S.T. (Neighbour.)

### Wavelength-Frequency Chart

(See page 613)

This chart permits the instantaneous determination of the frequency corresponding to any wavelength or the wavelength equivalent of any frequency throughout the entire radio spectrum.

To find the frequency corresponding to any wavelength between 10.1 meters and 100 meters, or the wavelength equivalent of any frequency between 29,690 and 2998, the chart may be read directly. Outside of this range the reading is made by shifting the decimal points. Thus, if one desires to find the frequency equivalent of 101 meters, for instance, shift the decimal point of the frequency one place to the left. This will show the frequency to be 2969 kc. If the frequency corresponding to 1010 meters is required, shift the wavelength decimal of the first item two places

(Continued on page 614)



# WAVELENGTH-FREQUENCY CHART

| M.   | KC.    | M.   | KC.    | M.   | KC.   | M.   | KC.   | M.   | KC.   | M.   | KC.   | M.   | KC.   | M.   | KC.   | M.   | KC.   |
|------|--------|------|--------|------|-------|------|-------|------|-------|------|-------|------|-------|------|-------|------|-------|
| 10.1 | 29,690 | 20.1 | 14,920 | 30.1 | 9,961 | 40.1 | 7,477 | 50.1 | 5,984 | 60.1 | 4,989 | 70.1 | 4,277 | 80.1 | 3,743 | 90.1 | 3,328 |
| 10.2 | 29,390 | 20.2 | 14,840 | 30.2 | 9,928 | 40.2 | 7,458 | 50.2 | 5,973 | 60.2 | 4,980 | 70.2 | 4,271 | 80.2 | 3,738 | 90.2 | 3,324 |
| 10.3 | 29,110 | 20.3 | 14,770 | 30.3 | 9,895 | 40.3 | 7,440 | 50.3 | 5,961 | 60.3 | 4,972 | 70.3 | 4,265 | 80.3 | 3,734 | 90.3 | 3,320 |
| 10.4 | 28,830 | 20.4 | 14,700 | 30.4 | 9,862 | 40.4 | 7,421 | 50.4 | 5,949 | 60.4 | 4,964 | 70.4 | 4,259 | 80.4 | 3,729 | 90.4 | 3,317 |
| 10.5 | 28,550 | 20.5 | 14,630 | 30.5 | 9,830 | 40.5 | 7,403 | 50.5 | 5,937 | 60.5 | 4,956 | 70.5 | 4,253 | 80.5 | 3,724 | 90.5 | 3,313 |
| 10.6 | 28,280 | 20.6 | 14,550 | 30.6 | 9,798 | 40.6 | 7,385 | 50.6 | 5,925 | 60.6 | 4,948 | 70.6 | 4,247 | 80.6 | 3,720 | 90.6 | 3,309 |
| 10.7 | 28,020 | 20.7 | 14,480 | 30.7 | 9,766 | 40.7 | 7,367 | 50.7 | 5,913 | 60.7 | 4,939 | 70.7 | 4,241 | 80.7 | 3,715 | 90.7 | 3,306 |
| 10.8 | 27,760 | 20.8 | 14,410 | 30.8 | 9,734 | 40.8 | 7,349 | 50.8 | 5,902 | 60.8 | 4,931 | 70.8 | 4,235 | 80.8 | 3,711 | 90.8 | 3,302 |
| 10.9 | 27,510 | 20.9 | 14,350 | 30.9 | 9,703 | 40.9 | 7,331 | 50.9 | 5,890 | 60.9 | 4,923 | 70.9 | 4,229 | 80.9 | 3,706 | 90.9 | 3,298 |
| 11.0 | 27,260 | 21.0 | 14,280 | 31.0 | 9,672 | 41.0 | 7,313 | 51.0 | 5,879 | 61.0 | 4,915 | 71.0 | 4,223 | 81.0 | 3,701 | 91.0 | 3,295 |
| 11.1 | 27,010 | 21.1 | 14,210 | 31.1 | 9,641 | 41.1 | 7,295 | 51.1 | 5,867 | 61.1 | 4,907 | 71.1 | 4,217 | 81.1 | 3,697 | 91.1 | 3,291 |
| 11.2 | 26,770 | 21.2 | 14,140 | 31.2 | 9,610 | 41.2 | 7,277 | 51.2 | 5,856 | 61.2 | 4,899 | 71.2 | 4,211 | 81.2 | 3,692 | 91.2 | 3,288 |
| 11.3 | 26,530 | 21.3 | 14,080 | 31.3 | 9,579 | 41.3 | 7,260 | 51.3 | 5,844 | 61.3 | 4,891 | 71.3 | 4,205 | 81.3 | 3,688 | 91.3 | 3,284 |
| 11.4 | 26,300 | 21.4 | 14,010 | 31.4 | 9,548 | 41.4 | 7,242 | 51.4 | 5,833 | 61.4 | 4,883 | 71.4 | 4,199 | 81.4 | 3,683 | 91.4 | 3,280 |
| 11.5 | 26,070 | 21.5 | 13,950 | 31.5 | 9,518 | 41.5 | 7,225 | 51.5 | 5,822 | 61.5 | 4,875 | 71.5 | 4,193 | 81.5 | 3,679 | 91.5 | 3,277 |
| 11.6 | 25,850 | 21.6 | 13,880 | 31.6 | 9,488 | 41.6 | 7,207 | 51.6 | 5,810 | 61.6 | 4,867 | 71.6 | 4,187 | 81.6 | 3,674 | 91.6 | 3,273 |
| 11.7 | 25,630 | 21.7 | 13,810 | 31.7 | 9,458 | 41.7 | 7,190 | 51.7 | 5,799 | 61.7 | 4,859 | 71.7 | 4,182 | 81.7 | 3,670 | 91.7 | 3,270 |
| 11.8 | 25,410 | 21.8 | 13,750 | 31.8 | 9,428 | 41.8 | 7,173 | 51.8 | 5,788 | 61.8 | 4,851 | 71.8 | 4,176 | 81.8 | 3,665 | 91.8 | 3,266 |
| 11.9 | 25,200 | 21.9 | 13,690 | 31.9 | 9,399 | 41.9 | 7,156 | 51.9 | 5,777 | 61.9 | 4,844 | 71.9 | 4,170 | 81.9 | 3,661 | 91.9 | 3,262 |
| 12.0 | 24,990 | 22.0 | 13,630 | 32.0 | 9,369 | 42.0 | 7,139 | 52.0 | 5,766 | 62.0 | 4,836 | 72.0 | 4,164 | 82.0 | 3,656 | 92.0 | 3,259 |
| 12.1 | 24,780 | 22.1 | 13,570 | 32.1 | 9,340 | 42.1 | 7,122 | 52.1 | 5,755 | 62.1 | 4,828 | 72.1 | 4,158 | 82.1 | 3,652 | 92.1 | 3,255 |
| 12.2 | 24,580 | 22.2 | 13,510 | 32.2 | 9,311 | 42.2 | 7,105 | 52.2 | 5,744 | 62.2 | 4,820 | 72.2 | 4,153 | 82.2 | 3,647 | 92.2 | 3,252 |
| 12.3 | 24,380 | 22.3 | 13,440 | 32.3 | 9,282 | 42.3 | 7,088 | 52.3 | 5,733 | 62.3 | 4,813 | 72.3 | 4,147 | 82.3 | 3,643 | 92.3 | 3,248 |
| 12.4 | 24,180 | 22.4 | 13,380 | 32.4 | 9,254 | 42.4 | 7,071 | 52.4 | 5,722 | 62.4 | 4,805 | 72.4 | 4,141 | 82.4 | 3,639 | 92.4 | 3,245 |
| 12.5 | 23,990 | 22.5 | 13,330 | 32.5 | 9,225 | 42.5 | 7,055 | 52.5 | 5,711 | 62.5 | 4,797 | 72.5 | 4,135 | 82.5 | 3,634 | 92.5 | 3,241 |
| 12.6 | 23,800 | 22.6 | 13,270 | 32.6 | 9,197 | 42.6 | 7,038 | 52.6 | 5,700 | 62.6 | 4,789 | 72.6 | 4,130 | 82.6 | 3,630 | 92.6 | 3,238 |
| 12.7 | 23,610 | 22.7 | 13,210 | 32.7 | 9,169 | 42.7 | 7,022 | 52.7 | 5,689 | 62.7 | 4,782 | 72.7 | 4,124 | 82.7 | 3,625 | 92.7 | 3,234 |
| 12.8 | 23,420 | 22.8 | 13,150 | 32.8 | 9,141 | 42.8 | 7,005 | 52.8 | 5,678 | 62.8 | 4,774 | 72.8 | 4,118 | 82.8 | 3,621 | 92.8 | 3,231 |
| 12.9 | 23,240 | 22.9 | 13,090 | 32.9 | 9,113 | 42.9 | 6,989 | 52.9 | 5,668 | 62.9 | 4,767 | 72.9 | 4,113 | 82.9 | 3,617 | 92.9 | 3,227 |
| 13.0 | 23,060 | 23.0 | 13,040 | 33.0 | 9,086 | 43.0 | 6,973 | 53.0 | 5,657 | 63.0 | 4,759 | 73.0 | 4,107 | 83.0 | 3,612 | 93.0 | 3,224 |
| 13.1 | 22,890 | 23.1 | 12,980 | 33.1 | 9,058 | 43.1 | 6,956 | 53.1 | 5,646 | 63.1 | 4,752 | 73.1 | 4,102 | 83.1 | 3,608 | 93.1 | 3,220 |
| 13.2 | 22,710 | 23.2 | 12,920 | 33.2 | 9,031 | 43.2 | 6,940 | 53.2 | 5,636 | 63.2 | 4,744 | 73.2 | 4,096 | 83.2 | 3,604 | 93.2 | 3,217 |
| 13.3 | 22,540 | 23.3 | 12,870 | 33.3 | 9,004 | 43.3 | 6,924 | 53.3 | 5,625 | 63.3 | 4,736 | 73.3 | 4,090 | 83.3 | 3,599 | 93.3 | 3,214 |
| 13.4 | 22,370 | 23.4 | 12,810 | 33.4 | 8,977 | 43.4 | 6,908 | 53.4 | 5,615 | 63.4 | 4,729 | 73.4 | 4,085 | 83.4 | 3,595 | 93.4 | 3,210 |
| 13.5 | 22,210 | 23.5 | 12,760 | 33.5 | 8,950 | 43.5 | 6,892 | 53.5 | 5,604 | 63.5 | 4,722 | 73.5 | 4,079 | 83.5 | 3,591 | 93.5 | 3,207 |
| 13.6 | 22,040 | 23.6 | 12,700 | 33.6 | 8,923 | 43.6 | 6,877 | 53.6 | 5,594 | 63.6 | 4,714 | 73.6 | 4,074 | 83.6 | 3,586 | 93.6 | 3,203 |
| 13.7 | 21,880 | 23.7 | 12,650 | 33.7 | 8,897 | 43.7 | 6,861 | 53.7 | 5,583 | 63.7 | 4,707 | 73.7 | 4,068 | 83.7 | 3,582 | 93.7 | 3,200 |
| 13.8 | 21,730 | 23.8 | 12,600 | 33.8 | 8,870 | 43.8 | 6,845 | 53.8 | 5,573 | 63.8 | 4,699 | 73.8 | 4,063 | 83.8 | 3,578 | 93.8 | 3,196 |
| 13.9 | 21,570 | 23.9 | 12,540 | 33.9 | 8,844 | 43.9 | 6,830 | 53.9 | 5,563 | 63.9 | 4,692 | 73.9 | 4,057 | 83.9 | 3,574 | 93.9 | 3,193 |
| 14.0 | 21,420 | 24.0 | 12,490 | 34.0 | 8,818 | 44.0 | 6,814 | 54.0 | 5,552 | 64.0 | 4,685 | 74.0 | 4,052 | 84.0 | 3,569 | 94.0 | 3,190 |
| 14.1 | 21,260 | 24.1 | 12,440 | 34.1 | 8,792 | 44.1 | 6,799 | 54.1 | 5,542 | 64.1 | 4,677 | 74.1 | 4,046 | 84.1 | 3,565 | 94.1 | 3,186 |
| 14.2 | 21,110 | 24.2 | 12,390 | 34.2 | 8,767 | 44.2 | 6,783 | 54.2 | 5,532 | 64.2 | 4,670 | 74.2 | 4,041 | 84.2 | 3,561 | 94.2 | 3,183 |
| 14.3 | 20,970 | 24.3 | 12,340 | 34.3 | 8,741 | 44.3 | 6,768 | 54.3 | 5,522 | 64.3 | 4,663 | 74.3 | 4,035 | 84.3 | 3,557 | 94.3 | 3,179 |
| 14.4 | 20,820 | 24.4 | 12,290 | 34.4 | 8,716 | 44.4 | 6,753 | 54.4 | 5,511 | 64.4 | 4,656 | 74.4 | 4,030 | 84.4 | 3,552 | 94.4 | 3,176 |
| 14.5 | 20,680 | 24.5 | 12,240 | 34.5 | 8,690 | 44.5 | 6,738 | 54.5 | 5,501 | 64.5 | 4,648 | 74.5 | 4,024 | 84.5 | 3,548 | 94.5 | 3,173 |
| 14.6 | 20,540 | 24.6 | 12,190 | 34.6 | 8,665 | 44.6 | 6,722 | 54.6 | 5,491 | 64.6 | 4,641 | 74.6 | 4,019 | 84.6 | 3,544 | 94.6 | 3,169 |
| 14.7 | 20,400 | 24.7 | 12,140 | 34.7 | 8,640 | 44.7 | 6,707 | 54.7 | 5,481 | 64.7 | 4,634 | 74.7 | 4,014 | 84.7 | 3,540 | 94.7 | 3,166 |
| 14.8 | 20,260 | 24.8 | 12,090 | 34.8 | 8,616 | 44.8 | 6,692 | 54.8 | 5,471 | 64.8 | 4,627 | 74.8 | 4,008 | 84.8 | 3,536 | 94.8 | 3,163 |
| 14.9 | 20,120 | 24.9 | 12,040 | 34.9 | 8,591 | 44.9 | 6,678 | 54.9 | 5,461 | 64.9 | 4,620 | 74.9 | 4,003 | 84.9 | 3,531 | 94.9 | 3,159 |
| 15.0 | 19,990 | 25.0 | 11,990 | 35.0 | 8,566 | 45.0 | 6,663 | 55.0 | 5,451 | 65.0 | 4,613 | 75.0 | 3,998 | 85.0 | 3,527 | 95.0 | 3,156 |
| 15.1 | 19,860 | 25.1 | 11,950 | 35.1 | 8,542 | 45.1 | 6,648 | 55.1 | 5,441 | 65.1 | 4,606 | 75.1 | 3,992 | 85.1 | 3,523 | 95.1 | 3,153 |
| 15.2 | 19,720 | 25.2 | 11,900 | 35.2 | 8,518 | 45.2 | 6,633 | 55.2 | 5,432 | 65.2 | 4,598 | 75.2 | 3,987 | 85.2 | 3,519 | 95.2 | 3,149 |
| 15.3 | 19,600 | 25.3 | 11,850 | 35.3 | 8,494 | 45.3 | 6,619 | 55.3 | 5,422 | 65.3 | 4,591 | 75.3 | 3,982 | 85.3 | 3,515 | 95.3 | 3,146 |
| 15.4 | 19,470 | 25.4 | 11,800 | 35.4 | 8,470 | 45.4 | 6,604 | 55.4 | 5,412 | 65.4 | 4,584 | 75.4 | 3,976 | 85.4 | 3,511 | 95.4 | 3,143 |
| 15.5 | 19,340 | 25.5 | 11,760 | 35.5 | 8,446 | 45.5 | 6,589 | 55.5 | 5,402 | 65.5 | 4,577 | 75.5 | 3,971 | 85.5 | 3,507 | 95.5 | 3,139 |
| 15.6 | 19,220 | 25.6 | 11,710 | 35.6 | 8,422 | 45.6 | 6,575 | 55.6 | 5,392 | 65.6 | 4,570 | 75.6 | 3,966 | 85.6 | 3,503 | 95.6 | 3,136 |
| 15.7 | 19,100 | 25.7 | 11,670 | 35.7 | 8,398 | 45.7 | 6,561 | 55.7 | 5,383 | 65.7 | 4,563 | 75.7 | 3,961 | 85.7 | 3,498 | 95.7 | 3,133 |
| 15.8 | 18,980 | 25.8 | 11,620 | 35.8 | 8,375 | 45.8 | 6,546 | 55.8 | 5,373 | 65.8 | 4,557 | 75.8 | 3,955 | 85.8 | 3,494 | 95.8 | 3,130 |
| 15.9 | 18,860 | 25.9 | 11,580 | 35.9 | 8,352 | 45.9 | 6,532 | 55.9 | 5,364 | 65.9 | 4,550 | 75.9 | 3,950 | 85.9 | 3,490 | 95.9 | 3,126 |
| 16.0 | 18,740 | 26.0 | 11,530 | 36.0 | 8,328 | 46.0 | 6,518 | 56.0 | 5,354 | 66.0 | 4,543 | 76.0 | 3,945 | 86.0 | 3,486 | 96.0 | 3,123 |
| 16.1 | 18,620 | 26.1 | 11,490 | 36.1 | 8,305 | 46.1 | 6,504 | 56.1 | 5,344 | 66.1 | 4,536 | 76.1 | 3,940 | 86.1 | 3,482 | 96.1 | 3,120 |
| 16.2 | 18,510 | 26.2 | 11,440 | 36.2 | 8,282 | 46.2 | 6,490 | 56.2 | 5,335 | 66.2 | 4,529 | 76.2 | 3,935 | 86.2 | 3,478 | 96.2 | 3,117 |
| 16.3 | 18,390 | 26.3 | 11,400 | 36.3 | 8,260 | 46.3 | 6,476 | 56.3 | 5,325 | 66.3 | 4,522 | 76.3 | 3,929 | 86.3 | 3,474 | 96.3 | 3,113 |
| 16.4 | 18,280 | 26.4 | 11,360 | 36.4 | 8,237 | 46.4 | 6,462 | 56.4 | 5,316 | 66.4 | 4,515 | 76.4 | 3,924 | 86.4 | 3,470 | 96.4 | 3,110 |
| 16.5 | 18,170 | 26.5 | 11,310 | 36.5 | 8,214 | 46.5 | 6,448 | 56.5 | 5,307 | 66.5 | 4,509 | 76.5 | 3,919 | 86.5 | 3,466 | 96.5 | 3,107 |
| 16.6 | 18,060 | 26.6 | 11,270 | 36.6 | 8,192 | 46.6 | 6,434 | 56.6 | 5,297 | 66.6 | 4,502 | 76.6 | 3,914 | 86.6 | 3,462 | 96.6 | 3,104 |
| 16.7 | 17,950 | 26.7 | 11,230 | 36.7 | 8,170 | 46.7 | 6,420 | 56.7 | 5,288 | 66.7 | 4,495 | 76.7 | 3,909 | 86.7 | 3,458 | 96.7 | 3,101 |
| 16.8 | 17,850 | 26.8 | 11,190 | 36.8 | 8,147 | 46.8 | 6,406 | 56.8 | 5,279 | 66.8 | 4,488 | 76.8 | 3,904 | 86.8 | 3,454 | 96.8 | 3,09  |



# WORLD DISTANCE CHART No. 6

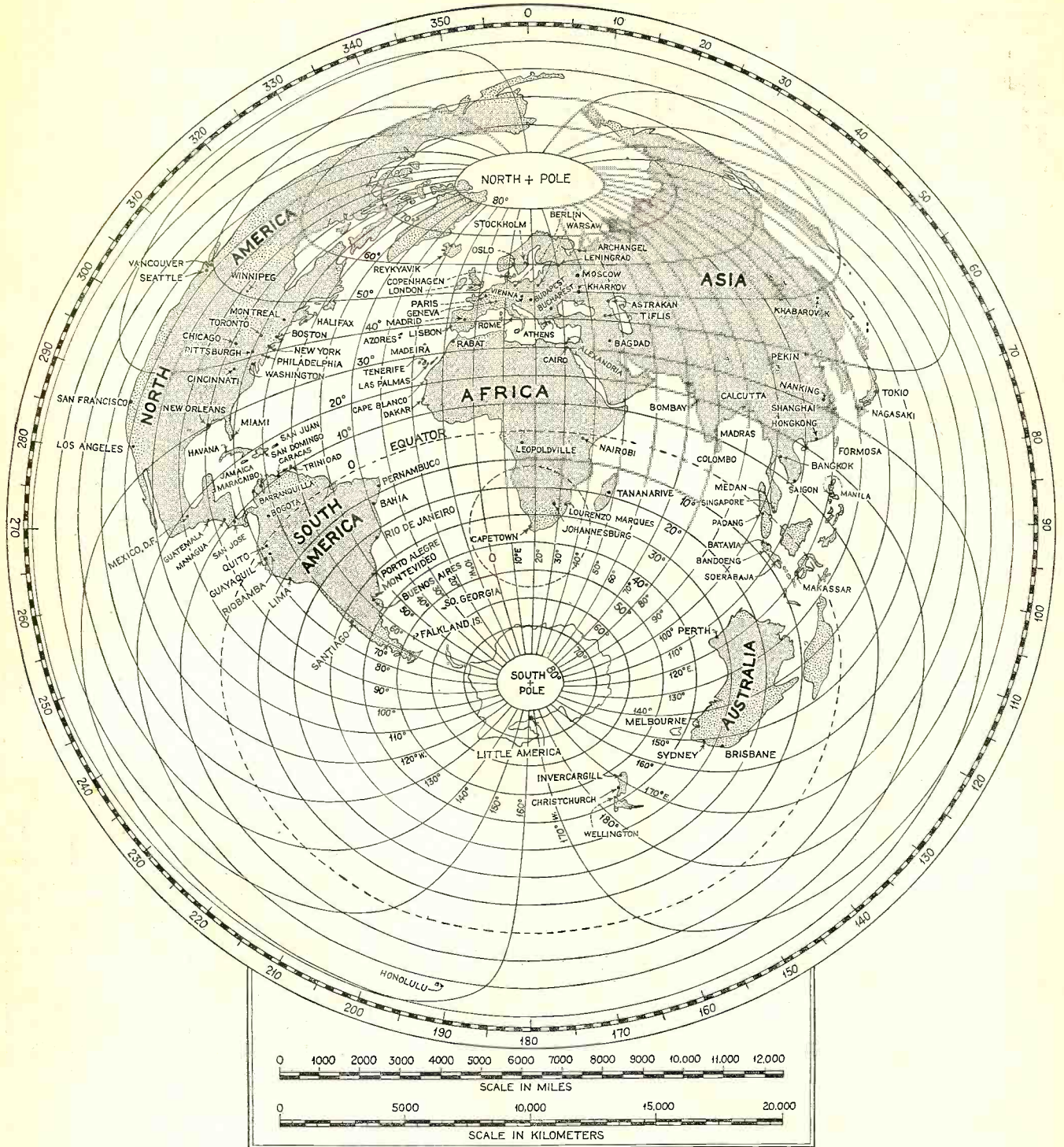

(Continued from page 612)

to the right and the frequency decimal two places in the opposite direction, and from this will be found that the required frequency is 296.9 kc.

In the same way, if the wavelength for a given frequency is desired, simply locate the frequency nearest to this value in the frequency column, moving the decimal point if necessary, and opposite it will be shown the corresponding wavelength, always shifting the decimal point in one column the same number of places (but in the opposite direction) as the point was shifted in the other column.

Where the frequency is known in terms of megacycles, its equivalent in kilocycles

### THE WORLD DISTANCE MAP FOR SOUTHERN AFRICA

Here is the sixth RADIO NEWS Azimuthal map, which is for the southernmost part of Africa, centered on Capetown. Measurements can accurately be made from any spot within the dotted circle to any other place on earth. Simply lay a ruler connecting any spot within this circle to any other location on the map and refer this distance to the scale in miles or kilometers; this will give the actual great circle distance. This is the sixth exclusive RADIO NEWS Distance Chart published in this series.

is found by simply adding three ciphers to the megacycle figure.

### Readers Who Helped Log Stations for This Month's Report

Larry Eisler, Chicago, Ill.; H. O. Graham, London, England; Thomas A. Pugh, Anchorage, Alaska; H. Mallet-Veale, Windhoek, S. W. Africa; A. Passini, Genova, Italy; Robert F. Kaiser, Albany, New York; E. M. O. Godee, Bandoeng, Java; Arthur B. Coover, Union City, Indiana; John C. Kalmbach, Jr., Buffalo, New York; James T. Spalding, Louisville, Ky.; Howard Singer, Chicago, Ill.; Joseph McKeon, St. Albans, N. Y.; A. C. Lyell, Johannesburg, South Africa; Werner Howard, Los Angeles, Calif.; Howard Morse, U. S. Radio DX Club; Albert Emerson, Cleveland, Ohio; Donald W. Shield, Roseville, Ohio; Lester Leo, Long Beach, Calif.

(Continued on page 620)



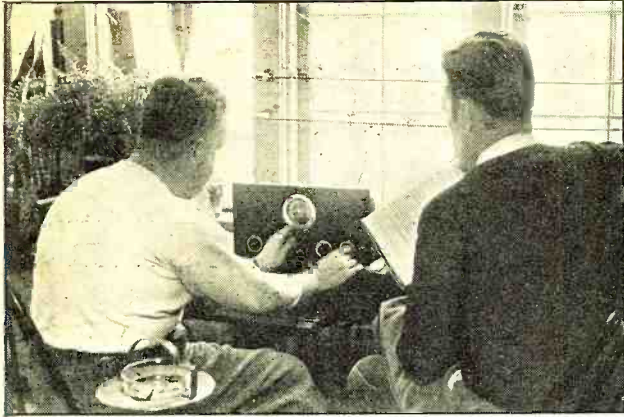

LISTENING TO FRANCE

*While this picture was being taken at the Listening Post, the signals of FYA on 25 meters were being received at full loudspeaker strength.*

**T**HE All-Star Junior receiver was taken up to the Westchester Listening Post to be put through its paces on both long and short-wave reception. The set is a 5-tube set utilizing a 6A7 tube as first detector and oscillator, a 6F7 as intermediate i.f. amplifier and beat-frequency oscillator, one of the new 77 tubes acting as the detector and coupling tube to the type

42 tube used as an output. The circuit is driven on a 60-cycle rectified supply, by means of a type 80 tube. The speaker coil is employed in the filter circuit (as a choke), as shown in the diagram on page 542 last month.

The extreme lower left-hand control, on the front panel, is the beat-frequency oscillator switch. Next, to the right, is the oscillator "tank" condenser; next in line is the local distance switch. Then comes the antenna "tank" condenser and the control at the extreme right is the "on-off" volume-control switch. The

middle dial and its knob is the band-spread control.

Six sets of plug-in coils are used with this receiver. Pair No. 1 tuned from 10 to almost 19 meters; pair No. 2 tuned from 19 to 39 meters; pair No. 3 go from 34 to 79 meters; pair No. 4 from 68 to 136 meters; pair No. 5 from 136 to 270; pair No. 6 from 270 to 550 meters.

Unless one has had experience in lining up a receiver like this, the process is rather a difficult one, without rough calibration figures being given. We are, therefore, giving the settings of the oscillator and antenna "tank" condensers for the main short-wave bands, so that the set (*Continued on page 652*)

## Testing a New DOUBLE DOUBLET

(RCA De Luxe Antenna)

By the Staff

**T**HIS new De Luxe antenna system, utilizing a double-doublet, twisted-pair transmission line and two special impedance-matching transformers (at the antenna and at the receiver), was erected at the Westchester Listening Post during adverse weather conditions and gave excellent results. The full recommended height of 30 feet was found necessary; at lower levels reception on the 19- and 25-meter bands fell off noticeably.

On all bands, the signal-noise ratio was better than with any of five other antennas against which this system was compared. These ranged from short, vertical wires to long horizontals. On the broadcast band the signal strength was better than with all the other aerials, except a 200-foot wire pointed west. On 49 meters the signal input to the receiver was equal to or better than that afforded by the other antennas. On 31 meters it was not quite as good. On 25 meters it was superior all around. On 19 meters signals were weaker than on the long, horizontal aerial and the short vertical, but the noise level was

lower and more of the receiver's amplification could be used.

On the 49-meter band signals from the best previous antenna suffered from a peculiar frequency distortion, due probably to irregular polarization phenomena. This effect was absent with the RCA antenna, probably because of the angular relationship of the wires of the double-doublet.

The test antenna was erected with the doublet pointing at a power pole that had been causing trouble and in the general direction of the only street through which any appreciable vehicular traffic passes.

The small coupling transformer attached to the junction point of the elevated doublet wires has its primary and



AERIAL INSTALLATION UNDER DIFFICULTIES

*The antenna was erected for tests in sub-zero weather, but outside of a few frost bites on ears and fingers there was no difficulty encountered, as the directions were followed exactly.*

secondary separated by a Faraday type electrostatic shield, which is grounded by an extra wire dropping from the transformer case. This acts to protect the antenna itself from noise energy picked up by the lead-in and reflected into the aerial wires through the otherwise appreciable capacity between the transformer windings. This shield has no effect on the (*Continued on page 643*)





# How I Won the DENTON TROPHY

(World-Wide DX Contest)

H. S. Bradley

AS a result of winning the Denton Trophy Contest, the writer has received many queries regarding tuning habits, interests and the general layout at his Listening Post. It is the purpose of this article, therefore, to give a brief answer to these questions. First, the receiving equipment may be said to be of an elementary nature, as a 4-tube set has been the sole receiver in use here during the past year. During the DX contest, an antenna, about 100 feet in length and about 40 feet from the ground, was in use; the general direction of this antenna was E.-W. The present antenna, erected at the new QRA, is slightly lower and runs approximately N.-S.

MANY hints have been offered to the listener, as aids to success in his s.w. tuning, but I shall not attempt to reiterate, in detail, what has already been well put forth by others. Were I to pick out

what I believe to be the two most important factors in successful tuning, in this part of the world, I would give those of a *knowledge of c.w.*, and the *ability to understand the letters of the alphabet when given in Spanish*. It is obvious that about 90% of the stations on s.w. operate solely on code. Knowing how to get the call-letters of such stations (operating on known frequencies) enables one to calibrate his dials to a far greater degree of accuracy than would be the case, were he to rely solely on fone stations for this purpose. When a new station is tuned in, its true wavelength may be generally checked with surrounding c.w. stations; on the other hand, when one learns of a new station, operating on a certain wavelength, the exact position of the fone may be quickly located by referring to c.w. stations in the vicinity. A final use, though certainly not the least

important of the uses of a knowledge of c.w., is in the identification of commercial fones that line up their circuit with i.c.w., and rarely announce their actual call. I think that those listeners who have mastered the trick of copying dots and dashes will agree that it is well worth the time and trouble that one may take in learning this art!

About 75% of the fone stations that may be heard in the eastern U. S. A. (after 5 p.m.) are Spanish-speaking; very few of them ever give English announcements and, in that many of them shift wavelengths slightly, one cannot identify them by dial-settings. POSITIVE IDENTIFICATION CANNOT BE MADE, UNLESS THE LISTENER KNOWS THE PRONUNCIATION OF CALL-LETTERS, IN SPANISH!!! I cannot claim to understand much Spanish, but can, however, catch Spanish letters that are given reasonably clearly; the identification of at least 90% of the Latin-American stations that have been received here (75 fones from South America and 50 Central America and the West Indies have been verified, so far) would have otherwise been passed up as hopeless!

Perhaps the sources of greatest tuning interest for the writer are the 20 and 40-meter amateur bands, where reside the greatest possibilities for low-powered DX reception. Among the foreign amateur fone verifications that have been collected, here, are 38 from England alone. Other low-powered amateur fones have been received from every South American country (with the exception of the Guianas), from the Canary Islands, Tunis, Italy, Azores, Czechoslovakia, Switzerland, Australia, and Norway, to mention only a few of the better DX catches. Amateur QSL's are prized more highly than any other type, primarily (Continued on page 640)

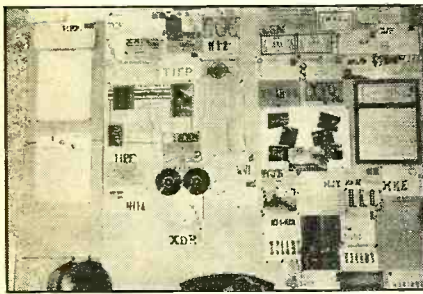

### MANY VERIFICATION CARDS

The four illustrations on this page show how the walls of Mr. Bradley's short-wave Listening Post are dotted with verification letters and cards from stations all over the world. Mr. Bradley's report card is also pictured on this page. (Apologies to the author, who moved his head when the photo was being taken. The Denton Trophy shows clearly enough, however.)

QRA: H. S. BRADLEY, 66 Main Street., HAMILTON, N. Y., U. S. A.

UR 5195 CSA R ON M. AT W-EST 193

# U S A

PSE QSL DIRECT OT! Vy 73, OM!

MEMBER OF INT. S. W. CLUB (In fones in over 30 Countries) SPANISH QUIKOTE RADIO CLUB

WINNER OF FIRST PLACE, IN WORLD-WIDE DENTON DX CONTEST, 1933-1934

20 M. CW2, CW5, CW6, CW8, XI, X2, T12, T13, T14, VPE, VPS, K4, K5, H5, H10, H15, H5.

Fone YV, HC, HD5, CA1, CA4, PY1, PY2, PY3, LUI, LUZ, LUS, CT, C2, EA3, EA4, PA, AB, LA, OK, 18, FA2, 14, Brazil (G), J., (Haiti) (1), S., (Poland) (N).

40 M. CW2, CW6, XI, X2, T12, T13, T14, H2, Y2, Y4, H5, H1, H3, H4, H5, H6, H1, H2, DA, CP, H1, H2, CW5, PY3, C1, C2, C3, C4, ZP, PY, LUI, LU2, LUS, L04, L05, L06, L08, L10, CT, EA3, EA4.

125

FONE: 31 Ships; 67 Countries (60 Verified) CW DX: 12 Countries

The Home of Colgate University, situated 150 M. N. W. of N. Y. City, in the 8th U. S. A. District

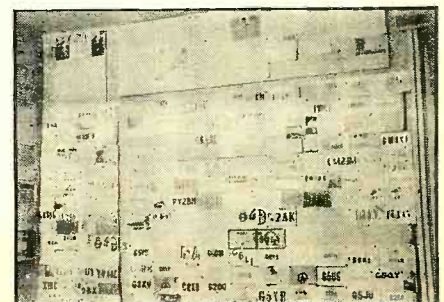



# WORLD TIME CONVERSION CHART

The short-wave or DX listener can, with this chart, instantly determine the time in any part of the world corresponding to any given hour in his own location

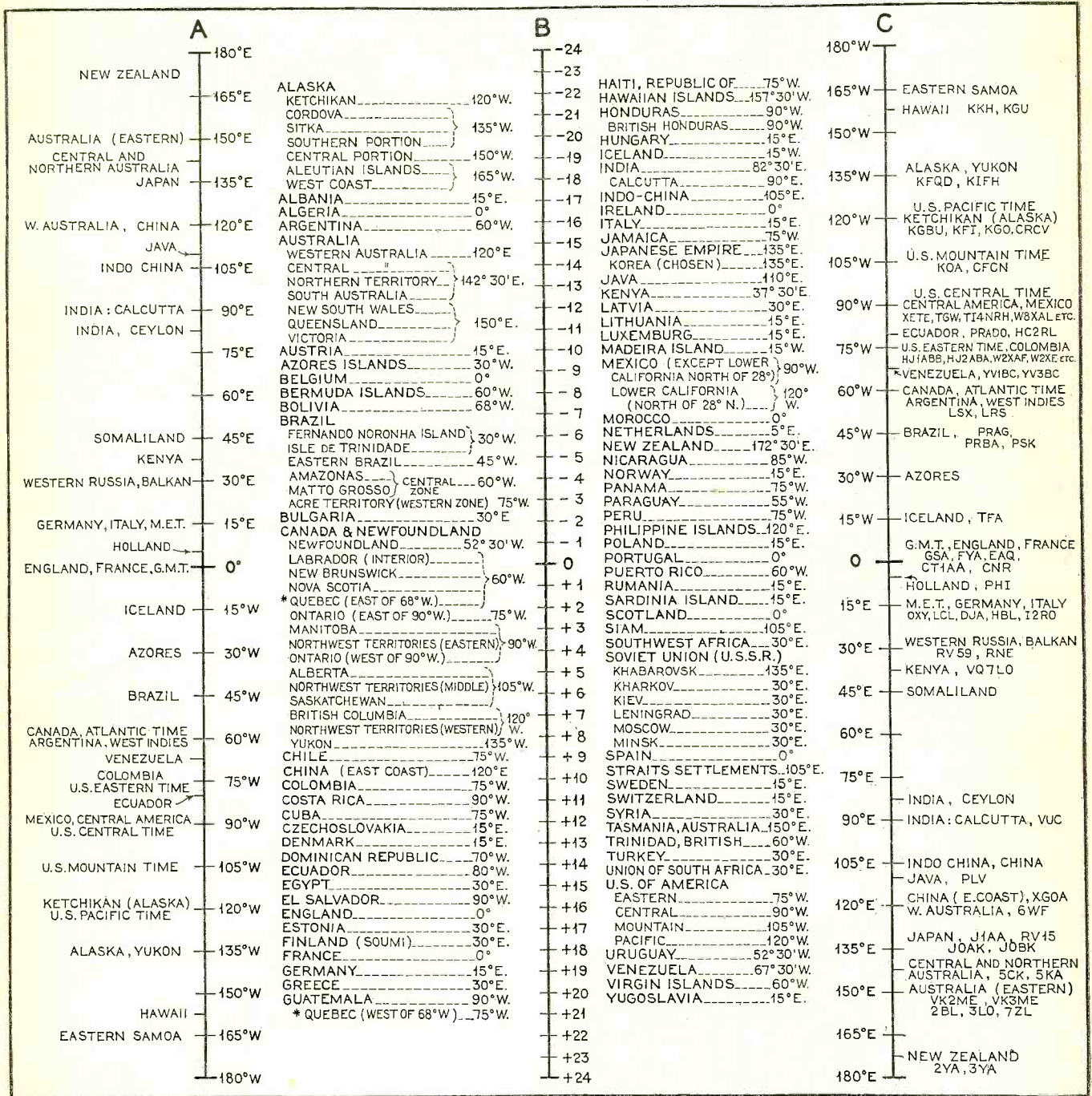



# Short-Wave Calculations

## FOR THE EXPERIMENTER

This article presents data of importance to amateurs and other short-wave constructors. It points out factors which can be neglected in broadcast design, but which assume increasing significance in short-wave and particularly ultra-short-wave design

**N**EARLY every radio experimenter is immediately struck with the simplicity of the tuning circuits in short-wave apparatus, particularly those adapted for reception on waves below 10 meters. The turn or so of wire and the miniature condenser indeed represent the nearest approach to a "wireless" receiver that can be imagined. When investigated, the actual story of short-wave receiver design is not so simple, however. There are several simple circuits in use, some regenerative circuits, working into a tube or a pair of tubes in push-pull. In some cases the plate potential is interrupted (à la super-regeneration), but in all cases the tuning circuit is based on a simple LC circuit.

One circuit that is frequently used is that in Figure 1. Here we have two similar coils, L1, L2 (usually having a diameter less than one inch), with from 1 to 10 turns of wire. Two tuning condensers, C1, C3, in series, make up the variable element. Now comes the difficulty. The circuit does not "know" that the inductance portion of the path is supposed to end at the terminals of the coils. In fact, the leads to the condensers and to the tube represent large turns of wire which may have an inductance greater than L1 + L2 unless precautions are taken to avoid excessive lengths. Actually the circuit should be drawn as per Figure 2, or simplified as Figure 3. Here the coils, L3, L4, represent the leads to the condenser C1 (actually the wires, condenser frame and shaft up to the center of capacity all contribute to this factor). Similarly the effect of the other leads are considered.

In order to be able to determine which of these factors are important, it will be necessary to determine possible values for all of these coils. The inductance of a single turn of No. 16 wire of various diameters such as are commonly found due to wiring loops is shown in Figure 4. However, connection wires do not often follow a circular route. In fact, they do not even lie in the same plane in ordinary cases. However, even though rectangular and irregular, it is not uncommon

to have effects equivalent to a two or three-inch turn of wire, which in conjunction with a 40 mmfd. condenser might have a wavelength of 6 meters. Frequently a rough estimation may be made by considering the inductance of small rectangular circuits, since the wiring leads are frequently in the same plane for a considerable portion of their length. Possible data in Figure 5 might be used to obtain a rough indication of the inductance of leads of various lengths and spacing. It is therein assumed that No. 16 wire is used for connections, although small differences in wire diameter will not affect the results much.

**[ By Ralph R. Batcher ]**

The inductance of the main coils, L1 and L2, depends upon a number of factors—wire size, turn spacing, diameter of coil and coil separation.

Due to the relatively large spacing between turns, the inductance formulæ usually used are not accurate unless correction factors are applied. Usually the coils are wound with large wire, around a mandrel which is later removed. The diameter of the coil will be a little larger than the diameter of the mandrel plus the diameter of the wire. To obtain representative inductance values for four types of coils, all formed of No. 16 wire, the curves in Figure 6 may be used. Two of these are wound on half-inch mandrels at the rate of 10 and 5 turns per inch, and two are wound on one-inch mandrels with the same spacing. The curves indicate the inductance of coils of various turns directly.

Referring to Figure 3, it may be assumed that the capacity C2 is usually very small in comparison with either C1 or C3. Neglecting for the moment the L7-L8-CGP circuit, it will be seen that the real tuning circuit is L1, L2, L3, L4, L5, L6 with C1, C3. In the specific example afforded by this circuit, let us assume that a wavelength of 5 meters is desired. The main coils, L1 and L2, are mounted about 3 inches from the center of the capacity of the condenser C1 (which has a capacity of 100 mmfd.). The condenser C3 might be a small fixed capacity of 15 mmfd. mounted

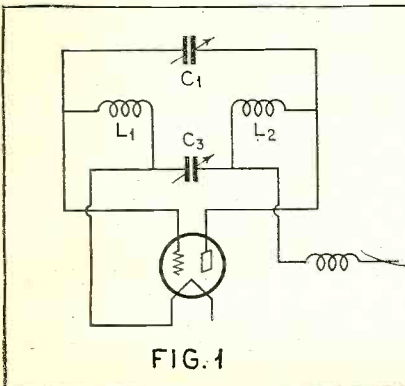
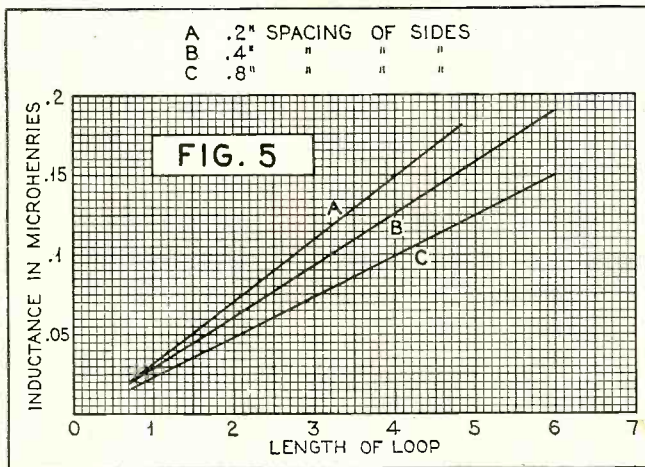

FIG. 1

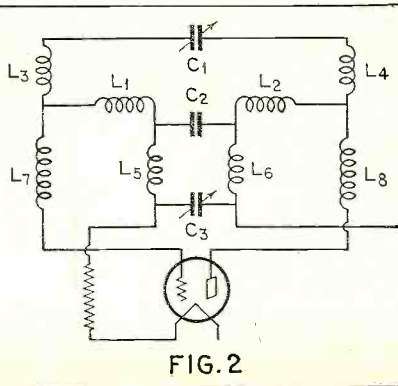

FIG. 2

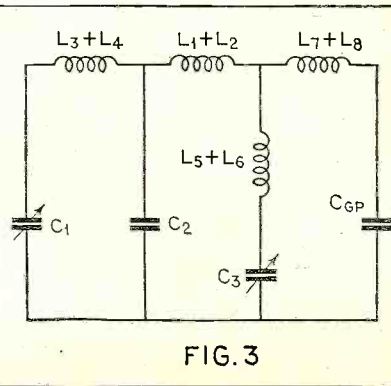
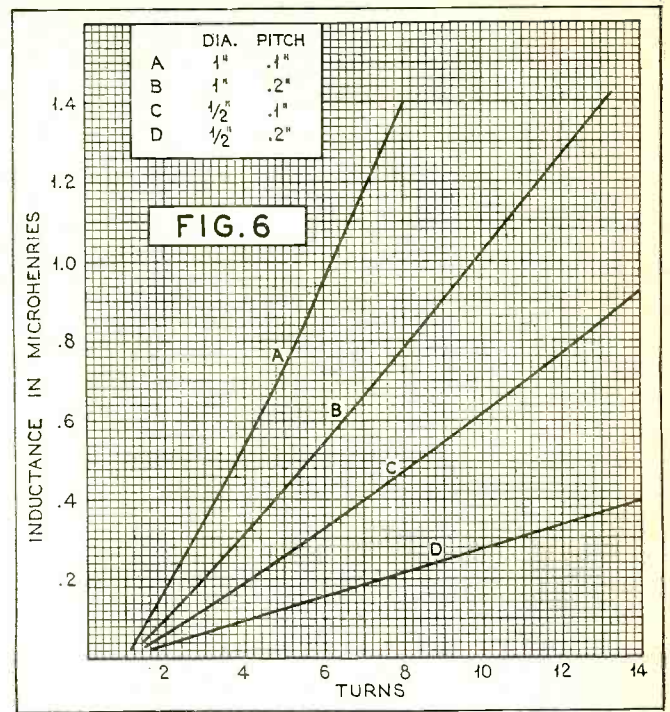
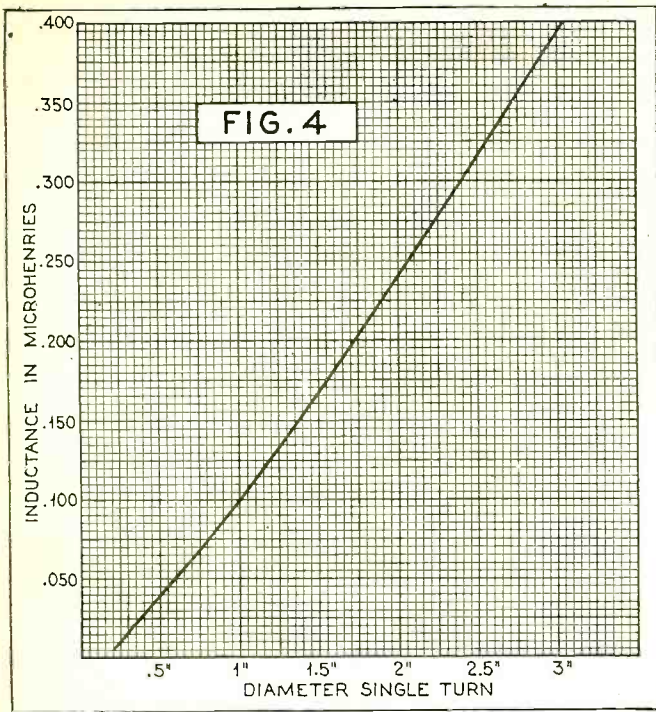

FIG. 3





one inch from the terminals of the coils. The inductance of the latter, with its leads, is thus about .040 microhenry. The leads to C1 include several bends, but an estimation based on the information of Figure 5 gives an approximate value of .125 microhenry.

The average capacity of C1 is 50 mmfd., which in series with C3 of 15 mmfd., is roughly equal to 12 mmfd. Neglecting the effect of L7, L8 for the moment, the capacity CGP might increase this to 20 mmfd. A chart, Figure 7, is given, by which the required inductance for any wavelength up to 10 meters may be obtained. A straight line across the scales from 5 meters and 20 mmfd. will intersect the inductance scale at .355 microhenry, which is the maximum value permissible for all the circuit. Of this we already have .040 + .125 microhenry, so that but .19 microhenry is needed in the coils. The coils L1 and L2 are actually coupled together so that the mutual inductance will contribute a little to this value, but the computation is rather tedious. A short cut is to find out how many turns are required for .19 microhenry and for .095 microhenry. The average between the latter and one-half of the former gives a fair value for the required number of turns for either L1 or L2. By adopting the conditions represented by Curve D, Figure 6, it will be found that each coil should have 4 turns of wire wound on a 1/2-inch mandrel, spaced at the rate of 5 turns per inch.

If in the circuit arrangement two variable condensers had been used, leads to them were poorly arranged and longer than 3 inches, it would have been found that the stray inductance would have made up the total permissible.

A number of assumptions have been made in the above computations, the most important of which was that L7 and L3 could be neglected. As long as their combined value is considerably smaller than the rest of the circuit, this is permissible. If, however, this circuit (L7, L3, CGP) has a resonance period within

the active range of the receiver, it will be impossible to regenerate at that wave, and at other points the circuit will resonate at two frequencies, one above and one below the period of the L7-L8-CGP circuit.

The capacity effect of the leads have been neglected. It is difficult to furnish rules whereby these effects can be computed, since the separation and length of the wires must be known, and also the effect of all metal objects in the vicinity. The wires have a capacity effect between themselves and also to ground, so the problem is not simple.

This article is mainly to call attention to the desirability of mounting the various items so that stray capacity and inductance is reduced, for short-wave circuits, in order that satisfactory results are readily obtained.

Finally, a few words concerning the wavelength chart, Figure 7. It is possible that in some circuits it may be desired

to use larger capacities than indicated on the scale on the diagonal. If the values of this scale are multiplied by 10, the inductance scale on the left must be divided by the same factor 10, whereby the relations will be correct.

While the preceding data is concerned with wavelengths below 10 meters, the same effects, due to stray inductive and capacitive conditions, are usually important on longer waves as well. In some cases broadcast receiver alignment is affected by changes in the inductive effect of the coil leads. Chart 7 may be used on longer wavelengths (up to 100 meters) by multiplying all values by 10.

That is, the capacity scale would then have a value of 1000 micro-microfarads, the inductance scale up to 10 microhenries and the wavelength scale 100 meters. Or, for a possibly more practical range of values, covering the same wavelength range (up to 100 meters), multiply the inductance scale by 100 and the wavelength scale by 10 and leaving the capacitance scale alone.

Since (Continued on page 646)

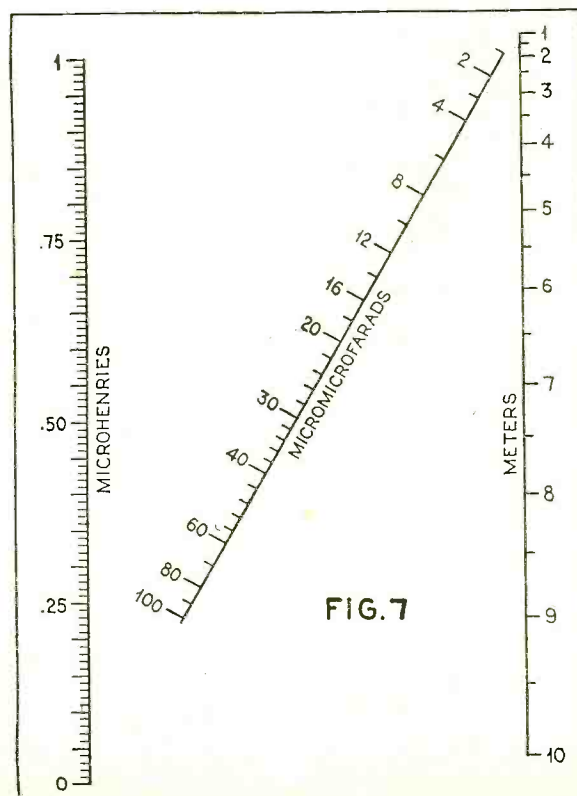





*Capt. Hall's*

## SHORT-WAVE PAGE

**T**WO questions that are frequently asked the writer are: "What receivers do you use?" and "What type of antenna do you find satisfactory for all-around short-wave reception?" It is difficult to give a detailed answer to these questions to each reader who writes me, so I am including the information in this department.

**A**T the present time I have in my tuning "studio" six receivers, one converter and one pre-selector, but for the past few months my DX'ing has been accomplished with a 10-tube all-wave receiver that ranges from 7 meters to 2000. During that time I have made many experiments with aerials that are best suited to this type of receiver. I have found that the ordinary flat-top antenna pulls in signals from all over the world. My motto for years has been "Your receiver is only as good as your antenna." The type of aerial that I am using is both easy to construct and inexpensive. The flat top is made of 75 feet of No. 14 solid, enameled copper wire used with a twisted-pair lead-in and six insulators. The insulators should be placed three at each end. Each one 6 inches apart. The lead-in should be soldered to the aerial about 12 inches from the insulator and the other wire of the lead-in fastened between the first two insulators to serve as a feeder.

Short-wave listeners in the eastern part of the United States wax enthusiastic when signals from Asiatic stations are logged. Our West Coast "cousins" are equally excited when a low-powered European finds its way into the loudspeaker. Speaking from my own point of view, I believe this expresses the opinion of many East Coast listeners. We are not in the least interested in the program value of a broadcast coming 10,000 miles, but it is the idea that we have logged a "catch" when we listen to the three "Aussie" stations. There is VK3LR, with their stock market reports and talks; VK2ME and VK3ME transmissions invariably consist of recordings of musical selections. What makes DX'ers of us all is that we want to reach out and snare a particular station we have just heard about. Maybe, because it has low power, maybe because it really is farther away than any station we have ever heard. Did you ever hear a DX'er say, "Oh, I must get up at 4 o'clock tomorrow morning because station — has such a beautiful program"? No! But you have heard

a fan say, "I must try for station — because no one else ever heard them here in the East"! Programs? All the DX fan wants to hear is station announcements. Not one fan in a thousand can tell the difference between Mendelssohn's Spring Song and "Old Man of the Mountain." When writing down his report it will be: "6:04 a.m. Musical selection."

If we start on a tour of the world, with a short-wave receiver by our side, thousands of miles can be covered. And the most unusual catches may cross our horizon. The past month we have had many of these. FZS, 25.02 meters, Saigon, Indo-China, was extremely active. This commercial phone circuit called "Paree" and occasionally sent musical selections. They were heard at 9 a.m., 10 a.m. and even after midday. VUB (31.36 meters), Bombay, India, did put in a fair signal on three Saturdays in succession. Station announcements were scarce and the programs consisted of European and Oriental music and some long dialogues. RIO (25.5 meters), a U.S.S.R. commercial phone in Baku, called Moscow and became real peeved at Moscow's indifference. (We sent for a verification, but we don't ever expect to receive it.)

The army airplanes and airports had us all baffled by their weird call letters, but after listening to them for about four mornings we did manage to find out that WO9 was in Mitchell Field and IO9 (that call that makes one think of iodine) is a plane.

The Japanese stations continue to be active. We received a verification which read: "The program you heard corresponds to our broadcast transmitted through the short-wave station belonging to the Japanese International Telephone Company. I am sorry that you did not receive answers to your previous correspondence, but I am sure it was well-meant. I doubt if there is anybody at the JVT, Nasaki, Ibaraki, Japan, who is able to write letters in English. If you wish to communicate, write us at: Osaka Building, Uchi-Saiwai-cho, Kojimachiku, Tokyo, Japan." Signed by Dorothy Mizoguchi, in Charge of International Broadcasting.

Many DX'ers, the writer included, were positive they were hearing TGW, Guatemala City, operating on 5940 kc., but according to a letter received from the well-known C. H. W. Nason, Ingeniero de Radio, Ministerio de Fomento, we were all wrong. Mr. Nason says, "The station you heard with the gongs, etc., was undoubtedly

TGX. As near as I can make out, they are supposed to be on 6000 kc. and I have been a bit frightened by the fact that they seem to be sliding up towards 5940, where I intend to operate. My antennas are up and ready and as they are cut for 5940 and my crystal is ordered for that frequency, I'll probably appear there in short order. The last orders for materials are now in New York, and I expect that the shipments will arrive here within the next two weeks. I'll need a bit of time after that to get going properly, as I don't intend to put anything on the air until tests into a dummy antenna shows that all is correct. TGWA, our 5940 kc. transmitter, will operate on a directive antenna for the United States. TG2X is in operation on 420 kc. with both code and phone. The power is 100 watts. The call will be changed following a brief experimental period."

One of the high lights of the winter season was the coming on the air of a short-wave station in Suva, Fiji Islands. Paul Findeisen sent us some very fine information about this newcomer; i.e., "Radio Suva." It is on the air every day except Sunday from 12:30 to 1:30 a.m., E.S.T. The hour's program consists of recordings and the announcer has a strong English accent. The frequency is 13,075 kc. (22.94 meters). The address is, Amalgamated Wireless of Australia, Ltd., Suva, Fiji.

A station that has been in operation by the National Broadcasting Company, for some time although not many reports have been received due to the scarcity of 7-meter receivers, is W2XDG. This station cannot be called a distant catch by DXers in New York but it would prove interesting to hear just how far these signals reach out. W2XDG is entirely experimental in nature and is located on the Empire State Building and transmits on a frequency of 41,000 kc.

*Capt. Horace E. Hall*

### The DX Corner (Short Waves)

(Continued from page 614)

Calif.; Chas. S. Potts, Kernville, Pa.; George H. Fletcher, Gainesville, Florida; Werner Dieffenbach, Berlin, Germany; Jack Dunlevie, Youkers, N. Y.; Walter Wianand, Mechanicsburg, Pa.; N. D. Brumgard, Mason City, Iowa; Wm. Fitzpatrick, Torrington, Conn.; Arthur Hamilton, Somerville, Mass.; H. Joachim Grimm, Long Island, N. Y.; Ned Smith, Nehalem, Ore.; R. Wright, Brooklyn, N. Y.; L. Clarkson, Montreal, Quebec; Earl F. McClary, Kalamazoo, Mich.; Bayard W. Johnson, Kissimmee, Florida; James G. Moore, West Memphis, Arkansas; James Porter, New Cumberland, W. Va.; J. T. Atkinson, Manitoba, Canada; Douglas S. Catching, Washington, D. C.; Sam. I. Emerson, Cleveland, Ohio; G. L. Harris, No. Adams, Mass.; George Sholin, San Francisco, Calif.; Jos. T. Boillot, Detroit, Mich.; H. M. Betters, Conquest, Saskatchewan; Robert Wright, Lennox, Calif.; V. M. Clark, Duluth, Minn.; Tyler Neber, Altus, Oklahoma; C. C. Sabor, Leavenworth, Kansas; C. H. Skatze, Delaware, Ohio; Lawrence Swenson, Eden, Idaho; H. S. Bradley, Hamilton, N. Y.; Walter L. Chambers, Cambridge, Mass.; Wesley W. Loudon, Oakland, Calif.; Earl Carlton, Woburn, Mass.; R. C. Hamrick, Macon, Georgia; J. M. Malast, Buffalo, N. Y.; Frank E. Baier, El Paso, Texas; Manuel E. Betances, Santurco, Puerto Rico; R. S. Houghton, Lancashire, England; L. C. Santos, Bahia, Brazil; Thurston Clarke, Pembroke, Bermuda; A. B. Baadsgaard, Alberta, Canada; John E. Moore, Alta, Canada; Bill Rambo, San Jose, Calif.; J. F. Fritsch, Baltimore, Md.; John Clark, Ancon, Canal Zone; Claude Manship, Kingman, Ariz.; B. A. Mead, Winthrop, Maine; Virgil C. Tramp, Marshfield, Oregon; Fred C. Lowe, Jr., Sumnerlee, W. Va.; James E. Moore, San Francisco, Calif.; Norman H. Miller, Buffalo, N. Y.; R. Edkins, Transcona, Manitoba; Jack Staton, Houston, Texas; Edmore Melanson, Albany, N. Y.; Kenneth Board, Smithfield, W. Va.; James W. Smith, Baltimore, Md.; Charles W. Havlena,

(Continued on page 647)



# HIGH FIDELITY

(With Adjustable Transformer)

This new input transformer permits wide control of the response characteristic of any amplifier in which it is incorporated as a coupling

I. A. Mitchell

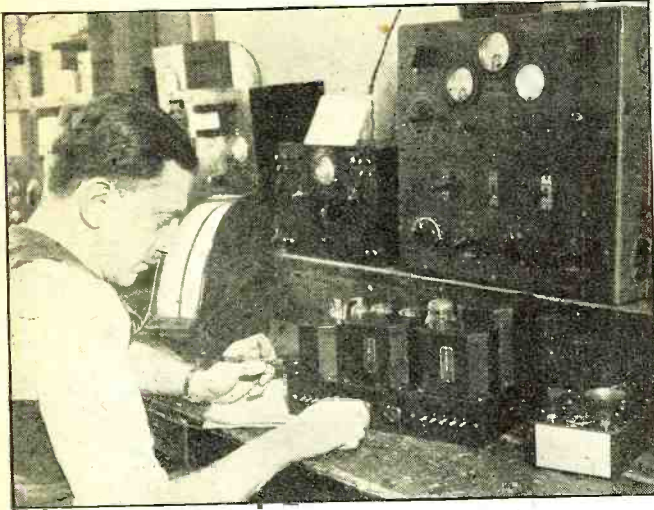

## HIGH-FIDELITY AMPLIFIER

The use of the new input transformer allows for adjustment of the response characteristic to compensate for deficiencies in the response of speaker or input equipment.

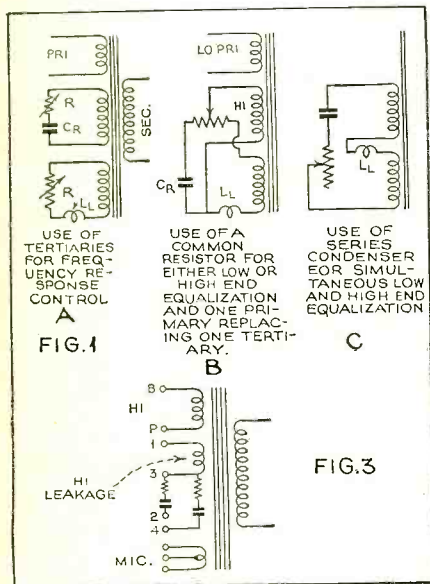

FEW engineers realize what equalizers can actually do with reference to obtaining linear response from non-linear devices. Through equalization new life can be given to radio and phonograph music. In addition, the use of a new type of equalizing transformer makes possible the conversion of an average amplifier system or radio receiver to greatly improved performance from the standpoint of fidelity.

The most common form of equalizer consists of a high-Q reactor with a parallel capacitor to tune it to resonance at the frequency at which maximum equalization is desired. A series resistor is used to control the degree of equalization. Through a proper choice of values, low-frequency equalization can be obtained, or high-frequency equalization. There are many types of more complex equalizers designed for specific applications. However, due to the limited scope of this article, they will not be considered here. The necessity for equalizers is not as greatly appreciated on paper as it is when one actually hears the comparison between normal devices and equalized devices.

Equalizers as applied to commercial equipment are quite expensive, generally running into hundreds of dollars. They also generally effect a high loss. For

example, one of the standard commercial equalizers when set to effect 10 db. simultaneous equalization at 100 and 8000 cycles throws a 32 db. loss in the circuit and an extra stage of amplification is required to regain this.

It is possible to simplify and reduce the cost of equalization by incorporating this tone correction in an audio transformer structure. Figure 1A shows the equivalent circuit of an audio transformer having two tertiary windings.  $L_L$  is the leakage reactance of one winding. If  $R$ , the load resistor on this winding, is set at a low value, it will effectively reduce the reflected impedance of the transformer primary to the source and consequently reduce the gain. In other words, the lower the value of  $R$ , the less efficient the transformer will be. However, the impedance of  $L_L$ , while very small at low frequencies, increases with frequency and may be several times the magnitude of  $R$  at the higher audio frequencies. It is apparent, therefore, that due to the fact that  $R$  and  $L_L$  are in series, the load effect on the transformer is decreased, and the transformer efficiency increased as the frequency increases. The result is a rising response curve which helps regain highs which (Continued on page 641)

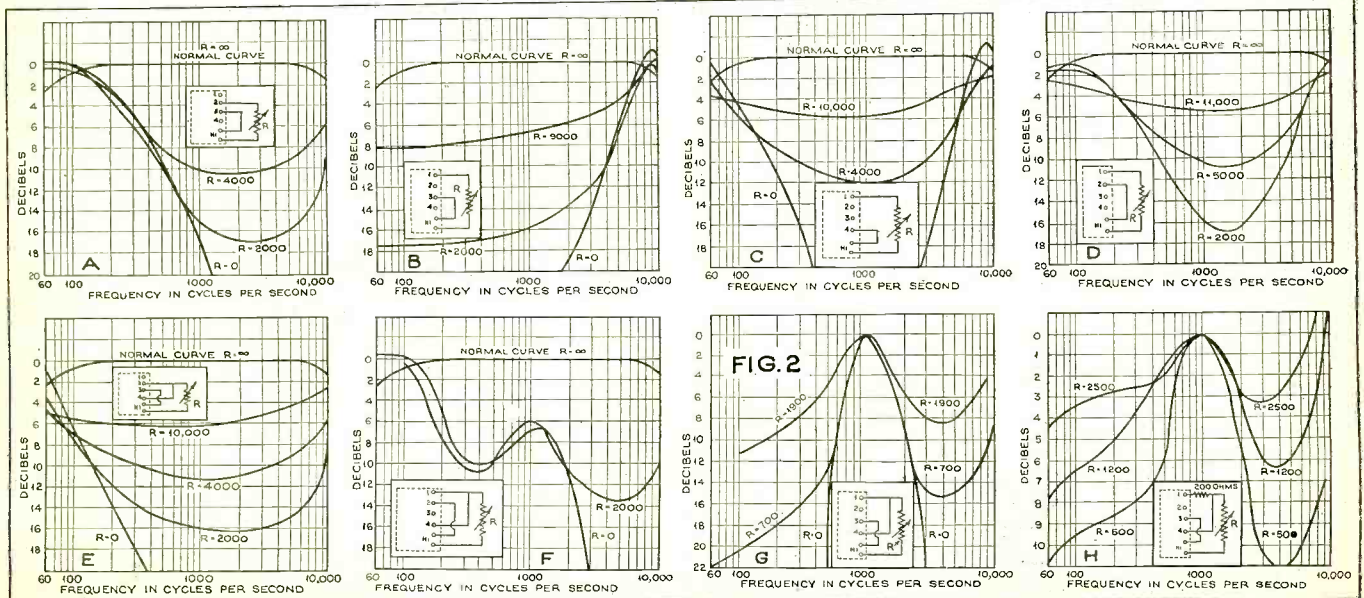



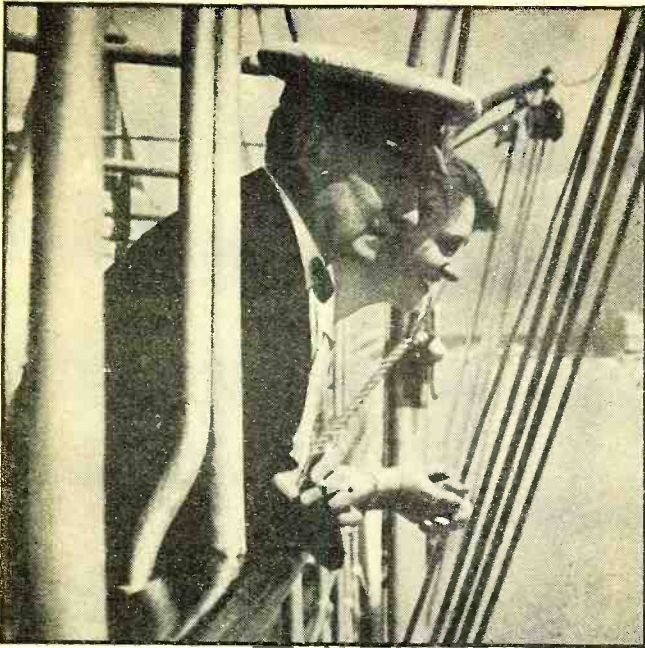

ABOARD THE ELETTRA

*Marconi has well earned every moment of pleasure he spends with his family aboard his famous yacht, the Elettra. He used his "own" inventions in his "own" organizations*

# FIRST AID to INVENTORS

*(Financing Your Invention)*

This is the sixth and concluding article of the series written exclusively for RADIO NEWS readers and explaining many little-known facts about radio patents and inventions

E. E. Free, Ph.D.

*Part Six*

**O**UT of the subjects which the Editor of RADIO NEWS originally suggested for this series of articles there remains to discuss but one item—how is an inventor to raise money to exploit his invention?

**O**NE way to make money out of your invention is not to bother organizing a company or taking any partners, but to *use your invention yourself* in your own business. Suppose, for example, that a radio service organization invents a new way of installing P.A. systems or of hooking up multiple radio antenna systems or something else in this field. There is no real need to take this elsewhere. The invention can be put to work at once in the inventor's own business! If the invention is good enough, the business will prosper correspondingly or someone else will come along and offer to buy either the business or the invention at a fair price. It is but seldom, however, that anything of this kind is possible. Most inventors seem to invent things not connected with their own ways of making a living and not immediately useful in their own occupations. There is a good psychological basis for this, the outsider being usually the person who thinks of new ways of doing things. Accordingly, the average inventor either must sell his invention to someone, as we discussed last month, or must provide capital and other facilities to use it. This is a new adventure in business, perhaps quite as new as was the invention itself.

If the inventor himself has money, it is a temptation to use this money, organize a company which he himself owns and go ahead. Only in the rarest instances is this to be approved. With exceptions so few that they are negligible, no one should finance his own brain child. The fond parent is apt to be *too fond* and to put in money when

the expenditure is *not justified!* It is much better to have the project examined by the cold and unsympathetic eye of someone else, who is being asked to risk his own good money for the sake of possible profits, not because of love for something which he has created. Anyway, it has been my experience that few people who have money do any inventing. By no means all inventors are poverty-stricken, yet the phrase "poor inventor" has a much more familiar ring than "rich inventor." So the real problem usually is not whether the inventor should put in his own money, but how and where he can get somebody else's money to help him.

This will not happen as a gift of the gods. It may be true that a man who builds the best mousetrap in existence will find the world beating a path to his door, but I have not observed it recently. Instead, it usually is necessary not only to build a new, smooth and easy-graded highway for the world to use in reaching your doorstep, but to stand out at the crossroads and offer considerable inducements for the world to use this highway and come in. Capital does not seek the inventor. Instead, the inventor must seek capital.

The first and most important point is that it seldom is capital which is the inventor's greatest need. His most urgent lack is usually that of business experience. No textbook is of more value to the inventor proposing to go into business than the column headed "business troubles" in the daily newspaper.

## INVENTION FOR MEASURING BRAIN CURRENTS

*A student at Brown University (with the special silver electrodes attached to his head and the apparatus above him) having the action currents of his brain measured by a new invention*

Concerns engaged in collecting and publishing business statistics study these lists of failed enterprises with the greatest care. University professors and other statisticians have analyzed them. Two causes account for more business failures than all others put together. One is insufficient capital. The other is lack of experience in the business. In my own belief, most of the cases classed as insufficient capital might have been classed more justly as insufficient experience, since it usually is lack of knowledge of the troubles and pitfalls to be anticipated which induces anyone to start a business without enough capital to tide him through, a point to which I shall return presently.

Virtually every business in the world, whether or not it is concerned with an invention, has three legs on which it must stand, like a three-legged stool. One of these is money and finance. The





business must command enough capital and it must have men who know how to use money well and efficiently. The second leg is relations with the public, including sales. With the partial exception of a few businesses such as gold mining which produce commodities for which there is automatic demand, no business can do without some measure of support and good will from the public. A successful sales manager or even a salesman is much more than an order taker or a high-pressure extractor of cash from the unwary. He is the business's ambassador to the world. The third necessary leg of every business is the technical one. No business, no matter how small, can afford to be ignorant of the best methods, products and technical developments in its field. Here is where most inventors themselves fit into the business picture, invention being usually one of the technical or engineering phases of the enterprise.

If a business lacks firmness in any one of these three legs it may balance precariously for a while on the other two, just as there are skillful jugglers who can teeter for a time on two legs of a stool or even on one leg. But such jugglers not only use too much energy for ordinary life, in addition, they are so rare that they all get jobs in vaudeville. Rarer still are the business men who can balance a business on good engineering alone or good salesmanship alone or good finance alone.

The first step of the inventor proposing to organize a business should be, therefore, to set up these three legs of his proposed stool. Often he himself will be competent for the engineering or technical leg. He must find men or organizations to provide the other two, or he must make sure that he himself has acquired enough ability to build and direct these.

Finance is relatively simple. Plenty of capitalists have money for schemes demonstrated to be sound. Plenty of bankers are able and willing to give sound advice on financial methods. The



**USED "OWN" INVENTIONS**

*George Westinghouse, founder of the company of that name, used his own inventions as the basis for a great manufacturing institution*

leg of sales and public relations often gives more trouble, for it is an unquestionable fact that sales ability of a high order is one of the rarest human abilities in the world, which is why good sales managers get, and deserve, the highest average salaries in the business

**WHAT TO DO WITH IT?**

*Dr. H. H. Jasper and Dr. L. Carmichael, of Brown University, shown with some of the apparatus of their invention for making pictures of amplified "action currents" given off by the human brain. A subject whose brain currents are being measured is pictured on the opposite page. What will they do with their invention?*



world. Scarce or plentiful, this is one of the three abilities which every inventor must provide to hold up his business stool before he tries to sit on it, or to put anybody else's money on it. This is especially true because the inventor's business usually will be, at least in the beginning, a small business.

Both small businesses and large businesses have their advantages, and both have disadvantages. The small business usually is a pleasanter place to work and attracts more active, original and hard-working employees. It has a small overhead and it can change policies or take other new actions far more quickly and efficiently than a large business. It is less likely to be hampered impossibly by governmental or similar interference, something which many business men deem likely to be the great business obstacle of the next two or three decades. I may be wrong, but I feel that these coming decades will see considerably greater advantages to small businesses than in the past few decades. However, the large business has one enormous advantage over the small one. It can afford to make mistakes! The managers of a large business can decide hastily to go into some line of sales or manufacture costing millions, find out that they were mistaken and retire still unbankrupt. Many large businesses do this all the time, apparently calculating that a few mistakes are small costs to pay for the business advantage of being first in a new field which turns out to be profitable. Examples will occur to anyone experienced either in business or in the technical industries.

The small business can afford nothing of the sort. One major mistake may ruin such a small business. Which is why the successful small business man needs to be a far shrewder and more far-sighted individual than the successful employee of a large corporation. It is good advice both to inventors and to other would-be business men that if they have any reason to feel uncertain of their own abilities, especially of their own foresight, they should seek the safe and easy shelter of a job with a large business, not the dangerous and exacting task of helping to run a small one. The fact that the small business dare not make mistakes puts still more weight on the necessity of experience. I would be inclined to set it down as a rule to which no exception can be permitted, that *no inventor or anyone else should even consider starting a business unless he or a thoroughly trustworthy partner or associate has at least five years' experience in that business or a closely related one.* So much is this the case that the traditional and wise expedient for people who want to enter a new business is first to get a job in some similar establishment and to study the business for a few years before beginning the venture of their own. For an inventor proposing to exploit a patent this may be impossible, in which case the best policy probably is to try to find a trustworthy associate who has the necessary experience; and, if such a person is not found, to abandon the idea.

Experience in the proposed business being available, (Continued on page 637)



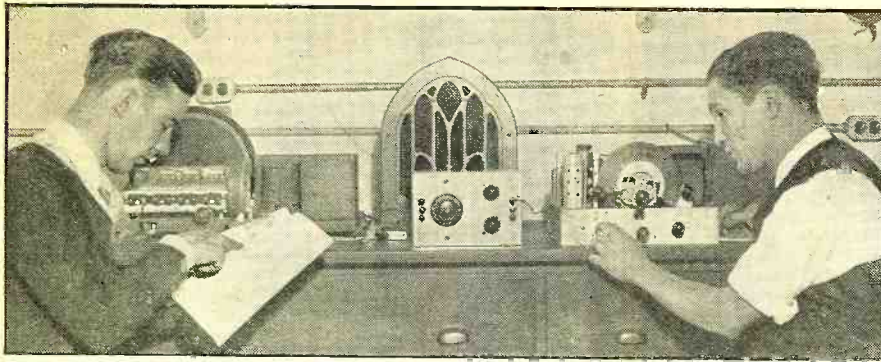

## THE DX CORNER

(For Broadcast Waves)

S. GORDON TAYLOR

FIRST of all, the editor would like to take this occasion to extend a vote of thanks to the Official Listening Post Observers who, through their monthly reports to this department, are making possible the publication of a wealth of DX information. They are doing excellent work and may be sure that their efforts are greatly appreciated by their fellow DX'ers.

COMMENTS from observers and other readers on the material presented in this department are especially invited. Do you find its various features helpful? Are there any you believe should be changed or eliminated? Are there any others that you can suggest? After all, this department is still in the developmental stage and constructive comments will help in moulding it for the greatest good of the greatest number of DX'ers.

It is suggested that Official Observers and others who report reception of foreign stations give the frequency and the hour or hours when best heard for all stations reported! This will permit the inclusion of more complete time data in the "Consolidated Foreign 'Best Bets'" list.

Those desiring appointments as Official Listening Post Observers should include in their applications an outline of their DX activities to date a brief description of the equipment used, etc. Address all applications to the editor of this department.

In planning ahead for the Summer issues, it is felt that this department can at that time devote more space to items on improving DX equipment. If you have any useful ideas on DX antennas, grounds, antenna tuning, "hopping-up" receivers, etc., shoot them along so that other readers may take advantage of the slack DX season to get their equipment in shape for next Winter.

### Advance DX Calendar

The following lists show special and periodic DX broadcasts which have been brought to the attention of this department by Observers, or by the DX Clubs or broadcast stations participating. Advance notices of such broadcasts are appreciated. These should reach RADIO NEWS by the first of the month preceding the month in which the broadcast takes place.

#### Special DX Broadcasts

March 6, Wed., 3:30-3:50 a.m., WSVS, Buffalo, 1370 kc., 50 w., Radio News.  
 March 10, Sun., 3:30-4:30 a.m., WBOQ (WABC) New York, 860 kc., 50 kw., NNRC.  
 March 15, Thur., 5:30-7:30 a.m., XGOD, Hanchow, China, 960 (978?) kc., 1 kw., IDA.

March 16, Fri., 5:30-7:30 a.m. XGOD, Hanchow, China, 960 (978?) kc., 1kw., IDA.  
 March 17, Sun., 3-4 a.m., CHRC, Quebec, 580 kc., 100 w.  
 March 17, Sun., 4:13-5:47 a.m., ? ? ? , 985 kc. (A mystery broadcast by a station never verified to a DX'er on this continent. Will verify all reports received.)  
 April 1, Mon., 1-4 a.m., TGX, Guatemala, Guat., 1400 kc., 150 w. IDA.  
 April 7, Sun., 4-6 a.m., CHRC, Quebec, 580 kc., 100 w.

#### Periodic DX Broadcasts

Tuesdays, 12-12:30 a.m., CFQC, Saskatoon, Sask., 840 kc., 1 kw. (DX Tips)  
 Wednesdays (third Wed., each month) 2-2:30 a.m., WROK, Rockford, Ill., 1410 kc., 5 kw.  
 Thursdays, 12-12:30 a.m., CFQC, Saskatoon, Sask., 840 kc., 1 kw. (DX Tips)  
 Fridays, 7:45-8 p.m., WORK, York, Pa., 1320 kc., 1 kw. (DX Tips)  
 Saturdays, 1 a.m., KSL, Salt Lake City, Utah, 1130 kc., 50 kw. NNRC-IDA.  
 Saturdays, 12:15-12:30 a.m., CKCK, Regina, Sask., 1010 kc., .5 kw. (DX Tips)  
 Saturdays, 12-12:30 a.m., CFQC, Saskatoon, Sask., 840 kc., 1 kw. (DX Tips)  
 Saturdays, 12:30-1 a.m., KDKA, Pittsburgh, Pa., 980 kc., 50 kw. (DX Tips)  
 Saturdays, 2:30-3 a.m., KFI, Los Angeles, 640 kc., 50 kw. (DX Tips)  
 Saturdays (March 2, 9 and 16) 5:30-6:30 a.m., 2UE, Sydney, Aust., 1025 kc., 1 kw. IDA.  
 Sundays, 1 a.m., KSL, Salt Lake City, Utah, 1130 kc., 50 kw. NNRC-IDA.  
 Sundays, 3-3:30 a.m., KIDW, Lamar, Colo., 1420 kc., 100 w.  
 Sundays, Beg. 3:30 a.m., CMBX, Havana, Cuba, 1425 kc., 150 w.  
 Daily, 1 a.m., WSM, Nashville, Tenn., 650 kc., 50 kw. (DX Tips) NNRC-IDA.  
 Daily, 3-4 a.m., W6XAI, Bakersfield, Calif., 1550 kc., 1 kw.  
 Daily, 4 a.m., WNEW, Newark, N. J., 1250 kc., 1 kw. (DX Tips) NNRC-IDA

#### Cuban DX Programs

Following is a list of DX transmission to be put on by Cuban stations. Arrangements for these broadcasts were made by the National Radio Club of York, Pennsylvania. All hours are a.m., Eastern Standard time.

| Date   | Time | Call | Kc.  | Location   |
|--------|------|------|------|------------|
| Mar. 5 | 2-3  | CMJP | 1360 | Moron      |
| 6      | 12-4 | CMHW | 910  | Cienfuegos |
| 9      | 1-2  | CMW  | 910  | Havana     |
| 10     | 2-3  | CMBS | 775  | Havana     |
| 13     | 1-5  | CMOX | 1325 | Havana     |
| 13     | 12-4 | CMHW | 910  | Cienfuegos |
| 20     | 12-4 | CMHW | 910  | Cienfuegos |
| 24     | 2-3  | CMBS | 775  | Havana     |
| 25     | 2-3  | CMJP | 1360 | Moron      |
| 27     | 12-4 | CMHW | 910  | Cienfuegos |
| 29     | 2-3  | CMCA | 1230 | Havana     |
| Apr. 4 | 12-4 | CMHW | 910  | Cienfuegos |
| 5      | 2-3  | CMJP | 1360 | Moron      |
| 6      | 1-2  | CMW  | 910  | Havana     |
| 7      | 2-3  | CMBS | 775  | Havana     |
| 11     | 12-4 | CMHW | 910  | Cienfuegos |
| 13     | 1-5  | CMOX | 1325 | Havana     |
| 18     | 12-4 | CMHW | 910  | Cienfuegos |
| 21     | 2-3  | CMBS | 775  | Havana     |
| 25     | 2-3  | CMJP | 1360 | Moron      |
| 28     | 12-4 | CMHW | 910  | Cienfuegos |

#### Consolidated Foreign "Best Bets"

Following is a list of the foreign stations reported heard by Official Observers in dif-

### Official RADIO NEWS Broadcast Band Listening Post Observers

#### United States

California: Randolph Hunt, Warren E. Winkley  
 Connecticut: Fred Burleigh, James A. Dunningan, Philip R. Nichols, R. L. Pelkey  
 Illinois: Herbert H. Diedrich, Ray E. Everly, H. E. Rebensdorf, D. Floyd Smith  
 Indiana: E. R. Roberts  
 Iowa: Ernest Byers, Lee F. Blodgett  
 Maine: Steadman O. Fountain  
 Maryland: William Rank, Henry Wilkinson, Jr.  
 Massachusetts: William W. Beal, Jr., Russell Foss, Evan B. Roberts  
 Michigan: John DeMyer, Howard W. Eck  
 Minnesota: F. L. Biss  
 Missouri: T. E. Gootee, C. H. Long  
 Montana: R. W. Schofield  
 New Jersey: Henry A. Dare, Jack B. Schneider, Alan B. Walker  
 New York: Jacob Altner, Edward F. Goss, Robert Hough, Robert Humphrey, John C. Kalmbach, Jr., Harry E. Kentzel, Maynard J. Louis, R. H. Tomlinson  
 North Carolina: Marvin D. Dixon  
 Ohio: Donald W. Shields, Richard J. Southward  
 Pennsylvania: Joseph Stokes  
 Texas: E. L. Kimmons  
 Wyoming: J. H. Woodhead

#### Foreign

Australia: Albert E. Faull, Victoria; George F. Ingle, New South Wales  
 Canada: William H. Ansell, Saskatchewan; C. R. Caravan, British Columbia; C. Holmes, British Columbia; Philip H. Robinson, Nova Scotia; Art Ling, Ontario  
 England: R. T. Coales, Hants; F. R. Crowder, Yorkshire; George Ellis, North Stockport  
 Newfoundland: A. L. Hynes, Clarendville  
 New Zealand: L. W. Mathie, Hawke's Bay; R. H. Shepherd, Christchurch; Eric W. Watson, Christchurch  
 South Africa: A. C. Lyell, Johannesburg  
 Sweden: John S. Bohm, Malung  
 Switzerland: Dr. Max Hausdorff, Viganello

ferent sections of the U. S. and Canada. Wherever either an asterisk (\*) or a number appears in a column it indicates that the station has been heard in the section represented by that column. Where a number appears it represents the approximate local time when the station is heard. Heavy numbers represent p.m. and light numbers a.m.

This list is made up from observers' reports as follows: Column 1 (vicinity New York City)—Jacob Altner, Brooklyn; Edward F. Goss, Brooklyn; Jack B. Schneider, Garwood, N. J.; R. H. Tomlinson, Port Chester. Column 2 (Connecticut)—Fred Burleigh, Meriden; James A. Dunningan, New Britain; Philip R. Nichols, East Hartford; R. L. Pelkey, New Haven. Column 3 (Massachusetts)—Russell W. Foss, Lynn; Simon Geller, Roxbury. Column 4 (Northern New York)—John C. Kalmbach, Jr., Buffalo; Harry E. Kentzel, Averill Park; Maynard J. Louis, Hannibal. Column 5 (Illinois)—Herbert H. Diedrich, Moline; R. E. Everly, Newton; H. E. Rebensdorf, Harvard. Column 6 (North Carolina and Maryland)—Marvin B. Dixon, Shelby, N. C.; William Rank, Frostburg, Md. Column 7 (Texas)—E. L. Kimmons, Austin. Column 8 (California)—Warren E. Winkley, Hughson. Column 9 (Saskatchewan)—Wm. H. Ansell, Regina.

The locations and power of all stations will be found in the "Foreign Station Locations" list.

| Kc. | Call        | 1 | 2 | 3 | 4 | 5 | 6 | 7 | 8 | 9 |
|-----|-------------|---|---|---|---|---|---|---|---|---|
| 540 | CJRM        | - | - | 3 | - | - | - | - | - | - |
| 546 | Budapest    | * | - | - | - | - | - | - | - | - |
| 550 | CFNB        | - | - | * | - | - | - | - | - | - |
| 556 | Beromunster | - | - | - | - | * | - | - | - | - |
| 560 | 2CO         | - | - | - | - | - | - | * | - | - |
| 565 | TGW         | * | 3 | - | * | * | 3 | - | - | 4 |



| Kc.   | Call              | 1 | 2 | 3 | 4 | 5 | 6 | 7 | 8 | 9 |
|-------|-------------------|---|---|---|---|---|---|---|---|---|
| 570   | 2YA               | * | - | - | - | - | - | - | - | - |
| 574   | Stuttgart         | * | - | - | - | - | - | - | - | - |
| 580   | CKUA              | * | - | - | - | - | - | - | - | - |
| 590   | XEPN              | - | - | - | 9 | * | - | - | - | - |
| 590   | JOAK-2            | - | - | - | - | - | - | - | - | * |
| 609   | Florence          | * | 2 | 2 | - | - | - | - | - | - |
| 618.5 | KZRM              | * | - | - | - | - | - | - | - | - |
| 621   | Cairo I           | * | - | - | - | - | - | - | - | - |
| 635   | 5CK               | * | - | - | - | - | - | - | - | 4 |
| 638   | Prague            | * | - | - | - | - | - | - | - | - |
| 645   | JQAK              | * | - | - | - | - | - | - | - | 3 |
| 648   | Lyons             | * | - | - | - | - | - | - | - | - |
| 650   | 1YA               | * | - | - | - | 3 | - | - | - | * |
| 658   | Cologne           | * | 1 | 1 | 2 | - | - | - | - | - |
| 660   | XGOA              | * | - | - | - | - | - | 4 | - | - |
| 665   | 2FC               | * | - | - | - | - | - | - | - | - |
| 670   | JFAK              | * | - | - | - | - | - | - | - | * |
| 677   | Sottens           | * | - | - | - | - | - | - | - | - |
| 681   | HJN               | * | - | - | - | - | - | - | - | - |
| 713   | 11KO              | * | - | 2 | - | - | - | - | - | - |
| 720   | 3YA               | - | 5 | - | - | - | - | - | - | - |
| 730   | CKAC              | - | - | - | 1 | - | - | - | - | - |
| 731   | Madrid            | - | 2 | - | - | - | - | - | - | - |
| 740   | Munich            | - | * | 2 | 2 | 3 | - | - | - | - |
| 750   | JOBK-1            | - | - | - | - | - | - | - | - | 4 |
| 750   | KGOK              | - | - | - | - | - | - | - | - | * |
| 750   | KGU               | - | - | - | - | - | - | 4 | - | 1 |
| 760   | 4QG               | * | 6 | - | - | 3 | - | - | - | - |
| 760   | XEBC              | - | - | - | - | - | - | 2 | - | - |
| 770   | JOHK              | - | - | - | - | - | - | - | - | 4 |
| 775   | CMBS              | - | - | - | - | - | - | - | - | - |
| 785   | Leipzig           | * | 1 | 1 | - | - | - | - | - | - |
| 790   | JOJK              | - | - | - | - | - | - | - | - | 4 |
| 800   | 3LO               | - | - | - | - | - | - | - | - | 4 |
| 804   | Scottish Regional | * | 2 | - | - | - | - | - | - | - |
| 810   | JOCK-1            | - | - | - | - | - | - | - | - | 4 |
| 814   | Milan             | * | 2 | 2 | 2 | - | - | - | - | - |
| 830   | LR5               | * | - | - | - | 3 | - | - | - | 1 |
| 830   | JOJK              | - | - | - | - | - | - | - | - | 4 |
| 840   | CMQ               | - | - | - | 7 | - | - | 1 | - | - |
| 840   | CFQC              | - | - | - | - | - | - | - | - | - |
| 841   | Berlin            | - | 1 | 2 | 2 | - | - | - | - | - |
| 850   | JOJK              | - | - | - | - | - | - | - | - | 4 |
| 855   | 2BL               | * | 6 | - | - | 6 | - | - | - | 4 |
| 860   | NEMO              | - | - | - | - | - | - | - | - | - |
| 870   | LR6               | - | 8 | - | - | - | - | - | - | - |
| 870   | JOAK-1            | - | - | - | - | - | - | - | - | 4 |
| 880   | CRCO              | - | - | - | - | - | - | - | - | 3 |
| 900   | JODK-2            | - | - | - | - | - | - | - | - | - |
| 900   | KGUB              | * | 1 | 1 | - | - | - | - | - | - |
| 904   | Hamburg           | - | - | - | - | - | - | - | - | - |
| 910   | CJAT              | - | - | - | - | - | - | - | - | 4 |
| 910   | 4RK               | - | - | - | - | - | - | - | - | - |
| 910   | XENT              | * | 5 | 5 | - | - | - | - | - | - |
| 913   | Toulouse          | * | - | - | - | - | - | - | - | - |
| 920   | HHK               | * | - | - | - | - | - | - | - | - |
| 920   | XHHE              | * | - | - | - | - | - | - | - | - |
| 922   | OKB               | - | - | - | - | - | - | - | - | - |
| 930   | CMW               | - | - | 1 | - | - | - | - | - | - |
| 940   | 3ZR               | - | - | - | - | - | - | - | - | 3 |
| 950   | Breslau           | - | - | - | - | - | - | - | - | - |
| 950   | LR3               | - | 1 | 1 | - | - | - | - | - | - |
| 950   | 2CB               | - | - | - | - | - | - | - | - | 4 |
| 959   | Poste Parisien    | * | 3 | 3 | 3 | 2 | - | - | - | - |
| 960   | XEAW              | - | - | - | - | - | - | - | - | - |
| 960   | YVIRC             | - | 6 | 7 | * | - | - | - | - | - |
| 977   | West Regional     | * | 5 | - | - | - | - | - | - | - |
| 986   | Genoa             | * | 2 | - | - | - | - | - | - | - |
| 990   | LR4               | * | - | - | - | - | - | - | - | - |
| 1034  | OKR               | * | - | - | - | - | - | - | - | - |
| 1040  | CKCK              | - | - | - | - | - | - | - | - | - |
| 1040  | CKCD              | - | - | - | - | - | - | - | - | - |
| 1020  | XEJ               | - | - | - | - | - | - | - | - | - |
| 1025  | 2UE               | - | - | - | - | - | - | - | - | 4 |
| 1031  | Konigsberg        | * | 1 | - | - | - | - | - | - | - |
| 1031  | CTIGL             | * | - | - | - | - | - | - | - | - |
| 1040  | CP4               | * | - | - | - | - | - | - | - | - |
| 1050  | CX26              | - | 3 | - | - | - | - | - | - | - |
| 1059  | Bari              | * | - | - | - | - | - | - | - | - |
| 1077  | Bordeaux          | - | 2 | 5 | - | - | - | - | - | - |
| 1085  | JOBK-2            | - | - | - | - | - | - | - | - | 4 |
| 1090  | 6AM               | * | - | - | - | - | - | - | - | - |
| 1095  | FAJ7              | * | - | - | - | - | - | - | - | - |
| 1110  | 2HD               | - | - | - | - | - | - | - | - | - |
| 1120  | CHSJ              | - | - | 4 | - | - | - | - | - | - |
| 1125  | 2UW               | - | - | - | 3 | - | - | - | - | 4 |
| 1140  | Turin             | - | 2 | 2 | - | - | - | - | - | - |
| 1145  | 4BC               | - | - | - | - | 6 | - | - | - | 4 |
| 1149  | West National     | * | - | - | - | - | - | - | - | - |
| 1158  | OKM               | * | - | - | - | - | - | - | - | - |
| 1170  | 4TO               | - | - | - | - | 6 | - | - | - | - |
| 1175  | JOCK-2            | - | - | - | - | - | - | - | - | * |
| 1175  | COA               | - | - | - | - | - | - | 2 | - | - |
| 1176  | Copenhagen        | * | - | - | - | - | - | - | - | - |
| 1180  | 3DB               | - | - | - | - | 6 | - | - | - | - |
| 1190  | VE9EK             | - | - | 4 | - | - | - | - | - | - |
| 1190  | LS2               | * | 6 | - | - | - | - | - | - | - |
| 1200  | CHAB              | - | 2 | 2 | - | - | - | - | - | - |
| 1210  | CKIB1             | - | - | - | - | - | - | - | - | - |
| 1210  | NETH              | - | - | - | 5 | - | - | - | - | - |
| 1210  | KEFV              | - | - | - | - | - | - | - | - | - |
| 1210  | CHNC              | - | - | - | 2 | 2 | 1 | - | - | - |
| 1222  | Trieste           | - | 2 | 2 | 2 | - | - | - | - | - |
| 1230  | NEFJ              | - | - | - | - | - | - | - | - | - |
| 1230  | CPX               | - | - | - | - | - | - | - | - | - |
| 1240  | WKAQ              | - | - | - | - | 4 | - | - | - | - |
| 1267  | Nurnburg          | - | 1 | - | - | - | - | - | - | - |
| 1270  | HIX               | - | - | - | - | - | - | - | - | - |
| 1290  | WNEL              | - | - | - | - | - | - | - | - | - |
| 1310  | CJLS              | - | - | 4 | - | - | - | - | - | - |
| 1312  | Malmo             | - | - | - | - | - | - | - | - | - |
| 1320  | KGMB              | - | - | - | - | - | - | - | - | - |
| 1325  | CMOX              | - | - | - | - | 4 | - | - | - | - |
| 1348  | Radio-Vitus       | - | 2 | - | - | - | - | - | - | - |
| 1380  | 4BH               | - | - | - | - | - | - | - | - | 4 |
| 1450  | CHGS              | - | - | - | - | - | - | - | - | - |
| 1450  | CPCT              | - | - | - | - | - | - | - | - | - |
| 1450  | COK               | - | - | - | - | - | - | - | - | - |
| 1456  | Radio-Normandie   | * | 2 | 2 | 2 | - | 2 | - | - | - |

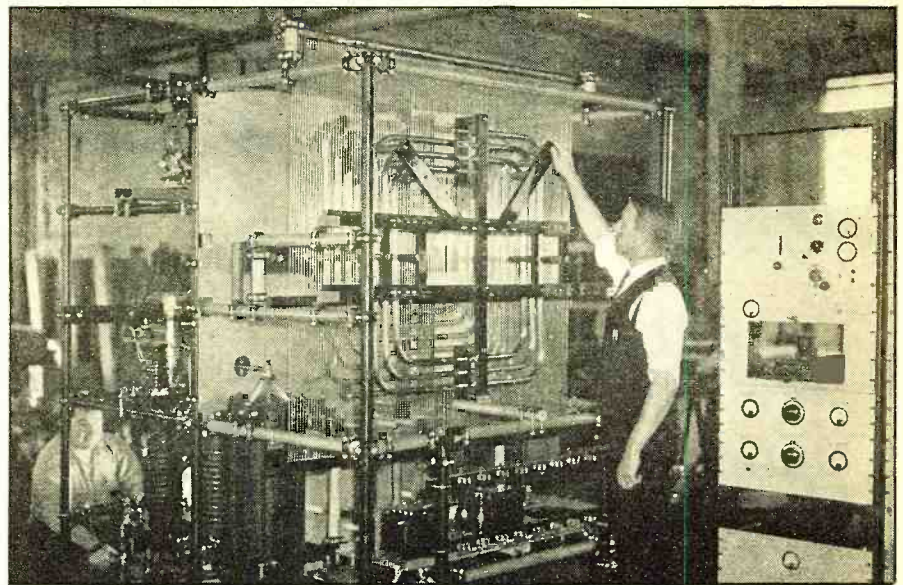

**STATIC SHIELD FOR TRANSMITTERS**  
*Much of the interference, variously known as "Harmonics," "Phantom Frequencies" (not the same as "Image Frequencies"), etc., encountered in tuning signals on both broadcast and short-wave ranges can be traced to the harmonics emitted by powerful broadcast transmitters. Westinghouse has now developed the electro-static shield shown here, a curtain of grounded wires suspended between the coils of the antenna coupler, which according to estimates will greatly reduce harmonic emission and aid materially in the elimination of interference.*

**Foreign Station Locations**

This list provides the call, location, frequency and power of each foreign station reported heard during January by Official L.P.O.'s. See the "Consolidated 'Best Bets'" lists for a record of foreign stations heard in your section of the country.

| Kc. | Kw. | Call          | Location                    |
|-----|-----|---------------|-----------------------------|
| 540 | 1   | CJRM          | Moose Jaw, Sask., Canada    |
| 546 | 120 | Budapest      | Hungary                     |
| 550 | .5  | CFNB          | Fredericton, N. B., Canada  |
| 556 | 100 | Beromunster   | Switzerland                 |
| 560 | 7.5 | 2CB           | Corowa, N.S.W., Australia   |
| 560 | 7.5 | 2CO           | Corowa, N.S.W., Australia   |
| 564 | 60  | Athlone       | Irish Free State            |
| 565 | 10  | TGW           | Guatemala City, Guatemala   |
| 570 | 5   | 2YA           | Wellington, New Zealand     |
| 574 | 100 | Stuttgart     | Germany                     |
| 580 | .5  | CKUA          | Edmonton, Alta., Canada     |
| 580 | 1   | 7ZL           | Hobart, Tasm., Australia    |
| 590 | 50  | XEPN          | Piedras Negras, Mexico      |
| 590 | 10  | JOAK-2        | Tokyo, Japan                |
| 592 | 120 | Vienna        | Austria                     |
| 600 | .2  | XMHA          | Shanghai, Kiang-su, China   |
| 601 | 6.5 | Rabat         | Morocco                     |
| 609 | 20  | Florence      | Italy                       |
| 610 | 10  | JODK-1        | Keijo, Korea, Japan         |
| 610 | 4.5 | 3AR           | Melbourne, Vict., Australia |
| 618 | 5.0 | KZRM          | Manila, Philippine Islands  |
| 620 | .5  | 4ZP           | Invercargill, New Zealand   |
| 621 | 20  | Cairo I       | Egypt                       |
| 625 | .5  | JOTK          | Matsuye, Japan              |
| 629 | 15  | Lisbon        | Portugal                    |
| 630 | 4.5 | LS3           | Buenos Aires, Argentina     |
| 630 | .1  | CKOV          | Kelowna, B. C., Canada      |
| 635 | .5  | JODG          | Hamamatsu, Japan            |
| 635 | 7.5 | 5CK           | Crystal Brook, Australia    |
| 638 | 120 | Prague        | Czechoslovakia              |
| 645 | .3  | JOJK          | Akita, Japan                |
| 645 | .5  | JQAK          | Dairen, Japan               |
| 648 | 15  | Lyons         | France                      |
| 650 | .5  | 1YA           | Auckland, New Zealand       |
| 655 | .3  | JOCC          | Asahogawa, Japan            |
| 658 | 100 | Langenburg    | Germany                     |
| 658 | 100 | Cologne       | Germany                     |
| 660 | 75  | XGOA          | Nanking, China              |
| 665 | 3.5 | 2FC           | Sydney, N.S.W., Australia   |
| 668 | 50  | North Reg'nal | Great Britain               |
| 670 | 10  | JFAK          | Taihoku, Formosa, Japan     |
| 675 | ... | YV6RV         | Valencia, Venezuela         |
| 677 | 25  | Sottens       | Switzerland                 |
| 680 | .5  | JOVK          | Hakodate, Japan             |
| 681 | 1   | HJN           | Bogota, Colombia            |
| 685 | 2   | VAS           | Glace Bay, N. S., Canada    |
| 690 | 3.5 | 6WF           | Perth, W. Austr., Australia |
| 695 | 7   | PTT           | Paris, France               |
| 700 | .5  | JOJK          | Okayama, Japan              |
| 704 | 55  | Stockholm     | Sweden                      |
| 710 | 3   | JOJK          | Kanazawa, Japan             |
| 713 | 50  | 11RO          | Rome, Italy                 |
| 720 | 1   | JFBK          | Taipei, Formosa, Japan      |
| 720 | .5  | JOJK          | Kobe, Japan                 |
| 730 | 2.5 | 3YA           | Christchurch, New Zealand   |
| 730 | .5  | CKAC          | St. Hyacinthe, Que., Canada |
| 730 | 2   | 5CL           | Adelaide, Australia         |
| 731 | 3   | Madrid        | Spain                       |
| 735 | 1   | JOSK          | Kokura, Japan               |
| 740 | 100 | Munich        | Germany                     |

|     |      |               |                             |
|-----|------|---------------|-----------------------------|
| 750 | 10   | JOBK-1        | Osaka, Japan                |
| 750 | 1    | KGOK          | Canton, Kwang-tung, China   |
| 750 | 2.5  | KGU           | Honolulu, Hawaii            |
| 760 | 2.5  | 4QG           | Brisbane, Qnsld., Australia |
| 760 | 5    | XEBC          | Agua Caliente, Mexico       |
| 767 | 25   | Midland Reg.  | Great Britain               |
| 770 | 10   | JOHK          | Sandai, Japan               |
| 775 | .13  | CMBS          | Havana, Cuba                |
| 780 | .5   | JOJK          | Shizuoka, Japan             |
| 780 | .25  | KFQD          | Anchorage, Alaska           |
| 785 | 120  | Leipzig       | Germany                     |
| 790 | 8    | LR10          | Buenos Aires, Argentina     |
| 790 | 10   | JOJK          | Kumamoto, Japan             |
| 790 | .5   | 4YA           | Dunedin, New Zealand        |
| 795 | 5    | Barcelona     | Spain                       |
| 800 | 5    | 3LO           | Melbourne, Vict., Australia |
| 804 | 50   | Scottish Reg. | Great Britain               |
| 810 | 10   | JOCK-1        | Nagoya, Japan               |
| 814 | 50   | Milan         | Italy                       |
| 815 | .25  | PRA6          | Rio de Janeiro, Brazil      |
| 820 | .065 | 2ZH           | Napier, New Zealand         |
| 830 | 16   | LR5           | Buenos Aires, Argentina     |
| 830 | 10   | JOJK          | Sapporo, Japan              |
| 832 | 100  | RW39          | Moscow IV, U.S.S.R.         |
| 840 | 1    | CFQC          | Saskatoon, Sask., Canada    |
| 840 | .34  | CMQ           | Havana, Cuba                |
| 840 | .4   | VOGY          | St. Johns, Newfoundland     |
| 840 | .2   | 2YC           | Wellington, New Zealand     |
| 841 | 100  | Berlin        | Germany                     |
| 845 | 2    | ZBW           | Hong Kong, China            |
| 850 | 1.5  | Valencia      | Spain                       |
| 850 | 10   | JOJK          | Hiroshima, Japan            |
| 855 | 3    | 2BL           | Sydney, N.S.W., Australia   |
| 859 | 15   | Strasbourg    | France                      |
| 860 | 2.5  | NEMO          | Tijuana, Mexico             |
| 870 | 2.1  | LR6           | Buenos Aires, Argentina     |
| 870 | 10   | JOAK-1        | Tokyo, Japan                |
| 877 | 50   | London Reg.   | Great Britain               |
| 880 | 1    | CRCO          | Hawthorne, Ont., Canada     |
| 880 | .15  | 1YX           | Auckland, New Zealand       |
| 890 | 50   | XEW           | Mexico City, Mexico         |
| 900 | 10   | JODK-2        | Keijo, Korea, Japan         |
| 900 | .5   | KGUB          | Ketchikan, Alaska           |
| 904 | 100  | Hamburg       | Germany                     |
| 910 |      |               |                             |



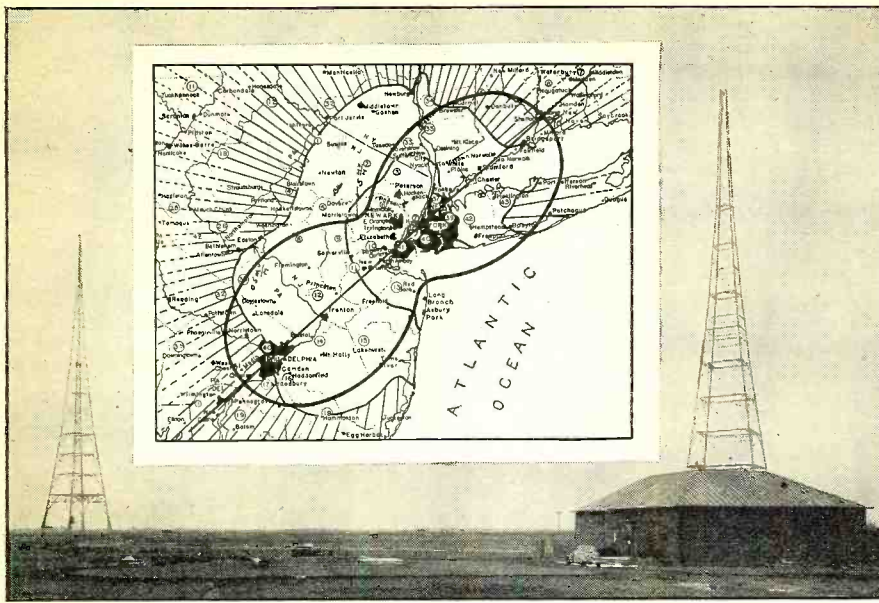

AS this article is being written, workers are putting the finishing touches on the new transmitter of WOR, of Newark, New Jersey. It is quite certain that by the time you read these lines, the new 50,000-watt transmitter at Carteret, New Jersey, will have already replaced the station's old 5,000-watt unit at Kearny.

THE new transmitter at Carteret was erected after considerable difficulty in finding a site that would be satisfactory for such a high-powered unit. Even at Carteret, opposition to the entrance of the 50-kw. WOR unit was argued to the extent that a special election had to be called. WOR rented a store as campaign headquarters and the electioneering was as heated as any political campaign. When the ballots were counted, WOR discovered that its fight was won. And the town discovered that it, too, won—in the obtaining of a new taxpayer.

The antenna was designed by the Bell Telephone Laboratories in conjunction with the Blaw-Knox Company, to suit the particular needs of WOR in obtaining maximum results from its 306 A 50-kw. Western Electric transmitter. Each tower is 385 feet tall and the masts are spaced 790 feet apart. The horizontal wire from tower to tower is merely a non-radiating guy-wire to support a vertical strand of No. 14 wire which, like each outside mast, serves as a vertical radiator. Thus, although but two towers are erected, the addition of the center wire permits the use of three vertical radiators.

J. R. Poppele, chief engineer of WOR, explained to the writer that the use of the  $\frac{3}{4}$ -wave antenna, linked by concentric transmission lines to the transmitter building, yielded greatest signal strength in two directions—towards New York and towards Philadelphia. The signals, instead of being distributed evenly in all directions, go out in a figure-of-eight fashion with the top part of the eight towards New York and the bottom part towards Philadelphia. According to Poppele, this system yields an apparent power of 120-kw. in the direction of New York and an equal

#### TRANSMITTER AND ANTENNA

Here is a picture of the new WOR installation. Insert shows field-strength map with signals directed to New York and Philadelphia.

apparent rating in the direction of Philadelphia. Thus, the heaviest energy is aimed at the zones of densest population.

Poppele showed that a straight line drawn through New York and Philadelphia, with Carteret as the point of

## New 10-50 KW KYW (Philadelphia, Pa.)

John Strong

THE moving of Station KYW, 10-kilowatt, 990-kilocycle broadcast unit, from Chicago to Philadelphia was recently accomplished. The station, still owned by the Westinghouse Electric & Manufacturing Company, has retained its old power and frequency assignments at its new location in the Quaker City. KYW transmitted its initial program in 1921 and has often been termed the pioneer station of the Midwest.

The equipment erected at Station KYW's new Eastern home is featured by a novel antenna system consisting of four 245-foot vertical radiators each connected separately to the transmitter. The transmitter's power is divided in these four units. Through this control of the phase relationship of the current delivered to the four masts, it is pos-

## New 50-KW WOR (Carteret, N. J.)

Samuel Kaufman

register, would continue on through most of the big coastal cities. The line would go through, or approach, such cities as Boston, New Haven, Bridgeport, Baltimore and Washington.

A minimum apparent power of 6 kw. will emanate from the left and right of the figure-of-eight's center. Thus, a minimum will be wasted towards the sea and an equal minimum will be adequate for residents in the mountain districts in the opposite direction.

WOR has also made application to the Federal Communications Commission for a sister short-wave station at Carteret, which would send out WOR programs on the short waves. Poppele expected that the short-wave unit would be in operation shortly after the 50-kw. set went on the air.

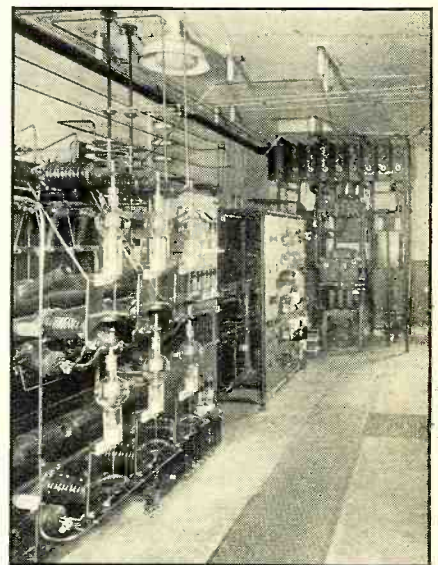

#### NEW TRANSMITTER ROOM

This view shows a part of the transmitter equipment, which is remote-controlled from the operator's panel-board.

sible to adjust the direction of the radio beam, with maximum signal strength aimed at Philadelphia. The directional antenna system serves a dual purpose, inasmuch that, in minimizing the power in directions other than Philadelphia, interference is avoided with other radio (Continued on page 636)



# List of U. S. TIME-SIGNAL TRANSMISSIONS

Robert Hertzberg

THE following lists show United States Naval Radio stations that regularly transmit time signals and weather forecasts. The daily time is given in Eastern Standard Time. Subtract one hour for Central Standard, two hours for Mountain Standard, and three hours for Pacific Standard; add five hours for Greenwich Mean Time.

Continental code is used for all weather forecasts except on the 690 kc. frequency of NAL, Washington, D. C. Note that this is well within the regular broadcast band. All the other frequencies are above or below. Voice transmission is also used by NAL for its time broadcasts.

One asterisk (\*) following the frequency indicates first-order time signals. These are precision signals for chronometer rating and scientific use, normally correct as broadcast to less than one-tenth of a second. The average error of the Arlington and Annapolis signals is only .02 second.

Two asterisks (\*\*) indicate second-order time signals, for chronometer rating and ordinary use, normally cor-

rect as broadcast to less than five-tenths of a second.

Three asterisks (\*\*\*) indicate third-order signals, which are satisfactory for ordinary commercial and domestic timing, but not for chronometer rating or precision timing.

### TIME SIGNALS

| Time            | Kc. Call    | Location          |
|-----------------|-------------|-------------------|
| 11:55 p.m. mid. | 113* NAA    | Washington, D. C. |
| 11:55 p.m.      | 64* NAA     | Washington, D. C. |
| 11:55 p.m.      | 4525* NAA   | Washington, D. C. |
| 2:55-3 a.m.     | 113* NAA    | Washington, D. C. |
| 2:55-3 a.m.     | 9050* NAA   | Washington, D. C. |
| 2:55-3 a.m.     | 42.8* NPG   | San Francisco     |
| 2:55-3 a.m.     | 108* NPG    | San Francisco     |
| 2:55-3 a.m.     | 8590* NPG   | San Francisco     |
| 2:55-3 a.m.     | 8090* NPM   | Honolulu          |
| 2:55-3 a.m.     | 22.9* NPO   | Cavite, P. I.     |
| 7:55-8 a.m.     | 9050* NPO   | Cavite, P. I.     |
| 11:55 a.m. noon | 690* NAL    | Washington, D. C. |
| 11:55 a.m.      | 64* NAA     | Washington, D. C. |
| 11:55 a.m.      | 113* NAA    | Washington, D. C. |
| 11:55 a.m.      | 8410* NAA   | Washington, D. C. |
| 11:55 a.m.      | 12,615* NAA | Washington, D. C. |
| 11:55 a.m.      | 16,820* NAA | Washington, D. C. |
| 11:55 a.m.      | 42.8* NPG   | San Francisco     |
| 11:55 a.m.      | 108* NPG    | San Francisco     |
| 11:55 a.m.      | 12,885* NPG | San Francisco     |
| 11:55 a.m.      | 8090 NPM    | Honolulu          |
| 12:55-1 p.m.    | 46*** NBA   | Balboa, C. Z.     |
| 3:55-4 p.m.     | 42.8* NPG   | San Francisco     |
| 3:55-4 p.m.     | 9050* NAA   | Washington, D. C. |
| 3:55-4 p.m.     | 113* NAA    | Washington, D. C. |
| 6:55-7 p.m.     | 42.8* NPG   | San Francisco     |

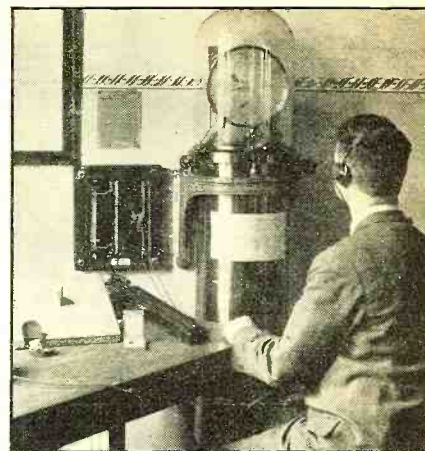

### ACCURATE TIME

Most governments maintain laboratories for determining time by astronomical methods and employ high-precision chronometers sealed in vacua.

|                  |             |                   |
|------------------|-------------|-------------------|
| 6:55-7 p.m.      | 113* NAA    | Washington, D. C. |
| 6:55-7 p.m.      | 9050* NAA   | Washington, D. C. |
| 6:55-7 p.m.      | 26.1* NPM   | Honolulu          |
| 6:55-7 p.m.      | 106* NPM    | Honolulu          |
| 9:55-10 p.m.     | 690* NAL    | Washington, D. C. |
| 9:55-10 p.m.     | 113* NAA    | Washington, D. C. |
| 9:55-10 p.m.     | 9050* NAA   | Washington, D. C. |
| 9:55-10 p.m.     | 42.8* NPG   | San Francisco     |
| 9:55-10 p.m.     | 108* NPG    | San Francisco     |
| 9:55-10 p.m.     | 12,885* NPG | San Francisco     |
| 9:55-10 p.m.     | 16,180* NPM | Honolulu          |
| 10:55-11 p.m.    | 46*** NBA   | Balboa, C. Z.     |
| 11:35-11:30 p.m. | 56* NPO     | Cavite, P. I.     |
| 11:25-11:30 p.m. | 8872* NPO   | Cavite, P. I.     |
| 11:25-11:30 p.m. | 17,744 NPO  | Cavite, P. I.     |

### WEATHER FORECASTS

| Time       | Kc. Call   | Location           |
|------------|------------|--------------------|
| Midnight   | 360 NKB    | Galveston, Tex.    |
| 8:00 a.m.  | 22.9 NPO   | Cavite, P. I.      |
| 8:00 a.m.  | 9050 NPO   | Cavite, P. I.      |
| 8:00 a.m.  | 102 NPC    | Puget Sound, Wash. |
| 8:00 a.m.  | 375 NPD    | Tatoosh, Wash.     |
| 8:30 a.m.  | 102 NPE    | Astoria, Ore.      |
| 10:10 a.m. | 690 NAL    | Washington, D. C.  |
| 10:30 a.m. | 122 NAO    | Charleston, S. C.  |
| 10:48 a.m. | 113 NAS    | Pensacola, Fla.    |
| 11:00 a.m. | 122 NAM    | Norfolk, Va.       |
| 11:30 a.m. | 102 NAD    | Boston, Mass.      |
| 11:30 a.m. | 185 NAO    | Jupiter, Fla.      |
| Noon       | 360 NKB    | Galveston, Tex.    |
| Noon       | 102 NPC    | Puget Sound, Wash. |
| Noon       | 375 NPD    | Tatoosh, Wash.     |
| 12:30 p.m. | 102 NPE    | Astoria, Ore.      |
| 1:00 p.m.  | 106 NAR    | Key West, Fla.     |
| 3:45 p.m.  | 690 NAL    | Washington, D. C.  |
| 4:00 p.m.  | 122 NAM    | Norfolk, Va.       |
| 4:00 p.m.  | 102 NPC    | Puget Sound, Wash. |
| 4:00 p.m.  | 375 NPD    | Tatoosh, Wash.     |
| 4:30 p.m.  | 102 NPE    | Astoria, Ore.      |
| 5:30 p.m.  | 500 NPM    | Honolulu, T. H.    |
| 6:00 p.m.  | 122 NAO    | Charleston, S. C.  |
| 7:00 p.m.  | 360 NKB    | Galveston, Tex.    |
| 8:00 p.m.  | 102 NPC    | Puget Sound, Wash. |
| 8:00 p.m.  | 375 NPD    | Tatoosh, Wash.     |
| 8:30 p.m.  | 102 NPE    | Astoria, Ore.      |
| 10:00 p.m. | 690 NAL    | Washington, D. C.  |
| 10:00 p.m. | 102 NPC    | Puget Sound, Wash. |
| 11:00 p.m. | 102 NPC    | Puget Sound, Wash. |
| 11:00 p.m. | 375 NPD    | Tatoosh, Wash.     |
| 11:00 p.m. | 106 NAR    | Key West, Fla.     |
| 11:30 p.m. | 56 NPO     | Cavite, P. I.      |
| 11:30 p.m. | 8872 NPO   | Cavite, P. I.      |
| 11:30 p.m. | 17,744 NPO | Cavite, P. I.      |

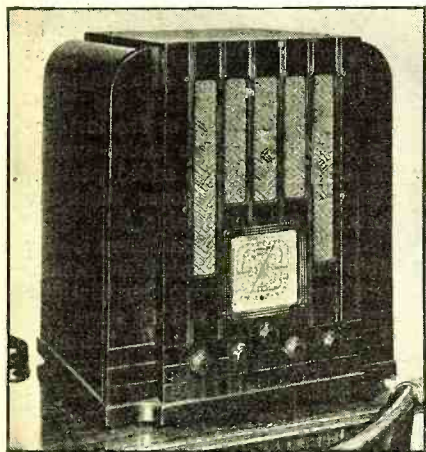

8-TUBE "SUPERHET"

This is the superheterodyne described, encased in table-model cabinet.

THIS new receiver is an 8-tube, 4-band superheterodyne of the all-wave type, with the unusually wide tuning range of 140 to 18,000 kc. (16.67 to 2143 meters), except for one break between 410 and 540 kc. (556-732 meters). This range permits the listener to cover all of the important broadcasting, police, aircraft and amateur bands used throughout the world.

Excellent sensitivity, selectivity and tone quality, together with the high

audio output of 4-watts, make this a desirable receiver. Operating features include an airplane type dial, double-ratio vernier drive, a visual band-indicator, and a special "second hand" on the dial to facilitate the logging of short-wave stations. Provision is made for the use of a magnetic type phonograph pick-up. The set is available for use on alternating current of 25-60 and 50-60 cycles frequency, and any voltage between 105 and 250. Power consumption of all models is 130 watts.

The general circuit arrangement consists of an r.f. stage using a 6D6, composite oscillator-mixer using a 6A7, one 6D6 i.f. stage, a combined second detector, automatic volume control and a.f. stage using (Continued on page 640)

Accurate time signals are also transmitted through experimental station W9XAM, located at Elgin, Ill., by the Elgin National Watch Company. This station operates on 4797.5 kc., with a crystal controlled 500-watt transmitter, on the following schedule (Central Standard Time):

|                 |                         |
|-----------------|-------------------------|
| 7:55-8:00 a.m.  | daily except Sunday     |
| 8:55-9:00 a.m.  | daily except Sunday     |
| 9:55-10:00 a.m. | daily except Sunday     |
| 11:55 a.m.-noon | daily except Sunday     |
| 1:55-2:00 p.m.  | daily except Sat., Sun. |
| 9:55-10:00 p.m. | daily except Sunday     |

These transmissions are especially convenient to owners of short-wave receivers.



# PROFITS FOR SERVICEMEN IN GROUP HEARING AIDS

Charles A. and Paul Bottorff

**I**T might at first seem that the extent of the group hearing aid field is limited. Nevertheless statistics show that over one percent of the population have hearing impaired to such an extent that some artificial aid is desirable. Since individuals in the course of everyday life frequent many places of assemblage, the potential market for group hearing aids is obviously large.

In general the complete group hearing aid system may be divided into five parts. These are the pick-up, amplifier, wiring, reproduction system, and the auxiliary equipment.

The pick-up system consists, in the case of a church or school, of a microphone, probably of the double button carbon type. In the case of movie theatres, a microphone is frequently suspended in front of the sound system loud speaker. A better plan is to tap off the theatre sound system, by means of a suitable transformer, having the secondary feed the group hearing aid amplifier. This latter arrangement has the advantage of eliminating extraneous noise, is more simple, and is frequently lower in cost.

With regard to the amplifying system, so much has already been said, (most articles dealing with group hearing aids have discussed this at great length) that it does not seem advisable to say much except that the amplifier must be good, and capable of providing ample undistorted volume. The input and output transformers must be such as to provide efficient coupling and the latter also serves to eliminate high d.c. voltage in the transmission line, thus reducing the cost of wiring since conduits are not required by the Underwriters for low voltages.

Upon the transmission system a considerable part of the success of the in-

stallation rests. Several general rules may be stated which should govern the selection of seats at which outlet boxes will be placed. First, the seats should be easily accessible from the aisles as a certain amount of explanation by the ushers may be necessary. Second, not more than two seats in a row should be provided with outlet boxes. If every seat in a row is wired, friends of the hard-of-hearing must sit elsewhere. In general, the seats selected in theatres should be in the rear half, while in churches somewhat more to the front, and in schools, the front seats so that the students may readily see the lips of the teacher.

The actual wiring consists of merely running wires from the amplifier to the individual outlet boxes. In some larger cities building codes may require that the wiring be placed in conduits, but in

## TYPICAL EQUIPMENT

*Below are shown a compact amplifier, a double-button carbon microphone, an individual outlet box with volume control, and two types of standard headphones. At the extreme lower left is a bone conductor which when placed behind the ear transmits sound through the bone to the inner ear. This latter unit provides good results for many who cannot hear with headphones*

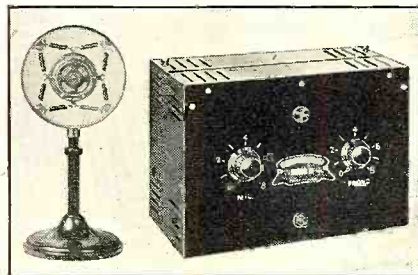

most communities these low-voltage wires are laid under carpets or seats, merely being protected against wear. Outlet boxes are available which contain a volume control and phone jack. These may be readily attached in some convenient place on the seats selected, as shown in one of the accompanying illustrations. The outlet boxes are obtainable in a variety of finishes to harmonize with the existing furniture.

The reproducing system normally consists of earphones. In church installations phones attached to a lorgnette handle are usually preferred, while in theatres and schools where the program is longer single earphones with light-weight headbands are used. Because of the ease and comfort, greater durability and better quality it is generally conceded that the very light weight flat earphone should be used. Two types of "Featherweight" (Trimm) earphones, as well as an outlet box, phone plug, and bone conduction oscillator are illustrated. Since the users of the installation generally judge the entire system by the earphones used, added prestige is obtained by using phones which are comfortable and dependable.

In place of the earphone there is now available the bone conduction oscillator, for use with group installations. This new Trimm unit will aid some who may be unable to hear through the outer ear, and will be preferred by others who may be able to hear better by means of bone conduction.

Auxiliary equipment may sometimes be used advantageously in conjunction with group hearing aids; a loudspeaker in the church parlors or nursery for instance, or perhaps a loudspeaker for monitoring purposes.

Selling the idea of a group hearing aid system to the potential customer is by far the most difficult part of the job. To sell a group hearing aid in a community, the approximate number of those requiring this service should first be ascertained. This may be done by interviewing the clergy who are generally able and willing to give such information. This survey will show the extent of the field, give an idea of the church affiliations, and most important, the prospect (Continued on page 629)



at which the first work in the community should be directed.

Churches are without doubt the best place to sell the first group hearing aid in a given community. It will probably be apparent that one church has far more persons with impaired hearing than another; so this is the first place to present the idea. Generally there are two places to attack in the case of a church: the church board, or some person who is willing to pay at least a large part of the cost. This person may have impaired hearing and wish to enjoy the advantages of such an installation, or he may merely wish to bring happiness into the lives of those less fortunate. Again, the hard-of-hearing group may be able to contribute the sum necessary.

After the first installation has been made, and if the work is well done, the road to future installations becomes much easier—experience has been gained, some of the resistance has been broken down, and the general interest in installations of this kind has been increased.

Theatre managers will almost always demand some assurance that a financial gain will result. If one or more installations have been made in churches within a given community, the number using these may serve as an index of the response from a group hearing aid in a theatre. There are many examples of theatres in which the installation has paid well. A theatre seating twelve hundred, located in a town of eight thousand population and having another ten thousand people from neighboring towns to draw from, has an average of ten customers each night using the phones—ten customers who would not otherwise come. Since the admission is 35 cents, the investment of \$225.00 was written off in a little more than two months. Another case is that of a metropolitan theatre seating four thousand, where a weekly average of over 300 persons take advantage of the facilities offered—not to mention others who have accompanied these hard-of-hearing patrons.

The schools are not generally an immediate place to work. Much missionary work must be done before the school boards will be induced to make the necessary expenditure. However, equipment especially adapted for school installations has been developed and is available at a reasonable price.

In order to sell a group hearing aid to a prospective customer, the seller should have an idea of the approximate cost in order that he may discuss intelligently the advantage of such installations. The cost may be split into components from which in a general way the cost of any installation may be estimated. The microphone costs from \$25 to \$40; the amplifier from \$60 to \$80, depending on the number of headphones to be used; the wiring and outlet boxes, including volume controls and ear-phones, would cost about \$12 to \$14 per person.

A word of warning is offered to servicemen who might try to use inferior parts or do the work in a slipshod fashion. Troubles soon develop in such installations and the reputation of the serviceman is seriously hurt. Manufacturers of quality goods stand back of every piece of equipment they make, and although the cost may be slightly more, the added assurance of quality of fully guaranteed equipment will help sell the installation and keep it sold.

### A New Radio Station in Moscow

MOSCOW, U. S. S. R.—A new 500-kilowatt broadcasting station will be opened in Moscow within the near future. It is expected that this station will be heard in all parts of Europe as well as in the north of Africa. The station was built and designed by Soviet engineers.

# Variable I.F. COUPLING

*provides SELECTIVITY or FIDELITY, as you choose*

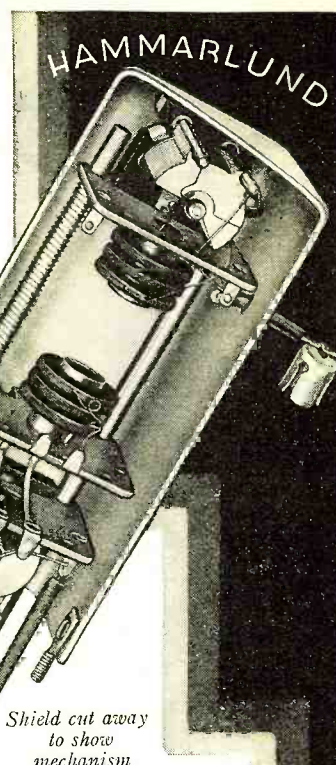
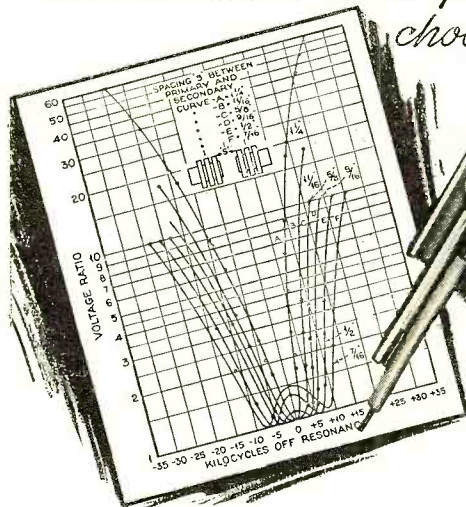

Shield cut away to show mechanism

**N**OW, the greatest single improvement in receiver flexibility in recent years.

**CONTINUOUSLY VARIABLE SELECTIVITY**, from a needle-sharp peak to the flat top required for fidelity—without affecting tuning.

The transformer, basically, is the time-tested Hammarlund I. F. T. design, with new triple-type, pie-wound Litz coils and air-dielectric condensers. Plus the startling feature of *continuously variable coupling* between the coils.

Adjustment of coupling in each transformer may be fixed at any point, or continuously varied by panel-control, either individually or ganged in groups, according to selectivity desired.

The diagram shows the variable selectivity characteristics of a single transformer only.

Designed primarily for use in the new COMET Super-“PRO” Receiver, soon to be announced, these transformers may easily be adapted to other superheterodynes.

Code No. VT-465 (465 kc.). List price, \$5.50 each, less 40% to experimenters.



Canadian Office:  
41 West Ave. North,  
Hamilton, Ontario

Hammarlund Manufacturing Co.  
424-438 W. 33rd St., New York

...Check here for details of new Variable-Coupling I. F. Transformer.

...Check here for 1935 General Catalog.

Name .....

Address .....

.....RN-4







JACK SMITH

Samuel Kaufman

WHEN we start reminiscing about radio's younger days we always recall the voice of Whispering Jack Smith coming through the headset of our crystal receiver. Most vivid in our minds is the way he sang "Does Your Mother Know You're Out, Cecilia?" It's a long way from those catwhisker and galena days but the same Whispering Jack Smith is now starred on NBC with his own orchestra in a Tuesday, Thursday and Saturday NBC program sponsored by the Ironized Yeast Company. After his early radio and recording success, Jack hied to England to appear in a stage revue. He scored so favorably that he spent three years abroad, touring the continent in addition to the British Isles.

JOHN GAMBLING, genial conductor of WOR's early morning gym classes, has been on the job for ten years and the job of getting up at dawn to rush to the studios has never perturbed him the least bit. "You see," he explained to the writer, "I was in the British Navy for eleven years so I'm used to getting up early even though it's by an alarm clock instead of a bugle call." John takes great pride in Vincent Sorey's 4-piece ensemble which he claims plays Wagner tunes as capably as jazz on his program. For a long time, John lived in a New Jersey suburb and had to motor 14 miles to the New York WOR studios to be at the microphone by 6:45 A.M. (E.S.T.). Now, he lives within

ALFRED W. McCANN, JR. AND JOHN GAMBLING



GRACE MOORE



"MAXINE"



CONRAD THIBAUT

Chatty Bits on Radio Personalities

BACKSTAGE in BROADCASTING

subway distance of the studios, so that he can get an extra wink or two before his dash to the station. In addition to his gym class, he is also featured daily on the Alfred W. McCann, Jr., food program over the same station.

GRACE MOORE, the opera star who won the hearts of moviegoers by her performance in "One Night of Love," has launched her first commercial radio series as star of the Tuesday night Vick's program over NBC. Miss Moore's previous radio assignments were confined to guest spots and on each occasion she scored favorably. Her addition to the ranks of regularly heard radio stars is a decided asset to the network's listeners. Her programs, at the start of the series, were picked up from Hollywood where she is engaged on a new talkie.

THE distinction of being designated the first woman announcer of NBC has been awarded Elsie Janis, noted stage star. Miss Janis had earned wide fame during the World War when she brought her songs and comic banter into the camps of the American Expeditionary Forces. Miss Janis is not entirely new to radio, having served as guest star on many network programs. But she went through the routine of studying intently for the announcers' role and got many pointers from her fellow workers. While on the subject of women in radio, we must comment on the entertaining new series on CBS known as the Hour of Charm, sponsored by Linit and featuring an all-girl cast supervised by Phil Spitalny.

ELSIE JANIS LEARNS ANNOUNCING



His vaudeville-famed girl band, the narration of Rosaline Greene, the vocal bits of Maxine, and a Waringesque choral technique all combine to make the program a bright Thursday night spot.

LOIS BENNETT, soprano; Conrad Thibault, baritone, and Don Voorhees Orchestra, all featured on NBC's Saturday Night Gibson Family program, are now co-starred on the new Sunday "Club Romance" series of CBS. The new program is sponsored by Lehn and Fink and utilizes a dramatico-musical theme, following the continued trend towards such presentations. Lee Patrick and Ned Weaver double in the speaking lead roles for Miss Bennett and Thibault. The series is from the typewriter of Carl Bixby.

THE CBS script series, "Buck Rogers in the 25th Century," launched three years ago, is now presented over fourteen additional Western stations making a total of forty transmitters conveying the melodramatic programs. The feature, authored by E. R. Johnstone, is sponsored by Cocomalt and deals with life and events on the various planets and in interstellar space, with such fantastic props as rocket ships, space suits and psychic restriction rays. Curtis Arnall has the title role while the heroine, Wilma Deering, is portrayed by Adele Ronson.

"BUCK ROGERS IN THE 25TH CENTURY"







ANDRE KOSTELANETZ

THE Chesterfield series of the past season which featured such an outstanding trio of soloists as Greta Stueckgold, Rosa Ponselle and Nino Martini, now stars Andre Kostelanetz, the orchestra leader of the old programs. In addition to the efficient musical organization of Kostelanetz, many vocal specialties are included in the new Monday, Wednesday and Saturday CBS programs. Andre labored for more than a month assembling a fourteen-voice chorus capable of blending with his forty-piece orchestra.

AN alert sponsor—Borden's—has signed Beatrice Lillie, the Lady Peel of British Peerage, to an NBC series presented Friday nights. All of Miss Lillie's recent visits to these shores were marked by bright guest appearances on stellar network programs, particularly the Rudy Vallee yeast hour. Now, in response to the demands of listeners and critics, Miss Lillie has a regular schedule for her songs and comedy which made her an outstanding musical comedy personality in two hemispheres. Chatting with Miss Lillie one afternoon, she made it clear that, in her opinion, American broadcasting is far ahead of England's. She told the writer that the commercial method of the U.S.A. made it possible to obtain a regular schedule of "big-name" headliners, while in England, sufficient microphone fees are not available to entice famous performers to Broadcasting House. The only grievance Lady Peel holds against our programs is the rigid censorship of continuities maintained by the network moguls.

BEATRICE LILLIE



# KENYON RACK AND PANEL AMPLIFIER KITS

as described in the February and March issues of Radio News.

This versatile panel can be made up by the use of two Kenyon Kits—one the 445 AB Kit, which makes the main amplifier (B) and power supply (C), and the other the All Purpose pre-amplifier Kit (A).

These two kits comprise a system which is dependable and economical to install and operate. It has been designed for rigid and mobile installations. The power output is either 18 or 36 watts which is more than adequate for most applications. The overall voltage gain is 140 db. thus insuring ample reserve when working from any low level input device. The frequency response is plus or minus 2 db. from 100 to 8000 cycles. The ideal Public Address System for the discriminating technician.

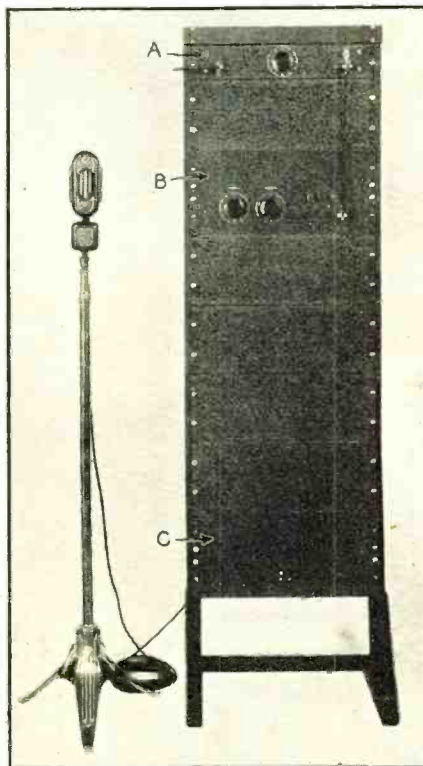

The completed system

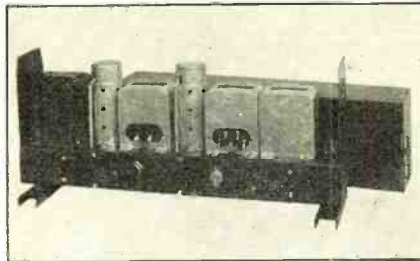

Back view of Pre-Amplifier

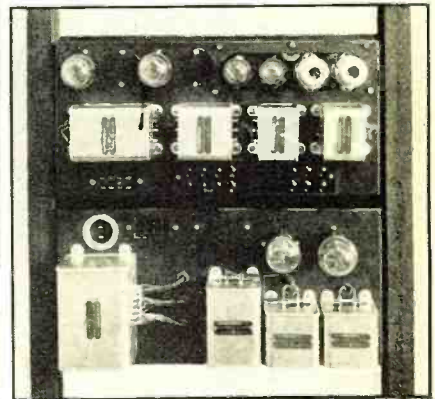

Top view of Audio Amplifier and Power Supply

**Kenyon Transformer Co., Inc.**



840 BARRY STREET  
NEW YORK, N. Y.

**KENYON TRANSFORMER CO., INC.**  
840 Barry Street, New York, N. Y.

Gentlemen:  
Enclosed find twenty cents for which please send me your Engineering News Bulletins Nos. 10 and 12.

NAME.....

STREET.....

CITY.....STATE.....

RN-4

## KENYON ENGINEERING News Bulletins

Full information is contained in 2 Engineering News Bulletins Nos. 10 and 12. These describe in detail the theory, construction and application of the complete public address amplifier. They also contain technical data on class AB operation of 45 tubes, power level rating of all microphones, decibel power conversion charts and much other valuable information. Order on attached coupon. Sent to you upon receipt of 20 cents.





... take Volume V  
as an example ...

1200 pages crammed with  
FACTS for Service Men—112  
leading manufacturers, covered  
as never before—elaborate  
data on 946 models, the most  
complicated American receivers—  
more schematics, more  
I-F peaks than any other manual  
—easily the best in the field!  
From 1920 right down to date,  
RIDER's five manuals cover the  
Radio Industry! Why even try  
to get along without them?  
"Successful Servicing", our  
8-page monthly house organ  
FREE for the asking—MONEY  
in your pocket—get on our list!  
Write us this very day!

**JOHN F. RIDER**  
Publisher

125 WEST 40th ST., N. Y. CITY



**H**OW to service an Auto-Radio  
so that you can GUARAN-  
TEE the job and make money  
on it! The thing that gives you  
the most trouble—power supply  
—is *thoroughly* covered in this  
manual. It is invaluable. Get  
your FREE copy before the sup-  
ply is exhausted and before the  
summer season starts!

**TEAR OUT THIS AD**, pin it  
to your letterhead (or write your  
name and address in the margin)  
and mail it together with 12c  
in stamps to cover costs of post-  
age, addressing, mailing, etc.

ORIGINAL  
PIONEER **GEN-E-MOTOR** CORP.  
458C W. SUPERIOR ST., CHICAGO, U. S. A.  
See our announcement to the Auto-Radio owner in  
the March 23, SATURDAY EVENING POST

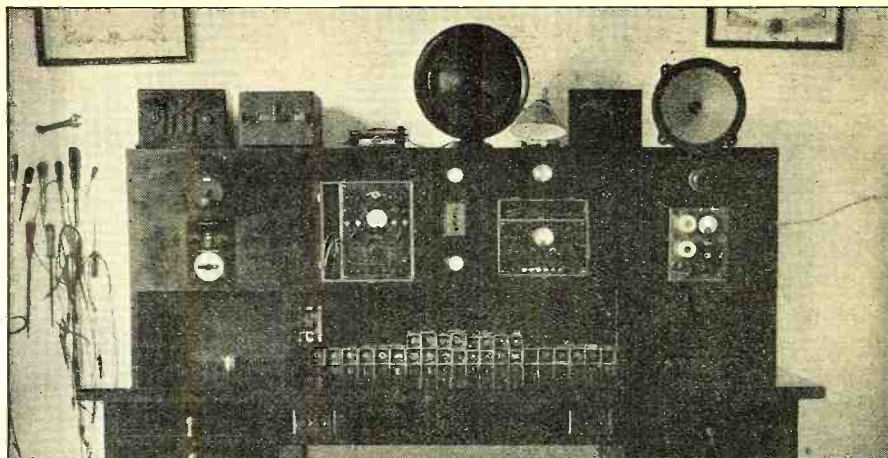

## THE SERVICE BENCH

ZEH BOUCK

### MORE DOPE ON THE NEON LAMP CON- DENSER TESTER

**T**HE description of a neon lamp con-  
denser tester for intermittent reception  
problems, which appeared on page  
436 of our January department, gave rise  
to a surprising amount of interest and com-  
ment, considering the fact that this simple  
gadget should be in fairly general use.  
Several servicemen readers have inquired  
concerning the possibility of transformer  
substitutions to suit their individual conveni-  
ences. Obviously enough, this can be done.  
Any transformer operable from the line

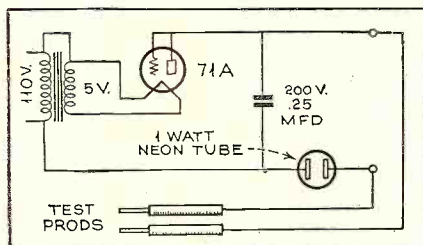

FIGURE 1

supply—bell-ringing, filament-lighting, toy,  
home-made, etc.—will be satisfactory pro-  
viding the secondary voltage is correct for  
the filament of the tube used in the tester.  
Also, practically any triode will make a  
satisfactory rectifier.

Harry J. Ferris, of St. Louis, Mo., sug-  
gests that the neon lamp be placed in series  
with the test-prod lead running to the  
110-volt line, rather than in the anode cir-  
cuit of the rectifier—thus protecting against  
possible shorts in the case of a grounded  
chassis. Mr. Ferris also prefers the slightly-  
modified circuit shown in Figure 1, and,  
as indicated, recommends a type 71A tube.

### THE DAY'S WORK

While on the subject of intermittent re-  
ception, we take pleasure in passing along  
an idea contributed by R. D. Payton—  
Payton Radio Service Laboratory—Oel-  
wein, Iowa. Admitting that trouble of this  
nature often presents problems of the  
baffling type, he goes about their detection  
in a thoroughly logical way. Mr. Payton  
writes, "The time spent testing, pulling out  
parts and watching meters has given me  
nothing but gray hairs. What I wanted was  
*something to do the watching for me*, and  
let me know when anything went wrong.  
The desirability of this will be appreciated

in those all-too-often encountered cases  
where a set will play perfectly for an hour  
or so, and then cut out until someone  
turns the switch off and on, or wallops the  
cabinet." Mr. Payton's radio sleuth con-  
sists of two sections, the first a modulated  
oscillator (with output control) that can  
be coupled anywhere between the antenna  
and the last detector; secondly, a special  
resistance-coupled amplifier that, similarly,  
can be tapped in anywhere along the re-  
ceiving circuit. This amplifier consists of a  
type 58 tube (with gain adjustment), re-  
sistance coupled to the input, feeding a type  
27 tube operating as a diode detector, fur-  
nishing a bias voltage for a type 47 power  
tube. This tube has no other bias, and the  
plate voltage is adjusted so that it draws  
20 milliamperes with no bias. A sensitive  
relay operating on slightly less than 20 ma.  
is included in the plate circuit. This relay  
can be used to operate a pilot lamp or a  
buzzer. The editor prefers the latter. In  
making a test, the oscillator is input some-  
where toward the antenna, and the signal  
picked-up on the special amplifier some-  
where between the input and the second  
detector. The signal output from the oscil-  
lator, and the gain in the r-c amplifier are  
so adjusted that sufficient bias is built up  
in the diode circuit to drop the space cur-  
rent through the 47 tube and open the  
relay. The modulated signal will of course  
be heard in the set speaker. When the set  
cuts out, the modulated tone will not be  
heard—obviously. If, at this moment, the  
buzzer does not start up, it is equally  
apparent that the test amplifier has been  
cut in too close to the oscillator.

As a general procedure, your Service Edi-  
tor would recommend inputting the oscilla-  
tor to the antenna circuit, and, unless a  
definite location of the trouble is suspected,  
starting backwards from the second detec-  
tor with the relay set-up, one stage at a  
time, as long as the buzzer comes on when  
the signal fails. When the buzzer no longer  
functions when the signal cuts, the answer  
is that trouble is in the stage just previ-  
ously tested.

### Pepping-Up Converter Efficiency

R. O. Lamb, manager of the Lamb Radio  
Service, Wilkensburg, Pa., writes that he  
has had several complaints of unsatisfac-  
tory converter operation—notably with the  
Stewart-Warner, a.c.-d.c., type R-113,  
when used with midget and other low-  
sensitivity receivers. As he was responsible  
for the sale of several such combinations,  
it behooved him to do something about it,



and he has succeeded in pepping-up performance with the aid of a minor operation. As in many cases of inefficient converter operation, the principal difficulty was found in the method of coupling the converter output to the broadcast receiver

holes and work back and forth with a rotary motion."—Russell L. Woolley, Seattle, Washington.

(Continued on page 653)



MR. R. O. LAMB

(usually through a simple coupling condenser). Mr. Lamb substituted a tuned r.f. transformer—of standard, high gain, r.f. design—the primary in the plate circuit of the converter output tube, and the secondary across ground and grid of the first r.f. tube in the broadcast receiver. The secondary was tuned to the i.f.—990 kc. in the case of the Stewart-Warner job—by means of a .00025-mfd. trimming condenser. An adequate switch, with shielded leads, was provided. (Incidentally, improvement in coupling will, in many instances, result in a reduction of noise level as well as in improvement of sensitivity.) Operation was still further improved by disconnecting the screen grid of the converter output tube from the plate, and feeding it through a separate 50,000-ohm resistor.

**THIS MONTH'S SERVICE SHOP**

Just to show that neatness and efficiency also thrive in the land of "Sloppy Joe's," Reinaldo D. Version sends us the photo shown in this month's Heading, showing the service shop in his Havana Lab. The usual equipment has been effectively distributed, and includes one Supreme, model 333, analyzer, one Supreme, type 85, tube tester, a grid dip oscillator and signal generator, and a power supply taking care of all conventional requirements. As the bench is built entirely of solid mahogany (!) we assume that it is used only for test purposes, and more strenuous endeavors are relegated to a less ornamental table. Its designer is in the U. S. A. at the present writing, purchasing additional equipment for the further elaboration of this bench.

**Tube Socket Cleaning Tool**

"The drawing of Figure 2 illustrates an easily made tool for cleaning tube socket contacts. A length of No. 9 or No. 10 copper wire is bent as shown to form a handle, and a slot is cut in the other end. Insert a piece of fine emery cloth and tap tight with a hammer. The cloth should be cut wide enough to leave trailing edges. To use, simply push the end into the pin-

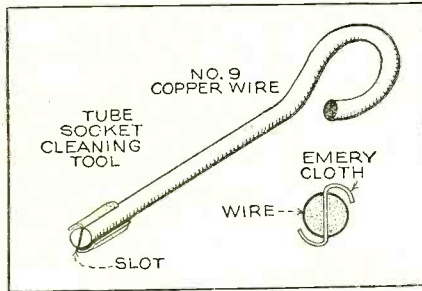

FIGURE 2

**A Single Tube A.C.-D.C. Set**

(Continued from page 606)

battery can be used. For the plate supply use 45 to 90 volts of B battery blocks. There are no other changes and the operating instructions remain the same as when the set is used on house-lighting current. When the set is used on battery operation, insulate the two prongs of the 110-volt line connecting cord, this is to prevent a possible short-circuit of the A battery terminals.

When the receiver is operated on 110-volt, direct-current supply, it is necessary to observe polarity! If the set does not produce a signal after a minute or so, reverse the line plug and a signal should be heard immediately!

In operation, the regeneration control should be advanced until the tube just oscillates, then by rotating the main tuning dial, C2, a whistle should be heard for every station. The detector tube should now be brought out of oscillation and this is done by slowly retarding the regeneration control until the signal is brought in with clarity and greater volume. The antenna coupling condenser, C1, should be adjusted for best results with the antenna being used. The position of the aerial condenser is very important, it is not only dependent upon the aerial but also on the coil that is employed. Do not use a ground connection unless it is coupled through a condenser of approximately .01 mfd. capacity!

The set is operated on 110-volt, 60-cycle lighting lines in the usual manner.

| COIL DATA        |           |              |
|------------------|-----------|--------------|
| Wavelength Range | Grid Coil | Tickler Coil |
| 40-100 meters    | 19 turns  | 13 turns     |
| 100-230 "        | 38 "      | 19 "         |
| 230-500 "        | 110 "     | 22 "         |

The above specifications are for either tube bases or standard 1½ inch coil forms when used with a .00014 mfd. tuning condenser. The two short-wave inductances employ No. 28 enameled wire for both the grid and tickler windings. The broadcast coil uses No. 32 enameled wire for both windings. The ticklers are spaced about one-eighth of an inch from the grid winding and it is important that the grid and tickler windings are wound in the same direction on the coil form. The complete kit of parts for this receiver, including a cadmium-plated chassis and a crackle-finished metal cabinet are made available to RADIO NEWS readers by Experimental Radio Labs.

**Learn RADIO in 10 WEEKS**

**BY ACTUAL SHOP WORK ON REAL EQUIPMENT**

**I'll Finance Your Training**



H. C. LEWIS

You can get your training in the World's most fascinating, best paid profession. I train you at Coyne in Chicago in a practical way so you can be prepared to take a real job and cash in quickly, and I'LL FINANCE YOUR TRAINING. The course takes only 10 weeks—but you don't start paying me back until FIVE MONTHS after you start school, or 2 ½ MONTHS after the regular training period! Take over a year to pay AFTER training. Mail coupon today for details of this plan.

**REAL OPPORTUNITIES For the Radio Trained Man**

The Coyne 10-Week Course opens the way to big-pay jobs as Designer, Inspector and Tester—as Radio Salesman and in Service and Installation—as Operator or Manager of a Broadcasting Station—as Wireless Operator on a Ship or Airplane—as a Talking Picture or Sound Expert—HUNDREDS of Opportunities for fascinating, WELL PAID JOBS!

**10 WEEKS' SHOP TRAINING**

No Experience or Advanced Education Needed

I don't teach by book study. You get your training at Coyne in Chicago by ACTUAL WORK on a great outlay of Radio, Broadcasting, Television, Talking Picture and Code equipment. And because we cut out useless theory, you get a practical training in 10 weeks. That's why you don't need advanced education or previous experience.

**TALKING PICTURES — TELEVISION**

Talking Pictures and address systems offer great opportunities to trained men. Television is the great new branch of Radio now developing very rapidly. Be ready for your chance in Television. At Coyne you are trained on real Talking Picture and Television equipment.

**ELECTRIC REFRIGERATION AND AIR CONDITIONING Included at NO EXTRA COST**

So my graduates may have an all around training which increases their earning capacity. I am including for a short time my big new course in Electric Refrigeration and Air Conditioning. Here is your chance to get a practical training in this great new field at no extra cost.

**Many Earn While Learning**

WHEN YOU ENROLL AT COYNE YOU GET A LIFE SCHOLARSHIP. You get Free Employment Service for Life after graduation. And if you need part-time work while at school to help pay expenses, I'll help you get it if you will tell me your problems. Coyne is 36 years old. Coyne Training is tested—you find out everything about my course and my "Pay After Graduation Plan" free. JUST MAIL Coupon for My BIG FREE RADIO BOOK, Coyne Electrical & Radio School, 500 S. Paulina St., Dept. 45-3K, Chicago, Ill.

*H. C. Lewis*

**SEND NOW FOR FULL DETAILS!**

H. C. LEWIS, President, Coyne Electrical & Radio School, 500 S. Paulina St., Dept. 45-3K, Chicago, Ill. Dear Mr. Lewis: Send me your big Free Radio Book and all details of your Special Introductory Offer—and your plan where I can pay my tuition in easy monthly payments after I graduate.

Name.....  
Address.....  
City.....State.....



## WHEN CHOOSING A RADIO SCHOOL

RCA Institutes, with its reputation firmly established by 25 years service, is an institution recognized as an important factor in the radio industry.

Whether elementary radio principles or advanced subjects, sound applications, mathematics or practical radio engineering, RCA Institutes is prepared to give you the instruction you need.

### Resident Schools at New York and Chicago

Modern Apparatus and Laboratory Equipment—Conveniently Located—Day and Evening Classes—Tuition Rates \$3 to \$10 Weekly.

Extension courses for home study on convenient "no obligation" plan. Examination and technical advisory services. Free post-graduate practical training at resident school with modern equipment under instruction of engineers.

Write for Catalog.

## RCA INSTITUTES, Inc.

Dept. RN-35

75 Varick Street  
NEW YORK

1154 Merchandise Mart  
CHICAGO

Recognized Standard in Radio Instruction Since 1909

## The Radio News SHORT WAVE CONVERTER IN KIT FORM for you to build

If you want a converter capable of providing unusual results on all types of broadcast receivers, from the best to the lowliest midset... start building this RADIO NEWS CONVERTER.

We are the only firm able to supply the complete foundation kit of essential parts which consists of: set of 4 special "Radio News" Short-Wave Converter coils; tuning condenser, 3-gang, each section 360 mmfd.; 2 Hammarlund midset condensers, 4-plate, 30 mmfd.; fixed mica condenser, 1500 mmfd.  $\pm 5\%$ ; variable padding condenser, 800-1600 mmfd.; cadmium plated chassis and panel, completely drilled; 4 tube sockets; 3 tube shields; and 2 terminal strips. Price **\$9.95** complete.

Remember the place to get the parts for the Radio News Converter is here at "Radio Headquarters".

**SEND** 50c for complete set of "Radio News" full-size picture wiring diagram, full-size working drawings, parts list, etc. Address Department N.X.—45.

**WHOLESALE RADIO SERVICE CO., Inc.**  
NEW YORK | NEWARK | ATLANTA  
100 Sixth Ave. | 219 Central Ave. | 430 W. Peachtree St., N.W.



## THE TECHNICAL REVIEW

JOSEPH CALCATERRA

*Radio Communication, Part I: History and Development.* Science Museum Handbook published by His Majesty's Stationery Office, London, England. This is one of the handbooks of the collections in the Science Museum of South Kensington and even though there are frequent references to these collections, the book is still useful to one who does not have access to the museum. The history of radio in all its phases is traced from Maxwell's electromagnetic theory in 1864 to the present day. This will prove very instructive to persons who labor under the delusion that radio started in 1921. Even those who are better informed will be surprised to hear, for instance, that a moving-coil "loudspeaker" was made by Sir Oliver Lodge in 1898 and that automatic volume control was attempted as early as 1925; it would have been successful, too, were it not for cross-modulation.

The opening chapters deal with the early experiments of Marconi and others and show several illustrations of the equipment used in those days. The reader learns how the radio telegraphic art gradually improved, how tubes were perfected, etc. The book is full of information on dates of new developments and the names of those responsible for them. Due to the fact that this is a British publication, attention is naturally centered around European developments and nearly all of the pictures refer to European equipment. There are, however, frequent references to the work on this side of the Atlantic.

### Review of Articles in the January, 1935, Issue of the Proceedings of the Inst. of Radio Engineers

*Transmission and Reception of Centimeter Waves,* by I. Wolff, E. G. Linder and R. A. Braden. Describes apparatus consisting of a new type split-anode magnetron, which has been used to generate 2.5 watts of energy at 9 centimeters wavelength, with an efficiency compared to direct-current plate dissipation of 12 percent.

*Horizontal Rhombic Antennas,* by E. Bruce, A. C. Beck and L. R. Lowry. A description of the theoretical methods employed by the authors in dimensioning horizontal rhombic receiving antennas.

*A New System for the Remote Control of Radio Broadcast Receivers,* by Jesse B. Sherman. A system of remote control in which tuning is effected by rotating the dial of a suitably designed rheostat which, by varying the field currents in a motor of novel construction, produces movement of the rotor and condenser gang synchronously with the rotation of the dial.

*A Note on Fundamental Suppression in Harmonic Measurements,* by Herbert M. Wagner. Discusses the methods used to exclude the fundamental component of a

periodic wave from the input terminals of a harmonic analyzing device.

### Review of Contemporary Literature

*The Mechanism of Electronic Oscillations,* by W. E. Benham. The Wireless Engineer and Experimental Wireless, January, 1935. An explanation of the new view, now gaining ground, that oscillations produced in a retarded field triode depend mainly on the phase differences between electron current and voltage brought about by electron inertia.

*A High-Speed Level Recorder for Acoustic Measurements,* by E. C. Wente, E. H. Bedell and K. D. Swartzel, Jr. The Journal of the Acoustical Society of America, January, 1935. Description of a new type of high-speed "level" recorder able to record rapidly-varying mean-intensities over a wide range of values.

*Monitoring of Broadcast Stations,* by L. B. Arguimbau. General Radio Experimenter, January, 1935. An explanation of the importance of constant and accurate monitoring to obtain maximum signal strength with the minimum of interference and distortion.

*'Phone Transmission with Voice-Controlled Carrier Power,* by G. W. Fyler. QST, January, 1935. A system of 'phone transmission in which the carrier level is automatically maintained just sufficient to carry the modulation.

*The Service Man's Side of High Fidelity,* by I. A. Mitchell. Service, January, 1935. Some facts regarding the frequency characteristics of radio receivers and public-address systems and how these characteristics may be improved by the use of equalizers or their equivalent. Also covers the design of a complete high-fidelity audio amplifier.

### Technical Booklets Available

PLEASE NOTE: To avoid disappointment, please make your selection of booklets from this current issue of Radio News since our supply of booklets not listed here is exhausted.

2. 1935 R. F. Parts Catalog. Specifications, illustrations and prices on the new line of Hammarlund variable, midset, band-spread and adjustable condensers; trimming and padding condensers; r.f. and i.f. transformers; coils and coil forms; sockets, shields, chokes and miscellaneous parts for receiving and transmitting.

3. How to Get a 1935 Short-Wave Manual. A circular containing a list of contents, excerpts and illustrations from the new Hammarlund Short-Wave Manual with instructions on how to obtain a copy.

4. Short-Wave Superheterodynes. Outstanding features of the standard and crystal type Hammarlund "Comet Pro" short-wave superheterodynes designed to meet the exacting demands of professional operators and advanced amateurs for a 15 to 250 meter code and phone receiver, but which can be used by anyone for laboratory, newspaper, police, airport and steamship use.

5. A 1935 Volume Control and Resistor Catalog. Standard and replacement volume controls, Truvalt adjustable resistors, vitreous wire wound fixed and adjustable resistors and voltage dividers, precision wire-wound non-



inductive resistors, center-tapped filament resistors, high-quality attenuators, power (50 and 150-watt) rheostats and other Electrad resistor specialties.

6. *Line Voltage Control.* Characteristics and uses of a voltage regulator and chart showing the correct Amperite recommended by set manufacturers for their receivers.

25. *Noise-Reducing Antenna Systems.* The Lynch transposition type system for both long and short-wave reception and the shielded transmission line type for broadcast use. Explains how the system can be used to make apartment house installations at a profit.

26. *Auto Radio Antennas, Filters and Noise Suppressors.* The line of Lynch antennas, filters and ignition noise suppressors especially designed for motor radio installations. Data on how to eliminate motor radio noise is included.

27. *The Autostat Charging Rate Booster.* The new Lynch Autostat to automatically increase the charging rate of the automobile car generator by five amperes every time the car radio is turned on, so as to eliminate the danger of running down the car battery while the radio set is in operation.

34. *Serviceman's 1935 Replacement Volume-Control Guide.* Revised list, in alphabetical order, of all old and new receivers showing model number, value of control in ohms and a recommended Electrad control for replacement purposes.

57. *How to Build a High-Quality Condenser or Ribbon Microphone.* The Amperite Microphone Kit, with which it is possible to build, easily and quickly, a high-quality condenser or ribbon microphone.

60. *Audio and Power Transformers and Choke Coils.* Descriptions, circuit diagrams and prices of the new AmerTran DeLuxe, standard and low-priced lines of transformers and chokes for public address systems, amplifiers and radio receivers.

65. *New 1935 Line of Testing Instruments.* Information on the Supreme line of testing instruments including the new 5-inch fan-shape meter, the Model 333 De Luxe and low-priced analyzers, the improved Model 85 tube tester, the Model 61 oscillator and the Model 180 Precision multi-wave signal generator.

66. *An A.C.-D.C. Tester Which Can Be Built at Home at Low Cost.* Information about the "Supreme 5" fan-shape meter, rectifier and resistor kit for the home kit for the home construction of an inexpensive A.C.-D.C. tester.

67. *Practical Mechanics of Radio Service.* Information, including cost, features and outline of lessons of the Frank L. Sprayberry course in radio servicing and list of Sprayberry data sheets for modernizing obsolete test equipment and receivers.

(Continued on page 642)

April, 1935  
RADIO NEWS Free Technical  
Booklet Service  
461 Eighth Avenue  
New York, N. Y.

Gentlemen: Please send me, without charge, the booklets or folders I have filled in below:

Numbers.....

My occupation or connection in radio is checked off below.

- Serviceman Operating Own Business
- Serviceman Employed By:
  - Manufacturer
  - Jobber
  - Dealer
  - Servicing Organization
- Dealer
- Jobber
- Radio Engineer
- Experimenter
- Laboratory Technician
- Professional or Amateur Set Builder
- Licensed Amateur
- Station Operator
- Public Address Work

I am a  subscriber  newsstand reader.

I buy approximately \$..... of radio material a month. (Please answer this question without exaggeration or not at all.)

Name.....

Address.....

City.....State.....

PLEASE USE PENCIL AND PRINT.  
IN FILLING IN COUPON

# MASTERPIECE III by

## McMurdo Silver

THE MOST COMPLETELY EQUIPPED ALL-WAVE RECEIVER



It's easy enough to build a receiver that will qualify to the name "all-wave." And most any all-wave receiver will get the three or four super-powered short wave foreigners such as London and Berlin. But it takes MASTERPIECE III to bridge the Atlantic and Pacific to bring you, with a thrill of satisfaction, the 200 or more other foreign stations you so much want to hear.

When "Dependability" is the First Consideration, Masterpiece is Chosen

The Byrd Antarctic Expedition wanted an all-wave receiver that could be depended upon for world-wide reception between 10 and 570 meters. Upon the advice of a leading engineering university which had tested all available equipment, MASTERPIECE III was selected. "Bing" Crosby and Richard Arlen wanted the most capable all-wave receiver for their International DX Contest. Both chose MASTERPIECE III and established new world records for long distance reception. MASTERPIECE III has been and is being selected by engineers, laboratories, universities, broadcast stations, and competent experts as the finest radio built today.

Most Advanced Because Laboratory Built  
MASTERPIECE III is a composite of the latest, most advanced developments of the radio science. It incorporates circuit designs impossible to use in "production type" all-

**McMurdo Silver, Inc.**  
3352-D N. Paulina St., Chicago, U. S. A.

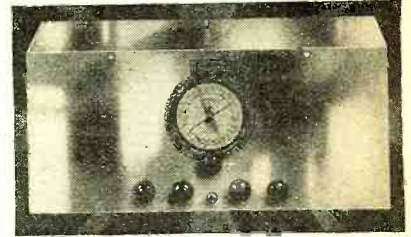

wave receivers. It has features that yield a degree of sensitivity, selectivity and tone quality that ordinary receivers may not give for years to come. MASTERPIECE III has all these advantages because each individual receiver is individually built to the advanced standards of precision known only to the research laboratory.

### 10 DAY TRIAL

Everything said about MASTERPIECE III can be demonstrated. Try it . . . prove it to yourself in 10 days and nights of competitive tuning side by side with any other receiver built. Then, if you want to return MASTERPIECE III for full, immediate refund, just send it back undamaged. It's just as simple as that. Send coupon for free book giving full description.

### SEND FOR BOOK

McMURDO SILVER, Inc.  
3352-D N. Paulina St., Chicago, Illinois.  
Send me full particulars and specifications of MASTERPIECE III.

Name.....

Street.....

Town.....State.....

## and now—THE IMPROVED MASTER TELEPLEX

TELEPLEX again shows the way by its improved MASTER TELEPLEX code teaching machine with the embossed copper tape plus Telespeed. No more fussing around with ink tapes; no more relays; no more complicated battery hook ups; no more fading of signals—all because Master Teleplex, "the choice of those who know," is now equipped with copper tapes on which the code signals are EMBOSSED.

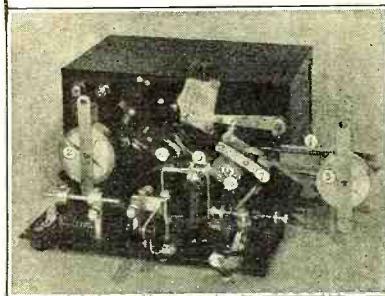

With Teleplex you get TELESPEED, an unbelievably smooth automatic key. Teleplex has taught code to more operators in past 10 years than all other methods combined. No experience needed. Beginners, amateurs, experienced ops get ahead faster with Teleplex. Only instrument ever produced which records your sending in visible dots and dashes—then sends back your own key work. Used by U.S. Army, Navy, R. C. A., A. T. & T., and many others. We give you complete course, lend all equipment. Nothing to buy—give personal service on MONEY BACK GUARANTEE. Low cost, easy terms. Write today for folder R. N. 28. No obligation.

### TELEPLEX CO

76 Cortlandt St. New York, N. Y.  
Master Teleplex—"The Choice of Those Who Know"

### World Famous INTERNATIONAL DX



3-Tube AC-DC ALL WAVE SET, New 1936 Model Out  
**675**  
Complete kit with built-in speaker. Four coils from 15 to 250 meters and diagram.  
Wiring, extra..... 1.75  
3 matched tubes..... 2.25  
Broadcast coil..... 0.75  
Metal cabinet..... 1.95

### THE SINGLE TUBE ALL-WAVE AC-DC-BATTERY SET

House current or No house current, it works everywhere. Use 12A7 tube on AC-DC and 12V battery. 6F7 on 6V, dry cell or storage battery. An "after late hours" set for every family. A real portable set. A fine gift for your nearest.  
Complete kit including all fine parts, crackle-finished metal cabinet, cadmium plated chassis, 3 coils from 40 to 300 meters, picture diagram and instructions.  
Send 10c in stamps Wired, extra..... 1.25  
for complete data, diagrams, 12A7 or 6F7 tube, each 1.00  
Sparephone, etc. .... 1.50



**4.99** FITS IN THE PALM OF A BOY'S HAND  
Only

EXPERIMENTAL RADIO LABS, 168 N. Washington St., NEW YORK, N. Y.

## RADIO SERVICING

Residence course, 6 months, modern methods, new courses, special work on service equipment and superheterodyne servicing; instruction on public address systems, photo cell and cathode ray tubes included. Other courses obtainable: Radio Engineering—9 months; Marine Radio—6 months; Morse telegraphy—6 months. School est. 1874. All expenses low. Catalog free.  
DODGE'S INSTITUTE, Eleventh St., Valparaiso, Ind.

## SEND FOR YOUR COPY



Here is the NEW 4955V Acorn Tube Socket. Ultra low loss. Highest quality. List pr. \$1.50.  
Send us the name and address of your supplier and get this new 16-page catalog of quality Na-AlD products.



ALDEN PRODUCTS CO.  
Dept. RN-4 715 Centre St.  
BROCKTON, MASS.





# RADIO PHYSICS COURSE

ALFRED A. GHIRARDI

## Lesson 39. Capacity of Condensers

### Ghirardi's Famous RADIO PHYSICS COURSE In One Convenient Volume

If Ghirardi's articles in RADIO NEWS are helpful to you, get his remarkable book, RADIO PHYSICS COURSE, that tells you everything you want to know about radio, electricity, television and the talkies. Used and praised by thousands of fans, students, and schools the world over—the most popular radio course ever written. THOROUGH—it covers the entire field from basic theory up to the latest applications and developments. PRACTICAL—it is a daily working tool and reference book as well as an instruction course. CONCISE—just the facts you want without any useless "trimmings". UNDERSTANDABLE—"a marvel of clearness" written in plain, every-day language. INEXPENSIVE—you'd have to pay many times its nominal cost for the same invaluable information. Get your copy now! 972 pages Over 500 illustrations

**\$4.00 Postpaid**  
Send for free descriptive circular

### DENTON

on SHORT-WAVE  
Clifford E. Denton gives you the real practical dope on short-wave. Every experimenter can put it to work—and get results! Here you'll get complete s.w. coil-winding data for all size forms and condensers, wire tables, dope on A-F amplifiers, R-F systems, band spreading, superhets, single-signal receivers, electron-coupled oscillators, construction of latest s.w. sets, etc., etc. 128 pp. Over 150 charts and diagrams. Only \$1 postpaid.

### "The Gadget"

From coast to coast service men are talking about Ghirardi and Freed's Pocket Trouble Shooter. "The gadget" they call it—and what a gadget! It gives you 275 remedies arranged according to symptom and source. Keep one in your pocket all the time—you'll use it a hundred times a day.



**ONLY 25c**

MAIL TODAY

RADIO & TECHNICAL PUBLISHING CO.  
45 Astor Place, New York. Dept. RN-4

Enclosed find \$4 for 1 copy of Ghirardi's RADIO PHYSICS COURSE (\$4.50 foreign).

Please send free descriptive circular on Ghirardi's RADIO PHYSICS COURSE.

Enclosed find \$1 for 1 copy of Denton's SHORT-WAVE HANDBOOK.

Please send free descriptive circular on Denton's SHORT-WAVE HANDBOOK.

Enclosed find \$..... for..... Pocket Trouble Shooters, at 25c each.

Name.....  
Address.....  
Occupation.....

CONDENSERS having air dielectric find their greatest use in the high-frequency (radio-frequency) tuning circuits of radio transmitters and receivers. They are commonly made *variable*; that is, their effective capacitance may be changed at will while the condenser is being used in the circuit. As a rule, such condensers are made continuously variable, so that the capacitance may be gradually increased or decreased, and not changed in abrupt steps.

The capacitance of a condenser can be varied by varying the number of plates, the active area of the plates, the material of the dielectric, or the separation between the plates. Variable air condensers employing practically all of these methods have been developed at one time or another, but the type in which the area of the plates actually effective between adjacent plates is varied, is practically the only one which has survived. This type of condenser is shown in Figure 1.

Variable air condensers which are used extensively for tuning radio-frequency circuits, consist of a group of stationary plates (stator) arranged so that a set of rotating plates (rotor) can be moved in and out between them without touching. The dielectric (the space between them) is air. When the plates are all meshed (Figure 1), the full areas of the plates are exposed to each other and the maximum

These strips should be mounted outside of the dense electrostatic field of the condenser, to avoid dielectric losses. The stator and rotor plates should not touch, for a short-circuit would then result. Rotor bearings should work smoothly and the entire condenser should be rigidly constructed.

The clearance between the plates is usually governed by mechanical considerations in most cases where the condenser is to be used in circuits where the voltages are low, as in the case of radio receivers. In radio transmitters where the condensers are in high-voltage circuits, the operating voltage determines the allowable spacing between the plates. Theoretically, it is desirable to mount the rotor and stator plates as close together as possible, so for a given capacitance the physical size of the condenser will be small. However, enough mechanical clearance must be left, so that the rotor plates will not touch or scrape against the stator plates if they should become slightly bent out of shape. If they touched, a short-circuit would occur and the radio receiver would either become noisy or would stop operating altogether. Also the plates must be thick enough so that mechanical vibrations due to the loudspeaker in the receiver do not make them vibrate enough to vary the clearance between the plates and thus vary the capaci-

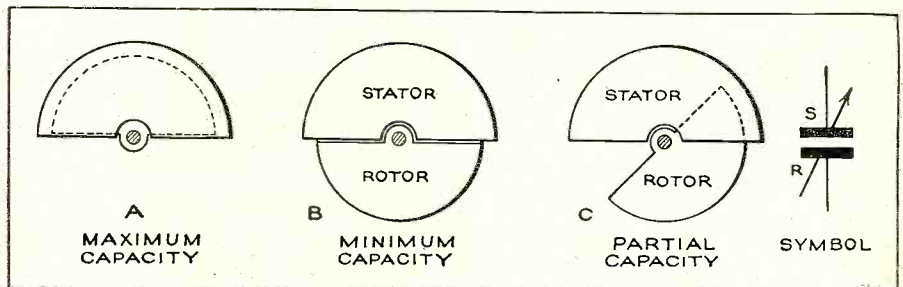

Figure 1. The capacitance of a variable air condenser is varied by moving the rotor plates so they mesh more or less with the stator plates. When they mesh completely, the capacitance is maximum.

capacitance exists; when they are all out of mesh, the minimum capacity exists; and for any positions in between these, various intermediate capacities exist. Any desired rate of variation of capacitance can be obtained by properly shaping the plates.

The plates are usually made of thin, hard, brass or aluminum, stamped out on punch-presses. The brass plate has the advantage of being easily soldered to the rotor shaft or stator block for good electrical connection, and of requiring less thickness of plate for proper stiffness. The aluminum plate condenser is light in weight. Brass is subject to corrosion while aluminum is not, under ordinary conditions. Brass condenser plates are often lacquered or given a special finish to prevent this corrosion. The rotor plates are swedged into grooves cut on the rotor shaft. The stator plates are swedged into grooves cut on the stator support blocks. The blocks are fastened to two small strips of hard rubber or bakelite which in turn are fastened to the metal frame. The rotor turns in bearings in the end plates. The insulating strips serve to insulate the stator assembly from the end plates and rotor.

tance. This would result in a howl from the loudspeaker.

### New KYW

(Continued from page 626)

broadcasting stations that are nearby. Two applications of science that resulted in the saving of considerable transmitter space were the use of extremely compact nitrogen-filled radio condensers and a new design of high-voltage rectifier. The transmitter, although designed as a 50-kilowatt unit, has been modified for operation on 10 kilowatts. One of the highlights of the new unit is that all of the KYW transmitting tube filaments operate direct from alternating current.

The station's Philadelphia debut was marked with a special NBC program featuring scores of the network's headliners. The station is now the NBC-WEAF outlet in Philadelphia. Dr. Leon Levy, long a popular Philadelphia broadcasting figure as a WCAU executive, is supervising the activities of the new NBC unit.



## Aid to Inventors

(Continued from page 623)

and the technical and sales ends of the proposed business being adequately provided for, there remains the problem of capital, for money still is needed no matter what else may be arranged, how shall the money be raised? This being a series of articles in which we are trying to be frank, it is necessary to admit that the *easiest* way to get money for an invention always has been to *lie for it!* Rosy promises of quick wealth in a few months always lure out more American dollars than sober statements of fact backed up by proof. Recently, there has been something of a slump in the "Rosy Dream" market but I suspect that even now bright lies will catch more dollars than the truth. The point is that such baseless good times soon fade. *No honest inventor wants to lose other people's money, and if he is not honest this series of articles is not intended for him.* Something else probably will catch up with him sooner or later anyway.

Assuming that the inventor is honest, that he has tested the commercial value of his invention (as I have outlined in previous articles) and that he has got together a group of people able to provide the needed technical skill, sales ability, etc., necessary for the enterprise, what should be his next step in seeking capital?

Different successful raisers of funds have extremely different methods, but I think I can say what method it is that the capitalist likes. He wants a *complete and accurate statement of the project*, accompanied by the *patent papers* and usually by a *working model of the invention*. In addition, he wants *detailed estimates of the market possibilities*, usually to be accompanied by *outside opinions* as to prices, market demands and so on. He wants a similarly *complete statement* of all technical matters involved, including the factory facilities available or to be created, cost estimates, sources and prices of raw materials and the like. Again, as much of this information as possible should be from *independent sources!* Lastly and still more important, he wants to know *precisely with whom he is dealing*, including the personal history of the inventor and his associates, especially the persons with business experience and the proposed manager of sales. It may be, of course, that the person asked for capital himself can handle one or more of the aspects of the business. If so, the presentation may be simplified but the principles remain the same.

I seldom see a request for capital for an invention presented with this completeness and authority, but I would like to; and I am sure that the average capitalist would like it even better.

One more word of advice to the inventor. *Do not resent being turned down!* It may be the most valuable experience you can have. There are only two possible reasons for it. One is that you did not properly present your case. The other is that there is some flaw in your enterprise which you and your advisers have not seen. In either case, you should thank sincerely the man who turns you down and go home to reconsider the whole matter anew. Obtaining capital is not the end of your effort. It is the beginning. It is far better to fail to get capital and never to start than it is to get the capital and then fail.

The amount of capital necessary is the next item to consider. Almost all inventors estimate this too low. This is where planning by a person experienced in finance is so valuable. My own rule (for what it may be worth) is simple. I first estimate how many years probably will be needed to put the enterprise on a profitable basis.

I then double this time. Next I estimate as carefully as possible the expenses of starting and the possible losses for the first year. This sum I multiply by the doubled number of years until profits are probable. Finally, I double this sum again. That is the capital I want to be available. Usually it is about ten times what the inventor estimates.

Critics probably will retort that if everybody set such large requirements for available capital there would be few new enterprises. Quite true, but when one remembers that out of a hundred new enterprises started in any given year probably not more than one ever will be successful, it would be better for everyone if most of them did not start. It merely is common sense for an inventor to be *sure* of ample capital as well as all other needs before he starts to exploit his own invention. If he cannot be, he had better sell his invention to some large business which can afford to make mistakes which he and his smaller associates cannot.

A final word about the professional money raiser or promoter. These persons are much less numerous than formerly, but even a slight return of prosperity probably will bring them back. Many of them are honest, some are not. A few are competent and really help their clients, most do not. Their chief defect is that their goal is only the inventor's beginning. When the money is raised the promoter is through. It is little or nothing to him how the money is to be spent or whether anyone makes a profit. Certainly, if a professional or amateur promoter is employed, there is still more reason for being extremely sure of all the facts behind the enterprise and for keeping the *control* of the enterprise in other hands, experienced and competent in the business to be entered.

## "More" on the Short Waves

(Continued from page 597)

receivers sold include short-wave tuning facilities, a prophecy realized in less than a year!

Quoting, again, from the same editorial is the following advice to Servicemen readers of RADIO NEWS, that we feel we cannot even now improve upon. *"And now a word to the Serviceman reader of RADIO NEWS. From time to time these readers write in to us questioning the advisability of publishing so much short-wave material in the magazine. They bring up the question, 'What have the short waves to do with servicing? Is there any direct relation between these two fields?' Our answer is most decidedly, 'Yes!' We must bring home to the Serviceman a definite understanding that unless he keeps pace with short-wave development he will lose a large amount of future trade. He must 'know' the short waves. He must be able to 'sell' the short waves. He must be able to keep short-wave receivers well serviced! He must know about short-wave antenna types. He must understand noise-reducing equipment, etc.*

*"Of course, there are some servicemen and dealers who today are already giving service and realizing excellent profits from their short-wave work. They have found a new way for getting customers and creating a new interest in radio. They have found that they can keep their customers interested in short-waves. They have found that they have had to instruct new users in the operation of short-wave sets.*

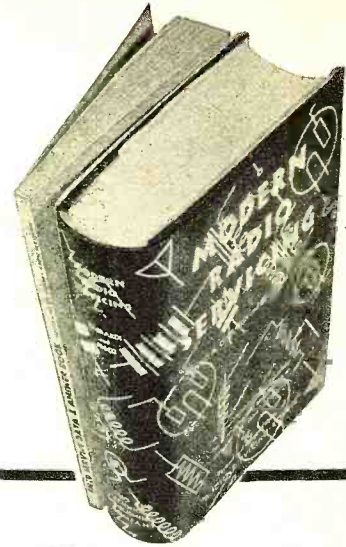

## The Book of the Day! MODERN Radio SERVICING by GHIRARDI and FREED Supplemented by FIELD SERVICE DATA AND ANSWER BOOK

The book of the day!—and the book of tomorrow too! A book you'll want to have with you all the time, because it shows you how to master the art of radio servicing. It's just packed full of new ideas, the latest tips and angles, the most up-to-date methods used by successful technicians. The most complete book of its kind ever put out—written in simple, easy-to-understand language—profusely illustrated with diagrams and charts. Send for the circular right now and find out how useful and practical this book will be in your business.

**Just a few of the outstanding features:** Complete descriptions and illustrations of latest 1935 testing instruments and servicing methods (including cathode-ray oscillographs). Trouble-shooting table of Symptoms and Remedies for over 500 different common receivers, listed by manufacturer and model number. How to install and service auto radios (recent models)—complete with ignition wiring diagrams. Data on quick location and elimination of electrical noises and interference in broadcast and all-wave receivers and in auto radios (for every make and model of car). Complete table of intermediate frequencies for all makes and models of superhets, new and old. (Essential in alignment work). Thorough explanation of all forms of AVC and QAVC circuits, all-wave and high-fidelity receivers, and their servicing problems. The first radio textbook to contain a complete explanation of the construction and use of the new Cathode Ray Oscillographs in radio service work. Modern Radio Servicing.....\$4.00 Field Service Data Supplement.....\$1.50

—Special Combination Offer—  
Both Books—if purchased together. \$5.00

SEND FOR FREE CIRCULAR

Radio & Technical Publishing Co.  
45 Astor Place, New York. Dept. RN-4  
Please send me free descriptive circular on MODERN RADIO SERVICING.

Name.....

Address.....



# 34,000 SERVICE MEN HAVE SENT FOR THIS BOOK

GET YOUR  
COPY  
FOR  
**10c**



Take the guess work out of tube application! You can if you will send 10c for a copy of the newest Sylvania Service help . . . a handy pocket manual with 104 pages crammed full of useful information that not only helps you recognize tube and set troubles, but how to solve these problems.

Descriptions of over 90 types of tubes, including types 15, 18, 25S, 25Y5, 46B1, and 182B . . . 150 cuts and diagrams . . . complete data no radio man can afford to be without are in this new booklet.

You'll find it so valuable you wouldn't take \$10 for it . . . and yet it's yours for only 10c in stamps. Send coupon today for your copy.

**HYGRADE SYLVANIA CORPORATION**  
Emporium, Pennsylvania

|   |  |  |
|---|--|--|
| <p>Makers of<br/>Sylvania Tubes<br/>Hygrade Lamps<br/>Electronic<br/>Products</p> |  | <p>Factories<br/>Emporium, Pa.<br/>St. Mary's, Pa.<br/>Salem, Mass.<br/>Clifton, N. J.</p> |
|---|--|--|



**Hygrade Sylvania Corporation**  
Emporium, Pennsylvania (A-21)

Please send me the new Sylvania Technical Manual.  
I enclose 10c in stamps.

Name .....

Address .....

City.....State.....

*"And here is the best point of all. They have found in RADIO NEWS their greatest ally, in creating and holding new short-wave enthusiasts as satisfied customers. They have found that with the Radio News World Short-Wave Time Schedule in the hands of their customers, they eliminate many complaints, from new and old users of short-wave sets, that they cannot get all the foreign stations. Of course, it is true that you must know when and where to tune in these stations to be able to get them. That is just what our time schedule tells you—at a glance."*

We hope that our readers will not feel that the repetitions, above, are given with any sense of "I told you so," but that they emphasize a viewpoint which has been realized and is even more true today. The future of World Radio lies in the Short Waves!

## S. W. Reception

(Continued from page 599)

rather of establishing direct contact with England, with the English people, the English way of doing things, and with those things that are in fact so typically English that they bring tears to the eyes of a son of Great Britain who, relegated to some isolated outpost of the British Empire, is thus brought into direct contact with the Mother country. It can be imagined what a thrill it is to this lonely individual to hear the cheery voice of the British announcer giving the latest cricket, or rugby scores, or in a transmission from the river Thames, with all of the every-day steamboat whistles and noises of river traffic which in themselves are of little importance, but to this man bring a real heart-throb. I read some time ago of a short-wave receiver which had been brought far into the interior of the African jungles, involving great difficulties in the carrying of heavy batteries on the backs of natives, these same batteries later being charged by the primitive method of generating power by hand, all that this man might thus be kept in direct touch with home. The Empire broadcasts from the great transmitting short-wave stations at Daventry, England, send out five transmissions daily, each one "beamed" (pointed) to a certain section of the world and so scheduled to reach that particular section of the world at their best time of reception.

The Empire broadcasting service of Zeesen, Germany, is officially recognized as its political voice and is used solely in the transmission of a cross-section right out of the heart of German life. Whether or not you can understand German, you cannot help but capture some of the enthusiasm that is created by listening to one of the German political rallies where the speakers hold forth with great enthusiasm and the cheers of the crowds, the playing of the bands, the singing of national songs, the laughter and sounds of marching feet are clearly brought to your ears. I personally never tire of listening to the German waltzes and folk songs at which these people are past masters. These stations transmit daily on different wavelengths and at certain scheduled hours, which are regulated, like the English, to coincide with the best periods of reception in the countries to which the programs are directed.

In France we find the same situation existing, as there the broadcasting service, which is directed to its colonies, is located at Pontoise, a suburb of Paris, and goes under the name of "Radio Coloniale." One of the most stirring pieces of music ever written is the French national anthem, "La Marseillaise" which is played at the con-

clusion of each transmission. These national anthems play an important part in all of the Empire broadcasts and in Great Britain each transmission is closed with the playing of "God Save the King," and at Zeesen, Germany, with the playing of the two German national anthems. A French broadcast can be easily picked out by the rapid-fire, slightly nasal, sharp-cut intonation of the voice. France carries on its national broadcasting services on three different wavelengths, which are also arranged on a definite daily schedule for various countries.

In Italy we now find a similar system, which is known as 'Le Voce di Roma'. This powerful Empire broadcast service consists of four separate transmitters, each for the use of a certain wavelength and beamed on a certain part of the world. These transmitters are of the very latest construction and each have a power of 20 kilowatts, which insures reliable reception in North America, and all parts of the world.

In Portugal, a national service has been installed at Lisbon, and operates under the call of CT1AA. This station also calls itself 'Radio Coloniale'. Although this station is not quite so well heard as some of the others previously mentioned, due no doubt to its lesser power, it is often the means of providing some enjoyable entertainment and typical Portuguese music.

There is no better known station in the world, than the famous EAQ (Ee Ah Coo) at Madrid, Spain, which, with its unusual music and programs of good-will, has endeared it to every short-wave listener. Soon Spain is to have a new national broadcasting service, but we know that no matter how many stations Spain erects, none will ever take the place of EAQ, Radio Madrid, España.

## R. N. Converter

(Continued from page 601)

for receivers with low-impedance inputs. Sufficient capacity range is provided in C5 to permit the selection of any intermediate frequency between approximately 500 and 600 kc. About 540 kc. is generally employed for this purpose.

Originally it was the intention to design the converter with home-made coils and provide data so that builders could wind their own. However, after extensive experimentation, the conclusion was reached that no matter how detailed the coil data might be, it would be utterly impossible for constructors to duplicate the inductance values of the three circuits close enough to permit anything like the accurate alignment required in gang tuning. Also three-gang tuning condensers, of standard make, do not have wide retail distribution, and there was, therefore, no certainty that the condenser with which the coils were originally designed to work would be obtainable by constructors. If not, then, of course, the coil specifications would not hold.

In view of these obstacles it was decided to have some manufacturer or distributor market uniform components for the tuned circuits. The Wholesale Radio Service Company undertook this and is supplying a complete foundation kit of coils, etc., made according to RADIO NEWS specifications. As a result the prospective constructor can build up this converter with full assurance that when it is complete it will duplicate the original model in frequency range, alignment, etc.

The next article on this converter will provide information on the assembly and



wiring. Also instructions for adjustment of the padding and trimming condensers, etc. In the meantime, however, the blue-prints (ready for mailing about March 1st) will enable those who desire to do so to go ahead with the construction.

**List of Parts**

*The Foundation Kit*

- L1, L2, L3, L4—Set of special "Radio News S.W. Converter" coils
- C1—Tuning condenser, 3-gang, each section 360 mmfd.
- C2, C3—Hammarlund midget condensers, 4-plate, 30 mmfd.
- C4—Special compression type padding condenser variable 800-1600 mmfd.
- C5—Supplied (built-in) with coil L3
- C12—Trimmer included in C1
- C13—Fixed mica condenser, .0015 mfd., accurate to  $\pm 5$  percent
- 1 Cadmium-plated, drilled chassis with panel welded in position; 4 tube sockets, 3 tube shields, 2 binding-post strips. Chassis 12 inches long,  $7\frac{1}{2}$  inches deep, 2 inches high. Panel 13 inches long, 8 inches high.

**Other Parts Required**

- C6, C7, C9, C10, C11—Sprague tubular by-pass condensers, .1 mfd., 600 volts peak
- C8—Sprague tubular by-pass condenser, .5 mfd., 600 volts peak
- C14—Solar mica condenser, pigtail type, .0001 mfd.
- C15—Mallory 2-section (8-8 mfd.) electrolytic condenser with grounded can, inverted type, 450 volts
- C16—Sprague 2-section by-pass condenser in shield can, .1-1 mfd., 400 volts
- Ch—Thordarson type T-4402 filter choke
- R1, R3—IRC pigtail resistors, 250 ohms,  $\frac{1}{2}$  watt
- R2, R6—IRC pigtail resistors, 50,000 ohms,  $\frac{1}{2}$  watt
- R4—IRC pigtail resistor, 5000 ohms,  $\frac{1}{2}$  watt
- R5—IRC pigtail resistor, 30,000 ohms,  $\frac{1}{2}$  watt
- R7—IRC pigtail resistor, 10,000 ohms, 1 watt
- R8—IRC pigtail resistor, 10,000 ohms,  $\frac{1}{2}$  watt
- R9—Electrad wire-wound resistor, 2000 ohms, 10 watts
- SW1—Toggle switch, s.p.s.t.
- SW2—Toggle switch, d.p.d.t.
- T—Thordarson power transformer, type T-5472 with secondary windings of 575 volts (c.t.), 5 volts and 6.3 volts (c.t.)
- 1 National "Velvet Vernier" dial, type B, with variable ratio, 100-0-100 scale and pilot light bracket
- 2 grid caps
- 1 line cord and plug
- Shielded wire (about 5 feet)
- Tubes, one 6D6, one 6A7, one 76, one 80

**Modern "Ham" Set**

*(Continued from page 603)*

combination circuit for the second detector and the beat-frequency oscillator using a 6F7 tube. The output stage utilizes a type-42 tube and the whole circuit is powered through a type-80 rectifier tube.

In looking at the front panel, the main tuning dial is shown, centered, with the small knob that operates it, directly below. Then below this is the snap-switch that turns "on-and-off" the beat oscillator; to

*Out of the Brain of*  
**SCIENCE**



*Comes the Super* **SKY-RIDER**

From the heart of fine laboratories where standards of precision are vital, Science and keen Craftsmanship bring you the Super SKY-RIDER—the incomparable Short Wave Receiver. Enthusiastic Amateurs and "DX" fans everywhere, endorse it heartily. It will bring you, too, an exciting adventure in Short Wave tuning, with sure power, acute selectivity, and an uncanny reach.

**FEATURES THAT CHALLENGE:**

- Four Short Wave Bands (Fifth Band-Broadcast-optional)
- 5 Band Selector Switch (no plug-in coils)
- Full 7-inch Bandspread
- Crystal Filter
- Pre-Selection
- Built-in Power Pack and Speaker
- Dual Air-tuned Intermediates, etc.

**the hallicrafters**

**HANDCRAFT  
MAKES PERFECT**

The Hallicrafters, Inc.

3001-H Southport Ave., Chicago, Ill.

Send me at once, complete FREE description of the Super SKY-RIDER—the Short Wave set that has been imitated but never equalled. Also send the name of my nearest jobber.

Address.....

Name.....

City.....State.....

Now **CHI-RAD** brings you  
the sensational  
**CRYSTAL CONTROLLED  
Super SKYRIDER**

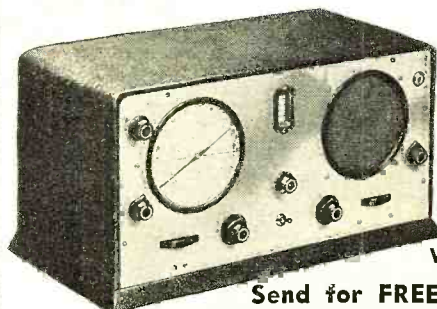

Get the real thrill of long distance short wave reception with the new Hallicrafters' Super SKYRIDER, "the short wave receiver that has everything." Join the thousands of CHI-RAD friends who trade here for quicker service, lower prices, and satisfaction always.

**Write For 10 Day FREE Trial Plan**

**Send for FREE booklet today!**

**CHICAGO RADIO APPARATUS CO.**  
415 S. Dearborn Street, Dept. RN-8, Chicago, Ill.



**POWERFUL NEW  
AMPLIFIERS**

*by*

**WEBSTER  
CHICAGO**

**THE SERIES 358  
15 WATT CLASS "A"  
AMPLIFIER**

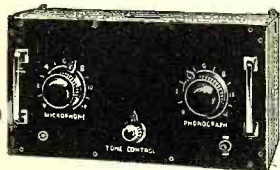

A new, flexible all-purpose Webster amplifier around which a variety of sound systems may be assembled. For auditoriums, churches, schools, clubs, factory and office call systems, and for all indoor installations requiring quality reproduction at an attractive price, the Webster 358 Class "A" amplifier is the ideal unit. Features a three stage Class "A" circuit distinguished for fidelity and for skillful minimizing of hum level. Incorporates the original Webster "stabilized bias" feature assuring maximum undistorted 15 watts output without the use of a separate bias tube. Provides dual control system for "mixing" both phonograph and microphone, with built-in microphone current supply. Equipped with tone control. Has universal output. Completely contained in a well-ventilated steel case, with tubes and terminal strip easily accessible. Effectively fused for protection. The Webster Class "A" 358 Amplifier is the logical choice for quality installations where fidelity and hum-free operation are of prime importance. Write for detailed descriptive bulletin.

**CLASS "B" 26 WATTS**

Where higher volume levels and wide range coverage are required, Webster offers the 26 watt Class "B" version of the 358 series. Essentially the same in appearance, input and output characteristics as the Class "A" unit. Particularly suited for out-door use with multiple speaker arrangements. There is a wide market for this moderately priced powerful unit. Send for complete details.

**WRITE FOR CATALOG!**

Sound specialists, Engineers, Radio Servicemen. Dealers and others who are interested in Sound installations—write for free bulletin describing the Series 358 units, as well as for the valuable complete Webster listing of Sound Equipment, covering all types of installation requirements. Submit your Sound problems to Webster engineers for complete recommendations and advice at no cost to you. Write now!

**WEBSTER  
CHICAGO**

3925 W. LAKE ST. CHICAGO, ILL. Dept. A

( ) Please send me Free bulletin covering the Series 358 Webster Amplifiers.

( ) Please send me the complete Webster Sound Catalog. I am interested in installations as described in the letter attached.

Name.....

Address.....

City..... State.....

the left and right of this switch, respectively, are the combination switch-and-tone-control and the 5-band switch. The horizontal control at the extreme left (shown just under the operator's thumb)

adjustment allows the set to be used as a "monitor."

The crystal unit, shown in the photograph, is equipped with two prongs which are inserted in the proper position in the

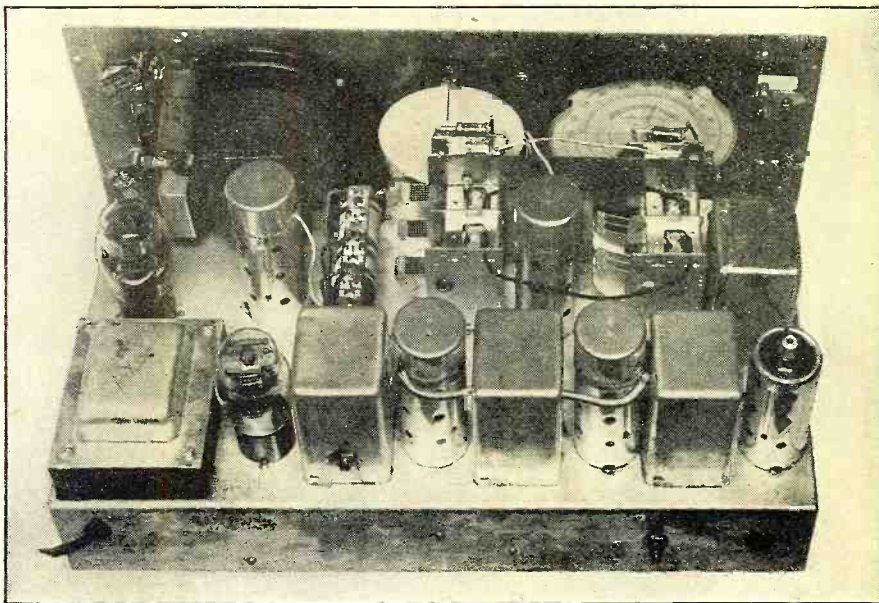

**REAR VIEW OF THE RECEIVER**

*This illustration shows the arrangement of the various tuning and amplifying components and tubes, as well as the positions and arrangement of the speaker and the two dials.*

is the control for the band-spread dial, directly above. The other horizontal control at the extreme right of the set is the volume control, with the loudspeaker grill above it. The knob at the right of the grill is the "transmit-receive" switch for use when the receiver is used at an amateur transmitting station. The phone plug, for listening-in with earphones, is directly above that. On the back of the cabinet there is another control for adjusting the "bias" when the "transmit-receive" switch is thrown to the transmitting position. This

socket, inside the cabinet. The unit also has a small adjustment screw (on top) for making proper "contact" with the crystal.

In tests at the Westchester Listening Post, on the amateur bands for telephone and using the crystal for c.w. work, as well as on short-wave broadcast reception, the receiver gave a performance that enabled steady contact with transmitters at great distances, demonstrating its high sensitivity and remarkable selectivity. The next article will describe the results of these tests.

**4-Band Super**

*(Continued from page 627)*

a 75, driver audio stage with a 76, and class A push-pull output stage with two 42's. The I.F. is 460 kc.

In conjunction with the three tuned circuits attached to the r.f., oscillator and first detector stages, respectively, it might be pointed out that four different groups of coils are used in each circuit. The wave selector switch has additional contacts to short circuit the lower frequency coils when the high frequency ranges are in use, to prevent "dead spots" due to absorption effects.

There are five knobs on the front of the set, which measures 20 inches high, 17½ inches wide and 13¾ inches deep. (This is no "midget" receiver by any means!) From left to right they are combined power switch and tone control, r.f. sensitivity control, station selector, wave range, and volume control. For quick tuning, the station selector knob is pushed in and then has a drive ratio of 10:1. For fine tuning, particularly on the short waves, the knob is pulled out, and a 50:1 ratio results.

The Model M-81 was tested at our Westchester Listening Post and worked very satisfactorily. It was turned on at about 7:00 a.m. on a Sunday morning, and operated casually, from time to time, until about 6:30 p.m. On the short waves the

following stations were heard: GSA, GSC, GSD, GSE, GSF, of the British Empire group; PHI and PCJ, Holland; DJA, DJB, DJC, DJE, DJN, of the Berlin group; FYA, Paris; I2RO, Rome; EAQ, Madrid; COC, COH, Havana; practically all the American and Canadian stations on the air that day; KEE, Bolinas, California, relaying a program to JOAK; an English phone carrying a concert from Monte Carlo; and a whole "bag" of Central and South Americans including XEBT, Mexico; TIEP, YV4RC, YV5RMO, Venezuela; HC2RL, Costa Rica; HP5B, Panama City; YV3RC, Ecuador; and HJ1ABB, Colombia.

**Trophy Winner**

*(Continued from page 616)*

because they come from stations using low power, rarely ever more than 100 watts. In fact, at least seven of the 38 British fones mentioned above, were using less than ten watts power when received, here, on the 14 mc. band. How much more satisfaction is gained from tuning in a ten-watt station, than the usual 5, 10 and 20-kilowatt ones, from the same distance!

In conclusion a brief mention will be made of the DX contest. It should first be pointed out that this contest limited reception to S.W. broadcasting stations. This alone precluded the possibility of one's compiling a large record of "choice" DX catches, for, at the time, there were prac-



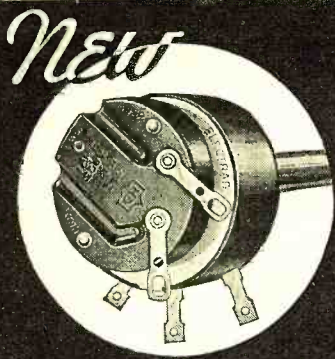

**ELECTRAD  
VOLUME CONTROL**

THE most sensational radio engineering development of recent times. Marvelously improves control of radio volume. More uniform distribution of current, greater ruggedness, less wear and smoother operation than ever before attained.

**Guaranteed  
QUIET**

Write Dept. **RN-4** for Descriptive Circular and the New 1935 Resistor Catalog

175 Varick St., New York, N.Y.  
**ELECTRAD**  
INC.

**Super SKYRIDER**  
*"has everything"*

**FREE** Complete information of this remarkable set, together with our wholesale supply guide packed with latest developments in radio sets, kits and parts for the Amateur Serviceman and Experimenter and Complete line **REFRIGERATION PARTS**

**Burstein-Applebee Company**  
1012-14 McGEE ST., Dept. S, KANSAS CITY, MO.  
"Specialists" in Supplies for the Amateur and Serviceman

**TRI-STATE COLLEGE**  
**Radio Engineering**  
**Degree in 2 Years**

Complete Radio Engineering course in 96 weeks. Bachelor of Science Degree. Radio (television, talking pictures and the vast electronic field) offers unusual opportunities for trained radio engineers. Courses also in Civil, Electrical, Mechanical, Chemical, Aeronautical, Architectural Engineering; Business Administration and Accounting. Low tuition, low living costs. World famous for technical two-year courses. Those who lack high school may make up work. Students from all parts of the world. Located in picturesque hill and lake region of northern Indiana. Enter September, January, March, June. Write for catalog.  
**1645 COLLEGE AVE. ANGOLA, IND.**

*Super Sky rider  
uses  
Raytheon 4-Pillar  
Radio Tubes*

tically no regular Asiatic or African broadcasters on the air. With tuning time being very limited, chances of catching any such stations that transmitted irregularly, were very small. PLE, PLV, VWVY, CNR (Radio Rabat), and EAR58-EA8AB were, however, heard and verified for the contest. This latter station was found to be operating on a wavelength between 40.2 and 40.6 meters and not in the amateur band, or on 41.6 as many listeners claimed (and as even the station owners announced!) Other contest verifications that may deserve mention (mainly because these stations are not among the "heard-daily" group), are: DFR, DIQ, DENNE (Graf Zeppelin, with 15 watts power, heard while somewhere over the West Indies), IRM, IRW, OA4B, PDV, PCK, OCM, CP5 (on all waves), HJ1ABE, HJ3ABD, HJ4ABB, HJ5ABG. Space does not permit a complete listing of all stations from which verifications were received during the contest period, but the above group is representative of what was heard.

**High-Fidelity**

(Continued from page 621)

may be lacking. The second tertiary is similar in nature except that capacity instead of reactance is present in the loading circuit and consequently the lows are augmented due to the high effective impedance of the condenser at low frequencies. Both of these effects can be accomplished simultaneously through the choice of a proper value of CR and LL used in series, Figure 1C.

This system of equalization has been developed to the point where it is now a practical possibility, an equalizer transformer (United Transformer Company) being available which allows controllable equalization at either the low or high ends, or equalization of both ends simultaneously with a minimum power loss, as in Figure 1B. Figure 2 illustrates the frequency response of this transformer, with 8 types of connections. A is used to bring up the lows. B to bring up the high. C, D, and E bring up lows and highs simultaneously. F is used to eliminate the typical speaker resonance generally found at about 400 and 4000 cycles. G and H are suitable for c.w. reception of a 1000-cycle note. All extraneous frequencies and heterodynes are eliminated or materially reduced, allowing greater accuracy and intelligibility in reception. A comparison with the response curves of many commercial receivers indicates that they can be brought to high-fidelity standards through equalization.

The actual application of this new equalizing transformer to a high-fidelity audio amplifier is shown in the halftone at the head of this article. The equalizing input transformer shown (the small transformer at the left) is universal in nature. Two primaries are supplied, one for a single- or double-button mike, a 200-ohm line, or a low-impedance pick-up. The other primary is a high-impedance winding suitable to work out of the plate a detector or amplifier tube, or from a high-impedance pick-up. The secondary can be operated into one or two tubes equally well. The internal connections of this transformer are shown in Figure 3.

**To Investigate and Allocate  
Program Percentages**

WASHINGTON, D. C.—The Federal Communications Commission is now holding hearings so that Congress may allocate, by statute, fixed percentages of radio broadcasting facilities to particular types or kinds of non-profit radio programs.

**MAKE MORE CALLS  
and BIGGER PROFITS**

*with New*  
**READRITE**  
*Point to Point*  
**TESTER**  
• No 720 •



Here is the tester that every serviceman needs for properly servicing radio receivers. The new Readrite No. 720 Tester enables you to make more calls per day at less cost per call—and make bigger profits because of its speed, its accuracy and its dependability.

The new No. 720 unit operates *faster . . . more efficiently* and with *less manipulation*. It tests all resistances, continuities, voltages, current and capacities from the set socket by the reliable point-to-point method. And it is built to withstand severe field service.

Two highly developed Vane-type AC and DC meters are incorporated into this new tester. They are simple in design and dependably accurate. The DC scales are 15, 150, 300 and 600 volts, 15-150 milliamperes. AC scales 10, 25, 150 and 750 volts.

**Your Jobber Can Supply You . . .**

with the Readrite No. 720 Tester at Dealer's net price of only \$15.00. Write direct for literature to

**READRITE METER WORKS**

143 College Avenue Bluffton, Ohio

**MAIL COUPON FOR CATALOG!**

Readrite Meter Works,  
143 College Ave., Bluffton, Ohio

Send me catalog on Readrite No. 720 Tester and folder proving Readrite leadership.

Name.....  
Address.....  
City.....State.....



An Event of  
**IMPORTANCE**

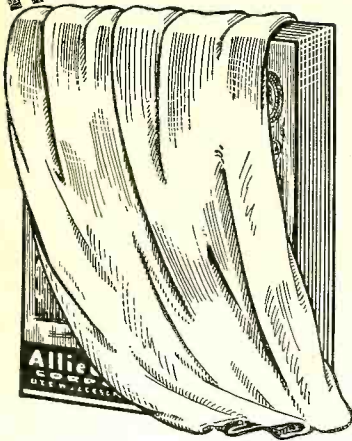

SEE PAGE 645

**ALLIED RADIO CORPORATION**  
333 W. JACKSON BLVD., CHICAGO, ILL.



*E. H. Rietzke*  
**SPEAKING!**

Mr. E. H. Rietzke, President of CREI, and originator of the first thorough course in Practical Radio Engineering.

...The **DIFFERENCE** between a "Future" and "Just a Job" is . . .

**TECHNICAL TRAINING**

Success depends upon adequate training. Men of ambition KNOW that they must have something better to offer than the next fellow, if they expect to obtain a better job. Technical training is more important today than ever.

**"TOOLS" TO BUILD A SUCCESS**

Our courses are written for the man ALREADY in Radio—in a language he can understand. CREI provides you with the "tools" in the form of knowledge and training, with which you can build a promising future, by being prepared to meet your opportunity when it arrives.

**FREE! 44-Page Illustrated Catalog**



It will explain our various Home Study and Residence Courses—and how easy it is to pay for them. Mail for your copy today. Inquiries are invited.

**CAPITOL RADIO ENGINEERING INST.**

Dept. R. N. 4

14th and Park Road—Washington, D. C.



**QRD? QRD? QRD?**

CONDUCTED BY GY

AH, yes. We forgot to mention what 1935 really has in store for us. Everyone had their say—Mr. Sarnoff, of the RCA, Mr. Morgan, *et al.*, gave their predictions as to what is to be expected for business and for the radio operator in the present year. Just to be "individual" we would like to ask the man in the Static Room what he thinks might happen to his welfare this 1935. We'll bet a plugged dime he'd say if this NRA business keeps up and makes ship owners realize that it means business on salary problems and conditions and hours, we would be able to make a livable wage. Also, organizations incorporated for the purpose of helping the radioman with his problems should keep politics and personalities out of its inner sanctums. Sez us'n company, "We also agree."

THIS column has always tried to be fair in all controversies which have arisen between the various organizations built for the betterment of radio ops and has always endeavored to give an unbiased opinion on all matters. Our opinions have not been personal ones, nor with a thought to deceive our readers into believing that one organization was better than another. From our many sources of information we gather together each statement, boil it down, tear it apart and try to give the finished product to you with a prayer that we are right. Sometimes too many organizations, trying to be of help to the same object, have destroyed instead of aided that object. Which brings to mind the case of a person in a small town. He needed help. Every one of the four "helping hand" organizations thought the other outfit was aiding him and after the smoke cleared away the man was still without any help!

From the ARTA bulletin it seems that they are going places and doing things. At station WEBR, a Buffalo broadcasting outfit, a decided victory was won by a strike which tied up that station for a week until the owners agreed to a code wage and proper working hours for the men. Station WHAM of Rochester, N. Y., has lined up solidly behind the ARTA by joining up 100% with them. In the Airways division they have tried to accomplish something and although a few wage increases were given, the full code limit has not been won; but hope is being held out for the near future. From all over the country reports are coming into the National Office, of progress which is being made in bringing new members under its banner. There is no doubt but that its recent victories have put the ARTA "over," in a big way, but still there are many who

are waiting to see what actually happens to their personal status before joining up with this organization. It is not a bad idea to be cagey and play 'possum while others do the real work, but, as the Bulletin states, the rewards will go to those who are in the boat now.

The picture in our Heading this month shows the operators in the London control room operating the short-wave circuits during the British King's Broadcast to the Empire. (Seems like they use a lot of "ops" for one speech!—Ed.)

Our West Coast reports that conditions are not so good out there due to the shutdown of canneries and the laying up of the fishing fleet, but swarms of ops have descended on Seattle, Frisco and L. A. with the result that the beach is plenty cluttered up with unemployed radiomen. Touring the various vessels in the harbor, we see almost as many second-class tickets as firsts, which shows that new men do get assignments, and speaking of assignments, practically all West Coast billets come out of the ARTA office. The delegates get a lot of free clerical work done

## The Technical Review

(Continued from page 635)

68. *How to Modernize the Supreme 400-B.* Data Sheet No. 4 of the Frank L. Sprayberry series of data sheets on how to modernize obsolete test equipment and receivers.

69. *Case Records of Broadcast Receiver Repairs.* Gives plan, contents and price of the Capitol Radio Research Laboratories' loose-leaf case records of 1500 service jobs showing how actual troubles were corrected. Serves as a guide in correcting troubles in all types of receivers and power supply units.

70. *Data Sheet on Building an Analyzer Adapter.* Compiled by the Capitol Radio Research Laboratories to show servicemen how any analyzer may be brought up to date or how to build a complete, modern analyzer out of spare parts with a multimeter.

71. *Radio Parts and Sets for 1935.* A catalog issued by Try-Mo Radio Co., Inc., listing the wide variety of sets, chassis, standard, special and replacement parts, tubes, tools, books, public-address systems, amplifiers and other electrical equipment required by radio dealers, servicemen, experimenters, set builders, radio operators and engineers.

72. *Short-Wave Receivers.* Describes the Skyrider tuned-radio frequency and Super-Skyrider superheterodyne short-wave receivers designed and built by Hallicraters, Inc. Feature range of 13 to 200 meters (with broadcast or 10-meter band optional), automatic wavechange switch, continuous band spread, built-in monitor, speaker and power supply (or batteries), high fidelity audio and other refinements.

73. *Home and Auto Radio Receivers and Accessories.* Descriptions, illustrations, list and net prices of the Hetro line of console, phonoradio and table-model home-radio receivers, auto radios, phonograph automatic record changers and motors, antenna systems and direct current converters.



# Dual-Section



## COMPACT ELECTROLYTICS



Ultra-Compact Hi-Farad Electrolytics... four leads instead of three... providing two negatives and two positives... for more applications and greater flexibility. Also mounting flanges.

In 4-4, 4-8 and 8-8 mfd. units.

Individual sections... not concentrically-wound dual sections.

Heavily wax-impregnated cardboard case with mounting flanges.

Flexible rubber-covered leads, color-coded for polarity.

FREE DATA: New 1935 Catalog is yours for the asking. Also sample copy of Research Worker. Ask your nearest jobber about the Aerovox line of condensers and resistors.

# AEROVOX

CORPORATION

77 Washington St. Brooklyn, N. Y.

### One of the SUPREME FIDELITY AMPLIFIERS

|               |            |
|---------------|------------|
| Three Stage   | 16 Watts   |
| High Gain     | \$24.50    |
| Push-Pull 2B6 | 18SS tubes |

SEND FOR A COPY OF OUR NEW 1935-100PAGE GENERAL CATALOG

WHOLESALE MERCHANTISERS, Inc., 626 Broadway, Dept. N, New York City

## The New EXPLORER

"Audio Modulated Oscillator" ALL-WAVE CONVERTER

A Sensational Advance in Short Wave Reception!

The new 1935 EXPLORER makes ANY standard radio a powerful world-wide all-wave receiver, for efficient short wave reception at lowest cost. Amazing performance! Exciting new "A. M. O." circuit affords tremendous reserve power for FULL Loud-Speaker reception of foreign short wave stations; aircraft, amateurs, police calls, etc. Complete short wave range of 15 to 200 meters in four bands.

The EXPLORER provides dual regeneration, heterodyne signal indication, precision calibrated dial, power reception, automatic band selector, balanced antenna coupler, Headphone Outlet, and many other features found only in expensive all-wave sets. Simple, permanent installation; output delivered to receiver antenna post. For 110 volt AC or DC current. Operates alone with phones as an independent short wave receiver. Price \$16.95. Satisfaction guaranteed or money back.

Send Now for FREE LITERATURE!  
RIM RADIO MFG. CO., 691 Grand St., Brooklyn, N. Y., U. S. A.

## ENGINEERING DEGREE IN TWO YEARS

B.S. Degree in Radio, Electrical, Civil, Chemical, Mechanical or Aeronautical Engineering in two years. Located in an industrial center with that Engineering atmosphere. Earn board. Low tuition. Preparatory Department. Enter March, June, September, December. Catalog.

### INDIANA TECHNICAL COLLEGE

241 E. Washington St., Fort Wayne, Ind.

by operators waiting for ship berths. The Frisco delegate told a steamship company to raise the operators' wages or he would call a strike and the result was that the line cut wages ten bucks a month. No jobs have been created in either broadcast or airways. On the contrary, two more oldtimers were laid off on airlines West of the Rockies. The airmail law is due for a modification so there ought to be a rehiring of at least ten former men, so we hear, probably about now, and it is also understood that aero radio is due for a boom this year! There were about fifteen Civil Service appointments made for the City, County and State jobs for operators, which isn't so bad for those who got them.

Our West Coaster continues... So far ARTA has done Nil for broadcast or airways operators in the West. Is it the fault of the men, the union, or a combination of both? Let us analyze the situation. In Marine Field ARTA has the radio act of 1912 on their side, and by calling a strike thirty minutes before sailing time is able to win out. To date no diplomacy has been used although as long as the victory is in hand, the means are not questioned. In the broadcast field, there is no legislation whereby the ops can win. Here is where diplomacy must be used to accomplish something, or else the cooperation with other unions to make a strike feared. We have spoken to technicians in a dozen stations, and this is also their opinion. We have also learned definitely that ARTA has the active opposition (in the Broadcast field) of the IBEW and that the ARTA should show some kind of action before the NIRA expires this Summer.

So with this in mind, it looks like quite a bit of action is in store for the operator this '35 and this column hopes that whatever happens, the billets will soon be opening up for those men who keep up the old spirit, waiting for a break... W. A. Clemens, owner of Gulf Radio School in N. O., is a frequent visitor to the West Coast and is giving a demonstration of a cotton picker he is marketing... Looks like the picker will pay more than the school... Joe Meloan stopped delegating for ARTA and now is opr at KFSD... Brownie Clouton, formerly at Albuquerque, now chief at KCRC, Enid, Okla. He studies Theoretical Mechanics, the Theory of the Potential and the Differential Calculus (for a pastime). Some day, he sez, he is going to enroll for a good course in Physics and Math... Dockendori, who took the usual college EE and plain integral calculus and generally used to try to keep up with Brownie, had to finally give up when the study of ellipsoidal harmonica brought on insomnia... so with a cheerio and 73... ge... GY.

## Double-Doublet

(Continued from page 615)

regular functioning of the transformer as an electromagnentic device, so radio signals continue to feed through the line to the receiver.

The coupling transformer at the set has no switch, and once installed requires no adjustment or manipulation.

The longer doublet section of the antenna is 39 feet long, each side of the center crossover insulator; the shorter section 16½ feet on each side. The matched transmission line, which must not be cut, is 80 feet long. Additional sections can be used where necessary to remove the antenna farther from the local interference zone. The whole antenna system is sold in convenient kit form.

# Announcing

## TRIPLITT

# VOLT - OHM - MILLIAMMETER IN KIT FORM!

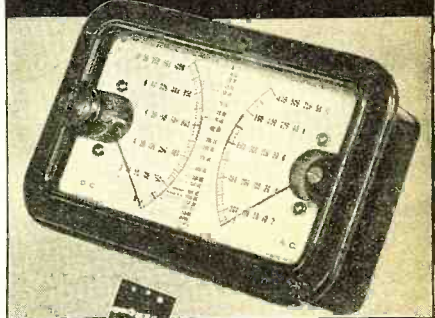

No. 1200



SERVICE men who want to build their own equipment, or who want to use instruments that can be made to fit special space and installation requirements, will be particularly interested in Triplitt No. 1200 Volt-Ohm - Milliammeter. Now, it is available in kit form, and is designed for use with built-in job equipment.

Every necessary item is included in this kit—and all assembly details have been carefully worked out. All you need is soldering iron and a pair of pliers. The complete kit includes these units:

|  |         |
|--|---------|
| Triplitt Twin Meter, net.....  | \$10.33 |
| Special Triplitt Selector Switch, net.....   | 1.67    |
| Shunt Board for 1-10-50-250 milliampere readings: 1500 ohms and 1.5 megohms, net.....  | 2.33    |
| Resistor board for 10-50-250-500-1000 DC volts and 50-250-500-1000 AC volts and current limiting resistors for 1500 ohms and 1.5 and 3 megohms, net..... | 4.83    |
| .5 MFD Condenser for output measurements, net.....   | .33     |
| Rheostat Assembly, consisting of 65-6000-9000 ohm resistors for ohmmeter zero adjustments, net.....  | 1.67    |
| Set of blue prints and instructions, net.....  | .67     |
| Hook up wire, net.....   | .33     |
| No. 32 Triplitt test leads, net.....   | .50     |

See Your Jobber

See this complete kit at your jobber's.  
Total price, net to dealers . . \$16.67

**THE TRIPLITT ELECTRICAL INSTRUMENT COMPANY**  
123 Main Street Bluffton, Ohio, U. S. A



# NATIONAL UNION

—gives to

## SERVICE MEN

### THIS BOOK TO

## HELP THEM SELL

—Radio Service

**EXTRA!** An Oscillograph has been added to the list of free shop equipment available with National Union tube purchases. Get details! Remember testers, analyzers and manuals are also still available.



• CONTENTS •

- Direct Mail
- Circularizing
- Newspaper Advertising
- Window Displays
- Business Forms
- Broadcasting
- Canvassing
- Special Selling Plans

Get your copy and tie up with National Union for better business!

National Union Radio Corporation of N. Y.  
400 Madison Ave., New York, N. Y. RN-435

Send me a copy of "Merchandising Radio Service under 'The Sign of Efficiency'."

Name.....

Street.....

City..... State.....

# WHAT'S NEW IN RADIO

WILLIAM C. DORF

## De Luxe 25-Tube Receiver

Here is an interesting announcement on the new Zenith Stratosphere 25-tube set, equipped with three speakers and employing eight 45 type tubes in a push-pull parallel output power stage. The speaker equipment comprises two concert dynamic-type speakers to handle the low-frequency response and a small horn-type dynamic speaker to take care of the high frequencies above 3000 cycles. The manufacturer

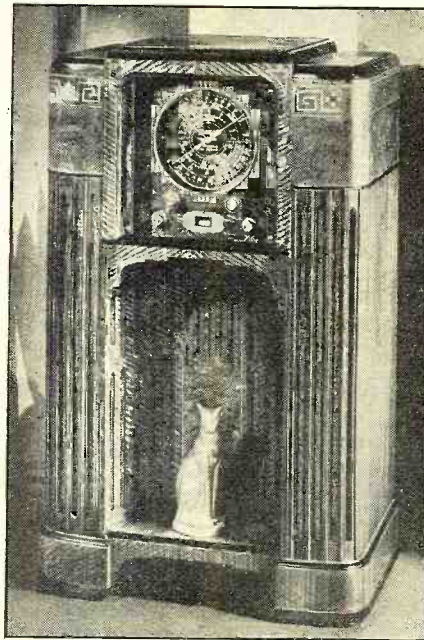

states that the frequency range response of the triple speaker combination is from 30 to 8000 cycles. With 8 of the 25 tubes accounted for, the remaining 17 tubes are employed as follows: six 6D6's for the first and second r.f. stages, the first and second i.f. stages, the shadow-tuning meter and automatic volume control amplifier; one 76 for the second detector and two 76's for the parallel first audio stage, one type 79 as a relay for "Q" circuit, one 6A7 as a combined first detector and oscillator, one 85 a.v.c., two 42's in the second push-pull audio stage and three 5Z3's as rectifiers. The tuning range of the set is from 535 to 63,600 kc. and is divided into five bands. The set is equipped with the latest developments including a high-fidelity control. Expert craftsmanship is at once apparent in the construction and design of the cabinet housing this unusual receiver.

## Simple Photo-Cell Amplifier

The photo-electric device shown here has

proven very simple and effective. It can be made from a few inexpensive parts and gives a change of 15 ma. from a 4½ volt flashlight at a distance of 3 feet. Moreover, it will operate from either 110 volt direct or alternating current.

The circuit, shown in Figure 1, makes use of a type 12A tube in a self-rectifier circuit. The filament is in series with a 25-watt lamp and a 100-ohm (10 watt) resistor. The plate circuit contains an 0-15 ma. meter as well as a relay. It is of course not essential that both be used and if a relay only is desired, the meter and one condenser can be omitted. However, it will be found that the meter is useful while the initial adjustments are being made. If only the meter is desired, the relay and one condenser can be left out. The Blan relay employed by the writer will trip at anywhere, from 2 to 15 ma.

The supply for the photo-cell is taken from a voltage divider and a 400-ohm potentiometer is used to vary the grid-bias of the tube.

The variations provided by the variable grid-bias and the adjustable grid-bias make it possible to trip the relay at almost any desired light intensity.

The photo-cell employed with the most success was the Cetron CE-1. In order to work the cell from a distance, a Blan Lightsource is used, comprising a transformer, a 21-candlepower automobile bulb, a reflector and lens all assembled in a suitable housing. This lightsource will concentrate the light in a narrow beam which makes it possible to work the device at greater distances.

The writer hereby thanks Mr. F. V. L. Smith, Chief Engineer, Continental Photo-Cell Co., for his assistance during the design of this device.

WALLACE M. MINTO,  
Jersey City, N. J.

## Special Cabinet and Panel for Senior and Junior All-Star Receivers

Owners of All-Star receivers will be glad to hear of the new Crowe model 246 cabinet and the de luxe etched aluminum, black enamel-filled panels especially made

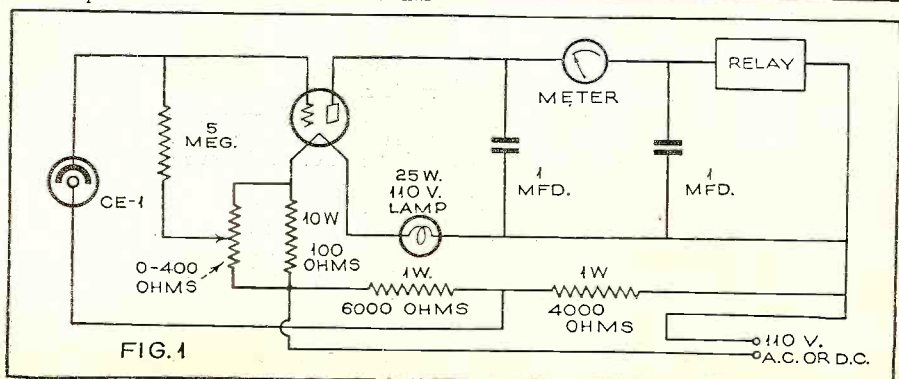
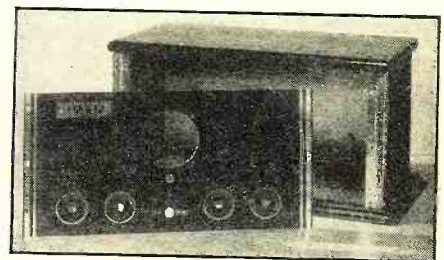



# Announcing the Spring & Summer Edition of RADIO'S LEADING CATALOG

A new ALLIED RADIO Catalog is on the press—not a meager supplement—but a full-size, meaty, complete book about Everything in Radio for Everyone in Radio. It's the kind of Value and Profit Guide for which ALLIED is famous. You need this new Catalog if you build, sell, service or operate radio equipment. Reserve your FREE copy immediately.

*What Will the New Allied Catalog Show in Sets?*

Everything: Short Wave, Dual Wave, All-Wave models—new Auto Radios—all types of electric, battery, and 32 Volt receivers. Prices are low, too.

*What About the Set Builder?*

He'll be in his element with more than a dozen great new kits to choose from. He'll find parts at lowest prices for building any radio circuit.

*Why Will The Amateur Want this New Book?*

Because it is complete in its listing of all the leading Amateur lines. It shows everything for Short Wave Transmitting and Receiving.

*Will There Be a Special Short Wave Section?*

Yes. With interests for everybody. There will be new receivers, transmitters, and parts for "DX" fans, Experimenters, Amateurs, and Set-Builders.

*What About the Serviceman?*

The new ALLIED Catalog will answer every Service need with the latest test equipment, and with thousands of parts priced for Servicemen's profits.

*Will There Be Anything New In Public Address?*

Yes, absolutely the most advanced Sound Equipment built today—portable, mobile and permanent—an amazing selection to fill every Public Address need.

## ALLIED RADIO CORPORATION

833 JACKSON BLVD., Dept. M1, CHICAGO, ILL.

Gentlemen: You may reserve my FREE copy of the new Spring and Summer ALLIED Catalog.

Name \_\_\_\_\_

Address \_\_\_\_\_

**RESERVE YOUR COPY NOW!**

for the six-tube Senior and five-tube Junior All-Star sets. The base and top of the cabinet is made of ebony-finished wood, the front corner moldings are of polished etched aluminum with sunken ornamentations, all of which make a most attractive cabinet. The inside length of the cabinet is 16 $\frac{7}{8}$  inches with an inside depth of 7 $\frac{1}{8}$  inches. Panels are available for either the Senior or Junior chassis. This company also make the Crowe airplane type dial called for in the construction of these sets.

### Battery Charger

The Automatic Electrical Devices Company announces the new "Hi-Rate Home-charger" for conveniently recharging automobile batteries in your own garage. This company points out the fact that automobile batteries are being subjected to an ever increasing drain, imposed by auto radios, extra lights, etc., and with this in mind the manufacturer has designed this new charger to provide a 10-ampere initial charging rate; this rate automatically tapering off as the battery becomes charged, thus preventing overcharging. It is equipped with a clamp-on plug-in type receptacle which requires but a single connection to the ammeter terminal behind the car dashboard.

### New Antenna Kit

The Corwico Noise Master antenna kit made by the Cornish Wire Company for use with either short-wave or broadcast receivers is recommended for those locations that are troubled with man-made radio interference. The aerial kit is so designed that from 1 to 4 sets can operate from the same antenna. This company offers a wide variety of antenna kits, all kinds of hook-up wire, lightning arresters and other antenna parts.



# VARITONE



Patent Pending

The UTC VARITONE is a revolutionary audio device which permits full control of the frequency response of any audio amplifier or receiver. Using this device, tone correction can be effected for defects in acoustic condition or overall audio response. It is also possible to produce new tonal effects from phonograph recordings or radio receptions and to bring back notes which would otherwise be lost completely.

Radio sets of Mediocre or Average quality can be converted to High Fidelity standards with the UTC VARITONE.

Hams and Short Wave Fans cannot afford to be without the VARITONE for it makes possible the ideal reception of essential voice frequencies as well as of CW. The VARITONE eliminates Static, Heterodyne and other QRM effects in Short Wave Receivers.

THE VARITONE IS AVAILABLE IN THREE TYPES.

VT-1. This VARITONE is incorporated with a universal audio transformer. Two primaries are provided. One is suitable for working from a single or double button microphone, a low impedance pickup, or a line; the other primary is designed to work out of the plate of a tube or from a high impedance pickup. The secondary winding is center-tapped and is equally suitable for working into one or two grids.

Net Price to Dealers or Hams.....\$5.10 List Price.....\$8.50

VT-2. The VT-2 is a varitone control unit, incorporated with an impedance matching device so that it can be connected directly across a 200 or 500 ohm line, or low impedance pickup or mike, or in shunt with the plate circuit of any triode or a high impedance pickup. The circuit is not changed in any other way. The VT-2 is solely an addition for tone correction. The original audio circuits are not disturbed.

Net Price to Dealers or Hams.....\$3.60

List Price.....\$6.00

VT-3. The VT-3 is a complete self-contained unit which does not use external control. The components are adjusted so that 10 db. equalization is effected at 80 and 7000 cycles. This unit is connected directly from plate to B plus of first audio triode. No other alteration is made.

Net Price to Dealers or Hams.....\$3.00

List Price.....\$5.00

Build yourself a VARITONE PA Amplifier with CONTROLLABLE High Fidelity features. It incorporates all the newest improvements including A prime amplification with 45 tubes. List price of complete transformer kit including VT-1 VARITONE \$39.00. Net to dealers \$23.40.

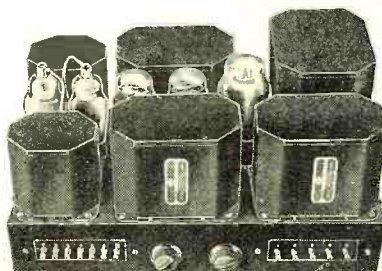

**UNITED TRANSFORMER CORP. 264 Canal Street, New York, N. Y.**  
EXPORT DIVISION, 15 LAIGHT STREET, NEW YORK, N. Y.



# BUILD THIS NEWEST ALL WAVE SET

## Browning 35

HERE is the newest all wave set that under actual tests by qualified authorities, has demonstrated its superiority over receivers costing several times as much. It includes the TOBE TUNER, the heart of the Browning 35. This tuner is a pre-adjusted unit including all R. F. Tuning circuits. The TOBE TUNER comes to you completely wired and aligned ready to be set into the chassis with only 7 simple connections! For ease of construction plus maximum efficiency—build the Browning 35. Write at once for our lowest WHOLE-SALE prices on complete kit of parts.

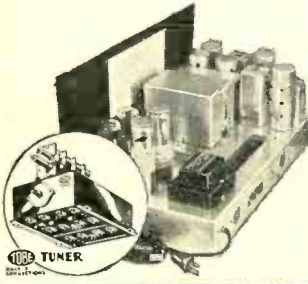

# BUILD YOUR OWN ALL STAR JR

★ ALL-WAVE Superheterodyne ★

YOU do not have to buy the entire kit to start building this famous Superhet All Wave Receiver! Only \$2.25 will bring you the Foundation Kit including completely drilled front and sub panel and other information. If you want the complete kit of parts—our lowest wholesale price, less tubes and speaker is only

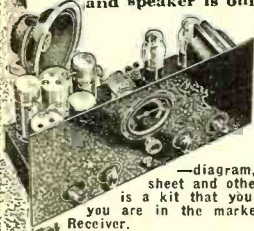

**\$26.19**  
**FREE**

—diagram, parts list, data sheet and other information. Here is a kit that you must investigate if you are in the market for an All Wave Receiver.

## This is SHORT WAVE HEADQUARTERS

THOUSANDS of Hams, Amateurs, and Experimenters from the Atlantic to the Pacific look to us for every latest development in Short Wave. The All Star, The All Star, Jr., The Browning 35, the RCA ACR-136, and many others are typical of the latest sets and kits that may be obtained here. Here you can be sure of having your order shipped promptly and accurately and you will save money, too, for here we sell at lowest WHOLESALE prices.

Wholesale Radio Service Co.  
100 Sixth Avenue, Dept. N-45  
New York, N. Y.

- Send me complete information on the BROWNING "35"
- Send me the All Star Jr. Kit at \$26.19.
- Send me the All Star Foundation Kit at \$2.25.
- Send me your FREE Bargain Book 36-C.

Name.....  
Address.....  
City..... State.....

**WHOLESALE RADIO SERVICE CO.**  
NEW YORK, N.Y. - 100 Sixth Avenue

ATLANTA, GA. 430 W. Peachtree St. NEWARK, N.J. 219 Central Ave.

## S. W. Calculations

(Continued from page 619)

"landmarks" are rather scarce in bands below 10 meters and the tuning range of such sets is rather limited, it may be necessary for rather accurate theoretical calibration of a receiver when work is started in this band. If a calibrated oscillator can be obtained, the work is much simplified. Transmitting circuits can be studied using the same rules as above, as well as wavemeter circuits.

## The Browning 35

(Continued from page 605)

should be taken in handling the tuner for it is completely wired and very carefully tracked at the factory. This tracking is done in a complete receiver identical to the one the set builder has constructed. This exact alignment is obtained by means of an all-wave signal generator with a calibrated attenuator so that absolute sensitivity of the tuner is measured after the tracking has been done. There are three connections leading into the tuner which should be as short as possible. One is from the plate of the first 58 tube which is used as a radio-frequency amplifier. This lead should be flexible and run directly from the plate to the terminal provided in the middle compartment of the tuner. This lead should be kept as far as possible away from all other leads and also a reasonable distance away from the

be found in the rear compartment of the tuner. The anode, or grid No. 2 of the 2A7, also connects to the tuner through a .002 mica condenser. This should be connected on the tube circuit similar to the one just described, and flexible leads run over to the tuner as previously stated. These three leads carry high frequency current and their capacity should be kept down to a minimum which means that they should be as far away from the chassis and other leads as reasonably possible and at the same time short. The other connection to the tuner on the left goes to the automatic volume control .1 meg resistor. The three connections on the right of the tuner go to the doublet antenna and plus B supply. In running the doublet leads into the tuner from the binding posts provided in the rear, care should be taken *not* to have these leads directly over any of the coils in the tuner. Otherwise, some feed-back between circuits might be encountered.

It will be noted that the tuner has a flexible metal lead soldered to it. The other end of this lead should be well soldered to the main chassis. Grounding the tuner in one point *only* is essential for the elimination of chassis currents.

The receiver is now ready for assembly of the front panel, and the dial. Before the front panel is put in place be sure to assemble the long pointer with collar and set screw attached on the main shaft of the tuning condenser. As will be noted, the two volume controls, the automatic volume control switch, and the tone control and power-supply switch hold the panel in place. When the panel is mounted by means of these, the coil switch and tuning condenser shaft should extend through

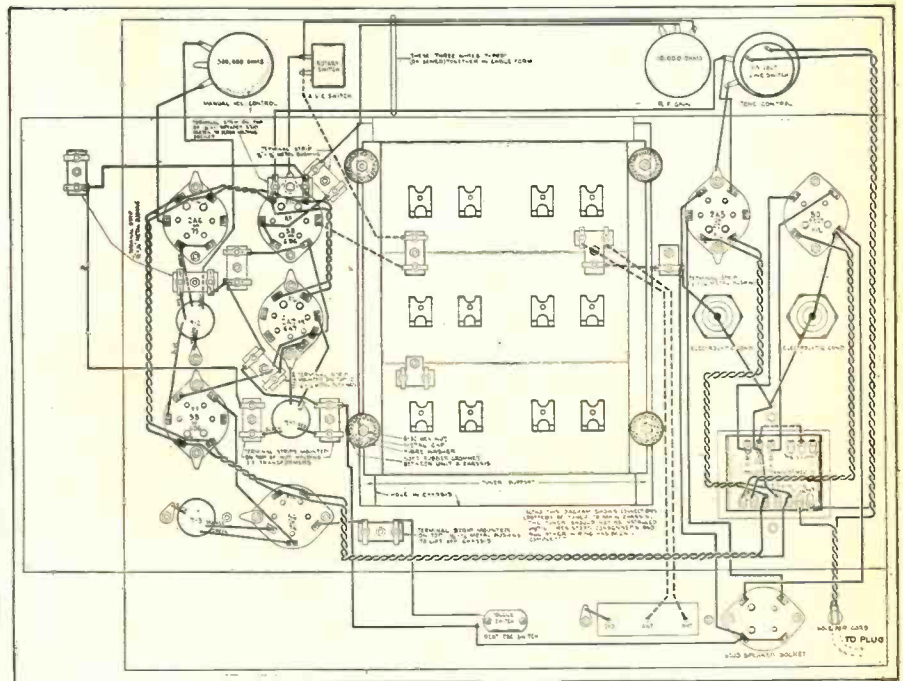

AN EXAMPLE OF THE PROGRESSIVE WIRING DIAGRAMS  
This is a miniature reproduction of one of the wiring diagrams prepared by the designer. The whole set contains five of these "blueprints."

metal chassis. It will be noted from the wiring diagram that grid No. 1 of the 2A7 or 6A7 is connected to the tuner through a .0001 mfd. condenser. This is one of the small mica condensers furnished in the kit and should be mounted on the tube socket of the 2A7 in a vertical position. A flexible lead is connected to the other side of the condenser and in turn connected to the proper terminal which will

holes in the panel. These holes are ample in size and the shaft should not touch the front panel. Otherwise, some chassis current might be introduced in to the tuner, setting up feed-backs and possibly some slight a.c. hum.

As will be noted on the back of the front panel, there are two dial slide-holders. The long pointer has already been attached

(Continued on page 648)



## The DX Corner (Short-Waves)

(Continued from page 620)

Washington, D. C.; Clifford Thompson, Gary, Indiana; Howard Adams, Jr., Baltimore, Maryland; Wm. Schumacher, Ellis, Kansas; Herbert Lennartz, Essen, Germany; H. K. Miller, Northampton, Mass.; Nicholas Schneider, Chicago, Ill.; J. Harold Lindblom, Lansing, Iowa; Oliver Harris, Hamilton, Ontario; N. C. Settle, Jr., Prosper, Texas; Paul F. Richer, Akron, Ohio; Andrew Anderson, Rockford, Ill.; W. B. Lumsden, Raleigh, N. C.; C. H. Armstrong, Atlanta, Georgia; M. Mickelson, Minneapolis, Minn.; Dr. G. W. Twomey, Minneapolis, Minn.; H. S. Bradley, Hamilton, N. Y.; Howard D. Leitten, Hamburg, N. Y.; Howard A. Olson, Chicago, Ill.; C. W. Bourne, Council Grove, Kansas; R. Stevens, Essex, Eng.; D. R. D. Wadia, India; Lino C. Herrera, Cristobal, Canal Zone; Western Australian Wireless News; Radio Club Venezolano; William Dixon, Plainfield, N. J.; R. Wright, Brooklyn, N. Y.; C. L. Davies, South Wales, England; A. C. Lyell, Johannesburg, South Africa; Baron von Huene, Tientsin, China; Otts Rehak, Baltimore, Md.; L. C. Styles, Essex, England; D. Neighbour, Lima, Peru; F. Mascarenhas, Bordeaux, France; H. Arthur Matthews, Victoria, Australia; Walter A. Jasiorkowski, Milwaukee, Wis.; D. Thwaites, Southfields, England.

## The "Ham" Shack

(Continued from page 602)

tubing. The coils were wound on a piece of pipe having an outside diameter of two inches. The tubing was wound close together and after it was slipped off the pipe, a screwdriver shank was passed between the turns several times until the desired spacing was obtained. This method of winding facilitates uniform spacing which probably could not be obtained readily if an attempt was made to wind the coil with the desired spacing.

Copper tubing of this size lends itself well to plug-in mounting. The threaded end of a banana plug will conveniently fit into the hole in the tubing and may be soldered by sweating. Porcelain stand-off insulators, with banana plug jacks, are used for mounting.

The electron-coupled oscillator is always preferable when there is no buffer stage. It provides frequency stability comparable to crystal-control, something that is essential, especially if the amplifier is to be modulated for voice transmission. Also mechanical vibration should be avoided. The link coupling coils used between the oscillator and amplifier also should be securely mounted. One turn, coupled closely to the oscillator plate coil and the amplifier grid coil at the cold ends of each, will be found sufficient. These also are made of copper tubing to insure stability. It was found that it was possible to obtain as high as 10 milliamperes of rectified grid current with such an arrangement, which is more than sufficient to excite a 210 tube or any tube of equivalent power. A grid-current meter in the amplifier circuit is almost essential. Plate meters are valuable too, but in order to obtain stable operation on this high frequency, it is necessary that the final tube have sufficient excitation, particularly if modulation is to be used. Those who have constructed 20-meter 'phone transmitters probably already have made this discovery.

The transmitter just described is only one of many possible combinations that may be used on this band. It will be found that the new 801-type tubes function exceptionally well on this band. It is a simple matter to substitute one of them for a 210. Also there are a number of

(Continued on page 648)

# NEW ALL-WAVE SET / EASY TO BUILD

## Browning 35

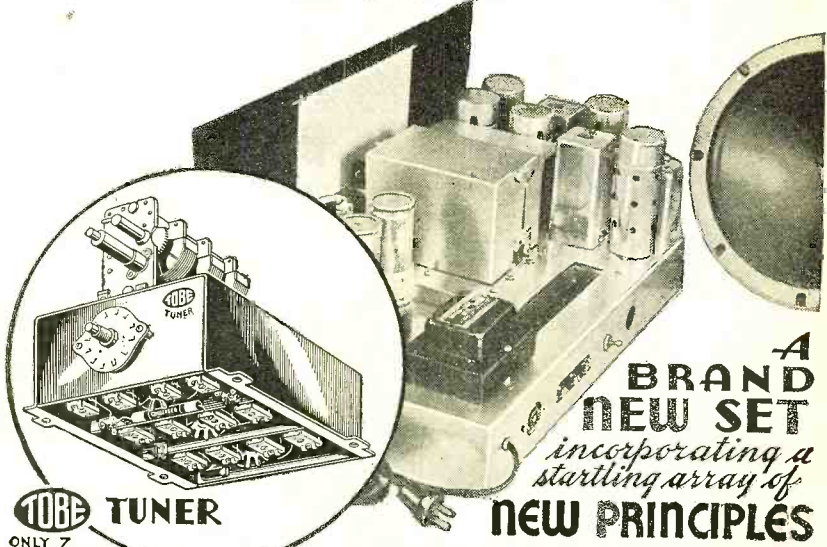
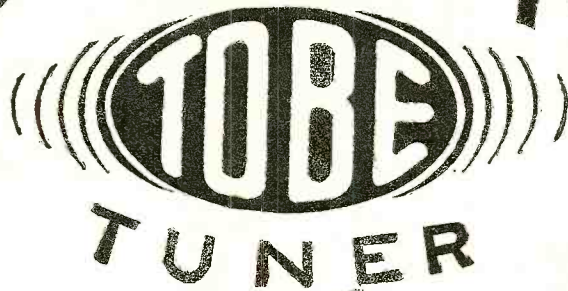

**A BRAND NEW SET**  
incorporating a  
startling array of  
**NEW PRINCIPLES**

**TOBE TUNER**  
ONLY 7 CONNECTIONS

Here is the newest all-wave set that under actual tests by qualified authorities, has demonstrated its superiority over receivers costing several times as much. It includes the TOBE TUNER, the heart of the Browning 35. This tuner is a pre-adjusted unit including all R.F. tuning circuits. The TOBE TUNER comes to you completely wired and aligned ready to be set into the chassis with only seven simple connections. Below are some of the other outstanding points of the Browning 35 Receiver.

1. Triple-Tuned Double-Band-Pass Intermediates-Link Circuit.
2. Mechanical and electrical arrangement of Tuner permitting maximum gain and efficiency.
3. No plug-in coils.
4. Pre-selection by means of R. F. stage.
5. Full vision dial accurately calibrated for all bands.
6. Sensitivity on all bands 1 microvolt or better.
7. Selectivity, 10 KC (absolute selectivity on all bands. Flat top tunings.)
8. Automatic and manual volume control.
9. Seven tubes.
10. Antenna connections for doublet or straight antenna.
11. Frequency range—540 KC to 22,000 KC, 4 bands.
12. Micro-vernier dial with 40 to 1 ratio.
13. Absolute single tuning control.
14. Beat frequency oscillator for C.W. reception.
15. Everything supplied in one container except tubes and speaker.

Special discount to experimenters and servicemen. Order direct from your jobber. If he cannot supply, write us direct for information and prices.

**Tobe Deutschmann Corporation**  
CANTON MASSACHUSETTS  
Export Dept., 105 Hudson Street, New York, N. Y.



for 5  
**\$100 PLANS**

For you who want advance technical information, we offer four Progressive Picture Diagrams (all actual size) and the schematic circuit diagram for \$1.00 plus complete information on kit parts and price discounts. 5 plans include: 1. Schematic drawing. 2. Arrangement of parts equipment, top view. 3. Filament wiring. 4. Resistor wiring showing color code. 5. Wiring of condensers, arrangement of tuner showing 7 connections where attached.

**TOBE DEUTSCHMANN CORP.,**  
Canton, Mass.

Gentlemen: Here is my dollar. Please send me the four full-scale Progressive Picture Diagrams (17" x 22") and the schematic circuit diagram with complete information on kit parts and prices; also the 24-page treatise by Glenn H. Browning describing the design, construction and operation of his latest and most remarkable engineering development.

Name.....  
Street.....  
City.....State.....



**OFFICIAL DISTRIBUTOR**  
**For the Southwest**  
 for the  
**Browning 35**  
 WITH  
  
**TUNER**



**EASY TO BUILD**

Here is the newest all wave set that under actual tests by qualified authorities, has demonstrated its superiority over receivers costing several times as much. It includes the TOBE TUNER, the heart of the Browning 35. This tuner is a pre-adjusted unit including all R.F. tuning circuits. The TOBE TUNER comes to you completely wired and aligned ready to be set into the chassis with only seven simple connections.

Write today for prices and complete information on the all-wave kit.

**BURSTEIN - APPLEBEE CO.**  
 1012-A McGee St., Dept. RN  
 Kansas City, Mo.

**THE NEWEST ALL WAVE SET**  
**Browning 35**  
 WITH  
  
**TUNER**

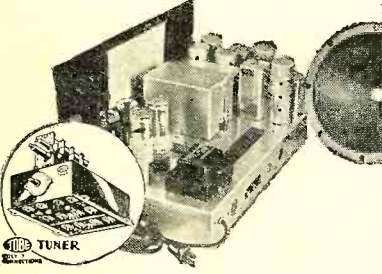

Here is the newest all wave set that under actual tests by qualified authorities, has demonstrated its superiority over receivers costing several times as much. It includes the TOBE TUNER, the heart of the Browning 35. The TOBE TUNER comes to you completely wired and aligned ready to be set into the chassis.

Let NEWARK ELECTRIC CO. supply you with ALL diagrams, constructional details, and parts list for the Browning 35 and all information on the TOBE TUNER. Write today.

See page 647 for additional details.  
**Write for Free Catalog**  
**NEWARK ELECTRIC CO.**  
 226 W. Madison St. Dept. RN Chicago, Ill.

## The Browning 35

(Continued from page 646)

to the main shaft of the tuning condenser. The pointer should be as close to the panel as possible without actually touching it. A short pointer with spring collar attached is provided. This should be slipped over the vernier tuning shaft which extends through the front panel. This should not touch the front panel itself but should have a small clearance. In turning over the chassis after the tuner has been assembled care should be taken not to rest it on the three-gang tuning condenser for the alignment of this condenser might be thrown out even in spite of its rugged construction.

After carefully checking the wiring of the receiver it is ready for trial operation and if correctly wired and constructed should, when an antenna and ground are connected, immediately bring in signals. If it does not, do not change any alignments on either i.f. transformers or trimming or padding condensers in the tuner itself. Look for wrong connections elsewhere. The next article in this series will consider the details of operation and tuning hints with complete instructions for alignment should it be necessary.

## The "Ham" Shack

(Continued from page 647)

other tubes that might have been chosen for the doubler-oscillator. The 2A5 will give results similar to the 59. Others that might be used are the 57 and the 24-A, although the latter tube will not provide nearly the harmonic output that the 59 and the 2A5 will. Therefore, if it is used, it will be necessary to use an additional amplifier stage.

Why not give ten meters a try? The more stations there are on the band, the better. It then will be possible to make a more complete survey of its possibilities. There is plenty of room for both C.W. and 'phone men.

### Calls Heard

By Oriente I. Noda, Piedmont Ave., Saratoga, Cal., on 20 meter 'phone: X1G, CO2VZ, CO2PC, K4SA, K6BAZ, K6FJF, K6KEF, W1CHI, W1GBE, W1CND, W1ARC, W1CJV, W2GP, W2GOO, W2EYG, W2OZ, W2HFS, W2BRO, W2MO, W21P, W2FOZ, W2BCP, W2ZC, W2AUT, W2HOY, W2JJ, W2TP, W2DVU, W3NK, W3Z, W3BOF, W3AXT, W3CIA, W3QV, W3APO, W3BSY, W3BBU, W3CKN, W3AMU, W3BFH, W3AWT, W3CII, W3ABN, W3DDO, W3PC, W3EGW, W3ACX, W3MD, W4BAM, W4CRE, W4CJ, W4FI, W4ABY, W4UP, W4ZE, W4KJM, W4HZI, W4BFB, W4QN, W4AZI, W4CVN, W4TI, W4IF, W4ALG, W5A, W5HK, W5AAK, W5AHK, W5FF, W5AOT, W5CQI, W5AGP, W5NT, W5AT, W5ASR, W5AEC, W5CCB, W5BA, W5BFS, W5AFP, W5BKV, W5AEB, W5AGO, W5BDB, W5ML, W5BEE, W5DYI, W5AFX, W5CRQ, W5AFF, W5BOC, W5EAZ, W5BAL, W5AXU, W5IT, W5ASG, W5DMD, W5FP, W5BAT, W5CIN, W5ZS, W5BS, W5BYV, W5AXA, W5IC, W5ECO, W5ALI, W5ECL, W5AA, W5BEQ, W5JZ, W5JM, W5LP, W5YV, W5BKS, W5BDP, W5AUX, W5AHJ, W5BOP, W5HJ, W5CXF, W5AVU, W6AAA, W6AOK, W6AND, W6BIV, W6BPV, W6BNU, W6BYW, W6BOW, W6DMN, W6DJZ, W6EFC, W6EGI, W6EFD, W6FFN, W6FDM, W6FBL, W6FG, W6GIO, W6HRT, W6KM, W6UF, W6ZH, W7AEM, W7BKC, W7FL, W7ARK, W7BL, W7CFC, W7BCL, W7CFX, W7BAW, W7BO, W7QC, W7JV, W7AIO, W7BBY, W7DRK, W7COO, W7EUO, W7CHT, W8BPC, W8GLY, W8FHE, W8AFM, W8GOY, W8GIL, W8AKU, W8DLD, W8FCO, W8HVZ, W8GHI, W8IO, W8FC, W8EQU, W8CYT, W8HAF, W8HH, W8CJG, W8LTO, W8CNZ, W8KAZ, W8CTN, W8BFD, W8ANO, W8IVF, W8GJF, W8IJZ, W9BXC, W9JL, W9BID, W8ARK, W9IRY, W9ARY, W9IGA, W9OYE, W9YL, W9DXI, W9ARE, W9LD, W9LYE, W9CCB, W9GA, W9APJ, W9IMZ.

New England Distributors for  
**Browning 35**  
 WITH  
  
**TUNER**

**BROWNING HEADQUARTERS**  
 SINCE 1925  
 And Still with Him  
 IN STOCK AT  
**SAGER ELECTRICAL SUPPLY CO.**  
 201 Congress Street, Boston, Mass.  
 and all branches

**NEW ENGLAND HEADQUARTERS**  
 for the Amateur and Experimenter  
**BROWNING 35 with**  
**TOBE TUNER**  
**THE RADIO SHACK**  
 46 Brattle Street, Boston, Mass.

Having Built and Sold BROWNING KITS since 1925, we are better equipped to serve you on the  
**BROWNING 35**  
 with TOBE TUNER  
 Nutter & Cross, Inc., W1HRF  
 99A Milk St., Boston, Mass.

**ELECTRICAL SUPPLY CORP.**  
 Wholesale Radio Service and Parts  
 Amateur Supplies—National Union Tubes  
 1739 Mass. Ave., Cambridge, Mass.  
 Tel. Kirkland 6646-6647

**NEW ENGLAND'S OLDEST**  
**AMATEUR SUPPLY HOUSE**  
 RADIO SINCE 1912  
 Let us demonstrate the  
**BROWNING 35 with TOBE TUNER**  
**HATRY & YOUNG, 203 AnnSt., Hartford, Conn.**  
 86 Meadow St., New Haven, Conn.

**BROWNING 35 with**  
**TOBE TUNER**  
 See and hear this new sensation.  
 Amateur and Servicemen supplies.  
**UNITED RADIO SERVICE**  
 616 Main Street New Britain, Conn.

**SOLAR** ★  
**WET AND DRY ELECTROLYTIC**  
**PAPER AND MICA CONDENSERS**  
 RECOGNIZED FOR  
**SUPERIOR QUALITY**  
 IN ALL CLIMATES  
 THE WORLD OVER  
 SOLD BY LEADING  
 JOBBERS EVERYWHERE  
**SOLAR MFG. CORP.**  
 399 BROADWAY  
 NEW YORK  
**BEST BY TEST!**  
 ASK FOR  
**CATALOG**  
 OF EXTREMELY  
**COMPACT TYPES**  
 HANDY FOR SERVICE

**EXPERIMENTERS**  
 ELECTRIC FUN! Book of 200 stunts with 110 volts. Tells how to make arc lights, motor, window display, \$1.50.  
 SPECTROSCOPE: Shows countless spectral lines of sun. Shows different sets of colored lines for each metal. New fascinating field of experiment. Instrument & \$2.50 instructions.  
 STROBOSCOPE: complete with 110 volt motor. \$1. neon lamp, and book of 100 experiments.....  
**Cutting & Sons 45 B St. Campbell, Calif**



**NEW! AND WE HAVE IT.**  
**THE TALK OF THE**  
**SHORT WAVE WORLD**  
**BUILD IT YOURSELF**

**Browning 35**  
 WITH  
**TOBE TUNER**



A brand new set incorporating a startling array of new principles. It includes the TOBE TUNER, the heart of the Browning 35. This tuner is a pre-adjusted unit including all R.F. tuning circuits. The TOBE TUNER comes to you completely wired and aligned ready to be set into the chassis with only seven simple connections.

**M & H Sporting Goods Co.**  
 512 Market St., Phila.

**Learn**  
**ELECTRICITY**  
**IN 12 WEEKS AT COYNE**

The great Coyne Shops in Chicago have a world-wide reputation for training men here in Chicago in this big-pay field in only 12 weeks. Then they get behind you to assure success by giving you lifetime employment service. By my new plan YOU can take advantage of their wonderful method of learning by doing NOW—no need to lose time and money while you strive and save to raise the necessary tuition.

**I WILL FINANCE YOUR TRAINING**  
 You can get your training first—then I'll give you over a year to pay me back, in small monthly payments starting 30 days after your required training period is over. If you will write to me at once I will send you complete details of this sensational new plan, together with the BIG FREE Illustrated BOOK telling all about COYNE. It tells how many earn white learning and about the training you get there without book study or useless theory.

*A. C. Lewis*  
 President

**COYNE ELECTRICAL SCHOOL**  
 600 S. Paulina Street, Dept. 45-81, Chicago, Illinois

**RADIO & AMPLIFIER HEADQUARTERS**

Send for Our Free Radio and Amplifier 1935 Catalog No. 29

We Specialize in P.A. Sound Amplifier Systems

Buy Direct From The Manufacturer And Pay Only One Small Profit!

**COAST-TO-COAST RADIO CORP.**  
 559-N SIXTH AVE., NEW YORK, N. Y.

**STEP AHEAD**  
 IN THE SERVICE PROFESSION WITH CASE RECORDS OF BROADCAST RECEIVER REPAIRS

ADD 10,000 HOURS to your experience! ELIMINATE GUESS-WORK in your SERVICE! **DON'T PUZZLE YOUR PROFITS AWAY!**

Your work is already done and recorded for you in "CASE RECORDS". This brief, descriptive binder CONTAINS 1,500 alphabetically and numerically arranged case records of SUCCESSFULLY COMPLETED SERVICE JOBS. Each Record tells—symptom—parts responsible—electrical values—location—and best replacement or repair. Fastest Servicing technique known. 105 Receiver Makes 100 Models. SUPPLEMENTED QUARTERLY FREE for 1 year. Free Consultation Service.

**CAPITOL RADIO RESEARCH LABORATORIES, INC.**  
 1503-21st. St. N. W., Wash., D. C.

\$4.75 Postpaid.

Kindly forward full details on "CASE RECORDS".

NAME.....  
 ADDRESS.....

W9JTS, W9JJA, W9EXI, W9CPM, W9BEZ, W9HOT, W9DRD, W9CCI, W9BHT, W9GDY, W9LCE, W9FDO, W9CTU, W9YB, W9BSZ, W9FK, W9FOU, W9JOS, W9EL, W9GMI, W9PV, W9AIO, W9IBR, W9BHM, W9AGS, W9GKU, W9KGR, W9BON, W9GML, W9BGL, W9GII, W9MIO, W9FLM, W9CIK, W9BRX, W9PZ, W9DEC, W9EMF, W9EZN, W9AA, W9CRQ, W9DUM, W9DEF, W9LNE, W9EIL, W9BIE, W9OOO, W9BPK, W9ATB, W9FJ, W9FTO, W9LDM, W9GYK, W9GHY, W9AJI, W9IHV, W9BBR, W9MXM, W9SBI, W9NNO, W9CCT, W9DIW, W9CSY, W9BJ, W9GYA, W9JIE, W9GUB, W9AUO, W9PDI, W9BSZ, W9GIC, W9AR, W9JLR, W9SP, W9LWJ, W9ANZ, W9CCU, W9PTR, W9NDG, VE4MP, VE4EA, VE5EH, VE4BF, VE4FI, VE9BE, VE3LL, VE4UQ, and VE5HA.

By Samuel J. Emerson, 1097 Galewood Drive, N.E., Cleveland, Ohio, on 20 meter 'phone band: CO2OY, CO2LL, CO2WW, CO2SE, CO2RA, HC1FG, K4SA, K5AJ, LU8BR, LU8DR, VP6MR, VP5PA, VE5HA, XU, VO8Z, VE4HR, VE3JL, VE3HC, VE1DC, VE2DX, VE3CF, WFFN, W6CLH, W6KT, W6AEW, W6AND, W6DIZ, W6DEP, W7AGW, W7BCU, W7ARK, W7BKC, W7BCI and W7BAW.

By John Woj Heilwie, 4523 St. David St., Philadelphia, Pa., on 20 meter 'phone band: W4AUP, W4CZG, W5BEE, W5YW, W5ASG, W5BOB, W6KNE, W6PHO, W6EHM, W6CNE, W6AAA, W7AO, CO2WZ, CO2RA, CO2LL, CO2WW, HI7G, and K4SA.

**NOTE:** "CO" is the new intermediate for Cuban stations replacing the "CM" formerly used. A number of the Cuban calls identified above were listed as "CM" but in view of the recent change, the current prefix has been listed.

**Chicago Amateurs Plan Spring "Ham-Fest"**

CHICAGO, ILL.—Amateurs in this district are to hold their Second Annual Spring Dance and "Ham-Fest" March 30th, in the Gold Room of the Congress Hotel, Chicago, Ill. Approximately 300 "Hams" are expected in attendance. \$5000 in prizes will be donated by various radio manufacturers, and RADIO NEWS is giving 10 subscriptions as door prizes.

**Code Practice Schedule**

Readers who desire to learn the code will be interested in the code practice schedule recently inaugurated by the new high-fidelity broadcast station, W9XBY, owned and operated by First National Television, Inc. This station is located at Kansas City, Missouri, and operates on a frequency of 1530 kc. with a power of 1 kw. These transmissions will take place three mornings per week: Thursday, 12:30-1 a.m., Saturday, 12:30-1 a.m., and Sunday 1-1:30 a.m. (all Central Standard Time). Each evening there will be a low-speed transmission for the beginner, medium speed and high speed transmissions. The transmissions will be in the form of a 500-cycle modulated note and all transmission will be by expert operators.

**The DX Corner (Broadcast Band)**

(Continued from page 625)

| Kc.  | Kw.  | Call        | Location                    |
|------|------|-------------|-----------------------------|
| 977  | 50   | West Reg.   | Great Britain               |
| 978  | 1    | XGOD        | Hangchow, China             |
| 980  | .5   | JOXK        | Tokushima, Japan            |
| 985  | 1    | CE98        | Santiago, Chile             |
| 986  | 10   | Genoa       | Italy                       |
| 990  | .3   | JOFG        | Fukui, Japan                |
| 990  | 12   | LR4         | Buenos Aires, Argentina     |
| 995  | 20   | Hilversum   | Holland                     |
| 1000 | .05  | 4GR         | Toowoomba, Qnsd., Australia |
| 1004 | 13.5 | OKR         | Bratislava, Czechoslovakia  |
| 1010 | .5   | CKCK        | Regina, Sask., Canada       |
| 1010 | .5   | CHWC        | Pilot Butte, Sask., Canada  |
| 1010 | .1   | CKCD        | Vancouver, B. C., Canada    |
| 1010 | .3   | 3HA         | Hamilton, Vict., Australia  |
| 1013 | .50  | N. National | Great Britain               |
| 1020 | .25  | XEJ         | Juarez, Mexico              |
| 1025 | 1    | 2UE         | Sydney, N. S. W., Australia |
| 1030 | 5    | LR9         | Buenos Aires, Argentina     |
| 1031 | 60   | Konigsberg  | Germany                     |
| 1031 | .5   | CT1GL       | Parade, Portugal            |
| 1040 | 2.5  | PTT         | Rennes, France              |
| 1040 | 10   | CP4         | La Paz, Bolivia             |



**FACTORY SEALED!**

**TO GUARANTEE LABORATORY QUALITY**

More than 95 minute pieces of wire, metal and chemicals are processed with microscopic accuracy in the assemblage of a Raytheon Tube.

4-Pillar support anchors these elements rigidly and gives Raytheon Tubes a matchless sturdiness and makes them outstanding favorites, particularly where dependability and long life are vital factors. Now Raytheon Tubes are packed in "Factory Sealed" Cartons.

Sold by good radio dealers. Recommended and used by reputable service men everywhere.

**Dealers Note:** New 1935 displays are ready—use the coupon.

**Service Men Note:** 1935 Tube Characteristic Chart now available—use the coupon.

**RAYTHEON PRODUCTION CORPORATION**  
 30 East 42nd Street, New York, N. Y. • 55 Chapel Street, Newton, Mass. • 445 Lake Shore Drive, Chicago, Ill. • 555 Howard Street, San Francisco, Cal.



**TO TEST...** Do not break corners. Push tube downward in box.

**RAYTHEON PRODUCTION CORP.**  
 Dept. D-4, 30 E. 42nd St., New York

Please send  1935 Display Material  1935 Tube Chart

Name \_\_\_\_\_

Address \_\_\_\_\_

Dealer:  (yes)  (no) Service Man:  (yes)  (no)

**RAYTHEON**  
 TRADE-MARK  
**4-PILLAR RADIO TUBES**



Now—a high-powered—



## Radio Engineering Library

- especially selected by radio specialists of McGraw-Hill publications
- to give most complete, dependable coverage of facts needed by all whose fields are grounded on radio fundamentals
- available at a special price and terms.

These books cover circuit phenomena, tube theory, networks, measurements, and other subjects—give specialized treatment of all fields of practical design and application. They are books of recognized position in the literature—books you will refer to and be referred to often. If you are practical designer, researcher or engineer in any field based on radio, you want these books for the help they give in hundreds of problems throughout the whole field of radio engineering.

5 volumes, 2981 pages, 2000 illustrations

1. Everitt's COMMUNICATION ENGINEERING
2. Terman's RADIO ENGINEERING
3. Chaffee's THEORY OF THERMIONIC VACUUM TUBES
4. Hund's HIGH-FREQUENCY MEASUREMENTS
5. Henney's RADIO ENGINEERING HANDBOOK

10 days' examination. Special price. Monthly payments. \$26.00 worth of books cost you only \$23.50 under this offer. Add these standard works to your library now; pay small monthly installments, while you use the books.

**SEND THIS ON-APPROVAL COUPON**

McGraw-Hill Book Co., Inc.  
330 W. 42nd St., New York, N. Y.

Send me Radio Engineering Library, 5 vols., for 10 days' examination on approval. In 10 days I will send \$2.50, plus few cents postage, and \$3.00 monthly till \$23.50 is paid, or return books postpaid. (We pay postage on orders accompanied by remittance of first installment.)

Name.....  
Address.....  
City and State.....  
Position.....  
Company..... RN-5-35

### BIRNBACH All-Wave ANTENNA

IMPROVES reception, strengthens signals, reduces interference and noise on all wavelengths.

Complete kit includes all parts—new-type coupler, (requiring no wave-change switch), wire, new-type insulators, accessories and instructions—only \$5.75 list.

Write Dept. EN-4 for FREE data on Antenna Kits, Aerial and Hook-up Wire, Standoff Insulators, etc.

**BIRNBACH RADIO CO., Inc.**  
145 HUDSON STREET NEW YORK CITY

### AUTOMOBILE COMPASS

Have you ever taken the wrong road and traveled many miles before discovering your mistake? This new AIR-PLANE TYPE COMPASS constantly tells you direction of travel. Sticks to windshield. Base 1 1/4" diameter. ONLY \$1.95 POSTPAID, including Compensator. SATISFACTION GUARANTEED or your money refunded if returned within ten days.

**DEALERS WANTED!**  
HULL MFG. CO., Box 246-K4, WARREN, O.

### PHOTO-CELLS SENSITIVE RELAYS CAPACITY DEVICES

Anything and Everything for the EXPERIMENTERS

SINCE 1923  
**BLAN THE RADIO MAN, Inc.**  
177 GREENWICH ST., N. Y.

|      |      |               |                               |
|------|------|---------------|-------------------------------|
| 1040 | 2    | 5PI           | Crystal Brook, Australia      |
| 1050 | 50   | Scottish Nat. | Great Britain                 |
| 1050 | 2    | CX26          | Montevideo, Uruguay           |
| 1059 | 20   | Bari          | Italy                         |
| 1077 | 12   | Bordeaux      | France                        |
| 1085 | 10   | JOBK-2        | Osaka, Japan                  |
| 1090 | .95  | 6AM           | Northam, N. Austr., Austr.    |
| 1095 | 7    | EAJ7          | Madrid, Spain                 |
| 1104 | 1.5  | Naples        | Italy                         |
| 1110 | 5    | 2HD           | Newcastle, N. S. W., Austr.   |
| 1120 | 1    | CHSJ          | St. John, N. B., Canada       |
| 1125 | 1    | 2UW           | Sydney, N. S. W., Australia   |
| 1121 | 10   | Horby         | Sweden                        |
| 1140 | 7    | Turin         | Italy                         |
| 1145 | .75  | 4BC           | Brisbane, Qnsld., Australia   |
| 1149 | 50   | West National | Great Britain                 |
| 1150 | 5    | LRS           | Buenos Aires, Argentina       |
| 1158 | 2.6  | OKM           | Kosice, Czechoslovakia        |
| 1170 | 2    | 4TO           | Townsville, Qnsld., Australia |
| 1175 | 10   | JOCK-2        | Nagoya, Japan                 |
| 1175 | .072 | COA           | Havana, Cuba                  |
| 1176 | 10   | Copenhagen    | Denmark                       |
| 1180 | 4    | 3DB           | Melbourne, Australia          |
| 1190 | .01  | VEBEK         | Montmagny, Que., Canada       |
| 1190 | 5    | LS2           | Buenos Aires, Argentina       |
| 1195 | 17   | Frankfurt     | Germany                       |
| 1200 | 1    | CHAB          | Moose Jaw, Sask., Canada      |
| 1210 | 1    | CHNC          | New Carlisle, Que., Canada    |
| 1210 | 1    | CKBI          | Prince Albert, Sask., Canada  |
| 1210 | 1    | XEPV          | Juarez, Mexico                |
| 1210 | 1    | XETH          | Mexico City, Mexico           |
| 1210 | 1    | 2CH           | Sydney, N. S. W., Australia   |
| 1222 | 10   | Trieste       | Italy                         |
| 1230 | 2    | LS8           | Buenos Aires, Argentina       |
| 1230 | 1    | XEPJ          | Monterrey, Mexico             |
| 1230 | —    | CPX           | La Paz, Bolivia               |
| 1240 | 1    | WKAQ          | San Juan, Puerto Rico         |
| 1245 | 2    | 2NC1          | New Castle, N. S. W., Austr.  |
| 1258 | 3    | San Sebastian | Spain                         |
| 1267 | 2    | Nurnburg      | Germany                       |
| 1270 | 1    | HIX1          | Santo Domingo, Dom. Rep.      |
| 1270 | 1    | 2SM           | Sydney, N. S. W., Australia   |
| 1290 | .5   | WNEL          | San Juan, Puerto Rico         |
| 1310 | 1    | CJLS          | Yarmouth, N. S., Canada       |
| 1312 | 1.25 | Malmo         | Sweden                        |
| 1320 | .25  | KGMB          | Honolulu, Hawaii              |
| 1325 | .25  | CMOX          | Havana, Cuba                  |
| 1348 | 2    | Radio-Vitus   | France                        |
| 1380 | 6    | 4BH           | Brisbane, Qnsld., Australia   |
| 1450 | .05  | CHGS          | Summerside, P. E. I., Canada  |
| 1450 | .05  | CFCT          | Victoria, B.C., Canada        |
| 1450 | .184 | COK           | Havana, Cuba                  |
| 1455 | 10   | Radio-Norman  | Fecamp, France                |
| 1474 | 1    | Bournemouth   | Great Britain                 |

### "Best Bets" for Foreign Listeners

The following list includes American and foreign stations heard by Official L.P.O.'s residing in foreign countries. An asterisk on the line with a station indicates that that station has been reported heard in the country corresponding with the column in which the asterisk is found. Following are the countries represented by each column and the names of Official L.P.O.'s whose reports are included. Column 1 (New Zealand)—L. W. Mathie, Hawkes Bay; R. H. Shepherd, Christchurch. Column 2 (England)—R. T. Coales, Hampshire; F. R. Crowder, Leeds. Column 3 (Australia)—Albert E. Faull, Victoria. Column 4 (Sweden)—John S. Bohm, Malung. Column 5 (South Africa)—A. C. Lyell, Johannesburg.

The frequency, location and power of foreign stations included in this list will be found in the "Foreign Station Locations" list. Space does not permit giving this information on American stations, but it can be found by referring to the complete U. S. list on pages 474-475 of the February, 1935, issue of RADIO NEWS.

| Kc. | Call         | 1 | 2 | 3 | 4 | 5 |
|-----|--------------|---|---|---|---|---|
| 546 | Budapest     | - | - | - | * | * |
| 556 | Berlin       | - | - | - | * | * |
| 565 | TGW          | * | - | - | - | - |
| 565 | Athlone      | - | - | - | - | - |
| 570 | KMTR         | - | - | - | - | - |
| 574 | Stuttgart    | - | - | - | - | * |
| 580 | KMJ          | * | - | - | - | - |
| 590 | WEFI         | * | - | - | - | - |
| 590 | WOW          | * | - | - | - | - |
| 590 | JOAK-2       | * | - | - | - | - |
| 590 | XEPN         | * | - | - | - | - |
| 590 | KHQ          | * | - | - | - | - |
| 592 | Vienna       | - | - | - | * | * |
| 600 | XMHA         | - | - | - | * | * |
| 600 | KFSB         | * | - | - | - | - |
| 609 | Florence     | - | - | - | - | * |
| 610 | KFRC         | * | - | - | - | - |
| 618 | KZRM         | - | - | * | - | - |
| 621 | Cairo        | - | * | - | - | - |
| 640 | KFI          | * | - | - | - | - |
| 660 | XGOA         | - | * | - | - | - |
| 660 | WEAF         | - | - | - | - | * |
| 668 | No. Regional | - | - | - | - | * |
| 680 | KPO          | * | - | - | - | - |
| 685 | VAS          | - | * | - | - | - |

### PORTABLE SOUND SYSTEMS

#### ELECTRO DYNAMIC UNITS

#### CARBON MICROPHONES

#### AMPLIFIERS

#### 4, 5 & 6 FT. ALL ALUMINUM TRUMPETS

#### FIELD EXCITERS

#### AIR COLUMN HORNS

#### LOW AND HIGH FREQUENCY UNITS FOR WIDE RANGE THEATRE USE

### ACCEPT OUR 5 Day FREE TRIAL

You can try any Toledo P.A. Equipment you need 5 days under any and all conditions absolutely without cost or obligation. Accept this challenge to duplicate Toledo's amazing performance and absolute dependability at any price. Write for folder giving complete details of free trial offer, prices and descriptions of Toledo's sensational, advanced 1935 equipment.

**TOLEDO SOUND EQUIPMENT LABORATORIES**  
Formerly Bud Speaker Co.  
1135 JACKSON STREET • TOLEDO, OHIO, U.S.A.

### You Can Become a Fast, Capable RADIO OPERATOR at Home

The CANDLER SYSTEM Makes it Easy for you! If you want to learn code QUICK ask about Junior Course for beginners. If you lack speed ask about Advanced Course — HIGH SPEED TELEGRAPHING. Whether Beginner, Amateur or Com'l op., tell us what ticket you're going up for and we'll show you how EASY it is to get. CANDLER SYSTEM gives you Speed, Accuracy and ability to Copy Behind—shows you how to use "mill" in copying fast stuff. All questions answered. Save time and money by sending for FREE BOOK today!

**Famous Candler Students**  
McElroy, champion 15 years. Watson, W1CJL, with Byrd Expedition. Jean Hudson, W3BAK, 9 yrs. old. Champion of world in Class "E."

**CANDLER SYSTEM CO., Dept. N-4**  
6343 So. Kedzie Ave., Chicago, Ill.

### free!

**100% SHORT-WAVES**  
52 Pages—50 Hookups

ALL ABOUT: Xmitting and Receiving Antennas, Bandsreading, Receiving Foreign Stations, Xmitting tubes. HOW TO BUILD "19" Twinplex, 5 and 10 Meter Xmitter. "203-A" Xmitter, Bandsread Doerle Set. How To Get Started in Short Waves, etc., etc. Send in (U. S. coin or stamps) for postage. Treatise sent by return post.

**RADIO TRADING CO.** 85 Hudson St. New York City

### Super Skyrider uses Raytheon 4-Pillar Radio Tubes



**CORWICO**

## "NOISE MASTER" Antenna



**Makes Bad Reception Good  
Makes Good Reception Better**

Catalogue No. 14  
List Price..... **\$6.75**

**AN IDEAL STORE DEMONSTRATION KIT**

Upholding our reputation for best antenna and radio wire products . . . a scientifically engineered unit which eliminates "man made" noises over both broadcast and short wave bands. Licensed under Amy, Aceves & King patents. Permits operation of more than one set from one aerial. Here is the peak of antenna efficiency . . . try it on your very next servicing job.

Write for Latest Bulletins  
**CORNISH WIRE CO.**  
30 Church Street New York City



## YOUR INVENTION

### How to Protect and Merchandise it

You may save a great many dollars in legal fees and perhaps hundreds more in mistakes avoided by getting this valuable new book by Elmore B. Lyford that gives you the "lowdown" on patents, trademarks and copyrights and "debunks" those practices designed to exploit the inexperienced inventor. From the very first step in protecting your idea down to the final stage of converting your invention into an income for yourself, Lyford gives you the true facts "straight from the shoulder," in plain, non-legal language.

**Get your copy today—  
only \$1 postpaid—or send  
for free descriptive circular**

**RADIO & TECHNICAL PUBLISHING CO.**  
45 Astor Place, New York. Dept. RN-4

## RADIO COURSES



**Radio Operating**  
*Prepare for Gov't. license exam.*

**Radio Amateur Code**  
*Radio Servicing*  
*Including short wave receivers.*

**Resident Courses**  
*Write for Booklet*

**New York YMCA Schools**  
7 West 63rd Street New York City

|      |                |   |   |   |   |   |
|------|----------------|---|---|---|---|---|
| 700  | WLW            | * | * | * | - | * |
| 713  | Rome           | - | - | - | - | * |
| 720  | WGN            | * | * | * | - | * |
| 740  | Munich         | - | - | - | - | * |
| 740  | WSB            | * | * | * | - | * |
| 740  | KMMJ           | * | * | * | - | * |
| 750  | WJR            | * | * | * | - | * |
| 750  | KGU            | * | * | * | - | * |
| 760  | WJZ            | * | * | * | - | * |
| 770  | KFAB           | * | * | * | - | * |
| 770  | JOHK           | * | * | * | - | * |
| 770  | WBBM           | * | * | * | - | * |
| 780  | KTM            | * | * | * | - | * |
| 780  | KELW           | * | * | * | - | * |
| 785  | Leipzig        | - | - | - | - | * |
| 790  | WGY            | - | - | - | - | * |
| 800  | WBAP           | * | * | * | - | * |
| 8100 | WCCO           | * | * | * | - | * |
| 820  | WHAS           | * | * | * | - | * |
| 830  | KOA            | * | * | * | - | * |
| 830  | LR5            | - | - | - | - | * |
| 830  | JOIK           | * | * | * | - | * |
| 832  | Moscow         | * | * | * | - | * |
| 850  | WWL            | * | * | * | - | * |
| 860  | WABC           | * | * | * | - | * |
| 870  | JOAK-1         | * | * | * | - | * |
| 870  | LR6            | - | - | - | - | * |
| 870  | WLS            | * | * | * | - | * |
| 870  | WENR           | * | * | * | - | * |
| 890  | XEW            | * | * | * | - | * |
| 900  | JODK           | - | - | - | - | * |
| 900  | KHJ            | * | * | * | - | * |
| 904  | Hamburg        | - | - | - | - | * |
| 910  | XENT           | - | - | - | - | * |
| 910  | LR2            | - | - | - | - | * |
| 910  | CRCM           | - | - | - | - | * |
| 913  | Toulouse       | - | - | - | - | * |
| 930  | CHNS           | - | - | - | - | * |
| 950  | KFWB           | * | * | * | - | * |
| 950  | VONF           | * | * | * | - | * |
| 950  | LR3            | - | - | - | - | * |
| 959  | Poste Parisien | - | - | - | - | * |
| 960  | SEAW           | - | - | - | - | * |
| 970  | KJR            | * | * | * | - | * |
| 990  | WBZ            | * | * | * | - | * |
| 990  | LR4            | - | - | - | - | * |
| 1010 | WHN            | - | - | - | - | * |
| 1020 | KYW            | - | - | - | - | * |
| 1040 | WTIC           | - | - | - | - | * |
| 1050 | CRCK           | - | - | - | - | * |
| 1050 | KNX            | * | * | * | - | * |
| 1050 | KFBI           | * | * | * | - | * |
| 1060 | WBAL           | - | - | - | - | * |
| 1070 | WTAM           | - | - | - | - | * |
| 1080 | WBT            | - | - | - | - | * |
| 1085 | JOBK           | - | - | - | - | * |
| 1090 | KMOX           | - | - | - | - | * |
| 1100 | WPG            | - | - | - | - | * |
| 1110 | WRVA           | - | - | - | - | * |
| 1130 | KSL            | * | * | * | - | * |
| 1130 | WJJD           | * | * | * | - | * |
| 1140 | KVOO           | * | * | * | - | * |
| 1150 | WHAM           | - | - | - | - | * |
| 1170 | WCAU           | - | - | - | - | * |
| 1180 | KEX            | * | * | * | - | * |
| 1190 | WOAI           | * | * | * | - | * |
| 1190 | LS2            | - | - | - | - | * |
| 1220 | WDAE           | - | - | - | - | * |
| 1230 | WNAC           | - | - | - | - | * |
| 1230 | LSS            | - | - | - | - | * |
| 1240 | WKAQ           | - | - | - | - | * |
| 1250 | WNEW           | - | - | - | - | * |
| 1250 | KFOX           | - | - | - | - | * |
| 1290 | KDYL           | - | - | - | - | * |
| 1290 | WNEI           | - | - | - | - | * |
| 1300 | KFAC           | - | - | - | - | * |
| 1300 | WBRR           | - | - | - | - | * |
| 1320 | WSMB           | - | - | - | - | * |
| 1320 | KGMB           | - | - | - | - | * |
| 1340 | WFEA           | - | - | - | - | * |
| 1340 | KFPY           | - | - | - | - | * |
| 1360 | WFBL           | - | - | - | - | * |
| 1370 | WOC            | - | - | - | - | * |
| 1400 | KTUL           | - | - | - | - | * |
| 1400 | WBBC           | - | - | - | - | * |
| 1410 | WAAB           | - | - | - | - | * |
| 1460 | KSTP           | * | * | * | - | * |

### New Zealand Notes

Through the courtesy of Observer Mathie of New Zealand, the following list is given showing the operating hours for New Zealand stations:

- 1YA, Auckland, 650 kc., Daily 6:30 a.m.; Su. 5:30 a.m.
- 1YN, Auckland, 880 kc., Daily 12:30-1:30 a.m., 2:30-5:30 a.m.; Su. 1:30-5:30 a.m.
- 2YA, Wellington, 570 kc., Daily 6:30 a.m.; Su. 5:30 a.m.
- 2YC, Wellington, 840 kc., Daily 12:30-1:30 a.m.; 2:30-5:30 a.m.; Su. 1:30-5:30 a.m.
- 3YA, Christchurch, 720 kc., Daily 6:30 a.m.; Su. 5:30 a.m.
- 4YA, Dunedin, 790 kc., Daily 6:30 a.m.; Su. 5:30 a.m.
- 4YO, Dunedin, 1140 kc., Daily 12:30-1:30 a.m., 2:30-5:30 a.m.; Su. 5:30 a.m.
- 3YL, Christchurch, 1200 kc., Daily 12:30-1:30 a.m., 2:30-5:30 a.m.; Su. 5:30 a.m.
- 1ZB, Auckland, 1090 kc., Tu., W., Th., F., 1:30-2:30 a.m., 3:30-5:30 a.m.; Su. 5 a.m.
- 1ZH, Hamilton, 770 kc., M., Tu., Th., Sa., 3:30-5:30 a.m.
- 1ZJ, Auckland, 1310 kc., W., 3-5 a.m.
- 1ZM, Manurewa, 1260 kc., M., F., 12:30-5:30 a.m., Sa., 12:30-7:30 a.m., Su., 2:30-5:30 a.m.
- 2YB, New Plymouth, 750 kc., 2:30-5:30 a.m.,

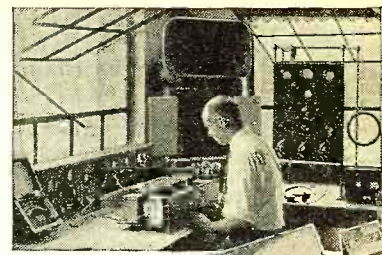

Mr. Scott in his Laboratory in 1929 creating this first SCOTT All-Wave (at right)

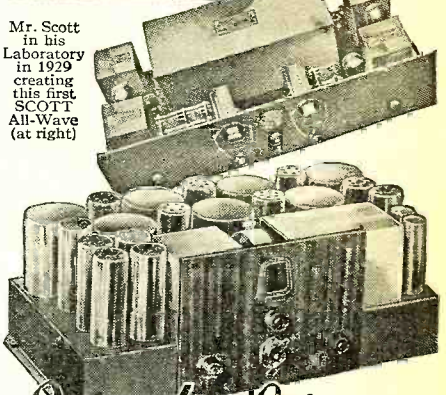

# It's the Years Behind THAT PUT THIS RADIO So Far Ahead

Since 1929, every SCOTT receiver has been an all-wave receiver. Because of painstaking, laboratory-precise methods of custom-building, the number of SCOTT receivers available has always been limited. Today . . . with many all-wave receivers using developments pioneered and perfected by SCOTT engineers . . . it is still a mark of distinction—and a source of satisfaction—to own a SCOTT. For only the SCOTT ALL-WAVE FIFTEEN can bring you the entire scope of regular broadcasts, as well as short wave programs from London, Paris, Rome, Berlin, Madrid, Sydney and the uttermost ends of earth, with so much more regularity, usable volume, and beauty of tone. Superiority of SCOTT performance over that of any other receiver is guaranteed. Send today for complete details and PROOF!

**Send Coupon for Details**

## Custom-built SCOTT ALL-WAVE Fifteen

E. H. SCOTT RADIOLABORATORIES, Inc.  
4440 Ravenswood Ave., Dept. 5F5, Chicago  
Send me complete information about the SCOTT ALL-WAVE FIFTEEN, including Proof of Performance and Technical Details.

Name \_\_\_\_\_

Address \_\_\_\_\_

City \_\_\_\_\_ State \_\_\_\_\_



# THEN THEY CAME TO SPRAYBERRY!



The list of Sprayberry students includes literally hundreds of servicemen who have first taken ordinary radio courses. And that is as it should be—for here alone can the forward-looking serviceman obtain sound **ADVANCED** training at a price so low he can't afford to miss it. For Sprayberry's Practical Mechanics of Radio Service will save you money—and it will help you make greater profits in a dozen different ways. It won't cost a cent to get the facts which may introduce you to the one thing needed to insure your future.

"I WANT TO SAY that the Sprayberry Course is the finest I have ever seen. It contains more information than many other courses combined." A. WALMSLEY, Vancouver, B. C.



"I AM A GRADUATE of three other home study schools—yet can truthfully say it was worthwhile in every sense to have taken your course." HORACE W. HART, Yonkers, N. Y.



"I HAVE TAKEN several radio courses, but none which have compared with yours. Sprayberry's is the best I have ever seen!" LLOYD HENDERSON, Grinnell, Iowa.

**NEWS FLASH!** Our three new and complete lessons on the use of the Cathode Ray Tube or Oscillograph may prove to be worth to you more than the surprisingly low price asked for the entire course!

**F. L. SPRAYBERRY** 2548 University Pl., N. W. Washington, D. C.

Sure—send me the dope—free! Also tell how I can get the NEW SERIES of Sprayberry Data Sheets at no extra cost.

Name.....  
Address.....  
.....RN-4-35

**SPRAYBERRY'S PRACTICAL MECHANICS OF RADIO SERVICE**



**KNOWN**

by the **Company They Keep**

In case you haven't already noticed it, we want to call your attention to an important fact you can readily verify: **Sprague Condensers are today featured by more of the better parts jobbers than any other make of condensers.**

Jobbers of this type know quality—and feature it accordingly. Even though they may carry other makes of condensers, chances are ten to one they'll recommend Sprague's to the man who wants the best. Ask your jobber and see! **SPRAGUE PRODUCTS CO., North Adams, Mass.**

**SPRAGUE CONDENSER**  
MADE RIGHT **600 FIVE** PRICED RIGHT

- W., Sa., 2-5:30 a.m., Su., 2:30-5:30 a.m.
- 2ZD, Masterton, 1170 kc., M.-Sa., 3:30-5:30 a.m.; Su. 1:30-5:30 a.m.
- 2ZF, Palmerston North, 960 kc., M., Th., Sa., 3:30-5:30 a.m.; W., 1:45-5:30 a.m.; F., Su., 2:30-5 a.m.
- 2ZH, Napier, 820 kc., M., Tu., W., F., 2:30-6 a.m., Sa., 2:30-6:30 a.m.; Su. 2:30-4 a.m.
- 2ZJ, Gisborne, 980 kc., Except Th., 2:30-5:30 a.m.; Th., 2:30-3:30 a.m.
- 2ZL, Hastings, 1240 kc., Th., 2-6:30 a.m.
- 2ZM, Gisborne, 1150 kc., Th., 3:30-6 a.m.; 2:30-5:30 a.m.
- 2ZO, Palmerston North, 1400 kc., Tu., 2-5:30 a.m.; Th., 2-4:30 a.m.
- 2ZP, Wairoa, 900 kc., 1:30-6 a.m.
- 2ZR, Nelson, 1360 kc., M., W., 12:30-5:30 a.m.; Tu., Th., F., Sa., 1:30-5:30 a.m.; Su., 2:15-5:30 a.m.
- 3ZE, Greymouth, 1300 kc., Sa., 4:45-6:30 a.m.
- 3ZM, Christchurch, 1470 kc., M.-Th., 12:30-1:30 a.m.; 2:30-5:30 a.m.; Sa., 3:30-7:30 a.m.; Su., 2:30-5:30 a.m.
- 3ZR, Greymouth, 940 kc., M.-F., 1:30-2:30 a.m., 3-5:30 a.m.; Sa., 1:30-4:30 a.m.; Su., 2:30-4:30 a.m.
- 4ZB, Dunedin, 105 kc., W., 2-6:30 a.m.; Th., 1:30-6:30 a.m.
- 4ZC, Cromwell, 1280 kc., M., 2:30-4:30 a.m.; Th., 2:30-5:30 a.m.; Sa., 1-2:30 a.m.
- 4ZL, Dunedin, 1220 kc., M., Th., 3-6:30 a.m.; Sa., 2:30-6:30 a.m.
- 4ZM, Dunedin, 1050 kc., Tu., 1:30-6:30 a.m.; Sa., 2:30-5:30 a.m.
- 4ZO, Dunedin, 1050 kc., M., F., 12:30-1:30 a.m., 3:30-6:30 a.m.
- 4ZP, Invercargill, 620 kc., M.-F., 2:30-5:30 a.m.; Sa., 1:30-5:30 a.m.; Su. 2-5:30 a.m.
- 4ZR, Balclutha, 1340 kc., Th., 2:30-6 a.m.
- 4ZW, Dunedin, 1450 kc., M.-F., Su., 2:30-6:30 a.m.; Sa., 2:30-7:30 a.m.

New Zealand Observers Mathie, Watson and Shepherd call attention to the fact that Station 1YA now has its new 10 kw. transmitter in regular operation.

W. E. Grover Lindsay Road, Waipukuruan, Hawkes Bay, New Zealand, would like to correspond with American listeners who are interested in both broadcast-band and short-wave reception.

## New European Transmitters

Observer Bohm of Sweden gives the following particulars concerning new European transmitters. Kracow, Poland, will have a new 120 kw. transmitter on 758 kc. Sottens, Switzerland, will soon increase power to 50 kw. Kuldiga, Latvia, has a new station operating on 1258 kc. with 20 kw. power.

Mr. Bohm will be glad to exchange stamps with any reader who is interested in stamp collecting. Presumably Observer Bohm refers to postage stamps, not verification stamps.

## VONF—VOGY

Observer Hynes reports that the proposed amalgamation of the Newfoundland stations VONF and VOGY has not materialized. They will continue to function as independent stations. After a recent shift, VONF has again returned to 1195 kc. VOWR is heard on 690 kc. instead of 681. Another Newfoundland station, VOAS, which is listed at 940 kc., has recently been working around 955-960 kc.

## All-Star, Jr.

(Continued from page 615)

may be tuned quickly to the highest frequency station in each band, with the band-spread set at 5. If the following calibrations are followed, one can, thereafter, follow through each band by simply increasing the setting of the band-spread dial. For the 16-meter band, the oscillator setting was 90 and the antenna setting was 80, using coil No. 1. For the 19-meter band, the oscillator setting was 11 and the antenna setting was approximately zero, with coil No. 2. For the 25-meter band, the oscillator setting was 45 and the antenna setting at 40, still with No. 2. For the 31-meter band, the oscillator setting

R C P

### New DEPENDABLE "RCP" MULTITESTER

Only \$13.95 Complete

**GUARANTEED FOR LIFE**

against defective materials and construction. Accurate, up-to-date testing assured when used with new 30L "RCP" Analyzer Unit, or your old analyzer. Contains 3-range ohmmeter; 4-range voltmeter; microammeter; batteries and set of fine illuminated prods. KIT, \$10.65. Write for complete data.

**RADIO CITY PRODUCTS CO.**  
Dept. RN-4, 28-30 W. Broadway, N. Y.

### Official "ALL-STAR" Cabinet

Fits ALL-STAR JUNIOR or SENIOR!

Available Through Your Jobber  
**Crowe Name Plate and Mfg. Co.**  
1746 Grace St. Chicago, Ill.

### CATHODE-RAY Testing and Analysis

A new booklet now on the press, written by Kendall Clough. Has over 50 illustrations. Tells how to test and service amplifiers, transmitters, and filter systems with Cathode-Ray Equipment. You must have a copy to be up to date. Ask your jobber, or write today.

Send 25c for your copy

**The CLOUGH-BREngle CO.**  
1136 W. Austin Ave. Chicago, U. S. A.

\*\*\*\*\*  
**FREE Parts List—Schematic**  
**BUILD YOUR OWN**  
**ALL-STAR JR**  
**ALL-WAVE Superheterodyne**  
 \*\*\*\*\*

**TRY-MO RADIO CO., INC.**  
85-R Cortland St., N. Y. C. 179-R Greenwich St., N. Y. C.

NOTE! Write for full particulars about FREE Membership to the Try-Mo Money-Saving Club

\*\*\*\*\*

## RADIO CODE

Learn at Home with **INSTRUCTOGRAPH CODE TEACHER**

CODE STUDENTS everywhere are turning to Instructograph, because there is no better way to learn radio code. No experience necessary. Just "listen" and imitate. Instructograph sends perfect code. It is available any time regardless of schedule or interference. Book of Instruction explains each step just as an Instructor would do. Instructograph, Tapes and Book of Instruction for sale or rent. Terms as low as \$3 per month. One additional month FREE if rented for two months. Rental applied on purchase price. Rent for a month. If Instructograph pleases you—BUY IT! If not, return it. Write for full details NOW! No obligation.

**INSTRUCTOGRAPH COMPANY,** Dept. NR-16  
312 Lakeside P.ace, Chicago, Ill.  
Representatives for Canada, Radio College of Canada, 863 Bay St., Toronto, Ont.

### 1935 RADIO CATALOG

30 DAY FREE TRIAL  
SAVE UP TO 50%  
DIRECT TO YOU

### Free Book

All models: Ae-De midgets; dual and world-wide all-wave, farm battery and car—at factory prices! Write for 24-page Bargain Catalog and 30-DAY TRIAL plan. Prices from \$9.95 UP.

**GOLDENTONE RADIO CO.**  
128 Oakman Bldg., Detroit, Mich.



# AMERTRAN TRANSFORMERS

For Public Address

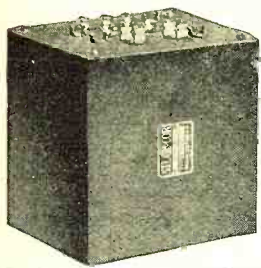

## BETTER QUALITY AT A MODERATE PRICE

AmerTran SilCor Components are designed to meet requirements in public-address amplifiers. All audio types are liberally designed to offer frequency characteristics uniform within  $\pm 2$  db from 60 to 8000 cycles; filter types give full inductance with rated d.c. flowing; and power transformers have better than 10% regulation. They are, indeed, thoroughly dependable amplifier parts offered at a moderate price within the reach of all.

Ask for Bulletin No. 1002

## AMERICAN TRANSFORMER COMPANY

177 EMMET ST. NEWARK, N. J.

**SEND FOR THIS**

**FREE**

**CATALOG**

Check full of **BARGAINS** in RADIO SETS, Long and Short Wave Apparatus, Servicemen's Repair and Replacement Parts, Electrical Appliances and hundreds of miscellaneous specials at **TREMENDOUS SAVINGS**. Get this big new Bargain Book. It's absolutely **FREE** without obligation—just send us Your Name and Address on a post card.

**RADIO CIRCULAR CO., INC.**  
225 Varick St., Dept. R. N., New York, N. Y.

**Browning All Wave ANTENNA KIT**

Write for information Send your jobber's name

**RIVARD MFG. COMPANY**  
1014 Madison Ave. Toledo Ohio

**5 METER TRANSRECEIVER**

**KIT \$6.50 COMPLETE**

## RADIO biggest opportunities still ahead

ALMOST in a decade radio has become a giant industry. The opportunities created will be enjoyed by trained men. The International Correspondence Schools Radio Course, prepared by leading authorities and constantly revised, will make you a trained man! A fascinating book—free.

**INTERNATIONAL CORRESPONDENCE SCHOOLS**

Box 8294-P, Scranton, Penna.

Send me—free—information on subject checked:

Radio  Radio Service Man  
 Radio Operator  Electrical Engineer

Name.....  
Address.....

was 65, the antenna at 71, again on coil No. 2. For the 48-meter band, the oscillator setting was 25, the antenna setting 20, with coil No. 3. It might also be mentioned that on coils 5 and 6, sufficient overlap was found so that the same station could be tuned in on the low-frequency end of one coil and on the high-frequency end of the larger one.

As to results obtained on listening to distant stations, we find the set was able to pick up distant stations with just as much ease as the original All-Star set, even though one less tube is used. The "local-distance" switch overcame overloading on the broadcast band, on local signals. Choosing one day's sheet from the Listening Post Log, at random, we find the following stations logged for good loud-speaker reception: CT1AA, COH, GSB, VK2ME, DJN, W1XAZ, I2RO, EAQ, DJB, FYA, W3PAL, GSE, GSD, W8XK, W2XE, RNE, GSA, DJC, YV6RV, YV3RC, VE9GW, W8XAL, W3XAU, HJ1ABB.

## The Service Bench

(Continued from page 633)

### SERVICE SALES PROMOTION

Consistent with the aims of the Radio Manufacturers Service to place the Service Business on a professional, ethical and profitable basis, Philco has just issued a 1935 catalog of radio parts, giving list prices only. This catalog can be displayed freely to any customer by the serviceman, and should prove an invaluable aid in securing a fair remuneration without the client feeling that he has been overcharged. This catalog lists a complete line of parts which can be effectively employed in receivers other than Philco. Your nearest Philco distributor will be glad to supply Radio News servicemen with one of these catalogs, as well as with information concerning discounts deservedly allowed the serviceman.

This catalog permits considerable latitude in the manner of estimating service charges, to suit conditions individually affecting servicemen in different parts of the country, and in the promotion of special sales campaigns. For instance, the serviceman may offer, as an enticement to new customers, an initial service job without any charges for labor. This he can do, and still be assured of a reasonable profit, by virtue of charging legitimate list prices for the parts used. On the other hand, during slack seasons, he can safely offer a special reduction on the cost of all replacement parts as an inducement for immediate servicing.

### "Radio Trouble Finder"

National Union has prepared an attractive 4-page folder (Figure 3) for serviceman distribution to his clients. It lists the more common radio troubles, giving first aid and common sense hints, and then tells your customer when to replace tubes, and when to call the serviceman. An excellent serviceman tie-up with first class sales psychology! These folders can be obtained with your imprint by mentioning RADIO NEWS.

The above amounts virtually to service insurance. Somewhat of a compromise between this scheme and the more usual service methods has been worked out quite successfully by J. Frederick Norlem, of Broken Bow, Nebraska, which he has called "The Custer County Radio Association." The members receive the certificate shown



for World-Wide Reception  
10 to 550 meters  
or 30 m. c. to 545 k. c.

Easy to build—splendid performance

Sponsored by 11 Prominent Radio Parts Manufacturers: Belden, Cornell-Dubilier, Crowe, Electrad, Erie, Hammarlund, Meissner, Oak, Ohmite, Oxford and Thordarson . . .

### Sensational Design!

A truly professional communication receiver that can be readily assembled without the use of special tools or test equipment. A soldering iron, screw-driver, and pliers are all you need to build the ALL-STAR JUNIOR.

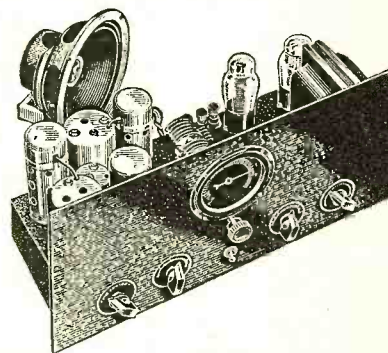

**CONTINUOUS BAND SPREAD**—over the entire tuning range makes possible the separation of hundreds of stations that are jammed together at a single spot on the ordinary receiver dial.

**BEAT-NOTE OSCILLATOR**—using the new 6F7 tube, brings in DX carrier waves inaudible on any other short wave receiver.

**SUPERHETERODYNE CIRCUIT**—Five tubes in the latest design; does the work of 7 tubes!

**PRE-ADJUSTED I. F. COILS**—Tuned at the factory to 370 k.c. No adjustment required.

**ALL ELECTRIC**—For 110-120 volt, 60 cycle, standard A. C. house current.

**STANDARD PARTS**—Ask your radio dealer or jobber for the ALL-STAR JUNIOR Foundation Unit that includes drilled sub and front panels, enlarged drawings of wiring and pictorial diagrams, three step assembly, and all instructions. Start with the Foundation Unit. Buy the remaining parts as you need them. For further information send for the

Ask Your Supplier or write Today!

**FREE**  
Circuit Diagram and Parts List!

**ALL-STAR HEADQUARTERS!**  
360 N. Michigan Ave., Chicago, Ill.

Name.....  
Address.....



# Train Now for New RADIO Opportunities

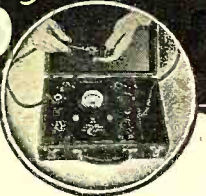

Get Into a Line Where There's Action—Every Day—And a Payday Every Week—You Be the Boss!

**Analyzer & Resistance Tester—Latest Design—Yours Without Extra Cost**

Right now while hundreds are looking for work where there isn't any, the radio service field can use trained men. With the proper training and the necessary equipment, you can enter this field and make a comfortable living. We include with our course this modern set analyzer and trouble shooter without any extra charge. This piece of equipment has proved to be a valuable help to our members. After a brief period of training, you can take the set analyzer out on service calls and really compete with "old timers." We show you how to wire rooms for radio—install auto sets—build and install short-wave receivers—analyze and repair all types of radio sets—and many other profitable jobs can be yours. Teaching you this interesting work is our business and we have provided ourselves with every facility to help you learn quickly yet thoroughly. If you possess average intelligence and the desire to make real progress on your own merits, you will be interested.

### ACT NOW—MAIL COUPON

Start this very minute! Send for full details of our plan and free booklet that explains how easily you can now cash in on radio quickly. Don't put it off! Write today! **Send Now!**

**RADIO TRAINING ASSN. of AMERICA**  
Dept. RN 54, 4513 Ravenswood Ave., Chicago, Ill.  
Gentlemen: Send me details of your Enrollment Plan and information on how to learn to make real money in radio quick.

Name.....  
Address.....  
City..... State.....

## SEND FOR IT TODAY!



**CAN'T AFFORD TO MISS THE NEW C-D CATALOG No. 128**

IT IS CHOCK FULL OF VALUABLE DATA ABOUT THE WORLD'S MOST COMPLETE LINE OF CONDENSERS FOR EVERY PURPOSE

WRITE AT ONCE FOR YOUR COPY

**CORNELL DUBILIER CORPORATION**

4387 BRONX BOULEVARD  
NEW YORK, U. S. A.

in Figure 4, which is pasted inside their radio cabinets. The idea is made clear in the following excerpts from the club contract: There will be a two dollar membership fee per year to be paid upon receipt of certificate. There will be no dues. The only additional money required will be the list price of parts and tubes replaced. Tubes will be replaced at the request of members only. One membership is good only for one radio for one year, therefore if service on two radios is required, it will be necessary to have two memberships. It is the purpose of the CCRA to eliminate man-made interference, and to bring better radio reception in general to the radio public of Custer County. A complete check of the radio and associated hookup will be made every three months, including tubes tested,

### Read Classified Advertising—It Pays

Advertisements in this section **twenty cents a word for each insertion.** Name and address must be included at the above rate. Cash should accompany all classified advertisements unless placed by an accredited advertising agency. No advertisements for less than 10 words accepted. Objectionable or misleading advertisements not accepted. Advertisements for these columns should reach us not later than 3rd of 2nd month preceding issue.

TECK PUBLICATIONS, INC.  
461 Eighth Ave. New York, N. Y.

### A.C. Generators

TWENTY practical and low cost changes converting Ford, Dodge, or Chevrolet generators into new generators and motors 100-500 watt capacity, direct or alternating current, with six to 400 volts for radio operation, power, light, or welding. Also instructions for rewinding armatures; 350 definitions of electrical terms, etc. All in new, revised book with simplified instructions and illustrations. Endorsed by thousands—Only \$1.00 postpaid. Auto Power—110-P S. Hoyne Ave., Chicago.

### Agents Wanted

AGENTS: Stick-on-Window Sign Letters, 500% profit. Write today. Metallic Letter Co., 422 N. Clark, Chicago

### Correspondence Courses

USED Correspondence Courses and Educational Books sold or rented. Inexpensive. Money-back guarantee. Write for Free Catalog listing 4000 bargains. (Courses Bought.) Lee Mountain, Pisgah, Alabama.

### Electrical Supplies

INSULATION, wire, varnishes, supplies, etc. Send 3c stamp for bulletin. Auto Power, 408-C S. Hoyne Ave., Chicago.

### Motion Pictures

LEARN motion pictures theatre business. Big opportunity as business or profession. Catalog free. Theatre Institute, 365 Washington, Elmira, New York.

### Patent Attorneys

PATENTS. Instruction "How to Establish Your Rights" and form, "Evidence of Conception"—sent Free! Lancaster, Allwine & Rommel, 414 Bowen Building, Washington, D. C.

PATENTS—Advice and booklet free. Highest references. Best results. Promptness assured. Watson E. Coleman, Patent Lawyer, 724 9th Street, Washington, D. C.

### Patents and Inventions

INVENTIONS COMMERCIALIZED. Patented or unpatented. Write Adam Fisher Company, 278 Enright, St. Louis, Missouri.

### Radio

RADIO ENGINEERING, broadcasting, aviation and police radio, servicing marine and Morse telegraphy taught, thoroughly. All expenses low. Catalog free. Dodge's Institute, Elm St., Valparaiso, Ind.

### Song Poems Wanted

WANTED: Original poems, songs. MMM Publishers, Studio Building, Portland, Ore.

### Wind Driven Lights

ELECTRIC LIGHTS—WIND DRIVEN—You build them. Write, Wind Motor Electric, Ridgway, Montana.

## NOISE-FREE RADIO RECEPTION



## ON GUARD AGAINST ALL MAN-MADE INTERFERENCE RCA WORLD-WIDE ANTENNA

Eliminates the noisy interference of street cars, your neighbor's vacuum cleaner and other man-made noise in your foreign reception—gets more foreign stations! \$6, plus installation.

The DeLuxe RCA World-Wide Antenna keeps out "man-made static" on all programs—domestic and foreign. \$7.75, plus installation.

You will never know how good your radio is until you use an RCA World-Wide Antenna.

Ask your radio service engineer or dealer for a *Certified* Installation of the Noise Reducing RCA World-Wide Antenna, or write for booklet, "Antenna Facts".

RCA PARTS DIVISION, Dept. N  
CAMDEN, NEW JERSEY



## WORLD-WIDE ANTENNA SYSTEM

### NEW! SENSATIONAL!

## 110 VOLTS AC FOR AUTOS

The new AUTONATOR generates 110 Volt A C Current in motor cars, aeroplanes and from all types of engines and motors, direct from fan belt. Costs nothing to operate. No service—no brushes, collector rings, commutator or wire wound armature. Ideal for operating PORTABLE Sound Equipment A C Radio Sets, Neon Signs, Electric Lights, searchlights. Send for complete details.

AUTONATOR LABORATORIES, Inc.  
8444 South Chicago Avenue, Dept. RN, Chicago, Illinois

## A.C. CURRENT-ANYWHERE!

### WITH Kato LIGHT PLANTS



A little gas and a Kato AC plant enables you to operate AC radios, amplifiers, refrigerators and other standard household appliances. Sizes 300 watts and up. Write for interesting descriptive literature on AC and DC models. Prices \$99.00 and up.

KATO ENGINEERING CO. Mankato, Minn., U. S. A.  
AC Generators \$16.00. Converters for operating AC radios from 6, 12, 28 and 110 volts DC \$18.00.

## \$19.95 AUTO RADIO

Amazing reception . . . distance and tone. Unheard of price . . . tubes and remote control included. Installed in 20 minutes . . . no experience necessary. Every car owner a prospect. Sell in spare time . . . demonstrate evenings . . . make yourself big profits quickly and easily. Pastest seller today. Exclusive franchise on territory . . . write quick for terms.

J. MATHESON BELL, INC. **AGENTS WANTED**  
308 W. Randolph St., Dept. A-1, Chicago

## Super Skysider uses Raytheon 4-Pillar Radio Tubes

## PATENTS

TIME COUNTS in applying for patents. Don't risk delay in protecting your ideas. Send sketch or model for instructions or write for new FREE book "Patent Guide for the Inventor" and "Record of Invention" form. No charge for information on how to proceed. Communications strictly confidential. Prompt, careful, efficient service. **Clarence A. O'Brien, Registered Patent Attorney, 395-T Adams Building, Washington, D. C.**









# NATIONAL

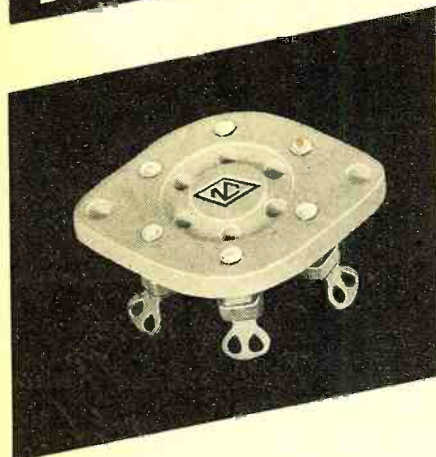

## SOCKETS... for Short and Ultra Short Wave Use

**DON'T FORGET**—Sockets must be **RIGHT** for short and ultra-short-wave work. The most careful layout and workmanship—the best coils and condensers—all may be rendered ineffective, if improper sockets are used for tubes and coils. It pays to use **NATIONAL SOCKETS**. Made of Steatite or Isolantite, they reduce high frequency losses to a minimum. The contacts are firm, positive and properly spaced. Convenient locator groove makes insertion easy. In standard 4, 5, 6 and 7-prong styles and in special 6-prong for **NATIONAL Coils**. List price each, Tube Sockets \$.60; Special Coil Sockets \$.75. (Subject to 40% discount when bought through an authorized **NATIONAL Distributor**.)

Send coupon below for New Catalogue No. 240

## NATIONAL SOCKETS

### COUPON

**NRA** National Company, Inc.  
Malden, Massachusetts

Gentlemen:  
Please send me your new catalogue No. 240.....I enclose 6c to cover mailing costs.

Name .....  
Address .....

RN-4-35



output circuits, an output circuit for the alternating component of the plate filament current containing a thermally sensitive resistance and a thermally nonsensitive resistance, a coupling between the output and input circuits, said resistances and coupling

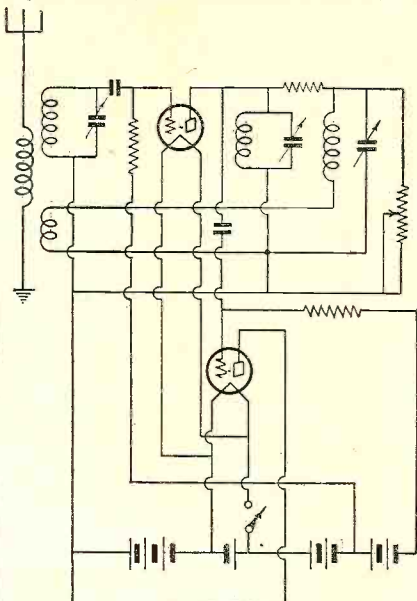

constituting means whereby in the absence of an incoming signal, the tube is caused to oscillate at a predetermined potential within the working range of the tube.

1,947,569. DETECTOR CIRCUIT. KLAAS POSTEUMUS, Eindhoven, Netherlands, assignor to Radio Corporation of America, a corporation of Delaware. Application April 9, 1930, Serial No. 442,811, and in the Netherlands May 23, 1929. 4 Claims.

1. In combination, a pair of detector tubes, a common input circuit for said tubes tuned to a desired signal frequency,

### Audio Transformer Catalogue

Radio dealers, servicemen and constructors will want to obtain the new American Transformer Company's convenient pocket-size, 32-page bulletin, No. 1002, which lists the complete line of AmerTran De Luxe audio and power transformers, the new



miniature transformer line, the precision line of audio components, special broadcast station equipment and other products.

Through the courtesy of this company, copies of the bulletin are available, free, to RADIO NEWS readers. Address requests to Department A, RADIO NEWS, 461 Eighth Avenue, New York City.

## Sensational NEW 1935

**HETRO DE LUXE ALL-WAVE RADIO**

**\$34<sup>50</sup> With SPEAKER and TUBES**

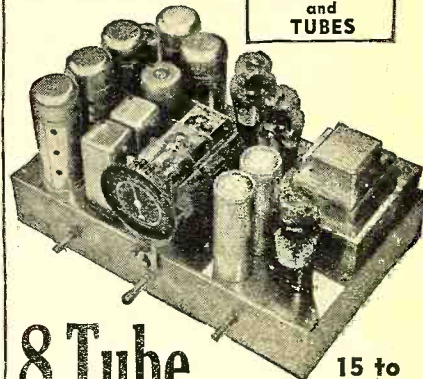

## 8 Tube

Custombuilt Super

15 to 2200 METERS

### Amazing New Low Price!

Why be satisfied with anything less than the New Hetro 8 tube All-Wave Super now offered for the first time at this truly remarkable price. Uses unique antenna, R.F. Pre-Selector, Oscillator Coil Assembly, big pot type speaker, and many other features found only in the highest priced receivers.

**7 DAY FREE TRIAL!**

Convince yourself that regular world-wide, high fidelity reception, need not be expensive. Try this set in your own home for seven days free trial. Foreign Reception Guaranteed or your Money back.

Write NOW for Details!

**HETRO ELECTRICAL INDUSTRIES, Inc.**  
4220 Lincoln Ave. Chicago, Ill., U. S. A.  
Cable Address "HETRO" All Codes

"We would have hesitated to demonstrate our New High-Fidelity Receiver without the



TRADE MARK REGISTERED (High-Fidelity)

### ANTENNA SYSTEMS"

We have used your No-Stat broadcast antenna system and your HI-FI All Wave Antenna System for demonstration on our broadcast and all wave receivers in many parts of the country with most gratifying results.

We were particularly pleased with the performance of your HI-FI system at a recent demonstration given by us at the Commodore Hotel—in the heart of New York City, where all kinds of electrical and automobile ignition interference are most severe—on which we had a 350 ft. lead-in, employing your Giant Killer Cable.

Without the use of this antenna, we would have hesitated to demonstrate our new High-Fidelity receiver.

—Leo McCann, Secretary & Manager, Sound Systems Division, Stromberg-Carlson Telephone Mfg. Co., Rochester, New York

"No Radio Can Be Better Than Its Aerial—No Aerial Is As Good As a LYNCH Aerial."

Full Information on Request

Arthur H. Lynch, Inc., 227 Fulton St., N. Y. PIONEER OF NOISE-REDUCING AERIALS

## LEARN IN LOS ANGELES Radio-Television

ELECTRICITY—TALKING PICTURES BROADCASTING—Special limited offer! GOOD JOBS WON BY TRAINED MEN R. R. coach fare allowed to L.A. Earn living while learning. 30,000 graduates. Latest facilities. No dummy equipment. Free employment service. Est. 30 yrs. Send for FREE illustrated Catalog. Tells how to earn good pay. NATIONAL RADIO & ELECTRICAL SCHOOL, Dept. 4-RN, 4006 S. Figueroa Los Angeles, Calif.

### FREE COLORED SHORT WAVE

Double MAP (Send 10c postage, etc.)

**FACTORY PRICES** Short-Wave-All-Wave-Kits

Free Catalog 0

**Radio City Labs, Suite 1222**  
30 Rockefeller Plaza New York, N.Y.



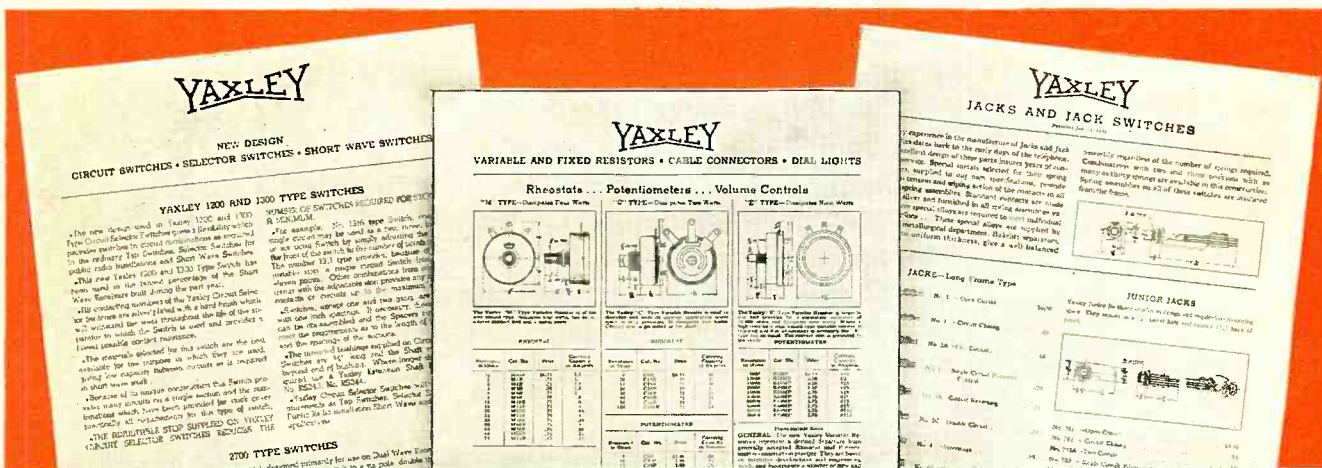

# Make the Yaxley Jobber Your Friend

## by STANDARDIZING on

# Genuine Yaxley Replacement Parts

### DON'T MISS THIS SPECIAL OFFER



The Yaxley Kit of 6 Volume Controls that service more than 2500 set models.



This handy wrench is FREE with each kit.

A copy of this complete and authoritative Replacement Manual is yours for the asking.



There is no better way to insure better profits in your radio service business than to give your customers still better service. And every service man knows that Yaxley Distributors who carry the Yaxley line 100% can give him the best service obtainable anywhere.

By being able to supply your needs promptly with a complete line of high quality parts, the Yaxley Jobber acts as your friend, and in so doing helps you build a profitable service business. He makes your job easier by being able to provide you with a product for which a wide acceptance has long been established by an extensive and sustained program of national advertising.

Mail the coupon today for your free copies of Yaxley catalogs Y-201, Y-202 and Y-203, illustrated above, which give full information and prices on the complete line of Yaxley parts. They will be very helpful in enabling you to give still better service.

**YAXLEY MANUFACTURING COMPANY, INC.**  
 Division of P. R. Mallory & Company, Incorporated  
 INDIANAPOLIS, INDIANA Cable Address: *Pelmallo*

YAXLEY MANUFACTURING CO., INC.  
 Indianapolis, Indiana  
 Gentlemen:

Please send me free copies of Catalogs Y-201, Y-202, Y-203.

I enclose \$3.60 (which is 40% less than the regular list price of individual controls) for kit of 6 Volume Controls, which entitles me to FREE Wrench.

I enclose 6 carton tops for FREE Wrench.

Please send free copy of Yaxley Replacement Volume Control Manual.

Name.....

Address.....

My Jobber's Name is.....



SAVE UP TO 50% by BUYING YOUR RADIO *Direct from* MIDWEST LABORATORIES

Thrill to Guaranteed World-Wide HIGH FIDELITY Performance with This  
**Amazing New MIDWEST SUPER Deluxe 16-TUBE ALL-WAVE Radio!**  
 (ALL FIVE WAVE BANDS)

**Only Midwest Gives You These Exclusive Features**

HERE are a few reasons why Midwest is generally accepted as the world's most "Universal" set. They explain why it is so popular in Africa, Spain, and other countries where reception conditions vary widely—illustrate why so many police, army, navy and consular officials as well as listening posts prefer it—prove why many "hams," who own a number of sets, use the Midwest in preference to any other.

**Perfect Preconversion Amplification on All Bands**

**Compact Centralized Band Switch**



Only the Midwest switch and coil arrangement makes it possible to use an efficient radio frequency amplifier stage in an ALL-WAVE receiver. If an attempt is made to get real amplification with other arrangements the usual result is howling and whistling due to oscillation. In the new Midwest 16-tube set, the inter-stage shielding in the radio frequency amplifier, is so complete that the utmost in gain and efficiency is obtained without regenerative efforts producing oscillation.

**Doublet Antenna Provision and Fully Loaded Plate Circuits**

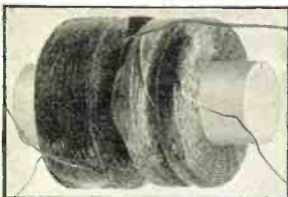

Due to the very recent development in coil design, the coils in the plate circuits of the RF tubes are of a phenomenally large inductance, in order to fully load the plate of the RF tube. This loading results in the gaining of maximum voltage amplification. The Primaries, in the antenna circuit, are brought out to insulated posts. They are especially designed to permit proper connection to the Doublet Antenna as well as to the more usual type—and have an inductance much greater than that used in the past. These very large coils are expensive to manufacture but give results not obtainable with old style coils.

**NEW STYLE CONSOLES**

The Midwest 36-page catalog pictures a complete line of beautiful, artistic deluxe consoles and chassis in four colors. Write for new FREE catalog . . . TODAY!

Midwest long-range radios are priced as **\$27.50** low as . . .



TERMS AS LOW AS \$5.00 DOWN

**30 DAYS FREE TRIAL**

**BEFORE** you buy any radio, write for the new FREE Midwest "Fifteenth Anniversary" catalog and see how you can save from 1/3 to 1/2 by buying direct from Midwest Laboratories. Learn why Midwest outperforms sets costing up to \$200 and more. Midwest gives you triple protection with: **One-Year Guarantee, Foreign Reception Guarantee, Money-Back Guarantee.**

**50 ADVANCED FEATURES**

Exclusive "Invisible Hands" features include: High Level Automatic Volume Control Action, Discriminating Automatic Tone Control, Multi-Function Dial, Micro-Tenuator, Fidel-A-Stat, etc. Only Midwest covers a tuning range of 9 to 2400 meters (33 Megacycles to 125 KC)—enabling you to easily and successfully tune in even low-powered foreign stations up to 12,000 miles away—with crystal-clear, loud speaker. High Fidelity reception. All 5 Wave bands enable you to enjoy today's finest High Fidelity American programs. In addition, you get Canadian, police, amateur, airplane broadcasts . . . commercial and ship signals . . . and delight in exciting world-wide broadcasts from England, France, Germany, Spain, Italy, Russia, Australia, etc. Send today for money-saving facts!

**Greater All-Wave Tuning Range**

9 to 2400 Meters (33 Megacycles to 125 KC)

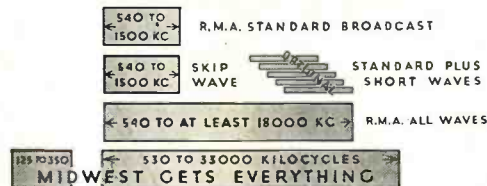

It is widely recognized that American-made radios are the best in the world—and that Midwest is the only American manufacturer who has sufficient acquaintance with world-wide reception problems to enable them to design a universally satisfactory all-wave radio. This experience has been gained through fifteen years of merchandising radios in almost every country of the world—from Australia to Greenland and from Japan to Portugal. Four years ago, Midwest developed and perfected an all-wave set. Each year, Midwest has consistently improved this set until, today, it represents the finest High Fidelity, super, all-wave radio you can buy anywhere. It has a greater all-wave tuning range of 9 to 2400 meters (33 megacycles to 125 KC) and is guaranteed to bring in foreign reception up to 12,000 miles and more away. Its tuning range covers every useful portion of the radio spectrum.

**ONLY RADIO COVERING 9 TO 2,400 METERS. 12,000 MILE TUNING RANGE**

**WORLD'S GREATEST RADIO VALUE**

**\$57.50** with New **Deluxe Auditorium-Type SPEAKER**

**EXPERIENCED RADIO MAN PRAISES MIDWEST**

Trenton, N. J.—I am firmly convinced that I have received the most for my money in my 15 years' experience. My Midwest-16 brought in 12RO, Rome; E.A.Q. Madrid; F.Y.A., France; G.S.A., G.S.B., Daventry; V.K2ME, Sydney, etc. It has remarkable selectivity! With WCAU at 1170 KC and WOAI at 1190 KC, both 50,000-watt stations, transmitting at their peak, about 9 P.M., I have cut between these stations and received KOB, New Mexico, at 1180 K with loud speaker volume—and no interference. R. M. Scheid, Jr., 28 Boudinot Street.



**DEAL DIRECT WITH LABORATORIES**

Increasing costs are sure to result in high radio prices soon. Buy before the big advance . . . NOW . . . while you can take advantage of Midwest's sensational values. No middlemen's profits to pay! You save 30% to 50% when you buy this popular way . . . You get 30 days FREE trial . . . as little as \$5.00 down puts a Midwest radio in your home. Foreign Reception, One-Year and Money-Back GUARANTEES protect you! Write for FREE catalog now . . . TODAY!

**SAVE UP TO 50%**

**MAIL COUPON TODAY! FOR FREE MINIATURE DIAL . . . FREE 30-DAY TRIAL OFFER . . . FREE CATALOG**

**MIDWEST RADIO CORP., Dept. 147A, Cincinnati, Ohio.** Without obligation on my part, send me your new FREE catalog, FREE Miniature Dial, and complete details of your liberal 30-day FREE trial offer. This is NOT an order.

User-Agents Make Easy Extra Money Check Here for Details

Name \_\_\_\_\_  
 Address \_\_\_\_\_  
 Town \_\_\_\_\_ State \_\_\_\_\_  
 Check here, if interested in Midwest World-Wide Battery Radio.  
 Check here, if interested in a Midwest Auto Radio.

**MIDWEST RADIO CORP.**  
**DEPT. 147A — CINCINNATI, OHIO, U. S. A.**  
 Established 1920 Cable Address Miraco. . . . All Codes