

CIRCULATION LARGER THAN THAT OF ANY OTHER RADIO PUBLICATION

# RADIO NEWS

REG. U.S. PAT. OFF.

25 Cents

APRIL

Over 200  
Illustrations

Edited by HUGO GERNSBACK

ONE GOOD TURN  
DESERVES ANOTHER



RADIO'S GREATEST MAGAZINE

EXPERIMENTER PUBLISHING COMPANY, NEW YORK, PUBLISHERS OF

SCIENCE and INVENTION

THE EXPERIMENTER

MOTOR CAMPER & TOURIST

[www.americanradiohistory.com](http://www.americanradiohistory.com)





*Latest  
Dance  
Hit!*

**Roll Up  
the Rugs**

Sway to the pulsating lilt of your favorite Metropolitan Orchestra.

Dance in unison with ten thousand other gliding couples. Tap the Limitless Ether for the Rhythmic Harmony that awaits your tuning-in.

Cunningham Radio Tubes give that bell-like clearness, that perfect re-creation of tone which you must have for the utmost in radio enjoyment.

*Since 1915 - Standard for all sets*

Types C301A, C299, C300, C11, C12

In the Orange and Blue Carton

PRICE \$3.00 EACH



*Cunningham*  
**RADIO TUBES**

*R. J. Cunningham, Inc.*

Home Office: 182 Second Street, San Francisco  
Chicago New York

Patent Notice: Cunningham Tubes are covered by Patents dated 2-18-08, 2-18-12, 12-30-13, 10-23-17, 10-23-17, and others issued and pending.



# Another Famous TOWER

# Tower's Scientific LOUD-SPEAKER

## \$8.50



### It had to be the **BEST**

We could have manufactured a loud speaker two years ago, but we wouldn't! We have waited—studying, planning, continually striving for perfection and now at last! WE HAVE IT—In the new TOWER'S LOUD SPEAKER. Surely a Wonderful TOWER Triumph.

The many features include, magnets that lift 2 lbs. 10 oz.; diaphragm of specially constructed material, perfect non-vibrating fibre horn, finished in beautiful golden bronze 10" bell. \*

TOWER'S phones are tested by Government Licensed Radio Operators. Weight only 8½ oz. On sale at all good dealers from coast to coast.



## THE TOWER MFG. CORPORATION

98 BROOKLINE AVE. Dept. U BOSTON, MASS.

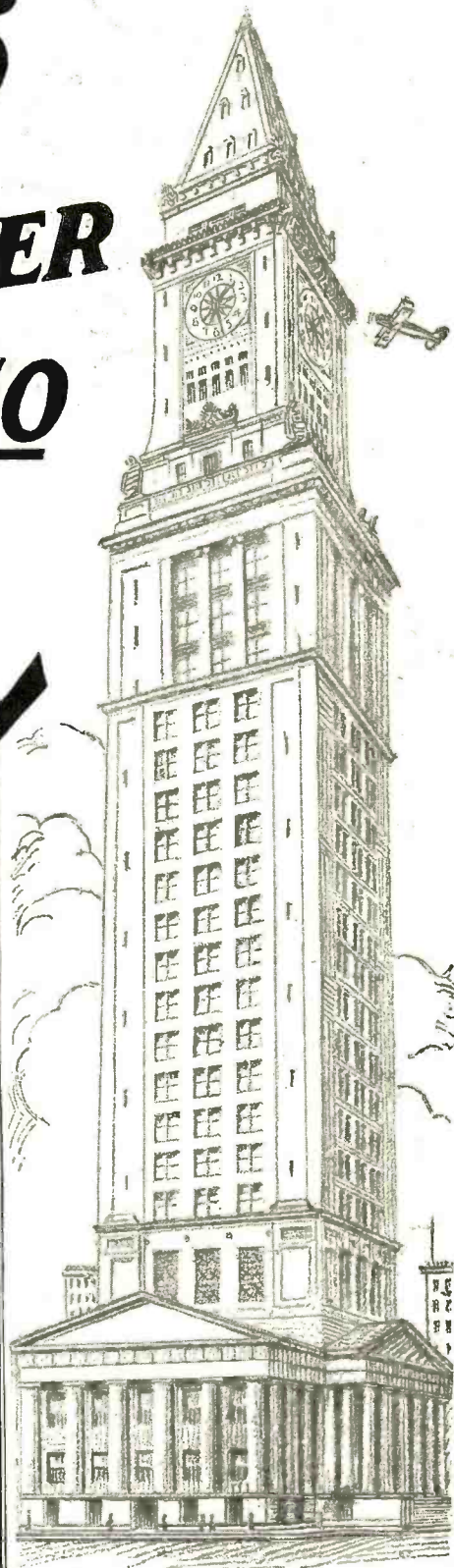

The U. S. Custom House Tower at Boston is 500 feet high and is situated in the business district overlooking Boston Harbor. It is the tallest Government building in America.

# Worlds Greatest Loud Speaker Value





# RADIO NEWS

Published by EXPERIMENTER PUBLISHING COMPANY, INC.  
 Publishers of "Radio News," "Science and Invention,"  
 "The Experimenter" and "Motor Camper & Tourist."  
 Editorial and General Offices: 53 Park Pl., New York City  
 H. GERNSBACK, President. S. GERNSBACK, Treasurer  
 R. W. DEMOTT, Secretary.  
 MEMBER: AUDIT BUREAU OF CIRCULATIONS

VOLUME 6

## CONTENTS

APRIL, 1925

NUMBER 10

### In Our Next Issue

**A New Anti-Radiation Device.**  
 The description of a simple radiation eliminator, developed in the Laboratories of the De Forest Radio Company. The device can be attached to any type of regenerative receiver.

**Radio and the Copyright Problem.**

By Hiram L. Jome.  
 There is great confusion at the present time over the copyright law in its adaption to radio broadcasting. Just what can and cannot be broadcast is a pertinent question. Mr. Jome casts light on the subject.

**Some Effects of Resistance in Radio Tuning Circuits.**

By Sylvan Harris.  
 Another excellent article by Mr. Harris, which, like the past ones, contains numerous helpful pointers for the layman.

**Why Does a Detector Detect?**

By Vernon C. MacNabb.  
 The ideas to be presented are made simple and elementary by the use of mechanical analogies, and explain the common methods used to detect radio currents.

**A New Intermediate Frequency Amplifier for the Super-Heterodyne.**

By The Staff of Radio News.  
 An interesting improvement in Intermediate Radio Frequency Amplifiers designed for use in Super-Heterodyne receivers.

### In This Issue

Editorial			
By H. Gernsback	1845	Building Compact Super-Heterodynes	
The Eclipse and Radio Reception		By D. J. Hall	1880
By G. C. B. Rowe	1846	The Regenerative Neutrodyne	
A University Radio Laboratory		By A. L. Groves	1882
By Joseph H. Wright	1848	Reflex Radio Receivers in Theory and Practice	
Commerce Department		By John Scott-Taggart	1884
Shifting Wave-Lengths.	1849	Five-Tube Cabinet Radio Set of 1892	
The Grid as Traffic Regulator		By John B. Brady	1886
By Sir Oliver Lodge	1850	Testing the Instruments of Your Receiver	
The Inventions of Reginald A. Fessenden	1851	By John R. Meagher	1887
The Effect of the Atmosphere on Radio Waves		Tuning Your Radio Set	
By Prof. J. M. Guinchant	1854	By A. P. Peck	1888
The Financial Side of Radio		International Radio	1891
By James A. Halsted	1856	With the Amateurs—Hamitorial	1892
The First Annual Radio Set Directory	1857	A Year's Work Below Forty Meters	
The Great Bedtime Story Conspiracy		By John L. Reinartz	1894
By Robert Francis Smith	1865	Lighting Main Plate Supply	
Radio Liars		By William C. Poole	1896
By F. A. Hill	1866	Low Loss Short Wave Set	
Russia's Radio Laboratory		By John Scott-Taggart	1897
By Prof. W. K. Lebedinsky	1867	A Test of Vacuum Tubes	
Underground Radio		By S. W. Marshall, Jr.	1898
By S. R. Winters	1868	Hints on Aerial and Ground Installation	1898
Results of the Super Power Broadcasting Vote	1869	Matching Tubes for Super-Heterodynes	
The Life and Work of Lee DeForest	1870	By S. Young White	1899
A New Method of Television		Lessons in Esperanto	
By W. G. Walton	1872	By J. D. Sayers	1899
The Vacuum Tube Situation		Radio Wrinkles	1900
By D. C. Wilkerson	1874	Standard Hook-Ups	1901
The Radiotoneotype		Radiotics	1903
By L. Spencer	1875	Correspondence From Readers	1904
The Latest in Tuned Radio Frequency		New Radio Patents. Compiled by John B. Brady	1905
By Arthur Reed	1876	Radio News Laboratories	1906
About Radio Losses		I-Want-to-Know	1903
By Wilfred Taylor	1878	Complete List of World's Broadcast Stations	1912

Index to Advertisers.....1828

RADIO NEWS is published on the 10th of each preceding month. There are 12 numbers per year. Subscription price is \$2.50 a year in U. S. and Possessions. Canada and foreign countries, \$3.00 a year. U. S. Coin as well as U. S. Stamps accepted (no foreign coins or stamps). Single copies, 25 cents each. A sample copy will be sent gratis on request. Checks and money orders should be drawn to order of EXPERIMENTER PUBLISHING CO., INC.

All communications and contributions to this journal should be addressed to Editor, RADIO NEWS, 53 Park Place, New York, N. Y. Unaccepted contributions cannot be returned unless full postage has been included. All accepted contributions are paid for on publication. A special rate is paid for novel experiments; good photographs accompanying them are highly desirable.

RADIO NEWS. Monthly. Entered as second-class matter at the Post Office, at New York, N. Y., with additional entry at Long Island City, N. Y., under the act of March 3, 1879. Entered on Sept. 15, 1924 at Post Office Atlanta, Ga., Chicago, Ill., Los Angeles, Calif. and San Francisco, Calif. Title registered U. S. Patent Office. Copyright, 1925, by E. P. Co., Inc., New York. The Experimenter Publishing Co., 53 Park Place, New York. The contents of this magazine are copyrighted and must not be reproduced without giving full credit to the publication. Copyright in Germany. Reproduction of articles in Germany is reserved for Radio, Berlin 42.

New York City  
 General Advertising Dept.  
 53 Park Place

Western Advertising Representatives  
 Finucan & McClure  
 720 Cass St., Chicago, Ill.

Pacific Coast Advertising Representatives  
 A. J. Norris Hill Co.  
 Hearst Bldg., San Francisco, Calif.

Kansas City Advertising Representatives  
 George F. Dillon  
 Republic Building, Kansas City, Mo.

RADIO NEWS is for sale at all newsstands in the United States and Canada, also at The International News Co., Ltd., Bream's Building, London, E. C. 4, England, and at Brentano's, 37 Avenue de l'Opera, Paris.

HOW TO SUBSCRIBE FOR RADIO NEWS. Send your name, address and remittance to Experimenter Publishing Co., 53 Park Place, New York. Mention the name of the magazine you are ordering. We also publish SCIENCE AND INVENTION, the EXPERIMENTER and MOTOR CAMPER & TOURIST. Write clearly.

RATES AND TERMS. The subscription rate for RADIO NEWS is \$2.50 per year. (12 numbers). When remitting do so by check, money order, or registered letter if cash is enclosed. Avoid sending cash through the mail if possible. Subscriptions for less than one year are not accepted. Subscription may be made in combination with SCIENCE AND INVENTION or the EXPERIMENTER.

POSTAGE. We prepay postage in all parts of the United States, Mexico and island possessions. For foreign or Canadian subscriptions we require 50 cents in addition to the subscription price for additional postage charges.

CHANGE OF ADDRESS. Notify us as far in advance as possible. It requires several weeks to make an address change on our records. Always write clearly. ON EXPIRATION of your subscription we enclose a renewal blank in our last number to you; we stop our delivery to you on expiration.





# THE GREBE SYNCHROPHASE

TRADE MARK

It is written:

"If there be no faith in our words,  
of what use are they?"

It is easy to prove the claims  
made for the Synchronphase.

*Doctor H. Grebe*

No other receiver has  
these features:

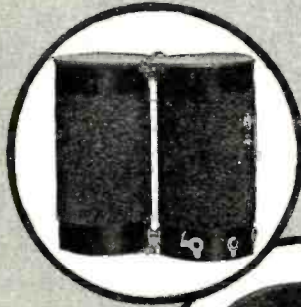

Binocular  
Coils

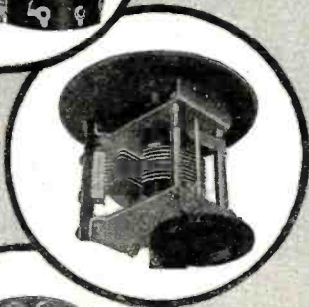

S-L-F  
Condensers

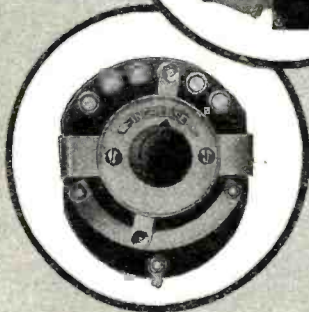

Volume  
Control

If you have once operated a Synchronphase you will not be satisfied with any other type of receiver, because Grebe exclusive and fundamental features provide reception that is unsurpassed.

**Binocular Coils**, which keep the set balanced against local interference, provide greater selectivity and sensitivity.

**S-L-F (straight line frequency) Condensers** make tuning-in quick, easy and positive. All stations are spaced at equal intervals around the dials; short-wave stations are not crowded onto the lower numbers.

**Grebe Volume Control** gives six gradations of sound without detuning or reducing tube current; thus maintaining the true character and shading of every note.

In sets made up of assembled parts, the assembler has no control over their design and quality. Therefore, every detail of the Synchronphase is designed and built in the Grebe factory. Thus, all parts coordinate perfectly. This makes possible the perfect performance of the Synchronphase.

This perfection extends also to the Synchronphase cabinet. It is beautifully designed and built of solid mahogany, highly polished and with delicately embossed gold escutcheons.

Compare all sets before you buy, but be sure to have the Synchronphase demonstrated by your dealer.

Ask your dealer or write us for full information

A. H. Grebe & Co., Inc.

Van Wyck Blvd., Richmond Hill, N. Y.

Western Branch: 443 So. San Pedro St., Los Angeles, Cal.

This company owns and operates station WAHG



Synchronphase with  
battery base

All Grebe apparatus  
is covered by patents  
granted and pending.









# Earn \$50 to \$200 a Week in RADIO

You can! Hundreds of ambitious men are already earning thousands of dollars in this wonderful new industry — you, too, can get your share. Mail coupon below for Free Book which describes fully the amazing money-making opportunities in Radio and tells you how YOU can earn from \$5,000 to over \$10,000 a year.

**T**HE astounding growth of Radio has created thousands of big money opportunities. Millions of dollars were spent during the past year on Radio, and thousands of young men are needed right now to meet the ever-increasing demand of work.

Men are needed to build, sell and install Radio sets — to design, test, repair — as Radio engineers and executives — as operators at land stations and on ships traveling the world over — as operators at the hundreds of broadcasting stations. And these are just a few of the wonderful opportunities.

## Easy to Learn Radio at Home in Spare Time

No matter if you know nothing about Radio now, you can quickly become a Radio expert, by our marvelous new method of practical instruction — instruction which includes all the material for building the latest up-to-date Radio apparatus.

### Pay Increases Over \$100 a Month



I am averaging anywhere from \$75 to \$150 a month more than I was making before enrolling with you. I would not consider \$10,000 too much for the course.

(Signed) A. N. LONG,  
Greenburg, Pa.

### Doubles Salary

I can very easily make double the amount of money now than before I enrolled with you. Your course has benefited me approximately \$3,000 over and above what I would have earned had I not taken it.

T. WINDER,  
Grand Junction, Colo.



### From \$15 to \$80 a Week

Before I enrolled with you I was making \$15 a week on a farm. Now I earn from \$2.080 to \$4,420 a year, and the work is a hundred times easier than before. Since graduating a little over a year ago, I have earned almost \$4,000, and I believe the course will be worth at least \$100,000 to me.

(Signed) GEO. A. ADAMS,  
Tamaqua, Pa.



Scores of young men who have taken our course are already earning from \$75 to \$200 a week. Merle Wetzel of Chicago Heights, Ill., advanced from line-man to Radio Engineer, increasing his salary 100%, *even while taking our course!* Emmett Welch, right after finishing his training, started earning \$300 a month and expenses. Another graduate is now an operator of a broadcasting station — PWX of Havana, Cuba — and earns \$250 a month. Still another graduate, only 16 years old, is averaging \$70 a week in a Radio store.

## Wonderful Opportunities

Hardly a week goes by without our receiving urgent calls for our graduates. "We need the services of a competent Radio Engineer." "We want men with executive ability in addition to Radio knowledge to become our local managers." "We require the services of several resident demonstrators" — these are just a few small indications of the great variety of opportunities open to our graduates.

Take advantage of our practical training and the unusual conditions in Radio to step into a big paying position in this wonderful new field. Radio offers you more money than you probably ever dreamed possible — fascinating, easy work — a chance to travel and see the world if you care to, or to take any one of the many Radio positions all around you at home. And Radio offers you a glorious future!

The National Radio Institute is one of America's Pioneer Radio Schools — established in 1914. Our course is an absolutely complete one which qualifies for a government first-class commercial license. It gets you *bigger* paying jobs in Radio.

## Send for FREE RADIO BOOK

Learn more about this tremendous new field and its remarkable opportunities.



Learn how you can quickly become a radio expert and make big money in Radio.

We have just prepared a new 32-page booklet which gives a thorough outline of the field of Radio — and describes our amazing practical training in detail. This Free Book, "Rich Rewards in Radio," will be sent to you without the slightest obligation. Mail coupon for it *now!*

For a short time we are offering a reduced rate to those who enroll at once. Act promptly and save money.

## National Radio Institute

Dept. 13FB  
Washington  
D. C.

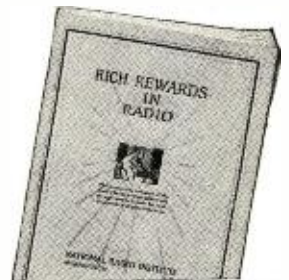

NATIONAL RADIO INSTITUTE,  
Dept. 13FB, Washington, D. C.

Please send me without the slightest obligation your Free Book, "Rich Rewards in Radio," and full details of your special Free Employment Service. Please write plainly.

Name ..... Age.....

Address .....

City .....State .....



# RADIO NEWS READERS' BUREAU

## Time and Postage Saver

**I**N every issue of RADIO NEWS you undoubtedly see numerous articles advertised about which you would like to have further information. To sit down and write an individual letter to each of these respective concerns, regarding the article on which you desire information, would be quite a task.

As a special service to our readers, we will write the letters for you, thus saving your time and money.

Just write the names of the products about which you want information, and to avoid error the addresses of the manufacturers, on the coupon below and mail it to us.

If the advertiser requires any money or stamps to be sent to pay the mailing charges on his catalogue or descriptive literature, please be sure to enclose the correct amount with the coupon.

We will transmit to the various advertisers your request for information on their products.

This service will appear regularly every month on this same page in RADIO NEWS.

If there is any Manufacturer not advertising in this month's issue of RADIO NEWS, from whom you would like to receive literature, write his name, address and the product in the special section of the coupon below.

TEAR ALONG THIS LINE

**READERS' SERVICE BUREAU,**  
 Experimenter Publishing Co., Inc., 53 Park Place, New York, N. Y.

RN-4-25

Please advise the firms listed below that I would like to receive detailed information on their product as advertised in the ..... issue of RADIO NEWS.

**DO NOT USE THIS COUPON FOR TECHNICAL QUESTIONS**

NAME	ADDRESS (Street — City — State)	List here specific article on which you wish literature.	If Catalogue of complete line is wanted, check in this column
.....	.....	.....	.....
.....	.....	.....	.....
.....	.....	.....	.....
.....	.....	.....	.....
.....	.....	.....	.....
.....	.....	.....	.....
.....	.....	.....	.....
.....	.....	.....	.....
.....	.....	.....	.....
.....	.....	.....	.....

Use this space if you desire information from a manufacturer whose advertisement does not appear in this month's issue.

NAME	ADDRESS (Street — City — State)	
.....	.....	.....
.....	.....	.....
.....	.....	.....

Your own name here .....

If you are dealer check here.      Address .....

City ..... State .....



Specify  
Belden

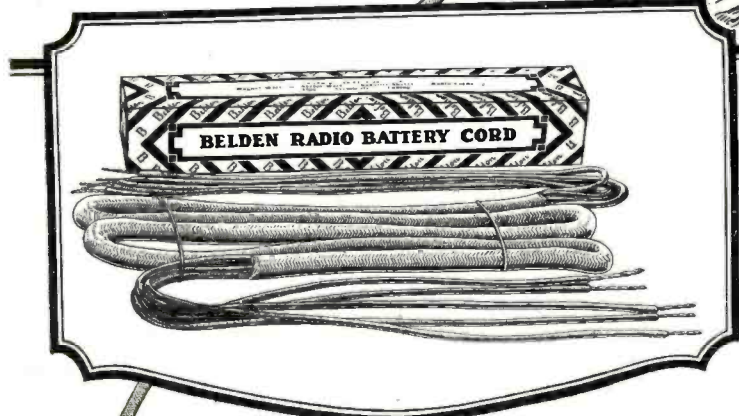
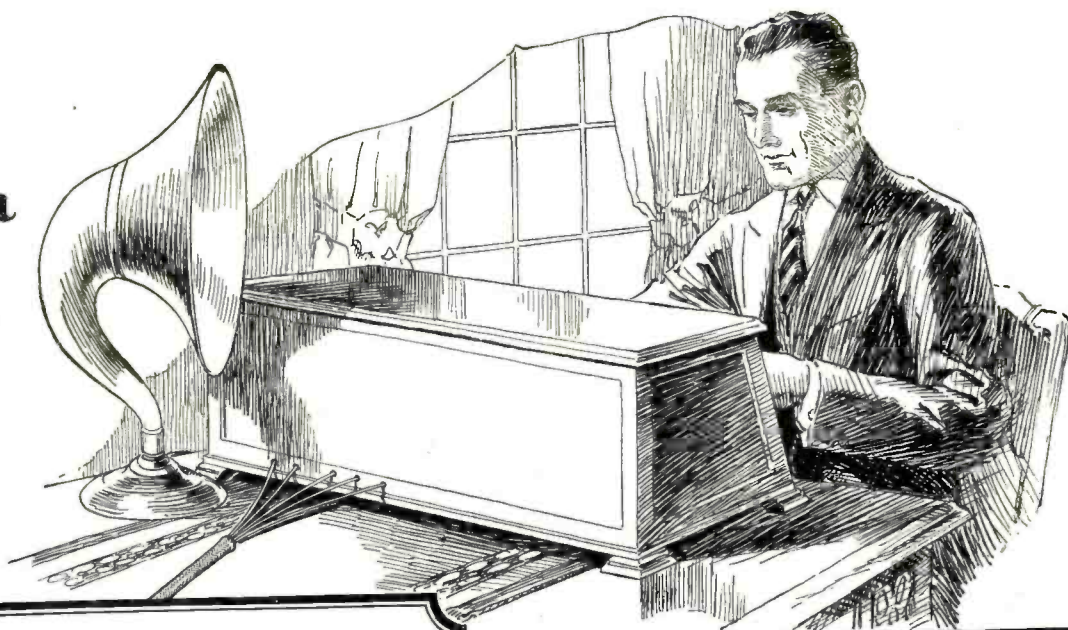

# Make Your Set Safe for Tubes and Batteries

## Improves Appearance of Set

The Belden Radio Battery Cord contains five flexible, rubber-covered conductors, each marked plainly with a colored tracer. Two conductors are No. 16, for the A-battery circuit, and three are No. 18 for the B-battery circuit. All conductors are enclosed in a glazed brown braid that resists wear and protects the conductors. The ends are soldered, and can be used with any type of terminal. Does away with all messy, dangerous battery wiring.

Just one accidental short circuit among the battery wires, that lead to your set, can burn out all the tubes or ruin the batteries. That is why the experienced radio fan does not trust to a mess of connecting wires, between the set and the batteries, but uses a sturdy, neat battery cord in their place.

Loose connections and poor joints are responsible for much noise in the receiver, and a good battery cord eliminates much of this trouble. The circuits are easily traced and B-battery taps can be changed without danger of wrong connections. Try a Belden Radio Battery Cord before you burn out your tubes. It is inexpensive insurance against trouble. Get one, today!

Free Booklet  
Send for it  
Now!

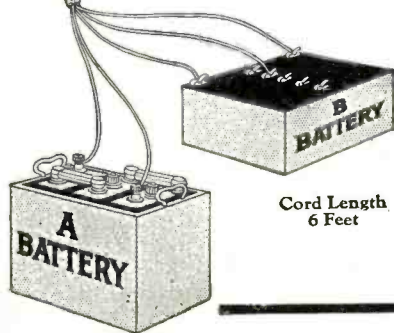

Cord Length  
6 Feet

**Belden**  
Manufacturing Company  
2314A So. Western Ave.  
CHICAGO, U. S. A.  
Manufacturers of Electrical Wire  
Products Since 1902

Belden Manufacturing Company  
2314A So. Western Ave., Chicago

Please send me "Helpful Hints for Radio Fans,"  
describing all Belden Radio Products.

Name \_\_\_\_\_

Address \_\_\_\_\_



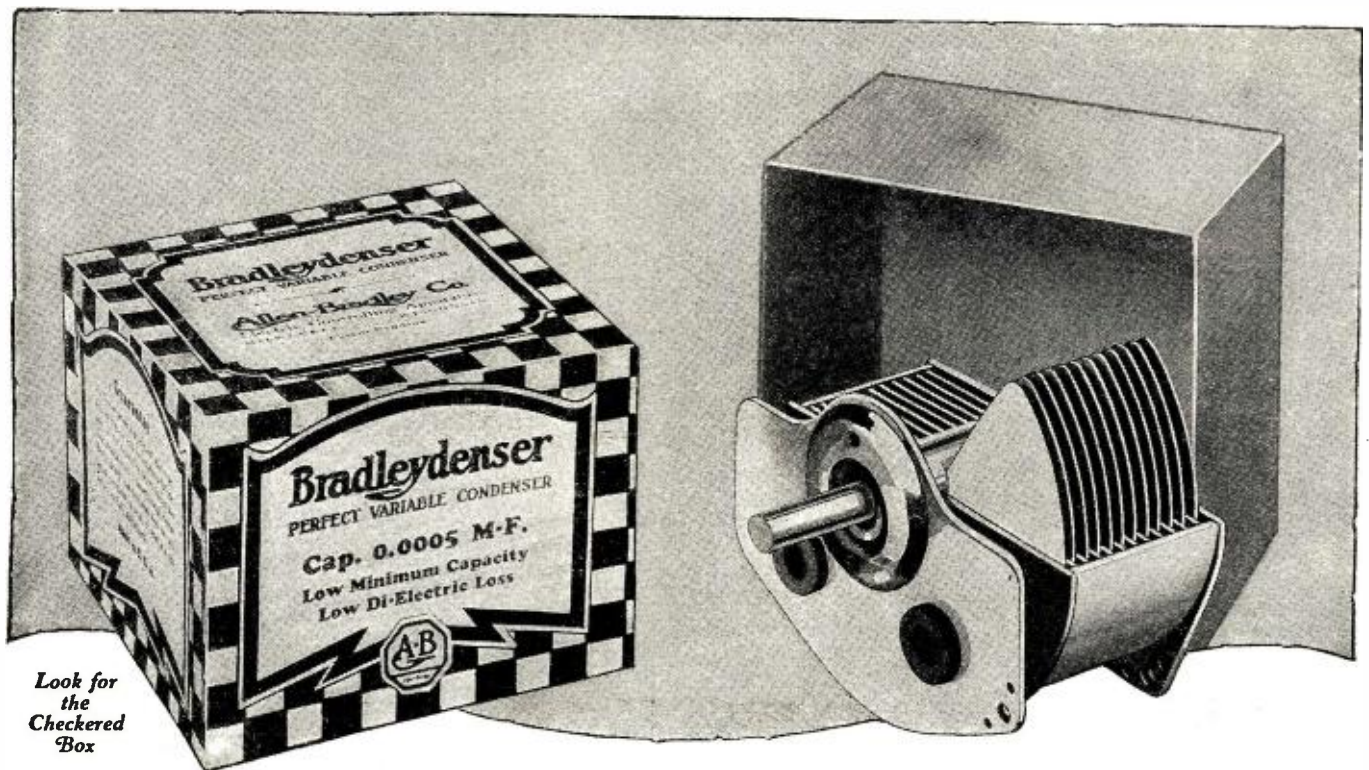

Look for  
the  
Checkered  
Box

## Brass Plates—Soldered Joints—Grounded Rotor *Are Standard Features of the Bradleydenser*

The Bradleydenser is a low-loss condenser with many distinctive features that insure long life and high efficiency. For instance, the brass stator and rotor plates are soldered at all joints. The plates cannot become loose, corrode at the joints or work out of alignment. The rotor is mounted on a long sleeve bearing that supports the rotor plates without the use of an outer end-plate. Therefore, the di-electric material is reduced to two small buttons. This means low loss and sharp tuning.

The stator plates are protected with a dust cap that can be detached without tools. The minimum capacity is extremely low, and body capacity effects are greatly reduced. The entire design makes for the highest efficiency in radio receivers.

*Build for  
Efficiency*

**Allen-Bradley Co.**

Electric Controlling Apparatus

287 Greenfield Ave.

Milwaukee, Wis.

*Use the  
Bradleydenser*

This filter tuner with resistance-coupled audio amplifier is equipped with Bradleydensers. The tuning is sharp and selective.

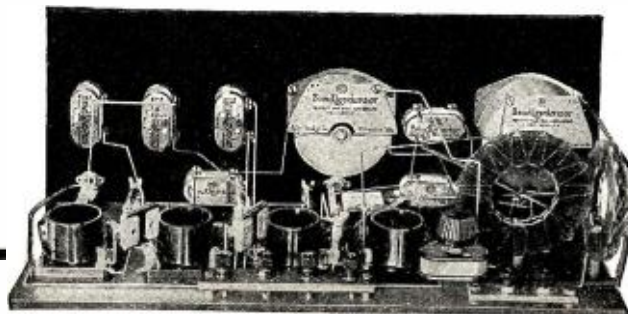

Send for the latest information on the Bradleydenser. It will pay you to know about this remarkable low-loss condenser before planning your next radioset.



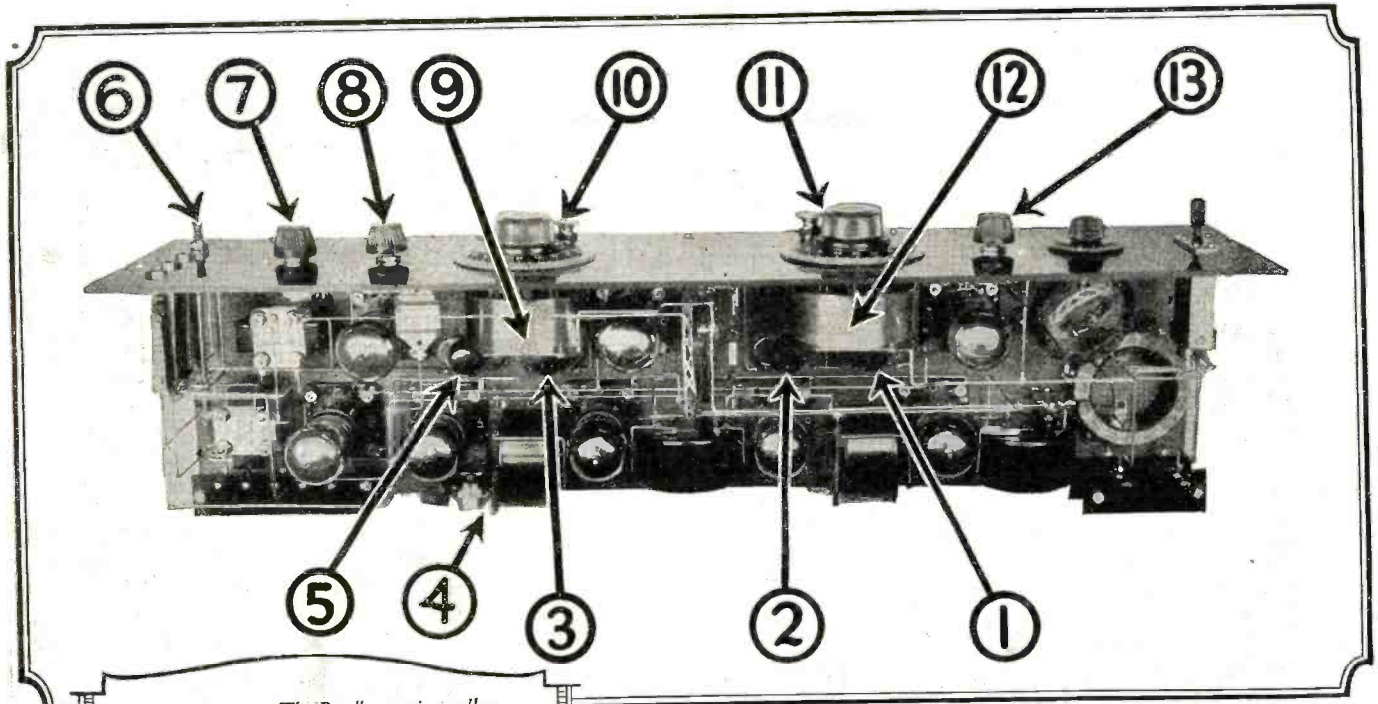

The Bradleystat is smaller than the UV-199 or C-299 tubes. It is much smaller than the 6-volt tube.



# Bradleystat

PERFECT FILAMENT CONTROL

FOR ALL SETS AND TUBES

## Graphite Discs provide smooth control

Observe the compact construction of the Bradleystat, shown below. Note the two columns of graphite discs, pressure screw and internal switch. Only two terminals, and yet the range is from approximately  $\frac{1}{4}$  ohm to 100 ohms. The range is stepless and noiseless.

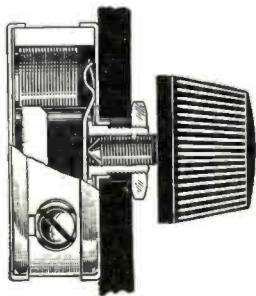

The new Bradleystat has taken the radio world by storm. Thousands of radio fans have replaced their old wire rheostats even in ready-built sets, with Bradleystats to get noiseless, stepless control, so essential in every radio set. The new Bradleystat is so compact, and the "one-hole" mounting so simple and convenient, that it is but a moment's work to install the new unit. Furthermore, a Bradleystat-equipped set can use any tube without change of rheostats or connections.

The super-heterodyne receiver, shown above, is equipped with Bradleystats at 1, 2, 3, 5, 8, and 13. Within the set, they are mounted on the baseboard; the others are on the panel. A Bradleyleak is used at 4, a Bradley switch at 6, and a Bradleyometer at 7. Bradleydensers are used at 9 and 12, and micrometer dial control is obtained with Bradleyniers at 10 and 11. This Allen-Bradley-equipped set is typical of thousands of multi-tube sets using the new Allen-Bradley line for maximum efficiency. Build for better radio by following this example.

**Allen-Bradley Co.**

Electric Controlling Apparatus

287 Greenfield Ave.

Milwaukee Wisconsin

Mfrs. of graphite disc rheostats for over 20 years

ALLEN-BRADLEY CO.

287 Greenfield Ave., Milwaukee, Wis.

Please send me the latest literature, describing the entire Allen-Bradley line of superior radio devices.

Name .....

Address .....



# THE NEW CROSLLEY 51-SPECIAL

**\$23<sup>50</sup>**

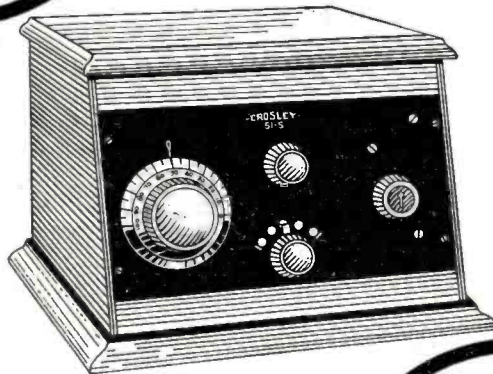

*Of Course  
the Famous  
Crosley 51 Regular at  
**\$18<sup>50</sup>**  
Will be Continued*

Here is the popular Crosley 51 dressed up in new clothes. It is known as the Crosley 51-Special. This two tube, genuine Armstrong regenerative receiver is exactly the same as the nationally known Crosley 51, except it is installed in a larger cabinet in which there is room for dry cell batteries. Also there is the slanting panel, a feature that adds to the appearance of the set and makes operation more comfort-

able. This radio is as artistic as it is efficient, appealing to the housewife who demands beautiful appearance and elimination of visible batteries. All Crosley radios are licensed under Armstrong Regenerative U. S. Pat. 1,113,149. Other models priced from one tube 50, at \$14.50 to the Trirdyn Special with sloping panel, at \$65. For sale by good dealers everywhere. Write for catalog.

*Prices West of Rockies—add 10%*

**THE CROSLLEY RADIO CORPORATION**  
422 Sassafras Street, Cincinnati, Ohio

*Crosley owns and operates Broadcast Station WLW*



# CROSLEY TRIRDYNS

*Special*  
**\$60**  
*Formerly \$75*

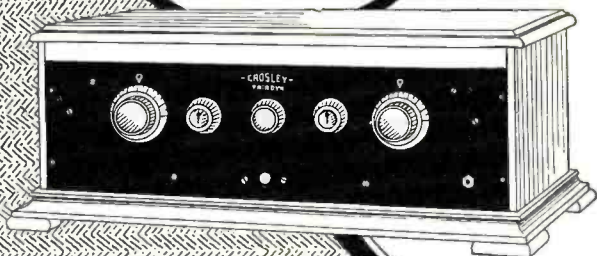

*Regular*  
**\$50**  
*Formerly \$65*

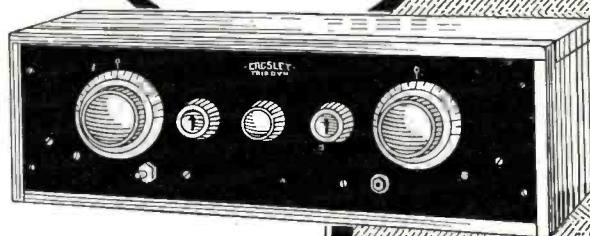

*Three Tubes  
 Do the work of  
 Five or Six  
 in the  
 Trirdyn*

The recognized outstanding achievement in radio is the Crosley Trirdyn. An overburdening amount of evidence proves that it is excelled by none and superior to most receivers costing many times more. It is a three tube radio combining one stage of tuned radio frequency, regenerative detector and reflex amplification. This combination enables three tubes to do the work of five or six. Brings in every large station in the country on the loud speaker. Is very selective, easy to tune and economical to operate.

The straight front Trirdyn Regular, formerly \$65; now \$50. The Trirdyn Special in large cabinet to house dry cell batteries formerly \$75; now \$60. To these have been added the new Trirdyn Regular with sloping panel at \$55 and the new Trirdyn Special in a beautiful cabinet with sloping panel at \$65. Demand a Crosley Trirdyn at any good dealer. All Crosley radios are licensed under Armstrong Regenerative U. S. Patent 1,113,149. Write for catalog.

*Prices West of Rockies add 10%*

**THE CROSLEY RADIO CORPORATION**  
 422 Sassafras Street, Cincinnati, Ohio  
*Crosley owns and operates Broadcasting Station WLW*





# AMERICA'S PIONEER RADIO DISTRIBUTORS

### Offer You a Radio Service Unequaled

250,000 customers from every part of the world have purchased their Radio needs from us

### SEND FOR THIS FREE CATALOG

Contains all the newest parts, sets and kits at prices that save you money



#### THIS GUARANTEE PROTECTS YOU

Examine the goods we ship you. They must suit you in every respect. If you are not satisfied with your purchase return the goods at once and we will refund the price you paid.

#### VACUUM TUBES

Standard Brands—Cunningham, Radiotron. Every one guaranteed new and perfect and in original carton. We will ship brand in stock unless you specify otherwise. Prices based on \$1.00 list. If list is reduced our prices will be proportionately lower.

- R105 Detector, UV200, C300. Each \$2.69
- R112 Amplifier, UV201A. C301A. Each 2.69
- R118 5-Watt Transmitter 7.48
- R107 WD11, C11. Each 2.69
- R108 WD12, C12. Each 2.69
- R102 UV199, C299. Each 2.69

#### BAKELITE SOCKET

- R140 Standard base. 30c
- R141 UV199 base. 30c
- R136 C11. 30c

Moulded of genuine red brown bakelite. Binding post connections. Strong contacts. Real values.

#### METAL TUBE SOCKET

- R134 Each. 25c

Nickel plated brass tube set in best grade brass mounting base. Plainly marked binding posts. An excellent value.

#### PANEL MOUNT SOCKET

- R143 Single Gang. \$3.48
- R144 Three Gang. \$1.60

The best socket value obtainable anywhere. Extra heavy, moulded, genuine brown bakelite. Double reinforced contact striations. Will mount on panel behind rheostat. Standard base.

#### CUSHION BASE SOCKET

- R145 199 Base. 60c
- R146 Standard base. 75c

A moulded socket with sponge rubber base. Prevents microphonic noises. Plainly marked binding post connections. Neat and compact.

#### SUPERIOR RHEOSTATS

- R147 6 ohm. Each. 62c
- R120 10 ohm. Each. 64c
- R148 20 ohm. Each. 66c
- R149 30 ohm. Each. 70c

One of the finest rheostats we have ever seen at a price that makes it the best value obtainable anywhere. Genuine bakelite base. Beautifully shaped black bakelite knob. Single hole mounting, with white arrow. Single hole mounting. A rheostat you will be proud to have in your set.

#### FILAMENT CONTROL RHEOSTATS

- R132 0 ohm. Each. 34c
- R129 20 ohm. Each. 36c
- R131 30 ohm. Each. 38c
- R135 6 ohm. Vernier. 78c

Best grade. Will give real service. High heat resisting base. Tapered polished black knob.

#### AMPERITES

Eliminates rheostats on amplifier tubes where adjustment is not critical. Automatically adjust resistance according to flow of current, keeping tubes at proper point for maximum efficiency. Complete with mounting.

- R221 For UV201A or 301A tubes. 98c
- R222 For UV200 or C300 tubes. 98c
- R223 For UV199 or C299 tubes. 95c
- R224 For WD11 or C11 tubes. 95c

#### BRADLEYSTAT AND BRADLEYOMETER

R208 Bradleystat. Each. \$1.74  
Latest improved type. Can be used with all types of tubes.

Bradleyometer  
R209 200 ohm. Each. \$1.89  
R210 400 ohm. Each. 2.89

#### HOWARD RHEOSTATS

A well known line of rheostats and potentiometers that is giving very satisfactory service to its users. Complete with knob and pointer. Supplied in 6%, 25 and 40 ohm. Either standard size base 2 5/32 diam. or midget base 1% in. diam. Specify which wanted. Price each. 98c.

#### STANDARD BRAND FIXED CRYSTAL DETECTORS

The latest developments in Crystal Detectors. Used in Reflex and all other circuits.

- R742 Grewol Detector. Each. \$1.12
- R747 RW Detector. 1.20
- R749 Brownlie Detector. 1.69
- R750 Brownlie Renewal. .69
- R760 Freshman Detector. 1.19
- R730 Patent Detector. .69
- R740 Erla Fixed Detector. \$1 value .59
- R748 Shamrock Crystal Detector. 1.69

## The Very Latest Radio Book

### Free

This Book Full of Radio Bargains

Shows Big Savings on parts, sets and accessories.

Our prices are lowest on highest quality standard goods.

Send for your copy today

ALL ORDERS SHIPPED SAME DAY RECEIVED

#### RADIO "BAKELITE" PANELS

We supply genuine Bakelite, Condensite, Celoron or Poronite, all of which have practically identical properties. Machines well without chipping. Won't warp. Waterproof. One side has attractive natural polished black finish which can be sanded and oiled. Other side mahogany finish. Either side may be used as front. Postage extra on 1/4 inch panels. 8c; 3/16 inch. 10c; 1/2 inch. 15c.

Panel Size	1/4" thick	3/16" thick	1/2" thick
Inches	Art. No. Price	Art. No. Price	Art. No. Price
6x7	R450 \$5.53	R460 \$8.89	R470 \$11.15
6x10 1/2	R451 .83	R461 1.20	R471 1.60
7x10	R455 1.28	R465 1.68	
7x14	R458 1.32	R468 1.85	R478 2.35
7x18	R453 1.67	R463 2.40	R473 3.15
7x21	R457 1.95	R467 2.80	R477 4.10
7x24	R459 2.35	R469 3.15	
7x26		R462 3.25	
9x14		R464 2.35	R474 3.15
12x14		R465 2.97	R475 3.98
12x21		R466 4.25	R476 5.70

#### RUBBER COMPOUND PANELS

Equal in appearance and in all essential points to any other class of panels. Fine smooth polished finish. Can be drilled or cut without chipping. Smooth clean edges. Thickness 3/16 inch.

Black		Mahogany	
Art. No.	Price	Art. No.	Price
R481	\$6.60	R493	\$7.75
R482	.75	R494	.92
R483	.87	R495	1.09
R484	1.15	R496	1.34
R485	1.32	R497	1.55
R486	1.50	R498	1.75

#### COMPOSITION DIALS

Handsome dials moulded in one piece of polished composition. 2 inch size has 27° scale marked 0 to 100 finely engraved in contrasting white enamel. 3 and 4 inch size have 180° scale marked 0 to 100.

Black		Mahogany	
No.	Price	No.	Price
R921	16c	R925	19c
R922	16c	R927	19c
R923	22c	R928	25c
R924	22c	R929	27c
R925	29c	R930	34c

#### GENUINE BAKELITE DIALS

- R1173 4-inch. Each. 63c
- R1174 3-inch. Each. 42c
- R1175 2-inch. Each. 30c

Moulded in one piece of genuine bakelite in polished black finish. Finely engraved scale in contrasting white enamel. Sure grip knob that fits the fingers. Higher grade dials for good sets. Match perfectly.

#### STANDARD BRAND HEADSETS

- R754 Baldwin Type C. \$9.80
- R764 Frost, 2,000 ohm. 3.57
- R766 Frost, 3,000 ohm. 4.35
- R751 Murdoch 56, 2000 ohm. 3.25
- R752 Murdoch 56, 3000 ohm. 3.60
- R768 Brandes Superior, 2000 ohm. 4.85
- R769 Brandes Navy, 3000 ohm. 6.85

#### PANEL MOUNTING VARIABLE CONDENSERS

These are especially high grade condensers and we guarantee them to be mechanically and electrically perfect. Fine polished end plates of heavy bakelite. Shafts 1/4 inch diameter. Sturdy, heavy aluminum alloy plates perfectly spaced to insure smooth even reliable capacity. Dial and knob on vernier type. No dial on plain type. Our low prices save you money.

No. Plates	Max. Cap.	Plain Type		Vernier Type	
		No.	Price	No.	Price
3		R815	\$7.79		
5	.00025	R816	.68	R825	\$1.85
17	.00035	R817	1.20		
23	.0005	R813	1.30	R824	2.25
43	.001	R812	1.45	R826	2.40

#### GROUND ROTOR LOW LOSS VARIABLE CONDENSERS

- R1231 11 plate. \$1.65
- R1232 17 plate. 1.85
- R1233 23 plate. 2.05
- R1234 43 plate. 2.35

Here is a low loss condenser made along the lines of the most advanced engineering developments yet at a price far lower than you would expect to pay for an article of this quality. Heavy aluminum plates rigidly constructed. Minimum amount of dielectric placed where electro static field density is lowest. Grounded rotor carefully balanced. Positive noiseless contacts. 1/4 inch shaft.

#### STANDARD BRAND VARIABLE CONDENSERS

- R810 Acme .0005 Vernier. \$5.65
- R784 Cofo .00025 Vernier. 3.95
- R785 Cofo .0005 Vernier. 4.25
- R789 Cofo .001 Vernier. 4.95
- R788 Cardwell .00025. 3.95
- R787 Cardwell .00025. 4.35
- R789 Cardwell .0005. 4.60
- R790 Cardwell .001. 5.55
- R791 Marco .00025. 3.95
- R792 Marco .0005. 4.95
- R793 Marco .0005. 4.95
- R794 Marco .001. 5.85
- R795 Flewelling .00025 Vernier. 4.50
- R793 Flewelling .0005 Vernier. 4.95
- R715 American Brand .00025 Vernier 3.10
- R716 American Brand .00035 Vernier 3.30
- R717 American Brand .0005 Vernier 3.60
- R780 Continental .00025 Vernier. 4.65
- R781 Continental .0005 Vernier. 4.80
- R753 Continental Low Loss Junior. 1.19
- R778 Chelton Midget Panel Mount. 1.35
- R779 Chelton Midget Base Mount. 1.35
- R318 Premier Crowfoot .00025. 2.95
- R319 Premier Crowfoot .0005. 3.35
- R775 B. T. Low Loss 13 plate. 4.05
- R776 B. T. Low Loss 23 plate. 4.50
- R777 B. T. Low Loss 35 plate. 5.85
- R820 Remler .00035. 4.45
- R821 Remler .0005. 4.45

You take no risk in dealing with us. We are one of the closest and most reliable radio supply houses. Radio News guarantees our reliability. Our guarantee protects you. Let us serve you and save money for you. All orders shipped same day received.

**ORDER DIRECT FROM THIS PAGE.** You will find many items you will need on this page. Send your order in for them at once. Prices quoted on this page are transportation charges prepaid in U. S. A. east of the Rocky Mountains, except on panels. Dealers send for our wholesale catalog.

#### OUR SPECIAL A. F. TRANSFORMER

- R549 3 to 1 ratio. \$2.25
- R550 5 to 1 ratio. 2.45

In quality of tone and volume of sound, the things a transformer is built for, we guarantee it to equal or surpass any other transformer. Neat in appearance. Carefully made. Fully mounted with plainly marked binding post connections. Wonderful results on one, two or three steps without distortion or howling. A quality item in every respect.

#### OTHER STANDARD BRAND AUDIO FREQUENCY TRANSFORMERS

Fresh, Clean Stock in Original Containers

- R587 Thordarson Ratio 3 1/2 to 1. \$3.30
- R588 Thordarson Ratio 6 to 1. 3.79
- R589 Thordarson Ratio 2 to 1. 3.95
- R590 Thordarson Push Pull. Pair. 11.25
- R531 All American 10 to 1. Each 4.25
- R532 All American 5 to 1. Each 4.25
- R533 All American 3 to 1. Each 4.05
- R534 All American Push Pull. Pair 10.80
- R535 Rauland Lyric. 8.10
- R536 Acme. 3.95
- R587 Erla 6 to 1. 3.95
- R598 Erla 3 1/2 to 1. 3.60
- R593 Modern 4 to 1. Each. 3.95
- R591 Modern 10 to 1. Each. 4.59
- R592 Modern Push Pull. Pair. 9.90
- R555 Federal No. 226. Each. 4.45
- R556 Federal No. 65. Each. 6.35
- R712 Radio Corp. No. 712. Each. 5.70
- R1131 Jefferson 45. Each. 5.70
- R1132 Jefferson 41. Each. 3.48
- R1133 Jefferson Star. Each. 2.45

#### STANDARD BRAND RADIO FREQUENCY TRANSFORMERS

- R596 Tricol for 201A tubes. \$1.65
- R597 Tricol for 199 tubes. 1.65
- R592 Dubilier Duratran. 3.45
- R565 Acme R3. 3.95
- R566 Acme R3. 3.95
- R567 Acme R4. 3.95
- R568 Erla Reflex No. 1. 3.95
- R579 Erla Reflex No. 2. 3.95

#### DAVEN RESISTANCE COUPLED AMPLIFIER

- R570 1st Stage Unit \$2.30
- R571 2nd Stage Unit 2.30
- R572 3rd Stage Unit 2.49

These amplifiers without distortion. Reproduce audio frequency transformers using same circuit. Each unit consists of a mounting with condenser, grid leak and resistance of proper value for best results.

#### BRADLEYLEAK

Latest improved type.  
R168 Without condenser. Resistance 1/2 to 10 megohms. \$1.74  
R169 With .00025 condenser 1.95

#### GLASS ENCLOSED GRID LEAKS

Any capacity. Each. 10c

#### STANDARD BRAND LOUD SPEAKERS AND UNITS

- R618 Brandes Table Talker. \$7.95
- R616 Atlas Loudspeaker. 21.95
- R611 Atlas Type 102. 24.50
- R620 Baldwin Loud Speaker. 19.50
- R621 Utah Loudspeaker. 19.50
- Music Master. 27.00
- R603 Magnavox M1 Loudspeaker. 21.09
- R612 Magnavox R2 Loudspeaker. 31.75
- Primo Home Speaker. 19.95
- R610 Prost Musette. 10.75
- R757 Morrison Adjustable Unit. 4.35
- R755 Genuine Baldwin Type C unit 4.75
- R608 Atlas Unit. Each. 10.75
- R609 Treble Dulce Tone Unit. 7.75

#### DUBILIER MICADON TYPE 601

- R502 .0001. 29c
- R503 .00025. 29c
- R504 .0005. 29c
- R505 .001. 33c
- R506 .002. 33c
- R507 .00025. 33c
- R508 .001. 40c
- R509 .001. 40c
- R510 .001. 48c
- R511 .001. 60c

#### DUBILIER MICADON 601G

Same style condenser as above with mounting for tubular grid leak. No grid leak included.

- R581 .00025. Ea. 38c
- R582 .0005. Ea. 39c

#### ACCURATONE CONTROL DIAL

- R914 Clockwise. \$3.05
- R915 Counterclockwise. 3.05

Has four inch silver finished dial with black knob. 80 to 1 ratio gives finest tuning adjustment.

#### UNIVERNIER CONTROL DIAL

- R918 For 3/16 in. shaft, silver dial, black knob. \$1.10
- R919 For 1/4 in. shaft, silver dial, black knob. 1.10
- R916 Gold dial, mahogany knob for 1/4 in. shaft. Each. 1.29
- E-Z-Tone 2" Dial. 1.75
- E-Z-Tone 4" Dial. 1.95
- Apex Vernier Dial. 2.10

# The Barawik Co.

102 So. Canal St. Chicago, Ill.



# It is Easy to Build Your Own Radio Set

PRICES QUOTED ARE PREPAID EXCEPT WHERE OTHERWISE SPECIFIED.

## STORAGE "A" BATTERY

The best battery buy on the market. Guaranteed for three years. Made of best new materials. Full capacity. Try one of these batteries for 10 days. If at the end of that time you are not fully satisfied return it and we will refund the purchase price. We save money for you on these high grade batteries. Prices quoted are F.O.B. Chicago, Philadelphia or San Francisco.  
R194 6 volt, 60 amp. size. Each...\$9.85  
R196 6 volt, 100 amp. size. Each...\$13.25

## BATTERY CHARGER

Connect charger to 110 volt 60 cycle light socket and your battery charges automatically over night at a cost of only a few cents. Cord and clips for connections included. Regular retail value \$18.50.  
R201 For 6 volt battery.....\$12.95  
R203 For 12 volt battery.....\$12.95

## STANDARD BRAND BATTERY CHARGING RECTIFIERS

R207 Balkite.....\$18.50  
R206 France Super Charger.....\$19.50  
Noiseless Bulb Type Chargers.  
King, Tungar or Rectigon. Complete with bulb.  
R255 2 amp. \$15.95 R256 5 amp. \$25.25  
Extra B's. \$1.00  
R257 2 amp. \$3.65 R258 5 amp. \$7.00

## PLATE CIRCUIT "B" BATTERIES

Reduced prices. A leading standard brand advertised to sell at much higher prices. No better battery made. Longest service. Prices quoted are F.O.B. Chicago. Be sure to allow extra for postage.  
R150 Small size 2 by 2 1/2 by 3 1/2 in. 22 1/2 volts. Each.....90c. Ten for.....\$8.60  
R184 Large size 5 taps. Size 3x4x6 1/2 22 1/2 volts. Each...\$1.55. Ten for...\$13.50  
R188 Large size, 6 taps. Size 3x3x5 1/2 45 volts. Each...\$2.75. Ten for...\$24.40  
R181 22 1/2 volt. New upright size 3x2 1/2x5 1/2 in. Takes less space in set. Each.....\$1.45  
R183 45 volt upright size 3x7x8 in. Each \$3.10. Ten for \$27.90  
R106 4 1/2 volt C battery size 4x1 1/2x3 1/2 in. Ba. 38c. Ten for...\$3.69

## "C" BATTERY

R189 Each.....85c  
Reads 0 to 50 volts. Accurately tells you condition of "B" battery. Convenient watch size. Tests 2 1/2 and 4 1/2 volt batteries. Very flexible. 11 ohm tensile strength. Best for aerials.  
R248 100 ft. coil 56c R249 500 ft. coil \$2.60

## B BATTERY ELIMINATORS

One of the most recent radio developments. No B batteries required when a device of this type is used. Can be used only on 110 volt 60 cycle alternating current.  
R157 Timmons B Eliminator, including Rectifying Tube.....\$32.00  
R158 Balkite. No bulb required...\$49.50

## STRANDED ANTENNA WIRE

Cabled of fine copper strands. Very flexible. 11 ohm tensile strength. Best for aerials.  
R248 100 ft. coil 56c R249 500 ft. coil \$2.60

## ANTENNA INSULATORS

R263 Ribbed Porcelain Insulator, 2 1/2 in. long, 2 for 12c Dozen.....55c R263  
R265 Ribbed Porcelain Insulator—5 inches long, 2 for 35c

## OUTDOOR ARRESTER

R980.....\$1.20  
Protect your instruments with this lightning arrester. Weatherproof Bakelite case. Underwriters approved.

## JEWEL LIGHTNING ARRESTER

R931 Each.....85c  
A dependable protector, always on guard. Small and compact. Weatherproof porcelain case. Easily fastened and connected. Underwriters approved.

## SUPERIOR RADIO SWITCH

R283 Each.....29c  
A switch fully equal to any on the market at a price about half what is usually asked for a switch of anywhere near equal quality.  
R287 Frost Radio Switch.....27c  
R282 Carter Panel Switch.....49c  
R284 Walbert Lock Switch.....40c

## SEND FOR OUR FREE CATALOG

On these pages are shown only a few of the bargains we offer. In our free Radio Catalog you will find hundreds of other radio bargains. In it are listed a complete line of parts for building radio sets and also many of the more popular complete sets. It is a dictionary of radio information that every radio fan should have.



**\$47.50**

## 5 Tube Bargain

The greatest radio value ever offered

A five-tube radio frequency set that brings in the distant stations on the loud speaker. All the volume you could want with the finest tone quality, clear and sweet. Careful designing with big quantity production make our low price possible. Only the finest quality materials used throughout. New style efficient low loss condensers and transformers. Bakelite panel size 7x18 in. Handsome mahogany finish cabinet. Neat convenient dials. We can recommend this set for either city or country use. Will not radiate and will bring in stations from coast to coast. No set approaches this for value. Equals many sets selling at double and triple our price. Try it for ten days. If you are not satisfied return it and we will refund your money.

R867 Set, only.....\$47.50  
R858 Set complete with five 201A tubes, 90 volts B battery, 100 ampere storage battery, one R613 Special Speaker, and complete antenna equipment. Nothing extra to buy. Price.....\$88.00

## PARTS FOR 5 TUBE HAZELTINE NEUTRODYNE CIRCUIT

R858 Complete set parts, including mahogany finished cabinet.....\$37.75  
All the parts needed to build this circuit which is the leader of all circuits today. Tunes thru interference. Easy to find stations once they have been located. Brings in distant stations on the loud speaker in clear pure tones of wonderful volume. Essential parts licensed under Hazeltine patents. Genuine bakelite panel 7x21x3/16" drilled ready to mount parts. Complete instructions furnished for assembling and wiring. With these parts you can easily build a high grade set at low cost. Note that all our prices are prepaid.

## COMPLETE PARTS FOR OTHER POPULAR CIRCUITS

All the parts needed to build a receiving set in handy, convenient form. All parts furnished have been carefully selected and when properly assembled will make a highly efficient set. All panels are genuine bakelite drilled ready to mount parts. The wiring diagrams and instructions for assembling these sets are the most complete and comprehensive furnished with any knocked down sets and the ease with which the sets can be assembled by following our instructions are one of their biggest features. Cabinet included only where specified in listing.  
2R866 5 Tube Phasiformer, including cabinet.....\$41.75  
R862 3 Tube Ambassador, including cabinet.....28.95  
R873 1 Tube Cockaday.....\$11.75 R862 1 Tube Reinhartz.....11.95  
R874 3 Tube Cockaday.....19.75 R863 3 Tube Reinhartz.....19.25  
R875 5 Tube Cockaday with resistance coupled amplifier.....48.95 R865 1 Tube Ultra Audion.....8.45  
R867 2 Tube Harkness.....17.95

## SETS

Each set supplied complete with tubes, 100 ampere hour battery, B battery, loud speaker and antenna equipment. All standard high grade parts at a big saving to you. Nothing extra to buy. Each set is fully described in this magazine or send for our free catalog.  
Thermodyne 5 Tube. Complete.....\$159.00  
R1109 Workrite 5 Tube Neurodyne. Complete.....145.00  
R1100 Mohawk 5 Tube One Dial Com. tral. Complete.....170.00  
R1116 Nordack 5 Tube Neurodyne 129.50  
R1114 Melec Supreme 5 Tube.....176.00  
R1117 Freed-Eisenann 5 Tube Neurodyne.....178.00  
R1112 Long distance Three Tube Regenerative Set.....74.50  
Crosley Trirdyn 3 Tube.....85.00  
Freshman Masterpiece 5 Tube.....90.00  
Arnold 5 Tube Neurodyne.....115.00  
Howard 5 Tube Neurodyne.....210.00

## ESSENTIAL PARTS KITS

These kits contain the essential parts for popular circuits. You will find complete descriptions in other parts of this magazine. Our low prices save you money. Wiring diagrams and instructions included with each outfit.  
R871 Fada Neurodyne Kit.....\$21.00  
R872 Freed-Eisenann Kit.....21.00  
Shantrock Two Tube Harkness Kit.....29.50  
Freshman Masterpiece Kit.....15.95  
Baldwin Pacific Heterodyne Kit 13.00  
R885 Raven Super Heterodyne Kit 21.00  
R887 Remier Super Heterodyne Kit 22.00  
R852 Workrite Neurodyne Kit.....15.95  
B. T. Nameless Kit.....23.40

## STANDARD BRAND VARIOMETERS AND VARIOCOUPERS

R406 Pfanstiehl Low Loss Variometer.....\$3.00  
R407 Pfanstiehl Low Loss Variocoupler.....3.95  
R408 Coto Variometer.....3.95  
R409 Coto Variocoupler.....4.30  
R528 Premier Variocoupler.....2.85

## STANDARD BRAND THREE CIRCUIT TUNING COILS

R551 Ambassador 3 Circuit.....\$5.95  
R552 Uncle Sam 3 Circuit.....4.60  
R547 Brecher-Tolly Low Loss.....4.45  
R558 Flewelling Type S.....6.95  
R559 Pfanstiehl Low Loss.....4.45  
R554 Lorez Low Loss Tuner.....8.95

## RADIO SOLDERING IRON

R540 \$1.19  
This guaranteed iron is exactly right for radio work. A neat solid connection quick and easily made. Operates on any lightning current 100 to 120 volts, 6 ft. cord with attaching plug. Length 13 inches.

## KITS OF COMPLETE PARTS

Factory built Kits containing all parts needed to build a complete receiver. Instructions and wiring diagrams included. Our low prices show you a big saving.  
R876 Erla 1 Tube Reflex Kit.....\$22.95  
R877 Erla 2 Tube Reflex Kit.....34.50  
R878 Erla 3 Tube Reflex Kit.....42.50  
R1883 Acme Flex 4 Tube Reflex Set 49.00  
R857 Fada complete Kit for 5 Tube Neurodyne.....57.50  
R1247 All-Amaz Senior—3 Tube Reflex.....37.80  
R1246 All-Amaz Junior—1 Tube Reflex.....19.75

## CONSOLE RADIO CABINET

R902 Each \$37.50  
Built-in loud speaker \$12.00 extra.  
Every radio fan should put his set in a cabinet like this.  
A high grade piece of furniture. Neat appearance. Elegant finish. Looks well among finest furnishings. Top compartment takes any set or panel size 9 in. high, 18 in. deep, 33 in. long or smaller. Lower compartments hold batteries, chargers and all accessories. Can be entirely closed and locked. Strong durable construction. Paueled doors. Fine mahogany or walnut finish. Size over all, 37 in. wide, 31 in. deep, 42 in. high. Price is F.O.B. Chicago. Be sure to allow extra for transportation.

## SUPREME SOLID WALNUT CABINETS

The finest quality cabinet. A piece of furniture worthy of the best set. Made of genuine solid walnut in elegant hand rubbed natural walnut finish. Top has piano hinge and lid support. Feet at base add to striking appearance. Inside depth 9 inches. Prices quoted on cabinets are not prepaid. Be sure to allow extra for transportation.

Panel Size	Art. No.	Price Each	Panel Size	Art. No.	Price Each
7x18	R444	\$7.65	7x26	R447	\$10.50
7x21	R445	8.25	7x38	R449	11.50
7x21	R446	8.95	7x36	R448	13.75

## CABINETS

Fine looking cabinets solidly built. Elegant hand rubbed dark mahogany finish. You will be proud of your set mounted in one of these cabinets. Hinged tops. Panel fits flush in front recess. Panels not included. Inside depth 7 inches except 9x12x14, 12x21, which are 10 in. deep. Prices quoted on cabinets are not prepaid. Be sure to allow extra for transportation.

Panel Size	Art. No.	Price Each	Panel Size	Art. No.	Price Each
6x7	R420	\$1.95	7x21	R425	\$3.23
6x10 1/2	R422	2.45	7x24	R429	3.40
7x10	R421	2.60	7x26	R431	3.50
7x12	R424	2.85	9x14	R428	3.55
7x14	R423	2.95	12x14	R430	4.00
7x18	R428	3.25	12x21	R432	5.05

## OUR SPECIAL LOUD SPEAKER

R613 Each.....\$5.95  
Careful tests have proven this speaker to be equal in quality of tone and volume to most speakers available at \$25.00 or less. That's a firm statement if you bear in mind the price we ask but we are so sure that this speaker will please you that you can try it for 10 days. If you don't like it at the end of that time, return it and get your money back. Beautifully finished fibre horn, bell diameter 10 inches. Height 21 in. Handsome heavy base prevents tipping. Connecting cord included.

## SUPERIOR RADIO JACKS

Finest grade jacks. Improved design. Best materials. Phosphor bronze springs. Silver contact points. Nickel finish. Mount on panels 3/8 to 1/2 in.  
R330 Open circuit. Each.....32c  
R391 Closed circuit. Each.....39c  
R392 Tun circuit. Each.....49c  
R393 Single circuit filament control. 45c  
R394 Two element filament control.....59c

## TUNED RADIO FREQUENCY UNIT

R853 Each.....\$2.75  
Three for.....7.85  
Consists of radio frequency transformer wound on bakelite tube tubing and high grade variable condenser. For use in tuned radio frequency circuits. Usually used in sets of three. Condenser shaft 1/2" diam.

## COLLAPSIBLE LOOP ANTENNA

R976 Each.....\$3.80  
A full size loop antenna 31 in. high 28 in. wide. Folds into compact case 18 in. long, 3 in. diam. Well made. Fine looking. Insulated wire, extra flexible. Suitable for use with any loop set. Case included. Quickly set up or taken down.



**The Barawick Co.**  
102 So. Canal St. Chicago, Ill.



# ATWATER KENT RECEIVING SETS

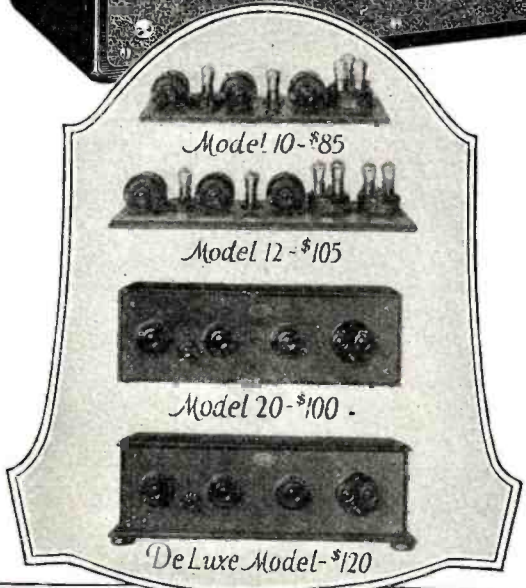

Pacific Coast prices slightly higher

TO own an ATWATER KENT—just think what it means! In one evening the thrills of a lifetime are crowded into a few short hours.

Set its dials and the melodies of a famous orchestra flood your home; another touch and you hear a lecture from a thousand miles away — turn again and you have the news of the day or the sweet voice of a renowned singer generously broadcasting for your entertainment.

Choose whatever program you will, with an ATWATER KENT you are master of the air.

There is an ATWATER KENT well within your means: it combines every feature that assures radio satisfaction for years to come — Any ATWATER KENT dealer will help you in your selection.

Interesting literature on request

ATWATER KENT MANUFACTURING COMPANY  
4713 Wissahickon Ave., Philadelphia, Pa.

THINK WHAT IS BACK OF IT



# ATWATER KENT LOUD SPEAKERS



THROUGH an ATWATER KENT Loud Speaker the true spirit of radio finds expression with exquisite fidelity. Its full volume of rich, natural tone, without a trace of the mechanical or suggestion of the artificial, is at once a credit to your receiver and to the artist at the distant microphone.

The ATWATER KENT Loud Speaker brings out the best from any set:—it is the final touch that makes your radio a living thing.

Decide today to buy one for your family. Let them all hear the wonderful things that are on the air.

Your dealer has three ATWATER KENT models for your selection.

*Interesting literature on request*

ATWATER KENT MANUFACTURING COMPANY  
4713 Wissahickon Ave., Philadelphia, Pa.

*Pacific Coast  
prices  
slightly higher*

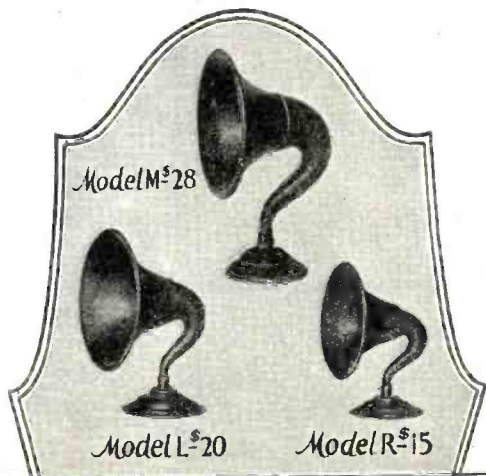

BRING OUT THE BEST FROM ANY SET





for all Long Wave Circuits

to make your phonograph a perfect loud speaker

for finer receiving!

for more distance on ear-phones

for bliss!

for better tuning

Each of these Rico products means added pleasure and value to your Radio Set.

RICO Products on this Page Will Improve Your Radio 100%



TROPAFORMERS

The sensitivity, selectivity and volume obtained in all types of long-wave circuits depends entirely upon the intermediate frequency transformer. TROPAFORMERS have been specifically designed to meet the new scientific requirements of long-wave circuits. The TROPAFORMER combines transformer and condenser. The condenser is shunted across the secondary winding of the transformer, and by its use the transformer may be tuned to any definite wave length between 3,000 and 9,500 meters. Only in TROPAFORMERS will long-wave circuit users find these advantages, and these advantages are patented for TROPAFORMERS exclusively!

\$6.75

Free Hook-up of the Famous Tropadyne Circuit with Each Tropafomer Ordered



MELOTONE PHONOGRAPH ATTACHMENT

Just adjust the simple MELOTONE PHONOGRAPH ATTACHMENT to your phonograph, and presto! you have converted your phonograph into a marvelous loud-speaker. That's all there is to it! The MELOTONE gives the clearest, purest shadings of speech and music. Dealers say it compares favorably with attachments selling at \$10 to \$15.

\$7.50

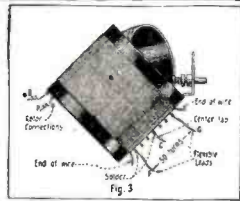

RICO TICKLER OSCILLATING COIL

In the RICO TICKLER OSCILLATING COIL, the rotor coil is used as the tickler. You will find low losses with this coil. It is a product of RICO scientific research, and has been proclaimed by experts as a masterpiece of construction.

\$3



RICOFONES

Probably the most popular headphones made, 500,000 RICO FONES are serving in every nook and corner of the world. There has never been so much quality put in a headphone at such a small price. For better tuning and distance, use RICOFONES, America's Favorite!

\$2.95



RICO FONEKUSHIONS

You'll know what real ear-phone comfort is when you use RICO FONEKUSHIONS. They are made of soft, pure sponge rubber, and fit any make of headphone. They are like soft, downy pillows for your distance-seeking ears.

50c

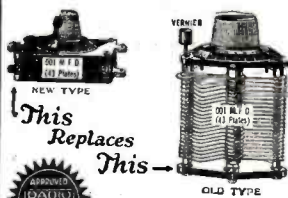

RICO STRAIGHT LINE CONDENSERS

In the old days, folks used horses. Now they can get as much power out of one auto as from 40 horses. It was all right, too, a few years ago, for folks to use the old-time condensers, but now, since Rico brought forth the RICO STRAIGHT LINE CONDENSER, which occupies two-thirds less space than the ordinary mesh plate type, everyone modernizes his set with the RICO STRAIGHT LINE CONDENSER.

- No. 411—00025 mfd. ....\$1.75
- No. 423—0005 mfd. .... 1.75
- No. 450—001 mfd. .... 1.75
- Inclusive with Dials. Without Dials, \$1.50.

IF YOUR DEALER CANNOT SUPPLY YOU—USE THIS COUPON. NO MONEY DOWN!

RADIO INDUSTRIES CORPORATION  
131 Duane Street, New York City

Please send me C. O. D. the following: ...Tropafomers, \$6.75 ...Straight Line Condensers, \$1.75 ...Ricofones, \$2.95 ...Oscillating Coil, \$3 ...Fonekushions, 50c ...Melotone Attachment, \$7.50.

Name ..... Address .....



# Did you ever build a Set that got Coast to Coast?

## You can with the RICO-DYNE

**AUTO BALANCED**

**5 TUBE Tuned Radio Frequency**



# COMPLETE KNOCKDOWN SET

*Ready to tune in within a few hours!*

**EXPERTS PLACE "RICO-DYNE" IN THE \$100 SET CLASS**

*and we will sell you the complete*

## KNOCKDOWN SET

Together with a set of **RICOFONES FREE**

All for **\$38<sup>75</sup>**

**GREATEST RADIO VALUE IN HISTORY**

This Is What You Get:

- 1—Pair Ricolones. 1—Genuine Bakelite Front Panel, completely drilled and engraved. 1—Genuine laminated Bakelite Sub-Panel—with sockets already mounted. All mounting holes properly drilled.
- 3—Auto Balanced Tuned Radio Frequency Units—perfectly matched and balanced. 3—Beautiful 4-inch Dials. 1—Variable Grid Leak and .00025 M.F. Condenser. 1—4 to 1 Audio Transformer. 1—2 to 1 Audio Transformer. 1—.002 Fixed Mica Condenser. 1—.006 Fixed Mica Condenser. 2—Single Circuit Jacks. 1—Filament Control Switch. 1—30-ohm Rheostat. 1—10-ohm Rheostat.

**READ WHAT "RICO-DYNE" FANS WRITE US:—**

"I was very careful to log every station that I tuned in on during the first week that I operated my Rico set which I built myself. I live in New York City and there are several other radio sets in my apartment house which are of the high-priced class. I find that Chicago comes in during the heavy broadcasting of New York stations much more clearly on my set than it does on theirs. Nebraska is easy to get and late at night, I have tuned in on the Pacific coast."

(Signed) T. B. NEWMAN.

"I thought you would like to know something about the very keen selectivity of your Rico Kit which I built. In my neighborhood, it is very difficult to receive stations because we are located so close to a very powerful broadcasting station. I was very much surprised when I found that the Rico selectivity is so keen that I have no trouble at all in bringing in the stations I want and tuning out the big brute so close at hand."

(Signed) J. E. HOWE.

"The Rico set which I built is a peach! It has plenty of "pep" and power. I always have to cut down on my batteries when local stations are broadcasting, for they come in much too loud. As a matter of fact, when the local stations are broadcasting I often disconnect the loud speaker and lay down the ear phones on the table and find that the programs come in so loud on the earphones alone that I hardly need the loud speaker. Distance is very easy to get on the Loud Speaker and many distant stations come in with the volume of the ordinary local."

(Signed) FRED WURZBURG.

**Two Exclusive Principles Have Made RICO-DYNE the Fastest-Selling Radio Set in the Country**

The combination of "RICO" CELLU-WELD Low Loss Coils and variable Condensers is made mechanically perfect.

The coils are the Lorenz type and are self starting. They are the low-loss type and are Cellu-Welded to a support on the Condenser end plate.

The condensers also are the low-loss metal end plate type, the stator and rotor being insulated from each other by means of hard rubber mounting strips.

Modern broadcasting requirements demand that a tuned radio frequency set be especially selective and non-oscillating. In the "RICO" "AUTO-BALANCED" Tuned Radio Frequency Set this is accomplished by carefully setting the Coils at the factory at the neutralizing angle. This adjustment remains permanent due to the CELLUWELD process.

Due to this method of coil mounting used exclusively in RICO-DYNE Sets and Kits, there is no magnetic interference between coils and condensers.

## FOR THOSE WHO WANT TO BUY ONLY THE RICO-DYNE KIT

*Here Is Just What They Want:*

It seems unusual that with the tremendous volume, selectivity and distance-range of the Rico Auto Balanced set, it should be so simple to construct. Yet, nevertheless, this is true. We have letters from fans who tell us that they constructed their Rico set within a few hours. The plans which accompany the Rico Kit are so simple that we believe this is so. Any beginner need only to read English in order to construct the Rico set. This Kit contains 3 Auto Balanced Tuned Radio Frequency Condensers, inductance Units, factory matched, book of instructions and drilling template. You can't go wrong!



**\$16.50**

**RICO-DYNE HAS SET NEW RECORDS IN RADIO!**

### NOT A CENT DOWN COUPON!

RADIO INDUSTRIES CORP., R.N. 4  
131 Duane Street,  
New York City.

Gentlemen:—  
As my dealer cannot supply me, please send me C. O. D.:—

- COMPLETE KNOCKDOWN SET—\$38.75
- KIT,—\$16.50

Name .....

Address .....

City ..... State.....



# "BUILD YOUR OWN" WITH "RASCO" PARTS!











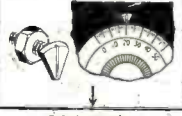
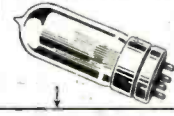
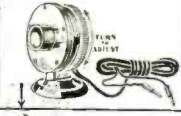
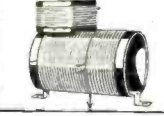
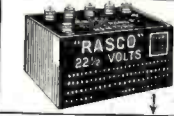

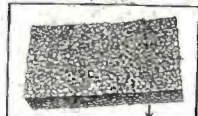





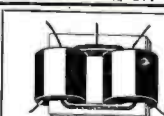

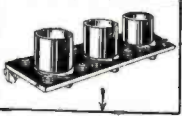

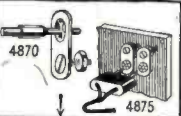
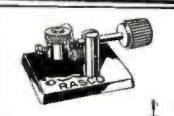

## Buy from the Oldest and Original Exclusive Radio Parts House in the United States

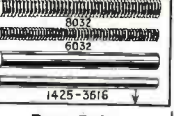
We pay ALL transportation charges in U. S. ALL GOODS SENT PREPAID IN 24 HOURS

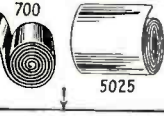
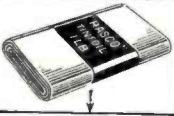
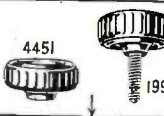
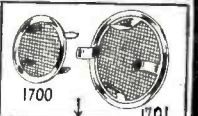
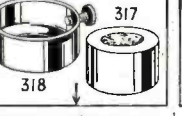
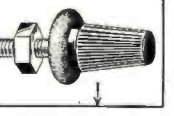
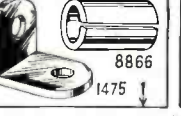
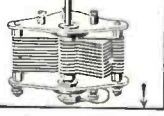
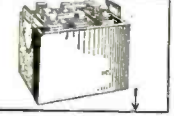
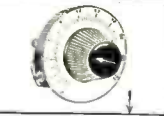
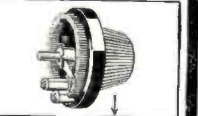
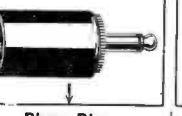
Order direct from this page.

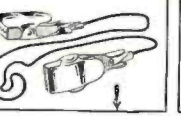
### NEW PRICES FOR THIS MONTH

Money refunded if goods do not satisfy

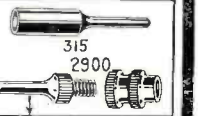
 <p><b>Dial Marker</b> The big little thing you have been waiting for. Just drill a hole in the panel and mount the marker above the dial. Nickel plated and polished. A7785 Dial Marker, each .....\$ .05</p>	 <p><b>Vacuum Tubes</b> Only best make tubes carried in stock. Any tube replaced if defective, providing filament lights. A701A 5 v., .25 amp. \$2.50 A799 3 v., .06 amp. 2.50 A72 1 1/2 v., .25 amp. 2.50</p>	 <p><b>Melotone Loud Speaker</b> The greatest and most powerful loud speaker phonograph attachment made. If, after five days trial, you do not proclaim it the best and most powerful speaker return it for refund. A6699 Melotone .....\$6.90</p>	 <p><b>Cockaday Coil</b> Guaranteed best make. Three windings of No. 18 Magnet wire. Has brass brackets for panel or base mounting. Satisfaction guaranteed or money back. A2750 Cockaday coil \$1.50</p>	 <p><b>Tapped "B" Batteries</b> We positively guarantee these batteries to be of long life. We carry only fresh stocks. All with taps. A2250 Sm. 2 1/2 v. ....\$ .85 A2251 Medium Navy size. 2 1/2 v. ....1.20 A4500 Medium size, 4 1/2 v. ....2.30</p>	 <p><b>Audio Frequency Transformer</b> No better Transformer made. Highest class materials. Impregnated coils. Silicon steel stampings used. Save 50 per cent by assembling it yourself. A1100 Ratio 4 1/2-1. ....\$2.00 A1150 Ratio 6 1/2-1. ....2.00</p>	 <p><b>Sponge-Rubber Cushions</b> Get rid of tube noises due to vibration. Softest sponge rubber made. Size 2 1/2"x3", 3/8" thick. A8989 Sponge-rubber cushions, each .....\$ .12 Six for .....\$ .60</p>	
 <p><b>Neutro-Transformer</b> Can be used for all tuned radio frequency circuits. Made for usual broadcast waves. Secondary has one center tap. Two genuine bakelite tubes. Silk wire. Furnished with 2 brackets. A1159 Transformer \$1.65 3 for .....\$4.45</p>	 <p><b>Moulded Variometer</b> Highly substantial instrument. Silk windings, 1/4" shaft. Bottom flange when placed into 4, 3 direction makes instrument panel mounting, 150 to 650 meters. Money back if this instrument is not all that we claim for it. A3550 Variometer.....\$3.00</p>	 <p><b>FONEKUSHIONS</b> Made of sponge rubber. Make wearing your receiver a pleasure. Positively exclude all noises and make reception a pleasure. Sponge rubber will last for years. Light as a feather. A3550 Fonekushions, set of two .....\$ .42</p>	 <p><b>Straight Line Condenser</b> Simplest and most practical type of condenser. A4430 "Rico" Condenser .001 mfd. 43 plate capacity .....\$1.75 A4230 .0005 mfd. 23 plate capacity .....\$1.75 A4110 .00025 mfd. 11 plate capacity .....\$1.75 All types no dials \$1.50 "1 1/2"x2 1/4" .....\$1.50</p>	 <p><b>Radio Frequency Transformers</b> Best Radio Frequency Transformer developed so far. Designed by R. E. Lacaul, Associate Editor RADIO NEWS. Air core type. 200-600 meters. A2800 Transformer, size 1 1/2"x2 1/4" .....\$1.50</p>	 <p><b>NEW!! Push Pull Transformer</b> For many new circuits. See any radio magazine. Made of best materials. Coils impregnated. Silicon steel laminations. Save 50 per cent by assembling yourself. Simple instructions furnished. A1159 Push-Pull Transformer, ratio 6 1/2 to 154.00</p>	 <p><b>Dilectryte Panels</b> Highest dielectric strength as per Bureau of Standards. Beautiful finish. A7100 7x10x3-16" .....\$ .70 A7120 7x12x3-16" .....\$ .85 A7140 7x14x3-16" .....\$ .95 A7180 7x18x3-16" .....\$ 1.25 A7210 7x21x3-16" .....\$ 1.45 A7240 7x24x3-16" .....\$ 1.65</p>	
 <p><b>Three-Gang Socket</b> Aluminum shells, genuine heavy bakelite base, 3 brackets for mounting, 12 nickel binding posts. Length 7 3/4". A5995 3 gang socket \$1.50</p>	 <p><b>Rasco 180° Variocoupler</b> Silk wire wound on bakelite tubes. Six taps. Wave length, 150 to 600 meters. For panel mounting. 1/4" shaft. Your money refunded if it is not all we claim. A3100 Variocoupler prepaid .....\$1.50</p>	 <p><b>Jiffy Jacks and Plugs</b> A4870 shows the best and cheapest cord tip. Mounted behind panel. Positive contact. A4875 shows new Jiffy Cord Plug and two Jiffy Jacks. A4870 Jiffy Jack nut and screw, ea. \$0.05 A4875 Two Jiffy Jacks and One Jiffy Cord Plug .20</p>	<p><b>BE SURE TO SEE PAGE 1929 OF "RADIO NEWS" FOR NEW "RASCO" GOODS</b></p>		 <p><b>Radiocite Detector</b> Base solid black composition. Automatic crystal holder. Triple adjustments. Smallest, neatest detector made. Radiocite crystal. 200,000 in use. A1899 Detector .....\$0.60 A1898 Galena detector .....\$ .50</p>	 <p><b>Spaghetti</b> Varnished flexible cambric tubing. 310 takes No. 22 wire; 320 takes 18 to 20 wire; 321 takes 16 to 18 wire; 341 takes 22 to 28 wire. A319-320-321 Per ft. \$0.9 A341 Flexible soft rubber tubing; 10 feet for .....\$2.00</p>	 <p><b>Soldering Iron</b> Smallest and handiest iron made. Fits any flat iron or percolator plug. Plug then becomes handle. 5" long. Complete but without plug or wire. A2200 Soldering Iron .....\$1.45</p>
 <p><b>Formica Panels Clearance Sale</b> As we are discontinuing these particular sizes, this material is now offered at cost. All 3-16" thick. A352 8x12" each .....\$1.75 A354 6 1/2x19 1/2" ea. ....1.90 A356 6x14" each .....1.60 A357 6x4" each ..... .65</p>	 <p><b>Brass Rods</b> Sold in 6" lengths only. A8032 Rod 8-32" thread length .....\$ .08 A6032 Rod, 6-32" thread length .....\$ .05 A1425 Rod, plain 3/4" round, length .....\$ .10 A882 E No. 20 I&amp;S .04 A3616 Rod, plain 3-16" round, length .....\$ .06</p>	 <p><b>Litz Wire</b> Prices are per foot. Equals. A823 E No. 25 R&amp;S .02 A890 E No. 28 I&amp;S .01 A891 E No. 21 I&amp;S .03 A892 E No. 20 I&amp;S .04 10 per cent discount in 100 foot lots.</p>	 <p><b>Copper Ribbon</b> .005" thick. A701 1/4" wide; A702 3-16" wide. All sizes per foot. ....\$ .01 <b>Copper Foil</b> .001" thick. 4" wide. A5025 Copper Foil, per foot .....\$ .10 10-foot length .....\$ .80</p>	 <p><b>Tin Foil</b> All our tin foils come 4" wide. Uniform product throughout. Best grade only A850 has 1500 sq. inches per lb. A851 700 sq. inches to lb. A850 Tin foil, 1 lb. \$4.8 A851 Tin foil, 1 lb. .48</p>	 <p><b>Switch Knob</b> A199 Knob, 1 1/8" dia., height 3/8"; 8-32" screw. A4451 Has 8-32" or 10-32" bushing, no screw. A199 Knob .....\$ .10 A4451 Knob .....\$ .06</p>	 <p><b>"Rasco" Bezels</b> Finest Bezel on the market. Bezel comes entirely nickel plated. Can be used on 3/8" or 3-16" panel. A1700 Bezel, 1 inch diam. ....\$ .15 A1701 Bezel, 1 1/8" diam. ....\$ .20</p>	
 <p><b>Mounted Crystal-Cup</b> Cup has screw and adjustment nut. Fits all standard mounted crystals. Nickel plated, polished. A318 Nickel Cup .....\$ .20 <b>Radiocite</b> Best most sensitive mounted crystal. U. S. Navy using it. Each tested. A317 Radiocite Crystal .....\$ .25</p>	 <p><b>Rasco Vernier</b> Why use a vernier condenser when a vernier attachment will do anything and everything a vernier condenser accomplishes? Cleverest vernier made. Can be used with any dial. Soft rubber ring engages dial. Nothing to come apart. A1450 Vernier .....\$ .18</p>	 <p><b>Angle Bushing</b> Angle piece used to mount panels, etc. 1,000 uses. 3-16" wide, height 7-16". A1475 Angle piece. Each .....\$ .03 <b>Adapter Bushing</b> Makes 3/4" dial fit 3-16" shaft. 1/2" long. A8866 Bushing .....\$ .01</p>	 <p><b>Panel Mounting Grounded Rotor Condensers</b> Positively no better condenser made. Lowest losses. Digital connection, binding posts, aluminum plates, rugged construction. Used by 9 big set manufacturers. A2113 13-plate .....\$1.50 A2123 23-plate .....1.90 A2143 43-plate .....2.85</p>	 <p><b>Storage Batteries</b> Guaranteed for two years. Only NEW material used. Acid proof terminals. Patent vents. A2400 Two volt, 40 amp. hours .....\$3.90 A400 Six volt, 40 amp. hours .....7.25 A666 Six volt, 60 amp. hours .....9.50 Shipped express collect.</p>	 <p><b>Rheostats and Potentiometers</b> Come with metal dials and composition knob. Excellent merchandise despite low price. A4210 6 ohm Rheo. ....\$ .27 A4211 30 ohm Rheo. ....\$ .30 A4212 200 ohm Potentiometer .....\$ .45</p>	 <p><b>Rheostats and Potentiometers</b> High heat dielectric base. Come with tapered, knurled knob, 2 1/8" dia. Complete with pointer. A4310 6 ohm .....\$ .38 A4311 20 ohm .....\$ .44 A4312 Potentiometer, 200 ohms .....\$ .65</p>	
 <p><b>Phone Plugs</b> Sold from 75c to \$1.00 everywhere. Hard rubber composition shell and patented cord tip holder. Finest workmanship throughout. A1030 Rasco Telephone Plug. Each .....\$ .35</p>	 <p><b>Bakelite Socket</b> Octagon shape. Four nickel binding posts, phosphor bronze contact springs. Best brown bakelite. A6510 Bakelite socket \$4.00 A6500 Tube Socket. Made entirely of composition. Best made. Each .....\$ .35</p>	 <p><b>Rasco Clip Leads</b> Invaluable for experimental work. Clip lead hooks in a Jiffy onto any wire, binding post or conductor. Safest experimental connection. Brass clips. 1 foot silk wire, green or red. A7887 Clip Leads, ea. \$ .12 Dozen lot .....\$ 1.35</p>	 <p><b>Name Plates</b> All name plates brass with silver letters. A8389 (Right or left) \$1.0 A8390 Comes in 35 styles. Any denomination, each style .....\$ .04 Panel Scale, 2 1/4" 90° metal, silver background, black lettering. A715 Scale, each .....\$ .15</p>	 <p><b>Binding Post Name Plates</b> Dia. 3/8". These styles: Phones, Ground, Out, In, "A" Bat., "B" Bat., Loud Speaker, "C" Bat., Aerial, Input, "A" Bat., "B" Bat., Loop "C" Bat., New "A" Bat., "B" Bat. A6000 Name Plates, all styles, each .....\$ .03</p>	 <p><b>"Rasco" Posts</b> Made of black composition. A650-51 Each .....\$ .06 A202 Has nickel-plated bottom, each .....\$ .08 Dozen, each style .....\$ .90 A122 Initialed Binding Posts. Six popular styles. Each .....\$ .06</p>	 <p><b>Cord Tips</b> Standard phone cord tips, nickel. A315 Each .....\$ .03 <b>Separable Cord Tips</b> No solder required. Wire goes in ferrule. Shank holds it tight. Nickel plated. A2900 Each .....\$ .06</p>	

# RADIO SPECIALTY COMPANY, 98 Park Place, New York City

Factories: Brooklyn, N. Y. Elkridge, Md.



# THE "LOLOS EXPLORER"

**1000 MILES ON LOUD-SPEAKER**



HERE is a 3-tube set that is positively a "knock-out." It is of the latest low loss type throughout. It contains a low loss 3-circuit tuner, a low loss Condenser, low loss Sockets, etc., and will bring in stations a thousand miles away on the loud speaker. See list of stations logged inside of two hours. This is not a newfangled new set, no latest revolution, no "wonder-dyne," no extravagant freak circuit. Instead, it is a good, old-fashioned 3-circuit set, but it reduces all the previous known losses to practically zero.

Its great secret lies in the fact that practically all losses are done away with and that the greater part of energy heretofore wasted in similar sets is conserved—hence the astonishing results possible with this set.

By means of the low loss 3-circuit Tuner and the low loss Condenser the set has razor sharp selectivity; that is why we furnish verniers, and even these must be handled carefully as distant stations can be brought in or lost by a 1/64-inch motion of one of the dials.

The great outstanding merit about this set is that it will cut right through locals and bring in distant stations. Moreover, as the chart shows, you can log stations and as there are only two dials you can always tune in stations at exactly the same settings, once you have brought them in.

At the price advertised, the set comes to you with all parts, even the screws, complete to assemble, which can be done within two hours. There is nothing missing—mahogany cabinet, a drilled panel, and baseboard are all included. All you have to get is three tubes, and "A" and "B" Batteries, which are not included in the price. We have never tested an outfit more suitable for long distance broadcast reception, and we guarantee the "LoLos Explorer" in every respect. Your money refunded if this set is not entirely satisfactory to you in all respects. Works equally well on 201A or dry battery tubes.

**IMPORTANT**—No technical knowledge required to build this set. Directions are so explicit, so simple, so clear that a 12 year old boy can readily put our set together.

**STATIONS LOGGED ON "LOLOS EXPLORER" in 2 hours at New York City**

Station	Dial	Location
WJZ	72 65	N. Y. City
WEAF	86 77	N. Y. City
WFBH	65 21	N. Y. City
WFAM	55 18	St. Cloud, Minn.
WQAO	73 40	N. Y. City
WEBB	75 43	Chicago, Ill.
WJY	72 52	N. Y. City
KDKA	70 32	Pittsburgh, Pa.
WTAS	67 25	Elgin, Ill.
WGBS	67 30	N. Y. City
WHN	72 39	N. Y. City
WJAX	88 48	Cleveland, Ohio
WIT	75 83	Philadelphia, Pa.
KYW	78 93	Chicago, Ill.
WOC	83 74	Davenport, Iowa

**ALL ON LOUD SPEAKER**

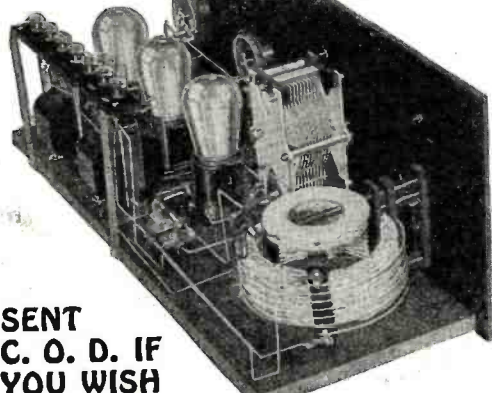











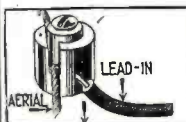
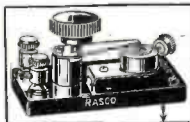



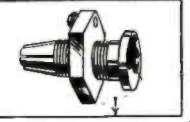
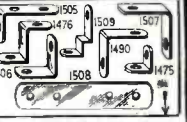

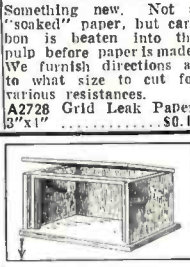
**SENT C. O. D. IF YOU WISH**

## List of Parts

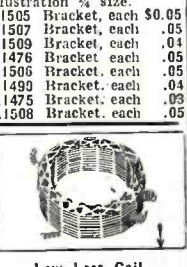
- 1 "Gen-Win" Low Loss Coupler; 1 7x18 Mahogany Cabinet; 1 7x18 Panel already drilled; 1 Baseboard; 2 "Calibrated Somerset" Audio Frequency Transformers; 1 "Certified" Low Loss Condenser; 2 Rheostats; 3 Bakelite Sockets; 2—3" Dials; 3 Jacks; 7 Binding Posts; 1 Grid Leak and Mounting; 1 .00025 Condenser; 2 Dial Markers; 2 RASCO Verniers; 2 Angle Plates; 10 ft. Bus Bar; 1 Switch; 1 Bakelite Binding Post Strip; 7 Binding Post Name Plates; 24 Screws; 1 Set of Directions. Total Price of Goods .....\$33.71

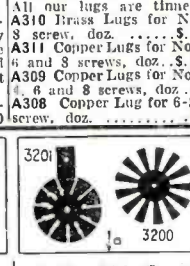
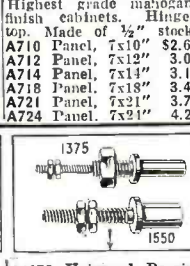
A6996 LOLOS EXPLORER OUR PRICE..... **\$30.25**

# NEW "RASCO" GOODS FROM CAT. No. 12

 <p><b>Antenna Connector</b> At last the solderless antenna connector, made entirely of brass in three pieces; clamps aerial and lead-in with vise-like grip, keeping perfect contact at all times. Dia. 5/8", height 1/2". A9994 Connector .....\$0.25</p>	 <p><b>Crystodyne Detector</b> For the famous Oscillating Crystal circuits. Crystodyne does anything and everything that can be done with vacuum tube. Hard rubber base, sliding cup. All parts nickel-plated. AC900 Detector .....\$1.75</p>	 <p><b>Grid Leak Paper</b> Something new. Not a "soaked" paper, but carbon is beaten into the pulp before paper is made. We furnish directions as to what size to cut for various resistances. A2728 Grid Leak Paper, 3"x11" .....\$0.15</p>	 <p><b>Dial Button</b> Made in blue enamel and gold, to be worn in button hole. Every radio fan wants one. 3/4" diameter, best gold plate. Perfect reproduction of radio dial. A7799 Dial Button, each .....\$0.25</p>	 <p><b>Vacuum Tube Shell</b> Nickel plated shell for the man who builds his own. 4 holes to attach to sub-base. Each shell comes complete with 4 phosphor bronze socket contacts. See illus. 4748. A4747 Vacuum Tube Shell and Contacts .....\$0.16</p>	 <p><b>Cord Tip Jack</b> Takes place of binding posts. Cord tip firmly gripped by jack. Made of brass, nickel plated. Screw to attach lead wire. No soldering necessary. A1500 Cord tip jack, Each .....\$0.15</p>	 <p><b>Brass Nickel plated Brackets</b> Illustration 1/4 size. A1505 Bracket, each \$0.05 A1507 Bracket, each .05 A1509 Bracket, each .04 A1476 Bracket each .05 A1506 Bracket, each .05 A1499 Bracket, each .04 A1475 Bracket, each .03 A1508 Bracket, each .05</p>
 <p><b>Storage "B" Battery</b> 48 volts, 4 1/2 amp. hours. Buy storage "B" batteries by capacity, not by looks. Charge lasts one month. Rubber tops and vents, wooden tray. Sent Express Collect. A4480 Storage "B" Battery .....\$14.00</p>	 <p><b>Tinned Nickel Lugs</b> All our lugs are tinned. A310 Brass Lugs for No. 8 screw, doz. ....\$1.10 A311 Copper Lugs for No. 6 and 8 screws, doz. ....\$1.10 A309 Copper Lugs for Nos. A714 Panel, 7x11" 3.15 A718 Panel, 7x18" 3.40 A721 Panel, 7x21" 3.75 A724 Panel, 7x24" 4.20</p>	 <p><b>Wood Cabinets</b> Highest grade mahogany finish cabinets. Hinged top. Made of 1/2" stock. A710 Panel, 7x10" \$2.69 A712 Panel, 7x12" 3.00 A714 Panel, 7x14" 3.15 A718 Panel, 7x18" 3.40 A721 Panel, 7x21" 3.75 A724 Panel, 7x24" 4.20</p>	 <p><b>Low Loss Tuner</b> Same type as used in our LOLOS EXPLORER. Tunes from 200 to 600 meters. Hard rubber insulation throughout. Silver plated primary. Secondary D. C. C. Ticker silk wire. A2690 Tuner .....\$5.00</p>	 <p><b>"T" Wire Connectors</b> This big little article solves all troubles when making "T" wire connections. Made to take 1/16" square or round bus-bar wire. Can be attached with a pair of pliers. A2975 "T" Wire Connectors, 12 for .....\$0.05</p>	 <p><b>Nosolder Lugs</b> Finally, a real solderless lug is here. Soldering positively done away with. Takes square or round bus-bar, which it holds with a vise-like grip. Perfect connection. Just slide bus-bar into slip-grip. A3727 Lug 10 for .....5c</p>	 <p><b>Low Loss Coil</b> Same type coil as used in Freshman and other Tuned Radio Frequency sets. D.-C.-C. wire, 200-550 wavelength. 3" diameter, 1" thick. 5-16" thick. 4 connections. 2 primary, 2 secondary. A2629 Low Loss Coil 85c</p>
 <p><b>"Perfect" Lugs</b> These new and improved lugs are brass, nickel plated, flattened on top as shown. Made of single piece of metal. Lead wire goes into tube. A3110, A3080 "Perfect" Lugs, Each .....\$0.02 Dozen lots .....20</p>	 <p><b>Spider Web Forms</b> Fine forms to wind your spider webs. Made from hard, well seasoned fibre, 1-16" thick, center and side holes for wiring. Both 5" diameter. A3200 Spider form, .25 A3201 Spider form, .25</p>	 <p><b>A1375 Universal Bearing</b> To hold rotors. Length of bearing 2 3/4", shaft 1 1/2", thread 1/8" long, threaded sleeve 3/4" long, each .....\$2.25 A1550 Sockettes. Four of these take one vacuum tube. Grasp tube firmly. Best by test. Set of 4 \$2.25</p>	 <p><b>Brass Strip and Tuning</b> Brass strip 1/2" wide; 1-16" thick; 6" long. A1430 Per length, ..\$.10 A1431 Brass tubing dia. 3/4", 6" long; length 5.15 Threaded Brass Rods Sold in 6" lengths only. A8032 8-32" thread \$0.08 A6032 6-32" thread .66</p>	 <p><b>Moulded Dials</b> Only very best grades handled. Bushings absolutely true. Dials cannot wobble. Letters inlaid in fast white enamel. All dia for 1/2" shaft. A3074 Dial .....\$.20 A3075 Dial 3" .....25 A3076 Dial 4" .....40</p>	 <p><b>Tuned Radio Frequency Kit</b> Here is the finest 5 tube low loss auto-balanced kit made. Reaches 2000 miles on loud speaker. Three low loss condensers with low loss coils attached. Complete booklet of instructions. A8779 R. F. Kit, \$16.50</p>	 <p><b>"Rasco" Switch Points</b> Nickel plated and polished. A301 1/4"x3/4", 6-32" \$1.18 doz. 1/2" dia. 1/2" thick, 6-32" doz. .18 A305 3/4" dia. 3-16" thick, 4-36" doz. .18 A375 Switch stop 3/4" long, with nut, doz. .18</p>

**New 1925 "Rasco" Catalog** No. 12  
CONTAINS 75 VACUUM TUBE HOOK-UPS, 300 ILLUSTRATIONS, 500 ARTICLES, NOW 100 PAGES

All Armstrong Circuits: These important circuits are explained clearly, all values having been given, leaving out nothing that could puzzle you.

Just to name a few of the Vacuum Tube circuits: The V.T. as a detector and one-step amplifier; all Armstrong circuits; one-step radio frequency amplifier and detector; three stage audio frequency amplifier; short wave regenerative circuits; 4-stage radio frequency amplifiers; radio and audio frequency amplifier; inductively coupled amplifier; all Reflex Circuits.

**FREE**  
A POSTAL CARD BRINGS IT

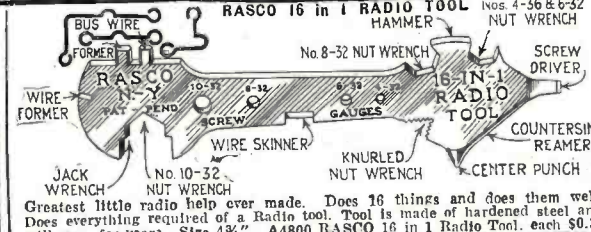

Greatest little radio help ever made. Does 16 things and does them well. Does everything required of a Radio tool. Tool is made of hardened steel and will wear for years. Size 4 3/4". A4800 RASCO 16 in 1 Radio Tool, each \$0.35

**RADIO SPECIALTY COMPANY, 98 PARK PLACE, NEW YORK CITY**





# Don't buy radio blindly

**M**OST radio instruments are bought blindly. The average buyer knows little of radio. He buys the kind of instrument that he "hears" at a friend's home or in a dealer's store. He hopes and expects to get the same results he has heard. Sometimes he does—but many times he doesn't—that's the unfortunate thing in so many radio purchases.

**There's just one safe way to buy radio**  
—and that is after a real demonstration in the home, with competent installation and servicing supplied as part of the sale.

YOU FIND OUT, WITHOUT OBLIGATION, how easy Ozarka is to operate—how it brings the radio results you want for tone, volume, distance, and costs far less (with service) than other radio instruments do, without service.



## Here's the Way Ozarka Instruments Are Demonstrated and Sold

**T**HE Ozarka man brings the Ozarka instrument to your home; he rigs up an aerial; he supplies all the batteries and tubes; he makes all the connections—and then, with a few brief and simple instructions, he turns the instrument over to you. You find out for yourself just how easy it is to tune Ozarka. You form your own impression of its tone and volume. You go out after distant stations and bring them in.

You call on your wife and children and try their hand at tuning, and discover they can tune in the stations as readily as you did yourself. This is very important. The successful radio instrument is an intimate part of the home life. Everybody should enjoy it.

If you decide that Ozarka gives the radio results

you want, the Ozarka man not only installs your instrument, but is near at hand to insure your constant and continued satisfaction.

### 4 Tube Sets as Low as \$39.50

When the Ozarka man calls at your door or phones you, arrange with him for a demonstration. We predict you will find that Ozarka gives the kind of radio results you have always wanted, at far less cost than you expected to pay—but you are the one to judge. Making the test costs you nothing and puts you under no obligation.

Meanwhile you'll be interested in reading our Large Illustrated Book No. 200, that tells something of the Ozarka Plan and the results users are getting in all parts of the country. In writing, please mention name of your county.

## More Men Wanted to Carry Out the Ozarka Plan

If you have been impressed with the good horse sense of the Ozarka way of demonstrating and selling radio, perhaps you will be interested in knowing more of the Ozarka representative's job. He is the trained Ozarka factory representative in his territory. He sells, delivers, services—and he makes a mighty nice income doing it, because Ozarka demonstrations result in so many sales. The Ozarka man usually knows little of radio when he comes with us. He gets an intensive training under our factory engineers in our own successful methods, that greatly increases his money-making abilities.

Sales experience is valuable but not essential. You can readily see that under our plan the Ozarka Instrument does the talking. It is designed to sell itself against all competition and is doing just that.

It is important that our men be upright, honest and favorably known; also some capital is needed, but not a great deal. If you are interested in the possibilities of becoming an Ozarka representative, write me fully about yourself—if you can qualify, I can train you to make more money than you are making. I have trained over 3100 men under the Ozarka Plan. In writing please mention name of your county.

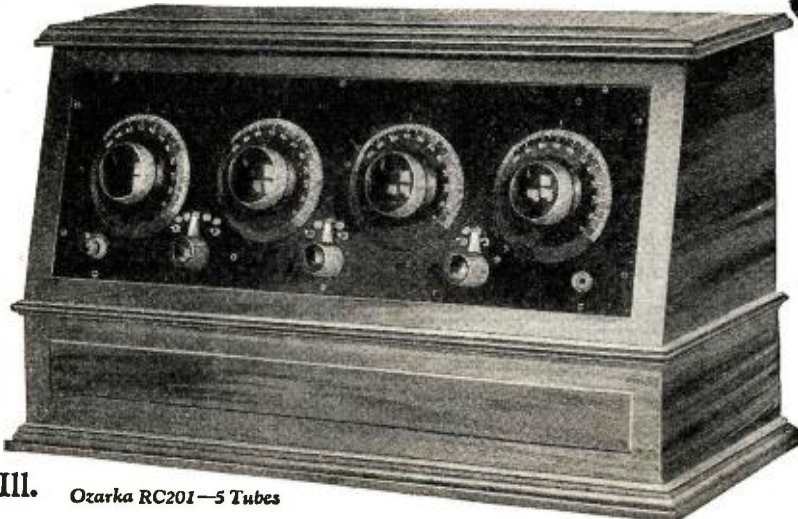

# OZARKA, Inc.

804 Washington Blvd.

Chicago, Ill.

Ozarka RC201—5 Tubes



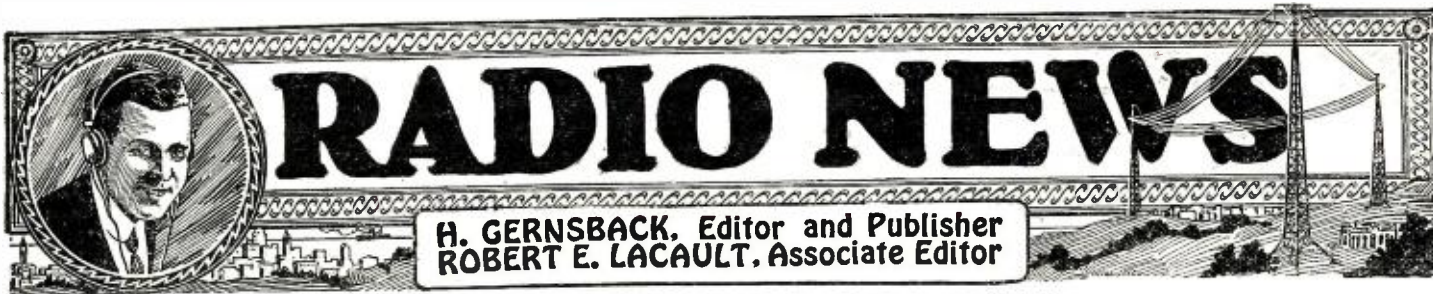

H. GERNSBACK, Editor and Publisher  
ROBERT E. LACAULL, Associate Editor

EDITORIAL AND GENERAL OFFICES, 53 PARK PLACE, NEW YORK

Vol. 6

APRIL, 1925

No. 10

## The Set Builders

By HUGO GERNSBACK

ONE of the most amazing things about the radio art is the astonishing speed of its evolution. Unlike other arts or utilities, its progress is so fast and its changes so swift that it sometimes becomes impossible to intelligently follow the drift.

Only a short year ago the one-tube set was in the majority. Today it is the five-tube set that reigns. A year ago no one had ever heard of a low loss condenser. Today you cannot buy a set which hasn't such condensers. A year ago even a broad tuning receiver found ready sale. Today, unless it tunes hair-sharp, no one will buy it.

The man who builds his own has, of course, moved with the times. Where last year he built every single-tube circuit that he could lay his hands on, this year he plays with five-tube tuned radio frequency sets, or builds six- or eight-tube Super-Heterodynes. While it is true that a tremendous number of ready-built sets have been sold during the past six months, it is also true that such sets will not last forever. To be sure, the average radio outfit of a good make has a life of from two to three years. Such sets can be counted upon to perform the work satisfactorily. Nevertheless, after you have once been bitten by the radio bug, you will wish to build sets for yourself, not because the ready-made set is not good, but because it is human nature to try to build one better than the "boughten" one. And there is nothing quite so dear to the heart of your average radio experimenter as his ability to point to his self-constructed set and proudly inform his visitor that, with THIS set, he "spins circles" around the \$150 "Novadyne," which, up to last week, was supposed to be the ultra-latest in radio. And, strange to say, your average experimenter accomplishes this, not once, but many times. The reason is fairly simple.

RADIO magazines abound with the latest circuits and with the latest information. If such is embodied in a set, and if it is built carefully, the chances are that such a receiver will perform remarkably well for the simple reason that it has embodied in it the latest available information. And, after all, why have only one radio outfit? There is no reason why one should not have four or five. A great number of people have sets in several rooms in their houses or apartments, in their offices, and so on.

After a set has served a year or two, usually the rising member of the family, anywhere from 8 to 15 years of age, is made a present of the old set. He immediately begins to take it apart and soon he has the "bug," after which he builds a number of sets himself. And, in the majority of cases, he can show his dad how a real set should be built, and in 90 per cent. of the cases, the youngsters have it all over their elders. The reason is simple: They read every available scrap of radio literature and know exactly what happens in a circuit. Also they are, as a rule, better mechanics than the fathers and, having more time at their disposal, can make a good job with fair intelligence.

One of the greatest detriments to set building in the past was the unwritten law that every connection must be soldered.

We are getting away from this very rapidly. In the writer's opinion, in another year, no one will wish to buy a set that has a single soldered connection. Soldered connections, so far

as radio frequency currents are concerned, are a false alarm. Such connections add high resistances to radio frequency currents and should be avoided. There is nothing better than a clean metal-to-metal connection, provided it is absolutely tight and mechanically perfect. Manufacturers have already seen the light, and a few of them are putting out sets with practically no soldered connections even now, all connections being riveted with copper eyelets and copper rivets.

Of course, the experimenter who builds his set has no such equipment. So, up to recently, he stuck to his soldering iron, usually making a poor job of it. Very recently, however, a number of firms have put out kits that require no soldered connections whatsoever in order to build a complete set. One concern offers a large number of kits, none of which require a single soldered connection. This seems to be a step in the right direction, because it makes set building easy. Not only that, but the resulting sets will be much better, because they will be more efficient. Furthermore, a set constructed with such methods can readily be taken apart without spoiling a number of instruments, as usually happens when you try to dismantle a set with soldered connections. With the solderless method it is a comparatively simple matter to change from one hook-up to another, and the game, therefore, becomes as interesting as a crossword puzzle.

WHEN the radio experimenter has built a number of sets, one of the interesting features is that of checking up on which set reaches the furthest. This is usually accomplished by having a double-pole double-throw switch, which can switch one set from the aerial and ground and the other set on. If the two sets have been tuned to the same wave-length, accurate comparisons can be made, as to which set really performs better. However, it will often be found that just getting distance is one thing, and actual results, another. For instance, you may build a set which will bring in a station 2,000 miles off on the loud speaker, but the quality may be poor and perhaps this set will not be so extra selective, whereas a set of a shorter range will have better quality, although perhaps will not be as selective. Often a good three-tube set will seemingly perform as well as a five-tube set, while, on the other hand, the five-tube set may develop qualities not inherent in the three-tube one. Also, certain sets will bring in certain far-off stations in nearly all cases, at your wish, whereas others will not be able to do so, and that is one reason why the average experimenter now has a number of sets, each being used for a definite purpose.

Thus, for instance, an acquaintance of ours has a relative employed as announcer at a Dallas, Texas, station. Naturally, he is interested in listening to that station whenever he cares to do so. This man has at least six sets, and of these, he finds that the only one he can rely upon to get the station at nearly all times in the evening is a specially constructed five-tube tuned radio frequency set. So he invariably uses this set in preference to others which do not seem to be able to bring that particular station in at all, although one of his sets, a Super-Heterodyne, brings in Pacific Coast stations, which are very much further away than the Texas station.

These are things worth studying, and perhaps some day we shall evolve a set that will bring in every station all over the world at will, but we have as yet not progressed this far.



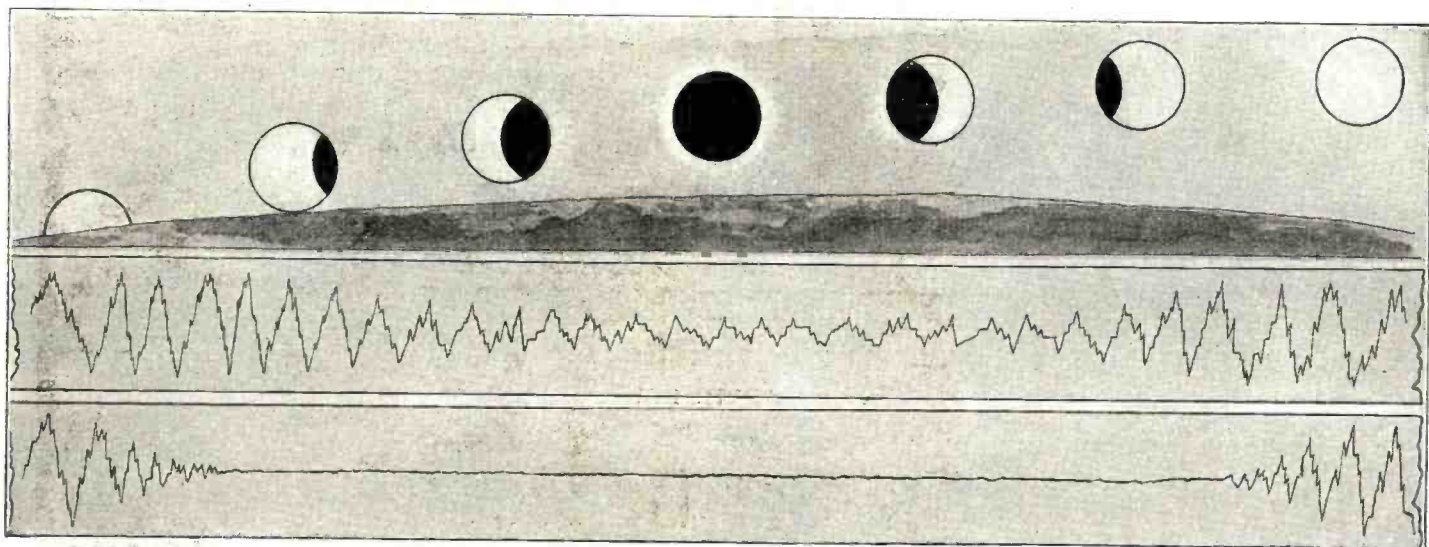

An idea of the variations of reception due to the eclipse, the greater the swing of the curve the more fading. The 380-meter wave (top) shows less fading at totality, while the 75-meter wave was lost during the entire eclipse.

## The Eclipse and Radio Reception

By G. C. B. ROWE



*Prof. G. W. Pickard is in charge of the compiling and digesting of the data collected by the Radio Corporation of America and the American Telephone and Telegraph Co.*



**T**HE 24th of January, 1925, was a date anxiously awaited by scientists in the northern portion of the United States. Formerly the passage of the moon across the sun had been of interest only to astronomers, but this year it was determined to ascertain what effect the sudden darkness would have upon radio waves.

It was known that radio broadcast signals generally became much stronger at nightfall. It was possible to get some idea how radio waves traveled by noticing how much stronger they became by night and the extent to which the signals "fade" in and out. It was also possible from such observations to get information as to whether radio waves travel along the ground exclusively as "ground waves," or whether they also traveled in part far over head (as "sky waves"). Some scientists think there is good reason to believe that the waves received during darkness for the most part travel at a height of 50 to 75 miles overhead, being reflected back to the ground eventually by a conducting layer of air at that height known as the Heaviside layer.

To study this effect, both the transmitting stations and the receiving equipment should be in approximately the same straight line running perpendicularly to the direction of the shadow of the eclipse. This is so that the degree of the eclipse will be the same at both places at the same time. Also suitable instruments for recording the atmospheric conditions, the power used in transmitting and the condition of the waves as they are received should be provided, in order that any changes in reception may be accounted for.

In New York City, where the eclipse was total, exhaustive tests were conducted in the laboratory of the Radio Corporation of America. Instruments for recording the amount of "fading" or "swinging" were installed and observations were taken at two wave-lengths from 6:30 a. m. until 11 a. m. for two days before and after the eclipse. Two Super-Heterodyne sets were tuned to signals being broadcast by station WGY and experimental station 2XI, at Schenectady, N. Y., a distance of approximately 160 miles from New York City. Station WGY broadcast on a wave-length of 380 meters and station 2XI sent out signals on a wave-length

of 75 meters. The reason for recording a short wave was because this was expected to be reflected more strongly by the shadow wall.

### EXPLANATION OF TERMS USED

It is well known that at night particularly, and over certain distances of 100 miles or more, the received signals are not steady.

The apparatus used in the eclipse reception experiments made by the Engineers of the Radio Corp. of America at their laboratory in New York City. The paper tape is fed through at the rate of one inch per minute. The operator keeps the wire, projecting over the meter scale, in line with the needle of the meter. The pen marking the curve on the tape is attached to the handle, so that the operator follows the needle variations; they are recorded as shown. © Underwood & Underwood.

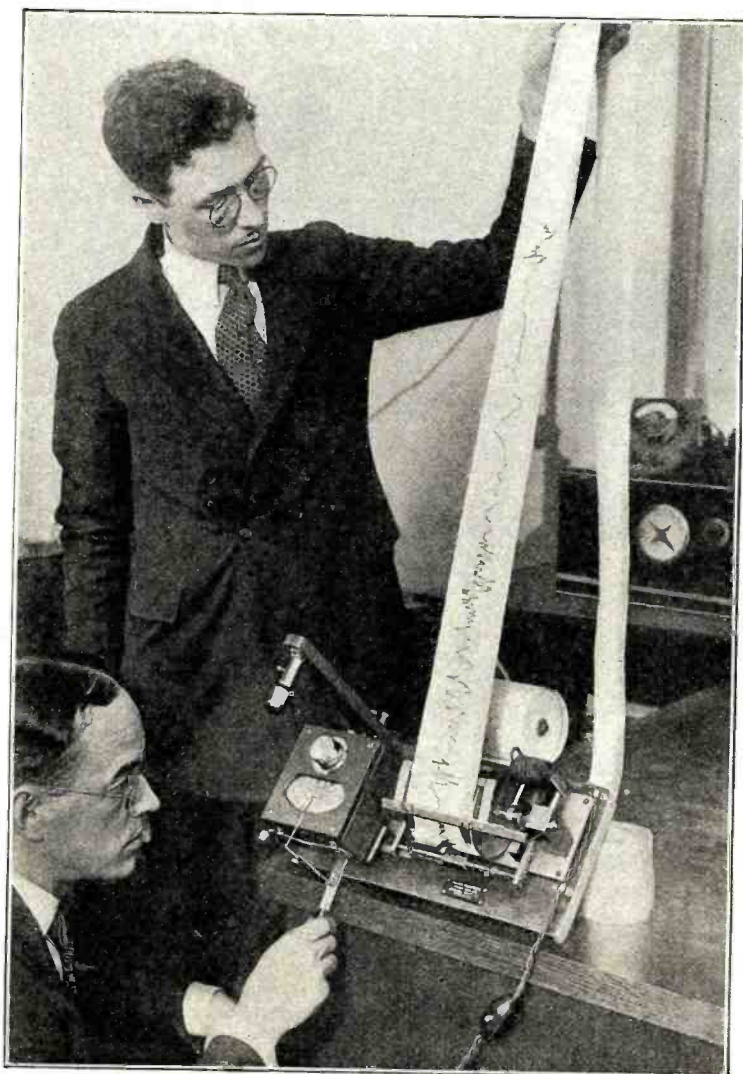



They will be loud for one moment and then gradually diminish in strength, returning after a while to their original strength. This is called "swinging" or "fading" of the signal and, of course, produces unpleasant reception effects. The usual wave-lengths used in broadcasting—that is, from 220 to 550 meters—do not show much daylight fading effect, although in the early morning hours there is some fading even on these wave-lengths. The shorter waves, those below 100 meters, do show considerable fading effect over certain distances of transmission by daylight.

It is also well known to radio listeners that there is a marked difference between daytime and night-time strength of signals. The average signal strength at night on the normal broadcasting waves is much greater than the day signals over any considerable distance. On some of the shorter wave-lengths the reverse is the case.

**RESULTS OF THE ECLIPSE TESTS**

The following results are more or less preliminary and tentative. They are all subject to later modification, to careful checking of the transmitted and receiving equipment, to make sure that the operation of these devices was constant and correct throughout the tests.

It was found during the five days of the observations that the 380-meter wave was swinging rather badly at sunrise and that the swinging gradually diminished, the signal becoming steady, as the sun rose higher. As a general rule, the signal became practically steady between 1/2 hour and 2 1/2 hours after sunrise. The more severe the fading at sunrise, the longer the fading lasted into the daylight hours. Furthermore, the more severe the swinging at sunrise, the more rapid the fading of the signal from loud signals to weak signals and back again.

During the totality of the eclipse it appeared to cause a reduction of swinging of the signals. However, the reduction of swinging apparently caused by the eclipse was not nearly as great a reduction as occurs between night time conditions and full daytime conditions. That is, the eclipse did not change swinging nearly as much as does full sunlight. While the above effects were noted, the eclipse did not affect the average signal strength at all. This, during the period of

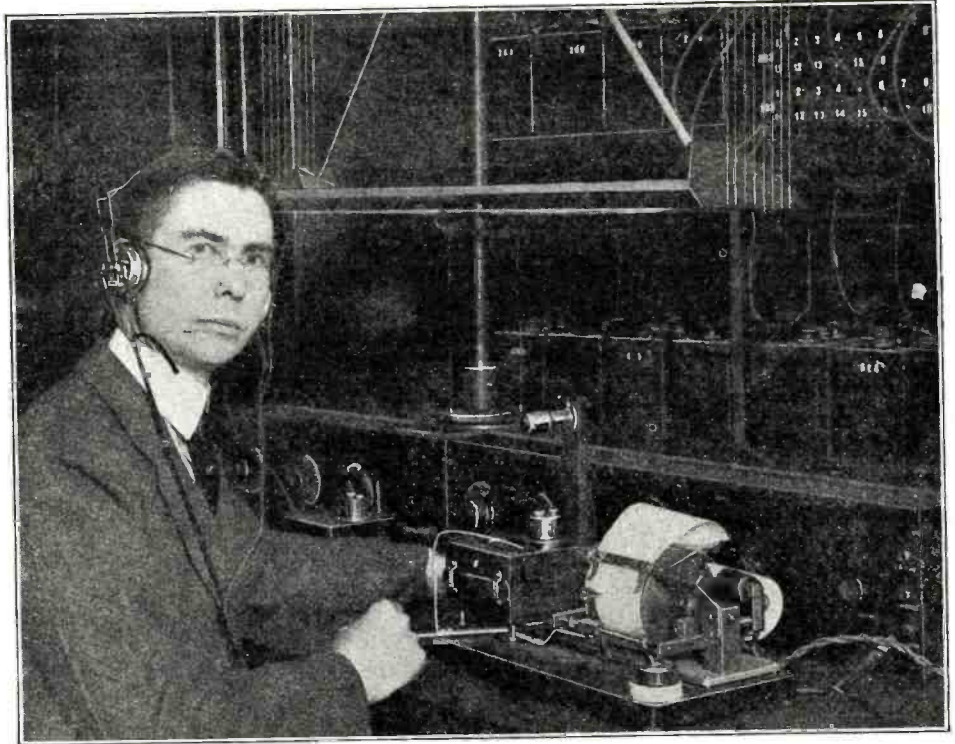

Another view of the special apparatus designed particularly for recording the effects of the eclipse, used by Mr. Parkinson at the Bureau of Standards in Washington, D. C. © United.

the eclipse, was about the same as it would be in full daylight. During the period of totality it was noticed that the static, which was present before this period, was lessened to a great extent.

Observations on the 75-meter wave during the five days when readings were taken showed that over the distance of 160 miles between Schenectady and New York, this wave had very marked swinging every day, and became weaker toward the middle of the day, although it never disappeared for more than a second or two, except during the eclipse period. During the entire period of partial and total eclipse, this wave disappeared altogether. In other words, this short wave is very sensitive to the sunlight conditions on the path over which it travels and even the partial darkness of the eclipse was apparently sufficient to prevent it from traveling between the transmitting and receiving stations. It

was heard loudly before and after the eclipse period.

**CONCLUSIONS**

So far as any general conclusions can be given at this time, it may be said that for transmission over this distance, the normal broadcasting waves are not affected in their average strength by the eclipse, but the swinging was somewhat reduced during the period, thus steadying the wave. The short wave of 75 meters was greatly reduced in intensity during the eclipse; these waves are much more sensitive to changes in illumination of their path than are the longer, normal broadcasting waves. The choice of wave-lengths between 220 and 550 meters for broadcasting appears to be a fortunate one and these waves seem on the whole to be the most acceptable for broadcasting purposes. Broadcast listeners need not, therefore, be concerned about any more desirable range of wave-lengths being found for broadcasting than those which their receivers can now tune for, at least so far as the eclipse experiments indicate.

*(Continued on page 1952)*

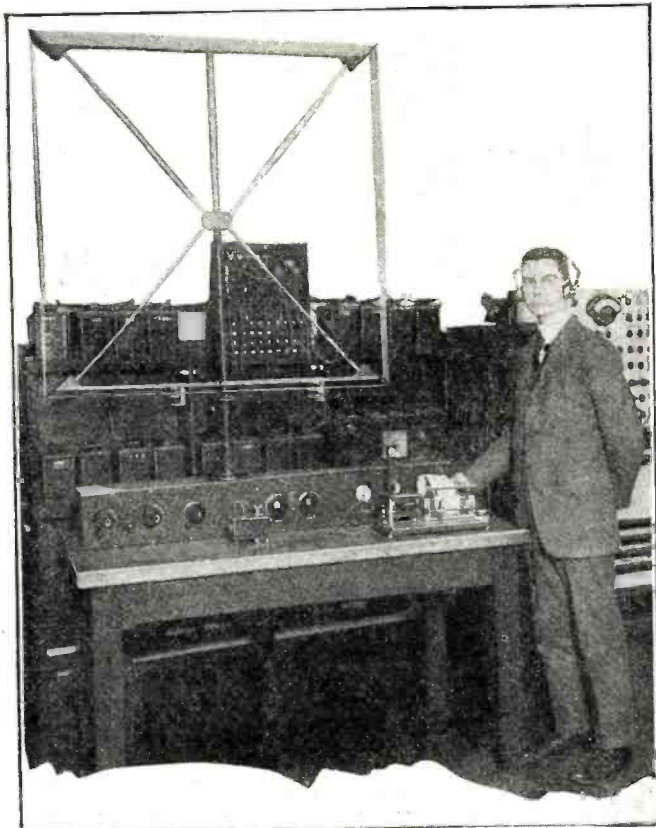

Mr. T. Parkinson, of the Bureau of Standards, and the apparatus he used in recording reception conditions during the eclipse. The recorder is the same type as that described and illustrated on the previous page. © Henry Miller News Pictures Service, Inc.

Right: A double exposure, showing the partial and total eclipse of the sun. In the foreground is a U. S. Signal Corps truck from which the eclipse reports were broadcast. © Keystone View Co.





# A University Radio Laboratory

By JOSEPH H. WRIGHT



*In the forefront of the experimental field is a group of workers at the University of Illinois. They are well organized and are bringing forth some surprising results. The present article tells of them.*

**W**HILE the large manufacturers of electrical, and especially radio, equipment are spending millions of dollars yearly in research work which has, is, and will cause radio to progress with almost unbelievable rapidity, some of the leading universities which have made great reputations in the research work they have carried on along other lines in years past and which are equipped to carry on investigations along radio lines, are working night and day to add their share to this progressive tendency in the radio field which seems to know no limit.

One of these institutions, which is already known from coast to coast for its other research and has been discussed a great deal within the past year because of its achievement in the radio field, is the University of Illinois. With expensive, necessary and oft-times original equipment to carry through problems which the faculty thought needed immediate solution, this great down-state university in Illinois is not only peculiarly fitted to carry on important work, but has already achieved success to a more or less large degree.

### INSTRUCTION AS WELL

Not only is this institution conducting research along several lines akin to radio, but it is instructing some of its seniors taking the electrical course, in the why's and wherefore's of radio.

One outstanding offering which this institution has brought to light, and another which seems to be just in the offing, might be mentioned.

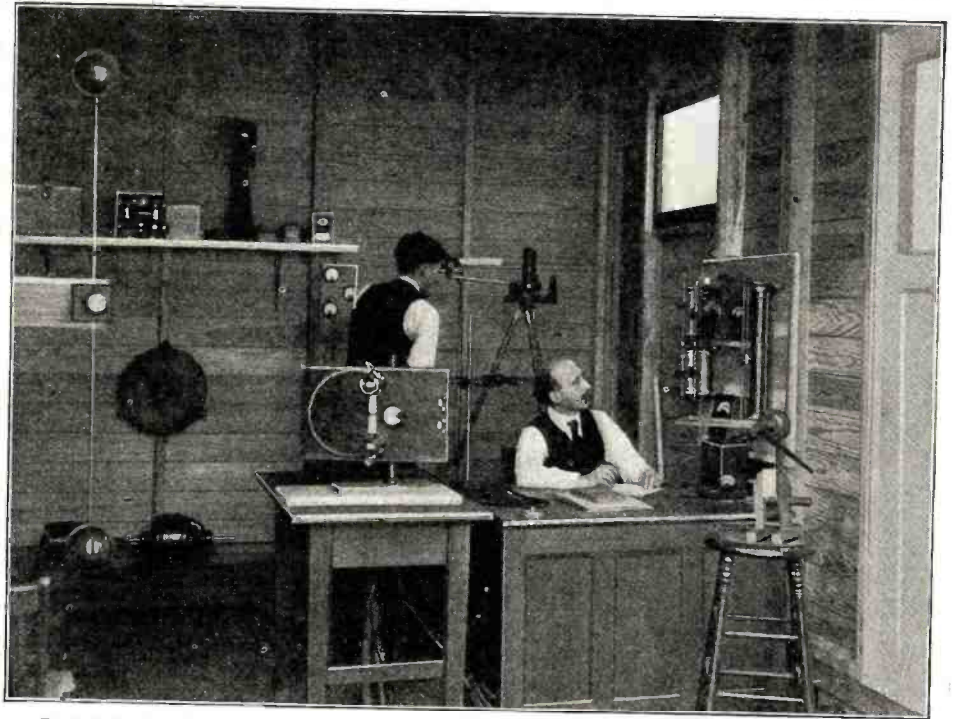

Prof. Tykociner is one of the important figures in the radio work of the university. He is shown in his laboratory above. An assistant is with him.

Success of the non-carrier wave system of broadcasting which was developed by H. A. Brown and C. A. Keener, members of the

electrical engineering staff of the university, has just been announced as positive after another series of tests which bore out the results of previous tests.

The elimination of fading is an added feature of the new broadcasting system which seems possible. In the last series of tests, instruments which accurately measured the curve of audibility of both the carrier wave system and the new non-carrier system were set up a distance of 100 miles from Station WRM, the University's radiophone, with which the experimental work is carried on. These instruments showed the usual fading when the old system was used, but did not vary a particle when the non-carrier system was employed. However, this advantage is not yet being claimed because it has not been subjected to enough tests to make it a fact.

Previous advantages which were claimed for the system and which the final tests show as outstanding over the system now in general use include increased sending efficiency, more selective tuning at the receiver with greater possibility to tune out local stations, opportunity to cover greater distances, and the elimination of all sorts of sounds which are impressed on the carrier wave and which only perfect modulation at the transmitting end and perfect detection at the receiver can eliminate.

The suppressed carrier or non-carrier system differs from the present type of broadcasting in that the carrier waves go out only when a note is sounded or a syllable spoken. Between notes or spoken words, the carrier wave does not go through the air. That is, the sound and the wave on which it rides leave the broadcasting apparatus simultaneously. This interval of time between sounds when there is no carrier wave in the air makes possible the advantages noted.

### A NEW TUBE

A new type of electron detector tube which at 10 volts is from three to five times as sensitive as the same tube of the gas content



The great interest in radio, manifested by the students of the university, is obvious from the view at the left, which shows a group of seniors in the radio telegraphy and engineering course.

Right: Prof. C. T. Knipp (left) and H. A. Brown working with their vacuum tube, which is told of in the accompanying article. The photograph was taken in one of the college laboratories.

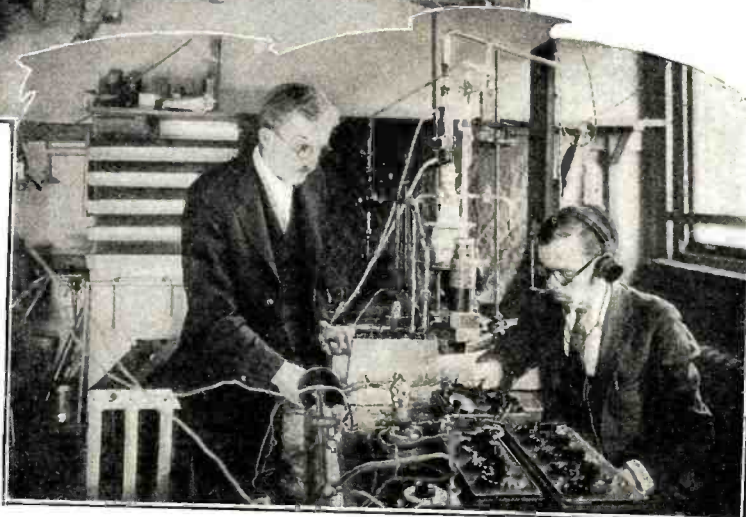



detector type, was perfected in the laboratories of this university more than a year ago. It is the accomplishments of Dr. C. T. Knipp, of the department of physics, and H. A. Brown, of the department of electrical engineering. These men are now at work improving this tube, the present work being an attempt to produce better dry cell tubes and alternating current filament tubes.

It is found that these tubes are sensitive detectors at any plate voltage from zero to 30 or 40 volts. At 10 volts they are most sensitive, and at this voltage they are three to five times as sensitive as the same type of tube used as a gas content detector.

The new type of electron detector is more efficient than the conventional type, and as it does not require so high a plate voltage on filament temperature, will be more economical.

Certain alloys or rare elements are introduced into a three-element electron tube. The vapor thus formed inside the glass walls causes the tube to function as a photoelectric cell.

Two other worth while projects have just been started. South of the famous Illinois Memorial Stadium there have been erected four garage-like buildings. These are isolated field laboratories where Prof. J. T. Tykociner, another of the University's research experts, is conducting a series of investigations into the field of ultra short wave-lengths. Each of the little buildings is a laboratory and each has its own mission to fulfill in the tests being carried on.

Mr. Brown, one of the originators of the new detector tube, during the past summer carried on some experiments which show that the problem of static is one which can be partially solved by the use of the proper type of receiver. This type is the combined one-stage radio frequency amplification and

At the right is a view of one corner of the University of Illinois' vacuum tube laboratory. A glance at the apparatus will show how completely the university is equipped to carry on investigations in this field.

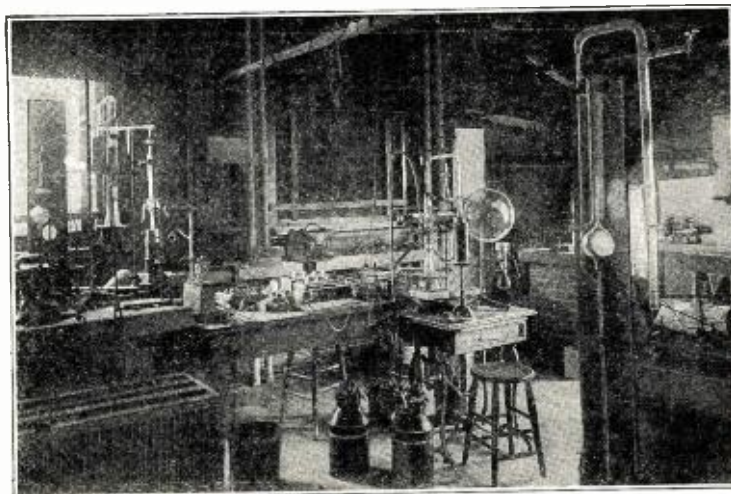

regenerative detector. Repeated comparison tests showed the signal-to-static ratio to be higher in this type of receiver than in any of the complicated multi-tube sets. This same conclusion was first arrived at theoretically and checked by experiments later.

The electrical engineering department gives a classroom and laboratory course in the theory and engineering of radio communication to seniors. Those who are taking the Signal Corps R. O. T. C. work are required to take the course in radio communication, and other seniors may elect the course as a technical elective. The equipment of the radio laboratory includes standards of the well-known constants of radio frequency circuits, and radio frequency measuring instruments such as thermo-galvanometers, precision wavemeters, precision variable condensers, calibrated variable condensers and

voltmeters, vacuum tube oscillators, power absorbing high frequency resistances, phantom antennae, etc.

#### COURSE OF STUDY

The laboratory work includes the more important radio measurements such as are necessary in radio engineering work. Among these are the measurements of high frequency resistances of coils and antennae, high frequency measurements of condenser capacity and phase differences, inductance and logarithmic decrement. Among the important vacuum tube measurement experiments are measurements of amplifier constants, mutual conductance, plate resistance, vacuum tube characteristics, detection coefficients, and power tube efficiencies. Also a few experiments on reception and radiation faults.

(Continued on page 2006)

## Commerce Department Shifting Wave-Lengths

WHAT Secretary Hoover and his radio force is trying to do with the wave-lengths in the broadcast field seems to be a mystery to many fans, despite considerable comment in the press each day. Briefly, he is trying to improve conditions in the broadcasting traffic, and has put every available channel in use.

When the Third National Radio Conference met in Washington last October, a plan for the re-allocation of wave-lengths in the whole field of radio transmission was proposed, chiefly in an effort to reduce interference and to create more channels for the growing broadcasting service. At that time there were 519 broadcast stations of three classes. They included 57 Class B, or higher powered stations; 78 Class A, and 382 Class C stations, the last stations on the original broadcast wave of 360 meters. Many more stations were contemplating transferring to Class B status, but wave-lengths were getting very scarce in that group, where each station desired and expected an individual and exclusive air route.

#### CONDITIONS

Developments in the past year had shown that many stations were reaching a position in type of programs, territory covered and reliability of equipment, which made it desirable to grant them exclusive wave-lengths and more power in the interest of high-class programs and public service. This was done gradually and 57 B stations were on the air when the conference met, besides which about 20 more had applied or were preparing to ask for Class B status. After considerable deliberation, the conference laid out a plan for allocation which would provide 47 separate channels for distribution among

the Class B stations, some few of which it was realized would have to use the same wave-length. Distance and time, it was believed, would make this practicable. But the Class B applications began to increase, and when the field representatives of the department tried to argue with the owners of high powered stations to split time and shift their channels, difficulties increased materially. The original conference plan had to be abandoned. It proved impracticable, although it was interesting on paper.

The radio experts of the Department of Commerce have tried out several other plans for increasing the number of channels in the band allotted to the B stations, but to date they have arrived at no practical scheme which insures a satisfactory arrangement between the broadcasters and the fans.

They have eliminated the old Class C stations which have carried on on the 360-meter wave, or practically so, only about a dozen remain. The others have either transferred to Classes A or B, or dropped out. No more Class C stations are being licensed. This leaves only two classes of broadcasters, except for two stations carrying on experiments under what is termed Class D, or development licenses.

To qualify as a Class B station special requirements are necessary. Studio arrangements to eliminate reverberations must be made; equipment must be such as to prevent harmonics; a special antenna must be erected so as to prevent swinging, and reliable equipment, with spare parts, must be used. These stations are granted power between 500 and 1,000 watts and, in a few cases, as high as 1,500 or 2,000 watts. They operate on wave-lengths between 280 meters and 545 meters. High-class programs are

required, which precludes the transmission of mechanical music, such as phonograph records.

#### CLASS A STATIONS

Class A stations are those operating with 500 watts power or less. They are assigned channels between 205 and 278 meters. There are 450 of these stations on the air. Supervisors of radio have pretty well settled the wave allocations of all these stations in their districts, but the wave-lengths are practically all repeated in each of the nine districts, except along the borderlands between them.

The real problem before the Department of Commerce concerns redistributing the Class B wave-lengths without making the interference worse than it is today. On January 17 there were 73 of these stations in operation and 20 more contemplated. In other words, there are approximately 47 wave channels, 10 kilocycles apart, for the use of 93 stations. Obviously, each station cannot have a separate wave-length.

Some changes have been made temporarily, but no definite list of permanent wave-lengths has been announced.

There are only three methods which the Chief Supervisor of radio can follow in his effort to untangle the national broadcasting situation: He can squeeze the stations closer together, that is, decrease the separation from 10 kilocycles on a graduated scale down to about seven kilocycles; he can make all stations divide time on the same wave-length, or he can duplicate wave-lengths in a sort of zoning system across the country. The question is, which is the best of these schemes? Increased power for seven of the broadcasters is causing further complications,

(Continued on page 1991)



# The Grid As Traffic Regulator

By SIR OLIVER LODGE, D.Sc., L.L.D., F.R.S.

The importance of the grid control electrode in the vacuum tube is explained by Sir Oliver in this article with his usual lucid method.



**S**UPPOSE you have acquired a new three-tube set, consisting of No. 1 tube, a radio frequency amplifier, No. 2 tube, a rectifier or detector, No. 3 tube, an audio frequency amplifier. And suppose, as sometimes happens, you find a difficulty in obtaining any but a very feeble result, or even, perhaps, no result at all, notwithstanding the fact that connections have all been properly made, all joints and contacts good and firm, the plus and minus properly attended to, the whole "B" battery fully connected up, and all the filaments glowing with adequate but not excessive brightness. You may then, perhaps, try whether you cannot get a signal by turning the rheostat or regulator of the No. 1 tube to zero, so that its filament is dark and it is no longer in action. You will then be working with only two tubes and without radio frequency amplification, and yet from neighboring stations you may now get a result. This will not always happen, but with some sets it will. Not that this is a correct way of working, but it shows where the trouble lies. For now, having obtained results with the other two tubes, if you switch on the No. 1 tube again, you will probably find that the loud speaker will become faint or silent. You ask yourself the

reason seems less attended to, and too little facility for it is generally provided. The result is distortion, if nothing worse. Too much regeneration is no remedy, but is an additional defect. Good and pure and clearly articulated reception cannot thus be obtained, though mere loud volume can.

The fact is that the plate potential may be too high or too low for the grid potential. There is a best relation between these potentials if the plate is too high, it overpowers the grid; if the plate is too low, it is overpowered by the grid.

Consider more closely what is happening. Electrons are given off by the filament as negatively charged particles, and are attracted by the positive plate. The grid stands in their way as a controller of current or regulator of traffic. The grid connected to the aerial is subject to fluctuations of potential; it may have a steady bias, but its potential is bound to fluctuate according to the received impulses. The whole reception depends on that. When a grid is negative, it drives the electrons down or prevents their rising; when a grid is positive, it helps them upward, and encourages them to shoot through to the plate beyond. It is the plate current which is ultimately utilized, and on which you are dependent for signals.

It is no use getting a strong plate current unless it is properly controlled and modified by the grid, and the grid potential must be strong enough to perform the regulation effectively. The electrons, which are the current conveyers, must be disciplined and controlled by the grid in accordance with the received fluctuations of potential, that is, in accordance with all the voice peculiarities impressed on the ether waves by the sending microphone and the transmitting apparatus. The plate may be so strong as to haul up all the electrons in spite of the efforts of the grid to keep them down. That is a common danger, especially with No. 1 tube. On the other hand, the grid may be so strong as not only to repel electrons when it is of negative sign, but to attract them so strongly when it is of positive sign that none or hardly any are able to escape its clutches. There are thus two opposite or alternative dangers, and the potentials must be adjusted so as to avoid them both.

It is manifest that the grids of the series of tubes are inevitably of different strengths, accordingly the plate should be of a different strength, too. No. 1 tube receives the aerial fluctuations not amplified, and from a distant station they may be very weak. Grid No. 2 receives amplified fluctuations, and in No. 3 they are amplified still more.

### CASE OF GRID TOO STRONG

The grid potential in the audio frequency amplifying tubes may be so strong as to monopolize all the electrons to itself, not allowing a sufficient number to go through to the plate; in that case, amplification will cease and the tube will actually diminish the



How the grid, when negative, actually impedes the electron stream generated by the hot filament is clearly shown in the above illustration.

current, which otherwise might have been obtained. Such a state of things is extremely unlikely in the No. 1 tube; the original oscillations in the aerial are bound to be rather feeble. They are probably insufficient to excite the grid too strongly anyhow, and a very moderate potential on the plate is sufficient to do the work. Indeed, a moderate potential is wisest, for it will then not overpower the grid. And this is the basis of the plan known as the Solodyne principle, which refrains from applying a high potential to the plate, even to the plate of the second tube. Nevertheless, the second tube can stand a greater amount of plate potential, since the grid is already receiving a magnified impulse. If we use the third tube, a high potential to the plate becomes necessary. Without high potential you cannot expect the third tube to amplify.

### PLATE POTENTIAL TOO STRONG

So far, we have mainly considered the case of bias on the grid too strong for the plate, it not so much regulates the traffic as stops it, absorbing too much of it into itself. But now take the converse case,—the more usual case when a "B" battery is employed,—that is, when the plate potential is too great for the grid. The electrons given off from the filament are now rushed up violently to the plate and the grid placed between them, in order to regulate the traffic, now stands helpless like a policeman standing in the middle of the New York Central Railway trying to regulate the Twentieth Century Limited. The speeds to be dealt with are beyond the grid's control. There is plenty of current, but it is steady, paying no adequate attention to the fluctuations of the grid, and therefore paying no adequate attention to the received impulses. Everything is in working order, but the tube is out of action and the grid is no longer a regulator or controller of traffic. The remedy obviously is to weaken

(Continued on page 1976)



The grid as a great radio traffic cop is a more or less new conception. But it is exactly the function of that small member.

reason for this, and conclude that the "B" battery is too strong for that tube. Variable taps are probably provided, and by moving the connection which feeds the No. 1 tube down a long way, to lower posts on the "B" battery, so as to apply a much lower potential to its plate, you may be able to get it into helpful action and after that you can proceed as usual.

### CONCERNING TUBES

Some tubes seem able to work in spite of harsh treatment, but it cannot be well to depend on that or to overstrain their capabilities. Everybody knows that the filament current must be adjusted neither too strong nor too weak, but regulation of plate poten-

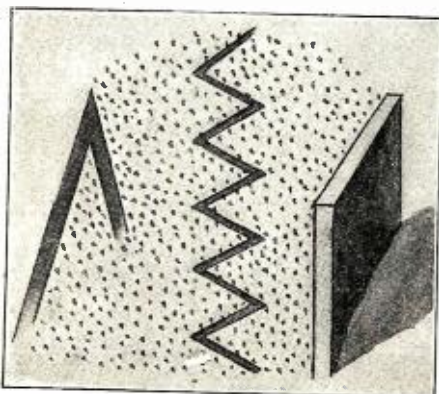

One point which many experimenters fail to hold in sufficient importance is the bias placed on the grid—the difference of potential between it and the negative end of the filament. A graphic analogy of it is given at the right. An illustration of the electron flow between the plate and the filament when it is not affected by the grid is given at the left.

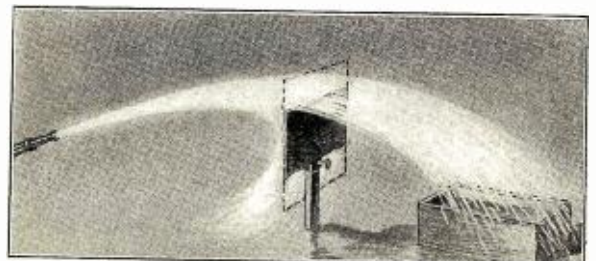



# The Inventions of Reginald A. Fessenden

## PART IV.

IF these articles are to be of use to men who are considering taking up invention, it will make some of the later articles more easy to follow if I give here the actual process of making an invention, illustrating it by the development proposed at the close of the previous article, *i. e.*, the invention of apparatus by which writing may be directly talked and read.

### UNDISCOVERED INVENTORS

The most important problem before business of today is that of obtaining inventors for its industries; and some of the corporations are beginning to realize this. Forty years ago, in the farming country where I lived, a farmer would hire a hand because he was a good milker, a good dividend producer so to speak. Or one who could obtain customers; a man of good personality; a good advertiser. When the milk production fell off economies were introduced and the farmers combined to raise the price of milk. Then there were more economies. Finally,

**T**HIS installment of Professor Fessenden should be of particular interest to those interested in the various phases of invention. It gives a most excellent illustration of how a great inventor's mind works when he sets about inventing a particular device. In the present case, Dr. Fessenden asks himself if it is possible to invent a machine or instrument whereby a message can be spoken directly onto a piece of paper, instead of first writing it down by hand or by typewriter. That such a machine would be a great boon to humanity cannot be doubted.

The inventor shows how he attacks the problem from various points, and what his mental processes are in trying to arrive at a solution. It all makes excellent reading.

EDITOR.

someone realized that it was a good deal more important to get cows which would give 400 quarts to the old breed's 100 than it was to cut the hay half an inch closer to the ground or to try and take away the other man's customers.

Business is about to learn this, too, that combination and personality are merely palliative. They shift, temporarily, but they do not produce. I was told recently of a great public utility company which, in answer to a question, said that it did not attach any importance to engineering qualifications in its employes, what they looked for was personality. If the man was a good engineer, so much the better, but personality was what they looked for, the engineering they considered a by-product. A few days previously I had passed by a place where the mains were being opened up and had noted that they were exactly the same as those laid down 40 years ago and that though, thanks to developments made by workers in another field, steam engineering, the utility company could now get more than 10 times the electric energy delivered at the bus bar per pound of coal than it could 40 years ago (30 per cent. in place of 3 per cent.), the price I was paying was just the same as then—12 cents a kilowatt hour. Less per-

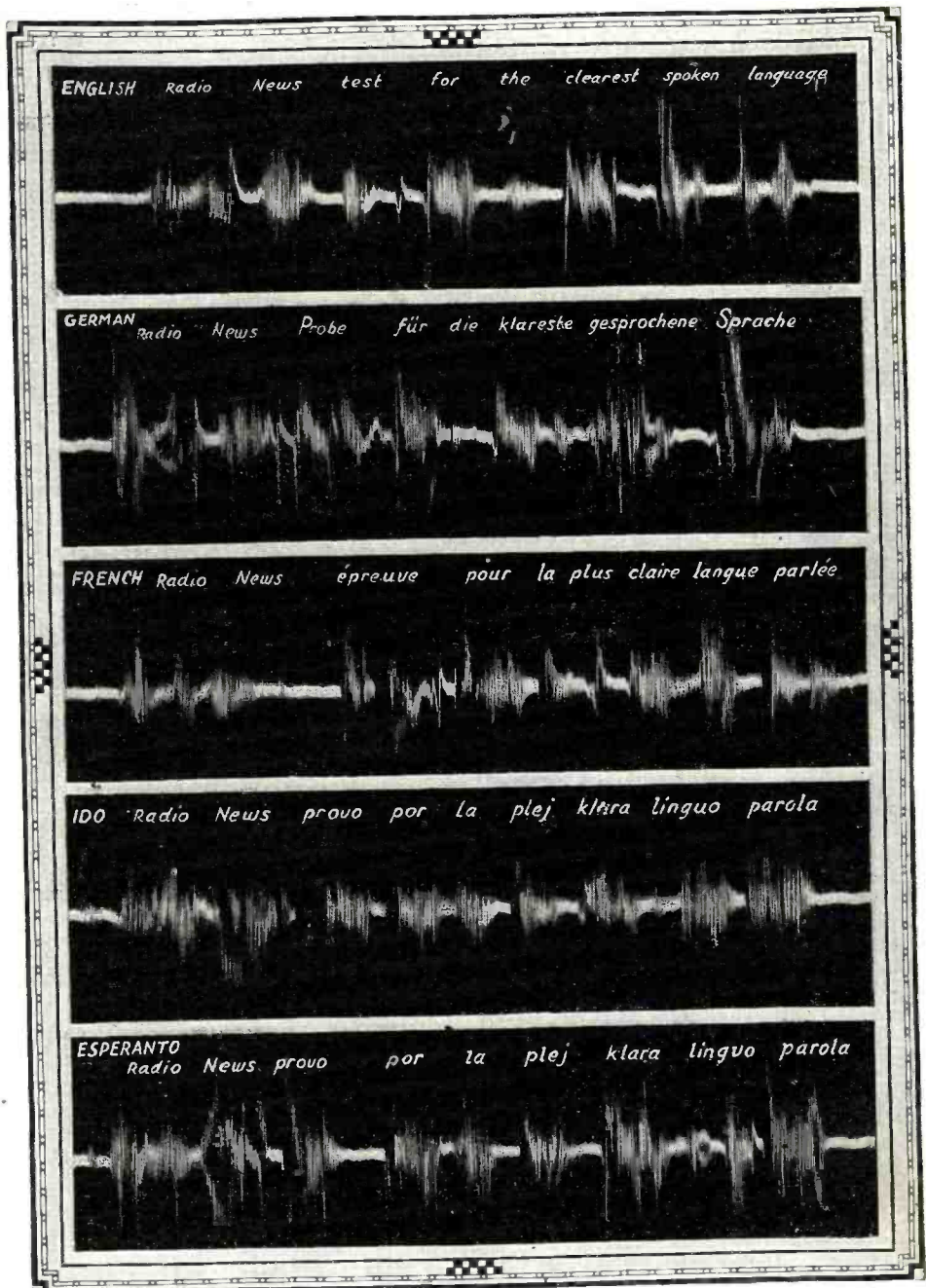

Actual oscillograph records showing the peculiarities of word sounds in five languages. It is possible that by means of an apparatus tracing the envelopes of these curves, a record of speech can be produced which will be readily legible to the trained eye. The slight distinction between the various records of "Radio News" is due to their having been pronounced with the accents of the various languages.

sonality and more engineering would have developed an up-to-date distribution system, given consumers one-half cent electricity and electric heating, with greater profits to the utility company. Personality is only of use where the buyer is incompetent, and only for competitive purposes; it does not produce.

Nor does combination produce. It does not even eliminate competition, merely transferring it from the unit to the group industry. A great watch company builds the best watch and buys the best machinery it knows how. It does not understand that a business cannot be conserved; it must grow or die. Instead of developing watch springs which do not change their elasticity and pendulums which do not change their length

with temperature, and oven and furnace time regulators and new types of timepieces, it waits till some company builds a new product and then it economizes. Then it buys out its competitor and raises prices. Then it combines again. Finally, when there is no longer any competition in the watch trade it finds itself up against group competition, with other groups of industries. It has failed to keep up the interest in and importance of time keeping mechanism and people are buying jewelry or pencils. The benefit has been only temporary, and we have the painful spectacle of a number of gentlemen of fine personality peppily engaged in trying to lift themselves by their boot-straps but merely achieving the flattening down in value of the dollar.



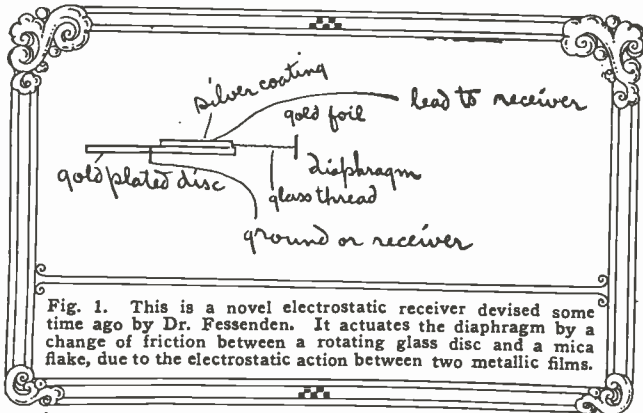

Fig. 1. This is a novel electrostatic receiver devised some time ago by Dr. Fessenden. It actuates the diaphragm by a change of friction between a rotating glass disc and a mica flake, due to the electrostatic action between two metallic films.

**CO-OPERATION BETWEEN INDUSTRIES AND INVENTORS**

Here is where the inventor can be of use to the industries, in providing better breeds of cows to milk, but the industries must go out and find them, on the outside. There is no use in discussing here the reasons why corporations do not develop or adopt inventions till forced by competition. All we are concerned with now is the fact that they do not, and that there is no known instance where they have. My first article contained a list of some dozens of instances, but these were merely samples. For instance, the most important of recent inventions which occur to me at the moment are Flettner's windmill and rotary sail; DeForest's talking pictures; Pickard's inductor compass; Jenkin's disc prism. The first was not invented by a shipping corporation; the second was not invented by a moving picture or a phonograph corporation; the third was not invented by an airplane corporation; the fourth was not invented by an optical company.

So the next point to take up is, "Where can the industries get the necessary supply of inventors?" We cannot neglect this if we are to continue to go forward, for though, to change our simile, the inventor is only one part of the machine, yet it is the inventor who puts civilizations on wheels.

**HOW MANY INVENTORS HAVE WE?**

If the results of our very rough and incomplete study of the influence of heredity are correct, and we are dealing with a recessive Mendelian character, we might expect to find about 10 per cent. of the original population of the New England states and about 4 per cent. of the present population of the United States possessing this characteristic. It is perhaps fortunate that there are probably not so many. Still, we may, I think, feel sure that there are a sufficient number of undiscovered inventors to supply our industries, if they can be located, and if they are given proper opportunity to exercise their ability.

**DISTINCTION BETWEEN RESEARCH, DREAMING AND INVENTION**

These three groups are very generally confused with each other, but they could hardly be more distinct than they actually are.

The dreamer and the inventor are confused because they both are apt to omit discussion of details. But their reasons for doing this are exactly opposite. The dreamer does so because he is ignorant of them or does not appreciate their importance. He has merely the idea that he would like to do something, but does not know how. The inventor does so because he is and has to be, or to become, a complete master of detail to such an extent that when he has the fundamentals of the problem solved he does not care whether he can or cannot do what he wants in one particular way; if he cannot do it in that way, his knowledge of detail is so complete that he can merely turn around and do it some other way.

The research man and the inventor are confused because they both examine the results of physical or chemical operations. But they are exact opposites, mirror images one of the other, positive and negative. The research man does something, and does not care what it is that happens, he measures it, whatever it is. The inventor wants something to happen, but he does not care how it happens or what it is that happens, if it is not what

he wants. The research man will sometimes make an invention, but it will be really a discovery. The inventor will sometimes conduct a research, but it will be only a step toward an invention.

The best way to tell whether one is interested really in invention, or in research, or in merely dreaming, is to follow through some simple example of the making of an invention, e.g., the one indicated above, the problem referred to in the previous article of inventing apparatus by means of which writing may be directly talked and read. As follows:

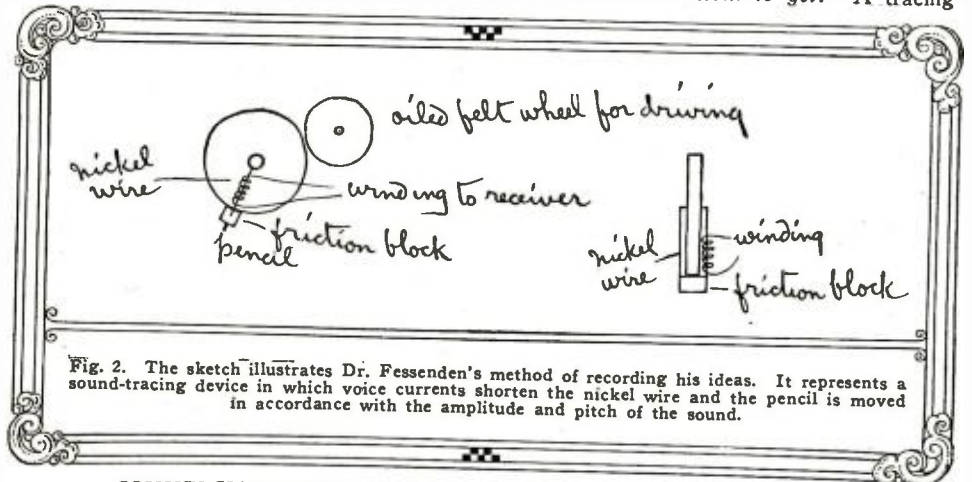

Fig. 2. The sketch illustrates Dr. Fessenden's method of recording his ideas. It represents a sound-tracing device in which voice currents shorten the nickel wire and the pencil is moved in accordance with the amplitude and pitch of the sound.

**COMMERCIAL VALUE**

The first thing to ask is, "Will the thing be any good if I get it?" This is not always easy to answer. Once, when I was working for Edison, he had me look through a lot of old records in connection with some patent matter. I came across the minutes of a meeting of eight of the ablest business men in New York City, about 1883 or thereabouts, who met to consider whether they would buy the rights to the Bell Telephone or the rights to the Printing Telegraph. Both had worked perfectly and both were offered at the same price, \$300,000, as I remember it. They finally decided unanimously to buy the Printing Telegraph, the recorded reason being that:

1. Either system would be mainly used in cities and for business transactions.

2. The Printing Telegraph made a record of the transaction and conversation; the Bell Telephone did not.

So the best judgment is sometimes at fault. But I have found one good rule is to ask this question, "If the thing were done now in the way I want to do it, and someone came along with the present means of doing it, what arguments would he have in his favor?" Answering this question, if I could talk this article onto a piece of paper after dinner and mail it to the editor, after correcting it with a pen, I should not like to go back to the present method. And there would be other advantages, recording radio speeches direct, music, etc.

Another pretty safe guide is the history

of the art and the tendency shown. After making some tests for the Signal Corps in 1901, it was admitted that the speed and distance reached were much beyond what had been previously obtained, but I was informed that it was absolutely essential that the messages should be recorded. I said, "General, every telegraph system has started out as a recording one and every one has ended up as a sound-read one, except the cable, where they cannot do it yet." So, though I had a recorder I declined to submit one. A year or so later there was no difficulty in selling sound reception apparatus. In the present case the tendency would seem to be along the line of the proposed development.

**IS IT PRACTICABLE?**

Next is the matter of practicability. We must ask these questions:

1. *Can such a trace be read*, especially when the tracings take up no more length than the present printed lines and the individual waves are not shown, but merely the different shaped humps. This required some experiment but the final result was that the tracings could be read and with as much or greater ease than many languages in use, and apparently with practice might be more easily read than the present system.

**LAYOUT OF PROBLEM**

1. *What do we want to get?* A tracing

of the waves, about the same length per word, if possible, as if it were printed. It must be direct on paper, without photographing, developing or the like. The paper must be of some cheap and common kind preferably.

2. *What is the record to be made in?* Ink might be used, with a fountain pen or syphon, as in the syphon recorder. But a fountain pen is heavy and a syphon too deli-

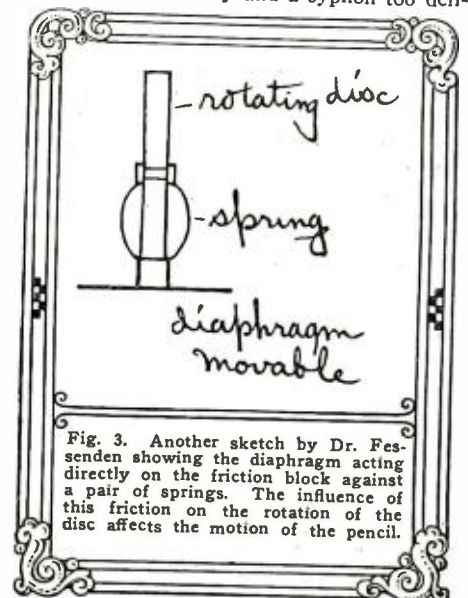
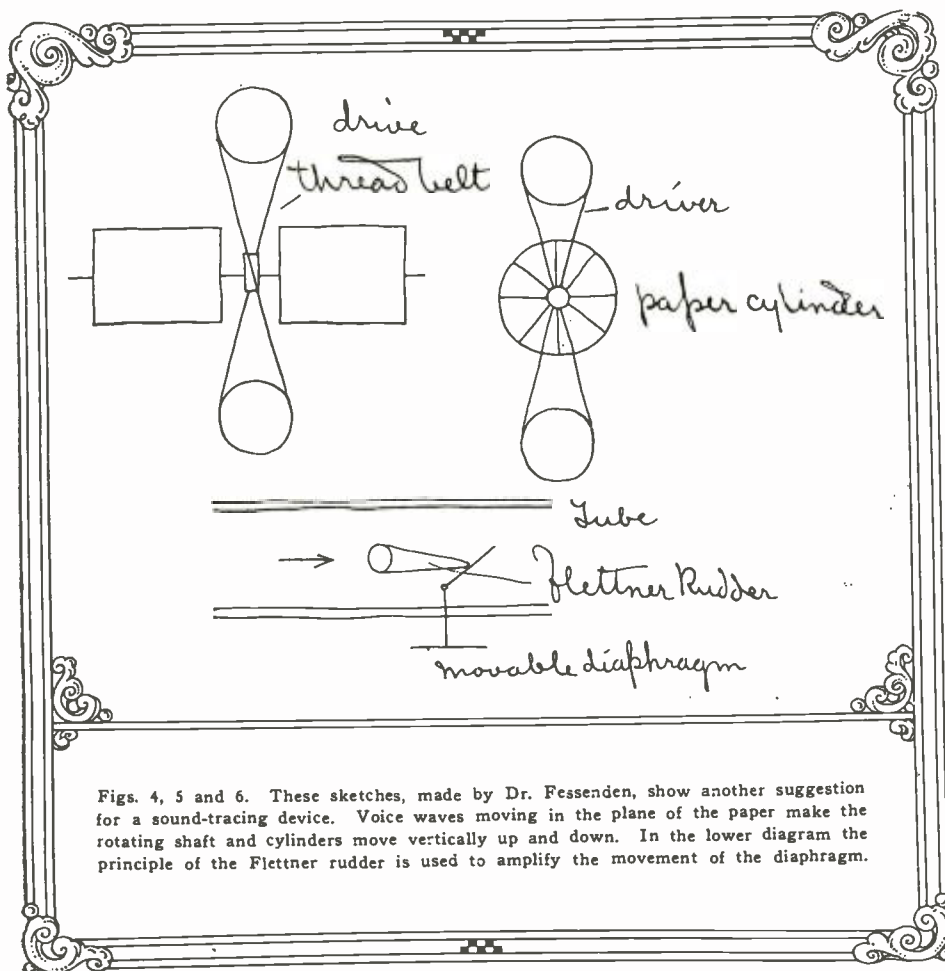

Fig. 3. Another sketch by Dr. Fessenden showing the diaphragm acting directly on the friction block against a pair of springs. The influence of this friction on the rotation of the disc affects the motion of the pencil.





Figs. 4, 5 and 6. These sketches, made by Dr. Fessenden, show another suggestion for a sound-tracing device. Voice waves moving in the plane of the paper make the rotating shaft and cylinders move vertically up and down. In the lower diagram the principle of the Flettner rudder is used to amplify the movement of the diaphragm.

cate for practical use. Besides, as Edison once said about a primary battery, "The blanked thing is wet." It would seem that some kind of lead pencil should be used, but small diameter, like the leads in the metallic pencils now on the market, so as to show the humps in the traces as clearly as possible.

Note.—When time comes, make tests to determine what kind of paper takes fine pencil marks most distinctly and smoothly. Also best material for lead of pencil.

3. *Is there energy enough for this direct, or do we need amplification?* (a) Make test by talking just about as loudly as one would want to talk when dictating, and have someone go away, at night when things are quiet, till they can just hear words. Then figure out, from Rayleigh's data for just audible sound energy, how much energy is available. (b) Dictate as before into standard microphone, and measure energy of currents modulated by voice, using transformer so as not to include anything but voice currents. Do this for different vowels and consonants. Measure ratio of different letters compared with each other, in same sentence.

Note.—"o," for example, has nearly 100 times the energy that "s" has.

4. *Measure energy necessary to make trace.* Make a little balance arm, fasten a piece of the lead pencil to one arm; fasten a piece of paper to a six-inch cylinder and rotate, lead pencil resting on paper; but balance arm should be balanced so there is no pressure. Add little weights to the lead pencil carrying arm till, with paper moving at about correct speed to give right length of words, the trace is sufficiently legible.

Then, figuring the width of the trace as about one-eighth inch to show the various shaped humps clearly, and the frequency of the sound waves as about the highest necessary, say 1,500, calculate the work necessary. Also the inertia forces of mass of pencil, etc.

#### PARTICULAR TYPE OF APPARATUS TO BE USED DIRECT

The energy available from the voice will have come out to be small compared with the energy required for moving the pencil lead. Still, something might be done by resonance. Resonance is peculiar in this way, which has never been called attention to before. If a wave strikes a resonant antenna and generates one volt and one ampere in it, this will be only one watt. But the next wave will make the current two amperes and the voltage two volts, *i. e.*, four watts in all. In other words, if you can once get a thing resonating, it *picks up* energy better each time. Of course if the energy available is too small, nothing can be done, but as in the present case the energy is not far off it might be possible to make the pencil lead respond to each one of a number of tuned reeds which were sufficiently close to each other's pitch to cover the voice frequencies desired.

Mark to be set aside for tests later.

#### MAGNETOSTRICTION

Pure nickel wire changes its length when magnetized; about one-millionth of its length for moderate magnetizing forces. If we take a piece of No. 18 pure nickel wire, about 18 inches long, and wind the middle 15 inches with enameled wire so that the total turns have a suitable resistance to use with the amplifier used, the nickel wire being rather loose inside the winding so that it can contract and expand, then on touching it to a sounding board, the board will talk. Or, holding one end between the back teeth in the same manner as Mr. H. Gernsback's well-known Osophone, the broadcast can be heard; and it can be made up to form a rather inconspicuous listening apparatus for deaf people.

Can we get sufficient motion? That depends on the length used. Obviously, the pulsation must travel out and back from the middle four times each wave. Sound travels in nickel approximately 20,000 feet

per second. For a note of 1,500 frequency the half length must not be more than three feet eight inches, or a total length of wire of about seven feet. One-millionth of this is only 1/10,000 inch, so the motion of the pencil point must be amplified more than 1,000 times to get the desired width of trace. This is not impossible, but such big amplifications of motion by leverage are not very mechanical as a rule.

#### CHANGE OF FRICTION BY MAGNETOSTRICTION

This reminds me that once before I made a very good receiver and telephone by letting a very thin flake of mica, silvered on one side, trail on a gold-plated disc, on its unsilvered side, so that when the flake was charged, the silver coating being one coating and the gold-plated rotating disc the other, the friction changed and, therefore, the drag on a diaphragm to which the mica flake was attached by two very fine glass threads, with a little strip of gold foil to make connection from receiver to silver coating, Fig. 1.

So why not change the friction by changing the length of the nickel wire? Fig. 2.

This time we have something that works for a ten-thousandth of an inch means a big change in friction, and since the energy is furnished by the rotating disc or cylinder, we may use 10 or more wires and so get 1,000-inch change in length, and if we run the wires parallel and close together we can use a single coil for all. We make the wires smaller than No. 18 now because the magnetism does not penetrate into iron very deeply when the frequency is high, not more than 22 or even less. In fact for perfect penetration the wire should be *very* fine, how fine can be calculated from formulae first given by Rayleigh.

Since the pencil has to move one-eighth inch in 1/1,000 second, the speed of rotation of the disc must be 1,000/8 inches or about seven miles an hour, which is a quite slow speed and we can run the apparatus by hand.

We put this aside as one of the forms to be taken up as workable.

#### DIRECT CHANGE OF FRICTION

This suggests, "Why not change the friction direct?" And as there is no reason why not, we get a device shown in Fig. 3. Which we also set aside as, so far, the thing to be tested out first; noting that some form of link motion or internally curved surface may be used to prevent variation of pressure when the pencil point moves.

#### MAGNUS EFFECT AND FLETTNER RUDDER EFFECT

Two small paper rotating cylinders should rise when spoken to if made as shown in Figs. 4 and 5. The speed of the cylinders should be high, at least half a mile a minute, and the centrifugal force will make the thin

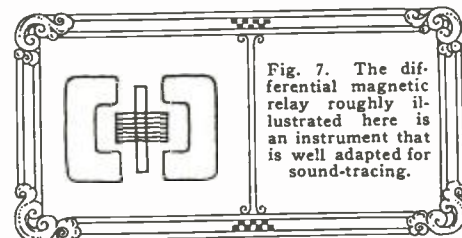

Fig. 7. The differential magnetic relay roughly illustrated here is an instrument that is well adapted for sound-tracing.

paper act as if very stiff. So also, by making the voice move the pilot edge of a Flettner rudder placed in a tube carrying a rapid current of air (Fig. 6) we should get very powerful effects. But this would come pretty near trespassing in another inventor's field, though I do not know that Flettner has ever considered such uses.

#### DIFFERENTIAL MAGNETIC RELAY

This is a commonly used device, but before fastening our pencil point to it we will try and see if it can be improved. The usual form is shown in Fig. 7.

(Continued on page 1999)



# The Effect of the Atmosphere on Radio Waves

By PROF. J. M. GUINCHANT



*In this article the author presents a new theory on the propagation of radio waves through space. He contests the existence of the Heaviside layer and explains the phenomenon of fading.*



Fig. 4. The black border represents the earth and the layer of air around it. These are in the same proportion as the thickness of the atmosphere and the diameter of the earth.

**T**HE propagation of electromagnetic waves through the atmosphere produces numerous and unexplained variations in intensity and direction, and up to this time neither engineers nor mathematicians have given a satisfactory explanation of these phenomena.

At first it was very difficult to explain the reception of radio signals beyond the horizon. On account of their great length, the electromagnetic waves act like sound waves and glide around obstacles. This is known as the diffraction of the waves. But calculations show that the diffraction around the earth, considered as the obstacle, would produce a decrease in intensity much greater than it is in practice.

Then was proposed the clever theory that the radiations going away toward the sky are not lost, but reflected by some conducting layer of the upper atmosphere and projected toward the surface of the earth, producing thereby a response at the distant receiving station. According to the theory, this conducting layer would envelope the earth entirely, acting as a tremendously large shield, screening our world from outside space. This reflecting layer is known as the Heaviside layer.

## INTENSITY

The intensity and the direction of electromagnetic waves are subjected in the atmosphere to strong variations. These variations are supposed to be of an electrical nature, but so far it has not been proved that they are such, or even what causes them. Some scientists admit, for instance, the existence in the upper atmosphere of a layer, the conductivity of which is supposed to be great and permanent. In attempting to prove the existence of this (Heaviside) layer, I mention an experiment of J. J. Thompson, showing that within a tube surrounded by a high frequency circuit, the air at reduced pressure may become as good a conductor as a 25 per cent. solution of sulphuric acid. One forgets, too, as the author points out, that

this conductivity is not a specific property of the gas, but an accidental property due to the ionization produced by the strong electromagnetic field. In a gas there is no conductivity without ionization, as is easy to prove by inclosing a condenser within a vacuum. The insulation does not vary as long as the tension across the plates does not exceed about 100 volts, and it is well known that the tension produced in the upper atmosphere by radio waves reaches only a fraction of a microvolt per centimeter.

Ecclès, Fleming and Arrhenius have developed another theory to justify the existence of the conducting layer. According to this theory, the upper atmosphere is bombarded by cosmic dust having the dimension of light wave-lengths. The shock of the particles against the molecules of air produce their ionization, which renders the gas very conductive.

These theories are not sufficient to explain the phenomenon observed in the propagation of these waves, *i.e.*, the great difference between day and night reception, the variation at dawn and sunset. This can only be explained by a great modification in the Heaviside layer. During the day reception is always weaker, while the ionization produced by the sun's rays should increase the conductivity in the higher atmosphere and accordingly its reflected action. To avoid this objection one imagines that the electrons of the ultra-violet light coming from the sun ionize more the atmospheric layers which are close to the Heaviside layer and under it. These layers, becoming poor conductors, absorb the electromagnetic waves and probably act as a layer of steam upon the surface of a mirror, thus reducing the reflecting action of the Heaviside layer.

These additional theories are based upon phenomena which may be contested. First, it is true that incandescent material can emit electrons. In electric lamps with an imperfect vacuum, the remaining gases are ionized by the electrons shot from the filament, but

this emission can only be continuous if the incandescent source loses the positive charges liberated by the departure of the negative electrons at the same time. It is for this reason that in an ordinary vacuum tube the filament must be connected to the grid and to the plate. The sun being insulated in space, possesses for a long time a sufficient positive charge to return all its electrons.

Second. The ionization by the ultra-violet light is not more evident. It is known that gases are slightly ionized by certain solids when subjected to ultra-violet rays. But even supposing that these bodies exist as a powder or dust in the upper atmosphere, the conductivity which they should give the air corresponds to a degree of ionization much higher than that which we know how to produce in the laboratory.

## A DIVERGENCE

In radio communication, the Heaviside layer is exclusively used to explain the intensity of the electromagnetic field calculated, but found to be very much weaker than the values which can actually be measured. Instead of asking scientists to accept such an advanced theory, would it not be better to ask them to establish theories more precise and to eliminate the hypothesis and the simplified facts upon which they base the actual calculated values which do not check with the actual measurements?

The law of propagation can easily be deduced from an undisputed experimental fact verified in all radio telegraphic communications. No matter how far from a transmitting station, even at the Antipodes, its waves are practically perpendicular to the surface of the earth, therefore seeming to postulate that propagation is in an arc concentric to the earth. While a light ray, OL' (see illustration) sent horizontally would travel in a straight line, an electromagnetic beam, on the contrary, would curve to remain parallel to the surface of the earth; it travels as a ray of light in the neighborhood of a plane which is parallel to it.

It is, therefore, easy to understand that this property necessitates, to explain it, some laws of propagation entirely different from those light rays and electromagnetic waves. It is not necessary to use the phenomenon of the *diffraction* to explain that the waves travel around the surface of the earth and it is possible to admit, on the contrary, that the propagation takes place in the neighborhood of the ground, exactly as if the earth were flat. This observation is not new, for in 1903, the well-known French physicist, Mr. Blondel, remarked that the curvature of the earth could not hamper the propagation, since, along a conductor, the waves bend so as to follow its surface. If the earth is supposedly flat, one calculates easily the electromagnetic field produced by a distant antenna, and obtains thus the simple formula

Fig. 2. This form of mirage sometimes takes place at sea. The cold air in contact with the water changes the refracting properties of the air layers which deviate the rays toward the bottom and the eye sees the object in the direction from which the rays come. The author assumes that a similar phenomenon takes place during the propagation of radio waves.

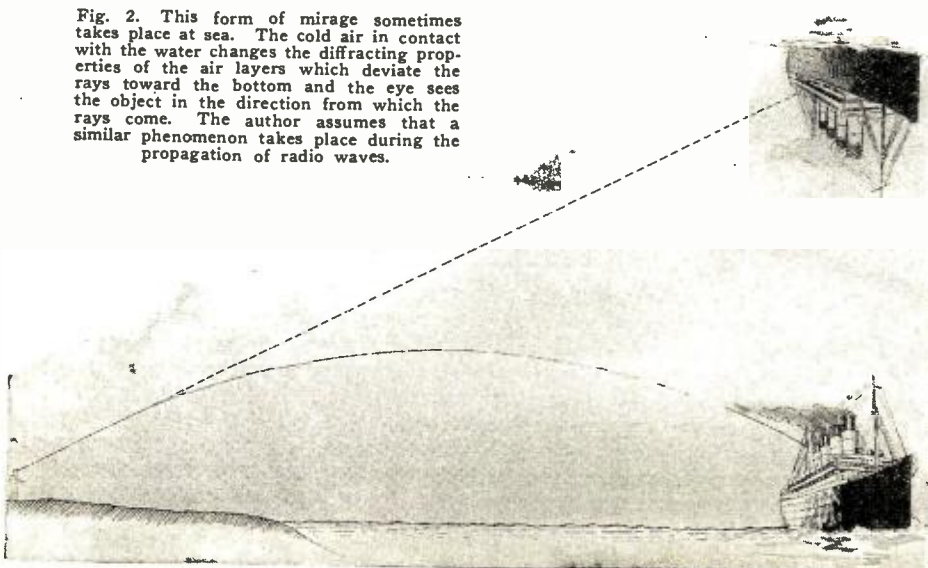



of Hertz and Blondel which furnishes practically exact values up to a distance of a few hundred miles. At great distances, the calculated values with these formulae are a little too great while the values furnished by the theories of diffraction are entirely too small. The slight difference noticed between the measurements and calculated values with the Hertz-Blondel formula can easily be accounted for, if one admits that the atmosphere is a medium of propagation not entirely ideal for electromagnetic waves.

The rôle which the air can play in the propagation of the wave has not been so far taken into consideration because the atmosphere has been considered as a homogenous medium of constant permeability equal to 1. In this algebraic form the theory seems so obvious that it is used in all the theories. This means that in the theory it is admitted that the atmosphere is for the electromagnetic waves identical to vacuum. This fact in questionable and may change the value of the theory.

As long as the air is given the electromagnetic properties of vacuum, it seems that only the electric or magnetic actions can disturb the propagation of the waves. But why eliminate as a disturbing cause this undoubted fact that the air exists?

For light waves which are physically different from electromagnetic waves only by their frequency, the atmosphere is far from acting as a medium identical to vacuum. Although the speed of propagation is almost the same through the air as through a vacuum, the light is subjected through the atmosphere to refraction, reflection and absorption producing some constant perturbations in the propagation. I shall now show that similar actions take place in the propagation of electromagnetic waves and are sufficient to explain the effect attributed to atmospheric ionization.

The atmosphere is essentially a heterogeneous medium, the temperature, the pressure and the hygrometric state may vary with the altitude, from place to place, and even from time to time. When traveling obliquely through some material layers whose physical states are different, the radiations must curve themselves and be partly reflected; this phenomena is well known in the case of light. Not only does the visibility of a light source vary much, depending upon the state of the atmosphere, but also the direction in which the distant object is seen may vary appreciably from its real direction. One of the most beautiful phenomena taking place in the atmosphere is the mirage which I shall explain hereafter.

Imagine that the atmospheric conditions produce through the air some layers, the diffracting properties of which vary regularly from one layer to the other. A light ray falling obliquely upon these surfaces is bent as if attracted toward the part where the density is greatest, more exactly, where the diffraction is greater. If the law of reduction and the thickness of the layers are of the proper value, deviation increasing progressively will bring the light ray parallel to

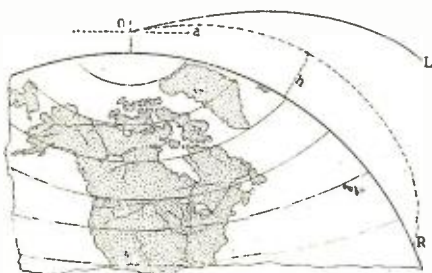

Fig. 5. Showing how a mirage may take place for radio waves. This would explain the fading and sudden re-enforcement effects observed by operators.

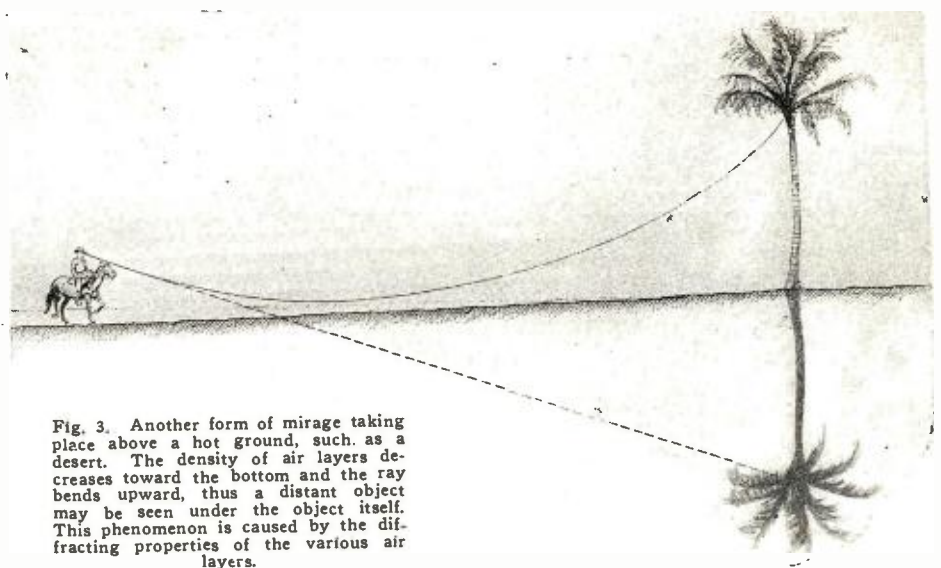

Fig. 3. Another form of mirage taking place above a hot ground, such as a desert. The density of air layers decreases toward the bottom and the ray bends upward, thus a distant object may be seen under the object itself. This phenomenon is caused by the diffracting properties of the various air layers.

the layers of air. From this point the light ray reflects and comes back toward the upper layers. That is why, during some hot days when the air is undisturbed, the picture of a distant ship appears some times above the horizon (Fig. 2). The cold air in contact with the water deviates the rays toward the bottom and the eye sees the object in the direction from which the rays come. On the contrary, above a hot ground, such as a sandy beach or desert, the density decreases toward the bottom and the ray bends upward. Thus distant objects can produce pictures which seem to be under the object itself, as shown in Fig. 3.

The blue of the sky is sometimes seen under the horizon, producing the illusion of a liquid surface. The local conditions may be such that the reflecting layers are not horizontal; in this case the mirage may be lateral and the pictures appear on the side instead of above or under.

The electromagnetic waves having practically the same exponent as that of light waves, probably curve themselves in the same way and produce the same phenomena. While the great deviations and the mirage are rare phenomena for light, they must be frequent and even normal for the electromagnetic waves used in radio; because their greater range tends to make them more subject to the numerous modifications of the atmosphere found along their route. Several other conditions are also more usually produced for a wave-length of about 1,000 meters than for wave-lengths of a thousandth of a millimeter. In particular, the reflection can only take place on a surface of which the irregularities do not exceed the order of magnitude of the wave-length. A surface must be highly polished to reflect light, but a cliff, a forest, reflects sounds, the wave-length of which are rather long. A very irregular surface, such as that of a cloud, may act as a fairly good reflector for a wave-length 1,000 meters long. Calculations show that such a cloud may, under the proper angle, reflect about one-quarter of a received intensity, in which case, the emitted intensity is reduced of the same amount.

These deviations and reflections to which radio waves are subjected during their long travel through the atmosphere, justify the introduction of a factor of reduction in the formula, which is necessary to make the calculations and the measured values of the electromagnetic field check. This modification is the formula of Dr. Austin, which has been verified almost exactly during the recent measurement made by the International Scientific Research Union.

These considerations usually explain the accidental variations which are noticeable

when receiving radio signals. When traveling over several thousand miles, the least variation in the state of the atmosphere may change the direction of the rays producing sometimes a reinforcing effect, but more often a reduction, or sometimes a complete disappearance, of the signal received. The periodic variations caused by the solar action is also easily explained by the motion of the air produced when it gets warm while in contact with the ground. During the day the earth is heated by the sun and the air getting warm produces some vertical currents, producing a great many layers of different densities diffusing the electromagnetic waves. Therefore, the atmosphere is more disturbed during the day than during night.

I shall not develop further these explanations of a theory which is not yet proved, but which is, however, more logical and can more easily be controlled than the others in which the phenomenon of ionization is supposed to take place. The study already begun on the possible relation between the variations of intensity and atmospheric variations will undoubtedly furnish much interesting data to confirm these theories.

I shall only mention the possibility of a mirage which might take place permanently due to the constant deflection produced by the decrease of the action of the ether at higher altitudes. The astronomical observations show that the pressure and temperature decrease and that the optical properties are equal to that of vacuum at an altitude of about 100 kilometers. This distance represents a small number of wave-lengths and a very small fraction of the earth's radius equal to 6,370 kilometers. Fig. 4 shows a circle, the thickness and radius of which are in the same proportion as the thickness of the atmosphere and the radius of the earth. This shows how thin this gaseous layer surrounding the earth is.

(Continued on page 1759)

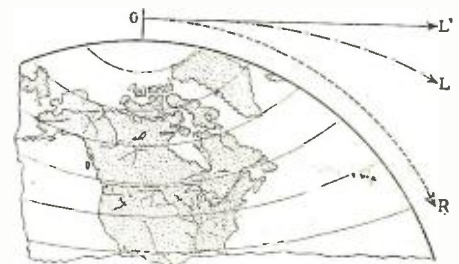
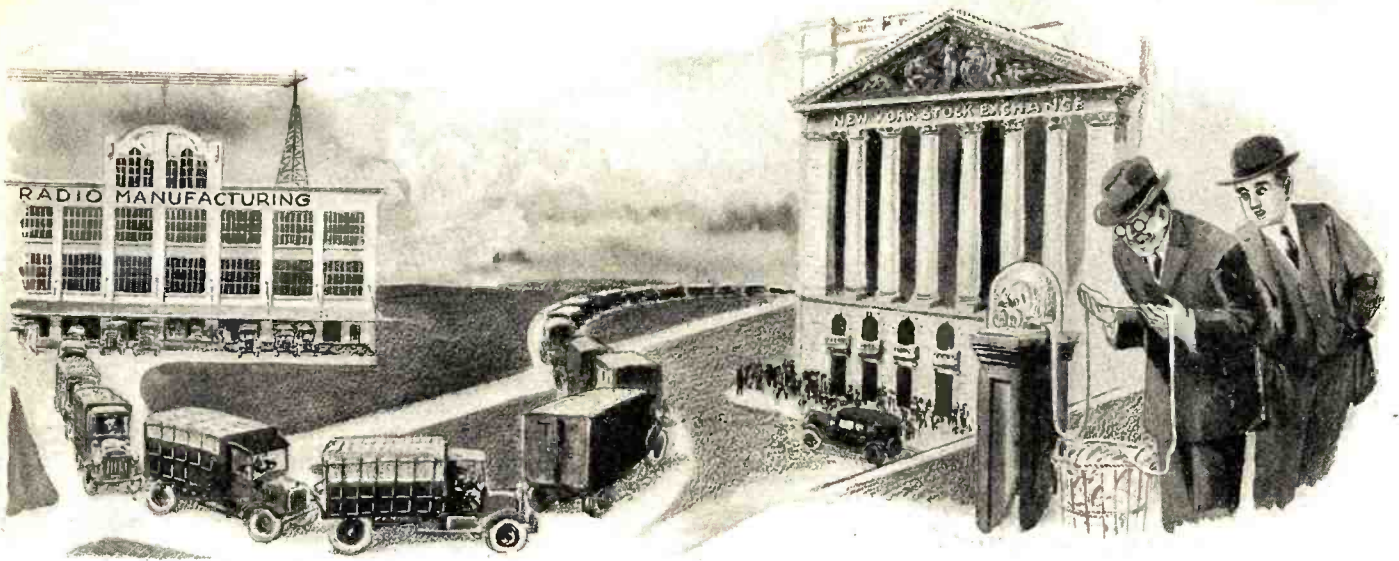

Fig. 1. This diagram shows the difference between the propagation of a light ray and radio waves. The light ray travels in a straight line while the radio waves travel around the earth, as shown by the line OR.





Radio is a good investment for the financier so long as it is good over the retail counter

# The Financial Side of Radio

By JAMES A. HALSTED

*Mr. Halsted, a New York broker, here discusses some points connected with the purely financial side of the radio industry which has, up to the present, been neglected.*

**T**HE first step of importance toward financing the radio industry in the United States came in 1919 when the General Electric Company caused the Radio Corporation of America to be organized, and turned over to it the entire stock interest which the British Marconi Company had previously held in the American Marconi Company. The Radio Corporation also received valuable patent rights of the largest electrical companies in the United States. In addition, cash was paid into the treasury of the Radio Corporation for its preferred stock, which was issued at par as follows: \$287,260 in January, 1920; \$2,500,000 in August, 1920; \$1,000,000 in February, 1921, and \$2,000,000 in September, 1922.

### PUBLIC BECOMES INTERESTED

Although this company reported very satisfactory progress, and radio passed from the experimental stage into that of a great industry, the public did not become interested in the financial side until 1924.

This is shown by the fact that at the end of 1923 there were only two radio stocks traded in on the New York Curb Market, while at the end of 1924 there were 14 stocks listed on the Curb and several more were waiting. Furthermore, Radio Corporation stock, which in 1923 had a high of 4¼, reached 13¾ in 1924. Dubilier, with a high of 135½ in 1923, reached 68 in 1924.

Within the last six months the financial end of the radio industry has greatly appealed to the speculating public. The avidity with which new stock issues have been taken up by the public has exceeded even the most sanguine expectations of the promoting houses. The doubling and tripling of the market value of the issues within a short time has been another feature of the "radio market." The latest approach to this was the famous "oil market" of 1919.

One reason for the "radio market" is found in the unprecedented growth in the sales of radio equipment, which has been reported as follows:

1920....	\$ 2,000,000
1921....	5,000,000
1922....	60,000,000

1923.... 120,000,000  
 1924.... 300,000,000 to \$350,000,000  
 In no other industry have sales increased at such a rate and reached so large an amount in so short a time.

The general improvement in the stock market and especially that since November 4, 1924, has also considerably helped the market for radio stocks, and is one reason why they received a belated recognition from the public in 1924.

ate future, it is most likely that the coming months will show an unusually large demand for radio equipment from the farming sections, because the purchasing power of the farmer is greater than it has been for a number of years. This is now being reflected in the large sales of the mail order houses and is bound to increase the sales of radio equipment in these sections. The general prosperity and revival of business confidence has helped and will continue.

It is estimated that there are 3,500,000 tube sets in the United States as compared with 10,000,000 phonographs. It needs no stretch of imagination to see a radio set in every home where there is now a phonograph. There are likewise 15,000,000 registered automobiles in the United States, and anyone who can afford an automobile, with an average cost of \$800, can easily afford a radio set.

These figures are not considered the maximum number of sets that can be sold in this country, but what the market can be expected to absorb in the next few years.

Furthermore, with the tremendous impetus that the industry has received in this country, our manufacturers will doubtless create a constantly growing market in foreign countries. It is reported that at present the value of radio exports is around \$300,000 monthly. It is understood that the British ban on radio equipment has been removed and a large increase in exports into that country is expected.

The first four months of 1925 are expected to be very good, and will likely be double those for the first four months of 1924.

### COMPETITION

There are now some 3,000 concerns manufacturing radio equipment and most of them are increasing their facilities. This increase in production should not be felt during the first four months of 1925, but when the unfilled orders have been taken care of during the summer and stocks of equipment have been built up, it is likely that competition

(Continued on page 1962)

## 40 Non-Technical Radio Articles

every month for the beginner, the layman and those who like radio from the non-technical side.

SCIENCE & INVENTION, which can be bought at any newsstand, contains the largest and most interesting section of radio articles of any non-radio magazine in existence.

Plenty of "How To Make It" radio articles and plenty of simplified hook-ups for the layman and experimenter. The radio section of SCIENCE & INVENTION is so good that many RADIO NEWS readers buy it solely for this feature.

### List of Radio Articles Appearing in the April Issue of "Science and Invention"

- Around the World Transmission  
By Donald H. Menzel, Ph.D.
- Multiple Wavemeter—How to Make It  
By Sidney E. Finkelstein, A.M.I.R.E.
- The Ritz Super-Het—Full Details  
By Charles Caesar Ritz
- Elementary Circuits for the Beginner
- Single Control Receivers With Circuits  
By Leon L. Adelman, A.M.I.R.E.
- European Broadcast Map
- How Far Does a Squeal Travel?
- Radio Oracle—Questions and Answers
- Radio Wrinkles—Numerous Hints and Kinks

### FUTURE OF THE RADIO INDUSTRY

The outlook for the radio industry appears very bright. Regarding the immedi-



# The First Annual Radio Set Directory

Continued from the March Issue

A further list of radio sets of American manufacture, with sufficient data on each for the prospective buyer to make an intelligent selection.

 <p>TRADE NAME: Inverse Duplex. MODEL: 3-X P. TUBES: Three. BATTERIES: 6 volts storage "A," 80 to 120 volts "B." CONTROLS: Three. AERIAL: Indoor or outdoor. PRICE: \$85.00 without accessories. MANUFACTURER'S NAME: David Grimes, Inc.</p>	<p>TRADE NAME: Wilcox Hexaircoil Set. MODEL: De Luxe. TYPE: Tuned radio frequency. TUBES: Five. BATTERIES: Storage "A," 60 to 90 volts "B" and a "C." CONTROLS: Three. AERIAL: Indoor or outdoor. PRICE: \$250.00 without accessories, but built-in loud speaker. \$300.00 completely equipped. MANUFACTURER'S NAME: Wilcox Laboratories.</p> 
 <p>TRADE NAME: Harco Crystal Set. TYPE: Crystal set. No tubes or batteries required. CONTROLS: One. AERIAL: Outdoor. PRICE: \$3.00 without accessories. MANUFACTURER'S NAME: Harcourt Radio Company.</p>	<p>TRADE NAME: Perflex. TYPE: One-stage tuned radio frequency, detector and two stages audio frequency. Reflexed inductive absorption coupling. TUBES: Two. Either 199 or 201-A type. BATTERIES: "A" and "B," voltage supplied from house lightning system, 110 volts A.C. CONTROLS: Two. AERIAL: Indoor or outdoor. PRICE: \$170.00 complete except tubes. MANUFACTURER'S NAME: Wireless Shop. NOTE: Same set with filament supply only from 110 volts A. C., \$145.00.</p> 
 <p>TRADE NAME: Hearwell Variometer Lyric. TYPE: Crystal set. No tubes or batteries required. CONTROLS: One. AERIAL: Outdoor. PRICE: \$10.00 without accessories. MANUFACTURER'S NAME: Hearwell Radio, Inc.</p>	<p>TRADE NAME: Acme Special. TYPE: Regenerative. TUBES: One 199 type. BATTERIES: Dry cell "A" and 22½ to 45 volts "B." CONTROLS: Two. AERIAL: Outdoor. PRICE: \$23.00 without accessories. MANUFACTURER'S NAME: Wright Radio Manufacturing Company.</p> 
 <p>TRADE NAME: Hearwell Whole Wave Receiver. TYPE: Double crystal set. No tubes or batteries required. CONTROLS: One. AERIAL: Outdoor. PRICE: \$8.00 without accessories. MANUFACTURER'S NAME: Hearwell Radio, Inc.</p>	<p>TRADE NAME: Wright. MODEL: B. TYPE: One-stage radio frequency and detector. TUBES: Two 199 type. BATTERIES: Dry cell "A" and 45 volts "B." CONTROLS: Two. AERIAL: Indoor or outdoor. PRICE: \$50.00 without accessories. MANUFACTURER'S NAME: Wright Radio Manufacturing Company.</p> 
 <p>TRADE NAME: Hercules Receiver. TYPE: Tuned radio frequency. TUBES: Five. BATTERIES: Six volt storage "A," 60 to 90 volts "B." CONTROLS: Three. AERIAL: Indoor or outdoor. PRICE: \$85.00 without accessories. MANUFACTURER'S NAME: B. F. Miller, Inc.</p>	<p>TRADE NAME: Wright. MODEL: III-W. TYPE: Detector and two-stage audio. TUBES: Three, 201-A type. BATTERIES: Six-volt storage "A," 60 to 90 volts "B." CONTROLS: Two. AERIAL: Outdoor. PRICE: \$60.00 without accessories. MANUFACTURER'S NAME: Wright Radio Manufacturing Company.</p> 
 <p>TRADE NAME: Operadio. TYPE: Three stages radio frequency, detector and two stages audio. TUBES: Six 199 type. BATTERIES: Dry cell "A," 60 to 90 volts "B." CONTROLS: Two. AERIAL: Loop. PRICE: \$195.00 including tubes, batteries, loud speaker and loop aerial. MANUFACTURER'S NAME: The Operadio Corporation.</p>	<p>TRADE NAME: Wright. MODEL: IV-D. TYPE: One radio, detector and two audio. TUBES: Four 199 type. BATTERIES: Dry cell "A," 45 to 90 volts "B." CONTROLS: Two. AERIAL: Indoor or outdoor. PRICE: \$85.00 without accessories. MANUFACTURER'S NAME: Wright Radio Manufacturing Company.</p> 
 <p>TRADE NAME: Wilcox Hexaircoil Set. MODEL: Standard. TYPE: 10-H tuned radio frequency. TUBES: Five. BATTERIES: Storage "A," 60 to 90 volts "B," and a "C." CONTROLS: Three. AERIAL: Indoor or outdoor. PRICE: \$100.00 without accessories. MANUFACTURER'S NAME: Wilcox Laboratories.</p>	<p>TRADE NAME: Wright. MODEL: VI. TYPE: One-stage radio, detector and four stages of resistance coupled audio frequency amplification. TUBES: Six 199 type. BATTERIES: Dry cell "A," 60 to 90 volts "B." CONTROLS: Two. AERIAL: Indoor or outdoor. PRICE: \$100.00 without accessories. MANUFACTURER'S NAME: Wright Radio Manufacturing Company.</p> 





**UNIQUE CANADIAN STATION.**  
The studio at Montreal in the Frontenac Breweries is the most unique one in the world. On the left is shown the studio, set up in the brewery. Below is the remote control room from which signals are sent on to Station CKAC. Prizes offered by the Frontenac Breweries are also of the popular order; Managing Director Pierre Beaubien had to award gold pieces instead of the usual 10-gallon barrels to American winners.

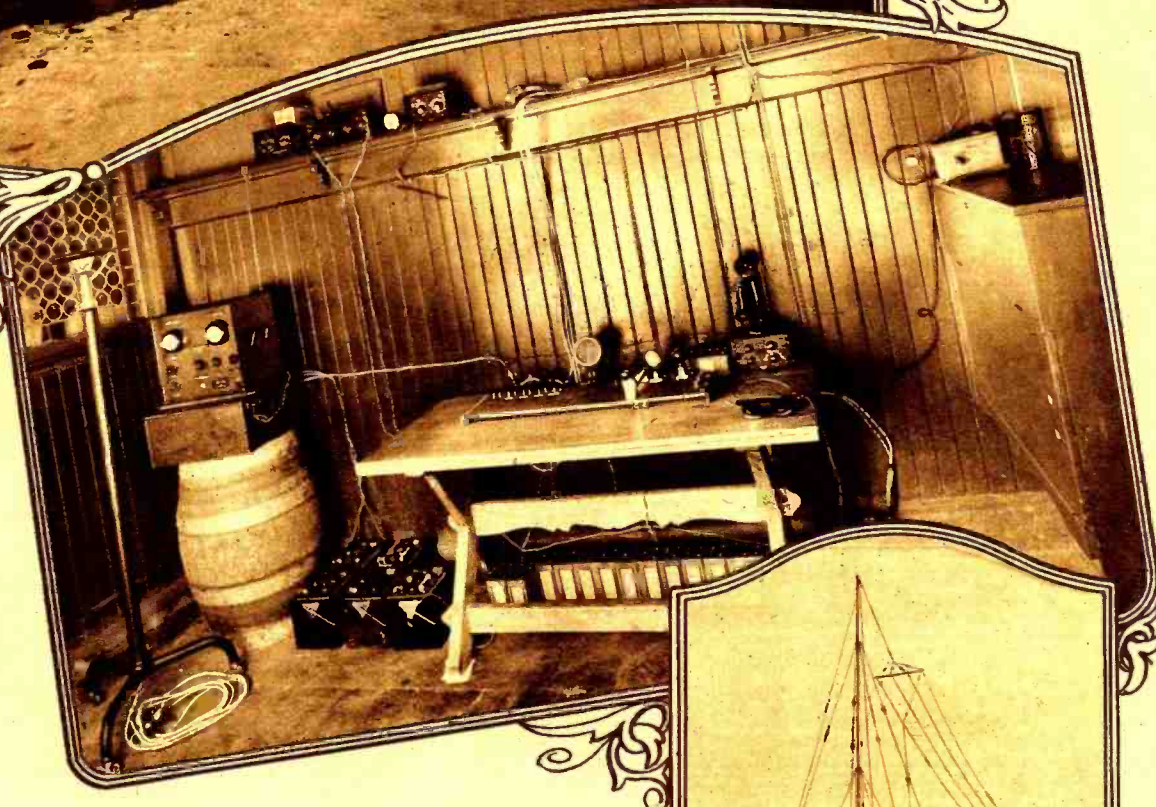

**ON THE BANKS OF THE MOHAWK.**  
Lower right. Main power house for radio transmitters at the Schenectady plant of the General Electric Co. In the building transmitters rated from 50 to 100 kilowatts may be housed. Below: Three masts 300 feet high on the 53-acre laboratory of the General Electric Company near Schenectady, N. Y. From these structures aerials may be hung for experimentation on wave-lengths from 600 to 3,000 meters.

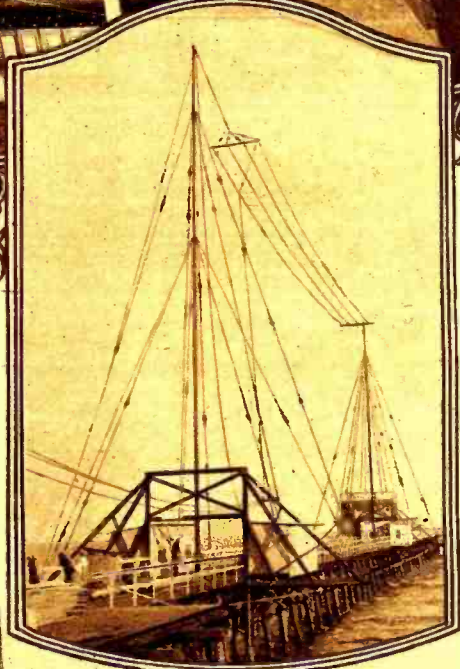

**SOUTHERN BROADCAST STATION ON PIER.** Station WOE, at Palm Beach, Fla., has an antenna 130 feet above the water and 240 feet long. The transmitter is located in the little house at the end of the pier. (© Fotograms.)

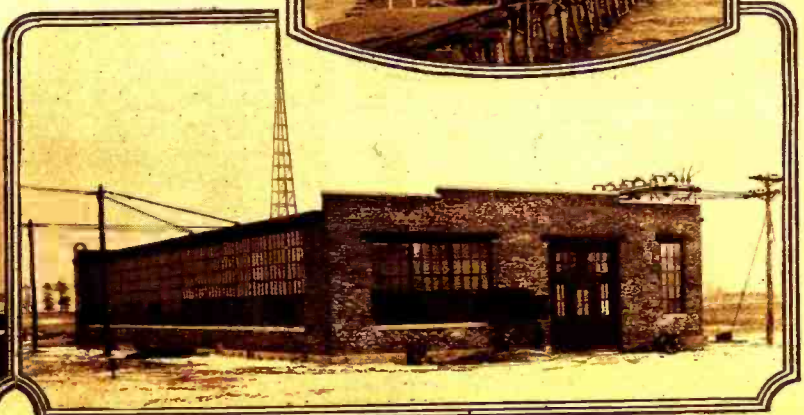
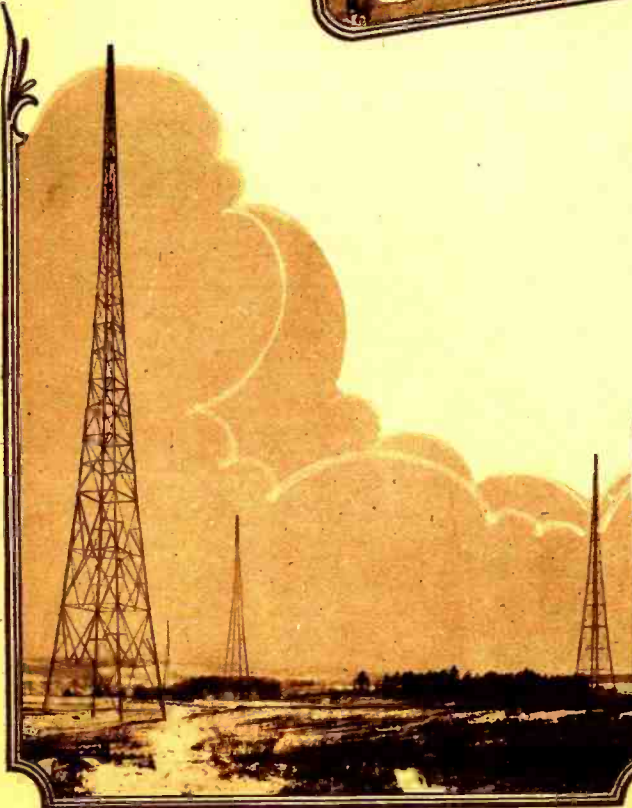





**CAPTAIN OF TUG RECEIVING RADIO ORDERS.**  
Radio receiving equipment in pilot house of New York Central Tug No. 18. (© Kadel & Herbert.)

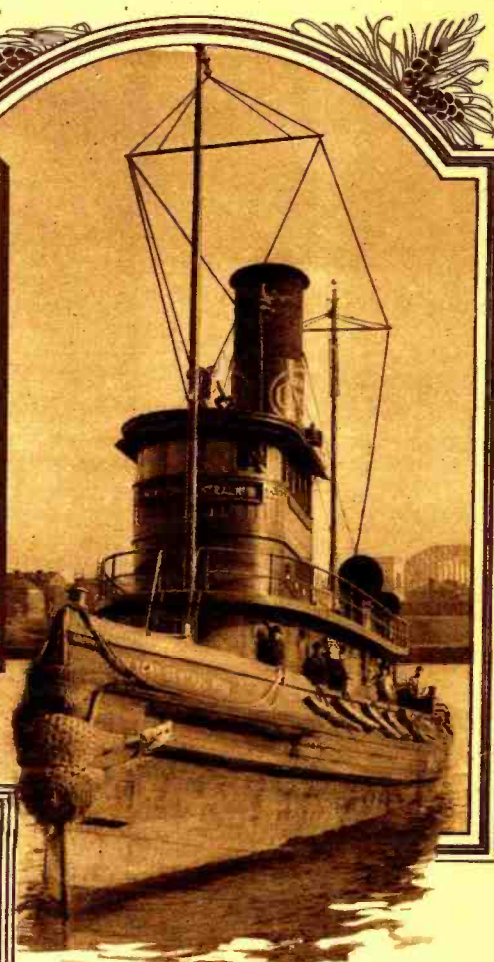

**TUGBOAT DIRECTED BY RADIO ORDERS.** Tug No. 12, of the New York Central Railroad, is equipped with receiving and transmitting apparatus, in order that time may be saved in its movements. Orders are received from headquarters ashore. (© Kadel & Herbert.)

**TUNING UP TUG BOATS EQUIPMENT.** G. W. Hamilton, radio operator on Tug No. 18 of the New York Central Railroad working on the 500-watt C.W. transmitting equipment. This set has an average transmitting range of from 500 to 1,000 miles. (© Kadel & Herbert.)

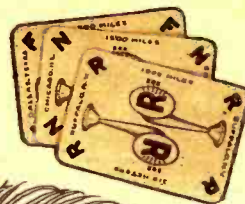
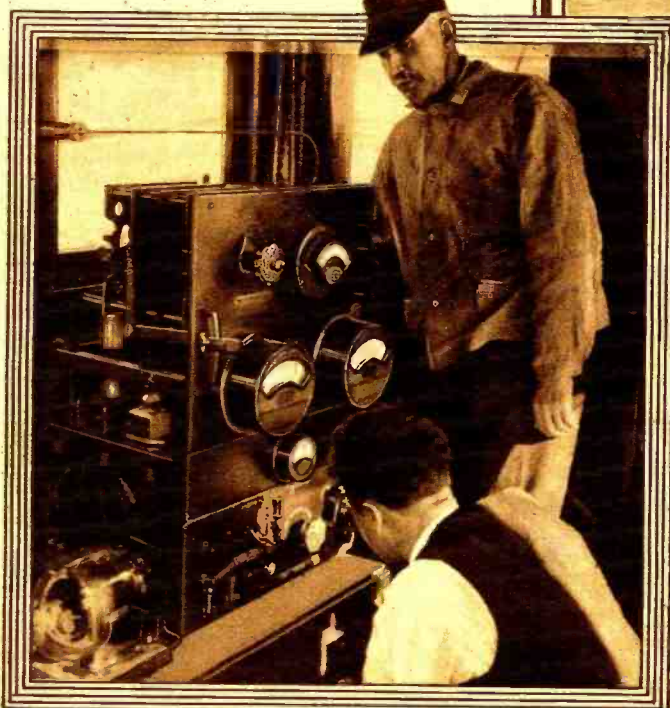

**NEW RADIO CARD GAME.** A most fascinating game for fans of all ages. It is similar to Rummy, only the cards are marked with the calls of broadcast stations.







**RADIO RECEIVER IN HOME ON WHEELS.** W. K. Kellogg, of Battle Creek, Mich., has a home-on-wheels. A radio set is placed in it with the loud speaker over the driver's seat. (© Kadel & Herbert.)

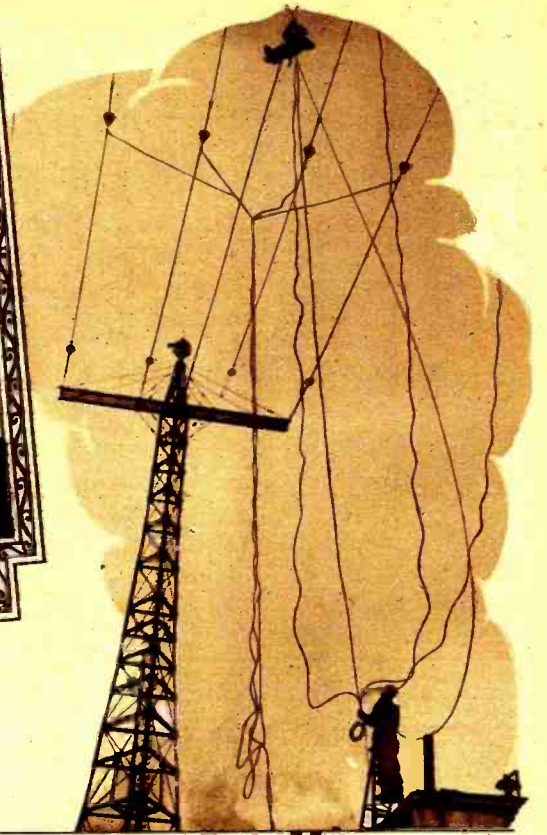

**NEW LEAD-IN WIRES INSTALLED AT WJZ.** Upper right. Workman suspended between the two towers twenty odd stories above Forty-second Street, New York City. (© Underwood & Underwood.)



**FIRST PORTUGUESE NEWSPAPER TO INSTALL RADIO.** Center. The largest daily newspaper of Lisbon, "O Seculo," has installed radio equipment to collect news items.



**SMALLEST RADIOPHONE TRANSMITTER KNOWN.** Lower left. Albert B. Caldwell, of New York City, is the constructor of a transmitter that uses a 201-A tube. (© Keystone View Co.)



**RADIO GOLD DETECTOR.** Herman Jeastor, a German inventor, constructed the instrument shown above, which is used in locating gold under the ground. It is called the "Radio Emanator." (© P. & A. Photos.)



**TRANS-ATLANTIC RADIO CHESS MATCH.** Haverford College, at Ambler, Pa., and Oxford University in England, recently played chess by radio. The Haverford team's moves were sent to Oxford by the college station 3ZG shown on the right, and received in England by Station 2NM in London. (© P. & A. Photos.)



**NEW CRYSTAL USED IN RADIO.** Mr. H. De Goot, of the Bureau of Standards, has been working with quartz crystals, which vibrate at radio frequencies and with extraordinary constancy. They are to be used for adjusting, and keeping constant, the wave-lengths of broadcast stations. They should not be confused with the so-called "oscillating crystals." (© Henry Miller News Picture Service, Inc.)

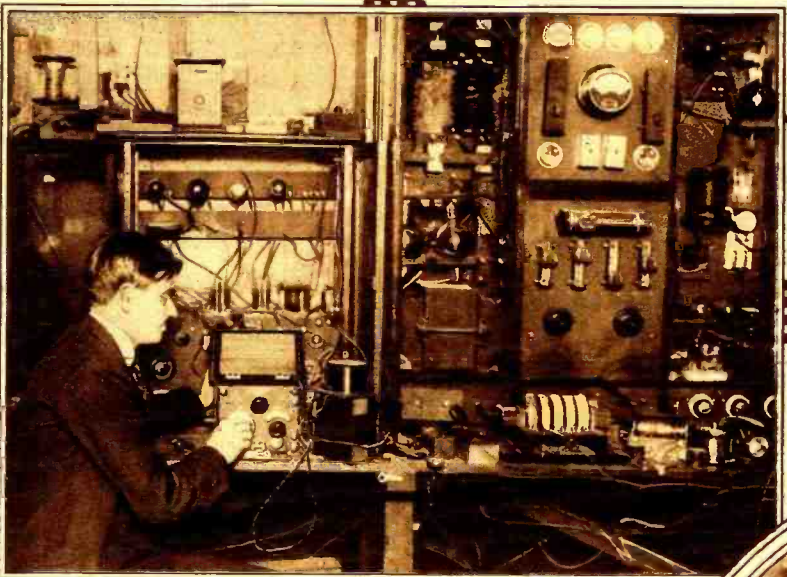

**GERMAN GIANT LOUD SPEAKER.** In order that everyone in the huge building of the Berlin Radio Exposition might hear the radio programs, this loud speaker was installed on the balcony solely for this exhibit. (© Williams Service.)

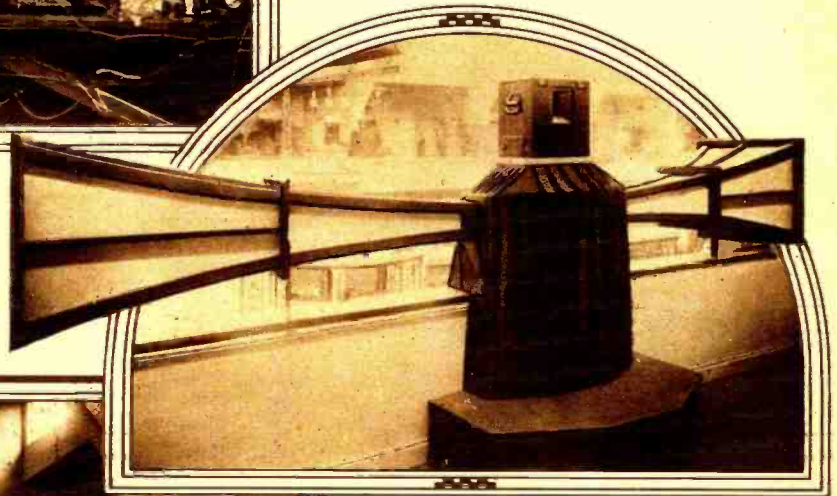

**INTERIOR OF BERLIN RADIO-HALL.** Left. This building was constructed especially for the exhibition of radio apparatus, as it is built entirely of wood, as designed by the architect, Prof. Heinrich Straumer. There are sound-proof booths provided so that the different types of loud speakers may be heard and compared. Connected with the building is a hall with seating capacity of 500, a restaurant, offices and living quarters for attendants.







**OPERA STARS BROADCAST.** Lucrezia Bori, at left, is pouring into the microphone those golden notes which were broadcast to millions early in January. On the right John McCormack, concert tenor, who broadcast the same evening, with Miss Bori, is preparing to sing: "Mother Macree." (© Kadel & Herbert.)



**"SNOWED UNDER."** This was the result at Station WEAF when the fans thanked the station for the broadcasting of the voices of the opera stars. Broadcast listeners are seldom given such a treat. (By United.)



**SINGER GAUGES VOICE BY LISTENING-IN.** Miss May Macrae, coloratura soprano, regulates her voice while broadcasting by listening to how it is put on the air. (© Wide World Photo.)



**MADAME ALDA BROADCASTS.** The third great singer to broadcast was Mme. Frances Alda, prima donna of the Metropolitan Opera Co. Several beautiful selections were broadcast through station WEAF. (© Wide World Photos.)



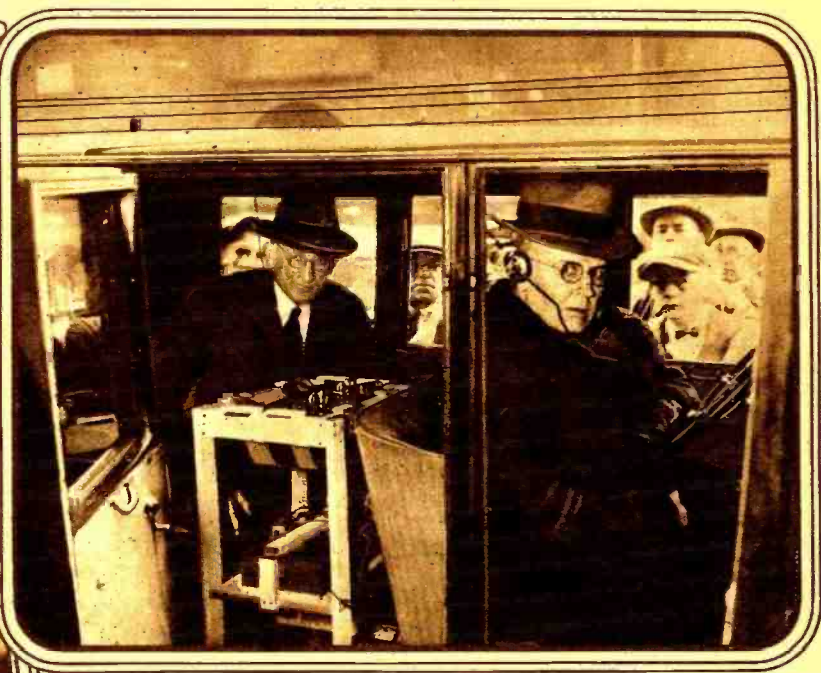

**RADIO FOR CHICAGO POLICE.** Above. Here you see a Chicago fast squad car carrying complete radio transmitting and receiving apparatus, ready for a dash into the underworld. Messages are transmitted and received at the city's own station. Keeping in touch with headquarters offers the detectives the opportunity of immediate information on the movements of those wanted. © United.

**PHANTOM TRIP ABOARD S.S. "LEVIATHAN."** Above. Capt. Herbert Hartley, of the world's largest liner, recently described from Station WNYC how a steamer was started on her long journeys. Fans who "took the trip" heard the giant boat getting under way. © Underwood & Underwood.)



**YOUNGEST REGULAR ANNOUNCER.** Below. Nancy Clancy, 16 years old, who attends school during the day, and announces at broadcast station WAHG, Long Island, N. Y. each evening for three hours. © P. & A. Photos.)

**NEWEST IN RADIO MILLINERY.** Right. From London comes this creation for Milady. A complete crystal set is built in the crown of the hat. (International Newsreel Photo.)



**ACTRESS DESERTS STAGE FOR RADIO.** Left. Alexandra Carlisle, famous classic actress, retired from the stage to aid her husband, J. Elliott Jenkins, one of America's foremost radio experts, in his experiments on radio. © Underwood & Underwood.)







**INDIAN WEDDING BROADCAST.** An Iroquois tribal wedding broadcast from a Chicago station, when Jacqueline Norris, an adopted daughter of the Iroquois, married Chief White Feather. (© Underwood & Underwood.)



**HUSKY YIELDS TO RADIO.** Jacques Suzanne, famous dogmusher of the Adirondacks, giving his guests on a sledge trip a treat with his Super-Heterodyne. (© Underwood & Underwood.)

**BRINGING THE JUNGLE TO THE HOME.** One of the New York broadcast stations has experimented with putting the sounds of different animals on the air. Above, the microphone is picking up the voices of the seals asking for a bite, and below is shown Old Man Turtle making his ethereal debut and evidently enjoying it. (© International News-reel Photos.)



**SKATING TO RADIO MUSIC.** In Quebec, Canada, radio furnishes entertainment to skaters and onlookers. The Misses Nobtreul and Barton certainly seem to enjoy it. (© K. & H.)

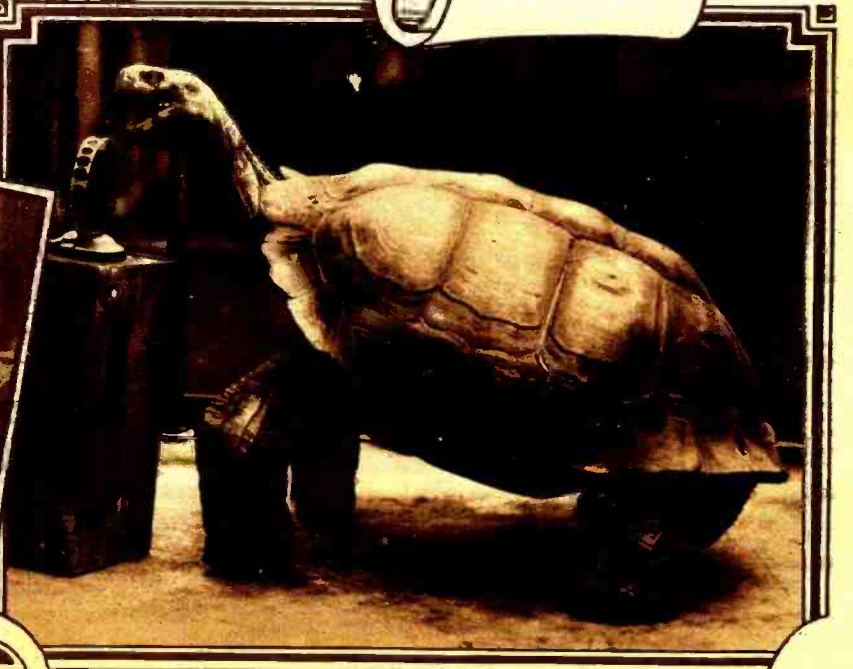
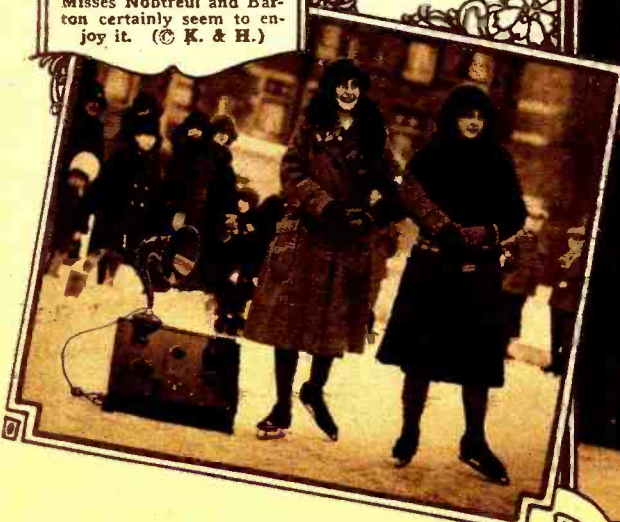



# The Great Bedtime Story Conspiracy

By ROBERT FRANCIS SMITH

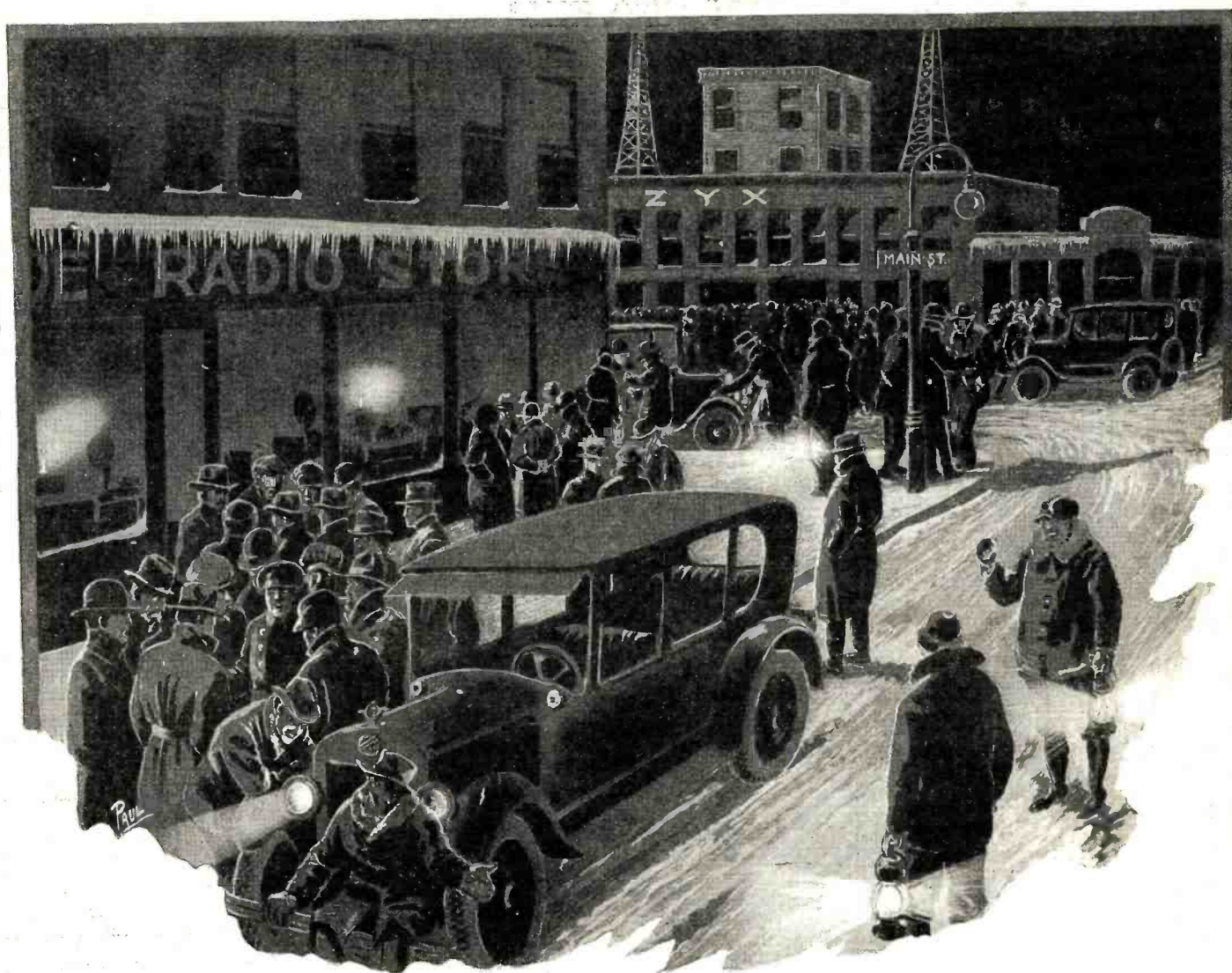

When we gets up to the station we find to our surprise that the said sounds ain't coming so much from the station as from groups of people gathered in the streets. The Master edges into one bunch and inquires why the excitement. "Something's wrong," said a voice. "All the lights are out for blocks, our radios are burnt out, I can't start my car because the starter isn't feeling well and nobody can get central on the phone."

"ONCE upon a time, oh, such a long time ago, almost a week, there lived a little girl named Gold-In-Hock. Now Gold-In-Hock was, oh, such a nice, nice little girl. She always helped her dear mamma, oh, just all she could, and practiced her music lessons a whole hour every day, and hardly ever went auto riding with strangers."

"Something tells me," I meditates, "that Gold-In-Hock is due for a bad fall."

"Shut up," suggests the other partner to our life booking. The program continues.

"And dear little Gold-In-Hock was out walking when, oh, just guess what she saw coming! Three bears from Wall Street! But do you think dear little Gold-In-Hock was afraid? Dear me, no! The sweet little girl just walked right up to the bears and stared straight into their mean old faces, so there!

"Well, whatcha want?" asked the dear girl.

"But the bears just didn't move!

"Who gyped me for a Jolts-Choice and then left me flat?" asked the biggest bear.

"And who vamped me into buying all those Paris gowns?" asked the middle-sized bear.

"And who took my bankroll?" asked the littlest bear.

"Now Gold-In-Hock was, oh, such a nice little girl and, oh, it made her feel so bad to hear the bears, so she stood right up and looked the biggest bear in his awful old face.

"Lissen, big boy," she said, 'your tin rattler's out under a switch engine in Yonkers.'

"Then the dear child turned to the middle-sized bear and said:

"Your Second Avenue rags are on Third Avenue now.'

"Then to the littlest bear she said:

"As for you, poor fish, get back to deep water before somebody else trims your fins.'

"Now, children, wasn't she the dearest, bravest little girl you ever heard of?"

There's a moment's silence while I tunes in Mobile, Alabama, to get the latest quotations on U. S. Steel. Then the wife offers her opinion, which has one salvation—it's only hers.

"These bedtime stories are the bunk," she declares.

"Really?" I remarks. "Since when did you find that out?"

Old Acid Disposition opens up with a broadside. "I don't see why I ever married you," she laments. "You can stir up more QRM than a convention of spark coils in the next block."

"Too bad your receiving set isn't big enough to tune 'em out," I comes back cheerful.

Whereat the wife decides I'm one too many for her in my present condition, so I'm left to the ether. To get the formalities over, we're Joe and Doris Hammerstein, members of that gang of swift ankles that dents up the stages of big-time vaudeville theatres. You've got it—were dancers. We're resting a few days in Chicago prior to resuming eastern bookings, after opening here next week. This giving us a fortnight in one town, I've hooked my suitcase set to an honest-to-galosh aerial and the outfit is stopping the show regular. So I'm feeling free and easy, made all the better by my having had the last word with Doris, which happens about as often as a New York ham gets Java on his coherer. Naturally, it's too good to last, and just as I'm thoroughly at ease, my missing rib sticks her sheared locks through the bedroom doorway and chortles her sweet, if a trifle weak, ultimatum.

"Just the same, Joe, dear, bedtime stories are the bunk, especially the ones you tell me."

"They are!" agrees a familiar voice emphatically.

(Continued on page 1977)



# Radio Liars

By F. A. HILL\*

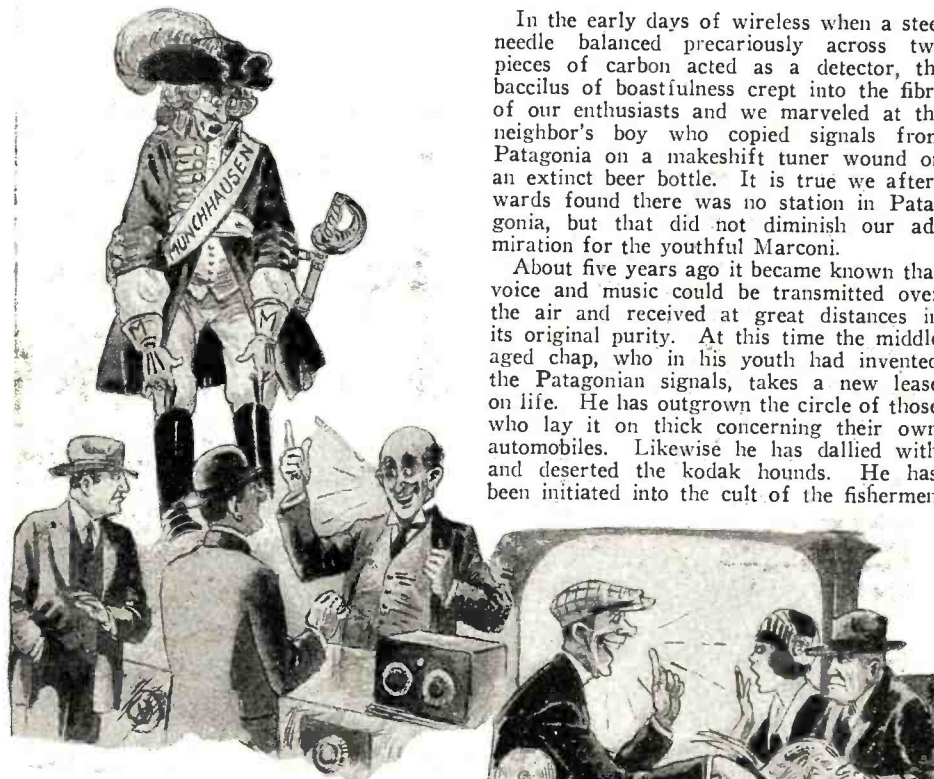

**S**HOULD Münchhausen's grave be viewed through a fluorescent screen, doubtless his dusty remains would be seen writhing in agony of despair and blighted hope. The Baron did not have the good fortune to stick it out until this age of radio. Even Annamias would be found grumbling at a fate that carried him off before this time.

And Wilde, who bewailed the decay of lying, would be today in a prevaricator's paradise where the artistry of truth distortion is as a mantle descended upon all who succumb to the rage of radio. And if Wilde were to award prizes for those who excelled in this art, none would merit them more than the Radio Liar, whose tribe increases daily and whose shadow never grows thinner.

## FISHERMAN PASSÉ

Heretofore, the fishing and hunting pretender was rather boastful without provocation and gloried in recounting imaginary bags or a fine catch. But this poor chap had only his arm's length with which to measure his alleged trophies. What a miserable span with which to do justice to fabled specimens when the Radio Liar has the breadth of a continent to gauge by, or if needs be, the distance from pole to pole as the crow flies.

Since the popularization of radio, the crop of Radio Liars harvested each year has reached such a stage that unless we are to be providentially visited with a plague of static locusts the whole nation will be engulfed in such a deluge of falsification as we have never before witnessed. This peril has reached such an alarming state it is no longer confined to the grown-ups, but is practiced by the youngsters, who are ever keen to seize upon a new toy and claim for it distinctions and advantages which no other boy's toys possess. Still, in an age when intelligence is conveyed by radio at the startling speed of 186,000 miles per second, it is perhaps natural for the art of lying to be geared up a trifle higher than in the horse and buggy epoch.

(Engineering Staff, Westinghouse, KYW.)

In the early days of wireless when a steel needle balanced precariously across two pieces of carbon acted as a detector, the bacillus of boastfulness crept into the fibre of our enthusiasts and we marveled at the neighbor's boy who copied signals from Patagonia on a makeshift tuner wound on an extinct beer bottle. It is true we afterwards found there was no station in Patagonia, but that did not diminish our admiration for the youthful Marconi.

About five years ago it became known that voice and music could be transmitted over the air and received at great distances in its original purity. At this time the middle aged chap, who in his youth had invented the Patagonian signals, takes a new lease on life. He has outgrown the circle of those who lay it on thick concerning their own automobiles. Likewise he has dallied with and deserted the kodak hounds. He has been initiated into the cult of the fishermen

not under shoot the mark, trebles the product to provide a generous safety factor for the imagination.

Thousands are being converted to radio. No walk of life is spared. The poor have the crystal sets; the rich possess the five- and ten-tube outfits. Each class of owner magnifies and elaborates on his set. The poor fellow has an especially designed cat whisker on his detector stand secured at great hazard from a mephitic feline. The man of wealth has a tube filled with a very helpful gas which acts as the good samaritan to anaemic signals and helps them across the threshold into the amplifier where they are rejuvenated and made quite vigorous.

On a wintry night the Radio Liar chances to catch a few bars from the old favorite, "There'll Be a Hot Time in the Old Town Tonight." With the mercury hugging the zero mark, the gentleman named above figures the signals could not have emanated from a northern clime. After a due process of reverse logic, he announces he tuned in Havana the night before, even furnishing you with a fictitious Spanish announcement which he had laboriously picked out of a Spanish dictionary.

## RETALIATION

Not to be outdone, Number Two of the species will tell how he heard a program the night before from KYW with no storage battery or "B" battery attached to his tubes, and that the volume was sufficient to fill a large-sized room.

Number Three jumps into the gap, telling of a mysterious vacuum tube which gives clearer signals when extinguished. He accounts for this by stating the cold resistance of the filament is so much lower when it is out, hence the signals have easier access to the tube. He can cite you eighteen other pseudo-technical reasons for this, but space will not permit their being cataloged at this time.

This clan may be found daily in any of the stores dealing in radio apparatus. You run into its members on the smoker as you go to work in the mornings. Instead of listening to an account of the doings on the c.l.r.b market, you are assaulted by your

(Continued on page 1991)



and hunters and is making a moderate success at stretching it, when the radio craze hits with a bang. He becomes like the ultra-successful liar in his creed, "I will lie, even if I have to tell the truth to do it."

## UNLIMITED OPPORTUNITIES

With such a wonderful field before him it is not long before the Patagonian signal creator is achieving boundless success. He starts by retailing conversations he has picked up out of the air, giving names, dates and other data for the sake of plausibility. Then he relates feats of talking across the block with his friend. This gives way to greater distances of alleged communication until his mileage has run up into the thousands. If his auditors should doubt him, he always has a map showing the distances. You are told you can verify the statement by writing to the man at the other end. As each scientist and researchist makes new discoveries, the Radio Liar simply multiplies these by  $\pi$ , and then to make certain he will





# Russia's Radio Laboratory

By PROF. W. K. LEBEDINSKY

*In this, the second half of Prof. Lebedinsky's article on the accomplishments of the Russian Radio Laboratory, Nijni-Novgorod, some of the later work dealing with the nature and characteristics of transmitted oscillations are detailed.*



**R**ECENTLY, the Nijni-Novgorod radio laboratory, in designing some new apparatus for transmitters, had reason to make a close analysis of the radiated field surrounding an antenna. Mr. W. W. Tatarinov evolved a most interesting method for making exact check of this phenomena. It was necessitated by the nature of the experiments being conducted that the test should be one made by test alone, since it was not desired to learn its intensity by the usual mathematical methods.

The techniques of the plan are simple, indeed: Two large copper plates (Fig. 2) approximately 3 feet square and spaced  $2\frac{3}{4}$  feet apart were suspended directly beneath the antenna. These two plates formed a rather large condenser in which oscillations were established when the station was transmitting. The plates were supported on insulating frames and a crystal detector connected between them. A mirror galvanometer was connected across the crystal in such a manner that the strength and variations of the current in the condenser, caused by the field originating at the antenna, could be read directly. The observer taking down the results of the observation was placed at some distance from the galvanometer and provided with a telescope with which to note the deflections. By this system, all influence except that of the antenna field was removed.

The deflection of the galvanometer is directly proportional to the mean square of the

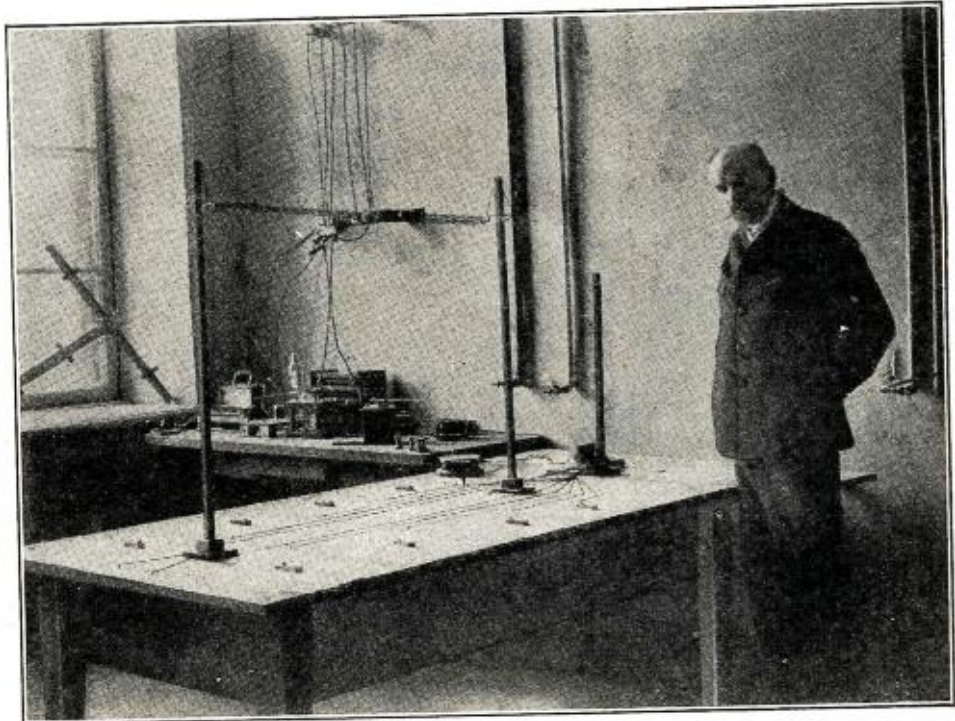

Above is shown Mr. B. A. Ostroumov at a table in the laboratory engaged in an experiment looking toward a plotting of the characteristics of oscillations from a radio transmitter. He made a new adaptation of the Braun tube which is very successful.

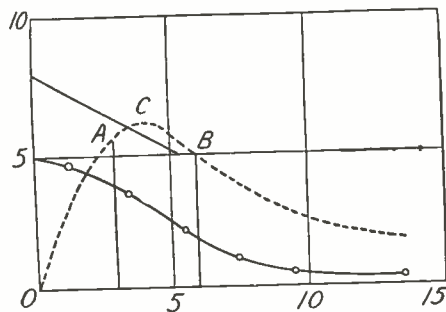

Fig. 3. A graph of the distribution of magnetic field beneath an antenna in a condition of oscillation is shown above.

field. The system of employing the condenser effect and making the apparatus as compact as possible allows portability of the testing set.

The distribution of the field strength and the displacement current through narrow rings at the earth's surface is shown in Fig. 3. The tests were made on an antenna of the umbrella type supported on a 25-foot antenna with 14 radiating wires each 20 feet long. The portability of the apparatus allows the making of a complete analysis of the field beneath the antenna.

Mr. Tatarinov is one of the foremost experimenters in the field of oscillating circuits. One of his greatest achievements was the perfection of a method by which it was possible to radiate two different waves from the same transmitting antenna without their mutual interference. This experiment is thoroughly covered in his article published in Nos. 17 and 20 of the magazine, "Radio-telegraphy and Telephony."

Along this same line of investigation one of the most interesting advancements made

by the laboratory is a new design of Braun tube, used in studying the oscillations of radio transmitters. When the investigations were begun, the desired tube being unavailable on the Russian market, the laboratory engineers immediately set out to manufacture their own.

Mr. B. A. Ostroumov, one of the laboratory engineers, was directly in charge of this work and carried it to success.

As to the design of the tube, it contains two anodes and a tantalum Wehnelt cathode (see Fig. 5). Oxides of the earth metals are enclosed in a small hollow fixed in the cathode. These metals are extremely rich in electron emission. Directly in front of the cathode is fixed a molybdenum disk with a small aperture in its center. A potential of 50 to 80 volts positive is placed upon it, and it performs the functions of a grid in the ordinary vacuum tube.

The tube being very rich in electron flow creates a veritable beam of electrons through the aperture in the plate. This stream is drawn by the main tubular anode which is supplied with a potential between 500 and 3,000 volts. This allows a perfect regula-

*(Continued on page 1950)*

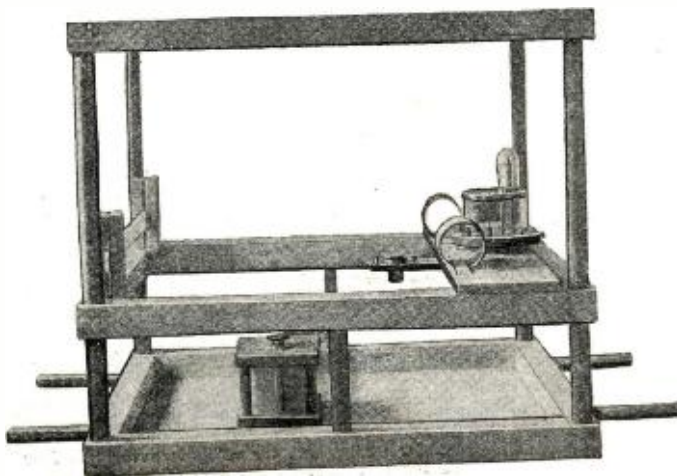

At the right is shown the umbrella type antenna with the field-strength measuring device beneath it. A close-up view of the complete measuring device, Fig. 2, is shown at the left. Note the galvanometer at the end of the frame and the handles for transporting the unit.

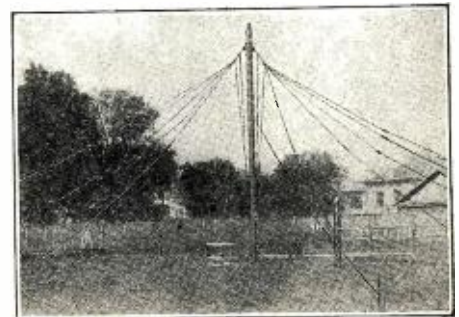



# Underground Radio

By S. R. WINTERS



Recent tests carried on with the underground antenna system of transmission have brought to light some interesting facts bearing on the present theories relative to the propagation of radio waves. Great success has been achieved with Dr. Roger's system, the signals having been heard 1,000 miles away.



WITH a broadcasting antenna system buried four feet in the ground, and with an output of a little less than two amperes of current, Dr. J. Harris Rogers, of Hyattsville, Md., has accomplished the remarkable achievement of radiating electromagnetic waves of sufficient strength to be heard with good audibility at a distance of approximately 1,000 miles.



Unusual photograph of making connection of transmitter with underground antenna. The copper tubing is placed in the terra cotta pipe.

In other words, he reversed the common practice of elevating the transmitting antenna to a height of 400 to 600 feet, and with seeming mockery at things conventional submerged the electric-radiating system under four feet of soil.\*

## THE ANTENNA

This underground antenna was only 100 feet long, consisting of  $\frac{3}{4}$ -inch copper tubing, encased in the center of a series of 18-inch joints of terra cotta pipe. After this, four-foot ditches were excavated and the terra cotta pipe, with the copper tubing, placed therein, the openings in the earth were completely filled up. One underground antenna extends in a northerly direction and the other points southward, thus affording opportunity for a study of the directional characteristics of radio signals propagated through the earth.

When the Rogers Radio Research Laboratory, with the call letters 3XR, issued the general call, CQ, the response was immediate and gratifying with respect to the range. Brass pounders—or radio amateurs, to speak with more dignity—by means of postal cards, acknowledged reception at 27 points, located in a dozen states. The geographical locations of the amateurs thus reporting are widely distributed—ranging from Maine to Florida, and with such intermediate states as Massachusetts, New York, Connecticut, Ohio, Pennsylvania, Georgia and North Carolina. Offside the directional ranges of true north and south, D. Marshall, operator of Station 9BRG, located at Aurora, Ill., reported that he received 3XR with exceptional strength and absence of fading.

E. Davis, an amateur of Coconut Grove, a suburb of Miami, Fla., acknowledged reception, indicating that at 4 o'clock in the afternoon the signals were "loud." The distance between this point and Hyattsville, Md., is approximately 1,000 miles. This

feat of transmission and reception appears all the more phenomenal when we are told that only 1.8 amperes were put into the antenna and the transmission occurred during daylight. Of the 27 amateur stations acknowledging reception of the signals, 16 specified the audibility as "very loud." Absence of fading or swinging was conspicuously evident in the reception reports.

## THE TRANSMITTER

The transmitting equipment employed in these remarkably successful tests is contained in a rear room of the Rogers Radio Research Laboratory. The well-known Hartley circuit is used. In conducting these novel transmission experiments, two 50-watt vacuum tubes were used. The battery quarters is apart from the transmitting compartment proper, the former occupying a small second-story room. There are available 500 individual storage battery cells, capable of impressing 1,000 volts on the plates of the transmitting tubes. The wave-length used during these tests was 185 meters.

## PAST EXPERIMENTS

Connection of the transmitting equipment proper with the buried antenna was effected in a simple way, namely, by the extension of an insulated wire or copper tube from the laboratory through the floor of the building to the underground copper tubing. Preliminary underground transmission tests, conducted by Dr. Rogers a number of months ago, involved three different arrangements of the transmitting apparatus with respect to the conducting medium. In one instance, a single conduit 100 feet in length was used, the transmitter being grounded. In another case, 100 feet of conductor was employed at each end of an ungrounded transmitter. The third arrangement consisted in the placement of 100 feet of conduit at each end of the

transmitting station, with the transmitter connected to the ground in the usual way for operating transmitting and receiving equipment.

## DIRECTIONAL CHARACTERISTICS

The peculiar directional properties common to a coil or loop of wire when used for receiving radio signals are accepted knowledge. Buried antennae for transmitting purposes likewise demonstrate pronounced directional characteristics. Not unlike the radio beam system the energy radiated is concentrated in one direction and its force is not dissipated as is true when electromagnetic waves are propagated in all directions. This, in part, probably accounts for the remarkable achievement of Dr. Rogers in radiating electric energy over great distances with the consumption of relatively low power. The Rogers Radio Research Laboratory is now engaged in laying terra cotta pipe for the placing of underground antennae pointing east and west, thus having facilities for radiating electric energy to all points of the compass. The installation of two 250-watt transmitting vacuum tubes will mean an appreciable increase in the output of power during subsequent transmission tests.

The results attending the recent tests justify, Dr. Rogers thinks, the following prediction: "I believe the greatest development of 1925 will be transmission and reception by buried antennae. By the use of such, fading will be eliminated, signal strength will be the same during the 24 hours, the difficulties of 'static' reduced, and, owing to the marked directivity of this form of antenna, less power will be required to cover great distances."

## THE EARTH AS A CONDUCTOR

That the earth acts as a conductor of electromagnetic waves is a theory long ago ad-



Laying of terra cotta pipe, in which is placed copper tubing, and the whole is covered in four feet of soil. These underground antennae, each 100 feet long, extend north, south, east, and west respectively.

\*Prior articles on the Underground Antenna System, invented by Dr. J. H. Rogers, appeared in the March and June, 1919, issues of Science and Invention, then the Electrical Experimenter, and the June, 1924, issue of Radio News.



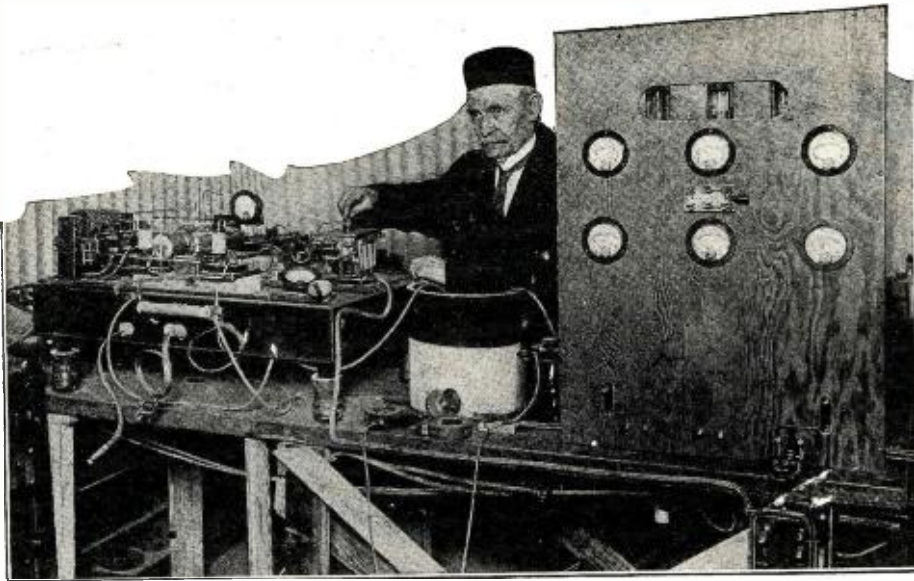

Dr. James Harris Rogers, inventor of the underground and underwater radio communication system, and the transmitting set used in recent tests of radiating signals underground for a distance of 1,000 miles. The panel on the right contains the two 50-watt tubes, and on the left is the new transmitter being built, consisting of two 250-watt tubes.

vanced by Dr. Rogers. He practically demonstrated this, then a revolutionary contention, during the World War. His successful efforts in intercepting and amplifying radio signals emanating from European stations by means of underground antennae are now a matter of history. Recent underground transmission tests further fortify the theory that the earth is a conducting medium for radio waves.

Dr. Rogers, in an interview with the writer, expressed the belief that many of the phenomena experienced in radio broadcasting and reception may be explained in the light of the earth as a conductor. For instance, there are so-called "dead spots" between Baltimore and Hyattsville, which means that it is practically impossible to intercept signals from Baltimore. The presence of vast

iron mines may be responsible for this. The fading or swinging of signals is another phenomenon that may be due to the hypothesis that radio waves travel through the earth. For instance, KDKA of East Pittsburgh, Pa., is widely known as radiating signals that frequently fade. The presence of mountains in that section containing an abundance of ore may explain this phenomenon, the minerals absorbing the radio waves.

"Electric waves propagated through the earth spread out perpendicularly to the surface of the earth," explains Dr. Rogers, "while waves propagated from elevated antennae travel diametrically opposite to this. One-half of the energy from elevated antennae actuates receivers over distances around the curvature of the earth. The other half of energy, which is dissipated by

elevated antennae, is never bent around or reflected around by the Heavside mirror. Buried antennae are very effective, even when using relatively lower power, because all of the energy is transmitted to the earth and thus effectively utilized."

Furthermore, as demonstrated by recent tests, Dr. Rogers believes that conditions in effect at the transmitting station influence fading. "The electrostatic lines of force do not, at all times," he explains, "embrace a uniform area, but this field of energy is constantly expanding and contracting. The result is that the strength of the electromagnetic waves radiated from elevated antennae varies in proportion to this contraction and expansion.

"This elastic condition in the electrostatic field may be attributed to changes in the space above the earth, such as passing clouds, and to the ionization of the atmosphere. However, when antennae are buried or submerged under the surface of the earth, the electromagnetic waves thus propagated are not subject to the fluctuating conditions prevalent in the hypothetical ether—or, at least, they do not exist to such a marked degree."

The results of these underground transmission tests indicate that radio waves thus propagated are not influenced by the seasonal changes of night and day. In the parlance of the street "it is fair weather all the time" for radio reception when shooting electromagnetic waves through the earth instead of radiating these invisible particles of energy through the ether. That is to say, in the 1,000-mile test between Hyattsville and a suburb of Miami, Fla., the signals transmitted during the day and after night-fall were the same with respect to audible strength and their absence of fading at the receiving point.

#### A NOTE OF THANKS

Dr. Rogers has made the following statement: "I desire to extend my thanks to the radio amateurs and others who have so generously assisted me in making these experiments. A special note of thanks is due D. S. Breitenhad, John Lunnemann and Captain E. F. French, the latter of the U. S. Army.

## Results of the Super Power Broadcasting Vote

THE hundreds of letters that have poured into the Editorial Department of RADIO NEWS have, in eight cases out of ten, been in favor of the increase of power for broadcast stations. Letters and votes have come in from every state of the Union and from all of Uncle Sam's possessions.

It has been interesting to note that in the majority of cases the people who are in favor of super-power broadcasting are those who live in more or less isolated districts, a great distance from any station. In a few letters from those who live in the vicinity of a station that at the present time is broadcasting with 500 watts or more, the desire for higher power was expressed, but in the majority of cases they were satisfied with conditions as they are.

Upon reflection, this point of view is most reasonable too. Those readers who live in New York City and who have endeavored to get some distant stations while WEAJ is working know what a difficult thing it is. And then what difficulties would be encountered if the power were increased! This is not true of New York alone, but also of any city where a station using 1,000 watts or more is located.

However, on the other hand, there is the rural populace, who are miles from any station whatsoever. Certainly they deserve every bit as much consideration as those who reside in cities. Perhaps they really deserve more, because they have not the advantage for amusement that the city dweller has. They have no theatres or con-

certs within thirty minutes of their front door. They depend entirely upon their radio receivers for amusement and also for prices of the commodities they grow or buy, weather reports, and all the other items that are broadcast daily. These people should indeed be given every consideration.

As has been mentioned above, eight persons out of every ten who sent in the voting blank or wrote a letter expressing their opinion were in favor of increasing the power of a few broadcast stations so that the entire country would be able to listen to the same programs. However, we cannot help thinking that many of the letters and votes for super-power were from users of crystal receivers and so did not give thought to the person with the tube set. We are not "knocking" the owner of the crystal set—far from it, because their number is legion for more causes than we care to mention. Yet the user of the crystal set should take into consideration many things. The man who has invested one or two hundred dollars in receiving equipment is certainly entitled to as good broadcasting as possible. And "good broadcasting" means that he should be able to listen to whatever station he may desire within the range of his receiver. With super-power this would be in a great many cases impossible, as the majority of receivers on the market today are not capable of such selective tuning as would be necessary. Consider just what would be necessary if power is increased. People in cities would only be able to get DX stations after the high-powered stations had signed off, even though

their sets were of the Super-Heterodyne type.

It may be that some of the voters who want more power have been noticing how much power stations in England and on the Continent are using. It is true that these stations use 5, 10 and even 25 k.w., but it is also true that these stations have not the range that those in this country have. We have heard of ships' operators who have listened to American stations two-thirds of the way across the Atlantic Ocean and even at that point it was most difficult to pick up English stations. The experimental station at Chelmsford, England, with an input of 25 k.w. was the first one to be heard at that point, and it is to be noted that the other stations were working at the same time. For some reason, therefore, the range of these stations must not be compared with those here in the United States. We cannot point out this reason, but it is either the operation of the equipment, the design of the apparatus, or conditions beyond the control of the engineers of the British Broadcasting Company.

As some very wise person has said, "There is much to be said on both sides of the question." This is indeed true of this question that is uppermost in the minds of many in this country today. We can only give both sides of the question. If stations do increase their power, many listeners-in will be overjoyed and many will be disgruntled. The only fair way to settle the question will be to arrange things so that the greatest number of people will be served and satisfied.





# The Life and Work of Lee DeForest



Dr. DeForest in 1905.

## PART VII

“ . . . and we indeed take great pleasure in presenting to you this medal for your unflagging effort and the great great instrumentality which it brought forth, the Audion.”

**T**HE hall was a blaze of lights, the seats were full of distinguished men of science and letters. The speaker was just finishing his remarks. Lee DeForest arose from his seat at the rear of the platform and went forward. All eyes were upon him. He was the man of the occasion. He was here expressly to receive recognition from these men, recognition at last, for his efforts. It was sweet after all those years. . . .

He left the Franklin Institute with the Elliot Cresson Gold Medal, and turned homeward. And he thought of all those struggles, those long months of privation, the literal fights with the treasurer of his own company for a necessary \$20 bill with which to pay the filing fee on a new patent—a patent on one of the phases of this same audion, too. But those times were gone forever. . . .

But they were not so far gone that he could not remember distinctly the whole development of the little vacuum tube which had brought this night's recognition. Decidedly not. Every step of it had been a clear-cut advance, and every bit of the work had been entirely original. The papers, some of them did not seem to think so; and as for Armstrong, well, he and several others would like to have shown that it was an adaptation of another man's ideas. But they would learn.

How clearly every step of the development came to mind.

First there was the idea. It came from the flickering of a Welsback burner that was affected by the transmission of signals from a testing transmitter consisting of a quarter inch spark coil with which he was working in Chicago twenty years before.

While working with his co-worker, Smythe, trying to better the old good detector, he had noticed the gas burner fluctuate with the spark coil signals so distinctly that the message could have been read with it. How they immediately became enthusiastic about it and made attempts to work a new

detector from it has already been told. And how they came to the inevitable end of the investigations when they found that it was not the electric waves at all, but the sound of the spark discharge which caused the fluctuations of light, and their disappointment, has also been told.

### THE FLAME DETECTOR

But the incident remained so clear in DeForest's mind that he could never quite give up the idea that the conductivity of gases would ultimately lead to the design of a really sensitive detector. So as soon as he had time away from the actual management of his company, he went back to the problem and began experiments. The first one he performed was with two electrodes in the flame of a Bunsen burner (see Fig. 1). With this arrangement, signals from a distant transmitter were distinctly audible, better than with the old good responder, in fact.

Of course, he had read of the conductivity of electric current in various papers, but no mention had been made of application to even alternating current, much less to currents of radio frequency. But all these experiments had to do with a sort of polarity indication using direct current. DeForest combined this idea with the adaptation and began with the arrangement shown in Fig. 1.

As soon as this arrangement was working, DeForest gave it a thorough commercial trial. The results were obvious. The reception of messages was dependent upon the stillness of the air. If the day was a quiet one and there were no draughts about, the detector worked perfectly. That, of course, could be easily remedied by placing the burner within some sort of casing which would protect it from the winds.

But, working ever toward a better detector, constantly seeking means for making it more sensitive, an examination of the circuit and device used showed him one point which was later to develop into the third electrode of the ultimate audion. He decided that so long as two common electrodes acted for both the antenna current and the local battery current there was a by-pass allowed for the signals which was bound to reduce the effectiveness of the device. Therefore, he set about designing another flame detector which would do away with this short-

coming. The resulting device is that shown in Fig. 2.

It was simply the addition of a separate local circuit thus attaining the maximum strength from the reproduced signal. The improvement in the results by the addition of the new elements was at once noticeable. From that time forward DeForest never forgot the advantages of the separate local circuit.

### A RELAY, NOT A RECTIFIER

It was in 1905 that he began concentrated work on the various forms of gas detectors. Ever since the experiment with the Welsback burner the idea had been slumbering in the back of his mind, but, due to the constant necessity of the company—his own company—and the technical problems connected with the operation and installation of the devices already in use in the commercial stations that they were constantly installing, he had little or no time to give to the outside investigations that he wished.

All during these years and while the actual work on the various forms of gas detectors was progressing, DeForest was obsessed with

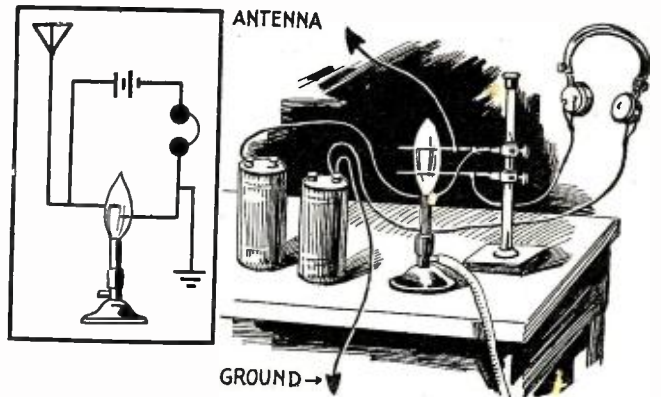
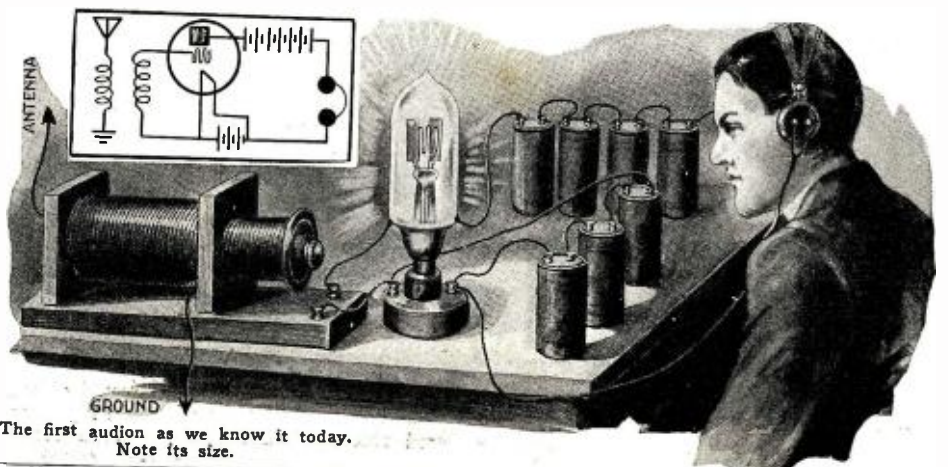

Fig. 1. The original idea of the audion in the conductivity of gases. Two electrodes in a flame was the first audion detector.



The first audion bulb consisted of two hot electrodes in a gaseous medium.



The first audion as we know it today. Note its size.



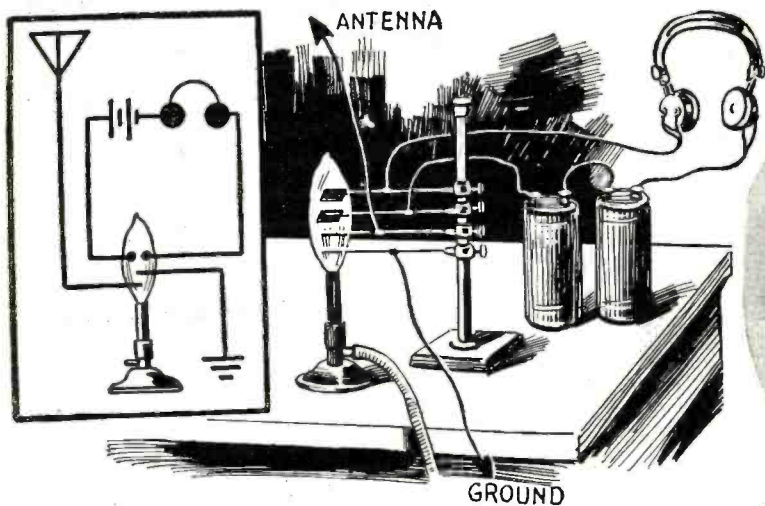

Above is the second "flame audion" with an independent local circuit. The connections are given at the left. At the right, Fig. 2a, is shown the second step in the bulb audion consisting of electrodes in sodium vapor.

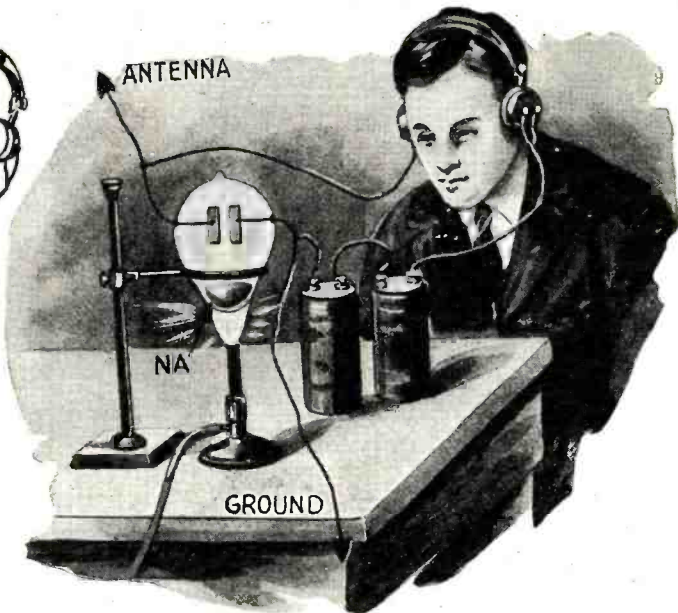

the idea that it was ionization of gases that was responsible for the action of his detector. It was not primarily a *rectifying* device that he was seeking to design. It was a *relay* which would control a local source of energy by the incoming radio waves. This point must be clearly borne in mind in order that an erroneous idea concerning the evolution of the audion may be corrected.

From 1903 onward, DeForest knew of the work of Fleming and others, and the investigations which were being made with the Edison effect, the flow of current from a hot filament to a cold anode or plate. But the point which must be borne in mind is that in spite of this work, DeForest continued along his own lines of investigation, seeking to find a relay rather than a rectifying device.

**THE ADDITION OF A FILAMENT**

As soon as the experiments with the gas flame were well under way he decided that the best method of obtaining stability in the detector was, of course, to place the electrodes in a closed bulb. Consequently, the form shown in Fig. 3 was the result. The elements were heated by local batteries and

were in the form of carbon or tantalum filaments, the substances of which they were made were simply selected according to the ease and availability with which they could be purchased and worked.

And it must be noted here that the bulbs into which they were sealed were only partly exhausted of air. This point is clearly illustrated by Fig. 2a which shows the form developed about the same time for laboratory use. It consisted of two small metal electrodes sealed into a glass bulb which had an aperture in the bottom filled with some halogen salt, potassium or sodium preferably, which was formed into a gaseous state by the flame of a bunsen burner or a heating coil with battery. Both forms were tried, although only the flame type is shown. It was found that the gases produced within the bulb in this method increased the sensitivity of the detector.

The only reason that any of the air was exhausted was in order to allow the burning of the filament without its oxidization.

**THE "B" BATTERY**

In all these devices there is included a "B" battery, or local source of energy, which the tube "triggered." This is the main point of difference between the DeForest devices and those which were working on the rectifier principle. In none of the others was there a local source which was triggered by the incoming wave. The separate battery used in them was employed usually to gain a certain polarity. It was not until well along in the

experiments that DeForest found the polarity of the two electrodes to make any appreciable difference in the operating characteristics.

The efficiency of the device was due to an increase in the flow of the local current during the positive half cycles of the incoming wave and to a decrease of the local current during the negative half cycles, or vice versa, thus giving the true relay and not the rectifier.

Following the adaptation of the two filament tube, DeForest devised the tube with plate, as shown in Fig. 4, in order to save one of the batteries, and it was at this point for the first time that the polarity of the "B" battery was found to enter appreciably into the operation of the tube. And it was here for the first time that any hint was made of the employment of the Edison effect in the tube. Always up to this time with two heated electrodes the ionization of the gases within the tube was given as the sole source of its operation.

Two were used in the Brooklyn Navy Yard station.

At this point the operation of the tube became so superior to the other types of detectors that DeForest literally settled down to the work of investigation in dead earnest. He had finally decided that it should be made the chief means of detecting radio frequency currents.

Consequently, several of the available types were manufactured for the various DeForest Company stations and put into operation.

But he was still dissatisfied with its operation, all the time holding tenaciously in his own mind to the belief that it could be made the most efficient detecting device. Then he remembered the addition to the separate local circuit which he had employed in the original flame audion. The logical step was at once evident. He added the outside, separate, local circuit to the filament and plate bulb in the form of another plate on the outside of the bulb. This form is shown clearly in Fig. 5. The control, in this case, was said to be electrostatic, in the Letters Patent covering its operation. The same form of tube was made with a coil on the outside of the glass instead of the plate. In this case the Patent read that the control was by electromagnetic means.

Accordingly, the apparatus was set up and another tube was made with two separate and individual plates in it. One was on one side of the filament and the second was on the opposite side. This form functioned unexpectedly well and DeForest continually asked himself if, after all, he had found the best possible location for the third electrode.

If the third electrode had such minute  
(Continued on page 2006)

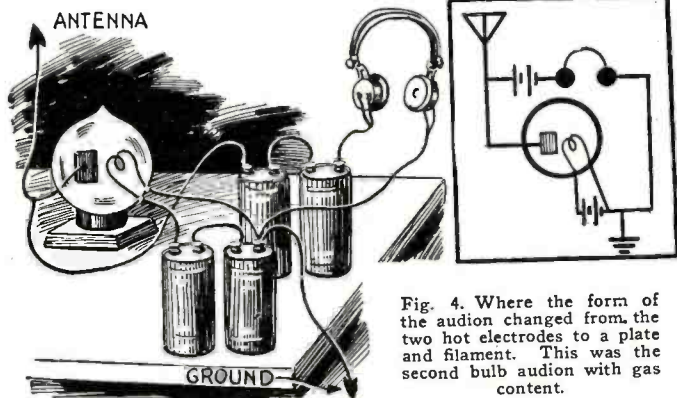
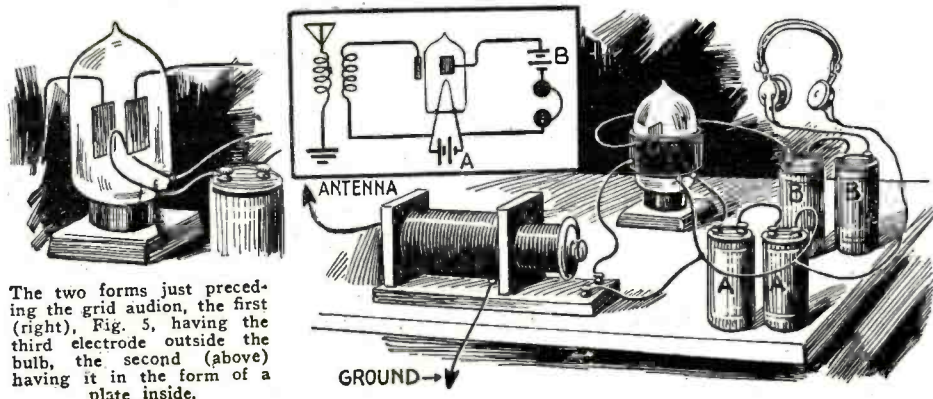

Fig. 4. Where the form of the audion changed from the two hot electrodes to a plate and filament. This was the second bulb audion with gas content.



The two forms just preceding the grid audion, the first (right), Fig. 5, having the third electrode outside the bulb, the second (above) having it in the form of a plate inside.



# A New Method of Television

By W. G. WALTON

*Below is given a description of the newest method of transmitting photographs by radio or wire at such a speed as to enable the distant envisioning of transpiring events.*

MR. W. G. WALTON, in the interest of scientific progress, has kindly given an interview for RADIO NEWS in which he explains the great difficulties in accomplishing the "Radio Movie," the ultimate object of his research. Both he and Mr. W. S. Stephenson, of the General Radio Company, London, have done a great deal of research work in the matter of the transmission of pictures by radio, and have made some highly interesting discoveries.

## WHAT HAS BEEN DONE

"For a matter of 30 to 40 years attempts to transmit pictures by electrical means have been made, and the advent of the motion picture led to dreams of transmitting pictures at such a speed that a motion picture effect could be produced," Mr. Walton said.

"The light sensitive device has been, and still is, the greatest source of our troubles. Selenium cells have the disadvantage of slow action and lag, while photo-electric cells, though faster, give only very minute currents which need amplifying by many stages of resistance coupled vacuum tube amplifiers. Neither of these devices is a desirable feature of commercial apparatus. The time required by the fastest apparatus is too long. To be an entire success, apparatus must be faster and such that it can be used at a moment's notice without many adjust-

ments, and the reception of a reasonable picture must be a certainty.

"Television or the radio movie," he continued, "is the transmission and reception of pictures by electricity in such rapid succession that a motion picture effect is obtained. Apparatus for this purpose is generally the same as that used in the transmission of photographs, but operating at a much greater speed."

## ONE METHOD

One of the methods is to traverse the picture in lines by optical arrangements and transmitting impulses, the strength of which depends on the intensity of the small sections of these lines as they are shown in succession on a light sensitive device.

At the receiving end a beam of light varied in intensity by a shutter actuated by the impulses received from the transmitting end is traversed over a screen by an optical arrangement similar to that used at the transmitting end. Everything depends upon the rate at which the light sensitive device can respond and also the light controlled shutter at the receiving end. This refers to schemes using one cell.

## MILLIONS OF DOTS

Before difficulties in the way of television can be appreciated, the number of dots necessary to produce a reasonable picture must be

known. Television to be a complete success must have almost as good a definition as the standard motion picture. With a picture of one square foot consisting of a million dots and held a foot away from the eye, an average person will be able to distinguish the dots. Such a picture will give good detail of a town or landscape view.

## SPEED

Motion pictures are shown at the rate of 16 per second. Taking this as the rate at which complete pictures must be repeated by television apparatus, our light sensitive device in single cell methods has to respond to 18,000,000 different impulses per second, and so must the light control shutters. This is, of course, putting the problem at its worst. Some investigators have stated that 300,000 (an enormous difference) will suffice. Allowing that the number of complete pictures is 10 per second, our picture consists of 30,000 dots, 150 lines of 200 dots each. Take any magazine or newspaper picture and mark off 30,000, the picture within this area can hardly be said to have good detail, certainly not in a landscape or incident picture.

We are striving to produce something as good as the motion picture, and though 18,000,000 per second is high, it is a good ideal to aim at. Light sensitive devices as used up to the present time have not been able to respond to anything like such a speed.

"Mr. W. S. Stephenson and I," Mr. Walton continued, "have done a considerable amount of research work. In an endeavor to discover something much faster, we tried the possibilities of vacuum tubes to see if light would affect a stream of electrons by bending the stream or otherwise producing some action. Results were doubtful, masked by other things such as light from the filaments.

"Although we have not abandoned this idea, we are trying another line of investigation which shows great possibilities. We have hopes of producing a light sensitive arrangement with a reverse effect, so that an extremely rapid shutter will not be required at the receiving end."

## HETERODYNING WAVE-LENGTHS

Light waves are electro-magnetic in nature, differing from radio waves only as regards wave-length, though the difference is great. Our endeavor is to convert light frequencies into radio frequencies by an action similar to heterodyning (super imposing one wave-length on another) in several steps. The radio frequency thus produced is, after amplification, transmitted direct without modulating a carrier wave. The possibility is now apparent. A picture consisting of light waves is converted into an invisible picture of radio waves which, after amplification and reconversion at the receiving end, produces a visible image on the screen. As just described, the trouble is in sorting out the waves and putting them in their respective positions at the receiving end. But if the picture at the sending end is split into sections, and each section has a frequency of its own, then the rearrangement at the receiving end is only a matter of reversing the operations which took place at the transmitter.

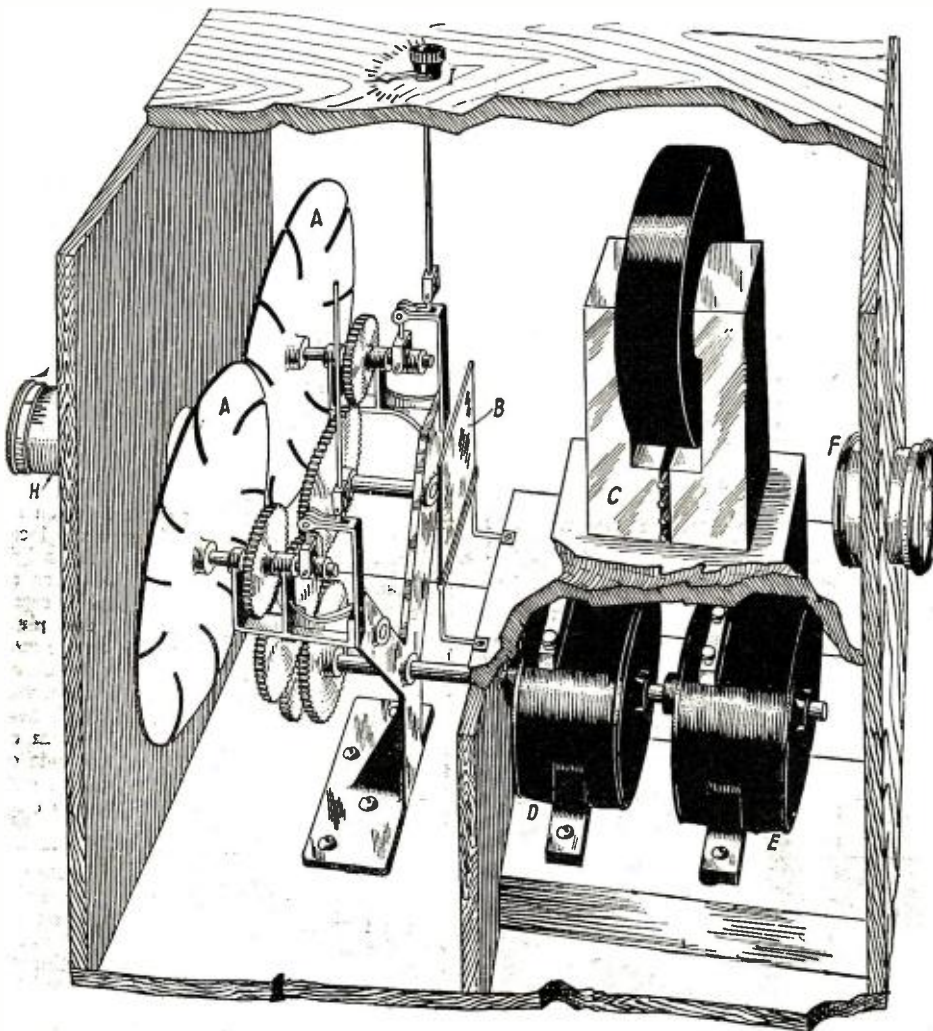

The reproducing apparatus which recreates the image transmitted to it by the sender.



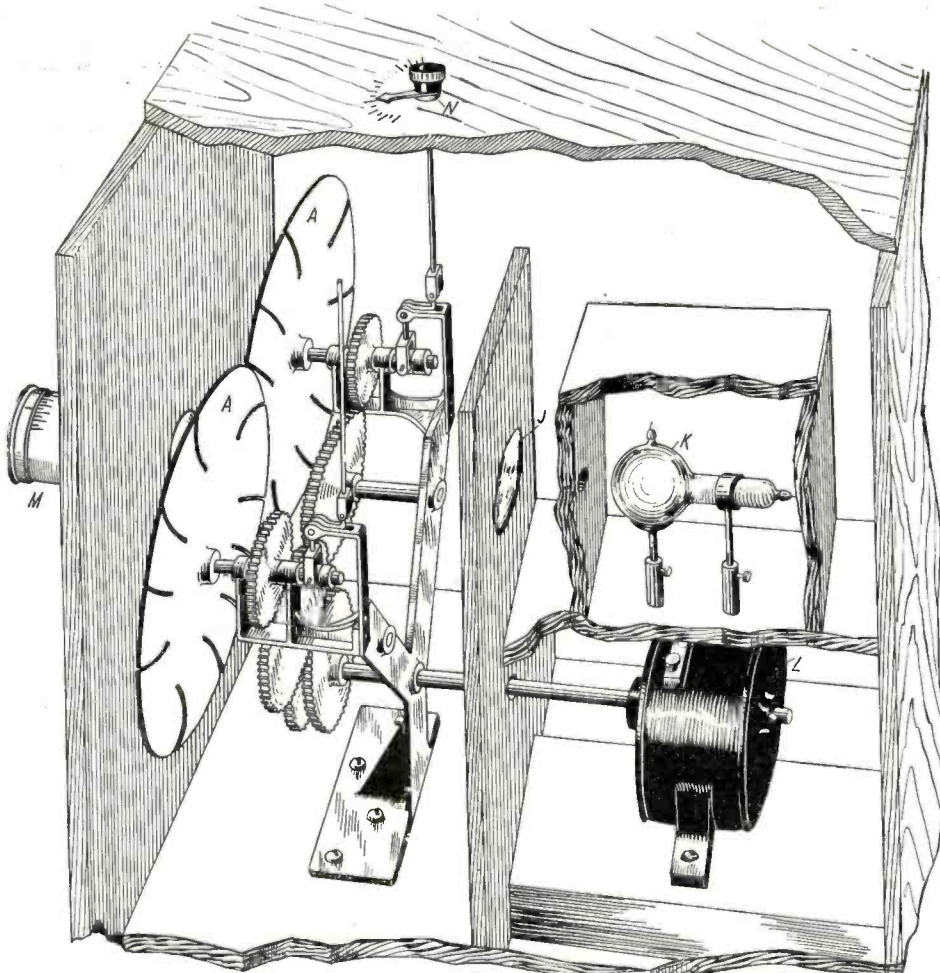

Above is a plan in perspective of the new television transmitter. Note the position of the lens, M, and the light sensitive cell, K.

arranged for a series of rapid flashes, and lastly, speed of traverse is practically the same over the whole area.

**THE TRANSMITTER**

"The transmitting instrument is arranged somewhat similar to a camera," explained Mr. Walton. "A lens (M) (on the sketch) throws an inverted image about one inch square in a plane parallel to and just between the overlapping discs (A, A). The slots in the discs are about .002 of an inch wide, therefore the pinhole formed by intersecting slots is about the same diameter. As I explained, the pinhole traverses the whole of the inverted image, allowing a small area of light at a time to pass through. This light is then focussed by a lens marked (J) onto a light sensitive cell (K). The varying electric currents from the cell and a speed control current are then transmitted by radio or other means to the receiving station.

**THE RECEIVING STATION**

"It is obvious that similar sets of discs must be used both at the transmitting and receiving stations," Mr. Walton continued. "At the receiving station a source of intense white light such as an electric arc is placed behind the lens marked (F), which concentrates the beam on a light control shutter (C), shown diagrammatically as a four-string Einthoven galvanometer. The light having been controlled by the shutter is then thrown on a white diffusing screen (B). An area of this screen throws light through the aperture formed by the slots of the discs onto the lens (H), which focusses the light in a spot on an ordinary projection screen. The received electric current, *i.e.*, current corresponding to the current from the light sensitive cell at the transmitting end, and the speed control current, are applied, the first to the light control shutter (C), and the second to maintain synchronism between the transmitting and receiving machines.

"It is possible when the two machines have just been started and synchronized that the spot of light shown on the screen is not in its correct position, in which case by means of the 'advance' or 'retard' control (I) can be rectified even while the machine is operating at full speed.

"I have mentioned the spot of light shown  
(Continued on page 2000)

The transmission of the pictures would mean the use of a band of wave-lengths, but, after all, radio telephony has the same difficulty. The speed of operation need not be considered with such an arrangement and natural colors mean little further complication.

**THE PROCESS USED AT PRESENT**

"I have explained," Mr. W. G. Walton told RADIO NEWS, "the difficulty in breaking up the picture into dots at a sufficiently high speed to produce an illusion of motion. I will now tell you how Mr. Stephenson and myself tackle the problem with our apparatus. The method used is by causing apertures formed by the intersection of slots arranged around the periphery of two discs to traverse the picture. These discs may be rotated in the same or opposite directions, according to the number and disposition of slots used and the relative speeds of the two discs. In the sketches, the discs (A) are of the same diameter, have the same number of slots each, and rotate in the same direction. They are arranged to overlap about 1½ inches, consequently the slots of one disc are moving downward and the slots of the second disc upwards. As the slots of one disc are at an angle to those in the second, a minute aperture is formed at the point of intersection, which, when the discs are rotating, passes from one side to the other. Immediately one pair of slots has become disengaged, the next pair engage. Should the two discs be rotating at the same speed, all the apertures will follow the same path, a line, curved or straight, depending on the shape of the slots, from right to left. Now should one disc rotate a little faster than the other, each successive aperture will traverse a line a little above or below the line traversed by the last aperture.

"The effect of all this," continued Mr.

Walton, "is equivalent to causing a pinhole to traverse an area in successive lines from right to left, each line just above the last, until the whole area has been covered, when the same process is repeated, starting at the bottom. The great advantages of this method are that there is no waste time, some part of the area is always covered by the pinhole, the pinhole is always open and not

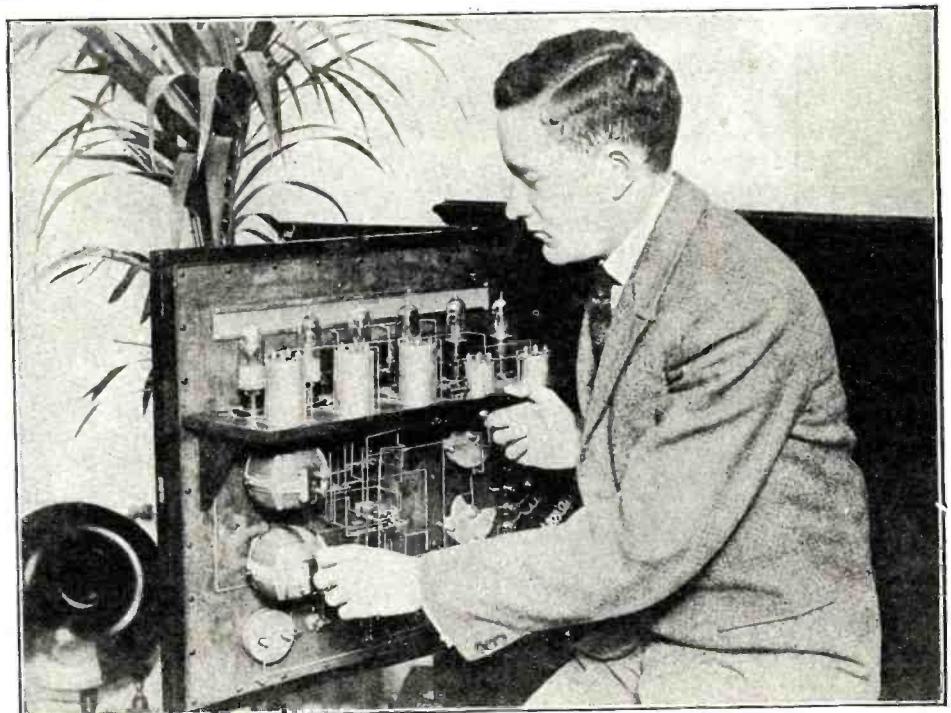

Mr. W. S. Stephenson, the co-inventor of the machine for the transmission of pictures by radio described in the accompanying article. © Keystone View Co.



# The Vacuum Tube Situation

By D. C. WILKERSON

Now that the DeForest three element vacuum tube patent has expired, we may expect numerous movements in the vacuum tube industry. Mr. Wilkerson explains the situation and the probable outcome.



A baby and a giant. The large transmitting tube is made of Silica and is rated at 30 K.W. The filament draws 50 amperes at 30 volts. The plate voltage is 12,000. The little tube is employed as detector or amplifier. The filament draws 0.25 amperes at 1.1 volts.

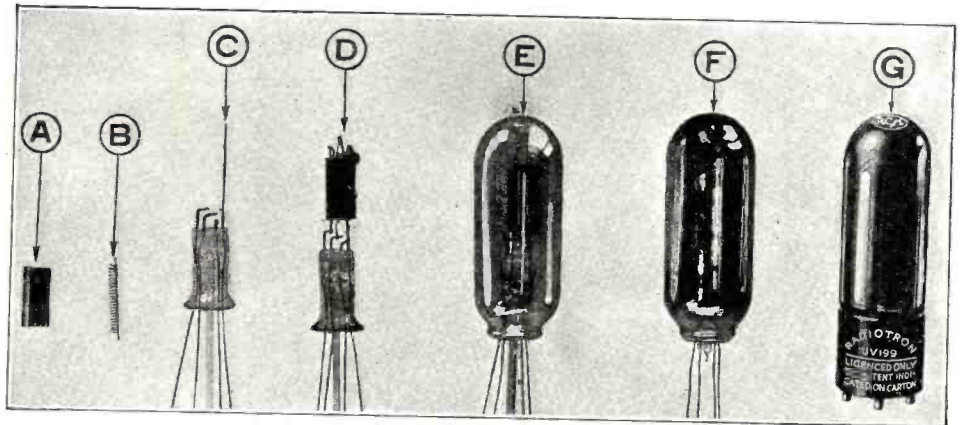

The successive steps in the manufacture of a UV-199 tube of the thoriated filament type. A is the plate, B the grid, C the "press" through which the leads are taken. D shows all the elements mounted on the press. At E the press and bulb have been joined. F is the tube as it appears sealed and evacuated. G shows the completed tube. © Radio Corp. of America.

most ordinary use, but such a condition is to be expected when the actual manufacturing handicaps in the places where such tubes were made, is considered.

### A BAD REPUTATION

In spite of the bad name given to many independent tubes, there are many which stand out as being really first class. The business is young, there is plenty of room for improvement, and the many original mistakes are being gradually ironed out.

Throughout the independent tube industry a strong rumor has been persistently noised about to the effect that after February 18, 1925, the date of the expiration of the DeForest "interposed between" patent, all independent tube makers will be able to come out in the open and continue to manufacture vacuum tubes without fear of molestation or legal interference.

The patent in question was issued to Dr. Lee DeForest on February 18, 1908, and is U. S. Serial No. 879,532. It covers the matter of a grid interposed between a filament and a plate.

The rights to this patent, along with about 75 or 80 others, were transferred by Dr. Lee DeForest to the American Telephone & Telegraph Company, and by a cross-licensing system, the General Electric Company, the Westinghouse Company, the Western

Electric Company and the Radio Corporation of America shared in their benefits.

The impression that this remaining DeForest patent stood alone in the way of the independent tube manufacturer is an erroneous one, for there are important filament use-and-methods patents and patents on the use of and the method of forming a high vacuum which must be circumvented.

Radio tubes made after this expiring tube patent will not function properly, and could be of little use to the average radio fan. A high vacuum and a thoriated tungsten filament or its equivalent are necessary to a successful vacuum tube as we know it today. The early DeForest tubes submitted were gassy and, in fact, Mr. DeForest's patent specifications call for a gassy content or gaseous envelope within the tube surrounding the elements.

Dr. Irving Langmuir, the noted General Electric engineer, filed patent claims covering the high vacuum characteristics, and the Bell Telephone engineer, Arnold, filed parallel and interlapping claims. On account of the interferences of parts of these two claims, the United States Patent Office has been unable to issue a clear patent on this important matter, and the interference proceedings are now in the hands of the Court of Appeals for adjudication. This controversy involves millions of dollars' worth of machinery, physical property, research laboratories and experimental work.

### THE FILAMENT

Beyond this high vacuum question stands the matter of the filament. For general production purposes the thoriated tungsten filament has shown its superiority, and the fundamental patent rights for this type of filament have been dragged into and out of various courts, both in electric lamp and vacuum tube manufacture, until the same interests controlling the three-element patents dominate the filament situation likewise. There are several independent filament patents for making filament wire for lamps and vacuum tubes. The Yunk and the Pintsch wire patents are available for independent use, and those covering the use of yttrium and other metal base wire as well.

Independent tube manufacturing interests are unable to buy thoriated tungsten filament wire from the owners of the process. Thus far, independent filament has shown

(Continued on page 1946)

THE manufacture of independent radio tubes, despite legal influences, has grown to be a young industry within the last two years. In the beginning, practically all of the tubes made outside the directive control of the alleged trust were put together in back alley buildings, hidden away from the sight of man, and they were structurally poor and carelessly designed for the most part.

Today it is estimated that more than five million dollars' capital is represented in up-to-date factories, on the Atlantic and Pacific coasts, as well as inland, and the production of independent tubes, it is believed, has jumped to high levels.

Much of the independent product in tubes is thoroughly rotten and unfit for even the

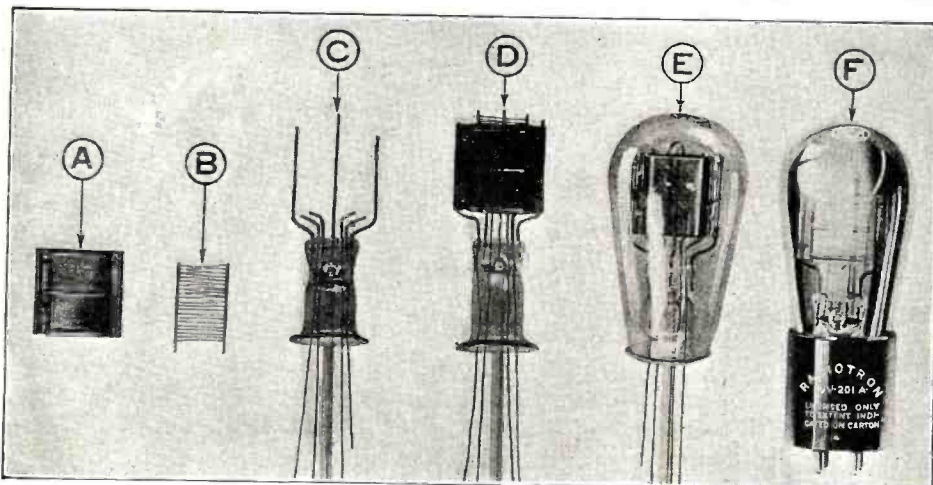

The successive stages in the manufacture of the UV-201A tube, practically the same as in the photo above. Note the wires embedded in the "press" at C. These serve as the supporting members for the elements. © Radio Corp. of America.



# The Radiotoneotype

By L. SPENCER

An elemental idea which might be used to advantage by the experimenter is given in this article. The system is novel.

THE radiotoneotype is the result of a series of experiments carried out by the writer in an attempt to determine the acoustic period of vibrating members, both electrical and mechanical, in amplifying circuits.

The radiotoneotype is not an instrument of entirely new form nor of particular value since its development has not been carried through to completion. The description is offered because it is believed that the unique arrangement and the notes on the experiments will be of interest to the readers of RADIO NEWS.

This instrument embodies a system of transmitting messages by employing musical notes at the transmitting end, which, in turn, actuate delicate instruments at the receiving end, and exert pressure on the keys of a typewriter, thus transferring the original musical notes into written copy.

Before relating the details of these novel experiments it might be well to go lightly into the underlying principles upon which

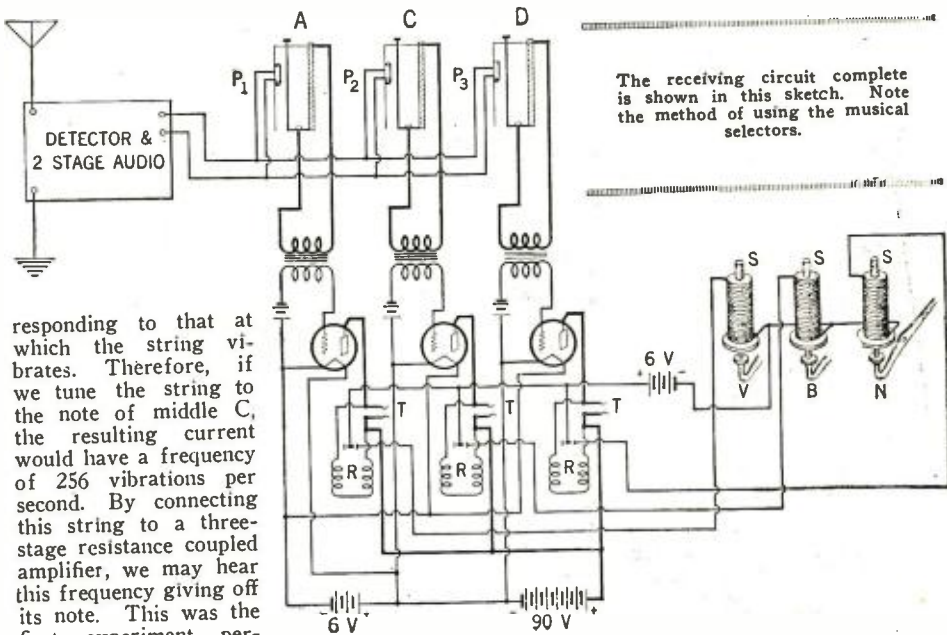

The receiving circuit complete is shown in this sketch. Note the method of using the musical selectors.

responding to that at which the string vibrates. Therefore, if we tune the string to the note of middle C, the resulting current would have a frequency of 256 vibrations per second. By connecting this string to a three-stage resistance coupled amplifier, we may hear this frequency giving off its note. This was the first experiment performed.

Now, if we place two strings in magnetic fields, we get two notes, providing the strings are tuned appreciably dissimilar; otherwise, the heterodyne effect is noticed, thus delivering three notes instead of the two former ones. But if the strings are vibrating at periods of sufficient differentiation, as many as 16 notes may be used together.

Only three notes were used in the experimental apparatus and they were well separated on the scale. The strings were mounted as shown in Fig. 3. The amplifier was connected to a radio telephone transmitter having an output of five watts. It is obvious that when one of the strings is vibrated it will produce an electrical current of the exact frequency of its period and will modulate an output of the transmitter. Thus we hear the note C transmitted, not as it would sound if vibrated by a piano or a violin, but very similar in tone to an AC hum of the same frequency.

A regenerative set with two stages of audio frequency amplification was used at the receiving end and served very efficiently. Again, steel strings were used and mounted directly in front of headphones. These strings were tuned to the same frequency as those used at the transmitter end.

Thus the investigator will see at once the underlying principles upon which the device works. The method of making the received

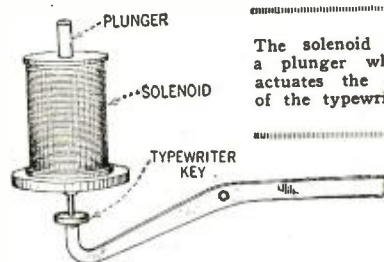

The solenoid has a plunger which actuates the key of the typewriter.

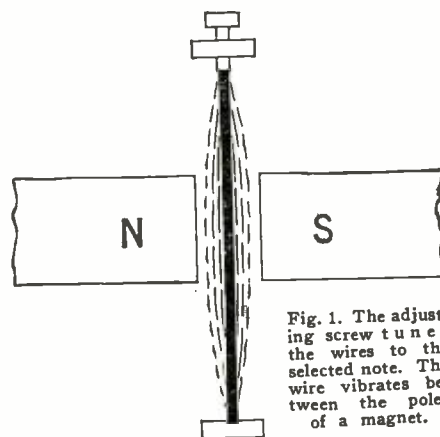

Fig. 1. The adjusting screw tunes the wires to the selected note. The wire vibrates between the poles of a magnet.

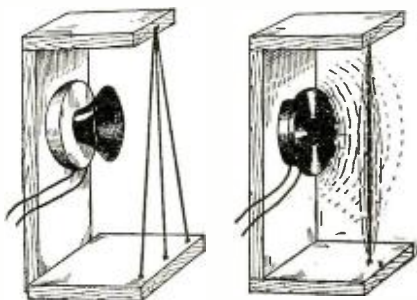

Fig. 3. The heart of Mr. Spencer's apparatus is shown above.

the machine operates. Take a steel string such as employed in banjos or pianos and mount it so that it can be tuned and vibrated by either electrical or mechanical means and arranged so that it can be set into vibration by a tuning fork or another string at resonance. When this steel string is vibrated it will emit a sound the pitch of which will vary as its length and tension. If this string is placed in a magnetic field depicted at Fig. 1 and vibrated, it will not only generate a sound but will generate electricity because it is playing a rôle similar to an armature in the ordinary motor generator. Since it is an armature consisting of a single wire, the voltage which it generates will be very small, but quite useful when amplified.

Obviously, the generated current is alternating in character and of a frequency cor-

vibrations operate the key of a typewriter is comparatively simple. For each string in the transmitter a second one is installed in the receiver. Before each one of them is placed a telephone receiver which is connected with the output of the audio stage. The bottom of the string is connected with a Brown relay, a very sensitive device, so that when the string is set in vibration the relay will close. Of course, a heavy current is keyed by the relay and a large electromagnet is operated by the current. This magnet is in the form of a solenoid with a sliding core which is attached to the key of a typewriter.

It can be seen that the vibration of the string at the transmitter will result in the

(Continued on page 1944)

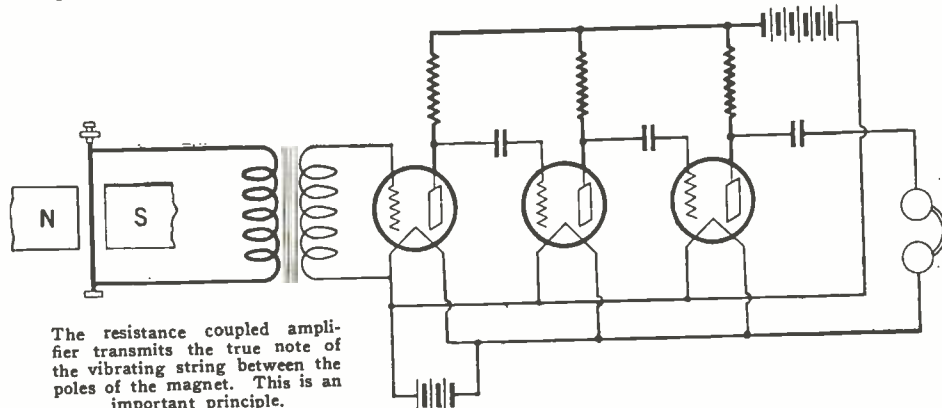

The resistance coupled amplifier transmits the true note of the vibrating string between the poles of the magnet. This is an important principle.



# The Latest in Tuned Radio Frequency

By ARTHUR REED

*With the constant advances in efficiency made by designers of radio receiving equipment, new adaptations are constantly emerging. The set described here is one of the most efficient and stable.*



The completed set described in this article is shown in the photograph at the left. The large discs at the front of the set are the dials of the condensers which are placed vertical to the panel front. The binocular coils, radio frequency transformers, are plainly visible between the sockets. Photos © 1925 by A. H. Grebe & Co., Inc.

WHEN radio left its swaddling clothes and took on a man's estate as one of the world's foremost methods of communication, radio frequency amplification became of extreme importance. The original investigations into this subject seem indeed crude beside the modern developments.

From the first transformer stages to the original investigations of Mr. Rice with neutralized coupling is a far step. A brief view of the developments from this time forward is enlightening, particularly the description of the latest design described here. At Fig. 1 is shown the theoretical plan worked out for the greatest transfer of energy and the greatest possible amplification from a tube. Both the grid and the plate circuits

are tuned. It will at once be obvious that a given alteration in the grid potential will produce the greatest change in the plate circuit, and through the phenomenon of resonance will give the greatest transfer of energy to the grid circuit of the following tube. But it will also be obvious that the circuit will oscillate violently, due to the internal capacity of the tube.

Following this investigation, and with the knowledge of the oscillation characteristics of the tube, many experimenters and engineers set about finding means of preventing it. The first result was a compromise with the problem. A resistance of some sort was included in the circuit to damp out the excess energy, usually a potentiometer. This is the well-known "loser" principle. (See Fig. 2.)

Then came the methods of neutralizing the internal capacity of the tube—a step much closer to the heart of the problem. In this case the grid and the plate circuits were tuned, but the plate circuit was tuned to a much lower wave-length than the grid.

When this point was reached, the efficiency of radio frequency amplification had reached a surprisingly high figure. There were some engineers, however, who still had the theoretically possible efficiency in mind. Accordingly, they set about to find a method whereby they could attain it.

The diagram at Fig. 3 shows how the grid circuit is tuned to the frequency of the incoming wave while the plate circuit is tuned to a much lower band. With the neutralization factor, the tuning of the plate may be brought much closer to that of the grid; however, not close enough to give the greatest possible efficiency.

And then came another method. Not really a method, but an advanced design incorporating some laws which had been overlooked previously.

It's a long step from the first sets constructed with neutralization to the latest advance, the binocular coils. The chief difficulty encountered after a means was found for counter-balancing the internal capacity of the tube was the magnetic and electrostatic field surrounding the various components of each separate stage of tuned radio

frequency amplification. These fields, if they interlock with the previous or succeeding stage, produce the necessary feed-back causing the tubes to oscillate—a state of affairs which is distinctly not desired. The first method employed, of course, was the placement of the various inductances at such a predetermined angle as to admit of the least interconnection of the stages.

Not only this were the engineers concerned with, but immediately they had determined the proper angle of the coils and constructed the set they found that the various wires necessary in connecting the tubes and inductances, if run parallel for any distance, gave rise to a certain amount of the same effect. They immediately pulled out the old drawing board and set the parts up in an attempt to arrange them sufficiently distanced and in proper angular relation so that the connecting wires would have the least possible mutual field. But this necessitates spreading the set over too large an area and made it too bulky. It was found that a radical change would be necessary in the design of the inductances.

The latest design being described here has built upon these foundations and an extremely novel and highly efficient tuned, "balanced" radio frequency set resulted, the ideas incorporated in which all experimenters—and engineers—might do well to copy.

Inductances had to be used. Consequently the designers began to cast about for the form in which it could be cast that would produce the best results in the situation for which it was intended. They found that the inductance should be of such a form as to have the least possible outside field, an obvious conclusion. Of the various forms known, of course, the usual large diameter

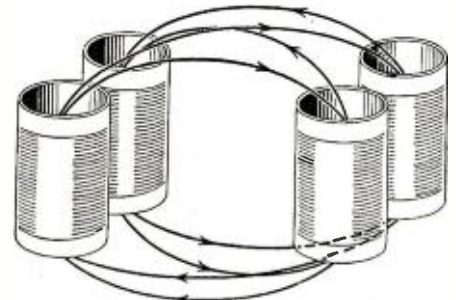

Fig. 7. The arrows designate the lines of force traveling from coil to coil between stages. Note how an equal amount of energy is transferred to each of the four coils. Below is another illustration of this principle.

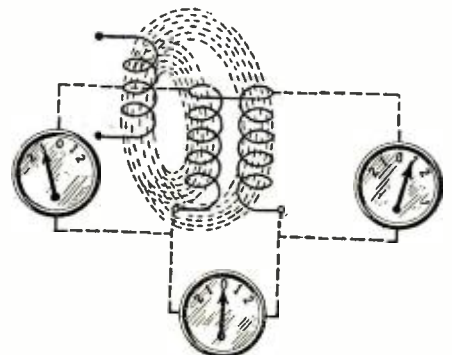

Fig. 6. The meters at the side measure the amount and direction of current on each of the two coils caused by the magnetic lines of force from the third one. Note how they counteract each other giving no net effect.

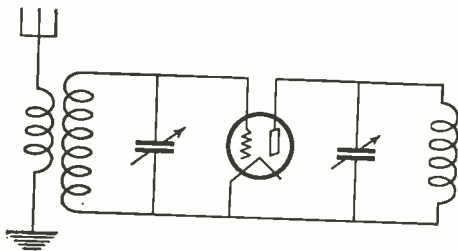

Fig. 1. For the greatest amplification through a tube, the grid and plate circuits should be tuned to the same frequency. Unluckily—or luckily—this gives rise to oscillation, a condition prohibiting clear reception.

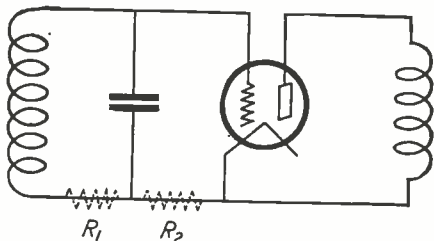

Fig. 2. This sketch shows the adaptation of the "loser" method of stopping oscillation in a circuit employing tuned radio frequency amplification. The plate circuit is tuned to a lower wave-length than the primary.



straight single layer coil now in such general use was at once dismissed on account of the strength of the exterior field. At the opposite extreme was the toroidal form which concentrates this field at the center of the winding. The common type was extremely easy to manufacture, but the latter type brought up problems which required special machinery and apparatus. A midway point was selected, *i.e.*, the binocular coil, which is nothing more or less than the straight coil wound on a small diameter tube cut in the middle and folded over upon itself, as shown in the photograph. This particular system of construction gained both the concentration of field, ease of manufacture and compactness.

Another problem faced was that of the proper size and type of wire to be used in the winding. Litz was at once selected.

This point being settled, designers passed on to the consideration of the proper condensers to be used with this new coil; comparatively easy sailing was found in this quarter. Everyone was agreed that the smallest value of condenser possible should be used; that is, one with an extremely low minimum value would be incorporated so that the inductance could be wound to cover the highest frequency to be received, and that the condenser would have only enough capacity to increase the natural period of the circuit to the longest wave-length to be handled.

Having a low loss coil, a companion low loss condenser was not at all a difficult matter. One said, air dielectric, the next designated no insulating end plates, a third piped up with long insulating strips supporting the stationary plates and another followed with pig tail connections. And then one manufacturer spoke, delivering himself as fol-

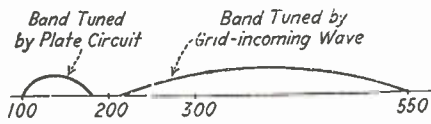

Fig. 3 shows the comparative wave bands covered by the primary and secondary coils. Transference is efficient and oscillation counteracted.

lows: "We'll stand them up on end instead of placing them sleepily on their sides as usual. This will give the set a distinctive appearance and cut down the advertising bill; since it will be so different from the rest, that once seen, it will always be remembered."

The result is shown in one of the accompanying photographs. The completed coil is shown in Figs. 5 and 8. The small meters on the dotted lines in Fig. 6 give an accurate idea of the concentration and reversion of the magnetic field, showing how they check the points of extreme distance on the potential within the immediate vicinity



The condensers used in the complete set are set vertically with dials and verniers which protrude through the cabinet at right angles to the panel.

of the coils and how the field of one neutralizes the other.

And here the really new feature was employed. Not actually new, in fact very old, simply an adaptation of old laws which the other engineers forgot to use. It is the arrangement of the coils so that their fields neutralize each other. In Fig. 6 the field of coil A is shown acting upon the binocular coil B. The dotted lines connect the meters across the two individual coils, one of them at the bottom of the illustration being connected across the two terminals of the complete coil. At the right the meter is showing a current of one unit in one direction induced in it by the magnetic effect of the field from the first coil. The meter across the other one shows an equal current in the opposite direction caused by the same field, since the coil is wound in the opposite direction. This reversal of inductive effect in each coil results in an absence of any net effect as shown by the meter across the bottom terminal of the coil.

Fig. 7 shows how the two binocular coils placed in proximity have no effect on each other since both their fields reverse. The arrows show how the direction of the fields from the various coils work to an exact neutralization of any net effect.

In the completed assembly another point manifested itself in the audio frequency amplification stages. A great many experimenters have found that the jump from one stage to two stages is a bit extreme, and that if the stages are balanced separately many times, they do not hold so well together, and that when adjusted together the individual stages are apt to be noisy, sometimes even metallic. The simple expedient of circumventing these troubles was found by shunting a variable choke across the primary of the first audio stage. Through this means the volume of reproduced sound may be adjusted to taste, at the same time allowing two stages balanced to each other to function undisturbed, thus giving the clearest possible production.

WINDING SPECIFICATIONS

The coils may be wound on tubes approximately 1 3/4 inches in diameter. The primary winding shown in the hook-up is wound on a tube, the outside diameter of which is slightly smaller than the inside diameter of the first. It is placed on the grid end of the large coil and may contain about 20 turns of wire. The two large tubes are wound with approximately 60 turns each in the same direction, *i.e.*, so that when they are placed side by side one is wound clock-wise and the other anti-clock-wise.

Neutralizing condensers may be made by connecting a small bit of copper to the stationary plate, bending it over to the outside of the hard rubber insulation strip which separates the stationary plates (supposing, of course, that one of the latter low loss designed condensers are being employed) and the other plate fastened to the other side of the supporting strip with small screws; a large screw through the center as is shown in the sketch serves for adjustment.

Not nearly the usual amount of difficulty will be encountered in assembling the vari-



Fig. 8. A photograph of the complete binocular coil is shown above. Note the size of the tubes and the Litz. winding.

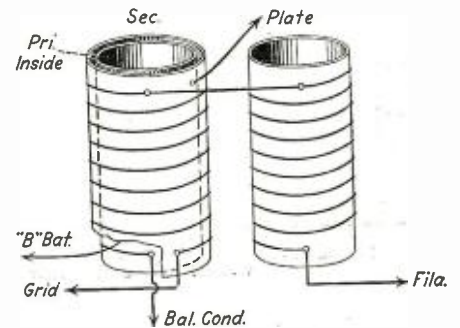

Fig. 5. The diagram gives schematically the method of winding and assembling the binocular unit shown in the photograph.

ous parts of a tuned radio frequency receiver as is found in some of the present very popular types, like the Neutrodyne. The only precaution necessary in the placement of the coils is that they be placed parallel with regard to the plane of their centers, which is to say they should be placed in the cabinet as illustrated in the photograph at the head of this article. This allows the equalization of the interlocking fields. This plan is not absolutely essential, but seems to lend itself most perfectly to the workman assembling the set.

The volume control is simply a shunt across the primary of the first audio frequency transformer. It consists of a small spool coil consisting of about 300 or less turns of a small sized wire, about No. 28. This shunt impedance is tapped at various places in order that a minute control may be obtained. The idea is an excellent one and gives admirable results.

Another point: In many parts of the country, particularly the outlying districts, current for charging storage batteries is not available. In this case the operator must perforce rely upon the use of the dull emitter tubes, the 199 type usually, which may have the filament current supplied by dry cells with some degree of economy.

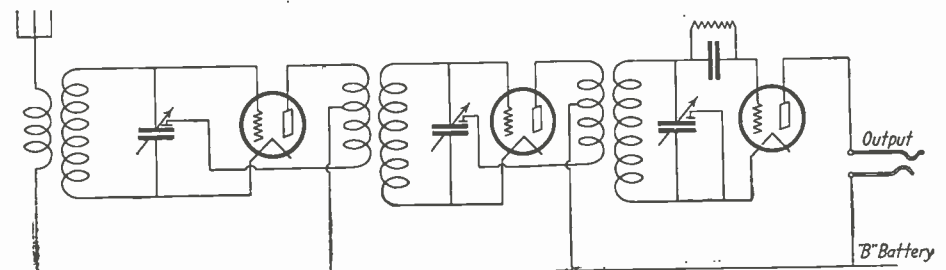

Fig. 4. Complete wiring diagram of the set described is given in the above sketch. Note the center tap on the primary for connecting the "B" battery and the bottom connection to the neutralizing condenser.



# About Radio Losses

By WILFRED TAYLOR

Mr. Taylor discusses the various losses in the present-day design of radio apparatus very interestingly in the article presented below.

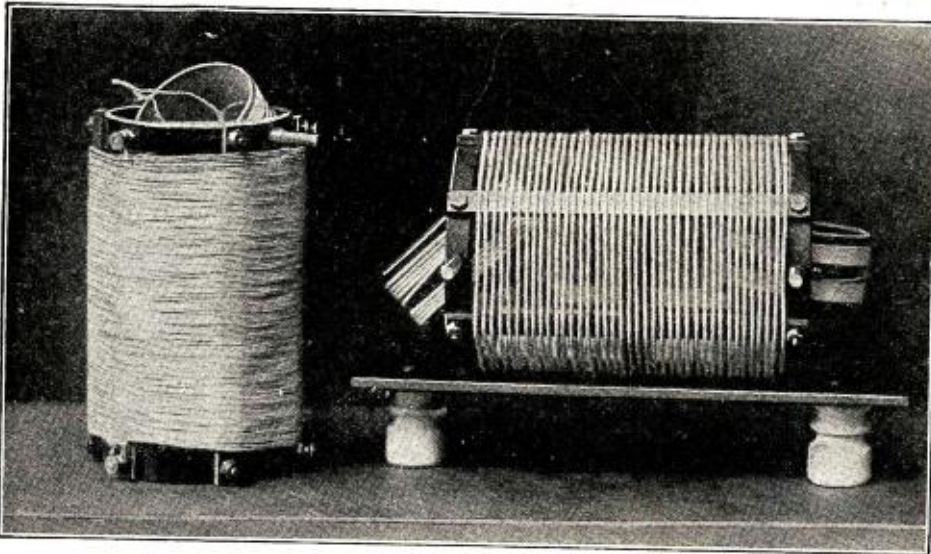

The photographs above give two modern, efficient forms in which radio inductances may be wound. The constructional details are given in the article.

**J**UST by way of starting an argument, I'll bet a top hat that none of you lads knows the difference between a cosine and an asterisk.

Neither do I. I wasted four arid, unproductive years trying to think in Equations instead of the Old Mother Tongue, and I was a pathetic failure; I never could cure myself of the habit of asking the waiter for a second helping in an argot he could get right off the bat, instead of charming him into action by scribbling a formula on a bit of paper. I have spent 40 years trying to forget the few formulæ which seem to have clung to me; I found early in the game that I could hire a lad with a slip-stick for 75 per who would figure my stresses and what-not while I was doing something he couldn't get away with. It has always made me peevish to pick up a book on a subject I happened to be interested in and have to wade through a lot of drivel like this:

$$\frac{Th}{e} \frac{(ro)}{se} = \frac{i}{s} \sqrt{\frac{r}{d}}$$

Factoring for: e we have

$$Th (ro \times s) = \frac{r}{d}$$

In which:

$$\frac{T}{h} \times \frac{s}{r} = \frac{i}{s} (r+d)$$

Substituting we have:

The rose is red  
From which it is clear that:  
The violet is blue

YES, YES!

Certainly; also, of course! Why didn't he say so in the first place? About one man in ten thousand buys the book. I am willing to admit, grudgingly, that mathematics is a necessary evil, and that there are times when it is distinctly useful, but I am fed up with the smoke screens a lot of

pseudo-highbrows fling up every time they approach a subject even remotely related to any branch of "engineering." I can build any old thing from a watch escapement to

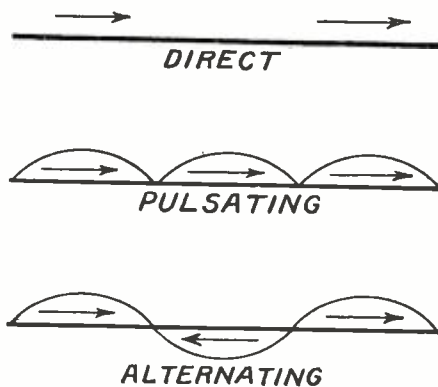

A graphical representation of the three types of currents is given in this sketch.

a battleship, and I have never found it necessary to hide my thoughts behind a barrage of equations every time someone has asked me how old is Ann! Most of us, and most particularly our colleges, spend our time showing the other fellow how much we know, and making it as difficult as possible for the poor devil to acquire any useful and usable information.

When a fellow tackles a new hobby, such as photography or radio, he immediately grabs everything in sight which will put him wise to what makes the wheels go 'round. He buys every book and magazine he can lay his hands on; and about 98 per centum of these are either "popular" effusions having a slight bowing acquaintance with the subject, or they are vury, vury dignified and up-stage and smudged all over with a lot of Greek letters and strange cuneiform writings which mean nothing at all to the man in the street (and little to anybody else, if the truth were known). The ramifications and wanderings of the Urdu verb have nothing on these birds. There doesn't seem to be any

middle ground, and radio is especially cursed in this respect; the woods are full of "popular" articles on hook-ups and such-like, which do not give the slightest inkling of how it works, and when one looks about for something more substantial to sink his teeth in, he runs into Morecroft or the Bureau of Standards—neither of whom descends to earth long enough to know that the War is over.

I have prefaced my remarks by admitting that I know no mathematics more complicated than my board bill, so all you chaps can sit in and be chummy. I have taken a jimmy and a little "soup" and extracted from the strong-box of "science" a little workable knowledge of radio; if any of you are sufficiently interested, I will endeavor to tell you in words of one syllable why it is good business to pay some attention to matters usually neglected by our more erudite friends. I have no intention of trying to cover the entire field, but I can fill in a few gaps which the "popular" scientist and the mathematical shark have seen fit to ignore.

Now that we have the stove good and hot and the cracker bar'l handy, I will say, for the benefit of those of you who run department store emporiums and such-like deadfalls that radio is merely the harnessing of various electrical manifestations of energy as correctly as our limited knowledge will permit. The reason some of us get away with murder is because we are polite and deferential to the lady and have found out that she can be coaxed but not coerced.

If we tap a source of electrical energy (battery or generator) and charge a conductor, we create a difference of potential—we have filled a tank on top of the hill; if we close the circuit (open a valve in the pipe) a current flows until the difference is equalized (ceases to exist); the wire or pipe offers frictional resistance to the passage of the current or water; we say, then, that we have a current under so many volts pressure flowing at a rate of so many amperes through a resistance of so many ohms. We find that there are substances which present little objection to the passage of an electric current; we call these substances conductors. Conversely, there are those materials which offer a high resistance to the passage of the current, and these we call non-conductors or insulators. When we speak of the insulating material surrounding or separating charged conductors, we call it the dielectric.

## KINDS OF CURRENT

There are several kinds of currents: one which flows in a steady stream in the same direction is called a direct current; one which flows in the same direction, but which flows in spasmodic gasps, we call a uni-directional or pulsating current; one which starts out in one direction but changes its mind and reverses itself is an alternating current. The alternating current is the one in which we are most interested and, of course, it is the one which cuts up about nine million different kinds of didoes. The direct current plods along like the tortoise and gets there if there isn't a fence in the way; the alternating current doesn't care a tu'penny rap about the fence—just jumps it and goes merrily on.

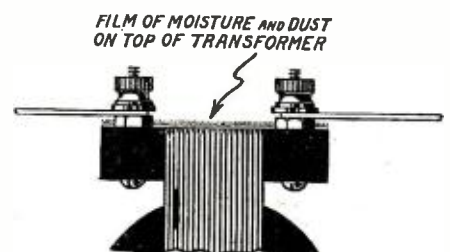

Such small matters as that illustrated above can make a world of difference in the operating efficiency of a radio set.



unless it changes its mind again and does some fool thing we are not looking for. Our batteries furnish us direct current and we know exactly what to expect from it and are governed accordingly; the current which comes to us from the receiving antenna or an oscillating tube is alternating, and nobody knows just what it is going to do next.

An alternating current changes its direction a certain number of times per second, and a complete alternation, that is, a start from a given point and a return to that point, is called a cycle; the number of cycles per second is known as its frequency. Ordinary commercial alternating current is usually 60 cycles—radio currents are not content with any such dignified movements, but hop about at an astonishing rate, sometimes 3,000,000 or more cycles per second.

These high frequency currents, as they are called, refuse to be governed by the rules applied to other currents; among other peculiarities they create a resistance of their own, so that a conductor having a known direct current resistance may have a high frequency resistance many times greater. Instead of traveling peacefully along the road provided for it and minding its own business, a high frequency current gets into other folks' apple orchard and misbehaves in an atrocious manner if it isn't watched. A direct current will toddle along without much external fuss, but a high pressure, high frequency current will be going along, apparently like Old Dobbin, when all of a sudden, without warning and without any obvious reason, it will reach out to some device in its field and burn the supporting screws out of it! Very temperamental, I assure you.

IN THE SET

We see, therefore, that we cannot wire up a set, secure in the thought that our electrical energy is trundling along the paths we have provided for it; the direct part of it does, pretty much, but the alternating can-

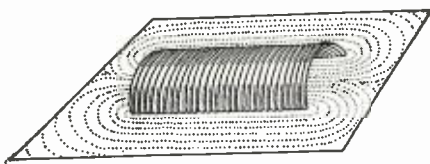

The sketch above illustrates the magnetic stress surrounding an inductance.

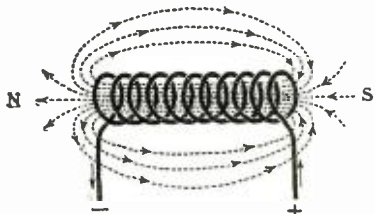

Another illustration of magnetic field with polarities is given here.

not be confined, and we must design our installation so that we eliminate all the possible sources of alternating current leakage and avoid producing high frequency resistance which will cut down our signal strength. When some of the energy represented by the alternating current in our set leaks off and is dissipated without doing any useful work, or when the slight currents available are compelled to overcome needless resistance, we speak of the faulty construction as producing losses; now let us look at some of the things which contribute to these losses.

Beginning with the antenna and going through the receiver to the ground, we find a number of places where ignorance or carelessness gets us into trouble. The way to get a competent, sensitive receiver is not by adding nine million stages of amplification

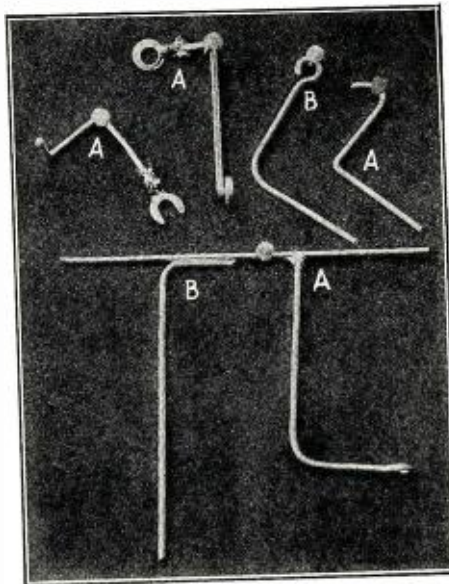

The right and wrong method of making connections. Those wires marked with an A are bent or soldered in the WRONG manner and those marked B are correct.

fore and aft, or by standing the poor thing on its head, or reflexing it, or dubbing around with strange devices, but by careful, accurate workmanlike construction, paying strict attention to the vagaries of high frequency currents!

If the pick-up device is a clothes line, clothes line results will be forthcoming; if it is a sure-enough antenna, built according to Hoyle and looking even to the uneducated eye like a million dollars, you will get signals the clothes line chap never hears. Our alternating current friend loses no time in showing how temperamental she is—the first thing she does is to lose some of her energy in heating up the antenna, but she does this before we can use any means of stopping her so that this slight indiscretion we cannot control. Then, if we have used some mud insulators, she hops merrily over them to the ground, especially if they are wet with a rain which has absorbed a lot of sulphurous acid in its descent through the coal smoke. If we have tied one end of our string to a large, leafy tree, the lady leaves us on another excursion, or if there is a tin roof or a cornice handy, she promptly takes advantage of them and slips to the ground; we should like very much to keep her on the wire until she gives up her energy in the set and then seeks the ground. The higher the wire above the ground, the more energy she will have, because the difference of potential will be greater due to the fact that the advancing wave from the transmitting station approaches our antenna in a plane perpendicular to the lead-in and the electric field will act in a direction parallel to it, therefore there will be a difference of potential equal to the length of the lead-in multiplied by the intensity of the field.

ANTENNA LOCATION

We are told that an antenna is one side of a huge condenser, the earth being the other. Right here let me digress long enough to call your attention to the fact that the earth is not a "ground" in the electrical sense, that it is the moisture in the earth which is the conducting medium. A wire grounded in ordinary dry soil or in rocky ground is worthless from an electrical point of view; it is the sap in a tree which makes it a conductor. Therefore, an antenna strung over moist earth or water is more efficient than one run over rocks, and one run over the top of a tree or a large clump of bushes will lose an appreciable amount of its energy through these leakage paths.

Dielectric losses, we call them. It is also

a good scheme to keep the antenna as far as possible from large trees, clumps of tall bushes and buildings with grounded spouting or metal lath sides, because an electric current, like everything else in nature, seeks the path of least resistance, and will get to the moisture in the earth through these large conductors rather than climb down our comparatively resistant antenna. This is one of the kinds of absorption losses which should be guarded against if we wish to get the maximum efficiency from the wire.

Another place to look for loss is the point where the antenna enters the house; be absolutely certain that this is dry, and that the lead-in runs from the antenna to a wall bracket and thence to the set without coming closer than a foot to the house before it enters.

After we get to the set, our sources of loss are legion and I shall only briefly mention the more common and easily remedied

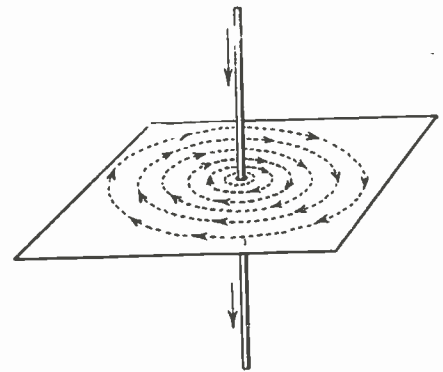

There is a magnetic field surrounding every conductor carrying a current, as shown in the above diagram.

ones so that you will be warned. The first thing we strike in most sets is the inductance coil. This coil usually consists of a number of turns of silk or cotton covered wire wound in one of several fashions about a tube of cardboard, rubber or composition. Here is some more dielectric loss; we have supposed that hard rubber was about the last word in insulating material, but we find that our high frequency currents have but little respect for it. Therefore, wind your coils as nearly on air as possible; I insert an illustration of two homemade coils, which may be of interest. These are wound on hard rubber strips fastened to hard rubber rings, the left-hand one wound double, using No. 18 D.C.C. wire and a fixed primary of No. 12 placed inside the base, and the other a spaced winding using No. 14 D.C.C. with a variable primary of the same wire. The tickler in both cases is No. 24 D.C.C., made with 24 turns on a 2½-inch tube. The diameters of the large coils are 3 inches and 4 inches, respectively, and the primary is 3 inches. The Fig. 1 coil gives particularly good results in DX hunting late at night and the other is better early in the evening when there are a few million stations struggling for the mastery of the air. Never use a tapped coil if it is avoidable; the part you are not using is a large breeder of loss and the switch points are excellent leakage paths. Considerable experiment is beginning to show that a spaced, single layer coil made up of cotton covered wire of sizes between No. 18 and No. 14, wound as nearly on air as possible, is to be preferred over all other types. This is, necessarily, a large coil and will not lend itself to the making of lunch-box receivers. The sooner we get away from this mania for making a radio receiver into everything under heaven except a radio receiver, the sooner we will begin to get adequate results from our apparatus—and we won't get far until we do. Avoid freak receivers as you would the itch.

(Continued on page 1954)



# Building Compact Super-Heterodynes

By D. J. HALL



The Super-Heterodyne is undoubtedly becoming more and more popular. Its one great defect, at the present time, has been its great size. A remedy for this point is given here.



At the beginning of the Super-Heterodyne period, that set usually occupied more room, with its necessary accessories, than the piano or the kitchen stove. But as time went on and improvements were made in its design, its size was constantly decreased, until today there are forms of it which occupy no more room than the regulation detector and two-step, or the Neutrodyne.

This diminution has been made possible through two causes: First, the perfection of the dry cell or dull emitter vacuum tube; and, second, through advances in set design.

In the present instance, we give two examples of the compact Super-Heterodyne. One form is for stationary use, in the home, while the other may be fitted into a suitcase or other traveling bag for portable use. The first is shown in Fig. 1. In this case little change is made in the conventional wiring or the principle of the set, the hook-up following closely the standard eight-tube design with only the addition of a small condenser in the plate circuit of the first tube so the regenerative feature may be incorporated.

With the home model, it will be noted that the arrangement of the parts is substantially the same as they appear on the hook-up, i. e., oscillator, first detector, intermediate frequency amplifier, second detector and the

audio stages. It is the same sequence as followed in drawing the plan of the circuit.

Under this system, the wiring is much easier as well as the placement of the parts. In the second instance, every possible advantage has been taken of space with the result that the parts are all situated as closely as possible to each other. Fig. 2 shows the back-of-panel arrangement in the compact form. The usual baseboard is dispensed with and the instruments are mounted upon a sub-panel which is placed across the center of the panel proper. This supporting device is of copper or aluminum or other metal and serves as a shield as well as a support for the apparatus.

For the completion of a portable set from the arrangement shown in Fig. 2, it is only necessary to select the proper size and shape in traveling bags and then install the panel. Of course, one compartment must be left for the accommodation of the batteries and the loop. A built-in loud speaker will be a bit more trouble to negotiate, but it can be arranged easily, as shown in the accompanying photograph.

One important point which must not be overlooked in such a set is, that the entire interior of the case, that is, the set, should be lined with copper or other metallic foil for the purpose of shielding the completed set from outside induction.

## LIST OF PARTS FOR THE COMPACT SUPER-HETERO-DYNE

- 1 Oscillator coupler.
- 1 Filter transformer.
- 4 Intermediate radio frequency transformers. (Note—These four instruments should be all of the same manufacture and should be matched).
- 2 .0005 mfd. variable condensers—and be sure they go up to .0005.
- 1 .006 mfd. fixed condenser.
- 3 .0025 mfd. fixed condensers.
- 3 .00025 mfd. fixed condensers.
- 1 .0005 mfd. fixed condenser.
- 1 1 mfd. fixed condenser.
- 2 Six-ohm rheostats.
- 1 Small vernier variable condenser.
- 2 Audio frequency transformers, 3:1 ratio.
- 1 Open circuit jack.
- 1 Filament control jack.
- 8 199 type tube sockets.
- 8 199 type tubes.
- 8 Binding posts.
- 1 Panel, 6 by 26 to 30 by 3/16 inches.
- 1 Base, same size, 7/8 inch thick.
- 2 4½-volt "C" batteries.
- 1 1½-volt "C" battery.
- 2 45-volt "B" batteries.
- 1 4½-volt "A" battery, storage or dry cells.
- 30 feet of tinned copper wire, No. 14.
- 14. Miscellaneous screws, nuts, etc.

Too, in connection with this point it might be well to note the small shield which is placed between the oscillator and the tuning condenser. With all the instruments

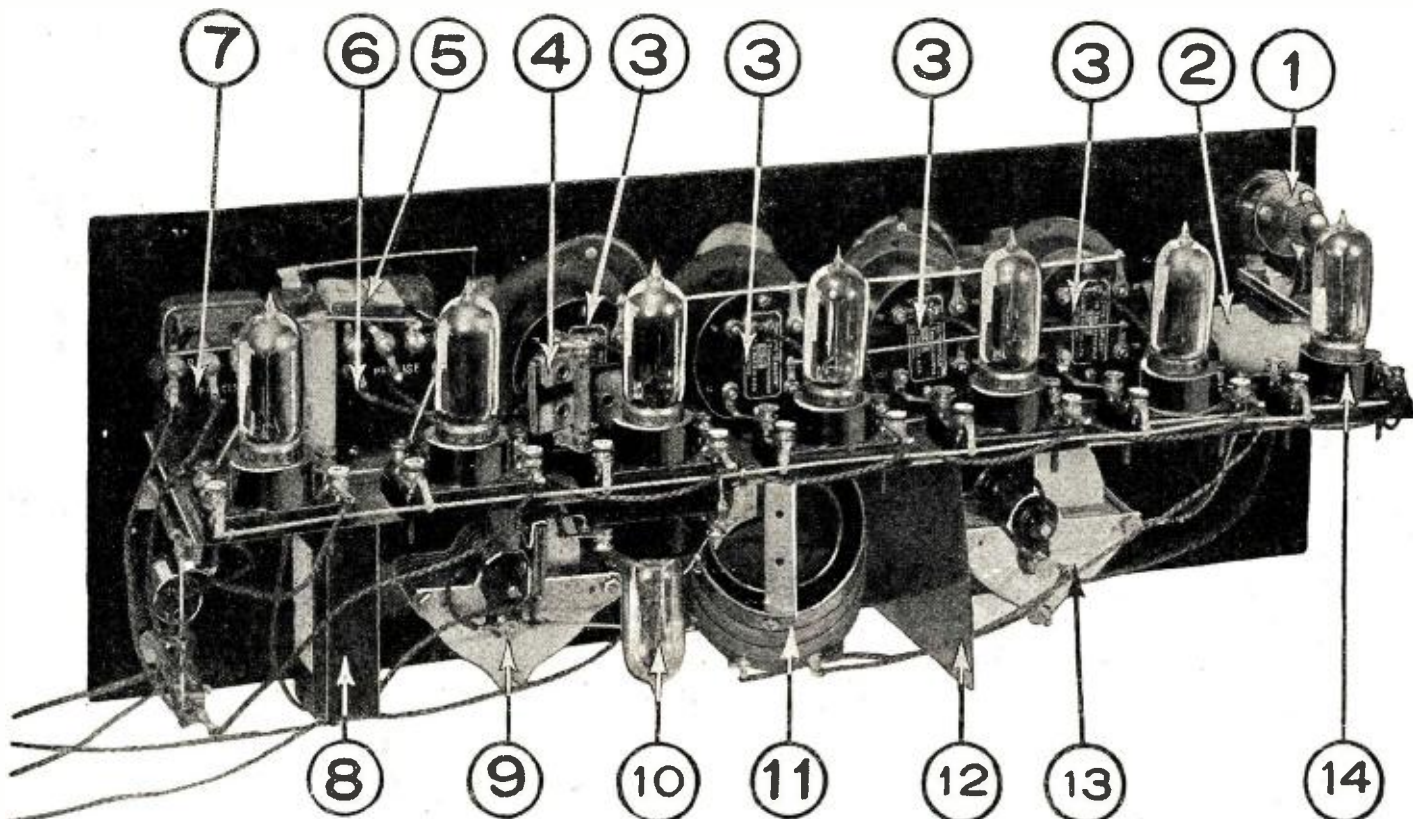
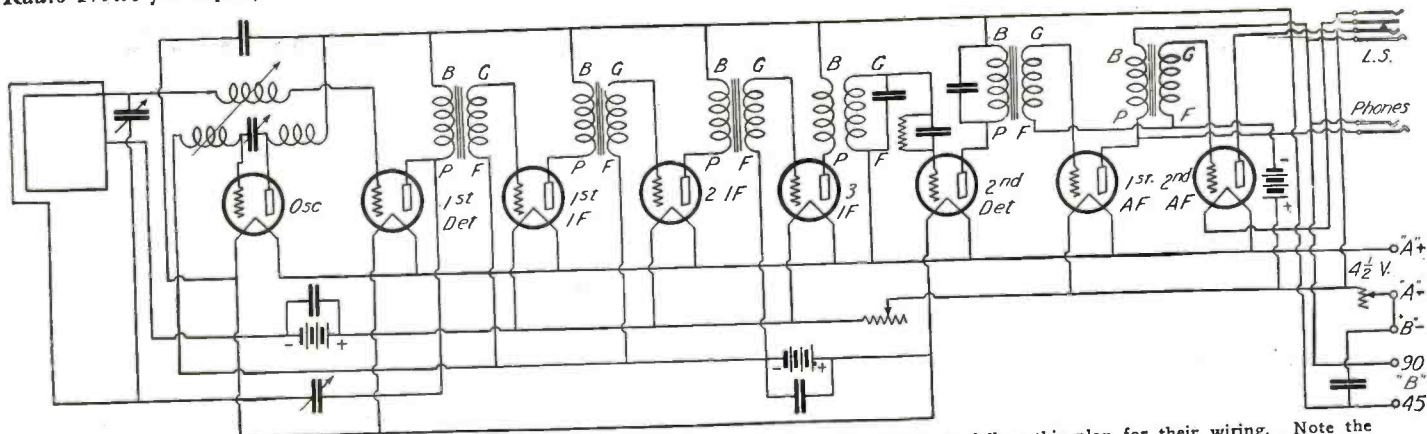

Fig. 2. The above photo shows an extremely compact Super-Heterodyne. As is shown, the whole trick lies in the placement of the apparatus. 1 is the regeneration feed-back condenser; 2, "C" battery; 3, the intermediate transformers; 4, the grid leak and condenser on the second detector; 5, by-pass condenser across the first audio frequency transformer; 6 and 7, the audio frequency transformers; 8, by-pass condenser; 9, oscillator condenser; 10, oscillator tube; 11, pick-up coupler; 12, shielding; 13, tuning condenser; 14, first detector. Photo © Baldwin Pacific Co.





The standard Super-Heterodyne hook-up is given above. The sets described in this article all follow this plan for their wiring. Note the variable condenser employed from the plate of the first detector to the loop. This gives regeneration, adding greatly to the signal strength and sensitivity of the set.

placed in such proximity, the shielding of the set is advisable.

One advantage is gained through the more compact arrangement which is not had in the first one, namely, a symmetrical arrangement of the panel front. In the second instance, the dials are placed one on each side of the vertical center line of the panel, and the other controls, including the jack, are grouped around them. In the first instance, the two dials are at the left end of the panel with the remainder of the instruments strung along the panel to the end.

In the construction of the second set for portable use, a collapsible loop is, of course, included in the equipment and a compartment left in the case for it.

To the experienced radio fan, it is obvious that the arrangement of the Super-Heterodyne is probably the most compact possible with the use of standard tubes. And one point which he will not miss is the use of three "C" batteries, which cut the consumption of "B" battery current to the neighborhood of 12 milliamperes with all tubes operating.

Many experimenters have long since  
(Continued on page 1962)



Of course, the greatest compactness possible is always desired in a set that is to be portable. Above, the photographs show a portable Super-Heterodyne employing 199 type tubes. It was completely home constructed. Note the use of the double baseboard or sub-panel for mounting the parts. In this case standard sockets were used with adapters.  
© Photographs.

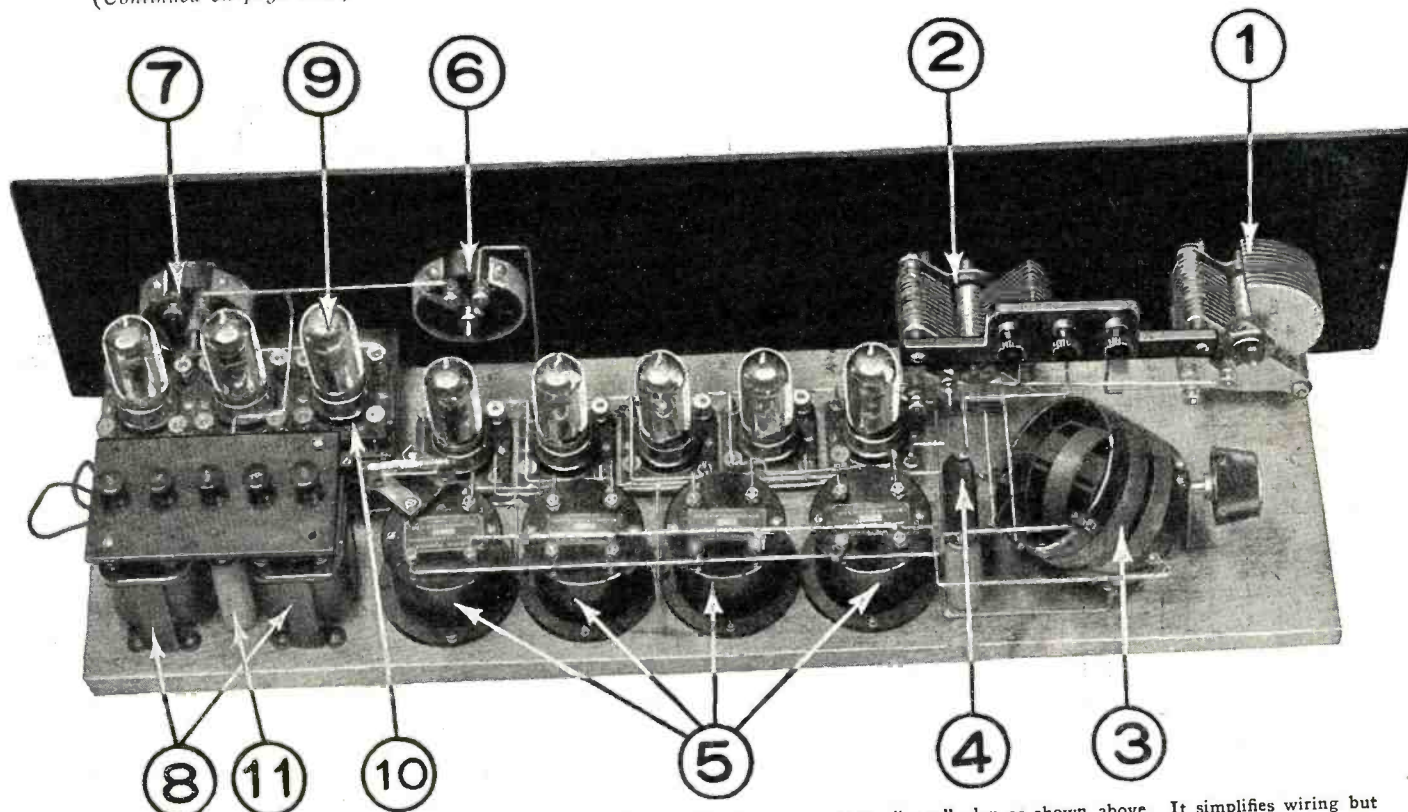

Fig. 1. By far the simplest method of mounting and assembling a Super-Heterodyne is the "open" plan as shown above. It simplifies wiring but entails the use of much more space than some of the other plans given with this article. 1 is the oscillator condenser and 2 is the tuning capacitor; 3, pick-up coil for the oscillator; 4, "C" battery; 5, intermediate frequency transformers 6 and 7, tube controls; 8, audio frequency condenser; 9, second detector; 10, gang sockets; 11, by-pass condenser. © Baldwin Pacific Co.



# The Regenerative Neutrodyne

By A. L. GROVES, 3B1D

The addition of efficient regeneration to the already excellent amplification of the Neutrodyne bids fair to result in a really distance getting set. The accompanying article shows how the addition is made.

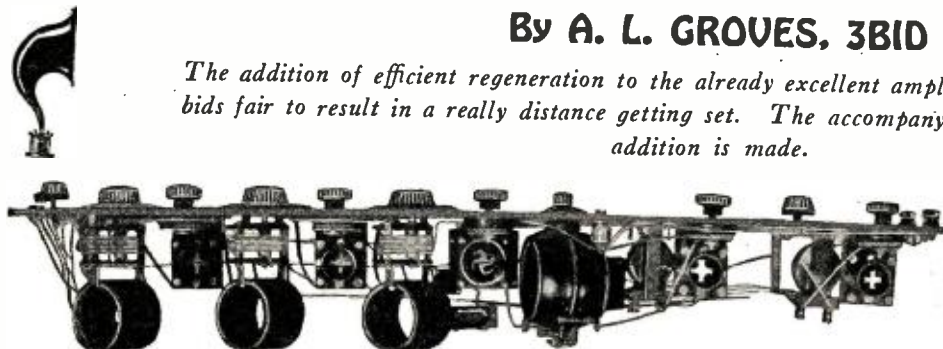

Above is a rear view of a standard Neutrodyne to which regeneration has been added by the installation of a variometer in the detector circuit.

**N**O better way to test the actual efficiency of any receiver from a distance-getting standpoint can be made than to put the receiver into actual service and note the stations logged at approximately midday during the winter months.

The tone, clarity and general faithfulness of reproduction of any receiver depends almost entirely upon the audio frequency transformers, the arrangement of the audio circuits and the loud speaker and with a given detector output from any type set the loud speaker results will be the same ∴ the signals are put through the same amplifier. Therefore, no set, from a musical standpoint, is better than its audio amplifier and any increase in efficiency of one set over another, provided the same audio amplifier arrangement is used, must come through some form of radio frequency amplification so as to give a greater detector output.

While minor variations in the detector output can be had by using different type instruments in the same type set, generally speaking, a greater detector output can only be obtained by the use of radio frequency amplification which may be divided into three classes, as follows: First, radio frequency amplification by regeneration; second, radio frequency amplification by using one or more vacuum tubes ahead of the detector so that they amplify the signals before they reach the detector, and third, radio frequency amplification by increased aerial efficiency.

The aerial is a very great radio frequency amplifier or, we may say, a collector of radio frequency energy in direct proportion to its size and general goodness and the maximum results obtained are in a large manner dependent upon it, yet so effective is the regenerative Neutrodyne combination in its radio frequency powers that excellent results can be obtained from it using only a loop, as will be discussed later.

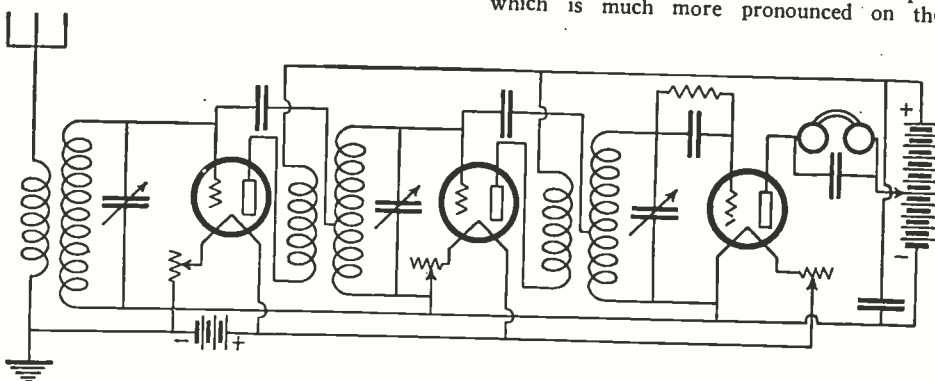
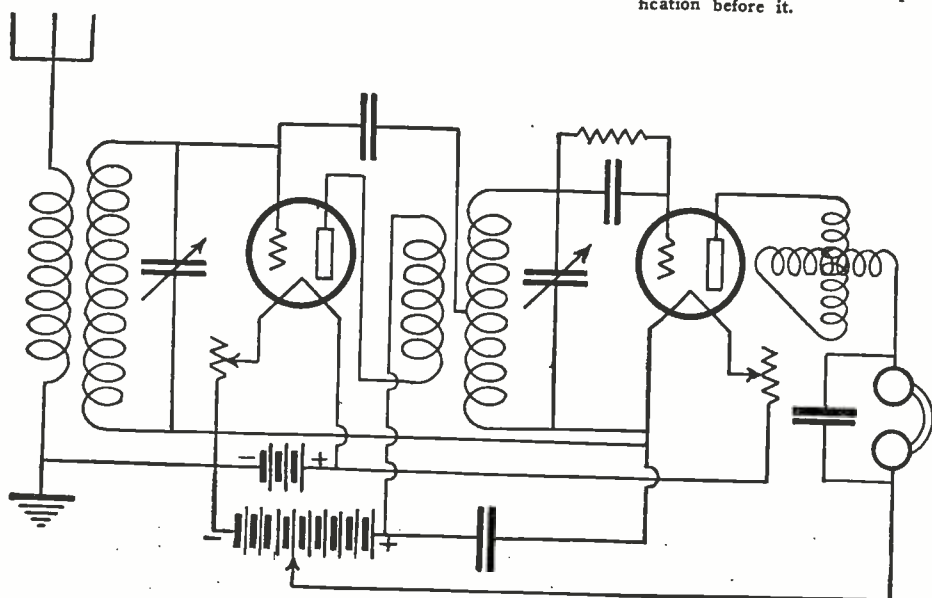

Fig. 4. Hook-up of the straight Neutrodyne using two stages of neutralized tuned radio frequency amplification.

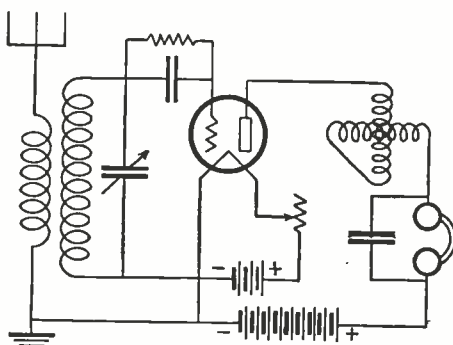

Fig. 1, above, shows the regenerative receiver, basis of regeneration in the Neutrodyne. Below, Fig. 2, shows the same regenerative receiver with a stage of tuned neutralized amplification before it.

## RADIO FREQUENCY

In the meantime, let us discuss the relative merits of radio frequency amplification by means of tuned neutralized amplifiers ahead of the detector and by means of regeneration as it applies in actual practice to the reception of radiophone signals over the broadcast range of wave-lengths.

It is found that radio frequency amplification by means of the Neutrodyne method increases the selectivity considerably and gives us a much greater detector output, which is much more pronounced on the

longer waves than on the shorter waves and will receive over very much greater distances than can be obtained from the detector alone.

Radio frequency amplification by means of regeneration also increases selectivity, gives us a much greater detector output, which is more pronounced upon the short waves than on the long waves, and will receive over much greater distances than can be obtained from the detector alone.

While the radio frequency method by means of amplifiers ahead of the detector has a peculiarity which causes weak signals to drop off rapidly and makes anything that is audible at all loud enough for loud speaker operation, radio frequency amplification by regeneration gives no such sudden dropping off of weak signals, but really gets in its best work from the very weakest signals.

The natural conclusion is to combine regeneration with radio frequency, thereby making a set which will respond to weak signals as well as giving stronger signals the undeniable increase in selectivity due to radio frequency amplification. However, until Prof. Hazeltine gave us the principle of Neutrodyne reception there was no satisfactory method of combining regeneration with radio frequency and we had all we could do to prevent regeneration in the radio frequency circuits instead of encouraging it afterward. Now, with regeneration automatically prevented in the radio frequency circuits, regeneration can be used to a great advantage in the detector circuit following neutralized radio frequency amplification without in the least affecting the regular working characteristics of either the tuned radio frequency circuits or of regeneration.

Let us compare the merits and demerits of the various combinations of the Neutrodyne receiver with and without regeneration. In Fig. 1 we have a simple one-tube, two-control receiver using one neutroformer and one variometer, giving in effect a single tube.





A top view of the Neutrodyne with regeneration showing the position of the variometer and neutrodon.

regenerative receiver. In Fig. 2 we have a two-tube, three-control receiver using two neutroformers and one variometer giving in effect one stage of radio frequency amplification and regeneration. In Fig. 3 we have a three-tube, four-control receiver using three neutroformers and one variometer, giving in effect two stages of radio frequency

those given by any of the other arrangements, and the just audible signal given by the circuit of Fig. 1 and inaudible signal of the circuits of Figs. 4 and 5 was of fair loud speaker intensity when the circuit of Fig. 3 was used with two stages of audio frequency amplification. Even the circuit of Fig. 2 gave a weak loud speaker reception on two

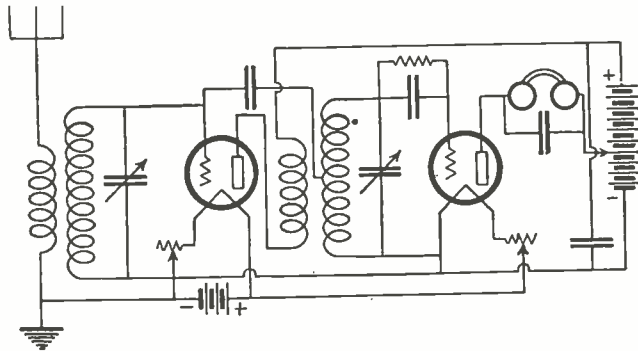

Fig. 5. At the left is shown a straight detector and one-stage tuned neutralized radio frequency amplification before it to boost the signals. Fig. 3, below, shows a second stage added making the regeneration neutrodyne.

amplification and regeneration. In Fig. 4 we have the regular non-regenerative three-tube, three-control, two-stage radio frequency amplifier using three neutroformers, and in Fig. 5 we have the regular non-regenerative two-tube, two-control, one-stage radio frequency amplifier using two neutroformers.

TESTS

To determine the relative efficiency of each of these arrangements in comparison to the others, three separate sets as represented in Figs. 1, 2 and 3 were constructed with a switch to cut regeneration in or out at will, giving the circuits of Figs. 4 and 5 when desired. Two stages of audio frequency amplification were available for each set.

First, a station working on a wave-length above 500 meters was tuned in, using the circuit of Fig. 1. The aerial was then cut down until the signal was just audible. The circuit of Fig. 2 was then tried and the signals showed a substantial increase in intensity due to the added one-stage or radio frequency amplification. The increase was not great, though very decided. The circuit represented by Fig. 5 was then tried with no signals at all being received from the test station, likewise the circuit represented by Fig. 4 was tried and still no signals could be heard from the test station. Then the circuit of Fig. 3 was tried and signals were immediately increased considerably over

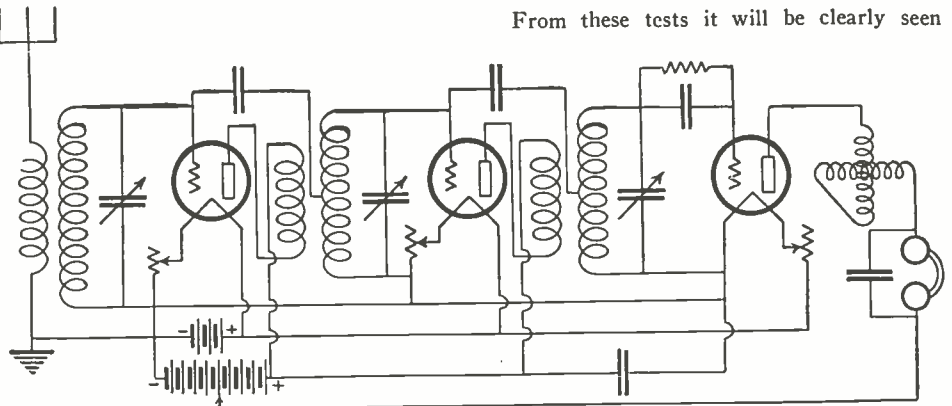

Fig. 6. A working diagram which the builder may follow. Audio stages are included.

stages of audio amplification—about the same as Fig. 3 showed on one stage.

Next the same experiments were carried out on a station working on a wave-length below 300 meters. After bringing in a just audible signal on the circuit of Fig. 1, only a very poor increase in intensity was noted when one-stage of radio frequency amplification was added by using the circuit of Fig. 2, while the best that could be done by adding two stages of radio frequency amplification as in Fig. 3 was perhaps just a little better than the increase made by one-stage on the longer wave-length. The signals on the circuit of Figs. 4 and 5 were, of course, hopelessly inaudible.

that the actual benefits of regeneration in the reception of very weak signals is more pronounced on the short waves than on the longer waves, and that two stages of tuned radio frequency amplification is about in the same proportion, more efficient on the longer waves than on the shorter waves. Therefore, by combining the two we not only obtain greater sensitivity over all of the wave-band, but obtain a more uniform action.

As will be noted, the above experiments were conducted on aerials that gave the same signal intensity on each wave in order to more clearly demonstrate the benefits of the two types of radio frequency amplification. This brings us to the third method of radio frequency amplification as a means of obtaining a greater detector output—radio frequency amplification by means of the aerial. (Continued on page 1994)

REGENERATION BEST ON SHORT WAVES

From these tests it will be clearly seen



# Reflex Radio Receivers in Theory and Practice

By JOHN SCOTT-TAGGART, F. Inst. P., A.M.I.E.E.

## Part VI



Some excellent reflex circuits, employing crystal detectors as rectifiers, are described in this article. A more or less novel method of energy transference from the tube to the crystal detector circuit is employed.

**W**E have so far considered, for the sake of simplicity, the use of loose coupling between the aerial and the tube.

Direct coupling, however, in the case of reflex circuits, introduces several important problems which have not received adequate attention until comparatively recently.

A typical direct-coupled arrangement using the reflex principle is that illustrated in Fig. 31. It will be seen that the audio frequency currents are fed back by means of a transformer  $T_1, T_2$ , the secondary  $T_2$  of which is connected between the bottom of the circuit  $L_1, C_1$ , and the negative terminal of the battery  $B_1$ . This was, until about a year and a half ago, the common method of reflexing, although, of course, various kinds of circuits were proposed. Nevertheless, the regular method of feeding back the audio frequency currents was that illustrated in Fig. 31.

Let us examine closely the disadvantages of feeding back the audio frequency currents

more closely the disadvantages of the Fig. 31 method of feeding back the audio frequency currents. A condenser  $C_4$  is shown in dotted lines connected between the battery and ground. This phantom condenser is not an actual one, but represents the capacity effect between the battery and ground. The battery and the apparatus connected to it forms one plate of a condenser, the other side of which is the ground.

In Fig. 32 is shown an enlarged view, as it were, of a portion of the Fig. 31 circuit, showing the capacity effects in detail and a possible leakage effect.

The battery  $B_1$  and the high voltage battery  $B_2$  are usually bulky pieces of apparatus which, standing on a table, have an appreciable capacity to ground. The capacity to ground between the battery  $B_1$  and the ground is shown as  $C_4$ , while the capacity to ground of the "B" battery is shown as  $C_5$ . The telephones being on the head of the wearer, will also have a considerable capacity to ground. All these capacities are represented as one large capacity  $C_4$  in Fig. 31. In addition, unless the batteries and phones are perfectly insulated from the earth, there will be a leakage effect which is shown as  $R_2$ . The leakage effect, of course, will lessen the potentials established across  $T_2$ , and, therefore, lessen the audio frequency potentials applied to the grid of the tube, but the beginner may not understand why these capacities should have an injurious effect.

A convenient analogy which the writer has previously used is that of an angler and a fishing rod. Fig. 33 shows an angler holding the end of his rod, and, by a wrist movement, swinging the tip up and down. A free action is obtained in this case, but if a heavy weight is attached to the tip of the rod, as shown in Fig. 34, a wrist motion on the part of the angler will hardly move the tip of the rod at all. In the same way, the fact that one end of the transformer winding  $T_2$  is connected to ground and the other end to the battery, of substantial mass, results in an effect very similar to that shown in Fig. 34.

Fig. 35 shows the transformer having a primary  $T_1$  and a secondary  $T_2$ . One end of  $T_2$  is marked E and the other F. At a certain given instant when a varying current is being fed into  $T_1$ , and the end E will be negative and the end F positive. It is obvious that we want to get the largest possible potential difference across E and F and,

consequently, nothing must be done which will lessen them unnecessarily.

If, as in Fig. 36, we connect the end E to the ground, the end F will vary positively and negatively with respect to the end E and, therefore, with respect to the ground. The fact that one end of the secondary is connected to the ground does not in any way affect the magnitude of the potentials estab-

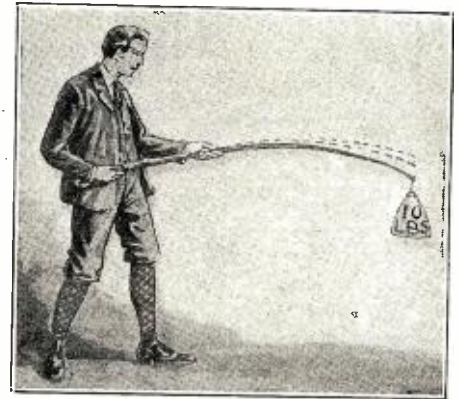

Fig. 34. Illustrating what happens when a weight is attached to the fishing-rod.

lished across it. It merely ties down one end of the transformer, making it vitally important that we should not in any way tie down the other end of the secondary.

In Fig. 37 we show the other end of the transformer  $T_2$ , formerly labeled F, connected to the grid G of a three-electrode tube. The grid, being a very light metal structure, has a negligible capacity and, consequently, the potentials on G will represent the full potentials established across  $T_2$ . If, on the other hand, we connect one side of the secondary to the ground, both ends of  $T_2$  would be tied, being practically short-circuited by the ground, since the current would flow from one to the other. The result would be that the potentials established across  $T_2$  would be very much smaller than those normally obtained.

In Fig. 38 we have part of the effect Fig. 31 illustrates. This effect is a leakage between the "A" and "B" batteries and phones to the ground and is frequently important. The resistance  $R_2$  in Fig. 38 will act as a partial short circuit for the secondary and, moreover, this leakage will vary from time to time and exactly the same results with

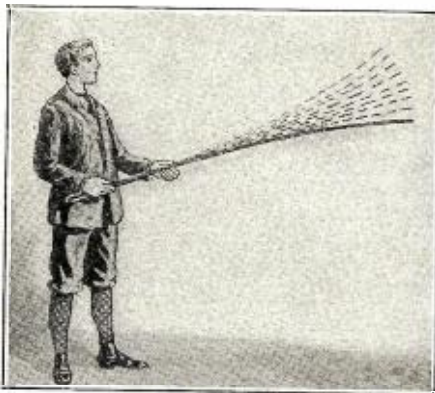

Fig. 33. Above is pictured the fish-pole analogy drawn in the article.

in this position. In reading the following remarks it must not be imagined that the arrangement of Fig. 31 will not work; the results are quite good, but various symptoms will be noticed. It will, for example, be impossible to touch the "A" or "B" battery, or one of the terminals of the telephone receivers without affecting the signal strength. Touching any of these parts may, moreover, set up an audio frequency buzzing.

### REASONS FOR THE DISADVANTAGES

In view of the importance of this section of our discussion it is proposed to examine

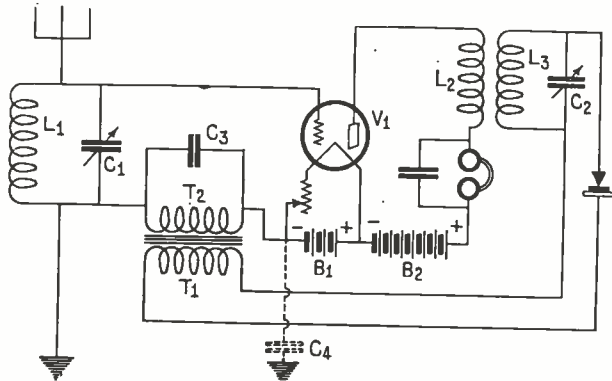

Fig. 31. An old standard method of feeding back the rectified audio frequency current to the grid circuit of the tube. Note the transformer and the phantom ground from the filament circuit.

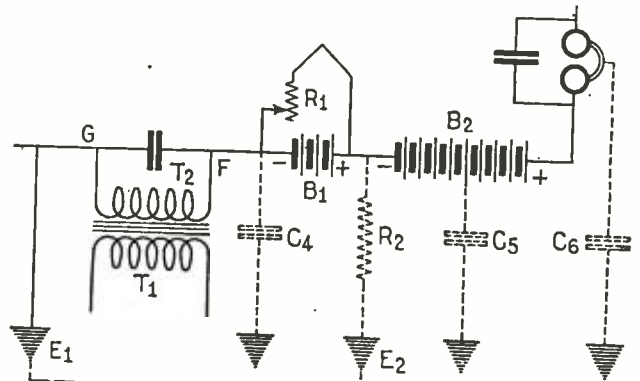

Fig. 32. All the possible capacities to ground from the circuit of Fig. 31 are illustrated above. The phones and batteries, of course, represent the largest values.



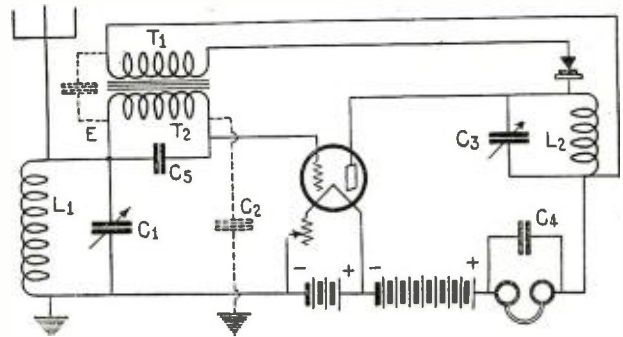
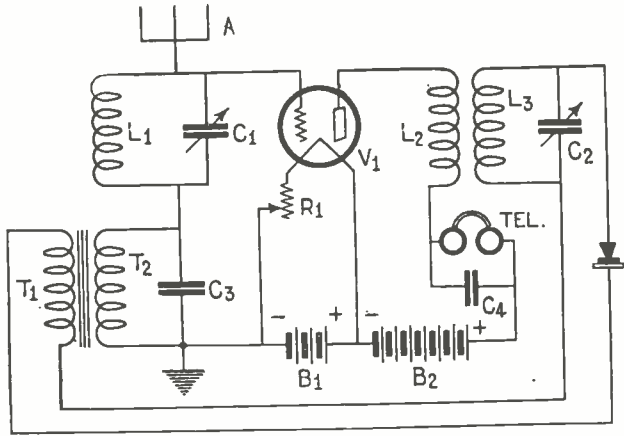

Fig. 42. At the left is shown another popular method of feedback. Fig. 41. Above is shown a hook-up of one of the early reflex circuits used by H. J. Round.

the apparatus may not be reproducible at will. The leakage effect, however, is not the most serious one because, provided the batteries, etc., are properly insulated, it will not occur. The most dangerous effect is the large capacity which they have. This is illustrated in Fig. 39.

If such a circuit be arranged, it will be seen that the condenser  $C_1$  shunts the secondary and if a large condenser is connected across the secondary  $T_2$  the potentials established across this winding will be reduced. If, for example, the condenser  $C_4$  had a value of five mfd., it would virtually short-circuit  $T_2$ , and the potentials across it would be too small to be of any value.

In Fig. 40 is illustrated the state of affairs existing in the Fig. 31 circuit, and it will readily be seen that the large capacity effects between  $B_1$  and the ground and  $B_2$  and the ground, not to mention the capacity of the telephones will act as a parallel capacity

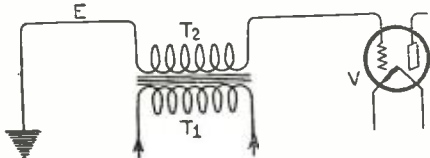

Fig. 37. The secondary is connected between grid and ground.

across  $T_2$  which will decrease the potentials. It will be noticed that in Fig. 40, as in Fig. 31, there is a small condenser  $C_3$  across  $T_2$  already. The value of  $T_2$  will depend very largely upon the particular transformer employed, and its sole purpose is to act as a by-pass for the radio frequency currents in the grid circuit. In most cases it will have a capacity of .0003 mfd. and if this is supplemented by the uncertain capacities of the batteries, the value will, in many cases, be too high and, the tendency toward buzzing will be increased. An additional and very important disadvantage is that the batteries, phone terminals, etc., cannot be touched with the hand without varying the signal strength and, in many cases, producing audio frequency buzzing.

The trouble due to the filament ground

connection of the transformer secondary is accentuated in receivers using regeneration, because any variation of the capacity across  $T_2$  will vary the amount of regeneration; an increase of the capacity, for example, will increase the tendency for the tube to oscillate, and once the tube oscillates the tendency to buzz is very greatly increased, and in many cases the radio frequency oscillation only takes place for a fraction of a second and is

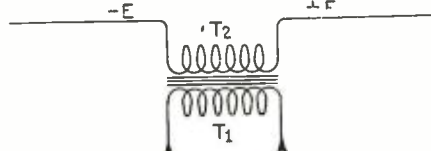

Fig. 35. The conditions existing in a transformer at a given moment.

immediately followed by an audio frequency buzzing.

**ROUND'S ORIGINAL METHOD**

The method which was used by H. J. Round in early experiments with reflex circuits is that illustrated in Fig. 41. The audio frequency circuits were fed into the grid circuit by means of a transformer, the secondary of which was connected between the grid and the aerial. The end E of the secondary was, so far as audio frequency currents were concerned, at ground potential, whereas the end G was connected to the grid. None of the trouble experienced with the Fig. 31 circuit were obtained. It is now a well known rule in radio design not to place

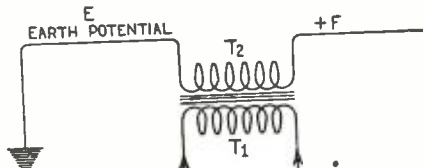

Fig. 36. Showing how potentials at the end of  $T_2$  vary.

apparatus at a point at radio frequency potential to ground. Across the circuit  $L_1 C_1$  radio frequency potentials are established and, consequently, the whole secondary of the transformer is at a varying radio frequency

potential to ground, and the transformer will consequently act in much the same way as the weight on the end of the fishing rod. This time it will be the radio frequency currents which will suffer, and these are much more susceptible to influence by parallel capacity. Every experimenter knows that if there is too great a capacity across his oscillatory circuit the potentials established across it will be small.

In Fig. 41 the substantial capacity between the two windings of the transformers is shown in dotted lines, and likewise the capacity of the secondary direct to ground. The capacity between the windings is very important because the primary winding is connected, virtually, direct to the ground as regards radio frequency currents. The net effect of this arrangement is that the potentials established across  $L_1$  and  $C_1$  are decreased.

The present writer of this series has de-

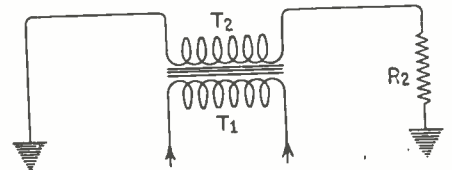

Fig. 38. Representing leakage path to earth.

veloped two fundamental methods of feeding back audio frequency currents so as to avoid both the troubles experienced with Fig. 31 and those found when the Fig. 41 arrangement is employed. H. J. Round has also employed another method which has been largely used commercially. This will be described later.

The first of the present author's methods, and the one which he has embodied in numerous reflex circuits, is that illustrated in Fig. 42.

It will be seen that the secondary of the transformer is now connected in the aerial circuit, as well as the grid circuit of the tube. A condenser is connected across  $T_2$ , and the capacity of this condenser may be fixed or variable. Experiment has shown that the best value is in the neighborhood

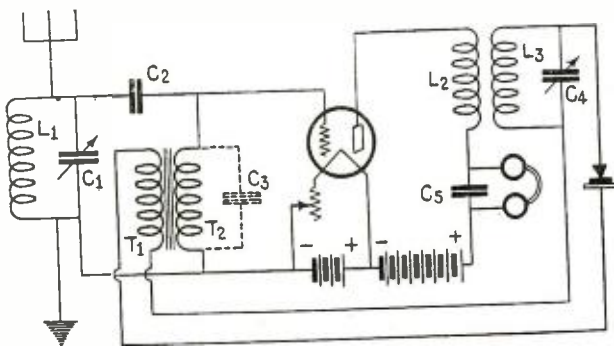

Fig. 48. Above is shown an adaptation of the Fig. 41 circuit which sometimes gives superior results. Note the placement of the phones and the condenser across the audio frequency transformer.

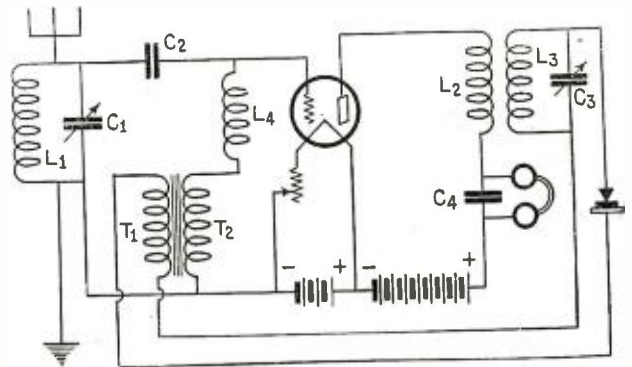

Fig. 49. This hook-up shows the place for installation of a choke coil for the elimination of alternating current hum which may get into the set by inductance.



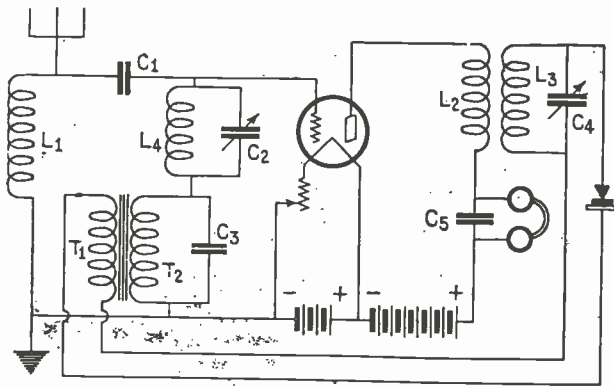

Fig. 50. A new method of eliminating A.C. hum devised by the author is shown above.

of .001 mfd. If the condenser is of too small a capacity it will interfere too radically with the aerial tuning arrangement, since it is an integral part of it. If, on the other hand, the condenser is too large, the audio frequency potentials will be reduced and there will consequently be a loss in efficiency.

The arrangement of Fig. 42 eliminates all trouble due to the transformer being at radio frequency potential to ground, and also all trouble due to the secondary of the transformer being tied down at both ends.

**EFFECT OF TRANSFORMER SECONDARY IN AERIAL CIRCUIT**

The only disadvantage of the Fig. 42 method is that there is a tendency to pick up interference from electric light mains, etc. This may be specially the case when alternating current is installed for domestic purposes, but it is impossible to state the effect of this interference without knowing the special circumstances. In some cases the interference is negligible, but in a few cases it may be desirable to use a feed-back method which cuts down this tendency.

**PARALLEL INPUT ARRANGEMENT**

In Fig. 43 we have the method which is an alternative of the Fig 42 arrangement and which is very largely used in commercial sets. The arrangement is not exactly what is commonly used, but the principle is the same. It will be seen that the audio fre-

quency currents produced by the rectification of the radio frequency currents by the crystal detector are fed into the grid circuit in parallel with the aerial input, a condenser  $C_2$  of .0003 mfd. being connected in the position shown to prevent the inductance  $L_1$  from short-circuiting the audio frequency currents. The secondary  $T_2$  will, in most cases, have an appreciable self-capacity which is shown as  $C_3$ . To counteract this self-capacity a separate inductance outside the secondary is connected in series with  $T_2$ . Alternatively, a high resistance may be used.

In the high resistance arrangement, the resistance  $R_2$  of one megohm is connected in series with  $T_2$ . This arrangement is not recommended, although it certainly helps to prevent the transformer secondary acting as a partial short circuit for the radio frequency current supplied by the aerial circuit.

Fig. 44 shows the common arrangement employed, and it will be seen that a high inductance  $L_3$  is connected in series with the secondary  $T_2$  in the position shown. This choke  $L_3$ , which is of the aircore pattern, will choke back any radio frequency currents which try to pass via  $T_2$ .

This arrangement possesses all the merits of previous arrangements and is also devoid of any serious tendency for the circuit to pick up A.C. hum.

A disadvantage of the Fig 44 arrangement is that an additional coil  $L_4$  is required, this coil requiring, for the best results, to have a minimum of self-capacity. Moreover, a different coil will be required for different wave bands, because obviously a small coil would not act as a choke at all for longer wave signals. The arrangement of Fig. 44, therefore, in this respect is not as good as the Fig. 42 simple circuit. Another trouble in connection with Fig. 44 is that the inductance  $L_4$  tends to resonate on account of its own self-capacity and stray capacities, and if it is tuned to certain specified wavelengths there will be a tendency for absorp-

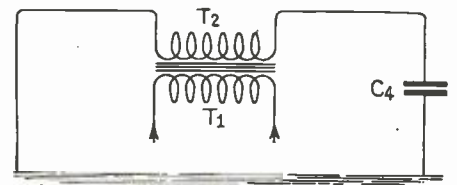

Fig. 39. Showing the effect of earth capacity of set parts.

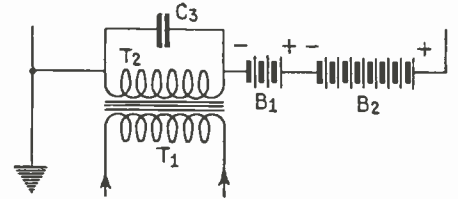

Fig. 40. Here are the chief offenders in the matter of ground capacity.

tion of energy from the main circuit. There are, consequently, complications which may arise on this account, but careful design may eliminate these troubles for a given wave band.

**A NEW METHOD OF FEEDING BACK THE AUDIO FREQUENCY CURRENTS**

The present author has introduced a new method of feeding back the audio frequency currents so as to obtain all the advantages of Fig. 42 and at the same time to cut out any trouble likely to arise through A. C. mains, etc. This is depicted in Fig. 45. It will be seen that there is an inductance  $L_1$  in the aerial circuit, a condenser  $C_1$  (which may have a capacity of .0003 mfds.) and the usual circuit  $L_4, C_2$ ; a condenser  $C_3$  of .001 mfds. capacity is connected across the secondary  $T_2$  of the feed-back low frequency transformer.

The inductance  $L_1$  may be a very high inductance choke coil and may take no active part in the tuning of the aerial circuit, which consequently consists of the aerial, the series condenser  $C_1$ , the circuit  $L_4, C_2$ , the condenser  $C_3$  and the ground. In this case, the condenser  $C_1$  will act as a stopping condenser to prevent  $T_2$  being short circuited by  $L_1$ .

(THE END.)

# Five-Tube Cabinet Radio Set of 1892

By JOHN B. BRADY\*

**DISCOVERED**—a five-tube radio cabinet set fully illustrated and published in a United States patent which was issued September 20, 1892! Below is shown the appearance of the cabinet and the five tubes mounted thereon. The application was filed by Sidney N. Johnson of Chicago, Ill., on October 5, 1891. It looks as though all of our previous knowledge on the develop-

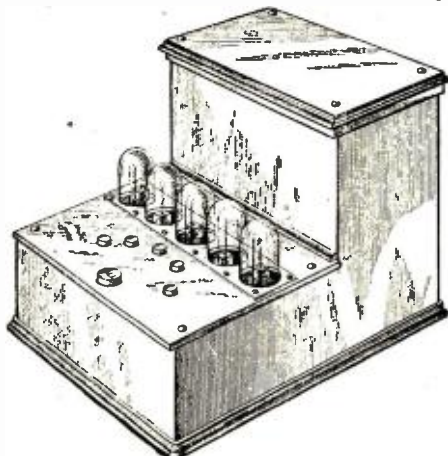

The "Five-tube cabinet set" patented in 1892, unearthed by Mr. Brady.

ment of radio has been all wrong. The 1892 cabinet looks like a modern Radiola.

The natural question is, what circuit did the 1892 radio set contain? Then, upon close investigation, we find that the cabinet, while very closely resembling a modern five-tube radio set, is, in fact, not a radio set at all, but gambling apparatus! The glass tubes projecting vertically from the cabinet are not vacuum tubes, but transparent coverings located over small disc-like tables, each of which supports a dice. There is a series of buttons at the front of the cabinet by which a player may close an electric circuit which agitates one of the little tables and shakes up the dice, and when the dice falls, the players can look through the glass cover and see what luck he has thrown. Five players can join in the game and each can punch a separate button and toss the dice to reach a score. There is also a separate button in front which can be punched to throw all of the dice simultaneously. The interior arrangement of the machine which outwardly looks like a radio set is shown in the illustration at the right.

The cabinet contains a battery and a series of electromagnets and a corresponding series of circuit closers, one for each electromagnet. One portion of the cabinet that is horizontal constitutes a table, in which is provided a

series of openings corresponding in number with the electromagnets, and in each of which works or vibrates a disc, adjustably secured to the free end of a spring-actuated armature lever to which is secured an armature of the corresponding electromagnet to which lever is also secured a spring tongue normally in contact with a contact post or point, which devices act as automatic circuit makers and breakers in substantially the same manner as like parts operate in an electric buzzer or bell.

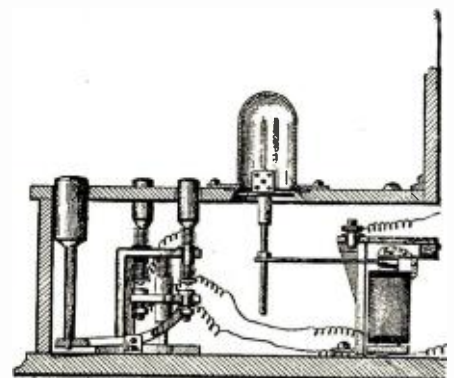

The electrical connections of the "Five-Tube Set." Note the plungers to shake the dice.

\*Patent Attorney, Ouray Bldg., Washington, D. C.



# Testing the Instruments of Your Receiver

By JOHN R. MEAGHER

A SIMPLE method of testing the instruments of a receiver which will save the experimenter a deal of trouble is delineated below. The apparatus and method are simple.

THE strangest thing that a radio writer observes is how some people will have good results with a receiver built from his specifications, while other fans will report poor reception with similar outfits built from the same description. Thus a single mail will contain letters of praise and letters of disparagement, letters of frank thankfulness and letters of pointed, biting sarcasm.

The letters of friendly appreciation, God bless 'em, are stowed away as peaceful mementos of a troubled period. The other letters, those regarding faults, poor results or no results at all, are sorted and arranged in two groups. One group contains the epistles from those fans who, when the set does not work, say to themselves: "Oh, that dumbbell writer, what he doesn't know about radio." The waste paper basket is always cluttered with these. The other group is from those chaps who, when the set will not work, say to themselves: "I'm an awful dumbbell not to be able to make this set work." They write nice, kind letters, apologizing for causing the writer trouble, hoping he will find time to give them a little help, enclosing a stamped envelope and thanking him in advance, etc. Their letters are always answered.

## INFORMATION FROM BUILDERS

But, by and large, the radio writer, from the written "kicks" as well as the written hand-claps, can gain a very good idea of the particular sort of trouble that most beginners experience when they start building multiple vacuum tube receivers.

The fault most commonly found in defective home-made sets is incorrect wiring. Sometimes a single connection will be on a wrong terminal and remain unnoticed even though checked and rechecked.

The source of greatest trouble is defective apparatus. A transformer with a broken lead; a fixed condenser with the supposedly insulated plates making contact; a variable condenser with the plates scraping through the entire movement or only in spots; a spider-web coil with single cotton or silk insulation and with one or more adjacent turns shorting; a tuning coil with a break in the wire or leads, unnoticed beneath the insulation; a socket with contacts of poor quality, so they fail to make contact with the tube studs; a grid leak with a value far different from the label indication; a jack with dead springs, so they fail to close the proper circuits when the plug is removed:

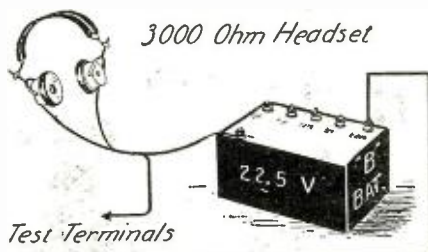

A high resistance head set and a "B" battery are the only instruments necessary for the valuable tests described.

The only course possible in the construction of a set in order to assure its operation upon completion is to be sure that the instruments are all perfect before they are connected.

Herewith is a photo of a well designed set employing sponge rubber bases for the tube sockets to eliminate tube noises.

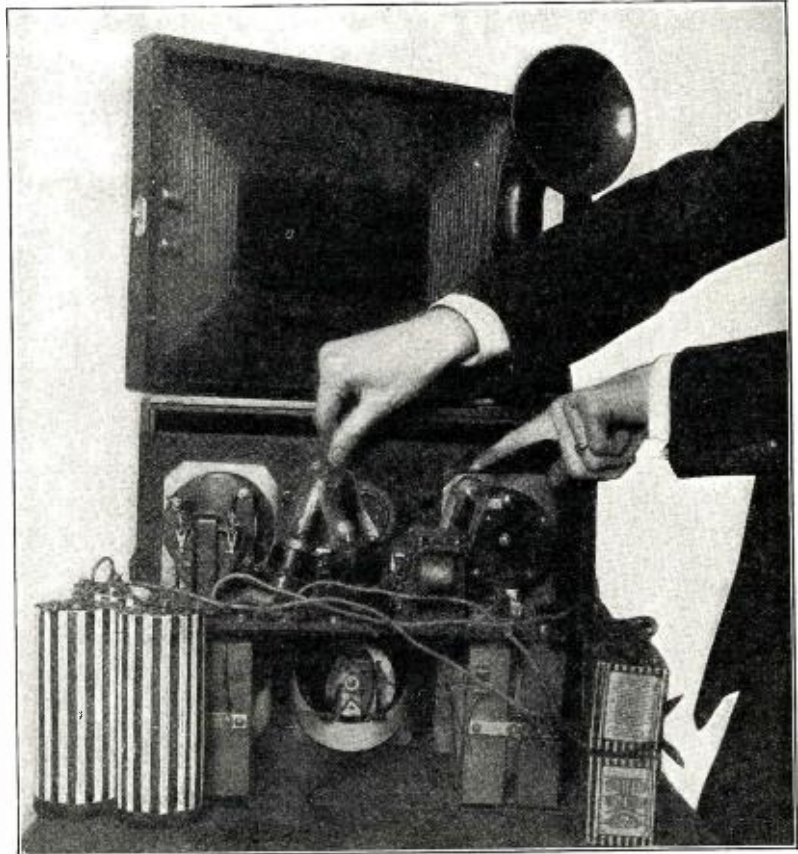

a potentiometer with an unnoticeable break in the wire; a vacuum tube that lights, but does not function; a "B" battery with a defective cell; a lightning arrester with a

set work as it should. It is so easy to do this before the parts are used and so difficult to accomplish after they are imbedded in the set that we say, "Test it, please, before using."

## SIMPLE TESTING OUTFIT

No elaborate or expensive equipment is needed to test the majority of parts for electrical defects. The headset and battery arranged as shown in the diagram will be entirely satisfactory.

If the headset has a resistance of about 3,000 ohms, the battery may be a regular 22½-volt type, as the maximum current through such an arrangement would be only slightly more than seven milliamperes. When the test terminals are touched together a loud click will be heard in the phones. Another click will be heard when the terminals are separated from each other. If the terminals are touched to the ends of a resistance, the click will not be so loud. The higher the resistance the fainter the clicking. When the resistance is infinitely high, that is, when the terminals do not make electrical contact, no clicks will be heard. Therefore, we can use this device to tell the nature of the electrical path between the points to which the terminals are touched. For instance, if the terminals are touched to the ends of a potentiometer winding we should hear a click because the resistance value is comparatively low. But if the terminals are touched to the connections of a condenser, no click should be heard, because there should not be any direct electrical contact between the plates of a condenser.

The following parts may be tested and rated as O.K. or defective in the following manner:

## COILS

Connect the test terminals to the ends of the coil; a click should be heard. If the click is not heard, it is an indication that the

(Continued on page 1968)

## The Experimenter

has come back! If you are one of the one hundred thousand readers of the old ELECTRICAL EXPERIMENTER, you will no doubt be glad to hear that the EXPERIMENTER has come back BIGGER AND BETTER THAN EVER.

### Experimental Radio

Nothing but experiments, written by the foremost radio authorities, also a monthly editorial by H. Gernsback. A fine roto-gravure section to brighten up the magazine. But best of all for you radio readers, is the big radio section of over twelve pages of some fifty radio experimental articles—and mind you, NOTHING BUT EXPERIMENTS.

### LIST OF INTERESTING ARTICLES TO APPEAR IN THE APRIL ISSUE OF THE EXPERIMENTER

Electrostatic Loud Speaker  
By Vilh. Wardinghausen, Copenhagen, Denmark.

Chemical Laboratory Manipulation  
By T. O'Connor Sloane, Ph.D.  
Making a Mercury Vapor Ultra-Violet Lamp  
By Raymond B. Wailes.

Experimenter's Glass Blowing Tools  
How to Make a Ring Armature Dynamo  
Getting On the Air  
By A. P. Peck, 3MO, Associate I.R.E.

Be sure to reserve a copy from your news-dealer before the issue is sold out.

THE EXPERIMENTER will be on sale at all newsstands March 20, 1925.

direct short; an inoperative speaker; and so on.

We feel certain, and surely it is only reasonable to believe, that if the constructor spends a little time testing each part, he will have less trouble and bother in making the



# The Radio Beginner

## Tuning Your Radio Set

By A. P. PECK

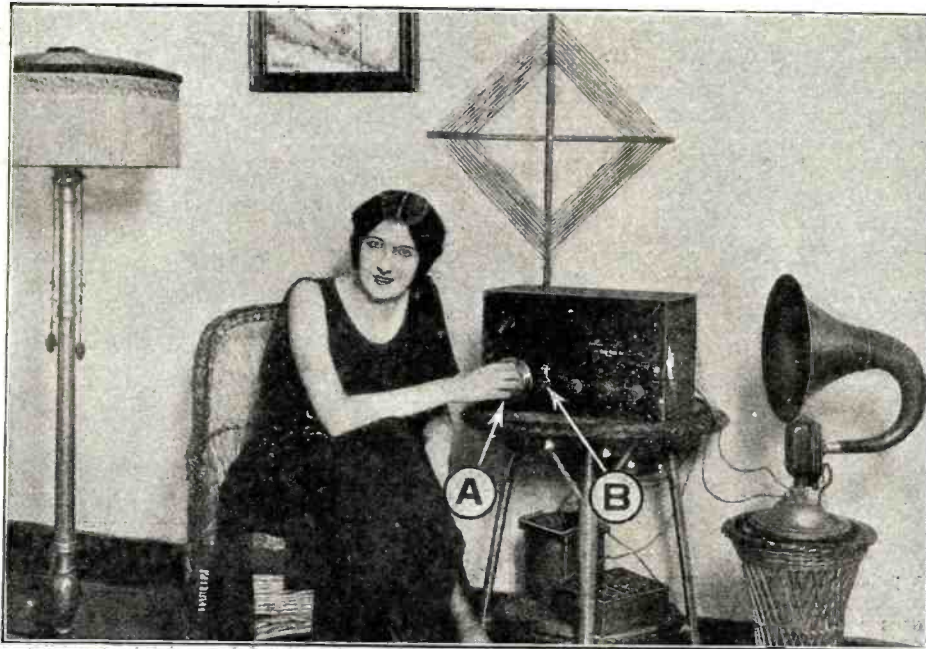

Fig. 9. Tuning a single control loop set. A is the tuning dial and B the knob for volume and clarity control.

**B**EFORE we enter into a detailed discussion of the methods of tuning various types of radio receivers, let us find out just what that subject covers.

In order thoroughly to understand the subject, let us first turn to the study of a simple analogy. Let us consider two violin strings stretched on a board as shown at A and B in Fig. 1. It is a well-known fact that, if two strings are tuned to the same pitch, one will commence to vibrate and give forth sounds when the other one is plucked or set into vibration, even though the first one is not touched by any mechanical means. Also, it is known that if the length or diameter of a violin string varies, it will give forth a different tone when plucked or vibrated. Stretching these strings to the proper tension is what is known as tuning in the musical sense of the term. Now let us consider, in order to illustrate this point, that string A in Fig. 1 is stretched to a certain tension. Let us start it vibrating by plucking it with the finger and keep it in vibration by the same method. At the same time let us consider that the key regulating string B is turned, tightening the string. We will find that as the string gets tighter, it will more nearly approach the same characteristics as A, and when it reaches that point, the two strings will be in tune, or resonance, as it is sometimes called, and string B will start to vibrate. Continue this experiment a little further and tighten string B still more. It will soon be found that the string will cease to vibrate even though string A is violently plucked. Thus we can see how a violin string may be brought from a certain point up to resonance

with another string and then, by further stretching, taken away from that resonant point so that it is no longer in tune with the first string.

This point is where the similarity between a radio receiving set and a tuned string shows up. We must remember that there are hundreds of broadcast stations in the country today and that if there were not such a thing as tuning, these many stations would find it impossible to operate. This is because of the fact that if they were all tuned alike, they would all "put our set in vibration," to harken back to the violin string analogy, and reception would not be possible. But, on the other hand, the various instruments in our radio set, which we will not deal with in particular in this article, allow us to so change the characteristics of our receiving set that we can tune in or tune out a station at will, just as

string B in the above described analogy was tuned to and away from string A.

Possibly we can see this point a little better by expanding the analogy illustrated by Fig. 1 and considering three strings mounted as at A, B and C in Fig. 2. Let us call string B the receiving station and A and C two different transmitting stations. Transmitting stations are the points from which the musical and other programs are sent out. Now let us say that strings A and B are in tune. Plucking A will cause B to vibrate, but if C is not in tune and it is set in vibration, it will not affect the action of B. If, however, the transmitting station or string C is tuned until it has the same period of vibration or is in resonance with string B, then we would have a different problem. Suppose we try to send signals by long and short plucks on string A and do the same thing with string C. The signals as reproduced by string B would be unintelligible and different from the originals because of the fact that B would respond to the vibrations of both the other strings. Thus we see that, by having transmitting stations of different characteristics, it is possible to change the characteristics of the receiving set until one or another of any desired broadcast station can be received at will without interference from others. By interference between stations, it is meant that it becomes possible to hear more than one station at a time. Under such conditions, reception is sometimes impossible because of the fact that the programs from the two stations clash with each other and cause interference. You could compare this effect with that of trying to listen to two persons talking at the same time. It is often impossible to understand either one or the other until one of them stops.

### WAVE-LENGTH

In the above few paragraphs we have mentioned in several places characteristics of stations. By this we mean the wave-length on which a transmitting station sends out programs or upon which a receiving station receives the same programs. Again let us refer to our comparison of strings described above. When a violin string is set

Fig. 10. Showing the various controls on a standard type of Neutrodyne set. A is the main tuning control. B and C adjust the radio frequency amplifiers to resonance with A. D is the vernier filament control rheostat.

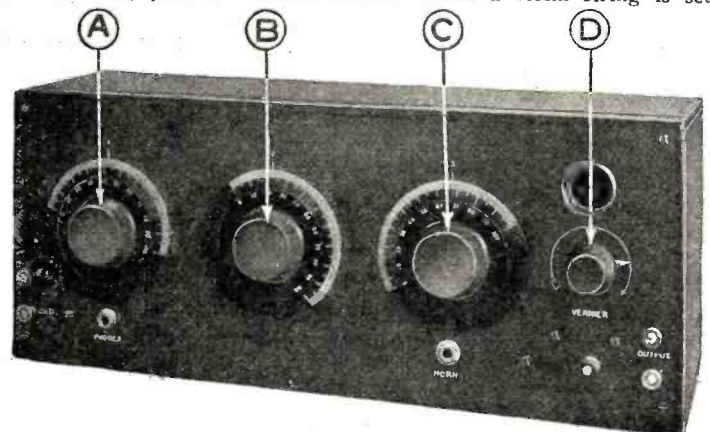



in vibration, we hear a sound. This sound is transferred to our ear through the medium of the air by means of sound waves. When a string is started in vibration these sound waves are set up in the air and radiate or go out from the string in every direction, unless interfered with by some solid object. Even in this case the air waves can often cause objects to vibrate and transmit the sound still further. In much the same way, the apparatus in a radio transmitting station sets up waves, not in the air, but rather in the ether. Ether is conceded to be an all-prevailing material which is not capable of being recognized by any of the human senses. It is present everywhere and it is this ether through which radio waves are transmitted. When these waves are picked up by a receiving station, the effect may be likened to the tuned string described above. Certain electrical changes, too complicated to describe here, take place and the loud speaker or phones give forth sounds in accordance with those made at the transmitting station. This is, of course, considering that the receiving set is tuned to the wave-length of the transmitter. We accomplish the tuning of the average radio set by turning one or more knobs or dials located on the front of a panel. The turning of these dials actuate certain instruments inside the cabinet that in turn so change the electrical characteristics of the set that radio waves of different length can be received and reproduced.

**STANDARD SETS ONLY**

In the remainder of this article we will only consider standard radio receiving sets.



FIG. 1



FIG. 2

Figs. 1 and 2 illustrate simple analogies for tuning.

There are many home-made sets that will come under the general discussion, and we will also deal with several types of manufactured sets that are on the market today.

We find that at the present time the radio fraternity is composed of not only all those who build their own sets and so gain some knowledge of radio, but also of hundreds and thousands who buy ready-made sets, knowing little or nothing about the subject of radio. Then the trouble starts. The

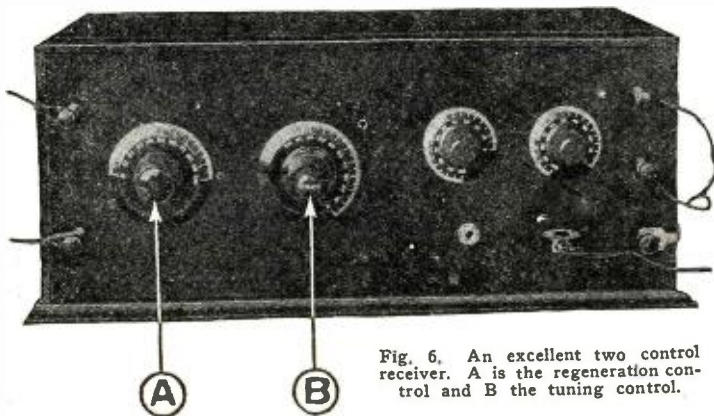
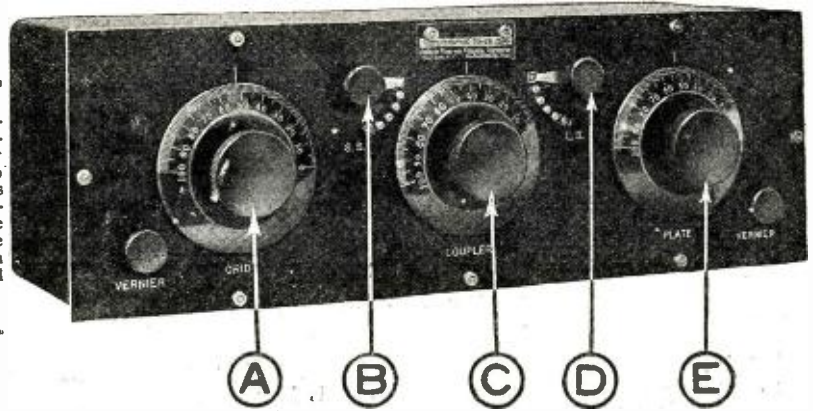

Fig. 6. An excellent two control receiver. A is the regeneration control and B the tuning control.

Fig. 7. A three-circuit regenerative tuner employing two variometers and a vario-coupler. Five controls are used which are explained in the text.



buyers of factory-made sets find that either they cannot get any stations at all or those they do get are not loud enough or not good enough. Very often these faults are present because the operator of the set does not know just how to tune it. Of course, we cannot lay down any hard and fast rules for the tuning of a radio set, but we can consider several different kinds of sets and discuss in general the tuning of each one. From these general rules anyone should be able, with practice, to properly operate almost any modern type of radio set. Combining some of the general rules laid down below with a little common sense, and with quite a little practice, no trouble should be encountered. Do not, however, expect to sit down at your new radio set and tune in all the stations within your range on the first night. You will find that certain fine points of tuning can only be learned by practice and that it may be a week or more before you thoroughly understand how to set the various knobs and dials of your set for the very best results.

First, however, if you have purchased a new set, it is suggested that you read the article appearing in this department in the January issue, which deals with the installation of a new radio set. It may be that the article will be of value to you and, after you get through with the installation, you will then be able to go ahead and get the best reception results out of your set that it is possible to obtain.

**CRYSTAL SETS**

Although the crystal receiving set is today considered passé by a majority of those interested in radio, still it holds its own to a very great extent. Its inherent simplicity, combined with its low cost and up-keep, make it a set that is very desirable for use when situated close to a broadcast station. The tones reproduced by a crystal receiving set are practically perfect. The one drawback, of course, is the lack of volume; but some music lovers use crystal sets with headphones because of the life-like reproduction that is obtained.

A typical crystal receiving set of the simplified type is illustrated in Fig. 3. With a receiver of this nature only one tuning control is used, namely, the dial indicated by A in the photograph. In order to receive signals with a set of this type it is only necessary to connect an aerial and ground to the clips provided for that purpose and so marked, connect the phones to the binding posts, adjust the detector and then turn the dial. With so many broadcast stations in the air today the latter two

may be accomplished at one and the same time. A piece of crystal, usually galena, is placed in the clip or cup and the fine wire or cat whisker touched to the surface of it. The dial is then slowly rotated, and if no signals are heard, the position of the cat whisker is changed. Rotate the dial once more, and continue this process until a station is heard. First, of course, make sure by referring to programs that some nearby

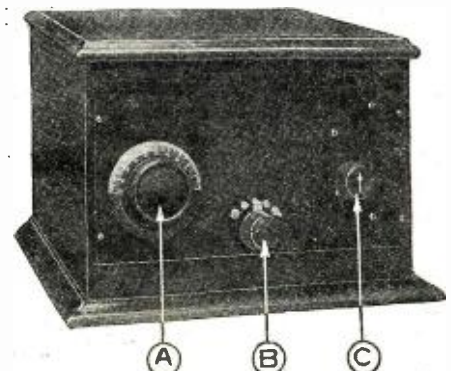

Fig. 4. A simple form of non-regenerative vacuum tube receiver. A and B are the tuning controls and C the filament rheostat.

broadcast station is in operation. If so, you will hear them as soon as your dial comes to the right position and you have found a sensitive spot on the crystal. After a station is once heard, carefully adjust the single dial until it comes in loudest. Then adjust the cat whisker over the surface of the crystal until the loudest possible signals are obtained. This spot is what is known as the most sensitive one on the surface of the crystal and should be maintained as long as possible. It may be necessary to readjust the wire occasionally, however, because jars or vibrations will remove the cat whisker from the sensitive spot. Also the crystal should occasionally be removed from the cup, using a pair of pliers and not the fingers, and washed in alcohol. This will remove any dust which may have collected on the surface and will restore the sensitivity of the crystal to a certain extent. Also, you should occasionally clean the point of the cat whisker.

Thus you can see that the tuning of this set is probably as simple as it is possible to make a radio receiving set.

There are, of course, other types of crystal sets using more complicated tuning apparatus than the one illustrated herewith. However, the adjustment of the crystal is the same in all cases and the other tuning controls may be manipulated in much the same way as described in connection with some of the single tube sets mentioned below.

**ONE TUBE RECEIVERS**

The tuning of most single tube receiving sets is somewhat more complicated than that of the crystal detector type described above. Let us first consider a single tube set similar to the one illustrated in Fig. 4. Here we find a dial indicated by A and a switch



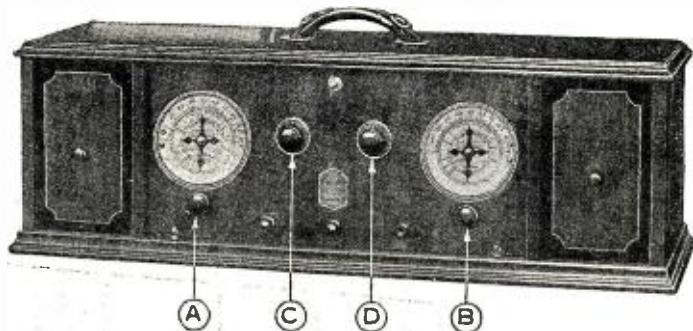

Fig. 11. The two control Super-Heterodyne receiver illustrated at the left is entirely self contained. Even the loop aerial is in the cabinet. A and B are the tuning controls, C the volume control and D the filament rheostat.

indicated by B. First, the set is connected up as per the directions given by the manufacturer, or in accordance with the directions of the article describing the construction of the set that you made. This same point, of course, applies to all receiving sets and will not be mentioned again in connection with the others described below. The tube is inserted in the socket and the phones placed on the head. The knob C in Fig. 4 is turned slowly to the right. This is the rheostat or instrument that controls the filament heat of the vacuum tube. A slight hissing noise soon will be heard and the rheostat should be left in this point for the time being. The switch B may then be placed on the first point and the dial A rotated slowly throughout its entire range of graduations. If no signals are heard, try the second point on switch B and again rotate the dial. Continue in this manner, using the third, fourth and fifth points of the switch until signals are heard. After a station is thus located, adjust the dial A carefully for louder signal strength and then try turning the rheostat slightly either one way or the other. You will soon locate the best operating position for the rheostat. This point will advance slightly to the right as the set is used more and more and the "A" battery is reduced in strength. However, when the storage battery is charged, or new

A single tube set of the regenerative type is illustrated in Fig. 5. Here the dial indicated by A is what is known as the tuning dial, B is a switch used in the same manner as the switch in Fig. 4 and C is the regeneration control. The tuning of this set is, in fact, quite simple, although some people try to make hard work of it. In essence, the process is as follows: The tube is lighted by closing the switch of the filament circuit and turning the rheostat part way. The regeneration dial is then set at about 10 degrees on the scale and the dial A and switch B manipulated as heretofore mentioned, until a signal is heard. If nothing happens, increase the setting of the regeneration dial and try again. Signals will soon be heard if any stations within the range of the set are operating. After a station is once located, carefully and slowly adjust dial A until they are at the loudest. Then increase the reading of dial C until the station comes in at its best. Further adjustment of this dial will cause the set to squeal and the music distort. Never advance the regeneration control so far as to cause this to happen, and always work your set with the rheostat turned to the left as far as is possible and still get results.

**RADIATION**

Making a set squeal as mentioned above causes it to act as a miniature transmitter and waves will be sent out from your aerial which will be received by your neighbors' and which will cause squealing and unpleasant noises in their sets. Therefore, always operate your set so that it does not squeal. This squeal-noise can always be controlled if care is taken not to advance the regeneration control too far. If you do advance it to the point where the set squeals, you gain nothing and you only cause trouble and hard feelings with your neighbors. Adjust your regeneration control carefully and you will obtain the best results from your set. These rules apply to the operation of any radio receiving set that employs regeneration.

**TWO-CONTROL RECEIVER**

What is probably the most satisfactory receiving set for all around use by the average beginner or even the advanced student of radio is illustrated in Fig. 6. It is what is known as a two-control receiver with only one tuning control. The particular set illustrated incorporates three tubes. The use of three tubes allows the operator to reproduce received signals with a loud speaker and does away with the necessity of constantly wearing headphones.

In the set illustrated herewith, one rheostat controls the detector and the other controls the two amplifier tubes. These rheostats are manipulated as described above and a plug connected to a loud speaker is inserted in the jack, which allows the use of all three tubes. Inserting the plug in the other jack would place only one detector and one ampli-

fyng tube in the circuit and would not allow the use of a loud speaker, except on nearby stations. You can, however, use headphones when the plug is placed in this jack and get excellent results, particularly on DX reception.

After the rheostats are turned on, the dial A is set at about 10 degrees. The dial B is then rotated very slowly until a signal is heard. Then adjust that dial closely and, if necessary, turn the vernier knob. This knob permits very close adjustment that could not be obtained by turning the dial itself. When the signal is brought to its loudest point by this method, advance dial A, which controls the regeneration, to just below the squealing point. Once this point is found, you will have located the setting where the signal will come in at its best.

**THREE-CIRCUIT TUNER**

Some time ago in this department, the writer described in detail the construction of a radio receiving set which is generally known as a three-circuit tuner. It incorporates a vario-coupler, a variometer and a variable condenser, connected with a single

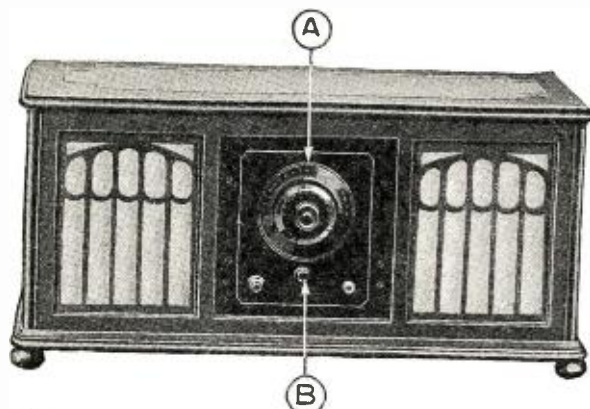

Fig. 8. A new type of self contained single control four-tube receiver. A is the tuning dial and B the vernier knob for fine adjustment.



Fig. 3. An elementary type of receiver using a crystal detector is illustrated above. A is the tuning control.

vacuum tube. For the benefit of those who have sets of this type, the following tuning directions are given. Referring to Fig. 7, we find dials marked A, C and E and switches marked B and D. In this particular case, the dial A controls the wave-length, as do also the switches B and D. Dial C controls the coupling between the stationary coil and the rotating coil of the vario-coupler and enables the operator to obtain finer tuning than would be possible if the coupler were fixed. Dial E controls the variometer which provides regeneration in this particular circuit and should be manipulated accordingly.

After the rheostat is set, the switch arm B, which controls the coarse tuning of the primary circuit, should be varied and the condenser A changed at the same time. This should be done with the coupling C set at maximum and regeneration control E at about 10 to 20 degrees on the scale. Signals will soon be heard, whereupon the regenera-

(Continued on page 1986)

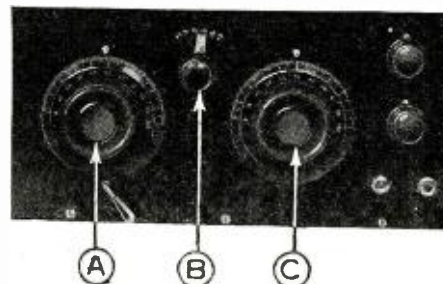

Fig. 4. A regenerative vacuum tube receiver of the single circuit type. A and B are the tuning controls and C the regeneration control.

dry cells placed in the circuit, as the case may be, the rheostat setting will again be toward the left. Be sure that you turn off the filament or "A" battery circuit every time you are through using your set. This may be accomplished either by turning the rheostat all the way to the left or opening a switch, if the set is equipped with such a device. If you do not take this precaution your "A" battery will quickly run down.

The set, the operation of which is described above, is what is known as a non-regenerative type and is not very sensitive. The use of regeneration increases the sensitiveness of a single vacuum tube receiving set to such a point that great "DX" (distance) reception often becomes possible and the signals are reproduced much louder than the type described above. However, the use of regeneration sometimes distorts the received signals somewhat, but if the set is handled properly, such need not be the case.



# International Radio



## ENGLAND

### Experiments in Westminster Abbey

Microphones and loudspeakers were recently installed in Westminster Abbey. Experiments are being performed along the lines of voice amplification.

### Curious Antennae in Scotland

Among the many curious antennae that have been experimented with in Scotland were the frame work of a piano, a brass parrot cage and a metal candle stick. In each case excellent results were reported as the Glasgow broadcast station was received over a distance of 100 miles.



The terminal shown above is an excellent one because the contact is tight and the lead may be connected or disconnected almost instantaneously. These terminals may be used in any place where an external lead is needed to be connected into a set. Other advantages are that the terminals take two leads; offer a larger surface of contact than ordinary terminals, and they may be attached easily to terminals already incorporated in the set.

### New Method for Broadcasting Plays

In Station 2LO in London a new system has been adopted for the broadcasting of plays. The actors gather about the microphone and instead of having the script of the play in their hands, page by page it is projected upon the wall of the studio from which they read their lines. This method eliminates any rustling of papers and also permits the artists to keep their heads raised, talking directly into the microphone.

### New High-Powered Station

Plans have been accepted and construction started on the new high-powered station for broadcasting at Daventry. The two antenna towers are to be 500 feet high and 800 feet apart, and there is to be a T-shaped antenna, the lead-in dropping from the center of the antenna directly to the station beneath. The power rating of the station is 25 k.w., although the actual consumption will be nearly 100 k.w.

One of the most interesting things about the new station is the equipment for the ground. This will consist of a continuous metal plate laid underground with a radius of 100 feet. The station will be in the center

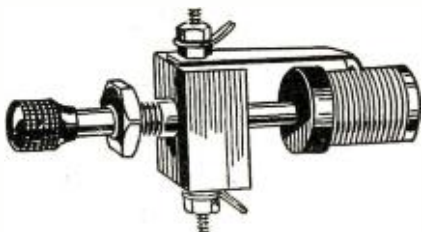

The filament rheostat shown above is rather a departure from conventional design, in that instead of having a movable arm the element on which the resistance is wound is controlled by the knob on the front of the panel.

of this ring and there will be leads from this ground going directly to the station's roof.



## FRANCE

### Prize Offered for Circuit

A manufacturer of radio apparatus in Paris has offered a prize of 1,000 francs to the amateur who demonstrates the best receiving set, using the power lines of the city as an antenna.

### Two Million Words Per Day

The powerful radio station at Ste. Assise is capable of transmitting approximately 2,000,000 words per day.

### French Stations

The situation in France of the broadcast stations is far from being as near perfect as the situation in England, mainly because of the unhappy conditions that have been imposed by the Post Office Department. Also the wave-lengths that are used are much more widespread than in the other countries, waves from 300 to 2,650 meters being employed. The system has been more or less criticized as nearly all the stations are in or near Paris and the maximum range of reception is about 500 miles, so that unless multi-tube sets are used, no concerts can be received.

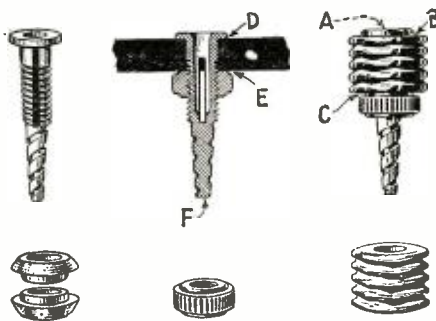

For the experimenters' convenience connections may be made to the terminals shown in the accompanying illustration in five different places, A, B, C, D and E. These points of connection furnish excellent contact and have the advantage of being easily disconnected by merely loosening the locknut. A permanent connection point is provided at F where wires may be soldered.

On the high wave-lengths France has two stations. One is the Eiffel Tower, which works on a wave-length of 2,650 meters and daily broadcasts concerts, news, weather reports, etc. This station is heard over the whole of Europe. On 1,780 meters there is Radio Paris, owned by the Compagnie Francaise de Radiophonie, which broadcasts concerts daily. There is another official station, PTT, an abbreviation of *Ecole Supérieure des Postes Telegraphes Telephones*, working every other day on 459 meters. However, its low input (500 watts) and the bad situation of its antenna make the range of this station only about 200 miles. Next in the wave band is the station of the Petit Parisien, working on 345 meters, which is one of the best stations in the country.

There are four other stations that transmit intermittently, Lyons, on 470 meters, which broadcasts phonograph records; Agen, on 325 meters; Les Concerts Radio-Nor-

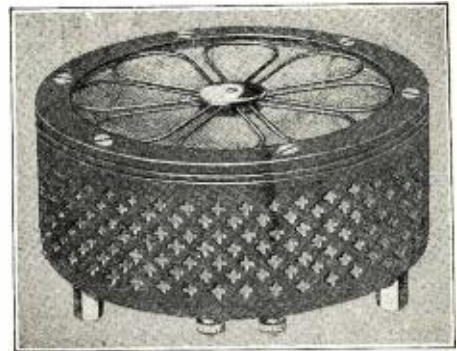

A hornless loud speaker, manufactured in Germany. This instrument has a diaphragm of aluminum and the reproduction of sound is remarkably free from distortion.

mands, on 380 meters, and Le Pic du Midi that transmits for the most part meteorological advices.



## GERMANY

### Short Waves Used For News Service

German experiments with short wave-lengths have met with great success in the case of news service between Nauen and Buenos Ayres. It was feared that the sun and the long days of the Argentine summer would interfere with any kind of regular service on a wave-length of 70 meters using only 2 k.w. to cover the 7,500 miles between the two countries.

By working during night time in Argentina, irrespective of the time in Germany, it has been found possible to keep up a regular 10-hour service, using no higher energy than before, but on a wave-length of 30 meters.

### Selling Information By Radio

From Berlin comes the report that an effective method has been devised for selling information sent out by radio. Prices and other agricultural information are sent out in code. Those who subscribe for the service are provided with an explanation of the code by which they are enabled to interpret the messages. When the time comes for renewal of subscriptions the code is changed.

### Breslau's Brain Wave

The station in Breslau has lately been trying out an ingenious idea, by testing the effect of broadcast music upon factory workers. Not only are special lunch-hour programs given, but by means of loudspeakers experiments are being conducted with a view to seeing if the output of workers doing mechanical duties can be accelerated by suitable tunes.

(Continued on page 2010)



A headset, made especially for listeners of the gentler sex, is mounted on a hollow, wooden handle. With this pair of phones Milady need not fear that her coiffure will be disarranged, due to the old style head set, while she is listening-in.





## Hamitorial Put It On Paper First!

**T**HERE'S theory and then there's practice. Both incorporate knowledge, one supplementing the other. One cannot be effectual without the other.

Here's the lay.

The man who pounds the key and adjusts the natural, grows gradually to hold himself superior to the gents who thumb the log tables and keep a copy of the Bureau of Standards on the desk. One makes notes and reports and the other makes stations. But if it were not for the notes, the station would still be wondering why it had trouble raising a neighbor in the daytime and were it not for the station, the notes would still be on the back shelves of the Public Library.

The moral is obvious.

The bird must be early to catch the worm or else take it, cold storage, from the nearest delicatessen.

All of which is to say that one of the surest methods of advancement in any field is to use both the mathematics and the meters. They seem a long way apart, the hammer and the slide rule, but they are brothers under the skin, although one is the

6BCP, the station of W. B. Magner, San Pedro, Calif., who held a two-way communication with A4AA in Australia. Not a bad bit of DX for a 20-watt master and four 5-watt amplifiers in a Hartley circuit.

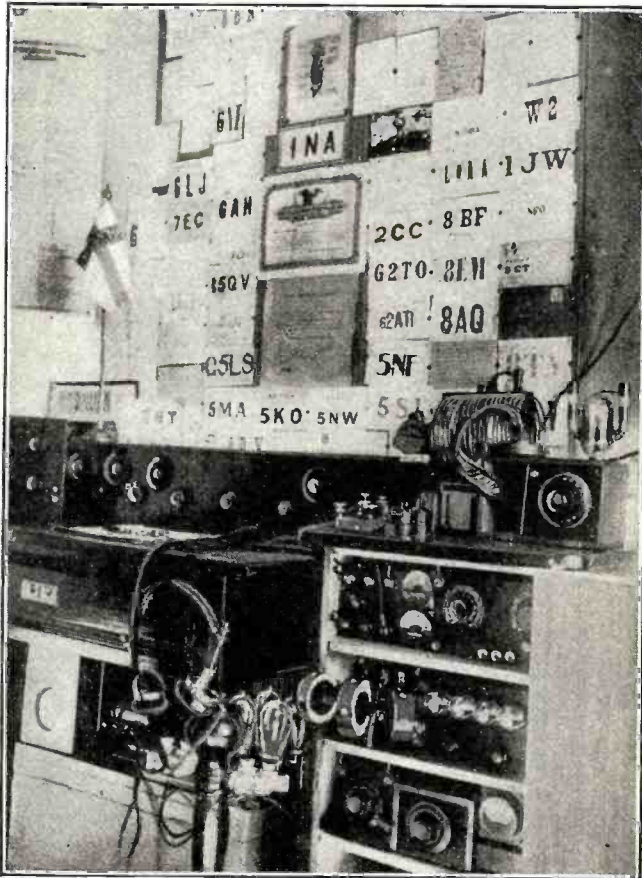
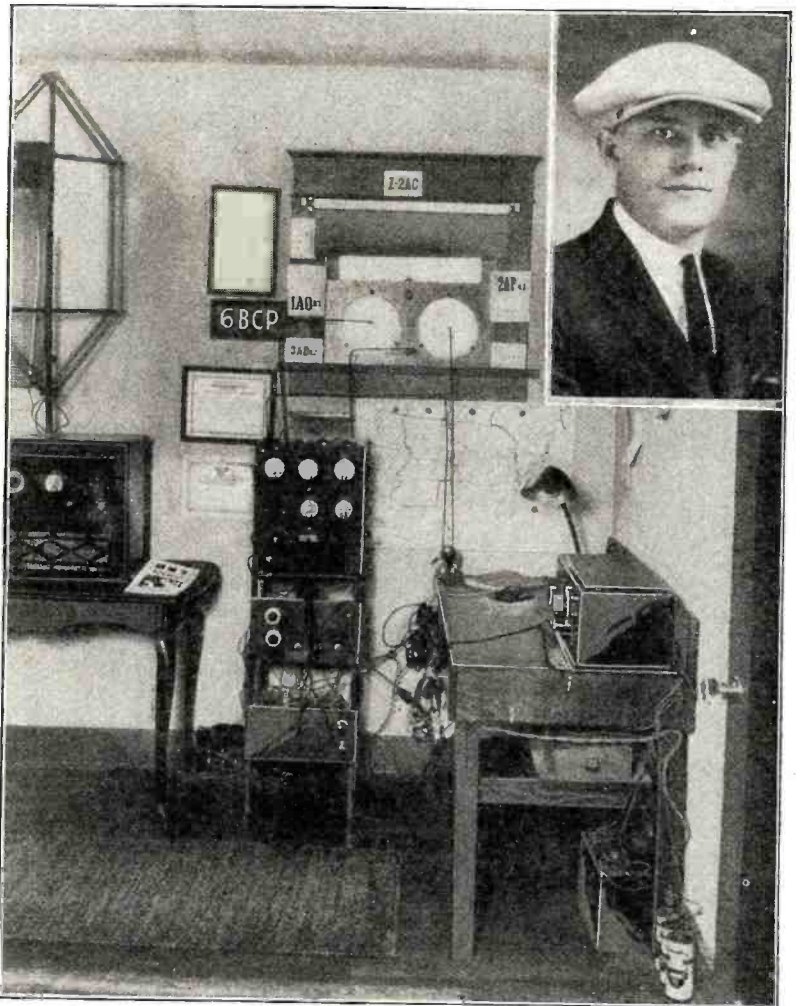

Above is 1NA, Suomi, Finland, owned and operated by Leo Lindell. Mr. Lindell has been president of the Finland Amateur radio league and one of the leaders of amateur work in his homeland. Twenty watts is the highest power allowed amateurs in his country.

younger and has a reputation for midnight oil.

As a matter of legal fact, they are both joint heirs under their father's will, and their ancestor is none other than old man Advancement himself. Of course, they have small independent means themselves, but they cannot make any major investment without a joint signature. So the logical conduct is the greatest co-operation. In other words, both of them must be wooed and won if they are to invest in the salesman's pet scheme.

And the salesman is the Ham who is trying to get 50 more miles without melting down the plate of the 50-watter.

Now, me hearties, here's me plea. When

you have an idea whereby you wish to perform the eighth or ninth wonder of the world, save time, your patience and your self-respect by first examining the idea thoroughly from the theoretical side. There may be many points which can be cleared up by a simple reference to Kent or Stanley. And then, many times, the gorgeous idea's pristine beauty may not be so hot as it appeared at first sight, it may be the glim of renovation. It may, perchance, have been invented before. You know regeneration was invented at least 15 times after the original patent was granted.

But the main dirge has to do with a number of failures of ideas in the hands of their originators, only to result in extreme success in the laboratory of a neighbor.

One of the most potent facts confronting the United States Patent Office is the habitual lack of data concerning the constants of circuits submitted to them for acceptance.

And any man who has tuned a C.W. squirter to a 195 fundamental knows that the ammeter refuses absolutely and positively to function until such times as proper attention and mathematics are brought to





Station 5AHD owned and operated by Mr. B. H. Huff, of Altus, Okla. Note the good old three-circuit honeycomb coil receiver to the left of the photo. The transmitter is a 10-watt C.W. and phone set.

was continued. Ergo, the tube.

How many Hams do you know who have an idea, decide to try it, draw an incomplete diagram, use any apparatus at hand which can be forced into service, and then start testing without so much, many times, as examining a complete hook-up of the complete arrangement.

And how many times does the test fail absolutely to give even the slightest result? How many times would it have given a result of some sort—a necessary beginning for any continued investigation—had some one constant been corrected according to known formulae?

Come on, the old physics and the reports of the Royal Society are pretty interesting. Read 'em while waiting for the broadcasters to finish.

Jay Hollander.

selectivity and a slight increase in signal strength as compared with No. 18 on waves of 100 and 200 meters. For C.W. reception a tickler of No. 18 wire gives better and clearer signals.

It is not suggested that the reader should attempt to compress this set into a small cabinet—if he tries he will in all probability meet with failure; the set will do nothing but oscillate when the two circuits are brought into tune.

The actual set used by the writer is laid out on a baseboard. All leads at R.F. potential are kept very short and well away from other wires. Ordinary honeycomb mountings are used for the coils, though for short wave work some other form of mounting would be more efficient. Honeycomb mountings are used for ease in covering a wide band of wave-lengths without using too much condenser. The grid leak is connected to the positive of the "A" battery.

$C_1$  in the antenna lead is variable. For waves below 100 meters it is set at 10-20 degrees (180 degree scale), for 100-200 meters it is set at about 40 degrees. For higher waves, as much as may be necessary. Increasing the capacity of this condenser increases the signal strength, but decreases the selectivity.

For  $C_3$  two values are given. The smaller one is normally used, but when atmospheric are bad the larger one is switched in. It seems to have the effect of reducing the ratio of static to signal strength and signals are more easily read.

OPERATION

When the set is assembled and wired and first switched on, the filament current, the "B" battery voltage on each tube and the grid leak must be so adjusted that the set goes into oscillation without a "plop"—overlap must be entirely absent for DX work. Separate "B" battery tappings for each tube are most desirable as they admit of fine adjustment. A hard or soft tube may be used for detector; the soft tube gives stronger signals, but the hard tube is more stable—the latter is, therefore, used in the writer's set. The circuit  $L_2C_3$  is set to the wave-length to be received and  $C_3$  varied until the set oscillates; of course, the tickler must be brought close to the aerial inductance, the coupling between tickler and antenna inductance must now be reduced until the set is only just oscillating. It is then in its most sensitive condition. It must be distinctly understood that if the set is allowed to oscillate furiously DX reception cannot be hoped for. It is a common fault to use too large a tickler coil, use one as small as possible—just large enough to make the set oscillate over the range required.

(Continued on page 2000)

An R.F. Short Wave Receiver

By J. V. NEWSON, G-2GF

THERE is no doubt that a stage of R.F. amplification, properly applied and handled, greatly increases the range of a receiver even on the very short waves at present used by amateurs.

The writer used the set to be described for the reception of signals from American and other amateur stations on all short wave-lengths. About 400 American and Canadian amateur stations have been heard, although the time devoted to this class of reception is of necessity limited. Some of the stations have been heard on different wave bands from time to time. For instance, 1CMP has been heard on 200, 100 and 75 meters. As a rule the signals are of very good strength.

The receiver is wired to the circuit in Fig. 1. The table gives the winding details for the coils. All coils are wound on spider-web forms cut from thin cardboard and having an inside diameter of 1 3/8 inches and 11 slots. The wire used is No. 22 D.C.C., No. 18 D.C.C. and Litz. Contrary to general opinion Litz. is found to give greater

bear on the number of henries and microfarads of the circuit. A simple, almost foolish illustration, but it shows the point. All points of great importance are simple—to steal Doc Crane's stuff—but it's the truth which is of interest.

How much trouble will you save yourself if, before you try some new idea, you dope out everything possible first? And how much greater are your chances of ultimate success with it if you do? Try it once and see.

But the climax is not yet. You not only save time and trouble, but you know at the time of investigation just exactly what you are looking for.

By first plotting the new circuit or idea on paper, and then going through it carefully, figuring out all the values for apparatus which functions in its usual capacity, you automatically make known to yourself just what it is in the circuit that is unknown, i. e., what you are looking for.

With this point clearly in mind, there is a base from which the experiment may be carried forward. The resulting notes, written after the power is cut off at the conclusion of work, will not be a simple jumble of disconnected facts, but a very definite and concise essay on the operation of certain apparatus being used in an effort to make certain improvements of the known methods. The clarity of purpose will make the end just seventeen and three-quarters as easy to gain. Instead of meandering about through country lanes, you go down an asphalted, well lighted, straight street. Much quicker.

And the climax: When the experiment is brought to a successful conclusion, instead of having a new method of producing a certain result without any definite knowledge as to how or why, you will know pretty nearly just the how and the why, and if sufficient attention has been paid to the Bureau of Standards you will know whether you have a new principle or just an adaptation of one of the established facts.

The vacuum tube was the direct result of such a research. Something was wanted. In an experiment to improve existent apparatus, certain facts were noted, elements in certain relation behaved in a strange manner. Never forgetting for a moment what was being sought, the investigation

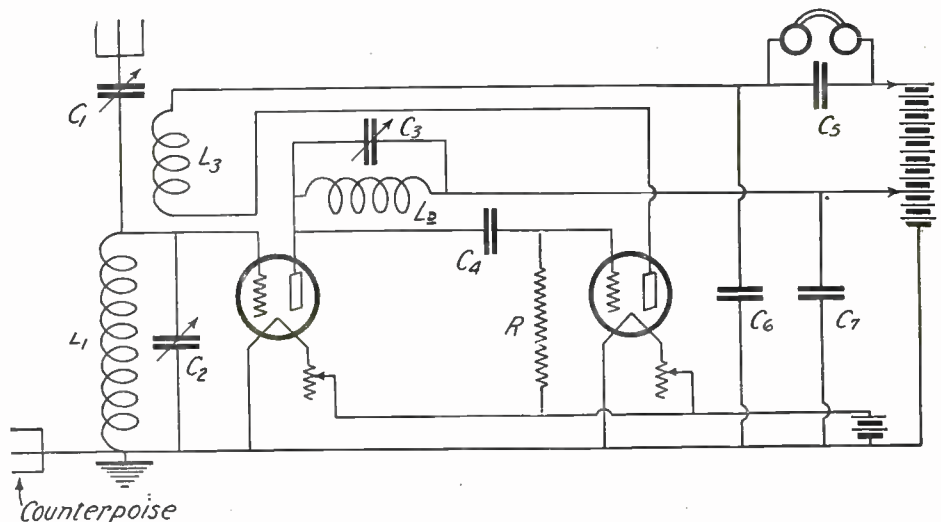

The circuit diagram of the R.F. short wave receiver. The capacity values are:  $C_1$ —.0004 mfd.,  $C_2$ —.0005 mfd.,  $C_3$ —.00025 mfd.,  $C_4$ —.0003 mfd.,  $C_5$ —.0002 or .006 mfd.,  $C_6$  and  $C_7$ —1 mfd. each, and  $R$ —2 megohms.



# A Year's Work Below Forty Meters

By JOHN L. REINARTZ, 1QP--1XAM



JOHN L. REINARTZ



Here is some real dope on short wave work. Mr. Reinartz has been collaborating with the Naval Research Laboratory, at Bellevue in these experiments and presents the outcome of the work in this interesting article.



**T**HE amateur is never satisfied long; his receiver, his transmitter or the wave-length is always being changed. This is just as it should be if the radio art is to advance. Who can say that the amateur is not responsible for some of its progress? And now it seems that the amateur may again be useful while exploring the short waves below 40 meters. A year has passed during which 1XAM has, with the co-operation of the Naval Research Laboratory at Bellevue and a host of amateurs, explored the region below 40 meters. Great credit is due Dr. Hoyt A. Taylor, Leo C. Young, H. T. Dalrymple, 8XC, Can. 9AV, Can. 3BP, 4XE, 9AXX, 9EK, 9DFH, 6TS and others whom I may not have mentioned, but who in many ways have helped me to obtain that information which I was seeking, the results of which are very interesting.

Soon after communicating with France on 100 meters, the next thing to do was to see just how far down it was possible to go and still maintain two-way contact. The farthest drop was to 50 meters, with PCII in Holland, who reported the signals during the test as being better than 60, 70 or 100 meters, PCII also being able to drop to 78 meters and still stay in perfect contact with 1XAM. Soon after that PCII got into trouble with the Dutch Government and the tests stopped. That not being a satisfactory situation,

1XAM got busy and broadcast the information that short wave tests would be conducted with any station which would be willing to test. The first station to comply was 8CU, now 8XC, who spent many hours recording test signals on 40 meters. Then word was received that the Naval Research Laboratory at Bellevue, D. C., under the direction of Dr. H. A. Taylor, wished to do some work on waves in the region above 100 meters. Trial tests during the noon hour quickly proved that waves below 100 meters would come through much better than waves above 100 meters. By March 26, 1924, the Naval Laboratory (NKF) had permanently dropped to 51 meters, while 1XAM had not lifted its head above 44 meters for some weeks, and was even creeping down a few meters daily, reaching 23 meters in one test on March 16, 1924. Then began a series of tests lasting through the year, which seemed like a game of tag. One day 1XAM could go to 23 meters and be heard and another day only to 30 or 27 meters. At first cloud formations were blamed for the inability of the shorter wave to get to NKF, but now we know better; the sun is to blame.

### EFFECTS OF SUN NOTICED

The first inkling that the sun was going to make us sit up and take notice was when L. C. Young, the operator at NKF, reported that he could not find 1XAM at night when he attempted to listen while at his home. We decided at once to make a test from noon until night on March 29, 1924. The result was that NKF could be heard for a longer period after the sun had gone down than could 1XAM on 40 meters. This seemed odd and did not look just right, so other daylight to dark tests followed, but with the same result for all. On top of that, Mr. H. T. Dalrymple, of Akron, Ohio, began to report that he could find 1XAM on the shorter waves around 22 meters during the noon hour tests when NKF said nil, even remarking that perhaps NKF needed a good receiver, and to mix things up still more, 4XE reported that he could hear 1XAM perfectly after dark when NKF could not find a trace of the signals. When 9BRI reported the same results that 4XE did, we began to wonder and to think. By that time it was summer and the Department of Commerce decided to allow the amateur the use of 4 to 5, 20 to 22, 40 to 43 and 75 to 80 meters. Within a few months thereafter,

quite a number of amateurs got busy on the 40-meter band and more information was gathered, among which was that 1XAM could be heard by stations outside of a 500-mile radius at noon on 21 meters when NKF, 8XC and Dalrymple reported "no sigs." Also that the signals were being copied on the west coast and in Europe nightly from 7 to 8 p.m., EST., on 40 meters during which period 1XAM was sending test signals. To this were added 21 meters from 6 to 7 p.m., EST., from which nothing was heard. Tak-

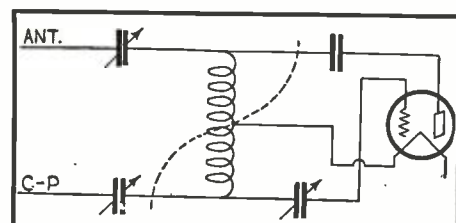

FIG. 1

The circuit first used in 1923. It gave trouble due to external high voltage at the tube elements.

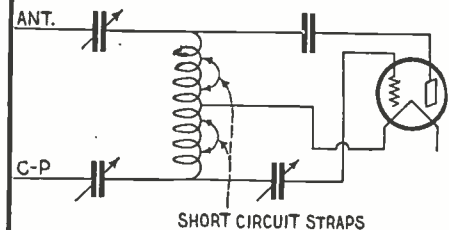

FIG. 2

Circuit used in early part of 1924 which turned out to be a splendid tank circuit.

ing all the past test information and piecing it together finally pointed to a solution.

### WAVE REFLECTION

Marconi in his work had pointed out that very short waves, less than one meter, could be reflected at will with the proper type of reflector, and at present is doing it on longer waves. This reflection is man-made. In our short wave tests we were being troubled with reflection also, but it was due to the sun's influence and could be put to a useful service. I told you how the signals at 21 meters could

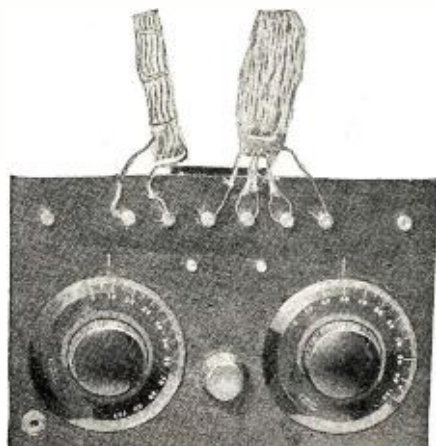

Front view of Mr. Reinartz's short wave receiver.

This is what happens to the short waves. The angle of reflection changes with the time of day. With a 20-meter transmitter, the radius of the circle at noon EST was 500 miles, at 5 p.m., 1,000 miles and at 9 p.m., 3,000 miles.

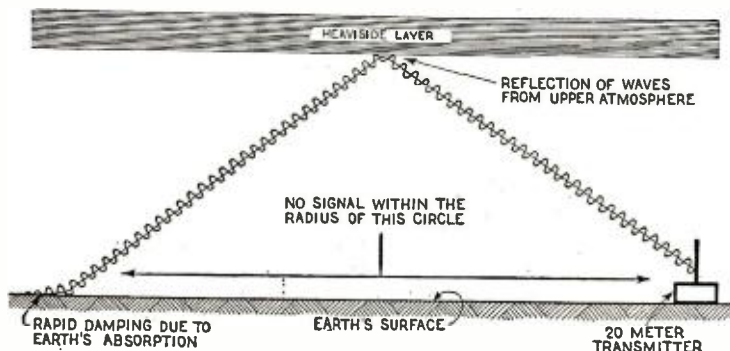



be found at one distance, but not at a shorter distance. It must be that the short waves are at once propagated into our higher atmosphere, and upon reaching a given height are reflected from a layer of our atmosphere back to earth. The radius to which they are initially reflected is that place inside of the circle of which the signal is a minus quantity, and outside of which it can be found. The reason for this is the capability of the sun to ionize our atmosphere. The depth to which this ionization is possible depends on the position of the sun with respect to any other position on earth, changing with every position of the sun during 24 hours

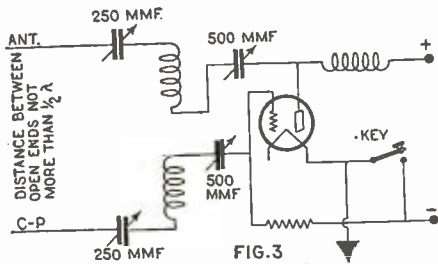

Final circuit which met requirements for low voltage at tube elements and which will easily oscillate at less than 5 meters.

with respect to a transmitting station located at one place. Also, the shorter the wave the higher its initial reflecting height for the same time of day and, therefore, the greater its initial radius to which it is reflected on earth. As the sun goes west with respect to a transmitting station, the station has to use a longer and longer wave to maintain contact with a given station, say, 300 miles away. This was proven in tests with NKF, in which 1XAM had to move up the wave-length scale as the sun went down. The abruptness at which the shorter wave went out of range tended to show that it was at the same speed at which the sun was going west, only a second or two being the time between strong signals and no signals. Knowing that the very short waves are subject to absorption in a greater degree than are the long waves was then the reason why the short waves did not carry far when traveling over the earth's surface after being reflected from the higher atmosphere. Also it was evident that but little initial power was lost during this sojourn to and from the ionized layer so that by using the proper wave-length it would be possible to transmit to the west coast at noon EST. Acting upon this reasoning, 1XAM began to transmit on 20 meters each Sunday from 8 a.m. until 6 p.m., which bore fruit on December 21, 1924, when reports came from the west coast that three amateurs had copied 1XAM solid

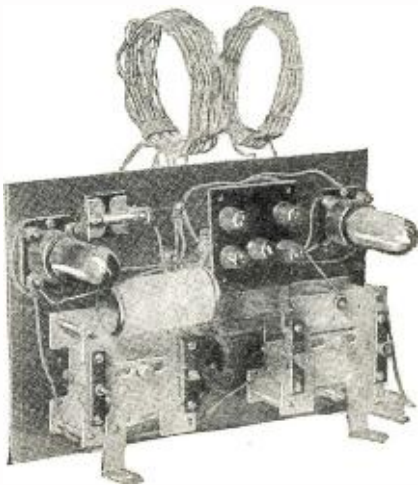

A rear view of the short wave low loss receiver. Two 199 tubes are employed, detector and audio frequency amplification.

on 21 meters, in the meantime working 9EG and 9AXX and finally 6TS and 4XE at noon EST on 21 meters.

ABSORPTION AT SHORT WAVES

Proof that absorption is great at the shorter waves is had through tests with 6TS, who cannot hear 1XAM until 7 p.m. EST. on 40 meters and who loses 1XAM on 20 meters at 6:30 p.m. EST. The 40 meter wave just comes near enough to gain sufficient strength to be received while the 20-meter wave is reaching that reflecting height which brings it back to earth at a radius which makes a greater circle than the bounds of the United States, and therefore beyond the west coast, probably reaching Australia soon after. And who can say that we will not be able to use such a proper wave-length and at the proper time of day which will allow contact with Australian amateurs while it is still early afternoon on the east coast of the United States? At present 6TS can copy 1XAM on 40 meters until 9:30 p.m., EST. This time will grow later as summer comes on and the sun



The 20-meter transmitter including grid and plate inductance, plate choke coil and grid leak.

reaches a higher point, gradually shortening as next winter will approach.

THE TRANSMITTER CIRCUITS

Needless to say, the discoveries of the past year have been worth while and should give the amateur a future right to short waves, even if only to try out transmitting circuits. This brings us to the troubles that had to be overcome in the transmitter while attempting to make it oscillate lower and still lower until now the set will work on four meters with a 204-A tube, it being possible to obtain rated output at even that wave-length. For a time the circuit which made successful contact with Europe was used and is described in Fig. 1. This circuit worked very well to the 50-meter point with several tubes in parallel, and down to 30 meters with single tubes. Below that there was considerable trouble with excessive grid voltages and parasitic tube frequencies, which would break the tube insulation down very readily. Even the 204-A tube with its high insulation value was not capable of standing the strain for long periods of transmission; hysteresis losses in the glass supporting the grid mounting would finally make the glass a conductor and a bad tube was the result. Evidently high voltage, high frequency was responsible for that trouble, and in the endeavor to find a remedy it was reasoned that if a method could be found which would reduce the high frequency voltage at the grid and plate element of the tube and yet allow

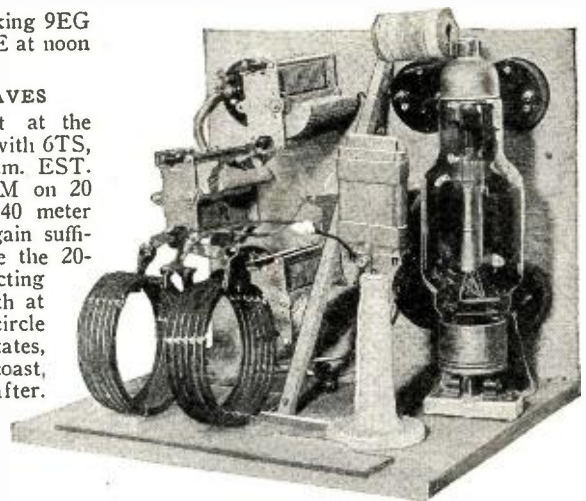

A rear view of the 250-watt short wave transmitter. Note the large porcelain insulating post.

proper operating conditions to exist, all the trouble would end. Various methods were tried among which was one which, while not getting rid of the trouble, provided a circuit arrangement which tended to stabilize the frequency at which it was oscillating to the extent that any size or type or other variation in the radiating system had no effect on its operation whatsoever; in fact, transmission through a two-wire cable 50 feet long to an antenna 50 feet from the transmitter was possible, and was actually done for long periods when in contact with NKF.

The frequency never shifts, whether the antenna is connected to one or the other wire in the cable; not even raising and lowering the antenna would cause the frequency to shift. This circuit is shown in Fig. 2. It will be noticed that the inductance to which the tube is connected is shunted in to places with a connection, this connection being equally spaced from the filament connection and shunting the same number of turns each side of the filament. This established full

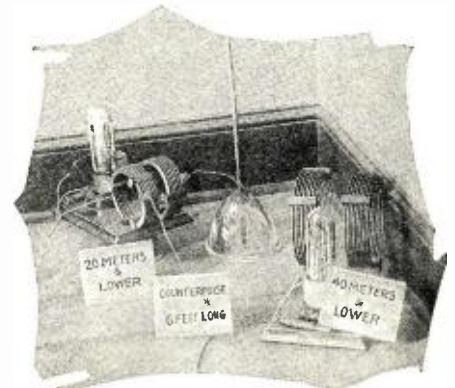

Two of the transmitters employed by Mr. Reinartz in his tests. Note the copper rod antenna between the two sets.

wave-length circuits, independent of the antenna or radiating circuit, and were in effect large tank circuits which, when connected to a radiating circuit which could not withdraw from this tank circuit as much energy as was being supplied to the tank circuit, would never have any effect on the frequency the tank circuit was operating at, nor did the radiation circuit have to be tuned to it.

IMPROVED CIRCUIT

But this circuit did not get rid of the tube troubles, though it would oscillate at 10 meters. It was evident that any circuit which used an inductance to which was connected the filament and the grid and plate elements must always have a more or less high voltage at the grid and plate of the tube. What

(Continued on page 1983)



# Lighting Main Plate Supply

By WILLIAM C. POOLE

Those who have alternating current available in their homes may use it to eliminate "B" batteries with the aid of the device described in this article.

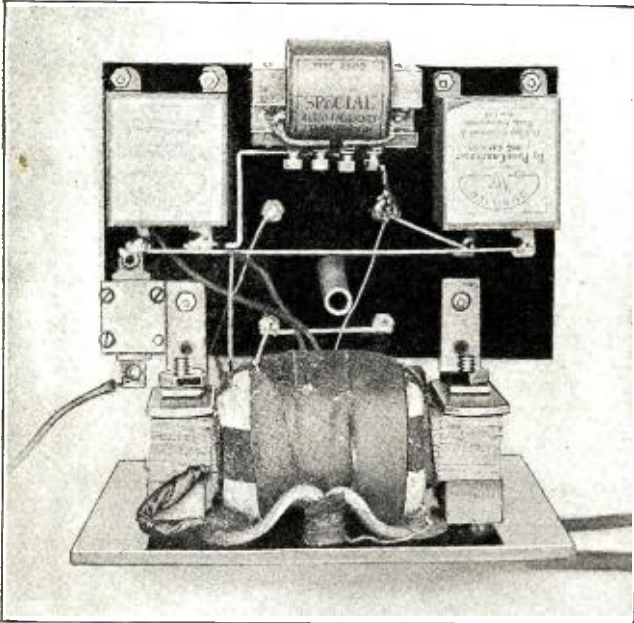

The appearance of the unit from above is shown in this photograph. Note the position of the transformer.

**T**HE problem of supplying "B" battery potential for the modern multi-tube set is one that has perplexed many of us. The drain on the "B" batteries of a set having more than three tubes is so great that their life is very short.

The rectifier described here is designed to operate from a 110-volt, 60-cycle lamp socket, and will rectify sufficient current to operate 12 UV-201A or eight WE-216A tubes, or any smaller number. The total cost should not exceed \$15, while the cost of operation is very low, being less than the cost of two ordinary incandescent lamps.

### RECTIFIER TUBE

In the rectifier described in this article the UV-201A tube was used to rectify the current. It proved to be very efficient and supplied practically 100 milliamperes. If more current is desired, the UV-203 (five-watt) may be used. If this tube is used,

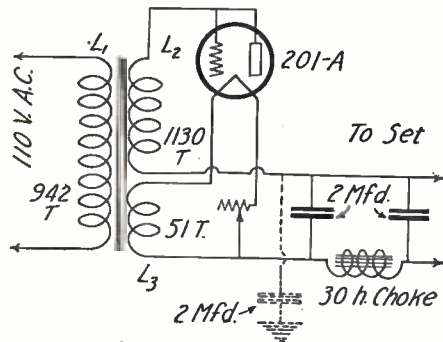

FIG. 1

the number of turns on the secondary winding will have to be increased from 51 turns to 72 in order to furnish 7.3 volts to light its filament.

### THE TRANSFORMER

We will first take into consideration the construction of the core of the transformer,

160 pieces, or laminations as they are called, are cut from .014-inch silicon steel. They are cut in the shape of a letter "L,"  $4\frac{1}{8} \times 3\frac{1}{2}$  inches, the width of the longer side being 1 inch and the width of the shorter side being  $\frac{7}{8}$  inch. They are cut with shears; thus, when the laminations are piled up, without the corners overlapping, we will have a core 5 inches long and  $3\frac{1}{2}$  inches wide.

The windings on the transformer consist of the following:

1. Primary ( $L_1$ )—942 turns of No. 28 wire. It is placed on one leg of the transformer.
2. Secondary ( $L_2$ )—1130 turns of No. 34 wire placed on the opposite leg of the transformer from the primary winding.
3. Secondary ( $L_3$ )—51 turns of No. 18 wire wound directly under the other secondary winding.

(Ratio of  $L_1 L_2 = 1.09:1$  and  $L_1 L_3 = 55:1$ )

In winding the coils, first make two soft pine blocks  $\frac{7}{8} \times \frac{1}{2}$  inch. These placed together will give you the exact cross-section size of the legs of the core of the transformer. They should be 3 inches long. Over these two blocks two layers of stiff paper should be wound and tightly bound with insulating tape. Two pieces of cardboard,  $2\frac{1}{2} \times 3$  inches, should be tacked to the winding form, one at each end. Cut four pieces of tape 10 inches long and place one on each side of it will extend beyond the ends of the form. After the coil is wound they will be used to tie the wires in place. The cardboard end pieces are used only during the winding and removed when the strips of tape are tied in place. It would be well

LIST OF PARTS NECESSARY	
1 V. T. Socket.....	\$ .35
10 ft. lamp cord (double).....	.25
4 lbs. .014" silicon steel for transformer core .....	1.00
$\frac{1}{2}$ lb. No. 23 enameled wire.....	.70
$\frac{1}{2}$ lb. No. 34 enameled wire.....	.80
$\frac{1}{4}$ lb. No. 18 D.C.C. wire.....	.25
1 amplifying transformer.....	2.50
2 2-mfd. Dubilier condensers..	3.00
1 7 x 9 hard rubber panel.....	.60
1 $4\frac{1}{2} \times 7$ hard rubber panel.....	.35
1 rheostat (20 ohm).....	.50
Tape, screws and other incidentals .....	.50
	<b>\$10.80</b>

to study the photo. The tapes are clearly shown there. The wire may be wound by hand or the spool may be clamped in the chuck of a hand drill by means of a long bolt passing through the entire form. If you use a hand drill, be sure and multiply the number of turns made by the crank, by the ratio of the gears of the drill. This will give you the number of revolutions the form has made. Solder a 10-inch piece of

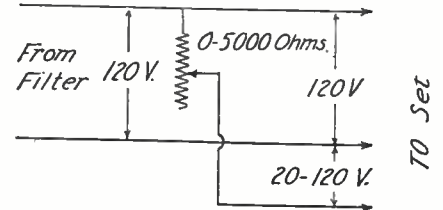
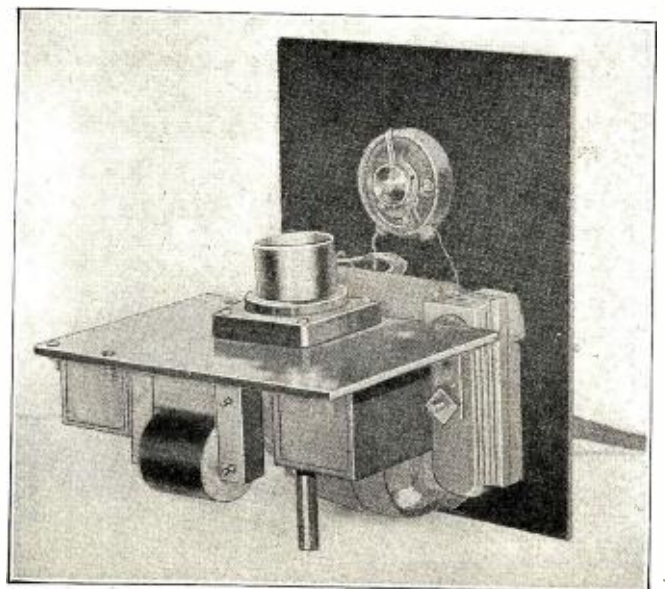

FIG. 2

The connection which enables a variable voltage to be obtained from the eliminator is shown above.

flexible wire to the end of the wire used in winding. Securely tie this in place before starting to wind the wire on. After the correct number of turns have been placed on the form, cut the end of the wire and solder another piece of flexible wire to the end. This piece is used as one of  
(Continued on page 1966)

At the left is shown the wiring diagram of the completed "B" battery eliminating unit. It is very simple of construction. Some idea as to the method of assembling the parts onto a panel is given by the photograph at the right. The instrument when completed is neat in appearance and efficient in operation.





# Low Loss Short Wave Set

By JOHN SCOTT-TAGGART

There are many experimenters who will welcome this description of the best tuner for work at the new short wave, high frequency bands. The description gives full details of construction.

EVER since the beginning of the repeating of broadcast programs on the short waves in the United States, and the entrance of the British Broadcasting Company on experiments of the same nature, there have appeared from time to time designs of receivers to be used in connection with these programs. The writer, in the present article, presents another design which he found exceedingly effective.

Following the first rule of this work, *i.e.*, low losses in all parts of the apparatus, the receiver differs in some respects from the standard hook-up which it follows. Care should be taken in the selection of the apparatus and in following the points of construction especially noted.

### CONDITIONS FOR RECEPTION

The conditions for successful reception appear to be: First, the use of a *short* single wire aerial, preferably vertical, and very carefully insulated, with a short direct lead-in. Second, the use of as few tubes as is practicable, two for phone use, detector followed by an *efficient and silent* stage of audio frequency amplification. Third, keep all tuning and distributed capacities as low as possible. This point is not due to any vague mysterious "leakage" of signal energy due to stray capacities on the short waves, as is often and inaccurately stated, but because the *total* available tuning capacity is necessarily low, and these stray capacities often act as poor high-loss condensers and so must be kept down to a reasonable proportion of the limited maximum.

### TURNING TO SHORT WAVES

On one-sixth of the ordinary broadcast wave-length we need one-sixth of the inductance and one-sixth of the tuning capacity (for the wave-length is proportional to the square root of the product of these according to the familiar formula), so that we may retain the ratio of inductance to

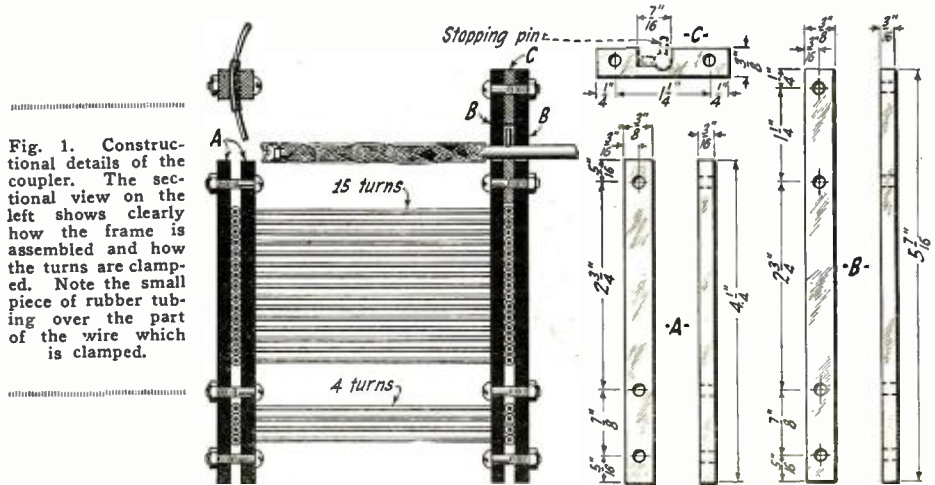

Fig. 1. Constructional details of the coupler. The sectional view on the left shows clearly how the frame is assembled and how the turns are clamped. Note the small piece of rubber tubing over the part of the wire which is clamped.

capacity in the tuning circuit. So with an inductance of the order of 20 microhenries we must combine a *total* tuning capacity of not much more than .0001 mfd. (100 micro-microfarads). This needs quite careful work in the design of the tuning inductance. The distributed capacity of the 15-turn honeycomb coil of a well-known type is near 20 mmf. and its natural wave-length is given as being close to 50 meters. Apart from its very appreciable radio frequency resistance, it is evident that such a type of closely wound fine wire coil is quite unsuitable for extremely short wave work, even if cut down to a small number of turns. The distributed capacity can actually be brought lower, by special types of winding, but at the cost of heavy dielectric losses and high radio frequency resistance through the use of fine wire.

### REDUCE RESISTANCE

It is essential for success on the very low waves to have the radio frequency resistance as low as possible in order that only a mini-

mum amount of regeneration will have to be used to bring the receiver into a sensitive condition.

While very little useful data on the subject is available, that which has been published shows that the high frequency resistance of wire increases with great rapidity with increase of frequency below 200 meters, and at 5,000,000 cycles (60 meters wave-length) is probably 5 to 7 (or more) times the direct current resistance even for the larger wire. Accordingly, it is necessary to break away from the practice of using wire that is easy to wind and cheap to buy and gives only fair results on the broadcast wave band, and to make the tuning inductance of a type purposely designed for short wave work. A lesson can be learned here from the transmitting fraternity, who are forced by the relentless logic of their aerial ammeter to give some heed to the quantitative efficiency of their tuning inductances. Their large air core coils of bare copper ribbon or rod represent the ideal, to which one must make some approximation in this instance. Hence the design indicated for the tuning inductance is that of an air core coil, well spaced, wound with No. 14 wire. As we are not dealing with high potentials and may allow some loss with the help of moderate regeneration we can use bare wire and a simple hard rubber bakelite or wooden frame.

### TUNING INDUCTANCE DESIGN

The design for the tuning inductance is indicated in the figures. Fifteen turns of No. 14 wire (which is stiff enough for such a purpose and has a fairly low resistance even on 60 meters) are first wound on a tube 3 1/2 inches in diameter. The diameter should be about 4 inches when sprung off.

(Continued on page 1972)

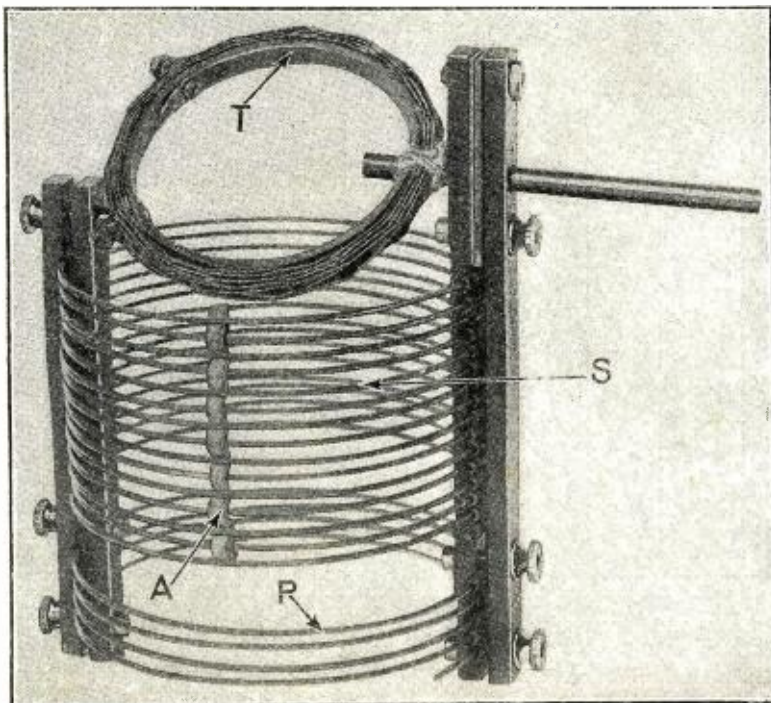
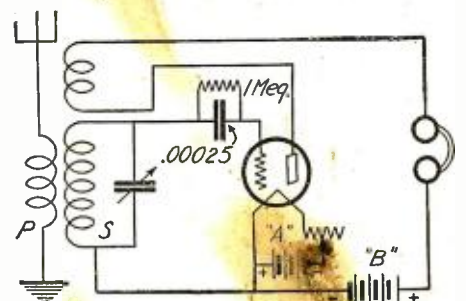

Fig. 2. The photo on the left shows the completed short wave coupler. P is the primary, S the secondary and T the tickler or feed-back coil. The rubber band shown as A may be used during the construction to hold the turns in place. On the right, Fig. 3 shows the complete circuit in which the coupler may be used. If desired, the Ultraudion or other standard oscillating circuits may be employed.





# A Test of Vacuum Tubes

By S. W. MARSHALL, Jr.



A concise table, in language understandable to all experimenters, is given by Mr. Marshall in this article, covering the characteristics of the various types of vacuum tubes in actual operation. This table will be found very helpful.



WHICH tube will give me the greatest satisfaction when used as a detector in my set?

This question comes up every time one purchases a tube, and the matter is usually settled by taking the clerk's advice about it, which may be right and again it may not.

At our laboratory we were confronted with that problem continually and we decided that the best way to settle this question once and for all was to run a test of the tubes commonly available on the market. This test was run over a period of about six months, and readings were taken in all kinds of weather and under all conditions to insure accurate results.

The set used was a single-circuit tuner (which type is used by the majority of listeners) with three stages of audio frequency amplification. The amplifier had been tested before and was found to be distortionless to a remarkable degree. The amplifier operated a Western Electric loud speaker. The efficiency of the set was probably slightly higher than that of the average receiver.

The current to the amplifying tubes was kept constant throughout the test, and the amplifying tubes were not switched or changed. Headphones were not used; the quality and volume results given below were those agreed upon by three listeners, all of

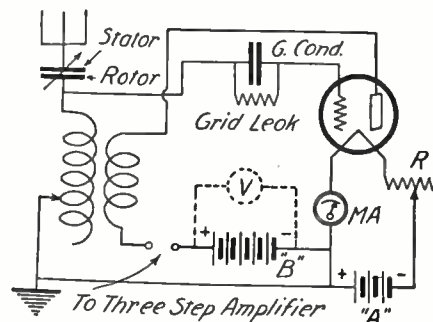

Above is a hook-up of the set employed in making the tests described and the results of which are given in the accompanying table. The aerial used was a single wire 60 ft. long and 16 ft. high.

## Table of Results

TUBE	FIL. CONTROL	FIL. CUR. LOW IN AMPERES	FIL. CUR. HIGH IN AMPERES	PLATE VOL. LOW	PLATE VOL. HIGH	REG.	AUD.	QUALITY
<b>WITH GRID LEAK</b>								
U.V.200	VERY CRIT.	0.95	1.16	<u>18</u>	37 PAR.	E & G	VL	FINE
C.300	" "	0.95	1.15	<u>18</u>	37	E & G	VL	FINE
U.V.201	NOT CRIT.	0.95	1.20	22.5	<u>45</u>	W	FAIR	GOOD
U.V.201-A	" "	0.20	0.29	<u>16</u>	37.5	G	LOUD	GOOD
C.301	" "	0.90	1.20	22.5	<u>45</u>	W	FAIR	GOOD
C.301-A	" "	0.21	0.31	<u>16</u>	37.5	G	LOUD	GOOD
VT-1	" "	0.85	1.21	<u>16</u>	<u>22.5</u>	G	LOUD	VG
VT-2*	" "	1.20	1.53	16 x	<u>45</u>	P	F	F
U.V.199	SLIGHTLY CRIT.	0.053	0.069	21	<u>45</u>	G	VG	VG
C.299	" "	0.054	0.070	21	<u>45</u>	G	VG	VG
WD-11	" "	0.23	0.29	<u>16</u>	45	VG	VG	EX
MOORHEAD	" "	0.97	1.14	<u>16</u>	45 x	P	P	F
DV-3	" "	0.049	0.074	22.5	<u>45</u>	E & EX	VL	EX
<b>WITHOUT GRID LEAK</b>								
U.V.200	VERY CRIT.	0.95	1.19	<u>18</u>	37 PAR.	E & EX	REMARKABLE	V FINE
C.300	" "	0.95	1.17	<u>18</u>	37	E & EX	" "	" "
U.V.201	NOT CRIT.	0.95	1.25	22.5	<u>45</u>	W	F	G
U.V.201-A	" "	0.20	0.30	16	<u>37.5</u>	VG	L	G
VT-1	" "	0.90	1.16	<u>16</u>	22.5	G	VG	FINE
VT-2	" "	1.20	1.41	16 x	<u>45</u>	F	F	G
U.V.199	SLIGHTLY CRIT.	0.053	0.070	<u>22.5</u>	<u>45</u>	G & E	VG	FINE
C.299	" "	0.054	0.070	<u>21</u>	<u>45</u>	E & G	VG	FINE
WD-11	" "	0.23	0.29	<u>16</u>	45	G	G	FINE
MOORHEAD	" "	0.97	1.15	<u>16</u>	45 x	F	P	G
DV-3	" "	0.049	0.073	22.5 x	<u>45</u>	E & EX	VL	EX
C.301	NOT CRIT.	0.90	1.23	<u>22.5</u>	<u>45</u>	VG	F	G
C.301-A	" "	0.30	0.30	16	<u>37.5</u>	VG	L	G

At the left is the table of results gained from Mr. Marshall's tube tests. The key at the bottom gives the meaning of the various letters used.

whom have been active in radio work for three years or more.

The tubes used in the test were "average" types, purchased from retailers in every case except the VT tubes. Needless to say, the entire test was conducted on an absolutely impartial basis. The tabulated results are given herewith.

Over 100 stations were listened to, to determine fully the quality of reception, and remarkable volume was obtained on favorable nights with some of the tubes.

### Hints on Aerial and Ground Installation

THE time of year is fast approaching when there is a noticeable increase in outdoor aerials, primarily because the warm weather enables one to do a good job without freezing. When you are putting up your aerial there are a few points you should keep well in mind. Keep the aerial away from electric light or power lines or any electric circuit which carries more than 600 volts. It should not be near railway or feeder wires. If placed near wires of this kind, it should be constructed and installed in a strong and durable manner and it should have considerable clearance from the wires as a precaution, in case the wire should sag or swing.

If there are any joints in the aerial, they should be soldered, and if it is impossible to solder the joints, they should be secured with some sort of splicing device. It is advisable to have the lead-in of No. 14 copper wire. Wire should be selected that will not corrode excessively.

The lead-in wires on the outside of the building should not come nearer than five inches to electric light or power lines, unless the lead-in is covered with an insulating tube that will maintain a permanent separation. The covering should be in addition to the insulation on the lead-in wire. When bringing the lead-in down the side of a wall, it should have at least four inches of clearance from the side of the building. The lead-in should be brought into the house through an insulating bushing and the bushing should

(Continued on page 1986)

\* TRANSMITTING TUBE  
 MOST SATISFACTORY PLATE VOLTAGE  
**SYMBOLS AND ABBREVIATIONS**  
 X INOPERATIVE  
 PAR TUBE PARALYZED AT APPLIED VOLTAGE  
 G GOOD F FAIR W WEAK V VERY E EVEN  
 L LOUD EX EXCELLENT P POOR



# Matching Tubes for Super-Heterodynes

By S. YOUNG WHITE

THE question among Super-Heterodyne builders at the present time seems to be, "Why does my set give so much better (or poorer) results than my friend's, when we both have the best of parts?" The mystery is further complicated by the fact that the good and indifferent models may be exact duplicates, built of similar apparatus furnished by the same manufacturer. Since these are factory products, we may assume that the great variation in results is not all due to their lack of uniformity. The experience of the writer would indicate that the most serious obstacle encountered by the average builder of this circuit lies in his inability to match the tubes in the set so they work together in perfect harmony.

It is a deplorable fact that commercially available tubes vary considerably in their characteristics, and proper facilities for ascertaining these necessary curves are not available to the average builder, so we shall attempt to show how the tubes may be intelligently inserted in their proper order in the circuit. The apparatus required is always available, being only the set itself. It will be assumed it is the standard model with three stages of intermediate frequency amplification controlled by one potentiometer.

The first test will be for oscillation. Since we have a part of the circuit especially designed for this test, we shall use the oscillator socket. Connect the "A" battery and

see if a tube inserted in it will light. If so, connect the negative of the "B" battery to the proper terminal on the set, but connect the positive terminal to the set through the headphones; that is, connect one phone cord tip to the positive post of the "B" battery and the other to the positive "B" battery

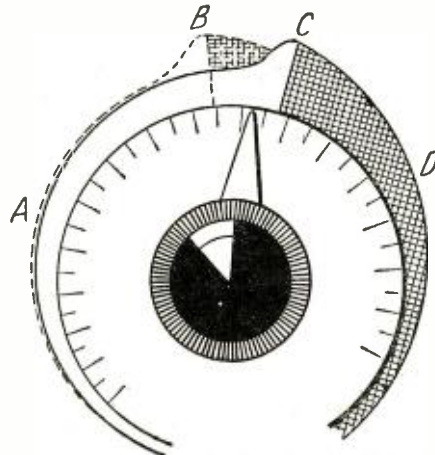

All the intermediate R. F. tubes should break into oscillation at the same point on the potentiometer scale, in this case at C. Should one of the tubes commence oscillating at point B, the sensitivity of the set is diminished. A represents the regeneration area and D the oscillation area.

binding post on the set. This is usually the one for the intermediate frequency amplifier, and is often marked "plus 90" or "RFB" or "Amp," and never "Det." Now take a fixed condenser of any value from .0005 mfd. to .005 mfd and connect it across the phones. The set should only have one tube in it, and that one in the oscillator socket. When the tube is lighted, a ringing sound should be heard in the phones when the tube is lightly tapped with the finger.

### OSCILLATION TEST

Now test for oscillation. Two tests are available. One is to touch the grid connection of the tube. If a loud click is heard, the tube is oscillating. The other is to attach the antenna direct on the grid of the tube, leaving the ground disconnected. On rotating the oscillator condenser, beat notes or whistles should be heard, as the connection is an oscillating receiver. If no oscillation occurs, other tubes should be tried, and if still no response is secured, the trouble is in the circuit and must be fixed before the set will operate. A very important point to be noted is that the tube must oscillate over the complete revolution of the oscillator condenser.

Every tube available should now be inserted in this socket, one at a time, and all should oscillate at all points of the condenser. If some do not, they should be rejected, or used as shown later. It is suggested

(Continued on page 1989)

## Lessons in Esperanto

(Prepared especially for RADIO NEWS by James Denson Sayers, Esperanto writer and editor, President of New York Esperanto Harmonio Club.)

### LESSON 5 CORRELATIVE WORDS

PRONOUNS, adjectives and adverbs, which are related to each other as corresponding demonstratives, interrogatives, relatives, etc., are called correlatives. In Esperanto the correlative system is more complete than in any other language. Many of the greatest linguists, after studying it, have declared Dr. Zamenhof's invention of the Esperanto table of correlatives is one of the definite marks of genius in his work. This table is given herewith.

To cover Esperanto efficiently in a short course of lessons, much condensation and careful selection is needed. I am much indebted in this work to the system used in the popular little booklet, "Esperanto For All," published by the British Esperanto Association. When you finish these few lessons, you will be perfectly equipped for reading any Esperanto text, for correspondence, and for beginning conversation, but the first and most important is reading for the acquirement of an easy vocabulary. To thoroughly demonstrate the manner of using each of the above 45 correlatives would require far more space than can be devoted in RADIO NEWS since it is not at all necessary. In every bit of Esperanto reading, letters you receive, etc., you will find these words used, and in a short time the extraordinary skill and logic of their arrangement will become apparent, so that you will never have to refer to

(Continued on page 2013)

TABLE OF CORRELATIVE WORDS

	I INDEFINITE <i>Some, any</i>	K INTERROGATIVE RELATIVE <i>What, which</i>	T DEFINITE <i>That</i>	Ĉ COLLECTIVE <i>Each, every, all</i>	Ne- NEGATIVE <i>No, none</i>
QUALITY Kind of (Adjectival)	Ia Some or Any kind	Kia What kind As	Tia That kind Such, as	Ĉia Each kind Every kind	Nenia No kind
MOTIVE Reason (Adverbial)	Ial For some reason Any	Kial Why	Tial For that reason Therefore	Ĉial For every reason	Nenial For no reason
TIME (Adverbial)	Iam At some time Any time Ever Once	Kiam At what time When	Tiam Then	Ĉiam Each time Every time Always	Neniam Never
PLACE (Adverbial)	Ie Somewhere Anywhere	Kie Where	Tie There	Ĉie Everywhere	Nenie Nowhere
MANNER (Adverbial)	Iel Some way Somehow	Kiel How In what way As, like	Tiel In that way So	Ĉiel In every way	Neniel Nohow No way
POSSESSION (Pronominal)	Ies Someone's Anyone's	Kies Whose	Ties That one's	Ĉies Each one's Everyone's	Nenies No one's
A THING NOT SPECIFIED (Noun)	Io Something Anything	Kio What thing	Tio That thing	Ĉio Everything	Nenio Nothing
QUANTITY (Adverbial)	Iom Some A little	Kiom How much	Tiom So much	Ĉiom All the quantity	Neniom None
INDIVIDUALITY (Pronoun)	Iu Someone Anyone	Kiu Who Which	Tiu That (person or specified thing)	Ĉiu Each Every Ĉiuj all, all the	Neniu No one Nobody



# Radio Wrinkles

## NOVEL RHEOSTAT

The dry cells used in flashlights have carbon centers which may be utilized to excellent advantage in a set. The resistance of

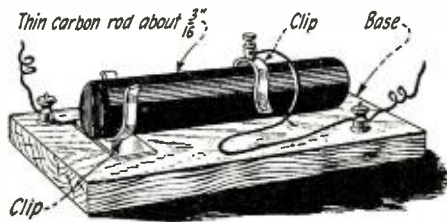

A handy laboratory rheostat made from a dry cell carbon.

such a carbon is between 67 and 70 ohms. This can be mounted in a clip and used as a resistance element in the filament circuit of tubes. The resistance can be varied by making a sliding contact on the rod. This may be done in several ways, but the easiest would be to use a clip as shown.

Contributed by Jess Fillmore.

## FASTENING FOR COIL WINDINGS

An excellent idea for the experimenter who winds coils and does not wish to go to the trouble of making permanent fastenings, is illustrated in the accompanying sketch. A

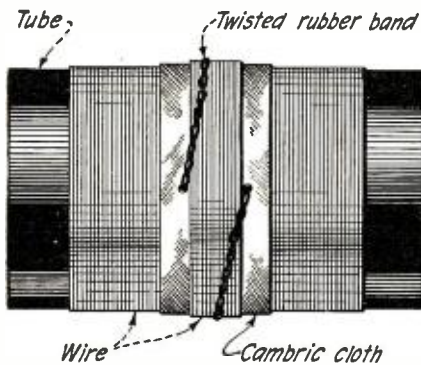

Coil ends can be successfully fastened with a rubber band, as shown.

twisted rubber band is attached to one end of the winding and around the windings to the opposite end of the coil. Here it is attached and the pull of the elastic keeps the windings in place.

Contributed by G. P. Longstreet.

## DOUBLE CIRCUIT JACK USED AS SWITCH

A quick-acting switch that will control two circuits may easily be made from a double circuit phone jack, having four leaves or contacts. A rod, 1/4 inch in diameter of an insulating material, is filed to the shape shown 1/4 inch from the end. On the opposite side, 1/2 inch from the same end, a similar notch is made. This will open both cir-

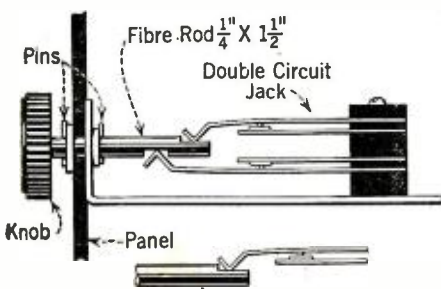

An easily constructed double pole quick acting switch.

uits at the same time. If it is desired to open one at a time, then the notches should be filed on the same side of the rod. To keep the rod in place, a pin is placed on the inside of the panel and one on the outside. A rubber knob is attached to the end of the rod so that the switch may be easily operated.

Contributed by Morton Shaw.

## COIL WINDING DEVICE

One of the most unhandy of radio processes is the winding of a coil when there is no one around to help. The scheme shown is a simple one and will aid wonderfully. A spring is placed over a nail, as shown, and

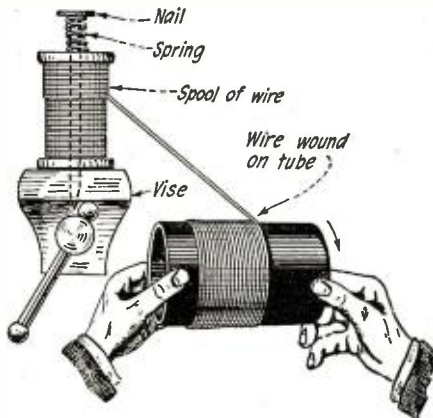

The spring and nail serve to keep the wire taut while winding a coil.

the spool of wire placed under it. The nail is then mounted in a vise so that the friction of the spool keeps the wire taut, helping greatly in the winding process.

Contributed by A. J. Hayward.

## SPLICING AND SECURING RADIO WIRES

Twisting a couple of wires together is not alone sufficient to make a good electrical joint. The joint should be made with some pretense to strength as well and there is the right way to do it. The three diagrams

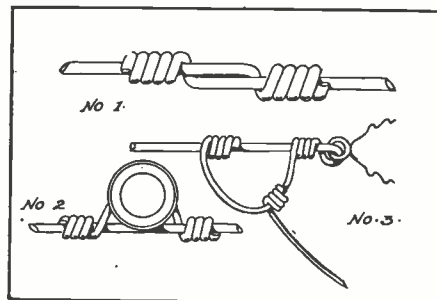

Showing three good ways of splicing wires.

in the accompanying sketch illustrate the main connections used in amateur radio work and are the proper ones for strength as well as conductivity of the feeble currents.

In No. 1 is shown the professional way of splicing two wires into a continuous length. It is known as the telephone splice. Lap the two ends several inches and then twist one wire bodily about the other. Soldering the twists at each end gives permanence to the union and makes a well jointed conductor.

Instead of wrapping a wire several times about an insulator, place it against one side and tie it with a yoke of wire wrapped half way around the insulator and then twisted at each end to the main wire. If wrapped

about in several turns, these are apt to chafe through and break under stress of wind or storm. See No. 2.

The lead-in from the antenna is usually twisted about the antenna next to the insulator, which is a poor way to accomplish good results. Constant swaying of the antenna tends to bend the lead-in back and forth, which may result in its breaking off at a time when you desire to listen in. The best way (see diagram No. 3) is to bring the antenna through the insulator eye, wrap it around several times, as shown, drop it in a small loop and then wrap it around again about a foot from the eye. Then wrap the lead-in about the loop. Solder all three joints. This loop has just enough slack to take up the strain of swinging and snapping in a storm and makes a much more lasting and workmanlike job.

Contributed by L. B. Robbins.

## LOW LOSS COIL FORM

A good form for low loss coils may be made by cutting a bakelite tube in half. There is a slot sawed down the center of each half, allowing space for the two halves to be bolted together. A strip of panel about 1 1/2 inches longer than the diameter of the tube is drilled at the center and slotted so as to coincide with the central slots in the tubes. These three pieces are fastened together with slots coinciding. The wire may be wound on in either of two methods:

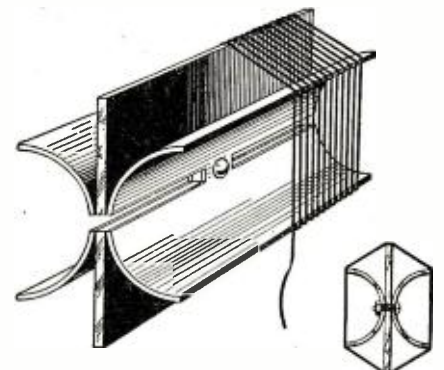

A low loss coil form made from hard rubber tubing and a panel.

Straight around the outside of the tubing, or wound as a "D" coil using the slot in the center.

Contributed by Reginald C. Requa.

## USE FOR BUS BAR

An emergency phone jack may be made, as shown in Fig. 1. A hole is drilled in the panel large enough so that the plug may be moved up and down slightly. Two pieces of bus bar are bent as shown, the one nearer the panel being bent so that the horizontal portion is just at the level of the bottom of the hole. The other one is bent so that the tip of the plug will fit in it snugly. The weight of the plug is sufficient to insure good contact.

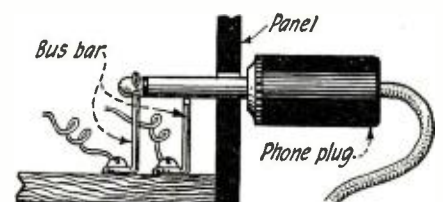

A simple single circuit jack made from bus bar wire.

Contributed by Arthur A. Blumenfeld.



# STANDARD HOOK-UPS

EVERY month we present here standard hook-ups which the Editors have tried out and which are known to give excellent results. This leaf has perforation marks on the left-hand margin and can be cut from the magazine and kept for further reference. These sheets can also be procured from us at the cost of 5c to pay for mailing charges.  
 RADIO NEWS has also prepared a handsome heavy cardboard binder into which these sheets may be fastened. This binder will be sent to any address, prepaid on receipt of 20c. In time there will be enough sheets to make a good-sized volume containing all important hook-ups. Every year an alphabetical index will be published enumerating and classifying the various hook-ups.

## Handy Reference Data for the Experimenter

**Circuit No. 88.** A new and ingenious system of resistance coupled radio frequency amplification is shown in the accompanying sketch. Not only are the vacuum tubes used as amplifiers, but they are also employed as resistances. The chief feature of the circuit is the minimization if not the complete elimination of foreign noises and distortion. The inductances L1 and L2 are wound on a three-inch tube. The secondary of 60 turns is wound on the tube first, over which is placed a strip of varnished cambric for insulation. On this cambric is wound the primary of 15 turns. The condensers C have a value of .0003 mfd. The resistance R1 is 1 megohm and R2 is 2 megohms. The second and fourth tubes are of the WD-11 type because a separate filament battery must be used for each. The other three tubes should be of the UV-201A type for best results. If it is desired to use a loop-antenna, the first coupler may be eliminated and the loop may be connected at the points marked X. As in all resistance coupled amplifiers, the voltage of the "B" battery must be higher than in the ordinary tuned plate or other style circuits. The exact plate potential required will vary with the type of tube used. The high degree of amplification and clarity of signal obtained with this circuit is truly remarkable. The construction is well within the scope of the average experimenter.

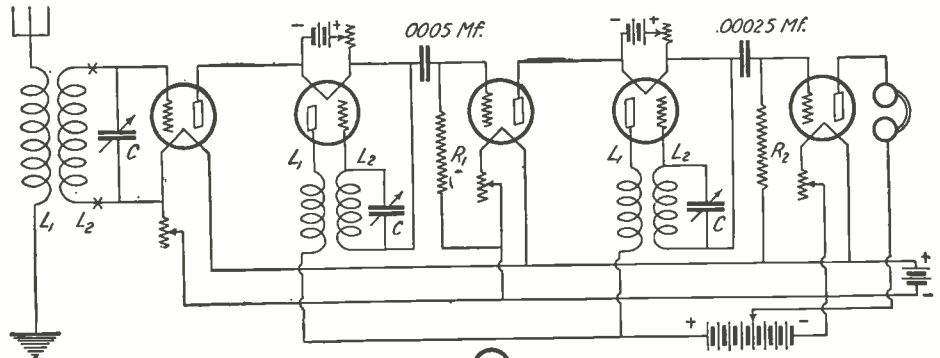

Circuit employing a unique method of radio frequency amplification. The use of two WD-11 tubes with separate "A" batteries is a new point. Extreme selectivity as well as high amplification is given by this circuit.

These oscillations are controlled by the .0005 mfd. variable condenser that is shunted across the 55-turn coil in the grid circuit of the oscillator tube. By examination of the circuit it may be seen that regeneration is introduced by using the 30-turn coil in the plate circuit of the first tube. The filament-plate space of the modulator tube acts as a resistance in the circuit. In this arrangement the plate of the modulator tube is supplied by high frequency current produced by the oscillator, the former being active only during half of each cycle when the plate is positive. This produces a change of filament-plate resistance which varies from practically infinity to about 20,000 ohms, during each half cycle of the oscillator current when no signal is being received. When the grid potential of the modulator tube is varied by incoming signals, the lower

resistance value is varied above and below the amount mentioned with various degrees of amplitude, according to the phase relation between the incoming signal and the local oscillation. This produces a beat note which is amplified and detected. The four intermediate frequency transformers should be so constructed that they function at a wave-length between 1,500 and 3,000 meters, which is most efficient frequency to work on. The oscillator and modulator coils should be of the same number of turns, as shown in the diagram, and wound on three-inch bakelite or hard rubber tubing. Amperites instead of rheostats are used throughout. The 200-400-ohm potentiometer shown is used to give the proper grid bias to the intermediate frequency tubes. It is hardly necessary to say that the apparatus should be so placed that leads may be as short as possible.

**Circuit No. 89.** In the circuit shown in Fig. 89 there is incorporated a different system of producing beat notes than is employed in any other Super-Heterodyne receiver. The incoming signal impressed on the first tube modulates the high frequency oscillations which are led to the plate of the tube instead of the regular "B" battery.

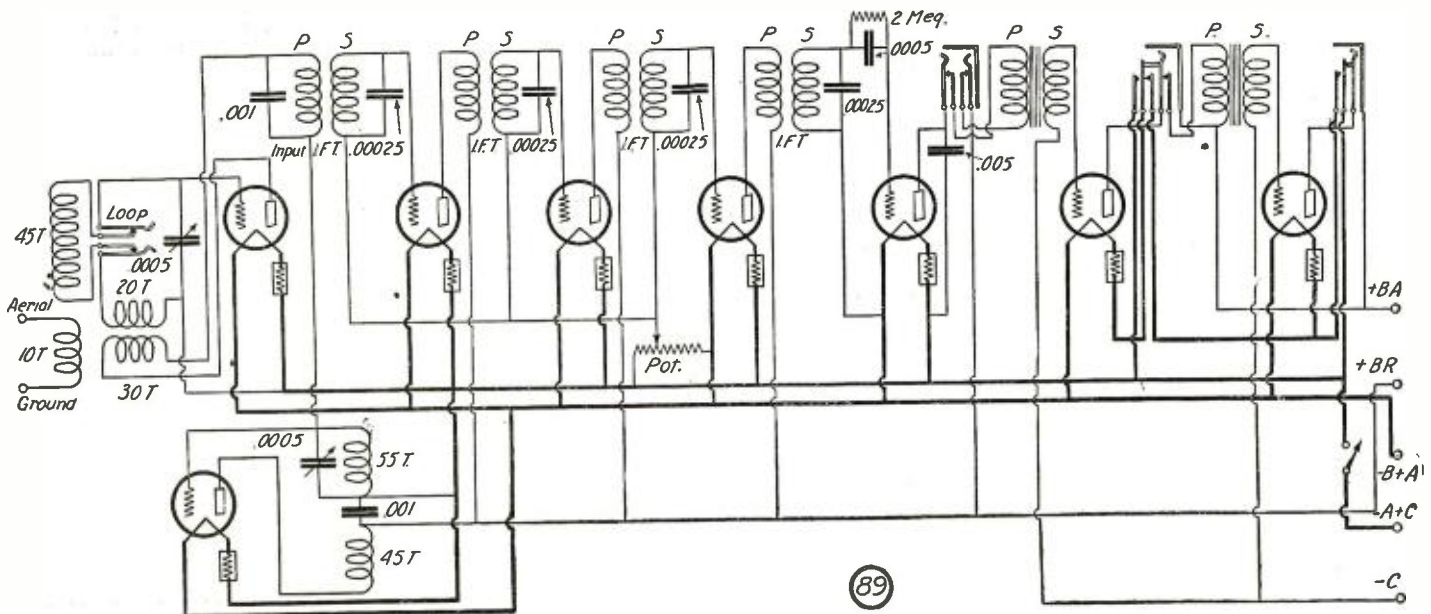

The Ultradyne Super-Heterodyne circuit, using the modulation system. Note the difference in the connection at the first tube and the form used in the absorption circuit. This hook-up gives the complete wiring diagram for the Ultradyne including two stages of audio frequency amplification.



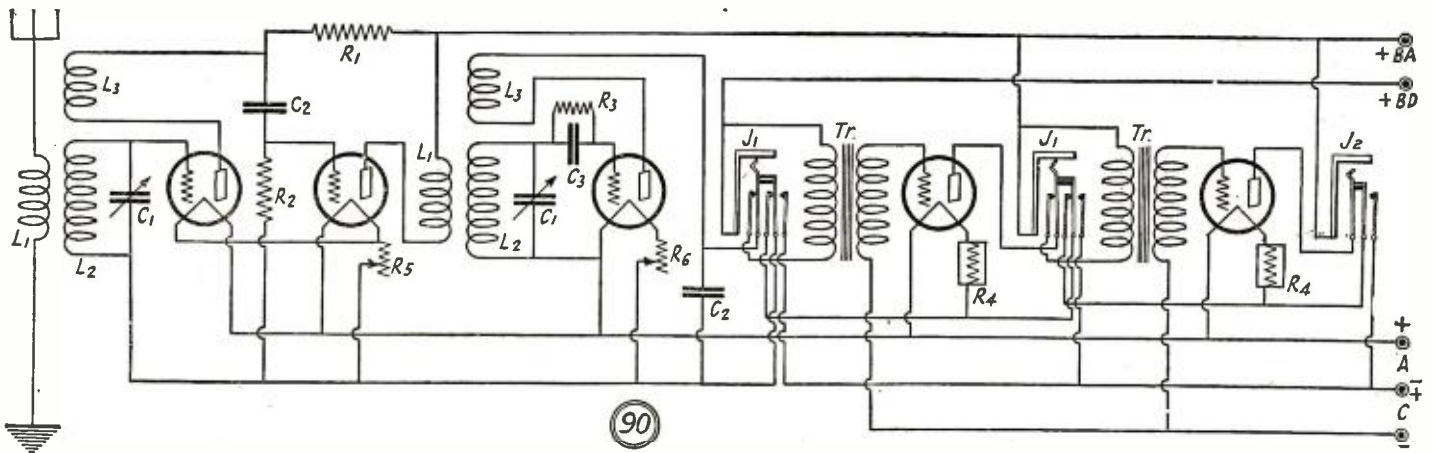

Five-tube cascade regenerative circuit including two stages of audio frequency amplification with filament control jacks.

Circuit No. 90. The secret of this set's success lies in the blocking tube used between the first and second regenerative circuits. Oscillations are controlled entirely by the two ticklers, there being no potentiometer, which adds greatly to the simplicity of control. The couplers are alike as to size and windings. They may be made with any 180-degree variocoupler form. First wind on the stationary form 40 turns of No. 24 D.S.C. wire. Directly over this winding, a strip of cambric should be placed, over which are wound seven turns of the same wire. The tickler coil should have 40 turns of the same size wire. These three windings should be wound in the same direction. The variable condensers C1 are .0005 mfd. and C2 have a value of .0005 mfd, C3, the grid condenser, is .00025 mfd. R2 and R3 are resistances having a value of 2 megohms and the resistances R4 are amperites. Results may be obtained using either a loop or an outside antenna, although the latter will doubtless give more satisfactory results. If a loop antenna is used, the primary of the first variocoupler is eliminated from the circuit, the loop being connected in series with the secondary. In this way both loop antenna and secondary of the coupler are tuned by the variable condenser, which is shunted across them.

The two tubes used as radio frequency amplifiers and the regenerative detector give approximately the same results as four stages of radio frequency amplification. The set is no more difficult to tune than an ordinary receiver, and at the same time is exceptionally stable. The plate current of the first tube is fed back through the tickler, giving regeneration in the antenna circuit. The output of this first tube is passed to a second tube which is used as a resistance coupled

radio frequency amplifier of the ordinary type and acts also as a blocking tube, keeping the first and second regenerative circuits entirely separated. The output of this second radio frequency amplifier is passed, in the regular manner, to the detector, which is also regenerative. Filament control jacks are used in the stages of A.F. amplification, and as the wiring of the filaments of these tubes is more or less complicated, it would be wise to test the circuits carefully.

Circuit No. 91. The hook-up shown in the accompanying sketch is the well-known Reinartz circuit. This circuit was published in the August, 1924, issue of RADIO NEWS, but this one has in it incorporated a potentiometer to give the proper bias to the grid of the tube. The efficiency of this circuit is due largely to the fact that all the inductances are brought together and concentrated in one small space. The coils forming the aerial-secondary and feed-back inductances may be wound on a 2 1/4-inch tube with No. 22 D.C.C. wire. The feed-back coil may be spaced about 1/4 inch from the other. If a spider-web coil is used the all around efficiency will be increased. The coils then are wound on a form that is 1 3/4 inches in diameter. The aerial-secondary coil is tapped at every turn for the first 10, the 12th turn is tapped and connected to ground and the movable contact of the potentiometer, and from the 26th to the 75th turn the coil is tapped every seven turns. The feed-back coil of 45 turns is tapped at every 15th turn. The movable plates of the .0005 mfd. condenser should be connected to the antenna and those of the 11-plate condenser, which should be of the vernier type, should be connected to ground. The inductance should be mounted at least three inches back of the

panel so that the leads from the inductance will extend directly to the switch points without crossing. The dry cell type of tube may be used, but the UV-201A type is recommended. With a potentiometer in the circuit, as illustrated, this set, if properly constructed, should be an excellent DX getter.

It is interesting to note that this circuit was designed primarily for C.W. reception, but it is one of the most selective broadcast receivers known today. The circuit shown in Fig. 91 has only one tube, but audio frequency amplification may be added very easily.

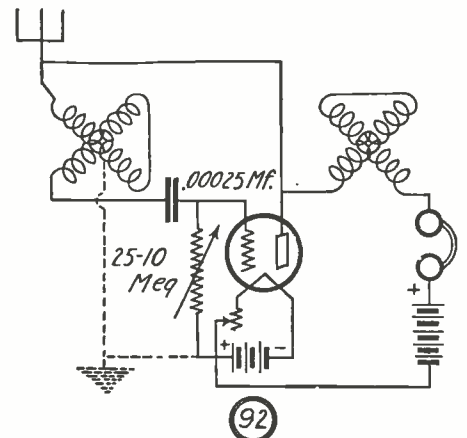

A two-variometer circuit that is excellent for a portable outfit, as it may be used with or without a ground connection.

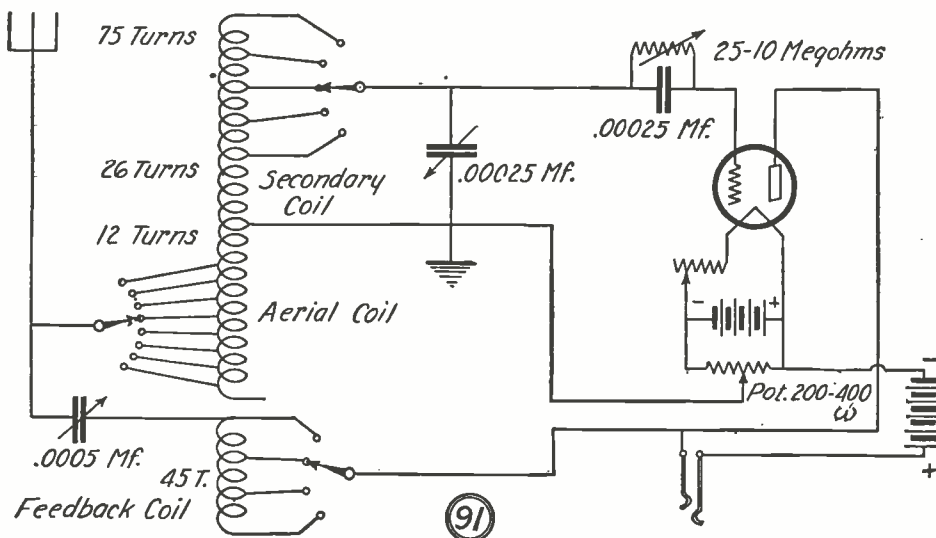

The selective and efficient Reinartz hook-up having in the circuit a potentiometer for controlling the grid bias.

Circuit No. 92. The accompanying diagram shows a circuit that is extremely sensitive; so much so that it will operate very satisfactorily on a ground alone without any antenna whatsoever. It is also selective and easy to control, as there are but two adjustments. The selectivity of this set is due to the fact that it oscillates continually, and unless the incoming signal has exactly the same period of oscillation as that generated by the set itself, it is very effectively blocked out, since the grid circuit cannot oscillate at any period except the one determined by the plate variometer setting. This causes most of the tuning to be done by the plate variometer. This means that tuning out the nearby stations and picking up a weak distant station operating at nearly the same wave-length is always possible. The ground tap is taken from the center of one coil of the variometer. One end of this same coil must go to the aerial binding post. When using a ground with no antenna, the ground is connected directly to the antenna binding post. Because of this, this set is especially adapted to being made into a portable outfit. A dry cell tube is recommended if this is to be a portable set, although better results will be found if a large tube is used.



# Radiotics

## HYSTERIA—NOT HYSTERESIS



Has the cause of howling in audio frequency transformers been discovered? *Wates Bros.* of London, England, advertising their A. F. transformer in *Popular Wireless and Wireless Review*, December 27, 1924, state that "the core is composed of 38 LAMENTATIONS." What a morbid affair it must be!

Contributed by *Thomas H. Crawley.*

## SAVE A LEG OR SO

In the December, 1924, issue of *RADIO NEWS*, the *Radio Specialty Co.* advertises a push pull transformer and with carefree recklessness complete their sales talk as per: "Save 50 per cent. by ASSEMBLING YOURSELF. Simple instructions furnished." So, if you are in pieces take advantage of the liberal offer and come out an ear or so ahead of the game.



Contributed by *Edward Lutz, Jr.*

## THEY WORK LIKE A SLIDE RULE



One of the greatest problems of the time has been solved by "Nattans" of Baltimore. *The Baltimore News* of January 3 carries their advertisement of "ADJUSTABLE Insuline Panels." Why didn't

someone think of this before? Stretch your two-tube set into a seven-tube set when visitors are expected.

Contributed by *Henry F. Reisz.*

## RATHER INCONVENIENT

The following choice bit appeared in the *Telegram and Evening Mail* Radio Section (New York) Sept. 27, 1924, under the heading of "Rectified Current for Plates of Tubes": "For the purpose of rectifying, the writer has used the old method of aluminum and HEAD." The method is so old we never heard of it. Who wants to dip his head into a solution of borax and water? One would contract corrosion of the scalp!



Contributed by *O. F. Ribeiro, Jr.*

## THE BOOTLEGGERS' DELIGHT



Sounds as though sets are being manufactured for bootleggers. The *Hudson Bay Co.* (Winnipeg) advertises in the Dec. 22, 1924, edition of the *Manitoba Free Press* "Atwater-Kent 4-tube sets, open model WET hook-up." If any of these sets get into the United States, the bootleggers will be able to receive their stuff without suspicion.

Contributed by *Edward Rutherford.*

## A NEW DEVICE FOR REDUCING



The *Buffalo Courier* of December 21, 1924, carried an article on Resistance Coupled Amplifiers in which it was stated "In all cases a BY-PASSER condenser must be included across the coupling resistor."

This sounds like an attachment for subway train doors for reducing the size of the passengers so that more can be packed into one car.

Contributed by *Wm. D. Wischeratti.*

## SOME IDEA

We learn from the June 7, 1924, issue of *The Radio Digest* that—"Steamboats on Lake Geneva, Switzerland, are being used with receivers!" Evidently they run better when listening to broadcast programs.



Contributed by *Arthur R. Hudson.*

## HE COULD, BUT WOULD HE?



In the January, 1925, issue of *RADIO NEWS*, the *Bremer-Tully Mfg. Co.* ran an advertisement containing a testimonial letter concerning reception in which it was stated: "Had the family not retired I could have

put them on the loud speaker." Just exactly what might the advantage be, and what kind of a family has he?

Contributed by *Howard V. Pugh.*

## THEY NEED A GOOD SPANKING

The *Sidbencel Radio Co.* of New York has a "list of parts used" in its advertising circular of a five-tube receiver, and there is included as a necessity, "1—.00025 FRESH grid condenser."

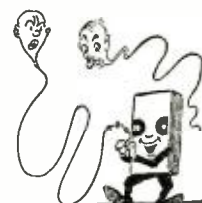

Wonder if it gets fresh with the incoming waves? Probably tries to trip them up.

Contributed by *Richard McKillip.*

## UP FOR THE SUMMER



The following classified advertisement appeared in the *Hazleton Standard-Sentinel*, (Penn.) for January, 20, 1925: "For Sale—One Freed Eiseman five-tube Neutrodyne . . . two "B" batteries, six COLD STORAGE

batteries and one loud speaker." If they are cold storage batteries they ain't fresh and if they ain't fresh who wants 'em?

Contributed by *Edward A. Lynch.*

If you happen to see any humorous misprints in the press, we will be glad to have you clip them out and send to us. No **RADIOTIC** will be accepted unless the printed original giving the name of the newspaper or magazine is submitted. We will pay \$2.00 for each **RADIOTIC** accepted and printed here. A few humorous lines from each correspondent should accompany each **RADIOTIC**. The most humorous ones will be printed. Address all **RADIOTICS** to

Editor **RADIOTIC DEPARTMENT**,  
c/o *Radio News*

## WDAP DELVES INTO ETHEREAL REALMS

The *Ozarka Co.* has a testimonial letter in its advertising bulletin which is a revelation. The writer states:—"This *Ozarka* of mine has amplified the ethereal waves to such an extent that I, and several friends, could see the spirits as they were broadcast from *WDAP*, Chicago, Ill. . . . with the naked eye." Enough said!



Contributed by *L. D. Seaman.*

## MUST HAVE BEEN SOME SET

The *Democratic Chronicle* (Rochester, N. Y.) of December 20, 1924, stated in a bold heading that "Pickpockets in Syracuse Take \$150 Radio Set." It must have been one of those vest pocket affairs; and considering the price it must have been set with jewels.



Contributed by *John C. Heberger.*

## SURE A POWERFUL SET



The *Boston Post* for January 2, 1925, ran a classified advertisement for the sale of a marvelous radio set, for its states of its power—"Has pulled in coast." Some haul from Boston we should say.

Contributed by *Horace Sargent.*

## CUTTING OUT INTERFERENCE

Mick: "Why do your condensers tune so sharp?"

Wick: "Simple, old horse. Using Gillette blades for plates."

Contributed by *Jack Bront.*

## UNNECESSARY CRUELTY



In an article entitled "Gelula's 3-Tube Superflex," appearing in the December 27, 1924, issue of the *Radio World*, we find this sentence: "Two rheostats control the filament **B E A T - I N G** of the three tubes." Who wants a set wherein it is necessary to whip the filaments of the tubes into submission. Is it that they refuse to work? Possibly they are Union Tubes.

Contributed by *John M. Clark.*



# Correspondence from Readers

## GREETINGS FROM MESOPOTAMIA

Editor, RADIO NEWS:

It is now five years since I have taken the first copies of RADIO NEWS to Europe in the R-34. What strides you have made! Good luck to you and the staff. I still get my copy regularly and value it. Radio out in Mesopotamia is our one link with home and the U. S. A. Hear a good many hams on 100 meters out here. Would be glad to test with them if they like.

REGINALD T. DURRANT,  
Radio Service,  
No. 6 Squadron, Royal Air Service,  
Mosul, Iraq.

A view of the air base of the Royal Air Service at Mosul, Iraq, Mesopotamia, where R. T. Durrant is located. His letter herewith tells how radio links them with the home country.

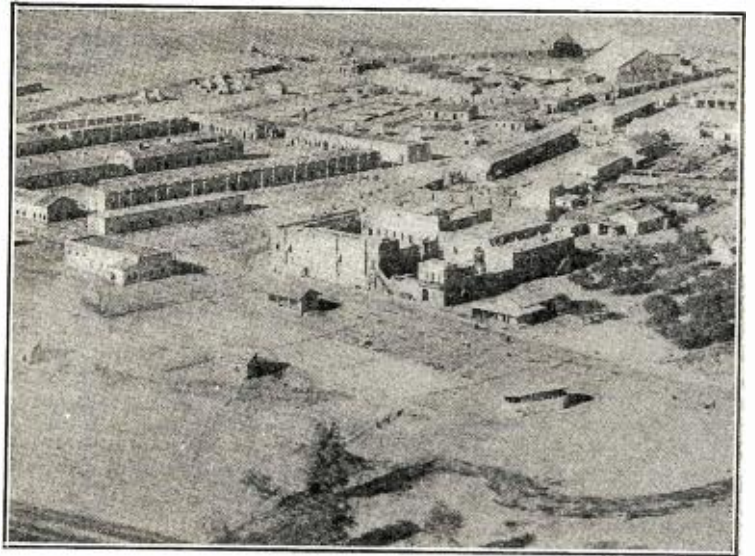

## BE A BOOSTER

Editor, RADIO NEWS:

I would like to take a few exceptions to the letter written by Mr. Wilfred Taylor in your February issue regarding half of the country being silent while he goes distance hunting.

He should not forget that he is just one of the many BCL's and that thousands of them are not fortunate enough to own tube sets, but must depend on crystal sets for their programs. Therefore, they must listen to local stations. He must also remember the many invalids who are bedridden and have been given sets by charity. I suppose he would be selfish enough to deprive them of their pleasure while he goes distance hunting.

I also think he judges his programs by the distance they come, instead of the kind of reception he receives. Personally, I have listened to WTAS quite often and think, as a rule, they have good programs.

As for distant reception, I listen to the West Coast regularly, but cannot see where their programs differ from the local stations.

A word for the distance hound: I think he causes as many unnecessary howls and squeals as beat notes from other stations.

If Mr. Taylor has ever listened to station KFNF, he probably has heard Mr. Fields state that "If you do not like our programs, tune our station out." This applies to all stations.

As for the artists appearing at the different stations, it must be remembered that the majority of these artists appear without pay and, no doubt, do their best when they appear before the microphone. As this service is free to any person who desires to listen, I think that every BCL should be a booster and if you can not boost, don't say anything.

Last, but not least, if I were obliged to suffer the interminable hours of rubbish that you claim to suffer, I certainly would stay off the air. You have this privilege if programs do not suit you.

LOTHAR H. KLINGEISEN,  
415 Sixth St.,  
Monaca, Pa.

## A LETTER FROM CHINA

Editor, RADIO NEWS:

I am a reader of RADIO NEWS more than two years since. I very much appreciate your devotion to the improvement of radio and especially to the holy idea of establishing international amateur radio communication.

Since you suggested the use of Esperanto as a medium of international communication,

a lengthy controversy arose among your readers, some favor the use of Esperanto while others advocate the adoption of Ido (Ilo). Seeing that no Chinese has ever participated in the discussion, I venture to add myself to the bunch and by writing these few lines I wish to express my humble opinion.

An international language is only valuable as such when its grammar is simple and when it can lend itself easily to the comprehension of the average man (by the term "man" I mean the international person, not only an American or a European), in such a way that one can put it into use after a minimum of time spent in learning it. Possessing these advantages, Esperanto is the ideal international language. It has been widely used on account of its simplicity in comparison with a host of other artificial tongues. Indeed, its fame has been established internationally. As regards Ido (Ilo), though one may see something in it better than Esperanto, yet with its more complicated grammar and redundant roots, it makes itself a very difficult language to master, only second place to French. In addition to these defects, it has only half the adherents of Esperanto, which shows that it is not popular enough to be an international radio

tongue in contrast with the widely accepted Esperanto. I express my view in much the same way as you did in your article published in your December issue, page 937.

I regret that I have not the chance of endeavoring to communicate with my American ham friends as Australian and Japanese amateurs have done, on account of the inability of obtaining amateur transmitting licenses owing to the political unrest now existing in our fatherland, China. Yet, I will not forget the idea that the peoples of this world should be unified instead of educated to intrude upon racial difference and to wage dreadful scientific wars to their fellow human beings. Confucius says, "All within the four seas are brethren." I hope the radio amateurs of America will remember these words.

TONGFONG LAUN,  
Hip Woo Charity Society,  
4th Fl., 19 D'aguilar St.,  
Hongkong, China.

## REGARDING BROADCAST STATION INTERFERENCE

Editor, RADIO NEWS:

I read RADIO NEWS regularly and have noticed a number of letters written to the editor in which the writers tell of interference from stations that put on continually poor programs by untalented artists. There is one in the February issue from Wilfred Taylor, of Thompson, Conn. In this letter he condemns about 456 stations; among the number, WTAS at Elgin, Ill., was used as an example. Now, WTAS is one of my favorite stations for numerous reasons. One is that I hear some of the best orchestra music from there and as a general rule their artists are very good. This station also helped greatly in getting Lieut. Griffiths out of the German prison; such work should not be forgotten. I can still remember the speech their announcer made that night.

Station KFKB at Milford, Kan., and WTAS operate on the same wave-length, but I never have the least difficulty in separating them, nor do I have trouble with interference from any other stations. I regularly hear KGO, KPO, KHJ, KFI and KNX on the loud speaker, also WBZ, WSB, WOR, WEEL, and have several times heard PWX at Havana. I use a set built by myself; it has one stage of R.F., regenerative detector and a three-stage audio frequency amplifier using 201-A Radiotrons throughout. I find that this type of set tunes very sharp and the owner of such a set will not be bothered much by interference if the set is properly constructed. I have built a number of sets for my friends, most of them like the one described. None of the owners

(Continued on page 1936)

無線電新聞主筆先生大鑒  
素仰貴雜誌注重于無線電學術  
尤切意于鼓吹列邦無線電家之互相聯絡冀得促進全球建  
于大同之目的僕得拜讀巨  
用世界語為  
或採用世界  
才願附諸公鑒  
吉本延實乎簡單而易於學習庶幾學者可于最短短促之時  
期即能實用之若採用世界語適與斯旨相合蓋世界語發  
稿思世界統一之語  
以莫衷一是僕不  
德矣自先生提倡

A photograph of Tongfong Laun, the correspondent whose letter is printed herewith and a page of his original letter.





# New Radio Patents

By JOHN B. BRADY\*

## METHOD OF AND MEANS FOR RECEIVING RADIO SIGNALS

(Patent No. 1,514,752, P. I. Wold. Filed September 14, 1920. Issued November 11, 1924. Assigned to Western Electric Company, Inc., New York.)

Method of and means for receiving radio signals which comprises combining the incoming waves with locally generated oscillations of a frequency different from that of the incoming waves. The resultant composite waves are transferred selectively with the substantial elimination of the locally generated oscillations and then the resultant selectivity transferred composite waves again combined with the locally generated oscillations reducing the frequency in such manner that it may be observed. The patent describes a single oscillator at the receiver which reacts a number of times upon the incoming signaling energy at different points in the amplification system and when the received energy has been modified in different conditions.

## ELECTRIC CONDENSER

(Patent No. 1,514,369, H. A. Bremer. Filed September 21, 1923. Issued November 4, 1924.)

Electric condenser having a vernier adjustment consisting of a supplemental plate element engaged by a spring connected with the movable

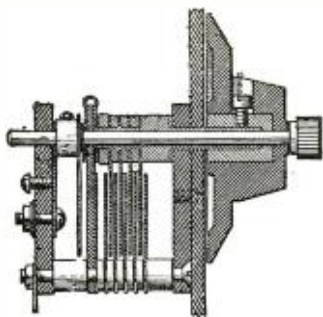

plates and arranged to be rotated with respect to both the movable and the stationary plates. A spring element is included between the supplemental plates and the shaft which carries the movable plates which spring element is in the form of a U-shaped clip.

## OSCILLATION DETECTOR

(Patent No. 1,515,994, A. W. Bowman. Filed April 4, 1923. Issued November 18, 1924.)

Oscillating detector of the crystal type in which a crystal is disposed adjacent one end of a cart-



ridge container while the surface is touched by a fine wire spiral spring projecting from the other end of the cartridge and controlled from a knob exterior of the barrel.

## SYSTEM OF RADIO TRANSMISSION

(Patent No. 1,517,568, J. O. Mauborgne and Guy Hill. Filed June 16, 1920. Issued December 2, 1924.)

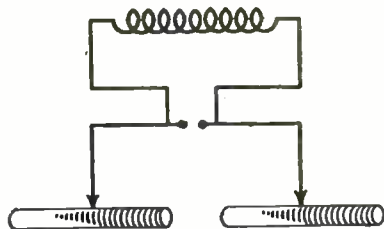

System of radio transmission which includes a power supply and two or more wave coils. Corresponding points are selected on the coils and a

suitable high frequency potential from the power supply impressed between the points for causing wave developments on the wave coils. The power supply is modulated for the purpose of signaling.

## EAR CUSHION

(Patent No. 1,514,152, Hugo Gernsback, of New York, N. Y. Filed December 28, 1923. Issued November 4, 1924.)

Ear cushion for telephone receivers and the like,

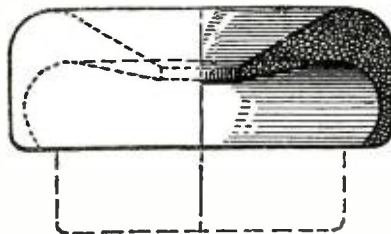

which can be readily applied to the receiver and will fit closely thereto, without adding materially to the bulk of same; which will be highly resilient and, therefore, afford the desired cushioning effect and fit closely to the ear so as to exclude external sounds, and which in addition to the foregoing will be of small size, light weight and neat appearance.

## RADIOTELEGRAPHY

(Patent No. 1,515,990, R. D. Bangay. Filed July 9, 1921. Issued November 18, 1924. Assigned to Radio Corporation of America, Delaware.)

Radiotelegraphy in which the wave-length of the transmitting system may be varied by movement of a variometer in the primary circuit. The primary inductance is in the form of a variometer while the antenna inductance is coupled with the variometer. By varying the angular position of the variometer coils in the primary circuit, the coupling is changed while maintaining the inductance constant.

## VARIABLE CONDENSER

(Patent No. 1,520,329, C. S. Cherpeck. Filed August 26, 1922. Issued December 23, 1924.)

Variable condenser of the book type in which plates which are normally paralleled may have

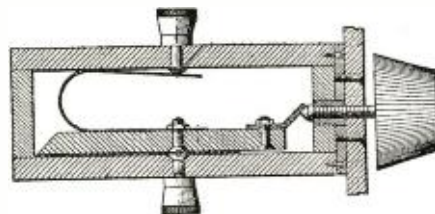

their capacity varied by angularly varying the pistons between the plates by means of a screw which may be advanced to introduce a cam movement arranged to vary the angularity of the plates.

## RADIOTELEGRAPHY

(Patent No. 1,515,670, L. P. Fuller. Filed September 25, 1919. Issued November 18, 1924. Assigned to Federal Telegraph Company, San Francisco, Calif.)

Radiotelegraphy system in which the ohmic resistance of the ground circuits is reduced with a view of raising the overall efficiency of a transmitting station. The specification points out that by reason of the large antenna current the  $I^2R$  losses in the usual ground system at a high power radio station has been so large as to considerably reduce the efficiency. By the present invention an ungrounded radiating circuit comprising a plurality of vertical loops in substantially the same plane is provided. The vertical sides of adjacent loops are near each other and current is supplied to each loop of such phase that the currents in the adjacent vertical sides are opposed and substantially nullify each other. The resistance losses in the entire structure may be thus maintained at a desired low value.

## RECEIVING SYSTEM

(Patent No. 1,521,380, D. G. McCaa. Filed November 17, 1922. Issued December 30, 1924. Assigned to The Electric Apparatus Co., Parkersburg, a corporation of Pennsylvania.)

Receiving system for radio signals in which a circuit arrangement is provided for discriminating against static, atmospheric, strays and other disturbances. The received energy representing both the desired signal and the disturbing effect is divided into two paths, including reactive devices, one of which is employed for effecting the translation of the desired signals and with another of which is associated a local source of oscillations in such manner as to cause the effect of said reactance to fluctuate within wide limits resulting in the fluctuation in amplitude of the signal representing energy in the first reactance and at certain instants to be reinforced by energy from the local source to the substantial exclusion or great reduction of the effects of the simultaneously existing disturbing energy.

## ELECTRIC CONDENSER

(Patent No. 1,520,461, H. A. Bremer. Filed September 21, 1923. Issued December 23, 1924.)

Electric condenser in which the plates are ar-

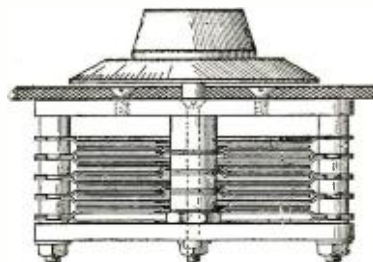

ranged in pairs and are dished in such manner that movable plates may be interleaved between the stationary plates, the offset portions of the movable plates moving between the offset portions of the stationary plates. In this way a smaller number of spacing members is required in the support of both the movable plates and the stationary plates.

## RADIO RECEIVING SYSTEM

(Patent No. 1,516,061, H. O. Rugh. Filed November 16, 1922. Issued November 18, 1924. Assigned to Rugh & Noble, Chicago, Ill.)

Radio receiving system which may be connected in the house lighting circuit similar to an incandescent lamp. A two-electrode tube is secured into the lighting socket and has its filament lighted from the source of current. A tuned circuit is provided across the input terminals, while a responsive device is connected in circuit with the second electrode.

## RADIO RECEIVING APPARATUS

(Patent No. 1,505,085, C. E. Brigham. Filed July 15, 1922. Issued August 19, 1924. Assigned to Dubilier Condenser and Radio Corporation, New York.)

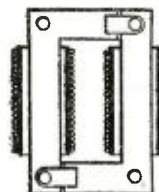

Radio receiving apparatus including a radio frequency amplification circuit wherein the tubes are interlinked by coupling transformers designed to amplify incoming signaling frequencies over a broad band of frequencies. The transformer is designed to have extremely small distributed capacity at the frequencies for which the transformer is designed to operate. A magnetic leak-

(Continued on page 1942)

\*Patent Attorney, Ouray Building, Washington, D. C.





# RADIO NEWS LABORATORIES



**R**ADIO manufacturers are invited to send to RADIO NEWS LABORATORIES, samples of their products for test. It does not matter whether or not they advertise in RADIO NEWS, the RADIO NEWS LABORATORIES being an independent organization, with the improvement of radio apparatus as its aim. If, after being tested, the instruments submitted prove to be built according to modern radio engineering practice, they will each be awarded a certificate of merit, and a "write-up" such as those given below will appear in this department of RADIO NEWS. If the apparatus does not pass the Laboratories tests, it will be returned to the manufacturers with suggestions for improvements. No "write-ups" sent by manufacturers are published on these pages, and only apparatus which has been tested by the Laboratories and found to be of good mechanical and electrical construction is described. Inasmuch as the service of the RADIO NEWS LABORATORIES is free to all manufacturers whether they are advertisers or not, it is necessary that all goods to be tested be forwarded prepaid, otherwise they cannot be accepted by the Laboratories. Address all communications and all parcels to RADIO NEWS LABORATORIES, 53 Park Place, New York City.

## Apparatus Awarded Certificates

**RADIO EXTENSION CORD**  
Sometimes it is not desirable to place the loud speaker near the radio set on account of poor acoustical conditions, or for other reasons, and the loud speaker must be placed in some other part of the room; this requires an extension cord like the one illustrated. This



30-foot flexible cord has a plug connection at both ends into which may be connected the loud speaker cord tips. Manufactured by the Deluxe Sales Company, 112 Trinity Place, New York City.

**AWARDED THE RADIO NEWS LABORATORIES CERTIFICATE OF MERIT NO. 679.**

**RE-NU "B" BATTERY**

The type 151 Re-Nu radio "B" battery manufactured by the Steiner Battery Co., Lancaster, Ohio, consists of a wooden box with a removable bottom into which may be clamped 15 large size flashlight cells. There are six terminals on



the top of the box with connections to the cells giving 16½ to 22½ volts in steps of 1½ volts. Thus when the cells wear out, the experimenter can easily replace them.

**AWARDED THE RADIO NEWS LABORATORIES CERTIFICATE OF MERIT NO. 680.**

**CUTLER HAMMER SOCKET**

The No. 8009 standard vacuum tube socket manufactured by the Cutler Hammer Manufacturing Co., Milwaukee, Wis., employs a bakelite shell with molded base and one piece



contacts with soldering terminals. The spring contacts are silver plated and make contact with both sides of the vacuum tube prongs. The use of these sockets entirely eliminates noises from poor connections that often occur in other types of sockets.

**AWARDED THE RADIO NEWS LABORATORIES CERTIFICATE OF MERIT NO. 610.**

**FIL-KO-LEAK**

This variable grid leak is calibrated and has a gradual control of resistance from ¼ to five megohms. The calibrations are marked on the dial so that the experimenter can set the leak to any desired resistance within the above range. The instrument runs very smoothly and is silent in operation. Manufactured by the DX Instrument Co., Harrisburg, Pa.

**AWARDED THE RADIO NEWS LABORATORIES CERTIFICATE OF MERIT NO. 669.**



**FIL-KO RESISTOR**

The Fil-Ko resistor is also made by the DX Instrument Co., Harrisburg, Pa., and is of similar construction to the Fil-Ko leak. It has a resistance range of 5,000 to 250,000 ohms and is very accurately rated. It may be used in many circuits such as resistance coupled amplifiers.

**AWARDED THE RADIO NEWS LABORATORIES CERTIFICATE OF MERIT NO. 670.**

**MULTI-PLUG AND CABLE**

Practically every radio set requires seven wires for connections to



the "A" and "B" batteries and antenna and ground. Usually, binding posts are used on the set for these connections. By using the Jones multi-plug and cable the binding posts may be eliminated and a much neater job will result. When disconnecting all the wires, simply pull out the plug. The wires are colored so that the connections are easily followed. Manufactured by Howard B. Jones, 614 South Canal Street, Chicago, Ill.

**AWARDED THE RADIO NEWS LABORATORIES CERTIFICATE OF MERIT NO. 681.**

**HEATH VACUUM TUBE SOCKET**

The Heath vacuum tube socket has a metal shell and molded base designed for both panel or base mounting. Small rubber shock ab-

sorbers are furnished with each socket which may be used when it is desired to eliminate noises caused by vibration of the vacuum tube elements. The spring contacts make excellent connections to both bottom and side of the vacuum tube



prongs. Manufactured by the Heath Radio & Electric Mfg. Co., Newark, N. J.

**AWARDED THE RADIO NEWS LABORATORIES CERTIFICATE OF MERIT NO. 609.**

**MAGNAVOX TUBE**

The type A Magnavox tube is designed for all purposes and circuits now used in radio receiving. It draws a filament current from .2 to .25 amperes at five volts and requires a plate voltage of 60 to 120. The construction is different



from that of tubes heretofore put on the market. The grid, or controlling electrode, is placed alongside of the filament instead of between filament and plate. The amplification factor is practically the same as that of standard tubes of this type. The internal capacity is low. Manufactured by the Magnavox Co., 2725 East 14th Street, Oakland, Calif.

**AWARDED THE RADIO NEWS LABORATORIES CERTIFICATE OF MERIT NO. 701.**

**FEDCO ANTENNA INSULATORS**

Efficiency in receiving circuits require well insulated antennae. The Fedco Blue Insulators are made of glazed porcelain which has been



found electrically and mechanically best suited for this purpose. Manufactured by the Federal Porcelain Company, Carey, Ohio.

**AWARDED THE RADIO NEWS LABORATORIES CERTIFICATE OF MERIT NO. 700.**

**VARIABLE RESISTANCE UNITS**

The Wireless Products Corporation, New York City, recently placed on the market variable resistances for grid leaks and other purposes of the same general appearance and construction as the ordinary rheostat. The type B resistance ranges from 1,500 to 150,000 ohms. The type A unit ranges from one-tenth to seven megohms. Contact is made to the resistance strip by means of a wire, similar to the wire used in rheostats, that encircles the strip and is slotted so as not to short-circuit it.



**AWARDED THE RADIO NEWS LABORATORIES CERTIFICATE OF MERIT NOS. 689 AND 690.**

**RADION LOUD SPEAKER HORN**

For portable receivers or receivers in which it is desired to conceal the loud speaker horn inside of the cabinet, the horn should be of small size and durable construction. This horn, made by the American Hard Rubber Co., 11 Mercer St., New York City, is made entirely of Radion hard rubber. It is furnished with a receiver cap that fits the average loud speaker unit.



**AWARDED THE RADIO NEWS LABORATORIES CERTIFICATE OF MERIT NO. 694.**

**WIZARD FIXED CONDENSERS**

The fixed condensers submitted by the Wizard Co., Boston, Mass., were all found very accurate as to capacity ratings and of excellent construction. They are small in size and easily attached or wired to the



set. The losses were also about equal to those in the average condenser of this type.



**AWARDED THE RADIO NEWS LABORATORIES CERTIFICATE OF MERIT NO. 698.**

**HOWE RADIO RECEIVER**

This complete radio receiving set is of very small size and is entirely enclosed in a metal case. Tuning is effected with a knob attached to a slider that makes contact with the tuning coil inside. An adjustable crystal detector is mounted on the



top. It works very well with the average size aerial for local broadcast reception. Manufactured by the Howe Auto Products Co., Chicago, Ill.

**AWARDED THE RADIO NEWS LABORATORIES CERTIFICATE OF MERIT NO. 697.**

**TELETRON TUBE**

The teletron type 201-A vacuum tube works very well as detector, amplifier and oscillator. The filament requires ¼ ampere of five volts for normal operation. Plate voltages up to 120 are recommended.



This tube was tested for a considerable length of time and stood up very well under the test. Made by the Champion Electric Co., Detroit, Mich.

**AWARDED THE RADIO NEWS LABORATORIES CERTIFICATE OF MERIT NO. 691.**

**SILVERTON TUBE**

The type 1-A Silverton vacuum tube is of the standard construction with a ¼-ampere five-volt filament. This tube is manufactured by the New York Radio Co., 71 West Broadway, New York City, N. Y. Of several tubes tested in standard broadcast receivers very good re-



sults were obtained as regards amplification and tone quality. The sample tubes submitted were found to have uniform characteristics, which is highly desirable.

**AWARDED THE RADIO NEWS LABORATORIES CERTIFICATE OF MERIT NO. 671.**

**ZINCITE AND TELLURIUM DETECTOR**

This combination detector works very well in crystal and reflex sets. It is of simple construction and very sensitive. The crystals are enclosed so as to be free from dust,



and adjustment is easily made. Manufactured by the Tool and Device Corporation, 520 Congress Street, Troy, N. Y.

**AWARDED THE RADIO NEWS LABORATORIES CERTIFICATE OF MERIT NO. 687.**

**VAN FIXED CRYSTAL RECEIVER**

Although of very simple construction, this radio receiving set gives very good results on local reception. The frame is of metal inside of which is a tuning coil with a slider



for adjusting the wave-length. On top is mounted the fixed crystal detector. Manufactured by L. D. Van Valkenburg Co., Holyoke, Mass.

**AWARDED THE RADIO NEWS LABORATORIES CERTIFICATE OF MERIT NO. 685.**

**RADIO PORCELAIN PEDESTAL**

The catalog No. 611 Barkeley porcelain pedestal may be used for supporting antenna wires and leads, or for other purposes where good insulation is required. This



pedestal is shown in the illustration. It is manufactured by the Barkeley Electric Manufacturing Co., Middletown, Ohio.

**AWARDED THE RADIO NEWS LABORATORIES CERTIFICATE OF MERIT NO. 682.**

**ELECTRAD GRID LEAK MOUNTING**

The Electrad certified grid leak mounting is of the standard size and conventional design as shown in the illustration. It is a well constructed grid leak base and the Electrad grid leak furnished with it was found very accurate as to rating. Manufactured by Electrad, Inc., 428 Broadway, New York City.



**AWARDED THE RADIO NEWS LABORATORIES CERTIFICATE OF MERIT NO. 672.**

**ELECTRAD AUDIOHM**

This instrument has a variable resistance range of 30,000 to 100,000 ohms. It may be used in resistance coupled amplifiers and for many other purposes, such as a shunt resistance across the secondary of the transformers in an audio amplifier. It is a well constructed instrument and has a very gradual resistance control. Manufactured by Electrad, Inc., 428 Broadway, New York City.

**AWARDED THE RADIO NEWS LABORATORIES CERTIFICATE OF MERIT NO. 674.**



**ELECTRAD VARIOHM**

The Electrad variohm is similar in construction to the other Electrad variable resistances and is used mainly for a grid leak. It has a range of ¼ to 10 megohms with a very uniform resistance control. Manufactured by Electrad, Inc., 428 Broadway, New York City.

**AWARDED THE RADIO NEWS LABORATORIES CERTIFICATE OF MERIT NO. 675.**

**ELECTRAD VARIABLE RESISTANCE UNIT**

The complete line of Electrad variable resistances will meet all the requirements of the radio experi-

menter. The type 25 unit is of the same general construction as the others and has a resistance range of 5,000 to 100,000 ohms. Manufactured by Electrad, Inc., 428 Broadway, New York City.

**AWARDED THE RADIO NEWS LABORATORIES CERTIFICATE OF MERIT NO. 676.**

**ELECTRAD GRID LEAK AND CONDENSER**

The combined Electrad variable grid leak and condenser is a very well constructed instrument of small size and neat design. The variable grid leak has a range of ¼ to 10 megohms. The construction of the instrument is similar to that of the variable grid leak shown in these columns. Manufactured by Electrad, Inc., 428 Broadway, New York City.



**AWARDED THE RADIO NEWS LABORATORIES CERTIFICATE OF MERIT NO. 673.**

**LAMP SOCKET ANTENNA**

The Electrad lamp socket antenna is a very simply constructed instrument. It consists of a standard 110-volt plug that fits the standard socket and a small attachment with one terminal connected through a fixed condenser to one of the plug terminals. The fixed condenser has a capacity of approximately .00012 mfd. The device works very well as



an antenna in some localities. Manufactured by Electrad, Inc., 428 Broadway, New York City.

**AWARDED THE RADIO NEWS LABORATORIES CERTIFICATE OF MERIT NO. 677.**

**OUTDOOR LIGHTNING ARRESTER**

Safe protection of the radio set and also the surroundings require a lightning arrester that will break down at a potential under 500 volts. The Electrad arrester consists of two copper electrodes forming a very small gap hermetically sealed and water tight. This arrester is bell-



shaped and mounted on a supporting bracket. Manufactured by Electrad, Inc., 428 Broadway, New York City.

**AWARDED THE RADIO NEWS LABORATORIES CERTIFICATE OF MERIT NO. 678.**

**SUPER BOOSTER**

This instrument consists of a coil and condenser mounted on a small panel and placed in a wooden cabinet. There are three terminals for the antenna and ground connections, the terminals used depending upon the length of the antenna. By placing the device in the vicinity



of the radio set, either on top of it or near to one of the tuning coils, the signals pass through by induction between the two circuits and

selectivity is considerably increased. It also functions as a wave trap. Made by the Liberty Radio Corp.

**AWARDED THE RADIO NEWS LABORATORIES CERTIFICATE OF MERIT NO. 703.**

**SENTINEL FUSE BLOCK**

For the protection of radio tubes against the destructive action of "B" battery current under short-circuit conditions, a fuse in the

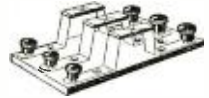

filament circuit is recommended. This triple fuse block is so arranged that when the fuses blow, new ones can be easily inserted. The fuses are connected in the "A" and "B" battery leads. Manufactured by the Davis Electric Co., Springfield, Ohio.

**AWARDED THE RADIO NEWS LABORATORIES CERTIFICATE OF MERIT NO. 702.**

**TRUE BLUE TUBES**

The True Blue radio tubes are elaborately packed singly or in sets of three or five in a case. The tubes



are of excellent construction and have many exclusive features. They are provided with sterling silver contact points. The filament consumes ¼ ampere at five volts. As detector, plate voltages of 20 to 40 are recommended, and as oscillators and amplifiers, plate voltages of 40 to 150 may be used. The base is of genuine bakelite, of mahogany color. The glass is steel blue. Manufactured by Brighton Laboratories, Inc., 16 West 34th Street, New York City.

**AWARDED THE RADIO NEWS LABORATORIES CERTIFICATE OF MERIT NO. 708.**

**ALLEN DIAL VERNIER**

Where an exceptionally fine micrometer adjustment of the tuning



dial is required, this vernier may be used. The small knob turns a spiral worm which operates a pinion. Attached to this is a rubber tired wheel that presses against the tuner dial and turns it. Exceptionally fine control is obtained. The instrument is easily mounted on the panel adjacent to the dial. Manufactured by General Engineering and Model Works, Pittsburgh, Pa.

**AWARDED THE RADIO NEWS LABORATORIES CERTIFICATE OF MERIT NO. 686.**

**KELMAN STORAGE "B" BATTERY**

The 12-cell, 24-volt Kelman storage "B" battery is of excellent construction and has an exceptionally



high ampere hour output. The voltages of the cells are comparatively uniform during charge and discharge. The battery is highly recommended where constant current supply and noiseless operation are essential. Manufactured by Kelman Electric Company, Rochester, N. Y.

**AWARDED THE RADIO NEWS LABORATORIES CERTIFICATE OF MERIT NO. 695**





**T**HIS Department is conducted for the benefit of our Radio Experimenter. We shall be glad to answer here questions for the benefit of all, but we can publish only such matter as is of sufficient interest to all.

1. This Department cannot answer more than three questions for each correspondent.
2. Only one side of the sheet should be written upon; all matter should be typewritten or else written in ink. No attention paid to penciled matter.
3. Sketches, diagrams, etc., must be on separate sheets. This Department does not answer questions by mail free of charge.
4. Our Editors will be glad to answer any letter, at the rate of 25c for each question. If, however, questions entail considerable research work, intricate calculations, patent research, etc., a special charge will be made. Before we answer such questions, correspondents will be informed as to the price charge. You will do the Editor a personal favor if you will make your letter as brief as possible.

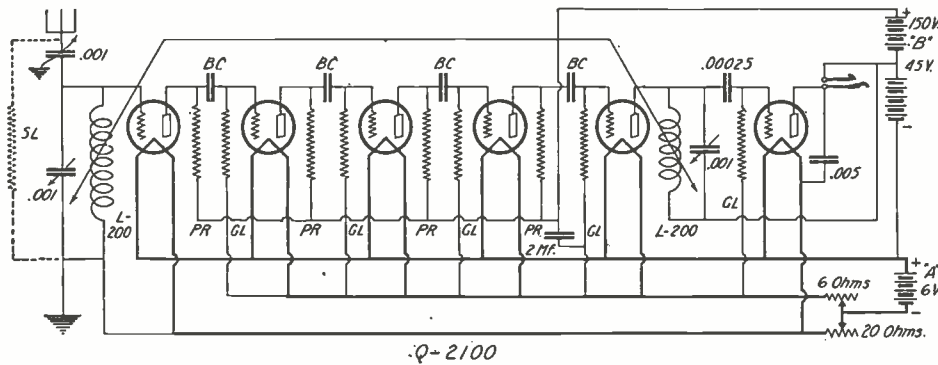

This efficient receiver is not difficult to tune. It is easy to construct. This is an "all-wave" receiver. One need only change coils, to cover practically all wave-lengths in use today.

**LONG WAVE RECEIVER**

(2100) Mrs. Lowell Price, Pelham Bay, N. Y., asks:

Q. 1. Please furnish me with a diagram which will enable me to construct a set capable of receiving the programs broadcast by certain French, Swedish, German, Italian, Spanish, Swiss, Dutch, Danish, Belgian and, I understand, some South American stations, on long wave-lengths.

A. 1. The long wave broadcast programs of stations in these and other countries may be tuned to with a set constructed in accordance with the diagram shown in these columns.

The wave-length range is dependent upon

the values of inductance and capacity used. Variable condensers of .001 mfd. capacity are more to be desired when tuning to the longer wave-lengths than those of lesser capacity. Otherwise, it would cause the unnecessary inconvenience of frequent inductance coil change.

The coil values shown will cover a wave-length range of approximately 1,000 to 3,000 meters. Simplification of control results by the use of only two honeycomb coils. The correct honeycomb coil value for various wave-length ranges may be determined from the table given in the "I Want to Know" department of the January, 1925, issue of RADIO NEWS, page 1229. When changing to

a different wave-length range, it will be necessary to replace both coils.

Plate resistors "PR" have a value approximating 70,000 ohms. The exact resistance, which is not critical, is readily determined by test. The value is governed mainly by the "B" battery voltage (which should be high, 135 to 150 volts) and tubes used (practically any make of amplifier tubes will be satisfactory, with the proper resistor values).

Good tubes, preferably balanced, are essential.

The grid resistors, or "grid leaks" as we know them (marked "GL"), may all be of the same size (about 2 megohms).

Blocking condensers "BC" are all of .0005 mfd. capacity. The detector grid condenser value is .00025 mfd. capacity, as usual.

The two L-200 honeycomb coils shown are placed in variable inductive relation; this is indicated by the arrow-head lines placed to show coupling.

Two variable condensers are shown in the aerial-grid circuits. If only one is used, either the aerial circuit or the grid circuit will be out of tune on all but one wave-length—the natural period of the aerial system or of the grid circuit.

Hand capacity will be evident from the aerial series condenser, unless the usual precautions are taken.

Investigators have termed a particular form of static prevalent at the lower frequencies (high wave-lengths) as "long

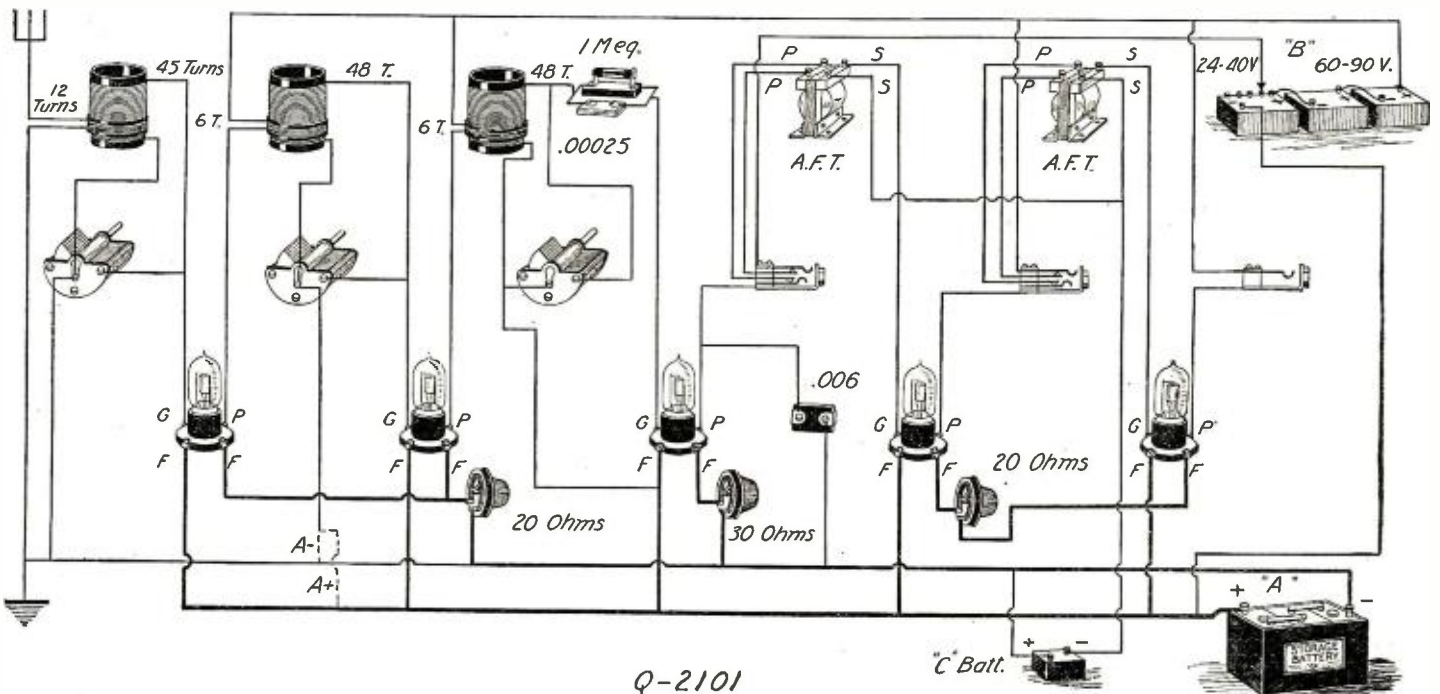

The Freshman circuit, two stages of tuned radio frequency amplification (non-oscillating), detector and two stages of audio frequency amplification. Twenty-three variable condensers may be used. Once logged, a station will always be received at the same three points on the dials.



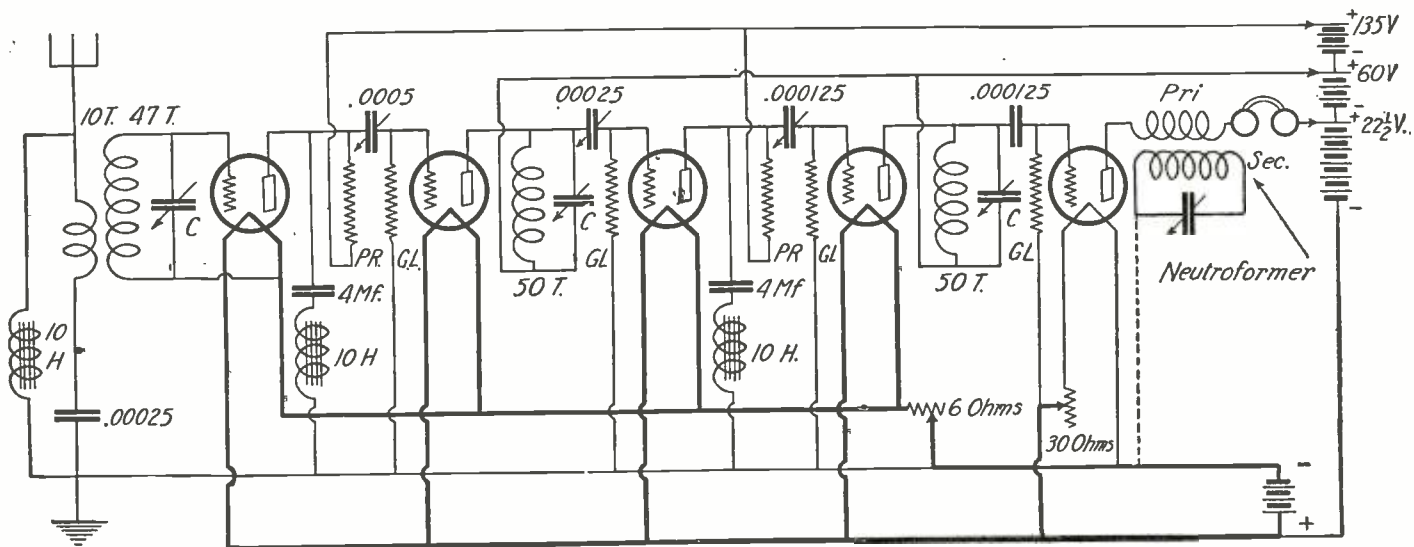

Q-2106

This circuit is designed for the reduction of static effects to a minimum. During exceptionally strong static it may be advisable to disconnect the aerial and change the ground connection over to the antenna post. Note the neutroformer for regeneration.

wave" static. A "static leak" (SL) of about 50,000 ohms is shown as a method for reducing, somewhat, static effects. This leak is of particular value as a means of causing a slow discharge to ground of static electricity (particularly the kind known as "snow" static, often observable during snowfall) which would otherwise accumulate on the aerial, due to the direct current insulation afforded by the antenna series condenser; fitfully discharging to ground, this stored-up electricity would cause loud, annoying clicks in the headphones.

Variable condenser rotors are indicated by the arrow-head.

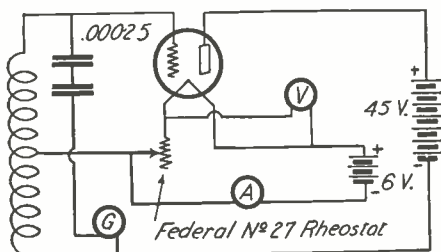

Q-2108

A simple tube testing circuit. Meter "G" only registers oscillating currents.

**FRESHMAN CIRCUIT**

(2101) Mr. Antonio Costello, Rome, Italy, asks:

Q. 1. What is the wiring diagram, and what are the constants, for a standard set of the radio frequency type, such as the Freshman, incorporating two stages of tuned radio frequency amplification, tube detector, and two stages of audio frequency amplification? I understand no neutralizing methods or potentiometers are required.

A. 1. We are showing this circuit in these columns.

All three variable condensers must be of the same make and capacity rating. Capacities of about .0005 mfd. will be about right.

The tuned radio frequency transformers may have to be changed slightly in order to make all the variable condensers balance.

If one desires to make their own radio frequency transformers, the number of turns indicated may be wound on a form about three inches in diameter. The primary may be wound directly over the secondary, at the filament end, with only slight spacing between the two windings. No. 24 D.C.C. wire will be quite satisfactory.

The grid return lead of the second radio frequency amplifying tube is shown in dotted

lines. It may be very difficult to prevent strong oscillation of this tube, unless this connection is made to "A" plus. If connection is made to "A" minus and the set oscillates strongly, it would be best to reduce the number of turns in the primary coil in the plate circuit of the first or second tube, still retaining the negative grid return connection. This is generally better practice than that of making an amplifier grid positive by connecting to the positive post of the "A" battery.

Any tubes may be used in this set, depending upon the sockets and rheostats used. If low-capacity tubes are used, it will be possible to almost triple the number of turns in the plate circuit winding of each tube, without the set going into oscillation. This increase in the number of turns will result in greater sensitivity.

If the "C" battery is not desired, at first, the binding posts for same are connected together with a piece of wire.

Q. 2. Is it true that many of the better broadcast stations use a control system that makes it possible for the station operator to increase the volume of either the high or low notes being broadcast, at will?

A. 2. It is true that programs are balanced in just this manner.

Q. 3. What is the softening point of hard rubber?

A. 3. About 150 degrees, Fahrenheit.

**HARD RUBBER DATA**

(2102) Mr. John Knox, Bensonhurst, Brooklyn, N. Y., asks:

Q. 1. What are the considerations to be observed in the drilling and sawing of hard rubber?

A. 1. When drilling hard rubber, use drills of the best, high carbon steel variety. Grind the drills frequently. Drill ends should be at an angle of 45 degrees. Use a drill speed of 1,500 r.p.m. for holes under 3/8-inch size. Use a speed of 800 r.p.m. for sizes up to 3/4-inch and a speed of about 300 r.p.m., depending upon the size, for holes larger than this. A very satisfactory lubricant, to prevent over-heating, is soda and water. When sawing this material for small work, use a hack saw having 24 teeth per inch. For large work a circular saw is not as satisfactory as most people would suppose. A cutting wheel is much more satisfactory. If quantity work is to be done, we would advise you to communicate with the manufacturer whose material you intend to use.

Q. 2. While operating the radio set owned

by a friend, a very peculiar effect was observed. When receiving the signals from a given station, the signals are clear and loud. Now, it is not possible to rapidly change the dial settings and hear other stations; the dials must be adjusted slowly. If the dials are turned quickly to a setting upon which a station is heard broadcasting it will be several seconds before the station is heard and gradually reaches maximum volume.

A. 2. One of your tubes is blocking. If you have any grid leaks in the set, such as a detector leak, try others in place of the one now in use. Look your connections over very carefully to make sure that every tube is connecting to the socket springs and that the grid and grid return leads are connecting to their respective points in the set. Some one of the tubes in your set has an open grid circuit. The grid inside the tube is continually receiving a charge of negative electricity from the negative electrons leaving the heated filament. This charge would ordinarily leak off, through the circuit, to the filament from which it started, if the circuit was complete, but it is prevented from so doing if the circuit is open. A normal, slow leakage would take place, but this would delay the amplifying action of the tube, resulting in the effect you name. This "blocking" action often takes place at a more rapid rate, producing a slow or fast clicking.

Q. 3. How many kilocycles are allowed to a broadcast station, to include every audible frequency transmitted?

A. 3. A frequency band 10 kilocycles wide is required to include all the audible frequencies.

If the carrier wave of one broadcast station is less than 10 kilocycles from the carrier wave of another station, the high audio

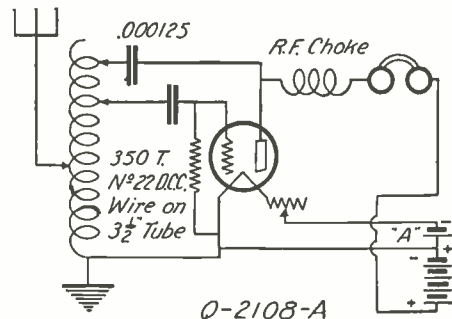

Q-2108-A

Weagant circuit applied to a 3-slide tuner. When oscillating, a loud click is heard as the sliders are moved.



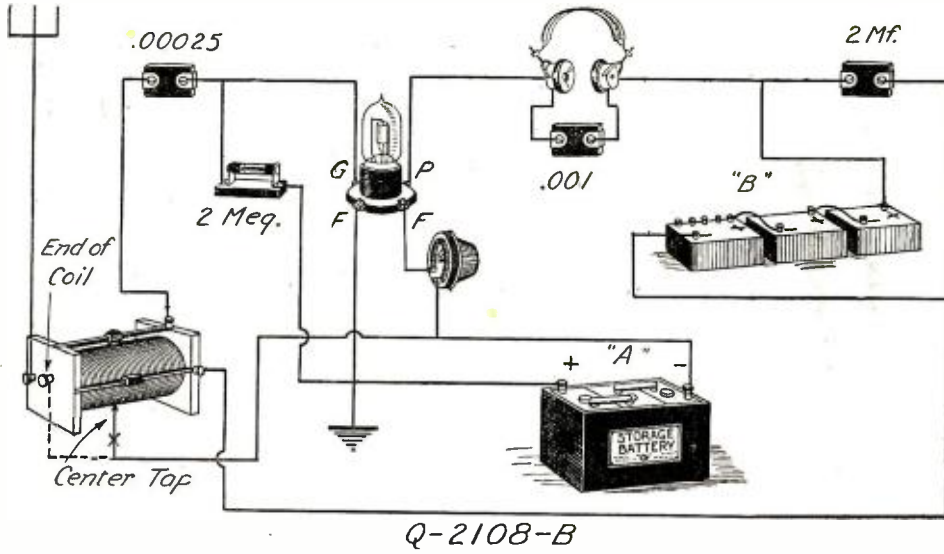

The old 3-slide tuner in a reliable circuit. Time signals direct from Arlington (Radio), Va., may be received on 2,500 meters. Broadcast stations re-transmit these accurate time ticks.

notes, first, of the one station will overlap the high audio notes of the other station.

**BEVERAGE ANTENNA**

(2103) Mr. John Hoskins, Boston, Mass., asks:

Q. 1. Where can the official list of Canadian stations be procured?

A. 1. Write to the Department of Marine and Fisheries, Ottawa, Canada.

Q. 2. Has the construction of a "D" coil been described in any past issue of RADIO NEWS?

A. 2. This type of inductance construction was covered in a two-page article starting on page 2106 of the June, 1923, issue of RADIO NEWS.

Q. 3. Has the Beverage antenna been described in a past issue of RADIO NEWS?

A. 3. A circuit showing the method employed will be found on page 897 of the January, 1924, issue of this magazine.

**BUS BAR WIRE**

(2104) Miss Ann Sempere, New York City, asks:

Q. 1. Is square or round bus wire best for wiring up a set?

A. 1. It makes no practical difference whether one or the other is used.

Q. 2. Can an indoor aerial be used with a Neutrodyne receiver?

A. 2. Excellent reports have been received from radio fans who have used indoor aerials, not only with Neutrodyne sets, but with other types of sets as well.

**A.C. ON FILAMENTS**

(2105) Mr. George Faulkner, Atlanta, Ga., asks:

Q. 1. Is it possible to make a radio frequency set using the electric light lines as a current supply for the filaments? The current rating is 110 volts, alternating current.

A. 1. We are showing a design that makes this possible. The biasing batteries C1, C2, C3, C4 and C5 have a value of approximately three to four and one-half volts. It is good practice to use a separate potentiometer across the filament of each tube in order to more surely arrive at the correct balance. P<sub>1</sub>, P<sub>2</sub>, P<sub>3</sub>, P<sub>4</sub> and P<sub>5</sub> should each be of about 400 ohms resistance.

The current supply transformer must have a secondary capable of supplying one and one-quarter to one and one-half amperes, at six volts.

Regular neutroformers, or else transformers designed for use in tuned radio frequency amplifier circuits of the un-neutralized type, may be satisfactorily used. The correct variable condensers for the particular coils employed should be used.

Since radio frequency amplification is being used, it would be best to use audio fre-

quency transformers of only medium ratio, such as 3:1, 4:1 or 5:1.

Q. 2. What size copper wire should I procure to have a resistance that need only be fairly close to the value of one ohm per foot?

A. 2. No. 40 B. & S. gauge copper wire will closely approximate this figure.

**ANTI-X CIRCUIT**

(2106) Mr. Raphael Lacosta, Mexico City, Mexico, asks:

Q. 1. Static is very strong in my locality. What would be a good system to employ in a receiving set capable of good reception under this adverse condition?

A. 1. We are showing a circuit using weeding out arrangements of large and small condensers, resistance coupling and choke coils.

Each resistance coupling serves to act as a blocking arrangement which prevents undesired oscillation of the tubes. If the inductances are placed in inductive relation to one another, it would be an easy matter to cause strong regeneration or oscillation, but sufficient regeneration or oscillation is obtained by the use of a neutroformer connected as shown. The regeneration then taking place is due to the capacity coupling between the elements of the tube, since the neutroformer is to be placed in non-inductive relation to the other inductances in the set.

The secondary of a high-ratio audio frequency transformer may be used for the iron core choke coils shown; the primary is left unconnected.

The maximum capacity for the variable blocking condensers is indicated. The value has not been stated in "number of plates," since plate sizes vary. The four microfarad capacity is readily obtained by connecting two condensers, each of two microfarads capacity, in parallel.

No. 24 D.C.C. wire, wound on a three-inch tube, will be satisfactory for the inductances. If neutroformers are used throughout, the primaries are left unconnected, where only the secondary is required as the tuned impedance, of which there are two.

The plate resistors (PR) are all of one-tenth megohm size. The grid leaks (GL) are all of one megohm size, with the exception of the detector grid leak, which is of two megohms size.

Keep all filaments and "B" battery voltages as low as is consistent with medium volume.

The "B" potentials shown are maximum and in all probability can be advantageously reduced.

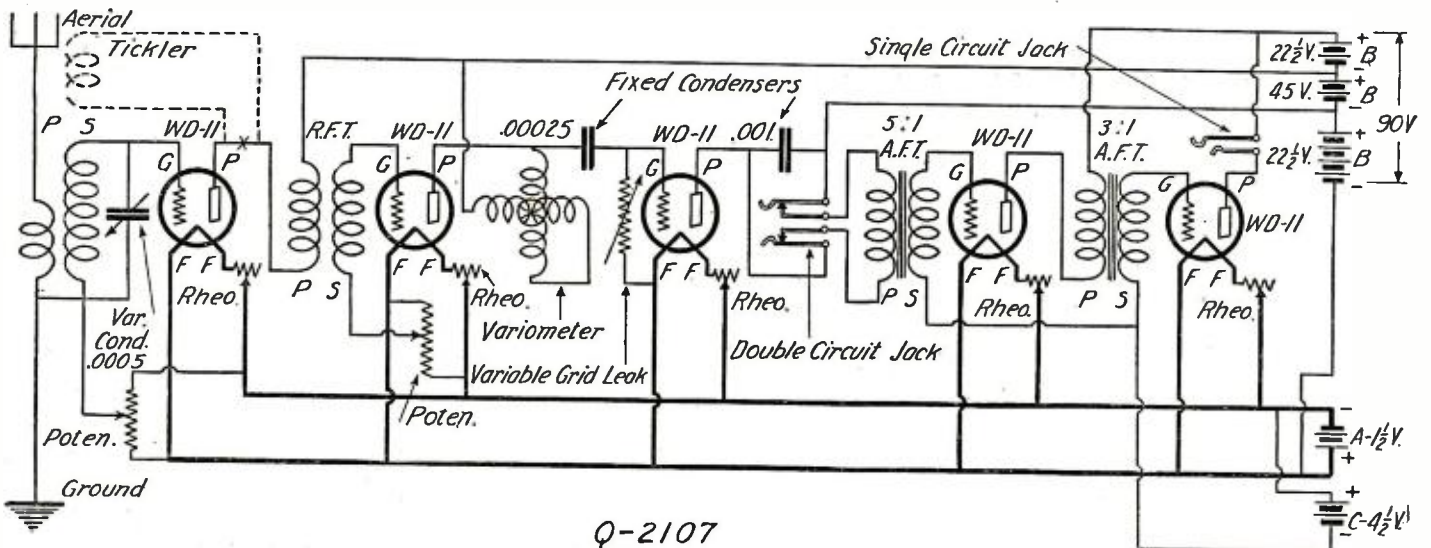

One of the many variations possible wherein a variocoupler, fixed-tune radio frequency transformer, and continuously variable inductance (variometer) are used. Only two dials are required for this set. The R.F. transformer should not have a sharp peak at one wave-length.



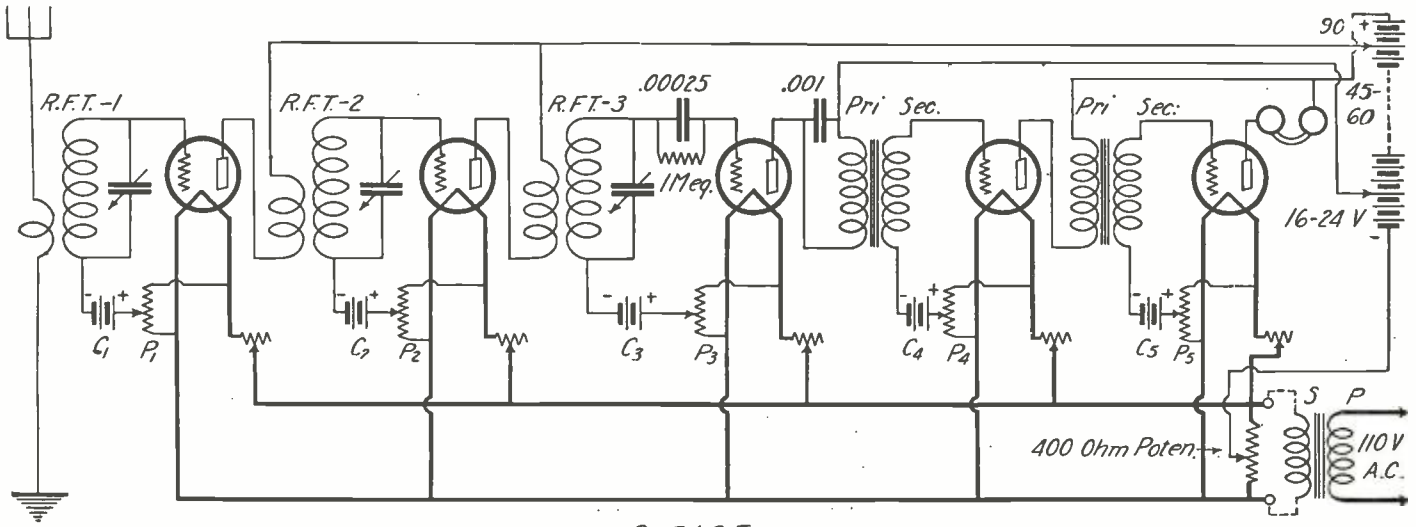

Q-2105

This circuit uses the house lighting current for filament heating. A transformer steps the current down to six volts A.C. To prevent a tube burn-out by overloading, all tubes should be left lighted when set is in use.

Use a fairly short aerial (about 30 to 50 feet) and a low one.

Q. 2. Some tuned radio frequency transformers are wound on what seems to be a white tube. What is this called?

A. 2. You probably refer to the tubes of Isolantite, a material much resembling an exceptionally fine porcelain.

Q. 3. If no tubes are lighted and I get a spark upon touching a "B" plus lead to the proper "B" plus post on the binding post strip, does that indicate a fault in the circuit?

A. 3. Yes. It indicates that your "B" battery is being short circuited. A short circuit of the battery lasting only a few seconds will discharge and practically ruin a dry cell type of battery and may cause damage to a lead type battery. A nickel-iron alkali battery would not be damaged under this condition.

Trace out your wiring in an effort to determine where the "B" plus is making contact with "B" minus.

**DRY CELL TUBE SET**

(2107) Mr. James Hardwick, South Dartmouth, Mass., asks:

Q. 1. Will you kindly furnish me with a schematic diagram of a set incorporating the following items I now have? A variocoupler, a fixed radio frequency transformer, a variometer, two audio frequency transformers, five WD-11 tubes and a variable grid leak.

A. 1. We are herein showing a circuit incorporating the parts you name and a few other necessary items.

You do not state whether your coil is of the two-coil or of the three-coil type. If

of the latter form of construction, it may be a good plan to connect the tickler coil as indicated by the dotted lines, resulting in a Superdyne effect that will enable you to move the potentiometer arm more toward the negative end, resulting in greater amplification. Since turning the tickler through a full circle will be the equivalent to reversing the connections on the tickler, it is not necessary to take especial pains as to which way the rotor is connected in the circuit.

Q. 2. Will the UV-712 audio frequency transformer work with the UV-199 tube?

A. 2. This transformer is quite suitable for amplification of code signals due to the high ratio of 9:1. It may also be used in the reflexed stage of a reflex set intended for broadcast reception. A lower ratio transformer is more suitable for an amplifier of broadcast programs.

Q. 3. Is there any difference between the grid lead and the grid return lead?

A. 3. Peculiarities of certain circuits modify the usual understanding of these two terms, which is that the grid return lead is the wire connecting the grid to the tuning inductance; a grid condenser is sometimes connected in series with this lead. The grid return lead is considered as that wire connecting the tuning inductance to the filament circuit.

**FIVE-STAGE NEUTRODYNE**

(2108) Mr. Jerome Fennimore, Basking Ridge, N. J., asks:

Q. 1. What is the tube tester diagram using an oscillating circuit?

A. 1. This is standard. It will be found in these columns.

The inductance may be made by winding 50 turns of No. 22 D.C.C. wire on a tube

about 1 1/4 inches in diameter. There is a tap at the middle of this collodion coated coil.

A Weston thermo-galvanometer ("G") model 425, is used, having a range of 0 to 115 milliamperes.

The D.C. ammeter ("A") is a Weston model 301, 0 to 1 amp. range, instrument. The D.C. voltmeter ("V") is also a model 301 Weston with a range of 0 to 7 volts.

The voltages shown must be used.

Tubes having 0.06, 0.25 and 1.0 amp. filaments at the respective voltages of four and one-half, six and six volts, may be tested. Different tubes known to operate satisfactorily should be put in the tester and the readings noted. An average reading may thus be determined, by which unknown tubes may be checked.

Q. 2. I would like very much to have you publish a picture diagram showing how to use a three-slide tuner in a regenerative circuit.

A. 2. We are showing you two ways of using your tuner in a regenerative circuit.

Circuit A shows the Weagant system of producing regeneration oscillation.

The radio frequency choke may be made by winding about 250 turns of No. 36 B. & S. gauge S.C.C. wire on a tube about two inches in diameter.

Circuit B shows the negative filament as connecting to a middle tap on the coil. Instead of tapping here, however, connection may be made to one end of the coil, as shown by the dotted line. Mark X denotes a break if the filament is connected as per the dotted line.

Q. 3. Since it is possible to make a satisfactory Neutrodyne having three dials, why would it not be possible to make one having five or six dials?

A. 3. It is possible, but not easily done. If care is taken in the construction of the set, it would be interesting to construct one along the lines of the Neutrodyne circuit illustrated in this issue.

Probably the best way to go at this unit is to first make up the set with only the usual two stages of neutralized radio frequency. Then, one-by-one, build additional stages, carefully neutralizing and balancing each successive one. As soon as a stage is balanced, the aerial and ground are removed and that coil to which the aerial and ground were connected now becomes the plate circuit primary winding for the next stage.

All neutroformers and condensers should be of the one make and type selected. N-1, etc., are the usual neutralizing capacities.

(Continued on page 1966)

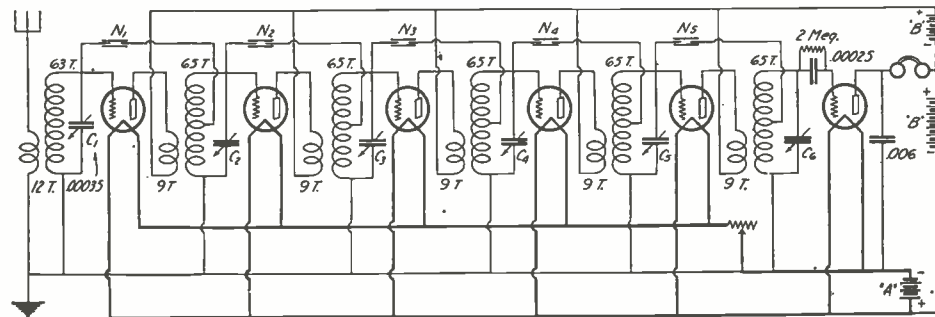

Q-2108

This is an experimental Neutrodyne diagram. A detector rheostat, not shown, is required in the positive lead of this tube. Reception reports should be addressed to the "I-Want-To-Know" department.



# Complete List of World's Broadcast Stations

## UNITED STATES STATIONS

Call Letters	Name	Location	Power & Wave Length	Call Letters	Name	Location	Power & Wave Length	
KDKA	Westinghouse Electric & Mfg. Co., East Pittsburgh, Pa.	1000—309.1	KFHA	Western State College of Colorado, Gunnison, Colo.	50—252	KFLW	Missoula Electric Supply Co., Missoula, Mont.	5—234
KDPM	Westinghouse Electric & Mfg. Co., Cleveland, Ohio	500—250	KFHJ	Fallon & Co., Santa Barbara, Calif.	100—360	KFLX	George R. Clough, 1214 40th St., Galveston, Texas	10—240
KDPT	Southern Electrical Co., San Diego, Calif.	50—244	KFHL	Penn College, Oskaloosa, Ia.	10—240	KFLZ	Atlantic Automobile Co., Atlantic, Iowa	100—273
KDYL	Newhouse Hotel, Salt Lake City, Utah	50—305.9	KFHR	Star Electric & Radio Co., Seattle, Wash.	100—263	KFMB	Christian Churches of Little Rock, Little Rock, Ark.	10—254
KDYM	Savoy Theatre, San Diego, Cal.	100—280	KFI	Earle C. Anthony, Inc., Los Angeles, Calif.	1500—467	KFMQ	University of Arkansas, Fayetteville, Ark.	500—275
KDYQ	Oregon Institute of Technology, Portland, Ore.	50—360	KFIF	Benson Polytechnic Institute, Portland, Ore.	100—248	KFMR	Morningside College, Sioux City, Iowa	10—261
KDZB	Frank E. Siefert, Bakersfield, Calif.	100—240	KFIO	North Central High School, Spokane, Wash.	50—266	KFMT	George W. Young, 2219 W. Bryant Ave., Minneapolis, Minn.	100—263
KDZE	Rhodes Department Store, Seattle, Wash.	100—270	KFIQ	First Methodist Church, Yakima, Wash.	50—256	KFMW	M. G. Sateren, 127 Blanche St., Houghton, Mich.	50—266
KFAB	Nebraska Buick Auto Co., Lincoln, Neb.	200—240	KFIU	Alaska Elec. Light & Power Co., Juneau, Alaska	10—226	KFMX	Carleton College, Northfield, Minn.	750—336.9
KFAD	McArthur Bros. Mercantile Co., Phoenix, Ariz.	100—360	KFIX	Reorganized Church of Jesus Christ of Latter Day Saints, Independence, Mo.	250—240	KFNF	Henry Field Seed Co., Shenandoah, Iowa	500—266
KFAE	State College of Washington, Pullman, Wash.	500—333.1	KFIZ	Daily Commonwealth and Oscar A. Huelmsan, Fond du Lac, Wis.	100—273	KFNG	Wooten's Radio Shop, Coldwater, Miss.	10—254
KFAF	Western Radio Corporation, Denver, Colo.	500—278	KFJB	Marshall Electric Co., Marshalltown, Iowa	10—248	KFNJ	Central Mo. State Teachers' College, Warrensburg Mo.	50—234
KFAJ	University of Colorado, Boulder, Colo.	100—261	KFJC	Seattle Post Intelligencer, Seattle, Wash.	100—270	KFNL	Radio Broadcast Association, Paso Robles, Calif.	10—240
KFAN	The Electric Shop, Moscow, Idaho	50—230	KFJD	National Radio Mfg. Co., Oklahoma City, Okla.	225—261	KFNV	L. A. Drake, 505 Third St., Santa Rosa, Calif.	5—227
KFAR	Studio Lighting Service Co. (O. K. Olsen), Hollywood, Calif.	200—280	KFJE	Liberty Theatre, Astoria, Ore.	10—252	KFNY	Montana Phonograph Co., Helena, Mont.	50—248
KFAU	Independent School District of Boise City, Boise High School, Boise, Idaho	500—275	KFJF	Delano Radio & Electric Co., Bristow, Okla.	100—233	KFNZ	Royal Radio Co., Burlingame, Calif.	10—231
KFAW	The Radio Den, Santa Ana, Calif.	10—280	KFJK	University of North Dakota, Grand Forks, N. D.	100—278	KFOA	Rhodes Dept. Store, Seattle, Wash.	500—450.2
KFBB	F. A. Buttrey & Co., Havre, Mont.	50—275	KFJM			KFOC	First Christian Church, Whittier, Calif.	100—236
KFBC	W. K. Azbill, San Diego, Calif.	5—278				KFOD	The Radio Shop, Wallace, Idaho	10—224
KFBG	First Presbyterian Church, Tacoma, Wash.	50—250				KFOJ	Moberly High School Radio Club, Moberly, Mo.	5—246
KFBK	Kimball-Upson Co., Sacramento, Calif.	100—283				KFOL	L. M. Schafbuch, Marengo, Ia.	10—234
KFBL	Leese Bros., Everett, Wash.	15—224				KFON	Echophone Radio Shop, Long Beach, Calif.	100—234
KFBU	The Cathedral, Laramie, Wyo.	50—270				KFOO	Latter Day Saints University, Salt Lake City, Utah	5—261
KFCB	Nielsen Radio Supply Co., Phoenix, Ariz.	10—238				KFOR	David City Tire & Electric Co., David City, Neb.	20—226
KFCB	Nielsen Radio Supply Co., Phoenix, Ariz.	10—238				KFOT	College Hill Radio Club, Wichita, Kan.	50—231
KFCF	Frank A. Moore, Walla Walla, Wash.	100—256				KFOU	Hommel Manufacturing Co., Richmond, Calif.	100—254
KFCF	Frank A. Moore, Walla Walla, Wash.	100—256				KFOX	Technical High School, Omaha, Neb.	100—248
KFCG	Leslie E. Rice, Los Angeles Union Stock Yards, Los Angeles, Calif.	500—236				KFOY	Beacon Radio Service, St. Paul, Minn.	50—252
KFCI	Ralph W. Flygare, Ogden, Utah	10—360				KFOZ	Leon Hudson Real Estate Co., Fort Smith, Ark.	20—233
KFCJ	Fred Mahafey, Jr., Houston, Texas	10—360				KFPG	Garretson & Dennis, Los Angeles, Calif.	10—238
KFCY	Western Union College, LeMars, Iowa	50—252				KFPH	Howard C. Mailander, 992 Lake St., Salt Lake City, Utah	50—242
KFCZ	Omaha Central High School, Omaha, Neb.	50—258				KFPL	C. C. Baxter, 205 Grafton St., Dublin, Texas	15—252
KFDD	St. Michaels Cathedral, Boise, Idaho	10—275				KFPM	New Furniture Co., Greenville, Texas	10—242
KFDH	University of Arizona, Tucson, Ariz.	50—258				KFPP	G. & G. Radio & Electric Shop, Olympia, Wash.	20—236
KFDJ	Oregon Agricultural College, Corvallis, Ore.	50—254				KFPR	Los Angeles County Forestry Department, Los Angeles, Cal.	500—231
KFDL	Knight-Campbell Music Co., Denver, Colo.	5—226				KFPT	Cope & Johnson, Salt Lake City, Utah	500—261
KFDM	Magnolia Petroleum Co., Beaumont, Texas	500—315.6				KFPV	Heintz & Kohlnoos, San Francisco, Calif.	50—236
KFDX	First Baptist Church, Shreveport, La.	100—250				KFPW	St. Johns Church, Cartersville, Mo.	20—268
KFDY	South Dakota State College, Brookings, S. D.	100—273				KFPX	First Presbyterian Church, Pine Bluff, Ark.	100—242
KFEC	Meier & Frank Co., Portland, Ore.	50—248				KFPY	Symons Investment Co., Spokane, Wash.	100—266
KFEL	Winner Radio Corp., Denver, Colo.	50—254				KFQA	The Principia, 5539 Page Ave., St. Louis, Mo.	50—261
KFEQ	Scroggin & Co. Bank, Oak, Neb.	100—268				KFQB	Searchlight Publishing Co., Fort Worth, Texas	100—254
KFER	Auto Electric Service Co., Fort Dodge, Iowa	10—231				KFQC	Kidd Brothers Radio Shop, Taft, Calif.	100—231
KFEX	Augshurg Seminary, Minneapolis, Minn.	100—261				KFQD	Chovin Supply Co., Anchorage, Alaska	100—280
KFEY	Bunker Hill & Sullivan Mining and Concentrating Co., Kellogg, Idaho	10—233				KFQE	Dickenson-Henry Radio Laboratories, Colorado Springs, Colo.	10—224
FFFB	Jenkins Furniture Co., Boise, Idaho	10—240				KFQF	Donald A. Boul, 2544 Pleasant Ave., Minneapolis, Minn.	10—224
KFFE	Eastern Oregon Radio Co., Pendleton, Ore.	10—360				KFQG	Southern California Radio Association, Los Angeles, Calif., Armory, Exposition Park	50—229
KFFP	First Baptist Church, Moberly, Mo.	50—266				KFQH	Albert Sherman, Hillsborough, Box 51, Burlingame, Calif.	50—231
KFFR	Nevada State Journal, Sparks, Nev.	10—226				KFQI	Thomas H. Ince Corp., Culver City, Calif.	100—234
KFFV	Graceland College, Lamoni, Ia.	100—250				KFQJ	Harbour-Longmire Co., Oklahoma, Okla.	50—236
KFFY	Pincus & Murphey, Alexandria, La.	50—275				KFQL	Oklahoma Free State Fair Association, Muskege, Okla.	20—252
KFGC	Louisiana State University, Baton Rouge, La.	100—268				KFQM	Texas Highway Bulletin, Austin, Texas	100—268
KFGD	Chickasha Radio & Electric Co., Chickasha, Okla.	100—252				KFQN	Third Baptist Church, Portland, Oregon	5—283
KFGH	Leland Stanford University, Stanford Univ., Calif.	500—273				KFQP	George S. Carson, Jr., 906 E. College St., Iowa City, Iowa	10—224
KFGL	Snell and Irvy, Arlington, Ore.	10—234						
KFGQ	Crary Hardware Co., Boone, Iowa	10—226						

## YOUR CAR!

Are you interested in motoring, touring or camping? If you are, do not fail to read the April issue of

## MOTOR CAMPER AND TOURIST

Here is a magazine that tells you things in connection with your car—things that you never even suspected.

Are you just running around the country or are you getting the full benefit of your car? MOTOR CAMPER & TOURIST shows you the way. On all newsstands.

### CONTENTS FOR APRIL ISSUE

- A Woman's View of Motor Camping By Jean Cunningham
- Featuring the State of Arkansas By the Managing Editor
- How Are the Roads? By Maurice H. Decker
- Are You Heading for the Old Southwest? By Ralph Pierson
- Selling the Canadian Winter By E. L. Chicanot
- Our National Forests By Harry Dickson
- Radio In Camp By W. R. McClelland

KFJQ	Electric Construction Co., Valley Radio Division, Grand Forks, N. D.	5—280
KFJR	Ashley C. Dixon & Son, Stevensville, Mont. (near)	5—263
KFJX	Iowa State Teachers College, Cedar Falls, Iowa	50—258
KFJY	Tunwall Radio Co., Fort Dodge, Iowa	50—246
KFJZ	Texas National Guard, 112th Cavalry, Fort Worth, Texas	20—254
KFKA	Colorado State Teachers College, Greeley, Colo.	50—273
KFKB	Brinkley-Jones Hospital Association, Milford, Kan.	500—273
KFKQ	Conway Radio Laboratories, Conway, Ark.	100—250
KFKU	University of Kansas, Lawrence, Kan.	500—275
KFKV	F. F. Gray, 3200 Richardson St., Butte, Mont.	50—283
KFKX	Westinghouse Electric & Mfg. Co., Hastings, Neb.	1500—288.3
KFLA	Abner R. Willson, 1321 W. Blatinum St., Butte, Mont.	5—258
KFLB	Signal Electric Mfg. Co., Menominee, Mich.	50—248
KFLE	National Educational Service, Denver, Colo.	25—268
KFLQ	Bizzell Radio Shop, Little Rock, Ark.	20—261
KFLR	University of New Mexico, Albuquerque, N. M.	100—254
KFLU	Rio Grande Radio Supply House, San Benito, Texas	15—236
KFLV	Swedish Evangelical Mission Church, Rockford, Ill.	100—229

(Continued on page 1914)



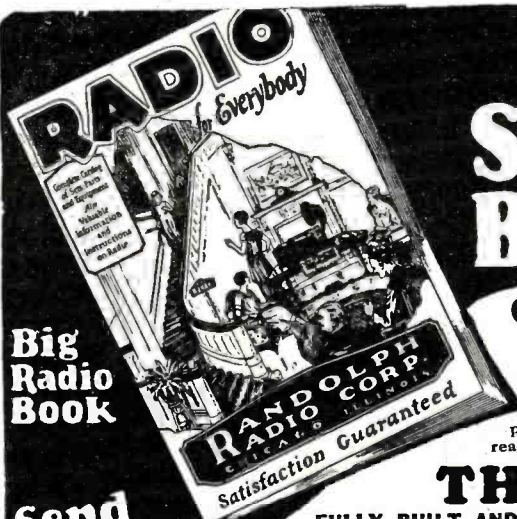

**Big Radio Book**

**Send For it At Once**

# Send For This Sensational Radio Bargain Book-FREE

**Order Direct From This Page! Save About One-half!**

Compare our prices with others. Only highest grade nationally known **GUARANTEED** parts. **OUR GUARANTEE PROTECTS YOU.** Money cheerfully refunded if you are not satisfied. Be sure to write your order and state prices plainly. Send post office or express money order or bank draft for total amount to insure prompt shipment. **ALL PRICES ON THIS PAGE INCLUDE SHIPPING CHARGES RIGHT TO YOUR DOOR** if you are east of the Rocky Mountains. Refer to any bank or commercial agency regarding our reliability. If your favorite circuit is shown here, order direct from this ad. No skill required to build your own radio with Randolph parts. Panels are all drilled. Instructions are simple and complete. Everything comes ready to assemble. Order direct! All shipping charges prepaid.

## THIS 5-TUBE SET \$39.50

FULLY BUILT AND WIRED COMPLETE IN DARK HEAVY MAHOGANY CABINET OF BEAUTIFUL DESIGN

The Biggest 5-Tube Value on the Market

which will bring in all distant stations on the loud speaker in clear loud tones. A value of three times the price. Shipped on a guarantee of satisfaction that requires no neutralizers and is self-balanced. Special features are low-loss coils, engraved bakelite panel, distortionless transformers and pure bakelite sockets. Wiring of the latest loose safety type. Perfect logging of stations. The set alone, shipped prepaid, is **\$39.50**

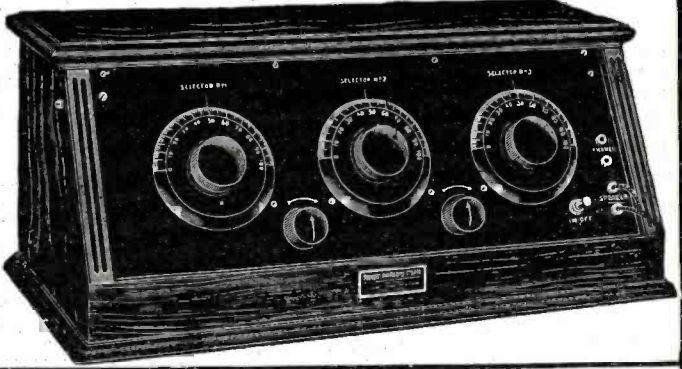

**This Set with All Accessories, including American Bell Loud Speaker, with adjustable unit, 5 R.C.A. UV201-A Tubes, 2 45-volt "B" batteries, 1 6-volt 90 amp. hour storage battery, complete antenna equipment, including approved lightning arrester, shipped prepaid, east of the Rocky Mountains. .... \$81.30**

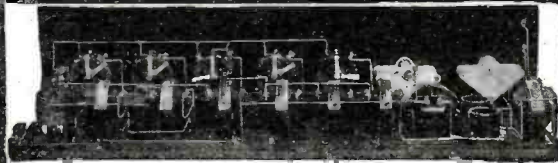

### COMPLETE PARTS FOR

- ACME 1-Tube REFLEX..... **\$15.85**
- ACME 4-Tube REFLEX..... **\$39.85**

with Genuine Acme parts as specified, drilled bakelite panel and full wiring diagram.



### COMPLETE PARTS FOR 8-TUBE SUPER-HETERODYNE

- 2 23-Plate Duplex or Laboratory Type Low Loss Condensers
  - 3 Remier or Columbia Intermediate Frequency Transformers
  - 1 Remier or Columbia Tuned Circuit Transformer
  - 1 Special Oscillator Coupler
  - 1 Midget Condenser
  - 8 Bakelite Sockets
  - 2 Thordarson or Columbia A. F. Transformers
  - 1 Connecticut Filament Switch
  - 2 Bakelite 6-ohm Rheostats
  - 2 Bakelite 30-ohm Rheostats
  - 1 Bakelite Potentiometer, 400 ohms
  - 1 Carter Double Circuit Jack
  - 1 Dubilier 1 mid. Condenser
  - 1 .006 Mica Condenser
  - 1 .0005 Mica Condenser and 2 megohm Grid Leak
  - 3 .0025 Mica Condensers
  - 10 Binding Posts
  - 1 .00025 Mica Condenser
  - 1 Bakelite Terminal Strip for Binding Posts
  - 1 Multicord Cable for connecting batteries
  - 1 7x30x3/4 Drilled Bakelite Panel
  - 1 Baseboard
  - 35 ft. Hook-up Wire
  - 2 4-in. Bakelite Dials
  - 2 4 1/2-volt C Batteries
- Complete wiring diagrams, base board layout, blue-prints and instructions. **\$52.75**

### COMPLETE PARTS FOR 2-TUBE HARKNESS SET

including Licensed Harkness Coils, Drilled Panel and wiring diagram. Easy to build. Wonderful results..... **\$17.95**

### COMPLETE PARTS FOR REINARTZ

- 1-Tube Reinartz Set..... **\$10.45**
- 3-Tube Reinartz Set..... **\$17.55**

### COMPLETE PARTS FOR 5-TUBE NEUTRODYNE RECEIVING SET

Genuine Hazeltine Licensed Fada, or other Genuine Licensed Parts

- 1 7x24x3/4 Drilled Panel
- 2 Thordarson or Columbia Audio Transformers
- 3 4-in. Bakelite Dials
- 2 Precision Jacks
- 1 Bakelite Rheostat, 30-ohm
- 1 Bakelite Rheostat, 6-ohm
- 1 Bakelite Binding Post Strip
- 7 Marked Binding Posts
- 1 Grid Leak and Condenser
- 5 Bakelite Sockets
- 1 .001 Condenser
- 1 .006 Mica Condenser
- 35 feet Hook-up Wire
- 1 Kit consisting of 3 Hazeltine Licensed Neutrodyne and 2 Neutrodyne
- 1 Baseboard
- 3 Bezels
- Complete blue-prints and working diagrams. **\$33.45**

### COMPLETE PARTS FOR 5-TUBE IMPROVED COCKADAY RECEIVING SET WITH RESISTANCE COUPLED AMPLIFICATION

As designed by L. M. Cockaday. Including drilled panel and wiring diagram, complete, ready to wire.

**\$39.65**



### COMPLETE PARTS FOR 3-TUBE COCKADAY RECEIVING SET

- 1 Cockaday Coil
- 2 23-Plate Hy-Grade Cond.
- 1 Bakelite Rheostat, 6-ohm
- 2 Bakelite Rheostat, 30-ohm
- 3 Bakelite Sockets
- 1 high ratio Columbia or Thordarson Transformer
- 1 Single Circuit Jack
- 1 low ratio Columbia or Thordarson Transformer
- 2 Double Circuit Jacks
- 2 3-in. Bakelite Dials
- 1 Grid Leak and Mica Cond.
- 7 Switch Points, 2 Stops.
- 1 Bakelite Binding Post Strip
- 7 Binding Posts
- 1 7x21x3/4 in. Drilled Bakelite Panel
- 3 Bezels
- 1 Baseboard
- 1 Switch Lever
- 24-ft. Hoop-up Wire
- Complete blue-prints and wiring diagrams. **\$18.55**
- 1-Tube Set **\$10.10**

### Genuine Radio Corporation Tubes UV201-A

- UV199, WD12 or WD11..... \$ 3.55
- Home Charger, 6-volt..... 12.95
- Soldering Iron..... .95
- Solderall Tube..... .19
- Approved Lightning Arrester..... .35
- Cockaday Coils..... 1.59
- Balancing Condensers, per pr..... .59
- Harkness Coils, per set..... 1.95
- Hydrometer, Best Quality..... .44
- Battery Meters, 0 to 50 volts..... .89
- Magnavox, M4, Loud Speaker..... 20.95
- Baldwin Loud Speaker..... 21.45
- Atlas Loud Speaker..... 8.45
- Brandes Table Talker..... 21.95
- Multiple Four Phone Plug..... .89
- Two Phone Plug..... .24
- Complete Antenna Outfit, including Lightning Arrester..... 2.59
- Bakelite Moulded Varlometer..... 3.25

- Low Loss Condensers: 11-plate..... \$1.85, 23-plate..... 2.05, 43-plate..... 2.85
- Bakelite Rheostats: 6-ohm..... \$0.35, 30-ohm..... .38
- Amperites: For all tubes... \$0.94
- Bakelite Dials: 2-inch..... \$0.26, 3-inch..... .35, 4-inch..... .48
- Composition Dials: 2-inch..... \$0.13, 3-inch..... .17, 4-inch..... .29
- Accuratune Dials: \$3.14
- Audio Transformers: Thordarson: 3 1/2 to 1..... \$3.25, 6 to 1..... 3.65, Acme..... 3.95, Columbia: 3 1/2 to 1..... \$3.79, 6 to 1..... 3.89
- American Bell: 3 1/2 to 1..... \$2.45, 6 to 1..... 2.79
- Randolph Special: 3 1/2 to 1..... \$1.89, 6 to 1..... 2.16
- Randolph Special Headphones..... \$2.24

### Easy to Build Your Own Radio Set

All complete parts for sets on this page consist of standard advertised guaranteed parts and include drilled bakelite panels and wiring diagrams for easy set construction. Everything guaranteed on money-back basis. All transportation charges paid. **Don't forget!** Only genuine guaranteed parts used. Lack of space does not permit us to itemize individual parts, but you are fully protected by our money-back guarantee. Our Service Division is behind you.

### FREE BIG MONEY SAVING RADIO CATALOG

containing a thousand bargains of everything on radio—parts, supplies, complete parts for sets, complete sets, etc., also a mine of very latest information on all different circuits, complete list of broadcasting stations, and other valuable, up-to-the-minute radio data. Send your name and address on a card or letter. Also the names of a few friends. We will send catalog free.

### Free Service Department

Our radio engineers will help you solve all your radio problems, and furnish up-to-date information on set construction, operation and improvement. This service is free to our customers.

## RANDOLPH RADIO CORPORATION

159 North Union Ave. Dept. 432 Chicago, Illinois



## RADIOLA III—FREE with course

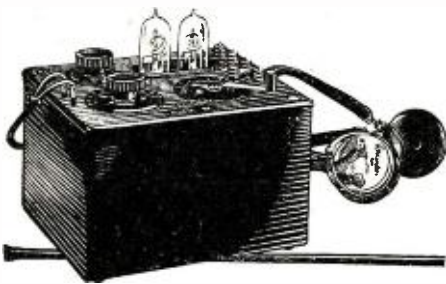

### A Life Career for YOU in RADIO

Thousands have won success in radio. Right now our graduates are voyaging to foreign ports as radio operators—ships' officers—with good pay—and no expense for rations and quarters. And hundreds of them are holding high salaried positions on land.

You, too, can earn big pay—and visit strange lands—or win success in radio right in this country! A few months of interesting study at home on the special Home Study Course of the Radio Institute of America and you can secure your Government Commercial Radio License—and your first radio job.

## RADIOLA III—FREE with course

The course is a new one, completely revised. New text-books. Radiola III with two tubes and Brandes headset and other exceptionally high grade apparatus free with course. Experts correct and grade your papers and answer all your questions. The most comprehensive and up-to-date radio instruction obtainable anywhere.

Don't delay. Fill out coupon and send it today for our new booklet.

**Radio Institute of America**  
(formerly Marconi Institute)  
Established 1909  
324 Broadway New York City

Radio Institute of America  
324 Broadway, New York City  
Please send me full information about your Home Study Course of radio instruction.

- I am interested in the complete course including code instruction.
- I am interested in the technical course without code instruction.

Name .....  
Address .....

## Complete List of World's Broadcast Stations

(Continued from page 1912)

Call Letters	Name	Location	Power & Wave Length
KFQR	Walter L. Ellis, 625 East 6th St., Oklahoma, Okla.	Okla.	50—209.7
KFQT	Texas National Guard, Thirty-sixth Signal Co., Denison, Texas	Texas	10—252
KFQU	W. Riker, Holy City, Calif.	Calif.	100—234
KFQV	Omaha Grain Exchange, Omaha, Neb.	Neb.	100—231
KFQW	C. F. Knierim Photo Radio & Electric Shop, North Bend, Wash.	Wash.	50—215.7
KFQX	American Radio Telephone Co., Smith Bldg., Seattle, Wash.	Wash.	1500—233
KFQY	Farmers State Bank, Belden, Neb.	Neb.	10—273
KFQZ	Taft Radio Co., 5653 De Longpre Ave., Hollywood, Calif.	Calif.	250—240
KFRC	Radioart Studio, San Francisco, Calif.	Calif.	50—278
KFRF	W. R. Brown, Alexandria, La.	La.	10—242
KFRH	The Radio Shop, Grafton, N. D.	N. D.	10—268
KFRJ	Guy Simmons, Jr., Conway, Ark.	Ark.	10—250
KFRM	James F. Roland, Fort Sill, Okla.	Okla.	50—263
KFRN	M. Laurence Short, Hanford, Calif.	Calif.	5—224
KFRO	Curtis Printing Co., Ft. Worth, Tex.	Tex.	50—246
KFRP	Trinity Episcopal Church, Redlands, Calif.	Calif.	10—211
KFRQ	Radio Market Service Co., Portland, Ore.	Ore.	5—213
KFRR	Nebraska Buick Auto Co., Lincoln, Neb.	Neb.	200—240
KFRW	United Churches of Olympia, Olympia, Wash.	Wash.	100—220
KFRX	J. Gordon Klemgard, Pullman, Wash.	Wash.	10—217.3
KFRY	New Mexico College of Agriculture & Mechanics Arts, State College, N. M.	N. M.	50—266
KFRZ	The Electric Shop, Hartington, Neb.	Neb.	15—222
KFSG	Echo Park Evangelistic Association, Los Angeles, Calif.	Calif.	500—278
KFSY	Van Blaricom Co., 20 So. Main St., Helena, Mont.	Mont.	10—248
KFUJ	Hoppert Plumbing & Heating Co., Breckenridge, Minn.	Minn.	50—242
KFUL	Thomas Goggan & Bros. Music Co., Galveston, Texas	Texas	10—258
KFUM	W. D. Corley, Colorado Springs, Colo.	Colo.	100—242
KFUO	Concordia Seminary, St. Louis, Mo.	Mo.	500—545.1
KFUP	Fitzsimmons General Hospital Educational & Recreational Dept., Denver, Colo.	Colo.	50—234
KFUQ	Julius Brunton & Sons Co., 1380 Bush St., San Francisco, Calif.	Calif.	5—234
KFUR	H. W. Peery & C. Redfield, 420 Twenty-fifth St., Ogden, Utah.	Utah	50—224
KFUS	Louis L. Sherman, 529 Twenty-eighth St., Oakland, Calif.	Calif.	50—233
KFUT	University of Utah, Salt Lake City, Utah.	Utah	100—261
KFUU	Colburn Radio Laboratories, Dowling Blvd., San Leandro, Calif.	Calif.	100—224
KGB	Tacoma Daily Ledger, Tacoma, Wash.	Wash.	50—250
KGO	General Electric Co., Oakland, Calif.	Calif.	1500—299.8
KGU	Marion A. Mulrony, Honolulu, Hawaii	Hawaii	500—360
KGW	Portland Morning Oregonian, Portland, Ore.	Ore.	500—485.1
KGY	St. Martins College, Lacey, Wash.	Wash.	5—246
KHJ	Times Mirror Co., Los Angeles, Calif.	Calif.	500—404.1
KHQ	Louis Wasmer, Seattle, Wash.	Wash.	100—273
KIQ	C. O. Gould, Stockton, Calif.	Calif.	5—273
KJR	Northwest Radio Service, Seattle, Wash.	Wash.	50—384.4
KJS	Bible Institute of Los Angeles, Los Angeles, Calif.	Calif.	500—293.9
KLS	Warner Bros. Radio Supplies Co., Oakland, Calif.	Calif.	250—360
KLX	Tribune Publishing Co., Oakland, Calif.	Calif.	500—509.9
KLZ	Reynolds Radio Co., Denver, Colo.	Colo.	250—283
KMJ	San Joaquin Lt. & Power Corp., Fresno, Calif.	Calif.	50—248
KMO	Love Electric Co., Tacoma, Wash.	Wash.	10—250
KNT	Walter Hemrich, Kukak Bay, Alaska	Alaska	100—263
KNX	"Hollywood" — Los Angeles Evening Express	Calif.	500—336.9
KOA	General Electric Co., 1370 Krameria St., Denver, Colo.	Colo.	1000—322.4



the Red Stripe tells

—you of the thorough and through quality of Dilecto. It is the guarantee mark that insures you of the best panel from the standpoint of — strength! — beauty! — finish! — service! — machinability! — dielectric resistance! Such rigid requirements as have met complete specifications of the U. S. Navy and Signal Corps for more than 9 years.

Your radio dealer can provide any size panel with any drillings. Remember, insist upon—

# Dilecto

(Distinguished by its red stripe)

**The Continental Fibre Co.**  
Factory: Newark, Del.

Service on Dilecto (also Conite, Contex and Vulcanized Fibre) from:

NEW YORK, Woolworth Bldg.  
CHICAGO, Wrigley Bldg.  
PITTSBURGH, Farmers Bank Bldg.  
LOS ANGELES, 307 S. Hill St.  
SAN FRANCISCO, 75 Fremont St.  
SEATTLE, 1041 Sixth Ave. So.  
(Offices and agents throught the world)



## FREE RADIO CATALOG

Sent You Every Month

ALL the latest improved apparatus is listed in our monthly bulletin: "The American Radio Transmitter." If it's new we have it.

**Lowest Prices in U. S.**  
Our prices to dealers are the lowest in the United States. All nationally advertised goods at discounts that make you real money. Get your name on our mailing list. Simply send name today for latest, big monthly bulletin, showing 75 nationally advertised factory lines and 4,866 items.

AMERICAN RADIO MFG. CO. 6 W. 14th St. Dept. A, Kansas City, Mo.

Insure your copy reaching you each month. Subscribe to RADIO NEWS—\$2.50 a year. Experimenter Publishing Co., 53 Park Pl., N.Y.C.



**EVEREADY HOUR**  
**EVERY TUESDAY AT 9 P. M.**  
*(Eastern Standard Time)*

For real radio enjoyment, tune in the  
 "Eveready Group." Broadcast through  
 stations

<b>WEAF</b> New York	<b>WFI</b> Philadelphia
<b>WJAR</b> Providence	<b>WGAE</b> Pittsburgh
<b>WEEL</b> Boston	<b>WGR</b> Buffalo

*Dry "B" Batteries  
 are an economical,  
 dependable and  
 convenient source  
 of plate  
 current!*

# Satisfaction Reliability Economy

You need three things in radio "B" Batteries—satisfaction, reliability and economy. You get them all in Eveready "B" Batteries. Satisfaction, because they produce all the current needed by your tubes, giving you the maximum results of which your set is capable. Reliability, because you can depend on them to work at full power. Economy, because they long maintain their strength, and because they are low in price.

Advances in the art of battery manufacture make Evereadys last longer than ever. You actually get much longer service for your money.

There is an Eveready Radio Battery for every radio use.

Buy Eveready Batteries.

*Manufactured and guaranteed by*

**NATIONAL CARBON COMPANY, INC.**  
 New York San Francisco  
 Canadian National Carbon Co., Limited, Toronto, Ontario

## EVEREADY Radio Batteries —they last longer

Eveready  
 Columbia  
 Ignitor  
 Dry Cell  
 "A"  
 Battery  
 for all  
 Dry Cell  
 Tubes  
 1½ volt

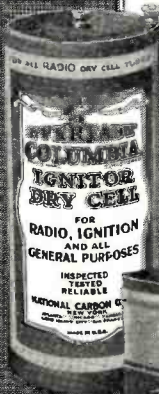

No. 766  
 22½-volt  
 Large  
 Horizontal  
 Price  
 \$2.00



No. 772  
 45-volt  
 Large  
 Vertical  
 Price  
 \$3.75



No. 771  
 4½-volt  
 "C"  
 Battery  
 improves  
 quality,  
 saves  
 "B"  
 Batteries  
 Price 60c



# GENWIN



The Silver Plated Primary does it

\$7

At your Dealer's or sent postpaid



Pat. App. for

A radio set embodying a GENWIN Low Loss Tuner, with the Silver Plated Primary, will afford you endless evenings of entertainment. The silver plating cuts down the resistance of the Tuner, enabling you to get greater distance more loudly and with less interference and distortion than can be had with other apparatus designed, not to be most efficient, but to look as much like a GENWIN Low Loss Tuner as possible.

A GENWIN set is easy to build. You can have one working in less than twenty minutes from the time you start. And the results will amaze you. One New York fan writes: "—using 3 UV-199 tubes, I heard KGO, Oakland, Calif., on the loud speaker. At times it could be heard throughout a three room apartment distinctly." And other GENWIN users get equally good results. Engineers, too, endorse "The Low Loss Tuner with the Silver Plated Primary." Radio News' Staff used the special short wave tuner in their Short Wave Set, described in the February issue. Experts everywhere use GENWIN Low Loss Tuners. They are unconditionally guaranteed.

With each tuner you get a complete set of detailed blue prints (full size panel pattern, instrument layout and picture wiring diagram) for latest GENWIN Low Loss Set. Separately 50c. Write for descriptive circular, Dept. RN 425.

**GENERAL RADIO WINDING CO.**  
214 Fulton St. New York

Call Letters	Name	Location	Power & Wave Length
KOB	New Mexico College of Agriculture and Mechanic Arts, State College, N. M.	500—348.6	
KOP	Detroit Police Dept., Detroit, Mich.	500—278	
KPO	Hale Bros., San Francisco, Cal.	500—429.5	
KPPC	Pasadena Presbyterian Church, Pasadena, Calif.	50—229	
KQV	Doubleday Hill Electric Co., Pittsburgh, Pa.	500—275	
KQW	Chas. D. Herrold, 467 First St., San Jose, Calif.	50—240	
KRE	Berkeley Daily Gazette, Berkeley, Calif.	50—275	
KSAC	Kansas State Agric. College, Manhattan, Kan.	500—340.7	
KSD	Post Dispatch (Pulitzer Pub. Co.), St. Louis, Mo.	500—545.1	
KTHS	Ner Arlington Hotel Co., Hot Springs, Ark.	500—374.8	
KTW	First Presbyterian Church, Seattle, Wash.	750—360	
KUO	Examiner Printing Co., San Francisco, Calif.	150—246	
KWG	Portable Wireless Telephone Co., Stockton, Calif.	50—360	
KWH	Los Angeles Examiner, Los Angeles, Calif.	250—360	
KYO	Electric Shop, Honolulu, Hawaii	100—270	
KYW	Westinghouse Electric & Mfg. Co., Chicago, Ill.	1500—535.4	
KZKZ	Electrical Supply Co., Manila, P. I., 109 Plaza Moraga	100—270	
KZM	Preston D. Allen, 13th & Franklin Sts., Oakland, Calif.	100—360	
KZRO	Manila Hotel, Manila, P. I.	500—222	
KZUY	F. Johnson Elser, 600 M. H. del Pillar, Manila, P. I.	500—370	
WAAB	Valdemar Jensen, 137 S. St. Patrick St., New Orleans, La.	100—268	
WAAC	Tulane University, New Orleans, La.	100—275	
WAAD	Ohio Mechanics Institute, Cincinnati, Ohio	25—258	
WAAF	Chicago Daily Drovers Journal, Chicago, Ill.	200—278	
WAAM	I. R. Nelson Co., Newark, N. J.	250—263	
WAAN	University of Missouri, Columbia, Mo.	50—254	
WAAW	Omaha Grain Exchange, Omaha, Neb.	500—278	
WABA	Lake Forest University, Lake Forest, Ill.	100—227	
WABB	Harrisburg Sporting Goods Co., Harrisburg, Pa.	10—266	
WABD	Parker High School, Dayton, Ohio	5—283	
WABH	Lake Shore Tire Co., Sandusky, Ohio	10—240	
WABI	Bangor Railway & Electric Co., Bangor, Maine	100—240	
WABL	Connecticut Agricultural College, Storrs, Conn.	100—275	
WABM	F. E. Doherty Automotive & Radio Equipment Co., Saginaw, Mich.	20—261	
WABN	Ott Radio, Inc., 1627 State St., LaCrosse, Wis.	500—244	
WABO	Lake Ave. Baptist Church, Rochester, N. Y.	100—278	
WABQ	Haverford College Radio Club, Haverford, Pa.	50—261	
WABR	Scott High School, Toledo, Ohio	50—263	
WABU	Victor Talking Machine Co., Camden, N. J.	50—226	
WABW	College of Wooster, Wooster, Ohio	20—206.8	
WABX	Henry B. Joy, Mount Clemens, Mich. (near)	250—254	
WABY	John Magaldi, Jr., 815 Kimball St., Philadelphia, Pa.	50—242	
WABZ	Coliseum Place Baptist Church, New Orleans, La.	50—263	
WBAA	Purdue University, West Lafayette, Ind.	250—273	
WBAN	Wireless Phone Corporation, Paterson, N. J.	100—244	
WBAO	James Millikin University, Decatur, Ill.	100—275	
WBAP	Wortham-Carter Publishing Co. (Star-Telegram), Fort Worth, Texas	1000—475.9	
WBAV	Erner & Hopkins Co., Columbus, Ohio	500—293.9	
WBAX	John H. Stenger, Jr., 66 Gildersleeve St., Wilkesbarre, Pa.	20—256	
WBAY	The Western Electric Co., New York, N. Y.	500—492	
WBBD	Barbey Battery Service, Reading, Pa.	50—234	
WBFB	Georgia School of Technology, Atlanta, Ga.	500—270	
WBBG	Irving Vermilya, Mattapoisett, Mass.	500—248	
WBBH	J. Irving Bell, 1511 Gordon St., Port Huron, Mich.	50—205.4	
WBBL	Grace Covenant Church, Richmond, Va.	100—229	
WBBM	H. L. Atlass, Chicago, Ill.	200—226	
WBBP	Petoskev High School, Petoskey, Mich.	100—214.2	
WBBR	Peoples Pulpit Association, Rossville, N. Y.	500—273	
WBBS	First Baptist Church, New Orleans, La.	50—252	

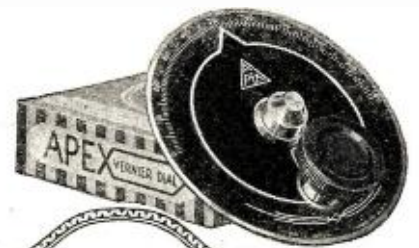

## MORE DISTANT STATIONS

WITH THE APEX VERNIER DIAL

Greater range, bigger volume, finer selectivity, less interference. Lasts forever. The one big advance yet made in tuning. Ratio 12 to 1.

Quickly applied to any shaft. For sale by all good Radio Dealers.

If unable to obtain from dealer, enclose

The Apex Super Five is a tuned radio frequency receiver of the highest type. Built into a highly finished walnut cabinet—complete with Jones Multiple Battery Cable—all settings highly gold plated. List price \$95.00 complete.

\$2.00 for Royal Brass Finish.

\$2.50 for Satin Silver Finish.

\$3.50 for De Luxe Gold Plated Finish.

**7 Tube Microdyne Super-Heterodyne for \$97.50**  
Receive the parts complete to assemble your set. Coast to coast on an 18 in. loop-rod Super-Heterodyne hours. Parts complete. Price of cabinet, to fit, on application. If your radio dealer cannot supply, send check or money order and name of dealer.

**Apex Electric Mfg. Co.**  
1410 West 59th Street Dept. 408 Chicago

**AMPLEX GRID-DENSER**

**W**ANT more distance, clearer tone? You can get it without ripping out a single wire. Just replace all fixed condensers with GRID-DENSERS!

Follow the lead of men like Cockaday, Haynes, and Sleeper. They ALWAYS specify GRID-DENSERS.

In either the 0005 with or without gridleak clips or .001 type or type N (neutralizing) **\$1.25**

**FREE**—11 Hook-Ups "How to Double the Efficiency of Your Set." Ask your dealer.

AMPLEX INSTRUMENT LABORATORIES  
88 W. B'way, Dept. RN4, N.Y.C.

*Better than a fixed Condenser*



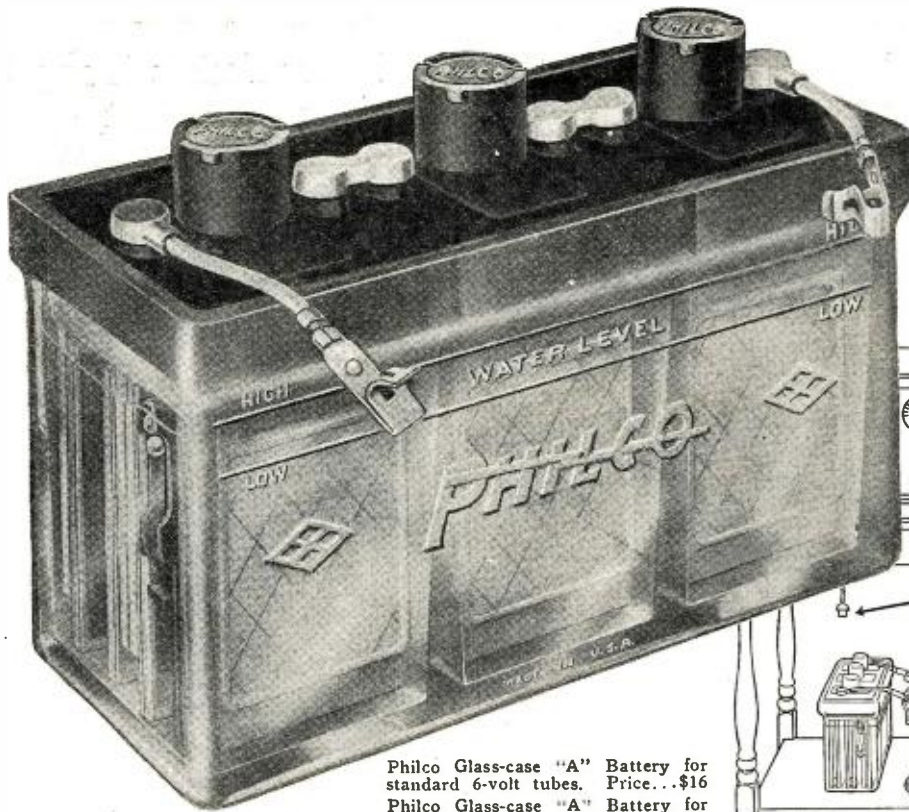

Philco Glass-case "A" Battery for standard 6-volt tubes. Price...\$16  
 Philco Glass-case "A" Battery for dry-cell tubes. Price.....\$8  
 Spray-proof. Acid-tight.

Philco Double Charger for all "B" Batteries and UD86 "A" Batteries. Noiseless. Price \$15  
 Philco Single Charger for all "B" Batteries and UD44 "A" Batteries. Noiseless. Price..\$9.75  
 Charger Prices include plugs and receptacles.

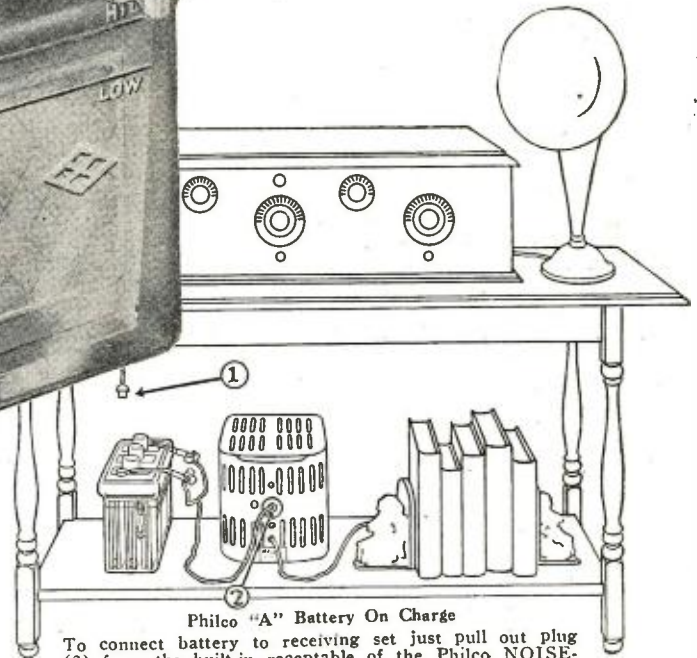

Philco "A" Battery On Charge  
 To connect battery to receiving set just pull out plug (2) from the built-in receptacle of the Philco NOISELESS Charger and push into receptacle (1).

## Recharge in your living room without changing a wire



Philco "B" Battery

Storage "B" Batteries are just as essential for clear and distant reception as storage "A" Batteries. Philco "B" Batteries stay clean and dry. To charge without disconnecting a single wire, use a Philco Charger and "B" Charging Panel (\$2.75).

"B" Battery in de luxe mahogany-finish case with cover (48 volts). Price....\$20  
 "B" Battery in handsome mahoganyized case without cover (48 volts). Price \$16.50



Philco Mahoganyized-Case "A" Batteries

Two types—RAR and RW—for 6-volt tubes. Both in beautiful Adam-brown mahogany-finish cases harmonizing with your radio cabinet. Price.....\$14.50 up  
 Philco Charge Tester—permanently mounted in filler cap; avoids fussing with hydrometer—\$1 extra.

Recharging a Philco Radio Battery with a Philco NOISELESS Charger means merely pulling a plug from your radio socket and pushing it into the charger socket. No changing wires. No moving the battery.

Philco Radio Batteries—both "A" and "B"—have other big advantages that make storage battery operation easy, convenient and economical.

They are assembled in attractive acid-tight, spill-proof glass cases—or in wood cases finished in beautiful Adam-brown mahogany. The glass case types have exclusive built-in Charge Indicators that tell you at a glance how far the battery is charged or discharged. Wood-case types are supplied with Philco Charge Testers, mounted in the filler caps, at \$1 extra.

No matter how expensive your radio set—whether it has one tube or many tubes—you must have the steady voltage and strong non-rippling current of a good STORAGE BATTERY for the best results.

Philco Radio Batteries deliver strong, non-rippling current *without hum, roar or buzz*. You can buy them from your nearest Philco Service Station, Radio or Music Dealer.

Philadelphia Storage Battery Company, Philadelphia

# PHILCO DYNAMIC RADIO BATTERIES

**JOBBERS and DEALERS**—Philco has brought of the cellar and put them in the living room. Our new Radio Manual tells how. Fill out coupon below and we will mail you a copy.

Name.....  
 Street..... City.....  
 State..... Jobber  Dealer





## We've mapped the air for Radio explorers!

Get your copy of this great new map today

Twist the dials until you catch a faint hum. Nurse it carefully and it becomes a murmur of distant music. Then a moment of silence. "This is station KLZ, Denver"—and you add another station to your list.

But how far away was it? What sort of country did the message flash over? You want to visualize your exploit and mark it for future reference.

You can—with the New Collier radio map of the United States and Canada. It's beautifully printed in three colors. Every station is clearly marked and the time zones outlined.

Instantly you can tell how many miles away a station is. Cut out the scale of miles provided and paste it on cardboard. Put a pin through one end at the point where you are located. Swing the other end across the country until you reach the station you are after.

Here are some more points worth noting:

- 1—If you use a directional aerial, you can pick out any station you want to get on the map, and point the loop towards the exact point where the station is located.
- 2—Around the map there is an alphabetical list of all stations which also gives the name of the operator of each. If you miss the letters given by an announcer, you often catch the name of the operator of a station, which can then be located by referring to the index.
- 3—The map outlines the boundaries of the radio districts, identifying them by number. This will be a help in locating amateur stations.

There's a lot of satisfaction in radio exploring with this great new map. And it costs only a quarter. Get your copy at your newsstand, bookstore or radio dealer's tonight. Or just mail 25c in coin or stamps with your name and address to us direct.

**P. F. COLLIER & SON CO.**  
Dept. R. M. 3131  
250 Park Avenue New York City

Call Letters	Name	Location	Power & Wave Length
WBBT	Lloyd Brothers,	Philadelphia, Pa.	5—234
WBBU	Jenks Motor Sales Co.,	Monmouth, Ill.	10—224
WBBV	Johnstown Radio Co.,	Johnstown, Pa.	5—248
WBBW	Ruffner Junior High School,	Norfolk, Va.	50—222
WBBY	Washington Light Infantry,	Charleston, S. C.	10—268
WBBZ	Noble B. Watson, 233 Iowa St.,	Indianapolis, Ind.	50—238
WBCN	Foster & McDonnell, 728 W. 65th St.,	Chicago, Ill.	500—266
WBDC	Baxter Laundry Co., Grand Rapids,	Mich.	50—256
WBS	D. W. May (Inc.), Newark,	N. J.	50—360
WBT	Southern Radio Corp.,	Charlotte, N. C.	250—275
WBZ	Westinghouse Electric & Mfg. Co.,	Springfield, Mass.	1500—333.3
WCAD	St. Lawrence University,	Canton, N. Y.	250—263
WCAE	Kaufmann & Baer Co.,	Pittsburgh, Pa.	500—461.3
WCAG	Clyde R. Randall, 2813 Calhoun St.,	New Orleans, La.	50—268
WCAH	Entrekin Electric Co.,	Columbus, Ohio	200—266
WCAJ	Nebraska Wesleyan University,	University Place, Neb.	500—275
WCAK	Alfred P. Daniel, 2504 Bagby St.,	Houston, Texas	10—263
WCAL	St. Olaf College,	Northfield, Minn.	500—336.9
WCAO	The Sanders and Stayman Co.,	Baltimore, Md.	50—275
WCAP	Chesapeake & Potomac Telephone Co.,	Washington, D. C.	500—468.5
WCAR	Southern Radio Corp. of Texas,	San Antonio, Texas	100—263
WCAS	Win. Hood Dunwoody Industrial Institute,	Minneapolis, Minn.	100—280
WCAT	South Dakota State School of Mines,	Rapid City, S. D.	50—240
WCAU	Durham & Co.,	Philadelphia, Pa.	500—278
WCAV	J. C. Dice Electric Co.,	Little Rock, Ark.	10—263
WCAX	University of Vermont,	Burlington, Vt.	100—250
WCAY	Milwaukee Civic Broadcasting Station,	Hotel Antlers, Milwaukee, Wis.	250—266
WCAZ	Carthage College,	Carthage, Ill.	50—246
WCBA	Charles W. Heimbach, 1015 Allen St.,	Allentown, Pa.	10—254
WCBC	University of Michigan,	Ann Arbor, Mich.	200—229
WCBD	Wilbur G. Voliva, Zion, Ill.		500—344.6
WCBE	Uhalt Radio Co.,	New Orleans, La.	5—263
WCBG	Howard S. Williams, Pascagouja, Miss.	(portable)	10—268
WCBH	University of Mississippi,	Oxford, Miss. (near)	10—242
WCBI	Nicoll, Duncan & Rush,	Benis, Tenn.	150—240
WCBJ	J. C. Mans, Jennings, La.		10—244
WCBK	E. Richard Hill, 2801 Central Ave.,	St. Petersburg, Fla.	500—266
WCBL	Northern Radio Mfg. Co.,	Houlton, Me.	50—266
WCBM	Charles Schwarz, Charles and North Aves.,	Baltimore, Md.	50—227
WCBO	Radio Shop (Inc.),	Memphis, Tenn.	20—250
WCBQ	First Baptist Church,	Nashville, Tenn.	100—236
WCBR	Charles H. Messter, Providence, R. I.	(portable)	30—205.4
WCBT	Clark University,	Worcester, Mass.	250—238
WCBU	Arnold Wireless Supply Co.,	Arnold, Pa.	50—220
WCBV	Tallahoma Radio Club,	Tallahoma, Tenn.	10—252
WCBW	George P. Rankin, Jr., and Maitland Solomon,	Macon, Ga.	10—226
WCBX	Radio Shop of Newark,	Newark, N. J.	100—233
WCBY	Forks Electrical Shop,	Buck Hill Falls, Pa.	10—268
WCBZ	Connotelli Brothers Music House,	Chicago Heights, Ill.	50—248
WCCO	Washburn Crosby Co.,	Twin Cities, Minn.	500—416.4
WCEE	C. E. Erbstein, Villa Road,	near Elgin, Ill.	500—275.1
WCK	Stix Baer & Fuller Dry Goods Co.,	St. Louis, Mo.	100—273
WCM	Texas Markets & Warehouse Dept.,	Austin, Texas	250—268
WCX	The Detroit Free Press,	Detroit, Mich.	500—516.9
WDAE	Tampa Daily Times,	Tampa, Fla.	250—273
WDAF	Kansas City Star,	Kansas City, Mo.	500—365.6
WDAG	J. Laurance Martin,	Amarillo, Texas	100—263
WDAH	Trinity Methodist Church	(South), El Paso, Texas	50—268

## A Remarkable Loop Improvement



Here's a loop as startling in its advantages as it is in construction. It gives a volume, selectivity and distance never before attained in loop reception.

"The height does the trick." The Volumax stands on the floor and is 7' 9" high. Yet it swings in a radius of only 7½". You have never seen a loop so downright convenient. In just a few seconds it can be collapsed into a box 7½"x3½"x20".

The Volumax is as big an advance over ordinary loop aerials as the "Super-Het" is over the old time crystal set. There's no other like it. No other can offer its marked advantages.

If your dealer hasn't the Volumax in stock, write direct to us and we will see that you are supplied. Price \$17.50.

**The Scott & Fetzer Co.**  
Radio Division  
Cleveland, Ohio

DEALERS—If you don't already carry the Volumax, write us for complete information and our dealer proposition. It is one of the biggest radio improvements of the year and by far the most important of its kind.

# VOLUMAX

LOOP

## FIL-KO-LEAK

SCIENTIFICALLY CORRECT VARIABLE GRID LEAK



its calibrated by Hand— in Megohms

Know the joy of faultless reception. Control your grid action with Fil-Ko-Leak. Clear up distortion; increase volume; get stations you never heard before. Resistance read in megohms through panel peephole—or baseboard mounting. Resistance element constant, accurate. Unconditionally guaranteed. At dealers or Dept. RN425

**\$2.00**

At Dealers \$2.90 in Canada

FIL-KO-LEAKS are specified for the Hoyt System of Signal Augmentation by the inventor, Francis R. Hoyt. We have a limited number of blueprinted copies of Mr. Hoyt's original laboratory notes on this new system together with nine circuit sketches, which will be sent free on receipt of four cents postage.

DX Instrument Co., - - Harrisburg, Pa.

Insure your copy reaching you each month. Subscribe to RADIO NEWS—\$2.50 a year. Experimenter Publishing Co., 53 Park Pl., N.Y.C.



# Bakelite - Faultless servant of Radio's invisible audience

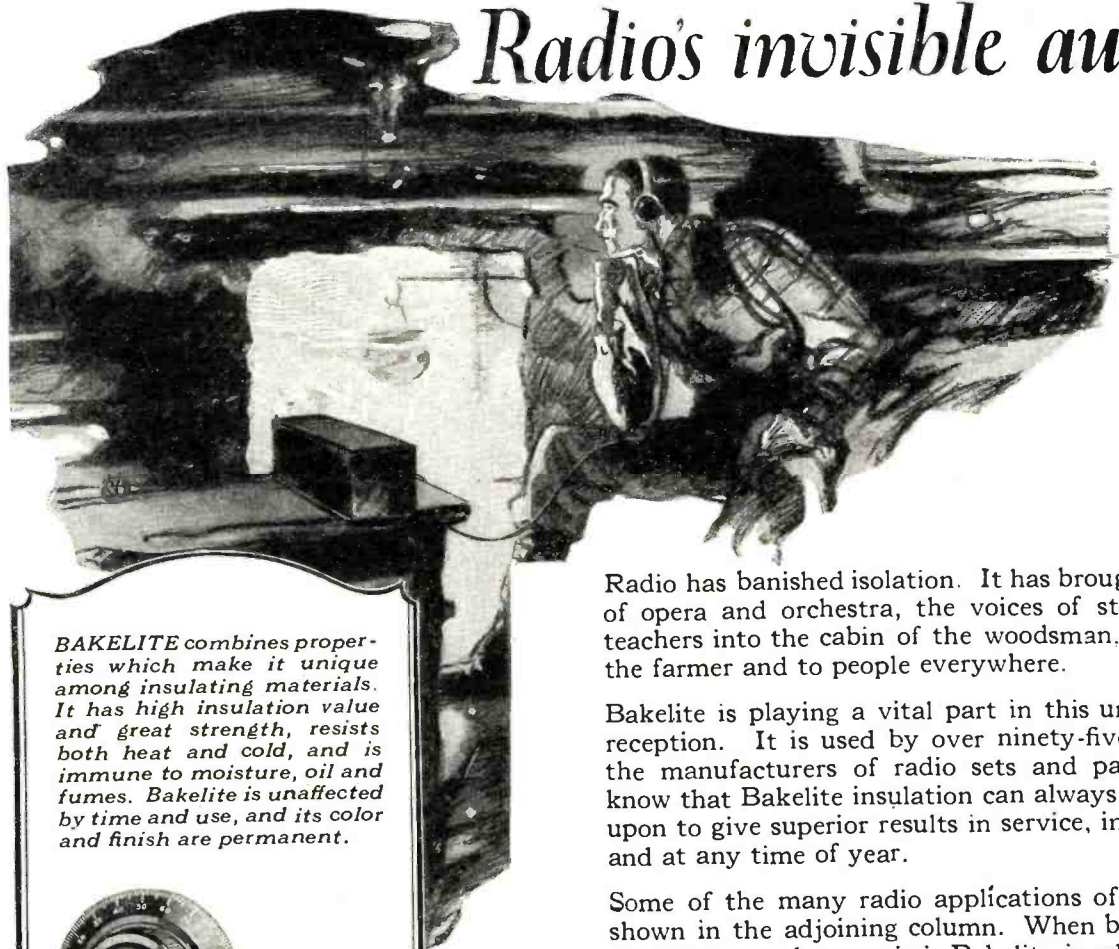

*BAKELITE* combines properties which make it unique among insulating materials. It has high insulation value and great strength, resists both heat and cold, and is immune to moisture, oil and fumes. Bakelite is unaffected by time and use, and its color and finish are permanent.



Na-ald Dial



Rathbun Condenser



Na-ald Tube Socket



R. C. A. Tube Base

Radio has banished isolation. It has brought the music of opera and orchestra, the voices of statesmen and teachers into the cabin of the woodsman, the home of the farmer and to people everywhere.

Bakelite is playing a vital part in this universal radio reception. It is used by over ninety-five per cent of the manufacturers of radio sets and parts, for they know that Bakelite insulation can always be depended upon to give superior results in service, in any climate and at any time of year.

Some of the many radio applications of Bakelite are shown in the adjoining column. When buying a radio set or part make sure it is Bakelite insulated, for this is a definite indication of quality.

Write for Booklet *B*

## BAKELITE CORPORATION

247 Park Avenue, New York, N. Y.  
Chicago Office: 636 West 22d Street

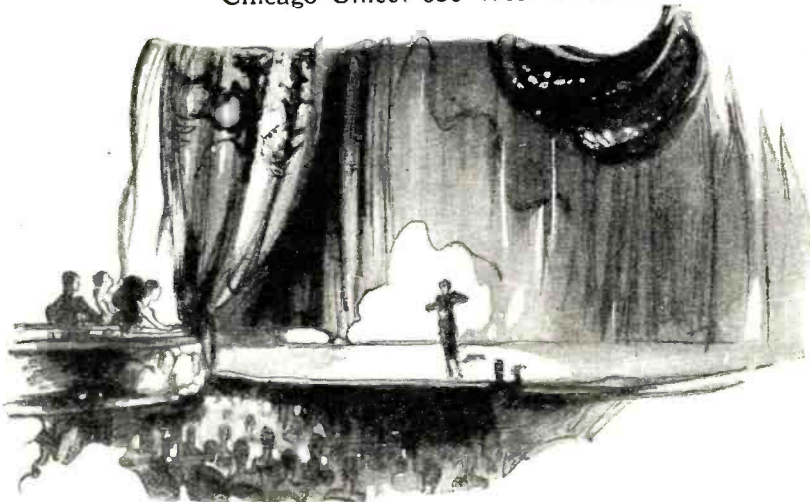

Bakelite is an exclusive trade mark and can be used only on products made from materials manufactured by the Bakelite Corporation. It is the only material which may bear this famous mark of excellence.

# BAKELITE

TRADE MARK REG. U. S. PAT. OFF.



BAKELITE is the registered trade mark for the phenol resin product manufactured under patents owned by the Bakelite Corporation

## THE MATERIAL OF A THOUSAND USES



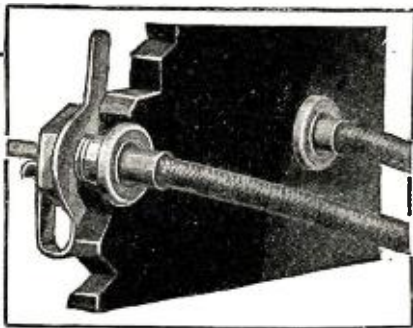

*For Experimental Hook-Ups*

## UNION RADIO TIP JACKS

*Are Just the Thing*  
Only 25c a pair

Or when building your own set, these neat, thoroughly practical little Jacks offer the best looking, most convenient positive contacts.

*Because They Are So Much Better Than Old Fashioned Binding Posts—They Are Used By Leading Set Manufacturers.*

No parts to lose or corrode. Heavily nickel plated. Firmly grip all wires from No. 11 to No. 24 B & S gauge. Easily reamed for antenna.

### Three Sizes for All Mountings

Standard Type A for panels 3/16" to 1/4" thick.

Special Type B for panels, cabinet walls and partitions 5/16" to 1/2" thick.

Special Type C for panels up to 1/8" thick.

### Other Guaranteed Union Radio Parts

**TUBE SOCKETS:** Of highly polished moulded condensite. Phosphor bronze contact springs. Reinforced bayonet slot. For all standard tubes. Price 70c.

**DIAL ADJUSTERS:** for minute adjustment of dials, necessary for close tuning. Price 60c.

RETAILERS—WHOLESALEERS!

*Write for free samples. Get details of our dealer proposition. Ask for illustrated pamphlet C.*

**UNION RADIO CORPORATION**  
124 S SUSSEX AVENUE NEWARK N.J.  
NEW YORK OFFICE 116 WEST 32nd STREET

Call Letters	Name	Location	Power & Wave Length
WDAR	Lit Bros., Philadelphia, Pa.	Philadelphia, Pa.	500—395
WDAS	Sam Waite's Radio Shop, Worcester, Mass.	Worcester, Mass.	10—360
WDAU	Slocum & Kilburn, New Bedford, Mass.	New Bedford, Mass.	100—360
WDAY	Radio Equipment Corp., Fargo, N. D.	Fargo, N. D.	50—244
WDBB	A. H. Waite & Co., Taunton, Mass.	Taunton, Mass.	10—229
WDBC	Kirk Johnson & Co., Lancaster, Pa.	Lancaster, Pa.	50—258
WDBD	Herman E. Burns, Martinsburg, W. Va.	Martinsburg, W. Va.	5—254
WDBE	Gilham-Schoen Electric Co., 80 Pryor St., Atlanta, Ga.	Atlanta, Ga.	100—278
WDBF	Robert G. Phillips, Youngstown, Ohio	Youngstown, Ohio	50—222
WDBH	C. T. Sherer Co., Worcester, Mass.	Worcester, Mass.	100—268
WDBI	Radio Specialty Co., St. Petersburg, Fla.	St. Petersburg, Fla.	20—226
WDBJ	Richardson-Wayland Electrical Corp., Roanoke, Va.	Roanoke, Va.	50—229
WDBK	M. F. Broz, Furniture, Hardware & Radio Co., Cleveland Ohio	Cleveland Ohio	100—248
WDBN	Maine Electric Light & Power Co., Bangor, Me.	Bangor, Me.	5—252
WDBO	Rollins College, Winter Park, Fla.	Winter Park, Fla.	50—240
WDBP	Superior State Normal School, Superior, Wis.	Superior, Wis.	50—261
WDBQ	Morton Radio Supply Co., Salem, N. J.	Salem, N. J.	50—234
WDBR	Tremont Temple Baptist Church, Boston, Mass.	Boston, Mass.	100—256
WDBS	S. M. K. Radio Corp., Dayton, Ohio	Dayton, Ohio	5—275
WDBT	Taylor's Book Store, Hattiesburg, Miss.	Hattiesburg, Miss.	10—236
WDBV	Strand Theater, Fort Wayne, Ind.	Fort Wayne, Ind.	100—258
WDBW	The Radio Den, Columbia, Tenn.	Columbia, Tenn.	20—268
WDBX	O'to Baur, 138 Dyckman St., New York, N. Y.	New York, N. Y.	5—233
WDBY	North Shore Congregational Church, Chicago, Ill.	Chicago, Ill.	500—258
WDBZ	Boy Scouts of America, Ulster County Council, Kingston, N. Y.	Kingston, N. Y.	5—233
WDM	The Church of the Covenant, Washington, D. C.	Washington, D. C.	50—234
WDZ	J. L. Bush, Tuscola, Ill.	Tuscola, Ill.	100—278
WEAA	Frank D. Fallain, Police Building, Flint, Mich.	Flint, Mich.	50—234
WEAF	American Telephone & Telegraph Co., New York, N. Y.	New York, N. Y.	2000—491.5
WEAH	Wichita Board of Trade, Wichita, Kan.	Wichita, Kan.	50—268
WEAI	Cornell University, Ithaca, N. Y.	Ithaca, N. Y.	500—254
WEAJ	University of South Dakota, Vermillion, S. D.	Vermillion, S. D.	100—278
WEAM	Borough of North Plainfield, North Plainfield, N. J.	North Plainfield, N. J.	250—261
WEAN	Shenard Co., Providence, R. I.	Providence, R. I.	100—270
WEAO	The Ohio State University, Columbus, Ohio	Columbus, Ohio	500—293.9
WEAP	Mobi's Radio Co., Mobile, Ala.	Mobile, Ala.	100—263
WEAR	Goodyear Tire & Rubber Co., Cleveland, Ohio	Cleveland, Ohio	1000—389.4
WEAU	Davidson Bros. Company, Sioux City, Iowa	Sioux City, Iowa	100—275
WEAY	Iris Theatre, Houston, Texas	Houston, Texas	500—340
WEBA	Benwood Co., St. Louis, Mo.	St. Louis, Mo.	100—273
WEBC	The Electric Shop, Highland Park, N. J.	Highland Park, N. J.	15—233
WEBD	Walter C. Bridges, Superior, Wis.	Superior, Wis.	10—242
WEBE	Electrical Equipment Service Co., Anderson, Ind.	Anderson, Ind.	10—246
WEBE	Rov W. Waller, Cambridge, Ohio	Cambridge, Ohio	10—234
WEBH	Elmerwater Beach Hotel Co., Chicago, Ill.	Chicago, Ill.	1000—370.2
WEBI	Walter Gibbons, Salisbury, Md.	Salisbury, Md.	15—242
WEBJ	Third Ave. Ry. Co., New York, N. Y.	New York, N. Y.	500—273
WEBK	Grand Rapids Radio Co., Grand Rapids, Mich.	Grand Rapids, Mich.	20—242
WEBL	R. C. A., United States (portable)	United States	100—226
WEBM	Radio Corp. of America, Portable Station, N. Y.	N. Y.	100—226
WEBP	Spanish Fort Amusement Park, New Orleans, La.	New Orleans, La.	50—280
WEBO	Tate Radio Co., Harrisburg, Ill.	Harrisburg, Ill.	10—226
WEBR	H. H. Howell, Buffalo, N. Y.	Buffalo, N. Y.	50—244
WEBT	Dayton Coop. Industrial H. S., Dayton, Ohio	Dayton, Ohio	5—256
WEBW	Beloit College, Beloit, Wis.	Beloit, Wis.	500—268
WEBX	John E. Cain, Jr., Nashville, Tenn.	Nashville, Tenn.	50—263
WEBY	Hobart Radio Co., Roslindale, Mass.	Roslindale, Mass.	10—226
WEBZ	Savannah Radio Corp., Savannah, Ga.	Savannah, Ga.	5—234
WEEL	Edison Electric Illuminating Co., 39 Bolyston St., Boston, Mass.	Boston, Mass.	500—475.9
WEMC	Emmanuel Missionary College, Berrien Springs, Mich.	Berrien Springs, Mich.	500—285.5
WEV	Hurlburt-Still Electrical Co., Houston, Texas	Houston, Texas	100—263

**THE RADIO INSTRUCTOR**  
HANDBOOK EDITION OF THE RADIO READING COURSE  
Associate Editor & Advisor  
**PROF. J.H. MORECROFT**  
COLUMBIA UNIVERSITY

PRICE \$1.00

## A solid foundation for your radio work

Here's a radio book that gives you the complete theory, design, construction, operation and maintenance of radio receiving apparatus.

The book is divided into five sections each completing a separate division of radio receiving information so that the reader can more easily use the book for handy reference.

It is a substantial foundation for anyone building or operating a radio receiver.

Book is 5 1/2 by 8 1/2 inches, and is bound with standard, stiff covers.

**Price \$1.00**

**THE E. I. COMPANY**  
Sole Distributors  
**THE CONSRAD COMPANY**  
233 Fulton St. New York City

# Consrad

ANT

SPEAKER +

SPEAKER -

A BATTERY +

## E B Y

### BINDING POSTS

LONG ANT

A BATTERY -

*Twenty-five Different Engraved Tops*

*They Don't Lose Their Heads*

INPUT

BATTERY +

Sold by dealers everywhere  
**H. H. EBY MFG. CO.**  
PHILADELPHIA

A BATTERY -

+

-

BATTERY +

Insure your copy reaching you each month. Subscribe to **RADIO NEWS** — \$2.50 a year. Experimenter Publishing Co., 53 Park Pl., N.Y.C.



# You can save about \$60.00 on your radio if you will put a Model "S" Acmeflex Kitset together

## Like earning \$60.00 cash for a few hours' fun

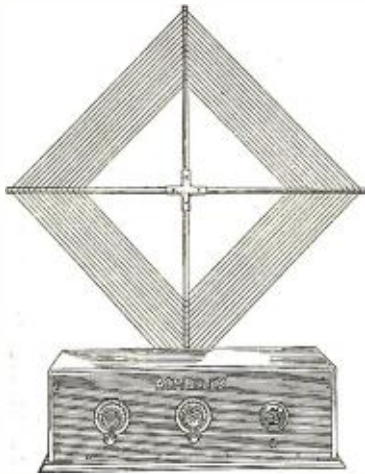

A set anyone can put together and enjoy all-the-year 'round radio.

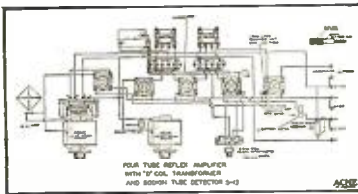

Wiring diagram new Model "S" Acmeflex Kitset

The radio fan will especially notice the use in the new Model "S" of the D-Coil radio frequency tuning unit and the vacuum tube detector, which together wonderfully improve distance, reception, and selectivity.

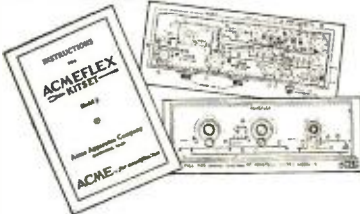

Directions given so simply that anyone can follow them

Above are illustrated the circular of printed instructions and the life-size diagrams of the wiring, which are packed with each Model "S" Kitset. Step by step the making of the set is described in clear, simple language—just simple operations which anyone can easily follow.



Only two tools required—a screw driver and pliers—and they are included in the Kit.

### Enthusiastic praise from Model "S" user

**FROM NEW YORK CITY:**  
 "Well, I believe we had every jerk-water station in the U. S. Stations I never heard of before. At 11:45 P. M. I pulled in KFI (Los Angeles, Calif.) on the loudspeaker. At 12:15 A. M. KGO (Oakland, Calif.). I went back and picked up KFI three times. My home is located in what is considered one of the worst sections for radio. The skyline of New York is directly opposite me. I am on the harbor, a mile from the Navy Yard, and have three bridges with electric trains to bother me, but with it all I got the coast. Forgot to mention that two locals were on—WHN and WJZ; some selectivity."

The wonderful new Model "S" Acmeflex Kitset would cost you, if assembled complete in our factory, \$150.00. But it costs you only \$80.00 (plus a small cost for a cabinet) if you put it together yourself. You can easily do it. We give complete directions. You save about \$60.00.

THE perfection by Acme engineers of the new model "S" Acmeflex Kitset not only makes it possible for you to get a \$150 worth of radio for only \$80 (plus a cabinet), but it also places in your home the famous Acme 4-tube Reflex (trade mark) now wonderfully improved through the combined use of a D-Coil radio frequency tuning unit and a Sodian S-13 Detector Tube. You get greater distance, greater selectivity and better reception. We could make it for less than \$80, but it would not give results.

### Contents of Kitset is complete

ALL the parts necessary for making the complete set are included in the Kitset. Even the loop is included. There is no antenna to erect. Each part is packed carefully in its own carton and not thrown in a jumbled heap. Each part is fresh, bright, new and well made. Screws, nuts and bolts are in a box of their own. Everything is included; nothing forgotten. The only accessories to get are the tubes, batteries, loud speaker and cabinet. We have put everything in the kit but the fun.

### No technical knowledge or workshop necessary

You do not have to be a radio engineer in order to put this set together. Anybody can do it. Many have done it easily in three hours—had the set complete and working all in one evening. Only two tools are needed, a screw-driver and a pair of special Acme pliers and they are included in the kit. Good tools which

you can use afterwards for other things. The panel is all drilled for you, and no soldering is necessary. If you do not want to assemble the set yourself, there are plenty of amateurs and dealers glad to do it for you at a nominal charge, still saving you a lot of money.

### Complete printed directions and diagrams

WITH each Kitset are included complete printed directions, telling you just how to put the set together, step by step; just simple operations that anyone can easily follow and have a good time doing it. In addition to these printed directions are two life-size printed diagrams, one giving the wiring diagram for the set both from the base-board view and the panel view, and the other showing, in actual size, exactly how every wire in the set is bent and connected.

### More, tube for tube than any other set

The finished Model "S" Acmeflex Kitset, a Reflex (trade mark) set, gives two stages of radio frequency amplification, two stages of audio frequency amplification plus a D-Coil radio frequency tuning unit and detector, with only five tubes.

The new Model "S" Acmeflex Kitset will pull in more stations, louder and clearer, on a loop and loud speaker, than any other set using the same number of tubes (five), and more than many sets using from six to eight tubes. It is easy to tune. There is only one tuning dial.

### Everything on Loudspeaker

The selectivity, range and volume of this set make it remarkable for loud, clear reception of stations near and far. The pleasure and the joy of it can be yours at a price only a little more than half what it would cost you to buy the set complete. Anyone can now sit down and put together a set that will perform on a plane with the highest-priced factory-made receivers.

### ACME APPARATUS COMPANY

Transformer and Radio Engineers and Manufacturers

Dept. K2,

Cambridge, Mass.

### Send this coupon

Send coupon now and start putting this wonderful set together

JUST tear out the coupon below; write your name and address on it plainly, mail it to us, and we will send you by return mail a special circular completely describing this set in every detail. Send coupon today.

ACME APPARATUS CO.,  
 Dept. K2, Cambridge, Mass.  
 Send complete information about the new Model "S" Acmeflex.

Name .....  
 Street .....  
 City..... State.....

# ACME ~for amplification



# "MODERN RADIO RECEPTION"

*A New Book*

By  
**Charles R. Leutz**

**325 PAGES  
200 ILLUSTRATIONS  
FULLY BOUND**

**Partial List of Contents:**

- Radiola Super-Heterodyne Diagram
- Western Electric 4B Receiver
- Model C Super-Heterodyne
- Model C7 Super-Heterodyne
- Long Distance Reception
- Short Wave Reception
- Long Wave Receivers
- Pliodynes and Super-Pliodynes
- Laboratory Equipment
- Broadcast Transmitters
- High Efficiency Amateur Transmitters
- Model L Super-Heterodyne and  
Everything of importance relating to Broadcast Reception
- This supersedes Mr. Leutz's earlier book entitled "Super-Heterodyne Receivers."*

**Price \$3.00 Postpaid**

**EXPERIMENTERS INFORMATION SERVICE, Inc.**

**476 Broadway New York City**

Call Letters	Name	Location	Power & Wave Length
WEW	St. Louis University,	St. Louis, Mo.	100-248
WFAA	The Dallas News, The Dallas Journal,	Dallas, Texas	500-475.9
WFAM	Times Publishing Co.,	St. Cloud, Minn.	10-273
WFAN	Hutchinson Electric Service Co.,	Hutchinson, Minn.	100-286
WFAV	University of Nebraska,	Lincoln, Neb.	250-275
WFBB	Eureka College,	Eureka, Ill.	100-240
WFBC	First Baptist Church,	Knoxville, Tenn.	50-250
WFBD	Gethsemane Baptist Church,	Philadelphia, Pa.	5-234
WFBE	John Van De Walle,	Saymour, Ind.	20-226
WFBG	William F. Gable Co.,	Altoona, Pa.	100-278
WFBH	Concourse Radio Corp.,	New York, N. Y.	500-273
WFBI	Galvin Radio Supply Co.,	Camden, N. J.	100-236
WFBK	Dartmouth College,	Hanover, N. H.	100-256
WFBL	Onondaga Hotel Co.,	Syracuse, N. Y.	100-252
WFBM	Merchants Heat & Light Co.,	Indianapolis, Ind.	250-268
WFBN	Radio Sales & Service Co.,	Bridgewater, Mass.	200-226
WFBQ	Wynne Radio Co.,	Raleigh, N. C.	50-252
WFBR	Fifth Int. Md. Nat'l Guard, 5th Reg. Armory,	Baltimore, Md.	100-254
WFBT	Gloucester Co. Civic League,	Pitman, N. J.	50-231
WFBU	Commonwealth Radio Ass'n,	Boston, Mass.	
WFBY	Signal Officer, Ft. Benjy,	Harison, Ind.	100-258
WFBZ	Knox College,	Galesburg, Ill.	10-254
WFI	Strawbridge & Clothier,	Philadelphia, Pa.	500-394.5
WGAL	Lancaster Elec. Supply & Const. Co.,	Lancaster, Pa.	10-248
WGAN	Cecil E. Lloyd, 216 W. Romana St.,	Pensacola, Fla.	50-360
WGAQ	Yoree Hotel,	Shreveport, La.	150-263
WGAZ	The South Bend Tribune,	South Bend, Ind.	250-275
WGBA	Jones Electric & Radio Mfg. Co.,	Baltimore, Md.	50-254
WGBB	Harry H. Carman,	217 Bedell St., Freeport, N. Y.	100-244
WGBC	First Baptist Church,	Memphis, Tenn.	10-266
WGBF	The Finke Furniture Co.,	307 So. 7th Ave., Evansville, Ind.	50-217.3
WGBG	Breitenhach's Radio Shop,	25 Franklin St., Thrifton, Va.	100-226
WGBH	Fall River Herald Publ. Co.,	Fall River, Mass., New England States (Portable)	10-209.7
WGBI	F. S. Megargee,	Scranton, Pa.	10-240
WGBS	Gimbel Bros.,	New York City	1000-315.6
WGBT	Furman University,	Greenville, S. C.	15-236
WGI	American Radio & Research Corp.,	Medford Hillside, Mass.	100-261
WGL	Thomas F. J. Howlette,	2303 N. Broad St., Philadelphia, Pa.	500-360
WGN	Drake Hotel,	Chicago, Ill.	1000-370.2
WGR	Federal Telephone Mfg. Co.,	Buffalo, N. Y.	750-319
WGY	General Electric Co.,	Schenectady, N. Y.	1500-379.5
WHA	Univ. of Wisconsin,	Madison, Wis.	500-535.4
WHAA	State University of Iowa,	Iowa City, Iowa	100-484
WHAD	Marquette University,	Milwaukee, Wis.	500-275
WHAG	University of Cincinnati,	Cincinnati, Ohio	100-233
WHAM	University of Rochester,	Rochester, N. Y.	100-278
WHAR	Seaside Hotel,	Atlantic City, N. J.	100-275
WHAS	Courier-Journal and Louisville Times,	Louisville, Ky.	500-399.8
WHAV	Wilmington Electrical Specialty Co., Inc.,	Wilmington, Del.	100-266
WHAZ	Rensselaer Polytechnic Institute,	Troy, N. Y.	500-379.5
WHB	Sweeney School Co.,	Kansas City, Mo.	500-365.6
WHK	Radiovox Co.,	Cleveland, Ohio	100-273
WHN	George Schubel, Loew's State Theatre Bldg.,	New York, N. Y.	500-361.2
WHO	Bankers Life Co.,	Des Moines, Iowa	500-526
WIAC	Galveston Tribune,	Galveston, Texas	100-360
WIAD	Howard R. Miller,	6318 N. Park Ave., Philadelphia, Pa.	100-250
WIAK	Journal-Stockman Co.,	Omaha, Neb.	250-278
WIAS	Home Electric Co.,	Burlington, Ia.	100-254

(Continued on page 1926)



**You Save 50%**

World 6-Volt Storage Batteries are famous for their guaranteed quality and service. Backed by years of Successful Manufacture and Thousands of Satisfied Users. You save 50% and get a **2-Year Guarantee Bond in Writing**. World Battery owners "tell their friends." That's our best proof of performance. Send your order in today.

**RADIO BATTERIES**  
 6-Volt, 100-Ampers ..... \$12.25  
 6-Volt, 120-Amp. res ..... 14.50  
 6-Volt, 140-Ampers ..... 15.00

**AUTO BATTERIES**  
 6-Volt, 11-Plate ..... \$12.25  
 6-Volt, 13-Plate ..... 13.50  
 12-Volt, 7-Plate ..... 17.00

**SEND NO MONEY**  
 Just state battery wanted and we will ship day order is received, by Express C. O. D., subject to your examination on arrival. **Extra Offer:** 5% discount for cash in full with order. Buy now and get a guaranteed battery at 50% saving to you.

**WORLD BATTERY COMPANY**  
 1219 S. Wabash Ave., Dept. 10 Chicago, Ill.

**World**

**ATLAS RADIO TUBE**  
 "BRINGS IN THE WORLD"

**ATLAS MATCHED TUBES INSTRUMENT TESTED**

*Made in All Standard Types*

Guaranteed to function efficiently in the most exacting circuits. Every Atlas Tube is individually instrument tested. Try them 30 days. Money refunded if you are not delighted. At best dealers, or direct from us for

**\$3**

Our guarantee includes safe delivery. Mail orders promptly filled. **SPECIAL OFFER:** At no extra charge, we will furnish selected Atlas Instrument-Tested Tubes in matched sets for Reflex, Neutrodyne, Radio Frequency, Superheterodyne or other sets. They will improve the performance of any set. **DEALERS:** Atlas Matched Sets are in great demand. Write or wire for proposition.

**THE RSK CO.**

312 Caxton Building, Cleveland, Ohio  
 771 Ellicott Square, Buffalo, N. Y.  
 609 Chamber of Commerce, Pittsburgh, Pa.

**5000 RADIO DEALERS buy from HUDSON-ROSS**  
 123 W. Madison St. Chicago  
 Send for dealers discount.

Insure your copy reaching you each month. Subscribe to **RADIO NEWS**—\$2.50 a year. Experimenter Publishing Co., 53 Park Pl., N.Y.C.



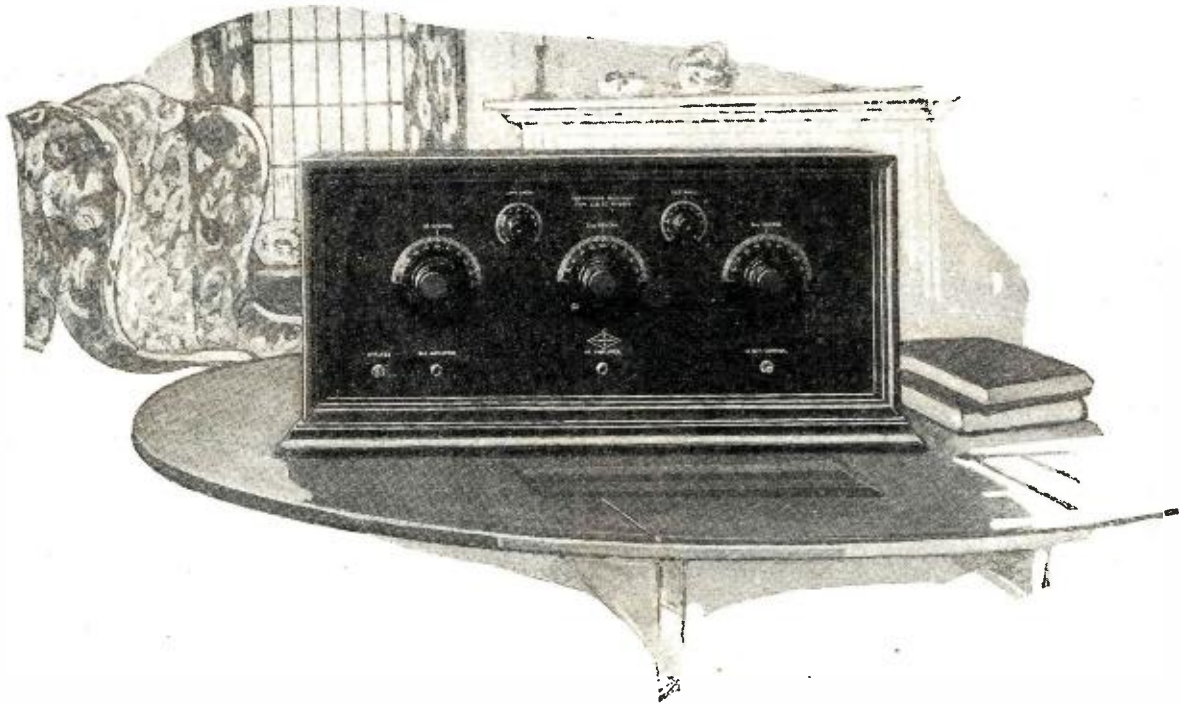

# Murdock Neutrodyne without loudspeaker \$92.50

**T**HIS well-known set can now be obtained without the built-in loudspeaker for \$92.50—a saving of \$7.50 on the cost of the set with the loudspeaker built-in.

This model is made so that people who already have a loudspeaker will not have to buy another. Any make of loudspeaker can be attached to this set.

This Murdock Five Tube Neutrodyne is a set of outstanding value. It is encased in a handsome mahogany-finished cabinet with room inside the cabinet for your "B" batteries. Batteries and tubes are the only accessories needed.

Every "Murdock" set is backed by our 20 years of successful experience in making radio apparatus.

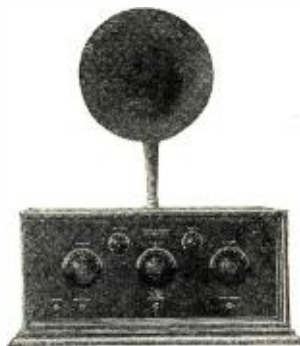

Same set with built-in loudspeaker complete for \$100. With adjustable loudspeaker unit \$110.

WM. J. MURDOCK COMPANY  
Dept. A-2, Washington Ave., Chelsea, Mass.

*Branch Offices*

New York      Washington      Chicago      Los Angeles  
San Francisco      Seattle

# MURDOCK RADIO PRODUCTS

Standard since 1904





# Somerset

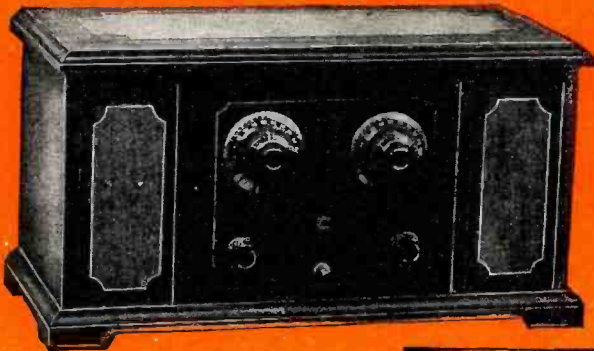

SOMERSET  
STRATFORD  
MODEL 4-A

\$65

SOMERSET  
MARS  
MODEL 5A

\$75

SOMERSET STRATFORD Model 4A 4 Tubes—Dual Control. A superior four tube, tuned radio frequency receiver—two dial control—operates on storage battery or dry cells. Automatic filament control insures long life of tubes. The finest "low loss" condensers and the famous SOMERSET Calibrated Transformers are features. "A" and "B" battery space is provided in the handsome two-tone mahogany finish cabinet. Size 21"x15"x11".

List \$65

SOMERSET MARS Model 5A 5 Tubes—Three Dial Control. Two stages tuned radio frequency, detector, and two stages audio frequency. Storage battery or dry cell operation, automatic filament control, highest quality "low loss" condensers and the famous SOMERSET Calibrated Transformers. Artistic cabinet hand-rubbed mahogany finish providing space for storage "A" and dry cell "B" batteries. Size 29"x14"x11".

List \$75

## Treasure Chests —Full of Delights for You!

SOMERSET Radio Receivers represent a new Idea in radio—an honest price for honest materials and workmanship. In performance and results they have set a new standard of excellence and they fairly shout "Quality" in every line. Every set is a piece of fine furniture that any woman will welcome in her drawing room, a high grade instrument of precision that will fascinate any man.

### Each a Jewel!

- THE Somerset line of Radio Receivers comprises four models—
- Stratford—Model 4A, 4 tube set, 2 dials, tuned radio frequency . . . . . \$65
  - Mars—Model 5A, 5 tube set, 3 dials, tuned radio frequency . . . . . \$75
  - Shelbourne—Model 4B, 4 tube set, 1 dial, synchronized control, tuned radio frequency . . . . . \$85
  - Standish—Model 4C, 4 tube set, 1 dial, synchronized control, tuned radio frequency with built-in loud speaker . . \$150

Prices West of Mississippi—add 10%.  
These receivers are all of the tuned radio frequency type, embodying all the newest radio engineering improvements. All sets have "A" and "B" battery compartments.

NATIONAL AIRPHONE CORPORATION  
18 HUDSON STREET NEW YORK CITY



Prices subject to change without notice

## Wonder Sets —in Wonder Settings

EVERY Somerset Radio Receiver is not only a marvel of engineering skill and master craftsmanship—truly "built like a watch"—but is also encased in a substantial cabinet of simple, artistic design, breathing distinction in every line. Note the unique two toned panel effect and the hand rubbed mahogany finish—quality is suprême.

### A Challenge!

OBVIOUSLY—definitely—unmistakably superior in *quality*, Somerset Radio Receivers also lead the radio field in *value*—in worth for the money. Just check Somerset Radio Receivers feature for feature with any others at or near their price—*bar none!* You will be amazed—and you will appreciate the full force of our statement—

"Each Somerset Radio Receiver is the best that can be offered at its price; the utmost in results and permanent satisfaction to its owner."

NATIONAL AIRPHONE CORPORATION  
18 HUDSON STREET NEW YORK CITY



# Radio

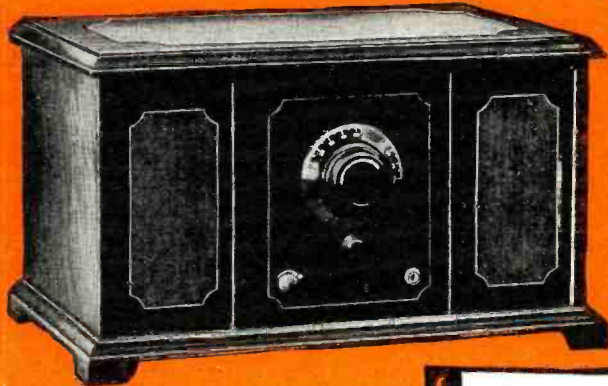

SOMERSET  
SHELBOURNE  
MODEL 4-B

\$85

SOMERSET  
STANDISH  
MODEL 4-C

\$150

SOMERSET SHELBOURNE Model 4B 4 Tubes—Single Dial Control. Our perfected tuned radio frequency circuit with single dial synchronized control. Storage battery or dry cell operation, automatic filament control, the finest "low loss" condensers, and the famous SOMERSET Calibrated Transformers. Compartments for large sized storage "A" and dry cell "B" batteries. Mahogany finish cabinet, hand-rubbed two-tone effect. Size 26"x 14"x12".....

List \$85

SOMERSET STANDISH Model 4C 4 Tubes—Single Dial Control with built-in loud speaker. Combining a built-in loud speaker of the highest type and the four tube tuned radio frequency circuit with single dial synchronized control—all the latest and best in radio. Storage battery or dry cell operation, automatic filament control, highest quality "low loss" condensers, and the famous SOMERSET Calibrated Trans-

formers. Ample space is reserved in this cabinet for standard size high ampere hour storage "A" batteries and dry "B" batteries. Exquisite cabinet, antique mahogany finish. Size 29"x13"x14". List \$150

## Radio Sets

— With A Conscience

**S**OMERSET Radio Receivers are not sold until the Purchaser is perfectly satisfied. For back of every set is Somerset Service—more than mere good intentions—it is definite tangible aid, and yours for the asking. It is based on

### The Famous Somerset Guarantee—

*"YOU must be satisfied with this receiver or we do not want you to keep it. If for any reason you feel that it is not exactly as represented or that it has not the quality and value which you have a right to expect, we want you to return it for exchange or for refund of your original purchase price, whichever you prefer. We will cheerfully and promptly make good any Somerset Radio Receiver which does not fully measure up to your expectations. This guarantee means exactly what it says, without reservations, and is backed by the entire resources of this institution."*

**E**VERY completed Somerset Radio Receiver must pass the rigid tests of the Somerset Engineering Laboratories before it can be certified "O.K." for shipment. And with each receiver is the Inspection tag bearing a record of these tests and signed by the inspectors. Look for it.

NATIONAL AIRPHONE CORPORATION  
18 HUDSON STREET NEW YORK CITY



© 1925.  
Natl. Airphone  
Corp.

## Somerset Features That Make Selling Easy!

1. Somerset Radio Receivers meet the popular demand for high quality at honest prices.
2. Somerset Radio Receivers cannot radiate or oscillate—the filament control is automatic—no potentiometer or stabilizer required.
3. Superior design gives clear, true, mellow tone without distortion—cannot squeal or howl—all body capacity effects eliminated.
4. Utilizing the highest grade "low loss" condensers and the famous Somerset Calibrated Transformers, extraordinary sensitivity and volume have been attained—securing wonderful range and local station reception without aerial.
5. Cabinets of surpassing beauty, gracing the most artistic surroundings—wiring and batteries concealed—everything accessible and conveniently arranged—sturdy construction, two-tone panel effect, hand-rubbed mahogany finish.
6. Made by a corporation of long experience in radio manufacturing with ample resources to insure the utmost in production economy and standing solidly behind every statement or claim—your assurance of reliability.

MAIL THIS COUPON TODAY  
NATIONAL AIRPHONE CORPORATION  
18 Hudson Street New York City  
Without any obligation to me, send me the Somerset Radio Primer and full details of Somerset Radio Receivers.

Name.....  
Address.....



# THE NEW MODEL C-7

## "The Rolls-Royce of Reception"



MODEL C-7 SUPER-HETERODYNE  
Wave-length Range, 200 to 575 meters. Dimensions, 40 in. x 8 in. x 8 in.  
Tube Arrangement: Regenerative Detector, Oscillator, 2 Stages Radio, Detector, 2 Stages Audio.

### Important Today

THE EXPERIMENTERS INFORMATION SERVICE, Inc., has been recommending the Super-Heterodyne method of reception since the early part of 1922. In February, 1923, a Super-Heterodyne of our design was installed on the *S.S. Western World*, pier 1, Hoboken, N. J., in the cabin of Dr. Horatio Belt. On the voyage to Rio de Janeiro, Brazil, at a distance of 3,000 miles, southeast of New York, the entire Greb-Gardner fight was received from WJZ, with sufficient audibility for the entire cabin full of passengers to hear the bout, blow by blow, plainly. At 3,300 miles southeast of New York, an entire evening church service was received from Pittsburgh. At that time there was not another single firm advertising or advocating the Super-Heterodyne. Since then Mr. A. Ancieux, Engineer, Trarivia Elec de Arequipa, Arequipa, Peru, has reported consistent reception from KDKA, WDAP, WEA, WGY and others, a distance of over 5,000 miles, using a Model "C" Super-Heterodyne. The Pratt & Brake Corp., of New York City, sent a Model C to Rio de Janeiro which received American broadcast station at a distance of over 7,000 miles.

Practically all concerns now featuring Super-Heterodyne have copied our original Model C design, and to prove again that we are far in advance of competition, we present this Improved Model C-7 Super-Heterodyne as the *Most Sensitive, Most Selective*, and finest reproducing Broadcast Receiver that can be built.

### 7 Tubes Give the Results of 10

**The Reason:**— When regeneration is added to a one tube non-regenerative receiver, the increased amplification is about equal to adding two stages of tuned radio frequency amplification. Heretofore it has been impossible to add regeneration in the 1st Detector of a Super-Heterodyne and accordingly this has been a big loss.

The new Model C-7 Super-Heterodyne has a special 1st Detector circuit with a split antenna inductance so arranged that normally the detector would oscillate continually. However, in addition, a neutralizing condenser is inserted in the circuit which gives absolute control of the oscillations to such an extent that the circuit can be adjusted to just below the oscillating point, as this adjustment gives the maximum regenerative amplification. The new circuit has a bias potential on the 1st Detector grid, in place of the usual grid leak and condenser, and this allows infinitely weak signals to be regenerated and heterodyned through the radio frequency amplifier, which an ordinary grid leak and condenser would block. On a weak signal the difference in sensitivity is very noticeable. Using a 22-foot indoor antenna in the suburbs of New York loud speaker reception has been obtained from KGO, Oakland, California. A normal range of 2000 miles is easily obtained on an average small antenna at night under average conditions.

Original Blue Print showing all data, diagrams, circuits, details, etc., \$1.00, postpaid.

## Experimenters Information Service, Inc.

476 Broadway - New York City

Designers of the Highest Class Radio Apparatus in the World

New Book, "Modern Radio Reception," by Charles R. Leutz  
325 Pages, 200 Illustrations, Fully Bound, \$3.00 Postpaid

Call Letters	Name	Location	Power & Wave Length
WIK	K & L Electric Co., McKeesport, Pa.	100—234	
WIP	Gimbel Bros., Philadelphia, Pa.	500—508.2	
WJAB	American Electric Co., Lincoln, Neb.	100—229	
WJAD	Jackson's Radio Engineering Laboratories, Waco, Texas.	500—352.7	
WJAG	The Norfolk Daily News, Norfolk, Neb.	250—270	
WJAK	Clifford L. White, Greentown, Ind.	50—254	
WJAM	D. M. Perham, 332 Third Ave. W., Cedar Rapids, Iowa.	20—268	
WJAN	Peoria Star, Peoria, Ill.	100—273	
WJAR	The Outlet Co., Providence, R. I.	500—305.9	
WJAS	Pittsburgh Radio Supply Co., Pittsburgh, Pa.	500—275	
WJAZ	Chicago Radio Laboratory, Chicago, Ill.	100—268	
WJD	Denison University, Granville, Ohio	10—217.3	
WJJD	Supreme Lodge Loyal Order of Moose, Mooseheart, Ill.	500—302.8	
WJY	R. C. A., New York, N. Y.	1000—405.2	
WJZ	R. C. A., New York, N. Y.	1000—454.3	
WKAA	H. F. Paar, 1444 Second Ave. E., Cedar Rapids, Iowa.	50—278	
WKAD	Charles Loeff (Crescent Park), East Providence, R. I.	20—240	
WKAF	W. S. Radio Supply Co., Wichita Falls, Texas.	100—360	
WKAN	United Battery Service Co., Montgomery, Ala.	15—226	
WKAP	Dutec W. Flinn, Cranston, R. I.	50—234	
WKAQ	Radio Corp. of Porto Rico, San Juan, Porto Rico	500—340.7	
WKAR	Michigan Agriculture College, East Lansing, Mich.	500—285.5	
WKAU	Laconia Radio Club, Laconia, N. H.	50—254	
WKBF	Dutec W. Flinn, Cranston, R. I.	500—286	
WKY	W. K. Y. Radio Shop, Oklahoma City, Okla.	100—275	
WLAL	Naylor Electrical Co., Tulsa, Okla.	100—360	
WLAP	W. V. Jordan, 306 W. Breckenridge St., Louisville, Ky.	20—275	
WLAX	Greencastle Community Broadcasting Sta., Greencastle, Ind.	10—231	
WLB	University of Minnesota, Minneapolis, Minn.	5—278	
WLBL	Wisconsin Department of Markets, Stevens Point, Wis.	500—278	
WLS	Sears, Roebuck & Co., Chicago, Ill.	500—344.6	
WLW	Crosley Radio Corp., Cincinnati, Ohio	1500—422.3	
WMAC	C. B. Meredith, Cazenovia, N. Y.	100—275	
WMAF	Round Hills Radio Corp., Dartmouth, Mass.	100—500—360	
WMAH	General Supply Co., Lincoln, Neb.	100—254	
WMAK	Lockport Board of Commerce, Lockport, N. Y.	500—266	
WMAN	First Baptist Church, Columbus, Ohio	50—278	
WMAQ	Chicago Daily News, Chicago, Ill.	500—447.5	
WMAV	Alabama Polytechnic Inst., Auburn, Ala.	500—250	
WMAY	Kingshighway Presbyterian Church, St. Louis, Mo.	100—248	
WMAZ	Mercer University, Macon, Ga.	100—261	
WMC	Commercial Appeal, Memphis, Tenn.	500—499.7	
WMH	Ainsworth-Gates Radio Co., Cincinnati, Ohio	750 { 422.3 325.9	
WMU	Doubleday-Hill Electric Co., Washington, D. C.	100—261	
WNAC	Shepard Stores, Boston, Mass.	500—280.2	
WNAD	University of Oklahoma, Norman, Okla.	250—254	
WNAL	Omaha Central High School, Omaha, Neb.	50—258	
WNAP	Wittenberg College, Springfield, Ohio	100—248	
WNAR	First Christian Church, Butler, Mo.	20—231	
WNAT	Lennig Bros. Co., Philadelphia, Pa.	100—250	
WNAW	Henry Kunzmann, Box 167, Port Monroe, Va.	5—240	
WNAX	Dakota Radio Apparatus Co., Yankton, S. D.	100—244	
WNYC	City of New York, New York, N. Y.	1000—526	
WOAC	Page Organ Co., Lima, Ohio.	50—266	
WOAE	Midland College, Fremont, Neb.	15—280	
WOAF	Tyler Commercial College, Tyler, Texas	10—360	
WOAI	Southern Equipment Co., San Antonio, Texas	500—394.5	
WOAJ	Erwins Electrical Co., Parsons, Kan.	15—258	
WOAN	Vaughn Conservatory of Music, Lawrenceburg, Tenn.	500—282.8	
WOAR	H. P. Lundskow, Kenosha, Wis.	50—229	
WOAV	2nd Battalion, 112th Inf., P. N. G., Erie, Pa.	50—242	
WOAW	Woodmen of the World, Omaha, Neb.	500—526	
WOAX	Franklyn J. Wolf, 600 Ingham Ave., Trenton, N. J.	500—240	
WOC	The Palmer School of Chiropractice, Davenport, Iowa.	1500—483.6	

ATTENTION DEALERS  
SEND FOR OUR 152 PAGE CATALOG



The finest and largest exclusive Radio Catalog in the United States.

SCHNEITTER RADIO CO.  
Dept. D. St. Joseph, Mo.

### MASTS

The Whittlessey System of Aerial Support consists of Self-Supporting Fabricated Steel Masts Shipped in Sections, Mast-Head Pulley, Cable and Hoisting Reel—the painter's "elevator." No Guys, Ladders or Platforms. These masts are solid, stiff, rigid and beautiful. 50-75-100-125 feet. Self-Supporting Broadcasting Masts erected anywhere, any height, any strain required. The Whittlessey Engineering Co., Cleveland Ohio.

## SUNSET REFLEX CRYSTALS

DeForest, Freshman, and Erisman Laboratories found Sunset supreme for sensitivity, distance and volume. A wood-metal mounted crystal that will NOT burn out.

50¢



Mfrs., Dealers, Jobbers: Write for Proposition.

U. S. MFG. & DIST. CO.  
45 CLINTON ST. NEWARK, N. J.

### BEL-CANTO LOUD SPEAKERS

NOW at YOUR DEALER

10" Bell—22" High .....\$10

15" Bell—28" High (Goose Neck) .....\$15

If Your Dealer Cannot Supply You, Write Us.

BEL-CANTO RADIO & TEL. EQUIP. CO., INC.  
872 Broadway, N. Y. C. Tel: Stuy. 1921



Dear Jim:

Here's something more important than has come out of your loudspeaker for a long, long time.

The leading broadcasting stations use Willards.

When a station broadcasts, voice and music must be amplified many, many times before the program can be put on the air.

The amplifiers used are like the ones in your set — only larger.

Quiet operation of the batteries employed to furnish this amplification is as essential to the broadcasting stations as it is to you.

You see, their requirements for a good sending job are the same as your requirements for a good receiving job.

And believe me, Jim, Willards have what it takes to do it.

Signing off.

Sam.

P. S. I have been looking at the map and there are 178 stations using Willards. That will tell you something, I guess.

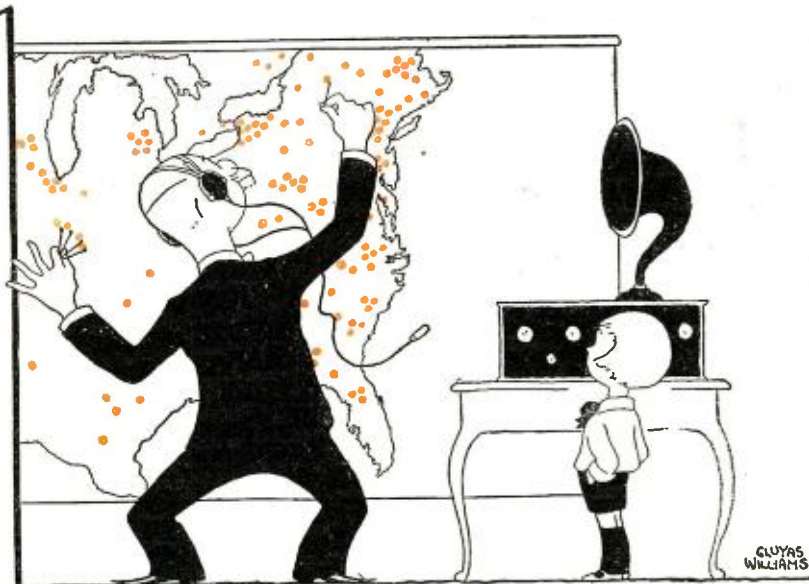

178 BROADCASTING STATIONS USE WILLARDS

# WILLARD RADIO BATTERIES

FOR SALE AT WILLARD SERVICE STATIONS AND RADIO DEALERS



These unusual batteries were developed by WTAM — the Broadcasting Station and Radio Research Laboratory of Willard Storage Battery Company, Cleveland, Ohio.

Write to **WTAM** for this booklet  
[The Voice of the Storage Battery]

Read how you can get greater distance, and added clearness from your set — how to get the longest life and greatest value from your batteries. It's all in the little booklet. Sent to you with our compliments. Just mail the coupon.



Mail me to WTAM. I'll bring you "Better Results."

Name

City and State

Street Address

RN7





# Super-Heterodyne C-7

Model C-7, the Long Distance Concert Receiver With a Telephone Range of 3,000 miles

NONE of the so-called new "circuits" or modifications of standards approach the C-7 in efficiency — for long range, for high audibility, for selectivity. Experimenters' Information Service design. *Seven tubes give the result of ten* because this model allows signals to be regenerated and heterodyned through radio frequency amplifier.

### For any Circuit

Prompt shipment can be made on tested, standard apparatus of the following manufacture:

- E. I. S., Inc.
- General Radio
- Ultradyme
- Sangamo Electric
- Benjamin Electric
- Allen Cardwell
- Dubilier
- Weston
- Jewell
- Western Electric
- Radio Corporation
- Music Master
- Cutler Hammer
- Federal
- Willard
- Formica
- Magnavox
- Amer Tram
- Acme
- Frost
- Kellogg

Pressley Circuit as described in Popular Radio. We furnish parts as specified.

### Plidyne

6 tubes—two stages tuned radio frequency detector and three stages audio frequency amplification, the famous Golden Leutz model—Completely constructed.

Price, without accessories . . . \$60

E. I. S. Model . . . All material we furnish is endorsed and recommended by the designers.

Using the finest apparatus and building to Naval standards, Model C-7 has a telephone range of 3,000 miles.

### Norden - Hauck Price List Saves You Money

Free Information—Write for descriptive matter and price list. Our service is as near as your mail box.

Full Stock on Hand—We carry complete stocks of laboratory tested apparatus for immediate shipment.

## NORDEN, HAUCK, INC.

• Engineers •

Office and Laboratories 1617 Chestnut St. - Philadelphia

Call Letters	Name	Location	Power & Wave Length
WOCL	Hotel Jamestown, Inc.	Jamestown, N. Y.	15-275
WOI	Iowa State College,	Ames, Ia.	500-270
WOO	John Wanamaker,	Phila., Pa.	500-508.2
WOQ	Unity School of Christianity,	Kansas City, Mo.	500-278
WOR	L. Bamberger & Co.,	Newark, N. J.	500-405.2
WORD	Peoples Pulpit Ass'n,	Batavia, Ill.	500-278
WOS	Missouri State Marketing Bureau,	Jefferson City, Mo.	500-440.9
WPAC	Donaldson Radio Co.,	Okmulgee, Okla.	100-360
WPAJ	Doolittle Radio Corp.,	New Haven, Conn.	100-268
WPAK	North Dakota Agricultural College,	Agricultural College, N.D.	50-275
WPAU	Concordia College,	Moorhead, Minn.	10-258
WPAZ	Dr. John R. Koch,	Charleston, W. Va.	10-268
WPSC	Pennsylvania State College,	State College, Pa.	500-261
WQAA	Horace A. Beale, Jr.,	Parkersburg, Pa.	500-220
WQAC	Gish Radio Service,	Amarillo, Texas	100-234
WQAE	Moore Radio News Station,	Springfield, Vt.	50-246
WQAM	Electrical Equipment Co.,	Miami, Fla.	100-268
WQAN	Scranton Times,	Scranton, Pa.	100-250
WQAO	Calvary Baptist Church,	New York, N. Y.	100-360
WQAQ	West Texas Radio Co. (Abilene Daily Reporter),	Abilene, Tex.	100-360
WQAS	Prince-Walter Co.,	Lowell, Mass.	100-252
WQJ	Calumet Rainbo Broadcasting Co.,	Chicago, Ill.	500-447.5
WRAA	Rice Institute,	Houston, Texas	100-256
WRAF	The Radio Club,	Laporte, Ind.	15-224
WRAL	Northern States Power Co.,	St. Croix Falls, Wis.	100-248
WRAM	Lombard College,	Galesburg, Ill.	100-244
WRAN	Black Hawk Electrical Co.,	Waterloo, Iowa	10-236
WRAO	St. Louis Radio Service Co.,	St. Louis, Mo.	10-227
WRAV	Antioch College,	Yellow Springs, Ohio	100-263
WRAW	Avenue Radio Shop,	Reading, Pa.	10-238
WRAX	Flexons Garage,	Gloucester City, N. J.	100-268
WRBC	Immanuel Lutheran Church,	Valparaiso, Ind.	500-278
WRC	Radio Corp. of America,	Washington, D. C.	500-468.5
WREO	Reo Motor Car Co.,	Lansing, Mich.	500-285.5
WRHF	Washington Radio Hospital Fund,	Washington, D. C.	50-256
WRK	Doron Bros. Elec. Co.,	Hamilton, Ohio	200-270
WRM	University of Illinois,	Urbana, Ill.	500-273
WRR	City of Dallas Police and Fire Signal Dept.,	Dallas, Texas	200-261
WRW	Tarrytown Radio Research Laboratory,	Tarrytown, N. Y.	500-273
WSAB	South East Missouri State Teachers College,	Cape Girardeau, Mo.	100-275
WSAC	Clemson Agricultural College,	Clemson College, S. C.	500-336.9
WSAD	J. A. Foster Co.,	Providence, R. I.	100-256
WSAG	Loren Venderbeck Davis,	10th St., St. Petersburg, Fla.	500-266
WSAI	United States Playing Cards Co.,	Cincinnati, Ohio	500-325.9
WSAJ	Grove City College,	Grove City, Pa.	250-229
WSAN	Allentown Call Pub. Co.,	Allentown, Pa.	10-229
WSAP	Seventh Day Adventist Church,	New York, N. Y.	250-263
WSAR	Doughty & Welch Elec. Co.,	Fall River, Mass.	100-254
WSAU	Camp Marienfeld,	Chesham, N. H.	10-229
WSAV	Clifford W. Vick Radio Construction Co.,	Houston, Texas	100-360
WSAZ	Chase Electric Shop,	Pomeroy, Ohio	50-244
WSB	Atlanta Journal,	Atlanta, Ga.	750-428.3
WSL	J. & M. Electric Co.,	Utica, N. Y.	100-273
WSOE	School of Engineering of Milwaukee,	Milwaukee, Wis.	100-246
WTAB	Fall River Daily Herald Pub. Co.,	Fall River, Mass.	100-266
WTAC	Penn. Traffic Co.,	Johnstown, Pa.	100-209.7
WTAF	Louis J. Gallo,	2222 Lapeyrouse St., New Orleans, La.	10-268
WTAL	Toledo Radio & Elec. Co.,	Toledo, Ohio	10-252
WTAM	Willard Storage Battery Co.,	Cleveland, Ohio	1500-389.4
WTAP	Cambridge Radio & Elec. Co.,	Cambridge, Ill.	50-242
WTAQ	S. H. Van Gorden & Son,	Osseo, Wis.	100-254

## A REAL FIXED DETECTOR



For CRYSTAL and REFLEX SETS or OPERATES

as a crystal set in itself. Stands battery current, lasts indefinitely because of readjustment feature and does away with bothersome catwhisker and hunting for Hot Spot. You can depend on it being always "Hot." Can be mounted in any position or connected without mounting. Save A and B battery and Tube life, get better detection than Vacuum Tubes. Get a RADETEC and know the joy of real reception. Packed in box with brackets and instructions. Prepaid for \$1.00.

Dealers write for Discounts.

TOWNER RADIO MFG. CO.

2620 B Victor St. Kansas City, Mo.

\$9<sup>00</sup> De Roy Phusiformer NOW \$5<sup>95</sup>

Buy Direct From the Factory and Save the Difference

DE ROY RADIO CORP.

284 Plane Street Newark, N. J.

## Ford Runs 57 Miles on Gallon of Gasoline

A new automatic and self-regulating device has been invented by John A. Stransky, 198 Fourth St., Pukwana, South Dakota, with which automobiles have made from 35 to 57 miles on a gallon of gasoline. It removes carbon and reduces spark plug trouble and overheating. It can be installed by anyone in five minutes. Mr. Stransky wants distributors and is willing to send a sample at his own risk. Write him today.—(Adv.)

## PATENTS

C. L. PARKER  
Formerly Member  
Examining Corps,  
U.S. Patent Office.  
PATENT - LAWYER  
McGill Bldg., Wash., D. C.

Patents, Trade Marks, Copyrights, Patent Litigation

Handbook for Inventors. "Protecting, Exploiting and Selling Inventions," sent upon request.



# Build the Set you have dreamed of

## TROPADYNE SUPERADIO OUTFIT

\$ **60**<sup>50</sup>

SEND NO MONEY

**T**HIS Superadio 6 Tube Set brings in Station KFKX (Hastings, Nebraska), 1200 miles, in New York City, clearly on a loud speaker, using only the small loop which comes with the outfit.

The outfit advertised here is complete, as listed below, everything needed is included, down to the last screw. The charts, blueprints, directions and photos furnished are so complete and explicit that anyone can build this set and have it working within a few hours. There is nothing additional to buy except the necessary batteries and tubes. Price includes mahogany cabinet and folding loop aerial.

You can pay \$150 or more for an outfit, or \$200 or more for a set, but you cannot possibly buy a better set than this one.

**READ THIS** Utmost sharpness—Cuts thru locals bringing in long distant stations as if they were locals.

Ease of Tuning—Only two dials.

Tuned Intermediate Transformers; the only real BALANCED set of its kind made. Once transformers are tuned they need not be touched again.

Your Money Refunded if this set does not satisfy you in all respects—if after 5 days' fair trial you do not proclaim the TROPADYNE the best radio set you ever listened to.



No. A4477

### Note These Important Features:

**DISTANCE, VOLUME AND TONE QUALITY** equal to any 8 tube set sold anywhere at any price.

**LOOP RECEPTION**—Outside aerial not to be used with this set—the complete loop is included in outfit.

**PERMANENT LOGGING OF STATIONS**—Follow chart furnished; there are only two tuning controls and you will always find the same station at the same spots on the dials. Our log chart shows you at what point to find any station.

**MICROMETER VERNIER DIALS** giving you the full advantage of the exceptionally sharp tuning.

**OUTFIT IS ABSOLUTELY COMPLETE**—Drilled panel, Mahogany Cabinet and everything else needed, except tubes and batteries.

**ECONOMY and SIMPLICITY**—This is not a reflex, yet six tubes do the work for which other sets require eight to ten.

REAR VIEW OF TROPADYNE

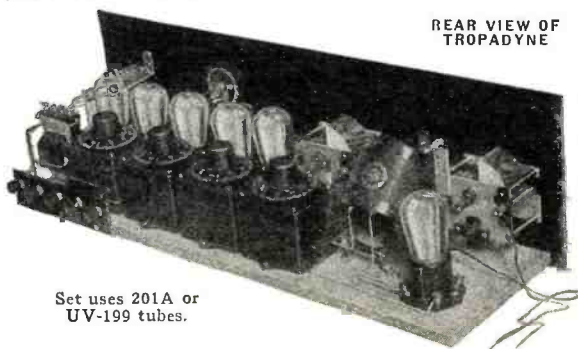

Set uses 201A or UV-199 tubes.

### The Editor of Radio News

In the August 1924 issue, said this about the Tropadyne: "Here is a remarkable receiver which we warmly recommend to our readers. It has several new and unusual features. In the first place only 6 tubes are used giving as much volume as the average 8 tube Heterodyne. The selectivity of this set is unusual. Unequalities of the intermediate transformers have now been done away with by tuning each transformer. After the transformer has been tuned, it can be left this way, no further tuning being necessary. "This system makes for maximum sharpness and maximum volume. Another outstanding point of superiority of the Tropadyne circuit is that it practically does not radiate, thereby not interfering with other nearby receiving stations. A saving of two tubes as well as an increase of selectivity is obtained with this new circuit."

### Complete List of Parts:

4 RICO Tropaformers; 1 Standard Variocoupler; 2 Certified Low Loss 23-plate Condensers; 1 Calibrated Transformer; 2 Jacks; 3 Fixed Condensers; 6 Bakelite Sockets; 2 Vernier Dials; 1 Rheostat; 1 Potentiometer; 1 7x24 Panel; 1 7x24 Mahogany Cabinet and Baseboard; 40 ft. Bus Bar Wire; 1 Folding Loop Aerial; 1 Grid Leak and Mounting; Binding Posts; Flexible Wire; 1 Bakelite Binding Post Strip; 4 doz. Screws; Full Directions.

We ship in 24 hours

**RADIO SPECIALTY COMPANY,**

**98 PARK PLACE, NEW YORK**

### Tropadyne Gets Europe!

"Received 2BD, Aberdeen, on November 25th. Results good, except noises. 11:30 to 11:40 talk, from 11:40 to 12:00 piano number. Piano number good, talk poor. Used Tropadyne Circuit."

J. ZIMMER, 157 James St., Newark, N. J.

The above has been verified by "RADIO NEWS"

SEE OUR 2-PAGE AD ON PAGES 1842 and 1843 RADIO NEWS

### RN4 SEND NO MONEY

RADIO SPECIALTY CO., 98 Park Place, New York, N. Y.

Please send at once one complete Tropadyne Superadio Outfit as advertised in April "Radio News." I will pay postman or expressman \$60.50 upon arrival.

NAME .....

STREET or R.F.D. ....

CITY ..... STATE .....



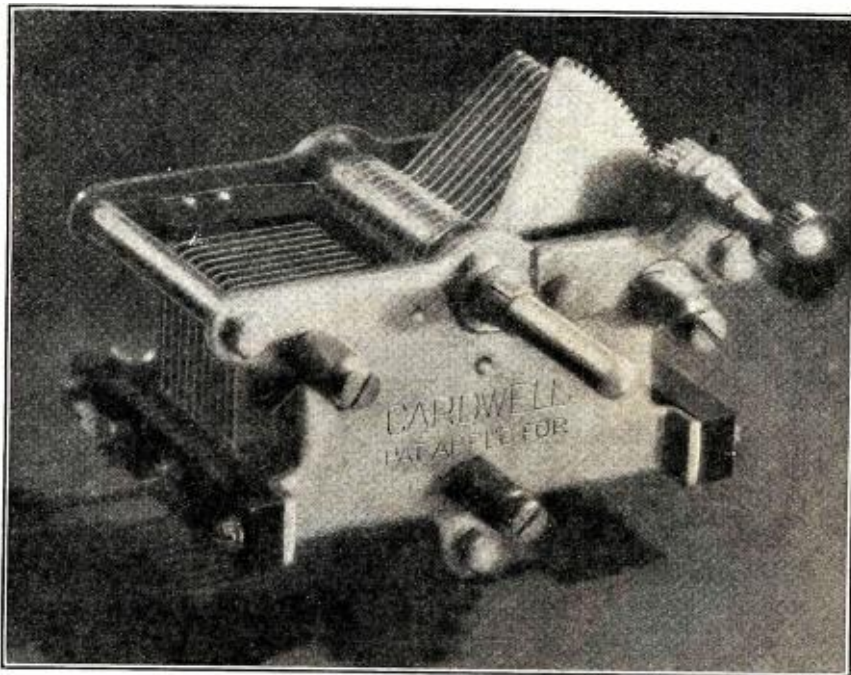

**"No fancy gewgaws to attract the eye and cause trouble in the end"**

SO writes Mr. Henry M. Neely, Editor of RADIO-IN-THE-HOME. Mr. Neely adds:

*"The present-day low-loss condenser approaches more nearly to a perfect instrument, the more nearly it approaches the design and workmanship of the Cardwell."*

Other points of merit have been praised by as many different experts. In fact, Cardwell condensers have received the universal approval of radio editors and engineers everywhere.

Simplicity is a distinctive characteristic of the Cardwell. There is no excessive bulk or weight — no intricate gears or complicated assembly.

Cardwell condensers are

rugged, free from play, noiseless and remarkably smooth in action. And there is nothing to work loose or get out of adjustment.

Cardwell invented the first "low-loss" condensers—a name originally applied only to Cardwells to distinguish them from ordinary varieties. Cardwell now makes seventy-six different types—a condenser for every requirement. Ask your dealer to show you his assortment.

A postcard brings you an education on condensers. Write today for the new Cardwell Condenser booklet.



The Allen D. Cardwell Manufacturing Corporation  
81 Prospect Street, Brooklyn, N. Y.

# CARDWELL UNITRADS

(RADIO UNITS OF MERIT)

CONDENSERS — INDUCTANCES — TRANSFORMERS

## STUDY RADIO

Under experts in a well equipped laboratory and code rooms or in your own home during spare time.

SEND FOR ILLUSTRATED BOOKLET describing our Resident and Home Study Courses.

Y. M. C. A. RADIO INSTITUTE  
158 East 86th Street New York, N. Y.

## EVERYTHING IN RADIO

Attractive Prices. Everything new. Mail order only. Orders shipped same day.  
ALL RADIO. 417 North Clark Street, Chicago, Ill.

**RADIO Bargains**

Lowest prices on highest quality standard radio sets and parts. Hundreds of big bargains. Guaranteed quality. Quick shipment. Write today for big free catalog.

**BENBEN RADIO HOUSE CHICAGO**  
12N MICHIGAN AVE Dept A-4 ILLINOIS

**WHY NOT** spend Spring, Summer and Fall gathering butterflies, insects? I buy hundreds of kinds for collections. Some worth \$1 to \$7 each. Simple outdoor work with my instructions, pictures, price-list. Send 10 cents (not stamp) for my illustrated prospectus before sending butterflies. Mr. Langstaff, Dealer in Insects, Box 1424, Dept. 37, San Diego, Cal.



Call Letters	Name	Location	Power & Wave Length
WTAR	Reliance Elec. Co.,	Norfolk, Va.	100—261
WTAS	Charles E. Erbstein, R. F. D. 6, Box 75,	Elgin, Ill. (near)	1000—302.8
WTAT	Edison Electric Illuminating Co.,	Boston, Mass. (portable)	100—244
WTAU	Ruegg Battery and Electric Co.,	Tecumseh, Neb.	10—242
WTAW	Agricultural & Mechanical College,	College Station, Texas	250—270
WTAX	Williams Hardware Co.,	Streator, Ill.	50—231
WTAY	Oak Leaves Broadcasting Station,	Oak Park, Ill.	500—250
WTAZ	Thomas J. McGuire,	Lambertville, N. J.	15—261
WTG	Kansas State Agricultural College,	Manhattan, Kan.	50—273
WTIC	The Travelers Insurance Co.,	26 Grove St., Hartford, Conn.	500—348.6
WTL	H. G. Saal Co.,	Chicago, Ill.	10—268
WWAD	Wright & Wright, Inc.,	Philadelphia, Pa.	100—250
WWAE	Alamo Ball Room,	Joliet, Ill.	500—242
WWAO	Michigan College of Mines,	Houghton, Mich.	250—244
WWI	Ford Motor Co.,	Dearborn, Mich.	250—266
WWJ	Detroit News,	Detroit, Mich.	500—352.7
WWL	Loyola University,	New Orleans, La.	5—275

### CANADA

		Wave-length Watts
CFAC	Calgary Herald, Calgary, Alberta	430—2000
CFCA	Star Printing Co., Toronto, Ont.	400—2000
CFCD	Marconi Wireless Telegraph Co., Vancouver, British Col.	440
CFCE	Marconi Wireless Telegraph Co., Halifax, Nova Scotia	440
CFCF	Marconi Wireless Telegraph Co., Montreal, Quebec	440—500
CFCH	Abitibi Power & Paper Co., Iroquois Falls, Ont.	400—500
CFCJ	La Cie de L'Evenement, Quebec, Canada	410
CFCK	Radio Supply Co., Edmonton, Alberta, Canada	410—250
CFCL	Centennial Methodist Church Victoria, British Columbia	400—500
CFCN	W. W. Grant Radio (Ltd.), Alberta, Ont.	440—1750
CFCO	Semmlhaack-Dickson (Ltd.), Bellevue, Nova Scotia	450—40
CFCQ	Radio Specialties, Ltd., Vancouver, B. C.	450—40
CFCR	Laurentide Air Service, Sudbury, Ont.	410—200
CFCS	Eastern Telephone & Telegraph Co., Halifax, Nova Scotia	410
CFCT	Victoria City Temple, Victoria, B. C.	410—500
CFCW	Radio Shop, London, Ont.	420—600
CFDC	Sparks Co., Nanaimo, B. C.	430—50
CFHC	H. Birks & Sons, Calgary, Alberta	440—1000
CFLE	C. G. Hunter, London, Ont.	430—100
CFQL	The Electric Shop, Saskatoon, Saskatchewan	400—200
CFRC	Queen's University, Kingston, Ont.	450—1500
CFTC	Bell Telephone Co., Toronto, Ont.	400
CFUC	University of Montreal, Montreal, Quebec	400
CFYC	Victor W. Odium, Vancouver, B. C.	400—20
CGAC	G. Melrose Bell, Calgary, Alberta, Can.	430
CHAC	Radio Engineers, Halifax, Nova Scotia	400—500
CHBC	Albertan Publishing Co., Calgary, Alberta, Can.	410—500
CHCB	Marconi Wireless Telegraph Co., Toronto, Ont.	440
CHCE	Western Canada Radio Supply (Ltd.), Victoria, British Columbia	400—20
CHCM	Riley & McCormick, Ltd., Calgary, Alberta	440—1000
CHCO	London Radio Shoppe, London, Ont.	410
CHCQ	Western Radio Co., Calgary, Alberta, Can.	400
CHCS	Hamilton Spectator, Hamilton, Ont.	410—2000
CHNC	Toronto Radio Research Society, Toronto, Ont.	350—200
CHVC	Metropolitan Motors, Toronto, Ont.	410
CHXC	J. R. Booth, Ottawa, Ont.	435—1200
CHYC	Northern Electric Co., Montreal, Que.	341—500
CJBC	Depuis Freres, Montreal, Que.	420
CJCA	Edmonton Journal, Edmonton, Alberta	450—500
CJCB	J. G. Bennet, Nelson, British Columbia	400
CJCD	T. Eaton Co., Toronto, Ont.	410—100

Insure your copy reaching you each month. Subscribe to Radio News—\$2.50 a year. Experimenter Publishing Co., 53 Park Place, N. Y. C.



**Balkite Battery Charger.**  
Charges 6-volt "A" storage batteries.

Price \$19.50  
West of Rockies, \$20  
In Canada, \$27.50

**Balkite "B"**—replaces "B" batteries and dry cells. Operates from light socket.

Price \$55  
In Canada, \$75



# Balkite Radio Power Units

*give your set greater clarity,  
distance and volume*

Your radio set will perform consistently only if your power supply is unfailing. Balkite Radio Power Units provide a convenient power supply that furnishes a constant, uniform voltage to both "A" and "B" circuits. The Balkite Charger keeps your "A" storage battery charged and operating at full efficiency. Balkite "B" replaces both "B" storage batteries and dry cells, and supplies plate current from the light socket.

The Balkite Battery Charger

and Balkite "B" are based on the same principle. Both are entirely noiseless in operation, have no moving parts or bulbs, have nothing to adjust, break or get out of order. They do not create disturbances in either your set or your neighbor's, require practically no attention, and can be put in operation at any time by merely connecting to the light socket. Their current consumption is very low. Both are guaranteed to give satisfaction.

*Sold by leading radio dealers everywhere*

**FANSTEEL**  
**Balkite** *Radio Power Units*

BALKITE BATTERY CHARGER — BALKITE "B" PLATE CURRENT SUPPLY

*Manufactured by FANSTEEL PRODUCTS COMPANY, Inc., North Chicago, Ill.*



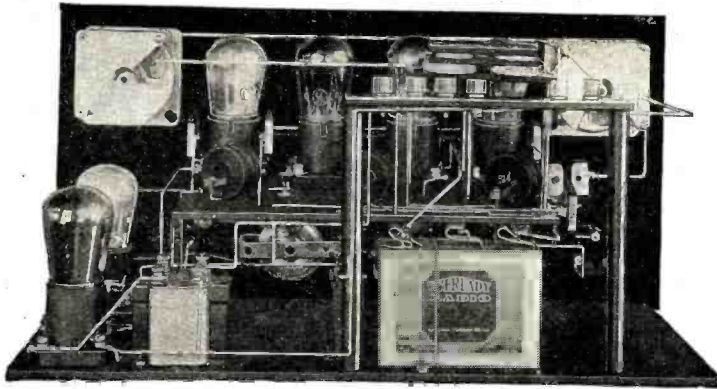

REAR VIEW OF SET SHOWING "SUPERUNIT"

# The "Superunit" Patent Applied for

One customer writes in:—"I have received on this set every 500 watt station in the U. S. with the exception of KFGX, almost all Canadian stations, two in Mexico as well as 6KW, WMAQ, WGAD, and PWX."

The "Superunit" can be used with any make of other apparatus without affecting results. If you have some of the parts on hand why not get a "Superunit" and make a real set?

Unconditionally guaranteed for results and shipped anywhere for \$37.50. Charges Collect.



**ALLAN T. HANSCOM**  
WOONSOCKET, R. I., U. S. A.

## ALL THE PARTS FOR \$75

We supply a bakelite panel and base all drilled with all parts mounted and ready for wiring for \$75. The list of parts is as follows:

- 1 Hanscom "Superunit"
- 2 .0005 Vernier Condensers
- 2 Apex Dials
- 1 Chelton Midget Condenser
- 1 6-ohm Rheostat
- 1 1 mfd. By-pass Condenser
- 1 30-ohm Rheostat
- 2 Thordarson Audio Frequency Transformers
- 2 Tube Sockets (Cutler Hammer)
- 1 Single Circuit Jack (Filament control)
- 1 Double Circuit Jack
- 1 Grid Bias Battery
- 6 Eby Binding Posts

	Wave-length Watts
CJCE	Sprott Shaw Radio Co., Vancouver, British Columbia... 420—150
CJCF	The News-Record (Ltd.), Kitchener, Ont. .... 295—300
CJCG	Manitoba Free Press, Winnipeg, Manitoba ..... 410
CJCI	Maritime Radio Corp., St. John, New Brunswick..... 400
CJCK	Radio Corp. of Calgary, Ltd., Calgary, Alberta ..... 316—500
CJCM	Dr. J. L. P. Landry, Mont-Joli, Quebec ..... 312—500
CJCN	Simons Agnew & Co., Toronto, Ont. .... 410
CJCX	Percival Wesley Shackleton Olds, Alberta ..... 400
CJGC	Free Press Printing Co., London, Ontario ..... 430—200
CJNC	Tribune Newspaper Co., Winnipeg, Manitoba ..... 400
CJSC	Evening Telegram, Toronto, Ont. .... 430—500
CKAC	La Presse Publishing Co., Montreal, Quebec ..... 425—2000
CKCD	Daily Province, Vancouver, British Columbia ..... 410—2000
CKCE	Canadian Ind. Telephone Co., Toronto, Ont. .... 450—2000
CKCI	Le Soleil Publ. Co., Quebec
CKCK	G. Melrose Bell (Leader Pub. Co.), Regina, Saskatchewan. 420—2000
CKCO	Dr. G. M. Geldert, Ottawa, Ont. .... 400—200
CKCR	Jones Electric Co., St. John, New Brunswick ..... 400
CKCS	Bell Telephone Co., Montreal, Que. .... 400
CKCX	P. Burns & Co., Calgary, Alberta ..... 440—1000
CKOC	Wentworth Radio Supply Co., Hamilton, Ont. .... 410—100
CKQC	Radio Supply Co., Ltd., London, Ont. .... 410
CKY	Manitoba Telephone System, Winnipeg, Manitoba ..... 450—500
CKZC	Salton Radio Engineering Co., Winnipeg, Manitoba ..... 420
CNRC	Canadian Nat'l Railways, Calgary, Alberta ..... 440—1000
CNRE	Canadian Nat'l Railways, Edmonton, Alberta ..... 450—500
CNRM	Canadian Nat'l Railways, Montreal Quebec ..... 341—2000
CNRO	Canadian Nat'l Railways, Ottawa, Ont. .... 435—500
CNRR	Canadian Nat'l Railways, Regina, Sask. .... 420—2000
CNRS	Canadian Nat'l Railways, Saskatoon, Sasks. .... 400—500
CNRT	Canadian Nat'l Railways, Toronto, Ont. .... 400—2000
CNRW	Canadian Nat'l Railways, Winnipeg, Manitoba ..... 450—2000

## CUBAN BROADCAST STATIONS

	Wave-length Watts
PWX	Cuban Telephone Co., Havana 400—500
2DW	Pedro Zayas, Havana ..... 300—100
2AB	Alberto S. de Bustamante, Havana ..... 240—20
2OK	Mario Garcia Vélez, Havana... 360—100
2BY	Frederick W. Borton, Havana 260—100
2CX	Frederick W. Borton, Havana 320—10
2EV	Westinghouse Elec. Co., Havana ..... 220—50
2TW	Roberto E. Ramirez, Havana 230—20
2HC	Heraldo de Cuba, Havana... 275—500
2LC	Luis Casas, Havana ..... 250—30
2KD	E. Sánchez de Fuentes, Havana ..... 350—100
2MN	Fausto Simón, Havana ..... 270—300
2MG	Manuel G. Salas, Havana ..... 280—20
2JQ	Raúl Pérez Falcón, Havana... 150—10
2KP	Alvaro Daza, Havana ..... 200—10
2HS	Julio Power, Havana ..... 180—20
2OL	Oscar Collado, Havana ..... 290—15
2WW	Amadeo Sáeng, Havana ..... 210—20
5EV	Leopoldo V. Figueroa, Colón... 360—100
6KW	Frank H. Jones, Tuinucú... 340—100
6KJ	Frank H. Jones, Tuinucú... 275—100
6CX	Antonio T. Figueroa, Cienfuegos ..... 170—20
6DW	Eduardo Terry, Cienfuegos.. 225—10
6BY	José Ganduxe, Cienfuegos... 300—100
6AZ	Valentin Ullivarri, Cienfuegos 200—10
6EV	Josefa Alvarez, Caibarién... 225—20
7AZ	Pedro Nogueras, Camaguey.. 225—
7BY	Salvador Rionda, Camaguey.. 350—
8AZ	Alfredo Broocks, Santiago de Cuba ..... 240—20
8BY	Alberto Ravelo, Santiago de Cuba ..... 250—100
8FU	Andrés Vinnat, Santiago de Cuba ..... 225—15
8DW	Pedro C. Anduz, Santiago de Cuba ..... 275—50
8EV	Eduardo Mateos, Santiago de Cuba ..... 180—75
8GT	Juan F. Chibas, Santiago de Cuba ..... 260—

**DEALERS**

Sharp Discounts On Standard Quality Parts

Every dealer should have our big bargain catalog showing hundreds of standard radio parts, kits and knock-down sets. Same day shipments. Write for free catalog now on your letterhead.

**FREE CATALOG**

**WESTERN RADIO**  
138 W. Lake St. Dept. 3-4 CHICAGO

**RADIO TUBE EXCHANGE**

We Repair All Standard Makes of Tubes Including

W.D.-11 or 12  
U.V.-199 or C.-299  
C.-11 or 12  
U.V.-201A or C-301-A  
D.V.-1 or D.V.-2  
U.V.-200 or 201  
C.-300 or 301

**\$1.50**

U. V. 202 Repaired, \$3.00

ALL TUBES GUARANTEED TO DO THE WORK

**RADIO TUBE EXCHANGE**  
200 BROADWAY NEW YORK CITY, N. Y.  
All Mail Orders Given Prompt Attention  
Orders Sent Parcel Post C. O. D.

OLD COINS, LARGE SPRING SELLING catalogue of coins for sale free. Catalogue quoting prices paid for coins, ten cents. William Hesselin, 101K Tremont Street, Boston, Mass.

**Print Your Own**

Cards, Stationery, Circulars, Paper, etc. Complete Outfits \$8.85 up. Save money Print for others, big profit. All easy, rules sent. Write for catalog presses type, paper etc. **THE PRESS CO., L-72, Meriden, Conn.**



# Radio Without the Horn!

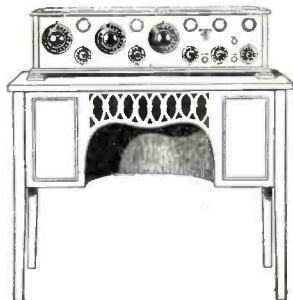

Goodbye to the Old-Fashioned Horn Speaker!

A Vastly Better Reproduction With this New Radio Console!

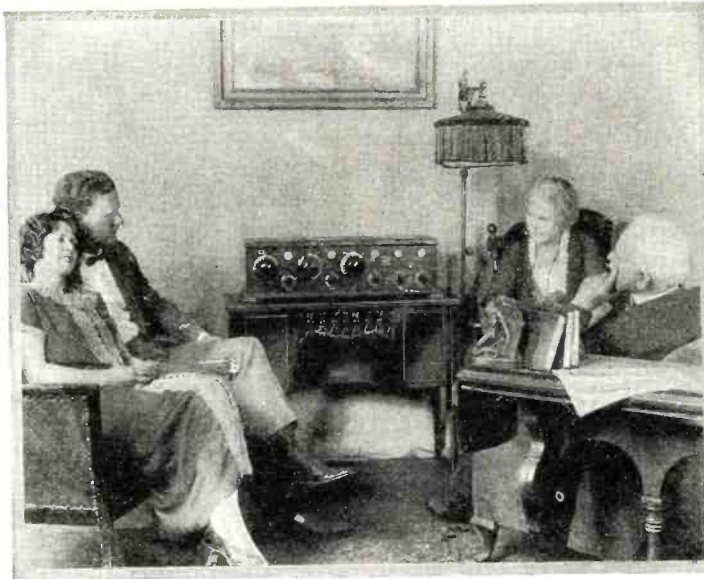

"Our old horn speaker never gave tones like this! An artistic addition to the living room—everything in its place—it's a joy!"

New Console Has Its Own Perfect Loudspeaker!

Ample Space for All the Rest of Your Outfit!

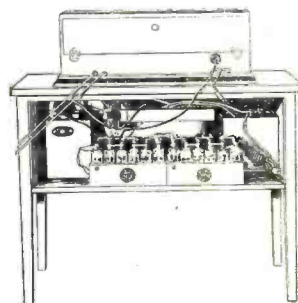

HERE is something that enables you to enjoy radio in the home without the clutter of unsightly apparatus that plays havoc in the decorative scheme of your living room! The horn speaker is out of date and out of place in radio for the home. This console with its in-built loudspeaker is scientific and sightly.

### A Truly Wonderful Tone

It does a good job of reproducing, for it has a good unit and its sound-box is of resonant wood instead of metal, fibre, or composition.

The appearance of a Windsor loudspeaker console is a delight. Its convenience is a joy. A piece of real living room furniture of pleasing lines and finish—and it accommodates all the miscellany of equipment which hitherto had no place except on table tops, shelves or floor. Ample space on top for any set, with plenty of elbow room in front. Nothing in sight but the console and receiving set. Everything else goes inside—from behind—in spaces cleverly designed to hold the largest batteries and outfit for home use—besides the self-contained loudspeaker—all unseen and protected from dust or disturbance.

### You Need This Console Whatever Your Present Outfit Is

It makes no difference what kind of radio outfit you have—this console was designed for your use. The graceful exterior of this console gives no hint of its inner utility, for it is a simple and effective piece of furniture in every line. But a glance at the interior reveals a most ingenious arrangement of the in-built loudspeaker with space either side and in back. These spaces are ample for the largest A battery, and the largest wet B batteries and the largest charging outfit for home use. It is 38 in. long 18 in. deep, and 29 in. high. Notice the artistic grill that conceals sound box, and the provision of "knee room" beneath. Made in mahogany or walnut finish, and the price is only \$40! (West of the Rockies \$42.50.)

### Dealers!

The sale of these consoles has already reached extraordinary figures. They are selling in surprising quantities in even smallest stores where there is one in the window or on the floor. It is a convenience and a value not to be duplicated.

Write us for discounts and particulars.

### Investigate!

Dealers everywhere are now showing the Windsor loudspeaker console, and have them for immediate delivery to your home. If you haven't already seen this remarkable contribution to radio enjoyment and convenience, write us now for the name of a nearby store where you may view it. We will also send you complete information. Remember, this console gives you not alone a reproducing unit and sound-box, but an altogether new beauty and utility in the provision for your entire radio outfit. Mail coupon or postal. If you wish to use your own favorite unit, a deduction will be made for omission of unit.



Pat. Nov. 18, 1924

**\$40**

Loudspeaker Included

*Windsor Loudspeaker Console*

West of the Rockies \$42.50

Windsor Furniture Company  
1422 Carroll Ave., Chicago

(17)

Please furnish pictures and full details, also name of nearest dealer who has the new Windsor loudspeaker console.

Name .....

Address .....



# 17-17-17 always gets **KDKA** on every **Day-Fan**

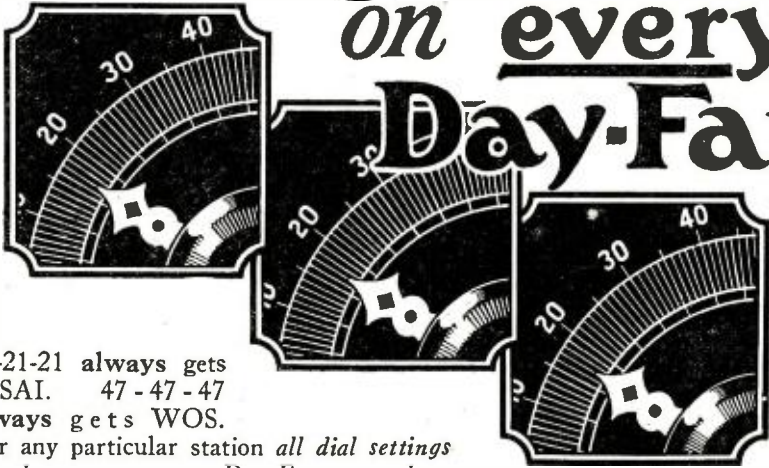

21-21-21 always gets WSAI. 47-47-47 always gets WOS. For any particular station all dial settings are the same on every Day-Fan—anywhere—with any antenna.

All uncertainty is eliminated. You know even before you get your Day-Fan, just where to set the dials to pick up any station you desire. Could any set be more simple?

Tone? Listen in on a Day-Fan and you will have to revise your ideas of tone. Selectivity? The equal of any five-tube set made. Appearance? The popular brown mahogany finish in the finest of cabinet work. Volume? So strong you have to dampen it for many stations. Range? Spans the continent. Models? Five different types. Price? \$90 to \$285.

Where else can you possibly get such values?

**The Dayton Fan & Motor Company**  
Dayton, Ohio

For 36 years, manufacturers of high-grade electrical apparatus.

# Day-Fan RADIO A YEAR AHEAD

## LEARN THE CODE AT HOME

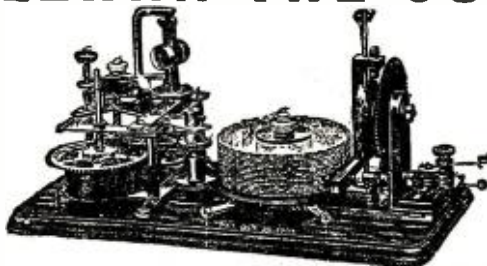

### WITH OMNIGRAPH

THE OMNIGRAPH Automatic Transmitter will teach you both the Wireless and Morse Codes—right in your own home—quickly, easily and inexpensively. Connected with Buzzer, Buzzer and Phone or to Sounder, it will send you unlimited messages, at any speed, from 5 to 50 words a minute.

THE OMNIGRAPH is not an experiment. For more than 15 years, it has been sold all over the world with a money back guarantee. The OMNIGRAPH is used by several Depts. of the U.S. Govt.—in fact, the Dept. of Commerce uses the OMNIGRAPH to test all applicants applying for a Radio license. The OMNIGRAPH has been successfully adopted by the leading Universities, Colleges and Radio Schools.

Send for FREE Catalog describing three models. DO IT TODAY.

**THE OMNIGRAPH MFG. CO., 20 HUDSON STREET, NEW YORK CITY**  
If you own a Radio Phone set and don't know the code—you are missing most of the fun

Insure your copy reaching you each month. Subscribe to Radio News—\$2.50 a year. Experimenter Publishing Co., 53 Park Place, N. Y. C.

### MEXICO

		Wave-length	Watts
CYA	Partido Liberal Avanzado, Mexico City	540—	100
CYB	El Buen Tono, S. A., Mexico City	380—	500
CYC	Ministerio de Comunicaciones, Mexico City (Experimental)		
CYG	Ministerio de Guerra & Marina, Mexico City (Experimental)		
CYL	El Universal and La Casa del Radio, Mexico City	510—	500
CYO	Constantino Tarnava, Jr., Monterrey, N. L.	280	
CYR	Sin. Rossiter & Compania, Mazatlan	440—	250
CYX	Excelsior-Parker, Mexico City	350—	500
CYZ	Liga Central Mexicana de Radio, Mexico City	400—	100
CZA	Departamento de Aviacion, Ministerio de Guerra, Mexico City	510—	100
IJ	Fabrica Nal. de Vestuario, Mexico City		
IR	F. C. Steffenex, Mexico City	250	
FAM	Fuerza Aerea Mexicana, Mexico City	500	

### AUSTRALIA

		Wave-length	Watts
2BL	Broadcasters, Ltd., Sidney, N. S. W.	350—	500
2FC	Farmer & Co., Ltd., Sidney, N. S. W.	1100—	5000
2FL	Farmer & Co., Ltd., Sidney, N. S. W.	770—	500
2SB	Sydney Broadcasters, Sydney, N. S. W.	—	500
3AR	Ass. Radio Co., Ltd., Melbourne, Victoria	480—	1600
3FL	Farmer & Co., Ltd., Melbourne, Victoria	400—	500
3LO	Farmer & Co., Ltd., Melbourne, Victoria	1720—	5000
5MA	Millswood Auto & Radio, Ltd., Adelaide, S. Aust.	850—	3000

### EUROPEAN RADIO STATIONS

#### AUSTRIA

		Wave-length	Watts
Radio—Wien	Vienna	530—	1000
Radio—Hekaphon	Vienna	600	

#### BELGIUM

		Wave-length	Watts
BAV	Haeren	1100	
SBR	Radio Electrique, Brussels	265	

#### CHINA

Macao (Portuguese colony), no particulars available except that an excellent station of high power is located there.

#### ITALY

		Wave-length	Watts
ICD	Unione Radio fonica Italiana, Rome	540,1800—	3200
	Radioaldo, Rome	426—	1.5

#### PORTUGAL

	Aero Lisboa, Lisbon	375—	410
--	---------------------	------	-----

#### SPAIN

EBX	Cartagena	1200	
	Radio Iberica	392	

#### SWEDEN

	Boden	2800	
	Nya Varvet, Gothenburg	460	
	Radiobolaget, Stockholm	470	
	Telegrafverket, Stockholm	440	

#### SWITZERLAND

MB1	Ste. Romande	1100	
HB2	Lausanne	850	
	Zurich University, Zurich	515	

#### ARGENTINA

LOR	Buenos Aires	400	
LOX	Palermo, Argentin Radio Cultura	375	
LOZ	Monte Grange, Arg. Broadcast Ass'n.	425	

#### PORTO RICO

WKAQ	San Juan, Radio Corp. of Porto Rico	360	
WPR	Ensenada, South R. R. Sugar Co.	600	
WGAD	Ensenada Sp. Am. School of Tel.	300	
WGW	Vieques, Bureau of Insular Tel.	600	
WKK	Ceiba, Bureau of Insular Tel.	600	

#### CZECHO SLOVAKIA

OKP	Kbley (near Prague)	1150	
Brunn	Komarov	1800	
PRG	Prague	1000	

#### DENMARK

OXE	Lyngby	2400	
-----	--------	------	--

#### FRANCE

FL	Eiffel Tower, Paris	2600—	8000
	Radio-Paris, Clichy	1780—	15000



# ZENITH

TRADE MARK REG.

## RADIO

→ LONG DISTANCE ←  
TRADE MARK REG.



Super-Zenith IX—  
the ideal radio set  
for the fine home

## Every Night Is "Distance Night" With Zenith—

**I**N Chicago twelve powerful broadcasting stations are on the air every night of the week except Monday. The wave-span ranges from WBCN (266 meters) to KYW (536 meters). No testing ground in radio reception offers the difficulties experienced in this location.

But—whether it's Monday night or any other night, Zenith receiving sets in Chicago bring in dozens of distant stations clearly and without the slightest hum of interference . . . and this in the very storm center of Chicago's broadcasting area, the near North Side.

Power to reach out and bring in distance—clarity of tone—selectivity—these are the factors which have made Zenith supreme in the field of radio reception, and in proof of that supremacy Zenith invites and welcomes side-by-side tests, in any location you may name. Its standing challenge: More stations in a given length of time, clearly and with volume, than can be brought in by any other receiving set on the market.

Zenith is handled only by selected dealers who give you service. We give the Zenith agency franchise only to dealers who will give you service AFTER THE RADIO IS SOLD. When you buy a ZENITH, we are not through. Our exclusive dealer's service man will call once a week or oftener if you want him. This costs you nothing. In other words, Zenith dealers have done your shopping for you.

Write us for the name of your nearest exclusive Zenith dealer

**ZENITH RADIO CORPORATION**  
332 South Michigan Avenue, Chicago  
ZENITH—the exclusive choice of MacMillan for his North Polar Expedition

The complete Zenith line ranges in price from \$95 to \$550.

With either Zenith 3R or Zenith 4R, satisfactory reception over distances of 2,000 to 3,000 miles is readily accomplished, using any ordinary loud speaker. Models 3R and 4R licensed under Armstrong U. S. Pat. No. 1,113,149. They are NON-RADIATING.

Zenith 4R - - \$95  
Zenith 3R - - \$160

The new Super-Zenith is a six-tube set with a new, unique, and really different patented circuit, controlled exclusively by the Zenith Radio Corporation. It is NOT regenerative.

**SUPER-ZENITH VII**—Six tubes—2 stages tuned frequency amplification—detector and 3 stages audio frequency amplification. Installed in a beautifully finished cabinet of solid mahogany—44 inches long, 16 inches wide, 10 inches high. Compartments at either end for dry batteries. Price (exclusive of tubes and batteries) **\$230**

**SUPER-ZENITH VIII**—Same as VII except—console type. Price (exclusive of tubes and batteries) **\$250**

**SUPER-ZENITH IX**—Console model with additional compartments containing built-in Zenith loud speaker and generous storage battery space. Price (exclusive of tubes and batteries) **\$350**

**SUPER-ZENITH X**—Contains two new features superseding all receivers. 1st—Built-in, patented, Super-Zenith Duo-Loud Speakers (harmonically synchronized twin speakers and horns), designed to reproduce both high and low pitch tones otherwise impossible with single-unit speakers. 2nd—Zenith Battery Eliminator, distinctly a Zenith achievement. Requires no A or B batteries. Price (exclusive of tubes) **\$550**

Price (without battery eliminator) **\$450**  
All Prices F. O. B. Factory.

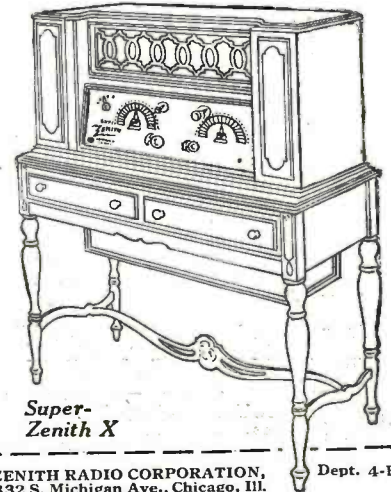

Super-Zenith X

ZENITH RADIO CORPORATION, Dept. 4-B  
332 S. Michigan Ave., Chicago, Ill.  
Gentlemen: Please send me literature describing Zenith radio sets.

Name.....

Address.....



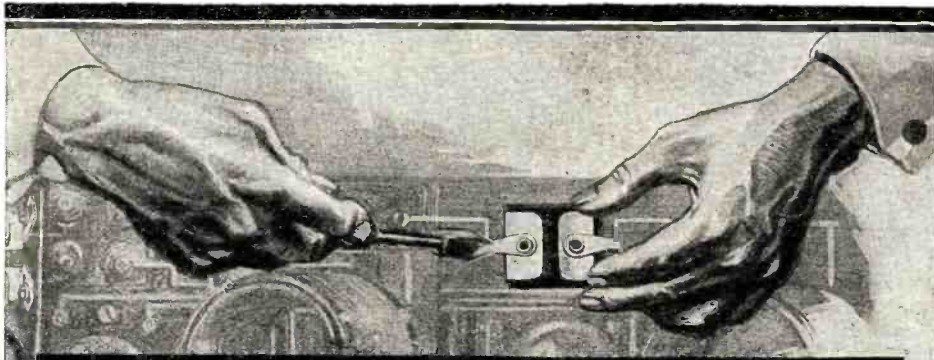

## Nine out of ten sets use MICADONS

**N**INE out of every ten sets made use Micadons—the standard fixed radio condenser. Set builders choose them for many reasons.

*They know that the Micadon is a Dubilier product: hence supreme in quality and efficiency.*

*They know that Micadons can be obtained in accurately matched capacities and the capacity is permanent.*

*They know that Micadons are easily installed, equipped as they are with extension tabs for soldering and eyelets for set screw assembly.*

*They know that Micadons are made with type variations to meet every possible requirement.*

*For best results use Micadons*

# Dubilier

CONDENSER AND RADIO CORPORATION

**Buy Now Pay Later**

### Let Boice Help You Build It!

No matter what you want to build, Boice can help you. He'll send you the

#### Boice-Crane JUNIOR SAW

or any other Boice-Crane machine on monthly payments. He gives you unsurpassed values at lowest prices with a positive money-back guarantee. Machine shown will saw, sand, grind, miller, rabbit, tenon, etc. Sturdy, accurate, economical. Saws 1½" stock. Sold with or without motor.

Write today for Descriptive Catalog of Bench Saws, Drills, Jointers and Band Saws and the Boice E-Z-Pay Plan.  
W. B. & J. E. BOICE Dept. 804-A Toledo, Ohio  
"World's Largest Makers of Small Bench Machines"

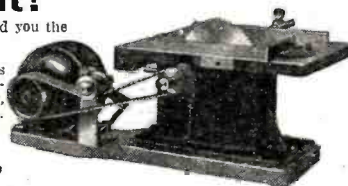

### "Radio" with Volume and Distance

A "COLYTT" Adjustable Grid-Leak improves receiving. Proper value of leak in grid circuit—gives greater distance—louder and clearer signals.

Try a "COLYTT" Grid-Leak tonight. MONEY BACK GUARANTEE. Sent postpaid with full directions for \$1.00.

THE COLYTT LABORATORIES  
565 West Washington Street. CHICAGO, ILL.



Know The REAL Flavor of PURE VERMONT MAPLE HONEY FRESH from the farm

5½ lb. tin, \$2.00      2½ lb. tin, \$1.10      11 lb. tin, \$3.75  
Shipped C. O. D. (Parcel Post added)  
Our supply is limited, order early  
RAYMOND V. PARKER      Lowell, Vermont

Insure your copy reaching you each month. Subscribe to Radio News—\$2.50 a year  
Experimenter Publishing Co., 53 Park Place, N. Y. C.

		Wave-lengths	Watts
PTT	L'Ecole Supérieure des Postes et Telegraphes	450—	500
	Le Petit Parisien, Paris	345—	500
YN	Lyons	470—	500

#### GERMANY

Vox Haus	Berlin	430
	Telefunken Co.	290
LP	Königswusterhausen, Berlin	680
	Breslau	415—1500
	Frankfort-on-Main	467—1000
	Hamburg	392—1500
	Königsburg	463—1500
	Leipzig	452—1500
	Munich	485—1500
	Munster	407—1000
	Stuttgart	437—1500

#### GREAT BRITAIN

2BD	Aberdeen	495 meters
51T	Birmingham	475
6BM	Bournemouth	385
5WA	Cardiff	350
5XX	Chelmsford	1600
2EH	Edinburgh (relay)	325
5SC	Glasgow	420
2LS	Leeds-Bradford (relay)	310—346
6LV	Liverpool (relay)	318
2LO	London	365
2ZY	Manchester	375
2NO	Newcastle	400
5PY	Plymouth	330
6FL	Sheffield (relay)	303

#### HOLLAND

PA5	Amsterdam	1050
PCFF	(Vas Diaz) Amsterdam	2000
NSF	Hilversum	1050
PCM	Ijmuiden (Middelroad)	1050
PCGG	The Hague	1070
PCKK	The Hague (Velthuisen)	1050
PCUU	The Hague Heussen Laboratory	1050

#### IRELAND

2BE	Belfast	435
-----	---------	-----

## Correspondence From Readers

(Continued from page 1904)

of these sets complain of interference. I also built an Ultradyne. This set brings in PWX at Havana with good volume on the loud speaker every time that station is on the air. The owner of this set, Mr. M. G. Peterson, at Pillebury, N. D., will verify this statement. He never is troubled with interference.

It appears to me that Wilfred Taylor is a DX hound trying to get DX stations without a DX receiver, otherwise he would not have trouble tuning WTAS on 286 meters out of the western stations, the nearest wavelength to Elgin being KGO on 312 meters. If Mr. Taylor's set cannot separate these two stations, I agree with him that it would be quite a sensation, almost a miracle, to hear a western station with that type of receiver. As for listening to rubbish and suffering for interminable hours, I have only this to say: If this so-called horrible music hurts you and you can't tune it out, just shut your radio off and it will no doubt stop. This feature is one advantage of the radio sets of this day. The broadcasting in the good old U. S. A. costs us nothing, so why kick about a thing we get free?

JOHN B. MONEAR,  
Dazey, N. D.

## EDITORIAL BRINGS MEMORIES OF BOYHOOD DAYS

Editor, RADIO NEWS:

I have had it on my mind for some time to impose on you for a moment to express my keen appreciation of that editorial in a recent issue, November, I believe, on giving the boy some electrical stuff to play with. It struck a responsive chord, as it were. It was about thirty-five years ago that I began playing with batteries and such. I well remember my home-made batteries in which the carbon element was a piece of electric light carbon that the lamp trimmer or whatever he was called had thrown away. There was no such thing as buying a battery in those days, not at least in my young life nor any of my boyhood friends.



# Formica Maintained its Leadership

**F**ORMICA again during the past season maintained the leadership it has held for several years as an insulating material for radio uses.

With few exceptions every important radio manufacturer in the country used Formica — more than 125 in all.

They find it pays. For Formica is thoroughly dependable as insulation and provides a strikingly handsome panel for the front of a radio set. Formica has set a standard of good appearance — and permanent and lasting good appearance — which creates sales resistance of considerable proportions for the manufacturer who uses cheaper material.

Of course, wise amateur set builders are moved by the same motives that determine the choice of the set manufacturer. They, too, want good looks and lasting beauty; perfect insulation, strength, and freedom from sagging, warping, softening and discoloring.

Formica is one of the most permanent materials available in the world today. In any climate, under any conditions, it remains almost forever — just as you see it when it is new.

Write for booklet, "What Formica Is."

**THE FORMICA INSULATION COMPANY**  
4618 Spring Grove Ave.  
Cin. O.

**SALES OFFICES**

50 Church Street.....	New York, N. Y.
9 South Clinton St.....	Chicago, Ill.
516 Caxton Bldg.....	Cleveland, Ohio
1142 Granite Bldg.....	Rochester, N. Y.
422 First Avenue.....	Pittsburg, Pa.
6 Beacon Street.....	Boston, Mass.
55 Calle Obispo.....	Habana, Cuba
289 Victoria St.....	Toronto, Ontario, Canada
1026 Second Avenue.....	Minneapolis, Minn.
1210 Arch Street.....	Philadelphia, Pa.
708 Title Building.....	Baltimore, Md.
585 Mission Street.....	San Francisco, Cal.
419 Ohio Building.....	Toledo, Ohio
309 Plymouth Bldg.....	New Haven, Conn.
Whitney Central Bldg.....	New Orleans, La.

## Write for Booklet "What Formica Is"

- 1 Formica is used by 125 leading makers — and has for years been used by more makers than all other materials.
- 2 Formica will last forever.
- 3 Formica, in appearance, is the finest of all panel materials and always remains so.
- 4 Formica's electrical qualities of every kind far exceed any possible requirement.
- 5 Formica has high mechanical strength and will not break in use.
- 6 Formica will not sag from heat or cold flow under pressure. It retains its dimensions. Everything you fasten to it stays tight and precisely where you put it.
- 7 Formica panels are sold in neat craft paper envelopes which assure you that you are getting the genuine.
- 8 Formica is one of the most widely approved materials in radio.

# FORMICA

Made from Anhydrous Bakelite Resins  
**SHEETS TUBES RODS**

Hear the Formica band every Wednesday evening from 9 to 10 Central Standard Time over WLW.





**GOLDEN-LEUTZ**

**PLIODYNE-6**

TRADE MARK REG.

"The Perfect Broadcast Receiver"

# A New Superior Broadcast Receiver

Simple—Long Range—Highest Quality  
Non Radiating — Non Regenerative

Two Stages Tuned Radio Frequency-Detector  
and Three Stages of Audio  
Frequency Amplification



**\$60.00**

Completely  
Constructed  
Without Accessories

PLIODYNE 6

Front View Showing Simplicity of Control

PLIODYNE 6

Interior View Showing Compact and Efficient Design

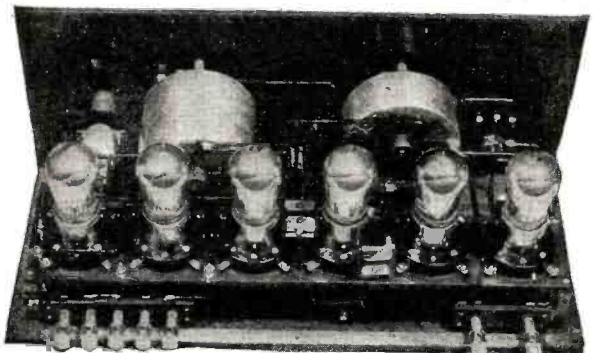

Sold Direct  
From  
Manufacturer  
To Consumer  
Only

Sent C. O. D. Subject to Examination

## OUR GUARANTEE

We guarantee every Golden-Leutz "Pliodyne 6" to be the finest broadcast receiver that can be manufactured using 6 tubes or less and to be satisfactory to you in every way and to reach you in perfect condition.

**GOLDEN-LEUTZ, Inc.**

476 BROADWAY

NEW YORK CITY

Licensed under Farrand Agreement and Hogan Patent No. 1,014,002

### "AIR ROAMER"

A McCall Compensated Circuit set, simple to operate, extremely selective, giving true tones, rugged and economical. Write for details.

KILBOURNE & CLARK MFG. CO.  
Seattle, Washington

BRANCHES: Portland, Ore.; Los Angeles; San Francisco. Distributors: Pacific Electric Co., Sydney, Australia.

### GOLD SEAL HOMCHARGER

The World's Most Popular Battery Charger  
Write for Booklet

THE AUTOMATIC ELECTRICAL DEVICES CO.  
121 West Third Street Cincinnati, Ohio

### RADIO TUBES REPAIRED

Like new **\$2.00** and guaranteed.  
ALL TYPES.

Mail in your burnt-out or broken tubes. Satisfaction guaranteed. Prompt service on mail orders.

OHIO RADIO SALES, Dept. R  
732 Rose Bldg. Cleveland, Ohio

### DUOTRON \$12

Floating Battery Charger

Durkee-Thomas Products Co.

1228 Folsom Street--San Francisco  
115 West 16th Street--Los Angeles

When my son reached an age at which he was interested in such things, he had a few dry cells, buzzers, key and sounder, etc. They gave him a great deal of amusement, interested him in electricity and no doubt helped materially in fitting him for practical work in electricity.

Pardon this imposition on your time, but I really did want to send an applause card for that editorial.

BEECHER OGDEN,  
Pleasantville, N. Y.

### FROM AN APPRECIATIVE READER

Editor, RADIO NEWS:

Coué said—"Every day, in every way, I am getting better and better." This phrase should be changed to "Every month, in every way, RADIO NEWS gets better and better."

I have a copy of the February issue on my desk and must say that it is simply fine. I cannot refrain from writing and telling you that your magazine is, without question, a most complete treatise on the subject of radio. The article by A. P. Peck on "When Your Set Stops Working" is particularly fine and calls for special mention. Also the continued article on "Reflex Radio Receivers in Theory and Practice," by John Scott-Taggart, is especially interesting and merits favorable comment. There are other articles in this issue which deserve special mention, and I want to congratulate you and your associates on the wonderful and excellent book which you are putting out.

I am a constant reader of RADIO NEWS and it gives me great pleasure to be able to enjoy the many interesting articles which are published in this magazine.

L. R. TABER,  
Box 455, Camden, Ark.

### THE EARTH AND THE HEAVISIDE LAYER SEEN AS THE PLATES OF A CONDENSER

Editor, RADIO NEWS:

In seeking a suitable theory to fit the transmission of radio energy around the curvature of the earth, why not consider the action of a condenser and see if it doesn't appear very probable that this is the way in which it is done? This idea suggested itself after reading the article by Sir Oliver Lodge in RADIO NEWS for December, 1924, entitled, "The Behavior of Radio Waves and the Heaviside Layer." In this article are presented some probable causes for radio waves curling around the earth instead of going in straight lines from the sending station and out into space.

In the two elements most involved in the transmission of radio waves, namely the earth's surface and the Heaviside layer, we have the two essential parts of an electrical condenser with an insulating layer of air between. Now it seems easily possible that the energy from a sending radio station as it spreads in all directions would soon reach the Heaviside layer and the earth's surface and would expend itself as a charge upon the surfaces of these two elements. Nor would it require as much energy to do this as would at first seem necessary because of the fact that they are already oppositely charged with respect to one another and only a small amount of energy is necessary to create a ripple or disturb their equilibrium. Also we would expect a reduction in the strength of signals by day on account of the fact that the layer of air between the plates of our condenser would be ionized by the action of sunlight, causing a partial short circuit, and this is exactly what happens. Possibly some of the energy in the daytime is carried to earth immediately after leaving the aerial by the stream of electrons from the sun in much the same manner that the

Insure your copy reaching you each month. Subscribe to Radio News—\$2.50 a year  
Experimenter Publishing Co., 53 Park Place, N. Y. C.





## In touch with two continents from mid-ocean

**T**HE world's biggest ship carries the world's greatest steamship radio. In crossing the Atlantic the Leviathan is never out of touch with Europe and America. Even if her main radio set should fail, there is an emergency radio always ready for any crisis. In these vital radio installations Exide Batteries are used because of their dependable power.

Exide Radio Batteries went to the Arctic on MacMillan's snug little ship Bowdoin. Exides were with the round-the-world fliers and on the Navy airship Shenandoah. They are being used

in the new radio photography. Exide Batteries are on duty in government and commercial radio stations all over America.

### In your home set

The Exides made for your home receiving set are built with the same care and have the same characteristics that make them trusted where life is at stake.

There is an Exide type for every tube and a size for every set. They give uniform current through a long period of discharge. You are assured the clearest reception.

At radio dealers and Exide Service

Stations you will find Exide "A" Batteries for 2-volt, 4-volt, 6-volt tubes, and glass cell "B" Batteries, 24 and 48 volt, of 6000 milliampere hour capacity. All these batteries are conservatively rated, rugged, long-lived, and right in price.

Ask for Exide Radio Batteries by name and get them from your dealer or Exide Service Stations.

THE ELECTRIC STORAGE BATTERY COMPANY, PHILADELPHIA

In Canada, Exide Batteries of Canada, Limited  
153 Dufferin Street, Toronto



The new Exide "B" Battery with glass cells, 24 and 48 volts, 6000 milliampere hour capacity.

# Exide

## RADIO BATTERIES

FOR BETTER RADIO RECEPTION  
USE STORAGE BATTERIES



# The MOZART Baby GRAND Radio Reproducer

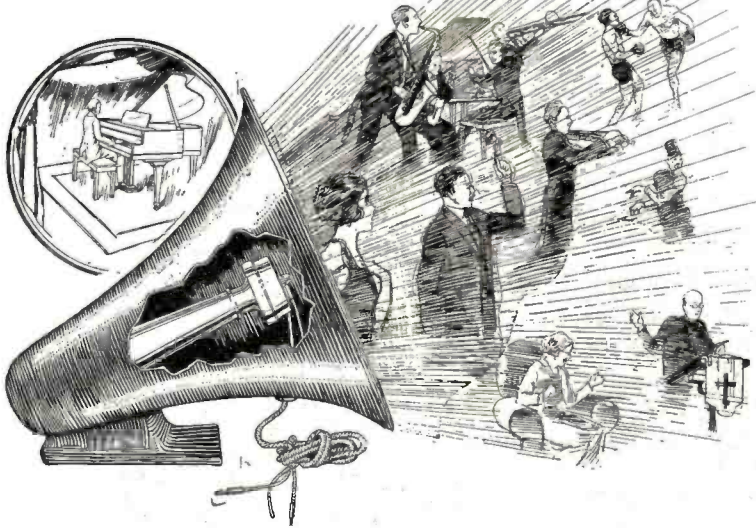

## Another

No piece of radio apparatus in any price class is best because its maker says so—or because its dealer says so. It is only the best when everybody else says so as well.

"Several times I have intended to write you or call on you when visiting Newark. I wanted to let you know of the fine service we have been getting from the Mozart Baby Grand. The clearness of music, voice and other entertainment seems so different from other loud speakers that we have experienced. We also use the Talkers, but we stick to the Baby Grand for accuracy."

(Signed) R. T. DONOVAN,  
5501 5th St., N. W.,  
Washington, D. C.

### PRICES

Baby Grand Reproducer, with gold plated unit, black and gold crackle or extra heavy coated all black satin finish (approx. 12" bell) .....	\$12.00
Baby Grand Reproducer, with nickel plated unit, black satin finish (approx. 11" bell) .....	10.00
Electro-magnetic unit (fits almost any horn or phonograph) with cord, nickel plated .....	4.00
Gold plated .....	5.00
Mozart Special Headset .....	6.00

No extra batteries required.

**ORDERS.** If your dealer cannot supply, order direct.  
**TRANSPORTATION.** Single shipments, strictly F. O. B. factory. Free on two or more orders for each item.  
**GUARANTEE.** One year from date of purchase or money back in ten days.

## The MOZART-GRAND CO.

Manufacturers of Fine Instruments

Newark, N. J.

U. S. A.

plate voltage is carried from the filament to the plate in a vacuum tube. The Heaviside layer is not very sharply defined and would not need to be to act as one plate of a condenser, so long as it proved to be a fairly good conductor. Another mystery which is explainable by this theory is the fading of signals, which is undoubtedly due to the shifting and movements in the upper strata of the atmosphere and the Heaviside layer.

In the article, "Super-power in Radio Broadcasting" in RADIO NEWS for January, 1925, it is stated that the signal strength of a transmitting station is very great for a certain distance, then falls rapidly for a short distance and then very gradually for the balance of the station's range. To explain this let us consider the receiving station at short distances as receiving the actual energy sent out by the sending station and those at greater distances as receiving energy carried by the earth and the Heaviside layer by condenser action. I believe that the above more nearly accounts for the curling of radio waves around the earth than any other.

THOMAS C. MAFFET,  
Box 242, Las Animas, Colo.

### CORRESPONDENTS WANTED

Mr. Alexander Kalachnikoff, of 66 Krasnoarmeiskaja Street, Tomsk, Siberia, Russia, wishes to get in communication with radio amateurs of the United States to exchange ideas.

### A CORRECTION

**Editor, RADIO NEWS:**  
In the January issue of RADIO NEWS we find in your foreign correspondence an item concerning Denmark. We beg to inform you that the figures are erroneous, both in regard to the numbers of amateurs and club members. The Danish Radio Society has at present a membership of 2,500 amateurs and the general number of amateurs is approximately 40,000.

GEORGE W. OLSEN,  
Chief Editor, Radio Uge Revue of  
Maanedsmagasinet,  
Copenhagen, K.

### THE CASCADE OF REGENERATIVE RECEIVER

**Editor, RADIO NEWS:**  
Just a line to let you know what I think of the "Cascade Regenerative Receiver" described in November issue of RADIO NEWS. If there is a five-tube receiver on the market that will equal it, I want to see it. The set is sure a knockout for both distance and volume. But, as actions speak louder than words, here goes to show you what she's done so far. Loud speaker reception is received nightly from the following stations:

KGO, Oakland; KLX, Oakland; KPO, San Francisco; KFRC, San Francisco; KHJ, KFI, KFSG and KJS, Los Angeles; KGW, Portland; KFOA, Seattle; KSD, St. Louis; KYW, Chicago; WHO, Des Moines; WOAW, Omaha; WAAW, Omaha; WOC, Davenport; WFAA, Dallas; WBAP, Ft. Worth; WHB and WDAF at Kansas City; KNX, Hollywood; KFKX, Hastings; KDYL and KFPT, Salt Lake City; KOA, KLZ, Denver; KOB, State College, N. M.; KFAD, Phoenix, Ariz.; KPNF, Shenandoah; KDZB, Bakersfield, Calif.; CKY, Winnipeg; CFAC, CFCN, CHBC, CHCM, Calgary; and CKCD, Vancouver, B. C.

Some little record! But just a minute, folks, I'm not half through yet. The above result, using nothing but ground wire. Have had: WBAP, KFKX, KGO, KGW, WHB and KPO. Get KGO every afternoon regularly at 2 p.m., M.T. KGO is about 600

### It's Your Money

and you can spend it for tubes or batteries if you want to; but I can show you how to bring long distant stations in on a simple crystal set. Same plans increase range of tube sets also. Copyrighted plans \$1.00. Complete parts for long distant sets \$5.00.

LEON LAMBERT

595 Kaufman Bldg. Wichita, Kansas.

## HEATH CONDENSERS

For Real Radio Reception

Write for Literature

HEATH RADIO & ELECTRIC MFG. CO.,  
206 First St., Newark, N. J.

Make  
\$100  
a Day

### FREE INSTRUCTION TELLS HOW

Many Sales Are Half Profit When you sell our nationally advertised radio sets and supplies. We Guarantee your success, under the "Gould Plan," by allowing you to return goods which you do not sell. It would pay you to get our price list and free instructions "How To Sell Radio." Write for it.

Federal Radio Co. 111 East 13th St. Kansas City, Mo.

### REFLEX

Eria-Acme-Harkness

Dealers: Send for Discounts

HUDSON-ROSS  
123 W. Madison St. Chicago



# Thorola

THE  
SPEAKING  
LIKENESS

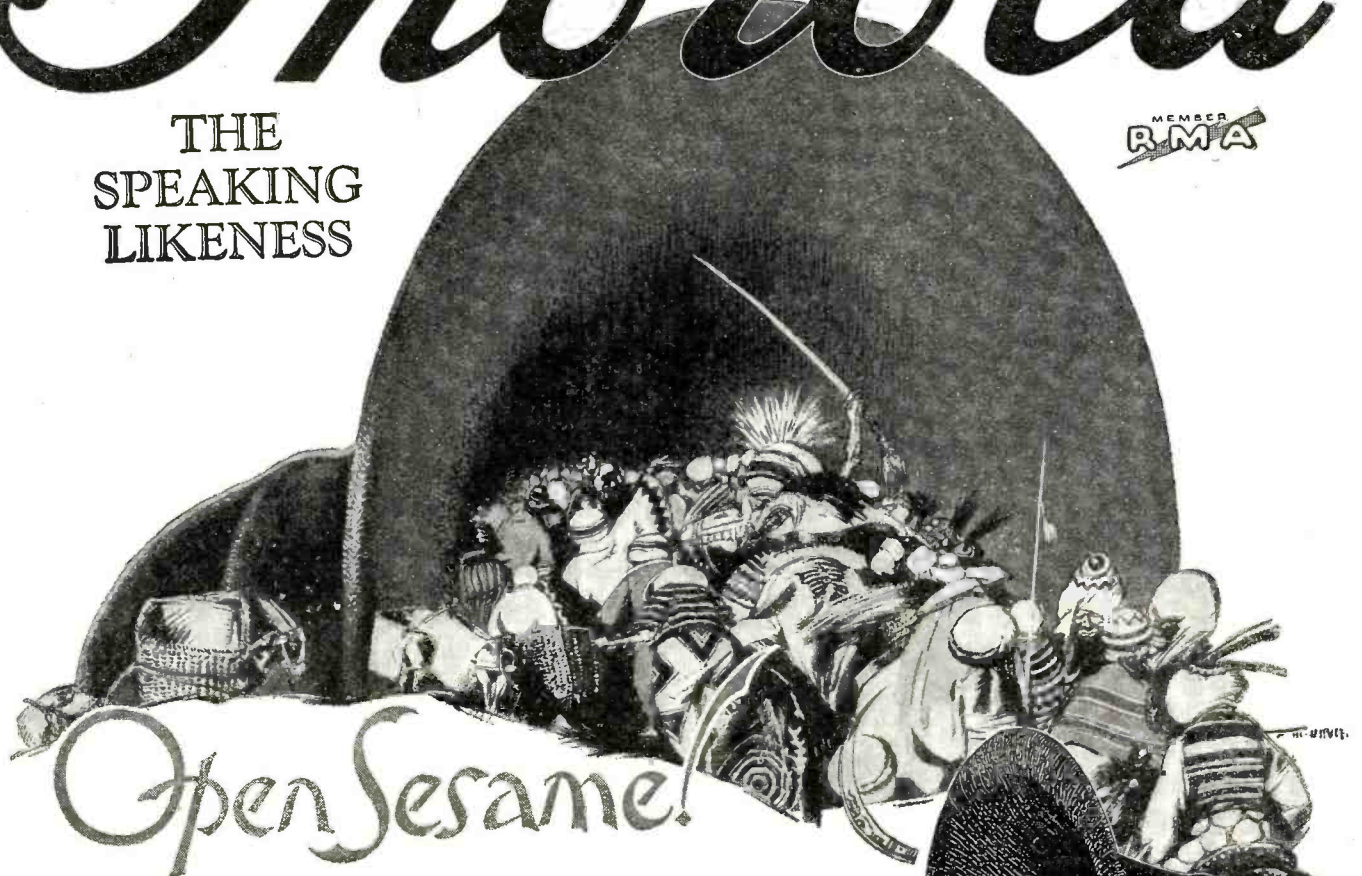

Open Sesame!

Magic words opened the way to a mystic, fabulous treasure cave.

Dials now magically open to you all the wealth of music and speech hidden in air.

Sift out every note, every word, every overtone, in all its original clearness, with beautiful Thorola Loud Speaker. Know radio now for its music, exquisite beyond anything heretofore.

Whatever your impressions have been, hear Thorola. With this loud speaker, radio goes into finest music rooms to stay.

With this loud speaker, new artistic possibilities are revealed in even the costliest radio receiver.

The difference is decisive, not only in tonal purity, but in volume. Thorola so far excels in amplifying efficiency that super-abundant volume remains when tuning for maximum clearness, even at extreme long distances.

Go to your Thorodealer. Examine all the specific, exclusive Thorola superiorities described below. Only Thorola construction permits surpassing Thorola music. Hearing is believing.

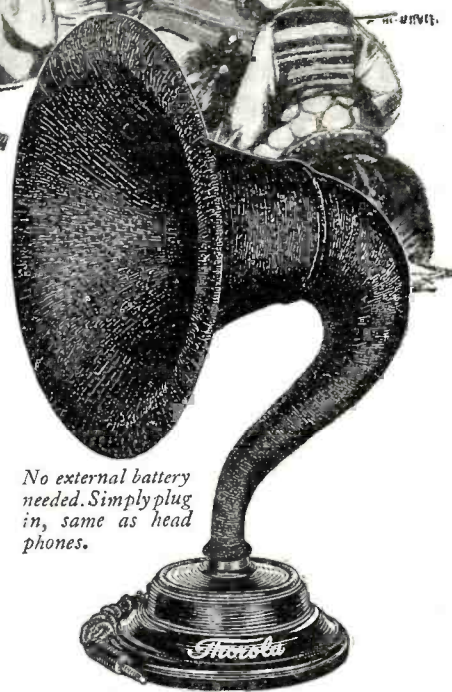

No external battery needed. Simply plug in, same as head phones.

**THE THOROLA REPRODUCER**

A toy piano cannot have the tone volume and purity of a concert grand. Compare the very size of Thorola Reproducer—*much larger*, permitting fine construction unduplicated in smaller reproducers.

**CONTROLLED MICA DIAPHRAGM**

Easily establishes Thorola as THE musical instrument among loud speakers, another accomplishment made possible by Thorola veteran loud speaker experience and technical facilities.

**EXCLUSIVE THOROLA SEPARIX**

Only Thorola Loud Speaker gives you the Separix, indispensable for faithful preservation of the deli-

cate note shadings and overtones, without which there cannot be true music, voice, tone—unblurred.

**THE HORN OF THORITE**

An exclusive laboratory compound, developed expressly to remove natural limitations. The value of Thorite superior acoustic accuracy cannot be overestimated.

**THE THOROLA SYNCHRONIZER**

The loud speaker, like every other circuit factor, must be in perfect balance for maximum results. Only Thorola can be harmonized with the exclusive Thorola Synchronizer, individually adapting *your* Thorola to *your* receiver, another reason even finest and most costly receivers do better with Thorola.

- THOROLA 4 . . . . \$25
- THOROLA 6 . . . . \$15  
*Phonograph Attachment*
- THOROLA 9 . . . . \$40  
*Cabinet Loud Speaker*
- THOROPHONE . . \$45  
*Power-plus Speaker (Storage Battery)*

The Thorola 10-day Refund Warranty is a guarantee to every user that Thorola will fulfill every claim.

REICHMANN COMPANY, 1725-39 W. 74th St., CHICAGO



# A Wonderful Radio Achievement!

## The First All-Glass Socket

Countless tests have proven glass to be the most effective insulation available to radio. After exhaustive research, our engineers have developed a new-idea socket made entirely of VIRALON—a special glass processed for 100% electrical efficiency.

VIRALON Glass is absolutely heat and moisture proof, and unaffected by those influences that commonly make rubber, rubber derivatives, porcelain and vitreous products so inefficient.

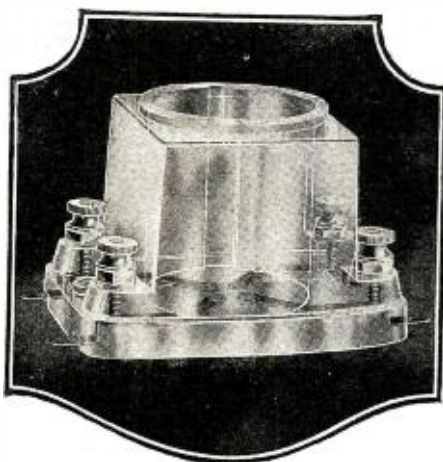

Duray All-Glass Sockets eliminate most of the so-called "tube noises"—cut down power losses—prevent short circuits—and eliminate radio frequency leakage.

**DURAY RADIO CORPORATION**  
Dept. 10, 263 Washington Ave., Newark, N. J.

# DURAY

## ALL-GLASS VIRALON SOCKET

You'll like all the exclusive Duray features—the all-glass construction—the one-piece contact springs—the knurled contact spots (corrosion-proof)—the handy soldering terminals.

Price \$1.25 (standard size). Packed in attractive cartons.

Until all dealers have been stocked, you can be supplied direct from the factory at the retail price, plus 10¢ each for packing and postage.

miles from here. Can pick up KDYL, a 100-watt station, 40 miles distant without aerial or ground, on loud speaker. On several nights have had WSAI at Cincinnati, about 1,600 miles from here. One night when the thermometer stood below zero, I had CHCD at Quebec, Canada, between 2,300 and 2,400 miles from here.

As a suggestion to those who built these sets:

Use a hard tube as a detector with 45 volts on the plate and 135 volts on the amplifier.

JAMES M. STAUTON,  
Apt. 31, La Frantz Apts.,  
Ogden, Utah.

### A SUGGESTION

Editor, RADIO NEWS:

In perusing the February issue of RADIO NEWS, my attention was called to the article by Carl H. Butman, page 1442.

The inability to distinguish call letters from various stations due to the close relation of sound of both vowels and constants has been my experience in the past. Now I am going to make a suggestion. We have 48 States in the Union and any number of broadcast stations per State. Why not use the abbreviations of each State followed by a numeral to designate the various BC stations, viz.:

- New York (WGY)—NY—1.
- New York (WEAF)—NY—2.
- Pennsylvania (KDKA)—PA—1.
- Pennsylvania (WCAE)—PA—2.
- Illinois (WEBB)—ILL—1.
- Illinois (WLS)—ILL—2.
- Illinois (WQJ)—ILL—3, etc.

Of course, some numerals such as five and nine could be eliminated if desired, due to close relation in sound quality. And when the number of stations in a State exceeded nine, the call letter would be announced (NY—11)—NY One One or (NY—17) NY One Seven. The foregoing would dispense with the necessity of assigning new calls for new stations, and at the same time avoid confusion in enunciation of various vowels and consonants peculiar to our alphabet.

Kindly ask the opinion of other listeners in as well as those in authority. Some relief might result.

JOHN R. ROORK,  
106 Hier Ave., Syracuse, N. Y.

### New Radio Patents

(Continued from page 1905)

age gap is introduced in the magnetic circuit for producing losses to a degree necessary to enable the transformer to operate effectively over a broad band of frequencies. The patent shows a number of curves which have been taken on different radio frequency transformers and shows the relatively flat characteristic curve which is possessed by the transformer of the present design.

### TELEPHONE HEADSET

(Patent No. 1,521,275, G. W. Carpenter and W. L. Carlson. Filed January 29, 1921. Issued December 30, 1924.)

Telephone headset where the cords of the telephone headset are electrostatically shielded by a flexible conductive plate which consists of woven



tinsel conductors. The shield extends over the telephone conductors and is grounded on the caps of the telephone receivers. The shielded headset is described for use with sensitive multi-stage electron tube amplifiers in long distance reception. The shield as covered by this patent is one of the features of the Brandes Navy Type headset.

### RADIO TELEPHONE AND TELEGRAPH APPARATUS

(Patent No. 1,518,564, T. S. Cole. Filed October 27, 1922. Issued December 9, 1924.)

Radio telephone and telegraph apparatus consisting of a battery system for connection in the

## HERCULES AERIAL MAST

20 Ft. Mast \$10  
40 Ft. Mast \$25  
60 Ft. Mast \$45

All steel construction complete with guy wires and masthead pulley. We pay freight.  
S. W. HULL & CO., Dept. A-5  
2048 E. 79th St., Cleveland, O.

Write for literature and FREE Blueprint

### ADJUSTABLE CIRCLE CUTTER

A great help to the Radio Builder. It drills own pilot and cuts out plug in one operation. Adjustable from 7/16 to 4 inch holes. Price, \$1.75 Same tool but does not drill own pilot. Price, \$1.50 Remit by Cash or Money Order Jobbers & Distributors write for discounts. Peenel Novelty Works 1800 Berenice Ave., Chicago

## The EAGLET Neutrodyne

3 TUBES  
DRY CELL  
OPERATED

\$75

Write for Literature



Operate your radio from your lamp socket with a  
**Gould UNIPOWER Battery**

for complete information address

GOULD STORAGE BATTERY CO.

30 East 42nd Street New York

Get a Handy Binder for your RADIO NEWS. Holds and preserves six issues, each of which can be inserted or removed at will. Price 65¢. Experimenter Pub. Co., Inc., Book Dept., 53 Park Place, N. Y.



**Prest-O-Lite**

**RADIO CHART**

Voltage of Tubes	No. of Tubes	Type of Tubes (see foot-note)	Total Rated Amperes Drain	Recommended Prest-O-Lite "A" Batteries			
				Order by following Types	Days between Charge		
5-Volt Tubes  C-300 and UV-200 are interchangeable C-301A, DV-2 and UV-201A are interchangeable	1	UV-200	1	69 WHR OR 67 WHR	22 16		
	2	UV-201A	1/2	67 WHR	33		
	2	1 UV-200 1 UV-201A	1 1/4	611 WHR OR 69 WHR	22 17		
	3	UV-201A	3/4	69 WHR OR 67 WHR	29 22		
	3	1 UV-200 2 UV-201A	1 1/2	611 RHR OR 69 WHR	21 14		
	4	UV-201A	1	69 WHR OR 67 WHR	22 16		
	4	1 UV-200 3 UV-201A	1 3/4	613 RHR OR 611 WHR	22 15		
	5	UV-201A	1 1/4	611 WHR OR 69 WHR	22 17		
	5	1 UV-200 4 UV-201A	2	613 RHR OR 611 WHR	19 13		
	6	UV-201A	1 1/2	611 RHR OR 69 WHR	21 14		
	For sets using current at a rate higher than 2 amperes.	8	UV-201A	2	69 KPR OR 67 KPR	21 15	
					69 KRL OR 69 KPR	22 16	
					2 1/4	69 KRL OR 67 KPR	22 13
					2 1/2	69 KRL OR 69 KPR	19 16

Copyright, 1925  
The Prest-O-Lite Co., Inc.

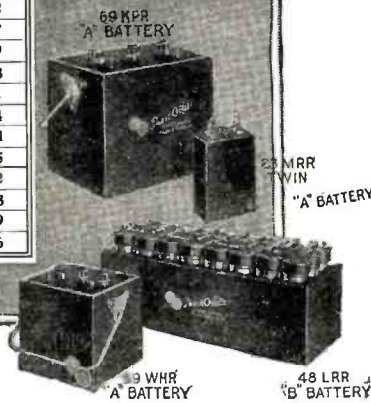

Write today for this free booklet

Whether you have a one-tube set or most advanced multi-tube outfit, you'll find a fund of interesting information in our booklet, "How to fit a storage battery to your set—and how to charge it."

This booklet gives you the complete Prest-O-Lite Radio Chart—technically accurate recommendations covering both "A" and "B" storage batteries for every type of set.

In addition, there is much vitally important data on battery care and upkeep—information that any radio fan will find of real value in keeping his set at its maximum efficiency. Write for your copy right now

## What size batteries will work best in your set?

SELECTING storage batteries of the right size and capacity is necessary, not only for the best reception, but also to arrange the time between chargings to suit your convenience.

The Prest-O-Lite Chart now makes this easy. Illustrated above is a section of the master chart showing Prest-O-Lite "A" Batteries for 5-volt tube sets. If your set has these tubes, you will find, in the fifth column, the Prest-O-Lite "A" Battery that fits it exactly. Two sizes are recommended, but the larger capacity battery will be found more desirable unless facilities for frequent and easy charging are provided. (The days between chargings are based on an average use of your set of three hours a day.)

Thousands of radio dealers have the complete chart, showing you also how to select Prest-O-Lite "B"

Batteries, as well as Prest-O-Lite "A" Batteries for peanut tube sets.

You'll prefer Prest-O-Lite Storage Batteries because of their special features designed for better radio reception. Improved separators and plates insure steady, unvarying current and years of life. They're easy to recharge. Handsomely finished to go well with the finest sets. Prest-O-Lite Batteries offer you truly remarkable savings. Though standard in every respect, they are priced as low as \$4.75 and up.

Let the Prest-O-Lite Chart guarantee you batteries scientifically correct for your set. It is endorsed by the world's largest electrochemical research laboratories. See it at your dealer's—or write for our interesting booklet, "How to fit a storage battery to your set—and how to charge it."

THE PREST-O-LITE CO., Inc., INDIANAPOLIS, IND.

New York

San Francisco

In Canada: Prest-O-Lite Company of Canada, Ltd., Toronto

**Prest-O-Lite**





# Keen as a Razor!

## 9 points of Superiority

1. Soldered brass plates, chemically treated against corrosion; perfect alignment.
2. Stator plates specially shined for easy tuning on low waves.
3. Adjustable ball-bearing rotor shaft, grounded through metal end-plates.
4. Soldered clock-spring pig-tail, with automatic stop.
5. Minimum dielectric losses too small to be measured.
6. Rugged, compact construction; cannot warp.
7. Micrometer cam-vernier moves all plates; no backlash.
8. Takes any size dial up to 4 inches.
9. The product of 11 years' experience, making precision instruments.

**E**VEN the greenest amateur knows that broad tuning is fatal to the separation of closely interfering radio signals.

One cause of broad tuning is poorly designed condensers, having high losses.

The model "C" Hammarlund Condenser is the newest product of 14 years' experience making the highest type of precision instruments. It is a mechanical masterpiece—so perfect electrically that its losses are too small to be measured. Its razor-edge sharpness is a delight to the expert and a revelation to the amateur.

Made in all capacities; plain and vernier. For sale by the better radio dealers.

Write for descriptive literature.

**HAMMARLUND MANUFACTURING CO.**  
424-438 West Thirty-third Street, New York

Pacific Coast Representatives:  
Atlantic-Pacific Agencies Corp.,  
204-212 Rialto Bldg., San Francisco  
Canadian Distributors: Radio, Ltd., Montreal

U. S. and Foreign Patents

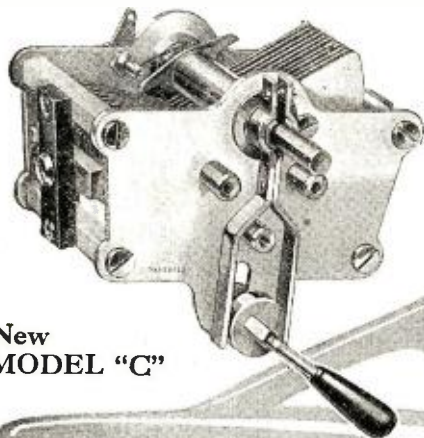

New MODEL "C"

For Better Radio  
**Hammarlund**  
PRECISION  
CONDENSER

plate circuit of an electron tube with a switching arrangement associated with the battery system whereby, in periods of non-use of the radio receiving circuit, the "B" battery may be connected in shunt with the "A" battery for enabling the "B" battery to be charged from the "A" battery. The "B" battery is constructed in the form of a secondary battery having its sections so arranged in parallel through the switching arrangement that the filament battery may be utilized to charge the plate battery.

### RADIOTELEPHONY

(Patent No. 1,513,973, F. M. Doolittle. Filed February 21, 1924. Issued November 4, 1924.) Radiotelephony system of broadcasting wherein the sounds reproduced at the receiving station may be so reproduced as to impart an effect of true tone values derived from a sense of location of the artists or the musical instruments at the broadcast studio. Two radio channels of transmission are provided, each under control of separate sound pick-up microphones so relatively positioned as to receive sound in a manner simulating the reception of sounds by the ears of a human being. The radio channels are non-interfering and are each separately adjusted to bring in the transmission from the same studio.

### CONDENSER

(Patent No. 1,514,733, A. H. Sass. Filed May 11, 1922. Issued November 11, 1924. Assigned to Western Electric Company, Inc., New York.) Condenser wherein both the movable and stationary plates are mounted on the same shaft, thereby decreasing the area occupied by the condenser. The shaft is insulated and arranged so that alternate plates are moved between the remaining plates, which are immovable upon the shaft.

### ANSWER TO THE CROSS-WORD PUZZLE PUBLISHED IN THE MARCH ISSUE OF RADIO NEWS

E	P	I		B	R	O	A	D	C	A	S	T		S	H	E							
R	A	D	I		E									R	O	T	O	R					
A	N	E	T		B	A	T	T	E	R		Y		W	A	R	E						
	E	A		W	R		F	E	W		A		M		A		R	N					
R	L			B	I	A	S		C		O	R	E	S		S	F						
E				M	O	R	S	E		T		A	N	D	D	E		E					
C				U	E	S		G	O	B		S	W		N		S						
E				R	B			F	A	R	A	D		O	Z		S						
I				N	D							S	O	L	O	D		Y	N				
V				O	S			P	O					E	M		N						
E				C				L	A			D	I	S		I	D	E	D				
R				K	N	O	B	S		R		U	N	I	T	S		E					
S				W		R	O	A	R		E	S	P	A	R		P	N					
A				S		P	T		A	L	E		U	L		D	H						
O				V	E	N		T		T	U	B	E	S	E	T		T	R	O	Y		
M				E	T	E	R			S				S	O			S	O		U	N	D
A				S		R		H	E	O	S	T	A	T	S		G	E	O				

### The Radiotoneotype

(Continued from page 1875)

vibration of a second string, of the same frequency, at the receiver through the principle of resonance. The mere vibration of the receiver in front of a string would not ordinarily be of enough force to set the string in vibration unless the note at which the receivers vibrate is in exact synchronism with the string.

The adjustment of the relays can be made in such delicacy that the solenoid will open only with the vibration of one of the strings at the transmitter; in other words, the absence of interference depends upon the care with which they are adjusted.

If three strings are employed it is necessary to provide a separate transformer, tube and relay for each one, and, of course, a separate electromagnet.

Tuning the strings at both the transmitter and receiver to, say A, C and D, and employing the letters V, B and N on the typewriter, it is possible, by striking one or another note at the transmitter end, to strike the corresponding letter on the typewriter,

## Keep your Radio set Clean!

You must have a NODUST to keep your set working its best! Each stroke of a NODUST forces a blast of compressed air into all the hard-to-get-at places and cleans out every speck of dust and dirt in a jiffy.

If your Dealer has not received his NODUSTS yet, we will send you one on receipt of one dollar. Satisfaction guaranteed.

**PEIFFER & CO.**  
80 Liberty St., Newark, N. J.



## AMBASSADOR Low Loss Products



**Master Tuning Coil**  
Perfectly Balanced Head Phone  
Low Loss Condenser

High grade, standard radio products that will increase the efficiency of any set and add to the satisfaction of the user. Ambassador Low Loss Products have long been the choice of particular fans. See them—compare them, and you will choose them too.

At all good dealers. Write for FREE diagrams of circuits in which Ambassador products can be used. **AMBASSADOR SALES COMPANY**  
108 Greenwich St., New York  
328 W. Madison St., Chicago





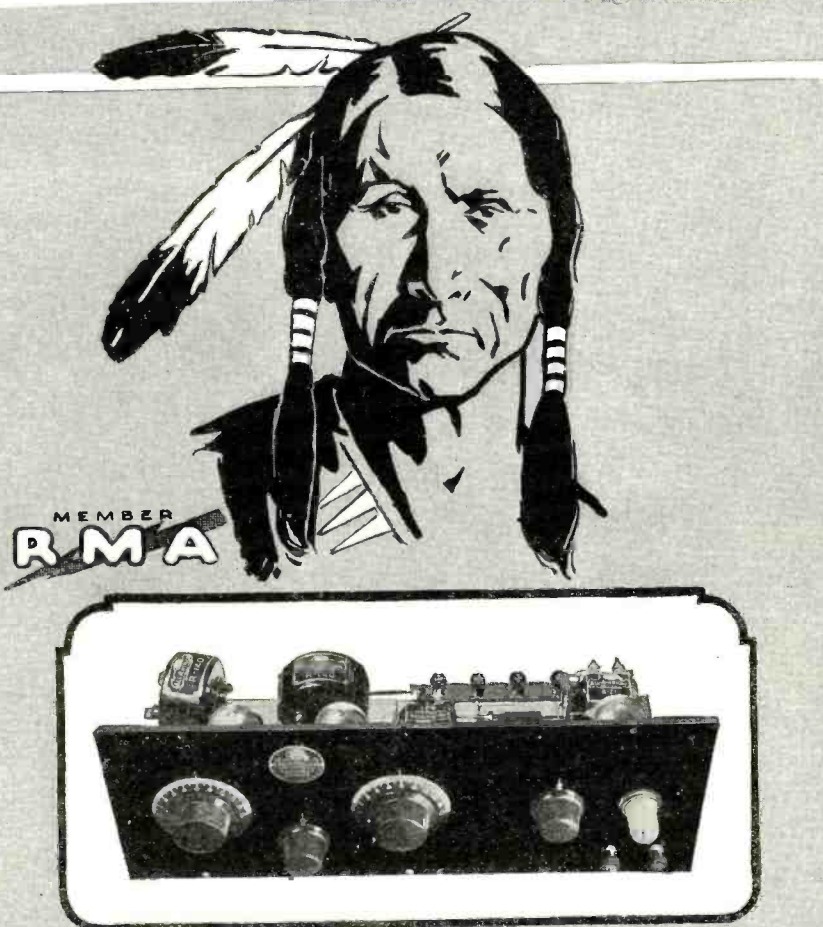

## Now You Can Afford — a modern precision-made set which "cuts through"

☞ Tuned radio frequency for distance and selectivity, reflex for economy, the unequaled loudspeaker tone quality and volume which comes with ALL-AMERICAN precision manufacture—all are present in this *non-radiating* three-tube receiver. ☞ And, owing to the economy of "wiring it yourself," ALL-AMAX SENIOR costs less than a finished one-tube set of equally high quality. ☞ Take it home today from your favorite radio store; wire it this evening, and "tour the country" before you retire for the night! Price \$42.

The RADIO KEY BOOK has, concentrated in its 48 pages, the answers to those questions you have been wondering about. It is a radio education in itself. Send ten cents, coin or stamps, for your copy.

ALL-AMERICAN RADIO CORPORATION  
PIONEERS IN THE INDUSTRY  
2646 Coyne Street . . . . . Chicago

### ALL-AMERICAN Guaranteed Radio Products

Standard Audio Transformers  
3 to 1 Ratio, type R-12... \$4.50  
5 to 1 Ratio, type R-21... 4.75  
10 to 1 Ratio, type R-13... 4.75

Power Amplifying Transformers  
(Push-Pull)  
Input type R-30..... \$6.00  
Output type R-31..... 6.00

Rauland-Lyric  
A laboratory grade audio transformer for music lovers. R-500..... \$9.00 

Universal Coupler  
Antenna coupler or tuned r. f. transformer. R-140..... \$4.00

Self-Tuned  
R. F. Transformer   
Wound to suit the tube. R-199 \$5.00. R-201A \$5.00

Long Wave Transformer  
(Intermediate Frequency)  
(15-75 kc.) R-110..... \$6.00

10,000 Meter (30 kc.)  
Transformer   
Tuned type (filter or input). R-120 . . \$6.00

Radio Frequency Coupler  
(Oscillator Coupler). R-130 \$5.00

Super-Fine Parts  
Consisting of three R-110's, one R-120 and one R-130 \$26.00 

The ALL-AMAX Sets  
This shows how they come to you—mounted complete on panel and base-board, with full photographic wiring instructions, blueprints, and a 48-page instruction book. 

### All-Amax Junior



A one-tube reflex set that brings in the locals on the loudspeaker, with wonderfully clear tone quality, or tunes them out and gets real distance. *Non-Radiating.*  
Price \$22

# ALL-AMERICAN

Largest Selling Transformers in the World







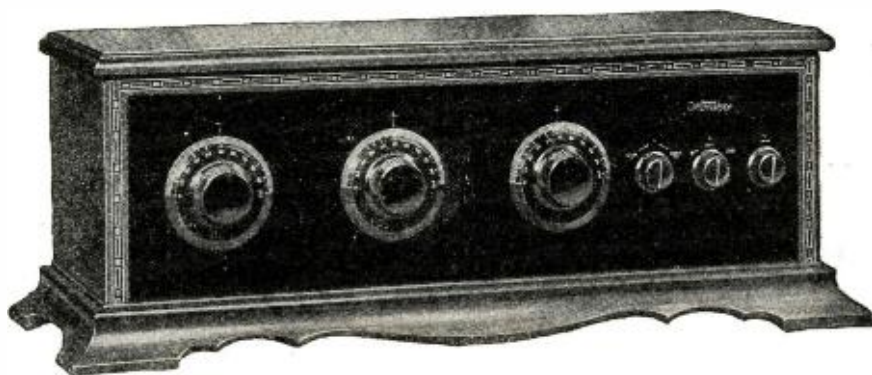

# And its tone quality is unequalled

## One Owner's Experience

47 stations  
in one night

Mr. T. A. Keen of Temple, Texas writes us as follows: "We have set up our Deresnadyne and logged 47 stations in one night. They range from Havana to Calgary and from Springfield, Mass. to Portland, Oregon. You can see from this that the Deresnadyne is all that is claimed for it."

Heretofore in speaking of the Deresnadyne we have talked about selectivity. For without selectivity a radio set is practically useless.

But perhaps the most remarkable feature of the Deresnadyne is its absolute fidelity of reproduction. It is noted for the absence of undesired noises. Its mellow tone is not equalled by any set. It maintains its mellowness even when operating at full volume.

The striking thing about the Deresnadyne is that it does not sacrifice one essential quality for another. When you buy it you do not choose between tone on the one hand and power on the other. You buy a set that combines both.

The Deresnadyne is not a Neutrodyne. It is not a Heterodyne. Based on a new principle—that of Deresonation—it is unlike any other set on the market, both in principle and results. Buy it at your dealer's.

*De Luxe Model \$165 without accessories*

DEALERS: Order through your jobber  
JOBBER: Write to us



*Andrews*  
**Deresnadyne**  
DĒ-RĒS-NĀ-DĪNE · PATENTS PENDING  
*Radio Receiving Set*

ANDREWS RADIO COMPANY, 327 S. LA SALLE STREET, CHICAGO



# Advertising Testimony

Exhibit E

**THE HAMMARLUND MANUFACTURING COMPANY INC.**  
 TELEGRAPH AND RADIO APPARATUS  
 424-438 WEST 33RD STREET  
TELEPHONE LAKESHORE 382-3834  
 NEW YORK

January  
Fifteenth  
Nineteen-twenty-five.

Experimenter Publishing Co., Inc.,  
53 Park Place,  
New York.

Gentlemen:-

Results from our advertising in "Radio News" have been so consistently gratifying that we felt you would be interested in learning of the high regard we have for the effectiveness of your publication

Our first advertisement in the November 1922 number of "Radio News" using small space, and similar subsequent copy, produced inquiries and orders from unbelievable numbers of fans, dealers and jobbers throughout the world, including China, New Zealand, Africa and most of the European and South American countries.

Since the very beginning we have always used the medium of "Radio News" for the purpose of introducing our new lines and models to the public and the trade. The results secured in each instance convinces us that this magazine is the logical instrument for this purpose.

Yours very truly,  
**THE HAMMARLUND MFG. COMPANY, INC.**  
 By *W. Hammarlund*  
 Secretary.

LAH:BH

Every advertisement in RADIO NEWS reaches two great audiences—the radio dealer who *sells* your product and the public who *buys* it

## NEW CARTER LOOP AERIAL



CARTER LOOP AERIAL \$15

Pat. Pending

Greater Volume  
More Selectivity  
Longer Distance  
Offices in Principal Cities

The new Compound Pentagon winding eliminates the frame work and resultant losses. It gives maximum inductance without increasing the distributed capacity. Only 18" in diameter.

Go to your dealer and see this new Carter product. Any dealer can show you. In Canada, Carter Radio Co., Limited, Toronto



Insure your copy reaching you each month. Subscribe to Radio News—\$2.50 a year. Experimenter Publishing Co., 53 Park Place, N. Y. C.

a reliable independent manufacturer endows a good research laboratory and painstakingly develops a new means for producing a good vacuum and keeping it "on the line" so that tubes can be exhausted on a production basis, the independent tube maker is going to be up against it in a legal way.

The personnel of the independent tube fraternity is a queer one. There are those who are in the game for the thrill of it— young adventurers in business and science, to whom the secrecy, the stealth, the dodging of detectives, gives a zest which is hard to resist. It is not believed that there is any great source of profit in making independent tubes. Great profits come from steady, reliable production—and from as steady sales and merchandising plans.

### LABOR PROBLEMS

In the high overturn of labor in the great factories where radio tubes are made, partially trained young girls and men, some bearing fancied grievances, others just being dropped, or quitting, drift into the independent factories, lured, possibly, by promises of better wages, and by the thought that they will be "getting even" with the alleged trust, in some cases.

Some get-rich-quick hopefuls try their luck at radio tube making and offer higher wages to some of the junior production executives of the legitimate factories to set up small independent plants.

Here is one loophole in the armor plate of legal protection thrown about the vacuum tube by the alleged trust. From the time of the expiration of the February DeForest patent until the day when the high vacuum patent is issued, there is a vast unknown gap. In fact, none can predict today just when this latter controversy will be settled. During the interim, independent tube making will flourish, for how can suit be instituted, and injunctions granted when there are no actual patent rights established upon which to sue?

Renewed activity is expected in the filament injunction cases since it will be the policy of the legal department of the patent owners to keep down and suppress the more obstreperous independents, and the filament patent is about the only one now existing in which grounds for infringement suit may be started with hope of success. Many of the independents are getting their filament from Germany and other foreign countries.

Summing up the foregoing in terms of what the independent tube man is going to be required to do to continue in business, the fact remains that should an independent come out in the open at the expiration of the DeForest "interposed-between" patent and make tubes under the shadow of the possible settlement of the Arnold-Langmuir controversy, that one will be the target of suit from whoever wins, for back royalty damages, which is not a pleasant prospect.

### A QUESTION OF COST

None of the present independent tube leaders seem sufficiently fixed financially to thus defy the established interests, which latter will control the high vacuum patent no matter which litigant wins the court battle.

Therefore, the elation among the independents is not justified by the facts and the customary secrecy of the past will continue on just the same, despite the expiration of the DeForest patent.

No great changes seem imminent in the radio industry for anything to supplant the vacuum tube. Should there be a sudden surge and a flooding of independent tubes into the radio market at the expiration of the DeForest patents, or shortly thereafter, it is expected that a drastic price cut will discourage it.

The hand labor, high breakage loss and



# Music Master Success



**Music Master**  
Resonant Wood Insures  
Natural Tone Quality

Model VI, 14" wood bell \$30  
Model VII, 21" wood bell \$35

Connect Music Master in place of headphones. No batteries. No adjustments.

Prices of all models slightly higher in Canada

— Its True Significance



Model VIII, Mahogany Cabinet \$35  
with "full-floating" wood horn



Model V, wood bell, Metal Cabinet, Mahogany finish \$18

THE advent of Music Master sounded the death knell of the mere "loud speaker." For it transformed the radio receiving set into a musical instrument—a triumph of re-creative art.

Two years ago Music Master's full voiced volume and characteristic tone qualities heralded the New Era of Radio Art. It made possible the re-creation of supreme Music, Song and Speech, in the wonderful stellar programme now an established feature of American nation-wide broadcasting.

Music Master does more than reproduce—it interprets, it re-creates—it transforms mere radio receiving into artistic enjoyment. Music Master has been inadequately imitated, but never equaled. Music Master remains the supreme musical instrument of radio—and there IS no substitute.

#### MUSIC MASTER—the Ultimate of Artistic Radio Re-Creation

Music Master's precision instrument is the acme of scientific perfection. Music Master's tone chamber of heavy cast aluminum is a marvelous mold of sound without distortion. Music Master's amplifying bell of resonant wood gives to every sound its full, vibrant qualities and natural and lifelike characteristics.

Music Master's manufacturers hold that every purchase of their product carries with it an implicit pledge of unreserved and unconditional protection. Back of your dealer's full and unflinching service stands the Music Master Corporation to guarantee its products direct, to anyone, anywhere, at any time.

## Music Master Corporation

Makers and Distributors of High-Grade Radio Apparatus  
Tenth and Cherry Streets

Chicago Philadelphia Pittsburgh  
Canadian Factory: Kitchener, Ontario



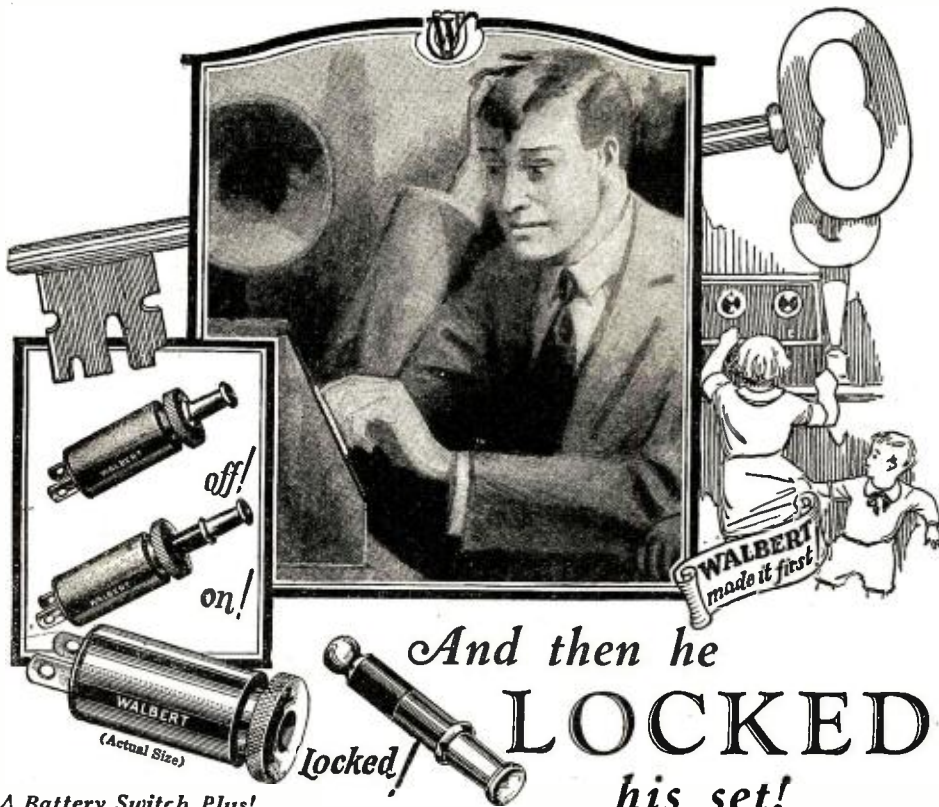

**A Battery Switch Plus!**

1. *Easily Installed*—One-hole mounting. Easily replaces your present switch.
2. *Compact*—Requires less room behind panel than any other switch.
3. *Sturdy, Simple*—Can't get out of order.
4. *Noiseless*—Positive wiping contact; can't wear out.
5. *Shockproof*—Shell mounting and key-handle insulated.
6. *Inexpensive*—Costs less than a good plain battery switch.

**SILENT** night. A chance to get some real DX stations—and there somebody had left his set on all day!!! Not enough "A" Battery power to bring in the locals.

That's what happened to H. M. D.—and why he replaced his old Battery Switch with a Walbert LOCK-SWITCH, the original locking Battery Switch!

There's no chance for any one meddling with your set when the key to the Walbert LOCK-SWITCH is in your pocket. *Your set is locked, and off!*

Play safe! Put a Walbert LOCK-SWITCH on your set tonight. It will give you silent and efficient filament control and absolute protection to your tubes and batteries. At your dealer or sent postpaid on receipt of purchase price.

Walbert LOCK-SWITCH . . . 50c Gold Plated . . . 65c  
Nickel Plated . . . . . Extra key with key ring attachment . 20c

Jobbers and Dealers: Write for Discounts

WALBERT MANUFACTURING CO.  
923 Wrightwood Ave., CHICAGO, U. S. A.

**WALBERT**  
**LOCK SWITCH**



**Russia's Radio Laboratory**

(Continued from page 1867)

tion of the flow of the stream as to speed, etc.

The actual electron emitting device is very small. It is enclosed in a small glass bulb, the inner surface of which is covered with a semi-transparent platinum sheet which is

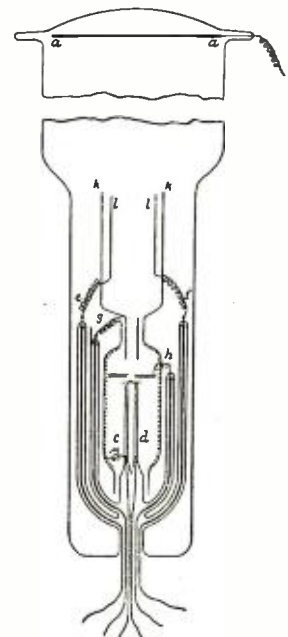

Fig. 5. Above is shown an adaptation of the Braun tube used and manufactured in the Nijni-Novgorod laboratory.

connected to the cathode. This arrangement—Faraday's tube—prohibits the action of any external field upon the stream of electrons until it has attained a high speed, its sensitivity to an electrostatic field being very high.

By employing Mr. Bontsh-Brujewitsh's vacuum pumping method, the tubes are exhausted with sufficient thoroughness to ad-

LONG ANT ANT SHORT ANT

THE NEW AND IMPROVED  
**"Read'em"**  
Binding Posts

18 Styles Engraved at Your Dealer's or Sent Post-paid 15c Each

The Utmost in Quality and Appearance at the Lowest Price.

MARSHALL-TOLEDO, OHIO GERKEN CO. OHIO

STANDARD FONES SPEAKER

**\$3 DOWN** Brings you a Genuine **UNDERWOOD** TYPEWRITER

**10 DAYS FREE TRIAL** Your \$3.00 unconditionally returned if at end of 10 days you are not satisfied with this late model UNDERWOOD typewriter rebuilt by the famous Shipman Ward process.

**GREAT PRICE SAVING** Direct to you from the largest typewriter factory in the world by our money saving methods.

**EASY MONTHLY PAYMENTS** So small that you will not notice it while you enjoy the use of this wonderful machine.

**FREE BOOK OF FACTS** Explaining Shipman Ward's wonderful system of rebuilding typewriters and also valuable information about the typewriter industry both instructive and entertaining.

Act Today! Mail Coupon **5 Year Guarantee**

Shipman Ward Mfg. Company  
1954 Shipman Building  
Montrose & Ravenswood Aves., Chicago

Please send me a copy of your free book of facts, explaining bargain offer.

Name.....  
St. and No.....  
City..... State.....







# RADIO FANS

*Get More Radio Miles Per Dollar Invested!*



## BUILD A B-T NAMELESS

Hair-line selectivity, distance, volume and tone purity are no longer a radio advertising myth. They're all to be found in the five tube Low Loss Nameless R.F. Circuit.

There's no mystery surrounding the ability of the Nameless to do these things. It's the natural result of combining the finest low loss parts with a tried and proven circuit which we have been able to improve greatly by unceasing research and investigation.

Don't spend a cent for sets or parts until you see the B-T Low Loss Nameless Kits. You'll be well repaid for this precaution for you can't get more value and real radio satisfaction anywhere else for the money. A line will bring you our folder RF-32 which gives complete details.

**Nameless Kit No. 3**  
 Contains three 3-Circuit Transformers, three 250 M.M.F. Laboratory Condensers, one 40 M.M.F. Control Condenser and complete blue prints, instructions and list of parts needed. **\$26.50**

**Nameless Kit No. 1**  
 Contains three 3-Circuit Transformers only. (Blue prints, etc., for building the Nameless are not furnished with Kit No. 1. These can be purchased separately for one dollar)..... **\$10.50**

### READ WHAT USERS HAVE TO SAY!

*From TITO SCHIPA, leading Grand Opera Tenor.*

"After using several other well-known radio receiving sets and discarding same, to say that I am pleased with your set is speaking mildly. The volume, selectivity, quality of tone and ease by which distant stations were tuned in whilst the other Chicago stations were broadcasting is simply marvelous and almost beyond understanding."

*From C. T. Y., Wichita, Kansas.*

"I get from Los Angeles to Washington, D. C., Saskatoon, Old Mexico, Cuba and Porto Rico. I can separate stations two meters apart by moving the center dial one half to one degree on this scale. What other set made can do anything like this? On most stations I get so much volume I don't use the fifth tube."

## BREMER-TULLY MFG. CO.

*"Pioneers of Better Tuning"*

532 S. Canal St.

Chicago, Ill.

**A Poor By-Pass Condenser Will Ruin Your Set**

**BOETTER BY-PASS CONDENSERS**

Made of Tinfoil and Linen Paper. Not a metallic powder sprayed on paper. Terminals soldered to all edges of Tinfoil, insuring perfect contact. Not laid on Tinfoil. Vacuum treated. Tested five times for capacity and breakdown. Special eyelet mounting (see cut). By-Pass Condensers assure a uniform flow of current and eliminate noises. Connected across the "R" Batteries. List Prices: 1 Mfd. 70c. 25 Mfd. 75c. 5 Mfd. 90c. 1. Mfd. \$1.25, 2. Mfd. \$1.75. Subject to Discounts in Quantities. Immediate delivery. Order from your dealer—if your dealer cannot supply you we will send them parcel post prepaid at list prices.

**A. V. BOETTER MANUFACTURING CO.**  
 612 S. Canal St. Chicago, Ill.

*Special Library of Information*

on

## RADIO PATENTS and TRADE MARKS

**JOHN B. BRADY**  
*Patent Lawyer*

Ouray Building Washington, D. C.

Cable address: RADIOPAT Telephone: Main 4806

Insure your copy reaching you each month. Subscribe to Radio News—\$2.50 a year. Experimenter Publishing Co., 53 Park Place, N. Y. C.

mit of very good working of the deflector plates. However, only a magnetic field may be used to direct or deflect the stream of electrons as emitted from the aperture in the plate.

This type of Braun tube is so stable in operation that the fluorescent spot will remain absolutely stationary on the screen for hours at a time. With the aid of the magnetic field, the most perfect regulation of the stream is attainable, thus giving the investigators a most reliable piece of apparatus for the investigation of electrically oscillating circuits.

A complete study of the laboratory leads one to the conclusion—in view of the small number of workers and innumerable difficulties encountered—that its work has been of the greatest diversity and originality. Its work has been one of the chief influences—if not the chief one—in the development of Russia's radio technical knowledge.

The official organ of the laboratory, "Radiotelegraphy and Telephony," is one of the most important factors in the country for the development of problems from the purely theoretical point of view. It has the added capacity of forming a sort of connecting link between the various scattered experimenters and tends to keep them in a spirit of closest co-operation.

### The Eclipse and Radio Reception

(Continued from page 1847)

The foregoing was embodied in a report made by Prof. Greenleaf Whittier Pickard at a meeting of the Institute of Radio Engineers in New York City the evening of February 5. As stated, the discussion was made after only the slightest investigation of the huge mass of material available. However, the cursory examination of the data reveals some extremely interesting facts concerning the propagation of radio waves.

Other interesting effects were observed in the reception of signals broadcast from England on a wave-length of 12,500 meters. These signals were also observed for two days before and after the day of the eclipse. There were two stations in America that were taking readings on these long wave signals, one at Riverhead, Long Island, which was in the path of totality, and the other station was located at Belfast, Maine, which was not in the path of totality. The readings of signal strength that were taken were automatically recorded.

The signal behavior up to a few minutes before totality was the same as the previous two days. There was a sharp drop of strength just after dawn and then the usual daytime diminution. However, just before totality there was another sharp drop in strength which lasted until after the moon had begun its journey off the face of the sun. Then the conditions were approximately the same until the time that the sun was eclipsed to its maximum value in England. At that time there was again a dip in the signal strength curve. These readings were taken at Riverhead, Long Island.

The signals that were recorded at Belfast, Maine, were of a different character in that there was no sharp diminution of strength at the time that the sun was totally eclipsed at the same longitude as the receiving station. However, when the sun had been eclipsed at the transmitting station in England a drop in strength was noted.

Just what these sudden drops in strength mean is impossible to say at the present time, because there has not been sufficient time as yet to check all the data, conditions,



# The Maker's Name is a Public Promise

**"BRISTOL"**  
Safeguards  
the Buyer  
Who Knows  
The Name

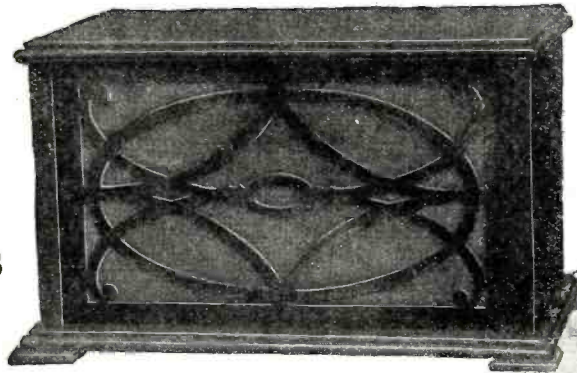

THE NEW  
BRISTOL  
CABINET  
MODEL "C"  
\$30.00

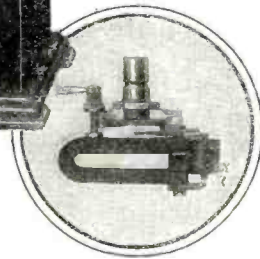

**T**HE "Bristol" name stamping the new product, the Bristol Loud Speaker, indicates a responsibility already established.

For 36 years the Bristol Company has made highly accurate and sensitive Recording Instruments.

In the great plants of America they measure in the most minute degrees the extremes of heat and cold, the humidity of the air and the density of liquids. To technical engineers the name "Bristol" is an unquestioned "Sign of Experience." They know that the makers of Bristol's Recording Instruments in all ways are qualified to make Loud Speakers of great excellence. They also know that Bristol experience, scientific knowledge and honest purpose must be this Loud Speaker's full inheritance.

There are five Bristol Loud Speaker models, but alike in those essentials which give true quality to the reproduction of voice or instrumental music. The "Voice" is not a mere phone unit but an electromagnetic device, and the horns of non-metallic material, with long sound chambers, allow free and full vibration.

Many manufacturers are honestly striving for the perfection of radio reception and The Bristol Company is one of these. The Bristol trade name always stands for "built in" Bristol Standards. Prices \$12.50 to \$30.00.

*The Voice  
of the  
Audiophone*



MODEL "S"  
AUDIOPHONE  
\$25.00.  
Rubber horn 14½"  
diameter. Velvet mat  
finish of mottled  
bronze and gold;  
classic base.

*Send for Bulletin 3022-S*

**THE BRISTOL COMPANY**  
WATERBURY, CONNECTICUT

**BRISTOL** TRADE MARK **AUDIOPHONE** THE U.S. PAT. OFFICE **Loud Speaker**





# Order Your Rheostats From This Chart

Tubes last longer—if you use the right rheostats. And you save current. And distortion is minimized. And you get maximum volume. You must have rheostats of the correct ohmage. You want genuine Klosner Rheostats, made by the pioneer makers of the vernier rheostat.

GO TO YOUR DEALER. Ask to see this Chart and the famous Klosner Rheostats. If he hasn't the genuine, order direct from this advertisement. Refuse substitutes.

## RHEOSTAT CHART

The correct Rheostat Ohmage for every use

TYPE OF TUBE	"A" BATTERY	NUMBER OF TUBES	OHMAGE	USE	REMARKS
5C 300 A 5V 2	6 VOLTS	1	20 OHMS	25 AMPERE	
5C 300 C 5V 3	6 VOLTS	1	20 OHMS	25 AMPERE	
5C 300 D 5V 3	6 VOLTS	1	20 OHMS	25 AMPERE	
5C 300 E 5V 3	6 VOLTS	1	20 OHMS	25 AMPERE	
5C 300 F 5V 3	6 VOLTS	1	20 OHMS	25 AMPERE	
5C 300 G 5V 3	6 VOLTS	1	20 OHMS	25 AMPERE	
5C 300 H 5V 3	6 VOLTS	1	20 OHMS	25 AMPERE	
5C 300 I 5V 3	6 VOLTS	1	20 OHMS	25 AMPERE	
5C 300 J 5V 3	6 VOLTS	1	20 OHMS	25 AMPERE	
5C 300 K 5V 3	6 VOLTS	1	20 OHMS	25 AMPERE	
5C 300 L 5V 3	6 VOLTS	1	20 OHMS	25 AMPERE	
5C 300 M 5V 3	6 VOLTS	1	20 OHMS	25 AMPERE	
5C 300 N 5V 3	6 VOLTS	1	20 OHMS	25 AMPERE	
5C 300 O 5V 3	6 VOLTS	1	20 OHMS	25 AMPERE	
5C 300 P 5V 3	6 VOLTS	1	20 OHMS	25 AMPERE	
5C 300 Q 5V 3	6 VOLTS	1	20 OHMS	25 AMPERE	
5C 300 R 5V 3	6 VOLTS	1	20 OHMS	25 AMPERE	
5C 300 S 5V 3	6 VOLTS	1	20 OHMS	25 AMPERE	
5C 300 T 5V 3	6 VOLTS	1	20 OHMS	25 AMPERE	
5C 300 U 5V 3	6 VOLTS	1	20 OHMS	25 AMPERE	
5C 300 V 5V 3	6 VOLTS	1	20 OHMS	25 AMPERE	
5C 300 W 5V 3	6 VOLTS	1	20 OHMS	25 AMPERE	
5C 300 X 5V 3	6 VOLTS	1	20 OHMS	25 AMPERE	
5C 300 Y 5V 3	6 VOLTS	1	20 OHMS	25 AMPERE	
5C 300 Z 5V 3	6 VOLTS	1	20 OHMS	25 AMPERE	

This Chart also applies to other types of Tubes with filament characteristics the same as those listed above.  
FOR LONG LIFE AND GOOD RECEPTION BURN TUBES LOW AND TURN THEM ON AND OFF SLOWLY.

KLOSNER RADIO CORPORATION, New York  
RHEOSTAT SPECIALISTS

### KLOSNER VERNIER



6 Ohms, with 2" Bakelite Dial \$1.50

### KLOSNER RHEOSTAT



with knob and pointer

6, 10, 20 or 30 Ohms.....\$ .90  
2 Ohms (Power Rheostat) or 60 Ohms .....\$1.15

### KLOSNER RHEOSTAT



with 2" Bakelite Dial

6, 10, 20 or 30 Ohms.....\$1.25  
2 Ohms (Power Rheostat) or 60 Ohms .....\$1.50

Send for free valuable information on the care and operation of vacuum tubes.

### Klosner Radio Corporation

Rheostat Specialists

1022 East 178 St., New York City

etc. The only conclusions so far reached are that the sun has a definite effect on radio waves. Just what wave-lengths are affected and in what degree is as yet undetermined. As we have mentioned above, these results are preliminary and are merely the effects observed.

Other tests were performed in Michigan at a point that was in the center of the path of totality. Programs of music were transmitted on a wave-length of 268 meters with a total power of 100 watts, the radiation being approximately three amperes, with a modulation of 0.4 ampere. The method of checking was by telegram sent from those who heard the station at different times, reporting strength of signals and other data. A program was started at 3 a. m. and continued until 9 a. m., Central Standard Time, the eclipse occurring at 8:02 a. m.

The results obtained were as follows: In the local range of the station, perhaps up to about 10 miles, no variation of any sort was noticed because the power of the station is so great that at that distance any variation was not noticeable. From about 10 to 25 miles is the station's daytime range and in this area during the period of totality a reduction of volume was recorded. This was expected, as daytime reception in this belt was of greater strength than night reception. From 25 to 80 miles the daylight effect was more strongly shown. This area hears the station with a fair volume during the day and only faintly at night. During the eclipse, the signal strength diminished, becoming minimum at totality and then regaining its strength after the phenomenon.

It is a well-known fact that there is a period just preceding the dawn when tremendous distances are covered, this being called the "dawn effect," and lasts but a very few minutes. Apparently, during the passage of the moon across the face of the sun, the moon's shadow gave an artificial reproduction and extenuation of this dawn effect, because the range of the station was more than doubled during the eclipse period. This increase of signal strength was also observed between Rocky Point, Long Island, and Belfast, Maine, when the former station was transmitting. The conditions were more or less the same, as the receiver in Belfast showed an increase during the period of the eclipse.

The conclusions that may be reached from these observations are that the theory of ionization and absorption of radio waves due to the sun's rays is proved almost beyond a doubt. There is also the additional fact that the shadow of the moon produced a continuation of the dawn effect by preventing this ionization until the moon had passed completely across the face of the sun. These observations will be of the greatest value to radio engineers, as it gives for the first time a proof of the theory which has so long been debated. However, the total results will not be available for some time as yet, because of the immense amount of data that has to be studied and digested.

## About Radio Losses

(Continued from page 1879)

### AS TO BUS BAR

If we charge an insulated conductor, the charge will stay put for some time, but if we plant a sharp needle on one end of this conductor, the charge promptly leaks off into the air and hunts more congenial company. Therefore, my friends, eliminate square bus wire, ragged edges on condensers, sharp ends to screws, etc.

If we are driving downtown at a good clip and decide to make a right turn at the

# PEERLESS

Built Up to the Peerless Standard of Quality—not down to a Price



\$8<sup>50</sup>

Peerless Loudspeaker ..... \$8.50

Peerless Phonograph Unit \$3.50

Peerless Headphones ..... \$3.50



\$3<sup>50</sup>

Jobbers, Dealers, now is the time to get samples and get posted on Peerless.

## UNITED RADIO CORPN.

115-117 Caledonia Ave.

Rochester, N. Y.

Since 1921, the reliable quality phones at a popular price.

Insure your copy reaching you each month. Subscribe to Radio News—\$2.50 a year. Experimenter Publishing Co., 53 Park Place, N. Y. C.



# *Greater distance for any set* *— with a Brandes!*

A headset adds just about thirty per cent to the distance that any receiving set can get

It means not only greater distance — but keener clarity of tone

It means listening in without disturbing others — and without being disturbed

It means getting the best out of your set — whether it be large or small

Buy the receiver that's equipped with a Brandes



**Brandes**

*The name to know in Radio*



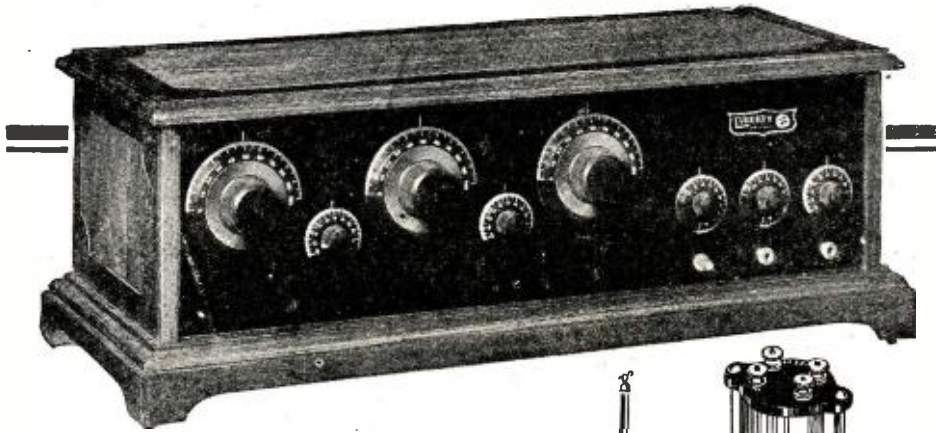

**Who is buying the Liberty this month?**

**Ans.—Friends of people who bought last month.**

**LIBERTY SEALED FIVE**

\$100 less accessories

Made by the manufacturer of  
**LIBERTY LOW-LOSS TRANSFORMERS**  
which assure clearest tone.

**Liberty Transformer Co., Inc.**

555 N. Parkside Ave., Chicago



**AUDIO FREQUENCY TRANSFORMER**

Base or panel mounting type Ratio	Price
3 to 1.....	\$4.50
5 to 1.....	4.75
9 to 1.....	4.75



(Air Core)  
**RADIO FREQUENCY TRANSFORMER, \$1.50**

next corner, we slow down for the turn; if we don't slow down, we don't make the turn as per schedule—we usually land in the corner drug store window. An electric current is subject to the same laws; a slow-moving current will take a sharp, right-angled bend without any fuss, but a high frequency current will keep on going straight ahead, or back up enough to increase the resistance at this point enormously. Try a stream of water through a hose with a bend of ample radius, and then try the same stream through the hose with a sharp bend in it. Stop making the prim and over-fussy right angle bends in your wiring!

Look out for dust. A slight, imperceptible film of moisture will take on a nice coating of dust and this makes an excellent leakage path.

So much for the more common leakage losses; our resistance losses are more difficult to find and much more difficult to remedy.

Going back to the antenna and inductance coil we find that in addition to the ordinary ohmic resistance we have a couple of others which are more deadly. A high frequency current behaves in such a manner that it is obliged to travel on the surface of the wire, and in the coil it not only has to travel on the surface, but it travels on the outside of the coil, pretty much, which results in its confining itself to a narrow path instead of spreading out all over and through the wire. This particular kind of meanness is called skin effect, and it is responsible for a lot of our high frequency troubles. It is easily seen that the obstruction to the flow of current can build itself up enormously, and the sad part of it is that we cannot remedy the trouble by increasing the size of the conductor, as we do with a direct current, and if we try using a lot of fine wires in a bundle we strike another snag—or several of them—because we increase the capacity between the wires, and if the wires are insulated and one of them becomes broken, the broken wire is not only a dead loss as a conductor, but it throws an added burden on the rest of the conductors increasing the heat of these and, therefore, the resistance; also, if we wind our coil with many turns of closely packed wire, our capacity effect slows up our current at an alarming rate. We say, approximately, that the resistance due to skin effect is proportional to the product of the frequency and the circular mils of the conductor. Coming down to earth we say—sheer off Litz and tape; use solid wire, No. 14 or bigger for the antenna, and No. 18 or No. 14 spaced for the secondary of the coil. All this is rank heresy to a lot of you, but—try it and see!

If we splice our lead-in to the antenna, we create a spot which may develop increased resistance due to oxidation at the joint; and this oxidation fault is present to a much greater extent in a stranded antenna wire, because at every spot one wire touches its neighbor a bit of oxide forms, the resistance of which is many times that of copper itself. Where possible, use a continuous run of solid wire (one-piece) for antenna and lead-in clear up to the set. If it is necessary to use two pieces of wire for lead-in and antenna, solder the joint thoroughly with a blow torch, tape it and paint the tape with insulating varnish; be absolutely sure that the parts to be soldered are bright and shining and that there is a tight mechanical contact before the solder is applied. This caution applies all along the line; wherever it is necessary to apply solder, be sure there is a clean, tight, mechanical contact first—then apply a sparing dose of solder to hold it tight and prevent oxide forming at the point where the two wires come together. A well soldered joint is "sweated" together so that the solder is hardly seen.

**W. L. DOUGLAS**

**\$5 \$6 \$7 & \$8 SHOES**



Boys' Shoes at Popular Prices



One of our many styles for Women

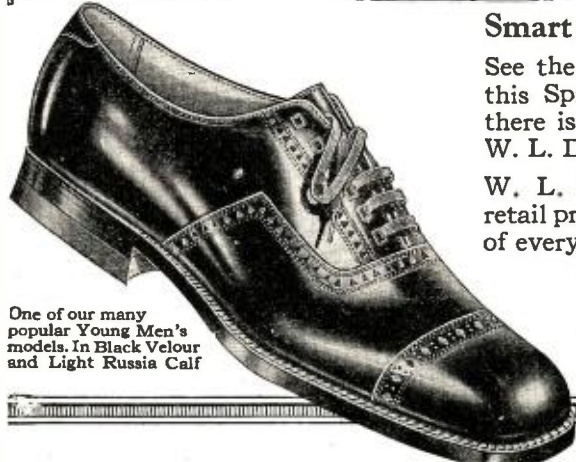

One of our many popular Young Men's models. In Black Velour and Light Russia Calf

**Smart Styles for Young Men**

See the new styles ready for you this Spring and remember that there is sure economy in buying W. L. Douglas Shoes.

W. L. Douglas' name and the retail price is stamped on the sole of every shoe at the factory.

We own and operate 120 Retail Shoe Stores in the principal cities. W. L. Douglas shoes are also sold by over 6000 retail shoe dealers.

**W. L. DOUGLAS SHOE CO.**  
Brockton, Mass.

Get a Handy Binder for your RADIO NEWS. Holds and preserves six issues, each of which can be inserted or removed at will. Price 65c. Experimentor Pub. Co., Inc., Book Dept., 53 Park Place, New York.



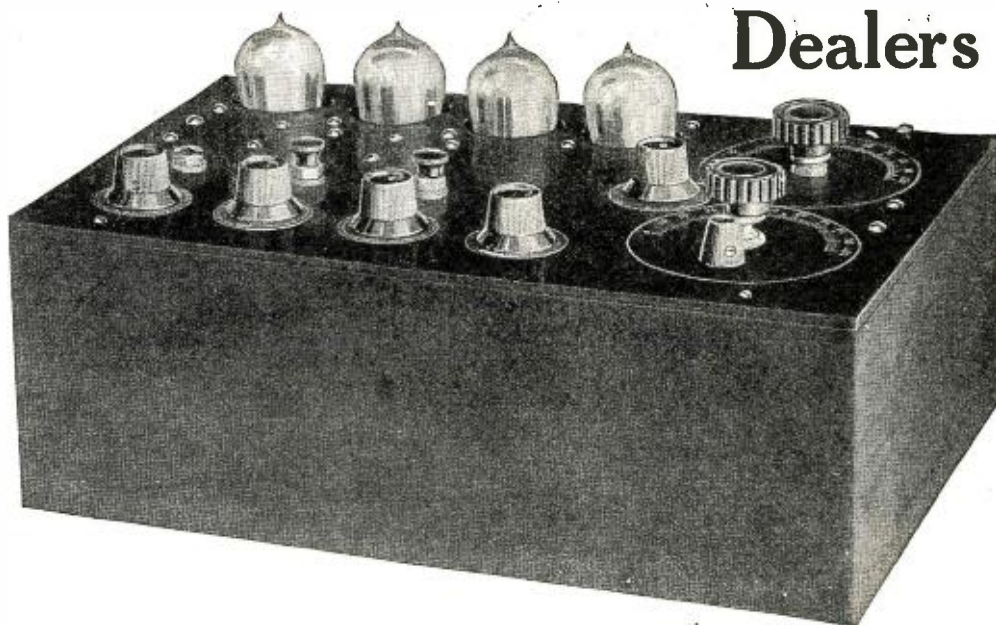

**Dealers find this  
a Quick  
Seller**

*The Jos. W. Jones  
Knockdown  
Receiver  
Completely  
Assembled*

*In your home, it will take its  
place pleasingly alongside the  
choicest furniture. Its cabinet  
is leather covered and its panel  
is beautifully arranged.*

## *Easy NOW to Build Your Own Radio*

All the parts and elements needed to build your new set—in one purchase—in one compact package. No more shopping around or doubts of results. Not just ordinary parts, but the famous Jos. W. Jones parts, made by expert precision parts makers. Remember, a radio receiver is only as efficient as the workmanship and precision of its parts.

**JOS. W. JONES**  
RADIO  
TRADE MARK.

### *4-Tube Knockdown Receiver*

With this complete kit you can quickly build a 4-tube set that will give you amazing volume and distance. It is non-regenerative—highly selective. Simple to operate—easy to build. Complete, detailed assembling directions with each kit, which any one can follow successfully. To be absolutely sure of results, get the Jos. W. Jones 4-Tube Knockdown Receiver.

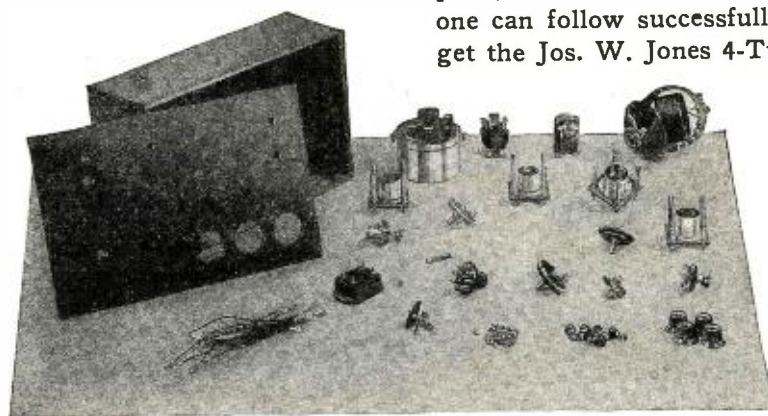

*The Jos. W. Jones Knockdown Receiver Showing  
the Parts Making the Kit*

The set consists of a finely finished oak cabinet, a completely drilled bakelite panel, and all the other parts and elements from a Vernier Condenser to the smallest bit of wiring—all ready to be assembled and give perfect results.

**Price \$50**  
at your dealers

**JOS. W. JONES RADIO  
MFG. CO., Inc.**

**40-42-44-46 W. 25th St., New York**

99 Bedford St.,  
Boston, Mass.

53 W. Jackson Blvd.,  
Chicago, Ill.

Victory Bldg., 1011 Chestnut St.,  
Philadelphia, Pa.

Branch Offices: Boston, Philadelphia and Chicago



ABOUT LUGS

About lugs: don't use them! Will someone kindly tell me just why it is considered such a refinement of workmanship to take a lug, cover it with cheap solder, cover the end of the wire with solder, join the two, and then screw the lug to the binding post? It isn't intelligent. Why not screw the wire to the binding post in the first place, thus eliminating an entirely unnecessary piece of metal, a tedious job and—most important—a point at which we have increased the resistance quite perceptibly. Good solder has a resistivity about 20 times that of copper; cheap solder is principally dross and has little conducting power for high frequency currents—it shouldn't take much imagination to see what happens in a set copiously daubed with solder at innumerable joints, and when these joints depend upon imperfectly applied solder to hold them together and not upon mechanical excellence, the trouble is magnified sufficiently to kill the set. Let me repeat and urge—make the best mechanical connection you can, with clean metal-to-metal contacts, then sweat a film of solder into the joint with a good, big, hot iron!

Pick out a condenser of the variable variety which has very little insulating material on it, no insulating bushings, and, preferably, pigtail connections; you can supply the last mentioned, if the rest of the condenser is satisfactory. Do not use oil to ease up the rotor and do not use a separate vernier attachment or extra vernier plates—use a vernier dial on a standard condenser. Your condenser is nothing but loss if you neglect these precautions.

MAGNETIC FIELDS

These, in brief, are the common or garden variety of losses we are up against; now comes some trouble many of us don't know about—and which mighty few pay any attention to. Take a wire, shove it through a sheet of paper, dust some iron filings on the paper and then shoot a fairly husky jolt of current through the wire; if you tap the paper you will find that the filings will arrange themselves in concentric rings about the wire. Repeat the experiment with a coil of wire; same result only more so—that is, we have demonstrated that there is a force acting outside the wire in the surrounding air. If we slip a soft iron rod into the coil, we have a lot more of these lines of force and we have increased the size of the field of force. An alternating current comes surging down the antenna to the primary coil, a stepped-up current is induced in the secondary coil, and this current shoots off to the set. Now suppose you have built a lunch-box set and the inductance coil is snuggled up against the condenser. Having in mind the antics of the iron filings when subjected to the influence of a current in a coil of wire, just what do you think is happening in the condenser by way of electrostatic and electromagnetic fields which do not belong there? And if the transformers are wedged up against the tubes with their centers less than an inch apart, is it any wonder that the tubes oscillate when we don't want them to—and without apparent reason? Again, if our battery leads are run so that they make complete loops, we get some more magnetic fields we don't want.

I think you will admit that building an efficient radio receiver is not a hit-or-miss proposition; and when we pay some attention to the various items I have cited, we will begin to get results not dreamed of by the lunch-box enthusiast. Avoid leakage—avoid preventable resistance—avoid stray fields; your results will surprise you.



**Here it is!**  
**Broadcasting: listen!**

"Business static hurts your cash register as much as weather static hurts reception."  
Now, listen in carefully.

The HOMMEL Dealer Service Department was developed for the one particular purpose to help alleviate business "static." That Department is vitally concerned in furthering your interests—as a Hommel Dealer.

We work shoulder to shoulder with our dealers—not in competition with them. We wholesale only and carry only the most reputable radio equipment. All user inquiries and orders resulting from our national advertising are forwarded promptly to our local dealer.

In our new six story building we carry larger stock and have better facilities for serving you than ever before.

We can't help you unless you ask us to. Write today for Hommel's Encyclopedia of Radio Apparatus 266-S. It's free and will help you.

DISTRIBUTORS FOR  
Radio Corporation of America

Westinghouse General Electric

Baldwin Brandes Burges  
Cardwell Crosley  
Cutler-Hammer  
Dubilier Fada Freed-Eisemann  
Freshman Frost  
General Radio Crebe  
Haynes-Griffin Magnavox  
Remler Rhamstine  
U. S. Tool Western Electric  
And other  
leading manufacturers

WHOLESALE EXCLUSIVELY  
**LUDWIG HOMMEL & CO**  
929 PENN AVENUE PITTSBURGH, PA.

No. 4 of a series of 10  
**"FILTER FACTS"**  
Follow them thru monthly

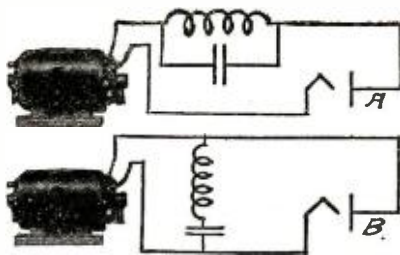

$$f_r = \frac{1}{2\pi\sqrt{LC}}$$

$f_r = \text{Resonance } f.$

$L = \text{Henries}$

$C = \text{Farads.}$

**SERIES AND PARALLEL RESONANCE.** Inductance or capacity when used separately as outlined in No. 2 and 3 of this series are indiscriminate in their action with the exception of the general rule, the higher the frequency the more effective. The combined use of them will result in a filter that will either stop, or pass, one or several frequencies or bands of frequencies. The two basic forms for such combinations are Series Resonance and Parallel Resonance.

**SERIES RESONANCE.** A choke and a condenser connected in series as shown in B will offer high impedance to all frequencies except one, i. e. resonant frequency ( $f_r$ ). This frequency, practically speaking, will pass with an impedance of the resistance of the choke only, i. e. better than condenser alone if R is small, but the impedance will be high for frequencies above and below resonance.

**PARALLEL RESONANCE.** When inductance and capacities are connected in parallel as in A the reverse characteristic of B will prevail. It will pass all frequencies except those near resonance. For resonance frequency it will be a dead stop except to supply the losses which are, practically speaking, negligible.

The effective application of these resonant circuits in their basic forms to generators is rather limited. One for slot ripple and one for commutator ripple will be required, neither one of which will be very effective in reducing moving contact disturbances. Also they are so very discriminate that slight variation in speed, such as caused by varying the load, would require readjustments.

**ELECTRIC SPECIALTY COMPANY**

TRADE "ESCO" MARK

211 SOUTH STREET

STAMFORD, CONN., U. S. A.

Makers of Motor Generators and Dynamotors with the least ripple and the most miles per watt.



# Now—more than ever the Right Set to Buy

*The self-contained set is the radio receiver of the future—and the only satisfactory type for summer use*

There are a host of people who will get fully as much pleasure out of radio this summer as they have all winter. They are the thousands of owners of the 1925 Operadio. Whether they stay at home or travel, splendid radio reception is always available. For with this complete, self-contained set they may listen in anywhere. Its extra large battery supply, six tubes, large loop in the removable cover, and efficient loud speaker—all enclosed in the compact carrying case—assure powerful distance performance. Think of it! No outside wires or connections, no accessories, nothing but a smart-looking case, opened and easily tuned in less than a minute. The 1925 Operadio is not to be confused with the ordinary so-called "portable" set. It has far longer battery life because three years of concentrated effort by nationally known radio engineers has resulted in extreme compactness, allowing space for six "A" batteries and four of the largest "B's." It has greater range and selectivity, greater ease of tuning, and much finer tonal qualities than any set of this type ever designed, and its performance is comparable with that of any set on the market. Before you buy any set, judge it by the standard established by the Operadio. Get the convenience and added enjoyment of a set that can be enjoyed anywhere. If your dealer is not yet handling Operadio, write us and mention his name.

**THE OPERADIO CORPORATION**  
8 South Dearborn Street CHICAGO, ILL.

# OPERADIO

The Original Self-Contained Radio Set

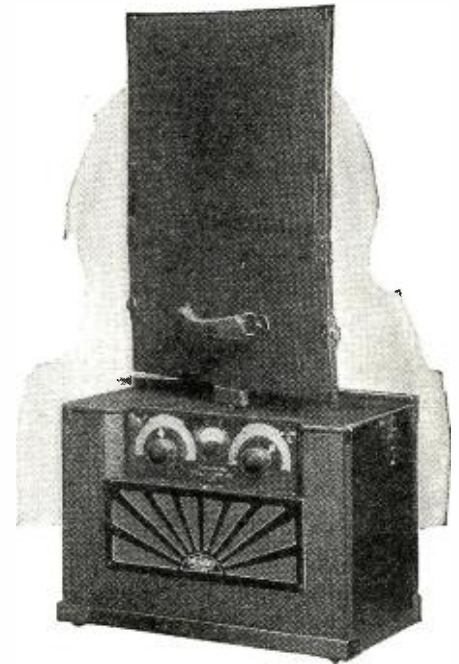

The Operadio is entirely complete in its smart leatherette carrying case. An attractive De Luxe Walnut Cabinet has also been designed for those desiring a furniture model in which the case may be placed.

Price Complete  
With Tubes and Batteries  
(Portable Type Only)  
**\$189<sup>00</sup>**



Close it up  
Take it with you  
Use it anywhere





The  
PRINCE  
of  
RADIO  
RECEIVERS

BILTMORE MASTER R.F.  
Model T5.

A \$150.00 RECEIVER SELLING FOR ONLY \$68.00

Here is as fine a five-tube receiver as was ever made. Fine in appearance, workmanship, materials and results.

The circuit is the Biltmore improved Radio frequency type. All materials are the finest which it is possible to obtain. The variable condensers and R. F. Transformers are low loss especially designed. The cabinet is heavy mahogany hand rubbed. The panel is mahogany and all metal parts are highly nickel plated.

The results match the appearance of the Receiver. Its extreme sensitiveness, matchless selectivity and perfect tone have made for the Biltmore a host of highly enthusiastic owners. "Absolutely the best Receiver which can be had at any price" is an example of the hundreds of testimonial letters in our files.

Model T 5 Price \$63.00

For Sale by all the better Radio Dealers. Write for descriptive literature Dept. M.

The Biltmore Radio Company.  
BOSTON 30 MASS.

BARKELEW Lightning Arresters



LIGHTNING ARRESTER SWITCH  
No. 602 Price \$3.00

OUR No. 602 Lightning Arrester Switch is universally recognized as the only device on the market which combines on one base all those functions essential for maximum protection.

The Vacuum tube arrester is permanently in the circuit from antenna to ground, ready to "spill" any overcharge. With the switch blade the antenna may be disconnected from the radio set and thrown directly on ground.

It meets not only the requirements but also the additional recommendations of the National Electric Code.

Our No. 606 Vacuum Tube Lightning Arrester is less expensive but it meets all the actual requirements of the National Electric Code.

Both are Approved by the Underwriters' Laboratories.

See our Radio Catalog No. 32 at your Dealer. If he hasn't his copy, we have one for him.

The Barkelew Electric Mfg. Co.  
Middletown, Ohio, U. S. A.

NEW YORK, 157 Chambers St.  
BOSTON, 31 Bedford St.

CHICAGO, 15 S. Clinton St.  
DENVER, Denham Bldg.

SEATTLE, 1014 Sixth Ave. S.  
SAN FRANCISCO, 75 Fremont St.

WASHINGTON, D. C. Mills Bldg.  
MINNEAPOLIS, 1017 Lumber Ex.  
LOS ANGELES, 443 S. San Pedro St.

TORONTO, Geo. R. Archdeacon, No. 7 Crang Ave.



LIGHTNING ARRESTER  
Vacuum Tube Type  
No. 606 Price \$1.50

The Effect of the Atmosphere on Radio Waves

(Continued from page 1855)

If a ray of light (OL, Fig. 1) is projected tangent to the ground through a homogeneous space, it would travel in a straight line, as shown. Through the atmosphere, it travels through layers having different refracting properties and it curves toward the ground following the line OL. If the atmospheric layers of equal densities were all concentric spheres around the earth, calculations show that the ray of light would go out of the atmosphere before coming back parallel to the spheric layer which it crosses; it will not be subjected to a mirage. In the case of electromagnetic waves it is entirely different, for on a good conducting ground, the line of propagation is an arc (OR, Fig. 1), concentric to the surface of the earth. The atmospheric layer through which it travels being homogeneous, not considering weather perturbations, produces no change in the direction, and this circular ray OR travels as a horizontal ray parallel to a flat surface. The thickness of the atmosphere is thin enough for this property, which is exact near the ground, to apply still at any height above the ground.

As an example, we may ask how a radio ray (OR, Fig. 5) emitted in a direction slightly inclined on the horizontal will behave? The mathematical solution of this problem is still to be found, but it seems logical to admit that for a slight inclination the deviation produced by the reduction of the refracting effects of the various layers will be still the same for a ray which is almost horizontal in the neighborhood of a flat surface. The calculations then become much simpler.

In a quiet atmosphere, at night, for instance, the direct wave which traveled along an arc will be reinforced by a mirage wave sent from the transmitting station in a slightly oblique direction. This reinforcement is very rare during the daytime, probably due to the air current produced by the heating of the ground changing the uniformity of the various atmospheric layers. The calculations also show the importance of the deviations produced by very slight variation in the diffracting effect of the various layers when these variations are spread over very long distances.

The theory of a very good conducting ground does not reduce the generality of the phenomenon just explained. The imperfect conductivity of the ground has for results the inclination of the wave fronts forward of about two or three degrees, thus contributing to the further inclination toward the ground of the electromagnetic waves and increasing the effect produced by the conductivity of the earth.

In conclusion: The theory of more or less conductive atmospheric layers is not necessary to explain the fact observed in the propagation of electromagnetic waves. These facts are explained by purely material modifications in the state of the lower atmosphere. The experimental researches published by the United States Bureau of Standards and by Mr. Mesny in France show beyond a doubt the influence of the weather, the temperature and atmospheric pressure, perhaps also of the dampness. For instance, the transmission which is more regular and strong along isobare and isotherme lines is a consequence of the even diffracting properties of various air layers following these lines. In all oblique directions the air behaves as a non-homogeneous medium, more or less disturbed.

For all calculations see the proceeding of the Paris Academy of Science, August 4, 1924 (t. 179, p. 327).

Terlee Acme Reflex Receiving Sets  
8-tube efficiency with only 5 tubes to take care of.  
Write today for circular. Dealers and jobbers, ask for prices and details.  
TERLEE ELECTRIC & MFG. CO. 443 So. Dearborn St. Chicago, Illinois



The new PARAGON Radio Receivers  
Introducing the new non-radiating Paradyne Circuit, new simplified tuning, and new low prices.  
Write for Folder  
ADAMS-MORGAN CO., Inc.  
18 Alvin Avenue Upper Montclair, N. J.

Insure your copy reaching you each month. Subscribe to Radio News—\$2.50 a year.  
Experimenter Publishing Co., 53 Park Place, N. Y. C.



**HELLO MARS  
THIS IS  
EARTH**

**"RADIO WILL SURELY DO IT"**

Set, complete with 5 matched and tested Radio Knight tubes . . . . . **55<sup>00</sup>**

## THE RADIO KNIGHT

Absolutely The **GREATEST** Radio Value On the Market Today

ONE HUNDRED CENTS WORTH OF VALUE FOR EVERY DOLLAR YOU INVEST! At our low list price of \$55, including 5 MATCHED AND TESTED TUBES, the RADIO KNIGHT represents a starting value—certainly the best that has yet been offered anywhere today.

### UNBEATABLE VALUE

5 MATCHED AND TESTED RADIO KNIGHT TUBES, Type 401A  
SOLID MAHOGANY CABINET—Lustrous Piano Finish  
STANDARD LOW LOSS PARTS THROUGHOUT  
SKILLFULLY CONSTRUCTED—SCIENTIFICALLY TESTED  
FROM BUS BAR TO CABINET—THE FINEST QUALITY  
PROCURABLE

### A 5 Tube Tuned Radio Frequency Receiver

The RADIO KNIGHT employs the most efficient principle known to radio science today—**TUNED RADIO FREQUENCY!** With this recently perfected circuit, sharp and selective tuning, long distance reception and remarkable ease of control are actual realities. The usual stray capacities inherent with the ordinary radio frequency circuits are entirely eliminated, insuring remarkably clear undistorted reception, volume, and mellow tonal qualities.

The RADIO KNIGHT is conscientiously built—under the personal supervision of skilled radio engineers. An inspection of this receiver will immediately convince you that only the finest and most efficient **LOW LOSS** parts have been incorporated in its construction.

The position of the radio frequency transformers and condensers has been scientifically and minutely adjusted for the permanent and exact capacity balance of the receiver. This circuit is self neutralizing—troublesome neutralizing condensers are entirely eliminated!

The RADIO KNIGHT is **FOOL-PROOF!**—exceptional results are obtained by the non-technical users.

### Satisfaction Insurance

Each and every one of these receivers is carefully and conscientiously tested under actual conditions. Therefore, we have no hesitancy in issuing our iron-bound guarantee of uniformly high quality results.

### Dealers! Attention!

Bring radio prices **DOWN**—where they belong! Get behind this revolutionary offer of a 5 tube tuned radio frequency receiver with a \$55 list price **INCLUDING 5 MATCHED AND TESTED TUBES.** **SURPRISINGLY** generous range of discounts in effect. Many desirable territories still available. Write now—**TODAY**, as we are allotting territories in the order of receipt.



### The RADIO KNIGHT Vacuum Tube

Bakelite Base—Tipless  
Current Consumption  
1/4 Ampere.

An improved, accurate instrument built to precision and minute scientifically gauged specifications. Can be used in any set, from the smallest one tube receiver to the finest and most intricate multi-tube set. Economical in current consumption. Impregnated thorium filament (not thorium coated).

List Price  
**\$3.00**

Every tube furnished with The **RADIO KNIGHT RECEIVER** has been individually matched and bears an identification mark for easy insertion in their proper sockets.

CHISHOLM-BARFIELD CORP.,  
206 Broadway, New York City.

Gentlemen:—Kindly ship the following articles, for which I am enclosing . . . . . Dollars.

- Radio Knight Set . . . . .
- Radio Knight Tubes . . . . .
- Dealer's Proposition . . . . .

Name . . . . .  
Address . . . . . City . . . . . NR

## Chisholm-Barfield Corp.

Originators of Radio Apparatus

206 Broadway  
New York City



# Amplification De Luxe

## The New GENERAL RADIO Audio Transformer



Type 285  
Price \$7.00

**GENERAL RADIO Co.**  
Cambridge, Mass.

TODAY, with the improved re-producing equipment now available, there is a definite need for a transformer which is capable of *higher* amplification and which will cover a *wider* band of audio frequencies.

The Type 285 Transformer amplifies evenly the low bass tones of an organ or the high tones of a violin, individually or in combination, with a naturalness formerly unknown to radio reception.

Ask your dealer for the New General Radio Type 285. It is a real "super" transformer—greater in volume, better in quality.

SOLD AT ALL GOOD RADIO STORES

Write for descriptive folder 285N  
and New Radio Catalog 920N

## New Improved AMPL-TONE Guaranteed RADIO HEADSET

Full  
2200  
Ohms



New  
Price  
\$5.00

For three years these Headsets have been tried, tested and proven their value. There are thousands in use to-day, still giving perfect satisfaction, having sold on their merits. Our production has allowed us to reduce the price and make improvements.

Unexcelled for crystal sets and capable of great distance reception with tube sets.

Your set, large or small, deserves a Real Good Headset for the best results.

Ampl-Tone Phonograph Attachment (fits any phonograph) only \$3.00. Insist on Ampl-Tones for greater distance—Volume and Clearer Reception. Your reliable dealer has them in stock, if not write us direct.

MANUFACTURED BY

**THE UNION FABRIC COMPANY, Derby, Connecticut**

**"PACIFIC QUINTET" \$15.00**  
Super Het Kit (45,000 Cycle)  
Consisting of 1 Pacific "Ranger" No. 30 Oscillator Coupler, 3 Pacific "Ranger" No. 25 Intermediate Frequency Transformers and 1 Pacific No. 20 "Ranger" Filter Transformer with hook up print and simple instructions.  
Sent to any address upon receipt of \$15.00, or by Parcel Post or Express C.O.D.  
Representatives—Manufacturers—Distributors  
Baldwin Pacific & Co., 441 Pacific Bldg., San Francisco

## HUDSON-ROSS

Sells only nationally advertised radio apparatus.

Send for discounts.

123 W. Madison St. Chicago

## Building Compact Super-Heterodynes

(Continued from page 1881)

learned the advantage of using the 199 type of tube in the construction of compact sets. It has the distinct advantage of consuming a great deal less "A" battery current than the standard tube, gives almost the same amount of amplification and serves very well as both detector and oscillator.

With the aid of these tubes one of the most compact and efficient portable Super-Heterodyne sets possible may be constructed. Fig. 4 gives a photograph of the set, completely home-made, including the built-in loud speaker.

By placing the tubes on one shelf and laying the intermediate transformers on a second one just beneath the tubes and making the connections as short as possible, the set, complete, is housed in a cabinet smaller than the regulation traveling case. The placement of the parts is obvious from the photograph, though the experimenter will have to select the size and dimensions for himself. In this instance, standard sockets were employed with adapters so that an interchange of tubes was possible. However, if the set is to be a purely portable one, this adjunct is hardly necessary, and may be dispensed with to advantage.

And here let a word be said about the practicability of Super-Heterodynes in portable form. If you must build a portable set, make it a Super-Heterodyne, since the interlocking of magnetic fields will have less deleterious effect than in any other type of outfit, and this is a point of no mean importance.

## The Financial Side of Radio

(Continued from page 1856)

in the fall will be keen enough to lower prices. However, the increase in sales should keep up net profits.

### THE FUTURE OF RADIO STOCKS

The future of the radio industry is bright and, likewise, the future of the radio companies as a class is most promising. All the companies have had exceptionally good business in the last four months of 1924 and should have for the first four months of 1925, and as these earnings come in, the radio stocks should tend to advance.

But it should be remembered that the general stock market has been advancing steadily since November 4, 1924, and there will probably be some kind of a reaction inside of the next six months. When this comes, it will doubtless have an effect on the radio stocks.

The radio industry is unusual, but because of the above reason it is not unlikely to expect a reaction in the radio stocks some time during the summer. Although the future may show that they are cheap at present levels, they will surely be worth their price after they have undergone a reaction.

### EFFECT OF A BOOM MARKET

In every boom market a number of inferior stocks are carried along with the good ones, and sell out of line for months at a time. During such a period it is very easy to be mistaken, for what appears to be the most favorable news is being issued about the stock with the least real value, and practically nothing is being published about the better companies, because certain interests are desirous of buying them.

### HOW TO JUDGE RADIO STOCKS

Therefore, before making an investment, it is best to consider what a radio company



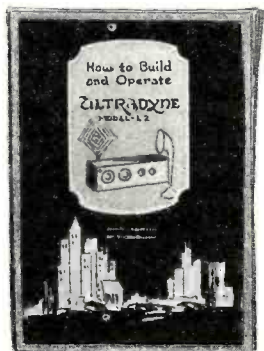

How to Build and Operate the ULTRADYNE

32-page illustrated book giving the latest authentic information on drilling, wiring, assembling and tuning the Model L-2 Ultradyne Receiver.....**50c**

**THE ULTRADYNE KIT**

Consists of 1 Low Loss Tuning Coil, 1 Special Low Loss Coupler, 1 Type "A" Ultraformer, 3 Type "B" Ultraformers, 4 Matched Fixed Condensers.

To protect the public, Mr. Lacault's personal monogram seal (R. E. L.) is placed on all genuine Ultraformers. All Ultraformers are guaranteed so long as this seal remains unbroken. **\$30.00**



**Heard Europe on a Home Built Ultradyne Model L-2**

Arthur Bender, 116 East 2nd St., Covington, Ky., had no trouble picking up European stations last week on his eight-tube Ultradyne which he constructed himself.—*Cincinnati Enquirer*, Nov. 30, 1924.

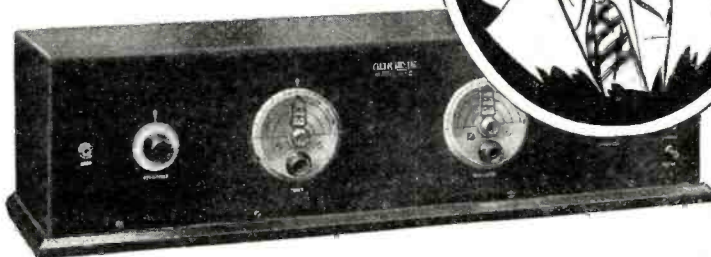

*Thousands have built it!*

**L**IKE Mr. Bender, thousands have successfully built the Model L-2 Ultradyne and claim it the most wonderful receiver they have ever known for great distance on the Loud Speaker.

In no other receiver is found the "Modulation System" of radio reception—an outstanding radio engineering development by R. E. Lacault, E.E., A.M.I.R.E., Chief Engineer of this Company and formerly Radio Research Engineer with the French Signal Corps Research Laboratories.

With the application of regeneration to the "Modulation System" the Ultradyne is capable of detecting the faintest broadcast signal, regenerating and making it audible on the loud speaker.

In addition, the Ultradyne is the most selective receiver known. Regardless of close similarity in wave length, it selects any station within range—brings in broadcasting clearly, distinctly, faithfully.

The Model L-2 Ultradyne will do everything better than any super-radio receiver operating under the same conditions.

*Write for free descriptive folder.*

**ULTRADYNE**

**MODEL L-2**

**Phenix Radio Corporation**

3-7 Beekman Street  
New York



# Quick Service by Mail

ON ALL STANDARD **RADIO** APPARATUS AT BIG SAVINGS

## Your Order Shipped Same Day Received

You Cannot Beat These Bargain Prices Anywhere!  
Every Item of Guaranteed High Quality

<b>TUBES</b>		<b>COILS FOR SPECIAL CIRCUITS</b>		<b>Bakelite, 2 inch.....</b> .30	
Cunningham or Radiotron, all types.....\$2.48		Silk Wound Reinartz Slider.....\$ .30		3 inch......40	
Kenrad, type 621A, guaranteed 1.95		Web.....3.75		4 inch......60	
		Cockaday Set.....1.50		Accuratune, 4 inch.....2.75	
		Harkness, pair.....1.75			
<b>LOUD SPEAKERS</b>		<b>VARIABLE CONDENSERS</b>		<b>SOCKETS</b>	
Atlas.....\$18.75		Acme.....\$4.95		Bakelite.....\$ .30	
Brandes Table Talker.....5.95		American Brand .0005.....3.75		Flewellling......60	
Spartan.....6.50		Coto.....3.75		Benjamin......70	
Music Master.....22.50		Super Low Loss 17-plate.....1.85		Workrite......60	
Pathe.....12.50		23-plate.....2.00			
Baldwin or Utah.....17.50		43-plate.....2.25			
Frost Musette.....9.25		Continental .0005, Vernier.....4.50			
		Mareo .000375.....3.75			
<b>HEAD PHONES</b>		<b>RHEOSTATS</b>		<b>BATTERIES &amp; CHARGERS</b>	
Little Gem.....\$1.95		Bakelite, any resistance \$1 val.....\$ .60		100 Ampere, Rubber Case, Storage Battery Guar. \$18 val. \$12.00	
Frost.....2.80		Pacent......70		Large 22 1/2 v. B Battery, \$2 val. 1.39	
Brandes.....4.75		Howard......80		Large 45v. B Battery, \$3.75 val. 2.25	
Murdeck.....2.80		Standard, 75c value, any resistance......35		Homecharger DeLuxe.....12.95	
Baldwin.....7.80		Amperites, any style......90		France Super Charger.....17.50	
				Tungar 2 Amp. Charger.....14.50	
<b>AUDIO TRANSFORMERS</b>		<b>DIALS</b>		<b>SPECIAL BARGAINS</b>	
All American.....\$3.35		Seranton, 2 inch.....\$ .15		Grid Leaks.....\$ .10	
Erla.....3.75		3 inch......22		2-Cord Plug, composition......25	
Thordarson.....3.25		4 inch......29		2-Cord Plug, \$1 value......40	
Star.....2.45				B Battery Meter......65	
				\$5 Folding Loop Antenna.....3.25	
<b>RADIO FR. TRANSFORMERS</b>				Daven Resistance Coupled Amp 1.95	
Tri Coil.....\$1.65				Saal Phusiformer.....6.50	
Erla.....3.75					
Dubilier.....3.00					
Acme.....3.45					
<b>LOW LOSS TUNERS</b>					
3-Circuit.....\$2.60					
Ambassador.....5.25					
Bremer-Tully.....3.75					
Erla Selectoformer.....3.75					

**POPULAR KITS**

Phenix Ultradyne.....\$27.00
Fada Neutrodyne.....21.00
Freed-Eisemann Neutrodyne.....21.00
Shamrock Harkness.....29.50

THESE PRICES VERY SPECIAL FOR QUICK ACCEPTANCE—MAIL YOUR ORDER NOW!

Ward Davis - Radio 631 North Michigan Ave. Chicago

## "ROICE" Radio Tubes



The Royalty of Radio Tubes. A powerful and durable tube that will greatly improve reception, increase range and volume with a maximum of clearness. Our direct sales plan enables you to buy "Roice" at the lowest possible price.

Type-00.....	.5 Volts, 1 Ampere Detector Tube
Type-01-A.....	.5 Volts, .25 Ampere Amplifier and Detector
Type-02.....	3-4 Volts, .06 Ampere Amplifier and Detector
Type-99-A.....	3-4 Volts, .06 Ampere with Standard Base Amplifier and Detector
Type-012.....	1 1/2 Volts, .25 Ampere Platinum Filament Amplifier and Detector

ALL TYPES \$2.00

Type-02.....5 Watt, Transmitters, \$3.00

EVERY TUBE GUARANTEED

to work in Radio Frequency, especially adapted for Neutrodyne, Reflex and Super-Heterodyne Sets.

When ordering mention type.

Roice Tube Co., Dept. N° 21 Norwood St., Newark, N. J.

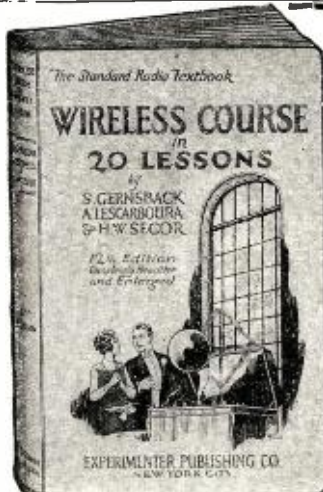

## 12th Edition

of the **Standard Radio Textbook**

The Finest, Most Complete Textbook On the Market

PRICE \$2.00

**Experimenter Publishing Co.**

Incorporated

53 Park Place

New York City

needs to make it successful and what is the record of the different companies.

What a radio company needs to be successful: It needs a good product, able men and strong financial backing, but the last named is not so important.

High-grade technical radio men (preferably with an inventive turn of mind) are very necessary to keep the company abreast of the constantly changing conditions. The possible advent of the radio television within the next few years is an example of what the companies must be prepared for.

Not so important now, but what will become more important as competition increases is a strong sales organization, including a good advertising policy.

Up to now the efficiency of manufacturing has hardly been considered by most companies in the rush to produce more and more. But this will become important and may eventually determine what concerns will be the largest producers. The factor that made Ford the outstanding figure in the automobile industry will sooner or later be felt in the radio industry.

Good banking connections will be useful in taking over a competitor, building a new plant, making additions, buying new machinery, establishing retail stores, etc.

The subject of patents must be considered. In some companies they are the largest asset. There may be infringement of the existing patent, necessitating an expensive legal suit, or a new invention may render it worthless. It may also be found that companies are manufacturing parts covered by patents, and that they will be estopped from this practice or required to pay a royalty.

As in any new industry, men not at first well known forge to the front in spite of all obstacles and their companies will be successful, but that does not invalidate what has been stated above.

### RADIO STOCKS

Name	Capital Outstanding Shares	Stock (1924-1925)	Price Range High Low
Boissonnault.....			2 1/2 2 1/4
De Forest.....	208,209		34 12
Dubilier.....	120,000		68 10 1/2
Pfd.....	\$390,000		
Duplex Radio.....			10 1/2 10 3/4
Freed-Eiseman.....	300,000		33 1/4 27 1/2
Freshman.....	225,000		24 21 1/2
Hazeltine.....	175,000		48 1/4 13
Inter-Ocean.....	46,400		16 1/2 8 1/4
Jones.....	225,000		10 3/4 7
Liberty.....	120,000		8 1/2 5 3/4
Music Master.....			15 3/4 14 1/4
Radio Corp. Pfd. old.....	\$19,779,870		5 3 3/4
New, Common.....	1,155,400		66 1/2 16 1/4
Rova.....	75,000		18 9 1/2
Sleeper.....	104,000		18 15
Thermodyne.....	250,000		19 1/2 12
Thompson.....	137,909		21 7
Tower Mfg.....			16 1/2 16 1/2
Ware.....	75,000		39 1/2 13 3/4
Pfd.....	\$100,000		

The person who will make a thorough examination of the listed radio stocks, giving due weight to the points above referred to and to the reported earnings, and can estimate the sales possibilities of the different companies, should be able to select several stocks having very good prospects.

It is better to choose three or four and not have all the eggs in one basket. No matter what issue or issues are taken, the purchaser should watch them very closely, because in a new industry conditions change very rapidly.

If properly bought, by taking advantage of any reaction in the market, these selected stocks should make a good investment with considerable possibilities of appreciation.



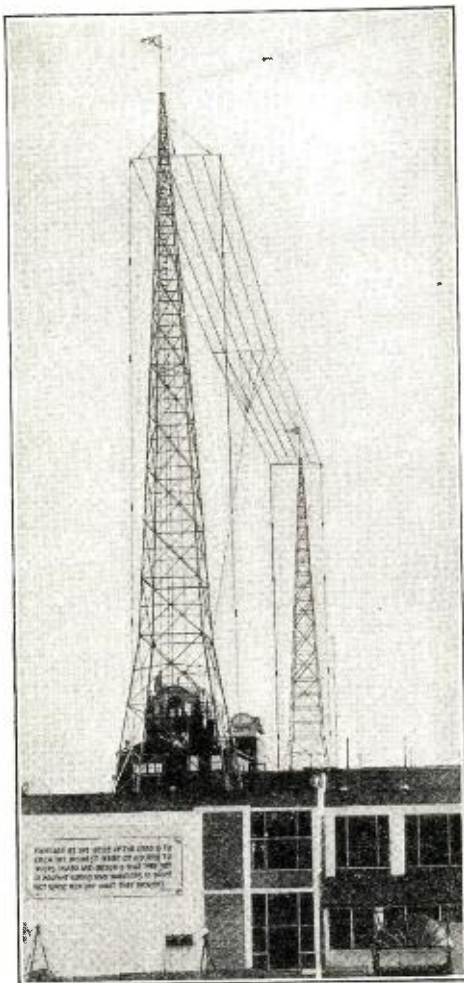

The Antenna System—The tops of the Towers stand 215 feet above the street; nearly 400 feet above the Mississippi River.

# The "Home" of W O C and the Famous Neurocalometer

WHERE fine young men and women are learning one of the greatest science of the age—Chiropractic. Where these men and women are taught how to use the outstanding scientifically approved instrument known as the NEUROCALOMETER. If you would enter a paying profession—if you would advance yourself—if you would enjoy the leisure and respect of your fellow men—write to THE PALMER SCHOOL OF CHIROPRACTIC and learn about the profession of Chiropractic—restoring the sick to health without medicine, without surgery, without osteopathic massages.

The NEUROCALOMETER invites the most severe investigation. It is an amazing instrument used by the highest class chiropractors. You are urged to visit an approved NCM Chiropractor. Investigate!



One of our Clinic Classes of P. S. C.

## The Demand for P. S. C. Graduates Exceeds Supply

The demand for competent chiropractors constantly exceeds the supply. People hear of Chiropractic. They take adjustments and obtain relief from their ills. They return to their home towns and find no chiropractor there. Then we are urged to send a chiropractor to these towns.

Upright, fine people can enjoy an enviable reward by attending the P. S. C. and graduating as chiropractors. Our graduates are recognized in many states. Anyone with a high school or equivalent education can master this new science of health. The work is intensely interesting.

Learn today about this new science of health. Decide now to enroll at the Palmer School—the ONLY school offering you Neurocalometer service—also finest X-Ray laboratory, unexcelled faculty, perfect school room facilities.

Write today for detailed information. Use the coupon.

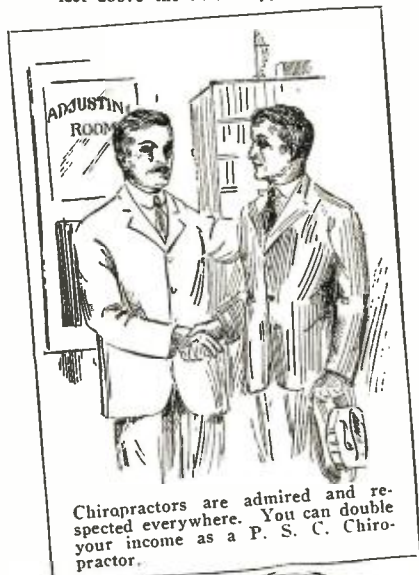

# The PALMER SCHOOL of CHIROPRACTIC

## CHIROPRACTIC FOUNTAIN HEAD

### DAVENPORT, IOWA, U. S. A.

The PALMER School and



"Where the West Begins"



P. S. C., Davenport, Iowa

Send me detailed information about your school.

Name .....

Street .....

City .....

State .....



# Silver-Marshall, Inc.

RADIO EQUIPMENT

## Look for This Tag

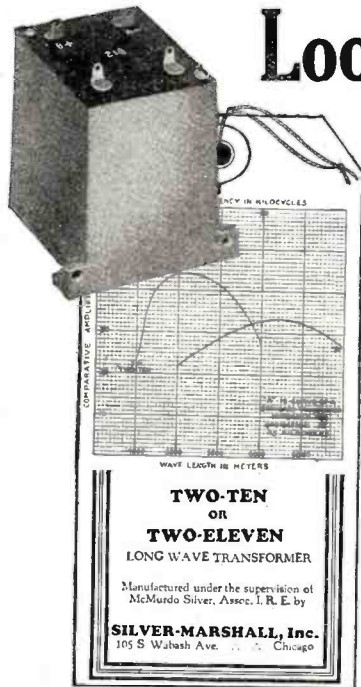

It represents a revolutionary idea made possible for the first time by S-M advanced engineering methods. SILVER-MARSHALL were the first to produce long-wave transformers so uniform that individual amplification curves could be supplied, on a tag, with each instrument. SILVER-MARSHALL were the first to supply you with definite proof that the transformers for your super were scientifically matched—to show you where they peak—what side-bands they will pass—what amplification can be expected of them in any circuit.

The Tag represents a standard of excellence that every progressive manufacturer will be forced to adopt. It demonstrates again the fact that S-M radio equipment is always a year ahead of the industry.

### TWO-TEN AND TWO-ELEVEN LONG-WAVE TRANSFORMERS

S-M Long-Wave Transformers are supplied in sets of two, or three TWO-TENS (iron-core inter-stage), and one TWO-ELEVEN (filter for input or output), with identical peaks and separate curves. Each curve is plotted in our laboratory and recorded directly on the tag tied to the transformer. Both peak at 5000 meters and pass an 11 kilocycle side-band without distortion. Price of either type, each \$8.00

Circulars will be mailed on request.

**Silver-Marshall, Inc. Dept. C.**  
105 So. Wabash Ave. CHICAGO

### SILVER SUPERS

The "Why of Silver Supers" will be mailed to anyone on request. It contains a complete account of the "Seven-tube Wonder Set," called by *Radio Broadcast* an "Electrical Masterpiece."

## I Want To Know

(Continued from page 1911)

C-1, etc., are the usual tuning variable condensers, all of the same capacity.

The combination shown is one of extreme sensitivity and selectivity. Audio frequency amplification may be added in the usual manner, if desired. One stage, using a transformer of about 3:1 ratio, is sufficient.

It may be quite difficult to neutralize some of the stages unless the neutroformers are mounted in such a way as to be rotatable through an arc of perhaps five degrees to the right or left of the calculated angle.

This set will not function if the parts are crowded.

The neutroformer windings are on tubes 2 3/4 inches in diameter. No. 26 S.S.C. wire is used. The neutrodon taps are taken 15 turns from the grid end of the secondary.

To prevent oscillation, it may be necessary to use only four to six turns in the radio frequency tube plate primaries.

## Lighting Main Plate Supply

(Continued from page 1896)

the lead wires of the coil. The strips of tape are now brought out to the center of the coil and a few turns of tape are wound over them to keep them in place. The cardboard end pieces are removed and the wooden blocks withdrawn. This will leave a self-supporting coil.

The secondary has two windings, a six-volt winding to light the filament of the rectifier tube and a high voltage winding to supply the plate potential. The form is prepared as before and 51 turns of No. 18 wire are wound on it. Over this winding two layers of paper are wound to separate the two windings. The secondary winding is wound the same as the primary winding.

After the windings are finished, the transformer is ready for assembly. The easiest method of placing the laminations and keeping them in the right order is to take a lamination in each hand and hold them so as to make an oblong 5 x 3 1/2 inches and slide them onto the coils, one on each side, so as to retain the same size rectangle. Now slide a lamination through each coil from opposite sides. Continue this procedure, but alternating sides, until the core has been built up to a height of one inch. This should completely fill the inside diameter of the windings. If they do not, cut more laminations and build up the core to fill the space.

### THE CHOKE COIL

It is not advisable to try and make the choke coil, as it can be bought for less than you can make it. If you have an amplifying transformer with a burnt out primary, its secondary will make an excellent choke coil of about 30 henries capacity. There are several reasonably priced amplifying transformers on the market which will do.

The wiring of the set is very simple (see Fig. 1). No explanation other than the diagram should be necessary. Lamp cord can be used for both the wires running to the set and to the lamp socket. This eliminates all binding posts and simplifies wiring.

The panel is 7 x 9 inches and the sub-panel 6 x 7 inches. The latter is mounted on the transformer by two iron brackets. The transformer is bolted directly onto the panel. The screws are taken out of the socket and reversed, making it possible to wire the socket under the sub-panel.

### THE FILTER SYSTEM

The filter system consists of two 2-mfd. fixed condensers connected across the output of the rectifier and a 30-henry choke coil connected between them; that is, in



## KIC-O the permanent power plant for your radio

If you are tired of buying new batteries every little while—if the stations are not coming in as loudly and clearly as you think they should—if you want better reception at lower cost—if you want a real permanent power plant that will last for years—then buy a KIC-O.

These new KIC-O Nickel zinc alkaline storage "B" Batteries are the product of years of research. They are not harmed by standing idle or overcharging. They give a slow, even discharge over a long period of time and by using the KIC-O Double Potential Charger, which can be attached to any electric light socket, you have a permanent power plant.

Write for full description which will tell why KIC-O units are better than dry cells, "B" eliminators and acid "B" batteries.

See your dealer or write today for full information.

## KIMLEY ELECTRIC COMPANY, Inc.

2665 MAIN STREET

BUFFALO, N. Y.

### Prices

PZ indicates panel type with switches.  
CZ is plain type without switches.

Voltage	M.A.H.	Type PZ	Type CZ
150	2500	\$36.00	\$33.00
100	2500	27.50	24.50
70	2500	21.50	18.50
45	2500	16.00	14.50
22 1/2	2500		7.50

### KIC-O Chargers

Type K-1 Single unmounted	.....	\$1.50
Type K-2 Single mounted	.....	3.50
Type K-3 Multi-Polar mounted	.....	5.00
KIC-O Special Charger Chemicals (one cell)	.....	.50



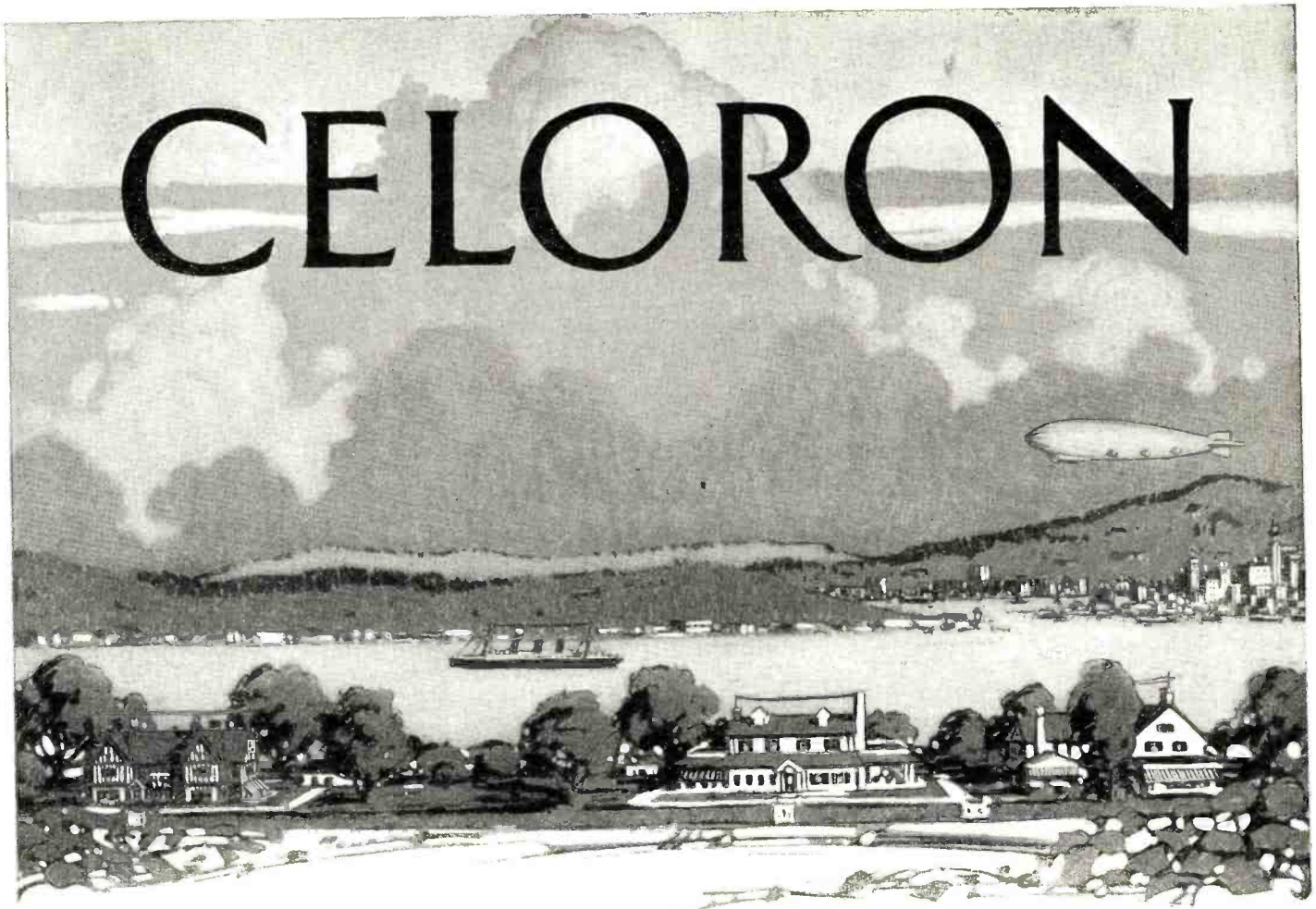

# Build your set around Celoron

*Celoron panels are the accepted standard of radio experts and are used today by leading set builders and by more than a million radio fans*

**T**HE distinctive characteristics of Celoron are its mechanical strength, its high insulating qualities, and its machinability. It is impervious to heat, oil, water, and most chemicals.

Celoron panels do not soften with heat or deteriorate with age as do rubber and composition panels. Nor do they split, warp, or discolor.

### *Better results with Celoron*

A Celoron panel in your radio set will give you thorough, leak-proof insulation. It will

help you get greater distance, better volume.

Celoron comes in eight panel sizes and in full-sized sheets, rods, and tubes. There are four beautiful finishes—gloss black, a dull mat black, walnut, and mahogany.

### *Send for Celoron sample*

We will gladly send you a sample of Celoron 5 inches wide and 7 inches long—a piece large enough to use in making a wave trap. Just send us ten cents—either stamps or coin—to cover the cost of packing and mailing.



*Celoron panels and tubing hold their shape. They do not soften with heat or deteriorate with age*

## DIAMOND STATE FIBRE COMPANY

*the oldest and largest manufacturer in the vulcanized hard fibre-laminated technical materials industry*

Bridgeport, Pa., and Chicago, Ill.  
Toronto, Can.

*Branches and Sales Offices in Principal Cities*

THE DIAMOND STATE FIBRE CO.,  
Bridgeport, Pa.

Enclosed find ten cents (stamps or coin) for a sample piece of Celoron 5 inches wide and 7 inches long.

Please send me also a copy of the illustrated booklet,

"FACTS ABOUT CELORON."

NAME .....

ADDRESS .....



# S-E-L-E-C-T-I-V-I-T-Y

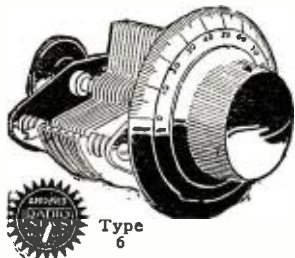

To a New Degree  
A RESULT OF THE  
IMPROVED  
MICROMETER DIAL

## I N U. S. Tool Condensers

Again in the van as a result of constant research and painstaking experimenting—U. S. Tool announces an improved micrometer dial, a boon to radio reception and a new degree in the selectivity of DX stations.

The separate knob turns the ENTIRE rotor slowly, accurately, too precisely to slip by any station within reach. Stations passed by on ordinary condensers are instantly detected with the micrometer dial. Factory-tested and guaranteed to be within 3%, plus or minus, of the indicated capacity.

**FACTORY  
GUARANTEE**

Write  
for  
Literature

**U. S. TOOL COMPANY, INC.**  
118 Mechanic Street Newark, N. J.

Mfrs. of Special Tools, Dies, Jigs, Automatic Machinery and Sub Presses

series with the line. The method of connecting is shown in the circuit diagram. If any hum is noticed in the operation of the set, another 2-mfd. condenser should be connected as shown by the dotted lines in the diagram. The 120-volt output of the rectifier may be cut down to any value by means of a variable resistance of about 5,000 ohms maximum resistance. Fig. 2 shows how to obtain a potential of 45 volts, or less, to operate the detector tube. This type of a rectifier seems to operate better in a non-regenerative receiving set and usually works perfectly without condenser "c."

If your alternating current supply is not 60 cycles, but 25, the size of the core will have to be doubled and for 40 cycles the cross-section will have to be increased one-third.

### Testing the Instruments of Your Receiver

(Continued from page 1887)

wire is broken at some point. Look at the winding for a kink or sag where the break might have occurred. Scrape off the insulation at any doubtful-looking place and solder the ends of the wire if the break is found. Otherwise, rewind the coil and again test for a continuous circuit. It is difficult to find short circuited turns in spider-web or other criss-cross windings; the best plan is to rewind with double cotton or double silk insulated wire.

#### CONDENSERS

Connect the test terminals to the proper set of contacts on the condenser. A faint plucking sound but no definite click should be heard. If a loud click is heard the condenser is defective. It is difficult and hardly worth the trouble to repair small fixed condensers, but frequently a slight adjustment of the bearings will fix a variable condenser so the rotary plates do not touch the stationary set. Of course, in testing a variable condenser, the plates should be rotated slowly while holding the test terminals on the two proper contacts of the condenser. If a click is heard at any spot, it is an indication that the plates are scraping at that point. Frequently this may be remedied by bending the plates that are causing the short circuit.

#### JACKS

Inspect the jack and determine which contacts are supposed to make connection with each other when the plug is removed. With the plug out, touch the test terminals to each set of springs that are supposed to be in contact. A click should be heard. If the click is not heard, bend the springs so that positive connection between the proper pairs will be assured. Only jacks with good springs should be used; others cause more annoyance than they are worth.

#### LIGHTNING ARRESTER

Touch the test terminals to the two binding posts on the arrester; no click should be heard, otherwise the arrester is defective and should be replaced.

#### POTENTIOMETERS

Touch the test terminals to the two end contacts of the resistance strip; a click should be heard. Otherwise the wire is broken at one or more places. To locate the break, touch the terminals to different sections of the winding. That section across which a click can not be secured contains the break. By narrowing down the section included between the test terminals the exact point of the break can be located. Solder the nearby turns together. Test again and repeat the process until the testing device indicates a complete circuit through the resistance. Also put one terminal on the center contact and the other terminal on the slider of the



# Atlas

TRADE MARK

## RADIO REPRODUCTION speaker

The ATLAS Unit with adjustment and compound diaphragm—the heart of the ATLAS Speaker. "It gives the best that's in your set."

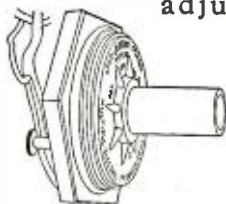

ATLAS Products are guaranteed

MULTIPLE ELECTRIC PRODUCTS CO., Inc.  
365 Ogden St., Newark, N. J.  
(Dept. W.)

New York Philadelphia  
Boston Baltimore Detroit  
Pittsburgh Chicago  
St. Louis San Francisco  
Marconi Wireless Telegraph Co.  
of Canada, Ltd.  
Sole Canadian Distributors

### The Andrews Paddlewheel-Coil

Insures maximum amplification, minimum distortion and much greater selectivity. We also manufacture DUO SPIRAL Folding Loop. Write for particulars.

RADIO UNITS, INC.  
1300 First Ave. Maywood, Ill.

Always Insist on

## POLYPLUG

Positive Permanent Contact



# Distance!

*These Stations Logged at New York Monday, January 26th*

ALL THESE COME IN AS CLEAR AS A BELL!

## BRUNSWICK TRADE MARK DELUXE

Our Inspection Includes Night Testing

WITH the perfection of THE BRUNSWICK DE LUXE a five-tube tuned frequency set has at last been developed that achieves the utmost in results and satisfaction.

Constructed through the joint efforts of famous radio engineers and experts, THE BRUNSWICK embodies a score of features found in no other instrument—features that endow it with performance qualities entirely new to radios.

Through its perfectly tuned radio frequency circuit, distant stations are quickly found—always at the same point on the dial. That annoying interference of local stations is completely overcome and broadcasting from those stations miles away comes through clear as a bell.

In volume, tone and selectivity THE BRUNSWICK has proved its superiority to radios of many times its price. Its ability to get distance quickly and easily, however, has established it as the masterpiece of radio engineering.

Guaranteed to Give Complete Satisfaction or we Authorize Your Dealer to Refund Your Money at Once.

**HAROLD M. SCHWAB, Inc.**

55 VESEY STREET, NEW YORK

SAN FRANCISCO  
HASTINGS, NEB.  
HOUSTON, TEXAS  
MEXICO CITY, MEX.  
CALGARY, CAN.  
CHICAGO, ILL.  
MONTREAL, CAN.  
KANSAS CITY, MO.

### Partial List of Stations Actually Heard on This Set from New York City

WJJD	Mooseheart, Ill.	WOS	Jefferson City Mo.
WDAF	Kansas City, Mo.	WMBF	Miami Beach, Florida
KGO	San Francisco, Cal.	WWAD	Philadelphia, Pa.
WSAI	Cincinnati, O.	KFKX	Hastings, Neb.
WTAS	Elgin, Illinois	WMH	Cincinnati, O.
WHB	Kansas City, Mo.	WDBX	New York City
WFI	Philadelphia, Pa.	WBS	Newark, N. J.
WGN	Chicago, Ill.	WAHG	Richmond Hill, N. Y.
WCBQ	Zion City, Ill.	WOR	Newark, N. J.
CKAC	Montreal, Can.	WJZ	New York City
WQJ	Chicago, Ill.	WNYC	New York City
WPG	Atlantic City, N. J.	WJY	New York City
WOAI	San Antonio, Texas	WHN	New York City
WCCO	Minneapolis-St. Paul, Minn.	WEBJ	New York City
WLW	Cincinnati, O.	WEAF	New York City
WTAS	Elgin, Ill.	WFBH	New York City
WEAN	Providence, R. I.	WGR	Buffalo, N. Y.
		WBZ	Springfield, Mass.
		WFI	Philadelphia, Pa.
		WOO	Philadelphia, Pa.

### Service

In addition, with your purchase of a BRUNSWICK you are entitled to the full benefit of the *Brunswick Service* which will be rendered you freely and cheerfully by our experts.

5-Tube  
Tuned  
Radio  
Frequency

\$60

HAROLD M. SCHWAB, Inc.  
55 Vesey Street  
N. Y. C.

Gentlemen: Kindly send details of the "BRUNSWICK" De Luxe Radio Set. I am interested and would like to arrange for demonstration.

Name.....

Address.....

### Special Features

Brunswick Sets are equipped with battery harness all connected with battery leads each individually colored in one solid cable, sixty inches long.

Brunswick Sets are equipped with gold plated lock switches with removable plug which automatically locks set when not in use.







**AMSCO**

**RHEOSTATS  
POTENTIOMETERS and  
LOW LOSS CONDENSERS**

Amsco quality radio parts—the standard of excellence, by which all other parts are judged. Used by many leading set manufacturers as well as by the foremost radio engineers for laboratory work.

*Ask your dealer or write  
for interesting literature*

**AMSCO PRODUCTS, INC.**  
Broome & Lafayette Sts., New York

potentiometer to see if there is the proper connection between them. A click should be heard. Otherwise bend up the small connecting link so as to make firm contact against the shaft and slider. Place one of the test terminals on the center contact of the potentiometer and touch one on to either end contact in order to determine whether the slider makes connection with the resistance wire. A click should be heard with the slider at any point on the wire. If not, then make certain that the resistance wire is not insulated, scraping off the insulation with fine sandpaper, if necessary, and then bend the slider so as to make positive contact with the resistance wire.

**RHEOSTATS**

Connect the test terminals to the two contacts of the rheostat; a click should be heard. If not, test to determine whether or not the slider makes contact to its binding post by placing one test terminal on the slider and the other terminal on the binding post in question. A click should be heard; otherwise adjust the small connecting link so it makes connection between the post and the shaft holding the slider. Also test to find if the end of the resistance wire is connected to its binding post. Test the wire (as above mentioned in potentiometers) to locate any break.

**TRANSFORMERS**

This includes all sorts of audio frequency, radio frequency and intermediate frequency transformers, most of which are of the inductively coupled type with no direct connection between the primary and secondary windings. First test the separate windings for continuity by touching the test terminals across the primary contacts and then across the secondary contacts; in each case a click should be heard. If not, examine the external leads for any signs of a break; repair if any are found. It is almost impossible to repair an internal break in an audio frequency transformer because the windings are sealed in with wax or some similar material. The air core transformers may be repaired after the manner described under "coils." Also test each transformer for a short circuit from the primary to the secondary circuit by placing one of the test terminals on one primary contact and the other test terminal on one of the secondary contacts. No click should be heard. It may be possible to find the short with air core transformers, but if such a short exists inside audio frequency transformers they should be replaced.

**BATTERIES**

If the dry cell "B" battery "goes dead" after being in use only a short time, cut off the bottom of the cardboard container so that the bases of the separate cells are exposed to view. With a voltmeter test across adjacent zinc terminals to find the defective cell. Short this cell out by bridging a wire across from the zinc terminal on either side. Of course, run-down or exhausted dry cells cannot be used and had better be replaced.

**SOCKETS**

Insert a tube in each socket and note how the springs press against each stud. If the contact is positive and if the springs bend up in place again when the tube is removed, the socket is satisfactory. However, before using tighten the four binding posts to insure positive connection to the springs.

Loud speakers, phones and tubes can only be tested properly on a receiver that is operating. Always try reversing the speaker or phone terminals for better results. Allowing for the slight difference in filament resistance of new tubes, it is almost impossible to tell when a filament is exhausted through use of ordinary measuring instruments nor can this be told accurately by the value of plate current. Therefore, the "tube-testing machines" are of but little value except to show that the filament lights. The best test is direct substitution in a receiving set.

The new **ULTRADYNE**  
MODEL L.2



Complete parts for this internationally famous improved Ultradyne, including cabinet with drilled and engraved panel and the New **\$97**

ULTRA-VERNIER Tuning Controls. These are genuine parts, endorsed by R. E. Lacault, E.E., A.M.I.R.E., Inventor of the Ultradyne.

**ULTRADYNE KIT** **\$30**

Carrying the last improvements of R. E. Lacault, whose personal monogram seal is on each Ultraformer. Kit contains 1 Low Loss Tuning Coil, 1 Low Loss Oscillator Coil, 1 Type A Ultraformer, 3 Type B Ultraformers, 4 Matched Fixed Condensers, 1 Low Loss 180 degree Coupler.

Send for 32-page illustrated book, giving latest authentic instructions on drilling, wiring, assembling and tuning, the Model L.2 Ultradyne receiver **50c**

REPAIRING AND WIRING ON ALL TYPES OF SETS  
*Write for Descriptive Folder*

**Keystone Radio Service**  
120 West 44th Street,  
New York, N. Y.

Insure your copy reaching you each month. Subscribe to Radio News—\$2.50 a year. Experimenter Publishing Co., 53 Park Place, N. Y. C.





**The Simplest Practical Radio Set Made**

**\$2.50**

**A Complete Radio Receiver including Radiogem, Phone and Aerial**

**The Complete Outfit Consists of Three Parts**

(One)

**The RADIOGEM**

The simplest radio outfit made—yet as practical as the most expensive. A crystal receiving set that you can operate and enjoy even though you know absolutely nothing about radio. You receive the RADIOGEM unassembled, together with a clearly written instruction book, which shows you how to quickly and easily construct the set, using only your hands and a scissors. The outfit comprises all the necessary wire, contact points, detector mineral, tube on which to wind the coil, etc., etc. The instruction book explains simply and completely the principles of radio and its graphic illustrations make the assembling of the RADIOGEM real fun.

(Two)

**The GEMPHONE**

An adjustable, 1,000-ohm phone complete with 3-ft. cord—the first inexpensive adjustable receiver made. The Gemphone is of standard type and made of the very best grade of materials throughout. The case is made of turned wood, an exclusive feature with the "GEMPHONE." This is responsible for its exceptionally rich, and mellow tone. Like RADIOGEM, the GEMPHONE is sold unassembled. Our instruction pamphlet shows how to assemble it in two minutes, using only a screw driver.

(Three)

**The AERIAL OUTFIT**

Consisting of 100 ft. of standard copper aerial wire and two porcelain insulators.

**Complete Radiogem Outfits - \$2.50**

**The Radiogem, only - 1.00**

**The Gemphone, only - 1.00**

**Aerial Outfit, only - .50**

**RAGEMCO**

**Radio Headquarters for the Finest and BEST Radio Tools**



**RADIO TOOLSET**

This is the handiest set of tools ever made for Radio Work by the makers of the famous "YANKEE" Tools. It contains the following: 1 Ratchet Screw-driver, 6 1/2 in. long holding all attachments; 1 Blade, 3 1/4 x 1/4; 1 Blade, 2 1/4 x 1/4; 1 Countersink; 2 Socket Wrenches for all small nuts; 1 Reamer to enlarge holes in panel from 1/4 x 1/2; 1 Wrench, one end 5-16" square or hex. for jack, other 3/4" hex., etc.  
**PRICE per set—No. 701.....\$3.00**

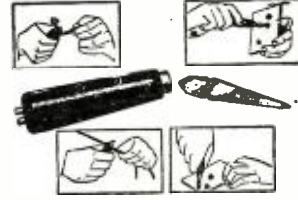

**RADIO HANDI-TOOL**

Bends Bus Bar or wire strips and scrapes wire, bores and reams holes, etc. Tool consists of 4 in. black japanned handle, to which is attached wire bending device, with nickeled ferrule and 3 in. long two sided reamer.  
**PRICE—No. 702.....50c**



**HAND DRILL**

The hardwood handle is hollow to store drills. Iron frame, nickeled parts, ball bearing three jawed chuck holding and centering accurately round shank drills from 0 to 3-16. Length of drill, 12 inches.  
**PRICE—No. 303.....\$2.25**



**TOOL CHEST**

Set consists of "LOCK-GRIP" master handle, 5" long, black Rubberoid finish with steel chuck, nickel plated, buffed and with the following 9 tools: Saw, bradawl, large screwdriver, file, scratch awl, gimlet, reamer, chisel, small screwdriver. Each tool of fine steel, drop forged tempered, hardened, and nicely finished. Set comes in leatheroid box with tray.  
**PRICE—No. 703.....\$1.85**



**WIREBENDING TOOL**

For making eyes, loops, bends, and offsets on Bus Bar wire. With this device any Radio Constructor can wire his set to compare favorably with any factory made set. Easier to use and more accurate than pliers. Full directions in box. Made of heavy steel, blued and finished.  
**PRICE—No. 205.....\$1.00**



**SCREWSTARTER and DRIVER**

Holds any screw by its slot with a firm grip, makes it easy to place and start screws in difficult places. Just the tool for the Radio Constructor. All parts heavily nickeled and polished.  
**PRICE—No. 304.....\$1.00**



**CIRCLE CUTTER**

Especially designed for the Radio Constructor. Made of the finest material and equipped with the highest grade high steel cutting bits. It does three things at once. It drills its own pilot, cuts out plug and puts bead or scroll around the hole in one operation. Cuts holes 3/4 to 4 in. in diam.  
**PRICE—No. 402.....\$3.00**  
**401. Same tool but smaller and not fitted with bead or scroll in one operation.**  
**PRICE—No. 401.....\$2.00**

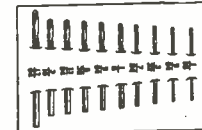

**RADIO DRILL SET**

Composed of 10 straight shank twist drills, fitting all hand and breast drills. The selection of these drills has been especially made for Radio Constructors and consists of the following sizes: 1-16, 5-64, 3-32, 7-64, 1/8, 9-64, 3-32, 11-64, 3-16, 17-64. Drills are mounted on white Holland Linen with sizes clearly marked.  
**PRICE—No. 305.....\$1.25**



**HAND DRILL**

Especially designed for Radio Work by the makers of the famous "Yankee" Tools. A beautiful balanced, small, powerful drill with 4 to 1 ratio of gears for speed. Special chuck 9-32" capacity, to take largest drill, mostly furnished with drill or tool sets. Length over all, 9 1/2 in. Weight 1 1/2 lbs.  
**PRICE—No. 302.....\$2.75**



**ELECTRIC SOLDERING IRON**

A perfect tool for Radio Work. Operates either on 110-volt A.C. or D.C. The heat element is of Nichrome, which prevents overheating and assures the desired even temperature. Size of iron, 10 1/2 in. long. A 4-ft. cord and plug is furnished.  
**PRICE—No. 800.....\$2.00**



Three-in-One Nut Wrench. Consists of handle with hollow stem 4 inches in length and three interchangeable sockets fitting popular sizes of nuts. The hexagon sockets grip the nut solidly.  
**PRICE per set—No. 301.....65c**



Combination Plier, Wire Cutter, Wire Former and Wrench. Drop forged, slender but exceptionally strong. 6 in. long.  
**PRICE—No. 202.....75c**



Side Cutting Nipper, Lap Joint. For cutting all kinds of wire. Jaws hardened and oil tempered. Natural steel finish with polished jaws. Length 6 inches.  
**PRICE—No. 201.....75c**



Long Sharp Nose, Side Cutting Pliers. Just the pliers for the radio constructor. Bends and cuts all kinds of soft wire. Nose 1 1/2 inches long, black body, polished jaws. Length 5 1/2 inches.  
**PRICE—No. 200.....75c**

Order all tools by order number. All goods are shipped free of transportation charges to all parts of the United States and possessions the same day as the order is received.

**MONEY REFUND GUARANTEE**

If you are not satisfied money will be refunded on return of goods.

**The RADIOGEM CORP., 66-R W. Broadway, New York**



**Out with the Old!  
In with the New!**



**UNCLE SAM  
Master Tuning COIL**

**THE COIL WITHOUT LOSSES.**

Replace your old Uncle Sam with one of the new type and you will increase your volume from 50% to 180%, also improve selectivity. Results from the new type are surprising. Try out a new Uncle Sam for five days. If it does not materially increase the volume and improve the selectivity of your set, your dealer will refund your money.

**FREE** Ask your dealer or send us four cents in stamps for wiring diagrams of circuits in which this remarkable coil can be used.

**UNCLE SAM ELECTRIC CO.**  
211 E. SIXTH ST. PLAINFIELD, N. J.

**A Low Loss Short Wave Set**

(Continued from page 1897)

For the supporting frame, four strips of good insulating material are required and should be cut as shown in Fig. 1. Two "A" pieces are cut to the same sizes and clamped by means of three small screws and nuts, as shown in the section view. Two "B" pieces slightly longer are also clamped together in the same way, but are provided with an extra piece, C, acting as a bearing and at the same time as a stop to limit the motion of the feed-back coil. The sketch, Fig. 1, also shows how the wire may be clamped between the various insulating strips. Small pieces of rubber or spaghetti tubing are slid over the wire and used as a sort of cushion to hold the wire tightly between the clamping strips.

The feed-back coil is an ordinary spider-web or duo-wound coil of about 10 or 12 turns mounted to fit inside of the secondary coil, as shown in the photograph. The shaft upon which this coil is mounted should preferably be of insulating material and of the proper length to reach through the panel if one is used. It is advisable not to mount the short wave coupler directly against the panel, but a few inches behind, mounting it on a base by means of small angle pieces to hold it in place.

The number of turns may be varied depending upon the band of wave-lengths to be covered, but the same construction may be used for couplers designed for the reception of very short wave-lengths.

On account of the small maximum capacity permissible, direct coupling to the aerial is hardly practicable. Hence a fixed aperiodic primary coil is used with a very small series condenser, if a long aerial is used. For this purpose a coil of only four turns of No. 14 D.C.C. wire is wound on the projecting frame ends of the tuning inductance.

**TYPES OF TUBES**

The tuning range depends upon the stray capacities present. As ordinary types of tubes and standard types of panel mounting were desired, the writer investigated to what extent these lend unwelcome stray capacities.

Two panels with sockets in place, grid-condenser and leak, showed capacities from the grid connection to earth of 5 and 7.7 mmf. respectively. A lead of about a foot of stranded wire, fairly well isolated, gave the surprising figure of 5.5 mmf., a thing seldom realized among amateur constructors. As the zero capacity of the low minimum .0001 mfd. tuning condensers used was 6.6 mmf., the total casual capacities, apart from distributed capacity in the inductance, were approximately 24 mmf., even if short leads were practicable. With a tuning condenser range of 100 mmf., the wave-length range could not be very great. With the experimental temporary bench hook-up, involving a total of more than two feet of leads to tuning condensers, the actual range was found to be from 40 to just below 80 meters when loaded to some extent by an aerial.

**WAVE-LENGTH RANGE**

Unloaded, it was possible to go a little lower. With a .0002 mfd. tuning condenser and the aerial load the highest point was about 105 meters. These were repeatedly checked against higher harmonics of a heterodyne wavemeter.

At first the aperiodic primary was wound on the frame directly over the tuning inductance, but the distributed capacity to earth of this arrangement proved excessive. The measured capacity between the coils arranged thus was actually 30 mmf. The range, accordingly, was limited and not as



**Complete with Connecting Plug**

Just fills the need, when you want to dance or take your loud speaker anywhere in the house or on the porch in summer. Longer lengths can be had as well. At your dealer or order direct from the factory.

**Crescent Braid Co., Inc.**  
Providence, R. I.  
Makers of Phone Cords, Extension Cords, Battery Cables and Spaghetti Tubing—Everything in Braided Insulation.

**20 FOOT EXTENSION CORD \$1.75**



**ON ONE TUBE**

**BIG FREE BOOKLET** tells the story. California users of **CROSS COUNTRY CIRCUIT** hear Atlantic Coast, Canada, Cuba, Mexico and Hawaii. Atlantic Coast users hear England to California. Our new plan makes this set easiest and cheapest to build. One hour puts in operation. One tuning control. No soldering. Any Novice can do it. **BIG BOOKLET FREE** or complete instructions for 25c stamps or coin.

**WHAT USERS SAY**

**EAST**—Am more than pleased with the parts ordered from you. The first night I hooked it up and received Omaha. Since then Minneapolis and Los Angeles. It works better without amplification than most sets with two stages. —Donals, S. C.

**WEST**—I am sending you a list of some of the stations heard on one tube: WSB, WGY, KDKA every night. PWX, WWJ, WTAM, WLW every night. CFAC, CHCB. Not long ago I purchased another set of parts from you and first night got WGR, Buffalo, and KDKA. —Ione, Calif.

**NORTH**—Received coils OK today. If I have same results with these that I had with last will be wanting more. I am 1,500 miles from nearest station and have picked 56 to date. Chicago, Havana, Mobile, New Orleans and TWO IN ENGLAND.—Lunenburg, Canada.

**Vesco Radio Shop**  
BOX RN-117  
OAKLAND, CALIF.

**Will You Get London?**



This licensed 5 tube Hetro Receiver only \$75.00

**HETRO-MAGNETIC**  
Receivers broke all distance records—

**DEMAND** a thousand mile daylight test from your dealer or send at once for descriptive literature, describing three types of five tube hetro-magnetic receivers ranging from \$55 up to \$150.

*Works in any location on loop or outside aerial*

**SIDBENEL RADIO EQUIPMENT MFG. CO.**  
29 W. Mt. Eden Ave. New York City  
Manufactured under special license granted Aug. 13, 1924.

Insure your copy reaching you each month. Subscribe to Radio News—\$2.50 a year. Experimenter Publishing Co., 53 Park Place, N. Y. C.



# Why Radio Receivers Differ so Widely in the Quality of their Tone

## *It's all in the Overtones*



*A 5-tube Receiver using the new Pfanstiehl system of tuned radio frequency*

**A**S RADIO becomes less of a stunt instrument for fans to play with and more of a musical instrument in the home, people are demanding, above every other value, TONAL BEAUTY. Clear tone, of course, but more than that, lovely tone—all of the beauty which distinguishes fine singing and the best in musical performance.

It is easy to get distance and volume with proper amplification. The difficulty has been to control the tone—to keep it free, flexible, full and rich.

In the average radio receiver the tone is sometimes clear, and sometimes not. That depends upon neutralization. But it is always flat, thin or hard. It lacks those delicate overtones which give to the tone itself its quality or timbre. It is the attendant overtones or harmonics which make real music. Without them you have merely pitch.

The difference between a fine piano tone and a pure piano tone is in the overtones. Middle "C," for instance, is Middle "C" all the time and everywhere, as far as pitch is concerned. But there is the widest difference in quality. One has a rich, sweet resonance. The other is thin and bare.

The same is true of the human voice. Its charm is all in the overtones. They identify it, make it an intimately personal thing.

*The matchless tone of the Pfanstiehl lies in its perfect control of the overtones—a simple thing and still the most important thing which has as yet happened to radio.*

### Overtones perfectly reproduced

Of course, no radio can receive a poor tone and make it sound beautiful. It does not create tones. It reproduces them. Its utmost achievement is to reproduce from a distance the full depth and individual beauty of fine music. That has not been possible hitherto. Radio has not been able to bring in and hold intact the full stream of radio energy embracing not only

the fundamental tone but also ALL the minute overtones which accompany it in transmission and should accompany it in reception, if enjoyable song or music is to result.

The radio stream gets out of bounds, as it were, in the set itself. It spills over between circuits and feeds back instead of forward. In entering the preceding circuit this feedback of stray energy causes a disturbance in it, the two being "out of phase," as an electrician would say. The true forward stream of radio energy does not mesh with the stray energy feeding back. They conflict. Squeals and noises result. To prevent them, neutralizing devices have been used. But these do not work unless perfectly adjusted. *And even if they do work, both they and the feedback tend to blur or spoil the delicate overtones of the true signal.*

### No errors to neutralize

In the Pfanstiehl there are no internal noises possible. The radio energy is completely controlled. There is no feedback. No absorbing or neutralizing devices are used. They are not needed. How this control is accomplished is a technical story of great interest to radio engineers, told elsewhere in this statement. Briefly, it consists of a new system of reception designed to hold in leash the full forward stream of radio energy, so that none of it spills over or escapes to cause feedback. All of the overtones are thus included. *And you get full tone quality, the timbre which makes the emotional appeal in music and gives to the human voice its supreme charm.*

Nothing could be simpler. Nothing could be more important, if radio is to become the enjoyable instrument people are looking for. The simplicity of the Pfanstiehl is unique. There are no complications. Nothing to adjust or get out of order. Operation is dependable and absolutely quiet. In this respect distance makes no difference. No lover of music who has once listened to a Pfanstiehl will ever be satisfied with any other system of radio reception, its superiority is so marked.

Hear the new Pfanstiehl Overtone Receiver at your radio or music dealer's. If he does not have one we can quickly get it to him.

**PFANSTIEHL RADIO COMPANY**

Sales Offices: 11 S. La Salle St., Chicago, Ill.

Dept. "C" Factories: Waukegan, Ill.



# Pfanstiehl

OVERTONE RECEIVER





**Dulce-Tone and your Talking Machine  
—the BEST Loud Speaker**

**W**ITHIN your talking machine is the finest radio amplifying unit that money can buy—link it to your radio with a Dulce-Tone. Radio will be reproduced with the same clear, undistorted precision you get in playing a record. No substitute will give equal results.

Hear Dulce-Tone today at your favorite radio or music store. If they have not Dulce-Tone in stock, order direct.

**THE TEAGLE COMPANY**  
1125 Oregon Ave. Cleveland, Ohio  
*Canadian Representative:*  
The Otto Higel Co., Ltd., Toronto

**Dulce-Tone**



Retail price complete, \$10  
(In Canada \$14)

**STORAD BATTERIES**

24 volt  
4½ amp. hr.  
No. 4524

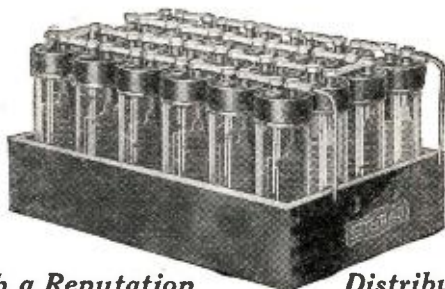

48 volt  
4½ amp. hr.  
No. 4548

**Batteries with a Reputation**

Storad Batteries have a reputation for giving reliable service under severe requirements of modern receiving sets.

**Distributors' Attention!**

Desirable territory for the Storad line of Storage Batteries is still available. We have an interesting proposition to offer.

Ask your dealer about Storads or write us direct.

**The Cleveland Engineering Laboratories Company**

2108 Superior Viaduct, N. W.

Cleveland, Ohio



**DONGAN**  
**AUDIO TRANSFORMERS**

Choice of  
28 Set Manufacturers

Ratio 3½ to 1 and 6 to 1. Fits all hook-ups. For consistently smooth performance use Dongan Audio Transformers. At all good dealers or supplied direct from factory. Special proposition to manufacturers, mounted or un-mounted type. Greatly increased manufacturing facilities insure prompt deliveries to manufacturers and jobbers.  
**DONGAN ELECTRIC MFG. CO.**  
2977 Franklin St. Detroit, Michigan  
Transformers of Merit for 15 Years



**REDUCE BATTERY CONSUMPTION**

50%

**INCREASE TONE QUALITY**

85%

**MAKE YOUR SET TALK**

100%

With a

**CRYSTECTOR**

\$4

Used instead of detector tube in Neutrodyne sets. Gives clearer tone, as it is crystal detection instead of tube detection.

Send for descriptive circular.

— AGENTS WANTED —

For this and a complete line of radio material. Mail Orders Only.

**AMERICAN RADIO SALES COMPANY**  
Not Inc.

3982 Barry Ave.,

Chicago, Ill.

low as it was desired to obtain. This was subsequently changed as indicated, the primary coil being arranged ½ inch below the other, with favorable results.

In order to keep the effect of stray capacities still lower and to give an effective but finely controllable regeneration, the grid coil may not be put between grid and ground, but arranged after the manner of a familiar type of transmitting circuit across grid and plate, with a blocking condenser in the plate lead. This forms a powerful circuit for use with loop antennae, if this plate condenser is a small, low minimum variable one. A center regenerative tap is needed in the tuning inductance and the grid condenser and leak are arranged in the conventional manner. Then no other regeneration coil is needed and stray capacities are kept at a minimum.

Another efficient circuit which may be used with this coupler is the Weagant or Reinartz, in which a series variable condenser is used to control the feed-back effect. This condenser may be of the 23-plate type, having a maximum capacity of .0005 mfd. connected in series with the feed-back coil.

**THE RADIO CHOKE**

The radio choke needed in this circuit must be a particularly good one; a layer wound solenoid which operated well on 400 meters was found useless. A very narrow slab coil of 300 turns of No. 32 enameled wire, wound edgewise in saw slots in a small wood frame, sufficed admirably and was easily made. The outside diameter was about 3 inches.

A two plate vernier condenser and at least a 6 inch handle on each condenser are quite necessary, as body capacity effects are very pronounced. So long as radio frequency leads are as short as possible and well insulated no other special features are needed in the arrangement of the receiver. The feedback condenser was a two plate one, as a very low minimum is called for at times, and a maximum approaching .0003 mfd. An extension handle was fitted to this. A further control over regeneration is provided by the filament control.

**HIGH AMPLIFICATION**

As one has to rely largely on audio frequency amplification, a high degree of amplification was demanded of the tube. A fairly high ratio transformer was used. The resulting amplification was terrific, and great care had to be taken as to grid bias and arrangement of primary leads to avoid whistling. The effect of the high ratio tubes and efficient transformer coupled amplification can be judged when it is mentioned that a buzzer wavemeter a couple of feet away from the set gave an overpowering roar from the loud speaker. At first, although real atmospheric were not very bad in the receiver, nothing could be done at all with three tubes until filter circuits were introduced into both detector and amplifier leads, consisting of audio chokes (audio frequency transformer secondaries) in series and 2 mfd. condensers across them, as otherwise battery noises sounded like distant artillery barrage. Then, although the real atmospheric were very bad on the longer waves, on the last occasion interfering appreciably with local broadcast reception, on 50 meters they were no more than an occasional swish or loud click, with the loose coupling and low resistance tuned circuits used.

The results obtained in a necessarily brief trial of the circuit were very encouraging. With the first arrangement of the primary directly over the grid inductance, a number of successive harmonics of different broadcast stations were picked up, using a vertical aerial of copper ribbon of about 8 feet effective height above a corrugated iron roof.

**RESULTS**

A test transmission from the German



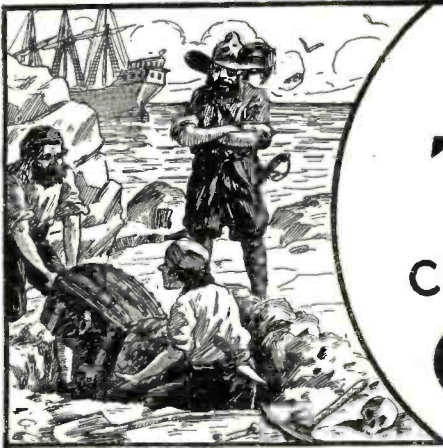

# BURIED TREASURE

can still be found in

# CHEMISTRY



## Good Chemists Command High Salaries

and you can make yourself independent for life by unearthing one of chemistry's yet undiscovered secrets.



T. O'CONNOR SLOANE.  
A.B., A.M., LL.D., Ph.D.

Noted Instructor, Lecturer and Author. Formerly Treasurer American Chemical Society and a practical chemist with many well known achievements to his credit. Not only has Dr. Sloane taught chemistry for years but he was for many years, engaged in commercial chemistry work.

Do you remember how the tales of pirate gold used to fire your imagination and make you want to sail the uncharted seas in search of treasure and adventure? And then you would regret that such things were no longer done. But that is a mistake. They *are* done—today and everyday—not on desert islands, but in the chemical laboratories throughout your own country. Quietly, systematically, the chemist works. His work is difficult, but more adventurous than the blood-curdling deeds of the Spanish Main. Instead of meeting an early and violent death on some forgotten shore, he gathers wealth and honor through his invaluable contributions to humanity. Alfred Nobel, the Swedish chemist who invented dynamite, made so many millions that the income alone from his bequests provides five \$40,000 prizes every year for the advancement of science and peace. C. M. Hall, the chemist who discovered how to manufacture aluminum made millions through this discovery. F. G. Cottrell, who devised a valuable process for recovering the waste from flue gases, James Gayley, who showed how to save enormous losses in steel manufacture, L. H. Baekeland, who invented Bakelite—these are only a few of the men to whom fortunes have come through their chemical achievements.

### What Some of Our Students Say of This Course:

I have not written since I received the big set. I can still say that it far exceeded my anticipations. Since I have been studying with your school I have been appointed chemist for the Scranton Coal Co. testing all the coal and ash by proximate analysis. The lessons are helping me wonderfully, and the interesting way in which they are written makes me wait patiently for each lesson.—MORLAIS COUZENS.

I wish to express my appreciation of your prompt reply to my letter and to the recommendation to the General Electric Co. I intend to start the student engineering course at the works. This is somewhat along electrical lines, but the fact that I had a recommendation from a reliable school no doubt had considerable influence in helping me to secure the job.—H. VAN BENTHUYSEN.

So far I've been more than pleased with your course and am still doing nicely. I hope to be your honor graduate this year.—J. M. NORKUS, JR.

I find your course excellent and your instruction, truthfully, the clearest and best assembled I have ever taken, and yours is the fifth one I've studied.—JAMES J. KELLY.

From the time I was having Chemistry it has never been thus explained to me as it is now. I am recommending you highly to my friends, and urging them to become members of such an organization.—CHARLES BENJAMIN.

I shall always recommend your school to my friends and let them know how simple your lessons are.—C. J. AMDAEL.

I am more than pleased. You dig right in from the start. I am going to get somewhere with this course. I am so glad that I found you.—A. A. CAMERON.

I use your lessons constantly as I find it more thorough than most text books I can secure.—WM. H. TIBBS.

Thanking you for your lessons, which I find not only clear and concise, but wonderfully interesting. I am—ROBT. H. TRAYLOR.

I received employment in the Consolidated Gas Co. I appreciate very much the good service of the school when a recommendation was asked for.—JOS. DECKER.

## Now Is the Time to Study Chemistry

Not only are there boundless opportunities for amassing wealth in Chemistry, but the profession affords congenial employment at good salaries to hundreds of thousands who merely follow out its present applications. These applications are innumerable, touching intimately every business and every product in the world. The work of the chemist can hardly be called work at all. It is the keenest and most enjoyable kind of pleasure. The days in a chemical laboratory are filled with thrilling and delightful experimentation, with the alluring prospect of a discovery that may spell Fortune always at hand to spur your enthusiasm.

### You Can Learn at Home

To qualify for this remarkable calling requires elaborate specialized training. Formerly it was necessary to attend a university for several years to acquire that training, but thanks to our highly perfected and thorough system of instruction, you can now stay at home, keep your position, and let us educate you in Chemistry during your spare time. Even with only common schooling you can take our course and equip yourself for immediate practical work in a chemical laboratory. Dr. Sloane gives every one of his students the same careful, personal supervision that made him celebrated throughout his long career as a college professor. Your instruction from the very beginning is made interesting and practical, and we supply you with apparatus and chemicals for performing the fascinating analyses and experimental work that plays such a large part in our method of teaching, and you are awarded the Institute's official diploma after you have satisfactorily completed the course.

### Easy Monthly Payments

You don't have to have even the small price of the course to start. You can pay for it in small monthly amounts—so small that you won't feel them. The cost of our course is very low, and includes everything, even the chemistry outfit—there are no extras to buy with our course. Our plan of monthly payments places a chemical education within the reach of everyone. Write us and let us explain our Plan in full—give us the opportunity of showing you how you can qualify for a highly trained technical position without even giving up your present employment.

### Special 30 Day Offer

Besides furnishing the student with his Experimental Equipment, we are making an additional special offer for a short while only. You owe it to yourself to find out about it. Write today for full information and free book "Opportunities for Chemists." Send the coupon right now while it is fresh in your mind. Or just write your name and address on a postal and mail it to us. But whatever you do, act today before this offer is withdrawn.

**DON'T WAIT—MAIL COUPON NOW!**

**CHEMICAL INSTITUTE OF NEW YORK**  
Home Extension Division 4  
66-R—West Broadway  
New York City

Please send me at once, without any obligation on my part, your free Book "Opportunities for Chemists," and full particulars about the Experimental Equipment given to every student. Also please tell me about your plan of payment and your special 30 day offer.



### Experimental Equipment Furnished to Every Student

We give to every student without additional charge this chemical equipment, including forty-nine pieces of laboratory apparatus and supplies, and forty different chemicals and reagents. These comprise the apparatus and chemicals used for the experimental work of the course. The fitted heavy wooden box serves not only as a case for the outfit but also as a useful laboratory accessory for performing countless experiments.

**CHEMICAL INSTITUTE OF NEW YORK, Inc.**

HOME EXTENSION DIVISION 4

66-R—WEST BROADWAY

NEW YORK CITY

NAME .....

ADDRESS .....

CITY ..... STATE .....

R.N., Apr. '25.



# YOU ARE BUILDING WRONGLY!

The Rotary Plate Condenser Which You Are Using Takes Up Room In Your Apparatus!

The professional and the radio amateur use nothing but

## "TELSIG"

Tested by the Physico-Technical Imperial Institute

The Smallest rotary plate condenser.



Adjusting Knob of the Modern Rotary Plate Condenser.

### DESCRIPTION:

The "Telsig" is a rotary plate condenser, whose new dielectric is adapted to let its individual plates be placed at such a minimum of distance that they find sufficient place to be contained in the hollow adjusting disc in spite of the slight amount of air space between them. The arrangement of the dielectric has two features, a movement of a single plate is quite impossible, and with the longest period of use no dust is formed, which happens with other dielectrics, which in the first place immediately changes the capacity and afterwards by the bits of detached metal a short-circuit is formed. The following recommendation of the Physico-Technical Imperial Institute discloses the high selectivity of the "Telsig."

by the repetition of the adjustments and they came within about 2 or 3 per cent.

#### PHYSICO-TECHNICAL IMPERIAL INSTITUTE SECTION II

The mounting surpasses in simplicity all existing systems, as only a single aperture has to be drilled to receive it, whereas three to four are required for the ordinary variable condensers, besides the space left beneath it is completely free for other purposes. The sets can be considerably thinner and narrower. The panel comes between the underlying discs and two nuts are drawn up firmly against it (the third nut serves for holding the second connection) and the knob is now free to turn on its shaft through 180 degrees against two fixed stops. For tightening up the nuts the knob is held by hand either at zero or at 100, so as not to turn. At zero the condenser is opened; at 100 it is completely closed.

The "Telsig" has a special advantage over the open plate condenser as a short-circuit cannot be caused either by pressure, by dropping it or by too tight screwing up of the nuts, and it is also entirely protected against any penetration of dust.

Finally, the connection of the flexible cord is made through a small drill hole about three-quarters of an inch from the aperture through which the shaft passes. The condensers can be obtained of the capacities: 100 cm, 250 cm, 500 cm, 1000 cm for \$2.00

**EXTRACT**  
The results of the tests are contained in the following table:

Adjustment	Capacity in cm
10	7
30	30
50	51
70	81
90	100

The accuracy of the values given above was verified

Order at once direct from us for which please send \$2.00 for one sample postfree.

### OSCAR SCHLIEPER

Retail Division of the Telephone & Signal Co.

39 Kaiserin Augusta Allee,

Charlottenburg 1, Germany

Discount on new orders!

## LOUD SPEAKER

Complete ready for immediate use—



**\$7.35**  
prepaid to any point in U. S. A.

Beautifully finished in black crystalline, standing 21" high and comparing with speakers at two and three times the price. Seeing is believing. Send today. If not thoroughly satisfied return in ten days and your money will be promptly refunded.

SHERIDAN RADIO SALES CO.

Dept. R. N. 4.

301 West 4th St., N. Y.

**MARVELOUS NEW AUDIO TRANSFORMER** adds a musical quality to any set far beyond anything you ever heard before. Karas Harmonik amplifies low, middle and high tones to the same big volume, eliminating distortion. Brings out vital harmonics and overtones of music. Price \$7.00. Write Karas Electric Co., Dept. 50-44, 4040 N. Rockwell St. Chicago.



## Best Reflex Crystal Detector



Says the **Acme Apparatus Co.**

No longer does the whisker scratch the crystal, or is the sensitiveness killed by heavy spring pressure—the Vernier Regulator takes care of that. It will surprise you to know how sensitive Crystal Detectors are when correctly made.

### BROWNLIE VERNIER DETECTOR

For Panel or Base Mounting including Crystal. Guaranteed **\$2.00**

At your dealers otherwise send Purchase Price and you will be supplied postpaid.

**ROLAND BROWNLIE & COMPANY**  
22 Saunders St. Medford, Mass.

## HUDSON-ROSS

Wholesale radio only.  
One of the first and still in the lead.  
Write for discounts.

123 W. Madison St. Chicago

## TO THE RADIO DEALER

Let us explain how you can make the sale of our publications a worth while, well paying part of your business. Write now and prepare for the Fall and Winter trade.

EXPERIMENTER PUBLISHING COMPANY, 53 PARK PLACE, NEW YORK CITY

Telefunken station came in at good strength in London, England, at around 80 meters or so, being readily tuned in on the loud speaker on two tubes. (The receiver had not yet been calibrated.) The speech was clearly intelligible, with extremely careful tuning, and the name of the station and nature of the transmission were distinct. Several amateur transmissions came in, some at loud speaker strength on two tubes.

When the modified arrangement, giving a lower range of wave-length, was tried on a succeeding night under quite favorable circumstances (very bad atmospheric, a damp, muggy, windless evening, and on a low horizontal 70-foot test aerial, thoroughly screened locally, in Essex) at 10 p. m. there appeared to be little going on, but presently, on between 60 and 70 meters (about 150 degrees on condenser) a powerful wave came in and by extremely careful tuning and reaction adjustment was recognized as speech and music, which persisted for a considerable time. The strength was about on a par with the irregular casual noises, so that, although the modulated wave was readily found on the loud speaker on three tubes without head phones, the effect was not intelligible or enjoyable. Under better circumstances, and on a more favorable night, undoubtedly KDKA would have been more enjoyable. Using the vertical 8-foot aerial without any series condenser, some amateurs were heard very low down on the wave-length scale, one persistent operator, utilizing apparently raw 60-cycle A.C., coming in strongly on the loud speaker.

With the larger aerial more noises came in, and care had to be taken to set the series condenser so that the natural wave-length of the whole aerial and aperiodic coil was less than that on which one was receiving, as otherwise the set mysteriously refused to oscillate at all.

## The Grid As Traffic Regulator

(Continued from page 1850)

the plate potential. And if you want to receive from a feeble or a distant station, which is only able to make the grid voltage oscillate slightly, it will be well to reduce it a good deal. Hence, doubtless, it is that the Solodyne is efficient in picking up distant stations.

The plate potential of the other tubes, to which grid alternations are supplied, may be higher, but still not too high. It is always important that the plate shall not overpower the grid. When listening to a strong nearby station, that is not likely to happen, but when listening to a distant station it is likely enough. One might imagine that the feebler the impulses received, the more plate potential ought to be supplied, whereas the fact is just the reverse. Perhaps many amateurs overwork their "B" batteries, especially with the harder tubes.

To sum up: The more distant or feeble the station listened to, the lower ought to be the "B" battery potential applied to the plate of the first tube. It is possible that constructors do not allow sufficient reduction of the numbers of cells of the "B" battery put into action on the plate, especially the plate of the first tube. Too high a potential is detrimental. The "B" battery ought to have binding posts all along so as to be capable of ready adjustment down to quite a low potential, and thus be made to suit different circumstances. The function of the number one tube is clear reception. If it does not receive all the fluctuations clearly, subsequent amplification, instead of remedying the defect, only increases it. Given clear reception, it can be amplified by subsequent tubes as much as desired. We must not de-



pend for amplification on the receiving tube, and must not try to force it either by regeneration or by high potential or too bright a filament, or in any other way.

## The Great Bedtime Story Conspiracy

(Continued from page 1865)

Doris gives a squeal and I turns around. It's The Master!

This last is what his butlers calls him. His family Bible wave-length is Gerard Lawson, of Brightmore-on-the-Deep, Long Island. He's rich, young, dark-haired and has too much of everything except a sense of humor, of which he has so little it's a puzzle how he can be a radio ham. Which he is—body and soul. Everywhere he goes he carries a traveling laboratory—but that'll wait.

"Hello, Jerry!" I yelps, surprised. "What're you doing, boy-humper? Playing tag with us?"

Jerry shakes hands and sits down. He's plainly troubled about something. For a while I politely avoids asking what it is, but finally I sees it's the real thing, maybe love, so I inquires. The Master casts a furtive look about the room.

"You may think I'm crazy, Joe, but I'm not," he declares. "I'm sincere."

"Sure you are," I agrees, knowing he couldn't be anything else if he wanted to. "Go on."

"I overheard Doris' remark, and she's right. Bedtime stories are the bunk!"

"Atta ol' boy!" praises my jarring partner. "You see, Joe, even Jerry knows it's true."

"Then it must be so," I admits, which same to any normal human being would constitute a dirty dig. To The Master it means as much as a seven-letter Eskimo word for "Gimme." I tells him to proceed.

"As you know, I've been in Los Angeles this winter, doing research work along radio lines. I was making a vital test, in which it was imperative that the receiving apparatus be set at one fixed wave-length. Before beginning the experiment, I selected an odd wave-length, which, to the best of my knowledge, was not being used either commercially or by any broadcast station. My signals were being sent from New York and all was well until—oh, I can't speak of it!"

"Go on," I coaxes. "Tell Joe all about it."

The Master braces up. "I was half way through the experiment, too late to alter the wave-length, when I discovered to my extreme displeasure that this particular wave had recently been assigned to a station in a certain city near here. I could not change my receiver's wave-length. It was vital to my test that I receive my signals within two definite hours in the evening. During these same hours this station broadcast—*bedtime stories!*"

"Sad," I admits. "Whatcha gonna do about it?"

"I wired them, radioed them to desist until I had finished my test, but they would not accommodate me; they even became insulting. In consequence, the experiment was ruined, and it will be a year before I shall be able to attempt it again. Valuable improvements in the field of static elimination have thus been delayed by this one, insignificant station. It's terrible."

"Sure," I soothes. "Whatcha gonna do about it now?"

Jerry grips his chair and restrains an earnest desire to kick my suitcase set into the gas fireplace. "Revenge!" he almost hisses.

"Aw, c-mon," I begs. "Don't be a cookoo."

# DUPLEX CONDENSERS

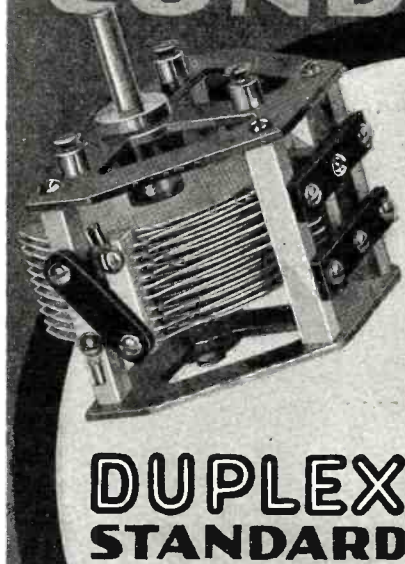

## The Accepted Standard

*DUPLEX Standard Condensers* (Series FR) have attained a generally recognized supremacy. They are especially designed to conform to Bureau of Standards specifications for lowest losses and best electrical characteristics. Bearings are brass on bronze, with automatic take-up at both ends. Four heavy metal posts further insure perfect alignment. Plain and vernier models both are unconditionally guaranteed to give absolute satisfaction.

## A DUPLEX KIT of Matched Condensers Affords Uniform Dial Settings

The discriminating parts buyer will appreciate this latest *DUPLEX* innovation! *Matched Condensers*—packed three in a kit—specially tested and guaranteed! Uniform dial readings and simplified logging are possible only with *DUPLEX Matched Condensers* in tuned radio frequency, Neutrodyne, and similar circuits. Don't just buy three condensers—insist on *DUPLEX Matched Kits!* Instructive literature sent on request.

**Duplex Condenser & Radio Corp., 52 Flatbush Ave. Extension, Brooklyn, N.Y.**

## Best At The Price

*DUPLEX Junior Condensers* (Series DR) will give you the same satisfactory service that you get from other, higher-priced condensers. True, they are not quite so fine an instrument as is the *DUPLEX Standard*—but they are better than any other condensers at the same price. *DUPLEX Junior Condensers*, plain or vernier models, are particularly suitable for use in portable sets as they are extremely small and are light in weight. Perfect operation guaranteed.

## DUPLEX JUNIOR

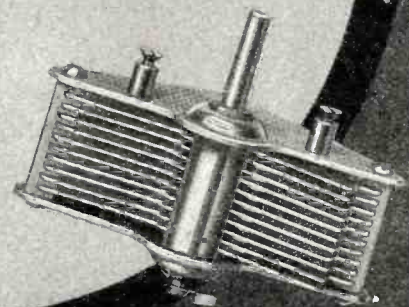



**30 years**  
have perfected and made it  
the finest loud speaker



Amplion  
Dragon AR-19  
\$42.50

**AMPLION LEADS IN SALES  
THE WORLD OVER. HEAR IT!**

Have you heard the favorite of music lovers the world over? The time-perfected development for radio of a famous electro-magnetic and acoustic instrument. The creation of the world's oldest loud speaker makers, thirty years experienced in sound reproduction, and internationally recognized authorities.\* The Amplion, with its supreme and enduring sensitivity, its pure, clear, natural tone, its extraordinary volume. With its "floating diaphragm," correct acoustic contour and non-resonating tone conduit. Hear it at your dealer's—in comparison! You will be converted. Literature on request.

Alfred Graham & Co., England, patentees

**THE AMPLION CORPORATION  
OF AMERICA**  
Executive Offices: Suite W, 280 Madison  
Ave., New York



Phonograph Units  
in two sizes



**AMPLION**  
The World's Standard  
Loud Speaker

 <p>The Amplion Junior DeLuxe. AR-114 \$27.50</p>	<p>Amplion Dragonfly. Model AR-142 \$13.50</p>	 <p>The Amplion Junior Model AR-111 \$24.00</p>
<p>Slightly higher in far west</p>		



**The Famous Truly Portable  
TELMACO P-1 Receiver**

*Four Tubes Do the Work of 7*

Coast-to-coast reception. Aerial, loud speaker, and batteries self-contained. Carry from room to room—take it anywhere. Size 8"x10"x18". Total weight only 26 lbs. Complete with tubes and batteries, **\$125.00** \$147.50. Receiver only

**P-1 Kit Saves You Money!**

In response to a popular demand we now offer the Telmaco P-1 Receiver in kit form. This contains all parts, as built by us, including case, drilled and engraved panel, and illustrated instructions. **\$80.00** Complete kit

Ask your dealer or write us. Descriptive folder free.

Radio Division:  
**Telephone Maintenance Co.**  
20 So. Wells St. Dept. B, Chicago, Ill.

**TELMACO**  
Quality Radio Exclusively Established 1918

**BIG SALE**

**ON TUBES**

VERY SPECIAL PRICE **\$2<sup>29</sup>**

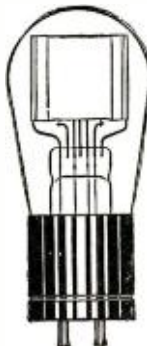

These high grade tubes are made in two popular sizes only, and are guaranteed Brand New, quiet in operation and highly sensitive.

No. P. V. 01A Detector and Amplifier Tube with standard base, Only **\$2.29**

No. P. V. 99 Detector and Amplifier Tube will fit all 99 sockets, Only **\$2.29**.

Just order quantity wanted by number and pay postman our low price plus postage upon arrival. Or if you prefer send \$2.29 for each tube and we ship prepaid. Prompt service and satisfaction guaranteed

**FREE CATALOG**

Contains most complete line of sensational Bargains in High Grade Radio Apparatus, Parts and Supplies.

Write for your free copy today.

**P. VON FRANTZIUS**  
608 Diversey Pkwy. D-14, Chicago, Ill.

SEND FOR YOUR FREE COPY

**TESTED HOOK-UPS**

SUBMITTED BY USERS OF OUR



**WONDERFUL  
TRANSMITTER  
BUTTON FOR LOUD  
SPEAKERS**

Price \$1.00  
POSTPAID  
with instructions

**AMPLIFICATION  
AND EXPERIMENTS**

**K. ELECTRIC CO.**

15 PARK ROW

NEW YORK

**KEYSTONE  
RADIO LIGHTNING  
ARRESTERS**

Get the Keystone Low Loss Lightning Arrestor installed now before the Spring thunder and lightning storms get severe. Your set and your home must be protected to comply with fire laws. Get the greatest protection and satisfaction—use the genuine Bakelite Keystone. Approved by Fire Underwriters, E1835. The Keystone is the only Low Loss Arrestor and forms perfect insulation between aerial and ground. Get one today. Sold by all dealers.



**ELECTRIC SERVICE SUPPLIES CO.**  
Philadelphia: 17th and Cambria Sts.  
New York: 50 Church St.  
Chicago: Monadnock Bldg.

**\$1.50** Complete  
**\$2.00** In Canada

"I'll get them, and I'll get them good," he declares vehemently.

"Easy on the vendetta," I advises. "What-cha planning to do?"

Knowing The Master's conscience won't let him do any real damage, I sorta eggs him on for the fun of it.

"I can't tell you just now, Joe," he says. "Will you be available if I should need you?"

I nods. "We're off this week, and I don't think Doris is gonna have any special uses to put me to, so I'm yours for the asking. At that, I do need a little diversion."

"Very well," says Jerry. "I'll call you if I need you. In the meantime, mum's the word, and keep a stiff upper lip."

So saying, he takes his leave. "Took an overdose of Conan Doyle," I grins. "He'll be all right in the A. M."

"Which is more than can be said of you," fires the frau. "Chuckle that one down."

Well, we don't hear from Jerry the next day, so that night we decides to take a flying trip to the Land of Nod via radio. Accidentally I tunes in the station Jerry's wreaking vengeance on. I laughs and tells Doris.

"I wonder what The Master's doing?" I laughs. "Forgotten all about it by now."

"Don't kid yourself," admonishes the gold band. "That boy was serious, and no foolin'."

"The trouble with you is, you radiate too much," I explains. "Jerry wouldn't have the heart to amputate the fingernail off a centipede."

However, I tunes in this station, which I'll tag ZYX, because that ain't its call. We listens through their program, and all's lovely.

"Jerry ain't on the job," I declares. "The ether is sweet."

"You never can tell," sighs the wife pointedly. I lets it lay.

Next morning brings The Master in person. He don't waste no time in fancy speeches, but gets down to copper nails.

"Have you any engagements for today, Joe?" he asks.

"Well, I was goin' downtown and watch the taxis bump pedestrians," I says. "However, that can wait."

"Can you be gone all day?"

"The rest of the week, if necessary. What's this lay?"

Jerry explains. "I want you to help me fulfill a contract."

"Good," I says. "What kind of a contract? Remember, I'm tied to one now."

"To paint a building," says The Master simply.

I'm open-eyed in astonishment. "To what?" I yelps.

"To apply a coating of lead oils to the exterior of an edifice," explains Jerry. "It's very easy. All one has to do is to rub a brush back and forth."

He's serious, too, which makes it harder. "Lissen," I begs. "Let me in on this, will you?"

"It will be necessary for us to go down to Umpsville," continues The Master.

"When we arrive I shall be able to elucidate."

"Seein' it's you, I'll let you." I grumbles. "This suspense is terrible."

We gets into Umpsville about three P. M. and it proves to be a fair to middling village, about 10,000 souls, out of which 4,999 are Baptists, 4,999 are Methodists, one is the mayor and the other is a drunk. Small towns are all right in their place, which is as far from me as possible.

Suddenly it dawns on me. "Say, ZYX is in Umpsville, isn't it?"

Jerry gives me an approving glance, which is the closest he can come to making a subtle wise crack. So I considers myself properly chastised.



We puts up at a hotel for the night; at least, we try to. I never knew one lodging house could harbor so many anti-sleep propagandists. But morning finally comes and Jerry brings forth a package. Therein are a coupla suits of overalls, caps and rough gloves. We puts them on.

"Now," says Jerry, "we're painters."

After breakfasting at the city's pride—a genuine one-arm Baltimore lunch—we takes a stroll down the lane to a garage. Here The Master takes possession of a flivver truck bearing a load of painting paraphernalia and the inscription

"HERMAN HEMPEL, ARTISTIC PAINTING."

"And who," I asks, "is Herman Hempel?"

"The painter who happened to have the contract I desired," explains Jerry. "I bought him out yesterday."

We drives down the chief alley a ways, then turns off on a side spurt. Pretty soon I sees an imposing aerial. Sure enough, it's ZYX.

"Now, Joe," requests The Master, "take a good look at ZYX and tell me any unusual features you may observe."

I gives the joint the long-distance inspection tour. "A frame building, directly in the center of an otherwise vacant block," I states. "Must have been a public school at one time. Main distinguishing feature—one square tower, three stories above the rest. Is that enough?"

"Very good, Joe," compliments Jerry. "After I've seen the janitor and made a few minor arrangements we'll start rigging up the scaffolds. In the meanwhile you can be mixing the paint."

"Sure I can," I agrees, "only I ain't going to. What I knows about paint is confined exclusively to the art of stage make-up."

"Oh, very well," sighs The Master. "I'll attend to it later myself."

He enters the joint and comes out about 15 minutes later.

"All ready, Joe," he calls. "Bring ropes and scaffolding."

Well, we spends the morning trying to get the planks and ropes to act all at the same time. We'll be done in about seven weeks, it looks like, and I tells The Master so.

"Don't worry," he cheers, "our purpose will be fulfilled shortly."

I'm cold and grumbling. "Whoever heard of anybody painting a building in mid-winter?" I says peevishly. "They'll think we're a bunch of nuts."

Jerry ignores the complaint. "I considered myself very fortunate to have heard of the existence of this unfinished contract," he says. "It saved me considerable worry."

The limit has been reached. "Jerry," I says, "let me in on this now, or I'll quit."

The Master sighs and gives in. "Come on down to the truck and I'll tell you," he says.

When we gets down and out to our car Jerry makes sure nobody's within hearing and spills his latest *non compos mentis*.

"The whole thing rests with that tower, Joe," he begins. "You will notice that it is about 15 feet square, with the top left flat. Of the three floors in the tower itself, ZYX's broadcasting room occupies the top floor, the station itself on the next-to-top floor, and the power plant on the lower of the three levels. Is it, by chance, any clearer?"

"My barometer still says cloudy," I replies. "Go on."

"Well, when I was here yesterday I discovered an odd, though important fact. The motor-generators in the power room on the bottom floor of the tower are fed almost directly from the line transformer. I mean, the power company for some reason placed their pole transformer for this district right inside the building. Why, I don't know—

## EACH A LEADER IN ITS FIELD!



POCKET METERS

PANEL METERS

AUDIO & RADIO TRANSFORMERS

MICROCONDENSERS



"SOFT TREAD" RHEOSTATS

Are You Completely Satisfied with Results?

Are You Able to Tell the Exact Condition of Your Batteries?

Are You Charging Your Batteries Safely, Economically and Conveniently?

Are You Getting the "Full Range" of Audio Reception?

Are You Able to Equalize as Easily as Setting the Hands of a Watch?

Are You Using a Soft Tread Rheostat?

Here Are Some Mighty Valuable Suggestions to Help You With Your Radio Problems:



PORTABLE RECTIFIER

**STERLING POCKET METERS** These meters have exactly the "right resistance." They do not overstrain the battery because of having too little resistance nor yet give a meaningless high reading due to too much resistance. They tell the actual ability of the battery to function under working conditions. Voltmeters, ammeters and voltmeters for every type of battery—"A" and "B," dry or wet. Specify "Sterling"—the meter that "tells the truth."

**STERLING "FULL RANGE" AUDIO TRANSFORMERS** The equal amplification of all audible vibrations has at last been made possible. In fact the whole gamut of sounds, musical or otherwise, are faithfully reproduced by the Sterling "Full Range" Audio Transformer. You'll think you're in the same room with the broadcaster. Rich in appearance, compact, improved wiring facilities. Price \$6.00.

**STERLING "SOFT TREAD" RHEOSTATS** With this rheostat you cannot feel the broad scientifically formed contact move from wire to wire and there is absolutely no wobbling. You obtain unbelievably free, smooth, noiseless movement in either direction. The customary grating sensation will not come later, either. Mounted through single hole, easily and securely. Price \$2.00 (5 and 15 ohm), \$2.25 (30 and 50 ohm).

**STERLING PANEL METERS** One or two panel meters mounted on the panel are of great assistance in obtaining efficient operation. It is good practice to obtain rheostat adjustments by measuring the voltage across the filament with a Sterling Panel Voltmeter. By having this information you may avoid premature burning out of the tubes and you get better results in reception.

**STERLING MICROCONDENSER** Balancing certain Reflex and other radio frequency circuits with the Sterling Microcondenser is just as easy as setting the hands of a watch. Simply turn the little rotary Plate to the correct position and let go. The work is done. Maximum capacity approx. 5 micromicrofarads. Price \$1.00 each.

**STERLING BATTERY CHARGER** This rectifier charges "A" and "B" batteries from a single unit. No separate attachment. The switch does it all. No confusing array of binding posts to connect. No resistance lamps to insert. No liquids or bulbs to replace. Nothing to get out of order. No metal contacts to fuse or burn out. Charging rate not merely assumed but shown by accurate ammeter. Model 19 Price \$22.50 (50 or 60 cycle), \$25.00 (25 cycle) Model 17 (for "A" and Auto Batteries only) \$18.50 (50 or 60 cycle), \$21.00 (25 cycle).

THE STERLING MANUFACTURING CO.

2831-53 Prospect Ave.

Dept. H

Cleveland, Ohio

Send for catalog and complete information.

# Sterling Radio Equipment



# Consrad's Greatest Book

## Table of Contents

- Information for the Broadcast Listener.
- Radio Broadcast Stations of the U. S., by Call Letters.
- Radio Broadcast Stations of the U. S., by States.
- Radio Broadcast Stations of Canada, by Call Letters.
- Foreign Radio Broadcast Stations, by Countries.
- Special Land and Experimental Radio Stations of the U. S.
- Table for Making Time Transitions.
- Time in All Parts of the World.
- Time Signals.
- Weather, Hydrographic, and Market Reports.
- American Radio Relay League and Directory.
- Amateur Radio Stations of the U. S., by Districts.
- Amateur Radio Stations of Canada, by Districts.
- Amateur Radio Stations of Europe and All Foreign Countries.
- Radio Maps of the U. S., North and South America, Canada, Europe, Asia, Africa, and Australia.

- 114 Large Pages of Real, Practical Information—No Advertising
- Size 9 by 12 inches.
- Contains 114 Pages.
- Bound with Beautiful Stiff Two-Color Cover.
- Published Twice a Year.

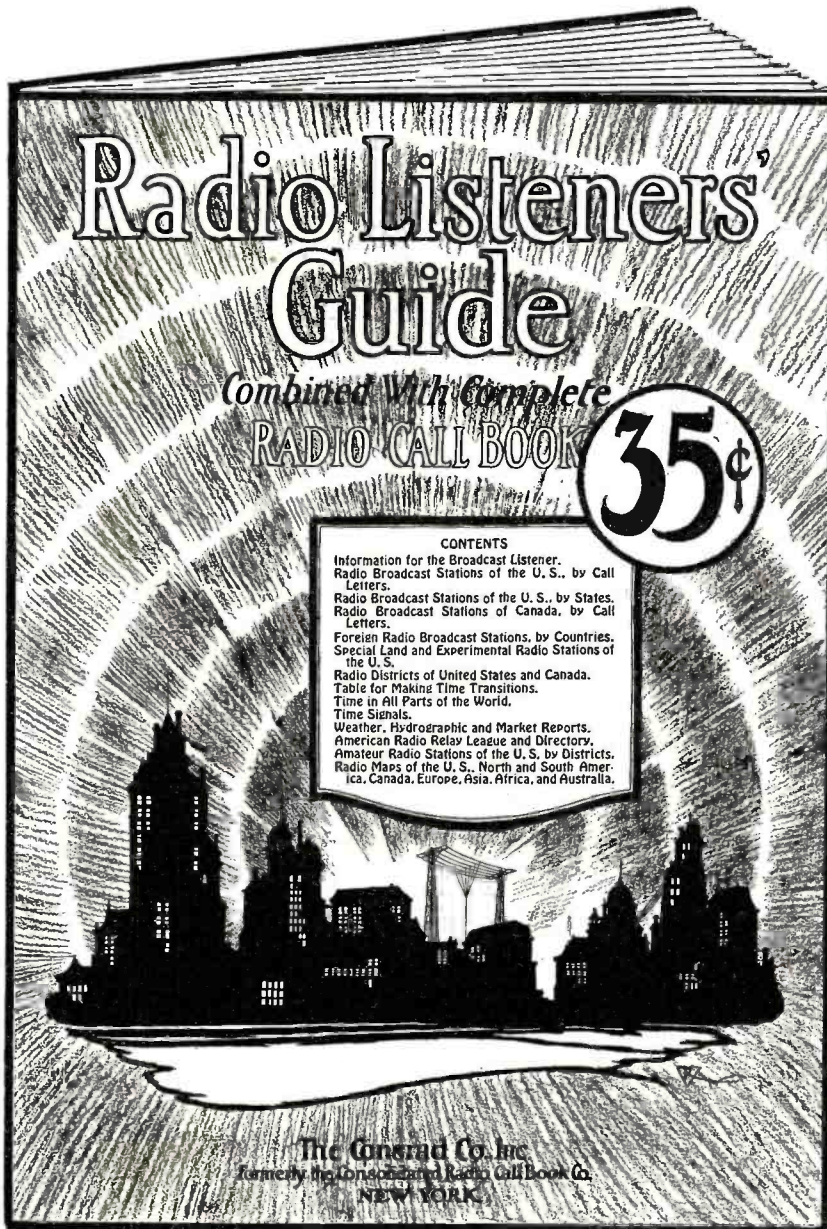

The Consrad Co. Inc.  
 Formerly the Consrad and Radio Call Book Co.  
 NEW YORK

1925 Edition Large Magazine Size

## Radio's Finest and Most Complete Call Book

There has never been any radio book for the amateur, the engineer or the regular radio broadcast listener exactly like this great Consrad edition.

Here is a book for *everybody*, covering all the information any listener needs to most thoroughly enjoy a radio program. It tells how to use and operate a radio set to the best advantage. It tells where, by whom, and on what wave length every radio broadcast station of the United States is operated, etc.

Altogether there are 114 pages filled to the brim with practical data. There is not a page of advertising—all text material for the user.

This is the one radio book that should be at the side of every radio receiving set in operation.

ASK YOUR RADIO OR NEWS DEALER OR WRITE TO US DIRECT

THE CONSRAD COMPANY, Inc., 233 Fulton St., New York, N. Y.

# Consrad



small towns do so many strange things. This makes a supply of high frequency current available."

"Bravo!" I replies. "For what?"

"That will show up in good time better than I can explain it now," answered The Master. "This afternoon we'll begin to act."

"All right," I agrees, "but I hopes we don't flop."

After lunch we gets back on the job. It's cold, and so the usual gang of neck-strainers ain't doing the gazing act for our benefit. Also, the windows in the tower are conveniently frosted, so the bunch inside can't see out. Really, things are lovely.

First, The Master hoists up a coil of what is labeled "rope," but proves to be heavy insulated wire, colored yellow. We lowers the scaffold and begins to wind this wire about the tower, working from the base up, dodging all windows and such on the way. As fast as Jerry winds the wire I applies the paint. By nightfall we're through, and Jerry goes in and explains to the owners that, due to this-and-that and so-and-such, the job will have to be postponed until warmer weather. They're real nice about it, too, seeing as how they'd forgotten they ever intended having the place tinted. With the exception of a little interior work in the generator room our careers as decorators is ended. So we beats it back to our so-called hotel and erects a barricade against the army of the unseen.

The next day we finishes the job in the generator room. This consists of my tacking up a fresh paint sign wherever I thinks anyone's liable to enter, while The Master completes the dirty work. Being a natural born expert he don't linger long. Soon he's connected the outside wire to the power line, and by a little strategy and considerable good fortune he's been able to fasten a lead of some sort to the transmitter, so that they turns on the juice when they starts to broadcast. I'm no marvel at these things—sufficient to say that Jerry takes a couple boards outa the floor and puts his regulating apparatus where no one but the rats'll find it, and we're through. It's six-thirty; by seven they begins to spread the rumors. I'm all grins as we moseys back to the only place in town we dares to take a chance sleeping at.

"Hot stuff!" I laughs. "Say, Jerry, won't the air be full of static tonight?"

"Static?" repeats The Master, puzzled. "What from?"

"Aw, can the innocence," I commands. "From that 12-ton spark coil we just created."

Jerry's silent a moment, then he grins. "Why, Joe, I thought you knew. That isn't a spark coil."

"The deuce it ain't!" I exclaims. "If not, what is it?"

The Master laughs. "I can see how you were deceived, Joe," he says. "At that, you were right in a way. But it isn't a spark coil. It's more properly an induction coil."

"Whassa diff?"

"This: a spark coil of those dimensions would create static, all right, but would be immediately detected, due to the necessity of having a vibrator to make and break the circuit. Besides, a spark coil would not accomplish my purpose. I have no desire to annoy any other station. I merely wish to stop ZYX, and I have!"

"How?"

"An induction coil induces an electrical current into every circuit within its field. To make it specific, this coil we just built is really only half a coil, an immense primary. Therefore, every other coil or circuit, of any nature whatsoever that may lie within the field of this primary, automatically becomes a small secondary. Do you follow me?"

"Just about," I replies, snickering. "This



F. W. STEIN

“~and **NOW,**  
I've Found  
Something Better  
for  
Crystal Set Users”

My amazing new discovery makes it possible to enjoy crystal reception, either local or distance, without ever adjusting the detector for hot spots. It's hot all over—this Steinite Rectifier—always on the job without interruption or bother.

**Steinite Rectifier** Takes Place of Crystal

Absolutely new and different from anything you ever tried before. Takes the place of the crystal on your set. Fits any standard crystal holder. Installed in a minute, without any tools. Does away with the crystal, catwhisker and critical adjusting. It uses a specially constructed graphite contact point, but is not to be confused in any way with the so-called fixed crystal. Developed for use in the simple crystal set, and gives amazing results in reflex circuits.

**Surprising Distance and Volume**

Revolutionizes the tuning of crystal sets for distance because the entire surface of rectifier is uniformly hot and amazingly super-sensitive. Users testify to unheard of distance and unusual volume.

**Wonderful Tone Quality**

Unbelievable improvement in tone. Always clear, steady, unfluctuating and bell-like. Everyone enthusiastic about reception with the Steinite Rectifiers.

**Money Back Guarantee**

Send \$1.00 for Steinite Rectifier complete with special Graphite contact point postpaid. Try ten days at my risk, and then if not more than delighted money will be sent back on request.

Bank References—Exchange National Bank and Atchison Savings Bank, Atchison, Kansas.

**ALWAYS HOT  
Supersensitive —  
New Radio Delight**

Think of the new joy this discovery will give you on your crystal set. Always adjusted ready to tune in. No loss of programs through tinkering with dead crystals. *The Steinite Rectifier is not a natural crystal. It is not a synthetic crystal. It is not a fixed crystal.* It is an entirely new and revolutionary principle giving the wonderful tonal quality of a perfect crystal with none of a crystal's annoying drawbacks.

**Order Direct from this Advertisement Now**

Test this for yourself today entirely at my risk. If not entirely satisfied and amazed with results get money back at once as specified in my written guarantee. Put a Steinite Rectifier on your set, tune in, then move the graphite contact point all over face of rectifier. If tone varies or entertainment is interrupted, send it back. It's worth trying. \$1.00 for perfect reception. Not a penny if it fails. Pin dollar bill to our name and address and mail today as present production is limited, and it may be impossible to have dealer distribution before September. Make sure of yours now.

**STEINITE LABORATORIES, 700 Radio Bldg., Atchison, Kans.**

Manufacturers of Famous Steinite Products—Steinite Crystals 3 for \$1.00—Crystal long distance set \$6.00—Single tube set \$12.00—2-tube set \$16.00—Steinite "5" Balanced T R F \$50. Literature on request.





B
R

E
a

L
d



**THE BELL RADIO PRODUCTS**  
THE BELL MFG. CO.

S
o

o
k

e
t

s
—

K
n

o
b

s
—

D
i

a
l

s
—

R
o

u
n

d
s

### Round Socket



High gloss brown Bakelite. Strong springs, positive contact. Nicked posts plainly marked. Ea. 45c.

### UV199 Socket

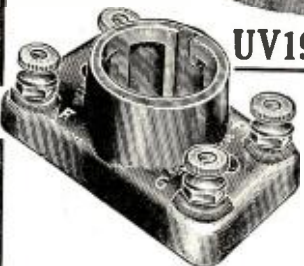

Black glossy Bakelite. Heavy double-spring contact. Nicked posts, plainly marked. Ea. 45c.

### Square Socket

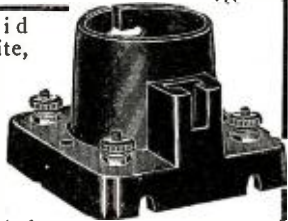

Heavy solid brown Bakelite, for base or panel mounting. Positive contact on side and bottom of prongs. Nicked posts. Each 80c.

BELL DIALS—built right and look right. High gloss Bakelite; clean white engraving. 2 in. to 4 in. sizes (including special vernier knobs) 35c to 80c each.

Ask for bell Radio Products—in the individual BLUE Boxes.

Dealers—Ask for radio circular and discounts.

## Bell Manufacturing Co.

11 Elkins St., Boston 27, Mass.

**How to pass U.S. Gov't. Radio Examination**



310 Actual questions answered by E.E. Bucher

50<sup>c</sup>

**RADIO INSTITUTE OF AMERICA**

324 Broadway New York City

**PASS** the U. S. Government Commercial or Amateur Radio License examination. This book will help you do it. Send fifty cents in stamps or coin for your copy—postage prepaid to any point in the U. S., Canada or Mexico.

big primary makes a lot of little secondaries, is that it? But where does the damage come in?"

The Master smiles. "The secondaries thus formed will be so comparatively small that the induction created will immediately burn them out."

"Won't that cripple the station completely?"

Jerry grins delightedly. "As your stage argot has it, the big coil will stop the show cold."

"Blow the works?"

"Or words to that effect."

I'm skeptical. "But won't they find it out easy?"

Again Jerry laughs. "My attaching the current through the transmitter assured us that we need not concern ourselves on that score. Inasmuch as the power is on only when they transmit, they will quite logically assume that the short circuit lies somewhere in the apparatus itself. I took great pains to conceal all my wire leads; they'll look for months without success."

I takes off my hat and bows low. "Your Royal Slynness," I compliments, "I hereby gives you the grand salaam. You're a wonder."

Jerry practically admits as much.

"However, are you sure you ain't forgotten anything?" I asks.

The Master smiles sorta self-satisfied. "Nothing, Joe," he assures me.

Back at the hotel we tunes in a small set we've brought along. For two hours we keeps the cans to our ears; ZYX ain't let out a peep.

"I think our medicine is acting," says Jerry, taking off his headset. "We might casually stroll down toward the station and see if we can hear any details. But, remember, don't give yourself away."

"No danger," I replies. "I know my own value too well."

When we gets within a block of ZYX we hears sounds. When we gets up to the station we finds to our surprise that the said sounds ain't coming so much from the station as from groups of people gathered in the streets. The Master edges into one bunch and inquires why the excitement.

"Something's wrong," said a voice. "All the lights are out for blocks, our radios are burnt out, I can't start my car because the starter isn't feeling well and nobody can get central on the phone."

"W-what seems to be the trouble?" asks Jerry, paling.

A cop supplies the information. "A wire's down some place, they say."

"But that doesn't account for our cars and radios," says the voice.

"Well, it's Greek to me," says the officer. "I can't savvy it."

The Master don't wait to hear no more, but draws me aside. "J-Joe," he stammers, "we've done it."

"Naturally," I agrees. "How?"

"I-I forgot that the induction from that coil would extend in all directions. We've blown out 'all the lights, coils and circuits for several blocks around!"

"Then we'd better cut it off," I says calmly.

"How?" asks The Master. "We won't be able to do anything tonight, and tomorrow may be too late. What'll we do?"

"This: just go up, say you forgot a brush or something, snip a wire when nobody's looking, and it's all K. O."

Jerry's face lights up like a spotlight on a dark stage. "Joe, you're a wonder, too," he admits, meaning it in the bargain.

He goes into ZYZ, emerging 15 minutes later with a relieved expression on his super-intelligent countenance.

"All set?" I asks.

Jerry wipes his brow. "I managed to cut the lead to the transmitter," he says. "We're safe for now, anyway."

**No. 2-A Loud Speaker**

Price **\$17.50**

including 5-ft. cord and plug



## Rich Tone and Volume

The No. 2-A Stromberg-Carlson Loud Speaker reproduces programs with naturalness of tone while its volume is sufficient to fill the largest room on distant station reception.

Graceful in design; so light it may be carried from place to place. Simple and economical to operate.

Ask Your Dealer

**Stromberg-Carlson Telephone Mfg. Co.**  
1060 University Avenue  
Rochester, N. Y.

**No. 3-A Head Set**

Price \$5.50

Stromberg-Carlson Head Sets and Loud Speakers have powerful magnets and layer wound and layer insulated coils—a superior type of construction.



# Stromberg-Carlson

## DX "mushy"?

**FREE BOOKLET**



on "Tube Control" tells how to bring in distant stations clear and loud. Just drop a post card to

**UNITY MFG. CO.**  
224 North Halsted Street,  
CHICAGO, U. S. A.

The **MU-RAD TRIPLEX** **\$75**

**3-TUBE DRY CELL**

Write for Literature

**MU-RAD LABORATORIES, Inc.**  
801 Fifth Ave. Asbury Park, N. J.

## HUDSON-ROSS

**Largest exclusive Radio Jobbers in middle West.**

Write for discounts.

**123 W. Madison St. Chicago**

**BOSCH BATTERY**

The Bosch NoBattery is a device which enables anyone to obtain from an electric light socket perfect and ample plate voltage for radio vacuum tubes. It takes the place of all "B" batteries and is decidedly more efficient, reliable, convenient and economical—correspondence invited.

**AMER. BOSCH MAGNETO CORP., Springfield, Mass.**



"Now, and from now on," I declares. "I'm gonna hit a rattler for Chi. and a real bed."

It's two weeks later, and we're in Cleveland. There's a knock on our hotel room door, and I ain't much surprised to see The Master walk in.

"Well, how did things come out?" I asks, when we're alone.

"They didn't discover anything," says Jerry. "They had to close the station for a week, and during that time I had my attorney purchase the entire outfit, building and all, and present it to the city as a gift from 'a lover of bedtime stories'."

"Yeh?"

"During this interim I went back to painting, removed the wires, and as an added salve to my conscience, I finished decorating the building all alone."

"You're a wonder, Jerry," I states. "Say, you poor sap, why didn't you buy the station in the first place?"

The Master's face becomes first clouded with thought and then rained with perspiration.

"Honestly, Joe, I never thought of that! Ain't it a pity?"

### A Year's Work Below Forty Meters

(Continued from page 1895)

was wanted was a circuit which would allow the elements of the tube to be so connected that they were at nearly the potential of the filament with sufficient voltage for proper operation. To find such a circuit, use was made of a dummy antenna system, low power and safe voltages. The circuit finally evolved met all these desirable conditions and is shown in Fig. 3. It will be seen that the grid and plate are so connected that their potential is but little more than zero. The circuit being so proportioned that sufficient voltage is procured for the proper operation of the tube. The circuit adapts itself to either capacity or inductive coupling. In the former case the size of the antenna has very little to do with its operation other than that there must be not more than one-half wave-length spacing between the far ends or open ends of the radiation system for proper electro-static coupling. The radiating system being one condenser of the whole circuit, it can be nearly any length, experiments up to 80 feet long for the antenna and 65 feet long for the counterpoise having given excellent results on 20 meters, it merely being necessary to proportion the antenna and counterpoise so that they would have the same capacity to earth, and being

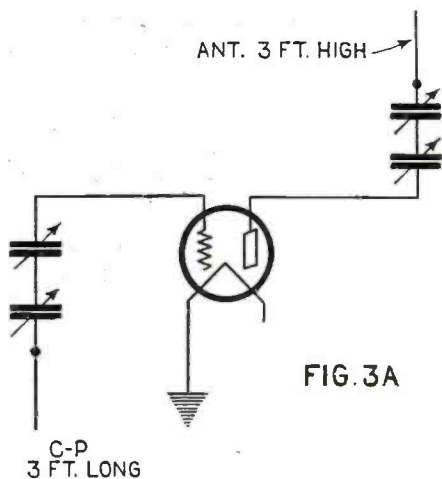
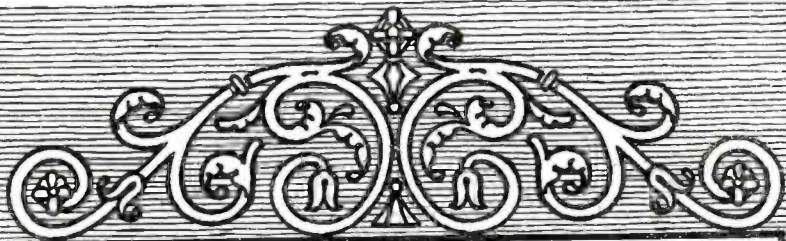
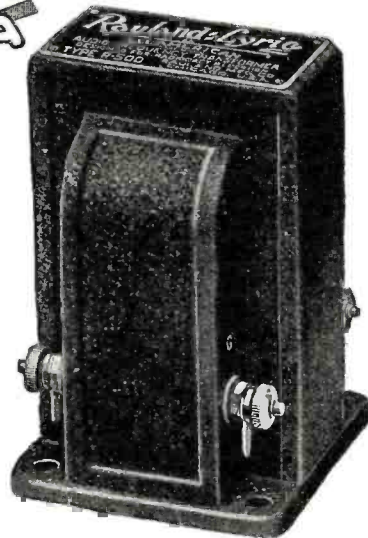

FIG. 3A

The arrangement as used for less than 15 meters. The dimensions for antenna and c-p given is for 4 meters.



MEMBER  
**RMA**



## Radio Music for the Critical

Music lovers find an especial delight in Rauland-Lyric. Used in all audio stages of a radio receiver, it reproduces with fidelity those elusive refinements of tone quality which, to the trained ear, mean artistic excellence.

Rauland-Lyric is a laboratory-grade audio transformer designed especially for music lovers. The price is nine dollars. Descriptive circular with amplification curve will be mailed on request. All-American Radio Corporation, 2646 Coyne Street, Chicago.

**Rauland-Lyric**  
AN

**ALL-AMERICAN**  
TRADE MARK  
**TRANSFORMER**

*The Choice of Noted Music Critics*





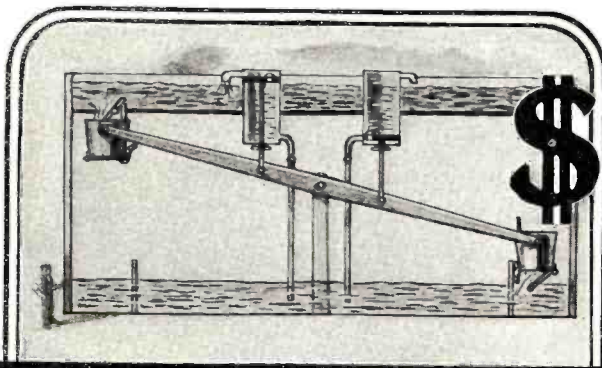

**\$5,000.00**  
*for*

# PERPETUAL MOTION

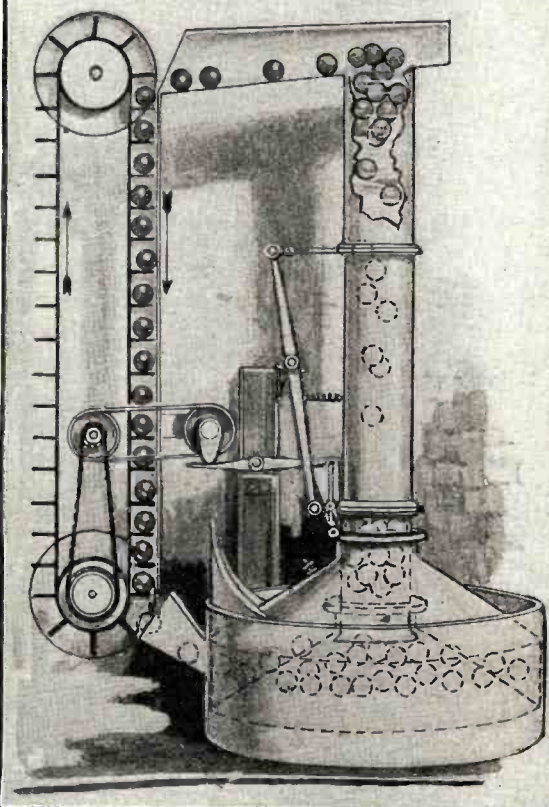
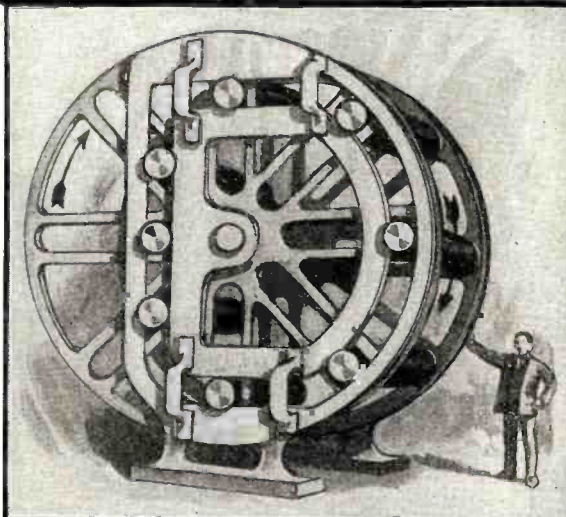

A few of the so-called Perpetual Motion Machines that have fooled the public.

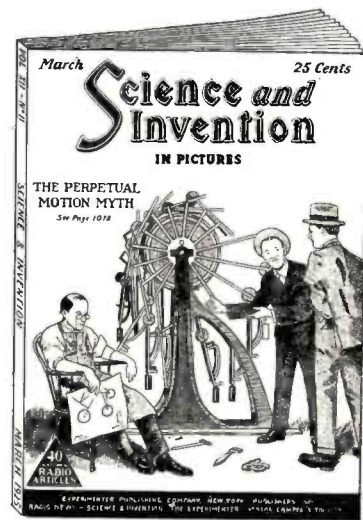

## Science and Invention

**Offers \$5,000 for demonstration of a practical perpetual motion machine.**

There is more swindle and fakery in the field of developing a Perpetual Motion machine than in practically any other branch of Scientific endeavor.

Many so-called perpetual motion machines have been designed and developed. Thousands of ingenious machines have been made and thousands of people have invested money, yet not one machine has been successful.

SCIENCE AND INVENTION tells all about these, so called, perpetual motion machines in its March issue and offers \$5,000 to any man who will demonstrate a successful machine.

**ON SALE AT ALL NEWSSTANDS**

**25c. the Copy**

**Experimenter Publishing Co., Inc.**  
53 Park Place New York City



separated at the open or far end not more than one-half wave-length to obtain the proper electrostatic coupling. The radiating system in this case is merely a capacity, the size of which has little effect on the wave-length of the transmitter as long as it is connected to the transmitter by a minimum capacity coupling which is not to exceed 100 MMF. If more capacity is used, the antenna system will tend to alter the frequency at which the tube circuit was oscillating; this is made use of when it is desired to shift from 40 meters to the 75-meter band, it only being necessary to shift the value of the antenna and counterpoise condensers from the 50 MMF. value to 500 MMF., no other ad-

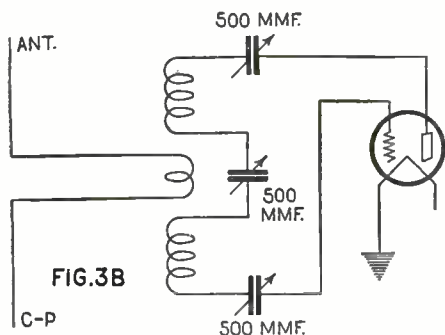

FIG. 3B  
An excellent circuit for short wave work employing inductive coupling.

justments being necessary. The antenna current is practically the same for any wave-length, if the input is kept constant, provided that the antenna system used has a fundamental frequency greater than the highest wave-length that is to be used. That is, the radiating system should have a fundamental period above 80 meters, if the highest wave to be used is nearly that. If a radiating system is used, the period of which is less than the wave-length it is desired to use, the antenna current will differ with the different wave-lengths when the input remains constant.

The inductances used in the circuit can be cut from the standard RCA inductance, two sections of five turns each being suitable for the 20-meter band and two sections of 10 turns each being suitable for the 40- and

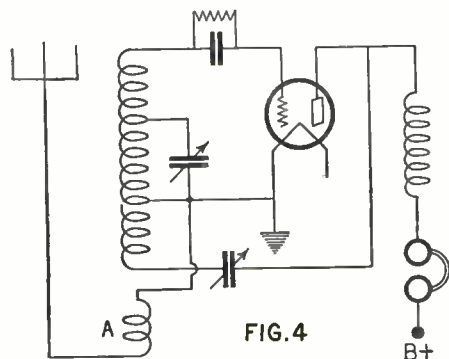

FIG. 4  
The short wave receiving circuit. The manner in which coil A is connected increases selectivity. This coil, in the improved Reinartz circuit, was the antenna detuning coil and in this case is used to couple the antenna to the tuner.

75-meter band. When it is desired to operate lower than 15 meters, the two 15-turn coils are removed entirely and the clips which were connected to the coils are connected to each other. A shorter antenna system is then desirable, as the radiating system is then in control of the frequency at which the tube will oscillate, there being no local circuit to determine the frequency, as the grid of the tube is connected by a short lead to the counterpoise series condenser and from that directly to the counterpoise. Also, the plate of the tube is connected by a short lead directly to the plate blocking condenser

# Surprising!... the improvement this discovery can make in your radio set

IN the electrical laboratory of a leading engineering university, a test has just been made which reveals some striking facts about sockets.

Out of 13 different makes of sockets, 12 showed losses higher than a good low loss condenser. Of these 13, only one—Na-Ald Sockets—showed losses lower than a good low loss condenser.

This means that many sockets are of such poor dielectric or insulating material that they nullify the efficiency of a good condenser. Na-Ald Sockets (of genuine Bakelite *Alden-processed*) have the qualities that enable a condenser to function efficiently.

The laboratory test also showed that Na-Ald Sockets have the lowest capacity of *any* socket. This is particularly important for short wave-length reception.

Also most important is the "Clean-easy" feature of Na-Ald DeLuxe Sockets. You simply turn the tubes several times and the tube terminals become bright and clean. The side-scraping contact (not merely side pressure) removes the film of corrosion that hinders the delicate minute current; this corrosion so often is the cause of disturbing noises in your set.

Use Na-Ald Sockets not only in the set you build but also install them in the set you buy, if not already adopted by the manufacturer. Sockets for all tubes. DeLuxe 75c; others 35c, 50c, 75c.

ALDEN MANUFACTURING COMPANY,  
Also manufacturers of the famous Na-Ald Dials  
Dept. K5, Willow St., Springfield, Mass.

*It's the Contact that Counts*

Send for free booklet and story of laboratory test.

Mail coupon for full particulars of the laboratory test; also free booklet "What to Build," giving tested, selected circuits.

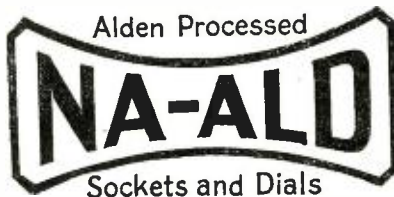

ALDEN MANUFACTURING CO.,  
Dept. K5, Willow St., Springfield, Mass.  
Please send me free booklet, "What to Build," and details of laboratory test.

Name .....

Address .....



**Wire Your Set With  
"CELATSITE"  
(Spaghetti Wire)**

**5 Colors**

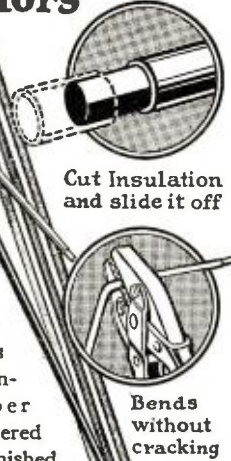

Cut Insulation  
and slide it off

Bends  
without  
cracking

You can't beat this for a neat job. It is No. 14 tinned copper wire covered with a varnished insulation in 5 beautiful colors. Looks like "spaghetti" but is smaller and goes into narrower places. It bends without cracking and strips like the bark on a whistle! Highly dielectric; thoroughly moisture proof. Sold by dealers in 30 inch lengths. Send for

Free Folder Telling  
HOW TO SOLDER

This folder also describes Acme "Celatsite", Spaghetti, and Stranded Enamel Antenna.

**THE ACME WIRE COMPANY**  
Dept. N. New Haven, Conn.

**ACME  
WIRE**  
Makes Better Sets

**INSULATORS**  
Weather, Storm and Water Proof

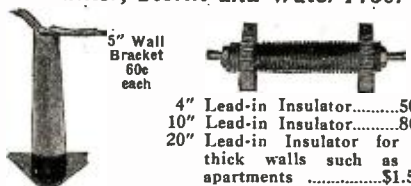

5" Wall Bracket 60c each

4" Lead-in Insulator.....50c  
10" Lead-in Insulator.....80c  
20" Lead-in Insulator for thick walls such as apartments .....\$1.50

**The M. & M. Co., Cleveland, Ohio**

**YOU GET WONDERFUL DISTANCE**

Marvelous Selectivity, Beautiful Tone and Tremendous Volume if you use in your set the NEW

**LOW LOSS TUN-A-FAR COIL**

The New Radio Wonder for One Knob Reflex or Radio Frequency.

TUN-A-FAR No. 1 \$1.25, No. 2 \$1.50

**FREE** Diagram for One Knob Hook-up with Each Coil.



A. H. WAAGE 6 Reade St., New York, N. Y.

and from that by a short lead to the antenna series condenser and from that directly to the antenna. The 4-meter band can be reached very readily when the antenna is a 3-foot vertical copper tube and the counterpoise is of the same length downward.

To use the circuit as an inductively coupled circuit it is only necessary to substitute a variable condenser for the antenna and counterpoise, and coupling the radiating system to the oscillatory circuit, as shown in 3-B.

The receiver used in all this work has been the one described by the writer in the June, 1924, issue of RADIO NEWS, with the change shown in Fig. 4. The writer wishes to thank all those who have written him of the good performance of the receiver described in the June issue, and hopes it will continue to perform to the satisfaction of everyone.

### Hints on Aerial and Ground Installation

(Continued from page 1898)

be placed in a slanting position so that water can readily run off. This bushing should slant upward to the inside of the building. The lead-in should be equipped with a lightning arrester or a lightning switch that is of the approved type. A lightning arrester should be selected which will operate at 500 volts or less. The lightning arrester should be placed either inside of the dwelling or outside, according to the building code of your particular location.

If a lightning switch is used, it should be of such type that it will withstand 600 volts or more at a current of 25 amperes or more. Should it be desired to mount the lightning switch outside of the building, it should be mounted on insulating supports that will keep the switch at least four inches away from the building. If fuses are used, do not place them through the protective device to the ground. The wire can be bare or insulated and may be of solid copper or solid-clad steel. Do not use a ground wire smaller than No. 14 gauge. Run the ground wire in as straight a line as possible from the protective device to a good permanent ground. Preference should be given to water piping for the ground connection. If the radio set is to be installed in a building with a grounded steel framework, the ground can be made to the steel frame.

T. Z. Muts.

### Tuning Your Radio Set

(Continued from page 1890)

tion control E may be advanced to maximum volume. Now, if interference is found, or, in other words, if two stations can be heard at the same time, the coupling C is loosened, that is, the dial is turned toward zero. Slight readjustments of the condenser A and possibly of the unit tap or fine tuning switch D will then bring in the desired station at the greatest volume possible and, in most cases, cut out the interfering station. If not, further loosening of the coupling C and readjustment of the tuning controls will undoubtedly perform the work desired. After all readjustments are made satisfactorily, it may be possible to bring in the station slightly louder by advancing the regeneration control E to just below the point where distortion takes place.

#### SINGLE-CONTROL RECEIVERS

Of late, the American market has been flooded with many different types of single-control receivers, some of them characteristically good and others on the contrary, of

**Red Devil Tools Better Made**

## The Handiest Tool for Radio

With this handy "Red Devil" Slip Joint Plier, you can make practically every repair and adjustment. Forged from steel; beautifully nickel plated. Style 1024, 6½ inches long. Ask for it at your dealers. If not in stock, send \$1 and dealer's name.



Mechanic's tool booklet free.

**Smith & Hemenway Company, Inc.**

Manufacturers of "Red Devil" Tools

273 Broadway  
New York, N. Y.

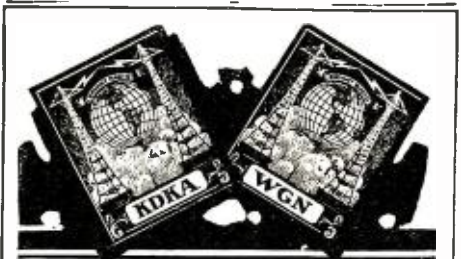

## New Way to Get Radio Stamps

Here is an amazing easy way for you to have one of the popular Radio Stamp Albums. I will send you free, engraved stamps for any radio broadcasting station your set has received, up to 50. Then I will furnish you additional stamps for any station you wish at the rate of 10 stamps for 25c, 50 stamps for 75c, 25 for 50c, and 100 stamps for \$1.00. This is my offer to those who send for the new Bryant Stamp Album, which is substantially bound with heavy cloth back cover attractively printed in two colors. This means an easier way for you to keep the stamp record of all stations you receive on your set, without the delay and expense of sending to each station for its stamp. And this album furnishes you a permanent record, with log, dial stations, wave lengths, dates, cities, etc. Get your album and stamps today and start your radio stamp collection. Simply give me the list of stations whose stamps you want. Send \$1.75 with your name and address. Your money back if you are not more than satisfied.

**P. M. BRYANT**  
Dept. 14 366 Wrigley Bldg.  
Chicago, Illinois

**Best for Reflex**



and Crystal Sets  
**FRESHMAN**  
Double Adjustable  
Crystal Detector

No more searching for the sensitive spot. —Merely turn the knob as you would a dial.

For base or panel mounting, complete with Freshman Super - Crystal

**\$1.50**

At your dealer's, otherwise send purchase price and you will be supplied postpaid.

CHAS. FRESHMAN CO., Inc.  
240 West 40th St., New York



little value. The main trouble with single control receivers is that selective tuning is almost an impossibility with the majority of them. In other words, if you live in a congested district where many broadcast stations are located and you obtain one of these unselective single-control receivers, you may have considerable trouble in trying to tune out various stations and bring in the one that you desire. However, in order to have this article all inclusive, the writer has chosen the very best of the many single control receivers on the market today for his description. This receiver is illustrated in Fig. 8. In this particular type, the control of the filaments is entirely automatic. You need not turn any rheostats whatsoever as all you have to do is turn on the filament switch located in the lower left-hand corner of the center panel. Tuning is then accomplished by slowly rotating the large dial A until a signal is heard. When this dial is set at the point where the station comes in the very best, the small knob B directly below it is rotated one way or the other and will usually be found to bring in the signal somewhat louder. Thus you can see that the tuning is extremely simple.

In the particular type of set illustrated herewith, the batteries and loud speaker are all contained within the cabinet. The only necessary outside accessories are the aerial and ground which are connected to conveniently located binding posts. The loud speaker horn is located directly behind one of the side panels and the sound issues through a strip of cloth. Since the entire set is self-contained, it is one that will surely please the broadcast listener. Combine this feature with ease of tuning and we have almost reached the ultimate in simplicity in radio receivers.

**LOOP RECEIVERS**

In a good many instances, people are so located that it becomes impossible for them to erect an antenna of any kind whatsoever or to install a ground connection. For these people and for those who are constantly on the move, loop receivers of the type illustrated in Fig. 9 are greatly to be desired. Furthermore, they are comparatively simple to operate and everything considered are very efficient and give excellent results.

A set such as illustrated in Fig. 9 is operated in the following manner. The tubes are turned on by means of rheostats and the control A rotated slowly. If the set starts to squeal, the control B, or potentiometer, is turned one way or the other, until the squealing just stops. This control is variously labeled stabilizer, volume control or potentiometer, according to the whims of the manufacturer. It is, however, regardless of its name, always set at a point just below the point where the set starts to squeal. If after turning the dial no signals are heard, the loop is rotated about one-eighth of a 360-degree circle and the tuning control again turned. This process is kept up until a signal is heard. If, however, you know the location of the particular station you want to receive, in reference to your position, you can point either one end or the other of the loop directly toward the station and then proceed with the tuning, knowing that if the station is in operation, you will be able to hear it without again adjusting the loop. This procedure is carried through for the reception of any or all stations.

**NEUTRODYNES**

Since the discovery of the neutralization principle by Professor Hazeltine, many sets embodying that principle have appeared on the market, and of late several different types of five-tube receivers, very similar in appearance to Neutrodynes, but not embodying the principle of neutralization, have been manufactured. In any event, the tuning of these sets is approximately the same. The fila-

# Here's a peculiar fact about radio insulation

**E**XPERIENCE has shown that best results in radio come with the use of material and apparatus designed especially for radio's peculiar demands. This is particularly true of insulating material. Radio reception deals with very weak currents at very high frequencies. Conditions are quite different from direct and alternating current use where ordinary insulating material is satisfactory. Radion IS a special material, developed to order by our engineers to meet the needs of radio. For

radio frequency insulation its characteristics are highest, as shown by authoritative laboratory tests.

The use of the most efficient insulation material is important not only for panels, but also for dials, sockets, knobs, binding post panels, rotors, stators, spaghetti tubes, etc. In all these there is a Radion product of the right type and size for your set. Radion is also used by leading set manufacturers who appreciate the superiority of "the supreme insulation."



*Surface leakage very low with Radion Panels*

**T**HE high-polished, satiny like finish of Radion Panels has a double value. It adds to the appearance of any set. It prevents moisture from gathering to form leakage paths and cause leakage noise. Surface leakage and dielectric absorption are shown to be exceptionally low.

Radion Panels resist warping. They are easy to cut, drill and saw. They do not chip. No special tools needed. Eighteen stock sizes, two kinds, Black and Mahoganite.

**AMERICAN HARD RUBBER COMPANY**

COMPANY

Dept. A4,

11 Mercer St., New York City

Chicago Office: Conway Building

Pacific Coast Agent: Goodyear Rubber Co., San Francisco—Portland

# RADION

*The Supreme Insulation*

Made to order for radio purposes exclusively



*Radion Dials help to keep down losses*

**R**ADION Dials on Radion Panels form the ideal mounting—they match perfectly. In design, quality and high-finish these Dials are exceptional. They are moulded with knob and dial plate in one piece with strong metal insert. Condensers and other radio instruments equipped with Radion dials show lower losses than those operated with dials of other materials. All standard sizes.



*Radion Sockets eliminate capacity effects*

**T**HE utmost protection against leaks and losses is provided by Sockets made of Radion—V-T Socket, Improved Type, Threaded metal bushings moulded in the socket insure positive contact between terminal points. The Radion collar with strong bayonet lock eliminates the capacity effects that may occur when metal collars are used.

*Mail coupon for Booklet, "Building Your Own Set"*

**AMERICAN HARD RUBBER COMPANY**  
Dept. A4, 11 Mercer St., New York City

Please send me your new booklet, "Building Your Own Set," giving wiring diagrams, front and rear views, showing a new set with slanting panel, sets with the new Radion built-in horn, lists of parts and directions for building the most popular circuits. I enclose 10 cents.

Name .....

Address .....



# Visco Dial



A dial operating on a NEW PRINCIPLE. NO GEARS, hence NO BACK LASH.

Both the quick and the precise adjustment without changing the grip or changing gears (there being no gears). A moderate pressure will turn the dial quickly to any desired position and with a light pressure it will creep without jerk or jar precisely to a hair line adjustment. Always ready.

Helps to steady condensers with loose bearings.

## Efficient, Practical and Cheap

To install, it is only necessary to take off the old dial and put on the new.

Genuine Bakelite, 3/4 inches in diameter, fits 1/4 inch shaft.

If after 10 days' trial you are not satisfied, return the dial and we will return the purchase price. Send for details.

Patented

Price \$1.00 Postpaid

**The Monosmith Brothers Company**

Spencer - - - - Ohio

## TUBES REPAIRED

Only middle west tube service station  
8 hour service. No extra charge for broken glass.

WD-11, WD-12, C-11,  
C-12  
UV-201, C-301  
UV-201-A, C-301-A,  
UV-199, C-299  
All styles DeForest  
UV-200, C-300

**\$2.25**

Discounts in quantities of six or more. May be had in assorted styles. We pay the postage.

Write for bulletin of other products.

**Dey's Radio Service**

Dept. 15, 5947 Superior St. Chicago, Ill.

Insure your copy reaching you each month. Subscribe to RADIO NEWS—\$2.50 a year. Experimenter Publishing Co., 53 Park Pl., N.Y.C.

ments of the five tubes are heated in the usual manner and then all three dials of the set placed at approximately the same position. A Neutrodyne receiver is illustrated in Fig. 10. Dials B and C will be found to have the most critical adjustment. The adjustment of A is rather coarse, although it should always be kept within five or six degrees of the settings of the dials B and C. Using both hands, slowly rotate B and C through about five degrees. Then bring up dial A to the same setting and repeat the process with B and C. In this way you will cover the entire range of the receiver and will locate any stations operating within the range of the set.

### SUPER-HETERODYNE RECEIVERS

Although the average Super-Heterodyne receiver employing seven or more tubes is somewhat too complicated for the beginner who has no knowledge of radio, still there are sets embodying the Super-Heterodyne principle that can very easily be operated by even the veriest tyro. One set is illustrated in Fig. 11. Here there are only two real tuning controls indicated by A and B. The indicators on the dials are controlled by the knobs located directly below. The tubes are lighted on this set by pulling a switch whereupon the filament current may be controlled, by means of knobs C and D. Then the two knobs A and B may be rotated, keeping the settings of the pointers at approximately the same points on the two scales. With a set of this nature, the settings for various stations may be written directly on the dials as shown in the illustration herewith. In this way, any particular station may be tuned in whenever desired.

### LOGGING A SET

After you have learned to tune your radio set, you will want to be able to tune in any particular station within your range at any desired time. This can be accomplished by making a record of the dial settings on the set when the dials are turned to the positions where the station comes in loudest. A list of these dial settings for various stations will enable you to tune those stations in very quickly without having to hunt for the correct settings. Charts often accompany manufactured sets on which these dial readings may be recorded. However, you can easily make one of these charts yourself or the readings may be merely jotted down in a notebook that is kept close to the radio set. Some sets are equipped with dials on which the call letters of stations may be written right below the settings for those stations. One notable example of this is shown in Fig. 11.

### GENERAL RULES

Before leaving the subject of tuning a radio receiving set, let us lay down a few general rules.

In the tuning of regenerative sets, regardless of their type or construction, never advance the regeneration control to a point where the set starts to squeal. This causes radiation that creates interference with your neighbor's set.

If you use a crystal receiving set, always keep the crystal itself clean and free from dust and dirt. Never touch it with your fingers, but always handle it with a pair of pliers or tweezers. Also keep the tip of the cat whisker clean at all times.

With vacuum tube sets, always burn all of the tubes at the lowest possible temperature conducive to good results. Such a procedure will lengthen the life of the tubes to a very great extent and will reduce the drain on your pocketbook.

If you start to tune your radio set and find that you cannot obtain any signals from any stations whatsoever, first see that your tube or tubes are lighted. If not, refer to the article in this department in the February issue. Here you will find complete in-

## ARROW BATTERY SLASHES Prices

Prices Smashed! Quality Not Sacrificed

TO CONSUMERS ONLY

Here is real battery quality, guaranteed to you, at prices that will astound the entire battery-buying public. Order direct from factory. Put the Dealer's Profit in your own pocket. You actually save much more than half, and so that you can be convinced of true quality and performance, we give a

**Written Two-Year Guarantee**

Here is your protection! No need to take a chance. Our battery is right—and the price is the lowest ever made. Convince yourself. Read the prices!

Special 2-Volt Radio Storage Battery, \$3.75  
Special 4-Volt Radio Storage Battery, 6.00  
6-Volt, 50 Amp. Radio Storage Battery, 7.00  
6-Volt, 80 Amp. Radio Storage Battery, 8.00  
6-Volt, 100 Amp. Radio Storage Battery, 9.50  
6-Volt, 120 Amp. Radio Storage Battery, 11.50  
6-Volt, 140 Amp. Radio Storage Battery, 13.00



We ask for no deposit. Simply send name and address and style wanted. Battery will be shipped the day we receive your order Express C. O. D., subject to your examination on arrival. Our guarantee accompanies each battery. We allow 6% discount for cash in full with order. You cannot lose! Act quick. Send your order today—NOW.

**Arrow Battery Co.**  
1215 South Wabash Ave.  
Dept. 6 Chicago, Ill.

## The most distant stations are heard

With Myers Tubes you can get virtually every station on this continent and elsewhere. England, France, Cuba, Hawaii, Porto Rico, Japan are being heard daily with one, two or three Myers Tubes.

They are noise free—locate stations easily—clear reception—and are interchangeable. Each Myers Tube passes 49 separate and individual tests. Each is actually tested for reception. Three types for dry and storage batteries. All ready to mount. At your dealer's or sent postpaid for.....

**\$4**

250 Craig Street, Montreal 10

## Myers Tubes

Practically Unbreakable



"The World On Your Dial"

Write for descriptive circular

## PERSONAL STATIONERY

200 SHEETS and 100 ENVELOPES **\$1.00**

Printed with your Name and Address  
Clear, white bond paper, with envelopes to match. Your name and address printed in beautiful, rich blue ink on both paper and envelopes, and sent to you postpaid for only \$1.00. (West of Mississippi river and outside of U. S. \$1.10.) If inconvenient to send the money, we will ship C. O. D. Money returned if you are not more than satisfied. Order today. Write name and address plainly.

**AGENTS MAKE BIG MONEY** taking orders us today for our agent's proposition. for us. Write

**ELITE STATIONERY COMPANY**  
7056 Main Street Smethport, Pa.

## BODINE BASKET-WEAVE LOOP AERIAL

Gives winter reception with no reduction in distance. Folding Loop. Ask your dealer.  
**BODINE ELECTRIC CO.**  
2250 West Ohio Street Chicago, Ill.



structions on how to proceed when your set stops working.

**NOTICE**

In the above-mentioned article, the writer made the following statement:

"If you have one of the carbon compression types of rheostats, illustrated in Fig. 7, there are one or two points to look for trouble here. The porcelain container indicated by A may have cracked and allowed moisture to get in the carbon content, in which case the discs or the grains may be sticking and the rheostat may not be making good contact."

This statement may have led some readers to form erroneous impressions. The writer has recently been in communication with the manufacturer of a well-known carbon pile type of compression rheostat. They state that several of their products when under test were allowed to remain out in the air under cover during a long rain storm. The resistance of the instruments before and after this test was measured and was found to differ only very slightly. The engineers making the tests were quite satisfied that such a small difference would have no effect whatsoever on the operation of radio receiving sets and that this particular carbon pile type of instrument would give excellent results under all conceivable operating conditions.

**Matching Tubes for Super-Heterodynes**

(Continued from page 1899)

gested that all tubes now be marked with relation to their oscillatory powers.

Now remove the tube from the oscillator socket and insert it in the following socket. Tapping the tube should produce a ringing

sound in the phones, as before. Make this test in the next two sockets, and if response is had in all three sockets of the intermediate stages, it is easy proof that the plate circuits in each are complete. Note: There should be only one tube in the set at any one time.

We shall now start to work from the other end. Take the phones out of the "B" battery circuit and connect all batteries to the set properly.

**THE DETECTOR**

Insert the telephones in the plate circuit of the second detector, usually by plugging them in the detector jack. If no jack is available, put them across the primary of the first audio transformer. It is inadvisable to use the audio frequency amplification at this time, as any trouble with it would complicate matters. Insert a tube in the second detector socket, after seeing no other tubes are in the set. On tapping as before, a slight ringing sound should be heard. Take one of the tubes which oscillated and insert it in the socket preceding the second detector, i.e., the last stage of intermediate frequency amplification. Slowly turn the potentiometer meanwhile listening with the phones, and tap the grid terminal of this last stage of intermediate amplification. A position of the potentiometer should be found which will give clicks of greatly increased volume when the grid connection is tapped. Careful note should be made of the setting of the potentiometer where this condition appears. This is very important, as it notes the point at which the tube goes into oscillation.

Now remove the tube preceding the detector, and insert another, and repeat the test. It is quite possible that it will begin to oscillate at a slightly different setting for the potentiometer. Of the tubes available, three should be chosen which go into oscillation at precisely the same point on



**RADIO PANELS TUBES and RODS**

Write today for new price list on 3384 sizes and kinds of FORMICA radio panels, 126 sizes of tubing, 21 sizes of round rod.

We ship plain panels cut accurately to any size same day order is received.

**LET US DRILL and ENGRAVE YOUR PANEL**

Send blueprint or rough sketch for estimate. Work beautifully done by automatic machinery.

**STARRETT MFG. CO.**

521 South Green St., Chicago, Ill.

**The Carborundum Crystal Detector**

**M**ONTHS of exhaustive research brings this remarkable Carborundum Crystal Detector Unit to the radio world. A specially made, carefully selected Carborundum Crystal, set in a protective cartridge.

Permanently fixed to retain its sensitivity indefinitely—it will not burn out.

Sharpens the tuning—increases the selectivity of any crystal or reflex set—and no booster battery is needed.

It gives results never before attained by any other crystal detector.

Every Carborundum Crystal Detector Unit is laboratory tested and is guaranteed for any properly designed circuit.

MANUFACTURED ONLY BY  
**THE CARBORUNDUM COMPANY**  
NIAGARA FALLS, N. Y.

\$ **1.50**



From your dealer or post-paid direct



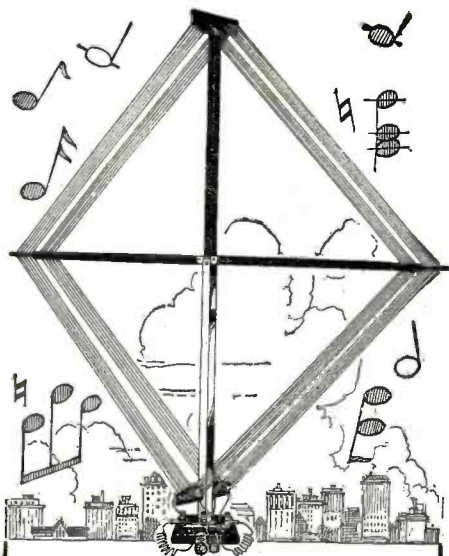

## It Brings 'Em In!

The "Signola" Portable Loop Aerial brings in "with a bang" stations far and wide—not just the powerful nearby stations, but many that you have never been able to hear on the average loop aerial. It is efficient enough for the hardest conditions; convenient enough for every occasion; beautiful enough to match the finest receiving set. The

# "SIGNOLA"

## Portable Loop Aerial

is wound with 110 feet of silk covered wire—flexible and non-kinkable. The genuine Formica spreaders entirely insulate windings from frame. Folds like an umbrella; wood parts are hand rubbed, dark mahogany finish; metal parts are polished nickel plated. It's a REAL radio accessory—and it looks it.

### Worth Its Price and More

A single glance and a few minutes use will prove this. The "Signola" Portable Loop Aerial costs you \$3.50—slightly more west of Denver and in Canada. Examine a "Signola" at your dealer's. If he hasn't stocked it yet, write to us, sending his name and address. You ought to have a copy of our latest illustrated book "Signal Sense" so write us anyway.

### SIGNAL ELECTRIC MFG. CO.

Menominee, Michigan

Branches In All Principal Cities

TUNE IN! Our Station KFLB, 247 Meters  
Wednesday and Saturday 8 P.M. to 10  
P.M. Central Standard Time.



EUREKA "B" Batteries are efficient, powerful and economical. Have long life; will minimize your battery costs and improve reception.

### GUARANTEED LONG LIFE

Specially Designed to Eliminate Unwanted Noises



Ask your dealer or write for name of nearest distributor.

JOBBERS and DEALERS Write for Proposition

EUREKA BATTERY CO., Inc.  
101 Wooster St. New York City

the potentiometer, as these three tubes will have to be controlled in a unit. If they go into oscillation at different points, it is evident that one will be at the point of oscillation before the other two, and if attempts are made to bring the other two up to the sensitive point, which is just below oscillation, the process will force the first tube into oscillation, and spoil reception. Therefore, all care possible should be taken to see that three tubes will work together. These three tubes control the amplification available in the set, and if one tube should lag behind in reaching this sensitive spot just below oscillation, the amplification obtained from this stage would be negligible.

Insert the three matched tubes into the intermediate frequency amplifier sockets and check over whether they are working together by the following test (the second detector is being used, of course): Place the potentiometer in a non-oscillating position, and touch each grid in turn to see if any one is oscillating. If none oscillate, carefully advance the potentiometer a little at a time, and continue to tap each grid in succession. If the constants of the circuit of any tube are different from the others, it will either go into oscillation before the others, or behind them. The tubes which oscillate at any given moment are told by the loud click in the phones when tapping the grid. Now, by careful adjustment of the potentiometer at the point where oscillation first occurs, try to get one tube oscillating when the others are not, and also try to get two oscillating when the other is not. If no such condition can be obtained, the tubes are perfectly matched. If, however, one tube leads the other two into oscillation, or lags behind, try all tubes available in this socket, until a tube is found which will go into oscillation at exactly the same point as the other two. The intermediate frequency is now in its best position, and we can turn our attention to the other positions.

The oscillator socket is next filled with any tube which passed the initial test for oscillation. The two detectors sometimes may be poorer tubes and the requirements for the audio frequency are too familiar to discuss. The set should now work upon the insertion of the first detector.

From the above it will easily be seen that out of eight tubes, it will be easy to pick three which work together, and in case one burns out, it will be a simple matter to run through the tests again, and the set will be in good working order. The advice on trouble shooting is of course quite incomplete, being outside the scope of this article.

Besides the small amount of apparatus required, the system will be found to have a distinct advantage over the method of placing tubes in the set by the relation of their mutual conductance, as frequently the circuit constants are different for each stage of intermediate frequency amplification due to the coupling of the connections, variation in coils, etc., for which no provision is made when three identical tubes are chosen to work together. In the method described full allowance is made for this condition.

It might be mentioned that the above system has been used for some time by the writer, and was in every case successful.

### HOT AIR

*Prof*—Explain how the orator, Patrick Henry, discovered the choke coil.

*Student*—Well, sir, the core of his orations wrapped each potential audience in turn with the thread of his emissions. They choked with emotion.

*Prof*—That's hot air.

*Student*—So are orations.

—Contributed by Jack Bront.

# VOLUME

IF you want volume without distortion use Supertran Audio Transformers. They are shielded, assuring absolute protection against damage to the coil while mounting

**\$6 AT ALL DEALERS**  
DISTRIBUTED BY

Phillip Chandler & Co., Boston, Mass.  
L. W. Cleveland & Co., Portland, Me.  
Gray Sales Co., Philadelphia, Pa.  
Waite Auto Supply Co., Providence, R. I.  
The Beckley-Ralston Co., Chicago  
Coast Radio Supply Co., San Francisco  
Radio Ltd., Montreal, Canada  
**FORD MICA CO., INC.**  
33 E. 8th St. New York

## AUDIO TRANSFORMER

## Radio Builders! write for this free booklet—

Tells why over 45 leading set manufacturers use Pacent Radio Essentials in their sets—

Why these essentials insure better reception and greater efficiency for your radio set—

Describes the complete Pacent line.

It's free. Simply dash off a card or note.

PACENT ELECTRIC COMPANY, Inc.  
91 Seventh Avenue,  
New York City

San Francisco  
Washington  
Minneapolis  
Birmingham  
Philadelphia  
Jacksonville  
Boston  
Chicago  
St. Louis  
Buffalo  
Detroit



Canadian Licensees:  
R. H. White Radio Co., Hamilton, Ont.

DONT IMPROVISE — PACENTIZE

**SUPER-HETERODYNE**  
Ultradyn—Haynes Griffin—Remler  
Dealers: Send for Discounts  
**HUDSON-ROSS**  
123 W. Madison St. Chicago



## Commerce Department Shifting Wave-lengths

(Continued from page 1849)

as these stations, although divided by the breadth of the continent, now begin to interfere, whereas they did not do so with 500 watts.

During the recent tests with wave-lengths closer together, in an effort to create additional channels, many protests that the stations operating on adjacent channels could not be separated, were received. Except with very selective receivers, difficulty in separating stations only seven kilocycles apart was found. The fans objected to fine tuning.

On the other hand, this is the only known method of creating more channels. If the second scheme, requiring stations to divide time on given wave-lengths, were followed, only about half the stations could operate at once, and if wave channels were duplicated, there would be interference on practically every wave-length all the time, as at least two stations would be using the same channel simultaneously.

Considering these plans, it would appear that the first method is generally the best, but the problem of educating the fans to this belief remains to be accomplished before peace in the air is secured.

## Radio Liars

(Continued from page 1866)

seat-mate with a list of the stations he logged the night before. You no sooner get ready to open your mail when one of your clerks can be heard telling the book-keeper he got 2LO (London) last night on a single tube "Sinewaver." If this does not contribute to your mental lunacy, you have another blow coming when you go out to lunch. Nearly every chair in the one-arm joints holds a radio listener, ready on the slightest provocation to immerse you in a sea of radio chatter about his "Crystalena" on which he tuned in St. Louis.

### AT THE STORES

At the radio stores is the greatest crowd, for here they congregate each day after lunch and swap yarns. The "static room" of the old Marconi employment offices could not hold a candle to the vaporings a radio store crowd exudes. Even the clerks have become imbued with the spirit. He sees that "nothing succeeds like lying," all the copy book maxims to the contrary, notwithstanding. If the customer has stranded wire, it is no good because the signals get lost in its labyrinthine twists. Nothing will do but ribbon wire, which has a wider surface on which the signals can pass.

If the customer has a galena crystal—it is no good. A "Fool's Gold—guaranteed to get Elgin and Zion" is the only thing. If the poor purchaser has a condenser with a pigtail connection, he is told they are lopping them off at the stockyards, and that the friction contact is much better because you can hitch it to a motor and rotate it rapidly without twisting off the connections. Should you have a "Whatzis" set, you are politely informed it cannot compare with the "Gilhooy" which the dealer has on his counter with its polished panel and dials just begging someone to take it home.

The manufacturer, having been tipped off by the dealer, joins the clan. He hires a rapid fire ad. writer and starts spilling subterfuges right and left in the radio papers. For a while it looks like a beer war in Chicago, with people almost being shot for not buying the "Gilhooy" brand. Finally

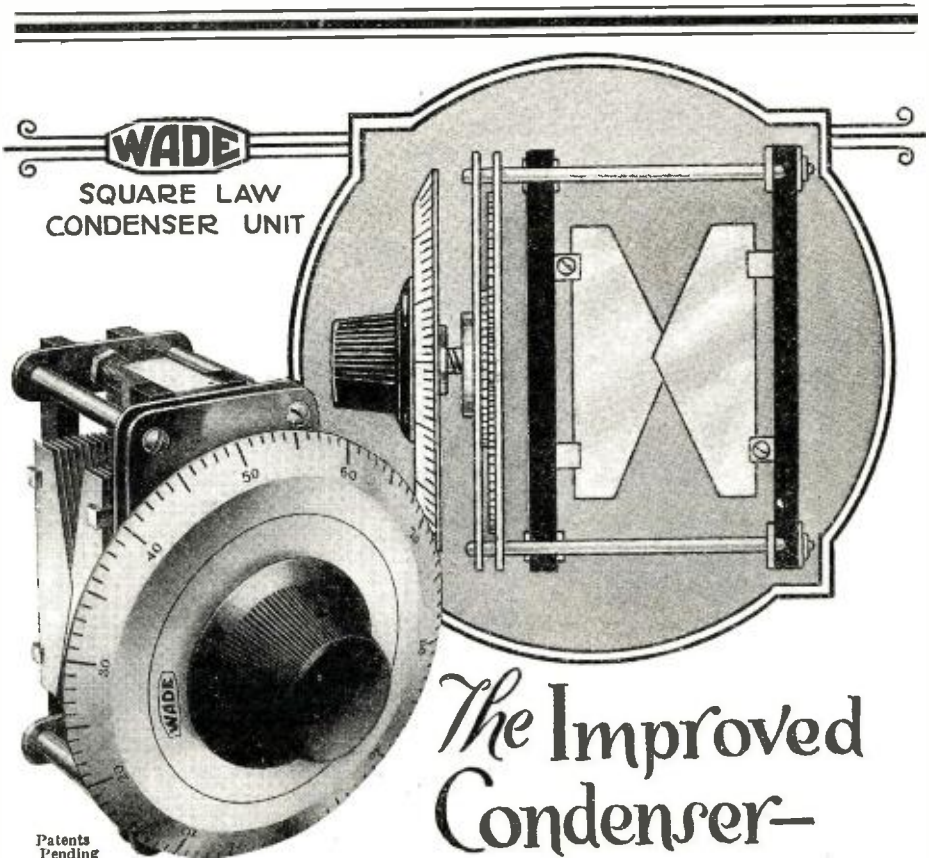

**WADE**  
SQUARE LAW  
CONDENSER UNIT

*The Improved  
Condenser—*

Patents Pending



All sizes, complete with 4-inch vernier dial, for:  
Short Wave, .000125 mfd. \$7.50

Tuned Radio Frequency .00025 mfd. \$7.75

Super-Heterodynes, .0005 mfd. \$8.00

Oscillators, Wavemeters, etc., .001 mfd. \$8.50

At your dealers, otherwise send us his name and purchase price and you will be supplied postpaid.

The Wade Square Law Condenser is revolutionary in condenser construction and offers many exclusive efficiency features.

**Square Law**—Angular cutting of plates gives perfect straight line wave-length curve—distributes the stations evenly over the dial.

**No Body Capacity**—Grounded frame insulated from both sets of plates shields the condenser from all body capacity effects—a vital feature, exclusively in WADE Condensers.

**Low Loss**—Laboratory tests show phase difference angle and dielectric absorption losses too low to be accurately measured.

**Low Minimum Capacity**—Pointed plates and open back construction give lower minimum capacity and wider tuning range than that of any other condenser on the market.

**Micrometer Dial**—Silvered, 4-inch, 16:1 ratio, 360 degree vernier dial, furnished with each WADE condenser, insures the finest possible tuning control.

**Constant Capacity Rating**—The capacity never changes, due to wearing of the bearings as in the ordinary rotary plate type.

*Manufacturers:—Double and triple condenser units with single vernier dial control, made to your specifications. Write for quotations.*

## WADE MANUFACTURING COMPANY, Inc.

1819-A Broadway

New York



Try this Test! Hook up a Diamond Battery and a battery of any other make. See which lasts the longer.

**DIAMOND** Radio

**"B" BATTERIES**  
DIAMOND ELECTRIC SPECIALTIES CORP.

103 South Orange Avenue, Newark, N. J.  
Dealers, Jobbers—Write for Proposition

**KEYSTONE VACUUM TUBES**



ALL TYPES \$3.00 GUARANTEED

Some Dealer Territory Still Open  
Unequaled for Clarity of Tone and Long Life.  
KEYSTONE ELECTRIC & RADIO COMPANY  
Cable Address: Keyras  
110-116 Nassau St. New York, N. Y.

Insure your copy reaching you each month. Subscribe to Radio News—\$2.50 a year  
Experimenter Publishing Co., 53 Park Place, N. Y. C.



# GEORGIA-The Empire State of the South

Georgia, the state of hidden beauties, is featured in the March issue of Motor Camper & Tourist. The tourist in Georgia obtains an education on the wonders of southern beauty that is unequalled anywhere in the southland.

Georgia has Atlanta, the Chicago of the south, Savannah on the sea, the famous battlefields of Lookout Mountain and Chicamauga, the

awe-inspiring sculpture on Stone Mountain in the beautiful Blue Ridge Mountains and last a thousand and one hidden spots of natural beauty and majesty that are waiting for the Motor Tourist.

When you take your car, near or far, read Motor Camper & Tourist. It's a complete, practical and useful guide to the selection of equipment, the selection of a route and the selection of good camps and camping comfort.

Owners: The Germott Pub. Co., Inc. Licensed Publishers: The Experimenter Pub. Co., Inc., 53 Park Place, N.Y

Sold on all Newsstands 25c the Copy

Subscriptions \$2.50 the Year

The image shows the cover of the March 1925 issue of 'Motor Camper & Tourist'. The cover art depicts a vintage car parked in front of a 'TOURIST CAMP WELCOME' archway. In the background, there are mountains, trees, and a building labeled 'OFFICE'. The magazine title 'MOTOR CAMPER & TOURIST' is prominently displayed in the center. The price '25 CENTS' is in the top right corner. The date 'MARCH 1925' appears in the top left and bottom left corners. On the left edge, 'VOL 1-Nº10' is written vertically. At the bottom of the cover, the publisher information reads: 'EXPERIMENTER PUBLISHING COMPANY NEW YORK RADIO NEWS SCIENCE & INVENTION - THE EXPERIMENT'.

RN4

Gentlemen: I am enclosing \$2.50 for one year's subscription to  
**MOTOR CAMPER & TOURIST.**

Name.....  
 Address.....  
 City.....State.....



through police intervention the thugs are run out of town and are now peaceably conducting throat cutting businesses in New York.

It did not take long for the idea to seep into the newspaper offices. Chaps who had run their legs off on the streets and were propped up against a desk to keep them from falling (the chaps, not the desks) and who knew radio like a book because they had seen a play on the stage with a radio in it, were inducted into office as radio editors. After journalistic experience the art of radio lying was easier than swiping the well-known bonbons from the adolescent.

**ON THE NEWSPAPERS**

The radio editor was wholly to blame for the radio engineer. Left to himself, this pest at best could have victimized only a few in his short existence. But the columns of the "Yelp" held forth such an alluring vista to the man who two months prior was delivering meat in a butcher wagon. (But is now a certified radio engineer after reading a few books and building two or three sets.)

Then would appear articles signed by the radio engineer in which a palpitating public is told "The Bozo," made from hook-ups appearing in the "Yelp," is the only set worth considering in these days of bluff and buncombe. Its merits are extolled to the skies and a Question and Answer column set up for the benefit of the nuts who follow the diagrams. Free advice to the radio-orn is always supplied in the Question and Answers. X. B. J., of Walla Walla, Wash., writes in to ask how his "Bloop" can be made to work. The next day the radio engineer wisely counsels as follows: "Throw it in Puget Sound and build a 'Bozo.'" Or maybe M. Y. B., of Sassafras, Tex., will gently inquire how he can prevent his loud speaker from squealing. The following day he is told: "Chloroform her."

Finally the germ invades the public schools, creating more havoc than the flu. Teachers, supervisors and pupils are bitten. Little Johnnie, aged 14, brings home a report card with zero in everything but radio. Musty attics are transformed into radio laboratories and countless Johnnies and Jimmies have started on their careers of fame. Football teams get flabby sitting in easy chairs before a loud speaker listening to Walter Krampf broadcasting on "Tackling, and where it is being done." Instead of recess, the kids glue receivers on their ears and listen to the noon quotations on hog on the hoof and goat on the horn.

At home, mothers and daughters listen to Mrs. Xenophon telling her audience, "You can do it better with—'Sudless soap.'" Meals are prepared by radio, and many eaten in the same manner. Fathers come home and raise aeriels higher so mother can tune in the afternoon tea-tasting session down at Kansas City. If your supper is late, it is so comforting to know the missus has been listening to such a charming talk that afternoon on "Blisters, and who causes them." If you are newly wed and your bride tells you Dr. Hazelcroft has invented a Neutrodyne circuit that completely neutralizes the static in the air, better not laugh at her if you value your life.

**IN POLITICS**

The politicians soon fell on the radio as a means to spreading their fables. Last election we nightly heard gentlemen of various political hues telling us how sick Uncle Sam was and which doctor to call in. Even the artists on the radio programs began telling how much money they received for broadcasting. Our whole social fabric is being contaminated. The women lie to embarrass their rivals; the kids for the adulation of their parents, and everybody furnishing high coloring with a vengeance.

Lord knows where it is going to end.

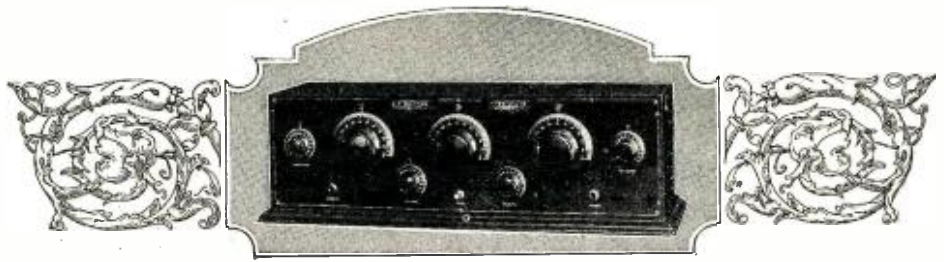

## You Can Be Sure Your New Receiver Will Perform As You Wish

**C**ERTAINLY the business of selecting and buying a new Radio Receiver is important enough to be given serious thought. There is no need to choose haphazardly, when you can demand and get a performance demonstration.

That's why we say "You can be sure your new Receiver will perform as you wish." Just ask the A-C DAYTON Dealer to make a thorough demonstration of the XL-5.

Let the XL-5 tell its own story to you and prove its worth by actual demonstration of its powers of selectivity, volume and distance. Operate it yourself and find real enjoyment in its clear, undistorted reception of the finest of vocal and musical programs.

We've built the XL-5 to satisfy those who want the very best in radio reception. The thousands of complaintless XL-5 owners all over the country are proof that we have succeeded.

Five tubes, with tuned radio frequency and balancing control. Compact, handsome cabinet of highly finished mahogany. Priced low for so fine a Receiver—\$115.00, less tubes and accessories (\$120.00 Denver and west).



**PROVEN BY PERFORMANCE**

**THE A-C ELECTRICAL MFG. COMPANY**  
DAYTON, OHIO

Makers of Electrical Devices for over Twenty Years

**XL-5 KNOCKED DOWN**

For those who prefer to build their own receiver, the A-C DAYTON XL-5 is furnished in knock-down form.





The price in knock-down form, complete with all parts and directions, is \$72.50 (\$76.50 Denver and west).

# A-C DAYTON

XL-5

**The HIGH QUALITY — LOW PRICE**

## CLARITRON TUBE \$2.30 BY MAIL

**NOT CHEAP TUBES, BUT GOOD TUBES, WHICH WE SELL CHEAPLY**  
You cannot get a better tube at any price—and why pay more? Our Price is low because we sell direct and are content with a fair profit. We guarantee that CLARITRON TUBES measure up to the highest standards. They will give complete satisfaction or WE will. The well known New York Testing Laboratories declared CLARITRON to be better than standard tubes selling for \$4.00.

We make all kinds of tubes including:  
 Our No. 501A—for same use as 201A    Our No. 499—for same use as 199  
 Our No. 112—for same use as WD12    \$2.30 for any type  
 We ship all orders as soon as received. Shipments made by Parcel Post, C. O. D., or Prepaid on Receipt of Express or Postal Money Order.  
**SUPERIOR RADIO COMPANY, Dept. 200**  
 176 Shephard Avenue    Newark, N. J.

**OUR TYPE 499**  
Detector and Amplifier

**OUR TYPE 501A**  
Tisless Detector and Amplifier

Get a Handy Binder for your RADIO NEWS. Holds and preserves six issues, each of which can be inserted or removed at will. Price 65c. Experimenter Pub. Co., Inc., Book Dept., 53 Park Place, N. Y.





No. 41—About 1/3 actual size.

## Test dry cells with safety

You can't expect to operate efficiently on dry cells without a short-circuit tester. Know what amperage your "A" batteries are giving. But don't ruin your batteries with a poorly made tester.

When you buy, demand the best—a Nagel! A strictly quality product and an adaptation of the well-known Nagel automobile ammeter of which over 6,000,000 are in service today.

If your dealer hasn't Nagel radio battery measuring instruments, send your order through him to The W. G. Nagel Electric Co., Hamilton St., Toledo, Ohio.

# NAGEL

Manufacturers of  
**DRY CELL TESTERS · AMMETERS**  
**HIGH-RESISTANCE VOLTMETERS**  
**and VOLTAMMETERS · BAKELITE**  
**HOT MOULDED INSULATIONS**

## Radio Inventors!

If you have a marketable idea, we have the necessary plant and facilities. Either royalty or outright purchase. Write us at once.

Box 225 - Radio News



**"Lighting Fixtures"**  
**READY TO HANG**  
 (Direct from Manufacturer)  
 Completely wired including glassware.  
 Send for Catalogue No. 26.  
 (Just off the Press)  
 Special Proposition to Dealers  
**ERIE FIXTURE SUPPLY CO.**  
 STATION R ERIE, PA.

There are about 15,000,000 people in the United States with some sort of a radio set. Of this number 14,999,998 are Radio Liars and the other two are—potentially. Yet this mob is spending more money every year than the dear public wastes on jewelry and athletic equipment simply for the privilege of fanning their fancy in a fling at falsification.

The industry has assumed such proportions the government has taken a hand in it. Having outgrown the Congressional Record and the departmental Joe Millers, Uncle Sam is now arranging programs for the benefit of those who will believe them. Instead of sending good pea seeds to the farmers, our senators and other gentry are telling what causes the seven-year itch, and how it may be blocked by digging ditches across the corn-fields and pouring asphaltum therein. It is even rumored Secretary Hoover recently held a conference to standardize the industry.

Personally, I never had a radio set and cannot understand the radio code.

That reminds me—the other night I was listening in at home on my "Sure-gets-em" when I heard a vessel in distress off the coast of China—let's see—about 7,800 miles from Chicago.

## The Regenerative Neutrodyne

(Continued from page 1883)

There are doubtless many who have wondered why stations of a given power and distance (other than local stations) are so much weaker on the longer waves than on the short ones. In this connection, however, there may be few exceptions due to local conditions either at the receiving station or at the transmitter or both which may reverse this order in very exceptional cases. Nevertheless, with very few such exceptions the strongest and most reliable signals will be found on the shorter wave-lengths and often the difference is so great that even the powerful 1,000-watt stations working at the higher end of the broadcast wave-lengths are much inferior to 500-watt stations of like distance working on the lower waves. This is largely due to the aerial at the receiving station being more nearly suited to the reception of the shorter wave-lengths.

A short aerial will give excellent results on very short waves (waves far below the broadcast limit), and, of course, will receive on any wave-length, but a short aerial with a natural wave-length of about 135 meters should not be expected to collect much energy from a signal whose energy is on a wave-length of 500 meters or thereabouts.

Tests have shown that the average aerial of this length gives just about one-half the volume at 300 meters, about one-third the volume at 450 meters and about one-fourth the volume at 600 meters as received on the detector in comparison to aerials more suited to the wave-lengths mentioned.

In circuits that use semi-tuned aerials, like the Neutrodyne, it is much better to use an aerial with a natural wave-length above the wave being received rather than below, yet there is a limit where it is practically impossible to gain anything by increasing the length, and consequently the natural wave-length, of the aerial, and when this condition is reached for any special wave-length (and consequently all wave-lengths below this wave) the maximum radio frequency amplification by means of the aerial has been reached for any given height of aerial. The actual height of the aerial will, to a large extent, determine just what this maximum is.

This brings us to the same point reached by means of regeneration and by tuned radio



Mellow Light  
 Beautiful Music

## Amazing Radiolamp a Perfect Loud Speaker

"WHERE does all the beautiful music come from," your friends will ask, never suspecting the magnificent lamp on the table. The beautiful parchment shade thru which streams a mellow golden light is in reality the most perfect Radio Loud Speaker yet produced. There is no metallic harshness—the tone is clarified by the heat from the electric lights and amplified by the parchment. The result is the most flawless reproduction of voice and instrument yet achieved. You can attach the wonderful new Radiolamp to any socket as a light—to any radio set as a loud speaker. It doesn't even need to be in the same room with the radio set—you can put the Radiolamp anywhere in the house and connect it to your receiving set by a long wire. Step into the nearest dealer today and see this remarkable lamp—if he hasn't one write for full information to

RADIOLAMP COMPANY

Dept. 14, 334 Fifth Ave. New York  
 (3rd. under U. S. Pats. No. 1,185,987,  
 1,272,843. Other patents pending.)

## TRIPLE TONE RADIO TUBES

TUBES ARE ALIVE  
**ALL \$2.00 EACH**  
**Types**

Fully Guaranteed  
 All tubes tested on laboratory Radio tube testing machine.  
 Mail Orders Promptly Filled  
 We Ship C. O. D.

Style 0199 .05 Amp. 3-4 Volts—Amplifier—Detector  
 Style 0201A 1/4 Amp. 5-6 Volts—Amplifier—Detector  
 Style 012 25 Amp. 1 1/2 Volts—Amplifier—Detector  
 Style 0200A 1/4 Amp. 5-6 Volts—Detector

Dealers—Write for Our Quantity Prices

**RADIO TUBE MFG. CO.**  
 154 Nassau St. Dept. 20 New York City

## FAHNESTOCK CLIPS

The Perfect Radio Connectors—Are Used



By manufacturers of standard sets and parts and makers of wet Battery and exclusive on Eveready Dry Batteries. Their Sure Patented Grip is recognized universally by enthusiastic users.

**FAHNESTOCK ELECTRIC COMPANY**  
 Long Island City

Insure your copy reaching you each month. Subscribe to RADIO NEWS—\$2.50 a year. Experimenter Publishing Co., 53 Park Pl., N.Y.C.



frequency amplification ahead of the detector, and when the practical limits of each—radio frequency by regeneration, by tuned amplifiers ahead of the detector and by the aerial—have been reached, it is possible to go no further, for the limits of present day radio receiving has been reached.

**METHODS AND ADVANTAGES**

In reviewing the foregoing we find that each of the different methods have their own peculiarities and advantages. The tuned radio frequency ahead of the detector makes a strong signal stronger, is more effective at long wave-lengths, increases selectivity and the practical present day limit (over the broadcast band) without the use of stabilizers or other devices to weaken the effects of regeneration in the radio frequency circuits is two stages. That regeneration is more effective on the short wave-lengths than on the long ones, that above a certain limit regeneration produces distortion, that it does not materially increase the volume of a very strong signal, that it requires one extra control on the set and it increases selectivity, are well-known facts. While only a very small aerial is necessary to receive over long distances, especially when used with regeneration and radio frequency amplification combined, much can be gained by using aerials suited to the maximum wave-length received.

Realizing that many radio fans cannot get up a long aerial and in many cases no aerial at all of an effective nature, experiments have been conducted with a view of adapting the regenerative Neutrodyne combination to a loop, a very effective arrangement of which is shown in Fig. 6. While results do not compare with those obtained from a large aerial, quite satisfactory loud speaker reception can be obtained over distances of several hundred miles under average night time conditions. Under more favorable conditions much greater distances may be covered, and it is not unusual to hear the higher power Pacific coast stations under good conditions with head phones.

Much can be gained by experimenting with different sized loops, a different number of turns on the loop and on the loop coil and with different sized condensers across the loop.

It is very important that the coil be placed at the same angle as that of the regular neutrodyne, and that the leads to the loop be kept well apart, otherwise trouble will certainly be experienced in properly neutralizing the set.

**BUILDING THE SET**

As a starting point the regular neutrodyne may be disassembled by taking the inside or primary coil entirely out. Then break the connection from the secondary winding to the stationary plates of the condenser and unwind about 15 turns, leaving about 50 turns on the coil. Make the wire fast so it will not unwind further and mount the remodeled unit on the panel in the usual position. The filament end of the coil is connected to the rotary plates of the condenser and the negative filament in the usual manner. The stationary side of the condenser is also connected to the grid of the first tube in the regular manner, but as the grid end of the coil has been disconnected from these plates, the only remaining thing to do is to complete this circuit with the loop. Therefore, the outside turn of the loop is connected to the grid post of the first tube and the inside turn to the end of the coil from which the 15 turns were removed. There is no other change in the wiring except that no ground connection is used. The loop should be made of very low resistance wire. It is not advisable to use a great number of turns on it. It may be operated either stationary or arranged to revolve, in which case a little advantage may be obtained of the directional properties of the loop.

**THE NEW FRESHMAN MASTERPIECE COMPLETE KNOCKDOWN SET**



**TO BUILD THE 5 TUBE \$39.50 Tuned Radio Frequency Receiver**

This wonder knockdown set contains every single part necessary to construct the FRESHMAN MASTERPIECE. Here's just what you get:

- 1 Genuine Bakelite Front Panel, completely drilled and engraved.
- 1 Genuine Bakelite Sub-Panel—with sockets, binding posts and grid condenser already in proper place. All mounting holes properly drilled.
- 3 Masterpiece Tuned Radio Frequency Units—perfectly matched and balanced.
- 3 Beautiful Genuine Bakelite 4-inch Dials.
- 1 Freshman Variable Grid Leak and .00025 M.F. Condenser.
- 1 Freshman 5 to 1 Audio Transformer.
- 1 Freshman 3 to 1 Audio Transformer.
- 1 Freshman .002 Fixed Mica Condenser.
- 1 Freshman .006 Fixed Mica Condenser.
- 2 Freshman Single Circuit Jacks.
- 1 Freshman Filament Control Switch.
- 1 Freshman 30-ohm Rheostat.
- 1 Freshman 6-ohm Rheostat.

and every bracket, screw, nut, bushing that you will require as well as an ample supply of spaghetti and bus bar. A 24-page book of instructions packed with every kit. Seven full-page illustrations and many smaller ones explain every operation step by step.

**THE KIT THE WHOLE WORLD'S BEEN WAITING FOR**

Ask to see it at your dealer's

Look for our trademark and serial number riveted on the sub-panel. The kit is not guaranteed if number has been removed or tampered with.

**Chas. Freshman Co. Inc.**  
Radio Receivers and Parts  
FRESHMAN BUILDING  
240-248 WEST 40TH ST.—NEW YORK, N.Y.

Beware of imitations and counterfeits. Insist upon the genuine.

**CARTER "HOLD-TITE" JACKS**



Pat. 1-30-23

**70c**

Spring combination for every circuit requirement.

In Canada, Carter Radio Co., Limited—Toronto

Write us for catalog.



Any dealer can supply.

Insure your copy reaching you each month. Subscribe to Radio News—\$2.50 a year  
Experimenter Publishing Co., 53 Park Place, N. Y. C.



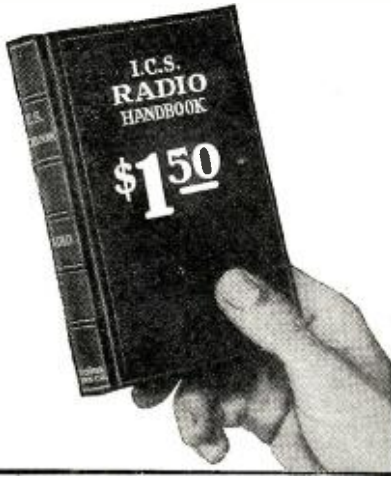

## Every Question ANSWERED for only \$1.50

At last you have under one cover a Complete Radio Handbook

New Leatheroid Edition

Compiled by HARRY F. DART, E.E., formerly with the Western Electric Co., and U. S. Army Instructor of Radio. Technically edited by F. H. Donne.

514 PAGES

**N**O MORE need you turn from book to book, hoping to find what you want. It is all here, in 514 pages crammed full of every possible radio detail. Written in plain language, by engineers for laymen. Clears up the mysteries, tells you what you want to know.

**IT EXPLAINS:** Electrical terms and circuits, antennas, batteries, generators and motors, electron (vacuum) tubes, most receiving hook-ups, radio and audio frequency amplification, broadcast and commercial transmitters and receivers, super-regeneration, codes, etc.

**Under one cover.** Yes, it is all in one volume of 514 pages of clear type with hundreds of diagrams and illustrations.

Send \$1.50 to-day and get this 514-page I. C. S. Radio Handbook—the biggest value in radio to-day. Money back if not satisfied.

—TEAR OUT HERE—

International Correspondence Schools  
Box 8281-E, Scranton, Penna.

I enclose \$1.50. Please send me—post-paid—the 514-page I. C. S. Radio Handbook. It is understood that if I am not entirely satisfied I may return this book within five days and you will refund my money.

Name.....

Address.....

Check here  and enclose \$1 if you wish the cloth-bound edition.

## TUBES REPAIRED

Burned out filament or broken bulb—send the tube to us. We guarantee it against defective workmanship; same as a new tube.

All Work Done in Our Own Laboratory

We are not agents but own and operate a fully equipped tube factory manned by experienced tube experts. Our work is, therefore, superior and you are certain of satisfaction. We guarantee to return genuine element to you. New glass bulb put on in every instance, insuring correct vacuum and proper "hardness" for the type of tube. Tubes returned parcel post C. O. D. Send yours in today.

EXPERIMENTERS! INVENTORS!

If you desire any particular high vacuum for any experimental purposes, outline your needs to us and we will quote you. We have complete equipment for filling any needs you may have.

CHICAGO ELECTRIC DEVICES COMPANY  
Established 1920. 70 E. 22nd St., Dept. 16, Chicago

Insure your copy reaching you each month. Subscribe to RADIO NEWS — \$2.50 a year. Experimenter Publishing Co., 53 Park Pl., N.Y.C.

### AUDIO FREQUENCY

The audio frequency transformers in such a set should be of comparatively high ratio; 9 to 1 for the first stage and 4½ to 1 for the second stage makes a good combination and the writer believes that those who are so situated that advantages cannot be taken of the use of an aerial that such a set will give a satisfactory performance.

To those who desire to get the very greatest distance possible with the only aerial system they can arrange, much can be obtained in this direction by experimenting with different methods of transferring the aerial energy to the set. In the factory made neutroformers, which are recommended to be used at all times in preference to home-made ones, the aerial is connected to the set either as shown in Figs. 1 to 6 by a separate primary coil placed inside of the first neutroformer, or by a tap placed directly on the secondary of the first neutroformer, as shown in Fig. 7. A little thought and experiment-

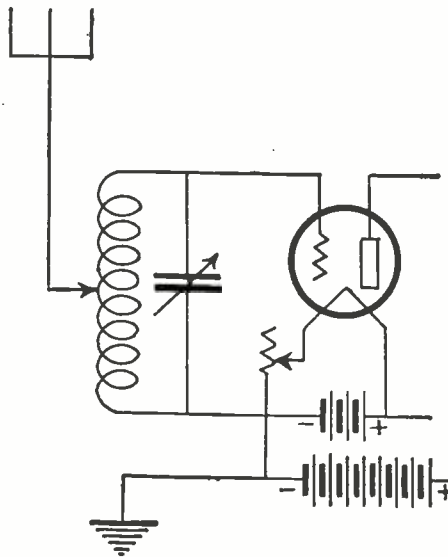

Fig. 7. The direct aerial coupling method shown may give a bit more signal strength, but the circuit will not be as selective.

ing will convince anyone that while either arrangement is effective, no fixed method of this kind can possibly give best results on every aerial over the entire broadcast wavelengths. The arrangement shown in Figs. 1 to 5 being perhaps just a little more selective and the arrangement in Fig. 7 giving perhaps a shade stronger signals, the actual signal strength can often be doubled on certain wave-lengths from that obtained with a given aerial and a fixed primary connection by using a greater or less number of turns in the primary coil if the connections of Figs. 1 to 5 are used, or by tapping the aerial onto the secondary coil at different points if the connection of Fig. 7 is used.

### RESULTS

Needless to say, if the very best results are to be obtained over the entire band of broadcast wave-lengths, taps leading to a switch should be used so as to allow the operator to cut in on any desired turn according to the wave-length being received. The exact tapping arrangement (the number of turns involved) will depend upon the aerial and can only be determined by experiments. A suggested arrangement, one that has been used to advantage for some time, is shown in Fig. 8, where, by means of a switch, either the separate primary coil or various taps on the secondary coil can be used at will.

In the improved circuits herewith submitted, note particularly that the negative "A" and "B" battery terminals are connected together and grounded and that all



### For All Batteries

### Valley Battery Charger

For 2-volt peanut tube cells, for 6-volt A batteries and for 24-volt B batteries in from one to four units, the Valley Battery Charger is the one charger and the only charger which you need.

It plugs into the ordinary light socket like a fan or other household necessity, and is just as easy to operate. Takes about a dime's worth of current to bring your battery up to full charge.

It has a grained and engraved Bakelite panel which harmonizes with any radio set. Clear glass top shows the simple, patented working parts at all times. Scientifically planned and substantially made by experienced manufacturers of storage battery charging equipment. At radio dealers everywhere. Further information furnished on request.

VALLEY ELECTRIC CO.  
3157 S. Kingshighway, St. Louis, Mo.

GEARED 80 to 1

No Back Lash  
No Wobble

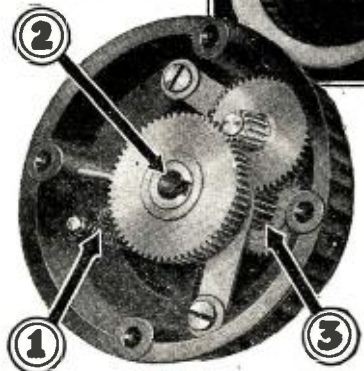

### PUT THIS DIAL ON YOUR PRESENT SET

for the closest possible tuning. Accuratune are actual micrometer tuning controls, geared 80:1 ratio for hair splitting adjustment. Give greater efficiency than any vernier condenser, vernier attachments or any other tuning device. Indispensable on all Super-Heterodynes. Fit all standard condenser shafts. Flush panel mounting—no cutting of condenser shafts.

Price \$3.50. At your dealer's—otherwise send purchase price and you will be supplied postpaid.

Write for descriptive circular

MYDAR RADIO COMPANY  
9-F Campbell St., Newark, N. J.  
Radio Ltd., Montreal, Canadian Representatives.

**ACCURATUNE**  
REGISTERED U.S. PAT. OFF. U.S. PAT. OFF.  
MICROMETER CONTROLS



amplifier tubes have the rheostats connected between the filament and the negative terminal of the "A" battery, and the detector tube has the rheostat connected between the filament and the positive terminal of the "A" battery. To make sure the set will operate with regeneration under complete control over the entire range of 200 to 600 meters, care must be taken in selecting a variometer that will cover the entire range. The greatest trouble is in getting variometers to tune down low enough, and while most any variometer will tune down to 300 meters or below, very few will reach the 200-meter mark efficiently unless a few turns are unwound from both sides of the stator and stationary windings. It is, therefore, well to select a variometer of small dimensions wound with large wire in preference to one of large dimensions wound with small wire.

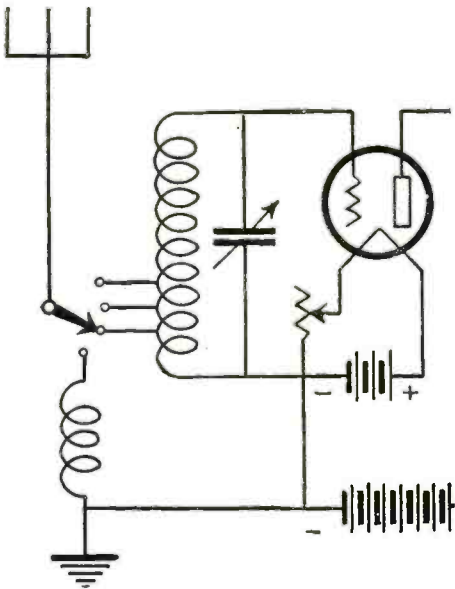

Fig. 8. With the switching arrangement, shown, one can select the best point on the secondary coil for a particular wave-length band, or run the aerial directly to the primary coil.

KGO at Oakland, Calif., has been received on a loud speaker using detector only (no audio frequency amplification at all) with spoken words understandable 20 to 25 feet away from the horn. CYL, Mexico City, has been received under like conditions just a trifle weaker and of very excellent loud speaker intensity on one stage of audio frequency amplification. WGN at Chicago, Ill., more than 600 miles distant, has been received three Sundays in succession between 12 noon and 1:45 p.m., E.S.T., plainly understandable anywhere within 15 feet of the horn on one-stage of audio frequency amplification. The above was accomplished during the month of November and, therefore, greater things are in prospect under more favorable conditions during the winter and spring months.

The photographs herewith show one of the sets. Note the slight angle of the variometer and the switch controlling the primary circuit in the upper left. Also note the exceptional spacing of all the instruments. The panel is 38 inches long and 8 inches wide.

**WHAT CRUELTY!**

Sid—My set squeals terribly.  
Lid—No wonder; you've twisted off a pig tail. —Contributed by Jack Bront.

**TRUE ENOUGH**

Jim: "There's one head-set that is particularly handy in radio work."  
Jam: "What kind is it?"  
Jim: "A set of brains."  
Contributed by Les Van Every.

FOR BETTER CONNECTIONS

*An Important Detail  
that Makes for  
PERFECTION*

*In  
Your  
Set!*

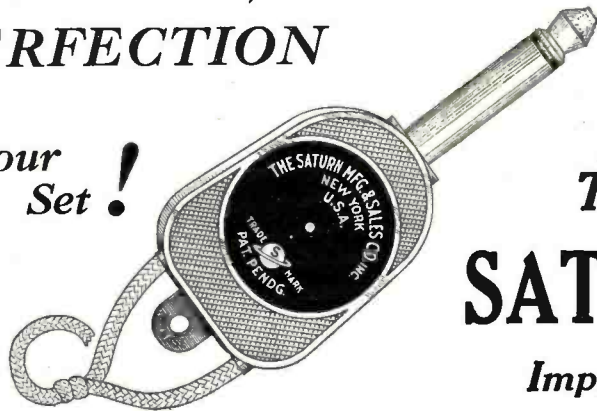

*The  
SATURN  
Improved  
Automatic  
RADIO PLUG*



"ANY old plug" won't do for the man who is proud of his set. There's as much difference in plugs as there is in radio sets. First there is CONVENIENCE! Common plugs have to be connected with the phone or loud speaker cords by tinkering with a screw driver or soldering iron. The SATURN Plug makes instant connection simply by inserting the cord terminal tips which are instantly held in a vise-like grip. When you want to take away or change the connection of phones or loud speaker, the SATURN Plug does not need to be removed: simply touch the release lever and the terminal tips can be pulled out.

**SATURN  
Perfect Jacks  
and  
Panel Switch**

You can't see the other advantages of the SATURN Plug because they're sealed up inside the neat Bakelite case but they're important enough so that Fada and Fried-Eisemann heartily approve of these plugs.

*Write for SATURN Book of Circuits*

**SATURN MFG. & SALES CO., Inc.**

Dept. RN  
48 Beekman Street New York City

*The Standard  
of the World*



The base-type  
**Freshman Variable Grid Leak**  
is the standard for those who build their own sets. It is the most compact and being entirely sealed it always remains unaffected by any climatic conditions.

Complete with either .00025 or .0005 Freshman Condenser—without condenser..... **\$1.00** .75  
At your dealer's, otherwise send purchase price and you will be supplied postpaid

Chas. Freshman Company, Inc.  
240 W. 40th St. New York

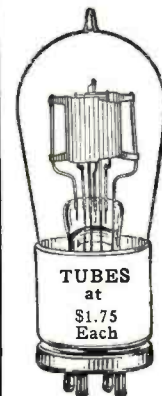

SAVE \$1.25 ON COST OF NEW TUBES BY HAVING YOUR OLD TUBES REBUILT AT \$1.75 EACH

Guaranteed equal to new. Send us your tubes by parcel post. We return them parcel post, C. O. D. and try to maintain 24 hour service.

**HARVARD RADIO LABORATORIES**

200 Old Colony Avenue  
South Boston, Mass.

TUBES  
at  
\$1.75  
Each

Insure your copy reaching you each month. Subscribe to Radio News—\$2.50 a year  
Experimenter Publishing Co., 53 Park Place, N. Y. C.



## Complete List of Titles in the E. I. Co. Books

### All About Radio Parts

Everyone who constructs a radio set should know the simple fundamentals of the various parts of his set. The E. I. Company has set these forth in a compact little book that is valuable at all times.

Book No. 8—Price 25c

### History and Operation of the Vacuum Tube

The Vacuum Tube is a marvelous piece of apparatus. A short study of it as given in this book gives you the principle on which every Vacuum Tube Radio Receiver operates.

Book No. 9—Price 25c

### The Neutrodyne—All About It

Everybody knows the famous Neutrodyne hookup. One of the finest Radio Receivers in use today. This 51-page E. I. Company book gives an explanation of every detail of the Neutrodyne and how it all works.

Book No. 10—Price 25c

### How Radio is Received

The simplest and yet most complete Radio Guide Book for any amateur broadcast listener. In print only two weeks, fresh from the press.

Book No. 11—Price 25c

### How to Locate Troubles in Your Radio Set

Anyone with this handy book as a guide can repair and keep in order his own radio set. Covers every detail of the modern radio sets and tells how to locate and repair any trouble.

Book No. 12—Price 25c

### Radio Reflex Receivers

Just off the press. Hookups galore on the finest and most up-to-date reflex circuits in use today. Diagrams and descriptions on every modern reflex.

Book No. 13—Price 25c

### Tips for the Radio Amateur Constructor

Many men fall in building their Radio sets because of some trivial error that could easily have been corrected before it was too late. The E. I. Company has compiled a book that will help you avoid all the common pitfalls while building your Radio sets.

Book No. 1—Price 25c

### How to Make PRACTICAL Radio Receiving Sets

The man who wants to build only those PRACTICAL Radio Sets that are guaranteed to give good results when properly constructed will need this book. Gives the principal successful hookups of practical Radio Construction.

Book No. 2—Price 25c

### Radio Questions Answered

Question No. 1—What is Radio? This is the nature of the questions that this book answers. Then it answers questions on all the principal parts of a Radio Receiver. It is a handy book to keep in your Radio File.

Book No. 3—Price 25c

### Radio Frequency Amplification

Distance lends enchantment—and it's the Radio Frequency Amplification that brings in the distance on your Radio Receiver. If you contemplate adding any Radio Frequency to your set you will want this book at your side.

Book No. 4—Price 25c

### How to Tune Your Radio Set

Don't struggle in the dark, looking for stations—here is an inexpensive book that gives you detailed instructions on just how to handle your Radio set. You will be surprised at the increased results that can be obtained through proper tuning.

Book No. 6—Price 25c

### 100 Radio Hookups

No better book for your work bench. Gives diagrams, hook-ups and details on Radio Hook-ups galore. One of the most complete hook-up books published. Authentic and up-to-date in every respect. Third edition now ready.

Book No. 7—Price 25c

## E. I. Co. Books

are sold throughout the country by all Radio and News Dealers

If Your Dealer Cannot Supply You, Write Direct

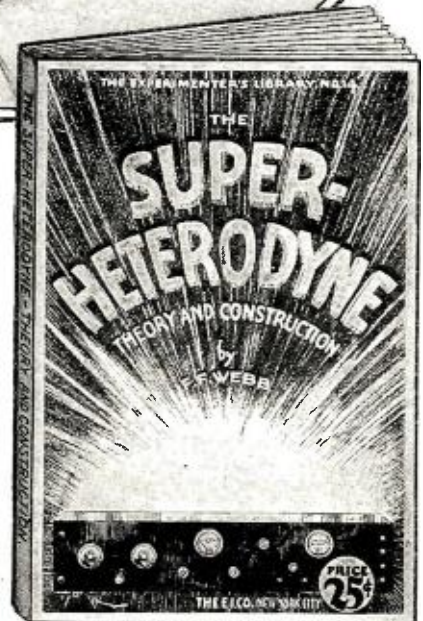
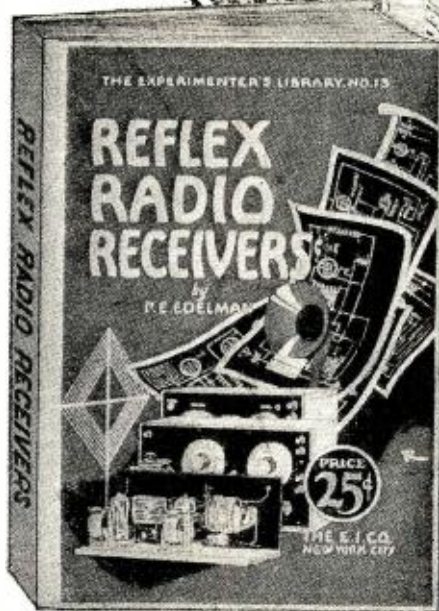

## Any radio receiver will give better results if you learn more about it

ANY radio receiver gives better results in the hands of an experienced radio man. The reason for this lies not in their intimate knowledge of radio parts but rather in their fundamental knowledge of how the receiver operates.

The radio books of the E. I. Company are written with this sole object in view, to give the average broadcast listener the fundamental knowledge that will enable him to understand the care and operation of the receiver he buys or builds.

Some of the E. I. books cover only the care and operation of general radio receivers, others cover the construction and operation of specific types of receivers, while a third class cover that intimate, general knowledge of radio transmitting and receiving that everyone should know.

Glance over the titles of the books listed on this page. They are sold everywhere. Or, if you wish you can obtain them direct from us.

All E. I. Co. Books are 25c. Each

Published by

E. I. Company, Inc.

*The Conrads Co.*  
INC.  
Sole Distributors

233 Fulton Street

New York, N. Y.









**The Complete Efficient and Economical Aerial**

**ANTENELLA**

NO AERIAL OR ANTENNA NEEDED

**WHY PAY \$10.00** or more to have an aerial spoil the appearance of your home? Antennella eliminates all unsightly wiring, lightning arresters, etc., and precludes the possibility of dangerous groundings on a power line. It also stops "canary bird" re-radiation from nearby oscillating sets from interfering.

**ANTENELLA** is not only a real distance getter, but also successfully overcomes static annoyances.

At your dealers, otherwise send purchase price and you will be supplied without further charge.

**Chas. Freshman Co. Inc.**  
Radio Condenser Products  
FRESHMAN BUILDING  
240-248 West 40th Street, New York

### A New Method of Television

(Continued from page 1873)

on the screen, but actually this spot would be moving at such a speed that a continuous image would be seen much the same as the motion picture image.

**SOME REMARKABLE FIGURES**

"This is the type of machine which was evolved after careful consideration of many ways of accomplishing the results. Quite the most important point is the amount of light passing through the shutters onto the light sensitive cell, and at the receiving end onto the screen. With the above method the focussing of the beam of light at the receiving end into a narrow pencil of light is unnecessary. The amount of definition available is purely a question of the width of the slots and the gearing of the discs. We use slots .002 inch wide, and one disc does 1,000 revolutions while the other does 999, consequently our picture consists of 1,000 lines with 50 per cent. overlap between lines. The number of dots in each line—if such a term may be used—depends on the speed of the light sensitive cell and the light control shutter. Should the cell be slow, it will respond only to an average effect beyond its speed of response; in other words, the reproduction would be very blurred. These remarks apply also to the light control shutter.

**THREE-COLOR METHOD**

"Another interesting arrangement we have brought out is for natural color reproductions. This is a three-color method similar to that used in photography. At the transmitting end there are three light sensitive cells, each of which respond only to one color and at the receiving end there are three light control shutters, each actuated by currents from one light sensitive cell only. The shutters pass light only of one of the three colors which are mixed and then shown on the screen. The shutter in this case could be a three-string Eindhoven, each string independently operated.

"I hope," concluded Mr. Walton, "that what I have told you will be of use to other experimenters along the same lines."



**\$150 now for the Ideal Radio Rheostat**

The old story of big demand and quantity production making for price reduction has worked out for the Marshall-st, the ideal radio rheostat. Its new price is \$1.50 now.

For your money you get the smoothest accurate adjustment rheostat on the market. It gives vernier precision throughout its entire range from 100 to 0.2 ohms. Yet there is only one adjustment to make—only one dial to turn.

In addition, it is compact (illustration above full size), requires only one hole in panel, and can be used with any tube or combination of tubes. You can't go wrong with the Marshall-st.

**MARSHALL ELECTRIC CO.,**  
3235 Locust Boul. St. Louis, Mo.

Get the Marshall-st at radio dealers everywhere. Write us for descriptive literature.



**Build Your Own Super-Heterodyne—Save \$100 or More—Have a Better Set**

**BRANSTON'S** Transformer Kit No. R-199 (\$35.00) contains eight matched transformers; Branston Accessory Kit No. R-199-A (\$50.00) contains panel, condensers, rheostats, wire, etc., etc. Partially assembled. Any amateur, in a few evenings, can easily build a reflexed Super Heterodyne of coast-to-coast range, remarkable selectivity, great volume, and hairline selectivity.

Send 25c for Super Heterodyne, Radio Frequency, and Honeycomb Coil circuits and complete catalog.

Your dealer has Branston Kits or can get them for you. If not, write us.

**CHAS. A. BRANSTON, Inc.**  
817 Main Street Buffalo, N. Y.  
Mfrs. of Branston Violet Ray High Frequency Generators  
In Canada—Chas. A. Branston, Ltd., Toronto, Ont.

### With the Amateurs

(Continued from page 1893)

**ANTENNA SYSTEM**

A few words on the antenna system may not be out of place. Numerous forms and arrangements were tried and it was found that a three-wire cage with hoops six inches in diameter, using 9/32 enameled stranded wire, gave the best results. A counterpoise was erected and found to be very good. The best results were, however, obtained when the counterpoise—which must, of course, be well insulated—was connected at the receiver to the ground, thus forming an earth screen. The counterpoise is a 12-wire fan, eight inches wide at the far end. The antenna is 23 feet and 32 feet high and 50 feet long. A short ground wire is a great help. The one in use at the writer's station is less than three feet long and is soldered to the water main.

**COIL WINDING TABLE**

Wave-length	L1	L2	L3
50-100 meters	8 turns	15 turns	20 turns
90-160 meters	13 turns	22 turns	25 turns
130-260 meters	22 turns	29 turns	25 turns
260-360 meters	35 turns	50 turns	25 turns
340-600 meters	50 turns	75 turns	30 turns



**JEWELL**



Price **\$1.10**

### The JEWELL LIGHTNING ARRESTER

The underwriters require that an approved arrester be used with outside antennas. The Jewell arrester has passed all their tests (No. E5403).

Order from Dealer

**Jewell Electrical Instrument Co.**  
1650 Walnut St., Chicago

**ABSOLUTELY FREE**  
Thousands of **RADIO BARGAINS**

You Can't Equal This Anywhere  
S R A C O head sets—2,000  
Ohms—head bands and cord complete. Write Dept. C for catalog. \$2.98

**STANDARD RADIO CORP.**  
227 WEST MADISON ST. CHICAGO

**CRESCENT LAVITE RESISTANCES**

12,000 Ohms  
48,000 Ohms  
50,000 Ohms  
100,000 Ohms



List **\$1.50**

Special Sizes to Order at \$2.50 each  
When better resistances are made Dealers write for they will bear the Crescent label. discount.

**CRESCENT RADIO SUPPLY CO.**  
1-5 Liberty St. Jamaica, N. Y.



**NEW QRA'S**

**9SJ**—Edward Reid, 221 East 50th Street, Chicago, Ill. Reports appreciated and acknowledged.

**9SE (ex 9CVZ)**—Reassigned to Dwight Bancroft, 73rd Street and Lyndale So., Minneapolis, Minn.; five watts CW 5-80 and 165 meters. All crds appreciated and answd.

**1AFJ**—LeRoy Johnson, 31 Perrine Avenue, Pittsfield, Mass. CW and Fone.

**2AKZ (Reassigned)**—J. A. Anderten, 94 Rossmore Place, Belleville, N. J. Ten watts CW and Fone. Pse QSL. All crds answd.

**9BPW**—Lyman Nylander, 2305 West Fifth Street, Duluth, Minn. All QSL's answd.

**8CFT (Reassigned)**—Kenneth Stelle, 312 Hanover Street, Northumberland, Penn. All reports appreciated.

**5ARR**—Tom J. Kindel, Carlsbad, New Mexico. Five watts CW and Fone. All QSL's appreciated and answd.

**8DLN**—R. W. McCracken, 46 South Third Street, Cuyahoga Falls, Ohio. Five watts CW. All crds answd.

**CORRECTION**

In the January list of new QRA's, the call of the station owned and operated by Mr. A. G. Shafer, 5526 Ridgewood Street, Philadelphia, Pa., was given as **3AGF**, which is not correct. His call is **3ACF**.

**6BBV**—J. BARSBY, 1511½ N. COMMONWEALTH, HOLLYWOOD, CALIF.

1aac, (1bsd), 1cab, (1cmp), (1pl), (1xz), (2apy), (2avu), (2cee), (2cvu), (2hj), (2hq), (2qt), 2rk, (2ry), (3chc), (3chg), 4iz, (4ku), (5aic), (5aj), (5ai), 5akn, (5aqw), (5hl), (5rh), (5uk), (6chl), (6oo), (6wi), 7mf, (7qd), (8atr), (8bau), 8bww, (8jq), (8zg), (9aju), (9bcj), 9bwx, (9cjj), (9csg), (9cp), (9pmj), 9drl, (9eky), (9ded), (C5BA).

**9AMX, ATCHISON, KANSAS**

1yd, 2ach, 3agf, 4je, 5ew, 6chl, 7gm, 8bsv, 9auw.

CANADA: 5bz.

MEXICO: BX, 1E, 1B, 1K.

BRITISH: 2od, 2nm, 2kf, 6aq.

9amx answers ALL crds.

**JOHN H-P. ANDREWS, COR. LAKE AND BELLONA AVES., GOVANS, BALTIMORE, MD. (DECEMBER) (1 TUBE, 3 CIRCUIT)**

6afg, 6ame, 6bgo, 6bbk, 6blh, 6bnt, 6bqr, 6crs, 6css, 6czx, 6eb, 6mm, 6ts.

ENGLISH: 2jf, 2kz, 2nm, 2od, 2sh, 2sz, 5lf, 6nf.

FRENCH: 8ap, 8go, 8sin, 8su.

**5ARR, THOMAS J. KINDEL, CARLSBAD, NEW MEXICO**

4ey, 4ii, 5rw, 5cz, 5hu, 5xaj, 5shan, 5oj, 5afa, 5ghe, 5na, 5dw, 5cb, 5ad, 5an, 5ij, 5cw, 5ax, 5aj, 5aki, 5ai, 5het, 5ara, 5ct, 5ak, 5ohn, 5rr, 5cat, 5cae, 5an, 5cfx, 5agl, 5cg, 5oj, 5cy, 5aal, 5aft, 5ac, 5fec, 5apl, 5ay.

**A-3XW, C. A. CULLINAN, DIGGERS REST, VICTORIA, AUSTRALIA**

1cmp, 1bg, 1kc, 3grq, 4oa, 5akn, 6ahp, 6abp, 6akz, 6awt, 6age, 6cgo, 6cjc, 6ou, 6vc, 6uc, 6bpo, 7nd, 8zg, 9exy, 9ke, WGH (110-M), NKF (abt 85-M), KGO (May 25 one-tube).

ENGLISH: 2nm.  
(Also 50X doubtful whether USA 50X or G-50X. Abt 8:15 PM Melb. time.)  
If u want a card send one pse om.

**S. JAMIESON, 2128 RUSSELL STREET, BRIXTON, LONDON S. W. 9, ENGLAND**

(December 25th, 0300-0700 GMT)

1ar, 1iv, 1bdx, 1cak, 1cmp, 1kc, 1my, 1pl, 2by, 2ax (Can), 2bn (Can), 2agw, 2brb, 2ce, 2cci, 2cgi, 2cgo, 2ud, 3ab, 3bdo, 3bva, 3cbl, 3hgd, 4io, 4jr, 8adg, 8amr, 8bbf, 8ced, 8cse, 8ccq, 8vq, 8bsu, 9mit.

(December 28th, 0330-0730 GMT)

1ana, 1atj, 1bbp, 1bv, 1bdx, 1bie, 1cab, 1cmp, 1ef, 1py, 1dq (Can), 2aay, 2awt, 2brb, 2hqb, 2byw, 2cbg, 2cgi, 2rk, 2kx, 3ab, 3adj, 3ot, 3zw, 4ti, 8ktc.

*—and still tight!*



Abused—twisted—bent back and forth dozens of times—yet every plate in this Red Seal Condenser is still firmly embedded in the shaft—every one still forms a perfect electrical joint.

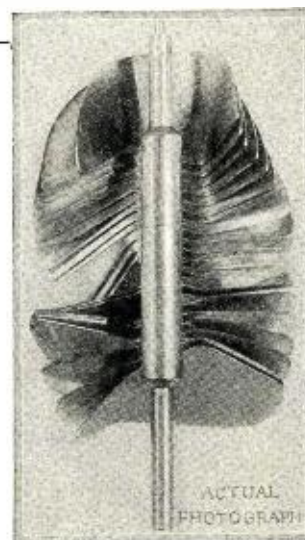

# Red Seal Condensers

*make good sets better*



Because of the difficulty in securing delicate adjustment you, probably, have often tuned your condenser plates right through the sharp peak of an incoming signal wave. The friction Vernier of the Red Seal permits adjustment to a hair-line. It is the ideal control for a precision condenser.

**I**N one of the well-known laboratories in New York City there is a special condenser, designed for making electrical measurements. It is a precision instrument in which every precaution and every known device have been employed to secure maximum efficiency. Its electrical losses are so low that they are negligible and to all intents and purposes it is a perfect condenser.

Recently a Red Seal Condenser—right out of stock, was tested against this instrument in a measuring circuit. The difference between the losses of the two condensers was so low as to be practically immeasurable.

The cost of the laboratory condenser was probably \$150—the 23 plate Red Seal Condenser costs \$6! It, too, is a precision instrument for critical sets—but its price is easily within the reach of every radio enthusiast desirous of making a good set better.

Made in four sizes:  
15 plate .00028 M.F.  
17 plate .00087 M.F.  
23 plate .0005 M.F.  
43 plate .001 M.F.



MAKERS OF THE FAMOUS RED SEAL BATTERIES

## RADIO DEALERS—Price Talks!!!

Write for new 1925 Catalogue just off press. Full complete line of Radio Merchandise at unusually attractive prices. Free hookups on request.

**RADIO SUPPLY CO., 17 S. 4th Street, Philadelphia, Pa.**



*Your Set Deserves a Solid Mahogany Cabinet*  
7 x 7 x 18, either straight or slanting front, made of Mahogany delivered anywhere in United States.  
PRICE \$8.20.

**FASHION FURNITURE CORP.**  
"Makers of fashion line" Youngsville, Pa.

Insure your copy reaching you each month. Subscribe to Radio News—\$2.50 a year. Experimenter Publishing Co., 53 Park Place, N. Y. C.



# Simple Tuning for the New Hook-Ups

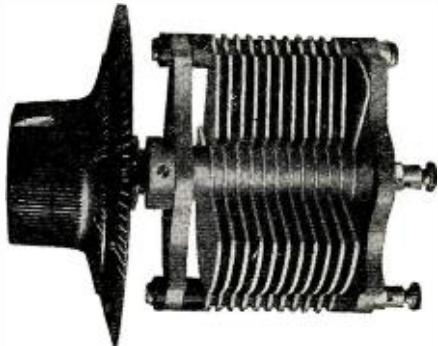

## Use a PROUDFOOT One Knob Low Loss Vernier Condenser

—it makes child's play of the tuning and logging of neutrodynes or radio frequency circuits. All other single plate vernier condensers require a preliminary adjustment of the vernier plate before tuning in order to insure a definite log. That is why they are seldom used.

The Proudfoot controls group and vernier plates with one knob. Vernier plate lines up at zero and automatically operates as one of the group plates. Vernier adjustment is then made by turning upper half of knob in opposite direction. You always get a definite vernier reading.

### Other Features

of the Proudfoot are:—two rod stator plate mounting, metal end plates, bronze bearings, dissimilar metals at friction points, positive electrical connections and single hole panel mounting which permits balancing the circuit by adjusting the unit to the most efficient working angle.

See the Proudfoot at your dealer's. Get one today. Made in the popular sizes and favorably priced.

Number of Plates	M. F. C.	With Vernier Dial and Knob	Without Vernier Dial and Knob
13	.00025	\$3.75	\$3.25
17	.00035	4.40	3.90
25	.0005	4.50	4.00
43	.001	5.75	5.25

CRUVER MANUFACTURING CO.

2456 W. Jackson Blvd., Chicago, Ill.

# A SURE CURE FOR 90% OF RADIO ILLS



## THE MOORE TUBE TESTER U. S. Standard

A positive curve of all types of Tubes increases your reception fully 100%.

The Moore Tube Tester.....\$18.50

The Moore "Tune-Tru" R.F. Power Amplifier

Can be adapted to any type receiver and brings in distance with volume. A Guaranteed Instrument...\$15.00

Moore-"4" Four-Tube Receiver

"Mighty Voice of The Great Lakes." Radio's Greatest Achievement.....\$55.00

Write for descriptive literature.

AGENTS and DISTRIBUTORS WANTED

MOORE RADIO PRODUCTS, Inc. 337 W. Madison Street Chicago, Ill. Department RN

Insure your copy reaching you each month. Subscribe to RADIO NEWS—\$2.50 a year. Experimenter Publishing Co., 53 Park PL, N.Y.C.

I should be very pleased to give reports to or communicate with any of the above mentioned "hams" whose calls I received on a single tube crystal reflex receiver.

9ACC, BLAKELEY, MINN. (DECEMBER)  
 U. S. FONE: 3bhy, 5ahw, 5akf, 5qd, 8aee, 8brc, 8dat, 8io, 9abx, 9ahj, 9avt, 9awt, 9ayq, 9atl, 9bpb, 9bsp, 9cbr, 9cjj, 9clb, 9cls, 9cop, 9coq, 9dch, 9dcp, 9dcs, 9ddc, 9dig, 9dhl, 9ecs, 9eiq, 9ekh, 9em, 9tf, 9ua.  
 CAN. FONE: 3gg.  
 CAN. C. W.: 4aw.  
 U. S. ICW: 8dfo, 9dci, 9dsi, 9ehq, vgg (qra?).  
 U. S. C.W.: 1bdh, 2acq, 2bgi, 2bi, 2bir, 2cir, 2iu, 3adb, 3ccv, 3tr, 4qw, 5fs, 5hi, 5vo, 6pl, 8ak, 8akk, 8bdi, 8bjt, 8bna, 8bni, 8bob, 8bqa, 8bse, 8byt, 8ccn, 8cm, 8ckm, 8dn, 8dsd, 8fg, 8na, 8ta, 9aag, 9aaq, 9afe, 9agu, 9aini, 9ato, 9atr, 9avv, 9bdt, 9bif, 9bhb, 8bhj, 9bh, 9bh, 9bir, 9bks, 9cde, 9cgh, 9cid, 9cln, 9cnl, 9dkl, 9dky, 9efj, 9egs, 9eiq, 9ejp, 9fl, 9up.  
 Evr hrd 9ACC? QRK? A card to ani of the above fr one fm U.

1CV, 18 PROSPECT HILL AVE., SOMERVILLE, MASS.

4ai, 4bq, 4ch, 4eh, 4eq, 4fg, 4fz, 4gw, 4hw, 4jr, 4mb, 4mi, 4nj, 4oa, 4pi, 4pr, 4sa, 4sh, 4si, 4tj, 4uk, 4xe, 4xc, 5aai, 5aaq, 5aat, 5ac, 5acf, 5aef, 5afn, 5agi, 5ail, 5air, 5aiu, 5ajh, 5aji, 5ajt, 5alj, 5alr, 5am, 5ame, 5amw, 5apv, 5asb, 5atf, 5asz, 5ek, 5en, 5cv, 5da, 5dm, 5ek, 5gk, 5hl, 5im, 5jf, 5kq, 5lu, 5mi, 5ml, 5nw, 5oq, 5ot, 5ph, 5qy, 5rh, 5ru, 5sd, 5se, 5ue, 5uk, 5vc, 5vv, 5zas, 5zav, 5xau 6adt, 6age, 6akw, 6alo, 6ame, 6arb, 6awt, 6bka, 6bql, 6bqr, 6can, 6cdn, 6cjb, 6mi, 6css, 6cto, 6gg, 6vc, 6wi, 6zh, 7co, 7ge, 7ec, 7mg.

ENGLISH: 2jf, 2nm, 2od, 2sh, 2sz, 5lf, 6nf.  
 FRENCH: 8go, 8dp, utf.  
 PORTO RICAN: 4sa.  
 MEXICAN: 1b.  
 A card to those who QSL.

9APY, 3337 OAK PARK AVE., BERWYN, ILL. (JANUARY)

1aao, 1af, 1ak, 1asu, 1avl, 1bdx, (1bhg), (1hub), 1bzq, 1cak, 1pl, 1xa, 2aay, (2aco), 2ahw, (2ale), 2auh, (2bbx), (2bhk), (2boo), 2box, 8bpg, 2bse, 2bum, (2bzj), 2cor, 2cqi, 2cub, (2cxy), (2cyu), 2gk, 2lm, 3adb, 3adq, 3ans, 3arz, (3awu), 3hhv, 3ipl, (3bms), 3bmt, 3br, 3chg, 3cm, 3ly, 3na, (3oe), 3ph, 3qt, 3rs, 3sm, 4dv, 4mi, (4og), 4tw, 4tx, (4vo), 5ail, 5aiy, 5ajp, (5api), 5aqf, 5ars, 5asb, 5asf, (5ash), 5att, 5aul, 5ek, 5es, 5ew, 5ex, 5ji, 5lh, 5lr, 5qk, 5qz, 5rw, 5se 5vc, 5wi, 6afh, 6aw, 6chx, 7ok, 7sb, 8act, 8ase, 8atp, (8azu), (8bj), 8hmo, 8hinv, 8hn, 8bqa, (8ckf), (8ckp), (8cl), 8dnu, (8dpx), 8eb, 8vo, 8wz.

CANADIAN: (C-3CK), C-3WS, C-4CH.  
 U. S. FONES: 3wf, 8dat.  
 GOV.: WGH.  
 QRK 9APY's 100 watts? Card for card.

9BHH, DAVENPORT, IOWA (JANUARY)

1aao, 1abp, 1ajl, 1ajp, 1ajx, 1all, 1aoo, 1apa, 1atj, 1auc, 1avu, 1axz, 1awf, 1bbx, 1bcl, 1bep, 1bes, 1bcq, 1bnt, 1btw, 1cak, 1cru, 1er, 1fa, 1fd, 1ga, 1kc 1lw, 1mj, 1my, 1nd, 1ow, 1py, 1sf, 1sm, 1wf, 1wg, 1xb, 1xbf, 1xj, 1xu, 1xz, 2aan, 2abf, 2ag, 2ana, 2ann, 2ax, 2ay, 2bg, 2hg, 2hm, 2bmi, 2br, 2brb, 2bse, 2bse, 2by, 2cd, 2cee, 2cef, 2cgl, 2cjb, 2cjc, 2cpa, 2cpk, 2cvj, 2cwf, 2cyw, 2dn, 2gk, 2ke, 2ku, 2mc, 2mu, 3wr, 2xhf, 2xi, 2xq, 2zb, 3aao, 3ab, 3ach, 3adp, 3ajd, 3aoj, 3bhw, 3blp, 3bsv, 3buq, 3ca, 3chc, 3chg, 3clw, 3eh, 3hg, 3hh, 3hj, 3kq, 3ll, 3oa, 3sf, 4bq, 4fy, 4fz, 4gw, 4gx, 5io, 4kl, 4mi, 4oa, 4pd, 4st, 4tj, 4xe, 5acf, 5afu, 5agi, 5agq, 5aic, 5aiy, 5ajg, 5ajz, 5alb, 5alr, 5aoq, 5aqn, 5aqp, 5aqy, 5aqz, 5asz, 5asw, 5atf, 5atx, 5azy, 5bn, 5cn, 5dm, 5dw, 5hy, 5ik, 5in, 5jf, 5ka, 5ll, 5ls, 5nj, 5nw, 5ot, 5qh, 5qy, 5sd, se, 5ss, 5us, 5vc, 5wa, 5xa, 6aiv, 6akw, 6ase, 6bho, 6bhw, 6cgy, 6cll, 6cso, 6cwi, 6pl, 6vc, 7fq, 7qd, 7nf, 7gh, 7kda.  
 CAN.: 3fc, 3bp, 3ly, 3nf, 3vh, 3xi.  
 CUBAN: 8do.

Will above pse QSL crd QRK? 9BHH 40-80 meters?

J. A. OSWALD. 3456 N. CLAREMONT AVE., CHICAGO, ILL. (DECEMBER)

1bz, 1gv, 1hn, 1qx, 1sz, 1wl, 1xz, 1za, 1abp, 1ary, 1avx, 1axz, 1bdx, 1biz, 1bvb, 1bqq, 1ccj, 1cmp, 1coj, 2al, 2be, 2by, 2ct, 2dn, 2fc, 2sf, 2xi, 2xq, 2aan, 2ana, 2agm, 2akb, 2bbn, 2blm, 2bls, 2byk, 2cbg, 2cdp, 2cfa, 2cgl, 2cnk, 2cqz, 2cty, 2cwi, 2czr, 3ac, 3bg, 3bo, 3dq, 3dx, 3gk, 3hd, 3hk, 3jo, 3kj, 3lg, 3mf, 3ot, 3ph, 3rs, 3sf, 3uy, 3wn, 3zt, 3abw, 3ach, 3agq, 3aih, 3auv, 3avk, 3bco, 3hmz, 3bp, 3fc, 3chg, 3chl, 3cjin, 3ckj, 3cvi, 3cyc, 3jee, 4bq, 5eq, 4fg, 4io, 4iz, 4je, 4jr, 4kt, 4mh, 4nv, 4pd, 4rl, 4si, 4ti, 4um, 5aq, 5aw, 5bj, 5ck, 5fv, 5hy, 5ic, 5ka, 5kc, 5mi, 5qk, 5qy, 5sd, 5se, 5sg, 5th, 5wa, 5wi, 5xa, 5zd, 5abc, 5acm, 5adf, 5aek, 5ax, 5afh, 5agj, 5ajt, 5akp, 5alz, 5amh, 5api, 5apc, 5aqw, 5aqy, 5ash, 5ak, 5bc, 5ing, 5rm, 6vc, 6akw, 6amo, 6awt, 6bcp, 6bh, 6bj, 6bon, 6bss, 7dd, 7gb, 7mf, 7mp, 7oy, 8ps, 8rj, 8rt, 8ta, 8tr, 8wz, 8xe, 8zd, 8ajf, 8arw, 8bdk, 8bjt, 8hiz, 8hoe, 8hoq, 8hvf, 8hyu, 8cdr, 8ces, 8cse, 8cpu, 8cuk, 8dae, 8ddq, 8dgl, 8dgr, 8dis, 8dnt, 8dt.

Type BM \$4.50

This is the

## Jones MULTI-PLUG

THE STANDARD SET CONNECTOR

used by

HOWARD WORKRITE  
 MU-RAD ZENITH

and Other Leading Set Manufacturers

Neat and simple to install, it provides a plug-in connection between set and batteries ground and antenna. The 8 foot cable permits placing batteries in basement or other suitable place.

Manufactured and Guaranteed by

HOWARD B. JONES  
 616 S. Canal St., Chicago  
 Jobbers, Dealers—Write!

## RADIO Storage "B" Battery

12 Cells 24 Volts

Lasts Indefinitely—Pays for Itself

Economy and performance unheard of before. Recharged at a negligible cost. Approved and listed as Standard by leading Radio Authorities, including Pop. Radio Laboratories, Pop. Sci. Inst. Standards, Radio News Lab., Lefax, Inc. and other important institutions. Equipped with Solid Rubber Case, an insurance against acid and leakage. Extra heavy glass jars. Heavy rugged plates. Order yours today!

SEND NO MONEY Just state number of batteries wanted and we will ship day order is received. Extra Offer: 4 batteries in series (96 volts), \$12. Pay expression after examining batteries. 5 per cent discount for cash with order. Mail your order now!

WORLD BATTERY COMPANY  
 1219 So. Wabash Ave., Dept. 75, Chicago, Ill.  
 Makers of the Famous World Radio "A" Storage Battery  
 Prices: 6-volt, 100 Amp. \$12.50; 150 Amp. \$14.50; 140 Amp. \$16.00.  
 All equipped with Solid Rubber Base.

World FOR STORAGE BATTERIES RADIO

INDIA - WEAF - WGN - WJS - KHJ - KGO - KFAX - WJY - KOP

## PATENTS

WRITE for our Four Guide Books and "RECORD OF INVENTION BLANK" before disclosing inventions. Send model or sketch and description of your invention for Examination and Instructions. Electrical cases a specialty. Highest references, reasonable terms, prompt attention.

No charge for the above information.

VICTOR J. EVANS & CO.  
 919 NINTH ST., WASHINGTON, D. C.

## LATEST WHOLESALE RADIO CATALOG

FREE Simply send name TODAY for big 48-page catalog of latest radio goods at Wholesale. Live dealers and agents wanted.

STANDARD RADIO CO., 108 East 13th, Kansas City, Mo.

Insure your copy reaching you each month. Subscribe to RADIO NEWS—\$2.50 a year. Experimenter Publishing Co., 53 Park PL, N. Y. C.







# The Boy's Electric Toys

## 100 Fundamental Experiments in One Electrical Outfit

The Boy's Electric Toys contains: Enough material to make and complete over twenty-five different electrical apparatus without any other tools except a screw-driver furnished with the outfit. Student's chromic plunge battery, compass-galvanometer, solenoid, telephone receiver, electric lamp, etc. Enough various parts, wire, etc., are furnished to make the following apparatus:

Electromagnet, electric cannon, magnetic pictures, dancing spiral, electric hammer, galvanometer, voltmeter, hook for telephone receiver, condenser, sensitive microphone, short distance wireless telephone, test storage battery, shocking coil, complete telegraph set, electric riveting machine, electric buzzer, dancing fishes, singing telephones, mysterious dancing man, electric jumping jack, magnetic geometric figures, rheostat, erratic pendulum, electric butterfly, thermo-electric motor, visual telegraph, etc., etc.

With the instruction book we furnish one hundred experiments that can be made with this outfit, nearly all of these being illustrated with superb illustrations. No other materials, goods or supplies are necessary.

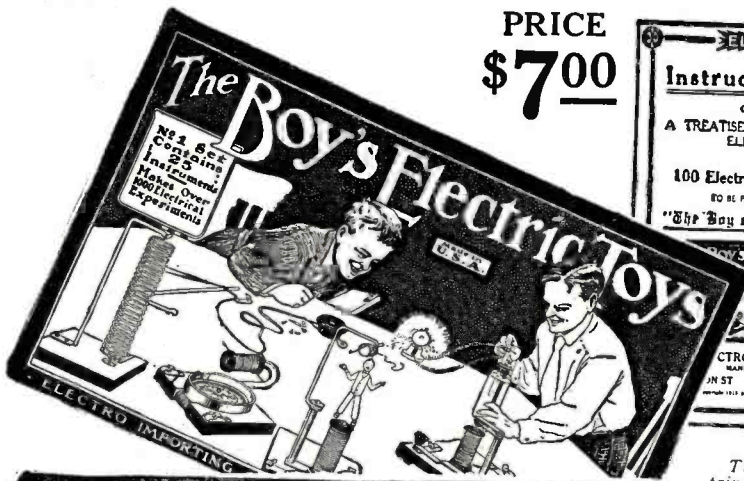

PRICE  
**\$7.00**

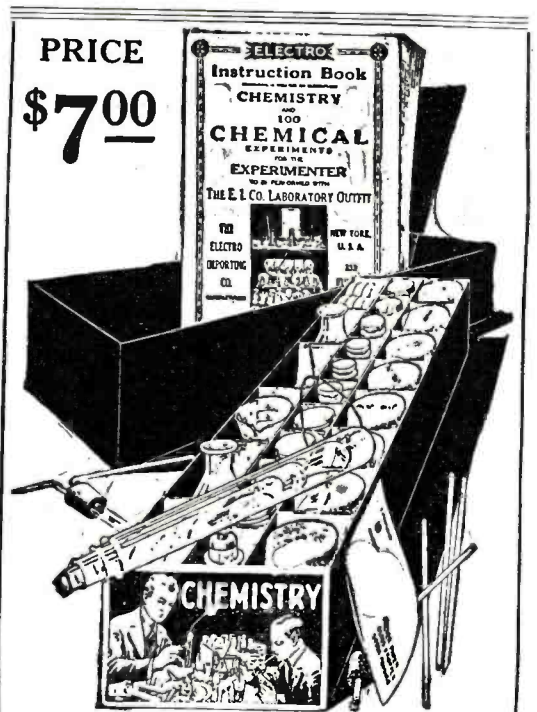

## Chemistry Outfit

Embracing Over 100 of Nature's Most Startling Experiments

Think of it, fellows! Here is a real chemistry outfit with regular chemical apparatus that performs those fascinating, actual chemical experiments. This outfit is not a toy, put up merely to amuse, but a practical laboratory set, with all the chemicals, apparatus and reagents necessary to perform real work and to teach the beginner all the secrets of inorganic chemistry.

The outfit consists of 44 Chemicals and Reagents all C. P. put up in appropriate wooden boxes, glass bottles, and hermetically closed jars. The acids are put up in glass bottles with ground-in glass stoppers, and there is a sufficient quantity of chemicals supplied (mostly one to two ounces) to make dozens of experiments with each.

The apparatus furnished are all of the best obtainable make and of standard laboratory size and shape.

The *Instruction Book* is a real *Chemistry Course for the Beginner*. Some of the Contents are: *Division of Matter*; This is a Treatise on Elementary Chemistry and deals with the theory of the Elements, Molecules and Atoms, etc. *Chemical Nomenclature*; This explains in simple language the derivation of the chemical names of the elements and their compounds. There is a chapter on *Laboratory Operations*; *Glass Working*; *First Aid*; *Fire Extinguishers*; *Experimenters' Aphorisms*, etc.

A good part of the book is devoted to Weights and Measures. The Metric System, The English System and the U. S. System are fully explained.

The following tables are furnished: Symbols and Atomic Weights of the Elements; Measures of Weights, Volume, Capacity and Length; per cent solutions; Conversion of Measure expressed in parts; poisons and their antidotes; technical and common name of chemical substances; formulas for cleaning various substances, etc., etc.

**Price \$7.00 Complete**

The outfit contains 114 separate pieces of material and 24 pieces of finished articles ready to use at once.

The size over all of the outfit is 14 x 9 x 2 3/4. Shipping weight 8 pounds.

"The Boy's Electric Toys" outfit as described, \$7.00. Immediate Shipment.

## SEND NO MONEY

We have so much confidence in these sets that we desire to ship either one to you by express C.O.D. with the privilege of inspection. In other words, we ship on approval. It does not cost you one cent to take a good look at whichever outfit you want, and see if it comes up to your expectations. If it does, pay the express man \$7.00, plus express charges. If not, you need not accept it, and we will pay the return charges as well.

**ELECTRO IMPORTING CO., 233 Fulton St., New York City**

RN4

ELECTRO IMPORTING CO., 233 Fulton St., New York, N. Y.

Please send me  "Boy's Electric Toys"  "Chemistry Outfit. If I decide to keep the outfit I will pay the full price upon delivery.

Name .....

Address..... City and State.....



**SHORT WAVE TRANSMISSION**  
By CHARLES F. FELSTEAD, 6CU

If there are any amateurs who do not yet fully realize the extreme value of the several new wave-length bands below 100 meters that have just been authorized for amateur transmission, the following facts should prove convincing that more energy can be radiated on the lower wave-lengths than on the higher ones.

The limited commercial transmitter at the Thomas H. Ince Studio, KZY, was tuned to 295 meters during a test, and at that wave-length the reading on the thermo-couple antenna ammeter was exactly five and one-quarter amperes. The station wavemeter, a very good one, was placed about three feet from the transmitter and carefully tuned to the transmitting wave-length. The current-squared thermo-galvanometer in the wavemeter gave a deflection of 15 divisions.

Without changing or moving anything but the clips on the transmitting inductance, the transmitter was then tuned down to 145 meters. Two antenna series condensers were used on this lower wave-length. The antenna ammeter read only three amperes on this wave-length. The wavemeter was left in exactly the same position as before, and carefully tuned to the working wave-length of the transmitter. The thermo-galvanometer then gave a deflection of 40 divisions.

With only about half the antenna ammeter reading on the lower wave-length as on the higher one, the transmitter was really radiating almost three times as much energy. This means that the transmitter would give a signal in a receiving set at a fixed distance almost three times stronger on the lower wave-length than on the higher one. Though the input to the transmitter was not recorded, it was practically the same for both wave-lengths. The radiated energy is what counts; an antenna ammeter is a very good liar.

**SHORT WAVE TRANSMITTER RESTRICTIONS**

Editor, RADIO NEWS:

I have just finished reading Mr. Bruno's article in the January, 1925, issue of RADIO NEWS, and found it to be very interesting. Hope we will often hear from him through RADIO NEWS.

It is not that I wish to discourage anyone from experimenting with low power transmitters—on the contrary, I would rather see more people interest themselves in this most fascinating of all phases of radio work—but attention must be called to a very serious error on Mr. Bruno's part in the article referred to above. At the end he says: "Remember that you do not need a license to operate this apparatus." This is entirely incorrect. Not only must a license be taken out, but the transmitter may only be operated over the band of wave-lengths specified—about 4 to 5 meters. It is against the law to operate an amateur C.W. transmitter on, say, 3 meters, or on 6 or 10 meters. This is, of course, to avoid interference with commercial and other stations operating on nearby short waves.

H. S. GOWAN, C-9BC,  
120 West King St.,  
Kitchener, Ont.

**3BHY TAKES NOTES ON ECLIPSE**

Gettysburg College amateur station, 3BHY, under supervision of E. G. Ports, Institute of Physics, was in operation during the period of the eclipse and noted the following: At about 8:45 a. m., E.S.T., amateur phone stations from the West began to come through with fair audibility; as the sun became further covered by the moon's disk, the signals increased very much in intensity. Several ninth district stations were worked

# Be A Radio Expert

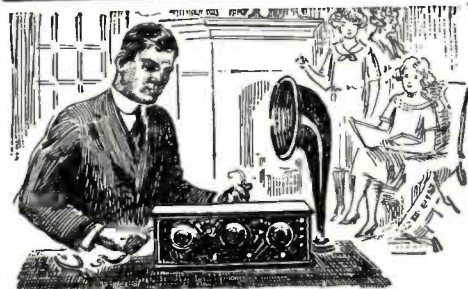

## Pleasant Home Study

During the next few months you can, by devoting a few hours each week in pleasant home study, qualify yourself to get into the biggest paying field of all time. My practical, understandable course of instruction enables you to be a Master of the Air. Every problem in radio becomes an open book to you. *Be a Master of the Air and you will be a master of your future.*

## \$3,000 to \$10,000 a Year as Radio Expert

15,000 ships, hundreds and hundreds of Radio stations, with new ones springing up every day, are all keenly competing for the services of the radio-trained man. So enormous is the call for the radio expert that the man who knows his business in this field is in a position to command the size of his salary. On land or sea, in Government or private service, there are boundless fine paying opportunities for the man who understands radio problems and how to solve them.

# RADIO <sup>where</sup> Knowledge is Power —and Power is Cash

I show you how to construct, install, operate, repair and sell radio equipment. Instead of being a spectator in this big game with big stakes, you become an active player. I qualify you to handle every branch of radio. There is nothing theoretical or practical that is not presented to you in complete, concise form. You are standing face to face with the greatest money-making chance ever presented to you. Will you turn your back on it or will you decide now, once for all, that you will get your share of the millions being divided among radio-trained men? Right in your own neighborhood you can make easy profits. Neighbors and friends will gladly give orders for sets and pay for advice on radio problems.



**A. G. MOHAUPT, B.A., M.S.**  
Head of the Radio Association of America. Graduate Electrical Engineer. University of Wisconsin. Former Radio Instructor for U. S. Government. Author of "Practice and Theory of Modern Radio."  
I give my personal attention to every student taking my course. Your individual problems and questions are answered by myself. I work with you at every stage of the course, guiding you, directing you to your goal to be a Radio Engineer in the big pay class. My course prepares you to successfully pass Gov't examination for Operator's License.

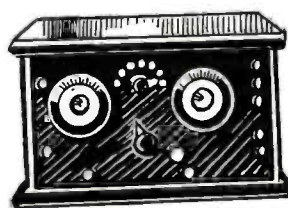

## FREE 1000 Mile Radio Outfit

This set, when completed, has a range of over a thousand miles. I give it free with my course. I give you practical training by having you work on this set. The knowledge you gain is not mere book knowledge, but is usable, practical experience. When you have finished my course, you can sell this set at a price that will more than pay the cost of the course.

## QUICK PRACTICAL TRAINING

Everything in my course is clearly and simply stated so that you can easily understand every point I bring out. No previous experience or education is required. I give you fundamental and practical training in every angle of radio. There is no time to lose. Now is the best time to pass the other fellow by. Mail coupon today and get full information on my course, also details of the thousand mile set that I give free.

**A. G. MOHAUPT, Radio Engineer**  
**RADIO ASSOCIATION OF AMERICA**  
4513 Ravenswood Ave., Dept. 154, Chicago, Ill.

## MAIL COUPON

A. G. MOHAUPT, Radio Engineer,  
Radio Association of America,  
4513 Ravenswood Ave., Dept. 154, Chicago.

Please send me details of your Home Study Course—also your Free "Radio Facts" and information on how I can get a FREE 1,000 mile Radio Set.

Name .....

Address .....

City ..... State .....



## Protects Radio Tubes

You can protect tubes against destruction from short circuits for a few cents by installing the "Gem" Radio Fuse. Then when there's a "short," the fuse blows and the tubes aren't injured. Easily installed.  
Sent postpaid for 60c with fuse block for attaching. If not at your dealer's. Write for booklet.  
**CHICAGO FUSE MFG. CO.**  
1501 South Laflin St. Chicago, Ill.

## "GEM" RADIO FUSE

## KITS TO BUILD YOUR OWN RECEIVER

- Roberts—2 tube, Parts.....\$31.44
- Roberts—4 tube, Parts..... 48.35
- Rasla—1 tube, Parts..... 23.78
- Rasla—2 tube, Parts..... 31.43

GENUINE ERLA KITS IN FACTORY SEALED CONTAINERS  
Write For Our 100-Page Free Catalog

**Liberty Mail Order House**  
S 43, 106 Liberty St., New York, N. Y.

Insure your copy reaching you each month. Subscribe to Radio News—\$2.50 a year  
Experimenter Publishing Co., 53 Park Place, N. Y. C.





Not an ordinary  
"Loud Speaker"

—but a faithful reproducer of tone

The new Kellogg Reproducer is not a "loud speaker" in the ordinary sense of the word, but is an instrument which faithfully reproduces the tone which it receives, whether that tone is loud or soft, low pitched or high pitched.

Complete programs never before thoroughly enjoyed because of poor reproduction, can now be received to the utmost satisfaction with this latest refinement in radio. See it at your nearest dealer.

Kellogg Switchboard & Supply Co.  
CHICAGO, ILL.

**KELLOGG**  
Reproducer

**Learn Electricity** in 12 Weeks in the Great Shops of **COYNE**

**EARN \$60 TO \$200 A WEEK**

Electricity the Big Pay Field. Fascinating work. Be an ELECTRICAL EXPERT. Coyne training is practical—simple. You do actual work on huge outlay **FOUNDATIONS** of electrical apparatus. New, ENLARGED COURSE. You don't need education or experience. Free courses in Radio and Auto Electricity right now. Earn while you learn. Write me at once for my big FREE Catalog—also particulars of my SPECIAL OFFER. ACT QUICK.

W. C. Lewis, President  
COYNE ELECTRICAL SCHOOL, Dept. 594-4  
1300-1310 W. Harrison St., Chicago, Illinois

**TUBES MADE NEW AGAIN \$1.00**

**New Process** Each brings back original strength to tubes that light but are weak or worn down.

**GUARANTEED 500 HOURS**  
Only U.V.-200, U.V.201-A, U.V.-199, C-300, C-301 A, C-299. Also corresponding tubes of other makes.

Mark Your Tubes and Wrap Securely  
Tubes Must Light to be Processed.  
Mail Orders Shipped P.P., C.O.D.  
24 Hour Service  
Dealers Write for Proposition.  
**SINGER RADIO CORP.**  
Times Bldg., Dept. R, New York City

HEAD SETS LOUD TALKERS  
PHONO ATTACHMENTS

**TRIMM**

RADIO MFG. CO., Dept. 66  
24-30 S. Clinton St. Chicago, Ill.

Insure your copy reaching you each month. Subscribe to RADIO NEWS — \$2.50 a year. Experimenter Publishing Co., 53 Park Pl., N.Y.C.

on voice during this period, and at the period of totality, 9DG, Dellville, Ill., was worked. His signals came in as loudly as at night and he in turn reported 3BM as very loud and clear. As the moon's disk passed off the sun, the signals again faded and by 9:12 a. m., E.S.T., Bellville, Ill., had faded so completely that they could not be heard. However, 9BSP of Olathe, Kan., continued to come in strong on phone until about 9:24 a. m., E. S. T.

**A University Radio Laboratory**

(Continued from page 1849)

A few practice experiments are given in the technique of connecting up and operating power tube oscillators, radiophone modulators, vacuum tube amplifiers, etc.

The experiments as well as the classroom work is designed to follow the class of work done in the standard courses in direct and alternating current theory and dynamo laboratory courses usually given in high grade engineering colleges. The electrical engineering point of view is striven for in these courses.

The University of Illinois also has a radio broadcast station. It is maintained and operated by the electrical engineering department, the transmitting apparatus being located in the electrical engineering laboratory.

The transmitter is of the permanent type, the apparatus being mounted in a heavy iron pipe framework, controls and meters mounted on a large panel. The oscillator consists of two 250-watt tubes in parallel, closed oscillator circuit of the Hartley type, with an inductively coupled antenna. The resistance of the antenna is 35 ohms at the frequency and wave-length used for broadcasting. With four amperes radiating, the power input into the antenna is 520 watts, this being the usual amount of radiation during broadcasting. The transmitter framework also contains three 250-watt modulator tubes in parallel in a separate sheltered compartment, the modulator tubes drawing 400 milliammeters during modulation with the vowel "a" and 75 milliammeters when no sound occurs, constant current modulation being used, and provided with the aid of a 20-henry iron core choke.

The speech amplifier furnishes amplified voice frequency power to broadcast this change in modulator plate current and oscillator output, the power speech amplifier containing three vacuum tubes, the last stage of which is a 50-watt power tube, and two 5-watt power tubes, furnishing agitation for the 50-watt tube.

**The Life and Work of Lee DeForest**

(Continued from page 1871)

control over the flow of current in the local circuit with the control placed at one side of the two terminals of the local circuit in the tube, why should it not exert an even greater influence over it with the new plate placed between the other terminals?

**THE FINAL STEP**

From this point the reasoning was comparatively simple. If the control electrode worked well outside the bulb and separated at a comparatively great distance from the other elements, why should it not give much better results if it were placed inside of the tube and comparatively close to the other

**The DAVEN RESISTANCE COUPLED AMPLIFIER KIT**

The aim of Radio is distortionless reproduction. The DAVEN RESISTANCE COUPLED AMPLIFIER hits the mark. Three or four stage kits bring its perfection to those who "build their own." Daven Amplifier Kits sold everywhere.

Obtain from your Dealer the "RESISTOR MANUAL," our complete handbook on Resistance Coupled Amplification. Price 25c. Post paid 35c.

**DAVEN RADIO CORP.**  
"Resistor Specialists"  
Newark, New Jersey

**The Genuine Standard Super-Heterodyne**

Here's the Best and Safest Guide—while building your New Super-Heterodyne

Conrad pattern No. 13 gives the have designed the most complete and practical pattern ever originated for the Standard Super-heterodyne.

Contains 2 extra large blueprints 19 1/4 by 44 inches and a 16-page instruction book. Everything is simplified, complete and ready for use.

**Price \$1.00**

SOLE BY ALL RADIO AND NEWS DEALERS

**The Conrad Company**  
233 Fulton Street - New York City

**Now Only \$6.45**

Greatest Bargain Ever Offered

**6-Shot Finest Perfected Revolver**

Sells elsewhere at \$12.00. Quick as a flash, safe, great penetrating power and true marksmanship. Blue steel or nickled, 38, 32 or 22 caliber all same price. Satisfaction or money back. **SEND NO MONEY.** Pay postman on arrival \$6.45 plus postage. If you send money with order **WE PAY ALL POSTAGE.**

Federal Mail Order Corporation  
414 Broadway, Dept. A, New York

**RADIO CATALOG AND HOOK-UPS FREE**

Our great new catalog, fresh from the press, contains the very newest in complete sets, parts and accessories—hundreds of amazing bargains. 250,000 customers testify to our wonderful values and reliability. Complete instructions with diagrams for making most practical popular sets **FREE. SEND QUICK** for your copy. (Please include name of friend who is interested in Radio.)

**THE BARAWIK CO.**  
Dept. 117 32-40 So. Clinton Street Chicago



elements? But the plate form would have to be dispensed with since the conduction of the current through the tube was by the ionized gases (at least that was the accepted explanation at the time), and a plate between the filament and the first plate would place an unnecessary obstacle in the path of the current carrying gases. Of course, he had decided to place the aerial control electrode between the plate and the filament in order to gain the greatest possible control over the flow of local current from the battery through the tube and to the telephone receivers. Consequently the usual plate form was dropped for the present day grid. The final form of the audion, as we know it today, was the result, shown in Fig. 7.

**REALIZATION**

After a few preliminary tests with the new detecting device, DeForest was so impressed with the results that he began to see dimly some of the changes it would make in the whole field of minute currents. He saw adaptations of it throughout the realm of electricity. He knew then, as he knew afterward when he read a paper before the Franklin Institute when he was given the Cresson medal, that the little grid was worthy of the greatest enthusiasm and praise.

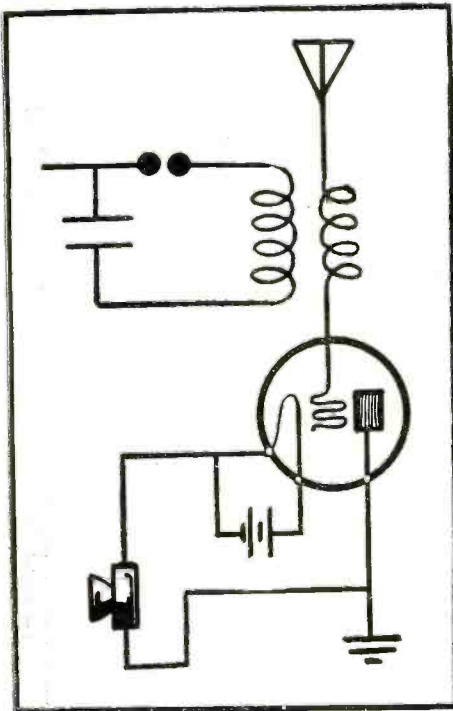

The circuit patented by DeForest in 1906 for voice modulation in connection with a spark transmitter. Were the plate and grid connections interchanged the circuit would be the same, basely, as the present-day modulation system employed in radio broadcasting.

He said of it at the Franklin Institute: "In surveying the wide field of electrical communication today one cannot look back at that little figure of the first grid electrode without a sense of wonder at the enormous changes which it has wrought. It has made possible commercial trans-oceanic radio telegraphy. It has realized trans-continental radio telephony, it has made reception of wireless signals half way round the globe an everyday occurrence. The uncanny accuracy of millions of shells from the allies' guns, the clock-like precision of the dancing barrages, would have been impossible save for the effectiveness of their trench and air-plane service, in which the grid audion was the essential part. Today this little grid controls and modulates an ever increasing kilowattage of radio telephone energy, which as early as 1915 conveyed the spoken voice from Arlington to Honolulu and more recently from New Brunswick to the trans-

# FROST-RADIO

*Ask Your Neighbor*

## Accessories for your radio set

THESE dependable **FROST-RADIO** Accessories add to the satisfaction you will get from your receiving set. They make its operation easier and the results derived from it greater than would be the case were inferior apparatus used.

No. 262  
2-Spring  
Type

**\$1.00**



**FROST-RADIO**  
**PAN-TAB JACK SWITCHES**  
A rugged, finely made jack switch, with on-and-off plate and pointer.



**Frost Radio**  
**MUSETTE Phonograph Unit.**  
A remarkable improvement over any similar device. \$5.50

You can select any of these or other items of **FROST-RADIO** from the store of your neighborhood dealer with a certain knowledge that you will find the apparatus of the highest quality and full value for the price you pay.



**FROST-RADIO**  
**MUSSELMAN Selective Antenna.**  
An aerial that increases the selectivity of any set. 75 feet. \$5.00.

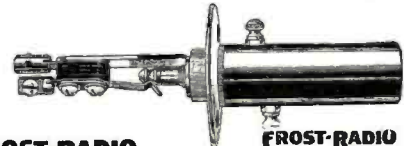

**FROST-RADIO**  
**LOOP AERIAL PLUG AND JACK.** May be mounted on top of set, with loop mounted in plug. A popular item. \$1.50.



**FROST-RADIO**  
**GROUND CLAMP.** Adjustable to pipes of varying size. Ground wire easily connected. 30c.

**FROST-RADIO**  
**48-page catalog FREE on request**

Write today for your copy of our 48-page catalog of all items. See your dealer for the merchandise.

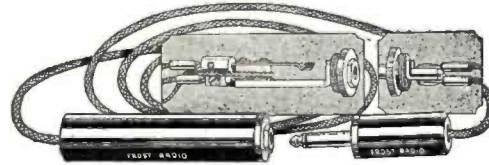

**FROST-RADIO EXTENSION CORD.** A handy means of connecting set to loud speaker, even when widely separated. Comes in convenient lengths. \$2.00 and up.

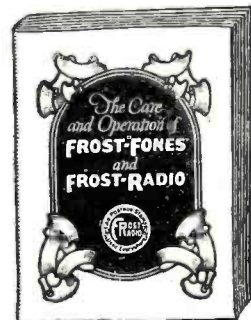

**HERBERT H. FROST, Inc.**  
314-324 WEST SUPERIOR STREET, CHICAGO  
NEW YORK CITY CLEVELAND KANSAS CITY LOS ANGELES



**Noiseless Grid Leak**

**40c**  
each in any value from 1/4 to 10

**FRESHMAN SUPERIOR**

*You can depend upon them to remain accurate at all times*

Made of high resistance material impregnated throughout (not coated paper). Unaffected by climatic conditions. Will not deteriorate. Clamped between solid knurled ferrules assuring rigid construction and firm contact at all times.

At your dealer's, otherwise send purchase price and you will be supplied postpaid. Chas. Freshman Co., Inc., 240 W. 40th St., N.Y.

**MAILED ABSOLUTELY GUARANTEED**

The internationally famous **DUTCH RADIO VALVE** will be \$1.90 plus postage mailed for All Standard Types

Three sent for \$5.50 plus postage (any type). Approved by Popular Radio laboratories. Order from nearest point.

St. Louis Radio Tube Lab. 3572 Olive St., St. Louis, Mo. D. R. V. Importing Co. 515 Orange St., Newark, N.J.

**FOR ANY CIRCUIT IN ANY SET "YOU CAN'T BEAT THE DUTCH"**



# A New Kind of Radio Magazine

# RADIO REVIEW

## A Digest of the Latest Radio Hookups

### 35<sup>c</sup>

THE COPY

### Partial Contents of First Issue

- The Four-Tube Roberts Receiver — How to make it.
- Construction of the new Pressley Super-Heterodyne.
- How to make the D-Coil Set.
- Construction of the Ultralyne, L2.
- How to build the new Press Reflex.
- The Browning-Drake Receiver.
- An efficient Low Loss set.
- The Two-Tube Harkness Counterflex.
- Modifying the Reinartz Receiver.
- Constructional details of Britain's latest Multi-stage R.F. Set.
- How to build a simple One-Tube Receiver.
- A Self-Neutralized R.F. Receiver.
- A One-Control Regenerative Set.
- How to make an Ultra-Short Wave Receiver.
- Hints to radio constructors, Etc., etc.



### 35<sup>c</sup>

THE COPY

### Description of Magazine

One Hundred pages —each completely filled with constructional information to satisfy the most critical or ardent enthusiast.

#### NO ADVERTISING

Over 200 illustrations of all kind and description.

Size of magazine, 9 by 12 inches—(Full magazine size).

Handsomely printed cover in three colors. Magazine is written plainly throughout so that everyone will be able to understand it completely.

It is the only magazine of its kind in existence — the kind of a magazine so many hook-up enthusiasts have been waiting for.

*Don't forget to get your copy NOW.*

## An absolutely impartial review and digest of Hook-ups, Diagrams and New Circuits appearing in the radio press the world over.

This new magazine is dedicated to those of the radio fraternity who wish to keep up-to-the-minute on all hook-ups, diagrams and new circuits appearing in the radio press the world over. We are publishing this new material as quickly as it is available with original photographs and drawings. This magazine will be absolutely impartial. New circuits or information of constructional nature from every source will be printed, making it a true Review and Digest of the latest achievements in radio.

All articles will be of a constructional nature rather than of an instructional. Each and every article will be illustrated and will contain complete data that will enable the constructor to build a radio set from the information therein.

In order to be absolutely impartial and unbiased, advertising of any kind will not be accepted. For this reason our magazine is selling for 35 cents.

**BUY THE FIRST NUMBER FROM YOUR RADIO OR NEWS DEALER TODAY — IF HE HAS NO SUPPLY ON HAND WRITE US DIRECT USING THE COUPON ON THIS PAGE.**

**THE CONSRAD COMPANY, 233 Fulton Street, New York, N. Y.**

Enclosed find 35c for which kindly send me the first issue of "RADIO REVIEW," or

Enter my subscription for 12 issues of the "RADIO REVIEW" for which find enclosed \$3.50.

Name .....

Address .....

Town .....

State .....

R.N.# .....

## The Consrad Company

233 Fulton Street New York, N. Y.

Radio's Foremost Publishers

Everything in Radio Books, Patterns and Diagrams



port *George Washington* in the harbor of Brest, France. It has already placed 20 simultaneous messages upon a single pair of wires. A few ounces of grid wire made possible the saving of hundreds of tons of copper in long distance telephone conductors. It has given to the physicists a tool for the exploration of unprobed fields of research and to the electrical engineer a generator without moving parts of alternating currents of any desired frequency from 1 to 10,000,000 cycles per second—a machine absolutely constant and reliable in its silent work."

A bit of egotism may be forgiven in such an instant, and concerning such a discovery.

**S**UCCESS of DeForest and his company had, up to this time, only been moderate. The World's Fair Exhibit in St. Louis, however, had given the work of the company and the inventor a great push forward. At the close of the air season, a British branch of the company was formed and DeForest took another flying trip to Europe. He was there just 10 days—long enough to allow him to settle some of the details as to patents and specifications and to receive a dinner at the Savoy Hotel from Lord Armstrong and a number of notables.

**COMPANY GETS NAVY CONTRACT**

As soon as the business was completed, DeForest rushed back to New York. There was great business afoot, the Navy was about to decide five contracts for stations to be erected in the vicinity of the Gulf of Mexico. DeForest and his laboratory staff set about figuring immediately.

A month later the contracts were awarded to the DeForest Company for the five stations. The stations were of huge power for that time; they were to be 20 and 25 kilowatts input.

There were four contestants for the contracts, the DeForest Company, the Telefunken Company, the German firm, The National Electric Signaling Company and the Marconi Company.

The experiences in the erection and operation of the stations were heart breaking. Static was evident in such forms as the engineers of the company had never before known. In the erection of the stations at Guantanamo and Colon (aside from these two there were stations at Key West, San Juan and Pensacola), climate and living conditions were such as to make life a veritable hell for those engaged in the construction. All of them were men from northern climes, unused to the terrific heat of the tropics.

**TROPICAL STATIC!**

After the completion of the Pensacola station and its sister at Key West, the crew made ready to open for traffic. And then the surprise came. Static conditions were so bad that operation was impossible for more than three or four hours per day during the summer time. And it could only be carried out then with the aid of the "Balancing Pan Cake Coils." This tuner was simply composed of three flat inductances, one connected to one end of the antenna, while the other end of the antenna was connected to the ground. The other two pan cakes were connected in the local circuit and astoundingly good tuning resulted from balancing the several circuits.

**A DEAD SPOT**

At the Key West station a dead spot was located between its antenna and the Pensacola station. Communication could be carried on in one direction, but not in the other. Things were at a desperate pass. The spark gaps were lengthened in order to get a bit larger charge on the condensers and immediately the high voltage broke over the condenser insulation. The spark gap was of the large open variety, and on a cool,

# MARCO CONDENSERS



Here's  
the  
**PROOF**  
that—

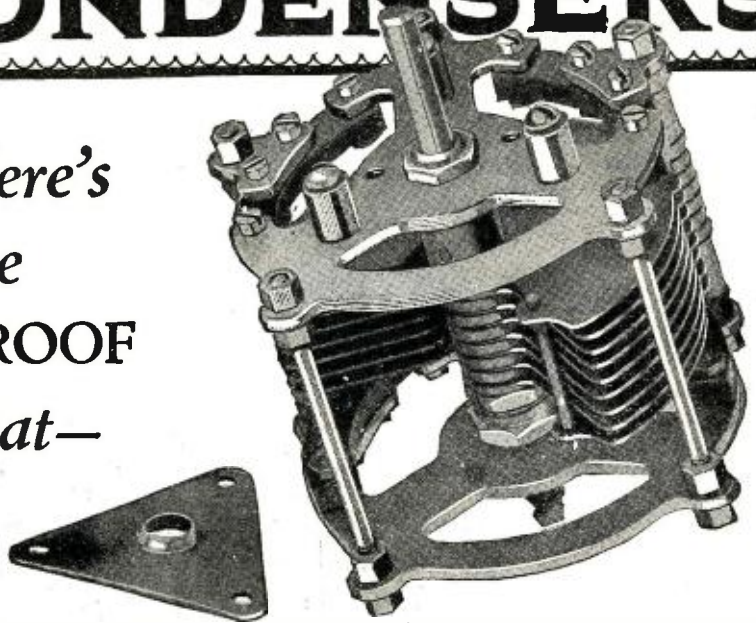

**"A better condenser makes any circuit better!"**

I have had built an 8-tube Super-Heterodyne and of course bought with care the best parts the market offered. The result was, I tried several well-known condensers which were not satisfactory and by chance tried a pair of "Mar-co Condensers" and was greatly pleased with the performance of my set. So much so I hoped to pick up one of the foreign stations during test week.

On tuning in on 470 meters, picked up "Lyons, France, Station PTT," which came in as loud and clear as a bell with orchestra music, and held them until they signed off at 12 midnight, Eastern Standard Time.

I am enclosing a confirmed telegram of my reception that you may know Mar-co Condensers proved 100% on a test with an amateur at the dials.

Yours very truly,

(Signed) H. W. DAHL

MARTIN-COPELAND COMPANY · Providence, R. I.

## SILVERTRONS

**\$2.25** The Fastest Selling Guaranteed Tubes **\$2.25**  
**== -- TO-DAY AT NEW LOW PRICE -- ==**

*BETTER THAN EVER — LONG LIFE — CLEAR RECEPTION*



Type 102A 5 volts operates as either Detector or Amplifier on ¼ amp. filament consumption. The Ideal Tubes for Neutrodyne and Super-Heterodyne.

The Silver Tube with the Golden Voice.

Type 112—1½ volts, Ampl. and Detec. Amp. ¼  
 Type 112—1½ volts, Detector only. Amp. 1-5.  
 Type 399 3-4 volts, Detector and Ampl. Amp. .06

*Sent C.O.D or parcel post prepaid, carefully packed to any address on receipt of \$2.25*

**7-1**

1st Stage

**\$3.00 Each**

**SILVER-TONE**

A New Audio Frequency Transformer

Better and Clearer Reception You Never Experienced, the Last Word and Achievement in Radio.

**BUY A PAIR — THEY ARE MATCHED MONEY BACK GUARANTEE**

**3-1**

2nd Stage

**\$5.50 Pair**

**DEALERS and JOBBERS—Write for Discounts and Circulars.**

**NEW YORK RADIO COMPANY 71 West Broadway New York City, N. Y.**



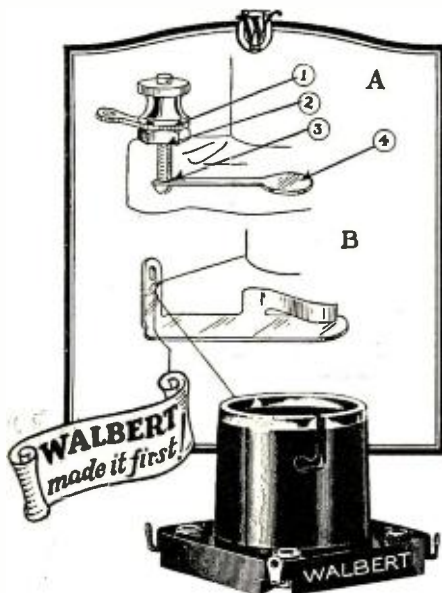

## 80 "LOSSES" ELIMINATED—

Count them!

Do you know that on each contact spring of the average socket there are at least 4 "contact-losses" (see Fig. A above) or 16 "losses" counting all four springs? On a 5-tube set there would be 80 possible "contact-losses." What a chance for increased volume if these "losses" could be eliminated.

They can be! The WALBERT SOCKET does it. Positive contact with each tube prong is made possible by a unique side-wiping and bottom-pressure phosphor bronze spring. There are no other contacts—soldering lug is part of the spring! (See Fig. B). Losses are eliminated where they count the most.

### And UNBREAKABLE!

A special protective rim absolutely prevents breaking or slipping at the slot. The WALBERT is the real life-time socket! Special All-bakelite design decreases inter-element capacity thereby utilizing all available grid voltage for producing signals. (New tubes have bakelite bases for same reason). Socket is extra deep. Covers entire base of tube. Aids in holding tube firmly and makes a strikingly handsome socket.

### Specified by COCKADAY!

In his latest hook-up, Mr. Cockaday specifies the new WALBERT SOCKET. Why? Use them on your set and you too, will note the improvement! At your dealer or sent postpaid on receipt of purchase price.

## Walbert Socket 75c

Jobbers and Dealers: Write for Discounts.

WALBERT MANUFACTURING CO.  
923 Wrightwood Ave. Chicago, U. S. A.



The Lowest Priced High Quality Kit

## WEL-BILT TRIPLE KIT HAS ONLY the BEST PARTS

Consisting of: Straight Line Low Loss Condensers  
High Grade Transformers  
Litz Wire Tuner  
Bakelite Sockets  
Engraved and Drilled Panel  
Midget Condensers  
Rheostats, Dials, Jacks, etc.

Satisfaction or money refunded.

FRIEDLANDER - KOPPLE RADIO SERVICE  
149 Chambers Street N. Y. City

Insure your copy reaching you each month. Subscribe to Radio News—\$2.50 a year. Experimenter Publishing Co., 53 Park Place, N. Y. C.

clear night the messages being sent from the Key West station could have been read all over the island by the simple method of reading the spark.

The troubles encountered at the Pensacola station were little smaller. The station could not get an efficient ground in the usual way. It was found necessary to drive hundreds of pipes into the ground in order to gain contact with good damp soil.

### FEVER AND QUARANTINE

Then they were quarantined at the Navy Yard, where the station was located for five weeks on account of fever.

All the winter and spring of 1905 were occupied in erecting the five stations and putting them into operation.

All during these times, while DeForest was busily engaged in the station work, he was finding time now and then to work on the new vacuum tube detector. They were still being only partially exhausted; in fact, the plate element was being coated with a halogen salt which would vaporize when the tube was placed in operation.

It was not until a year later when DeForest was adapting the tube as a telephone amplifier that the advantages of the hard or highly exhausted tube were evident.

### DEFOREST'S MODULATION SYSTEM

And one point is very important. At this early date DeForest was working toward the radio telephone. The circuit shown in Fig. 8 shows how closely he came to the present method of modulation with a tube. The high frequency carrier was to be supplied by a spark arrangement producing undamped waves. The antenna current was to be passed through a tube and thereby modulated.

This is one point showing how close an experimenter may come to a really new adaptation and miss it. Shortly after DeForest had started the experiments with this modulation method—in fact, while he was in the midst of them—he was called away on business of the company so that he did not have time to try the usual procedure of interchanging the electrodes of the tube. When he returned, the work had been so disorganized that it was not taken up again in its logical form until years later.

A few months later he came, in some of his experiments along this same line, to the heart of the oscillator detector of Heterodyne reception—but more of this later.

In looking back over the history of the audion and compressing it into cold written fact, it loses something of its romance and beauty. Really an invention which has had such far-reaching effects throughout the whole field of electrical and radio engineering should almost take the form of a saga. However, the story is one that is filled with fights, villains, great characters, strenuous circumstances and all the ingredients of an epic. But, like most really good tales, these things are mostly found between the lines. Nevertheless, it is a tale of one of the world's greatest inventions.

## International Radio

(Continued from page 1891)



### SWEDEN

New International Swedish Station

The completion of a new Government radio station at Varburg will make direct communication with the United States possible. Heretofore, it was necessary to communicate with Sweden through Norway.



## Reflectone

only 4½ inches high  
Cigarette Box Amplifier

GIVES clear, full, natural reception of anything on the air . . . and offers an added convenience—a cigarette box! Place this amplifier—remarkable, small and attractive—on the smoking stand, in your library, anywhere as an ornament . . . then tune in! By a new scientific development, tone is reflected from one tonal chamber of Model "C" Reflectone to another. Vibration is neutralized, the faintest sound reflected—no note is added, none destroyed.

\$12.00

The Midget Loud Speaker  
With the Giant Voice.

At your dealers, otherwise send purchase price and you will be supplied postpaid. Write for descriptive circular.

RICE & HOCHSTER  
134 Washington Place New York City

## BROWNLIE CRYSTAL

Guaranteed the Best \$1.00

"REFLEX SPECIAL" QUICK CONTACT RECTIFIER

Withstands Heavy Plate Voltage  
The Acme Apparatus Co. says "prevent distortion and howling by using a BROWNLIE CRYSTAL in REFLEX SETS."

Order From Your Dealer or Direct  
ROLAND BROWNLIE & CO.  
22 Saunders Street Medford, Mass.

Insure your copy reaching you each month. Subscribe to RADIO NEWS—\$2.50 a year. Experimenter Publishing Co., 53 Park Pl., N. Y. C.



**Broadcasting in Sweden Promising**

Pending the erection of the regular broadcast stations to be operated under the "Radiotjanst," the Swedish Telegraph Administration will operate temporary stations for the benefit of some 40,000 radio fans. Stations of this type are already operating at Stockholm, Malmo and Gothenburg. During January the equipment of the Boden station was installed and it is expected that another will be erected and equipped soon at Sundswall. At the beginning of this year new regulations went into effect and new licenses were required of all. Licenses for private receiving sets cost 12 kronen, but when loudspeakers are employed in public places, special permits at increased fees are necessary.

**Country Without a Broadcast Station**

**BRAZIL**  
The Para district of Brazil is without a broadcast station and so the fans living there are forced to listen to outside stations. The stations of the United States are received best and advices state that American made sets are giving the greatest satisfaction and results.

**ARGENTINE**

**Have You Heard Station LOR?**

Station LOR broadcasts every evening about 8:30 p.m. E. S. T., on a wave-length of 400 meters. This station transmits with a power of 1½ k.w., so it should be picked up by North American amateurs. The station may be easily recognized because its call letters are transmitted in Morse code at the beginning and end of every program.

**CHINA**

**Far East To Get Station**

The Colonial Government of Hongkong plans to erect a broadcast station for the purpose of transmitting typhoon and police warnings and matters of public interest in "plain language." Owing to the apparent high cost of operation, the local government will operate the station itself and the station will probably work on a wave-length of 350 or 369 meters.

**INDIA**

**American Stations Heard In India**

Two Marconi engineers in India intercepted a beam short-wave message from England to South Africa, and then listened to short-wave broadcasts from KDKA at Pittsburgh. This occurred in Bombay and served as a boost for American made sets as these results were obtained with this apparatus. In fact, all through the East, American sets are considered to be of the best grade.

**MEXICO**

**American Sets In Mexico**

Of the 20,000 radio receiving sets operated in Mexico and about 12,000 more in the other parts of the country, nearly 95 per cent. is reported to be of American make. Government licenses, regulations and inspection are required for all these stations, as well as the four large and six small broadcast stations on the air in Mexico.

**A NEW STUNT**

Super: "Smithy's going on the stage."  
Het: "Certainemente?"  
Super: "Yeah, he learned to whistle off his super-regenerator."  
*Contributed by Jack Bront.*



# Hook-ups!

All the latest and best "Kits" in our new

## RADIO CATALOG

sent to you  
**FREE**

**N**O other Radio Catalog includes such a complete assortment of the best and latest Knock-Down Kits, Parts, and Accessories. You need this book—write for your FREE copy today!

**An Unequaled "Kit" Service**

All parts for each "KIT" have been carefully selected and tested by our staff of graduate Radio Engineers—satisfactory results are guaranteed.

Completely drilled and engraved panel included with each "KIT." Makes set building easy and sure. No other concern gives this FREE service. Easy to understand Instruction Book and Blue-Prints included with each Outfit. No technical knowledge required to build your radio set.

**Save Money ON GUARANTEED APPARATUS**

Our business is to buy up manufacturers' and government surplus stocks, jobber and dealer bankrupt stocks—but only brand-new, fully guaranteed nationally advertised apparatus. Our enormous buying power permits us to pay spot cash and get rock-bottom prices—even way below manufacturer's costs. That's why our catalog is crammed with thousands of wonderful Radio Bargains.

**Dealers! Jobbers! Manufacturers!**

**ATTENTION!**  
We will pay you spot cash for your surplus stocks—brand-new apparatus only! Write and tell us what you have.

Remember our motto: Salvage means—**SAVE, SERVICE, SATISFACTION**



509 S. State Street, Dept. R.N.6, Chicago  
Write for your FREE copy of our new catalog today—just your name and address on a postcard will do. Please add the names of any of your friends interested in Radio.



## BLUEBIRD Radio Tubes

*Distinctly New and Efficient*

Satisfying every radio fan's wish in performance and price. Our direct sales plan enables us to sell at this low figure. "Bluebird" is a sensitive and powerful tube, assuring increased range and clear volume.

Type-400	.....5 Volts, 1 Ampere Detector Tube
Type-401A	.....5 Volts, .25 Ampere Amplifier and Detector
Type-499	.....3-4 Volts, .06 Ampere Amplifier and Detector
Type-499A	.....3-4 Volts, .06 Ampere with Standard Base Amplifier and Detector
Type-412	.....1½ Volts, .25 Ampere Platinum Filament Amplifier and Detector

**ALL ABOVE TYPES \$2.00**

Type-402 .....5 Watt, Transmitters. \$3.00  
*Shipped Parcel Post C.O.D. When Ordering Mention Type.*

Designed to give best results in all circuits—Radio Frequency, Neutrodyne, Reflex and Super-Heterodyne Sets, etc.  
*Every Tube Guaranteed*

### BLUEBIRD TUBE CO.,

Dept. N,  
**200 BROADWAY**  
New York City

Insure your copy reaching you each month. Subscribe to Radio News—\$2.50 a year  
Experimenter Publishing Co., 53 Park Place, N. Y. C.



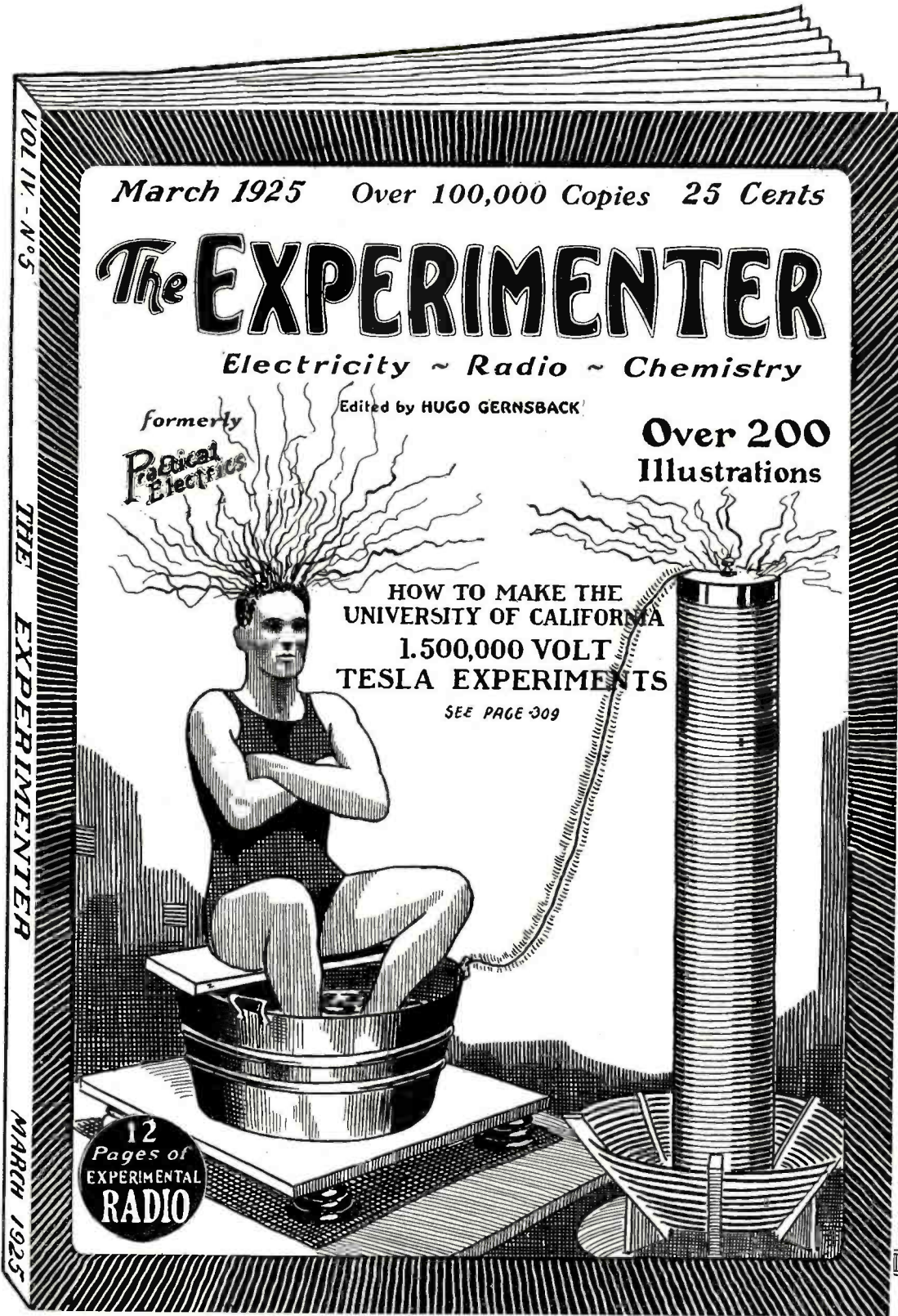

# The Sensations of a 1,500,000 Volt Shock

Some amazingly interesting experiments carried on by the University of California with extreme high-frequency electrical currents show that a man can stand 1,500,000 volts. The reason is that the extreme high-frequency permits the electric currents to travel only along the person's skin and do not penetrate the body.

The March EXPERIMENTER tells all about these remark-

able experiments, together with many pages of new and novel experiments in electricity, chemistry and radio as it is being developed at the present time.

Every line of The EXPERIMENTER is interesting, novel and practical. Its full to the brim with unusual and astonishing tests and happenings.

**GERMOTT PUBLISHING CO., Owners**

**Licensed Publishers: The Experimenter Pub. Co., Inc., 53 Park Pl., N. Y.**



## Lessons in Esperanto

(Continued from page 1899)

the dictionary for their definitions, but will instantly grasp their meaning by their classification.

The following summary will show you how to study the table.

To become master of the entire 45 words, it is only necessary to learn the nine indefinite words in the left-hand column and the three letters, K, T, Ĉ and sign of the negative, Nen-, at the top. Let us suppose that I is the root-word conveyning an idea of anything, that is, something indefinite.

To form a noun add O. IO = something.

To form an adjective add A. IA = some sort of.

To form an adverb add E. IE = somewhere.

In English we are accustomed to associate A. M. with time. Thus IAM means at some time, and 'S we usually connect with possession, thus IES means somebody's. We have thus broken the back of the problem. Only the following forms remain, and no doubt you will develop your own plan for remembering these:

U for individual; thus IU = somebody.  
OM for quantity; thus IOM = some quantity, somewhat.

AL for cause, reason; thus IAL = for some cause, reason.

EL for manner; thus IEL = in some way, somehow.

So much for the indefinite forms.

In order to transform them into relative or interrogative forms, prefix K, which always indicates a question is being asked, and takes the place of ĉu as the sign of interrogation. K usually corresponds to the English wh. Thus: kio = what (thing); kiu = who (what person), etc. For others see the table, under heading K.

Similarly, for demonstratives, instead of K, prefix T, which always points out objects or indicates a definite thought. It usually corresponds to English th. Tio = that thing, that; tiu, that person. For others, see table under heading T.

Similarly, for negatives substitute Nen for T or K, and you have nenio, nothing; neni, nobody, no one. For others see the table under heading Nen.

Similarly, for distributives substitute Ĉ for Nen, T or K, and you have ĉio, everything; ĉiu, everybody, every one. For others see the table under heading Ĉ.

As various people have various ways to overcome difficulties, you may find the following little rhyme helpful with the foregoing:

I-, Ĉi-, Ti-, Neni-, and Ki-,  
Then add -a for Quality,  
-al for Reason, -am for Time,  
-e for Place, excuse the rhyme.  
Manner -el; Possession -es,  
which must always sound like bless,  
Thing add -o, -om Quantity,  
Person -u should always be.

(From The Esperantist.)

U refers to individuality, person or specified object. Iu pentristo, any. (or some certain) painter; iuj libroj, some (or any) books.

### VOCABULARY

Konstrui, to build; nur, only; eble, possible; baterio, battery; transformatoro, transformer; kurento, current; povo, power; mejlo, mile; detektoro, detector; cirkvito, circuit; sen, without; intenci, to intend; jes, yes; uzi, to use; preskaŭ, almost; opinio, opinion; longa, long; aŭdi,

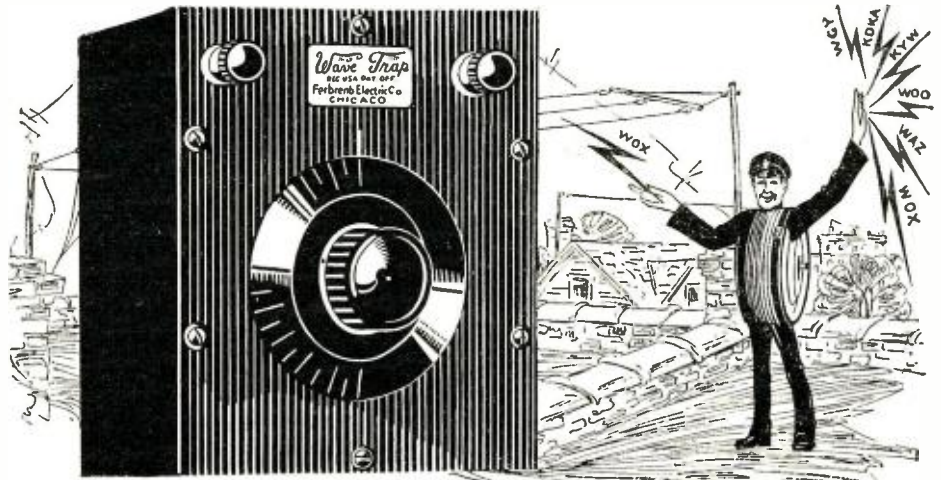

## "The Traffic Cop of the Air"

"KYW—stop! Enter not into the realm of Music and Fancies! Know ye not that WOX has the stage? Thou shalt not enter to interfere!"

... 'Tis the far-famed Traffic Cop speaking—and his word is law. The Ferbend Wave Trap is respected and the interfering station pleasantly bows out.

You, too, can make your set selective—separate the interfering station, by simply putting the Traffic Cop on guard.

The Ferbend Wave Trap will tune out interfering local stations, no matter how troublesome. Never reduces, but nearly always increases volume. By the addition of a new, improved circuit, the Ferbend Wave Trap now gives you several new hook-ups, and at the same time can be used to convert a single circuit regenerative set into a three-circuit regenerative receiver thereby practically eliminating all radiation from the set.

Designed and manufactured complete by us after years of careful experimenting. It is not to be confused with imitations, hastily assembled from ordinary parts. The price is \$8.50. Shipment is made Parcel Post C.O.D., plus a few cents postage. If you prefer, you can send cash in full with order, and we will ship postage prepaid. Clip and mail the COUPON today!

### FERBEND ELECTRIC COMPANY

25 E. South Water Street Chicago, Illinois



FERBEND ELECTRIC CO., 25 E. So. Water St., Chicago, Ill.  
Gentlemen: Please send me:  
 WAVE TRAP. Send postpaid. I am enclosing (check, M. O., etc.), for \$8.50.  
 WAVE TRAP. Send C. O. D. I will pay postman \$8.50, plus few cents postage, when it arrives.  
 FREE BOOKLET on Interference.  
Name \_\_\_\_\_  
Address \_\_\_\_\_  
City \_\_\_\_\_ State \_\_\_\_\_

East Pittsburgh, Pa.  
December 20, 1924.  
Ferbend Electric Co.  
Gentlemen: I live less than two miles from the antenna of KDKA, the powerful Westinghouse Station (1000 watts), at present, and while they were on I could get absolutely no other stations—even other locals a few miles away. You can imagine my amazement last night when I tried my Ferbend out to receive WOX, Davenport, WBZ, Springfield, (ONLY 11 METERS FROM KDKA) KSD, St. Louis, WTAM, Cleveland WFAF, N. Y. City, WXY, N. Y. City, WBAV, Columbus and eight or nine others without so much as a whisper from KDKA which was broadcasting full power.  
Very truly yours,  
CHAS. MARBERRY

## VOLT-X

### VARIABLE GRID LEAK

**NEW!**  
A BALL-BEARING Grid Leak That Stays Put  
Screw adjustment, expansion contact and resistance unit that cannot wear or tear.  
VOLT-X GRID LEAKS are positive and smooth in action with an accurate range of from one-half to fifteen megohms.  
They fit any standard leak mounting, and get the absolute maximum from your tubes. They do not wear out.  
Grid Leak ..... \$1.00  
Grid Leak Mounting .. 30  
Balancing Resistances for Super-heterodyne and other circuits 30,000-150,000 ohms.

## BURTON & ROGERS

MFG. CO.  
755 BOYLSTON ST., BOSTON, MASS.

## Praised by Experts!



Enjoyable volume and marvelous clarity are ensured with Airtron Tubes.

Every tube is a product of scientific skill and accuracy, and fully guaranteed. Bases are of Bakelite, which ensures highest efficiency. Tested and approved by Radio Authorities. Ask your favorite dealer for Airtron Tubes. All standard types, \$3.00.

Dealers write for discounts.  
We Repair all types of tubes. \$2.00.  
H. & H. RADIO CO.  
Dept. 105, 514 Clinton Ave.  
NEWARK, N. J.

# AIRTRON

## RADIO TUBES

Insure your copy reaching you each month. Subscribe to Radio News—\$2.50 a year  
Experimenter Publishing Co., 53 Park Place, N. Y. C.



# RADIO DEALERS

**ELECTRICAL DEALERS, MUSIC DEALERS, Etc.**

Get our new No. 28-B Catalog and Wholesale Price List. Dealers who have this say it is the finest and most complete Radio Catalog they have ever seen. All standard quality "tested and proven" lines listed. Discounts liberal. A real policy of merchandising backs up our Catalog, our Dealers and our Salesmen. viz.—"Wholesale Only."



Send quick for this Catalog and try us on your next order. Prompt shipments guaranteed.

**OHIO RUBBER**  
228 W. 7th St. Cincinnati

## OHIO MOTOR GENERATOR CHARGER



### NO MORE WEAK BATTERIES

Why lose an evening's entertainment because of run-down batteries? An Ohio Motor Generator charges in one-third the usual time at 3 to 20 amperes, 6 to 10 volts.

It's a real motor generator with no expensive bulbs to break—no chemicals to renew—no contacts to burn or fuse. It has sufficient capacity to charge several batteries in parallel.

Merely hook it to a light socket—Fully automatic—Needs no watching while charging—Cannot charge in the wrong direction—Regularly equipped with 110 volt, 60 cycle A.C. Motor, 6 to 10 volt Generator. Equipped for other service if desired. Lasts a life time.

**SATISFACTION GUARANTEED OR MONEY BACK**

In writing for details and special prices, state service current and if Charger is to be used for "A" batteries only or both "A" and "B" Batteries.

THE OHIO ELECTRIC & CONTROLLER CO.  
5907 Maurice Avenue Cleveland, Ohio

## BIG SAVINGS

On All Standard Sets and Parts

Dealers and Builders—Write for Quotations. You'll Find Our Prices Mighty Low.

BROOKLYN RADIO SERVICE CO.  
Myrtle and Classon Aves. Brooklyn, N. Y.

**Spaulding**  
-BAKELITE  
RADIO PANELS  
SPAULDING FIBRE CO., inc.  
TONAWANDA, N.Y.

**PATENTS**

**DON'T LOSE YOUR RIGHTS**  
Before disclosing your invention to anyone send for free blank form "EVIDENCE OF CONCEPTION" to be signed and witnessed.  
**LANCASTER & ALLWINE**  
Reg. Pat. Attys. in U. S. and Canada  
270 Ouray Bldg., Washington, D. C.  
Originators of the form "Evidence of Conception"

to hear; malalta frekvenco, low frequency (audio); mikrofarado, microfarad; fadeno, wire, thread; ricevi, to receive; sendi, to send; alterna, alternating; amatoro, amateur; fonto, source, fountain; ĝi, it; laŭtparolilo, loud speaker; perda, loss; kondensatoro, condenser.

### READING EXERCISE

Mi volas konstrui ian senfadenan aparaton. Kian aparaton vi volas? Mi nur intencas konstrui ricevaraparton kiam tio estas eble. Ĉu vi havas radio-aparaton? Jes, mi havas bonan ricevaraparton kaj ankaŭ sendaparaton. Kie ĝi estas. Ĝi estas tie en mia domo. Kian baterion uzas vi? Mi uzas alternan kurenton kun transformatoro. Preskaŭ ĉiu senfadena amatoro nun uzas elektran kurenton. Jes, estas ĉies opinio ke tia estas la plej bona fonto de povo. Kiom estas via plej longa DX? Ĝi estas 2,400 mejloj. Mi aŭdis stacion en Nova Zelando per laŭtparolilo uzante detektoron kaj unu malalta frekvenco en malalta perda cirkvito, Meissner, kun .0006 mikrofarado Kellogg kondensatoro.

### TRANSLATE TO ESPERANTO

I have a wireless sending set there in my house. I heard Z2AC in New Zealand with my receiving set, using detector and one audio. I heard a Spanish (hispanan) station last night (lastan nokton) but could not speak with him because (ĉar) I could not speak Spanish and he could not speak English. When I learn Esperanto I will talk to him because I heard him send the word Esperanto, therefore (tia) he uses it.

### LESSON 6

#### WORD-BUILDING IN ESPERANTO

From most words in Esperanto there may be formed, by the application of certain fixed rules, a number of derived words, to express all shades of thought. Thanks to this, the amount of material required for a vocabulary of all words likely to occur in everyday life, is enormously reduced.

The flexibility of Esperanto is amazing, as you will learn in this and the rest of these lessons, since all that is left for you to learn now is the system of affixes and a few special points that need explanation. Suppose you learn 500 root words in Esperanto. Then:

(1) By applying the grammatical endings, -O, -A, -E, and -I you have 2,000 words at your command.

(2) Applying an average of 10 of the 30 affixes to each of the 2,000, you now have 20,000 words at your command. This is a conservative estimate.

(3) Adding words formed with two or more words, made by adding one root to another root, we easily bring the number of words at your command up to 25,000.

Suppose you learn 500 root words in Latin, French, Spanish, German or Russian. You cannot with certainty apply any principle of word-building. So that: Learn 500 Esperanto words and you have a vocabulary of 25,000; learn 500 words of any national language and you have but the 500, and for the derivations you must learn about 2,000 new root words.

To create new words in Esperanto, as mentioned above, we make use of:

(1) Grammatical Terminations: For example, from the root parol' (which expresses the idea of speaking), we can form:

paroli, to speak; parolo, speech; parola, oral, spoken; parolanto, speaker; mi parolas, I speak, and a great number of others.

### Radio Broadcast Listeners

## GET THIS!

Don't Let Wave-Length Changes Worry You!!

**"FIND-ME-QUICK" RADIO CHART FOR ANY KIND OF RECEIVING SET ALWAYS UP-TO-DATE**

Complete, self-indexed information CON-STANTLY IN FULL VIEW OF OPERATOR. When equipped with this practical time-saving chart for rapidly logging Broadcasting Stations, your Radio at once brings Joy and Education to the whole family.

**PRICE 50c. POSTPAID INVALUABLE WHEN COMPLETED**

Size of chart 23 x 11 inches Heavy white ledger linen paper.

New Elimination Tabulator, with over 600 Broadcasting Stations classified, GIVEN WITH EACH CHART.

One Dollar Bill brings you 2 charts and you can make a most appreciated gift to your best radio friend.

Published by

**RADIO CHART BUREAU**  
Fresno, Calif.

2nd Floor Patterson Bldg.

Member: Chamber of Commerce, Merchants Association, Better Business Bureau.

Liberal Discount to Dealers (1 doz.) Wholesale to Jobbers Copyrights 1925 Patent Pending



## Eastern Low-Loss Coils

IN THE FAMOUS PICKLE BOTTLE FORM OF WINDING, DESIGNED BY M. B. SLEEPER

Incomparable for DX and Volume Reception

THREE CIRCUIT .....	\$6.00
SUPERDYNE CIRCUIT .....	\$8.00
ROBERTS CIRCUIT .....	\$8.50
TUNED R. F. COILS .....	each \$2.00
Set of three .....	\$6.00

At your dealers or direct postpaid

**EASTERN COIL CORP.**  
22 Warren St., Dept. R.N., New York, N.Y.

**FREE** Send your name and address with a stamp for the complete working drawings of the famous

## ELGIN SUPER-REINARTZ

This is the set that has heard the many European stations—the set of unequalled selectivity and clarity.

ELGIN RADIO SUPPLY CO.  
Dept. C, 207 E. Chicago St. Elgin, Ill.

## Send for TUSKA Catalog FREE

Before you decide which set to buy or build, investigate TUSKA. Write for instructive Tuska Catalog, latest edition, giving valuable hints on tuning. Listing Tuska sets and parts. Sent FREE. Address Dept. 5-T.

THE C. D. TUSKA CO.  
Hartford, Conn.



# PATENTS

If you have an invention and desire to secure a patent, send for our Free Guide Book, HOW TO GET YOUR PATENT. Tells our Terms, Methods etc. Send model or sketch and description for our opinion of its patentable nature.

**RANDOLPH & CO.**  
Dept. 459 Washington, D. C.



\$5.50

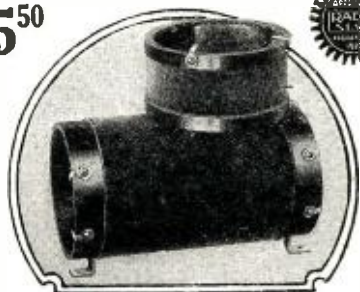

New and Improved  
Authorized

### Cockaday Coil

NO more loose winding—special new feature holds coil windings fast. Built throughout of moulded hard rubber, not affected by atmospheric conditions. Wound with No. 18 D. S. C. copper wire.

The only coil specified by L. M. Cockaday in his New Four Circuit Tuner with Resistance Coupled Amplification because it meets all his specifications. Described in October Popular Radio as Cockaday Precision Coil. Hundreds have substituted this quality coil for those of inferior make and are amazed at the improved reception, selectivity and general D-X results.

At your dealers, otherwise send purchase price and you will be supplied postpaid.

In Canada \$7.75. Canadian Distributor Perkins, Ltd., Montreal

Precision Coil Co., Inc.  
209-D Centre St., New York

S. HAMMER RADIO CO.  
307 Atkins Ave., Brooklyn, N. Y.

At the Lowest Prices!

8 TUBE NEW COCKADAY SUPERHETERODYNE REFLEX RECEIVER KIT

5 TUBE NEW COCKADAY 4 CIRCUIT TUNER WITH Resistance Coupled Amplifier KIT

GENUINE PARTS exactly as authorized and specified by Mr. Lawrence M. Cockaday.

Write for our RADIO CATALOG and special circular about these Kits. We Specialize in Cockaday Kits

Orders over \$5.00 Shipped Prepaid. Money Orders or C.O.D. One-third must accompany all C.O.D. orders. Not insured unless insurance charges included.

## E-Z-TOON (EASY TUNE) RADIO DIALS

THE KEY TO SIMPLIFIED TUNING

Read What John F. Barry of White Plains, N. Y. Says. "Tuesday night, November 25th, I heard station 2L.O. London, England, with a 3 tube single circuit type receiving set, built by myself and equipped with an E-Z-TOON 4" dial on aerial tuning condenser. My whole success I contribute to the exceptional close tuning of the variable condenser, with vernier type dial. This condenser was not in itself a vernier type, but became one and better with the addition of your dial." If your dealer cannot supply, write us. 3" Dial, Black \$2, Mahogany \$2.20; 4" Dial, Black \$2.25, Mahogany \$2.45; 2" Non-Vernier Dials for rheostats, switches, etc., Black 40c, Mahogany 45c. All vernier dials made with zero mark on either right or left side. E-Z-TOON RADIO CO. 3234 W. Washington St. Indianapolis, Ind.

(2) Compound Words: For example: eniri, to enter (en in, iri to go); eliri, to go out (el out, iri to go); rulkurteno, window blind (ruli, to roll, kurteno, curtain).

In order to have all the Esperanto affixes together, they are printed in this lesson, but this leaves no space for needful illustration of the manner of using them. This treatment of them will be given in the next lesson. Their definitions as given here are full enough to enable a student reading any Esperanto text to clearly understand them.

#### THE ESPERANTO AFFIXES

- aĉ—denotes contempt: dom'o, a house; dom'aĉ'o, a hovel. hundo, a dog; hund'aĉ'o, a cur.
- ad—denotes the continuation of an action: ir'i, to go; ir'ad'i, to continue going; parol'i, to speak; parol'ad'o, a speech.
- aj—denotes something made from, or having the quality of what is mentioned: mal'nov'a, old; mal'nov'ajo, an antique. bov'o, an ox; bov'aj'o, beef.
- an—denotes an inhabitant, or partisan: vilaĝ'o, a village; vilaĝ'an'o, a villager; London'o, London; London'an'o, Londoner; klub'o, club; klub'an'o, member of a club.
- ar—denotes a collection of what is mentioned: arb'o, a tree; arb'ar'o, a forest; vort'o, a word; vort'ar'a, a dictionary. libr'o, a book; libr'ar'o, a library.
- bo— denotes a relation by marriage: fil'in'o, daughter; bo'fil'in'o, daughter-in-law.
- ĉj—these letters added to the first few letters of a masculine name make of it an affectionate diminutive: Vilhelm'o, William; Vil'ĉj'o, Willie. Will, Bill;
- for feminine names add nj instead of ĉj: Mari'o, Mary; Ma'nj'o, Polly.
- dis— denotes separation (as in English): sem'i, to sow; dis'sem'i, to scatter, disseminate.
- ebl—denotes possibility (English -able, -ible): fleks'i, to bend; fleks'ebl'a, flexible.
- ec—denotes a quality (English-ness): bel'a, beautiful; bel'ec'o, beauty. bon'a, good; bon'ec'o, goodness.
- edz—denotes a married person: doktor'o, doctor; doktor'edz'in'o, doctor's wife; lav'ist'in'o, washerwoman; lav'ist'in'edz'o, washerwoman's husband.
- eg—denotes enlargement or intensity of degree: pord'o, door; pord'eg'o, portal, outer-door; grand'a, great; grand'eg'a, immense.
- ej—denotes the place where an action occurs: kuir'i, to cook; kuir'ej'o, kitchen; preĝ'i, to pray; preĝ'ej'o, church; dorm'i, to sleep; dorm'ej'o, a dormitory.
- ek— denotes the beginning or short duration of an action: bril'i, to shine; ek'bril'i, to flash; rid'i, to laugh; ek-rid'i, to burst out laughing.
- em—denotes propensity or disposition: kred'i, to believe; kred'em'a, credulous.
- er—denotes one object of a collection: sab'l'o, sand; sab'ler'o, a grain of sand; fajr'o, fire; fajr'er'o, a spark; mon'o, money; mon'er'o, a coin.
- estr—denotes a chief or leader (English -master): ŝip'o, ship; ŝip'estr'o, captain.
- et—denotes decrease or diminution of degree: rid'e, laughingly; rid'et'e, smilingly; dorm'i, to sleep; dorm'et'i, to doze;

## ROFFY TRANSFORMER

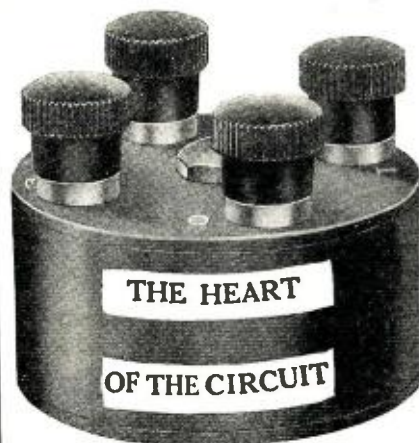

### Who Is ROFFY?

- inventor of the focusing electric flashlight
- father of auto spot lamps
- former chief engineer in one of the Westinghouse research departments
- inventor of the first variable speed current generator for autos and Pullmans
- widely known for work in railroad signalling.

With a record like that, it doesn't surprise you that Roffy has invented the most powerful, most sensitive and most selective radio frequency transformer and hook-up yet produced.

SEND THIS COUPON for the booklet which tells you all about it.

Enclosed find 4c postage for your booklet "The Secret of Distance—Selectivity—Tone Quality."

Name .....

Address .....

STAMM - LAWSON  
RADIO MFG. CO.  
Upland California

DEALERS and JOBBERS—You will find us ready with an attractive proposition. Write!

ATTENTION DEALERS  
SEND FOR OUR 152 PAGE CATALOG



The finest and largest exclusive Radio Catalog in the United States.  
SCHNEITER RADIO CO.  
Dept. D. St. Joseph, Mo.

ESBY  
A-TENA  
Outdoor and Indoor  
100 Ft. Coil Antenna  
Complete with wall hooks and insulators only 50c postpaid.  
Dealers write for prices.  
ESBY CO., 45 Arch St., Boston



THE SILENT  
**FRANCE**  
MULTI-DUTY  
SUPER-CHARGER



**No Bulbs!  
No Acids!**  
and No Sparking or  
Sticking Contacts

A new application of the push-pull principle eliminates all the old drawbacks of battery charging.

UP TO 120 VOLTS OF "B" BATTERY CAN BE CHARGED IN SERIES. No fuss or trouble, just connect the charger clips to the battery terminals and turn on the current. Simple—Speedy and Efficient. The France Super-Charger also charges 2, 4, 6 or 8 volt radio or auto batteries at a 5 to 7 ampere rate, tapering as the battery is charged.

Price of Super-Charger, \$22.00; West of the Rockies, \$23.00. Canadian prices furnished on request. Write today for complete information on this highest attainment in battery charging.

DEALERS AND JOBBERS: Write today for sales proposition and literature.

**THE FRANCE MFG. CO.**  
10320 Berea Rd., Cleveland, O.  
Stocks carried at convenient points throughout the United States and Canada.

THE **Antennaphone**  
REPLACES THE AERIAL  
NO LOOP  
INCREASES SELECTIVITY  
IMPROVES RECEPTION  
NO AERIAL

Complete with wire  
Easy to install

The Antennaphone is not attached to, but merely placed under the telephone. Sold with a money-back guarantee. AT YOUR DEALER or sent by mail upon receipt of one dollar.

**ANTENNAPHONE COMPANY**  
90 West St., New York City, N. Y.

**RADIO DEALERS WANTED**  
BIG DISCOUNTS ON STANDARD PRODUCTS  
**W. C. BRAUN CO.**  
32-40 S. Clinton St., Chicago  
ASK DEPT. 103 FOR DEALERS CATALOG

- river'o, a river; river'et'o, a rivulet.
- ge- — denotes persons of both sexes: patr'o, father; ge-patr'o'i, parents; ge'mastr'o'j, master and mistress; edz'o, husband; ge'edz'o'j, married pair.
- id—denotes a child or descendant: Izrael'o, Israel; Izrael'id'o, Israelite; ŝaf'o, sheep; ŝaf'id'o, lamb.
- ig—denotes the causing anything to be in a certain state: brul'i, to burn; bul'ig'i, to set on fire; edz'o, married person; edz'ig'i, to marry; pli'grand'a, larger; pli'grand'ig'i, to enlarge.
- ig—denotes the action of becoming, turning to: pal'a, pale; pal'ig'i, to turn pale; fluid'a, fluid; fluid'ig'i, to melt.
- il—denotes the instrument by whose means an action takes place: hak'i, to hew; hak'il'o, axe; kudr'i, to sew; kudr'il'o, needle; paf'i, to shoot; paf'il'o, rifle.
- in—denotes the feminine gender: kok'o, cock; kok'in'o, hen; hero'o, hero; hero'in'o, heroine.
- ind—denotes worthiness: laud'i, to praise; laud'ind'a, praise-worthy.
- ing—denotes a holder, that into which an object is appropriately put; or "in goes": kandel'o, a candle; kandel'ing'o, a candle-stick; cigar'o, a cigar; cigar'ing'o, a cigar-holder.
- ism—distinctive doctrine, practice, cult, "ism": idealismo, idealism.
- ist—denotes a person following a given occupation: kurac'i, to heal; kurac'ist'o, physician; ŝtel'i, to steal; ŝtel'ist'o, thief; bot'o, boot; bot'ist'o, bootmaker ("bootist").
- mal- — denotes the direct opposite of any idea: bon'a, good; mal'bon'a, bad; estim'i, to esteem; mal'estim'i, to despise; supr'e, above; mal'supr'e, below; varm'a, warm; mal'varm'a, cold; lum'o, light; mal'lum'o, darkness.
- obl—multiple: duobla, double; dekobla, ten fold.
- on—fraction of: triono, one-third; duona, (adjective), one-half part of.
- op—numeral collective: kvinope, five together.
- re- — is the English re, again, or back: ir'i, to go; re'ir'i, to return; don'i, to give; re'don'i, to give back.
- uj—denotes that which bears or contains: mon'o, money; mon'uj'o, purse; Turk'o, a Turk; Turk'uj'o, Turkey.
- ul—denotes a person remarkable for a given quality: bel'a, beautiful; bel'ul'in'o, a beauty; mal'sag'a, foolish; mal'sag'ul'o, a fool; riĉ'a, rich; riĉ'ul'o, a rich person.
- um—this syllable is amongst the suffixes as je is amongst prepositions. It may be occasionally used when we are not sure just which suffix we want: plen'a, full; plen'um'i, to fulfil; mal'varm'a, cold; mal'varm'um'i, to take cold; vent'o, wind; vent'um'il'o, fan.

Editor's Note: For the convenience of those following these lessons, attention is called to the little Esperanto dictionary advertised in Classified Ad. columns of RADIO NEWS.

*Everywhere!* \$1.10

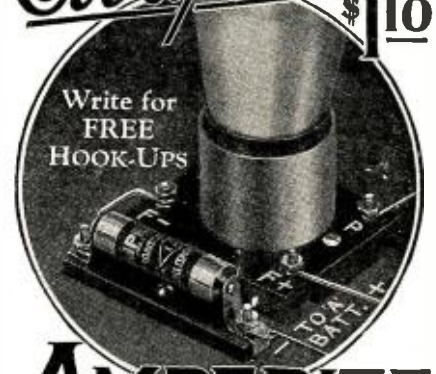

**AMPERITE**  
"means right amperes"

The self-adjusting rheostat that automatically controls tube current, eliminates hand rheostats, filament meters, guessing and tube worry. Simplifies wiring. Increases compactness. Doubles tube life. Makes every operator an expert. Tested and approved by all leading laboratories. Used by more than 50 foremost set manufacturers. Be sure the set you build or buy has AMPERITE.

**RADIALL COMPANY**  
Dept. R. N.-9 50 Franklin Street, New York City

**Radio Parts of Quality**

If you want radio parts of quality try the MAZDA line.

**MUZADA SOCKET**

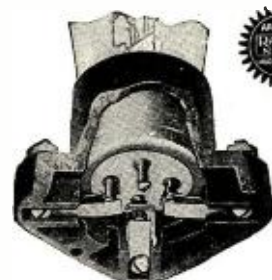

It's a quality socket of the higher class with a double contact, triple pull in every prong of the tube.

Price \$1.00

We also manufacture:

- Diats
- Jacks
- Rheostats
- Potentiometers
- Plugs
- Audio Transformers 3 to 1 and 5 to 1
- Horns
- Condensers
- Switches
- Radio Frequency Tuner
- Consomelle Grand seven tube set

**The MAZDA RADIO MFG. CO.**  
3407 Perkins Ave., Cleveland, Ohio

**SEND NO MONEY!**

**YOUR OWN Name and Address Printed Free on Thank You Cards**  
Just what YOU like. Stations are glad to put on numbers at your request. We print Special cards that get ATTENTION. All the RAGE. Cards (Printing FREE) 100—only \$1.35; 200—\$1.85; 500—\$2.35 plus low cents postage. Order TODAY. MONEY REFUNDED If Not Delighted. Quality cards. High grade printing. FREE with 1st order; log for your set, Call stations, 4 dial settings, etc. Heavy rippled cover. Send no money—just pay postman when you get cards. Order NOW!

**RADIO PRINTERS, 3924 Main Street, Mendota, Ill.**

Build Your Radio Set to Last  
**USE CENTRALAB PARTS**  
Battery Switch - Potentiometer  
Rheostat - Grid Leak

**Centralab**  
CENTRAL RADIO LABORATORIES  
303 Sixteenth Street, Milwaukee, Wisconsin





**YAXLEY No. 10**

### The Switch for Service

You will like these features of the Yaxley Midget Battery Switch:

- Very compact. One nut mounting in single panel hole. Hard rolled bronze springs. Pure silver contacts. Insulated from frame. Quick, positive snap-break. Good for years of service.

Code No. 10.....60

Other Yaxley Approved Radio Products include Jacks, Jack Switches, Rheostats, Plugs, etc. Fully Guaranteed.

Order from your dealer or send his name with your order to

**YAXLEY 217 No Desplaines St Chicago**

# PATENTS

To the Man with an Idea

I offer a comprehensive, experienced, efficient service for his prompt, legal protection and the development of his proposition. Send sketch, or model and description, for advice as to cost, search through prior United States patents, etc. Preliminary advice gladly furnished without charge. My experience and familiarity with various arts frequently enable me to accurately advise clients as to probable patentability before they go to any expense.

Booklet of valuable information and form for properly disclosing your idea free on request. Write today.

**RICHARD B. OWEN**  
 PATENT LAWYER  
 2 Owen Building, Washington, D. C.  
 2276A Woolworth Bldg., N. Y. City



## GILFILLAN NEUTRODYNE SETS - KITS - PARTS

Made in our three Radio factories with years of Radio experience behind them.

Send for Literature

**GILFILLAN BROS. INC.**  
 1815 W. 16th St., Los Angeles, Calif.  
 KANSAS CITY NEW YORK  
 2525 W. Penn Way 225 W. 57th St.

### Do Away with Dangers of Soldering

Use Erla solderless connections. Extra panels and baseboards for Erla sets, also complete line of Erla kits, parts and blueprints at special prices. We carry supplies for all the latest circuits.

Write for prices.

**WACHTER HARDWARE CO., Radio Dept.**  
 2623 Cottage Grove Ave. Chicago, Ill.

Insure your copy reaching you each month. Subscribe to **RADIO NEWS** — \$2.50 a year. Experimenter Publishing Co., 53 Park Pl., N.Y.C.

## ENGLISH-ESPERANTO RADIO DICTIONARY

Compiled by **HARRY A. EPTON, F.B.E.A.,** Vice-Chairman of the Hackney & District Radio Society and Hon. Secretary of the Internacia Radio-Asocio.

[Editor's Note: April 16 to 20 there will be held in Paris a conference of the world's leading radio authorities. As a part of this Congress there will be sittings of members of the Esperanto Academy in co-operation with radio-Esperanto experts to adopt finally and officially by the Academy an Esperanto-radio dictionary. The following vocabulary will, without doubt, be essentially the same as the one to be officialized.]

Several Esperanto radio vocabularies have already appeared, one by Dr. Corret, in "Radio Annuaire," in France, one by Prof. Christaller, in "Germana Esperantisto," and one in "Radio Rundschau" (Austria).

The author of this English-Esperanto Radio Dictionary desires to acknowledge his indebtedness to the sources named, from which he has derived much assistance in the present compilation.

It is believed that the dictionary here presented will supply the common needs of our radio friends. On account of lack of space, it is impossible to include a complete cross-index of every word and phrase; the method adopted is the grouping, so far as possible, of all adjectival terms under the substantives from which they are derived.

A

Accumulator, akumulatoro. adjustable, alĝustigebla, variebla. aerial, antenna, anteno; artificial, artefarita; cage, kaĝforma; directional (fixed), direktita; frame, kadsa, anteno, kadro; funnel-shaped, funela; horizontal, horizonta; L-shaped, L-forma; open, nefermita; receiving, riceva; sausage, kolbasa; sending, transmitting, senda; trailing, pendanta; T-shaped, T-forma; umbrella-shaped, ombrela; vertical, vertikala. alternating, alterna;—current, alterna kurento.

alternator, alternatoro, alternilo; high-frequency—, altfrekvenca a.; induction—, a kun turna fero; motor alternator disc set, mtoralternatora grupo kun diska sparkilo; multiphase, polyphase—, multifaza a.; turbine—, turbo-alternatoro; two-phase—, dufoza a.

aluminum, aluminio. amateur, amatoro; wireless, radio—, senfadena, radio-amatoro. ammeter, ampermetro; alternating current—, alternkurenta a.; direct current—, kontinukurenta a.; moving coil—, movbobena a.

ampere, ampero; milli—, miliampero; turns, amperturnoj. amplification, (action) amplifilo, amplifado, (state) amplifeco; high frequency, altfrekvenca; low frequency, malaltfrekvenca; dual, duala.

amplifier, amplifikatoro, amplifilo; high, low, frequency—, altfrekvenca, malaltfrekvenca, amplifikatoro; magnetic—, magneta a.; resistance—, rezistanca a.; transformer—, transformatora a.

amplify, to, amplifi. amplitude, amplitudo. anode, anodo; tuned—, agordita anodo. antenna, anteno, (see Aerial); damping of—, antena amortizo; radiating—, radianta anteno; —support, antena portilo. aperiodic, aperioda. apparatus, aparato. arc, arko.

asynchronous, asinkrona. atmospherics, atmosferaĵoj, atmosferaĵperturboj. audio-frequency, malalta frekvenco. audible, aŭdebla; audibility, aŭdebleco.



**LONG RANGE BEARCAT RADIO VACUUM TUBE KIT NOW ONLY**

**WORLD'S latest, most amazing radio discovery.** "Truly wonderful," say experts. BEARCAT gives distance and tone of expensive sets. Most selective set ever built, bar none. Includes, with five stations, on BEARCAT brought in stations clearly 1000 miles away. Outside of Chicago, BEARCAT brings them in from all over. Easiest set to use—one dial controls all tuning. No squeals. Stations come in instantly. World's most efficient and lowest priced receiver.

**SEND NO MONEY** Pay postman price plus a few cents postage on arrival. Try BEARCAT 10 days. Money back if you are not enthusiastic and entirely satisfied. Mail coupon today and BEARCAT will be sent at once. (If remittance accompanies order we pay postage.) You take no risk. Mail coupon NOW. Only 5,000 sets at this special introductory price. Be sure to check off wanted. Bearcat Radio Co., 646 N. Mich. Ave., Dept. 35 Chicago

**MAIL COUPON NOW**

Bearcat Radio Co., 646 N. Mich. Ave., Dept. 35, Chicago

( ) Send me Bearcat Kit complete with cabinet \$9.98.

( ) Send me factory built set, \$12.98.

( ) Send me Bearcat Set complete with tube, batteries, special introductory price. Be sure to check off wanted.

I will pay postman correct amount plus small postage. If after 10 days' trial I am not satisfied, you will refund my money upon receipt of outfit in good condition.

Name .....

Street .....

City ..... State .....

## Put a Sound Heart In Your Radio Set!

use the genuine **MASTERTONE RADIO TUBES**

Standard Guaranteed  
 \$4.00 Tube - Now  
**\$2.00**

**ALL TYPES**

5L	Volts— 5.....	.25
"	"— 3.....	.06
"	"— 1.1.....	.25
"	"— 1.....	.25
"	"— 5.....	.85

LIST \$4.00 — 50% \$2.00

A trial order will prove that they are the ideal tubes for all makes of receiving sets.

We want good, live dealers to handle these tubes... Write for our "Exclusive Agency Proposition." Less 2% 10 days to rated dealers.

**MASTERTONE RADIO COMPANY**  
 903 Broad Street Newark, N. J.



At your dealer **\$1.25**

**WALBERT made it first**

**WANT more stations? JOIN the "Distance-getters" — Replace your dials with WALBERT WUNI VERNIER**

**WALBERT MFG. CO., CHICAGO**



**TOWN-CRIER SPEAKER**



*The Voice that Thrills!*

Price \$17.50  
WEST OF ROCKIES \$18.50

**thrilling—**

Describes the performance of the Town Crier! It has volume—clarity—tone range in perfect balance . . . most natural reproduction. Exquisitely molded of composition material (ideal for reception purposes) in mahogany or polychrome finish . . . vibration-proof—devoid of wooden or metallic sounds. Small, compact, sturdy . . . not easily overturned. . . . Unit of the finest type made. All superiorities that lend to the Town Crier the voice that thrills.

**TRIAL OFFER**

Try the Town Crier (Polychrome or Mahogany) for 10 days. Send \$2 with your order. Balance \$15.50 on arrival. Return for refund of \$17.50 if unsatisfied. This offer guaranteed.

**DEALERS—JOBBER**

Samples sent for your inspection. Circulars Upon Request.

**GALE RADIO LABS.**  
2514 Irving Park Blvd., Chicago

**VACUUM TUBES REPAIRED**

WD-11, WD-12, \$2.00  
UV-201A, UV-199,  
And others for

Quick service. All tubes repaired by us guaranteed to work as good as new. Send your dead tubes. All you pay is \$2.00 plus Postage to Postman.

**THOMAS BROWN CO.**  
511-519 Orange St., Newark, N. J.



**Find Your Radio Trouble With the Milavolt Detector**

It generates an Electro-motive-force—0.853 volt. Simply attach to cord tip of your receiver. No danger burning out tubes. For testing through anything from dead short circuit to 1,000,000 ohms. Internal resistance—70,000 ohms. Last for years. Sent C.O.D. to any address in U. S. for \$1.25. Your money back if not all we claim.

**ADBRO MFG. CO.**  
French Street Pittsburgh, Pa.



Wholesale Radio Equipment  
Same Day Shipments

Insure your copy reaching you each month. Subscribe to RADIO NEWS—\$2.50 a year. Experimenter Publishing Co., 53 Park Pl., N.Y.C.

autodine, aütodino.  
automatic, aütomata.

B

Bakelite, bakelito.  
balanced, kompensita; —crystal detector, kompensita kristala detektoro; —receiver, kompensita ricevilo.

balancing signals, kompensitaj (or ekvilibrataj) signaloj.

bare wire, nuda fadeno.

battery, baterio, pilaro; anode, filament, —; anoda; filamenta baterio; high tension, low tension—, altatensia, malaltatensia, baterio; storage—, akumulato.

beats, batoj.

broadcast, to, brodkasti, disaüdigi, disendi.

broadcasting (noun), brodkasto, brodkastado; (adj.) brodkasta; —station, brodkasta stacio.

buzzer, zumilo.

calibrate, to, kalibri; calibration, kalibro, kalibrajo.

C

Call, to, voki; —sign, voksignalo.

capacitance, kapacitanco.

capacity, kapacito; aerial—, antena k.; resistance—, rezistanca k.; self—, memk.; stray capacities, superflujaj kapacitoj.

carbon, karbono.

carborundum, karborundo.

carrier wave, portanta ondo.

cascade, kaskado; —formation, kaskada formo; in—, kaskade.

cathode, katodo; incandescent—, inkan-deska katodo.

cat-whisker, kontakt-fadeneto por kristalo, "Katlipharo."

cell, pilo; battery, pilaro, baterio; dry cell, seka, pilo.

change of connections, komuto; —for receiving, k. por ricevo; —for transmitting, k. por sendo.

change-over switch, komutatoro, komutilo.

charge, to, ŝargi.

charging switch, interuptoro por ŝargo, ŝarginteruptoro.

choke coil, reaktanca bobeno, ŝokbobeno; air core protecting—, aerkerna—.

choking coil, indukta bobeno.

circuit, cirkuito; closed oscillating—, fermita oscila c.; grid—, krada c.; intermediate—, intera (or pera) c.; open oscillation—, nefermita oscila r.; short—, mallonga c.

circuit breaker, cirkuita interuptoro.  
close (or tight) coupling, apuda kupleco.

coarse, kruda.

coefficient, koeficiento, grado; coupling—, kupla g.

coherer, koheroro, koherilo; filings—, fajlaja k.; gradular—, grajna k.

coil, bobeno, spulo; air core protecting choke—, aerkerna reaktanca b.; anode—, anoda b.; basket (or spiderweb)—, korba (areaneaja) b.; choking—, indukta b.; coupling—, kupla b.; cylindrical—, cilindra b.; honeycomb—, ĉelara b.; induction—, induktanca b.; loading—, aldona (longiga) b.; measuring—, mezura b.; plug-in—, enŝtopa b.; solenoid—, solenoida b.; Tesla—, Tesla b.

coil-holder, stand, bobenujo; bobenitenilo.

commutator, komutatoro, komutilo.

compensator, kompensatoro, kompensilo.

component (part), komponaĵo.

compound, kompunda, malsimpla.

condenser, kondensatoro, kondensilo adjustable—, alĝustigebla k.; aerial tuning—, antenagorda k.; blocking—, bloka k.; closed circuit—, fermita k. cirkuita;

secondary circuit—, sekundaria k. cirku

**ONE RADIO BOOK EVERYONE READS**

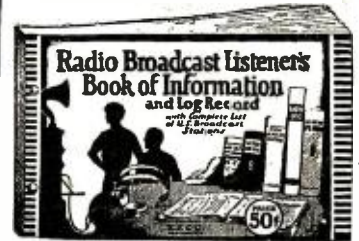

**The Radio Broadcast Listener's Book of Information and Log Record**

Not only a complete, practical book of those essential Radio facts that everyone who owns a radio should know, but it is also a handy log record for those who want to keep a record of the stations they receive. The book is enclosed in a handsome two-color cover bound in a Loose-Leaf fashion, so that new pages can be inserted if necessary. It contains 80 pages, each one containing information more valuable than the last.

The following is a brief summary of the information contained in this book:  
Information for the Broadcast Listener:  
Vacuum Tube Table: Meter wave lengths:  
Radio Batteries: Wireless code chart:  
Station log chart:

Complete list of Broadcast Stations of the United States, giving Power, wave length, and Time of Operation each day of the week. Log Sheets for tabulating the dial settings of the stations you receive on your radio. Size of Book, 6 in. by 9 in., with handsome 2-color cover.

PRICE 50¢

Postage Paid

PUBLISHED BY  
The E. I. COMPANY

The Consrad Company  
SOLE DISTRIBUTORS  
233 Fulton St., New York  
N. Y.

**Consrad**

"RADIO'S FOREMOST PUBLISHERS"

DeForest License



**HONEYCOMB COILS**

Back and Front Panel Mountings Plain or Ganged Genuine Bakelite

The Universal all-wave inductance; standard as to superior construction and electrical units. Ask your "Old Timer" radio friend why sets using honeycomb coils are better; they give closer tuning, greater selectivity and range. No dead end losses, easy to operate. 16 sizes, mounted and unmounted.  
Send 25c for Super Heterodyne, Radio Frequency and Honeycomb Coil Circuits and Complete Catalog.  
**CHAS. A. BRANSTON, INC.**  
Dept. 6, 815 MAIN ST. BUFFALO, N. Y.  
In Canada—Chas. A. Branston, Ltd., Toronto

**GO into the RADIO BUSINESS**

We specialize in Equipping New Dealers with entire stock—advice free.

Send for Our Radio CATALOG & BARGAIN LISTS Wholesale Only  
**MANHATTAN RADIO COMPANY**  
112 Trinity Place New York City





*Burns*  
**LOUD SPEAKER**

Distinctive in design  
Pyralin bell  
Aluminum column

*Volume—Clarity—Beauty*

No. 205B—Polished black flare... \$22.50  
No. 205D—Shell pyralin flare... 25.00  
No. 100 —Phonograph unit ..... 10.00

Manufacturers  
**American Electric**  
COMPANY  
State and 64th Sts. Chicago, U. S. A.



**De JUR**  
ONE HOLE MOUNT  
**RHEOSTATS**

- 1—Easiest to mount.
- 2—No back panel fussing.
- 3—Perfect control always.
- 4—Genuine bakelite throughout.
- 5—Contact slider and shaft made in one piece.

At All Dealers  
**De Jur Products Co.**  
Broome & Lafayette Sts. New York



**Motor to Work or Sport**  
at 1/3¢ per Mile!



Say goodbye to crowded trains and trolleys. Motor to work or sport for less than carfare. New Indian Prince, the Personal Motor, goes 90 miles on a gallon. Light—safe—clean. Only half the weight of an ordinary motorcycle. You learn to ride it in 5 minutes. Costs less than any other high-grade machine. Write today for illustrated booklet containing full information about this new Indian Prince, the Personal Motor, and how easily you can buy it.

**Indian Motorcycle Co.**  
Dept. Z4 Springfield, Mass.

ita; twin-coupled—, duopa k.; variable—, variigebla k.; vernier—, verniera k. conduct, to, konduki; conductive, kondukiva; conductively, kondukeco. connect, to, konekti; connection (action) konekto; (thing) konektaĵo. constant, konstanto; dielectric—, dielektrika k. continuous wave, kontinua onda. control, to, kontroli. converter, konvertitoro, konvertilo. copper, kupro; tinned—, stanita k.; —pyrites, kupra pirito. coulomb, kulombo. counterpoise, capacity earth, kontraŭpezo. couple, to, kupli; coupled, kuplita; inductively—, induktokuplita. coupler, kuplilo; vario-coupler, vario-kuplilo. coupling, (action) kuplo, kuplado, (state) kupleco; close (or tight)—, apuda k.; electromagnetic, electrostatic—, elektromagneta, elektrostatika, k.; fixed—, fiksa k.; inductive—, indukta k.; loose—, malapuda k.; reaction—, reakcia k.; variable—, varia, variigebla k. coupling coefficient, kupla koeficiento. crystal, kristalo; —detector, kristala detektoro. current, kurento; alternating—, alterna k.; direct—, kontinua k.; high frequency—, altfrekvenca k.; low frequency—, malaltfrekvenca k.; primary alternating—, primaria alterna k. current interrupter, kurenta interuptoro. current loop, ventro de intenseco; current node, nodo de intenseco. curve (graph), kurvo; characteristic—, karakteriza k. cycle, ciklo.

D

Damped waves, amortizaj ondoj. damper, silentigilo. damping, amortizo; high—, granda a.; —of antenna, antena a. decohere, to, malkoheri; decolierer, malkoherilo, dekoherero. decrement, dekremento. decrementer, dekremetro. detector, detektoro, detektilo; balanced crystal—, kompensita kristala d.; crystal—, kristala d.; magnetic—, magneta d.; perikon—, perikona d.; thermo—, termod.; thermo-electric—, termoelektra d.; valve—, valv-d. device, arango. dial, ciferplato. diaphragm, (of telephone receiver), plato (de telefonilo). dielectric, dielektriko (noun). dielectric (adj.), dielektrika; —constant (specific inductive capacity), d. konstanto; —strength, d. firmeco; —stress, d. streĉo. diode (two-electrode valve), diodo. diplex, dipleksa. direct current, kontinua kurento. directional aerial (fixed), direkta anteno; (moveable), direktebla anteno. direction finder, direkto-trovilo. disc, disko. discharger, sparkilo; asynchronous—, asinkrona s.; synchronous—, sinkrona s. distort, to, distordi; distortion, distordo. disturbances, perturboj. double-pole, dupolusa. double-throw, duvoĵa. dual amplification; duala amplif-o, -ado, -eco. dull emitter (valve), malhela (valvo). duplex, dupleksa. dynamo, dynamo; compound—, kompunda d.; self-excited—, memekscita do; separately excited—, d. kun sendependa ekscito; shunt—, ŝunta (or deriva) d.

**Morrison**  
**Loud Speaker Unit**



**\$5.00**

**Volume Tone**  
**The Best in Radio**

Every set reaches its maximum performance when it reproduces through a Morrison Unit. Volume on long distance work and the marvelous Morrison tone quality are unmatched. Thousands of Morrison owners from coast to coast know this. Of all the elements in radio receiving there is one you can be certain of—buy a Morrison and you've got the best reproducing unit you can buy. Use it indefinitely—it's built to stand long service. Morrison is an adjustable unit. Ask for our booklet on Loud Speaker Facts. On sale at all good radio and phonograph dealers. Mail-orders shipped promptly from factory.

**Morrison Laboratories, Inc.**  
339 E. Jefferson Avenue, Detroit, Michigan

**“The Crystal With the Power of a Tube”**

Tested and Approved.—RADIO JOURNAL.

IDEAL FOR REFLEX

L. H. B., Hamilton, Montana, loaned his A-1 CRYSTAL to a friend who had built a reflex set. “A difference could be heard as soon as the A-1 CRYSTAL was hooked in,” he writes. “Stations began to come in with great volume and loud speaker was attached.”

“Stations heard in just two or three days are: CFCN, GKCX, CFAC, CFCF, CJCA, CKCD, WOC, WJAZ, WLAG, WFAA, WQAQ, KYW, KFI, KHJ, KPO, KGW, and others.”

**A-1 The WONDER CRYSTAL**

FOR REFLEX OR CRYSTAL SET

“Far superior to the ordinary kind. More than worth the difference in price.”—T. H. M., San Francisco, California.

GUARANTEED CONCERT TESTED

IF YOUR DEALER CAN NOT SUPPLY SENT POSTPAID BY INSURED MAIL 50c EACH 60c C. O. D.

“It is the fastest selling article of its kind on the market.”—Tustin Radio & Electric, San Francisco, California.

Dealers write for Discounts  
**California Radio Minerals**  
Harry Grant, Jr.  
904 Oak Grove Ave.  
Burlingame, California

**RADIO DEALERS WANTED**

BIG DISCOUNTS ON STANDARD PRODUCTS

**W. C. BRAUN CO.**  
32-40 S. Clinton St., Chicago  
ASK DEPT. 103 FOR DEALERS CATALOG





## The Ekko Broadcasting Station Stamp Album

Here's just what you have wanted for a long time—a convenient, permanent and authentic means of recording all the stations you have heard over your set.

**Verified Reception** The Ekko Broadcasting Station Stamp Album contains spaces for the stamp of each of all the recognized stations in the United States and Canada—more than 550 in all. With the album are furnished PROOF OF RECEPTION CARDS. You send these cards to the station, together with facts that prove you have heard their broadcasting and 10 cents to cover the cost of verification and mailing. The station then sends you its Ekko Stamp as verified proof of reception. You then paste the stamp in your album.

**Beautiful Stamps and Album** Each station has its own beautifully engraved stamp showing call letters. The album is 9 1/2 x 11 inches, handsomely bound in a two color cover. It contains 96 pages with spaces for stamps of all recognized stations arranged alphabetically by states and call letters. Contains also a log and official names of call stations.

**A Fascinating Hobby** Think of how much fun you can have showing your friends your album and proving to them at once how many stations you have heard. And think of how much more fun you'll have collecting the stamps themselves

**Begin Today!** You too can join this new radio game that is sweeping the country. Buy your copy of the Ekko Album from your dealer and begin collecting Ekko Stamps today.

If your dealer cannot supply you, sent direct, postpaid, on receipt of price. Money back if not satisfied.

**Price \$1.75**  
\$2.50 in Canada

### THE EKKO COMPANY

111 West Monroe Street · Chicago, Illinois

## New Super-Sensitive Crystal Gives Remarkable Results

A recent invention in crystals is amazing Reflex and Crystal Set owners everywhere. It is stated that this marvelous Crystal gets stations loud and clear, and there is no disagreeable "hunting" for spots because the entire surface is sensitive. Many are finding it far superior for reflex work and claim it is the last word in mounted synthetic crystals.

### A Trial Costs You Nothing

In order to introduce his invention, the owner, Mr. Hick, offers you two \$1.00 Crystals for the price of one. Sell one, and put the other on your own set without cost to you. Just send name and address to Mr. Hick, Dept. 24, 1018 S. Wabash Ave., Chicago. Pay postman \$1.00 (plus postage). Unless you are absolutely satisfied, write Mr. Hick, and money will be cheerfully refunded.

**E**

Earpiece (of telephone receiver), orelpeco; —cap, ĉapo de o.  
earth, tero; capacity—, kontraŭpezo;  
—connection, t. konektaĵo.  
ebonite, ebonito.  
effective, efektiva.  
efficiency, rendimento, efikeco.  
electricity, elektro.  
electrode, elektrodo.  
electrolytic, elektroliza.  
electromagnetic, elektromagneta.  
electron, elektrono; —emission, elektrona elsendo.  
electrostatic, elektrostatika.  
emission, elsendo.  
endodyne, aŭtodino.  
energy, energio.  
ether, aether, etero.  
excite, to, eksciti; exciter, ekscitatoro, ekscitilo.  
experiment, to, eksperimenti; experimenter, eksperimentisto.

**F**

Factor, faktoro; power—, f. de potenco. farad, farado; microfarad, mikrofarado.  
feed-back, reakcio.  
fibre, fibro.  
field, kampo; electric, magnet,—; electric field, magneta k.  
field break switch, interuptoro de kampo.  
filament, filamento; bright, dull,—; hela, malhela, f.  
filter, filtrilo.  
fine tuning, delikata (or subtila) agordo.  
flat tuning, neakuta agordo.  
flexible, fleksebla.  
formula, fomulo.  
frame (aerial), kadro, kadra anteno.  
frequency, frekvenco; group—, ondaraj f.; high (or radio)—, alta f.; low (or audio)—, malalta f.; wave—, onda f.  
function, to, funkcii.

**G**

Galena, galeno.  
galvanometer, galvanometro.  
generate, to, generi.  
generator, generatoro, generilo; continuous current—, g. de kontinua kurento.  
grid, krado; —circuit, krada cirkuito; —leak, krada rezistanco.  
ground, tero.

**H**

Hammer break, martela interuptoro.  
harmonic, harmoniko.  
henry, henrio; microhenry, mikrohenrio.  
Hertzian wave, Hertza ondo, elektromagneta ondo.  
heterodyne, heterodino; self—, memheterodino, aŭtodino.  
high damping, granda amortizo.  
high frequency, alta frekvenco; —group, altfrekvenco grupo.  
high tension, alto tensio.  
hook-up, cirkuito.  
hot-wire ammeter, varmfadena ampermetro.  
howl, to, ululi; howling, ululado.

**I**

Impedance, impedanco.  
inductance, induktanco; aerial—, antena i.; aerial tuning—, antenagorda i.; primary, secondary—, primaria, sekundaria i.  
induction, indukto; self—, mem-i.; alternator, alternatoro kun turna fero.  
inductive, indukta; —transmitter, induktokuplita sendilo.  
inert, inerta; inertia, inerteco.  
inner primary (of transformer), eniro de primario.  
inner secondary (of transformer), eniro de sekundario.  
input, enmeto.

## CUT YOUR "B" BATTERY COST



### SERVICE

Rechargeable "B" Batteries in all-rubber cases

Rubber case prevents leakage or short circuiting. Rechargeable from any A.C. or D.C. line. Will last for years with ordinary care. Shipped dry-charged and ready for use after acid is added.	50 VOLTS	\$5.50
	100 VOLTS	\$10.00
	125 VOLTS	\$12.50

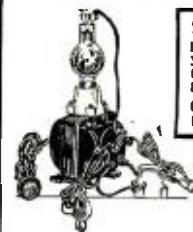

**Service "A" Batteries**  
Indestructible rubber case. Two year guarantee.  
6 volt 80-100 amp. hr. .. \$14.00  
6 volt, 100-120 amp. hr. .. \$16.00

### SERVICE Double-Duty CHARGER

Charges 6-volt A or Auto Batteries or up to 125-volts of B Battery IN SERIES. Easy to use. Noiseless in operation. Very efficient.

Complete with Bulb \$14.50

### SERVICE BATTERY CO.

704 East 102nd St. Cleveland, O.

### SERVICE BATTERY CO. OF CANADA

137 Roncesvalles Ave., Toronto, Ont.

50 VOLTS	\$7.75	100 VOLTS	\$14.50	125 VOLTS	\$17.00
----------	--------	-----------	---------	-----------	---------

## A Pleasant Surprise Awaits the User of the A.C.H. Sharp Tuner Dials

WORM DRIVE

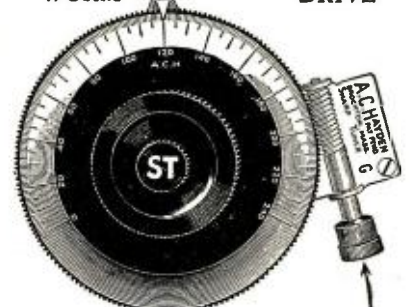

### Why the A.C.H. is different

3 in. DIAL → ACH → 156-10-1  
4 in. DIAL → ACH → 215-10-1

### Money Back Guarantee

Price 3-inch size...\$2.50 Price 4-inch size...\$5.00  
Regular fitting 5/16 shaft 3/4 and 3/16, 5c each extra  
EXTRA ADVANTAGE OF THE A.C.H.

- Can be attached or removed from any instrument.
- Rough tuning same as any dial.
- Movement so fine that the eye cannot detect but the ear can.
- Automatically locks instrument so no jar can disturb it.
- Dial grounded reducing the body capacity to a minimum.
- Special dial 2 graduations where ordinarily one.

Mall Orders Sent Prepaid in U. S. A.  
**A. C. HAYDEN RADIO & RESEARCH CO.**  
25 E. Battle St., BROCKTON, MASS., U. S. A.

Insure your copy reaching you each month. Subscribe to RADIO NEWS—\$2.50 a year. Experimenter Publishing Co., 53 Park Place, N. Y. C.



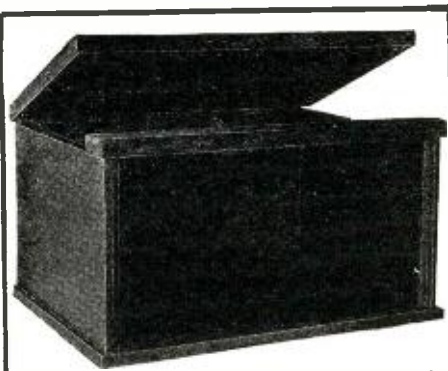

**Radio Cabinets Strong and Rigid. Remember That We Pay Mail and Express Charges. It Makes Quite a Difference When Comparing Prices.**

**Specifications**

Hardwood, rubbed mahogany finish. Top hinged, ends of top splined to prevent warping.

Panel size	Depth	Price
7 x 14	10	\$3.00
7 x 18	10	3.25
7 x 21	10	3.50
7 x 24	10	3.75
7 x 26	10	4.50
7 x 27	9	5.00
7 x 28	10	6.00

Mail and express prepaid east of Mississippi River. We also make Radio Desks and Tables. Send for free catalogue.

Mail and express prepaid east of Mississippi River. We also make Radio Desks and Tables. Send for free catalogue.

**The Southern Toy Company, Inc.**  
Dept. N. HICKORY, N. C.

insulate, to, izoli; insulated, izolita; insulation, izoleco.  
insulator, izolatoro, izolilo; flexible—, fleksebla i.; leading-in—, i. de eniro.  
interference, interfero.  
interruptor, interuptoro, interrompilo;  
current—, i. de kurento; electrolytic—, elektronza i.; induction—, i. de indukta bobeno; mercury—, hidrarga i.; mercury turbine—, hidrarga turbo- i.  
intervalve, intervalva.  
iron core, fera kerno, ferkerno.  
iron pyrites, ferpirito.

**J**

Jack, jacko.  
jam, to, interferi, jami; jamming, interfero, jamo, —ado.  
jigger, oscila transformatoro, ĝigero.  
joule julo.

**K**

Key, manipulatoro, senda klavo.

**L**

Laminations, lamenaĵoj; laminated, lamenita.  
lead (wire connection), konduktoro, kondukilo.  
lead-in, enira fadeno.

Leyden jar, Lejdna botelo.  
license, permeso; receiving, transmitting—, riceva, senda, p.  
lightning arrester, fulmsirmilo.  
log, to, registri; —book, r.— - libro.  
loop (antenna) kadro.  
loud-speaker, laŭtparolilo.  
low frequency, malalta frekvenco.  
low-loss (condenser), (kondensatoro kun) malgranda perdo.

**M**

Magnet, magneto.  
make and break, interuptoro.  
mast, masto; compound—, dismuntebla m.; portable—, portebla m.  
maximum, maksimumo.  
measuring coil, mezura bebena.  
mercury, hidrargo.  
meter, metro; frequency—, frekvenca m.

mica, glimo.  
micrometer, mikrometro.  
microphone, mikrofono; carbon disc—, karbondiska m.; carbon rod—, karboncilindra m.; contact—, kontakta m.; granular—, grajna m.; powder—, pulvora m.  
minimum, mimimumo.  
modulate, to, moduli; modulation, modulo, modulado, moduleco.  
Morse code, Morsa kodo.

motor, motoro; alternating current—, alternkurenta m.; asynchronous—, asinkrona m.; induction—, indukta m.  
motor alternator disc set, motor-alternatora grupo kun diska sparkilo.  
mount, to, munti; to dismount, dismunti.

moving coil ammeter, movbobena ampermerto.  
multiphase, multifaza.  
multiple, multopa, multobla.  
multi-stage, multopa, multetaĝa.  
multi-vibrator, multvibrilo.  
mutual conductance, komuna konduktanco.

(To be continued)

**LET'S GO**

First Single Circuit Fan: "My radio set must be a railroad hook-up."  
Second Ditto: How come?"

First Single Circuit Fan: "Well, every time I come to a station on my dial it whistles." —Contributed by Lloyd Culver.

**THE REMEDY**

Dear Editor: My Heterodyne is entirely too big and cumbersome. What shall I do?  
The Editor: "Get a condenser."  
Contributed by Joseph Strangham.



**Grand \$4.75**

The Grand Headset is a highly efficient Camco product of surprising beauty. It will delight the eye of your most discriminating friend.

Users know that a Camco Headset clearly sings, speaks or plays the things they want to hear—presents Radio as they like it. A Camco Grand Headset will please your head and ears because it is light in weight, comfortable. Before buying your next headset, inspect the Camco Grand or write for folder

**"Radio As You Like It"**

Camco Grand: Cases, highly polished aluminum; Magnets, chrome magnet steel; Cores, special alloy; Core Heads, Formica; Diaphragms, silicon steel; Wire, copper enamel insulation; Terminals, inside; Caps, brown Bakelite; Resistance, about 2,200 ohms D.C.; Turns, 5,000 per coil, 20,000 per set; Impedance, about 23,000 ohms at 1,000 cycles; Cords, black mercerized cotton, 5 feet long; Headbands, adjustable type, wire covered with brown Kid leather; Weight, complete with headband and cord, 10½ ounces.

Compare Camco Grand and Camco Cannon-Ball Headsets. Then choose the one you like best. Both are sold on a MONEY-BACK GUARANTEE.



**Cannon-Ball \$3.50**

DEALERS: Ask your jobber about Camco products or write for complete details.

**CANNON & MILLER CO., Inc.**  
SPRINGWATER, N. Y.

**EARN \$2,000 TO \$10,000 A YEAR**



**TRAINED AUTO MEN ARE WANTED!**

Why work for small pay? Learn a good trade. Know autos—how to repair them. Get a better job—NOW! Or a business of your own. I can train you in a few weeks here at my great auto-trade school in the heart of the auto industry. Think of the repair work on fifteen million cars! There are not nearly enough trained men to do this work. You can be a skilled mechanic and auto electrician and Earn Big Money. Experience isn't necessary. If you are mechanically inclined come to Detroit now, to my School.

**Learn Autos in Detroit (The Heart of the Industry)**

Here you have wonderful advantages. Study autos, trucks, engines, auto electricity, tractors. All on best equipment, up-to-date, Packard "Straight Eight", and many other new cars; expert instructors to teach you; a thorough course that slights nothing. Visit the great plants of Ford, Cadillac, Packard, Lincoln, Dodge, Hupp, Hudson, Studebaker, many others. These great companies approve this School. Get factory endorsed training at Detroit the Auto Center.

**Good Positions Open** The demand for men who know auto mechanics and electrics is greater than the supply. Here's your chance to be independent. Write today for full information about Detroit training to make the most money.

A. G. Zeller, President.  
**Michigan State Automobile School**  
5344 Auto Building Detroit, Mich.

**RADIO DEALERS WANTED**  
BIG DISCOUNTS ON STANDARD PRODUCTS  
**W. C. BRAUN CO.**  
32-40 S. Clinton St., Chicago  
ASK DEPT. 103 FOR DEALERS CATALOG

**Fits Grid Leak any mounting**

**FRESHMAN PLUNGER TYPE VARIABLE GRID LEAK** was designed especially for the non-technical set owner who can replace in an instant the fixed grid leak with this new, efficient cartridge type Variable Grid Leak without requiring the change of a single wire.

At your dealer or by mail post-paid. Write for free catalogue. **65c**  
240 W. 40th St New York





# OPPORTUNITY AD-LETS

Follow these advertisements every month. Reliable advertisers from all over the country offer their most attractive specials in these columns.

Classified advertising rate twenty-two cents a word for each insertion. Ten per cent discount for 6 issues, 20 per cent discount for 12 issues. Name and address must be included at the above rate. Cash should accompany all classified advertisements unless placed by an accredited advertising agency. No advertisement for less than 10 words accepted.

Objectionable or misleading advertisements not accepted. Advertisements for the June issue must reach us not later than April 1st.

**CIRCULATION LARGER THAN THAT OF ANY OTHER RADIO PUBLICATION**

EXPERIMENTER PUBLISHING CO., INC., 53 Park Place, New York, N. Y.

## Agents Wanted

Agents Wanted in every city and town to sell standard radio apparatus. Attractive discounts given. If interested write us at once stating age and radio experience. Wilmington Electrical Specialty Co., Inc., 405 Delaware Ave., Wilmington, Delaware.

Agents—Write for Free Samples. Sell Madison "Better-Made" Shirts for large Manufacturer direct to wearer. No capital or experience required. Many earn \$100 weekly and bonus. Madison Mills, 564 Broadway, New York.

Big Money and fast sales. Every owner buys gold initials for his auto. You charge \$1.50; make \$1.35. Ten orders daily easy. Write for particulars and free samples. American Monogram Co., Dept. 133, East Orange, N. J.

Write and learn how to start profitable business without capital or experience. Silvering mirrors, refinishing auto headlights, tableware plating. Outfit furnished. International Laboratories, Dept. 25, 809 Fifth Ave., New York.

Guaranteed Genuine Gold Leaf Letters anyone can put on store windows. Large profits, enormous demand. Free samples. Metallic Letter Co., 422 N. Clark, Chicago.

At Last! Diamond Rival Discovered! Amazing blue white Rajah Gem astounds jewelry world and deceives experts! Beautiful Sample Case Free! \$100 weekly! Write quick! Rajah Diamond Co., Dept. F42, Salisbury, N. C.

Radio Salesmen and Set Builders—We need you and you need us. If you are reliable and well known in your community, we will appoint you our representative and furnish you with standard well advertised sets and parts at prices that will enable you to sell at a handsome profit. Write at once for catalogue and sales plan. Waveland Radio Co., Div. 40, 1027 N. State St., Chicago, Ill.

Agents—500% profit. "Happy Home Maker Shampoo" builds your own big business. Martin of Indiana made \$75.00 in one day. Missouri man made \$750.00 one month. Exclusive territory. Geo. A. Schmidt & Co., 226 W. North Ave., Chicago.

Can You Sell? All-wool, union made, tailored-to-measure suits for \$19.75. Universal Tailors, 199 Bedford Street, Boston.

Radio—Join our sales organization and make big money. We want a man in every country to sell well advertised sets and parts made by the leading manufacturers. Widener of Kansas City makes \$150.00 weekly. You can do as well or better. Write today for catalogue and discounts. Name your county. Waveland Radio Company, Div. 40, 1027 No. State St., Chicago, Ill.

Agents—Signs for stores and offices. Entirely new. \$50 week easily made. World Signs, P166 W. Washington, Chicago.

Big money and fast sales, every owner buys gold initials for his auto. You charge \$1.50 make \$1.44 profit. 10 orders daily easy. Samples and information free. World Monogram Co., Dept. 27, Newark, N. J.

Free Book. Start your own little Mail Order business. Pier, 911 Cortland St., New York.

Go into Business for Yourself. Make storekeepers' profits without storekeepers' troubles or expenses. No investment necessary. We furnish everything and carry all stock for you. We have started hundreds of men who are now making \$4000 to \$10,000 a year. We can do the same for you. Write for facts at once. Address Dept. 625, Goodwear Chicago Inc., West Adams Street at Peoria, Chicago.

## Business Opportunities

Make \$100 Weekly In Spare Time. Sell what the public wants—long distance radio receiving sets. Two sales weekly pays \$100 profit. No big investment, no canvassing. Sharpe of Colorado made \$955 in one month. Representatives wanted at once. This plan is sweeping the country—write today before your county is gone. Ozarka, 813 Washington Blvd., Chicago.

Advertise, hundred magazines, three issues, 10c word. Pennell Company, Covington, Kentucky.

Free Booklet, How to Become Successful in Real Estate. Macdonald Cooperative Realty, San Diego, California.

## Chemistry

Learn Chemistry at home. Dr. T. O'Connor Sloane, noted educator and scientific authority will teach you. Our home study correspondence course fits you to take a position as chemist. See our full page ad on page 1975 of this issue. Chemical Institute of New York, 66 W. Broadway, New York.

## Home Study Courses

Correspondence Courses bought and sold. Handling, R-799 Broadway, New York.

## Educational

Correspondence Courses—All schools sold complete at lowest prices. Easy terms, money-back guarantee. Courses bought for cash. Catalog Free. Mention subject. Economy Educator Service, 442-F Sansome, San Francisco.

Used Correspondence School courses save over half. Bargain catalogue 1000 courses free. Used courses bought. Students' Exchange, Dept. A, 47 West 42d St., New York.

## Esperanto

Esperanto Books. Special for Radio News readers studying Esperanto—You need the excellent little Edinburgh Dictionary—\$.75. Clothbound Grammar and Dictionary combined \$1.50. James Denson Sayers, Box 223, City Hall Station, New York.

Esperanto. Easiest and most successful method for studying the Esperanto Language ever published. Booklet of sample Pages Illustrated by 145 illustrations sent on request. Benson School of Esperanto, Inc., 20 Mercer St., Newark, N. J.

## Exchange

200-20,000 meter Receiver including Radiotron \$25.00. Two step Amplifier \$18.00. Smith, 4416 Market, Philadelphia.

## For Advertisers

24 Words—355 Rural Weeklies \$14.20. Admeyer, 4112-R Hartford, St. Louis.

## For Sale

Typewriter—Cost \$100, will sell for \$35. Carnegie College, Rogers, Ohio.

Get Hundreds of Shaves from a single blade. Outfit complete \$2.00. Satisfaction or money refunded. Edmund J. Coyne, Box 236, Desk C, Baltimore, Md.

For Sale—Why bother with dry cells? Build an everlasting "Hawley" storage "B" Battery of the nickel-iron type. No frying or hissing, clearer reception and greater volume. Put up in both knock-down units and assembled types. Requires no soldering or former experience to put together. Knock-down units contain all the parts to build the following sizes: 90 volts \$8.95; 100 volts \$9.95; 120 volts \$11.60; 135 volts \$12.75; 150 volts \$13.90; 200 volts \$17.50. Sold on a 2 year guarantee with 30 day trial offer with return of your money without any ifs or ands. Sample cell 35c prepaid. 8 page illustrated folder of instructions containing simple means of putting together, making charger and charging. Complete manufactured charger \$2.75. Order direct or write for my literature, guarantee and testimonials. Same day shipments. Address B. R. Smith, 31 Washington Ave., Danbury, Conn.

Radiophone Generators new \$10. Wood 151 E. 108. New York.

## Health

Free—Stop using tobacco. We will give free information how to conquer habit easily and permanently. Results guaranteed. Anti-Tobacco League, Box M, Omaha, Neb.

## Help Wanted

All Men, Women, Boys, Girls, 17 to 65 willing to accept Government Positions \$117-\$250 travelling or stationary; Write Mr. Ozment, 251, St. Louis, Mo., immediately.

Detectives Needed Everywhere. Travel. Experience unnecessary. Write George Wagner, former Government Detective, 1968 Broadway, N. Y.

Become a Landscape Architect. Uncrowded profession of wonderful opportunity for money-making. Easily mastered by mail. Earn while you learn. Write for book. American Landscape School, 11-E, Newark, New York.

Get posted. Good prices paid for butterflies, insects. See Sinclair display advertisement, page 1930.

Earn \$25 weekly, spare time, writing for newspapers, magazines. Experience unnecessary. Copyright book free. Press Syndicate, 972, St. Louis, Mo.

Men to build radio sets in spare time. Leon Lambert, 595-H Kaufman Bldg., Wichita, Kansas.

Detectives needed everywhere; large salaries; free particulars; write National Headquarters, 188 East 79th, New York.

## Indian Goods

Indian hunting bows, \$2.50. Indian relics, minerals, butterflies, archery. Catalogue, thousand articles 10c. Indian-craft R.N. Company, 466 Connecticut, Buffalo, N. Y.

## Insects Wanted

Get posted. Good prices paid for butterflies, insects. See Sinclair display advertisement, page 1930.

## Instruction

Learn Chemistry at Home. Dr. T. O'Connor Sloane, noted educator and scientific authority, will teach you. Our home study correspondence course fits you to take a position as chemist. See our full page ad on page 1975 of this issue. Chemical Institute of New York, 66 W. Broadway, New York City.

World-Romie System, Masterkey to All Languages. Primers, \$1.94; Chinese, French, Spanish, Pronunciation-Tables, 30c. Dictionaries, \$1.98. Languages, 8 West 40th, New York.

Double Entry Bookkeeping mastered in 60 hours; guaranteed; diplomas. International Bookkeeping Institute, Dept. 28, Springfield, Missouri.

## Miscellaneous

Beautiful registered bull pups cheap. Bulldogs. 501 Rockwood, Dallas, Texas.

Get posted. Good prices paid for butterflies, insects. See Sinclair display advertisement, page 1930.

Free Katalog Klan Jewelry. Sample Kluxer pocketpiece with big money-making plan 10c. Morris, Box 1174-RN, Omaha, Neb.

## Motorcycles, Bicycles

Don't Buy a Bicycle Motor Attachment until you get our catalog and prices. Shaw Mfg. Co., Dept. 6, Galesburg, Kansas.

## Musical Instruments

(Patent Pending) Wonder dollar instrument, anybody play, everybody surprised. Imitate orchestra, become professional entertainer; other valuable information. Multitone 448 F West 38th, New York.

## News Correspondence

Earn \$25 weekly, spare time, writing for newspapers, magazines. Experience unnecessary. Copyright book free. Press Syndicate, 973, St. Louis, Mo.

## Old Money Wanted

\$2 to \$500 each paid for hundreds of Old or Odd Coins. Keep all old money, it may be very valuable. Send 10c for New Illustrated Coin Value Book, 4x8. Guaranteed prices. Get posted. We pay Cash. Clarke Coin Company, 14 Street, LeRoy, N. Y.

Patent-Sense—As one of the oldest Patent firms in America we give inventors at lowest consistent charge, a service noted for results, evidenced by many well-known Patents of extraordinary value. Book, Patent-Sense, free. Lacey & Lacey, 631-F St., Washington, D. C. Estab. 1869.

## Patent Attorneys

Inventors—Should write for our Free Guide Books and "Record of Invention Blank" before disclosing inventions. Send model or sketch of your invention for our Free Examination and Instructions. Radio, Electrical, Chemical, Mechanical and Trademark experts. Terms reasonable. Victor J. Evans & Co., 922 Ninth, Washington, D. C.

Patents. Send drawing or model for examination and report as to patentability. Advice and booklet free. Highest references. Best results. Promptness assured. Watson E. Coleman, Patent Lawyer, 644 G Street, N. W., Washington, D. C.

Patents—Send for form "Evidence of Conception" to be signed and witnessed. Form, fee schedule, information free. Lancaster and Allwine, Registered Patent Attorneys in United States and Canada, 269 Ouray Bldg., Washington, D. C.

Patents for inventions. Long experience, highest grade work, rates reasonable, best references. Advice as to patentability. Wm. Ashley Kelly, 41 Park Row, New York.



**Patents**

**Inventions Commercialized.** Patented or unpatented. Write Adam Fisher Mfg. Co., 278 Barlett St., St. Louis, Mo.

**Unpatented Ideas Can Be Sold.** I tell you how and help you make the sale. Free particulars (Copyrighted). Write W. T. Greene, 804 Jenifer Building, Washington, D. C.

**Personal**

**Lonely Hearts—Exchange letters;** make interesting new friends in our jolly club. Eva Moore, Box 908, Jacksonville, Florida. Enclose stamp.

**Lonely—Join Our Club.** Make friends everywhere. Particulars free. Write Mrs. Matthews, Box 26, Oakland, Calif.

**Radio**

**Boys! Don't Overlook This.** The "Rasco" Baby Detector. Greatest detector ever brought out with unlined base. Fully adjustable. See former advertisements in this publication, or our catalog. Detector with Galena crystal, complete 50c, the same detector with Radiolite crystal, 75c prepaid. Send for yours today. Radio Specialty Company, 96-98 Park Place, New York City.

**Ivory Radio Panel;** Grained white "Ivorylite" makes most beautiful set of all. Guaranteed satisfactory. Any size 3-16" thick sent prepaid 3c per square inch. Sample free. E. P. Haiton, Dept. N, 614 Main St., Fort Worth, Texas.

**Tetradyne—Transcontinental** all standard parts. simple to build, three tube, powerful receiver. Your opportunity to enter the radio business or build your own set. For full particulars address, Tetradyne, 335 43th St., Milwaukee, Wis.

**Attention!—50 Vacuum tube hook-ups.** The greatest collection of vacuum tube circuits ever brought under two covers at such insignificant cost. These diagrams will be found in the great "Rasco" catalog, which contains ray materials and parts in a greater profusion than any other catalog. Use in stamps, or coin, will bring the catalog to you. Radio Specialty Co., 96-98 Park Place, New York City.

**2650 Miles Distance with one tube.** Any Novice understands our simplified instructions. Big free booklet tells the story. Vesco Radio Co., Box RC-117, Oakland, Calif.

**Wanted by large manufacturer—a well designed modern variable condenser including designs tools, etc.** Cash. Explain fully. Box 220 Radio News.

**Crystal Cleaner** a fluid which will clean your radio crystals and make them as good as new. Send 35c for a bottle. Temple Electric Shops, Olathe, Kansas.

**Free Tested Crystal—**Send no money, just two cent stamp for postage. Pitts Novelty Sales, 561 W. Washington St., Chicago.

**Changing wavelengths to Kilocycles, Velocity and Frequency;** Problems involving Ohm's Law: One winding of a transformer is given additional voltages and windings are solved instantly. Solution of Radios and Propotions, Squaring and a Square Roots, Multiplication and Division, and hundreds of other problems made easy. Don't pay exhorbitant prices for a slide rule. I will send you a set of 10" slide rule scales for \$1 with instructions, stamps or coin. Geo. W. Richardson, 4212—24th Place, Chicago.

**Neutrodyne Hunchbaaks—**Change that Neut, or build instead of a Neut, the Kladsag Coast to Coast Circuit. Same panel same layout as Neut—fewer parts. Selective with deep resonant volume. Not obtainable elsewhere. One different part, 22 feet gold buswire, lithographed print complete, simple instructions—prepaid anywhere—\$5.00. Nothing else to buy. Details—10c. 48 page parts catalog—10c. Stamps accepted, same as cash. Kladsag Radio Laboratories, Kent, Ohio.

**A Bargain. Tropadyne Kits, Neutro Reflex Kits, Acme Radio transformers.** Chadwick, Sutton, N. H.

**Build Your own wave trap.** complete kit \$1.50 with cabinet. Cuts out interfering stations, assures selectivity permits greater volume, blue print. 27 cents. W. Bullen, 1418 Clairmont, Detroit, Mich.

**Jobber Closing out stock of radio, all kinds including Crosleys, Atwater-Kents, Mu-Rads, etc.** Send stamp for list. Box D, Nora Springs, Ia.

**Attention Mfrs. Jobbers, Dealers.** Radio Salesman desires communication with parties to equip him with motor truck and samples and ship sets and accessories direct to consumers in small towns. Bond furnished. Box 215 Radio News.

**Edison Elements 5c per pair.** Co-operative Merchandise Co. Chelsea, Mass.

**Salesmen Wanted**

**A Salesman wanted in every town or city within 25 miles of a broadcasting station to sell Radiogram, the complete radio receiving set that retails for \$2.50.** With Radiogram there is nothing else to buy—the outfit includes the Radiogram receiving apparatus, 1,000 ohm phone, and aerial outfit. The cheapest radio outfit on the market—yet as practical as the most expensive. Big money to the right man. Send \$2.00 for sample outfit. The Radiogram Corp., 66-R West Broadway, New York City.

**Sell Guaranteed shirts, factory to wearer.** Big commission paid in advance. We deliver. Make \$5.00 to \$20.00 daily. Write for our "Wonder Sales Outfit". Curtis Shirt Co., 508 So. Wells, Dept. 20, Chicago.

**Salesmen Wanted (Continued)**

**Salesmen—Sell Four Square Suits \$12.50;** guaranteed two years. Five different patterns. Profit in advance, \$3 to \$5.50. Complete line, coat, vest, pants, riding pants, slip-ons, caps. One day delivery. Stone-Field W2550 S. Wabash, Chicago.

**Lightning Strange Battery Compound.** Charges discharged batteries instantly. Eliminates old method entirely. Gallon free to agents. Lightning Co., St. Paul, Minn.

**Scenery to Rent**

**Settings for Opera, Plays, Minstrels. Plush Drops.** Address Amelia Grain, Philadelphia.

**Song Writers**

**Songwriters: Let me furnish the music for your songs,** guaranteeing you absolute satisfaction. Copyrights secured. Submit your scripts for estimate and free advice. Walter W. Newcomer, 1674 Broadway, New York.

**Stamps and Coins**

**158 Genuine Foreign Stamps, Mexico War Issues, Venezuela, Salvador and India Service, Guatemala, China, etc.,** only 5c. Finest appraisal sheets 50 to 60%. Agents wanted. Big 72-p. Lists Free. We buy stamps. Estab. 20 years. Hussman Stamp Co., Dept. 146, St. Louis, Mo.

**You'll get profit and pleasure collecting old coins.** Send 10c for genuine old coin and large coin catalog. This is just a get-acquainted offer. Send today. You'll be delighted with it. B. Max Mehl, Numismatist, Dept. R, Mehl Building, Fort Worth, Texas. Largest Coin Firm in U. S.

**Telegraphy**

**Telegraphy—Both Morse and Wireless taught thoroughly.** Big salaries. Wonderful opportunities. Expenses low: chance to earn part. School established fifty years. Catalog free. Dodge's Institute, Cour St., Valparaiso, Ind.

**Wanted to Buy**

**Full Value Paid for Old Gold, Jewelry, Watches, Diamonds, crowns, bridges, dental gold, silver, platinum, gold or silver ore; magnetite points, old false teeth.** Packages returned if our offer is not satisfactory. United States Smelting Works (The Old Reliable) 120 So. State St., Dept. 16, Chicago, Ill.

**FOR SALE**

**RADIO NEWS, through Radio News Laboratories, has a number of experimental sets which were specially built for "The Constructor" pages in RADIO NEWS.** These sets, as a rule, are kept for prospective users. It does not pay the Laboratories to dismantle the sets once they have been assembled. Of late we have started to sell a few of these. We shall be glad to send you a list of the material we have. These sets are offered for the reason that they are in our way. Of course, there is only one of each kind in existence, as the Laboratories are not in the set business, but merely constructing the sets for editorial purposes. Once the information about the set has been published, as a rule, such sets are of no further use. For further particulars and list of sets on hand—

—WRITE—

**Radio News Laboratories**  
53 Park Place New York, N. Y.

**Good Radio Advice**



**RADIO INSTRUMENTS for the RADIO ENTHUSIAST**

**AMERICA'S** pioneer instrument maker has prepared a booklet for you showing typical radio receiving hook-ups and how to properly connect instruments in circuit.

Complete information is also given on the Weston Radio Plug and the Weston Radio Table Voltmeter, indispensable to radio pleasure and success. This double range table voltmeter (150 and 7.5 volts) is invaluable for improving reception, for prolonging the useful life of tubes, for locating trouble and for preventing the discarding of batteries prematurely. Write for "Weston Radio Instruments" today.

**WESTON ELECTRICAL INSTRUMENT CORPORATION**  
173 Weston Avenue, Newark, N. J.



**NEW MODEL C-7 SUPER-HETERODYNE THE SET THAT MADE RADIO FAMOUS**

7 TUBES GIVE THE RESULTS OF 10

The greatest set known for long distance, volume and quality of reception. The Model C-7 is the result of many years' work by the best known radio engineers, and is made up of the highest quality apparatus available. It is the most sensitive and most selective broadcast receiver that can be built.

We distribute only the original E. I. S. parts and make immediate shipment from stock.

Write for catalog and price list.

**RADIO PARTS CO.—Laboratories**

8 South Austin Blvd.

OAK PARK, ILL.

Insure your copy reaching you each month. Subscribe to Radio News—\$2.50 a year  
Experimenter Publishing Co., 53 Park Place, N. Y. C.





## Why we call the ROLA a "Re\*Creator"

**I**T is one thing to transmit sound as the telegraph wire carries the dots and dashes of the code. But it is another thing to *re\*create* all the subtle expression of the symphony orchestra—the piping trebles and the resounding basses—each one as perfect, as full and round and clear as if you were sitting in the same room.

This is the Rola. Because its reproduction of sound is so faithful, because its range of reception is so great, we have called it a "Re\*Creator."

But the Rola "Re\*Creator" speaks for itself. No argument in its favor is so convincing as an actual demonstration. Drop in to your dealer's and ask to hear the Rola. Then you will know the difference between a "Re\*Creator" and a loud speaker.

Price complete with 14-inch horn and cord, \$36. Phonograph unit with adaptor, \$22.50.

A product of the Rola Company, 4250 Hollis Street, Oakland, California.  
Distributed nationally to the jobbing trade by Baker-Smith Company,  
Call Building, San Francisco.

# Rola

## RE \* CREATOR