

FEBRUARY 1946

RADIO

MAINTENANCE

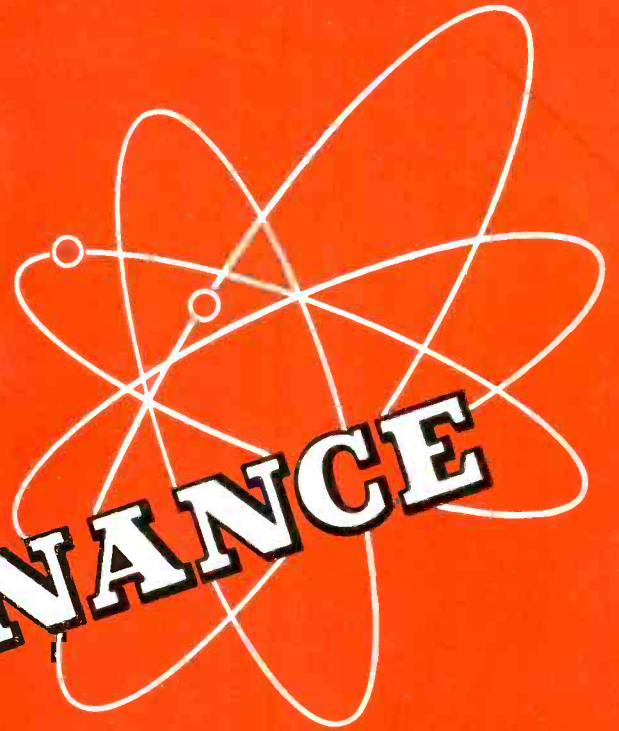

MODERN BENCH CONSTRUCTION
SYMPOSIUM ON TEST EQUIPMENT
FUNDAMENTALS OF VACUUM TUBE VOLTMETERS
REPAIR OR RECONDITIONING

A BOLAND AND BOYCE PUBLICATION

For Peak Performance



Depend on
RAYTHEON BONDED
ELECTRONIC TECHNICIANS

Bonded by



A "STAR SALESMAN" FOR YOU!

Every customer who comes to your counter will see this effective wall banner. It tells them you're a dependable, square-dealing Raytheon Bonded Electronic Technician — and brings them back to spend money with you.

This selling wall banner is only one of many carefully designed sales-aids — displays, decals, mailing pieces, job record cards — for you to use in building a lasting, money-making radio service business. Bonded service means better customer relations. See your Raytheon distributor today.

Another reason why it pays to qualify as a Raytheon Bonded Electronic Technician.



Excellence in Electronics

RADIO RECEIVING TUBE DIVISION

NEWTON, MASS. NEW YORK CHICAGO

RADIO

MAINTENANCE

INCLUDING
ELECTRONIC
MAINTENANCE



Volume 2

FEBRUARY 1946

Number 2

Contents

Modern Bench Construction	Joseph J. Roche	3
How to build a better service bench		
Symposium on Test Equipment		6
Compilation of test instruments		
Fundamentals of Vacuum Tube Voltmeters	C. G. McProud	14
The various types and how they operate		
Repair or Reconditioning	Elton T. Barrett	18
More customer satisfaction		
Servicing Aircraft Radio Power Packs	Myron F. Eddy	22
A new field for servicemen		

Departments

The Radio Service Bench		20
Shop problems		
Service Kit		24
Outside servicing		
Electronically Speaking		28
News in the radio field		
Review of Trade Literature		29
Industry Presents		32
New Products		
Radio Men's Opinions		36
Letters from our readers		

MYRON J. BOYCE
Publisher

WILLIAM F. BOYCE
Editor

C. G. MCPROUD
Managing Editor

JOSEPH J. ROCHE
Production Manager

ALFRED E. GREY
Assistant Editor

AL JOHNSTON
Circulation Manager

SANFORD L. CAHN
Advertising Manager

JOSEPH COLGAN
Art Director

Copyright 1946, Boland & Boyce, Inc.

Radio Maintenance is published monthly by Boland & Boyce, Inc., 295 Broadway, New York 7, N. Y. Subscription Rates: In U. S., Mexico, South and Central America, and U. S. possessions, \$2.00 for 1 year, \$3.00 for 2 years, single copies 25 cents; in Canada, \$2.50 for 1 year, \$4.00 for 2 years, single copies 30 cents; in British Empire, \$3.00 for 1 year, \$5.00 for 2 years, single copies 40 cents; all other foreign countries, \$4.00 for 1 year. Subscribers should allow at least two weeks for change of address.

IMMEDIATE SHIPMENT!

Radio Parts Electronic Equipment



Mail Coupon Below for FREE Victory Clearance Flyer

32 pages of money-saving bargains in hundreds of standard-line, top-quality radio and electronic parts. Note these typical Victory Clearance values—

Neutralizing Tool Kit
Consists of all tools necessary for neutralizing work. 12 tools telescoped into 5 units in leatherette pouch.
586547 **\$263**

Ohmite Model G Potentiometer
15 Ohms, 75 Watts, 1/4" diam. shaft.
5B2075
\$195



**Order Today for Shipment Tomorrow
from CHICAGO or ATLANTA**

Huge stocks in TWO convenient warehouses—one in CHICAGO and one in ATLANTA—are ready NOW to make IMMEDIATE SHIPMENT of radio and electronic parts and equipment of dependable, nationally-known quality—and at Victory Clearance prices that mean important savings on Meters, Condensers, Transformers, Resistors, Controls, Switches, Relays, Test Equipment, Generators, Microphones, Tools, and hundreds of Repair, Replacement and Accessory Parts. Whatever your needs, see the surprising values offered in CONCORD'S Victory Clearance Flyer. Mail the coupon for your FREE copy now.

CONCORD RADIO CORP.

Lafayette Radio Corporation

CHICAGO 7, ILL.
901 W. Jackson Blvd.

ATLANTA 3, GA.
265 Peachtree Street

CONCORD RADIO CORPORATION
901 W. Jackson Blvd., Dept. RM-26
Chicago 7, Illinois

Please rush free copy of CONCORD'S
new 32-page VICTORY CLEARANCE Flyer.

Name.....

Address.....

City..... State.....



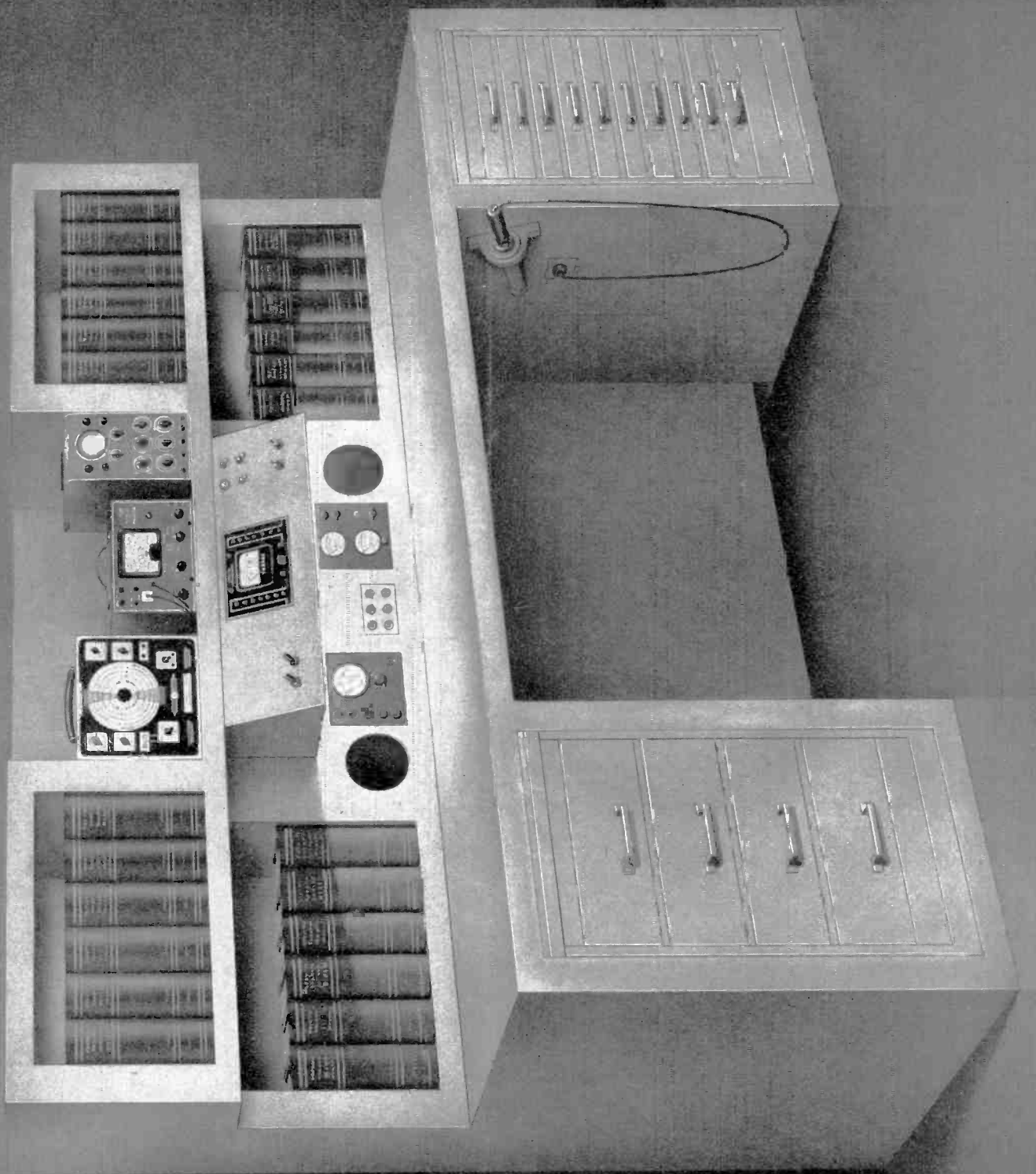

Modern Bench Construction

by **JOSEPH J. ROCHE**

Incorporating Motion Saving Features — Increased Production Facilities — Optimum Tool Location — Filed Replacement Part Storage — Ample Portable Test Equipment Stations — Complete Provision for Maintenance Manuals and Power and Antenna Facilities.

SPEED IS ESSENTIAL to profitable radio servicing. Less time spent on a repair job means more profit to the serviceman. The real answer to this problem of time lies in the radio service bench itself. Proper design and construction of the bench can cut the time spent on a service job in half.

To realize this increased efficiency, all of the many problems of motion, fatigue, and so on, must be taken into consideration and the best design to cover each of these problems incorporated into the bench. In the design presented here, all of these things have been done. A detailed analysis was made of all the motions a serviceman makes while working at the bench with the idea in mind of cutting all unnecessary movement to a minimum and making all necessary movement as easy as possible.

This bench design was developed by the staff of RADIO MAINTENANCE for the exclusive purpose of increasing production from the average radio service shop. The facilities incorporated in this bench make increased production possible without increased effort. This object has been achieved by the use of all the elements known to the science of modern production practice.

The bench is the oldest tool used by man in production, and yet one of the least developed today. Great consideration has been given to the development of benches of maximum efficiency by many large organizations, both for production and service use. Probably the greatest single factor in the development of service benches has been the radio maintenance equipment made up for the portable repair requirements of the armed forces in action during the war. The second and third echelons have been provided with traveling repair stations in trucks and trailers. The designers of these have incorporated the maximum possible facilities into the minimum space.

The first step in the design of this bench was the making of a detailed analysis of the requirements of the radio serviceman in the shop. Having considered all of these requirements, it was thought that the most important need was the desirability of producing more radio repairs per labor unit, and of producing them more easily. In order to achieve this result, the following points were thoroughly considered:

- 1) Bench height should be suitable for either a standing or sitting position, and for the sitting position, comfortable knee space should be provided.
- 2) The working surface should be suitable for the roughest usage.
- 3) The most used test instrument—the multimeter—should be prominently mounted at the optimum position with respect to the operator and to the receiver being

worked on. Other often-used facilities should be provided on this same panel in order to be of easy access.

4) Space should be provided for the convenient placement of a complete file of service manuals, with additional space to take care of future issues for at least five more years.

5) Space should be provided for convenient placement of additional test instruments which will be used in alignment, trouble shooting, signal tracing, and operations involving the use of other than the multimeter. These instruments should be at such a position as to be readily visible.

6) A variety of power sources should be provided to supply line power of 115 volts, A.C., 6 volts D.C. for use with automobile receivers, 6.3 volts A.C. as a convenient heater source for substitution in certain troublesome cases, and a source of D.C. adjustable from zero to 400 volts.

7) Tools and replacement parts should be located within easy reach in systematized order.

8) The soldering iron should be placed where it is out of the way but within arm's reach.

9) Solder and hookup wire should be available at arm's reach when required.

10) Illumination of the bench surface as well as the instrument panels should be evenly diffused over the entire working area.

11) As a safety precaution, little or no metal should be used on the bench top.

12) The entire bench should be of modern design in appearance in order to be attractive to customers, and to instill in their minds the idea that the serviceman is adequately equipped, both with the facilities for successfully servicing their radios and with the wide-awake mental outlook necessary in any good business man.

Taking each of these points in order, we consider first the proper height for a bench top. There are apparently two schools of thought on this—some people want a service bench made so that they can sit down to work at it, and others want to stand to do their work. These two desires are not irreconcilable, even though they may seem so at first thought. It is possible to work sitting down at a bench of any height, with the proper stool, but it is possible to work efficiently while standing only at a bench of one height. The correct height for a working surface of this type has been the subject of much research on the part of kitchen cabinet designers, and the general consensus of opinion is that for the average woman, the most efficient height is 35 inches. Based on the average height of women of about 5'4",

MODERN BENCH CONSTRUCTION

→ From Preceding Page

this brings the most efficient bench height for the average man (5'8") to 39 inches. This would apply to the top of the bench if the work were actually being done right on the surface of the bench. However, it must be remembered that the height of the average radio chassis is about four inches to the tube sockets and other components when the chassis is inverted. This would indicate that the optimum height should be approximately 35 inches. Another consideration is that the arms of different people vary in length, so another criterion might be set up—that the top of the bench be eight inches below the tip of the elbow when standing with the arm bent. For the purpose of the average man and the average shop, the bench height selected for this model was 35 inches. Bear this in mind in case you should plan on the construction of such a bench, and if you are much above or below average in height, adjust the height of your bench accordingly. Having determined the height of the working surface for a standing position, it is only necessary to put yourself in the correct working position for sitting. For this purpose, a telephone operator's chair is recommended. This is a very well designed stool of adjustable height, and with a comfortable foot rest. These chairs have been designed by experts for the most efficient operation by girls who must sit at their work and who do so at high production for relatively long periods. They are quite comfortable, and well worth the investment.

The selection of a suitable working surface will be highly controversial, but the RADIO MAINTENANCE staff has come to the conclusion that a hardwood surface, well oiled, is the most practical. The use of linoleum is not recommended, nor is it considered that the masonite top is sufficiently wear-resistant for this application. Linoleum has a very good appearance, but much work with sharp cornered chassis will soon mar its surface, and it is extremely subject to damage from a hot soldering iron, which is certain to come into contact with it occasionally. Masonite, even though tempered, is subject to abrasions, and will not retain its surface under great usage.

For the bench surface, therefore, the use of 2x6 tongue-and-groove maple is recommended. It may be

difficult to obtain in some parts of the country, and if so, a good surface of hardwood flooring can be laid over a subsurface of 2x6 tongue-and-groove Oregon Pine, or whatever is available. A tongue-and-groove bench top is used because the interlocking feature of the boards will transmit flexure throughout the entire surface, thus making a much stronger top.

While many servicemen may prefer to use one multimeter for both shop work and outside service calls, it is believed that a permanently mounted multimeter should be provided in most efficient location possible. Figure 1 shows the reason for the placement selected for this bench. When working on a chassis, the serviceman is constantly looking from the set to the meter he is using—locating the prods on the correct terminal and then reading the voltage or resistance from the meter. If the meter dial is so placed that it is not necessary to change the focus of the eyes when looking from the chassis to the meter and back, considerable reduction in eye strain will be effected. In Fig. 1, the chassis and instrument panel are shown in relation to the eye of the serviceman, and it will be noted that

the two are equidistant from the eye as are also the instruments on the upper shelf. Naturally, this is an ideal case, but it must be remembered that the design must be made to accommodate the average set and the average condition, rather than for any particular set of conditions. A compromise has to be effected to achieve the best results in the greatest number of cases. This same instrument panel provides antenna and ground connections, both on retract-

→ To Page 34

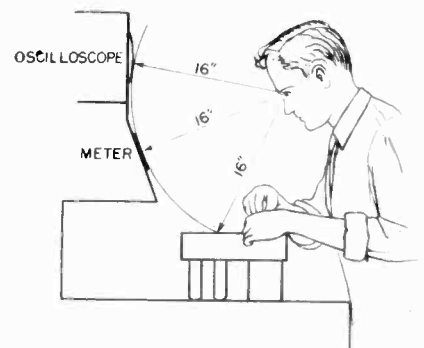

Fig. 1. Relationship of instruments and repair job to eye.

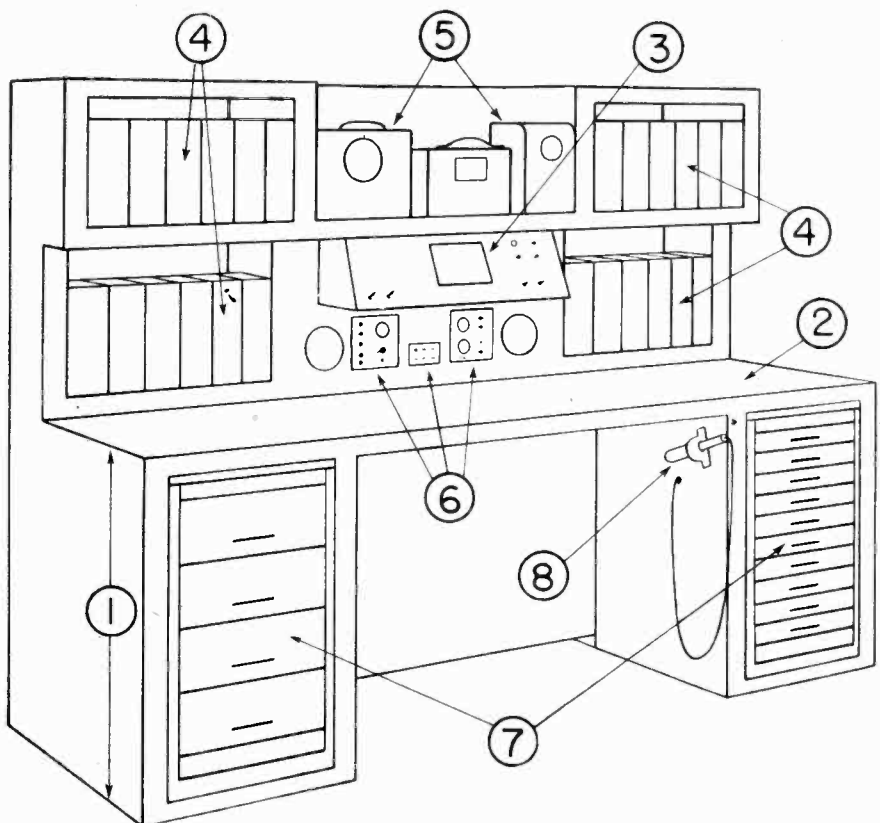

Fig. 2. Front view of bench.

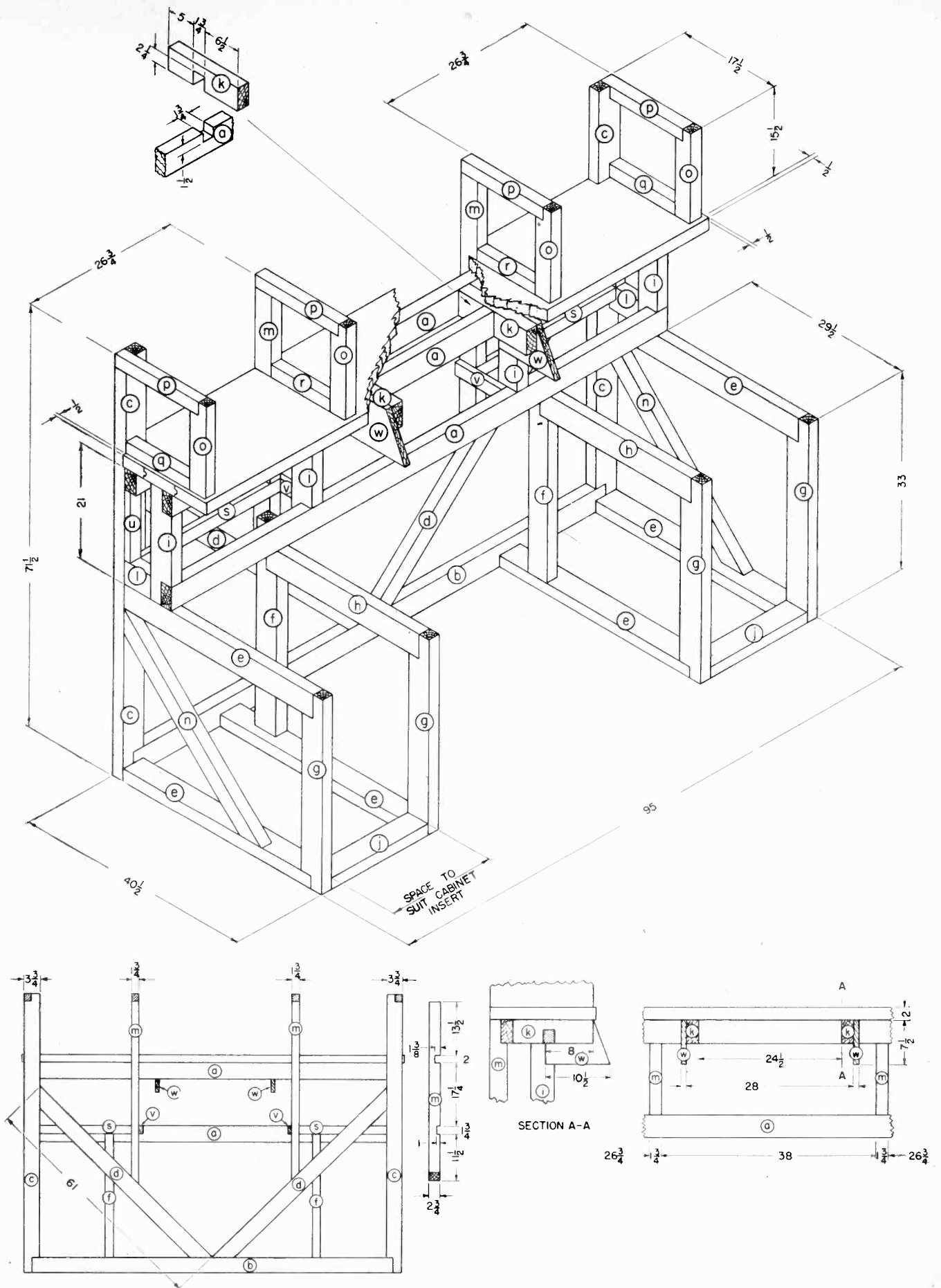

Fig. 3. Isometric view of the bench frame.

Symposium on Test Equipment

Twice-postponed, but finally ready is this tabulation of test equipment from those manufacturers who have announced the 1946 line.

WITH THE COMING of F-M and Television servicing into prominence due to increased activity in these fields, the year 1946 is certain to see the introduction of many new items of test equipment designed to fulfill the more rigid requirements of these receivers. Much of the new equipment is still in the drawing board stage, and as it is announced, Radio Maintenance will describe it thoroughly. In the meantime, however, many servicemen are badly in need of new equipment, even of the simpler yet indispensable units.

As an aid in the selection of new equipment, the following tabulation

of a large percentage of the models now offered by the manufacturers is presented. It is not a complete listing of every item on the market now, nor is it assured that every unit described is immediately available. Several manufacturers do not have their line sufficiently ready to include in these tables. Prices are shown in those instances where pricing has already been set by the OPA. It is suggested that as the prices are announced in future advertising, they be entered in the tables, thus keeping this listing up-to-date as reference material.

The grouping has been chosen with

a view toward simplifying the use of the tables by listing equipment by type rather than by manufacturer. This tabulation was originally scheduled for the October issue, but the chaotic conditions among radio and test equipment manufacturers immediately following V-J made it imperative to postpone the presentation of this information.

We acknowledge our appreciation of the co-operation of all the manufacturers whose products are listed herein in assembling this information and for furnishing the photographs of their many models.



RCA Chanalyst Model 162



Superior Model CA-11



RCA Audio Chanalyst Model 170

SIGNAL TRACERS

Manufacturer	Model	Tubes	Type	Input Ranges	Misc. Ranges	Features	Size	Weight	Price
RCA	162-C "Chanalyst"	1-SK7, 1-6K7, 1-6H6, 4-6E5, 1-1852, 1-76, 1-6X5, 1-6Q7	Tuned amplifier and tuned oscillator	50 microvolts RF to close eye 0.15 v. AF to close eye	5-25-100-500 DC v.; 25-250 watts	D-C meter reads + or - volts; other circuits close magic-eye tube	10 3/4 x 16 x 9	26	
	170-A "Audio Chanalyst"	1-5Y3, 1-6E5, 1-6H6, 1-6J5, 2-6K6, 1-6SA7, 4-6SJ7, 1-6SN7, 1-6V6, 1-6X5, 1-2050	AF amplifier stages and beat-frequency oscillator with sweep; speaker	5-10-50-100-500-1000 DC v.; 5-10-50-100-500-1000 AF v (flat 30-20,000 cps)	0-150-and 0-15,000 ohms impedance measurement	Incorporates VoltOhmyst (195); Four A-F Amps totaling 110 db gain; Oscillator-20 cps to 10 kc; automatic sweep from 3000 to 0 cps.	14x21x10 3/4	47	
Superior	CA-11	1-1T4	Biased detector in probe	.06 to 1.82		Battery operated. Output read on meter or monitored by phones	5x6x7	5	\$18.75
Supreme	562	2-6SK7, 1-6SQ7, 1-6V6, 1-6J5, 1-80	Tuned amplifier, meter, audio amplifier and speaker		1-3-10-30-100-300-1000 D-C volts; 200-2,000-200,000 ohms 2-20 meg	Center scale voltage readings; enables measurement of gain, location of faults and distortion	15 1/2 x 11 1/2 x 8 3/4	9	99.95

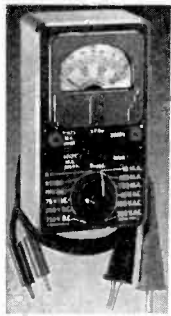

Simpson Model 240



G-E Unimeter UM-3



Radio City Model 448

MULTIMETERS

Manufacturer	Model	D-C V Ranges	Ohms/V	A-C V Ranges	Ohms/V	Current Ranges	Ohm Ranges	Misc Ranges	Size In.	Weight Lb.	Price	
General Electric	UM-3	2.5-10-50-250-1000	2000	2.5-10-50-250-1000	1300	1-10-100 ma DC 1-10 Amps DC	1000-100,000-1 Meg	-12 to +52 db	9x10x4 3/8	9 1/4		
Hickok	4957	10-50-250-500-2500	1000	10-50-250-500	1000	0.5-1-5-50-500 ma DC; 1.0 ma AC	30-10,000-1 meg-10 meg	Output—10-50-250-500 V.	4 3/4x7 3/8x3 1/2	6		
Jackson	610	5-50-100-250-1000				1-5-50-250 ma DC	1000-500,000		7x4 1/4x3			
	615	5-50-100-250-1000-2500		10-100-200-500-2000		1-5-250 ma DC	1000-500,000		7x4 1/4x3			
	642	10-100-250-500-1000-5000	20,000	10-100-250-500-1000-5000		0.1-10-100-250 ma DC; 10 Amps DC	3000-300,000 30 meg	-10 to +54 db	8 1/2x8 1/2x6	6		
	643	10-100-250-500-1000-5000	1000	10-100-250-500-1000-5000		1-10-100-250 ma DC; 10 Amps DC	3000-300,000 3 meg	-10 to +54 db	8 1/2x8 1/2x6	6		
Precision	832A	6-30-150-300-600-1200	1000	12-60-300-600-1200-2400	500	1.2-12-60-600 ma DC	5000-500,000-5 meg	-10 to +62 db; Output—same as AC V	7x4 1/2x3		\$19.48	
	834	12-60-300-600-1200-6000	1000	12-60-300-600-1200-6000	1000	1.2-12-60-600 ma DC	5000-500,000 5 meg	-10 to +70 db; Output—same as AC V	7x4 1/2x3		23.60	
	844P	12-60-300-600-1200-6000	1000	12-60-300-600-1200-6000	1000	1.2-12-60-600 ma DC; 1.2-12 Amp DC	400-100,000 1 meg-10 meg	-12 to +70 db; Output—same AC V	7x8x4		33.10	
	845P	12-60-300-600-1200-6000	1000 & 5000	12-60-300-600-1200-6000	1000	0.3-1.2-12-60 300 ma DC; 1.2-12 Amps DC	2000-200,000 2 meg-20 meg	-12 to +70 db; Output—same as AC V	7x8x4		35.70	
	856P	3-12-16-300-600-1200-6000	20,000 & 1000	3-12-16-300-600-1200-6000	1000	.06-0.3-3-30-120-600 ma DC; 12 Amps DC	6000-600,000 60 meg	-12 to +70 db; Output—same as AC V	9x10x6		43.95	
	864	Same as 845 except has remote control switching box and 9" Meter; Rack mounting								19x12 1/2x6		50.55
Radio City Products	420S 420SP*	2.5-10-50-250-1000-5000		10-50-250-1000-5000		1-10-100 ma DC 1.0 Amp DC	1500-100,000 1 meg	-10 to +69 db; Output—same as AC V	6 3/8x3 1/2x3 6 3/8x4 1/2x4 1/4	25 4 oz.	23.50 27.50	
	424 424P*	2.5-10-50-250-1000	1000	10-50-250-1000	1000	1-10-100 ma DC 1-10 Amp DC	500-100,000-1 meg-10 meg	-10 to +55 db	7 1/2x5 3/4x3 3/4 8x6x 3/4x4 3/8	2 3 3/8	29.50 33.50	
	448	5-50-250-1000	5000	5-50-250-1000		0.3-6-30-150 ma DC 0.5-10-100 ma DC 1 Amp DC	2000-20,000 200,000-2 meg	-6 to +50 db Output—same as AC V	5 7/8x3 1/2x2 1/8	1 3/4	24.50	
	461A 461AP	2.5-10-50-250-1000-5000	20,000	2.5-10-50-250-1000-500	1000	0.1-10-100-500 ma DC	1000-100,000 10 meg	-10 to +55 db	8x7 5/8x3 3/8	4	39.50 43.50	
	488	3-12-60-300-600-1200-6000	1000 & 20,000	3-12-60-300-600-1200-6000	1000	.06-0.3-3-30-600 ma DC; 12 Amps; 3-6-12 Amps AC	3000-300,000 30 meg	Output—same as AC V	13x12 1/2x5 1/2	10 1/2	59.50	
	447 447P*	5-50-250-500-2500		10-100-500-1000		1-10-100 ma DC; 1-10 Amp DC	500-100,000-1 meg	-8 to +55 db; Output—same as AC V	5x8 1/2x3 6 1/2x8 1/2x4 1/2	21 oz 24 oz	17.95 21.95	
Simpson	215	2.5-10-50-250-1000-5000	5000	2.5-10-50-250-1000-5000	1000	0.25-10-100-500-ma DC	4000-400,000 4 meg	-12 to +52 db	5x7x3	2 1/2	27.75	
	230	10-50-250-1000	1000	10-250-1000	1000	10-50-250 ma DC	1000-100,000		2 7/8x5 1/2x1 3/4	1 1/4	17.25	
	240	15-75-300-750-3000	1000	15-150-750-3000	1000	15-150-750 ma DC	3000-300,000		2 7/8x5 1/4x1 3/4	1 1/4	18.00	
	260	2.5-10-50-250-1000-5000	20,000	2.5-10-50-250-1000-5000	1000	.05-0.1-10-100-500 ma DC	1000-100,000 10 meg	-12 to +53 db	5 1/2x7x3	2 1/2	33.25	
	286			5-10-25-50-100-250-500-1000	1000				2 7/8x5 1/4x1 3/4	1 1/4	11.75	
	287	1-2.5-5-10-25-50-100-250-500-1000	1000						2 7/8x5 1/4x1 3/4	1 1/4	11.25	

SYMPOSIUM ON TEST EQUIPMENT

MULTIMETERS (Continued)

Manufacturer	Model	D-C V Ranges	Ohms/V	A-C V Ranges	Ohms/V	Current Ranges	Ohm Ranges	Misc Ranges	Size In.	Weight Lb.	Price
Superior	PB100	5-25-50-250-500-2500	1000	10-50-100-500-1000		10-250 ma DC 2.5 Amps DC	10,000-100,000 1 meg	Output—same as AC V -10 to +55 db			28.40
	PB210	10-50-250-500-1000	1000	10-50-250-500-1000		1-10-100 ma DC 1 Amp DC	200-20,000 200,000-2 meg	Output—same as AC -10 to +55 db Capacity .0005 to 0.3 mfd, 0.25 to 100 mfd			35.75
	710	15-60-150-300-600-1500	1000	15-60-150-300-600-1500	1000	3-15-60-150 ma DC; 3-15-30 Amps DC; 3 Amps DC	1000-10,000 100,000-1 meg 10 meg		6x10x10	11	34.50
Supreme	543	6-150-300-1500	5000	6-30-150-600		0.3-6-30-150 ma DC	2000-20,000 200,000-2 meg	-6 to +50 db	5 1/8x3 1/2x3 3/8	1 1/2	20.75B 22.95M
	543	15-150-600-3000	1000	15-150-600-3000		6-60-600 ma DC	200-200,000		5 7/8x3 1/2x2 3/8	1 1/2	16.25B 17.95M
	592	3.5-7-35-140-350-700-1400	1000 & 25000	7-35-140-350-700-1400		.07-0.7-7-35-140-350 ma DC, 1.4-14 Amps	500-5000- 50,000-500,000 5 meg 50 meg	0 to -46 db	9 1/8x6 3/4x5 3/4	9	55.95
Triplet	666	10-50-250-500-1000	1000	10-50-250-500-1000	1000	1-10-50-250 ma DC	300-250,000		3 1/8x5 7/8x2 3/8	1 1/2	
	666H	10-50-250-1000-5000	1000	10-50-250-1000-5000	1000	10-100-500 ma DC	300-250,000		3 1/8x5 7/8x2 3/8	1 1/2	16.00
	666C	3-30-300-600-1500	1000				1000-10,000- 100,000-1 meg		3x5 7/8x2 3/8	1 3/4	
	625N	1.25-5-25-125-500-2500 2.5-10-50-250-1000-5000	20,000 10,000	2.5-10-50-250-1000-5000	1000	.05-1-10-100 ma DC; 1-10 Amps DC	400-50,000 10 meg	-30 to +69 db	6x5 1/2x2 1/2		37.50
	2400	10-50-250-500-1000	5000	10-50-250-500-1000	1000	0.2-1-10-50-250 ma DC; 10 Amps DC; 0.5-1-5-10 Amp AC	500-1500 1.5-7.5 megs	-10 to +55 db	10x10x5 3/4	11	
	2405	10-50-250-500-1000	25,000	10-50-250-500-1000	1000	.05-1-10-50-250 ma DC; 10 Amps DC; 0.05-1-5-10 Amp AC	5000-40,000- 4-40 megs	-10 to +55 db	10x10x5 3/4	11	
Weston	663	2.5-10-50-250-500-1000				1-5-25-100 ma DC	200-1000-10,000- 100,000 1 meg 10 meg		8 1/2x5 1/2x3 3/8	4 1/2	49.13
	665	1-2.5-5-10-25-50-100-250-500-1000	1000	1-2.5-5-10-25-50-100-250-500-1000	1000	1-2.5-5-10-25-50-100-250-500 ma DC	1000-10,000- 100,000 1 meg	Output—same as AC V	8 1/4x5 1/2x3 3/8	5	58.50
	772	2.5-10-50-250-1000	20,000 & 1000	2.5-10-50-250-1000		0.1-1-10-50-250 ma DC 1-10 Amp DC	3000-30,000 3 meg-30 meg	-14 to +54 db	15 1/8x8 3/4x5 1/8	8 1/2	49.50
	697	7.5-15-150-750	1000	7.5-15-150-750	1000	7.5-75 ma DC	5000-500,000		5 3/8x3 3/4x3 3/8	1 3/4	34.00
	785	1-10-50-200-500-1000	20,000	5-15-30-150-300-750	1000	.05-1-10-100 ma DC; 1-10 Amp DC; 0.5-1-5-10 Amp AC	3000-30,000 3-30 meg		13x12 1/2x5 1/2	13 1/2	93.75

* Portable Case.



Weston Model 697

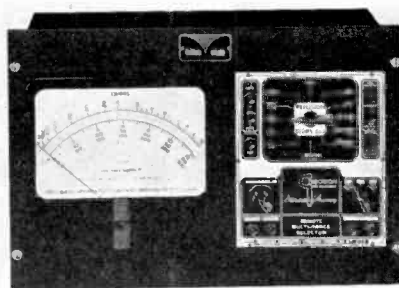

Precision Model 864

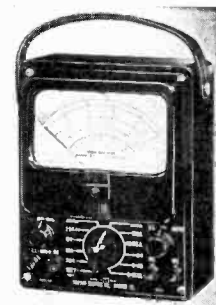

Simpson Model 260

MULTIMETERS with TUBE CHECKERS

Manufacturer	Model	D-C V Ranges	Ohms/V	A-C V Ranges	Ohms/V	Current Ranges	Ohm Ranges	Misc Ranges	Size In.	Weight Lb.	Price
Hickok	534	20-200-500-1000	1000	20-200-500-1000	1000	20-200-ma DC	2500-250,000 25 meg	Tubes tested in micromhos by mutual conductance test. Capacity—.001 to 50 mfd in 2 ranges	15x14 3/4x6 1/2	25	
Jackson	637	10-100-250-500-1000-2500		10-100-250-500-1000-2500		1-10-100-250 ma DC 10 Amps DC	3000-300,000 30 meg	Dynamic output tube test; leakage test; -10 to +54 db; Ballast tube test	14 3/4x13 3/4x6	14	
Precision	920P	12-60-300-600-1200-3000	1000	12-60-300-600-1200-3000	1000	1.2-12-120-600 ma 12 Amps DC	400-100,000-1 meg-10 meg	-12 to +64 db; Mutual conductance tube test; Noise test; Ballast test; Condenser tube and leakage test	12x13x6		\$65.95
	954P	3-12-60-300-600-1200-6000	20,000	3-12-60-300-600-1200-6000	1000	.06-0.3-3-30-120-600-ma DC 12 Amps DC	6000-600,000-60 meg	-12 to +70 db; Mutual conductance test; Noise test; Ballast test; Tube and condenser leakage test	12x13x6		81.35
Radio City Products	805	2.5-10-50-250-1000-5000	1000	10-50-250-1000-5000	1000	0.5-2.5-10-50-1-10 Amps DC	250-2500-25,000-2.5 meg-25 meg	-8 to +55 db; Battery tests; Condenser leakage test; "Dynoptimum" tube test; Noise and hum tests	14 1/4x13x6	12 1/4	89.50
	802N	10-50-500-1000	1000	10-50-500-1000	1000	1-10-100 ma DC 1-10 Amps DC	500-5000 ohms-1-10 megohms. Low ohm center	-8 to +55 db; Leakage test; Noise test	12 3/4x12x5 1/4	11 1/2	57.50
Supreme	505A	5-25-100-250-500-1000-2500	1000	5-10-50-250-1000	1000	0.5-2-5-10-50-250-ma DC 1-10 Amps DC	200-2000-20,000-2 meg-20 meg	Output—same as AC V; Condenser leakage test; Battery test	14 3/8x12 7/8x5 3/8	10	49.95
	599	6-15-150-600-1500	1000	15-150-600	1000	6-60-600 ma DC	200-20,000 2 meg-20 meg	Emission tube test; Battery test; Condenser leakage test	11 1/8x8 7/8x5 3/8	18	97.50
Weston	778	2.5-10-50-250-1000	20,000 & 1000	2.5-10-50-250-1000	1000	0.1-1-10-50-250 ma DC; 1-10 Amps DC	3000-30,000 3 meg-30 meg	-14 to +54 db; Emission test; leakage test	17 1/4x14 1/4x5 5/8	18	97.50

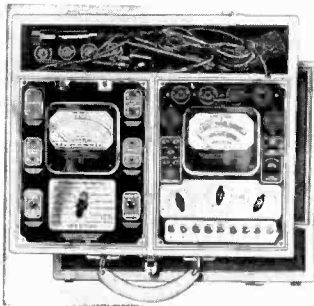

Weston Model 778

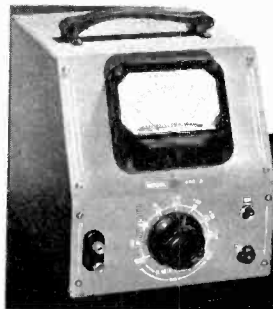

Hewlett Packard 400A

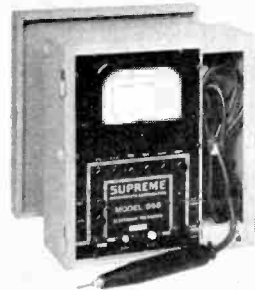

Supreme Model 565

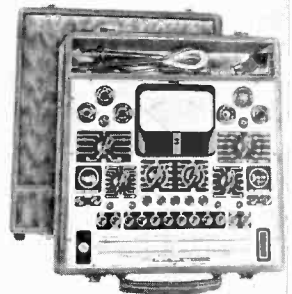

Precision Model 954P

R-F AND A-F VOLTMETERS

Manufacturer	Model	Range	Type	Size	Weight	Price
Hewlett-Packard	400A	.03-0.1-0.3-1.0-3.0-10-30-100-300	Feedback v-t amplifier with rectifier. Calibration in volts and in db above 1 mw/600 ohms. Input impedance—1 meg shunted by 17 mmf. Accuracy 30% below 100 kc, 5% from 100 to 1000 kc	7 1/4x8x9	15	\$175.00
Radio City Products	666	3-6-30-150 v AC	Flat from 20 cps to 150 kc; input impedance 16 megs. Also operated from external battery source	9 3/8x9 3/8x4 3/8	9 1/2	35.50
Silver	900 Vomax	See description under Electronic V-O meters				
Supreme	565	1-2.5-10-50-250 v AC 1-2.5-10-50-250-500 v DC	Negligible frequency error from 50 cps to 100 mc	9x9 3/4x4 3/4	8	63.50
Weston	695	2-5-8-20-50-80-200 v AC; -8 to +46 db (0db = 6mw/500ohms) in 11 overlapping ranges	20,000 ohms constant impedance; calibrated in volts and in db above 6 mw/500 ohms; accuracy 3% from 50 to 20,000 cps.	5 1/8x3 3/4x3 3/16	1 3/4	28.50

SYMPOSIUM ON TEST EQUIPMENT

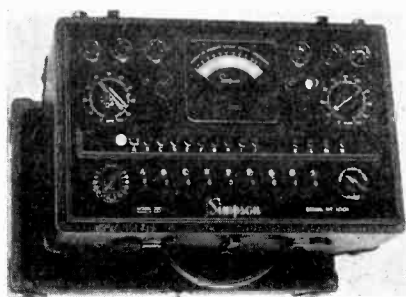

Simpson Tube Checker
Model 330



Superior Tube Checker
Model 450



General Electric
Square Wave Generator

TUBE CHECKERS

Manufacturer	Model	Type	Features	Size In.	Weight Lb.	Price
General Electric	TC-3	Emission	Filament voltages—1 to 117 V; Short Tests; Battery Tests; 10-100-1000 V. DC	15 1/2 x 13 1/2 x 6 1/2	18	
	TC-3P	"	Same as TC-3 except in portable case	14 1/2 x 14 x 7 1/2	13	
Hickok	532P (portable)	Mutual Conductance	Filament voltages—1.5 to 117 V. Tests ballast, lock-in, octal, miniature and indicator tubes. Test data on roller chart. Noise test, hot or cold short tests, line voltage adjustment from 100 to 130 volts	15 x 14 3/4 x 6 1/2	24	
	532C (counter)			15 x 14 x 6 1/2	24	
Jackson	634	Dynamic Output	Filament voltages—0.75 to 115 V. Leakage Test; Tests all receiving types; noise tests	8 1/2 x 8 1/2 x 6	9	
	636	" "	Same as 634 with Roller Charts; Leatherette covered case	14 x 12 x 5 1/2	11	
	636B	" "	Same as 636 except in metal case, no cover	13 1/2 x 9 1/2 x 5 1/2	10	
Precision	910P	Mutual Conductance	Noise test; Ballast test; Condenser leakage test; Tests all receiving types; Roller charts—3" meter	12 x 13 x 6		\$41.75
	912P	" "	Same as 910P except meter is 4 3/8"	12 x 13 x 6		46.15
	914	" "	Same as 910P except meter is 7", Swivel mounted, counter type	16 x 13 1/2 x 7		50.55
	915	" "	Same as 910P except meter is 9", sloping counter rack	23 x 16 x 10 taper to 4"		63.75
Radio City Products	315	Dynamic	"Dynoptimum" tube test, noise test, free point checker	14 1/4 x 13 x 6	12 1/4	59.50
Simpson	305	Emission	Tests all Receiving tubes, including acorn, bantam and miniature	8 x 11 x 5 1/2		
	330	Mutual Conductance	Tests percentage of rated mutual conductance. Automatic reset feature on all switches. Includes acorn socket	10 x 16 x 6		
Superior	450	Emission	Filament voltages—1.4 to 117 V. Short and leakage tests; Noise test; Condenser leakage test	13 x 12 x 6	8	39.50
Supreme	589	Emission	Noise tests; Battery tests; Leakage tests; Filament voltages—0.75 to 117 V. Roller charts	11 1/8 x 8 1/2 x 5 3/8	11	38.50
Triplet	2413		Filament voltage—0.75 to 117 V. in 18 steps; neon short and open tests; line voltage indication	10 x 10 x 5 1/2	12	
	2425		Transconductance tube tests at working voltages	10 x 10 x 5 1/4	12	
	3212		Filament voltages—0.75 to 117 V. in 18 steps; neon short and open tests; line voltage indication	15 1/2 x 11 3/4 x 6	13 1/4	
Weston	777	Emission	Tests for total emission and Cathode leakage; Noise tests; Line voltage control; Individual electrode load test; Neon short check	14 1/2 x 10 1/2 x 7	11 1/2	49.50

SQUARE WAVE GENERATORS

Manufacturer	Model	Frequency Range	Output Impedance	Output	Features	Size	Weight	Price
General Electric	SG-13	5 cps to 125 kc	100-200-300-500-1000-1500	0 to 75 volts	Synchronizing voltage, 7 volts max; impedance, 100 ohms	15 1/4 x 21 x 10 1/2	45	
Hewlett Packard	210 AR	20 to 10,000 cps	1000 ohms balanced to ground	60 v peak to peak open circuit	Input voltage required—2 volts, sine wave Input impedance 25,000 ohms Output attenuator—70 db range, 5 db steps	19 x 10 3/8 x 7	30	\$125.00
Reiner Electronic	530	10 cps to 100 kc	100-200-500-600-1000-2500	App. 20 volts		8 x 9 x 15	18	95.00

SIGNAL GENERATORS

Manufacturer	Model	Ranges	Modulation	Output	Features	Metering	Attenuator	Size	Weight	Price
Hickok	277	1000 kc to 133 mc " " " " " "	Wide band— FM-750 kc sweep at 60 cps	1 volt (below 3 mc)	100 to 10,000 cps A-F output, or 400 cps fixed A-F output at 0 to 1 v. voltage regu- lation	None	2 stage	13x13x7	25	
		100 kc to 110 mc " " " " " "	FM-150 sweep at 400 cps							
		" " " " " "	FM-30 kc sweep at 60 cps AM-400 cps un- modulated							
	277X	Same as 277 with addition of crystal controlled outputs of 100 and 1000 kc, mod at 400 cps, or unmod.							13x13x7	
	288	Same as 277, with addition of db meter, -10 to +38 db and A-C voltage ranges of 3.5-20-140v							13x13x7	
	288X	Same as 277X, with meter as in 288							13x13x7	
Jackson	640	100 kc to 30 mc (6 ranges)	400 cps at 30% Amp Mod.		Accuracy 1/2 of 1% on all ranges	None	2 stage	8 1/2x8 1/2x6		
Precision	E-200	90 kc to 88 mc (6 ranges)	400 cps Amp Mod, 0-100%; Variable Ext. Amp. Mod.; Ext. Freq. Mod.	Approx. 0.1 volts. Impedance 50 and 4000 ohms	Accuracy better than 1% on all ranges. Features AVC sub- stitution and Signal Substitution. 400 cps A-F 100 v peak avail- able on jacks. E.C. oscillator	None	2 stage	10 1/2x12x6		\$43.95
Radio City Products	705	95 kc to 100 mc (5 ranges)	400 cps 30% and 80% Amp. Mod.		400 and 1000 cps avail- able on tip jacks	None	2 stage	8x11 3/4x5	11 1/2	49.50
R.C.A.	167B	100 kc to 30 mc (6 bands)	400 cps 30% Amp. Mod.	.01-0.25-1.0; Impedance 10-750-4000 ohms	500 cps, 8 v available on jacks	None	Single Attenuator	9 1/4x13 1/4x6 1/2	14	
Simpson	315	75 kc to 30 mc (6 ranges)	400 cps, 30% Amp. Mod.			None	2 stage	10x16x4		43.95
	415	75 kc to 130 mc (7 ranges)	0-100% internal 400 cps. Amp. Mod. or external 60 to 10,000 cps	0.3 to 0.6 v across 100 ohms	Low leakage. Controlled 400 cps A-F output; Turret construction	None	2 stage	11 1/2x15x5 1/2		
Supreme	576	65 kc to 20.5 mc (5 ranges)	400 cps 50% or external Mod.		400 cps available on jacks continuously variable voltage	None	2 stage	9 1/2x8 1/4x7 3/8	17	49.50
Triplet	1632	100 kc to 120 mc (9 ranges)	400 cps 30% Amp. Mod. or Ext. Mod.		Air trimmers; perme- ability tuned coils; plug in crystal avail- able; heterodyne de- tector	Carrier meter	2 stage	15x9x6 3/4		87.83
	2432	75 kc to 50 mc (6 ranges)	400 cps, 30% Amp. Mod.		Air Trimmers; perme- ability tuned coils	None	2 stage	10x10x5 3/4	12	49.50

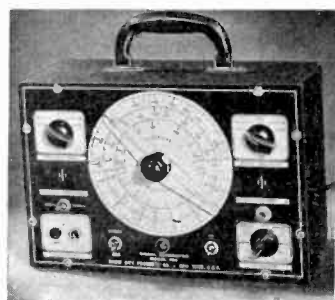

Radio City Sig. Gen. Model 705



Supreme Sig. Gen. Model 576

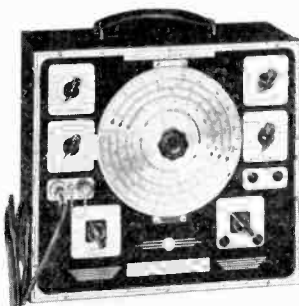

Precision Sig. Gen. Model E-200



Supreme Aud. Osc. Model 563

AUDIO OSCILLATORS

Manufacturer	Model	Type	Range	Output Impedance	Output and Miscellaneous	Size	Weight	Price
Hewlett- Packard	200-B	Resistance- Capacity	20-200 cps; 200-2000 cps; 2000-20,000 cps	500 ohms	1 watt into 500 ohms; Hum level 60 db below rated output; Freq. characteristic, ±1 db from 20 to 15,000 cps. Less than 1.0 = har- monic distortion at rated output. Stability ±2 = under normal temperature	16x8x9	32	\$95.00
Hickok	198	Resistance- Capacity	20-200 cps; 200-2000 cps; 2000-20,000 cps	10-250-500-5000	250 mw output; Hum level 60 db below maximum output; Freq. characteristic, ±1 db from 60 to 20,000 cps. Less than 3% harmonic dis- tortion. Tubes 1-6X5, 1-6SJ7, 1-6V6, 1-6SN7	11 7/8x10 3/8x7	17	
Jackson	642	Resistance- Capacity	20-200 cps; 200-2000 cps; 2000-20,000 cps	10-250-500-5000 high	500 mw output; distortion below 5% 30-15,000 cps; tubes 1-6SJ7, 2-6F7, 1-80. Freq. char- acteristic ±1 db 30-15,000 cps	13x9 1/2x9 3/8	26	
R.C.A.	154	Beat fre- quency	30-15,000 cps	250-500-5000	5.2 v; 250-ohm load, 125 mw; Hum 60 db below maximum output; Distortion below 5% over entire range. Tubes 2-6J7, 1-6C5, 1-6J5, 1-5Y3G	9 1/2x13 1/4x6 1/2	17	
Supreme	563	Beat fre- quency	15-15,000 cps	250-500-5000 all center tapped	50 v/5000 ohms; 14 v/500 ohms; 9 v/250 ohms. Distortion below 5%	13 1/4x9x6x7/16	19	56.15

SYMPOSIUM ON TEST EQUIPMENT

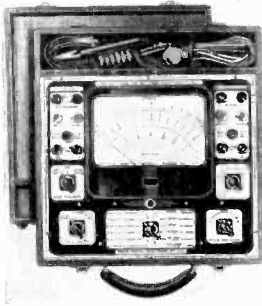

Precision EV-10-P

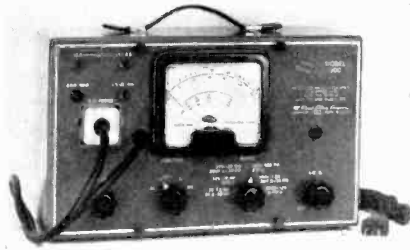

Silver Vomax Model 900



RCA Model 195

ELECTRONIC VOLT-OHMMETERS

Manu- facturers	Model	DC V Ranges	AC V Ranges	Ohm Ranges	Misc Ranges	Tubes	Input Impedance	Size	Weight Price
Hickok	110D	2.5-10-50-250- 1000-2500- 10,000	2.5-10-50-250- rms; 10 cps to over 300 mc			1-9006 1-6SN7 1-VR150 1-6X5	DC—10 megs to 1000 v.; 100 megs on 2500 & 10,000 volts AC—5 mmf and 15 megs	7 1/4x10 3/4x12 1/2	22
	203	2.5-10-50-250- 1000	0.5-2.5-10-50- 250-1000	0.1 ohm to 1000 megs in 6 ranges	2.5-10-50-250- 1000 ma DC	1-6X5 1-6SN7 1-6SJ7 1-VR150	DC—14 megs AC—2.5 megs	7 1/2x8x10 1/2	1 1/2
Jackson	645	4-10-40-100- 400-1000	1-4-10-40-100- 400-1000	1000-10,000- 100,000 ohms 1-10-100-1000 megs	1-4-10-40-100- 400 ma DC; -3 to +55 db	1-7N7 1-6K6GT 6-1X5GT	DC—12 megs AC—4.4 megs	8 1/2x8 1/2x6	9
Precision	EV-10-P (RF probe optional)	3-6-12-60-300- 600-1200-6000	3-6-12-60-300- 600-1200-6000	2000-200,000 ohms; 2-20- 200-2000 megs	0.6-3-12-60-300 300 ma DC; 1.2-12 Amps DC; -26 to +70 db; 7" zero-center meter	1-6C5 1-6X5 1-VR150 (1-9002 in probe)	13.33 meg to 600 v. 26.67 meg for 1200 v. 133.33 meg for 6000 v.	12x13x6	59.35
Radio City Products	668	6-30-150-600- 1500-6000	3-6-30-150-600- 1500-6000	1000-10,000- 100,000 ohms 1-10-100-1000 megs	.002-.02-0.2-2- 20-200-2000 mfd		16 megs, low ranges 160 megs, high ranges; 50 mmfd input capacity	9 3/4x9 1/2x7 3/8	7 3/4 74.50
	665A	6-30-150-600- 1500-6000	3-6-30-150-600- 1500-6000	100-10,000 ohms; 1-10- 100-1000- 10,000 meg ohms at 500 to 1000 volts	.002-.02-0.2-2- 20-200-2000 mfd	1-6X5 1-6K6 1-VR105	16 megs, low ranges 160 megs high ranges; 50 mmfd input capacity	9 3/4x12 1/2x6	13 94.50
R.C.A.	195	5-10-50-100- 500-1000	5-10-50-100- 500-1000	1000-10,000 100,000 ohms 1-10-1000 megs (Low range— 10 ohms at center of scale)	-20 to +62 db	1-6H6 1-6K6GT 1-6X5GT	10 megs, DC	9 3/8x5 1/8x5 3/8	7
Reiner	451 (101 Ampli- fier)	2.5-10-25-100- 250-1000	.025-0.1-0.25- with amplifier; 2.5-10-25-100- 250-1000	0.1 ohm to 1000 megs	2.5-10-25-100- 250 ma DC; 1.0 Amp DC; meas- ures AC, with amplifier from 10 to 5000 cps. Without ampli- fier, 50 cps to 700 mc			10 3/4 x9x8	20 150.00 (ampli- fier) 50.00
Silver	900 "Vomax"	3-12-30-120- 300-1200 (51 megs input re- sistance) 20 cps to 100 mc	3-12-30-120- 300-1200 (6.6 megs input im- pedance) 20 cps to 100 mc	200-20,000- 200,000 ohms 2-20-2000 megs	R-F volts—3- 12-30-120-300- 1200; 1.2-30- 120-300 ma DC; 1.2-12 Amps DC; -10 to +50 db (0 db = 1 mw/ 600 ohms)	1-6AL5 2-SN7 1-5Y3GT	70 meg resistive; 6.6 megs shunted by 8 mmfd to AC	12 3/8x7 3/8x5 3/4	10 59.85
Superior	400	3-15-30-75-150- 300-750-1500- 1500-3000	3-15-30-75-150- 300-750-1500- 1500-3000 (*1000 ohms/v)	1000-10,000 ohms 1-10- 1000 meg	.005 to 200 mfd .035 to 14,000 Hy. Reactance- 10 ohms to 5 meg; -10 to +58 db; 3-15- 30-75-150-300- 750 ma DC; 3- 15 Amps DC	1-6X5 1-6SN7	11 megs up to 300 v. or 1000 ohms/ volt AC & DC	9 1/2x10x5 1/2	11
Triplet	2450	2.5-10-50-250- 500-1000	2.5-10-50-250- 500-1000	1000-100,000; 1-10-100-1000 megs	5 mmfd to 50 mfd (5 ranges)		51 meg on DC v. 50 meg, 6 mmfd on AC V.	10x10x5 3/4	11

OSCILLOGRAPHS

Manufacturer	Model	Tube Size	Deflection Factor, with Ampl.		Input Impedance		Sweep Range	Misc. Features	Size	Weight	Price
			V	H	V	H					
Dumont	164E	3	0.7 v(rms)/in.	0.55 v(rms)/in.	1 meg	0.8 meg	15-30,000	5-100,000 cps	11 5/8x7 3/8x14	20	
	208B	5	.01 v(rms)/in.	0.5 v(rms)/in.	2 meg 30 mmfd	5 meg 25 mmfd	2-50,000	2-100,000 cps	14 1/8x8 7/8x20 1/4	54	
	241	5	.07 v(rms)/in.	0.7 v(rms)/in.	2 meg 40 mmfd	2 meg 40 mmfd	15-30,000	20 cps to 2000 kc	17 1/4x10 3/4x21	65	
	224A	3	0.1 v(rms)/in.	0.7 v(rms)/in.	2 meg 20 mmfd	2 meg 30 mmfd	15-30,000	10-100,000 cps	14 1/8x8 3/8x15 1/8	49	
General Electric	CRO-3A	3					10-30,000				
Hickok	305	3	0.2 v/inch	0.2 v/inch			10-25,000	Contains signal tracing facilities, wide band FM oscillator (23 mc) narrow band FM oscillator (1000 kc) detector, return sweep eliminator. Wide band FM osc. can be modulated with audio signal	11x13x15 1/4	50	
Jackson	523	3	0.4 v/inch				20-20,000	20-100,000 cps	17x8 3/4x12 3/4	20	
R.C.A.	155C	3	1.0 v(rms)/in.	0.5 v/inch	0.5 meg 22 mfd		10-60,000	±10% response, 7 cps to 40 kc; ±20% response, 10 cps to 80 kc; useful response to 200 kc	14 3/8x8x14 1/4	21	
	160B	5	.02 v(rms)/in.		0.5 meg 70 mmfd		4 to 18,000	Flat within 1 db to 12 kc Flat within 3 db to 35 kc Useful to 100 kc	14 3/8x8x19 1/4	30	
Supreme	546	3	0.6 v/inch	0.6 v/inch			15-30,000		13 1/16x11 1/16x7 7/16	21	\$82.50



Dumont

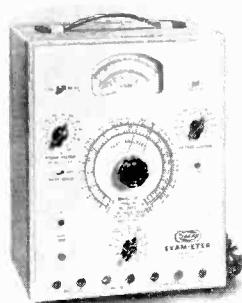

Solar Exammeter
Model CF

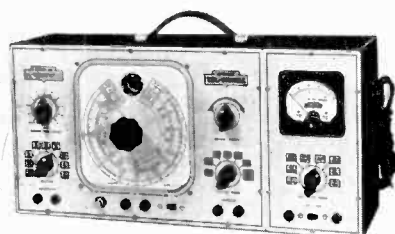

Sprague Tel-Ohmike
Model TO-2



General Electric

RESISTANCE-CAPACITY BRIDGES

Manufacturer	Model	Tubes	Type	Range-C	Range-R	Polarizing Voltage	Miscellaneous	Size	Weight	Price
Aerovox	75	1-6C8G, 1-1v, 1-15	Bridge, with VTVM	.001 to 100 mfd (6 ranges)	10 ohm to 1 meg (5 ranges)	Adj. 0 to 600 v DC	60-300-600 v DC volt- meter 1000 ohm/V	10 3/4x7 3/4x8	11	
Cornell-Dubilier	BF-50		Wien Bridge with null indicator tube	10 mmfd to 240 mfd	Insulation resistance to 1500 megohms		Power factor—0 to 50%; Leakage checks	6 1/2x12x9 3/4	9	
Jackson	650-A		Bridge, with null indicator tube	10 mmfd to 1000 mfd (4 ranges)		20 to 500 v DC	Measures leakage and power factor	8 1/2x8 1/2x6	9	
Silver	901		Resistance Bridge		.01 ohms to 10 megs in 8 ranges		Accuracy ±1% or better on all ranges	12 3/8x7 3/8x6	8	\$59.85
Solar	CB	1-6ES 1-1v	Bridge, with null indicator tube	10 mmfd to 800 mfd	50 ohms to 2 megs	0-600 v DC	Makes leakage checks and measures power factor to 50%	9 1/2x7 1/8x6 1/4	7	
	CF "Exam- meter"	1-6L6 2-6J5G	Wien Bridge with meter indicator	10 mmfd to 75 mfd	100 ohms to 7.5 megs. Insulation resist- ance check to 50,000 megs	0-550 v DC	D-C voltmeter—0-550 v. A-C VTVM 10- 50 v Leakage test; power factor to 55%	12 3/4x10x5 1/2	12 3/4	
Sprague	TO-1 Tel-Ohmike		Bridge, with null indicator tube	10 mmfd to 200 mfd	0.5 ohms to 5 megs; Insulation resist- ance to 10,000 megs	0-1000 v DC		13 1/8x8 3/4x6 1/4	10	34.50
	TO-2 Delux Tel-Ohmike				Same as TO-1, except has D-C voltage ranges of 15-150-500-1500 v. at 1000 ohms/v and D-C current ranges of 1.5-15-50 ma.			17 1/2x9x6	12 3/4	44.90

Fundamentals of Vacuum Tube Voltmeters

If you are considering adding new items of test equipment to your shop you will find this article helpful.

By C. G. McProud

WITH THE COMING AVAILABILITY of test equipment many service men will be buying new instruments. One very useful piece of equipment which should be given careful consideration is the Vacuum Tube Volt-ohmmeter. Compared to an ordinary volt-ohmmeter, the vacuum tube volt-ohmmeter has advantages and limitations. To make a judicious decision about such a selection both sides must be carefully weighed. We shall, therefore, endeavor to present all the facts about vacuum tube meters, and with that information, the reader will be able to make his own decisions.

There are three principal advantages of the vacuum tube volt-ohmmeter. The primary advantage is its ability to measure voltages at various points without loading the circuit to such an extent that the readings are incorrect. The ordinary voltmeter, by drawing even a very small amount of current, causes incorrect readings due to the voltage drop which results from this additional current drain. As an example of this loading, the circuit shown in Fig. 1 was constructed, and some tabulations made of the various voltage readings which were obtained at the plate of the tube, a 6SF5. Fig. 2 shows these readings plotted on a curve as a function of the meter resistance. Under the conditions shown, the tube is biased so that its plate resistance is 0.1 megohms; the plate load resistor is 0.2 megohms. With the constants arranged so that the actual plate voltage is 100, the readings are then indications of the percentage of accuracy. A 1,000 ohm-per-volt meter on the 100-volt scale indicated a voltage of 60 on the plate. This is not an extreme example. In pentode circuits where higher resist-

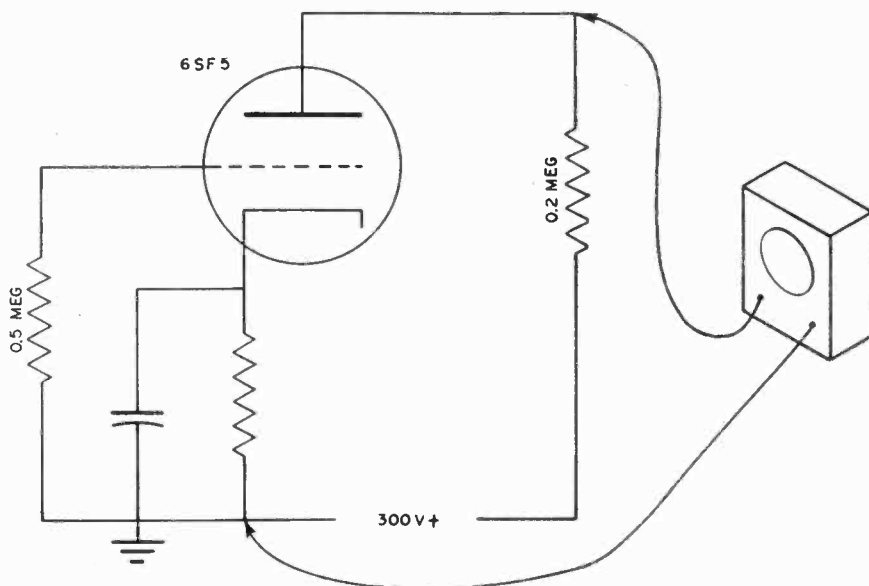

Fig. 1. Simple circuit set-up to study effect of meter resistance on voltage readings.

ance values are likely to be encountered, the errors are greater. You have undoubtedly seen this very same effect when reading the voltage on the screen of a pentode voltage amplifier—the meter indicated 30 volts on a 100-volt scale, so you changed to the 50-volt scale, and the meter indicated 15 volts, the pointer apparently having moved very slightly.

The chart shows fairly well the need for a meter of higher resistance than 1,000 ohms-per-volt. The resistance of most vacuum tube meters is from 10 to 125 megohms, thus almost completely eliminating the loading due to the meter. Excellent regular voltmeters without vacuum tubes are available with sensitivities of 10,000, 20,000, and 25,000 ohms-per-volt, but these are somewhat more delicate

than the lesser sensitive types, and are easier to burn out.

This brings us to the second advantage of the vacuum tube meter. This is the protective feature. Well designed meters of this type are so arranged that the curves of the tubes employed "flatten" out at about 125 per cent of the full-scale reading of the meter, making highly improbable any meter damage due to attempting to measure voltages higher than the range for which the instrument is set.

A third advantage of the vacuum tube meter is the isolating resistor generally located in the tip of the probe. This makes it possible to take readings on the grid of R-F tubes while the set is on without disturbing its operation. It is therefore possible to check a-v-c voltages under

operating conditions. Vacuum tube voltmeters are indispensable for making such checks in receiver servicing.

Limitations

The limitations of vacuum tube meters are listed below.

1. They are generally more expensive than the average good quality multimeter.

2. As a rule they are equipped with less ranges than ordinary multimeters.

3. Vacuum tube meters must have some source of supply—either a set of heavy duty self-contained batteries, or a source of 117-volt A.C., while ordinary multimeters require a much smaller source, which is used only for resistance measurements.

4. Vacuum tube voltmeters are subject to greater number of failures due to greater number of components required; tubes must be changed occasionally; there is always the possibility of breaking the probe tube, where one is used, by careless handling; and the instruments require warm-up time and periodic adjustments. However, in spite of these limitations, it cannot be denied that the vacuum tube voltohmmeter is an extremely valuable servicing instrument, and probably should be listed about third in importance for shop equipment—the first two pieces of test equipment being a good 1000-ohm-per-volt all-purpose multimeter, and a signal generator.

Circuit Functioning

There are a great many types of vacuum tube voltmeters, each of which has its uses. Some are used for measuring D-C voltages only, and some for A-C voltages only. Of the latter, some measure peak voltages and others measure rms voltages. However, the ones of greatest interest to the radio serviceman are equipped with various circuit arrangements to permit measurement of D-C volts, ohms, and A-F and R-F voltages.

The general principle of operation is to apply a voltage to the grid of a tube and measure the change this voltage causes in the plate current of the tube. The tube is normally operated over the linear portion of the grid voltage-plate current curve. By suitably calibrating the instrument, it is possible to determine the applied voltage with a great degree of accuracy. Simple vacuum tube meter circuits are subject to variations with line voltage changes, so means are used to balance out the effect of these variations. By adding

a battery and a group of known resistances, and again calibrating, it is possible to add the functions of an ohmmeter to the instrument. And by adding some form of rectifier, such as a diode, or a triode used as a grid-leak detector or as a biased detector, A-C voltages can be measured well up into the megacycle spectrum.

Simple Single-Tube Voltmeters

One of the simplest types of VTVM circuits is known as the "slide-back" voltmeter, shown in the circuit of Fig. 3. It consists of a triode with a plate supply battery,

→ To Following Page

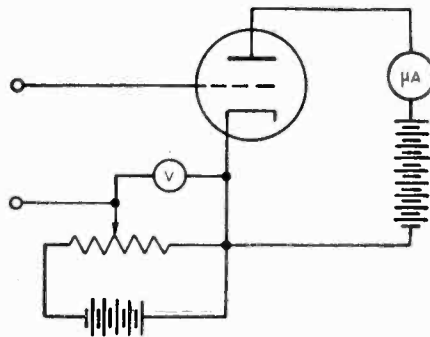

Fig. 3. Circuit of simple "slide-back" vacuum tube voltmeter.

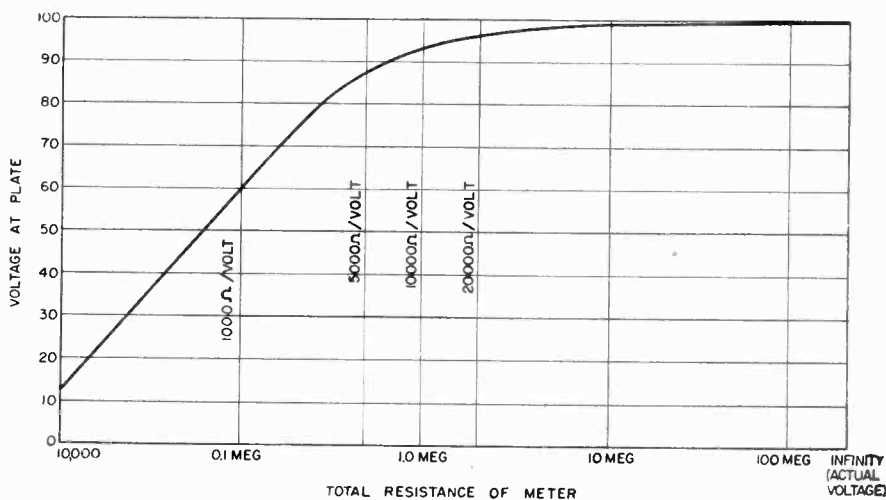

Fig. 2. Curve showing voltages measured on circuit of Fig. 1. As actual voltage on plate of tube was set at 100, meter reading indicates percentage of accuracy.

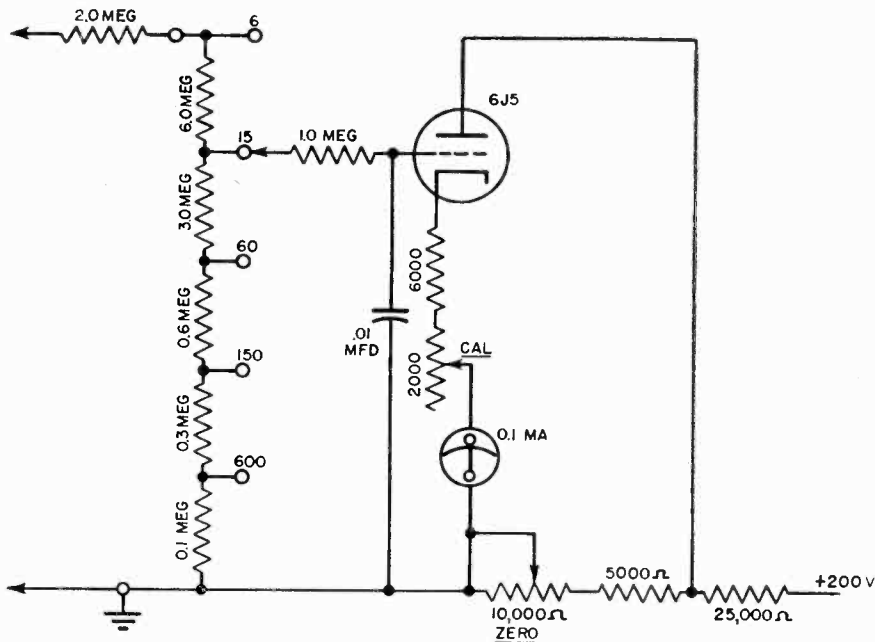

Fig. 4. Circuit of zero-center vacuum tube voltmeter suitable for general service use.

Fundamentals of Vacuum Tube Voltmeters

→ From Preceding Page

a meter in the plate circuit; and a bias battery, a potentiometer, and a voltmeter in the grid circuit. In operation, the input terminals are shorted and the potentiometer adjusted to give a plate current of a very small value, generally in the order of 0.1 ma. The reading of the grid voltmeter is noted. Then the unknown voltage source is applied to the grid terminals, and the potentiometer again adjusted to obtain the same plate current. The reading of the grid bias voltmeter is again noted. The voltage of the unknown source is equal to the difference between the two readings of the grid voltmeter. This type of meter is rather slow to use, and though it measures both A-C and D-C voltages, is little used in modern service instruments.

The so-called zero-center meter is a very simple one to construct, and uses components which are generally available in the average shop. The schematic is shown in Fig. 4. This type of meter is employed in a large number of signal tracing instruments, and is quite rugged and reliable. It has the obvious advantage of requiring no change of leads or no switching of polarity when shifting from positive to negative measurements, which is a great convenience when servicing a radio chassis. The advantage of the center-zero is somewhat offset by the smaller scale divisions. The two adjustments provide for calibration when meter, tube, or any of the resistors are changed. This control is normally located within the chassis. The zero adjustment should be mounted on the panel. Once set up, this instrument is simple and convenient to use. It will be noted that provision is made for a 2 meg. isolating resistor in the probe, and there is a 1 meg. resistor and .01 mfd condenser in the grid circuit to filter out any R-F that might be present in the grid circuit. The scales relationship.

The balanced VTVM has achieved wide popularity in the last few years. This type of circuit shown in simplified form in Fig. 5, is used in the RCA VoltOhmyst, the Silver Vomax, and others. The use of a bridge circuit, and of degeneration in the cathode circuit of the tubes makes a very stable instrument which is practically unsusceptible to

line voltage variations. As two legs of the bridge are tubes, and two others are resistors, changes in supply voltage affect both halves of the circuit alike, and practically no change is noted in the meter readings.

Referring to Fig. 5, R-1 is an isolating resistor in the probe which removes the effect of cable capacity from the circuit being measured. R-2 is a voltage divider, enabling the instrument to measure voltages many times higher than its basic range,

which is generally from 2 to 6 volts. R-3 and C-1 act as an R-F filter and effectively remove all traces of R-F from the grid of the tube, V-1. It will be noted that the grids of both V-1 and V-2 are grounded when no voltage is applied to the probe. Under this condition, sufficient current flows in the circuits so that the cathodes of both tubes attain an equilibrium about 3 volts above ground. Across the plate load resistors R-4 and R-5, equal voltage drops are developed. Consequently,

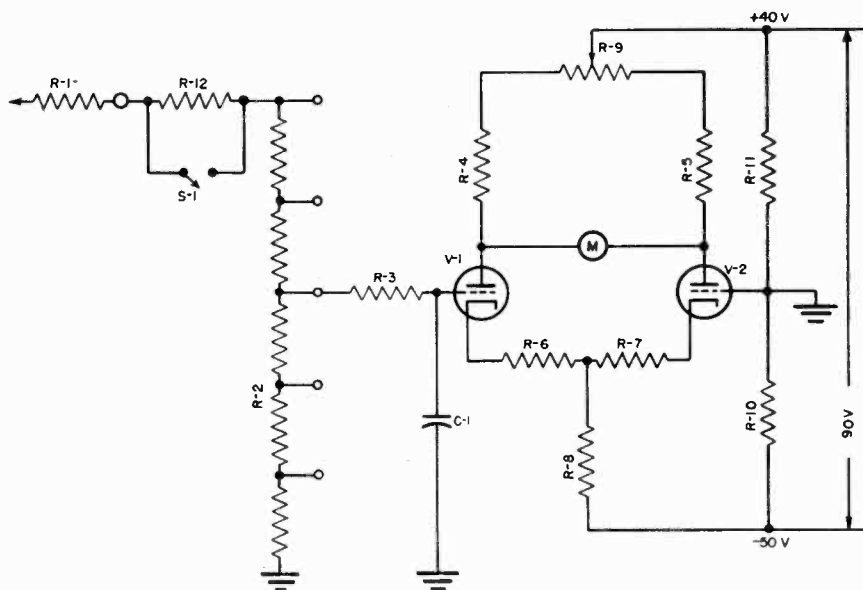

Fig. 5. Bridge type of VTVM, developed to reduce effect of line voltage variation on indications.

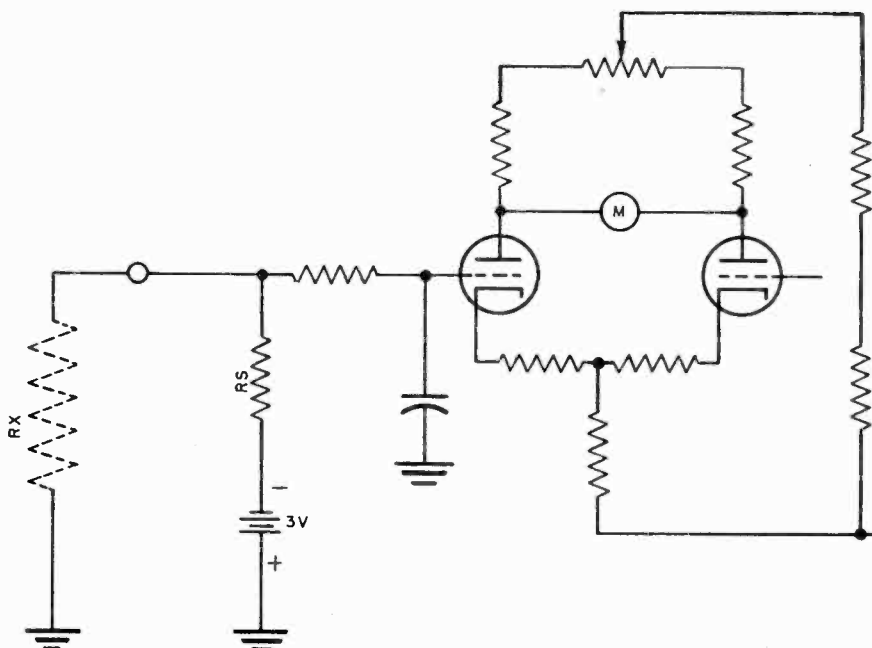

Fig. 6. Method of using VTVM with battery and a standard resistance to measure ohms.

no potential difference is measured between the plates of the tubes. R-9 serves to balance the two tubes and is the zero adjustment for the meter. R-8 in the common cathode return carries the plate current of both tubes.

Voltage Measurements

When a voltage is applied to the grid of V-1, this tube tends to draw more current. This increased current passing through R-8 increases the bias on both V-1 and V-2, reducing the current through V-2 to such an extent that the total current through R-8 remains fairly constant, although the current through the two tubes is no longer the same. Due to this difference in current, the voltage drops across R-4 and R-5 are no longer the same, and the meter indicates this difference; the calibration is expressed in volts on the grid of V-1 (or more accurately stated, in volts applied to the tip of the probe). R-10 and R-11 fix the supply voltages that are applied to the tube circuits with respect to ground. The resistor R-12 serves to multiply the range by a fixed amount when S-1 is opened. Besides increasing the range, R-12 also increases the input resistance by the same factor. Some instruments of this type have this feature.

Although not shown in the simplified diagram, there are several additional resistors in the meter circuit for the purpose of equalizing the readings for positive and negative voltages applied to the grid of V-1, and a reversing switch is necessary to make the meter read in the right direction, regardless of the polarity of the applied voltage. Minor refinements are used to enable calibration with different tubes, but these are not required to be shown for an explanation of the circuit. In order to reduce grid current in the tubes, they are operated at low plate voltage and with reduced heater voltage, thus giving a long tube life.

Resistance Measurements

With the addition of a battery and a number of standard resistances, this circuit is readily adapted to the measurement of resistance. Referring to Fig. 6, the same circuit is seen connected to two resistances and a battery. With the instrument properly adjusted for zero, the circuit switch is set to OHMS, which connects the 3-volt battery through Rs to the grid of V-11. By means of another variable resistor in the meter circuit, the meter is adjusted to a full scale deflection, which corresponds to infinity. If an unknown resist-

ance, Rx, is connected as shown, the tube circuit measures the voltage across the unknown. Rs and Rx comprise a voltage divider, and the voltage across Rx is directly proportional to its resistance. Inasmuch as the tube circuit draws no current, it can be seen that very high values of resistance can be measured with but little battery voltage, the range being limited only by the insulation resistance of the instrument and the leads, and by the grid current of the tube V-1, which is very small. Actually, satisfactory readings may be obtained up to 1000 megohms.

A-F and R-F Measurements

By adding some form of rectifier to the circuit previously shown, it is possible to measure A-C voltages over a frequency range determined largely by the type of rectifier employed and its physical location. For measurements of R-F voltages, it is most advantageous to mount the rectifier tube in a probe, thus reducing capacity losses in the input circuit. Figure 7 shows a suggested modification using a 955 as the rectifier. This circuit was fully described in the July 1945 issue of Radio Maintenance, and by selecting a suitable value of R-1 as a function of the resistance of the voltage divider potentiometer, the instrument will indicate rms volts. The rectifier circuit is one which actually measures peak volts, but so long as the waveform of the applied signal is substantial-

ly a sine wave, the calibration can be made to indicate rms volts. It can be shown that when the total resistance of the voltage divider pot is Rx ohms, and the isolating resistor in the D-C probe is Rx/10 ohms, the value of R-1 to give rms A-C readings corresponding to the D-C scale calibrations is 0.555 Rx. For the commonly encountered 10-megohm voltage divider and 1-megohm isolating resistor, R-1 becomes 5.55 megohms. The value of C-1 is in the order of .01 mfd, as C-2 should be about .02 mfd. If the probe is to be used for R-F measurements exclusively, the value of C-1 could be reduced to .001 to .0001, depending upon the range of frequencies to be measured.

Figure 8 shows a simplified diode circuit as used in the later models of the RCA VoltOhmyst, Model 195. In this circuit, R-1 is the conventional voltage divider; R-2 is a calibration adjustment, and with

→ To Page 26

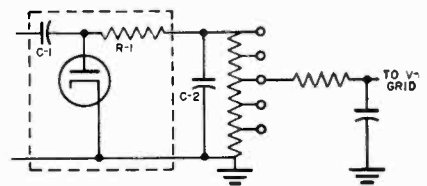

Fig. 7. Probe tube added to input circuit to enable measurement of A-F and R-F voltages.

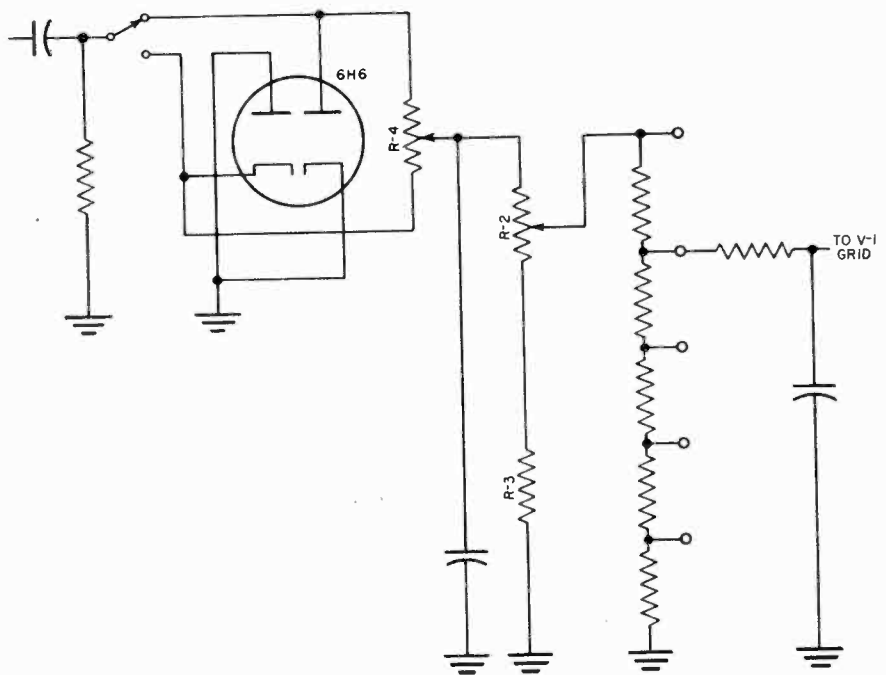

Fig. 8. Diode circuit used to measure positive or negative A-F voltages. Tube is not in a probe so upper limit of frequency is around 10,000 cps.

Repair or Reconditioning

by ELTON T. BARRETT

The author assumes here that you are in the radio service business to make money in an ethical manner. His purpose is to show how selling a reconditioning job is in many cases both more honest and more profitable than merely doing a repair job.

EVERY RADIO servicing transaction involves two jobs—(1) selling the service, and (2) fixing the radio. Sell the customer yourself first. Sell him on the soundness and sincerity of your attitude and on your judgment and skill. When your customers begin to feel that you are honest in your convictions and that you have the necessary technical ability to properly care for their radios, the largest boulder on the road to a successful service business has been removed. As to the second step—repairing the radio—in many cases you are more honest and serve the customer better if you recommend an overhaul job instead of temporary repairs.

What does the typical customer want in the way of radio service? We all know. He wants good radio reception. He wants it as economically as

possible and he wants as little interference with reception continuity as possible. He is going to do business with the radio serviceman whom he *believes* will give him that service. In the long run the public in general will ascertain with surprising astuteness exactly which radio repairmen are actually providing that service. From my own experience I believe that the radio man who does a reconditioning job often renders a better service than if he restricted the job to trouble-shooting and repair. To illustrate this thought, let us consider a rather common situation with which we must all occasionally contend—the radio that operates intermittently. There are three ways this can be handled.

1. It takes five hours to find the leaky condenser. It takes three minutes to replace it and the condenser costs twenty cents. Your service rate is two dollars per hour. You proudly tell yourself that you are going to do business on an honest basis—you bill the customer for ten dollars labor and twenty cents for parts. You are being honest. But are you being both honest and wise? I think not.

2. You charge the customer only two hours' time and increase the labor charge on the "quickie" jobs that take only two minutes to find the trouble. But this only means that you have actually charged for your knowledge on the "quickie" jobs, not your time, and you have *lost* money on this job.

3. The radio is now four years old; the customer complains that it is intermittent so I suggest you make a cursory examination in the presence of the customer if possible. Then explain to him that it may take you considerable time to ascertain the actual cause of the present trouble and therefore you cannot immediately make an accurate estimate of the

total cost of repairs. Better spend some time explaining that the most difficult task of repairing the radio will be to find the trouble and that while doing this you will be partly overhauling the set. Therefore the most logical thing to do for a set of this age is to recondition the set entirely. Explain that by reconditioning you mean placing the set in new operating condition and giving him a *New Radio Guarantee!* You will thoroughly clean the chassis. You recommend that you replace all tubes that show any indication of deterioration, all by-pass, coupling and filter condensers and all resistors. In addition you agree to replace those particular parts which eventually give trouble on that particular make and model. Last, you want to realign the set.

For this complete overhaul and reconditioning job you can immediately

→ To Page 33



It was only last week that I had this 1?@x-1* set in here for repair



I had my radio reconditioned at Barretts Radio Shop

SILVER

"VOMAX"

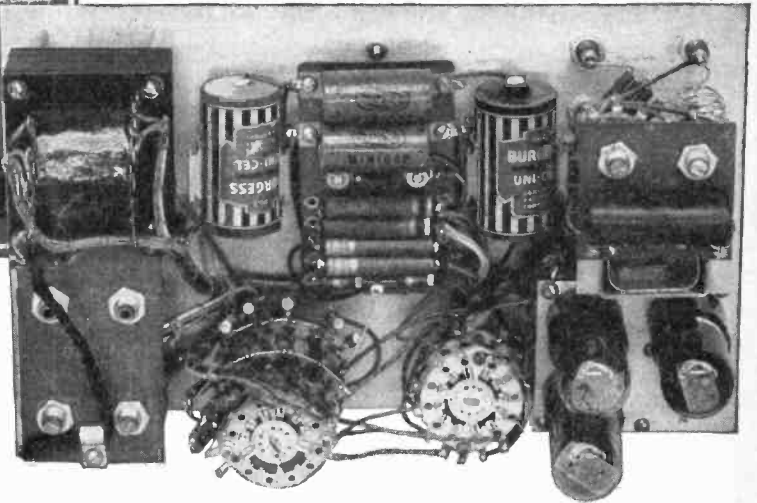

Of construction and quality unmatched by meters selling at far higher prices . . . giving performance exceeding that of three separate instruments costing nearly four times its price . . . it is no wonder we are told that "VOMAX" is today the standard of comparison.

"VOMAX" is new . . . different . . . and outstandingly superior . . . because it is a brand new **post-war** v.t.v.m. . . . and truly universal. With "VOMAX" you can measure **every** voltage required in radio servicing . . . even in the design laboratory. Not only does it enable you to measure d.c. and a.c. voltage at meter resistance so high as not to affect the circuit being measured, but "VOMAX" at last lets you measure a.f. and r.f. voltages from 20 cycles to over 100 megacycles . . . resistance from .2 ohms through 2,000 megohms is "duck soup" with "VOMAX" . . . as is direct current from 50 microamperes through 12 amperes.

Add to all this new visual dynamic signal tracing . . . direct measurement of **every** voltage from receiver antenna to speaker voice coil . . . and you know why many government departments, serious industrial, radio engineering, university research laboratories . . . and service technicians by the thousands clamor for "VOMAX."

"VOMAX" makes you the master, no longer the victim, of tough service problems. Your favorite jobber . . . among nearly 500 progressive SILVER distributors all over the country . . . can give you prompt delivery from his regular monthly allotment . . . if you order now . . . for only \$59.85 Net

OVER 34 YEARS OF RADIO ENGINEERING ACHIEVEMENT

McMurdo Silver Company

1240 MAIN STREET, HARTFORD 3, CONNECTICUT

Measures EVERY Voltage

1. Brand new post-war design . . . positively not a "warmed-over" pre-war model.
2. More than an "electronic" voltmeter, VOMAX is a true vacuum tube voltmeter in every voltage resistance db. function.
3. Complete visual signal tracing from 20 cycles through over 100 megacycles by withdrawable r.f. diode probe.
4. 3 through 1200 volts d.c. full scale in 6 ranges at 51 and in 6 added ranges to 3000 volts at 120 megohms input resistance. Plus-minus polarity reversing switch.
5. 3 through 1200 volts a.c. full scale in 6 ranges at honest effective circuit loading of 6.6 megohms and 8 mfd.
6. 0.2 through 2000 megohms in six easily read ranges.
7. - 10 through + 50 db. (0 db. = 1 mw. in 600 ohms) in 3 ranges.
8. 1.2 ma through 12 amperes full scale in 6 d.c. ranges.
9. Absolutely stable—one zero adjustment sets all ranges. No probe shorting to set a meaningless zero which shifts as soon as probes are separated. Grid current errors completely eliminated.
10. Honest factual accuracy: $\pm 3\%$ on d.c.; $\pm 5\%$ on a.c.; 2000 through 100 megacycles; $\pm 2\%$ of full scale, $\pm 1\%$ of indicated resistance value.
11. Only five color-differentiated scales on 4" D'Arsonval meter for 51 ranges (including d.c. volts polarity reversal) eliminate confusion.
12. Meter 100% protected against overload burnout on volts ohms db.
13. Substantial leather carrying handle. Size on y 12 $\frac{3}{4}$ " x 7 $\frac{3}{4}$ " x 5 $\frac{1}{2}$ ".

Send postcard for free catalog of measurement and communication equipment.

The Radio Service Bench

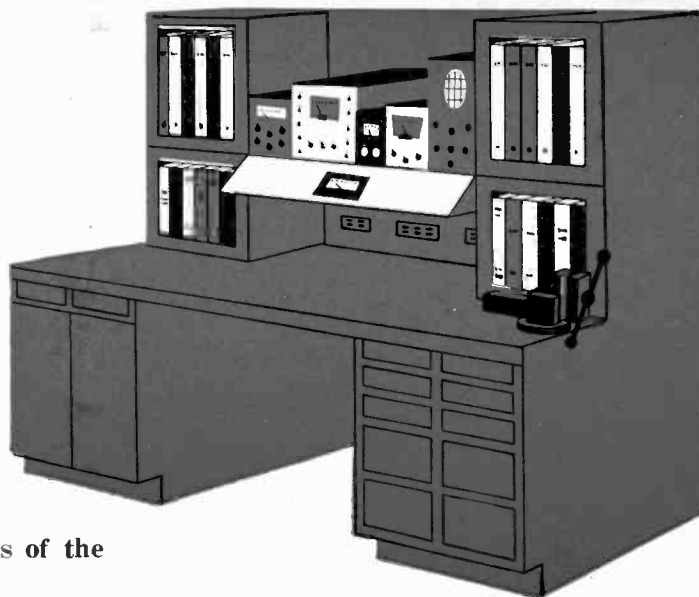

A regular department under which problems of the radio shop will be discussed.

by John Joseph

WHEN TOOLS are considered, there appear to be three types of service men.

Some unfortunates manage with less than they need. Yet, in the long run, delays in work because of an improper instrument for the job at hand, and repairs required for unnecessary damages cost more than the initial outlay for the needed tools.

A second type seems never able to resist an advertisement. His shop is a laboratory student's paradise, a tool and instrument show room.

The third is the average radio service man who purchases his tools with the attitude of a business man. He weighs the expenditure required against the use he is to receive and the wear he expects. From his monthly income he sets aside an appropriate amount as a tool fund which he uses to buy the replacements and the new tools he requires.

This column proposes to analyze the initial and ordinary tooling almost universally required. However, there can be no set rules applicable to all service men. To decide the needs of each individual shop, it is necessary to study such items as: the size of the business, the number of employees, the density of service, the normal charge rate in the area, and even the cost of power.

The accompanying list of the more important tools will be of particular assistance to those men who are just beginning a radio service career and are contemplating their initial selection.

The service man usually first requires two screwdrivers, one a general purpose 8" heavy duty tool, and the other, a midget. For safety rea-

sons, it is preferable that the handle of the heavy screwdriver be insulated and shaped as a convenient and guarded grip. The midget must be insulated and should be provided with a pocket clip to prevent loss. Both screwdrivers may be magnetized and thus provide a simple means to retain screws until a sufficient portion of thread has been engaged, or to retrieve screws from places in the radio chassis inaccessible to the fingers.

There are also available certain other convenient types of screwdrivers which should be purchased as soon as the service man's business warrants and permits. These include: offset screwdrivers which are invaluable for reaching screws in difficult places; the flexible screwdriver which will go under objects, or around corners to reach hard-to-get screws; and screw-holding screwdrivers which provide an excellent mechanical means for holding the screw until engaged, in cases where a dropped screw would require time and effort to retrieve.

Two pairs of pliers are essential. One is the 5" diagonals, and as it is the service man's constant companion, it should be of excellent quality. This pair is needed for cutting wires, leads, and rivets. It should never be used on iron nor on steel spring wire as it would soon lose its cutting edge. A 6" pair of the best quality steel is recommended. These pliers are also used for stripping, and the added feature which is provided by some tool manufacturers consists of a stripping notch. A very desirable secondary use is provided when the throat and jaws of the diagonal cutting pliers are shaped for crushing the insula-

tion of wire. Other features which may be obtained are insulated handles and a spring to keep the pliers open when not in use.

The second pair is the 6" long-nose pliers. It is an inseparable partner of the soldering iron. These are used to reach into the radio chassis whenever it is necessary to grip small parts, or to bend and hold wire ends during soldering. It is best that these pliers not be provided with side cutters, as the serviceman might accidentally slip and cut or damage wires he desires only to hold.

The slip-joint combination pliers is a third pair which should be added when convenient. These should be the 6" pair with an extension adjustment. It has a varied general use for gripping, twisting and pulling on such items as rods, bolts, nuts, cords, tubing and others.

Finally, a small pair of ignition pliers is a handy tool for removing small lock nuts in places hard to reach.

When it comes to the choice of soldering irons, many factors must be considered, including personal preferences. Regarding size alone, two irons appear to be desirable. One rated at 100 watts is suitable for heavy work such as chassis spotting. A smaller iron rated 50 watts is lighter and more convenient for soldering the connections from circuit elements to lugs. With this iron there is less danger of the heat reaching from the connection to melt condenser wax or burn wire insulation. The small iron is easier to handle and will

→ To Page 30

Specified

BY AMERICA'S MOST CRITICAL SERVICE ENGINEERS

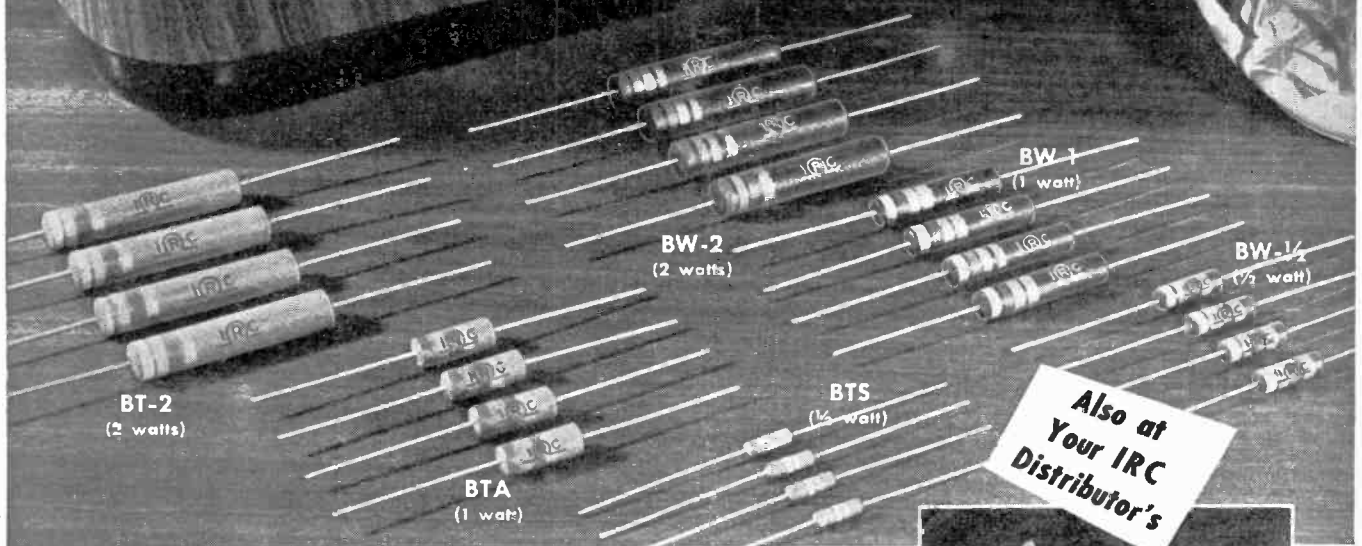

TYPE BT INSULATED Metallized RESISTORS TYPE BW INSULATED Wire Wound RESISTORS

... the perfect combination for speedy, dependable servicing!

Almost any piece of carbon is a "resistor". But a really *good* resistor, scientifically designed to meet every requirement of exacting radio and other electronic servicing, is something else again. For example, users of the famous Type BT have found that IRC's exclusive *Metallized* filament-type construction is a far cry from ordinary resistors. Since the beginning of Radio, this unique design principle has made possible far greater stability, more rugged construction and complete dependability in a very compact, low-cost unit.

Now, two new BT types, the BTS and BTA, are available. Designed to meet all the exacting requirements of modern servicing, they are conservatively rated at 1/2 watt and 1 watt, respectively, and incorporate all the excellent characteristics of older, larger types in a much smaller, more convenient size.

For greater stability and all-around efficiency in the lower ranges, the IRC Type BW Insulated Wire Wounds are recommended. A stock of these units and the Type BT in assorted ranges and wattages give you the ideal combination to solve almost any servicing problem... quickly and profitably.

The Resistor You Need . . . When You Need It!

Your local IRC Distributor now has quite complete stocks of BT's and BW's, in standard RMA ranges, ready for you. You'll find him a dependable source (and a very cooperative guy) for all of the IRC products shown on this page. He'll also be glad to give you your copy of IRC Service Catalog #50.

FOR BETTER-THAN-STANDARD QUALITY

Standardize on 

INTERNATIONAL RESISTANCE CO.

Dept. 28B 401 N. Broad Street, Phila. 8, Pa.

Makers of more types of resistance units, in more shapes, for more applications, than any other manufacturer in the world.

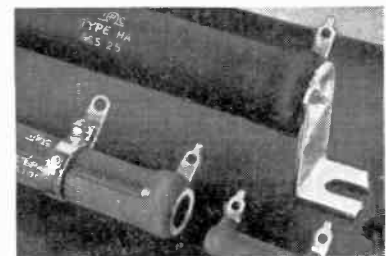
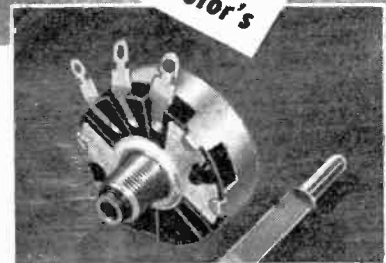

Servicing Aircraft Radio Power Packs

By Lt. Myron F. Eddy, USN Ret.

THE BIGGER the plane you fly nowadays, the more "juice" you have aboard. The larger transports carry a central electrical power plant which supplies radio and many other needs, but small commercial and private planes usually carry either a battery and dynamotor or an engine-driven generator for their radio.

Maintaining Aircraft Batteries

You will find both twelve and twenty-eight-volt radio battery systems in use aboard airplanes. The care involved is the same in every case. A log is kept showing load carried and how long; the time the battery was last charged, the specific gravity and voltage attained at that time. From this data—or even without it—you will be able to estimate the state of charge by use of the voltmeter and hydrometer.

At large air terminals the battery maintenance men have no duties other than to charge and repair batteries. Each air line sets up its own rules as to this work. An "outside" radio service man dealing with aircraft radio batteries should become familiar with the voltages to be attained by charging; this data is furnished by the manufacturers of each battery. Aircraft radio batteries are charged ordinarily to a specific gravity of 1.270; when this drops to 1.170 they should be recharged. (In the tropics 1.250 is considered the proper high charge.) When an airplane battery is about three-fourths discharged it is recharged or replaced by a fully charged battery.

The battery usually runs a dynamotor. If so, this machine should be run while readings are taken. It will sometimes be found that the machine draws more amperage than rated, indicating trouble in the motor end of the dynamotor and hinting that a too-fast discharge of the battery is to be expected.

If you can take a run-down battery to a well equipped battery shop for servicing, you had better do so. If this is not possible, remember that

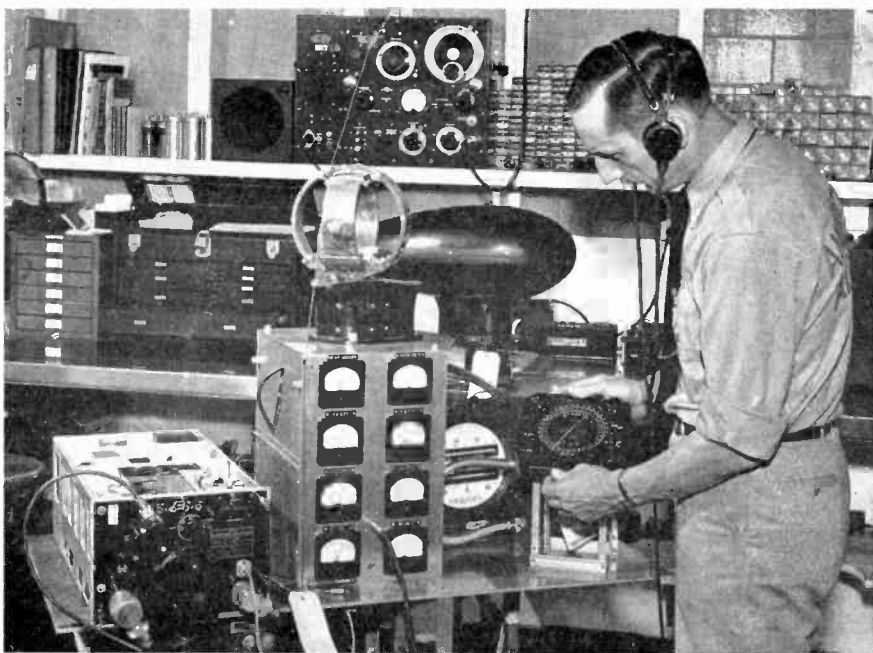

One section of the radio overhaul shop of American Airlines, where a radio technician is shown testing an automatic direction finder.

the proper charging rate varies with the ampere-hour capacity, according to the following table:

AMPERE-HOUR CAPACITY	CHARGING RATE
2 to 5	$\frac{1}{4}$ to $\frac{1}{2}$ ampere
20 to 50	2 to $2\frac{1}{2}$ amperes
120 to 180	5 to 8 amperes
200 to 250	10 amperes or more

When charging a battery, adjust the series resistor in the charging circuit at the start to give the correct charging rate, and readjust to compensate for the increase in battery voltage as the battery becomes charged.

It might seem that the time required to bring a storage battery up to full charge would be equal to the number of ampere-hours that have been drawn from the battery divided by the charging rate. In practice, however, the time required for charging is always greater than the discharge time. This is because the battery voltage increases as it is charged, which increases the back pressure exerted on the charging line

by the battery. No battery is 100 per cent efficient.

This voltage increase is fairly steady, as shown in Figure 1, resulting in a falling off in the current during the charging process.

Batteries should always be charged at their normal charging rate. If this is exceeded, the cell may overheat, the plates buckle and the life of the cell will be shortened. They should not be over-charged because this also decreases the life of the cell.

On the other hand, batteries on charge should always be brought up to full charge. If continually operated in an under-charged condition, sulphation will take place, that is, an excess amount of lead sulphate will form on the plates and as lead sulphate is more bulky than the original material, the plates will tend to buckle. Batteries that have been subjected to "undercharging" should be fully charged and discharged several times until all the excess lead sulphate has been driven from the plates.

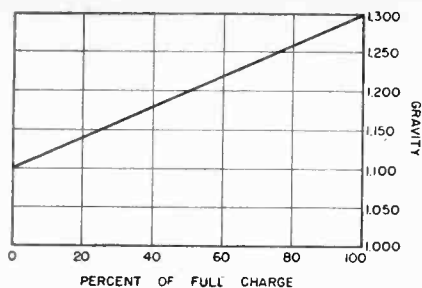

Fig. 1. Relationship of charge of a battery to the specific gravity of the electrolyte. Voltage across the terminals of a battery is approximately proportional to the gravity.

While on charge, a lead cell will give off gases (mostly hydrogen) and a means must be provided for their escape. The vent in the cell cap provides a means of escape for gases that are generated during normal operation but do not provide for excessive gassing when the battery is on charge. For this reason the cell caps of a battery on charge should be removed.

When the cells gas freely, the charging rate should be reduced to one-half to two-fifths of the normal rate and the charge continued. When the cells are again freely gassing, a full charge is indicated and charging should be discontinued. The charge should be checked, of course, by means of hydrometer readings.

Servicing Aircraft Generators

In the earlier days of aviation, wind-driven generators were often used and you may be called upon to service this type occasionally. If so you will use the same technique, (electrically) as with an engine-driven type. Also the generator end of a dynamotor presents trouble-shooting problems similar to those found in the other two types. In every case maintenance procedure includes inspection, testing and repair.

Preflight Inspection Of Generators

A generator should be inspected before each flight. At this time you will plainly see the effect of vibration—it shows up in the form of excessive sparking. Sometimes it pays to remove the pigtail from the brushes because the extra weight of the pigtail causes the brush tension on the commutator to vary.

Included in inspection is the very important item of lubrication. Generators should not be oiled too frequently nor too profusely. They should be oiled at regular intervals, however, and a record kept of such oilings.

The Western Electric Company recommends that their dynamotors should be inspected after 1000 hours of operation and then lubricated with N.Y.-N.J. Lubrication Company grease No. F-927 The ball bearings of the motor are lubricated with Sperry gyroscope oil at the time of manufacture and for intermittent service inspection should only be required at yearly intervals. If lubrication is required, add only a few drops of oil else the excess may reach the commutator.

Testing and Overhauling Generators

Generators should be tested after every flight. At this time, undue tendency toward overheating should be carefully noted. It is usually a very simple matter to determine whether or not the generator is maintaining a proper temperature by feeling it with your hand. A tendency to overheat may usually be attributed to one of several things: dirt, loose or worn bearings, insufficient oil, or poor ventilation.

At periodic intervals—usually about once a month—the generator should be removed from the plane, mounted on a test bench, and given

a complete test. The voltage delivered at its rated speed, at a higher-than-rated speed, and at a lower-than-rated speed is noted. The generator is then disassembled and thoroughly cleaned and inspected minutely as to the condition of its various parts. At this time, it is customary to conduct an insulation test as well as continuity test on the various windings. If the carbon brushes have worn down considerably, they are replaced by new ones, and the new ones properly fitted to the commutator (in the case of a D-C generator). The shaft is checked for alignment and the bearing calibrated to determine whether or not they are wearing badly. The machine is then reassembled and again tested for voltage at various speeds. It is coupled to its normal load and also coupled to a built-up load which requires about twenty-five per cent more wattage than the generator is rated to deliver. If the machine has previously developed any tendency toward overheating, the reason for this is usually discovered at this time and decision is then made as to whether or not it will be kept in service. It is interesting to note that armature

→ To Page 25

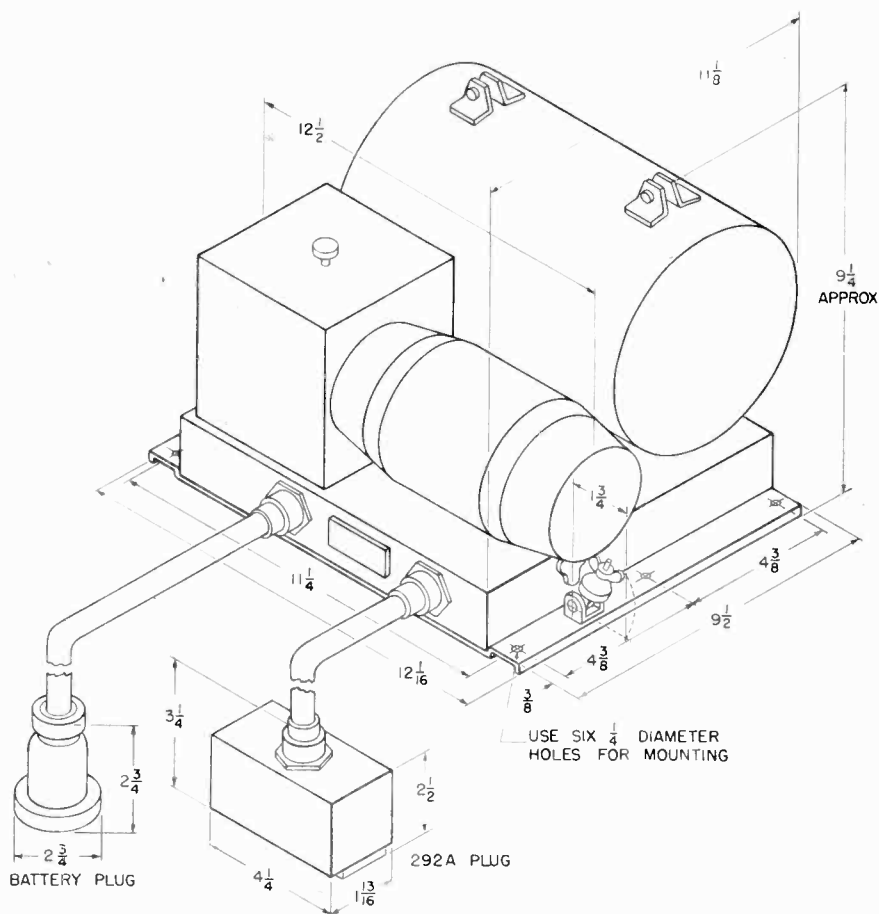
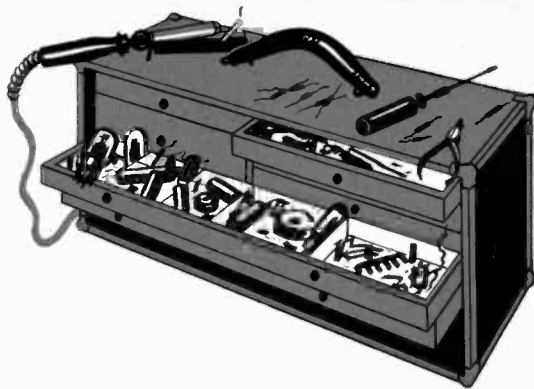

Fig. 2. Outline dimensional drawing of Western Electric KS-7588 Power Unit.

Service Kit



Devoted to the problems of the outside serviceman.

by E. T. Bicak

AMONG THE PROFITABLE opportunities open to radio maintenance men is the opportunity to sell noise filters, those handy gadgets which can mean the difference between pleasurable and annoying radio reception and which are mighty good to have along when delivering a repaired set to a customer. Relatively few radio repairmen seem to recognize the existence of this opportunity and of those who do, not many fully capitalize this business potential. Yet I doubt if there is a repairman who has not had a repair job "go sour" on him during a home demonstration because of noise. Nor do I doubt that the repairman disliked the necessity of explaining to the customer that "the radio is okay; the noise is caused by something else that you have around here in the house or probably nearby." It's an embarrassing situation, in a way, and not infrequently leads to suspicion and doubt—suspicion in the technician's mind that the customer doubts his competence. It is also an unprofitable situation, since the establishment of such a doubt is detrimental to any radioman's business and to the good will of the radio service industry as a whole.

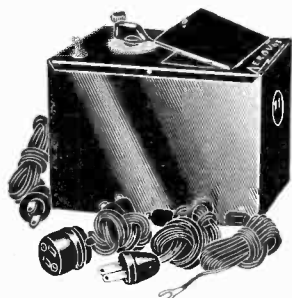

Aerovox Interference Analyzer—plugs between interfering device and outlet, and setting of tap switch which gives least noise indicates type of filter to be used.

Obviously the cause of the radioman's embarrassment should be remedied immediately, on the spot. He should not have to return to his shop or go to a distributor to pick up the means of remedying the disturbance. He should turn his tough luck to profitable advantage quickly by selling the customer a noise filter, provided of course that the noise reaches the radio receiver via the power lines.

Now, how is this to be done? What are the requirements to do the job? Well, the requirements are really elementary and the radioman already possesses most of them. Let us see what they are.

The radioman is already acquainted with the principles of filter operation. He knows that the lower the frequency the larger must be the filter to suppress it and vice versa. His hearing enables him to judge relatively the audio range of the noise, notably the predominant frequency of the various components. And his business intuition tells him that the other requirements to make the filter sale and to please the customer are preparedness and salesmanship. The repairman is aware, too, that noise filters lend themselves to convincing demonstration and so these accessories are in themselves silent salesmen ready to help the radioman boost the volume of his business.

Preparedness for the sale obviously requires a carefully selected stock of noise filters of assorted sizes. A portable case in which a representative assortment can be transported is a convenience. He should have a radio receiver in his delivery car which should be turned on as he approaches the customer's home, particularly if there are overhead power lines in its vicinity. In this way he can inform himself of noisy areas, prepare himself for the sale to the customer on whom he is calling as well as locate other prospects from whom he can solicit additional noise-filter business. Inside the home he should not demonstrate the repaired receiver until he has assured himself that the power lines are clear of noise. If the set is turned on for a brief moment and the lines are found to be noisy he should be so prepared that he can return to his car for his kit of noise-filters and when inside the house again select the filter which will suppress the noise or best reduce it. Or he can locate the source of the noise and insert the filter in its supply circuit. If the noise originates at some electrical apparatus in the home, he should locate that source and install a filter in its supply circuit. Beyond this preparedness he may apply his salesmanship—to be more specific, his noise-filter salesmanship.

The expression, "noise-filter salesmanship," implies that there is some

→ To Page 38

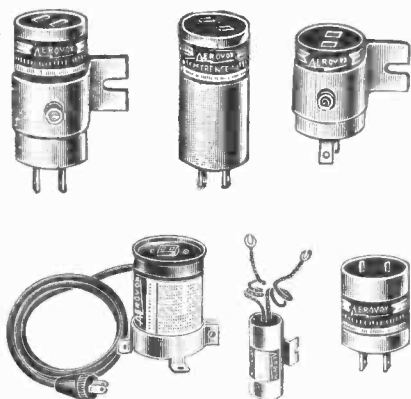

Group of Aerovox Interference Filters for installation between set and line, or for best results, between interfering device and line.

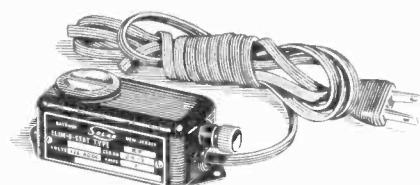

Solar Elim-O-Stat, for insertion between set and line or between interfering device and line. This model is for circuits drawing up to 1.0 amperes.

Servicing Aircraft Radio Power Packs

→ From Page 23

coils which have been found to be open, shorted or grounded, are seldom, if ever, replaced in aircraft generators. The machine is discarded or the generator armature is replaced with a new one.

While running the generator on the test bench connected to its normal load and also while connected to the overload circuit, the voltage regulating device is carefully checked. The electrical type of voltage regulator must be kept clean, in proper adjustment and with good contact between the vibrating points of the apparatus. If a directly driven constant speed generator is used, the mechanical coupling which maintains the speeds of the generator constant must also be inspected for performance.

When testing a wind driven generator, it is customary to remove the entire propeller mechanism and drive this generator from another motor. However, some transport companies have a wind tunnel, the blast of which drives the Deslauriers (wind) propeller. In this case, the strength of the wind stream in the tunnel is varied considerably in order that the effectiveness of the speed control mechanism may be properly judged.

If there is a filter in the ground lead this should be carefully inspected. The Deslauriers propeller should maintain a constant speed in spite of the variations in the air speed of the airplane by as much as 50%. The wind tunnel can be operated to give an air blast equivalent to that against a plane in flight at almost any speed that can actually be accomplished by the plane so that if the generator is designed to maintain constant speed with an air speed due to the movement of the plane of, for example 80 miles an hour, this generator is actually tested at a wind tunnel air speed of approximately 120 miles an hour and 40 miles an hour.

Overhauling Dynamotors

It is customary in aviation to remove dynamotors from the airplane about once a month. At this time they are disassembled and the same general procedure is carried out in regard to inspection, cleaning and testing as has been described for the generator.

Dynamotors are generally overhauled in electrical shops after which they are "run in" in the radio shop. Dummy resistive loads show the volt-

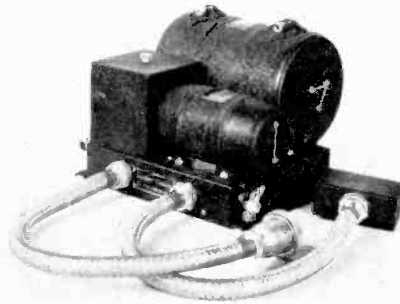

Fig. 3. KS-7588 Power Unit, typical of dynamotor sets used for aircraft transmitter and receiver installations.

age at normal current operation. Sometimes the test stand is equipped with a noise tester. Connect a sensitive A-C voltmeter in series with a 1.0 mfd condenser across the D-C supply between the generator half of the dynamotor and the load. The condenser blocks D-C and passes A-C. Do not leave the voltmeter connected across the machine; use a push button while testing. The meter should have both a sensitive and a non-sensitive scale each connected through separate push buttons. This will enable you to make a rough test first, without danger of blowing out the meter in case the noise is very high.

Installing a Typical Power Unit

It quite often happens that a radio service man not familiar with aviation equipment is called upon to install or remove and then replace a complete power unit. In this case get hold of the manufacturer's instruc-

tions as to installation, including dimensional drawings. (See Figure #2.) Refer also to any notes available dealing with routine maintenance procedure for this particular unit. (See paragraph below, titled, "Maintenance of KS-7588 Power Unit.") In every case a service man should know, before he begins to work on a power unit, what function it performs and how it operates since such knowledge provides an essential background for trouble shooting. The data furnished below is for reference in handling a specific, typical unit.

The Western Electric KS-7588 Power Unit

See figure #3. This power pack will supply high voltages to certain Western Electric radio transmitters and radio receivers when it is desired to use a twelve-volt storage battery as the primary power source. In airplane radio telephone service, its use in conjunction with the 12-volt, 65-ampere-hour airplane storage battery will permit operation of the radio equipment while the airplane is on the ground as well as in flight.

Figure #4 shows the hook-up. Note that there are two dynamotors which operate from the twelve-volt power source. These furnish current at the high voltages required for the plate circuits of the radio transmitter and radio receivers. Filters are supplied to reduce noise currents in the dynamotor output circuits due to sparking between commutators and brushes; otherwise objectionable interfer-

→ To Following Page

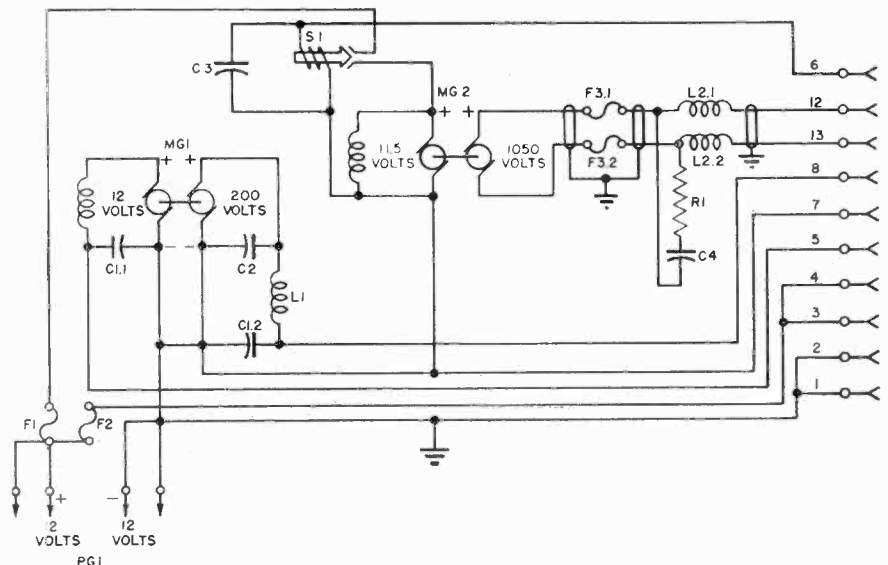

Fig. 4. Schematic of power unit of Fig. 3.

Servicing Aircraft Radio Power Packs

→ From Preceding Page

ence in the radio receivers might result.

The radio transmitter dynamotor draws a current of approximately 51 amperes at 11.5 volts from the storage battery. It will deliver a current of 0.35 amperes at 1050 volts D-C to the radio transmitter.

The radio receiver dynamotor furnishes 0.085 ampere at 200 volts D-C to the radio receivers. Approximately 3.3 amperes from the twelve-volt storage battery is required for its operation.

Because of its light-weight construction, the transmitter dynamotor has a load-time rating which limits the continuous use of the machine to periods of five minutes followed by periods of ten minutes. However, the machine may be operated continuously at full load for a period of one hour without damage due to overheating provided that sufficient time is allowed for cooling before further operation is attempted and that during the operation there is a circulation of cool air around the dynamotor.

The dynamotors are assembled on a box type chassis in which the filter elements are mounted. Holders are provided for fuses in all circuits where necessary. The fuse holders are enclosed by a cover which may be removed readily when fuse replacements are required. A separate enclosure is provided within the outer cover for the fuses in the high voltage circuit to prevent accidental contact with that circuit when the outer cover is removed.

Electrical connections to the unit are made through quickly detachable plugs. The power unit is provided with a base plate which may be permanently attached to the mounting surface so the unit may be removed readily for inspection and/or maintenance.

Installation Procedure For Power Unit

The KS-7588 Power Unit may be installed in any available space where the axes of the dynamotors will be horizontal during normal operation of the unit. The unit should not be located in a small closed compartment where there is not a free circulation of air around the dynamotors.

In an airplane installation where excess weight is objectionable the unit should be installed in a location as near the storage battery as possible

so as to reduce to a minimum the weight of the high-current battery cable. The maximum allowable voltage drop in this cable is 0.6 volt. This value will not be exceeded if the total resistance of the battery circuit is not more than 0.0075 ohm.

If vibration conditions are severe at the location in an airplane where it is proposed to install the unit, the unit should be attached to the airplane structure through an auxiliary vibration-absorbing medium. For this purpose Lord* mountings may be used. The power unit base plate, which is intended to be bolted to a rigid flat surface, must be supplemented by suitable stiffening members to prevent buckling due to stresses set up by the clamping screws which attach the unit to the mounting plate. Due to uneven weight distribution over the power unit chassis, mountings which have different load carrying capacities must be used at the front and rear corners of the unit in order that equal deflections due to load will result; four mountings are required.

Maintenance of KS-7588 Power Unit

After intervals of approximately 500 hours of use, the spun aluminum end covers and bearing cover plates should be removed from the dynamotors and the bearings lubricated with Master M2 Lubricant or equivalent.

The commutators may be cleaned with a soft cloth moistened with gasoline. No attempt should be made to remove a chocolate-brown coating from the commutators unless they are pitted. If they are pitted they should be carefully sanded with No. 00 sandpaper and polished with No. 0000 sandpaper.

Before the end covers are replaced, any accumulation of brush or commutator dust should be blown out with clean air. Worn brushes should be replaced with new brushes of the same type, which may be obtained from the Western Electric Company.

Servicing Miscellaneous Units

WIRING AND TERMINAL BOARDS. Terminal boards should be frequently inspected and the tightness of the terminals checked with a socket wrench. If terminal box covers have a blueprint of the connections shellacked to the inside of the cover this will facilitate rapid identification of the terminals. Fuses in terminal boxes are inspected visually; they should be replaced about every 6 months and a record of replacement kept.

To inspect switches, operate them

*Lord Manufacturing Company of Erie, Pa.

and note the ease with which they come into contact.

Relays and Magnetos

High current solenoid relays generally have sealed contacts and so cannot be inspected visually. Nevertheless, they should be taken apart for inspection and cleaning at regular intervals. When inspecting relays be careful not to touch the relay itself—simply watch its operation.

Magnetos generally go to an electrical shop for testing and overhaul but sometimes a radioman will find a magneto in service having a distributor gap so large that it produces loud radio noises. In this case he should replace it with one that has been recently overhauled. In handling magnetos it is important to keep distributor cover tight, contacts clean, ground lead filter intact. ✓ ✓

Fundamentals of Vacuum Tube Voltmeters

→ From Page 17

R-3 serves as the load resistor for the diode circuit. R-4 is a balancing adjustment. The switch S-1 enables the circuit to measure either the positive or the negative peaks of the A-C voltage. This convenience is helpful in locating certain types of distortion due to unsymmetrical waveforms.

Operation

Specific operating instructions will accompany any instrument of this type. It should suffice to outline a few precautionary measures. Before making any measurements, any vacuum tube volt-ohmmeter should be allowed to attain its normal operating temperature, where the greatest accuracy is desired. For this reason, it is well to apply power to the instrument about thirty minutes before it is to be used. When ready for use, set the selector switch to the desired function, and the range switch to a range above the voltage to be measured. Then adjust the meter to "zero" as specified in the instructions. If there is an "ohms" adjustment, this control should be correctly set at this time. Then, allowing for occasional checks of the zero readings on the meter, the instrument is ready for use for all of its available functions and ranges. The bridge-type instrument is extremely reliable, and requires but little adjustment after it has reached a stable operating temperature.

Applications

As previously stressed, there are a number of measurements that a multimeter is incapable of making. A large part of radio servicing can be done successfully without a vacuum tube volt-ohmmeter. But it is quite true that such an instrument has its uses, and can save considerable time in the location of certain faults.

As a D-C meter, it can measure actual a-v-c voltages present in a receiver while operating, either across the diode load resistor, or at the ground end of any of the R-F or I-F coils, or even at the grids of the tubes. This is an aid in checking continuity of the coils, partially or completely grounded by-pass condensers in the a-v-c return, or faulty components in the diode circuit. It can measure discriminator voltages in F-M receivers or in sets using automatic frequency control circuits. The latter of these are rapidly being displaced by the former, but the principles of operation are the same. One of the most important uses of the vacuum tube volt-ohmmeter is in locating leaky or intermittently leaky coupling condensers in the audio amplifier. The D-C probe is simply applied to the grid side of the suspected condenser. A positive D-C voltage appearing at this point indicates a defective coupling condenser, which should be replaced.

Voltages on tube elements are measured without having the conditions changed by loading the circuit with a low resistance. This is especially useful in pentode or high-mu triode audio amplifiers.

As an A-C voltmeter, the instrument may be used as a signal tracing indicator, enabling the measurement of stage gain throughout a receiver. The limits of gain per stage are gradually being included in service notes for most receivers, and this practice is certain to increase. It is far easier to service a set when all the characteristics are known. This ability to measure A-C voltages applies to A-F as well as to R-F circuits. Most multimeters offer a loading of as low as 1000 ohms-per-volt on the A-C ranges, even though they may have a sensitivity of 20,000 ohms-per-volt on the D-C ranges. This amount of loading makes it difficult to measure the signal voltage on audio amplifier grids with the standard multimeter, and in addition, the indications are rarely compensated over a wide frequency range. The vacuum tube-volt-ohm-

DON'T SETTLE FOR LESS THAN:

THE MOST

Complete!

There are three essentials to the successful operation of any radio repair shop: 1. Competent personnel; 2. Good test equipment; 3. Complete service data. All are of equal importance, so don't compromise with quality in your manuals, don't settle for less than the most complete source of authorized information. Remember, if you are called upon to service any and all models of radio receivers, only Rider Manuals can meet your needs.

Rider Manuals represent the only single source upon which you can depend for all the information you need on such vital material as receiver schematics, voltage data, alignment data, resistance values, chassis layouts and wiring, trimmer connections—in fact all the things that lead to quick diagnosis of troubles in ailing receivers.

—And they're complete! Since the publication of Volume I over 42,000 models have been covered—only Rider Manuals contain wiring diagrams on Scott receivers. (These diagrams were received officially from the E. H. Scott Radio Labs., Inc.)

So, see your jobber and place your order today to guarantee fastest possible delivery.

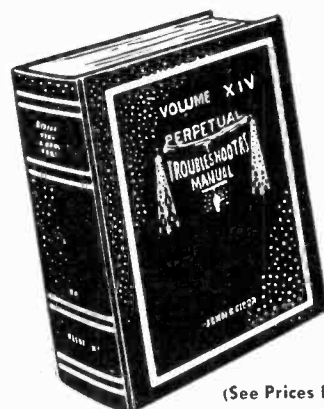

(See Prices Below)

Get on the Mailing List for
"Successful Servicing"

A monthly paper, dedicated to the financial and technical advancement of the electronic and radio maintenance man. Free distribution—just

MAIL COUPON

JOHN F. RIDER PUBLISHER, INC.
404 (d) FOURTH AVE., NEW YORK, N. Y.

NAME _____

ADDRESS _____

CITY _____

STATE _____

YOU MUST STUDY TO KEEP UP TO DATE

Just Out "INSIDE THE VACUUM TUBE"...424 Pages, \$4.50

RIDER MANUALS (14 VOLUMES)

Volumes XIV to VII	\$12.50 each volume
Volume VI	9.50 each volume
Abridged Manuals I to V (1 Vol.)	\$15.00
Record Changers and Recorders	7.50
The Cathode Ray Tube at Work	4.00
Frequency Modulation	2.00
Servicing by Signal Tracing	4.00
The Meter at Work	2.00

The Oscillator at Work	\$2.50
Vacuum Tube Voltmeters	2.50
Automatic Frequency Control Systems	1.75
A-C Calculation Charts	7.50
Hour-A-Day-with-Rider Series—	
On "Alternating Currents in Radio Receivers"	
On "Resonance & Alignment"	
On "Automatic Volume Control"	
On "D-C Voltage Distribution"	1.25 each

JOHN F. RIDER PUBLISHER, INC. 404 Fourth Avenue, New York 16, N. Y.

Export Division: Rocke-International Electric Corp. 13 E. 40th Street New York City Cable: ARLAB

RIDER MANUALS *are complete* IN 14 VOLUMES

meter makes these measurements easily.

As an ohmmeter, this type of instrument is capable of measuring very high as well as very low resistances with an accuracy limited only by the accuracy of the resistors used as standards. Insulation resistance of condensers is checked up to as high as 1000 megohms, and the D-C resistance of transformer secondaries can be measured well below one ohm. The voltage across the unknown resistance varies from zero to three volts, in most instruments of this type, and this voltage is pro-

portional to the resistance being measured.

Conclusions

With all of these advantages of use, the vacuum tube volt-ohmmeter is certainly worth considering as an addition to any well-equipped radio shop, in spite of the limitations as outlined above. Regardless of these there are some measurements which cannot be made with any other type of instrument, and the time to be saved in the location of certain faults makes it a very important instrument in the servicing field. ✓ ✓

ELECTRONICALLY SPEAKING

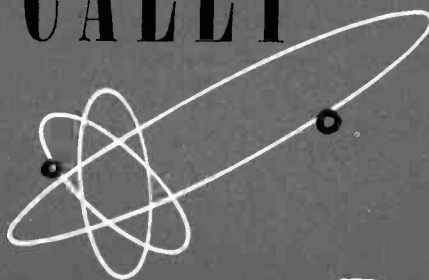

GIs Show Interest in Opening Radio shops. Among approximately 225 letters received weekly by the Commerce Department from service men interested in new business, GIs planning to open radio or electrical shops lead the list. Other principal business interests in order of their appeal are restaurants, filling stations, apparel stores, groceries, real estate and insurance offices.

There are applications for nearly as many new Broadcasting Stations as are presently in use today. If all the Radio Industry expands proportionately, there will be approximately 140 thousand Radio Servicemen by 1947.

The Federal Communications Commission has handled a difficult problem with courage and intelligence in its announcement of television channel allocations to 140 principal communities. This is the first of several important steps which will soon speed television's development as a full-blown industry. Dumont's factory will begin filling back orders for television transmitters as soon as the broadcasters who have requested transmitters are assigned channels by the FCC.

Large volume production is not expected before the summer or fall of 1946 if current deterrents continue, and it may be delayed longer if they increase.

The OPA says in their 1946 business forecast estimate, that the Radio Industry will have a 394% increase in average monthly volume by June 30, 1946. All this in spite of price controls. . . . And in the next breath we learn that despite a rising rate of radio set price approvals, OPA at the end of the third week of weekly reporting had priced only a small proportion, probably less than 5%, of the expected number of 1946 models

of radios and phonographs, according to industrial estimates.

Threatened revocation of 230 manufacturer-agent contracts for the disposal of radio and electronic surplus was halted and arrangements were made to eliminate trouble spots in the RFC-industry distribution and sales plan at an RMA hearing, before RFC Director Sam H. Husbands, and other RFC and Surplus Property Administration officials.

Surplus equipment disposal machinery is set up and operating. Merchandise has been trickling through although a greater quantity is in storage and will be available as soon as the big-shots decide how.

Eight reasons why the radio manufacturer offers the best outlet for radio surplus and the greatest protection to the Government and the public were offered by Mr. Bond Geddes, Executive Vice-President of RMA, in his general presentation at an RMA meeting recently. He also pointed out that radio surplus to date has been small but that it is now starting to move in sizeable quantities and much more is expected within the next year.

Get Ready to Serve Irrigation Systems—Communications. Acting on the first application of its kind, the Federal Communications Commission today authorized the Garwood Irrigation Company of Garwood, Texas, to construct a portable radio transmitter and receiver system to be used in the operation of its irrigation networks serving 100,000 acres of rice and other crops.

"A broadcaster told me recently," remarked Mr. Paul A. Porter, Chairman of the FCC, at a luncheon honoring the 25th anniversary of broadcasting in the U. S., "that the radio industry must be *more* than 25 years

old. He observed that things could not have become so confused in such a short period of time. I think, however, that confusion was mistaken for growing pains and that perhaps what he meant was that we have not yet evolved a philosophy about this form of communications."

The Federal Communications Commission today released the results of tests made by its Engineering Laboratory at Laurel, Maryland, which established the exact opposite of claims made by the Zenith Radio Corporation that FM operation in the higher band allocated by the FCC requires substantially more power.

See the greatest sound engineering installations ever built at NBC Radio City, N. Y. It is the new Studio 6D, which is air conditioned and will hold an audience of 227. It was designed to coordinate and blend the architectural and acoustical requirements into a pleasing harmony. The ceiling of the new studio is sawtooth in shape, which diffusely reflects sound and aids in the proper direction and reflection of the fluorescent lighting. The rear wall of the stage is wholly reflective and applied on it, distributed at random, are hemispheres, or "diffuspheres" as they have been dubbed, which prevent discrete reflections. A drapery is provided at the rear wall of the stage to control acoustical conditions on the stage for the proper microphone balance.

Do you need service business? It is suggested that you move to India where it is authoritatively estimated that there will be a 400% increase in radio production and 200,000 sets a year to fix. Besides, you will have fame as a technical genius over there.

RSM Will Repair Radar Soon. . . . Hallicrafters envisions a number of peacetime applications for its port-

→ To Page 38

REVIEW OF TRADE LITERATURE

A TWENTY-PAGE Reference Guide to Magnavox Electrolytic Capacitors, giving complete reference material for all standard sizes of Magnavox Capacitors available, with cross references to standard production numbers has just been published. Write The Magnavox Company, Fort Wayne 4, Indiana, for your copy. It may come in handy.

William Brand & Company, 276 Fourth Avenue in New York City, and 325 W. Huron Street, Chicago, Ill., have prepared a reference manual on insulating material which they will send together with their appended Standard Catalog. The manual is a brief treatise on the subject of dielectrics covering theory and behavior, mica and mica plate, natural oils as dielectrics, varnishes for electrical insulation, inorganic insulations, and coordinated and standard conductor insulation.

Altec Lansing Corporation, has an interesting Gold Brochure on their new two-way multi-cellular speaker for monitoring, radio, public address, home radio, recording, phonograph, paging systems, television and F-M. Address your request to 1210 Taft Bldg., Hollywood, Calif., or 250 West 57th St., in New York City.

This month's mail brought a huge flow of pamphlets and literature from the RCA Service Division, Camden, N. J. Among them were the Supplementary Information pamphlet for their 1939-1940 models; Supplementary Information pamphlets numbers 2 through 8; a booklet discussing the Cathode-Ray Tube as used in the RCA Cathode-Ray Oscillographs; and Technical Information and Service Data describing Models TRK-9, TRK-12, TRK-90, TRK-120.

When writing, inquire about the magazine called Practical Analysis of Ultra High Frequency, written by J. R. Meagher and H. J. Markley, two field engineers who prepared the

magazine for members of the armed forces engaged in installation, operation and maintenance of Ultra High Frequency Radio-Electronic Equipment, and who feel that it will be of benefit to anyone concerned with the design and production of this type of equipment.

The Radiart Corporation, 3571 West 62nd Street, Cleveland, Ohio, has made available their catalog on Radiart Vibrators which can be obtained upon request, and the Aireon Catalog on Piezoelectric Crystals can be had by addressing the Aireon Mfg. Corporation, Advertising Dept., Kansas City, Kansas.

BOOKS

Introduction to Practical Radio
by Durward J. Tucker MacMillan
322 pages, 155 illus. \$3.00

For the person interested in theory, this book covers laws, principles and fundamental working parts of radio with the necessary mathematics needed for each step. The most outstanding feature of this book is the clarity and thoroughness in which it is written. Numerous examples are used and exercise problems are distributed throughout the text.

Principles of Radio for Operators
by Ralph Atherton MacMillan
344 pages, 500 illus. \$3.75

A book on basic electrical and radio principles explaining working of radio equipment parts. It is a training manual for radio operators and maintenance men, written especially for those with no previous training.

Electrical Essentials of Radio
by Morris Slurzberg & William Osterheld McGraw-Hill
529 pages, 366 illus. \$4.00

Practical, simple and thorough explanations of electrical principles of radio.

→ To Page 33

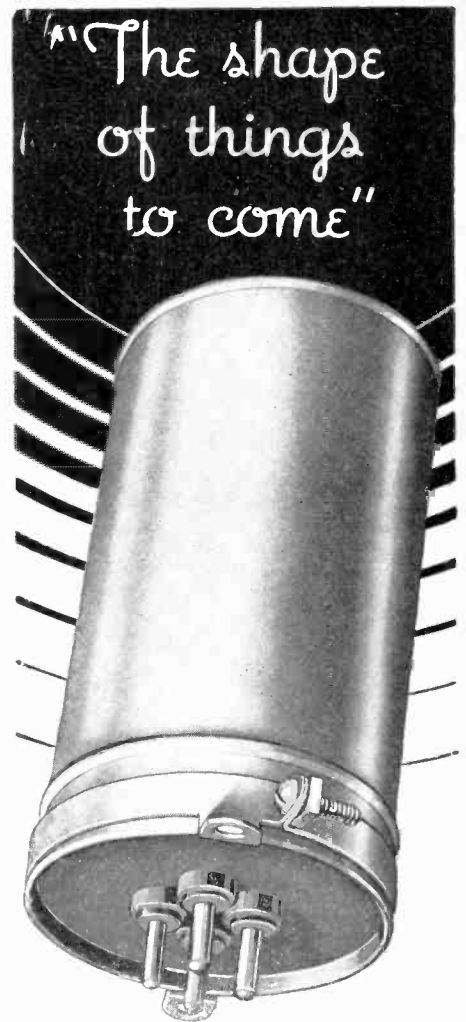

• These Aerovox plug-in capacitors are mighty significant. They are to radio-electronic equipment what the demountable rim was to automobiles—a quick, easy, simple means of replacing components in continuous use. Yes, plug-ins mark the dawn of the real electronic age.

With this and other types, Aerovox is laying the foundation for vastly expanded radio and electronic servicing. Thus "The shape of things to come."

• Ask Our Jobber . . .

Ask for the new postwar Aerovox catalog. Also for a free subscription to the monthly AEROVOX RESEARCH WORKER. Or write us direct.



FOR RADIO-ELECTRONIC AND INDUSTRIAL APPLICATIONS

AEROVOX CORP., NEW BEDFORD, MASS., U.S.A.
Export: 13 E. 40th St., New York 16, N.Y. • Cable: 'ARLAB'
In Canada: AEROVOX CANADA LTD., Hamilton, Ont.

The Radio Service Bench

→ From Page 20

penetrate into small places.

The choice of an iron to do a particular job depends on the rate of heat conduction away from the point of soldering. Soldering irons are manufactured in different sizes for any given rated wattage element. Let us examine just what this means. The smaller the iron, the faster the temperature rises when current is applied. But also, with the current left on, the higher the temperature attained, before heat conduction away from the iron to the surrounding air is equal to the heat supplied by the element of the iron. Therefore, although a small iron will reach operating temperature more quickly, it is in more danger of being burned out than a larger iron of the same rating. The service man must compromise between speed and durability.

When the tin burns off of the tip of the soldering iron, it oxidizes. Not only does this happen on the surface, but to an appreciable depth. The tip then becomes porous, and because of its larger heat radiating surface, and the cushion of air insulation, it may no longer be possible to melt solder. When a tip has become unusable, it must be replaced. Therefore the service man must keep replacement tips on hand.

A solution of the problem of overheating of soldering irons consists of providing a heat-controlling stand. The stand allows the iron to remain at a lower-than-operating temperature when it is not in use. This may be provided by a thermostatic element which switches the current on or off, by a manual switch, or by an automatic switch operated by the weight of the iron on the stand. A simple heat control device which may be installed by the service man himself consists of a 100-watt bulb connected in series with the iron, and a switch which is used to short out the bulb at will.

The handle of a soldering iron should be comfortable to grasp. It should be well insulated, and should be protected from heat by a baffle plate which may be finned. There should be no metal screw heads at the grip. The cords of some irons have a third wire which permits grounding the iron itself. This eliminates the danger of shock should the element come in electrical contact with the iron.

The 8" flat mill file is suitable for

cleaning the soldering iron. This is necessary to prepare the tip for a new tinning, and in order to reshape the point.

Every service man needs a pocket knife. It is used for cutting off insulation, for scraping bare copper wire and joints to clean them in preparation for soldering. The electrician's two-bladed folding pocket knife is suitable for these purposes and also provides a useful heavy screwdriver

List of Important Tools

	Approximate Cost
Screwdriver, 8" insulated handle, 1/4" blade	\$1.15
Screwdriver, 1/8" blade, insulated handle60
Pliers, 5" diagonals, best steel, with insulation crushing jaws	1.90
Pliers, 6" long nose, best steel, sturdy and streamlined	1.40
Pliers, 6" combination	1.25
Soldering iron, 100 watts, 3/8" tip diameter	7.20
Pocket knife, electrician's two bladed	2.50
Hammer, medium weight claw, one piece	2.25
Aligning tools, 3-in-1, bakelite with clip65
Tuning wand, bakelite, with brass and iron ends60
File, 8" flat mill25

as an added feature of the second blade.

The medium weight claw hammer is recommended for installing antenna and feeder systems, for general purposes such as driving and drawing nails, and for riveting and punching. For use at the bench alone, an 8-ounce ball-peen hammer is satisfactory.

The selection of aligning tools is another which depends considerably on the service man's needs and preferences. He may find that it pays to obtain a complete set, or he may prefer to purchase the tools individually. The hexagon neutralizing wrench, and the tuning screwdriver are essential. The wrench may be of fiber, and hollow so that the screwdriver may be inserted through it. When the hexagon wears, it may be cut short and used again. The screwdriver should contain little or no metal, and the higher the frequency of the alignment signal, the more important this feature becomes. For work at very high frequencies it is

suggested that low capacity, high "Q" alignment tools be chosen. The tuning wand with brass and iron tips is the tool to determine if the inductance of radio frequency coils is high or low. Alignment tools come in various combinations and provided with pocket clips.

A more expensive tool, but one which many service men with a growing business desire, is an electric drill. A 1/4" light duty unit is satisfactory. It can be used for chassis drilling.

A set of nut drivers is a handy addition to the service bench. They should be deep enough to handle two nuts, and may be obtained with hollow handles for extended shafts. Nut sizes in radio maintenance work usually run from 3/8" to 3/8".

A tool which is normally desirable is an adjustable hack saw designed to take 8" to 12" blades. It is used for cutting chassis, volume control shafts and other items.

There are other tools which are useful additions to the service bench. One of these is the volume control wrench with 1/4" hollow handle. Another is the general purpose 1/2"-5/8" combination box wrench. A set of open-end wrenches may be obtained at very low cost. Tools for chassis work consist of the 4 1/2" center punch, assorted shearing punches, socket punches, the square hole shearing punch for odd shaped holes, and rivet and eyelet punches. In some cases a circle cutter is desirable.

Two items which can be considered tools for the radio service bench are the extension cord set, and a radio repair light. The light should be small so as to reach those out of the way places in the chassis which are hard to see.

Finally there are chassis supports or jacks. Many service men prefer to manage without this aid and place the radio chassis on end turning it as necessary to complete their work. Certainly supports or jacks which take too much time to install, or are unstable when installed are not suitable.

Today, the market for service men's tools is highly competitive. He who is expanding his supply, or purchasing for the first time, should take advantage of this situation by availing himself of a catalogue of parts and equipment of the radio industry. The selection should be made only after comparing prices and advantages as shown by the specifications and descriptions of the manufacturers. Previous experience and the advice of others are of course invaluable aids. ✓ ✓

HOME MOVIES IS A BIG, GROWING BUSINESS!

8mm and 16mm movies for showing in the home, at clubs and civic groups are becoming increasingly popular among the general public. The demand for these particular types of films has grown to tremendous proportions during the past few years. Today, one of the major money-making sections in photographic stores and stores carrying photographic merchandise is the Home Movie Department.

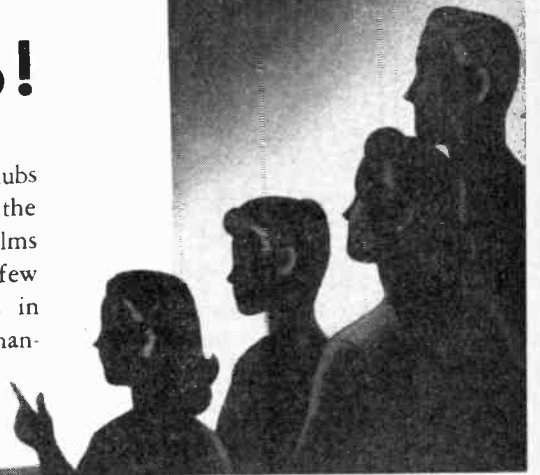

If You Have a Photographic Department, or Are Looking for a New and Profitable Line, Let Us Show You the Vast Potentialities of ...

PICTOREELS
THE FINEST IN REEL ENTERTAINMENT

Known and Demanded by Thousands of Home Movie Fans!

Here is a line of home movie productions that have a real success story written all over them. Here is a line of home movie productions that can step along with any one of your volume departments, and produce real business for you. PICTOREELS home movies are a "natural" for any store catering to the home market . . . like radios, they are entertaining . . . like appliances, they are a definite part of today's living. What can be more fitting for you to carry than these fast-moving, profitable films?

In the PICTOREELS home movie line you have comedies, musical features, cartoons, sports films, educational films — in fact, the whole wide scope of the professional motion picture field brought down to 8mm and 16mm size. PICTOREELS are well advertised in national consumer photographic books. They are well publicized among clubs, schools and organizations. We'll supply you with display fixtures, booklets, folders and other promotional material. The time to get started is now. MAIL COUPON TODAY for full details of PICTOREELS Home Movie Department.

PICTORIAL FILMS, INC.
RKO Building
New York 20, N. Y.

We're interested in a PICTOREELS Home Movie Department. Please send full details, without obligation on our part.

STORE NAME

ADDRESS

CITY

STATE

Dept. R.M.

CLIP THIS COUPON AND MAIL TODAY...

PICTORIAL FILMS, Inc.

R. K. O. BUILDING

RADIO CITY 20, N. Y.

THE INDUSTRY PRESENTS

"LITTLE DEVIL" RESISTORS

A new series of small size fixed, insulated, composition resistors is announced by the Ohmite Manufacturing Company.

The "Little Devils" are full $\frac{1}{2}$ watt, 1 watt and 2 watt resistors, yet the size of the $\frac{1}{2}$ watt is only $\frac{3}{8}$ " long x $\frac{9}{64}$ " diameter, the 1 watt is $\frac{9}{16}$ " long x $\frac{7}{32}$ " diameter, and the 2 watt is $\frac{11}{16}$ " long x $\frac{5}{16}$ " diameter. They meet all test requirements, including salt water immersion cycling and high humidity tests.

They are sturdy, light, compact, dissipate heat rapidly, and have low noise level and low voltage coefficient. They are completely sealed and insulated, with soft copper wire leads hardened near the resistor body, strongly anchored and hot solder coated.

Complete information obtainable from Ohmite Mfg. Co., Chicago.

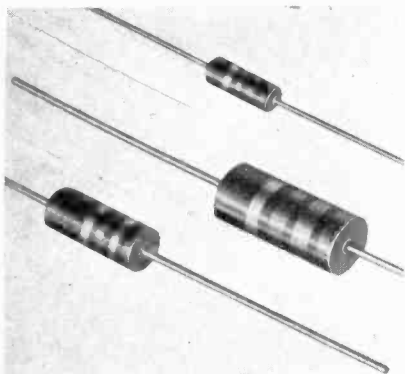

"GHIRARDI" BOOK DISPLAY

A combination book display for Ghirardi radio books is now ready for distribution to radio dealers, by Murray Hill Books. This handsome stand saves the time of store attendants by placing the three most popular and fast-selling of these books on convenient display where prospects may examine them in detail, but not walk off with them.

Attractive red, white and blue lettering on a light blue background, with a durable overall finish of washable lacquer, achieves an effect that focuses attention on the display and invites examination of the books. The books themselves are safely attached to the display by silk covered flexible wire cords so they can be

examined easily but not taken away.

Detailed information may be obtained from Murray Hill Books, Inc., 232 Madison Avenue, New York 16, New York.



CONTEMPORARY DESIGN CONSOLE

A distinguished example of the contemporary design, this radio-phonograph console is being produced by Stromberg-Carlson Company. It is a superheterodyne having a standard broadcast band and an international short wave broadcast band, and both present and newly approved FM bands. The cabinet is available in walnut or a new wood for home use, pinstriped oak. The receiver is equipped for push-button and manual tuning, with ten watts audio output and using a 12-inch electrodynamic speaker in floating suspension. The cabinet size is 36 inches high by 34 inches wide by 18 $\frac{3}{8}$ inches deep.

Stromberg-Carlson also presents a table model radio receiver with high-

quality radio features and cabinet design—the "Nocturne" model. The cabinet is walnut, in the newest trend, with a louvred front. This AC-DC receiver is equipped for standard broadcast reception, has an illuminated slide-rule dial, an electrodynamic speaker, a built-in loop antenna and a tuned radio frequency stage, using a 3-gang condenser. The cabinet dimensions are 8 inches high by 13 $\frac{1}{4}$ inches wide by 6 $\frac{3}{8}$ inches deep.

Manufactured by Stromberg-Carlson Company, Rochester, N. Y.

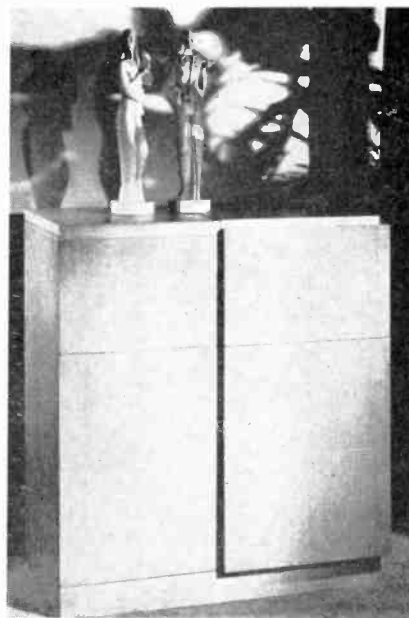

HOME MOVIES PROFITABLE

Home movies may prove a source of unsuspected profits in the radio store. With the increase in sound projectors

→ To Page 39

Repair or Reconditioning

→ From Page 18

make a fairly accurate estimate for the customer. Suppose this price is 28 to 30 dollars. Suppose the customer complains that the set is only four years old, never has had anything go wrong before and says he cannot understand why it should require all that work now. Your next move is to explain that stationary parts in a radio set are subject to wear just the same as moving parts in his automobile; that a condenser has a definite life—it will actually wear out; that the trouble now is caused by the breakdown of one or more of those parts. How near the others are to breaking down no one can tell—except that they are four years nearer to breaking down than when he bought the set.

As you have previously explained, to find the defective part and repair or replace it may take considerable time—it may take as much of your time as a complete systematic reconditioning job. The repair bill in that case may be three, five or ten dollars. What does the customer get for this money? He gets *that* particular defective part replaced—the remainder of the radio is just as it was. Perhaps next week another part will give way, then another, and the customer becomes annoyed because you did a poor job of servicing. So you had best spend some time *now* explaining to the customer just what may happen and how reconditioning will be the most satisfactory, trouble free, and least expensive solution in the long run. If he complains that it is a lot of money, ascertain the original cost of the radio and point out that the service is only costing him about seven dollars per year.

Should the customer insist that he doesn't believe the reconditioning is the thing to do, assure him at once that you will be happy to find the defective part and replace that. But again advise him that you honestly believe he should have it reconditioned or trade it in on a new radio rather than face a series of small or medium sized repair bills and the consequent periodical interruption of his reception!

If you stick to your story you are now in the best possible bargaining position. You have given the customer your advice. If he has the set reconditioned you have sold him a real service. You have helped the

customer and you have helped yourself! If the customer doggedly insists that he does not want any such reconditioning, you have warned him. If the set breaks down in a month or so, you have merely been proved to be a radio man who knows his business rather than being in the more usual position of having replaced a coupling condenser and a month later being roundly sworn at when a tube becomes defective! So you have profited *even though you didn't sell the reconditioning job!*

What about the situation after you have convinced the customer that the set should be reconditioned? If you are merely repairing the radio, it must be worked on almost exclusively by a highly skilled radio mechanic. But *most* of the labor involved in a reconditioning job can be performed by a semi-skilled mechanic. The condensers and resistors should be laid out by the serviceman, and the ones indicated which they are to replace. Tagging each part proves a satisfactory method of insuring proper replacement values. The semi-skilled helper can then make the routine replacements, and he can clean the chassis and tuning condensers. He can check the power cord, and if it shows signs of wear replace it! The cost is small and it is one of the few things the customer can see. Whether reconditioning or repairing a radio, the cord and plug are *very* important.

After the preliminary work has been done by the apprentice or by the serviceman himself, the set should be checked for alignment. This requires the skill of long training and adequate instruments. Do not attempt realignment unless you have *both!* Now the radio has been placed in the best working condition with all necessary parts replaced. Plug it in and the chances are the intermittent condition has disappeared without any trouble shooting on your part! If it hasn't you have eliminated a lot of places for the trouble to be and the time for finding it will have been materially reduced. As a final check let the radio play a minimum of *five hours* before returning it to the customer.

The radio is now in perfect condition and we are safe enough on our new radio guarantee. But there is still one more job to be done that is fully as important as fixing the radio. Fix the cabinet! That is the part of the radio that the customer sees. A properly reconditioned cabinet will do more to convince the customer that you have really done something to his radio than anything else. Because of the psychological importance of a re-

juvenated cabinet, it becomes an important part of your job to know how to remove scratches, fix dents, and make other minor repairs. You should polish any metal dial fittings and knobs on the front of the cabinet—and don't ever fail to clean the calibrated portion of the tuning dial! Polish and wax the cabinet. This shining cabinet returned in place of the stodgy old set you took away will add money to your bank account—and that makes polishing the cabinet important!

All this does not mean that it is good business to recommend a reconditioning job on every radio that comes into your shop. But if the set is in such condition that the *customer* will profit by reconditioning—do not overlook the possibility to help the customer *and* help yourself.

A business conducted along these lines will attract the better class of customers, the class of customer who wants quality service and has the money to buy it.

Since you probably can't do all the service business in your vicinity, why not get the profitable business by selling your customers on reconditioning instead of repairing? If you do, I assure you your profits will increase, your headaches decrease. ✓ ✓

Trade Literature

→ From Page 29

Soul of Amber
by Alfred M. Still Murray Hill
274 pages \$2.50

For 21 years a professor of Electrical Engineering at Purdue University, the author has gone back through the ages to the beginning of time, climbing a ladder built on ignorance, superstition and faith. Generations of men were gripped in a vise of work and study which gradually produced the modern electrical age.

Mr. Still's style lends enchantment to the progress of electricity in an appeal to the human interest of the general reader and makes an interesting presentation of the history of this science.

Meet The Electron
by David Grimes Pitman
120 pages, illus. \$2.00

A charming, informative book for the child as well as the adult, describing the amazing electron which makes your phone and doorbell ring, runs your vacuum cleaner, heats the iron pressing your pants, and illuminates the lamp above your bed during the delightful hour or two spent in reading about the mysteries of your home.

MODERN BENCH CONSTRUCTION

→ From Page 4

able leads; continuity test leads, also retractable, which connect to a small battery and a buzzer; light switches for overhead illumination, which should be attached to the top of the bench, and for underpanel illumination. This latter consists of a 20-watt fluorescent lamp mounted within the instrument panel projection, thus illuminating the back panel and the portion of the working surface which is otherwise shadowed by this projection. In addition, the power switch for the soldering iron and a pilot light indicating when the iron is on are also mounted on this panel.

To date there have been some fourteen manuals of diagrams and alignment instructions. A complete set of these should be handy to the service bench, and even in shops with several employees, it is felt that the additional expense of having a set of manuals on each bench is justified in time saved. Since the bench is to be of permanent construction, it is fully expected to last for at least five years, so space has been provided for twenty such manuals. Beyond that time, it is probable that the earlier manuals may be stored elsewhere, as the older sets are gradually disappearing from the field.

Space must be provided for the oscillograph, signal generator, vacuum tube volt-ohmmeter, and possibly a signal tracer. This group of instruments is not used as continuously as the multimeter, but even so, the space provided for these instruments is very nearly the optimum. One feature of this arrangement is that when the oscillograph is used, the overhead light can be shaded to darken the screen as much as possible, or the light may be turned off if desired. Electrical outlets are provided at the back of this space for the power cords to these various instruments.

Power sources for the sets and auxiliary testing equipment is also made available on the back panel, which is visible directly below the projecting instrument panel. On this panel is provided a number of outlets for 115-volt A-C line current; a source of 6.3 volts A-C for substitution in such cases where the normal power transformer is burned out or where the power supply is separate from the receiver chassis proper, or for any other reason; a source of 6-volt D.C., which may come either from a battery or from a heavy duty A-battery eliminator; and a source

of D.C. variable in voltage from zero to about 400 volts, and controlled by means of a knob on this same back panel. In addition, a loudspeaker with a universal output transformer providing a large number of impedances is mounted on this panel, together with a substitute field coil, providing a number of resistance values.

The 0-400 volt D-C source is furnished by a regulated power supply mounted within the structure of the bench, and is provided with a voltmeter to indicate the source voltage. The 6.3-volt A-C source is supplied by a secondary on the transformer in the regulated power supply, and is capable of furnishing four amperes. The provision for the six-volt D-C supply for working with automobile receivers is somewhat unusual. Most auto sets obtain their supply through a simple little bayonet plug arrangement within which is the fuse for the supply. Unfortunately, not all automobiles have the same terminal of the storage battery grounded. Considering all this, it was decided to insert a switch in the battery supply which would ground whichever side of the battery should be grounded for the set being serviced, and would connect the other side of the battery to the "hot" bayonet plug. Because of the fact that the fuses for automobile radios are small and easily lost, the circuit was fused by a standard plug fuse, screwed into a regular socket. This makes for easy renewal. Both an ammeter and a voltmeter are provided in this circuit to read the supply voltage and the current drawn by the set.

Another feature of the bench is the provision of a "trash hole" cut into the back panel, of the same size as and symmetrically placed with the loudspeaker opening. This makes an easy place to dispose of old electrolytics, volume controls, scraps of wire, and other trash that accumulates on a bench top and slows down work. It is believed that this innovation will save time and will aid in keeping the bench top clear. Provision is made within the bench structure for a removable box to contain all the waste material thrown into this trash hole, permitting it to be emptied at intervals. There is also sufficient room on the back panel for the mounting of a wattmeter or any of a number of other instruments and accessories that the serviceman may use.

While many servicemen believe that

tools should be arranged on a board over a bench to be instantly available as required, this belief is not shared by us. Undoubtedly there is some basis for such an arrangement of the less-used tools, but it is felt that there are other things that are of more importance for the preferred position. In the day-to-day servicing of radio sets, the most used tools are screwdrivers, long-nosed pliers, and diagonals. These are constantly in use, and are most conveniently available directly on the bench top. The other tools can be stored easily in drawers, in some systematic arrangement, and are readily reached as required. The same reasoning applies to the replacement parts, which are also systematically stored in drawers. As to the drawers, more will be said later.

One of the most convenient locations for the soldering iron is in a permanent mounting of some sort directly below the bench top, and at the right of the normal working position. This prevents the iron from burning hands, cords, or cabinets. The mounting herein provided is composed of a piece of 1½" pipe eight inches long, with a cap on one end, and screwed into a floor flange on the other. This flange, in turn, is mounted on a bracket made of a piece of 2" hardwood, and attached at the right of the knee space. As mentioned before, the 115-volt supply for the iron is controlled by a switch on the instrument panel, and a pilot light indicates when the current is on.

An ideal arrangement for the soldering iron would be the incorporation of some form of thermostatic control. However, such a device which would meet the other requirements for the mounting is apparently not available. An alternate is the use of a 100-watt lamp connected in series with the iron, with a switch across the lamp to short it out when the iron is being used continuously. In this fashion, it is possible to keep the iron very close to operating temperature without actually burning up the tip.

Since hook-up wire and solder are used quite frequently, they are located on supports at the left and right of the instrument panel extension. This places them in an accessible location, and saves searching for them.

Satisfactory lighting is a very important consideration. The space under the instrument panel extension

is illuminated by a 20-watt fluorescent lamp mounted within the extension, the light being shaded from the serviceman's eyes, yet lighting up the back panel effectively. The overhead lighting should be provided by another fixture which can be attached to the top of the bench, although not shown in the drawing. A dual-unit fixture such as those used over a drafting table is recommended—adjustable, and furnishing sufficient light, yet with little stroboscopic effect due to the phase-correcting network used in this type of fixture.

Some constructors prefer the use of an ornamental metal trim around the edges of the bench top. It has been avoided in this design due to the danger of shock. No metal should be used on the bench top, and the use of a good hardwood surface precludes the necessity for any such trim.

The main illustration of the bench demonstrates the modern appearance, and Fig. 2 indicates these various features.

General Features

In our design of a radio bench, everything has been done to make the most efficient unit that the combined ideas of the entire staff could produce. The recommended construction consists of a pair of desk-height, steel, office cabinets. On the left side, the type of cabinet selected consisted of a four-drawer unit, each drawer being approximately five inches deep. This side is used for the storage of heavier and larger tools in the top drawer, and for the larger replacement parts, such as volume and tone controls, output transformers, chokes, and the smaller loudspeakers, in the three remaining drawers. On the

right side, a ten-drawer cabinet was selected. The top three drawers, each of which is two inches in depth, are intended for the smaller tools that are used in servicing, and the remaining seven drawers are used for storage of small hardware such as nuts, machine screws, tie points, lock washers, and the like, and for resistors, by-pass and filter capacitors, pilot lamps, and so on. The drawers in this type of cabinet are mounted on rollers, and are very easy running, yet are quite strong and durable. One of the greatest advantages of the metal drawer construction lies in the fact that the drawers cannot be removed from the slides accidentally—to remove them, it is necessary to make an effort to do so. This will be an attractive feature if one remembers pulling a drawer well filled with small parts out beyond the guides, and spending fifteen minutes picking all the stuff up again.

Admittedly, the steel cabinets are rather expensive as far as the number of dollars is concerned. But, when the life of the bench is considered, and the smoothness and efficiency of the drawer arrangement is considered, the additional expense is justified. The use of this type of cabinet is not necessary, and the constructor can undoubtedly find other cabinets which will serve quite satisfactorily. Most of the unpainted furniture manufacturers make drawer units which can be employed, and such units should cost less than ten dollars each, whereas the steel cabinets will cost (new) about \$70 each.

The exterior finish of the bench is made of $\frac{1}{2}$ " plywood, five-ply. The entire construction is made with flush joints, and no projections have been

tolerated, thus making the bench as streamlined as possible. While toe space is generally furnished in cabinets of the kitchen type, it was not considered necessary for this bench as most of the work will be done at the center section, where plenty of clearance is provided.

The "library" space in the bench is entirely walled by plywood in the same manner as the exterior walls of the bench, with appropriate stops located at the right depth to keep the front edges of the books flush with the edge of the shelves. These stops are pieces of 1"x2" pine, nailed in at the proper location.

Construction

The constructional details of the bench are shown in the various drawings. Figure 3 shows the framework 2"x2", 2"x3", and 2"x4" members, which is actually the backbone of the entire bench. The dimensions shown provide for the metal cabinets selected, which were 30 $\frac{5}{8}$ " high, 18 $\frac{1}{8}$ " wide, and 28 $\frac{1}{2}$ " deep. In case any other type drawer cabinet is used, be sure to make provision for the exact size of the unit selected.

The lumber required for the bench is as follows:

- 10 pcs 2"x6" tongue-and-groove, 8' long, Maple or Oregon Pine
- 10 pcs 2"x4"—12' S4S Oregon Pine
- 2 pcs 2"x3"—12' S4S Oregon Pine
- 1 pc 2"x2"—10' S4S Oregon Pine
- 1 pc 1"x2"—14' S4S Oregon Pine
- 4 pcs $\frac{1}{2}$ " 5-ply, 4'x8'

All of the above are standard lumber dimensions, which when finished are slightly less than the nominal sizes mentioned. The following pieces are

→ To Page 40

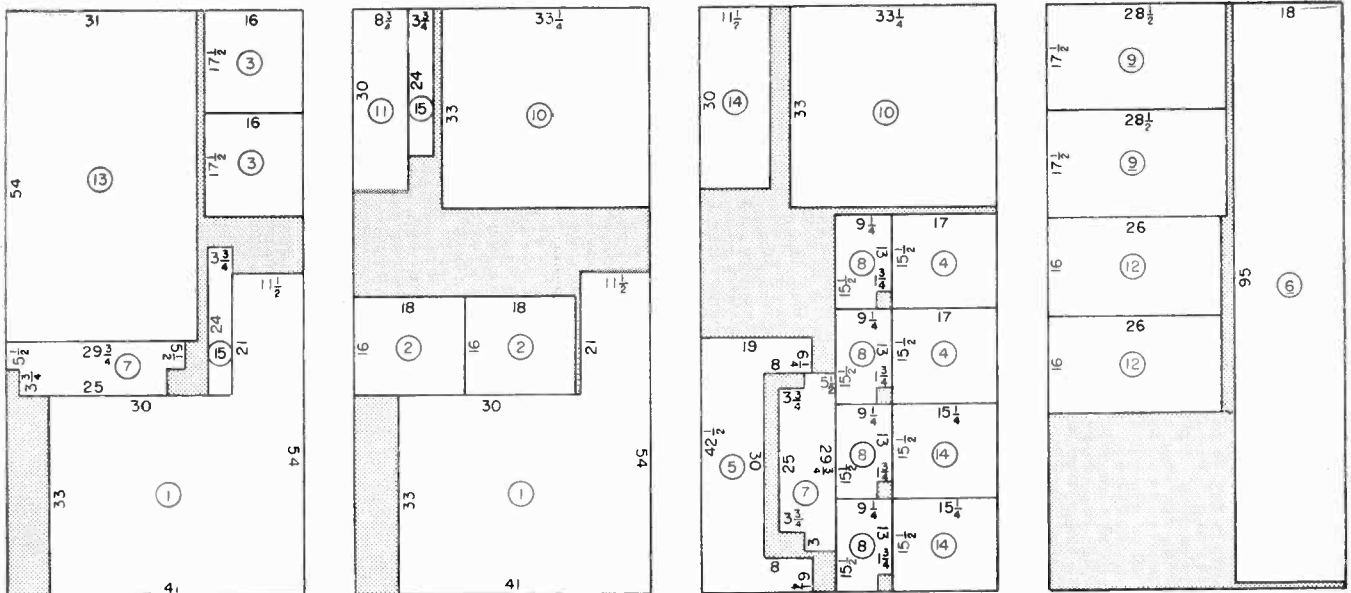

Fig. 4. Diagram of four pieces showing layout for cutting.

A PAGE DEVOTED
TO LETTERS FROM
OUR READERS



Radio Men's Opinions

Radio Technicians' Guild
of Rochester
229 Malden Street
Rochester, New York

Dear Sirs:

A short time ago I received through the mail a #2 copy of your magazine. After looking it over I passed it on to some of the members of our executive committee, and as a result, at our last meeting I was delegated to write you and offer the congratulations of R.T.G. upon the excellent job you have done.

Prior to the war there was considerable sentiment among members of R.T.G. for a periodic publication that was to be subscribed to and paid for out of each member's yearly dues. However, each time the subject of selecting a suitable magazine was brought up there was always the fact that whichever publication was mentioned, several of the members said no because they had already paid for a subscription.

But after discussing it at the last meeting we decided that your magazine could fill the bill nicely as we believe that very few if any of our members have subscribed to it as yet. Therefore, will you at your earliest convenience write me at the above address and tell me what your group subscription rates are. It is our plan to have all the copies of the group subscription sent to one address, and then distribute them at one of our regular bi-monthly meetings.

If you happen to have on hand any of your #1 copies, I would appreciate it if you would send me one and I will send you a check for whatever it costs.

Sincerely yours,

William E. Brewerton
Past President
R.T.G. of Rochester

Lincoln, Nebraska

Dear Editor:

In your October issue of Radio Maintenance, "Business Management for the Radio Dealer" (suggested advertising) page 26, I read with considerable interest your comments regarding telephone directory advertising.

To further substantiate your expressions regarding display space being used to a more profitable advantage, I am enclosing a tear sheet from our directory, and can advise you that the firms using the larger ads, have been most successful, and spend a greater part of their advertising appropriation in the telephone directory.

May I make one correction in your editorial regarding directories that do not have a classified section, (with the exception of some Bell System directories) most directories have cover space and spaces at the top and bottom of the alphabetical pages, which are most popular with radio shops, because of the permanency of the media, its daily usage, and the small expense per prospective customer. The charges in most instances are less than 2 cents per directory per year.

I would appreciate your adding my name to your mailing list, and I am enclosing my check.

Very truly yours,

E. A. McKenna
Directory Sales Mgr.
Lincoln Tel. & Tel.

Los Angeles, Calif.

Gentlemen:

In regard to your articles on business management, please be advised that the servicemen in this locality think that this is just exactly the information that they need and would appreciate it very much if

Radio Maintenance magazine would publish more business information for the radio service shop.

One of the most baffling problems that confronts us is how to plan our advertising economically so that we can get plenty of business at the proper cost without breaking the bank.

While we realize that advertising is necessary, we do not know what forms of advertising give the most return for our money and in many cases we spend money on advertising that does not produce results. We know that large organizations have specialists for determining where the greatest return is for money spent in advertising, and we know that if we had specialists that, for a small amount of money spent in proper advertising, we could get proportionate results.

I suggest Radio Maintenance have some sort of advertising suggestion column.

Yours very truly,

Bert Astrove

Martin Radio & Electronic Service
Brooklyn, New York
Gentlemen:

Enclosed find money order in the amount of two dollars in advance payment for a one-year subscription to your monthly paper.

I think the series of writings you contemplate placing before the servicing trade will be worth many times the cost of the magazine. However, there seem to be a lack of looking to the possible enormous field for the financial growth of ALL RADIO MAGAZINES because they seem to want to steer away from the tremendous numbers of persons who have lately taken up the radio trade as a

→ To Page 38

PLEASE PLACE YOUR ORDER WITH YOUR REGULAR RADIO PARTS JOBBER. IF YOUR LOCAL JOBBER CANNOT SUPPLY YOU, KINDLY WRITE FOR A LIST OF JOBBERS IN YOUR STATE WHO DO DISTRIBUTE OUR INSTRUMENTS OR SEND YOUR ORDER DIRECTLY TO US.

The New Model CA-11 SIGNAL TRACER

Simple to operate . . . because signal intensity readings are indicated directly on the meter!

Essentially "Signal Tracing" means following the signal in a radio receiver and using the signal itself as a basis of measurement and as a means of locating the cause of trouble. In the CA-11 the Detector Probe is used to follow the signal from the antenna to the speaker — with relative signal intensity readings available on the scale of the meter which is calibrated to permit constant comparison of signal intensity as the probe is moved to follow the signal through the various stages.

Features:

- ★ SIMPLE TO OPERATE — only 1 connecting cable — NO TUNING CONTROLS.
- ★ HIGHLY SENSITIVE — uses an improved Vacuum Tube Voltmeter circuit.
- ★ Tube and resistor-capacity network are built into the Detector Probe.
- ★ COMPLETELY PORTABLE — weighs 5 lbs. and measures 5" x 6" x 7".
- ★ Comparative Signal Intensity readings are indicated directly on the meter as the Detector Probe is moved to follow the Signal from Antenna to Speaker.
- ★ Provision is made for insertion of phones.



The Model CA-11 comes housed in a beautiful hand-rubbed wooden cabinet. Complete with Probe, test leads and instructions. Net price

\$18⁷⁵

The New Model 450 TUBE TESTER

Specifications:

- Tests all tubes up to 117 Volts including 4, 5, 6, 7, 7L, Octals, Loctals, Bantam Junior, Peanut, Television, Magic Eye, Hearing Aid, Thyatrons, Single Ended, Floating Filament, Mercury Vapor Rectifiers, etc. Also Pilot Lights.
- Tests by the well-established emission method for tube quality, directly read on the scale of the meter.
- Tests shorts and leakages up to 3 Megohms in all tubes.
- Tests individual sections such as diodes, triodes, pentodes, etc., in multi-purpose tubes.
- New type line voltage adjuster.
- NOISE TEST: Tip jacks on front panel for plugging in either phones or external amplifier will detect microphonic tubes or noise due to faulty elements and loose internal connections.
- Works on 90 to 125 Volts 60 Cycles A.C.



SPEEDY OPERATION assured by newly designed rotary selector switch which replaces the usual snap, toggle, or lever action switches.

The model 450 comes complete with all operating instructions. Size 13" x 12" x 6". Net weight 8 lbs. **\$39⁵⁰** Our Net Price.....

The Model PB-100 VOLT-OHM-MILLIAMMETER

Features:

- ★ Push Button Operation
- ★ Direct Reading
- ★ Housed in Portable Oak Cabinet
- ★ No External Source of Current Required

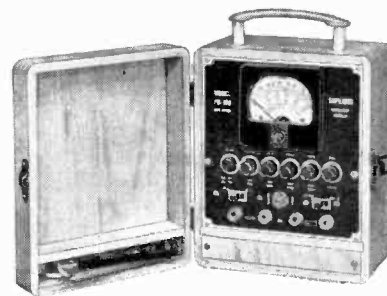

Specifications:

6 D.C. VOLTAGE RANGES: 0 to 5/25/50/250/500/2500 Volts
 5 A.C. VOLTAGE RANGES: 0 to 10/50/100/500/1000 Volts
 5 OUTPUT METER RANGES: 0 to 10/50/100/500/1000 Volts
 3 D.C. CURRENT RANGES: 0 to 10/250 Ma. 0 to 2.5 Amp.
 3 RESISTANCE RANGES: 0 to 10,000/100,000 Ohms, 0-1 Meg.
 3 DECIBEL RANGES: -10 to +15; 0 to +35; +30 to +55.
 Model PB-100 comes housed in a hand-rubbed oak cabinet, self contained battery, test leads and instructions. Net price..... **\$28⁴⁰**



SUPERIOR INSTRUMENTS CO.

Dept. RM 227 FULTON ST., NEW YORK 7, N. Y.

Service Kit

→ From Page 24

other kind of salesmanship — that salesmanship is of more than one category. Actually, the classification in mind is that defined by the words *tangible* and *intangible*. The writer's intention here is to point out that the radio repairman is inclined to direct his energy to the selling of the intangible—his services or labor—and to overlook the opportunities for profit that accrue from the selling of tangible or real things. To sell noise filters the radioman must break with this habit and develop skill in the sale of tangibles. The successful sale of

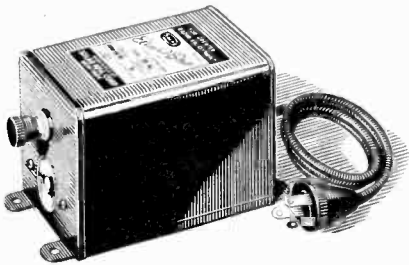

Heavy duty Solar Elim-O-Stat, for sets or electrical devices drawing up to 5.0 amperes.

the tangible requires as much concentration and practice as the sale of the intangible. And when two sales are in prospect—one involving the tangible and the other the intangible, such as the sale of a noise filter and that of a repair job—the two should be disassociated in the customer's mind. This is necessary to avoid a possible illusion that the total charges made are for the repair work, and that the supplying of a noise filter is part of the contract to restore the radio receiver to proper operating condition. ✓ ✓

Radiomen's Opinions

→ From Page 36

means of full or part time income. For every service store there seems to be hundreds of such people who would gladly subscribe to any trade publication which would devote a part of its pages to the fundamentals of servicing for the person who is starting out and is hungry for articles on how the experienced servicer goes about getting the bugs out of home sets. Within a radius of three blocks around me there must be about twenty or more men who are hungry

for such material and would be more than happy to subscribe to a paper that was not over their heads.

Yours sincerely,
J. F. Martin

Lou's Radio Service
Minden, Nebraska

Gentlemen:

Received your magazine "Radio Maintenance" this morning and it is just the type magazine I've wanted for years but didn't know where to get one. I sure think the part about short cuts in Radio servicing is swell, I hope you keep up the good work. I think different servicemen sending in their ideas is swell as many a short cut can save lots of our time. So many of the other magazines have left the service out lately and all they have is selling of the new radios. (Someday). But right now what the majority of radiomen need is like your "Short Cuts."

I'm enclosing my personal check amounting to \$3.00 for two years of Radio Maintenance. Please try to start with the January 1946 issue. Keep up the good work.

Respectfully yours,
Louis T. Haws

Cuff's Radio Service
Hancock, Michigan

Dear Sir:

Keep up the good work. If the rest of your magazines are as good as the first two, then I know that this is the one we servicemen have been waiting for.

Enclosed find my check for three dollars for which please send me Radio Maintenance for the next two years. Please be sure I get the January issue.

Yours truly,
Fran Cuff

Gary, Indiana

Editor:

As I am a radio serviceman please send me your magazine as I want to keep up on radio and it looks like yours will be one of the "tops." I have the July number on hand and any published since then will be appreciated.

Yours truly,
E. P. Merritt

Chicago, Illinois

Dear Sirs:

I am writing this letter to inquire about special rates for your magazine to radio service clubs.

We should like to know if we subscribe in quantity, how much rate reduction we can get per member and what is the minimum number of

members required in order to receive the special rate?

Very truly yours,
Benjamin Russell Williams

Rt. 1, Box 112
Columbus, Miss.

Gentlemen:

Here is a note that may be of interest to readers of your new publication—"Radio Maintenance."

Can we have the instructions for the rewiring or making-over of the battery D-C receiver-CROSLEY 6B1, a typical "B" power built-in, 6-volt storage battery receiver, a superhet., so well adapted to A-C changeover for the rural population who now have the 115-volt "TVA" A-C power. Write it up in your new publication, as there are many of similar types ready for changeover, over the U. S.

Yours truly,
Lewis C. Chapman

Philadelphia, Pa.

Dear Editor:

You sent me Vol. I, No. 2 issue as a "sample." If possible, please send me Vol. I, No. 1. It looks like this magazine is the answer to the Radio Serviceman's prayers and I don't want to miss any issue.

Very truly,
Franklin Hill

Bedford, Ohio

Gentlemen:

Yes I feel the way the rest of the readers do about your magazine and as a result I am enclosing \$3.00 for two years. I am in charge of the radio service department at Shaker Heights, Ohio, and that is where I first read your magazine. Good luck to you.

Yours,
K. N. Gray

Electronically Speaking

→ From Page 28

able radar beacons—as shoreline markers in navigation; protective devices on mountains, tall buildings and other flying hazards; air strip markers for control of blind landings; and as identification equipment for small airports to steer civilian pilots home, especially in areas where the presence of a number of airfields might otherwise result in confusion. Beacon signals could be received in planes equipped with simple radar systems.

Industry Presents

→ From Page 32

in home and school, there will be more service work in maintaining the audio systems of the projectors since most photographic dealers are not equipped to handle the sound side of the machine.

The service contact will enable many servicemen and dealers to cash in on a profitable side of the Home Movie field-films. Most Home Movie makers do not make sound films because there is little equipment available for the purpose, so they depend on retail outlets for their supply of sound films, renting and purchasing them for home showings. The rental field is largely confined to feature length pictures but shorts are freely purchased since parents have found



the children like to see a familiar film over and over.

A related source of profit is in the color slide and slide-film field. This is particularly true of school business. Color slides differ from the old standard glass slides. They measure 2 by 2 inches outside. The picture is equivalent to one or two frames of standard motion picture film. The slidefilm is slightly different. Instead of each picture being separately mounted in a slide, the pictures are printed in sequence on a strip of standard-width movie film, 35mm wide. Occasionally these slidefilms are accompanied by recorded sound, with the sound on a 33 1/3 rpm record.

Pictorial Films, Inc., is putting three new films on the market. They are based on the literary classics, "Treasure Island," "Ivanhoe" and "The Three Musketeers." Furnished in 8 mm, 16 mm, in color slides, and in slidefilm form this type of material is very popular with children.

Pictorial Films has established an

→ To Page 40

60 new faces on your jobber's shelf . . .



the Stamford "60"

Meet the gentlemen from Stamford! Look them over! New faces, yes, with a determined look about them that gives you a rare feeling of complete confidence. Sixty of the finest tried and tested transformers. You can scour the market, if you wish, and find transformers that are almost as accurate . . . almost as well built, but none quite like the Stamford "60".

TEST THEM YOURSELF AT THE STAMFORD "60" DISPENSER

Their overall economy, their sturdy construction, their "He-Man" performance in every repair job, put them in a class apart. For the address of your nearest Stamford "60" jobber, write: Stamford Electric Products Company, Inc., Stamford, Conn.

stamford
Transformers

THE STAMFORD DISPENSER

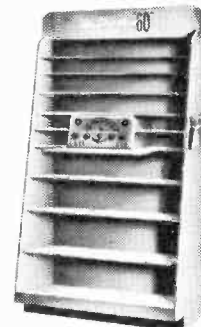

Industry Presents

→ From Page 39

information division to aid radio dealers who desire to expand their field into this part of the entertainment and educational fields and will supply literature and dealers' aids free upon request to Pictorial Films, Inc., 1270 Sixth Avenue, New York City.

A NEW TYPE SOLDERING IRON

The Baker-Phillips Company makes an Instant Heating Soldering Iron with a carbon heating element. It heats instantly, allows the operator complete control over the heat because of a button trigger arrangement, is lightweight and perfectly balanced, and has a cool protected grip.

The contacts in the gun are silver, and are fully enclosed. The switch is of phosphor bronze, with terminals made to army and navy specifications, and the gun is fitted with heavy duty type S cable. The only parts to be replaced from time to time are the element and the tip. They are easily replaceable at a small cost.

The "Flash" soldering gun does not operate directly from the 110 volt line, but from any 6-12 volt transformer for 110-volt 60-cycle line, from any 12 volt or 32 volt light plant, or from any standard storage battery or "hot leads" from any truck, car or tractor.

Manufactured by Baker-Phillips Company, Minneapolis, Minn.



ELECTRONIC SWITCH

An electronic switch, type YE-9, has been announced by the Specialty Division of the General Electric Company's Electronics Department at Syracuse, N. Y.

The new switch was designed for special electrical studies of wave form, phase, frequency relationship, and for the comparison of amplitude. By using two type YE-9 electronic switches in cascade, three independent circuits can be studied simultaneously. The switch may also be used with any oscilloscope with a horizontal sweep voltage and available connections to the deflection plates of the cathode-ray tube. Mechanical vibrations, sound, light, and other quantities transferable into electrical functions may be compared.

Operating on any sweep frequency of from 10 cps to 12,000 cps, continuously variable, the YE-9 has an amplifier frequency response of 4

cps to 450 kc (flat within 3 db). The device operates from a 110-125 volt, 50-60 cycle supply, and its maximum signal input is 250 volts rms.

A copy of the specification sheet on the electronic switch may be had on request to the G.E. Specialty Division, Wolf Street Plant, Syracuse, N. Y.

Modern Bench Construction

→ From Page 35

also required cut to net sizes as indicated:

- 4 pcs $\frac{1}{2}$ "x $2\frac{1}{4}$ " x 33"
- 2 pcs $\frac{1}{2}$ "x $2\frac{1}{4}$ " x 28 $\frac{3}{4}$ "
- 2 pcs $\frac{1}{2}$ "x $2\frac{1}{4}$ " x 24"
- 2 pcs $\frac{1}{2}$ "x $2\frac{3}{4}$ " x 19 $\frac{1}{4}$ "
- 4 pcs $\frac{1}{2}$ "x $2\frac{3}{4}$ " x 14"

The 2"x6" tongue-and-groove pieces
2 pcs 1"x7 $\frac{1}{2}$ " x 10 $\frac{1}{2}$ " (w)

should be assembled at the mill with furniture glue into two boards, one 30" wide, and one 18" wide. The latter will have to be ripped down to the indicated dimension. The ends should be carefully squared, and length cut to exactly 8 feet. The first of these boards is to be used as the bench top and the second serves as the bottom of the upper library compartments and as the secondary instrument shelf.

The 1"x7 $\frac{1}{2}$ "x10 $\frac{1}{2}$ " pieces, w, are cut off at an angle, being 10 $\frac{1}{2}$ " on one side, and 8" on the other. They are used as the end supports for the instrument panel.

The 2"x4" material should be cut into the following lengths, the letters indicating the piece number, as referred to on the framework drawing, Fig. 3:

- | | |
|-------------------------------|------------------------------|
| a) 3 pcs 7'11" | g) 4 pcs 2'9" |
| b) 1 pc 7'7 $\frac{1}{2}$ " | h) 2 pcs 2'5 $\frac{1}{2}$ " |
| c) 2 pcs 5'11 $\frac{1}{2}$ " | i) 4 pcs 1'9" |
| d) 2 pcs 5'1" | j) 2 pcs 1'6 $\frac{1}{2}$ " |
| e) 6 pcs 3'0 $\frac{1}{2}$ " | k) 2 pcs 13 $\frac{1}{4}$ " |
| f) 2 pcs 2'10 $\frac{3}{4}$ " | l) 2 pcs 5 $\frac{1}{2}$ " |

In order to conserve the lumber as much as possible, the above lettered pieces are cut from the 12-foot lengths as follows: From three of the lengths, cut one each of pieces a and e; from the fourth, one each of pieces b, e, and f; from the fifth and sixth, one each of pieces c, e, and f; from the seventh and eighth, one each of pieces d, and k, and two of piece g; from the ninth, two of pieces h, and four of pieces i; and from the tenth two pieces j and l.

The cutting of the remainder of the lengths of lumber is fairly obvious. The 2"x3" material is to be cut into pieces as follows:

- m) 2 pcs 3'11 $\frac{1}{2}$ "
- n) 2 pcs 3'2"
- o) 4 pcs 15 $\frac{1}{2}$ "

The 2"x2" material is to be cut as follows:

- p) 4 pcs 16 $\frac{1}{4}$ "
- q) 2 pcs 13"
- r) 2 pcs 12"

The 1"x2" is to be cut into the following lengths:

- s) 2 pcs 2'1 $\frac{1}{2}$ "
- t) 2 pcs 24"
- u) 2 pcs 13 $\frac{1}{2}$ "
- v) 2 pcs 9 $\frac{1}{4}$ "

For the outer surfaces of the entire structure, five-ply is used, cut as shown in Fig. 4. It is advisable to follow this diagram carefully in order to get all the pieces out of the specified lumber.

The letters and numbers of the various pieces of lumber are to be followed in the assembly, and the pieces will be referred to by their respective designation. After the completion of the bench construction, the unlettered pieces listed above as to be of "net" dimensions are used as trim. The four 33" pieces are used over the vertical 2"x4"; members at the sides of the drawer cabinets after the plywood is nailed on. This will give a finished appearance to the pedestal and leave none of the unsightly plywood edges visible. The 28 $\frac{3}{4}$ " pieces are used along the top of the upper "library" compartments, and the 24" pieces are used at the bottom of the lower library compartments. The wider pieces, 19 $\frac{1}{4}$ " in length are used for trim at the sides of the lower library compartments. The four 14" pieces are used as trim at the sides of the upper compartments. The remaining pieces of trim are to be used to cover the frame members below the drawer cabinets.

It must be kept in mind that the selection of a different type of drawer cabinet than the one used in this design will alter the lumber requirements slightly. However, the overall length of the bench will remain the same, regardless of the drawers used—the length of the knee space will be reduced. If the height of the cabinet is the same as in this design, then the only change in dimension is for the lower front 2"x4", (j), in each pedestal. The remainder of the construction will be as shown, and, of course, the superstructure will not be changed in any case.

Next month, the details of the auxiliary equipment will be given, together with the mounting provisions for the power supplies, wiring diagrams for the entire bench, and such other constructional data as may be required. ✓

N. U. BATTERIES

by the Carload!

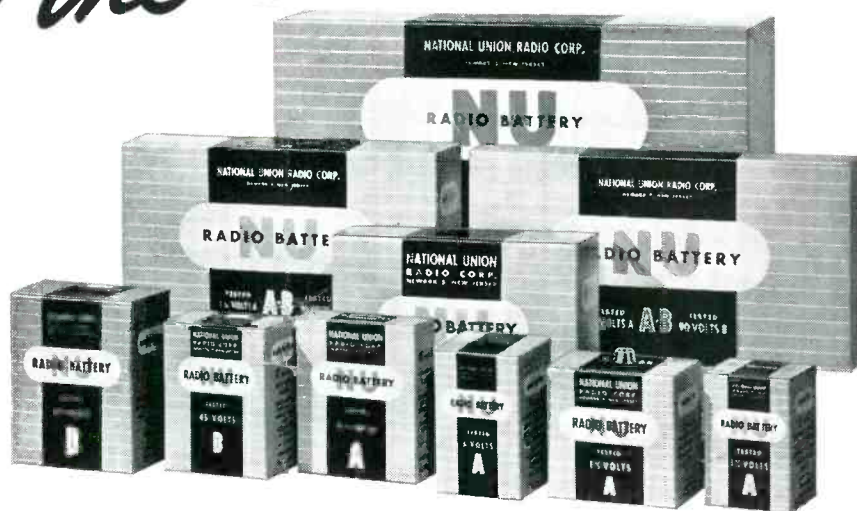

Get Immediate Deliveries of All Types for Standard Radio and Other Replacements

Now you can bring many thousands of good, serviceable battery-powered radio sets *back to life*. Portables—Farm Radios—"carry-about" sets! Here are the batteries you need to bring in this flood of profitable service and parts business. Order now and *tell* your customers to come on the run for the batteries they need.

In batteries as in other products, N. U. quality helps you build for the future. The patented construction of N. U. Batteries permits more active materials—more service hours per dollar. Every N. U. Battery is engineered to the highest initial equipment standards and is designed for universal replacement.

PLACE YOUR BATTERY ORDER TODAY—with YOUR N. U. DISTRIBUTOR

Renew with N. U. . . . the quality line that brings repeat sales at full profit to radio service men!

NATIONAL UNION RADIO CORPORATION, Newark 2, New Jersey

NATIONAL UNION RADIO TUBES AND PARTS

Transmitting, Cathode Ray, Receiving, Special Purpose Tubes • Condensers • Volume Controls • Photo Electric Cells • Panel Lamps • Flashlight Bulbs



THE TUBE WITH A HERITAGE

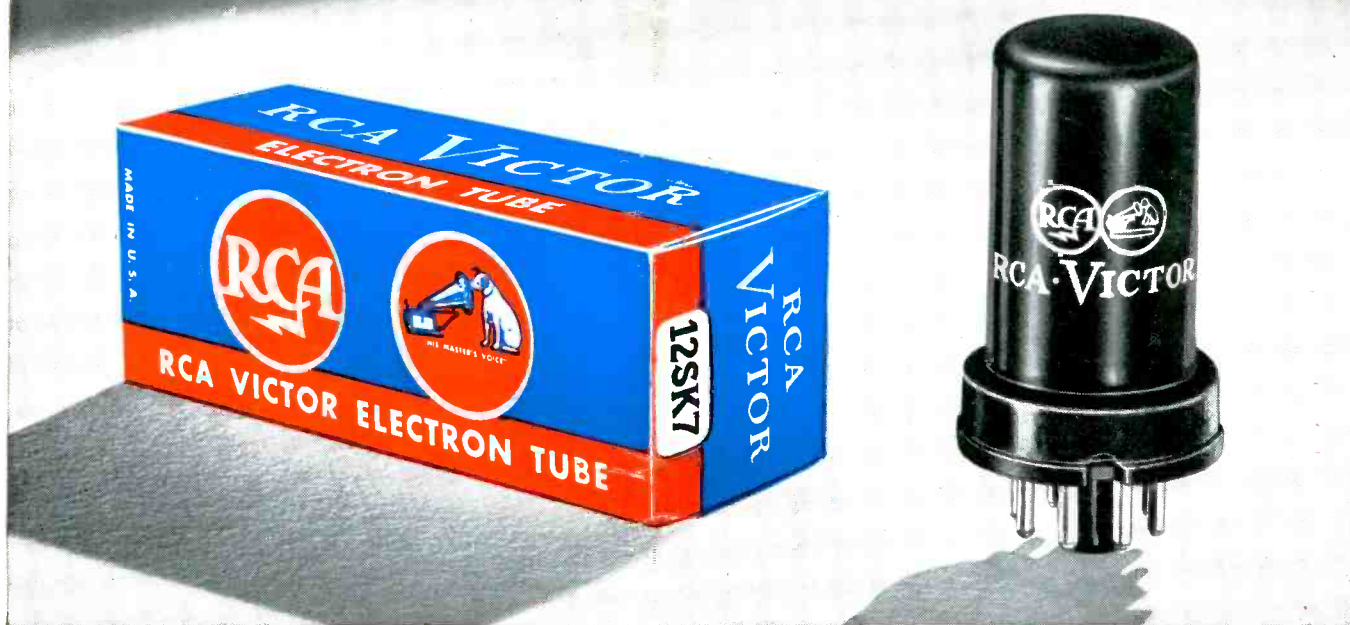

MAKE A NAME FOR YOURSELF WITH RCA VICTOR ELECTRON TUBES

THE NAMES RCA and Victor are as familiar as they are famous. Combined, they have stood as a symbol of the finest in music-producing instruments for over a quarter of a century.

Equally as familiar and famous are the RCA Victor Electron Tubes—the tubes with a heritage! For years they have been the selection wherever quality is demanded.

Your customers naturally want replacement tubes of unquestioned quality and performance at established

prices. You will find that they have implicit confidence in RCA Victor Electron Tubes.

And remember—RCA products serve to enlarge your patronage.

RCA
sells a complete line of
Preferred-Type Radio
Batteries and Test Equipment.

Listen to
"THE RCA VICTOR SHOW"
Sundays, 4:30 P. M., EST
NBC Network.

THE FOUNTAINHEAD OF MODERN TUBE DEVELOPMENT IS RCA



TUBE DIVISION

RADIO CORPORATION of AMERICA

HARRISON, N. J.