

Eleventh Year of Service

# RADIO ENGINEERING

Vol. XI FEBRUARY, 1931 No. 2

pp. 52, 55, 56, 60, 64

## IN THIS ISSUE



### CHOOSING A LOUDSPEAKER

By Kenneth W. Jarvis

### SIDEBANDS IN RADIO—ARE THEY REAL OR IMAGINARY?

By Ralph P. Glover

### A REVIEW OF REMOTE CONTROL DEVELOPMENT

By Gerson Lewis and Alfred A. Ghirardi

### SALES PRODUCTION CONTROL

By Austin C. Lescarbours

### MAXIMUM UNDISTORTED POWER OUTPUT

By Gilbert Smiley

### DESIGN OF THE SUPERHETERODYNE RECEIVER USING SCREEN-GRID TUBES

By C. H. W. Nason

Sold only by subscription  
\$2.00 per year



*The Journal of the Radio Industry*

# What tube engineers say about Cenco Hypervac pumps

**“have lowest operating cost...**

**the most efficient”**

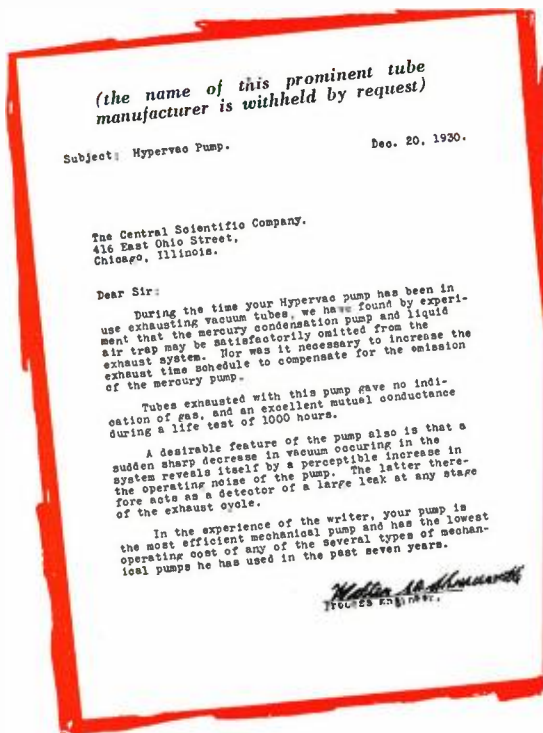

Radio tube engineers who know the keen necessity of good exhaustion are finding totally new possibilities in the Cenco Hypervac pump. Reports from tests everywhere confirm its supreme performance under service conditions.

They say it has remarkably better speed and recovers instantly on automatic machines . . . that mercury pumps are a waste of space when the Hypervac is put on hand stations . . . that tubes pumped by Hypervacs pass the severest life tests with perfect records. There are four new design principles back of this exceptional capacity for radio tube exhaust.

For details address, Central Scientific Company, 460 E. Ohio St., Chicago.

**CENTRAL SCIENTIFIC COMPANY**  
**CENCO HIGH VACUUM PUMPS**  
Hyvac Megavac Super CENCO vac Rotovac Hypervac  
NEW YORK - BOSTON - CHICAGO - TORONTO - LOS ANGELES



# EVERY RESOURCE

*for Quality  
and Uniformity!*

THE Formica organization is well equipped to give the electrical and radio industries prompt service on high quality insulating material.

It has the largest equipment for producing and fabricating materials of this kind in the country. It has a well equipped and competently manned laboratory for the control of production and the development of new and better formulas.

For 18 years it has specialized on just one product. During most of that time it has served some of the leading American technical organizations.

# FORMICA

THE FORMICA INSULATION COMPANY

4638 Spring Grove Avenue  
CINCINNATI, OHIO

# RADIO ENGINEERING

Reg. U. S. Patent Office

Member, Audit Bureau of Circulations

Western Editor  
ULMER G. TURNER

Editor  
DONALD MCNICOL

Managing Editor  
F. WALLEN

Vol. XI

FEBRUARY, 1931

Number 2

## Contents

	PAGE
EDITORIAL .....	4
IMPRESSIONS AND EXPRESSIONS <i>By Austin C. Lescarboua</i>	16
CHOOSING A LOUDSPEAKER..... <i>By Kenneth W. Jarvis</i>	23
SIDEBANDS IN RADIO—ARE THEY REAL OR IMAGINARY? <i>By Ralph P. Glover</i>	27
A REVIEW OF REMOTE CONTROL DEVELOPMENT <i>By Gerson Lewis and Alfred A. Ghirardi</i>	29
THE "STENODE," PART II..... <i>By J. Robinson</i>	33
SALES PRODUCTION CONTROL. <i>By Austin C. Lescarboua</i>	34
MAXIMUM UNDISTORTED POWER OUTPUT <i>By Gilbert Smiley</i>	36
DESIGN OF THE SUPERHETERODYNE RECEIVER USING SCREEN-GRID TUBES..... <i>By C. H. W. Nason</i>	40
ENGINEERING ASPECTS OF THE BROADCAST ANTENNA <i>By Henry E. Hallborg</i>	43

## Departments

NEWS OF THE INDUSTRY.....	52
NEW DEVELOPMENTS OF THE MONTH.....	55
INDEX OF ADVERTISERS.....	68

## \$22,000,000 EARNED IN 1930

IN the month of January, 1931, there could be no more encouraging morsel of information than that contained in the annual report of the National Broadcasting Company. We are thinking of the opportunities for radio engineers and for radio receiver sales in 1931.

The report of the president of N. B. C. states that in 1930 the company's earnings totaled \$22,000,000, which was a gain of \$7,000,000 over the year 1929.

The power of radio broadcasting as an advertising medium, in a year of general business depression, was recognized to an extent that yielded nearly a 45 per cent increase in support from 263 sponsors—to this one system.

The significance of this material increase may be noted from two viewpoints. First, radio advertising brings desired results to the sponsors. The number of radio listeners determines the degree of reaction to broadcast good will publicity. The service rendered the sponsors certainly points to the conclusion that the homes of the nation are rapidly being equipped with the ears of radio which hear all.

Second: the need for and the fear of a tax on individual radio receivers from which might be financed broadcast entertainment, is removed satisfactorily to all concerned.

The radio receiver industry has the task of supplying dependable sets to all who can afford them. The first figures of the 1930 census indicate that but 44.4 per cent of homes are now equipped with receivers.

BRYAN S. DAVIS  
*President*

JAS. A. WALKER  
*Secretary*

Published Monthly by  
Bryan Davis Publishing Co., Inc.  
52 Vanderbilt Ave.  
New York City

E. M. BACON  
*Advertising Manager*

J. E. NIELSEN  
*Circulation Manager*

Publication Office—North Broadway, Albany, New York  
Chicago Office—333 N. Michigan Ave.—Charles H. Farrell, Mgr.  
St. Louis Office—505 Star Building—F. J. Wright

Kansas City Office—306 Coca Cola Building—R. W. Mitchell  
San Francisco Office—318 Kohl Bldg.—R. J. Birch  
Los Angeles Office—846 S. Broadway—R. J. Birch

Entered as second class matter at the post office at Albany, N. Y., January 9, 1925, under the act of March 3, 1879. Yearly subscription rate \$2.00 in U. S. and Canada; \$3.00 in foreign countries.

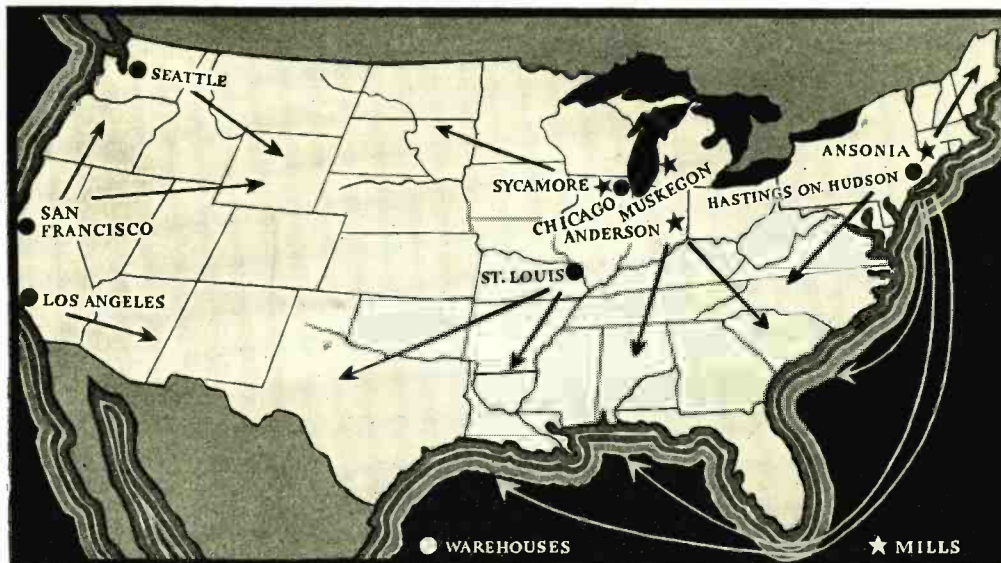

# MAPS and MAGNET WIRE

**W**E seem to be running to maps in advertising. They appear to be the vogue . . . and a good vogue, at that . . . for how could we picture better our ability to serve our magnet wire customers, than by the above map?

From 4 of our 12 strategically located mills and from complete warehouse stocks in 6 other cities, you can depend on prompt shipments of magnet wire . . . which is but one of our line of 65 products.



## ANACONDA WIRE AND CABLE COMPANY

GENERAL OFFICES: 25 BROADWAY, NEW YORK

CHICAGO OFFICE: 20 NORTH WACKER DRIVE

*Sales Offices in Principal Cities*

Magnet Wire Mills at Anderson, Indiana; Muskegon, Michigan; Sycamore, Illinois; and Ansonia, Connecticut

# E d i t o r i a l

February, 1931

## DESIGN IN RADIO

WHAT the merchandising department of a radio manufacturing organization thinks of the design and engineering department is of the tenor of the regard entertained by an infantry regiment for an adversary's poison gas. There are times when it would seem that if the inventors and designers would take a year off, the radio product already manufactured and on the shelves might be heralded as the ultimate and so be converted into receipts.

In a young industry—one which has not as yet come under the spell of monopolistic control—however, there is no escape from the ceaseless output of energetic improvers. In older industries where monopolistic control obtains the products of research, invention and the laboratories may be consolidated and spread over the years with an approved economic relation between customers' requirements and manufacturing dividend requirements.

Because it is a business not likely destined to become a public service in the sense that wire telephony and telegraphy are public services radio manufacturing will continue to be a fertile field for the exploitation of whatever is brought out from time to time that will add to the entertainment values of radio reception.

The field is wide and is open to all. Naturally, the very large manufacturing organizations have an advantage in their financial resources and in established laboratory facilities and staff, but even the large companies agree that had it not been for the wide attack upon the problems of radio by independent engineers, colleges, Governmental departments, amateur experimenters and individuals, progress would not have been nearly so rapid.

In this situation it is understandable why engineering and design are at the present time viewed as of paramount importance. One can sense what is possible in improvements in design during the next five years only by considering the multitude of improvements made in practically all elements of radio receiver makeup during the past five years.

The attack of designing engineers, widely scattered, upon the problems of radio is incessant and continuous. No other procedure would be consistent with the sensed possibilities of radio applications. In a growing number of homes radio receivers are no longer regarded as a luxury, but rather as a necessity.

The peak of improvement and change may be reached some day but that day is not in the immediate future.

## INTERCITY RADIO TELEGRAPHS

THE Federal Radio Commission has granted construction permits to Press Wireless, Inc., for 20 continental point to point frequencies and 20 additional frequencies for transoceanic service. The grants are effective as of February 17, 1931.

At the same time the Commission announced the frequencies to be used in the various cities throughout the United States in which Press Wireless and Western Radio Telegraph Company plan to erect transmitters.

Frequencies granted were the same ones previously allocated to Press Wireless and Western Radio Telegraph Company, which were held up by a stay order in the Court of Appeals of the District of Columbia, which was lifted January 6, 1931, by that court in so far as it affected Press Wireless and Western Radio Telegraph Company.

Grants to Western Radio Telegraph Company provide for 2 exclusive U. S. frequencies and 3 Canadian channels, the former to be used for day time operation only in the Southern part of the United States. In addition the Commission granted to Western Radio Telegraph Company 4 low frequencies for point to point service.

Press Wireless, Inc., is granted permits for stations at San Francisco; Dallas, Texas; Kansas City, Mo.; Denver, Colo.; Los Angeles, Cal.; Minneapolis, Minn.; Chicago, Ill.; Atlanta, Ga.; Cleveland, Ohio; Memphis, Tenn.; Detroit, Mich.; Miami, Fla.; Philadelphia, Pa.; New Orleans, La.; Little Neck, N. Y.; and Upper Newton Falls, Mass.

The Western Radio Telegraph Company has been granted permits for stations at Near Wink, Texas; Near Crane, Texas; Kings Mill, Texas; Panca City, Okla.; Burkburnett, Texas; McCamey, Texas; Borger, Texas; Bartlesville, Okla.; Breckenridge, Texas; El Dorado, Kan.; New Skellytown, Texas; and Tulsa, Okla.

The Press Wireless Stations are to be 10 kw. plants and the Western Radio stations range from 5 kw. down to 150 watts. The purpose of these stations is to be for intercommunication between the stations mentioned and contiguous cities and towns.

Thus, plans for intercity radio telegraph working again are in the making.

*Donald Mc-Nicol*

Editor.

# Convincing Proof

... that Hardened Metallic Drive Screws make *stronger* as well as cheaper fastenings

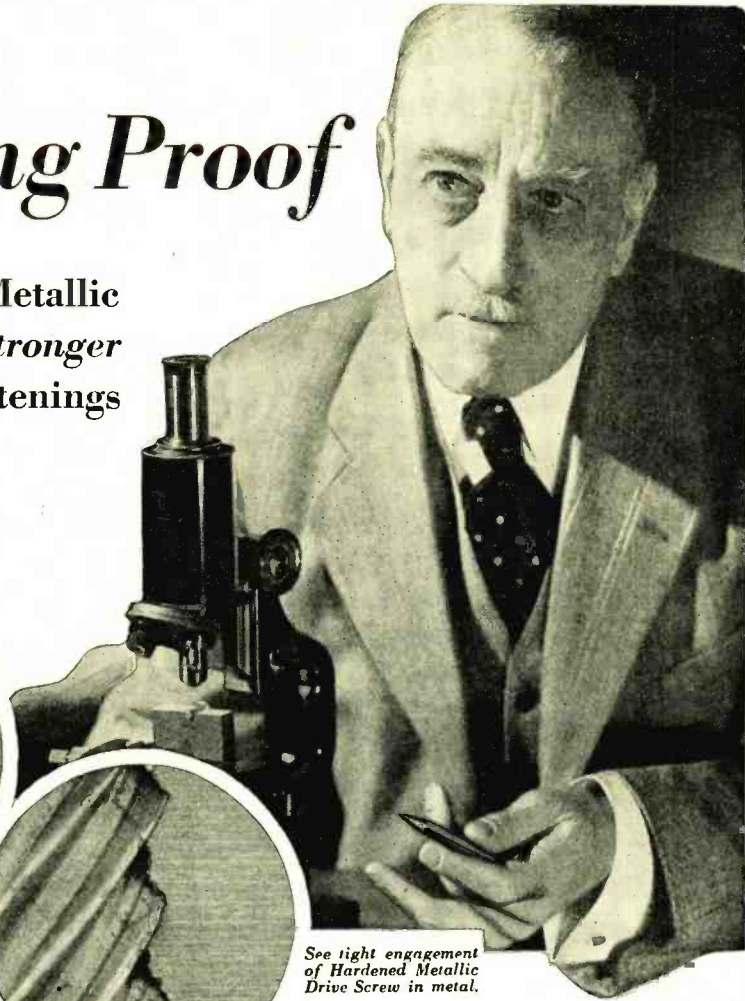

Note loose fit of the Machine Screw in tapped hole.

See tight engagement of Hardened Metallic Drive Screw in metal.



The easiest and cheapest way of making permanent fastenings is also the strongest. Merely hammering Hardened Metallic Drive Screws into holes, drilled or formed in iron, brass and aluminum castings, steel or Bakelite, makes better fastenings than those made with machine screws or bolts and nuts. This is proven by comparative laboratory tests conducted by unbiased authorities.

A convincing explanation of the greater holding power of a Hardened Metallic Drive Screw under vibration, the chief cause of fastening failure, is offered by the microscope. Remembering that the security of a fastening under vibration depends upon how tightly the Screw threads are engaged in the metal, look at the unretouched microphotographs here. It is easy to see why the Hardened Metallic Drive Screw holds better.

Note how this unique Screw forms a thread in the metal as it is driven . . . how that action embeds the screw threads so firmly in the metal that screw and metal are practically one. Then observe that between the machine screw threads and the tapped threads

(commercial tolerance) there is considerable space . . . space which permits the machine screw to loosen under vibration.

Under stresses of tension and shear, a stronger fastening is obtained with a Hardened Metallic Drive Screw because it possesses greater tensile strength than an ordinary screw, being made of a special steel, scientifically treated.

The booklet offered here shows how users of these Screws effect substantial savings through elimination of slow and costly tapping, fumbling with bolts and nuts and other assembly difficulties. Use coupon to obtain it.

**PARKER-KALON**  
HARDENED METALLIC  
**Drive Screws**



PAT. JAN. 29, 1924 - No. 1462151 - OTHERS PENDING

Parker-Kalon Corp., Dept. M., 192-200 Varick St., New York.  
Send free booklet on Economy and Security of Drive Screws.  
(Samples for trial will be sent if you tell us what you fasten.)

Name and Co. ....  
Address .....



# A BOW

No. 600  
Full 1/32"  
insulator  
always used.

No. 800  
1/16" or 3/64"  
Base.

**WE RETAIN  
THESE  
TWO  
DEPENDABLE  
SOCKETS  
FOR 1931**

## To the Radio Industry We Now Offer a COMPLETE SOCKET SERVICE

To meet the trend toward consolette and midget sets, where space is a factor, we now offer 1 11/16" mounting centers along with our original (and now RMA Standard) 1 27/32" centers. All models available with both M.C. Our line offers you numerous contact arrangements as well as the two mounting centers, so that we can fill any requirement.

*Our No. 600 Socket*—King of them all—is retained. This socket is widely used for heavy duty requirements. It is ideal for use with power tube on any set.

*Our No. 800 Socket*—Similar in design to the No. 600 and incorporating its desirable features, but at a slightly lower price, is very popular with all types of manufacturers.

*We Invite Engineering Tests and Comparisons!*

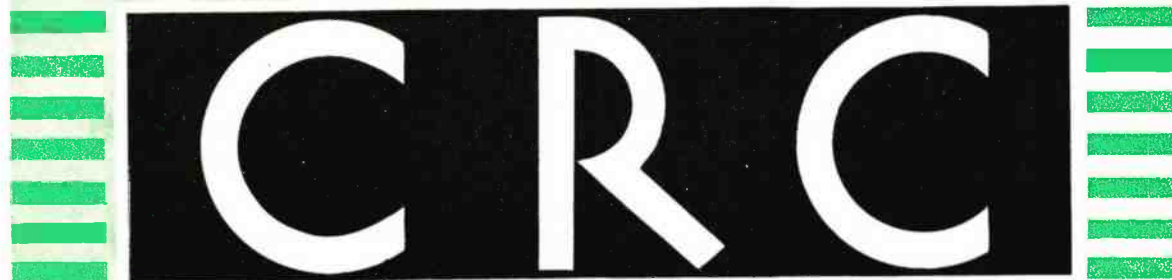



# TO THE MIDGET

**Central Radio Corporation**

**Meets the New Order of Things**

with

**The Model 700 Tube Socket**

(Patent Applied for)



## A Product of the Pioneer Socket Manufacturers!

Each year the industry looks for something new and better from this company, which in the past has contributed many improvements to tube socket design. This year it is the model 700 socket—designed to meet new manufacturing demands. This socket has been thoroughly tested, and is of the same rugged construction which characterizes all of our products. The contact is backed by a *steel re-inforcing spring*—a feature originated by us. As usual, *full insulation* of high quality Bakelite is afforded. *Sufficient clearance and low capacity* between contacts is provided—a very important feature. This socket can be used wherever a vacuum tube is used—with perfect results—and is fully guaranteed by us.

*Send for Your Samples for Test Today!*

**CENTRAL RADIO CORPORATION** ▼ ▼ P. O. Box 357 ▼ ▼ **Beloit, Wisc.**

Representatives: **FRANK A. EMMET SALES CO.**  
324 North San Pedro Street  
Los Angeles, California

**R. C. JAMES COMPANY**  
2321 Second Avenue  
Seattle, Washington

**A. C. SIMMONDS**  
218 Front Street, East  
Toronto, Ontario, Canada

# SOCKETS

# CONTROL *rides with the winner*

. . . he rounds "death curve" on two wheels . . . every nerve tense. Yet his mighty steed roars along under perfect control.

In spite of its mechanical perfection the "human element" decides the winner.

In your radio set the human element is limited to the turning of the dials . . . all else has been previously built-in by the engineer and technician. That's why every coil; every resistance must be correctly calibrated; perfectly made for satisfactory results.

Radio reception must be smooth, noiseless, sputterless. If turning the knob of the volume control brings in an accompaniment of self-inflicted noises you may be certain that

it isn't a CENTRALAB control.

More than twenty million of our controls have been placed on duty all over the world.

There is a CENTRALAB for practically every receiver now or previously made.

SEND 25c for the new VOLUME CONTROL GUIDE just off the press. It gives resistance circuits for almost all old and new sets. Service them all with a mere handfull of CENTRALAB controls.

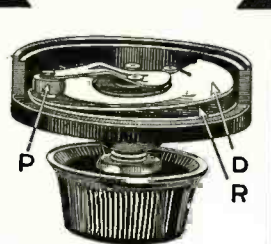

This shows the exclusive rocking disc construction of Centralab volume control. "R" is the resistance. Contact disc "D" has only a rocking action on the resistance. Pressure arm "P" together with shaft and bushing is fully insulated.

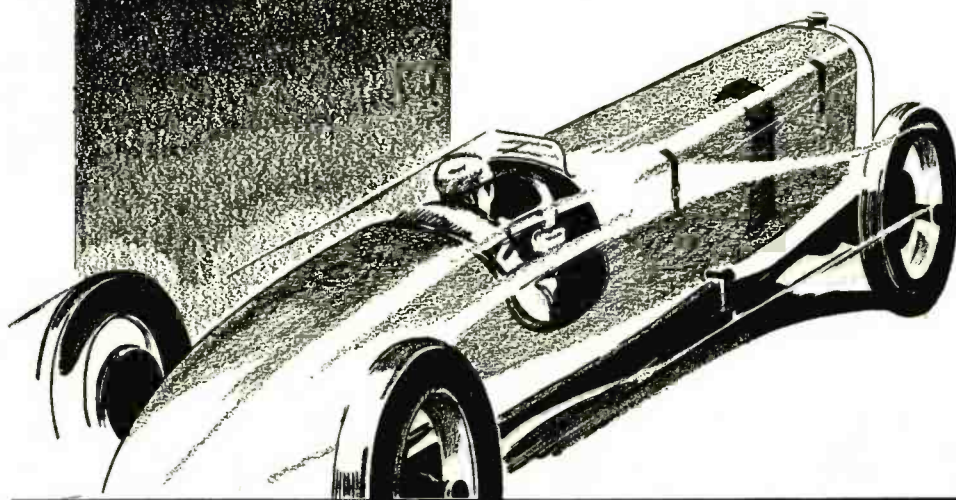

**IS YOUR RADIO CENTRALAB EQUIPPED?**

# Centralab

CENTRAL RADIO  
Dept. 103-A, 14 Keefe Ave.,



LABORATORIES  
Milwaukee, Wis.

# INCA WINS ITS PLACE IN THE SUN . . .

The impossible, somehow, is always being accomplished. Methods which were considered faultless a year or two ago are being discarded as obsolete today. And Inca, organized by pioneers in the industry, leads the way with a complete knowledge of magnet wire and coil requirements . . . a knowledge based on years of specialized experience.

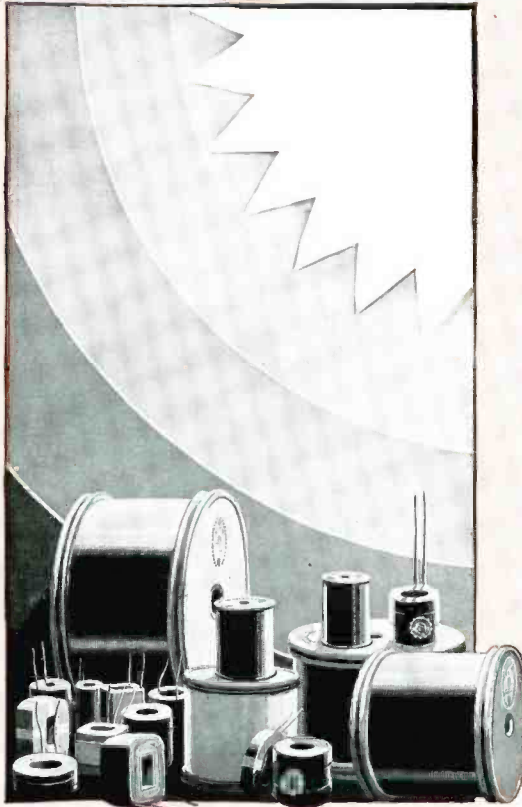

## BUILDING TO A NEW PRECISION

With the additional advantage of a new plant laid out for highest efficiency . . . specially designed machinery and equipment years in advance, new standards of precision are now possible.

Improved methods of drawing the wire insure uniformly accurate diameters.

Improved enameling provides more perfect insulation.

Improved spooling now assures freedom from tangles and makes possible more efficient application in your own plant.

Improved packing means more protection and brings the wire to its final destination just as it left the last inspector at the Inca plant.

Samples of wire, and sample coils wound to your specifications sent on request . . . no obligation.



*The chief deity of the Incas was the sun, the Inca leader himself being called the child of the sun. Great, massive temples were erected, the walls of which are still standing at Cuzco and other ancient cities.*

# INCA MANUFACTURING DIVISION

of NATIONAL ELECTRIC  
PRODUCTS CORPORATION  
FORT WAYNE, INDIANA



*Symbolic of the best in copper wire products.*

*Eastern Office: Newark, N. J., Industrial Office Building.*

*Western Office: 1547 Venice Blvd., Los Angeles, Calif.*

# WASHERS Everlock TERMINALS

U. S. Patent No. 1775705

*Everlock* washers and terminals utilizing a new construction principle afford a positive and lasting contact.

Washers can be furnished either plain, parkerized, tinned, or cadmium plated.



*Note particularly the locking construction. Here you have the secret of the tenacious grip—the positive lock—which is an exclusive Everlock feature.*

*Everlock* terminals speed up production and lower costs.

They are hot solder coated after fabrication which makes them easier to solder and insures a positive connection that will not come loose.

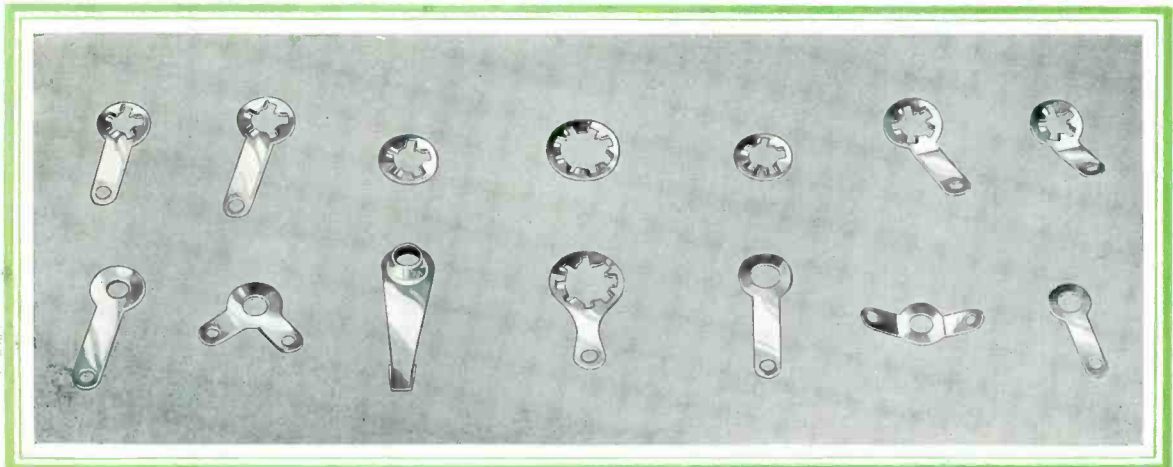

Special hot solder coated terminals either plain, eyeleted, or lock-made to order.

*Send us your specifications.*

MANUFACTURED BY

## THOMPSON-BREMER & Co.

1642 West Austin Avenue

....

Chicago, Illinois

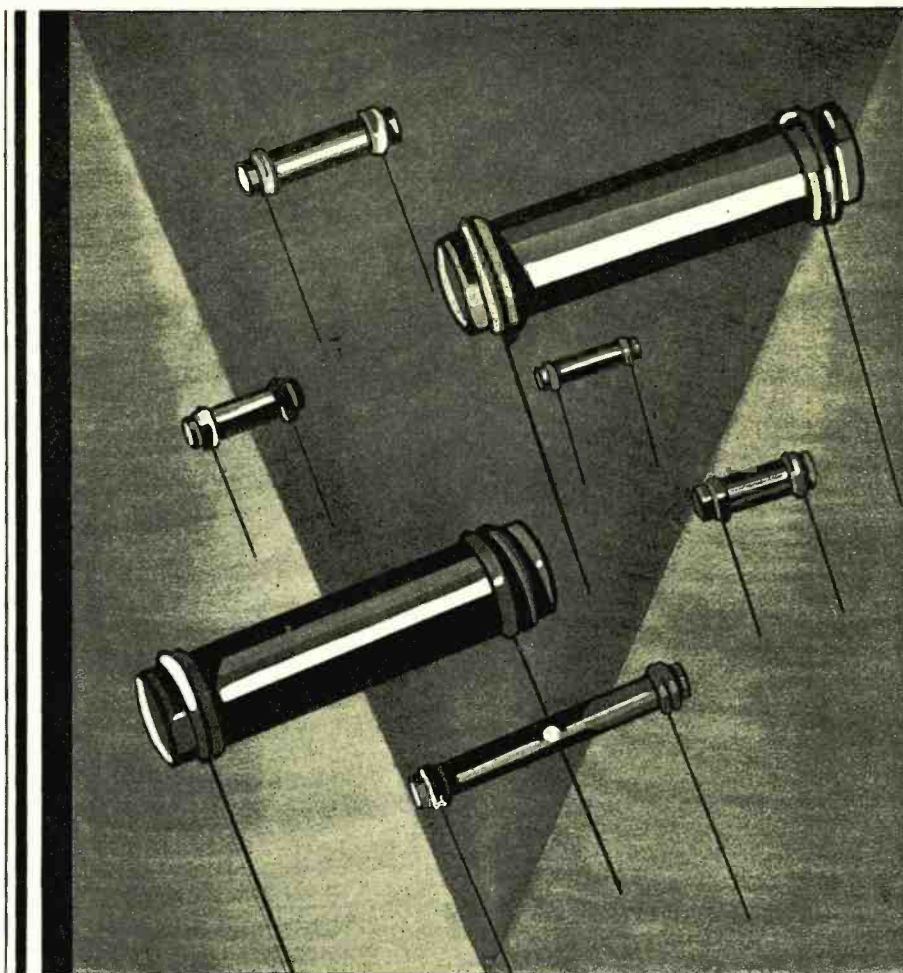

Found 99½% perfect by one of the world's largest radio manufacturers ERIE RESISTORS established a record heretofore deemed impossible in the industry. Less than 5 resistors in every thousand furnished (and there were millions of them) were found to be under standard.

Surely here is a most unusual showing—a tribute to our manufacturing and double inspection methods. We were told that a much larger percentage of rejections could be expected!

ERIE RESISTORS have a constant resistance value which is not affected by age or temperature. They are noiseless and will pass every test of your engineers.

Samples, prices and other information on request.

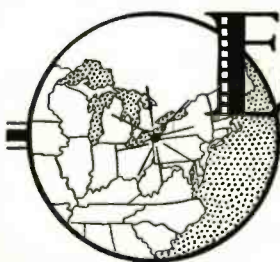

# ERIE RESISTORS

**Erie Resistor Corporation, Erie, Pa.**

*In the Center of The Radio Industry*

# The ELKON Non-Aqueous



Typical can size 16 Mfd. Condenser, 4 1/4" x 2" x 1 1/4"

**450 Working Volts**  
**Any Combination of Capacities**  
**Wide Variety of Can Sizes**

**Outstanding Characteristics**

- 1 **High Working Voltage:** 450 volts—withstands without injury transient peaks in excess of 600 volts.
- 2 **Absolutely Dry:** A condenser from which all water is eliminated.
- 3 **Low Leakage:** Normal rated leakage 0.1 mil per mfd. (After operating short period the leakage is 0.025 mils per mfd.)
- 4 **Impervious to Low Temperatures:** Operates efficiently from minus 40° F to 150° F.
- 5 **Long Life:** To reduce replacements and interrupted service periods to a minimum.
- 6 **Self Healing:** Transient peaks in excess of 600 volts do not injure the Elkon condenser.
- 7 **Compactness:** Smallest cubical volume per microfarad of any condenser on the market.
- 8 **Maximum Filtering:** Due to low power factor, the Elkon condenser has the greatest filtering action of any electrolytic condenser on the market.
- 9 **Stability in Operation:** To guard against mechanical and electrical variation that would affect action of the circuit.
- 10 **Low Cost Per Microfarad Per Voltage Rating:** A large safety factor in volt rating for the same cost as lower voltage condensers.

**T**HE Elkon Non-Aqueous Hi-Volt condenser marks a new milestone in the condenser art.

Although the Elkon condenser was favorably introduced to the commercial field in October 1930, its development extends over a period of seven years.

This new condenser has all of the essential characteristics of a high grade filter.

It has the smallest capacity content per microfarad of any condenser. It has the greatest filtering capacity of any electrolytic condenser—and closely approximates the filtering capacity of a paper condenser. It is self-healing. It operates at 450 volts DC. It is not injured by transient peaks even in excess of 600 volts. Study the oscillographs and charts on the opposite page. They tell the story.

Already a number of leading set and instrument manufacturers have adopted Elkon condensers as standard equipment. Samples built to your specifications will be sent to all recognized manufacturers. Send for the booklet which gives complete description and technical data.

**Standard Can Sizes and Their Microfarad Capacities**

Vertical and Horizontal Cans								
MFD Capacity of Sections	Total Capacity MFDs	Can Size	MFD Capacity of Sections	Total Capacity MFDs	Can Size	MFD Capacity of Sections	Total Capacity MFDs	Can Size
1	1	2 3/4 x 1 x 1/2	6	6	4 1/4 x 1 1/2 x 3/4	4-8-12	24	4 1/4 x 2 1/2 x 1 3/4
2	2	2 3/4 x 1 3/8 x 3/4	8	8	4 1/4 x 2 x 3/4	<b>ROUND CANS</b>		
2-2	4	2 3/4 x 1 3/8 x 1 1/2	8-8	16	4 1/4 x 2 x 1 1/2			
2-2-2	6	2 3/4 x 1 3/8 x 2	8-8-8	24	4 1/4 x 2 1/4 x 1 3/4			
2-2-2-2	8	2 3/4 x 1 3/8 x 2 3/4	8-8-8-8	32	4 1/4 x 3 x 2			
4	4	4 1/4 x 1 x 1	2-4-8	14	4 1/4 x 2 x 1 1/2			
4-4	8	4 1/4 x 2 x 1	2-8-8	18	4 1/4 x 2 x 1 3/4			
4-4-4	12	4 1/4 x 1 3/4 x 1 3/4	2-8-16	26	4 1/4 x 2 1/4 x 1 3/4			
4-4-4-4	16	4 1/4 x 2 1/2 x 1 3/4	20	20	4 1/4 x 2 x 1 1/4			
5	5	4 1/4 x 1 1/2 x 3/4	30	30	4 1/4 x 2 x 2			

— A CONDENSER FOR ALL POWER PACK ASSEMBLIES —

— A Condenser for All Power Pack Assemblies —

# Hi-Volt Condenser.....

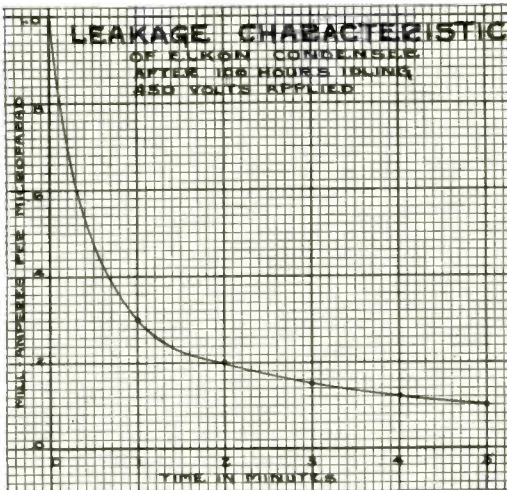
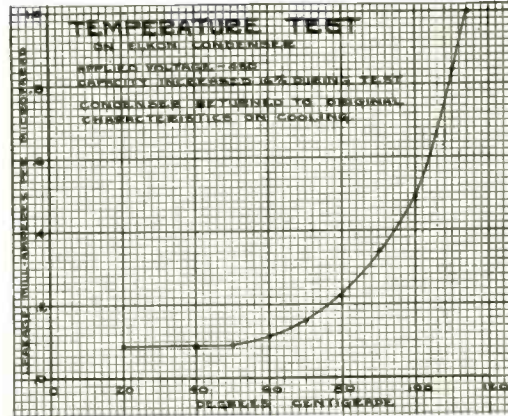
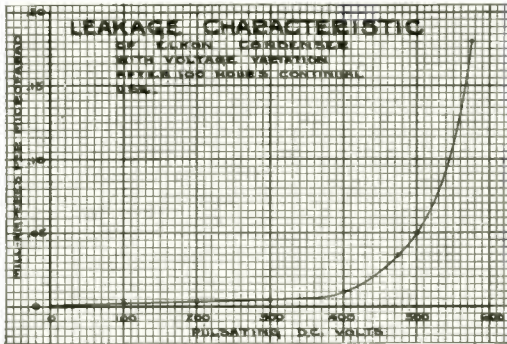

(Above and at left) Temperature and leakage characteristics as shown by the accompanying charts, indicate the efficiency of the Elkon Hi-Volt condenser.

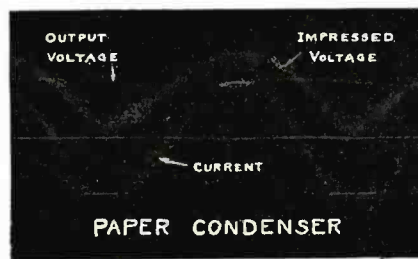
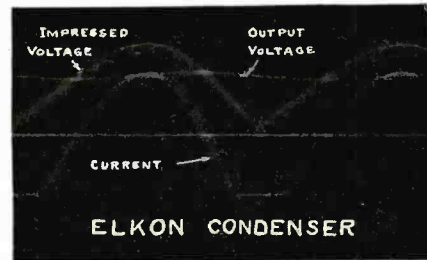

Oscillographs show comparative filtering action of the Elkon, the paper and wet types of condenser. Note the variation between the Elkon and the wet condenser.

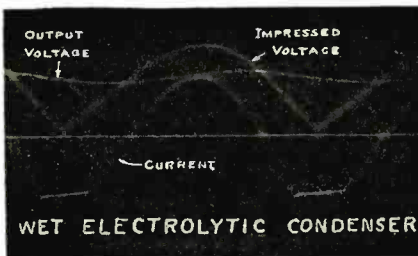

Booklet with complete data upon request.



**ELKON DIVISION**

**P. R. MALLORY & CO., Incorporated, - INDIANAPOLIS, IND.**

# CLAROSTAT

TRADE MARK REG. U. S. A.

## BUILT-IN PROTECTION

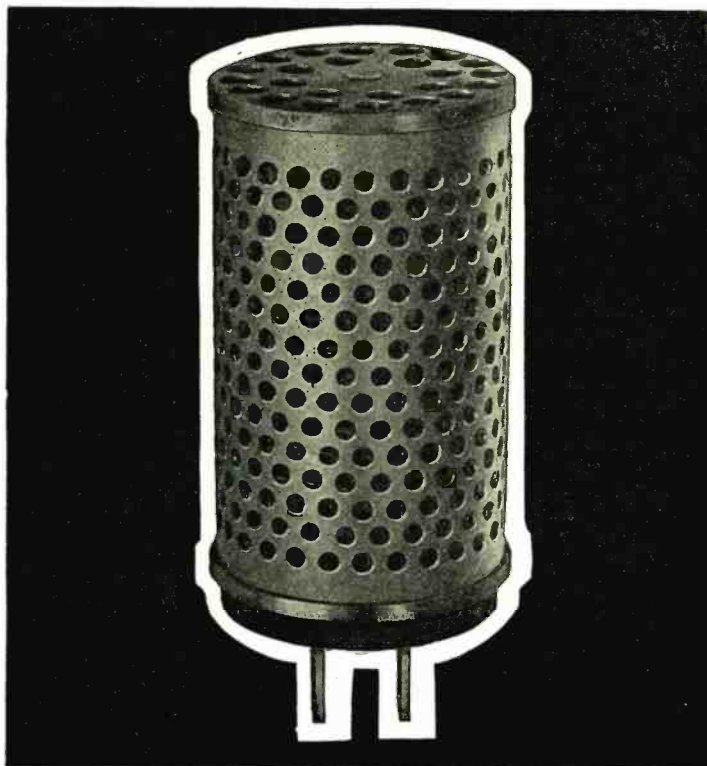

**D**ON'T leave it to your consumers to add voltage compensators to your otherwise well engineered receiver or sound equipment.

When line voltage drops below normal a booster is needed. When it rises to values unsafe for tubes and components it must be cut to normal.

The Clarostat Line Ballast does *both* automatically and instantaneously.

Guaranteed for one year and actually withstands considerably over 10,000 hours of operation under varying line conditions.

**Real protection at very little cost.**

Design your sets for Clarostat Ballasts and insure good demonstrations in all localities and protect the whole equipment from premature breakdown.

**1931 is a Voltage Regulator Year.**

A new technical bulletin on line voltage regulation and the Clarostat Line Ballast is ready now, and yours for the asking. Write for it.

Samples available to match your transformer and load condition.

## EXTERNAL PROTECTION

The Clarostat Automatic Line Voltage Regulator—a real protection for the sets already built. Plugs in between receptacle and attachment plug. Automatically changes its own resistance to compensate for line voltages between 110 and 140.

Recommended by several set manufacturers in their Service Manuals.

Specify the Clarostat Automatic Line Voltage Regulator in districts giving unusual trouble due to high or fluctuating lines.



**CLAROSTAT MFG. CO. 285-287 N. 6TH ST. BKLYN. N.Y.**





---

# COMPARE

---

# AND THEN

---

# DECIDE

---

# ON ACRACON\*

---

THE inverted electrolytic construction principle featured in the Acracoon Electrolytic Condenser was pioneered by the Condenser Corporation of America. Although the design of our unit has been copied by other manufacturers, comparison of the Acracoon Condenser and any other make will quickly prove Acracoon's superiority in both construction and electrical efficiency.

Consider these advantages. No moulded threads to strip in production. Better contact area with chassis, through both nut and the container itself. No loss of electrolyte, regardless of the amount of pressure on the nut. Contact made below chassis, eliminating wiring above the chassis.

Acracoon Electrolytic Condensers are now available in capacities of 8 mfd. or 16 mfd., 440 volts peak, in the same containers. The 8 mfd. unit can also be supplied for 475 volts peak. Write today enclosing your specifications.

\*All Acracoon Features Are Protected by Patents Pending

## CONDENSER CORPORATION OF AMERICA

259-271 Cornelson Ave.

Jersey City, N. J.

Chicago  
Cincinnati

Factory Representatives in:

St. Louis  
San Francisco

Los Angeles  
Toronto

and other Principal Cities

---

# Impressions and Expressions

By AUSTIN C. LESCARBOURA

## A MIDGET YEAR

**O**UR guess is that the radio trade will go about two-thirds midget this coming season, unless console sets spring some worthy and really logical features. On the basis of a straight radio set, however, we can see no other answer but a growing midget radio market because the American public is more price conscious today than ever before. Price talks.

If we are to maintain a sales volume for higher priced units, we must make those units quite different from the midget sets. Mere size, appearance and better performance on radio rendition will not suffice. However, the combination idea will do the trick, although in time the midgets will also go combination and catch up to the console on that score. Our bet is that the combination set—phonograph and radio—together with the home recording feature, will offset the price advantage of the midget sets in many cases. Also, we have an idea that a time switch would help the console set. But on the straight radio basis, the midgets have the edge on the market this season.

## AUTOMOBILE RADIO

**R**UMOR has it that the coming season will see automobile radio in the radio trade picture, not as a novelty and a sales flop, as in the past seasons, but as a big seller or headliner. We learn that several manufacturers are planning to introduce simple, compact, practical radio sets for the average automobile, at a list price of \$65.00 or thereabouts. Well, compared with \$175.00 list asked during the past seasons, the automobile radio set certainly stages a powerful comeback.

Perhaps the decline in radio billings on set sales, due to the preponderance of the midget set with its low list price, may in part be made up by the additional sales of automobile radio sets. Automobile radio is a logical appeal, but not at former list prices. Whether this additional business comes through the usual radio trade channels or through the automotive channels, is something to be determined. No doubt it will come through both major trade channels, since the automobile dealer certainly can sell such an attractive accessory as the automobile radio set at less than \$75.00 complete.

## BETTER NEON LAMPS

**J**UST what the candlepower of the average television lamp actually is, we don't profess to know. Indeed, we doubt if anyone has bothered to measure it. Off hand, we would place the candlepower at considerably less than one candlepower. And when it is borne in mind that this feeble source of illumination is viewed through the tiny holes of the scanning disc, we may well wonder that we get any kind of picture from our present television apparatus.

What an opportunity here for neon lamp specialists! Some of the neon lamp manufacturers who supply the requirements of the advertising sign trade might well be enlisted in this work. Some of them know more about this gaseous conduction art than we can ever hope to know. In going after brilliancy and long life for advertising signs, they have tried everything and anything for their purposes.

We have a hunch that sooner or later our neon sign friends are going to provide us with some remarkable light sources, whereupon the television workers will not hesitate to move on to 72-line and even 96-line scanning. For the present, an insufficient light source is the greatest obstacle in the path of progress.

## POOR TUBES

**I**N our travels about the trade we hear many complaints regarding poor radio tubes. Dealers tell us that out of every one hundred tubes, as many as forty may prove defective within the 90-day guarantee period covering radio set sales. That's a serious indictment of the products of radio tube manufacturers. Indeed, in the face of such an indictment, the 100 per cent replacement policy seems unavoidable, even with its admitted abuses by unscrupulous dealers.

What has gone wrong with the tube industry? Of course we are speaking in general terms, addressing the industry as a whole. Can it be that materials, workmanship and inspections have dropped to low standards? Are tubes being shipped to the trade not properly matched to present-day circuit requirements? Are set designers working the tubes too hard?

We opine that the real cause of trouble is the lack of co-ordination between set manufacturers and tube manufacturers. Sets today are far more critical in their tube requirements. Unless tubes are designed specifically for present-day circuit requirements, they are apt to fail miserably. The over-produced tubes of a year or more ago are hardly suitable for new sets, although in old sets they perform as well as ever. Dealers bear out this assumption in their reports on defective tubes, which are mainly those used in new sets.

## ELECTROLYTIC CONDENSERS

**V**ERY definitely has the industry gone electrolytic, so far as filter condensers are concerned. There will be a minimum of paper condensers employed for filter circuits in 1931 radio assemblies. What with bulk and cost reduced to about one-fifth that of paper condensers of equivalent capacity, it is quite logical that the industry should adopt the electrolytic type condenser.

It seems that a controversy is raging over the relative merits of wet and dry electrolytic condensers. Much can be said on both sides. But as for the relative merits of electrolytic and paper condensers, the industry has very definitely voted for the former. The so-called dry electrolytic, which is really a semi-dry proposition, is exceedingly compact. Several 8 mfd. units can be packed into the space formerly occupied by 8 mfd. of paper condensers. Recent improvements have served to make electrolytic condensers quite efficient in filtering action, so that the greatly augmented capacity now available really means something.

There is still something to be said in favor of paper, even though minimum bulk and low cost, as well as standardization at last, are strong arguments to overcome. Also, it may be that the last word has not yet been spoken for the paper condenser. Perhaps in the research laboratories of condenser manufacturers, entirely new dielectrics may sometime be developed so that the wound condenser of the future may not even be called a paper condenser.

But for the present, it's electrolytics.

FEBRUARY, 1931

# IT'S EASY TO IDENTIFY 1931 TUBES

## ② Look for these Power Tube Refinements

The loud-speaker voice can be no better than its power tube lungs. That is why De Forest engineers have spared no efforts in refining power tube design. In the De Forest 445 Audion:

1. Special alloy filament insuring intimate contact between coating and base metal. Extreme ruggedness. Uniform resistance throughout life.
2. Mica spacer maintaining proper spacing of elements for positive characteristics.
3. Ceramic spacers keeping mica spacer clear of grid.
4. Ribbed or reinforced plate insuring uniform operation at all temperatures. Buckle-proof.
5. Molybdenum grid wire—20 times the cost of usual nickel—with extreme melting point permitting complete degasification.

These and many other advanced features found in every type of *fresh* DeForest Audion, insure the 1931 performance of the 1931 radio sets.

This is the second of a series of *debunking* messages dealing with 1931 radio tube features. The entire story, of vital interest to radio consumer and trade alike, is yours for the asking.

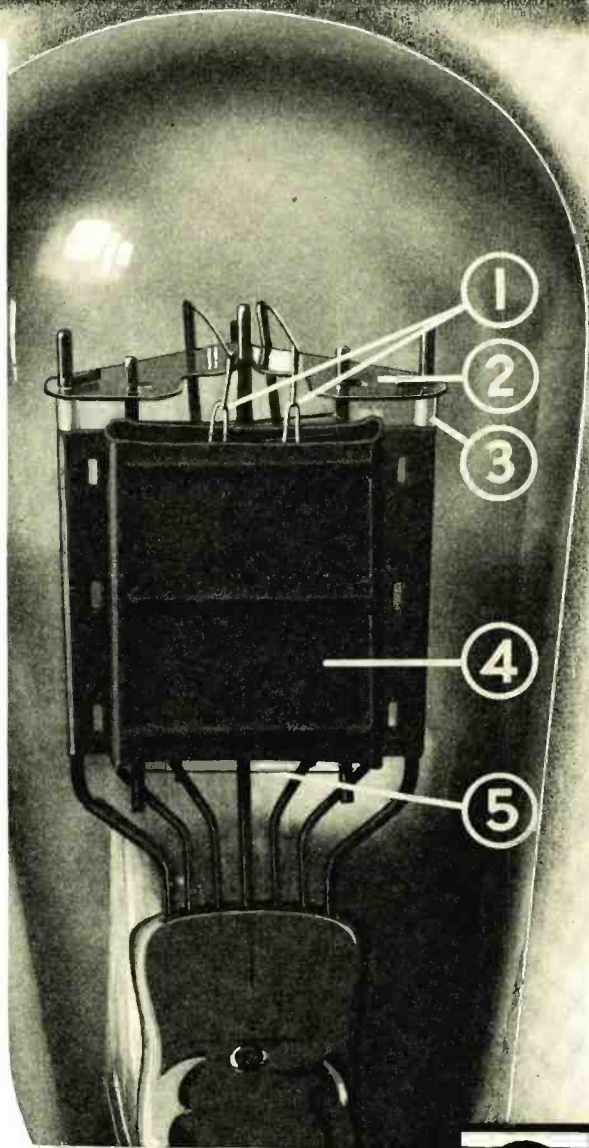

**de Forest**  
AUDIONS  
**RADIO TUBES**

DE FOREST RADIO CO., PASSAIC, N. J.



After all, there's no substitute for 25 years' experience



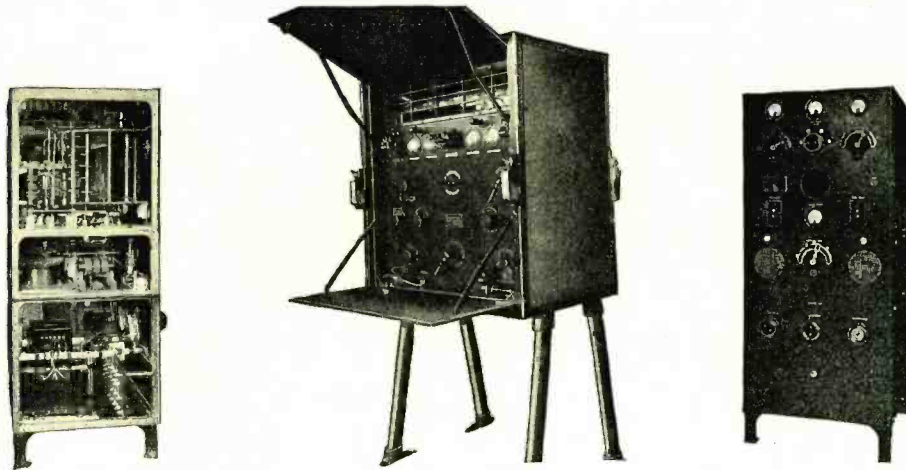

---

# Rigid Performance Requirements *are constantly being met by* Cardwell-built Equipment

---

Cardwell built-to-order instruments and apparatus, manufactured with scrupulous exactness, meet every requirement of a discriminating clientele.

*Cardwell Condensers* in commercial service, in broadcasting and amateur stations

large and small, on the Airways, and with the Army and Navy, are daily vindicating the judgment of designers who expected much of "Cardwell Condensed" installations and find their faith justified by fine, consistent *performance*.



recently announced by Cardwell is compact, small, light (weighing from 4 to 7 ounces). It is admirably adapted for use in aircraft receivers and for transmitters using up to 75 watt tubes; for portable sets and for neutraliz-

ing capacitors in intermediate stages of vacuum tube transmitters. The CARDWELL line comprises many other types of condensers, large and small, for transmitting and receiving. Send for literature.

---

CARDWELL CONDENSERS AND MANUFACTURING SERVICE

---

**THE ALLEN D. CARDWELL MFG. CORP.**  
91 PROSPECT STREET, BROOKLYN, NEW YORK

"THE STANDARD OF COMPARISON"

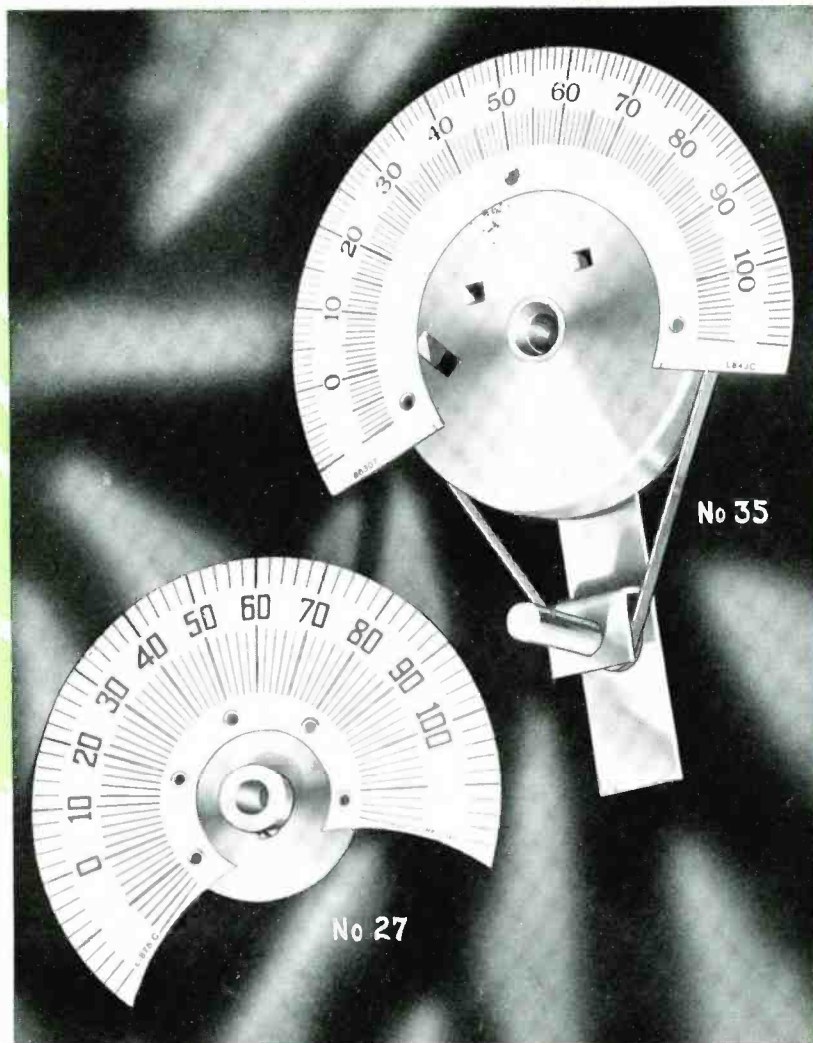

ILLUSTRATION APPROXIMATELY FOUR-FIFTHS ACTUAL SIZE.

**A**BOVE are shown two popular Crowe Tuning Units from the new series, descriptions of which appear in our new Bulletin 41.

The Number 35 unit in the upper right corner is operated by a metal belt friction drive and is very smooth in action. The scale is pyralin and

graduated from 0 at the left to 100 at the right through 180 degrees unless otherwise specified. The Number 27 unit at the lower left is a direct drive dial with pyralin scale graduated as shown. Both units are well adapted for use in midget and popular-priced sets.

Send for your copy of Bulletin 41 if you have not already done so.

**C R O W E**

**NAME PLATE & MANUFACTURING COMPANY**  
 1744 Grace Street Chicago, U. S. A.

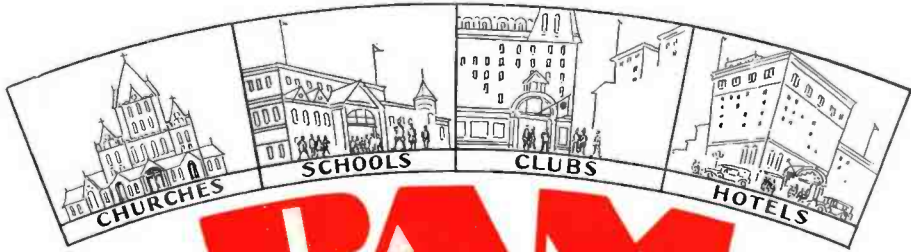
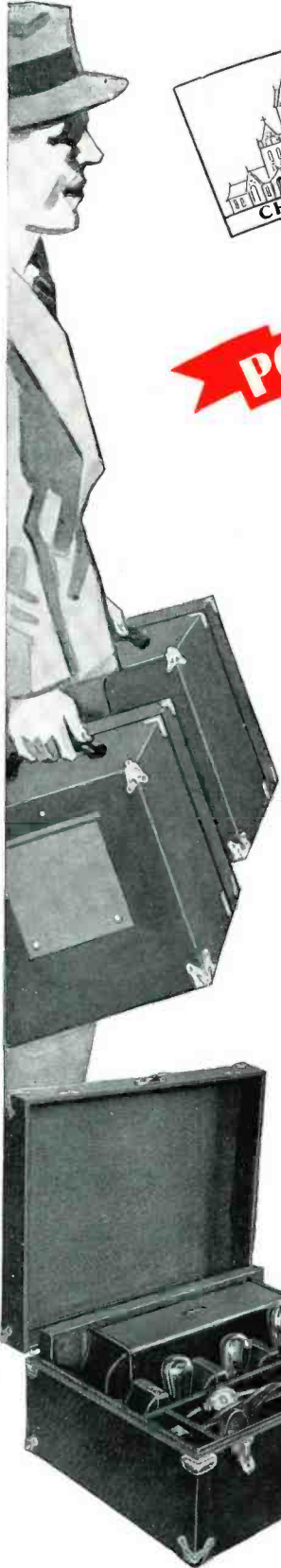

# PAM

## PORTABLE ADDRESS SYSTEM

*quickly*

# Pays for Itself

Schools, churches, clubs, hotels need the portable PAM Address system. With it, a speaker addresses 500 people as easily as half a dozen. Speech and music, both vocal and instrumental, are amplified with excellent quality.

The units in this system are completely matched and designed to operate together. Naturally the results obtained are superior to a combination of units procured from different sources which were not designed to operate together.

The two units that are required (MIK 100 and PAM 100) together weigh less than 75 pounds, and the system can be set up ready for use in less than five minutes. No batteries are required . . . and the price complete with tubes, microphone, etc., and nothing left to buy, is \$343.00.

Send for twin folders RE1; one descriptive of the PAM-100 and the other of the MIK-100.

### SELL

Portable PAM Address system to institutions that hold regular meetings and need the equipment permanently. This price is reasonable and the profits are large.

### RENT

Portable PAM Address systems for special occasions. One man can transport the entire system and set it up in five minutes. After a few rentals the cost is recovered and future income is all profit.

Main Office:  
Canton, Mass.

**Samson Electric Co.**

Factories: Canton and  
Watertown, Mass.

MANUFACTURERS SINCE 1892

MEMBER  
**RMA**



# TO COIL USERS WHO DO NOT ANSWER ADVERTISEMENTS

In view of the intensified search for lowered costs or betterment of products in which coils play so vital a role—

You can make profitable use of General Cable's extensive coil manufacturing facilities, rich experience in coil design, and modern research laboratories.

It is reasonable to believe that opportunities for profit unknown

to you are waiting your investigation of what General Cable coils and Coil Engineering service can offer you. Both coils and service cover every kind of coil requirement.

It is a simple matter to make that investigation. A letter to Headquarters will bring a representative from the General Cable office nearest you. You have nothing to lose, and very likely much to gain.

CALL GENERAL CABLE

## GENERAL CABLE CORPORATION

EXECUTIVE OFFICES: 420 LEXINGTON AVENUE, NEW YORK • OFFICES IN PRINCIPAL CITIES



# TEXTOLITE LAMINATED

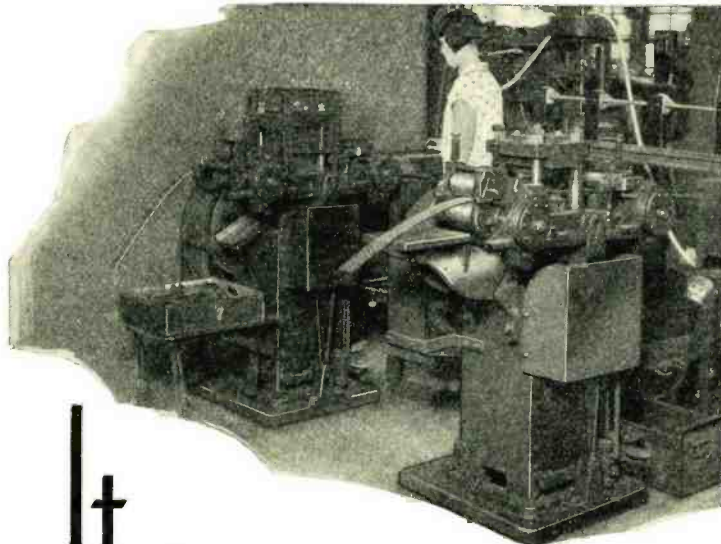

It cold punches cleanly-smoothly

**A**MONG the many grades of Textolite laminated, General Electric has developed one particularly adapted for audio frequencies and other applications where insulation requirements are not relatively exacting. This grade has unusual facility for cold fabricating: its machinability and electrical properties exceed those of material hitherto available in this class.

Our eastern and western fabricators are available for consultation and are completely equipped to prepare special dies and to manufacture difficult pieces.

There is a Textolite specialist in your nearby G-E sales office.

General Fabricating Co.,  
37 East 18th Street  
New York City

Electrical Insulation Corp.,  
308 West Washington Street  
Chicago, Illinois



JOIN US IN THE GENERAL ELECTRIC PROGRAM, BROADCAST EVERY SATURDAY EVENING ON A NATION-WIDE N.B.C. NETWORK 885-46

**GENERAL**  **ELECTRIC**  
SALES AND ENGINEERING SERVICE IN PRINCIPAL CITIES



# RADIO ENGINEERING

Production, Administration, Engineering, Servicing

FEBRUARY, 1931

## Choosing a Loudspeaker

By KENNETH W. JARVIS

Ordinary Aural Tests Are Not Sufficient in Determining Performance of Loudspeakers. Mr. Jarvis Here Describes Modern Methods of Testing Commercial Speakers.

THE various published notes on loudspeakers are of primary interest mainly to speaker manufacturers and designers. There are, however, almost as many speakers used by those who purchase from some other manufacturer. The choice of a particular loudspeaker from many offered, especially considering the link formed by the speaker in the translating system, is an extremely important problem. A poor speaker will ruin a good reproducing system, obviously. The customary test of a loudspeaker is to listen to it in operation, and if it sounds good, consider it a satisfactory speaker. This is quite a simple and effective test, but savors very much of the old days when the entire radio receiver was given a listening test as a measure of merit. In an effort to avoid the crudeness of such testing methods, or at least give some good technical reasons to back up a particular choice, certain other tests were applied to a group of representative speakers recently with interesting results. This article is based on the data from such tests as applied to about thirty different models<sup>1</sup> of loudspeakers. The technical points are discussed without reference to any individual speaker, and the curves given are typical rather than the best or worst of their kind. Further, no questions regarding cost, patents, reli-

ability of manufacturer, delivery, etc., which must always influence a final decision leading to a purchase, are considered. In other words, the "choosing" as connoted here, means merely the best choice as based on performance standards rather arbitrarily fixed. Probably the most important feature of a loudspeaker is its frequency response characteristic, as this determines largely how the speaker sounds. It may be of interest, as well as of value, to discuss briefly how such a test is made and the apparatus used.

### Speaker Mounted in Booth

The loudspeaker to be measured is placed inside a sound-proof booth together with a microphone. The booth is made sound-proof primarily to prevent the microphone picking up external sounds and so destroying the accuracy of the reading. The booth used for these tests was about ten feet long,

six feet high and five feet wide, inside dimensions. The walls were constructed of two layers of one inch Celotex with a four-inch air space between. The inside of the booth was completely lined with  $\frac{3}{8}$ -inch hair-felt lightly fastened about  $\frac{1}{8}$ -inch from the inner Celotex wall. The purpose of such a lining material is to absorb all the incident sound energy so that none can reflect and set up standing waves. Standing waves vary in position of peaks and valleys with respect to frequency, and would therefore add peaks and valleys to the loudspeaker response curve which were due only to the mechanics of the sound booth and not to the speaker under test.

If the results are to mean anything, all such errors must be substantially eliminated. Thanks to a lot of work by Sabine, Watson, and others, the technique of producing desired sound absorption characteristics is fairly well understood. In the case of hair-felt as used in this test booth, the absorption is fairly high for frequencies above a few hundred cycles. This is due to the relation between the wavelength of the sound waves and the size of the absorbing air spaces in the hair-felt. At very low frequencies, the wavelength is greater and very little absorption of sound energy takes place. To prevent standing waves at low frequencies, two precautions were taken. The hair-felt lining was loosely hung away from the inner Celotex wall to make the reflecting surface less rigid, and felt baffles were hung from the ceiling and sides, adding more absorbing material and producing many corners which tend to prevent regular reflections.

Although quite simple, such sound

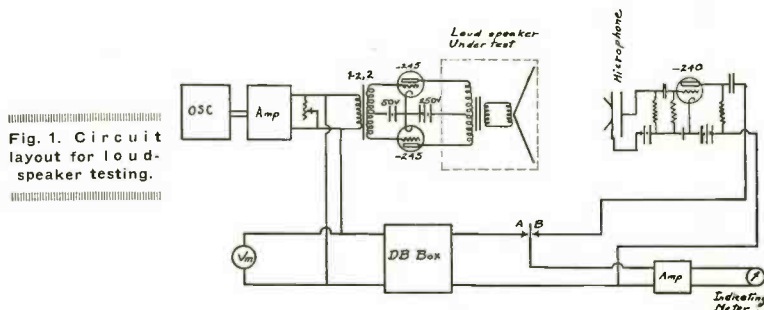

Fig. 1. Circuit layout for loudspeaker testing.

<sup>1</sup>The manufacturers and number of different models for each are as follows: Farrand 1, Jensen 4, Magnavox 3, Majestic 1, O'Neil 2, Operadio 3, RCA 2, Sonochord 2, Stromberg-Carlson 1, Utah 4, Valley Appliance 5, Victor 1.

treatment has been unusually effective (it is somewhat a matter of luck, and considerable re-arrangement is often necessary to make the treatment effective for all frequencies) in this booth, for in comparing a great many sound pressure curves there has been found no major peak or valley which is due to the structure of the sound booth. The irregularities of the sound pressure curve can be assumed due to the speaker alone, a comforting fact as will be appreciated when considering the curves in detail.

A schematic circuit diagram of the layout used is shown in Fig. 1. An audio oscillator and amplifier furnishes the power to drive the speaker. The output of the amplifier is measured with a voltmeter and applied to the primary of a two to one (each side) step-up transformer which excites the push-pull 245 amplifier. The output transformer of these tubes is that furnished with the speaker. The pickup is a Jenkins and Adair late model capacity microphone and a short coupled flat resistance amplifier. The transmission characteristic between the input to the 245 amplifiers and the output of the microphone is obtained by equalizing to the output of an attenuator connected to correspond to these two points. Another amplifier and indicating meter completes the equipment.

#### Mounting the Loudspeaker

The details of measuring a speaker are briefly as follows. The speaker is mounted in the center of a three foot Celotex baffle board suspended from the ceiling of the sound booth and about two feet from the back. The microphone, with its adjustable stand, is placed eighteen inches directly in front of the speaker cone. For measuring frequency response, the applied primary voltage was maintained constant at five or ten volts, depending on the test conditions desired. With the comparison switch on B, the indicating meter would swing back and forth as the audio-frequency was changed, indicating peaks and valleys in the translating efficiency. The curve was plotted by observing the indicating meter reading at a known frequency with the switch on B, then throwing to A and adjusting the calibrated (decibels) attenuator

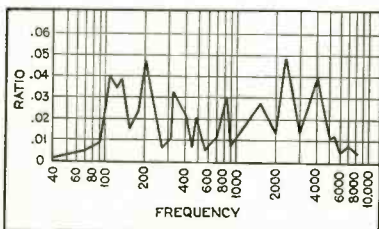

Fig. 2

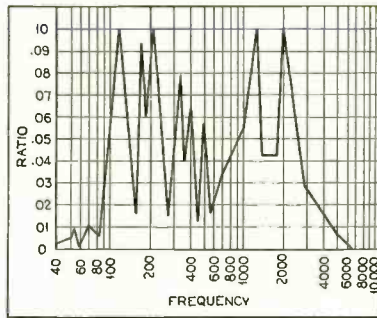

Fig. 3

to give the same indication. The curves shown are actually plotted in attenuation ratio rather than db. down. With this setup, the range was roughly from 10 db. to 50 db. down with various speakers and frequencies.

In speaker design work, and particularly in the study of cone response, a similar test is often employed, except that the current in the voice coil is maintained constant. The characteristics obtained are often quite different than those obtained in the manner outlined, as the variation in effective impedance of the transformer and voice coil when following an amplifier tube influences the response. As these speakers were all to be used with 245's as amplifiers, all tests including speaker overload, were made with this setup.

A rotating speaker or swinging microphone is often used in such setups to minimize directional radiation from the speaker or to reduce the effects of room resonance and standing wave patterns. Experiments in this booth showed it possible to disregard standing waves, while directional effects could be determined by moving the position of the microphone. It is often quite desirable to know something of the directional effects of a speaker as will be noted later.

#### Sound Pressure Curves

In Figs. 2, 3, 4, and 5 are shown typical sound pressure curves. It may be noted that the output against frequency is an extremely sharp and irregular curve. In drawing these curves, the peaks and valleys were observed and connecting lines drawn between them. In case of doubt, or when maximum (peaks) and minimum (valleys) points were widely separated, intermediate points were taken. As drawn, each peak or valley is shown as a saw tooth; actually they are slightly rounded corresponding to the resonance curves which they represent.

Fortunately the ear cannot perceive of the exact effect of these peaks and valleys in a complex sound wave. When running through the frequency

range of the speaker with a pure wave variable frequency oscillator the peaks and valleys may be readily observed, but as the speaker is seldom used in such a manner, the extremes of variation are not noticed. A sort of average curve may be drawn through these peaks and valleys to give an indication of how the speaker will sound. As all of these curves are drawn to the same scale, the amplitude of these average curves gives the comparative sensitivity. (The input was constant at 5 volts.)

These four curves all are from dynamic or moving voice coil type speakers. The sudden acceptance, or perhaps demand, for this type of speaker a few years ago was due to its greater capability of reproducing accurately low frequencies than previously used speakers. This "low" frequency range was not so low, averaging between limits of roughly 100 to 250 cycles. As the musical range can be considered as low as 32 cycles as an extreme, and down to 64 cycles for good reproduction, it may be seen that there is still a gap to be filled (64 to 100 cycles). The low frequency cutoff of these (and the others obtained) curves is obviously a most important

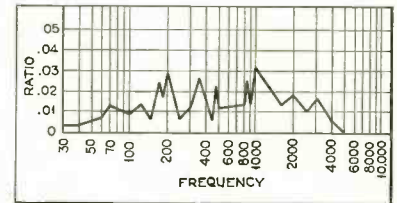

Fig. 4

characteristic. As this cutoff point is closely connected with the overload point, further discussion may be temporarily deferred.

In justification for "roughly averaging" the jagged curves obtained from the sound pressure booth, it has been found that aural comparison of two speakers checks very closely to their relative response curves. This may be most easily done by picking out (a process of mental selection) a narrow frequency range such as extreme bass or extreme highs or in the 2000 cycles region and comparing the two speakers by a throw-over switch.

#### Response Characteristic

One more interesting point should be noted before detailing these curves. The great majority of speakers have an extremely high response somewhere between 2000 and 3000 cycles, and averaging about 2200 cycles. Sometimes high double peaks are observed; sometimes they show only a single peak. The reason is not definitely known except that it is associated with the paper used in the cone and its

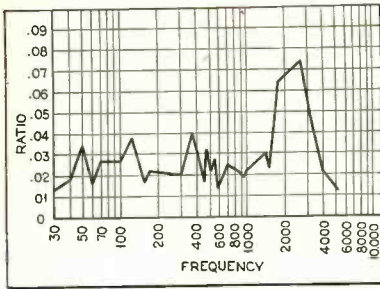

Fig. 5.

mechanical characteristic. Ribbing, fluting, corrugating, all definitely affect this region. Stiffness, texture, moisture resisting treatment of the paper contribute to the effect in varying degrees. The response in this region may often be the determining factor in the choice of a speaker.

Fig. 2 is the curve of a speaker which was sold by the thousands in combination with a popular radio receiver in 1929. It is typical of a good average speaker. The middle range is low while showing the high peak (double) just beyond 2000 cycles. The response curve climbs slightly to about 105 cycles, the so-called cone resonance period. This contributes greatly to the apparent bass response which made this speaker so popular. Below 100 cycles the response falls rapidly and can practically be neglected.

The makers of the speakers shown in Fig. 3 were the victims of several errors. Their magnetic field excitation (due to iron, copper, and field watts) was low. To compensate and increase sensitivity a short length of air gap was used, thus limiting cone movement. The lower limit of frequency cutoff was therefore raised, giving less bass response. To compensate for this decrease, an extremely resonant cone structure was used to further increase the sensitivity in this range. The results, while hardly apparent at first glance, were appalling. The cone resonance landed on 120 cycles and increased the hum output enormously. The restricted cone movement produced low frequency overload as will be shown. At first appearance in a listening test, the speaker seemed satisfactory, but detailed comparison with other speakers, quickly revealed its flaws.

**A High Grade Speaker**

Fig. 4 was acknowledged by most engineers (and strangely enough, by the listening public) to be probably the best speaker produced in 1929. Fortunately it was coupled to a very excellent receiver so that its merits were not diminished. It is a good example of special cone treatment being used to prevent the high-frequency peak so

commonly found. Notice that it has more real bass response than either Fig. 2 or Fig. 3, and is rather flat throughout the useful range. Its major defect is in having a somewhat lower sensitivity than the average speaker.

Fig. 5 is an example of a late 1930 model speaker and shows excellent characteristics. It has still more bass than that shown in Fig. 4, having a slightly larger cone with a free travel of about one quarter of an inch. It has a rather high peak, about 2300 cycles. These high frequencies are extremely directional, and as the microphone was placed directly in front of the speaker, it recorded the maximum output. As the normal listening position is scarcely in this location, it often happens that an increase of high-frequency response (as measured here) is an advantage rather than a detriment. An extreme example of this is in choosing a speaker for use in a table model speaker where the sound is directed straight down toward the floor. Especially when placed over absorbing material such as a heavy carpet, the average speaker in such a position will be very noticeably lacking in high frequencies. For such a use, therefore, a rising high frequency characteristic is a desirable correction. Fig. 5 was not used as a table model speaker, but the directional characteristics were such that for normal radiation it proved very satisfactory. The experimental data indicated its extreme desirability (there were other conditions as well) and later an audience not familiar with this data, but solely on listening tests, chose this speaker as the best from about a dozen which had proved eligible for consideration.

**Cone Movement Proportional to Current**

A somewhat different viewpoint of speaker requirements leads to what is believed an entirely new test of speaker characteristics. A pure note would send a sine-wave current through the voice-coil. For perfect reproduction the cone movement through space should also be sinusoidal. The cone movement (or rather position, neglect-

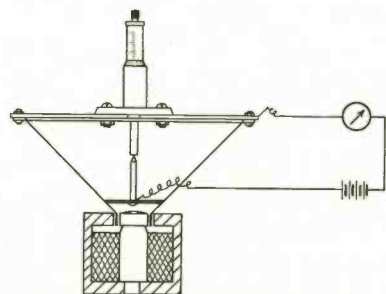

Fig. 6.

ing for the moment the dynamic concept) is determined by the acting force and the restraint of the supporting members. The ideal condition is one of linearity, so that the cone movement is directly proportional to the current in the voice coil.

In general, for this condition to obtain, the flux density in the air gap must be uniform and the restoring force of the supporting (and cone locating) members must be proportional to the deflection. Such a condition is almost never present in practice. Due to the usual design of the "pot" or field structure, the flux density slowly changes from the front to the back of the air gap. Directly adjacent to the air gap the fringing of the flux prevents the flux density from dropping directly to zero, and many speakers utilize the fringing flux to increase the

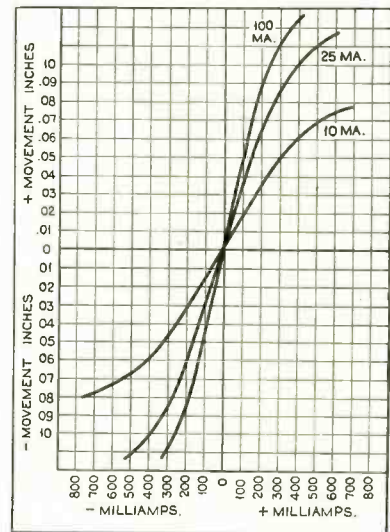

Fig. 7.

effective length of the air gap and so the possible movement of the cone. Such a practice is questionable as tests have shown that the flux density is not always uniform throughout the range which is often considered practical for the cone to move.

**Deflection Ratio**

Even less uniform is the force-deflection ratio of the supporting structure. Many free edge cones have cloth centering rings at the outside edge of the cone. Near the center of the cone travel this cloth ring exercises no restraint at all, but at the end brings up the traveler with a bump. Simple bending of a cantilever is uniform under pressure (for small deflections). When the cone is centered with two rather short stiff supports on either side of the voice coil (or inside the voice coil) the restoring force increases not linearly, but far faster as

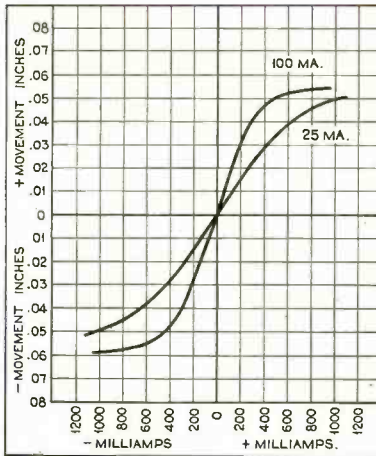

Fig. 8.

the deflection does not simply bend the supporting members, but places them in tension. A long supporting arm is necessary to give a uniform stress-strain ratio.

In order to measure the movement of the speaker cone with respect to the voice-coil current an arrangement as shown in Fig. 6 was set up. One contact was fastened to the cone close to the voice-coil. Another connection was made to a micrometer depth gauge, which was fastened to a cross piece over the cone. The cone movement was measured by the closing of the contacts with a battery and meter in series. Quite accurate measurements were possible if the cone was kept where it was quiet. Otherwise the room noises would shake the cone making an interrupted contact and indecisive observations.

Fig. 7 shows a series of three curves taken on one speaker with three different field currents. The horizontal axis is plus and minus voice-coil current (d-c. was used in the voice-coil for these tests) and the corresponding plus and minus cone movement is plotted on a vertical axis. A first glance makes these comparable to a vacuum tube characteristic, and it is true that they can be analyzed much the same as regards distortion, overload, dynamic characteristics, etc. This is an example of a very good speaker. The zero point is approximately in the center of the useful operating range, which is long and straight. The cone movement and sound output of this unit is (within the range shown) limited practically by flux fringing alone. As the field strength is increased, the flux density increases, increasing the sensitivity as shown by the steepness of the curves. This speaker had a rather wide air gap which aided in making a uniform gap flux density and also produced considerable fringing which was utilized as contributing to the permissible cone movement. The

limitation of movement in Fig. 7 is largely due to the length of the space having uniform flux density.

#### Cone Movement Limited

Fig. 8 is an example of a different case. Here the cone movement is mechanically limited. Increasing the field current and so the flux density, increases the sensitivity in the operating range, but does not give a greater output as the limit of cone travel is still the same. This cone had a stiff bakelite centering ring and a flexible cloth ring at the periphery which quickly stopped the movement.

Another quite common case was the existence of a hysteresis loop. The cone supporting members showed fatigue under the strain and so would not return to the zero position. A complete cycle of in and out movement gave a hysteresis loop of quite appreciable area. This is a power loss which lowers the efficiency of the speaker and is seemingly unnecessary.

An analysis of the various speakers in this manner predicted good or bad results in the way of distortion and maximum sound output in close accordance with other observations. This test certainly contributed to the best choice of a speaker.

#### Input to Output Ratio

The last test was simple and instructive. It consisted in measuring the ratio between input and output as

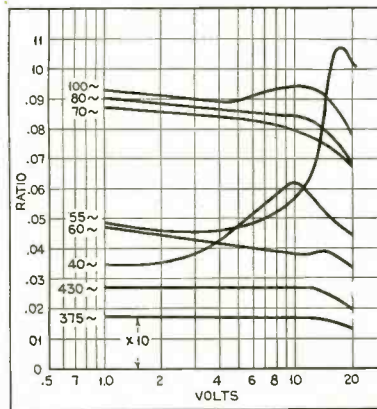

Fig. 9.

in the sound pressure test, with a variable input. A non-overloaded speaker should have a constant input-output ratio, and any deviation indicated overload and the presence of harmonics. In Fig. 9 are shown a series of curves taken on a speaker of rather good characteristics. The applied voltages (see Fig. 1) are noted as abscissa with the corresponding attenuation ratio as ordinates. The frequency at which each curve was taken is noted to the left of the corresponding curve. The amplitudes show the values which

would be obtained on a sound response curve at the same frequency.

From the previous discussion it should be obvious that at high frequencies the full output of the 245's may be applied to the cone and only a small displacement result. The cone should therefore show no overload at high audio frequencies, the 245's alone limiting the output. The curves taken at 375 and 430 cycles show this conclusively. The ratio is constant to the point where the amplifiers begin to overload at about 15 volts. The theoretical amplifier overload voltage is 18.2 volts, and shows how well the system is standing up. Three hundred and seventy-five cycles corresponded to a peak in the sound pressure response curve and 430 cycles to the next valley. Both show the same characteristic curve, indicating that the peaks and valleys of the response curve are not overload phenomena. The remaining curves form an interesting series. All of them show a dropping characteristic, indicating that even at 100 cycles the speaker is not capable of delivering the full output of a push-pull 245 amplifier undistorted. The principal contributing cause in this speaker was lack of uniform flux density. At low frequencies and large cone movement, the voice-coil moved into a region of decreasing flux and the resulting response decreased, producing the curves shown. Fortunately the distortion is only gradually increased with input for the curves of 100, 80, 70 and 60 cycles, and at the worst condition is far superior to the distortion produced by mechanical limitations. This can be considered as a fair speaker down to 60 cycles.

The curves at 55 and 40 cycles reveal quite clearly what happens in a speaker at low frequencies when resonance and non-linear response characteristics are present. The 55-cycle curve begins normally, but due to a change in elasticity with displacement (non-linear relation) the response suddenly increases. This is presumably due partly to a change in position of a resonance peak and partly due to a characteristic.

The majority of speakers show overload with much higher frequencies and far lower inputs. The non-criticalness of the human ear has often been commented upon, and these tests have shown how little it can be fully trusted in loudspeaker work. In justice to both the measurements and aural observation it should be said that critical consideration of the speakers results in an identical choice a great many times.

The interest aroused developing these tests and the experimental results derived from them have paid for the labor expended.

# Sidebands in Radio— Are They Real or Imaginary?

By RALPH P. GLOVER\*

ONE of the most interesting developments in the field of theoretical radio during the past year has been the rather startling disavowal of what we call the sideband theory, by Dr. J. A. Fleming, the eminent British radio authority. Dr. Fleming denies (*Nature*, Jan. 18, 1930) that side frequencies are present in the radiation spectrum of a modulated wave and declares (*Television*, April 1930) " . . . that the effect which traverses space between the broadcast transmitter and the receivers is a single modulated wave of one frequency but of varying amplitude or modulation." This stand is by no means a new one, as evidenced by articles and correspondence in several technical journals during the past few years, but Dr. Fleming's enviable position in the scientific world has lent an official sanction to a controversy which had hitherto been an entirely informal affair. Considerable editorial space is now being devoted to the various aspects of the matter and a great deal of discussion on the subject is almost certain to ensue whenever and wherever radio engineers come together.

Undoubtedly the reader is familiar with the prevalent theory that an amplitude-modulated wave may be analyzed into a steady carrier and side frequencies which are spaced above and below the carrier by the amount of the modulation frequency. This equivalence follows from a very simple mathematical treatment of the amplitude-modulated wave. Those who deny the existence of the side frequencies maintain that the equivalence is only mathematical and has no significant physical interpretation. They conclude that there is no inherent relationship

between the selectivity of a receiving system and the fidelity of its output, provided the circuits are so arranged that they can accommodate the rapid changes in amplitude produced by high modulation frequencies. It is claimed that the idea that it is necessary for the receiving system to respond to a band of frequencies has its foundation in the fact that heavily damped circuits which permit the rapid amplitude

This speculative subject is sure to be widely discussed among engineers until the general understanding is clear.

changes, essential to good quality of reproduction, are inherently less selective than circuits of lighter damping.

## Oscillograph Examination

There is a great deal to be said for this sort of reasoning. It is perfectly true that current will persist in a lightly damped circuit for a much longer period than the time of application of the exciting potential. Examination of the form of a modulated wave, by means of a high-speed oscillograph, for instance, seems to indicate that we have but one frequency to deal with, namely, that which corresponds to the periodic time of the wave regardless of whatever changes in amplitude may take place. Do these side

frequencies, then, exist in any real sense?

A number of proofs of the "existence" of side frequencies have been suggested. It is necessary to point out, however, that entirely satisfactory conclusions can only be reached provided proper definitions for such terms as "existence" and "frequency" are decided upon. Inasmuch as our sense organs do not function or respond at these high frequencies, and would likely be of little or no value in arriving at the solution of our problem even if they did, it is necessary to employ auxiliary apparatus of some sort in order to investigate the nature of the waves. Obviously whatever we discover about radio waves in this manner must be described in one way or another in terms of the performance of the analyzing instrument. Thus it is rather easy to imagine that certain peculiar characteristics might be attributed to the wave when in reality we are only witnessing some unfamiliar mode of operation of the analyzer.

## What About Modulation?

The fact that a variable frequency oscillator may be tuned to the frequency of a second oscillator by the familiar zero-beat method, is often made use of in radio measurements. If, however, the second oscillator is modulated in the usual manner, two additional zero-beat points may be located above and below the original point. The frequency interval between the original point and each of the side points, as determined from the calibration curve of the frequency meter, will be found numerically equal to the modulation frequency. Response peaks, corresponding to these same frequencies, may be observed with a resonant-circuit frequency meter of the ordinary sort. These experiments are frequently cited as proof of the existence of side frequencies but fundamentally their conclusiveness must be judged in the light of what has been said in the foregoing paragraph.

Such difficulties in evaluating the true worth of experimental evidence are by no means limited to the study of modulated waves. Similar troubles are encountered in almost every phase of experimental and mathematical physics, emphasizing our slight knowledge of what actually constitutes physical reality.

Undoubtedly a great deal of confusion has been introduced into the study of complex waves by a rather loose use of the term "frequency." We usually

\*Engineering Department, Crosley Radio Corporation.

employ this term to mean the number of repetitions or cycles of the phenomenon which occur during unit time. There is no difficulty in applying this conception to sine waves of constant amplitude which repeat themselves indefinitely. Specifying the frequency of such a wave is also equivalent to specifying the rate at which the current or voltage is varying with time, a fact which at once permits us to solve innumerable problems in electrical engineering. In more complex waves, however, this rate of change is not wholly determined by the periodic frequency. It is usual to consider such waves as the resultant of the periodic frequency and components of higher frequencies. While to some this is merely a convenient mathematical artifice, it can be argued with a great deal of sound reasoning that the higher frequency components actually exist in a very real sense. This is a point of some importance in the sideband controversy, for the opponents of the theory only concede the reality of the carrier or periodic frequency of the wave.

It can be mathematically demonstrated that a considerable spectrum of frequencies is generated by rapidly interrupting a continuous wave as in the case of high-speed radio telegraphy.

Similar effects can be shown for frequency modulation such as is occasionally employed in radio telephony and in radio telegraphy by the compensating-wave method. Evidently, then, we get these side frequencies, at least by mathematical analysis, whenever any irregularities, variations or discontinuances are imparted to the wave train by some signaling process. In ordinary radio telegraphy, the presence of the side frequencies is a great deal less obvious by casual inspection than in the case of the amplitude-modulated wave of radio telephony and it is quite surprising that no attack has been directed on this particular case.

### What of Selectivity?

The most practical phases of the whole discussion are those which have to do with the regulation of broadcast stations and the design of radio receivers. The receiving system should be highly selective in order to discriminate against unwanted signals but the classic theory restricts this discrimination to those frequencies lying outside of a transmission band which is twice as wide as the signal frequency, if ideal reception is to be had. By similar reasoning, it is thought to be good practice to separate broadcast stations

by a frequency interval which is at least as great as the width of band required for high-quality transmission. A number of years of experience with receiving systems of the ordinary sort seems to bear out the classic theory. It also seems to be well agreed that whenever, for economic, practical or other reasons, the selectivity of the system markedly departs from the ideal of uniform transmission over the required band of frequencies, some compensation is required elsewhere in the system if high-quality reproduction is to be had. This principle has been made use of in a recently announced ultra-selective receiver which, it is claimed, responds only to the carrier frequency.

This discussion does not, of course, "prove" that side frequencies "exist." On the other hand, no conclusive scientific evidence to the contrary has been presented up to this time. Just what will emerge from the current scramble of mathematical physics, vague descriptions and ambiguous explanations, is an interesting subject for speculation. In the meantime, many engineers will content themselves with the resolution of the modulated wave into component carrier and side frequencies.



### SLOW-SPEED RECORDS GAINING IN POPULARITY

THE usual phonograph disc record revolves at 78 revolutions per minute. The 12-inch record plays for four minutes, while the 10-inch records play but 2½ minutes. However, for theatrical and broadcasting purposes, the 16-inch record, playing for 14 minutes and operating at 33¾ r. p. m., is rapidly becoming a favorite.

No less an authority on phonographs than Clifford E. Stevens, chief engineer of the Stevens Manufacturing Corporation of Newark, N. J., predicts the growing popularity of the 16-inch records. "Many broadcast advertisers," states Mr. Stevens, "are now having their broadcast programs recorded in permanent form, for various uses. In some instances these recorded programs are intended for supplementary broadcasting through independent radio stations seeking the better types of programs. In others they are intended for entertainment before large gatherings.

"While a greater degree of accuracy is required for the turntable and driving motor to handle the large records at 33¾ r. p. m., there are no insurmountable difficulties involved. In view of the much finer musical qualities of these records, it is necessary to guard against a turntable wobble, a center pin off center, and an unsteady

motor. It is believed that the 16-inch records will gain steadily in popularity and may even find their way into homes, thereby permitting radio enthusiasts to repeat favorite broadcast programs at will."

### NICKEL IN SILVER SOLDERS AND THE SOLDERING OF NICKEL AND NICKEL ALLOYS

THE increasing use of silver solders resulted, some few years ago, in the appointment by the American Society for Testing Materials of a subcommittee charged with the investigation of gold and silver solders, and the recommendation of compositions likely to meet a variety of trade requirements. A tentative specification was adopted as standard in 1929, and supplemental work carried out under the aegis of the subcommittee has recently been published in the form of a paper to the society. The author deals mainly with ternary alloys of copper, silver and zinc, and covers a consideration of melting point, the effect of other metals, the physical and mechanical properties of the alloys, and methods to be adopted in using them as solders. The presence of nickel in this type of alloy hardens the solder and increases its flow point, and it is possible, by the

judicious addition of this element, to produce a silver solder which contains 40-50 per cent of silver, flows below 1450° F. (800° C.), has a white color, and makes strong joints, suitable, *inter alia*, for use with stainless steel. Data are included on optimum procedure for the joining of various materials, including nickel-copper-zinc alloys, Monel metal, and nickel; and particulars are given of types of fabricated parts for which silver solders may suitably be used.

R. H. LEACH,—"Silver Solders," American Society for Testing Materials, Preprint, June, 1930.

### WHAT IS IN A MODERN RADIO RECEIVER?

A STANDARD make of 1931 radio broadcast receiver having four —24 type screen-grid tubes, four —27 tubes, two —45 tubes and an —S0 rectifier tube, contains in its makeup also the following parts: Nineteen resistors, thirty-two condensers, four transformers, three i-f. coils, one oscillator coil, two r-f. coils, one detector coil, one choke, one volume control, one tone control, one voice coil, one field coil, two switches, one pilot lamp, a chassis and various assembly shackle bolts and nuts.

# A Review of Remote Control Development

By GERSON LEWIS AND ALFRED A. GHIRARDI\*

Satisfactory Remote Control of Tuning and of Volume in Radio Receivers Has Many Problems. In this Article is Presented an Engineering Account of the Requirements

**R**EMOTE control of radio receivers is a feature that is now attracting wide attention from set manufacturers and engineers, and to a somewhat lesser extent, from the general buying public.

Remote control in a practical, inexpensive, fool-proof form would surely be welcomed most enthusiastically by the public. Remote control devices can be divided into two classes:

(1) Pre-selection, in which several stations, for which the receiver has been previously adjusted, may be tuned in.

(2) Full-scale tuning, in which the full range of the dial can be obtained, precisely as at the set.

Regardless of which type is used, the remote control device must meet the following requirements if it is to become at all popular;

(a) It must permit of the use of more than one control unit. (b) It must provide for full control of volume. (c) It must provide means for turning the set on and off. (d) It must tune as sharply as is possible at the set. (e) It must not do away with the ordinary

means of tuning at the set. (f) The connecting cable must be of such size that it can be easily installed by being tacked around moldings and baseboards to permit of low installation costs. (g) The unit must operate on a fairly low voltage. Not more than about thirty volts should be used. Cables carrying voltages of 110 volts or more become subject to the various regulations of the fire underwriters. (h) It must not be subject to mechanical troubles. (i) It must be easily serviced. (j) It must not set up any interfering noises in the speaker or in a neighbor's radio set. (k) With the pre-selection type, adjusting to the different stations must be easily made. (l) The full-scale type must provide some means of synchronizing between the indicators at the various control boxes and the tuning condenser on the set. (m) No control unit must tie up the operation of any other control unit. (n) The unit must be designed so it can be easily and successfully installed on the majority of the receivers now in use. (o) And last, but not the least important, the selling cost must be low enough to be well within the reach of the average radio set owner.

Here we have at least fifteen important conditions which a successful remote control device must fulfill. To elaborate each point slightly: (a) It must permit of the use of more than one control station. If the unit will permit only one box there is no need of it, since the radio could usually be placed at that spot. The merchandizing feature of remote control is that the set can be tuned from bedroom, living room, kitchen and as many other points as desired. (b) It must provide for full control of volume. It is just as important to control volume at the remote point as at the set. Furthermore, simply taking the volume control resistor out of the receiver, and placing it in the control box is not satisfactory, for in many cases it may lead to a severe unbalancing of the radio set, due to the capacity between the long leads in the cables. Secondly, this method will limit the practical usefulness of the control to one box. This is easily explained by Fig. 1.

## Operation

Let us assume we have a typical screen-grid set in which volume is controlled by the usual potentiometer arrangement which varies the voltage on the screen-grids. For purposes of dancing we turn up the volume at control box A in the living room. We go now to room C, upstairs, and find that the music is much too loud for comfort. It is evident that using the volume control at C will not have a direct effect on the screen-grid voltage, for this voltage will be a resultant of the voltage settings of the various control box potentiometers. It will be necessary to go to room A to turn the volume down completely. This ruins the feature of remote control. Of course, a separate volume control could be placed on the speaker at C, but this would complicate the installation and lead to other difficulties. One would have to go over to the speaker to vary its volume control. The volume control resistor should be at the chassis and controlled by a means similar to that used for the tuning condensers. (c) Some means must be provided for turning the set on and off. This of course is a necessity easily understood. The most obvious means is

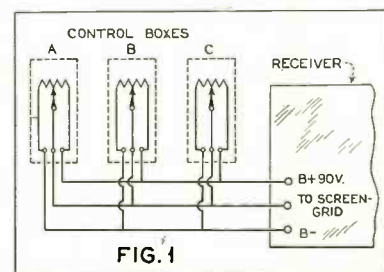

Fig. 1. Control positions.

\* Technical Consultant.

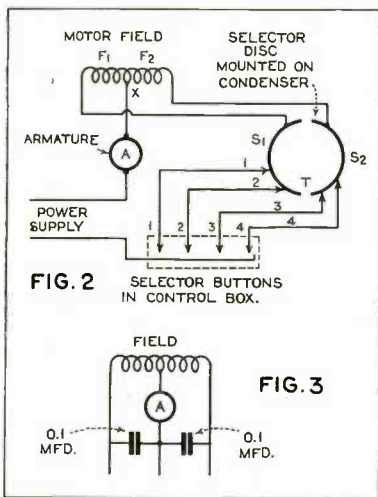

Fig. 2. Motor Circuit.  
Fig. 3. Filter for brush disturbances.

to run switch leads to the control boxes. However, in doing this we have 110 volts in the cable and to conform to the Underwriter's regulations we would have to put the cable in BX armor or piping. Needless to say, this would be undesirable on account of cost and general prejudice against ripping up floors and walls for installing conduit.

**Duo-Control**

Also it is essential that we be able to turn the set on from one room and turn it off from a different room. The best way is to mount the switch so that when the volume control is turned to zero the set is turned off. In some types a switch is arranged so that when the condensers are at maximum or minimum the set is turned off. Relays could also be used. They, however, greatly increase the cost. (d) It must tune sharply. This is a very prominent consideration as the new sets are very selective and must be tuned to exact resonance, otherwise the reproduction suffers. (e) It must not do away with the tuning control at the receiver. In many cases it will be found that the set is to be placed in the living room while control units are desired in the bedrooms and perhaps the kitchen and dining room. Therefore some means of tuning must be kept at the receiver itself. Of course, another control box could be placed at the set or in the living room but this increases the cost unnecessarily. (f) The connecting cable must be of a fairly small size. Perhaps the quickest answer to this is to ask any serviceman how the woman of the house feels about having a large size cable tacked around, which would collect dust and mar the appearance of walls. Some systems employ a flat type cable, but it is a question how much abuse and knocking around a cable of

this type can endure. The cable is liable to be bruised and buffeted by brooms and vacuum cleaners. Three-eighths inch seems to be the maximum allowable diameter for the cable. The majority of floor and wall mouldings accommodate a three-eighths inch cable. (g) It must operate on a low voltage. Wires carrying more than thirty-two volts must be encased in BX conduit or piping. The voltages must be kept below that value if the inexpensive, open type wiring is to be used. (h) It must not be prone to mechanical troubles. Any remote control device subject to periodic indispositions due to mechanical or electrical faults or failures will not stay sold. (i) It must be easily serviced. (j) It must not set up any interfering noises in the speaker. In the pre-selection type a silence key is used, but this can not be employed on the full-scale type. Some of the pre-selection remote control devices on the market short-circuit the voice coil of the loudspeaker while the remote control mechanism is operating. Others short-circuit the screen-grids of the r-f. tubes to B-. (k) Adjustments to stations must be easily made. In the pre-selection type the adjustments must be quickly and easily made by the layman as well as the serviceman. (l) Some means of keeping the indicators in step on the full-scale type is essential. It is very confusing and annoying to have one control unit read, say, 80, and another 60, with perhaps as third reading 30. (m) No control unit must tie up any other unit. Each unit must be wholly independent of any other control unit in the system. It must be possible to tune in in one room and regulate the volume in a second room. (n) The unit must be designed so that it can be installed on sets now in use. Perhaps the greatest field for remote control device sales is to owners for installation on their present sets. (o) The price must be reasonably low. With complete receivers being sold at such reasonable prices today the remote control unit can not be priced at a figure above twenty-five or thirty per cent of the selling price of the receiver. That would figure out to a unit priced from twenty to thirty-five dollars with one control box. Additional control boxes could be supplied on a unit cost basis.

**Various Developments**

Remote control development had its inception in the numerous automatic tuning devices used by many set manufacturers. These ranged from Zenith's "cash-register" system to the lightomatic of Edison's. These systems were a logical step toward the trend to pre-selection remote control.

Practically all the pre-selection remote control systems use the series wound motor which has a center tap on

the field. The operation of this type of motor is shown in the simplified diagram of Fig. 2.

A is the armature of the motor; F1F2 the motor field winding with the center tap at X. The power supply is generally a step-down transformer designed for open circuit work. A number of push-buttons are mounted in the control box. These connect to adjustable contacts, which are the station selectors placed on S1 and S2. S1 and S2 are two sectors mounted on the condenser shaft. They are insulated from each other and connect to the outside ends of the field. If we press button No. 1 connected to sector S1, the current is sent through field F1, causing the motor to rotate in one direction, turning the condenser gang to which it is belted or geared, until the contact is on the insulated break T which opens the circuit. During this rotation the tuning condenser has turned to some pre-selected position. If button 4 is pressed the current goes through F2, the motor runs in the opposite direction until contact 4 is opposite the break T. Usually two contacts are provided so that one will turn the condensers from zero to 100 and the other button will turn the condensers from 100 to zero. This allows tuning in stations not previously selected. All of these small motors run at a high speed so that considerable belting or gearing is necessary to reduce the speed. A similar motor may be used to operate the volume control. Any brush noise may be filtered by connecting 0.1 mfd. condensers from the field to the armature return as shown in Fig. 3. These condensers should be connected as close to the motor as possible. As many control boxes as may be desired can be connected in parallel provided the

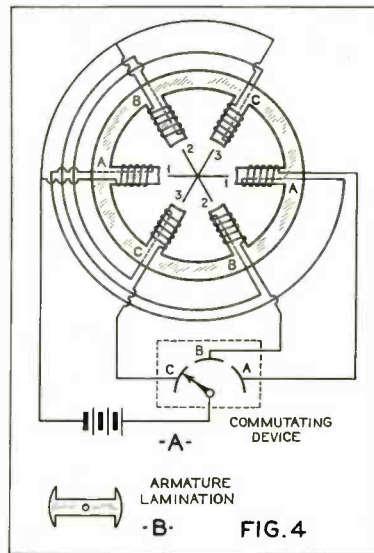

Fig. 4. Full-scale tuning device.



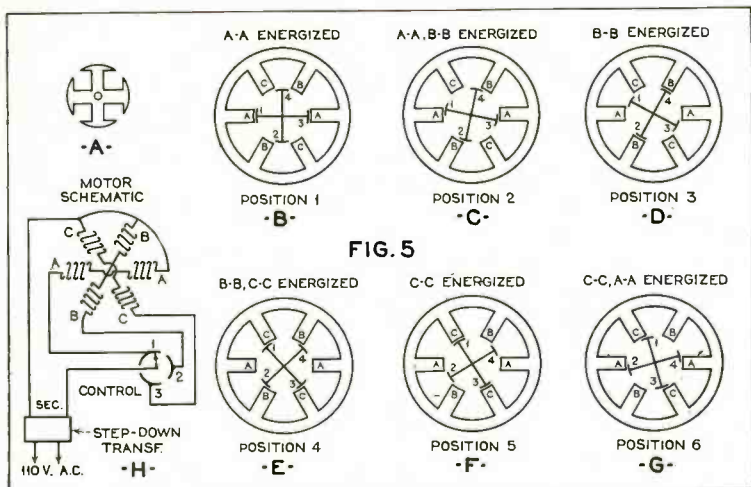

Fig. 5. Theory of control.

selector buttons in the control box are of the type that are normally open.

**Full Scale Device**

The full-scale tuning device in its simplest form consists of a field with six pole-pieces with magnet windings. These are connected as shown in Fig. 4A through a commutating device which is located at the remote control point. The armature is merely a pile of soft iron shuttle shaped stampings without windings as in Fig. 4B. Now if the contact arm be placed on A, current will flow through coils A, A, and the armature will take position 1. If the contact arm then be moved to B, current will be sent through coils B, B, and the armature will take position 2. With current sent through coils C, C, the armature will take position 3. By reversing the direction of commutation, the direction of rotation of the armature will be reversed. We can see that this will give the armature six positions to a revolution.

The desired sharp tuning may be obtained by providing for twenty-four positions.

This increases the torque and stability of operation. The first change is to make the armature a four-pole type as shown in Fig. 5A. Then we increase the width of the contacting arm in the control unit to obtain positions called "double positions." That is, the sequence of contacting becomes 1, 1, 2 — 2, 2, 3 — 3, 1 and so on.

The contactor arm is placed on contact 1, energizing coils A, A, bringing the armature in line with A, A, poles 1 and 3 being attracted. This is shown in Fig. 5B. The commutator's next position, sends current through coils AA and BB. The armature moving to conform with the magnetic fields produced, takes an intermediate position where armature poles 1 and 2 and poles 3 and 4, take a position midway between field

poles A and B. This is position 2 shown in Fig. 5C. Current is sent through coils BB, next, bringing poles 2 and 4 into line with poles BB, in position 3 shown in Fig. 5D. The next position is a double position with current going through BB and CC pulling the armature into position 3 where poles 1 and 4, and poles 2 and 3 of the armature are brought into a midway position between B and C, as in Fig. 5E. With the contactor placed on 3, current is sent through coils C.C bringing armature poles 1 and 3 into line with poles C.C. The next position is a double position sending current through C.C and A.A pulling armature poles 1 and 2 and poles 3 and 4 into position midway between A and C; this is shown in Fig. 5G. The armature has now been rotated through a quarter revolution and has taken six positions, or twenty-four positions for the complete rotation.

By using the proper reduction between the condenser shaft and the motor shaft (about one to sixty-four) there is a motion fine enough to have four steps to a division on the regular 100 division scale. A similar motor may be used for the volume control which can also carry the on-off switch actuated when the volume control arm goes to the zero volume position. A schematic diagram of the motor is shown in Fig. 5H. Current is supplied from a step-down transformer giving about 25 volts.

**Careful Engineering Important**

There are some problems connected with the design which if not handled carefully will cause improper action. The field coils must be matched very closely to see that they have the same impedances. Furthermore, the definition must be right. By "definition" we mean that the amount of movement for single position must be the same as for double position. To balance for defini-

tion the amount of armature iron is reduced by cutting the lips off the lamination as shown in Fig. 6A and Fig. 6B. There should be about 40 per cent laminations with lips and 60 per cent without lips.

When these small step-by-step motors are used on a-c. they have a strong tendency to hunt; that is, tend to run in a manner similar to a single-phase induction motor. To prevent this, it is necessary to use a brake on the shaft of the motor. This should be adjustable and can be used to compensate for different mechanical loads. This is a most important part, as without the friction brake the power of the motors is expended in their tendency to hunt and there is no power available for the operation of the condensers. They must be operated at the voltage for which they are designed, as a 10 per cent drop in voltage will cut the power from the motors about 40 per cent.

In the control boxes, the contactor must be designed so that it is normally open and the circuit closed only when the actual tuning is being done. The selection of the material for contacts is important, as quite a heavy inductive discharge takes place across them. Brass is too soft and will tend to pit and burn in a very short time. Molybdenum is satisfactory as it resists arcing. This same inductive discharge causes clicks in the speaker. They can in most cases be filtered out by placing .01 mfd. condensers from the common return wire to each winding. The cable used is covered with a copper braid. This braid is used as the common return wire and is grounded. Antenna, ground and speaker leads must be kept away from the control leads. The motor frames must be grounded to the set chassis.

**The Station Indicator**

The most important part of the equipment is a suitable and accurate

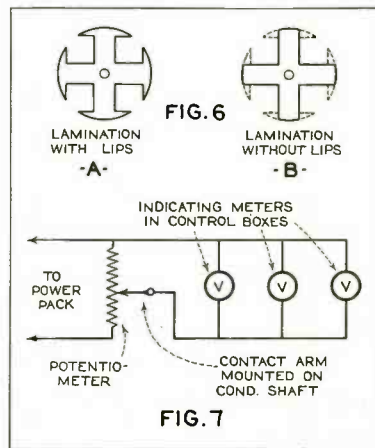

Fig. 6. Reduction of iron. Fig. 7. Dialing meters.

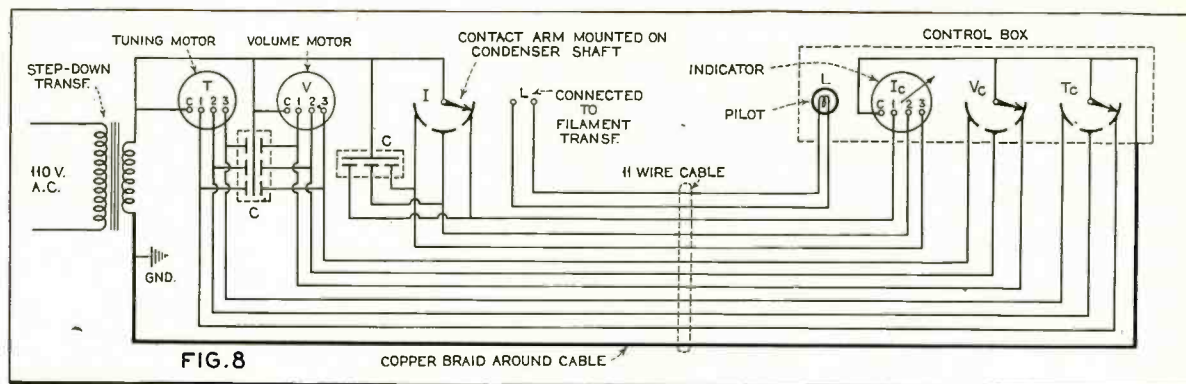

Fig. 8. Full-scale remote control system for radio reception.

station indicator. One method is to gear a dial directly to the tuning knob at the control box. This has many disadvantages as it does not indicate the true setting. There is no means of resetting it, and turning the dial at any one box immediately throws the others off. The only advantage it enjoys is its cheapness and simplicity. A second way is to mount a resistor on the condenser shaft so that the resistance is varied as the condenser is turned. Using it as a potentiometer, meters may be included at the different remote control points. Meters will have scales calibrated in kilocycles and will indicate the frequency. If the voltage for the indicating meters is taken from the power pack on the set it will also indicate when the set is on or off. This arrangement is shown in Fig. 7. The objection to the use of a meter is primarily the cost. Also it is not absolutely accurate. A change in the voltage will cause false readings on the meters.

A third method is to have a replica of the tuning motor in the control box with contacts arranged on the condenser shaft. This method will not give true readings as the steps made by the pointer in the control box will be about four divisions each or about twenty-five steps over the one hundred division scale. Using this system requires mounting contact sectors on the receiver and means making the control box fairly large.

Of all the station indicator methods the voltmeter method seems the most feasible and practical at the present time.

A remote control system of the full scale type is shown in the schematic diagram of Fig. 8. This circuit shows the use of the indicator system employing the indicators which comprise a step-by-step motor in the control box. This step by step motor is belted to the condenser gang and controls the tuning. V is a similar motor and actuates the volume control. The volume control carries a switch which

is operated at zero volume. This switch controls the a-c. supply to the receiver. I is the indicator. The contact arm of the indicator is mounted on the condenser shaft. The contacts connect through the cable to the indicating motor at the different control boxes. L is merely a pilot lamp connected to the filament transformer winding in the receiver to indicate when the set is on or off. C, C are condenser blocks containing condensers of about .01 mfd. per section. They are connected from the common to one end of the motor windings. They are used to filter out possible interference from the control. A step-down transformer is used to supply power to operate the controls. The transformer is usually designed to give about 25-volts from the secondary. This part of the equipment is mounted at the set and is connected to the control boxes with an eleven wire cable. The copper braid shield around the cable is used for the common return and is grounded. In the control box we have the pilot lamp L, and the indicating motor I which carries a pointer that moves over some convenient scale. The control box contains also the commutating devices Tc and Vc which control the motors T and V. Extra boxes are connected in parallel.

#### Extra Speakers

A consideration of remote control systems is not complete when we have accounted for the tuning and volume control. It is necessary also to take into account the problem of connecting extra speakers. It is about time that manufacturers began to plan their sets to permit of the use of extra speakers, easily connected. Connecting extra speakers into the line will depend greatly on the type of receiver and speakers used. In any case, if quality is not to suffer the actual load into which the set works must remain fairly close to that for which it was designed, and if the speakers are so connected that they can be cut in and out of the line, some impedance compensating pro-

vision must be included to keep the load constant.

In some instances where 110-volt direct current is furnished a motor-generator installation is used to supply 110 volts a-c. for the set. It then becomes necessary to control the generator from a number of remote points. One of the best means of doing this is by a special relay which actuates a ratchet. Every time the relay operates it moves the ratchet one tooth, making or breaking the circuit. Units of this kind can be obtained for any current or voltage rating required.

It must be remembered that the remote control installation is going into the home. The remote control must be fool-proof and trouble-free. It must stand abuse and misuse. There is a choice between pre-selection or full scale tuning. Pre-selection control is simple and cheap. Full scale control costs more, is more complicated, more liable to trouble, but gives a more satisfactory degree of remote control. This is the status of remote control development at the present time.

#### ARTHUR H. LYNCH GOES TO STENODE COMPANY

Arthur H. Lynch, heretofore editor of *Radio News*, New York, has become identified with the American Radiostat Corporation, as vice-president and joint general manager.

The company is developing the radio receiver inventions of Dr. James Robinson, of England.

#### NO TAX ON RADIO RECEIVERS

A sweeping decision prohibiting taxation of radio receiving set owners, as proposed by a South Carolina law, has been handed down at Columbia, S. C., in the Federal District Court, in the first test case brought at the instance of the Radio Manufacturers Association.

# The "Stenode"

## Part II, Appendix

By J. ROBINSON, D.Sc., Ph.D.  
MIEE, F. Inst. P.

The following is in the nature of an appendix to Dr. Robinson's paper on the Stenode system of radio reception which appeared in the December, 1930 issue of RADIO ENGINEERING.

Taken by itself the mathematical analysis here presented has for its objective an attempt to explain the mechanism of radio transmission and reception, particularly with reference to the carrier frequency and the hypothetical side frequencies.

THE following analysis was obtained in discussions with Dr. Alexander Russell, F.R.S., principal of Faraday House, London.

### Transmitting Waves

Let us suppose that the carrier wave has a frequency  $n$  and that  $\omega_1 = 2\pi n$ . Then the magnetic flux produced at a point in the receiver may be written  $\Phi \sin \omega_1 t$  where  $\Phi$  is a constant which depends on the kind of transmitter used and its distance from the receiver, and  $t$  is the time in seconds. In practice  $\Phi$  is modulated in various ways. Let us suppose that a pure note  $C \sin \omega_2 t$  is sounding at the transmitter and is modulating the amplitude of the current producing the carrier wave. In this case the instantaneous value of the flux at the receiver with the modulated transmitting current is given by

$$\phi = \Phi (1 + m \sin \omega_2 t) \sin \omega_1 t \quad (1)$$

where  $m$  is a constant independent of the frequency and the time. By trigonometry this may be written

$$\phi = \Phi \sin \omega_1 t + m \frac{\Phi}{2} \{ \cos (\omega_1 - \omega_2) t + \cos (\omega_1 + \omega_2) t \}$$

### Resonating Receiver

The impressed e.m.f. in the resonating circuit  $e$  is given by

$$e = \frac{d\phi}{dt} = \omega_1 \Phi \cos \omega_1 t + m \frac{\Phi}{2} \{ (\omega_1 + \omega_2) \sin \omega_1 t + \omega_2 t - (\omega_1 - \omega_2) \sin \omega_1 t - \omega_2 t \}$$

If the resonating receiver consists merely of an inductive coil of resistance  $r$  and inductance  $L$  and a condenser  $K$  in series with it we have

$$e = ri + L \frac{di}{dt} + \frac{fi}{c} \dots \dots \dots (2)$$

where  $i$  is the current in the circuit where  $fi\delta t = q$  is the charge on the condenser at the time  $t$ . Writing for  $e$  its value from (1) and substituting in (2) and solving the equation we get

$$I = \frac{\omega_1 \Phi \cos (\omega_1 t + \alpha_0)}{\left\{ r^2 + \left( L \omega_1 - \frac{1}{c \omega_1} \right)^2 \right\}^{\frac{1}{2}}} + \frac{\Phi}{2} m \frac{(\omega_1 + \omega_2) \sin \{ \omega_1 + \omega_2 t - \alpha_1 \}}{\left\{ r^2 + \left( L \omega_1 + \omega_2 - \frac{1}{c (\omega_1 + \omega_2)} \right)^2 \right\}^{\frac{1}{2}}} - \frac{\Phi}{2} m \frac{(\omega_1 - \omega_2) \sin \{ \omega_1 - \omega_2 t - \alpha_2 \}}{\left\{ r^2 + \left( L \omega_1 - \omega_2 - \frac{1}{c (\omega_1 - \omega_2)} \right)^2 \right\}^{\frac{1}{2}}} \quad (3)$$

Where  $\tan \alpha_0 = \frac{L \omega_1 - \frac{1}{c \omega_1}}{r}$   
 $\tan \alpha_1 = \frac{L (\omega_1 + \omega_2) - \frac{1}{c (\omega_1 + \omega_2)}}{r}$   
 $\tan \alpha_2 = \frac{L (\omega_1 - \omega_2) - \frac{1}{c (\omega_1 - \omega_2)}}{r}$

The formula (3) gives the complete solution when the steady oscillating state is attained. In practice the ratio

$$\frac{\omega_2}{\omega_1} = \frac{f_2}{f_1} = x \text{ is less than one in a hundred.}$$

If the resonating receiver is adjusted to resonance with the carrier wave we have  $L \omega_1 - \frac{1}{c \omega_1} = 0$ . Thus  $\tan \alpha_0 = 0$ , and consequently  $\alpha_0 = 0$ .

In addition we have  $L (\omega_1 + \omega_2) - \frac{1}{c (\omega_1 + \omega_2)} = L \omega_1 (1 + x) - \frac{1}{c \omega_1 (1 + x)}$

$$= L \omega_1 \left\{ 1 + x - \frac{1}{1 + x} \right\} = L \omega_1 \{ 1 + x - (1 - x + x^2 - x^3 \dots) \} = L \omega_1 (2x - x^2) = L \omega_2 (2 - x) \text{ very approximately.}$$

Similarly  $L (\omega_1 - \omega_2) - \frac{1}{c (\omega_1 - \omega_2)} = L \omega_1 \{ 1 - x - (1 - x + x^2 \dots) \} = -L \omega_2 (2 + x) \text{ very approximately.}$

When  $x$  can be neglected compared with (2) we can therefore write

$$\tan \alpha_1 = \frac{2 \omega_2 L}{r} = \tan \alpha_2. \text{ Hence } \alpha_1 = -\alpha_2 = \alpha \text{ say.}$$

Thus substituting in (3) the formula for the current  $I$  in the resonating circuit is

$$I = \frac{\omega_1 \Phi \cos \omega_1 t}{r} + \frac{m \omega_1 \Phi}{2 \{ r^2 + 4 L^2 \omega_2^2 \}^{\frac{1}{2}}} \left\{ \begin{array}{l} 1 + x \sin \omega_1 t + \omega_2 t - \alpha \\ - 1 - x \sin \omega_1 t - \omega_2 t - \alpha \end{array} \right\} \quad (4)$$

Now the expression inside the large bracket equals

$$\sin (\omega_1 + \omega_2 t - \alpha) - \sin (\omega_1 t - \omega_2 t - \alpha) + x \{ \sin (\omega_1 t - \omega_2 t - \alpha) + \sin (\omega_1 t - \omega_2 t - \alpha) \}$$

which equals  $2 \cos \omega_1 t + \sin (\omega_2 t - \alpha) + 2x \sin \omega_1 t \cos (\omega_2 t - \alpha)$ .

If  $2L\omega_2$  is greater than  $25r$  the error made in assuming that  $(r^2 + 4L^2\omega_2^2)^{\frac{1}{2}} = 2L\omega_2$  is less than one in a thousand.

We see that (4) can be written

$$I = \frac{\omega_1 \Phi \cos \omega_1 t}{r} + \frac{m \omega_1 \Phi}{2L\omega_2} \left\{ \cos \omega_1 t \sin (\omega_2 t - \alpha) + x \sin \omega_2 t \cos (\omega_2 t - \alpha) \right\}$$

The second term in the bracket being multiplied by  $x$  the ratio of the frequencies can in practice be made negligibly small compared with the first. Neglecting it we get finally

$$I = \left\{ A + \frac{B}{f_2} \sin (\omega_2 - \alpha) \right\} \cos \omega_1 t \quad (5)$$

where  $A = \frac{\omega_1 \Phi}{r}$   $B = \frac{m \omega_1 \Phi}{4L\pi} \tan \alpha = \frac{2L\omega_2}{r}$

Since we have supposed that  $\frac{2L\omega_2}{r}$  is

25 or greater than 25,  $\alpha = 90^\circ$  very approximately and thus (5) becomes

$$i = \left\{ A - \frac{B}{f_2} \cos \omega_2 t \right\} \cos \omega_1 t \quad (6)$$

Comparing (6) with (1) we see that the current in the resonant circuit consists of a modulated carrier wave and would produce an audible note the frequency of which is  $f_2$ .

It is to be noticed, however, that the amplitude of this audible note is inversely proportional to the frequency, the higher the note, the smaller the amplitude.

If there are notes of several frequencies  $f_2, f_3, \dots$  sounding at the transmitting apparatus, the current would be given by

$$I = \left\{ A^I - \frac{B^I}{f_2} \cos \omega_2 t - \frac{B^{II}}{f_3} \cos \omega_3 t \dots \right\} \cos \omega_1 t$$

where  $B^I, B^{II}$  are constants which depend on the amplitude of the pure tone sounding at the transmitter.

Equation (6) can be written

$$I = A \left( 1 - \frac{B}{A f_2} \cos \omega_2 t \right) \cos \omega_1 t = A \left\{ 1 - \frac{m \delta n}{2 \pi f_2} \cos \omega_2 t \right\} \cos \omega_1 t \text{ where } \delta = \frac{r}{2 n L}$$

Thus the modulation factor which for the input is  $m_1$  becomes for the output

$$\frac{\delta}{3 \pi f_2} m$$

and we have the result that a very selective receiver changes the modulation factor.

By the factor  $\frac{\delta}{2 \pi f_2}$  where  $\delta$  is the logarithmic decrement,  $n$  is the carrier frequency and  $f_2$  the modulation frequency.



▲  
Here is a photograph of a modern, confidence-inspiring radio retail window display. (Southern California Music Co., San Diego, Cal.)  
▼

## Sales Production Control

By AUSTIN C. LESCARBOURA  
Mem. I.R.E. Mem. A.I.E.E.

**T**HE solution of the yearly radio dumping party lies in production control."

"The solution of the war problem lies in armament control."

"The solution of the wild youth problem lies in boy and girl control." Absolutely.

But in all cases we come to the primary questions, "Who? How?" About armaments and boys and girls, we are not prepared to speak with any degree of certainty. But in radio we can say that there is very little chance that any organization other than the individual manufacturer can do anything about production control in time to have any effect on the dumping of the excess production of 1931. (1930 over-production was dumped in time to help ruin last year's

Christmas prices). The setup of the industry is such as to preclude any cooperative action so that each manufacturer will have to be his own "George" and figure out how to control his own production. As in the case of so many basically simple operations, the technical language that has grown up around production control has so obscured its functions and operating details that it begins to look as intricate as calculus and as mysterious as chemical synthesis. Being addicted to the joyous task of debunking technical jargon, we try to present a plan of sales production control in such language that we can understand it ourselves.

Webster gives as a definition of control, "To exercise restraining or directing influence over; curb." And that is just the sort of treatment that radio production needs. The system now in use has been taken over to some extent from the automobile industry as it existed at the time of radio's greatest growth, and usually consists of a pretty terrible guess on the part of each manufacturer as to how many sets he can sell during the year.

The first point we must realize is that to make it anything but a terrible guess is going to take the services of a good man for the entire year, radio production control calls for a series of constantly revised guesses over the entire length of the year. Other industries are doing it, and if radio is to rid itself of the consequences of the dumping evil, it must stop making hopeful guesses and start using facts. The manufacturer must look closer than six months away in his planning; he must plan his production in the shortest periods possible. The sales department cannot set the schedules, for the sales quotas are usually a goal to shoot at rather than an honest prediction based on fact. The production man should not set the schedules, for the production man is interested mostly in economic production and cares little how that production can be sold. Let us, therefore, create a special planning department which will use the machinery of the sales department to collect facts on how much can be sold, and the machinery of the production department to collect facts on how that quantity can best be made. We are interested

▲  
**The Sales Production Man  
Stands With One Foot in  
the Sales Department and  
the Other in Production**

in a special planning department that will "restrain and curb" the wheels of production in the light of the sales possibilities.

At the head of this planning department is the Sales Production Manager, who will first determine how far ahead he has to schedule production. This, of course, will depend largely on how long a time must elapse between the setting of a schedule and the delivery of the finished product. If the product can be in the shipping room one month after it is scheduled, the Sales Production Manager must have his schedule at least a month ahead of production. He now sends to the point in the merchandising setup farthest away from the plant a sales prediction form to be filled out. This means that at regular intervals, in some cases as close as two weeks apart, the district managers, or the distributors, send direct to the sales production department a record of how much material they said they would sell when they reported for this two weeks, how much they actually sold, and how much they expect to sell in the corresponding two weeks of next month. These reports are tabulated and the information immediately available is how many sales were predicted for the current period, and how near that prediction was to actual sales with the resultant over-production or under-production, together with a prediction of how much we can expect to sell in the two weeks beginning a month from now.

Suppose we find that we fell behind the estimate by 1000 sets, and we find that our prediction for the next schedule is 10,000 sets for the two-week schedule. We schedule 9,000 sets and so balance our current error. So much for the schedule of quantities. We are never more than a month away from our market, and each schedule makes adjustment for the errors in the last schedule. We can never over-produce more than one month's supply of sets, and we shut down at first indication that we are more than a month ahead.

The work of the planning department is by no means over. The schedule is only for one month ahead. There may be certain parts that take more than one month to procure. There may be parts that are made much more economically in very large quantities. These are the rocks which must be removed before the sales production control plan can really operate to anything like complete satisfaction.

First we must make some concessions to expediency, the laboratory will maintain that all the special parts made to your individual specifications are necessary to the proper functioning of your set. In most cases you will

find this statement to be unmitigated blah. If your laboratory is worth the salt in its soup it will be able to adapt your circuit to standard parts, or to devise a way for you to manufacture those parts as economically yourself. At least it will be able to reduce the number of special parts to such an extent that the burden of carrying an adequate supply will be but a fraction of the burden now assumed because of obsolescence of completed sets. Once you have lined up your parts requirements, you have practically won the battle, but you may expect that same laboratory to be one of the hardest points to get over.

But to get on with the work, let us assume that your engineering problems are adequately handled, in which case the sales production department will schedule the quantities to go into production for each department of the plant, and send to the purchasing department a list of its required material for the period under schedule. It is the function of the plant production department to maintain those schedules, and a function of the purchasing department to see that the material is on hand for that schedule. The planning department already knows just what it can expect in the matter of production and deliveries, for it has a complete reference file of the stand-

ards of every department in the plant and the delivery time on every material, both raw and semi-finished, from an outside source. For every part it has noted in the files the most economical quantity to manufacture in one scheduled run, and it translates the predictions of the field men in sales modified by current performance of the sales department, into terms of near-at-hand production.

On paper it will work. In practice it has been made to work. Let us suppose that you wish to install the system in a radio receiver plant, how would you go about it?

The first consideration is the Sales Production Manager. He must be a high-grade man, tactful, with an engineering mind, and with sales experience preferably in sales management. He first studies the plant and collects his information on what materials you use, how long it takes to get them and how much you buy at a time to get the best price. He then finds out the standards of the production departments and arranges his information on production. He then studies his market conditions and sets the scheduling periods.

These points tentatively set, he will make recommendations as to what changes are necessary to maintain

*(Continued on page 42)*



And here is a picture of a type of radio receiver outlet in a midwest city, which it is hoped is on its way out.

# Maximum Undistorted Power Output

By GILBERT SMILEY\*

Here is an Engineering Analysis of the Factors Determining Amplifier Design and Performance

THE first word of the title of this article is "maximum." It signifies an outer or upper limit. When applied to an audio-frequency amplifier, in describing power output, "maximum" means the utmost of which the amplifier is capable. Amplifiers, in practice, are seldom called upon to deliver their utmost. Were such calls more frequent, some of them, undoubtedly, would demand more than the utmost, and the reproduced matter would suffer accordingly. In order successfully to meet maximum output demands, amplifiers must commonly be operated so that they deliver but a small fraction of such maximum. In thinking of amplifier behavior, however, it is a common failure to associate normal output volume with maximum output rating. Thus the use of the word, "maximum," in power output ratings has led to an erroneous concept, wherein the non-technician interprets maximum possibilities in terms of average volume levels, with no regard for such extremely important matters as the relative intensities of peak and average signal impulses.

The second word of the title is "undistorted." Sad to relate, the distortionless amplifier is yet to be made. Distortion, however, is not objectionable in itself. Only as it passes certain limits does it become a detrimental factor in audio-frequency reproduction. Actually, the word, "undistorted," in the title merely signifies that the distortion is of a magnitude insufficient to affect the audible quality of the reproduced matter.

The third word of the title is "power." In reputable electrical engineering circles there is a nice differentiation between the words "power" and "volt-amperes"—power, for present purposes, being expressed in watts. Power definitely signifies that energy

is being supplied at a given rate. Volt-amperes may, or may not, represent power. If the load connected to the output terminals of the amplifier operates with unity power-factor, the amplifier will supply it with an identical number of watts or volt-amperes. If, in addition to operating with unity power-factor, the load presents a proper terminal impedance, the amplifier will deliver it to maximum rated power with no more than permissible distortion, other operating conditions being proper. If, however, the power-factor of the load is not unity—i. e. if the load presents a reactive component in its terminal impedance—under proper conditions the amplifier may deliver volt-amperes in excess of the watt rating, but the actual power output must always be less than rating for permissible distortion for such loads. It is because of these niceties of definition that the term, "power," as applied to amplifier output is meaningless in practice, for conventional loads fail to present either constant or non-reactive impedance over the audio-frequency spectrum.

The fourth, and final, word of the title is "output." With this word we do not choose to quibble.

## Peak Output

Returning to the complete title, it is evident that "maximum undistorted power output" signifies the peak output of an amplifier into a non-reactive load of the correct impedance with no more than permissible harmonic, or distortion, introduction. Further, it must be realized that peak output is much greater than average output, and that the limits of permissible distortion vary with the nature and volume of the reproduced matter. Now to expand on distortion, especially upon its omnipresence in audio-frequency amplifiers.

Whence comes distortion? The answer is almost too simple; distortion

comes in at every point in a "sound" system. The distortion under discussion is waveform, or amplitude, distortion, as distinguished from frequency discrimination. As the title refers particularly to the rating of audio-frequency amplifiers alone, distortion arising in such amplifiers will be discussed, but, lest the reader forget, every part of a sound system adds its share of distortion, and amplifiers, properly operated, show a much cleaner slate than many accessory units, notably microphone transmitters, record pickups, or radio detectors.

## Waveform Distortion

In a system free from waveform distortion a sinusoidal entering impulse would emerge as it entered, altered only in magnitude. In actual sound systems, sinusoidal signal components emerge as non-sinusoidal components, having suffered mutilation to a greater or less extent depending upon the relative freedom from waveform distortion for the amplitude and frequency of the impulses in question.

Waveform distortion in audio-frequency amplifiers originates primarily in vacuum tubes as considered with their terminal impedances, secondarily in iron-cored coupling units and in power supply sources.

Vacuum tubes used as "class A" amplifiers, i. e. with control grid bias located approximately midway between zero bias and cutoff, function as con-

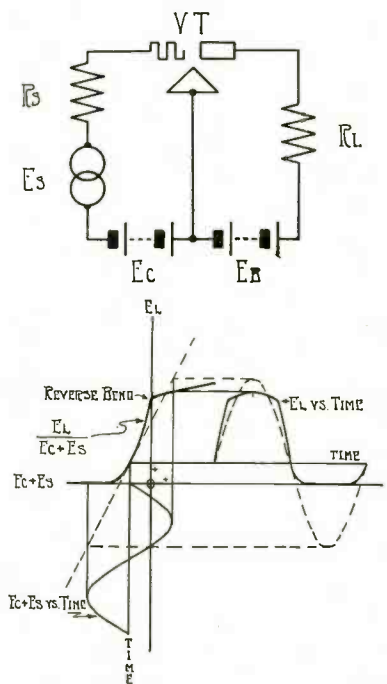

Fig. 1 (at top). Diagram of a class A amplifier.

Fig. 2 (below). Graphic representation of behavior of amplifier.

\*Engineer, Samson Electric Company.

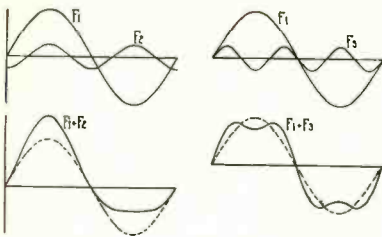

Fig. 3. Fig. 4. Voltage wave relations.

trolled relays. A relatively small power input applied to the control element is made to release a relatively great amount of power, conforming, in the main, to the nature of the controlling impulse, through the action of the tube. Ideally, the class A vacuum tube amplifier is supposed to release an enlarged facsimile of the input impulse. However, the output of a vacuum tube amplifier always misses being a facsimile of the input. As the control element is electrostatic in operation, it is expedient—and, we hope, permissible—to continue the discussion in terms of voltage waves, neglecting for the time the power concept.

Fig. 1 is a simplified circuit diagram of a class A amplifier. The source, indicated by the alternator symbol, of negligible impedance, impresses the sinusoidal voltage,  $E_s$ , upon the control element, or grid, of the triode, VT. Grid bias is supplied by the battery,  $E_c$ . In the plate, or anode, circuit is the load,  $R_L$ , anode current being supplied by the battery,  $E_b$ . Cathode excitation is purposely omitted as having no particular bearing on the problem.

Fig. 2 is a graphical representation of the behavior of the amplifier of Fig. 1. Control and load voltages are referred to horizontal and vertical axes respectively. The applied control voltage is the algebraic sum of the source and bias voltages,  $E_s + E_c$ . This resultant voltage is operated upon by the performance curve,  $\frac{E_L}{E_s + E_c}$ , yielding

the load voltage curve,  $E_L$ . Tangent to the actual performance curve is a dotted line, representing that ideal performance curve—never realized, of course—which is necessary to complete absence of waveform distortion. The straightness of the idealized dotted line indicates that a linear relationship must exist between control and load voltages if distortion is to be avoided. Coincident with the actual load voltage curve is a dotted curve indicative of the load voltage were the performance curve the straight, dotted line rather than the curved line. The dotted curve is sinusoidal and represents an enlarged facsimile of the input wave. The departure of the actual load curve from the dotted curve shows distortion.

Fig. 3 is illustrative of the synthesis

of a non-sinusoidal wave from sinusoidal components. The example chosen is very simple, consisting of the algebraic addition of the voltage wave,  $F_1$ , to the voltage wave,  $F_2$ , yielding the resultant complex wave,  $F_1 + F_2$ . The process is reversible, allowing the breaking down of the complex wave into its components. Though the illustration is incomplete, it demonstrates in part the process by which any complex wave may be synthesized or analyzed, out of, or into, sinusoidal components. Note particularly that the complex wave in Fig. 3 closely resembles the load voltage wave in Fig. 2. Further to emphasize the similarity, a dotted curve is drawn coincident with the complex curve,  $F_1 + F_2$ . It may

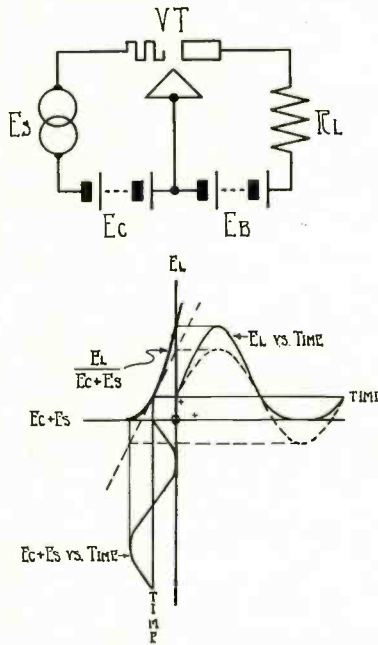

Fig. 6 (at top). Compare with Fig. 1, where source impedance appears. Fig. 7 (below). Compare with Fig. 2.

readily be observed that the departures from the dotted curves of the complex curves in both Figs. 2 and 3 are approximately the same, indicating that distortion magnitudes are comparable, and that the distortion is relatively the same.

Examination of Fig. 3 shows that  $F_2$  is twice  $F_1$  in frequency. If  $F_1$  be considered as the fundamental, then  $F_2$  becomes a second harmonic of  $F_1$ —the two being an octave apart—and  $F_1 + F_2$  represents a fundamental plus considerable second harmonic as a distortion component. The relative amplitudes chosen are somewhat greater than would properly be permissible in audio-frequency reproduction, in order more effectively to emphasize the disparities between pure tones and the same pure tones plus harmonic distortion. The

resemblance of the complex waves in the two figures exists because of the fact that the vacuum tube amplifier performance curve,  $E_L/E_s + E_c$ , very closely approximates a quadratic, the mathematical curve necessary to produce second harmonic distortion only. However, in the load voltage curve in Fig. 2 there are other harmonic distortion components.

Presence of Harmonics

Fig. 4 is included to show the resultant when an odd harmonic is present. To the fundamental,  $F_1$ , is added the third harmonic,  $F_3$ , producing the complex wave,  $F_1 + F_3$ . As before, the coincident sinusoidal curve shows the magnitude and nature of the departure due to distortion. Comparison of Figs. 3 and 4 yields the observation that odd harmonic components lead to a resultant that is symmetrical about the time axis, while even harmonic components cause the resultant to be asymmetrical about the same axis. In a perfectly symmetrical waveform there can be no even harmonic components. Asymmetry, however, does not deny the presence of odd harmonics, inasmuch as the fundamental, or first harmonic, must perforce be present together with such other odd harmonics as are inherent in the waveform under consideration. Asymmetry does serve as a positive indication of the presence of at least one even harmonic.

Figs. 5-A and 5-B correspond to Figs. 3 and 4 with the harmonic advanced  $90^\circ$  in phase in the former, and retarded  $90^\circ$  in the latter. Note that, in Fig. 5-A, the curve is asymmetrical, for the positive and negative loops do not duplicate amplitude variations with respect to time, reversing such variations, instead. Thus, regardless of phase displacement, even harmonics are productive of asymmetry. Fig. 5-B, on the other hand, is symmetrical, proving the case for odd harmonics. The waveforms of these two figures are not as commonly encountered as the results of distortion as are those of Figs. 3 and 4, but are included to complete, in part, the simplified illustration of complex wave synthesis and analysis.

The preceding discussion has been

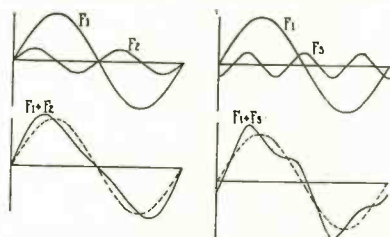

Figs. 5A and 5B. These curves correspond with Figs. 3 and 4, with the harmonic advanced  $90^\circ$  in 5A, and retarded  $90^\circ$  in 5B.

inserted as essential to an intelligent comprehension of the nature of waveform distortion. It has already been shown that tube distortion, within the limits of class A amplification, consists mainly of the introduction of even harmonic components, with the second harmonic predominating because of the close approximation of the amplifier characteristic to a quadratic. It is further necessary to state that the curvature of the performance curve is altered by the ratio of load to plate resistance. As the load impedance approaches an infinite value, the performance curve tends to approach the idealized shape necessary for distortionless amplification, which shape is, as previously shown, a straight line. There is, therefore, a strong incentive to operate tubes into high load impedances in order to minimize distortion components introduced by the tube.

### Tube Performance

Equally strong, however, is the incentive to secure a maximum power output from the tubes. The condition for the fulfillment of this requirement is that the load impedance equal the plate impedance of the tube—the theory of impedance matching. As a result, the load impedance for a maximum energy transfer within definite distortion limitations is a compromise, lying between the limits of plate impedance and infinity, though generally some low

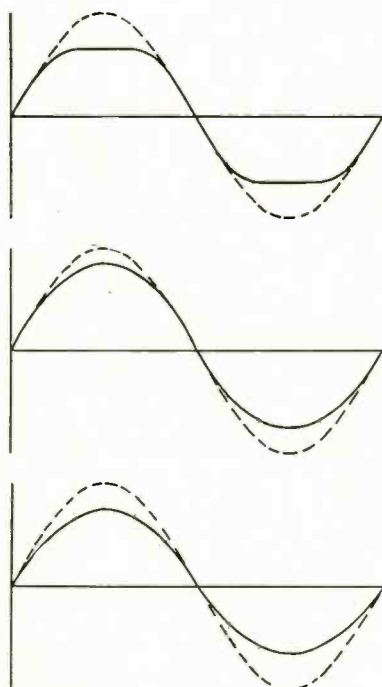

Fig. 11 (at top). Resultant load voltage.

Figs. 12 and 13. Representative of load curves for the same two coupling units with direct current in the winding.

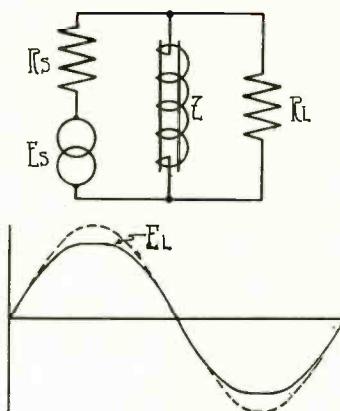

Fig. 8. (at top). Set-up of choke

Fig. 9 (below).  $E_L$  curve, load voltage.

multiple of plate impedance. As load impedance decreases below plate impedance, the curvature of the performance characteristic becomes more and more pronounced, and distortion components enter rapidly.

So far the argument has been concerned with tubes operated within the limits of class A amplification, in which case arbitrarily the peak grid swing never exceeds the bias potential, or, in other words, the grid voltage never becomes positive. Under these conditions, distortion introduced takes the form of a slight flattening of the lower half of the cycles owing to the approach of cutoff, and a slight extension of the upper half due to the rapid rise of the quadratic characteristic. Should the signal amplitude be increased beyond the proper limits of class A amplification, so that the peak grid swing will exceed the bias potential, the grid will become positive with respect to the cathode for a portion of each cycle, though this, in itself, will have no ill effects other than a normal increase in distortion owing to the inclusion of more of the quadratic within the operating region, provided, of course, that the amplitude is insufficient to produce grid emission or space current saturation. As long as the source impedance is negligibly low the current drawn by the grid when it becomes positive will have no appreciable effect upon the performance curve.

Again it is necessary to reject an ideal case in favor of more practical considerations. Source impedances, in practical cases, are not always negligible, and are, generally, highly important. Fig. 6 is an illustration of a generalized practical case. It resembles Fig. 1 with the single exception of the introduction in Fig. 1 of the source impedance,  $R_s$ . Similarly, Fig. 7 alters the performance curve of Fig. 2 by the inclusion of the sharp reverse curvature at the point where  $E_s + E_c$  becomes

zero. This reverse curvature is the result of the fact that when the grid becomes positive the grid-cathode path impedance gradually drops to a relatively low value as compared with the relatively high value in the negative grid region.

The low impedance of the control element circuit, taken with the source impedance, forms an effective drop wire for the reduction of applied control voltages over the positive grid region, with a consequent and similar reduction of load voltage. The resultant load curve is shown together with a dotted curve illustrative of undistorted amplification. The change in grid-cathode impedance occurs abruptly as the grid voltage crosses the zero point, and the resulting discontinuity in the performance curve is decidedly marked. The effect of this discontinuity is to introduce harmonics of an extremely high order, many times the fundamental frequency, which are most objectionable in audio-frequency reproduction.

### Tube Limitations

Distortion introduced by vacuum tubes in the ways outlined above may be attributed directly to the tubes as a natural consequence of their inherent limitations. With a proper load impedance and reasonable signal input, the

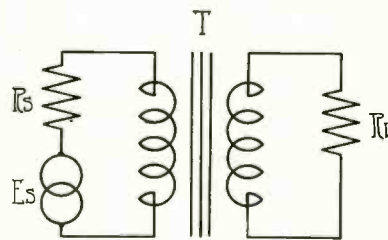

Fig. 10. Transformer set-up.

distortion introduced by tubes is entirely permissible, provided they are operated in accordance with the requirements of class A amplifiers, but such distortion can, and often does, become most objectionable through oversight on the part of designers and operators with regard to these points.

Following tubes in importance as sources of distortion components are iron-cored coupling devices, transformers and chokes. Figs. 8, 9, 10 and 11 illustrate a choke setup, resultant load voltage, a transformer setup, and its resultant load voltage. In neither case are the windings carrying direct current. The distortion is due to the changing reluctance of iron as a magnetic material with changes in flux density. Such changes in reluctance effect the impedance of the unit over the cycle, varying the transfer constant between source and load, and introducing considerable distortion. The trans-



former introduces more distortion inasmuch as the changing core reluctance has a double effect, one on primary impedance and the other on the coefficient of coupling.

Figs. 12 and 13 are representative of the load curves obtained from the same two coupling units with direct current in the windings. In this case the d-c. and a-c. flux components are additive for one half of the cycle, and subtractive for the other half. Saturation and increased reluctance is, therefore, more pronounced during the additive half of the cycle, with consequently greater distortion at that time. Where no direct-current exists in the windings the distortion introduced by coupling units with iron cores is odd harmonic in nature. Where direct-current is present, some even harmonics will result in addition to the odd harmonics normally present. Like vacuum tubes, coupling units may be designed and operated with their limitations in mind, in which case very excellent results may be obtained.

### Tube Voltage Supply

Vacuum tube supply circuits enter, generally, as a minor source of distortion. Before supply circuits can have an appreciable effect on amplifier distortion behavior there must be some form of distortion in the associated vacuum tubes. Where tubes are cascaded on a common power supply a certain amount of the energy released in final stages may be fed back to earlier stages. If there be distortion present in the feedback energy, and the common supply impedance is appreciable, sufficient distortion will be supplied to early stages to appear as a considerable factor in the output. If, however, the supply circuit is sufficiently well designed to permit normally stable amplifier action, there is little to be feared from it as a factor in increasing distortion components.

Multi-element tubes often require a drop-wire supply for space charge elements and the like. Often, during operation, there is apt to be considerable rectification by such secondary elements. Unless the drop-wire circuit and by-pass condenser be properly designed with a view towards maintaining a proper operating voltage over the entire operating range for the

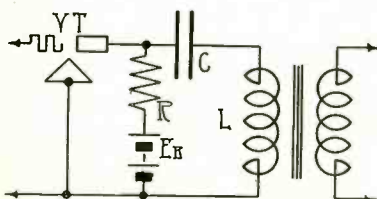

Fig. 15. Circuit for raising low end of amplifier response characteristic.

duration of a low frequency cycle, the effect of such rectification will be to alter the secondary element operating voltage, either cyclically, or during sustained wave trains, altering, in turn, the characteristic performance of the tube and introducing marked, and erratic, distortion components.

The question, "Whence comes distortion?" has been, in part at least, answered. Having examined the mechanics, as it were, of distortion, it is now time to see how and where such sources of trouble can exist in audio-frequency amplifiers. In other words, now that the reader has become aware of the conditions necessary for the rise of distortion components, it is well to ferret out such actual conditions.

The discussion of Figs. 1 and 2 presumed to show that vacuum tubes, especially when operated with too low a plate load, produced distortion com-

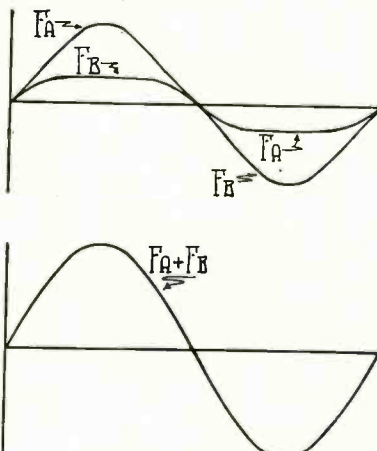

Fig. 14. Curves showing distorted outputs of two tubes, with resultant waveform free from distortion.

ponents of considerable importance. All too often, designers of audio-frequency amplifiers, in their zeal to secure maximum energy transfer or appropriately equalized response characteristics, overlook this point, with the result that tubes are worked into loads of equal or less impedance than that of the plate circuit of the tube. The error is most frequently encountered in the output stage, in a desire to present a matching load for maximum energy transfer rather than maximum output for permissible distortion, in which case the terminal impedance is reflected as equal to the plate impedance of the tube or tubes in the power stage, with a consequent generation of harmonics, largely in the form of rectification. If tube characteristics were of the pure quadratic nature, the use of symmetrical amplification in the power stage would escape the difficulty as shown in Fig. 14. In this figure, the distorted out-

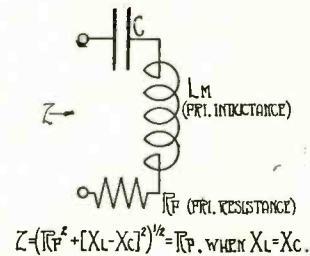

Fig. 16. Equivalent circuit of plate circuit of tube.

puts of two tubes in symmetry is algebraically summed up giving a resultant sinusoidal waveform free from distortion.

Transfer characteristics are not pure quadratics, and all harmonic distortion does not cancel out when tubes are employed in symmetry. Even harmonics are eliminated, and complete elimination of these calls for exact symmetry of all elements in the stage under consideration. Odd harmonics emerge unsuppressed. Thus, even when symmetrical amplification is used, the plate load should, as nearly as possible, conform to the proper value for maximum output with minimum harmonic content.

Over-shooting the mark in equalization is also extremely easy to do. It is common practice, in order effectively to raise the low end of an amplifier response characteristic, to employ a resonant circuit, tuned to a low frequency, and of such sharpness that the characteristic, down to the resonant frequency is essentially flat or even slightly above the zero level in some instances. Fig. 15 shows such a circuit. Fig. 16 gives the equivalent circuit as seen by the plate circuit of the tube. Since inductive and capacitive reactances are equal at resonance, they effectively cancel, leaving only the transformer primary resistance as a plate load. This resistance is as a rule low compared to the plate impedance of the tube and the result is somewhat damaging to the quality of reproduction of frequencies at or near the resonant frequency of the tuned circuit. Harmonics are generated freely, passed on to the following stage or stages and emerge full of vitality in the output. If, however, the grid swing of the tube so used be small, or if it be one of two tubes in symmetry, or if the sharpness of the tuned circuit be rather great, the harmonic generation can be considerably reduced.

### Coupling Units

One further cause of low plate load is common to improper design of coupling units, and consists of a coupling unit whose shunting load on the plate circuit of the tube falls below a per-

(Concluded on page 50)

# Design of the Superheterodyne Receiver, using Screen-Grid Tubes

By C. H. W. NASON

## Need for Close Selectivity Prompts Engineers to Look to the Virtues of the Superhet

**A**FTER some years of forgetfulness designers turn again to the superheterodyne receiver of Armstrong for the solution to problems of sensitivity and selectivity. Just where the super has advantages over the t. r. f. circuit or over any other system is a problem for the individual designer. It is the present writer's purpose to refresh the memories of designers on certain points which demand consideration in the design of superheterodyne receivers, without regard for relative merit. Selectivity, in the case of the "super" resolves itself into four separate and distinct problems and is the major consideration. Perfect adjacent channel selectivity is provided without loss of the higher modulation frequencies when the cutoff of the overall response characteristic is rapid beyond 5,000 cycles to either side of the carrier frequency. Adjacent channel selectivity is of the same order as that defined simply as *selectivity* in the case of receivers employing straightforward amplification at the carrier frequency only. In the case of the superheterodyne the selectivity is greatly enhanced in the process of frequency changing. Let us assume as an example of this quality that two carriers are at 1000 and 1010 kc. respectively. The 1000 kc. signal is removed from the other by 1 per cent of its total frequency. If these two signals are beat against a local oscillation of 1100 kc. a frequency of 100 kc. in the first instance and of 110 kc. in the case of the interfering signal will result. The separation will now be 10 per cent of the frequency of the desired oscillation. It might be noted here that in the process of intermediate amplification the modulation frequencies will occupy a correspond-

ingly wide band when considered in the light of percentage-of-carrier-frequency and it will be almost imperative that some form of flat topped response curve obtain in the interstage coupling devices if loss of the higher modulation frequencies is to be avoided.

In the foregoing paragraph the choice of an intermediate or beat frequency of 100 kc. was arbitrarily made to simplify the explanation. The choice of the intermediate frequency employed is more complex. With single control operation a necessity at the outset we will avoid any consideration of the "repeat-point" bug-a-boo so common in the early superheterodyne. Prior to single control it was usual to choose an intermediate frequency equal to the width of the broadcast band so that either the sum or difference of the carrier and local oscillation could be amplified without the possibility of the unused beat appearing within the tuning range of either dial. It is obvious that if single control is to be achieved by means of ganged s.l.f. condensers the upper beat will be the one amplified. If the obviousness fails to make itself self-evident this is assumed from the fact that single control can be partially effected by employing matched condensers with a smaller inductance in the oscillator circuit—the stray capacitances being equalized by the use of a fairly large trimmer condenser in the oscillator circuit.

### Image Frequency

Assume once more an arbitrary situation where a 1000 kc. signal is beat down to 30 kc. by means of a local oscillation at 1030 kc. Now if by any chance a signal having a frequency of 1060 kc. is present at the input to the modulator or first detector tube another 30 kc. signal will result and we

will have what is known as "image frequency" interference. The problem is one of having a sufficiently high intermediate frequency to avoid "image frequency" interference and a sufficiently low one to avoid the possibility of any harmonic of the intermediate frequency present in the output of the second detector finding its way back to the input to produce spurious beats. In practice it has been found that a frequency of 175 kc. is a fair compromise and this frequency has been chosen for most of the designs which have appeared on the market to date.

It is still essential that a high degree of adjacent channel selectivity be obtained prior to the first detector if cross-talk or image frequency interference is to be avoided in totality. The frequency of 175 kc. is high enough to expect large gain-per-stage in the intermediate circuits and so low that no harmonics of lower order than the fourth fall within the broadcast band to cause possible trouble through the leakage mentioned above.

Inasmuch as adjacent channel selectivity is a function of the over-all characteristic of the receiver we might assume our work to be done if a certain degree of selectivity is obtained in the over-all response. That this is not true was commented on above. While it is almost certain that enough selectivity will obtain ahead of the first detector to avoid image-frequency interference where a high beat is employed we are still subject to two effects common to broadcast receivers of all types but which have received all too little attention in many designs. These are the inter-related effects of "cross-talk" or cross-modulation and of beat interference.

### The Screen-Grid Tube

Although in many ways the screen-grid tube does not differ from the triodes which went before there are certain phases of operation which have received all too little consideration. It is rarely appreciated that the screen-grid tube will not accept large signals without departing from its most favorable operating condition. If for example a signal from a distant transmitter appears in an antenna circuit together with a powerful local oscillation many kilocycles removed and which is strong enough to cause the first tube to operate on a portion of its characteristic favorable to rectification, no amount of selectivity in the succeeding stages will suffice to remove the interfering modulation. This form of interference is termed cross-talk or secondary modulation. While it is possible to avoid this in a measure by the use of a volume control in the antenna circuit, in the majority of cases when the interfering signal has been reduced to a level where it no longer endangers

the proper operation of the first tube the desired carrier will have disappeared altogether. The sole cure lies in the use of some form of coupled-circuit system or band-selector in the antenna tuning.

Even at best the screen-grid tube is likely to rectify to a certain extent and in localities where there are many powerful locals and in cases where these carriers are permitted to impress even a small potential on the grid of the first tube the plate circuit of that tube will carry a rather complex output. For example we may find when tuned to a station having a frequency of 550 kc. that we are experiencing a peculiar interference where the desired modulation will have superposed upon it the modulations of two other stations—one at 1450 kc. and the other at 900 kc. Again, the use of a coupled circuit antenna system will be the only sure means of effecting a cure. These effects are particularly marked where the first detector is not preceded by an r-f. stage.

As will be seen from the above remarks the basic arithmetical selectivity gain from the use of the superheterodyne system—that is, the enhancement of selectivity normal to the process of frequency changing, does not leave us with the solution to the entire problem of selectivity as was once thought. Instead, rather than having a problem of straightforward tuned circuit selectivity in combination, we find that there are a great many compromises to be made. We may now turn to the other considerations in superheterodyne design.

**Gain in Superheterodyne Receivers**

The problem of "gain" in the superheterodyne system does not differ greatly from that encountered in the

case of r.f. receivers. We have by this time become accustomed to the use of the screen-grid detector and to an acceptance of the fact that the detector stage may be counted upon to add to the overall sensitivity of the receiver. You may also have filed in your memories the fact that the principle of the superheterodyne was in its ability to produce large gains at frequencies higher than r-f. amplifiers of the day were able to cope with. At the frequency chosen—175 kc.—it is possible to effect prodigious gains with the screen-grid tube. One point in the superheterodyne's favor lies in the ease with which we may obtain uniform sensitivity over the full band of broadcast frequencies. The superheterodyne—because of the large gains possible at radio frequencies—lends itself admirably to the present practice of operating the detector directly into the power stage. Recent developments in audio amplification render it logical to work a 24 detector into push-pull output tubes without loss in gain or distortion of amplitude or phase.

**The Oscillator Circuit**

With a relatively low intermediate frequency it would be quite practicable to obtain single control operation through the use of ganged condensers having s.l.f. plates. The sole expedient necessary in procuring single control at 30 kc. separation would be the use of a slightly smaller tuning inductance in the case of the oscillator. It is necessary with the 175 kc. intermediate frequency to employ sharp interstage coupling circuits with the result that—should the oscillator deviate but slightly from the desired separation over the broadcast band—the gain through the receiver would be seriously affected. For this reason the

new superheterodynes employ a special bridge tuned oscillator circuit. A reference to Fig. 1 will show that the grid of the tube is connected across but half of the tuning inductance. This is in order that the tube capacitance—which may vary slightly from tube to tube—will have but slight effect upon the tuning of the circuit which is adjusted with an average tube at the factory. The oscillator tuning capacitance consists of one section of the gang condenser together with one fixed condenser and two trimmers. One of these trimmers adjusts the separation frequency at the upper end of the band and the other takes care of any deviation which may exist at the lower end.

**Detection for the Modern Superheterodyne**

As noted, the second detector should be of the "power" or "high level" type to avoid the necessity for an intermediate low-frequency amplifier stage. With an a-f. coupling system such as shown in Fig. 1 the detector should be capable of establishing a voltage of about 50 (peak) across its load. The load should consist of a 250,000-ohm feed resistance in parallel with a 500 henry choke. The coupling may be improved by resonating the system at a low frequency. Employing an impedance tapped at its electrical center no deviation from true push-pull operation will be experienced. For maximum power output the peak r-f. input must attain a value of 5 volts at 30 per cent modulation.

It may readily be assumed that in all cases the amplitude of the local oscillation as impressed upon the first detector will be much greater than the amplitude of any signal encountered in normal operation. We have already

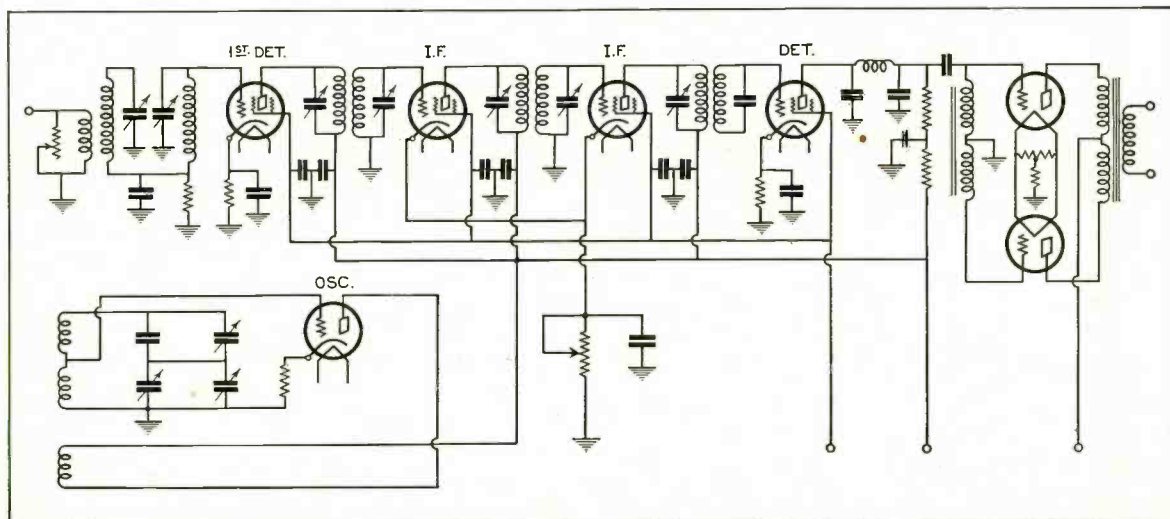

Fig. 1. Modern Superheterodyne Circuits.

assumed linear operation in the case of the second detector because of its functioning at a high signal level. It is assumed that the modulation system at the transmitter will produce an amplitude variation which is a linear function of the variations in sound pressure at the microphone. Inasmuch as the local oscillation will be at a fairly high level an overall linear functioning of the demodulation process at the receiver will obtain when linear detection is employed at the mixer tube or first detector also.

#### Fidelity in the Superheterodyne

We have already noted the fact that because of the high percentage of the intermediate frequency represented by the modulation some sort of coupled circuit system will be necessary in order to produce a flat-topped characteristic. If the highest possible degree of selectivity is obtained it stands to reason that a small amount of sideband cutting will creep into the system. This can readily be nullified by the use of a peaked a-f. characteristic. The design of an a-f. system for a radio receiver is a less exacting task than the design of a similar system for sound motion picture work as the upper limit attained in broadcasting is 5,000 cycles. If the coupled-circuit system ahead of the first detector is so designed as to compensate for

variations in coupling and selectivity with frequency the fidelity of the superheterodyne receiver may be made uniform over the broadcast band. It is certain that a system such as that laid out in the diagram may be designed more readily to have a pre-assigned performance than can be a t.r.f. system of like sensitivity.

#### A Modern Superheterodyne

The receiver shown in schematic is typical of modern practice in receiver design. Certain concessions to sales organizations—namely, tone control and automatic volume control have not been included in the design as they merely serve to complicate the structure. Off-channel selectivity prior to the mixer tube has been obtained through the use of a coupled circuit system. Volume control is achieved through the use of a double resistance unit having the proper curve of resistance against angular displacement and controlling the input from the antenna in conjunction with the grid bias potential of the intermediate r-f. tubes. The plate current of the screen-grid tubes is such that the variation in drain entailed in this system of control will have little effect upon the regulation of the power supply output. No attempt has been made to show the power supply or potential distribution circuits as these will vary widely with

the tastes of the individual designer.

Many tricks common to the circuits of superheterodyne receivers now on the market have been avoided in this design, for example: the practice of stabilizing the biasing potential of the first detector by taking the plate current of the oscillator through the biasing resistance. The oscillator-first detector coupling is secured by mutual inductance between the oscillator tuning inductance and the winding of the band selector circuit nearest the grid of the mixer tube. The superheterodyne lends itself to many refinements in design impracticable with the t.r.f. receiver. On the other hand it presents many production problems which are likely to render it an expensive manufacturing proposition.

There is no reason why the "super" in the hands of competent designers should not be made to eclipse the performance of even the best of modern t.r.f. receivers—but on the other hand there is no reason why the t.r.f. receiver should not be capable of a performance quite equal to that obtainable with the super. It should be remembered that in the years between we have conquered the problem which was the real cause of the superheterodyne's being—the inability to achieve reasonable r-f. gain at relatively high frequencies.



#### MEXICAN BROADCAST ADDITION

**M**EXICO made an important step in advancing the quality of its broadcasting structure recently with the erection of a new 5000 watt radio station, the most powerful in the country, at Mexico City.

The new station, which will be known as "The Voice of Latin America," is owned and operated by the Mexico Music Company. This prominent Mexican business firm erected the station to be the nucleus of what they hope will be a national network of radio stations operating along the same lines as the large radio networks in the United States.

If its plans materialize, it hopes to effect an exchange of programs with the United States, and with Central America. The Mexico Music Company also operates station XET, which is rated at 500 watts power. The transmitting apparatus used by the latter station is the old WJZ, New York, equipment.

Station XEW, Mexico's newest and most powerful voice, has just been completed and turned over to its owners by engineers of the RCA-Victor Company who designed and built it.

Embodying the most advanced radio broadcasting technique, such as 100 per cent modulation and crystal control, the new station has already made a successful debut on the air, and reception reports have been received from many parts of the United States. It operates on a wavelength of 384.7 meters. While recorded music is featured a good deal in its programs, the management is developing commercially sponsored programs as well as sustaining programs of native talent.



#### SALES PRODUCTION CONTROL

*(Concluded from page 35)*

these tentative schedules. He will be reasonable and enough of an engineer to know whether he is asking the impossible, and to adapt his plans accordingly.

The time element settled he will prepare forms for the sales department to give him his necessary information and the forms necessary for his department to issue the proper orders. Each week or each fortnight the sales department forms will come, with their estimate of orders for the suc-

ceeding period. One or two clerks tabulate them and make a master sheet of predicted sales compared with actual, together with summaries. The sales engineer then sets the schedule of production on finished product. Clerks prepare the production orders for the operating department, and the material requisitions for the purchasing department.

The schedule adjusted, the individual returns are then checked for accuracy. John Jones at Pasadena, California, has been twenty-five sets too optimistic for the last two months. John Jones is politely warned that if he continues to misgauge his market, he will wake up some morning with twenty-five extra sets to sell or eat as he sees fit. He will usually take the hint. Ike Smith in Maine consistently underestimates his requirements and is likewise warned that unless he comes closer to his actual sales he will find himself with sales and no sets to deliver. A bit of pressure here and there, with a slight touch of the whip now and then, brings the prediction and the sales ever nearer to each other until at last the department is functioning smoothly and well.

# Engineering Aspects of the Broadcast Antenna<sup>†</sup>

By HENRY E. HALLBORG\*

### Introductory

**B**ROADCAST service has become inseparately a part of American life. We now cut it on or off with the throw of a switch. We normally give no more thought to the vast and complicated system behind it than we bestow on those other great services—power and the telephone. We expect it to be there, and seldom are we disappointed.

Broadcast service, however, differs fundamentally from power and telephone services in that there is no tangible medium, no copper wires connecting the service source and the home. The effectiveness of the medium that links the broadcast station and the home is subject to many influences. One of these influences is the design of the broadcast antenna. It will be the purpose of this paper to consider many of the engineering aspects of the broadcast antenna that influence its reliability, economics and service range.

<sup>†</sup> Presented before the Radio Club of America, December 10, 1930.

\*R.C.A. Communications, Inc., New York City

### Modes of Antenna Operation

The American broadcast waveband—200 to 600 meters—is intermediate between what is commonly referred to as the “short wave” and the “medium long wave” bands. It is consequently so placed in the frequency spectrum that physical dimensions do not prohibit the application of antennas longer than one-quarter of a wavelength. In fact, it has been found desirable to operate the broadcast antenna at lengths varying from one-quarter of a wavelength to five-eighths of a wavelength. The selection of the mode of operation in any particular case is determined by the best compromise of theoretical, practical and economic factors.

Three of the many possible modes of operation of the broadcast antenna are:

1. One-quarter wave, or 100 per cent fundamental.
2. One-third wave or 75 per cent fundamental.
3. Five-eighths wave, or 40 per cent fundamental.

These modes of operation are typical, and their characteristics will be con-

sidered. In Fig. 1 is shown the current and voltage relations which exist in the above three modes of operation. The full hatched portions represent the current distributions along the wire, and the dotted lines the voltage distributions from ground to open end of the antenna. The current at the ground decreases as the length of the antenna increases above one-quarter wavelength. The maximum of current, or the current loop, moves progressively up the antenna. Operation at an antenna length greater than one-quarter wavelength has two advantages:

(a) It reduces the current loading of the ground wires.

(b) It produces a more horizontal type of radiation.

These factors both affect the efficiency of the antenna system. It is at once apparent, that it is desirable to operate a broadcast antenna at a length

POSSIBLE MODES OF OPERATION OF THE BROADCAST ANTENNA SHOWING THE RESULTING CURRENT AND VOLTAGE RELATIONS.

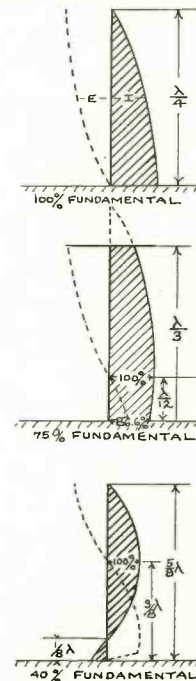

Fig. 1.

Technical Data of Antenna Design and Descriptions of  
Actual Broadcast Antenna Installations

POWER DISTRIBUTION CHARACTERISTICS IN VERTICAL PLANE OF THE ONE-THIRD WAVE AND FIVE-EIGHTHS WAVE T TYPE ANTENNAS.

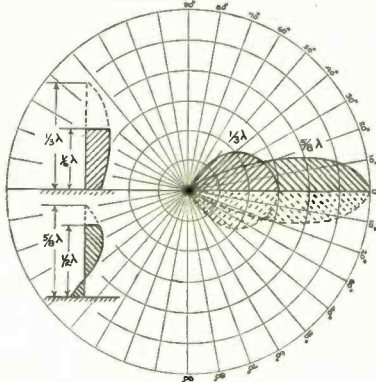

Fig. 2.

greatly in excess of a quarter of the wavelength.

It is well to consider at this point the role played by physical limitations and economics. For example, a five-eighths wave vertical antenna designed for 480 meters would be 984 feet in height. However, the cause is still not hopeless. While the straight vertical antenna for this wavelength is impractical most of the benefits of the vertical current distribution may be retained by the adoption of the T type antenna.

The horizontal top of the T type antenna contributes nothing to the radiated field, but it does permit of a better current distribution in the vertical, or radiating portion of the antenna. The middle diagram of Fig. 1 shows a T type antenna operating as a one-third wave system. It will be noted that the current maximum occurs one-twelfth wavelength above ground.

P. S. Carter of R. C. A. Communications, Inc., has calculated the power distribution in the vertical plane of a one-third wave, and a five-eighths wave, single wire, T type antenna. The diagrams of Fig. 2 illustrate graphically the results of these calculations. The small diagrams at the left of the figure illustrate the current distributions in the two antennas. The upper T antenna is assumed one-sixth wavelength high, and to have an electrical length of one-third

wavelength. The lower T antenna is assumed one-half wavelength high, and to have an electrical length of five-eighths wavelength.

It will be observed from Fig. 2 that a considerable portion of the energy of the one-third wave antenna is projected at a vertical angle of approximately 35° while the corresponding angle of the five-eighths wave antenna is about 15°. The five-eighths wave antenna radiates twice the power in the horizontal plane that is obtained from the one-third wave antenna.

The graphs of Fig. 2 assume a perfectly conducting ground. The effect of imperfectly conducting soil is to raise the angle of radiation above the horizontal. The angle of elevation will be higher as the conductivity of the soil becomes lower. Not all of this theoretical gain in power radiation by use of the five-eighths wave antenna can be obtained in practice. The theoretical gain

RELATION BETWEEN HEIGHT AND INSTALLED COST OF GALVANIZED STEEL SELF SUPPORTING TOWERS WITHOUT TOP STRUCTURES.

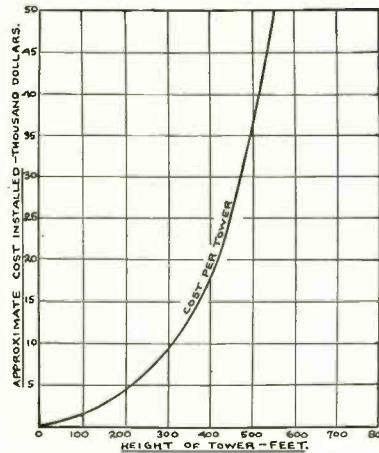

Fig. 4.

is reduced by absorption in guys, and supports, even in the so-called tower type radiators. If the theoretical gain of 2 could be obtained, the signal increase will be  $\sqrt{2}$  or 1.41, a theoretical signal increase of 41 per cent.

Typical Arrangement of RCA Broadcast Antenna

Reference has already been made to the single wire T type antenna. It is well to consider at this point why this type of antenna has been standardized for RCA broadcast service. The essential features of an antenna system for broadcast service may be summarized briefly as follows:

- (a) Radiation efficiency.
- (b) Uniform field pattern.
- (c) Low angle radiation.
- (d) Reliability under all weather conditions.

- (e) Serviceability.
- (f) Economy and simplicity.

If an antenna has all these characteristics it may be considered to be well engineered. In attempting to comply with all the above conditions many compromises between the theoretical and the practical must be resorted to. For instance, it may be possible to achieve conditions (a), (b) and (c) and to completely violate conditions (d), (e) and (f). On the other hand, conditions (d), (e) and (f) may be met, to the disparagement of conditions (a), (b) and (c). The compromise arrived at in the RCA broadcast antenna system is the single wire T type illustrated in Fig. 3.

The RCA single wire, T type broadcast antenna system is normally adjusted as a one-third wave antenna. The supports are standard, lattice type, self supporting steel towers 165 feet, 200 feet, 250 feet and 300 feet in height depending upon the wavelength. The normal tower spacing is two and one-half times the tower height. The towers may be insulated or not depending upon frequency assignments.

The use of a single wire in the antenna system reduces the capacity of the antenna, and increases the insulation required; but the wires are readily kept below the corona point even with 100 per cent modulation. Such a single wire system is almost immune to damage by high winds, and by means of a counter-weight system, as indicated, is not rendered inoperative by sleet accumulation.

The high radiation resistance of an antenna of the one-third wave type allows for high radiation efficiency with a relatively simple ground system. A star ground system is provided for both antenna and towers. The required lengths of the ground wires are determined by local soil conditions. These conditions will herein be considered in greater detail.

(Continued on page 46)

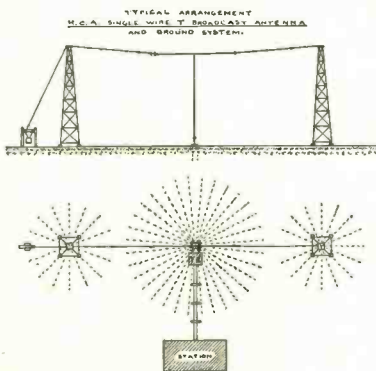

Fig. 3.

SINGLE WIRE T ANTENNA. RELATION BETWEEN OVERALL LENGTH IN FEET - VERTICAL AND ONE HALF HORIZONTAL - AND FUNDAMENTAL IN METERS.  $\lambda_0 = \text{LENGTH} \times K$  FOR OPERATION AT 75% OF THE FUNDAMENTAL THE FOLLOWING RELATIONS APPLY:  $\lambda_0 = \frac{\lambda}{.75}$  AND LENGTH =  $\frac{\lambda_0}{K}$

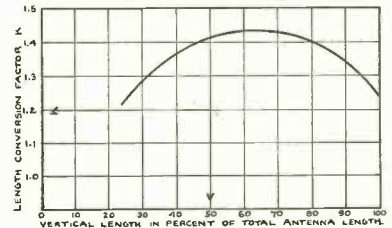

Fig. 5.

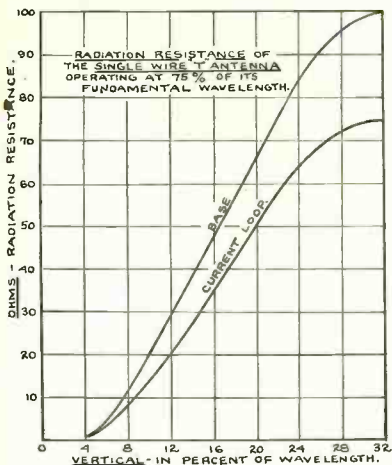

Fig. 6.

The distortion of the field pattern by secondary radiations from the towers can be corrected by detuning the towers either by the insertion of tower leg insulators, or by adjusting lengths of guy wires attached to the towers. Tower radiation may even be helpful under the condition in which it is desired to increase radiation in the direction of a certain important town; but usually it is desired to keep the radiated field pattern as nearly circular as practical.

The horizontal wire of the T type antenna produces no useful radiation, since the currents in the two sides flow in opposition. The top merely serves as a highly efficient loader and as a means for improving the current distribution in the vertical, or radiating portion of the antenna. Reference is again made to the middle diagram of Fig. 1.

The comparative costs of towers vary in a ratio roughly proportional to the square of their heights. A 400 ft. tower will cost about three times as much as a 250 foot tower. If a T type antenna supported by two 250 ft. towers is constructed of the same electrical length as a single vertical wire type

supported by a single 400 foot tower, the electrical preference will be slight due to the detrimental effects of the supports of the 400 ft. tower, and the cost will favor the 250 foot T type in the ratio of nearly one and one-half to one.

The approximate relation between installed costs and heights of self supporting steel towers of the same general type is shown in Fig. 4. It will be understood, of course, that actual costs are a function of general market and labor conditions, as well as the accessibility of the station site. The graph is typical of average conditions only. The foregoing analysis briefly summarizes the reasons for the selection of the single wire, T type of antenna for broadcast service in installations made by the Radio Corporation of America and its subsidiaries.

RELATION BETWEEN WAVELENGTH AND THE MAXIMUM EFFECTIVE LENGTH OF BURIED GROUND WIRE IN VARIOUS SOILS.

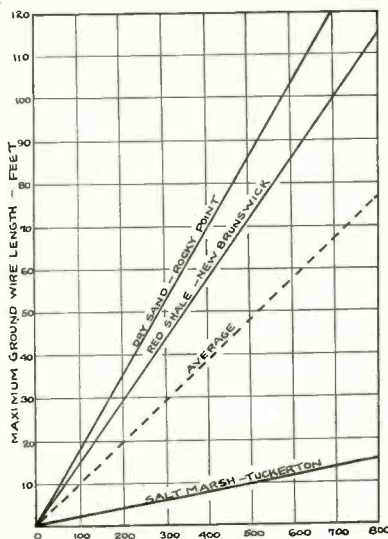

Fig. 8.

Determination of Fundamental Wavelength

It is necessary to know the relation that exists between the physical length of the T type single wire antenna and its fundamental wavelength in order to design for a particular mode of operation. This relation has been expressed in terms of a practical conversion factor from overall length in feet (vertical plus half horizontal) to fundamental in Fig. 5. Applying this figure, it will be observed that a vertical wire 100 feet long will have a fundamental of 123 meters. If the antenna has a total horizontal T top of 100 feet and is 50 feet high it will have a fundamental of 142 meters. It is thus possible to calculate the physical dimensions of the single wire T antenna for any practical mode of operation. This data is transcribed from theoretical

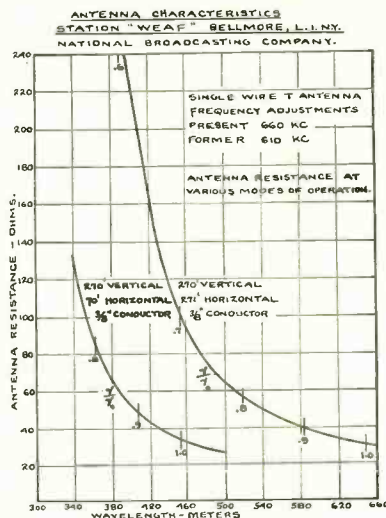

Fig. 7.

cal calculations by Mr. Carter. The conversion factor K is subject in practice to a variation with the capacity of insulator end fittings, ground and tower effect and may run as high as 10 per cent above the theoretical value given in Fig. 5.

Radiation Resistance

The radiation resistance of an antenna is that portion of its total resistance that is useful in producing the radiated field. The efficiency of the antenna is the ratio of radiation resistance to total resistance.

The radiation resistance of the one-third wave single wire T type antenna (75 per cent operation) in terms of the height of the vertical has been calculated by Mr. Carter. The calculated values of radiation resistances at the base, and at the current loop of this antenna are shown in the graphs of Fig. 6. It was previously noted that the current loop of the one-third wave antenna occurs at one-twelfth of a wavelength above the ground.

I am indebted to Raymond F. Guy of the National Broadcasting Company

FIELD PATTERN AT ONE MILE STATION "WEAF" BELLMORE, L.I., N.Y. 660 KC. NATIONAL BROADCASTING COMPANY.

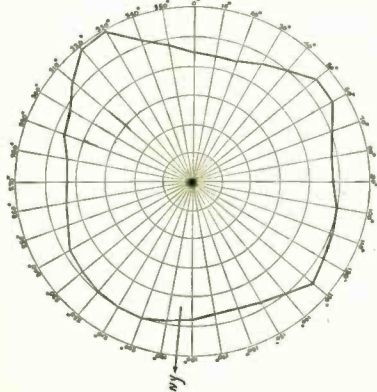

Fig. 9.

FIELD PATTERN AT DISTANCE OF ONE MILE FROM STATION WFAA DALLAS, TEXAS. SINGLE WIRE, T ANTENNA, ONE THIRD WAVE OPERATION 800 KC.

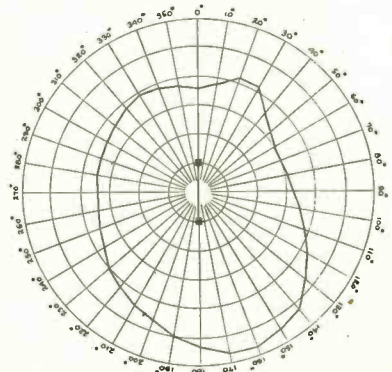

Fig. 10.

for the antenna resistance measurement of the WEA F antenna at Bellmore, L. I., with two different single wire, T type antennas, and for different modes of operation. These measurements are shown in Fig. 7. Bellmore is located in dry, sandy soil which plays an important part in the determination of the total resistance.

The efficiency of the WEA F antenna in soil of very high absorption averages about 60 per cent. The WJZ antenna efficiency in much better soil, averages about 80 per cent.

**The Ground System**

The efficiency of the broadcast antenna is largely determined by the relative conductivity of the soil upon which the station is located. The soil conductivity will be a maximum in salt, marshy ground and a minimum in loose, dry sand. Building a counterpoise system whose wires are clear of the ground will not eliminate the ground

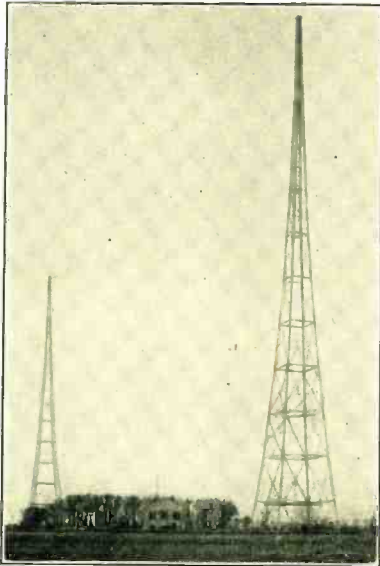

Fig. 12. View of 300 foot Insulated towers, single T type antenna, WEA F, Bellmore, L. I., N. Y.

effect. Experiments on the effects of ground at short wavelengths has indicated that ground losses cannot be neglected until a height of two wavelengths above ground is obtained. It is obviously impractical to attain such a height at broadcast wavelengths. It is apparent, consequently, that ground losses must be given full consideration when selecting the location of a broadcast station.

An extensive series of ground system tests conducted by R. C. A. Communications, Inc., has indicated that the useful length of a ground wire is a function of soil conductivity and wavelength. The soil conductivity determines the rate of propagation of the current in the buried wire. The



Fig. 13. Close-up view of insulated tower footing.

propagation is slower with high soil conductivity, consequently the length of wire that can be used effectively in such soil is shorter. Increase of the wire length above a critical length may increase the resistance since the added length of wire acts as a series reactance. Since the condition of a soil is a variable with diurnal and seasonal conditions, an average ground wire length for a typical kind of soil should be applied.

A typical relation which was found to exist in the broadcast waveband, between maximum ground wire length and various soils at Rocky Point, New Brunswick and Tuckerton, is shown in Fig. 8. It may be calculated from this data that there is no advantage in using a ground wire in the poorest soil longer than 5 per cent of a wavelength.

In salt, marshy soil a wire length of 1 per cent of the wavelength is all that is required.

In soils having a strata of high moisture content relatively close to the surface, a number of ground rods driven into this strata, and connected to the terminal of the wire ground forms a useful supplementary ground system.



Fig. 14. Tuning house, antenna down lead and lead-in, WEA F.

This method is indicated in the typical ground system of Fig. 3.

**Field Pattern and Coverage**

The ideal field pattern of a broadcast station would consist of a series of concentric circles, each point representing the equisignal locus for that particular distance with respect to the transmitting station at the exact center. Such an ideal pattern is seldom obtained. This is partly because of the necessity for using supports, such as steel towers, which are in themselves in effect re-radiating antennas, and partly because of the varying absorption of the terrain over which the wave passes. The first of these factors is, to a large extent, in the control of the engineer; the second factor is out of his control except for a judicious selection of the station site.

Recognizing that the supporting towers are sources of field distortion,

RELATION OF SIGNAL TO DISTANCE FOR A 5 KW AND A 50 KW STATION. ALL CONDITIONS CONSTANT EXCEPT 10 TO 1 POWER INCREASE.

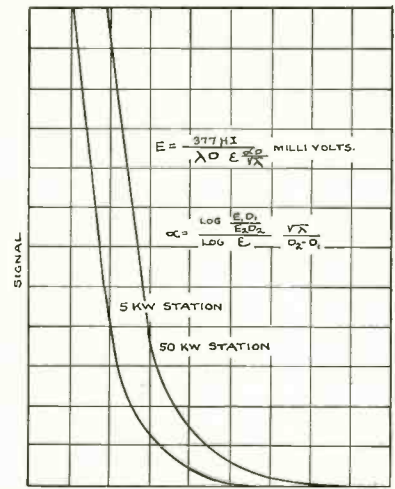

Fig. 11.

means may be applied for minimizing the effects of tower radiation. The most effective of these corrective means is to detune the towers. This procedure usually takes the form of insulation at the base for shortening the period of the tower, and the addition of stays without insulation to lengthen the tower period. It will also be recognized that a certain control of the field distribution is available by the relative spacing of the towers with respect to a definite assigned frequency, so that the radiation may favor the line of the tower array, or the broadside direction as in directive antenna design. Usually the effect of the tower radiation on field distortion is not a serious consideration.

The observed field pattern of station WEA F of the National Broadcasting Company, Bellmore, L. I., taken at a distance of 1 mile, is shown in Fig. 9. This station has a single wire, T type





# "Here's a New SPRAGUE INVERTED CONDENSER that does the work"

Metal enclosed vent

One piece anode

One hole mounting

Can—dull nickel finish

Small space—high capacity

High voltage—self-healing.

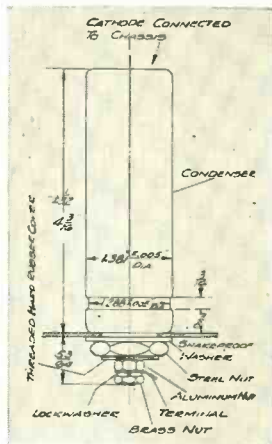

RADIO engineers of 1931 receiving sets will receive with unqualified approval this announcement of a Sprague Electrolytic Condenser that helps materially in their problems to make the new radio receivers as simple as possible, more efficient than ever before—and at the same time conserve time, space and expense.

Only an organization like SPRAGUE, with superb modern manufacturing facilities, highly developed research laboratories, an engineering department devoted to the problems of the set manufacturer, and a highly trained personnel could produce the tremendous improvement represented by this new SPRAGUE INVERTED ELECTROLYTIC CONDENSER in tremendous quantities with unqualified UNIFORMITY.

Send for illustrated booklet, diagrams, etc. Address Dept. 13B

SPRAGUE SPECIALTIES COMPANY  
North Adams, Mass.

# SPRAGUE

## Electrolytic CONDENSERS



Fig. 15. General view of WFAA, Dallas, Texas.

antenna supported by two 300 foot, insulated steel towers. It operates on a frequency of 660 kc. (454 meters). The capacitive effect of the tower insulators reduces the period of the towers to approximately 60 per cent of their normal non insulated values. The difference in periods resulting between the antenna at 454 meters, and the towers is seen to result in a nearly circular type of field pattern.

The observed field pattern at a distance of one mile of 50 kw. station WFAA, Dallas, Texas, owned and operated by the *Dallas News* and *Dallas Journal* is shown in Fig. 10. The antenna of this station is also of the single wire, T type, supported by 300 foot, insulated steel towers. The operating frequency is 800 kc. (375 meters). The field pattern shows more distortion than WFAF, particularly on one side. This distortion is due in part to necessary attachments on one tower, and to nearby telegraph and power wires. The operating frequency 800 kc. approaches more nearly the natural frequency of the towers, than is the case at WFAF. The field pattern of Fig. 10 was obtained by the engineers of the RCA-Victor Company, Inc.

General field surveys made at many broadcast stations have indicated that prediction of the coverage of a given station is not a straightforward mathematical proposition. It depends principally upon topographical and geological conditions. The coverage obtainable from a given station is subject to variations in the attenuation of the wave as it passes over soils having different absorption factors, over lakes, bays and rivers, and is subject to high attenuation and local shadows in passing over large cities. Another very human variable encountered is the wide variation in the sensitivities of receivers in the homes of the broadcast listeners.

The writer has calculated the relation of signal to distance for a known daylight value of attenuation constant and an antenna power of 5 kw. and 50 kw. from the equations shown in Fig. 11. In these expressions the following legend applies:

E=Signal strength in millivolts.

$\alpha$ =Attenuation constant.

HI=Kilometer ampere antenna output.

$\lambda$ =Wavelength in kilometers.

D=Distance in kilometers.

It will be observed that the distance covered between the 5 kw. and the 50 kw. station is much less than the ratio of the powers used; but that a considerably larger service area is covered satisfactorily by the 50 kw. station. Since the studio expenses, pickup outlay, program production costs and the like, are about equal in the two cases,

the 50 kw. station will, in most instances, be a more economical investment in terms of cost of service per listener.

A power increase far in excess of what is now known as a super-power station, 50 kw. need cause no serious apprehension as to interference.

#### Typical Installation

A few typical illustrations of broadcast stations will be of interest. In Fig. 12 is shown a view of the 300 foot insulated towers and the single wire T type antenna of station WFAF of the National Broadcasting Company at Bellmore, L. I., N. Y. The simplicity of this antenna system is apparent.

A close up view of an insulated tower footing is shown in Fig. 13.

The tuning house, antenna down-lead and antenna lead-in arrangement of station WFAF is illustrated in Fig. 14. This picture also shows to the right the radio frequency transmission line, and to the left the lightning protection on the antenna.

The writer is indebted to George E. Chase, manager of station WFAA, Dallas, Texas, for the views of this 50 kw., 800 kc. station. Fig. 15 is a general view of the station showing the station building, tuning house and aircraft camouflaged towers supporting the single wire, T type antenna. The flatness of the immediately surrounding country is well illustrated.

In Fig. 16 is a general view of the transmitter room of station WFAA showing the general arrangement of the 50 kw. transmitter and the radio-frequency transmission line outlet to the antenna.

The line amplifier and control line  
(Continued on page 50)

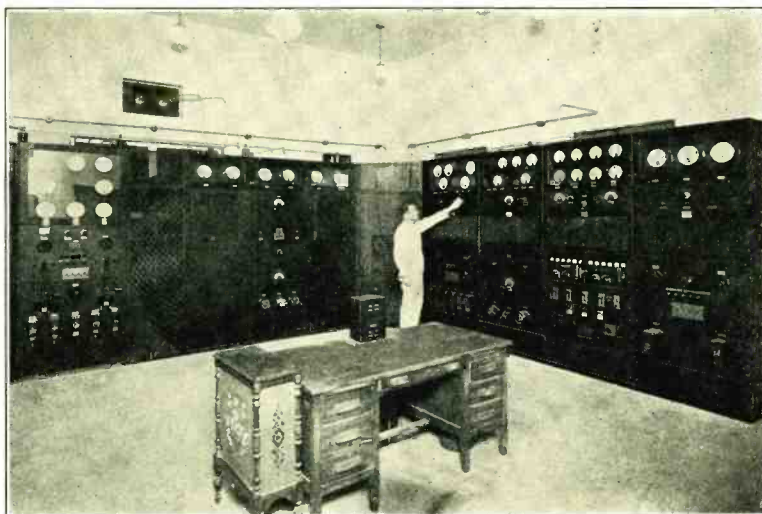

Fig. 16. General view of transmitter room, WFAA.

▼  
**It's the  
 little details  
 that make the  
 big difference**

*by George Lewis, Vice-President  
 Arcturus Radio Tube Company*

THERE'S no side-stepping this fact—tubes do make a noticeable difference in the performance of any set... After all the months you've spent engineering your new model, in the long run you're virtually staking the sales of the set on the tubes. The ears of the public hear only what passes through the tubes. Why risk sales of a perfectly-engineered set on tubes that will not show the set at its best? The danger is greatest at the dealer's demonstration, where inferior tubes often lose the sale... That's why set builders and critical engineers specify Arcturus Blue Tubes, to insure first-class performance. Their 7-second action helps sell your set and keep it sold. *Extreme durability* and clear, *life-like tone* of Arcturus Tubes mean continual satisfaction to the purchaser of your set. It takes so little time and thought to insure perfect performance for your set. Just specify Arcturus Blue Tubes *now* both for factory testing and standard equipment.



The TUBE with the  
**LIFE-LIKE TONE**  
*Arcturus Radio Tube Co.  
 Newark, New Jersey*

**FOR  
 UNEQUALLED  
 RELIABILITY**

The unequalled reliability of Weston instruments is acknowledged by the leading radio engineers and laboratories. Test after test in laboratory and in practice have proven the value of the refinements in design, the unusually close electrical and mechanical tolerances in manufacture that combine to make Weston instruments unequalled in performance and dependability.

The three model instruments illustrated on this page are typical of this superior Weston quality construction and reliable operation. For years the radio laboratories, factories and service shops have used them on small panels. They cover an unusually wide scope of measurement, meeting practically every measurement requirement.

**MODEL 301**

Made as Permanent Magnet Movable Coil Type D.C. Voltmeters, Ammeters, Milliammeters, Microammeters, and Resistance Meters. Also as Rectifier type A.C. Voltmeters and Milliammeters. Size: 3 1/4 inches in diameter.



**MODEL 301**

**MODEL 476**

Movable Iron Type A.C. Voltmeters, Ammeters, Milliammeters, and Condenser Meters. Size: 3 1/4 inches in diameter.

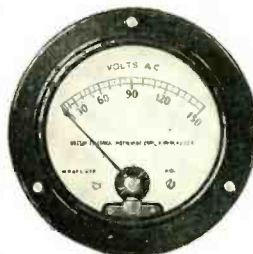

**MODEL 476**

**MODEL 425**

Thermocouple type D.C. A.C. Ammeters and A.C. Milliammeters and Galvanometers for any frequency. Size: 3 1/4 inches in diameter.

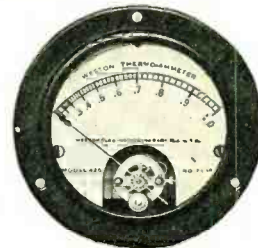

**MODEL 425**



Weston Electrical Instrument Corporation  
 618 Frelinghuysen Avenue, Newark, N. J.

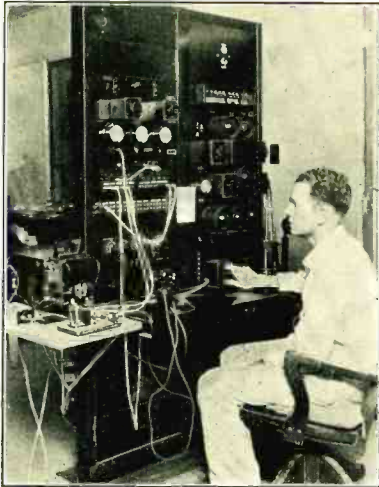

Fig. 17. Line amplifier and control line panels, WFAA.

panels at which the incoming voice signals from the Dallas studio of WFAA are manipulated, amplified and fed to the transmitter are shown in Fig. 17.

### Radio Engineering and Public Service

No other public service gets so close to the hearts of the populace as radio broadcasting. In a little less than a decade it has become the oracle and sentinel of the nation. It has bridged that heretofore impassable void between the distant rural community and the great metropolitan centers, bringing the learning, music, sports and culture of the city to any urban fireside that has the will to listen. This indeed is service of an inestimable type.

The direct link between the broadcast listener and the broadcasting station is the transmitting and receiving antenna and the transmission medium. The effectiveness of the service rendered to the listener is largely determined, as has been demonstrated in the foregoing, by the skill and thoroughness of the work of the radio engineer. Success is due to his application of sound principles to the design of the broadcast antenna, as well as to his knowledge and understanding of the many factors that affect transmission through that cosmic and sometimes turbulent medium, which the broadcast listener familiarly refers to as "the air."



### MAXIMUM UNDISTORTED POWER OUTPUT

(Concluded from page 40)

missible value within the audio-frequency spectrum. Practically all such units, and especially interstate units, present a capacitive load at very high frequencies of altogether too low an impedance, and it is most fortunate that the ear is relatively insensitive to distortion components in this region. A further, and far less permissible fault in such units may be traced to low shunt inductance. The effect of this is most marked at low frequencies where harmonic distortion is most objectionable, and such niggardly design should be avoided. Such units also are extremely apt to behave as the units discussed under Figs. 8 to 13 inclusive.

The presence of direct current in the windings of improperly designed coupling units can introduce considerable distortion. Much of this distortion can be eliminated by the use of tubes in symmetry, which permits a balancing of magnetizing forces from direct current. Symmetry, therefore, can claim at least one definite advantage.

All the preceding sources of distortion may be kept well within control by careful operation and design. There is one final source, discussed under Figs. 6 and 7, which cannot conveniently be avoided. Modern prac-

tice operates vacuum tube grid circuits as though they were of very high impedance. Thus grid circuits are commonly operated from transformers or other sources with output terminal impedances ranging up to 500,000 ohms. Obviously, since tubes are operated as though voltage were the only input requirement, the high impedance source yields a high voltage, and is, therefore, most efficient from an amplification standpoint. With such high impedance input sources it is not surprising to find that the performance curve takes on the form of that shown in Fig. 7, so that the real limiting factor in amplifier power output is the point at which some tube grid swings are considerably positive. Inasmuch as maximum power output is desired it would be foolish to permit tubes preceding the power stage to overload, so, as a rule the limitation of power output in a properly designed amplifier is that point at which the power tube grids swing positive on the peak of the signal wave. Symmetrical connection is unavailing materially to increase the power output beyond the positive grid limitation. Distortion below this limitation may be entirely negligible, but once the amplitude reaches the point where grids commence to go positive the limit has been reached.

Maximum undistorted power output

### Acknowledgment

The writer wishes to express appreciation to those who have contributed directly, or indirectly, to the material of this paper. Engineering application has become so diversified that the accomplishments of any great projects are invariably the works of not one, but many men. Now, as always, the most lasting reward of the engineer is the satisfaction of a difficult job well done. The writer expresses appreciation to C. H. Taylor, vice-president of R.C.A. Communications, Inc., under whose supervision this work has been undertaken; to P. S. Carter of R.C.A. Communications, Inc., for theoretical calculations on the single wire, T type antenna; to R. F. Guy of the National Broadcasting Company for photographs and data of stations owned and operated by that company; to G. E. Chase, general manager of Station WFAA, Dallas, Texas, for photographs of that interesting station; and to RCA-Victor Company, Inc., engineers for the use of data obtained by them at station WFAA Dallas, Texas.

signifies only that the amplifier is comparable in power output to another amplifier of the same rating tested by the same methods to the same limits. And, for all that, the output is generally not power, it is seldom maximum, and most certainly is not undistorted.

### RADIO MAKERS ACT ON BROADCAST POLICIES

INTERESTS of the radio public and industry in broadcasting has led the Radio Manufacturers Association, comprising virtually all prominent manufacturers, to urge several measures in the development of broadcasting policies.

Meeting in Chicago, recently the board of directors of the RMA received reports from C. C. Colby of Canton, Mass., chairman of its legislative committee, and H. B. Richmond of Cambridge, Mass., director of its engineering division, and decided to oppose changing the present broadcast band, as is being urged by some foreign interests. Foreign demands for increased radio facilities will be considered at the international conference in 1932 in Madrid, according to a report by Frank D. Scott, Washington counsel for the RMA, and the American radio industry, under the decision of the manufacturers, will oppose reducing or changing the existing U. S. broadcast band.

# MOLYBDENUM TUNGSTEN TANTALUM

WIRE,  
ROD or  
SHEET

*Fansteel metals are obtainable in all commercial forms. Wire comes wound on standard bakelite spools, packed in individual boxes, both plainly labeled to show dimensions and characteristics.*

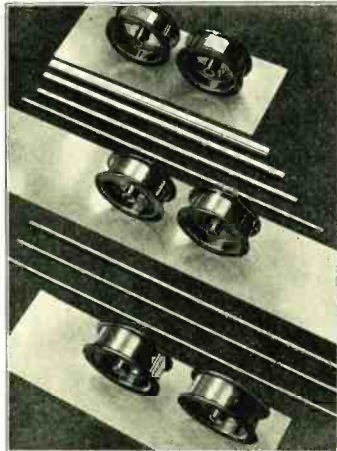

## FANSTEEL . . best source of supply

Here vacuum tube metals are refined from ores or basic materials to high purity, then finished to accurate dimensions and uniform characteristics—all under one laboratory control.

A widely assorted stock of wire and sheet is constantly maintained so practically any specification can be met and the material shipped promptly from stock. Think of the convenience when small lots or odd sizes are needed for experimental use!

And the Fansteel research laboratory, with an enviable record of developments in the vacuum tube field, is available to tube manufacturers as a source of practical assistance on metallurgical problems. Write for samples and prices.

**Fansteel Products Co., Inc.**  
NORTH CHICAGO, ILL.

**TANTALUM • TUNGSTEN • MOLYBDENUM  
• CAESIUM • RUBIDIUM AND ALLOYS •**

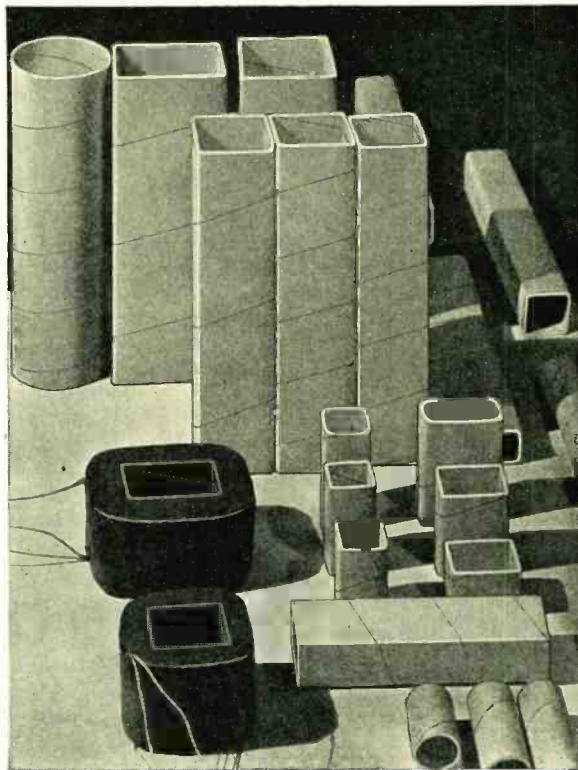

## PAPER TUBES FOR COIL WINDING

MACHINE MADE      SPIRAL WRAPPED

ONLY OUR special improved machinery can produce such tubes as these—accurate, uniform, rigid, blister-free, and running close to dimensions. They come in all shapes and sizes, too—from  $\frac{3}{8}$ " I.D. and up, any wall thickness.

This tubing is built up layer by layer with each lamination securely cemented to the next. It is spiral-wrapped in a criss-cross or diagonal manner to give the side walls maximum strength.

It contains no minerals or acids to injure the smallest enameled wires, and it has a high dielectric test.

*Samples and full details will be sent gladly to engineers and manufacturers interested in securing a tubing which will help produce economically a better coil. . . . Write us today.*

**THE PAPER TUBE COMPANY**

Manufacturers of Spiral-Wrapped Tubing for the Electrical Industry

1718-20 N. DAMEN AVE.



CHICAGO, ILLINOIS

SPIRAL-WRAPPED



# NEWS OF THE INDUSTRY

## U. S. RADIO RENEWS NATIONAL UNION CONTRACT

J. Clark Coit, President of the U. S. Radio & Television Company of Chicago, makers of U. S., Apex and Gloritone sets, announced recently the renewal of his company's contract with National Union Radio Corporation for the shipment of National Union tubes as exclusive equipment in all U. S. sets.

"During the past nine months," said Mr. Coit, "we have shipped well over a million National Union tubes as standard equipment with our sets and feel that the consistently high class performance of these tubes has been a dominant factor in the success of our line."

Mr. Coit believes that set manufacturers cannot afford to gamble their reputation and selling success against the possible disaster which might result from inferior vacuum tube equipment. He says that the U. S. radio engineering experts have worked closely with the National Union engineering staff with evident resulting satisfaction to everyone concerned, not only in the manufacturing organization but among the consumers who have put the U. S. set to the acid test of satisfactory home performance. The radio set manufacturer who maintains exacting standards of production in his own factory cannot afford to take a chance with lax methods of vacuum tube manufacture which might wreck his entire sales structure because of consumer dissatisfaction.

## LOCK WASHERS

Announcement has been made by the Thompson-Bremer Company of the acquisition of a new and larger plant located at 1640 Austin Avenue, Chicago.

This expansion in manufacturing facilities was made necessary by the universal approval which was accorded the Thompson-Bremer line of Evenlock washers and terminals.

Production in the new plant was in full swing on January first, and the Thompson-Bremer Company is now in a position to add larger sizes of lock washers and terminals to its line which heretofore included mainly the smaller sizes used by the radio industry.

## FADA CONTROL SYSTEM HAS KEPT STOCK INVENTORY INVESTMENT AT MINIMUM

"The Fada Company as one of the oldest radio manufacturers in the country, established a special system of inventory control several years ago so that the number of Fada radios manufactured is throttled down or expanded from week to week to meet the actual conditions in the field. This method, of course has a distinct advantage over one that has been unfortunately common in the radio industry, viz: to make a total estimate for the year and then proceed to manufacture this estimation of needs as rapidly as possible. This gearing of production to hopefully optimistic estimates instead of constantly gearing production to demand has proved disastrous to many radio manufacturers," said R. M. Klein, general manager of Fada.

"Our inventory of Fada receivers stands at present at a negligible minimum. Our

distributor inventories are in the same condition yet we have been able to meet the demand for Fada merchandise with a constant flow of shipments to all distributing points in the country. We constantly receive detailed reports of dealer and distributor inventories and their anticipated needs which governs our production schedule at the factory."

## H. H. EBY EXPANDS

Hugh H. Eby, president of the H. H. Eby Manufacturing Co., Inc., of Philadelphia, Pa., announces the appointment of Charles D. White, formerly chief design engineer and plant manager for Kolster Radio Corp., Newark, N. J., as sales engineer for the Eby Company.

Mr. White's experience in the radio field dates back to 1916, at which time he became associated with the bureau of steam engineering, Navy Department, Washington, D. C., on the design of radio transmitting and receiving equipment for the U. S. Navy.

Since 1923, Mr. White was associated with the Brandes Products Corporation, and Kolster Radio Corporation, both of Newark, N. J., in the design and production of radio receiving sets, and possesses a varied technical and practical knowledge of the requirements of the trade.

It is the desire of Mr. Eby that manufacturers of radio equipment will make available to themselves Mr. White's experience when dealing with problems of design.

## TEXTOLITE

Due to steady progress the General Fabricating Company, eastern distributors for Textolite Laminated, have found it necessary to move recently to new, commodious quarters at 37 East 18th Street, New York City.

At the new address they announce greatly increased facilities for punching machinery and engraving of Textolite and Bakelite materials. Here they will have on hand a full line of Textolite Laminated in sheets, tubes, rods and fabricated parts.

Textolite Laminated is the fine grade of phenolic insulation manufactured by the General Electric Company and distributed to the trade by the General Fabricating Company.

## HOLYOKE COMPANY APPOINTMENT

The Holyoke Co., Inc., manufacturers of Gutta Percha Insulated Wire, midjet and other set assemblies, remote control cables, etc., for the radio trade have appointed Charles G. Stevens Co., 360 West Monroe Street, sales representatives for Chicago territory, including Indiana, Michigan, St. Louis, Mo., and Dayton, Ohio.

## SPRAGUE TO ENTER FIELD OF HOME TALKING MOVIES

R. C. Sprague, president of the Sprague Specialties Company, Quincy and North Adams, Mass., announces:

"After a careful survey into the manufacture and merchandising possibilities of a home talking moving picture machine, we have contracted for the exclusive manufac-

turing and sales rights for a unit that can be produced at an attractively low list price.

"It is our purpose to manufacture two models for sale to distributors and dealers throughout the United States and Canada. Model A will consist of a talking picture unit to plug into a radio set using the amplifier and speaker of the radio. Model B—a talking picture unit incorporating an amplifier and speaker to operate independently of a radio set. This unit, will be attractively priced, simple in construction, and easy to operate.

"Merchandising authorities consulted to date are enthusiastic, and we see no reason why the demand for this unit will not closely parallel that of the early days of radio receivers.

"We also intend to make available for radio set manufacturers a compact unit consisting of the turntable and projector mechanism, so that manufacturers can produce for their trade a complete talking picture machine, together with a complete radio set, at a reasonable price.

"Agreements have been made with some of the leading film producing companies whereby one, two and six reel feature talking pictures released by them will be available to all dealers of Sprague machines."

## ELMENCO CONDENSERS AND RESISTORS

Due to increased demand for Elmenco products, the Electro-Motive Engineering Corp., moved February 1 to 797 East 140th street, Bronx, New York City.

They have taken over all of a large new four story building. A number of new items have been added to the Elmenco line. The new factory is equipped with the latest, improved machinery so as to cater in more extended way to the leading manufacturers, many of whom are users of Elmenco products.

## ALLIED DIE CASTINGS

The Allied Die Casting Corp., Long Island City, N. Y., has appointed L. H. Zintgraff, 907 Security Building, St. Louis, Mo., representative for that territory.

## SYNTHANE APPOINTS MID-WEST REPRESENTATIVE

Synthane Corporation, Oaks, Pa., have recently appointed Donald A. Cox as their mid-west representative, with offices at the Miami Savings Building, Dayton, Ohio. Mr. Cox will handle their complete line of Synthane uniform laminated bakelite, sheets, rods, tubes, fabricated parts and Synthane stabilized gear stock.

## STANDARD TRANSFORMER CORPN.

The Standard Transformer Corp., Chicago, announces the appointment of Everett E. Gramer as chief engineer.

Mr. Gramer is very widely known among the users of transformers and is considered an authority on transformer design and production. He was formerly active in the success of the Transformer Corporation of America during the period in which they made transformers exclusively.

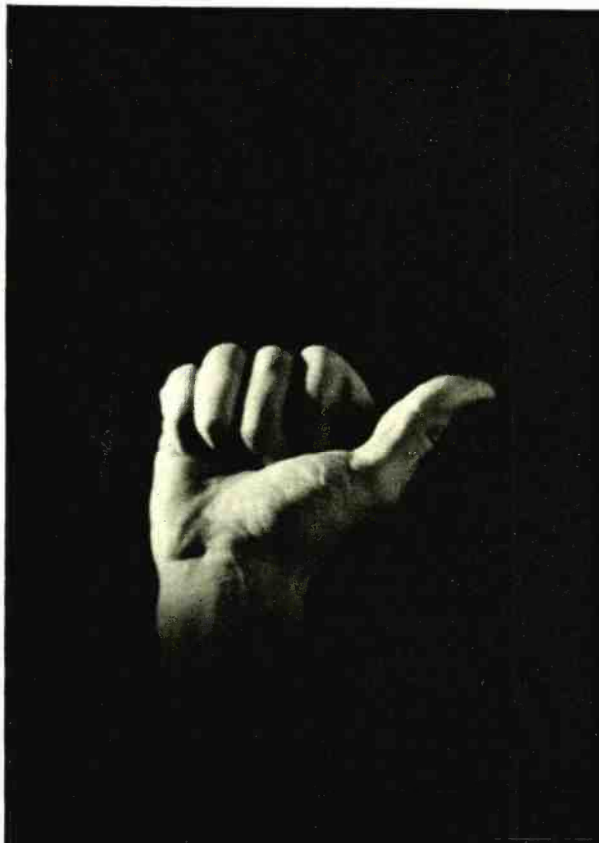

## ***STOP or GO***

Uninterrupted production rests largely on the dependability of your sources of supply. Synthane understands this. Synthane, the product, carries with it Synthane service—service more conscientious in your behalf. By close application to your specifications, by vigilant care in each step of production, by rigid inspection of your order before shipment—Synthane is consistently reliable in meeting your demands for prompt and accurate delivery. Your production need never slow down on Synthane's account. We are jealous of this reputation! Turn the page — and study the product.



---

SHEETS—RODS—TUBES—FABRICATED PARTS—STABILIZED GEAR STOCK

---

# SYNTHANE LAMINATED BAKELITE

## FOR EVERY SPECIFICATION

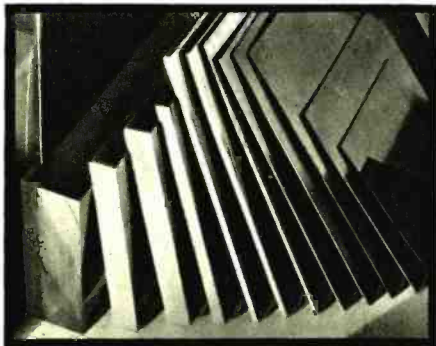

SHEETS

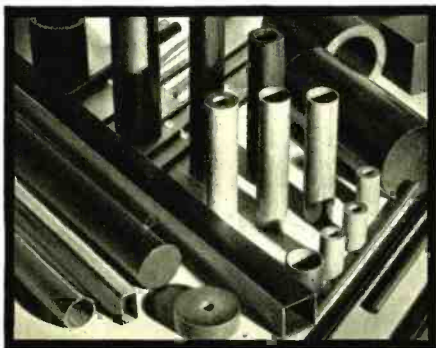

TUBES & RODS

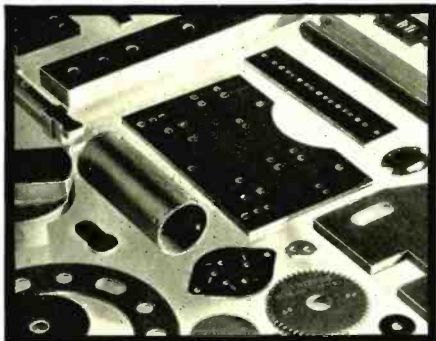

FABRICATED PARTS



STABILIZED GEARS

No matter what your requirements, you will find a grade of Synthane specially designed to meet them.

Special grades made at no additional cost. All standard grades of Synthane, listed according to N. E. M. A. standards, are ready for immediate shipment.

**GRADE X.** For General Use where low moisture absorption and good machining and electrical properties are required. Paper base. Will punch up to 1/32" cold, and when heated, to greater thicknesses. Machines readily. See "Sheets", "Tubes".

**GRADE XX.** For Extremely Low Moisture Absorption and High Dielectric Strength. Paper base. Good machining qualities. Low moisture absorption. See "Sheets", "Tubes", "Rods".

**GRADE XP.** For Punching Operations. Paper base. Punches and shears cold up to 3/32"; punches and shears in thicker sizes depending on design of die and temperature of material. See "Sheets".

**GRADE C.** For Exceptional Structural and Impact Strength. Canvas base. Punches and machines readily. For use where high impact and transverse strength are required in connection with good insulating properties. See "Sheets", "Tubes", "Rods", "Gears".

**GRADE L.** For Fine Machining. Linen base. Usually required not over 1/8". See "Sheets", "Tubes", "Rods".

**SHEETS.** Size—36" square. Thickness—.010" upwards to 8". Color—Natural, Chocolate Brown and Black. Finish—Dull, High Gloss. Grades—X, XX, XXX, XP, C, L. Special as required.

**TUBES.** Length—36". Diameter—Inside diameter from 1/8" upwards. Outside diameter as required. Color—Natural and Black. Finish—Dull, High Gloss. Stocks—Round, Square, Rectangular. Grades—Wrapped X, C, L; Molded X, XX, C, L. Special as required.

**RODS.** Length—36". Diameter—1/8" upward. Color—Natural, Black. Finish—Dull, High Gloss. Stocks—Round, Square. Grades—Molded XX, C, L.

**FABRICATED PARTS.** Complete fabricated parts made to specifications in any of the above grades. Prompt deliveries to customers' requirements.

**SYNTHANE STABILIZED GEAR STOCK** for Silent Gears. Standard sheets 36" square. Thickness—upwards to 8". Easy to machine, strong, resilient and light. Gear blanks of any diameter in stock for immediate shipment.

SYNTHANE does not crack, break, dent, swell, warp, or cold flow. It has high dielectric strength, low moisture absorption, low surface leakage, good punching qualities, easy machineability, and high resistance to oils and chemicals. Genuine Bakelite resins, high-grade raw materials, specially designed machinery, controlled processes and supervised workmanship insure absolute uniformity of all Synthane products.

**SYNTHANE**  
CORPORATION  OAKS · PENNA

NEW YORK — CHICAGO — BOSTON — DAYTON — LOS ANGELES — SAN FRANCISCO



# NEW DEVELOPMENTS OF THE MONTH

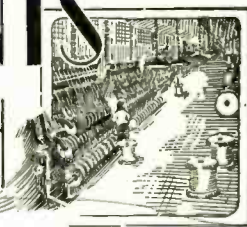
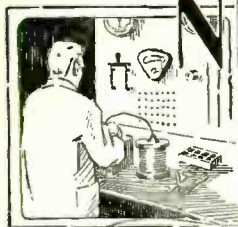

## PORTABLE CONDENSER MICROPHONES

The Astatic Microphone Laboratory of Youngstown, O., has placed on the market a complete line of portable condenser type microphones suitable for general use and which they are marketing through dealer channels.

These instruments come with both high and low impedance outputs in order that they may be used on existing amplifiers without the necessity of installing matching transformers. The cases are lined with sponge rubber and the amplifier assembly is suspended in like material. The cases are equipped with rubber feet to further cushion the assembly. A handle is provided for ease in carrying or hanging. The standard finish is black crackle with sprayed-on gold. Other finishes are also available.

The type 2P and 2C use two of the 230 type tubes with their filaments wired in series so that ordinary dry cells may be used for the filament supply. Six volts at 60 ma. is required. The "B" voltage can be taken from the amplifier supply as only 5 ma. at 180 volts is required. The output from these two types is approximately three times that obtained from the better double-button carbon types, or approximately 20 db. These two types are recommended for use with amplifiers having a gain of 50 db. or over.

The types 3P and 3C have exceptionally high output as they use 2 240 and 1, 112-A tubes. They are recommended for use with amplifiers having a gain of only 20 to 40 db. The output level on the 3C is almost plus 4 db. which makes it particularly suitable for a remote pickup for broadcast stations.

The frequency response of these instruments is almost uniformly responsive to all frequencies within the audio spectrum. They have a wide angle of pickup and have no internal noises. The type "B" unit is of the sealed type having a compensating diaphragm and a sealed-in chemical dryer which insures a quiet, precision operating unit under the most severe operating conditions.

## MANUFACTURE OF TIPLESS TUBES

The Eisler Electric Corporation, 744-772 South 13th street, Newark, N. J., have produced a new tipless tube bending machine which is finding favor with tube manufacturers.

For many years, the independent lamp and tube industry has suffered because it feared to infringe on patented tipless lamps or tubes, but this has been entirely overcome by the introduction of the Eisler method (the use of the bent exhaust tube), a non-infringing way of producing tipless lamps.

## MIDGET TYPE TUNING CONDENSERS

A series of midget type tuning condensers ranging in capacity from 19 mmfd. to 322 mmfd., having the famous Midline characteristics, have just been developed in the laboratories of the Hammarlund Manufacturing Company, 424 West 33rd Street, New York City, for manufacturer's use. A series of straight line capacity models have also been produced.

The smallest condenser is 2-3/4 inches

long and the largest, 4 inches long. All Midline types are 2 inches wide, with plates fully extended. The capacity type is only 1-1/2 inches wide.

Solid "bright-dipped" brass plates are used in all models. All plates are well spaced and soldered, the stator being soldered to brass slotted bars and the rotor to a slotted brass shaft.

A continuous brush contact of phosphor bronze is provided, thus affording perfect contact throughout the entire capacity range.

There are also end stops so that neither rotor nor stator plates can be damaged by jamming. A set screw is provided for locking plates in any position permanently. This is ideal for balancing purposes, also for capacity bridges, oscillators, beacon sets, etc.

No screws or nuts are used anywhere in the construction of this condenser, soldered eyelets being employed. Thus all possibility of parts vibration is eliminated. This is an excellent feature for aeroplane and automobile sets.

The models are made in both clock and anticlockwise fashion, and for base or one hole panel mounting. The shaft is 1/4 inch in diameter.

To further increase the efficiency of the unit, the special Hammarlund low loss in-

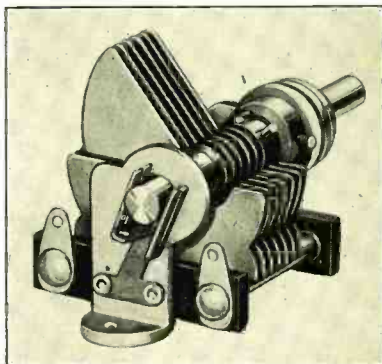

sulation Parmica is used. The rotor rests in small aluminum ground end pieces, which also serve as a base mounting. The compact and high capacity features also make this condenser especially useful for antenna tuning, for Midget broadcast sets, and short wave receivers.

The Midline type are known as the MC-(number of plates)-M type and the capacity as the MC-(number of plates)-S type. They are made in the following capacities: 19.2 mmfd.; 34.2 mmfd.; 49.2 mmfd.; 78.6 mmfd.; 93.6 mmfd.; 100.2 mmfd.; 138. mmfd.; 198.6 mmfd.; 242.4 mmfd.; 294. mmfd.; and 322 mmfd.

## DAYRAD TYPE L (SELF RAISING) TUBE CHECKER

This newest product of The Radio Products Company of Dayton, Ohio, is the result of considerable research.

This tube checker indicates the "End of Life" of all types of amplifier, power, and rectifier tubes. Six sockets are provided so that tests may be made at the rated filament voltage.

Manipulation is simplified by the use of colored push buttons. The meter is a D'Arsonval type meter with a 0-40 scale.

Besides the "End of Life" tests this tube checker will test separately both plates of 80 rectifier tubes. Another test is for noisy tubes and this point is covered by patents pending. Supplied with or without lid in professional carrying case. Furnished for a-c. operation at all commercial voltages and frequencies.

## DE FOREST ANNOUNCES TWO-VOLT AUDIONS

Three standard two-volt audions including an all-purpose type, a screen-grid type and a power tube, are announced by the DeForest Radio Company of Passaic, N. J.

The DeForest 430 audion is an all-purpose tube with the following characteristics: Filament voltage, 2.0 volts; filament current, 60 milliamperes; maximum plate voltage, 90 volts; grid voltage, -7 1/2; plate current, 2 milliamperes; amplification factor, 8.8; plate resistance, 12,500 ohms; mutual conductance, 700 micromhos.

The 431 audion is a screen-grid amplifier, with the following characteristics: Filament voltage, 2 volts; filament current, 60 milliamperes; maximum plate voltage, 135 volts; plate current, 1.5 milliamperes; control grid, 3 volts; screen grid, 67 1/2 volts; amplification factor, 440; plate resistance, 800,000 ohms; mutual conductance, 550 micromhos.

The 432 audion is a power tube, with the following characteristics: Filament voltage, 2 volts; filament current, 130 milliamperes; maximum plate voltage, 135 volts; grid voltage, 22.5 volts; plate current, 8.0 milliamperes; amplification factor, 3.5; plate resistance, 4,000 ohms; mutual conductance, 875 micromhos; undistorted power output, 170 milliwatts.

## NEW CONDENSERS FOR SUPERHETS

A high-grade line of condenser units, particularly applicable to superheterodyne receiving circuits, is being marketed by the De Jur-Amsco Corp., 95 Morton Street, New York. These condenser units are mounted on an insulating base of isolantite.

There are three types: duplex semi-variable, duplex variable and single variable. The duplex types are mounted electrically and mechanically independent of each other with mica dielectric between the plates.

The duplex semi-variable units have capacities up to 140 mmfs. per condenser with a minimum of approximately 70 mmfs. The standard size is 2 7/16 inch diameter, and the midget unit 1 15/16 inch diameter.

This type can be used in any circuit requiring small variable or semi-variable condensers. An important use is in tuning primary and secondary circuits to a desired frequency in intermediate-frequency amplifiers in superheterodyne receivers, where the intermediate frequency is of the order of 170 kc. It is used also for capacity coupling in pre-selector type tuners.

The duplex variable unit and the single variable unit have various uses in assembling gang condensers and for neutralizing purposes in t.r.f. circuits. The duplex unit has a maximum capacity up to 70 mmfs. per condenser: Standard size 2 7/16 inches diameter, midget, 1 15/16 inch diameter. The single unit is: standard 1 1/4 inch by 1 11/16 inch, the midget, 1 inch by 1 11/16 inch.

### UNIVERSAL HIGH-VOLTAGE TESTING SET

A highly accurate testing set of unusually flexible design is found in the AmerTran Type TS-15A which has just been announced by the American Transformer Company, 179 Emmet Street, Newark, N. J. This apparatus is ideally suited for light testing in either the factory or laboratory where potentials from 500 to 20,000 volts at 1 kva. are required. It is being used successfully in making accurate dielectric strength measurements on materials such as paper, tape, compound, varnished cambric, condensers, and insulation in small apparatus.

The new AmerTran testing set operates from standard 110-volt 60-cycle circuits and contains a special air-cooled testing transformer with a four-section secondary winding which permits of obtaining three different voltages at full output—5,000, 10,000 and 20,000. In addition the equipment includes a wire-wound potentiometer for adjusting the voltage to any value between zero and maximum the exact value being indicated at all times by a precision double-range voltmeter connected to a special winding on the transformer. For protection against damage due to overload a quick-acting circuit breaker is provided.

AmerTran Type TS-15A is completely housed in a compact metal case on the front of which is mounted a bakelite panel containing all operating controls. The eight high-tension terminals are brought out through porcelain bushings mounted on the top of the case and a socket at the side provides a convenient means for connecting the device with the power circuit. The equipment includes connection cord and "jumpers" for connecting secondary sections in series, parallel, or series-parallel.

### NEW SHAKEPROOF PRODUCT

The Shakeproof Lock Washer Company, 2501 North Keeler Avenue, Chicago, Ill., has produced a new self-locking set screw. The slotted end of the screw is off-set. When inserted, the sharp edges bite into the work. Shaking or vibration will not loosen it.

### PARTS FOR MIDGETS

After months of laboratory investigation and experimentation, the Polymet Manufacturing Corporation manufactures almost every essential part for midget set manufacture, in addition to making parts for the standard models.

Far in advance of the trend, Polymet foresaw this probable development and took precautions to engineer small parts especially suited for pigmy apparatus. As a result a large volume of this business has come

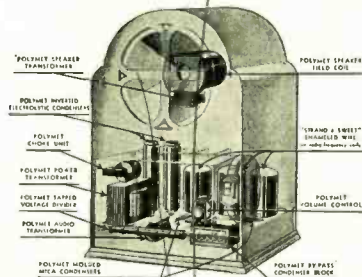

Polymet's way for the two-fold reason that the products are of true Polymet quality, and are not slap-dash parts hastily converted from larger designs, and because the preparedness and large-scale operation of this company, with its three factory units, makes possible immediate service and fast delivery.

Speaker transformers, electrolytic condensers, volume controls, by-pass condenser blocks, power transformers, tapped voltage dividers, chokes, coils and magnet wire are among the parts in the average midget and among the parts manufactured by Polymet specifically for the midget.

### WINDING MACHINE FOR PAPER-INSULATED COILS

The Universal Winding Company, Boston, Mass., has developed an automatic winding machine for paper-section coils, this latest addition to their present models to be known as the No. 104 type.

Fully adjustable, it can readily be set to handle different types of coils, using any size of wire from No. 20 to No. 40 (B&S gauge), and by means of a variable traverse cam, will produce any required length of wire layer from 1/4 inch to 5 inches.

One of the interesting features in this machine is the manner in which the insulating paper is handled. This element is injected between the wire layers at high speed, without interruption to the normal winding rate, and each successive insert is automatically lengthened to take care of the constantly increasing coil diameter, thus insuring a uniform amount of overlap throughout the coil.

Several other ingenious features have been incorporated in the machine, such as coil-slitting attachment for separating the coils before removal from the winding arbor; quick-changing type of wire spool

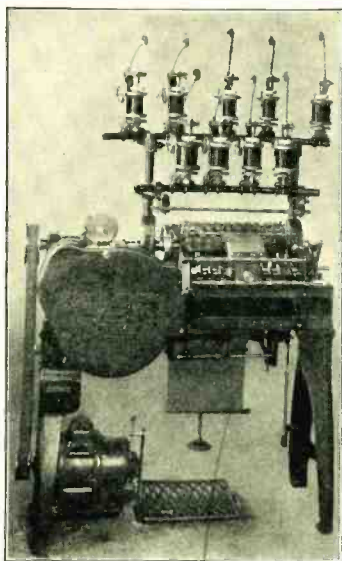

holders; winding speeds of 3000 to 3300 r.p.m.; slow start and rapid acceleration of the winding spindle by means of variable speed electric motor; semi-automatic counter which meters individual wire turns up to 2500, stops machine mechanically, and resets in a fraction of a second.

### SPARKS-WITHINGTON COMPANY

The Sparks-Withington Company, including Cardon Phonocraft Corporation reports for the six months ended December 31 net profit of \$495,430, after depreciation and taxes, equal, after preferred dividend requirements, to 54 cents a share on common against net profit excluding Cardon Phonocraft, of \$1,639,365, or \$2.36 a share in the 1929 period. Net profit, excluding Cardon Phonocraft, for the last six months was \$401,730.

### SHORT TESTER AND PREHEATER

The Supreme Instruments Corporation of Greenwood, Mississippi, has developed a very unique device, known as the Supreme short tester and preheater that it is believed will prove of great value, not only in the testing of radio tubes, but in the merchandising of tubes.

As the name indicates, the device not only serves the purpose of preheating heater type tubes in advance of more thorough testing,

but also detects open filaments and shorts between the various elements of the tube.

The operation is extremely simple and can be handled and understood by the layman just as well as by the trained technician.

### NEWS FROM SYLVANIA

Through a consolidation of territories of Sylvania-St. Louis Company, a subsidiary of the Sylvania Products Company and of the Nilco Lamp Works will handle the distribution of Sylvania lamps and tubes in Kansas, Missouri and Southern Illinois. The added territory, which formerly had headquarters at Kansas City, includes the entire state of Kansas, and the state of Missouri west of Springfield.

The management of the enlarged territory is in the hands of John F. Meyn, who was appointed manager of the Sylvania-St. Louis Company upon its organization in October, 1930. He has selected Frank W. Broadhurst as resident representative for Kansas City. A complete warehouse stock of tubes and lamps will be maintained both at St. Louis and at Kansas City, and it is believed that the new arrangement will add materially to the efficiency of distribution in the middle west.

### THE GREATEST YEAR IN ROLA HISTORY

To those in the industry who are at times inclined to pessimism, a trip through the Rola plant at Cleveland, Ohio, should prove an excellent stimulant.

Here a beehive of activity is turning out loudspeaker units in paying quantities.

When interviewed, B. A. Engholm, vice-president in charge of the eastern plant, proclaimed 1930 "The Best Year in Rola History."

### A-C. ELECTRIC PLANTS

A line of alternating-current electric plants has just been announced by D. W. Onan & Sons, 65 Royalston Avenue, Minneapolis, Minnesota.

This is a gasoline electric plant generating 110-volt, 60 cycle, alternating current, made in three sizes, 500, 1000, and 2000-watts and in six models, manual and self starting.

There are many original features in these plants. A four cycle, single cylinder engine is connected through a special flexible coupling to an alternating current generator of compound, separate excited type, which is so wound and balanced as to produce even voltage and accurate cycle—a duplicate of that furnished by power companies and service corporations.

These plants are ideal for country homes, farms, ranches, and for standby and emergency equipment for power service when transmission lines fail. They are ideal for commercial work in operating electric tools, radio amplifications and will run all domestic

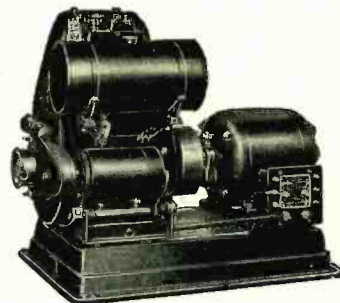

appliances regularly furnished for use on city service. They are suitable wherever alternating current is necessary.

The radio, refrigerator, washing machine, and other equipments now purchased for city use can be taken anywhere and run from Onan a-c. plants.

# AMERTRAN SOUND SYSTEM PANELS

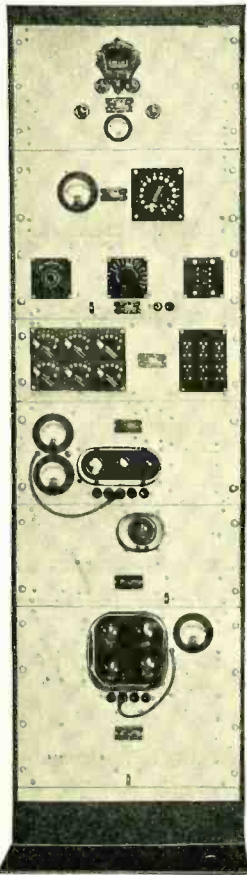

Long recognized as typifying the "Standard of Excellence" in audio products, the Amertran line now includes a wide assortment of standard panels designed to fill every requirement for complete sound systems.

Amertran panels are so constructed that they may be assembled on racks in various combinations for every purpose. They are the best that engineering genius can produce with the finest of materials and workmanship.

Before placing these Sound Systems on the market, months of research were spent in perfecting them, and thousands of panels were built for special applications — tested for true fidelity and satisfactory service, both in the laboratory and in actual installations.

Suggested Panel Layout No. 2  
(For Undistorted Outputs of 12.5 Watts)

Bulletin 1200 gives complete information and illustrations of Standard Amertran Panels. Write for it on your business stationery, and send specifications of your particular problem. Our engineering staff is at your service.

# AMERTRAN

Send the Coupon for Full Information

AMERICAN TRANSFORMER COMPANY (RE-2-31)  
176 Emmet Street, Newark, N. J.  
Please send me Bulletin 1200 describing Amertran Sound System Panels.

Name .....

Street & No. ....

Town ..... State .....



"Since  
we've used Kester...  
we're building better sets!"

The one safe soldering flux for radio construction work is rosin. It's an organic mixture that is non-conducting and non-corrosive. And the residue it leaves impairs *neither* the physical nor the electrical properties of metals or insulations.

Ordinary rosin is powdered. Air and moisture can seep through, causing the decomposition that is so detrimental to rosin's fluxing properties.

But in Kester Rosin-Core Solder, *the rosin is in blastic form*. Air and moisture are kept absolutely out. There can't be any decomposition. And as a result, even old age won't lessen the fluxing capacity of the rosin, and the effectiveness of the solder.

Our Industrial Development Department, working with our Research Laboratory, has helped many radio manufacturers solve all their soldering problems. Let us help you with yours. There's no obligation. Write today.



KESTER SOLDER COMPANY  
4224 Wrightwood Avenue, Chicago, Ill.  
Incorporated 1899

**KESTER**  
**FLUX-CORE**  
**SOLDER**  
Acid-Core Paste-Core Rosin-Core

# GEN-ERAL COILS

Reg. U. S.: Pat.

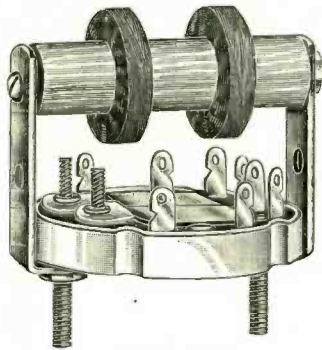

CX 100—D.



R. F.—S. H. Antenna

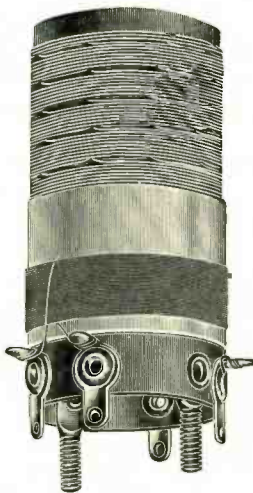

R. F. B. No. 100



S. H.—R. F. Oscillator



R. F. B. No. 14



CX 100—Mounted



CX 200

**GENERAL MANUFACTURING CO.**

8065 So. Chicago Ave., Chicago

# Experience

For nearly fifty years  
The Zapon Company  
has been outstanding  
in the manufacture of

## PYROXYLIN LACQUER



The experience of half  
a century is an ingredi-  
ent in every formula of  
Zapon Products.

## THE ZAPON COMPANY

*A Division of Atlas Powder Company*

STAMFORD, CONN.

# A 1931 Necessity

## A DAYRAD TEST OSCILLATOR

(And Output Meter)

for

Servicing Super  
Heterodyne and  
all other types  
of Radio Sets.

Made in two styles,  
with or without the  
high-resistance Output  
Meter (using rectifier  
bridge circuit).

Type 180 Test Oscil-  
lator. Provides all  
Broadcast Frequencies  
plus the Intermediate  
Frequencies of 175  
(with vernier) and 180  
kilocycles.

Dealers Net Price (including Output Meter)..... \$57.50

Dealers Net Price (less Output Meter)..... \$39.50

Type 183 Test Oscillator. Provides all Broadcast Frequencies plus  
the Intermediate Frequencies of 130, 175 (with vernier), and 180  
kilocycles.

Dealers Net Price (including Output Meter)..... \$62.50

Dealers Net Price (less Output Meter)..... \$44.50

*Guaranteed Accuracy—Thorough Shielding*

*Write for Full Information*



## THE RADIO PRODUCTS COMPANY

5th & Norwood Dept. E. Dayton, Ohio, U. S. A.

*Satisfaction*  
**year after year**  
*IS sure . . . with*  
**FLYER**  
**Electrics**

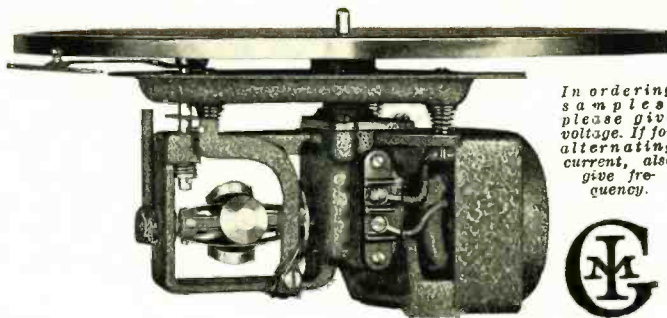

*In ordering samples, please give voltage. If for alternating current, also give frequency.*



*Ontario Hydro-Electric Power Commission Approval No. 2685.*

The Blue Flyer Motor unit. Specially designed for Radio-Phonographs. Both this motor and the smaller and lower priced Green Flyer are self starting, with automatic stop equipment optional. Induction type, and both have silent spiral-cut fibre gears and long oversize bearings. Open construction with complete ventilation—no overheating. For A. C., operates on all commercial voltages and frequencies. For D. C., either 110 or 220 volts. Flyer Motors are furnished as shown, complete with mounting plate, turntable and speed regulator. *Responsibly Guaranteed.*

**T**HE record of Flyer Electric Motors shows why they are the choice of more and more leading builders of quality Radio-Phonographs. Service with satisfaction year after year. Because specially designed and produced for Radio-Phonographs under unequalled advantages.

Flyer Electrics will exactly fill your requirements too. Due to co-ordinated simplicity and efficiency of design. Due to superior precision manufacturing. Due to specialized electrical manufacturing for a quarter century and leadership in large-scale production of quality phonograph motors for 15 years. Advantages obtained only in these simplest, soundest and most dependable motors. Both the Blue Flyer and the smaller Green Flyer give real satisfaction . . . self-starting abundant power, uniform speed and uninterrupted service.

*The* **GENERAL INDUSTRIES CO.**  
 3147 Taylor Street, Elyria, Ohio

*Escutcheons*  
**— DIALS**  
*and* **NAME PLATES**

**— LICENSE PLATES —**

Our large and modern plant affords excellent facilities for the speedy production of your requirements in etched and lithographed also



embossed metal specialties. A large variety of stock dies enables Radio Manufacturers to effect great savings on escutcheons, for regular models, Midget sets, and auto radio sets.

Cut slightly over half actual size  
 Send your blueprints—our Art Department will gladly submit original sketches for your approval.

**General Etching and Mfg. Co.**

MANUFACTURERS OF  
**ETCHED AND LITHOGRAPHED METAL PRODUCTS**

3070-82 W. Grand Ave., Chicago, Ill.

**ACME TRANSFORMERS**



Acme Step Down Transformer. 50 to 350-watt sizes available.

Power and Audio Transformers for Radio Manufacturers' use. Prompt quotations given on your specifications.

*Send for these new bulletins:—*

- Voltage Step Down Transformers for export shipments, Bulletin No. 121
- Replacement Transformers for service organizations, Bulletin No. 122



**The Acme Electric & Manufacturing Co.**  
 1440 Hamilton Ave. Cleveland, Ohio

# RADIO WIRE

TO RADIO ENGINEERS—

Send us your specifications or blue-prints for Assemblies, Cables and Remote Control Cords—

for

Midget and all other Radio Sets—using GUTTA PERCHA, Rubber Insulated or special constructed wire.

**For Radio Hook-up—**

GUTTA PERCHA wire is used extensively as it affords free stripping, easy push back and is impervious to moisture. Made exclusively by us.

Shielded, armored and other type wires for Radio Use.

**THE HOLYOKE COMPANY, Inc.**  
621 BROADWAY  
NEW YORK CITY

**M&W.C. 1876**

**LACQUERS ENAMELS**

**One Coat Gloss White**

How many coats of White Lacquer Enamel do you apply in finishing metal? If more than one, you will be interested in—

**Gloss White Enamel No. 64**

Another M & W designed Quality Enamel of unusual merit. A trial sample will show if you can reduce the number of coats with Equal or Better results.

You are invited to write our nearest branch office.

**MAAS & WALDSTEIN COMPANY**

Executive Offices and Plants:

**438 Riverside Ave., Newark, N. J.**

Chicago Office and Warehouse: 1115 W. Washington Blvd.  
Los Angeles Office and Warehouse: 2416 Enterprise Street

The border of this advertisement is a photographic reproduction of M & W Prismatic.

**ACHESON OILDAG CO.**  
PORT HURON, MICH.

**TONE CONTROL**

is not a matter of muffling the treble to emphasize the bass.

It is a delicate blending of the two, accomplishable with sensitive resistance elements only, as produced by "Aquadag" Colloidal Graphited Water.

Send for Technical Bulletin No. E 11.1

**Home Recording in 1932 RADIO SETS**

**ATTENTION!**  
*Designing Engineers*

The 2-button ELLIS Hand Microphone merits the careful consideration of those Radio Engineers who are contemplating the inclusion of Home Recording with their 1932 Radio Sets.

Unlike the single-button microphones now employed for this purpose, the ELLIS 2-button Hand Microphone employs the same type of buttons that are incorporated in the larger and more expensive broadcast type microphones. These buttons account for the superior, true tone quality.

The advancement of the Science of Home Recording demands the same high quality equipment as has been included in every department of the Radio Set in recent years. The ELLIS 2-button Hand Microphone has been designed by the manufacturers of the line of ELLIS Microphones now so famous in Broadcasting and in Public Address systems everywhere.

Engineers of those Radio Manufacturers who are interested in this problem should write us at once. We will have our representative call with samples.

**ELLIS ELECTRICAL LABORATORY**

337 WEST MADISON ST. Chicago, Illinois

Export "Simons," 25 Warren St., New York. Cable: Simontrco.

# RACON

LATEST  
TYPE  
PORTABLE  
HORNS

New type portable horn number 3320A air column length slightly less than 7 feet. Oval bell 27" x 35", depth 28"

Can be separated in two halves for portability. Excellent for speech as well as music.



Portable Horn  
Model 3320A



## Giant Electro Dynamic Unit

Weight 20 lbs. Field consumption approx. 1 amp. at 6 volts. Rating 30 watts, continuous operating load 10 watts.

Racon horns and units are covered by U. S. Patents Nos. 1,507,711, 1,501,982, 1,577,270, 73,217, 73,218, 1,722,448, 1,711,514, 1,781,489.

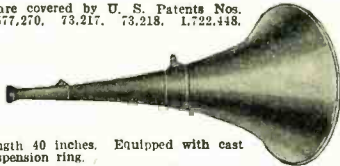

## Storm-proof Trumpet Horn

Bell 22 inches round, length 40 inches. Equipped with cast aluminum ferrule and suspension ring. For Public Address and all Outdoor use. Will withstand all weather conditions. Requires no replacements or servicing after heavy rain-storms. . . Guaranteed for one year. Prices slightly higher than regular horns.

Our Latest Catalog is Yours Upon the Asking  
**RACON ELECTRIC CO., INC.**

FACTORIES: 18 to 24 WASHINGTON PLACE, NEW YORK  
ENGLAND AND CANADA

# •FOIL•

FOR  
CONDENSERS  
TIN, LEAD, ALUMINUM

OUR MANUFACTURING  
EXPERIENCE OF OVER  
40 YEARS IS YOUR  
GUARANTEE OF QUALITY  
MATERIAL AND  
SATISFACTORY SERVICE

STANDARD WIDTHS IN STOCK  
FOR PROMPT SHIPMENT

## The Johnston Tin Foil & Metal Co.

6016-6106 S. BROADWAY  
ST. LOUIS, MO.

EASTERN OFFICE  
1224 HALSEY ST.  
BROOKLYN, N. Y.

EST. 1889

F. W. FLAD, SR.  
Tel. JE 1549

# JOHNSON'S INDUSTRIAL TAPE

**D**OES not need a loud-speaker to broadcast its perfection.

Radio engineers all know of and recognize its superiority, its insulating properties, its non-corrosive action and lasting adhesion. It will outlast any other tape put to similar usage.

Write for free sample and convince yourself of its excellence

**JOHNSON & JOHNSON**  
New Brunswick, N. J.

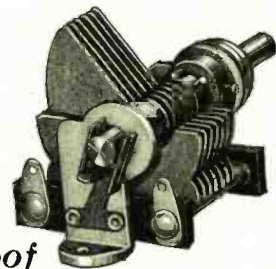

The New  
Vibration-Proof

## HAMMARLUND MIDGET Condenser

**H**IGH capacity and wide range—20 to 325 mmfd.—in a small condenser of many uses. Without nuts or screws—everything rivetted—it is ideally adapted for airplane or automobile receivers, where vibration is a serious factor.

Soldered brass plates, sturdy frame, accurately fitted bearings, Parmica insulation. Double four-point bronze wiping contact.

Adjustment screw works in a groove—cannot burr the shaft.

Straight line or "Midline" tuning curve. Base-board or one-hole mounting. Ideal for tuning Short-Wave Receivers.

Mail coupon for Technical  
Data and Blueprints

For Better Radio  
**Hammarlund**  
PRECISION  
PRODUCTS

HAMMARLUND MFG CO.  
428-438 W. 31st  
St., N. Y.  
Please send technical data and blue-  
prints on Improved Midget Con-  
denser. Name \_\_\_\_\_ Firm \_\_\_\_\_  
Address \_\_\_\_\_  
RE-2



For Sound Equipment,  
Radio, Television,  
Laboratory  
and  
Industrial  
Uses

## SUPER-DAVOHM

Wire Wound Precision Resistors

Engineers and manufacturers are invited to bring their resistor problems to Daven. We manufacture a complete line of resistors ranging from 0.1 ohms to 30 megohms or more. Voltage dividers and heavy duty resistors a specialty.



Type BWE



Type BLT

**THE DAVEN COMPANY**  
RESISTOR SPECIALISTS  
General Office and Factory  
158-160 Summit Street, Newark, N. J.

# AMPLION



TYPE T M  
\$65.00  
Less Stand



TYPE H M  
\$25.00



TYPE J M  
\$25.00  
Less Stand

Transverse Current

## MICROPHONES

Write for 20-page catalogue and price list describing microphones, microphone amplifiers, 50-watt power amplifiers, giant dynamic air column units, exponential horns, synchronous and non-synchronous turntables, and complete panel mounted equipment for schools, hotels, hospitals, parks, skating rinks, steamships, airplanes, auditoriums, theatres, etc.

*Centralize Responsibility for the Success of Your Installations by Purchasing All the Parts From One Source.*

**Amplion Corporation of America**  
133 W. 21st St., New York City

## JENKINS & ADAIR

### Plate Supply Rectifier

TYPE D

This new rectifier panel, making use of type 866 mercury rectifiers, is designed to supply plate current to standard speech input equipment up to 200 milliamperes at 350 volts, and 2 to 3 milliamperes at 135 volts. It is not limited to a single amplifier but will supply associated level indicators, monitors, etc. It is free from hum even at highest gain settings. Both voltage supplies are completely controllable and metered. Power required is 110 volt, 60 cycle, AC. The panel is finished in black enamel with nickel fittings. The dimensions are 19 x 21 in. and total depth is 1 1/2 in. The weight is 90 lbs. The price is \$450.00, net, f.o.b. Chicago, in the U. S. A.



**JENKINS & ADAIR, INC.**  
ENGINEERS  
CHICAGO, U. S. A.  
Cable Address: JENKADAIR  
Phones, Keystone 2130 3333 Belmont Avenue  
British Offices: 76 Old Hall Street, Liverpool, England  
40 Buckingham Gate, London SW1, England  
French Office: 15 Rue de Chateaudun, Asnieres, France  
Mexican Office: Av. 5 de Mayo 10, Mexico D.F., Mexico

## For 1931 Designs

# SPECIFY FAIRMONT ALUMINUM

Special Aluminum  
Sheet for Condenser  
Plates and Shielding.

▲

Prompt shipments  
from your nearest  
warehouse.

**Fairmont Aluminum Company**  
FAIRMONT, W. VA.

Warehouse Distributors

Central Steel and Wire Company, Chicago, Dayton and Detroit  
Chas. A. Strelinger Co., Detroit J. M. & L. A. Osborn Co., Cleveland  
Ducommun Corporation, Los Angeles and San Francisco



## Beat-Frequency Oscillator



Type 413-B Beat-Frequency Oscillator  
Price \$175.00

Any frequency in the band between 50 and 10,000 cycles per second is available by setting the single control of this beat-frequency oscillator. Operated by batteries, it is readily portable and makes a practically indispensable instrument for the laboratory engaged in measurements and other experimental work at audio frequencies.

A request on your business letterhead will bring you a catalog description of this and other General Radio laboratory instruments. Please ask for Catalog F-A.

### GENERAL RADIO COMPANY

Offices Laboratories Factory

CAMBRIDGE A, MASSACHUSETTS

## THE NEW HOME OF



Where the latest improved machinery assures complete satisfaction in the following **ELMENCO** Leaders—

Molded Bakelite Condensers  
Canvas Bakelite Condensers  
Filter Condensers  
R. F. Coils  
Voltage Drop Resistors

Synthetic Resistors  
Wire Wound Resistors  
Carbon Resistors  
Strip Resistors  
"Sealdohm" Resistors

Write for Samples and Catalog

### Electro-Motive Engineering Corp.

797 E. 140th St.

Bronx, New York City

## Our new address is 44 West 18th St., New York

where we are equipped to give you even better service than before. In over 15,000 square ft. our shipping facilities have been tripled. We have made a move—a move to serve you better.

Radio & Electrical Wholesale  
Bargain Bulletin No. 66

DEALERS, SERVICE - MEN,  
JOBBER, MANUFACTURERS  
!! NOW READY !!

New Wholesale Bargain Bulletin No. 66. Full of Real Low Prices on: Condensers, Transformers, Speakers, and Replacement Parts.

WRITE!  
A card will put you on our list!

### AMERICAN SALES CO.

44 West 18th St. (Dept. R) New York City

# DeJUR-AMSCO VARIATOR

Small Fixed — Variable Capacitor for Superhets



Single  
Duplex  
Variable  
Semi-Variable

These units are mounted on an insulating base of Isolantite. The Duplex Types are mounted electrically and mechanically independent of each other with mica di-electric between the plates.

The various types have various uses in circuits requiring small variable or semi-variable condensers; as trimmers in gang condensers and for neutralizing purposes in T.R.F. circuits.

Write for Booklet Giving Complete Specifications

## DeJUR-AMSCO CORP.

Variators — Variable Condensers — Power Rheostats  
95 Morton Street New York City





**GEARS**  
 In Stock—Immediate Delivery  
 Gears, speed reducers, sprockets, thrust bearings, flexible couplings, pulleys, etc. A complete line is carried in our Chicago stock. Can also quote on special gears of any kind. Send us your blue prints and inquiries.  
 Write for Catalog No. 200  
**CHICAGO GEAR WORKS**  
 769-773 W. Jackson Blvd., CHICAGO, ILL.

FOR  
**COMPOUNDS**  
 CONSULT  
**COCHRANE CHEMICAL CO.**  
 JERSEY CITY, N. J.

••• **FELT** •••  
 For Every Radio Purpose  
**AETNA FELT COMPANY**  
 200 Centre Street - - New York City

BARE AND TINNED  
**COPPER WIRE**  
 For All Purposes  
 Fine Sizes Our Specialty  
**SPARGO WIRE COMPANY**  
 ROME, NEW YORK  
 Established 1885

\* **CLAMP NAILS**  
 For All Mitered Joints  



★ So good that the finest Craftsmen can find nothing better. So economical that the Master of the Fast-Bag production never affords to use anything cheaper.  
 Used on Millwork, Cabinet Empaneling, Furniture, Tables.  
**CLAMP NAIL CO.**  
 1542 Palmer St., CHICAGO, ILL.

Send for FREE Samples and Catalog

**Baach-International Compound High Vacuum Pumps**  
 We manufacture all sizes of High Vacuum Pumps from 1-200 cu. ft. per min. All pumps tested at 1/2 micron before leaving factory. Write for details.  
**INTERNATIONAL MACHINE WORKS, Inc.**  
 527-529 Thirty-Second St., Union City, New Jersey

**ALPHA WIRE ALPHA**  
 Quality wire for every type of hook-up "Alpha" a slip back braided hook-up wire made under a patented process.  
 Alpha "Hitension" Wire (Colored Rubber) BARE-TINNED-ENAMELED-RUBBER COVERED CABLES TO SPECIFICATION—  
**ALPHA WIRE CORPORATION**  
 50 Howard St., New York City

OVERLOOKING BEAUTIFUL JUNEAU PARK AND LAKE MICHIGAN



**THE Plaza APARTMENT HOTEL**  
 A Dignified Place of Residence for Permanent and Transient Guests  
 FURNISHED APARTMENTS AND HOTEL ROOMS FOR TRANSIENTS  
 Ideal for women traveling alone  
 Personal Direction Of O. F. HOEBERG  
**Milwaukee**  
 ON CASS AT EAST STATE STREET  
 ON U.S. HIGHWAY NO. 141

Convenient Transportation to Everywhere  
 200 APARTMENTS 300 ROOMS



**HOTEL HENRY**  
 IN THE HEART OF EVERYTHING WORTHWHILE  
 SINGLE ROOM \$2.00 & UP  
 DOUBLE ROOM \$3.00 & UP  
 Excellent Restaurant  
 Breakfast 40c to 75c  
 Luncheon 85c  
 Table D'Hote Dinner \$1.25  
 Popular priced Coffee Shop  
 FIFTH AVENUE NEAR SMITHFIELD  
**PITTSBURGH, PENN.**

13-RT  

**TIPLESS EXHAUST TUBE BENDER-EISLER METHOD**  
 AVOID PATENT SUITS  
 SEND FOR BULLETIN ?  
**EISLER ELECTRIC**  
 760 South 13th Street, NEWARK, N. J.

No. 13-RT

**Rocke International Electric Corp.**  
 15 Laight Street, New York  
 Export sales managers for nationally known radio manufacturers.

# LAMINATIONS

for Audio & Power Transformers  
SPECIALIZED METHODS—YEARS OF EXPERIENCE  
Wide Variety of Stock Standard Sizes  
Dimension and Price Sheets on request

We Also Make  
PERMANENT MAGNETS—DIES—TOOLS—  
METAL STAMPINGS  
Facilities for prompt service

**Thomas & Skinner Steel Products Co.** 1100 to 1120 E. Twenty-Third St. INDIANAPOLIS, IND.

WE offer to manufacturers interested in

## EXPORT

the services of a dependable organization, well established in the entire foreign field

**AD. AURIEMA, Inc.**

Manufacturers' Export Managers  
116 Broad Street, New York, N. Y.

We Cater to Laboratories—Broadcasting Stations—Talking Movies, Etc. Parts for any and every item you may need always on hand. Call on us for your requirements



45 VESEY STREET, NEW YORK CITY

## CONDENSER PAPER

182 Cornelson Ave. — Mills at — Newark Ave. Jersey City, N. J. Elizabeth, N. J.  
**PETER J. SCHWEITZER, Inc.,**  
200 Fifth Ave. New York

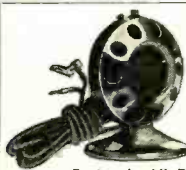

**MICROPHONES** All Kinds from \$7.50 to \$350.00  
For Connection to Radio Set..... \$7.50  
For Home Recording..... \$10.00  
For Public Address, etc., list..... \$25  
Standard Broadcast Model, list..... \$75  
Condenser Models for Film and Record Work, list \$300.00, \$350.00  
Also Desk and Floor Stands, Covers, Cords, etc.  
EXPERT MICROPHONE REPAIRS  
**UNIVERSAL MICROPHONE CO., LTD.**  
Inglewood, Calif.

Dealers in All Principal Cities  
New York—Howard F. Smith—142 Liberty St. Export Rep. Ad. Aurisma, Inc., 116 Broad St., N. Y. C.



**Microphone Stands  
Relay Racks  
Special Amplifier Boxes  
Incidental Steel Work**

Especially designed for use in conjunction with Broadcasting, Public Address, Sound Systems

Yes, we do special metal work—send in your sketches.

**Jerome A. Schwartz**  
246 Fifth Avenue  
New York, N. Y.



## GILBY WIRE PRODUCTS

Filament Wire—Gilby Selvage Mesh (pat. app.)  
Plain Nickel Mesh—Support Wire—Nickel Ribbon, Plain and Carbonized—Grid Wire—Seamless Tubing—Carbonized Nickel Ribbon.  
Standard Nickel Chrome Resistance Wires.

TOPHET "A", TOPHET "C"  
Bare & Enameled & Textile Insulated

## GILBY WIRE COMPANY

WILBUR B. DRIVER, Pres.  
NEWARK NEW JERSEY

Make a **PROFIT** from Every Service Call



When tubes blow... filter equipment fails... tone quality suffers... install AMPERITE. Automatically regulates line voltage fluctuations, up and down, between 100 and 140 volts to exact requirements.

Easily installed in 5 minutes without chassis changes. Satisfies customers... reduces free service... pays you a profit. A type for every electric radio.



**AMPERITE Corporation**  
501 BROADWAY NEW YORK

### AMPERITE

Self-Adjusting  
LINE VOLTAGE CONTROL

Ask your dealer or write us giving set name and model. Address Dept. RE-2

**NEW DEVELOPMENTS** Complete Data on All Recent Radio Inventions Now Included in This One Big Guide Book of Radio. Byrd's Antarctic Radio Equipment—Television—Interference Elimination—Short-Wave Apparatus—Broadcasting Equipment—these are only a few of the NEW subjects in the most complete radio handbook ever published—

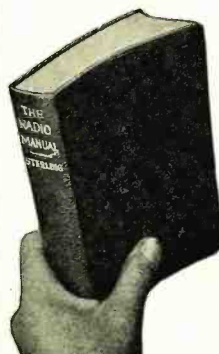

### The RADIO MANUAL

A Handbook for Students, Amateurs, Operators, and Inspectors  
Here's the answer to every question about the principles, operation, and maintenance of radio apparatus. A complete radio course in one volume. Prepared by G. E. Sterling, Official Examining Officer, Radio Division, U. S. Dept. of Commerce. 20 big chapters. 369 illustrations.

EXAMINE IT FREE! MAIL THIS COUPON

D. VAN NOSTRAND CO., Inc., 250-4th Ave., N. Y.  
Send me the Revised edition of THE RADIO MANUAL for examination. Within ten days after receipt I will either return the volume or send you \$6.00, the price in full. (R.E. 2-31)

Name.....  
St. and No.....  
City and State.....  
Business Connection.....

# FOR BETTER BUSINESS VISIT NEW YORK

★ **2<sup>50</sup>** daily ★

... secures a fine room *and bath* ...  
*others at \$3<sup>00</sup> and \$3<sup>50</sup>*

AT ONE OF NEW YORK'S BEST HOTELS

## The **BRISTOL**

48<sup>th</sup> ST. EAST OF B'WAY ▲▲ NEW YORK CITY  
OWNERSHIP MANAGEMENT ▲▲ T. ELLIOTT TOLSON, Pres.

LATZ, INC.

# HOTEL LOCKERBIE

Just a block or two from  
everywhere...one and one-  
half blocks from Union  
Station and two blocks  
from Traction Terminal



ALL OUTSIDE ROOMS  
AND EACH WITH BATH

### RATES

\$3<sup>50</sup> and up double    \$2<sup>00</sup> and up single

GARAGE SERVICE

ARTHUR ZINK  
Managing Director



ATTENTION SERVICE

121 SOUTH ILLINOIS STREET  
**INDIANAPOLIS**

## The Home Hotel of New York

Homelike in service, ap-  
pointments and location ...  
away from noise and con-  
gestion, yet but a few minutes  
from Times Square ... garage  
facilities for tourists.

Room and Bath from  
\$3 single \$4 double  
500 Rooms

Home folks will  
like this hotel

**HOTEL**

# BRETTON HALL

BROADWAY at 86<sup>th</sup> STREET

NEW YORK

ANNOUNCING THE REMOVAL OF THE  
GENERAL FABRICATING CO.

TO THEIR NEW AND SPACIOUS QUARTERS AT  
37 EAST 18TH STREET, NEW YORK CITY

DISTRIBUTORS OF



SHEETS—RODS—TUBES of all sizes carried in stock. SPECIAL sizes cut to order at short notice.

Complete facilities for punching, drilling, machining and engraving.



**RADIO APPARATUS TESTING**

Life tests and characteristics of vacuum tubes. Calibration of all kinds of instruments. Determination of inductance and capacitance at various frequencies. Resistance measurements, motor tests, magnetic tests, etc.

Electrical Testing Laboratories  
80th St. and East End Ave.  
New York



**Portable Condenser Microphones**



2P 2 stage plate output... List \$110.00  
2C 2 stage 200 ohm output List 125.00  
Uses 2 type 230 low drain tubes.  
3P 3 stage plate output... List \$125.00  
3C 3 stage 500 ohm output List 150.00  
Uses 2 240 and 1 112-A tube.

These prices for type "A" unit.  
For type "B" unit add \$40.00 each list. Standard finish is black and gold. Prices include tubes and 20 ft. cord. Interesting dealer proposition.

Astatic Microphone Laboratory  
21 Olive Street  
YOUNGSTOWN, OHIO

**DeWALD**

Licensed  
by  
R.C.A.

A.C. and D.C.

**Midget Receivers**

Write for complete details.

**PIERCE AIRO, INC.**

115-117 Fourth Ave.,

New York City

Licensed  
by  
R.C.A.

**Stampings**

**Pressed Metal for Radio Industry**

Steel, Aluminum, Copper, Brass and all Alloys

Send Inquiries and Drawings

**METAL SPECIALTY CO.** 1533 Riverside Dr.  
Cincinnati, Ohio



**NICKEL  
WIRE CLOTH**



for the

**RADIO TUBE INDUSTRY**

Any mesh woven accurately to your specifications.

**"CLEVELAND"**

Wire Cloth renowned for its Uniformity, its Superiority,  
its Durability.

Advise us of your Requirements

**The Cleveland Wire Cloth & Manufacturing Co.**  
3571 E. 78th Street, CLEVELAND, Ohio

**Condensers..**

FILTER » BY-PASS » IGNITION » TELEPHONE » TELEGRAPH

**Kellogg Switchboard and Supply Company**

1066 West ADAMS Street - - CHICAGO

# DEPENDABLE QUALITY — UNIFORMITY SERVICE

ON  
WAXES — & — MELTABLE  
INSULATING and WEATHER-  
PROOFING COMPOUNDS

WAXES—All kinds.

IMPREGNATIONS—Condensers, Coils, Rubber-  
Covered and Weather-Proofed Wire, Telephone  
and Electrical Cables, Etc.

SEALING COMPOUNDS—Coils, Condensers,  
Batteries (Wet & Dry), Pot Heads, Cables, Wir-  
ing Devices and Specials.

FINISHING—All grades of Weather Proof and  
Rubber-Covered Wire.

SPECIAL COMPOUNDS



35th St. & Maplewood Ave.  
Chicago, Ill.

"For over 35 yrs."

# ROEBLING

MAGNET  
(Cotton or Silk)

BUS BAR  
Litzendraht-Loop

STRAND  
Antennae (plain or enameled)  
—Double Galvanized.

WIRE  
Antennae (plain or enameled).  
Connecting and Ground (Rubber  
covered, braided or plain).

JOHN A. ROEBLING'S SONS CO.  
Trenton, N. J. *Branches in Principal Cities*

# WIRE PRODUCTS

## INDEX OF ADVERTISERS

<b>A</b>	Acheson Oildag Co. . . . .	60	<b>E</b>	Ellis Elec. Laboratory . . . . .	60	<b>M</b>	Maas & Walstein Co. . . . .	60
	Acme Electric & Mfg. Co. . . . .	59		Eric Resistor Corp. . . . .	11		Mallory & Co., P. R. . . . .	12, 13
	Ad. Aurlima, Inc. . . . .	65					Metal Specialty Co., The . . . . .	67
	Aetna Felt Co. . . . .	64	<b>F</b>	Fairmont Aluminum Co. . . . .	62	<b>N</b>	Nat'l. Elec. Prod. Corp. . . . .	9
	Allied Die Casting Corp., The . . . . .	70		Fansteel Products Co., Inc. . . . .	51			
	Alpha Wire Corp. . . . .	64		Ferranti, Inc. . . . .	69	<b>P</b>	Paper Tube Co., The . . . . .	51
	American Sales Co. . . . .	63		Formica Insulation Co. . . . .	1		Parker-Kalon Corp. . . . .	5
	American Transformer Co. . . . .	57		Frost, Herbert H., Inc. . . . .	70		Pierce Airo, Inc. . . . .	67
	Amperite Corp. . . . .	65	<b>G</b>			<b>R</b>	Racon Elec. Co., Inc. . . . .	61
	Amplion Corp. of America . . . . .	62		General Cable Corp. . . . .	21		Radio Products Co., The . . . . .	58
	Anaconda Wire and Cable Co. . . . .	3		General Electric Co. . . . .	22		Rocke Int'l. Elec. Corp. . . . .	64
	Arcturus Radio Tube Co. . . . .	49		General Etching & Mfg. Co. . . . .	59		Roebing, J. A., Sons Co. . . . .	68
	Astatic Microphone Lab. . . . .	67		General Fabricating Co. . . . .	67	<b>S</b>		
	Automatic Winding Co. . . . .	64		General Mfg. Co. . . . .	58		Samson Electric Co. . . . .	20
<b>B</b>				General Industries Co., The . . . . .	59		Schwartz, Jerome A. . . . .	65
	Bakelite Corp. . . . .	Back Cover		General Radio Co. . . . .	63		Schweitzer, Peter J., Inc. . . . .	65
	Brawley Felt Co., T. R. . . . .	69		Gilby Wire Co. . . . .	65		Soreng Manegold Co. . . . .	69
<b>C</b>							Spargo Wire Co. . . . .	64
	Candy & Co. . . . .	68	<b>H</b>				Sprague Specialties Co. . . . .	47
	Cardwell Mfg. Corp., Allen D. . . . .	18		Hammarlund Mfg. Co. . . . .	61		Synthane Corp., Inc. . . . .	53, 54
	Central Radio Corp. . . . .	6, 7		Holyoke Company, Inc., The . . . . .	60	<b>I</b>		
	Central Radio Laboratories . . . . .	5					Inca Mfg. Division . . . . .	9
	Central Scientific Co. . . . .	Second Cover				<b>J</b>	Int'l. Machine Works, Inc. . . . .	64
	Chicago Gear Works. . . . .	64					Jenkins & Adair Inc. . . . .	62
	Clamp Nail Co. . . . .	64					Johnson & Johnson. . . . .	61
	Clarostat Mfg. Co., Inc. . . . .	14					Johnston Tin Foil & Metal Co. . . . .	61
	Cleveland Wire Cloth & Mfg. Co., The . . . . .	67	<b>I</b>			<b>K</b>		
	Cochrane Chemical Co. . . . .	64					Kellogg Switchboard & Supply Co. . . . .	67
	Condenser Corp. of America . . . . .	15					Kester Solder Co. . . . .	57
	Crowley & Co., Henry L. . . . .	69				<b>L</b>		
	Crowe Name Plate & Mfg. Co. . . . .	19					Leeds Radio Co. . . . .	65
<b>D</b>						<b>T</b>		
	Daven Company, The . . . . .	62					Thomas & Skinner Steel Products Co. . . . .	65
	DeForest Radio Co. . . . .	17					Thompson-Bremer & Co. . . . .	10
	DeJur-Amsco Corp. . . . .	63				<b>U</b>		
	Dongan Elec. Mfg. Co. . . . .	Third Cover					Universal Microphone Co., Ltd. . . . .	65
<b>E</b>						<b>V</b>		
	Eisler Electric Corp. . . . .	64					Van Nostrand Co., Inc., D. . . . .	65
	Electrical Testing Labs. . . . .	67				<b>W</b>		
	Electro-Motive Eng. Corp. . . . .	63					Weston Elec. Inst. Corp. . . . .	49
	Elkon Division . . . . .	12, 13				<b>Z</b>		
							Zapon Co., The . . . . .	58

## VOLUME CONTROLS POTENTIOMETERS FIXED RESISTANCES

After many months of development we are pleased to announce the perfection of a new process whereby we can *save you money* on the above items and give you *closer limits* and *absolutely permanent values of resistances*.

Send us your blue prints and specifications for estimates.

**SORENG-MANEGOLD CO.**

771 Mather St.  
Chicago.

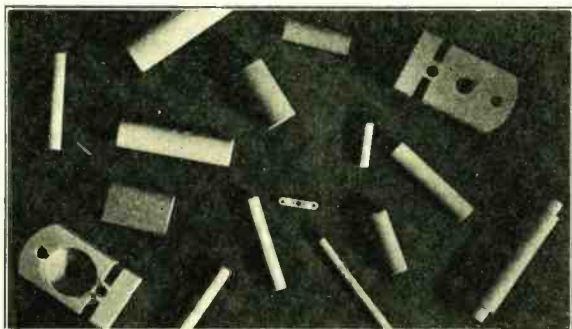

## Precise Insulation

Whether the precision be in electrical, thermal, mechanical or chemical terms, or any combination of these terms, you can bank on the experience and production skill of our organization. Just specify



The name of a complete line of ceramic products of precise formula and machining to meet your specific requirements.

*Write* us no matter what your radio or electrical insulation problems may be. Either we already have the ceramic you need or we can develop a special ceramic for your requirements.

**HENRY L. CROWLEY & COMPANY, Inc.**

*Specialists in Severe Service Materials*

1 Central Avenue     :::     West Orange, N. J.

## Brawley felt feet on Radios

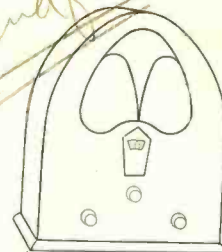

1931 will see the production of an ever-increasing number of midget types.

Equipped with Brawley Felt Feet, these can be set directly on a polished surface without danger of scratches or marks. Look into the advantages of Brawley Felt Feet from a sales appealing angle.

Three types—machine screw, wood screw and nail.

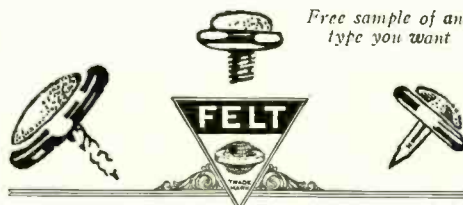

*Free sample of any type you want*

**T. R. BRAWLEY  
FELT COMPANY, INC.**  
279-20th Street, Brooklyn, N. Y.

## Special FLAT CURVE Audio and Output TRANSFORMERS

*Now made in the U. S. A. Shipped in 48 hours.*

**SPECIAL FERRANTI** Transformers, designed for the exacting needs of broadcast stations, public address systems, recording devices, laboratories, speech transmission—and other uses where a *flat curve* over a wide frequency band is necessary—are now made in the U. S. A. and can be shipped in 48 hours from receipt of your order.

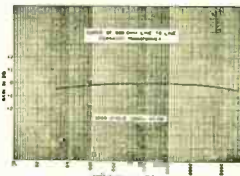

*This curve is typical of this newly developed series of FERRANTI Transformers*

### Better Amplifying Equipment

The New FERRANTI Type D Rack Amplifying Equipment gives faithful reproduction of voice and music, and is recommended where heavy duty amplification is required. Unit Assembly. Combinations may be bought from stock units, and added without disturbing existing equipment. Units instantly interchangeable.

*Write for Further Information and Catalog*

**FERRANTI, Inc.**     130 West 42d Street  
New York City

# FROST- RADIO RELIABILITY



No. 590—590



No. 2880—2880



No. 890



No. 280—280



No. 1880—1880

Not an empty phrase, this statement of FROST-RADIO RELIABILITY, but a fact which has been demonstrated during the entire life of the radio industry. As a matter of fact, this habit of building reliability into all of its products extends back more than twenty years beyond the birth of radio, for this company have been builders of precision telephonic equipment for nearly a third of a century. That is why, when you specify FROST-RADIO, you obtain not only the finest possible apparatus, but also the very best possible results in the finished product. If you are not now using these parts in your apparatus, why not become acquainted with them today?

MAY WE SEND YOU A COPY OF OUR COMPLETE CATALOG OF ALL FROST-RADIO PARTS AND ACCESSORIES? TO OBTAIN YOUR COPY JUST FILL OUT AND MAIL COUPON.

## HERBERT H. FROST, Inc.

Main Offices and Factory: Elkhart, Ind.  
160 North La Salle Street, Chicago

HERBERT H. FROST, INC.,  
ELKHART, INDIANA, U. S. A.

Please send me a copy of your complete catalog of FROST-RADIO Parts and Accessories and tell me how your products will improve our own.

Name.....Address.....

City.....State.....

# Die Cast by Allied

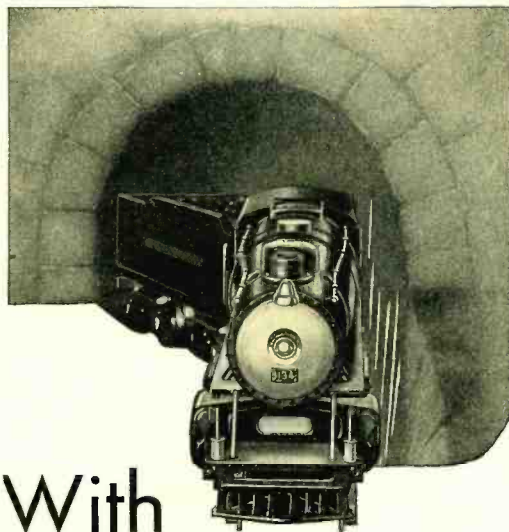

## With the throttle wide open

this toy locomotive, die cast by Allied, speeds 'round the track to delight its youthful owner.

Speeding the production schedules of industry is one of the functions for which the Allied Die Casting Process is particularly known.

And hand in hand with the high speed production of parts and products possible at the Allied Plant - goes reduced costs for the manufacturer. In addition the Allied Process offers die castings that are accurate to thousandths of an inch, plus adequate strength and fine finish as inherent qualities.

The Allied Die Casting Corporation, 43rd Avenue from 38th to 39th Streets, Long Island City, New York.







**DONGAN**

## For Your New Designs —If you are interested in a Transformer that has “Made Good”

The big names of 1930—many of them at least—were unknown on Radio Receivers 10 years ago. Each season sees its new galaxy of stars.

Each one of these sets has been equipped with Transformers, usually unthought of but nevertheless a faithful and so essential a part in Radio's brilliant onward march. A

great many of these Transformers, from the very earliest days, have been branded “Dongan.”

In designing your new models for this still another season give consideration to a Transformer that, emphatically, has “made good”—and take advantage of Dongan engineering cooperation.

## REPLACEMENT TRANSFORMERS

No. 6952

New Transformers, like new Tubes, may rejuvenate that old set for another year. Dongan Replacements are universal—fit all sets, slotted brackets permit mounting on side or end without drilling holes.



A universal type for use with midget receiving sets using up to four UY 227 or UY 224 tubes, one 245 and one 280 tube.

Secondary voltages; 315-315 volts 60 mils, 2½ volts, 8½ amperes C.T. 2½ volts 1½ amperes C.T.; 5 volts 2 amperes. List \$7.00.

*New Replacement Transformer Booklet mailed on request—ask for copy*

**Dongan Electric Mfg. Co.**  
2991-3001 Franklin St., Detroit





Multi Speaker Relay with Bakelite Laminated panel and Bakelite Molded knob. Insuline Corp., New York.

## New developments in radio accessories make use of Bakelite Materials

Multi Speaker Relay is but one of the many new developments in I.C.A. radio accessories, but it is typical of the others in its dependence upon Bakelite Materials. In this ingenious and attractive device, the panel is of Bakelite Laminated in brown mahogany finish, and the knob is of Bakelite Molded in a color to match.

In adhering to the use of Bakelite Materials for its line of fine radio accessories, the Insuline Corp. is following the established practice of radio engineers and manufacturers everywhere. If there is one advantage above all others that has made Bakelite Materials supreme in radio, it is their dependable uniformity. This is only

possible because of our unapproached experience in the manufacture of phenol resinoid products of all kinds, and the maintenance of extensive laboratories for checking and controlling all processes.

Bakelite Materials include molded, laminated and varnish. The molding material is made in many varieties to meet the different needs of industry. Our engineers and research laboratories are always at the service of radio manufacturers to aid them in the solution of unusual problems. Write for our interesting and informative booklets 38M and 38L, "Bakelite Molded" and "Bakelite Laminated".

BAKELITE CORPORATION, 247 Park Avenue, New York.

CHICAGO OFFICE, 635 West Twenty-second Street

BAKELITE CORPORATION OF CANADA, LIMITED, 163 Dufferin Street, Toronto, Ontario

# BAKELITE

REGISTERED U. S. PAT. OFF.

The registered trade marks shown above distinguish materials manufactured by Bakelite Corporation. Under the capital "B" is the numerical sign for infinity, or unlimited quantity. It symbolizes the infinite number of present and future uses of Bakelite Corporation's products.

## THE MATERIAL OF A THOUSAND USES