

Radio and Model Engineering

10 cents a Copy -

570 West 184th Street, New York City

\$1.00 Per Year

Vol. I

AUGUST and SEPTEMBER, 1921

No. 4

Editorial

OU know how you feel when, after carefully planning a new set and working it out with all the care and thoughtfulness you can, testing out each step as you go along to avoid mistakes, perhaps investing a little more than you really should, and when you connect it up—it works!

That's just the way I feel about Radio and Model Engineering. The idea dates back nearly five years. During that time, it gradually rounded out until, last winter, I had the details well in hand. It would start with at least fifty pages of articles written by a staff of half a dozen men. If things went well, it should be on a paying basis in three years.

But one evening, when the idea was under discussion, a man who didn't know the difference between a B battery and a spark gap, altho he had been unusually successful in business, said, "If you wait until you can finance such a magazine, it will never be published, but if you start with a two-page folder, and put the right stuff in it, you can put it across."

We took that man's advice. The plans for R and M were revamped on the theory that it is safer to take off from the ground than to launch out in mid-air. The indicating needle that points to the success of the Radio and Model Engineering experiment is the additional pages in this number. The pleasure which I have in seeing this increase is due to those who have made it possible by their subscriptions.

I thank you.

M. B. SLEEPER, Editor.

A Real Receiving Equipment

Altho this detector and two-step amplifier is designed particularly for the 150- to 2,600-meter regenerative set, it will work admirably with any receiver

By W. H. BULLOCK

Notes on Amplifier Design.

THERE are so many different types of amplifiers on the market that one may gain the impression that any combination of sockets, rheostats, and transformers will give good results. Experimenters who have neither time nor

distastance across the grid and filament of each tube. Leakage, either thru or over the surface of the material of which the base is composed, slight as it may be, reduces the tiny voltage applied to the grid by the incoming signal. The result of this loss, possibly not percepti-

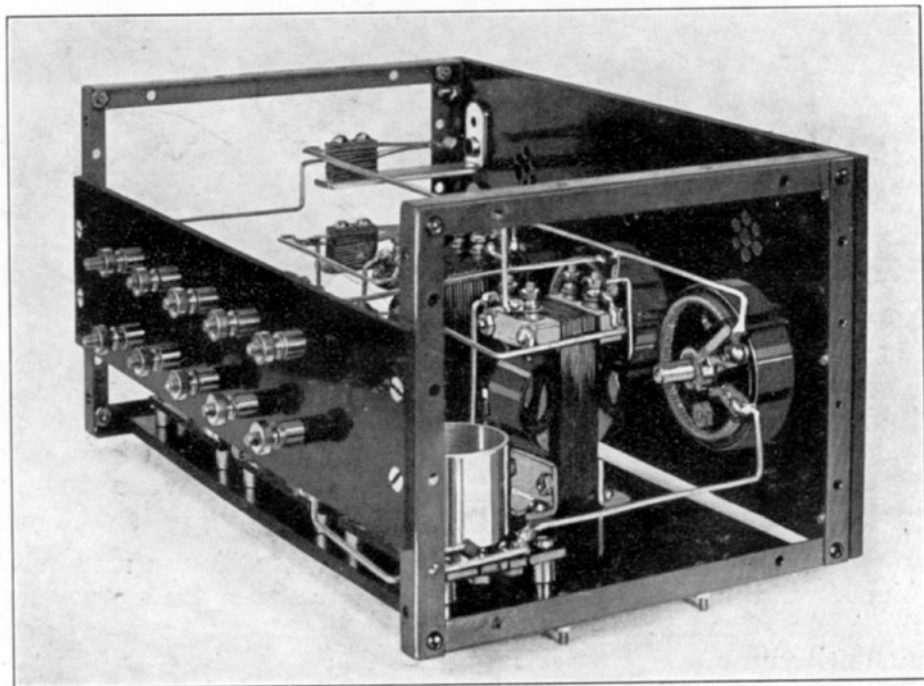

Fig. 2. A machine shop is not needed to turn out business-like radio apparatus if a correct design is chosen.

equipment to make comparative tests are particularly given to drawing conclusions not based on laboratory results but mere impressions, when, as a matter of fact, two stations with identical apparatus may show quite different operating characteristics.

Tube Socket Details.

THE sockets to be used may be taken up first. Experimenters cannot be impressed too forcibly with the necessity of maintaining a maximum re-

ble in the detector, is surprising when multiplied in successive stages of amplification.

It is for this reason that L.P.F. was chosen for the bases of the new GA-STD-A1 tube sockets. A very striking example of low resistances in the so-called perfect molded compositions is that of a grid leak mounting widely sold by one of the leading manufacturers. The leak is fitted between springs set in a molded base. Altho the only conductivity was supposed

to occur in the 1,000,000-ohm grid leak, a number of the mountings showed as low as 50,000 ohms across the terminals, rendering the grid leak worthless as a high resistance by-pass.

Another important feature is the tightness of the audion in the socket tube. If

Selection of Transformers IF the amplifier is to produce maximum signals the transformers must be of a design to conform with certain requirements. The ordinary square core transformer is not to be recommended in spite of its lower price. In the first place, this type is generally of too low

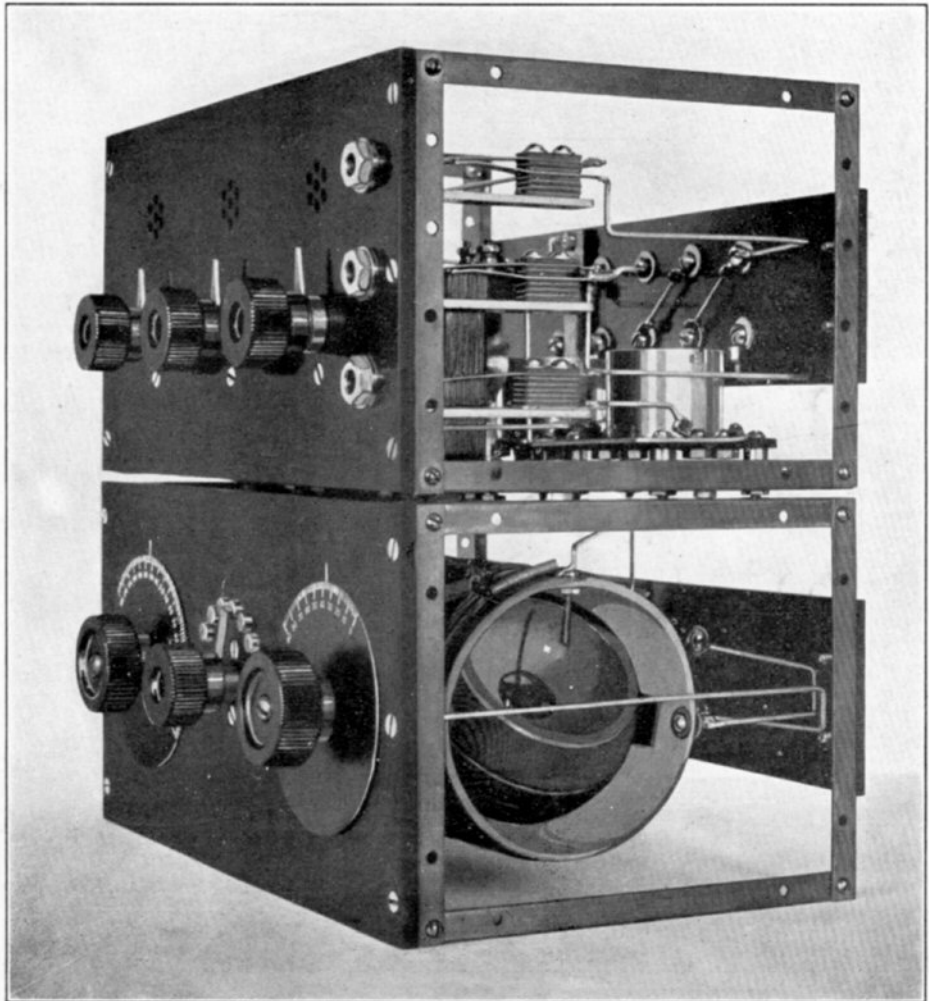

Fig. 1. A 150- to 2,600-meter receiving set which can be assembled with no other tools but a hand drill, screw driver, pliers, and soldering iron.

it is loose the springs will not make perfect contact and even slight vibration will cause a varying resistance between the contact springs and tube pins, giving a noise that is often supposed to be from the B batteries.

impedance to match the tubes. These transformers howl readily because of their large exterior magnetic field.

The shell type core, such as is employed on the Federal transformers, permits the use of a very small winding yet it gives

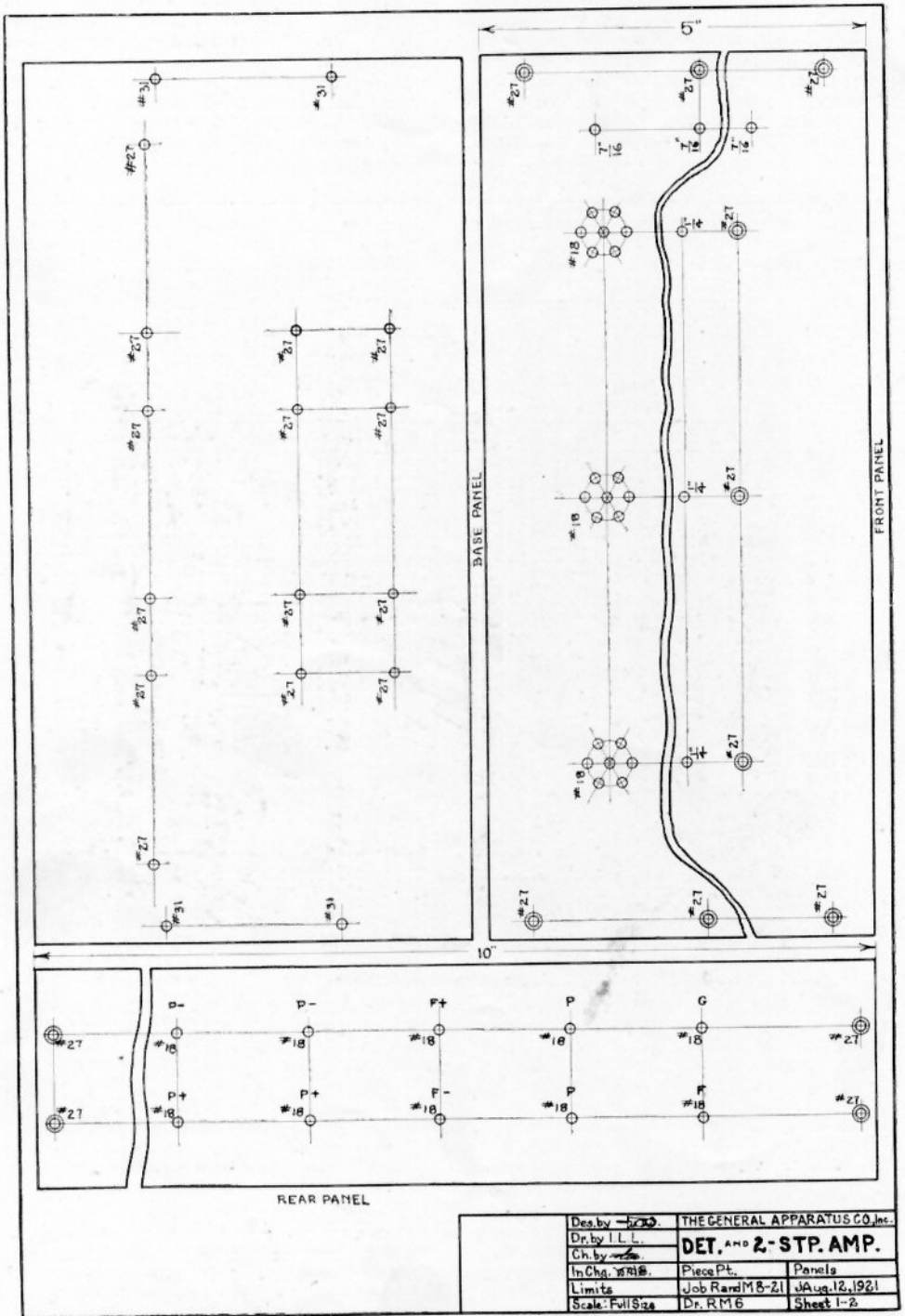

Fig. 3. Exactly one-half size Note.—On this drawing the center lines for the rheostats and peep holes are shown $2 \frac{31}{32}$ ins. apart; they should be $2 \frac{1}{2}$ ins. apart to give clearance between third rheostat and center jack.

a high impedance. When wired properly these transformers can be placed close together without any interference from howling on account of their slight exterior field. While the shell type is strongly recommended in preference to the square core, the advantages are only found in types where the core laminations are at right angles to the turns on the coil. Some transformers have circular laminations in the same direction as the turns on the winding with the result that the magnetic field is perfectly short circuited. In addition to introducing serious

combination giving minimum inter-tube coupling and the shortest possible connections, both important features. In the first model the jacks were placed beneath the rheostats. This was altered, as can be seen in Fig. 1, for the telephone cord hung down over the receiving set. In any set it is better to keep the jacks at one side.

A special convenience is the angle brass supports for the panel. They make it possible to mount the detector and amplifier above the receiving set, or support

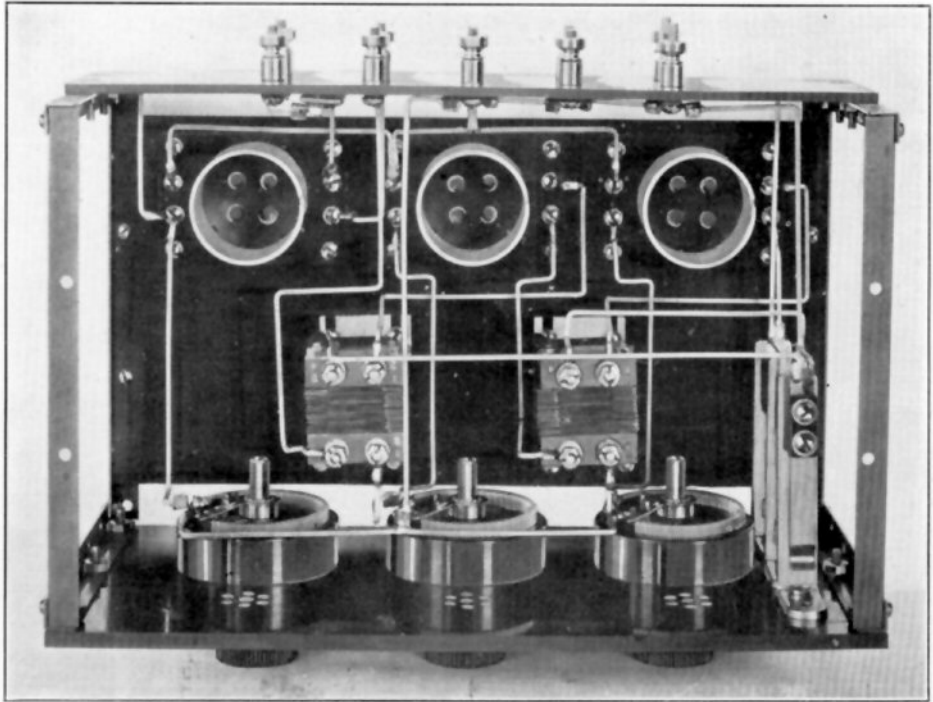

Fig. 5. Looking down on the amplifier, showing the effect of symmetrical arrangement.

losses it causes distortion in the reception of speech and music. Other special designs produce resonance effects for given audio frequencies. That is all right for spark reception, but bad for telephonic signals.

Mechanical Design Features.

ALL that is gained by careful selection of parts can be nullified by incorrect mechanical design. In the set shown in Fig. 1 a combination of efficient arrangement and convenience was attempted which proved quite successful in the completed instrument.

The arrangement of the parts is a modification of the GA-STD-A5 and -A6 detector and amplifiers, resulting in a com-

it directly on the table. The arrangement of the binding posts is such that only four connecting wires to the receiver are required at the back. All the wiring which, at best, does not add to the appearance of the outfit is out of sight, giving the front a clean cut appearance.

Figs. 2 and 3 show the layout of the parts. The holes are symmetrically lined up to make the location of their centers easy, and a minimum number of drill sizes employed. Since the original drawing in Fig. 3 has been reduced exactly one-half the dimensions can be quickly scaled off with dividers and transferred to the panels with a square and scribe. The angle brass supports are identical to those used for the receiving set, dimensions for which have been given already.

Assembling the Instrument. ALL the panels and the supports should be drilled and sanded or polished before the assembly is started. Put the transformers and sockets on the bottom panel first, making sure that they are set in the proper direction. Then come the rheostats and jacks on the front panel. The binding posts should be tightened firmly on the back panel because they are difficult to get at once the panels are assembled on the supports.

The greatest care must be exercised in wiring. Tinned square copper wire, coming in straightened lengths, makes this

heavy current drawn by three tubes the plates of the battery, if of a cheap make, are very liable to buckle, and for this reason a standard make, such as the Witherbee, is recommended. Two 22½-volt B batteries are also needed. When wired as indicated by the connection panel marking, 22½ volts are applied to the detector and 45 to the amplifiers.

The only connections to the receiving set are for the grid and filament and the tickler coil. If the amplifier is used with a variometer type receiver the plate variometer should be joined to the posts marked P P. In the case of an ordinary

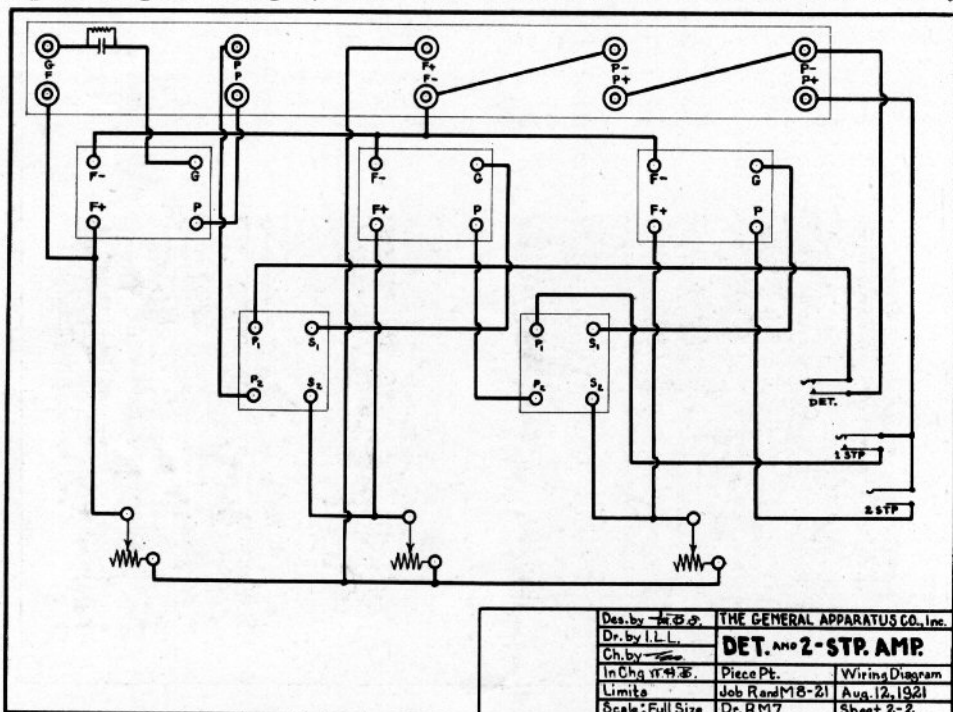

work much easier. What additional time is spent in fitting the wires is well repaid in the results and appearance. The greatest danger lies in excessive use of soldering paste. No tinning is needed on the wires if they are wiped off with a clean cloth, and the soldering lugs can be tinned before the parts are mounted. Then, in connecting up, no paste at all, or the tinnest bit, is needed.

Operating the Instrument. THE first requisite for the successful operation of an amplifier is a good filament lighting battery. Tubes now available take almost the full 6 volts of the battery, and will not operate when this voltage drops appreciably. With the

non-oscillating set the P P posts should be short circuited to close the plate circuit.

Frequently a regenerative receiver will not oscillate, when connected with an amplifier, unless a fixed condenser of 0.001 or 0.002 mfd. is put across the primary of the first amplifying transformer. This is not shown in the wiring diagram because it is not always needed.

The completed instrument shown in the accompanying illustrations, tested against two other standard makes, gave appreciably louder signals, due to the careful attention given to each detail of this outfit. Those results can be readily duplicated by any experimenter who is equally conscientious about his work.

Commercial Practice Applied To Experimental Radio Stations

The first receiving set. The beginner should start out with a receiver so simple that he will have no difficulty in making it work.

The First Problem.

WHEN a man makes up his mind to install a radio set he generally asks a friend who has a station already for advice as to what he should buy. He is usually told to get an audion detector outfit, with a loose coupler, condensers, and so many other things, that if he does not lose heart immediately, he probably will before he learns to use the apparatus.

The proper start is with a set so simple that it cannot fail to work, yet designed to

ing, than is obtained on a loosely coupled signals very loudly, but with broader tuning.

On the front of the panel are the switch controlling the inductance and a crystal detector; at the rear the tuning coil and phone condenser. The switch is used in preference to a slider because the latter wears away the wire, leaving a copper dust to short circuit the winding. Galena is the most sensitive crystal for the detector, and, with a fine copper wire for the contact, will keep its adjustment.

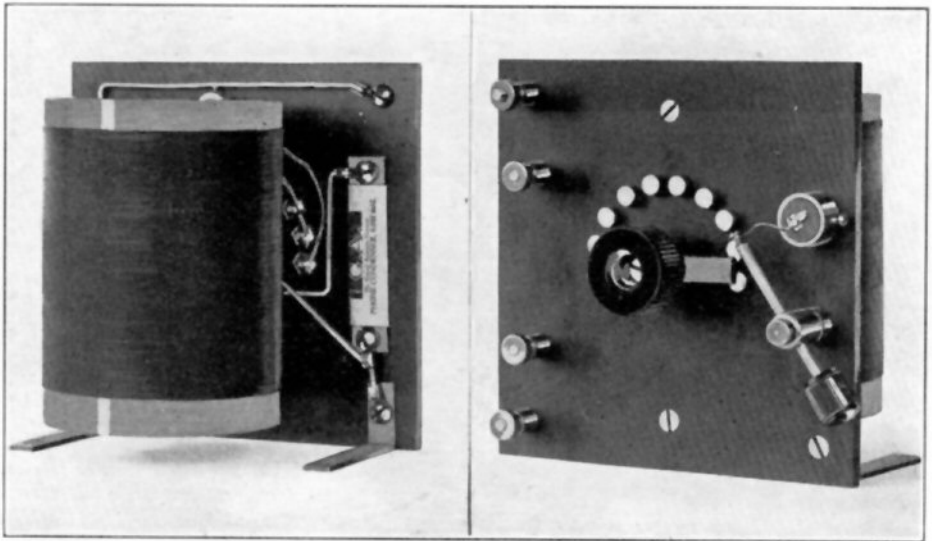

Fig. 1. Front and rear views of the beginner's receiver. Note the simplicity of the wiring and assembly.

conform with standard practice. In addition, the arrangement should be such that other instruments can be added to improve the operation as the beginner's experience is broadened. To get the most fun from the set it must be strictly home made.

A Beginner's Outfit.

A receiving set which conforms with the requirements just given is shown in Fig. 1. Built on a standard 5- by 5-in panel, all the parts are conveniently located and so connected that there is no mystery about the circuit. This outfit is commonly known as a single-circuit receiver, a type that brings in

Putting the Parts Together.

FIG. 2 shows the holes in the 5- by 5- by 3/16-in. L.P.F. panel. This material can be drilled readily with an ordinary hand drill after the holes have been located with a center punch. A drawing is also given for the panel support brackets, cut from 3/8- by 1/16-in. brass strip.

The hardest work is on the coil. This is wound with No. 24 S.S.C. wire on a G. A.-Lite tube 3 ins. in diameter. To start the winding, put a pin into the tube 1/2 in. from one end, and twist the wire around it. Then wind to the first tap as

indicated in Fig. 2. At this point bend the wire toward the start of the coil and put one turn around the part already wound. Bring the end of this turn around to the place where it was started and wind on to the next tap. Secure the last turn with another pin. When the coil is finished, cut those extra turns, twist them together where they started, and bring them out for taps to the switch.

Before the coil is mounted, the detector parts, switch, switch points, fixed condenser, and binding posts should be put on. Then comes the coil, supported on the two mounting pillars. Great care must be taken in connecting the taps to the switch point, so that extra soldering

only way to insure perfect and permanent contact, and is well worth the additional work involved.

Operating the Receiver

This receiver is designed to operate on a single-wire antenna 100 to 150 ft. long and 30 to 50 ft. high, with the lead-in brought from any part of the antenna. One 3-in. HF insulator is needed at each end. The lead-in should be connected to the upper binding post on the panel, and a wire from a water pipe to the lower. The phones, preferably 2,000-ohm Murdocks, go to the center posts. A buzzer is needed to test the adjustment of the detector. It should be connected with a dry cell and push button,

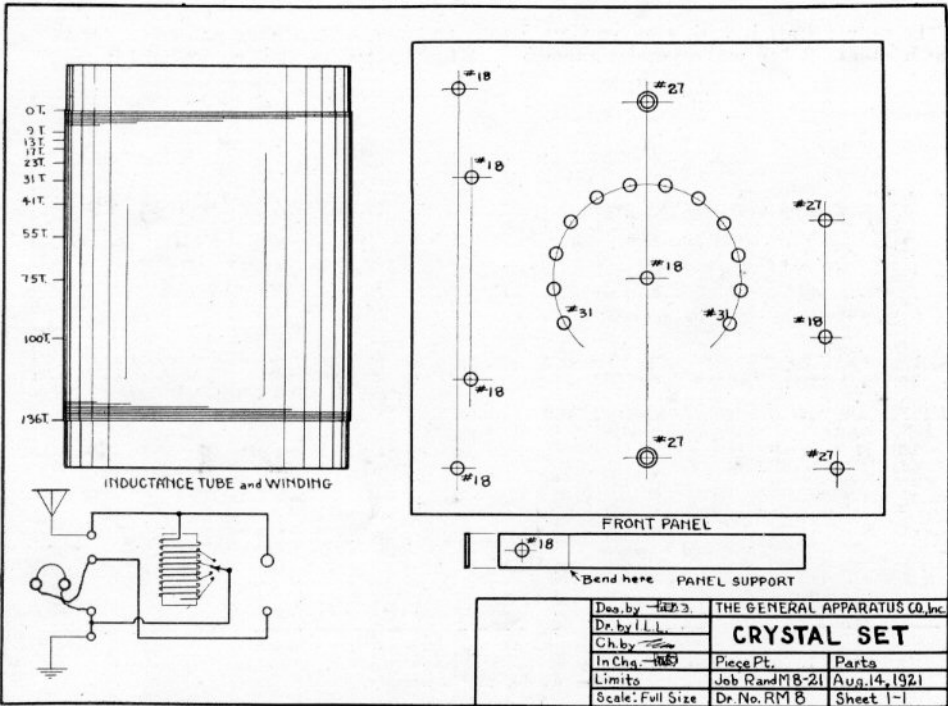

Fig. 2. Exactly one-half size. Showing the parts and the wiring of the completed outfit.

paste will not run over the panel. An old tooth brush is handy for cleaning out of the way places. The best practice is to increase controls by turning clockwise. Therefore, the first tap should be brought to the left hand switch point, and so on until the last tap goes to the last right hand point.

Connections are given in Fig. 2. Made with square tinned copper wire, they can be easily fitted and soldered. That is the

with a wire running from one terminal of the buzzer to the ground lead. When the detector is in adjustment the buzzing can be heard in the telephone. To tune the set for incoming signals simply turn the switch back and forth until sounds are heard at maximum strength.

If this outfit is properly installed, it will tune from 200 to 1,000 meters and bring in the larger stations up to 500 miles away.

NOTICE—On account of misunderstandings concerning the receipt of copies due to the fact that R. and M. has appeared at the end of the current month instead of the first, this issue is called August and September. This is not, however, a double number. Yearly subscriptions will receive twelve issues.

WHERE TO BUY

These Companies Can Supply GA-STD Parts and Supplies. If they Do Not Have in Stock What You Want, They Will Order It for You

<p>PHILADELPHIA SCHOOL OF WIRELESS TELEGRAPHY 1553 Pine Street, Philadelphia, Pa. GA-STD Parts for Building Instruments described in R. and M. Walk—Don't Write</p>	<p>THE CINO RADIO MFG. CO. 218 West 12th Street Cincinnati, Ohio Save Time—Buy Your GA-STD Parts at Our Retail Store Mail Orders Filled Promptly</p>
<p>THE SOUTHWEST RADIO SUPPLY CO. 217 St. Paul Street Dallas, Texas The Place to Get Your GA-STD Supplies —It's in Dallas</p>	<p>THE BARWICK RADIO CO. 89 Britannia Ave., Hamilton, Ont., Canada Radio Is Our Business —Not A Side Line—</p>
<p>BANGERT ELECTRICAL CO., Inc. 297 Fulton St. 27 Main St. Jamaica, N. Y. Hempstead, L. I. We supply all GA-STD parts to Readers of R. and M.</p>	<p>DeLANCEY, FELCH & COMPANY 12 Meeting Street, Pawtucket, R. I. Order GA-STD Supplies From Us By Mail or Get Them at Our Retail Store</p>
<p>ADVERTISING SECTIONS Bring to Radio Dealers orders for GA-STD supplies to make apparatus described in R and M \$2.00 per month per section</p>	<p>R and M STIMULATES SALES for parts and Supplies. Dealers put in an order for monthly delivery. Generous discount, fully returnable</p>

STANDARDIZED PARTS FOR THE DETECTOR AND TWO-STEP AMPLIFIER

2—L.P.F. panels 5x10x3-16 in...	(24 oz.)	\$2.62
1—L.P.F. rear panel 2½x10¼ in...	(4 oz.)	.45
4—Lengths ⅜ in. angle brass.....	(8 oz.)	.80
6—Lengths square tinned copper wire	(4 oz.)	.36
3—Paragon rheostats	(16 oz.)	5.25
2—New type Federal transformer (16 oz.)		14.00
2—Federal closed circuit jacks.....	(6 oz.)	1.75
1—Federal open circuit jacks.....	(3 oz.)	.70
3—GA-STD-A1 sockets	(12 oz.)	2.40
10—GA-STD-A10 binding posts.....	(5 oz.)	1.00
1—Pkg. small soldering lugs.....	(1 oz.)	.25
2—Pkgs. F.H. 6-32 ½-in. screws, nickeled	(2 oz.)	.24
1—Pkg. R.H. 6-32 ½-in. screws, nickeled	(1 oz.)	.12
1—Pkg. R.H. 4-36 ½-in. screws, nickeled	(1oz.)	.11
3—Pkgs. 6-32 nuts, nickeled.....	(2 oz.)	.24
1—Pkg. 4-36 nuts, nickeled.....	(1 oz.)	.08
3—Standard Navy knobs for rheostats	(1 oz.)	.50
1—GA-STD-A4 grid leak condenser (1 oz.)		.50

As listed above, ready to assemble in your own shop.....(7 lb.) \$29.90

SEMI-FINISHED PARTS

Front panel drilled extra.....	\$.95
Bottom panel drilled, extra.....	.90
Rear panel drilled, extra.....	\$.50
Complete support frames, rickeled, per pr.	1.25
Drilling all panels and mounting all parts ready to wire	4.96

COMPLETE AMPLIFIER

Ready to operate, as described.....(7 lb.) \$60.00

AUXILIARY PARTS

G.A. standardized B battery Navv size, 22½ volts.....	(5 lbs.)	\$2.00
With "be" 6-volt, 40-amp-hour storage battery	(15 lbs.)	15.00

Radiotron detector tube, UV 200..	(8 oz.)	5.00
Radiotron amplifier tube, UV 201..	(8 oz.)	6.50
Federal telephone plug.....	(4 oz.)	2.00
Fada rheostat, to use in place of Paragons	(6 oz.)	1.25

STANDARDIZED PARTS FOR THE SINGLE CIRCUIT CRYSTAL RECEIVER

1—L.P.F. panel 5x5x3-16 in.....	(6 oz.)	\$.67
1—G.A. Lite tube 3 ins diam.....	(5 oz.)	.32
1—¼ lb. spool No. 24 S.S.C. wire.....	(5 oz.)	.70
10—G.A.-STD-A13 switch points.....	(1 oz.)	.40
1—Switch, complete	(2 oz.)	.40
2—Coil mounting pillars.....	(3 oz.)	.16
1—Detector parts	(3 oz.)	1.00
1—Mounted galena crystal.....	(1 oz.)	.50
4—GA-STD-A10 binding posts.....	(4 oz.)	.40
1—Brass strip ½x1-16 in.....	(3 oz.)	.13
2—Lengths sq. tinned cop. wire.....	(2 oz.)	.12
1—Pkg. F.H. 6-32 ½-in. screws, nickeled	(2 oz.)	.12
1—Pkg. 6-32 ¼-in. screws, nickeled (1 oz.)		.11
1—Pkg. 6-32 nuts, nickeled.....	(1 oz.)	.08
1—Pkg. No. 6 washers.....	(1 oz.)	.04
1—G.A.-STD-A3 phone condenser (1 oz.)		.35

COMPLETE SET OF PARTS

As listed above ready to assemble in your own shop.....(4 lb.) \$4.92

SEMI-FINISHED PARTS

Front panel drilled, extra.....	.50
Coil wound and tapped, complete..	(10 oz.) 1.30
Pan-1 switch switch points and coil mounted with taps soldered (2 lbs.)	4.30

COMPLETE RCFIVER

Ready to operate, as described.....(4 lbs.) 9.65

AUXILIARY PARTS

Antenna wire, No. 14 bare copper, per 100 ft.....	(2 lbs.)	\$.94
3-in. RR insulators, 33 000 volts, 350 lb.....	(6 oz.)	.25
Murder-1 phones, 2,000 ohms, with headband	(1 lb.)	4.50
Midget test buzzer.....	(6 oz.)	.75

TERMINAL SWITCH POINT



AN all-purpose binding post, finely finished in polished nickel. Will hold several wires as well as cord tips. Looks well against an L.P.F. panel. Base 5/16-in. high, 5/16-in. diameter, 8/32 screw.

PRICE: GA-STD—A10 Binding Post\$0.10
 GA-STD—8 Binding Post Base..... .04
 GA-STD—9 Binding Post Thumb Nut05

CLASS 2-D

MAKING the A-13 switch point 1/8 in. high allows the switch arm to be horizontal. Handsomely finished in polished nickel, this point, 1/4-in. diameter, 3/8-in. shank threaded 4/36, is fitted with an extra small nut for large clearance between points.

PRICE: GA-STD—A13 Switch Point\$0.04
 GA-STD—10 extra small 4/36 nut, per 1015

CLASS 1-D

S O C K E T

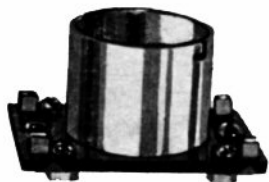

YOU will find, when you test the A1 socket in the laboratory, that at any price there is none better because the L.P.F. base, 1 3/4 x 2 1/2 ins., gives a higher resistance between the grid and filament than any other make because of the low surface leakage assuring maximum potential on the grid. Phosphor bronze springs

make perfect contact, solid tube of polished aluminum holds the tube snugly.

PRICE: GA-STD—A1 Socket, 5 oz.\$0.80
 GA-STD—1 Aluminum Socket Tube, 2 oz.40
 GA-STD—2 Contact Springs, set of 415

CLASS 5-D

GA-STD

G.A. STANDARDIZED EXPERIMENTAL SUPPLIES

THE GENERAL APPARATUS COMPANY, Inc.

570 West 184th Street

New York City